

# Model D3012-D3016 Wood Clamp Hardware Kit Instruction Sheet



Phone #: (360) 734-3482 • Online Tech Support: [tech-support@shopfox.biz](mailto:tech-support@shopfox.biz) • Web: [www.shopfox.biz](http://www.shopfox.biz)

## Introduction

The Shop Fox Wood Clamp Hardware Kit provides all the necessary hardware to make your own wood clamp. Wood clamps are very handy during many woodworking applications. Wood jaws are non-marring and eliminate the need for pads, and two wood clamps can work together for a quick and easy bench vise. The jaws of the clamp should be made from a hardwood such as maple.

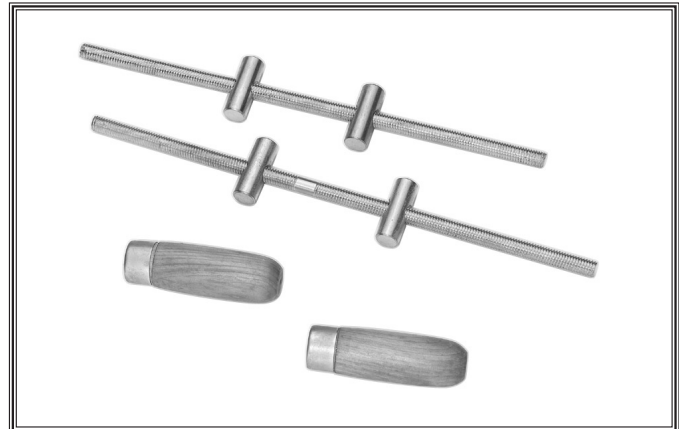

Figure 1. Wood Clamp Hardware Kit.

## **!WARNING**

Be sure to read the entire instruction sheet before beginning the construction of the wood clamps. Follow every step and use the recommended tools and supplies. Also, read the instruction manuals and follow all safety precautions for any tools you are using to complete this project. Be certain that the tools used for this installation are intended for the task that will be performed. Failure to do this could result in serious personal injury.



## **!WARNING**

Wear safety glasses during the entire assembly process. Failure to comply may result in serious personal injury.

We stand behind our products! In the event that questions arise about this product, please contact Woodstock International Technical Support at (360) 734-3482 or send e-mail to:

[tech-support@shopfox.biz](mailto:tech-support@shopfox.biz).

## Inventory

Item	Qty.
Wooden Handles .....	2
Threaded Clamp Rods .....	2
Handle Pins .....	2
Dowel Nuts (Right-Hand Threads) .....	2
Dowel Nuts (Left-Hand Threads) .....	2

## Tools Required

- Saw (Hand Saw, Bandsaw, Table Saw or Jig Saw)
- Drill Press/Drill Bit Set
- Ball Peen Hammer
- Sandpaper

## Materials Required

- Hardwood Stock (see **Sizing Information** for approximate dimensions).

**COPYRIGHT © 2001 BY WOODSTOCK INTERNATIONAL, INC. REVISED JUNE, 2011 (JB)**

**WARNING: NO PORTION OF THIS MANUAL MAY BE REPRODUCED IN ANY SHAPE OR FORM WITHOUT THE WRITTEN APPROVAL OF WOODSTOCK INTERNATIONAL, INC.**

Printed in China

### Sizing Information

The dimensions below are based on standard wood hand-screw clamps for each size kit. The jaws can be created according to these dimensions or customized to your own needs. Due to the custom nature of the kit, the overall size and shape of the clamp can vary significantly. Keep in mind, however, that the clamping capability is determined by the hardware included, so you should adhere to the basic overall dimensions to avoid creating oversized clamps with undersized hardware!

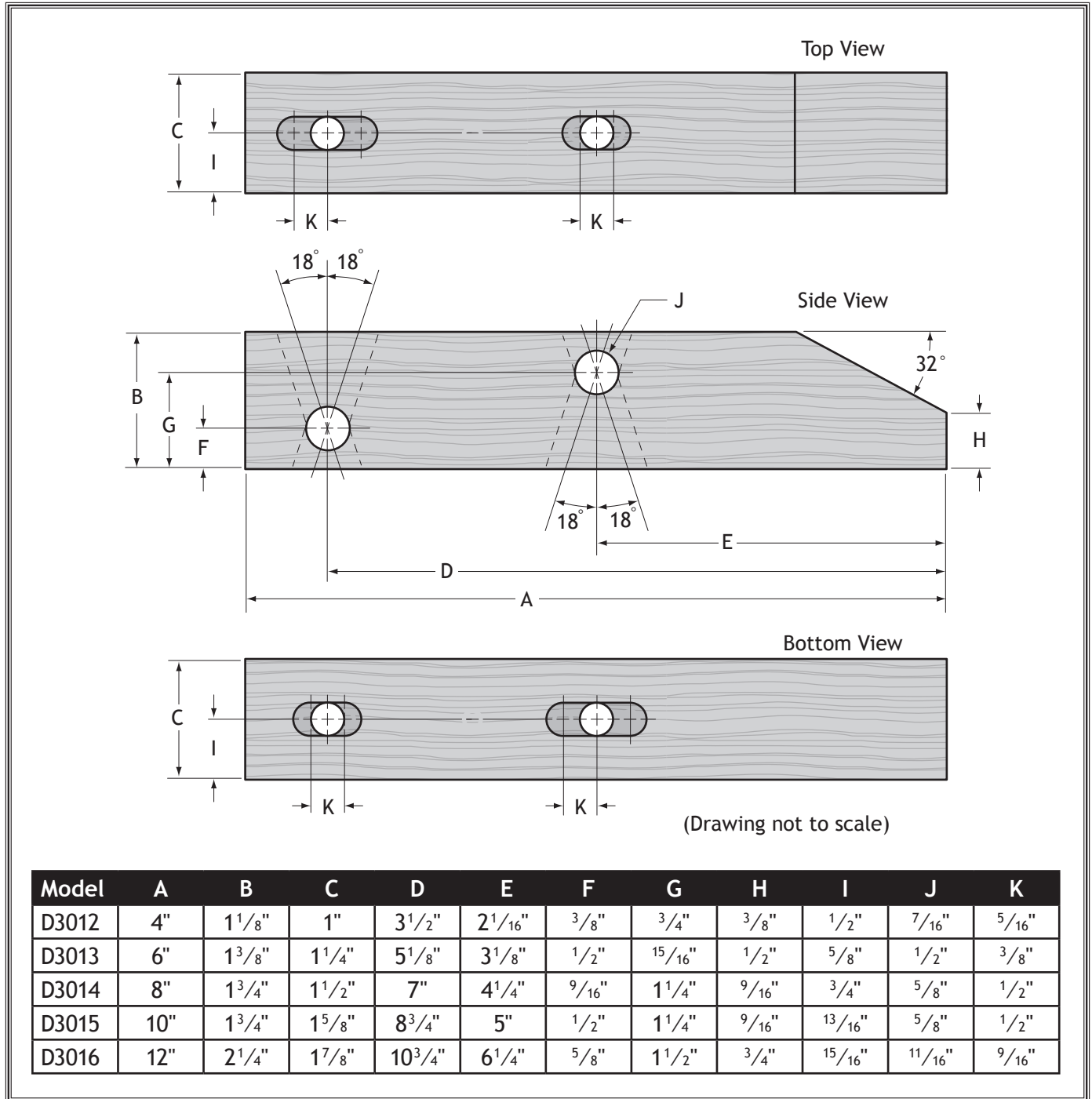

Figure 2. Sizing information.

## Construction and Assembly

Once you have determined the material you will use and the size and shape of your clamp jaws, you are ready to begin construction and assembly.

To construct and assemble the clamps, do these steps:

1. Use the drawing and dimensions from **Figure 2** or your own design to cut out the shape of the clamp jaws. Sand all edges to reduce splinters and workpiece marring.

**Note:** The following illustrations show a standard jaw shape. The jaws you create for your clamp can be customized as desired.

2. Drill four holes for the dowel pins in the locations shown in **Figure 2** or the approximate locations shown in **Figure 3**. Refer to **Sizing Information** on the **Page 2** for the proper hole size.

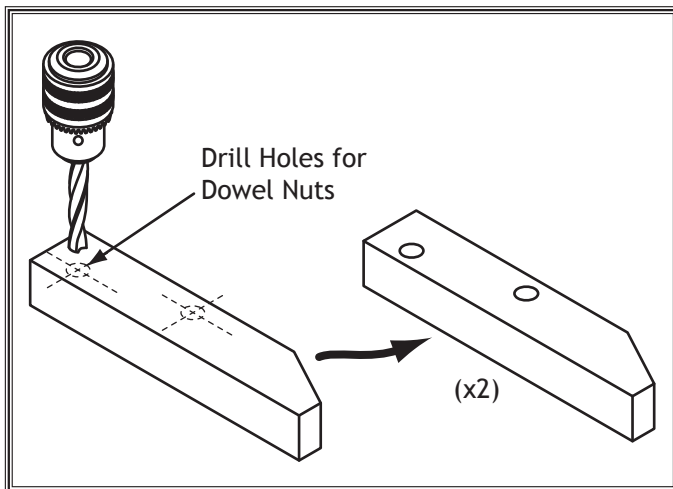

**Figure 3.** Drilling dowel nut holes.

3. Rotate the jaws, then drill four holes for the threaded rods. Make sure the holes are centered in the jaws and that they are aligned with the dowel nut holes (see **Figure 4**). Refer to **Sizing Information** on **Page 2** for the proper hole size.

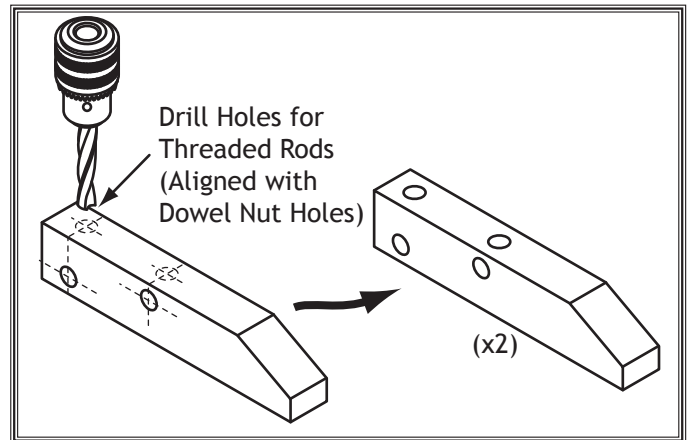

**Figure 4.** Drilling threaded rod holes.

4. If greater clamping flexibility is desired, drill additional holes at  $18^\circ$  &  $-18^\circ$  in the positions shown in **Figure 5**. Make additional passes with the drill bit as needed to clear all remaining material from the elongated holes to prevent binding during use.

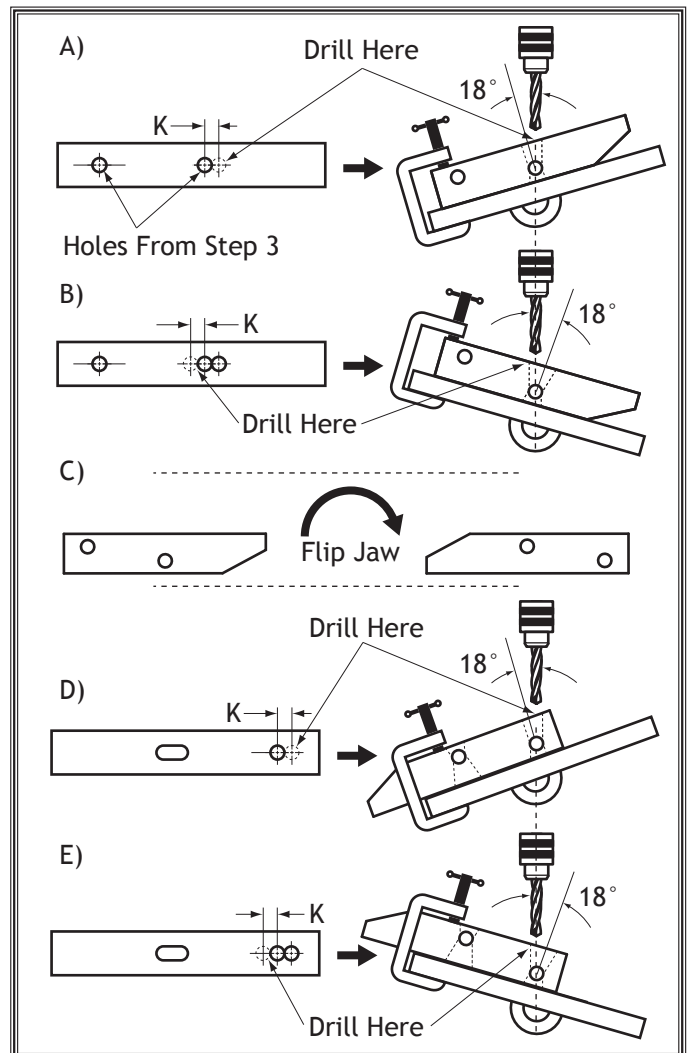

**Figure 5.** Elongating threaded rod holes.

5. Insert the four dowel nuts into the holes drilled in **Step 2**, making sure the left-hand threaded dowel nuts go into the positions shown in **Figure 6**.

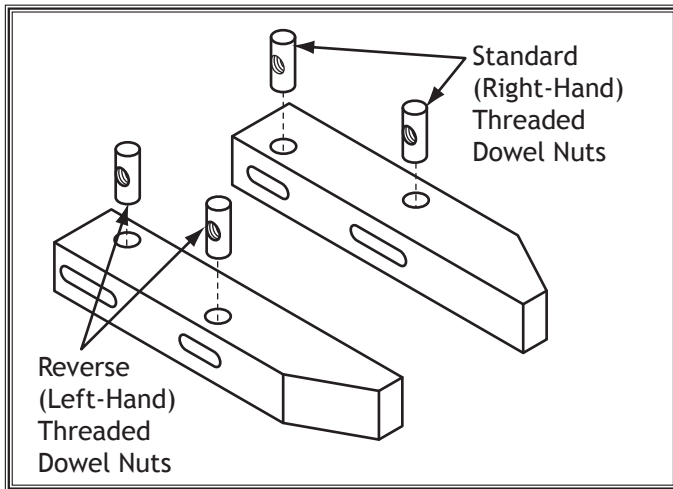

**Figure 6.** Inserting dowel nuts.

6. Evenly thread each end of both threaded rods into the dowel nuts, as shown in **Figure 7**, until enough rod is exposed to slide the handles all the way over the rods.

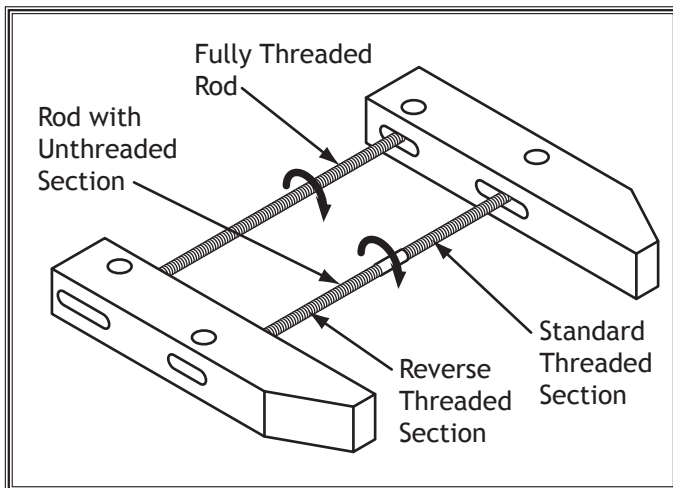

**Figure 7.** Inserting threaded rods.

7. Drill two  $\frac{1}{8}$ " holes completely through the handles and the threaded rods, as shown in **Figure 8**.

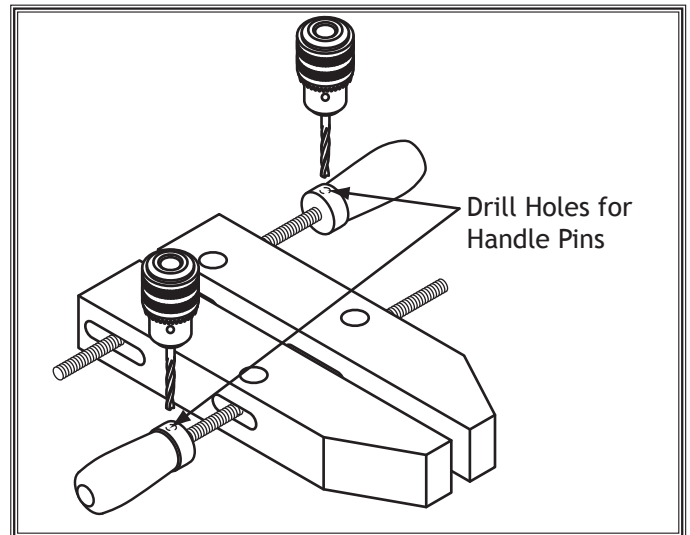

**Figure 8.** Drilling holes for handle pins.

8. Insert a handle pin through each handle and threaded rod, support the head of the pin from beneath, then use a small hammer to mushroom the exposed end of the handle pin, as shown in **Figure 9**, to prevent it from falling out.

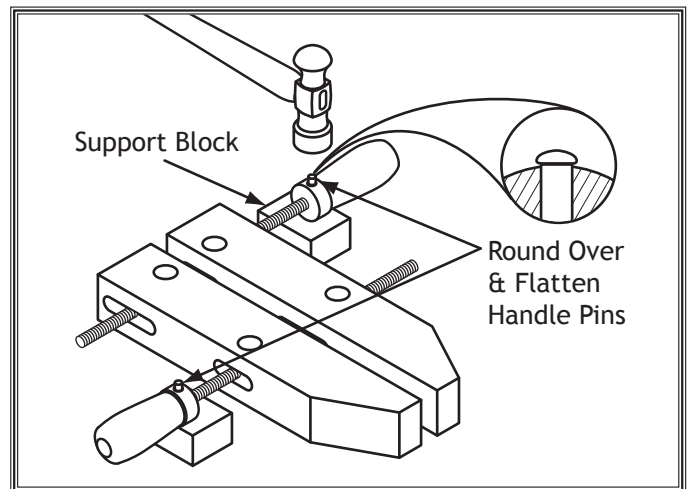

**Figure 9.** Inserting handle pins.

Congratulations—construction and assembly of the clamp is complete!

## Free Manuals Download Website

<http://myh66.com>

<http://usermanuals.us>

<http://www.somanuals.com>

<http://www.4manuals.cc>

<http://www.manual-lib.com>

<http://www.404manual.com>

<http://www.luxmanual.com>

<http://aubethermostatmanual.com>

Golf course search by state

<http://golfingnear.com>

Email search by domain

<http://emailbydomain.com>

Auto manuals search

<http://auto.somanuals.com>

TV manuals search

<http://tv.somanuals.com>