

MODEL W1737/W1738 37" WIDE-BELT SANDER



OWNER'S MANUAL (FOR MODELS MANUFACTURED AFTER 10/09)

Phone: 360-734-3482 • On-Line Technical Support: tech-support@shopfox.biz

COPYRIGHT © JULY 2005 BY WOODSTOCK INTERNATIONAL, INC. REVISED NOVEMBER, 2009 (JB)

WARNING: NO PORTION OF THIS MANUAL MAY BE REPRODUCED IN ANY SHAPE OR FORM WITHOUT

#6965CR

THE WRITTEN APPROVAL OF WOODSTOCK INTERNATIONAL, INC.

Printed in Taiwan

WARNING

Some dust created by power sanding, sawing, grinding, drilling, and other construction activities contains chemicals known to the State of California to cause cancer, birth defects or other reproductive harm. Some examples of these chemicals are:

- Lead from lead-based paints.
- Crystalline silica from bricks, cement, and other masonry products.
- Arsenic and chromium from chemically treated lumber.

Your risk from these exposures varies, depending on how often you do this type of work. To reduce your exposure to these chemicals: work in a well ventilated area, and work with approved safety equipment, such as those dust masks that are specially designed to filter out microscopic particles.

Contents

INTRODUCTION	3
About Your New Sander	3
Woodstock Technical Support	3
Specifications (W1737 and W1738).....	4
Controls and Features	5
Standard Safety Instructions	6
Additional Safety Instructions for Sanders	8
Avoiding Potential Injuries.....	9
ELECTRICAL REQUIREMENTS	10
220V/440V Operation.....	10
Phase Converter Connection	10
440V Conversion (W1738).....	11
Phase Converter Connection	11
SETUP	12
Unpacking	12
Box Contents.....	12
Machine Placement	13
Cleaning Machine.....	13
Air Hose Installation	14
Sanding Belt Installation	14
Breather Pin.....	15
Dust Collection	15
OPERATIONS	16
Control Panel	16
Test Run.....	17
General Operation	17
Using the Amp Draw Meter	18
Selecting Sandpaper	18
Setting Feed Speed	18
Emergency Stop	19
Keypad and Display	19
Calibrating the Table	19
Basic Sanding	20
Using the Platen.....	21
Jet Air Flow	21
Belt Tracking.....	22
Belt Oscillation Speed	23
MAINTENANCE	24
General	24
Lubrication	24
Cleaning Belts	25
Maintaining Air System	25

Continued on next page 

USE THE QUICK GUIDE PAGE LABELS TO SEARCH OUT INFORMATION FAST! 

Contents

SERVICE	26
Table Stop Switches	26
Brake Service	27
Changing V-Belts	28
V-Belt Tension.....	29
Table Parallelism	30
Feed Belt Tension and Tracking	31
Belt Tracking Safety Switch	32
Belt Tension Safety Switch.....	32
Pressure Rollers.....	33
General Motor and Transformer Connection	34
W1737 and W1738 Control Panel Wiring	35
W1737 General Wiring Diagram.....	36
W1738 General Wiring Diagram.....	37
W1738 Electrical Box Component Locations	38
W1738 Electrical Box Wiring Diagram	39
W1737 Electrical Box Component Locations	40
W1737 Electrical Box Wiring Diagram	41
Electrical Parts	42
Tools and Cabinet Parts	44
Sanding Motor and Frame Parts.....	46
Table Lift System Parts.....	48
Feed System and Conveyor Parts.....	50
Upper Roller System Parts	52
Air System Parts	54
Sanding Drum and Roller Parts.....	56
Safety Label Placement	58
Notes	60
Troubleshooting.....	62
Warranty.....	63
Warranty Registration	64



USE THE QUICK GUIDE PAGE LABELS TO SEARCH OUT INFORMATION FAST!

INTRODUCTION

About Your New Sander

Your new **SHOP FOX®** Sander has been specially designed to provide many years of trouble-free service. Close attention to detail, ruggedly built parts and a rigid quality control program assure safe and reliable operation.

Built for industrial shop use, the 37" wide-belt sander is available as the Model W1737, 10 HP, 220V single-phase unit, and the Model W1738, 15 HP, 220V/440V, three-phase unit. Both machines use triple V-belt driven double sanding drums with a 1 HP variable-speed conveyor, and can sand doors and panels up to 36 1/2" wide. For light-feather sanding, the key pad and digital readout, and the micro-adjustable felt/graphite platen provide excellent sanding to tolerances within 0.005". For aggressive sanding, the amp draw meter enables the operator to prevent motor overload, and the air-operated oscillation system allow for superb gouge-free finished panels.

Woodstock International, Inc. is committed to customer satisfaction in providing this manual. It is our intent to make sure all the information necessary for safety, ease of assembly, practical use and durability of this product be included.

If you need the latest edition of this manual, you can download it from <http://www.shopfox.biz>.
If you still have questions after reading the latest manual, or if you have comments please contact us at:

Woodstock International, Inc.
Attn: Technical Support Department
P.O. Box 2309
Bellingham, WA 98227

Woodstock Technical Support

We stand behind our machines! In the event that a defect is found, parts are missing or questions arise about your machine, please contact Woodstock International Technical Support at 1-360-734-3482 or send e-mail to: tech-support@shopfox.biz. Our knowledgeable staff will help you troubleshoot problems, send out parts or arrange warranty returns.



Specifications (W1737 and W1738)

W1737 Sanding Motor 10 HP, 220V, Single-Phase, 50A, 1725 RPM, 60 Hz
 W1737 Conveyor Motor 1 HP, 220v, Single-Phase, 7A, 1725 RPM, 60 Hz
 W1737 Elevation Motor 1/3 HP, 220V, Single-Phase, 3.6A, 1725 RPM, 60 Hz

W1738 Sanding Motor 15 HP, 220/440V*, 3-Phase, 36/18A, 1725 RPM, 60 Hz
 W1738 Conveyor Motor 1 HP, 220/440V*, 3-Phase, 3.4/1.7A, 1725 RPM, 60 Hz
 W1738 Elevation Motor 1/4 HP, 220/440V, 3-Phase, 1.2/0.6A, 1725 RPM, 60 Hz

*440V Overload Relay Conversion Kit Sold Separately.

W1737 and W1738:

Table Elevation Drive..... V-Belt
 Cabinet Size 69⁵/₈" High X 52¹/₈" Wide X 49³/₈" Deep
 Air Control Built-in Air Filter/Regulator
 Oscillation System 75 PSI Pneumatic Belt Tracking and Tensioning System
 Sanding Drum Material Heavy-Duty Rubber
 Sanding Drum Drive..... Triple V-belt
 Sanding Drum Surface Speed..... 2,565 FPM
 Conveyor Drive Variable Speed Belt/gearbox
 Conveyor Feed Rate Variable, 15-49 FPM
 Infeed Drum Material..... Heavy-Duty Rubber
 Outfeed Drum Material Steel
 Maximum Board Width 36¹/₂"
 Maximum Board Thickness..... 6"
 Minimum Board Length 14"
 Dust Ports (Three) 4"
 Power Control Independent Motor Control System
 Machine Control..... Unified Main Control Panel with Key Pad and Digital Readout
 Sanding Load Indication Amp Draw Meter
 Light Sanding Control Micro-Adjustable Graphite/Felt Platen System
 Safety Control Safety Shut-Off Bar
 Net Weight 1984 Lbs

Controls and Features (W1737/W1738)

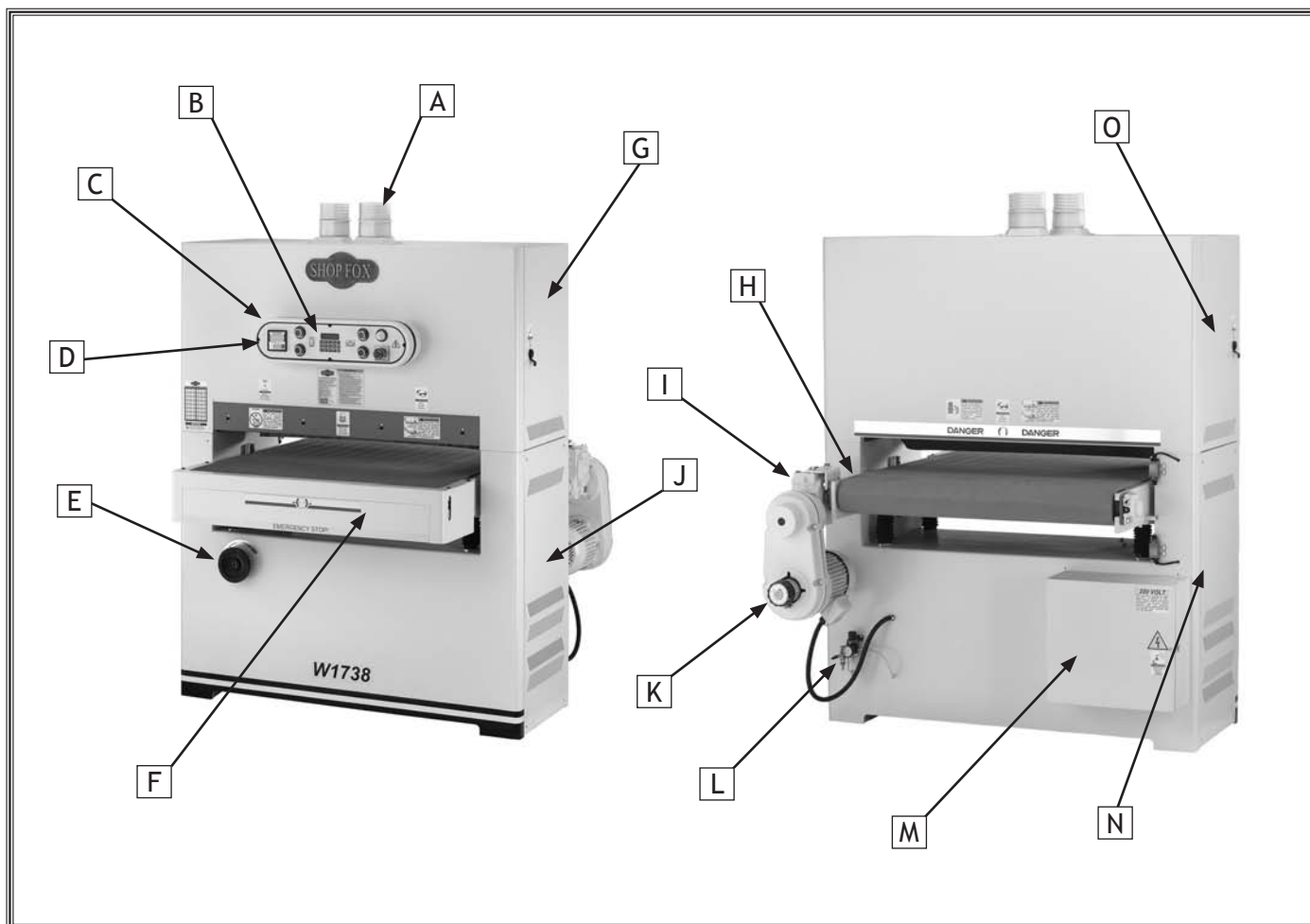

- A. Three 4" Dust Ports and Adapters
- B. Digital Table Height Key Pad
- C. Control Panel
- D. Digital Amp Draw Meter
- E. Table Height Handwheel
- F. Emergency Stop Push-Panel
- G. Upper Right Access Door
- H. Non-Slip Conveyor Belt

- I. Conveyor Gear Box
- J. Sanding Motor Access Panel
- K. Conveyor Speed Control
- L. Air Pressure Regulator
- M. Main Wiring Box
- N. Table Lift Motor Access Panel
- O. Upper Left Access Door

SAFETY FIRST!

**READ MANUAL BEFORE OPERATING MACHINE.
FAILURE TO FOLLOW INSTRUCTIONS BELOW WILL
RESULT IN PERSONAL INJURY.**



Indicates an imminently hazardous situation which, if not avoided, **WILL** result in death or serious injury.



Indicates a potentially hazardous situation which, if not avoided, **COULD** result in death or serious injury.



Indicates a potentially hazardous situation which, if not avoided, **MAY** result in minor or moderate injury, **MAY** result in property damage.

NOTICE

This symbol is used to alert the user to useful information about proper operation of the equipment.

Standard Safety Instructions

1. **Thoroughly read the instruction manual before operating your machine.** Learn the applications, limitations and potential hazards of this machine. Keep manual in a safe, convenient place for future reference. Make sure any other operators have read and understand the manual as well.
2. **Keep work area clean and well lighted.** Clutter and inadequate lighting invite potential hazards.
3. **Ground all tools.** If a machine is equipped with a three-prong plug, it must be plugged into a three-hole grounded electrical outlet or grounded extension cord. If using an adapter to aid in accommodating a two-hole receptacle, ground using a screw to a known ground.
4. **Wear eye protection at all times.** Use safety glasses with side shields or safety goggles that meet the national safety standards, while operating this machine.
5. **Avoid dangerous environments.** Do not operate this machine in wet or open flame environments. Airborne dust particles could cause an explosion and severe fire hazard.
6. **Ensure all guards are securely in place and in working condition.**
7. **Make sure switch is in the "OFF" position** before connecting power to machine.
8. **Keep work area clean, free of clutter, grease, etc.**
9. **Keep children and visitors away.** Visitors should be kept at a safe distance away while operating unit.
10. **Childproof workshop with padlocks, master switches or by removing starter keys.**
11. **Disconnect machine when cleaning, adjusting or servicing.**

12. **Do not force the machine.** The machine will do a safer and better job if it does the work.
13. **Use the correct tool.** Do not force the tool or attachment to do a job for which it was not designed.
14. **Wear proper apparel.** Do not wear loose clothing, gloves, jewelry, keep long hair tied up, etc.
15. **Remove adjusting keys and wrenches.** Before turning the machine on, make a habit of checking that all adjusting keys and wrenches have been removed before turning the machine *ON*.
16. **DO NOT use extension cord.** Due to the high-amperage draw of this industrial machine, we do not recommend using an extension cord. If you use an extension cord with an undersized gauge or one that is too long, excessive heat will be generated within the circuit increasing the chance of a fire or damage to the circuit.
17. **Keep stable footing and balance** at all times.
18. **Do not leave machine unattended.** Wait until it comes to a complete stop before leaving the area.
19. **Perform machine maintenance and care.** Follow lubrication and accessory attachment instructions in the manual.
20. **Keep machine away from open flame.** Operating machines near pilot lights and/or open flames creates a high risk if dust is dispersed in the area. Dust particles and an ignition source may cause an explosion. Do not operate the machine in high-risk areas, including but not limited to, those mentioned above.
21. **If at any time you are experiencing** difficulties performing the intended operation, stop using the machine! Then contact our Service Department or ask a qualified expert how the operation should be performed.
22. **Habits—good and bad—are hard to break.** Develop good habits in your shop and safety will become second-nature to you.

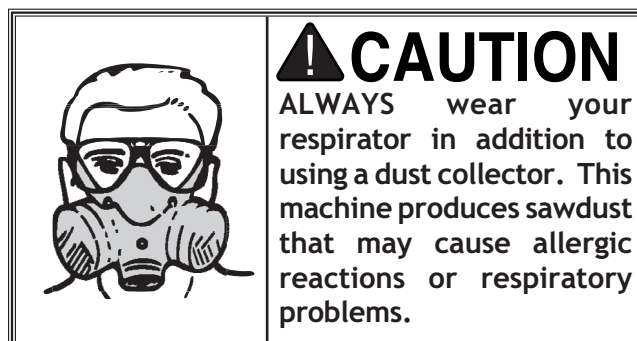

Additional Safety Instructions for Sanders

SAFETY

	<p>! WARNING</p> <p>READ and understand this entire instruction manual before using this machine. Serious personal injury may occur if safety and operational information is not understood and followed. DO NOT risk your safety by not reading!</p>
---	---

<p>! CAUTION</p> <p>USE this and other machinery with caution and respect, and always consider safety first, as it applies to your individual working conditions. Remember, no list of safety guidelines can be complete, and every shop environment is different. Failure to follow guidelines can result in serious personal injury, damage to equipment and/or poor work results.</p>

1. **PROTECTING YOUR LUNGS.** Sanding operations create large amounts of fine dust. Some types of dust may cause allergic reactions or respiratory problems. In addition to wearing a dust mask, always use a dust collector and overhead air filter for maximum protection.
2. **AVOIDING ENTANGLEMENT.** Do not allow your fingers to get pinched between the board and the conveyor belt during feeding. The grip of the conveyor belt may pull the operator's hand into the machine and cause serious injury or death. Similarly, do not place hands near the sanding belts during operation.
3. **AVOIDING SANDING HAZARDS.** Know the limits of the sander. Do not sand stock thinner than 1/8" or shorter than 14".
4. **AVOIDING ENTANGLEMENT.** Never perform sanding operations with the access doors open.
5. **AVOIDING PROJECTILES.** Always inspect stock for staples, nails, dirt or other foreign objects before sanding. These items may cause damage to your sander or may even be thrown at a high rate of speed from the sander at you.
6. **AVOIDING PROJECTILES.** Never allow anyone to stand directly in front or behind the path of the stock as it is being fed through the sander. The stock may be ejected at a high rate of speed and could cause serious injury to the operator or bystanders.
7. **SANDING CORRECTLY.** Seek proper training/supervision before operating this sander. Do not force stock into the sander during operation or overload the sanding drums beyond reasonable limits. Also, only sand natural wood fiber through your sander. Other materials may damage your machine and open the possibility for operator injury. Keep the internal components clean and lubricated to ensure that the sander can perform the way it was intended.
8. **USING DUST COLLECTION SYSTEMS.** Never operate the sander without a working dust collection system. The sander is designed to properly do its job only when wood dust is being evacuated. The buildup of too much wood dust in the internal components will cause performance problems and may increase the likelihood of operator injury.
9. **AVOIDING ENTANGLEMENT.** Loose clothing or long hair creates the potential for operator injury because they can easily be caught in the moving parts of the machine. Roll up loose sleeves, tie back long hair and take any other necessary steps to reduce this hazard.

Avoiding Potential Injuries



Figure 1. Correct body and hand positioning.



Figure 2. DO NOT operate without safety glasses/respirator!



Figure 4. DO NOT stand behind workpiece!



Figure 3. DO NOT operate with side door open!



Figure 5. DO NOT allow hand to get pinched in belt!

ELECTRICAL REQUIREMENTS

220V/440V Operation

The SHOP FOX® Model W1737 has a 10 HP, 220V single-phase sanding motor, a 1 HP, 220V feed motor, and a 1/3 HP table lift motor; the Model W1738 has 15 HP, 220V/440V three-phase sanding motor, a 1 HP, 220V/440V feed motor, and a 1/4 HP table lift motor.

Note: *If you do not have three-phase power available to supply the Model W1738, you will have to install a phase converter at the power supply.*

With either machine, you must hard-wire it to your power panel and install an electrical box with a locking shut-off lever. Keep in mind that a circuit being used by other machines or tools at the same time will add to the total load being applied. Add up the load ratings of all machines on the circuit. If this number exceeds the rating of the circuit breaker or wiring, use a different circuit.

- For the Model W1737 220V single-phase operation, use a 50 amp circuit that has wiring rated to handle this amperage draw.
- For the Model W1738 220V three-phase operation, use a 40 amp circuit that has wiring rated to handle this amperage draw.
- For the Model W1738 440V three-phase operation, use a 20 amp circuit that has wiring rated to handle this amperage draw.

Phase Converter Connection

If you do not have three-phase power available to the W1738 sander, you will have to install a phase converter.

When using a phase converter, the power from the manufactured power leg (sometimes called the wild wire) can fluctuate. Connect the manufactured power leg to the T terminal to prevent damage to the transformer. The wire from the T terminal can handle some fluctuation because it goes directly to the motor. The power going to the R and S terminals goes to the transformer and must not fluctuate to prevent damage.

⚠ WARNING



DO NOT attempt to work on your shop electrical system if you are unsure about electrical codes and wiring! Seek assistance from a qualified electrician. Ignoring this warning can cause electrocution!

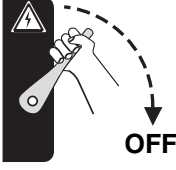

⚠ WARNING

TURN OFF and **LOCK** your master power switch so no power is available to the sander before connecting electrical wires! If you ignore this warning serious electrical shock may occur causing injury or death!



⚠ WARNING

This machine must be grounded! If you have any questions about correct electrical installation, contact a qualified electrician for assistance to make sure all connections are safe and adhere to your local electrical codes.

ELECTRICAL

440V Conversion (W1738)

To connect this machine to 440V three-phase, you must purchase one LR3D-076 overload relay (Shop Fox PN: X1738003-1) and one LR3D-3322 overload relay (Shop Fox PN: X1738011-1).

To wire the W1738 to 440V, do these steps:

1. Disconnect the sander from the power source!
2. Open the electrical box located on the back of the machine.
3. Remove the wire labeled "1" at the 220V terminal of the control power transformer (Figure 6) and connect it to the 440V terminal (Figure 7).
4. Remove the LR3D-3355 overload relay (Figure 6), and replace it with an LR3D-3322 (X1738003-1) type, with the dial set to 18A.
5. Remove the LR3D-086 overload relay (Figure 6), and replace it with an LR3D-076 (X1738011-1) type, with the dial set to 1.7A.
6. Wire the sanding motor, conveyor motor, and table elevation motor as shown on the diagrams on the inside of each motor wire cover.

Note: The circled references on the diagrams represent labels on the wires. Also, Figure 8 has been provided for your reference and is current at the time of writing. However, always use the diagram on the wire cover that comes with your motor!

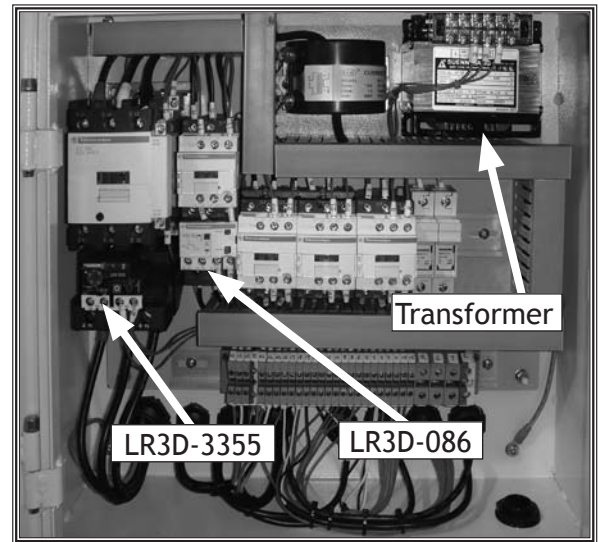

Figure 6. Overload relay and transformer location.

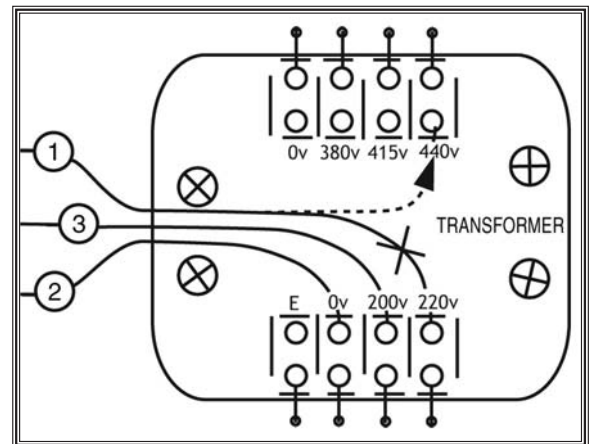

Figure 7. Transformer 220V to 440V connection.

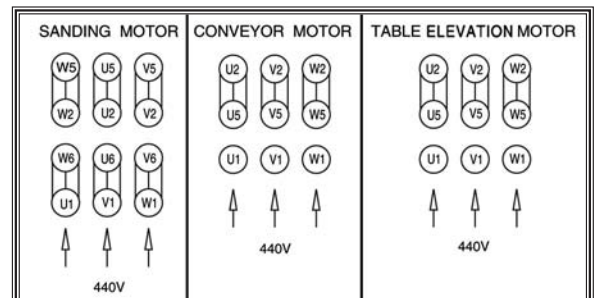

Figure 8. Motor 220V to 440V connection.

ELECTRICAL

SETUP

Unpacking

The Model W1737/W1738 has been carefully packaged for safe transporting. If you notice the machine has been damaged in shipment, contact your machine dealer and the shipping company immediately.

NOTICE

To gain access to the lag bolts that attach the machine to the shipping pallet, you must temporarily remove both lower side panels.



WARNING

SUFFOCATION HAZARD!

Immediately discard all plastic bags and packing materials to eliminate choking/suffocation hazards for children and animals.



Box Contents

The following is a description of the components shipped with the **SHOP FOX®** W1737/W1738. Lay the components out, and use **Figure 9** and the list below to inventory your package. If any parts are missing, find the part number in the back of this manual and call Woodstock International, Inc. at 360-734-3482 or e-mail: tech-support@shopfox.biz.



Figure 9. Parts and tool inventory.

Item	Qty.
Sanding Unit (Not Pictured)	(1)
Dust Ports 4"	(3)
Sanding Belt 100 Grit	(1)
Sanding Belt 180 Grit	(1)
Platen Graphite Flap	(2)
Platen Felt	(1)
Tool Box	(1)
–Phillips Head Screwdriver #2.....	(1)
–Standard Screwdriver #2.....	(1)
–Open-End Wrench 8/10mm	(1)
–Open-End Wrench 12/14mm	(1)
–Open-End Wrench 17/19mm	(1)
–Metric Hex Wrench Set.....	(1)
–Door Keys.....	(2)
–Ceramic Limit Switch Rods	(2)
–Flexible Grease Gun Extension	(1)
–Platen Removal Tool	(1)
–Fuses 4 Amp.....	(2)

SETUP

Machine Placement

- **Floor Load:** Your sander weighs 1781 lbs and has a 52¹/₈" X 49³/₈" footprint. Some floors may require additional bracing to support both machine and operator.
- **Working Clearances:** Consider existing and anticipated needs, size of material to be processed through the machine, and space for auxiliary stands, work tables or other machinery when establishing a location for your sander.
- **Lighting:** Lighting should be bright enough to eliminate shadow and prevent eye strain.
- **Electrical:** Electrical circuits must be dedicated or large enough to handle amperage requirements. Outlets must be located near each machine, so power or extension cords are clear of high-traffic areas. Follow local electrical codes for proper installation of new lighting, outlets, or circuits.

Cleaning Machine

The upper sanding drum of your sander is coated with a waxy grease that protects it from corrosion during shipment. Clean this grease off with a solvent cleaner or citrus-based degreaser. DO NOT use chlorine-based solvents such as brake parts cleaner or acetone—if you happen to splash some onto a painted surface, you will ruin the finish.

	<p>! WARNING NEVER use gasoline or other petroleum-based solvents to clean with. Most have low flash points, which make them extremely flammable. A risk of explosion and burning exists if these products are used. Serious personal injury may occur if this warning is ignored!</p>
--	--

	<p>! WARNING The Model W1737/W1738 is a heavy machine at 1781 lbs. Use power or hydraulic equipment to avoid serious personal injury or death.</p>
--	--

	<p>! CAUTION ALWAYS work in well-ventilated areas far from possible ignition sources when using solvents to clean machinery. Many solvents are toxic when inhaled or ingested. Use care when disposing of waste rags and towels to be sure they DO NOT create fire or environmental hazards.</p>
--	--

	<p>! CAUTION MAKE your shop "child safe." Ensure that your workplace is inaccessible to youngsters by closing and locking all entrances when you are away. NEVER allow untrained visitors in your shop when assembling, adjusting or operating equipment.</p>
--	---

SETUP

Air Hose Installation

Push your air supply hose onto the air pressure regulator inlet fitting, and clamp it in place with a hose clamp as shown in **Figure 10**. If you prefer, you can replace the included air nozzle with a $\frac{3}{8}$ " male quick connect air coupling.

When the air hose is installed, pull up and rotate the regulator air pressure knob until the gauge reads 70 PSI then push down. **DO NOT** attempt to regulate the air pressure with the ON/OFF air supply lever. This lever is the ON/OFF air pressure to the machine only.

NOTICE

To achieve maximum life of the air system o-rings, gaskets, and components, keep the air pressure shut off when not using the sander, and **DO NOT** exceed 75 PSI.



Figure 10. Air hose attached to regulator.

Sanding Belt Installation

Before installing belt, clean the protective grease from the upper metal sanding belt roller as per the **Cleaning Machine** instructions on **Page 13**.

To install the sanding belt, do these steps:

1. **TURN OFF** and **LOCK** your master power switch, but keep the air pressure going into the machine.
2. Turn and remove the lever and support spacer as shown in **Figure 11**.
3. Install the sanding belt so the belt is centered in the fork (see **Figure 12a**), and the belt arrows are pointing in the direction of drum rotation (see **Figure 12**).
4. Center the belt on the rollers.
5. Reinstall the support spacer and lever.
6. Turn the belt tension knob to the 12:00 position and the belt will automatically tighten to the correct tension. At the 9:00 position the belt will have no tension.



Figure 11. Lever removal/installation.

NOTICE

TENSION the sanding belt before starting the sander, and **DE-TENSION** the belt when sander is not in use, or you will damage the belt.

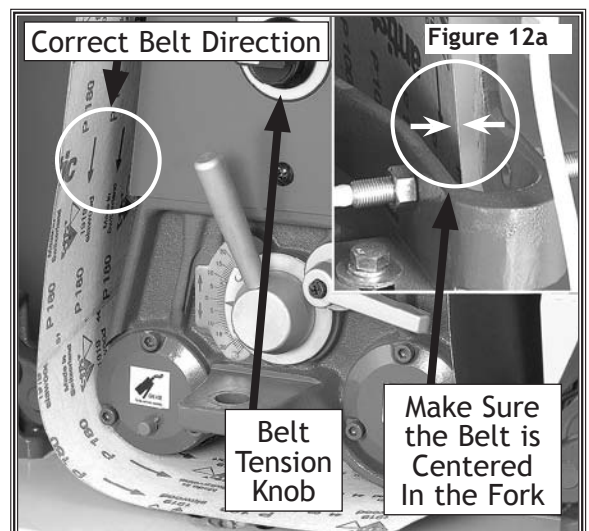

Figure 12. Installing sanding belt left and right machine view.

SETUP

Breather Pin

The Model W1737/W1738 has a breather sealing pin installed in the breather plug for the gear reducer.

Remove this pin before using your sander (see **Figure 13**); otherwise, the gear oil will expand with heat and the seals in the gear reducer may leak due to the pressure build up.

You may want to retain this pin if you plan on storing your sander for a long period of time.

Dust Collection

The Model W1737/W1738 features dust ports and adapters located on top of the machine as shown in **Figures 14 and 15**. Before performing any sanding operations, attach the dust ports to a 2HP or better dust collector, which can draw at least 1,500 CFM, or dust buildup will hinder the performance of your sander.

Even with a sufficient dust collection system, a fine layer of dust may still be present on your stock as it comes out of the sander. This residual dust is a normal condition.

	<p>⚠ CAUTION</p> <p>REMEMBER, this machine produces fine sawdust particles that can be inhaled, causing allergic reactions or respiratory problems. ALWAYS wear your respirator in addition to using an adequate dust collection system that draws at least 1500 CFM.</p>
---	--

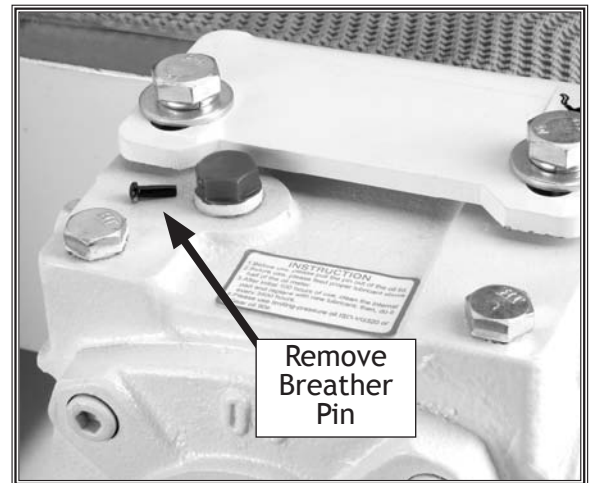

Figure 13. Breather sealing pin removed.



Figure 14. Dust collection adapters.



Figure 15. Dust collection hose attached to dust port.

OPERATIONS

Control Panel

Below is a summary of your sander control panel and the components that it controls. Use the list with **Figure 16** to become familiar with your sander.

- **Sanding Load Amp Meter:**
Indicates the current amp load on the sanding motor when a sanding operation is in progress.
- **Sanding Belt Start and Stop Buttons:**
Turns the sanding motor **ON** and **OFF** if the sander has air pressure and the belt is tensioned.
- **Run LED:** Indicates the conveyor lift motor is operating.
- **Input LED:** Indicates the sander is waiting for new numerical dimension values.
- **Digital Readout:** Displays current sander settings.
- **Table Up and Down Keys:**
Manually cycles the table lift motor to raise and lower the table.
- **SET Key:** Press and hold the SET button for 3 seconds to calibrate display at the current board thickness; or press and hold key for 10 seconds to toggle the display between metric and standard measurement.
- **Feed Belt Start and Stop Buttons:** Cycles the conveyor motor **ON** and **OFF** for feeding wood into the sander.
- **Power Lamp:** Indicates when machine has power to the control panel.
- **Emergency Stop Button:** Stops all electrical power to motors in event of emergency, and stops sanding drums with an air-disc brake.
- **Table Start and Stop Keys:** Cycles the table lift motor in and out of the automatic raise and lower function.
- **Key Pad:** Allows you to input your numerical sanding specifications for automated sanding control.

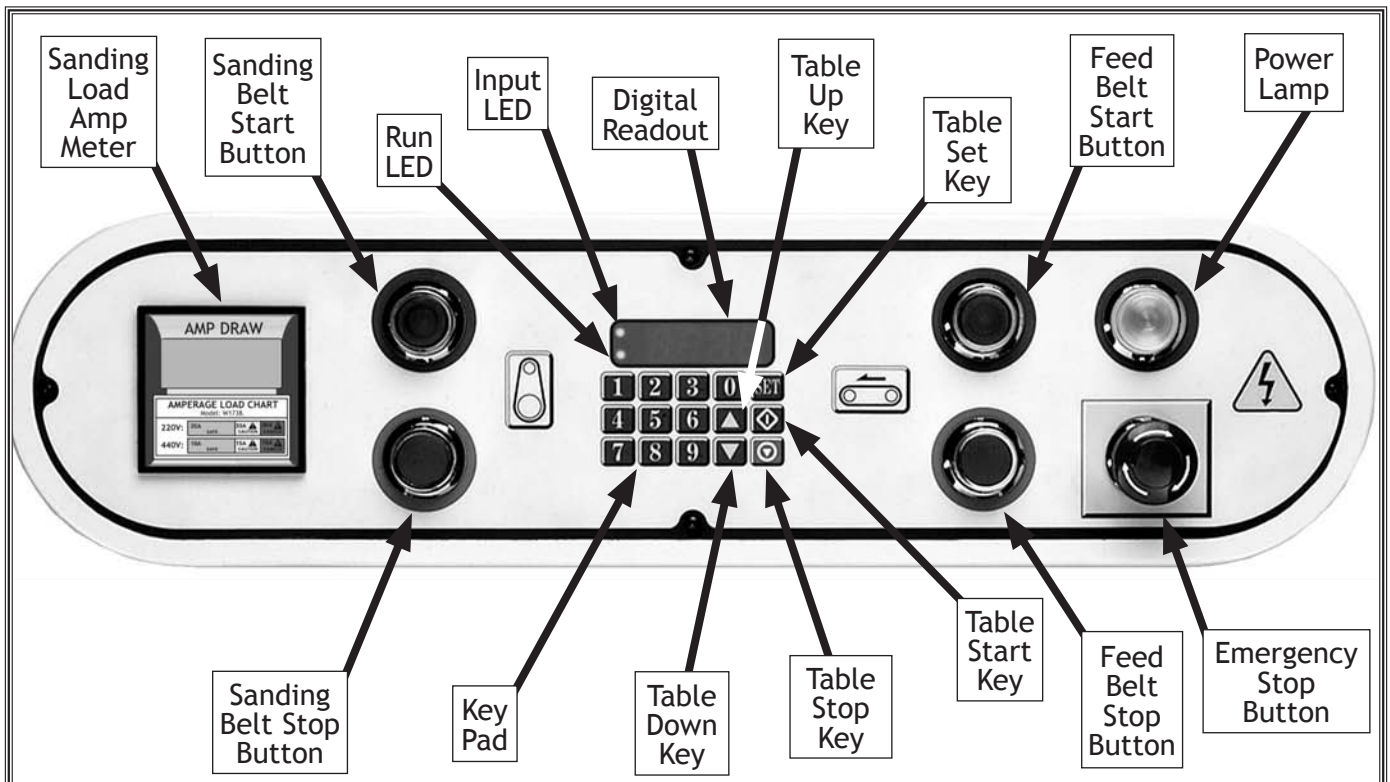

Figure 16. Control panel interface.

General Operation

Your sander will perform many types of operations that are beyond the scope of this manual. If performed incorrectly, many of these operations can be dangerous or deadly.

The instructions in this section are written with the understanding that the operator has the necessary knowledge and skills to operate this machine. **If at any time you are experiencing difficulties performing any operation, or you are inexperienced with this machine, stop using the machine and consult your supervisor for help!**

If you are an inexperienced operator, we strongly recommend that you read books, trade articles, or seek training from an experienced wide belt sander operator before performing any unfamiliar operations. **Above all, your safety should come first!**

Test Run

Once assembly is complete, the machine is ready for a test run. The purpose of a test run is to identify any unusual noises and vibrations, as well as to confirm that the machine is performing as intended.

To complete the test run, do these steps:

1. Tie back loose clothing and hair, and wear a respirator and safety glasses.
2. Make sure all access doors and handles are secured.
3. Start the dust collection system.
4. Connect power to the sander and connect the supply air to the sander. Make sure the air pressure is set at 70 PSI.
5. Turn the sander and feed belt **ON**.
6. Listen for any unusual noises. *A slow, rhythmic air hiss is normal.* The machine should run smoothly with little or no vibrations.

–If there are any unusual noises or vibrations, shut the machine **OFF** immediately. **TURN OFF** and **LOCK** the master power switch so power cannot go to your sander, and disconnect the air line.

Investigate the source of the noise or vibration. **DO NOT** make any adjustments to the machine while it is plugged in. The machine should not be run any further until the problems are corrected.

CAUTION



REMEMBER, this machine produces fine sawdust particles that can be inhaled, causing allergic reactions or respiratory problems. **ALWAYS** wear your respirator in addition to using an adequate dust collection system that draws at least 1500 CFM.

Setting Feed Speed

The feed belt motor offers variable speeds from 15 to 49 FPM. **Figure 17** points out the variable conveyor feed speed control knob.

To change the feed belt speed do these steps:

1. Start the conveyor.
2. Rotate the control knob to the required conveyor speed as indicated by the speed indicator. Only adjust the speed when the conveyor is operating.

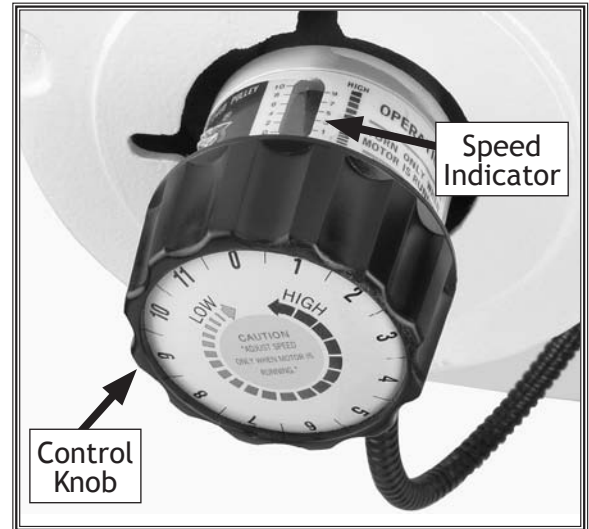

Figure 17. Variable feed speed control knob.

Using the Amp Draw Meter

The amperage draw meter (**Figure 18**) is used to keep the machine from being overloaded during sanding operations.

As a general rule, always start with a shallow sanding depth and carefully increase the sanding depth. Keep the amp load in the green range during operation. Generally, the normal depth of cut is no more than 1/64" or 0.016" for a 37" wide board using coarse sandpaper. **DO NOT** work your machine in the red zone as shown on the Amperage Load Chart. If operated in the red zone, the motor will lose RPM, the start capacitor will energize, and capacitor or motor damage will occur.

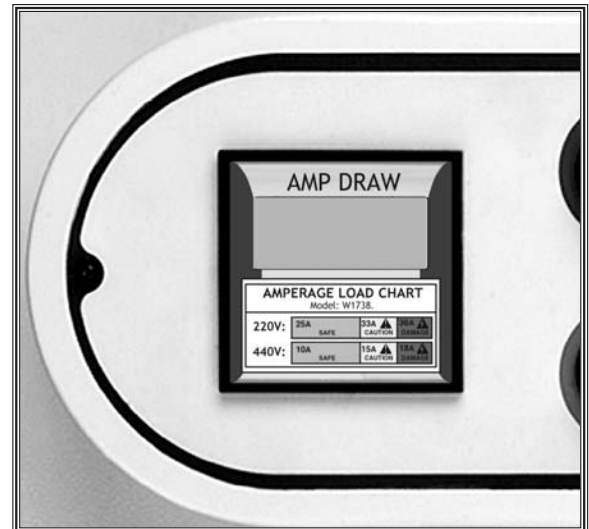

Figure 18. Amp draw meter.

Amp load will be directly affected by many factors such as feed rate, depth of cut, wood type, sandpaper grit, and workpiece width.

Selecting Sandpaper

When selecting sandpaper, keep in mind that the Model W1737/W1738 accepts only 37" wide x 60" long belts. Consider the type of work, the species of wood and the stage of finishing. When choosing which sandpaper to use, use these grit numbers as a general guide to sandpaper type:

- 60 Grit or lessCoarse
- 80-100 GritMedium
- 120-150 Grit.....Fine

Note: For best results, do not increase grit numbers more than 50 on any successive pass.

NOTICE

DO NOT VOID MACHINE WARRANTY! Keep the amp draw within the GREEN zone shown on the AMP LOAD CHART. If you operate the sander in the RED zone, capacitor or motor failure will occur and will not be covered under warranty.

Emergency Stop

When pushed, the emergency stop plate shown in **Figure 19** stops the electricity to the motors and also applies an air-disc brake to stop the sander immediately.

To use the emergency stop, do these steps:

1. Push the bottom of the emergency stop plate.
2. Hold the emergency stop plate until the sander has come to a complete stop.

CAUTION

KEEP the sanding drum drive belts correctly adjusted. Otherwise, the sanding drum pulley will slip when the emergency brake is applied and not immediately stop the machine in the event of an emergency!



Figure 19. Emergency stop plate.

Keypad and Display

You can push the **UP** or **DOWN** arrow keys to lift or lower the table, or you can use the automated function of auto height adjustment for your next sanding pass. All functions are controlled through the key pad and are presented on the digital display. See **Figure 20**.

Calibrating the Table

When you change the sandpaper or you notice an inconsistency with the actual sanding thickness in relationship to your digital setting, you must re-calibrate the table.

To re-calibrate your table, do these steps:

1. Sand a workpiece multiple times at the same thickness until no sanding occurs when the workpiece goes through the sander.
2. Using a caliper capable of measuring 0.001", measure and record the workpiece thickness.
3. Type the recorded thickness of the workpiece on the key pad, and the digital display will show the thickness. **Example:** For 1 $\frac{1}{2}$ " thickness, type 1.500; or for 1 $\frac{3}{8}$ " thickness, type 1.375.
4. Now press and hold the **SET**  key for 3 seconds: The table is now calibrated.

Note: Holding the set key for 10 seconds toggles the digital readout between metric and standard measurements.

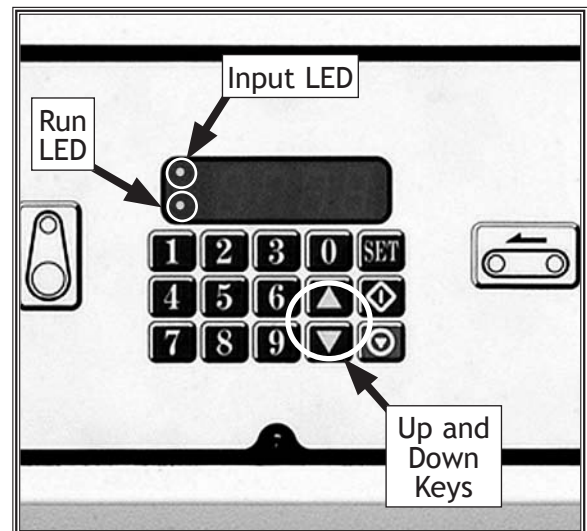

Figure 20. Digital display and key pad.



Figure 21. Table height handwheel.

Basic Sanding

To achieve the best sanding results experiment with conveyor feed rate, sanding depth, various grits of sandpaper, and oscillation speed.

To sand a workpiece, do these steps:

1. Measure the workpiece and record the thickest spot.
1. With the table already calibrated, turn the sander **ON**, set the feed rate.
4. Type in the thickness of your workpiece using the numeric key pad (Example: for a 2" thick workpiece type 2.000"), and press the table start key:

Note: The upper left corner input LED will illuminate (See **Figure 20**), and the display numbers will flash when entering measurements.

5. Measure the sanding depth needed. Example: let's say you need $\frac{1}{64}$ ". **Note:** Removing too much material can burn the workpiece, tear the paper, or give poor sanding results.
6. Convert $\frac{1}{64}$ " fraction to a 0.016" decimal measurement using the conversion table on the sander.
7. Calculate the resulting workpiece thickness ($2.000" - 0.016" = 1.984"$), and type that thickness (1.984") on the key pad.
8. Press the table start key:  The table will raise to the new setting.

Note: The computer rounds the sanding thickness measurements in increments of 0.005".

Note: The lower left corner Run LED will illuminate and the display numbers will glow steadily when measurements have been accepted and the table is auto-adjusting. When the correct sanding depth is achieved, the lower left corner Run LED will turn off and the final resulting workpiece thickness is displayed.

10. Start the conveyor, stand to the side as shown in **Figure 22**, and feed the workpiece into the sander.
11. Observe the amp draw meter, and press the table down arrow key on the key pad to reduce the sanding depth if the amp load meter indicates motor overload.
12. Remove the workpiece from the outfeed side, which is now sanded down $\frac{1}{64}$ ". Re-sand the workpiece a couple of times more at this depth to ensure a consistent sanding depth.
13. Add a new sanding depth the same way as in **Steps 7 and 8**, and sand again.

Tip

For best results when finish sanding, feed each piece through the sander two or three times without adjusting the depth of cut. Turn the workpiece 180° and feed it through two or three more times at this same depth. As always, use your best judgement. If you no longer hear the sanding belt making contact with the workpiece on successive cuts, then no further passes are needed at that depth.



Figure 22. Operator feeding workpiece at correct body position and out of the way of potential kickback.

Using the Platen

The platen controls (Figure 25) on your sander allow for three basic types of sanding. **Note:** *The platen scale is broken down in millimeter increments, and is for only reduced-platen sanding depth positions. For aggressive sanding, retract the platen to the **Platen Up** position, adjust the table, and let the drums make the deep cut.*

Platen Up – The platen is above the level of the sanding rollers, so the front roller removes large amounts of material quickly, but leaves a rough finish.

Platen Even – The platen is even with the sanding rollers, so the rollers work together with the platen to produce intermediate/final finishing.

Platen Down – The platen is 2mm below the sanding rollers, so the platen gives a smooth and feathered finish. Avoid lowering the platen more than 2MM below the sanding belt rollers.

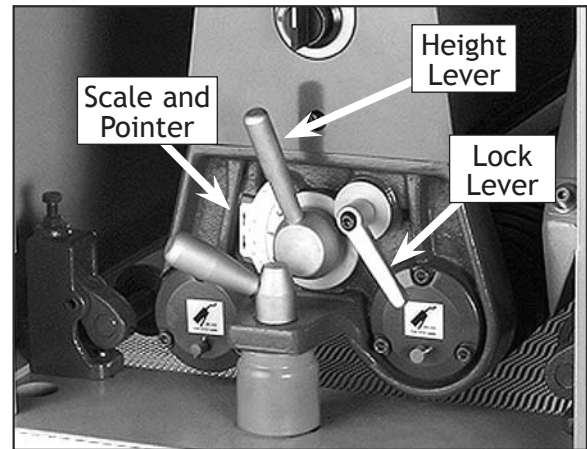

Figure 25. Platen controls.

Jet Air Flow

The air jet located at the air fork sends a stream of air across the air fork and into the air stream receiver (see Figure 23). As soon as the sanding belt obstructs this stream of air, a piston changes the direction of belt movement to the left. Your goal is to adjust this stream of air so the system uses the least amount of air and yet the machine still oscillates consistently.

To adjust the jet air flow, do these steps:

1. **TURN OFF** and **LOCK** your master power switch.
2. Adjust the air regulator to 70 PSI.
3. Open both upper access doors on the sander, loosen the sanding belt tension, and slide the belt so the air stream is unobstructed.
4. Loosen the jam nut and turn the jet adjustment knob (Figure 24) clockwise until the air stream is reduced to a minimum.
5. Turn the jet adjustment knob counterclockwise, and use a piece of cardboard to alternately block and unblock the air stream until the upper drum just begins to react and move left and right.
6. Turn the jet adjustment knob counterclockwise an additional $\frac{1}{2}$ turn and tighten the jam nut.
7. Complete **Belt Tracking** on Page 22.

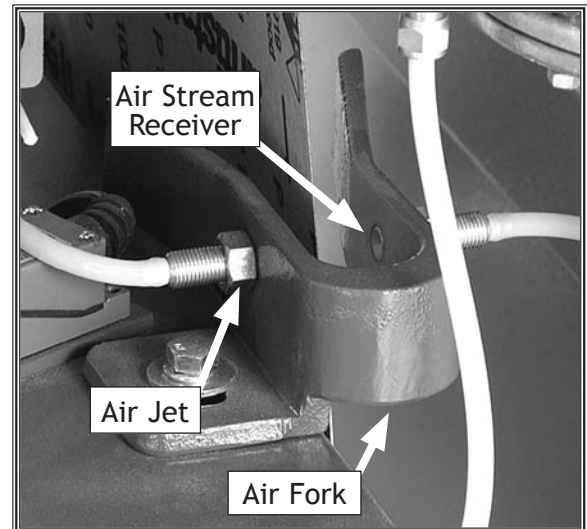

Figure 23. Air Jet and air fork assembly.



Figure 24. Air Stream adjustment knob.

Belt Tracking

The belt tracking knob and lever (**Figure 26**) stops the belt from tracking off of the drums and shutting down the machine. Your goal is to position the belt tracking lever so the belt tracks in the center of the drums and the left-and-right belt movement takes a similar amount of time.

Note: To fine-tune the left-and-right movement you will adjust **Belt Oscillation Speed** outlined on **Page 23**.

⚠ CAUTION

KEEP your hands clear of the sanding belt when making these adjustments!

⚠ WARNING



KEEP loose clothing and long hair secured and away from moving parts.

To set the belt tracking, do these steps:

1. Complete the **Jet Air Flow** adjustment on **Page 21**.
2. Put on safety glasses, tie back all loose clothing, remove jewelry, pull back sleeves, and tie back long hair so it will not get caught by the sanding belt.
3. Turn the sander **ON**.
4. Observe the left-to-right motion of the belt as it moves along the drum while looking from the front of the sander.
 - If the belt tracks faster to the right, but is slow to track back to the left, loosen the belt tracking knob and push it slightly to the left and retighten the knob. See **Figure 26**.
 - If the belt tracks faster to the left, but is slow to track back to the right, loosen the belt tracking knob and push it slightly to the right and retighten the knob. See **Figure 26**.
5. Make sure the belt tracks left and right at approximately the same speed.
6. Keep the sander running, and now complete the **Belt Oscillation Speed** adjustment as outlined on **Page 23**.

Note: You may have to repeat the belt tracking adjustment after the **Belt Oscillation Speed** adjustment as both of these adjustment affect one another.



Figure 26. Belt tracking adjustment.

OPERATIONS

Belt Oscillation Speed

For normal operations, the oscillation speed should be set so that it takes approximately a second or two to complete each direction of travel; however, you can experiment with different speeds to see how the results may affect your finished product. Often, you may find that certain speeds yield better results for different varieties of stock and the feed rates chosen.

CAUTION

KEEP your hands clear of the sanding belt when making these adjustments!

To set the belt oscillation speed, do these steps:

1. Complete the **Belt Tracking** adjustments on **Page 22**.
2. Put on safety glasses, tie back all loose clothing, remove jewelry, pull back sleeves, and tie back long hair so it will not get caught by the sanding belt.
3. If you have not already done so, turn the sander **ON**.
4. Looking from the front of the sander, observe the left-to-right motion of the belt as it moves along the drum.
 - If you want the belt oscillation to oscillate from left to right in shorter and faster sweeps, loosen the jam nut and then rotate the oscillation speed knob counterclockwise (**Figures 27 and 28**).
 - If you want the belt oscillation to oscillate from left to right in longer and slower sweeps, loosen the jam nut and then rotate the oscillation speed knob clockwise (**Figures 27 and 28**).
5. Tighten the jam nut.
6. Observe belt tracking and oscillation, and repeat the **Belt Tracking** adjustments on **Page 22** if needed.

WARNING

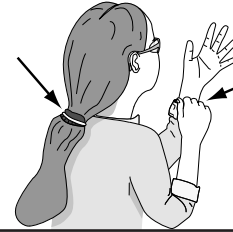

KEEP loose clothing and long hair secured and away from moving parts.

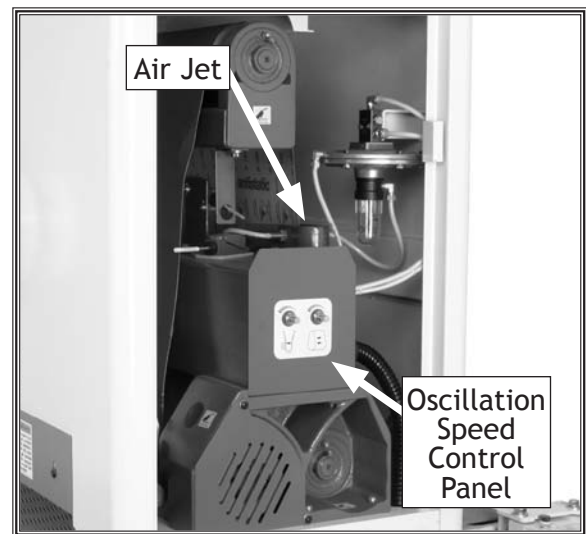

Figure 27. Oscillation system.

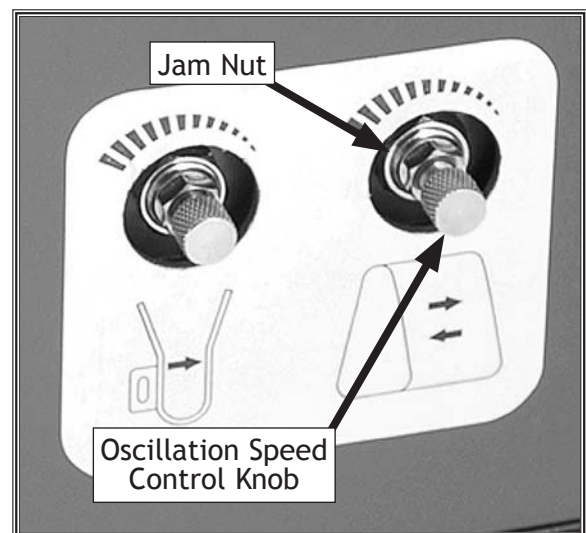
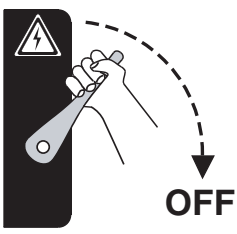

Figure 28. Oscillation speed knob.

MAINTENANCE



! WARNING
 TURN OFF and LOCK the master power switch when doing maintenance so no power is available to the sander! If you ignore this warning serious electrical shock or accidental start may cause injury or death!

General

Regular maintenance on your Model W1737/W1738 ensures optimum performance. Inspect your machine each time you use it. At the end of the day, remove the sanding belt and clean the back-side of the sanding belt and the drum surfaces. Remove wood and abrasive dusts from the inside of the machine.

Lubrication

Wipe off all sawdust and abrasives from grease fittings and plugs before lubrication. When lubricating machine parts, your goal is to achieve adequate lubrication to prevent rust, and a thin layer of lubricant to prevent metal-to-metal friction. Too much lubrication will attract dirt and sawdust, causing machine parts to bind.

- After the first 300 hours of use, replace the gear reducer (Figure 29) lubricant with straight 140W gear oil (available at most automotive parts stores) up to the center of the sight glass. DO NOT use the common 85-140 gear lube as the viscosity is too low and oil can leak past seals.
- After 2,500 hours of use thereafter, replace the gear lube and always clean the vented plug (Figure 29) to make sure it vents the gear case.
- After every 150 hours of use, lubricate the bearings (Figure 30 & 31) with one squirt of automotive-grade grease at the designated points.
- After every 20-40 hours of use, lubricate the elevation screws with grease, and brush or lightly spray the table chain and sprockets with a light coat of oil and wipe any drips off (see Figure 31).

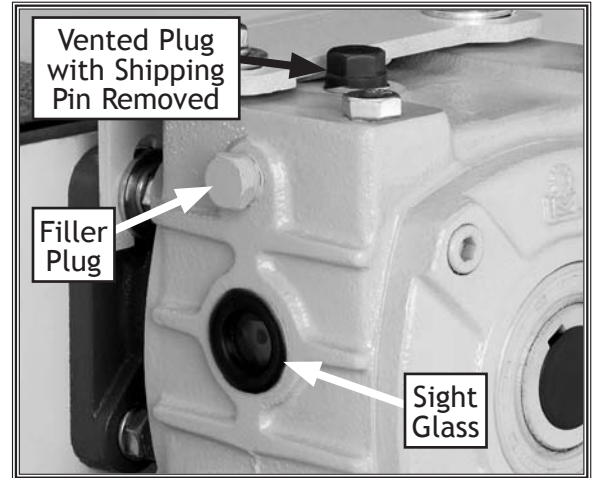

Figure 29. Gear reducer breather and filler plug.

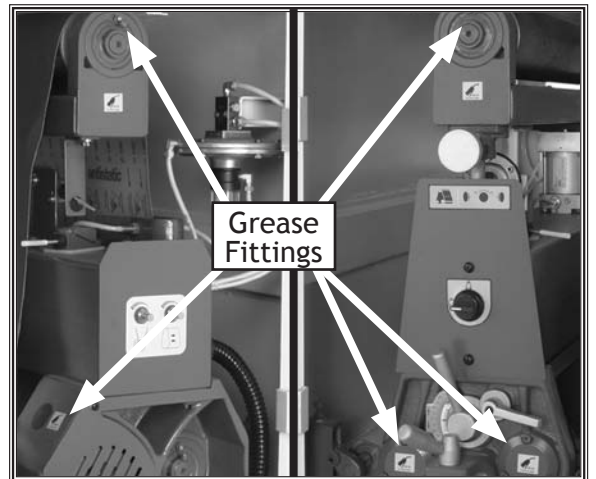

Figure 30. Left/right grease fitting locations.

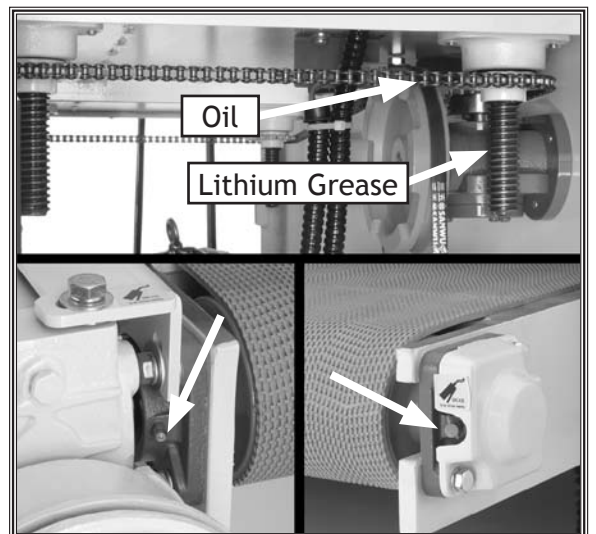

Figure 31. Conveyor grease fitting locations.

MAINTENANCE

Cleaning Belts

To increase the working life of your sanding belts, clean them whenever they decrease in performance due to heavy loading. Use a Pro-Stik® Cleaning Pad shown in Figure 32.

To clean the belts, simply set your table to the thickness of the cleaning pad, and run the pad through the sander two or three times. **DO NOT take too deep of a cut—the belt should barely touch the cleaning pad!**

Maintaining Air System

Empty the diaphragm dust bowl and air regulator moisture bowl when they become half full, and make sure that the regulator is maintaining the system air pressure to 70 PSI (see Figure 33).



Figure 32. Pro-Stik® Cleaning Pad.

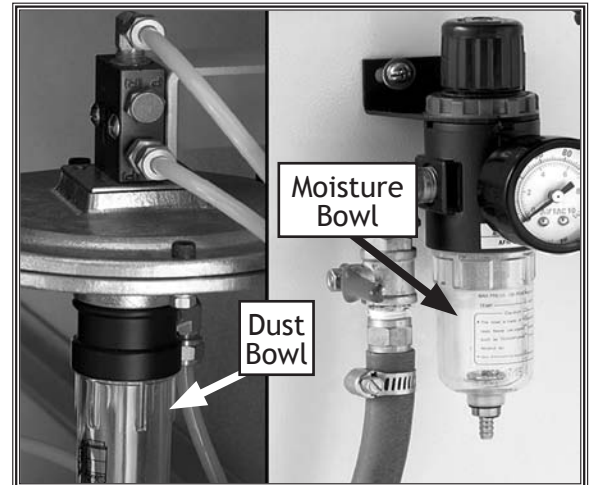
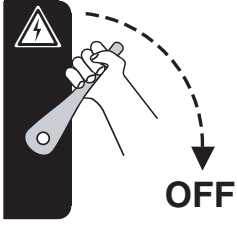

Figure 33. Diaphragm dust bowl and air regulator moisture bowl.

SERVICE



WARNING
 TURN OFF and LOCK the master power switch when doing service so no power is available to the sander! If you ignore this warning serious electrical shock or accidental start may cause injury or death!

Table Stop Switches

The table stop switches prevent the table lift motor from driving the table into the sanding drum. Periodically check and adjust (if required) the table stop switches to protect the conveyor.

To adjust table stop switches, do these steps:

1. Supply air to the sander and tension the sanding belt.
2. Push the down arrow key and lower the table until you achieve six inches between the sanding drum and the conveyor table surface (see **Figure 34**).
3. Loosen the mounting bolt for the table-down stop switch and slide the switch so the switch plunger depresses against the stop block and you hear the switch click (see **Figure 35**).
4. Re-tighten the mounting bolt.
5. Push the up arrow key and raise the table until you achieve an 1/8 inch between the sanding drum and the conveyor table surface.
6. Loosen the mounting bolt for the table-up stop switch and move the switch so the switch plunger depresses against the stop block and you hear the switch click (see **Figure 35**).
7. Re-tighten the mounting bolt.
8. Use the up and down buttons to test the table operation and make sure the switches shut the table lift motor **OFF** when the table is at the minimum and maximum distance from the sanding drum.

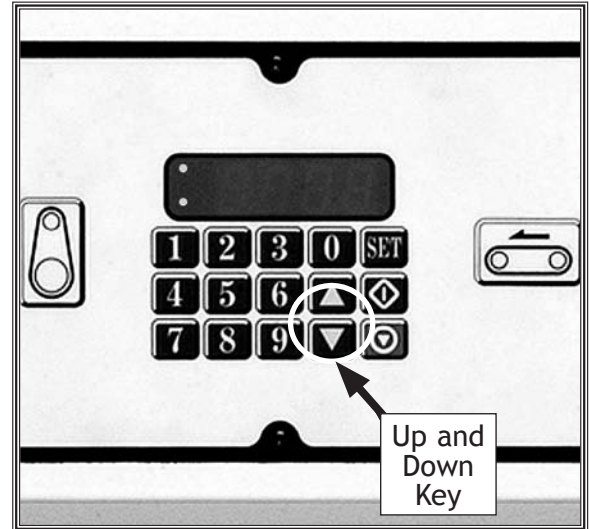

Figure 34. Key pad table-lift controls.

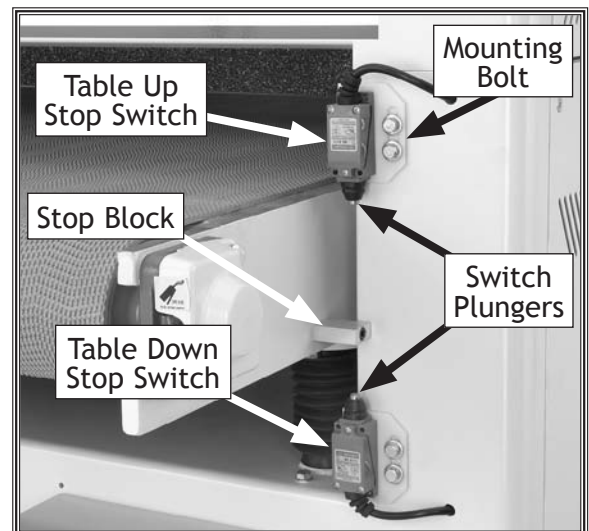

Figure 35. Table stop switch adjustment locations.

Brake Service

Check the brake rotor (shown in **Figure 36**) regularly to make sure it is clean and the pads are still in good condition (thicker than $\frac{1}{8}$ ", see **Figure 37**). Using the emergency stop system for daily machine shutdown will wear out the sanding belts and the brake pads. Inspect for any grease or oil on the brake rotor as oil reduces emergency braking ability. To clean any lubricants from the rotor, only use automotive brake parts cleaner and a dry rag. Replace brake shoes if they are contaminated with oil. **DO NOT** re-use!

To check the condition of the brake pads, do these steps:

1. **TURN OFF** and **LOCK** the master power switch so no power can go to your sander, and shut **OFF** and relieve the air pressure!
2. Remove the lower-right motor-access panel.
3. Measure the thickness of each pad. If a pad is below $\frac{1}{8}$ ", then replace both.

To replace the brake pads, do these steps:

1. **TURN OFF** and **LOCK** the master power switch so no power can go to your sander, and shut **OFF** and relieve the air pressure!
2. Use a 14mm wrench and remove the two caliper anchor pin retaining nuts and washer (see **Figure 36**).
3. Use locking pliers to clamp on the anchor pin end and pull the pin from the caliper mount, and remove the springs and caliper (see **Figure 37**).
4. If the rotor is damaged, remove the rotor and have it surfaced at a machine shop. Clean the rotor with automotive brake parts cleaner and handle it with a dry rag when installing.
5. To finish the job, install the new brake pads, reassemble and mount the caliper, and reconnect the air line if removed.
6. Test the emergency brake operation!

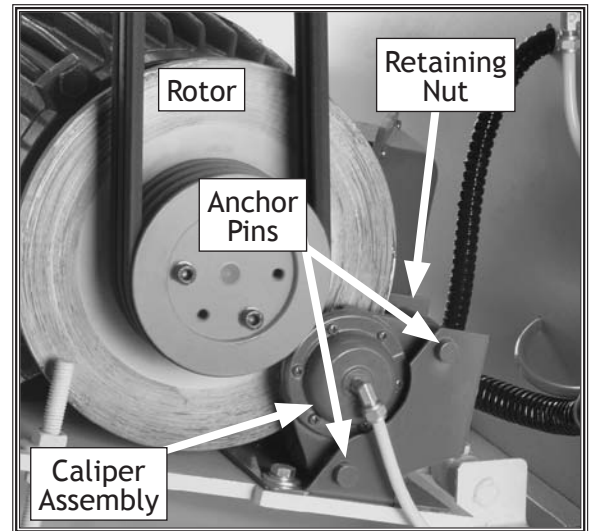

Figure 36. Brake assembly.

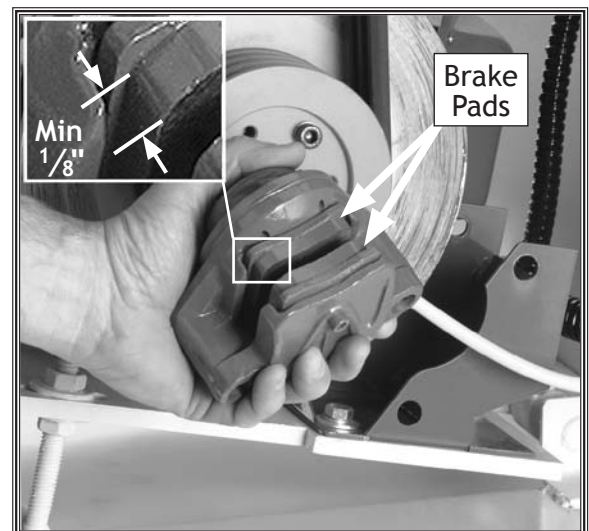

Figure 37. Brake caliper removed for access to brake pads.

Changing V-Belts

Check the V-belts periodically to check for signs of glazing, cracking or fraying. If any of these conditions are present, change both V-belts.

Note: *If the emergency stop system is used to stop the machine as a normal daily event, the breaking system and belts will prematurely wear and require replacement. When shutting down the machine under non-emergency conditions, use the red OFF push buttons.*

To change the V-belts, do these steps:

1. **TURN OFF** and **LOCK** the master power switch so no power can go to your sander and shut **OFF** the air pressure!
2. Open both right-side upper and lower access panels.
3. Remove the screws and the safety cover for access to the upper pulley. See **Figures 38** and **39**.
4. Use a 14mm wrench and remove the upper caliper anchor pin retaining nut and washer. See **Figure 40**.
5. Use locking pliers to clamp on the anchor pin end, pull the pin from the caliper mount, and remove the springs. See **Figure 40**.
6. Pivot the caliper down and away from the rotor for belt clearance.
7. Remove the upper belt adjustment nut and washer (**Figure 40**).
8. Pry the motor base plate upward to de-tension the belts, and roll the belts off of the motor pulley.
9. Install the new V-belts.
10. Replace the upper belt adjustment nut and washer, and tension the belt as necessary.
11. The V-belt is properly tensioned when it will move no more than $\frac{3}{4}$ " in the center with moderate pressure from your thumb. See **V-Belt Tension** on **Page 29** for details.
12. Reassemble in reverse order and test the emergency brake operation.

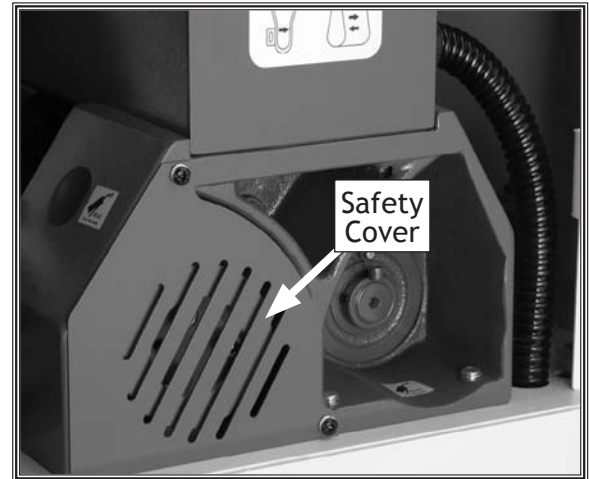

Figure 38. Safety cover and mounting screws.

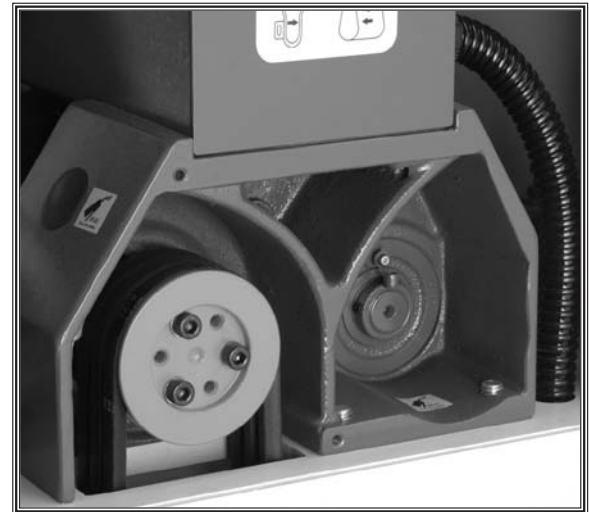

Figure 39. Upper pulley exposed.

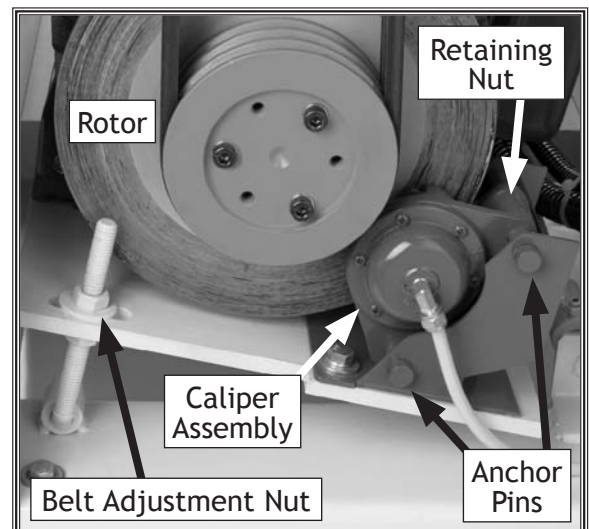

Figure 40. Belt removal access.

V-Belt Tension

The sanding motor (Figure 41) and table lift motor (Figure 42) V-belts must be tensioned properly for best performance. No adjustment is necessary for the conveyor motor belt, as it uses a variable width pulley. See Figure 43. Only replace the belt if it becomes frayed, cracked, or glazed. If one belt is bad, always replace both belts as a matched set. Both table lift and sanding motor belts are adjusted the same way.

CAUTION

KEEP the sanding drum drive belts correctly adjusted. If the belts are loose, and the emergency stop is engaged, the sanding drum pulley will slip and not immediately stop in the event of an emergency!

To tension the V-belts, do these steps:

1. **TURN OFF** and **LOCK** the master power switch so your sander cannot accidentally start!
2. Remove the lower cover(s) on the sander (right cover for sanding belt motor; left cover for the conveyor height motor).
3. Turn both tension adjustment nuts clockwise to tighten the V-belts, or turn both nuts counterclockwise to loosen the V-belts.
4. The V-belt is properly tightened when it will move no more than $\frac{3}{4}$ " in the center with moderate pressure from your thumb.

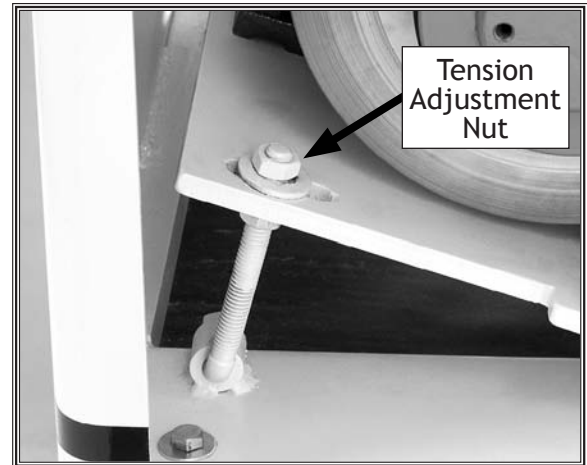

Figure 41. Sanding motor V-belt adjustment.

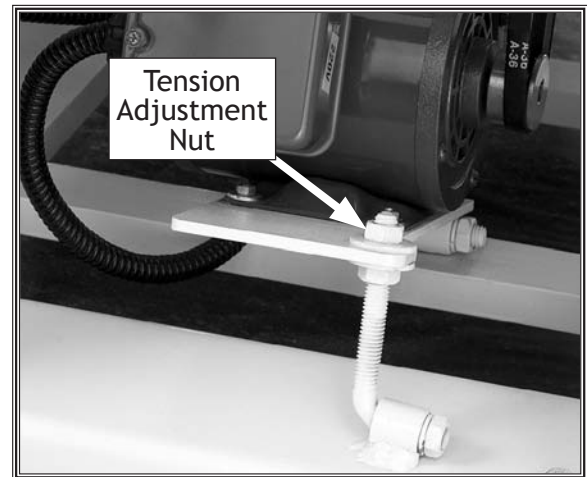

Figure 42. Table lift motor V-belt adjustment.

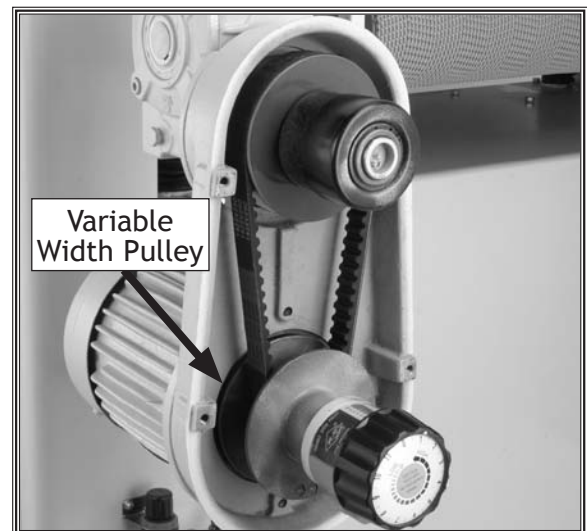

Figure 43. Non-adjustable conveyor motor belt.

Table Parallelism

NOTICE

The table has been adjusted at the factory and should require no further attention. However, we recommend verifying its parallelism with the sanding roller.

The corners of the table can be independently adjusted up or down. By disconnecting the chain and turning the pertinent table elevation screw sprocket (Figure 44), table parallelism can be achieved.

Adjusting the table parallelism can be a very tedious task that takes a great amount of patience. DO NOT adjust the table unless you are having trouble sanding your workpiece to a uniform thickness.

If a table adjustment is needed, take precise notes on the positioning of the table elevation screws. This will allow the original setting to be re-established.

To adjust the table parallelism, do these steps:

1. Pass a 37" wide board through the sander until the entire surface of the board is making contact with the sanding belt.
2. Measure the thickness of the board at various points around the edge.
3. If there is a variation of thickness, the table can be adjusted accordingly.
4. Disconnect the sander from the power source!
 - For minor adjustment, loosen the table mounting bolts shown in Figure 45 and rotate the elevation screw flange.
 - For major adjustment, mark the chain location on all sprockets, remove the chain from only the sprocket to be adjusted, and turn the sprocket counterclockwise to raise the table. One quarter of a turn raises or lowers an elevation screw approximately 0.020".
5. Reinstall the chain, tighten the bolts, and test the machine.

NOTICE

When adjusting the left front elevation screw, make the same adjustment to the left rear elevation screw. This ensures the height from the front to the back of the table remains unchanged. Do the same when adjusting the right elevation screws.

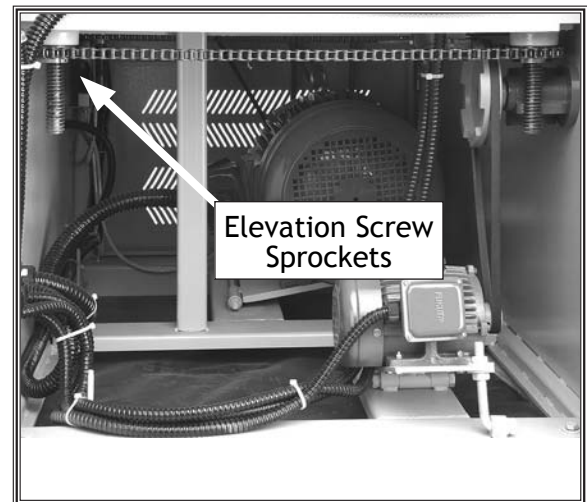

Figure 44. View of elevation screw sprockets.

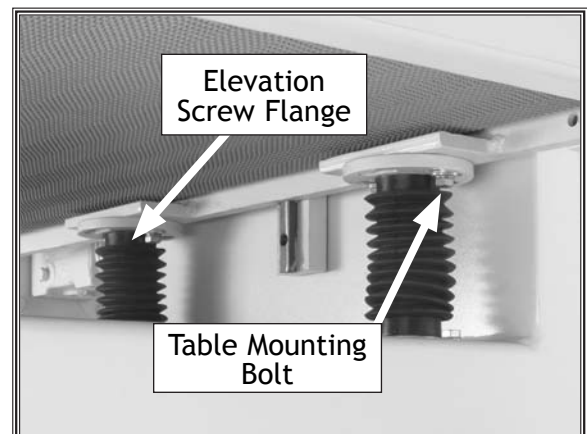

Figure 45. Table mounting bolts and elevation screw flange.

Feed Belt Tension and Tracking

The feed belt tension and tracking has been set at the factory. However, adjust the feed belt tension and tracking if you notice that your feed belt is slipping or is tracking off center and loading up against the positioning wheels (Figure 46) under the conveyor table, you must .

To adjust the feed belt tension and tracking, do these steps:

1. Turn the feed belt tension and tracking bolts equal amounts from side-to-side and set the belt tension so it is snug and will not slip when sanding at a maximum load.
2. Start the conveyor.
3. Turn the feed belt tension and tracking bolt to position the feed belt roller evenly on each side. See Figure 47.
 - If the conveyor tracks to the right, turn the right-side tension and tracking bolt clockwise approximately in $\frac{1}{4}$ turn increments.
 - If the conveyor tracks to the left, turn the left-side tension and tracking bolt clockwise in approximately $\frac{1}{4}$ turn increments.
4. Run the feed belt for at least three minutes to determine if the tracking is correct and the tension stays the same.
5. Repeat steps as required to achieve the correct tension and tracking.

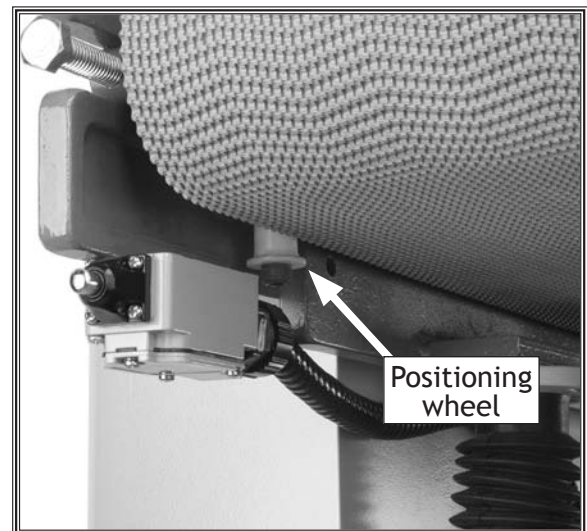

Figure 46. One of four positioning wheels.



Figure 47. Feed belt tension bolt.

Belt Tracking Safety Switch

Belt tracking safety switches are placed on both sides of the belt to act as emergency machine stops if the belt travels too far to one side during oscillation. See **Figure 48**.

To adjust the belt tracking safety switches, do these steps:

1. **TURN OFF** and **LOCK** the master power switch so that no power can go to your sander!
2. Make sure the belt tracking and oscillation is adjusted.
3. Release the belt tension, center the sanding belt on the top roller, then re-tension the belt.
4. Measure the distance from the edge of the sanding belt to the ceramic rod protruding from the switch.
5. Loosen the adjustment bolt shown in **Figure 48**, and move the switch so the belt and the ceramic rod have approximately $\frac{1}{2}$ " clearance from each other.
6. Tighten the bolt and repeat the adjustment with the other side if necessary.
7. Start the sander and make sure it is working properly.

Belt Tension Safety Switch

The belt tension safety switch shuts the sanding motor **OFF** if the belt breaks or has no tension when the lock flange pushes the belt tension safety switch lever. See **Figures 49** and **50**.

To adjust the belt tension safety switch, do these steps:

1. **TURN OFF** and **LOCK** your master power switch.
2. Apply normal system air pressure of 70 PSI, and tension the belt.
3. Loosen the mounting screw and position the switch so the lever is in the center of the lock flange hole.
4. Re-tighten the screw and test the switch operation.

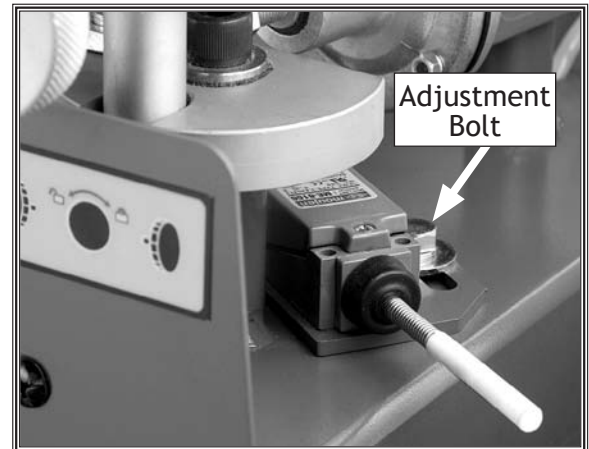

Figure 48. Tracking safety switch adjustment bolt.

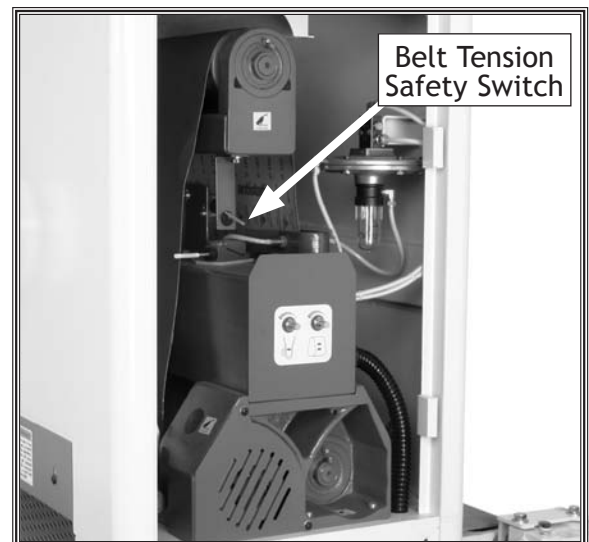

Figure 49. Belt tension safety switch location.

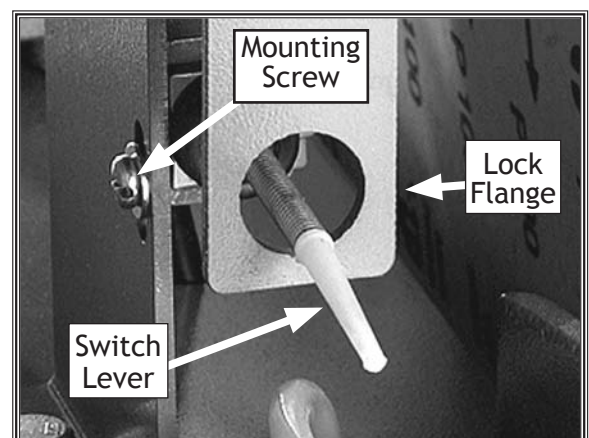

Figure 50. Belt Tension safety switch.

Pressure Rollers

The pressure rollers are factory set so they are parallel with each other, parallel with the sanding drum, and parallel with the surface of the conveyor table.

Additionally, the front pressure rollers must be set 0.040" below the sanding drum, and the rear rollers set at 0.020" below the sanding drum. When these settings are achieved, the pressure-roller spring tension will be correct.

To adjust the pressure rollers, do these steps:

1. **TURN OFF** and **LOCK** the master power switch so no power can go to your sander!
2. Make two gauge boards that are 37" long and uniform in thickness.
3. Connect the air pressure and set it to 70 PSI.
4. Install the sanding belt and turn the belt tensioning knob to the 12:00 position to tension the belt. See **Figure 51**.
5. Position each board on each side of the conveyor belt and directly below the front and back pressure rollers. See **Figure 52**.
6. Loosen the adjustment jam nuts and raise the pressure rollers above the sanding belt roller with the adjustment bolts shown in **Figure 51**.
7. Raise the table up until the boards barely touch the sanding belt.
8. Turn the table-height handwheel counterclockwise one complete turn, to lower the table approximately 0.020".
9. Lower the rear pressure rollers so that both ends barely touch the gauge boards. The rear pressure rollers are now set at 0.020" below the sanding drum.
10. Turn the table-height handwheel counterclockwise again one complete turn, which lowers the table an additional 0.020".
11. Lower the front pressure rollers so that both ends just touch the boards. The front pressure rollers are now set at 0.040" below the sanding drum.
12. Tighten the adjustment jam nuts.

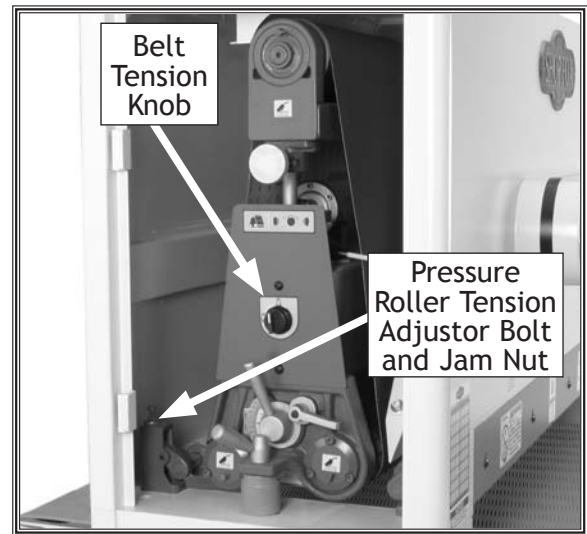

Figure 51. Belt and pressure roller adjustments.

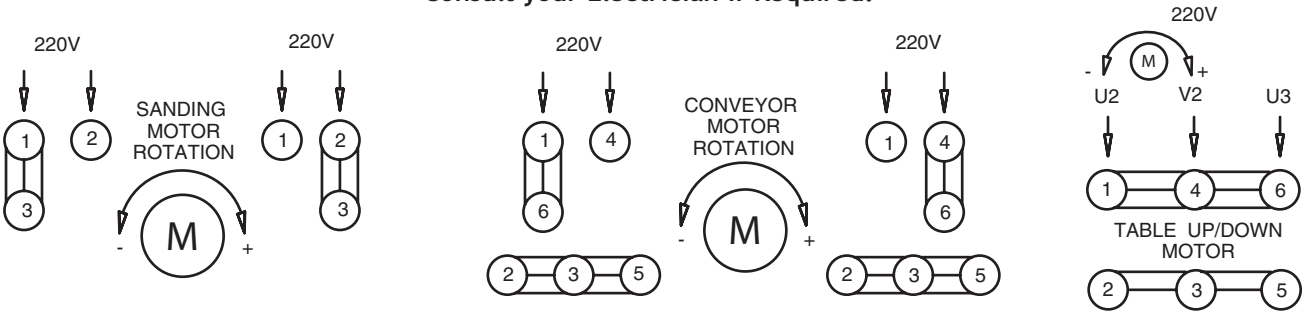

Figure 52. Gauge boards placed under pressure rollers.

General Motor and Transformer Connection

W1737 220V Single-Phase Motor Connection

Consult your Electrician if Required.



W1738 220V Three-Phase Motor/Transformer Connection †

† Power Supply Phase Converter Installation Required—Consult your Electrician if Required.

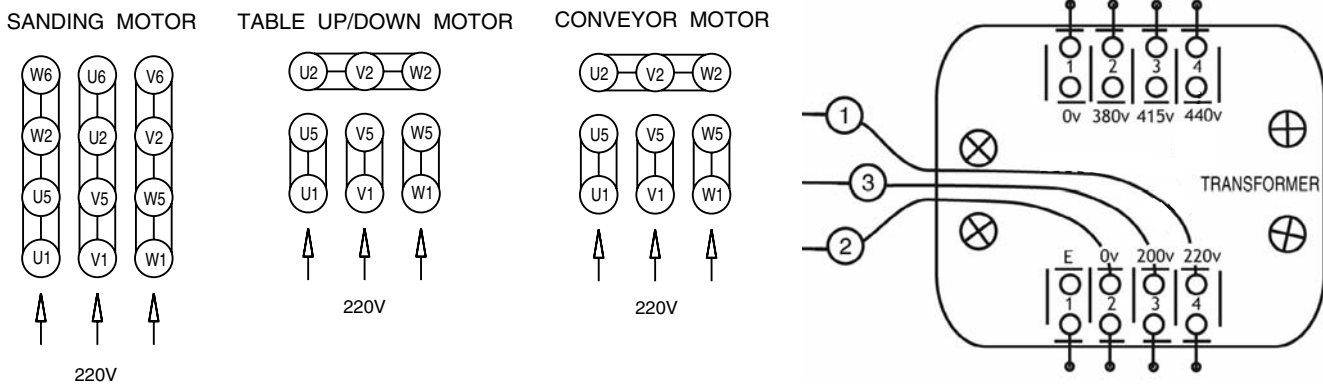

W1738 440V Three-Phase Motor/Transformer Connection ††

†† Thermal Protection Circuit Breaker Replacement Required—Consult your Electrician if Required.

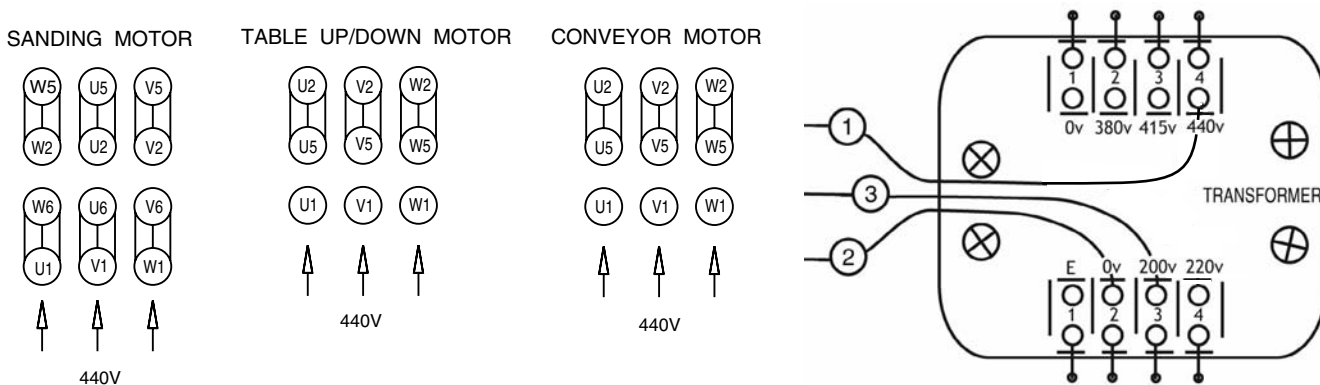

1. DISCONNECT POWER, remove the LR3-D3355 overload relay, and replace it with an LR3D-3322 type (Part # X1738003-1), and the dial set to 18A.
2. Remove the LR3D-086 overload relay, and replace it with an LR3D-076 type (Part # X1738011-1), and set the dial set to 1.7A.

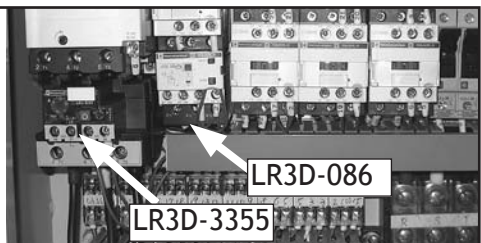

W1737 and W1738 Control Panel Wiring

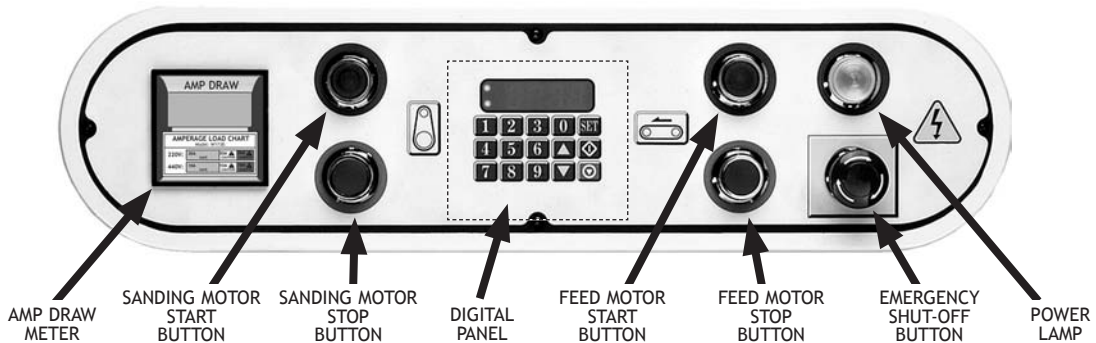
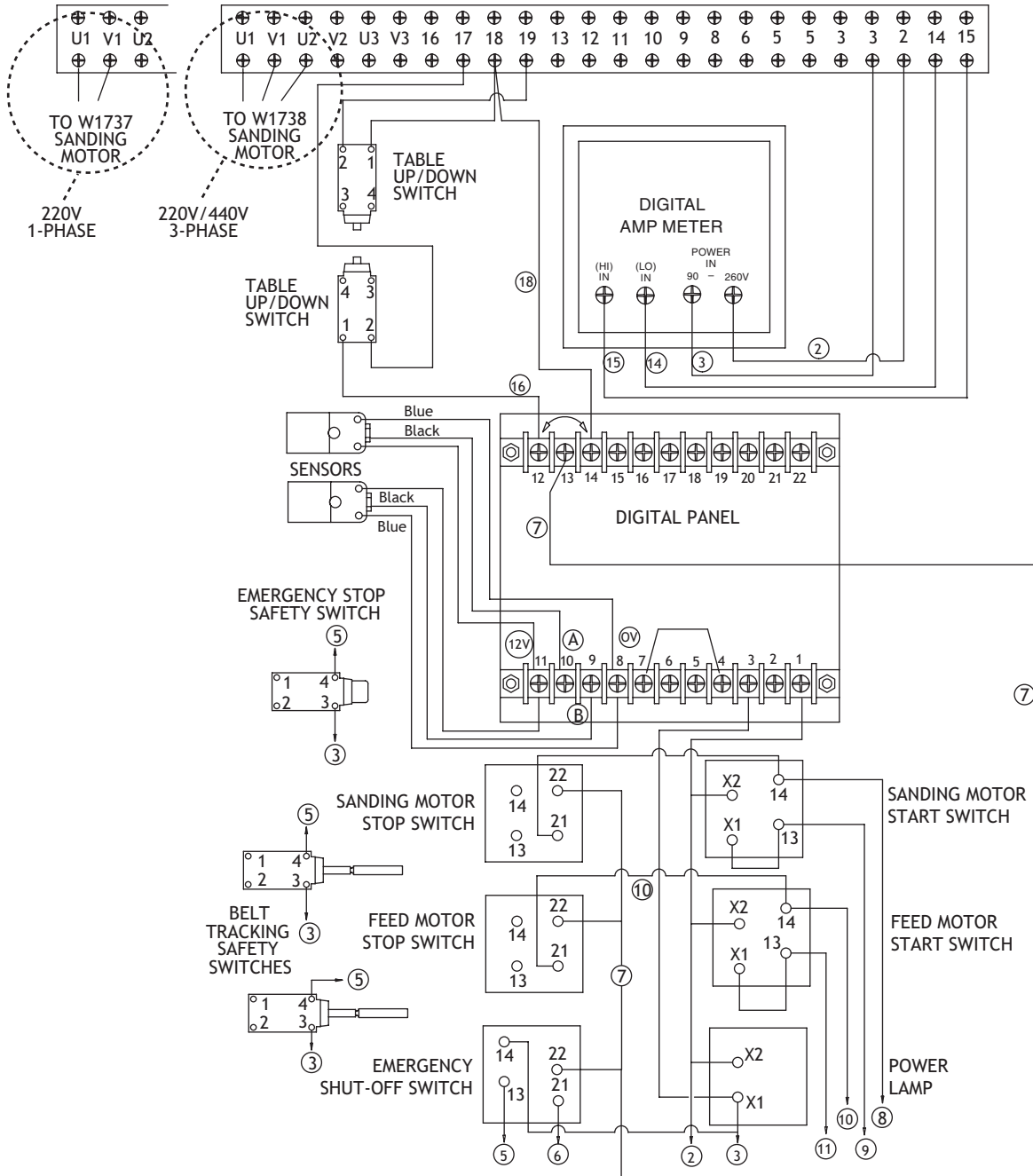

SERVICE

W1737 General Wiring Diagram

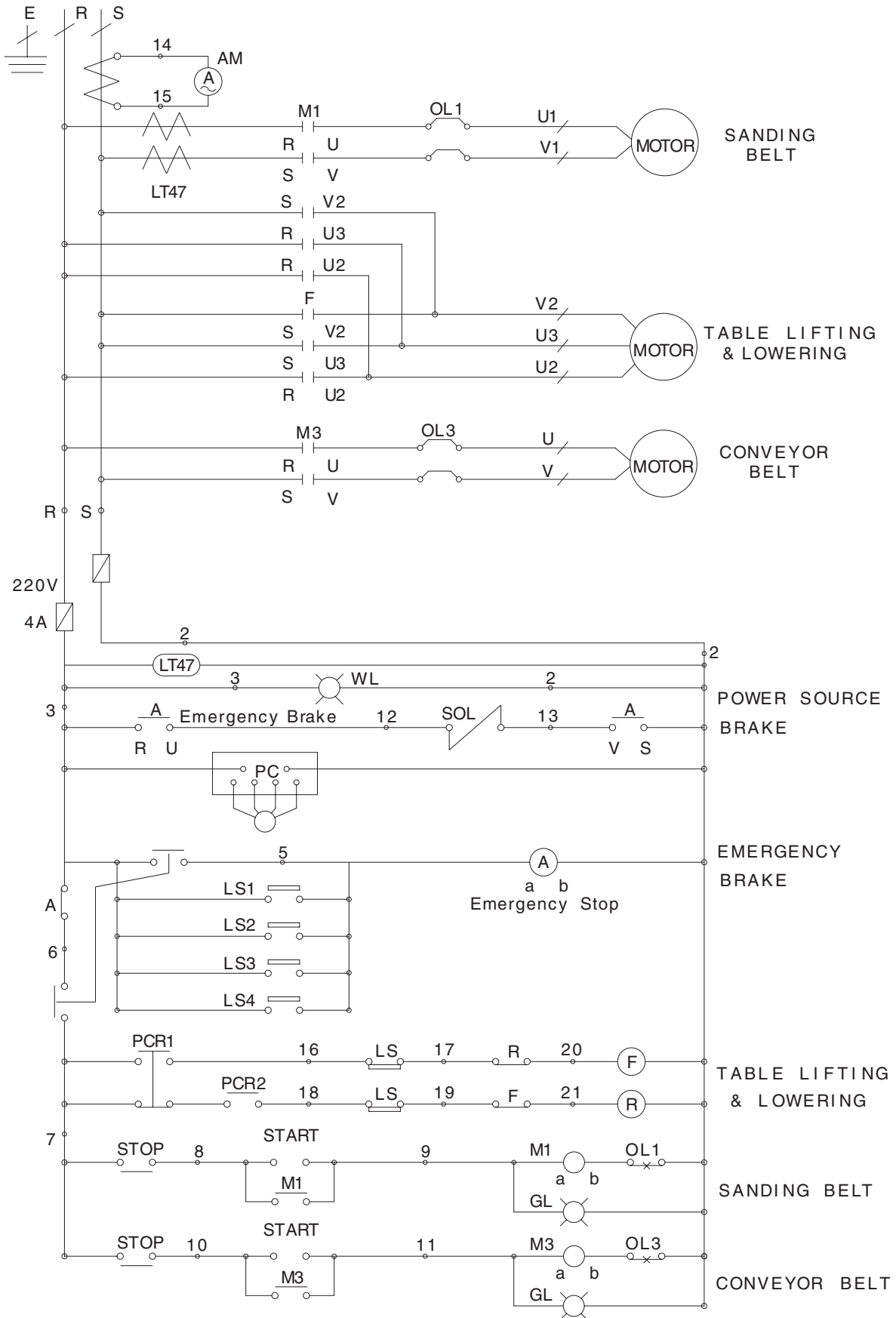

SERVICE

W1738 General Wiring Diagram

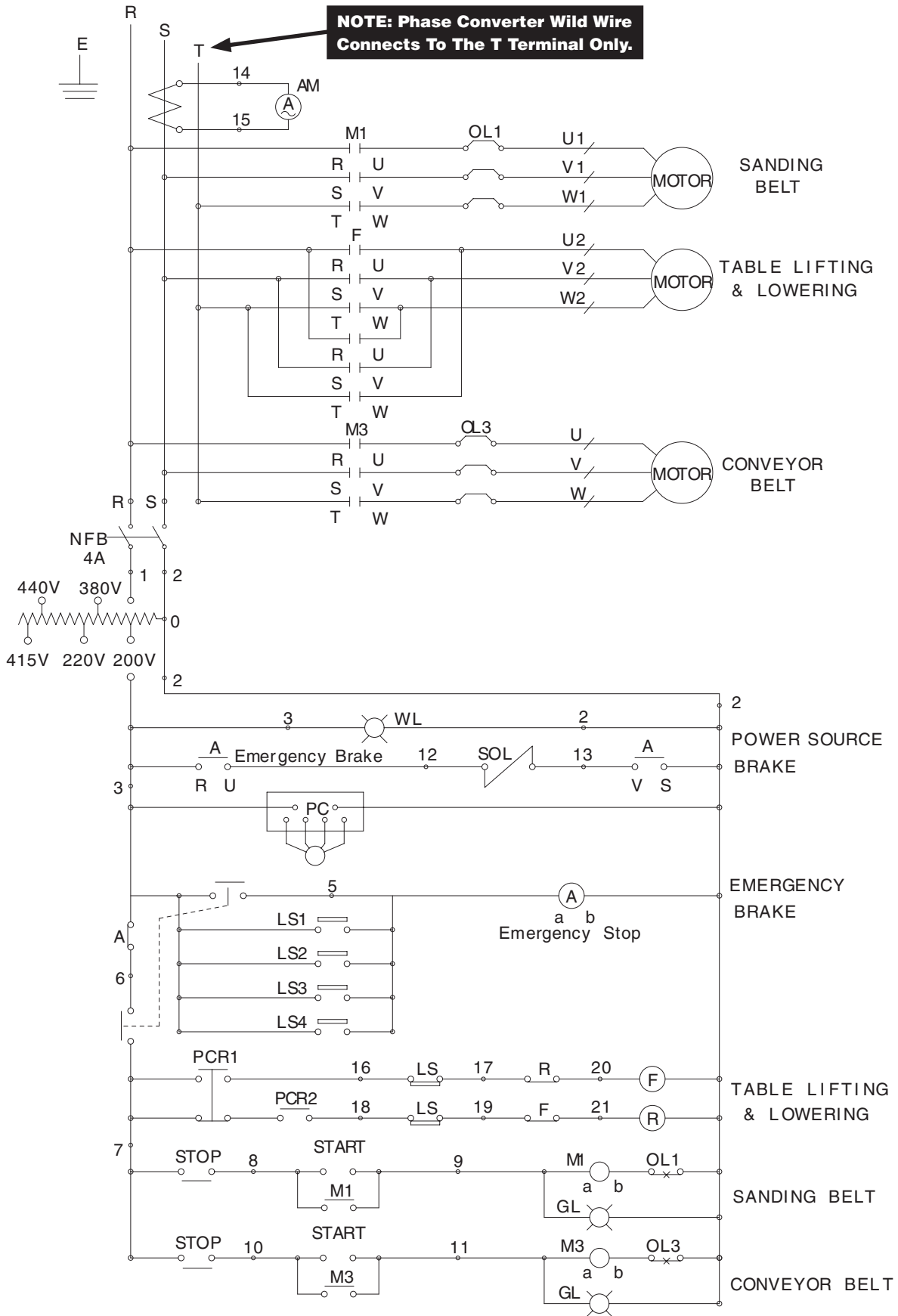

SERVICE

W1738 Electrical Box Component Locations

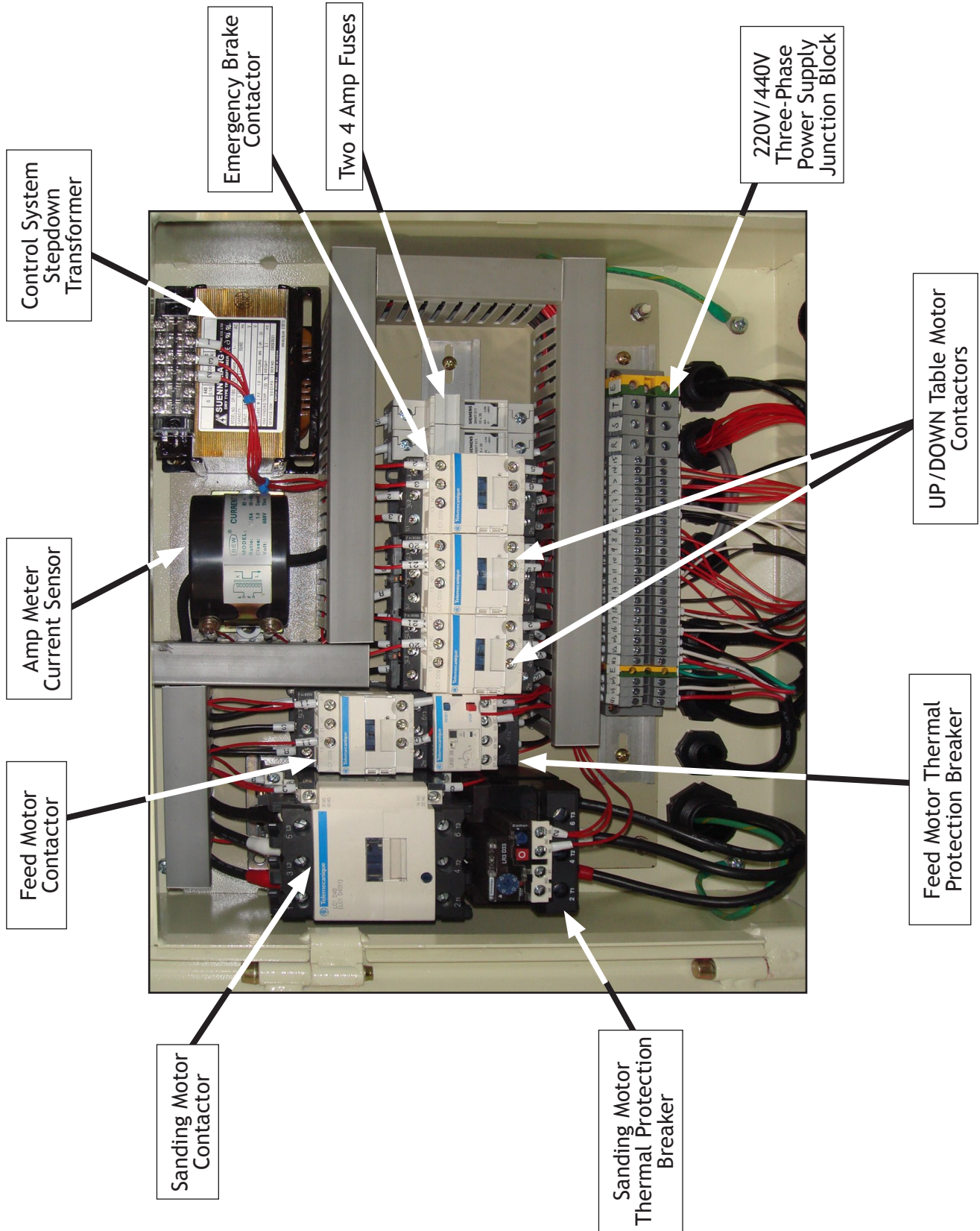

SERVICE

W1738 Electrical Box Wiring Diagram

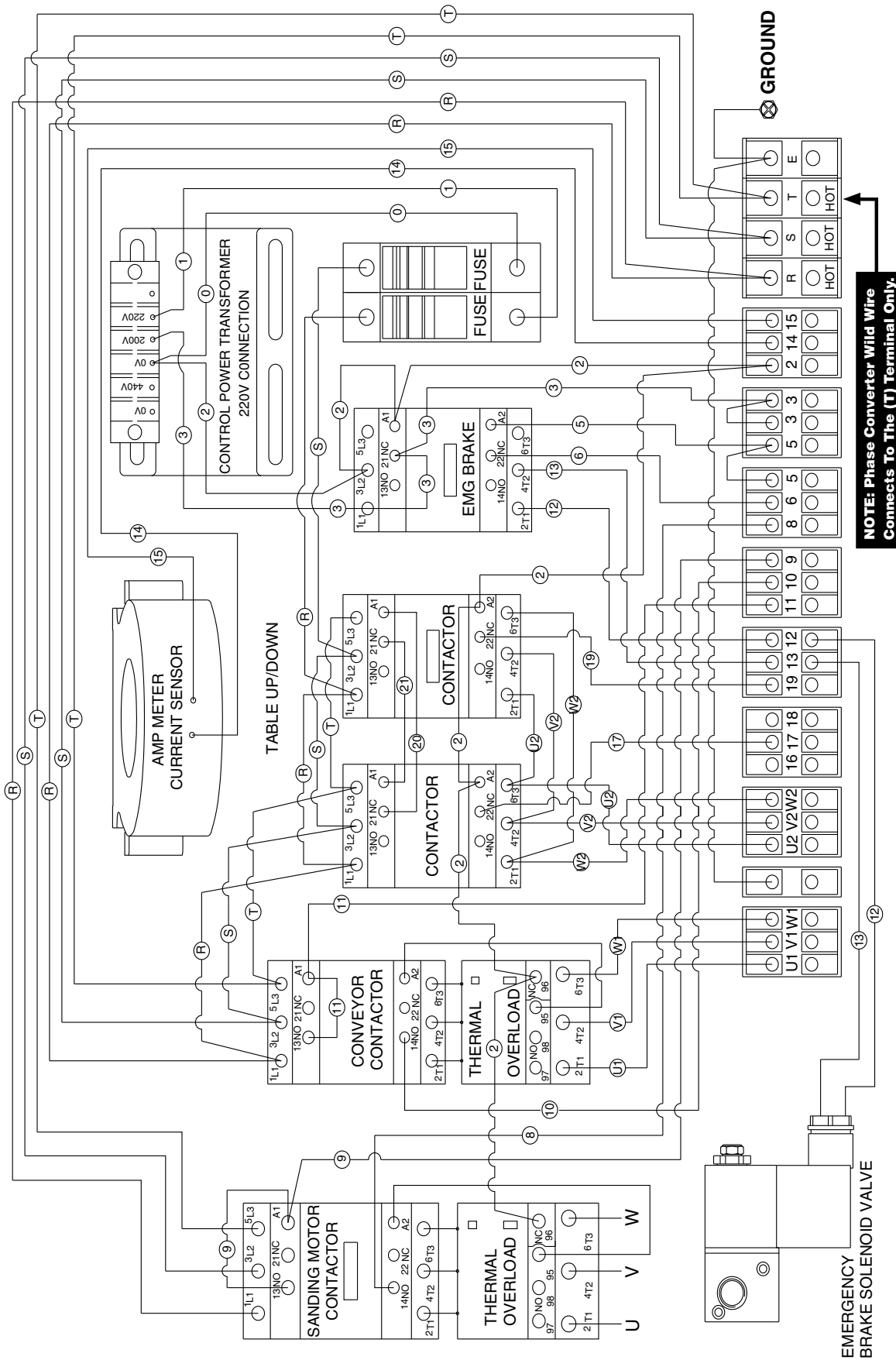

NOTE: Phase Converter Wild Wire Connects To The (T) Terminal Only.

SERVICE

W1737 Electrical Box Component Locations

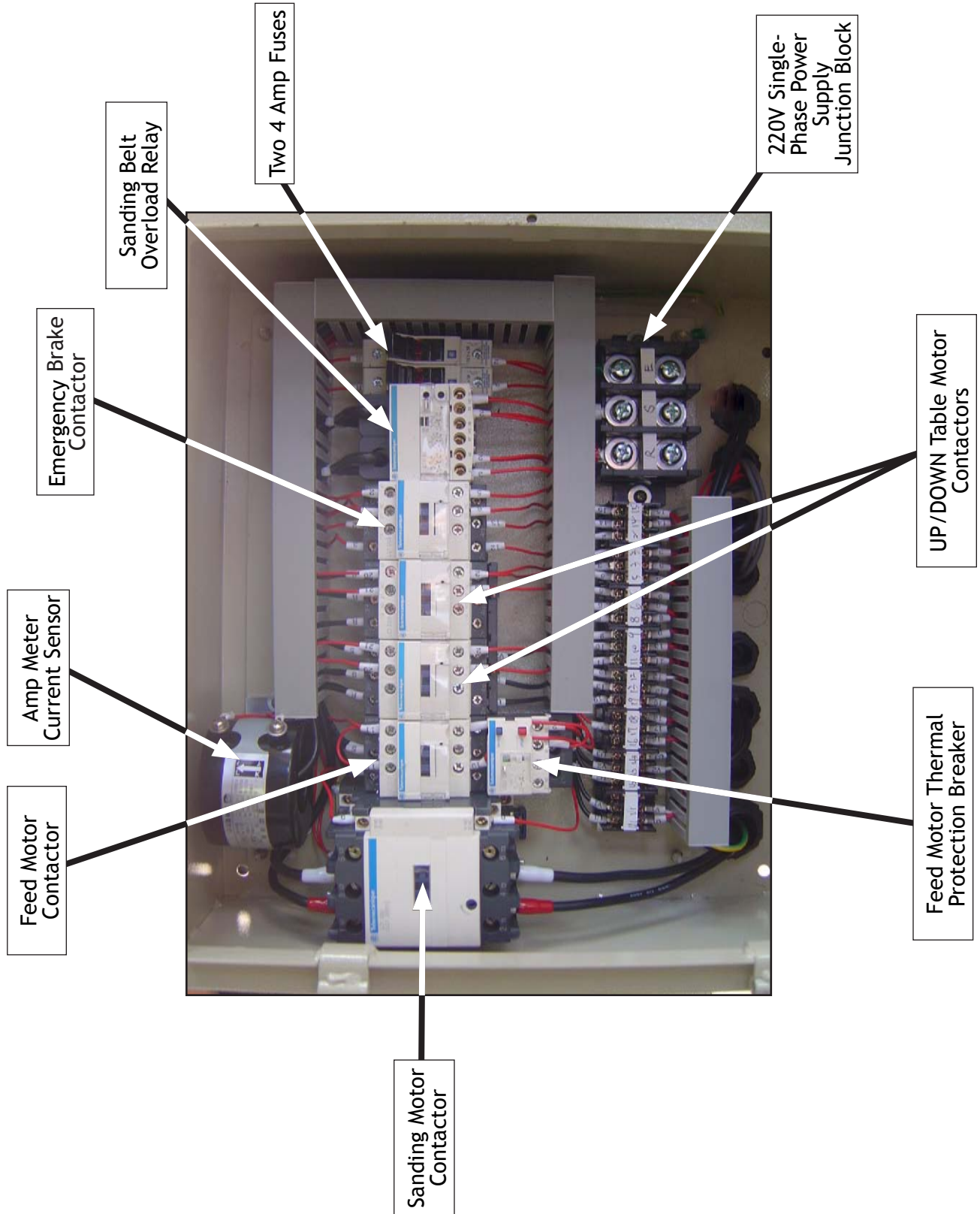

W1737 Electrical Box Wiring Diagram

⚠ DANGER
SHOCK HAZARD!
 Disconnect power before servicing electrical parts. Touching electrified parts will result in severe burns, electrocution, or death.

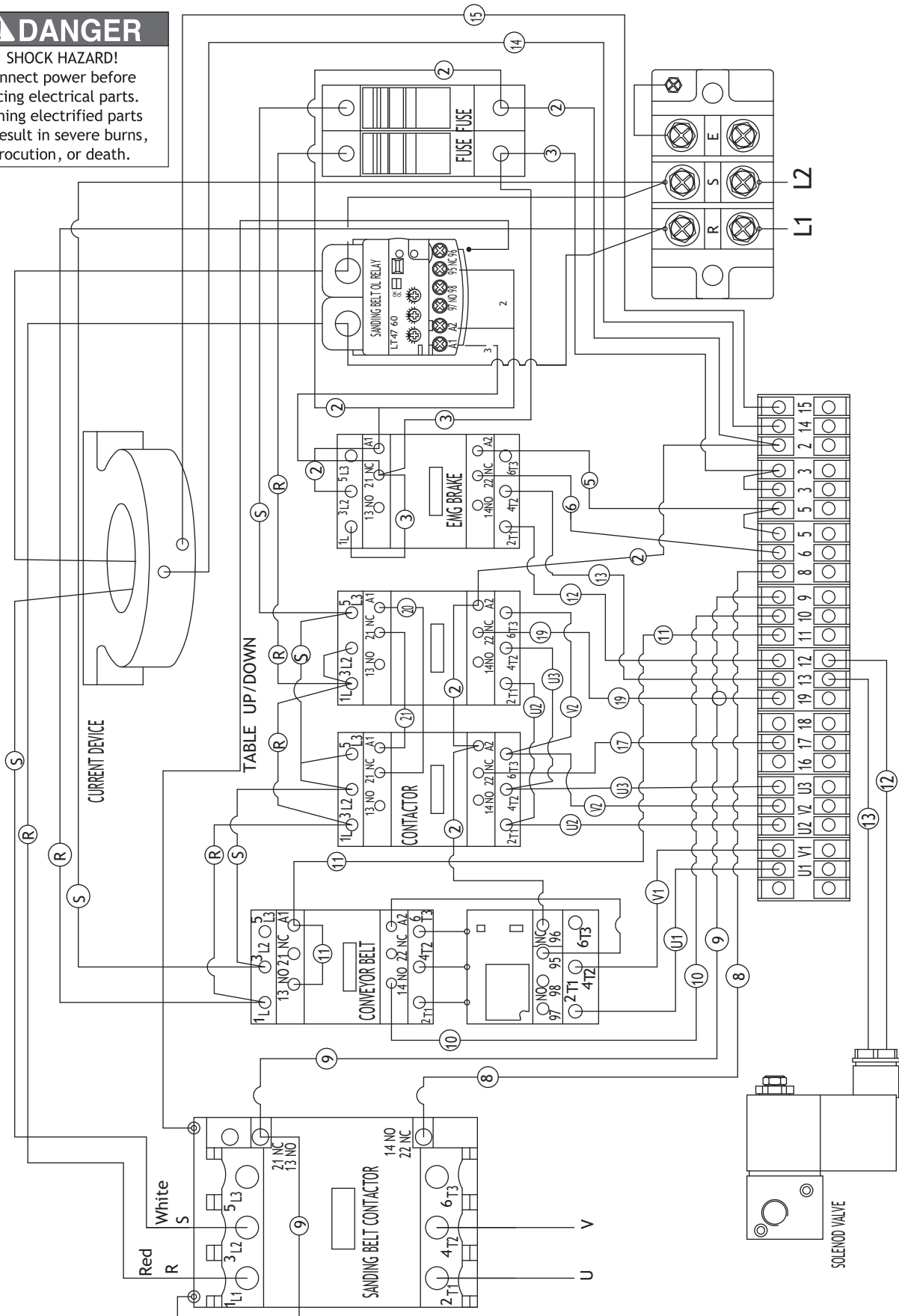

SERVICE

Electrical Parts

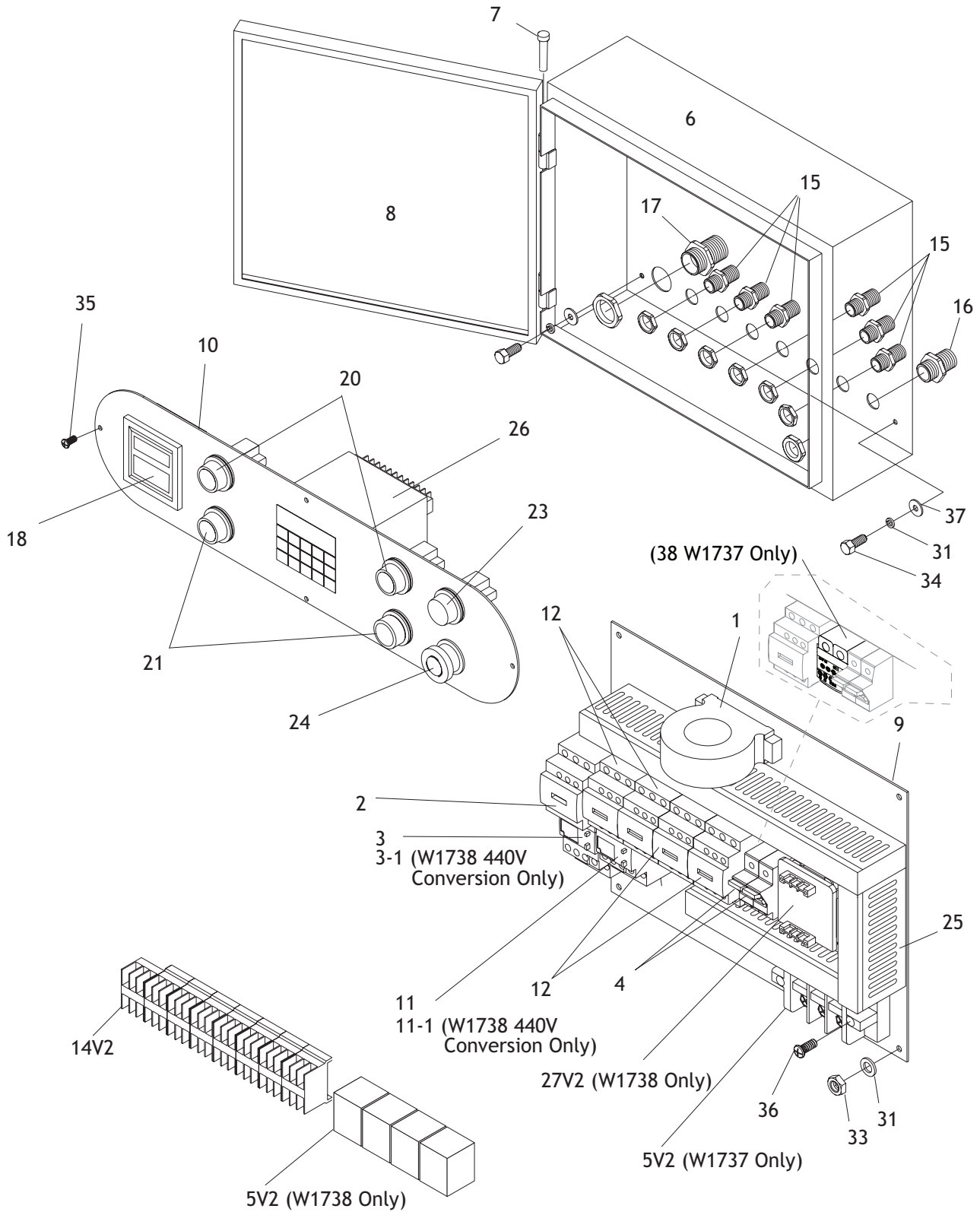

REF	PART #	DESCRIPTION
1	X1737001	CURRENT SENSOR
2	X1737002	CONTACTOR LC1-D50 (W1737 220V 1PH)
2	X1738002	CONTACTOR LC1-D40 (W1738 220V/440V 3PH)
3	X1737003	RELAY LR3D-3359 (48-65A) (W1737 220V 1PH)
3	X1738003	RELAY LR3D-3355 (30-40A) (W1738 220V 3PH)
4	X1737004	FUSE 4A
5V2	X1737005V2	TERM. BLK. (W1737) V2.10.09
5V2	X1738005V2	TERM. BLK. (W1738) V2.10.09
6	X1737006	ELECTRICAL CONTROL BOX
7	X1737007	HINGE
8	X1737008	DOOR
9	X1737009	BASE PLATE
10	X1737010	CONTROL PANEL
11	X1737011	RELAY LR3D-126 (W1737 220V 1PH)
11	X1738011	RELAY LR3D-086 (W1738 220V 3PH)
12	X1737012	CONTACTOR LC1-D096M7

REF	PART #	DESCRIPTION
14V2	X1737014V2	TERMINAL PLATE (W1737) V2.10.09
14V2	X1738014V2	TERMINAL PLATE (W1738) V2.10.09
15	X1737015	PU CONNECTOR 1/2
16	X1737016	PU CONNECTOR 3/4
17	X1737017	CABLE CONNECTOR 1"
18	X1737018	DIGITAL AMP METER
20	X1737020	START SWITCH
21	X1737021	STOP SWITCH
23	X1737023	POWER INDICATION LIGHT
24	X1737024	EMERGENCY STOP SWITCH
25	X1737025	WIRE COLUMN
26	X1737026	COMPUTER
27V2	X1738027V2	TRANSFORMER 3PH (W1738) V2.10.09
31	XPLW02	LOCK WASHER 1/4
33	XPN05	HEX NUT 1/4-20
34	XPB19	HEX BOLT 1/4-20 X 1/2
35	XPS07M	PHLP HD SCR M4-.7 X 8
36	XPS51M	PHLP HD SCR M4-.7 X 30
37	XPW06	FLAT WASHER 1/4
38	X1689624	OL RELAY TELE TESYS-LT47 5-60A (W1737)

W1738 440V Conversion Parts

3-1	X1738003-1	RELAY LR3D-3322 (17-25A) (W1738 440V 3PH)
11-1	X1738011-1	RELAY LR3D-076 (1.6-2.5A) (W1738 440V 3PH)

Tools and Cabinet Parts

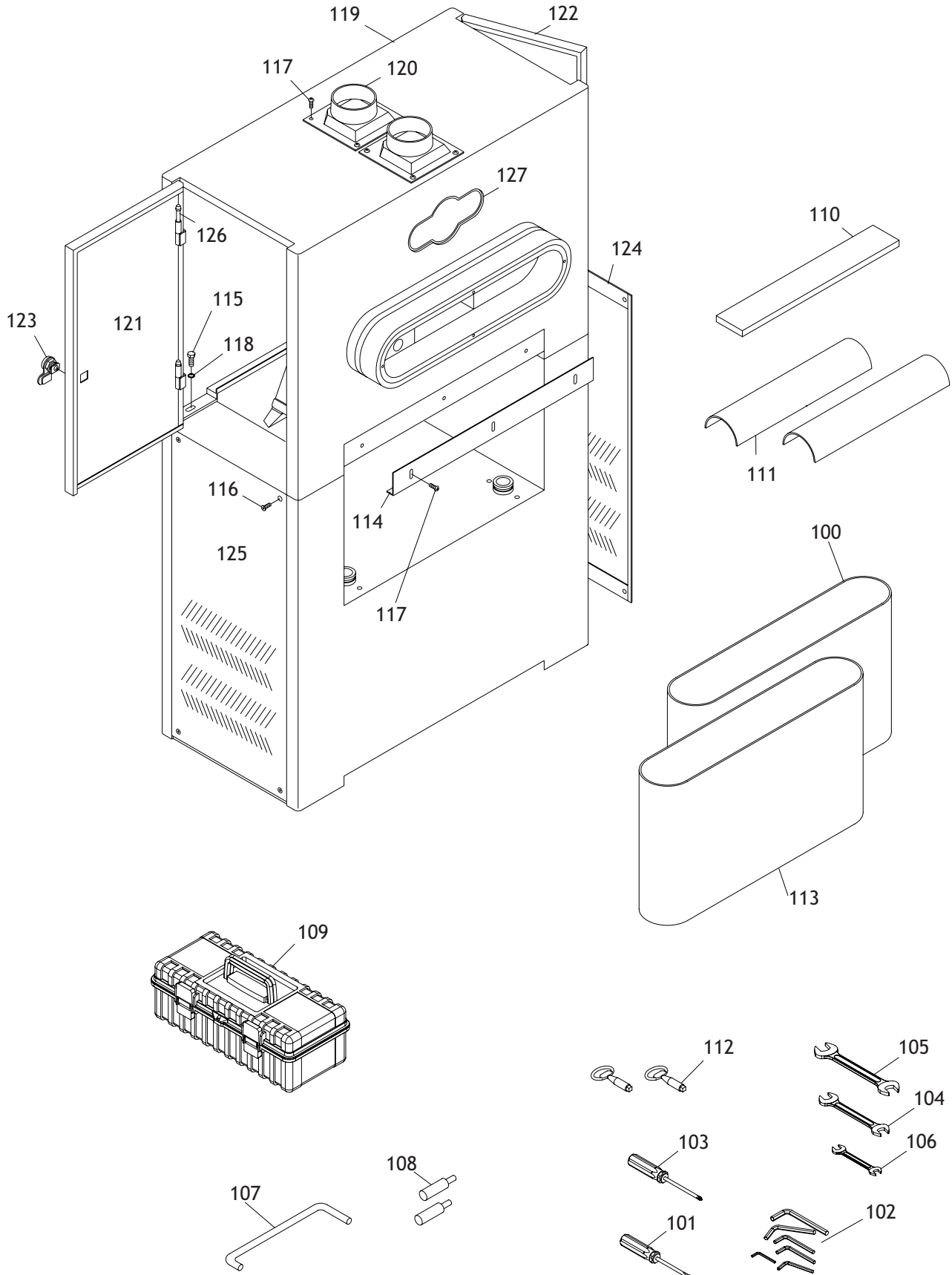



REF	PART #	DESCRIPTION
100	X1737100	SANDPAPER: #180
101	X1737101	FLAT SCREWDRIVER
102	X1737102	HEX WRENCH SET
103	X1737103	PHILLIP'S SCREWDRIVER
104	XPWR1214	WRENCH 12 X 14
105	XPWR1719	WRENCH 17 X 19
106	XPWR810	WRENCH 8 X 10
107	X1737107	PLATEN REMOVAL TOOL
108	X1737108	LIMIT SWITCH TUBE
109	X1737109	TOOL BOX
110	X1737110	FELT
111	X1737111	GRAPHITE PAD
112	X1737112	DOOR KEY
113	X1737113	SANDPAPER: #100

REF	PART #	DESCRIPTION
114	X1737114	FRONT PLATE
115	XPB07	HEX BOLT 5/16-18 X 3/4
116	XPFH03	FLAT HD SCR 1/4-20 X 1/2
117	XPS14M	PHLP HD SCR M6-1 X 12
118	XPW07	FLAT WASHER 5/16
119	X1737119	UPPER FRAME COVER
120	X1737120	4" DUST PORT
121	X1737121	LEFT UPPER DOOR
122	X1737122	RIGHT UPPER DOOR
123	X1737123	DOOR LOCK
124	X1737124	RIGHT LOWER PANEL
125	X1737125	LEFT LOWER PANEL
126	X1737126	HINGE PIN
127	X1737127	LOGO PLATE

REF	PART #	DESCRIPTION
200	X1737200	MACHINE FRAME
201	X1737201	MOTOR BASE
202	X1737202	MOTOR BASE HINGE
203	X1737203	BASE ADJUSTMENT ROD
204	X1737204	MOTOR 10HP 1-PH (W1737)
204	X1738204	MOTOR 15HP 3-PH (W1738)
204-1	X1737204-1	WIRING BOX (W1737)
204-1	X1738204-1	WIRING BOX (W1738)
204-2	X1737204-2	S. CAPACITOR (W1737)
204-3	X1737204-3	R. CAPACITOR (W1737)
204-4	X1737204-4	FAN COVER (W1737)
204-4	X1738204-4	FAN COVER (W1738)
204-5	X1737204-5	FAN (W1737)
204-5	X1738204-5	FAN (W1738)
214	X1737214	PULLEY
215	X1737215	MOTOR KEY
216	X1737216	ROTOR
217	X1737217	PULLEY BUSHING
218	X1737218	BRAKE BRACKET
219	X1737219	FLAT HEAD NUT
220	X1737220	LIMIT SWITCH
221	X1737221	LIMIT SWITCH PLATE
222	X1737222	COVER
223	X1737223	BRAKE ARBOR

REF	PART #	DESCRIPTION
224	X1737224	BRAKE PIN
225	X1737225	BRAKE PAD
226	X1737226	COMPLETE BRAKE ASSY.
227	X1737227	BRAKE SPRING
228	X1737228	BRAKE INSIDE PIECE
229	XPB03	HEX BOLT 5/16-18 X 1
230	XPB21	HEX BOLT 3/8-16 X 3/4
231	XPB24	HEX BOLT 3/8-16 X 1 1/4
232	XPFH12M	FLAT HD SCR M6-1 X 25
233	XPLW01	LOCK WASHER 5/16
235	XPLW02	LOCK WASHER 1/4
236	XPLW04	LOCK WASHER 3/8
237	XPLW07	LOCK WASHER 1/2
238	XPNO6	HEX NUT 1/2-12
239	XPNO8	HEX NUT 3/8-16
240	XPS04	PHLP HD SCR 1/4-20 X 1/2
241	XPSB05	CAP SCREW 1/4-20 X 3/4
242	XPSB07	CAP SCREW 5/16-18 X 3/4
243	XPSB08	CAP SCREW 5/16-18 x 1 1/2
244	XPSB10M	CAP SCREW M5-.8 X 15
245	XPVA71	V-BELT A-71 4L710
246	XPW01	FLAT WASHER 1/2
247	XPW02	FLAT WASHER 3/8
248	XPW06	FLAT WASHER 1/4

Table Lift System Parts

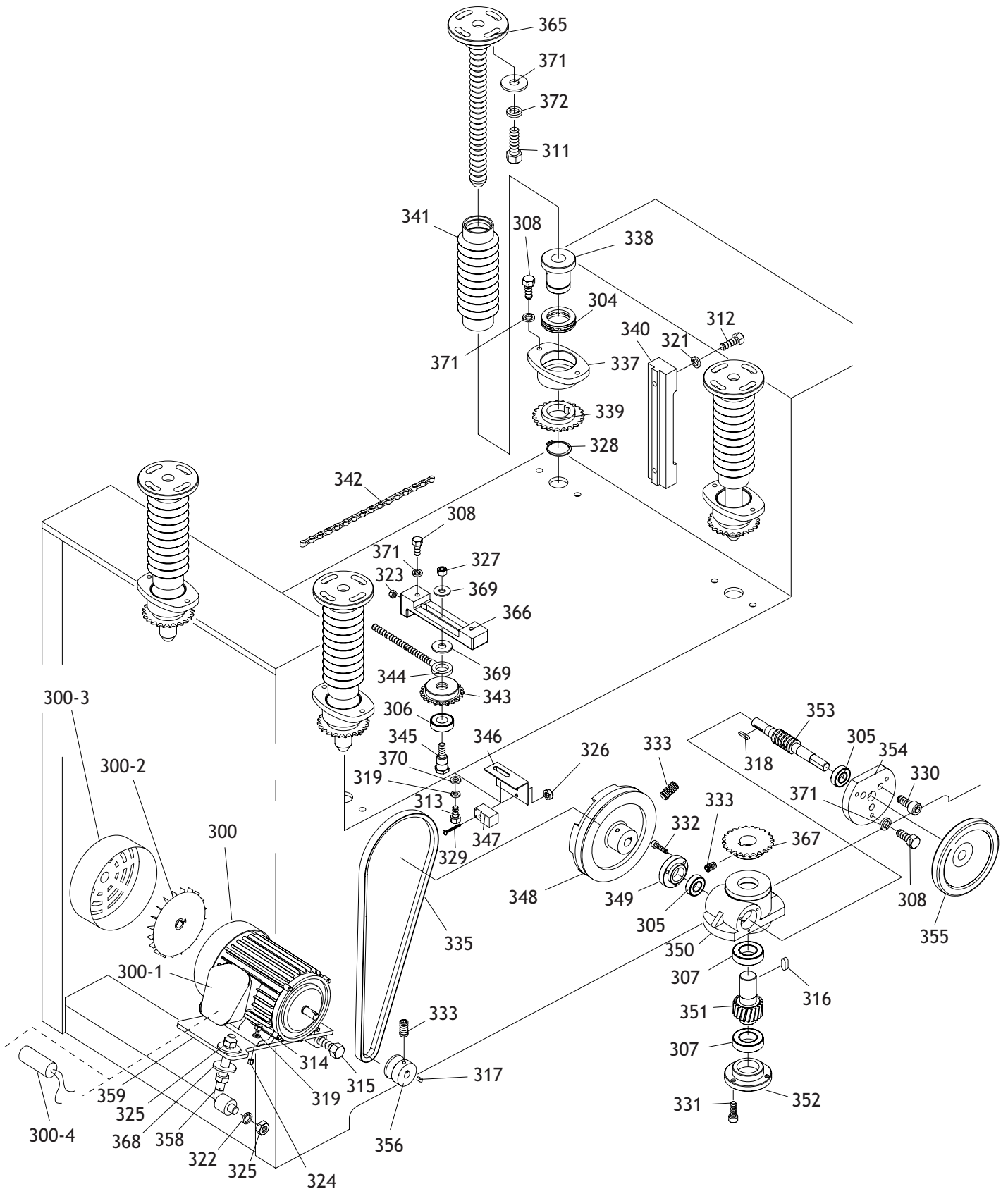

REF	PART #	DESCRIPTION
300	X1738300	MOTOR 1/4 HP 3-PH (W1738)
300	X1737300	MOTOR 1/3 HP 1-PH (W1737)
300-1	X1738300-1	ELECTRICAL BOX (W1738)
300-1	X1737300-1	ELECTRICAL BOX (W1737)
300-2	X1738300-2	FAN (W1738)
300-2	X1737300-2	FAN (W1737)
300-3	X1738300-3	FAN COVER (W1738)
300-3	X1737300-3	FAN COVER (W1737)
300-4	XPC100A	CAPACITOR 100MFD/250V (W1737)
304	XP51107	THRUST BEARING 51107
305	XP6002	BALL BEARING 6002Z
306	XP6003	BALL BEARING 6003ZZ
307	XP6005	BALL BEARING 6005Z
308	XPB07	HEX BOLT 5/16-18 X 3/4
311	XPB12	HEX BOLT 5/16-18 X 1 1/4
312	XPB18	HEX BOLT 3/8-16 X 1
313	XPB20	HEX BOLT 1/2-12 X 2 1/2
314	XPB31	HEX BOLT 1/4-20 X 1
315	XPB89	HEX BOLT 1/2-12 X 4 1/2
316	XPK14	KEY 5/16 X 5/16 X 3/4
317	XPK37M	KEY 4 X 4 X 16
318	XPK48M	KEY 4 X 4 X 20
319	XPLW02	LOCK WASHER 1/4
321	XPLW04	LOCK WASHER 3/8
322	XPLW07	LOCK WASHER 1/2
323	XPN02	HEX NUT 5/16-18
324	XPN05	HEX NUT 1/4-20
325	XPN06	HEX NUT 1/2-12
326	XPN07M	HEX NUT M3-.5
327	XPN08	HEX NUT 3/8-16
328	XPR12M	EXT RETAINING RING 35MM
329	XPS97M	PHLP HD SCR M3-.5 X 35
330	XPSB01	CAP SCREW 1/4-20 X 5/8
331	XPSB05	CAP SCREW 1/4-20 X 3/4

REF	PART #	DESCRIPTION
332	XPSB31	CAP SCREW 10-24 X 5/8
333	XPSS07	SET SCREW 1/4-20 X 1/2
335	XPVA37	V-BELT A-37 4L370
337	X1737337	HEX NUT HOUSING
338	X1737338	COLUMN NUT
339	X1737339	SPROCKET WHEEL
340	X1737340	ELEVATION SLIDE
341	X1737341	DUST BOOT
342	X1737342	CHAIN
343	X1737343	SPROCKET
344	X1737344	WHEEL ROD
345	X1737345	SPROCKET SHAFT
346	X1737346	SWITCH PLATE
347	X1737347	PROXIMITY SWITCH
348	X1737348	PULLEY
349	X1737349	BEARING CAP
350	X1737350	ELEVATION GEAR BOX
351	X1737351	WORM GEAR
352	X1737352	BEARING CAP
353	X1737353	WORM GEAR
354	X1737354	BEARING CAP
355	X1737355	HAND WHEEL
356	X1737356	PULLEY (W1738)
356	X1737356	PULLEY (W1737)
358	X1737358	ADJUSTMENT ROD
359	X1737359	MOTOR BASE
365	X1737365	ELEVATION SCREW
366	X1737366	WHEEL ADJUSTER
367	X1737367	SPROCKET WHEEL
368	XPW01	FLAT WASHER 1/2
369	XPW02	FLAT WASHER 3/8
370	XPW06	FLAT WASHER 1/4
371	XPW07	FLAT WASHER 5/16
372	XPLW01	LOCK WASHER 5/16

Feed System and Conveyor Parts

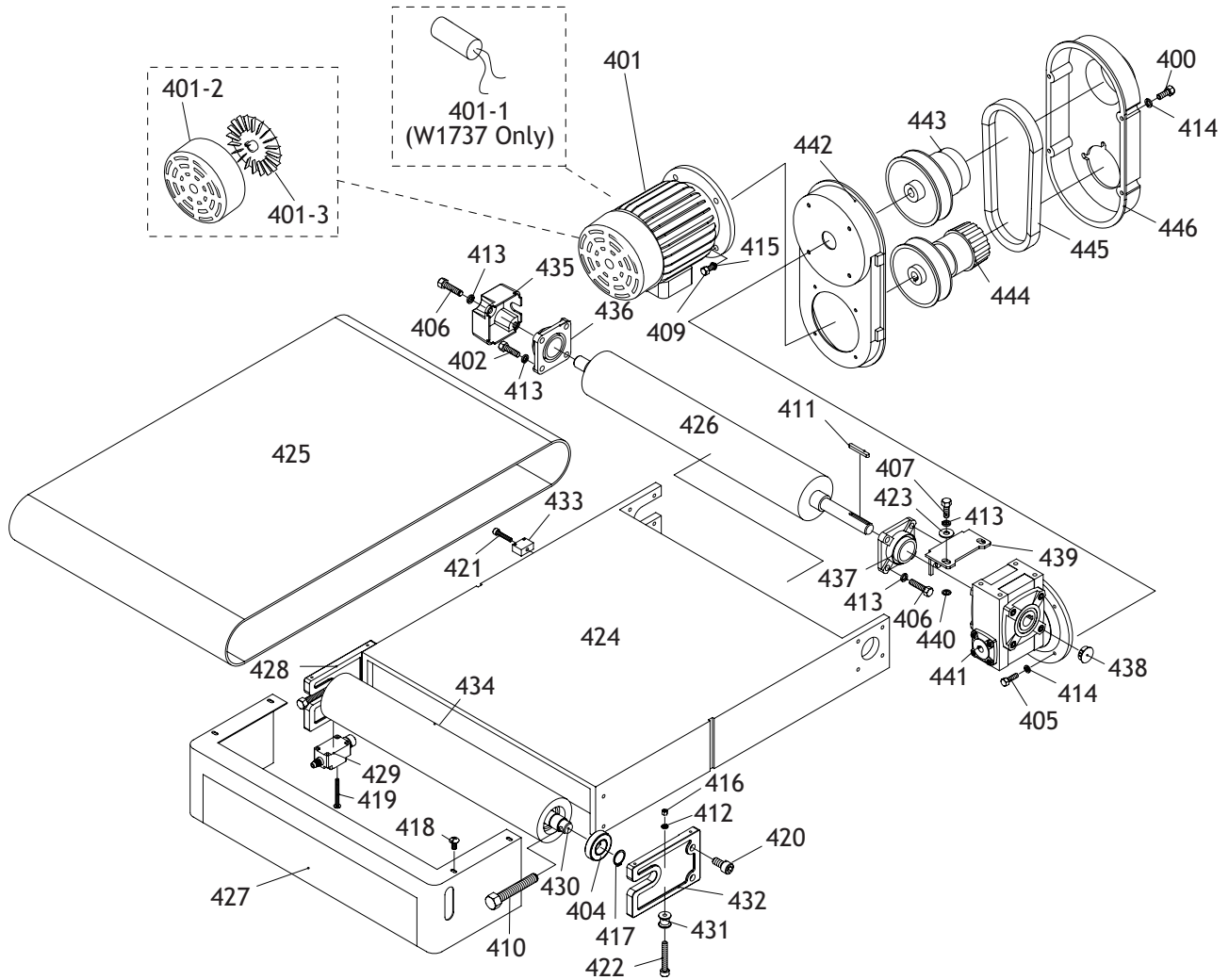

REF	PART #	DESCRIPTION
400	X1737400	SPECIAL SCR M8-1.25 X 20
401	X1738401	MOTOR 1HP 3PH (W1738)
401	X1737401	MOTOR 1HP 1PH (W1737)
401-1	XPC400C	CAPACITOR 400MFD/250V (W1737)
401-2	X1738401-2	FAN (W1738)
401-2	X1737401-2	FAN (W1737)
401-3	X1738401-3	FAN COVER (W1738)
401-3	X1737401-3	FAN COVER (W1737)
402	XPB16	HEX BOLT 3/8-16 X 1 1/2
404	XP2606	BALL BEARING 6206-2RS
405	XPB07M	HEX BOLT M8-1.25 X 25
406	XPB16	HEX BOLT 3/8-16 X 1 1/2
407	XPB18	HEX BOLT 3/8-16 X 1
409	XPB32M	HEX BOLT M10-1.5 x 25
410	XPB95	HEX BOLT 1/2-12 X 3
411	XPK66M	KEY 7 X 7 X 55
412	XPLW01	LOCK WASHER 5/16
413	XPLW04	LOCK WASHER 3/8
414	XPLW04M	LOCK WASHER 8MM
415	XPLW06M	LOCK WASHER 10MM
416	XPN02	HEX NUT 5/16-18
417	XPR15M	EXT RETAINING RING 30MM
418	XPS04	PHLP HD SCR 1/4-20 X 1/2
419	XPS10	PHLP HD SCR 10-24 x 1 1/2
420	XPSB16	CAP SCREW 3/8-16 X 3/4
421	XPSB62	CAP SCREW 1/4-20 X 1 1/2

REF	PART #	DESCRIPTION
422	XPSB70	CAP SCREW 5/16-18 X 2
423	XPW02	FLAT WASHER 3/8
424	X1737424	TABLE
425	X1737425	CONVEYOR BELT
426	X1737426	OUTFEED ROLLER
427	X1737427	FRONT BRAKE COVER
428	X1737428	INFEED ROLLER BRACKET
429	X1737429	LIMIT SWITCH
430	X1737430	INFEED ROLLER SHAFT
431	X1737431	POSITIONING WHEEL
432	X1737432	INFEED ROLLER BRACKET
433	X1737433	ELEVATION LIMITER
434	X1737434	INFEED ROLLER
435	X1737435	BEARING CAP
436	X1737436	BEARING UCF205
437	X1737437	BEARING UCF205
438	X1737438	PLUG
439	X1737439	GEARBOX PLATE
440	X1737440	CUSHION
441	X1737441	REDUCER
442	X1737442	SPEED UNIT BASE PLATE
443	X1737443	DRIVEN PULLEY
444	X1737444	DRIVING PULLEY
445	X1737445	TIMING BELT
446	X1737446	SPEED UNIT COVER

Upper Roller System Parts

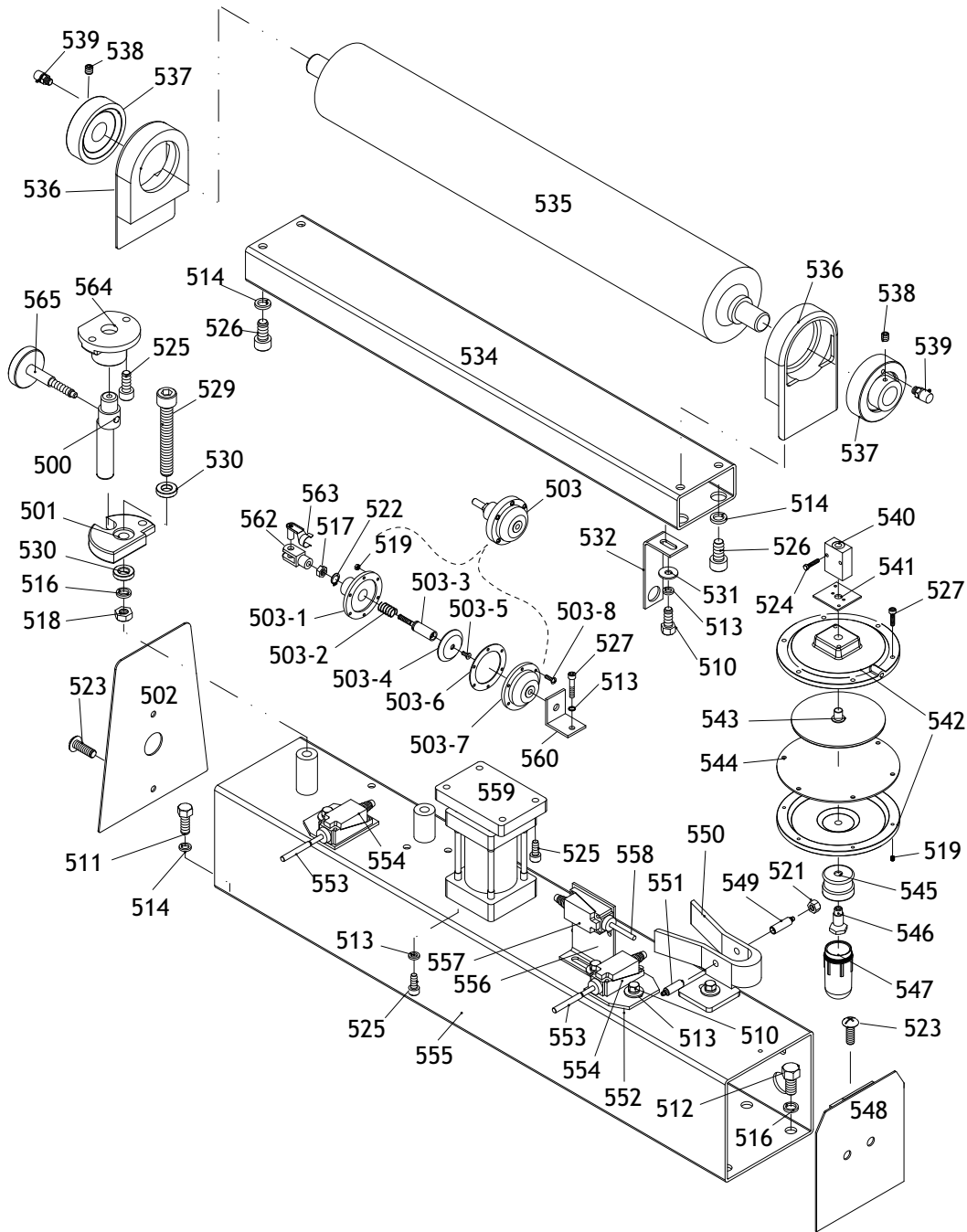



REF	PART #	DESCRIPTION
500	X1737500	ECCENTRIC ROD
501	X1737501	ECCENTRIC
502	X1737502	FRAME SEAL
503	X1737503	DIAPHRAM ASSY
503-1	X1737503-1	PUSHROD COVER
503-2	X1737503-2	COMPRESSION SPRING
503-3	X1737503-3	PUSHROD
503-4	X1737503-4	DIAPHRAM
503-5	X1737503-5	SPECIAL SCREW
503-6	X1737503-6	GASKET
503-7	X1737503-7	REAR HOUSING
503-8	XPS52M	PHLP HD SCR M4-.7 X 20
510	XPB07	HEX BOLT 5/16-18 X 3/4
511	XPB18	HEX BOLT 3/8-16 X 1
512	XPB53	HEX BOLT 1/2-12 X 1
513	XPLW01	LOCK WASHER 5/16
514	XPLW04	LOCK WASHER 3/8
516	XPLW07	LOCK WASHER 1/2
517	XPN02M	HEX NUT M10-1.5
518	XPN06	HEX NUT 1/2-12
519	XPN07	HEX NUT 10-24
521	XPN11	HEX NUT 3/8-24
522	XPR05M	EXT RETAINING RING 15MM
523	XPS04	PHLP HD SCR 1/4-20 X 1/2
524	XPS52M	PHLP HD SCR M4-.7 X 20
525	XPSB07	CAP SCREW 5/16-18 X 3/4
526	XPSB16	CAP SCREW 3/8-16 X 3/4
527	XPSB33	CAP SCREW 10-24 x 3/4
529	XPSB79	CAP SCREW 1/2-12 X 3 1/2
530	XPW01	FLAT WASHER 1/2
531	XPW07	FLAT WASHER 5/16
532	X1737532	POWER OFF PLATE

REF	PART #	DESCRIPTION
534	X1737534	UPPER ROLLER BRACKET
535	X1737535	UPPER ROLLER
536	X1737536	UPPER ROLLER BRACKET
537	X1737537	BEARING UCC205
538	X1737538	SET SCREW M6-1 X 6
539	X1737539	FILTER
540	X1737540	THROTTLE VALVE
541	X1737541	THROTTLE VALVE BASE
542	X1737542	ALUMINUM DISC
543	X1737543	ALUMINUM PLATE
544	X1737544	PLATE
545	X1737545	OIL CAP CONNECTOR
546	X1737546	SHAFT OF OIL CAP
547	X1737547	OIL CAP
548	X1737548	FRAME SEAL, (RIGHT)
549	X1737549	AIR NOZZLE (FEMALE)
550	X1737550	AIR CYLINDER BRACKET
551	X1737551	AIR RECEIVER (MALE)
552	X1737552	LIMIT SWITCH HOLDER
553	X1737553	LIMIT SWITCH TUBE
554	X1737554	LIMIT SWITCH W/CERAMIC TIP
555	X1737555	SQUARE FRAME
556	X1737556	HOLDER (L TYPE)
557	X1737557	LIMIT SWITCH
558	X1737558	PLASTIC LIMIT SWITCH ROD
559	X1737559	AIR CYLINDER
560	X1737560	BASE
562	X1737562	UNIVERSAL JOINT FORK
563	X1737563	LOCKING CLEVIS
564	X1737564	FRAME
565	X1737565	TRIMMING SCREW

Air System Parts

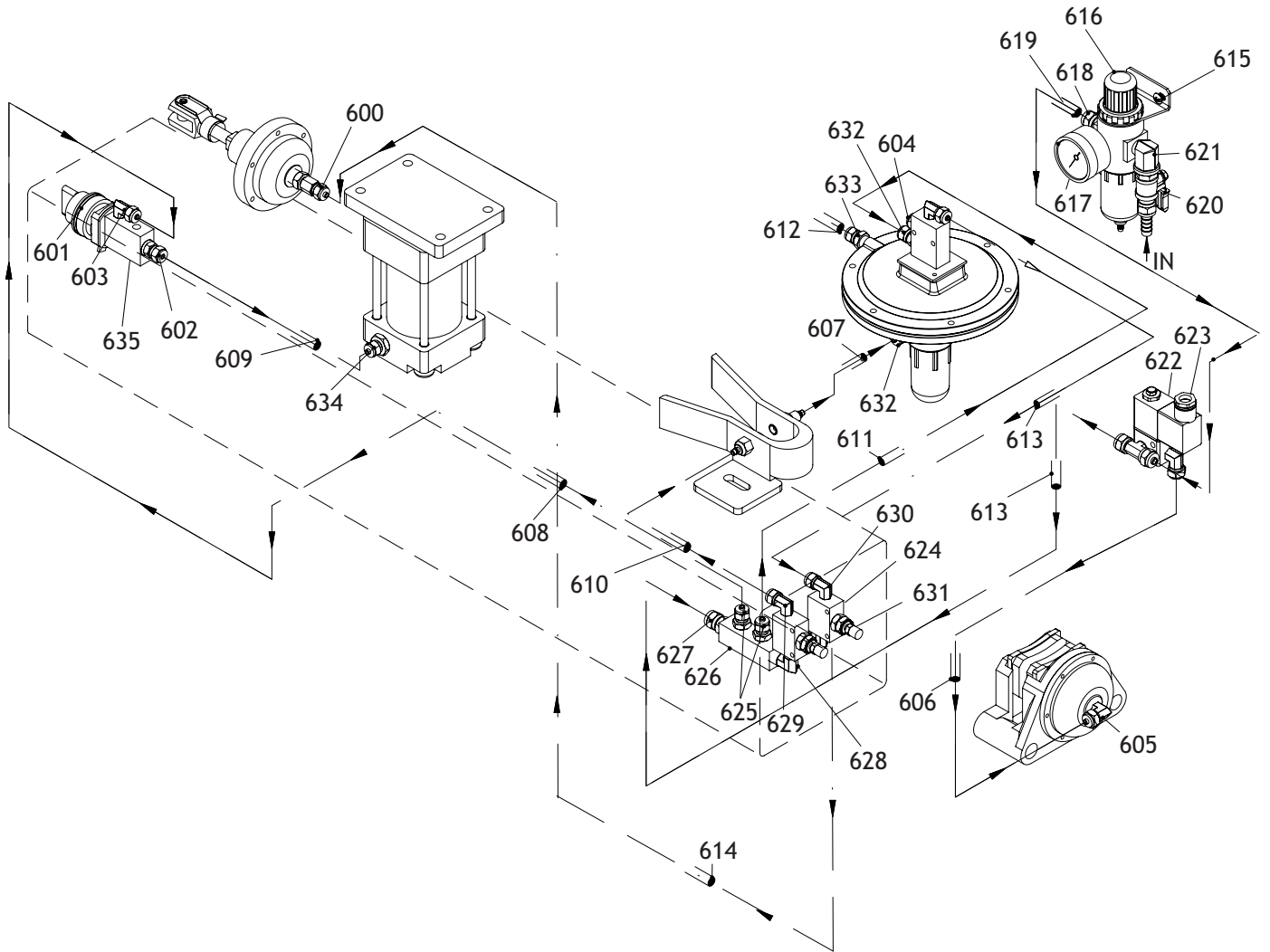

REF	PART #	DESCRIPTION
600	X1737600	CONNECTOR 1/4N X 1/8T
601	X1737601	AIR SWITCH 1/8
602	X1737602	CONNECTOR 1/4N X 1/8T
603	X1737603	CONNECTOR 1/4N X 90°
604	X1737604	BUFFER (BRONZE)
605	X1737605	CONNECTOR 5/16N X 1/8T 90°
606	X1737606	8MM FLEXIBLE HOSE
607	X1737607	6MM FLEXIBLE HOSE
608	X1737608	6MM FLEXIBLE HOSE
609	X1737609	6MM FLEXIBLE HOSE
610	X1737610	6MM FLEXIBLE HOSE
611	X1737611	6MM FLEXIBLE HOSE
612	X1737612	6MM FLEXIBLE HOSE
613	X1737613	6MM FLEXIBLE HOSE
614	X1737614	6MM FLEXIBLE HOSE
615	XPS22	PHLP HD SCR 10-24 x 5/8
616	X1737616	PRESSURE REGULATOR
617	X1737617	PSI GAUGE

REF	PART #	DESCRIPTION
618	X1737618	CONNECTOR 5/16N X 1/8T
619	X1737619	8MM FLEXIBLE HOSE
620	X1737620	AIR SWITCH 1/4
621	X1737621	ELBOW 5/16N X 1/8T 90°
622	X1737622	SOLENOID VALVE
623	X1737623	SOLENOID VALVE
624	X1737624	THROTTLE VALVE 1/8
625	X1737625	CONNECTOR 1/4N X 1/8T
626	X1737626	CONNECTOR 1/4N X 1/8T
627	X1737627	CONNECTOR 5/16N X 1/4T
628	X1737628	BRONZE ELBOW 1/4T X 1/8T 90°
629	X1737629	MALE CONNECTOR 1/4N X 1/8T 90°
630	X1737630	MALE CONNECTOR 1/4N X 1/8T 90°
631	X1737631	NEEDLE VALVE
632	X1737632	CONNECTOR 1/4N X 1/4T
633	X1737633	BRONZE CONNECTOR 1/4N X 1/8T
634	X1737634	CONNECTOR 1/8N X 3/8T
635	X1737635	AIR VALVE

Sanding Drum and Roller Parts

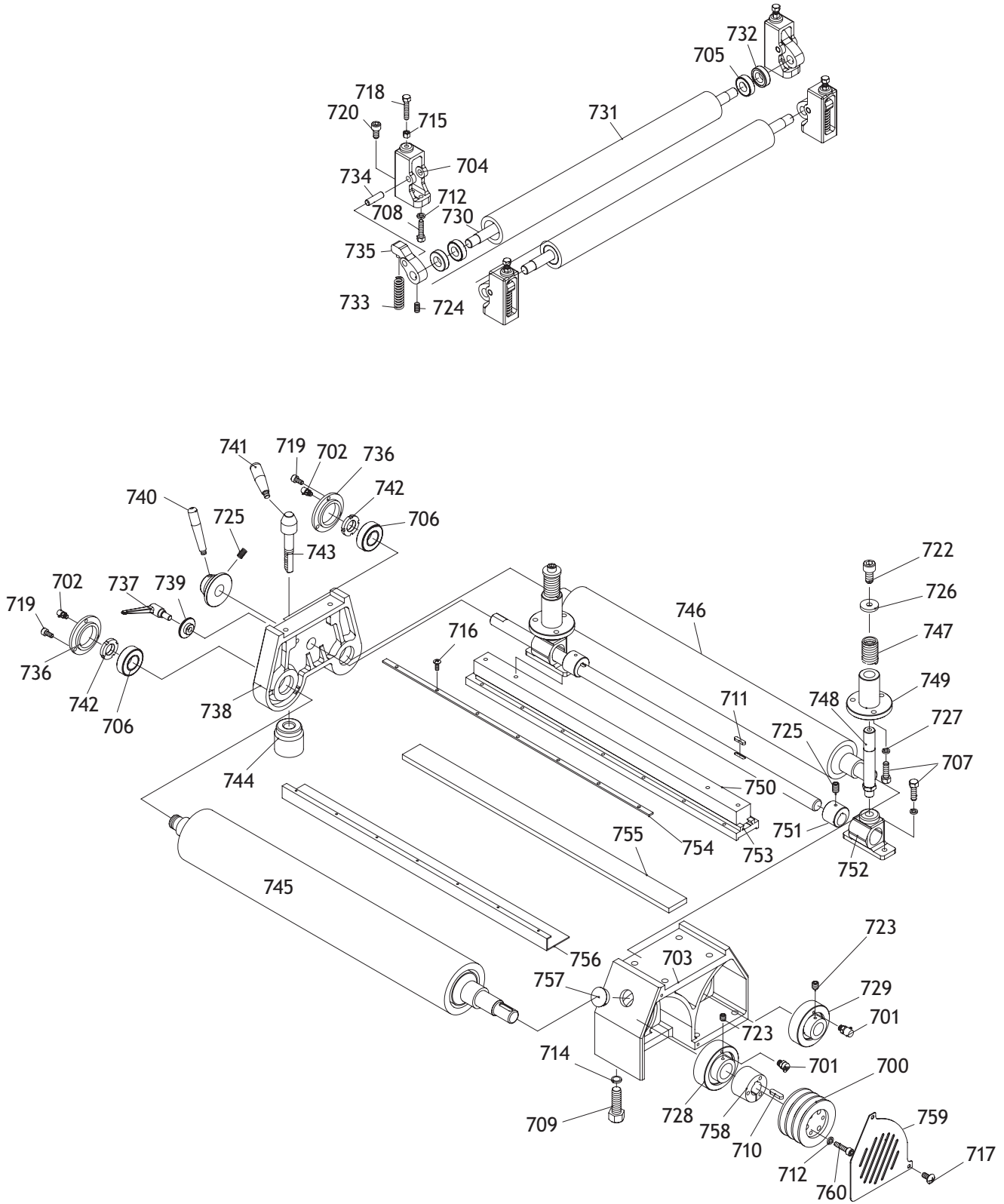

REF	PART #	DESCRIPTION
700	X1737700	PULLEY
701	X1737701	GREASE FITTING/W DUST CAP
703	X1737703	BEARING HOUSING
704	X1737704	PISTON BRACKET
705	XP6003	BALL BEARING 6001ZZ
706	XP6205A	BALL BEARING 6205-2RS
707	XPB03	HEX BOLT 5/16-18 X 1
708	XPB12	HEX BOLT 5/16-18 X 1 1/4
709	XPB41	HEX BOLT 1/2-12 X 1 1/2
710	XPB11	KEY 5/16 X 5/16 X 1 3/16
711	XPB34M	KEY 5 X 5 X 20
712	XPLW01	LOCK WASHER 5/16
714	XPLW07	LOCK WASHER 1/2
715	XPB02	HEX NUT 5/16-18
716	XPS01	PHLP HD SCR 10-24 X 1/2
717	XPS07	PHLP HD SCR 1/4-20 X 3/8
718	XPS11	PHLP HD SCR 5/16-18 X 1 1/4
719	XPSB04	CAP SCREW 1/4-20 X 1/2
720	XPSB05	CAP SCREW 1/4-20 X 3/4
722	XPSB16	CAP SCREW 3/8-16 X 3/4
723	XPSS02M	SET SCREW M6-1 X 6
724	XPSS03	SET SCREW 1/4-20 X 3/8
725	XPSS08	SET SCREW 5/16-18 X 1/2
727	XPW07	FLAT WASHER 5/16
728	X1737728	BEARING UCC206
729	X1737729	BEARING UCC205
730	X1737730	PISTON ROLLER SHAFT
731	X1737731	PISTON ROLLER

REF	PART #	DESCRIPTION
733	X1737733	COMPRESSION SPRING
734	X1737734	SPECIAL PIN 10MM
735	X1737735	PISTON SIDERAIL
736	X1737736	BEARING CAP
737	X1737737	HANDLE
738	X1737738	BEARING HOUSING
739	X1737739	SPECIAL WASHER
740	X1737740	HANDLE
741	X1737741	HANDLE
742	X1737742	SPANNER NUT
743	X1737743	LEVER SHANK
744	X1737744	SPACER
745	X1737745	RUBBER ROLLER
746	X1737746	STEEL ROLLER
747	X1737747	COMPRESSION SPRING
748	X1737748	FIXING SHAFT
749	X1737749	HOUSING
750	X1737750	BRACKET (MALE)
751	X1737751	TUBE
752	X1737752	BASE
753	X1737753	BRACKET (FEMALE)
754	X1737754	PRESSURE PLATE
755	X1737755	FELT
756	X1737756	GRAPHITE PAD
757	X1737757	PLUG 25 MM
758	X1737758	FASTENING TUBE
759	X1737759	COVER OF PULLEY
760	XPSB11	CAP SCREW 5/16-18 X 1-1/4

⚠️ WARNING

The safety labels on this machine warn and indicate how to protect the operator or bystander from machine hazards. The machine owner **MUST** maintain the original label location and readability. If a label is removed or becomes unreadable, **REPLACE** the label before using the machine. For new labels, contact Woodstock International at (360) 734-3482 or www.shopfox.biz.

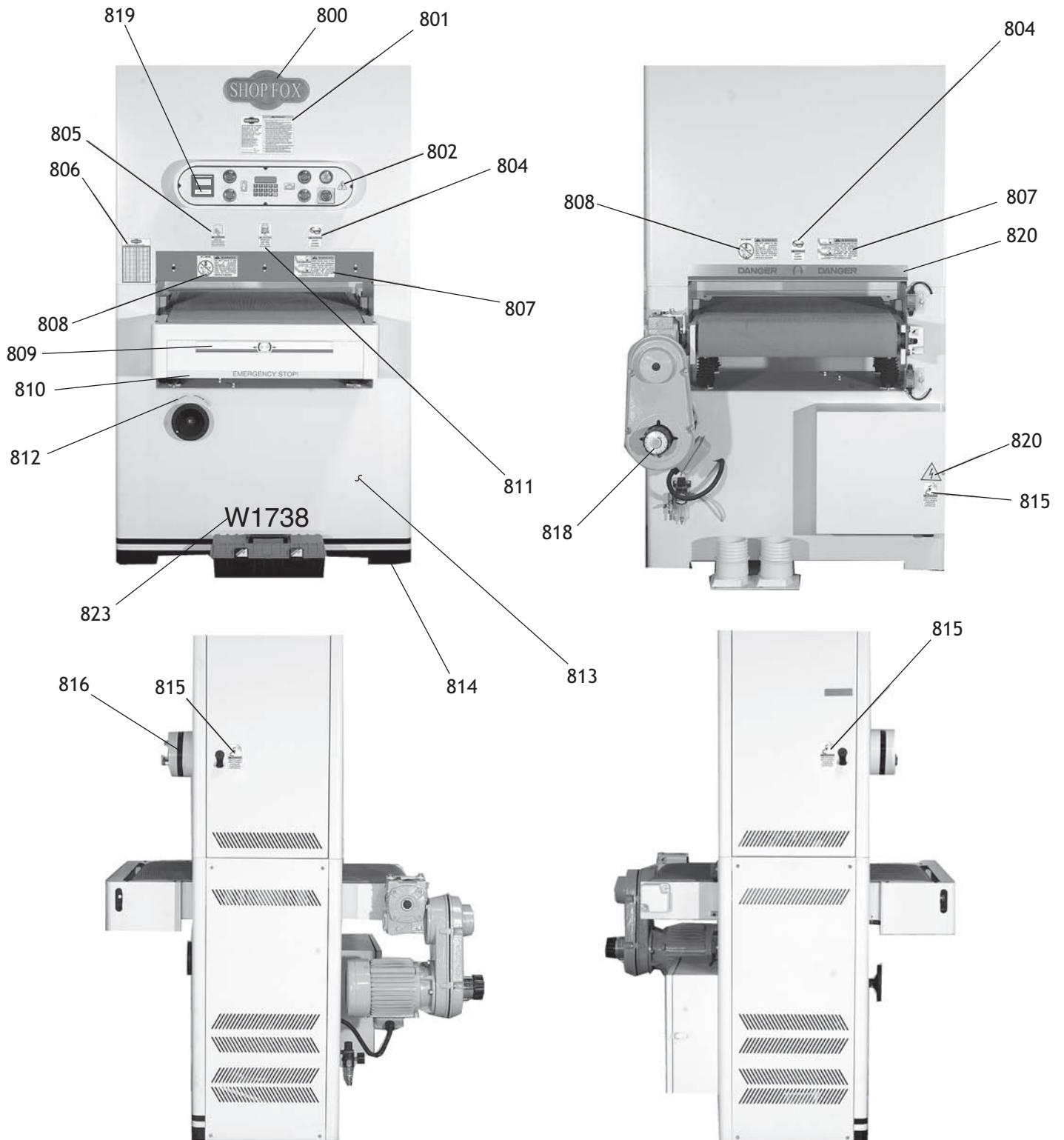

REF	PART #	DESCRIPTION
800	X1737127	SHOP FOX LOGO PLATE
801	X1737801	DATA LABEL (W1737)
801	X1738801	DATA LABEL (W1738)
802	X1737802	LABEL (CONTROL PANEL)
803	XLABEL02B	LABEL (DISCONNECT POWER)
804	XLABEL01	LABEL (SAFETY GLASSES)
805	XLABEL06	LABEL (READ MANUAL)
806	XLABEL11	LABEL (CONVERSION CHART)
807	XLABEL13	LABEL (CONVEYOR PINCH)
808	XLABEL12	LABEL (SANDER KICKBACK)
809	X1738809	LABEL (BRAKE)
810	X1738810	LABEL (EMERGENCY)

REF	PART #	DESCRIPTION
811	XLABEL06	LABEL (USE RESPIRATOR)
812	X1737812	LABEL (DIRECTION)
813	XPAINTSF102	TAN TOUCH-UP PAINT
814	X1738814	BLACK/TAN TRIM TAPE
815	XLABEL03	LABEL (CLOSE DOOR)
816	X1738816	BLACK TRIM TAPE
818	X1737818	LABEL (SPEED LABEL)
819	X1737819	LABEL AMP LOAD (W1737)
819	X1738819	LABEL AMP LOAD (W1738)
820	X1738820	LABEL (CAUTION STRIPE)
823	X1737823	LABEL (W1737)
823	X1738823	LABEL (W1738)

Notes

Troubleshooting

SYMPTOM	POSSIBLE CAUSE	HOW TO REMEDY
Motor will not start; fuses or circuit breakers blow.	<ol style="list-style-type: none"> 1. Low voltage. 2. Open circuit in motor or loose or shorted connections. 3. Short circuit in motor or loose connections. 4. Incorrect fuses or circuit breakers. 5. Faulty start capacitor. 6. Faulty motor. 	<ol style="list-style-type: none"> 1. Check power line for proper voltage. 2. Inspect all lead connections on motor for loose, shorted, or open connections and replace or repair. 3. Inspect all connections on motor for loose or shorted terminals or worn insulation. 4. Install correct fuses or circuit breakers. 5. Replace the start capacitor and do not to overload motor. 6. Replace motor.
Motor overheats.	<ol style="list-style-type: none"> 1. Motor overloaded. 2. Air circulation through the motor restricted. 	<ol style="list-style-type: none"> 1. Reduce load on motor. 2. Clean out motor to provide normal air circulation.
Motor stalls (resulting in blown fuses or tripped circuit).	<ol style="list-style-type: none"> 1. Short circuit in motor or loose connections. 2. Low voltage. 3. Incorrect fuses or circuit breakers in power line. 4. Motor overloaded. 5. Faulty run capacitor. 	<ol style="list-style-type: none"> 1. Inspect connections on motor for loose or shorted terminals or worn insulation. 2. Correct the low voltage conditions. 3. Install correct fuses or circuit breakers. 4. Reduce load on motor. 5. Replace the run capacitor.
Machine slows when operating.	<ol style="list-style-type: none"> 1. Feed rate too high. 2. Depth of cut too great. 	<ol style="list-style-type: none"> 1. Feed workpiece slower. 2. Reduce depth of cut.
Loud, repetitious noise coming from machine	<ol style="list-style-type: none"> 1. Pulley set screws or keys are missing or loose. 2. Motor fan is hitting the cover. 3. V-belt is defective. 	<ol style="list-style-type: none"> 1. Inspect keys and set screws. Replace or tighten if necessary. 2. Tighten fan. 3. Replace V-belt. See Maintenance section.
Machine is loud, overheats or bogs down in the cut.	<ol style="list-style-type: none"> 1. Excessive depth of cut. 2. Dull sanding belt. 	<ol style="list-style-type: none"> 1. Decrease depth of cut. 2. Replace sanding belt.
Edges of wood are rounded.	<ol style="list-style-type: none"> 1. Excessive depth of cut. 	<ol style="list-style-type: none"> 1. Reduce depth of cut.
Uneven thickness from left to right of board.	<ol style="list-style-type: none"> 1. Feed table not parallel to sanding roller. 2. Feed belt is worn. 	<ol style="list-style-type: none"> 1. Adjust the table. 2. Replace feed belt.
Workpiece slips on feed belt.	<ol style="list-style-type: none"> 1. Pressure rollers set too high. 2. Dirty feed belt. 3. Feed belt is worn. 	<ol style="list-style-type: none"> 1. Lower pressure rollers. 2. Clean feed belt. 3. Replace feed belt.
Straight strip of notches on workpiece.	<ol style="list-style-type: none"> 1. Pressure rollers are dirty or damaged. 	<ol style="list-style-type: none"> 1. Clean or repair pressure rollers.
Snake shaped marks on workpiece.	<ol style="list-style-type: none"> 1. Sanding belt damaged or dirty. 	<ol style="list-style-type: none"> 1. Clean or replace sanding belt.



Warranty

Woodstock International, Inc. warrants all **SHOP FOX**[®] machinery to be free of defects from workmanship and materials for a period of two years from the date of original purchase by the original owner. This warranty does not apply to defects due directly or indirectly to misuse, abuse, negligence or accidents, lack of maintenance, or reimbursement of third party expenses incurred.

Woodstock International, Inc. will repair or replace, at its expense and at its option, the **SHOP FOX**[®] machine or machine part which in normal use has proven to be defective, provided that the original owner returns the product prepaid to the **SHOP FOX**[®] factory service center or authorized repair facility designated by our Bellingham, WA office, with proof of their purchase of the product within two years, and provides Woodstock International, Inc. reasonable opportunity to verify the alleged defect through inspection. If it is determined there is no defect, or that the defect resulted from causes not within the scope of Woodstock International Inc.'s warranty, then the original owner must bear the cost of storing and returning the product.

This is Woodstock International, Inc.'s sole written warranty and any and all warranties that may be implied by law, including any merchantability or fitness, for any particular purpose, are hereby limited to the duration of this written warranty. We do not warrant that **SHOP FOX**[®] machinery complies with the provisions of any law or acts. In no event shall Woodstock International, Inc.'s liability under this warranty exceed the purchase price paid for the product, and any legal actions brought against Woodstock International, Inc. shall be tried in the State of Washington, County of Whatcom. We shall in no event be liable for death, injuries to persons or property or for incidental, contingent, special or consequential damages arising from the use of our products.

Every effort has been made to ensure that all **SHOP FOX**[®] machinery meets high quality and durability standards. We reserve the right to change specifications at any time because of our commitment to continuously improve the quality of our products.



WXXXX Machine Name

Warranty Registration

Name _____
 Street _____
 City _____ State _____ Zip _____
 Phone # _____ Email _____ Invoice # _____
 Model # _____ Serial # _____ Dealer Name _____ Purchase Date _____

The following information is given on a voluntary basis. It will be used for marketing purposes to help us develop better products and services. Of course, all information is strictly confidential.

- How did you learn about us?
 Advertisement Friend Local Store
 Mail Order Catalog Website Other:
- How long have you been a woodworker/metalworker?
 0-2 Years 2-8 Years 8-20 Years 20+ Years
- How many of your machines or tools are Shop Fox®?
 0-2 3-5 6-9 10+
- Do you think your machine represents a good value? Yes No
- Would you recommend Shop Fox® products to a friend? Yes No
- What is your age group?
 20-29 30-39 40-49
 50-59 60-69 70+
- What is your annual household income?
 \$20,000-\$29,000 \$30,000-\$39,000 \$40,000-\$49,000
 \$50,000-\$59,000 \$60,000-\$69,000 \$70,000+
- Which of the following magazines do you subscribe to?

<input type="checkbox"/> Cabinet Maker	<input type="checkbox"/> Popular Mechanics	<input type="checkbox"/> Today's Homeowner
<input type="checkbox"/> Family Handyman	<input type="checkbox"/> Popular Science	<input type="checkbox"/> Wood
<input type="checkbox"/> Hand Loader	<input type="checkbox"/> Popular Woodworking	<input type="checkbox"/> Wooden Boat
<input type="checkbox"/> Handy	<input type="checkbox"/> Practical Homeowner	<input type="checkbox"/> Woodshop News
<input type="checkbox"/> Home Shop Machinist	<input type="checkbox"/> Precision Shooter	<input type="checkbox"/> Woodsmith
<input type="checkbox"/> Journal of Light Cont.	<input type="checkbox"/> Projects in Metal	<input type="checkbox"/> Woodwork
<input type="checkbox"/> Live Steam	<input type="checkbox"/> RC Modeler	<input type="checkbox"/> Woodworker West
<input type="checkbox"/> Model Airplane News	<input type="checkbox"/> Rifle	<input type="checkbox"/> Woodworker's Journal
<input type="checkbox"/> Modeltec	<input type="checkbox"/> Shop Notes	<input type="checkbox"/> Other:
<input type="checkbox"/> Old House Journal	<input type="checkbox"/> Shotgun News	

9. Comments: _____

CUT ALONG DOTTED LINE

FOLD ALONG DOTTED LINE

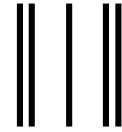
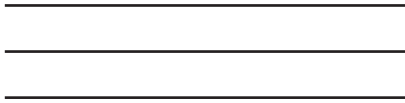

Place
Stamp
Here



WOODSTOCK INTERNATIONAL, INC.
P.O. BOX 2309
BELLINGHAM, WA 98227-2309



FOLD ALONG DOTTED LINE

TAPE ALONG EDGES--PLEASE DO NOT STAPLE



High Quality Machines and Tools

Woodstock International, Inc. carries thousands of products designed to meet the needs of today's woodworkers and metalworkers.

Ask your dealer about these fine products:

BROSMA
PRECISION STOP BLOCK

THE REBEL

BOARD BUDDIES®

PLANER PAL®

SLICKPLANE®

ACCU-SHARP



JOINTER PAL®

DURASTICK®



STEELEX
FINE TOOLS

STEELEX
PLUS

Rotacator®

Gutmann®

Junglee®

PARROT VISE®

PRO-STIK®
ABRASIVE BELT & DISC CLEANER

Aluma-Classic®



WHOLESALE ONLY

WOODSTOCK INTERNATIONAL, INC.

Phone: (360) 734-3482 • Fax: (360) 671-3053 • Toll Free Fax: (800) 647-8801

P.O.Box 2309 • Bellingham, WA 98227

SHOPFOX.BIZ

Free Manuals Download Website

<http://myh66.com>

<http://usermanuals.us>

<http://www.somanuals.com>

<http://www.4manuals.cc>

<http://www.manual-lib.com>

<http://www.404manual.com>

<http://www.luxmanual.com>

<http://aubethermostatmanual.com>

Golf course search by state

<http://golfingnear.com>

Email search by domain

<http://emailbydomain.com>

Auto manuals search

<http://auto.somanuals.com>

TV manuals search

<http://tv.somanuals.com>