

# MODEL M1014 7" X 12" METAL CUTTING BANDSAW



## INSTRUCTION MANUAL

Phone: 1-360-734-3482 • On-Line Technical Support: [tech-support@shopfox.biz](mailto:tech-support@shopfox.biz)

COPYRIGHT © JANUARY, 2005 BY WOODSTOCK INTERNATIONAL, INC. REVISED NOVEMBER, 2010 (TR)

WARNING: NO PORTION OF THIS MANUAL MAY BE REPRODUCED IN ANY SHAPE OR FORM WITHOUT

THE WRITTEN APPROVAL OF WOODSTOCK INTERNATIONAL, INC.

#6753CR

Printed in China



## **WARNING!**

This manual provides critical safety instructions on the proper setup, operation, maintenance, and service of this machine/tool. Save this document, refer to it often, and use it to instruct other operators.

Failure to read, understand and follow the instructions in this manual may result in fire or serious personal injury—including amputation, electrocution, or death.

The owner of this machine/tool is solely responsible for its safe use. This responsibility includes but is not limited to proper installation in a safe environment, personnel training and usage authorization, proper inspection and maintenance, manual availability and comprehension, application of safety devices, cutting/sanding/grinding tool integrity, and the usage of personal protective equipment.

The manufacturer will not be held liable for injury or property damage from negligence, improper training, machine modifications or misuse.



## **WARNING!**

Some dust created by power sanding, sawing, grinding, drilling, and other construction activities contains chemicals known to the State of California to cause cancer, birth defects or other reproductive harm. Some examples of these chemicals are:

- Lead from lead-based paints.
- Crystalline silica from bricks, cement and other masonry products.
- Arsenic and chromium from chemically-treated lumber.

Your risk from these exposures varies, depending on how often you do this type of work. To reduce your exposure to these chemicals: Work in a well ventilated area, and work with approved safety equipment, such as those dust masks that are specially designed to filter out microscopic particles.

# Contents

<b>INTRODUCTION</b> .....	<b>2</b>	<b>OPERATIONS</b> .....	<b>22</b>
Woodstock Technical Support .....	2	General .....	22
Specifications .....	2	Operation.....	22
Controls and Features .....	3	Blade Selection .....	24
<b>SAFETY</b> .....	<b>4</b>	Blade Changes .....	25
Standard Machinery Safety Instructions .....	4	Cutting Fluid .....	26
Additional Safety for Metal Cutting Bandsaws.....	6	Feed Rate .....	27
Avoiding Potential Injuries.....	7	<b>MAINTENANCE</b> .....	<b>28</b>
<b>ELECTRICAL</b> .....	<b>8</b>	General .....	28
Circuit Requirements .....	8	Cleaning .....	28
Grounding Requirements.....	9	Lubrication .....	29
Extension Cords .....	9	<b>SERVICE</b> .....	<b>30</b>
<b>SET UP</b> .....	<b>10</b>	General .....	30
Unpacking .....	10	Cutting Fluid System.....	30
Items Needed for Set Up.....	10	Blade Tracking .....	31
Inventory .....	11	Wiring Diagram (110V) .....	33
Machine Placement .....	12	Wiring Diagram (220V) .....	34
Cleaning Machine.....	12	Troubleshooting.....	35
Handle, Wheels, and Feet .....	13	Parts List.....	38
Cutting Fluid System.....	14	Parts List.....	40
Cast Iron Stop.....	14	Parts List.....	42
Pulley Cover.....	15	Parts List.....	44
Vertical Cutting Table .....	16	Notes .....	45
Shipping Strap and ON/OFF Switch .....	16	Notes .....	46
<b>ADJUSTMENTS</b> .....	<b>18</b>	<b>WARRANTY</b> .....	<b>49</b>
Belt Tension .....	18		
Changing Cutting Speed.....	19		
Blade Tension .....	20		
Blade Guides .....	21		



# INTRODUCTION

## Woodstock Technical Support

This machine has been specially designed to provide many years of trouble-free service. Close attention to detail, ruggedly built parts and a rigid quality control program assure safe and reliable operation.

Woodstock International, Inc. is committed to customer satisfaction. Our intent with this manual is to include the basic information for safety, setup, operation, maintenance, and service of this product.

We stand behind our machines! In the event that questions arise about your machine, please contact Woodstock International Technical Support at (360) 734-3482 or send e-mail to: [tech-support@shopfox.biz](mailto:tech-support@shopfox.biz). Our knowledgeable staff will help you troubleshoot problems and process warranty claims.

If you need the latest edition of this manual, you can download it from <http://www.shopfox.biz>.

If you have comments about this manual, please contact us at:

**Woodstock International, Inc.**  
**Attn: Technical Documentation Manager**  
**P.O. Box 2309**  
**Bellingham, WA 98227**  
**Email: manuals@woodstockint.com**

## Specifications

Bandsaw Motor Size .....	1 HP, 110V/220V (Prewired 110V), 12A/6A, Single-Phase
Motor Speed .....	1,725 RPM
Power Transfer.....	V-Belt Drive and Worm-Gear Reduction
Maximum Circular Capacity .....	5" at 45°
Maximum Rectangular Capacity .....	4-3/4" x 4-1/2" at 45°
Maximum Rectangular Capacity .....	7" x 12" at 90°
Maximum Circular Capacity .....	7" at 90°
Coolant Capacity .....	2-1/2 gal.
Coolant Pump Motor.....	1/8 HP, 110V/220V (Prewired 110V), 0.6A/0.3A, Single-Phase
Footprint .....	13" x 38"
Overall Dimensions .....	48"L x 16"W x 37-5/8"H
Blade Speeds.....	90, 135, 195, 255 FPM
Blade Size .....	93" x 3/4"
Bearings .....	Permanently-Lubricated Ball Bearings
Power Control .....	Toggle ON/OFF Switch
Net Weight .....	275 lbs.

## Controls and Features

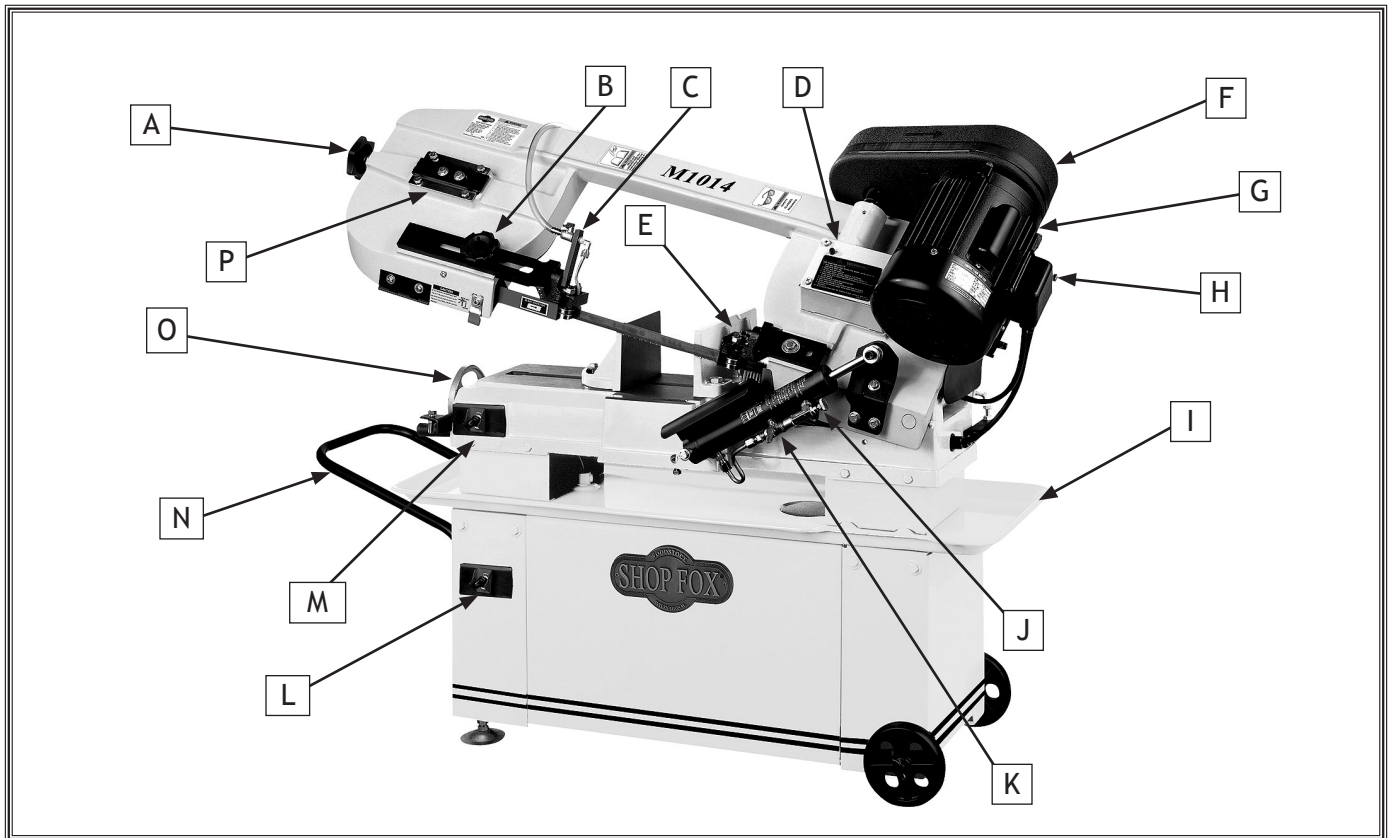

**Bandsaw controls and features.**

- |   |  |
|---|--|
| <p><b>A. Blade Tension Knob</b>—Allows you to quickly tension or de-tension the blade.</p> <p><b>B. Blade Guide Knob</b>—Allows you to move and lock the blade guide in place.</p> <p><b>C. Cutting Fluid Flow Valve</b>—Allows you to adjust the cutting fluid flow rate.</p> <p><b>D. Gear Box</b>—Allows the motor to achieve a mechanical advantage when cutting.</p> <p><b>E. Blade Guide/Chip Brush</b>—Guides stop blade twist and brush removes chips from blade.</p> <p><b>F. Pulley Cover</b>—Covers the pulleys for safety. Open cover to make blade speed changes.</p> <p><b>G. Heavy Duty Motor</b>—Dual voltage (prewired 110V), 1 HP motor drives the bandsaw wheels for smooth cutting.</p> <p><b>H. Circuit Breaker</b>—Protects the bandsaw motor and pump electrical system from overload.</p> | <p><b>I. Drain and Chip Pan</b>—Collects chips and cutting fluid, and directs fluid to the reservoir.</p> <p><b>J. Hydraulic Cylinder Feed Rate Dial</b>—Allows you to adjust the bandsaw feed rate accurately.</p> <p><b>K. Feed ON/OFF Valve</b>—Toggles the headstock feed <i>ON</i> and <i>OFF</i> for operation or Service.</p> <p><b>L. Cutting Fluid Pump ON/OFF Switch</b>—Toggles power <i>ON</i> and <i>OFF</i> to the pump motor.</p> <p><b>M. Bandsaw ON/OFF Switch</b>—Toggles power <i>ON</i> and <i>OFF</i> to the bandsaw motor.</p> <p><b>N. Handle</b>—Allows you to tilt the bandsaw and use the wheels to move the machine.</p> <p><b>O. Vise Clamp Wheel</b>—Allows you to quickly close and clamp the vise on the workpiece.</p> <p><b>P. Blade Tension Gauge</b>—Allows you to visually locate the correct blade tension.</p> |
|---|--|

# SAFETY

## For Your Own Safety, Read Manual Before Operating Machine

SAFETY

The purpose of safety symbols is to attract your attention to possible hazardous conditions. This manual uses a series of symbols and signal words intended to convey the level of importance of the safety messages. The progression of symbols is described below. Remember that safety messages by themselves do not eliminate danger and are not a substitute for proper accident prevention measures—this responsibility is ultimately up to the operator!



Indicates an imminently hazardous situation which, if not avoided, **WILL** result in death or serious injury.



Indicates a potentially hazardous situation which, if not avoided, **COULD** result in death or serious injury.



Indicates a potentially hazardous situation which, if not avoided, **MAY** result in minor or moderate injury.

### NOTICE

This symbol is used to alert the user to useful information about proper operation of the equipment, and/or a situation that may cause damage to the machinery.

## Standard Machinery Safety Instructions

**OWNER'S MANUAL.** Read and understand this owner's manual **BEFORE** using machine. Untrained users can be seriously hurt.

**EYE PROTECTION.** Always wear ANSI-approved safety glasses or a face shield when operating or observing machinery to reduce the risk of eye injury or blindness from flying particles. Everyday eyeglasses are not approved safety glasses.

**HAZARDOUS DUST.** Dust created while using machinery may cause cancer, birth defects, or long-term respiratory damage. Be aware of dust hazards associated with workpiece materials, and always wear a NIOSH-approved respirator to reduce your risk.

**WEARING PROPER APPAREL.** Do not wear clothing, apparel, or jewelry that can become entangled in moving parts. Always tie back or cover long hair. Wear non-slip footwear to avoid accidental slips which could cause a loss of workpiece control.

**HEARING PROTECTION.** Always wear hearing protection when operating or observing loud machinery. Extended exposure to this noise without hearing protection can cause permanent hearing loss.

**MENTAL ALERTNESS.** Be mentally alert when running machinery. Never operate under the influence of drugs or alcohol, when tired, or when distracted.

**DISCONNECTING POWER SUPPLY.** Always disconnect machine from power supply before servicing, adjusting, or changing cutting tools (bits, blades, cutters, etc.). Make sure switch is in **OFF** position before reconnecting to avoid an unexpected or unintentional start.

**DANGEROUS ENVIRONMENTS.** Do not use machinery in wet or rainy locations, cluttered areas, around flammables, or in poorly-lit areas. Keep work area clean, dry, and well-lit to minimize risk of injury.

**APPROVED OPERATION.** Untrained operators can be seriously hurt by machinery. Only allow trained or properly supervised people to use machine. When machine is not being used, disconnect power, remove switch keys, or lock-out machine to prevent unauthorized use—especially around children. Make workshop kid proof!

**ONLY USE AS INTENDED.** Only use machine for its intended purpose. Never modify or alter machine for a purpose not intended by the manufacturer or serious injury may result!

**USE RECOMMENDED ACCESSORIES.** Consult this owner's manual or the manufacturer for recommended accessories. Using improper accessories will increase the risk of serious injury.

**CHILDREN & BYSTANDERS.** Keep children and bystanders a safe distance away from work area. Stop using machine if children or bystanders become a distraction.

**REMOVE ADJUSTING TOOLS.** Never leave adjustment tools, chuck keys, wrenches, etc. in or on machine—especially near moving parts. Verify removal before starting!

**SECURING WORKPIECE.** When required, use clamps or vises to secure workpiece. A secured workpiece protects hands and frees both of them to operate the machine.

**FEED DIRECTION.** Unless otherwise noted, feed work against the rotation of blades or cutters. Feeding in the same direction of rotation may pull your hand into the cut.

**GUARDS & COVERS.** Guards and covers can protect you from accidental contact with moving parts or flying debris. Make sure they are properly installed, undamaged, and working correctly before using machine.

**STABLE MACHINE.** Unexpected movement during operations greatly increases the risk of injury and loss of control. Verify machines are stable/secure and mobile bases (if used) are locked before starting.

**FORCING MACHINERY.** Do not force machine. It will do the job safer and better at the rate for which it was designed.

**AWKWARD POSITIONS.** Keep proper footing and balance at all times when operating machine. Do not overreach! Avoid awkward hand positions that make workpiece control difficult or increase the risk of accidental injury.

**UNATTENDED OPERATION.** Never leave machine running while unattended. Turn machine off and ensure all moving parts completely stop before walking away.

**MAINTAIN WITH CARE.** Follow all maintenance instructions and lubrication schedules to keep machine in good working condition. An improperly maintained machine may increase the risk of serious injury.

**CHECK DAMAGED PARTS.** Regularly inspect machine for damaged parts, loose bolts, mis-adjusted or mis-aligned parts, binding, or any other conditions that may affect safe operation. Always repair or replace damaged parts, wires, cords, or plugs before operating machine.

**MAINTAIN POWER CORDS.** When disconnecting cord-connected machines from power, grab and pull the plug—NOT the cord. Pulling the cord may damage the wires inside. Do not handle the cord/plug with wet hands. Avoid cord damage by keeping it away from heated surfaces, high traffic areas, harsh chemicals, and wet or damp locations.

**EXPERIENCING DIFFICULTIES.** If at any time you are experiencing difficulties performing the

# Additional Safety for Metal Bandsaws



**⚠️ WARNING**  
 READ and understand this entire instruction manual before using this machine. Serious personal injury may occur if safety and operational information is not understood and followed.

**⚠️ CAUTION**  
 USE this and other machinery with caution and respect. Always consider safety first, as it applies to your individual working conditions. No list of safety guidelines can be complete—every shop environment is different. Failure to follow guidelines could result in serious personal injury, damage to equipment or poor work results.

1. **SAFETY GUARDS.** DO NOT operate bandsaw without wheel covers, pulley covers, or blade guards in place.
2. **SERVICE PREPARATION.** Turn **OFF** and unplug machine before blade replacement, machine adjustments, and maintenance are done. Allow all moving parts to come to a complete stop before doing any of the above.
3. **SAFETY TOOLS.** Use push sticks or other safety devices whenever possible, especially when the bandsaw is set up for vertical cutting.
4. **KEEPING HANDS CLEAR.** Never reach under table, in the blade path, or around the blade guides while blade is in motion.
5. **FURTHER INFORMATION.** If at any time you are experiencing difficulties performing the intended operation, stop using the machine! Then contact our technical support department or ask a qualified expert how the operation should be performed.
6. **SHOP SAFETY.** Habits—good and bad—are hard to break. Develop good habits in your shop and safety will become second-nature to you.
7. **WORKPIECE REMOVAL.** Never back the workpiece from the blade when the bandsaw is set up for vertical cutting and while the bandsaw blade is in motion. Turn **OFF** machine and wait for blade to come to a complete stop before backing workpiece out.
8. **MANUAL INSPECTIONS.** Unplug the machine and manually test blade tracking and tension before starting the machine. Blades that are loose or not tracking correctly can come off and cause serious personal injury.
9. **SUPPORTING LONG WORKPIECECS.** Long workpieces should be well supported at both ends with extension tables when cuts are made. Otherwise, after a cut is made, the cut piece may fall to the floor and the stock may tilt out of the vise and break the blade.
10. **SAFELY USING CUTTING FLUIDS.** Make sure you know what type of metal and cutting fluid you will be exposed to and how to avoid contamination. Be aware that certain metal shavings and cutting fluids may cause an allergic reaction in people and animals, especially when cutting fumes can be inhaled.



## Avoiding Potential Injuries

SAFETY

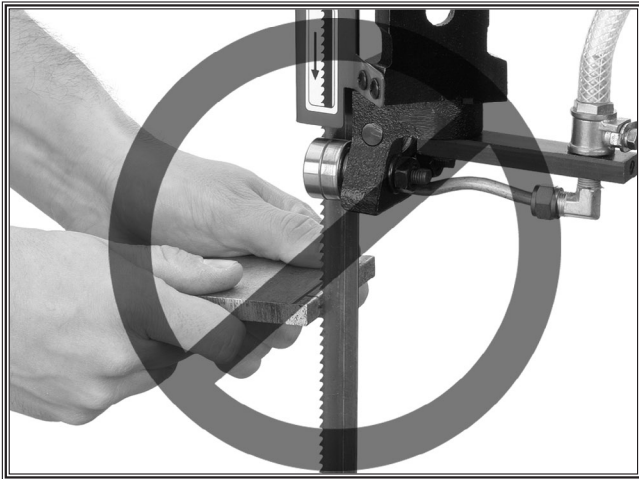

**Figure 3.** Never attempt to freehand cut.



**Figure 6.** Always use the table for freehand cutting and keep fingers clear of blade.

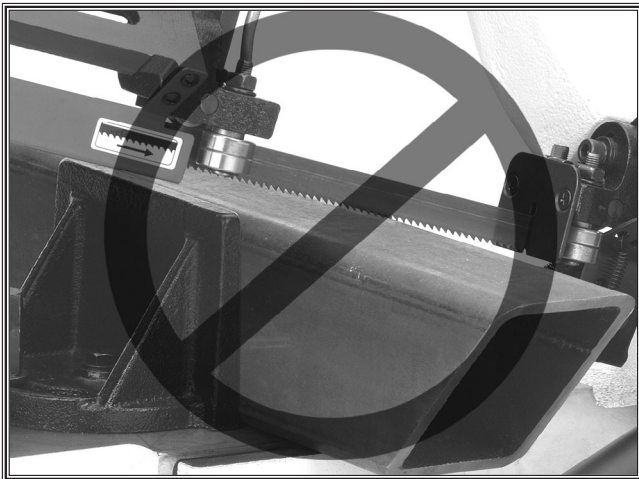

**Figure 4.** Never start the saw with the blade resting on the workpiece.



**Figure 7.** Always start the saw with the blade clear of the workpiece.



**Figure 5.** Never hold the workpiece by hand.

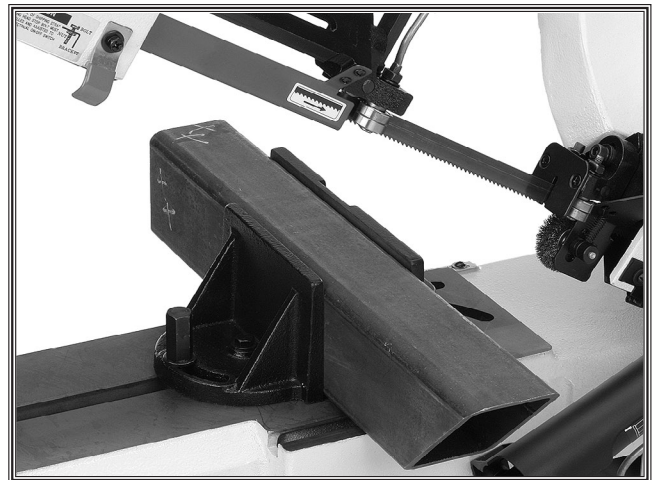

**Figure 8.** Always use the vise to hold workpiece.

# ELECTRICAL

## Circuit Requirements

This machine must be connected to the correct size and type of power supply circuit, or fire or electrical damage may occur. Read through this section to determine if an adequate power supply circuit is available. If a correct circuit is not available, a qualified electrician **MUST** install one before you can connect the machine to power.

A power supply circuit includes all electrical equipment between the breaker box or fuse panel in the building and the machine. The power supply circuit used for this machine must be sized to safely handle the full-load current drawn from the machine for an extended period of time. (If this machine is connected to a circuit protected by fuses, use a time delay fuse marked D.)

### Full-Load Current Rating

The full-load current rating is the amperage a machine draws at 100% of the rated output power. On machines with multiple motors, this is the amperage drawn by the largest motor or sum of all motors and electrical devices that might operate at one time during normal operations.

Full-Load Current Rating at 110V ..... 12.6 Amps  
 Full-Load Current Rating at 220V ..... 6.3 Amps

### Circuit Requirements for 110V (Prewired)

This machine is prewired to operate on a 110V power supply circuit that has a verified ground and meets the following requirements:

Circuit Type ..... 110V/120V, 60 Hz, Single-Phase  
 Circuit Size ..... 20 Amps  
 Plug/Receptacle ..... NEMA 5-20

### Circuit Requirements for 220V

This machine can be converted to operate on a 220V power supply (details about voltage conversion can be found later in this manual). The 220V power supply circuit must have a verified ground and meet the requirements that follow:

Circuit Type ..... 220V/240V, 60 Hz, Single-Phase  
 Circuit Size ..... 15 Amps  
 Plug/Receptacle ..... NEMA 6-15

## ⚠ WARNING

The machine must be properly set up before it is safe to operate. **DO NOT** connect this machine to the power source until instructed to do later in this manual.

## ⚠ WARNING



Incorrectly wiring or grounding this machine can cause electrocution, fire, or machine damage. To reduce this risk, only a qualified electrician or service personnel should do any required electrical work for this machine.

## NOTICE

The circuit requirements listed in this manual apply to a dedicated circuit—where only one machine will be running at a time. If this machine will be connected to a shared circuit where multiple machines will be running at the same time, consult a qualified electrician to ensure that the circuit is properly sized for safe operation.

ELECTRICAL

# Grounding Requirements

This machine **MUST** be grounded. In the event of certain types of malfunctions or breakdowns, grounding provides a path of least resistance for electric current to travel—in order to reduce the risk of electric shock.

Improper connection of the equipment-grounding wire will increase the risk of electric shock. The wire with green insulation (with/without yellow stripes) is the equipment-grounding wire. If repair or replacement of the power cord or plug is necessary, do not connect the equipment-grounding wire to a live (current carrying) terminal.

Check with a qualified electrician or service personnel if you do not understand these grounding requirements, or if you are in doubt about whether the tool is properly grounded. If you ever notice that a cord or plug is damaged or worn, disconnect it from power, and immediately replace it with a new one.

## For 110V Connection (Prewired)

This machine is equipped with a power cord that has an equipment-grounding wire and NEMA 5-15 grounding plug. The plug must only be inserted into a matching receptacle (see **Figure**) that is properly installed and grounded in accordance with local codes and ordinances.

## For 220V Connection (Must be Rewired)

A NEMA 6-15 plug has a grounding prong that must be attached to the equipment-grounding wire inside the included power cord. The plug must only be inserted into a matching receptacle (see **Figure**) that is properly installed and grounded in accordance with all local codes and ordinances.

# Extension Cords

We do not recommend using an extension cord with this machine. Extension cords cause voltage drop, which may damage electrical components and shorten motor life. Voltage drop increases with longer extension cords and the gauge smaller gauge sizes (higher gauge numbers indicate smaller sizes).

Any extension cord used with this machine must contain a ground wire, match the required plug and receptacle, and meet the following requirements:

- Minimum Gauge Size at 220V ..... 14 AWG
- Maximum Length (Shorter is Better) ..... 50 ft.

**⚠ WARNING**

The machine must be properly set up before it is safe to operate. **DO NOT** connect this machine to the power source until instructed to do later in this manual.

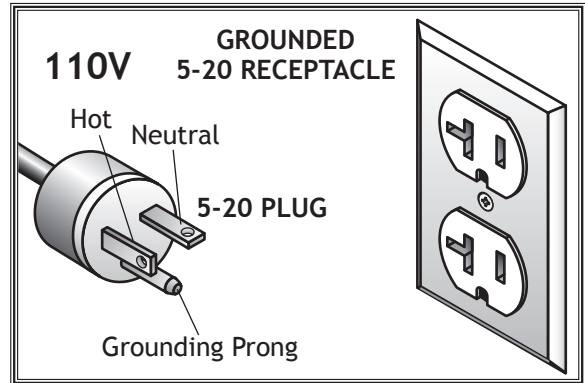

Figure 9. NEMA 5-20 plug & receptacle.

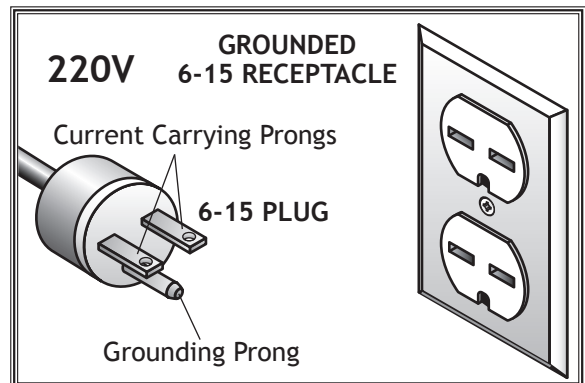

Figure 10. NEMA 6-15 plug & receptacle.

**⚠ CAUTION**

**DO NOT** modify the provided plug or use an adapter if the plug will not fit your receptacle. This is an indication that your power supply circuit does not meet the requirements for the machine; have an electrician install the correct power supply circuit. If the machine must be reconnected for use on a different type of electric circuit, the reconnection should be made by a qualified electrician or service personnel; after reconnection, the machine must comply with all local codes and ordinances.

**ELECTRICAL**

# SET UP

## Unpacking

This machine has been carefully packaged for safe transportation. If you notice the machine has been damaged during shipping, please contact your authorized Shop Fox dealer immediately.

## Items Needed for Set Up

The following items are needed, but not included, to set up your machine:

- An Assistant.
- Phillips Screwdriver #2.
- Standard Screwdriver #2.
- Hex Wrench 6mm.
- Open-End Wrench 6mm, 12mm, 14mm, 19mm.
- Open-End Wrench 3/8", 7/16", 1/2."

SET UP

### WARNING



**READ** and understand this entire instruction manual before using this machine. Serious personal injury may occur if safety and operational information is not understood and followed. **DO NOT** risk your safety by not reading!

### WARNING

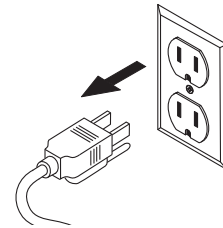

**KEEP** the power cord **UNPLUGGED** during assembly or adjustment tasks! Otherwise, serious personal injury to you or others may occur!

### WARNING



**SEEK** assistance when lifting the machine from the box it was shipped in. The SHOP FOX® Model M1014 is a heavy machine.

# Inventory

The following is a description of the main components shipped with the **SHOP FOX®** Model M1014. Lay the components out to inventory them.

Box Contents (Figure 11)	Qty.
A. Pulley Cover .....	2
B. Vertical Work Table .....	1
C. Table Bracket .....	1
D. Handle.....	1
E. Wheels .....	2
F. Collar .....	1
G. Axle.....	1
H. Work Stop Rod .....	1
I. Work Stop.....	1
J. Leveling Feet with Hex Nuts.....	2
K. Chip Screen.....	1
L. Bolt Bag.....	1
–Flat Washers $\frac{3}{8}$ " (Leveling Feet) .....	2
–Hex Nuts $\frac{3}{8}$ "-16 (Leveling Feet) .....	2
–Cotter Pins 3 x 25mm (Wheels) .....	2
–Hex Bolts $\frac{5}{16}$ "-18 x $1\frac{1}{2}$ " (Handle) .....	4
–Flat Head Screw $\frac{1}{4}$ "-20 x $\frac{1}{2}$ " (Table).....	1
–Hex Nut $\frac{1}{4}$ " x 20 (Table) .....	1
–Phillips Head Screws $\frac{1}{4}$ "-20 x $\frac{5}{8}$ " (Pulley Cover) ..	2

If any parts appear to be missing, examine the packaging carefully to be sure those parts are not among the packing materials. If any parts are missing, find the part number in the back of this manual and contact Woodstock International, Inc. at 360-734-3482 or at [tech-support@shopfox.biz](mailto:tech-support@shopfox.biz)



**WARNING**  
**SUFFOCATION HAZARD!**  
 Immediately discard all plastic bags and packing materials to eliminate choking/suffocation hazards for children and animals.



SET UP

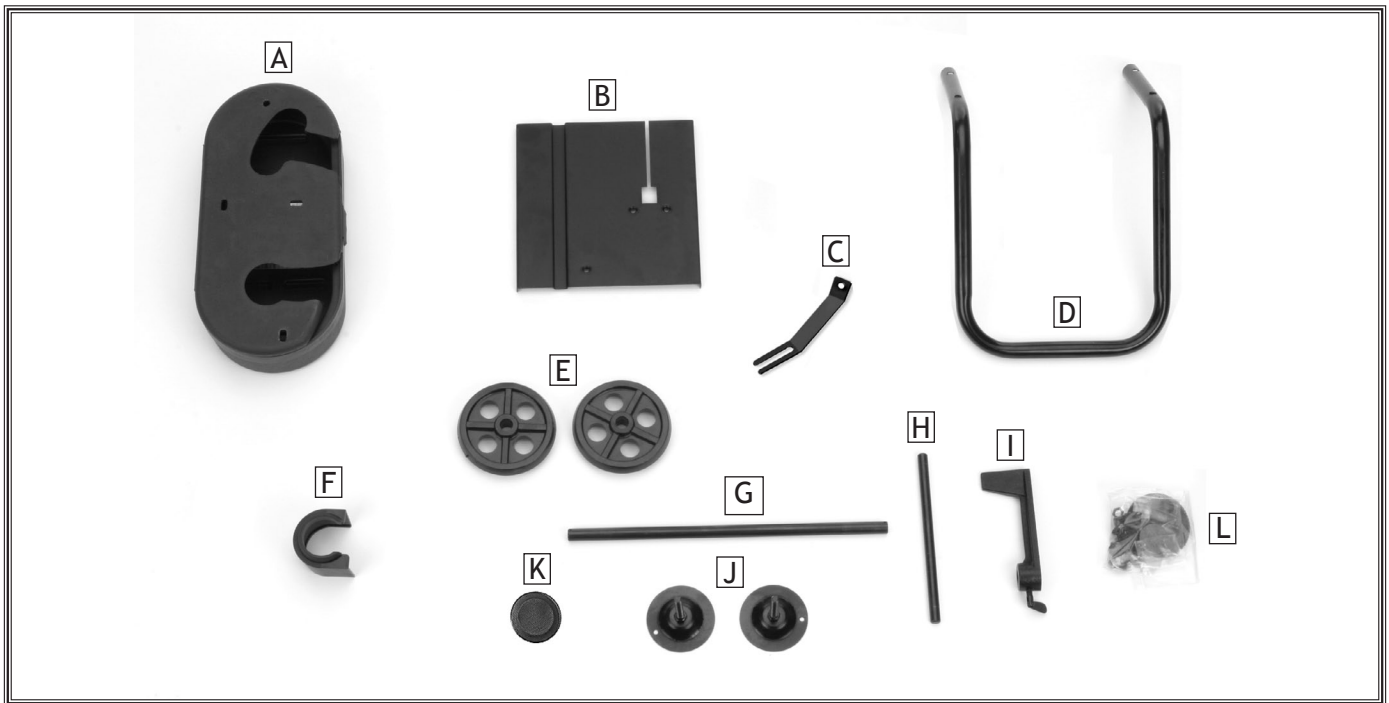

Figure 11. Inventory.

# Machine Placement

- **Floor Load:** This machine distributes a heavy load in a small footprint. Some residential floors may require additional bracing to support both machine and operator.
- **Working Clearances:** Consider existing and anticipated needs, size of material to be processed through the machine, and space for auxiliary stands, work tables or other machinery when establishing a location for your Machine Type.
- **Lighting:** Lighting should be bright enough to eliminate shadow and prevent eye strain.
- **Electrical:** Electrical circuits must be dedicated or large enough to handle amperage requirements. Outlets must be located near each machine, so power or extension cords are clear of high-traffic areas. Follow local electrical codes for proper installation of new lighting, outlets, or circuits.

# Cleaning Machine

The table and other unpainted parts of your bandsaw are coated with a waxy grease that protects them from corrosion during shipment. Clean this grease off with a solvent cleaner or citrus-based degreaser. **DO NOT** use chlorine-based solvents such as brake parts cleaner or acetone—if you happen to splash some onto a painted surface, you will ruin the finish.

SET UP

	<p><b>⚠ WARNING</b></p> <p><b>NEVER</b> use gasoline or other petroleum-based solvents to clean with. Most have low flash points, which make them extremely flammable. A risk of explosion and burning exists if these products are used. Serious personal injury may occur if this warning is ignored!</p>
--	---

	<p><b>⚠ WARNING</b></p> <p>USE helpers or power lifting equipment to lift this Machine Name. Otherwise, serious personal injury may occur.</p>
--	--

	<p><b>⚠ CAUTION</b></p> <p><b>ALWAYS</b> work in well-ventilated areas far from possible ignition sources when using solvents to clean machinery. Many solvents are toxic when inhaled or ingested. Use care when disposing of waste rags and towels to be sure they <b>DO NOT</b> create fire or environmental hazards.</p>
--	--

	<p><b>⚠ CAUTION</b></p> <p><b>MAKE</b> your shop "child safe." Ensure that your workplace is inaccessible to children by closing and locking all entrances when you are away. <b>NEVER</b> allow untrained visitors in your shop when assembling, adjusting or operating equipment.</p>
--	---

## Handle, Wheels, and Feet

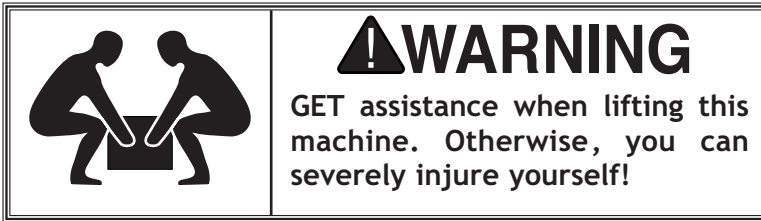

To install the handle, wheels, and feet, do these steps:

1. With the help of an assistant, support the bandsaw on wooden blocks approximately 4" from the ground so you have room to install the handle, wheels, and feet.
2. Align the handle mounting holes with the bandsaw holes, and install the 5/16"-18 x 1-1/4" hex bolts, washers, and nuts (see **Figure 12**).
3. Insert the axle into the cabinet, and slide the wheels onto the axles.
4. Slide the two 5/8" flat washers onto the axles, and install the two cotter pins (see **Figure 13**).
5. Thread one 3/8"-18 hex nut and install one 3/8" washer onto each threaded foot shaft (see **Figure 14**).
6. Thread the foot shafts into the underside of the bandsaw cabinet (see **Figure 14**).
7. With the help of an assistant, remove the bandsaw from the blocks.
8. Turn the feet until the bandsaw is level, and tighten the hex nut to lock the feet in place.

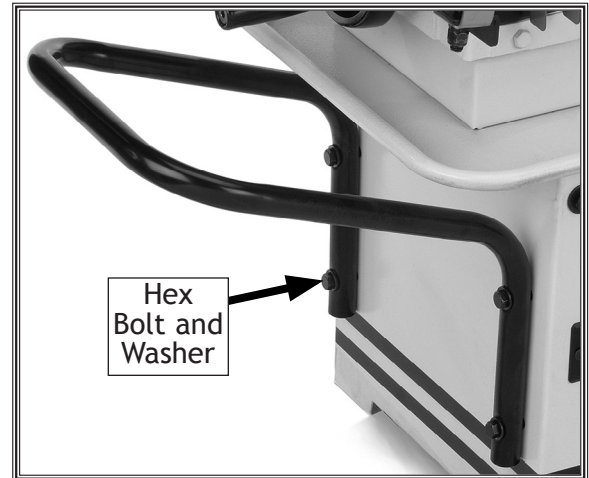

Figure 12. Installed handle.

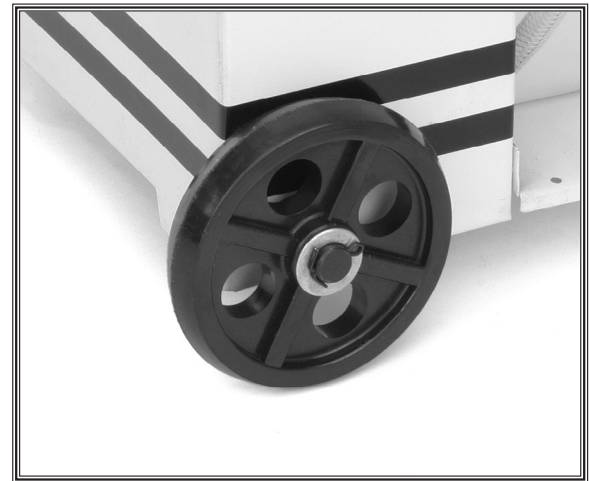

Figure 13. Installed wheel.

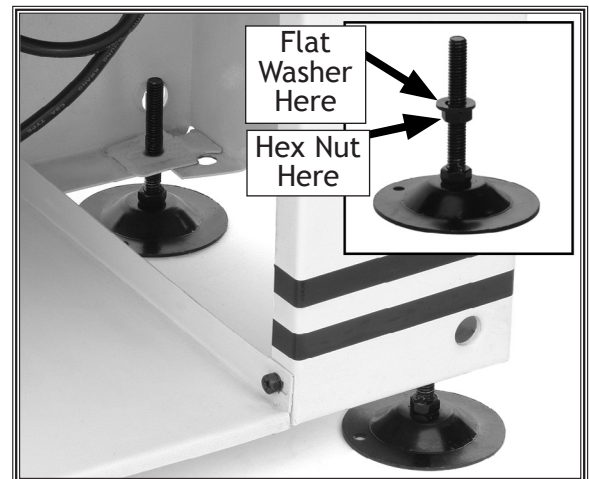

Figure 14. Installed feet.

# Cutting Fluid System

This bandsaw has a built-in cutting fluid system that prolongs the life of your bandsaw blades and produces smoother cuts at a lower temperature. Refer to **Cutting Fluid** on **Page 26** for fluid choice and safety precautions.

To set up the cutting fluid system, do these steps:

1. Place the filter screen dome-side up as shown in **Figure 15** in the bandsaw catch pan.
2. Inspect and remove any foreign material that may have fallen inside the reservoir during shipping.
3. Make sure the drain tube points toward the reservoir intake screen, and that all tube connections are tight and will not leak (see **Figure 16**).
4. Make sure the waterproof rubber switch boot is installed on the pump ON/OFF toggle switch (**Figure 16**), and that the toggle switch is in the down position.

**Note:** DO NOT plug in the bandsaw at this time to prime the pump. Priming will be done in the **Operations** section.

5. Fill the reservoir with 2-1/2 gallons of your chosen cutting fluid solution.

**NOTICE:** NEVER operate the pump with the reservoir below the low mark (**Figure 16**), or the pump can be destroyed!

## Cast Iron Stop

The cast iron stop allows you to repeat many cuts at the same length.

To install the cast iron stop, do these steps:

1. Insert the stop rod approximately 3/4" into the saw until the end of the rod is just flush with the inside casting surface (see **Figure 17**).
2. Use a 12mm wrench, and tighten the hex bolt (see **Figure 17**).
3. Slide the cast iron stop onto the stop rod and tighten the thumb screw.

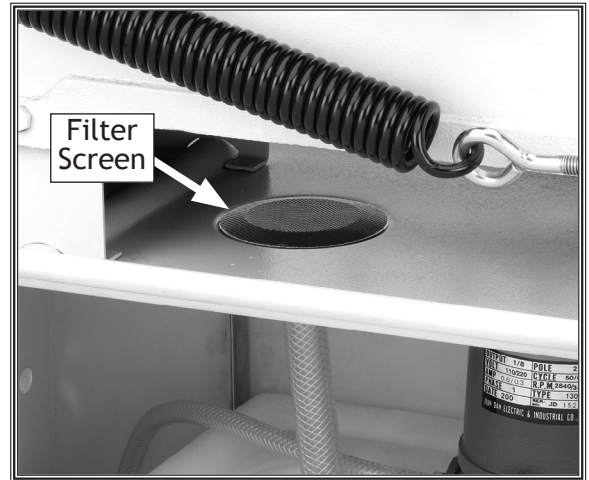

Figure 15. Installed drain screen.

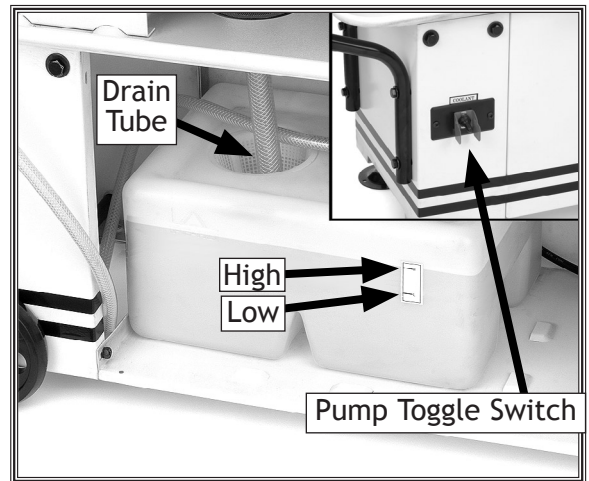

Figure 16. Correctly filled tank ready to be pumped.

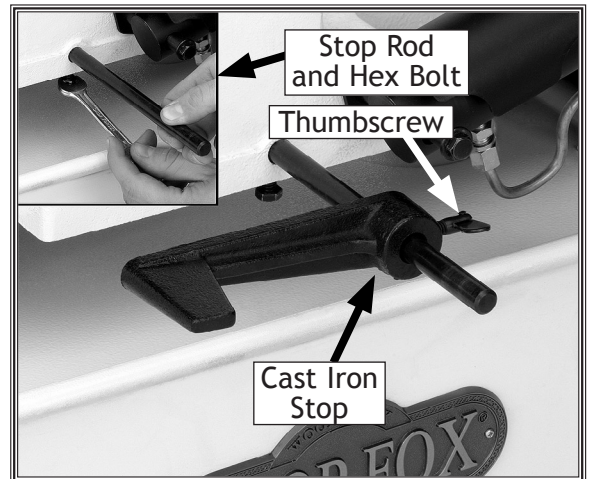
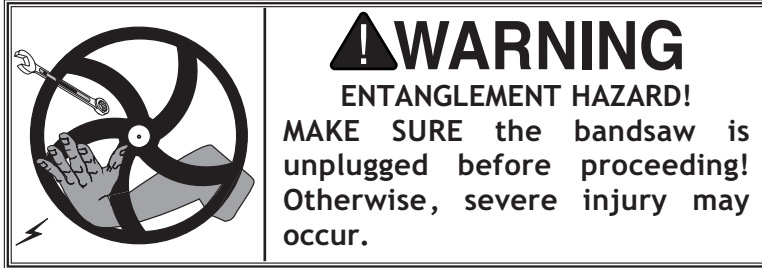

Figure 17. Installing the cast iron stop.



## Pulley Cover

When opened, the pulley cover gives you the ability to change the pulley ratio so the bandsaw can cut at one of four speeds.



To install the pulley cover, do these steps:

1. **UNPLUG THE BANDSAW POWER CORD!**
2. Snap the bearing guard into the pulley cover (see **Figure 18**).
3. Position and rotate the pulley cover mounting plate onto the motor as shown in **Figure 19**.
4. Install the pulley cover mounting screws, as shown in **Figure 20**.
5. Make sure the pulley ratio will produce the speed that you want.
  - If the speed needs to be changed, complete the **Changing Cutting Speed** procedure on **Page 19**.
6. Install the belt and make sure it has 1/4" deflection when pressed.
  - If the belt is out of adjustment, complete the **Belt Tension** procedure on **Page 18**.



**Figure 18.** Installing the bearing guard.



**Figure 19.** Positioning the pulley cover.



**Figure 20.** Securing the pulley cover.

# Shipping Strap and ON/OFF Switch

To ensure that your bandsaw arrives to you without damage to the hinge system, a shipping strap was installed. After shipping strap removal, adjust the headstock-stop bolt so the bandsaw ON/OFF switch is not damaged by the headstock.

**Note:** Keep this shipping strap in the event that you must transport the bandsaw.

To remove the shipping strap, do these steps:

1. Turn the feed lever **OFF** (Figure 22) so the headstock is supported when the shipping strap is removed.
2. Remove the ON/OFF switch push strap and save it for reinstallation later (see Figure 21).
3. Using a screwdriver and a 14mm wrench, remove the screw, headstock stop bolt, and shipping strap.
4. Reinstall the headstock stop bolt to the lowest setting, and engage the feed lever so the headstock settles naturally to the lowest position.
5. Rotate the stop bolt counterclockwise so the headstock is slightly supported by the stop bolt, and tighten the jam nut.
6. With the bandsaw unplugged, flip the ON/OFF switch to the **ON** position.
7. Reinstall the ON/OFF switch push strap so it has just pushed the toggle switch downward to the **OFF** position, but does not force the toggle past the **OFF** position and tear the rubber boot or damage the switch.

## Vertical Cutting Table

If you install the vertical cutting table, this bandsaw can be set up and used as a vertical-cutting bandsaw.

To install the vertical cutting table, do these steps:

1. **MAKE SURE THE POWER CORD IS UNPLUGGED!**
2. Raise the bandsaw headstock to the vertical position, and with the feed lever, lock the headstock in place (see Figure 22).
3. Remove the screws and stop plate as shown in Figure 23.

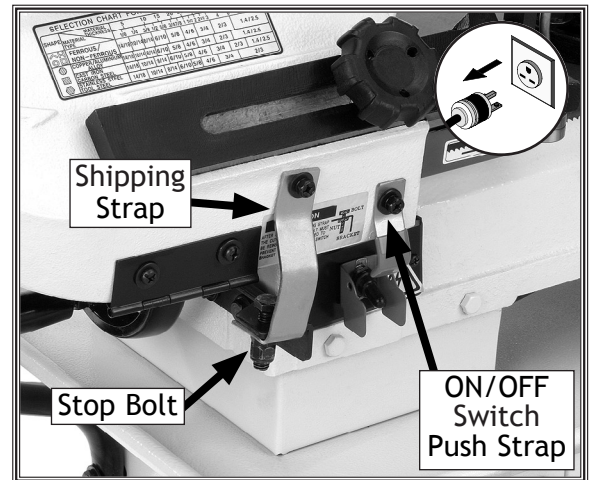

Figure 21. Shipping strap location.

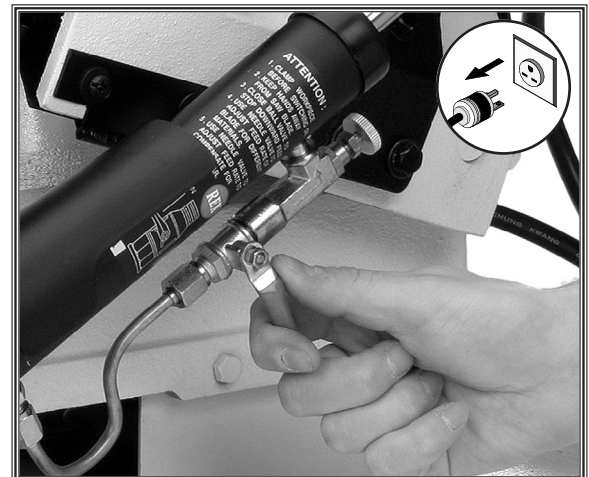
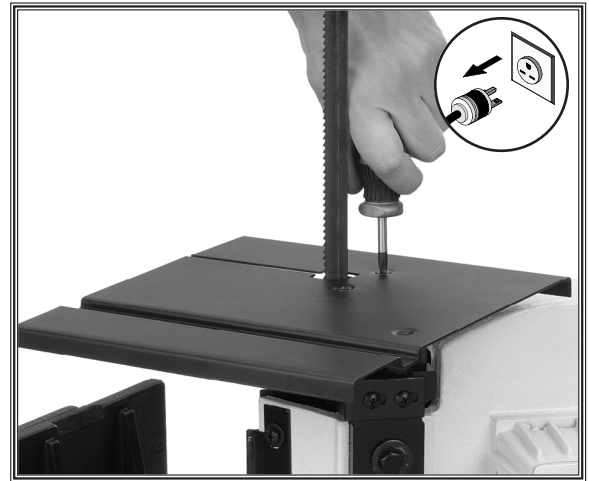

Figure 22. Feed lever in the locked position.

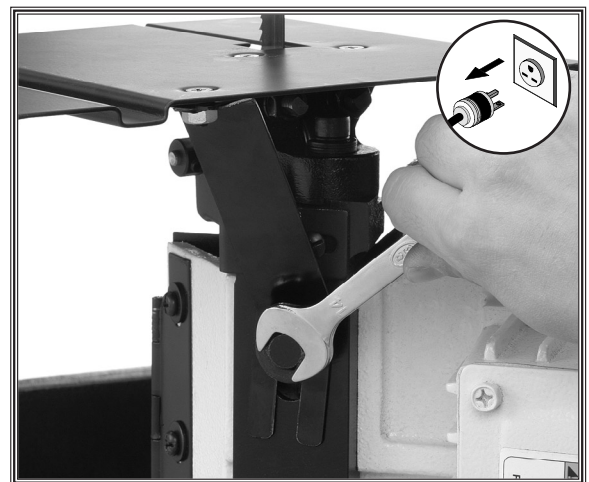

Figure 23. Removing the stop plate.

4. Position and install the vertical cutting table with the two stop plate mounting screws as shown in **Figure 24**).
5. Use a 14 mm wrench to loosen the blade guide lock bolt and install the table support as shown in **Figure 25**.
6. Place a machinist's square on the table as shown in **Figure 26**, and make sure that the table and blade are square with each other.
  - If the table and blade are out of square, adjust the table support bracket.



**Figure 24.** Installing the table.



**Figure 25.** Installing the table support.

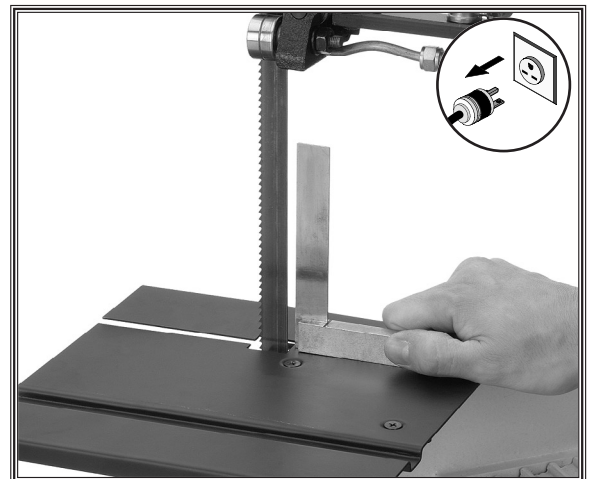

**Figure 26.** Checking table-to-blade squareness.

SET UP

# ADJUSTMENTS

## Belt Tension

During the life of your bandsaw, you will find it necessary to change the location of the belt so the saw blade can cut at a different speed. To change the belt location you must use the belt adjustment mechanism to move the motor, which loosens or tightens the belt.

To adjust the belt, do these steps:

1. **UNPLUG THE BANDSAW POWER CORD!**
2. Open the pulley cover and determine if the belt must be loosened or tightened. The belt should only have 1/4" of deflection when the belt is pressed in the middle.
3. Use a 12mm wrench and loosen the two slide bolts and both jack-bolt and jam nuts shown in **Figure 27**.
  - If the belt needs to be tightened, turn the lower jack bolt counterclockwise until only a few threads are holding the bolt in place, and then turn the upper jack bolt clockwise until the belt has 1/4" of deflection.
  - If the belt needs to be loosened, turn the upper jack bolt counterclockwise until only a few threads are holding the bolt in place, and then turn the lower jack bolt clockwise until the belt has 1/4" of deflection.
4. Tighten both jam nuts and both slide bolts.
5. Close the pulley cover.

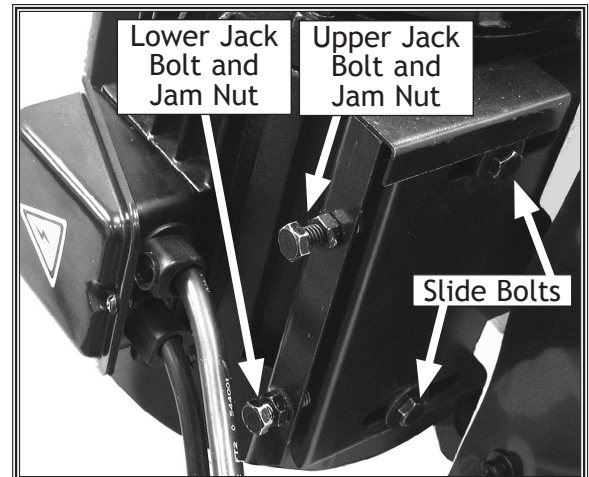

Figure 27. Belt adjustment mechanism.

# Changing Cutting Speed

Along with the correct blade selection and feed rate, the correct pulley ratio must be selected to produce the best cutting speed. With all settings correct, the metal chips should be curly and silvery, they should not be overheated and blue, or thin and powdery.

To change the cutting speed, do these steps:

1. **UNPLUG THE BANDSAW POWER CORD!**
2. Refer to **Figure 28** and match the workpiece material with the suggested blade speed, and then find the correct pulley ratio to get that blade speed.
3. Open the pulley cover and loosen the belt tension. Refer to **Belt Tension** on **Page 18** for any details.
4. Roll the belt into the new pulley grooves.
5. Adjust the belt tension, and close the pulley cover.

**Note:** These suggested blade speeds are an average for both High Carbon Blades and Bi-Metal Blades. Refer to your saw blade manufacturer for exact speeds.

Workpiece Material	Speed in FPM
Tool Steel	90
Stainless Steel	90
Alloy Steel	90
Bearing Bronze	90
High Carbon Steel	135
Medium Carbon Steel	135, 195
Hard Brass	195
Hard Bronze	195
Low Carbon Steel	195
Soft Brass	195
Copper	255
Aluminum	255
Plastics	255

**Note:** Feet Per Minunite is (FPM).

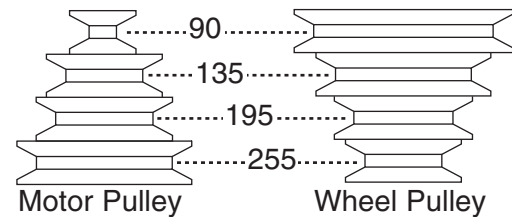

**Figure 28.** Blade cutting speed chart.

# Blade Tension

If blade tension is set incorrectly, the blade can fracture and break, become belled, or slip off of the bandsaw. You must make sure the blade tension is set in the correct range to prevent these problems.

To set the blade tension, do these steps:

1. Make sure the blade tracking is set correctly. Refer to **Blade Tracking** on **Page 31** for details.
2. Raise the headstock to the vertical position and close the feed valve to lock the headstock in place (see **Figure 46** on **Page 31**).
3. Open the blade cover and remove the blade guides (see **Figure 29**).
4. Turn the blade tension knob until the blade is snug and the blade tension notch indicates "medium," which is in the green area shown in **Figures 30** and **31**.
5. Reinstall the blade guides and adjust as outlined in the **Blade Guide** instructions on **Page 21**.
6. Close the blade guard.



Figure 29. Bandsaw ready for blade tracking.

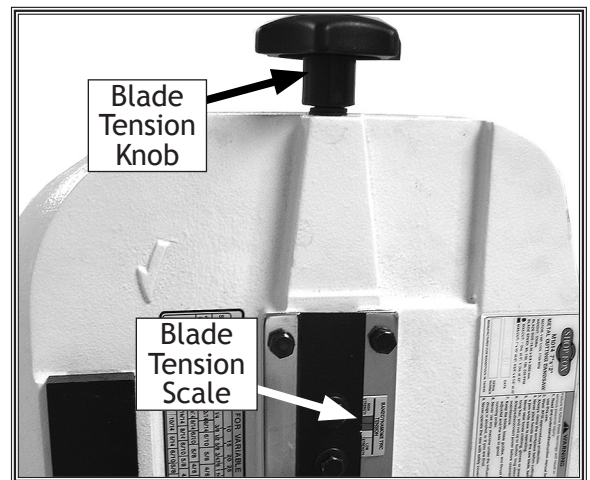

Figure 30. Blade tension adjustment knob.

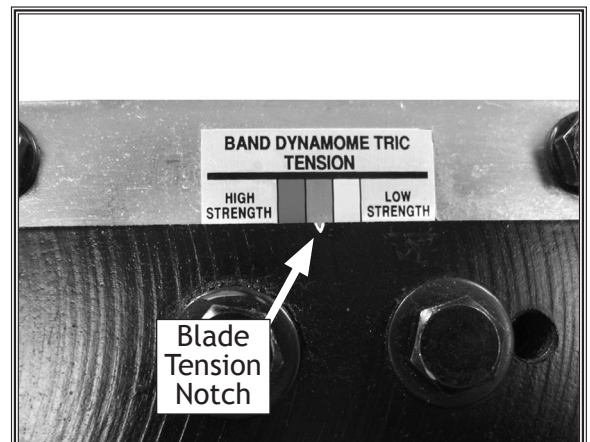
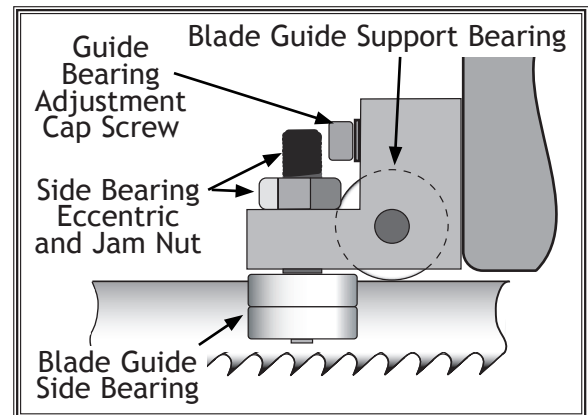
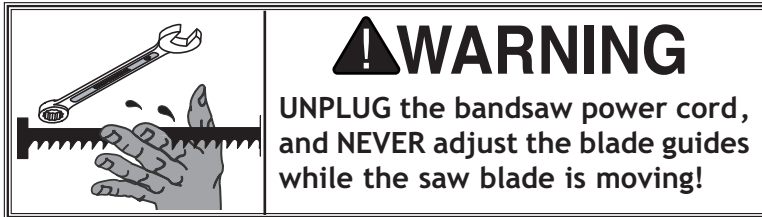

Figure 31. Blade tension scale.

## Blade Guides

The blade guide side bearings support the blade so the blade will enter the workpiece perpendicular to the table surface (see **Figure 32**).

The blade guide support bearings prevent blade twist by stopping the blade from being pushed back during a cut. Both adjustments are the most critical saw adjustments.



**Figure 32.** Blade guide adjustment locations.

To adjust the guide bearings, do these steps:

**Note:** Make sure the blade is tensioned and tracks correctly before you adjust the blade guide bearings. Refer to **Blade Tension** or **Blade Tracking** on Pages 20 and 31 for further instructions.

1. UNPLUG THE BANDSAW POWER CORD!
2. Let the bandsaw headstock park in the full down position.
3. Using a 6mm hex wrench, loosen the guide bearing adjustment cap screw (see **Figures 32** and **33**).
4. Adjust the blade guide housing so the support bearing rests against the rear of the blade (see **Figure 32**).
5. Tighten the cap screw.
6. Using a 14mm wrench, loosen the outer side bearing eccentric jam nuts.

**Note:** The inner side bearings are not on eccentric shafts and cannot be adjusted.

7. Using a 6mm wrench, rotate the side bearing eccentrics (**Figure 33**) until the bearings hold the blade perpendicular to the table surface and have a bearing-to-blade clearance of 0.000" to 0.001". The bearings must not pinch the blade.

**Note:** To make sure the blade is perpendicular to the table, use a standard machinist's square.

8. Tighten the jam nuts and slide the blade guide close to the workpiece so the blade is supported and will not twist during the cut (see **Figure 34**).

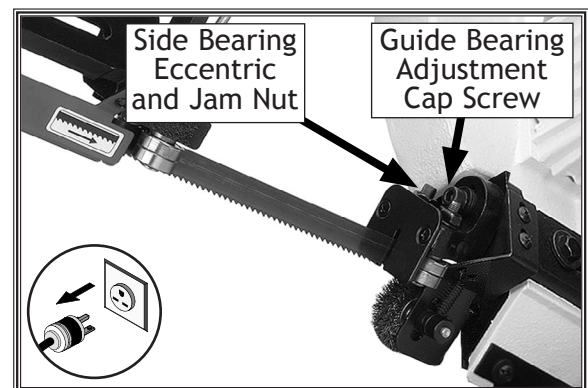

**Figure 33.** Blade guide location.

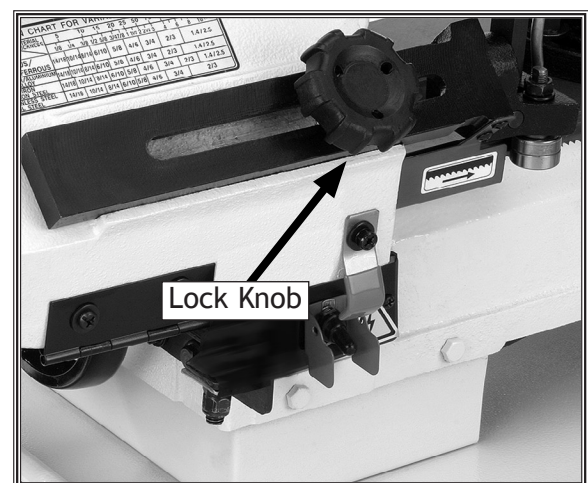

**Figure 34.** Blade guide position lock knob.

# OPERATIONS

## General

The Model M1014 will perform many types of operations that are beyond the scope of this manual. Many of these operations can be dangerous or deadly if performed incorrectly.

The instructions in this section are written with the understanding that the operator has the necessary knowledge and skills to operate this machine. **If at any time you are experiencing difficulties performing any operation, stop using the machine!**

If you are an inexperienced operator, we strongly recommend that you read books, trade articles, or seek training from an experienced bandsaw operator before performing any unfamiliar operations. **Above all, your safety should come first!**

## Operation

Before making cuts to the workpiece, it is important that all safety precautions and bandsaw adjustments are addressed. For vertical cutting, refer to **Vertical Cutting Table** on **Page 16** for table installation steps.

For basic cutting operations, do these steps:

1. Check oil level and top it off if required (refer to **Lubrication** on **Page 29** for instructions).
2. Select and install the required blade (refer to **Blade Selection** on **Page 24** for blade TPI).
3. Select the required cutting speed, (refer to **Changing Cutting Speed** on **Page 19** for instructions).
4. Make sure cutting fluid reservoir is full and the fluid is correct for the type of blade and material to be cut (refer to **Cutting Fluid** on **Page 26** for instructions).
5. Raise and lock the headstock, so the blade is approximately 3" from the workpiece, and open the vise to accept the workpiece.

**NOTICE:** NEVER let the saw blade rest on the workpiece without the saw running. Otherwise, you will permanently damage the saw blade!

### ! WARNING



**READ** and understand this entire instruction manual before using this machine. Serious personal injury may occur if safety and operational information is not understood and followed. **DO NOT** risk your safety by not reading!

### ! WARNING



Always wear safety glasses when operating the 7" x 12" Metal Cutting Bandsaw. Failure to comply may result in serious personal injury.

### ! WARNING

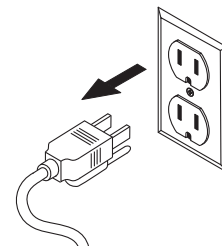

**DO NOT** investigate problems or adjust the Bandsaw while it is running. Wait until the machine is turned **OFF**, unplugged, and all working parts have come to a complete stop before proceeding!



6. Insert the workpiece into the vise, so the blade will contact the flattest part of the workpiece first, and clamp the workpiece in the vise.
7. Set the cast iron stop for duplicate cuts.
8. Set the blade guide so the guides hold the blade close to the workpiece and the blade will not twist under the cutting load (refer to **Blade Guides** on **Page 21** for instructions).
9. Make sure cutting fluid reservoir is full and correct for the type of blade and material to be cut, (refer to **Cutting Fluid** on **Page 26** for instructions).

	<p style="text-align: center;"><b>! WARNING</b></p> <p>NEVER attempt to cut Magnesium when using soluble oils or emulsions (oil-water solutions) as a cutting fluid! The water in the solution will greatly intensify an accidental magnesium-chip fire. For cutting magnesium alloys, use a specific cutting fluid intended for magnesium.</p>
--	---

10. Turn the pump and bandsaw *ON*.
11. Adjust the flow lever so enough cutting fluid is pumped so that both sides of the blade are cooled, lubricated, and the chips are washed from the cut (see **Figure 35**).
12. Open the feed ON/OFF valve and turn the feed rate knob so the feed rate is correct, based on your observations of the blade chip characteristics. Refer to **Feed Rate** on **Page 27** for details.

**Note:** When the cut is complete, the ON/OFF switch push strap will shut *OFF* the bandsaw, but you must manually turn the pump *OFF*.

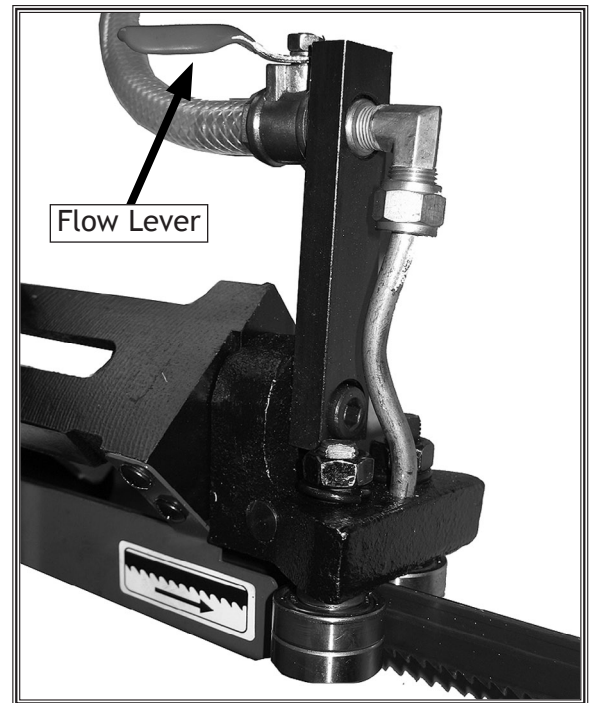

Figure 35. Lubricator flow control lever.

# Blade Selection

The chart below is a basic starting point for choosing blade type based on teeth per inch (TPI) for variable tooth pitch blades and for standard raker type bi-metal blades/HSS blades. However, for exact specifications of bandsaw blades, contact the blade manufacturer.

There are three general rules of thumb with respect to bandsaw blade use.

- At least three teeth must contact the metal at any phase of the cut. Otherwise the teeth can load up with metal, fracture, and break off. If the TPI is too high, the teeth can load up with material and overheat damaging the blade.
- For a faster but rougher cut, use a blade with a lower TPI and a higher feed rate.
- For a slower but smoother cut, use a blade with a lower TPI and a lower feed rate.

To select the correct blade TPI do these steps:

1. Measure the material thickness. This measurement is the length of cut taken from where the tooth enters the workpiece, sweeps through, and exits the workpiece.
2. Refer to the "Material Thickness" row of the blade selection chart in **Figure 36** and read across to find your workpiece thickness you need to cut.
3. Refer to the "Shape" of metal and "Material Type" columns and find the shape and material to be cut.
4. In the applicable row, read across to the right and find the box where the row and column intersect. Listed in the box is the minimum TPI recommended for the variable tooth pitch blades; and the TPI for bi-metal raker blades in parentheses.

OPERATIONS

SHAPE	MATERIAL TYPE	MATERIAL THICKNESS															
		5	10	15	20	25	50	75	100	150	200	250 (mm)					
		1/8	1/4	3/8	1/2	5/8	3/4	7/8	1	1 1/2	2	2 1/2	3	4	6	8	10 (in)
	FERROUS/ NON-FERROUS	14/18 (24)	10/14 (12)	8/14 (12)	6/10 (10)	5/8 (10)	4/6 (10)	3/4 (10)	2/3 (10)	1.4 / 2.5 (10)							
	COPPER/ALUMINIUM ALLOY	14/18 (24)	10/14 (12)	8/14 (12)	6/10 (10)	5/8 (10)	4/6 (10)	3/4 (10)	2/3 (10)	1.4 / 2.5 (10)							
	CAST IRON CARBON STEEL	14/18 (24)	10/14 (12)	8/14 (12)	6/10 (10)	5/8 (10)	4/6 (10)	3/4 (10)	2/3 (10)	1.4 / 2.5 (10)							
	STAINLESS STEEL TOOL STEEL	14/18 (24)	10/14 (12)	8/14 (12)	6/10 (10)	5/8 (10)	4/6 (10)	3/4 (10)	2/3 (10)								

Figure 36. Blade selection chart. **Note:** The TPI numbers in parentheses apply to bi-metal/HSS blades only.

## Blade Changes

You will find it necessary to change blades depending on the type of material to be cut. Knowing how to correctly select, change, track, and tension the blade will extend the life of your bandsaw and blades.

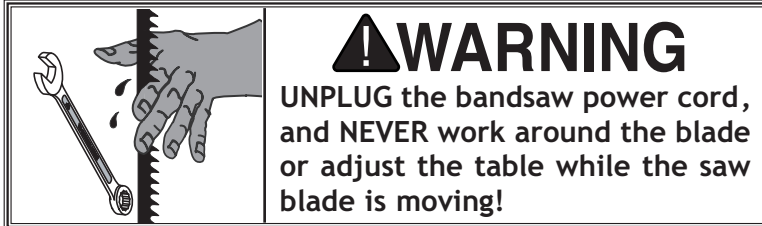

To change the bandsaw blade, do these steps:

1. **UNPLUG THE BANDSAW POWER CORD!**
  2. Raise the headstock to the vertical position and close the feed valve to lock the headstock in place (see **Figure 37**).
  3. Open the blade guard door, and use a screwdriver to remove the blade guide blade guard and the wire wheel brush (see **Figure 38**).
- ▲ CAUTION:** WEAR LEATHER GLOVES when changing the bandsaw blade. Otherwise, you may seriously cut your hand!
4. Put on thick leather gloves.
  5. Loosen the blade tension knob, note the direction of teeth, and remove the blade from the wheels and the blade guides (see **Figure 39**).
  6. Wipe the new blade with oil, and insert it into the blade guides with the teeth down.
  7. While keeping the blade in the guides, slide the blade onto the lower wheel and then the upper wheel.
  8. Carefully make sure that the blade is seated on the wheels correctly and re-tension the blade. Refer to **Blade Tension on Page 20** for instructions.
  9. Reinstall the blade guide blade guard and the wire wheel so the blade sinks into wire wheel center line.
  10. Close the blade guard door and check and set the blade tracking. Refer to **Blade Tracking on Page 31** for instructions.
  11. Check and readjust the blade guides if required. Refer to **Blade Guides on Page 21** for instructions.

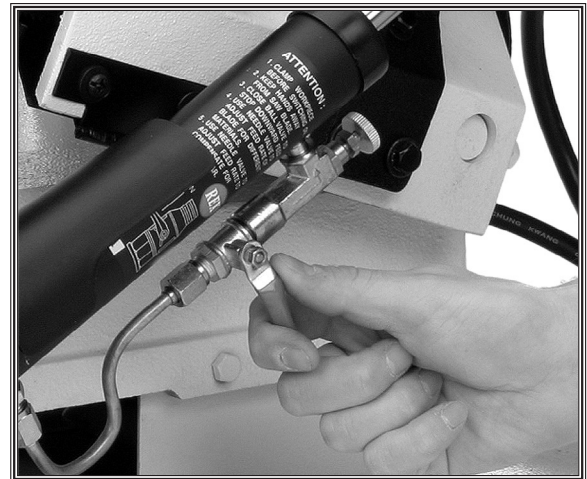

Figure 37. Stopping the feed cylinder.

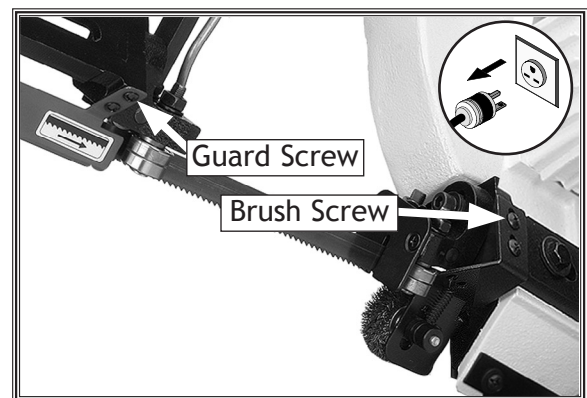

Figure 38. Blade accessories.

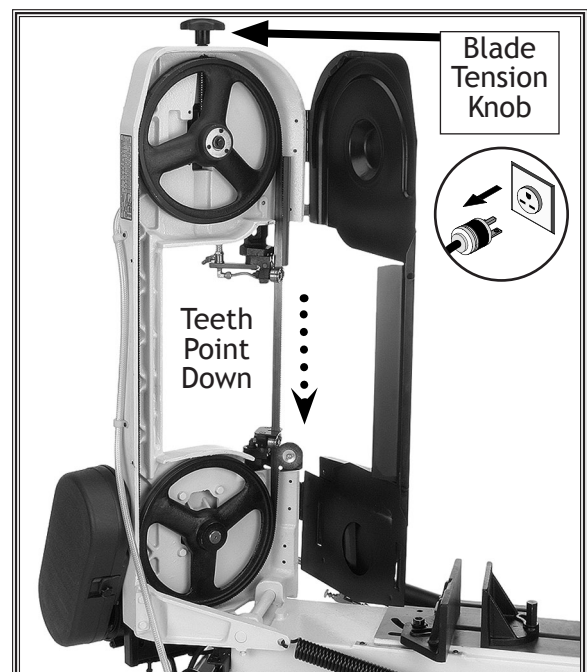

Figure 39. Open blade guard door.

# Cutting Fluid

While simple in concept and function, many issues must be taken into account and addressed to find and use the correct cutting fluid. Always follow all product warnings and contact the fluid manufacturer for unanswered questions.

Use the selections below to choose the appropriate cutting fluids:

- For cutting low alloy, low carbon, and general-purpose category metals with a bi-metal blade—use a water soluble cutting fluid.
- For cutting stainless steels, high carbon, and high alloy metals, brass, copper and mild steels—use "Neat Cutting Oil" (commonly undiluted mineral oils) that have extreme pressure additives (EP additives).
- For cutting cast iron, cutting fluid is not recommended.

	<p><b>!WARNING</b></p> <p><b>NEVER</b> attempt to cut magnesium when using soluble oils or emulsions (oil-water solutions) as a cutting fluid! The water in the solution will greatly intensify an accidental magnesium-chip fire. For cutting magnesium alloys, use a specific cutting fluid intended for magnesium.</p>
--	---

**Remember:** Too much flow at the cutting fluid nozzle will make a mess and can make the work area unsafe; and not enough fluid at the cut will heat the blade, causing the blade teeth to load up and break.

Adjust the flow rate lever so the coolant will cool and lubricate the blade, and flush the chips away so they do not stick to the blade. If the chips build up on the blade, eventually they will bind and skid in the next cut, breaking blade teeth, and damaging the bandsaw wheels.

<p><b>!WARNING</b></p> <p><b>BIOLOGICAL and POISON HAZARD!</b></p> <div data-bbox="959 430 1485 661"> </div> <p>The reservoir on this machine is designed to store cutting fluid. During storage some fluids grow dangerous microbes, or due to the collection of toxic metal chips in the fluid, the fluid can become a potent and extremely poisonous solution to humans and animals.</p> <p>USE the correct personal protection equipment when handling cutting fluids to prevent infections and poisoning.</p> <p>FOLLOW federal, state, and the fluid manufacturer requirements to properly dispose of cutting fluid when it becomes unsafe.</p>
---

## Feed Rate

The speed at which the saw blade will cut through a workpiece is controlled by blade type, feed rate, and feed pressure.

**Note:** If a lubricant is used on the cut, the feed rate can be increased by approximately 15%.

To set the feed rate, do these steps:

1. Raise the headstock.
2. Using a 14mm wrench, adjust the feed pressure tension spring so the spring coils are not in tension, but the spring is still held firmly in place (see **Figure 41**).

**Note:** This spring adjustment is an initial setting and depending on cutting circumstances, you will have to fine-tune the feed pressure with this adjustment. Increasing the spring tension will reduce the feed pressure.

3. Clamp the workpiece in the table vise.
4. Close the feed ON/OFF valve to lock the headstock and blade a few inches above the workpiece (see **Figure 40**).
5. With the correct saw blade and blade speed selected, turn the saw and lubricant pump ON.
6. Slowly rotate the feed rate dial to a conservative feed rate until the saw begins to cut the workpiece (see **Figure 41**).
7. Observe the chips that exit the cut, and increase or decrease the feed rate according to the chip characteristics (see **Figure 42**).

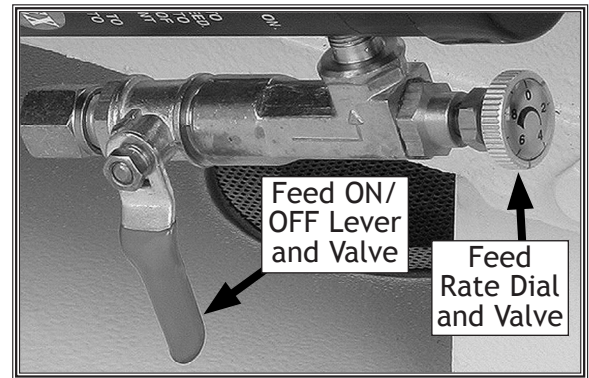

**Figure 40.** Feed rate controls.

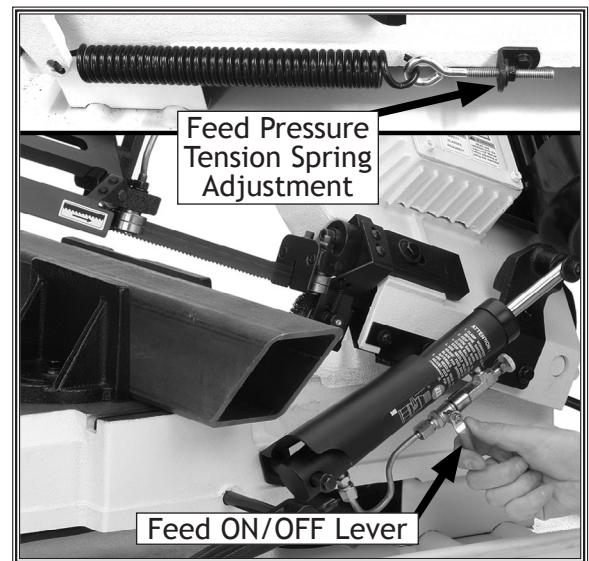

**Figure 41.** Bandsaw operating and starting feed before blade contacts workpiece.

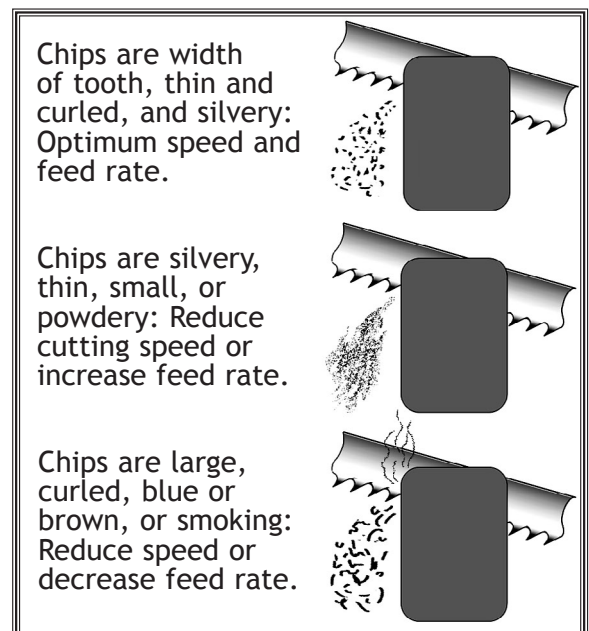

**Figure 42.** Reading chip characteristics.

# MAINTENANCE

## General

Regular periodic maintenance on your **SHOP FOX**® Model M1014 will ensure its optimum performance. Make a habit of inspecting your machine each time you use it.

Check for the following conditions and repair or replace when necessary:

- Loose mounting bolts.
- Missing or leaking rubber toggle switch boots.
- Worn or damaged cords, switches, or plugs.
- Damaged V-belt.
- Any other condition that could hamper the safe operation of this machine.

## Cleaning

Frequently brush-off metal chips with a brush, or use a shop vacume to remove the chips. Keeping metal chips away from bandsaw mechanisms is important to making sure that your bandsaw lasts a long time.

This machine is equipped with a cutting fluid system, which pumps water and oil based cutting lubricants. It is especially important to make sure the internal working parts of the motor and electrical switches are kept dry and splash free.

**! WARNING**

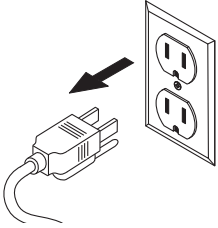

**MAKE SURE** that your machine is unplugged during all maintenance procedures! If this warning is ignored, serious personal injury may occur.

## Lubrication

Since all bearings are sealed and permanently lubricated, simply leave them alone until they need to be replaced. Do not lubricate them. However, you must periodically lubricate threaded adjustment locations and check the gear box oil level.

Lubricate the following areas as follows:

- **Gear Box:** With the headstock in the down position, wipe all dirt and metal from the fill plug, remove it, and check or add 80W-90W gear oil (see **Figure 43**). Change the oil every six months under heavy use; otherwise, change it annually.
- **Blade Tension Mechanism:** Open the main blade guard and drop a few drops of oil on the tension knob lead screw (see **Figure 44**).
- **Blade and Guides:** Drop a few drops of light machine oil on the blade and the blade guides daily, especially when cutting cast iron, as no cutting fluid is recommended.
- **Table and Machined Surfaces:** Tables can be kept rust-free with regular applications of products like SLIPIT®. For long term storage you may want to consider products like Boeshield T-9™.
- **Vise lead screw:** Drop a few drops of light machine oil on the vise lead screw weekly (see **Figure 44**).

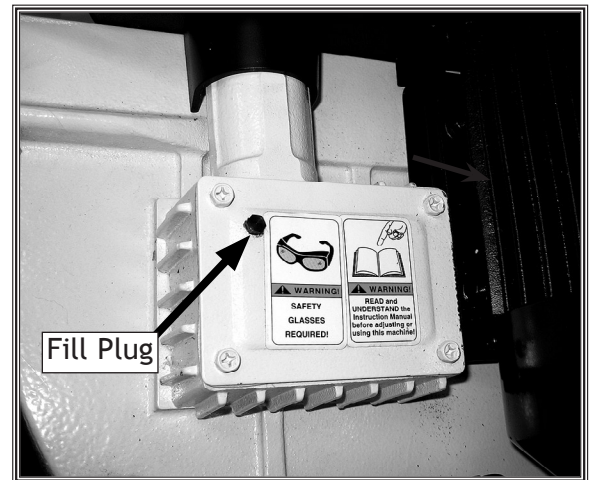

Figure 43. Gear box.

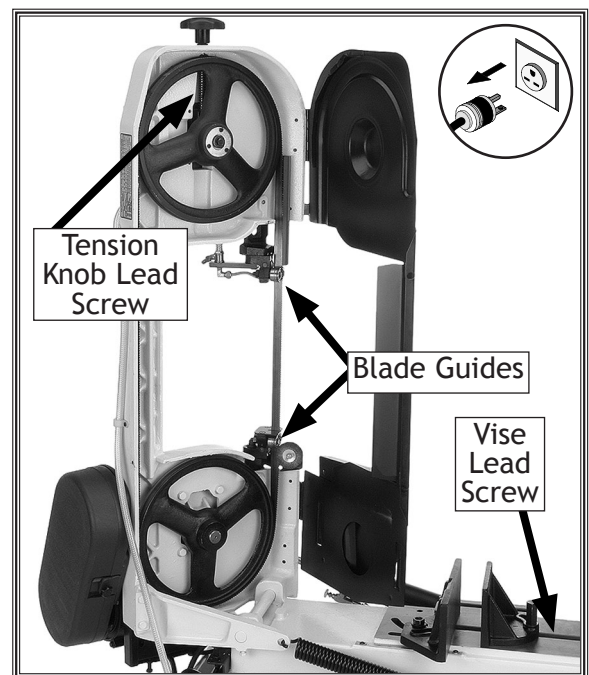

Figure 44. Main lubrication points.

# SERVICE

## General

This section covers the most common service adjustments or procedures that may need to be made during the life of your machine.

If you require additional machine service not included in this section, please contact Woodstock International Technical Support at (360) 734-3482 or send e-mail to: [tech-support@shopfox.biz](mailto:tech-support@shopfox.biz).

## Cutting Fluid System

Cutting fluid is usually poisonous and can be a biological hazard! Always use the correct personal protection equipment when working with cutting fluids, pumps, fittings, and lines.

Maintain the cutting fluid system as follows:

- **Reservoir and Pump:** Remove four screws and the pump from the reservoir every six months and clean sludge from the tank and remove any restricting material around the pump intake (see **Figure 45**).
- **Screens and Lines:** Inspect fittings and lines for leaks and kinks, and repair as required. Make sure all screens are unclogged.
- **Electrical:** Unplug and inspect electrical switches and wiring for potential shorting with liquids and repair as required.

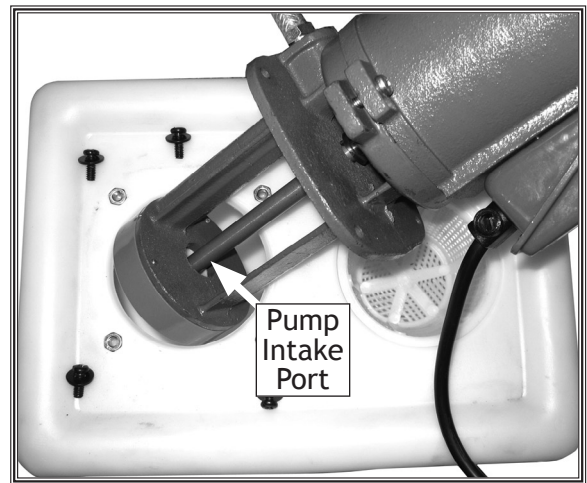
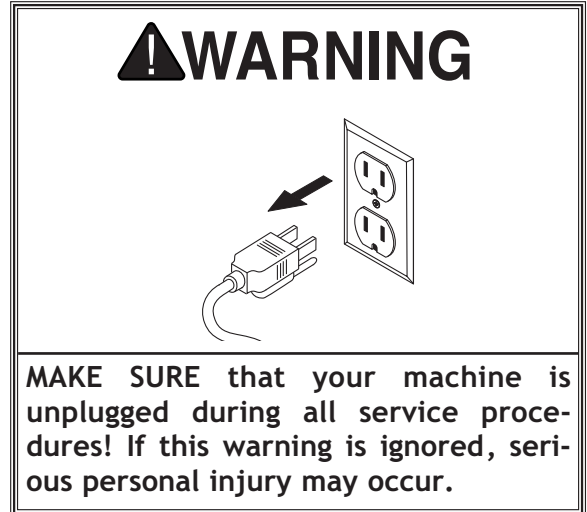

Figure 45. Pump intake port.



## Blade Tracking

A blade that tracks incorrectly can wear out the wheel flanges or come off of the bandsaw. You must make sure the blade tracks on the wheel so the rear of the blade is supported by the lip on the wheel or wheel flange.



To set the blade tension, do these steps:

1. **UNPLUG THE BANDSAW POWER CORD!**
2. Raise the headstock to the vertical position and close the feed valve to lock the headstock in place (see **Figure 46**).
3. Slide the lower sliding cover up, open the main blade guard, and remove the blade guide assemblies (See **Figure 47**).
4. Plug the bandsaw in and start the machine.

**Note:** For the next step, turning the set screw and blade tension knob in opposite directions keeps the blade in tension during this adjustment process.

5. Using a 4mm hex wrench, adjust the set screw and blade tension knob simultaneously in opposite directions, and observe the blade position on the wheels. If the setscrew does not turn, you may have to loosen one or both hex bolts shown in **Figure 48**.
  - If tracking is correct, the rear of the blade should be just touching the wheel flange or wheel shoulder. Unplug the saw and reinstall and adjust the blade guides and close the blade guard.
  - If there is a gap between the wheel shoulder or the blade is riding on top of the shoulder, repeat the adjustment as required to get the correct tracking.

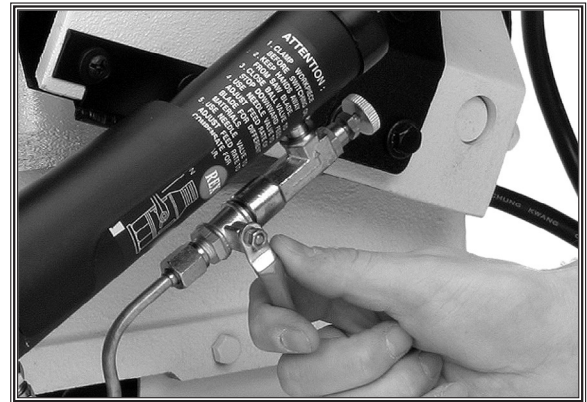

Figure 46. Stopping the feed cylinder.

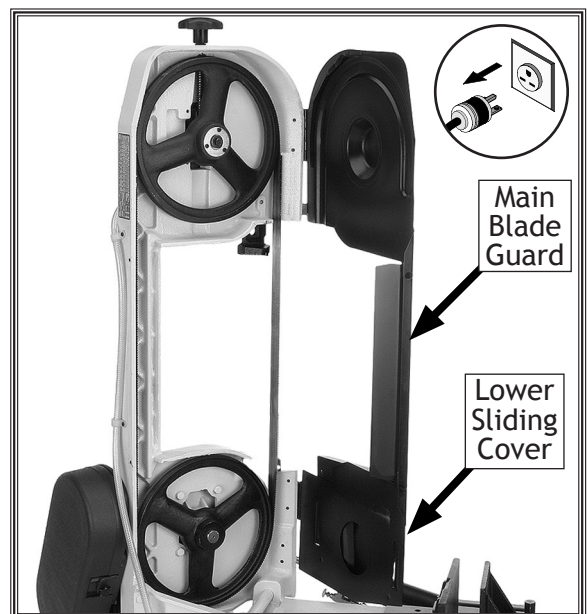

Figure 47. Bandsaw blade guard and the lower sliding cover.

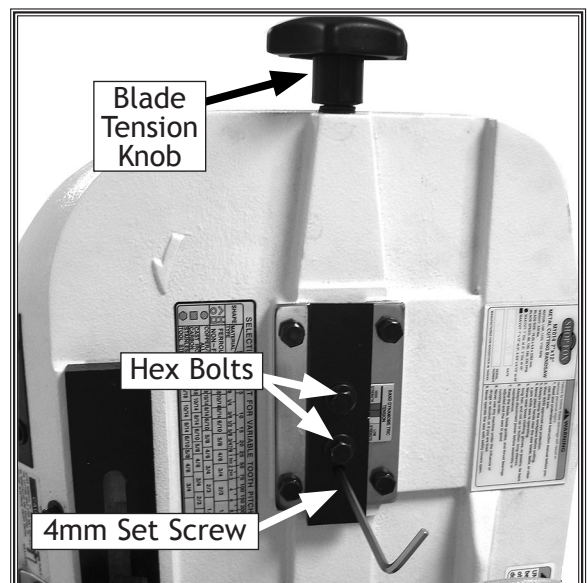
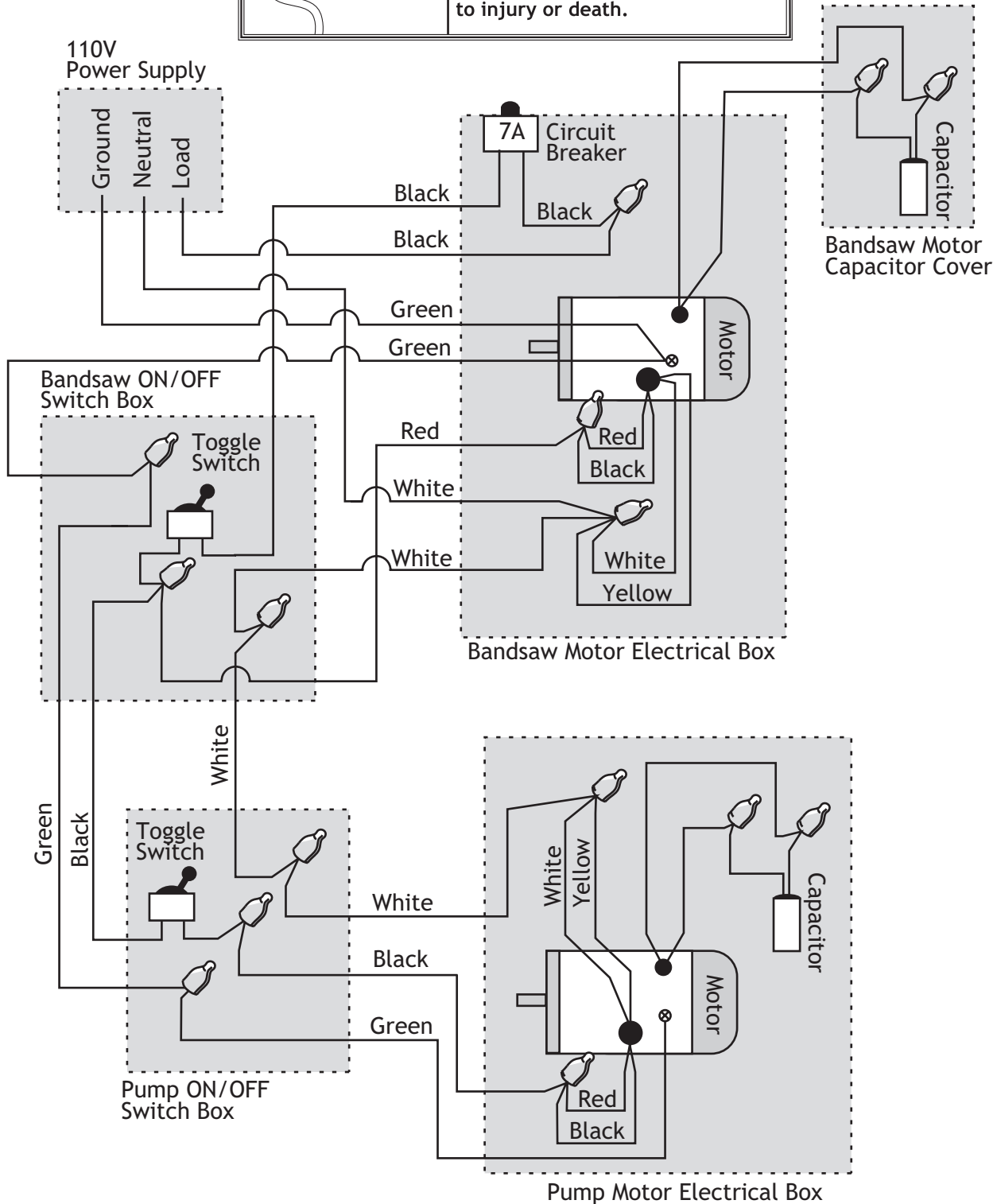

Figure 48. Tracking adjustment controls.

- If the blade tracking cannot be adjusted with this procedure, the wheel must be re-aligned. Go to **Step 6** and complete the procedure. Otherwise, this procedure is complete.
6. With the bandsaw unplugged, loosen the set screw, and back it out as far as it will go without it falling out.
  7. Use a 12mm wrench and tighten the hex bolts until they are almost snug, but still loose enough so you can still turn the flat washers with your fingers.
  8. Turn the set screw in until it bottoms out, then turn it an additional 1/2 turn.
  9. Start the bandsaw, and observe the tracking.
    - If the tracking is correct, the rear of the blade should be just touching the wheel flange or wheel shoulder. Unplug the saw and reinstall and adjust the blade guides and close the blade guard.
    - If there is a gap between the wheel shoulder or the blade is riding on top of the shoulder, repeat the adjustment as required to get the correct tracking.

# Wiring Diagram (110V)

**⚠ DANGER**  
 Disconnect power from machine before performing any electrical service. Failure to do this will result in a shock hazard leading to injury or death.



SERVICE

# Wiring Diagram (220V)

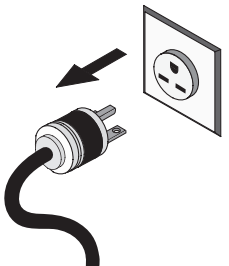

**⚠ DANGER**  
Disconnect power from machine before performing any electrical service. Failure to do this will result in a shock hazard leading to injury or death.

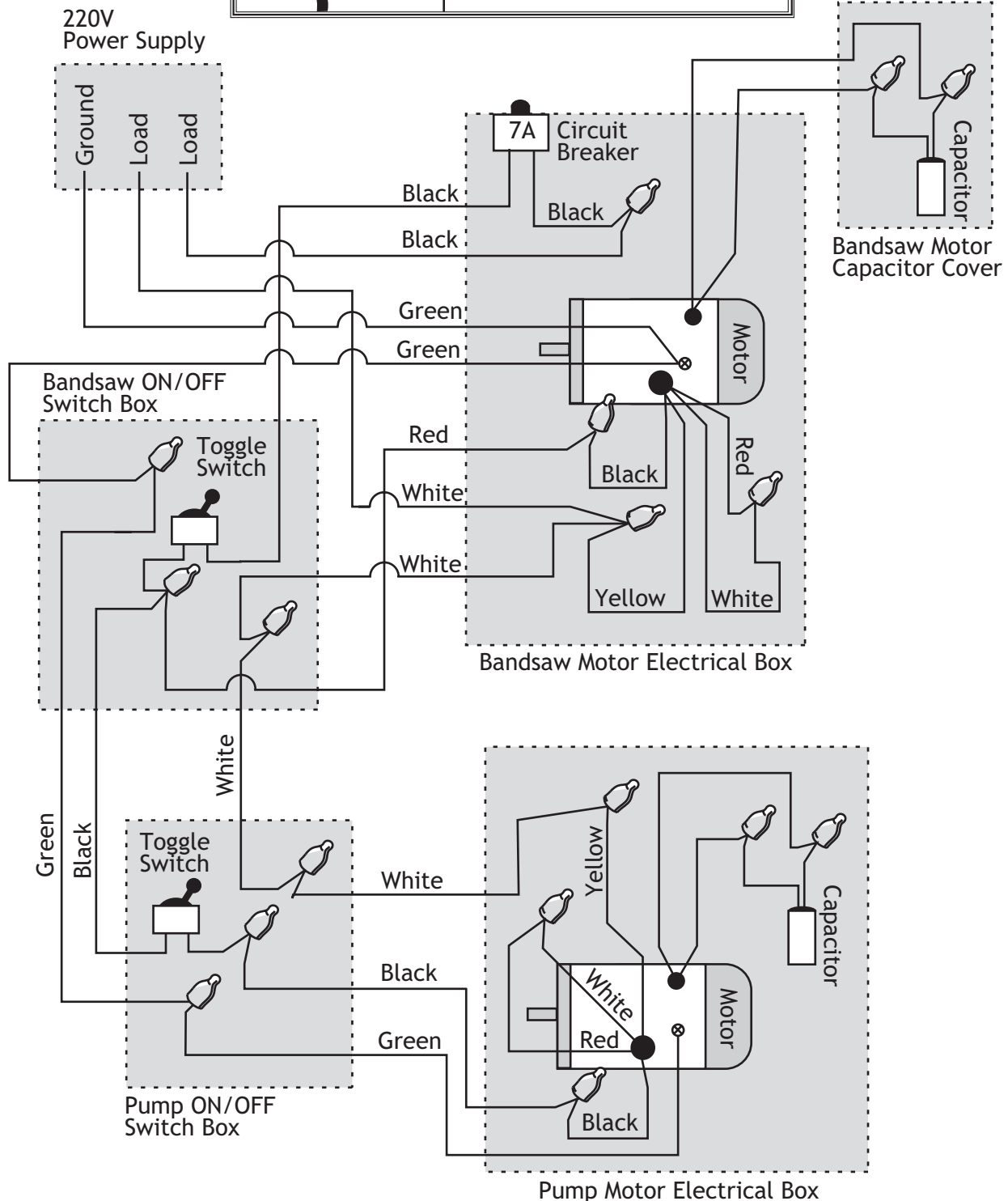

SERVICE

# Troubleshooting

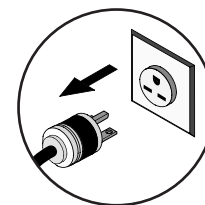

This section covers the most common symptoms and corrections with this type of machine. **WARNING! DO NOT** make any adjustments until power is disconnected and moving parts have come to a complete stop!

SYMPTOM	POSSIBLE CAUSE	CORRECTIVE ACTION
Motor will not start.	<ol style="list-style-type: none"> <li>1. Low or no voltage.</li> <li>2. Faulty start capacitor.</li> <li>3. Motor is at fault.</li> </ol>	<ol style="list-style-type: none"> <li>1. Open or short circuit in line cord or plug resulting in blown fuse or tripped breaker. Repair for cause of short or open circuit.</li> <li>2. Replace start capacitor.</li> <li>3. Motor has shorted or open windings. Replace motor.</li> </ol>
Motor automatically shuts off (possibly resulting in blown fuse or tripped circuit breaker or in power supply circuit).	<ol style="list-style-type: none"> <li>1. Faulty start capacitor.</li> <li>2. Bandsaw is jammed.</li> <li>3. Short circuit in motor or loose connections.</li> </ol>	<ol style="list-style-type: none"> <li>1. Replace start capacitor.</li> <li>2. Remove part or metal that is binding bandsaw.</li> <li>3. Refer to <b>Wiring Diagrams</b> on <b>Pages 33 and 34</b>, and inspect connections on motor for loose or shorted terminals or worn insulation and repair.</li> </ol>
Machine is loud when cutting or bogs down in the cut.	<ol style="list-style-type: none"> <li>1. Excessive feed rate.</li> <li>2. The blade TPI is too great, or the material is too coarse.</li> <li>3. The run capacitor is at fault.</li> </ol>	<ol style="list-style-type: none"> <li>1. Refer to <b>Feed Rate</b> on <b>Page 27</b>, or <b>Changing Cutting Speed</b> on <b>Page 19</b>, and adjust as required.</li> <li>2. Refer to <b>Blade Selection</b> on <b>Page 24</b> and adjust as required.</li> <li>3. Replace the run capacitor.</li> </ol>
Blades break often.	<ol style="list-style-type: none"> <li>1. The workpiece is loose in the vise.</li> <li>2. The feed or cut speed is wrong.</li> <li>3. The blade TPI is too great, or the material is too coarse.</li> <li>4. The blade is rubbing on the wheel flange.</li> <li>5. The bandsaw is being started with the blade resting on the workpiece.</li> <li>6. The guide bearings are misaligned, or the blade is rubbing on the wheel flange.</li> <li>7. The blade is too thick, or the blades are of low quality.</li> </ol>	<ol style="list-style-type: none"> <li>1. Clamp the workpiece tighter, or use a jig to hold the workpiece.</li> <li>2. Refer to <b>Feed Rate</b> on <b>Page 27</b>, or <b>Changing Cutting Speed</b> on <b>Page 19</b>, and adjust as required.</li> <li>3. Refer to <b>Blade Selection</b> on <b>Page 24</b>, and adjust as required.</li> <li>4. Refer to <b>Blade Tracking</b> on <b>Page 31</b>, and adjust as required.</li> <li>5. Start bandsaw and then slowly lower the headstock by setting the feed rate.</li> <li>6. Refer to <b>Blade Tracking</b> on <b>Page 31</b>, or <b>Blade Guides</b> on <b>Page 21</b>, and adjust as required.</li> <li>7. Use a higher quality blade.</li> </ol>
Blade dulls prematurely.	<ol style="list-style-type: none"> <li>1. The cut speed is too fast.</li> <li>2. The blade TPI is too coarse.</li> <li>3. The blade feed pressure is too light.</li> <li>4. The workpiece has hard spots, welds, or scale is on the material.</li> <li>5. The blade is twisted.</li> <li>6. The blade is sipping on the wheels.</li> </ol>	<ol style="list-style-type: none"> <li>1. Refer to <b>Changing Cutting Speed</b> on <b>Page 19</b>, and adjust as required.</li> <li>2. Refer to <b>Blade Selection</b> on <b>Page 24</b>, and adjust as required.</li> <li>3. Refer to <b>Feed Rate</b> on <b>Page 27</b>, and adjust as required.</li> <li>4. Increase the feed pressure, and reduce the cutting speed.</li> <li>5. Replace the blade.</li> <li>6. Refer to <b>Blade Tension</b> on <b>Page 20</b>, and adjust as required.</li> </ol>
Blade wears on one side.	<ol style="list-style-type: none"> <li>1. The blade guides are worn or mis-adjusted.</li> <li>2. The blade guide slide bracket is loose.</li> <li>3. The wheels are out of alignment.</li> </ol>	<ol style="list-style-type: none"> <li>1. Refer to <b>Blade Guides</b> on <b>Page 21</b> and replace or adjust.</li> <li>2. Tighten the blade guide bracket.</li> <li>3. Refer to <b>Blade Tracking</b> on <b>Page 31</b>, and adjust as required.</li> </ol>

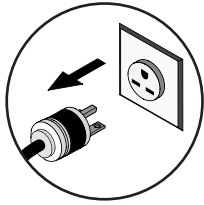

# Troubleshooting

This section covers the most common symptoms and corrections with this type of machine. **WARNING! DO NOT** make any adjustments until power is disconnected and moving parts have come to a complete stop!

SYMPTOM	POSSIBLE CAUSE	CORRECTIVE ACTION
Teeth are ripping from the blade.	<ol style="list-style-type: none"> <li>1. The feed pressure is too heavy and the blade speed is too slow; or the blade TPI is too coarse for the workpiece.</li> <li>2. The workpiece is vibrating in the vise.</li> <li>3. The blade gullets are loading up with chips.</li> </ol>	<ol style="list-style-type: none"> <li>1. Refer to <b>Blade Selection</b> on <b>Page 24</b> and decrease the feed pressure. Refer to <b>Feed Rate</b> on <b>Page 27</b>, and adjust as required.</li> <li>2. Re-clamp the workpiece in the vise, and use a jig if required.</li> <li>3. Use a coarser-tooth blade, make sure the brush is working, and use cutting fluid to cool the blade and flush the cut if required. Refer to <b>Cutting Fluid</b> on <b>Page 26</b> for fluid selection.</li> </ol>
Motor is running too hot.	<ol style="list-style-type: none"> <li>1. The blade tension is too high.</li> <li>2. The drive belt is slipping.</li> <li>3. The blade TPI is incorrect.</li> <li>4. The saw is being overloaded.</li> </ol>	<ol style="list-style-type: none"> <li>1. Refer to <b>Blade Tension</b> on <b>Page 20</b>, and adjust as required.</li> <li>2. Refer to <b>Belt Tension</b> on <b>Page 18</b>, and adjust as required.</li> <li>3. Refer to <b>Blade Selection</b> on <b>Page 24</b>, and adjust as required.</li> <li>4. Refer to <b>Blade Selection</b> on <b>Page 24</b> and decrease the feed pressure, refer to <b>Feed Rate</b> on <b>Page 27</b>. Use cutting fluid if required.</li> </ol>
The cuts are crooked.	<ol style="list-style-type: none"> <li>1. The feed pressure is too high.</li> <li>2. The guide bearings are out of adjustment, or too far away from the workpiece.</li> <li>3. The blade tension is low.</li> <li>4. The blade is dull.</li> <li>5. The blade speed is wrong.</li> <li>6. The blade tracking is wrong.</li> </ol>	<ol style="list-style-type: none"> <li>1. Refer to <b>Feed Rate</b> on <b>Page 27</b>, and adjust as required.</li> <li>2. Refer to <b>Blade Guides</b> on <b>Page 21</b> and replace or adjust.</li> <li>3. Refer to <b>Blade Tension</b> on <b>Page 20</b>, and adjust as required.</li> <li>4. Refer to <b>Blade Selection</b> on <b>Page 24</b> and replace the blade.</li> <li>5. Refer to <b>Changing Cutting Speed</b> on <b>Page 19</b>, and adjust as required.</li> <li>6. Refer to <b>Blade Tracking</b> on <b>Page 31</b>, and adjust as required.</li> </ol>
The cuts are rough.	<ol style="list-style-type: none"> <li>1. The feed pressure is too high.</li> <li>2. The blade TPI is too coarse.</li> <li>3. The blade is loose and slipping on wheels.</li> <li>4. The blade tracking is wrong.</li> </ol>	<ol style="list-style-type: none"> <li>1. Refer to <b>Feed Rate</b> on <b>Page 27</b>, and adjust as required.</li> <li>2. Refer to <b>Blade Selection</b> on <b>Page 24</b>, and adjust as required.</li> <li>3. Refer to <b>Blade Tension</b> on <b>Page 20</b>, and adjust as required.</li> <li>4. Refer to <b>Blade Tracking</b> on <b>Page 31</b>, and adjust as required.</li> </ol>

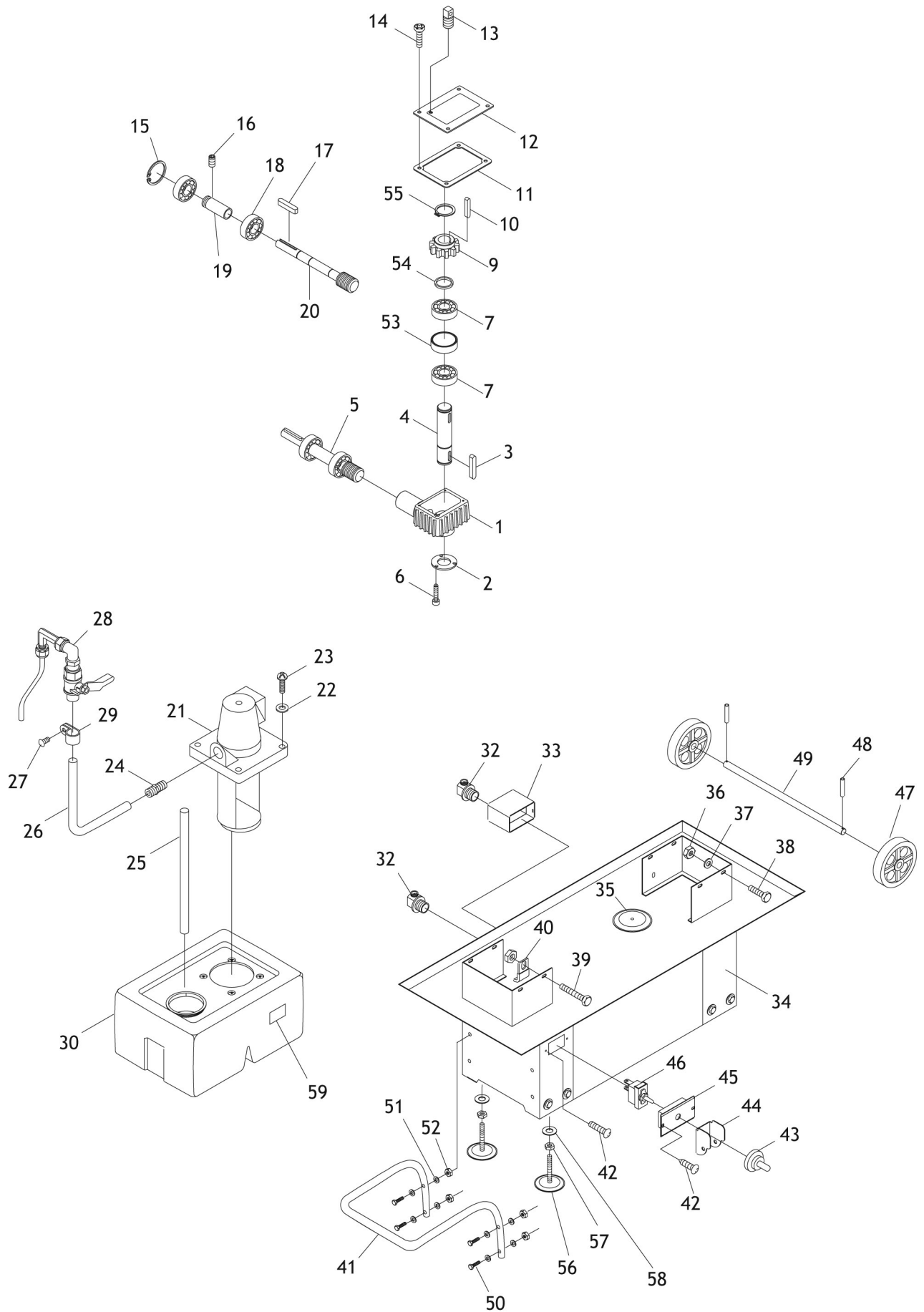

# Parts List

REF	PART #	DESCRIPTION
1	XM1014001	GEAR BOX
2	XM1014002	BEARING COVER
3	XPK07M	KEY 6 X 6 X 20MM
4	XM1014004	SHAFT
5	XM1014005	WORM GEAR SHAFT ASSEMBLY
6	XPS06	PHLP HD SCR #10-24 X 3/8"
7	XP6205	BALL BEARING 6205
9	XM1014009	PINION GEAR
10	XPK07M	KEY 6 X 6 X 20MM
11	XM1014011	GEAR BOX GASKET
12	XM1014012	GEAR BOX COVER
13	XM1014013	VENT PLUG
14	XPS04	PHLP HD SCR 1/4"-20 X 1/2"
15	XPR18M	EXT RETAINING RING 17MM
16	XPSS08	SET SCREW 5/16"-18 X 1/2"
17	XPK12M	KEY 5 X 5 X 30MM
18	XP6003	BALL BEARING 6003ZZ
19	XM1014019	BEARING BUSHING
20	XM1014020	WORM SHAFT
21	XM1014021	PUMP
21-1	XM1014021-1	S. CAPACITOR 4MFD/300VAC
22	XPW06	FLAT WASHER 1/4"
23	XPS04	PHLP HD SCR 1/4"-20 X 1/2"
24	XM1014024	COUPLER 3/8" X 5/16"
25	XM1014025	HOSE 5/8" X 200MM
26	XM1014026	HOSE OD12 X ID8 X 2000
27	XPS06	PHLP HD SCR #10-24 X 3/8"
28	XM1014028	FITTING 1/8"PT X 5/16"D X 90°
29	XM1014029	HOSE CLIP 5/8"
30	XM1014030	COOLANT TANK

REF	PART #	DESCRIPTION
32	XM1014032	STRAIN RELIEF 1/2"
33	XM1014033	ELECTRICAL BOX
34	XM1014034	STAND COMPLETE ASSEMBLY
35	XM1014035	FILTER
36	XPN08	HEX NUT 3/8"-16
37	XPW07	FLAT WASHER 5/16"
38	XPB03	HEX BOLT 5/16"-18 X 1"
39	XPB24	HEX BOLT 3/8"-16 X 1-1/4"
40	XM1014040	SWITCH CUT OFF TIP
41	XM1014041	HANDLE
42	XPHTK6	TAP SCREW #10 X 3/8"
43	XM1014043	TOGGLE SWITCH COVER
44	XM1014044	SWITCH COVER
45	XM1014045	COVER
46	XM1014046	SWITCH
47	XM1014047	WHEEL
48	XM1014048	COTTER PIN 3 X 25MM
49	XM1014049	AXLE
50	XPB24	HEX BOLT 3/8"-16 X 1-1/4"
51	XPW02	LOCK WASHER 3/8"
52	XPN08	HEX NUT 3/8"-16
53	XM1014053	BUSHING
53	XM1014053	BUSHING
54	XM1014054	BUSHING
55	XPR11M	EXT RETAINING RING 25MM
56	XM1014056	METAL FOOT
57	XPN08	HEX NUT 3/8"-16
58	XPW02	FLAT WASHER 3/8"
59	XM1014059	HIGH/LOW LABEL



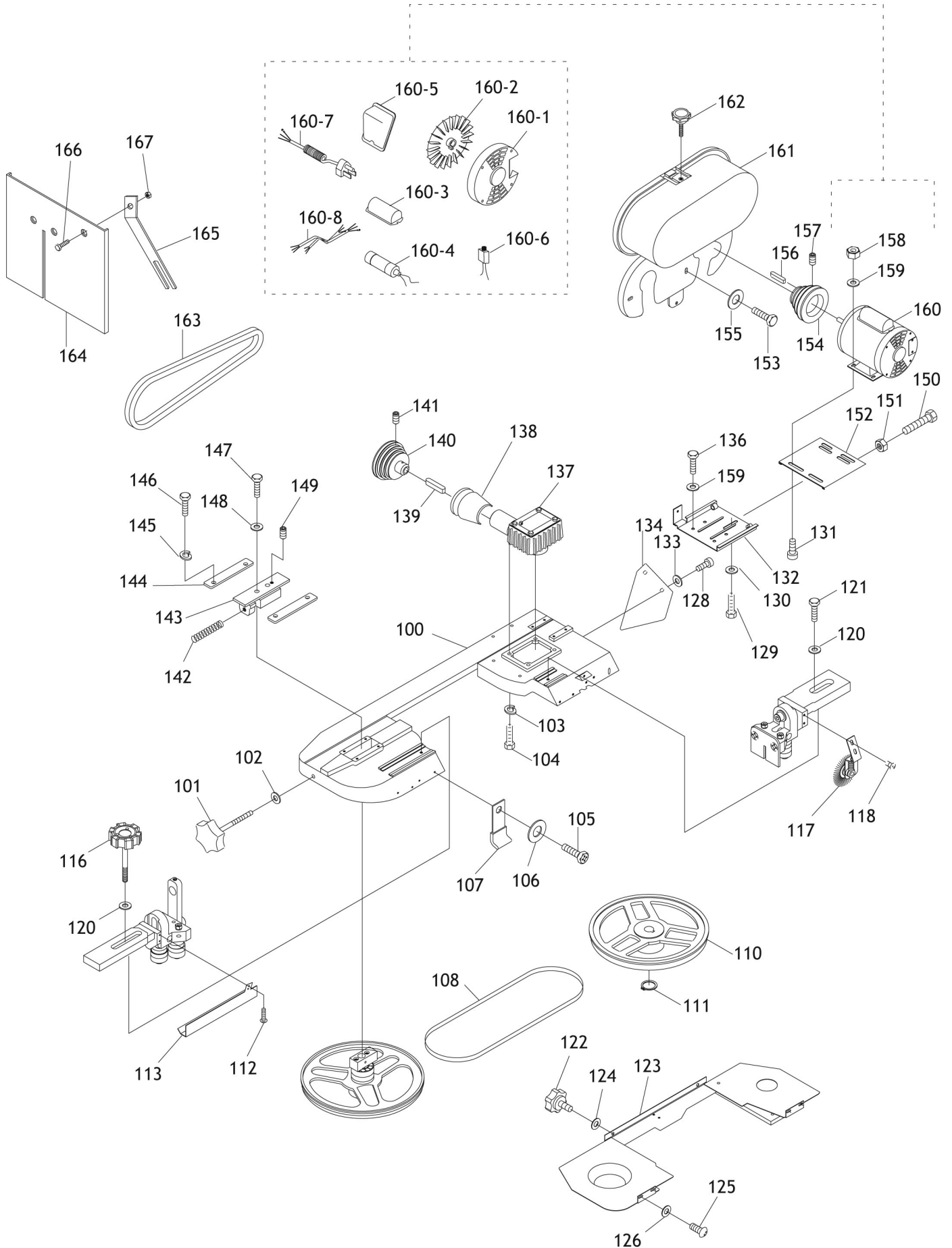

# Parts List

REF	PART #	DESCRIPTION
100	XM1014100	BODY FRAME
101	XM1014101	KNOB BOLT
102	XPW02	FLAT WASHER 3/8"
103	XPLW04	LOCK WASHER 3/8"
104	XPB24	HEX BOLT 3/8"-16 X 1-1/4"
105	XPS04	PHLP HD SCR 1/4"-20 X 1/2"
106	XPW06	FLAT WASHER 1/4"
107	XM1014107	SWITCH CUT OFF TIP
108	XM1014108	BLADE 0.032 X 3/4 X 93 X 6-10T
110	XM1014110	DRIVE WHEEL ASSEMBLY
111	XPR11M	EXT RETAINING RING 25MM
112	XPS01	PHLP HD SCR 10-24 X 1/2"
113	XM1014113	BLADE COVER (FRONT)
116	XM1014116	KNOB BOLT
117	XM1014117	BRUSH ASSEMBLY
118	XPS06	PHLP HD SCR 10-24 X 3/8"
120	XPW02	FLAT WASHER 3/8"
121	XPB24	HEX BOLT 3/8"-16 X 1-1/4"
122	XM1014122	KNOB BOLT
123	XM1014123	BLADE BACK COVER
124	XPW06	FLAT WASHER 1/4"
125	XPS04	PHLP HD SCR 1/4"-20 X 1/2"
126	XPW06	FLAT WASHER 1/4"
128	XPS04	PHLP HD SCR 1/4"-20 X 1/2"
129	XPB07	HEX BOLT 5/16"-18 x 3/4"
130	XPW07	FLAT WASHER 5/16"
131	XPCB11	CARRIAGE BOLT 5/16"-18 X 1"
132	XM1014132	MOTOR MOUNT BRACKET
133	XPW06	FLAT WASHER 1/4"
134	XM1014134	SUPPORT PLATE
136	XPB07	HEX BOLT 5/16"-18 x 3/4"
137	XM1014137	GEAR BOX ASSEMBLY
138	XM1014138	BEARING COVER
139	XPK12M	KEY 5 X 5 X 30MM
140	XM1014140	SPINDLE PULLEY

REF	PART #	DESCRIPTION
141	XPSS03	SET SCREW 1/4"-20 X 3/8"
142	XM1014142	COMPRESSION SPRING
143	XM1014143	BLADE TENSION SLIDING BLOCK
144	XM1014144	SLIDING PLATE
145	XPLW01	LOCK WASHER 5/16"
146	XPB07	HEX BOLT 5/16"-18 x 3/4"
147	XPB11	HEX BOLT 5/16"-18 X 1-1/2"
148	XPW07	FLAT WASHER 5/16"
149	XPSS18	SET SCREW 5/16"-18 X 3/4"
150	XPB06	HEX BOLT 5/16"-18 X 2"
151	XPNO2	HEX NUT 5/16"-18
152	XM1014152	MOTOR MOUNT PLATE
153	XPB19	HEX BOLT 1/4"-20 X 1/2"
154	XM1014154	MOTOR PULLEY
155	XPW06	FLAT WASHER 1/4"
156	XPK12M	KEY 5 X 5 X 30MM
157	XPSS03	SET SCREW 1/4"-20 X 3/8"
158	XPNO2	HEX NUT 5/16"-18
159	XPW07	FLAT WASHER 5/16"
160	XM1014160	MOTOR
160-1	XM1014160-1	MOTOR FAN COVER
160-2	XM1014160-2	MOTOR FAN
160-3	XM1014160-3	CAPACITOR COVER
160-4	XM1014160-4	S. CAPACITOR 150MFD/250VAC
160-5	XM1014160-5	ELECTRICAL BOX COVER
160-6	XM1014160-6	13 AMP CIRCUIT BREAKER
160-7	XM1014160-7	POWER CORD
160-8	XM1014160-8	COMPLETE WIRING HARNESS
161	XM1014161	MOTOR PULLEY COVER
162	XM1014162	KNOB BOLT 1/4"-20 X 5/8"
163	XPVM27	V-BELT M-27 3L270
164	XM1014164	VERTICAL SAW TABLE
165	XM1014165	TABLE SUPPORT
166	XPFH19	FLAT HD SCR 1/4"-20 X 3/8"
167	XPNO5	HEX NUT 1/4"-20

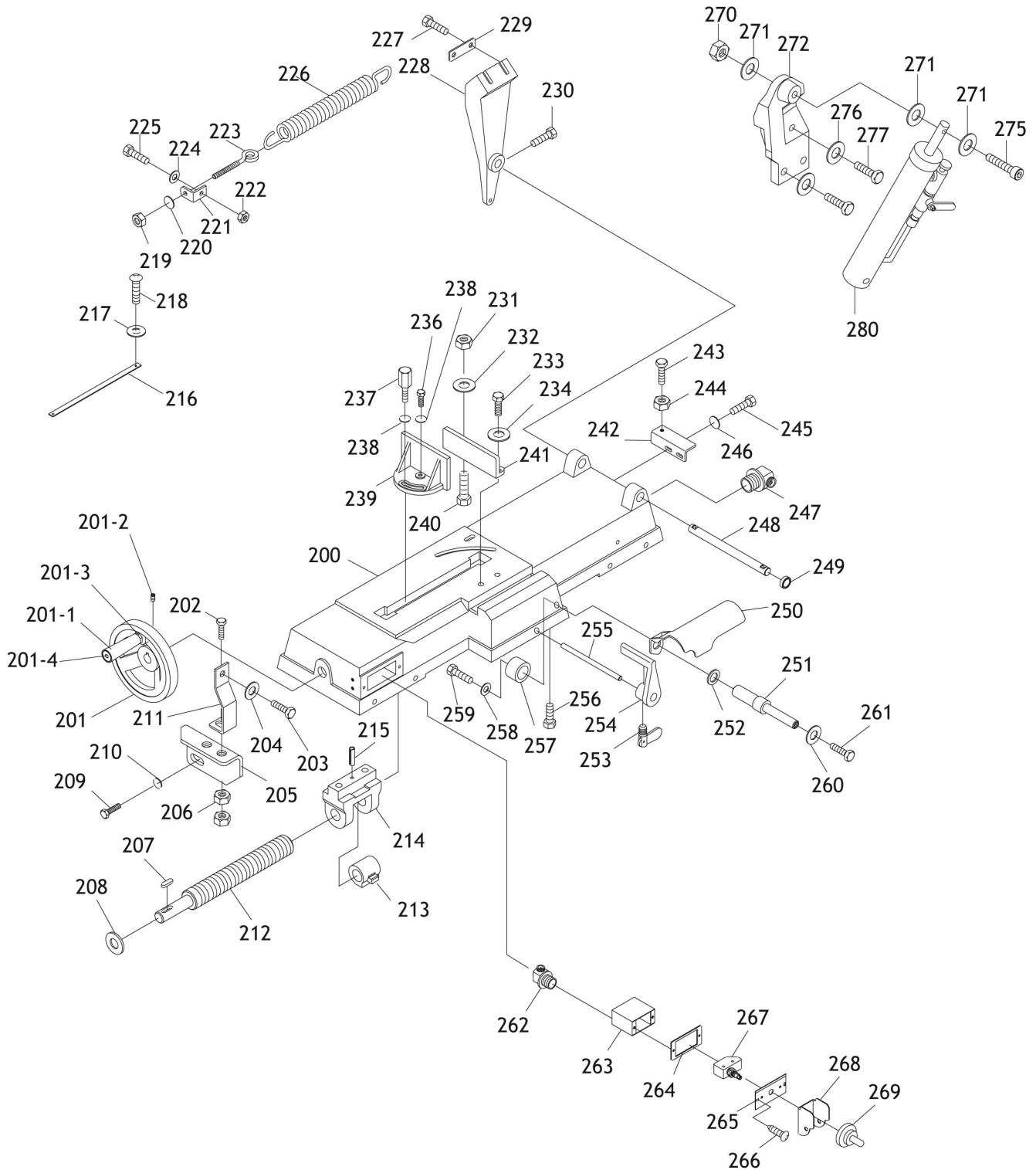

# Parts List

REF	PART #	DESCRIPTION
200	XM1014200	BASE
201	XM1014201	WHEEL
201-1	XM1014201-1	WHEEL HANDLE
201-2	XPSS17	SET SCREW 5/16"-18 X 5/16"
201-3	XPN08	HEX NUT 3/8"-16"
201-4	XM1014201-4	SPECIAL CAP SCREW
202	XPB25	HEX BOLT 3/8"-16 X 1-3/4"
203	XPB11	HEX BOLT 5/16"-18 X 1-1/2"
204	XPW06	FLAT WASHER 1/4"
205	XM1014205	SUPPORT PLATE
206	XPN08	HEX NUT 3/8"-16
207	XPK20M	KEY 5 X 5 X 15MM
208	XPW01	FLAT WASHER 1/2"
209	XPB07	HEX BOLT 5/16"-18 x 3/4"
210	XPW07	FLAT WASHER 5/16"
211	XM1014211	FIXED PLATE
212	XM1014212	ACME SCREW
213	XM1014213	ACME NUT ASSY
214	XM1014214	BRACKET
215	XM1014215	PIN 5 X 34MM
216	XM1014216	SCALE
217	XPW03	FLAT WASHER #10
218	XPS06	PHLP HD SCR #10-24 X 3/8"
219	XPN08	HEX NUT 3/8"-16
220	XPW02	FLAT WASHER 3/8"
221	XM1014221	SPRING HANDLE BRACKET
222	XPN02	HEX NUT 5/16"-18
223	XM1014223	SPRING ADJUSTING ROD
224	XPW07	FLAT WASHER 5/16"
225	XPB07	HEX BOLT 5/16"-18 x 3/4"
226	XM1014226	EXTENSION SPRING
227	XPB16	HEX BOLT 3/8"-16 X 1-1/2"
228	XM1014228	PIVOT BRACKET
229	XM1014229	SPACER PLATE
230	XPS35	PHLP HD SCREW 5/16"-18 X 3/4"
231	XPN06	HEX NUT 1/2"-12
232	XPW01	FLAT WASHER 1/2"
233	XPB42	HEX BOLT 1/2"-12 X 2"
234	XPW01	FLAT WASHER 1/2"
236	XPB16	HEX BOLT 3/8"-16 X 1-1/2"

REF	PART #	DESCRIPTION
237	XM1014237	SPECIAL BOLT 3/8"-18 X 1-1/2"
238	XPW02	FLAT WASHER 3/8"
239	XM1014239	WISE JAW BRACKET (FRONT)
240	XPB72	HEX BOLT 1/2"-13 X 2"
241	XM1014241	WISE JAW BRACKET (REAR)
242	XM1014242	SUPPORT PLATE
243	XPB25	HEX BOLT 3/8"-16 X 1-3/4"
244	XPN08	HEX NUT 3/8"-16
245	XPB07	HEX BOLT 5/16"-18 x 3/4"
246	XPW07	FLAT WASHER 5/16"
247	XM1014247	STRAIN RELIEF 5/8"
248	XM1014248	SUPPORT ROD
249	XM1014249	BUSHING
250	XM1014250	CYLINDER PROTECTOR
251	XM1014251	CYLINDER LOWER SUPPORT
252	XM1014252	SPACER WASHER
253	XM1014253	TAB SCREW 5/16"-18 X 1/2"
254	XM1014254	STOP BLOCK
255	XM1014255	STOCK STOP ROD
256	XPB07	HEX BOLT 5/16"-18 x 3/4"
257	XM1014257	BUSHING
258	XPW07	FLAT WASHER 5/16"
259	XPB07	HEX BOLT 5/16"-18 x 3/4"
260	XPW07	FLAT WASHER 5/16"
261	XPB09	HEX BOLT 5/16"-18 X 1/2"
262	XM1014262	STRAIN RELIEF 1/2"
263	XM1014263	SWITCH BOX
264	XM1014264	RUBBER GASKET
265	XM1014265	MOUNTING PLATE
266	XPHTK4	#10-24 X 3/8"
267	XM1014267	TOGGLE SWITCH
268	XM1014268	SWITCH COVER
269	XM1014269	TOGGLE SWITCH COVER
270	XPN08	HEX NUT 3/8"-16
271	XPW02	FLAT WASHER 3/8"
272	XM1014272	CYLINDER UPPER SUPPORT
275	XPSB29	CAP SCREW 3/8"-16 X 2-1/4"
276	XPW07	FLAT WASHER 5/16"
277	XPB03	HEX BOLT 5/16"-18 X 1"
280	XM1014280	CYLINDER SET

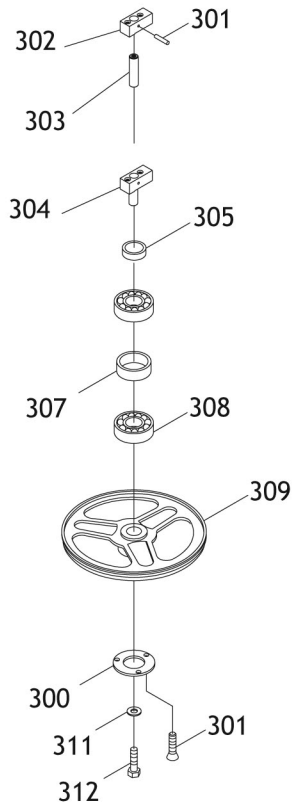
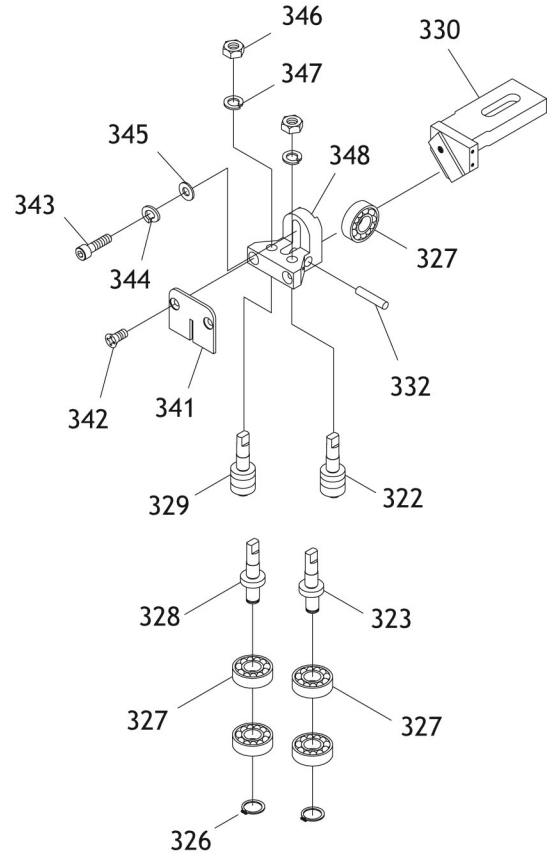
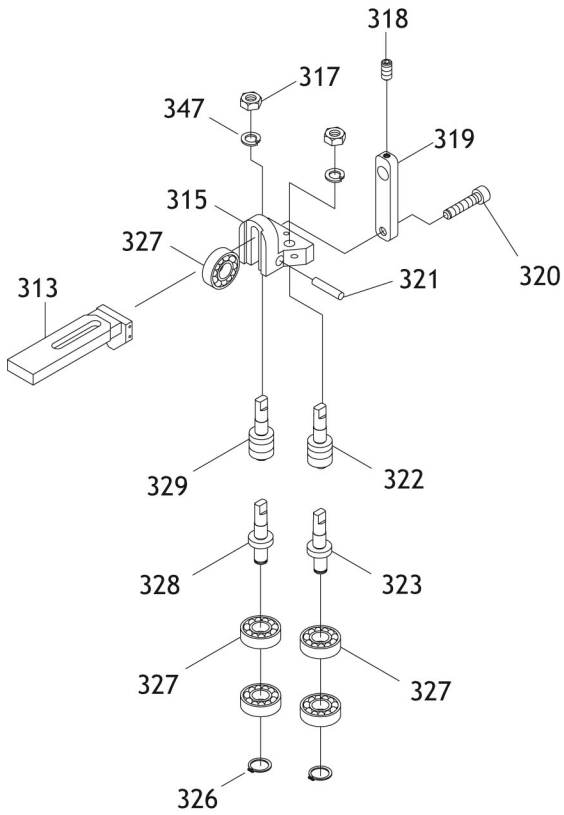

# Parts List

REF	PART #	DESCRIPTION
300	XM1014300	RETAINER
301	XM1014301	ROLL PIN 4 X 22MM
302	XM1014302	HOUSING
303	XM1014303	AXLE
304	XM1014304	AXLE ASSEMBLY
305	XM1014305	SPACER
307	XM1014307	SPACER
308	XP6202	BEARING 6202-ZZ
309	XM1014309	WHEEL
310	XPFH01	FLAT HD SCR #10-24 X 3/8"
311	XM1014311	LOCK WASHER 5/16"
312	XPB07	HEX BOLT 5/16"-18 X 3/4"
313	XM1014313	GUIDE SLIDE
315	XM1014315	GUIDE CASTING
317	XPN11	HEX NUT 3/8"-24
318	XPSS03	SET SCREW 1/4"-20"X 3/8"
319	XM1014319	EXTENSION
320	XPSB11	CAP SCREW 5/16"-18 X 1-1/4"

REF	PART #	DESCRIPTION
321	XM1014321	ROLL PIN 10 X 42MM
322	XM1014322	ECCENTRIC SET
323	XM1014323	ECCENTRIC ONLY
326	XPR39M	EXTERNAL RETAINING RING 8MM
327	XP6000	BALL BEARING 6000ZZ
328	XM1014328	ECCENTRIC ONLY
329	XM1014329	ECCENTRIC SET
330	XM1014330	GUIDE CASTING
332	XM1014332	ROLL PIN 10 X 42MM
341	XM1014341	STOP PLATE
342	XPFH03	FLAT HD SCR 1/4"-20 X 1/2"
343	XPSB11	CAP SCREW 5/16"-18 X 1-1/4"
344	XPLW01	LOCK WASHER 5/16"
345	XPW07	FLAT WASHER 5/16"
346	XPN11	HEX NUT 3/8"-24
347	XPLW04	LOCK WASHER 3/8"
348	XM1014348	GUIDE HOUSING

---

---

# Notes

# Notes





# Warranty Registration

Name \_\_\_\_\_  
 Street \_\_\_\_\_  
 City \_\_\_\_\_ State \_\_\_\_\_ Zip \_\_\_\_\_  
 Phone # \_\_\_\_\_ Email \_\_\_\_\_ Invoice # \_\_\_\_\_  
 Model # \_\_\_\_\_ Serial # \_\_\_\_\_ Dealer Name \_\_\_\_\_ Purchase Date \_\_\_\_\_

The following information is given on a voluntary basis. It will be used for marketing purposes to help us develop better products and services. **Of course, all information is strictly confidential.**

1. How did you learn about us?
 

<input type="checkbox"/> Advertisement	<input type="checkbox"/> Friend	<input type="checkbox"/> Local Store
<input type="checkbox"/> Mail Order Catalog	<input type="checkbox"/> Website	<input type="checkbox"/> Other:
  
2. How long have you been a woodworker/metalworker?
 

<input type="checkbox"/> 0-2 Years	<input type="checkbox"/> 2-8 Years	<input type="checkbox"/> 8-20 Years	<input type="checkbox"/> 20+ Years
------------------------------------	------------------------------------	-------------------------------------	------------------------------------
  
3. How many of your machines or tools are Shop Fox?
 

<input type="checkbox"/> 0-2	<input type="checkbox"/> 3-5	<input type="checkbox"/> 6-9	<input type="checkbox"/> 10+
------------------------------	------------------------------	------------------------------	------------------------------
  
4. Do you think your machine represents a good value?      Yes                              No
  
5. Would you recommend Shop Fox products to a friend?      Yes                              No
  
6. What is your age group?
 

<input type="checkbox"/> 20-29	<input type="checkbox"/> 30-39	<input type="checkbox"/> 40-49
<input type="checkbox"/> 50-59	<input type="checkbox"/> 60-69	<input type="checkbox"/> 70+
  
7. What is your annual household income?
 

<input type="checkbox"/> \$20,000-\$29,000	<input type="checkbox"/> \$30,000-\$39,000	<input type="checkbox"/> \$40,000-\$49,000
<input type="checkbox"/> \$50,000-\$59,000	<input type="checkbox"/> \$60,000-\$69,000	<input type="checkbox"/> \$70,000+
  
8. Which of the following magazines do you subscribe to?
 

<input type="checkbox"/> Cabinet Maker	<input type="checkbox"/> Popular Mechanics	<input type="checkbox"/> Today's Homeowner
<input type="checkbox"/> Family Handyman	<input type="checkbox"/> Popular Science	<input type="checkbox"/> Wood
<input type="checkbox"/> Hand Loader	<input type="checkbox"/> Popular Woodworking	<input type="checkbox"/> Wooden Boat
<input type="checkbox"/> Handy	<input type="checkbox"/> Practical Homeowner	<input type="checkbox"/> Woodshop News
<input type="checkbox"/> Home Shop Machinist	<input type="checkbox"/> Precision Shooter	<input type="checkbox"/> Woodsmith
<input type="checkbox"/> Journal of Light Cont.	<input type="checkbox"/> Projects in Metal	<input type="checkbox"/> Woodwork
<input type="checkbox"/> Live Steam	<input type="checkbox"/> RC Modeler	<input type="checkbox"/> Woodworker West
<input type="checkbox"/> Model Airplane News	<input type="checkbox"/> Rifle	<input type="checkbox"/> Woodworker's Journal
<input type="checkbox"/> Modeltec	<input type="checkbox"/> Shop Notes	<input type="checkbox"/> Other:
<input type="checkbox"/> Old House Journal	<input type="checkbox"/> Shotgun News	

9. Comments: \_\_\_\_\_  
 \_\_\_\_\_  
 \_\_\_\_\_  
 \_\_\_\_\_  
 \_\_\_\_\_

CUT ALONG DOTTED LINE

FOLD ALONG DOTTED LINE

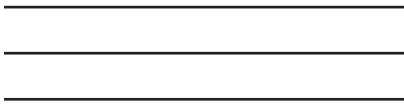

Place  
Stamp  
Here



WOODSTOCK INTERNATIONAL INC.  
P.O. BOX 2309  
BELLINGHAM, WA 98227-2309



FOLD ALONG DOTTED LINE

TAPE ALONG EDGES--PLEASE DO NOT STAPLE

# WARRANTY

Woodstock International, Inc. warrants all Shop Fox machinery to be free of defects from workmanship and materials for a period of two years from the date of original purchase by the original owner. This warranty does not apply to defects due directly or indirectly to misuse, abuse, negligence or accidents, lack of maintenance, or reimbursement of third party expenses incurred.

Woodstock International, Inc. will repair or replace, at its expense and at its option, the Shop Fox machine or machine part, which in normal use has proven to be defective, provided that the original owner returns the product prepaid to a Shop Fox factory service center with proof of their purchase of the product within two years, and provides Woodstock International, Inc. reasonable opportunity to verify the alleged defect through inspection. If it is determined there is no defect, or that the defect resulted from causes not within the scope of Woodstock International Inc.'s warranty, then the original owner must bear the cost of storing and returning the product.

This is Woodstock International, Inc.'s sole written warranty and any and all warranties that may be implied by law, including any merchantability or fitness, for any particular purpose, are hereby limited to the duration of this written warranty. We do not warrant that Shop Fox machinery complies with the provisions of any law or acts. In no event shall Woodstock International, Inc.'s liability under this warranty exceed the purchase price paid for the product, and any legal actions brought against Woodstock International, Inc. shall be tried in the State of Washington, County of Whatcom. We shall in no event be liable for death, injuries to persons or property or for incidental, contingent, special or consequential damages arising from the use of our products.

Every effort has been made to ensure that all Shop Fox machinery meets high quality and durability standards. We reserve the right to change specifications at any time because of our commitment to continuously improve the quality of our products.



## High Quality Machines and Tools

Woodstock International, Inc. carries thousands of products designed to meet the needs of today's woodworkers and metalworkers. Ask your dealer about these fine products:

**BROSENA**  
PRECISION STOP BLOCK

**JOINTER PAL**<sup>®</sup>

**Rotacator**<sup>®</sup>

**THE REBEL**<sup>®</sup>

**DURASTICK**<sup>®</sup>

**Gutmann**<sup>®</sup>

**BOARD BUDDIES**<sup>®</sup>



*Junglee*<sup>®</sup>

**PLANER PAL**<sup>®</sup>

**PARROT VISE**<sup>®</sup>

*SLICKPLANE*<sup>®</sup>

**PRO-STIK**<sup>®</sup>  
ABRASIVE BELT & DISC CLEANER

**ACCU-SHARP**<sup>®</sup>

*Aluma-Classic*<sup>®</sup>



**STEELEX**<sup>®</sup>  
FINE TOOLS

**STEELEX**<sup>®</sup>  
*PLUS*



**WHOLESALE ONLY**

**WOODSTOCK INTERNATIONAL, INC.**

Phone: (360) 734-3482 • Fax: (360) 671-3053 • Toll Free Fax: (800) 647-8801

P.O.Box 2309 • Bellingham, WA 98227

**SHOPFOX.BIZ**

## Free Manuals Download Website

<http://myh66.com>

<http://usermanuals.us>

<http://www.somanuals.com>

<http://www.4manuals.cc>

<http://www.manual-lib.com>

<http://www.404manual.com>

<http://www.luxmanual.com>

<http://aubethermostatmanual.com>

Golf course search by state

<http://golfingnear.com>

Email search by domain

<http://emailbydomain.com>

Auto manuals search

<http://auto.somanuals.com>

TV manuals search

<http://tv.somanuals.com>