

Model D4327/D4328 Quick Release Wood Vise Instruction Sheet



Phone #: (360) 734-3482 • Online Tech Support: tech-support@shopfox.biz • Web: www.shopfox.biz

Introduction

Your new Model D4327/D4328 Quick Release Wood Vise (Figure 1) is designed to fit on workbenches $2\frac{1}{4}$ " and thicker, but can be adapted to workbenches down to $1\frac{1}{2}$ " thick by using a shim. Holes are pre-drilled in the jaw faces to attach aftermarket or shop-built wood clamping vise jaw pads.

D4327 Specifications

- Jaw Width7"
- Mounting Height (Workbench Thickness) $2\frac{1}{4}$ "
- Maximum Jaw Opening8"
- Weight.....21 lbs.

D4328 Specifications

- Jaw Width9"
- Mounting Height (Workbench Thickness) $2\frac{1}{4}$ "
- Maximum Jaw Opening 10"
- Weight.....25 lbs.

Installation

1. Have another person hold the vise up against the workbench in the desired mounting location. If the workbench has holes for bench dogs, make sure the bench dog on the vise is aligned with those holes.

Note: If the workbench is less than $2\frac{1}{4}$ " thick, use a piece of scrap wood (Figure 2) between the vise and workbench as a shim. Cut the shim to the necessary thickness so the vise does not protrude above the workbench after mounting.

2. Pencil mark the workbench through the mounting holes to establish locations to drill pilot holes.
3. Use a $\frac{1}{8}$ " drill bit to drill pilot holes approximately $1\frac{1}{2}$ " deep in the face of the workbench, where the wood screws will be used (see Figure 3).

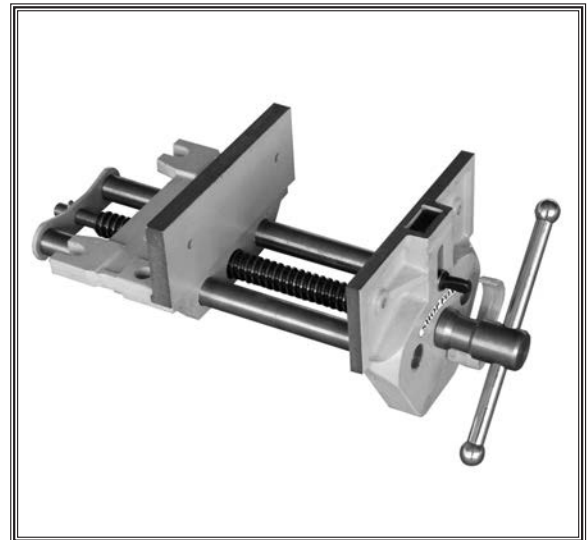

Figure 1. Quick release wood vise.

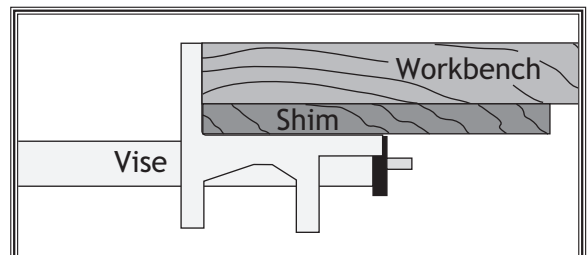

Figure 2. Shim placed between workbench and vise for workbenches under $2\frac{1}{4}$ ".

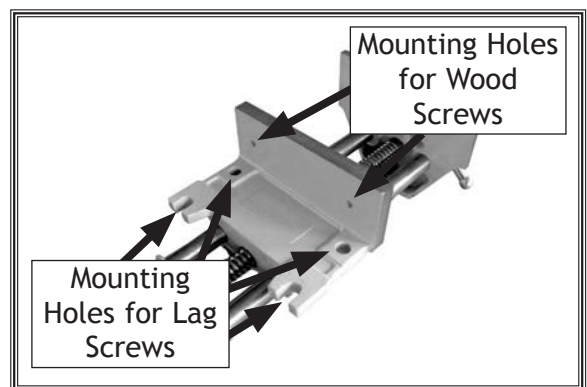

Figure 3. Mounting hole locations.

COPYRIGHT © MARCH, 2012 BY WOODSTOCK INTERNATIONAL, INC.

WARNING: NO PORTION OF THIS MANUAL MAY BE REPRODUCED IN ANY SHAPE OR FORM WITHOUT THE WRITTEN APPROVAL OF WOODSTOCK INTERNATIONAL, INC.

#14922ST

Printed in China

4. Use a 1/4" drill bit to drill pilot holes approximately 1" deep in the underside of the workbench, where the lag screws will be used.
5. Attach the vise to the workbench with two #10 x 2" wood screws through the face of the vise jaw, as shown in **Figure 4**.
6. Secure the vise to the underside of the workbench with four 5/16" x 1 3/4" lag screws and 5/16" flat washers as shown in **Figure 4**.

Note: If you're using a shim, make sure the lag screws pass completely through the shim and secure at least halfway into the workbench thickness, as shown in **Figure 5**.

Operation

Rotating the handle (**Figure 6**) clockwise moves the sliding jaw toward the fixed jaw; rotating handle counter-clockwise moves the sliding jaw away from the fixed jaw.

Moving the quick release lever (**Figure 6**) towards the vise handle disengages the leadscrew so the sliding jaw can be freely moved by pushing or pulling it.

Tightening/loosening the finger bolt (**Figure 6**) allows for adjustment the height of the bench dog.

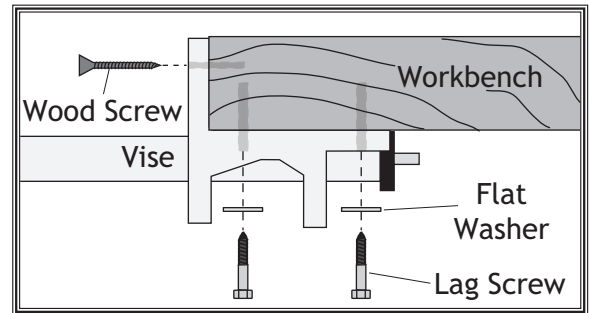

Figure 4. Attaching vise to workbench.

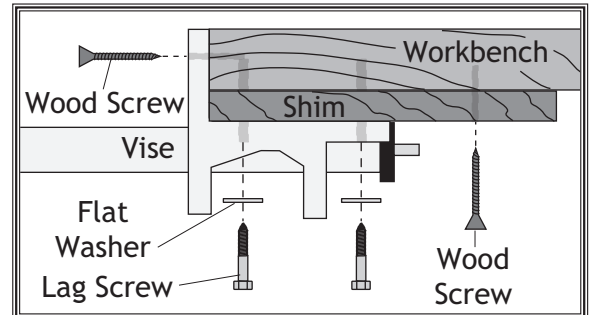

Figure 5. Attaching vise to workbench with shim between vise and workbench.

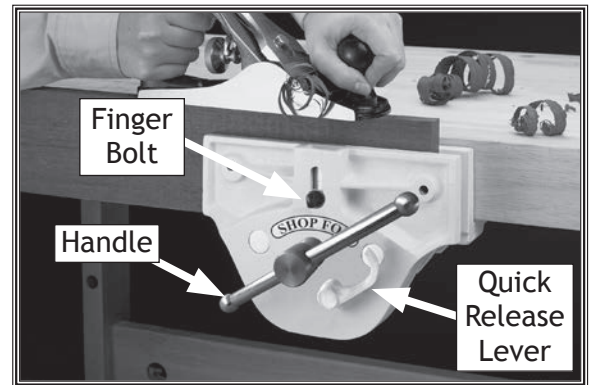

Figure 6. Operation controls of vise.

⚠ WARNING

This vise is not a toy. DO NOT use as a crushing tool. Never clamp containers with compressed or explosive contents. Using incorrectly may cause serious injury.

Accessories

Ask your Shop Fox dealer for the wood-faced magnetic jaw pads shown in **Figure 7**.

Maintenance

The painted parts of the vise can be cleaned with a damp rag. If wood pitch has built up on the components, clean this with a pitch dissolver or blade and bit cleaner.

Lubricate the leadscrew with dry lubrication, such as silicone or graphite, that will not cause sawdust to stick to the threads.

If material becomes built up on the threads, clean thoroughly with a pitch dissolver.

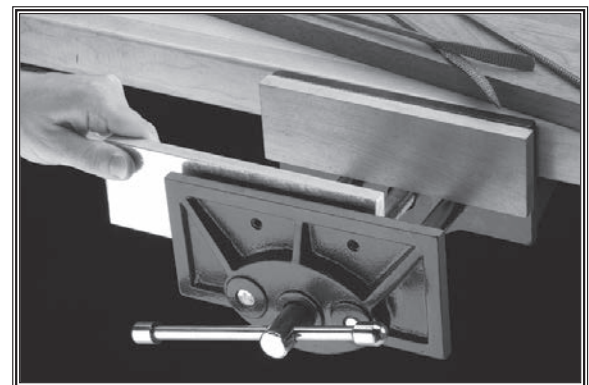
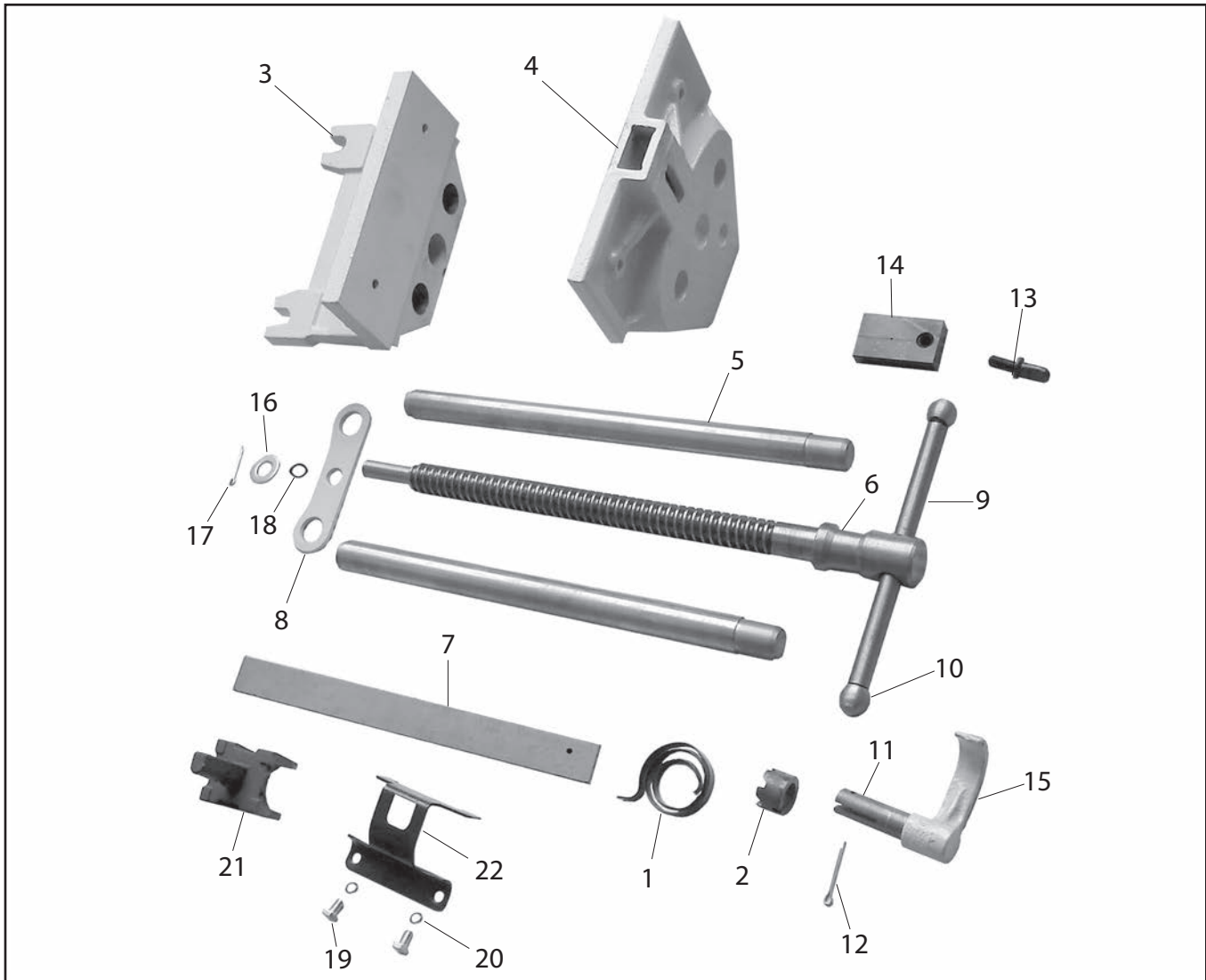

Figure 7. Shop Fox wood-faced magnetic jaw pads (Models D3127-D3133).

D4327 Parts



REF	PART #	DESCRIPTION
1	XD4327001	FLAT COIL SPRING 4 X 3
2	XD4327002	SLOTTED NUT M12-1.75
3	XD4327003	FIXED HOUSING 180 X 160 X 30
4	XD4327004	SLIDING HOUSING 110 X 110 X 180
5	XD4327005	GUIDE ROD 22 X 320
6	XD4327006	LEADSCREW 33 X 400
7	XD4327007	TORSION BAR 26 X 285 X 2
8	XD4327008	GUIDE ROD SUPPORT
9	XD4327009	HANDLE BAR W/KNOB
10	XD4327010	REMOVABLE HANDLE KNOB
11	XD4327011	RETAINER FORK

REF	PART #	DESCRIPTION
12	XPS08M	PHLP HD SCR M5-.8 X 12
13	XD4327013	FINGER BOLT M8-1.25 X 20
14	XD4327014	LOCK DOG 50 X 25 X 10
15	XD4327015	QUICK RELEASE LEVER
16	XPW06M	FLAT WASHER 12MM
17	XD4327017	COTTER PIN 3 X 40
18	XD4327018	WAVY WASHER 12MM
19	XPB04M	HEX BOLT M6-1 X 10
20	XPLW03M	LOCK WASHER 6MM
21	XD4327021	QUICK RELEASE HALF NUT
22	XD4327022	HALF NUT HOUSING BRACKET

Parts breakdown provided for reference only. Not all parts shown are available for purchase.

D4328 Parts

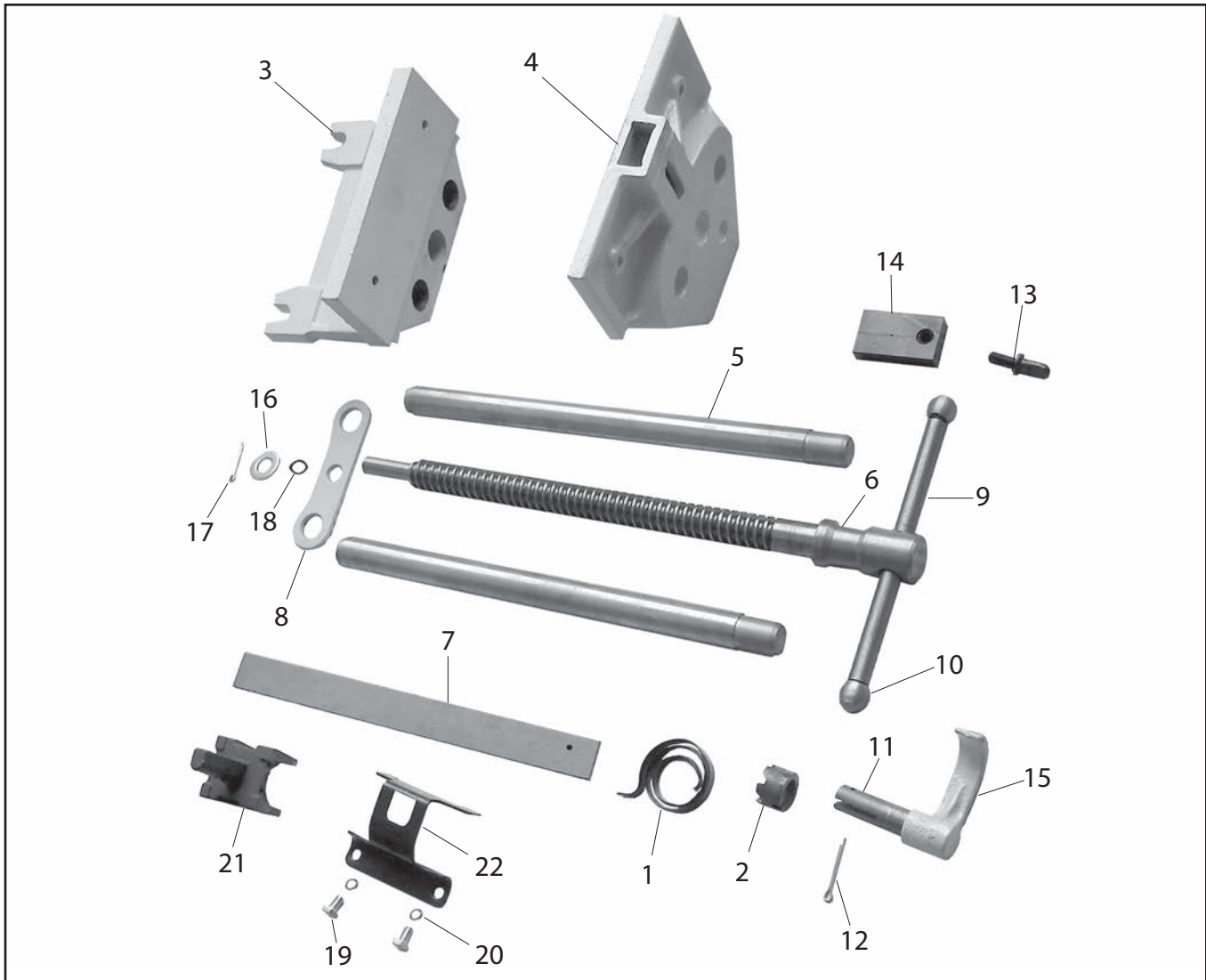

REF	PART #	DESCRIPTION
1	XD4327001	FLAT COIL SPRING 4 X 3
2	XD4327002	SLOTTED NUT M12-1.75
3	XD4328003	FIXED HOUSING 230 X 160 X 30
4	XD4328004	SLIDING HOUSING 230 X 110 X 110
5	XD4328005	GUIDE ROD 22 X 380
6	XD4328006	LEADSCREW 33 X 460
7	XD4328007	TORSION BAR 26 X 335 X 2
8	XD4328008	GUIDE ROD SUPPORT
9	XD4328009	HANDLE BAR W/KNOB
10	XD4327010	REMOVABLE HANDLE KNOB
11	XD4327011	RETAINER FORK

REF	PART #	DESCRIPTION
12	XPS08M	PHLP HD SCR M5-.8 X 12
13	XD4327013	FINGER BOLT M8-1.25 X 20
14	XD4327014	LOCK DOG 50 X 25 X 10
15	XD4327015	QUICK RELEASE LEVER
16	XPW06M	FLAT WASHER 12MM
17	XD4327017	COTTER PIN 3 X 40
18	XD4327018	WAVY WASHER 12MM
19	XPB04M	HEX BOLT M6-1 X 10
20	XPLW03M	LOCK WASHER 6MM
21	XD4327021	QUICK RELEASE HALF NUT
22	XD4327022	HALF NUT HOUSING BRACKET

Parts breakdown provided for reference only. Not all parts shown are available for purchase.

Free Manuals Download Website

<http://myh66.com>

<http://usermanuals.us>

<http://www.somanuals.com>

<http://www.4manuals.cc>

<http://www.manual-lib.com>

<http://www.404manual.com>

<http://www.luxmanual.com>

<http://aubethermostatmanual.com>

Golf course search by state

<http://golfingnear.com>

Email search by domain

<http://emailbydomain.com>

Auto manuals search

<http://auto.somanuals.com>

TV manuals search

<http://tv.somanuals.com>