

# MODEL W1823 PORTABLE CYCLONE



## OWNER'S MANUAL

*(FOR MODELS MANUFACTURED SINCE 9/10)*

Phone: (360) 734-3482 • Online Technical Support: [tech-support@shopfox.biz](mailto:tech-support@shopfox.biz)

COPYRIGHT © OCTOBER, 2010 BY WOODSTOCK INTERNATIONAL, INC.  
WARNING: NO PORTION OF THIS MANUAL MAY BE REPRODUCED IN ANY SHAPE OR FORM WITHOUT  
THE WRITTEN APPROVAL OF WOODSTOCK INTERNATIONAL, INC.

#13286TRCRBLTSJB Printed in Taiwan



# WARNING!

This manual provides critical safety instructions on the proper setup, operation, maintenance, and service of this machine/tool. Save this document, refer to it often, and use it to instruct other operators.

Failure to read, understand and follow the instructions in this manual may result in fire or serious personal injury—including amputation, electrocution, or death.

The owner of this machine/tool is solely responsible for its safe use. This responsibility includes but is not limited to proper installation in a safe environment, personnel training and usage authorization, proper inspection and maintenance, manual availability and comprehension, application of safety devices, cutting/sanding/grinding tool integrity, and the usage of personal protective equipment.

The manufacturer will not be held liable for injury or property damage from negligence, improper training, machine modifications or misuse.



# WARNING!

Some dust created by power sanding, sawing, grinding, drilling, and other construction activities contains chemicals known to the State of California to cause cancer, birth defects or other reproductive harm. Some examples of these chemicals are:

- Lead from lead-based paints.
- Crystalline silica from bricks, cement and other masonry products.
- Arsenic and chromium from chemically-treated lumber.

Your risk from these exposures varies, depending on how often you do this type of work. To reduce your exposure to these chemicals: Work in a well ventilated area, and work with approved safety equipment, such as those dust masks that are specially designed to filter out microscopic particles.

# Contents

|  |           |                                      |           |
|--|-----------|--------------------------------------|-----------|
| <b>INTRODUCTION</b> .....                    | <b>2</b>  | <b>MAINTENANCE</b> .....             | <b>27</b> |
| Woodstock Technical Support .....            | 2         | General .....                        | 27        |
| Machine Description .....                    | 2         | Emptying Drum .....                  | 27        |
| <b>SAFETY</b> .....                          | <b>6</b>  | Normal Filter Cleaning .....         | 27        |
| Standard Machinery Safety Instructions ..... | 6         | <b>SERVICE</b> .....                 | <b>28</b> |
| Additional Safety for Dust Collectors .....  | 8         | General .....                        | 28        |
| <b>ELECTRICAL</b> .....                      | <b>9</b>  | Major Filter Cleaning .....          | 28        |
| Circuit Requirements .....                   | 9         | Remote Control Reprogramming .....   | 29        |
| Grounding Requirements .....                 | 10        | Electrical Safety Instructions ..... | 30        |
| Extension Cords .....                        | 10        | Wiring Diagram .....                 | 31        |
| <b>SETUP</b> .....                           | <b>11</b> | 220V Conversion .....                | 32        |
| Unpacking .....                              | 11        | Troubleshooting .....                | 34        |
| Inventory .....                              | 11        | <b>PARTS</b> .....                   | <b>36</b> |
| Machine Placement .....                      | 13        | Main .....                           | 36        |
| Assembly .....                               | 14        | Main Parts List .....                | 37        |
| Test Run .....                               | 19        | Label Placement .....                | 38        |
| <b>COLLECTION SYSTEM</b> .....               | <b>20</b> | <b>WARRANTY</b> .....                | <b>41</b> |
| System Setup .....                           | 20        |                                      |           |
| Duct Material .....                          | 21        |                                      |           |
| System Grounding .....                       | 23        |                                      |           |
| <b>OPERATIONS</b> .....                      | <b>24</b> |                                      |           |
| General Operation .....                      | 24        |                                      |           |
| Remote Control Operation .....               | 25        |                                      |           |
| Cyclone Dust Collector Accessories .....     | 26        |                                      |           |

USE THE QUICK GUIDE PAGE LABELS TO SEARCH OUT INFORMATION FAST!





# INTRODUCTION

## Woodstock Technical Support

This machine has been specially designed to provide many years of trouble-free service. Close attention to detail, ruggedly built parts and a rigid quality control program assure safe and reliable operation.

Woodstock International, Inc. is committed to customer satisfaction. Our intent with this manual is to include the basic information for safety, setup, operation, maintenance, and service of this product.

We stand behind our machines! In the event that questions arise about your machine, please contact Woodstock International Technical Support at (360) 734-3482 or send e-mail to: [tech-support@shopfox.biz](mailto:tech-support@shopfox.biz). Our knowledgeable staff will help you troubleshoot problems and process warranty claims.

If you need the latest edition of this manual, you can download it from <http://www.shopfox.biz>.  
If you have comments about this manual, please contact us at:

**Woodstock International, Inc.**  
**Attn: Technical Documentation Manager**  
**P.O. Box 2309**  
**Bellingham, WA 98227**  
**Email: [manuals@woodstockint.com](mailto:manuals@woodstockint.com)**

## Machine Description

The Model W1823 is a 2-stage cyclone dust collector designed to capture dust from woodworking machines.

The pleated cartridge filter provides a large surface area and has a built-in cleaning mechanism that loosens built-up dust to maintain filter efficiency. The included 4"x 6" Y-adapter allows the machine to connect to multiple machines or various dust collection accessories. This machine is intended for collecting dust from one large machine or two small machines at a time (depends on size of dust port and length of ducting).

A radio-frequency remote control allows the dust collector to be operated from virtually anywhere in the shop. Casters on the dust collector stand and collection drum enable the unit to move easily around the shop. A clear window on the collection drum allows monitoring of the internal sawdust level. Also, a quick release lever makes it easy to remove the collection drum lid when cleaning.

# Controls and Features

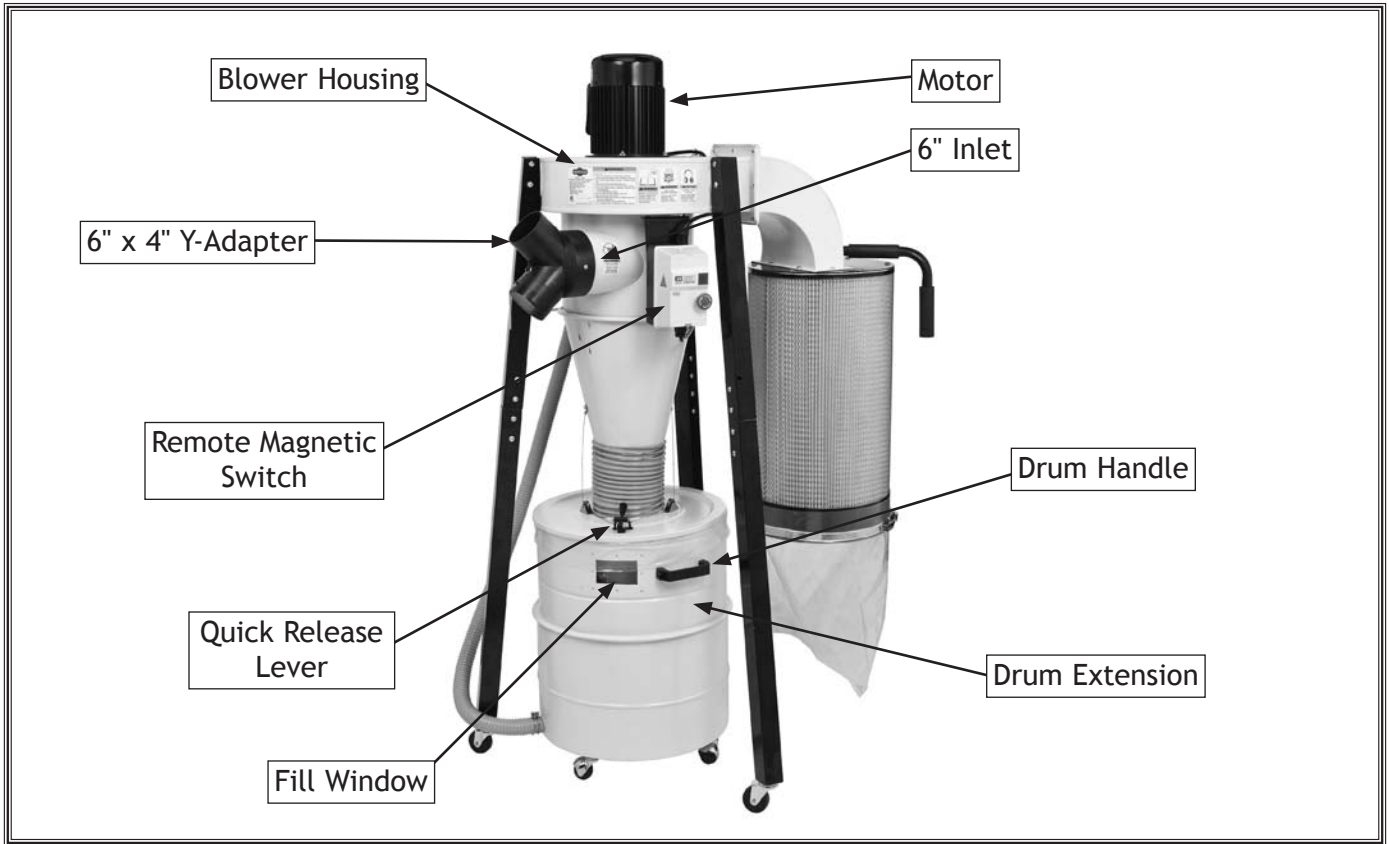

Figure 1. Right side view.

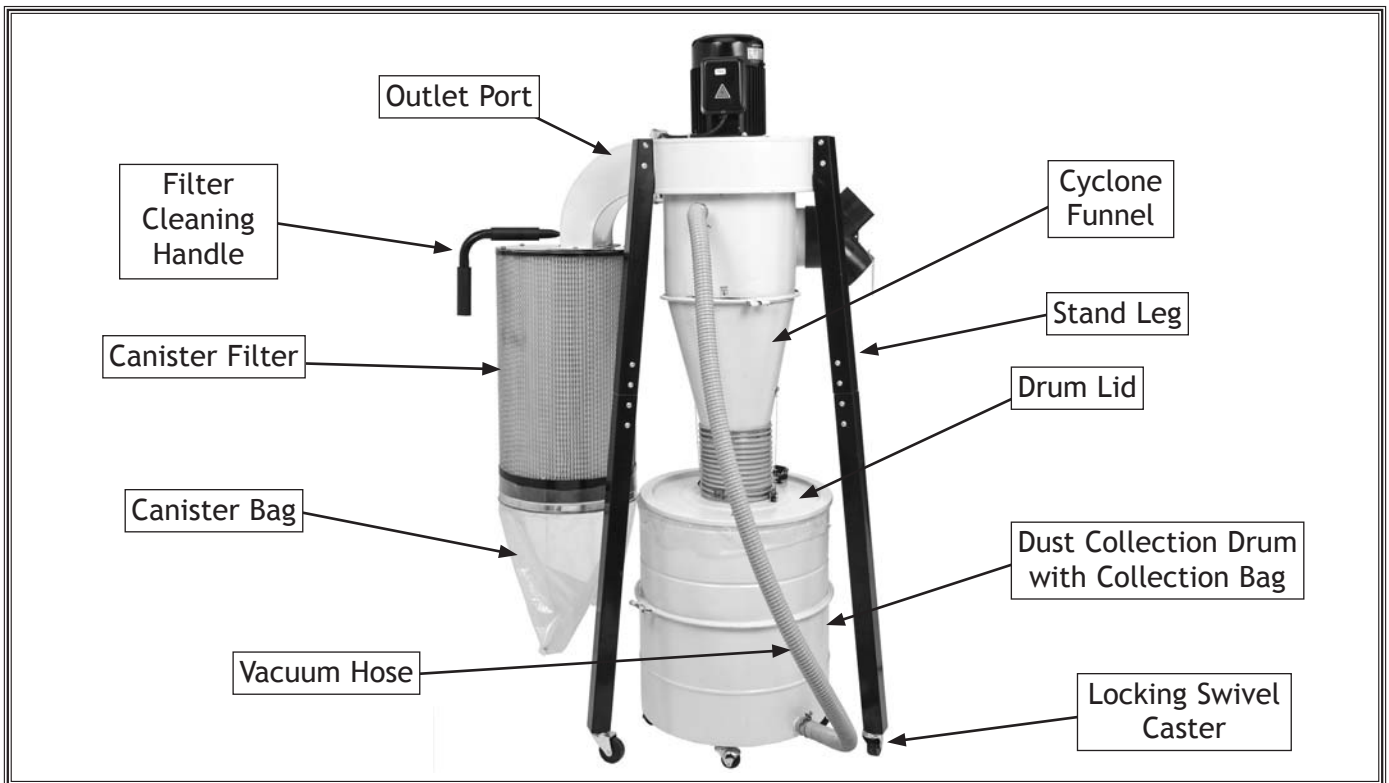

Figure 2. Left side view.



# MACHINE SPECIFICATIONS



Phone #: (360) 734-3482 • Online Tech Support: tech-support@shopfox.biz • Web: www.shopfox.biz

## MODEL W1823 PORTABLE CYCLONE

### Motor

|                        |                                |
|------------------------|--------------------------------|
| Type .....             | TEFC Capacitor Start Induction |
| Class .....            | Class "E"                      |
| Horsepower .....       | 1 1/2 HP                       |
| Voltage .....          | 110V/220V                      |
| Phase .....            | Single                         |
| Amps .....             | 15/7.5A                        |
| Speed .....            | 3450 RPM                       |
| Cycle .....            | 60 Hz                          |
| Number Of Speeds ..... | 1                              |
| Pre-Wired .....        | 110V                           |
| Power Transfer .....   | Direct Drive                   |
| Bearings .....         | Sealed and Lubricated          |

### Main Specifications

#### Operation

|   |                 |
|---|-----------------|
| Air Suction Capacity .....                      | 806 CFM         |
| Maximum Static Pressure (Inches of Water) ..... | 10.4            |
| Main Inlet Size .....                           | 6"              |
| 4" x 6" Y-Adapter Included .....                | Yes             |
| Y-Adapter Main Port Size .....                  | 6"              |
| Number of Y-Adapter Inlets .....                | 2               |
| Y-Adapter Inlet Size .....                      | 4"              |
| Machine Material Collection Capacity .....      | 4.3 cu. ft.     |
| Canister Filter Capacity .....                  | 0.2-2.0 Microns |

#### Bag Information

|                            |   |
|----------------------------|---|
| Number of Lower Bags ..... | 2   |
| Capacity .....             | 1.13 cu. ft.  |
| Diameter x Length .....    | 14 <sup>5</sup> / <sub>8</sub> "D x 11 <sup>7</sup> / <sub>8</sub> "L |

#### Canister Filter

|                                  |   |
|----------------------------------|---|
| Number of Canister Filters ..... | 1   |
| Diameter x Length .....          | 14 <sup>1</sup> / <sub>2</sub> "D x 23 <sup>5</sup> / <sub>8</sub> "L |
| Collection Drum Size .....       | 20 gallons  |

#### Impeller Information

|                       |                                  |
|-----------------------|----------------------------------|
| Type .....            | Radial Fin                       |
| Diameter .....        | 12 <sup>3</sup> / <sub>4</sub> " |
| Blade Thickness ..... | 1/8"                             |

### Overall Dimensions

|                                   |   |
|-----------------------------------|---|
| Weight .....                      | 140 lbs.  |
| Length x Width x Height .....     | 37"L x 32"W x 70 <sup>1</sup> / <sub>2</sub> "H |
| Foot Print (Length x Width) ..... | 37"L x 32"W                                     |

**Construction Materials**

|                        |                     |
|------------------------|---------------------|
| Lower Bag .....        | Clear Plastic       |
| Canister Filter .....  | Spun Bond Polyester |
| Frame .....            | Steel               |
| Impeller .....         | Steel               |
| Impeller Housing ..... | Steel               |
| Collection Drum .....  | Steel               |
| Casters .....          | Plastic             |

**Shipping Dimensions**

**Carton #1**

|                               |                    |
|-------------------------------|--------------------|
| Type .....                    | Cardboard          |
| Content .....                 | Machine            |
| Weight .....                  | 119 lbs.           |
| Length x Width x Height ..... | 22"L x 22"W x 34"H |

**Carton #2**

|                               |                    |
|-------------------------------|--------------------|
| Type .....                    | Cardboard          |
| Content .....                 | Canister Filter    |
| Weight .....                  | 27 lbs.            |
| Length x Width x Height ..... | 18"L x 18"W x 31"H |

**Electrical**

|   |   |
|---|---|
| Power Requirement .....                     | 110V/220V, Single-Phase, 60 Hz                |
| Switch .....                                | Magnetic Switch w/Thermal Overload Protection |
| Switch Voltage .....                        | 110V  |
| Phase .....                                 | Single-Phase                                  |
| Cord Length .....                           | 7 ft.   |
| Cord Gauge .....                            | 14 gauge                                      |
| Required Power Supply Circuit .....         | 20/15 Amp                                     |
| Plug Included .....                         | Yes   |
| Recommended Plug/Outlet Type for 220V ..... | 6-15  |
| Included Plug Type .....                    | 5-15 for 110V                                 |

**Other**

|                              |                                    |
|------------------------------|------------------------------------|
| Customer Assembly Time ..... | Approximately 30 Minutes           |
| Warranty .....               | 2 Year                             |
| Country of Origin .....      | Taiwan                             |
| ISO 9001 Factory .....       | Yes                                |
| Sound Rating .....           | 82 dB                              |
| Paint .....                  | Powder Coated                      |
| Serial Number Location ..... | Machine Id Label on Blower Housing |

**Features**

- Class "E" motor
- Casters mounted on drum and stand legs allow for easy mobility
- Clear disposable plastic collection bags
- Top-mounted lever for removing built up dust from canister filter
- Steel drum with easy-to-open lid

# SAFETY

## For Your Own Safety, Read Manual Before Operating Machine

SAFETY

The purpose of safety symbols is to attract your attention to possible hazardous conditions. This manual uses a series of symbols and signal words intended to convey the level of importance of the safety messages. The progression of symbols is described below. Remember that safety messages by themselves do not eliminate danger and are not a substitute for proper accident prevention measures—this responsibility is ultimately up to the operator!



Indicates an imminently hazardous situation which, if not avoided, **WILL** result in death or serious injury.



Indicates a potentially hazardous situation which, if not avoided, **COULD** result in death or serious injury.



Indicates a potentially hazardous situation which, if not avoided, **MAY** result in minor or moderate injury.

### **NOTICE**

This symbol is used to alert the user to useful information about proper operation of the equipment, and/or a situation that may cause damage to the machinery.

## Standard Machinery Safety Instructions

**OWNER'S MANUAL.** Read and understand this owner's manual **BEFORE** using machine. Untrained users can be seriously hurt.

**EYE PROTECTION.** Always wear ANSI-approved safety glasses or a face shield when operating or observing machinery to reduce the risk of eye injury or blindness from flying particles. Everyday eyeglasses are not approved safety glasses.

**HAZARDOUS DUST.** Dust created while using machinery may cause cancer, birth defects, or long-term respiratory damage. Be aware of dust hazards associated with workpiece materials, and always wear a NIOSH-approved respirator to reduce your risk.

**WEARING PROPER APPAREL.** Do not wear clothing, apparel, or jewelry that can become entangled in moving parts. Always tie back or cover long hair. Wear non-slip footwear to avoid accidental slips which could cause a loss of workpiece control.

**HEARING PROTECTION.** Always wear hearing protection when operating or observing loud machinery. Extended exposure to this noise without hearing protection can cause permanent hearing loss.

**MENTAL ALERTNESS.** Be mentally alert when running machinery. Never operate under the influence of drugs or alcohol, when tired, or when distracted.

**DISCONNECTING POWER SUPPLY.** Always disconnect machine from power supply before servicing, adjusting, or changing cutting tools (bits, blades, cutters, etc.). Make sure switch is in **OFF** position before reconnecting to avoid an unexpected or unintentional start.

**DANGEROUS ENVIRONMENTS.** Do not use machinery in wet or rainy locations, cluttered areas, around flammables, or in poorly-lit areas. Keep work area clean, dry, and well-lit to minimize risk of injury.



**APPROVED OPERATION.** Untrained operators can be seriously hurt by machinery. Only allow trained or properly supervised people to use machine. When machine is not being used, disconnect power, remove switch keys, or lock-out machine to prevent unauthorized use—especially around children. Make workshop kid proof!

**ONLY USE AS INTENDED.** Only use machine for its intended purpose. Never modify or alter machine for a purpose not intended by the manufacturer or serious injury may result!

**USE RECOMMENDED ACCESSORIES.** Consult this owner's manual or the manufacturer for recommended accessories. Using improper accessories will increase the risk of serious injury.

**CHILDREN & BYSTANDERS.** Keep children and bystanders a safe distance away from work area. Stop using machine if children or bystanders become a distraction.

**REMOVE ADJUSTING TOOLS.** Never leave adjustment tools, chuck keys, wrenches, etc. in or on machine—especially near moving parts. Verify removal before starting!

**SECURING WORKPIECE.** When required, use clamps or vises to secure workpiece. A secured workpiece protects hands and frees both of them to operate the machine.

**FEED DIRECTION.** Unless otherwise noted, feed work against the rotation of blades or cutters. Feeding in the same direction of rotation may pull your hand into the cut.

**GUARDS & COVERS.** Guards and covers can protect you from accidental contact with moving parts or flying debris. Make sure they are properly installed, undamaged, and working correctly before using machine.

**NEVER STAND ON MACHINE.** Serious injury or accidental contact with cutting tool may occur if machine is tipped. Machine may be damaged.

**STABLE MACHINE.** Unexpected movement during operations greatly increases the risk of injury and loss of control. Verify machines are stable/secure and mobile bases (if used) are locked before starting.

**FORCING MACHINERY.** Do not force machine. It will do the job safer and better at the rate for which it was designed.

**AWKWARD POSITIONS.** Keep proper footing and balance at all times when operating machine. Do not overreach! Avoid awkward hand positions that make workpiece control difficult or increase the risk of accidental injury.

**UNATTENDED OPERATION.** Never leave machine running while unattended. Turn machine off and ensure all moving parts completely stop before walking away.

**MAINTAIN WITH CARE.** Follow all maintenance instructions and lubrication schedules to keep machine in good working condition. An improperly maintained machine may increase the risk of serious injury.

**CHECK DAMAGED PARTS.** Regularly inspect machine for damaged parts, loose bolts, mis-adjusted or mis-aligned parts, binding, or any other conditions that may affect safe operation. Always repair or replace damaged or mis-adjusted parts before operating machine.

**EXPERIENCING DIFFICULTIES.** If at any time you are experiencing difficulties performing the intended operation, stop using the machine! Contact our Technical Support for help at (360) 734-3482.

# Additional Safety for Dust Collectors

**INTENDED USE.** This dust collector is only intended for collecting wood dust and chips from woodworking machines. **DO NOT** use this dust collector to collect metal, dirt, pebbles, drywall, asbestos, lead paint, silica, liquids, aerosols, or any flammable, combustible, or hazardous materials.

**OPERATING LOCATION.** To reduce respiratory exposure to fine dust, locate permanently installed dust collectors away from the working area, or in another room that is equipped with a smoke detector. **DO NOT** operate the dust collector in rainy or wet locations—exposure to water may create a shock hazard or decrease machine life.

**DISCONNECTING POWER SUPPLY.** Turn the switch **OFF**, disconnect the dust collector from the power supply, and allow the impeller to completely stop before leaving the machine unattended or doing any service, cleaning, maintenance, or adjustments.

**IMPELLER HAZARDS.** **DO NOT** place your hands or tools near the open inlet during operation for any reason. The powerful suction could easily cause accidental contact with the impeller, which will cause serious personal injury or damage to the machine. Always keep small animals and children away from open dust collection inlets.

**HAZARDOUS DUST—WEAR RESPIRATOR.** Fine dust that is too small to be caught in the filter will be blown into the ambient air during operation. Always wear a NIOSH-approved respirator during operation and for a short time after to reduce your risk of permanent respiratory damage.

**DUST ALLERGIES.** Dust from certain woods may cause an allergic reaction in people and animals. Make sure you know what type of wood dust you will be exposed to in case there is a possibility of an allergic reaction.

**EMPTYING DUST.** When emptying dust from the collection container, wear a respirator and safety glasses. Empty dust away from ignition sources and into an approved container.

**FIRE SUPPRESSION.** Only operate the dust collector in locations that contain a fire suppression system or have a fire extinguisher nearby.

**SUSPENDED DUST PARTICLES AND IGNITION SOURCES.** **DO NOT** operate the dust collector in areas where explosion risks are high. Areas of high risk include, but are not limited to, areas near pilot lights, open flames, or other ignition sources.

**AVOIDING SPARKS.** **DO NOT** allow steel or rocks to strike the impeller—this may produce sparks. Sparks can smolder in wood dust for a long time before a fire is detected. If you accidentally cut into wood containing tramp metal (nails, staples, spikes, etc.), immediately turn **OFF** the dust collector, disconnect it from power, and wait for the impeller to stop—then empty the collection container into an approved airtight metal container.

**STATIC ELECTRICITY.** High amounts of static electricity are generated when plastic ducting is used for dust collection lines. Although rare, sparks caused by static electricity can cause explosions or fire. To reduce this risk, thoroughly ground all plastic ducting used in the dust collection system.

**REGULAR CLEANING.** Regularly check/empty the collection bags or drum to avoid buildup of fine dust that can increase the risk of fire. Make sure to regularly clean the surrounding area where the machine is operated—excessive dust buildup on overhead lights, heaters, electrical panels, or other heat sources will increase the risk of fire.

# ELECTRICAL

## Circuit Requirements

This machine must be connected to the correct size and type of power supply circuit, or fire or electrical damage may occur. Read through this section to determine if an adequate power supply circuit is available for this machine. If a correct circuit is not available, you must have a qualified electrician install one before you can operate the machine.

A power supply circuit includes all electrical equipment between the main breaker box or fuse panel in the building and the incoming power connections at the machine. The power supply circuit used for this machine must be sized to safely handle the full-load current drawn from the machine for an extended period of time.

### Full-Load Current Rating

The full-load current rating is the amperage a machine draws at 100% of the rated output power. On machines with multiple motors, this is the amperage drawn by the largest motor or sum of all motors and electrical devices that might operate at one time during normal operations.

Full-Load Current Rating at 110V ..... 15 Amps  
Full-Load Current Rating at 220V ..... 7.5 Amps

### Circuit Requirements for 110V (Prewired)

This machine is prewired to operate on a 110V power supply circuit that has a verified ground and meets the following requirements:

Circuit Type ..... 110V/120V, 60 Hz, Single-Phase  
Circuit Size ..... 20 Amps  
Plug/Receptacle ..... NEMA 5-15

### Circuit Requirements for 220V

This machine can be converted to operate on a 220V power supply (details about voltage conversion can be found later in this manual). The 220V power supply circuit must have a verified ground and meet the requirements that follow:

Circuit Type ..... 220V/240V, 60 Hz, Single-Phase  
Circuit Size ..... 15 Amps  
Plug/Receptacle ..... NEMA 6-15

**⚠ WARNING**

The machine must be properly set up before it is safe to operate. **DO NOT** connect this machine to the power source until instructed to do later in this manual.

**⚠ WARNING**



Incorrectly wiring or grounding this machine can cause electrocution, fire, or machine damage. To reduce this risk, only a qualified electrician or service personnel should do any required electrical work for this machine.

**NOTICE**

The circuit requirements listed in this manual apply to a dedicated circuit—where only one machine will be running at a time. If this machine will be connected to a shared circuit where multiple machines will be running at the same time, consult a qualified electrician to ensure that the circuit is properly sized for safe operation.

ELECTRICAL

# Grounding Requirements

In the event of certain types of malfunctions or breakdowns, grounding provides a path of least resistance for electric current to travel—in order to reduce the risk of electric shock.

Improper connection of the equipment-grounding wire will increase the risk of electric shock. The wire with green insulation (with/without yellow stripes) is the equipment-grounding wire. If repair or replacement of the power cord or plug is necessary, do not connect the equipment-grounding wire to a live (current carrying) terminal.

Check with a qualified electrician or service personnel if you do not understand these grounding requirements, or if you are in doubt about whether the tool is properly grounded. If you ever notice that a cord or plug is damaged or worn, disconnect it from power, and immediately replace it with a new one.

## For 110V Connection (Prewired)

This machine is equipped with a power cord that has an equipment-grounding wire and NEMA 5-15 grounding plug. The plug must only be inserted into a matching receptacle (see Figure) that is properly installed and grounded in accordance with local codes and ordinances.

## For 220V Connection (Must be Rewired)

A NEMA 6-15 plug has a grounding prong that must be attached to the equipment-grounding wire inside the included power cord. The plug must only be inserted into a matching receptacle (see Figure) that is properly installed and grounded in accordance with all local codes and ordinances.

# Extension Cords

We do not recommend using an extension cord with this machine. Extension cords cause voltage drop, which may damage electrical components and shorten motor life. Voltage drop increases with longer extension cords and the gauge smaller gauge sizes (higher gauge numbers indicate smaller sizes).

Any extension cord used with this machine must contain a ground wire, match the required plug and receptacle, and meet the following requirements:

- Minimum Gauge Size at 110V ..... 12 AWG
- Minimum Gauge Size at 220V ..... 14 AWG
- Maximum Length (Shorter is Better) ..... 50 ft.

## ⚠ WARNING

The machine must be properly set up before it is safe to operate. **DO NOT** connect this machine to the power source until instructed to do later in this manual.

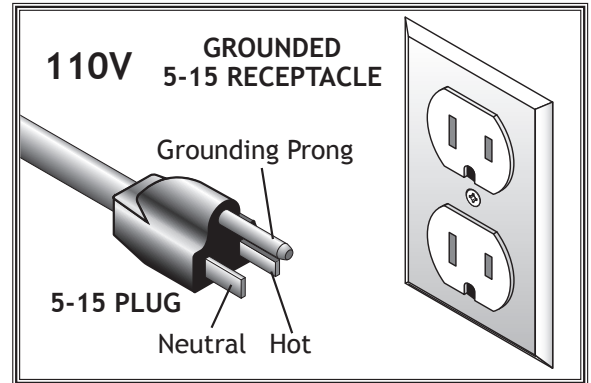

Figure 3. NEMA 5-20 plug & receptacle.

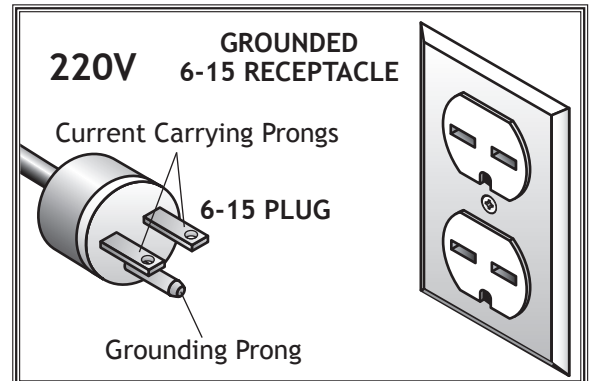

Figure 4. NEMA 6-15 plug & receptacle.

## ⚠ CAUTION

**DO NOT** modify the provided plug or use an adapter if the plug will not fit your receptacle. This is an indication that your power supply circuit does not meet the requirements for the machine; have an electrician install the correct power supply circuit. If the machine must be reconnected for use on a different type of electric circuit, the reconnection should be made by a qualified electrician or service personnel; after reconnection, the machine must comply with all local codes and ordinances.

ELECTRICAL

# SETUP

## Unpacking

This machine has been carefully packaged for safe transportation. If you notice the machine has been damaged during shipping, please contact your authorized Shop Fox dealer immediately.

## Inventory

The following is a description of the main components shipped with the Model W1823. Lay the components out to inventory them.

**Note:** If you can't find an item on this list, check the mounting location on the machine or examine the packaging materials carefully. Occasionally we pre-install certain components for safer shipping.

| Main Inventory (Figure 5)                                     | Qty |
|---|-----|
| A. Outlet Port.....   | 1   |
| B. Outlet Port Gasket Set .....                               | 1   |
| C. Blower and Collector Assembly .....                        | 1   |
| D. Magnetic Switch Assembly for 110V .....                    | 1   |
| E. RF Remote Control .....                                    | 1   |
| F. Collection Drum .....                                      | 1   |
| G. Cyclone Funnel.....  | 1   |
| H. Collection Drum Extension.....                             | 1   |
| I. Dust Hose 7" Diameter.....                                 | 1   |
| J. Collection Drum Bag .....                                  | 1   |
| K. Collection Drum Lid w/Lift System.....                     | 1   |
| L. Hose Clamps 7" Diameter .....                              | 2   |
| M. Foam Tape .....  | 1   |
| N. Collection Drum Clamp .....                                | 1   |
| O. Barrel Clamp .....   | 1   |
| P. Hose Clamps 1 <sup>3</sup> / <sub>4</sub> " Diameter ..... | 2   |
| Q. Stand Leg Swivel Casters .....                             | 3   |
| R. Quick-Release Canister Bag Clamp .....                     | 1   |
| S. Collection Drum Handle .....                               | 1   |
| T. Upper Legs.....  | 3   |
| U. Lower Legs.....  | 3   |
| V. Leg Connectors .....                                       | 3   |
| W. Canister Bag.....  | 1   |
| X. Collection Drum Swivel Casters .....                       | 4   |
| Y. Ground Wire.....   | 1   |
| Z. Hardware and Tool Bag (see Figure 6).....                  | 1   |
| AA. Y-Adapter 6" x 4" x 4" w/Cap .....                        | 1   |

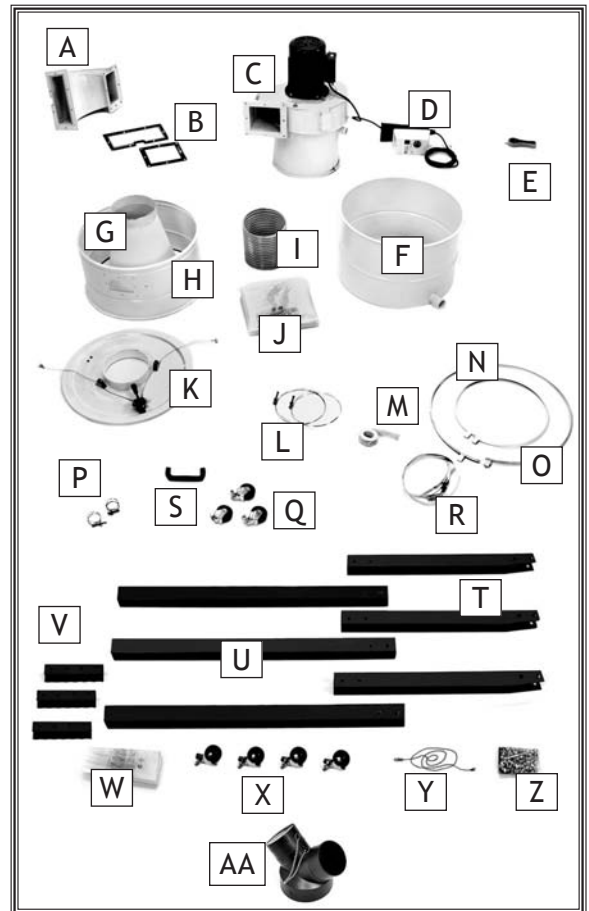
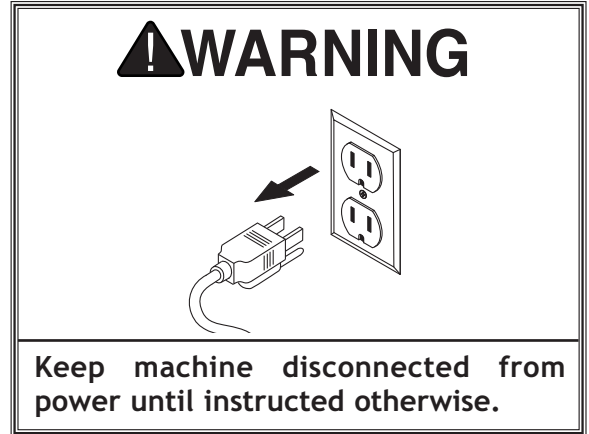

Figure 5. Main inventory.

SETUP

| Hardware and Tool Bag Inventory (Figure 6)   | Qty |
|--|-----|
| A. Hex Bolts 1/4"-20 x 3/4" (Lift Cable).....                                      | 2   |
| B. Flat Washers 1/4" (Lift Cable).....   | 2   |
| C. Lock Nuts 1/4"-20 (Lift Cable).....   | 2   |
| D. Phillips Head Screw 10-24 x 3/8" (Y-Adapter).....                               | 1   |
| E. Acorn Nuts 1/4"-20 (Handle) .....   | 2   |
| F. Phillips Head Screws 1/4"-20 x 5/8" (Handle).....                               | 2   |
| G. Button Head Cap Screws 5/16"-18 x 1/2" (Legs) .....                             | 36  |
| H. Button Head Cap Screws 5/16"-18 x 3/4"<br>(Outlet Port to Canister) .....       | 6   |
| I. Button Head Cap Screws 5/16"-18 x 1/2"<br>(Outlet Port to Blower Housing) ..... | 8   |
| J. Hex Wrench 6mm.....   | 1   |
| K. Combo Wrench 10 x 12mm.....   | 1   |
| L. Flange Screws 5/16"-18 x 1/2" (Ground Wire) .....                               | 2   |

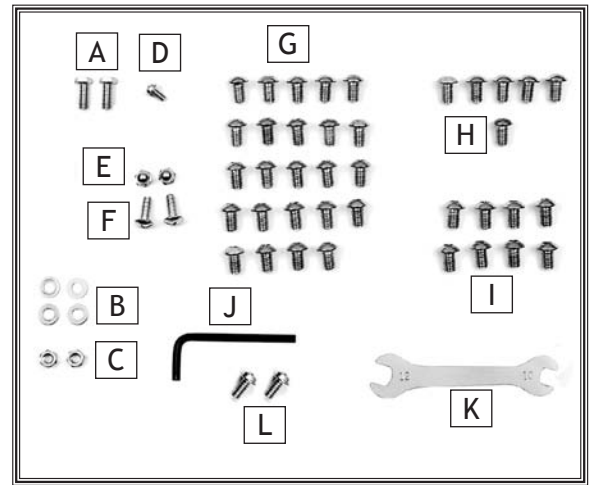

Figure 6. Hardware and tool bag inventory.

| Canister Inventory (Figure 7)               | Qty |
|---|-----|
| A. Filter Canister w/Cleaning Assembly..... | 1   |
| B. Filter Cleaning Handle.....              | 1   |
| C. Vacuum Hose 1 1/2" x 68".....            | 1   |

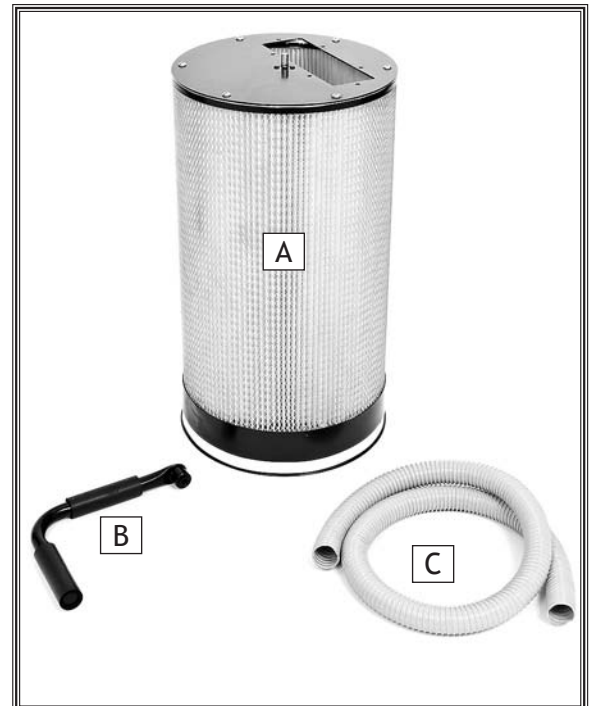

Figure 7. Canister inventory.

# Machine Placement

## Weight Load

Refer to the **Machine Specifications** for the weight of your machine. Make sure that the surface upon which the machine is placed will bear the weight of the machine, additional equipment that may be installed on the machine, and the heaviest workpiece that will be used. Additionally, consider the weight of the operator and any dynamic loading that may occur when operating the machine.

## Space Allocation

Consider the largest size of workpiece that will be processed through this machine and provide enough space around the machine for adequate operator material handling or the installation of auxiliary equipment. With permanent installations, leave enough space around the machine to open or remove doors/covers as required by the maintenance and service described in this manual. See below for required space allocation.

## Physical Environment

The physical environment where your machine is operated is important for safe operation and the longevity of its components. For best results, operate this machine in a dry environment that is free from excessive moisture, hazardous chemicals, airborne abrasives, or extreme conditions. Extreme conditions for this type of machinery are generally those where the ambient temperature range exceeds 41°-104°F; the relative humidity range exceeds 20-95% (non-condensing); or the environment is subject to vibration, shocks, or bumps.

## Electrical Installation

Place this machine near an existing power source. Make sure all power cords are protected from traffic, material handling, moisture, chemicals, or other hazards. Make sure to leave access to a means of disconnecting the power source or engaging a lockout/tagout device.

## Lighting

Lighting around the machine must be adequate enough that operations can be performed safely. Shadows, glare, or strobe effects that may distract or impede the operator must be eliminated.

SETUP

|  |  |
|--|--|
|  | <p><b>⚠ CAUTION</b></p> <p>Children or untrained people may be seriously injured by this machine. Only install in an access restricted location.</p> |
|--|--|

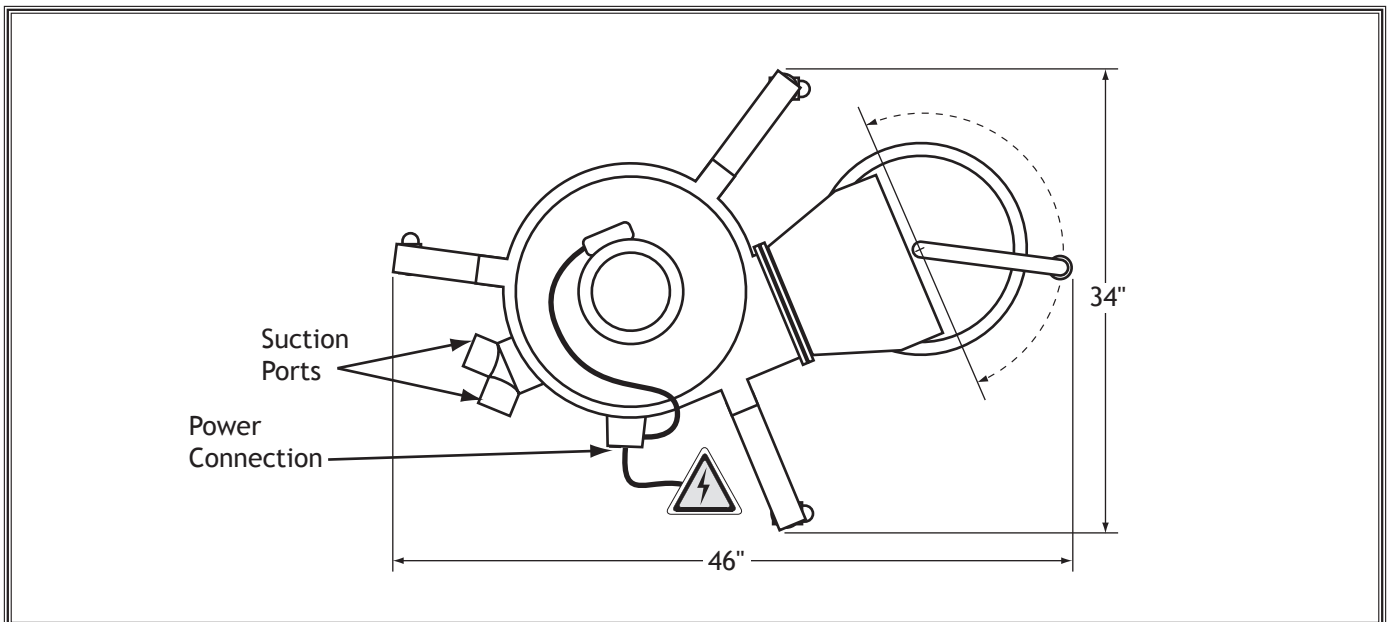

Figure 8. Model W1823 working clearances.

# Assembly

Before beginning assembly, refer to the inventory list and group all fasteners with their intended components. Doing this will make assembly easier.

When assembling this machine, tighten fasteners using hand tools only. Avoid using air or electric impact tools because fasteners can easily be over-tightened, causing them to dig into the paint, strip threads, and over-compress gaskets—causing flanges to deform and leak. Using silicone sealant at connection points is optional.

To assemble the dust collector, do these steps:

1. With the help of another person, place the blower housing on its side carefully as not to scratch the paint.
2. Fasten the three upper legs to the leg support bosses on the blower housing with (12)  $\frac{5}{16}$ "-18 x  $\frac{1}{2}$ " button head cap screws, as shown in **Figure 9**.
3. Thread the caster wheels into the lower legs and tighten.
4. Insert and fasten the leg connectors in the lower legs using (12)  $\frac{5}{16}$ "-18 x  $\frac{1}{2}$ " button head cap screws, as shown in **Figure 10**.
5. Insert the leg connectors into the upper legs, as shown in **Figure 11**, and secure together with (12)  $\frac{5}{16}$ "-18 x  $\frac{1}{2}$ " button head cap screws.

**Note:** You will notice that the bolt pattern in the upper legs and the leg connectors (**Figure 11**) is off-center to ensure that the lower legs can only be installed in the correct direction.

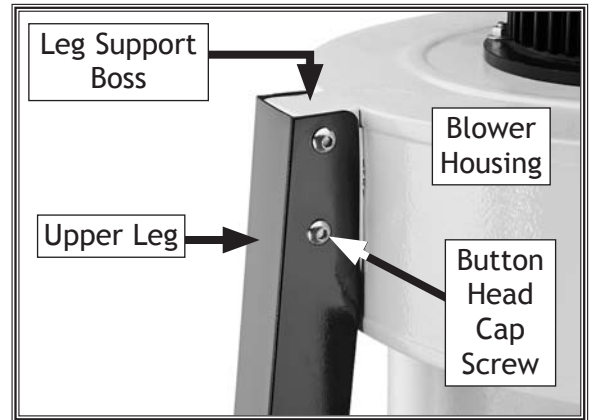

**Figure 9.** Upper leg installed on blower housing leg support boss.

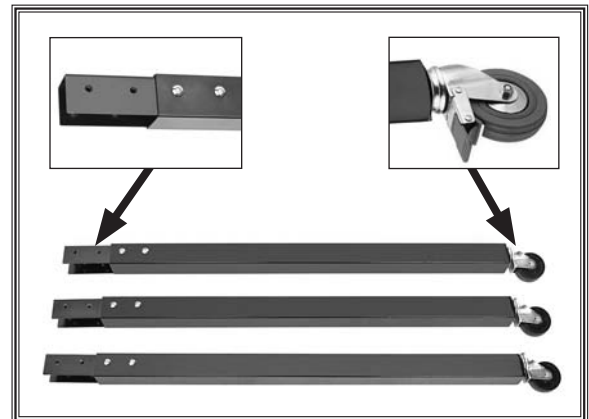

**Figure 10.** Lower leg connector and swivel caster installation.

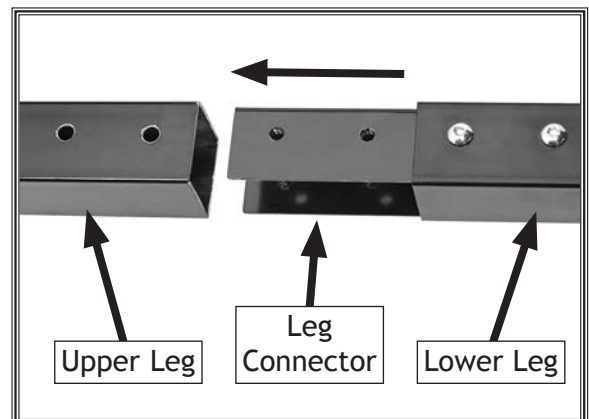

**Figure 11.** Inserting a lower leg into an upper leg.



6. Using the square port in the blower housing (see **Figure 12**) for access, fasten the magnetic switch bracket on the studs with (2)  $\frac{5}{16}$ " flat washers and (2)  $\frac{5}{16}$ "-18 hex nuts.
7. With the help of another person, lift and position the dust collector upright, then lock the casters so the unit will not move during the rest of the assembly process.

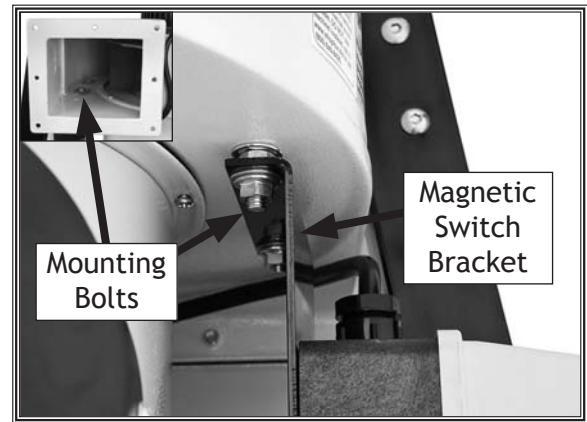

**Figure 12.** Magnetic switch installation.

8. Have another person hold the cyclone funnel in place against the intake barrel, and align the datum point labels, as shown in **Figure 13**, then clamp the cyclone funnel and the intake barrel together using the barrel clamp. To ensure a tight seal, make sure the clamp is tight when it overlaps, as shown in **Figure 13**.



**Figure 13.** Cyclone funnel installation.

9. Connect the outlet port and its larger gasket to the filter canister with (6)  $\frac{5}{16}$ "-18 x  $\frac{3}{4}$ " button head cap screws. Do not overtighten the screws, or the outlet port flanges will bend and cause the gaskets to leak.
10. Have another person hold the canister filter in place while you fasten the outlet port and its smaller gasket to the blower housing with (8)  $\frac{5}{16}$ "-18 x  $\frac{1}{2}$ " button head cap screws, as shown in **Figure 14**.
11. Reach inside the canister filter and rotate the cleaning flap so the flat on the filter cleaning rod faces outward.
12. Place the cleaning handle onto the shaft, align the flat and set screw, then tighten the set screw (see **Figure 14**).



**Figure 14.** Filter canister installation.

SETUP

13. Fasten one end of the 1½" diameter vacuum hose to the intake barrel using one of the 1¾" hose clamps, as shown in **Figure 15**.



**Figure 15.** Vacuum tube installed.

14. Fasten the inlet Y-adapter to the intake barrel suction port and secure in place with the 5/16"-18 x 3/8" Phillips head screw, as shown in **Figure 16**.



**Figure 16.** Inlet Y-adapter installed.

15. Affix the 1" wide foam tape to the underside of the drum lid, as shown in **Figure 17**.

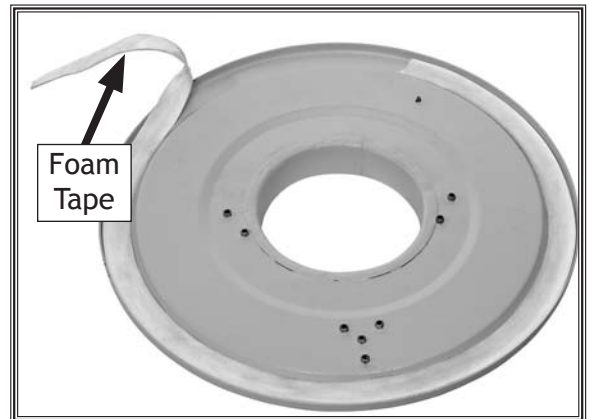
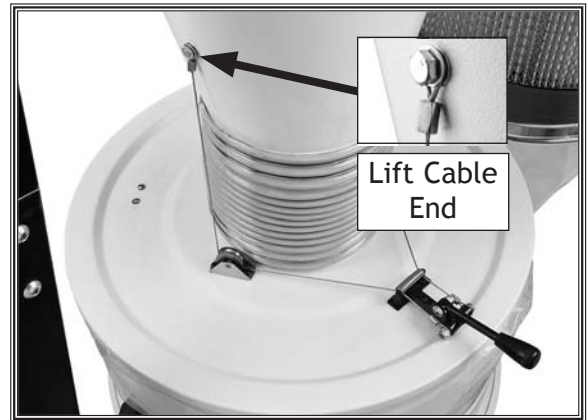

**Figure 17.** Collection drum cover seal and lift cable clamping location.

16. With the cyclone funnel port still open for access to the hex nuts inside, fasten the ends of the lift cables to the outside of the cyclone funnel, as shown in **Figure 18**, using the pre-installed hex bolts.
17. Slide the 7" hose clamps onto the ports of the collection drum lid and the cyclone funnel (see **Figure 18**).

**Tip:** You can disassemble the hose clamps for more clearance to get the clamps positioned over the hose. To reassemble the clamps, refer to **Figure 19**.

18. Work the 7" hose onto both ports, position the hose clamps on the hose, then tighten them.
19. Connect the ground wire between the drum cover and leg with the included (2)  $\frac{5}{16}$ "-18 x  $\frac{1}{2}$ " flange screws, as shown in **Figure 20**. This wire prevents accumulation of static electricity at the collection drum.
20. Position the lift cable in the wheel grooves.



**Figure 18.** Collection lid installation.

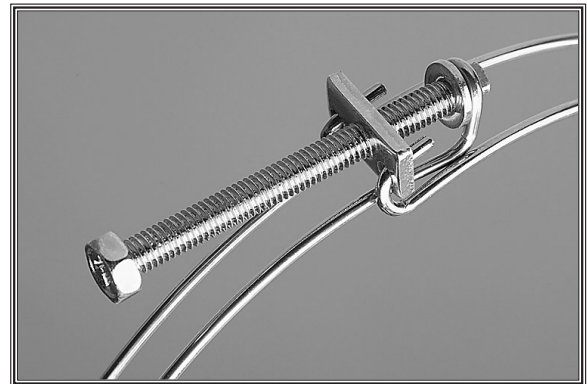

**Figure 19.** Correct hose clamp assembly.

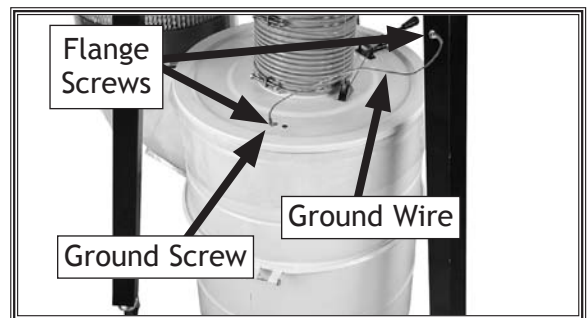

**Figure 20.** Ground wire location.

21. Lower the lid release lever and verify that the lower edge of the lid flange is approximately  $25\frac{1}{2}$ " above the floor, as shown **Figure 21** so the dust collection drum can be rolled under the dust collector without interference from the lid.
  - If the drum hits the lid when it is raised, loosen the hose and reposition the lid higher. Do not attempt to adjust the cables.



**Figure 21.** Checking collection lid lift.

22. Place the drum extension on top of the collection drum, and orient the window, vacuum hose port, and the clamp bolt, as shown in **Figure 22**.
23. Install and tighten the drum clamp, as shown in **Figure 22**.
24. Thread the four swivel casters into the underside of the drum.
25. Fasten the 1½" diameter vacuum hose onto the collection drum with the 1¾" hose clamp, as shown **Figure 22**.

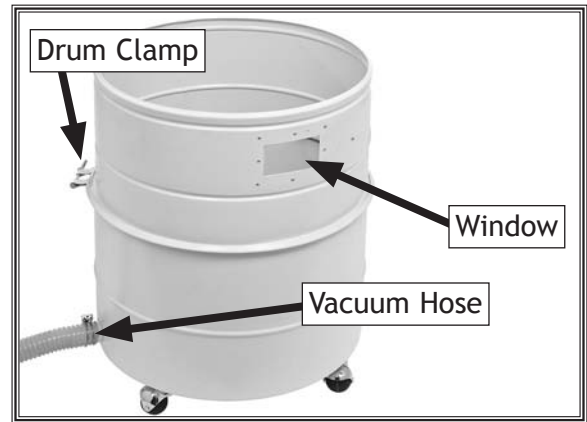

**Figure 22.** Drum and drum extension positioning and installation.

26. Place two ¼"-20 acorn nuts in the handle, and fasten the handle to the drum extension with two ¼"-20 x 5/8" Phillips head screws, as shown **Figure 23**.
27. Place the dust collection drum bag in the drum and roll approximately 2" of the bag over the edge of the drum.

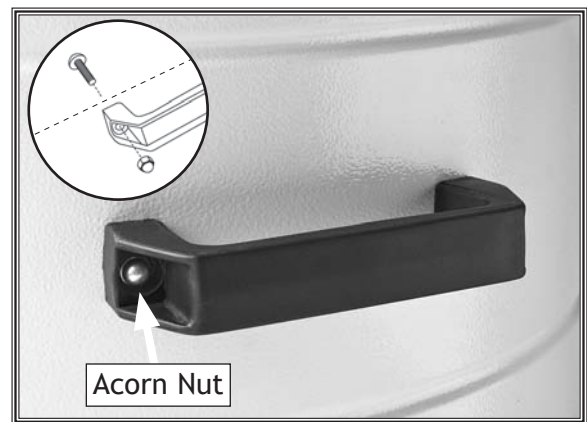

**Figure 23.** Handle installation.

28. Pull the release lever down to lift the drum cover, roll the drum under the lid, and push the lever upward to lower the lid on the drum (see **Figure 24**).

**Note:** *The lid is not designed to rest on top of the drum with any real force, nor is it designed to snap into place to create a seal. Instead, a tight seal is established by the vacuum created when the dust collector is in operation.*

29. Place the canister bag around the bottom edge of the canister, and clamp it in place with the quick release bag clamp, as shown **Figure 25**.

Congratulations! Assembly is complete.

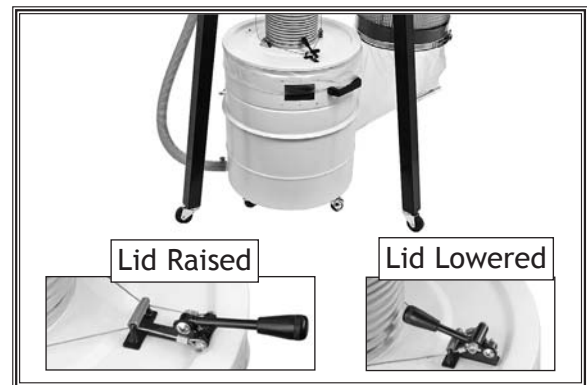

**Figure 24.** Drum positioning at front of machine.



**Figure 25.** Canister bag installed.

# Test Run

Once the assembly is complete, test run your machine to make sure it runs properly.

If, during the test run, you cannot easily locate the source of an unusual noise or vibration, stop using the machine immediately, then review the **Troubleshooting** on **Page 34**.

If you still cannot remedy a problem, contact our Technical Support at (360) 734-3482 for assistance.

**To test run the machine, do these steps:**

1. Make sure you have read the safety instructions at the beginning of the manual and that the machine is set up properly.
2. Make sure all tools and objects used during setup are cleared away from the machine.
3. Connect the machine to the power source.
4. On the magnetic switch cover, push the OFF button in, then twist it clockwise so it pops out to verify that the switch has not disabled the machine.
5. Press the ON/OFF button on the RF remote control to turn the machine **ON**.
6. Listen and watch for abnormal noises or actions. The machine should run smoothly with little or no vibration or rubbing noises.
  - Strange or unusual noises must be corrected before operating the machine further. Always disconnect the machine from power before investigating or correcting potential problems.
7. Press the TIMER button and cycle through each of the times to make sure the lights illuminate on the hand-held remote.
8. Press the ON/OFF button on the remote control to make sure it is working properly and test the OFF button operation on the magnetic switch. When the OFF button is pushed-in, the machine should not start with the remote control or the start button on the magnetic switch cover. When the OFF button is popped-out, the machine can be started.

**⚠ WARNING**

Projectiles thrown from the machine could cause serious eye injury. Wear safety goggles to reduce the risk of injury.

**⚠ WARNING**

Loose hair and clothing could get caught in machinery and cause serious personal injury. Keep loose clothing rolled up and long hair tied up and away from machinery.

**SETUP**

---

---

# COLLECTION SYSTEM

## System Setup

The Model W1823 is designed to collect dust from one large machine or two small machines at a time. This can be accomplished by either connecting it to one machine at a time or by connecting it to multiple machines and using blast gates to isolate different dust lines. This machine also works quite well as a point-of-use dust collector.

### Tips for Optimum Performance

- Keep ducts between the dust collector and machines as short as possible.
- Note that flex hose reduces CFM more than smooth-walled duct.
- Keep ducting directional changes to a minimum. The more curved fittings you use, the more resistance to flow, resulting in loss of suction.
- Gradual directional changes are more efficient than sudden directional changes (i.e. use 45° elbows in place of 90° elbows whenever possible).
- Use smooth-walled duct whenever possible.
- The simpler the system, the more efficient and less costly it will be.
- If the dust collector is attached to a 2" or 2½" collection port, open another blast gate to increase the amount of CFM or airflow to maintain proper cyclonic action and dust separation.

## Duct Material

You have many choices regarding main line and branch line duct material. For best results, use metal duct for the main line and branch lines, then use a short length of flexible hose to connect each machine to the branch lines.

Plastic duct is also a popular material for home shops. However, be aware that there is a fire or explosion hazard if plastic duct material is used for dust collection without being grounded against static electrical charge build-up. This topic will be discussed later in the manual.

### Metal Duct

The advantage of metal duct (**Figure 26**) is its conductivity, and it does not contribute to static electrical charge build-up. However, static charges are still produced when dust particles strike other dust particles as they move through the duct. Since metal duct is a conductor, it can be grounded quite easily to dissipate any static electrical charges.

There are quite a number of options when it comes to metal duct, but metal duct that is specially manufactured for dust collection is the best choice. When selecting your metal duct, choose high quality metal duct with smooth welded internal seams that will minimize airflow resistance. This type of duct usually connects to other ducts or elbows with a simple, self-sealing clamp, is very quick and easy to assemble, and can be dismantled and re-installed with no problems. This is especially important if you ever need to change things around in your shop or add more tools.

Avoid inferior metal duct that requires you to cut it to length and snap it together. This type of duct is time consuming to install because it requires you to seal all the seams with silicone and screw the components on the ends with sheet metal screws. Another disadvantage is the rough internal seams and crimped ends that unavoidably increase static pressure.



**Figure 26.** Examples of metal pipe and components.

## Flexible Duct

Flexible hose is generally used for short runs, small shops and at rigid duct-to-tool connections. There are many different types of flex hose on the market today. These are manufactured from materials such as polyethylene, PVC, cloth hose dipped in rubber and even metal, including steel and aluminum.

The superior choice here is metal flex hose that is designed to be flexible, yet be as smooth as possible to reduce static pressure loss.

There are also many kinds of pure plastic flexible hose, such as non-perforated drainage type hose and dryer vent hose. Drainage type hose, while being economical, does not quite have the flexibility required for dust collection. The inside of the duct is also deeply corrugated and can increase the static pressure loss by as much as 50% over smooth wall duct. Dryer vent hose, while being completely flexible, is non-resistant to abrasion and has a tendency to collapse in a negative pressure system. We DO NOT recommend using dryer drainage-type vent hose in your dust collection system.

If using flex-hose, you should choose one of the many types that are designed specifically for the movement of solid particles, i.e. dust, grains and plastics. However, the cost of specifically designed flexible duct can vary greatly. For example, polyethylene hose is well suited for the removal of particulate matter, especially sawdust, since it is durable and completely flexible. Also, it is very economical and available in a wide variety of diameters and lengths for most applications.

## Plastic Duct

The popularity of plastic duct (**Figure 28**) is due to the fact that it is an economical and readily available product. It is also simple to assemble and easily sealed against air loss. The primary disadvantage of plastic duct for dust collection is the inherent danger of static electrical build-up.

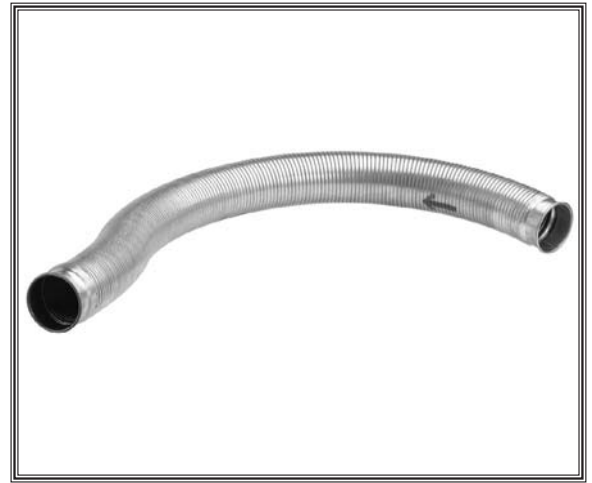

Figure 27. Example of flexible metal duct.



Figure 28. Example of plastic duct and components.



# System Grounding

Since plastic hose is abundant, relatively inexpensive, easily assembled and air tight, it is a very popular material for conveying dust from woodworking machines to the dust collector. We recommend using flexible hose (flex-hose) to connect the woodworking machine to the dust collector. However, plastic flex-hose and plastic duct are an insulator, and dust particles moving against the walls of the plastic duct create a static electrical build up. This charge will build until it discharges to a ground. If a grounding medium is not available to prevent static electrical build up, the electrical charge will arc to the nearest grounded source. This electrical discharge may cause an explosion and subsequent fire inside the system.

To protect against static electrical build up inside a non-conducting duct, a bare copper wire should be placed inside the duct along its length and grounded to the dust collector. You must also confirm that the dust collector is continuously grounded through the electrical circuit to the electric service panel.

If you connect the dust collector to more than one machine by way of a non-conducting branching duct system and blast gates, the system must still be grounded as mentioned above. We recommend inserting a continuous bare copper ground wire (**Figure 29**) inside the entire duct system and attaching the wire to each grounded woodworking machine and dust collector.

Be sure that you extend the bare copper wire down all branches of the system. Do not forget to connect the wires to each other with wire nuts when two branches meet at a "Y" or "T" connection.

Ensure that the entire system is grounded. If using plastic blast gates to direct air flow, the grounding wire must be jumped (**Figure 30**) around the blast gate without interruption to the grounding system.

We also recommend wrapping the outside of all plastic ducts with bare copper wire to ground the outside of the system against static electrical build up. Wire connections at Y's and T's should be made with wire nuts.

Attach the bare ground wire to each stationary woodworking machine and attach the dust collector frame with a ground screw, as shown in **Figure 29**. Ensure that each machine is continuously grounded to the grounding terminal in your electric service panel.

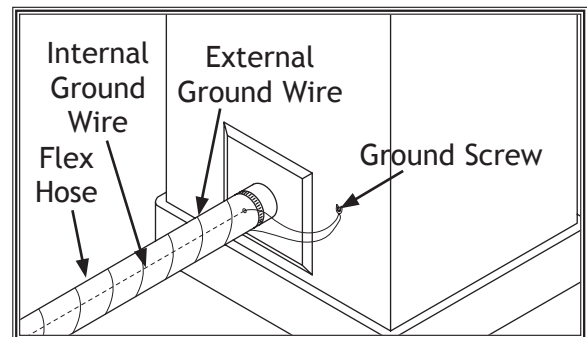
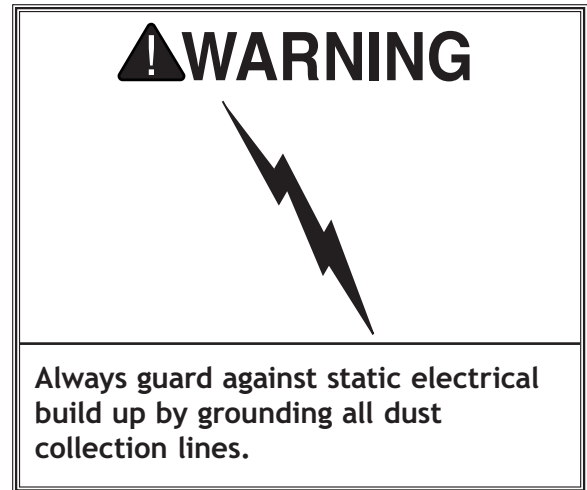

**Figure 29.** Flex-hose grounded to machine.

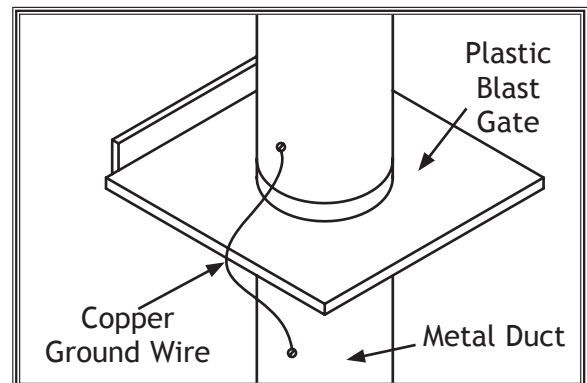

**Figure 30.** Ground jumper wire when using plastic blast gates and metal duct.

OPERATIONS

# OPERATIONS

## General Operation

The Model W1823 is designed to be a point-of-source dust collector system, and is capable of collecting dust from one large machine or two small machines at a time.

This cyclone dust collector creates a vortex from incoming air that extracts most dust particles and drops them into the steel collection drum below, while the remaining fine dust (see **Figure 31**) travels past the impeller and into the canister filter. The filter is made of spun-bond polyester, which catches 99.9% of particles from 0.2 to 2 microns in size, and is pleated to provide maximum surface area for efficient airflow.

The canister filter is equipped with a cleaning mechanism inside that loosens built-up dust so it falls into the bag below, which improves airflow for a well-used filter.

**⚠ WARNING**

Damage to your eyes, lungs, and ears could result from using this machine without proper protective gear. Always wear safety goggles, a respirator, and hearing protection when operating this machine.

|  |   |   |
|--|---|---|
|  |  |  |
|--|---|---|

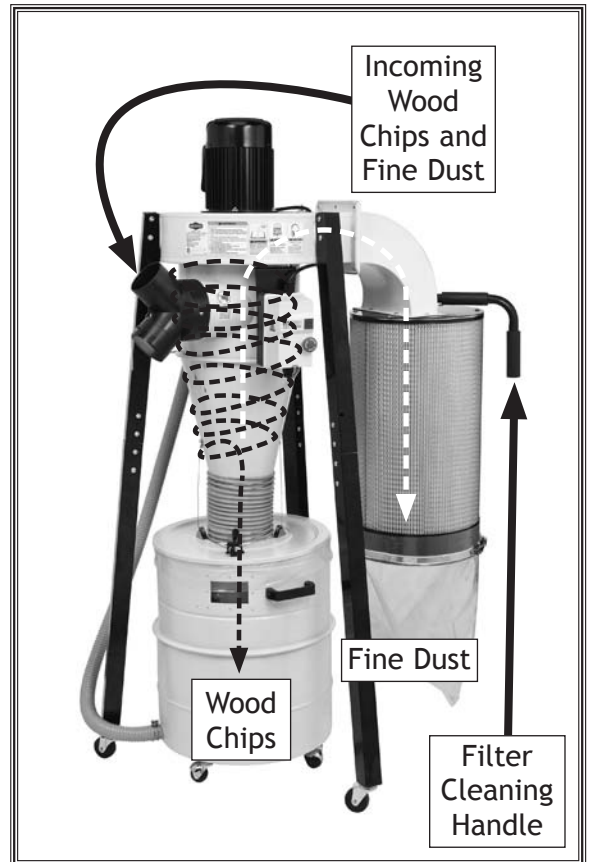

Figure 31. Model W1823 flow.

OPERATIONS

# Remote Control Operation

An RF (radio frequency) remote control receiver (Figure 32) and hand-held control (Figure 33) allow the dust collector to be turned **ON** and **OFF** from more than 75-feet away or from another room. The range will vary depending upon the density of materials between the receiver and the control, and the power level of the battery in the remote.

**Note:** *If you need to have one remote simultaneously control more than one Model W1823 dust collector, you can reprogram additional dust collector receivers to recognize the remote control currently being used. Refer to Remote Control Reprogramming on Page 29 to do this.*

The ON/OFF buttons (see Figure 33) turn the dust collector **ON** and **OFF**. The forward or backward buttons cycle the auto shut down time from always **ON**, to timed operation intervals of 2 hours, 4 hours, 6 hours, and 8 hours. When illuminated, the red LED lamp indicates which timed operation mode the machine is in.

If the motor gets too hot the thermal overload on the motor will trip, shutting the dust collector down.

**If the machine overload trips during operation, do these steps:**

1. Verify that cooling around the motor is not obstructed and improve ventilation if restricted.
2. Let the motor and electrical circuit cool for 30 minutes.
3. Press the motor reset button (see Figure 34), then press the ON button on the remote control to restart the dust collector.
4. If the reset button does not function the first time, repeat **Steps 1-3** as needed until the dust collector turns **ON**.



Figure 32. Remote control receiver.

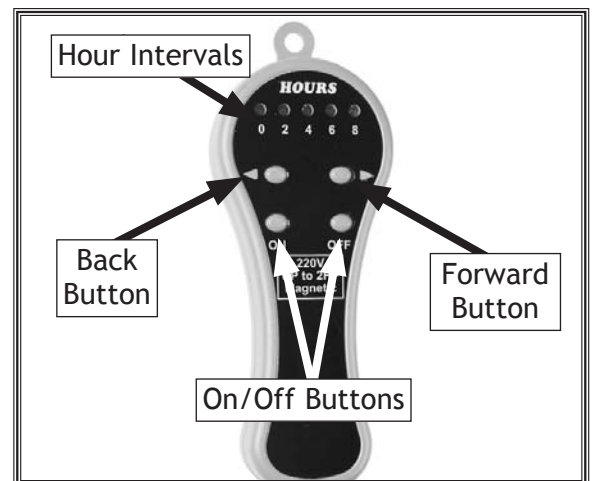

Figure 33. RF remote control.

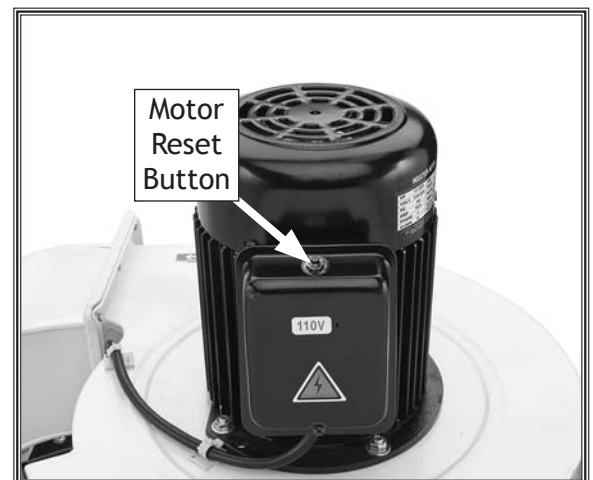

Figure 34. Reset button on motor.

# Cyclone Dust Collector Accessories

The following cyclone dust collector accessories may be available through your local Woodstock International Inc. Dealer. If you do not have a dealer in your area, these products are also available through online dealers. Please call or e-mail Woodstock International Inc. Customer Service to get a current listing of dealers at: 1-800-840-8420 or at [sales@woodstockint.com](mailto:sales@woodstockint.com).

**Blast Gates** are available in both black ABS plastic and aluminum. Plastic blast gates are economically priced, have a textured surface and an easy sliding gate action. For those customers who prefer metal, our top quality aluminum blast gates feature a cast aluminum body with steel gate and locking knob. The following types and models are available:

**Black ABS Plastic Blast Gates**  
 W1006 3" Outer Diameter  
 W1007 4" Outer Diameter  
 W1008 5" Outer Diameter  
 W1009 6" Outer Diameter

**Aluminum Blast Gates**  
 W1141 3" Outer Diameter  
 W1142 4" Outer Diameter

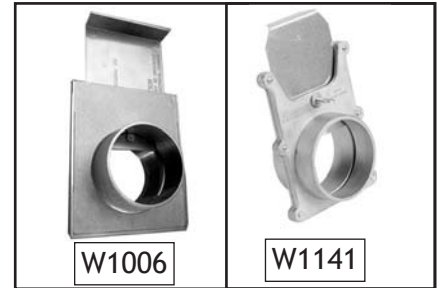

The **Model W1053 Grounding Kit** provides everything you need to ground a dust collection system, including directions for installation. A large system may need more than one kit, so keep plenty of these on hand. This safety accessory is essential to any complete dust collection assortment.



The **Model W1055 Dust Collection Accessories Kit #2** provides the necessary hoses, clamps, hoods and fittings to connect two woodworking machines to a dust collector. Air flow to each machine is controlled by a blast gate. Kit comes complete with comprehensive instructions and can be expanded even further using our other dust collection accessories (list enclosed in each box).



Kit includes:

- (2) 4" Blast gates (W1007)
- (2) 4" x 10' Hose (W1031)
- (1) Table saw dust hood (W1004)
- (1) Universal dust hood (W1010)
- (1) 4" Y-fitting (W1015)
- (10) 4" Wire hose clamps (W1317)
- Shipping weight: 15 lbs. 14 oz.
- Package size: 24" x 24" x 12"

**Y-Fittings** are used to attach branch lines to service more than one machine. This design provides increased lateral air flow and efficiency over other types of fittings.

W1014: 3" Outer Diameter  
 W1015: 4" Outer Diameter



# MAINTENANCE

## General

No maintenance such as bearing lubrication is required on this machine. But it is important to empty the drum and clean the filter during use. To catch any potential problems, make it a habit to inspect your machine before and after you use it.

Check for the following conditions and repair or replace when necessary:

- Check loose mounting bolts and ducting.
- Check worn or damaged wires.
- Check system for leaks.
- Check for tears in the filter or bags.
- Look for any other unsafe condition.

## Emptying Drum

Empty the collection drum when it is approximately  $\frac{3}{4}$  full as seen through the viewing window. If the drum is overfilled, dust will be sucked into the inlet cylinder and pass through to the filter. Sawdust and wood chips collected from different machines will require you to adjust the frequency of inspections.

To empty the sawdust from the drum, use the clamping lever (see **Figure 35**) on the drum lid to lift the lid and roll the drum out for emptying.

To empty the canister bag, use the canister quick release clamp to remove and dump the bag. The bags may be reused several times. We do not recommend using plain garbage bags as the wall thickness is insufficient to prevent blow-out.

## Normal Filter Cleaning

Your cyclone dust collector has a set of paddles inside the filter for cleaning. This paddle system is controlled by the filter cleaning handle (see **Figure 35**). To clean the filter, simply rotate the handle left and right, so the paddles ripple against the internal filter pleats and knock off the caked-on dust. The dust will then fall into the collection bag below. During heavy sanding operations, the canister may have to be cleaned this way several times during the day. Periodically inspect the bag, the quick release clamp, and the canister filter for evidence of any leakage or tears. If damage is found, immediately replace as required. Refer to **SERVICE** for major filter cleaning.

**⚠ WARNING**

**MAKE SURE** that your machine is unplugged during all maintenance procedures! And Always wear goggles and a respirator when emptying the dust collection bags. Sawdust may cause allergic reactions or respiratory problems.

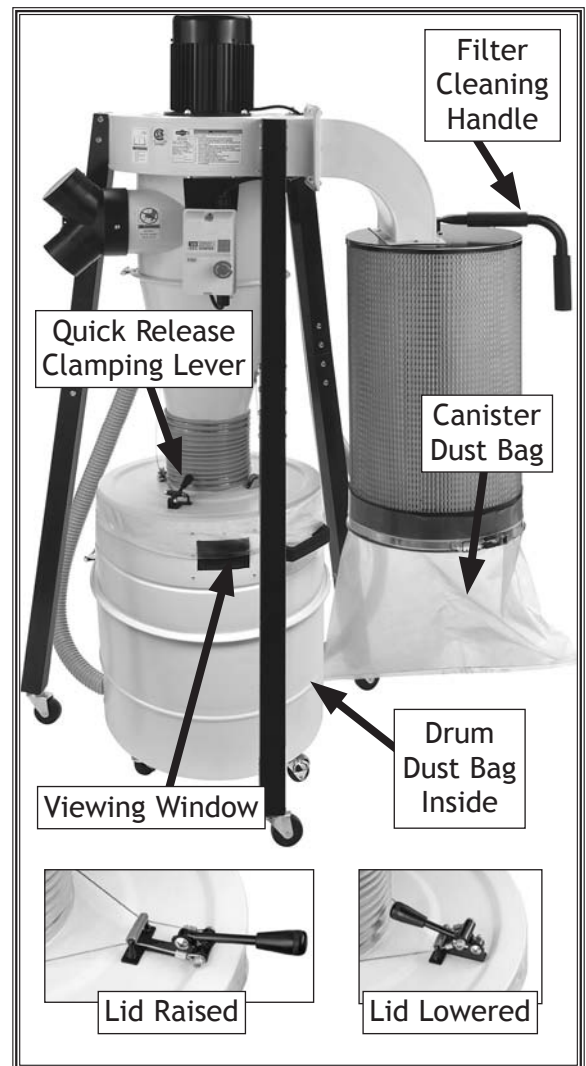

**Figure 35.** Maintenance locations.

# SERVICE

## General

This section covers the most common service adjustments or procedures that may need to be made during the life of your machine. If you require additional machine service not included in this section, please contact Woodstock International Technical Support at (360) 734-3482 or send e-mail to: [tech-support@shopfox.biz](mailto:tech-support@shopfox.biz).

## Major Filter Cleaning

### NOTICE

Using compressed air for cleaning or drying can tear the filter element. Using soapy water or solvents can also leave residue behind that attracts and bonds dust particles to the filter, resulting in a permanently clogged filter. **ONLY** use the cleaning handle, a soft brush, or plain water to clean the inside of the canister filter.

Use the filter cleaning handle for an initial filter cleaning. Next put on safety goggles and a respirator, and remove and empty the canister dust collection bag. To reach deep in the pleat-valleys, you can use a straw brush or stiff paint brush.

For extremely dirty filters, the filter can be carefully rinsed out with warm water and allowed to air dry. However, never leave the filter in the sun to dry or it could shrink and distort. Washing the filter when the ambient temperature is below 65 degrees or placing the wet filter in a closed environment without ventilation to dry can cause mold to grow between the filter pleats. If possible, use a fan to assist in the drying process, and never use compressed air to clean or blow-dry the filter.

### ⚠ WARNING

**MAKE SURE** that your machine is unplugged during all service procedures! And Always wear goggles and a respirator when emptying the dust collection bags. Sawdust may cause allergic reactions or respiratory problems.



Figure 36. Canister filter and bag.

# Remote Control Reprogramming



**⚠ WARNING**

Reprogramming the receiver on this machine is done with the machine connected to power. As a result, a hazard for shock, fire, or machine damage exists. **ONLY** a qualified electrician or service person should do this procedure.

This procedure covers how to reprogram the RF receiver to accept the new remote control frequency. Use these instructions if you ever replace either of these components, or convert the machine to operate on 220V. This procedure can also be used to control multiple models of this machine with one remote control.

To reprogram the remote control, do these steps:

1. DISCONNECT MACHINE FROM POWER!
2. Install a new battery in the remote control.
3. Remove the magnetic switch cover (Figure 37), and locate the receiver reset button shown in Figure 38.
4. CONNECT THE MACHINE TO POWER.
5. On the receiver (see Figure 38), use an insulated wooden or plastic dowel to press and hold the reset button until a triple beep is heard. The original remote control code is now erased.
6. Press and hold the reset button for 1-second. The receiver is ready for the new code.
7. On the remote control, press and hold the "ON" button until a double beep is heard. The remote control has sent a new code to the receiver that has been accepted.
8. On the receiver, press the reset button for 1-second. The new activation code is now stored in the receiver, and the remote control is operational.
9. DISCONNECT THE MACHINE FROM POWER, and reinstall the magnetic switch cover.



Figure 37. Remote control receiver location.

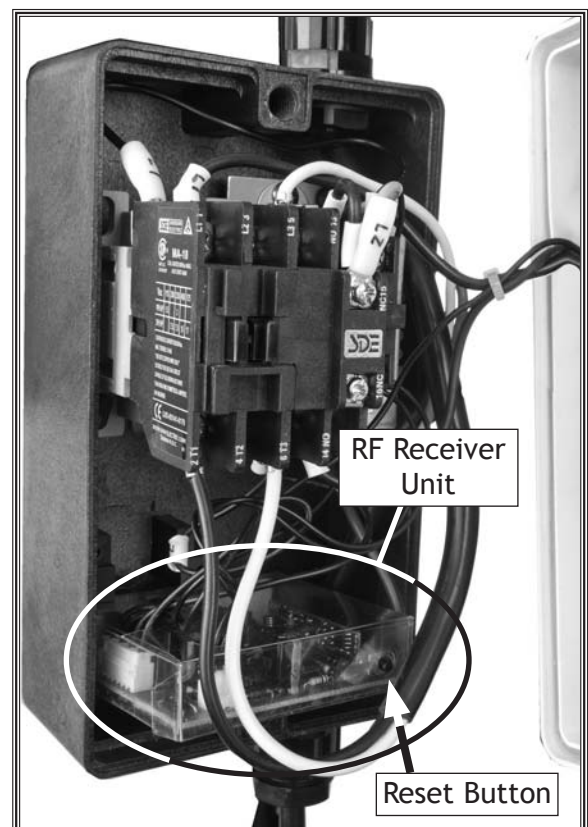

Figure 38. Remote control receiver.

**SERVICE**

# Electrical Safety Instructions

These pages are current at the time of printing. However, in the spirit of improvement, we may make changes to the electrical systems of future machines. Study this diagram carefully. If you notice differences between your machine and these wiring diagrams, call Woodstock International Technical Support at (360) 734-3482.

## WARNING

1. **SHOCK HAZARD.** Working on wiring that is connected to a power source is extremely dangerous. Touching electrified parts will result in personal injury including but not limited to severe burns, electrocution, or death. Disconnect the power from the machine before servicing electrical components!
2. **QUALIFIED ELECTRICIAN.** Due to the inherent hazards of electricity, only a qualified electrician should perform wiring tasks on this machine. If you are not a qualified electrician, get help from one before attempting any kind of wiring job.
3. **WIRE CONNECTIONS.** All connections must be tight to prevent wires from loosening during machine operation. Double-check all wires disconnected or connected during any wiring task to ensure tight connections.
4. **WIRE/COMPONENT DAMAGE.** Damaged wires or components increase the risk of serious personal injury, fire, or machine damage. If you notice that any wires or components are damaged while performing a wiring task, replace those wires or components before completing the task.
5. **MOTOR WIRING.** The motor wiring shown in these diagrams is current at the time of printing, but it may not match your machine. Always use the wiring diagram inside the motor junction box.
6. **MODIFICATIONS.** Using aftermarket parts or modifying the wiring beyond what is shown in the diagram may lead to unpredictable results, including serious injury or fire.
7. **CAPACITORS/INVERTERS.** Some capacitors and power inverters store an electrical charge for up to five minutes after being disconnected from the power source. To avoid being shocked, wait at least this long before working on these components.
8. **ELECTRICAL REQUIREMENTS.** You **MUST** follow the electrical requirements at the beginning of this manual when connecting your machine to a power source.
9. **EXPERIENCING DIFFICULTIES.** If you are experiencing difficulties understanding the information included in this section, contact our Technical Support at (360) 734-3482.

### NOTICE

The photos and diagrams included in this section are best viewed in color. You can view these pages in color at [www.shopfox.biz](http://www.shopfox.biz).

### WIRING DIAGRAM COLOR KEY

|       |        |              |            |
|-------|--------|--------------|------------|
| BLACK | BLUE   | YELLOW       | LIGHT BLUE |
| WHITE | BROWN  | YELLOW GREEN | BLUE WHITE |
| GREEN | GRAY   | PURPLE       | TURQUOISE  |
| RED   | ORANGE | PINK         |            |



# Wiring Diagram

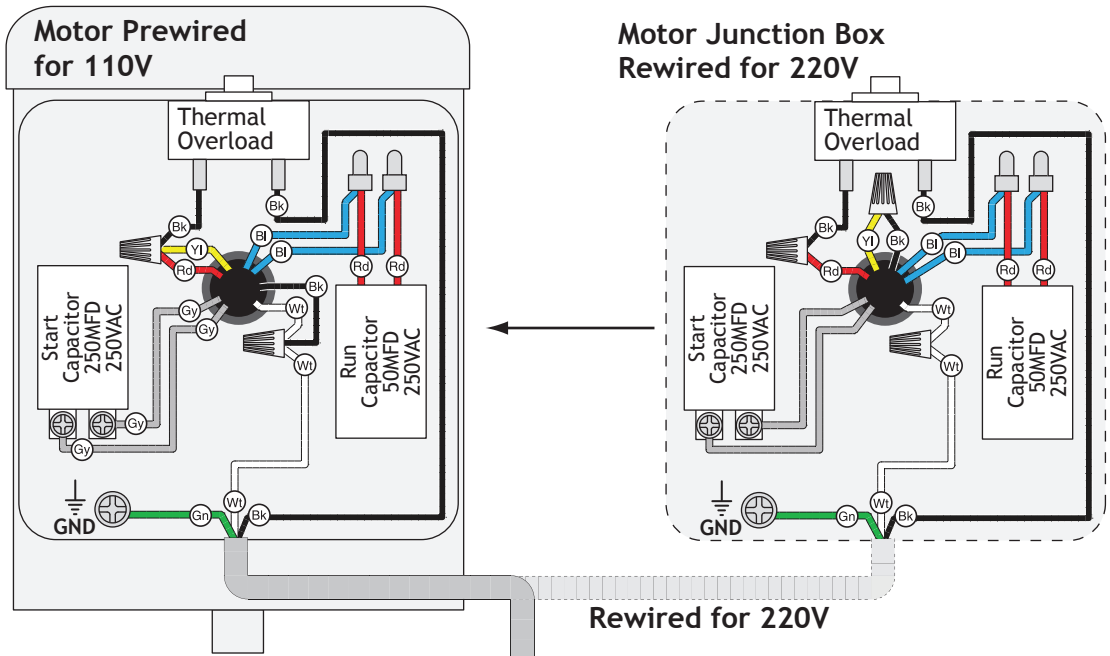

**NOTICE**  
Magnetic switch box assembly must be replaced with 220V model for 220V use.

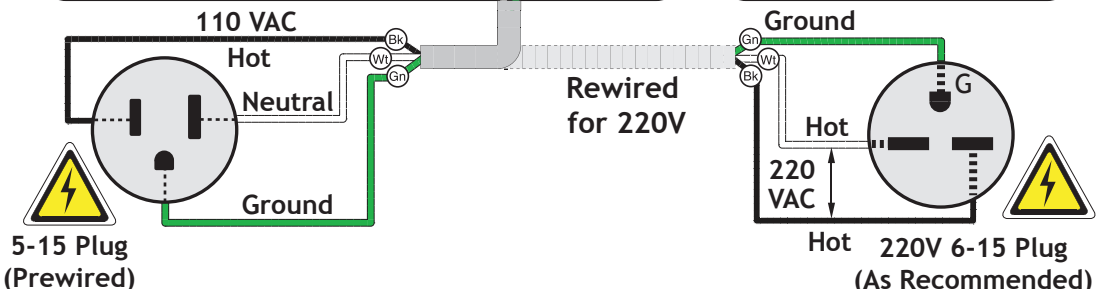
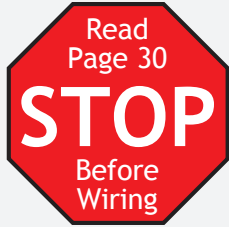
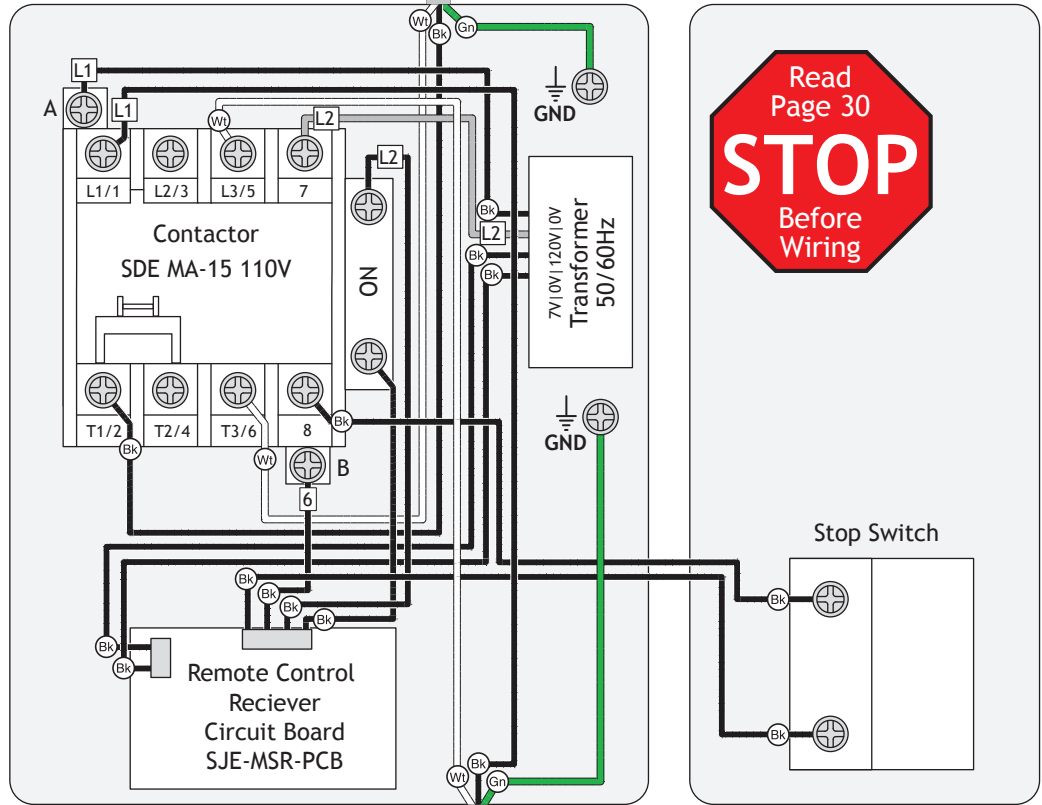

SERVICE

# 220V Conversion

The Model W1823 can be converted for 220V. This conversion requires re-wiring the motor, installing a 220V plug, a 220V magnetic switch box assembly, and reprogramming the remote control receiver. **Only a qualified electrician or service personnel should perform this procedure!**

To convert the Model W1823 to 220V, do these steps:

1. DISCONNECT MACHINE FROM POWER!
2. Remove the 110V plug from the power cord, then install a NEMA 6-15 plug, according to the instructions included with the plug. If no instructions were included, use the wiring diagram on **Page 31**.
3. Open the motor junction box, then remove the wire nuts indicated in **Figure 39**.

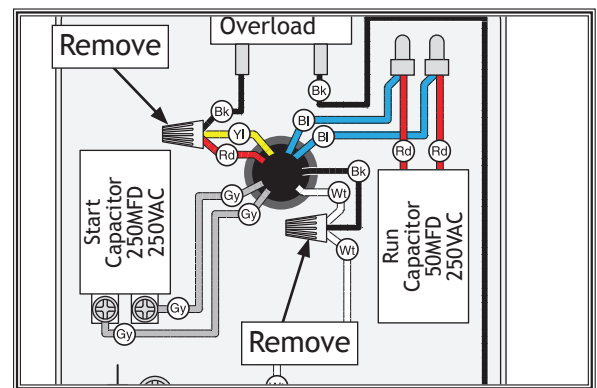

**Figure 39.** Motor wires at 110V.

4. Connect the motor wires as shown in **Figure 40** by twisting them together, then twisting a wire nut over them. Once snug, wrap the wire nut and the wires it contains with electrical tape to reduce the likelihood of the wire nut loosening during use, and reinstall the junction box cover.

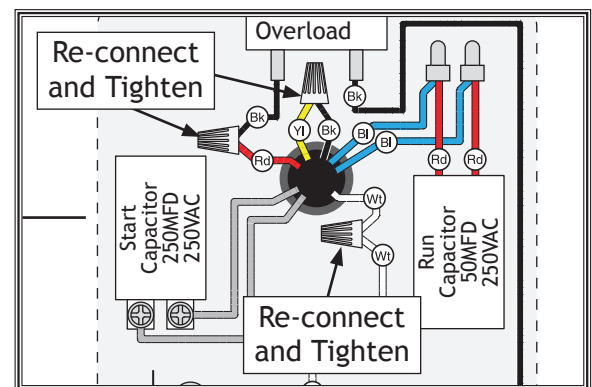

**Figure 40.** Motor wires re-positioned for 220V.

- Loosen the two plastic screws that secure the cover of the magnetic switch box shown in **Figure 41**, then remove the cover.

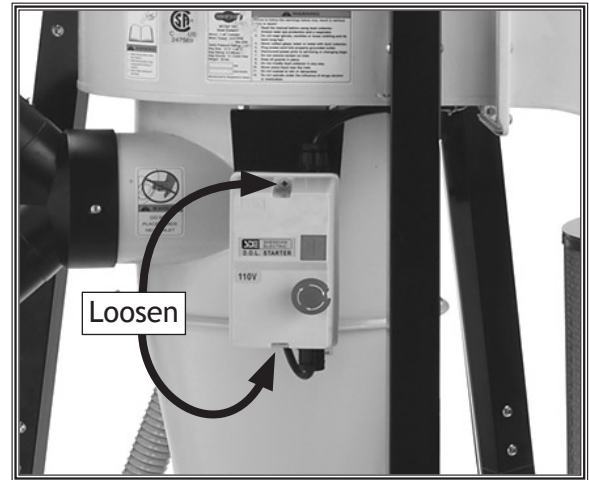

Figure 41. Magnetic switch box.

- Locate the incoming power and outgoing motor cords (shown in **Figure 42**) inside the magnetic switch box. Carefully note the destination of all of the wires associated with these two cords, and record their position so that you can return them to the corresponding positions in the 220V magnetic switch box assembly later.
- Loosen all of the terminal screws that have wires from the power cord or motor cord attached, then remove the wires.
- Remove the entire 110V magnetic switch box assembly from the dust collector frame.
- Install the 220V magnetic switch box assembly (purchased separately) in place of the 110V switch removed in **Step 8**, then re-install power and motor wires on the 220V switch box assembly in the same positions that they were in on the 110V switch. Tighten all terminals.

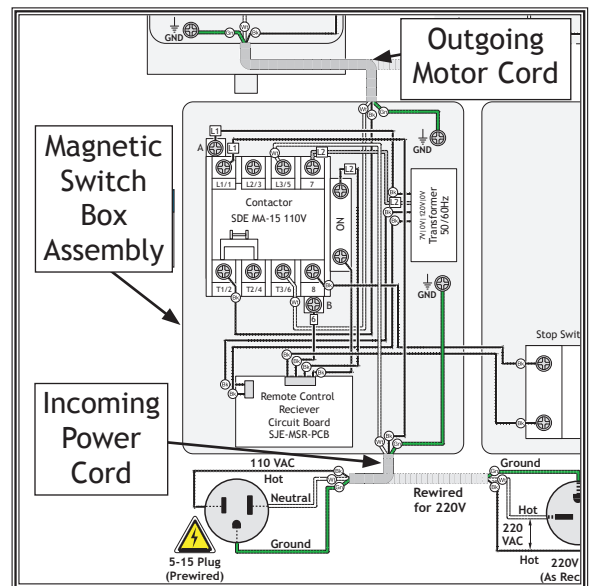
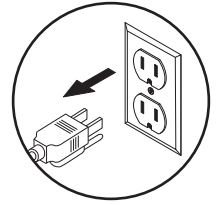

Figure 42. Magnetic switch.

- At this point, the new remote control receiver inside your new magnetic switch must be reprogrammed so it can communicate with your old hand-held control. To do this, complete the **Remote Control Reprogramming** procedure on **Page 29**.
- Close the magnetic switch box cover and secure it with the two plastic screws.

# Troubleshooting



This section covers the most common problems and corrections with this type of machine. **WARNING! DO NOT** make any adjustments until power is disconnected and moving parts have come to a complete stop!

| PROBLEM  | POSSIBLE CAUSE  | CORRECTIVE ACTION   |
|--|---|---|
| Motor will not start.  | <ol style="list-style-type: none"> <li>1. Stop button is pushed in.</li> <li>2. Remote control batteries are dead.</li> <li>3. Remote control frequency is incorrect.</li> <li>4. Power supply fuse or circuit breaker has tripped.</li> <li>5. Contactor/transformer at fault.</li> <li>6. Thermal overload has tripped.</li> <li>7. Start capacitor is at fault.</li> <li>8. Remote control or receiver at fault.</li> <li>9. Motor is at fault.</li> </ol> | <ol style="list-style-type: none"> <li>1. Rotate stop button clockwise so it pops out and is reset.</li> <li>2. Replace batteries.</li> <li>3. Reprogram the receiver to the remote control (Page 29).</li> <li>4. Disconnect power, and inspect circuit for electrical shorts and repair. Replace circuit breaker if it is old or has tripped many times.</li> <li>5. Test/replace contactor or transformer.</li> <li>6. Allow motor and overload to cool, push overload button back in. Reduce machine load/improve motor fan air flow for better cooling.</li> <li>7. Replace start capacitor.</li> <li>8. Replace remote control or receiver.</li> <li>9. Replace motor.</li> </ol> |
| Motor runs slower than normal.   | <ol style="list-style-type: none"> <li>1. Poor electrical connection.</li> <li>2. Run capacitor at fault.</li> <li>3. Motor is wired incorrectly.</li> <li>4. Impeller is loose on the motor shaft.</li> <li>5. Motor is at fault.</li> </ol>   | <ol style="list-style-type: none"> <li>1. Inspect the power supply for loose, corroded, or overheated electrical connections and repair.</li> <li>2. Replace run capacitor.</li> <li>3. Have the power source voltage checked and check wiring.</li> <li>4. Replace the motor and impeller as a set if the motor shaft or the impeller hub is damaged.</li> <li>5. Replace the motor.</li> </ol>  |
| Loud, repetitious noise, squealing, or excessive vibration coming from dust collector. | <ol style="list-style-type: none"> <li>1. Dust collector is not on a flat surface and wobbles.</li> <li>2. Impeller fan is damaged and unbalanced.</li> <li>3. The motor mounting is loose.</li> <li>4. Motor fan cover is dented, causing the motor fan to hit the cover while spinning.</li> <li>5. Impeller is loose on the motor shaft.</li> <li>6. Motor bearings at fault.</li> </ol>   | <ol style="list-style-type: none"> <li>1. Stabilize the dust collector.</li> <li>2. Unplug dust collector, and inspect the impeller for dents, bends, loose fins. Replace impeller if any damage is found.</li> <li>3. Make sure all fasteners on the dust collector are tight.</li> <li>4. Replace motor fan cover.</li> <li>5. Replace the motor and impeller as a set if the motor shaft or the impeller hub is damaged.</li> <li>6. Replace the motor.</li> </ol>   |

| PROBLEM  | POSSIBLE CAUSE  | CORRECTIVE ACTION   |
|--|---|---|
| <p>Dust collector does not adequately collect dust or chips; poor performance.</p> | <ol style="list-style-type: none"> <li>1. Dust collection drum is full.</li> <li>2. Filter is dirty, drum is full.</li> <li>3. Dust collector is undersized for the task.</li> <li>4. Ducting is at fault.</li> <li>5. The dust collector is too far away from the point of suction, or there are too many sharp bends in the ducting.</li> <li>6. The lumber is wet and wood chips are not flowing through the ducting smoothly.</li> <li>7. There is a leak in the ducting, or a series of small leaks, or too many open ports.</li> <li>8. There are not enough open branch lines at one time, thereby causing a velocity drop in the main line.</li> <li>9. The ducting and ports are incorrectly sized.</li> <li>10. The machine overall dust collection design is inadequate.</li> <li>11. The dust collector is too small for the dust collection system.</li> </ol> | <ol style="list-style-type: none"> <li>1. Empty collection drum.</li> <li>2. Clean filter, empty collection drum.</li> <li>3. Use the correct size duct collector for the type of machine.</li> <li>4. Remove dust line from dust collector inlet and unblock the restriction in the duct line.</li> <li>5. Relocate the dust collector closer to the point of suction, and rework ducting without sharp bends. Refer to Collection System, beginning on <b>Page 20</b>.</li> <li>6. Process lumber with less than 20% moisture content.</li> <li>7. Rework the ducting to eliminate all leaks. Close dust ports for lines not being used.</li> <li>8. Open 1 or 2 more blast gates to different branch lines to allow the velocity in the main line to increase.</li> <li>9. Re-install correctly sized ducts and fittings, contact machine manufacture for larger port dust collection shroud. Some machines have poor design for dust collector use.</li> <li>10. Use a dust collection nozzle on a stand.</li> <li>11. Install a larger dust collector to power your dust collection system.</li> </ol> |

# PARTS

## Main

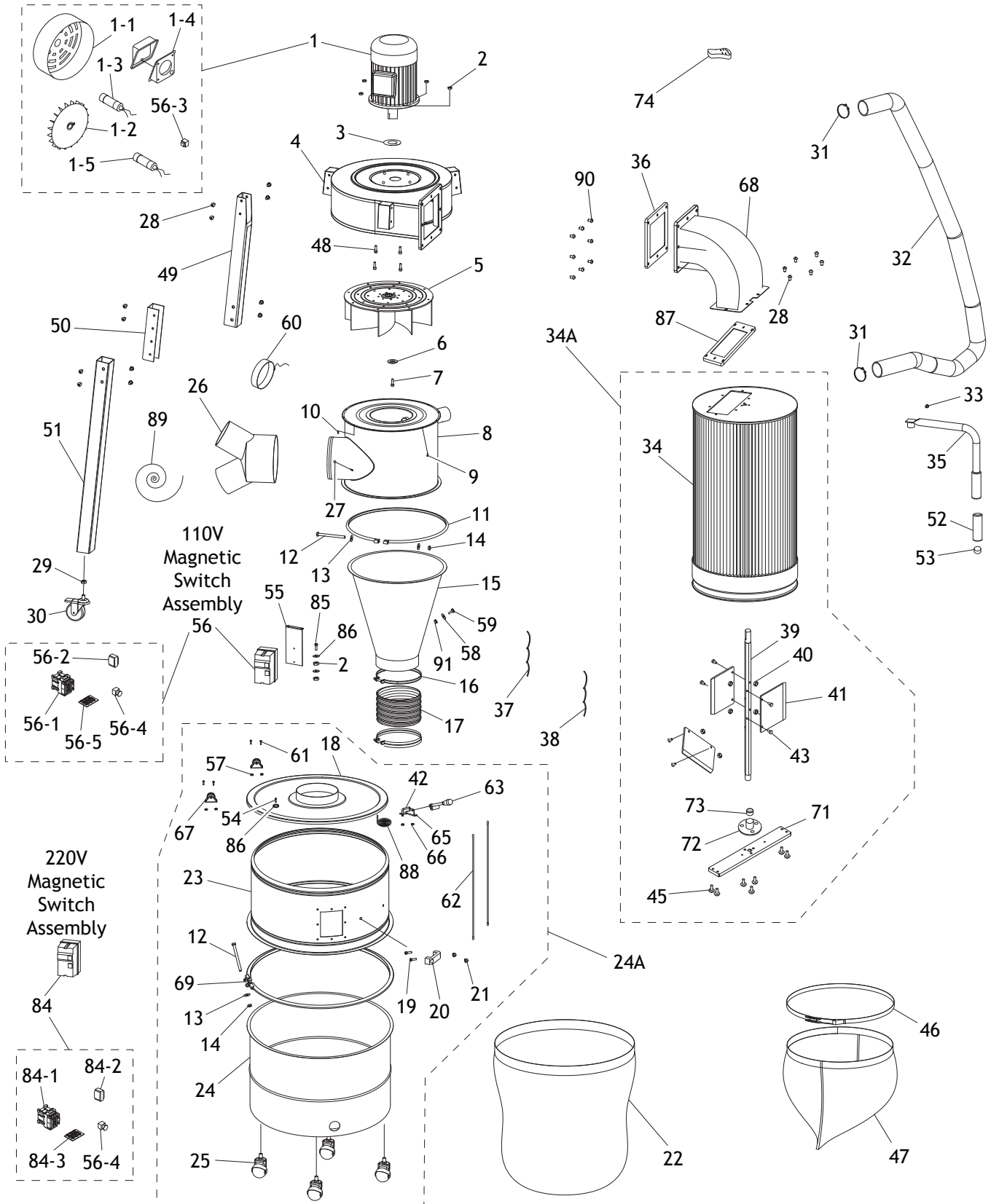

PARTS

# Main Parts List

| REF | PART #     | DESCRIPTION                     |
|-----|------------|---------------------------------|
| 1   | X1823001   | MOTOR 1-1/2HP 110/220V 1PH      |
| 1-1 | X1823001-1 | MOTOR FAN COVER                 |
| 1-2 | X1823001-2 | MOTOR FAN                       |
| 1-3 | X1823001-3 | S CAPACITOR 250M 250V           |
| 1-4 | X1823001-4 | MOTOR JUNCTION BOX              |
| 1-5 | X1823001-5 | R CAPACITOR 50M 250V            |
| 2   | XPNO2      | HEX NUT 5/16-18                 |
| 3   | X1823003   | MOTOR SPACER                    |
| 4   | X1823004   | BLOWER HOUSING                  |
| 5   | X1823005   | IMPELLER 12-3/4"                |
| 6   | X1823006   | IMPELLER FLAT WASHER            |
| 7   | XPCAP112M  | CAP SCREW M6-1 X 15 LH          |
| 8   | X1823008   | INTAKE BARREL                   |
| 9   | XPS06      | PHLP HD SCR 10-24 X 3/8         |
| 10  | XPCAP02    | CAP SCREW 10-24 X 3/8           |
| 11  | X1823011   | BARREL CLAMP                    |
| 12  | XPB96      | HEX BOLT 1/4-20 X 4             |
| 13  | XPW06      | FLAT WASHER 1/4                 |
| 14  | XPNO5      | HEX NUT 1/4-20                  |
| 15  | X1823015   | CYCLONE FUNNEL                  |
| 16  | X1823016   | HOSE CLAMP 7"                   |
| 17  | X1823017   | DUST HOST 7"                    |
| 18  | X1823018   | COLLECTION DRUM LID             |
| 19  | XPS12      | PHLP HD SCR 1/4-20 X 5/8        |
| 20  | X1823020   | COLLECTION DRUM HANDLE          |
| 21  | XPNO47     | ACORN NUT 1/4-20                |
| 22  | X1823022   | COLLECTION DRUM BAG             |
| 23  | X1823023   | UPPER COLLECTION DRUM           |
| 24A | X1823024A  | COLLECTION DRUM ASSEMBLY        |
| 24  | X1823024   | LOWER COLLECTION DRUM           |
| 25  | X1823025   | COLLECTION DRUM CASTER          |
| 26  | X1823026   | INLET Y-PORT 6" X 4" X 4"       |
| 27  | XPS06      | PHLP HD SCR 10-24 X 3/8         |
| 28  | XPBHS23    | BUTTON HD CAP SCR 5/16-18 X 1/2 |
| 29  | XPNO7      | HEX NUT 10-24                   |
| 30  | X1823030   | STAND CASTER W/BRAKE 3"         |
| 31  | X1823031   | HOSE CLAMP 1-3/4"               |
| 32  | X1823032   | VACUUM HOSE 1-1/2"              |
| 33  | XPSS01M    | SET SCREW M6-1 X 10             |
| 34A | X1823034A  | CANISTER FILTER ASSEMBLY        |
| 34  | X1823034   | CANISTER FILTER                 |
| 35  | X1823035   | FILTER CLEANING HANDLE          |
| 36  | X1823036   | OUTLET PORT GASKET              |
| 37  | X1823037   | MOTOR CORD 14AWG 3C             |
| 38  | X1823038   | POWER CORD 14AWG 3C             |
| 39  | X1823039   | FILTER CLEANING ROD             |
| 40  | XPLN04     | LOCK NUT 10-24                  |

| REF  | PART #     | DESCRIPTION                     |
|------|------------|---------------------------------|
| 41   | X1823041   | FILTER CLEANING FLAPPER         |
| 42   | X1823042   | STEEL WIRE RING                 |
| 43   | XPS06      | PHLP HD SCR 10-24 X 3/8         |
| 45   | XPS05M     | PHLP HD SCR M5-.8 X 8           |
| 46   | X1823046   | CANISTER BAG CLAMP              |
| 47   | X1823047   | CANISTER BAG                    |
| 48   | XPB07      | HEX BOLT 5/16-18 X 3/4          |
| 49   | X1823049   | UPPER STAND LEG                 |
| 50   | X1823050   | STAND LEG CONNECTOR             |
| 51   | X1823051   | LOWER STAND LEG                 |
| 52   | X1823052   | FILTER CLEANING HANDLE GRIP     |
| 53   | X1823053   | TUBE CAP 1"                     |
| 54   | XPFS20     | FLANGE SCREW 5/16-18 X 1/2      |
| 55   | X1823055   | SWITCH MOUNTING BRACKET         |
| 56   | X1823056   | MAGNETIC SWITCH ASSEMBLY 110V   |
| 56-1 | X1823056-1 | CONTACTOR SDE MA-15 110V        |
| 56-2 | X1823056-2 | TRANSFORMER GDM 0-120V          |
| 56-3 | X1823056-3 | THERMAL RELAY YEU SHANG 28A     |
| 56-4 | X1823056-4 | STOP BUTTON                     |
| 56-5 | X1823056-5 | CIRCUIT BOARD 110V              |
| 57   | XPLN04     | LOCK NUT 10-24                  |
| 58   | XPW06      | FLAT WASHER 1/4                 |
| 59   | XPB05      | HEX BOLT 1/4-20 X 3/4           |
| 60   | X1823060   | INLET PORT CAP                  |
| 61   | XPS01      | PHLP HD SCR 10-24 X 1/2         |
| 62   | X1823062   | STEEL BRAIDED WIRE 1.5MM DIA    |
| 63   | X1823063   | LID CLAMPING HANDLE ASSY        |
| 65   | X1823065   | CLAMPING HANDLE BRACKET         |
| 66   | XPLN04     | LOCK NUT 10-24                  |
| 67   | X1823067   | PULLEY ASSEMBLY                 |
| 68   | X1823068   | OUTLET PORT                     |
| 69   | X1823069   | COLLECTION DRUM CLAMP           |
| 71   | X1823071   | CLEANING ROD SUPPORT            |
| 72   | X1823072   | CLEANING ROD BASE               |
| 73   | X1823073   | BUSHING                         |
| 74   | X1823074   | REMOTE CONTROL                  |
| 84   | X1823084   | MAGNETIC SWITCH ASSEMBLY 220V   |
| 84-1 | X1823084-1 | CONTACTOR SDE MA-18 220V        |
| 84-2 | X1823084-2 | TRANSFORMER GDM 0-230V          |
| 84-3 | X1823084-3 | CIRCUIT BOARD 220V              |
| 85   | XPBHS24    | BUTTON HD CAP SCR 5/16-18 X 1   |
| 86   | XPW07      | FLAT WASHER 5/16                |
| 87   | X1823087   | CANISTER FILTER TOP GASKET      |
| 88   | X1823088   | FOAM TAPE 1" X 64"              |
| 89   | X1823089   | GROUND WIRE                     |
| 90   | XPBHS21    | BUTTON HD CAP SCR 5/16-18 X 3/4 |
| 91   | XPLN02     | LOCK NUT 1/4-20                 |

# Label Placement

## ⚠️ WARNING

Safety labels warn about machine hazards and how to prevent machine damage or injury. The owner of this machine **MUST** maintain the original location and readability of all labels on this machine. If any label is removed or becomes unreadable, **REPLACE** that label before allowing the machine to enter service again. Contact Woodstock International, Inc. at (360) 734-3482 or [www.shopfoxtools.com](http://www.shopfoxtools.com) to order new labels.

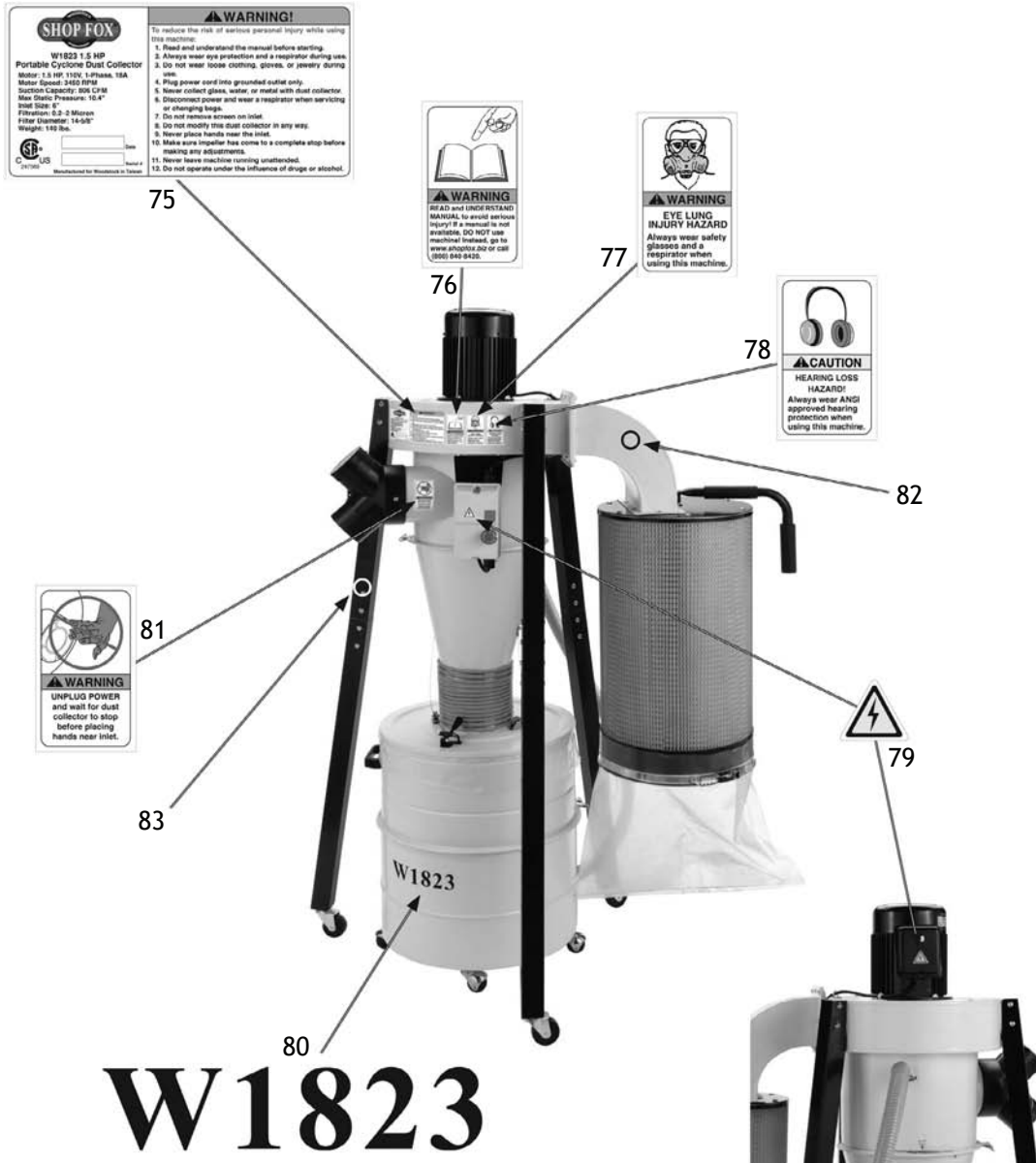

# W1823

| REF | PART #     | DESCRIPTION           |
|-----|------------|-----------------------|
| 75  | X1823075   | MACHINE ID LABEL      |
| 76  | XLABEL-08  | READ MANUAL LABEL     |
| 77  | XLABEL-06  | EYE/LUNG HAZARD LABEL |
| 78  | XLABEL-15A | HEAR HAZARD LABEL     |
| 79  | XLABEL-04  | ELECTRICITY LABEL     |

| REF | PART #    | DESCRIPTION             |
|-----|-----------|-------------------------|
| 80  | X1823080  | MODEL NUMBER LABEL      |
| 81  | X1823081  | INLET WARNING LABEL     |
| 82  | XPPAINT-1 | SF WHITE TOUCH-UP PAINT |
| 83  | XPPAINT-7 | SF BLACK TOUCH-UP PAINT |





# Warranty Registration

Name \_\_\_\_\_  
 Street \_\_\_\_\_  
 City \_\_\_\_\_ State \_\_\_\_\_ Zip \_\_\_\_\_  
 Phone # \_\_\_\_\_ Email \_\_\_\_\_ Invoice # \_\_\_\_\_  
 Model # \_\_\_\_\_ Serial # \_\_\_\_\_ Dealer Name \_\_\_\_\_ Purchase Date \_\_\_\_\_

The following information is given on a voluntary basis. It will be used for marketing purposes to help us develop better products and services. Of course, all information is strictly confidential.

- How did you learn about us?  
 Advertisement       Friend       Local Store  
 Mail Order Catalog       Website       Other:
- How long have you been a woodworker/metalworker?  
 0-2 Years       2-8 Years       8-20 Years       20+ Years
- How many of your machines or tools are Shop Fox?  
 0-2       3-5       6-9       10+
- Do you think your machine represents a good value?       Yes       No
- Would you recommend Shop Fox products to a friend?       Yes       No
- What is your age group?  
 20-29       30-39       40-49  
 50-59       60-69       70+
- What is your annual household income?  
 \$20,000-\$29,000       \$30,000-\$39,000       \$40,000-\$49,000  
 \$50,000-\$59,000       \$60,000-\$69,000       \$70,000+
- Which of the following magazines do you subscribe to?  
 Cabinet Maker       Popular Mechanics       Today's Homeowner  
 Family Handyman       Popular Science       Wood  
 Hand Loader       Popular Woodworking       Wooden Boat  
 Handy       Practical Homeowner       Woodshop News  
 Home Shop Machinist       Precision Shooter       Woodsmith  
 Journal of Light Cont.       Projects in Metal       Woodwork  
 Live Steam       RC Modeler       Woodworker West  
 Model Airplane News       Rifle       Woodworker's Journal  
 Modeltec       Shop Notes       Other:  
 Old House Journal       Shotgun News

9. Comments: \_\_\_\_\_  
 \_\_\_\_\_  
 \_\_\_\_\_  
 \_\_\_\_\_  
 \_\_\_\_\_

CUT ALONG DOTTED LINE

FOLD ALONG DOTTED LINE

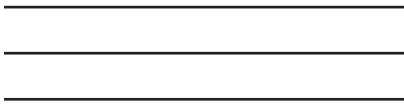

Place  
Stamp  
Here



WOODSTOCK INTERNATIONAL INC.  
P.O. BOX 2309  
BELLINGHAM, WA 98227-2309



FOLD ALONG DOTTED LINE

TAPE ALONG EDGES--PLEASE DO NOT STAPLE

# WARRANTY

Woodstock International, Inc. warrants all Shop Fox machinery to be free of defects from workmanship and materials for a period of two years from the date of original purchase by the original owner. This warranty does not apply to defects due directly or indirectly to misuse, abuse, negligence or accidents, lack of maintenance, or reimbursement of third party expenses incurred.

Woodstock International, Inc. will repair or replace, at its expense and at its option, the Shop Fox machine or machine part, which in normal use has proven to be defective, provided that the original owner returns the product prepaid to a Shop Fox factory service center with proof of their purchase of the product within two years, and provides Woodstock International, Inc. reasonable opportunity to verify the alleged defect through inspection. If it is determined there is no defect, or that the defect resulted from causes not within the scope of Woodstock International Inc.'s warranty, then the original owner must bear the cost of storing and returning the product.

This is Woodstock International, Inc.'s sole written warranty and any and all warranties that may be implied by law, including any merchantability or fitness, for any particular purpose, are hereby limited to the duration of this written warranty. We do not warrant that Shop Fox machinery complies with the provisions of any law or acts. In no event shall Woodstock International, Inc.'s liability under this warranty exceed the purchase price paid for the product, and any legal actions brought against Woodstock International, Inc. shall be tried in the State of Washington, County of Whatcom. We shall in no event be liable for death, injuries to persons or property or for incidental, contingent, special or consequential damages arising from the use of our products.

Every effort has been made to ensure that all Shop Fox machinery meets high quality and durability standards. We reserve the right to change specifications at any time because of our commitment to continuously improve the quality of our products.



## High Quality Machines and Tools

Woodstock International, Inc. carries thousands of products designed to meet the needs of today's woodworkers and metalworkers. Ask your dealer about these fine products:

**BROSEA**  
PRECISION STOP BLOCK

**JOINTER PAL**<sup>®</sup>

**Rotacator**<sup>®</sup>

**THE REBEL**<sup>®</sup>

**DURASTICK**<sup>®</sup>

**Gutmann**<sup>®</sup>

**BOARD BUDDIES**<sup>®</sup>



*Junglee*<sup>®</sup>

**PLANER PAL**<sup>®</sup>

**PARROT VISE**<sup>®</sup>

*SLICKPLANE*<sup>®</sup>

**PRO-STIK**<sup>®</sup>  
ABRASIVE BELT & DISC CLEANER

**ACCU-SHARP**<sup>®</sup>

*Aluma-Classic*<sup>®</sup>



**STEELEX**<sup>®</sup>  
FINE TOOLS

**STEELEX**<sup>®</sup>  
*PLUS*



**WHOLESALE ONLY**

**WOODSTOCK INTERNATIONAL, INC.**

Phone: (360) 734-3482 • Fax: (360) 671-3053 • Toll Free Fax: (800) 647-8801

P.O.Box 2309 • Bellingham, WA 98227

**SHOPFOX.BIZ**

## Free Manuals Download Website

<http://myh66.com>

<http://usermanuals.us>

<http://www.somanuals.com>

<http://www.4manuals.cc>

<http://www.manual-lib.com>

<http://www.404manual.com>

<http://www.luxmanual.com>

<http://aubethermostatmanual.com>

Golf course search by state

<http://golfingnear.com>

Email search by domain

<http://emailbydomain.com>

Auto manuals search

<http://auto.somanuals.com>

TV manuals search

<http://tv.somanuals.com>