

TONGSHI

WorldSpace Radio



User Manual

Please read this manual carefully and follow its instructions before using Tongshi WorldSpace Radio ("Radio").

Precautions:

- ◆ This Radio is designed to perform optimally when used with the genuine Tongshi designated accessories ("Tongshi Accessories"). You may use non-Tongshi Accessories with this Radio. However, Tongshi makes no warranties concerning, and is not responsible for damages resulting from, use of non Tongshi Accessories.
- ◆ While the power is on, the Radio's internal or external wire should not be unplugged or disconnected. This misuse may damage the Radio, antenna or computer permanently.
- ◆ Never place the Radio in close proximity to electric motors or other equipment generating strong magnetic fields that may cause malfunctions or corrupt image data.

Trademark Acknowledgements:

- ◆ TONGSHI is a trademark of Xi'an Tongshi Data Corp. Limited.
- ◆ Xi'an Tongshi Technology Limited ("Xi'an Tongshi") is authorized to use TONGSHI as agreed.
- ◆  WorldSpace is a trademark of WorldSpace Corp.
- ◆ Xi'an Tongshi is authorized to use  WorldSpace as agreed.
- ◆ Other names and products not mentioned above may be registered trademarks or trademarks of their respective companies.
- ◆ Copyright@2003 Xi'an Tongshi Technology Limited.
- ◆ All rights reserved.

Disclaimers:

- ◆ While every effort has been made to ensure that the information contained in this manual is accurate and complete, no liability can be accepted for any errors or omissions.
- ◆ Xi'an Tongshi reserves the right to change the specifications of the hardware and software described herein at any time without prior notice.
- ◆ Any software not provided upon the sale of the Radio may be considered additional accessories to be purchased from Xi'an Tongshi or third parties.
- ◆ No part of this manual may be reproduced, transmitted, transcribed, stored in a retrieval system, or translated into any language in any form, by any means, without the prior written permission of Xi'an Tongshi.
- ◆ Xi'an Tongshi makes no warranties for damages resulting from corrupted or lost data due to a mistaken operation or malfunction of the Radio, Tongshi

Accessories, the software, personal computers, peripheral devices, or use of non Tongshi Accessories.

- ◆ Xi'an Tongshi has no influence over the contents or services delivered by the Radio and will not be responsible for the contents or services in any respects.
- ◆ Please note that the Radios are intended for personal use and should never be used in a manner that infringes upon or contravenes international or domestic copyright laws and regulations.
- ◆ The Radio's warranty is only effective in the country of sale. If a problem arises while the Radio is in use, please contact the dealer who sold you the Radio.

CONTENT

Chapter One Preparing the Radio

1. Services	3
2. Product View and Technical Features	3
3. Face	4
4. Buttons	4
5. Connectors	5
6. LCD Display	5
7. Remote Control	6

Chapter Two Radio Service Mode

1. Install Batteries	6
2. Connect Antenna	7
3. Fix Antenna	7
4. Setup Radio	7
5. Play and Enjoy	8
6. Advanced Setup	8

Chapter Three Computer Service Mode

1. Preparing Computer	10
2. Install Software	10
3. Connect Radio with Computer	12
4. Install DAMB-R Driver	12
5. Radio Services	12
6. Data Services	16
7. Setup Radio	16

Appendix A Service Website of Xi'an Tongshi Corp	18
Appendix B Tongshi Accessories	18
Appendix C Mobile Reception	19
Appendix D Install DAMB-R Driver Manually	19

Appendix E	Force to Reinstall DAMB-R Driver -----	21
Appendix F	Country-List for AsiaStar™ -----	22
Appendix G	Country-List for AfriStar™ -----	23

Chapter One Preparing the Radio

1. Services

The Radio, along with a hand-size satellite antenna, is able to receive abundant satellite audio and data programs in most of the areas in Asia and Africa via WorldSpace satellites (AsiaStar, AfriStar) under suitable satellite signal reception conditions. Due to the strong reception technical capability, the Radio may be equipped to enjoy the WorldSpace satellite services in suitable mobile conditions.

WorldSpace Satellite Coverage Map:

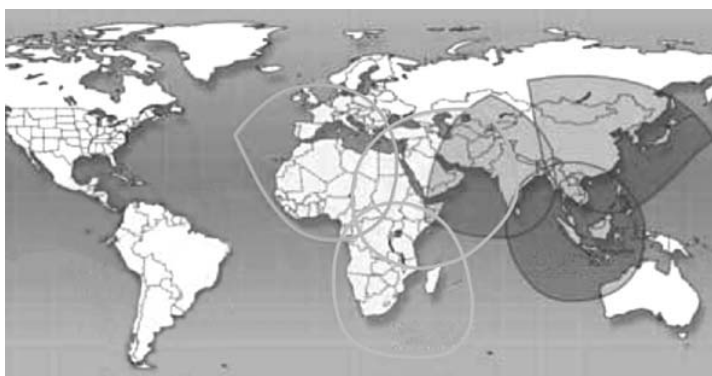

2. Product View and Technical Features



	Item	Spec
1	Band	WorldSpace band
2	RF frequency	1452-1492 MHz
3	Modulation	QPSK
4	Audio coding	MPEG 1, 2, 2.5 Layer 3
5	Inputs	WorldSpace Antenna
6	Outputs	Earphone Line Out USB 1.1 Interface
7	Display	LCD Display with EL backlight
8	Preset Channel	12 Programs
9	Tier of password	12 tiers
10	Power Source	2 AA Batteries DC Adapter USB
11	Power Consumption	Less than 1 Watt
12	Computer Services	DATA Receiving up to 128 Kbps
13	Dimensions	120mm*90mm*25mm
14	Weight	Approx: 168g (without batteries)

3. Face







1	Product's name: WorldSpace Radio
2	Product's type: DAMB-R
3	Earphone jack
4	Infrared reception window
5	LCD display
6	Power switch

4. Buttons



Five buttons placed on top of Radio. They are:



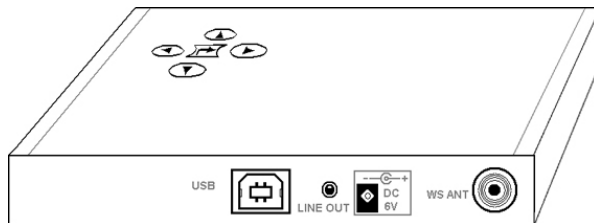

Sign	Buttons'	Operation	Functions

	Names		
	Channel+ BAND	Click Press	Access all channels in upper direction Skip channels' bands
	Channel- SCAN	Click Press	Access all channels in lower direction Enter scan mode
	Program- Volume-	Click Press	Skip to previous prefixed program Decrease volume
	Program+ Volume+	Click Press	Skip to next prefixed program Increase volume
	Ok	Click Press	Display status Store or erase program

5. Connectors



Four connectors placed in rear of Radio. They are:



	Sign	Name	Functions
1		USB connector	Connect to Computer with USB cable
2		Line out jack	Connect to sound system
3		DC-input connector	Power supply $+ \rightarrow \ominus$ DC:6V, Peak Current:300mA
4		F-Type connector	Connect to WS ANT

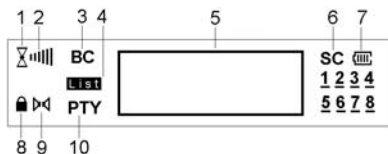

Note: USB connector shall be used in computer service mode only.

6. LCD Display

In front of Radio, there is LCD display:





	Display segments	Meaning
1		Show satellite signal on/off. If the sign appears, you can play Radio.
2		Receiving quality.

3	BC	Broadcast Channel.
4	List	Preset mode on/off. It will appear when you skip programs.
5		Window, show character strings.
6	SC	Service component.
7		Showing battery status. Only appear when batteries used.
8		Encrypted services
9		Mono/stereo
10	PTY	Program type
11	1 2 ... 8	SC index

7. Remote Control



Twelve keys placed on face of Remote Control. They are:

	Sign	Function
1		Mute
2		Power off switch
3	PRG+ / PRG-	Next/previous program
4	VOL+ / VOL-	Adjust volume
5	1,2, ... 6	Select program

Note: When the lithium battery CR 2025 is used up, please change it according to up figure.

Warning: Put the lithium battery out of children's reach.

Chapter Two Radio Service Mode

In this mode, you can control Radio through buttons or keys.

1. Install Battery

There are 3 ways for Radio power supply: Battery, DC adapter (AC/DC adapter or Car power adapter) and USB. Batteries will stop working when DC adapter or USB used.

Put 2 AA batteries into battery box of Radio. Both "Ni-MH" and "Alkaline" are usable.

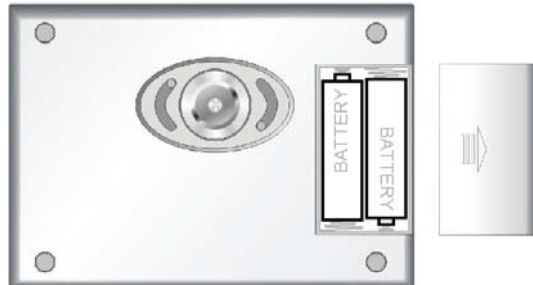

2. Connect Antenna

Connect antenna cable with Radio F-Type connector.

3. Fix Antenna

In general, you only need to set up Antenna within line of sight of the WorldSpace Satellite you want to receive the services from. For example, from your location, AfriStar is at your Southwest direction, if you can make Antenna face southwest without blockage of sky, you may receive its signal. After some angle and direction adjustments, you will have a better reception.

For more precise and professional analysis, here is certain operation:

- ◆ Elevation angle and azimuth are related with user's location.
- ◆ Please check the relevant angle information from Appendix F and G of this manual.
- ◆ Adjust antenna orientation and make it face to WorldSpace Satellites.

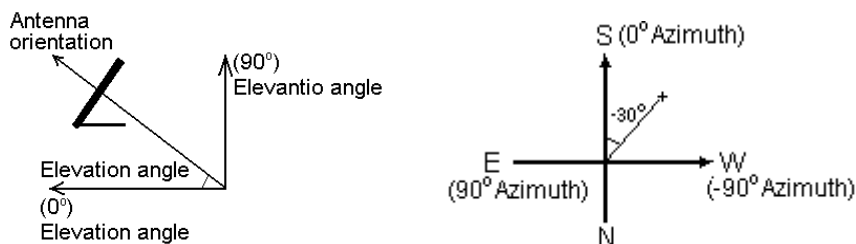

For example, in Shanghai, you can find out values of Elevation angle and Azimuth from Appendix F: Elevation angle=49 and Azimuth=-30. Then, put antenna face to up sky (49°) of southwest (-30°).

Note: Approximate orientation is enough.





4. Setup Radio

You must do initial setup for the first usage. The setup can be done by computer also. Please view chapter three, section 7.

1) Power On:

- ◆ Press  button to turn on Radio.







2) Scan:



- ◆ Press  button for 2 seconds, into scan mode.
Note: Press ,  or  select star and band manually.
- ◆ Press  scan and save all channels. Please wait about 2 minutes.

Note: Press  cancels scan operation.

3) Preset Channels as Programs:

You can preset 12 favorite channels as programs. Remote control or buttons can access these programs easily.

- ◆ Click  or  button to select a channel.
- ◆ Press  button for 2 seconds to get into preset menu.
Note: Click  or  button can skip digits from 1 to 12 in preset menu.
- ◆ Click  button to save channel as present program.
- ◆ Repeat above steps till all 12 programs are preset.

Note: In preset mode (**List** sign appeared), Press  button for 2 seconds can delete the program or press  button for 5 seconds can delete all programs.



5. Play and Enjoy

You can play and enjoy Radio by select channel or preset program. This function can be achieved by the following operations:





Select a Channel:

- ◆ Click  or  button to skip channels.

Select Preset Program:

- ◆ Click  or  button to skip programs.
- ◆ Press PRG+/- key to skip programs or press digital number keys 1, 2, ...6 by Remote control.

Note:







- ◆ Press  button for 2 seconds, Radio will skip to another band.
- ◆ Press and hold on  or  button can adjust volumes.
- ◆ Press  button or  key for 3 seconds can turn off Radio.

6. Advanced Setup

1) Access Radio ID and Setup Password:

When turn into a pay channel,  appears on the LCD display. To receive it, you need to have a subscription agreement with the services provider and get a set of password (22 or 25 digits number). This function can be achieved by the following operations:

When the power is on,



- ◆ Press  and  button simultaneously to list ID of the Radio.
- ◆ Press  into password entry mode.
- ◆ Press  or  button to add or subtract the current digit.
- ◆ Press  to skips to the next digit.

Note: Press /I aborts the password entry mode.

2) Setup ANT Type:

There are three types of WS ANT called LINEAR, CIRCULAR and CABLE. You must setup up the correct ANT type used for Radio. If you don't know which ANT type used, please refer to the label stuck on ANT back. Setup ANT type can be achieved by the following operations:

When the power is off,

- ◆ Press  button and hold it, then turn on Radio.
- ◆ Press  button to skip ANT type from Circular, Cable and Linear.
- ◆ Press  button to save present ANT type and return.



Note: Press /I cancels ANT setup mode.

Warning: All programs in LIST will be cleared after ANT type changed.

3) Setup BATT Type:

There are two types of batteries for Radio, called Ni-MH and Alkaline. In order to show batteries volume correctly, you must select the right type of batteries. This setup can be achieved by the following operations:



When the power is off,

- ◆ Press  button and hold it, then turn on Radio.
- ◆ Press  button to skip BATT type from NiMH and Alka.
- ◆ Press  button to save present BATT type and return.

4) Setup Autopower Function:

If batteries are used and no key or button pressed for 12 minutes, Radio will beep every 4 seconds for ten times. If no key or button are pressed, Radio will be turned off automatically for power saving. This function can be enabled or disabled by the following operations:

When the power is off,

- ◆ Press  button and power on the Radio.
- ◆ Press  button to skip Autopower from ON to OFF.
- ◆ Press  button to save and return.

Chapter Three Computer Service Mode

In this mode, computer controls Radio. Buttons and keys are not operational.

1. Preparing Computer

The basic computer requirements are as follows:

- ◆ Computer: X86 PC, Pentium II 266 or higher.
- ◆ Operation system: Windows 98SE/Me/2000/XP.
- ◆ Monitor: multimedia monitor, 800*600, 256 colors or higher.

2. Install Software

Notice: Software installation operation should be done firstly. DAMB software cannot work under Win95/WinNT4.

Put DAMB software CD into CD-ROM, do installation operation step by step as follows:

- ◆ "Choose Setup Language" dialog box pops up, select a language from the list, click "OK" to continue.

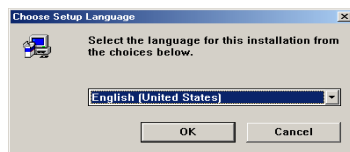

- ◆ "Welcome" dialog box pops up, click "Next" to continue.

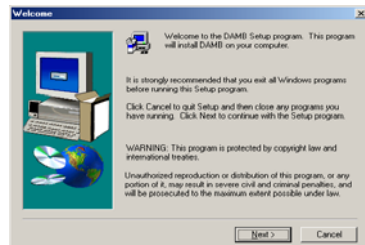

- ◆ "Software License Agreement" dialog box pops up, click "Yes" to continue.

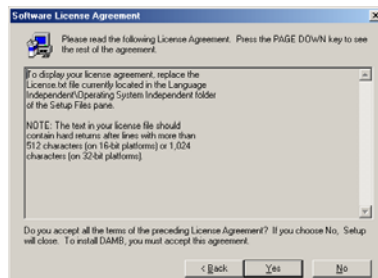

- ◆ "User Information" dialog box pops up, input correct information of Name, Company. Don't modify Serial item, it's reserved for future. Click "Next" to continue.

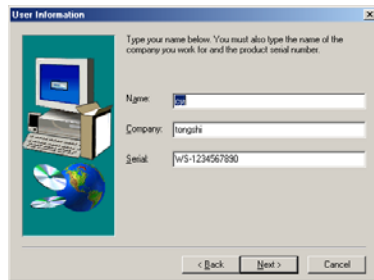

- ◆ "Choose Destination Location" dialog box pops up, select destination folder and click "Next" to continue.

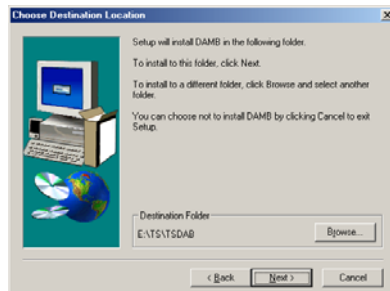

- ◆ "Select Program Folder" dialog box pops up, click "Next" to continue.

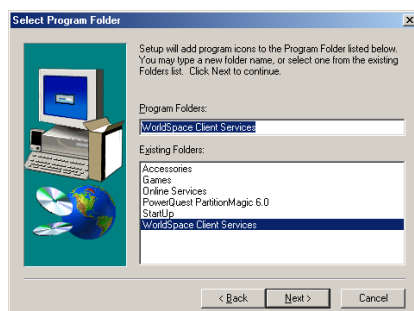

- ◆ "Setup Complete" dialog box pops up, select "ShutDown And PowerOff" and click "Finish" to finish installation. Computer will shut down automatically.

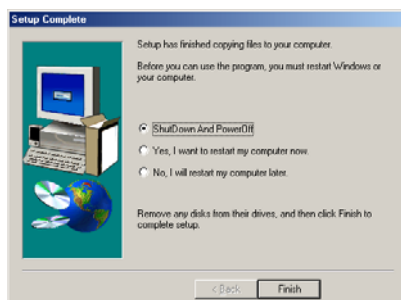

Note: In Win2000/XP, if "Digital Signature Not Found" dialog box pops up, click "Yes" to continue.

3. Connect Radio with Computer

Notice: Connecting Radio with Computer must succeed the installation of software.

- ◆ Make sure both computer and Radio power are off.
- ◆ Connect Antenna, Radio and Computer.

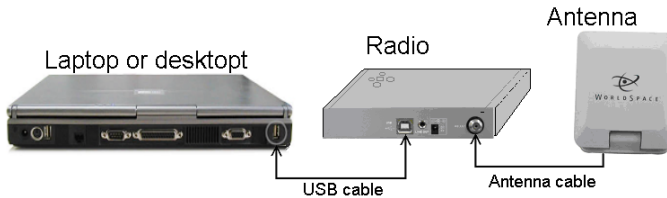

- ◆ Fix antenna. Refer to chapter two, section 3.

4. Install DAMB-R Driver

After software is properly installed and Radio connection is in order, start up computer. Driver will be installed automatically.



Note: In Win2000/XP, when "Digital Signature Not Found" dialog box pops up, click "Yes" to continue. In Win98/Me, when "System Settings Change" dialog box pops up, click "Yes" to continue.

5. Radio Service

MP3 player is software-based player used to play WS audio channel in computer.

1) Run MP3 Player

Double click MP3 player icon in "WorldSpace Client Services" folder. Then, MP3 player interface will be displayed.

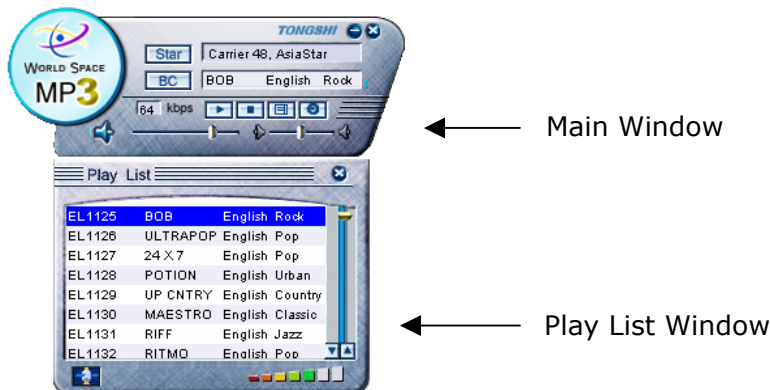

2) Scan Channel

You must scan channel when you first use MP3 player:

- ◆ Right click on the Main Window and select "Do scan" menu item.
- ◆ For the first time, you are prompted to select antenna type.
- ◆ "Scan now" pops up, click "Yes".
- ◆ Waiting for scanning patiently.
- ◆ First channel in "Play List" will be played automatically.
- ◆ All channels will be listed after scanning.

Note: Scanning is needed when you change antenna type. Right click Main Window again and select "Cancel scan" can stop scanning.

3) Play Channel

Double click a channel in Play List window.

4) Main Window

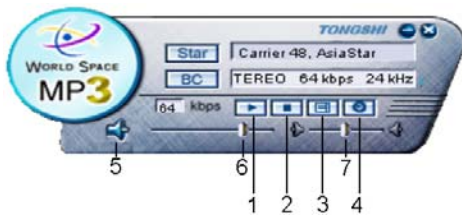

Seven buttons placed in the Main Window. They are:

	Sign	Name	Functions
1		Play	Play Channel
2		Stop	Stop playing
3		Show/Hide	Show or hide the Play List
4		Config	Select player skin*
5		Mute	Mute on or off
6		Volume	Volume control
7		Balance	Left or right track control

*Player Skin means shell or style of the interface.

Three items are placed in Main Window. The means of these items are:

Star: WS star name and carrier number.

BC: Broadcast Channel information.

Kbps: Present channel's bit-rate.

Right click Main Window, a menu displayed.

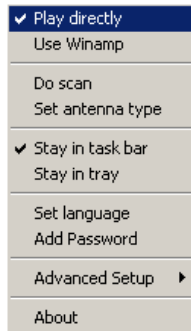

There are ten items for selecting.

	Item	Function
1	Play directly	Play channel using the MP3 decoder embedded in the player
2	Use Winamp	Install Winamp first and run it to play channel.
3	Do scan	Scan channel
4	Set antenna type	Refer to the label stuck on ANT back and select LINEAR, CIRCULAR or CABLE
5	Stay in task bar	MP3 player is shown in WINDOWS taskbar
6	Stay in tray	MP3 player icon is shown in tray at down right corner of screen
7	Set language	When a channel is broadcasted in several languages, select a preferential language from the list for Player
8	Add Password	Input audio password *
9	Advanced Setup	Refresh Play List when BC changed
10	About	About MP3 player version information

* When receiving a pay channel,  appears on the left BC window. To receive it, you need to have a subscription agreement with the services provider and get a set of password (22 or 25 digits number). This function can be achieved by the following operations:

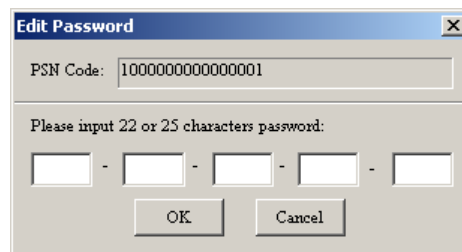
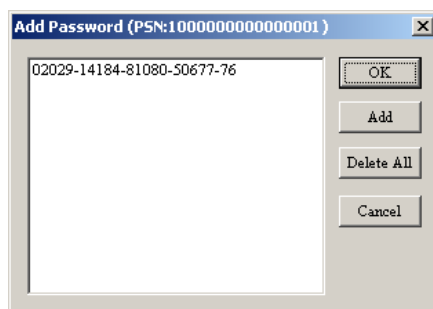

- OK: Save input password and exit.
- Add: Add audio password.
- Delete All: Delete all passwords.
- Cancel: Exit dialog without saving.

5) Play List Window :



All scanned information is displayed in Play List window. There are five columns in the list:

BCID: Broadcast Channel ID, such as EL1125

SC No.: Service Component number. No display if only one SC within the BC

Service label: Name of BC provider, such as MAESTRO

Language: Language of the channel using, such as English

Type: Music type of the channel, such as Rock.



Light or gray means satellite signal on or off. If the icon is light, you can enjoy the channel.



Receiving quality. More bars lighten, much better the signal.

Right click a channel and a menu displayed. There are five items for selecting.

	Item	Function
1	Play	Play selected channel.
2	Hide list	Hide Play List Window. Click "Show/Hide play list" button to show the window again
3	Search	Search matched channels*
4	Show all BCs	Show all the scanned channels in Play List.
5	Sort list	Sort list by BCID, service label, language or program type. The list is arranged in ascending order.

* User can search some favorite channels according to selected language and type. For example, select pop music in English.

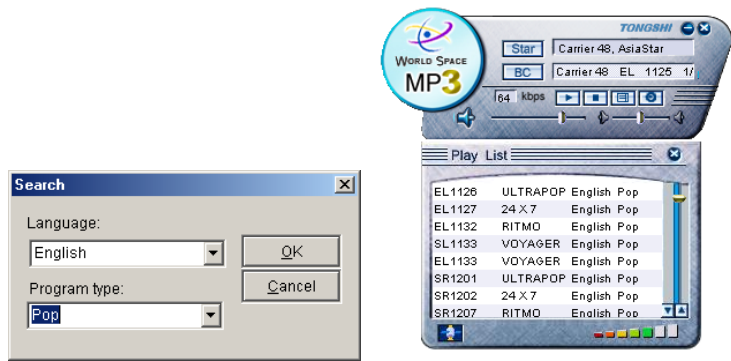

6. Data Service

DAMB-R supports DMS, CLASS and TONGSHI DATACAST that used in WorldSpace system now. Data service provider will provide manual of data reception.

7. Setup Radio

DAMB-R Setup is application software used to setup Radio with computer. Before read this section, you must know Radio functions and MP3 Player described in this manual.

1) Run DAMB-R Setup

Double click  icon in "WorldSpace Client Services" folder. Then, DAMB-R Setup interface displayed.

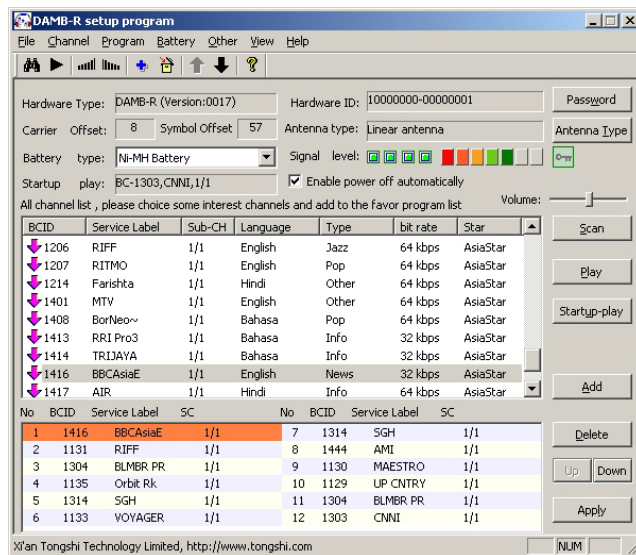

2) Buttons

There are 11 buttons for setup operation. They are:

	Name	Functions
1	Password	Input password
2	Antenna Type	Setup antenna type

3	Battery Type	Setup battery type
4	Scan	Scan channel
5	Play	Play a selected channel
6	Startup-play	Set a channel as Startup play program which will play automatically when Radio turn on.
7	Add	Add a selected channel as a program
8	Delete	Delete a selected program from Program List
9	Up	Move a selected program in upper direction
10	Down	Move a selected program in lower direction
11	Apply	Save parameters to Radio

3) Items



There are 7 items in the interface. The meaning of them is:

Name	Meaning or function
Hardware Type	Show Radio version
Hardware ID	Show Radio ID number
Carrier offset	Digital number use for technical support
Symbol Offset	Digital number use for technical support
Signal level	Indicates the signal lock status and quality
Startup Play	Show a program information setup by startup-play button
Enable Power off automatically.	Setup Radio with Autopower function

4) Setup Steps

- ◆ For first time, select antenna type.
- ◆ Scan channel.
- ◆ Select channels from Channel List and add to programs.
- ◆ Setup Battery type and others.
- ◆ Click "Apply" to finish setup.

5) Encryption status indicator

- ◆  Means the current playing SC is not encrypted or decrypted successfully.
- ◆  Means the current playing SC cannot be decrypted.

Appendix A Service Website of Tongshi Corp.







<http://www.tongshi.com> is our company service website. Some convenient services are provided on the website, include:

1. Notification and bulletin.
2. Download the latest upgrade.
3. Software upgrade of the third party.

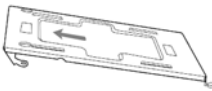
If you have any question, please contact us in E-mail: support@Tongshi.com. We shall answer you as soon as possible. Some advices, minds or suggestions are all welcomed. Thanks.

Appendix B Tongshi Accessories

Tongshi accessories include Magnetic stand, Car Power Adapter, AC/DC Adapter, Cassette Adapter, Audio Line and Holder.

	Accessories	Photos	Function and parameter
1	Magnetic Stand		Use for Installation car antenna
2	Car power Adapter		Providing power in automobile Input: DC 12/24V Output: DC 6V, 300mA, 3.5mm plug, +→- -
3	Music earphone		Frequency Range: 20Hz-20KHz Sensitivity: 113dB±5dB Impedance: 32Ω±15% Normal Input: 1mW
4	Cassette Adapter		Connecting to car stereo
5	Audio Line		Connecting to sound system
6	Holder		Stuck to the place you want. Put or remove Radio easily.

Appendix C Mobile Reception

As excellent signal receiving capability, you can enjoy high quality audio in car, in train, in ship or in airplane under most of the case.

Manual of mobile reception will be provided with Tongshi accessories.

Appendix D Install DAMB-R Driver Manually

This method is for professionals only.

- ◆ If you connect DAMB-R with computer without install software, when computer starts up, a new device will be found. A dialog box will pop up.

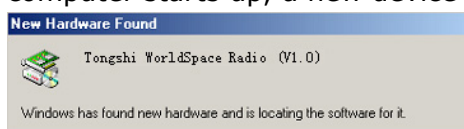

- ◆ "Add New Hardware Wizard" dialog box pops up, click "Next" to continue.

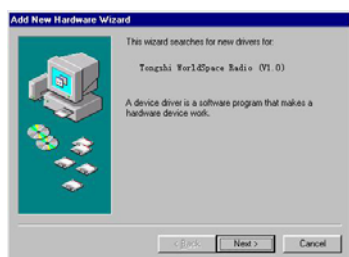

- ◆ Select "Automatic search for a better driver (Recommended)", click "Next" to continue.



- ◆ "Add New Hardware Wizard" dialog box pops up, select "Specify a location" and clicks "Browse" or input CD-ROM disk root path "G:\\" (G is supposed to be letter of CD-ROM disk). Click "Next" to continue.

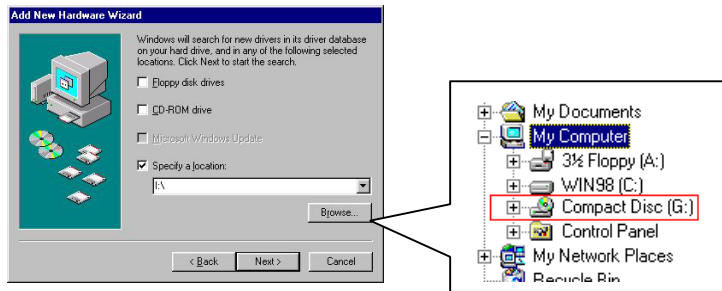

- ◆ "Add New Hardware Wizard" dialog box pops up, click "Next" to continue.



- ◆ "Add New Hardware Wizard" dialog box pops up, click "Finish" to finish installation.



Note:

- 1) In process of installing, system will prompt need "Win98 System Disk" or "DAMB Installation Disk". Please insert that CD into CD-ROM.
- 2) In Win2000/XP, if "Digital Signature Not Found" dialog box pops up, click "Yes" to continue.

Appendix E Force to Reinstall DAMB-R Driver

This method is for professionals only.

If the driver was installed incorrectly, you can reinstall the driver step by step as follows:

- ◆ Open "Control Panel" and double click "System" icon.
- ◆ In Win98/Me, "System Properties" dialog box will pop up. Select "Device Manager" and select "Tongshi WorldSpace Radio (V1.0)" in Other devices or Network adapters lists.

System Properties interface in Win98/Me:

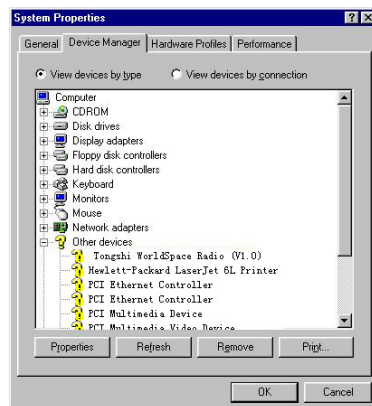

- ◆ In Win2000/XP, "System Properties" dialog box pops up. Select "Hardware" and click "Device Manager...". "Device Manager" window pops up, select "Tongshi WorldSpace Radio (V1.0)" in Other devices or Network adapters lists.

System Properties interface in Win2000/XP:

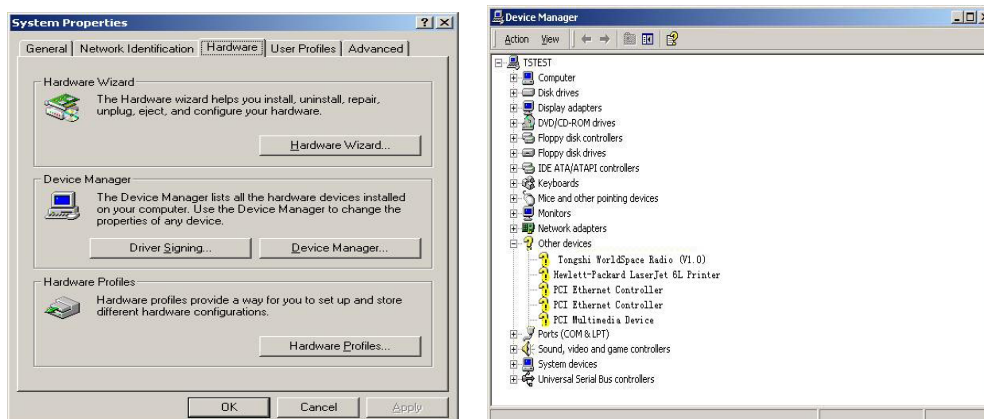

- ◆ In Win98/Me, click "Remove" button (In Win2000/XP, click right button will pop up a menu, then click "Uninstall..."), "Confirm Device Removal" dialog box pops up, click "OK" to remove the DAMB-R.



Please reboot your computer and install driver according to chapter Three, section 4.

Appendix F Country-List for AsiaStar™

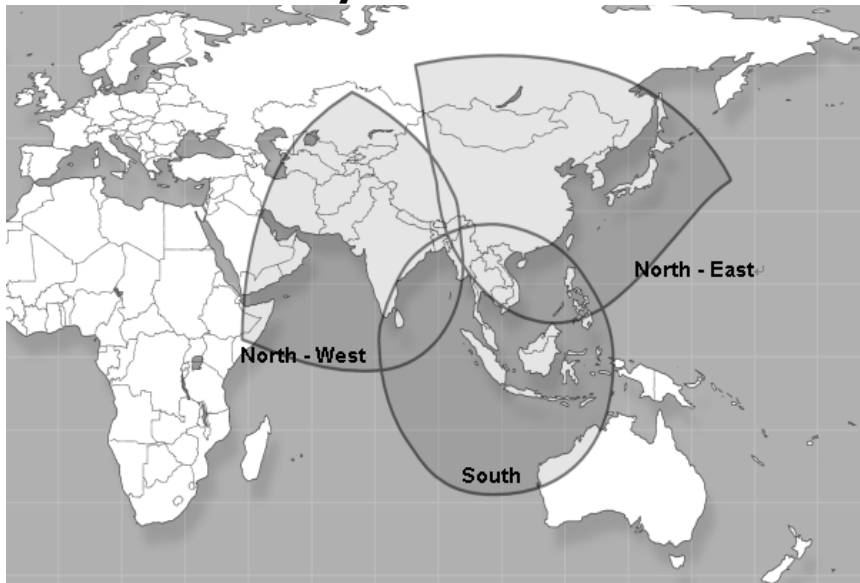

WorldSpace AsiaStar™					
"- of azimuth express southwest		This country coverage list is valid only for an unobstructed line of side connection to the satellite.			
"+ of azimuth express southeast					
Country	Azimuth	Elevation	Country	Azimuth	Elevation
Afghanistan	55	33	Kyrgyzstan	41	33
Christm.lsl. (Australia)	-177	78	Laos	3	68
Bahrain	72	24	Malaysia	-51	84
Bangladesh	33	58	(Kuala Lumpur)	46	85
Bhutan	30	54	(Kuching)	-74	84
Brunei	-65	78	Maldives	83	53
Burma	24	64	Mongolia	2	37
Cambodia	0	75	Nepal	39	50
China	3	51	North Korea	-32	38
(Yining)	32	34	Oman	73	31
(Chongqing)	-3	56	Pakistan	55	38
(Canton)	-20	61	Palau	-79	56
(Shanghai)	-30	49	Philippines	-58	66
India	52	52	Qatar	73	24
(Bombay)	62	47	Russian Federation	16	17

(Madras)	64	58	(Irkutsk)	1	30
(Kalkutta)	37	58	(Magadan)	-50	12
Indonesia	-100	76	(Chabarowsk)	-38	27
(Medan)	60	82	Saudi Arabia	77	20
(Jambi)	139	88	Singapore	43	88
(Jakarta)	-164	82	Somalia	87	24
(Surabaya)	-135	77	South Korea	-36	42
(Manado)	-86	67	Sri Lanka	74	60
Iran	66	25	Taiwan	-35	57
Japan	-48	36	Tajikistan	47	33
(Naha)	-43	50	Thailand	18	74
(Osaka)	-46	38	Turkmenistan	59	25
(Tokyo)	-50	35	United Arab Emirates	71	28
(Sapporo)	-47	28	Uzbekistan	53	27
Kazakhstan	45	24	Vietnam	-4	71
Kuwait	73	20	Yemen	80	23

Appendix G Country-List for AfriStar™

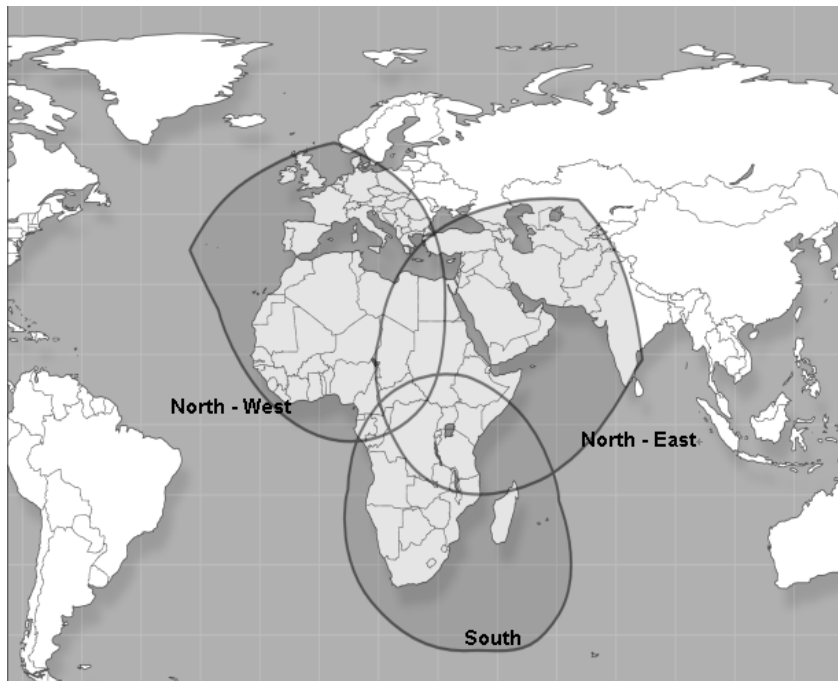

WorldSpace AfriStar™					
"-“of azimuth express southwest			This country coverage list is valid only for an unobstructed line of		
"+“of azimuth express southeast			side connection to the satellite.		
Country	Azimuth	Elevation	Country	Azimuth	Elevation
Afghanistan	-60	29	Libya	7	58
Algeria	36	52	Madagascar	-125	53
Andorra	28	37	Malawi	-135	69

Angola	166	75	Mali	57	56
Armenia	-34	37	Malta	11	48
Azerbaijan	-38	36	Mauritania	61	47
Bahrain	-52	45	Mayotte (France)	-116	58
Benin	64	65	Mocambique	-141	63
Botswana	-172	64	Morocco	45	42
Burkina Faso	62	60	Namibia	170	64
Burundi	-111	79	Niger	34	66
Cameroon	56	78	Nigeria	56	71
Cape Verde	75	36	Oman	-64	43
Centr.African.Repub.	8	82	Pakistan	-66	28
Chad	8	72	Portugal	41	36
Comores	-116	60	Portugal (Azores)	61	24
Congo	102	83	Portugal (Madeira)	55	34
Corse (France)	17	40	Qatar	-54	45
Cyprus	-21	47	Rwanda	-103	79
Dem.Rep.of Congo	-136	86	Sao Tome and Princi.	89	73
Djibouti	-63	62	Sardegna (Italy)	18	42
Egypt	-19	57	Saudi Arabia	-49	51
Equatorial Guinea	82	77	Senegal	71	46
Eritrea	-52	62	Seychelles	-101	52
Ethiopia	-64	66	Sierra Leone	77	51
France	25	33	Socotra (Yemen)	-71	50
Gabon	93	79	Somalia	-79	59
Gambia	71	46	South Africa	-171	56
Georgia	-32	36	Spain	35	37
Ghana	71	63	Spain (Isl.Baleares)	28	40
Guinea	73	51	Spain (Isl.Canarias)	58	38
Guinea-Bissau	74	46	Sudan	-33	71
Iran	-51	38	Swaziland	-158	57
Iraq	-38	45	Syria	-29	45
Israel	-25	50	Tanzania	-115	72
Italy	13	40	Togo	68	65
Ivory Coast	75	58	Tunisia	20	48
Jemen	-62	54	Turkey	-22	43
Jordan	-28	50	Turkmenistan	-51	30
Kenya	-89	70	Uganda	-84	76
Kriti (Greece)	-6	49	Unit.Arab.Emirate	-59	44
Kuwait	-45	45	Vatican City	13	41
Lebanon	-26	47	Western Sahara	59	42
Lesotho	-166	55	Zambia	-154	72
Liberia	79	54	Zimbabwe	-155	65

Free Manuals Download Website

<http://myh66.com>

<http://usermanuals.us>

<http://www.somanuals.com>

<http://www.4manuals.cc>

<http://www.manual-lib.com>

<http://www.404manual.com>

<http://www.luxmanual.com>

<http://aubethermostatmanual.com>

Golf course search by state

<http://golfingnear.com>

Email search by domain

<http://emailbydomain.com>

Auto manuals search

<http://auto.somanuals.com>

TV manuals search

<http://tv.somanuals.com>