



Installation Manual
XM Satellite Weather and Radio Wireless Receiver
Model No. XMD076A

Revision Level: C
Revision Date: 06/22/06
Document Control No.: XMD076A-3
File Name: XMD076A-3_C.doc

This document contains copyrighted material and confidential trade secret information belonging exclusively to Heads Up Technologies, Inc. Unauthorized use, disclosure, or duplication of any of this material may result in liability under applicable laws.

Approvals:

Prepared By:

J. Header, Engineering

Checked By:

M. Wootton, Engineering

Approved By:

D. Groos, Marketing

Heads Up Technologies, Inc.
2033 Chenault Dr., Suite 100
Carrollton, Texas 75006



Important Information

CHANGES OR MODIFICATIONS TO THIS DEVICE NOT EXPRESSLY APPROVED BY THE MANUFACTURER COULD VOID THE USERS AUTHORITY TO OPERATE THE EQUIPMENT.

WARNING: INFORMATION SUBJECT TO EXPORT CONTROL LAWS

This manual may contain information subject to the International Traffic in Arms Regulation (ITAR) or the Export Administration Regulation (EAR) of 1979 which may not be exported, released, or disclosed to foreign nationals inside or outside of the United States without first obtaining an export license. A violator of the ITAR or EAR may be subject to a penalty of up to 10 years imprisonment and a fine of up to \$1,000,000 under 22 USC 2778 of the Arms Export Control Act of 1976 or section 2410 of the Export Administration Act of 1979. Include this notice with any reproduced portion of this document.

PROPRIETARY NOTICE

NOTICE: FREEDOM OF INFORMATION ACT (5 USC 552) AND DISCLOSURE OF CONFIDENTIAL INFORMATION GENERALLY (18 USC 1905).

This document and the information disclosed herein are proprietary data of Heads Up Technologies. Neither this document nor the information contained herein shall be used, reproduced, or disclosed to others without the written authorization of Heads Up Technologies, except to the extent required for installation or maintenance of recipient's equipment. This document is being furnished in confidence by Heads Up Technologies. The information disclosed herein falls within exemption (b) (4) of 5 USC 552 and the prohibitions of 18 USC 1905.

SOFTWARE COPYRIGHT NOTICE

COPYRIGHT, 1998, 1999, 2000, 2001, 2002, 2003, 2004, 2005, 2006
HEADS UP TECHNOLOGIES

All software resident in this equipment is protected by copyright.

We welcome your comments concerning this manual. Although every effort has been made to keep it free from errors, some may occur. When reporting a specific problem, please describe it briefly and include the manual number, the paragraph or figure number, and the page number.

Please submit comments regarding this manual to the following address:

Document Control Manager
Heads Up Technologies
2033 Chenault Dr., Suite 100
Carrollton, TX 75006-5097



Installation Manual XMD076A

Revision Record

Revision Level	Description of Changes	Author	Approved by	Release Date
-	Initial Release	JH	DJG	9/27/05
A	Added Bluetooth antenna specifications and professional installation warning.	JH	DJG	11/18/05
B	Changed Satellite Antenna cable requirements: Added Section 2.4.1 and changed Note 3 in App. B diagram. Added pre-activation information for XM Radio operation. Updated XM Radio phone number.		DJG	04/05/06
C	Antenna coax cable length equation re-formatted to avoid confusion.	JH	JH	06/22/06



Table of Contents

Section	Description	Page
1.0	GENERAL INFORMATION	1
1.1	EQUIPMENT DESCRIPTION	1
1.2	TECHNICAL SPECIFICATIONS	3
1.2.1	<i>Environmental Qualification Identification.....</i>	<i>3</i>
2.0	INSTALLATION INSTRUCTIONS	4
2.1	UNPACKING AND INSPECTION.....	4
2.2	SYSTEM IDENTIFICATION NUMBERS.....	4
2.3	XMD076A RECEIVER INSTALLATION.....	5
2.3.1	<i>Installation Considerations</i>	<i>5</i>
2.3.2	<i>Mounting the XMD076A</i>	<i>5</i>
2.3.3	<i>Electrical Interface Wiring.....</i>	<i>6</i>
2.3.4	<i>Electrical Load Analysis</i>	<i>8</i>
2.4	XM SATELLITE ANTENNA INSTALLATION CONSIDERATIONS	9
2.4.1	<i>Antenna Coaxial Cable Installation.....</i>	<i>9</i>
2.4.2	<i>Interference from VHF and SATCOM Transmitters</i>	<i>10</i>
2.5	WEIGHT AND BALANCE.....	12
3.0	SYSTEM CHECKOUT	13
3.1	INITIAL INSTALLATION VALIDATION TEST	13
3.2	SYSTEM TEST	13
3.2.1	<i>Service Activation</i>	<i>13</i>
3.2.2	<i>Power System and Initial Test</i>	<i>14</i>
3.3	GROUND EMI CHECK	17
4.0	FACTORY SERVICE POLICIES	18
4.1	TECHNICAL SUPPORT	18
4.2	GENERAL SERVICE PROCEDURES	18
APPENDIX A ENVIRONMENTAL QUALIFICATION FORMS		19
APPENDIX B MECHANICAL INSTALLATION DIAGRAM.....		22
APPENDIX C ELECTRICAL INSTALLATION DIAGRAM.....		23



1.0 General Information

This manual provides product description and installation reference information for the Heads Up Technologies XMD076A XM Satellite Weather and Radio Wireless Receiver.

This receiver is for use with specific Avidyne XM WX software equipped Multi-Function Displays (MFD's) only. Please refer to the Avidyne MFD documentation for software configuration requirements and operating instructions.

1.1 Equipment Description

The XMD076A is a dual function device serving as a broadcast datalink for the cockpit MFD and provides entertainment audio. The XMD076A receives streaming weather and audio data transmitted from XM Satellite Radio, Inc. The XMD076A is a remote mounted "sensor" which requires 14-28V DC power, ground, a connection to an external antenna and audio interface. It interfaces to the MFD over a single receive/transmit pair of RS232 signals. Audio interfaces include headphones or connection to aircraft audio panels.

A complete system would consist of the following components, sold separately:

- Heads Up Technologies XMD076A (illustrated here)

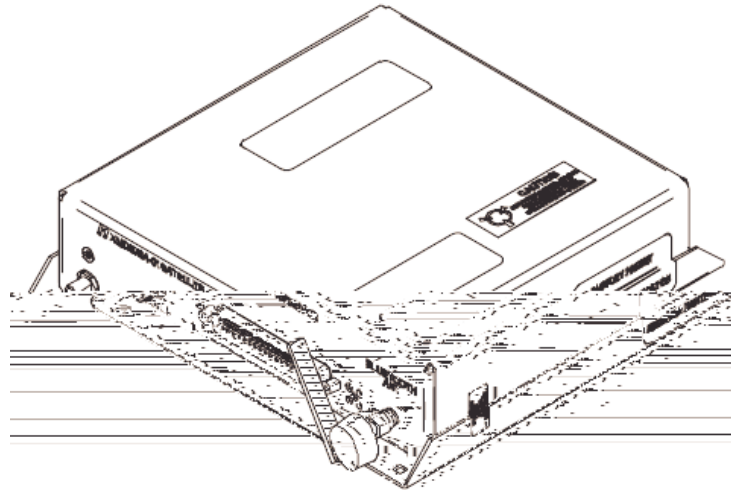



Installation Manual XMD076A

- XMC050 XM Radio
Wireless Remote
Controller (illustrated here)

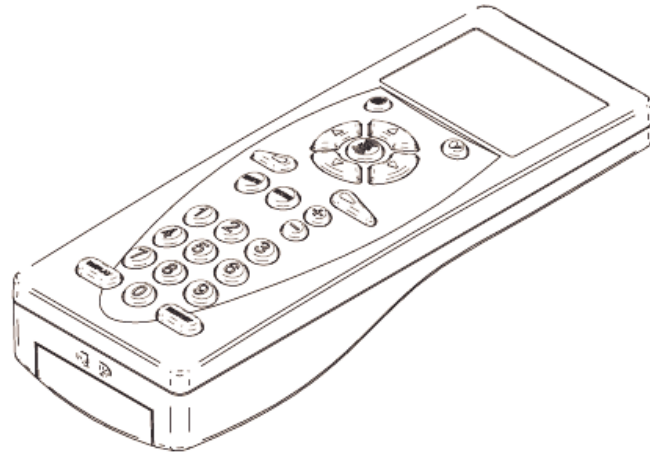

- Many options of XM Satellite Radio certified antennas are available and manufactured by Comant Industries. Single and combination function antennas are available. For a complete listing of available antennas, contact the Heads Up Technologies sales department at:

Email: info@heads-up.com **Web:** www.heads-up.com

Voice: 972-980-4890 **Fax:** 972-980-4843

- Optional system installation kit including necessary connectors and installation documentation



1.2 Technical Specifications

STANDARD FEATURES	
Display	None. User interface through XMC050 controller
WX Interface	RS232, 115.2Kbaud, No parity, 8-bit, 1 stop bit
Audio Interface (Typical)	Stereo 600-ohm balanced transformer, 0dBV nominal level, <-50dBV (when muted) to +12dBV (Full volume)
Wireless Link	Bluetooth Class 2 (low power, 25 Ft. LOS Range) FCC ID # TGVXMSC63. This device complies with Part 15 of the FCC rules subject to the following two conditions: 1. This device may not cause harmful interference. 2. This device must accept all interference received, including interference that may cause undesired operation.
Wireless Antenna	GigaAnt Titanis 2.4GHz, P/N 2010B4844-01 Gain: 4.4dBi
PHYSICAL CHARACTERISTICS	
Receiver Weight	1.7 lbs.
Receiver Dimensions H, W, L	1.8 X 6.5 X 7.8 Inches (Refer to Appendix B for more detail)
Antenna Weight	Refer to specific antenna installation drawing
OPERATING LIMITS	
Power Input Voltage	11-32VDC, negative ground
Steady State Current	0.63A at 11.0VDC minimum power input voltage 0.48A at 13.8VDC power input voltage 0.26A at 27.6VDC power input voltage

1.2.1 Environmental Qualification Identification

IAW RTCA DO-160E Appendix A and Heads Up Technologies document XMD076A-34, the following environmental category identification applies to the XMD076A:

“DO-160E Env. Cat.,[(F2)X]BBB[SBM]HXXXXFXZ[(B)(Z)]AZ[ZC][RR]M[Z2XXX]XXAX”

For a description of the equipment categories, refer to Environmental Qualification Forms included in Appendix A.



2.0 Installation Instructions

2.1 Unpacking and Inspection

Verify all ordered parts were received and sustained no shipping damage. Where evidence of shipping damage exists, save the shipping carton and packing material to help substantiate your claim to the shipping company. Retain the original shipping carton and packing material in case you need to ship the unit for service.

2.2 System Identification Numbers

Take note of the (3) identification numbers that will be needed later after installation. The numbers are used for activating the XM Satellite Weather and Radio services, and communication addressing with the XMC050 controller. These numbers are as follows:

- Receiver ID – This is a 2-digit number printed on the nameplate next to the 9-digit serial number. This number will be the “receiver ID” set in the remote controller per the XMC050 user guide.
- Satellite Radio ID – This is the 8-digit alphanumeric code printed on the placard marked “Audio” located on the rear of the XMD076A. This code will be presented to XM Satellite Radio for activation of the audio portion of the XMD076A.
- Satellite Weather ID – This is the 8-digit alphanumeric code printed on the placard marked “Weather” located on the rear of the XMD076A. This code will be presented to XM Satellite Radio for activation of the weather portion of the XMD076A.

NOTE:

For installation purposes only, temporary XM WX Satellite Weather and XM Satellite Radio services are pre-activated from the factory **This activation will terminate automatically without prior notice. To avoid unexpected deactivation, customers should contact XM Satellite Radio Inc. to transfer the subscriptions immediately after installation.**



2.3 XMD076A Receiver Installation

2.3.1 Installation Considerations

The XMD076A is intended for application as a “sensor” to the MFD, providing a datalink to the weather information transmitted by XM Satellite Radio. The software contained in the XMD076A meets the requirements of RTCA DO-178B, Level E.

2.3.1.1 Location

The XMD076A shall be installed in any interior location of the aircraft that is within the environmental limits specified in Section 1.2.1. The receiver location should be at least 12 inches away from transmitting radio equipment and is within 40 feet of cable to the XM antenna.

2.3.1.2 Orientation

The XMD076A can be positioned in any orientation, however the effects of condensation that could develop in the selected area of the aircraft should be considered. If the XMD076A is located in such areas, the XMD076A should be positioned to prevent condensation from entering the D-Sub inter-connect as water wicks through the wire harness. Drip loops routed in the harness can usually prevent such action.

Another consideration to the orientation of the XMD076A is to allow easier viewing of the on-board power-on indicator during troubleshooting. The power LED is located next to the main interface connector, J1.

2.3.1.3 Cooling

The XMD076A is not equipped with air vents or fans, which can be blocked and therefore this consideration is not required.

2.3.1.4 XMD076A and XMC050 Communications

The wireless communications between the receiver and the controller uses Bluetooth Class 2 technology. This wireless link has a line-of-sight (LOS) range of at least 25-ft. Since the XMD076A is typically located in remote locations of the aircraft, this range must be considered. In addition, if the XMD076A is located in an effective radio frequency shielded area, the link may be weak or unable to be established.

In such cases where the location of the XMD076A may produce undesired operation with the XMC050 controller, the on-board antenna of the XMD076A can be extended. Refer to Section 2.3.3.1 for more information.

2.3.2 Mounting the XMD076A

The XMD076A should be securely mounted to the aircraft structure using the (4) provided #10 diameter mounting holes IAW AC 43.13-2A, Chapter 2. An interface



Installation Manual

XMD076A

bracket or plate can be fabricated to attach to the aircraft structure, as required, IAW AC 43.13-2A, Chapter 2.

The mounting of the XMD076A enclosure must provide a DC bond to airframe ground of 0.003 Ohms or less.

2.3.3 Electrical Interface Wiring

Refer to Appendix C for system wiring diagrams and wire type requirements. Wiring is to be performed IAW AC 43.13-1B, Chapter 11. The following connectors or similar, support the XMD076A and antenna installation:

Designation Box/Wiring	Vendor	Part Number	Description
P1	Military Specification	M24308/2-4F	D-Sub 37 Socket (Female) mates to the XMD076A J1
Ant. IN	Tyco/Amp	225532-3	M39012 SMA Plug, Straight
Ant. IN	Tyco/Amp	225609-3	M39012 SMA Plug, R/A

2.3.3.1 Wiring Notes

The following notes apply to aircraft wiring to be used with the XMD076A and antenna installation:

1. Power, P1-19: Use 22AWG (M22759/16-22 or equivalent) wire fed from a 1-Amp circuit breaker for both 14V and 28V aircraft.
2. Power Enable, P1-18: Must be energized for system operation. Apply power through switch or jumper to P1-19.
3. RS-232: P1-22, 4 and 23: Use 22AWG shielded triple, M2750022TE3T14 or similar with a maximum length of 50-feet. Connect dedicated signal ground (J1-23) to the MFD signal ground. Terminate shield on both ends to the P1 backshell and the MFD connector shell or chassis ground.
4. Stereo Audio Output: P1-20, 1, 21 and 2. Stereo entertainment audio is provided from left and right 600-ohm transformer balanced outputs. This stereo entertainment output has sufficient output impedance and level range to be connected directly to headphones or to the "music" input of various crew audio panels or intercom systems. Connection directly to speakers is not recommended.

The illustration below is for a headphone jack:

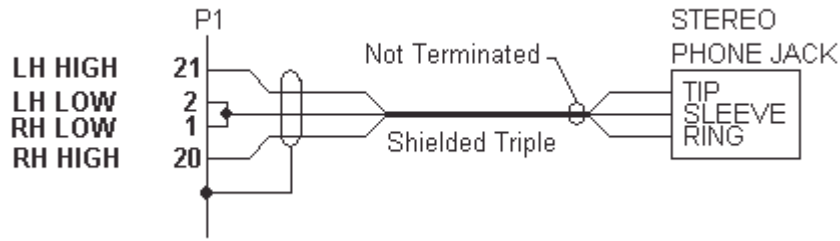

NOTE: Use a ground isolated headphone jack where the “sleeve” of the jack is not electrically connected to the aircraft ground. If the audio cable run is less than 10 Ft. from the receiver to the jack, then ground isolation should not be required.

The below illustrations show typical connections to aircraft audio panels:

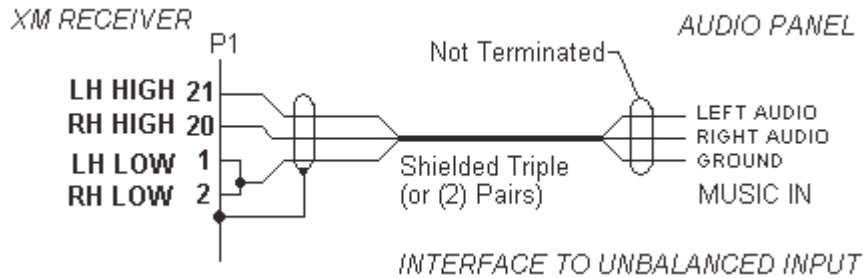
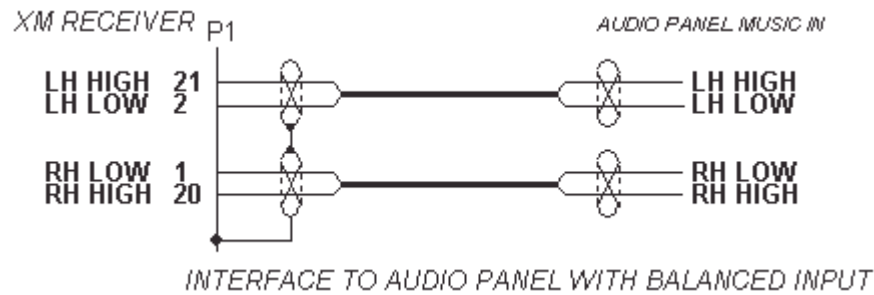

5. Audio Muting: The XMD076A is equipped with a discrete input (active ground) that immediately mutes the audio, bypassing any volume control input from the user. In cases where the XMD076A audio is not routed through the aircraft audio panel and connected directly (such as to headphones or amplified speakers), this function may be required.
6. Satellite Antenna: Refer to Section 2.4 for antenna installation information.
7. Wireless Antenna Extension: If required, the on-board Bluetooth Antenna of the receiver can be re-located exactly as shown below to allow the wireless link to reach the cabin area of the aircraft.



Installation Manual XMD076A

WARNING: The below extension shall be performed by a professional installer and only after determining through analysis or test that this extension is necessary for proper operation.

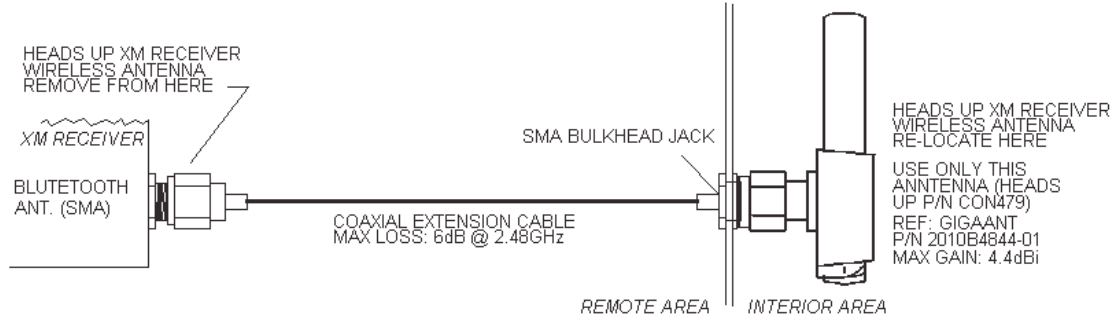

8. Ground Terminations: Wire ground straps used to terminate cable shields and equipment shall be as short as possible. All bonds shall be 0.003 Ohms or less.

2.3.4 Electrical Load Analysis

Prior to installation, an electrical load analysis should be performed specific to the aircraft. This analysis should be IAW AC 43.13-1B, Chapter 11. The following values may be used to support the analysis:

Equipment	14 VDC Aircraft Nominal/Maximum Load	28 VDC Aircraft Nominal/Maximum Load
XMD076A	0.48 A	0.26 A

2.3.4.1 Power Circuit Protection

The power input to the XMD076A shall be circuit protected IAW the guidelines of AC 43.13-1B, Chapter 11, Section 2. A 1-Amp circuit breaker is required for use with the XMD076A.



2.4 XM Satellite Antenna Installation Considerations

The XMD076A is designed for use with various XM Radio type-certified antennas covering the S-Band from 2.332 GHz to 2.345 GHz. Due to the low signal levels inherent with satellite communications, the following guidelines and recommended practices should be adhered to for the design of the antenna installation:

- Install IAW AC 43.13-2A Chapter 3, AC 43.13-1B Chapter 11, antenna manufacturer instructions, and in a manner acceptable to the administrator.
- Mount the antenna on the top of the aircraft to an external surface such as the fuselage, away from vertical obstructions as to not “shadow” the antenna from line-of-sight reception of the satellites. (Mount antenna as high on the fuselage as practical). Relocation of other less location-sensitive transmitters may be necessary to achieve optimal XM reception performance.
- The mounting of the antenna must provide an electrical bond of 0.003 Ohms or less the airframe ground.

2.4.1 Antenna Coaxial Cable Installation

The correct cable loss of the antenna feed cable is critical to the performance of the system operation. The design configuration of the receiver’s input is preset to expect a total gain range of 22dB (+/- 2dB).

Typical XM Radio type-certified aircraft antennas are configured with a total gain of 30-34dB where 10dB of total cable loss provides the correct gain to the receiver. Always refer to the antenna specifications to insure the correct gain. If desired, additional loss of 0.3dB for each SMA connector can be added but is not crucial to system performance.

Table 1 below provides reference information for lengths for various 50-ohm cable types that are commonly used with SMA connectors to produce the acceptable loss when used with antennas with 30-34dB of gain.



Table 1 - Cable Length Chart

RG Type (Mil-C-17)	Loss Rating (dB/100-Ft.) @ 2.339GHz	Length Range (Ft.) @ 8 - 12dB Loss
142	20.6	38.8 – 58.3
400	23.41	34.2 – 51.3
316	40.87	19.6 – 29.4
178	68.82	11.62 – 17.4

When antennas of other gain values or other cable types are installed, the cable length can be determined using the equation below:

$$\text{Cable Length (Feet)} = \left(\frac{\text{Antenna Gain} - 22}{\text{Cable Loss Rating (in dB/100-Ft.)}} \right) \times 100$$

When the distance between the antenna and receiver is short, run the amount of cable required to meet the loss requirement and stow excess length. An alternative to stowing large amounts of excess cable is to install a low power RF attenuator in-line with the cable. This system requires a DC bias passing type attenuator that has a frequency rating that falls within the maximum satellite frequency of 2.345 GHz.

2.4.2 Interference from VHF and SATCOM Transmitters

- Mount the antenna no closer than 36 inches to VHF-Comm transmitters of 15 Watts or less. For more powerful transmitting antennas, XM separation should be a minimum of 48-inches. Installation pre-testing (see note below) should be performed if the separation is less than 60-inches.

If a XM/VHF-Comm combo style antenna is being installed and replacing the operation of an existing approved antenna installation, the existing separations are acceptable.

- SATCOM antennas transmit at 40 Watts and should be separated by the largest distance possible, or a minimum of 36-inches.
- When routing the XM antenna cable, the maximum possible separation from transmitter antenna feed cables must be considered, especially with SATCOM and other high power transmitters. Antenna feed cables of VHF transmitters of 15 Watts or less should only require a minimal separation.



Installation Manual

XMD076A

- Receive only antennas such as ADF and GPS do not produce interference and require little separation. The XM antenna should be placed as close as possible to these types of antennas to gain separation from transmitters.

NOTE:

Installation pre-testing is advised if this installation is being performed on several similar aircraft such as a fleet. A pre-test can be performed by mounting the antenna on a piece of aluminum sheet, approximately 24" in diameter or square, to serve as a temporary ground plane. This antenna assembly would then lay on the aircraft skin near the proposed installation location for an active ground test prior to cutting mounting holes. This has proven both beneficial and cost effective in past fleet installations since all transmit equipment can be operated and tested for XM receiver interference prior to the actual installation.

NOTE:

This installation manual does not contain approved data for type specific aircraft antenna installations.



2.5 Weight and Balance

A Weight and Balance calculation of the aircraft is required as part of the installation approval process. Following the guidelines as established in AC 43.13-1B, Chapter 10, Section 2, the W/B of the aircraft can be calculated using the weights of the system components listed below.

Description	Weight (lbs.)
XMD076A Receiver	1.7
XMRANT-01 (standard XM Antenna)	0.26
For other XM antennas not listed, refer to the applicable antenna installation drawing.	



3.0 System Checkout

The following XMD076A system-checkout aides are intended to assure proper installation and interfacing to the MFD, antenna and audio system. Familiarize yourself with:

- The MFD operational guide for explanations of using the MFD to communicate with the XMD076A.
- The XMC050 Controller operations guide.
- The audio system configuration to verify the XMD076A audio performs as intended.

3.1 Initial Installation Validation Test

Before applying power to the system, verify and complete the following:

- 100% continuity check performed and satisfactory.
- All interconnects and ground connections are fully made and seated.
- The aircraft's power source is at the proper voltage, 11VDC - 16VDC for 14V aircraft and 22VDC - 32VDC for 28V aircraft.
- Move aircraft to an outdoor area with a clear view of the southern sky, free of buildings, trees or other obstructions.
- Verify the XMC050 remote controller is set to the "receiver ID" of the XMD076A. The "receiver ID" is located on the nameplate of the XMD076A.

3.2 System Test

3.2.1 Service Activation

The system requires two service activations from XM Satellite Radio Inc. - one for the XM WX Satellite Weather service and another for the XM Radio. For installation purposes only, temporary XM WX and the XM Radio services are pre-activated from the factory. **This activation will terminate automatically without prior notice. To avoid unexpected deactivation, customers should contact XM Satellite Radio Inc. at 1-800-985-9200 to transfer the subscriptions immediately after installation.**

NOTE: The weather activation process for the XMD076A is the same as the XMD076.

Please contact Heads Up Technologies via email at service@heads-up.com for additional information on the process to activate receivers if required.



3.2.2 Power System and Initial Test

1. Apply power to the XMD076A receiver and any other system applicable to the MFD or audio equipment. Some installations may include a WX Data power switch and if equipped, toggle to the ON position. The receiver is equipped with an on-board red LED indicator to show the receiver is powered-on.

XM WX: The MFD operations manual may be required to continue.

2. Power up the MFD. Go into Maintenance Mode using the procedure in the MFD installation manual and select the RS232 port to which the XM Receiver is wired.
3. Restart the MFD. Select the Trip page on the MFD. Press the Display button until Broadcast (a down pointing arrow) Status is displayed in the Display button label.
4. The MFD should report the “XM Serial Number” matching the “Satellite Weather ID” code noted in Section 2.2 above. The MFD should also show the Signal Quality of the XMD076A. If this data is shown on the MFD, the communication link between the MFD and receiver is operational.
5. If the Signal Quality is reported as “Good”, the antenna and cabling are installed correctly and are operating normally and, the aircraft is in view of at least one of the XM satellites.

Note: The “Satellite Weather ID” code must be presented to the aircraft owner, who will need it to acquire the subscription service and for other customer service needs with XM Satellite Radio.

6. If the Signal Quality is reported as “Marginal”, “Weak”, or “None”, reposition the aircraft away from obstructions to get a better view to the sky. After verification of the aircraft position and if the Signal Quality is still not “Good”, inspect the antenna and cable.
7. If the information is not reported, check the following:
 - The software configuration of the MFD. Verify the MFD is configured for use with the XMD076A (or XMD076). Refer to the MFD documentation.
 - The RS232 data wiring to the MFD. Refer to Appendix C and Section 2.3.3 for wiring information.
 - Power to the XM receiver. Verify red power indicator (located next to J1) on the XM receiver is illuminated.

XM Audio: The XMC050 operations manual may be required to continue.

8. Power up the XMC050 controller and set the “Receiver ID” as required. If the “Receiver ID” is not known, put XMC050 controller in search mode as follows:



Installation Manual

XMD076A

- With the XMC050 powered, press the "receiver select" button on the remote (top right button).
 - Enter 4881 for password, then enter 88.
 - The display will show "Receiver ID Search". XMC050 is now searching for available receivers that are in range of the communication link (25 feet).
 - When a receiver is found, the display will change to "Receiver ID Found" and list the ID number of the receiver. Note: If multiple receivers are active, all of the receiver ID's will be listed. It is recommended to have only one receiver active at a time to avoid confusion.
 - Once the ID is determined, press the "receiver select" key again and type in the number then proceed at Step 9 below.
9. Verify the remote display is showing "Connecting to XX" where XX is the "Receiver ID" noted in Section 2.2 above. Allow at least 30-seconds for the initial connection link to establish. Ignore the connection retry message displayed on the controller during this time. Once this initial connection is made, further connections establish in a few seconds up the XMC050 controller and set the "Receiver ID" as required.
10. If the connection fails to establish after 1-minute, try the following:
- Move the controller closer to the XMD076A
 - Evaluate the location of the XMD076A and determine if an extension is required. Refer to Section 2.3.3.1(7) above.
 - Verify the XMD076A is still powered. Check circuit breaker, connectors, etc.
 - Verify the charge indicator on the controller display shows a good charge. Replace batteries as required.
11. Activate the audio equipment being fed by the XMD076A and adjust the volume using the XMC050 controller as needed.

NOTE:

At power-up, the XMD076A defaults to mute mode and will only output audio when connected to the XMC050 wireless controller.

12. Change the XM channel to zero, "0". The controller display should read "RADIO ID, SW VER" and verify the 8-digit code matches the "Satellite Radio ID" noted in Section 2.2 above.



Installation Manual XMD076A

Note: The “Satellite Radio ID” code must be presented to the aircraft owner, who will need it to acquire the subscription service and for other customer service needs with XM Satellite Radio.



3.3 Ground EMI Check

The following procedure is to be performed to verify that no interference is noted through the use of the XMD076A system on other aircraft systems and vice-versa. The operation of the XMD076A system shall not result in NAV flags, constant location lightning strikes on any installed Stormscope, noise on COMM channels, or other phenomena.

A ground test should be adequate for the XMD076A since it operates the same in flight. If some aircraft systems cannot be verified on the ground, a flight test may be required.

Operate the aircraft systems as listed below and check the operation of both that system and the XMD076A system.

NOTE:

The XMC050 wireless controller is designed to conserve battery power and will enter power-save mode if no key presses have been made for 30-seconds. During aircraft system checks, press any key such as the "MEMORY" key as required to keep the XMC050 in an active mode.

A. Comm Radios:

1. Scan through radio channels to ensure there is no interference caused by the XMD076A and XMC050 controller.
2. Check local ground and tower frequencies to ensure there is no break in squelch caused by the installation.
3. Monitor the signal strength values of the XMD076A on the MFD (refer to Sec. 3.2.2 above) and transmit on various frequencies.

B. GPS:

1. Ensure the correct position is displayed.
2. Verify no change in GPS signal strength with the XMD076A powered ON and OFF.

C. Autopilot:

1. Ensure the autopilot self-test passes OK with the XMD076A and XMC050 controller operating.

D. Other Aircraft Systems:

1. Verify that there is no adverse effect on flight instruments with the XMD076A operating.
2. Operate other aircraft systems, especially radio transmitters, while monitoring the XM signal strength values of the XMD076A on the MFD and XMC050 controller.



4.0 Factory Service Policies

4.1 Technical Support

Technical support or service questions may be submitted to the following:

Email: service@heads-up.com

Voice: **972-980-4890**

Fax: **972-980-4743**

A Heads Up Technologies customer support representative will respond as soon as possible. Heads Up Technologies business hours are 8:00 AM to 5:00 PM Central Time, Monday through Friday.

Issues with the MFD must be resolved through the MFD manufacturer.

4.2 General Service Procedures

Service of a XMD076A component performed at the factory typically includes an overhaul consisting of a thorough inspection, repair as needed and functional tests. Antennas that are used in this system are not serviceable and can only be inspected and tested. Faulty or damaged antennas must be replaced.

Prepare a packing slip that includes the part number(s) and serial number(s) of the items to be returned, along with a complete description of the problem, requested service and special instructions. The packing slip must also include a contact name, daytime telephone number and return shipping address.

To return an item, securely pack it in the original shipping container, if possible. Ship it to the address provided by the Heads Up Technologies customer service representative.



Appendix A Environmental Qualification Forms

XMD076A DO-160 Environmental Qualification Form

UUT NOMENCLATURE XM Weather / Radio Wireless Receiver, RS232 Type		
TYPE/MODEL/PART NO. XMD076A-01	TSO NUMBER N/A	
MANUFACTURER'S SPECIFICATION AND/OR OTHER APPLICABLE SPECIFICATION XMD076A-32, XMD076A-01 Qualification Test Plan		
MANUFACTURER Heads Up Technologies, Inc, 2033 Chenault Dr. #100 Carrollton, TX 75006		
REVISION & CHANGE OF DO-160 E, No Change	TESTING DATES 06-08-2005 and 07-01-2005	
TEST CONDITION	SECTION	QUALIFICATION CATEGORY / DESCRIPTION
TEMPERATURE AND ALTITUDE LOSS OF COOLING	4.0	F2 (-55°C+70°C, up to 55Kft) X
TEMPERATURE VARIATION	5.0	B (5°C/minute)
HUMIDITY	6.0	B (Severe Environment)
OPERATIONAL SHOCKS AND CRASH SAFETY	7.0	B (Crash: 20g random)
VIBRATION	8.0	S, Curves B and M
EXPLOSION	9.0	H (Env. II)
WATERPROOFNESS	10.0	X (Not qualified for this environment)
FLUIDS SUSCEPIBILITY	11.0	X (Not qualified for this environment)
SAND AND DUST	12.0	X (Not qualified for this environment)
FUNGUS	13.0	F (Qualified by Analysis)
SALT SPRAY	14.0	X (Not qualified for this environment)
MAGNETIC EFFECT	15.0	Z (0.3m separation)
POWER INPUT	16.0	B and Z 14V-28V (All A/C DC systems)
VOLTAGE SPIKE	17.0	A (600V)
AUDIO FREQUENCY SUSCEPIBILTY	18.0	Z
INDUCED SIGNAL SUSCEPTIBILITY	19.0	ZC
RF SUSCEPTIBILITY	20.0	RR (Standard HIRF)
EMISSION OF RADIO FREQUENCY	21.0	M (See Note ¹)
LIGHTNING INDUCED TRANSIENT SUSCEPTIBILITY	22.0	Z2XXX (Partially protected env.)

¹ This equipment intentionally transmits low power energy in the frequency range of 2.40 to 2.48GHz and is exempt from DO-160E Section 21.4. The EUT is qualified for these transmissions as a Class 2 Bluetooth wireless device under FCC part 15 regulations.



Installation Manual

XMD076A

UUT NOMENCLATURE XM Weather / Radio Wireless Receiver, RS232 Type		
TYPE/MODEL/PART NO. XMD076A-01	TSO NUMBER N/A	
MANUFACTURER'S SPECIFICATION AND/OR OTHER APPLICABLE SPECIFICATION XMD076A-32, XMD076A-01 Qualification Test Plan		
MANUFACTURER Heads Up Technologies, Inc, 2033 Chenault Dr. #100 Carrollton, TX 75006		
REVISION & CHANGE OF DO-160 E, No Change	TESTING DATES 06-08-2005 and 07-01-2005	
TEST CONDITION	SECTION	QUALIFICATION CATEGORY / DESCRIPTION
LIGHTNING DIRECT EFFECTS	23.0	X (N/A)
ICING	24.0	X (N/A)
ELECTROSTATIC DISCHARGE	25.0	A (15KV Human Contact)
FIRE AND FLAMMABILITY	26.0	X (Metal External Construction)

XMC050 DO-160 Environmental Qualification Form

UUT NOMENCLATURE XM Radio Wireless Controller		
TYPE/MODEL/PART NO. XMC050-()	TSO NUMBER N/A	
MANUFACTURER'S SPECIFICATION AND/OR OTHER APPLICABLE SPECIFICATION XMC050-32, XMC050 Env. Qualification Test Plan		
MANUFACTURER Heads Up Technologies, Inc, 2033 Chenault Dr. #100 Carrollton, TX 75006		
REVISION & CHANGE OF DO-160 E, No Change	TESTING DATES 06-20-2005 and 07-12-2005	
TEST CONDITION	SECTION	QUALIFICATION CATEGORY / DESCRIPTION
TEMPERATURE AND ALTITUDE LOSS OF COOLING	4.0	A1 (-15°C-+55°C, De-Comp- 55KFt) X
TEMPERATURE VARIATION	5.0	C (2°C/minute)
HUMIDITY	6.0	A (Standard Environment)
OPERATIONAL SHOCKS AND CRASH SAFETY	7.0	X (Not qualified for this environment)
VIBRATION	8.0	X (Not qualified for this environment)
EXPLOSION	9.0	X (Not qualified for this environment)
WATERPROOFNESS	10.0	X (Not qualified for this environment)
FLUIDS SUSCEPIBILITY	11.0	X (Not qualified for this environment)
SAND AND DUST	12.0	X (Not qualified for this environment)
FUNGUS	13.0	X (Not qualified for this environment)
SALT SPRAY	14.0	X (Not qualified for this environment)
MAGNETIC EFFECT	15.0	Z (0.3m separation)



Installation Manual

XMD076A

UUT NOMENCLATURE XM Radio Wireless Controller		
TYPE/MODEL/PART NO. XMC050-()	TSO NUMBER N/A	
MANUFACTURER'S SPECIFICATION AND/OR OTHER APPLICABLE SPECIFICATION XMC050-32, XMC050 Env. Qualification Test Plan		
MANUFACTURER Heads Up Technologies, Inc, 2033 Chenault Dr. #100 Carrollton, TX 75006		
REVISION & CHANGE OF DO-160 E, No Change	TESTING DATES 06-20-2005 and 07-12-2005	
TEST CONDITION	SECTION	QUALIFICATION CATEGORY / DESCRIPTION
POWER INPUT	16.0	X (Not qualified for this environment)
VOLTAGE SPIKE	17.0	X (Not qualified for this environment)
AUDIO FREQUENCY SUSCEPTIBILITY	18.0	X (Not qualified for this environment)
INDUCED SIGNAL SUSCEPTIBILITY	19.0	X (Not qualified for this environment)
RF SUSCEPTIBILITY	20.0	X (Not qualified for this environment)
EMISSION OF RADIO FREQUENCY	21.0	M (See Note ²)
LIGHTNING INDUCED TRANSIENT SUSCEPTIBILITY	22.0	X (Not qualified for this environment)
LIGHTNING DIRECT EFFECTS	23.0	X (Not qualified for this environment)
ICING	24.0	X (Not qualified for this environment)
ELECTROSTATIC DISCHARGE	25.0	A (15KV Human Contact)
FIRE AND FLAMMABILITY	26.0	C (By comparison analysis to UL 94V-0)

² This equipment intentionally transmits low power energy in the frequency range of 2.40 to 2.48GHz and is exempt from DO-160E Section 21.4. The EUT is qualified for these transmissions as a Class 2 Bluetooth wireless device under FCC part 15 regulations.



Installation Manual XMD076A

Appendix B Mechanical Installation Diagram

XMD076A RECEIVER DIMENSIONS

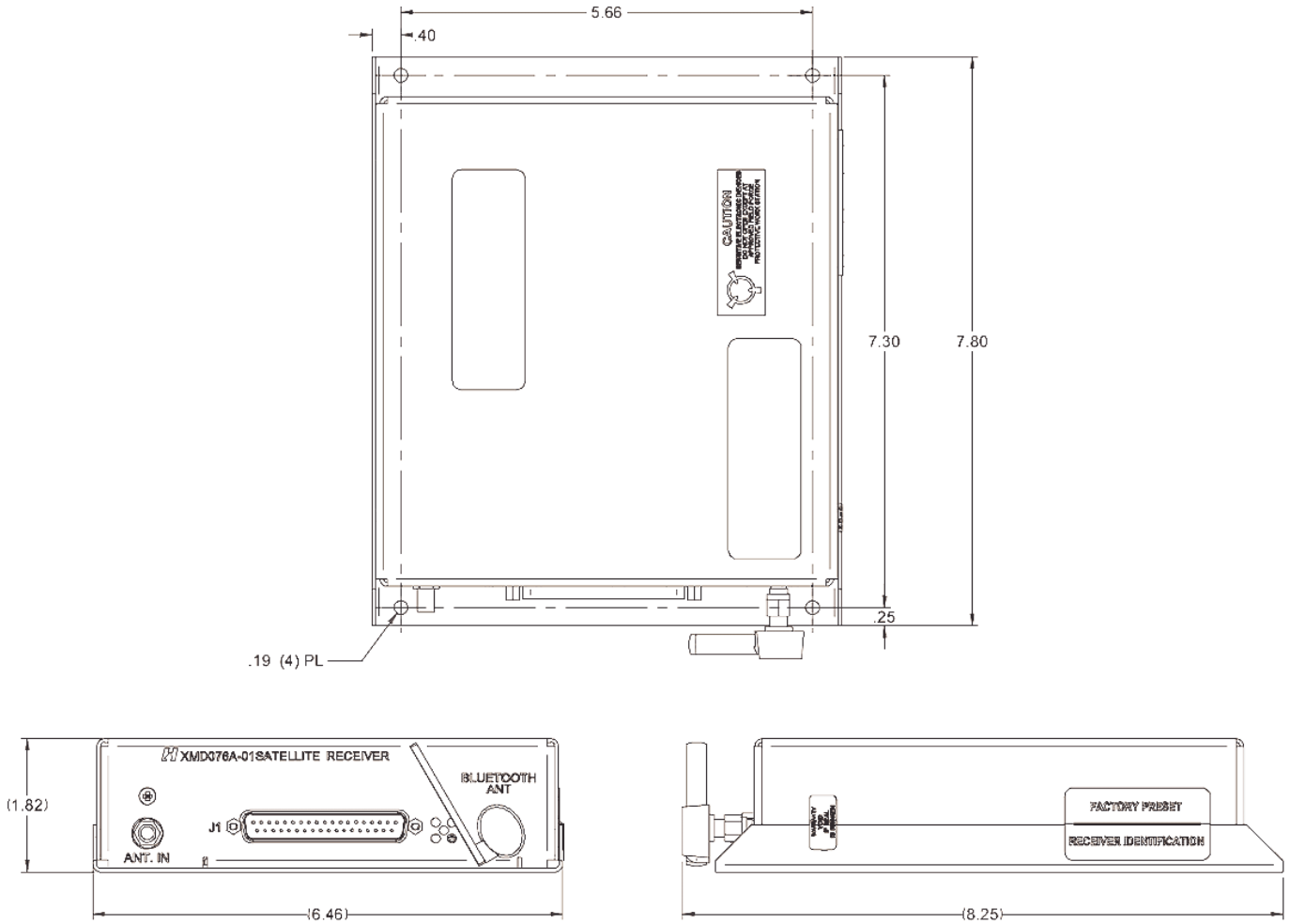

Appendix C Electrical Installation Diagram

XMD076A RECEIVER WIRING

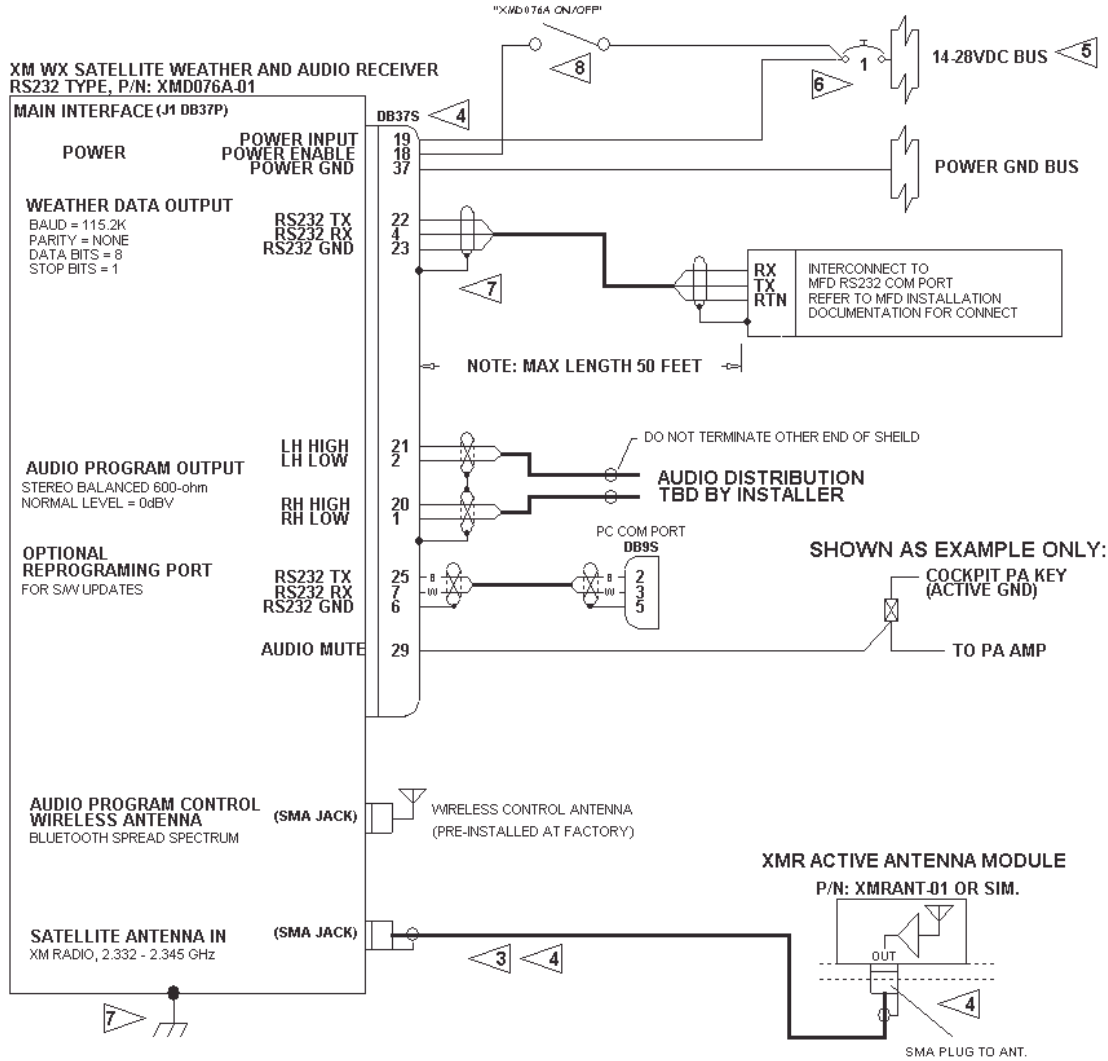

NOTES: UNLESS OTHERWISE SPECIFIED

- 1. ALL EQUIPMENT AND WIRING TO BE INSTALLED PER A/C MANUFACTURER AND FEDERAL AVIATION REQUIREMENTS, AS REQUIRED.
- 2. ALL WIRE PER M22579/16-22 AND CABLE PER M27500 22TE3T14 OR AS REQUIRED BY AIRCRAFT REQUIREMENTS.
- 3. REFER TO "XM SATELLITE ANTENNA INSTALLATION CONSIDERATIONS" SECTION FOR ANTENNA AND COAXIAL CABLE INSTALLATION REQUIREMENTS.
- 4. RECOMMENDED MATING CONNECTORS:
(SMA PLUG, STRAIGHT) TYCO/AMP P/N 225532-3
(SMA PLUG, R/A) TYCO/AMP P/N 225609-3
(DB37S) M24308/2-4F
RECOMMENDED CONNECTOR CRIMPERS:
(SMA PLUG) TYCO/AMP P/N 220061-1
(DB) M22520/2-01 AND M22520/2-08 POSITIONER
OTHER CONNECTORS USED ARE TBD BY INSTALLER.
- 5. POWER BUS VOLTAGE SHALL NOT EXCEED RTCA/DO160D CATEGORY B AND Z.
- 6. ALL WIRE, CABLE AND EQUIPMENT SHOWN FOR REFERENCE ONLY. TO BE SUPPLIED BY INSTALLER/USER.
- 7. MOUNTING STRUCTURE SHALL PROVIDE CHASSIS GROUND CONNECTION TO AIRFRAME GROUND. CABLE SHIELDS TO BE TERMINATED TO CONNECTOR BACKSHELL.
- 8. ENERGIZE (APPLY 14-28VDC/30mA) POWER ENABLE FOR UNIT OPERATION. USE SWITCH AS SHOWN OR OR JUMPER DIRECT TO POWER WIRE.

Free Manuals Download Website

<http://myh66.com>

<http://usermanuals.us>

<http://www.somanuals.com>

<http://www.4manuals.cc>

<http://www.manual-lib.com>

<http://www.404manual.com>

<http://www.luxmanual.com>

<http://aubethermostatmanual.com>

Golf course search by state

<http://golfingnear.com>

Email search by domain

<http://emailbydomain.com>

Auto manuals search

<http://auto.somanuals.com>

TV manuals search

<http://tv.somanuals.com>