

Smart choice for power

**xantrex**

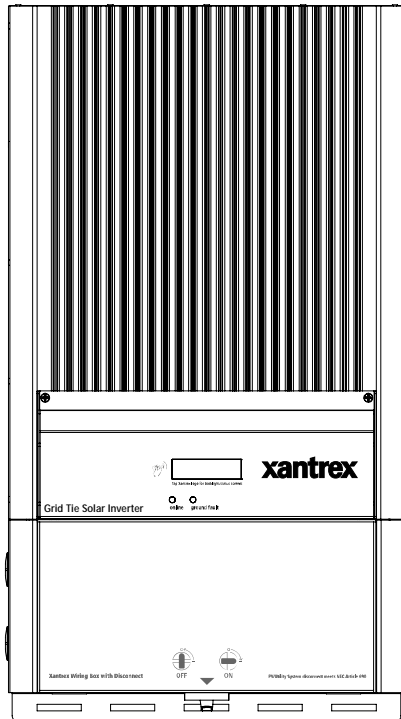

GT5.0-NA

Owner's Manual

# Xantrex Grid Tie Solar Inverter

[www.xantrex.com](http://www.xantrex.com)



# Xantrex Grid Tie Solar Inverter

## Owner's Manual

## About Xantrex

Xantrex Technology Inc. is a world-leading supplier of advanced power electronics and controls with products from 50 watt mobile units to one MW utility-scale systems for wind, solar, batteries, fuel cells, microturbines, and backup power applications in both grid-connected and stand-alone systems. Xantrex products include inverters, battery chargers, programmable power supplies, and variable speed drives that convert, supply, control, clean, and distribute electrical power.

## Trademarks

Xantrex Grid Tie Solar Inverter is a trademark of Xantrex International. Xantrex and Xanbus are registered trademarks of Xantrex International.

Other trademarks, registered trademarks, and product names are the property of their respective owners and are used herein for identification purposes only.

## Notice of Copyright

*Xantrex Grid Tie Solar Inverter Owner's Manual* © November 2006 Xantrex International. All rights reserved.

## Exclusion for Documentation

UNLESS SPECIFICALLY AGREED TO IN WRITING, XANTREX TECHNOLOGY INC. ("XANTREX")

(A) MAKES NO WARRANTY AS TO THE ACCURACY, SUFFICIENCY OR SUITABILITY OF ANY TECHNICAL OR OTHER INFORMATION PROVIDED IN ITS MANUALS OR OTHER DOCUMENTATION.

(B) ASSUMES NO RESPONSIBILITY OR LIABILITY FOR LOSSES, DAMAGES, COSTS OR EXPENSES, WHETHER SPECIAL, DIRECT, INDIRECT, CONSEQUENTIAL OR INCIDENTAL, WHICH MIGHT ARISE OUT OF THE USE OF SUCH INFORMATION. THE USE OF ANY SUCH INFORMATION WILL BE ENTIRELY AT THE USER'S RISK; AND

(C) REMINDS YOU THAT IF THIS MANUAL IS IN ANY LANGUAGE OTHER THAN ENGLISH, ALTHOUGH STEPS HAVE BEEN TAKEN TO MAINTAIN THE ACCURACY OF THE TRANSLATION, THE ACCURACY CANNOT BE GUARANTEED. APPROVED XANTREX CONTENT IS CONTAINED WITH THE ENGLISH LANGUAGE VERSION WHICH IS POSTED AT [WWW.XANTREX.COM](http://WWW.XANTREX.COM).

## Date and Revision

November 2006 Revision A

## Manual Part Number

975-0320-01-01

## Product Part Number

864-0118

## Contact Information

Telephone: 1 800 670 0707 (toll free North America)  
1 360 925 5097 (direct)

Fax: 1 360 925 5143 (direct)

Email: [customerservice@xantrex.com](mailto:customerservice@xantrex.com)

Web: [www.xantrex.com](http://www.xantrex.com)

# About This Manual

The purpose of this Owner's Manual is to provide explanations and procedures for installing, operating, maintaining, and troubleshooting the Xantrex Grid Tie Solar Inverter™.

## Scope

The manual provides safety guidelines, detailed planning and setup information. It provides procedures for installing the inverter and information about operating and troubleshooting the unit. It does not provide details about particular brands of photovoltaic (PV) panels. You need to consult individual PV manufacturers for this information.

## Audience

This manual does not provide sufficient information for anyone but a qualified installer to install this product. Installers should be electricians or technicians fully educated on the hazards of installing electrical equipment. The monitoring and operation information in this manual is intended for anyone who needs to operate a GT Inverter.

## Organization

This manual is organized into 6 chapters and an appendix.

Chapter 1 contains information about the features and functions of the Xantrex Grid Tie Solar Inverter.

Chapter 2 provides information about installing the GT Inverter. It contains information on determining a suitable location for installation, PV array requirements, and procedures for mounting the unit.

Chapter 3 provides information about DC and AC wiring, and grounding the GT Inverter and the PV array.

Chapter 4 contains information on starting up the Xantrex Grid Tie Solar Inverter and performing a functional test.

Chapter 5 contains information for understanding the LCD screens and the LED indicators.

Chapter 6 contains information about how to provide general maintenance for the Xantrex Grid Tie Solar Inverter. It also provides information about troubleshooting the unit.

Appendix A contains information about the specifications of the Xantrex Grid Tie Solar Inverter.

## Conventions Used

The following conventions are used in this guide.



### WARNING

Warnings identify conditions that could result in personal injury or loss of life.

---



### CAUTION

Cautions identify conditions or practices that could result in damage to the unit or other equipment.

---

**Important:** These notes describe things which are important for you to know, but not as serious as a caution or warning.

---

## Abbreviations and Acronyms

CEC	California Energy Commission
CSA	Canadian Standards Association
GT	Grid Tie
LCD	Liquid Crystal Display
LED	Light Emitting Diode
MPPT	Maximum Power Point Tracking
NEC	US National Electrical Code NFPA-70
PV	Photovoltaic
PVGFP	PV Ground Fault Protection
STC	Standard Test Condition
UL	Underwriters Laboratories
Vac	Volts AC
Vdc	Volts DC
$V_{MPP}$	Voltage at Maximum Power
$V_{OC}$	Open Circuit Voltage

## Symbols Used



Ground



In this guide: Important information, warnings, or cautions.  
On the product: Important information, warnings or cautions with further explanation in the product guide.



Caution, risk of electric shock.



Hot surface—risk of burns.



5 min.

**FOR AUTHORIZED SERVICE PERSONNEL:** Before opening cover, disconnect DC and AC power and wait 5 minutes to allow internal voltages to reach safe levels.

NOTE: there are no user-serviceable parts inside.



Refer to the operating instructions.

## Related Information

You can find more information about Xantrex Technology Inc. as well as its products and services at [www.xantrex.com](http://www.xantrex.com).





# Important Safety Instructions

SAVE THESE INSTRUCTIONS—This manual contains important instructions that shall be followed during the installation and maintenance of the Xantrex Grid Tie Solar Inverter.



## WARNING

The following warnings identify conditions or practices that could result in personal injury or loss of life.

1. Before installing and using the GT Inverter, read all instructions and cautionary markings on the inverter, wiring box, and all appropriate sections of this guide.
2. To reduce risk of fire hazard, do not cover or obstruct the heat sink.
3. Under some conditions, the GT Inverter heat sink can reach temperatures hot enough to cause skin burns if accidentally touched. Ensure that the GT Inverter is located away from normal traffic areas.
4. Use only accessories recommended or sold by the manufacturer. Doing otherwise may result in a risk of fire, electric shock, or injury to persons.
5. To avoid a risk of fire and electric shock, make sure that existing wiring is in good condition and that wire is not undersized. Do not operate the GT Inverter with damaged or substandard wiring.
6. Do not operate the GT Inverter if it has received a sharp blow, been dropped, or otherwise damaged in any way. If the GT Inverter is damaged, see the Warranty section.
7. Do not disassemble the GT Inverter. It contains no user-serviceable parts. See Warranty for instructions on obtaining service. Attempting to service the GT Inverter yourself may result in a risk of electrical shock or fire and will void the factory warranty.
8. Authorized service personnel should reduce the risk of electrical shock by disconnecting both AC and DC power from the GT Inverter before attempting any maintenance or cleaning or working on any circuits connected to the inverter. Turning off controls will not reduce this risk. Internal capacitors remain charged for 5 minutes after disconnecting all sources of power.
9. Normally grounded conductors may be ungrounded and energized when a ground fault is indicated.
10. The GT Inverter must be connected to an AC equipment-grounding conductor directly and a DC grounding electrode conductor to a single point ground.
11. The AC Neutral connection is for voltage sensing only and is not used as a current carrying conductor, nor is it bonded to ground.



## CAUTION

The following caution identifies conditions or practices that could result in damage to the unit or other equipment.

Observe the clearance recommendations as described on page 2–7. Do not install the GT Inverter in a zero-clearance or non-ventilated compartment. Overheating may result.

## Location of Safety and Data Labels

The figure below shows the location of the safety label and the data label with model, serial and part number information.

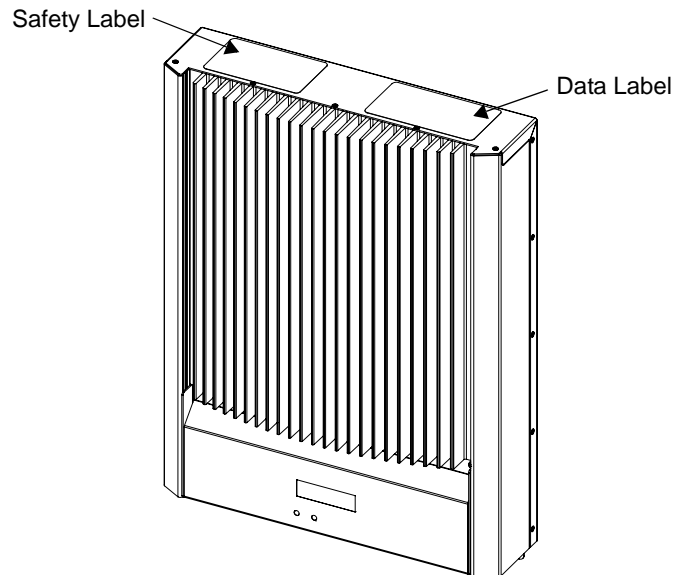

## FCC Information to the User

This equipment has been tested and found to comply with the limits for a Class B digital device, pursuant to part 15 of the FCC Rules. These limits are designed to provide reasonable protection against harmful interference in a residential installation. This equipment generates, uses and can radiate radio frequency energy and, if not installed and used in accordance with the instructions, may cause harmful interference to radio communications. However, there is no guarantee that interference will not occur in a particular installation. If this equipment does cause harmful interference to radio or television reception, which can be determined by turning the equipment off and on, the user is encouraged to try to correct the interference by one or more of the following measures:

- Reorient or relocate the receiving antenna.
- Increase the separation between the equipment and the receiver.
- Connect the equipment into an outlet on a circuit different from that to which the receiver is connected.
- Consult the dealer or an experienced radio/TV technician for help.

# Contents

<b>Important Safety Instructions</b> .....	<b>vii</b>
Location of Safety and Data Labels .....	viii
FCC Information to the User .....	viii
<b>1 Introduction</b>	
About the Xantrex Grid Tie Solar Inverter .....	1-1
Standard Features .....	1-2
Front Panel Features .....	1-3
Wiring/Disconnect Box .....	1-3
<b>2 Installation</b>	
Installation Options .....	2-1
Planning the Installation .....	2-1
Inverter Location .....	2-1
PV Array Voltage and MPPT Requirements .....	2-3
Mounting the Inverter .....	2-5
Dimensions and Knockout Locations .....	2-5
Installing the Mounting Bracket .....	2-6
Mounting the Inverter on the Bracket .....	2-8
<b>3 Wiring the Inverter</b>	
Grounding Requirements .....	3-1
Ground Fault Fuse .....	3-3
Wiring Requirements .....	3-4
AC Circuit Breaker Requirements .....	3-4
DC/AC Disconnect Switch .....	3-4
Accessing the Wiring Terminals .....	3-5
Connecting the DC Wiring .....	3-7
DC Wiring for Multiple Inverters .....	3-9
Connecting the AC Wiring .....	3-10
DC and AC Wiring for Multiple Inverters .....	3-11
Communications Wiring for Multiple Inverters .....	3-12
Xanbus Network Technology .....	3-12
Guidelines for Routing the Network Cables .....	3-15
Connecting Network Cable Between Multiple Inverters .....	3-15
Communications Wiring for Monitoring a Single Inverter .....	3-15

## 4 Starting the Inverter

Startup Procedure	4-1
Checking the PV Array DC Voltage	4-2
Checking the AC Utility Voltage	4-2
Replacing the Wiring/Disconnect Box Cover	4-2
Starting up the GT Inverter	4-3
Commissioning Multiple Inverters	4-3
Disconnect Test	4-5
Locating the Firmware Version Number	4-5

## 5 Monitoring the Inverter

Monitoring the Front Panel Display	5-1
Front Panel Display Screens and What They Mean	5-2
Startup Mode	5-2
Normal Operation Mode	5-4
Offline Mode	5-6
Fault Mode	5-8
Special Screens	5-10
Custom Screens	5-10
Status Indicator Lights	5-11

## 6 Maintenance and Troubleshooting

Factors Affecting GT Inverter Performance	6-1
PV Array Factors	6-1
Other Factors	6-2
Performing General Maintenance	6-3
Replacing Parts	6-3
Replacing the Ground Fault Protection Fuse	6-4
Replacing the Inverter	6-6
Identifying Error/Fault Conditions and Solutions	6-9

## A Specifications

Electrical Specifications	A-2
Input	A-2
Output	A-2
Adjustable Voltage, Frequency and Reconnection Settings	A-3
Output Power Versus Ambient Temperature	A-3
Efficiency	A-4
Environmental Specifications	A-4
User Display	A-4
Display Accuracy	A-5

---

Mechanical Specifications - - - - - A-5  
Regulatory Approvals - - - - - A-5  
**Warranty and Return Information - - - - -WA-1**  
**Index - - - - -IX-1**



# 1

## Introduction

Chapter 1 contains information about the features and functions of the Xantrex Grid Tie Solar Inverter.

### About the Xantrex Grid Tie Solar Inverter

The Xantrex Grid Tie Solar Inverter (GT Inverter) is designed to convert solar electric (photovoltaic or PV) power into utility-grade electricity that can be used by the home or sold to the local power company.

Installing the GT Inverter consists of mounting it to the wall and connecting the DC input to a PV array and the AC output to the utility. See Figure 1-1 for a simple diagram of a typical installation.

In order to operate, the GT Inverter must have grid power available and connected. It will not provide backup power if the AC grid fails.

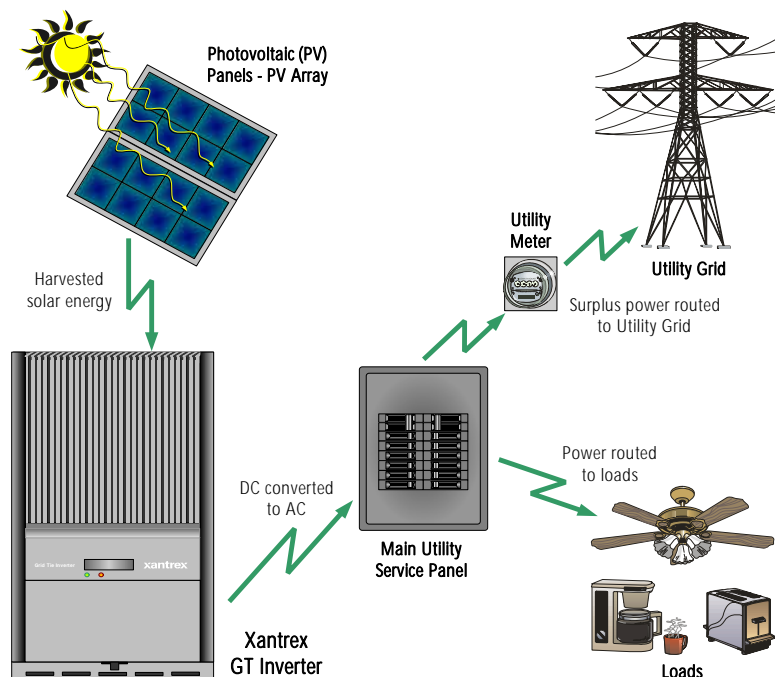

Figure 1-1 Basic System Overview

PV compatibility	The GT Inverter is designed to take advantage of solar modules configured as high voltage PV string arrays—single crystalline, poly crystalline, or thin film—with a 240 to 550 Vdc input voltage Maximum Power Point range.
Maximum Power Point Tracking (MPPT)	The GT Inverter uses Xantrex proprietary Maximum Power Point Tracking (MPPT) technology to harvest the maximum amount of energy from the solar array. Xantrex MPPT learns your array’s specific characteristics, maximizing its output at all times.
High efficiency	The high-frequency, solid-state design of the GT Inverter is extremely efficient—up to 96.2%.
Expandable	Multiple GT Inverters may be networked together for increased net metering capacity or future system growth. The GT Inverter GT5.0 has adjustable voltage and frequency disconnect settings and can be aggregated above 30 kW on a single point-of-common-coupling (PCC). See “Adjustable Voltage, Frequency and Reconnection Settings” on page A-3.
Communications protocol	The GT Inverter uses the Xanbus <sup>®</sup> communications protocol, enabling it to communicate with multiple units connected within the system. For more information, see “Xanbus Network Technology” on page 3-12.

## Standard Features

The GT Inverter has the following standard features:

- Sealed inverter section protecting power electronic components;
- Liquid Crystal Display (LCD) providing easy-to-read system status and daily cumulative energy production information;
- Two LED indicator lights providing status and ground fault indication;
- Wiring/disconnect box providing protection for all AC and DC connections and eliminating exposed “live” wiring if the inverter is removed.

The wiring/disconnect box has been designed to be physically mated to the electronics section of the GT Inverter at the factory, but remains in place as a non-serviceable item in the event that the inverter electronics section is ever required to be removed. The inverter and wiring/disconnect box together form an NEMA 3R enclosure to allow outdoor installation.



### **WARNING: Shock hazard**

The 600 volt DC/AC disconnect in the wiring/disconnect box meets NEC Article 690. It is a non-serviceable component and shall remain in place. Separating the inverter and wiring/disconnect box, or removing the wiring/disconnect box cover can expose energized conductors. PV input circuits in the wiring box ahead of the switch remain energized even when the switch is in the “off” position—hazardous voltage will still be present on the DC input (PV) terminals under the clear plastic insulation barrier inside the wiring/disconnect box.

---



## Front Panel Features

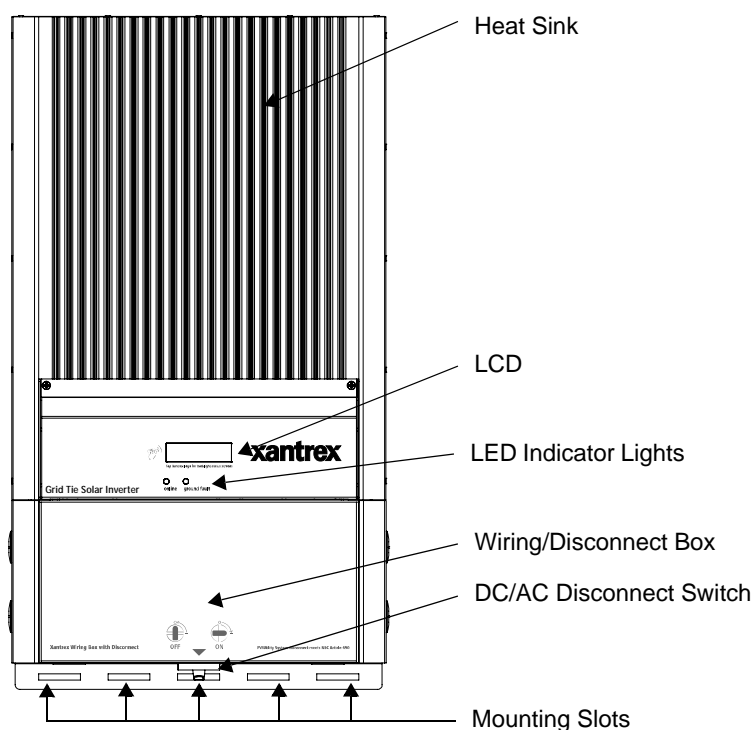

Figure 1-2 Main Features of the GT Inverter

## Wiring/Disconnect Box

The wiring/disconnect box is standard for all North American models of the GT Inverter. The wiring/disconnect box provides a location for making AC, DC and ground connections. It also contains the DC/AC (PV array/utility) disconnect switch. When used with the GT Inverter, the DC/AC disconnect switch is 600V AC and DC rated and is identified on the outside by an illustration showing the open and closed switch positions. The switch is lockable, and meets NEC section 690 requirements as a means of disconnect.

In jurisdictions where the local utility requires that the AC disconnect be capable of being locked in the open position by its service personnel, this disconnect switch can also serve as a lockable isolating device.

---

**Important:** In North America and other locations the wiring/disconnect box is an electrical code requirement. Regulatory approval is based on the wiring/disconnect box always being attached to the inverter during operation. Any attempt to remove this box will invalidate the approvals and create an electrical hazard.

---



# 2

# Installation

Chapter 2 provides information about installing the GT Inverter. It contains information on determining a suitable location for installation, PV array requirements, and procedures for mounting the unit.

## Installation Options

The GT Inverter may be installed as a single inverter for a single PV array of one to three PV strings (an external fuse box is required when three PV strings are connected), or in a multiple inverter configuration for multiple PV arrays.

If multiple inverters are used, each inverter must be wired to an independent PV array.

Communications between inverters can be enabled by installing network cabling to the inverter RJ45 ports. See “Connecting Network Cable Between Multiple Inverters” on page 3–15.

## Planning the Installation

Ensure that you have obtained all permits required by local authorities or utilities before beginning installation.

## Inverter Location



### **WARNING: Burn hazard**

Do not install in a location where people can accidentally come into contact with the front of the inverter. High temperatures can be present on the face of the inverter, causing a potential burn hazard.

In extreme conditions, the GT Inverter chassis can reach temperatures over 70° C (158° F), which can cause skin burns if accidentally touched. Ensure that the GT Inverter is located away from normal traffic areas.

---

Inverter failure due to improper installation will void the inverter warranty. Consider the following when determining where to install the inverter.

- Indoor/  
Outdoor**
  - The GT Inverter uses a Type 3R-rated enclosure (vertical mount only) that can be mounted indoors or outdoors. (Type 3R enclosures are intended for outdoor use primarily to provide a degree of protection against falling rain; and to be undamaged by the formation of ice on the enclosure.)
  - While the 3R-rated enclosure protects the GT Inverter from moisture, outdoor installations should be located away from lawn sprinklers and other sources of spray.
  - A sun shade is recommended for outdoor installations. In bright sun conditions, when the GT Inverter is at or near full output with an ambient temperature above 40 °C (104 °F), shading the unit will help increase inverter performance. A sun shade can also protect the inverter from dust, debris, and birds. The sun shade should be made from an opaque material that provides shade for the heat sink. It should be large enough and positioned so that it shades the heat sink for all sun angles. Ensure that the shade is installed according to the minimum clearances specified on page 2–7.
- Orientation**
  - The GT Inverter must be mounted vertically on a wall or pole.
  - Do not mount the GT Inverter horizontally.
  - If mounting the inverter indoors on a south-facing wall, ensure the wall is insulated to reduce the amount of heat absorbed by the inverter. Unless walls are properly insulated, avoid mounting the inverter indoors on any wall that is directly exposed to the sun.
- Temperature**
  - Ensure that the GT Inverter is mounted in a location where the ambient temperature range is -25 to +65 °C (-13 to +149 °F).
  - Above 40 °C (104 °F), the GT Inverter may derate power output. See “Output Power vs. Ambient Temperature” on page A–3 and “Environmental Specifications” on page A–4.
  - At extreme hot or cold temperatures, the front panel LCD may not function normally.
- Ground  
Clearance**
  - Outdoors, the GT Inverter requires at least 100 cm (39 inches) of clearance between the bottom of the unit and the ground.
- Distance**
  - To minimize resistance and resulting power loss, ensure that wire lengths between the PV array and the GT Inverter and between the inverter and the Main Utility Service Panel are kept to a minimum.
  - Maximum distances will depend on wire gauges used and PV array output voltages.
- Debris free**
  - Excessive debris (such as dust, leaves, and cobwebs) can accumulate on the unit, interfering with wiring connections and ventilation. Do not install in a location where debris can accumulate (under a tree, for example).

## PV Array Voltage and MPPT Requirements



### WARNING: Shock hazard

Whenever a PV array is exposed to sunlight, a shock hazard exists at the output wires or exposed terminals. To reduce the risk of shock during installation, cover the array with an opaque (dark) material before making any connections, and always test for voltage before touching exposed wiring or devices.

MPPT operational window

The MPPT software maximizes the output energy of solar arrays as long as the operating voltage is within the MPPT operational window. Ensure that the PV array used in the system operates within the MPPT operational window.

Effects of array voltages outside of the MPPT operational window are shown in Table 2-1.

Table 2-1 MPPT Operational Window

Voltage	Effect of Array Voltage	Inverter Mode
$V_{oc} < 240 \text{ Vdc}$	Inverter not operating.	Off-line
$V_{MPP} < 240 \text{ Vdc}$ ( $V_{oc} > 240 \text{ Vdc}$ )	Operating voltage shifts to 240 Vdc; the array is not at its maximum power point.	On-line (low power)
$V_{MPP} 240 \text{ to } 550 \text{ Vdc}$	Maximum harvest of solar energy.	On-line (MPPT window)
$V_{MPP} 550 \text{ to } 600 \text{ Vdc}$	Does not allow maximum harvest of solar energy.	On-line (power derating)
$V_{MPP} > 600 \text{ Vdc}$ (or $V_{oc} > 600 \text{ Vdc}$ )	Inverter stops delivering power and shuts down. Inverter may be damaged.	Off-line (shutdown)

Voltage requirements

The maximum power point voltage of a string connected to the GT Inverter should preferably be above 240 Vdc. If it is less than 240 Vdc, the inverter continues to operate, but it regulates the PV voltage to 240 V. Because the array is not operating at its maximum power point, this may result in lower than expected energy harvest. If  $V_{oc}$  is below 240 Vdc, the inverter remains off-line and does not deliver power.



### CAUTION: Equipment damage

To prevent damage to the inverter, the array voltage must never exceed 600  $V_{oc}$  (open circuit voltage) under any condition.

The open circuit voltage of the array under normal conditions should be above 240 Vdc.

The short circuit current ( $I_{sc}$ ) rating of the array at any temperature must not exceed the  $I_{sc}$  rating of the inverter. For maximum solar energy harvest, it is recommended that the effective power output of the array be matched with the input power capacity of the inverter.

## Guidelines for Matching PV Array Size to Xantrex Grid Tie Solar Inverter Input

- Consider the expected  $V_{oc}$  of the string under all possible conditions. The panel manufacturer provides a  $V_{oc}$  rating per panel, but it is usually rated at 25 °C (77 °F). Ensure that the  $V_{oc}$  rating at the coldest ambient temperature does not exceed 600 Vdc. Panel voltage increases in cold temperatures—the panel manufacturer should be able to provide a coefficient of voltage increase per degree.
- The NEC also has required temperature/voltage deratings that must be used; these can be found in article 690 of the NEC. You need to determine the coldest temperatures expected on the site, and size the array strings accordingly. To prevent inverter damage, the array's maximum DC voltage in the coldest expected temperature, with both manufacturer coefficient and NEC derating, must not exceed 600 Vdc.
- Panel voltage decreases in high temperatures. This will affect the panels'  $V_{MPP}$  and  $V_{oc}$ . Again, the manufacturer's coefficient must be used with the highest expected temperature to determine the minimum  $V_{MPP}$  and  $V_{oc}$ .

---

**Note:** The GT PV array sizing tool is available at [www.xantrex.com](http://www.xantrex.com).

---

# Mounting the Inverter

## Dimensions and Knockout Locations

The dimensions of the inverter and the mounting bracket and some of the knockout locations on the wiring/disconnect box are shown in Figure 2-1 and Figure 2-2.

Four 27 or 35 mm (1 or 1-3/8 inch) dual knockouts are provided on the back and bottom of the unit to accommodate wiring.

Four 27 mm (1 inch) conduit holes on the sides of the wiring/disconnect box (two on each side) are filled with plastic plugs, which can be removed to insert conduit nipples as required for multiple inverter installations. One or two of these side conduit holes may be used to accommodate Xanbus network cables connected between multiple inverters.

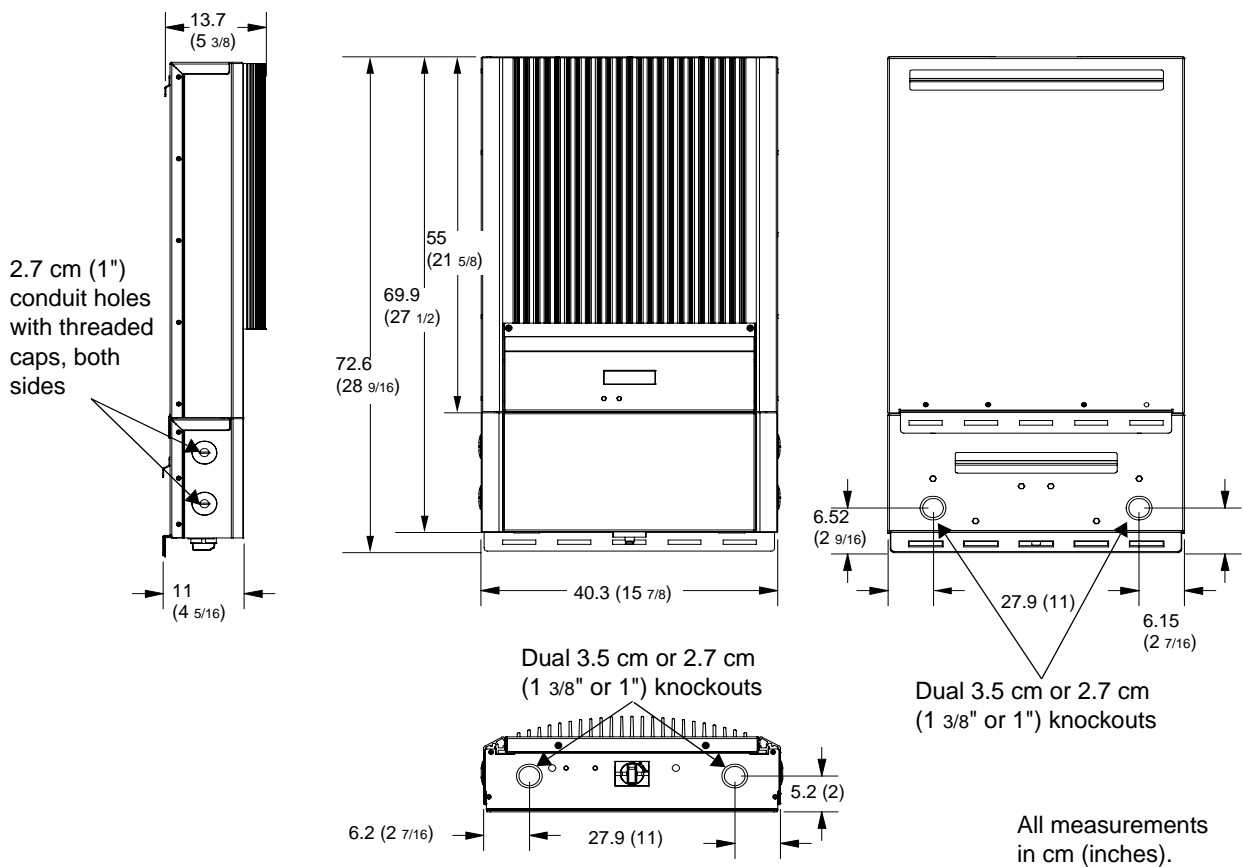

Figure 2-1 Dimensions of GT Inverter and Knockout Locations

## Installing the Mounting Bracket

The mounting bracket is designed to be affixed to the vertical structure or surface to which the GT Inverter will be mounted. The GT Inverter mounting hooks attach to the flanges on the mounting bracket.

If mounting more than one inverter, install each mounting bracket at least 15 cm (6 inches) apart to provide enough space for the inverters to hang side by side.

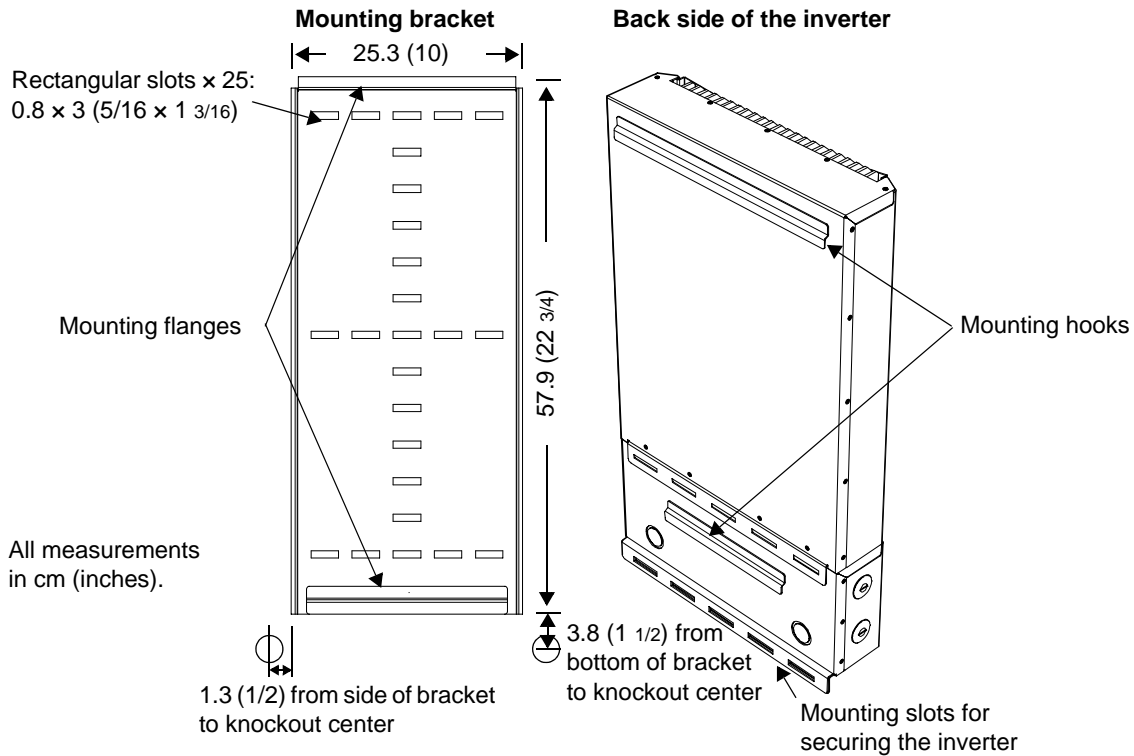

Figure 2-2 Mounting Bracket and GT Inverter



## Clearance Requirements

For optimal and safe operation, ensure there is adequate clearance around the inverter. If the minimum clearances in Table 2-2 are not met, rated power may not be achieved.

**Table 2-2** Inverter Clearance Requirements

Location	Minimum Clearance
Above	30 cm (12 inches)
Below:	Outdoors: The inverter extends below the bracket by approximately 10 cm (4 inches)
• Inverter	• 100 cm (39 inches)
• Bracket	• 110 cm (43 inches)
	For indoor installations, there is no clearance requirement between the bottom of the inverter and the ground.
In front	30 cm (12 inches) minimum. 91 cm (36 inches) are recommended for easy access for reading the display, avoiding accidental contact with hot surface, and servicing the inverter.
On sides	Units can be mounted side by side with no clearance between them, but 15 cm (6 inches) of clearance around the outside edges of the outermost two units is recommended. In hot climates, some clearance between units may be needed to prevent thermal derating.

## Surfaces for Mounting

The GT Inverter can be mounted to a vertical surface such as wallboard, wood siding, concrete wall, or pole assembly. Ensure the mounting surface or structure can support the weight of the inverter (26 kg/58 lb) as well as the associated wiring and conduit. Installation onto wallboard requires either the use of a supporting material such as plywood or securing the mounting screws to supporting wall studs.

### Important:

- Local codes may impose additional mounting requirements in earthquake or other high-risk areas.
- No mounting hardware is supplied with the GT Inverter. It is recommended to use 6 mm (¼ inch) diameter fasteners. However, because mounting surfaces can vary, installers must select appropriate hardware for each installation.

## Mounting the Inverter on the Bracket

Place the inverter's mounting hooks over the flanges on the bracket. Ensure the inverter is seated properly, then secure the bottom of the inverter with appropriate screws or anchors through the mounting slots.

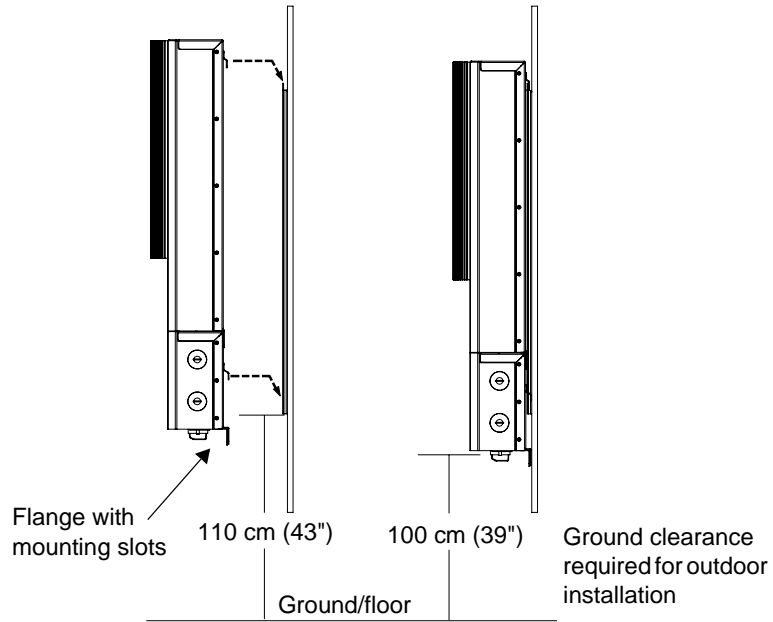

**Figure 2-3** Placing the Inverter on the Mounting Bracket

# 3

## Wiring the Inverter

Chapter 3 provides information about DC and AC wiring, and grounding the GT Inverter and the PV array.

This chapter does not provide sufficient information for anyone but a qualified installer to install this product. Installers should be electricians or technicians fully educated on the hazards of installing electrical equipment.

### Grounding Requirements

AC Grounding	The GT Inverter must be connected to the AC ground from the utility via the GT Inverter ground bar.
PV Grounding	<p>The PV array (frame) ground should be connected to the GT Inverter ground bar. The size for the conductor is usually based on the size of the largest conductor in the DC system.</p> <p>A DC grounding electrode conductor may be required by the Authority Having Jurisdiction (AHJ). Use the GT Inverter ground bar for this connection (see Figure 3-2 on page 3-3).</p>



#### **CAUTION: Equipment damage**

Provide adequate clearance for grounding wires inside the GT Inverter wiring box. Ensure that the bare copper grounding wire is more than ½ inch clear of the DC/AC interconnect circuit board.

---

Two ¼-inch (7 mm) knockouts in the bottom of the wiring box are intended for routing the ground conductors to the ground bar. See Figure 3-1.

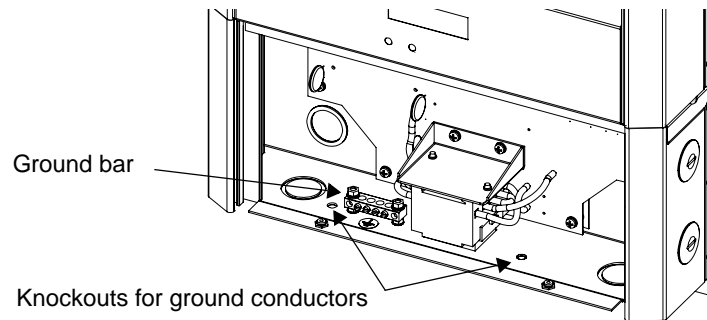

**Figure 3-1** Ground Conductor Knockouts

The ground bar accepts wires up to #4 AWG. Torque ground wires as specified in Table 3-1.

**Table 3-1** Torque Values for Ground Wiring

Wire Size		Torque Value	
AWG	mm <sup>2</sup>	in-lb	Nm
14-10	2.5-6.0	25-35	3.0-4.0
8	10	30-40	3.4-4.5
6-4	16-25	35-45	4.0-5.0

---

**Important:** In most models, the negative PV conductor is internally bonded to the ground system within the inverter’s ground fault detection circuit. Inverter models marked with the “-POS” suffix are positive grounded and have the positive PV conductor internally bonded to the ground system through the inverter’s ground fault protection circuit. It is important that the negative (or positive) PV conductor is not bonded to the ground at any other point in the system.

---

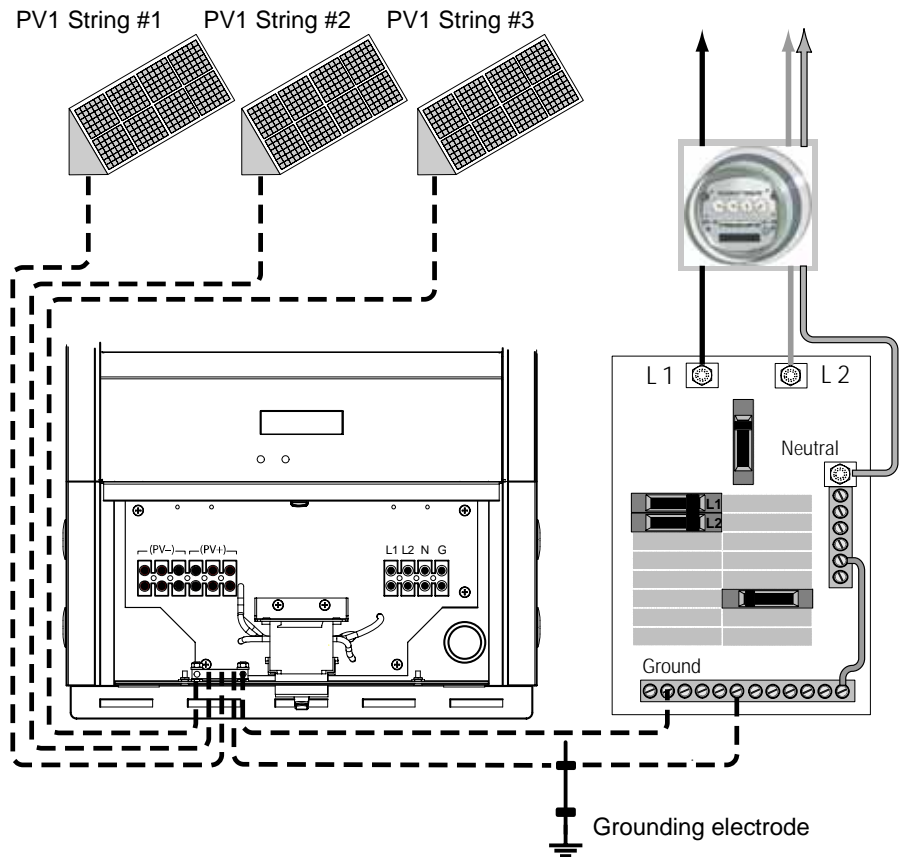

Figure 3-2 Grounding Diagram

## Ground Fault Fuse

The GT Inverter is equipped with a 600 volt, 1 amp ground fault protection fuse (replace with Littelfuse KLKD 1 or equivalent).



### **WARNING: Shock hazard**

Do not attempt to service the ground fault protection fuse yourself. This should only be done by qualified service personnel, such as certified electricians or technicians. See “Replacing the Ground Fault Protection Fuse” on page 6-4.

## Wiring Requirements

---



### **WARNING: Shock hazard**

Check for existing electrical or plumbing prior to drilling holes in the walls.

---

The AC and DC terminal blocks in the GT Inverter accept wire sizes from #14 AWG to #6 AWG. Undersized wiring can result in significant power losses and reduction in system efficiency. Strip all wires 9 mm (3/8 inch) and torque to a maximum 16 in-lb (1.8 Nm). Use copper conductors only, rated 90 °C.

For safety and compliance with the NEC, run AC, DC, and communication wires in separate conduits.

---



### **WARNING: Fire hazard**

Wiring should not be undersized. Wire sizes must be coordinated with the array maximum short circuit current or the AC breaker sizes used. Ensure wiring is in accordance with the NEC or applicable codes.

---

## AC Circuit Breaker Requirements

The main utility service panel must dedicate a double pole breaker to operate each GT Inverter installed. This breaker must be sized to handle the rated maximum output voltage and current of the GT Inverter (see “Electrical Specifications”, “Output” on page A-2).

## DC/AC Disconnect Switch

The wiring box includes a 600 volt PV/Utility disconnect switch that switches both AC and DC at the same time.

Depending on the installation, an external AC and/or DC disconnect may be required if the inverter is installed in a location not easily accessible to utility or fire personnel. Consult local authorities for additional information.

---

**Important:** The DC terminal block has six inputs for connecting up to three PV strings. In accordance with applicable codes, if the array consists of more than two strings, external fusing may be required to prevent conductor overloads.

---



### **WARNING: Shock hazard**

Do not remove the wiring/disconnect box. The 600 volt DC/AC disconnect in the wiring box meets NEC Article 690. It is a non-serviceable component and shall remain in place. Removal can expose energized conductors.

Use caution when working around sources of DC power. Although the DC/AC disconnect switch disconnects the inverter from DC power, hazardous voltages from paralleled PV strings will still be present upstream of the switch and inside the wiring box. To reduce the risk of shock during installation, cover the array with an opaque (dark) material before making any connections, and always test for voltage before touching exposed wiring or devices.

## Accessing the Wiring Terminals

You must remove the GT Inverter wiring box cover to access the terminal blocks, ground bar and communications ports.

### **To remove the wiring box cover:**

- Using a Phillips screwdriver, remove the two screws on the bottom side of the wiring box and lift the cover off the wiring box (see Figure 3-3).

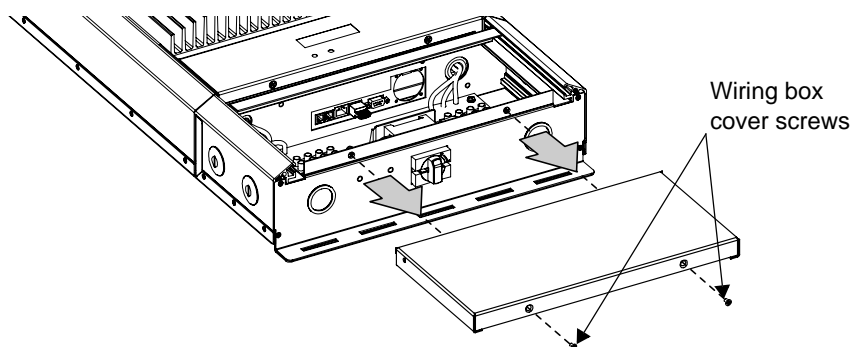

**Figure 3-3** Removing the Wiring Box Cover

AC and DC connections are made at the wiring terminals shown in Figure 3-5.

### Insulating barrier

The clear plastic insulating barrier inside the wiring box is a permanent component. It is intended to separate the high-voltage AC and DC wiring from any communications cabling.

When wiring the unit, it is necessary to pull the barrier back to access the wiring terminals. See Figure 3-4. After completing the wiring, return the insulating barrier to its original position.

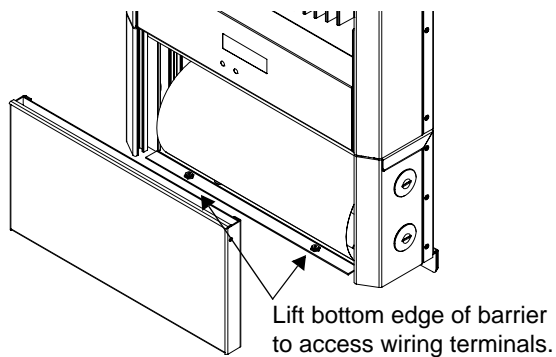

Figure 3-4 Insulating Barrier Location

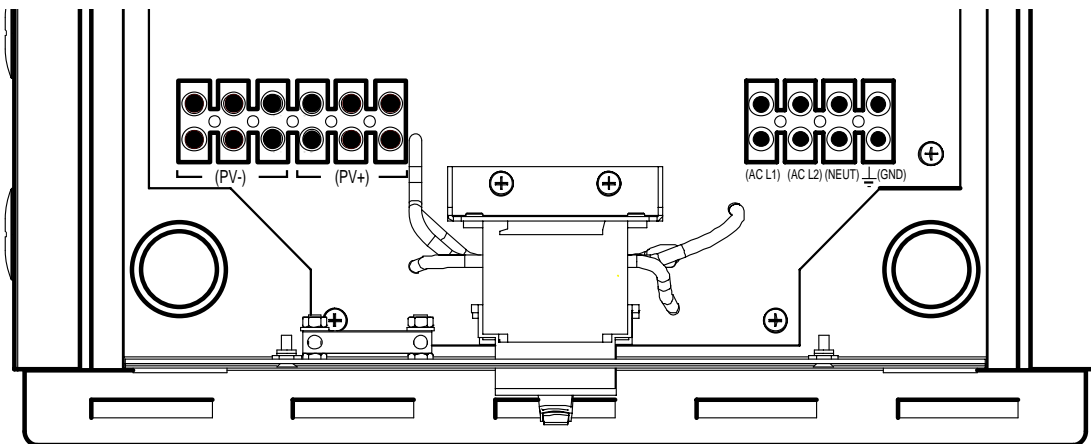

Figure 3-5 AC and DC Terminal Block Location



## Connecting the DC Wiring



### WARNING: Shock hazard

Use caution when working around sources of DC power. Although the DC/AC disconnect switch disconnects the inverter from DC power, hazardous voltages from paralleled PV strings will still be present upstream of the switch and inside the wiring box. To reduce the risk of shock during installation, cover the array with an opaque (dark) material before making any connections, ensure the DC/AC Disconnect Switch is set to OFF (see Figure 3-6), and always test for voltage before touching exposed wiring or devices.

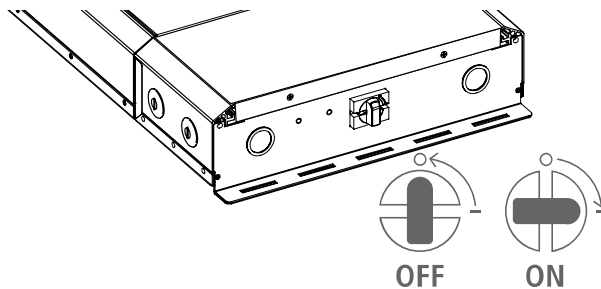
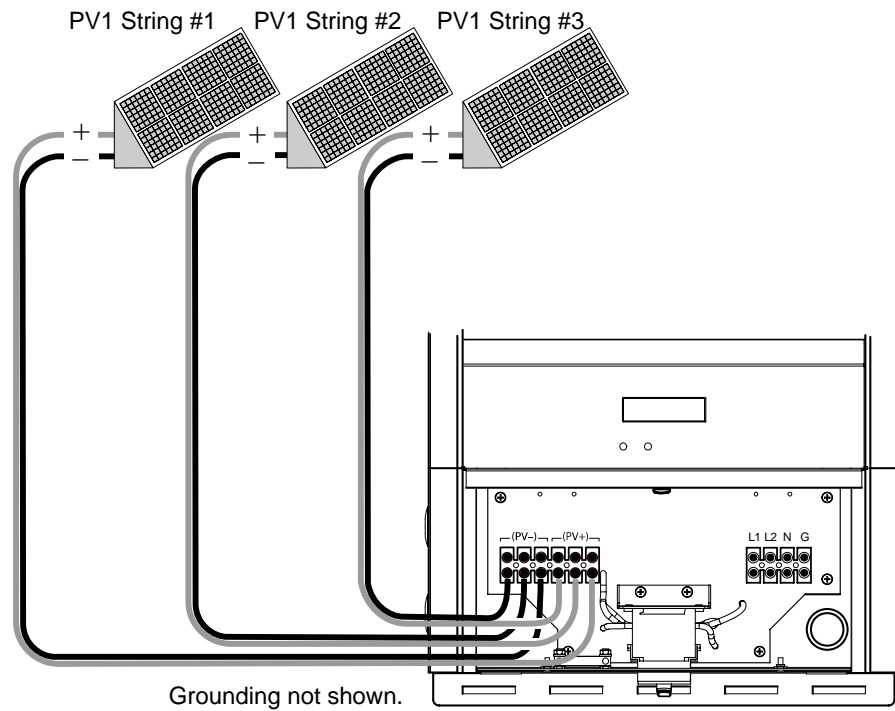

**Figure 3-6** DC/AC Disconnect Switch Positions

The following procedure is illustrated in Figure 3-7. If there is more than one PV string, label the positive and negative wire pairs appropriately (for example: PV1-String #1 POS, PV1-String #1 NEG, PV1-String #1 GND, PV1-String #2 POS, etc.).

#### To wire the PV array to the GT Inverter:

1. Connect the POSITIVE (+) wire from the PV1 string #1 to one of the PV+ terminals.
2. Connect the NEGATIVE (–) wire from the PV1 string #1 to one of the PV– terminals.
3. Repeat for the PV1 string #2, if there is one.
4. Repeat for the PV1 string #3, if there is one.
5. Ensure all connections are correctly wired and properly torqued to a maximum 16 in-lb (1.8 Nm).



**Figure 3-7** DC Connections for Multiple PV Strings

---

**Important:** Depending upon installation and local codes, fusing and/or a combiner box may be required. This fusing and combiner box are to be provided by the installer.

---

**Important:** A DC grounding electrode conductor may be required by the AHJ. Check local codes before installation.

---

## DC Wiring for Multiple Inverters

For installations with multiple GT Inverters, separate solar arrays are required for each unit. The output of each GT Inverter feeds a separate dual-pole 30-amp circuit breaker (L1 and L2) in the main utility service panel.

For such installations, complete the wiring and perform the commissioning procedure for each inverter one at a time. For the commissioning procedure, see “Commissioning Multiple Inverters” on page 4–3.



### WARNING: Shock hazard and equipment failure

Ensure each inverter is correctly connected to its own PV array(s) and that no wires are crossed. If inverters “share” more than one PV array, an input current difference of over 1 A between arrays can cause each inverter to fail—the ground fault protection fuse will blow, followed by short circuit failure. This failure will also generate hazardous voltages at the DC/AC disconnect switch on each unit.

For example, connect PV1 positive (+) and PV1 negative (–) to inverter 1 and PV2 positive (+) and PV2 negative (–) to inverter 2.

**Do not** connect PV1 positive (+) and PV2 negative (–) to inverter 1 and PV2 positive (+) and PV1 negative (–) to inverter 2. See Figure 3-6.

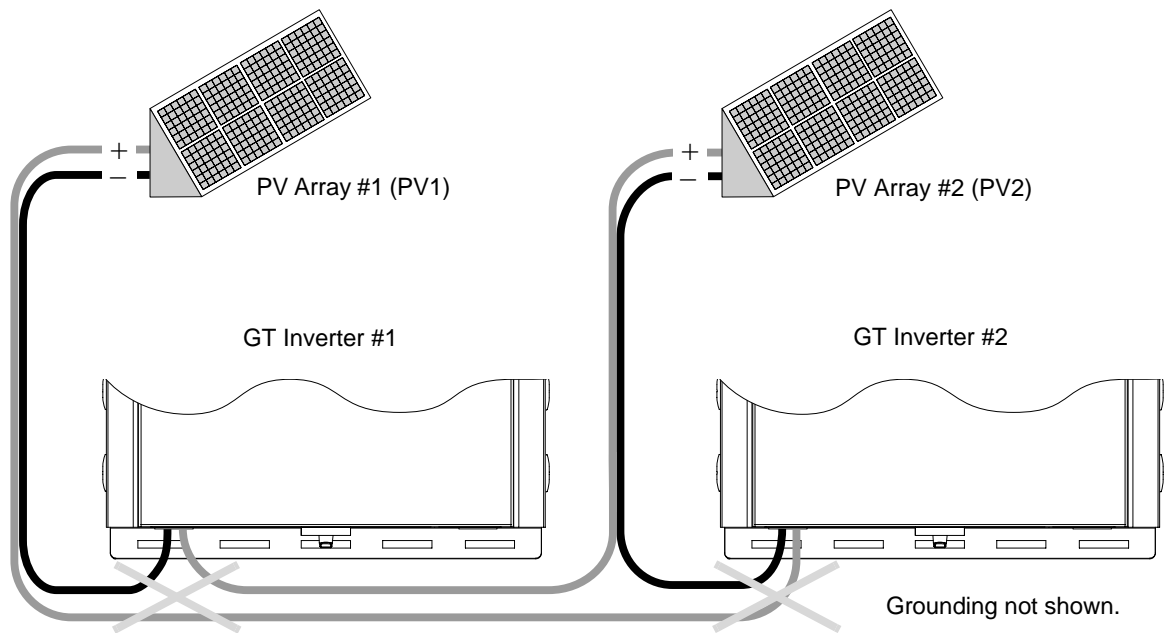

Figure 3-8 Improper Multiple Inverter Connections

## Connecting the AC Wiring



### WARNING: Shock hazard

Before wiring the GT Inverter, ensure the **main breaker** in the primary utility breaker box is switched OFF. Switch this breaker ON only after all wiring is completed as instructed in the procedures.

The GT Inverter can be connected to a single bi-directional meter, or to dual meters, where one meter indicates power used and the second meter indicates power sold (power supplied back to the utility). Consult the local utility to determine the proper components to install, and obtain any permits required prior to installation.

Ensure all connections are correctly wired and properly torqued to a maximum 16 in-lb (1.8 Nm).

The AC wiring procedure is illustrated in Figure 3-9.

**Important:** The neutral conductor must be attached to the inverter in all cases. The neutral conductor is used for phase-to-neutral voltage sensing only and is not a current carrying conductor. This conductor is not bonded to ground in the inverter.

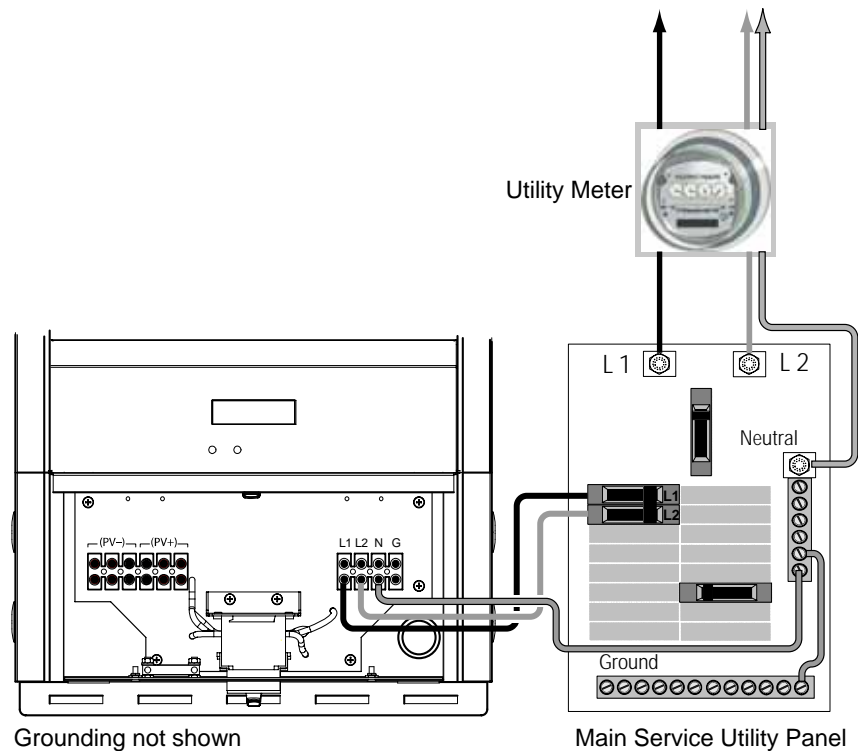

Figure 3-9 AC Connections from GT Inverter to Utility Service Panel

## DC and AC Wiring for Multiple Inverters

DC and AC wiring for multiple inverters is illustrated in Figure 3-10.

If there will be more than one PV array, label the positive and negative wire pairs appropriately (for example: PV1 POS, PV1 NEG, PV1 GND, PV2 POS, etc.).

If required by the AHJ, a DC grounding conductor may be connected to each inverter's ground bar. One inverter will connect to a common grounding conductor. The other inverters will use tap connectors. Connection is then made to the DC or AC grounding electrode as per NEC 690.47.

Ensure all connections are correctly wired and properly torqued to a maximum 16 in-lb (1.8 Nm).

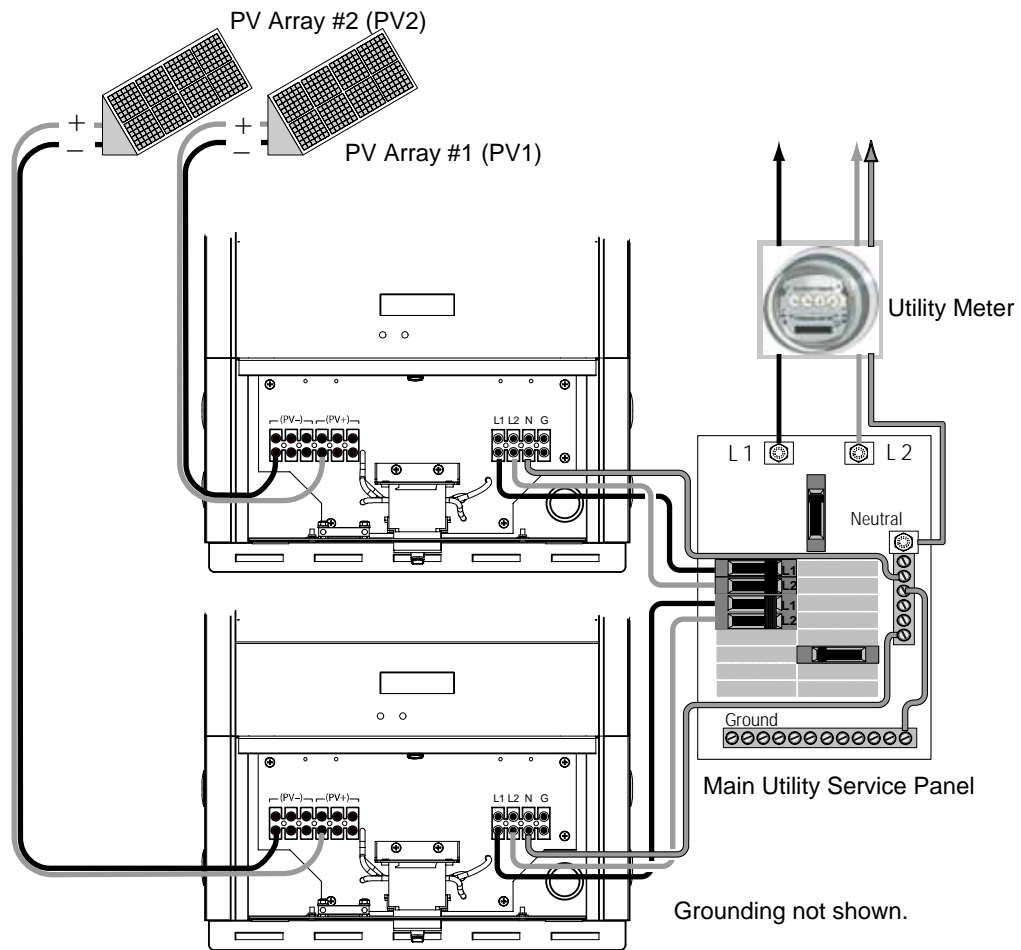

Figure 3-10 DC and AC Wiring With Multiple GT Inverters

## Communications Wiring for Multiple Inverters

Communications wiring between multiple GT Inverters allows information about each inverter and its associated PV array to be communicated between all of the inverters in the system. Information about the entire system can be displayed on any inverter LCD in the system.

For example, in a two-inverter system, if inverter #1 is producing 1500 W and inverter #2 is producing 2000 W, both inverters display a total system power of 3500 W. The cumulative energy produced by both inverters that day is also displayed.

You can still view information for an individual inverter in a system. See “To view unit-specific screens in a multiple unit system:” on page 5–5.

Without communications wiring (network cables) each inverter in a system will only display information pertinent to the unit and its associated PV array.

### Xanbus Network Technology

GT Inverters use Xanbus technology to communicate with other GT Inverters. Network connections for multiple inverters are laid out in a “daisy chain” pattern, each device on the network linked together with separate lengths of cable, as shown in Figure 3-11.

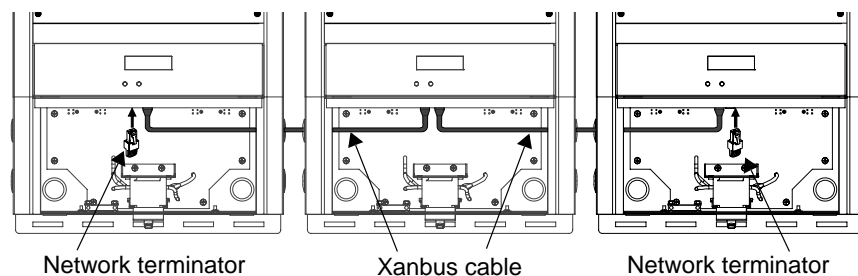

Figure 3-11 Daisy Chain Layout



#### CAUTION: Equipment damage

Connect only Xanbus-enabled devices.

Although the cabling and connectors used in this network system are the same as ethernet connectors, **this network is not an ethernet system**. Equipment damage may result from attempting to connect Xanbus to different systems.

Terminators

The male network terminator supplied with each GT Inverter (Figure 3-12) is required at each end of the network to ensure the communication signal quality on the network.

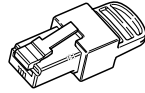

Figure 3-12 Male Network Terminator

GT Inverter Xanbus Ports

Two RJ45 ports are provided in the GT Inverter, accessible from the wiring box. See Figure 3-13 for the location of these ports.

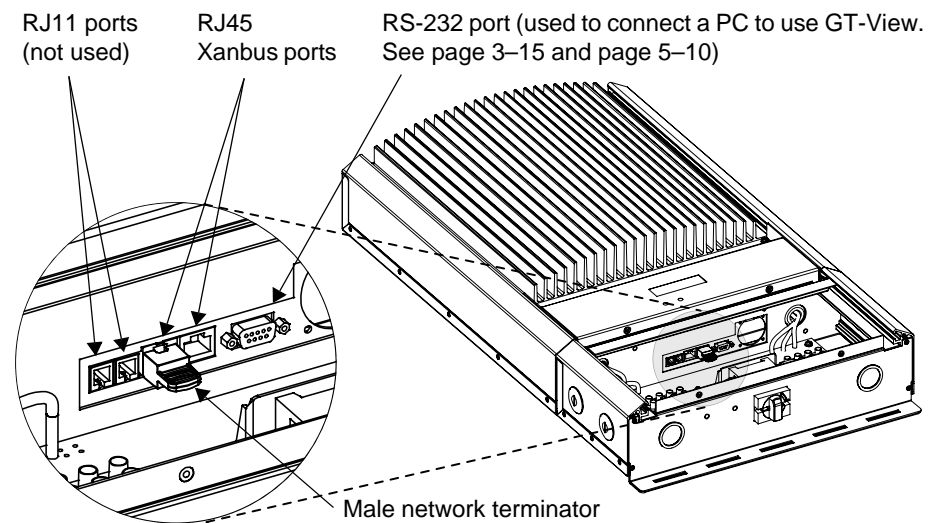

Figure 3-13 Xanbus RJ45 Ports in the GT Inverter Wiring Box

Cabling Requirements



**CAUTION: Equipment damage**

Do not use crossover cable in a Xanbus system.

The network uses Category 5 (CAT 5 or CAT5e) cable, a standard cable available from any computer supply store. The cable consists of eight conductors in four twisted pairs with an RJ45 modular connector wired to the T568A standard. Table 3-2 contains the arrangements of wire colors to pin numbers for the T568A standard.

**Table 3-2** T568A Standard Wiring

Pin Number	Conductor Name	CAT 5 Cable Insulation Color	CAT 5e Cable Insulation Color
1	NET_S	White/Green	White/Orange
2	NET_S	Green	Orange
3	NET_C	White/Orange	White/Green
4	CAN_L	Blue	Blue
5	CAN_H	White/Blue	White/Blue
6	NET_C	Orange	Green
7	NET_S	White/Brown	White/Brown
8	NET_C	Brown	Brown

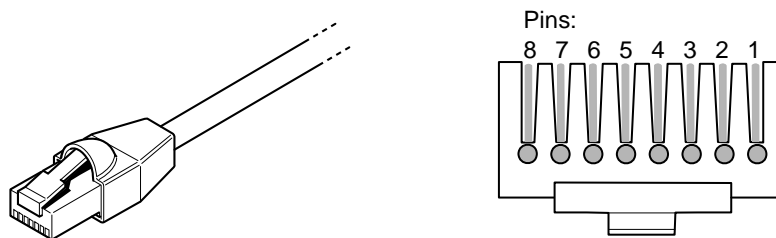

**Figure 3-14** RJ45 Connector

### Purchasing Network Components

Consult your system designer to determine what network components will be needed for your specific installation. Table 3-3 provides a partial list of network components and part numbers. Pre-made cables are available in standard lengths from 3 feet to 75 feet.

Call your dealer or visit [www.xantrex.com](http://www.xantrex.com) to purchase network components.

**Table 3-3** Network Components and Part Numbers

Network Component	Part Number
Network termination — Male (2 per pack)	809-0901
Network cable 3 ft. (0.9 m)	809-0935
Network cable 5 feet (1.5 m)	809-0936
Network cable 7 feet (2.0 m)	809-0937
Network cable 10 feet (3.0 m)	809-0938
Network cable 14 feet (4.3 m)	809-0939
Network cable 25 feet (7.6 m)	809-0940
Network cable 50 feet (15.2 m)	809-0941
Network cable 75 feet (22.9 m)	809-0942



---

## Guidelines for Routing the Network Cables

**WARNING: Shock hazard**

Do not route the network cables in the same conduit or panel as the AC and DC power cabling. The cables should run on top of the insulation barrier inside the wiring/disconnect box and out the side conduit hole, avoiding any contact with the AC and DC wiring.

**CAUTION: Unpredictable device behavior**

Do not connect one end of the network to the other to make a ring or loop.

---

## Connecting Network Cable Between Multiple Inverters

The following procedure is illustrated in Figure 3-11. The procedure assumes only two inverters are connected. However, there can be up to ten inverters wired in this configuration.

**WARNING: Shock hazard**

Before opening the GT Inverter wiring/disconnect box, turn OFF the breaker switches connected to the GT Inverter AC output, and turn the DC/AC Disconnect switch to the OFF position. Hazardous voltage will still be present on the DC input (PV) terminals located under the clear plastic insulation barrier. Do not remove the insulation barrier during this procedure. To reduce the risk of shock, cover the array with an opaque (dark) material.

**To provide communication between multiple inverters:**

1. Remove the wiring/disconnect box cover from each unit.
2. Connect the network cable to any RJ45 port in Inverter #1.
3. Route the cable along the top of the insulation barrier and through a side conduit hole to Inverter #2.
4. Connect the network cable to any RJ45 port in Inverter #2.
5. For more than two inverters, continue connecting cable as described above.
6. Insert male network terminators into the empty RJ45 ports in the inverters at the beginning and end of the network. There should be no empty RJ45 ports in any of the inverters.

---

## Communications Wiring for Monitoring a Single Inverter

You can view GT Inverter operational data on a personal computer using the Xantrex GT Solar Inverter Viewer (“GT-View”), which you can download free of charge at [www.xantrex.com](http://www.xantrex.com).

To use GT-View, you must connect your computer’s serial port to the GT Inverter RS-232 port (see Figure 3-13).

### RS-232 cable requirements

To connect your computer to the GT Inverter, you must use a serial DB9 “straight through” cable.

The RS-232 connector on the GT is configured as follows:

- Pin 2: transmit
- Pin 3: received
- Pin 5: ground.

All other pins are unused.

**To connect a single GT Inverter to a personal computer:**

---



### **WARNING: Shock hazard**

Before opening the GT Inverter wiring/disconnect box, turn OFF the breaker switches connected to the GT Inverter AC output, and turn the DC/AC Disconnect switch to the OFF position. Hazardous voltage will still be present on the DC input (PV) terminals located under the clear plastic insulation barrier. Do not remove the insulation barrier during this procedure. To reduce the risk of shock, cover the array with an opaque (dark) material.

---

1. Feed the male end of the serial cable through a side conduit hole on the GT Inverter.  

If the end of the serial cable is too large to fit through the conduit hole, you may need to use two DB9 to CAT 5 adaptors. Plug the DB9 end of the adapter into the GT Inverter, and feed the CAT 5 end of the cable out the conduit hole. Use another adapter to convert the CAT 5 end of the cable back to DB9.
2. Plug the male end of the serial cable into the GT Inverter RS-232 port.
3. Plug the female end of the serial cable into your computer’s serial port.
4. Replace the wiring/disconnect box cover.
5. Turn the DC/AC disconnect switch to the ON position and turn the main utility panel breaker switches ON.

When power is restored to the GT Inverter, you can run GT-View on your computer to monitor the inverter’s operation.

---

**Note:** In multiple installations, GT-View monitors only the inverter to which the computer is connected. However, if the inverters are connected with a Xanbus network cable, GT-View will display total system wattage and the accumulated daily energy produced by all inverters. To monitor multiple inverters, you require multiple DB9 cable connections (one per inverter) to your computer.

---

For more information about GT-View, see the *GT-View User Manual*, included with the GT-View software.

# 4

## Starting the Inverter

Chapter 4 contains information on starting up the Xantrex Grid Tie Solar Inverter and performing a functional test.

The topics in this chapter are organized as follows:

- “Startup Procedure” on page 4–1
- “Commissioning Multiple Inverters” on page 4–3
- “Disconnect Test” on page 4–5

### Startup Procedure

Starting up the GT Inverter requires several steps. You will need to:

1. Ensure the DC/AC Disconnect switch is in the OFF position (see Figure 4-1).
2. Check the PV array DC voltage (see procedure below).
3. Check the AC utility voltage (see procedure below).
4. Replace the cover on the wiring box (see “Replacing the Wiring/Disconnect Box Cover” on page 4–2).
5. Start up the GT Inverter by switching the DC/AC Disconnect switch ON.



#### **WARNING: Shock hazard**

Hazardous voltages are present from two sources. Use extreme caution during startup procedure. Before applying power to the GT Inverter, ensure all AC and DC wiring is correct.

---

## Checking the PV Array DC Voltage

### To check the PV array DC voltage:

1. Uncover the PV arrays and expose them to full sunlight. The sunlight must be intense enough to produce the required output voltage.
2. Measure the PV array open circuit DC voltage across the DC positive (+) and negative (-) terminals. This voltage must be greater than 150 volts DC (to energize the electronics) and less than 600 volts DC (to prevent damage to the inverter).

## Checking the AC Utility Voltage

### To check the AC utility voltage:

1. Switch on the main and inverter breakers in the main electrical service panel.
2. Using an AC voltmeter, measure the AC open circuit utility voltage between L1 and L2. Ensure this voltage is at approximately the nominal value. The inverter operates with a line-to-line voltage (L1 to L2) range around the nominal value.

See “Electrical Specifications”, “Output” on page A-2 for the utility voltage operating range for your GT Inverter model.

## Replacing the Wiring/Disconnect Box Cover

After performing the voltage checks, replace all covers that were removed during installation and startup.



### **WARNING: Shock hazard**

Before reattaching covers, turn OFF the breaker switches in the main utility service panel and the DC/AC Disconnect switch on the GT Inverter.

---

### To replace the wiring/disconnect box cover:

1. Ensure the clear plastic insulating barrier is properly positioned in the wiring box.
2. Place the cover in position on the wiring box, being careful not to pinch any wires inside.
3. Ensure that the two screw holes in the bottom of the wiring box cover are aligned with the corresponding holes in the bottom of the wiring box.
4. Replace the two screws removed when the cover was removed (see “Accessing the Wiring Terminals” on page 3-5), and tighten securely.

## Starting up the GT Inverter

### To start up the inverter:

1. Switch the DC/AC disconnect switch to the ON position (see Figure 4-1).
2. Check the GT Inverter LCD. The startup screens (see Table 5-1 on page 5-2) should appear for five seconds each, and then the “Reconnecting in sss seconds” special screen (see Table 5-10 on page 5-10) will appear until the 305 second (default value) protection timer countdown is completed.

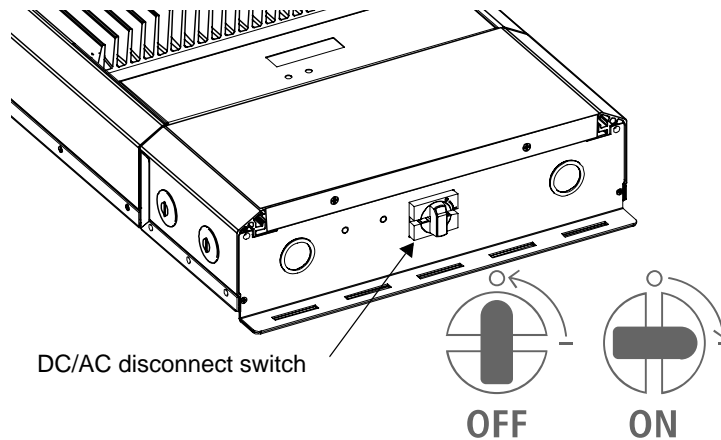

Figure 4-1 DC/AC Disconnect Switch Positions

## Commissioning Multiple Inverters

In an installation with multiple GT Inverters, special commissioning procedures must be followed in order to safely determine if any DC wiring problems exist.

---

**Important:** Before performing this procedure, all inverters should be off, with the DC/AC disconnect switch in the OFF position.

---

### To commission multiple inverters:

1. Uncover the PV arrays and/or close the main DC disconnect switch, if one is installed.
2. Start the first inverter by turning the DC/AC disconnect switch to the ON position.
3. Wait for the input current to rise above 1 A.  
This information is displayed on the Array Readings screen. To display the Array Readings screen, tap the unit four times.
4. After the input current has risen above 1 A, if the inverter is still operating normally, switch off the inverter by turning the DC/AC disconnect switch to the OFF position. Proceed to step 5.

If the inverter stops operating after the input current has risen above 1 A, turn the unit off, remove DC power, and have a certified electrician or technician inspect the ground fault protection fuse. If the fuse has blown, a DC wiring problem may exist. Check all DC wiring to ensure that the unit is connected to a single PV array.

5. Proceed to the next inverter and perform the same test. See Figure 4-2 for an example of the recommended commissioning sequence.

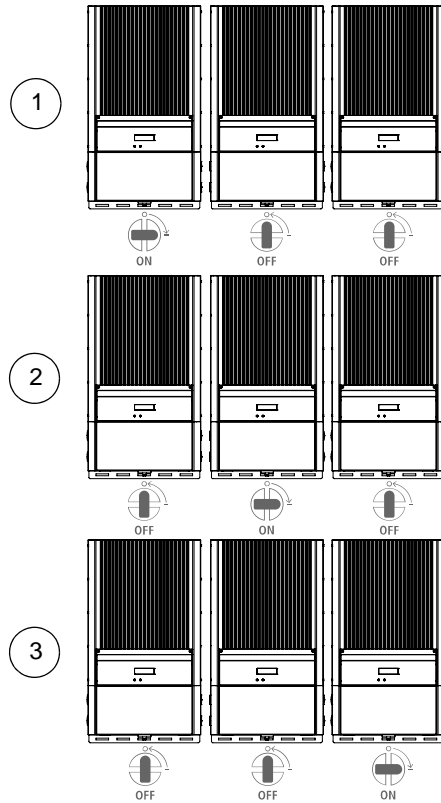

Figure 4-2 Commissioning Sequence for Multiple Inverters

---

## Disconnect Test

The disconnect test is designed to verify correct operation of the GT Inverter both on initial operation and periodically through its life as required by the utilities. This test ensures that the Xantrex Grid Tie Solar Inverter does not send electricity to the utility grid when the local utility has shut off the grid for repairs, or when the utility wiring is damaged.

When operation of the inverter has been verified and the unit is producing power, run the disconnect test as described in this procedure.

### To run the disconnect test:

1. Switch off the AC circuit for the inverter. This can be accomplished by switching the breaker on the main panel that feeds the inverter(s). The disconnect for the home or business may be used as well.
2. Have someone watch the front panel of the inverter to ensure the green light on the front of the inverter goes out within two seconds.

The green light goes out when the AC circuit is switched off, disconnecting the inverter from the AC grid. The front panel display will show an AC Fault display, indicating that the AC is out of the operating range.

3. Switch on the AC circuit for the inverter.

The inverter responds by starting its 305 second protection timer. Ensure that the inverter does not produce power before the countdown is over. After completing the countdown, the green light turns on and the inverter begins delivering power. The display returns to showing the power being produced and the total kWh produced to date.

---

**Important:** The default voltage, frequency and reconnect delay values are programmed into the unit at the time of shipment from the factory. With the utility's approval, these settings can be adjusted in the field using the GTConfigLite software tool. See "Adjustable Voltage, Frequency and Reconnection Settings" on page A-3.

---

4. If you have another GT Inverter to commission, switch off the AC circuit for the inverter you have just commissioned and tested by switching off the breaker on the main panel. You can then run the commissioning procedure and disconnect test on the next inverter.

## Locating the Firmware Version Number

The firmware version number for the protection processor is visible on a screen that appears when the unit starts up or is powered up after switching the DC/AC disconnect switch to "on." The screen reads:

<b>Flash = 03.00</b>
<b>ROM = 03.00</b>

The number appearing after "ROM" is the firmware version number for the protection processor.





# 5

## Monitoring the Inverter

Chapter 5 contains information for understanding the LCD screens and the LED indicators.

### Monitoring the Front Panel Display

During startup	During startup, the inverter’s front panel LCD (see Figure 5-1) shows the screens described in Table 5-1, “Startup Screens on GT Inverter Front Panel Display” on page 5–2.
During waiting period	When the 305 second protection timer begins, the inverter displays “Reconnecting in <i>sss</i> seconds” (see Table 5-10, “Special Message Screens” on page 5–10).
During operation	When the protection timer stops, the GT Inverter begins delivering power, indicated by the power output reading in the display (see Table 5-2, “Normal Operation Default Screen” on page 5–4).
When the inverter is offline or there is fault condition	When the GT Inverter is offline (at night, for example) or a fault condition has been detected, the LCD shows a message screen to indicate that the inverter is offline and to identify the specific fault condition. See Table 5-5, “Offline Mode Default Display” on page 5–6 and Table 5-8, “Fault Message Screens” on page 5–8.

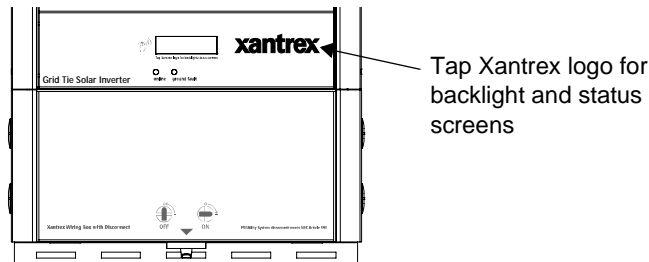

Figure 5-1 Front Panel LCD

## Viewing more information

Additional screens of information about the performance of the GT Inverter can be displayed by tapping the Xantrex logo on the inverter front panel. This causes the LCD to cycle through a series of information screens in Normal Operation, Offline or Fault modes. These are described in detail in the following section, “Front Panel Display Screens and What They Mean”.

## Front Panel Display Screens and What They Mean

The front panel display shows different message screens during different modes of operation (Startup, Normal, Offline, and Fault). All single units display a basic set of message screens; multiple unit systems display additional screens in Normal Operation and Offline modes.

In addition there are Special message screens that may appear in any operational mode. All these message screens are described in more detail in the following tables.

### Startup Mode

During startup, the GT Inverter displays several message screens on its front panel LCD. These screens appear in the following order (Table 5-1).

**Table 5-1** Startup Screens on GT Inverter Front Panel Display

Display	Duration	Description
<b>Power 5000W</b> <b>Region NA-240V</b>	5 seconds	<b>Startup message 1:</b> Maximum output power and Region-nominal output voltage
<b>Flash = 03.00</b> <b>ROM = 03.00</b>	5 seconds	<b>Startup message 2:</b> Model and revision numbers for Flash and ROM memory on the GT Inverter. The ROM revision number applies to the protection processor.
<b>Vh= 261V</b> <b>Clr t &lt; 1.00s</b>	3 seconds	<b>Vh:</b> phase-to-phase (rms) high threshold voltage setting, the threshold at which the inverter disconnects itself from the power grid when abnormally high phase-to-phase AC voltage is detected.* <b>Clr t:</b> clear time.†
<b>Vl= 214V</b> <b>Clr t &lt; 2.00s</b>	3 seconds	<b>Vl:</b> phase-to-phase (rms) low threshold voltage setting, the threshold at which the inverter disconnects itself from the power grid when abnormally low phase-to-phase AC voltage is detected. <b>Clr t:</b> clear time.

Table 5-1 Startup Screens on GT Inverter Front Panel Display

Display	Duration	Description
<b>Vph= 130V</b> <b>Clr t &lt; 1.00s</b>	3 seconds	<b>Vph:</b> phase-to-neutral (rms) high threshold voltage setting, the threshold at which the inverter disconnects itself from the power grid when abnormally high phase-to-neutral AC voltage is detected. <b>Clr t:</b> clear time.
<b>Vpl= 107V</b> <b>Clr t &lt; 2.00s</b>	3 seconds	<b>Vpl:</b> phase-to-neutral (rms) low threshold voltage setting, the threshold at which the inverter disconnects itself from the power grid when abnormally low phase-to-neutral AC voltage is detected. <b>Clr t:</b> clear time.
<b>Fh= 60.4Hz</b> <b>Clr t &lt; 0.16s</b>	3 seconds	<b>Fh:</b> frequency high threshold setting, the threshold at which the inverter disconnects itself from the power grid when abnormally high frequency is detected. <b>Clr t:</b> clear time.
<b>F1= 59.4Hz</b> <b>Clr t &lt; 0.16s</b>	3 seconds	<b>F1:</b> frequency low threshold setting, the threshold at which the inverter disconnects itself from the power grid when abnormally low frequency is detected. <b>Clr t:</b> clear time.
<b>Reconnect Delay</b> <b>305.00s</b>	3 seconds	Setting for the reconnect delay for the protection timer. After a fault clears for the specified clear time, the protection timer starts counting down before the inverter attempts to deliver power to the grid.

\* The voltage and frequency thresholds, clear times and reconnect delay in Table 5-1 can be adjusted for multi-unit installations producing 30 kW or more (with the permission of the local utility) using GTConfigLite software.

† The clear time is the total time to disconnect the output from the grid. It is the sum of the debounce time and the hardware delay time. The debounce time is the protection processor waiting time before it declares a fault. This delay is necessary to avoid nuisance trips. The hardware delay time (100 ms maximum) is the time taken by the hardware to disconnect the output from the grid after a fault has been declared.

The protection timer begins counting down the reconnect delay during startup and the “Reconnecting in *sss* seconds” screen appears until the timer countdown is complete.

## Normal Operation Mode

The LCD on the GT Inverter is refreshed every two seconds, so all readings are current to within two seconds. There is a default display available at all times, and a series of additional screens that can be displayed by tapping the Xantrex logo near the LCD to change the display.

Normal Operation default display

After the protection timer has completed its countdown and during normal operation, the GT Inverter displays the normal operation message screen shown in Table 5-2.

**Table 5-2** Normal Operation Default Screen

Display*	Description
<b>System 2000W</b>	Power being produced by the system now.
<b>Today 9.875kWh</b>	Cumulative energy produced by the system today.

\* all numbers in this and following tables are examples only.

If there is sufficient energy from the PV array, the default screen is displayed continuously while the system is operating normally. In a multiple unit system with communications cables properly connected, the power and cumulative energy values displayed are for the entire system.

During low light conditions when the GT Inverter cannot produce any power, the Normal Operation default screen flashes alternately (every two seconds) with the Insufficient Solar Energy screen (see Table 5-10, “Special Message Screens” on page 5–10).

More screens for all systems

Besides the default normal operation display, more system information messages can be viewed.

**To view more Normal Operation information:**

- Tap the Xantrex logo near the LCD to advance the display to the next screen. Normal operation screens shown in Table 5-3 are displayed in the order given, as you tap successively on the unit. They are common to all GT Inverter systems, no matter how many units are installed.

If you continue to tap the unit, then the LCD continues to cycle through all of the available normal operation screens. Each screen is displayed for a maximum of 30 seconds. If you do not tap again during that time period, then the LCD backlight turns off and the display reverts to the default system message screen.

**Table 5-3** Normal Operation Screens for All GT Inverter Units

Tap	Display*	Description
1st time	<b>System 2000W</b> <b>Today 2.500kWh</b>	LCD backlight turns on for better readability and default Normal Operation screen is displayed.
2nd time	<b>System Lifetime</b> <b>305kWh</b>	Lifetime energy produced by the GT Inverter system.
3rd time	<b>Time Online</b> <b>Today hh:mm:ss</b>	Length of time inverter has been online today, in hours (hh), minutes (mm) and seconds (ss).
4th time	<b>Array Readings</b> <b>350.5V 8.4A</b>	Immediate DC voltage and current readings from the PV array.
5th time	<b>Grid Readings</b> <b>242.6V 60.0Hz</b>	Immediate AC voltage and frequency readings from the Grid

\* In a multiple unit system with network cables properly installed, the system values displayed are for the entire system. For example, in a two-inverter system, if inverter #1 is producing 1500 W and inverter #2 is producing 2000 W, both inverters display a total system power of 3500 W. Time online and array readings are for the local inverter and PV array associated with that inverter.

**Additional screens for multiple units**

In addition to the normal system message screens, additional screens specific to each GT Inverter unit can be displayed when the unit is networked to other GT Inverters. These screens are only available on multiple unit systems.

**To view unit-specific screens in a multiple unit system:**

1. Tap the Xantrex logo near the LCD to advance the display to the next screen. Continue tapping until the final system message screen (“Grid Readings”, in Table 5-3 above) is displayed.
2. Tap again. Normal operation screens shown in Table 5-4 are displayed in the order given, as you tap successively on the unit.

If you continue to tap the unit, then the LCD will cycle through all of the available normal operation screens. Each message is displayed for up to 30 seconds. If you do not tap again within that time period, then the LCD backlight turns off and the display reverts to the default normal operation screen (Table 5-2).

**Table 5-4** Additional Normal Operation Screens for Each GT Inverter Unit in a Multiple Unit System

Tap	Display	Description
6th time	<b>Unit 1500W</b> <b>Today 1.250kWh</b>	Power being produced by this unit now. Cumulative energy produced by this unit today.
7th time	<b>Unit Lifetime</b> <b>150kWh</b>	Lifetime energy produced by this GT Inverter unit

## Offline Mode

Offline default display

At night and when no power is being produced by the PV array (offline mode), the GT Inverter displays the screen shown in Table 5-5.

**Table 5-5** Offline Mode Default Display

Display	Description
<b>Inverter Offline</b>	Displayed at all times while the system is offline.

Offline messages for all systems

Additional message screens can be viewed when the system is offline by tapping the Xantrex logo near the LCD. Each additional tap displays the next screen, in the order shown in Table 5-6.

These message screens are common to all GT Inverter systems, no matter how many units are installed. If you continue to tap the unit, then the LCD will continue to cycle through all of the available offline mode screens.

**Table 5-6** Offline Mode Screens for All GT Inverter Units

Tap	Display*	Description
1st time	<b>Inverter Offline</b>	LCD back light turns on for better readability and default Offline Mode screen is displayed.
2nd time	<b>System On Today 2.50kWh</b>	Power being produced by the system now. Cumulative energy produced by the system today.
3rd time	<b>System Lifetime 305kWh</b>	Lifetime energy produced by the system.
4th time	<b>Time Online hh:mm:ss</b>	Total time that the system was online today, in hours (hh), minutes (mm) and seconds (ss).

\* *In a multiple unit system with communications cables properly installed, the system values displayed are for the entire system. Time online is for the local inverter.*

Additional Offline messages for multiple unit systems

Multiple unit systems in offline mode display all of the message screens shown in Table 5-6, plus the additional screens shown in Table 5-7. These additional screens are displayed following the “Time Online” screen.

These screens are only displayed on multiple unit GT Inverter systems with communications cables installed. If you continue to tap the unit, then the LCD continues to cycle through all of the available offline mode screens.

**Table 5-7** Additional Offline Mode Screens for Each GT Inverter Unit in a Multiple Unit System

Tap	Display	Description
5th time	<b>Unit 0W</b> <b>Today 1.25kWh</b>	Power being produced by this unit now. Cumulative energy produced by this unit today.
6th time	<b>Unit Lifetime</b> <b>150kWh</b>	Lifetime energy produced by this unit.

## Fault Mode

When a fault state is detected, the appropriate fault message appears on the front panel display at the next screen refresh (within 2 seconds). The GT Inverter fault message screens are shown in Table 5-8.

### Fault Mode causes

These message screens only appear when there is a fault, and then flash alternately with the Inverter Offline default screen (Table 5-5) until the fault is corrected.

**Table 5-8** Fault Message Screens

Display	Appears When...
<b>DC Voltage Fault</b> <b>145.5V</b>	The actual DC voltage is over or under the allowable range, 240 to 600 Vdc. Self-clearing, no action required. The PV array should be configured such that DC voltage does not fall below 240 Vdc or rise above 600 Vdc.*
<b>AC Voltage Fault</b> <b>280V</b>	The actual AC voltage is over or under the allowable range, as specified in “Output” on page A-2. This is a utility fault; it will clear itself when the AC voltage comes within the specified range.†
<b>Frequency Fault</b> <b>0.0Hz</b>	The actual Frequency is over or under the allowable range, as specified in “Output” on page A-2. This is a utility fault; it will clear itself when the frequency comes within the specified range.†
<b>Over Temp Fault</b> <b>81.4C 178.5F</b>	The unit’s internal temperature is greater than 80° C (176° F), the unit will shut down automatically and only restart when the temperature has dropped to less than 70° C (158° F).
<b>Neutral Loss</b> <b>Detected</b>	The GT Inverter is configured for North America, and the phase-to-neutral voltage is outside the allowable range. Either this is a utility fault or a phase-to-neutral line is not connected properly.
<b>Ground Fault</b> <b>Reset System</b>	A grounding fault is detected. The ground fault fuse will be blown. The system must be shut down completely, the fault corrected, the fuse replaced (see “Replacing the Ground Fault Protection Fuse” on page 6-4) and then the system restarted. Troubleshooting a grounding fault should be performed by qualified personnel, such as a certified electrician or technician.
<b>Unit Shutdown</b> <b>via Remote</b>	The GT Inverter unit has been shut down via a computer connected to the RS-232 port.
<b>Protection uP</b> <b>Not Responding</b>	The protection microprocessor is not responding.



- \* It is normal to receive this fault during low light conditions at dawn or dusk. At such times, the array does not have sufficient energy to power the inverter, so the PV voltage drops below 240 volts occasionally.
- † Grid fault. When this fault is cleared the protection timer will begin its countdown and you will see the “Reconnecting in sss seconds” and “Inverter Offline” special screens (see Table 5-10) flashing alternately until the countdown is complete.

Additional Fault messages for all systems

Additional message screens can be viewed in fault mode by tapping the Xantrex logo near the LCD. Each additional tap displays the next screen in the order shown in Table 5-9.

**Table 5-9** Additional Fault Mode Screens

Tap	Display*	Description
1st time	Current fault message screen (see Table 5-8)	LCD backlight turns on for better readability.
2nd time	<b>System On Today 2.500kWh</b>	Energy being produced by the system now. Cumulative energy produced by the system today.
3rd time	<b>System Lifetime 305kWh</b>	Lifetime energy produced by the GT Inverter system.
4th time	<b>Time Online Today hh:mm:ss</b>	Length of time inverter was online today, in hours (hh), minutes (mm) and seconds (ss).
5th time	<b>Array Readings 350.5V 8.4A</b>	Immediate DC voltage and current readings of power from the PV array.
6th time	<b>Grid Readings 242.6V 60.0Hz</b>	Immediate AC voltage and frequency readings of power from the grid.

\* *In a multiple unit system with network cables installed, the system values displayed are for the entire system. Time online and array readings are for the local inverter and PV array associated with that inverter.*

## Special Screens

Special message screens are displayed in specific situations that are not considered fault situations. They can appear in any mode of operation. These screens are described in Table 5-10.

**Table 5-10** Special Message Screens

Display	Description
<b>Reconnecting in sss seconds</b>	Time remaining in seconds (sss) before the GT Inverter reconnects to the grid. This is a protection timer; it runs for approximately five minutes at startup and after any grid fault.
<b>Inverter Offline</b>	GT Inverter switching (or has switched) from Normal Operation to Offline mode. This screen may flash alternately with a Fault message screen.
<b>System *3500W Today 15.56kWh</b>	The “*” in these two screens (see Table 5-2 and Table 5-4) indicates that the unit is derating its output power because the inverter heat sink temperature is above 75° C (167° F).  The asterisk only appears when the power is actually being limited by the inverter.
<b>Unit *1800W Today 7.82kWh</b>	
<b>Insufficient Solar Energy</b>	Indicates the GT Inverter is not producing power due to insufficient solar energy during low light conditions in early morning or late afternoon or when the PV array is in shade. This screen flashes alternately with the Normal Operation default screen.

## Custom Screens

Two custom screens are available. The inverter does not display them unless they are configured using GT-View (see page 3–15). If programmed, the custom screens display as the fourth and fifth screens during the startup sequence. They can also be viewed by tapping the unit during normal operation and fault mode.

The first custom screen is intended for the home owner to display information such as the name or location of the PV array associated with the inverter.

The second custom screen is intended for installers, who can configure the screen to display, for example, contact information for service.

## Status Indicator Lights

The GT Inverter has two status indicator lights (LEDs) located below the front panel LCD (Figure 5-2). These LEDs indicate the inverter's status (Table 5-11) and assist in troubleshooting the performance of the unit.

Only one indicator light will be lit at any time.

**Table 5-11** Status Indicator LEDs

LED on	Means
GREEN	GT Inverter is on (DC voltage and AC voltage are qualified and the protection timer has finished) and delivering power. No action required. Turns off when a fault state is detected.
RED	Ground fault condition detected. Check for any fault messages on the display (see Table 5-8), and refer also to Table 6-1, "Troubleshooting the GT Inverter" on page 6-9 to resolve the fault condition.

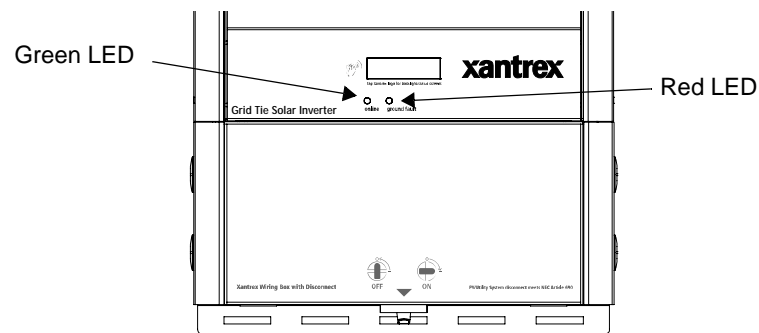

**Figure 5-2** Status Indicator Lights



# 6

## Maintenance and Troubleshooting

Chapter 6 contains information about how to provide general maintenance for the Xantrex Grid Tie Solar Inverter. It also provides information about troubleshooting the unit.

The topics in this chapter are organized as follows:

- “Factors Affecting GT Inverter Performance” on page 6–1
- “Performing General Maintenance” on page 6–3
- “Replacing Parts” on page 6–3
- “Identifying Error/Fault Conditions and Solutions” on page 6–9.

### Factors Affecting GT Inverter Performance

This section describes several factors that will affect the amount of power that a properly installed and operating GT Inverter can produce.

#### PV Array Factors

PV array ratings	PV arrays are rated at ideal factory conditions, such as specified illumination ( $1000 \text{ W/m}^2$ ), spectrum of the light and specified temperature ( $25 \text{ }^\circ\text{C} / 77 \text{ }^\circ\text{F}$ ), which seldom reflect real-world installations. This is called the STC (Standard Test Condition) rating and is the figure that appears on the PV module nameplate label.
Expected performance	Because of several unavoidable environmental factors, you can expect your PV array to produce around 60% to 70% of its peak STC-rated output for a properly designed and installed PV system on a typical day.
Temperature and reduced output	PV array temperature affects the output of the entire system. As the temperature on the array surface heats up, its energy output goes down. Roof-mounted arrays also collect the heat generated by the roof surface (or trapped under the array) and will produce less output than pole-mounted arrays, which allow greater air circulation behind the panels.

**Important:** The GT Inverter will reduce its energy output to protect its electronic circuits from overheating and possible damage in high heat conditions. For maximum output in hot climates, mount the GT Inverter in a shaded location with good air flow.

---

Angle of the sun	The angle of the sun in relation to the PV array surface—the array orientation—can dramatically affect the PV array output. The array energy output will vary depending on the time of day and time of year as the sun’s angle in relation to the array changes. Sunlight output decreases as the sun approaches the horizons (such as in winter in North America) due to the greater atmospheric air mass it must penetrate, reducing both the light intensity that strikes the array’s surface and spectrum of the light. In general, you can expect only four to six hours of direct sunlight per day.
Partial shade	Shading of only a single module of the array will reduce the output of the entire system. Such shading can be caused by something as simple as the shadow of a utility wire or tree branch on part of the array’s surface. This condition, in effect, acts like a weak battery in a flashlight, reducing the total output, even though the other batteries are good. However, the output loss is not proportionate to shading. The GT Inverter is designed to maximize its energy production in all of the above situations using its MPPT algorithm.

## Other Factors

Other factors that contribute to system losses are:

- Dust or dirt on the array
- Fog or smog
- Mismatched PV array modules, with slight inconsistencies in performance from one module to another.
- Inverter efficiency
- Wire losses
- Utility grid voltage.

For additional information and technical notes concerning PV array performance, please visit our Web site at [www.xantrex.com](http://www.xantrex.com).

---

## Performing General Maintenance

Follow these simple routines to ensure many years of service and optimal performance of your solar energy system.

1. Keep the heat sink clear of dust and debris.



### **WARNING: Shock and fire hazard**

Do not use a pressure washer to clean the GT Inverter, or use other cleaning methods that could allow water to enter the unit.

- 
2. Clean the PV array, during the cool part of the day, whenever it is visibly dirty.
  3. Periodically inspect the system to make sure that all wiring and supports are securely in place.
  4. On a sunny day near noon on March 21 and September 21 of each year, review the output of the system and compare with previous year's reading. Maintain a log of system performance readings so that you can recognize when system performance becomes inconsistent.

## Replacing Parts



### **WARNING: Shock hazard**

There are no user-replaceable parts on the GT Inverter. Do not attempt to service the unit yourself.

---

See the “Warranty and Return Information” on page WA-1 for information on how to get service for your GT Inverter.

## Replacing the Ground Fault Protection Fuse



### **WARNING: Shock and fire hazard**

Fuses should only be replaced by qualified service personnel, such as a certified electrician or technician. For continued protection against risk of fire, replace only with same type and ratings of fuse.



### **WARNING: Shock hazard**

After disconnecting both AC and DC power from the GT Inverter, wait five minutes before attempting any maintenance or cleaning or working on any circuits connected to the inverter. Internal capacitors remain charged for five minutes after disconnecting all sources of power.



### **WARNING: Shock hazard**

- Dangerous voltages can exist inside the inverter. If there is leakage current from the ungrounded conductor to ground at the array, touching the grounded lead could cause a life-threatening shock even with the disconnect switch turned off. Ungrounded DC current within the inverter presents an extreme shock hazard.
- Cover PV arrays with an opaque material during this procedure.
- When the fuse has blown due to a fault, incorrect handling can be life-threatening. Use an insulated fuse puller.

The ground fault protection fuse will blow when severe leakage occurs between the PV array and earth ground, or when the system has been installed with faulty wiring. Before replacing the fuse, it is important to have qualified service personnel, such as a certified electrician or technician, determine the cause of the ground fault.

#### **To replace a ground fault protection fuse:**

1. Remove the wiring/disconnect box cover, as described on page 3–5.
2. Remove the display front panel cover (see Figure 6-2), located below the heat sink. Use a Phillips screwdriver to remove the two external panhead screws and washers and the two screws along the bottom edge of the cover.

The ground fault protection fuse is located to the left side of the LCD panel (see Figure 6-1), and to the left of the DC interconnect board for positive grounded units (marked with the “-POS” suffix).

3. Using an insulated fuse puller, remove the blown fuse and replace it with a new AC/DC midget cartridge, rated 600 Vdc, 1A (Littelfuse KLKD 1 or equivalent).
4. Replace the display front panel cover and tighten all four screws securely.
5. Replace the wiring/disconnect box cover.



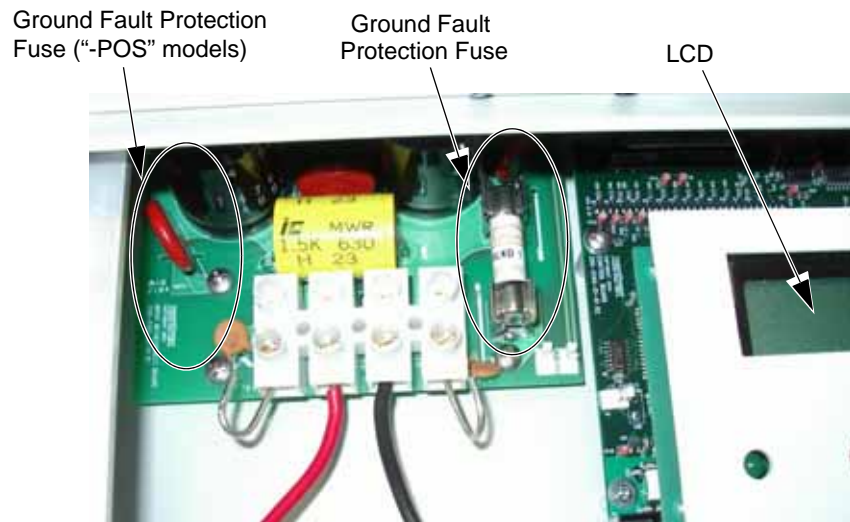

Figure 6-1 Location of Fuse, Front Panel Cover Removed

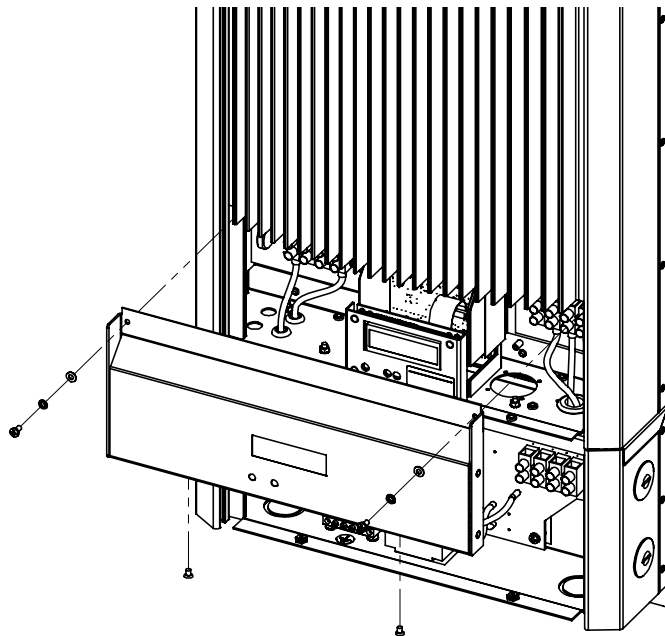

Figure 6-2 Display Front Panel Assembly

## Replacing the Inverter

If your GT Inverter requires servicing, you can replace it with another inverter, leaving the existing wiring box in place. This means that you do not have to disturb wiring connections in the wiring/disconnect box. However, you do have to disconnect wiring between the inverter and the wiring/disconnect box.



### **WARNING: Shock hazard**

- Replacing the inverter according to these procedures should only be performed by qualified service personnel, such as a certified electrician or technician.
- Separating the inverter from the wiring box breaks the ground path between the grounded conductor and earth ground. When the wires between the inverter and wiring box are disconnected and exposed, both PV leads are floating at the array open circuit voltage. If there is leakage current from the POSITIVE PV lead to ground at the array, touching the NEGATIVE PV lead could cause a life-threatening shock even with the disconnect switch turned off. Ungrounded DC current within the inverter presents an extreme shock hazard.
- Cover PV arrays with an opaque material during this procedure.
- Use insulated tools only when disconnecting wires between the inverter and wiring box. Cap all disconnected wires with wire nuts.

---

Recommended tools:

- Insulated screwdriver
- Wire nuts
- 7 mm socket and small ratchet, or 7 mm open wrench.



### **WARNING: Shock hazard**

The inverter should only be removed from the wiring box when a replacement inverter is immediately available. When replacing an inverter, ensure the DC/AC Disconnect switch is locked (or otherwise secured) in the OFF position. Do not leave the top of the wiring box exposed for extended periods of time.



### **WARNING: Shock hazard**

Before replacing the inverter, turn OFF the breaker switches in the main utility service panel and the DC/AC Disconnect switch on the GT Inverter. Cover the PV arrays with an opaque material.

---

#### **To remove the inverter from the wiring box:**

1. Turn OFF the breaker switches in the main utility service panel and the DC/AC Disconnect switch on the GT Inverter. Disable the output of the PV arrays by covering them with an opaque material.
2. Remove the wiring/disconnect box cover and the display front panel cover (see Figure 3-3 on page 3–5 and Figure 6-2 on page 6–5).

3. Using an insulated screwdriver, disconnect the PV NEGATIVE (–) wire from the terminal block inside the inverter. Cap the wire immediately with a wire nut.
4. Disconnect the remaining AC, DC and network cables between the inverter and the wiring box, inside the inverter. Cap all disconnected AC and DC wires with wire nuts.
5. Inside the inverter, remove the four nuts attaching the wiring box to the inverter. See Figure 6-3.
6. Push the connecting DC and AC wires down inside the wiring box.
7. Lift the inverter off the mounting bracket, leaving the wiring box in place.
8. Ensure the gasket on the wiring/disconnect box is clean and undamaged. The gasket must create a water-tight seal between the inverter and wiring/disconnect box.

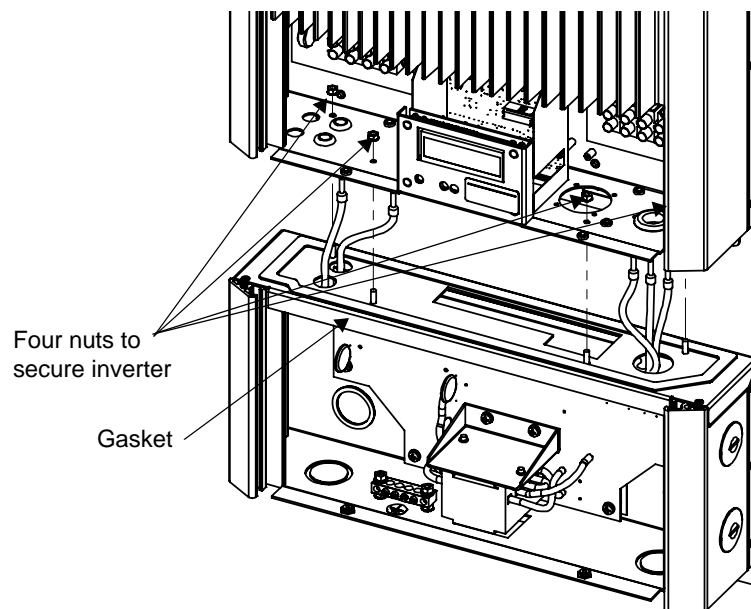
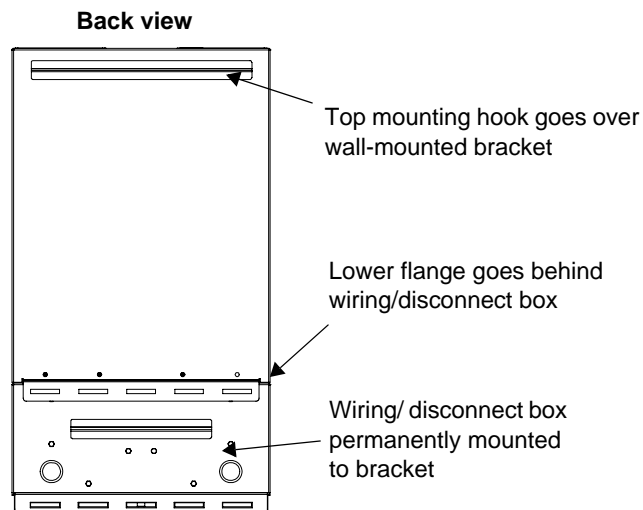

Figure 6-3 Wiring/Disconnect Box and Removable Inverter



**Figure 6-4** Inverter and Wiring/Disconnect Box Sections

**To replace the inverter on the wiring box:**

1. If it has not already been removed, remove the display front panel cover on the inverter.
2. Mount the inverter on the upper mounting bracket above the wiring/disconnect box, ensuring that the inverter's lower flange goes behind the wiring/disconnect box. See Figure 6-4.
3. Pull the connecting DC and AC wires back out of the wiring box and into the inverter.
4. Replace the nuts that connect the inverter and the wiring/disconnect box. Tighten each nut alternately to clamp the gasket between the inverter and wiring/disconnect box. Secure all nuts tightly.
5. Remove the wire nut from the PV NEGATIVE (-) wire and reconnect it to the terminal block inside the inverter.
6. Uncap the remaining DC and AC wires and reconnect them to the terminal blocks inside the inverter.
7. Ensure all connections are correctly wired and properly torqued to a maximum 16 in-lb (1.8 Nm).
8. Follow the startup procedure as described on page 4-1.

## Identifying Error/Fault Conditions and Solutions

Most error or fault conditions will be identified by fault message screens on the GT Inverter front panel LCD. These are described in the “Fault Mode” section on page 5–8 of this manual. Most of these fault conditions are self-correcting and require no user action to remedy.

See “Front Panel Display Screens and What They Mean” on page 5–2 for more information.

Table 6-1 is intended to assist in determining fault conditions that may require user action to remedy.

**Table 6-1** Troubleshooting the GT Inverter

Problem	Possible Cause	Solution
The inverter’s LEDs and display are blank and the inverter does not operate in sufficient sunlight.	DC/AC Disconnect Switch is off.	Turn on DC/AC Disconnect Switch and breakers in the sequence described in “Startup Procedure” on page 4–1.
The display reads “Inverter Offline” and “AC Voltage Fault.”	Utility service panel breakers are switched off.  AC grid voltage is not present or incorrect.	Turn on utility panel breakers.  Check AC connections at the inverter’s terminals. Ensure AC voltage within the range specified in “Output” on page A–2 is present.
The display reads “Inverter Offline” with sufficient sunlight.	DC breakers are switched off (if installed), or external DC fuses are blown (if installed).  DC array voltage is not present.	Turn on any DC breakers and check any DC fuses.  Check DC connections at the inverter’s positive and negative DC terminals. Check for incorrectly wired PV arrays.
The display reads “Inverter Offline” and “DC Voltage Fault” with sufficient sunlight.	DC voltage is present but incorrect.	Check DC connections at the inverter’s positive and negative DC terminals. Check for incorrectly wired PV arrays. Ensure a voltage between 240 and 550 Vdc is present at the inverter’s terminals.
Only the inverter RED LED is illuminated and the display reads “Ground Fault.”	Ground fault condition detected on the PV array.	The PV system should be checked by a qualified electrician and repaired. See Table 5-8 on page 5–8.



# A

# Specifications

Appendix A contains information about the specifications of the Xantrex Grid Tie Solar Inverter.

The topics in this appendix are organized as follows:

- “Electrical Specifications” on page A-2
- “Output Power Versus Ambient Temperature” on page A-3
- “Efficiency” on page A-4
- “Environmental Specifications” on page A-4
- “User Display” on page A-4
- “Mechanical Specifications” on page A-5
- “Regulatory Approvals” on page A-5

## Electrical Specifications

### Input

Input voltage, Maximum Power Point range	240 to 550 Vdc
Absolute maximum array open circuit voltage	600 Vdc
Maximum input current	22.0 Adc
Maximum array short circuit current	24 Adc
Reverse polarity protection	Short circuit diode
Ground fault protection	GF detection, $I_{DIF} > 1 \text{ A}$

### Output

Maximum output power	5000 W AC
Nominal output voltage	240 V
Operating range, utility voltage*	211 to 264 Vac
Nominal output frequency	60 Hz
Operating range, utility frequency*	59.3 to 60.5 Hz
Startup current	0 Aac
Maximum continuous output current	21 A
Output overcurrent protection	30 A RMS
Maximum utility backfeed current	0 A
Total Harmonic Distortion	<5%
Power factor	>0.95%
Utility monitoring— islanding protection	Vac, fac as per UL 1741 (2005)
Output characteristics	Current source
Output current waveform	Sine wave

\* Factory settings can be adjusted with the approval of the utility. This unit is provided with adjustable trip limits and may be aggregated above 30 kW on a single Point of Common Coupling. See “Adjustable Voltage, Frequency and Reconnection Settings” on page A-3.



## Adjustable Voltage, Frequency and Reconnection Settings

Utility disconnect settings can be adjusted using the GTConfigLite software tool. Permission of the utility must be granted before adjusting any of these settings.

For more information about installing and using GTConfigLite, see the *GTConfigLite User's Guide* (p/n 976-0260-01-01), available on the software CD.

Setting	Default	Range	Tolerance
Phase-to-phase (rms) high threshold voltage	261.00	261.00–264.00	±3 V
Phase-to-phase (rms) low threshold voltage	214.00	204.00–214.00	
Phase-to-neutral (rms) high threshold voltage	130.50	130.50–132.00	±1.5 V
Phase-to-neutral (rms) low threshold voltage	107.10	102.00–107.10	
Frequency high threshold	60.40	60.40–60.60	±0.1 Hz
Frequency low threshold	59.40	57.00–59.80	
Voltage (rms) High Clearing Time (ms)	<1000	1000–2000	+0, –0.1 s
Voltage (rms) Low Clearing Time (ms)	<2000	2000–5000	
Frequency High Clearing Time (ms)	<160	160–200	
Frequency Low Clearing Time (ms)	<160	160–300000	
Reconnect Delay (ms)	305000	60000–305000	n/a

## Output Power Versus Ambient Temperature

Once the heat sink on the inverter reaches a maximum temperature limit, the GT Inverter reduces its energy output to ensure maximum component ratings are not exceeded.

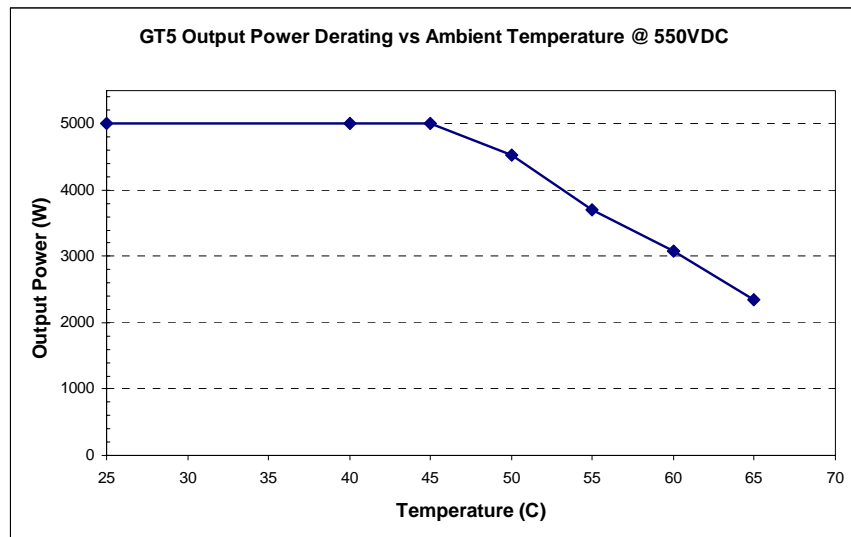

Figure A-1 Output Power vs. Ambient Temperature

# Efficiency

Maximum efficiency	96.2%
CEC efficiency	95.5%
Night-time tare loss	1 W

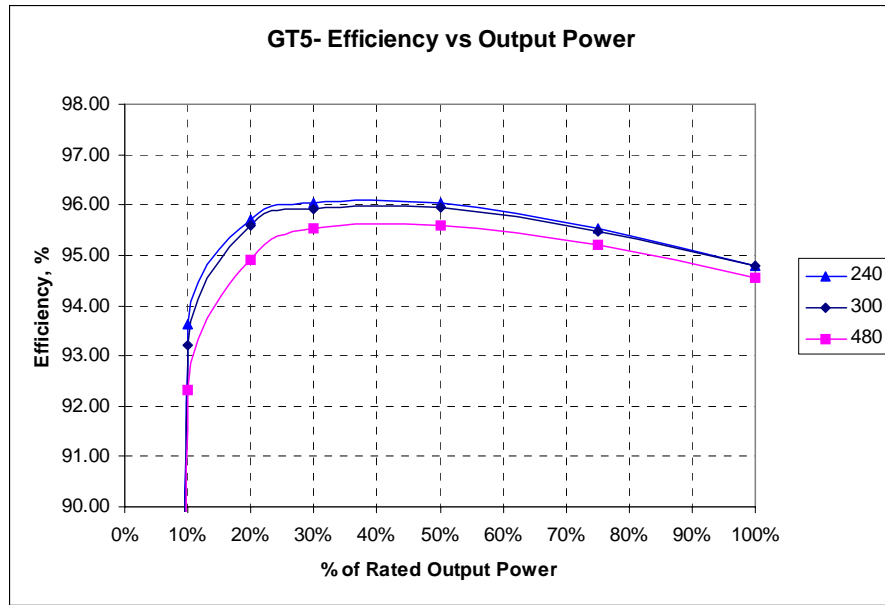

Figure A-2 Typical Efficiency

# Environmental Specifications

Operating temperature range	-25° to +65° C (-13° to +149° F)
Storage temperature range	-40° to +85° C (-40° to +185° F)
Power derating	See Figure A-1 on page A-3
Tolerable relative humidity limit	<b>Operating:</b> <95%, non-condensing <b>Storage:</b> 100% condensing

# User Display

Type	alphanumeric liquid crystal display with backlight
Size	2 lines by 16 characters

## Display Accuracy

Instantaneous Power	+/- (30 W + 1% of reading)
Voltage	+/- (1% of rating + 1% of reading)
Current	+/- (1% of rating + 1% of reading)
System Lifetime energy	+/- 5%

## Mechanical Specifications

Outdoor enclosure	NEMA 3R, Rainproof
Inverter dimensions (H × W × D)	28.5 × 15.9 × 5.7 inches (72.4 × 40.3 × 14.5 cm)
Shipping dimensions (H × W × D)	34.1 × 20.4 × 10.3 inches (86.6 × 51.8 × 26.2 cm)
Inverter weight	58 lb (26.3 kg)
Shipping weight	76 lb (34.5 kg)
Input and output terminals	AC and DC terminals accept wire sizes of 2.5 to 16 mm <sup>2</sup> (#14 to #6 AWG)
Disconnect switch	Integrated switch, disconnects both AC and DC (meets NEC article 690), rated @ 600 Vdc

## Regulatory Approvals

The GT Inverter has complete on-board over-current, over-temperature and anti-islanding protection, and meets U.S., Canadian and international safety operating standards and code requirements:

- UL 1741 1st Edition 2005 Revision – Standard for Inverters, Converters, Controllers and Interconnection System Equipment for Use with Distributed Energy Resources (Includes IEEE 1547 and 1547.1)
- CSA C22.2 No. 107.1-01 General Use Power Supplies
- IEEE C62.41.2 – IEEE Recommended Practice on the Characterization of surges in Low-Voltage AC Power Circuits (Location Category B). Part of UL 1741-2005. Refer to approval certificate for details.

**Note:** This inverter is compliant with IEEE 1547 for those requirements referenced in UL1741 (2005), section 46.1.1.:

A utility interactive inverter and interconnection system equipment (ISE) shall comply with the Standard for Interconnecting Distributed Resources With Electric Power Systems, IEEE 1547, and the Standard for Conformance Test Procedures for Equipment Interconnecting Distributed Resources with Electric Power Systems, IEEE 1547.1, excluding the requirements for Interconnection Installation Evaluation, Commissioning Tests, and Periodic Interconnection Tests.



# Warranty and Return Information

## Warranty

**What does this warranty cover?** This Limited Warranty is provided by Xantrex Technology Inc. ("Xantrex") and covers defects in workmanship and materials in your Xantrex Grid Tie Solar Inverter. This warranty period lasts for five years from the date of purchase at the point of sale to you, the original end user customer. You require proof of purchase to make warranty claims.

This Limited Warranty is transferable to subsequent owners but only for the unexpired portion of the Warranty Period. Subsequent owners also require proof of purchase.

**What will Xantrex do?** Xantrex will, at its option, repair or replace the defective product free of charge, provided that you notify Xantrex of the product defect within the Warranty Period, and provided that Xantrex through inspection establishes the existence of such a defect and that it is covered by this Limited Warranty.

Xantrex will, at its option, use new and/or reconditioned parts in performing warranty repair and building replacement products. Xantrex reserves the right to use parts or products of original or improved design in the repair or replacement. If Xantrex repairs or replaces a product, its warranty continues for the remaining portion of the original Warranty Period or 90 days from the date of the return shipment to the customer, whichever is greater. All replaced products and all parts removed from repaired products become the property of Xantrex.

Xantrex covers both parts and labor necessary to repair the product, and return shipment to the customer via a Xantrex-selected non-expedited surface freight within the contiguous United States and Canada. Alaska and Hawaii are excluded. Contact Xantrex Customer Service for details on freight policy for return shipments outside of the contiguous United States and Canada.

**How do you get service?** If your product requires troubleshooting or warranty service, contact your merchant. If you are unable to contact your merchant, or the merchant is unable to provide service, contact Xantrex directly at:

Telephone: 1 800 670 0707 (toll free North America)

1 360 925 5097 (direct)

Fax: 1 360 925 5143 (direct)

Email: customerservice@xantrex.com

Direct returns may be performed according to the Xantrex Return Material Authorization Policy described in your product manual. For some products, Xantrex maintains a network of regional Authorized Service Centers. Call Xantrex or check our website to see if your product can be repaired at one of these facilities.

**What proof of purchase is required?** In any warranty claim, dated proof of purchase must accompany the product and the product must not have been disassembled or modified without prior written authorization by Xantrex.

Proof of purchase may be in any one of the following forms:

- The dated purchase receipt from the original purchase of the product at point of sale to the end user, or
- The dated dealer invoice or purchase receipt showing original equipment manufacturer (OEM) status, or
- The dated invoice or purchase receipt showing the product exchanged under warranty

**What does this warranty not cover?** This Limited Warranty does not cover normal wear and tear of the product or costs related to the removal, installation, or troubleshooting of the customer's electrical systems. This warranty does not apply to and Xantrex will not be responsible for any defect in or damage to:

- a) the product if it has been misused, neglected, improperly installed, physically damaged or altered, either internally or externally, or damaged from improper use or use in an unsuitable environment;
- b) the product if it has been subjected to fire, water, generalized corrosion, biological infestations, or input voltage that creates operating conditions beyond the maximum or minimum limits listed in the Xantrex product specifications including high input voltage from generators and lightning strikes;
- c) the product if repairs have been done to it other than by Xantrex or its authorized service centers (hereafter "ASCs");
- d) the product if it is used as a component part of a product expressly warranted by another manufacturer;
- e) the product if its original identification (trade-mark, serial number) markings have been defaced, altered, or removed.

## Disclaimer

### Product

THIS LIMITED WARRANTY IS THE SOLE AND EXCLUSIVE WARRANTY PROVIDED BY XANTREX IN CONNECTION WITH YOUR XANTREX PRODUCT AND IS, WHERE PERMITTED BY LAW, IN LIEU OF ALL OTHER WARRANTIES, CONDITIONS, GUARANTEES, REPRESENTATIONS, OBLIGATIONS AND LIABILITIES, EXPRESS OR IMPLIED, STATUTORY OR OTHERWISE IN CONNECTION WITH THE PRODUCT, HOWEVER ARISING (WHETHER BY CONTRACT, TORT, NEGLIGENCE, PRINCIPLES OF MANUFACTURER'S LIABILITY, OPERATION OF LAW, CONDUCT, STATEMENT OR OTHERWISE), INCLUDING WITHOUT RESTRICTION ANY IMPLIED WARRANTY OR CONDITION OF QUALITY, MERCHANTABILITY OR FITNESS FOR A PARTICULAR PURPOSE. ANY IMPLIED WARRANTY OF MERCHANTABILITY OR FITNESS FOR A PARTICULAR PURPOSE TO THE EXTENT REQUIRED UNDER APPLICABLE LAW TO APPLY TO THE PRODUCT SHALL BE LIMITED IN DURATION TO THE PERIOD STIPULATED UNDER THIS LIMITED WARRANTY.

IN NO EVENT WILL XANTREX BE LIABLE FOR ANY SPECIAL, DIRECT, INDIRECT, INCIDENTAL OR CONSEQUENTIAL DAMAGES, LOSSES, COSTS OR EXPENSES HOWEVER ARISING WHETHER IN CONTRACT OR TORT INCLUDING WITHOUT RESTRICTION ANY ECONOMIC LOSSES OF ANY KIND, ANY LOSS OR DAMAGE TO PROPERTY, ANY PERSONAL INJURY, ANY DAMAGE OR INJURY ARISING FROM OR AS A RESULT OF MISUSE OR ABUSE, OR THE INCORRECT INSTALLATION, INTEGRATION OR OPERATION OF THE PRODUCT.

### Exclusions

If this product is a consumer product, federal law does not allow an exclusion of implied warranties. To the extent you are entitled to implied warranties under federal law, to the extent permitted by applicable law they are limited to the duration of this Limited Warranty. Some states and provinces do not allow limitations or exclusions on implied warranties or on the duration of an implied warranty or on the limitation or exclusion of incidental or consequential damages, so the above limitation(s) or exclusion(s) may not apply to you. This Limited Warranty gives you specific legal rights. You may have other rights which may vary from state to state or province to province.

### Warning: Limitations On Use

Please refer to your product manual for limitations on uses of the product.

SPECIFICALLY, PLEASE NOTE THAT THE XANTREX GRID TIE SOLAR INVERTER SHOULD NOT BE USED IN CONNECTION WITH LIFE SUPPORT SYSTEMS OR OTHER MEDICAL EQUIPMENT OR DEVICES. WITHOUT LIMITING THE GENERALITY OF THE FOREGOING, XANTREX MAKES NO REPRESENTATIONS OR WARRANTIES REGARDING THE USE OF THE XANTREX XANTREX GRID TIE SOLAR INVERTER IN CONNECTION WITH LIFE SUPPORT SYSTEMS OR OTHER MEDICAL EQUIPMENT OR DEVICES.

---

## Return Material Authorization Policy

Before returning a product directly to Xantrex you must obtain a Return Material Authorization (RMA) number and the correct factory "Ship To" address. Products must also be shipped prepaid. Product shipments will be refused and returned at your expense if they are unauthorized, returned without an RMA number clearly marked on the outside of the shipping box, if they are shipped collect, or if they are shipped to the wrong location.

When you contact Xantrex to obtain service, please have your instruction manual ready for reference and be prepared to supply:

- The serial number of your product
- Information about the installation and use of the unit
- Information about the failure and/or reason for the return
- A copy of your dated proof of purchase

Record these details in on page WA-4.

## Return Procedure

1. Package the unit safely, preferably using the original box and packing materials. Please ensure that your product is shipped fully insured in the original packaging or equivalent. This warranty will not apply where the product is damaged due to improper packaging.
2. Include the following:
  - The RMA number supplied by Xantrex Technology Inc. clearly marked on the outside of the box.
  - A return address where the unit can be shipped. Post office boxes are not acceptable.
  - A contact telephone number where you can be reached during work hours.
  - A brief description of the problem.
3. Ship the unit prepaid to the address provided by your Xantrex customer service representative.

**If you are returning a product from outside of the USA or Canada** In addition to the above, you **MUST** include return freight funds and are fully responsible for all documents, duties, tariffs, and deposits.

**If you are returning a product to a Xantrex Authorized Service Center (ASC)** A Xantrex return material authorization (RMA) number is not required. However, you must contact the ASC prior to returning the product or presenting the unit to verify any return procedures that may apply to that particular facility.

## Out of Warranty Service

If the warranty period for your Xantrex Grid Tie Solar Inverter has expired, if the unit was damaged by misuse or incorrect installation, if other conditions of the warranty have not been met, or if no dated proof of purchase is available, your product may be serviced or replaced for a flat fee.

To return your Xantrex Grid Tie Solar Inverter for out of warranty service, contact Xantrex Customer Service for a Return Material Authorization (RMA) number and follow the other steps outlined in "Return Procedure" on page WA-3.

Payment options such as credit card or money order will be explained by the Customer Service Representative. In cases where the minimum flat fee does not apply, as with incomplete units or units with excessive damage, an additional fee will be charged. If applicable, you will be contacted by Customer Service once your unit has been received.

## Information About Your System

As soon as you open your Xantrex Grid Tie Solar Inverter package, record the following information and be sure to keep your proof of purchase.

Product Number      **864-0118**  
Your Model Number    \_\_\_\_\_  
Serial Number        \_\_\_\_\_  
Purchased From      \_\_\_\_\_  
Purchase Date        \_\_\_\_\_

If you need to contact Customer Service, please record the following details before calling. This information will help our representatives give you better service.

### Inverter Details

Type of installation (e.g. Residential/Commercial)    \_\_\_\_\_  
Length of time inverter has been installed            \_\_\_\_\_  
AC wiring size and length                                    \_\_\_\_\_  
DC wiring size and length                                    \_\_\_\_\_  
Description of fault messages and/or indicators on front panel \_\_\_\_\_  
\_\_\_\_\_  
\_\_\_\_\_  
Description of problem                                        \_\_\_\_\_  
\_\_\_\_\_  
\_\_\_\_\_

### PV Details

Solar Panel Mount:       Roof       Pole       Ground  
Solar Panel Brand and Model: \_\_\_\_\_  
Nominal Voltage Range:    \_\_\_\_\_ Vdc  
Peak Open Circuit Voltage: \_\_\_\_\_ Vdc  
Nominal Current Rating:    \_\_\_\_\_ Adc  
Maximum Current Rating:    \_\_\_\_\_ Adc  
Solar Tracker?               Yes       No  
String #1:      # of Panels: \_\_\_\_\_  Series       Parallel  
String #2:      # of Panels: \_\_\_\_\_  Series       Parallel  
String #3:      # of Panels: \_\_\_\_\_  Series       Parallel  
String #4:      # of Panels: \_\_\_\_\_  Series       Parallel



# Index

## A

- abbreviations and acronyms iv
- AC circuit breaker requirements 3–4
- AC grounding requirements 3–1
- AC output voltage ratings A–2
- AC wiring instructions 3–10
- acceptable wire sizes A–5
- accessing AC and DC terminals 3–5
- adjusting utility disconnect settings A–3

## C

- checking AC utility voltage 4–2
- checking PV array DC voltage 4–2
- communication between multiple inverters 3–12
- communications cabling 3–13
  - installing for inverters in parallel 3–15
  - standard CAT 5 wiring 3–14
- Customer Service
  - preparing to call WA–4

## D

- DC wiring instructions 3–7
- derating chart A–3
- dimensions A–5
- display accuracy A–5

## E

- efficiency chart A–4
- electrical specifications A–2
- enclosure type A–5
- error messages and solutions 6–9

## F

- fault conditions and solutions 6–9
- FCC information to the user viii
- features and options 1–2
- front panel display 1–2, 5–1
  - fault messages 5–8
  - normal operation messages 5–4
  - offline mode messages 5–6
  - reading messages 5–2
  - special messages 5–10
  - startup messages 5–2

- fuse, location of ground fault protection 6–5

## G

- general maintenance 6–3
- ground clearance required for installation 2–2, 2–7
- ground fault protection fuse 3–3
  - replacing 6–4
- grounding requirements 3–1
- GT-View 3–15, 5–10

## H

- humidity limits A–4

## I

- information about your system form WA–4
- installation
  - ground clearance 2–2, 2–7
  - grounding requirements 3–1
  - location concerns 2–2
  - mounting 2–7
  - options 2–1
  - PV array requirements 2–3
- inverter
  - features and options 1–2
  - removing from wiring box 6–6
  - serial number WA–4

## L

- LEDs, *See* status LEDs

## M

- maintenance, general 6–3
- maximum power point tracking, *See* MPPT
- mechanical specifications A–5
- messages, *See* front panel display
- model number WA–4
- MPPT
  - operational window 2–3
  - technology 1–2
- multiple inverters
  - AC and DC wiring 3–11
  - communication between 3–12
  - communications wiring 3–15

- configuration 2-1
- messages in normal operation 5-5
- messages in offline mode 5-6

## O

- operation
  - factors affecting performance 6-1
  - inverter startup 4-3
  - messages at startup 5-2
  - reassembling the unit 4-2
  - startup procedure 4-1

## P

- parallel configuration
  - communication between inverters 3-12
  - communications wiring 3-15
- power derating A-4
- proof of purchase WA-4
- purchase date WA-4
- PV arrays
  - angle of the sun 6-2
  - checking DC voltage 4-2
  - effect of shade on performance 6-2
  - factory ratings 6-1
  - temperature affecting performance 6-1
  - types of modules 2-3
  - voltage requirements 2-3

## R

- RJ45 ports
  - communication between inverters 3-13
  - location in wiring box 3-6
- RS-232 port 3-13, 3-15, 5-8

## S

- safety instructions vii
- serial number WA-4
- specifications
  - electrical A-2
  - mechanical A-5
- standard features and options 1-2
- standard test condition 6-1
- startup procedure
  - check PV array DC voltage 4-2
  - check utility AC voltage 4-2
  - monitor front panel display 5-1
  - overview 4-1
  - replace wiring box cover 4-2

- start the inverter 4-3
- status LEDs
  - description 5-11
  - do not illuminate 6-9
  - red LED is on 6-9

## T

- temperature
  - affecting PV array performance 6-1
  - range for locating inverter 2-2
- terminal blocks in wiring box 3-6
- terminators, male network 3-13
- thermal derating chart A-3
- torque values for wires 3-7
- troubleshooting the inverter 6-9

## U

- utility disconnect settings 5-3, A-3

## W

- warranty
  - out of warranty service WA-3
  - terms and conditions WA-1
- weight A-5
- wiring
  - acceptable wire sizes A-5
  - PV array to Xantrex GT Inverter 3-7
  - torquing 3-7
  - wire sizes 3-4
- wiring box
  - description 1-3
  - removing the cover 3-5
  - removing the inverter from 6-6
  - RJ45 connectors 3-6
  - terminal block location 3-6

## X

- Xanbus technology 3-12
- Xantrex web site v



**Xantrex Technology Inc.**

1 800 670 0707 Tel toll free NA

1 360 925 5097 Tel direct

1 360 925 5143 Fax direct

customerservice@xantrex.com

www.xantrex.com

975-0320-01-01

Printed in China

## Free Manuals Download Website

<http://myh66.com>

<http://usermanuals.us>

<http://www.somanuals.com>

<http://www.4manuals.cc>

<http://www.manual-lib.com>

<http://www.404manual.com>

<http://www.luxmanual.com>

<http://aubethermostatmanual.com>

Golf course search by state

<http://golfingnear.com>

Email search by domain

<http://emailbydomain.com>

Auto manuals search

<http://auto.somanuals.com>

TV manuals search

<http://tv.somanuals.com>