

Smart choice for power

**xantrex**

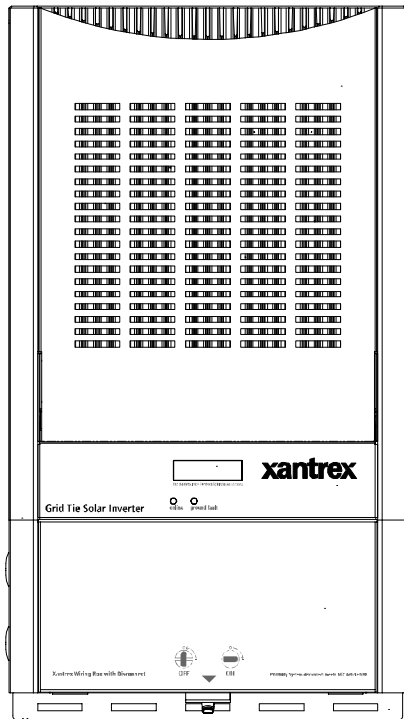

GT3.0

**Owner's Manual**

# Xantrex Grid Tie Solar Inverter

[www.xantrex.com](http://www.xantrex.com)



# Xantrex Grid Tie Solar Inverter

## Owner's Manual

## About Xantrex

Xantrex Technology Inc. is a world-leading supplier of advanced power electronics and controls with products from 50 watt mobile units to one MW utility-scale systems for wind, solar, batteries, fuel cells, microturbines, and backup power applications in both grid-connected and stand-alone systems. Xantrex products include inverters, battery chargers, programmable power supplies, and variable speed drives that convert, supply, control, clean, and distribute electrical power.

## Trademarks

Xantrex Grid Tie Solar Inverter is a trademark of Xantrex International. Xantrex and Xanbus are registered trademarks of Xantrex International.

Other trademarks, registered trademarks, and product names are the property of their respective owners and are used herein for identification purposes only.

## Notice of Copyright

*Xantrex Grid Tie Solar Inverter Owner's Manual* © September 2004 Xantrex International. All rights reserved.

## Disclaimer

UNLESS SPECIFICALLY AGREED TO IN WRITING, XANTREX TECHNOLOGY INC. ("XANTREX")

(a) MAKES NO WARRANTY AS TO THE ACCURACY, SUFFICIENCY OR SUITABILITY OF ANY TECHNICAL OR OTHER INFORMATION PROVIDED IN ITS MANUALS OR OTHER DOCUMENTATION.

(b) ASSUMES NO RESPONSIBILITY OR LIABILITY FOR LOSS OR DAMAGE, WHETHER DIRECT, INDIRECT, CONSEQUENTIAL OR INCIDENTAL, WHICH MIGHT ARISE OUT OF THE USE OF SUCH INFORMATION. THE USE OF ANY SUCH INFORMATION WILL BE ENTIRELY AT THE USER'S RISK.

## Date and Revision

September 2004 Revision B

## Part Number

975-0131-01-01

## Contact Information

Telephone: 1 800 670 0707 (toll free North America)  
1 360 925 5097 (direct)

Fax: 1 800 994 7828 (toll free North America)  
1 360 925 5143 (direct)

Email: [customerservice@xantrex.com](mailto:customerservice@xantrex.com)

Web: [www.xantrex.com](http://www.xantrex.com)

# About This Manual

The purpose of this Owner's Manual is to provide explanations and procedures for installing, operating, maintaining, and troubleshooting the Xantrex Grid Tie Solar Inverter™.

## Scope

The manual provides safety guidelines, detailed planning and setup information. It provides procedures for installing the inverter and information about operating and troubleshooting the unit. It does not provide details about particular brands of photovoltaic (PV) panels. You need to consult individual PV manufacturers for this information.

## Audience

The manual is intended for anyone who needs to install and operate the GT Inverter. Installers should be fully educated on the hazards of installing electrical equipment. Certified electricians or technicians are recommended.

## Organization

This manual is organized into 6 chapters and an appendix.

Chapter 1, "Introduction", contains information about the features and functions of the Xantrex Grid Tie Solar Inverter.

Chapter 2, "Installation", provides information about planning for and installing the GT Inverter. It contains information to help you plan wire routes, AC and DC connections, and find a suitable location for installation. It also discusses requirements for grounding the GT Inverter and your PV array.

Chapter 3, "Wiring the Inverter", provides procedures for making DC and AC wiring connections, and grounding the GT Inverter and the PV array. Instructions for wiring inverters in parallel are also provided.

Chapter 4, "Starting the Inverter", contains information on starting up the Xantrex Grid Tie Solar Inverter and performing a Functional Test.

Chapter 5, "Monitoring the Inverter", contains information for understanding the LCD screens and the LED indicators.

Chapter 6, "Maintenance and Troubleshooting", contains information about how to provide general maintenance for the Xantrex Grid Tie Solar Inverter. It also provides information about troubleshooting the unit.

Appendix A, "Specifications", contains information about the electrical and environmental specifications of the Xantrex Grid Tie Solar Inverter.

## Conventions Used

The following conventions are used in this guide.



### WARNING

Warnings identify conditions that could result in personal injury or loss of life.

---



### CAUTION

Cautions identify conditions or practices that could result in damage to the unit or other equipment.

---

**Important:** These notes describe things which are important for you to know, but not as serious as a caution or warning.

---

## Abbreviations and Acronyms

AC	Alternating Current
CSA	Canadian Standards Association
DC	Direct Current
GT	Grid Tie
GUI	Graphical User Interface
LCD	Liquid Crystal Display
LED	Light Emitting Diode
MPPT	Maximum Power Point Tracking
PC	Personal Computer
PV	Photovoltaic
PVGFP	PV Ground Fault Protection
PWM	Pulse Width Modulation
STC	Standard Test Condition
UL	Underwriters Laboratories
Vac	Volts AC
Vdc	Volts DC
$V_{MP}$	Voltage at Maximum Power
$V_{OC}$	Open Circuit Voltage

## Related Information

You can find more information about Xantrex Technology Inc. as well as its products and services at **[www.xantrex.com](http://www.xantrex.com)**

Other useful documentation on photovoltaic systems includes:

- “A Guide to Photovoltaic (PV) System Design and Installation”, California Energy Commission (CEC), publication #500-01-020, June 2001 (available at **[www.energy.ca.gov](http://www.energy.ca.gov)**).
- “California Interconnection Guidebook: a Guide to Interconnecting Customer-owned Electric Generation Equipment to the Electric Utility Distribution System using California’s Electric Rule 21”, California Energy Commission (CEC), publication #500-03-083, September 2003 (available at **[www.energy.ca.gov](http://www.energy.ca.gov)**).





# Important Safety Instructions

**SAVE THESE INSTRUCTIONS**—This manual contains important instructions that shall be followed during the installation and maintenance of the Xantrex Grid Tie Solar Inverter.

1. Before installing and using the GT Inverter, read all instructions and cautionary markings on the inverter, wiring box, and all appropriate sections of this guide.
2. To reduce risk of fire hazard, do not cover or obstruct the heat sink.
3. Observe the clearance recommendations as described on page 2–18. Do not install the GT Inverter in a zero-clearance or non-ventilated compartment. Overheating may result.
4. Use only accessories recommended or sold by the manufacturer. Doing otherwise may result in a risk of fire, electric shock, or injury to persons.
5. To avoid a risk of fire and electric shock, make sure that existing wiring is in good condition and that wire is not undersized. Do not operate the GT Inverter with damaged or substandard wiring.
6. Do not operate the GT Inverter if it has received a sharp blow, been dropped, or otherwise damaged in any way. If the GT Inverter is damaged, see the Warranty section.
7. Do not disassemble the GT Inverter. It contains no user-serviceable parts. See Warranty for instructions on obtaining service. Attempting to service the GT Inverter yourself may result in a risk of electrical shock or fire and will void the factory warranty.
8. To reduce the risk of electrical shock, disconnect both AC and DC power from the GT Inverter before attempting any maintenance or cleaning or working on any circuits connected to the inverter. Turning off controls will not reduce this risk. Internal capacitors remain charged for 5 minutes after disconnecting all sources of power.
9. The GT Inverter must be provided with an equipment-grounding conductor connected to the AC ground.

## Regulatory Compliance

The GT Inverter has complete on-board over-current, over-temperature and anti-islanding protection, and meets U.S., Canadian and international safety operating standards and code requirements:

- UL 1741 – Standard for Inverters, Converters, and Controllers for Use in Independent Power Systems
- CSA C22.2 No. 107.1-01 General Use Power Supplies
- IEEE C62.41 Recommended Practice on Surge Voltages in Low-Voltage AC Power Circuits (Location Category B3).

### To locate the firmware version number

The firmware version number for the protection processor is visible on a screen that appears when the unit starts up or is powered up after switching the AC/DC Disconnect switch to “on.” The screen reads:

Flash = 01.01
ROM = 01.01

The number appearing after “ROM” is the firmware version number for the protection processor.

## FCC Information to the User

This equipment has been tested and found to comply with the limits for a Class B digital device, pursuant to part 15 of the FCC Rules. These limits are designed to provide reasonable protection against harmful interference in a residential installation. This equipment generates, uses and can radiate radio frequency energy and, if not installed and used in accordance with the instructions, may cause harmful interference to radio communications. However, there is no guarantee that interference will not occur in a particular installation. If this equipment does cause harmful interference to radio or television reception, which can be determined by turning the equipment off and on, the user is encouraged to try to correct the interference by one or more of the following measures:

- Reorient or relocate the receiving antenna.
- Increase the separation between the equipment and the receiver.
- Connect the equipment into an outlet on a circuit different from that to which the receiver is connected.
- Consult the dealer or an experienced radio/TV technician for help.

---

## Verification and Commissioning Test

### **Purpose**

This procedure is designed to verify correct operation of the Xantrex Grid Tie Solar Inverter both on initial operation and periodically through its life as required by the utilities.

### **Commissioning Test**

Follow the startup and monitoring procedures as documented in Chapters 4 and 5.

When operation of the inverter has been verified and the unit is producing power, run the Non-Islanding test as described in this procedure.

### **Verification Test**

Periodically run the Non-Islanding test. The inverter must respond within the 2-second limit for compliance and then hold off on producing power for the required delay (default value of 5 minutes).

### **Non-Islanding Test**

This test requires that the AC circuit for the inverter be switched off. This can be accomplished by switching the breaker on the main panel that feeds the inverter(s). As an alternate, the disconnect for the home or business may be used as well. Have someone watch the front panel of the inverter. Within 2 seconds of switching the breaker, the green light on the front of the inverter must go out. The display will respond with an AC Fault display, indicating that the AC is out of the operating range.

Re-energize the breaker to the inverter. The unit will respond by beginning its countdown. The green light will be off during this time. Five minutes after applying AC (default value), the green light will turn on and the inverter will begin to push power to the grid. The display will then return to its on-line display showing the power being produced along with the total kWh produced to date.

Note: The default voltage, frequency and reconnect delay values as defined by UL1741 and CSA 107.1-01 are programmed into the unit at time of shipment from the factory. No changes to these settings can be made in the field by the user. Only authorized personnel with the utility's permission may change these settings. Contact Xantrex Technology to gain permission and the procedure/equipment to make these changes.



# Contents

## Important Safety Instructions

Regulatory Compliance	viii
FCC Information to the User	viii
Verification and Commissioning Test	ix

## 1 Introduction

About the Xantrex Grid Tie Solar Inverter	1-2
Standard Features	1-3
Optional Features	1-4
Safety and Standards	1-5
Removable Components	1-6
Wiring Box (standard on North American models)	1-6
Optional Heat Sink Cover and Fan	1-7
Model Configurations	1-8

## 2 Installation

Installation Options	2-2
Single Inverter Installation	2-2
Multiple Inverter Installations	2-2
Planning the Installation	2-2
Inverter Location	2-4
PV Array Requirements	2-5
Grounding Requirements	2-8
Routing the Wires	2-11
Preparing for the Installation	2-13
Wiring	2-13
Circuit Breakers and Disconnect Switch	2-13
Other Materials Needed	2-14
Equipment Needed	2-14
Mounting the Inverter	2-15
Overview	2-15
Preparing to Mount the Unit	2-16
Installing the Mounting Bracket	2-17
Mounting the Inverter on the Bracket	2-22
Installing Accessories	2-23

### 3 Wiring the Inverter

Accessing the Wiring Terminals - - - - -	3-2
Connecting the DC Wiring- - - - -	3-4
Connecting the AC Wiring- - - - -	3-7
Connecting Inverters in Parallel - - - - -	3-10
DC and AC Wiring for Inverters in Parallel - - - - -	3-10
Communications Wiring for Inverters in Parallel- - - - -	3-12
Xanbus Network Technology - - - - -	3-12
Guidelines for Routing the Network Cables - - - - -	3-15
Connect the Communications Cable between Inverters in Parallel - - - - -	3-16

### 4 Starting the Inverter

Startup Procedure - - - - -	4-2
Checking the PV Array DC Voltage - - - - -	4-2
Checking the AC Utility Voltage - - - - -	4-2
Replacing the Wiring Box Cover - - - - -	4-3
Starting up the GT Inverter - - - - -	4-4

### 5 Monitoring the Inverter

Monitoring the Front Panel Display- - - - -	5-2
Front Panel Display Screens and What They Mean - - - - -	5-3
Startup Mode - - - - -	5-3
Normal Operation Mode - - - - -	5-3
Offline Mode - - - - -	5-5
Fault Mode - - - - -	5-6
Special Screens - - - - -	5-8
Custom Screens - - - - -	5-9
Status Indicator Lights- - - - -	5-9

### 6 Maintenance and Troubleshooting

Factors Affecting GT Inverter Performance - - - - -	6-2
PV Array Factors - - - - -	6-2
Other Factors - - - - -	6-3
Performing General Maintenance - - - - -	6-3
Replacing Parts - - - - -	6-3
Replacing the Ground Fault Protection Fuse - - - - -	6-4
Replacing the Inverter - - - - -	6-5
Identifying Error/Fault Conditions and Solutions- - - - -	6-8

## A Specifications

Electrical Specifications	A-2
Input	A-2
Output	A-2
Adjustable disconnect settings	A-3
Efficiency	A-4
Environmental Specifications	A-5
User Display	A-5
Mechanical Specifications	A-5
Accessories	A-6

## Warranty and Return Information

Warranty	WA-1
Disclaimer	WA-2
Return Material Authorization Policy	WA-3
Return Procedure	WA-3
Out of Warranty Service	WA-3
Information About Your System	WA-4

## Index





# Figures

Figure 1-1	Basic System Overview	1-2
Figure 1-2	Main Features of the GT Inverter	1-4
Figure 1-3	Safety and Data Label Locations	1-5
Figure 1-4	Wiring Box for the GT Inverter	1-6
Figure 1-5	Optional Heat Sink Cover and Fan Assembly for the GT Inverter	1-7
Figure 2-1	Installation Options Overview	2-3
Figure 2-2	Basic Grounding Overview	2-9
Figure 2-3	Long Distance Grounding Overview	2-10
Figure 2-4	Grounding With Extra Lightning Protection Overview	2-11
Figure 2-5	Knockout Locations on Bottom of Wiring Box	2-12
Figure 2-6	Installation Overview	2-15
Figure 2-7	Dimensions of GT Inverter and Knockout Locations	2-17
Figure 2-8	Mounting Bracket and GT Inverter	2-18
Figure 2-9	Examples of Mounting on a Pole or Rails	2-20
Figure 2-10	Installing the Mounting Bracket using Plywood Support	2-21
Figure 2-11	Proper Placement of the Inverter on the Mounting Bracket	2-22
Figure 2-12	Attaching the fan assembly	2-24
Figure 2-13	Location of Fan Connector	2-25
Figure 3-1	Removing the Wiring Box Cover	3-2
Figure 3-2	AC and DC Terminal Block Location in the Wiring Box	3-3
Figure 3-3	AC/DC Disconnect Switch Positions	3-4
Figure 3-4	DC Connections for Grounded PV Array	3-6
Figure 3-5	AC Connections from GT Inverter to Utility Service Panel	3-9
Figure 3-6	Parallel GT Inverter DC and AC Wiring	3-11
Figure 3-7	Daisy Chain Layout	3-12
Figure 3-8	Male Network Terminator	3-13
Figure 3-9	Xanbus RJ45 Ports in the GT Inverter Wiring Box	3-13
Figure 3-10	RJ45 Connector	3-14
Figure 3-11	Communications Wiring for GT Inverters in Parallel	3-17
Figure 4-1	AC/DC Disconnect Switch Positions	4-4
Figure 5-1	Front Panel LCD Location	5-2
Figure 5-2	Location of Status Indicator Lights	5-10
Figure 6-1	Location of Fuse, Front Panel Cover Removed	6-5
Figure 6-2	Inverter and Wiring Box Sections	6-7
Figure A-1	Output Power vs. Ambient Temperature	A-3
Figure A-2	Typical Efficiency	A-4



# Tables

Table 1-1	GT Inverter Models - - - - -	1-8
Table 2-1	MPPT Operational Window - - - - -	2-6
Table 2-2	Inverter Clearance Requirements - - - - -	2-18
Table 3-1	Torque Values for Wires* - - - - -	3-5
Table 3-2	T568A Standard Wiring - - - - -	3-14
Table 3-3	Network Components and Part Numbers- - - - -	3-15
Table 5-1	Startup Screens on GT Inverter Front Panel Display - - - - -	5-3
Table 5-2	Normal Operation Default Screen - - - - -	5-4
Table 5-3	Normal Operation Screens for All GT Inverter Units - - - - -	5-4
Table 5-4	Additional Normal Operation Screens for Each GT Inverter Unit in a Multiple Unit System- - - - -	5-5
Table 5-5	Offline Mode Default Display - - - - -	5-5
Table 5-6	Offline Mode Screens for All GT Inverter Units- - - - -	5-6
Table 5-7	Additional Offline Mode Screens for Each GT Inverter Unit in a Multiple Unit System - - - - -	5-6
Table 5-8	Fault Message Screens - - - - -	5-7
Table 5-9	Additional Fault Mode Screens - - - - -	5-8
Table 5-10	Special Message Screens - - - - -	5-8
Table 5-11	Status Indicator LEDs - - - - -	5-9
Table 6-1	Troubleshooting the GT Inverter - - - - -	6-8



# 1

## Introduction

Chapter 1, “Introduction”, contains information about the features and functions of the Xantrex Grid Tie Solar Inverter.

The topics in this chapter are organized as follows.

“About the Xantrex Grid Tie Solar Inverter”:

- “Standard Features” on page 1–3
- “Safety and Standards” on page 1–5

“Removable Components”:

- “Wiring Box (standard on North American models)” on page 1–6
- “Optional Heat Sink Cover and Fan” on page 1–7.

“Model Configurations”.

## About the Xantrex Grid Tie Solar Inverter

The Xantrex Grid Tie Solar Inverter (GT Inverter) is designed to convert solar electric (photovoltaic or PV) power into utility-grade electricity that can be used by the home or sold to the local power company.

Installing the GT Inverter consists of mounting it to the wall and connecting the DC input to a PV array and the AC output to the utility. See Figure 1-1 for a simple diagram of a typical installation.

In order to operate, the GT Inverter must have grid power available and connected. It will not provide backup power if the AC grid fails.

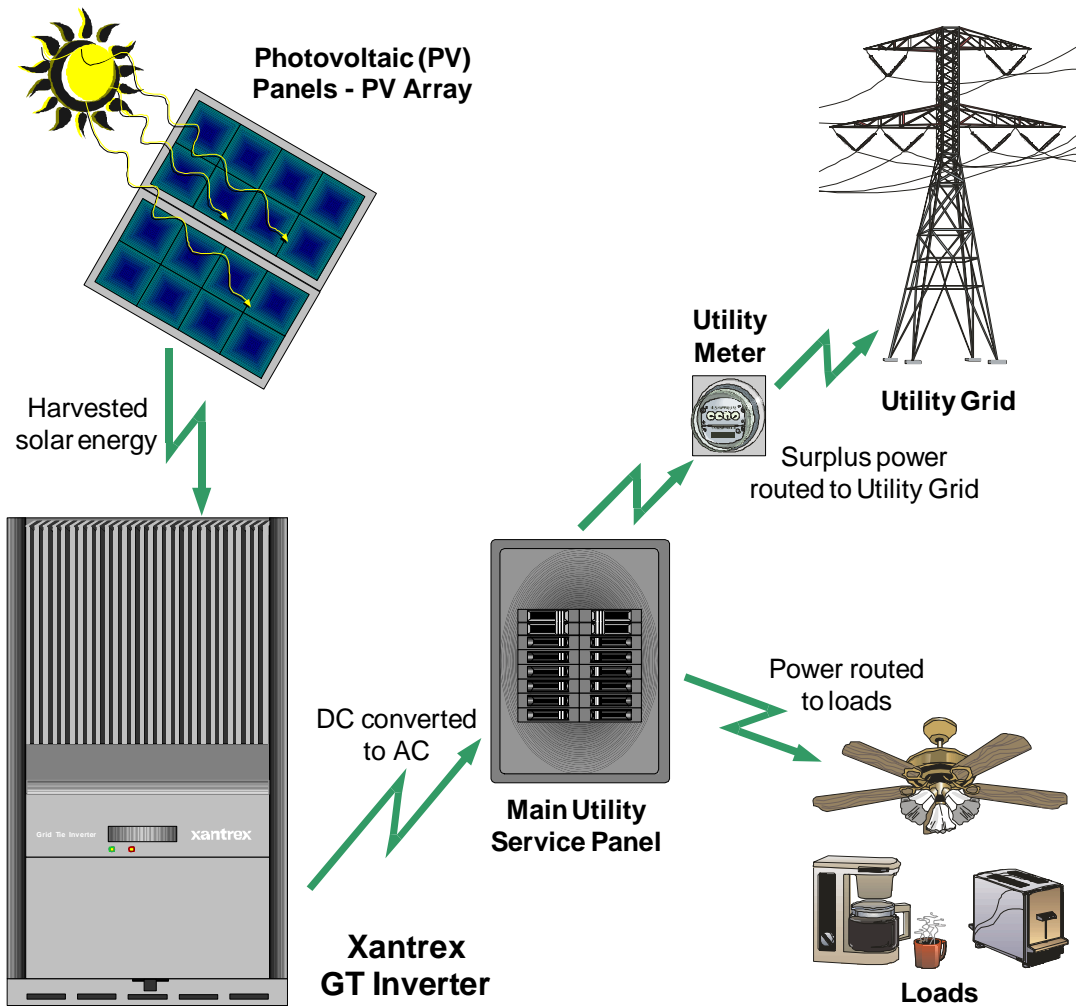

Figure 1-1 Basic System Overview

PV compatibility	The GT Inverter is designed to take advantage of solar modules configured as high voltage PV string arrays—single crystalline, poly crystalline, or thin film—with a 195 to 550 Vdc input voltage Maximum Power Point range.
Maximum Power Point Tracking (MPPT)	The GT Inverter uses Xantrex proprietary Maximum Power Point Tracking (MPPT) technology to harvest the maximum amount of energy from the solar array. MPPT learns your array’s specific characteristics, maximizing its output at all times.
High efficiency	The high-frequency, solid-state design of the GT Inverter is extremely efficient—up to 95%.
Expandable	Multiple GT Inverters may be connected in a parallel configuration for increased net metering capacity or future system growth.
Communications protocol	The GT Inverter uses the Xanbus® Communications protocol, enabling it to communicate with other units connected in parallel within the system. For more information, see “Xanbus Network Technology” on page 3–12.

## Standard Features

The GT Inverter has the following standard features:

- Sealed inverter section with multiple wiring options to facilitate a variety of installation requirements (e.g., hard-wired, “quick-connects,” wiring box with terminals, or with AC/DC disconnect);
- LCD providing easy-to-read system status and daily cumulative energy production information;
- Two LED indicator lights providing status and ground fault indication;
- Wiring box providing protection for all AC and DC connections and eliminating exposed “live” wiring if the inverter is removed.



### **WARNING: Shock hazard**

The 600 volt DC/AC disconnect in the wiring box meets NEC Article 690. It is a non-serviceable component and shall remain in place. Removal can expose energized conductors.

## Optional Features

GT Fan Kit (Xantrex part # 864-0201) includes:

- Heat sink cover
- Fan assembly.

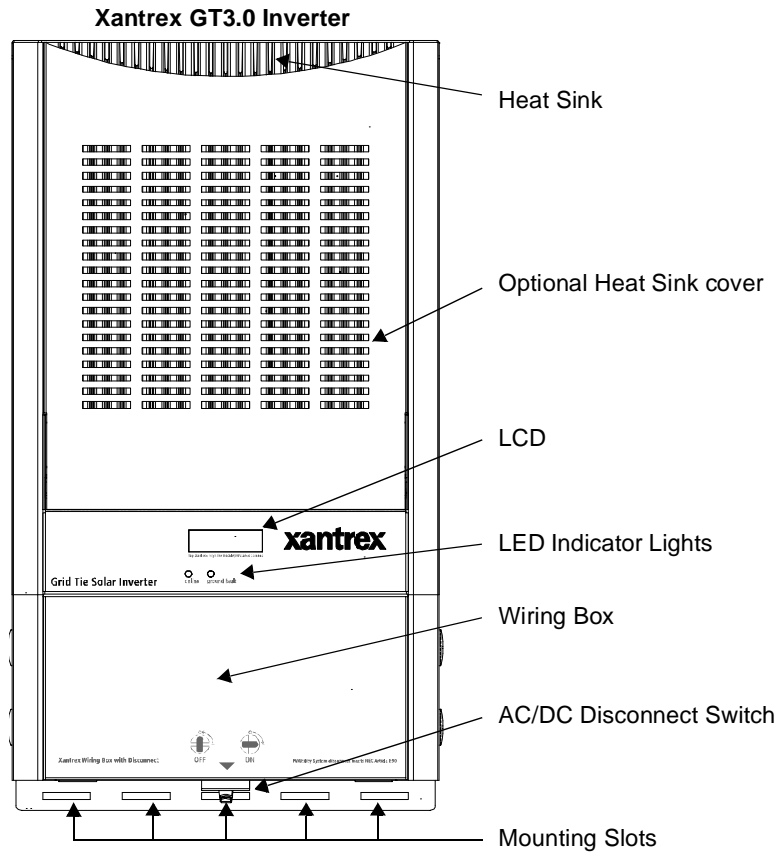

Figure 1-2 Main Features of the GT Inverter



## Safety and Standards

Meets standards and requirements

The GT Inverter has complete on-board over-current, over-temperature and anti-islanding protection, and meets U.S., Canadian and international safety operating standards and code requirements:

- UL 1741 – Standard for Inverters, Converters, and Controllers for Use in Independent Power Systems
- CSA C22.2 No. 107.1-01 General Use Power Supplies.

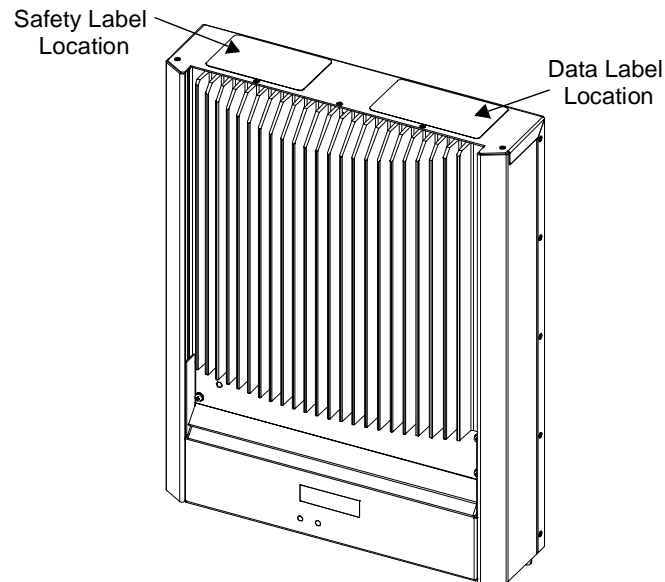

**Figure 1-3** Safety and Data Label Locations

Figure 1-3 shows the location of the safety label and the data label with model, serial and part number information.

## Removable Components

The wiring box is standard for all North American models of the GT Inverter. Some European models are available without the wiring box. See “Model Configurations” on page 1–8 for specific details. The heat sink cover and fan assembly are available in the optional Fan Kit.

### Wiring Box (standard on North American models)

The wiring box provides a location for making AC, DC and ground connections. It also contains the combined AC/DC (Utility/PV array) Disconnect Switch.

The GT Inverter unit may be easily removed from the wiring box in the event that the inverter requires servicing.

---

**Important:** In North America and other locations the wiring box is an electrical code requirement. It must be attached during operation. Check with your local authorities before removing the GT Inverter wiring box.

---

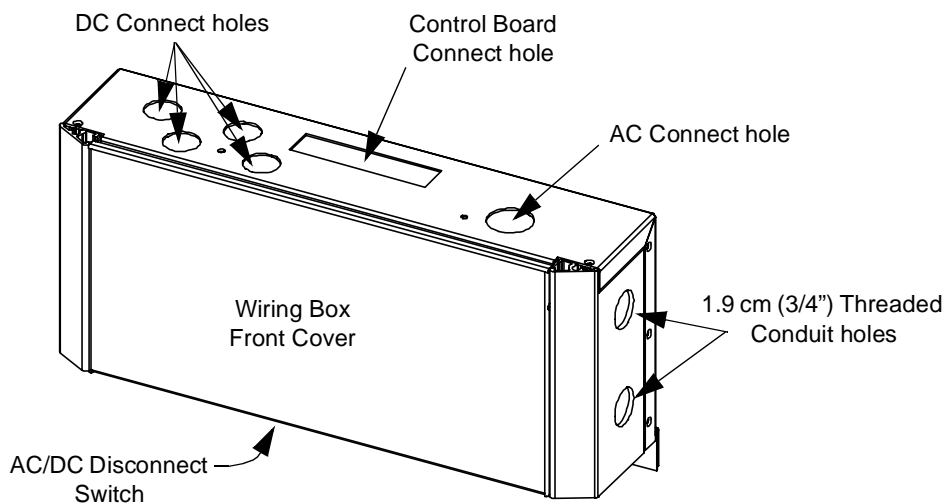

Figure 1-4 Wiring Box for the GT Inverter

## Optional Heat Sink Cover and Fan

In areas where high ambient temperatures ( $>45^{\circ}\text{C}/110^{\circ}\text{F}$ ) may be experienced (such a south-facing installation), a heat sink cover and fan assembly (GT Fan Kit, Xantrex part # 864-0201) can be added to the front of the unit. The fan assembly provides forced-air ventilation directly over the heat sink. The heat sink cover shades the heat sink from direct sunlight and provides a pathway to funnel the forced-air from the fans over the heat sink to optimize cooling.



### WARNING: Burn hazard

In extreme conditions, the GT Inverter chassis can reach temperatures over  $70^{\circ}\text{C}$  ( $158^{\circ}\text{F}$ ), which can cause skin burns if accidentally touched. Ensure that the GT Inverter is located away from normal traffic areas.

See Figure 1-3 on page 1-5 for safety label location.

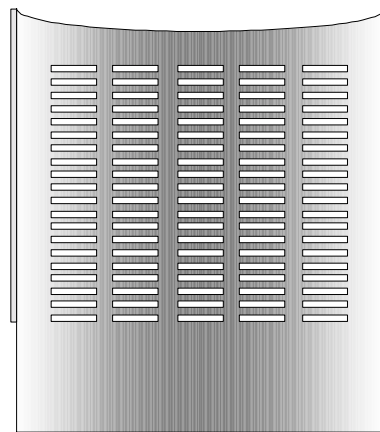

Heat Sink Cover

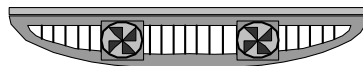

Top view

Fan Assembly



Front view

Figure 1-5 Optional Heat Sink Cover and Fan Assembly for the GT Inverter

## Model Configurations

The GT Inverter model number is in the format **GTx.x-aa-bb-ccc**, where:

- **x.x** Output Power: **3.0 KW**
- **aa** Region: **NA** (North America)  
**DE** (Germany)  
**SP** (Spain)  
**IT** (Italy)  
**FR** (France)
- **bb** Wiring Box: **WB** (wiring box only)  
**DS** (wiring box with AC/DC disconnect switch)  
**HW** (no wiring box)  
**QC** (Quick Connects and no wiring box , Europe only, not available at this time)
- **ccc** Output Voltage: **208** Vac/60 Hz (North America) 3 phase  
**230** Vac/50 Hz (Europe) 3 phase  
**240** Vac/60 Hz (North America).

See Figure 1-3 on page 1–5 for data label location.

Table 1-1 shows the different model configurations available.

**Table 1-1** GT Inverter Models

Model Number	Output Power (x.x)	Output Voltage (ccc)	Wiring Box (bb)			
			WB	DS	HW	QC
GT3.0-NA-bb-208 <sup>1</sup>	3.0	208	√	√	√	
GT3.0-aa <sup>2</sup> -bb-230 <sup>1</sup>		230	√	√	√	√
GT3.0-NA-bb-240		240		√		

1. 208 Vac/60 Hz and 230 Vac/50 Hz models not available at this time

2. any region (aa) except NA

Installation and wiring instructions are provided in Chapter 2, “Installation”, and Chapter 3, “Wiring the Inverter”.

# 2

## Installation

Chapter 2, “Installation”, provides information about planning for and installing the GT Inverter. It contains information to help you plan wire routes, AC and DC connections, and find a suitable location for installation. It also discusses requirements for grounding the GT Inverter and your PV array.

Procedures are provided for installing the Xantrex Grid Tie Solar Inverter.

The topics in this chapter are organized as follows:

- “Installation Options” on page 2–2
- “Planning the Installation” on page 2–2
- “Preparing for the Installation” on page 2–13
- “Mounting the Inverter” on page 2–15
- “Installing Accessories” on page 2–23.

## Installation Options

The GT Inverter may be installed as a single inverter for a single PV array of one or two PV strings, or in a multiple inverter configuration for multiple PV arrays (see Figure 2-1 for diagrams of both options).

### Single Inverter Installation

In this configuration, a single inverter collects the harvested solar energy and routes the power to the main utility service panel to be used by the loads. Any surplus power not used by the loads will be injected into the utility grid.

### Multiple Inverter Installations

If multiple inverters are used, each inverter must be wired to an independent PV array. In this configuration, each inverter collects the harvested solar energy from a separate PV array and routes the power to the main utility service panel to be used by the loads. Any surplus power not used by the loads will be injected into the utility grid.

Communications between inverters is optional, but can be enabled by installing communications cabling to the inverter RJ45 ports. See “Connect the Communications Cable between Inverters in Parallel” on page 3–16.

## Planning the Installation

The following issues need to be considered when planning for an installation using the GT Inverter. See the specified sections for more information.

- “Inverter Location” on page 2–4
- “PV Array Requirements” on page 2–5
- “Grounding Requirements” on page 2–8
- “Routing the Wires” on page 2–11.

Ensure that you have obtained all permits required by local authorities or utilities before commencing installation.

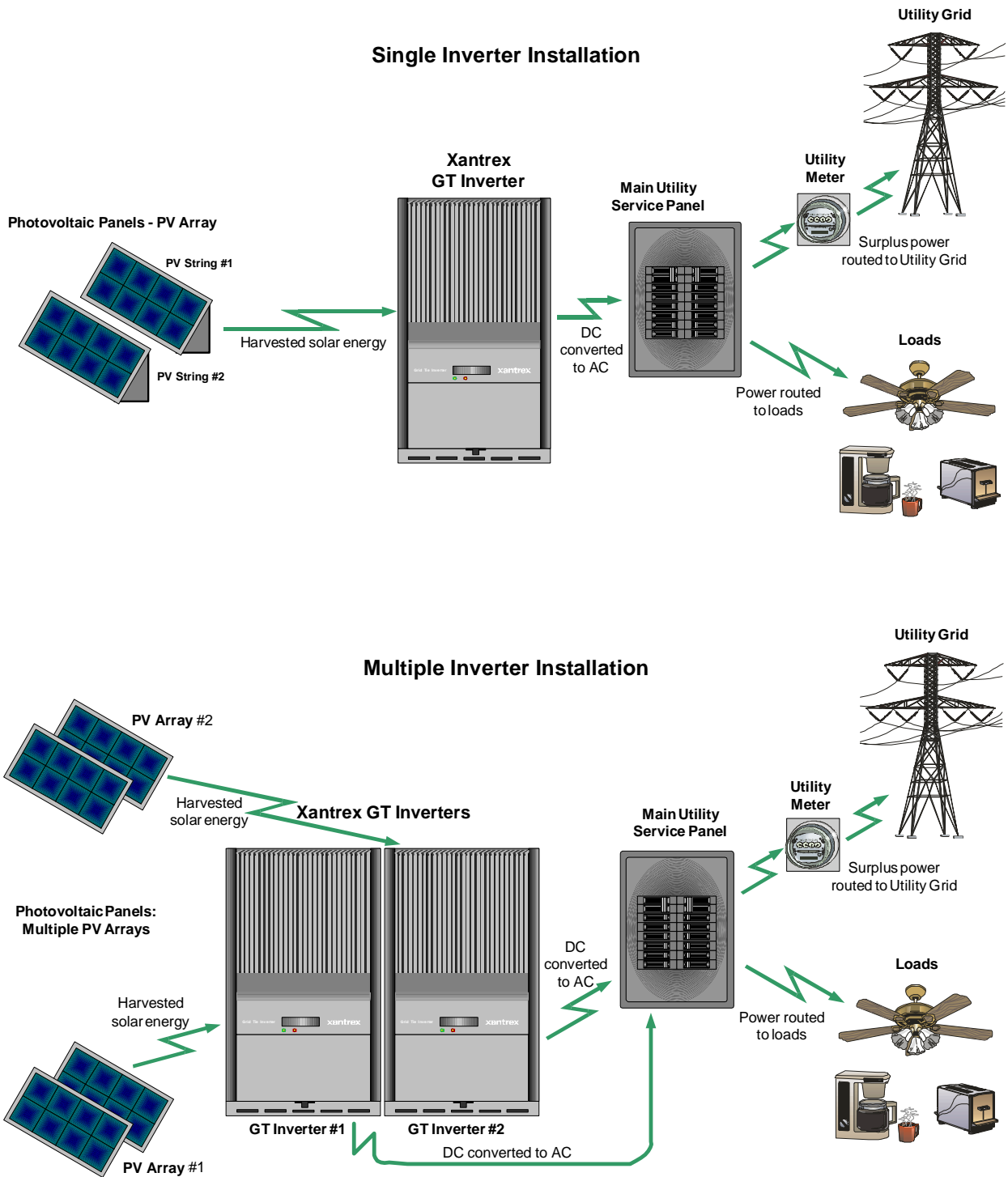

Figure 2-1 Installation Options Overview

---

## Inverter Location

---



### WARNING: Burn hazard

Do not install in a location where people can accidentally come into contact with the front of the inverter. High temperatures can be present on the face of the inverter, causing a potential burn hazard.

In extreme conditions, the GT Inverter chassis can reach temperatures over 70°C (158°F), which can cause skin burns if accidentally touched. Ensure that the GT Inverter is located away from normal traffic areas.

---

Inverter failure due to improper installation will void the inverter warranty. Consider the following when determining where to install the inverter.

- |                         |  |
|-------------------------|--|
| <b>Fire Safety</b>      | <ul style="list-style-type: none"><li>Do not install <i>anywhere</i> near combustible or flammable materials.</li></ul>  |
| <b>Indoor/Outdoor</b>   | <ul style="list-style-type: none"><li>The GT Inverter uses a Type 3R-rated enclosure (vertical mount only) that can be mounted indoors or outdoors. (Type 3R enclosures are intended for outdoor use primarily to provide a degree of protection against falling rain; and to be undamaged by the formation of ice on the enclosure.)</li><li>While the 3R-rated enclosure protects the GT Inverter from moisture, outdoor installations should be located away from lawn sprinklers and other sources of spray.</li></ul> |
| <b>Orientation</b>      | <ul style="list-style-type: none"><li>The GT Inverter must be mounted vertically on a wall or pole.</li><li>Do not mount the GT Inverter horizontally.</li></ul>   |
| <b>Temperature</b>      | <ul style="list-style-type: none"><li>Ensure that the GT Inverter is mounted in a location where the ambient temperature range is -25° to +65° C (-13° to +149° F).</li><li>At extreme hot or cold temperatures, the front panel LCD may not function normally. Above 45° C (113° F), the unit begins derating power. See “Environmental Specifications” on page A-5 and “Output Power vs. Ambient Temperature” on page A-3.</li></ul>   |
| <b>Ground Clearance</b> | <ul style="list-style-type: none"><li>Outdoors, the GT Inverter requires at least 100 cm (39 inches) of clearance between the bottom of the unit and the ground.</li><li>Indoors, it is recommended that the same clearance between the bottom of the unit and the floor be used.</li></ul>  |
| <b>Distance</b>         | <ul style="list-style-type: none"><li>To minimize copper losses, ensure that wire lengths between the PV array and the GT Inverter and between the inverter and the Main Utility Service Panel are kept to a minimum.</li><li>Maximum distances will depend on wire gauges used and PV array output voltages.</li></ul>  |
| <b>Debris free</b>      | <ul style="list-style-type: none"><li>Excessive debris (e.g., dust, leaves, cobwebs) can accumulate on the unit, interfering with wiring connections and ventilation. Do not install in a location where debris can accumulate (such as under a tree).</li></ul>   |



## PV Array Requirements



### **WARNING: Shock hazard**

Whenever a PV array is exposed to sunlight, a shock hazard exists at the output wires or exposed terminals. To reduce the risk of shock during installation, cover the array with an opaque (dark) material before making any connections.

## General Recommendations

It is important that the PV array is installed correctly to the manufacturer's specifications and to local code requirements.

For general recommendations on PV array installation, the CEC Guide to Photovoltaic System Design and Installation document referenced in "Related Information" on page v is recommended. It is available at [www.energy.ca.gov](http://www.energy.ca.gov).

## Equipment and Installation Recommendations

The following PV array equipment and installation recommendations are taken from the CEC Guide to Photovoltaic System Design and Installation document referred to above.

**Important:** The PV array should be free of shade between 9:00 AM and 4:00 PM. This requirement includes even small obstructions such as vent pipes, chimneys and power lines. A small amount of shade can have a disproportionately high impact on system performance.

### Equipment recommendations

- ***All electrical equipment should be listed for the voltage and current ratings necessary for the application.***
- All wiring should be sized correctly to minimize voltage drop.
- All exposed wires or conduits should be sunlight resistant.
- All required overcurrent protections should be included in the system and accessible for maintenance.
- Depending on the installation, an external disconnect may be required if the inverter is installed in a location not easily accessible to utility or fire personnel. Consult local authorities for additional information.
- Integral roofing products should be properly rated.

### Installation recommendations

- All electrical terminations should be fully tightened, secured, and strain relieved as appropriate.
- All mounting equipment should be installed according to the manufacturer's specifications.
- All roof penetrations should be sealed with an acceptable sealing method that does not adversely impact the roof warranty.
- All wires, conduit, exposed conductors and electrical boxes should be secured and supported according to code requirements.

## Voltage and MPPT Requirements

MPPT operational window      Ensure that the PV array used in the system operates within the MPPT operational window (Table 2-1).

**Table 2-1** MPPT Operational Window

Voltage	Effect of Array Voltage	Inverter Mode
< 195 Vdc	Operating voltage will be shifted to 195 Vdc; the array will not be at its maximum power point	Low power
195 to 550 Vdc	Maximum harvest of solar energy	MPPT window
550 to 600 Vdc	Will not allow maximum harvest of solar energy	Power derating
> 600	Will shut down and may cause damage to the inverter; stops selling surplus energy	Shutdown

Voltage requirements      The maximum power point voltage of a string connected to the GT Inverter should be a minimum of 195 Vdc. If it is less than 195 Vdc, then the power point is shifted and the PV voltage is regulated to 195 Vdc.

By regulating the operating voltage of the solar modules, the MPPT software maximizes their output energy.

Effects of array voltages outside of the MPPT operational window are shown in Table 2-1.

Maximum PV Power      The solar array should be sized such that its maximum power output does not exceed the limits of the MPPT operational window (195 to 550 Vdc). See “Guidelines for Matching PV Array Size to Xantrex Grid Tie Solar Inverter Input”.

Under no conditions should the array voltage exceed 600 V<sub>OC</sub> (open circuit voltage).

---

## Guidelines for Matching PV Array Size to Xantrex Grid Tie Solar Inverter Input

For determining the number of panels required in the PV string (panels connected in series), you must ensure that the following two requirements are met:

1. To avoid damage to the inverter, ensure that the PV array output will never exceed 600 Vdc under any conditions.
2. To achieve maximum energy harvest from your array, ensure that the  $V_{MP}$  (voltage at maximum power) does not drop below 195 Vdc or increase above 550 Vdc under most conditions.

Guidelines to help you meet these requirements:

- Consider the expected  $V_{OC}$  of the string under all possible conditions. The panel manufacturer provides a  $V_{OC}$  rating per panel, but it is usually rated at 25°C (77°F). Panel voltage increases in cold temperatures—the panel manufacturer should be able to provide a coefficient of voltage increase per degree.
- The NEC also has required temperature/voltage deratings that must be used; these can be found in Table 690.7 of the 2002 NEC handbook. You need to determine the coldest temperatures expected on the site, and size the array strings accordingly. The array's maximum DC voltage in coldest expected temperature, with both manufacturer coefficient and NEC derating, must not exceed 600 Vdc to prevent inverter damage.
- Panel voltage decreases in high temperatures. This will affect the panels'  $V_{MP}$ . Again, the manufacturer's coefficient must be used with the highest expected temperature to determine the minimum  $V_{MP}$ .

Once you know the specifications of your panels, all these factors will help determine the maximum and minimum number of panels that can be used.

Visit [www.xantrex.com/support](http://www.xantrex.com/support) to use an online PV array sizing tool.

## Grounding Requirements

---



### **WARNING: Shock hazard**

The GT Inverter must be grounded by connection to a grounded permanent wiring system.

---

### AC Grounding

- North America      The GT Inverter must be connected to a grounded, permanent wiring system. The negative PV conductor must be bonded to the grounding system at only one point in the system, through the internal Ground Fault Detection circuit. See Figure 2-2 for the location of the GT Inverter ground bar.
- Elsewhere          In other locations, AC grounding is governed by local codes. Consult with the local utility for specific grounding requirements.

### PV Grounding

In North America, PV arrays are required to be connected to earth ground; in Europe they are not. PV Ground Fault Protection (PVGFP) is required in North America for roof-mounted PV arrays.

The GT Inverter is designed to have all PV positive, negative, and ground conductors connected inside its wiring box. The PV equipment ground should be connected to the GT Inverter ground bar. This ground bar must also be connected to the main utility breaker panel ground bar and to the house grounding rod according to NEC requirements (see Figure 2-2).

The size for the conductor is usually based on the size of the largest conductor in the DC system.

### Long Distance Grounding

If the PV array is more than 30 m (100 feet) from the inverter, then there must also be a direct connection from the array frame to an earth ground next to the array. A connection between this ground and the building ground connection via a buried wire between the two points is also necessary (see Figure 2-3).

### Lightning Protection

Reduce the risk of lightning damage by using a single-point grounding system. In this system, all ground lines terminate at the same point. This point normally is the main utility ground installed by the utility company to provide a ground for the house wiring (see Figure 2-4). This ground usually consists of a copper rod driven 1.5 to 2.5 meters (6 to 8 feet) into the earth.

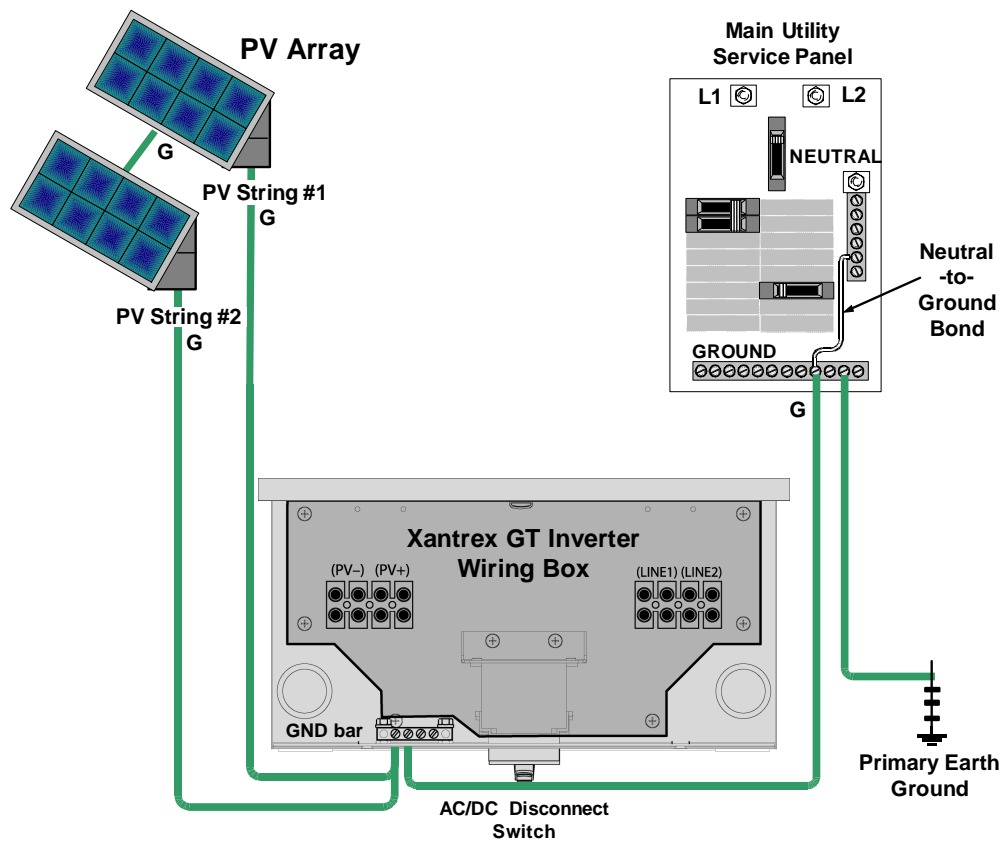
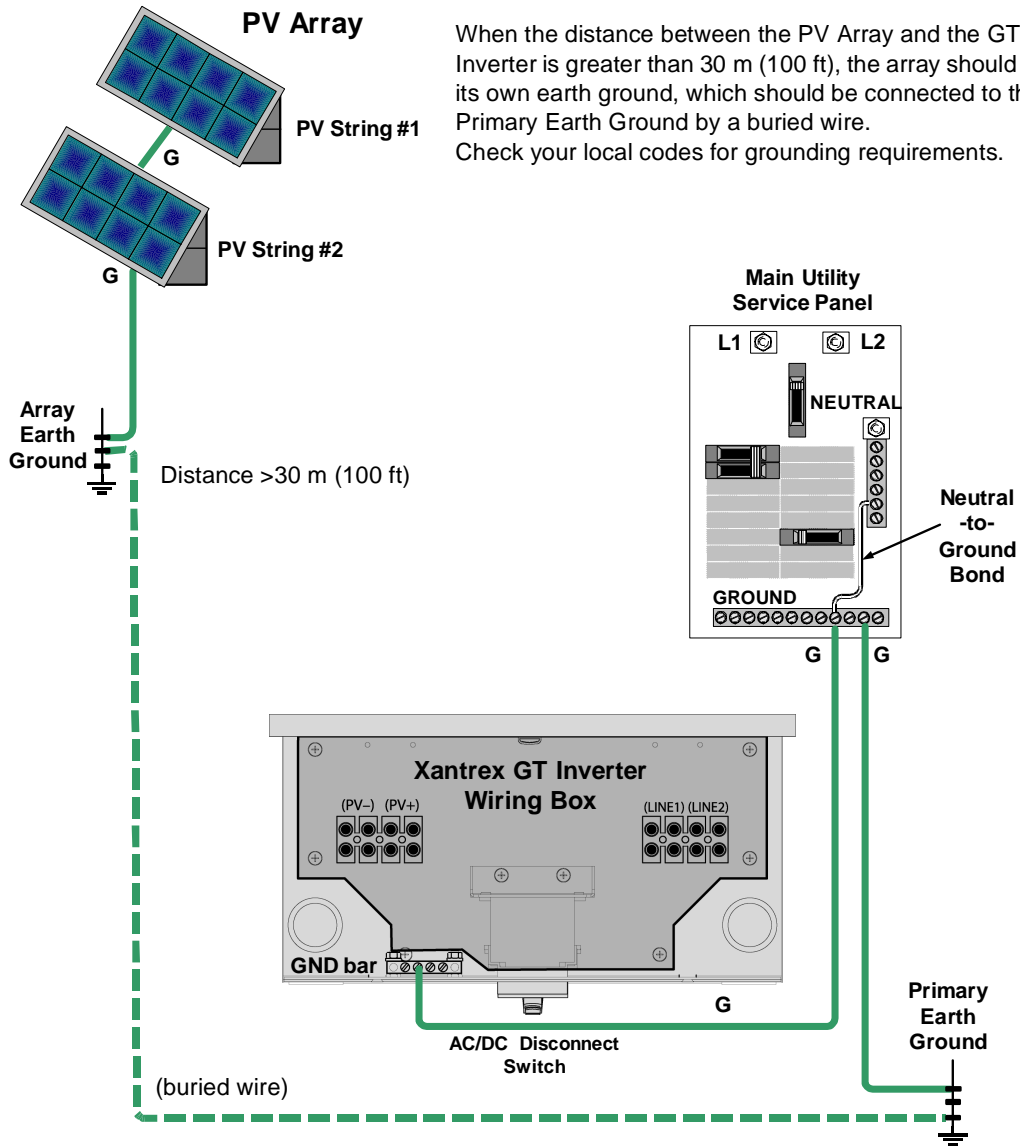

Figure 2-2 Basic Grounding Overview



When the distance between the PV Array and the GT Inverter is greater than 30 m (100 ft), the array should have its own earth ground, which should be connected to the Primary Earth Ground by a buried wire. Check your local codes for grounding requirements.

Figure 2-3 Long Distance Grounding Overview

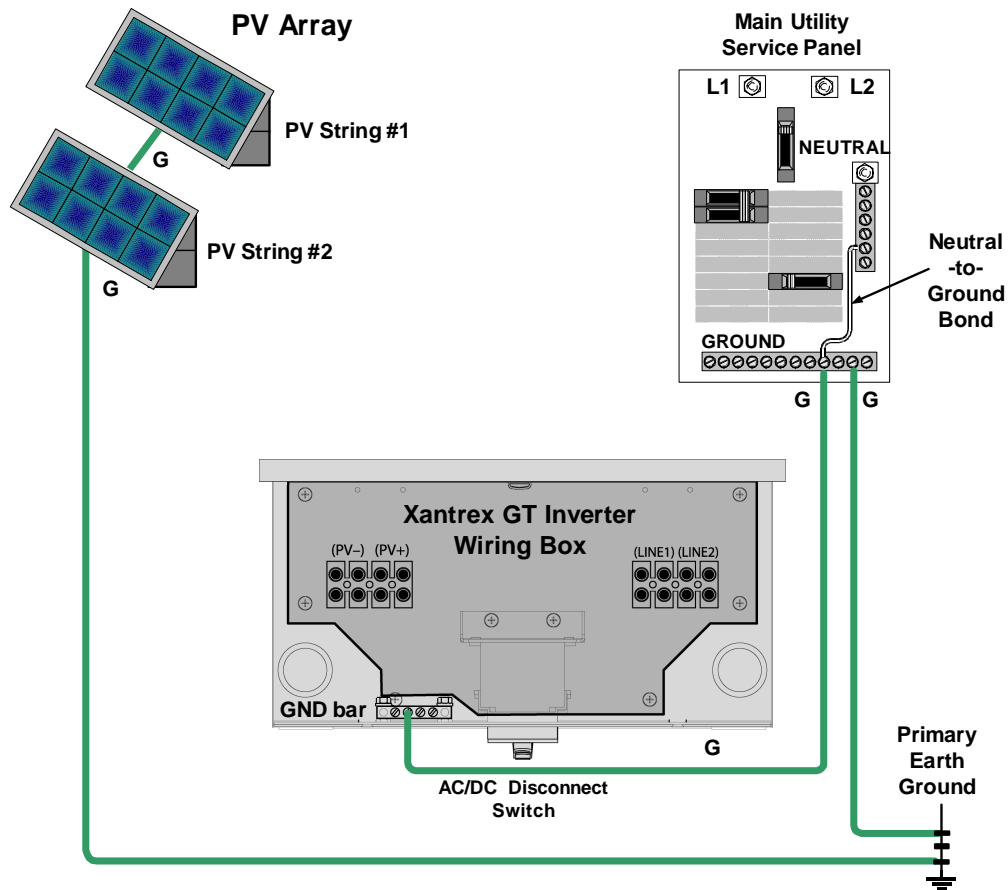

Figure 2-4 Grounding With Extra Lightning Protection Overview

## Routing the Wires

Typical configurations

Determine all wire routes to and from the GT Inverter. Typical routing configurations include:

- AC wiring from the GT Inverter to the main utility service panel
- DC input wiring from the PV array to the GT Inverter
- DC ground from the PV array to the Primary Earth Ground.

All wiring and installation methods should conform to applicable electrical and building codes.

For installations in the United States, the National Electrical Code (NEC) and local codes apply. For installations in Canada, the Canadian Electrical Code (CEC) and local codes apply.

For all installations, local utilities may have additional requirements.

Conduit holes/knockouts

Pre-plan the wire and conduit runs. Knockouts for 1.9 cm (3/4 inch) or 2.5 cm (1 inch) conduit holes are located on the bottom and back of the wiring box. Threaded 3/4" conduit holes are located on each side of the wiring box (Figure 2-5).

For maximum safety, run AC, DC, and communication wires in separate conduits.

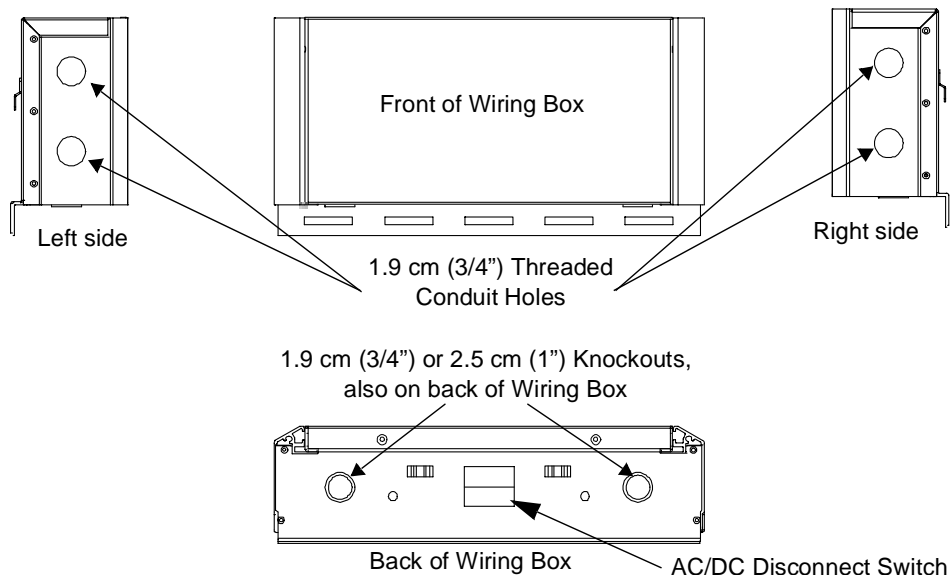

Figure 2-5 Knockout Locations on Bottom of Wiring Box



**WARNING: Shock hazard**

Check for existing electrical or plumbing prior to drilling holes in the walls.

**Planning AC Wire Routing**

AC connections include all the wires and connectors between the GT Inverter AC terminals and the main utility service panel. Pre-plan these routes carefully before installing the components.

**Planning DC Wire Routing**

DC connections include all the wires and connectors between your PV array and the DC terminals of the GT Inverter. Pre-plan these routes carefully before installing the components.



## Preparing for the Installation

Ensure your local utility is consulted for any requirements for connecting to or returning power to the grid. Obtain all permits necessary to complete the installation. Consult your local/national electrical code for more information.

This section includes the following topics:

- “Wiring” on page 2–13
- “Circuit Breakers and Disconnect Switch” on page 2–13
- “Other Materials Needed” on page 2–14
- “Equipment Needed” on page 2–14.

---

**Important:** In this manual “wiring” and “wires” are used in reference to both AC and DC wiring/cabling and wires/cables.

---

## Wiring

Wire size and length will be determined by the location of each component and their relative distance to each other. Wire sizes may also be affected by whether or not conduit is used.

Recommended wire stripping length

Strip all wires 9 mm (3/8 inch).

Acceptable wire sizes

The AC and DC terminal blocks in the GT Inverter accept wire sizes from #14 AWG to #6 AWG.

Wiring should be sized such that the maximum voltage drop at full power from the PV array to the inverter is 2% or less.

---

**Important:** Wiring should not be undersized. Undersizing of wiring can result in significant power losses and reduction in system efficiency.

---

## Circuit Breakers and Disconnect Switch

The following circuit breakers, disconnect switch and fuse are required for installing this equipment.

### AC Circuit Breaker Requirements

In North America, the main utility service panel must dedicate a double pole breaker (240 volts AC) to operate each GT Inverter installed. The GT Inverter requires a 20-Amp breaker.

## AC/DC Disconnect Switch

The wiring box includes a PV/Utility disconnect switch that switches both AC and DC at the same time. If the inverter is to be installed without the integral Xantrex Wiring Box with Disconnect (Xantrex Part # 100-0243-01-01), separate approved AC and DC disconnects may be required by local authorities having jurisdiction.



### **WARNING: Shock hazard**

The 600 volt DC/AC disconnect in the wiring box meets NEC Article 690. It is a non-serviceable component and shall remain in place. Removal can expose energized conductors.

---

## Ground Fault Fuse

There is a 600 volt 1-Amp ground fault protection fuse (Littelfuse KLKD 1 or equivalent) in the GT Inverter.



### **WARNING: Shock hazard**

Do not attempt to service the ground fault fuse yourself. This should only be done by qualified service personnel.

---

## Other Materials Needed

- Mounting support material, such as plywood or poles
- Conduit for wire runs and appropriate fittings/bushings
- Wood screws and anchors for screws, depending on mounting surface.

## Equipment Needed

- Wire cutters/wire crimpers/wire strippers
- Assorted screwdrivers, drill, etc.
- Level
- Digital Voltmeter
- Frequency counter (optional, for troubleshooting).

# Mounting the Inverter

## Overview



### WARNING: Fire, Shock and Energy Hazards

Before installing the GT Inverter, read all instructions and cautionary markings located in this manual, on the PV array, and on the main service panel.

#### General installation steps

There are four main steps in the installation of the GT Inverter:

1. Mounting the GT Inverter and installing accessories (this chapter)
2. Making the DC connections from the PV array to the GT Inverter (“Connecting the DC Wiring” on page 3–4)
3. Making the AC connections from the GT Inverter to the main utility service panel (“Connecting the AC Wiring” on page 3–7)
4. Grounding the PV array (see your PV equipment documentation).

Figure 2-6 summarizes these four steps.

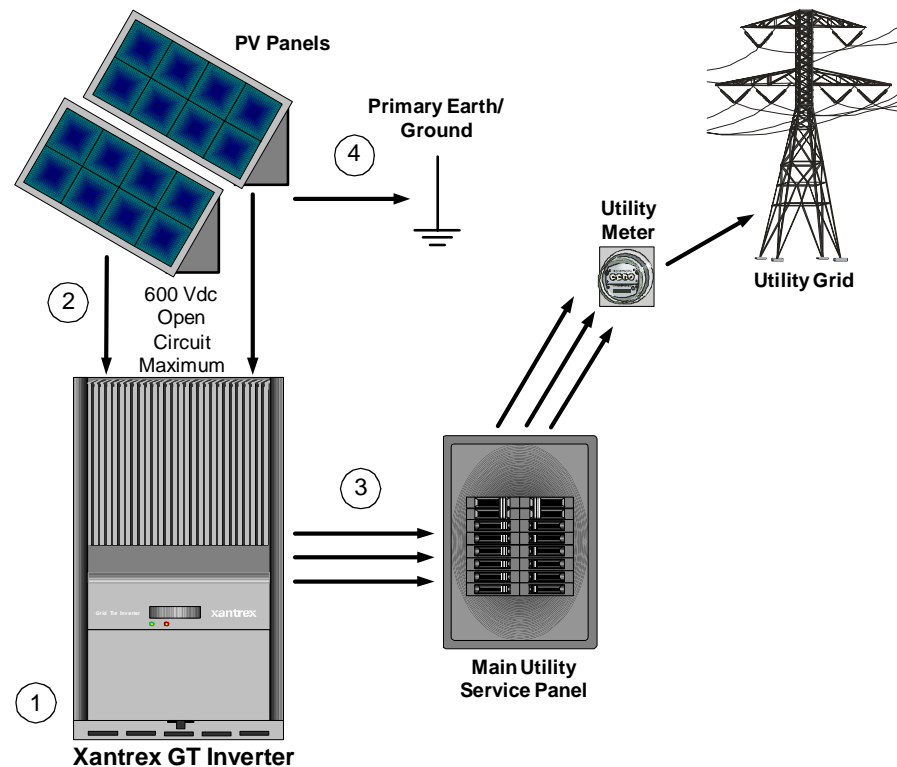

Figure 2-6 Installation Overview

	In this chapter only the first step, mounting the inverter and installing accessories, is described.
Mounting steps	Instructions for mounting the GT Inverter are described in the following sections: <ul style="list-style-type: none"><li>• “Preparing to Mount the Unit” on page 2–16</li><li>• “Installing the Mounting Bracket” on page 2–17</li><li>• “Mounting the Inverter on the Bracket” on page 2–22</li><li>• “Installing Accessories” on page 2–23.</li></ul>
Multiple inverter instructions	Mounting instructions for multiple inverters connected in parallel are described in “Mounting Multiple Inverters in Parallel” on page 2–23. Special wiring instructions for multiple inverters connected in parallel are described in “Connecting Inverters in Parallel” on page 3–10.

## Preparing to Mount the Unit

### Dimensions and Knockout Locations

The dimensions of the inverter and the mounting bracket and some of the knockout locations on the wiring box are shown in Figure 2-7.

Four 2 cm or 2.5 cm (3/4 inch or 1 inch) knockouts are provided on the back and bottom of the unit to accommodate wiring:

- two on the bottom of the wiring box, on either side of the AC/DC Disconnect Switch
- two on the back of the wiring box.

Four 2 cm (3/4 inch) conduit holes on the sides of the wiring box are filled with plastic plugs, which can be removed to insert conduit nipples as required for inverters mounted in parallel. One or two of these side conduit holes may be used to accommodate communications wiring for multiple inverters mounted in parallel.

### Knockout Preparation

Remove your choice of knockouts from the wiring box to facilitate conduit installation for wire runs. This is much easier to do prior to mounting the inverter.

---

**Important:** Ensure there are no metal shavings left in the inverter after removing the knockouts. Be sure to install bushings or conduits in the knockout holes to protect the wires from damage.

---

If installed outdoors, conduit must be sealed where it enters the wiring box.

---

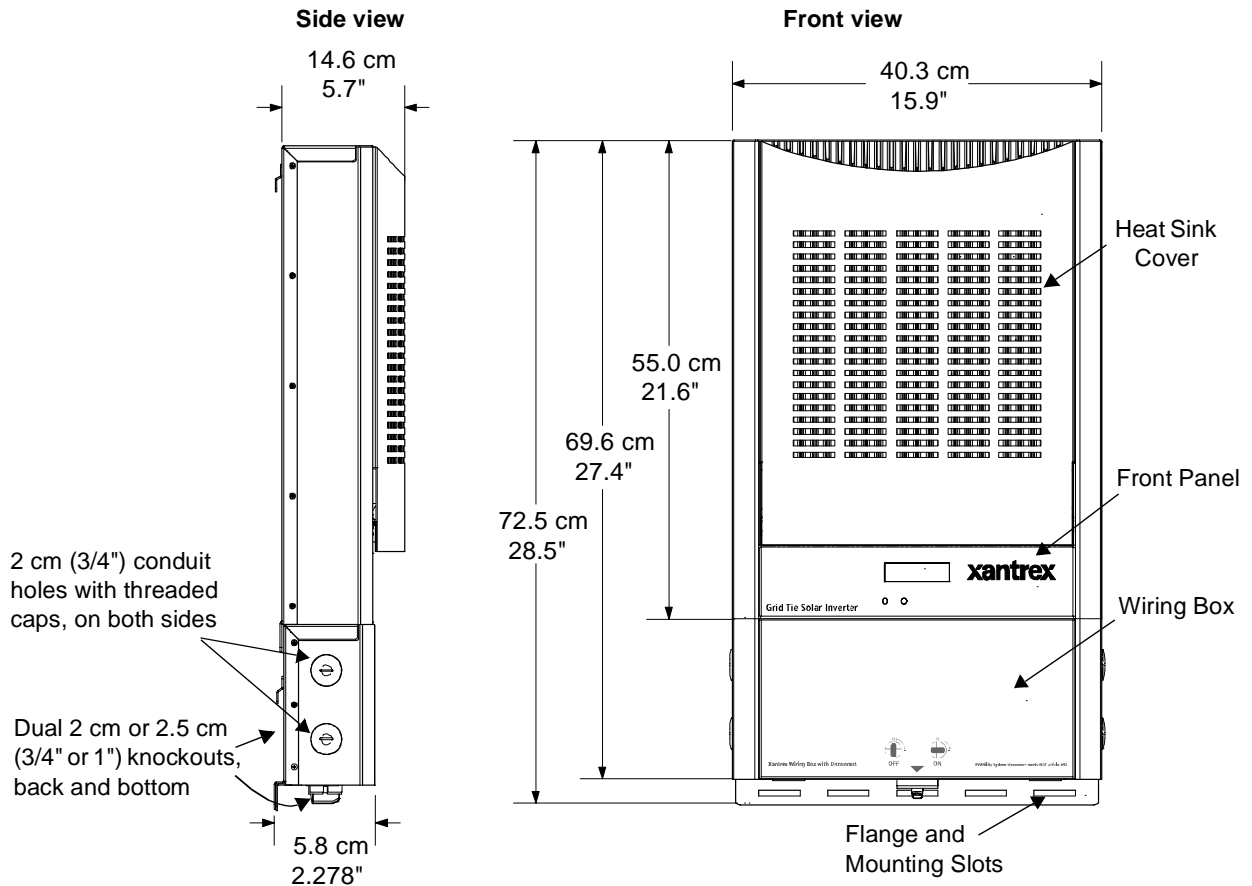

Figure 2-7 Dimensions of GT Inverter and Knockout Locations

## Installing the Mounting Bracket

The mounting bracket for the GT Inverter allows the unit to be easily mounted and dismounted for servicing. It has two hooks that match corresponding hooks on the back side of the inverter and wiring box. The inverter can be separated from the wiring box and removed from the bracket, leaving the wiring box in place.

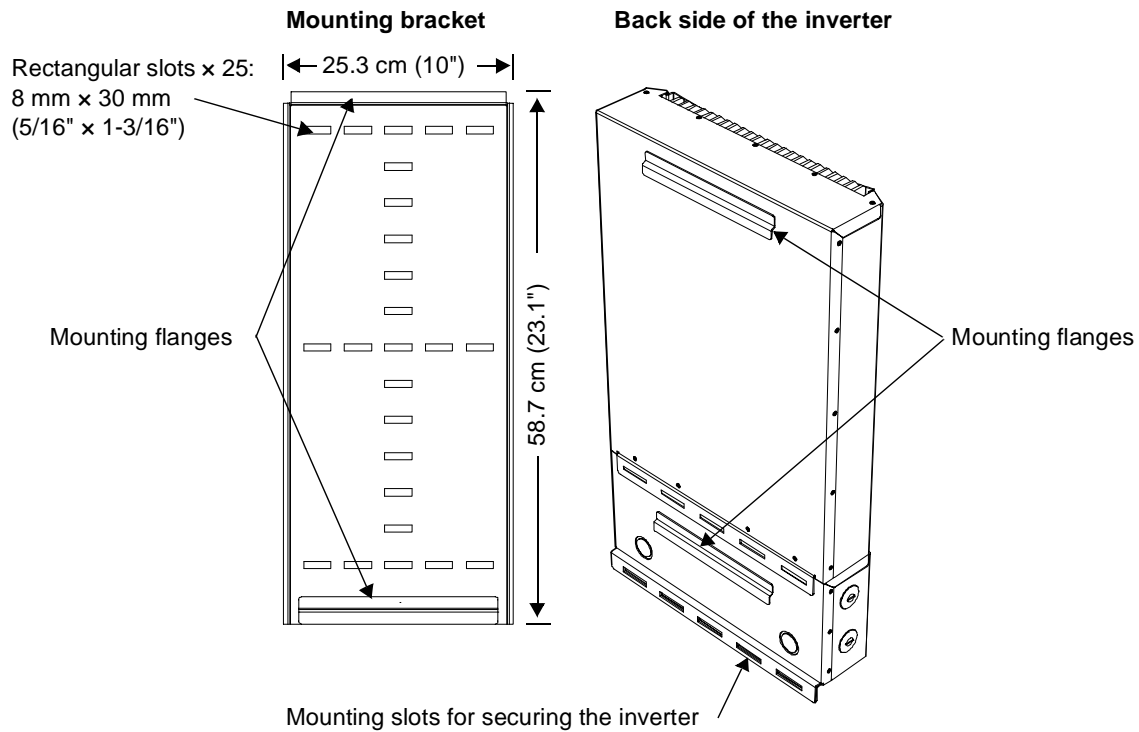

Figure 2-8 Mounting Bracket and GT Inverter

### Clearance Requirements

For optimal and safe operation, ensure there is adequate clearance around the inverter. The minimum clearance recommendations in Table 2-2 assume a vertical mounting. If clearances are reduced below these minimums, rated power may not be achieved.

Table 2-2 Inverter Clearance Requirements

Location	Minimum Clearance	
Above	30 cm (12 inches)	
Below:	Outdoors:	
• Inverter	• 100 cm (39 inches)	The inverter extends below the bracket by approximately 10 cm (4 inches)
• Bracket	• 110 cm (43 inches)	
	Indoors: the same clearances are recommended but not required.	
In front	Sufficient room to allow for easy access to read the display and to prevent accidental contact with hot surface.	
On sides	15 cm (6 inches) to prevent thermal derating. When mounting units side by side, 30 cm (12 inches) of clearance between the two units is recommended.	

**WARNING: Shock hazard**

Before drilling holes to mount the GT Inverter, ensure there are no electrical wires or plumbing in this area.

**WARNING: Personal injury**

The GT Inverter weighs approximately 20 kg (45 lbs). Always use proper lifting techniques during installation to prevent personal injury.

**WARNING: Explosion hazard**

Do not store combustible or flammable materials *anywhere* near the inverter.

## Surfaces for Mounting

The GT Inverter weighs approximately 20 kg (45 lbs). The supporting surface must be strong enough to handle 75 kg (160 lb). If the supporting surface is not strong enough to handle that weight, then supporting material such as a sheet of plywood can be used to enhance the strength of the mounting surface.

The GT Inverter can be mounted to a vertical surface such as wallboard, wood siding, concrete wall or pole assembly.

Mounting on poles or rails

- See “Mounting on Poles or Rails” on page 2–20. Ensure the bottom of the unit is a minimum of 100 cm (39 inches) from the ground if mounted outdoors.

Mounting to wallboard with support

- Installation onto wallboard requires either the use of a supporting material such as plywood or securing the mounting screws to supporting wall studs. Use at least two screws and anchors to secure the unit to the supporting material.

Mounting to siding using wall studs

- If mounting to exterior siding using a wall stud for support, the plywood backing will not be needed. Use at least two lag screws to secure the unit to the supporting material. Ensure the screws enter the stud at least 4 cm (1.5 inches) to adequately support the weight of the unit. See “Mounting on Wallboard, Siding or Concrete” on page 2–21.

Mounting to concrete surface

- If mounting the unit on a concrete surface using anchors with no supporting material, use four screws and anchors, instead of two, to adequately secure the unit and distribute the weight.

---

**Important:** Local codes may impose additional mounting requirements in earthquake or other high-risk areas.

---



---

**Important:** Other than the mounting bracket, no mounting hardware is supplied with the GT Inverter.

---

## Mounting on Poles or Rails

### To mount the unit using poles:

1. Ensure that poles or rails are securely assembled in place. If using horizontal rails, three rails are required: two for the mounting bracket and a third for securing the bottom edge of the inverter wiring box (see Figure 2-9).
2. Connect the mounting bracket vertically to the poles or rails (Figure 2-9):
  - Be sure to use at least two bolts to secure the mounting bracket to the support.
  - Position the lower edge of the bracket a minimum of 110 cm (43 inches) above the floor or ground.
3. If using a single vertical pole, ensure that the inverter is secure and unable to rotate around the pole.

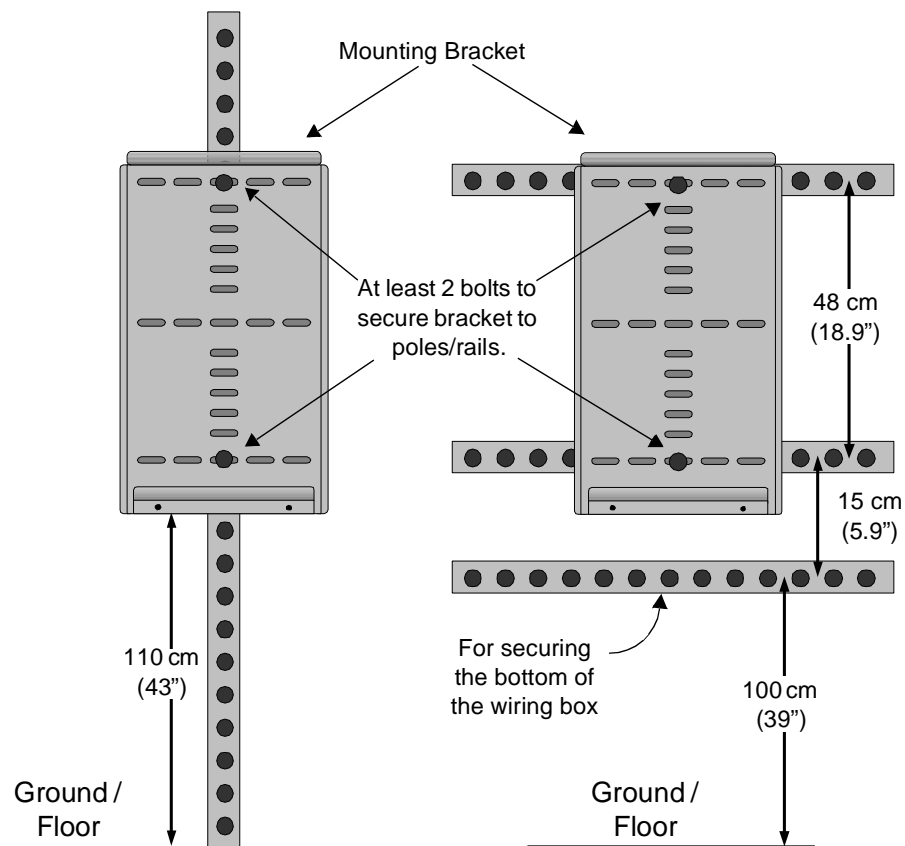

Figure 2-9 Examples of Mounting on a Pole or Rails



## Mounting on Wallboard, Siding or Concrete

### To mount the GT Inverter to wallboard, siding, or concrete:

1. Locate the area where the GT Inverter is to be installed.
2. Install backing support material if required. See Figure 2-10.

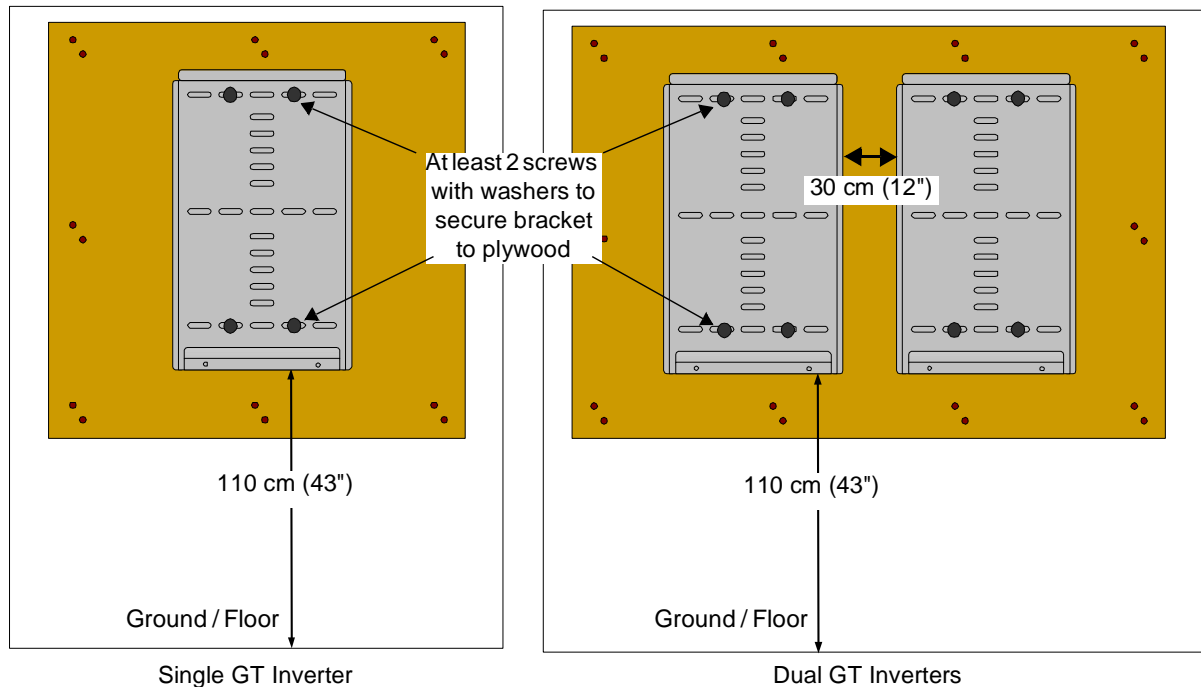

**Figure 2-10** Installing the Mounting Bracket using Plywood Support

3. Using a level, place the mounting bracket against the wall surface at least 110 cm (43 inches) from the ground. See Table 2-2 on page 2-18 to ensure minimum clearance requirements are met.
4. Mark the location for mounting screws if using a wall stud for support. At least four mounting screws and anchors are needed for concrete installations or wallboard installations where no wall studs are available for support.  
For multiple inverters mounted in parallel, the brackets should be mounted 30 cm (12 inches) apart. Inverters mounted less than 30 cm (12 inches) apart may not achieve full rated power.
5. Remove the bracket and drill the holes using an appropriately sized drill bit. Drill appropriately sized holes for screws or anchors.
6. Secure the bracket to the supporting surface using at least two screws and washers.

## Mounting the Inverter on the Bracket

### Mounting a Single Inverter

**To mount the inverter on the mounting bracket:**

1. Place the GT Inverter's mounting hooks, located on the back of the enclosure, over the bracket and ensure the inverter is seated properly, as shown in Figure 2-11.
2. After the unit is correctly seated on the bracket hooks, locate the mounting slots in the flange below the wiring box and mark the location on the wall for securing screws.
3. Remove the inverter and drill pilot holes in the wallboard or siding for the securing screws.
4. Reinstall the GT Inverter on the bracket and secure the bottom of the unit with appropriate screws or anchors, and tighten.

Slide the mounting hooks on the inverter over the hooks on the mounting bracket.

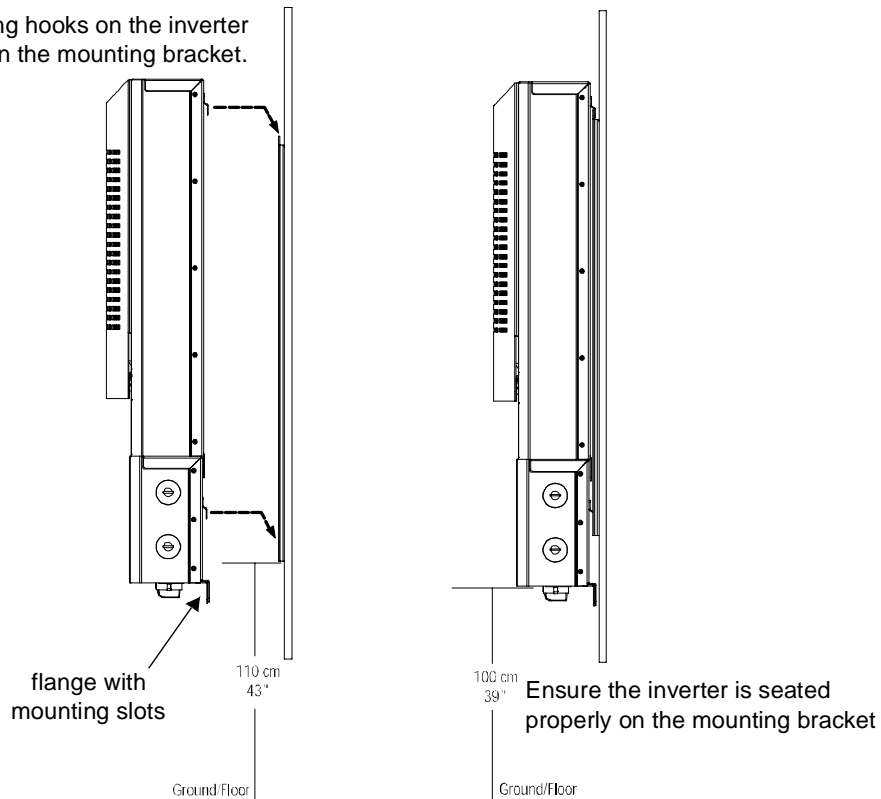

**Figure 2-11** Proper Placement of the Inverter on the Mounting Bracket

---

## Mounting Multiple Inverters in Parallel

As shown in Figure 2-10, inverters can be mounted side by side on wallboard or a plywood support. A minimum of 30 cm (12 inches) of clearance between the units is recommended.

Conduit nipples should be installed on one side of the first inverter before mounting on the bracket. Ensure that the sealing ring is located on the conduit nipple between inverters, i.e., on the outside of the wiring box. The lock nut is attached after the nipple is inserted into the conduit hole of the second inverter

## Installing Accessories

The optional fan assembly and heat sink cover (see Figure 1-5 on page 1–7) should be installed together. Neither accessory should be installed without the other.

### Installing the Fan Assembly

**WARNING: Shock hazard**

If the inverter is already installed and operational, turn OFF the breaker switches in the main utility service panel and the AC/DC Disconnect switch on the inverter wiring box before performing this procedure.

**WARNING: Shock hazard**

Hazardous voltages may be present when cover is removed. After disconnecting all sources of energy, wait 5 minutes before removing cover.

**WARNING: Burn hazard**

Ensure that the inverter and heat sink are not too hot to touch before attempting this procedure.

---

**Important:** The fan assembly should only be installed by qualified personnel.

---

The fan assembly (see Figure 1-5 on page 1–7) is optional for the GT Inverter. Installing the fan assembly involves two main steps:

1. Attaching the fan assembly to the inverter.
2. Connecting the fan wires.

**To attach the fan assembly to the inverter:**

1. Using a Phillips screwdriver, remove the four panhead screws and washers from the front panel of the inverter (two screws on each side), immediately below the heat sink (see Figure 2-12).
2. Place the fan bracket with screw holes overlapping the screw holes on the inverter. The fans should be facing up, on the upper side of the fan bracket.
3. Replace the four panhead screws and washers removed in step 1.

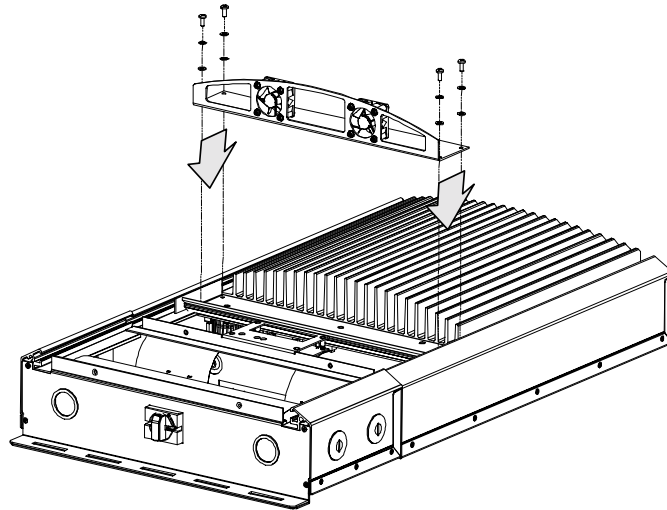

**Figure 2-12** Attaching the fan assembly

**To connect the fan wires:**

1. Remove the wiring box cover by removing the two screws on the underside of the wiring box. Removing the wiring box cover will expose the screws that secure the front panel cover.
2. Remove the front panel cover by removing the two screws on the underside of the front panel.
3. Plug the wire leads from the fan assembly into the pin connectors on the DC circuit board. The pins are located to the left of the LCD below the ground fault protection fuse.
4. Replace the front panel cover using the screws removed in step 2, with the wire leads passing through the notch at the top of the cover, ensuring that the wires are not pinched.
5. Replace the wiring box cover using the screws removed in step 1.

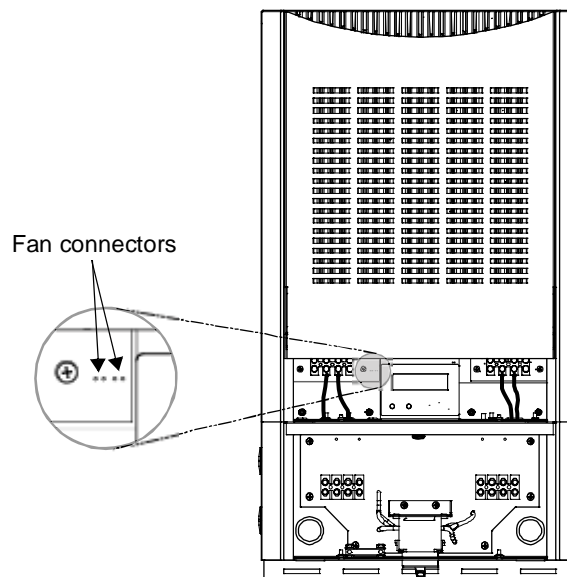
**Figure 2-13** Location of Fan Connector

## Installing the Heat Sink Cover

You may find it easier to install the heat sink cover before mounting the inverter.

If the inverter is already installed and in operation, it is best to perform the following procedures after dark or on an overcast day when the unit is cool.



### **WARNING: Burn hazard**

Ensure that the inverter and cover are not too hot to hold firmly before installing or removing the heat sink cover.

---

#### **To install the heat sink cover on the inverter:**

1. Hold the heat sink cover vertically in front of you with the curved edge upward and the flanges bent away from you.
2. Insert the heat sink cover left side flange into the groove on the left side of the inverter heat sink. It should snap into place.
3. Push the cover so that it curves outward (away from the inverter) and insert the right side flange into the groove on the right side of the inverter heat sink. It should snap into place.

#### **To remove the heat sink cover from the inverter:**

---

**Important:** You may start with the left or right side of the cover. This example starts on the right side.

---

1. Press the right side of the heat sink cover inward (i.e., toward the left side) and simultaneously lift it upwards to pull it out of the groove on the right side of the inverter.
2. Pull the left side of the cover out of the inverter left side groove.

# 3

## Wiring the Inverter

Chapter 3, “Wiring the Inverter”, provides procedures for making DC and AC wiring connections, and grounding the GT Inverter and the PV array. Instructions for wiring inverters in parallel are also provided.

The topics in this chapter are organized as follows:

- “Accessing the Wiring Terminals” on page 3–2
- “Connecting the DC Wiring” on page 3–4
- “Connecting the AC Wiring” on page 3–7
- “Connecting Inverters in Parallel” on page 3–10.

## Accessing the Wiring Terminals

You must remove the GT Inverter wiring box cover to access the terminal blocks, ground bar and communications ports (for inverters in parallel).

### To remove the wiring box cover:

1. Using a Phillips screwdriver, remove the two screws on the bottom side of the wiring box and set in a safe place (see Figure 3-1 for location of screws).
2. Lift the cover off the wiring box.

When replacing the wiring box cover, be careful not to pinch any wires in the wiring box.

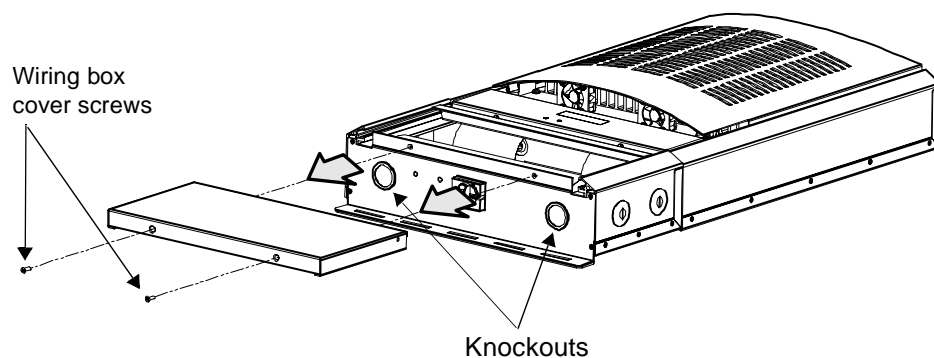

**Figure 3-1** Removing the Wiring Box Cover

AC and DC connections are made at the wiring terminals shown in Figure 3-2.

### Insulating barrier

The clear plastic insulating barrier inside the wiring box is a permanent component. It is intended to separate the high-voltage AC and DC wiring from any communications cabling and to prevent wiring from coming into contact with the wiring box cover.

When wiring the unit, it is necessary to pull the cover back to access the wiring terminals. After completing the wiring, replace the insulating barrier to its original position.

### Communications wiring

For multiple inverters in parallel, communications wiring is connected between RJ45 connectors on each inverter (see Figure 3-9).



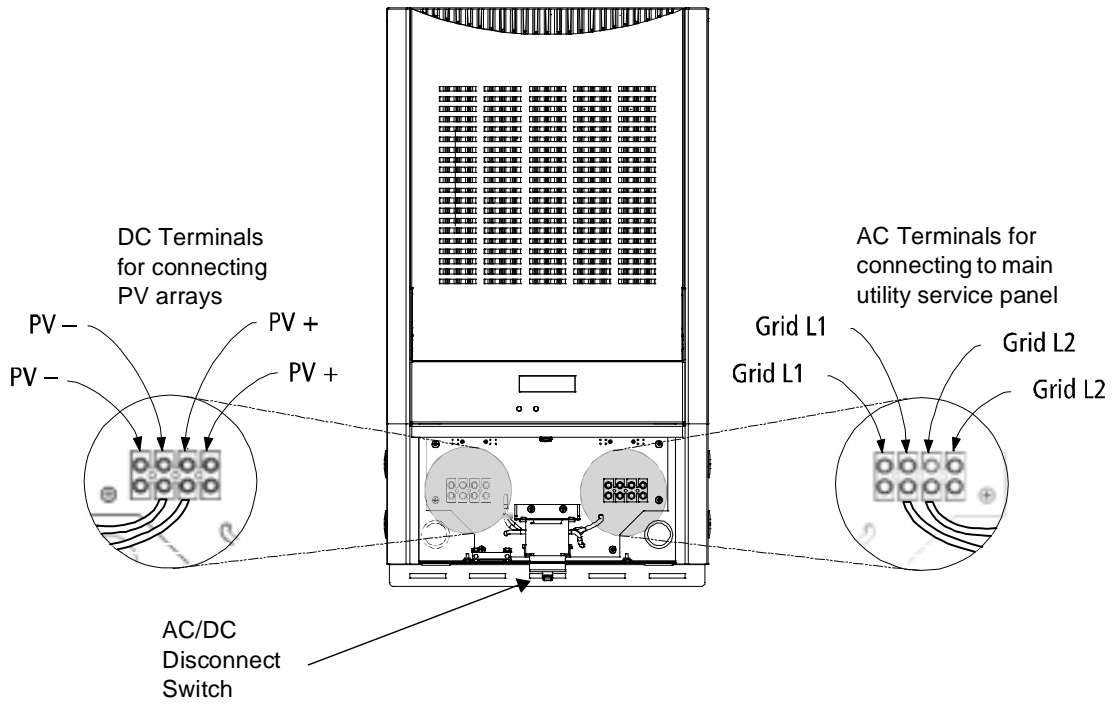

Figure 3-2 AC and DC Terminal Block Location in the Wiring Box

## Connecting the DC Wiring



### WARNING: Shock hazard

Whenever a PV array is exposed to sunlight, a shock hazard exists at the output wires or exposed terminals. Ensure that the AC/DC Disconnect Switch is set to OFF before commencing any wiring. See Figure 3-3.



### WARNING: Shock hazard

The 600 volt AC/DC disconnect in the wiring box meets NEC Article 690. It is a non-serviceable component and shall remain in place. Removal can expose energized conductors.

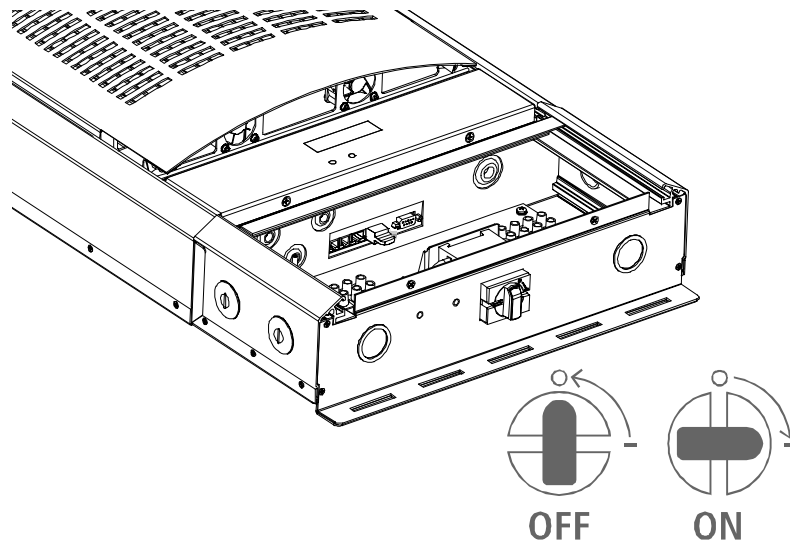

Figure 3-3 AC/DC Disconnect Switch Positions

The following procedure is illustrated in Figure 3-4. If there will be more than one PV string, label the positive and negative wire pairs appropriately (for example: PV 1, PV 2).

**To wire the PV array to GT Inverter:**

1. Install DC conduit from the PV string(s) to the GT Inverter wiring box, through one of the knockout holes.
2. Remove the wiring box cover (see page 3–2).
3. Route the wires from the PV string(s) through the conduit and into the wiring box.
4. Connect the DC Ground from each PV string to the GROUND bar in the wiring box.
5. Connect the POSITIVE (+) wire from the #1 PV string to the PV1 (+) terminal. Double check that the wire is in the proper location and tighten the screw.
6. Connect the NEGATIVE (–) wire from the #1 PV string to the PV1 (–) terminal. Double check that the wire is in the proper location and tighten the screw.
7. Repeat for the #2 PV string, if there is one. Double check that the wires are in the proper locations and tighten the screws:
  - a) Connect the POSITIVE (+) wire from the #2 PV string to the PV2 (+) terminal.
  - b) Connect the NEGATIVE (–) wire from the #2 PV string to the PV2 (–) terminal.
8. Ensure all connections are correctly wired and properly torqued according to values shown in Table 3-1.

**Table 3-1** Torque Values for Wires\*

Wire Size		Torque	
AWG	mm <sup>2</sup>	in-lb	Nm
14 to 10	2.5 to 6.0	35	4.0
8	10.0	40	4.5
6	25.0	45	5.1

\*Use copper conductors only.

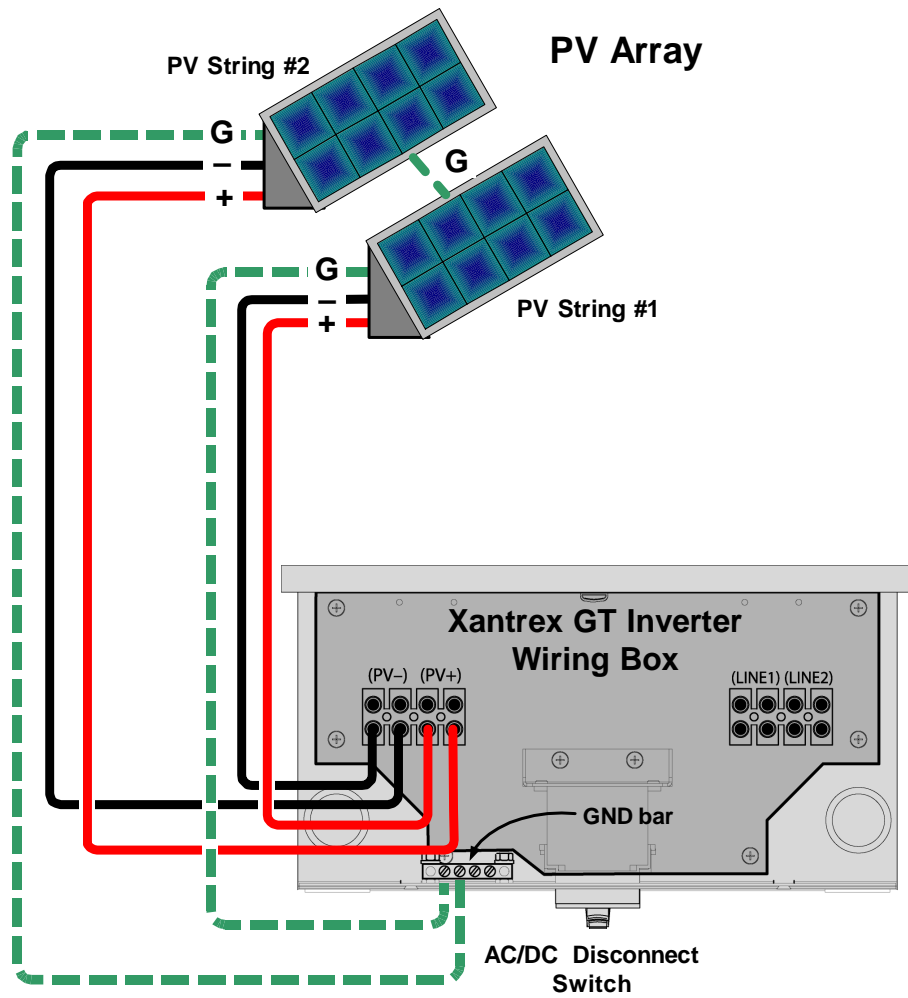

Figure 3-4 DC Connections for Grounded PV Array

---

**Important:** Depending upon installation and local codes, fusing and/or a combiner box may be required. This fusing is to be provided by the installer.

---

---

## Connecting the AC Wiring

---

**WARNING: Shock hazard**

AC utility wiring to the GT Inverter unit is performed directly at the main breaker panel. This should be done only by a qualified installer or electrician.

---

**WARNING: Shock hazard**

Before wiring the GT Inverter, ensure the **main breaker** in the primary utility breaker box is switched OFF. Switch this breaker ON only after all wiring is completed as instructed in the procedures.

---

**Important:** In the United States, the National Electrical Code (NEC) requires the inverter to be connected to a dedicated circuit and no other outlets or devices may be connected to this circuit. The NEC also imposes limitations on the size of the inverter and the manner in which it is connected to the utility grid. The circuit breakers that are used in the main panel that feed the inverter circuit must be for back-fed operation and labeled as such.

---

The GT Inverter can be connected to a single bi-directional meter, or to dual meters, where one meter indicates power used and the second meter indicates power sold (power supplied back to the utility). Consult with the local utility to determine the proper components to install, and obtain any permits required prior to installation.

The following procedure is illustrated in Figure 3-5.

**Important:** Neutral conductor wiring is not required in this installation.

---

**To wire the main utility service panel to the GT Inverter:**

1. Install conduit from the main utility service panel to the wiring box of the GT Inverter. Run the two HOT wires (L1 and L2) and ground wire from the service panel through the conduit and into the inverter wiring box.
2. Install or use an existing double-pole 20-Amp circuit breaker (or two single-pole breakers, ganged) in the main utility service panel, and ensure that the breakers are set to OFF.
3. Connect the ground wire (green or bare copper) from the ground bar in the main utility service panel to the GND bar in the wiring box.
4. Connect the L1 HOT wire (black) from the double-pole breaker installed in the main utility service panel, to the L1 GRID terminal in the wiring box.
5. Connect the L2 HOT wire (red) from the double-pole breaker installed in the main utility service panel, to the L2 GRID terminal in the wiring box.
6. Ensure all connections are correctly wired and properly torqued according to values shown in Table 3-1 on page 3-5.

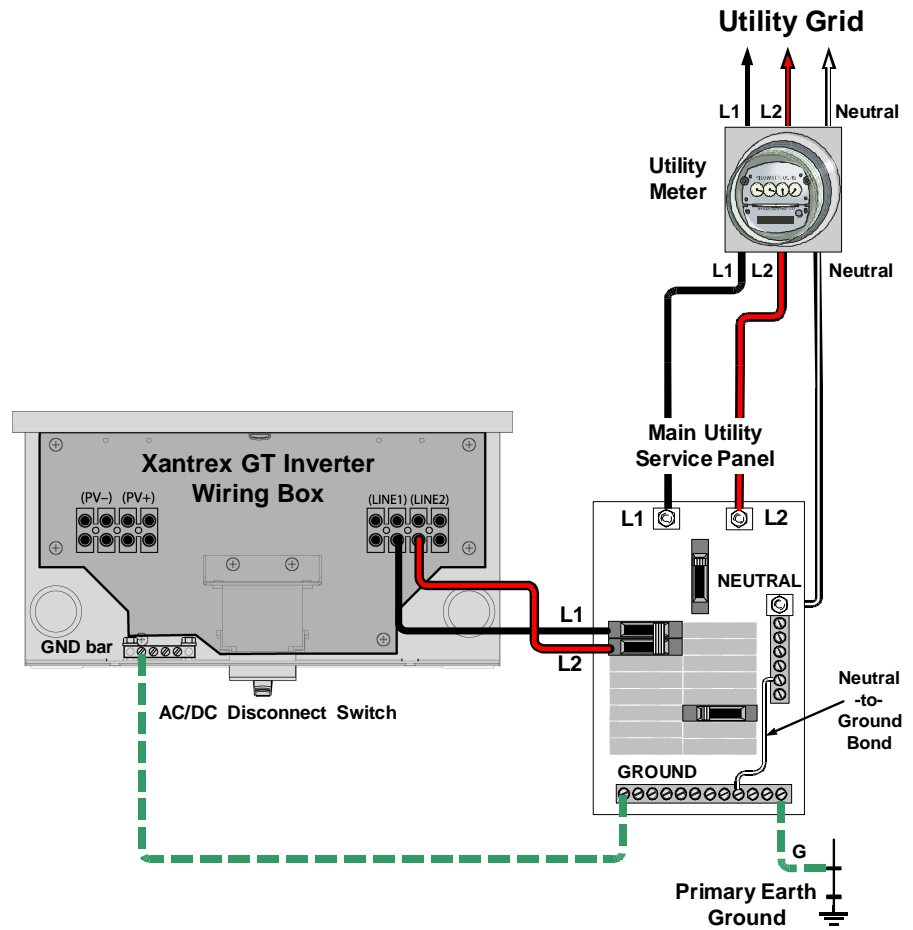

Figure 3-5 AC Connections from GT Inverter to Utility Service Panel

## Connecting Inverters in Parallel

GT Inverters can be connected in a parallel configuration for larger PV array systems. In this configuration, separate solar arrays are required for each GT Inverter unit. The output of each GT Inverter feeds a separate dual-pole 20-Amp circuit breaker (L1 and L2) in the main utility service panel.

### DC and AC Wiring for Inverters in Parallel

The following procedures are illustrated in Figure 3-6. The illustration and instructions assume only two inverters, but in fact more than two inverters can be used in a parallel configuration.

If there will be more than one PV string, label the positive and negative wire pairs appropriately (for example: PV 1, PV 2).

#### Connecting DC wiring

##### **To wire the PV array to GT Inverters in parallel:**

1. Install the DC conduit from the PV strings to the GT Inverter wiring boxes, through appropriate knockout holes. Metal conduit is highly recommended.
2. Remove the wiring box cover (see page 3-2).
3. Route the wires from the PV string(s) through the conduit and into the wiring box.
4. Connect the DC Ground from each PV array to the GND bar in the wiring box.
5. Follow the instructions on page 3-4 for connecting POSITIVE (+) and NEGATIVE (-) wires from each PV array to each GT Inverter.
6. Ensure all connections are correctly wired and properly torqued according to values shown in Table 3-1 on page 3-5.

#### Connecting AC wiring

##### **To wire the main utility service panel to the GT Inverters in parallel:**

1. Run conduit from the main utility service panel to the wiring boxes of the GT Inverters.
2. Follow the instructions on page 3-7 for connecting L1 and L2 HOT wires and ground wire from the main utility service panel to each GT Inverter.
3. Ensure all connections are correctly wired and properly torqued according to values shown in Table 3-1 on page 3-5.



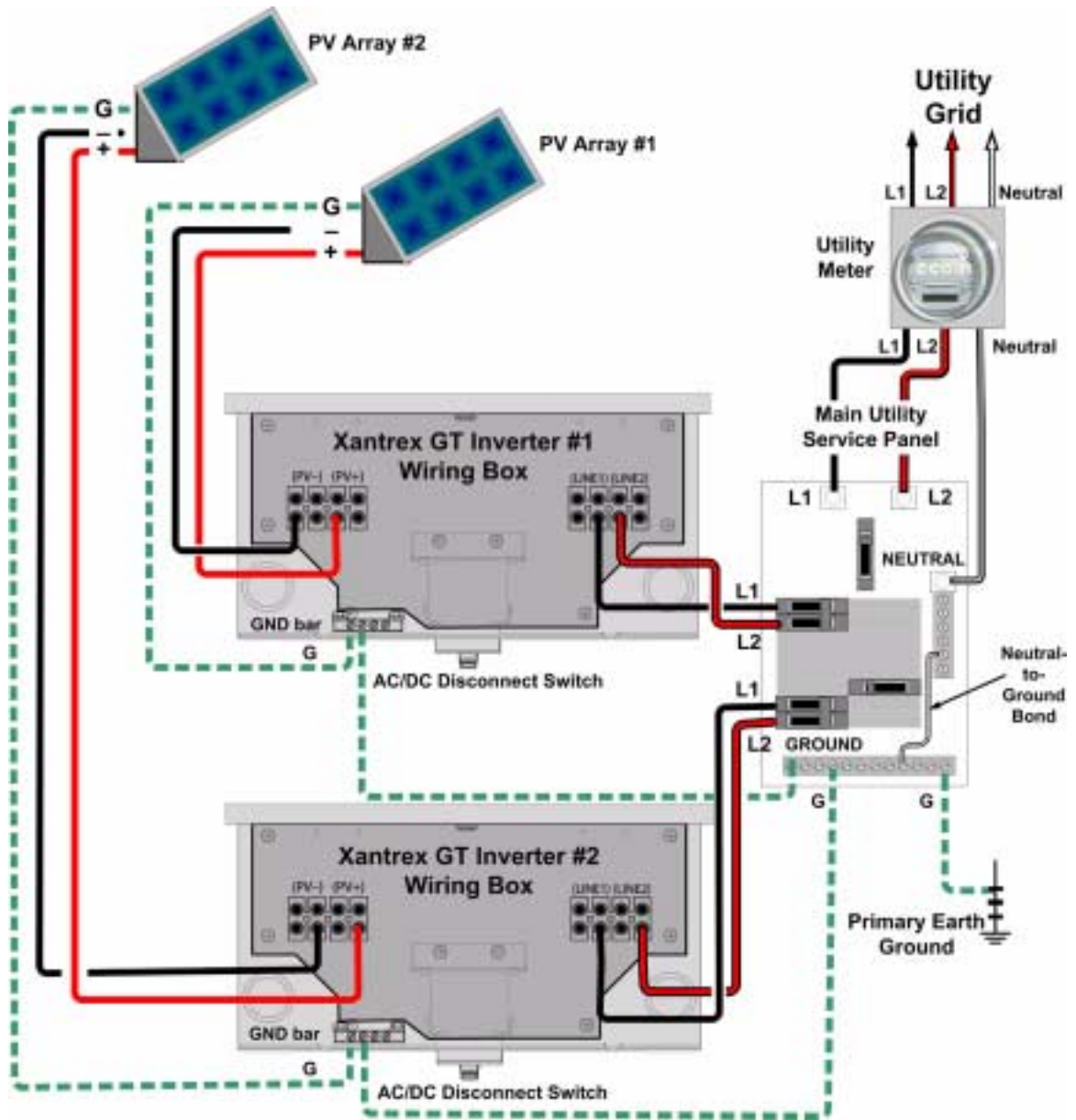

Figure 3-6 Parallel GT Inverter DC and AC Wiring

## Communications Wiring for Inverters in Parallel

Communications wiring between GT Inverters mounted in parallel allows information about each inverter and its associated PV array to be communicated between all of the inverters in the system. Information about the entire system can be displayed on any inverter LCD in the system.

For example, in a two-inverter system, if inverter #1 is producing 1500 W and inverter #2 is producing 2000 W, both inverters display a total system power of 3500 W. The cumulative energy produced by both inverters that day is also displayed.

You can still view information for an individual inverter in a system. See “To view unit-specific screens in a multiple unit system:” on page 5–5.

Without communications wiring each inverter in a system will only display information pertinent to the unit and its associated PV array.

## Xanbus Network Technology

GT Inverters use Xanbus technology to communicate with other inverters in parallel. Communications wiring between inverters is laid out in a “daisy chain” pattern, each device on the network linked together with separate lengths of cable, as shown in Figure 3-7.

For more information on installing a Xanbus network, see the *Xanbus System Installation Guide*, available at [www.xantrex.com](http://www.xantrex.com).

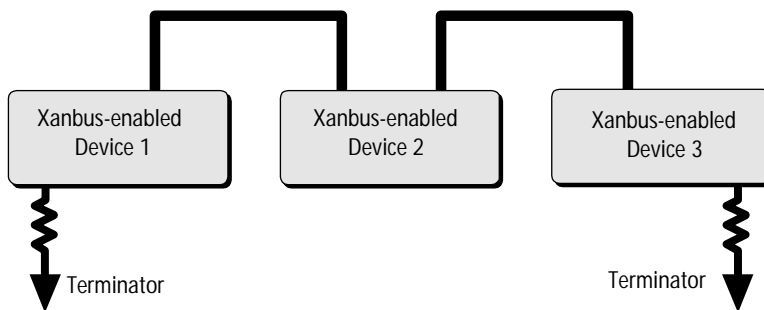

Figure 3-7 Daisy Chain Layout



### CAUTION: Equipment damage

Connect only Xanbus-enabled devices.

Although the cabling and connectors used in this network system are the same as ethernet connectors, **this network is not an ethernet system**. Equipment damage may result from attempting to connect Xanbus to different systems.

Terminators

Male network terminators (Figure 3-8) are required at both ends of the network to ensure the communication signal quality on the network.

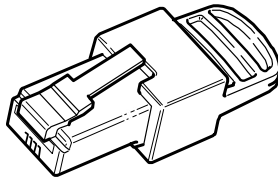

**Figure 3-8** Male Network Terminator

GT Inverter Xanbus Ports

Two RJ45 ports are provided in the GT Inverter, accessible from the wiring box. See Figure 3-9 for the location of these ports.

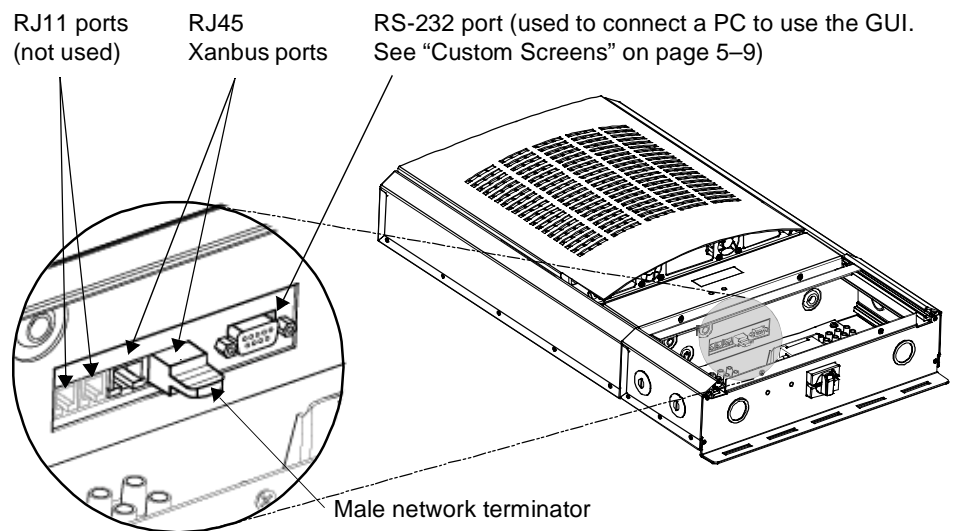

**Figure 3-9** Xanbus RJ45 Ports in the GT Inverter Wiring Box

---

## Cabling Requirements



### CAUTION: Equipment damage

Do not use crossover cable in a Xanbus system.

---

The network uses Category 5 (CAT 5) cable, a standard cable available from any computer supply store. The cable consists of eight conductors in four twisted pairs with an RJ45 modular connector wired to the T568A standard. Table 3-2 contains the arrangements of wire colors to pin numbers for the T568A standard.

**Table 3-2** T568A Standard Wiring

Pin Number	Conductor Name	CAT 5 Cable Insulation Color
1	NET_S	White/Green
2	NET_S	Green
3	NET_C	White/Orange
4	CAN_L	Blue
5	CAN_H	White/Blue
6	NET_C	Orange
7	NET_S	White/Brown
8	NET_C	Brown

## RJ45 Connector Requirements

The network cable uses modular RJ45 connectors, as shown in Figure 3-10. The connector is suitable for cost-sensitive applications and is easily installed. The RJ45 connector should be a modular plug, 8-position, 8-contact for round, stranded, unshielded cable.

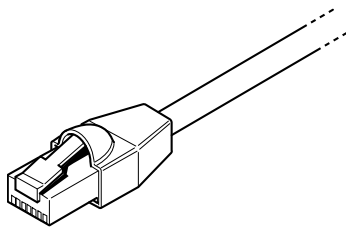

**Figure 3-10** RJ45 Connector

## Purchasing Network Components

Consult with your system designer to determine what network components will be needed for your specific installation. Table 3-3 provides a partial list of network components and part numbers. Pre-made cables are available in standard lengths from 3 feet to 75 feet.

Call your dealer or visit [www.xantrex.com](http://www.xantrex.com) to purchase network components.

**Table 3-3** Network Components and Part Numbers

Network Component	Part Number
Network termination — Male (2 per pack)	809-0901
Network cable 3 ft. (0.9 m)	809-0935
Network cable 5 feet (1.5 m)	809-0936
Network cable 7 feet (2.0 m)	809-0937
Network cable 10 feet (3.0 m)	809-0938
Network cable 14 feet (4.3 m)	809-0939
Network cable 25 feet (7.6 m)	809-0940
Network cable 50 feet (15.2 m)	809-0941
Network cable 75 feet (22.9 m)	809-0942

## Guidelines for Routing the Network Cables



### WARNING: Shock hazard

Do not route the network cables in the same conduit or panel as the AC and DC power cabling.

To ensure maximum performance of your network, follow these guidelines when routing the network cables. Route the cables before installing Xanbus-enabled devices.

- Route the cables away from sharp edges that might damage the insulation. Avoid sharp bends in the cable—no less than a 10-cm (4-inch) radius.
- Allow for some slack in the cable tension.
- Keep the alignment of wire pairs inside the sheath as straight as possible.
- Allow separation between data and power cables (data cables should only cross a power cable at right angles).
- Do not staple the cable with metal cable staples. Use the appropriate hardware fasteners to avoid damage to the cable.



### CAUTION: Unpredictable device behavior

Do not connect one end of the network to the other to make a ring.

## Connect the Communications Cable between Inverters in Parallel

---



### **WARNING: Shock hazard**

If the inverter is already installed and operational, turn OFF the breaker switches in the main utility service panel and the AC/DC Disconnect switch on the inverter wiring box before performing this procedure.

---



### **WARNING: Shock hazard**

Hazardous voltages may be present when cover is removed. After disconnecting all sources of energy, wait 5 minutes before removing cover.

---

The following procedure is illustrated in Figure 3-11 on page 3–17. The illustration and procedure assume only two inverters connected in parallel. However, there can be more than two inverters wired in this configuration.

#### **To provide communication between inverters mounted in parallel:**

1. Remove the wiring box cover from each unit.
2. On each unit, remove the plug from a 1.9 cm (3/4") side conduit hole and install appropriate conduit between the two units.
3. Connect the communication cable to any RJ45 port in Inverter #1.
4. Pass the cable through the conduit between Inverter #1 and Inverter #2.  
Inside each unit's wiring box, ensure the communication cable runs horizontally along the flat-bottomed channel formed when the insulation barrier is in place. The cable should run on top of the insulation barrier and out the side conduit hole, avoiding any contact with the AC and DC wiring.
5. Connect the communication cable to any RJ45 port in Inverter #2.
6. For more than two inverters in parallel, continue connecting cable as described above.
7. Insert male network terminators into the empty RJ45 ports in the inverters at the beginning and end of the network. There should be no empty RJ45 ports.

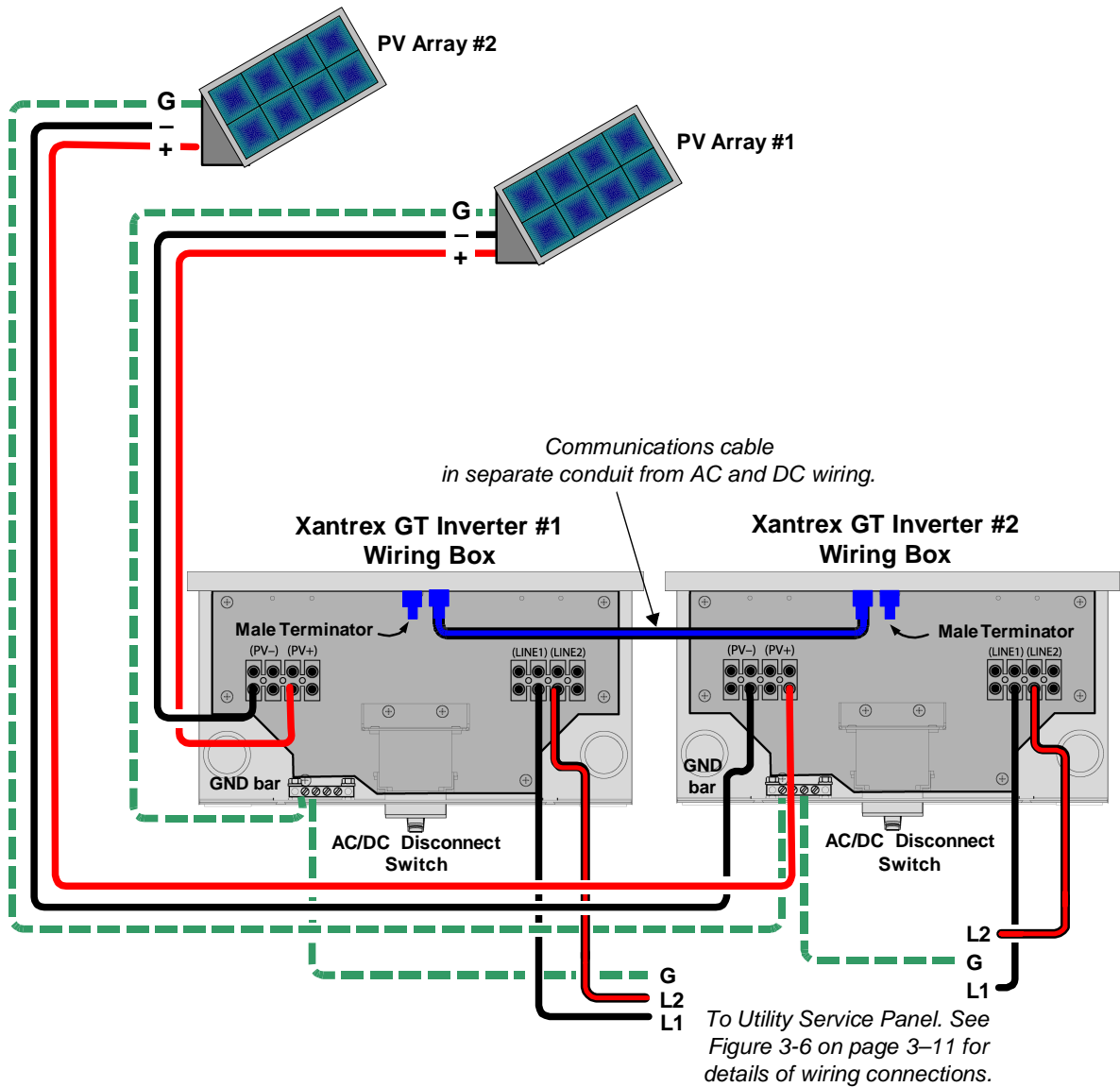

Figure 3-11 Communications Wiring for GT Inverters in Parallel





# 4

## Starting the Inverter

Chapter 4, “Starting the Inverter”, contains information on starting up the Xantrex Grid Tie Solar Inverter and performing a Functional Test.

The topics in this chapter are organized as follows:

- “Startup Procedure” on page 4-2
- “Replacing the Wiring Box Cover” on page 4-3.

## Startup Procedure

Starting up the GT Inverter requires several steps. You will need to:

1. Ensure the AC/DC Disconnect switch located on the bottom of the GT Inverter unit is in the OFF position (see Figure 4-1).
2. Check the PV array DC voltage (see procedure below).
3. Check the AC utility voltage (see procedure below).
4. Replace the cover on the wiring box (see “Replacing the Wiring Box Cover” on page 4–3).
5. Start up the GT Inverter by switching the AC/DC Disconnect switch ON.



### **WARNING: Shock hazard**

Hazardous voltages are present from two sources. Use extreme caution during startup procedure. Before applying power to the GT Inverter, ensure all AC and DC wiring is correct.

---

## Checking the PV Array DC Voltage

### **To check the PV array DC voltage:**

1. Uncover the PV arrays and expose them to full sunlight. The sunlight must be intense enough to produce the required output voltage.
2. Measure the PV array open circuit DC voltage across the DC positive (+) and negative (–) terminals. This voltage must be greater than 150 volts DC to energize the electronics.

## Checking the AC Utility Voltage

### **To check the AC utility voltage:**

1. Switch on the main and inverter breakers in the main electrical service panel.
2. Using an AC voltmeter, measure the AC open circuit utility voltage between L1 and L2. Ensure this voltage is at approximately the nominal value. The inverter operates with a line-to-line voltage (L1 to L2) range around the nominal value.

See “Output” on page A–2 for the operating utility voltage range for the GT Inverter.

---

## Replacing the Wiring Box Cover

After performing the voltage checks, replace all covers that were removed during installation and startup.



### **WARNING: Shock hazard**

Before reattaching covers, turn OFF the breaker switches in the main utility service panel and the AC/DC Disconnect switch on the GT Inverter.

---

If the front panel cover was removed from the GT Inverter, then it must be replaced before the wiring box cover is replaced.

#### **To replace the front panel cover:**

1. Place the cover in position on the front panel, being careful not to pinch any wires. The fan wires should pass through the notch in the upper edge of the front panel cover.
2. Ensure that the two screw holes in the bottom of the front panel cover are aligned with the corresponding holes in the bottom of the inverter (not the wiring box).
3. Replace the two screws removed when the cover was removed (see “Installing the Fan Assembly” on page 2–23), and tighten securely.

#### **To replace the wiring box cover:**

1. Place the cover in position on the wiring box, being careful not to pinch any wires in the wiring box.
2. Ensure that the two screw holes in the bottom of the wiring box cover are aligned with the corresponding holes in the bottom of the wiring box.
3. Replace the two screws removed when the cover was removed (see “Accessing the Wiring Terminals” on page 3–2), and tighten securely.

## Starting up the GT Inverter

### To start up the inverter:

1. Switch the AC/DC Disconnect switch to the ON position (see Figure 4-1).
2. Check the GT Inverter LCD. The startup screens (see Table 5-1 on page 5-3) should appear for five seconds each, and then the “Reconnecting in sss seconds” special screen (see Table 5-10 on page 5-8) will appear until the five-minute, five-second (default value) protection timer countdown is completed.

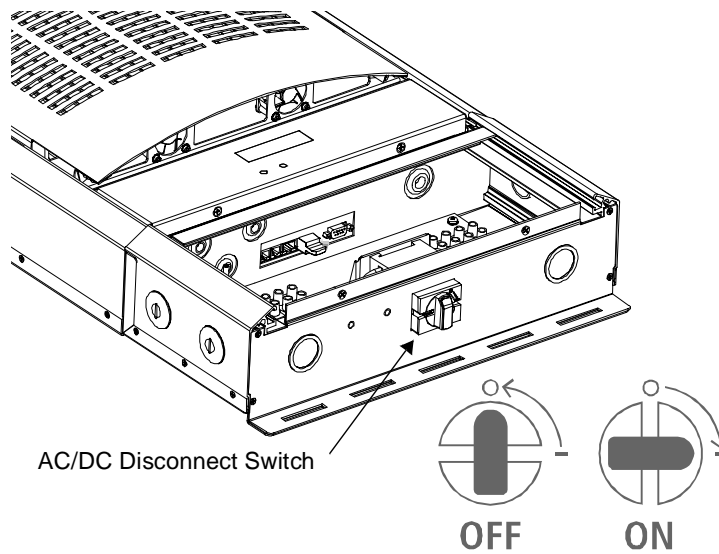

Figure 4-1 AC/DC Disconnect Switch Positions

# 5

## Monitoring the Inverter

Chapter 5, “Monitoring the Inverter”, contains information for understanding the LCD screens and the LED indicators.

The topics in this chapter are organized as follows:

- “Monitoring the Front Panel Display” on page 5–2
- “Front Panel Display Screens and What They Mean” on page 5–3
- “Status Indicator Lights” on page 5–9.

## Monitoring the Front Panel Display

During startup	During startup, the inverter’s front panel LCD (see Figure 5-1) shows the first three screens described in Table 5-1, “Startup Screens on GT Inverter Front Panel Display” on page 5–3.
During waiting period	When the five-minute, five-second (305 seconds) protection timer begins, the inverter displays “Reconnecting in sss seconds” (see Table 5-10, “Special Message Screens” on page 5–8).
During operation	When the protection timer stops, the GT Inverter begins selling power, indicated by the power output reading in the display (see Table 5-2, “Normal Operation Default Screen” on page 5–4).
When the inverter is offline or there is fault condition	When the GT Inverter is offline (e.g., at night) or a fault condition has been detected, the LCD shows a message screen to indicate that state. The specific fault condition will be identified. See Table 5-5, “Offline Mode Default Display” on page 5–5 and Table 5-8, “Fault Message Screens” on page 5–7.

---

**Important:** The values in the front panel LCD are not user adjustable.

---

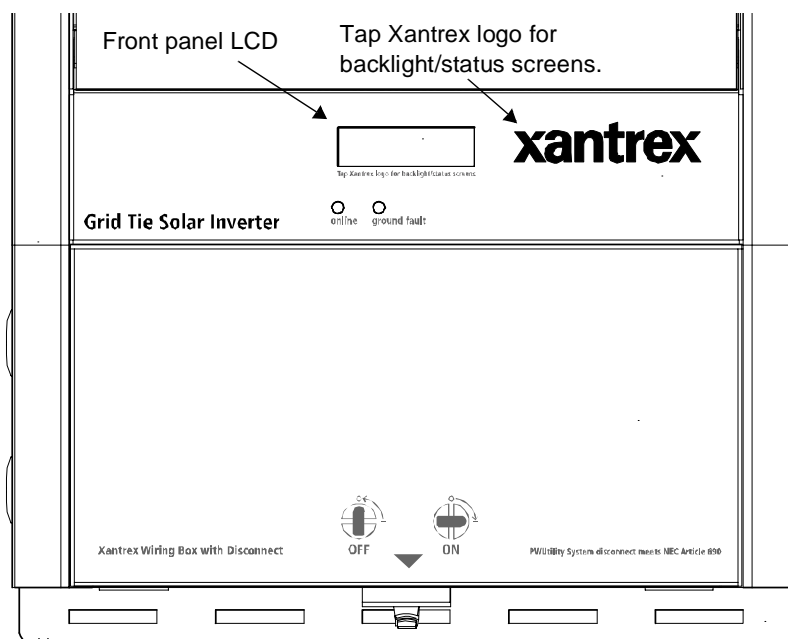

**Figure 5-1** Front Panel LCD Location

Viewing more information

Additional screens of information about the performance of the GT Inverter can be displayed by tapping the Xantrex logo on the inverter front panel. This causes the LCD to cycle through a series of information screens in Normal Operation, Offline or Fault modes. These are described in detail in the following section, “Front Panel Display Screens and What They Mean”.

## Front Panel Display Screens and What They Mean

The front panel display shows different message screens during different modes of operation (Startup, Normal, Offline, and Fault). All single units display a basic set of message screens; multiple unit systems display additional screens in Normal Operation and Offline modes.

In addition there are Special message screens that may appear in any operational mode. All of these message screens are described in more detail in the following tables.

### Startup Mode

During startup, the GT Inverter displays three message screens on its front panel LCD. These screens appear in the following order (Table 5-1).

**Table 5-1** Startup Screens on GT Inverter Front Panel Display

Display*	Duration	Description
Xantrex GT3.0-NA-240	5 sec.	<b>Startup message 1:</b> Inverter name and model number
Flash = 01.01 ROM = 01.01	5 sec	<b>Startup message 2:</b> Model and revision numbers for Flash and ROM memory on the GT Inverter. The ROM revision number applies to the protection processor.
Vh=262 V1=212 Fh=60.5 F1=59.3	5 sec	<b>Startup message 3:</b> Anti-islanding Utility Grid trip points. <b>Vh:</b> high voltage threshold <b>Vl:</b> low voltage threshold <b>Fh:</b> high frequency threshold <b>F1:</b> low frequency threshold

\* all numbers in this and following tables are examples only.

The five-minute, five second protection timer begins its countdown during startup and the “Reconnecting in *sss* seconds” screen appears until the timer countdown is complete.

### Normal Operation Mode

The LCD on the GT Inverter is refreshed every two seconds, so all readings are current to within two seconds. There is a default display available at all times, and a series of additional screens that can be displayed by tapping the Xantrex logo near the LCD to change the display.

Normal Operation  
default display

After the protection timer has completed its countdown and during normal operation, the GT Inverter displays the normal operation message screen shown in Table 5-2.

**Table 5-2** Normal Operation Default Screen

Display	Description
System 2000W	Power being produced by the system now.
Today 9.875kWh	Cumulative energy produced by the system today.

If there is sufficient energy from the PV array, this screen is displayed continuously while the system is operating normally. In a multiple unit system with communications cables properly connected, the power and cumulative energy values displayed are for the entire system.

During low light conditions when the GT Inverter cannot produce any power, the Normal Operation default screen flashes alternately (every two seconds) with the Insufficient Solar Energy screen (see Table 5-10, “Special Message Screens” on page 5–8).

More screens for all systems

Besides the default normal operation display, more system information messages can be viewed.

**To view more Normal Operation information:**

- Tap the Xantrex logo near the LCD to advance the display to the next screen. Normal operation screens shown in Table 5-3 are displayed in the order given, as you tap successively on the unit. They are common to all GT Inverter systems, no matter how many units are installed.

If you continue to tap the unit, then the LCD continues to cycle through all of the available normal operation screens. Each screen is displayed for a maximum of 30 seconds. If you do not tap again during that time period, then the LCD backlight turns off and the display reverts to the default system message screen.

**Table 5-3** Normal Operation Screens for All GT Inverter Units

Tap	Display*	Description
1st time	System 2000W Today 2.500kWh	LCD backlight turns on for better readability and default Normal Operation screen is displayed.
2nd time	System Lifetime 305kWh	Lifetime energy produced by the GT Inverter system.
3rd time	Time Online Today hh:mm:ss	Length of time inverter has been online today, in hours (hh), minutes (mm) and seconds (ss).
4th time	Array Readings 350.5V 8.4A	Immediate DC voltage and current readings from the PV array.
5th time	Grid Readings 242.6V 60.0Hz	Immediate AC voltage and frequency readings from the Grid



\* In a multiple unit system with communications cables properly installed, the system values displayed are for the entire system. For example, in a two-inverter system, if inverter #1 is producing 1500 W and inverter #2 is producing 2000 W, both inverters display a total system power of 3500 W. Time online and array readings are for the local inverter and PV array associated with that inverter.

Additional messages for multiple unit systems only

In addition, to the normal system message screens, additional screens specific to each GT Inverter unit can be displayed when the unit is networked to other GT Inverters. These screens are only available on multiple unit systems.

**To view unit-specific screens in a multiple unit system:**

1. Tap the Xantrex logo near the LCD to advance the display to the next screen. Continue tapping until the final system message screen (“Grid Readings”, in Table 5-3 above) is displayed.
2. Tap again. Normal operation screens shown in Table 5-4 are displayed in the order given, as you tap successively on the unit.

If you continue to tap the unit, then the LCD will cycle through all of the available normal operation screens. Each message is displayed for up to 30 seconds. If you do not tap again within that time period, then the LCD backlight turns off and the display reverts to the default normal operation screen (Table 5-2).

**Table 5-4** Additional Normal Operation Screens for Each GT Inverter Unit in a Multiple Unit System

Tap	Display	Description
6th time	Unit 1500W Today 1.250kWh	Power being produced by this unit now. Cumulative energy produced by this unit today.
7th time	Unit Lifetime 150kWh	Lifetime energy produced by this GT Inverter unit

## Offline Mode

Offline default display

At night and when no power is being produced by the PV array (offline mode), the GT Inverter displays the screen shown in Table 5-5.

**Table 5-5** Offline Mode Default Display

Display	Description
Inverter Offline	Displayed at all times while the system is offline.

Offline messages for all systems

Additional message screens can be viewed when the system is offline by tapping the Xantrex logo near the LCD. Each additional tap displays the next screen, in the order shown in Table 5-6.

These message screens are common to all GT Inverter systems, no matter how many units are installed. If you continue to tap the unit, then the LCD will continue to cycle through all of the available offline mode screens.

**Table 5-6** Offline Mode Screens for All GT Inverter Units

Tap	Display*	Description
1st time	Inverter Offline	LCD back light turns on for better readability and default Offline Mode screen is displayed.
2nd time	System Pw Today 2.50kWh	Power being produced by the system now. Cumulative energy produced by the system today.
3rd time	System Lifetime 305kWh	Lifetime energy produced by the system.
4th time	Time Online hh:mm:ss	Total time that the system was online today, in hours (hh), minutes (mm) and seconds (ss).

\* In a multiple unit system with communications cables properly installed, the system values displayed are for the entire system. Time online is for the local inverter.

Additional Offline messages for multiple unit systems

Multiple unit systems in offline mode display all of the message screens shown in Table 5-6, plus the additional screens shown in Table 5-7. These additional screens are displayed following the “Time Online” screen.

These screens are only displayed on multiple unit GT Inverter systems with communications cabling properly installed. If you continue to tap the unit, then the LCD continues to cycle through all of the available offline mode screens.

**Table 5-7** Additional Offline Mode Screens for Each GT Inverter Unit in a Multiple Unit System

Tap	Display	Description
5th time	Unit Pw Today 1.25kWh	Power being produced by this unit now. Cumulative energy produced by this unit today.
6th time	Unit Lifetime 150kWh	Lifetime energy produced by this unit.

## Fault Mode

When a fault state is detected, the appropriate fault message appears on the front panel display at the next screen refresh (i.e., within 2 seconds). The GT Inverter fault message screens are shown in Table 5-8.

## Fault Mode causes

These message screens only appear when there is a fault, and then flash alternately with the Inverter Offline default screen (Table 5-5) until the fault is corrected.

Table 5-8 Fault Message Screens

Display	Description
DC Voltage Fault 145.5V	When the actual DC voltage is over or under the allowable range, 165 to 600 Vdc. Self-clearing, no action required. The PV array should be configured such that DC voltage does not fall below 195 Vdc or rise above 600 Vdc.*
AC Voltage Fault 280V	When the actual AC voltage is over or under the allowable range, as specified in “Output” on page A-2. This is a utility fault; it will clear itself when the AC voltage comes within the specified range.†
Frequency Fault 0.0Hz	When the actual Frequency is over or under the allowable range, as specified in “Output” on page A-2. This is a utility fault; it will clear itself when the frequency comes within the specified range.†
Over Temp Fault 81.4C 178.5F	When the unit’s internal temperature is greater than 80° C (176° F), the unit will shut down automatically and only restart when the temperature has dropped to less than 70° C (158° F).
Ground Fault Reset System	When a grounding fault is detected. The ground fault fuse will be blown. The system must be shut down completely, the fault corrected, the fuse replaced (see “Replacing the Ground Fault Protection Fuse” on page 6-4) and then the system restarted. Troubleshooting a grounding fault should be performed by qualified personnel.
Impedance Fault Detected	Applicable only in German installations.†
Unit Shutdown via Remote	Appears if the GT Inverter unit has been shut down via a computer connected to the RS-232 port.
Protection uP Not Responding	The protection processor is not responding.

\* It is normal to receive this fault during low light conditions at dawn or dusk. At such times, the array does not have sufficient energy to power the inverter, so the PV voltage drops below 165 volts occasionally.

† Grid fault. When this fault is cleared the protection timer will begin its countdown and you will see the “Reconnecting in sss seconds” and “Inverter Offline” special screens (see Table 5-10) flashing alternately until the countdown is complete.

Additional Fault messages for all systems

Additional message screens can be viewed in fault mode by tapping the Xantrex logo near the LCD. Each additional tap displays the next screen in the order shown in Table 5-9.

**Table 5-9** Additional Fault Mode Screens

Tap	Display*	Description
1st time	Current fault message screen (see Table 5-8)	LCD backlight turns on for better readability.
2nd time	System On Today 2.500kWh	Energy being produced by the system now. Cumulative energy produced by the system today.
3rd time	System Lifetime 305kWh	Lifetime energy produced by the GT Inverter system.
4th time	Time Online Today hh:mm:ss	Length of time inverter was online today, in hours (hh), minutes (mm) and seconds (ss).
5th time	Array Readings 350.5V 8.4A	Immediate DC voltage and current readings of power from the PV array.
6th time	Grid Readings 242.6V 60.0Hz	Immediate AC voltage and frequency readings of power from the Grid.

\* In a multiple unit system with communications cables properly installed, the system values displayed are for the entire system. Time online and array readings are for the local inverter and PV array associated with that inverter.

## Special Screens

Special message screens are displayed in specific situations that are not considered fault situations. They can appear in any mode of operation. These screens are described in Table 5-10.

**Table 5-10** Special Message Screens

Display	Description
Reconnecting in sss seconds	Time remaining in seconds (sss) before the GT Inverter reconnects to the Grid. This is a protection timer; it runs for approximately five minutes at startup and after any Grid fault.
Inverter Offline	GT Inverter switching (or has switched) from Normal Operation to Offline mode. This screen may flash alternately with a Fault message screen.

**Table 5-10** Special Message Screens

Display	Description
System *3500W Today 15.56kWh	The “*” in these two screens (see Table 5-2 and Table 5-4) indicates that the unit is derating its output power because the inverter heat sink temperature is above 75° C (167° F).
Unit *1800W Today 7.82kWh	The asterisk only appears when the power is actually being limited by the inverter.
Insufficient Solar Energy	Indicates the GT Inverter is not producing power due to insufficient solar energy during low light conditions in early morning or late afternoon or when the PV array is in shade. This screen flashes alternately with the Normal Operation default screen.

## Custom Screens

Two custom screens are available. The inverter does not display them unless they are configured using a computer connected to the RS-232 port inside the wiring box. If programmed, the custom screens display as the fourth and fifth screens during the startup sequence. They can also be viewed by tapping the unit during normal operation and fault mode.

The first custom screen is intended for the home owner to display information such as the name or location of the PV array associated with the inverter.

The second custom screen is intended for installers, who can configure the screen to display, for example, contact information for service.

A PC graphical user interface that can be used for configuring custom screens is available for download at [www.xantrex.com](http://www.xantrex.com).

## Status Indicator Lights

The GT Inverter is equipped with two status indicator lights (LEDs) located below the front panel LCD (Figure 5-2). These LEDs indicate the inverter’s current status (Table 5-11) and assist in troubleshooting the performance of the unit.

Only one indicator light will be lit at any time.

**Table 5-11** Status Indicator LEDs

LED on	Means
GREEN	GT Inverter is on (DC voltage and AC voltage are qualified and the protection timer has finished) and delivering energy to the grid. No action required. Turns off when a fault state is detected.

**Table 5-11** Status Indicator LEDs

LED on	Means
RED	Ground fault condition detected. Check for any fault messages on the display (see Table 5-8), and refer also to Table 6-1, “Troubleshooting the GT Inverter” on page 6–8 to resolve the fault condition.

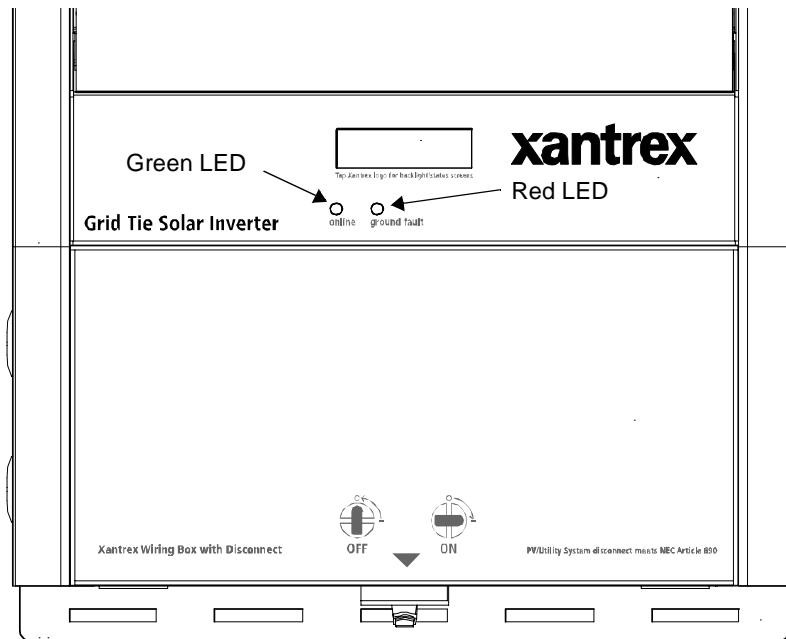

**Figure 5-2** Location of Status Indicator Lights

# 6

## Maintenance and Troubleshooting

Chapter 6, “Maintenance and Troubleshooting”, contains information about how to provide general maintenance for the Xantrex Grid Tie Solar Inverter. It also provides information about troubleshooting the unit.

The topics in this chapter are organized as follows:

- “Factors Affecting GT Inverter Performance” on page 6–2
- “Performing General Maintenance” on page 6–3
- “Replacing Parts” on page 6–3
- “Identifying Error/Fault Conditions and Solutions” on page 6–8.

## Factors Affecting GT Inverter Performance

This section describes several factors that will affect the amount of power that a properly installed and operating GT Inverter can produce.

### PV Array Factors

PV array ratings	PV arrays are rated at ideal factory conditions, such as specified illumination ( $1000 \text{ W/m}^2$ ), spectrum of the light and specified temperature ( $25^\circ\text{C} / 77^\circ\text{F}$ ), which seldom reflect real-world installations. This is called the STC (Standard Test Condition) rating and is the figure that appears on the PV module nameplate label.
Expected performance	Because of several unavoidable environmental factors, you can expect your PV array to produce around 60% to 70% of its peak STC-rated output for a properly designed and installed PV system on a typical day.
Temperature and reduced output	PV array temperature affects the output of the entire system. As the temperature on the array surface heats up, its energy output goes down. Roof-mounted arrays also collect the heat generated by the roof surface (or trapped under the array) and will produce less output than pole-mounted arrays, which allow greater air circulation behind the panels.

---

**Important:** The GT Inverter will reduce its energy output to protect its electronic circuits from overheating and possible damage in high heat conditions. For maximum output in hot climates, mount the GT Inverter in a shaded location with good air flow.

---

Angle of the sun	The angle of the sun in relation to the PV array surface—the array orientation—can dramatically affect the PV array output. The array energy output will vary depending on the time of day and time of year as the sun's angle in relation to the array changes. Sunlight output decreases as the sun approaches the horizons (such as in winter in North America) due to the greater atmospheric air mass it must penetrate, reducing both the light intensity that strikes the array's surface and spectrum of the light. In general, you can expect only four to six hours of direct sunlight per day.
Partial shade	Shading of only a single module of the array will reduce the output of the entire system. Such shading can be caused by something as simple as the shadow of a utility wire or tree branch on part of the array's surface. This condition, in effect, acts like a weak battery in a flashlight, reducing the total output, even though the other batteries are good. However, the output loss is not proportionate to shading. The GT Inverter is designed to maximize its energy production in all of the above situations using its MPPT algorithm.



## Other Factors

Other factors that contribute to system losses are:

- Dust or dirt on the array
- Fog or smog
- Mismatched PV array modules, with slight inconsistencies in performance from one module to another.
- Inverter efficiency
- Wire losses
- Utility grid voltage.

For additional information and technical notes concerning PV array performance, please visit our Web site at [www.xantrex.com](http://www.xantrex.com).

## Performing General Maintenance

Follow these simple routines to ensure many years of service and optimal performance of your solar energy system.

1. Keep the heatsink clear of dust and debris.



### **WARNING: Shock and fire hazard**

Do not use a pressure washer to clean the GT Inverter, or use other cleaning methods that could allow water to enter the unit.

2. Clean the PV array, during the cool part of the day, whenever it is visibly dirty.
3. Periodically inspect the system to make sure that all wiring and supports are securely in place.
4. On a sunny day near noon on March 21 and September 21 of each year, review the output of the system and compare with previous year's reading. Maintain a log of system performance readings so that you can recognize when system performance becomes inconsistent.

## Replacing Parts



### **WARNING: Shock hazard**

There are no user-replaceable parts on the GT Inverter. Do not attempt to service the unit yourself.

See the "Warranty and Return Information" on page WA-1 for information on how to get service for your GT Inverter.

## Replacing the Ground Fault Protection Fuse

---



### **WARNING: Shock and fire hazard**

Fuses should only be replaced by qualified service personnel. For continued protection against risk of fire, replace only with same type and ratings of fuse.

---



### **WARNING: Shock hazard**

After disconnecting both AC and DC power from the GT Inverter, wait five minutes before attempting any maintenance or cleaning or working on any circuits connected to the inverter. Internal capacitors remain charged for five minutes after disconnecting all sources of power.

---



### **WARNING: Shock hazard**

Dangerous voltages can exist inside the inverter. If there is leakage current from the POSITIVE PV lead to ground at the array, touching the NEGATIVE PV lead could cause a life-threatening shock even with the disconnect switch turned off. Ungrounded negative DC current on the PV NEGATIVE (-) wire presents an extreme shock hazard.

When the fuse has blown due to a fault, incorrect handling can be life-threatening. Use an insulated fuse puller.

If possible, cover PV arrays with an opaque material during this procedure.

---

The ground fault protection fuse will blow when severe leakage occurs between the PV array and earth ground, or when the system has been installed with faulty wiring. Before replacing the fuse, it is important to have qualified service personnel determine the cause of the ground fault.

#### **To replace a ground fault protection fuse:**

1. Remove the wiring box and front panel covers (described on page 2–23 and page 3–2). The ground fault protection fuse is located on the left side of the LCD panel, behind the front panel cover (Figure 6-1).
2. Using an insulated fuse puller, remove the blown fuse and replace it with a new AC/DC midjet cartridge, rated 600 Vdc, 1A (Littelfuse KLKD 1 or equivalent).
3. Replace the front panel and wiring box covers (described on page 2–23 and page 4–3).



Figure 6-1 Location of Fuse, Front Panel Cover Removed

## Replacing the Inverter

You can swap out the inverter and replace it with another GT Inverter, leaving the existing wiring box in place. This means that you do not have to disturb wiring connections in the wiring box. However, you do have to disconnect wiring between the inverter and the wiring box.



### **WARNING: Shock hazard**

Separating the inverter from the wiring box breaks the ground path between PV NEGATIVE (–) and earth ground. When the wires between the inverter and wiring box are disconnected and exposed, both PV leads are floating at the array open circuit voltage. If there is leakage current from the POSITIVE PV lead to ground at the array, touching the NEGATIVE PV lead could cause a life-threatening shock even with the disconnect switch turned off. Ungrounded negative DC current on the PV NEGATIVE (–) wire presents an extreme shock hazard.

Use insulated tools only when disconnecting wires between the inverter and wiring box. Cap all disconnected wires with wire nuts.

If possible, cover PV arrays with an opaque material during this procedure.

Recommended tools:

- Insulated screwdriver
- Wire nut for PV NEGATIVE (–) wire
- 7 mm socket and small ratchet, or 7 mm open wrench.



**WARNING: Shock hazard**

The inverter should only be removed from the wiring box when a replacement inverter is immediately available. When replacing an inverter, ensure the AC/DC Disconnect switch is locked (or otherwise secured) in the OFF position. Do not leave the top of the wiring box exposed for extended periods of time.



**WARNING: Shock hazard**

Before replacing the inverter, turn OFF the breaker switches in the main utility service panel and the AC/DC Disconnect switch on the GT Inverter.

---

**To remove the inverter from the wiring box:**

1. Turn OFF the breaker switches in the main utility service panel and the AC/DC Disconnect switch on the GT Inverter. If possible, cover the PV arrays with an opaque material.
2. Remove the covers from the wiring box and inverter front (described on page 2–23 and page 3–2).
3. Using an insulated screwdriver, disconnect the PV NEGATIVE (–) wire from the terminal block inside the inverter. Cap the wire immediately with a wire nut.
4. Disconnect the remaining AC, DC and communications wires between the inverter and the wiring box, inside the inverter. Cap all disconnected AC and DC wires with wire nuts.
5. Inside the inverter, remove the four nuts attaching the wiring box to the inverter.
6. Lift the inverter off the mounting bracket, leaving the wiring box in place.

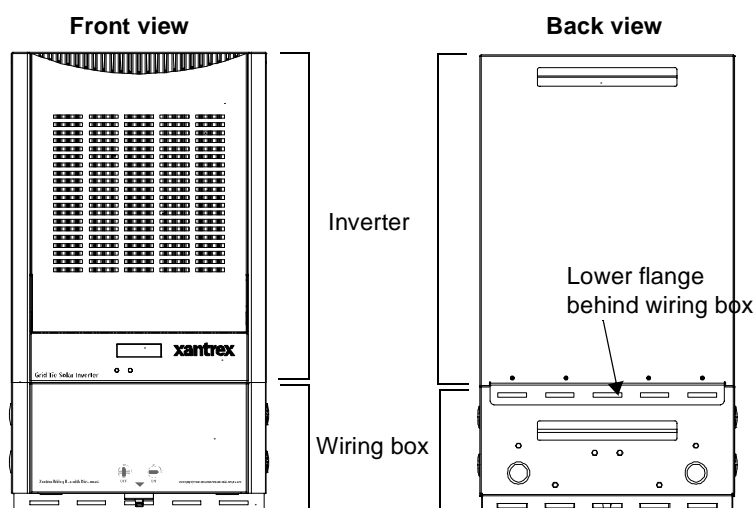

Figure 6-2 Inverter and Wiring Box Sections

**To replace the inverter on the wiring box:**

1. If it has not already been removed, remove the front panel cover on the inverter now. The wiring box cover should have been removed in the previous procedure.
2. Mount the inverter on the upper mounting bracket above the wiring box, with the lower flange behind the wiring box.
3. Replace the nuts that connect the inverter and the wiring box. Secure all nuts tightly.
4. Remove the wire nut from the PV NEGATIVE (–) wire and reconnect it to the terminal block inside the inverter.
5. Uncap the remaining DC and AC wires and reconnect them to the terminal block inside the inverter.
6. Replace the front panel and wiring box covers (described on page 2–23 and page 4–3).
7. Turn ON the breaker switches in the main utility service panel and the AC/DC Disconnect switch on the GT Inverter.

## Identifying Error/Fault Conditions and Solutions

Most error or fault conditions will be identified by fault message screens on the GT Inverter front panel LCD. These are described in the “Fault Mode” section on page 5–6 of this manual. Most of these fault conditions are self-correcting and require no user action to remedy.

See “Front Panel Display Screens and What They Mean” on page 5–3 for more information.

Table 6-1 is intended to assist in determining fault conditions that may require user action to remedy.

**Table 6-1** Troubleshooting the GT Inverter

<b>Problem</b>	<b>Cause</b>	<b>Remedy</b>
<ul style="list-style-type: none"> <li>• The inverter LED indicator lights do not illuminate, and the inverter does not operate in sufficient sunlight</li> <li>• The display reads “Inverter Offline”</li> <li>• The Vdc reading is 0.</li> </ul>	<p>AC/DC Disconnect Switch is off, or utility service panel AC or DC breakers are switched off.</p> <p>No AC grid or DC array voltage is present.</p>	<p>Turn on AC/DC Disconnect Switch and breakers in the sequence described in “Startup Procedure” on page 4–2.</p> <p>Check source of the AC voltage. Ensure that the inverter AC/DC Disconnect Switch is set ON.</p> <p>Check AC connections and ensure AC voltage within the range specified in “Output” on page A–2 is present.</p> <p>Check DC connections. Check the DC voltage on the positive and negative input terminals and ensure 195–550 Vdc is present.</p> <p>Check for incorrectly wired PV arrays or try again on a day with brighter sunlight intensity.</p>
Only the inverter RED LED is illuminated.	Ground fault condition detected.	Check for any fault messages on the display (see Table 5-8 on page 5–7). System should be checked by a qualified electrician and repaired.

# A

## Specifications

Appendix A, “Specifications”, contains information about the electrical and environmental specifications of the Xantrex Grid Tie Solar Inverter.

The topics in this appendix are organized as follows:

- “Electrical Specifications” on page A-2
- “Environmental Specifications” on page A-5
- “Mechanical Specifications” on page A-5

## Electrical Specifications

### Input

Input voltage, Maximum Power Point range	195 to 550 Vdc
Absolute maximum array open circuit voltage	600 Vdc
Maximum input current	16.6 A DC
Maximum array short circuit current	19 A DC
Recommended PV array power	Up to 3300 W
Reverse polarity protection	Short circuit diode
Ground fault protection	GF detection, $I_{DIF} > 1$ A

### Output

	GT3.0 North American	GT3.0 European
Maximum output power	3000 W AC	3000 W AC
Nominal output power over rated temp range	2500 W AC	2500 W AC
Maximum utility backfeed current	20 A	20 A
Nominal output voltage	240 V	230 V
Operating range, utility voltage (default)*	211 to 264 Vac	202 to 253 Vac
Nominal output frequency	60 Hz	50 Hz
Operating range, utility frequency (default)*	59.3 to 60.5 Hz	47.1 to 50.9 Hz
Maximum continuous output current	14.2 A	14.9 A
Output overcurrent protection	20 A RMS	20 A RMS
Total Harmonic Distortion (THD)	<5%	<5%
Power factor	>0.9	>0.9
Utility monitoring— islanding protection	Vac, fac as per UL1741	
Output characteristics	Current source	
Output current waveform	Sine wave	

\* Requires Utility permission and qualified service personnel to change settings.



## Adjustable Disconnect Settings

The adjustable disconnect setting values vary depending on whether the inverter is a 208 Vac/60 Hz, 240 Vac/60 Hz, or 230 Vac/50 Hz model. Utility permission is required prior to changing the settings on the inverter.

The default values of these settings differ from the utility specifications on page A-2. These differences take into account the accuracy ranges listed in the table below, and are intended to ensure that utility specifications are always met.

Setting	Default Values			Adjustment Range		Accuracy
	208 Vac/60 Hz	240 Vac/60 Hz	230 Vac/50 Hz	From...	To...	
AC Low Voltage	186 Vac	214 Vac	205 Vac	180 Vac	269 Vac	+/- 3 Vac
AC High Voltage	225 Vac	261 Vac	250 Vac			
AC Low Frequency	59.4 Hz		47.1 Hz	46.0 Hz	62.0 Hz	+/- 0.1 Hz
AC High Frequency	60.4 Hz		50.9 Hz			
Reconnect Delay	305 sec.			60 sec.	600 sec.	+/- 5 sec.

## Output Power Versus Ambient Temperature

Once the heat sink on the inverter reaches a maximum temperature limit, the GT Inverter reduces its energy output to ensure maximum component ratings are not exceeded.

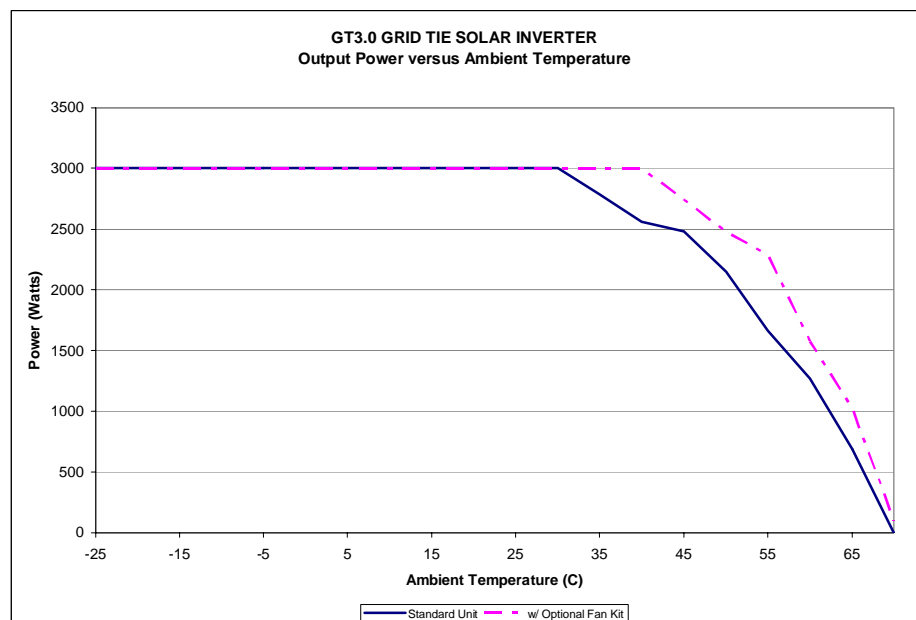

Figure A-1 Output Power vs. Ambient Temperature

## Efficiency

Maximum efficiency	94.6%
Efficiency at 75% of nominal output power rating	94.5%
Euro efficiency	93.3%
Nighttime tare loss	1 W

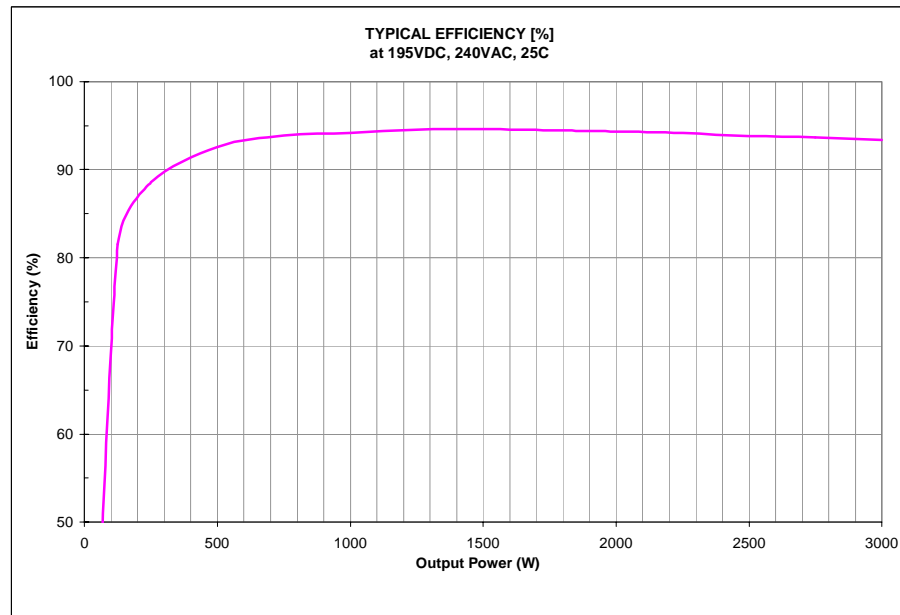

Figure A-2 Typical Efficiency

## Environmental Specifications

Rated operating temperature range	-25° to +45° C (-13° to +113° F)
Tolerable operating temperature range	-25° to +65° C (-13° to +149° F)
Storage temperature range	-40° to +85° C (-40° to +185° F)
Power derating	Derating curve above +45° C (+113° F); see Figure A-1 on page A-3
Tolerable relative humidity limit	<b>Operating:</b> 100% condensing <b>Storage:</b> <95%, non-condensing

## User Display

Type	alphanumeric liquid crystal
Size	2 lines by 16 characters
Backlight	yes

## Display Accuracy

Instantaneous Power	+/- (30 W + 1% of reading)
Voltage	+/- (1% of rating + 1% of reading)
Current	+/- (1% of rating + 1% of reading)
System Lifetime energy	+/- 5%

## Mechanical Specifications

Outdoor enclosure	NEMA 3R, Rainproof
Inverter dimensions (H × W × D)	72.5 × 40.3 × 14.6 cm (28.5 × 15.9 × 5.7 inches)
Shipping dimensions (H × W × D)	86.6 × 51.8 × 26.2 cm (34 × 20.4 × 10.3 inches)
Inverter weight	20.4 kg (45 lb)
Shipping weight	26.6 kg (58.7 lb)
Input and output terminals	AC and DC terminals accept wire sizes of 2.5 to 25 mm <sup>2</sup> (#14 to #6 AWG)
Disconnect switch	Integrated switch, disconnects both AC and DC (meets NEC article 690), rated @ 600 Vdc

## Accessories

### GT Fan Kit (includes fan assembly and heat sink cover)

Part number	864-0201
Fan control	Thermal, activates when the internal surface of the heat sink reaches 60° C (140° F).
Fan power consumption (operating)	3.84 W

# Warranty and Return Information

## Warranty

**What does this warranty cover?** This Limited Warranty is provided by Xantrex Technology, Inc. ("Xantrex") and covers defects in workmanship and materials in your Xantrex Grid Tie Solar Inverter. This warranty period lasts for five year from the date of purchase at the point of sale to you, the original end user customer. You require proof of purchase to make warranty claims.

This Limited Warranty is transferable to subsequent owners but only for the unexpired portion of the Warranty Period. Subsequent owners also require proof of purchase.

**What will Xantrex do?** Xantrex will, at its option, repair or replace the defective product free of charge, provided that you notify Xantrex of the product defect within the Warranty Period, and provided that Xantrex through inspection establishes the existence of such a defect and that it is covered by this Limited Warranty.

Xantrex will, at its option, use new and/or reconditioned parts in performing warranty repair and building replacement products. Xantrex reserves the right to use parts or products of original or improved design in the repair or replacement. If Xantrex repairs or replaces a product, its warranty continues for the remaining portion of the original Warranty Period or 90 days from the date of the return shipment to the customer, whichever is greater. All replaced products and all parts removed from repaired products become the property of Xantrex.

Xantrex covers both parts and labor necessary to repair the product, and return shipment to the customer via a Xantrex-selected non-expedited surface freight within the contiguous United States and Canada. Alaska and Hawaii are excluded. Contact Xantrex Customer Service for details on freight policy for return shipments outside of the contiguous United States and Canada.

**How do you get service?** If your product requires troubleshooting or warranty service, contact your merchant. If you are unable to contact your merchant, or the merchant is unable to provide service, contact Xantrex directly at:

Telephone: 1 800 670 0707 (toll free North America)

1 360 925 5097 (direct)

Fax: 1 800 994 7828 (toll free North America)

1 360 925 5143 (direct)

Email: customerservice@xantrex.com

Direct returns may be performed according to the Xantrex Return Material Authorization Policy described in your product manual. For some products, Xantrex maintains a network of regional Authorized Service Centers. Call Xantrex or check our website to see if your product can be repaired at one of these facilities.

**What proof of purchase is required?** In any warranty claim, dated proof of purchase must accompany the product and the product must not have been disassembled or modified without prior written authorization by Xantrex.

Proof of purchase may be in any one of the following forms:

- The dated purchase receipt from the original purchase of the product at point of sale to the end user, or
- The dated dealer invoice or purchase receipt showing original equipment manufacturer (OEM) status, or
- The dated invoice or purchase receipt showing the product exchanged under warranty

**What does this warranty not cover?** This Limited Warranty does not cover normal wear and tear of the product or costs related to the removal, installation, or troubleshooting of the customer's electrical systems. This warranty does not apply to and Xantrex will not be responsible for any defect in or damage to:

- a) the product if it has been misused, neglected, improperly installed, physically damaged or altered, either internally or externally, or damaged from improper use or use in an unsuitable environment;
- b) the product if it has been subjected to fire, water, generalized corrosion, biological infestations, or input voltage that creates operating conditions beyond the maximum or minimum limits listed in the Xantrex product specifications including high input voltage from generators and lightning strikes;
- c) the product if repairs have been done to it other than by Xantrex or its authorized service centers (hereafter "ASCs");
- d) the product if it is used as a component part of a product expressly warranted by another manufacturer;
- e) the product if its original identification (trade-mark, serial number) markings have been defaced, altered, or removed.

## Disclaimer

### Product

THIS LIMITED WARRANTY IS THE SOLE AND EXCLUSIVE WARRANTY PROVIDED BY XANTREX IN CONNECTION WITH YOUR XANTREX PRODUCT AND IS, WHERE PERMITTED BY LAW, IN LIEU OF ALL OTHER WARRANTIES, CONDITIONS, GUARANTEES, REPRESENTATIONS, OBLIGATIONS AND LIABILITIES, EXPRESS OR IMPLIED, STATUTORY OR OTHERWISE IN CONNECTION WITH THE PRODUCT, HOWEVER ARISING (WHETHER BY CONTRACT, TORT, NEGLIGENCE, PRINCIPLES OF MANUFACTURER'S LIABILITY, OPERATION OF LAW, CONDUCT, STATEMENT OR OTHERWISE), INCLUDING WITHOUT RESTRICTION ANY IMPLIED WARRANTY OR CONDITION OF QUALITY, MERCHANTABILITY OR FITNESS FOR A PARTICULAR PURPOSE. ANY IMPLIED WARRANTY OF MERCHANTABILITY OR FITNESS FOR A PARTICULAR PURPOSE TO THE EXTENT REQUIRED UNDER APPLICABLE LAW TO APPLY TO THE PRODUCT SHALL BE LIMITED IN DURATION TO THE PERIOD STIPULATED UNDER THIS LIMITED WARRANTY.

IN NO EVENT WILL XANTREX BE LIABLE FOR ANY SPECIAL, DIRECT, INDIRECT, INCIDENTAL OR CONSEQUENTIAL DAMAGES, LOSSES, COSTS OR EXPENSES HOWEVER ARISING WHETHER IN CONTRACT OR TORT INCLUDING WITHOUT RESTRICTION ANY ECONOMIC LOSSES OF ANY KIND, ANY LOSS OR DAMAGE TO PROPERTY, ANY PERSONAL INJURY, ANY DAMAGE OR INJURY ARISING FROM OR AS A RESULT OF MISUSE OR ABUSE, OR THE INCORRECT INSTALLATION, INTEGRATION OR OPERATION OF THE PRODUCT.

### Exclusions

If this product is a consumer product, federal law does not allow an exclusion of implied warranties. To the extent you are entitled to implied warranties under federal law, to the extent permitted by applicable law they are limited to the duration of this Limited Warranty. Some states and provinces do not allow limitations or exclusions on implied warranties or on the duration of an implied warranty or on the limitation or exclusion of incidental or consequential damages, so the above limitation(s) or exclusion(s) may not apply to you. This Limited Warranty gives you specific legal rights. You may have other rights which may vary from state to state or province to province.

### Warning: Limitations On Use

Please refer to your product manual for limitations on uses of the product.

SPECIFICALLY, PLEASE NOTE THAT THE XANTREX GRID TIE SOLAR INVERTER SHOULD NOT BE USED IN CONNECTION WITH LIFE SUPPORT SYSTEMS OR OTHER MEDICAL EQUIPMENT OR DEVICES. WITHOUT LIMITING THE GENERALITY OF THE FOREGOING, XANTREX MAKES NO REPRESENTATIONS OR WARRANTIES REGARDING THE USE OF THE XANTREX XANTREX GRID TIE SOLAR INVERTER IN CONNECTION WITH LIFE SUPPORT SYSTEMS OR OTHER MEDICAL EQUIPMENT OR DEVICES.

Please note that the Xantrex Grid Tie Solar Inverter is not intended for use as an uninterruptible power supply and Xantrex makes no warranty or representation in connection with any use of the product for such purposes.

---

## Return Material Authorization Policy

Before returning a product directly to Xantrex you must obtain a Return Material Authorization (RMA) number and the correct factory "Ship To" address. Products must also be shipped prepaid. Product shipments will be refused and returned at your expense if they are unauthorized, returned without an RMA number clearly marked on the outside of the shipping box, if they are shipped collect, or if they are shipped to the wrong location.

When you contact Xantrex to obtain service, please have your instruction manual ready for reference and be prepared to supply:

- The serial number of your product
- Information about the installation and use of the unit
- Information about the failure and/or reason for the return
- A copy of your dated proof of purchase

Record these details in on page WA-4.

## Return Procedure

1. Package the unit safely, preferably using the original box and packing materials. Please ensure that your product is shipped fully insured in the original packaging or equivalent. This warranty will not apply where the product is damaged due to improper packaging.
2. Include the following:
  - The RMA number supplied by Xantrex Technology, Inc. clearly marked on the outside of the box.
  - A return address where the unit can be shipped. Post office boxes are not acceptable.
  - A contact telephone number where you can be reached during work hours.
  - A brief description of the problem.
3. Ship the unit prepaid to the address provided by your Xantrex customer service representative.

**If you are returning a product from outside of the USA or Canada** In addition to the above, you **MUST** include return freight funds and are fully responsible for all documents, duties, tariffs, and deposits.

**If you are returning a product to a Xantrex Authorized Service Center (ASC)** A Xantrex return material authorization (RMA) number is not required. However, you must contact the ASC prior to returning the product or presenting the unit to verify any return procedures that may apply to that particular facility.

## Out of Warranty Service

If the warranty period for your Xantrex Grid Tie Solar Inverter has expired, if the unit was damaged by misuse or incorrect installation, if other conditions of the warranty have not been met, or if no dated proof of purchase is available, your product may be serviced or replaced for a flat fee.

To return your Xantrex Grid Tie Solar Inverter for out of warranty service, contact Xantrex Customer Service for a Return Material Authorization (RMA) number and follow the other steps outlined in "Return Procedure" on page WA-3.

Payment options such as credit card or money order will be explained by the Customer Service Representative. In cases where the minimum flat fee does not apply, as with incomplete units or units with excessive damage, an additional fee will be charged. If applicable, you will be contacted by Customer Service once your unit has been received.

## Information About Your System

As soon as you open your Xantrex Grid Tie Solar Inverter package, record the following information and be sure to keep your proof of purchase.

Model Number \_\_\_\_\_  
Serial Number \_\_\_\_\_  
Purchased From \_\_\_\_\_  
Purchase Date \_\_\_\_\_

If you need to contact Customer Service, please record the following details before calling. This information will help our representatives give you better service.

### Inverter Details

Type of installation (e.g. Residential/Commercial) \_\_\_\_\_  
Length of time inverter has been installed \_\_\_\_\_  
AC wiring size and length \_\_\_\_\_  
DC wiring size and length \_\_\_\_\_  
Description of fault messages and/or indicators on front panel \_\_\_\_\_  
\_\_\_\_\_  
\_\_\_\_\_

Description of problem \_\_\_\_\_  
\_\_\_\_\_  
\_\_\_\_\_

### PV Details

Solar Panel Mount:       Roof       Pole       Ground

Solar Panel Brand and Model:

Nominal Voltage Range: \_\_\_\_\_ Vdc

Peak Open Circuit Voltage: \_\_\_\_\_ Vdc

Nominal Current Rating: \_\_\_\_\_ Adc

Maximum Current Rating: \_\_\_\_\_ Adc

Solar Tracker?       Yes       No

String #1:      # of Panels: \_\_\_\_\_  Series       Parallel

String #2:      # of Panels: \_\_\_\_\_  Series       Parallel

String #3:      # of Panels: \_\_\_\_\_  Series       Parallel

String #4:      # of Panels: \_\_\_\_\_  Series       Parallel



# Index

## A

abbreviations and acronyms iv  
AC circuit breaker requirements 2–13  
AC grounding requirements 2–8  
AC output voltage ratings A–2  
AC utility voltage 4–2  
AC wiring instructions 3–7  
acceptable wire sizes A–5  
accessing AC and DC terminals 3–2  
accessories 1–7, A–6  
adjustable disconnect settings A–3

## C

checking AC utility voltage 4–2  
checking PV array DC voltage 4–2  
circuit breakers and fuses 2–13  
communication between multiple inverters 3–12  
communications cabling 3–14  
    installing for inverters in parallel 3–16  
    standard CAT 5 wiring 3–14  
conduit holes 2–12  
conduit nipples  
    installing 2–23  
Customer Service  
    preparing to call WA–4

## D

DC wiring instructions 3–4  
derating chart A–3  
dimensions 2–16, A–5  
display accuracy A–5

## E

efficiency chart A–4  
electrical specifications A–2  
enclosure type A–5  
error messages and solutions 6–8

## F

fan kit 1–7, 2–23, A–6  
fault conditions and solutions 6–8  
FCC information to the user viii  
features and options 1–3

front panel display 1–3, 5–2  
    fault messages 5–6  
    normal operation messages 5–3  
    offline mode messages 5–5  
    reading messages 5–3  
    special messages 5–8  
    startup messages 5–3  
fuse, location of ground fault protection 6–5  
fuses and circuit breakers 2–13

## G

general maintenance 6–3  
ground clearance required for installation 2–4, 2–18  
ground fault protection fuse 2–14  
    replacing 6–4  
grounding requirements 2–8  
guidelines for matching PV array size to inverter input  
    2–7

## H

heat sink cover 1–7, 2–26  
humidity limits A–5

## I

information about your system form WA–4  
installation  
    fan assembly 2–23  
    grounding requirements 2–8  
    location concerns 2–4  
    mounting 2–19  
    options 2–2  
    overview 2–15  
    planning issues 2–2  
    preparing for 2–13  
    PV array requirements 2–5  
    routing wires 2–11  
inverter  
    features and options 1–3  
    installation 2–15  
    model number WA–4  
    models 1–8  
    purchase date WA–4  
    purpose 1–2  
    removing from wiring box 6–6

serial number WA-4

## K

knockout locations 2-16

## L

LEDs, *See* status LEDs  
lightning protection 2-8  
long-distance grounding 2-8

## M

maintenance, general 6-3  
maximum power point tracking, *See* MPPT  
mechanical specifications A-5  
messages, *See* front panel display  
model configurations 1-8  
model number WA-4  
mounting bracket  
  installing 2-17  
  on backing support 2-21  
  on poles or rails 2-20  
mounting the inverter  
  clearance requirements 2-18  
  multiple inverters 2-23  
  on wallboard, siding or concrete 2-21  
  overview 2-16  
  preparation 2-16  
  single inverter 2-22  
  surfaces for 2-19  
  using poles or rails 2-20  
MPPT  
  operational window 2-6  
  technology 1-3  
multiple inverters  
  AC and DC wiring 3-10  
  communication between 3-12  
  communications wiring 3-16  
  configuration 2-2  
  messages in normal operation 5-5  
  messages in offline mode 5-6

## O

operation  
  factors affecting performance 6-2  
  inverter startup 4-4  
  messages at startup 5-3  
  reassembling the unit 4-3  
  startup procedure 4-2

## P

parallel configuration 1-3, 3-10  
  AC wiring 3-10  
  communication between inverters 3-12  
  communications wiring 3-16  
  DC wiring 3-10  
photovoltaic (PV) power 1-2  
power derating A-5  
preparing for installation 2-13  
proof of purchase WA-4  
purchase date WA-4  
PV arrays  
  angle of the sun 6-2  
  checking DC voltage 4-2  
  effect of shade on performance 6-2  
  factory ratings 6-2  
  grounding requirements 2-8  
  installation recommendations 2-5  
  matching size to inverter input 2-7  
  requirements 2-5  
  temperature affecting performance 6-2  
  types of modules 2-6  
  voltage requirements 2-6

## R

RJ45 connector requirements 3-14  
RJ45 ports  
  communication between inverters 3-13  
  location in wiring box 3-3  
RS-232 port 3-13, 5-7, 5-9

## S

safety instructions vii  
serial number WA-4  
single inverter configuration 2-2  
specifications  
  electrical A-2  
  mechanical A-5  
standard features and options 1-3  
standard test condition 6-2  
startup procedure  
  check PV array DC voltage 4-2  
  check utility AC voltage 4-2  
  monitor front panel display 5-2  
  overview 4-2  
  replace wiring box cover 4-3  
  start the inverter 4-4  
status LEDs  
  description 5-9

---

- do not illuminate 6–8
- red LED is on 6–8

## T

- temperature
  - affecting PV array performance 6–2
  - range for locating Xantrex GT Inverter 2–4
- terminal blocks in wiring box 3–3
- terminators, male network 3–13
- thermal derating chart A–3
- torque values for wires 3–5
- troubleshooting the GT Inverter 6–8

## V

- voltmeter
  - measuring PV array DC at startup 4–2
  - measuring utility AC at startup 4–2

## W

- warranty
  - out of warranty service WA–3
  - terms and conditions WA–1
- weight A–5
- wire stripping length, recommended 2–13
- wiring
  - AC connection planning 2–12
  - acceptable wire sizes A–5
  - conduit planning 2–12
  - DC connection planning 2–12
  - information 2–13
  - knockouts for 2–12
  - main utility service panel to Xantrex GT Inverter 3–8
  - preparation for 2–13
  - PV array to Xantrex GT Inverter 3–5
  - routing wires 2–11
  - torquing 3–5, 3–10
  - wire sizes 2–13
- wiring box
  - description 1–6
  - removing the cover 3–2
  - removing the inverter from 6–6
  - RJ45 connectors 3–3
  - terminal block location 3–3

## X

- Xanbus technology 3–12
- Xantrex web site v





**Xantrex Technology Inc.**

1 800 670 0707 Tel toll free NA  
1 360 925 5097 Tel direct  
1 800 994 7828 Fax toll free NA  
1 360 925 5143 Fax direct  
customerservice@xantrex.com  
www.xantrex.com

975-0131-01-01

Printed in China

## Free Manuals Download Website

<http://myh66.com>

<http://usermanuals.us>

<http://www.somanuals.com>

<http://www.4manuals.cc>

<http://www.manual-lib.com>

<http://www.404manual.com>

<http://www.luxmanual.com>

<http://aubethermostatmanual.com>

Golf course search by state

<http://golfingnear.com>

Email search by domain

<http://emailbydomain.com>

Auto manuals search

<http://auto.somanuals.com>

TV manuals search

<http://tv.somanuals.com>