



English

Français

Deutsch

User Guide

Guide de l'utilisateur

Bedienungsanleitung



COMPLIANCE INFORMATION STATEMENT

(DECLARATION OF CONFORMITY PROCEDURE)

Responsible Party: Yamaha Systems Technology, Inc.
Address: 100 Century Center Court
San Jose, California 95112
Telephone: (408) 467-2330
FAX: (408) 437-8791
Type of Equipment: CD Recorder
Model Name: CRW2216E
CRW2216E-NB

This device complies with Part 15 of the FCC Rules.

Operation is subject to the following conditions:

- 1) this device may not cause harmful interference, and
- 2) this device must accept any interference received including interference that may cause undesired operation.

See user manual instructions if interference to radio reception is suspected.

FCC INFORMATION (U.S.A.)

1. **IMPORTANT NOTICE: DO NOT MODIFY THIS UNIT!**

This product, when installed as indicated in the instructions contained in this manual, meets FCC requirements. Modifications not expressly approved by Yamaha may void your authority, granted by the FCC, to use the product.

2. **IMPORTANT:** When connecting this product to accessories and/or another product use only high quality shielded cables. Cable/s supplied with this product **MUST** be used. Follow all installation instructions. Failure to follow instructions could void your FCC authorization to use this product in the USA.

3. **NOTE:** This product has been tested and found to comply with the requirements listed in FCC Regulations, Part 15 for Class "B" digital devices. Compliance with these requirements provides a reasonable level of assurance that your use of this product in a residential environment will not result in harmful interference with other electronic devices. This equipment generates/uses radio frequencies and, if not installed and used according to the instructions found in the users manual, may cause interference harmful to the operation of other electronic devices. Compliance with FCC regulations does not guarantee that interference will not occur in all installations. If this product is found to be the source of interference, which can be determined by turning the product "OFF" and "ON", please try to eliminate the problem by using one of the following measures:

Relocate either this product or the device that is being affected by the interference.

Utilize power outlets that are on different branch (circuit breaker or fuse) circuits or install AC line filter/s.

In the case of radio or TV interference, relocate/reorient the antenna. If the antenna lead-in is 300 ohm ribbon lead, change the lead-in to coaxial type cable.

If these corrective measures do not produce satisfactory results, please contact the local retailer authorized to distribute this type of product. If you can not locate the appropriate retailer, please contact Yamaha Systems Technology, Inc. 100 Century Center Court, San Jose, CA95112, U.S.A.

- This manual applies to the CRW2216E and CRW2216E-NB.
The CRW2216E front panel displays the YAMAHA brand name.
The CRW2216E-NB front panel does not display a brand name.

Laser Diode Properties

Material : GaAlAs

Wavelength : 783-789 nm

Emission Duration : Continuous

Laser Output Power : Less than 44.6 μ W*

* This output is value measured at a distance 200mm from the objective lens surface on the optical pick-up block.

ANSI Class : Class 1

CAUTION

Use of controls or adjustments or performance of procedures other than those specified herein may result in hazardous radiation exposure.

CLASS 1 LASER PRODUCT
LASER KLASSE 1 PRODUKT

This compact disc player is classified as a CLASS 1 LASER product. The CLASS 1 LASER PRODUCT label must be located on the exterior.

VORSICHT : UNSICHTBARE LASERSTRAHLUNG WENN ABDECKUNG
GEOFFNET. NICHT DEM STRAHL AUSSETZEN.
VARNING : OSYNLIG LASERSTRÅLNING NÄR DENNA DEL ÄR ÖPPNAD OCH
SPÄRREN ÄR URKOPPLAD. BETRAKTA EJ STRÅLEN ÄR FARLIG.
VARO! AVATAESSA JA SUOJALLIKITUS OHITETTAESSA OLET
ALTTINA NÄKYMÄTTÖMÄLLE LASERS TEILYLLE. ÄLÄ KÄTSO SÄTÄESSEN.
ADVARSEL : USYNLIG LASERSTRÅLNING VED ÅBNING NÄR SIKKERHETS-
AFBYDERE ER UDE AF FUNKTION. UNDGÅ UDSETTELS FOR STRÅLING.

Varningsanvisning för
laserstrålning.

! WARNING !

- The temperature where CRW2216E is located should be between 5°C and 40°C (41°F – 104°F), when used in a fan-cooled system.
- Do not disassemble the CRW2216E cover to reduce the risk of electric shock.
- Always remove the disc before transporting CRW2216E.

Important Precautions

Please read the following precautions before attempting to operate the CRW2216E.

- Before recording a disc, be sure to clean the disc and tray using an air aerosol-type dust remover. A dust particle on the disc may cause recording to fail, producing an unusable disc.
- Always record in a dust-free environment. If the disc must be removed from the CRW2216E before recording is finished, store the disc in a clean, dust-free environment.
- The CRW2216E contains no user serviceable parts. Refer all servicing to qualified personnel.
- If any of the following should occur, the CRW2216E should be serviced by qualified personnel:
 - Metal objects or liquids get inside the CRW2216E.
 - The CRW2216E does not operate normally or a marked change in performance is noticed.
- Do not place heavy objects on the CD-RW discs.
- Do not subject the CRW2216E and computer to impact or shock when in use, as this may impair recording or playback.
- Yamaha is not responsible for any data or information losses resulting from the operation of the CRW2216E.

Table of Contents

Introduction	1
CRW2216E Features	1
Orange Book Compatible Recording	2
Chapter 1 - System Configuration	3
Computer	3
Software	3
Tools	4
Discs	4
Chapter 2 - Installing the Yamaha CRW2216E Drive	5
MASTER/SLAVE settings	5
Installing the CRW2216E drive	7
Chapter 3 - Operation	12
Front Panel	12
Loading a Disc	13
Ejecting the Disc	14
Manual Eject (emergency use)	15
Troubleshooting	16
Appendix	17
Specifications	17
Front Panel Indicator Key	18

©1998 Yamaha Corporation. All Rights Reserved.

This document may not, in whole or in part, be copied, photocopied, reproduced, translated, transmitted or reduced to any electronic medium of machine readable form without prior consent in writing from Yamaha.

MS-DOS and Windows are registered trademarks of Microsoft, Inc.

Unix is a registered trademark of UNIX System Laboratories.

All other trademarks are the property of their respective companies.

Introduction

Thank you for purchasing a Yamaha CRW2216E drive.

Please read this manual before using the drive in order to make the best use of the superior CRW2216E functions.

After reading, please retain this manual for future reference.

CRW2216E Features

■ **2xS Recording (Rewritable) - 2xS Recording (Recordable) - 16xS Reading**

The CRW2216E is able to write (overwrite) CD-RW discs at double speed, and is able to write CD-R discs at double speed, or normal speed.

CD-R discs can also be read at a maximum of 16X speed.

■ **Compatible with Seven Different Formats**

The CRW2216E can both record and read seven different formats: CD-ROM, CD-ROM XA, CD-I, CD-DA, CD-Bridge (multisession), CD-Extra, and Video CD.

The CRW2216E is also equipped with an analog audio output terminal (headphones) for CD-DA.

■ **ATAPI for High-Volume, High-Speed Data Transfer**

The CRW2216E features ATAPI/IDE interface for connecting computers and peripheral devices.

ATAPI provides high-speed transmission of large quantities of data, which is especially important when working with image data.

■ **Orange Book Part 2, Part 3 Compatible 5-Mode Recording**

The CRW2216E conforms to the five recording modes outlined in the Orange Book Part 2 and 3: Track at Once, Multisession, Disc at Once, Session at Once, and Packet Writing.

Orange Book Compatible Recording

Track at Once

In this mode, data can be recorded to disc one track at a time. Discs recorded in this mode cannot be played in CD players or CD-ROM drives other than a CD-RW or a CD-R drive until the session is closed.

Multisession

In this mode, data can be recorded to disc in stages (one session at a time). Additional data can be written later.

Disc at Once

In this mode, data can be recorded to an entire disc in one pass. It is not possible to write additional data later.

Session at Once

In this mode, data can be recorded to disc one session at a time. To use this mode, your software must support Session at Once recording. New sessions can be written later.

Packet Writing

This is useful for data back-up. Smaller units of data can be added to tracks. To use this mode, your software must support Packet Writing. The CRW2216E supports both sequential and random packet writing.

Chapter 1 - System Configuration

Before using the CRW2216E, make sure that you have all of the items on the list of included items.

In order to use the CRW2216E, you will require the following.

Computer

The following operating environment is required:

- An IBM/AT compatible computer with a 100 MHz or faster Pentium CPU
- A vacant IDE interface connector
- A vacant half-height bay
- Windows 95, Windows 98 or Windows NT4.0(Service Pack 3)
- Sufficient hard disk space

Note: *If you wish to create an image file and write it to a CD-R or CD-RW, you will need approximately 750 MB of free space on your hard disk as work area.*

Software

Use writing software or packet writing software which supports the CRW2216E.

For software-related questions, please read the owner's manual for your software.

Tools

Phillips screwdriver

This is used to remove the cover of your computer, and to install the Yamaha CRW2216E drive.

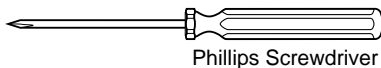

Long nose pliers

These are used to insert or remove the jumper pin when setting the MASTER/SLAVE settings of the Yamaha CRW2216E drive.

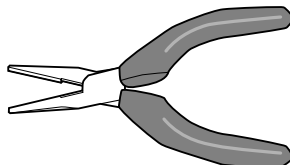

Long nose pliers

Discs

■ CD-R discs

Please use discs that are compliant with Orange Book Part 2. (If you wish to write data at 4X speed, you must use discs which support high-speed writing.)



■ CD-RW discs

Please use discs that are compliant with Orange Book Part 3. (If you wish to write data at 4X speed, you must use discs which support 4X speed writing.)

Yamaha recommends the following Yamaha CD-RW discs:

- CRWM74B4X (φ120mm, 74 minutes)
- CRWM74R4X (φ120mm, 74 minutes)

■ Read-only Discs

You can use discs with the  logo which conform to the Compact Disc Read Only Memory standard (CD-ROM standard, Yellow Book). If you wish to use the audio functions, use discs with the  logo, which conform to the Compact Disc Digital Audio standard (Red Book).

Chapter 2 - Installing the Yamaha CRW2216E Drive

MASTER/SLAVE settings

Before you install the CRW2216E in your computer, you must make the MASTER/SLAVE setting.

This setting is set by inserting a jumper pin in the jumper switch located on the rear panel of the CRW2216E drive.

Important: *When the unit is shipped from the factory, this setting is in the MASTER position.*

Note: *Use long-nose pliers to remove or insert the jumper pin.*

Rear Panel

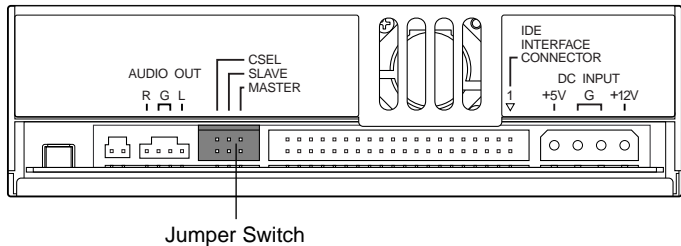

Enhanced IDE compatible computers normally have two IDE interface connectors; a primary one and a secondary one.

Each IDE interface connector of the host computer allows up to two IDE devices to be connected. This means that a total of up to four IDE devices can be connected.

Normally, a hard disk is connected to the primary connector, and a CD-ROM drive is connected to the secondary connector.

Important: *Avoid connecting the CRW2216E or a CD-ROM drive to the same primary connector as the hard disk drive.*

In order to take full advantage of the system's performance, we recommend that you connect the CRW2216E to the secondary connector by itself as the MASTER.

Setting the CRW2216E as the MASTER

As shown in the diagram at the right, insert the jumper pin into the right edge of the jumper switch.

Note: *If only the CRW2216E will be connected to the IDE interface connector, connect the CRW2216E to the end of the connector.*

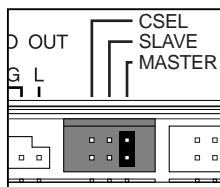

Setting the CRW2216E as the SLAVE

As shown in the diagram at the right, insert the jumper pin into the middle of the jumper switch.

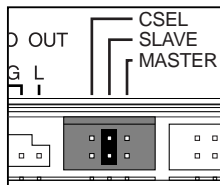

CSEL (Cable SElect)

If you use the CSEL setting, the MASTER/SLAVE setting will be made automatically depending on the hardware configuration. For details refer to the manual of your computer.

Installing the CRW2216E drive

The following steps will differ slightly depending on the type of computer you are using.

For details on removing the cover from your computer, and installing or removing internal devices, refer to the manual for your computer. (This user guide assumes that a SCSI card has already been installed.)

1. Switch off your computer, and unplug it from the AC outlet.

If you fail to do this, there is a danger of electric shock and/or of causing short circuits, which may damage the computer and/or CRW2216E drive.

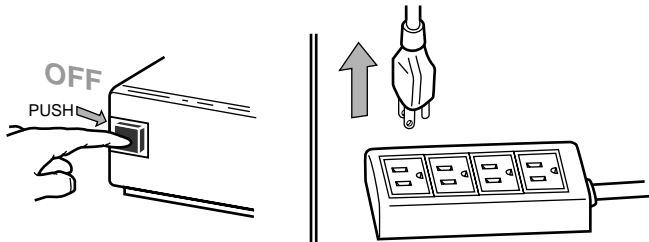

2. Remove the cover from your computer.

Be careful not to lose the screws that were removed.

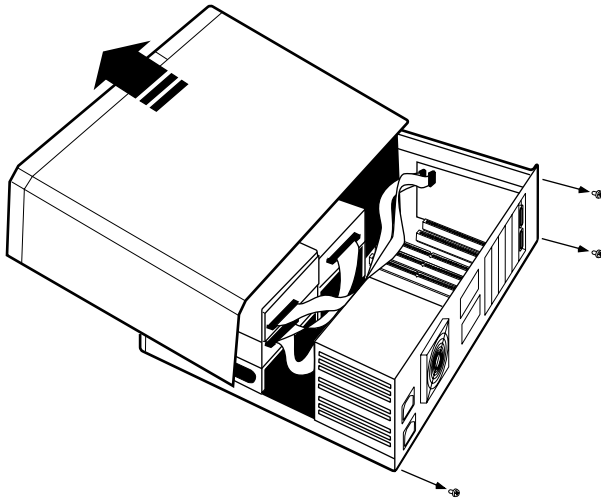

3. Your hands or body may be holding a charge of static electricity.

Touch a metallic portion of the chassis or power supply to release any such charge.

4. Remove the front cover of a vacant half-height drive bay.

For details refer to the manual of your computer.

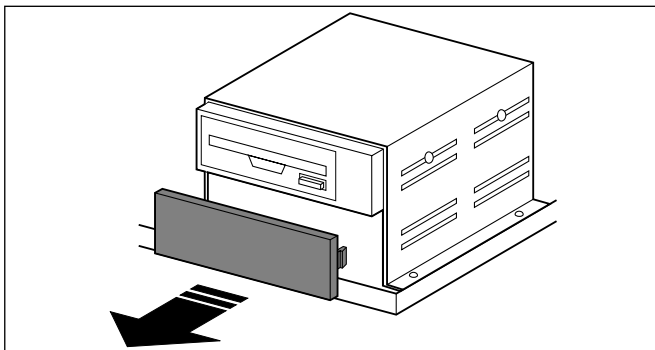

5. Slide the CRW2216E drive into the drive bay from the front.

At this time, be careful not to apply excessive force to the drive itself. Finger-tighten the four fastening screws, and check that there is enough room to connect the power supply cable, IDE interface connector, and AUDIO cables.

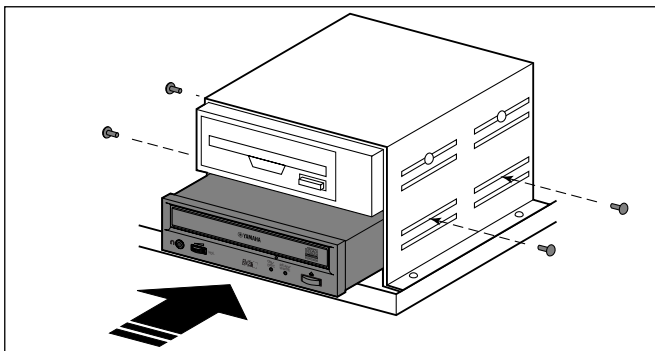

6. Connect the IDE interface connector.

Connect the 40-pin IDE interface connector to the IDE interface located on the rear panel of the CRW2216E drive.

Position the connector so that the colored line is at pin 1 (your lower right).

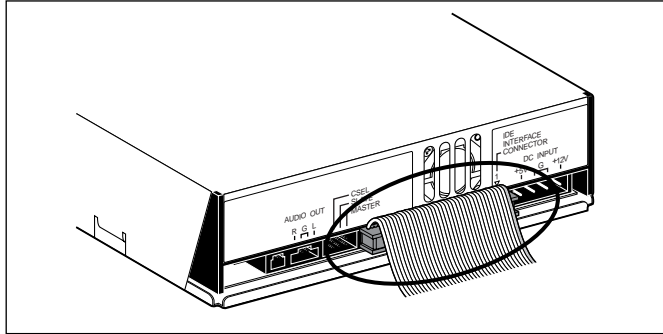

7. Connect the AUDIO cable.

Connect the single 4-pin connector (Sound Blaster compatible) to the sound card.

Connect the 4-pin connector at the other end of the cable (the larger connector) to the AUDIO OUT connector on the CRW2216E drive.

The polarizing lug should be at the top.

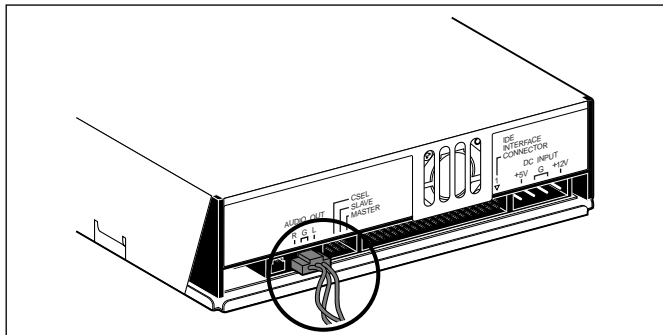

AUDIO cable

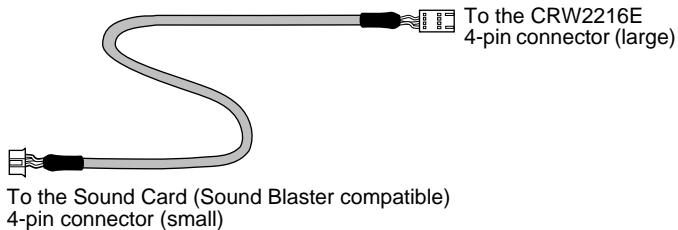

8. Connect the power supply cable.

Connect the +12V and +5V 4-pin power cable to the power supply interface located on the rear panel of the CRW2216E drive.

The shape of the connector makes it impossible to reverse the connections.

If you have difficulty when inserting the connector, try wiggling the connector left and right while inserting it.

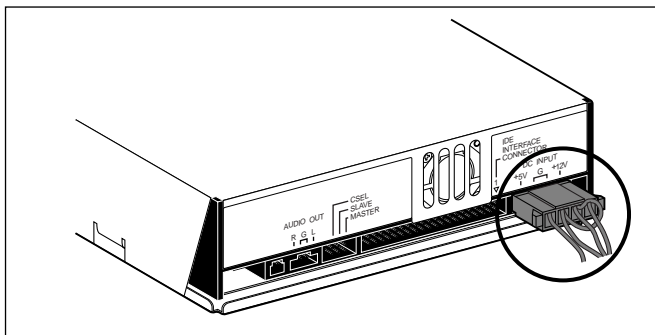

9. Tighten the four fastening screws securely.

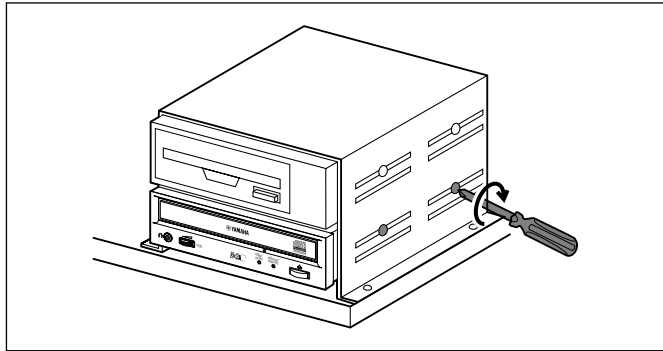

10. Attach the cover of your computer.

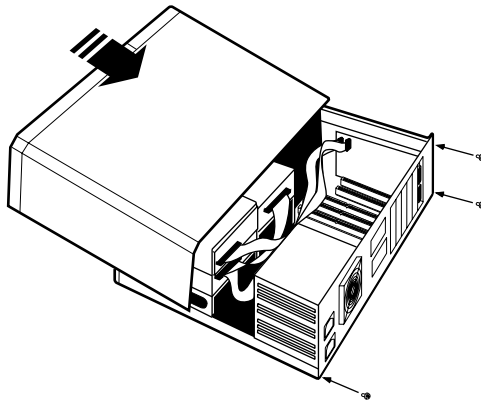

11. Connect the power cable to an AC outlet, and switch on your computer.

Make sure that the LED located on the panel of the CRW2216E drive is lit.

12. Start up your operating system, and verify that the CRW2216E is recognized by the operating system.

For the procedure, refer to the manual for your operation system.

13. Install the writing software.

For the installation procedure, refer to the manual for your writing software.

Chapter 3 - Operation

Front Panel

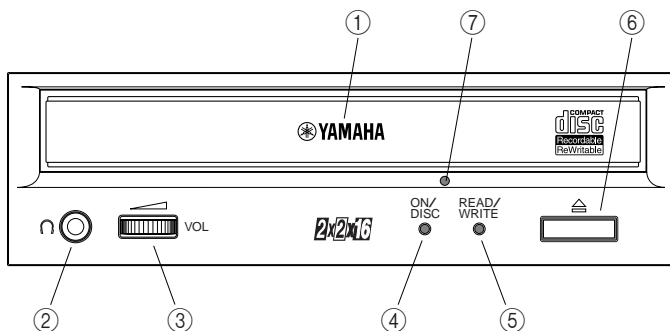

① **Disc tray**

The disc is inserted and ejected here. Pressing the eject button will open the tray.

② **Headphone jack**

This stereo mini jack allows you to connect headphones and listen to audio.

③ **Headphone volume control**

This control adjusts the volume level of the headphone output. Rotating the control clockwise will increase the volume level.

④ **ON/DISC LED**

This indicator lights up in orange when the CRW2216E is powered on, and lights up in green when the CRW2216E contains a disc.

⑤ **READ/WRITE LED**

This indicator lights up in green when data is being read, and flashes when data is being accessed. It also lights up in orange when data is being recorded on a disc.

⑥ **Eject button**

This button is used to open or close the tray.

⑦ **Manual Eject hole**

This is used to manually eject a disc that cannot be ejected in the normal way. It is for emergency use only.

Loading a Disc

- 1. Press the eject button to open the tray.**
- 2. Carefully place the disc, label-side up, on the disc tray.**
- 3. Press the eject button again to close the disc tray.**

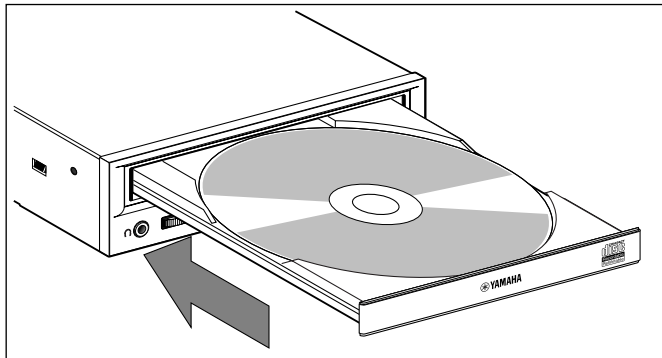

Ejecting the Disc

If the CRW2216E is powered on:

Press the eject button to eject the disc.

Note: *You cannot eject the disc if the ATAPI command prohibits the eject operation while the CRW2216E is reading data.*

Caution: *Be sure to remove the disc after it is completely ejected. (Trying to remove the disc before it is completely ejected may cause the drive to malfunction.)*

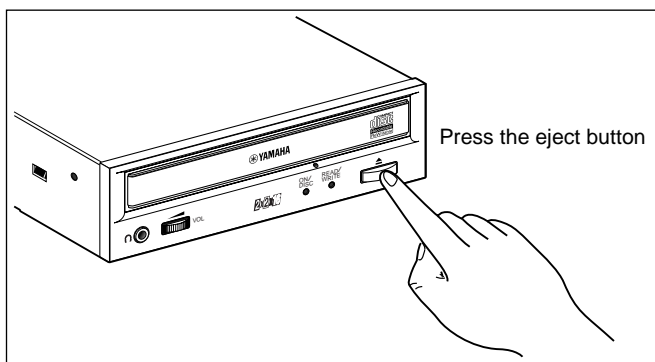

If the CRW2216E is not powered on:

Pressing the eject button will not eject the disc.

Manual Eject (emergency use)

Here we explain how to eject the disc when it cannot be ejected in the normal way; for example, the power is shut off inadvertently or the loading mechanism fails. This technique should be used only as a last resort. Frequent use may lead to malfunction.

You'll need a pin-like object of 2 mm or less in diameter to do this. A straightened paper clip makes an ideal tool.

- 1. Insert the pin-like tool into the manual eject hole and push gently.**

The spring-loaded mechanism ejects the disc.

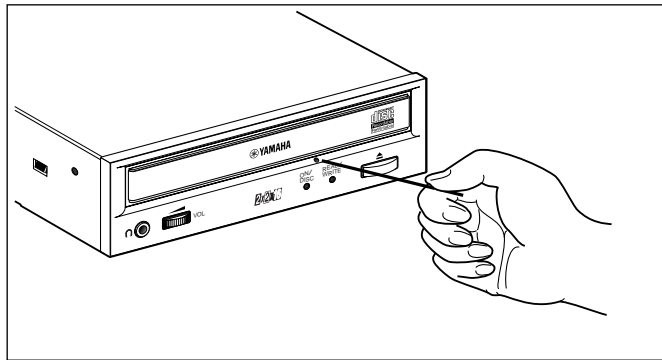

- 2. After manually ejecting a disc, you must turn off the power supplied to the CRW2216E, then turn it on before continuing.**

Troubleshooting

If CRW2216E is not performing as expected, look up the symptoms in the following table, and take the appropriate corrective action.

Symptoms	Corrective action
The power to the CRW2216E is off	<ul style="list-style-type: none">• Check the DC power cable connection.
The CRW2216E is not recognized by the computer	<ul style="list-style-type: none">• Check the IDE interface connector connection.• Is the MASTER/SLAVE setting correct?• If there is only one device connected to the IDE interface connector, is it connected to the end of the connector?
The disc tray will not open	<ul style="list-style-type: none">• Make sure that the power to the drive is turned on.
The disc ejects	<ul style="list-style-type: none">• Make sure that the disc is seated in the tray correctly.
Incorrect operation	<ul style="list-style-type: none">• Make sure that the disc is seated in the tray correctly.• Make sure that you are using the correct disc.• Make sure that there is no dust, dirt, or condensation on the disc or tray.

Caution: *Applying physical shock or vibration to the CRW2216E while a CD-R disc or CD-RW disc is being written may produce writing errors.*

Note: *In the case of CD-RW fixed packet writing, the recordable capacity will be approximately 100 Mbytes less than the capacity indicated on the blank disc. This is due to differences in the recording format.*

Appendix

Specifications

Interface	ATAPI (E-IDE)
Data Capacity	650MB (74 minutes disc) 550MB (63 minutes disc)
Record/Read Speed	Writing (CD-RW): 2X speed Writing (CD-R): 1X speed (real-time), 2X speed playback: 9 - 16X speed [Max] (partial CAV) Note) Read CD-DA : 10X speed [Max] Read Video CD: 6X speed [Max] CD-DA output is 1X speed playback only Finalized Disc CD-R: 16X speed [Max] (packet writing is 10X speed [Max]) CD-RW: 6X speed [Max] (packet writing is 6X speed [Max]) Unfinalized Disc: 6X speed [Max]
Data Transfer Rate	150 - 2400KB/sec
Burst Transfer Rate	Maximum 13.3MB/sec
Buffer Size	1MB (325 sectors)
Access Speed	180 ms (Random access at reading)
Installation	Horizontal
Disc Loading	Tray
Audio Out (normal speed)	Frequency Response 20 - 20,000Hz (Line Out) Output Level 1 Vrms (Line Out)
Power Consumption	11W (read/write)
Power Supply	5V \pm 5%, 12V \pm 10%
Environment	Temperature: +5°C - +40°C (read/write, when used in a fan-cooled system) Humidity: 25 - 80% (condensation must not occur)
Dimensions (WxHxD)	146 x 41.3 x 193.1 mm (excluding front panel)
Weight	950g

Specifications are subject to change without prior notice.

Front Panel Indicator Key

- on: green ☼ flashing: green — off
- on: orange ☼ flashing: orange

Status	ON/DISC	READ/WRITE
Reset	○ ■■ —	○ ■■ —
Ready (no disc)	○	—
Inserting disc	☼ ■■ ☼	—
Ejecting disc	☼	—
Ready (disc inserted)	●	—
Seeking	●	☼
Preparing to write	●	☼
Writing	●	○
Writing (test mode)	●	☼
Playback	●	●



English: If you have any questions, please contact your dealer or one of the following companies.

French: Pour plus de détails sur les produits, veuillez vous adresser à Yamaha ou au distributeur le plus proche figurant dans la liste suivante :

German: Bei weiteren Fragen wenden Sie sich bitte an Ihren Händler oder eine der folgenden Firmen.

JAPAN

Yamaha Corporation

Electronic Systems Division

203 Matsunokijima, Toyooka-mura, Iwata-gun,

Shizuoka-ken, 438-0192 JAPAN

TEL: +81 539 62 3125

FAX: +81 539 62 5346

Internet: www.yamaha.co.jp

U.S.A

Yamaha Systems Technology, Inc.

100 Century Center Court, San Jose, CA 95112

U.S.A

TEL: +1 408 467 2330

FAX: +1 408 437 8791

Internet: www.yamahayst.com

CANADA

Yamaha Canada Music Ltd.

135 Milner Avenue, Scarborough,

Ontario M1S 3R1, CANADA

TEL: +1 416 298 1311

FAX: +1 416 292 0732

UNITED KINGDOM, BENELUX, PORTUGAL, SPAIN, GREECE, CYPRUS, TURKEY and EGYPT

Yamaha-Kemble Music (U.K.) Ltd.

Media Technology Division

Sherbourne Drive, Tilbrook, Milton Keynes

MK7 8BL ENGLAND

TEL: +44 1 908 366700

FAX: +44 1 908 368872

GERMANY, SWITZERLAND, AUSTRIA, EASTERN EUROPE and RUSSIA

Yamaha Europa GmbH

Multi Media Division

Siemensstrasse 22-34,

D-25462 Rellingen, GERMANY

TEL: +49 4101 303 200

FAX: +49 4101 303 277

Internet: www.yamaha-europe.com

FRANCE

Yamaha Musique France S.A.

B.P. 70, 77312 Marne-la Vallée Cedex 2,

FRANCE

TEL: +33 1 6461 4060

FAX: +33 1 6461 4097

ITALY

Yamaha Musica Italia s.p.a.

Keyboard & Multimedia Division

Viale Italia 88, 20020, Lainate (Milano) ITALY

TEL: +39 2 935771

FAX: +39 2 9370956

SWEDEN and SCANDINAVIA

Yamaha Scandinavia AB

J A Wettergrens Gate 1, Box 300 53,

S-400 43 Gothenburg SWEDEN

TEL: +46 31 89 34 00

FAX: +46 31 45 96 07

Internet: www.yamaha.se

SINGAPORE, MALAYSIA, INDIA, INDONESIA and PHILIPPINES

Yamaha Systems Technology, Singapore Pte Ltd.

138 Cecil Street, #03-01A Cecil Court,

SINGAPORE 069538

TEL: +65 225 0050

FAX: +65 225 3669

YAMAHA CORPORATION
Electronic Systems Division

Printed in Japan

V299920-0

Free Manuals Download Website

<http://myh66.com>

<http://usermanuals.us>

<http://www.somanuals.com>

<http://www.4manuals.cc>

<http://www.manual-lib.com>

<http://www.404manual.com>

<http://www.luxmanual.com>

<http://aubethermostatmanual.com>

Golf course search by state

<http://golfingnear.com>

Email search by domain

<http://emailbydomain.com>

Auto manuals search

<http://auto.somanuals.com>

TV manuals search

<http://tv.somanuals.com>