



**YAMAHA**

# Clavinova®

## CLP-920

**Owner's Manual**

**Bedienungsanleitung**

**Mode d'emploi**

**Manual de instrucciones**

ENGLISH

DEUTSCH

FRANÇAIS

ESPAÑOL

### IMPORTANT

#### Check your power supply

Make sure that your local AC mains voltage matches the voltage specified on the name plate on the bottom panel. In some areas a voltage selector may be provided on the bottom panel of the main keyboard unit near the power cord. Make sure that the voltage selector is set for the voltage in your area. The voltage selector is set at 240V when the unit is initially shipped. To change the setting use a "minus" screwdriver to rotate the selector dial so that the correct voltage appears next to the pointer on the panel.

### WICHTIG

#### Überprüfung der Stromversorgung

Vergewissern Sie sich vor dem Anschließen an das Stromnetz, daß die örtliche Netzspannung den Betriebsspannungswerten auf dem Typenschild an der Unterseite des Instruments entspricht. In bestimmten Verkaufsgebieten ist das Instrument mit einem Spannungswähler an der Unterseite neben der Netzkabeldurchführung ausgestattet. Falls vorhanden, muß der Spannungswähler auf die örtliche Netzspannung eingestellt werden. Der Spannungswähler wurde werkseitig auf 240 V voreingestellt. Zum Verstellen drehen Sie den Spannungsregler mit einem Schlitzschraubendreher, bis der Zeiger auf den korrekten Spannungswert weist.

### IMPORTANT

#### Contrôler la source d'alimentation

Vérifiez que la tension spécifiée sur le panneau arrière correspond à la tension du secteur. Dans certaines régions, l'instrument peut être équipé d'un sélecteur de tension situé sur le panneau inférieur du clavier à proximité du cordon d'alimentation. Vérifiez que ce sélecteur est bien réglé en fonction de la tension secteur de votre région. Le sélecteur de tension est réglé sur 240 V au départ d'usine. Pour modifier ce réglage, utilisez un tournevis à lame plate pour tourner le sélecteur afin de mettre l'indication correspondant à la tension de votre région vis à vis du repère triangulaire situé sur le panneau.

### IMPORTANTE

#### Verifique la alimentación de corriente

Asegúrese de que tensión de alimentación de CA de su área corresponde con la tensión especificada en la placa de características del panel inferior de la unidad del teclado principal, cerca del cable de alimentación. Asegúrese de que el selector de tensión esté ajustado a la tensión de su área. El selector de tensión se ajusta a 240V cuando la unidad sale de fábrica. Para cambiar el ajuste, emplee un destornillador de cabeza "recta" para girar el selector de modo que aparezca la tensión correcta al lado del indicador del panel.

# SPECIAL MESSAGE SECTION

**PRODUCT SAFETY MARKINGS:** Yamaha electronic products may have either labels similar to the graphics shown below or molded/stamped facsimiles of these graphics on the enclosure. The explanation of these graphics appears on this page. Please observe all cautions indicated on this page and those indicated in the safety instruction section.

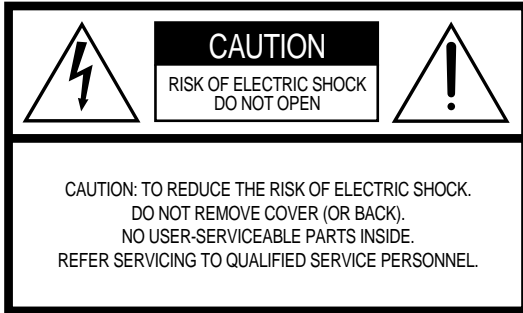

See bottom of Keyboard enclosure for graphic symbol markings



The exclamation point within the equilateral triangle is intended to alert the user to the presence of important operating and maintenance (servicing) instructions in the literature accompanying the product.

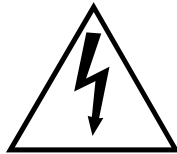

The lightning flash with arrowhead symbol, within the equilateral triangle, is intended to alert the user to the presence of uninsulated "dangerous voltage" within the product's enclosure that may be of sufficient magnitude to constitute a risk of electrical shock.

**IMPORTANT NOTICE:** All Yamaha electronic products are tested and approved by an independent safety testing laboratory in order that you may be sure that when it is properly installed and used in its normal and customary manner, all foreseeable risks have been eliminated. **DO NOT** modify this unit or commission others to do so unless specifically authorized by Yamaha. Product performance and/or safety standards may be diminished. Claims filed under the expressed warranty may be denied if the unit is/has been modified. Implied warranties may also be affected.

**SPECIFICATIONS SUBJECT TO CHANGE:** The information contained in this manual is believed to be correct at the time of printing. However, Yamaha reserves the right to change or modify any of the specifications without notice or obligation to update existing units.

**ENVIRONMENTAL ISSUES:** Yamaha strives to produce products that are both user safe and environmentally friendly. We sincerely believe that our products and the production methods used to produce them, meet these goals. In keeping with both the letter and the spirit of the law, we want you to be aware of the following:

**Battery Notice:** This product MAY contain a small non-rechargeable battery which (if applicable) is soldered in place. The average life span of this type of battery is approximately five years. When replacement becomes necessary, contact a qualified service representative to perform the replacement.

**Warning:** Do not attempt to recharge, disassemble, or incinerate this type of battery. Keep all batteries away from children. Dispose of used batteries promptly and as regulated by applicable laws. Note: In some areas, the servicer is required by law to return the defective parts. However, you do have the option of having the servicer dispose of these parts for you.

**Disposal Notice:** Should this product become damaged beyond repair, or for some reason its useful life is considered to be at an end, please observe all local, state, and federal regulations that relate to the disposal of products that contain lead, batteries, plastics, etc.

**NOTICE:** Service charges incurred due to lack of knowledge relating to how a function or effect works (when the unit is operating as designed) are not covered by the manufacturer's warranty, and are therefore the owners responsibility. Please study this manual carefully and consult your dealer before requesting service.

**NAME PLATE LOCATION:** The graphic below indicates the location of the name plate. The model number, serial number, power requirements, etc., are located on this plate. You should record the model number, serial number, and the date of purchase in the spaces provided below and retain this manual as a permanent record of your purchase.

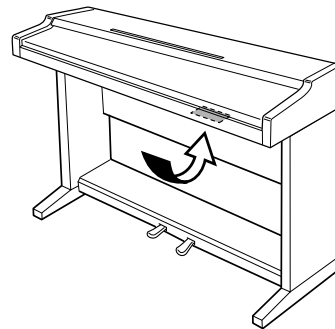

**Model** \_\_\_\_\_

**Serial No.** \_\_\_\_\_

**Purchase Date** \_\_\_\_\_

# PRECAUTIONS

## PLEASE READ CAREFULLY BEFORE PROCEEDING

\* Please keep these precautions in a safe place for future reference.



### WARNING

Always follow the basic precautions listed below to avoid the possibility of serious injury or even death from electrical shock, short-circuiting, damages, fire or other hazards. These precautions include, but are not limited to, the following:

- Do not open the instrument or attempt to disassemble the internal parts or modify them in any way. The instrument contains no user-serviceable parts. If it should appear to be malfunctioning, discontinue use immediately and have it inspected by qualified Yamaha service personnel.
- Do not expose the instrument to rain, use it near water or in damp or wet conditions, or place containers on it containing liquids which might spill into any openings.
- If the power cord or plug becomes frayed or damaged, or if there is a sudden loss of sound during use of the instrument, or if any unusual smells or smoke should appear to be caused by it, immediately turn off the power switch, disconnect the electric plug from the outlet, and have the instrument inspected by qualified Yamaha service personnel.
- Only use the voltage specified as correct for the instrument. The required voltage is printed on the name plate of the instrument.
- Before cleaning the instrument, always remove the electric plug from the outlet. Never insert or remove an electric plug with wet hands.
- Check the electric plug periodically and remove any dirt or dust which may have accumulated on it.



### CAUTION

Always follow the basic precautions listed below to avoid the possibility of physical injury to you or others, or damage to the instrument or other property. These precautions include, but are not limited to, the following:

- Do not place the power cord near heat sources such as heaters or radiators, and do not excessively bend or otherwise damage the cord, place heavy objects on it, or place it in a position where anyone could walk on, trip over, or roll anything over it.
- When removing the electric plug from the instrument or an outlet, always hold the plug itself and not the cord. Pulling by the cord can damage it.
- Do not connect the instrument to an electrical outlet using a multiple-connector. Doing so can result in lower sound quality, or possibly cause overheating in the outlet.
- Remove the electric plug from the outlet when the instrument is not to be used for extended periods of time, or during electrical storms.
- Before connecting the instrument to other electronic components, turn off the power for all components. Before turning the power on or off for all components, set all volume levels to minimum. Also, be sure to set the volumes of all components at their minimum levels and gradually raise the volume controls while playing the instrument to set the desired listening level.
- Do not expose the instrument to excessive dust or vibrations, or extreme cold or heat (such as in direct sunlight, near a heater, or in a car during the day) to prevent the possibility of panel disfiguration or damage to the internal components.
- Do not use the instrument near other electrical products such as televisions, radios, or speakers, since this might cause interference which can affect proper operation of the other products.
- Do not place the instrument in an unstable position where it might accidentally fall over.
- Before moving the instrument, remove all connected cables.
- When cleaning the instrument, use a soft, dry or slightly damp cloth. Do not use paint thinners, solvents, cleaning fluids, or chemical-impregnated wiping cloths. Also, do not place vinyl, plastic or rubber objects on the instrument, since this might discolor the panel or keyboard.
- Do not rest your weight on, or place heavy objects on the instrument, and do not use excessive force on the buttons, switches or connectors.
- Take care that the key cover does not pinch your fingers, and do not insert a finger or hand in the key cover gap.
- Never insert or drop paper or metallic or other objects between the slits of the key cover and the keyboard. If this happens, immediately turn off the power and remove the electric plug from the outlet and have the instrument inspected by qualified Yamaha service personnel.
- Do not place the instrument against a wall (allow at least 3 cm/one-inch from the wall), since this can cause inadequate air circulation, and possibly result in the instrument overheating.
- Read carefully the attached documentation explaining the assembly process. Failure to assemble the instrument in the proper sequence might result in damage to the instrument or even injury.
- Do not operate the instrument for a long period of time at a high or uncomfortable volume level, since this can cause permanent hearing loss. If you experience any hearing loss or ringing in the ears, consult a physician.

#### ■ USING THE BENCH (if included)

- Do not play carelessly with or stand on the bench. Using it as a tool or step-ladder or for any other purpose might result in accident or injury.
- Only one person should sit on the bench at a time, in order to prevent the possibility of accident or injury.
- If the bench screws become loose due to extensive long-term use, tighten them periodically using the included tool.

Yamaha cannot be held responsible for damage caused by improper use or modifications to the instrument, or data that is lost or destroyed.

Always turn the power off when the instrument is not in use.

# Introduction

Thank you for choosing a Yamaha CLP-920 Clavinova. Your Clavinova is a fine musical instrument that employs advanced Yamaha music technology. With the proper care, your Clavinova will give you many years of musical pleasure.

- The Clavinova CLP-920 digital piano offers unmatched sonic realism and natural grand-piano type playability with Yamaha's original "AWM Stereo Sampling" tone generation technology for rich, musical voices, and a special "Graded Hammer" keyboard which provides graded key weight and response throughout the keyboard range. The grand piano voice features totally new samples painstakingly recorded from a full concert grand piano.
- Dual mode allows 2 voices to be played simultaneously.
- The digital reverb effect adds extra depth and expressiveness to the Clavinova's sound.
- With MIDI compatibility and a range of MIDI functions, the Clavinova can easily be incorporated into advanced MIDI systems.
- Built-in computer interface for direct connection to personal computers running advanced music software. The music stand can be removed to allow placement of a laptop-type personal computer or other equipment on top of the instrument.

In order to make the most of your Clavinova's performance potential and features, we urge you to read this Owner's Manual thoroughly, and keep it in a safe place for later reference.

## ■ Trademarks

- Apple and Macintosh are trademarks of Apple Computer, Inc., registered in the U.S. and other countries.
  - IBM-PC/AT is a trademark of International Business Machines Corporation.
  - Windows is the registered trademark of Microsoft® Corporation.
- All other trademarks are the property of their respective holders.

# Contents

<b>The Control Panel</b> .....	5	<b>MIDI Functions</b> .....	13
<b>Key Cover &amp; Music Stand</b> .....	6	• A Brief Introduction to MIDI .....	13
• Key Cover .....	6	• MIDI Transmit & Receive Channel Selection .....	13
• Music Stand .....	6	• Local Control ON/OFF .....	14
<b>Connections</b> .....	7	<b>Connecting to a Personal Computer</b> .....	15
<b>Selecting &amp; Playing Voices</b> .....	8	• Connecting to an Apple Macintosh Series Computer ..	15
<b>Playing the Demonstration Tunes</b> .....	9	• Connecting to an IBM-PC/AT Series Computer ..	16
<b>The Dual Mode</b> .....	9	• Using a USB Interface (such as the Yamaha UX256) ..	17
<b>Reverb</b> .....	10	<b>Troubleshooting</b> .....	18
<b>The Pedals</b> .....	10	<b>Options &amp; Expander Modules</b> .....	18
• Damper (Right) Pedal .....	10	<b>MIDI Data Format</b> .....	19
• Soft (Left) Pedal .....	10	<b>MIDI Implementation Chart</b> .....	21
<b>Transposition</b> .....	11	<b>Keyboard Stand Assembly</b> .....	22
<b>Tuning</b> .....	12	<b>Voice Descriptions</b> .....	28
• Tuning Up .....	12	<b>Demo Song List</b> .....	28
• Tuning Down .....	12	<b>Specifications</b> .....	29
• To Restore Standard Pitch .....	12		

## Included Accessories

- Owner's Manual
- Bench  
(included or optional depending on locale)

"The Clavinova-Computer Connection" is a supplementary guidebook that describes, for beginners, what you can do with your Clavinova and a personal computer and how to set up a Clavinova-Computer system (the manual is not written for any specific models). The document is available as a PDF file (in English) at the following Internet address:

### Clavinova Home Page:

<http://www.yamaha.co.jp/english/product/cl/>

### Yamaha Manual Library (Electronic Musical Instruments)

<http://www2.yamaha.co.jp/manual/english/>

# The Control Panel

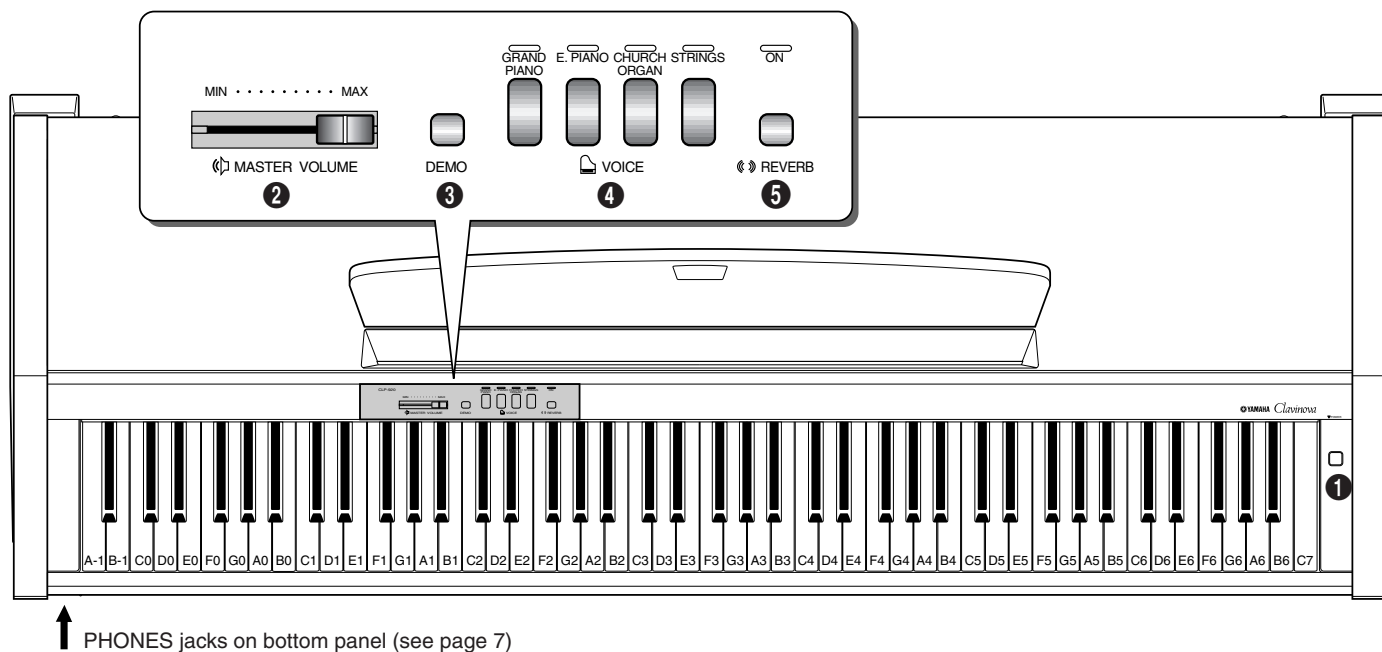

## 1 [POWER] Switch

Press the [POWER] switch once to turn the power ON, a second time to turn the power OFF. When the power is turned ON, the POWER indicator (located to the left of the keyboard) will light.

## 2 [MASTER VOLUME] Control

The [MASTER VOLUME] control adjusts the volume (level) of sound produced by the Clavinova's internal stereo sound system. The [MASTER VOLUME] control also adjusts headphone volume when a pair of headphones is plugged into the PHONES jack (page 8).

## 3 [DEMO] Button

Activates the demo playback mode in which you can select playback of different demonstration sequences for each of the Clavinova's voices. See page 9 for details.

## 4 Voice Selectors

Simply press any of the voice selectors to select the corresponding voice. The voice selector LED will light to indicate which voice is currently selected.

There is also a dual mode in which two voices can be played simultaneously across the full range of the keyboard (see page 9 for details).

## 5 [REVERB] Button

The [REVERB] effect switches the Clavinova's reverb effect on and off — see page 10 for details.

## 6 Pedals

The CLP-920's soft (left) and damper (right) pedals provide a range of expressive control capabilities similar to the pedal functions on an acoustic piano. See page 10 for details.

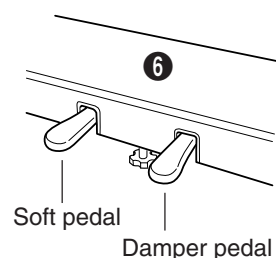

# Key Cover & Music Stand

## Key Cover

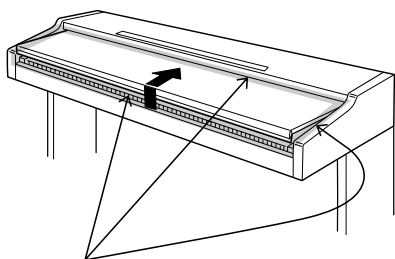

Be careful to avoid catching your fingers when opening or closing the cover.

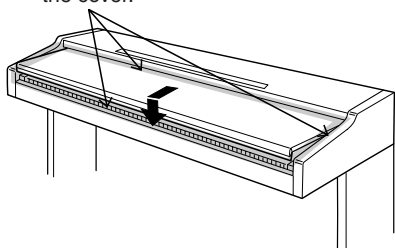

**To open the key cover:**

- 1** Lift the cover slightly.
- 2** Slide the cover open.

**To close the key cover:**

- 1** Slide the cover toward you.
- 2** Gently lower the cover over the keys.

### **CAUTION**

- Hold the cover with both hands when moving it, and do not release it until it is fully opened or closed. Be careful to avoid catching fingers (yours or others) between the cover and main unit.
- Do not place objects on top of the key cover. Small objects placed on the key cover may fall inside the main unit when the cover is opened and may not be able to be removed. This could cause electric shock, short circuit, fire or other serious damage to the instrument.

## Music Stand

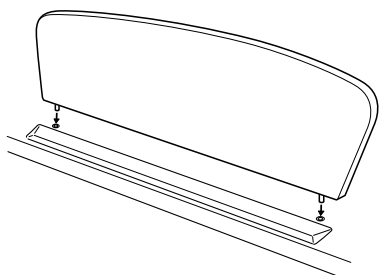

The Clavinova is supplied with a music stand that can be attached to the instrument by inserting it into the holes at the top of panel.

### **NOTE**

- The music stand can be removed to allow placement of a laptop-type personal computer or other equipment on top of the instrument.

# Connections

**CAUTION** • Before connecting the Clavinova to other electronic components, turn off the power for all components. Before turning the power on or off for all components, set all-volume levels to minimum.

## Bottom Panel

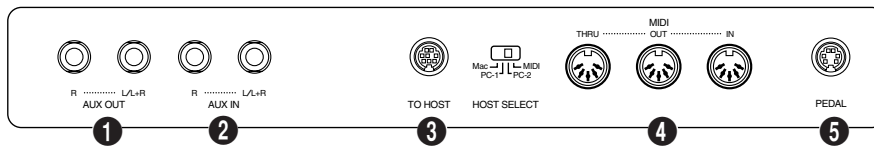

### 1 AUX OUT L/L+R and R Jacks

The AUX OUT L/L+R and R jacks deliver the output of the Clavinova for connection to an instrument amplifier, mixing console, PA system, or recording equipment. If you will be connecting the Clavinova to a monaural sound system, use only the L/L+R jack. When a plug is inserted into the L/L+R jack only, the left- and right-channel signals are combined and delivered via the L/L+R jack so you don't lose any of the Clavinova's sound.

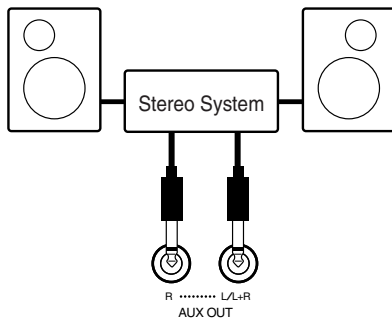

### CAUTION

- When the Clavinova's AUX OUT jacks are connected to an external sound system, first turn the Clavinova power on, and then the power to the external amplifier/speaker system. Reverse this order when turning the power off.
- The AUX OUT jack signal must never be returned to the AUX IN jacks, either directly or through external equipment.

### NOTE

- The AUX OUT jack signal is not controlled by the Clavinova's volume control. Use the volume control on the external audio equipment to adjust the level.

### 2 AUX IN L/L+R and R Jacks

These jacks are intended for use with an external tone generator module such as the Yamaha DOU-10 Disk Orchestra Unit. The stereo outputs from the external tone generator module are connected to the AUX IN L/L+R and R jacks, allowing the sound of the tone generator to be reproduced via the Clavinova's internal sound system and speakers. A line-level mono source can be connected to the L/L+R jack.

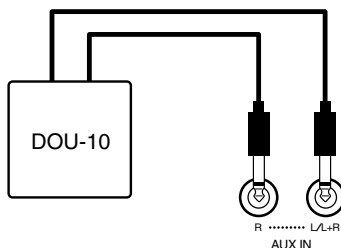

### CAUTION

- When the Clavinova's AUX IN jacks are connected to an external source, first turn the power to the external device on, and then the power to the Clavinova. Reverse this order when turning the power off.

### NOTE

- The input signal from the AUX IN jacks is controlled by the Clavinova's volume control. Reverb function will have no affect.
- The input signal from the AUX IN jacks is delivered to the AUX OUT jacks.

### 3 TO HOST Connector & HOST SELECT Switch

This jack and selector switch allow direct connection to a personal computer for sequencing and other music applications — without the need for a separate MIDI interface. See page 15 for details.

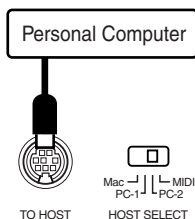

### 4 MIDI IN, THRU and OUT Connectors

The MIDI IN connector receives MIDI data from an external MIDI device (such as the DOU-10 Disk Orchestra Unit) which can be used to control the Clavinova. The MIDI THRU connector re-transmits any data received at the MIDI IN connector, allowing "chaining" of several MIDI instruments or other devices. The MIDI OUT connector transmits MIDI data generated by the Clavinova (e.g. note and velocity data produced by playing the Clavinova keyboard).

More details on MIDI are given in "MIDI Functions" on page 13.

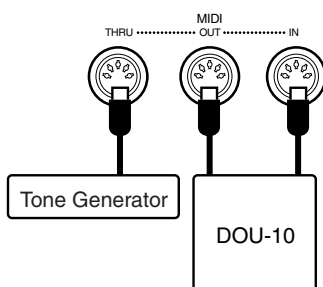

### 5 PEDAL Jack

This terminal is for connecting the pedal cord from the pedal box (refer to the "Keyboard Stand Assembly" on pages 26-27).

### PHONES Jacks (Bottom Panel)

Two sets of standard stereo headphones can be plugged in here for private practice or late-night playing. The internal speaker system is automatically shut off when a pair of headphones is plugged into either of the PHONES jacks.

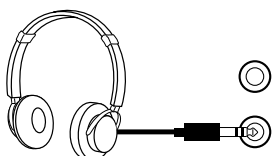

# Selecting & Playing Voices

▽ POWER



## 1 Turn Power On.....

After making sure that the Clavinova's AC cord is properly plugged into the Clavinova itself and plugged into a convenient AC wall outlet, press the [POWER] switch located to the right of the keyboard to turn the power ON. In some areas a plug adaptor may be provided to match the pin configuration of the AC wall outlets in your area.

When the power is turned ON, the POWER indicator located to the left of the keyboard will light.

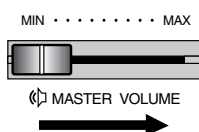

## 2 Set the Volume .....

Initially set the [MASTER VOLUME] control about half way between the "MIN" and "MAX" settings. Then, when you start playing, re-adjust the [MASTER VOLUME] control for the most comfortable listening level.

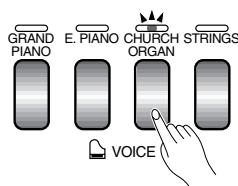

## 3 Select a Voice .....

Select the desired voice by pressing one of the voice selectors.



• See "Voice Descriptions" on page 28.

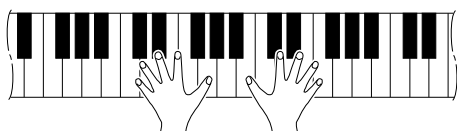

## 4 Play .....

The Clavinova also offers keyboard touch response, so the volume and timbre of notes played can be controlled according to how "hard" you play the keys. The amount of variation available depends on the selected voice.



• The CHURCH ORGAN voice has no keyboard touch response.



# Playing the Demonstration Tunes

The CLP-920 includes four demo tunes that demonstrate its sound capabilities. Here is how you can select and play the demo tunes:



- No MIDI reception occurs in the demo song mode.
- The demo song data is not transmitted via the MIDI connectors.

\* See page 28 for a complete listing of the demo tunes.



## 1 Engage the Demo Mode .....

Press the [DEMO] button to engage the demo mode — the voice selector indicators will flash in sequence.

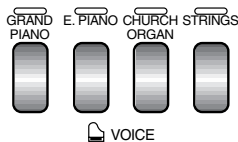

## 2 Play a Voice Demo .....

Press one of the voice selectors to start playback of all songs starting from the corresponding voice demo tune — featuring the voice normally selected by that voice selector button. The indicator of the selected voice selector button will flash during playback. You can start playback of any other voice demo tune during playback by simply pressing the corresponding voice selector. You can stop playback at any time by pressing the voice selector of the currently playing demo.



- Use the [MASTER VOLUME] control to adjust the volume.



## 3 Exit From the Demo Mode .....

Press the [DEMO] button to exit from the demo mode and return to the normal play mode.

# The Dual Mode

The dual mode makes it possible to play two voices simultaneously across the entire range of the keyboard.

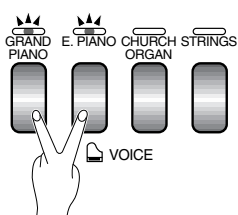

To activate the dual mode simply press two voice selectors at the same time (or press one voice selector while holding another). The voice indicators of both selected voices will light when the dual mode is active. To return to the normal single-voice play mode, press any single voice selector.



- The reverb effect (page 10) will be on for both voices if it has been individually turned on for either voice.

# Reverb

The reverb effect, turned on and off by the [REVERB] button, can be used to add extra ambience and depth to the Clavinova sound.

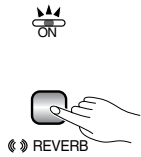

Press the [REVERB] button to turn the reverb effect on (the indicator will light). When the reverb effect is on, pressing the [REVERB] button turns the reverb effect off (the indicator will go out).

#### NOTE

- The reverb on/off settings are individually memorized for each voice (reverb is initially ON for all voices by default).

# The Pedals

The CLP-920 has two foot pedals that produce a range of expressive effects similar to those produced by the pedals on an acoustic piano.

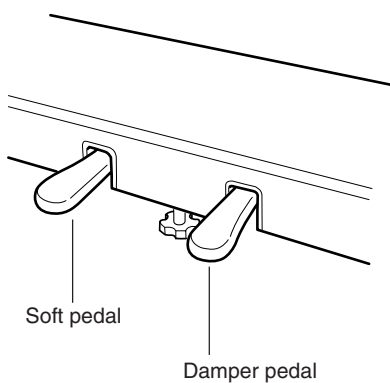

## Damper (Right) Pedal .....

The damper pedal functions in the same way as a damper pedal on an acoustic piano. When the damper pedal is pressed notes played have a long sustain. Releasing the pedal immediately stops (damps) any sustained notes.

#### NOTE

- If the damper pedal doesn't work, or notes are sustained even when the pedal is not pressed, make sure that the pedal cord is properly plugged into the main unit (page 26).

## Soft (Left) Pedal .....

The soft pedal reduces the volume and slightly changes the timbre of notes played while the pedal is pressed. The soft pedal will not affect notes which are already playing when it is pressed.

# Transposition

The Clavinova's TRANPOSE function makes it possible to shift the pitch of the entire keyboard up or down in semitone intervals up to a maximum of six semitones. "Transposing" the pitch of the Clavinova keyboard facilitates playing in difficult key signatures, and you can easily match the pitch of the keyboard to the range of a singer or other instrumentalist.

The **A-1** and **C#0** keys plus keys **F#2** through **F#3** on the keyboard are used for transposition.

- 1** Simultaneously press and hold the **A-1** and **C#0** keys.
- 2** Press any key between **F#2** and **F#3** according to the desired amount of transposition.\*
- 3** Release the **A-1** and **C#0** keys.

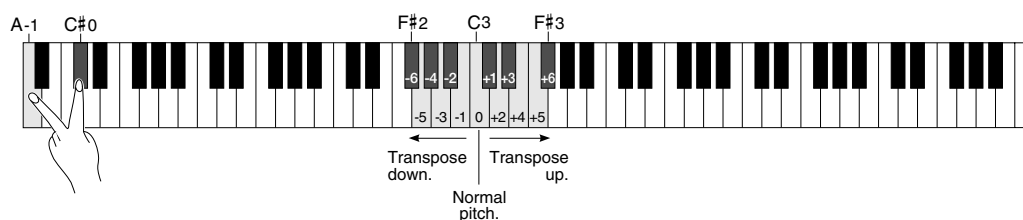

- \* Pressing the **C3** key produces normal keyboard pitch. Pressing the key to the left of **C3** (= **B2**) transposes the pitch of the keyboard down a semitone, the next key to the left (= **B $\flat$ 2**) transposes down a whole tone (two semitones), etc., down to the **F#2** key which transposes down 6 semitones. Upward transposition is accomplished in the same way using the keys to the right of **C3**, up to **F#3** which transposes up 6 semitones.

**NOTE**

- Notes below and above the **A-1** — **C7** of the Clavinova sound one octave higher and lower, respectively.

# Tuning

Tuning makes it possible to adjust the pitch of the Clavinova over a 427.0 Hz ... 453.0 Hz (corresponding to the A3 note's Hz) range in approximately 0.2 Hertz intervals. Pitch control is useful for tuning the Clavinova to match other instruments or recorded music.

## Tuning Up .....

- 1** To tune up (raise pitch), hold the **A-1** and **B-1** keys simultaneously.
- 2** Press any key between **C3** and **B3**. Each time a key in this range is pressed the pitch is increased by approximately 0.2 Hz.
- 3** Release the **A-1** and **B-1** keys.

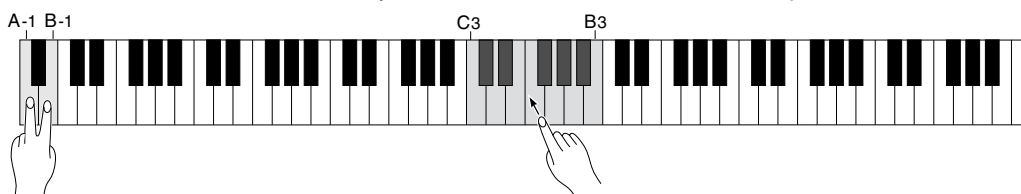

## Tuning Down .....

- 1** To tune down (lower pitch), hold the **A-1** and **A#-1** keys simultaneously.
- 2** Press any key between **C3** and **B3**. Each time a key in this range is pressed the pitch is decreased by approximately 0.2 Hz.
- 3** Release the **A-1** and **A#-1** keys.

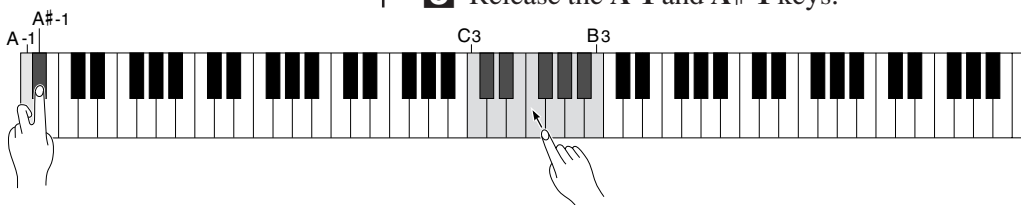

## To Restore Standard Pitch\* .....

- 1** To restore standard pitch (A3 = 440 Hz), hold the **A-1**, **A#-1** and **B-1** keys simultaneously.
- 2** Press any key between **C3** and **B3**.  
(Pressing once will restore the keyboard to standard pitch, regardless of the amount of pitch adjustment.)
- 3** Release the **A-1**, **A#-1** and **B-1** keys.

\* Standard pitch (A3 = 440 Hz) is set when the **[POWER]** switch is initially turned ON.

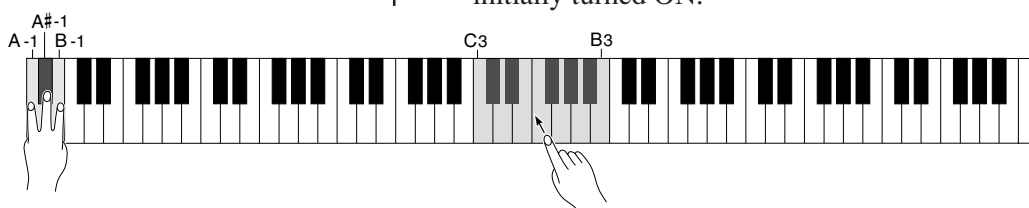

# MIDI Functions

## ● A Brief Introduction to MIDI

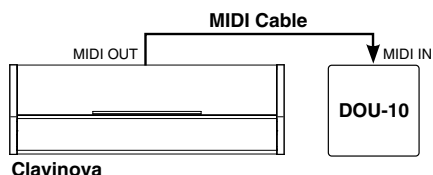

MIDI, the Musical Instrument Digital Interface, is a world-standard communication interface that allows MIDI-compatible musical instruments, computers, and other equipment to share musical information and control one another. This makes it possible to create “systems” of MIDI instruments, computers, and other equipment that offer far greater versatility and control than is available with isolated instruments. For example, most MIDI keyboards (including the Clavinova, of course) transmit note and velocity (touch response) information via the MIDI OUT connector whenever a note is played on the keyboard. If the MIDI OUT connector is connected to the MIDI IN connector of a second keyboard (synthesizer, etc.) or a tone generator (essentially a synthesizer with no keyboard), the second keyboard or tone generator will respond precisely to notes played on the original transmitting keyboard. The result is that you can effectively play two instruments at once, providing thick multi-instrument sounds.

### NOTE

- The bottom-panel *HOST SELECT* switch must be set to “MIDI” in order to use the MIDI connectors. When you use the *TO HOST* connector, set the *HOST SELECT* switch to the appropriate position for the type of computer you are using (see page 15). In this situation, all MIDI settings described below will have affect on the MIDI signal in and out of the *TO HOST* connector.
- Always use a high-quality MIDI cable to connect MIDI OUT to MIDI IN terminals. Never use MIDI cables longer than about 15 meters, since cables longer than this can pick up noise which can cause data errors.

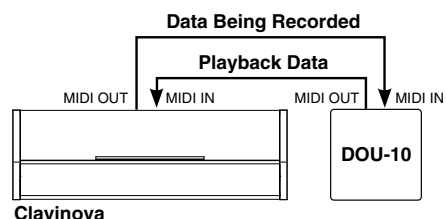

This same type of musical information transfer is used for MIDI sequence recording. A sequence recorder can be used to “record” MIDI data received from a Clavinova, for example. When the recorded data is played back, the Clavinova automatically “plays” the recorded performance in precise detail.

The examples given above really only scratch the surface. MIDI can do much, much more. The CLP-920 offers a number of MIDI functions that allows it to be used in fairly sophisticated MIDI systems.

## □ MIDI Transmit & Receive Channel Selection .....

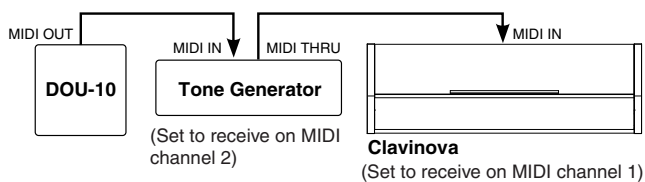

The MIDI system allows transmission and reception of MIDI data on 16 different channels. Multiple channels have been implemented to allow selective control of certain instruments or devices connected in series. For example, a single MIDI sequence recorder could be used to “play” two different instruments or tone generators. One of the instruments or tone generators could be set to receive only on channel 1, while the other is set to receive on channel 2. In this situation the first instrument or tone generator will respond only to channel-1 information transmitted by the sequence recorder, while the second instrument or tone generator will respond only to channel-2 information. This allows the sequence recorder to “play” two completely different parts on the receiving instruments or tone generators.

In any MIDI control setup, the MIDI channels of the transmitting and receiving equipment must be matched for proper data transfer. A “Multi-timbre” receive mode is also available, which allows simultaneous reception of different parts on all 16 MIDI channels, allowing the Clavinova to play multi-channel song data received from a music computer or sequencer. To select the multi-timbre receive mode, set the receive channel to “ALL”.

# MIDI Functions

## ● Setting the Clavinova MIDI Channels

- 1** Simultaneously press and hold the **A-1** and **C#0** keys.
- 2** Press the key on the keyboard corresponding to the desired MIDI transmit or receive channel.\*
- 3** Release the **A-1** and **C#0** keys.

\* Keys **C1** through **D#2** on the keyboard are used to set the MIDI transmit channel. The **E2** key turns transmission "OFF" if you don't want the Clavinova to transmit MIDI data. Keys **C4** through **D#5** are used to set the MIDI receive channel as shown in the illustration below. The **E5** key sets the receive mode to "ALL".

### NOTE

- When the power is initially turned ON, MIDI receive is set to the ALL mode and the transmit channel is set to 1.
- In the dual mode the left-button voice will be transmitted on the specified transmit channel number while the right-button voice will be transmitted on the next channel number (i.e. the specified transmit channel number + 1). Neither voice will be transmitted when the transmit channel is set to "OFF".
- Demo song data is not transmitted via MIDI.
- No MIDI reception occurs when the demo song mode is engaged.
- Program change and other like channel messages received will not affect the Clavinova's panel settings or what is being played on the keyboard.

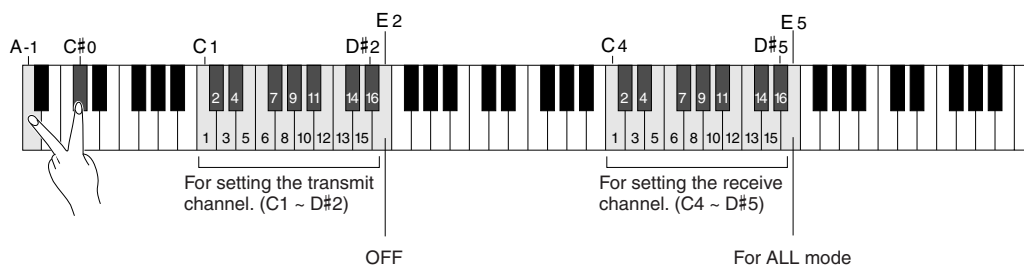

## Local Control ON/OFF

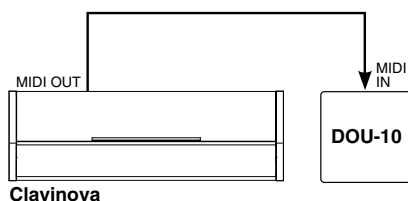

"Local Control" refers to the fact that, normally, the Clavinova keyboard controls its internal tone generator, allowing the internal voices to be played directly from the keyboard. This situation is "Local Control ON" since the internal tone generator is controlled locally by its own keyboard.

Local control can be turned OFF, however, so that the Clavinova keyboard does not play the internal voices, but the appropriate MIDI information is still transmitted via the MIDI OUT connector when notes are played on the keyboard. At the same time, the internal tone generator responds to MIDI information received via the MIDI IN connector.

When using the DOU-10 Disk Orchestra Unit with the Clavinova, for example, Local Control should be turned OFF when recording using the DOU-10 voices only, and ON when recording the Clavinova voices while listening to playback of the DOU-10 voices.

- 1** Simultaneously press and hold the **A-1** and **C#0** keys.
- 2** Press the **C6** key to switch the Local Control between OFF and ON.
- 3** Release the **A-1** and **C#0** keys.

### NOTE

- When the power is initially turned ON, Local Control is set to "ON".

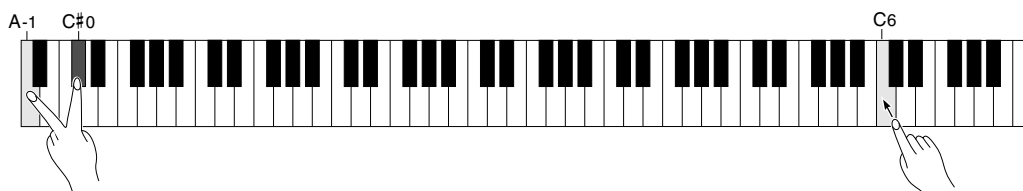

# Connecting to a Personal Computer

Although the Clavinova can be connected to a personal computer via the MIDI IN/OUT connectors and a MIDI interface, the TO HOST connector and HOST SELECT switch allow direct connection to Apple Macintosh or IBM-PC/AT personal computers for sequencing and other music applications without the need for a separate MIDI interface.

“The Clavinova-Computer Connection” is a supplementary guidebook that describes, for beginners, what you can do with your Clavinova and a personal computer and how to set up a Clavinova-Computer system (the manual is not written for any specific models). The document is available as a PDF file (in English) at the following Internet address:

**Clavinova Home Page:**

<http://www.yamaha.co.jp/english/product/cl/>

**Yamaha Manual Library** (Electronic Musical Instruments)

<http://www2.yamaha.co.jp/manual/english/>

**NOTE**

- When connecting the Clavinova to a personal computer, first turn the power to both the Clavinova and the computer OFF before connecting the cable and setting the HOST SELECT switch. After connecting the cable and making the appropriate HOST SELECT switch setting, turn the power to the computer on first, then turn on the Clavinova.
- When not using the [TO HOST] terminal of the Clavinova, make sure the cable is disconnected from the [TO HOST] terminal. If the cable is left connected, the Clavinova may not function properly.
- When the HOST SELECT switch is set to “Mac”, “PC-1”, or “PC-2”, no data transfer occurs via the MIDI connectors. To use the MIDI connectors for connection via a standard MIDI interface, set the HOST SELECT switch to “MIDI”.

## Connecting to an Apple Macintosh Series Computer

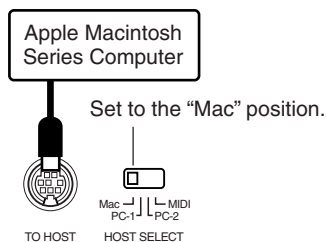

Connect the TO HOST connector of the Clavinova to the modem or printer port on your Macintosh, depending on which port your MIDI software is using for MIDI data communication, using a standard Macintosh 8-pin system peripheral cable. Set the HOST SELECT switch to the “Mac” position.

You may also have to make other MIDI interface settings on the computer side, depending on the type of software you use (refer to your software owner’s manual). In any case the clock speed should be set to 1 MHz.

### ● “Mac” Cable Connections

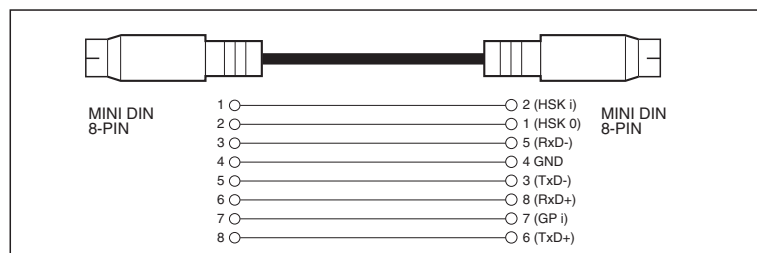

- 8-pin system peripheral cable.
- Data transfer rate: 31,250 bps.

# Connecting to a Personal Computer

## Connecting to an IBM-PC/AT Series Computer .....

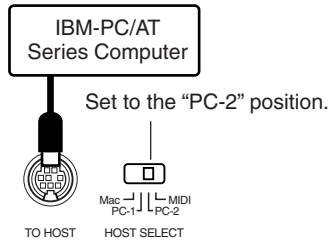

Connect the TO HOST connector of the Clavinova to the RS-232C port on your IBM computer, using a standard 8-pin MINI DIN → 9-pin D-SUB cross cable. Set the HOST SELECT switch to the "PC-2" position.

Refer to your software owner's manual for information on any settings you might have to make on the computer side.

### ● "PC-2" Cable Connections

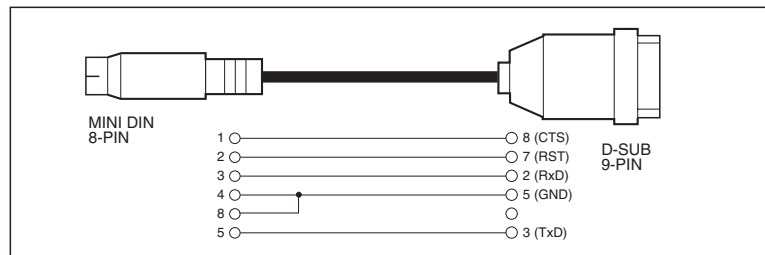

- 8-pin mini DIN → 9-pin D-SUB cable.
- Data transfer rate: 38,400 bps.

#### NOTE

- If your system doesn't work properly with the connections and settings listed above, your software may require different settings. Check your software operation manual and if it requires a 31,250 bps. data transfer rate, set the HOST SELECT switch to "PC-1".
- When using the TO HOST terminal to connect to a personal computer using Windows, a Yamaha MIDI driver must be installed in the personal computer. The Yamaha MIDI driver can be obtained at Yamaha's home page on the World Wide Web, <<http://www.yamaha.co.jp/english/xg/>>.

### ● Connector Pin Numbers

MINI DIN 8-PIN



D-SUB 9-PIN

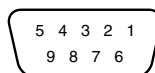



## Using a USB Interface (such as the Yamaha UX256)

Connect the USB interface (Yamaha UX256 or equivalent) to your computer using a USB cable. Install the driver software supplied with the interface (or other appropriate driver software) on your computer according to the supplied instructions. Connect your instrument to the USB interface using either a standard Macintosh 8-pin system peripheral cable or MIDI cables. Refer to the manual supplied with your USB interface for details.

### ● Connecting the USB Interface and Instrument via a Serial Cable

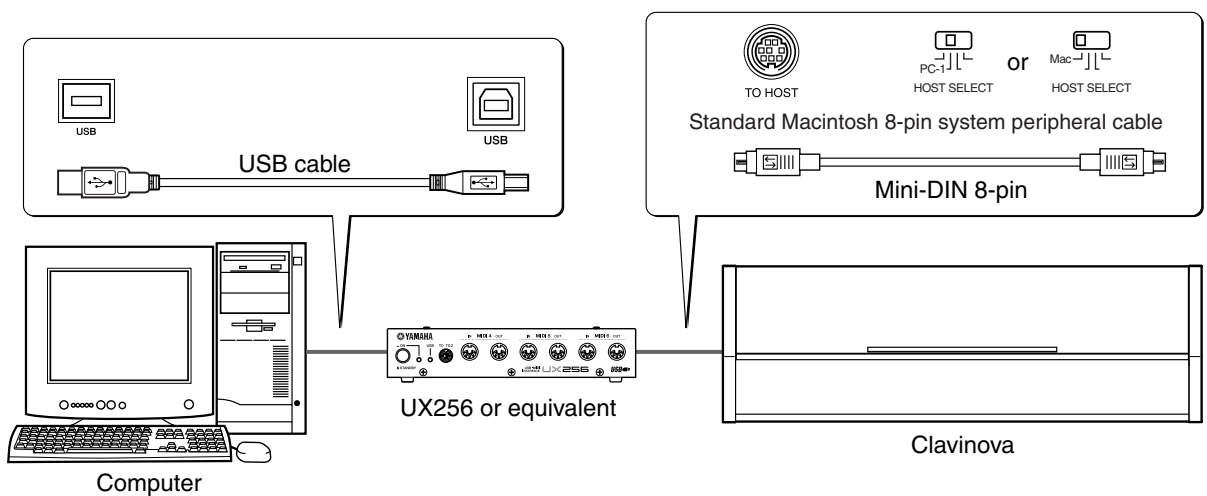

### ● Connecting the USB Interface and Instrument via MIDI Cables

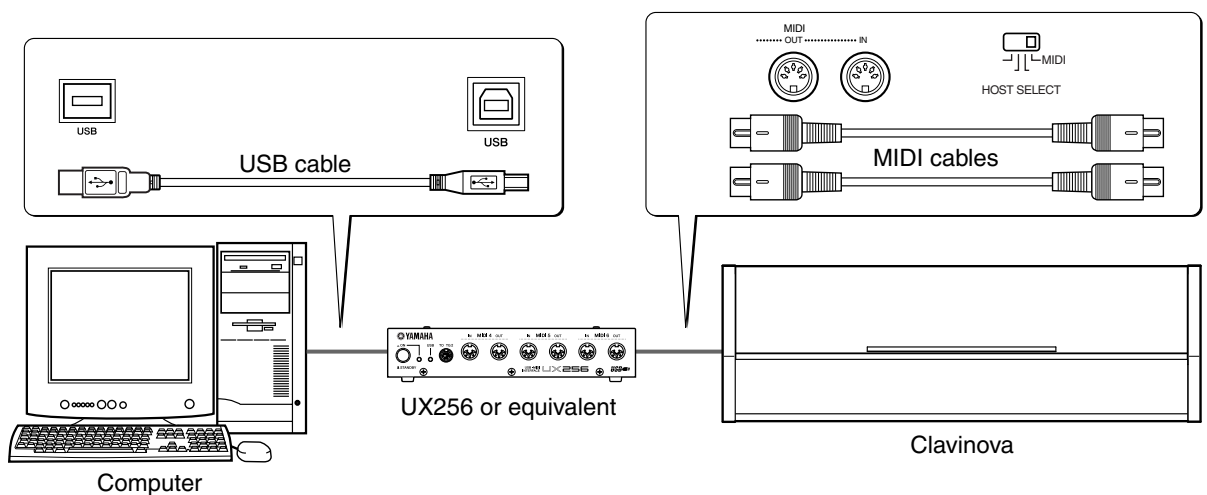

# Troubleshooting

If you encounter what appears to be a malfunction, please check the following points before assuming that your Clavinova is faulty.

## 1. No Sound When the Power is Turned ON

Is the AC plug properly connected to the Clavinova and an AC wall outlet? Check the AC connection carefully. Is the MASTER VOLUME control turned up to a reasonable listening level?

Also make sure that a pair of headphones is not plugged into the PHONES jack, and the Local Control (page 14) is ON.

## 2. The Damper Pedal Doesn't Work

If the damper pedal doesn't work, or notes are sustained even when the pedal is not pressed, make sure that the pedal cord is properly plugged into the main unit (page 26).

## 3. The Clavinova Reproduces Radio or TV Sound

This can occur if there is a high-power transmitter in your vicinity. Contact your Yamaha dealer.

## 4. Intermittent Static Noise

This is usually due to turning ON or OFF a household appliance or other electronic equipment which is fed by the same AC mains line as your Clavinova.

## 5. Interference Appears On Radio or TV Sets Located Near the Clavinova

The Clavinova contains digital circuitry which can generate radio-frequency noise. The solution is to move the Clavinova further away from the affected equipment, or vice versa.

## 6. Noise is heard from the speakers or headphones.

The noise may be due to interference caused by the use of a mobile phone in close proximity to the Clavinova.

Turn off the mobile phone, or use it further away from the Clavinova.

## 7. Distorted Sound When the Clavinova is Connected to An External Amplifier/Speaker System

If the Clavinova is connected to a stereo system or instrument amplifier and the sound is distorted, reduce the volume of the external equipment to a level at which the distortion ceases.

# Options & Expander Modules

## ● Options

### BC-8 Bench

A comfortable bench styled to match your Yamaha Clavinova.

### HPE-160 Stereo Headphones

High-performance lightweight dynamic headphones with extra-soft ear pads.

## ● Expander Modules

### DOU-10 Disk Orchestra Unit

A range of MIDI recording and playback functions, plus Yamaha DOC software, Disklavier PianoSoft™, and General MIDI/Standard MIDI File disk playback capability.

# MIDI Data Format / MIDI-Datenformat / Format des données MIDI / Formato de datos MIDI

If you're already very familiar with MIDI, or are using a computer to control your music hardware with computer-generated MIDI messages, the data provided in this section can help you to control the Clavinova.

Falls Sie bereits mit MIDI vertraut sind oder einen Computer zur Erzeugung von MIDI-Steuermeldungen für die Instrumente verwenden, können Sie sich zur Steuerung des Clavinovas nach den im folgenden Abschnitt aufgeführten Spezifikationen richten.

## 1. NOTE ON/OFF

Data format: [9nH] -> [kk] -> [vv]

9nH = Note ON/OFF event (n = channel number)  
kk = Note number (Transmit: 0FH ~ 72H = E<sub>b</sub>-1 ~ F#7 / Receive: 00H ~ 7FH = C-2 ~ G8)\*  
vv = Velocity (Key ON = 01H ~ 7FH, Key OFF = 00H)

Data format: [8nH] -> [kk] -> [vv] (reception only)

8nH = Note OFF event (n = channel number)  
kk = Note number: 00H ~ 7FH = C-2 ~ G8  
vv = Velocity

\* If received value exceeds the supported range for the selected voice, the note is adjusted by the necessary number of octaves.

## 2. CONTROL CHANGE

Data format: [BnH] -> [cc] -> [vv]

BnH = Control change (n = channel number)  
cc = Control number  
vv = Data Range

### (1) Bank Select

ccH	Parameter	Data Range (vvH)
00H	Bank Select MSB	00H:Normal
20H	Bank Select LSB	00H...7FH

Bank selection processing does not occur until receipt of next Program Change message.

### (2) Main Volume (reception only)

ccH	Parameter	Data Range (vvH)
07H	Volume MSB	00H...7FH

### (3) Expression

ccH	Parameter	Data Range (vvH)
0BH	Expression MSB	00H...7FH

### (4) Damper

ccH	Parameter	Data Range (vvH)
40H	Damper MSB	00H...7FH

### (5) Sostenuto

ccH	Parameter	Data Range (vvH)
42H	Sostenuto	00H-3FH:off, 40H-7FH:on

### (6) Soft Pedal

ccH	Parameter	Data Range (vvH)
43H	Soft Pedal	00H-3FH:off, 40H-7FH:on

### (7) Reverb Depth

ccH	Parameter	Data Range (vvH)
5BH	Reverb Depth	00H...7FH

Adjusts the reverb send level.

## 3. MODE MESSAGES

Data format: [BnH] -> [cc] -> [vv]

BnH = Control event (n = channel number)  
cc = Control number  
vv = Data Range

### (1) All Sound Off

ccH	Parameter	Data Range (vvH)
78H	All Sound Off	00H

Switches off all sound from the channel. Does not reset Note On and Hold On conditions established by Channel Messages.

### (2) Reset All Controllers

ccH	Parameter	Data Range (vvH)
79H	Reset All Controllers	00H

Resets controllers as follows.

Controller	Value
Expression	127 (max)

Si vous êtes très familier avec l'interface MIDI ou si vous utilisez un ordinateur pour commander votre matériel de musique au moyen de messages MIDI générés par ordinateur, les données suivantes vous seront utiles et vous aideront à commander le Clavinova.

Si usted está ya familiarizado con MIDI, o si emplea una computadora para controlar sus aparatos musicales con mensajes MIDI generados por computadora, los datos proporcionados en esta sección le ayudarán a controlar la Clavinova.

Damper Pedal	0 (off)
Sostenuto	0 (off)
Soft Pedal	0 (off)

### (3) Local Control (reception only)

ccH	Parameter	Data Range (vvH)
7AH	Local Control	00H (off), 7FH (on)

### (4) All Notes Off

ccH	Parameter	Data Range (vvH)
7BH	All Notes Off	00H

Switches OFF all the notes that are currently ON on the specified channel. Any notes being held by the damper pedal will continue to sound until the pedal is released.

### (5) Omni Off (reception only)

ccH	Parameter	Data Range (vvH)
7CH	Omni Off	00H

Same processing as for All Notes Off.

### (6) Omni On (reception only)

ccH	Parameter	Data Range (vvH)
7DH	Omni On	00H

Same processing as for All Notes Off.

### (7) Mono (reception only)

ccH	Parameter	Data Range (vvH)
7EH	Mono	00H

Same processing as for All Sound Off.

### (8) Poly (reception only)

ccH	Parameter	Data Range (vvH)
7FH	Poly	00H

Same processing as for All Sound Off.

- When a voice bank MSB/LSB is received, the number is stored in the internal buffer regardless of the received order, then the stored value is used to select the appropriate voice when a program change message is received.
- The Multi-timbre and Poly modes are always active. No change occurs when OMNI ON, OMNI OFF, MONO, or POLY mode messages are received.

## 4. PROGRAM CHANGE

Data format: [CnH] -> [ppH]

CnH = Program event (n = channel number)  
ppH = Program change number

### Program change number

Vioce	Bank MSB	Bank LSB	Program Change Number
GRAND PIANO	0	112	0
E.PIANO	0	112	5
CHURCH ORGAN	0	112	19
STRINGS	0	112	48

## 5. SYSTEM REALTIME MESSAGES

### Active sensing

[FEH]

- Transmitted every 200 milliseconds.
- If a signal is not received via MIDI for more than 400 milliseconds, the same processing will take place for All Sound Off, All Notes Off and Reset All Controllers as when those signals are received.

- Caution: If an error occurs during MIDI reception, the Damper and Soft effects for all channels are turned off and an All Note Off occurs.

## 6. SYSTEM EXCLUSIVE MESSAGES

### (Universal System Exclusive)

#### (1) Universal Realtime Message

Data format: [F0H] -> [7FH] -> [XnH] -> [04H] -> [01H] -> [//H] -> [mmH] -> [F7H]

**MIDI Master Volume**

- Simultaneously changes the volume of all channels.
- When a MIDI master volume message is received, the volume only has affect on the MIDI receive channel, not the panel master volume.

F0H = Exclusive status  
 7FH = Universal Realtime  
 7FH = ID of target device  
 04H = Sub-ID #1=Device Control Message  
 01H = Sub-ID #2=Master Volume  
 //H = Volume LSB  
 mmH = Volume MSB  
 F7H = End of Exclusive

or

F0H = Exclusive status  
 7FH = Universal Realtime  
 XnH = When received, n=0-F. X = don't care  
 04H = Sub-ID #1=Device Control Message  
 01H = Sub-ID #2=Master Volume  
 //H = Volume LSB  
 mmH = Volume MSB  
 F7H = End of Exclusive

**(2) Universal Non-Realtime Message (GM 0n)**

**General MIDI Mode On**

Data format: [F0H] -> [7EH] -> [XnH] -> [09H] -> [01H] -> [F7H]

F0H = Exclusive status  
 7EH = Universal Non-Realtime  
 7FH = ID of target device  
 09H = Sub-ID #1=General MIDI Message  
 01H = Sub-ID #2=General MIDI On  
 F7H = End of Exclusive

or

F0H = Exclusive status  
 7EH = Universal Non-Realtime  
 XnH = When received, n=0-F. X = don't care  
 09H = Sub-ID #1=General MIDI Message  
 01H = Sub-ID #2=General MIDI On  
 F7H = End of Exclusive

When the General MIDI mode ON message is received, the MIDI system will be reset to its default settings. This message requires approximately 50ms to execute, so sufficient time should be allowed before the next message is sent.

**7. SYSTEM EXCLUSIVE MESSAGES (XG Standard)**

**(1) XG Native Parameter Change**

Data format: [F0H] -> [43H] -> [1nH] -> [4CH] -> [hhH] -> [mmH] -> [//H] -> [ddH] -> [F7H]

F0H = Exclusive status  
 43H = YAMAHA ID  
 1nH = When received, n=0-F. When transmitted, n=0.  
 4CH = Model ID of XG  
 hhH = Address High  
 mmH = Address Mid  
 //H = Address Low  
 ddH = Data

F7H = End of Exclusive

Data size must match parameter size.

When the XG System On message is received, the MIDI system will be reset to its default settings.

The message requires approximately 50ms to execute, so sufficient time should be allowed before the next message is sent.

**(2) XG Native Bulk Data (reception only)**

Data format: [F0H] -> [43H] -> [0nH] -> [4CH] -> [aaH] -> [bbH] -> [hhH] -> [mmH] -> [//H] -> [ddH] ->...-> [ccH] -> [F7H]

F0H Exclusive status  
 43H YAMAHA ID  
 0nH When received, n=0-F. When transmitted, n=0.  
 4CH Model ID of XG  
 aaH ByteCount  
 bbH ByteCount  
 hhH Address High  
 mmH Address Mid  
 //H Address Low  
 ddH Data

ccH Check sum  
 F7H End of Exclusive

- Receipt of the XG SYSTEM ON message causes reinitialization of relevant parameters and Control Change values. Allow sufficient time for processing to execute (about 50 msec) before sending the Clavinova another message.
- XG Native Parameter Change message may contain two or four bytes of parameter data (depending on the parameter size).
- For information about the Address and Byte Count values, refer to Table 1 below. Note that the table's Total Size value gives the size of a bulk block. Only the top address of the block (00H, 00H, 00H) is valid as a bulk data address.

**8. SYSTEM EXCLUSIVE MESSAGES (Special Control)**

Data format: [F0H] -> [43H] -> [73H] -> [xxH] -> [11H] -> [0nH] -> [ccH] -> [vvH] -> [F7H]

F0H = Exclusive status  
 43H = Yamaha ID  
 73H = Clavinova ID  
 67H = CLP-920 ID  
 11H = Clavinova special control  
 0nH = Control MIDI change (n=channel number)  
 cc = Control number  
 vv = Value  
 F7H = End of Exclusive

**Control On ccH vvH**  
 Voice Reserve ch: 00H-0FH 45H 00H : Reserve off  
 7FH : on\*

\* When Volume, Expression is received for Reserve On, they will be effective from the next Key On. Reserve Off is normal.

**9. SYSTEM EXCLUSIVE MESSAGES (Others)**

Data format: [F0H] -> [43H] -> [1nH] -> [27H] -> [30H] -> [00H] -> [00H] -> [mmH] -> [//H] -> [ccH] -> [F7H]

Master Tuning (XG and last message priority) simultaneously changes the pitch of all channels.  
 F0H = Exclusive Status  
 43H = Yamaha ID  
 1nH = Transmission from n=CLP is always 0. 0-F is received.  
 27H = Model ID of TG100  
 30H = Sub ID  
 00H =  
 00H =  
 mmH = Master Tune MSB  
 //H = Master Tune LSB  
 ccH = don't care (under 7FH)  
 F7H = End of Exclusive

<Table 1>

**MIDI Parameter Change table ( SYSTEM )**

Address (H)	Size (H)	Data (H)	Parameter	Description	Default value (H)
00 00 00	4	020C - 05F4(*1)	MASTER TUNE	-50 - +50[cent]	00 04 00 00
01				1st bit 3 - 0 → bit 15 - 12	400
02				2nd bit 3 - 0 → bit 11 - 8	
03				3rd bit 3 - 0 → bit 7 - 4	
04	1	00 - 7F	MASTER VOLUME	4th bit 3 - 0 → bit 3 - 0	7F
05	1	—		0 - 127	
06	1	34 - 4C(*2)	TRANSPOSE	-12 - +12[semitones]	40
7E		00	XG SYSTEM ON	00=XG sytem ON	
7F		00	RESET ALL PARAMETERS	00=ON (receive only)	
TOTAL SIZE	07				

\*1: Values lower than 020CH select -50 cents. Values higher than 05F4H select +50 cents.

\*2: Values from 28H through 33H are interpreted as -12 through -1. Values from 4DH through 58H are interpreted as +1 through +12.

MIDI Implementation Chart

Function	Transmitted	Recognized	Remarks
Basic Default Channel Changed	1 1~16	1 1~16	
Mode Default Messages Altered	3 × *****	1 × ×	*1 Poly Mode only
Note Number : True voice	15~114 *****	0~127 21~108	
Velocity Note on Note off	○ 9nH, v=1~127 × 9nH, v=0	○ v=1~127 ×	
After key's Touch Ch's	× ×	× ×	
Pitch Bender	×	×	
Control Change	0, 32 ○ 07 × 11 ○ 64 ○ 66 × 67 ○ 91 ○ 94 ×  120 × 121 ×	○ ○ ○ ○ ○ ○ ○ ○ ×  ○ ○	Bank Select Volume Expression Damper Sostenuto Soft pedal Reverb Depth Effect Depth  All sounds off Reset All Controllers
Program Change : True #	○ *****	○	
System Exclusive	○	○	
System : Song Position : Song Select Common : Tune	× × ×	× × ×	
System : Clock Real Time : Commands	○ ×	× ×	
Aux : Local ON/OFF : All Notes Off Messages : Active Sense : Reset	× × ○ ×	○ ○ (123~127) ○ ×	

Notes : \*1 = Recieve Mode is always multi timbre and Poly mode.

# Assembly Parts / Bauteile / Éléments à assembler / Partes del conjunto

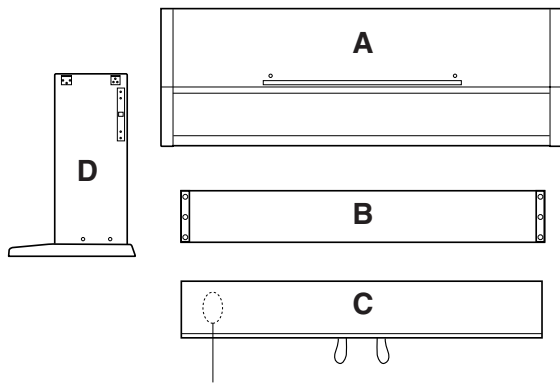

Bundled pedal cord inside  
Gebündeltes Pedalkabel  
Cordon de pédalier enroulé à l'intérieur  
Cable de pedales enrollado en el interior

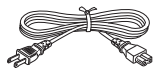

- AC power cord
- Netzkabel
- Cordon d'alimentation
- Cable de alimentación de CA



- Cord holders x 2
- Kabelhalter x 2
- Serre-câble x 2
- Soportes de cable x 2



6 x 25 mm round-head screws  
6 x 25 mm Halbrundschraben  
Vis à tête ronde de 6 x 25 mm  
Tornillos de cabeza redonda de 6 x 25 mm

x 4 ①



6 x 16 mm flat-head screws  
6 x 16 mm Senkschrauben  
Vis à tête plate de 6 x 16 mm  
Tornillos de cabeza plana de 6 x 16 mm

x 8 ②

- The music stand is packaged in cardboard, and included inside the box. Do not forget to remove it from the box.
- Der Notenständer ist in einer separaten Verpackung im Karton enthalten. Vergessen Sie beim Auspacken nicht, auch den Notenständer aus dem Karton zu nehmen.
- Le pupitre à partition est emballé dans du carton et se trouve dans la boîte. Ne pas oublier de le retirer de la boîte.
- El atril está embalado con cartón y se encuentra dentro de la caja. No se olvide de sacarlo de la caja.

## Keyboard Stand Assembly

### ⚠ CAUTION

- Be careful not to confuse parts, and be sure to install all parts in the correct direction. Please assemble in accordance with the sequence given below.
- Assembly should be carried out by at least two persons.
- Be sure to use the correct screw size, as indicated above. Use of incorrect screws can cause damage.
- Be sure to tighten up all screws upon completing assembly of each unit.
- To disassemble, reverse the assembly sequence given below.

Have a Phillips-head (+) screwdriver ready.

The parts shown in the "Assembly Parts" illustration will be used. Follow the assembly instructions and select the parts as needed.

### 1 Attach the side panels (D) to the pedal box (C).

Before installing the pedal box, untie and straighten out the bundled cord attached to the bottom of the pedal box. Don't discard the vinyl tie, you'll need it later in step 4.

Align the holes on the side of the pedal box (C) with those on the side panels (D), attach the pedal box to the side panels using the four 6 x 25 millimeter round-head screws ① — two screws on each side. Make sure the pedals extend in the same direction as the feet.

## Zusammenbau und Aufstellung

### ⚠ VORSICHT

- Achten Sie darauf, die Teile nicht zu verwechseln, und installieren Sie alle Teile in der richtigen Ausrichtung. Gehen Sie beim Zusammenbau bitte in der angegebenen Reihenfolge vor.
- Die Montage sollte von mindestens zwei Personen vorgenommen werden.
- Achten Sie darauf, die richtige Schraubengröße zu verwenden, wie es oben gezeigt ist. Die Verwendung der falschen Schrauben kann zu Schäden führen.
- Achten Sie während der Montage darauf, bei jedem Arbeitsschritt alle Schrauben festzuziehen.
- Für die Demontage muß die angegebene Reihenfolge umgekehrt befolgt werden.

Sie benötigen einen Kreuzschlitzschraubendreher (+).

Es werden die in der "Bauteile"-Zeichnung abgebildeten Teile verwendet. Folgen Sie beim Zusammenbau den Anweisungen, und wählen Sie die jeweils benötigten Teile.

### 1 Befestigen Sie die Seitenwände (D) am Pedalkasten (C).

Bevor Sie den Pedalkasten montieren, nehmen Sie zunächst das gebündelte Kabel aus dem Pedalkasten, entfernen den Kabelbinder und ziehen das Kabel dann gerade aus. Werfen Sie den Kabelbinder nicht weg, er wird in Schritt 4 wieder gebraucht.

Bringen Sie die Schraubenbohrungen an der Seite des Pedalkastens (C) mit denen an den Seitenwänden (D) zur Deckung, und schrauben Sie den Pedalkasten mit den vier 6 x 25 mm Halbrundschraben ①, jeweils zwei Schrauben links und rechts, an den Seitenwänden fest. Achten Sie dabei darauf, daß die Pedale in dieselbe Richtung weisen wie die vorspringenden Teile der Füße.

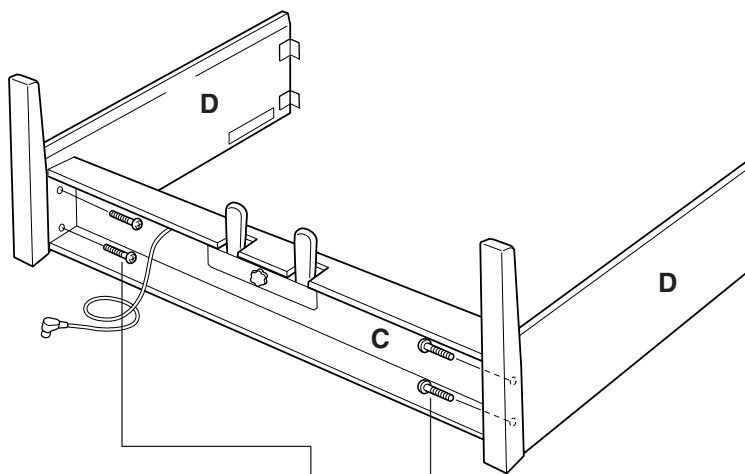
**1**

- 6 x 25 mm round-head screws ❶
- 6 x 25 mm Halbrundsrauben ❶
- Vis à tête ronde de 6 x 25 mm ❶
- Tornillos de cabeza redonda de 6 x 25 mm ❶

## Assemblage du support de clavier

### **⚠ PRECAUTION**

- Veiller à ne pas mélanger les pièces et à les installer dans le sens correct. Veuillez assembler l'instrument dans l'ordre indiqué ci-dessous.
- La présence de deux personnes minimum est nécessaire pour procéder au montage.
- Toujours utiliser des vis aux dimensions correctes, comme indiqué cidessus. L'utilisation de vis aux dimensions incorrectes pourrait en effet endommager l'instrument.
- Resserrer convenablement toutes les vis après le montage de chaque élément.
- Pour démonter le Clavinova, inverser l'ordre des indications données ci-dessous.

Munissez-vous d'un tournevis Phillips (cruciforme).

Les éléments qui sont représentés sur la figure intitulée "Éléments à assembler" seront utilisés. Veuillez vous conformer aux instructions d'assemblage et sélectionner les éléments nécessaires.

### **❶ Fixez les panneaux latéraux (D) au pédalier (C)**

Avant de poser le pédalier, détacher le cordon de la partie inférieure du pédalier et le dérouler. Ne jetez pas l'attache en vinyle, vous la réutiliserez ultérieurement à l'étape 4.

Faites correspondre les trous visibles sur le flanc du pédalier (C) avec deux des panneaux latéraux (D), puis fixer le pédalier sur les panneaux latéraux à l'aide de quatre vis de fixation à tête ronde de 6 x 25 millimètres ❶ - soit deux vis de chaque côté. Veillez à ce que les pédales soient dirigées dans le même sens que les supports inférieurs.

## Conjunto del soporte del teclado

### **⚠ CUIDADO**

- Observe cuidado para no confundir las piezas, y asegúrese de montar todas ellas en el sentido correcto. Proceda al montaje en el orden indicado a continuación.
- El montaje deberá realizarse al menos por dos personas.
- Procure utilizar los tornillos del tamaño adecuado, según se indica arriba. El empleo de tornillos inadecuados puede ocasionar daños en el instrumento.
- Asegúrese de apretar bien todos los tornillos después de montar cada unidad.
- Para desmontar las unidades, invierta la secuencia de montaje facilitada a continuación.

Tenga preparado un destornillador de cabeza en cruz (+).

Se usarán las partes mostradas en la ilustración de "Partes del conjunto". Siga las instrucciones de montaje y seleccione las partes a medida que se requieran.

### **❶ Acople los paneles laterales (D) en la caja de pedales (C).**

Antes de instalar la caja de pedales, desate y enderezca el cable plegado unido a la parte inferior de la caja de pedales. No tire la abrazadera de vinilo, porque la necesitará en el paso 4 de más adelante.

Alinee los orificios del lado de la caja de pedales (C) con los de los paneles laterales (D), y acople la caja de pedales a los paneles laterales empleando los cuatro tornillos de cabeza redonda de 6 x 25 milímetros ❶ — dos tornillos en cada lado. Asegúrese de que el pedal se extiende en la misma dirección que la pata.

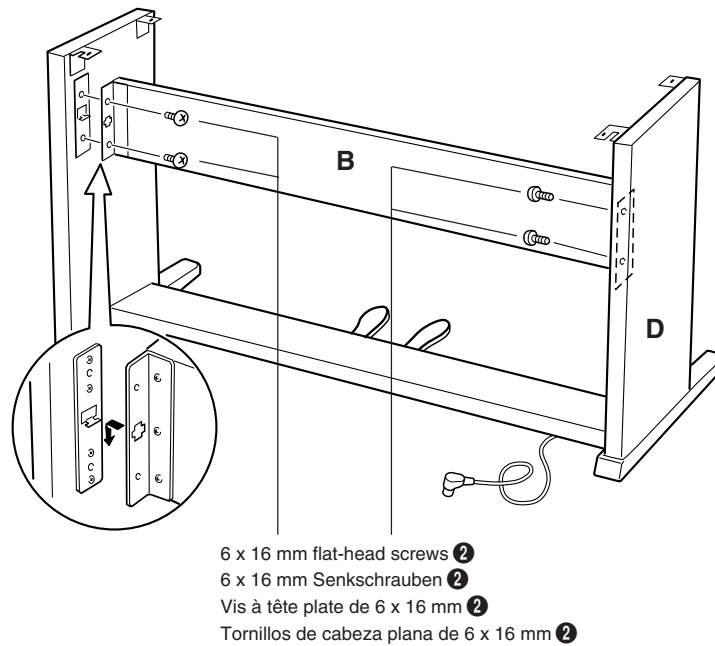

## 2 Attach the rear panel (B) to the side panels (D).

The rear panel (B) is installed between the side panels (D) with the brackets on each end toward the rear of the stand assembly. Place the square holes in the rear-panel brackets over the lugs extending from the side panels, then slide down. Each side of the rear panel is attached using two 6 x 16 flat-head screws ②.

## 3 Install the main unit (A).

Place the main unit (A) on the side panels (D) with the screws on its bottom panel (toward the rear of the main unit) just behind the grooves in the brackets located at the top of the side panels. Then slide the main unit forward until it stops. **WATCH YOUR FINGERS WHEN DOING THIS!!**

Align the holes on the bottom panel of the main unit with the holes in the brackets on the side panels (also center the main unit to produce equal clearance on the left and right sides, as shown in the illustration), then use the four 6 x 16 millimeter flat-head screws ② to attach the main unit. Two screws can be attached from the front side and two screws from the rear.

### ⚠ CAUTION

- Do not hold the keyboard in any position other than the position shown in the above illustration.
- Fingers can become pinched between the main unit and the side panels, be extra careful so as not to drop the main unit.

## 2 Schrauben Sie die Rückwand (B) an die beiden Seitenwände (D).

Die Rückwand (B) wird mit den Winkelblechen an beiden Enden nach hinten weisend an den Seitenwänden (D) befestigt. Lassen Sie dabei die Führungsnasen an den Seitenwänden in die Schlitzbohrungen in den beiden Winkelblechen greifen, und drücken Sie die Rückwand dann nach unten. Sichern Sie die Rückwand dann mit jeweils zwei kurzen schwarzen Schrauben ② an den Seitenwänden.

## 3 Montieren Sie die Tastatureinheit (A).

Setzen Sie die Tastatureinheit (A) so auf den fertigen Ständer, daß die beiden Schrauben an ihrer Unterseite hinter den Winkelblechen mit Führungsschlitz an der Hinterseite des Ständers zu liegen kommen. Schieben Sie die Tastatureinheit dann bis zum Anschlag in die Schlitzbohrungen. **KLEMMEN SIE IHRE FINGER DABEI NICHT EIN!!**

Richten Sie die Schraubenbohrungen an der Unterseite der Tastatureinheit mit den Bohrungen der Winkelbleche aus (achten Sie auch darauf, daß sie mittig auf dem Ständer steht, wie in der Abbildung gezeigt), um die Tastatureinheit dann mit den vier 6 x 16 mm Senkschrauben ② festzuschrauben. Zwei Schrauben werden von der Vorderseite her eingeführt, die beiden anderen von der Rückseite her.

### ⚠ VORSICHT

- Halten Sie die Tastatureinheit nur wie in der obigen Abbildung!
- Achten Sie darauf, daß Sie Ihre Finger nicht zwischen Tastatureinheit und den Seitenwänden einklemmen — die Tastatureinheit könnte dadurch zu Fall kommen!

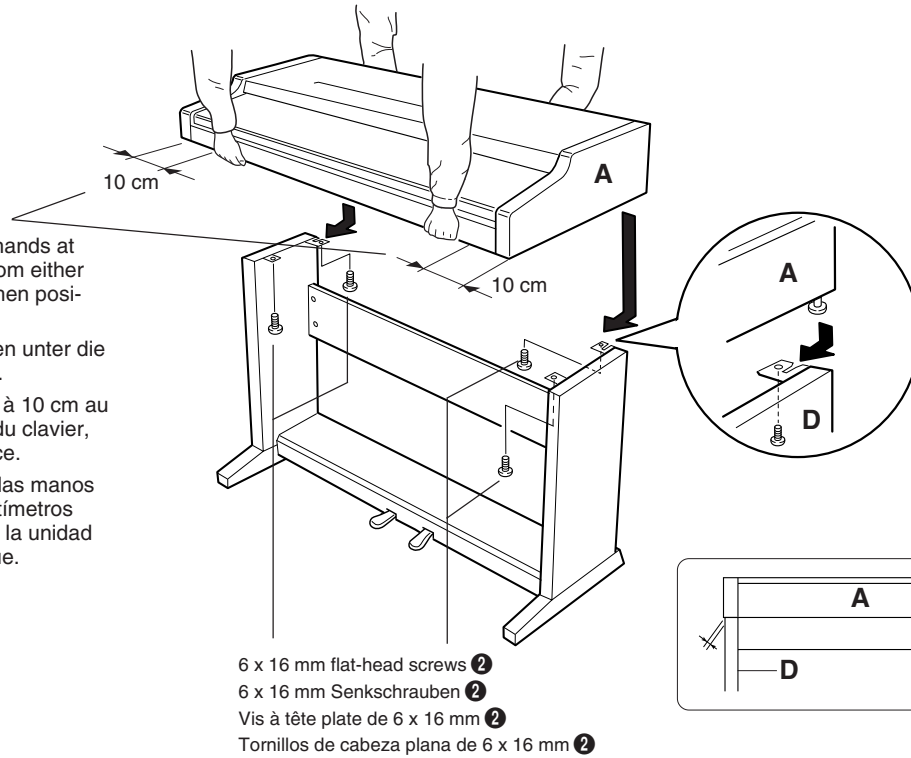

**3**

- Be sure to place your hands at least 10 centimeters from either end of the main unit when positioning it.
- Mindestens 10 cm innen unter die Tastatureinheit greifen.
- Placez bien vos mains à 10 cm au moins des extrémités du clavier, lors de sa mise en place.
- Asegúrese de colocar las manos por lo menos a 10 centímetros desde los extremos de la unidad principal cuando la sitúe.

6 x 16 mm flat-head screws ②  
 6 x 16 mm Senkschrauben ②  
 Vis à tête plate de 6 x 16 mm ②  
 Tornillos de cabeza plana de 6 x 16 mm ②

## 2 Fixez le panneau arrière (B) aux panneaux latéraux (D)

Le panneau arrière (B) doit être posé entre les panneaux latéraux (D) en prenant soin de diriger la ferrure située à chaque extrémité vers l'arrière du support. Placez les orifices carrés des ferrures du panneau arrière sur les languettes dépassant des panneaux latéraux et faites glisser vers le bas. Chaque côté du panneau arrière doit être fixé à l'aide de deux vis courtes noires ②.

## 3 Installez le clavier (A)

Placez le clavier sur les panneaux latéraux (D), avec les vis de son panneau inférieur (situées vers l'arrière du clavier) placées immédiatement derrière les rainures des ferrures situées à la partie supérieure des panneaux latéraux (D), puis faites glisser le clavier vers l'avant jusqu'à ce qu'il vienne en butée. **FAITES ATTENTION A VOS DOIGTS EN EXECUTANT CETTE OPERATION!!**

Alignez les trous du panneau inférieur du clavier sur les trous des ferrures des panneaux latéraux (centrez également le clavier de manière à avoir un jeu identique de chaque côté) utilisez ensuite quatre vis de fixation à tête plate de 6 x 16 millimètres ② pour immobiliser le clavier. Deux des vis de fixation peuvent être mises en place de l'avant et deux vis de fixation peuvent être mises en place de l'arrière.

### ⚠ PRECAUTION

- Ne tenez pas le clavier d'une autre manière que celle indiquée sur l'illustration ci-dessus.
- Attention car vous risquez de vous faire pincer les doigts entre le clavier et les panneaux latéraux de sorte que vous devez veiller à ne pas faire tomber le clavier.

## 2 Acople el panel posterior (B) en los paneles laterales (D).

El panel posterior (B) se instala entre los paneles laterales (D) con las ménsulas de cada extremo encaradas hacia la parte posterior del conjunto del soporte. Coloque los orificios cuadrados de las ménsulas del panel posterior por encima de las lengüetas que se extienden desde los paneles laterales, después deslice hacia abajo. Cada lado del panel posterior se acopla usando dos tornillos negros cortos ②.

## 3 Instale la unidad principal (A).

Coloque la unidad principal en los paneles laterales (D) con los tornillos de su panel inferior (hacia la parte posterior de la unidad principal) justo detrás de las ranuras de la ménsula ubicada en la parte superior de los paneles laterales (D), después deslice el teclado hacia adelante hasta que se pare. **¡TENGA CUIDADO CON SUS DEDOS MIENTRAS LO HACE!**

Alinee los orificios del panel inferior de la unidad principal con los orificios de las ménsulas de los paneles laterales (también centre la unidad principal para producir una holgura igual en los lados derecho e izquierdo, como se muestra en la ilustración), y emplee entonces los cuatro tornillos de cabeza plana de 6 x 16 milímetros ② para montar la unidad principal. Dos tornillos pueden colocarse desde el lado frontal y dos desde el lado posterior.

### ⚠ CUIDADO

- No sostenga el teclado en ninguna posición que no sea la posición mostrada en la ilustración de arriba.
- Podría pillarse los dedos ente la unidad principal y los paneles laterales, por lo que deberá tener mucho cuidado que no se caiga la unidad principal.

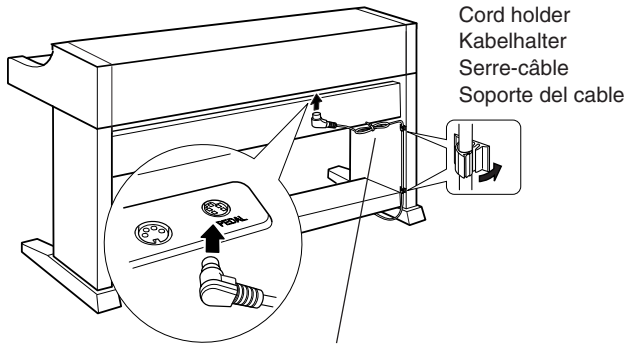
**4**

- Use the vinyl tie that was removed from the bundled pedal cord in step 1 to tie up any slack in the pedal cord.
- Nehmen Sie überlanges Kabel mit dem in Schritt 1 entfernten Kabelbinder auf.
- Utilisez l'attache en vinyle qui a été enlevée du cordon de pédalier à l'étape 1 pour attacher le fil excédentaire du cordon de pédalier.
- Emplee la abrazadera de vinilo que se sacó del cable plegado de los pedales en el paso 1 para fijar el cable de pedales sobrante.

**5**

- A voltage selector is provided in some areas.
- Spannungswähler (nur in bestimmten Verkaufsgebieten)
- Un sélecteur de tension est prévu pour certaines régions
- El selector de tensión está provisto para ciertos destinos.

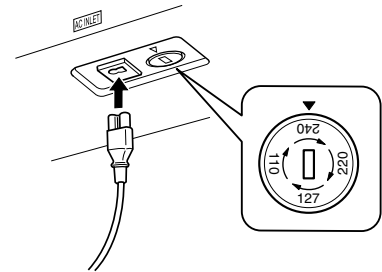

#### 4 Connect the pedal cord.

The pedal cord from the pedal box must be plugged into the PEDAL connector located at the rear of the main unit's underside. Once connected, attach the cord holders to the side panel as shown, then clip the cord into the holders.

#### 5 Voltage Selector

Before connecting the AC power cord, check the setting of the voltage selector which is provided in some areas. To set the selector for 110V, 127V, 220V or 240V main voltages, use a "minus" screwdriver to rotate the selector dial so that the correct voltage for your region appears next to the pointer on the panel. The voltage selector is set at 240V when the unit is initially shipped.

After the proper voltage has been selected, connect the AC power cord to the AC INLET and an AC wall outlet. A plug adaptor may be also provided in some areas to match the pin configuration of the AC wall outlets in your area.

#### ! CAUTION

- An improper voltage setting can cause serious damage to the Clavinova or result in improper operation.

#### 6 Set the adjuster.

For stability, an adjuster is provided on the bottom of the pedal box (C). Rotate the adjuster until it comes in firm contact with the floor surface. The adjuster ensures stable pedal operation and facilitates pedal effect control. If the adjuster is not in firm contact with the floor surface, distorted sound may result.

#### ■ After completing the assembly, please check the following.

- Are there any parts left over?
  - Review the assembly procedure and correct any errors.
- Is the Clavinova clear of doors and other movable fixtures?
  - Move the Clavinova to an appropriate location.
- Does the Clavinova make a rattling noise when you shake it?
  - Tighten all screws.
- Does the pedal box rattle or give way when you step on the pedals?
  - Turn the adjuster so that it is set firmly against the floor.
- Are the pedal and power cords inserted securely into the sockets?
  - Check the connection.
- If the main unit creaks or is otherwise unsteady when you play on the keyboard, refer to the assembly diagrams and retighten all screws.

- After assembly is complete, it will be necessary to remove the keyboard string. This procedure is performed once only and the string will never have to be reattached again. For instructions on its removal, refer to the paper titled "REQUEST" that can be found on the keys underneath the key cover (see page 6).

#### 4 Schließen Sie das Pedalkabel an.

Das vom Pedalkasten kommende Pedalkabel wird an die PEDAL-Buchse hinten an der Unterseite der Tastatureinheit angeschlossen. Bringen Sie nach dem Anschluß die Kabelhalter an der Seitenwand an, um das Kabel dann in diese Halter zu klemmen.

#### 5 Den Spannungswähler einstellen.

Bevor Sie nun das Netzkabel anschließen, müssen Sie den Spannungswähler (falls vorhanden) auf die örtliche Netzspannung einstellen. Zum Verstellen drehen Sie den Spannungswähler mit einem Schlitzschraubendreher, bis der richtige Spannungswert (110, 127, 220 oder 240) an der Pfeilmarkierung steht. Bei der Auslieferung werden alle Instrumente mit Spannungswähler auf "240" voreingestellt.

Nachdem Sie den Spannungswähler auf den richtigen Spannungswert eingestellt haben, stecken Sie das Netzkabel in die AC INLET-Buchse und schließen es an eine Steckdose an. In manchen Gebieten wird ein Steckeradapter mitgeliefert, um den Anschluß an die evtl. unterschiedlich geformte Steckdose zu ermöglichen.

#### ! VORSICHT

- Eine falsche Spannungseinstellung kann das Clavinova schwer beschädigen und Funktionsstörungen zur Folge haben.

#### 6 Justieren Sie schließlich noch den Höhenversteller.

Zur Stabilisierung ist an der Unterseite des Pedalkastens (C) ein Höhenversteller vorgesehen. Schrauben Sie den Höhenversteller heraus, bis er fest auf dem Fußboden steht. Der Höhenversteller sorgt für stabile Pedalbetätigung und ermöglicht eine präzise Regelung des Betätigungshubs. Wenn er nicht fest auf dem Boden steht, können beim Treten der Pedale Klangverzerrungen auftreten.

#### ■ Wenn der Zusammenbau beendet ist, prüfen Sie bitte folgende Dinge:

- Sind Teile übrig geblieben?
  - Gehen Sie den Vorgang des Zusammenbaus noch einmal durch und korrigieren Sie eventuelle Fehler.
- Befindet sich das Clavinova weit genug von Türen und anderen beweglichen Vorrichtungen entfernt?
  - Bewegen Sie das Clavinova an einen entsprechend sicheren Ort.
- Macht das Clavinova Klappergeräusche, wenn Sie es schütteln?
  - Ziehen Sie alle Schrauben fest.
- Klappert der Pedalkasten oder gibt er nach, wenn Sie das Pedal treten?
  - Drehen Sie den Höhenversteller, bis er fest auf dem Fußboden steht.
- Sind Pedal- und Netzkabel richtig an den Buchsen angeschlossen?
  - Prüfen Sie die Verbindung.
- Wenn die Haupteinheit knarrt oder beim Spielen wackelt, betrachten Sie die Abbildungen und ziehen Sie alle Schrauben noch einmal nach.

- Nach dem Zusammenbau müssen Sie den Tastatur-Sicherungsdraht entfernen. Diese Arbeit wird nur einmal ausgeführt, und der Draht braucht später nicht wieder angebracht zu werden. Anweisungen hierzu entnehmen Sie bitte dem unter der Tastaturabdeckung auf den Tasten liegenden Hinweisblatt (siehe Seite 6).

6

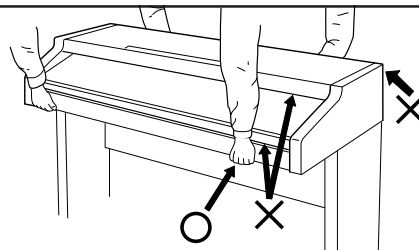
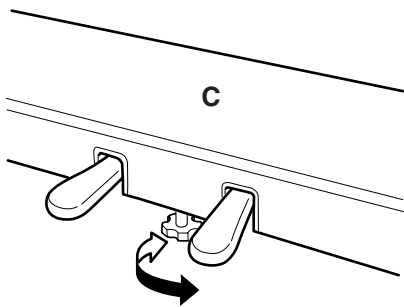

#### ⚠ CAUTION

- When moving the instrument after assembly, always hold the lower surface of the main unit, NEVER the top portion or keyboard cover. Improper handling can result in damage to the instrument or personal injury.

#### ⚠ VORSICHT

- Fassen Sie zum Umstellen des Instruments nach dem Zusammenbau stets unter das Gehäuse; heben Sie es NIEMALS am oberen Teil des Gehäuses oder am Tastaturdeckel. Bei Nichtbeachtung dieses Punkts kann das Instrument beschädigt und im Extremfall eine Verletzung hervorgerufen werden.

#### ⚠ PRECAUTION

- Pour déplacer l'instrument après le montage, toujours tenir l'instrument par la surface inférieure, JAMAIS par sa partie supérieure ou par le protège-clavier. Une mauvaise manipulation peut provoquer des dommages ou des blessures.

#### ⚠ CUIDADO

- Cuando mueva el instrumento después del montaje, sostenga siempre la superficie inferior de la unidad principal, y NUNCA la parte superior de la cubierta del teclado. La manipulación indebida puede causar daños en el instrumento o personales.

## 4 Raccordez le câble du pédalier

Le câble du pédalier qui sort du logement de pédalier doit être raccordé au connecteur PEDAL implanté à l'arrière du panneau de dessus de l'instrument. Une fois branché, fixez les attaches de câble sur le panneau latéral en procédant de la façon représentée sur la figure, puis emboîtez le câble dans les attaches.

## 5 Sélecteur de tension

Avant de connecter le cordon d'alimentation, vérifiez le réglage du sélecteur de tension qui est prévu pour certaines régions. Pour régler le sélecteur sur 110 V, 127 V, 220 V ou 240 V, utilisez un tournevis à lame plate pour tourner le cadran du sélecteur afin de mettre l'indication correspondant à la tension de votre région vis à vis du repère triangulaire situé sur le panneau. Le sélecteur de tension est réglé sur 240 V au départ d'usine.

Après avoir choisi la tension appropriée, branchez le cordon d'alimentation secteur dans la prise AC INLET de l'instrument et une prise de sortie secteur. Un adaptateur de prise peut également être fourni dans certaines régions pour pouvoir brancher le cordon à la prise secteur murale.

#### ⚠ PRECAUTION

- Vous risquez de sérieusement endommager le Clavinova ou de provoquer un fonctionnement anormal de l'instrument en ne choisissant pas correctement la tension d'alimentation.

## 6 N'oubliez pas de régler la hauteur du pédalier

Pour assurer la stabilité du pédalier (C), un dispositif de réglage a été prévu à sa partie inférieure. Tournez ce dispositif jusqu'à ce qu'il soit en contact ferme avec la surface du sol. Ce dispositif assure la stabilité du pédalier lors de son utilisation et facilite la commande au pied des effets. Si ce dispositif n'est pas en contact ferme avec le sol, il pourra se produire une distorsion du son.

### ■ Lorsque le montage est terminé, veuillez mener à bien les vérifications suivantes.

- Reste-t-il des pièces non utilisées?  
→ Passer en revue la procédure de montage et corriger toute erreur éventuelle.
- Le Clavinova est-il placé à l'écart des portes et de toute autre structure mobile?  
→ Déplacer le Clavinova vers un emplacement approprié.
- Lorsque vous secouez quelque peu le Clavinova, entendez-vous un cliquetis?  
→ Serrer convenablement toutes les vis.
- Le pédalier fait-il du bruit ou s'écarte-t-il lorsque vous appuyez sur les pédales?  
→ Tourner le stabilisateur de sorte que le Clavinova repose fermement sur le sol.
- Les cordons des pédales et d'alimentation sont-ils bien enfoncés dans les prises?  
→ Vérifier toutes les connexions.
- Si la partie principale de l'appareil craque ou est instable lorsque vous jouez sur le clavier, consulter les diagrammes de montage et resserrer toutes les vis.

- Dès que l'assemblage est complètement terminé, la corde de clavier doit être retirée. Ceci n'est exécuté qu'une seule fois et il ne sera plus nécessaire de fixer la corde à nouveau. En ce qui concerne les instructions pour retirer cette corde, veuillez vous référer à la page intitulée "REQUEST" qui est placée sur les touches du clavier sous le couvre-clavier (voir page 6).

## 4 Conecte el cable de los pedales.

El cable de los pedales procedente de la caja de pedales debe enchufarse al conector PEDAL situado en la parte posterior del lado inferior de la unidad principal. Una vez se ha conectado, coloque los soportes de cable del panel lateral como se muestra, y sujete el cable en los soportes.

## 5 Selector de tensión

Antes de conectar el cable de alimentación de CA, compruebe el ajuste del selector de tensión que se incorpora para ciertos destinos. Para ajustar el selector a 110V, 127V, 220V ó 240V de la red de alimentación, emplee un destornillador de cabeza recta "-" para girar el selector de modo que la tensión correcta de su zona aparezca al lado del indicador del panel. El selector de tensión se ajusta a 240V cuando la unidad sale de fábrica.

Después de haber seleccionado la tensión correcta, enchufe el cable de alimentación de CA a la toma AC INLET y a una toma de corriente de la pared. En algunas zonas puede suministrarse también un adaptador para adaptar la configuración de las patillas de los tomacorrientes de CA de su localidad.

#### ⚠ CUIDADO

- Un ajuste incorrecto de la tensión puede causar daños serios a la Clavinova o ser motivo de mal funcionamiento.

## 6 Asegúrese de ajustar el ajustador.

Para la estabilidad del aparato, se proporciona un ajustador en la parte inferior de la caja de pedales (C). Gire el ajustador hasta que contacte firmemente con el suelo. El ajustador asegura una operación estable de los pedales y facilita el control del efecto de los pedales. Si el ajustador no contacta firmemente con el suelo, puede resultar en sonido distorsionado.

### ■ Cuando haya concluido el montaje, compruebe los siguientes puntos:

- ¿Ha quedado alguna pieza sin instalar?  
→ Revise el procedimiento de montaje y corrija cualquier error que se haya podido cometer.
- ¿Está el Clavinova alejado del recorrido de puertas y muebles?  
→ Traslade el Clavinova a una posición adecuada.
- ¿Suena algún ruido de holgura cuando se mueve el Clavinova?  
→ Apriete con firmeza todos los tornillos.
- ¿Vibra o cede la caja de pedales cuando se pisan los pedales?  
→ Gire el estabilizador hasta que apoye firmemente sobre el suelo.
- ¿Están perfectamente insertados los cables de pedal y alimentación en los conectores?  
→ Revise las conexiones.
- Si la unidad principal cruje o presenta algún signo de inestabilidad cuando se toca el teclado, consulte los esquemas de montaje y vuelva a apretar todos los tornillos.

- Después de haber terminado el montaje, será necesario extraer la cuerda del teclado. Este procedimiento sólo se lleva a cabo una vez y la cuerda no se tendrá que volver a atar nunca más. Para las instrucciones sobre la extracción de la cuerda, consulte el documento titulado "RUEGO" que encontrará sobre las teclas debajo de la cubierta del teclado (vea la página 6).

# Voice Descriptions / Beschreibung der Stimmen / Description des voix / Descripciones de las voces

Voice	Stereo/ Mono	Touch Response	Voice Descriptions
GRAND PIANO	Stereo	○	Newly-recorded samples from a full concert grand piano. Perfect for classical compositions as well as any other style that requires acoustic piano.
			Neu aufgezeichnete Samples eines echten Konzertflügels. Perfekt für klassische Kompositionen sowie viele andere Musikrichtungen, für die ein akustischer Klavierklang wichtig ist.
			Nouveaux échantillons enregistrés d'un vrai piano de concert. Parfaits pour les compositions classiques comme pour tout autre style nécessitant un piano acoustique.
			Muestras nuevas grabadas en un piano de cola para conciertos. Son perfectas para composiciones clásicas así como para otros estilos que requieren piano acústico.
E.PIANO	Stereo	○	An electronic piano sound created by FM synthesis. Extremely "musical" response with varying timbre according to keyboard dynamics.
			Ein elektronischer Pianosound, der durch FM-Synthese erzeugt wird. Äußerst "musikalische" Ansprache mit anschlagstärkeabhängiger Klangfärbung.
			Sonorité de piano électronique créée par synthèse FM. Réponse extrêmement "musicale" avec un timbre variant en proportion de la dynamique du clavier.
			Sonido de piano electrónico creado con síntesis de FM. Tiene una respuesta muy "musical" con variación del timbre de acuerdo con la dinámica del teclado.
CHURCH ORGAN	Stereo	×	A soft pipe-organ type voice that is ideal for hymn accompaniment and other styles.
			Ein sanfter pfeifenorgelähnlicher Klang, der sich ideal für Hymnenbegleitung und andere Musikstile eignet.
			Voix de type orgue à tuyaux et sonorité enveloppée convenant parfaitement pour l'accompagnement d'un hymne ou d'autres styles.
			Una voz del tipo de órgano de tubos que es ideal para acompañamientos de himnos y otros estilos.
STRINGS	Stereo	○	A large string ensemble. Try combining this voice with piano in the DUAL mode.
			Ein großes Streicherensemble. Probieren Sie diese Stimme einmal kombiniert mit Piano im Dualmodus aus.
			Grand ensemble à cordes. Essayez d'associer cette voix avec le piano en mode DUAL.
			Un conjunto de instrumentos de cuerdas grande. Pruebe combinando esta voz con la de piano en el modo DUAL.

## Demo Song List / Verzeichnis der Demo-Songs / Liste des morceaux de démonstration / Lista de canciones de demostración

Voice Name	Title	Composer
GRAND PIANO	Étude op. 10-5 "Black Key"	F.F.Chopin
E.PIANO	Clair de lune	C.A.Debussy
CHURCH ORGAN	Organ Concerto op.4 No.2	G.F.Händel
STRINGS	Brandenburgisches Konzert No.3	J.S.Bach

- Some of the demonstration pieces listed above are short rearranged excerpts from the original compositions.
- Bei manchen der oben aufgeführten Demo-Stücke handelt es sich um kurze, umgestaltete Auszüge aus den Originalkompositionen.
- Certains des morceaux de démonstration cités ci-dessus sont de courts extraits arrangés des compositions originales.
- Algunas de las piezas de demostración arriba mencionadas son pasajes cortos arreglados de las composiciones originales.

# Specifications/Technische Daten/Caractéristiques techniques/Especificaciones

		CLP-920
<b>KEYBOARD</b>		88 KEYS (A-1 ~ C7)
<b>POLYPHONY</b>		32 NOTES MAX.
<b>VOICES</b>		GRAND PIANO, E.PIANO, CHURCH ORGAN, STRINGS
<b>REVERB CONTROL</b>		ON/OFF
<b>PEDAL CONTROLS</b>		SOFT, DAMPER
<b>OTHER CONTROL</b>		MASTER VOLUME
<b>JACKS/CONNECTORS</b>		PHONES x 2, AUX OUT R & L/L+R, AUX IN R & L/L+R, MIDI IN/OUT/THRU, HOST SELECT, TO HOST, PEDAL
<b>INPUT &amp; OUTPUT LEVEL/IMPEDANCE</b>		AUX OUT: Output impedance 600 Ω AUX IN: Input impedance 10 kΩ / Input sensitivity 0.26V
<b>MAIN AMPLIFIERS</b>		20W x 2
<b>SPEAKERS</b>		16 cm x 2
<b>DIMENSIONS (W x D x H)</b>	without music stand	1370 x 501 x 843 mm (54" x 19-3/4" x 33-1/4")
	with music stand	1370 x 501 x 1030 mm (54" x 19-3/4" x 40-1/2")
<b>WEIGHT</b>		49.0 kg (108 lbs.)

• Specifications and descriptions in this owner's manual are for information purposes only. Yamaha Corp. reserves the right to change or modify products or specifications at any time without prior notice. Since specifications, equipment or options may not be the same in every locale, please check with your Yamaha dealer.

• Die technischen Daten und Beschreibungen in dieser Bedienungsanleitung dienen nur der Information. Yamaha Corp. behält sich das Recht vor, Produkte oder deren technische Daten jederzeit ohne vorherige Ankündigung zu verändern oder zu modifizieren. Da die technischen Daten, das Gerät selbst oder Sonderzubehör nicht in jedem Land gleich sind, setzen Sie sich im Zweifel bitte mit Ihrem Yamaha-Händler in Verbindung.

• Les caractéristiques techniques et les descriptions du mode d'emploi ne sont données que pour information. Yamaha Corp. se réserve le droit de changer ou modifier les produits et leurs caractéristiques techniques à tout moment sans aucun avis. Du fait que les caractéristiques techniques, les équipements et les options peuvent différer d'un pays à l'autre, adressez-vous au distributeur Yamaha le plus proche.

• Las especificaciones y descripciones de este manual del propietario tienen sólo el propósito de servir como información. Yamaha Corp. se reserva el derecho a efectuar cambios o modificaciones en los productos o especificaciones en cualquier momento sin previo aviso. Puesto que las especificaciones, equipos u opciones pueden no ser las mismas en todos los mercados, solicite información a su distribuidor Yamaha.

# IMPORTANT SAFETY INSTRUCTIONS

## INFORMATION RELATING TO PERSONAL INJURY, ELECTRICAL SHOCK, AND FIRE HAZARD POSSIBILITIES HAS BEEN INCLUDED IN THIS LIST.

**WARNING-** When using any electrical or electronic product, basic precautions should always be followed. These precautions include, but are not limited to, the following:

- 1.** Read all Safety Instructions, Installation Instructions, Special Message Section items, and any Assembly Instructions found in this manual **BEFORE** marking any connections, including connection to the main supply.
- 2.** Main Power Supply Verification: Yamaha products are manufactured specifically for the supply voltage in the area where they are to be sold. If you should move, or if any doubt exists about the supply voltage in your area, please contact your dealer for supply voltage verification and (if applicable) instructions. The required supply voltage is printed on the name plate. For name plate location, please refer to the graphic found in the Special Message Section of this manual.
- 3.** This product may be equipped with a polarized plug (one blade wider than the other). If you are unable to insert the plug into the outlet, turn the plug over and try again. If the problem persists, contact an electrician to have the obsolete outlet replaced. Do **NOT** defeat the safety purpose of the plug.
- 4.** Some electronic products utilize external power supplies or adapters. Do **NOT** connect this type of product to any power supply or adapter other than one described in the owners manual, on the name plate, or specifically recommended by Yamaha.
- 5.** **WARNING:** Do not place this product or any other objects on the power cord or place it in a position where anyone could walk on, trip over, or roll anything over power or connecting cords of any kind. The use of an extension cord is not recommended! If you must use an extension cord, the minimum wire size for a 25' cord (or less) is 18 AWG. **NOTE:** The smaller the AWG number, the larger the current handling capacity. For longer extension cords, consult a local electrician.
- 6.** Ventilation: Electronic products, unless specifically designed for enclosed installations, should be placed in locations that do not interfere with proper ventilation. If instructions for enclosed installations are not provided, it must be assumed that unobstructed ventilation is required.
- 7.** Temperature considerations: Electronic products should be installed in locations that do not significantly contribute to their operating temperature. Placement of this product close to heat sources such as; radiators, heat registers and other devices that produce heat should be avoided.
- 8.** This product was **NOT** designed for use in wet/damp locations and should not be used near water or exposed to rain. Examples of wet/damp locations are; near a swimming pool, spa, tub, sink, or wet basement.
- 9.** This product should be used only with the components supplied or; a cart, rack, or stand that is recommended by the manufacturer. If a cart, rack, or stand is used, please observe all safety markings and instructions that accompany the accessory product.
- 10.** The power supply cord (plug) should be disconnected from the outlet when electronic products are to be left unused for extended periods of time. Cords should also be disconnected when there is a high probability of lightning and/or electrical storm activity.
- 11.** Care should be taken that objects do not fall and liquids are not spilled into the enclosure through any openings that may exist.
- 12.** Electrical/electronic products should be serviced by a qualified service person when:
  - a. The power supply cord has been damaged; or
  - b. Objects have fallen, been inserted, or liquids have been spilled into the enclosure through openings; or
  - c. The product has been exposed to rain; or
  - d. The product does not operate, exhibits a marked change in performance; or
  - e. The product has been dropped, or the enclosure of the product has been damaged.
- 13.** Do not attempt to service this product beyond that described in the user-maintenance instructions. All other servicing should be referred to qualified service personnel.
- 14.** This product, either alone or in combination with an amplifier and headphones or speaker/s, may be capable of producing sound levels that could cause permanent hearing loss. **DO NOT** operate for a long period of time at a high volume level or at a level that is uncomfortable. If you experience any hearing loss or ringing in the ears, you should consult an audiologist. **IMPORTANT:** The louder the sound, the shorter the time period before damage occurs.
- 15.** Some Yamaha products may have benches and/or accessory mounting fixtures that are either supplied as a part of the product or as optional accessories. Some of these items are designed to be dealer assembled or installed. Please make sure that benches are stable and any optional fixtures (where applicable) are well secured **BEFORE** using. Benches supplied by Yamaha are designed for seating only. No other uses are recommended.

## PLEASE KEEP THIS MANUAL

For details of products, please contact your nearest Yamaha or the authorized distributor listed below.

Pour plus de détails sur les produits, veuillez-vous adresser à Yamaha ou au distributeur le plus proche de vous figurant dans la liste suivante.

Die Einzelheiten zu Produkten sind bei Ihrer unten aufgeführten Niederlassung und bei Yamaha Vertragshändlern in den jeweiligen Bestimmungsländern erhältlich.

Para detalles sobre productos, contacte su tienda Yamaha más cercana o el distribuidor autorizado que se lista debajo.

## NORTH AMERICA

### CANADA

**Yamaha Canada Music Ltd.**  
135 Milner Avenue, Scarborough, Ontario,  
M1S 3R1, Canada  
Tel: 416-298-1311

### U.S.A.

**Yamaha Corporation of America,  
Keyboard Division**  
6600 Orangethorpe Ave., Buena Park, Calif. 90620,  
U.S.A.  
Tel: 714-522-9011

## CENTRAL & SOUTH AMERICA

### MEXICO

**Yamaha de Mexico S.A. De C.V.,  
Departamento de ventas**  
Javier Rojo Gomez No.1149, Col. Gpe Del  
Moral, Deleg. Iztapalapa, 09300 Mexico, D.F.  
Tel: 686-00-33

### BRAZIL

**Yamaha Musical do Brasil LTDA.**  
Av. Rebouças 2636, São Paulo, Brasil  
Tel: 011-853-1377

### ARGENTINA

**Yamaha Music Argentina S.A.**  
Viamonte 1145 Piso-2-B 1053,  
Buenos Aires, Argentina  
Tel: 1-4371-7021

### PANAMA AND OTHER LATIN AMERICAN COUNTRIES/ CARIBBEAN COUNTRIES

**Yamaha de Panama S.A.**  
Torre Banco General, Piso 7, Urbanización Marbella,  
Calle 47 y Aquilino de la Guardia,  
Ciudad de Panamá, Panamá  
Tel: 507-269-5311

## EUROPE

### THE UNITED KINGDOM

**Yamaha-Kemble Music (U.K.) Ltd.**  
Sherbourne Drive, Tilbrook, Milton Keynes,  
MK7 8BL, England  
Tel: 01908-366700

### IRELAND

**Danfay Ltd.**  
61D, Sallynoggin Road, Dun Laoghaire, Co. Dublin  
Tel: 01-2859177

### GERMANY/SWITZERLAND

**Yamaha Europa GmbH.**  
Siemensstraße 22-34, 25462 Rellingen,  
F.R. of Germany  
Tel: 04101-3030

### AUSTRIA

**Yamaha Music Austria**  
Schleiergasse 20, A-1100 Wien Austria  
Tel: 01-60203900

### THE NETHERLANDS

**Yamaha Music Nederland**  
Kanaalweg 18G, 3526KL, Utrecht, The Netherlands  
Tel: 030-2828411

### BELGIUM

**Yamaha Music Belgium**  
Keiberg Imperiastraat 8, 1930 Zaventem, Belgium  
Tel: 02-7258220

### FRANCE

**Yamaha Musique France,  
Division Claviers**  
BP 70-77312 Marne-la-Vallée Cedex 2, France  
Tel: 01-64-61-4000

### ITALY

**Yamaha Musica Italia S.P.A.,  
Home Keyboard Division**  
Viale Italia 88, 20020 Lainate (Milano), Italy  
Tel: 02-935-771

### SPAIN/PORTUGAL

**Yamaha-Hazen Electronica Musical, S.A.**  
Ctra. de la Coruna km. 17, 200, 28230  
Las Rozas (Madrid) Spain  
Tel: 91-201-0700

### GREECE

**Philippe Nakas S.A.**  
Navarinou Street 13, P.Code 10680, Athens, Greece  
Tel: 01-364-7111

### SWEDEN

**Yamaha Scandinavia AB**  
J. A. Wettergrens Gata 1  
Box 30053  
S-400 43 Göteborg, Sweden  
Tel: 031 89 34 00

### DENMARK

**YS Copenhagen Liaison Office**  
Generatorvej 8B  
DK-2730 Herlev, Denmark  
Tel: 44 92 49 00

### FINLAND

**F-Musiikki Oy**  
Kluuvikatu 6, P.O. Box 260,  
SF-00101 Helsinki, Finland  
Tel: 09 618511

### NORWAY

**Norsk filial av Yamaha Scandinavia AB**  
Grini Næringspark 1  
N-1345 Østerås, Norway  
Tel: 67 16 77 70

### ICELAND

**Skifan HF**  
Skeifan 17 P.O. Box 8120  
IS-128 Reykjavik, Iceland  
Tel: 525 5000

### OTHER EUROPEAN COUNTRIES

**Yamaha Europa GmbH.**  
Siemensstraße 22-34, 25462 Rellingen,  
F.R. of Germany  
Tel: 04101-3030

## AFRICA

**Yamaha Corporation,  
Asia-Pacific Music Marketing Group**  
Nakazawa-cho 10-1, Hamamatsu, Japan 430-8650  
Tel: 053-460-2312

## MIDDLE EAST

### TURKEY/CYPRUS

**Yamaha Europa GmbH.**  
Siemensstraße 22-34, 25462 Rellingen,  
F.R. of Germany  
Tel: 04101-3030

### OTHER COUNTRIES

**Yamaha Music Gulf FZE**  
LB21-128 Jebel Ali Freezone  
P.O.Box 17328, Dubai, U.A.E.  
Tel: 971-4-881-5868

## ASIA

### HONG KONG

**Tom Lee Music Co., Ltd.**  
11/F., Silvercord Tower 1, 30 Canton Road,  
Tsimshatsui, Kowloon, Hong Kong  
Tel: 2737-7688

### INDONESIA

**PT. Yamaha Music Indonesia (Distributor)  
PT. Nusantik**  
Gedung Yamaha Music Center, Jalan Jend. Gatot  
Subroto Kav. 4, Jakarta 12930, Indonesia  
Tel: 21-520-2577

### KOREA

**Cosmos Corporation**  
1461-9, Seocho Dong, Seocho Gu, Seoul, Korea  
Tel: 21-3486-0011

### MALAYSIA

**Yamaha Music Malaysia, Sdn., Bhd.**  
Lot 8, Jalan Perbandaran, 47301 Kelana Jaya,  
Petaling Jaya, Selangor, Malaysia  
Tel: 3-703-0900

### PHILIPPINES

**Yupango Music Corporation**  
339 Gil J. Puyat Avenue, P.O. Box 885 MCPO,  
Makati, Metro Manila, Philippines  
Tel: 819-7551

### SINGAPORE

**Yamaha Music Asia Pte., Ltd.**  
11 Ubi Road #06-00, Meiban Industrial Building,  
Singapore  
Tel: 65-747-4374

### TAIWAN

**Yamaha KHS Music Co., Ltd.**  
10F, 150, Tun-Hwa Northroad,  
Taipei, Taiwan, R.O.C.  
Tel: 02-2713-8999

### THAILAND

**Siam Music Yamaha Co., Ltd.**  
121/60-61 RS Tower 17th Floor,  
Ratchadaphisek RD., Dindaeng,  
Bangkok 10320, Thailand  
Tel: 02-641-2951

### THE PEOPLE'S REPUBLIC OF CHINA AND OTHER ASIAN COUNTRIES

**Yamaha Corporation,  
Asia-Pacific Music Marketing Group**  
Nakazawa-cho 10-1, Hamamatsu, Japan 430-8650  
Tel: 053-460-2317

## OCEANIA

### AUSTRALIA

**Yamaha Music Australia Pty. Ltd.**  
Level 1, 99 Queensbridge Street, Southbank, Victoria  
3006, Australia  
Tel: 3-9693-5111

### NEW ZEALAND

**Music Houses of N.Z. Ltd.**  
146/148 Captain Springs Road, Te Papapa,  
Auckland, New Zealand  
Tel: 9-634-0099

### COUNTRIES AND TRUST TERRITORIES IN PACIFIC OCEAN

**Yamaha Corporation,  
Asia-Pacific Music Marketing Group**  
Nakazawa-cho 10-1, Hamamatsu, Japan 430-8650  
Tel: 053-460-2312

**HEAD OFFICE** Yamaha Corporation, Pro Audio & Digital Musical Instrument Division  
Nakazawa-cho 10-1, Hamamatsu, Japan 430-8650  
Tel: 053-460-3273

## FCC INFORMATION (U.S.A.)

### 1. IMPORTANT NOTICE: DO NOT MODIFY THIS UNIT!

This product, when installed as indicated in the instructions contained in this manual, meets FCC requirements. Modifications not expressly approved by Yamaha may void your authority, granted by the FCC, to use the product.

### 2. IMPORTANT:

When connecting this product to accessories and/or another product use only high quality shielded cables. Cable/s supplied with this product MUST be used. Follow all installation instructions. Failure to follow instructions could void your FCC authorization to use this product in the USA.

### 3. NOTE:

This product has been tested and found to comply with the requirements listed in FCC Regulations, Part 15 for Class "B" digital devices. Compliance with these requirements provides a reasonable level of assurance that your use of this product in a residential environment will not result in harmful interference with other electronic devices. This equipment generates/uses radio frequencies and, if not installed and used according to the instructions found in the users manual, may cause interference harmful to the operation of other electronic devices. Compliance with FCC

regulations does not guarantee that interference will not occur in all installations. If this product is found to be the source of interference, which can be determined by turning the unit "OFF" and "ON", please try to eliminate the problem by using one of the following measures:

Relocate either this product or the device that is being affected by the interference.

Utilize power outlets that are on different branch (circuit breaker or fuse) circuits or install AC line filter/s.

In the case of radio or TV interference, relocate/reorient the antenna. If the antenna lead-in is 300 ohm ribbon lead, change the lead-in to co-axial type cable.

If these corrective measures do not produce satisfactory results, please contact the local retailer authorized to distribute this type of product. If you can not locate the appropriate retailer, please contact Yamaha Corporation of America, Electronic Service Division, 6600 Orangethorpe Ave, Buena Park, CA90620

The above statements apply ONLY to those products distributed by Yamaha Corporation of America or its subsidiaries.

\* This applies only to products distributed by YAMAHA CORPORATION OF AMERICA.

(class B)

### IMPORTANT NOTICE FOR THE UNITED KINGDOM Connecting the Plug and Cord

IMPORTANT. The wires in this mains lead are coloured in accordance with the following code:

BLUE : NEUTRAL  
BROWN : LIVE

As the colours of the wires in the mains lead of this apparatus may not correspond with the coloured markings identifying the terminals in your plug proceed as follows:

The wire which is coloured BLUE must be connected to the terminal which is marked with the letter N or coloured BLACK.

The wire which is coloured BROWN must be connected to the terminal which is marked with the letter L or coloured RED.

Making sure that neither core is connected to the earth terminal of the three pin plug.

(2 wires)

• This applies only to products distributed by Yamaha-Kemble Music (U.K.) Ltd.

**CAUTION:** TO PREVENT ELECTRIC SHOCK, MATCH WIDE BLADE OF PLUG TO WIDE SLOT, FULLY INSERT.

**ATTENTION:** POUR ÉVITER LES CHOCS ÉLECTRIQUES, INTRODUIRE LA LAME LA PLUS LARGE DE LA FICHE DANS LA BORNE CORRESPONDANTE DE LA PRISE ET POUSSER JUSQU'AU FOND.

• This applies only to products distributed by Yamaha Canada Music Ltd. (polarity)  
• Ceci ne s'applique qu'aux produits distribués par Yamaha Canada Musique Ltée.



Clavinova Web site (English only)

<http://www.yamaha.co.jp/english/product/cl/>

Yamaha Manual Library (English versions only)

<http://www2.yamaha.co.jp/manual/english/>

M.D.G., Pro Audio & Digital Musical Instrument Division, Yamaha Corporation  
© 2000 Yamaha Corporation

V576720 0??POZC??-??B0 Printed in Indonesia



## Free Manuals Download Website

<http://myh66.com>

<http://usermanuals.us>

<http://www.somanuals.com>

<http://www.4manuals.cc>

<http://www.manual-lib.com>

<http://www.404manual.com>

<http://www.luxmanual.com>

<http://aubethermostatmanual.com>

Golf course search by state

<http://golfingnear.com>

Email search by domain

<http://emailbydomain.com>

Auto manuals search

<http://auto.somanuals.com>

TV manuals search

<http://tv.somanuals.com>