

ZANUSSI

**MAGNETRONOVEN
MICROWAVE OVEN
MICRO-ONDES
MIKROWELLENOFEN**

ZMD30Q

Contents

Before using your microwave oven	4	Charts	22
– Utensil safety	5	– Recommendations for Cooking with Grill	22
Technical data	4	– Recommendations for Cooking with Microwave and Grill	22
Safety instructions	5	– Recommendations for Manual Defrost	23
– Safety Instructions when Cooking with Grill	5	– Auto Cook Programmes Chart	24
– Testing suitability of	6	Microwave Hints	26
– Food safety	6	Care and cleaning	27
– Oven utensils and accessories guide	7	– Cleaning the accessories (turntable and support)	27
Getting Started	8	– Cleaning the interior	27
– Unpacking	8	– Cleaning the Grill	27
Installation	8	– Cleaning the exterior	27
– Building in	8	Guarantee Conditions	28
– Electrical Connections	11		
How to operate your microwave oven	12		
– Name and function of parts	12		
– Turntable Installation	12		
– Control panel	13		
– Setting the Clock	14		
– Child Safety Lock	14		
– To Stop the Oven	14		
– Turntable stop key	15		
– Kitchen Timer	15		
– Quick Start	15		
– Manual Defrosting	15		
– Microwave Power setting Guide	15		
– Microwave cooking	16		
– Cooking with Grill	16		
– Combination Cooking	17		
– Defrost	18		
– Two Stage Cooking	19		
– Auto Cook	20		
– ' Crunchie ' Function	21		

Congratulations on the purchase of your new Microwave Oven

Thank you for having chosen a Zanussi product. We are convinced that you will find your new microwave oven very useful and that it will be of great help to you. As with all new kitchen appliances, it will take some time to learn all the new functions and features, but with time, this oven will become indispensable to you.

Before using your Microwave Oven

Read through the instruction manual carefully. In order that you can get the best from your new Zanussi Microwave Oven, the following instructions have been prepared. Please make sure you read them carefully. It is important that this instruction book is retained with the appliance for future reference. Should the appliance be sold or transferred to another owner, or if you move house and leave the appliance, always ensure that the book is supplied with the appliance or that the new owner can be acquainted with the functioning of the appliance and the relevant warnings.

Please ensure you have read the whole instruction book before using the appliance and that you follow the recommendations given.

Technical data

Overall dimension	Weight 30 kg
Width 595 mm	Volume 30 Litre
Depth 560 mm	
Height 458 mm	Power source 230V, 50 Hz
Cavity dimension	Fuse 16A
Width 360 mm	Power consumption 3000W
Depth 350 mm	
Height 235 mm	Power output 900W
	Grill 1550W

Safety Instructions

- The built-in safety interlock switches prevent the microwave oven from operating when the door is open.
- Do not tamper with them, or attempt to operate the oven with the door open as open door operation can result in exposure to microwave energy.
- Do not allow food spills or cleaner residue to accumulate on door sealing surfaces. See the Cleaning and Care section for cleaning instructions.
- Do not operate the oven if it is damaged until it has been repaired by qualified service personnel.
- It is particularly important that the oven door closes properly and that there is no damage to the: (1) door (warped), (2) hinges and latches (broken or insecure), (3) door seals and sealing surface.
- Under no circumstances should you attempt to repair the appliance yourself. Repairs carried out by inexperienced persons may cause injury or serious malfunctioning. Contact your local Service Force Centre.
- Do not remove the outer case, door or control panel at any time. Doing so may cause exposure to extremely high voltage.
- Install or locate this oven only in accordance with **“INSTALLATION INSTRUCTIONS”** found in this manual.
- Use the appliance for its intended use as described in this manual. Do not use corrosive chemicals in this appliance. This type of oven is specifically designed to heat, cook, or defrost food. It is not designed for industrial or laboratory use neither for commercial use as this will invalidate the guarantee.
- Do not operate the oven empty. If food or water is not present to absorb the microwave energy, the magnetron tube can be damaged.
- Close supervision is necessary when the oven is used by children.
- Do not store this appliance outdoors. Do not use this product near water.
- Do not attempt to dry clothing or newspapers in the microwave oven. These items can ignite.
- Do not use the cavity for storage purposes. Do not leave paper products, cooking utensils, or food in the cavity when not in use.

Utensil safety

Most glass, glass ceramic and heat-resistant glassware utensils are excellent for use in the microwave oven. Although microwave energy will not heat most glass and ceramic items, these utensils can become hot as heat transfers from the food to the container. The use of oven gloves to remove dishes is recommended.

Safety instructions when cooking with grill or combination modes.

1. The glass viewing window may break if water is spilled on it during grilling or convection cooking.
2. Be sure to use an oven glove when loading and unloading the oven. Containers get very hot in the oven, so be careful not to burn yourself. The turntable and metal rack also get very hot so be sure to use an oven glove when handling them.
3. Do not touch the inner or outer viewing window with metal components when loading or unloading the oven. The inside of the door and oven get very hot so take care when attending food in the oven.
4. Do not put the turntable or containers in cold water or try to cool them quickly after use.
5. Do not place items on top of the cabinet. The top of the cabinet gets very hot, so anything placed on it may be damaged by the heat.



It is quite normal for steam to be emitted around the door, or for misting to occur on the door, or even for water droplets to appear below the door during the cooking cycle. This is merely condensation from the heat of the food and does not affect the safety of your oven. The door is not intended to seal the oven cavity completely.

- Do not force the turntable to rotate by hand. This may cause malfunctioning.
- Arcing in the oven during microwave operation usually occurs from use of metallic utensils. Continuous arcing, however, can damage the unit. Stop the programme and check the utensil.
- Care should be taken not to obstruct any air vents located on the top, rear, side and bottom of the oven.



Do not use this oven for commercial purposes. This oven is made for domestic use only.

Testing suitability of cookware

- Place the cookware in the microwave along with a glass half full of water. Heat on 900 W (100%) for one minute. If the cookware feels hot, you should not use it. If it is just slightly warm, you can use it for reheating but not for cooking. If the dish is room temperature, it is suitable for microwave cooking.
- Paper napkins, wax paper, paper towels, plates, cups, cartons, freezer wrap and cardboard are great convenience utensils. Always be sure containers are filled with food to absorb energy and thus avoid the possibility of overheating.
- Many plastic dishes, cups, freezer containers and plastic wraps may be used in the microwave oven. Follow manufacturer's instructions when using plastics in the oven. Avoid using plastic utensils with foods that have high fat or sugar content since these foods reach high temperatures and could melt some plastics.
- Metal utensils and utensils with metallic trim should not be used in the microwave oven, unless specifically recommended for microwave use.
- Containers with restricted openings, such as bottles, should not be used for microwave cooking.
- Use caution when removing a lid or cover from a dish to avoid steam burns.

WARNING : Do not leave oven unattended, and look at it from time to time when heating or cooking food in plastic, paper or other combustible containers. If smoke is observed, keep door closed, switch the oven off or disconnect oven until smoke stops.

Food safety

- Do not heat food in a can in the microwave oven. Always remove the food to a suitable container.
- Deep fat frying should not be done in the microwave oven, because the fat temperature cannot be controlled, hazardous situations can result.
- Popcorn may be prepared in the microwave oven, but only in special packages or utensils designed specifically for this purpose. This cooking operation should never be un-attended.
- Pierce foods with non-porous skins or membranes to prevent steam build-up and bursting. Apples, potatoes, chicken livers, and egg yolks are examples of items that should be pierced.

WARNING: When heating liquids, e.g. soups, sauces and beverages in your microwave oven, overheating the liquid beyond boiling point can occur without evidence of bubbling. This could result in a sudden boil over of the hot liquid. To prevent this possibility the following steps should be taken:

1. Avoid using straight-sided containers with narrow necks.
 2. Do not overheat.
 3. Stir the liquid before placing the container in the oven and again halfway through the heating time.
 4. After heating, allow to stand in the oven for a short time, stirring again before carefully removing the container.
- Some products such as whole eggs and sealed containers – for example, closed glass jars – may explode and should not be heated in this oven. Occasionally, poached eggs may explode during cooking. Always pierce the yolk, then cover and allow the standing time of one minute before removing cover.

NOTE:

- Do not force the turntable to rotate by hand. This may cause malfunctioning.
- Arcing in the oven during microwave operation usually occurs from use of metallic utensils. Continuous arcing, however, can damage the unit. Stop the programme and check the utensil.
- Care should be taken not to obstruct any air vents located on the top, rear, side and bottom of the oven.

Do not use this oven for commercial purposes.

This oven is made for domestic use only.

Keep these instructions

Oven utensils and accessories guide

A variety of Utensils and Materials may be used for cooking in your microwave oven. For your safety and to prevent damaging utensils and your oven choose appropriate utensils and materials for each cooking method. The list below is a general guide.

Material	Utensils	Mode of operation		
		Microwave	Grill	Combination
Ceramic & Glass	Corning ware	YES	YES	YES
	Heat resistant glass ware	YES*1	YES	YES*1
	Glass ware with metal decoration	NO	NO	NO
	Lead crystal glass	NO	NO	NO
China	Without metal decoration	YES	YES	NO
Pottery*2		YES	YES	YES
Plastic	Microwave oven heat-proof wear	YES	NO	NO
	Plastic wrap	YES	NO	NO
Metal	Baking pan	NO	YES	NO
	Aluminium foil*3	YES	YES	YES
Paper	Cups, plates, towels	YES	NO	NO
	Waxed paper	YES	NO	NO
Wood		NO	NO	NO
Accessories	Grill rack	NO	YES	YES
	Turntable	YES	YES	YES
	Turntable support	YES	YES	YES

YES: Utensils and accessories to use

NO: Utensils and accessories to avoid

*1 Only if there is no metal trim.

*2 Only if it does not have a glaze containing metal.

*3 NOTE: Use aluminium foil only for shielding purposes, over use may cause arcing.

Unpacking

N.B. When you unpack the oven, check that the product is free from damage. Damage or any missing parts must be reported immediately to the retailer. The oven, parts of the oven or the accessories may be wrapped by a protection foil. If so, you must remove this foil before using the oven. Do not leave packing material so that small children can play with it. This can be hazardous.

Installation

Building In

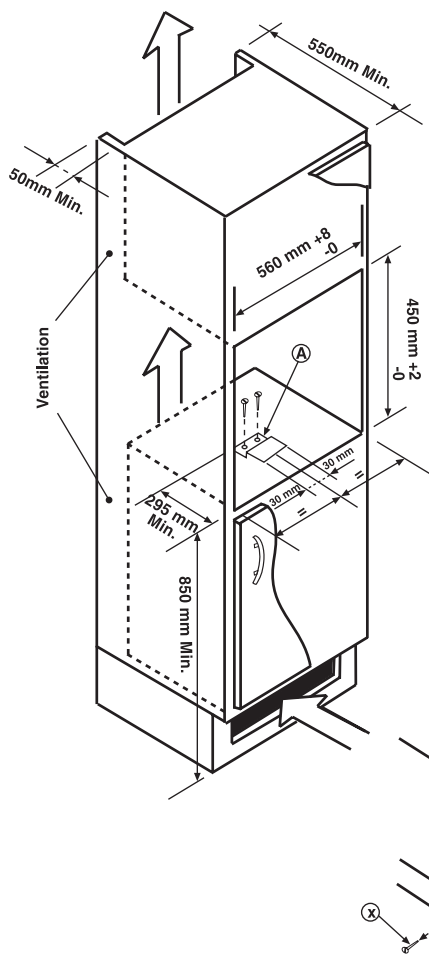

Inside the oven there is a plastic bag with fixing material. Take this bag out of the oven.

1. Remove the two screws 'X' from the fastening bar under the microwave oven.
2. Fasten metal strip 'A' using the two screws 'X' that have just been removed.

The appliance needs sufficient ventilation. Make an opening in the plinth at least 280 cm^2 large for this purpose.

Building In

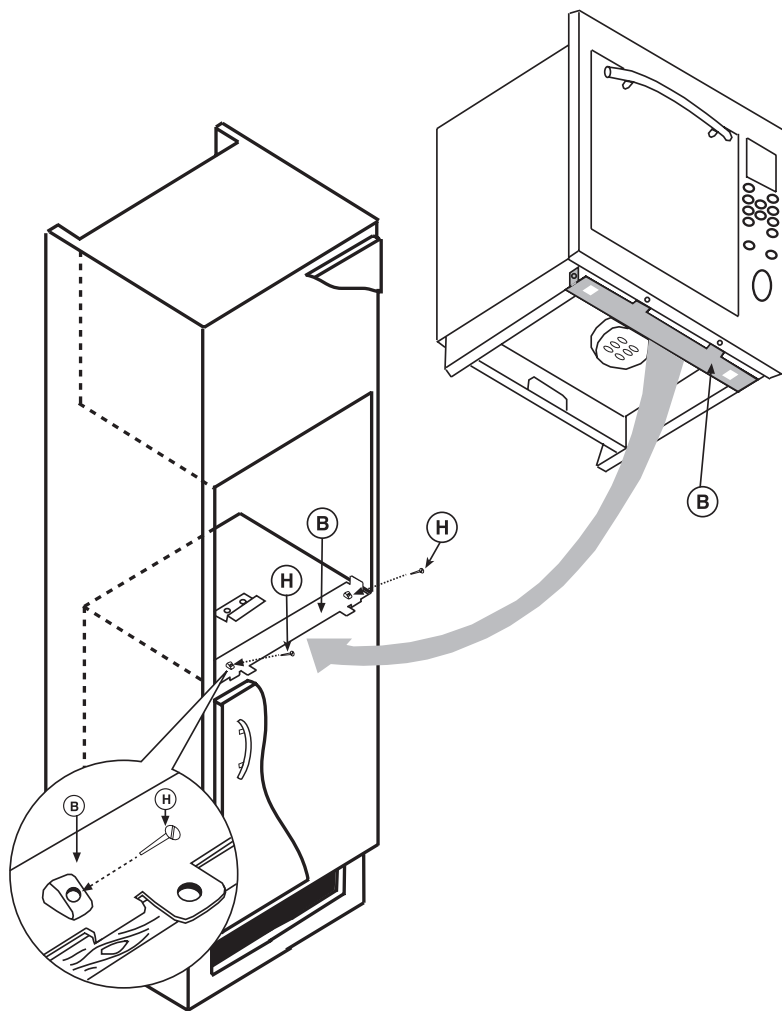

3. Fit the fastening bar 'B' at the correct position in the recess. Make sure that there is the same amount of free space at each side of the fastening bar. Fasten the bar with screws 'H'.

Fix the fastening bar such that the two lips stick out over the edge of the bottom of the recess and rest against it at the front.

Building In

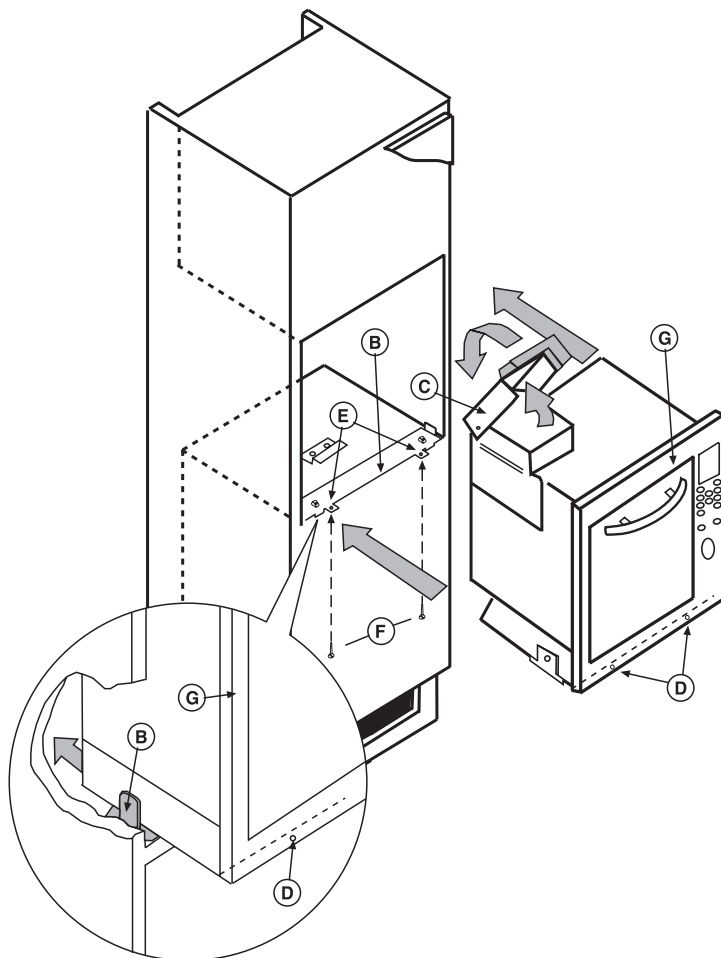

4. Open the lid of the warm air ventilation duct 'C' fully.
5. Slide the appliance into the recess. Slide the front of the appliance over the fastening bar 'B'. Keep sliding it until the front of the oven 'G' is resting against the cupboard and the holes 'D' under the oven are aligned with the holes 'E' in the fastening bar 'B'.
6. Fasten the appliance to the fastening bar 'B' using screws 'F'.

Attention.

The plug for the appliance should be accessible at all times.

Electrical connections

WARNING! THIS APPLIANCE MUST BE EARTHED.

The manufacturer declines any liability should this safety measure not be observed.

- If the plug that is fitted to your appliance is not suitable for your socket outlet, it must be cut off and the appropriate plug fitted.
- Remove the fuse from the cut off plug. The cut off plug should then be disposed of to prevent the hazard of shocks in case it should be plugged into a 13 Amp socket in another part of your home.

How to operate your microwave oven

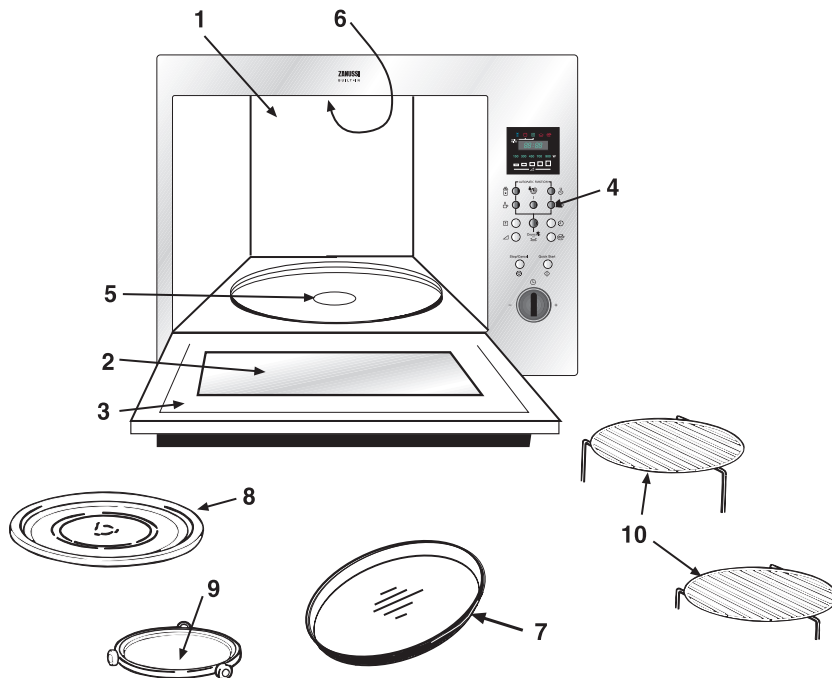

Name and function of parts

1. Cooking compartment. Wipe the compartment clean after using the oven.
2. Viewing window. Food can be checked while the microwave oven is in operation.
3. Oven door. The door must always be firmly closed while cooking.
4. Control panel.
5. Drive shaft for turntable.
6. Grill Element.
7. Crunch Dish
8. Turntable.
9. Turntable support.
10. Grilling racks, one high and one low, used for most cooking and browning/grilling.

IMPORTANT - Use either high or low grill rack only. Do not use both grill racks at the same time.

Turntable Installation

1. Place the turntable support on the cavity Bottom.
2. Place the turntable on top of the turntable support as shown in the diagram. Make sure that turntable hub is securely locked in the turntable shaft. **Never place the turntable upside down.**
 - Both turntable and turntable support must always be used during cooking.
 - All food and containers of food are always placed on this turntable for cooking.
 - This turntable rotates clockwise and anticlockwise; this is normal.

Turntable

Roller rest

Turntable Shaft

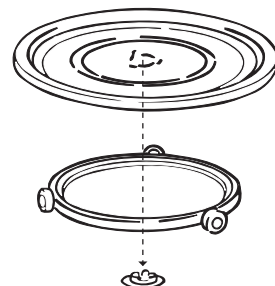

Control Panel

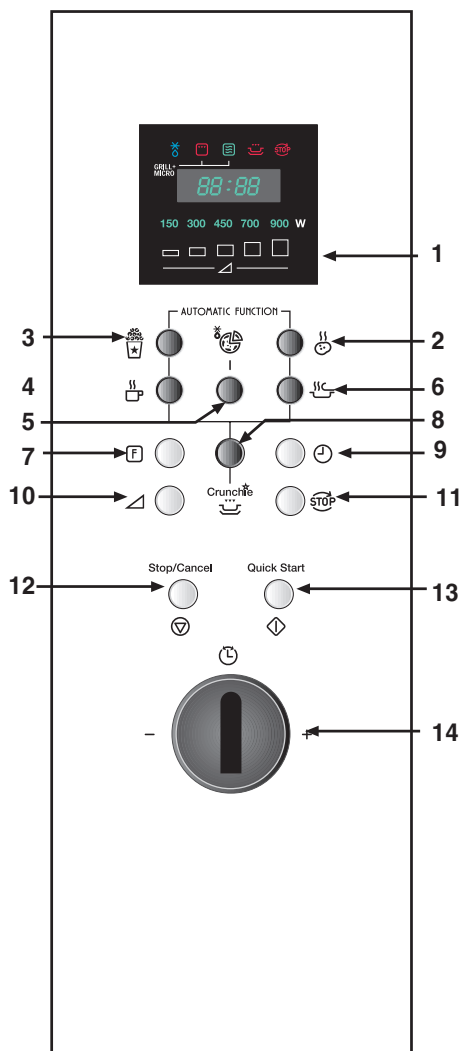

- 1. Display Window**
To view either Cook time, Power level and time of day.
- 2. Potato Function**
Used to automatically cook potatoes
- 3. Popcorn**
Used to automatically cook popcorn
- 4. Beverages**
Used to automatically ReHeat beverages
- 5. Pizza**
Used to automatically cook pizza
- 6. Ready Meals**
Used to automatically cook ready meals
- 7. Function**
To select Microwave, Grill and combination modes.
- 8. 'Crunchie'**
For 'Crunchie' cooking
- 9. Clock**
To set the time of day
- 10. Power**
To set the desired Microwave power level
- 11. Turntable Stop Key**
To Stop the turntable
- 12. Stop/Clear**
To stop or pause your Microwave
- 13. Quick Start**
To start your microwave
- 14. Setting Control Knob**
Used to set desired cooking times.

Setting the Clock

When your oven is plugged in for the first time or when power resumes after a power interruption, the display window flash and show "----"

Example: To set 4.30

1. Touch the Clock button.
2. Set the time to " 4:00 " using the setting control knob
3. Touch the Clock Button
4. Set the time to " 4:30 " using the setting control knob
5. Touch the Clock button. (The Time will now be set)

NOTE : It is possible to display the current time even after starting the mode set, by pressing the Clock button (the time is displayed for 2 seconds).

Child safety lock

This oven has a safety feature which prevents the accidental running of the oven by a child. After the lock has been set, no part of the microwave oven will operate until the child lock feature has been cancelled.

To set:

1. Touch and hold the ' **Stop** ' button for 5 sec's, a beep will be heard.

To cancel the child lock, simply touch and hold the ' **Stop** ' button for 5 sec's, a beep will be heard.

To Stop the Oven

There are two way to stop the oven whilst it is in use.

1. Press the Stop/Clear button
 - You may restart the oven by pressing the Start button
 - Pressing Stop/Clear again will reset the current programme
2. Open the door
 - You may restart the oven by closing the door and pressing the Start button
 - Pressing Stop/Clear again will cancel the current programme

At the end of each cooking the cooling fan will remain in operation until the oven door is opened

Turntable Stop Key

When using large sized containers/recipient (or containers with handles) that are not able to rotate, the movement of the turntable can be stopped. Press the TURNTABLE STOP key (15), after having first set a cooking function: the LED in the top right will start flashing.

After having pressed START, the LED will flash a further 5 times, and will then remain on for the entire set time; for best results, the food should be mixed/stirred a number of times during cooking. The TURNTABLE STOP function will remain on the next time the oven is used, that is until the TURNTABLE STOP key is pressed again.

For the microwave-only function, the maximum power available is 700W (reduced automatically by the electronic controller when pressing the TURNTABLE STOP key).

Kitchen Timer

This function allows for the use of the timer, with the oven NOT functioning, for up to 60 minutes.

1. Press the FUNCTION key until 3 dashes appear on the (lower) temperature display
2. Select the desired time by turning the setting control knob
3. Press START.

At the end, 3 beeps will be heard the "end" warning will appear on display 1.

Quick Start

Pressing the 'Start' button allows you to start your microwave at full power (900W) for 30 seconds.

Each time you press the 'Start' button you will increase the cooking time by 30 seconds, up to a maximum of 3 minutes.

This mode is activated only if it is carried out within 1 minute after the food has been placed in the oven.

Microwave Power setting Guide

Power Setting	Suggested use
150W	Keeping warm : Keeping foods warm
	Thawing frozen foods.
300W	Simmer : Completing the cooking cycle of some pot roasts. Casseroles and stews.
	Baked custards or cheesecakes.
450W	Medium : Faster defrosting for casseroles and stews.
	Baking cakes and sponge puddings
700W	Reheat : Reheating of casseroles and stews..
	Reheating pre-cooked foods.
	Roasting joints of meat and poultry.
900W	Max Power ; Boiling or reheating liquids. Cooking vegetables. Preheating a browning dish.

Microwave Cooking

1. Open the door, place the food on the turntable. Close the door. To turn off the oven during cooking, simply touch the Stop/Clear button.
2. Press The Function Key once.
3. Press the ' Power ' button until the desired power level is reached. **Note: After use, be sure to press the Stop/Clear button Twice as this will ensure that you have reset the microwave.**
4. Set the desired time by turning the setting control knob.
5. Press Start **(The oven begins cooking.)**

Example: To cook at 450W for 15 minutes

1. Press the function key once.
2. Touch the Power button 3 times (' 450 ' should now be showing in the display window).
3. Turn the setting control knob (' 15:00 ' should now be showing in the display window).
4. Press start. The Oven will now start cooking.

Cooking With Grill

1. Open the door, place the food on the High Rack. Close the door. To turn off the oven during cooking, simply touch the Stop/Clear button.
2. Press The Function Key 6 times.
3. Set the desired time by turning the setting control knob. **Note: After use, be sure to press the Stop/Clear button Twice as this will ensure that you have reset the microwave.**
4. Press Start **(The oven begins cooking.)**

Example: To cook with Grill for 15 minutes

1. Touch the Function button X 6 ('  ' should now be showing in the display window) .
 2. Turn the setting control knob. (' 15:00 ' Should now be showing in the display window).
 3. Press start. The Oven will now start.
-



Combination Cooking

This oven offers you a choice of one method of Combination cooking. This is ' Microwave and Grill '

1. Open the door, place the food on the turntable.
Close the door. To turn off the oven during cooking, simply touch the Stop/Clear button.
2. Press the ' Function ' button until the desired programme is reached. **NOTE : After use, be sure to press the Stop/Clear button Twice as this will ensure that you have reset the microwave.**
3. Set the desired time by turning the setting control knob.
4. Press Start (The oven begins cooking.)

NOTE : During this mode the Microwave power can be altered by pressing the Power Button.

Example: To cook with ' Microwave and Grill ' for 29 minutes.

1. Touch the ' **Function** ' button 4 times.
('   ' should now be showing in the display window).
 2. Set the desired time by turning the setting control knob.
(' **29:00** ' should now be showing in the display window)
 3. Press start. The Oven will now start cooking.
-

Defrost

For manual, use the defrost function. To speed up the defrosting of dense foods over 450g (1lb), the oven may be started on 900W (100%) power for 1 - 3 minutes, then reduced to (100W) until defrosting is complete.

1. Open the door, place the food on the turntable.
Close the door. To turn off the oven during defrosting, simply touch the Stop/Clear button.
2. Press function button twice. **NOTE : After use, be sure to press the Stop/Clear button Twice as this will ensure that you have reset the microwave.**
3. Set the desired time by turning the setting control knob.
4. Press Start (The oven begins defrosting.)

Example: To defrost some food for 12 minutes.

1. Touch the function button twice
 2. Set the desired time by turning the setting control knob.
 3. Press start. The Oven will now start defrosting.
-

Defrosting Tips

1. It is better to underestimate defrosting time if you are unsure. Food will continue to defrost during the standing time.
2. Separate food as soon as possible.
3. Turn large items, e.g. joints, halfway through the defrosting time.
4. Remove any thawed food as soon as possible.
5. Remove or open any packaging before defrosting.
6. Place food in a larger container than that which it was frozen in, this will allow for easy stirring.
7. Begin thawing poultry, breast side down and turn over halfway through defrosting time or at pause. Delicate areas such as wing tips can be shielded with small pieces of smooth foil.
8. Standing time is very important, particularly for large, dense foods which cannot be stirred to ensure that the centre is completely defrosted before cooking.

Two Stage Cooking

Most frozen foods should be defrosted before cooking. This oven can be set for Two Stage Cooking which will allow you to defrost your food and then cook it in one easy step.

1. Open the door, place the food on the turntable. Close the door.
2. Press the Function button twice.
3. Set the desired time by turning the setting control knob.
4. Set the desired cooking mode
5. Set the desired time by turning the setting control knob.
6. Press Start (**The oven begins cooking.**)

Note: After use, be sure to press the Stop/Clear button Twice as this will ensure that you have reset the microwave.

Example: To defrost for 12 minutes and then cook at 700W for 29 minutes

1. Touch the function button twice.
 2. Set the desired time by turning the setting control knob. (12:00 should now be showing in the display window).
 3. Touch the function button once.
 4. Touch the power button 4 times (700 W should now be showing in the display window).
 5. Set the desired time by turning the setting control knob. (29:00 should now be showing in the display window).
 6. Press start. The Oven will now start cooking.
-

NOTE : For two stage cooking, after you have set the defrost time you can select any of the Five cooking modes (Microwave, Microwave and Grill, Microwave and Convection, Convection only, Grill only).

Auto Cook

This oven can be used to automatically ReHeat Drinks, potatoes, Chilled ready meals, Frozen Pizza / ready meals and Popcorn.

1. Open the door, place the food on the turntable. Close the door.
2. Press the desired ' Auto Cook ' button until the desired programme is reached.
3. Press Start (The oven begins cooking.)

To turn off the oven during cooking, simply touch the Stop/Clear button.

NOTE : After use, be sure to press the Stop/Clear button Twice as this will ensure that you have reset the microwave.

NOTE : For details See Table Below

NOTE : During AUTO COOK the oven will automatically select the required microwave power and cooking time.

Selection Chart for Auto Cook functions :-

Auto Programme	Press Button	Programme Description
Beverage	Once	Reheat one small cup (50cc) (room temperature)
	Twice	Reheat one medium cup (125cc) (room temperature)
	Three Times	Reheat one large cup (200cc) (room temperature)
	Four Times	Reheat 1 soup bowl (300cc) (chilled)
Potato	Once	Cook 200 g of potatoes
	Twice	Cook 400 g of potatoes
	Three Times	Cook 600 g of potatoes
Chilled Ready Meals	Once	Reheat 1 portion (250-350 g)
	Twice	Reheat 2 portion (450-550 g)
Frozen Pizza / Ready Meals	Once	Reheat 1 frozen pizza (250-500 g)
	Twice	Reheat 1 portion (250-350 g)
	Three Times	Reheat 2 portion (450-550 g)
Popcorn	Once	Cook 1 100 g packet of microwave popcorn

Example: To automatically cook 600g of Potatoes.

1. Touch the potato button 3 times
 2. Press start. The Oven will now start cooking.
-

See Auto Cook Programme Chart for further details.

' Crunchie ' Function

This function is used to cook/reheat all types of FROZEN "snacks" available on the market, such as: bread, savouries, pizzas, pies, flavoured hamburgers, "patate duchessa", various pastries, croissants, etc. For best results, follow these simple general rules/suggestions:

Note : The CRUNCH dish should ALWAYS be pre-heated before cooking (the oven performs this operation automatically on setting an "Sn" program and pressing START.

Note : ALWAYS refer to the table (page 25) before cooking, to check which category the food being cooked falls into.

1. Press the CRUNCHIE button repeatedly until the desired category appears on the display (each time the button is pressed, the display will show the message " Sn01 ", " Sn02 ", " Sn03 ", etc. and the corresponding LED at the top will light up).
2. Once the category has been selected, place the CRUNCH dish in the oven (directly on the turntable), close the door and press the START button. The oven will automatically heat the plate for 2 minutes, displaying the alternating messages " PRE -HEAT " (preheating).
3. At the end of the preheating phase (signalled by 4 "beeps"), remove the CRUNCH dish from the oven, using oven gloves (careful, it will be very hot!) and place the food being cooked/reheated on the plate. Put the CRUNCH dish back in the oven and press the START button again. The display will show the remaining cooking time and the microwave power level indicator will light up.

WARNING : Caution: when cooking/reheating the food, the oven works in combigrill mode; as a result, pay careful attention when removing the food from the oven, as both the CRUNCH dish and the heating element at the top of the cavity will be very hot.

Charts

Recommendations for cooking with Grill

All foods should be placed on the High rack with a non metal dish placed underneath to catch any food spillage or juices to minimise cleaning. Turn all food halfway through the cooking time.

Food	QTY. (Weight)	Cooking time	Special notes
Toast	2 Slices	4 – 5 min	
Cheese on Toast	4 Slices	6 – 7 min	4 – 5 min. to toast. 2 min. with topping

General recommendations for cooking with Microwave and Grill

Use the low rack on turntable for roast beef and pork, shield thin parts and edges. Place a non metal dish on the turn-table under the low rack to catch food spillage and juices. Turn food, as appropriate during the cooking time.

Food	QTY (Weight)	Power Selector position	Cooking time	Special notes
Bacon	4 (100 g)	Microwave 700W + Grill	7- 9 min	
Roast Beef (Boned)	900 g	Microwave only 700W	25 min	Brush with oil. Season with salt and pepper. Allow 15 – 20 minutes standing time after cooking.
Roast Pork (Loin)	900 g	Microwave 700W + Grill	5 - 6 min	
Pork Chops	2 - 3(450 g)	Microwave 700W + Grill	20 - 25 min	Brush with oil. Season with salt, pepper and paprika.
Chicken, Halved lengthways Legs	450 g	Microwave only 700W	15 - 20 min	Brush with oil. Season with salt, pepper and paprika.
	800 g	Microwave 700W + Grill	25 - 30 min	
Frozen Hamburger	4 (200 g)	Microwave 700W + Grill	12 - 15 min	
Sausages	450 g Only	Microwave 700W + Grill	10 - 15 min	
Fish Steak	2 (350 g)	Microwave 700W + Grill	22 – 24 min	Brush with oil, Season with salt and pepper.
Frozen Potato, Hash Brown	2 (150 g)	Microwave 700W + Grill	16 – 18 min.	

Recommendations for Manual Defrost

Some foods such as bread and fruit, can successfully be thawed manually by using this power setting (150W).

FOOD	PREPARATION	Defrost time	STANDING TIME
Bread			
Small loaf	Place on microwave-proof rack or kitchen paper. Turn over halfway through defrosting time.	8–10 min.	10–15 min.
Sliced large loaf	Place on microwave-proof rack or kitchen paper. Turn over halfway through defrosting time.	10–13 min.	10 min
2 slices	Place on kitchen paper.	45–60 sec.	5 min.
1 bread roll	Place on kitchen paper.	45–60 sec.	5 min.
2 bread rolls	Place on kitchen paper.	1–1½ min.	5 min.
Cakes and Pastry			
Gateau 450g/1 lb	Remove from packaging, place on plate.	9–11 min.	15–30 min.
Cheesecake 450g/1 lb	Remove from packaging, place on plate.	9–11 min.	15–30 min.
Pie (cooked) 450g/1 lb	Remove from packaging, place on plate.	7–9 min.	15–30 min.
Pastry 450g/1 lb	Remove from packaging, place on plate.	7–9 min.	15–30 min.
Butter			
250g/8.8 oz (1 packet)	If foil wrapped, remove from wrapper and place on a plate	3–4 min.	5–10 min.
Fruit			
225g/8 oz Soft berry fruits	Place in a single layer in a shallow dish.	5–6 min.	5–10 min.
450g/1 lb Soft berry fruits	Place in a single layer in a shallow dish.	7–8 min.	5–10 min.
Plated meal			
400g/14 oz	Cover with a plate or non P.V.C. cling film. To reheat, microwave on 100% (900W) for 3–4 minutes.	7–8 min	5–10 min.
Vegetables			
	It is not necessary to defrost vegetables before cooking. All vegetables can be thawed and cooked on 100% (900W)		

Auto Cook Programmes Chart

Auto Programme	Press Button	Programme Description	Special Notes
Beverage	Once	Reheat one small cup (50cc) (room temperature)	After reheating the liquid, stir well to spread the temperature evenly
	Twice	Reheat one medium cup (125cc) (room temperature)	
	Three Times	Reheat one large cup (200cc) (room temperature)	
	Four Times	Reheat 1 soup bowl (300cc) (chilled)	
Potato	Once	Cook 200 g of potatoes	Wash the potatoes thoroughly in their jackets, pierce them and put them on the turntable. They can be served stuffed with butter or cheese
	Twice	Cook 400 g of potatoes	
	Three Times	Cook 600 g of potatoes	
Chilled Ready Meals	Once	Reheat 1 portion (250-350 g)	Suitable for cooked portions of food, stored in the refrigerator on the plate (the one from which the food is to be eaten). In the case of pre-cooked food products, remove the food from any aluminium packaging/containers and place it on an ovenproof plate.
	Twice	Reheat 2 portions (450-550 g)	
Frozen Pizza / Ready Meals	Once	Reheat 1 frozen pizza (250-500 g)	Place the pizza directly on the turntable. Place the packet on the turntable, being careful to remove any covers (film, bags). If the packet is not suitable for microwaves, however, (e.g. metal pans), remove the food from the packet on to the serving dish, placing it uncovered on the turntable.
	Twice	Reheat 1 portion (250-350 g)	
	Three Times	Reheat 2 portions (450-550 g)	
Popcorn	Once	Cook 1 x 100 g packet of microwave popcorn	Follow the instructions written on the box closely and place it on the turntable.

Auto Cook Programmes Chart

Category	Notes / Suggestions	Possible Actions
SN01	This category is ideal for cooking/reheating uncooked frozen sandwiches (rolls, baguettes, etc.) available on the market. It is also perfect for reheating slices of pizza (max 200g) that are sold pre-cooked (e.g. speedy pizza) and slices of "focaccia" bread (150-180g).	Do not cook more than 300g of bread (4-5 pieces) at a time. To avoid burning your mouth, break the bread in half after removing it from the oven, so as to release the heat from inside the soft part.
SN02	This category is ideal for cooking raw pastry mini pizzas (max 10-12 pieces). Depending on the type of pizza, they may be cooked either in this category or in the "Sn03" category. In addition, it is also ideal for reheating chicken pieces and for cooking hamburgers (max 2, that is, 150g).	Keep the pizzas an equal distance apart, because during cooking they rise and risk, if overlapping, not being cooked evenly. Hamburgers should be turned over halfway through cooking.
SN03	This category is ideal for cooking hamburgers (max 3-4, that is, 300g) and for cooking savouries (max 280g), all types of potatoes (croquettes, "patate duchessa", etc.) and some types of mini pizzas (max 10-12).	The hamburgers should be turned over halfway through cooking. Keep the savouries and the pizzas an equal distance apart to prevent them from sticking together.
SN04	This category is ideal for heating frozen pre-cooked pies (courgette pies, "stracchino" pie, etc.) available on the market. It is also ideal for raw frozen croissants (min. 3-4) and for cooking savouries (min. 300g).	In the case of croissants or savouries, keep them an equal distance apart, as during cooking they swell and risk sticking together (and thus not cooking properly).
SN05	This category is ideal for cooking raw frozen pies ("torta pasqualina", artichoke pie, ricotta and spinach pies, etc.) available on the market (that is, to be cooked rather than just reheated).	Remove the pie from the packaging and place it directly on the pre-heated grill plate. Recommended for pies weighing around 700g.

Microwave Hints

- Always keep the oven clean – avoid spill-overs and do not forget to clean under the glass tray and the inside of the door.
- Preferably use round or oval casseroles with a lid when cooking in your microwave oven.
- Do not use metal or metal decorated casseroles. Certain plastic materials can melt and be warped by hot food.
- Cover the food when cooking. Use a glass lid, a plate or grease proof paper.
- Pastry, bread and the like can be defrosted directly in a bread basket or on a paper towel.
- If frozen food is heated in its packaging, the packaging should be opened. Packaging containing metal or metal decoration must not be used unless specifically recommended for use in the microwave. Remove metal clips and wire ties.
- Smaller pieces of aluminium foil can be used to cover parts that easily over cook such as chicken legs.
- Food with peel or skin should be pierced with a fork – e.g. potatoes and sausages. Do not boil eggs in the microwave oven as they can explode.
- Put large, thick pieces close to the edge of the casserole and try to cut the food in to even sized pieces. Always place the food in the centre of the oven.
- The food will be evenly cooked if you stir or turn it a few times.
- Always set a shorter cooking time than indicated in your recipe to avoid over cooking. The larger the amount of food the longer it takes.
- Use little or no water for vegetables.
- Use less salt and spices than for 'normal' cooking.
- Season afterwards.
- Allow a few minutes 'standing' time after the oven has switched off to ensure complete and even cooking results.
- Always ensure food is piping hot throughout before serving.
- Use pot holders or gloves when taking dishes and food from the oven.

Microwave Tips

- **Softening Honey**
If you have a jar of honey which has crystallised, remove lid and place the jar in the oven, microwave on medium power for 2 minutes.
- **Melting Chocolate**
Break 100g of chocolate into squares, place in A bowl and heat on high power for 1-2 minutes and stir well.
- **Softening or Melting Butter**
Melting takes a few seconds on high power. Softening is best done more gently on low power.
- **Freshen or Warm Bread**
Use medium power for few seconds.
- **Peeling Garlic easily**
Heat 3 or 4 cloves of garlic on high power for 15 seconds. Squeeze at one end until the clove pops out.
- **Fruit Juice**
Citrus fruits will yield more juice if they are heated on high power for 15 seconds before squeezing.
- **Cooking Porridge**
Porridge is easily cooked in the serving dish with no sticky pan to wash. Follow food manufacturers' recommendations.

Care and cleaning

The oven must always be clean. Residue of food from spillovers or splatters will attract microwave energy causing it to burn on. This could reduce the efficiency of the oven and may cause bad odours. Do not attempt to tamper with or make any adjustments or repairs to any part of the oven. Repairs should only be done by a qualified service technician.

Be sure the oven is disconnected from the electricity supply before cleaning.

Cleaning the accessories (turntable and support)

Clean them with mild detergent after removing them from the cavity. The turntable support should be carefully handled.

CAUTION: The inside of the oven and turntable get very hot, so do not touch them immediately after use.

Cleaning the interior

Always keep the inside of the oven clean. Wipe up spill-overs and food splatters immediately. Deposits that are allowed to remain on the oven walls, door seal and door surface will absorb microwave energy, reduce the efficiency of the oven, and possibly damage the oven interior. Use mild, liquid detergent, warm water and a soft, clean cloth to remove deposits.

NEVER USE ABRASIVE CLEANERS, COMMERCIAL OVEN CLEANERS OR STEEL WOOL PADS ON ANY PART OF THE MICROWAVE OVEN.

To loosen difficult deposits, boil a cup of water in the microwave oven for 2 or 3 minutes.

NEVER USE A KNIFE OR ANY UTENSIL TO REMOVE DEPOSITS FROM OVEN SURFACES.

To remove odours from the oven interior, boil a cup of water plus 2 tablespoons of lemon juice for 5 minutes.

Cleaning the Grill

The element may be stained with splattered fat or oil while the oven is in use. Wait until the cavity cools down and wipe off the splattered oil before next using of the oven. Stains grill may cause unpleasant odours and smoke.

The turntable motor is sealed. Nevertheless, be careful to avoid the water penetrating under the turntable spindle (D) when the bottom of the oven is being cleaned.

To make the cleaning of the inside of the oven easier, the upper heating element can be lowered by turning the ceramic hook.

Cleaning the exterior

Open the oven door when cleaning the control panel. This will prevent the oven from being turned on accidentally. You should clean outside surfaces of the oven with mild liquid detergent and water followed by a wiping with clear water to remove any excess detergent. Dry with a soft cloth.

Spray-on window cleaners or all purpose spray-on kitchen cleaners can also be used. Never use abrasive cleaners, scouring pads or harsh chemicals on outside surfaces of your oven. To prevent damage to the working parts, do not allow water to seep into ventilation openings.

DECLARATION OF GUARANTEE TERMS.

Our appliances are produced with the greatest of care. However, a defect may still occur. Our consumer services department will repair this upon request, either during or after the guarantee period. The service life of the appliance will not, however, be reduced as a result.

This declaration of guarantee terms is based on European Union Directive 99/44/EC and the provisions of the Civil Code. The statutory rights that the consumer has under this legislation are not affected by this declaration of guarantee terms.

This declaration does not affect the vendor's statutory warranty to the end user. The appliance is guaranteed within the context of and in adherence with the following terms:

1. In accordance with provisions laid down in paragraphs 2 to 15, we will remedy free of charge any defect that occurs within 24 months from the date the appliance is delivered to the first end user.

These guarantee terms do not apply in the event of use for professional or equivalent purposes.

2. Performing the guarantee means that the appliance is returned to the condition it was in before the defect occurred. Defective parts are replaced or repaired. Parts replaced free of charge become our property.
3. So as to avoid more severe damage, the defect must be brought to our attention immediately.
4. Applying the guarantee is subject to the consumer providing proof of purchase showing the purchase and/or delivery date.
5. The guarantee will not apply if damage caused to delicate parts, such as glass (vitreous ceramic), synthetic materials and rubber, is the result of inappropriate use.
6. The guarantee cannot be called on for minor faults that do not affect the value or the overall reliability of the appliance.
7. The statutory warranty does not apply when defects are caused by:
 - a chemical or electrochemical reaction caused by water,
 - abnormal environmental conditions in general,
 - unsuitable operating conditions,
 - contact with harsh substances.
8. The guarantee does not apply to defects due to transport which have occurred outside of our responsibility. Nor will the guarantee cover those caused by inadequate installation or assembly, lack of maintenance or failure to respect the assembly instructions or directions for use.
9. Defects that result from repairs or measures carried out by people who are not qualified or expert or defects that result from the addition of non-original accessories or spare parts are not covered by the guarantee.
10. Appliances that are easy to transport may be delivered or sent to the consumer services department. Home repairs are only anticipated for bulky appliances or built-in appliances.
11. If the appliances are built-in, built-under, fixed or suspended in such a way that removing and replacing

them in the place where they are fitted takes more than half an hour, the costs that result therefrom will be charged for. Connected damage caused by these removal and replacement operations will be the responsibility of the user.

12. If, during the guarantee period, repairing the same defect repeatedly is not conclusive, or if the repair costs are considered disproportionate, in agreement with the consumer, the defective appliance may be replaced with another appliance of the same value. In this event, we reserve the right to ask for a financial contribution calculated according to the length of time it has been used.
13. A repair under guarantee does not mean that the normal guarantee period will be extended nor that a new guarantee period begins.
14. We give a twelve month guarantee for repairs, limited to the same defect.
15. Except in the event where liability is legally imposed, this declaration of guarantee terms excludes any compensation for damage outside the appliance for which the consumer wishes to assert his rights. In the event of legally admitted liability, compensation will not exceed the purchase price paid for the appliance.

These guarantee terms are only valid for appliances purchased and used in Belgium. For exported appliances, the user must first make sure that they satisfy the technical conditions (e.g.: voltage, frequency, installation instructions, type of gas, etc.) for the country concerned and that they can withstand the local climatic and environmental conditions. For appliances purchased abroad, the user must first ensure that they meet the qualifications required in Belgium. Non-essential or requested adjustments are not covered by the guarantee and are not possible in all cases.

Our consumer services department is always at your disposal, even after the guarantee period has expired.

Address for our consumer services department:

ELECTROLUX HOME PRODUCTS BELGIUM
Bergensesteenweg, 719 – 1502 LEMBEEK
Tel. 02.3630444



Free Manuals Download Website

<http://myh66.com>

<http://usermanuals.us>

<http://www.somanuals.com>

<http://www.4manuals.cc>

<http://www.manual-lib.com>

<http://www.404manual.com>

<http://www.luxmanual.com>

<http://aubethermostatmanual.com>

Golf course search by state

<http://golfingnear.com>

Email search by domain

<http://emailbydomain.com>

Auto manuals search

<http://auto.somanuals.com>

TV manuals search

<http://tv.somanuals.com>