

## RANGE COMPOSITION

Chilling means bringing the temperature of cooked food from +90°C to +3°C in a short time lap to minimize bacteria proliferation and avoid loss of food consistency and texture. The ZANUSSI easyChill Blast Chillers reduce temperature to +3°C at food core in less than 90 minutes. After the Blast Chilling a holding cycle starts automatically to maintain food at +3°C. Blast chilled food has a solid 5 days shelf life without loss of flavour, nutritional values and weight. The opportunity to prepare in a single shot the food to be used in different times during the week enables a better work scheduling and therefore a sensible reduction in labour costs.



# 120-180 KG 20 GN 2/1

## ACTIVE BLAST CHILLERS **ZANUSSI** PROFESSIONAL

### FUNCTIONAL AND CONSTRUCTION FEATURES

- ◆ Soft Chilling (Air temperature -2°C).
- ◆ Hard Chilling (Air temperature -12°C).

- ◆ All the probe-driven cycles feature ARTE (Algorithm for Remaining Time Estimation): the machine displays the actual time needed to end the cycle and to make planning the activities easier.
- ◆ Holding at +3°C (automatically

- activated at the end of each cycle).
- ◆ Turbo cooling: the chiller works continuously at the desired temperature. Ideal for continuous production and for pastry application.

CHARACTERISTICS	MODELS						
	BC120A 110089	BC120RA 110090	BC180A 110005	BC180RA 110007	BC180RPA 110009	BC180RDA 110008	BC180DA 110006
Productivity per cycle - kg.							
NF Regulations - chilling / freezing			144	144	144	144	144
UK Guide lines - chilling / freezing	120	120	180	180	180	180	180
Cooling unit	Built-In	Remote	Built-In	Remote	Remote	Remote	Built-In
External dimensions - mm							
width	1400	1400	1400	1400	1400	1400	1400
depth/with open doors	1285, 2099	1285, 2099	1285, 2099	1285, 2099	1285, 2099	1285, 2099	1285, 2099
height	2470	2470	2471	2230	2230	2230	2471
Internal dimensions - mm							
width	772	772	752	752	752	752	752
depth	920	920	946	946	946	946	946
height	1850	1850	1850	1850	1850	1850	1850
N° and type of door	1	1	1;	1;	2;	1;	1;
Door hinges	Right Side	Right Side	Right Side	Right Side	Right Side	Right Side	Right Side
Trays type	600x400; GN 2/1	600x400; GN 2/1	600x400; GN 2/1	600x400; GN 2/1	600x400; GN 2/1	600x400; GN 2/1	600x400; GN 2/1
Max load capacity - trays h 65 mm - n°			20	20		20	20
Compressor power - HP	4		7.5	minimum 7.5;			7.5;
N° defrost in 24 hrs.	4/20'	4/20'	4/20'	4/20'	4/20'	4/20'	4/20'
Refrigerant type	R404a	R404a	R404a;	R404a;	R404a;	R404a;	R404a;
Refrigeration power - W	11100		20200	20200	20200	20200	20200
Refrigerant power							
at evaporation temperature - °C	-10		-10	-10	-10	-10	-10
Power - kW							
installed-electric	6.515	1.83	8.33	1.735	1.735	1.735	8.335
Net weight - kg.	300	180	605	438	438	180	605
Power supply - V, phases, Hz	400 V, 3N, 50	400 V, 3N, 50	400 V, 3N, 50	400 V, 3N, 50	400 V, 3N, 50	400 V, 3N, 50	400 V, 3N, 50
Disassembled						●	●
<b>INCLUDED ACCESSORIES</b>							
1 SINGLE SENSOR PROBE CHILLER+C/FREEZER	1	1	1	1	1	1	1

- ◆ Single sensor core probe as standard.
- ◆ Automatic recognition of the insertion of the food probe (cycles piloted either by food probe temperature or by time)
- ◆ The control unit provides several operating settings: time/core temperature according to NF and UK regulations, time/air temperature/probe personalised according to national regulations, sterilizing cycle: UV lamps built-in (on request), 3 single sensor or 3-sensor temperature probes (as accessory), ideal for meats, automatic defrosting and manual defrosting. All parameters are programmable.
- ◆ The control unit provides two large displays to read out: time, core temperature, residual time, alarms, service information.
- ◆ Two customizable cycles for each operating modes, allowing setting time and air temperature. These two programs (P1-P2) can be converted into ice-cream specialist cycles (shape maintenance and holding).
- ◆ All information related to the different operating models are recorded: date, time, cycle, core temperature, holding temperature, HACCP accordance.
- ◆ An audible alarm starts when the cycle ends or terminates abnormally.
- ◆ Chilling times can vary according to food quantity, density, moisture contents and type of containers.
- ◆ Internal and external finishing in 304 AISI stainless steel and backpanel in galvanized steel.
- ◆ HCFC, CFC and HFC free insulation (Cyclopentane), HCFC and CFC free refrigerant gas (R404a).
- ◆ Developed and produced in ISO 9001 and ISO 14001 certified factory.
- ◆ Inner cell with rounded corners.
- ◆ Door equipped with removable magnetic gasket with hygienic

design.

- ◆ Evaporator with antirust protection.
- ◆ Ventilator swinging panel foreasy access to the evaporator.
- ◆ Automatic heated door frame.
- ◆ Thermostatic expansion valve to optimize the cooling unit efficiency.
- ◆ Adjustable feet 150 mm high.
- ◆ Stand alone printer as accessory.
- ◆ PC connection as accessory, gate RS 485.
- ◆ No water connections required: Waste water can be plumbed into drain, but can also be collected in an optional waste container.

\*NF HYGIENE ALIMENTAIRE certifying authority: AFAQ AFNOR CERTIFICATION. Address:11, Avenue Francis de Pressense - 93571 Saint-Denis La Plaine Cedex - France. Conformity with regulation NF031. Certified guarantees: fitness for cleaning, thermal performance.

ACCESSORIES	MODELS						
	BC120A 110089	BC120RA 110090	BC180A 110005	BC180RA 110007	BC180RPA 110009	BC180RDA 110008	BC180DA 110006
1 SINGLE SENSOR PROBE CHILLER+C/FREEZER	880089	880089	880089	880089	880089	880089	880089
2 SINGLE SENSOR PROBES CHILLER+C/FREEZER	880096	880096	880096	880096	880096	880096	880096
3-SENSOR PROBE FOR CHILLER+C/FREEZER	880088	880088	880088	880088	880088	880088	880088
60 MM PITCH ROLL-IN RACK FOR 20X2/1	922204		922204	922204	922204	922204	922204
80MM PITCH ROLL-IN RACK 14X2/1GN	922206		922206	922206	922206	922206	922206
AIR REMOTE UNIT CHILLER+C/FREEZER180KG		880051		880051	880051	880051	
BANQ.TROLLEY-92PLATES 85MM PITCH-20GN2/1	922055	922055	922055	922055	922055	922055	922055
BASE FOR 20X2/1 ROLL-IN RACK	922142	922142	922142	922142	922142	922142	922142
BASE FOR ROLL-IN-RACK	880018		880018	880018	880018	880018	880018
KIT 3 SINGLE SENSOR PROBES FOR BC/BCF	880269	880269	880269	880269	880269	880269	880269
KIT HACCP ADVANCED CONNECT. BC/BCF LW+CW	880183	880183	880183	880183	880183	880183	880183
KIT HACCP EKIS	922166	922166	922166	922166	922166	922166	922166
PASTRY TROLLEY 16(400X600)80MM-20 2/1 LW	922069	922069	922069	922069	922069	922069	922069
PRINTER FOR HACCP BASIC VERSION	881532	881532	881532	881532	881532	881532	881532
ROLL-IN RACK FOR 2/1 GASTRONORM GRIDS	881449	881449	881449	881449	881449	881449	881449
THERMAL COVER FOR 20 GN 2/1-LW	922049	922049	922049	922049	922049	922049	922049
TROLLEY FOR 2/1-GN ROLL-IN RACK	880017	880017	880017	880017	880017	880017	880017
TROLLEY FOR 20X2/1 ROLL-IN RACK	922134	922134	922134	922134	922134	922134	922134
TROLLEY TRAY RACK F. 20X2/1GN,63MM PITCH	922044	922044	922044	922044	922044	922044	922044
TROLLEY TRAY RACK F. 20X2/1GN,80MM PITCH	922046	922046	922046	922046	922046	922046	922046
WATER REMOTE UNIT CHILLER+C/FREEZER180KG		880052		880052	880052	880052	



www.zanussiprofessional.com

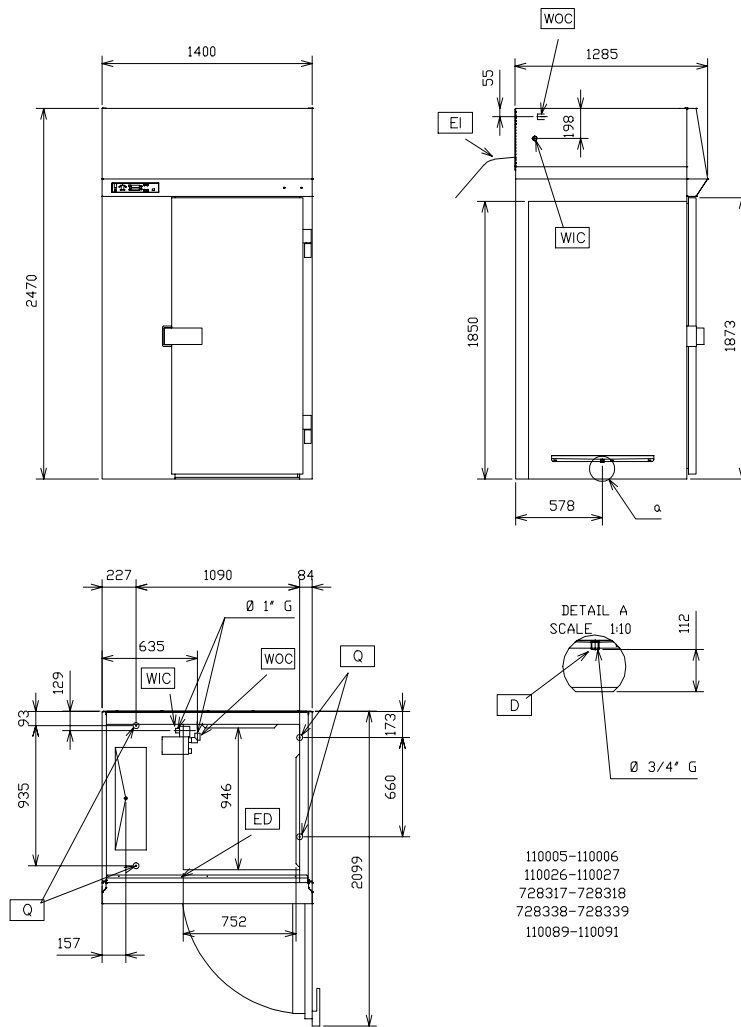

	BC120A 110089	BC180A 110005	BC180DA 110006
CWI - Cold water inlet		1"	1"
D - Water drain		3/4"	3/4"
EI - Electrical connection	400 V, 3N, 50	400 V, 3N, 50	400 V, 3N, 50
Q - Appliance lifting connection		●	●
WOC - Cooling water outlet	●	●	●



www.zanussiprofessional.com

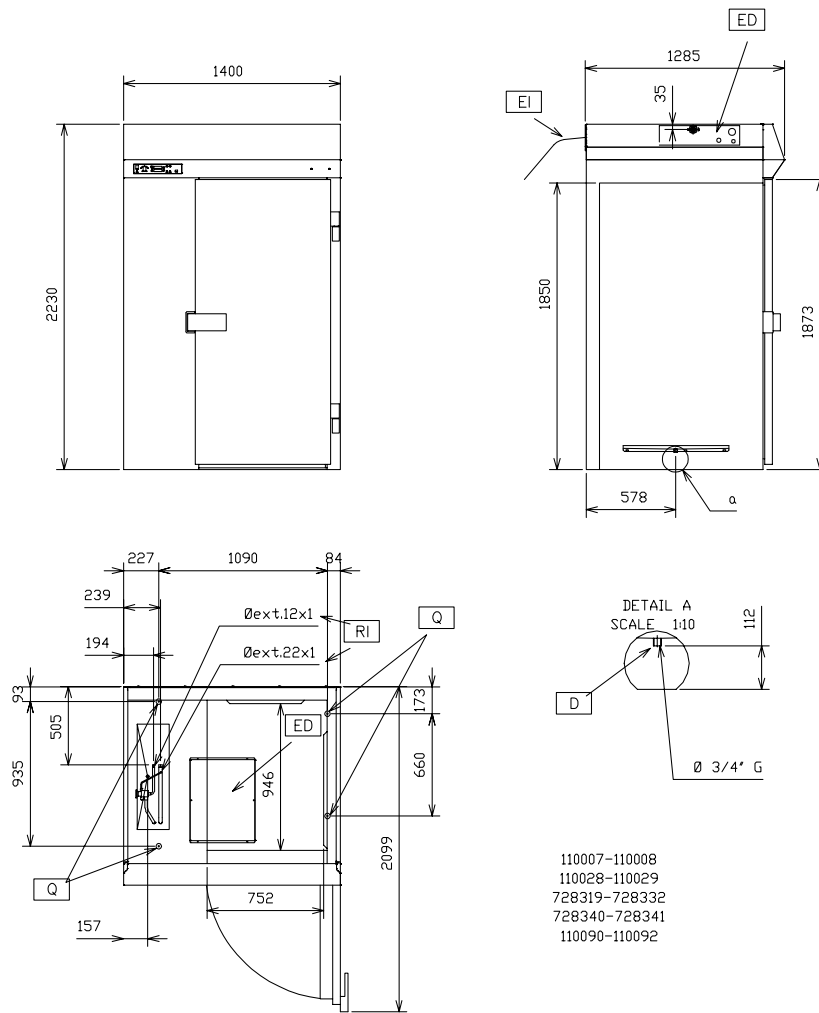

	BC120RA 110090	BC180RA 110007	BC180RDA 110008
D - Water drain		3/4"	3/4"
ED - Remote electrical connection	●	●	●
EI - Electrical connection	400 V, 3N, 50	400 V, 3N, 50	400 V, 3N, 50
Q - Appliance lifting connection		●	●
RI - Remote refrigeration connection	●	●	●



www.zanussiprofessional.com

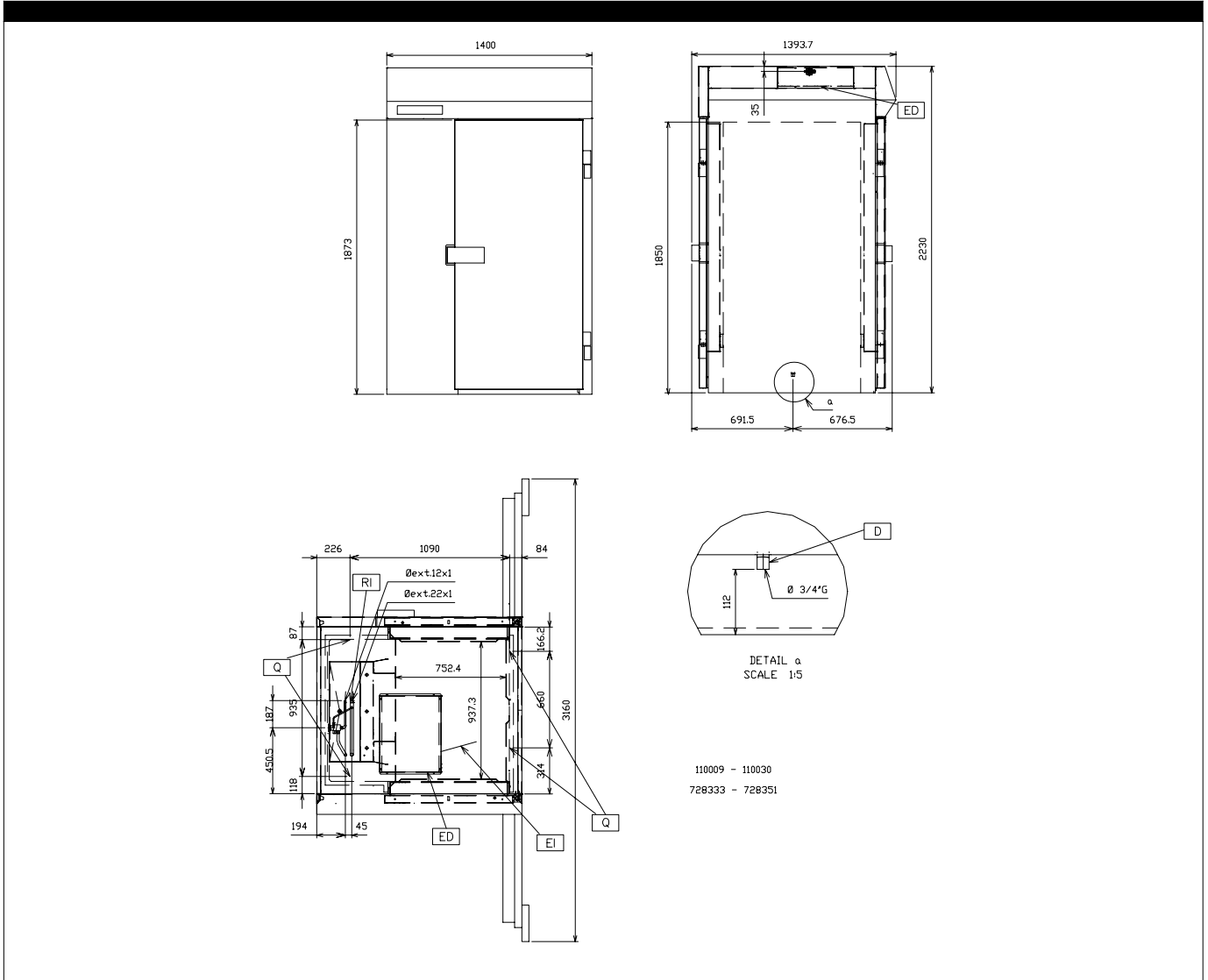

	BC180RPA 110009
D - Water drain	3/4"
ED - Remote electrical connection	●
EI - Electrical connection	400 V, 3N, 50
RI - Remote refrigeration connection	●



www.zanussiprofessional.com

## Free Manuals Download Website

<http://myh66.com>

<http://usermanuals.us>

<http://www.somanuals.com>

<http://www.4manuals.cc>

<http://www.manual-lib.com>

<http://www.404manual.com>

<http://www.luxmanual.com>

<http://aubethermostatmanual.com>

Golf course search by state

<http://golfingnear.com>

Email search by domain

<http://emailbydomain.com>

Auto manuals search

<http://auto.somanuals.com>

TV manuals search

<http://tv.somanuals.com>