

ZANUSSI

REFRIGERATOR ZT 51/2 R

INSTRUCTION BOOKLET

Contents

Instructions for the user		Instructions for the installer	
Important Safety Instructions	3	Technical specifications	13
Description of the Appliance	4	Installation	13
Operation	5	Positioning	13
Before use	5	Door reversal	14
Setting the temperature	5	Electrical Connection	15
The  - star compartment	5		
Frozen food storage	5		
Thawing	6		
Making ice cubes	6		
Normal operating sounds	6		
Fresh food refrigeration	6		
Health and safety guidelines	7		
Defrosting	8		
Maintenance and Cleaning	9		
Internal cleaning	9		
External cleaning	9		
Changing the light bulb	9		
When the appliance is not use	9		
Something not Working?	10		
Service and Spare Parts	11		
Customer Care Department	11		
Guarantee Conditions	12		

Important Safety Instructions

These warnings are provided in the interests of your safety. Ensure that you understand them all before installing or using this appliance. Your safety is of paramount importance. If you are unsure about any of the meanings of these warnings contact the Customer Care Department.

Prior to Installation

- Check the appliance for transport damage. Under no circumstance should a damaged appliance be installed. In the event of damage please contact your retailer.

Installation

- This appliance is heavy. Care should be taken when moving it.
- It is dangerous to alter the specifications or attempt to modify this product in any way.
- Ensure that the appliance does not stand on the electrical supply cable.
Important: If the supply cable is damaged, it must be replaced by a special cord or assembly available from the manufacturer or its service agent.
- Any electrical work required to install this appliance should be carried out by a qualified electrician or competent person.
- Parts which heat up should not be exposed. Whenever possible, the back of the appliance should be close to a wall, but leaving the required distance for ventilation, as stated in the installation instructions.
- The appliance should be left for 2 hours after installation before it is turned on, in order to allow the refrigerant to settle.

Refrigerant

- During transportation and installation of the appliance, be certain that none of the components of the refrigerant circuit become damaged.
- If the refrigerant circuit should become damaged: thoroughly ventilate the room in which the appliance is situated.

Child Safety

- Do not allow children to tamper with the controls or play with the product.
- There is a risk of suffocation! Keep packaging material away from children!

During Use

- This appliance is designed for domestic use only, specifically for the storage of edible foodstuffs only. It is not intended for commercial or industrial use.

- Containers with flammable gases or liquids can leak at low temperatures. Do not store any containers with flammable materials, such as spray cans, fire extinguisher refill cartridges etc. in the refrigerator.
- Frozen food should not be refrozen once it has thawed out.
- Do not place carbonated or fizzy drinks in the freezer compartment.
- Ice lollies can cause 'frost/freezer burns' if consumed straight from the (X X)-star compartment.
- Do not remove items from the freezer compartment if your hands are damp/wet, as this could cause skin abrasions or frost/freezer burns.
- Bottles and cans must not be placed in the freezer compartment they can burst when the contents freeze.
- Manufacturers' recommended storage times should be adhered to. Refer to relevant instructions.

Maintenance and Cleaning

- Before cleaning, always switch off the appliance and disconnect from the electrical supply.
- When unplugging always pull the plug from the mains socket, do not pull on the cable.

Servicing

- This product should be serviced by an authorised engineer and only genuine spare parts should be used.
- Under no circumstances should you attempt to repair the appliance yourself. Repairs carried out by inexperienced persons may cause injury or serious malfunctioning. Contact your local Zanussi Service Force Centre.

At the end of the Appliance Life

- When disposing of your appliance use an authorised disposal site.
- Remove the plug and ensure that any locks or catches are removed, to prevent young children being trapped inside.

Description of the Appliance

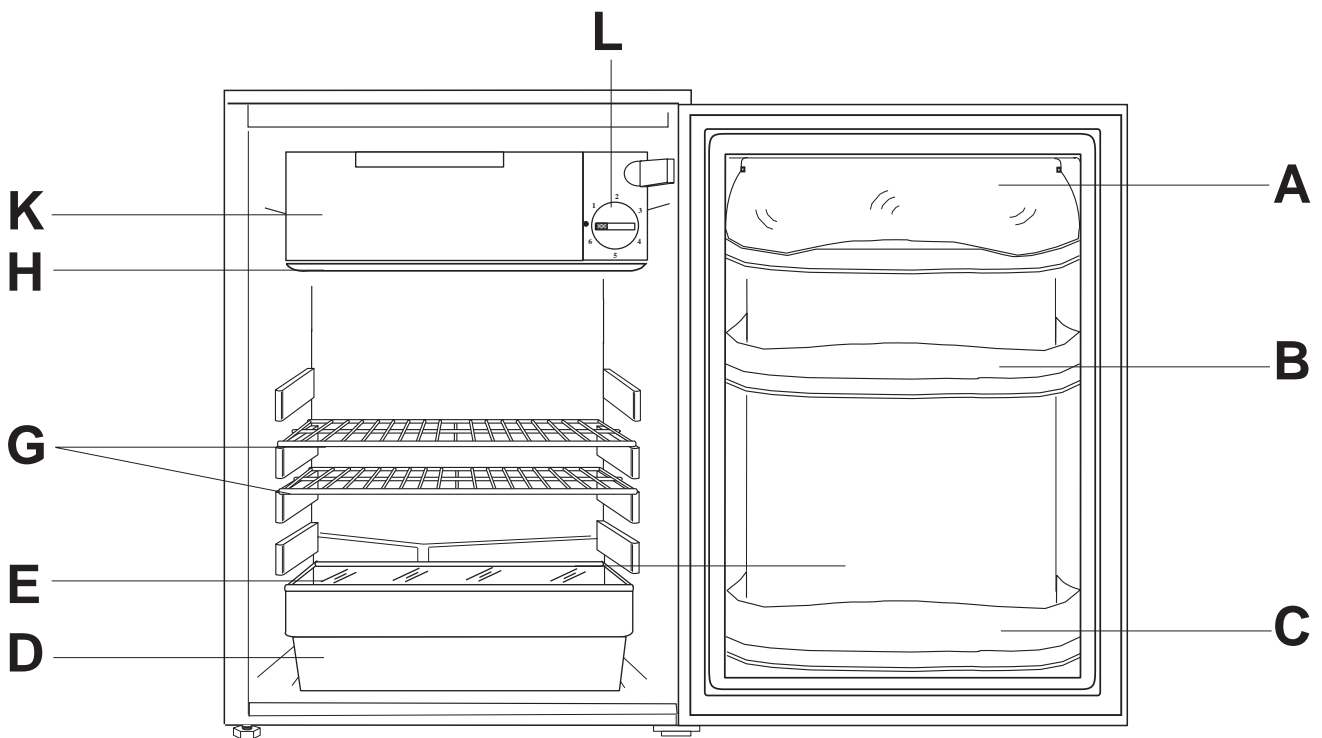

A - Dairy compartment

B - Can storage shelf with egg tray

C - Bottle storage shelf

D - Salad drawer

E - Glass shelf

G - Storage shelves

H - Conveyor

K - Freezer compartment

L - Thermostat control

Operation

Before use

Remove all securing tapes. Wash inside the appliance with lukewarm water and bicarbonate of soda (5 ml to 0.5 litre of water). Do not use soap or detergent as the smell may linger. Dry thoroughly.

Setting the temperature

The temperature inside the **refrigerator** and the -star compartment is regulated by a thermostat with 6 temperature positions and one «OFF» (O) position.

Position 1 = minimum coldness

Position 6 = maximum coldness



Turn the thermostat dial to the required position; **the intermediate position is usually the most suitable (3-4).**



The required thermostat setting can be varied as the temperature inside the refrigeration compartment depends on the following factors:

- room temperature
- how often the door is opened
- how much food is stored
- position of the appliance



Important

The temperature inside the refrigerator and -star compartment can be regulated by adjusting the conveyor located under the -star compartment.

To obtain a lower temperature in the -star compartment when frozen food is stored inside and when the ambient temperature is 25°C or lower slightly raise the conveyor (A) and push it all the way in. When frozen food is not stored in the -star compartment and when the ambient temperature is higher than 25°C return the conveyor to its initial position. This reduces the temperature in the refrigerator compartment.

The -star compartment

This compartment is suitable for the storage of commercially frozen food and for ice cube making.

Frozen food storage

Storing ready-frozen foods is quite straightforward. The packs can be placed beside each other or on top of each other.

You are strongly advised to place ready-frozen food in the compartment as quickly as possible after purchase. Also ensure that the external packaging is intact.

Packaging which is swollen or has traces of refrozen water droplets on the pack could indicate that the product has not been kept at a suitable temperature and that it may have lost its original quality.

Partially thawed food must not be refrozen, it must be consumed within 24 hours.

Never exceed the storage times indicated.

Do not open the -star compartment door too often and do not leave open longer than necessary.



Important

In the event of a power cut the food in the -star compartment will not be affected if the power cut is short and if the compartment is full. Do not open the door. Should the food begin to thaw, it must be consumed quickly and must not be refrozen.

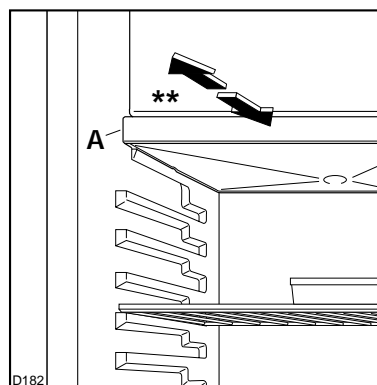

Thawing

Food can be thawed in a number of ways, depending on the type of food and the size of the packs. Meat, fish and fruit should be thawed in the refrigeration compartment and small pieces of meat can even be cooked while still frozen, but you must ensure that it is thoroughly cooked through. Vegetables should be directly immersed in boiling water; ready-cooked dishes can be placed directly in the oven in their aluminium wrapping. A microwave oven is particularly suitable for thawing any type of frozen or deep-frozen food: follow the oven instructions, particularly regarding the placement of aluminium wrapping in the oven.

Making ice cubes

The appliance is provided with a plastic ice cube tray. Fill the tray 3/4 full to allow the ice to expand and place it in the ☒-star compartment. To turn out the ice cubes simply give the tray a slight twist to release the cubes.



Important

Do not consume ice-lollies which have just come out of the ☒-star compartment. Their extremely low temperature can cause frost burns. Do not remove items from the ☒-star compartment if your hands are damp/wet, as this could cause skin abrasions or "frost/freezer burns".

Normal operating sounds

You may hear faint gurgling or bubbling sounds when the refrigerant is pumped through the coils or tubing at the rear and the cooling evaporator.

When the compressor is on, the refrigerant is being pumped round, and you will hear a whirring sound or pulsating noise from the compressor.

A thermostat controls the compressor, and you will hear a faint 'click' when the thermostat cuts in and out.

Fresh food refrigeration

To obtain the best performance, do not store warm food or evaporating liquids in the refrigerator; do cover or wrap the food, particularly if it has a strong flavour.

Do not cover the shelves with any protective material, such as paper, cardboard or plastic, which may obstruct the air circulation through them.

To help you use your refrigerator correctly, here are some more useful hints:

Raw meat (beef, pork, lamb & wild fowl): wrap in polythene bags and place on the first shelf under the ☒-star compartment.

Meat can only be stored safely in this way for one or two days at the most.

Fruit & vegetables: these should be thoroughly cleaned and placed in the bottom salad crisper.

Butter & cheese: these should be placed in special airtight containers or wrapped in aluminium foil or polythene bags to exclude as much air as possible.

Milk bottles: these should have a cap and should be stored in the bottle rack on the door.

The walls of the refrigerator are equipped with runners so that shelves can be positioned as desired.

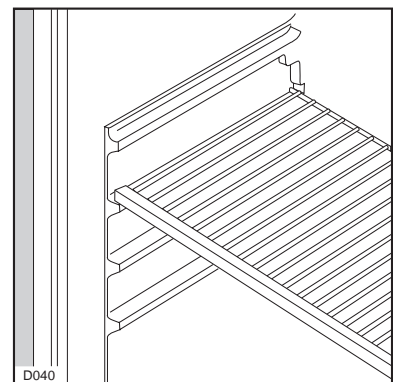

Health and Safety Guidelines

Because of consumer demand, preservatives have been removed from many pre-prepared foods. This together with the changes in shopping habits to a once-a-week shop, mean that safe handling and storage of food is even more important than ever.

The following tips should help you to ensure that the food in your home is in as perfect condition as possible.

- Keep the time between buying chilled food and placing it in your fridge as short as possible. Tests showed that the temperature of 1 litre of orange juice rose to 22°C in an hour between the super-market and home. It then took 11 hours to get down to 7°C in the refrigerator.
- Keep the refrigerator door closed as much as possible.
- Do not push food together too much, try to allow air to circulate around each item.
- Cool cooked food as quickly as possible but do NOT place in the refrigerator until cool. (Leave food in a cool place in order that it can then be placed in the refrigerator as soon as possible).
- Do NOT mix raw and cooked meat, they must be in separate containers. Take care not to let the meat juices drip onto other food. If the meat does drip, remove everything and clean thoroughly.
- Do not store food uncovered.
- Remove suspect food from your refrigerator and clean (Refer to "Maintenance and cleaning").
- Never allow spillages to dry and harden.
- Store eggs in the egg rack provided in the refrigerator door. Discard any broken or chipped eggs.
- Regularly check the refrigerator door seal to ensure that it is clean and free from debris.
- Always wash your hands with soapy water and dry them with a clean towel before handling food.
- Keep work surfaces clean and avoid cross contamination by not using the same work surface or knife, without washing them thoroughly in between.

Defrosting

While in operation the -star compartment becomes progressively covered with frost. This frost, which acts as an insulator and thus prevents the cold from reaching the food should be removed whenever the thickness of the frost exceeds 1/4".

To carry out complete defrosting proceed as follows:

1. Push the conveyor completely in.
2. Place a tray on the upper shelf of the refrigerator under the drain hole of the conveyor.
3. Remove any food from inside the -star compartment, wrap it in several sheets of newspaper and store in a cool dry place.
4. Push the button at the centre of the thermostat knob. To accelerate defrosting, place a bowl of hot water inside the compartment (with a piece of cardboard underneath the bowl as protection).
5. When defrosting is completed, dry thoroughly and remove the water collected in the tray.
The refrigerator starts operating automatically following defrosting.

After letting the appliance run for at least half an hour, replace the previously removed food into the -star compartment.

When defrosting it is not necessary to remove the foods from the inner door and the refrigerator compartment.



Important

A temperature rise of the frozen food packs during defrosting may shorten their storage life.

Never use sharp metal tools to scrape off frost from the evaporator as you could damage it beyond repair.



Maintenance and Cleaning

Before any maintenance or cleaning work is carried out, DISCONNECT the appliance from the ELECTRICITY supply.

Internal cleaning

Clean the inside and accessories with warm water and bicarbonate of soda (5ml to 0.5 litre of water). Rinse and dry thoroughly.

NEVER USE DETERGENTS, ABRASIVE POWDERS, HIGHLY PERFUMED CLEANING PRODUCTS OR WAX POLISHES, TO CLEAN THE INTERIOR AS THESE WILL DAMAGE THE SURFACE AND LEAVE A STRONG SMELL.

External cleaning

Wash the outer cabinet with warm soapy water. Do NOT use abrasive products.

Once or twice a year dust the condenser (black grill) and the compressor at the back of the appliance, with a brush or vacuum cleaner, see figure.

You MUST ensure that the appliance is switched OFF. An accumulation of dust will affect the performance of the appliance and cause excessive electricity consumption.

Changing the light bulb

Should the interior light fail to work, switch off and disconnect the appliance from the electricity supply. Replace the bulb as follows:

1. Remove conveyor
2. Unscrew light bulb
3. Replace with a 12 watt bulb available from your nearest Zanussi Service Force Centre.
4. Replace conveyor

When the appliance is not in use

When the appliance is not in use for long periods, disconnect from the electricity supply, empty all foods and clean the appliance, leaving the door ajar to prevent unpleasant smells.

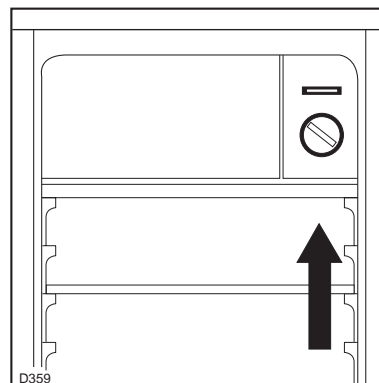
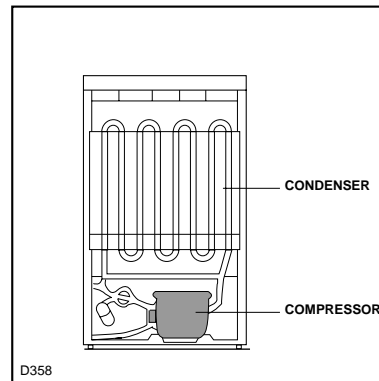

Something not Working?

Important: If you call out an engineer to a fault listed below, or to repair a fault caused by incorrect use or installation a charge will be made, even if the appliance is under guarantee.

Before contacting your local Service Force Centre check the following points.

Symptom	Solution
No power to appliance	<ul style="list-style-type: none"> - Check there is power at the socket. - Check there is not a power cut by checking the household lights. - Check the fuse has not blown.
The light does not come on	<ul style="list-style-type: none"> - Ensure that the bulb is correctly fitted. - Replace the bulb if it has blown. - Check the door light switch is not jammed.
The temperature in the fridge or freezer section is too high	<ul style="list-style-type: none"> - Check the thermostat in the fridge is turned to the correct setting relative to ambient conditions. - Check the ambient temperature is within the appliances operating limits of 10°C to 32°C. Relocate the appliance if necessary.
The compressor runs continuously	<ul style="list-style-type: none"> - Adjust the thermostat to give correct temperature control. See page 5. - Check that the door is closed. - Large quantities of food have recently been placed in the cabinet/and or door is frequently opened. - Check that air ventilation is not obstructed.
Excessive frost and ice has built up	<ul style="list-style-type: none"> - Ensure the door is not left open. - Check that nothing is preventing the door from closing. - Is the door gasket intact and clean. - Has advised periodic defrosting been carried out.
Noise	<ul style="list-style-type: none"> - Refer to normal operating sounds.

If after the above checks, there is still a fault, call your local Service Force Centre.

In-guarantee customers should ensure that the above checks have been made as the engineer will make a charge if the fault is not a mechanical or electrical breakdown.

Please note that proof of purchase is required for any in-guarantee service calls.

Service and Spare Parts



In the event of your appliance requiring service, or if you wish to purchase spare parts please contact your local Zanussi Service Force Centre by telephoning:

08705 929929

Your call will be routed to the Service Force Centre covering your post code area. The address of your local Service Force Centre is detailed in the accompanying Customer Care Book.

Before calling out an engineer, please ensure you have read the details under the heading 'Something Not Working?'

When you contact the Service Centre you will need to give the following details.

1. Your name, address and post code
2. Your telephone number
3. Clear and concise details of the fault
(found on the rating plate)
4. The model serial no. of the appliance (found on the rating plate)
5. The purchase date

Customer Care Department

For general enquiries concerning your Zanussi appliance or for further information on Zanussi products, you are invited to contact our Customer Care Department by letter or telephone as follows:

Customer Care Department
Zanussi
55-77 High Street
Slough
Berkshire
SL1 1DZ

Tel: 08705 727727

Guarantee Conditions

Standard guarantee conditions

We, Zanussi Limited, undertake that if within 12 months of the date of purchase this Zanussi appliance or any part thereof is proved to be defective by reason only of faulty workmanship or materials, we will, at our option repair or replace the same FREE OF CHARGE for labour, materials or carriage on condition that:

- The appliance has been correctly installed and used only on the electricity supply stated on the rating plate.
- The appliance has been used for normal domestic purposes only, and in accordance with the manufacturer's instructions.
- The appliance has not been serviced, maintained repaired, taken apart or tampered with by any person not authorised by us.
- All service work under this guarantee must be undertaken by a Zanussi Service Force Centre.
- Any appliance or defective part replaced shall become the Company's property.
- This guarantee is in addition to your statutory and other legal rights.

Home visits are made between **8.30am** and **5.30pm** Monday to Friday. Visits may be available outside these hours in which case a **premium** will be charged.

Exclusions

This guarantee does not cover:

- Damage or calls resulting from transportation, improper use or neglect, the replacement of any light bulbs or removable parts of glass or plastic.
- Costs incurred for calls to put right an appliance which is improperly installed or calls to appliances outside the United Kingdom.
- Appliances found to be in use within a commercial environment, plus those which are subject to rental agreements.
- Products of Zanussi manufacture which are not marketed by Zanussi Limited.

European Guarantee

If you should move to another country within Europe then your guarantee moves with you to your new home subject to the following qualifications:

- The guarantee starts from the date you first purchased your product.
- The guarantee is for the same period and to the same extent for labour and parts as exists in the new country of use for this brand or range of products.
- This guarantee relates to you and cannot be transferred to another user.
- Your new home is within European Community (EC) or European Free Trade Area.
- The product is installed and used in accordance with our instructions and is only used domestically, i.e. a normal household.
- The product is installed taking into account regulations in your new country.

Before you move please contact your nearest Customer Care centre, listed below, to give them details of your new home. They will then ensure that the local Service Organisation is aware of your move and able to look after you and your appliance.

France	Senlis	+33 (0) 44 62 29 99
Germany	Nuremberg	+49 (0) 911 323 2600
Italy	Pordenone	+39 (0) 1678 47053
Sweden	Stockholm	+46 (0) 8 738 79 50
UK	Slough	+44 (0) 1753 219897

Technical specifications

DIMENSIONS	Height	85	cm
	Width	49,5	cm
	Depth	60	cm

POWER SUPPLY VOLTAGE AND FREQUENCY	220-240 V / 50 Hz
TOTAL POWER ABSORBED	90 W
AVERAGE DAILY UNITS ELECTRICITY	0,74 kWh

GROSS CAPACITY Fridge/Freezer 140 l

NET CAPACITY Fridge/Freezer 118 l

STAR RATING 

Installation

Positioning

For this appliance to work efficiently, it should be located away from heat sources, e.g. cookers, radiators, boilers, direct sunlight etc. This also includes locations or rooms where the ambient temperature reaches above 32 degrees C or drops below 10 degrees (e.g. conservatories).

You should also ensure that air can circulate freely around the back and the top of the cabinet. There must also be a minimum distance between the top of the cabinet and any overhanging kitchen furniture as shown in the figure.

Do not obstruct the space underneath. The back of the cabinet may be placed close to the wall but must not touch it. DO NOT install in places with restricted ventilation.

Adjust the level of the appliance by screwing out the adjustable foot, or feet, at the bottom of the cabinet using your fingers.

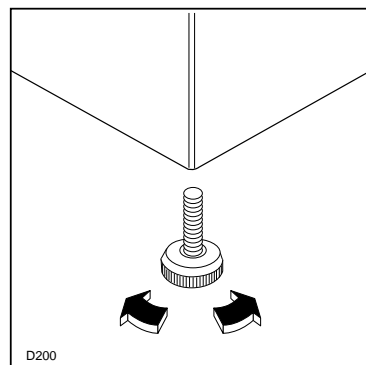
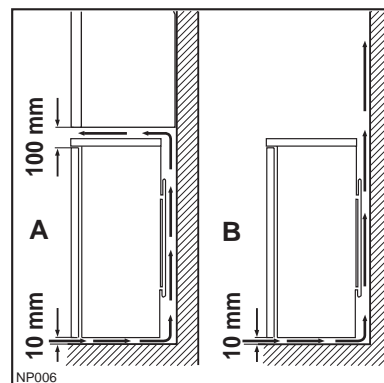

Door reversal

Before carrying out the operations described below, pull out the mains plug from the wall socket.

To carry out this reversal go through the following steps:

1. Gently lay the appliance on its back with the top held away from the floor by 5-8 cm (2-3 inches) of packing.
2. Remove the bottom door hinge (5).
3. Remove the door (4) by opening it and pulling it gently downwards to remove it from the top hinge pin (2).
4. Unscrew the top hinge pin (2) from the top hinge (1) and replace it in the opposite hole on the left hand side.
5. Unscrew the foot at the base (6) of the appliance and refit it on the opposite side.
6. Refit the door and the bottom hinge to the left hand side.

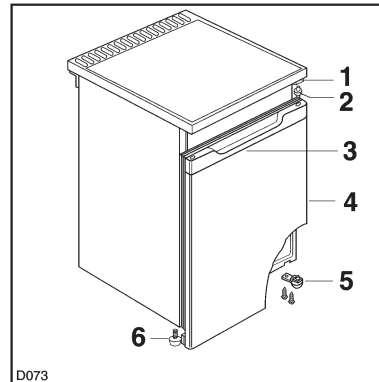

When the bottom hinge is screwed in, a certain amount of force is exerted on the screws. It is therefore advisable to lubricate the screw tips before starting this operation.



Important

After completion of the door reversal operation, verify that the door gasket is sealing onto the cabinet.

If the ambient temperature is cold (i.e. in Winter), the gasket may not fit perfectly to the cabinet. In that case, wait for the natural fitting of the gasket or accelerate this process by heating up the part involved with a normal hairdrier on a low setting.

Electrical Connection



WARNING:

THIS APPLIANCE MUST BE EARTHED.
The manufacturer declines any inability should this safety measure not be observed.

If the plug that is fitted to your appliance is not suitable for your socket outlet, it must be cut off and the appropriate plug fitted.

Remove the fuse from the cut off plug.

The cut off plug should then be disposed of to prevent the hazard of shocks in case it should be plugged into a 13amp socket in another part of your home.



Important

The wires in the mains lead are coloured in accordance with the following code:

Green and Yellow	- Earth
Blue	- Neutral
Brown	- Live

If you fit your own plug, the colours of the wires in the mains lead of your appliance, may not correspond with the markings identifying the terminals in your plug, proceed as follows:

Connect the Green and the Yellow (earth) wire to the terminal in the plug which is marked with the letter «E» or the earth symbol \oplus , or coloured green and yellow.

Connect the blue (neutral) wire to the terminal in the plug which is marked with the letter «N» or coloured black.

Connect the brown (live) wire to the terminal in the plug which is marked with the letter «L» or coloured red.

The plug moulded onto the lead incorporates a fuse. For replacement, use a 13amp BS1362 fuse. Only ASTA or BSI approved fuses should be used.

The plug must not be used if the fuse cover/carrier is lost. The cover/carrier is indicated by the coloured insert at the base of the plug.

A replacement cover/carrier must be obtained from your local Zanussi Service Force Centre whose address is listed in the Customer Care Booklet which accompanies your instruction manual.

This appliance complies with the E.E.C. Directive No. 87/308 of 2.6.87 relative to radio interference suppression.



This appliance complies with the following E.E.C. Directive:

- **73/23 EEC** of 19.2.73 (Low Voltage Directive) and subsequent amendments.
- **89/336 EEC** of 3.5.89 (Electromagnetic Compatibility Directive) and subsequent amendments.

Please ensure that when the appliance is installed it is easily accessible for the engineer in the event of breakdown.

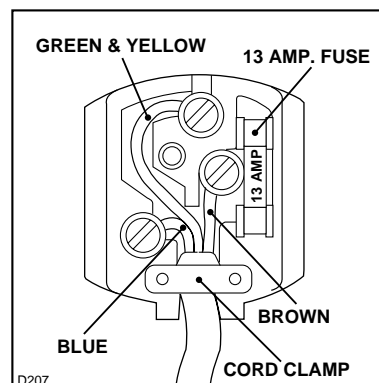

Free Manuals Download Website

<http://myh66.com>

<http://usermanuals.us>

<http://www.somanuals.com>

<http://www.4manuals.cc>

<http://www.manual-lib.com>

<http://www.404manual.com>

<http://www.luxmanual.com>

<http://aubethermostatmanual.com>

Golf course search by state

<http://golfingnear.com>

Email search by domain

<http://emailbydomain.com>

Auto manuals search

<http://auto.somanuals.com>

TV manuals search

<http://tv.somanuals.com>