



**Zebra® 105SL™**  
Industrial/Commercial Printer

---

**User Guide**

© 2006 ZIH Corp. The copyrights in this manual and the software and/or firmware in the label printer described therein are owned by ZIH Corp. Unauthorized reproduction of this manual or the software and/or firmware in the label printer may result in imprisonment of up to one year and fines of up to \$10,000 (17 U.S.C.506). Copyright violators may be subject to civil liability.

This product may contain ZPL<sup>®</sup>, ZPL II<sup>®</sup>, and ZebraLink<sup>™</sup> programs; Element Energy Equalizer<sup>®</sup> Circuit; E<sup>3</sup><sup>®</sup>; and Monotype Imaging fonts. Software © ZIH Corp. All rights reserved worldwide.

ZebraLink and all product names and numbers are trademarks, and Zebra, the Zebra logo, ZPL, ZPL II, Element Energy Equalizer Circuit, and E<sup>3</sup> Circuit are registered trademarks of ZIH Corp. All rights reserved worldwide.

All other brand names, product names, or trademarks belong to their respective holders. For additional trademark information, please see “Trademarks” on the product CD.

**Proprietary Statement** This manual contains proprietary information of Zebra Technologies Corporation and its subsidiaries (“Zebra Technologies”). It is intended solely for the information and use of parties operating and maintaining the equipment described herein. Such proprietary information may not be used, reproduced, or disclosed to any other parties for any other purpose without the express, written permission of Zebra Technologies Corporation.

**Product Improvements** Continuous improvement of products is a policy of Zebra Technologies Corporation. All specifications and designs are subject to change without notice.

**Liability Disclaimer** Zebra Technologies Corporation takes steps to ensure that its published Engineering specifications and manuals are correct; however, errors do occur. Zebra Technologies Corporation reserves the right to correct any such errors and disclaims liability resulting therefrom.

**Limitation of Liability** In no event shall Zebra Technologies Corporation or anyone else involved in the creation, production, or delivery of the accompanying product (including hardware and software) be liable for any damages whatsoever (including, without limitation, consequential damages including loss of business profits, business interruption, or loss of business information) arising out of the use of, the results of use of, or inability to use such product, even if Zebra Technologies Corporation has been advised of the possibility of such damages. Some jurisdictions do not allow the exclusion or limitation of incidental or consequential damages, so the above limitation or exclusion may not apply to you.

**Part Number: 11342L-001 Rev. A**



---

# Declaration of Conformity

I have determined that the Zebra printers identified as the

SL Series

105SL

manufactured by:

**Zebra Technologies Corporation**  
333 Corporate Woods Parkway  
Vernon Hills, Illinois 60061-3109 U.S.A.

Have been shown to comply with the applicable technical standards of the FCC

**For Home, Office, Commercial, and Industrial use**

If no unauthorized change is made in the equipment,  
and if the equipment is properly maintained and operated.

  
M. Charles DeSisto

## Compliance Information

### FCC Compliance Statement

This device complies with Part 15 rules. Operation is subject to the following two conditions:

1. This device may not cause harmful interference, and
2. This device must accept any interference received, including interference that may cause undesired operation.

The user is cautioned that any changes or modifications not expressly approved by Zebra Technologies Corporation could void the user's authority to operate the equipment. To ensure compliance, this printer must be used with Shielded Communication Cables.

### Canadian DOC Compliance Statement

This Class B digital apparatus complies with Canadian ICES-003.

Cet appareil numérique de la classe B est conforme à la norme NMB-003 du Canada.

---

# Contents



<b>About This Document</b> .....	<b>1</b>
Who Should Use This Document .....	2
How This Document Is Organized .....	2
Contacts .....	3
Web Site .....	3
The Americas .....	3
Europe, Africa, Middle East, and India .....	3
Asia Pacific .....	3
Document Conventions .....	4
<b>1 • Introduction</b> .....	<b>7</b>
External View .....	8
Control Panel .....	9
Control Panel LCD .....	10
Control Panel Buttons .....	10
Control Panel Lights .....	11
Printer Media Compartment .....	13
<b>2 • Printer Setup</b> .....	<b>15</b>
Before You Begin .....	16
Handling the Printer .....	17
Unpack and Inspect the Printer .....	17
Store the Printer .....	17
Ship the Printer .....	17
Recycle the Printer .....	17

Select a Site for the Printer . . . . .	18
Select a Surface . . . . .	18
Provide Proper Operating Conditions . . . . .	18
Allow Proper Space . . . . .	18
Provide a Data Source . . . . .	18
Provide a Power Source . . . . .	18
Select a Communication Interface . . . . .	19
Connector Locations . . . . .	19
Types of Connections . . . . .	20
Data Cable Requirements . . . . .	22
Connect the Printer to a Power Source . . . . .	23
Power Cord Specifications . . . . .	24
Types of Media . . . . .	25
Ribbon Overview . . . . .	27
When to Use Ribbon . . . . .	27
Coated Side of Ribbon . . . . .	27
<b>3 • Operations . . . . .</b>	<b>29</b>
Media Loading Overview . . . . .	30
Print Modes . . . . .	30
Insert Media into the Printer . . . . .	31
Load Media in Tear-Off Mode . . . . .	34
Load Media in Peel-Off Mode . . . . .	38
Load Media in Rewind Mode . . . . .	49
Remove Labels from the Rewind Spindle . . . . .	55
Load Media in Cutter Mode . . . . .	57
Load Ribbon . . . . .	61
Remove Used Ribbon . . . . .	65
Adjust Media Sensors . . . . .	66
Black Mark Sensor . . . . .	66
Transmissive Sensor . . . . .	66
Adjust Printhead Balance and Pressure . . . . .	68
Adjust Printhead Balance . . . . .	68
Printhead Pressure Adjustment . . . . .	70
Calibrate the Printer . . . . .	71
<b>4 • Configuration . . . . .</b>	<b>73</b>
Setup Mode . . . . .	74
Enter Setup Mode . . . . .	74
Exit Setup Mode . . . . .	75
Change Password-Protected Parameters . . . . .	76
Default Password Value . . . . .	76
Disable the Password Protection Feature . . . . .	76

Print a Configuration Label . . . . .	77
Print a Network Configuration Label . . . . .	78
Control Panel Parameters. . . . .	79
Print Server LCD Displays . . . . .	98
<b>5 • PC and Memory Cards . . . . .</b>	<b>103</b>
PCMCIA PC Cards . . . . .	104
<b>6 • Routine Maintenance . . . . .</b>	<b>107</b>
Lubrication . . . . .	108
Cleaning Schedule . . . . .	108
Clean the Exterior . . . . .	109
Clean the Printhead and Platen Roller . . . . .	109
Clean the Media Compartment and Sensors . . . . .	112
Clean the Snap Plate . . . . .	114
Clean the Cutter . . . . .	115
Replace the Fuse . . . . .	116
<b>7 • Troubleshooting . . . . .</b>	<b>117</b>
Troubleshooting Checklists . . . . .	118
LCD Error Messages . . . . .	119
Print Quality Problems . . . . .	122
Calibration Problems. . . . .	125
Communications Problems. . . . .	126
Ribbon Problems . . . . .	127
Miscellaneous Printer Problems . . . . .	128
Printer Diagnostics . . . . .	130
Power-On Self Test. . . . .	130
CANCEL Self Test . . . . .	131
PAUSE Self Test . . . . .	133
FEED Self Test . . . . .	134
FEED and PAUSE Self Test . . . . .	138
Communications Diagnostics Test . . . . .	139
Sensor Profile . . . . .	140
<b>8 • Specifications . . . . .</b>	<b>141</b>
General Specifications . . . . .	142
Physical . . . . .	142
Environmental Conditions for Operation and Storage . . . . .	142
Electrical Specifications . . . . .	142
Communications Specifications . . . . .	143
Other Standard Features . . . . .	143
Additional Options. . . . .	143
Agency Approvals. . . . .	144

Printing Specifications . . . . .	145
Ribbon Specifications . . . . .	145
Media Specifications . . . . .	146
Zebra Programming Language (ZPL II) . . . . .	147
Bar Codes . . . . .	147
<b>Glossary . . . . .</b>	<b>149</b>
<b>End User License Agreement . . . . .</b>	<b>153</b>
<b>Index . . . . .</b>	<b>159</b>





---

# About This Document

This section provides you with contact information, document structure and organization, and additional reference documents.

## Contents

Who Should Use This Document . . . . .	2
How This Document Is Organized . . . . .	2
Contacts . . . . .	3
Web Site . . . . .	3
The Americas . . . . .	3
Europe, Africa, Middle East, and India . . . . .	3
Asia Pacific . . . . .	3
Document Conventions . . . . .	4

## Who Should Use This Document

This User Guide is intended for use by any person who needs to perform routine maintenance, upgrade, or troubleshoot problems with the printer.

## How This Document Is Organized

The User Guide is set up as follows:

<b>Section</b>	<b>Description</b>
<i>Introduction on page 7</i>	This section shows the operational controls and location of major components used when loading media and ribbon. Other features of the printer are discussed.
<i>Printer Setup on page 15</i>	This section provides the tasks that you must complete and the issues that you must consider before you load and configure your printer.
<i>Operations on page 29</i>	This section provides the procedures for loading and calibrating the printer.
<i>Configuration on page 73</i>	This section describes the control panel parameters that are used to configure the printer for operation.
<i>PC and Memory Cards on page 103</i>	This section describes the optional cards that can be used with the printer and gives instructions for installation.
<i>Routine Maintenance on page 107</i>	This section provides routine cleaning and maintenance procedures.
<i>Troubleshooting on page 117</i>	This section provides information about errors that you might need to troubleshoot. Assorted diagnostic tests are included.
<i>Specifications on page 141</i>	This section provides the features of and specifications for the printer.
<i>Glossary on page 149</i>	The glossary provides a list of common terms.

## Contacts

You can contact Zebra Technologies Corporation at the following.

### Web Site

<http://www.zebra.com>

Technical Support via the Internet is available 24 hours per day, 365 days per year. Go to <http://www.zebra.com/support>.

### The Americas

Regional Headquarters	Technical Support	Customer Service Dept.
Zebra Technologies International, LLC 333 Corporate Woods Parkway Vernon Hills, Illinois 60061.3109 U.S.A T: +1 847 793 2600 Toll-free +1 800 423 0422 F: +1 847 913 8766	T: +1 847 913 2259 F: +1 847 913 2578 Hardware: hwtsamerica@zebra.com Software: swtsamerica@zebra.com	For printers, parts, media, and ribbon, please call your distributor, or contact us. T: +1 866 230 9494 E: VHCustServ@zebra.com

### Europe, Africa, Middle East, and India

Regional Headquarters	Technical Support	Internal Sales Dept.
Zebra Technologies Europe Limited Zebra House The Valley Centre, Gordon Road High Wycombe Buckinghamshire HP13 6EQ, UK T: +44 (0)1494 472872 F: +44 (0) 1494 450103	T: +44 (0) 1494 768298 F: +44 (0) 1494 768210 Germany: Tsgermany@zebra.com France: Tsfrance@zebra.com Spain/Portugal: Tsspain@zebra.com All other areas: Tseurope@zebra.com	For printers, parts, media, and ribbon, please call your distributor, or contact us. T: +44 (0) 1494 768316 F: +44 (0) 1494 768244 E: mseurope@zebra.com

### Asia Pacific

Regional Headquarters	Technical Support	Customer Service
Zebra Technologies Asia Pacific, LLC 16 New Industrial Road #05-03 Hudson TechnoCentre Singapore 536204 T: +65 6858 0722 F: +65 6885 0838	T: +65 6858 0722 F: +65 6885 0838 E: tsasiapacific@zebra.com	For printers, parts, media, and ribbon, please call your distributor, or contact us. T: +65 6858 0722 F: +65 6885 0837

## Document Conventions

The following conventions are used throughout this document to convey certain information.

**Alternate Color** (online only) Cross-references contain hot links to other sections in this guide. If you are viewing this guide online in .pdf format, you can click the cross-reference ([blue text](#)) to jump directly to its location.

**LCD Display Examples** Text from a printer's Liquid Crystal Display (LCD) appears in **Bubbledot ICG** font.

**Command Line Examples** Command line examples appear in `Courier New` font. For example, type `ZTools` to get to the Post-Install scripts in the `bin` directory.

**Files and Directories** File names and directories appear in `Courier New` font. For example, the `Zebra<version number>.tar` file and the `/root` directory.

### Icons Used



---

**Caution** • Warns you of the potential for electrostatic discharge.

---



---

**Caution** • Warns you of a potential electric shock situation.

---



---

**Caution** • Warns you of a situation where excessive heat could cause a burn.

---



---

**Caution** • Advises you that failure to take or avoid a specific action could result in physical harm to you.

---

---

**Caution** • (No icon) Advises you that failure to take or avoid a specific action could result in physical harm to the hardware.

---



**Important** • Advises you of information that is essential to complete a task.



**Note** • Indicates neutral or positive information that emphasizes or supplements important points of the main text.



**Example** • Provides an example, often a scenario, to better clarify a section of text.



**Tools** • Tells you what tools you need to complete a given task.

**Illustration Callouts** Callouts are used when an illustration contains information that needs to be labeled and described. A table that contains the labels and descriptions follows the graphic. [Figure 1](#) provides an example.

**Figure 1 • Sample Figure with Callouts**

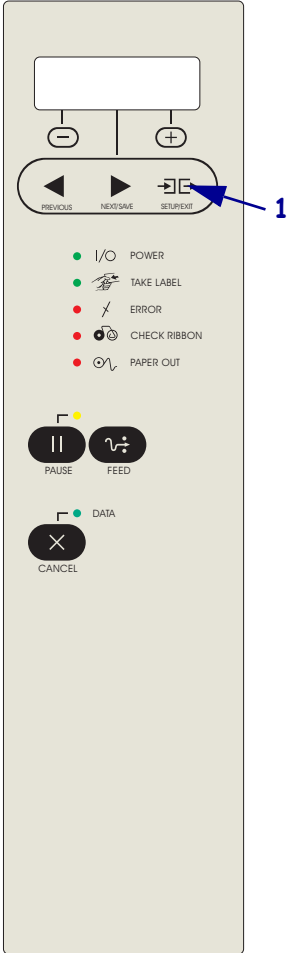

1	SETUP/EXIT button
---	-------------------



**Notes •** \_\_\_\_\_

\_\_\_\_\_

\_\_\_\_\_

\_\_\_\_\_

\_\_\_\_\_

\_\_\_\_\_

\_\_\_\_\_

\_\_\_\_\_

\_\_\_\_\_

\_\_\_\_\_

\_\_\_\_\_



---

# Introduction

This section shows the operational controls and location of major components used when loading media and ribbon. Other features of the printer are discussed.

## Contents

External View . . . . .	8
Control Panel . . . . .	9
Control Panel LCD . . . . .	10
Control Panel Buttons . . . . .	10
Control Panel Lights . . . . .	11
Printer Media Compartment . . . . .	13

## External View

Figure 2 shows the outside of the printer.

Figure 2 • Exterior of Printer

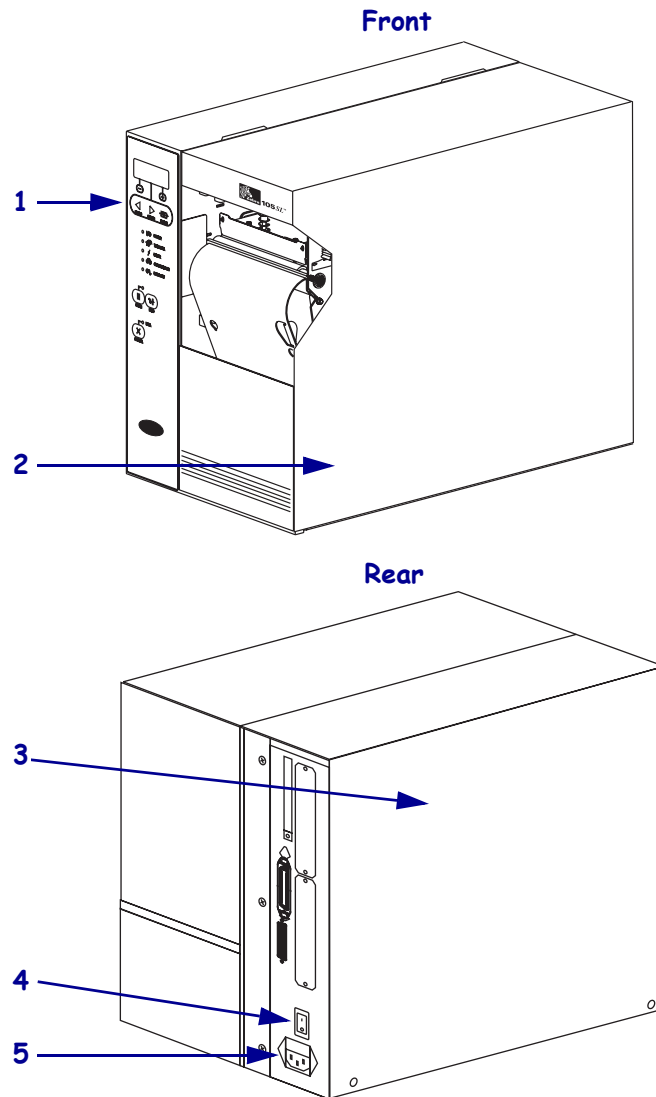

1	Control panel
2	Media door
3	Electronics cover
4	Power switch (O = Off, I = On)
5	AC power connector



## Control Panel

All controls and indicators for the printer are located on the control panel (Figure 3).

- The **control panel Liquid Crystal Display (LCD)** shows the operating status and printer parameters.
- The **control panel buttons** are used to control the printer operations and to set parameters.
- The **control panel lights (LEDs)** show the printer's operating status or indicate which control panel buttons are active.

**Figure 3 • Location of Control Panel Buttons and Lights**

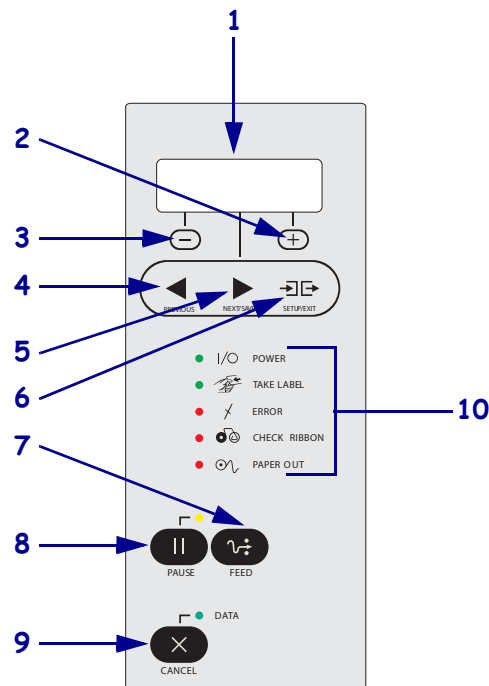

1	LCD
2	PLUS button
3	MINUS button
4	PREVIOUS button
5	NEXT/SAVE button
6	SETUP/EXIT button
7	FEED button
8	PAUSE button
9	CANCEL button
10	Control panel lights

## Control Panel LCD

The control panel LCD functions differently in different printer modes.

- In **Operating mode**, the LCD displays the printer's status, sometimes in conjunction with a control panel light (see [Control Panel Lights](#) on page 11).
- In **Pause mode**, the printer stops printing temporarily.
- In **Setup mode**, you can use the control panel LCD to view or modify printer parameters (see [Control Panel Parameters](#) on page 79).
- In **Error mode**, the LCD may display an alert or error message (see [LCD Error Messages](#) on page 119).

## Control Panel Buttons

Table 1 describes the function of each button.

Table 1 • Control Panel Buttons









Button	Appearance	Function
PAUSE		Stops and restarts the printing process or removes error messages and clears the LCD. <ul style="list-style-type: none"> <li>• If the printer is idle, it enters Pause mode immediately.</li> <li>• If the printer is printing, the label is completed before the printer pauses.</li> </ul>
FEED		Advances a blank label. <ul style="list-style-type: none"> <li>• If the printer is idle or paused, the label is fed immediately.</li> <li>• If the printer is printing, the label is fed after printing finishes.</li> </ul>
CANCEL		CANCEL functions only in Pause mode. Pressing CANCEL once has these effects: <ul style="list-style-type: none"> <li>• Cancels the label format that is currently printing.</li> <li>• If no label format is printing, the next one to be printed is canceled.</li> <li>• If no label formats are waiting to be printed, CANCEL is ignored.</li> </ul> To clear the printer's entire label format memory, press and hold CANCEL. When the formats are cleared, the DATA light turns off.
PREVIOUS		When in Setup mode, scrolls the LCD to the previous parameter. Press and hold to scroll quickly.
NEXT/SAVE		<ul style="list-style-type: none"> <li>• When in Setup mode, scrolls the LCD to the next parameter. Press and hold to scroll quickly.</li> <li>• When exiting Setup mode, saves any changes you have made in the configuration and calibration sequence.</li> </ul>
SETUP/EXIT		Enters and exits Setup mode.

Table 1 • Control Panel Buttons (Continued)

Button	Appearance	Function
MINUS		Changes the parameter values. Common uses are to decrease a value, to answer “no,” to scroll through choices, or to change the cursor position while entering the password.
PLUS		Changes the parameter values. Common uses are to increase a value, to answer “yes,” to scroll through choices, or to change values while entering the password.







## Control Panel Lights

Table 2 describes lights on the control panel that indicate different printer conditions.



**Note** • If two operating conditions occur simultaneously (for example, one that causes a light to be on constantly and one that causes the same light to flash), the light flashes.

Table 2 • Control Panel Lights

Light	Appearance	Status	Indication
POWER		Off	The printer is off or power is not applied.
		On	The printer is on.
TAKE LABEL		Off	Normal operation.
		Flashing	(Peel mode only.) The label is available. Printing pauses until the label is removed.
ERROR		Off	Normal operation—no printer errors.
		Flashing	A printer error exists. Check the LCD for more information.
CHECK RIBBON		Off	Normal operation—ribbon (if used) is properly loaded.
		On	Printing pauses, the LCD displays a warning message, and the PAUSE light is on. <ul style="list-style-type: none"> <li>If the printer is in Direct Thermal Mode: ribbon is loaded.</li> <li>If the printer is in Thermal Transfer Mode: no ribbon is loaded, or ribbon is loaded incorrectly.</li> </ul>
PAPER OUT		Off	Normal operation—media is properly loaded.
		On	No media is under the media sensor. Printing pauses, the LCD shows an error message, and the PAUSE light is on.
PAUSE (located above the PAUSE button)		Off	Normal operation.
		On	The printer stopped all printing operations. Causes include: <ul style="list-style-type: none"> <li>PAUSE was pressed</li> <li>A label format included a pause command</li> <li>A printer error was detected.</li> </ul> The LCD gives additional information.

**Table 2 • Control Panel Lights (Continued)**

Light	Appearance	Status	Indication
DATA (located above the CANCEL button)		Off	Normal operation. No data being received or processed.
		On	The printer is processing data or is printing. No data is being received.
		Flashing	The printer is receiving data from or sending status information to the host computer.

## Printer Media Compartment

Figure 4 shows a simplified view of the media compartment of your printer. Depending on installed options, your printer may look slightly different.

Figure 4 • Media Compartment

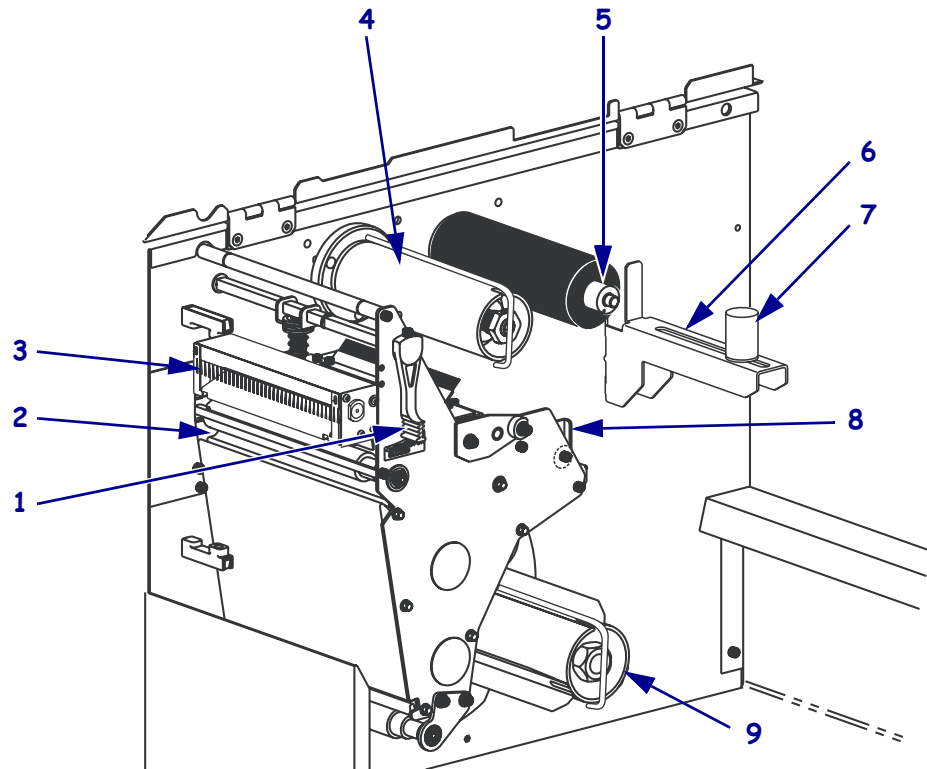

1	Printhead-open lever
2	Platen roller
3	Cutter (optional)
4	Ribbon take-up spindle
5	Ribbon supply spindle
6	Media supply hanger
7	Media supply guide
8	Outer media guide
9	Rewind spindle (optional)



**Notes •** \_\_\_\_\_

\_\_\_\_\_

\_\_\_\_\_

\_\_\_\_\_

\_\_\_\_\_

\_\_\_\_\_

\_\_\_\_\_

\_\_\_\_\_

\_\_\_\_\_

\_\_\_\_\_

\_\_\_\_\_



---

# Printer Setup

This section provides the tasks that you must complete and the issues that you must consider before you load and configure your printer.

## Contents

Before You Begin . . . . .	16
Handling the Printer . . . . .	17
Unpack and Inspect the Printer . . . . .	17
Store the Printer . . . . .	17
Ship the Printer . . . . .	17
Recycle the Printer . . . . .	17
Select a Site for the Printer . . . . .	18
Select a Surface . . . . .	18
Provide Proper Operating Conditions . . . . .	18
Allow Proper Space . . . . .	18
Provide a Data Source . . . . .	18
Provide a Power Source . . . . .	18
Select a Communication Interface . . . . .	19
Connector Locations . . . . .	19
Types of Connections . . . . .	20
Data Cable Requirements . . . . .	22
Connect the Printer to a Power Source . . . . .	23
Power Cord Specifications . . . . .	24
Types of Media . . . . .	25
Ribbon Overview . . . . .	27
When to Use Ribbon . . . . .	27
Coated Side of Ribbon . . . . .	27

## Before You Begin

Review this checklist, and resolve any issues before you set up or use your printer.

- Unpack and Inspect the Printer** Have you unpacked the printer and inspected it for damage? If you have not, see *Unpack and Inspect the Printer on page 17*.
- Select a Site** Have you selected an appropriate location for the printer? If you have not, see *Select a Site for the Printer on page 18*.
- Attach a Power Cord** Do you have the correct power cord for your printer? If you are unsure, see *Power Cord Specifications on page 24*. To attach the power cord and connect the printer to a power source, see *Connect the Printer to a Power Source on page 23*.
- Connect to a Data Source** Have you determined how the printer will connect to a data source (usually a computer)? For more information, see *Select a Communication Interface on page 19*.
- Select Media** Do you have the correct media for your application? If you are unsure, see *Types of Media on page 25*.
- Select Ribbon** Do you need to use ribbon, and is the appropriate ribbon available, if needed? If you are unsure, see *Ribbon Overview on page 27*.



## Handling the Printer

This section describes how to handle your printer.

### Unpack and Inspect the Printer

When you receive the printer, immediately unpack it and inspect for shipping damage.

- Save all packing materials.
- Check all exterior surfaces for damage.
- Raise the media door, and inspect the media compartment for damage to components.

If you discover shipping damage upon inspection:

- Immediately notify the shipping company and file a damage report.
- Keep all packaging material for shipping company inspection.
- Notify your authorized Zebra reseller.



**Important** • Zebra Technologies Corporation is not responsible for any damage incurred during the shipment of the equipment and will not repair this damage under warranty.

### Store the Printer

If you are not placing the printer into immediate operation, repackage it using the original packing materials. You may store the printer under the conditions shown in [Table 3](#).

**Table 3 • Storage Temperature and Humidity**

Temperature	Relative Humidity
-40°F to 140°F (-40° to 60°C)	5% to 85% non-condensing

### Ship the Printer

If you must ship the printer:

- Remove any media or ribbon from the printer to avoid damaging the printer.
- Carefully pack the printer into the original container or a suitable alternate container to avoid damage during transit. A shipping container can be purchased from Zebra if the original packaging has been lost or destroyed.

### Recycle the Printer



This printer is recyclable. If you must dispose of the printer, do not do so in unsorted municipal waste. Please recycle according to your local standards. For more information, see <http://www.zebra.com/environment>.

## Select a Site for the Printer

Consider the following when selecting an appropriate location for your printer.

### Select a Surface

Select a solid, level surface of sufficient size and strength to accommodate the printer and other equipment (such as a computer), if necessary. The choices include a table, countertop, desk, or cart. For the printer's weight and dimensions, see [General Specifications on page 142](#).

### Provide Proper Operating Conditions

This printer is designed to function in a wide range of environmental and electrical conditions, including a warehouse or factory floor. For more information on the required conditions, see [General Specifications on page 142](#).

[Table 4](#) shows the temperature and relative humidity requirements for the printer when it is operating.

**Table 4 • Operating Temperature and Humidity**

Mode	Temperature	Relative Humidity
Thermal Transfer	41° to 104°F (5° to 40°C)	20 to 85% non-condensing
Direct Thermal	32° to 104°F (0° to 40°C)	20 to 85% non-condensing

### Allow Proper Space

The printer should have enough space around it for you to be able to open the media door. To allow for proper ventilation and cooling, leave open space on all sides of the printer.



**Caution** • Do not place any padding or cushioning material behind or under the printer because this restricts air flow and could cause the printer to overheat.

### Provide a Data Source

If the printer will be located away from the data source, the selected site must provide the appropriate connections to that data source. For more information on the types of communication interfaces and their limitations, see [Select a Communication Interface on page 19](#).

### Provide a Power Source

Place the printer within a short distance of a power outlet that is easily accessible.

## Select a Communication Interface

The way that you connect your printer to a data source depends on the communication options installed in the printer. You may use any available connection to send commands and label formats from a host computer to the printer.

---

**Caution** • Ensure that the printer power is off (O) before connecting data communications cables. Connecting a data communications cable while the power is on (I) may damage the printer.

---



**Note** • You must supply all interface cables or wireless cards for your application. Refer to *Data Cable Requirements* on page 22 for specific cable requirements.

### Connector Locations

Refer to [Figure 5](#). The printer comes standard with both an Electronics Industries Association (EIA) RS-232 serial interface (DB-9 connector) and an IEEE 1284 bidirectional parallel interface. You may use either of these interface methods to send commands and label formats from a computer to the printer.

**Figure 5 • Cable Connections**

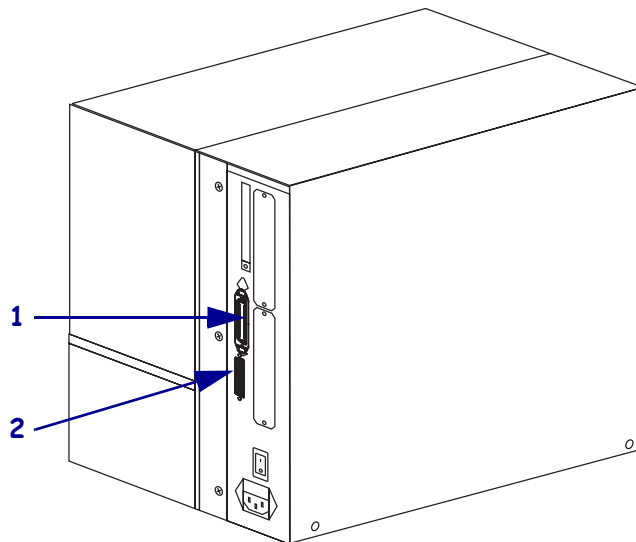

<b>1</b>	Parallel interface connector
<b>2</b>	DB-9 serial interface connector

## Types of Connections

The method of connecting the printer to a data source depends on the communication options installed in the printer and the host computer. This section provides basic information about common interfaces.

When communicating via the serial data port (RS-232), the baud rate, number of data and stop bits, the parity, and the XON/XOFF or DTR control should be set to match those of the host computer. See [Table 9, Printer Parameters on page 79](#) to configure these parameters. When communicating via the parallel port, the previously mentioned parameters do not apply.

**RS-232 Serial** A serial communication method consisting of data and control signals; available as a standard feature on most personal computers and other hosts.

- *Advantages:* Cables and connectors are readily available from computer equipment stores and suppliers; easy to connect; two-way communication between the computer and the printer; relatively long cable length.
- *Disadvantages:* Slower than the parallel connection; limited to 50 feet (15.24 m) of cable; may need to change printer parameters to match host computer; need to use a null-modem adaptor to connect to the printer if using a standard modem cable.

**Figure 6 • Connecting the Printer through the Serial Data Port**

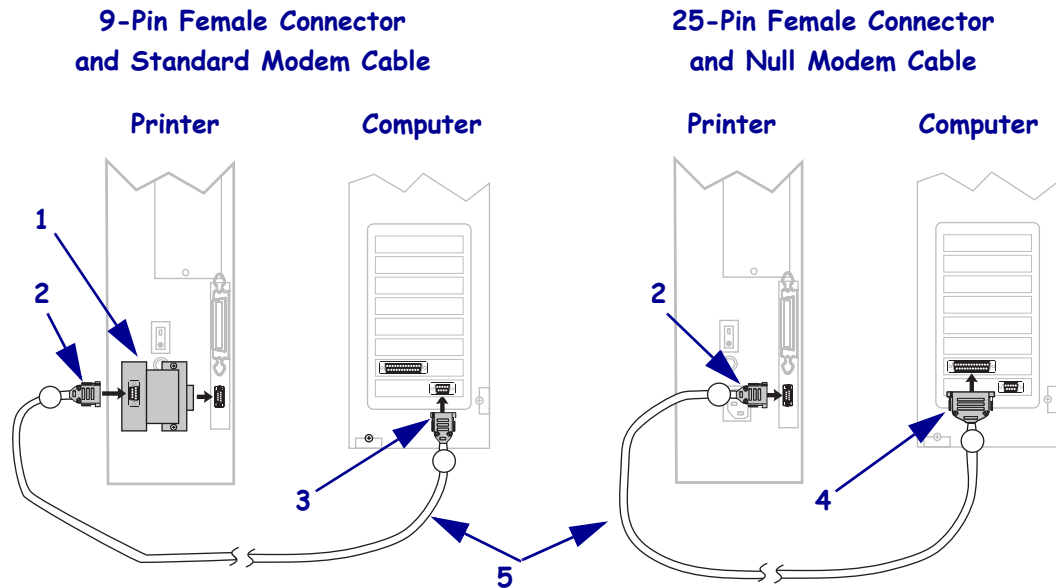

1	Null-modem adaptor (if using a standard modem cable)
2	9-pin male connector, connected to printer or null-modem adaptor
3	9-pin female connector, connected to computer
4	25-pin female connector, connected to computer
5	Maximum cable length = 50 ft. (15 m)

**IEEE 1284 Bidirectional Parallel** A common communication method available on most personal computers and other hosts.

- *Advantages:* Faster than the serial connection; cables and connectors are readily available from computer equipment stores and suppliers; easy to connect; two-way communication between the computer and the printer; no printer parameter changes required to match the host computer.
- *Disadvantages:* Recommended cable length of only 6 feet (1.83 m) with a maximum length of 10 ft (3 m); many computers are equipped with only one parallel port, allowing only one IEEE 1284 bidirectional device to be connected at a time; an Ethernet print server takes up or covers this port on the printer.

**Figure 7 • Connecting the Printer through the Parallel Port**

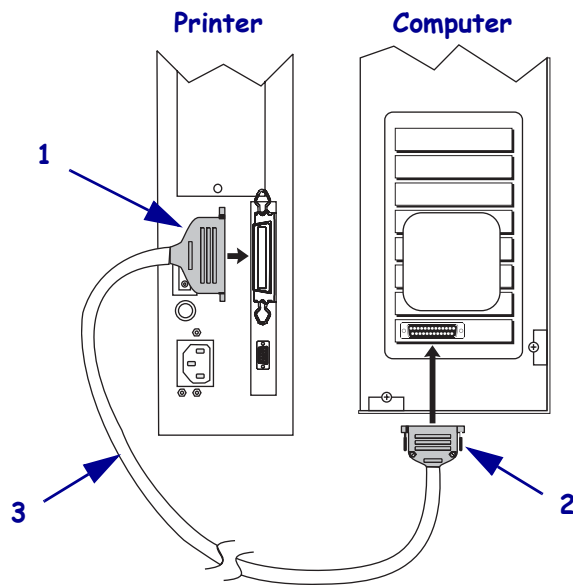

<b>1</b>	36-pin male connector, attaching to printer
<b>2</b>	25-pin male connector, attaching to computer
<b>3</b>	Maximum cable length = 10 ft. (3 m)

**Optional Ethernet Print Servers** Ethernet-based print servers also are available to connect your printer to a data source. Both wired and wireless options are available. Manuals are available at <http://www.zebra.com/manuals> or on the user CD that came with your printer.



**Note** • The parallel connection on your printer is not operational when one of these print servers is installed. Wireless and external wired print servers plug directly into the printer's parallel port. Internal print servers include a mounting bracket that covers the parallel port.

- With the ZebraNet Wireless or Wireless Plus Print Server board installed, a wireless PCMCIA, CardBus, or Compact Flash<sup>®</sup> card can be used to communicate with a network. For more information on this option, see the ZebraNet Wireless and Wireless Plus Print Server User Guide.
- With the ZebraNet 10/100 Print Server (10/100 PS), the printer can communicate with a 10BaseT or 100BaseT network. For more information on 10/100 PS, see the *ZebraNet 10/100 Print Server User and Reference Guide*.
- With the ZebraNet Print Server II (PSII), the printer can communicate with a 10BaseT network. For more information on PSII, see the *PrintServer II User and Reference Guide*.

## Data Cable Requirements

Data cables must be fully shielded and fitted with metal or metallized connector shells. Shielded cables and connectors are required to prevent radiation and reception of electrical noise.

To minimize electrical noise pickup in the cable:

- Keep data cables as short as possible.
- Do not bundle the data cables tightly with the power cords.
- Do not tie the data cables to power wire conduits.



**Note** • Zebra printers comply with FCC Rules and Regulations, Part 15 for Class B Equipment using fully shielded, 6.5 ft. (2 m) data cables. Use of unshielded cables may increase radiation above the Class B limits.

## Connect the Printer to a Power Source

The AC power cord must have a three-prong female connector on one end that plugs into the mating AC power connector at the rear of the printer. If a power cable was not included with your printer, refer to *Power Cord Specifications* on page 24.



**Caution** • For personnel and equipment safety, always use an approved three-conductor power cord specific to the region or country intended for installation. This cord must use an IEC 320 female connector and the appropriate region-specific three-conductor grounded plug configuration.

### To connect the printer to a power source, complete these steps:

1. Toggle the printer power switch to the off (O) position.
2. See [Figure 8](#). Plug the power cord into the AC power connector on the rear of the printer.

**Figure 8 • Power Connection**

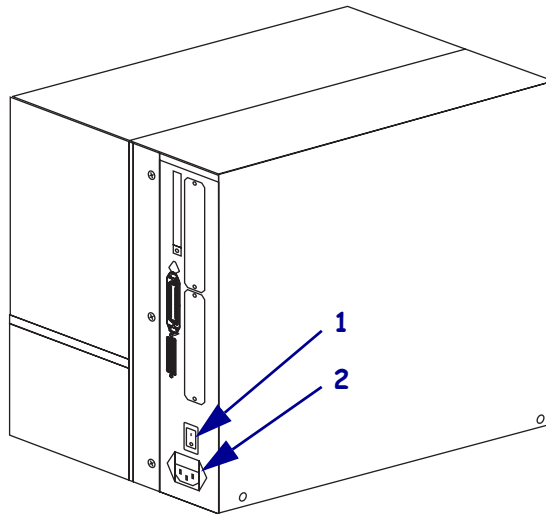

<b>1</b>	Power switch
<b>2</b>	AC power connector

3. Plug the other end of the power cord into a power outlet near the printer.
4. Turn on (I) the printer.  
 The front panel LCD and lights activate, indicating that the printer is booting up.

## Power Cord Specifications



**Caution** • For personnel and equipment safety, always use an approved three-conductor power cord specific to the region or country intended for installation. This cord must use an IEC 320 female connector and the appropriate region-specific, three-conductor grounded plug configuration.

Depending on how your printer was ordered, a power cord may or may not be included. If one is not included or if the one included is not suitable for your requirements, refer to the following guidelines:

- The overall cord length must be less than 9.8 ft. (3.0 m).
- The cord must be rated for at least 10 A, 250 V.
- The chassis ground (earth) **must** be connected to ensure safety and reduce electromagnetic interference. The third wire in the power cord grounds the connection (Figure 9).

Figure 9 • Power Cord Specifications

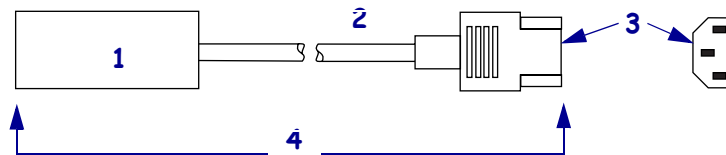

<b>1</b>	AC power plug for your country—This should bear the certification mark of at least one of the known international safety organizations (Figure 10).
<b>2</b>	3-conductor HAR cable or other cable approved for your country.
<b>3</b>	IEC 320 connector—This should bear the certification mark of at least one of the known international safety organizations (Figure 10).
<b>4</b>	Length ≤ 9.8 ft. (3 m). Rating 10 Amp, 250 VAC.

Figure 10 • International Safety Organization Certifications





## Types of Media

The printer can use various types of media (Table 5). Zebra strongly recommends the use of Zebra-brand supplies for continuous high-quality printing. A wide range of paper, polypropylene, polyester, and vinyl stock has been specifically engineered to enhance the printing capabilities of the printer and to prevent premature printhead wear. To purchase supplies, go to <http://www.zebra.com/howtobuy>.

**Table 5 • Types of Media**

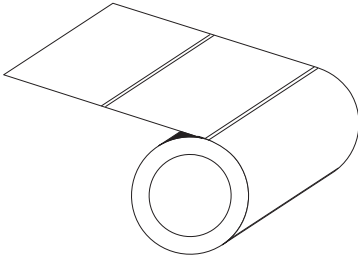
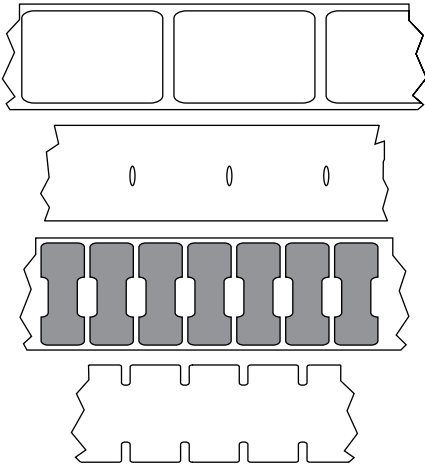
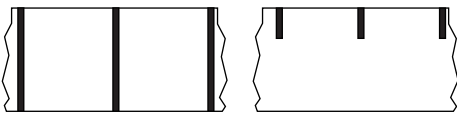
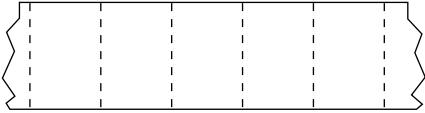
Media Type	How It Looks	Description
<p><b>Non-Continuous Roll Media</b></p>		<p>Roll media is wound on a 3-in. (76-mm) core. Labels have adhesive backing that sticks them to a liner, and they are separated by gaps, holes, notches, or black marks. Tags are separated by perforations.</p> <p><b>Figure 11 • Non-Continuous Web Media</b></p>  <p><b>Figure 12 • Black Mark Media</b></p>  <p><b>Figure 13 • Tag Stock</b></p> 

**Table 5 • Types of Media (Continued)**

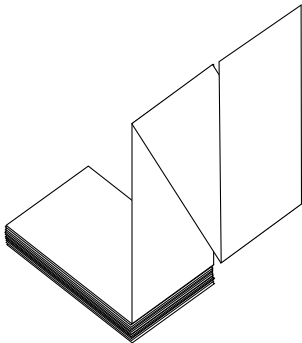
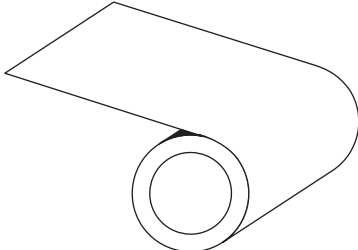
<b>Media Type</b>	<b>How It Looks</b>	<b>Description</b>
<p><b>Non-Continuous Fanfold Media</b></p>		<p>Fanfold media is folded in a zigzag pattern. Fanfold media can have the same label divisions as non-continuous roll media. The divisions would fall on or near the folds.</p>
<p><b>Continuous Roll Media</b></p>		<p>Continuous media is wound on a core and is without gaps, holes, notches, or black marks. This allows the image to be printed anywhere on the label. With continuous media, use the transmissive sensor so the printer can detect when the media runs out.</p>

## Ribbon Overview

Ribbon is a thin film that is coated on one side with wax, resin, or wax resin, which is transferred to the media during the thermal transfer process. The media determines whether you need to use ribbon and how wide the ribbon must be.

When ribbon is used, it must be as wide as or wider than the media being used. If the ribbon is narrower than the media, areas of the printhead are unprotected and subject to premature wear.

### When to Use Ribbon

Thermal transfer media requires ribbon for printing while direct thermal media does not. To determine if ribbon must be used with a particular media, perform a media scratch test.

#### To perform a media scratch test, complete these steps:

1. Scratch the print surface of the media rapidly with your fingernail.
2. Did a black mark appear on the media?

If a black mark...	Then the media is...
Does not appear on the media	<b>Thermal transfer.</b> A ribbon is required.
Appears on the media	<b>Direct thermal.</b> No ribbon is required.

### Coated Side of Ribbon

Ribbon can be wound with the coated side on the inside or outside (Figure 14). This printer can only use ribbon that is coated on the outside. If you are unsure which side of a particular roll of ribbon is coated, perform an adhesive test or a ribbon scratch test to determine which side is coated.

Figure 14 • Ribbon Coated on Outside or Inside



## Adhesive Test

If you have labels available, perform the adhesive test to determine which side of a ribbon is coated. This method works well for ribbon that is already installed.

### To perform an adhesive test, complete these steps:

1. Peel a label from its liner.
2. Press a corner of the sticky side of the label to the outer surface of the roll of ribbon.
3. Peel the label off of the ribbon.
4. Observe the results. Did flakes or particles of ink from the ribbon adhere to the label?

If ink from the ribbon...	Then...
Adhered to the label	The ribbon is coated on the <b>outer</b> surface.
Did not adhere to the label	The ribbon is coated on the <b>inner</b> surface and cannot be used in this printer. To verify this, repeat the test on the other surface of the roll of ribbon.

## Ribbon Scratch Test

Perform the ribbon scratch test when labels are unavailable.

### To perform a ribbon scratch test, complete these steps:

1. Unroll a short length of ribbon.
2. Place the unrolled section of ribbon on a piece of paper with the outer surface of the ribbon in contact with the paper.
3. Scratch the inner surface of the unrolled ribbon with your fingernail.
4. Lift the ribbon from the paper.
5. Observe the results. Did the ribbon leave a mark on the paper?

If the ribbon...	Then...
Left a mark on the paper	The ribbon is coated on the <b>outer</b> surface.
Did not leave a mark on the paper	The ribbon is coated on the <b>inner</b> surface and cannot be used in this printer. To verify this, repeat the test on the other surface of the roll of ribbon.



---

# Operations

This section provides the procedures for loading and calibrating the printer.



**Note** • Complete the tasks and resolve the issues in [Printer Setup on page 15](#) before operating the printer.

## Contents

Media Loading Overview . . . . .	30
Print Modes . . . . .	30
Insert Media into the Printer . . . . .	31
Load Media in Tear-Off Mode . . . . .	34
Load Media in Peel-Off Mode . . . . .	38
Remove Media Liner from the Rewind or Peel Spindle . . . . .	47
Load Media in Rewind Mode . . . . .	49
Remove Labels from the Rewind Spindle . . . . .	55
Load Media in Cutter Mode . . . . .	57
Load Ribbon . . . . .	61
Remove Used Ribbon . . . . .	65
Adjust Media Sensors . . . . .	66
Black Mark Sensor . . . . .	66
Transmissive Sensor . . . . .	66
Adjust Printhead Balance and Pressure . . . . .	68
Adjust Printhead Balance . . . . .	68
Printhead Pressure Adjustment . . . . .	70
Calibrate the Printer . . . . .	71

## Media Loading Overview

The printer can print on roll or fanfold media and use different print modes for label removal.

### Print Modes

The methods for loading media for each print mode follow in this section. Use a print mode that matches the media being used and the printer options available (Table 6). For more information on the types of media, see *Types of Media* on page 25.

**Table 6 • Print Modes**

Mode	When to Use	Printer Action
Tear-Off (default)	Use for most applications. See <i>Load Media in Tear-Off Mode</i> on page 34.	Each label or strip of labels can be torn off after printing.
Peel-Off	Use only if printer has the Peel-Off or Rewind option. See <i>Load Media in Peel-Off Mode</i> on page 38.	The media liner is peeled away from the label during printing. When the printed label is removed, the next label prints.
Cutter	Use only if printer has a cutter option. See <i>Load Media in Cutter Mode</i> on page 57.	The printer automatically cuts the label after it is printed.
Rewind	Use only if printer has the Rewind option. See <i>Load Media in Rewind Mode</i> on page 49.	The media and/or media liner are rewound onto a core as they are printed.

## Insert Media into the Printer

This section shows how to insert roll or fanfold media into the printer. Fanfold media is loaded the same way as roll media.

### Roll Media

To insert roll media, complete these steps:

1. Remove and discard any tags or labels that are dirty or that are held by adhesives or tape.

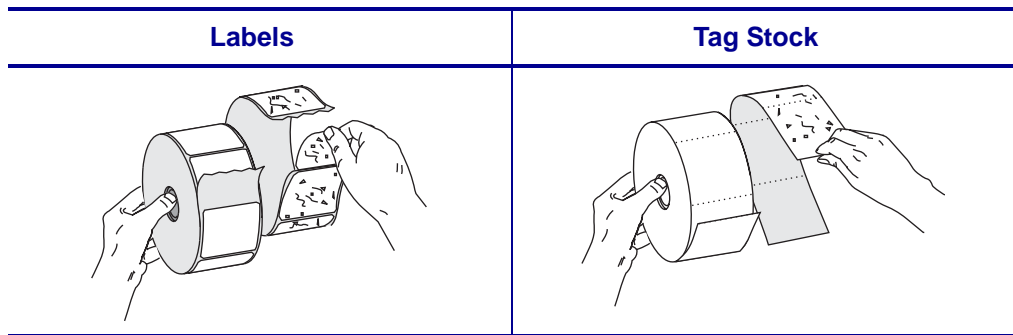

2. Pull out the media supply guide as far as it goes.

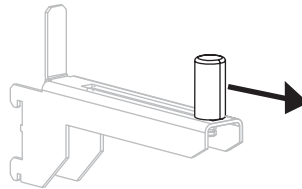

3. Place the roll of media on the media supply hanger. Push the roll as far back as it will go.

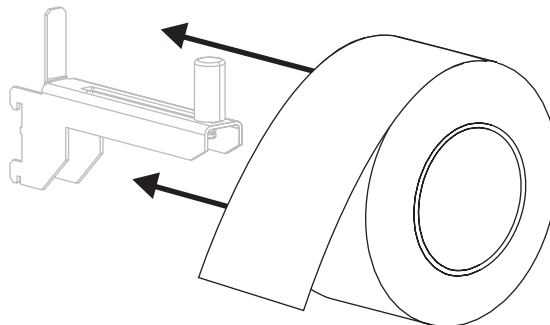

- Slide in the media supply guide until it touches the edge of the roll.

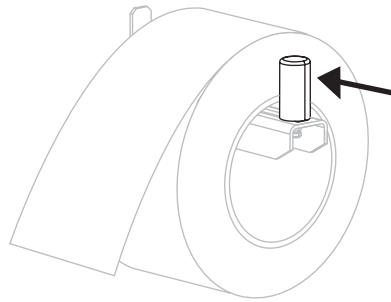

## Fanfold Media

To load fanfold media, complete these steps:

- Thread the fanfold media through the rear access slot (1) or the bottom access slot (2). Using the media supply hanger is optional.

Figure 15 • Rear Feed Using Media Supply Hanger

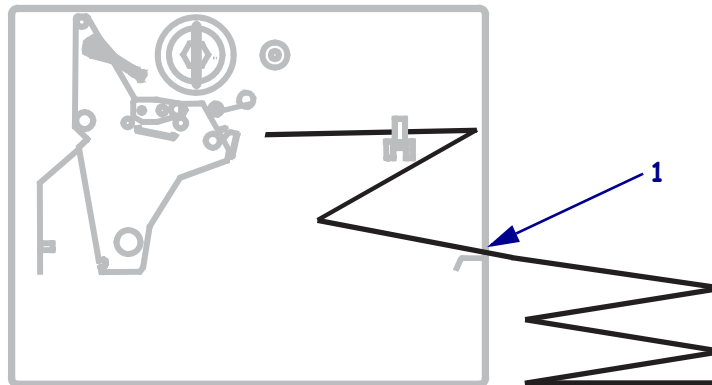
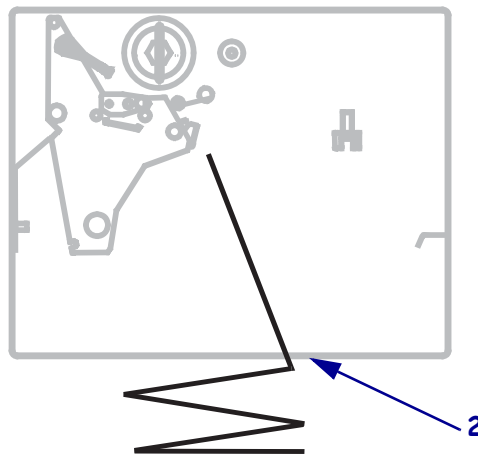
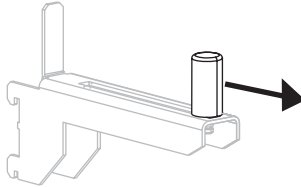
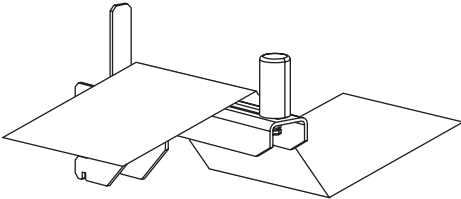
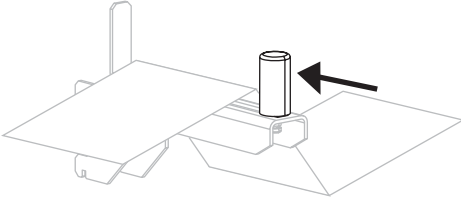

Figure 16 • Bottom Feed Without Using Media Supply Hanger





2. Do you wish to use the media supply guide?

If...	Then...
No	Continue with the media loading procedure for the desired print mode.
Yes	<p data-bbox="529 373 1117 401"><b>a.</b> Pull the media supply guide out as far as it goes.</p>  <p data-bbox="529 638 1105 665"><b>b.</b> Drape the media over the media supply hanger.</p>  <p data-bbox="529 917 1386 978"><b>c.</b> Slide in the media supply guide until it touches, but does not restrict, the edge of the media.</p> 

## Load Media in Tear-Off Mode

Tear-Off is the default mode. [Figure 17](#) shows roll media loaded in Tear-Off mode.

Figure 17 • Tear-Off Mode

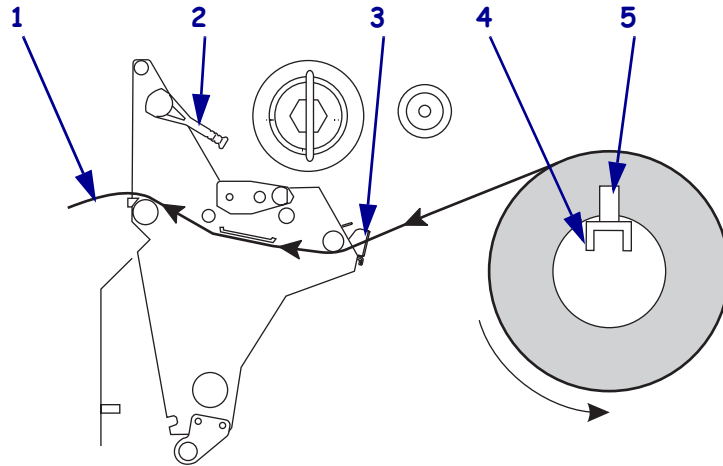

1	Printed label
2	Printhead-open lever
3	Outer media guide
4	Media supply hanger
5	Media supply guide

### To load media in Tear-Off mode, complete these steps:

1. Set the printer to Tear-Off mode. See [Select Print Mode on page 80](#) for instructions.
2. Insert media into the printer. See [Insert Media into the Printer on page 31](#) for instructions.
3. Open the printhead assembly by rotating the printhead-open lever counterclockwise.

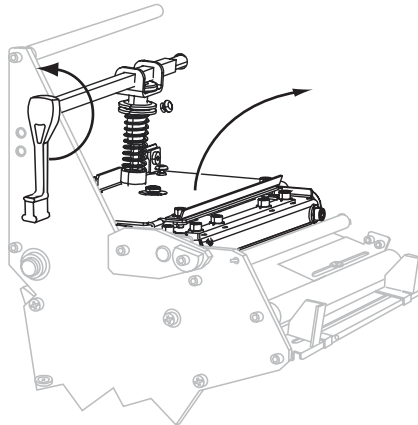

4. Loosen the thumb screw (not visible from this angle) that is located on the bottom of the outer media guide (1).

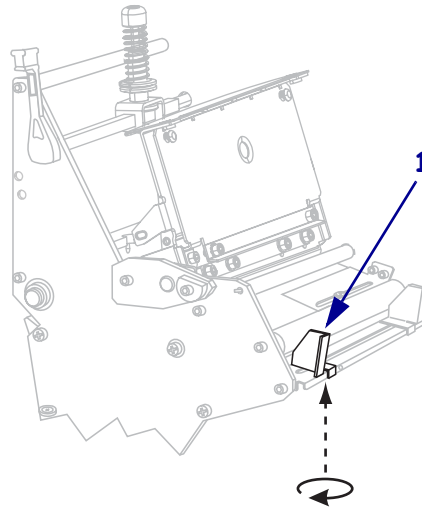

5. Slide the outer media guide all the way out.

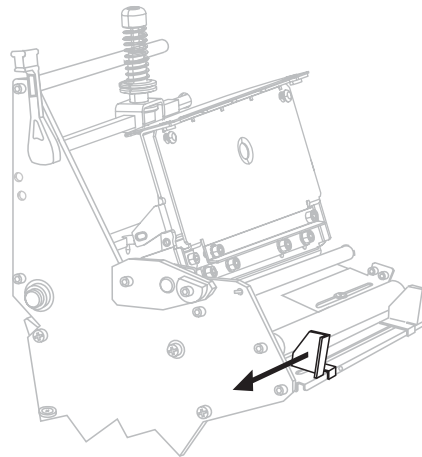

6. Thread the media under the lower roller (1) and the upper media sensor assembly (2).

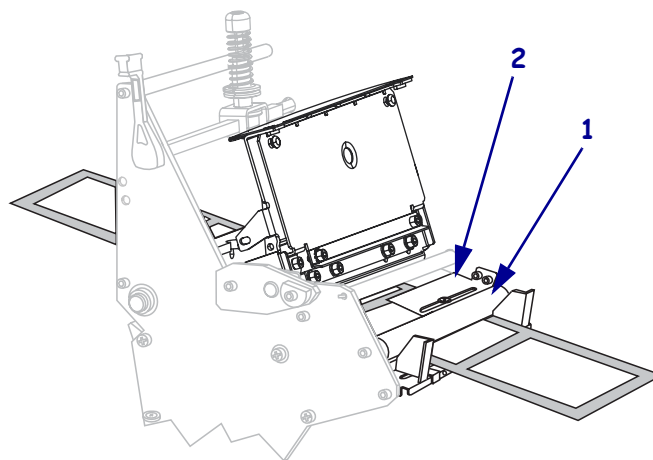

7. Push the media forward until it passes under the printhead assembly (1), under the snap plate (2), and then over the platen roller (3).

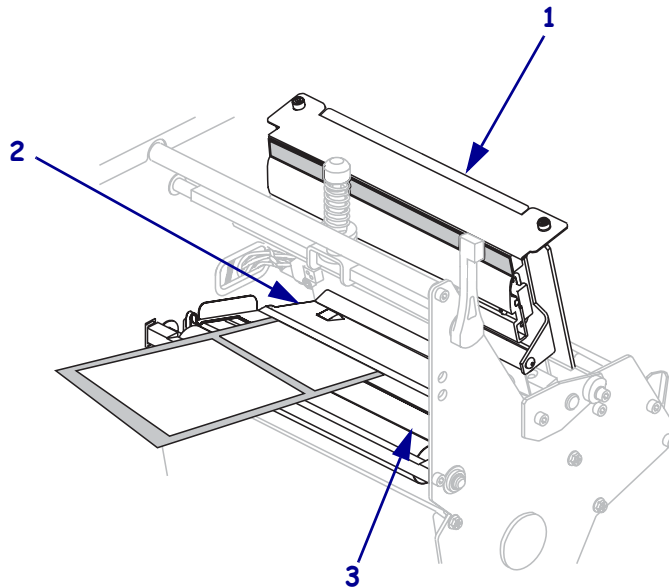

8. Align the media with the inner media guide (1). Slide in the outer media guide (2) until it just touches the edge of the media.

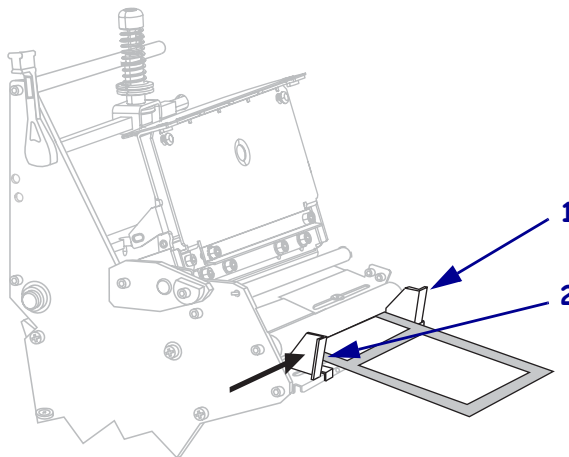

9. Tighten the thumb screw (not visible from this angle) that is located on the bottom of the outer media guide (1).

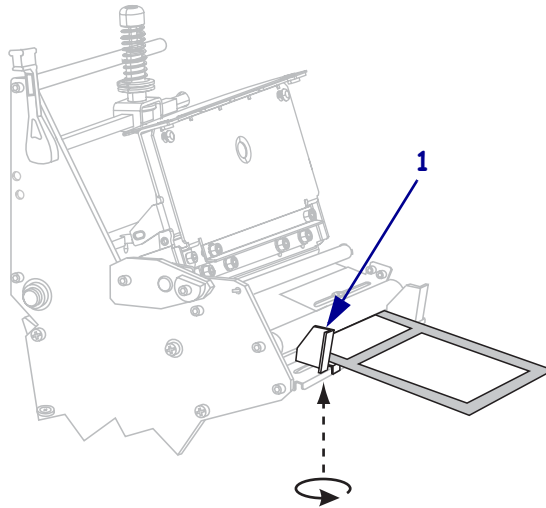

10. Push down the printhead assembly (1), and then rotate the printhead-open lever clockwise until it locks into place (2).

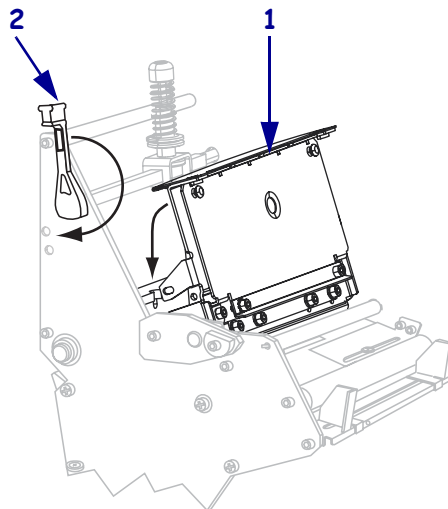

## Load Media in Peel-Off Mode

Refer to [Figure 18](#). This section applies only if the Rewind option or the Peel option is installed.

**Figure 18 • Peel-Off Mode**

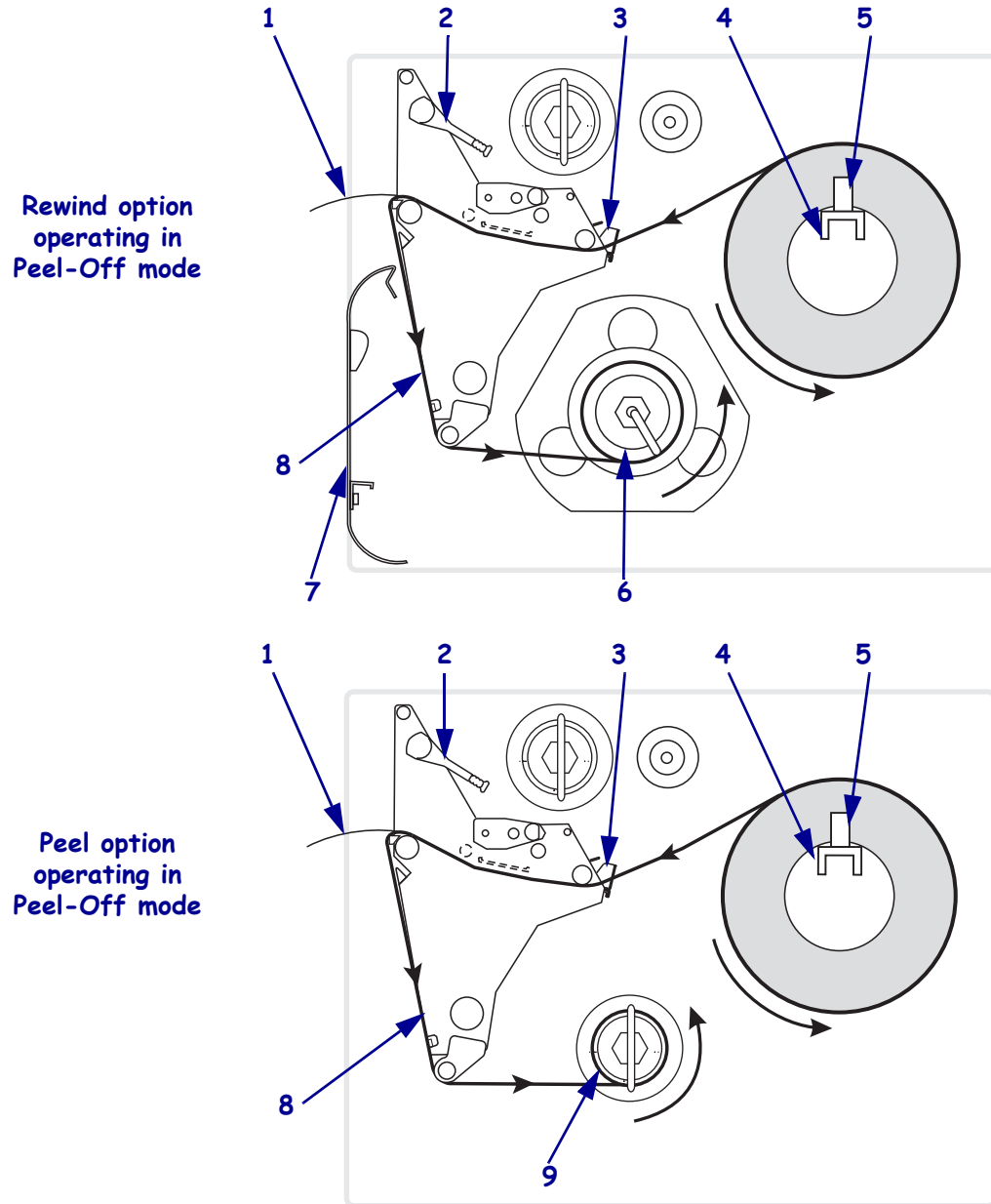

<b>1</b>	Printed label
<b>2</b>	Printhead-open lever
<b>3</b>	Outer media guide
<b>4</b>	Media supply hanger
<b>5</b>	Media supply guide

<b>6</b>	Rewind spindle
<b>7</b>	Rewind plate
<b>8</b>	Media liner
<b>9</b>	Peel spindle

**To load media in Peel-Off mode, complete these steps:**

1. Prepare the printer for Peel-Off mode.

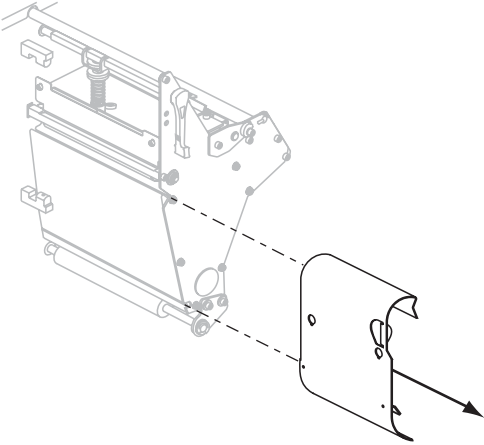
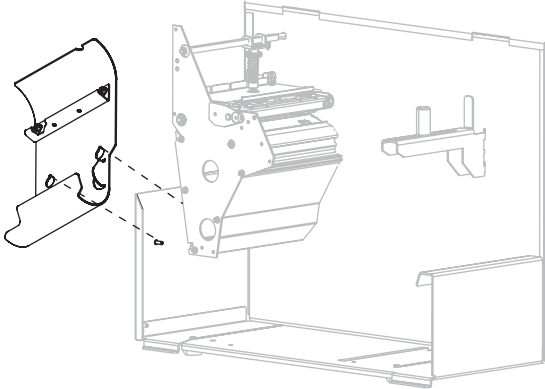
If the printer has the...	Then...
Rewind option	<p><b>a.</b> If the rewind plate is installed, remove it from the print mechanism.</p>  <p><b>b.</b> Hang the rewind plate upside-down on the two mounting screws on the inside of the front panel. Secure the rewind plate to the front panel with two thumb nuts.</p> 

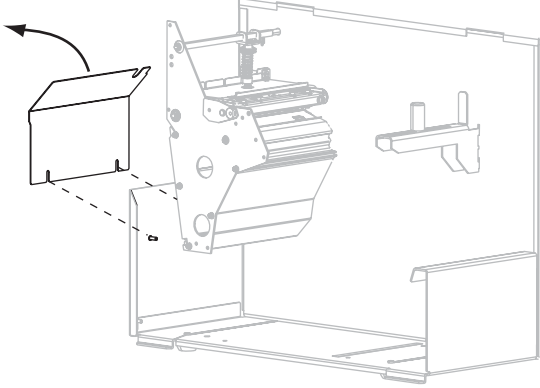
If the printer has the...	Then...
Peel option	<p data-bbox="675 302 1398 436"><b>a.</b> Remove the two thumb nuts that secure the front cover bracket to the mounting screws on the inside of the front panel. <b>b.</b> Remove the front cover bracket from the printer and store it.</p> 

2. Set the printer to Peel-Off mode. See [Select Print Mode on page 80](#) for instructions.
3. Insert media into the printer. See [Insert Media into the Printer on page 31](#) for instructions.
4. Open the printhead assembly by rotating the printhead open lever counterclockwise.

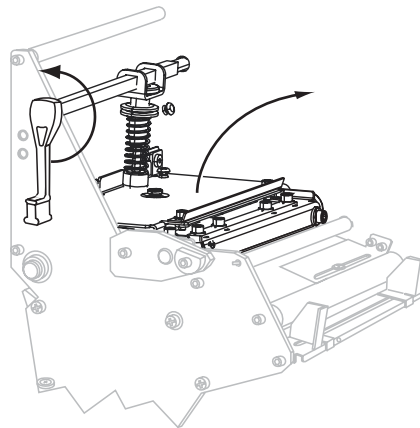



- Loosen the thumb screw on the bottom of the outer media guide (not visible from this angle).

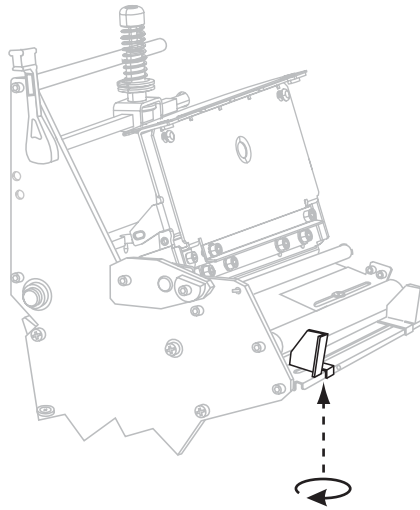

- Slide the outer media guide all the way out.

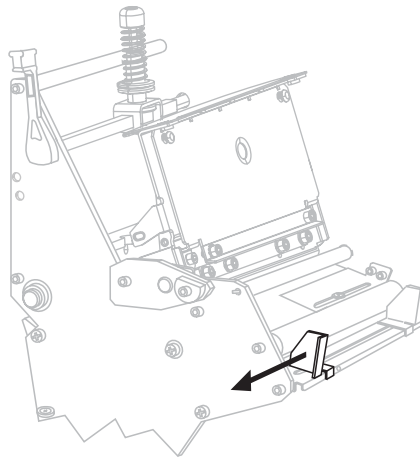

- Thread the media past the inner media guide (1). Continue under the lower roller (2) and the upper media sensor (3). Ensure that the media touches the inner media guide.

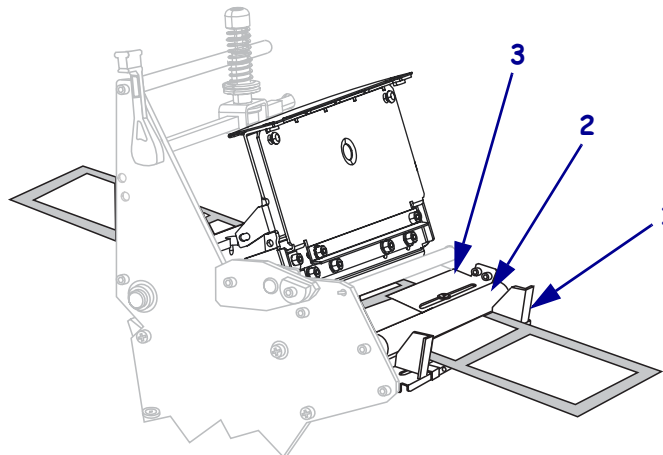

8. Thread the media forward until it passes under the printhead assembly (1), under the snap plate (2), over the platen roller (3), and out the front of the printer (4).

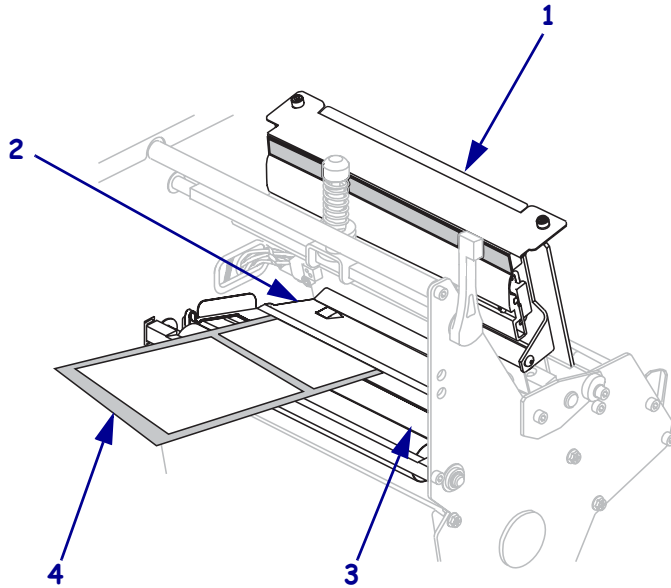

9. Extend approximately 36 in. (920 mm) of media out of the printer. Remove and discard the labels from this exposed media.

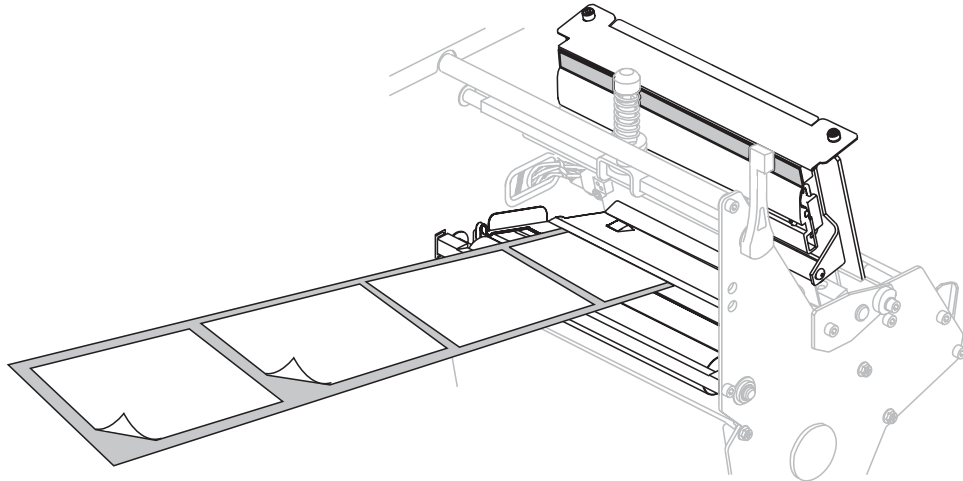

10. Wind the media liner around the rewind or peel spindle as instructed.

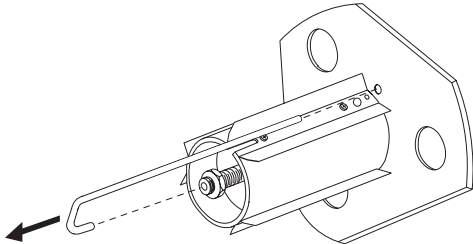
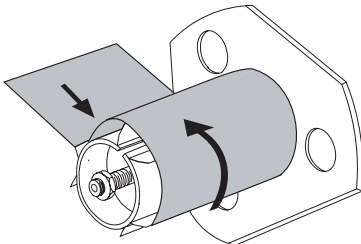
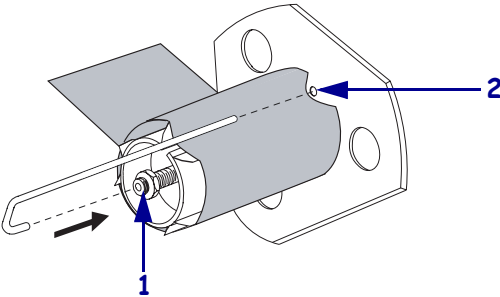
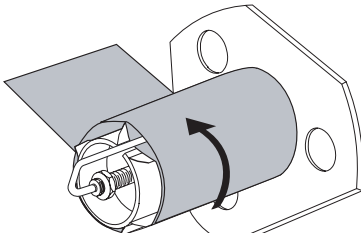
If the printer has the...	Then...
Rewind option	<p data-bbox="673 367 1412 462">  <b>Note</b> • You may opt to install a core on the rewind spindle for the used media liner. However, a core is not required and typically is not used for peel-off mode.         </p> <p data-bbox="673 472 1201 504"> <b>a.</b> Remove the hook from the rewind spindle.         </p>  <p data-bbox="673 787 1372 861"> <b>b.</b> Wind the media liner counterclockwise around the rewind spindle.         </p>  <p data-bbox="673 1144 1404 1249"> <b>c.</b> Reinstall the hook. Insert the short end of the hook into the hole in the center of the adjusting nut (1). Insert the long end of the hook into the small hole on the guide plate (2).         </p>  <p data-bbox="673 1596 1412 1669"> <b>d.</b> Rotate the spindle counterclockwise several turns to wind the media liner over the hook and remove any slack.         </p> 

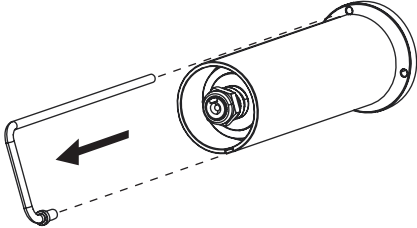
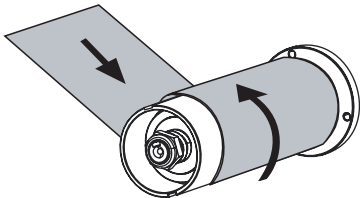
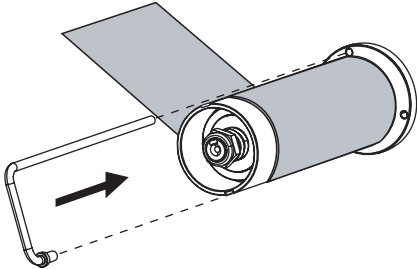
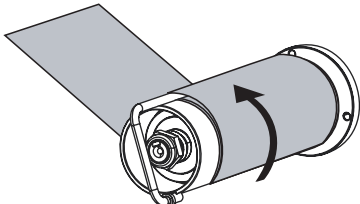
If the printer has the...	Then...
Peel option	<p data-bbox="675 302 1170 331"><b>a.</b> Remove the hook from the peel spindle.</p>  <p data-bbox="675 611 1341 674"><b>b.</b> Wind the media liner counterclockwise around the peel spindle.</p>  <p data-bbox="675 919 1393 1016"><b>c.</b> Reinstall the hook. The short end of the hook fits into the notch on the peel spindle. The long end of the hook fits into the groove on the opposite side of the notch.</p>  <p data-bbox="675 1333 1409 1396"><b>d.</b> Rotate the spindle counterclockwise several turns to wind the media liner over the hook and remove any slack.</p> 

11. Align the media with the inner media guide (1). Slide in the outer media guide (2) until it just touches the edge of the media.

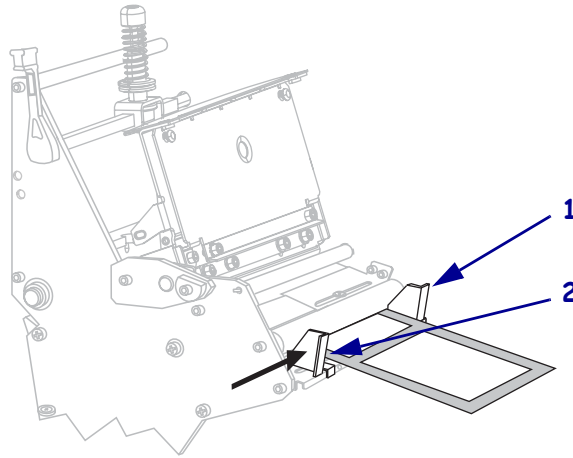

12. Tighten the thumb screw on the bottom of the outer media guide (not visible from this angle).

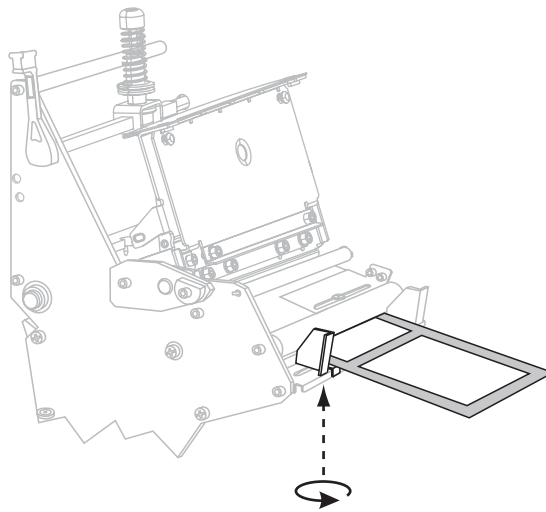

13. Push the printhead assembly down (1), and then rotate the printhead-open lever clockwise until it locks into place (2).

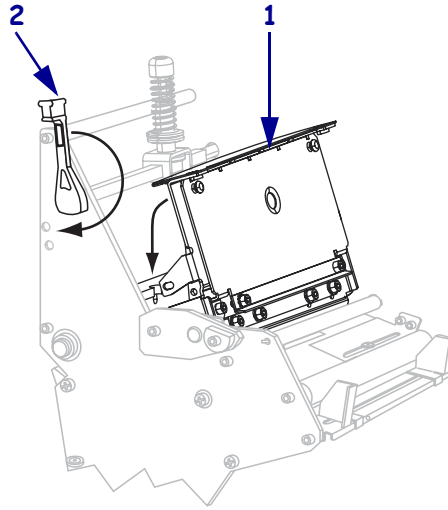

## Remove Media Liner from the Rewind or Peel Spindle

Rewind mode and Peel-Off mode each use spindles to wind used media liner. Remove the media liner from the spindle each time that you change labels.



**Important** • It is **not** necessary to turn off the power to remove media liner from the spindles. If power is turned off, all label formats and images, as well as any temporarily saved parameter settings stored in the printer's internal memory, are lost. When power is turned back on, these items must be reloaded.

**To remove media liner from the rewind or peel spindle, complete these steps:**

1. Has the media run out?

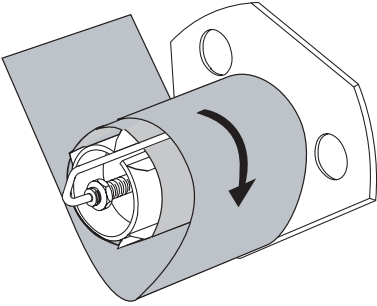
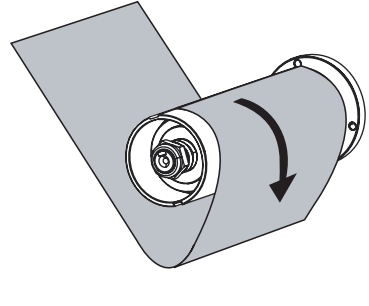
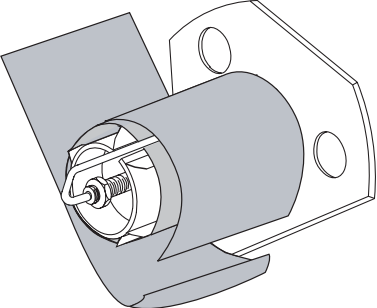
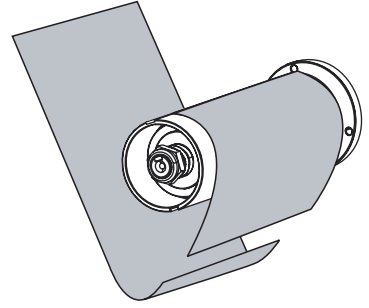
If...	Then...
No	<p><b>a.</b> Create slack in the media liner by rotating the spindle slightly clockwise.</p> <div style="display: flex; justify-content: space-around; align-items: center;"> <div style="text-align: center;"> <p><b>Rewind</b></p>  </div> <div style="text-align: center;"> <p><b>Peel</b></p>  </div> </div> <p><b>b.</b> Cut or tear the media liner at the spindle.</p> <div style="display: flex; justify-content: space-around; align-items: center;"> <div style="text-align: center;"> <p><b>Rewind</b></p>  </div> <div style="text-align: center;"> <p><b>Peel</b></p>  </div> </div>
Yes	Continue with the next step.

2. Pull out the spindle hook.

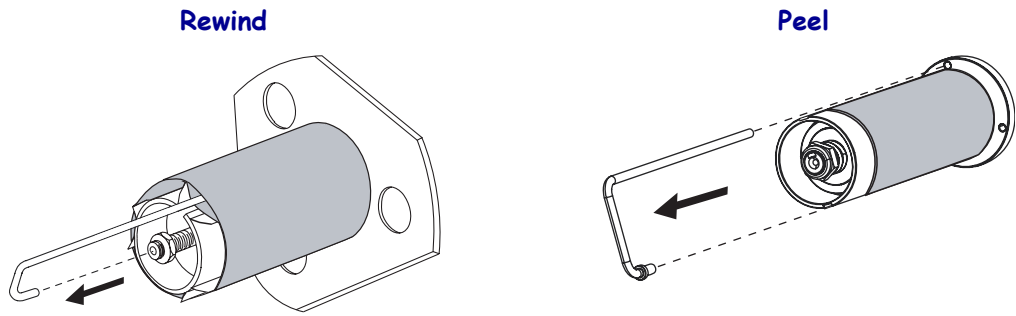

3. Slide the media liner off of the spindle and discard.

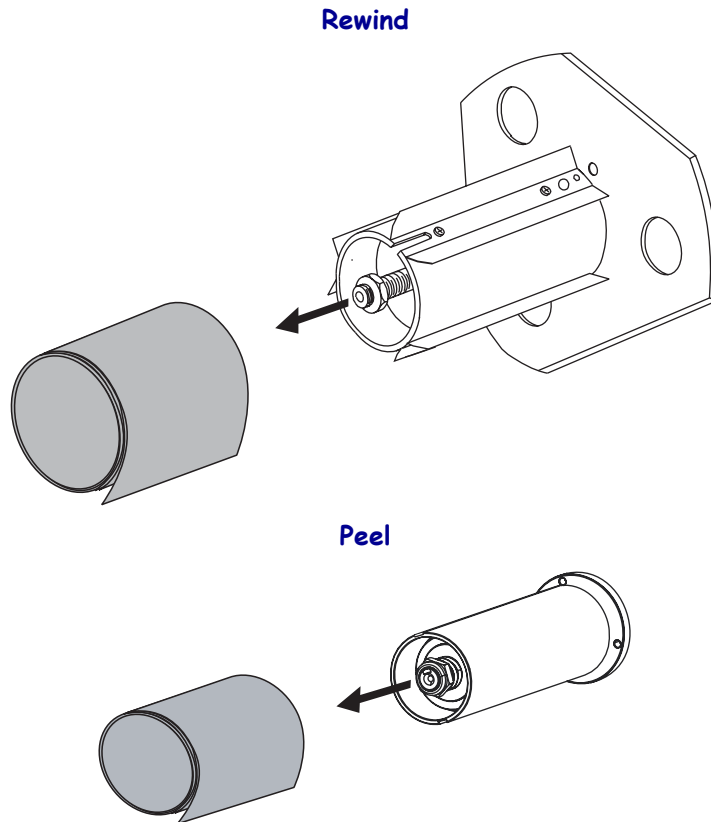



## Load Media in Rewind Mode

Refer to [Figure 19](#). This section applies only if the Rewind option is installed. Use a 3-inch core on the rewind spindle to wind printed labels.



**Note** • Before closing the printhead, make sure that:

- The media is positioned against the inside guides.
- The media is taut and parallel with itself and the pathway when wound onto the rewind spindle or core.

**Figure 19 • Rewind Mode**

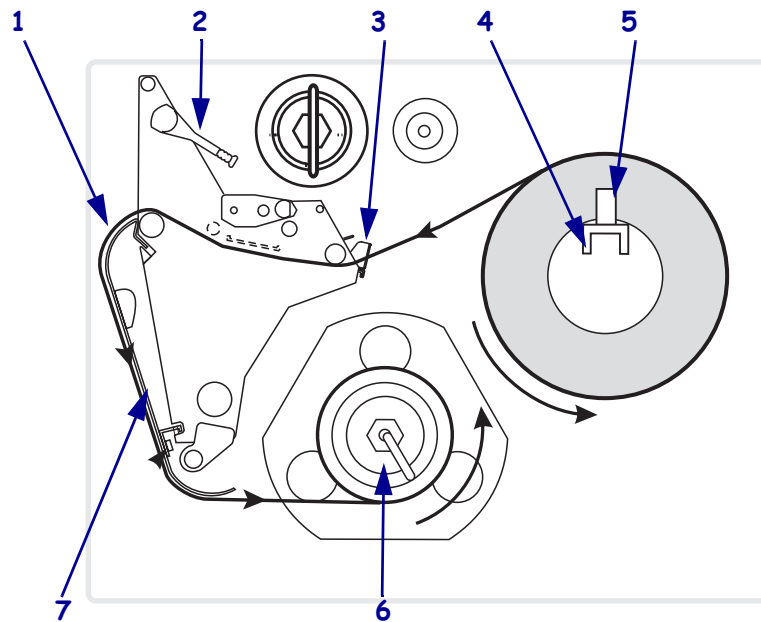

<b>1</b>	Printed label
<b>2</b>	Printhead-open lever
<b>3</b>	Outer media guide
<b>4</b>	Media supply hanger
<b>5</b>	Media supply guide
<b>6</b>	Rewind spindle
<b>7</b>	Rewind plate

**To load media in Rewind mode, complete these steps:**

1. Is the rewind plate installed as shown in [Figure 19](#)?

If...	Then...
Yes	Continue with the next step
No	<p><b>a.</b> Remove the rewind plate from its storage location in front of the print mechanism inside the media compartment.</p> <p><b>b.</b> Invert the rewind plate so that the top lip (<b>1</b>) and the adjustable hook plate (<b>2</b>) point down.</p> <div data-bbox="802 646 1149 989" data-label="Image"> </div> <p><b>c.</b> Engage the top lip and the adjustable hook plate into the two mounting slots on the side plate of the print mechanism. Slide in the rewind plate as far as it will go.</p> <div data-bbox="769 1136 1182 1566" data-label="Image"> </div>

2. Set the printer to Rewind mode. See [Select Print Mode on page 80](#) for instructions.
3. Insert media into the printer. See [Insert Media into the Printer on page 31](#) for instructions.

4. Open the printhead assembly by rotating the printhead-open lever counterclockwise.

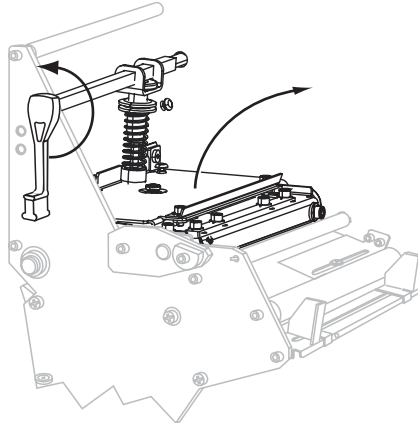

5. Loosen the thumb screw on the bottom of the outer media guide (not visible from this angle).

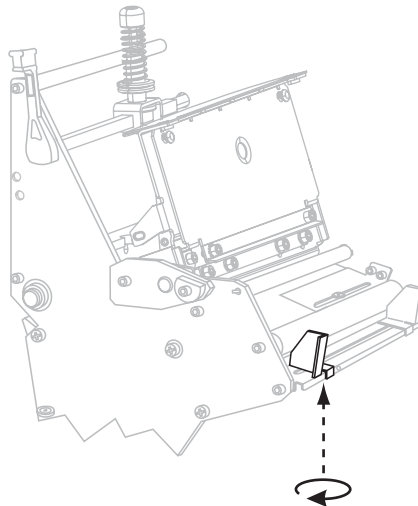

6. Slide the outer media guide all the way out.

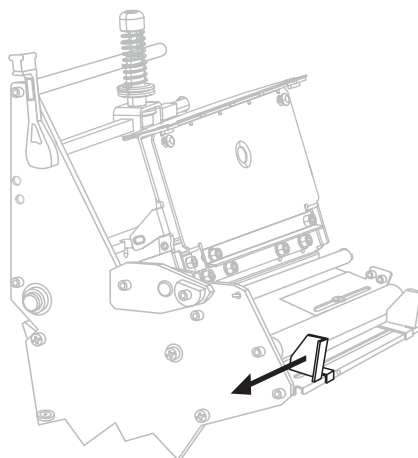

7. Thread the media past the inner media guide (1). Continue under the lower roller (2) and the upper media sensor (3). Ensure that the media touches the inner media guide.

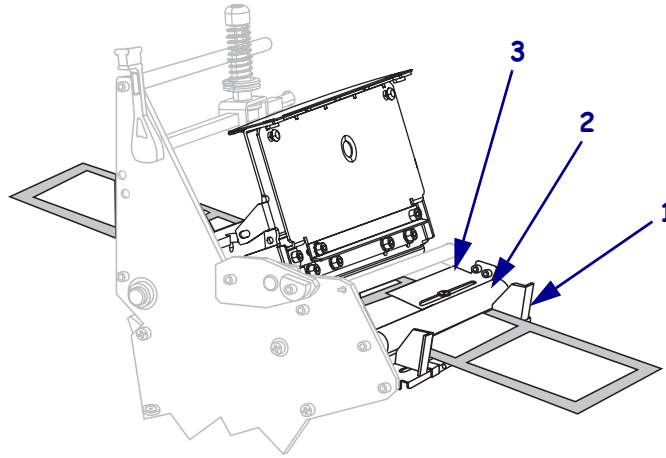

8. Thread the media forward until it passes under the printhead assembly (1), under the snap plate (2), over the platen roller (3), and out the front of the printer (4).

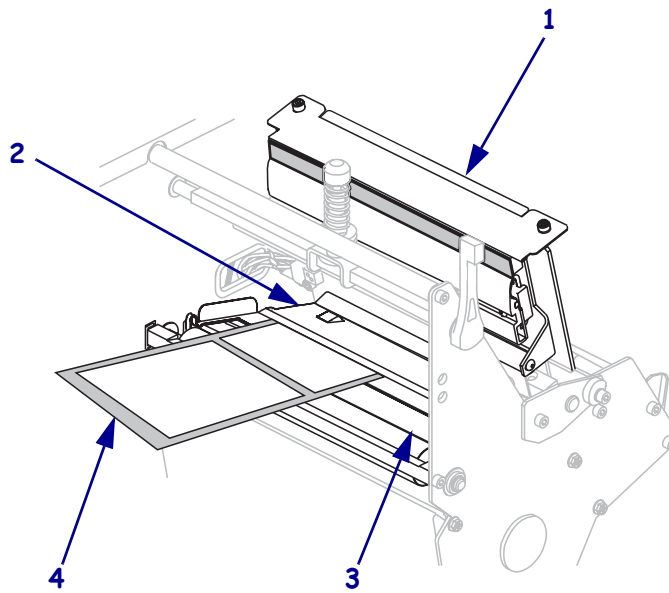

9. Extend approximately 36 in. (920 mm) of media out of the printer. Remove and discard the labels from this exposed media.

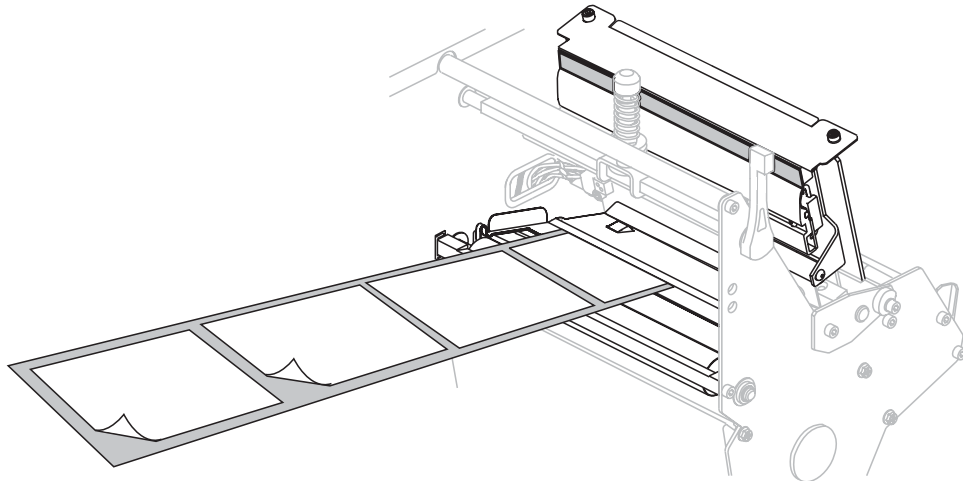

10. Remove the hook from the rewind spindle. Store the hook in the bottom of the printer.

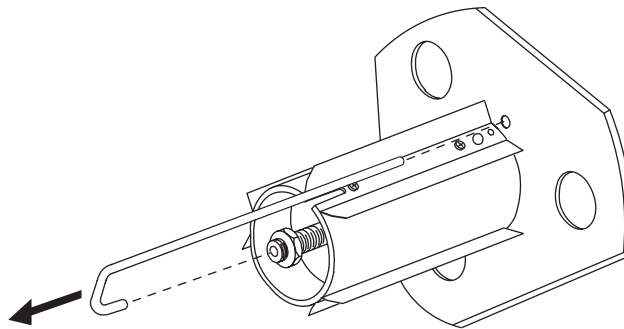

11. Slide an empty 3-in. (76.2-mm) core onto the rewind spindle until it is flush against the guide plate.

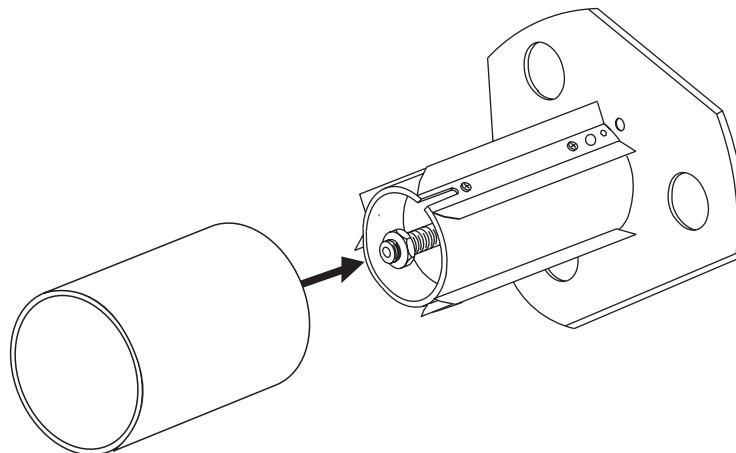

12. Rotate the rewind spindle counterclockwise several turns to wind the media liner around the core and remove any slack.

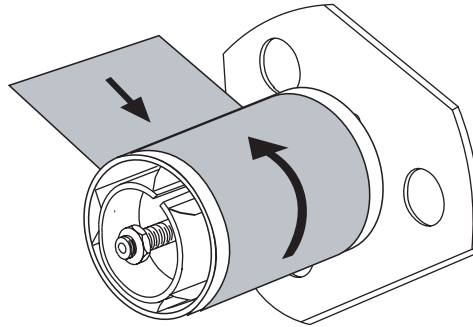

13. Align the media with the inner media guide (1). Slide in the outer media guide (2) until it just touches the edge of the media.

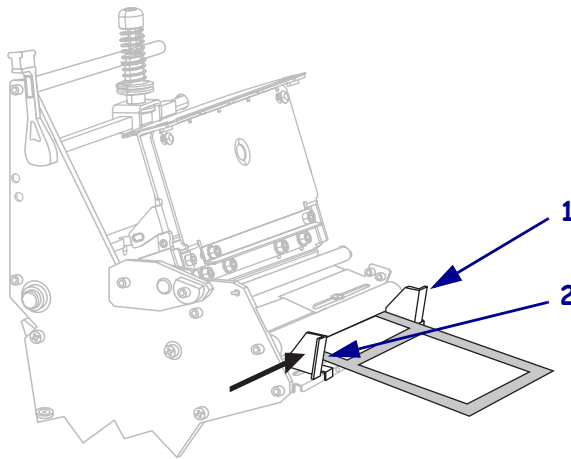

14. Tighten the thumb screw on the bottom of the outer media guide (not visible from this angle).

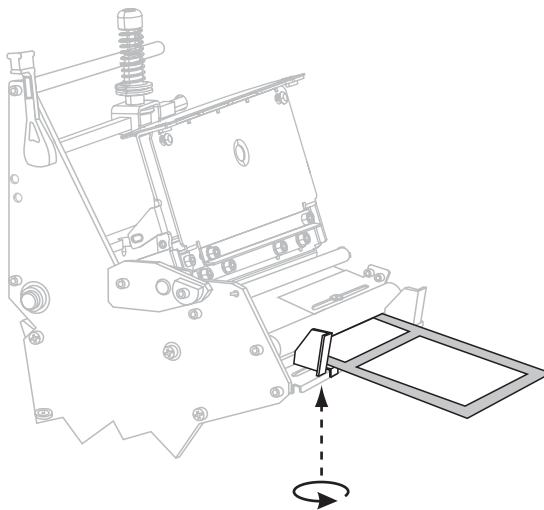

15. Push the printhead assembly down (1), and then rotate the printhead-open lever clockwise until it locks into place (2).

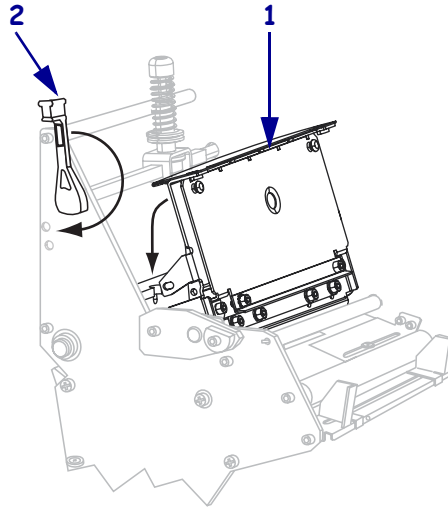

## Remove Labels from the Rewind Spindle

Rewind mode uses a core to wind printed labels. Remove the core with the printed labels every time you change labels for the Rewind option to work correctly.



**Important** • It is **not** necessary to turn off the power to remove printed labels. If power is turned off, all label formats and images, as well as any temporarily saved parameter settings stored in the printer's internal memory, are lost. When power is turned back on, these items must be reloaded.

**To remove media liner from the rewind spindle, complete these steps:**

1. Have the labels run out?

If...	Then...
Yes	Slide the core from the rewind spindle.

The diagram shows a cylindrical core being slid off a spindle. An arrow points from the spindle towards the core, indicating the direction of removal. The spindle is part of a larger mechanical assembly with various components and a mounting bracket.

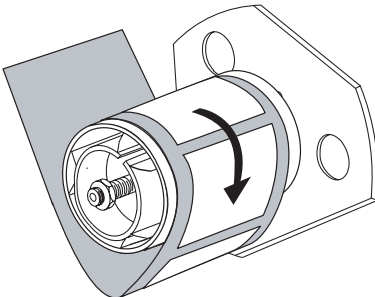
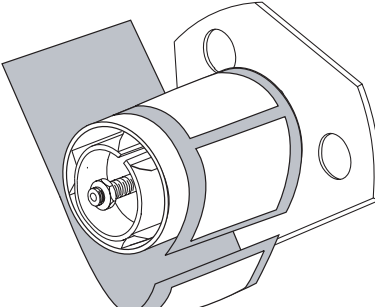
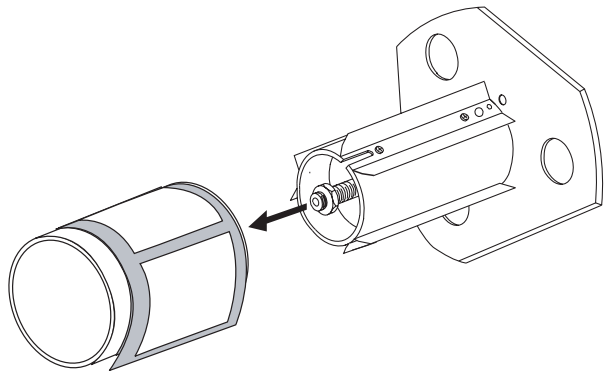
<b>If...</b>	<b>Then...</b>
<b>No</b>	<p data-bbox="586 268 1432 304"><b>a.</b> Rotate the rewind spindle clockwise to create slack in the media.</p>  <p data-bbox="586 640 1432 676"><b>b.</b> Cut or tear the media between labels.</p>  <p data-bbox="586 1039 1432 1075"><b>2.</b> Slide the core from the rewind spindle.</p> 



## Load Media in Cutter Mode

Refer to [Figure 20](#). The following instructions pertain to printers with the cutter option only.

**Figure 20 • Cutter Mode**

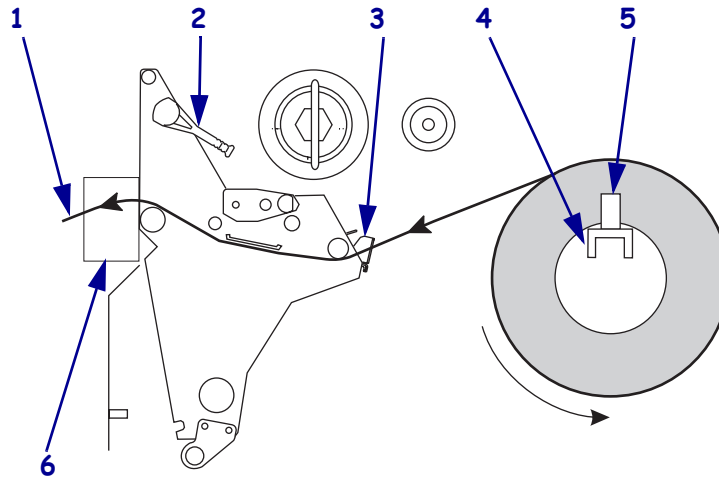

1	Printed label
2	Printhead-open lever
3	Outer media guide
4	Media supply hanger
5	Media supply guide
6	Cutter

### To load media in Cutter mode, complete these steps:

1. Set the printer to Cutter mode. See [Select Print Mode on page 80](#) for instructions.
2. Insert media into the printer. See [Insert Media into the Printer on page 31](#) for instructions.
3. Open the printhead assembly by rotating the printhead-open lever counterclockwise.

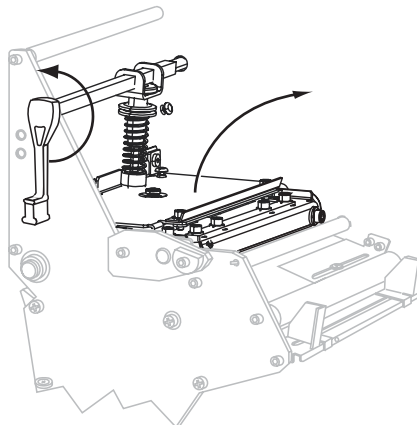

4. Loosen the thumb screw on the bottom of the outer media guide (not visible from this angle).

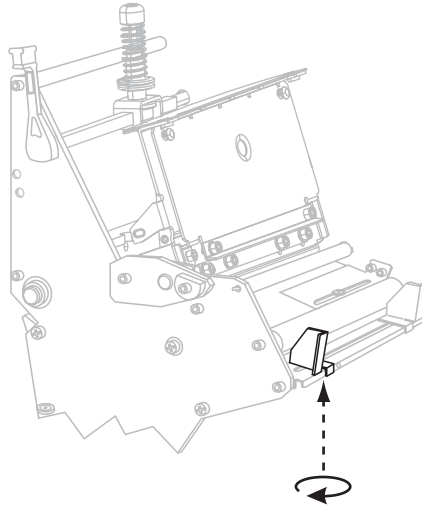

5. Slide the outer media guide all the way out.

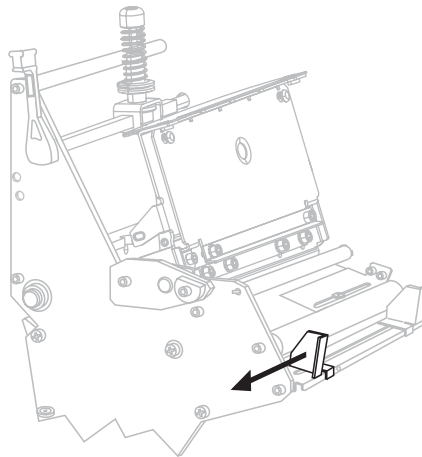

6. Thread the media past the inner media guide (1). Continue under the lower roller (2) and the upper media sensor (3). Ensure that the media touches the inner media guide.

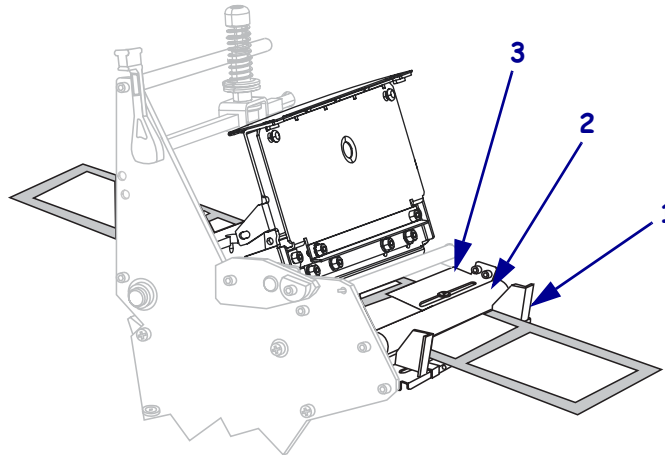



7. **Caution** • The cutter blade is sharp. Do not touch or rub the blade with your fingers.

Thread the media forward until it passes under the printhead assembly (1), under the snap plate (2), and through the cutter assembly (3). (An optional cutter catch tray (4) is shown in this illustration.)

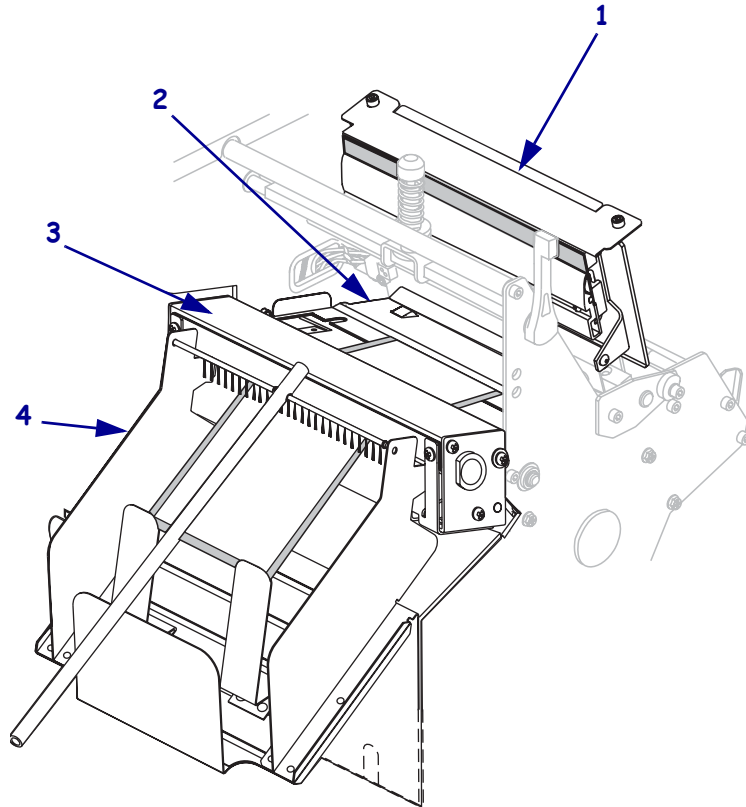

8. Align the media with the inner media guide (1). Slide in the outer media guide (2) until it just touches the edge of the media.

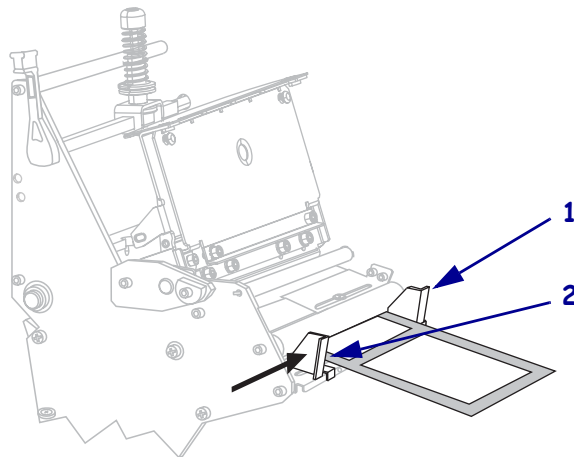

9. Tighten the thumb screw on the bottom of the outer media guide (not visible from this angle).

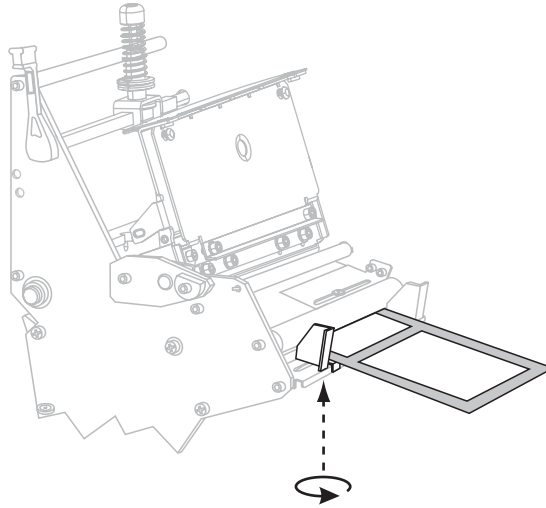

10. Push the printhead assembly down (1), and then rotate the printhead-open lever clockwise until it locks into place (2).

The printer automatically feeds and cuts one label after the printhead is closed.

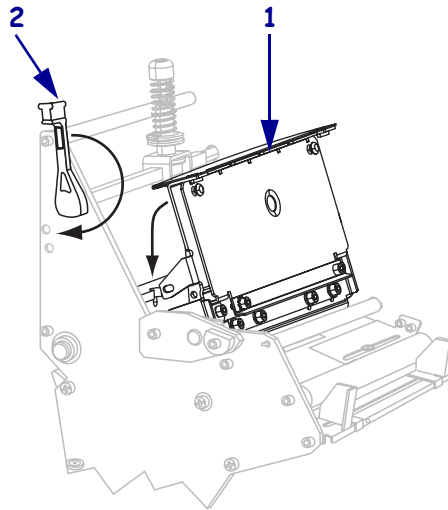

## Load Ribbon

Always use ribbon that is wider than the media to protect the printhead from wear. Ribbon must be coated on the outside (see [Coated Side of Ribbon on page 27](#) to determine which side of a ribbon is coated). For direct thermal printing, do not load ribbon in the printer.

Figure 21 • Ribbon Path

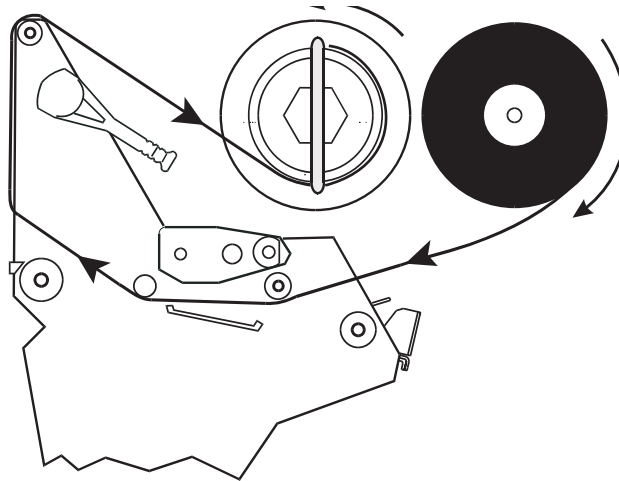

### To load ribbon, complete these steps:

1. Align the segments of the ribbon supply spindle.

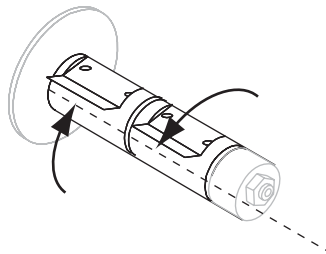

2. Orient the ribbon with the loose end unrolling clockwise.

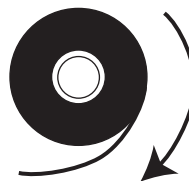

3. Place the roll of ribbon on the ribbon supply spindle and push it all the way back.

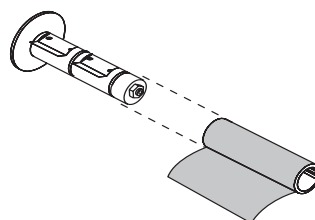

4. A ribbon leader makes ribbon loading and unloading easier. Does your roll of ribbon have paper or something else attached to the end to serve as a ribbon leader?

If...	Then...
Yes	Continue with the next step.
No	<p><b>a.</b> Tear off a strip of media (labels and liner) about 6–12 in. (150–305 mm) long from the roll.</p> <p><b>b.</b> Peel a label from the media strip.</p> <p><b>c.</b> Use this label (1) to attach the end of the ribbon (2) to the media strip (3). The media strip acts as a leader.</p>

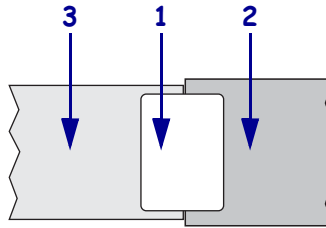

5. Open the printhead assembly by rotating the printhead-open lever counter-clockwise.

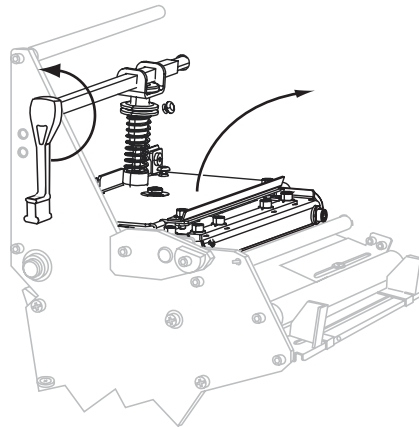

6. Thread the ribbon leader and attached ribbon over the lower roller (1) and under the upper roller (2).

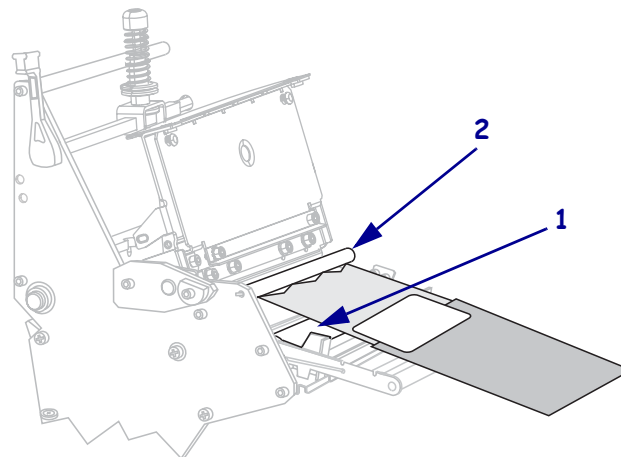

7. Push the ribbon leader forward until it passes under the printhead assembly (1), over the snap plate (2), and then over the platen roller (3).

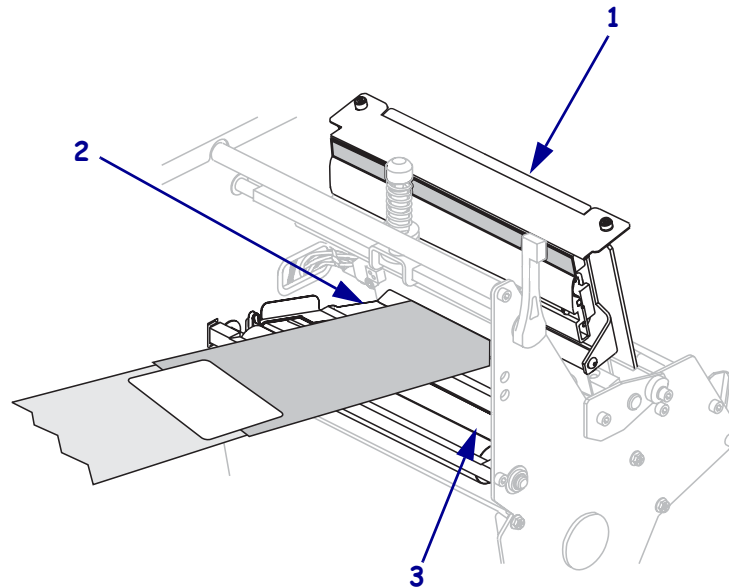

8. Bring the ribbon leader over the upper ribbon roller (1) and toward the ribbon take-up spindle (2).

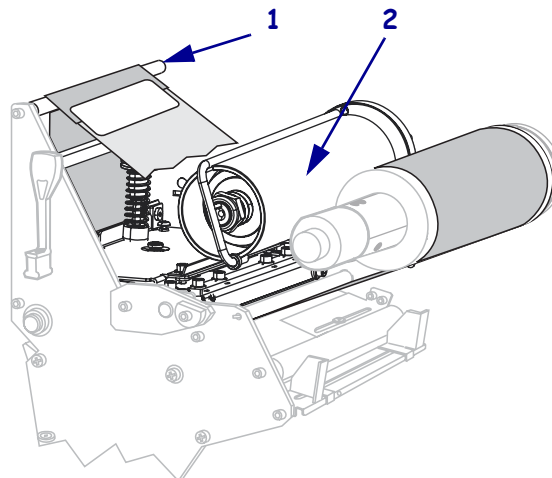

9. Remove the hook from the ribbon take-up spindle.

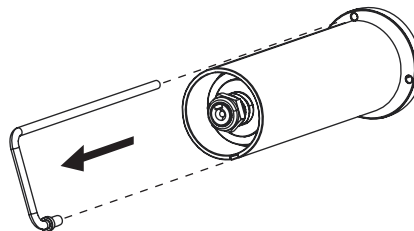

10. Wind the ribbon leader and the attached ribbon counterclockwise around the ribbon take-up spindle.

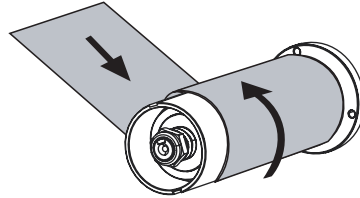

11. Reinstall the hook. The short end of the hook fits into the notch on the ribbon take-up spindle. The long end of the hook fits into the groove on the opposite side of the notch.

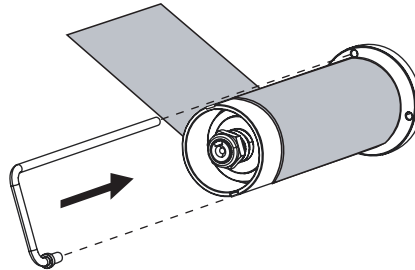

12. Rotate the spindle counterclockwise several turns to wind the ribbon over the hook and remove any slack.

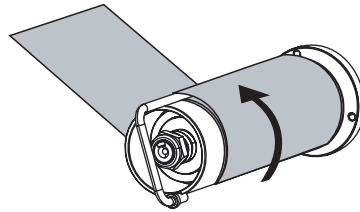

13. Push down the printhead assembly (1), and then rotate the printhead-open lever clockwise until it locks into place (2).

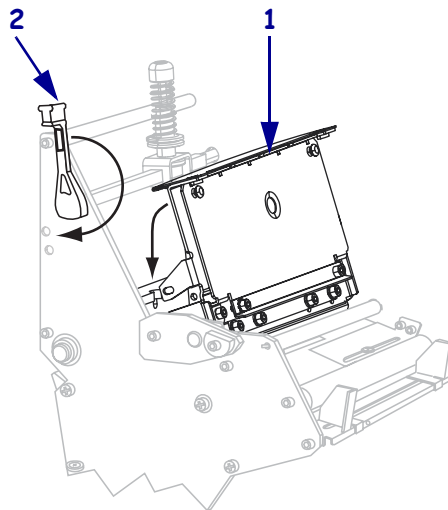



## Remove Used Ribbon

Remove used ribbon from the ribbon take-up spindle each time you change the roll of ribbon.

### To remove used ribbon, complete these steps:

1. If the ribbon has not run out, cut or break it before the ribbon take-up spindle.

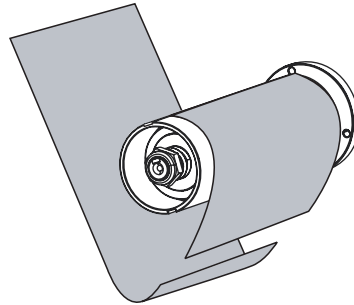

2. Push the hook until it slips out of the groove in the ribbon take-up spindle. Move the hook back and forth to loosen the ribbon.

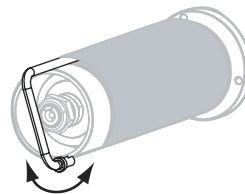

3. Remove the loosened hook from the ribbon take-up spindle.

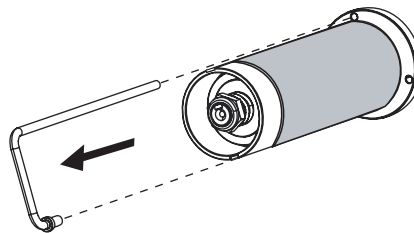

4. Slide the used ribbon off of the ribbon take-up spindle and discard.

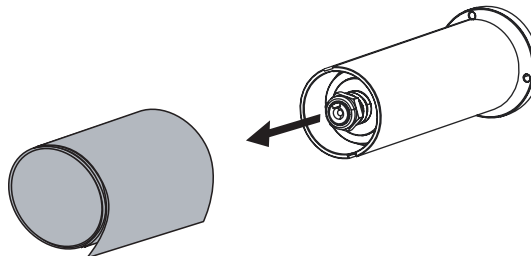

## Adjust Media Sensors

This section describes how to adjust the media sensors.

### Black Mark Sensor

The optional black mark sensor is in a fixed position and is enabled via the control panel (see [Set the Sensor Type on page 81](#) for details).

### Transmissive Sensor

The transmissive sensor, which is used to detect web media, consists of two sections: a light source (the lower media sensor) and a light sensor (the upper media sensor). The media passes between the two.

Adjust these sensors only when the printer cannot detect the top of the label. The control panel LCD displays **ERROR CONDITION PAPER OUT**, even though there are labels loaded in the printer.

### Upper Media Sensor

The upper media sensor must be positioned:

- Directly over the hole or notch, or
- Anywhere along the width of the media if there is a gap between labels.



**Note** • If you are using continuous media, position the upper media sensor over the media with the lower media sensor directly below it so that the printer can detect an out-of-paper condition.

### To adjust the upper and lower media sensors, complete these steps:

1. Remove media and ribbon.
2. Locate the upper media sensor (1). The upper media sensor “eye” is directly below the adjustment screw head.

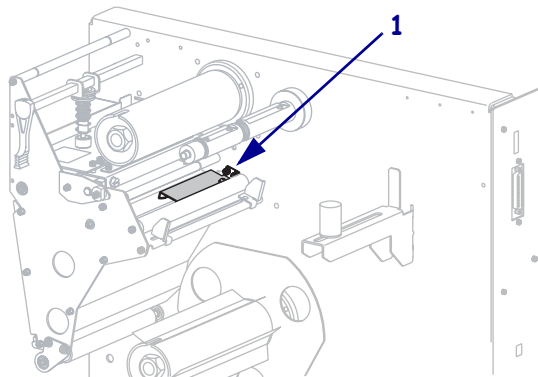

- Using a Phillips-head screwdriver, slightly loosen the upper media sensor adjustment screw (1).

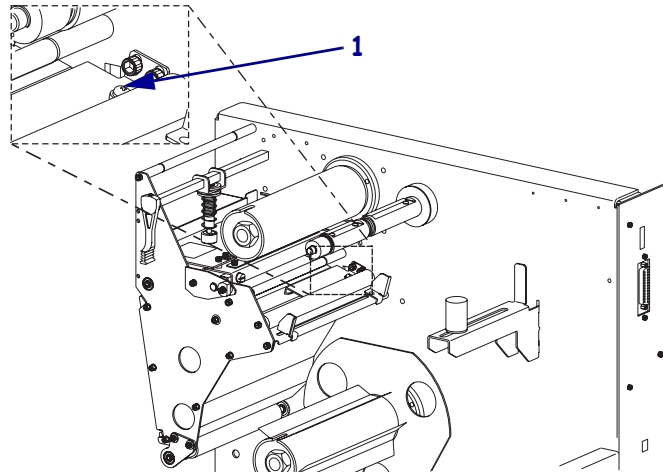

- Using the tip of the screwdriver, slide the upper sensor along the slot to the desired position (for non-continuous media with a notch or hole in the media, the sensor must be directly above the notch or hole).
- Tighten the upper media sensor adjustment screw.

## Lower Media Sensor

### To adjust the lower media sensor, complete these steps:

- Locate the lower media sensor assembly (1) under the rear roller. The sensor is a spring clip holding a circuit board.

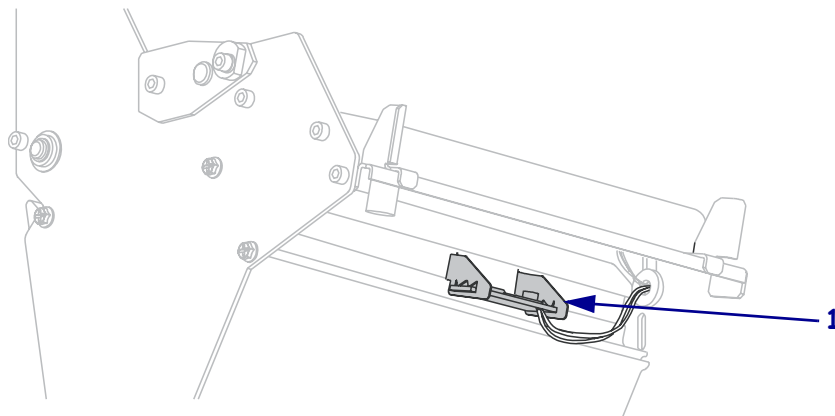

- Slide the lower media sensor in its slot until the lower media sensor (light source) is positioned directly below the upper media sensor.

## Adjust Printhead Balance and Pressure

Printhead toggle position (balance) and printhead pressure affect print quality. If the pressure is too light or uneven, the labels and ribbon may slip.



**Important** • Print quality depends on the labels and ribbon used as well as the toggle position and pressure. Make sure that your labels and ribbon are right for your application.

### Adjust Printhead Balance

You may need to adjust the printhead balance by moving the toggle if printing is too light on one side of the labels.

#### To position the toggle, complete these steps:

1. Print some labels at 2.4 in. (61 mm) per second by running the *PAUSE Self Test* on page 133.
2. While printing labels, use the control panel to lower the darkness setting until the labels are printing gray instead of black. See *Adjust Print Darkness* on page 79 for instructions.
3. Loosen the locking nut at the top of the toggle assembly.

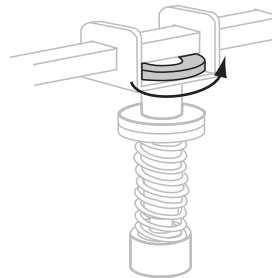

4. Position the toggle over the center of the labels by sliding it to the left or right.

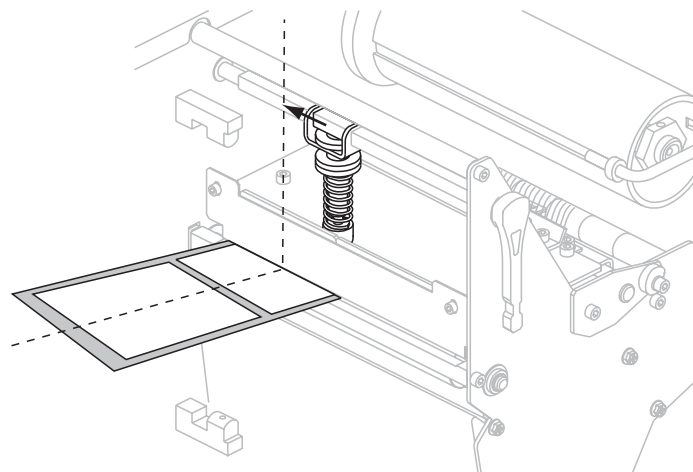

5. Tighten the locking nut.

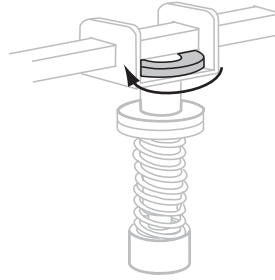

6. Print additional labels at 2.4 in. (61 mm) per second by again running the *PAUSE Self Test* on page 133.

7. Do both sides of the label print at the same level of gray?

If...	Then...
Yes	The toggle is positioned correctly. Increase the darkness setting to the optimum level for the media being used.
No	<ol style="list-style-type: none"> <li>a. Loosen the locking nut at the top of the toggle assembly.</li> <li>b. Slide the toggle slightly toward the side of the label that printed lighter.</li> <li>c. Print additional labels at 2.4 in. (61 mm) per second by again running the <i>PAUSE Self Test</i> on page 133.</li> <li>d. Tighten the locking nut.</li> <li>e. Repeat this step until both sides of the label print at the same level of gray.</li> <li>f. Increase the darkness setting to the optimum level for the media being used.</li> </ol>

## Printhead Pressure Adjustment

You may need to increase the printhead pressure if you are using thick media or if the ribbon slips during printing. To maximize printhead life, use the lowest pressure that produces the desired print quality without allowing the ribbon or media to slip.

### To change printhead pressure, complete these steps:

1. Loosen the upper knurled nut on the toggle assembly.

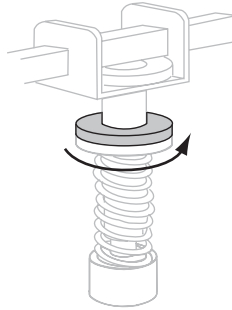

2. Adjust spring pressure by moving the lower knurled adjusting nut.
  - To increase printhead pressure, move the lower knurled nut downward.
  - To decrease printhead pressure, move the lower knurled nut upward.

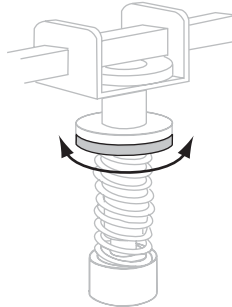

3. To lock the toggle pressure, tighten the upper knurled nut against the lower knurled nut.

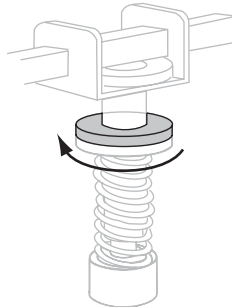

4. Print some labels at 2.4 in. (61 mm) per second by running the *PAUSE Self Test* on page 133.
5. Verify that the labels printed correctly and that the ribbon is not slipping. Readjust the spring pressure if necessary.
6. If necessary, use the control panel to adjust the darkness setting. See *Adjust Print Darkness* on page 79 for instructions.

## Calibrate the Printer

Calibrate the printer when it is first put into service. Calibration allows the printer to establish the proper settings for the specific media and ribbon used in your application. You may calibrate the printer at other times as needed. [Table 7](#) shows the different methods for calibration.

**Table 7 • Types of Calibration**

Type of Calibration	Description	When/How It Occurs
<b>Auto-calibration</b>	The printer automatically sets the value it detects for the spaces between labels.	Occurs at the following times: <ul style="list-style-type: none"> <li>• When the printer is first turned on if CALIBRATION is selected for MEDIA POWER UP (see <a href="#">Select Media Power-Up Option on page 92</a>)</li> <li>• When the printer feeds media after the printhead is closed if CALIBRATION is selected for HEAD CLOSE (see <a href="#">Select Head Close Option on page 93</a>).</li> <li>• As part of both the sensor profile and media and ribbon sensor calibration procedures.</li> </ul>
<b>Long (Standard) Calibration</b>	The printer does the following: <ul style="list-style-type: none"> <li>• feeds media and ribbon</li> <li>• sets the values it detects for media length, media type (continuous or non-continuous), and print mode (thermal transfer or direct thermal)</li> <li>• updates the sensor values</li> </ul>	To perform a long calibration, do one of the following: <ul style="list-style-type: none"> <li>• Press PAUSE on the control panel to pause the printer, and then press CALIBRATE.</li> <li>• Select CALIBRATION for the MEDIA POWER UP or HEAD CLOSE parameter (see <a href="#">Select Media Power-Up Option on page 92</a> or <a href="#">Select Head Close Option on page 93</a>).</li> </ul>
<b>Short Calibration</b>	The printer calibrates using the current sensor values rather than detecting the spaces between labels and resetting the sensors. This calibration sequence uses fewer labels than the long calibration sequence, but it is less reliable because the values that are stored in the sensors could be incorrect.	Select SHORT CAL for the MEDIA POWER UP or HEAD CLOSE parameter (see <a href="#">Select Media Power-Up Option on page 92</a> or <a href="#">Select Head Close Option on page 93</a> ).
<b>Sensor Profile Calibration</b>	The printer auto-calibrates and prints a media sensor profile. See <a href="#">Sensor Profile on page 140</a> .	Select the SENSOR PROFILE option on the control panel. See <a href="#">Print Sensor Profile on page 87</a> for instructions.

Table 7 • Types of Calibration (Continued)

Type of Calibration	Description	When/How It Occurs
<b>Media and Ribbon Sensor Sensitivity Calibration</b>	This calibration is one of the most common adjustments made to printer settings. The printer resets the sensitivity of the sensors specifically for the media and ribbon that you are using. If you change the type of ribbon and/or media, you might need to reset the sensitivity of the media and ribbon sensors. When the sensors are at their new sensitivity, the printer performs an auto-calibration.	Select the MEDIA AND RIBBON CALIBRATE option on the control panel. See <i>Calibrate Media and Ribbon Sensor Sensitivity</i> on page 88 for instructions.





---

# Configuration

This section describes the control panel parameters that are used to configure the printer for operation.

## Contents

Setup Mode . . . . .	74
Enter Setup Mode . . . . .	74
Exit Setup Mode. . . . .	75
Change Password-Protected Parameters . . . . .	76
Default Password Value. . . . .	76
Disable the Password Protection Feature . . . . .	76
Print a Configuration Label. . . . .	77
Print a Network Configuration Label . . . . .	78
Control Panel Parameters . . . . .	79
Print Server LCD Displays . . . . .	98

## Setup Mode

After you have installed the media and ribbon and the Power-On Self Test (POST) is complete, the control panel displays **PRINTER READY**. You may now set printer parameters for your application using the control panel display and the buttons directly below it. If it becomes necessary to restore the initial printer defaults, see [FEED and PAUSE Self Test on page 138](#).



**Important** • Certain printing conditions may require that you adjust printing parameters, such as print speed, darkness, or print mode. These conditions include (but are not limited to):

- printing at high speeds
- peeling the media
- the use of extremely thin, small, synthetic, or coated labels

Because these and other factors affect print quality, run tests to determine the best combination of printer settings and media for your application. A poor match may limit print quality or print rate, or the printer may not function properly in the desired print mode.



**Note** • If the printer is operating on an IP network, you can change the printer's parameters in these additional ways:

- with ZebraLink™ WebView (ZebraNet 10/100 PrintServer, PSII, or Wireless Print Server required). For information, see the appropriate print server user guide.
- with the SetWLAN configuration utility or the ZebraNet Bridge Wireless Setup Wizard (ZebraNet Wireless Print Server required). For information, see the *ZebraNet Wireless Print Server User Guide*.

## Enter Setup Mode

**To enter Setup Mode, complete these steps:**

1. Press SETUP/EXIT.
2. Press NEXT/SAVE or PREVIOUS to scroll through the parameters.

## Exit Setup Mode

To leave Setup mode, complete these steps:

1. Press SETUP/EXIT.  
The LCD displays **SAVE CHANGES**.
2. Press PLUS (+) or MINUS (-) to display the save options (Table 8).

**Table 8 • Save Options When Leaving Setup Mode**

LCD	Description
PERMANENT	Stores values in the printer even when power is turned off.
TEMPORARY	Saves the changes until power is turned off.
CANCEL	Cancels all changes made since you entered Setup mode, except for changes made to the darkness and tear-off settings, which go into effect as soon as they are made.
LOAD DEFAULTS	Restores all parameters other than the network settings back to the factory defaults. Use care when loading defaults because you will need to reload all settings that you changed manually.  <b>Note</b> • Loading factory defaults causes the printer to auto-calibrate.
LOAD LAST SAVE	Loads values from the last permanent save.
DEFAULT NET	Restores the wired and wireless network settings back to factory defaults.

3. Press NEXT/SAVE to select the displayed choice.  
When the configuration and calibration sequence is done, **PRINTER READY** displays.

## Change Password-Protected Parameters

Certain parameters, including the communication parameters, are password-protected by factory default.

---

**Caution** • Do not change password-protected parameters unless you have a complete understanding of the parameters' functions. If the parameters are set incorrectly, the printer may function unpredictably.

---

The first time that you attempt to change a password-protected parameter, the printer displays **ENTER PASSWORD**. Before you can change the parameter, you must enter the four-digit numeric password. After you have entered the password correctly, you do not have to enter it again unless you leave Setup mode by pressing **SETUP/EXIT** or by turning off (O) the printer.

### To enter a password for a password-protected parameter, complete these steps:

1. At the password prompt, use **MINUS (-)** to change the selected digit position.
2. When you have selected the digit that you wish to change, use **PLUS (+)** to increase the selected digit value. Repeat these two steps for each digit of the password.
3. After entering the password, press **NEXT**.

The parameter you selected to change is displayed. If the password was entered correctly, you can change the value.

## Default Password Value

The default password value is **1234**. The password can be changed using the Zebra Programming Language (ZPL) command **^KP** (Define Password) or using the printer's web pages (ZebraNet® PrintServer II, 10/100 Print Server, or Wireless Print Server required).

## Disable the Password Protection Feature

You can disable the password protection feature so that it no longer prompts you for a password by setting the password to **0000** via the **^KP** ZPL command. To re-enable the password-protection feature, send the ZPL command **^KPx**, where **x** can be any number from 1 to 9999.

## Print a Configuration Label

A configuration label lists the printer settings that are stored in configuration memory. After you load the media and ribbon (if necessary), print a configuration label as a record of your printer's current settings. Keep the label to use when troubleshooting printing problems.

### To print a configuration label, complete these steps:

1. On the control panel, press SETUP/EXIT.
2. Press NEXT or PREVIOUS to scroll through the parameters until you reach **LIST SETUP**.
3. Press PLUS (+) to confirm printing.

A configuration label prints (Figure 22).

Figure 22 • Configuration Label

PRINTER CONFIGURATION	
Zebra Technologies	
ZTC 105SL-200dpi	
ZBR11362166	
+10.....	DARKNESS
+000.....	TEAR OFF
TEAR OFF.....	PRINT MODE
NON-CONTINUOUS.....	MEDIA TYPE
WEB.....	SENSOR TYPE
THERMAL-TRANS.....	PRINT METHOD
104 0/8 MM.....	PRINT WIDTH
1239.....	LABEL LENGTH
39.0IN 988MM.....	MAXIMUM LENGTH
BIDIRECTIONAL.....	PARALLEL COMM.
RS232.....	SERIAL COMM.
9600.....	BAUD
8 BITS.....	DATA BITS
NONE.....	PARITY
XON/XOFF.....	HOST HANDSHAKE
NONE.....	PROTOCOL
000.....	NETWORK ID
NORMAL MODE.....	COMMUNICATIONS
<~> 7EH.....	CONTROL PREFIX
<^> 5EH.....	FORMAT PREFIX
<,> 2CH.....	DELIMITER CHAR
ZPL II.....	ZPL MODE
CALIBRATION.....	MEDIA POWER UP
CALIBRATION.....	HEAD CLOSE
DEFAULT.....	BACKFEED
+000.....	LABEL TOP
+0000.....	LEFT POSITION
047.....	WEB S.
079.....	MEDIA S.
065.....	RIBBON S.
050.....	TAKE LABEL
050.....	MARK S.
000.....	MARK MED S.
063.....	MEDIA LED
009.....	RIBBON LED
000.....	MARK LED
+10.....	LCD ADJUST
DPSWFXM.....	MODES ENABLED
.....	MODES DISABLED
832 8/MM FULL.....	RESOLUTION
V60.13.0.0P15 <-.....	FIRMWARE
V30 SW3 56.....	HARDWARE ID
CUSTOMIZED.....	CONFIGURATION
NONE.....A:	COMPACT FLASH
3584k.....R:	RAM
NONE.....B:	MEMORY CARD
0448k.....E:	ONBOARD FLASH
NONE.....	FORMAT CONVERT
005 DISPLAY.....	P32 INTERFACE
.....	TWINAX/COAX ID
2004-05-28 09:55:13	TIME STAMP

FIRMWARE IN THIS PRINTER IS COPYRIGHTED

## Print a Network Configuration Label

If you are using a print server, you can print a network configuration label after the printer is connected to the network.

### To print a network configuration label, complete these steps:

1. On the control panel, press SETUP/EXIT.
2. Press NEXT or PREVIOUS to scroll through the parameters until you reach **LIST NETWORK**.
3. Press the PLUS (+) to confirm printing.

A network configuration label prints (Figure 23). An asterisk designates whether the wired or wireless print server is active. If no wireless print server is installed, the wireless portion of the label does not print.

Figure 23 • Network Configuration Label (With a Wireless Print Server Installed)

Network Configuration	
Zebra Technologies PRINTER MODEL XXXdpi USER-DEFINED TEXT	
NO.....	WIRED PS CHECK?
Printer.....	LOAD LAN FROM?
Wired	
ALL.....	IP PROTOCOL
000.000.000.000.....	IP ADDRESS
000.000.000.000.....	SUBNET MASK
000.000.000.000.....	DEFAULT GATEWAY
000.000.000.000.....	WINS SERVER IP
YES.....	TIMEOUT CHECKING
0300.....	TIMEOUT VALUE
0000.....	ARP INTERVAL
9100.....	BASE RAW PORT
Wireless*	
ALL.....	IP PROTOCOL
010.003.015.089.....	IP ADDRESS
255.255.255.000.....	SUBNET MASK
010.003.015.001.....	DEFAULT GATEWAY
010.003.001.015.....	WINS SERVER IP
YES.....	TIMEOUT CHECKING
0300.....	TIMEOUT VALUE
0000.....	ARP INTERVAL
9100.....	BASE RAW PORT
YES.....	CARD INSERTED
015FH.....	CARD MFG ID
000AH.....	CARD PRODUCT ID
000e83df3bc?.....	MAC ADDRESS
YES.....	DRIVER INSTALLED
INFRASTRUCTURE.....	OPERATING MODE
vh-CTC-PRD.....	ESSID
100.....	TX POWER
0N.....	1 Mb/s
0N.....	2 Mb/s
0N.....	5.5 Mb/s
0N.....	11 Mb/s
11 Mb/s.....	CURRENT TX RATE
DIVERSITY.....	RECEIVE ANTENNA
DIVERSITY.....	XMIT ANTENNA
OPEN.....	AUTH. TYPE
OFF.....	LEAP MODE
128-bit.....	ENCRYPTION MODE
1.....	ENCRYPT. INDEX
020.....	POOR SIGNAL
LONG.....	PREAMBLE
YES.....	ASSOCIATED

FIRMWARE IN THIS PRINTER IS COPYRIGHTED

## Control Panel Parameters

Use the LCD on the control panel to adjust printer settings. [Table 9](#) shows parameters in the order in which they are displayed when you press NEXT/SAVE after entering Setup mode. [Table 10 on page 98](#) shows the additional parameters that appear when a wired or wireless print server is installed in the printer.



**Note** • Your label preparation software or the printer driver may override adjustments made through the control panel. Refer to the software or driver documentation for more information.

While viewing parameters, press NEXT/SAVE to continue to the next parameter, or press PREVIOUS to return to the previous parameter in the cycle. When a parameter is changed, an asterisk (\*) appears in the upper left corner of the display to indicate that the value is different from the one currently active in the printer.

**Table 9 • Printer Parameters (Page 1 of 19)**

Parameter	Action/Explanation
	<p><b>Adjust Print Darkness</b></p> <p>Darkness (burn duration) settings depend on a variety of factors, including ribbon type, media type, and the condition of the printhead. You may adjust the darkness for consistent high-quality printing.</p> <p> <b>Important</b> • Set the darkness to the lowest setting that provides good print quality. If the darkness is set too high, the ink may smear, the ribbon may burn through, or the printhead may wear prematurely.</p> <p>If printing is too light or if there are voids in printed areas, increase the darkness. If printing is too dark or if there is spreading or bleeding of printed areas, decrease the darkness.</p> <p>The <a href="#">FEED Self Test on page 134</a> can be used to determine the best darkness setting. You may want to adjust darkness while performing the <a href="#">PAUSE Self Test on page 133</a>. Because the darkness setting takes effect immediately, you can see the results on labels that are currently printing. Darkness settings also may be changed by the driver or software settings.</p> <p><b>Default:</b> +10 <b>Range:</b> 0 to 30</p> <p><b>To change the value shown:</b></p> <ol style="list-style-type: none"> <li>1. Press PLUS (+) to increase darkness.</li> <li>2. Press MINUS (-) to decrease darkness.</li> </ol>

Table 9 • Printer Parameters (Page 2 of 19)

Parameter	Action/Explanation				
<div style="border: 1px solid black; padding: 5px; display: inline-block;"> TEAR OFF      +000  - ■■■■■      + </div>	<p><b>Adjust the Tear-Off Position</b></p> <p>This parameter establishes the position of the media over the tear-off/peel-off bar after printing.</p> <p>See <a href="#">Figure 24</a>. Higher numbers move the media out (the tear line moves closer to the leading edge of the next label), and lower numbers move the media in (the tear line moves closer to the edge of the label just printed).</p> <div style="text-align: center;"> <p><b>Figure 24 • Tear-Off Position Adjustment</b></p>  <table border="1" style="margin-left: auto; margin-right: auto;"> <tr> <td style="text-align: center;">1</td> <td>Media direction</td> </tr> <tr> <td style="text-align: center;">2</td> <td>Factory-set tear line location at position 00</td> </tr> </table> </div> <p><b>Default:</b> +0  <b>Range:</b> -120 to +120</p> <p><b>To change the value shown:</b></p> <ol style="list-style-type: none"> <li>1. Press PLUS (+) to increase the value. Each press adjusts the tear-off position by four dot rows.</li> <li>2. Press MINUS (-) to decrease the value. Each press adjusts the tear-off position by four dot rows.</li> </ol>	1	Media direction	2	Factory-set tear line location at position 00
1	Media direction				
2	Factory-set tear line location at position 00				
<div style="border: 1px solid black; padding: 5px; display: inline-block;"> PRINT MODE  -TEAR-OFF      + </div>	<p><b>Select Print Mode</b></p> <p>Print mode settings tell the printer the method of media delivery that you wish to use. Make sure that your printer can support the selected option.</p> <p><b>Default:</b> TEAR-OFF  <b>Selections:</b> TEAR-OFF, PEEL-OFF, CUTTER, REWIND</p> <p><b>To change the value shown:</b></p> <ol style="list-style-type: none"> <li>1. Press PLUS (+) or MINUS (-) to scroll through the options.</li> </ol>				



Table 9 • Printer Parameters (Page 3 of 19)

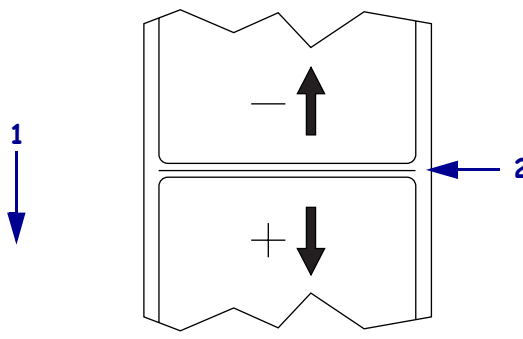

Parameter	Action/Explanation
<div style="border: 1px solid black; padding: 5px;">                     MEDIA TYPE -NON-CONTINUOUS +                 </div>	<p><b>Set Media Type</b></p> <p>This parameter tells the printer the type of media that you are using (see <i>Types of Media</i> on page 25 for more information). Selecting continuous media requires that you include a label length instruction in your label format (^Lxxxxx if you are using ZPL or ZPL II).</p> <p>When non-continuous media is selected, the printer feeds media to calculate label length (the distance between two recognized registration points of the inter-label gap, webbing, or alignment notch or hole).</p> <p><b>Default:</b> NON-CONTINUOUS</p> <p><b>Selections:</b> CONTINUOUS, NON-CONTINUOUS</p> <p><b>To change the value shown:</b></p> <ol style="list-style-type: none"> <li>1. Press PLUS (+) or MINUS (-) to toggle between the options.</li> </ol>
<div style="border: 1px solid black; padding: 5px;">                     SENSOR TYPE -WEB +                 </div>	<p><b>Set the Sensor Type</b></p> <p> <b>Note</b> • The black mark sensor is a purchasable option.</p> <p>This parameter tells the printer whether you are using media with a web (gap/space between labels, notch, or hole) to indicate the separations between labels or if you are using media with a black mark printed on the back. If your media does not have black marks for registration on the back, leave your printer at the default (WEB).</p> <p><b>Default:</b> WEB</p> <p><b>Selections:</b> WEB, MARK</p> <p><b>To change the value shown:</b></p> <ol style="list-style-type: none"> <li>1. Press PLUS (+) or MINUS (-) to toggle between the options.</li> </ol>
<div style="border: 1px solid black; padding: 5px;">                     PRINT METHOD -THERMAL-TRANS. +                 </div>	<p><b>Select Print Method</b></p> <p>The print method parameter tells the printer the method of printing that you wish to use: direct thermal (no ribbon) or thermal transfer (using thermal transfer media and ribbon).</p> <p><b>Default:</b> THERMAL TRANSFER</p> <p><b>Selections:</b> THERMAL TRANSFER, DIRECT THERMAL</p> <p> <b>Note</b> • Selecting direct thermal when using thermal transfer media and ribbon creates an error condition, but printing continues.</p> <p><b>To change the value shown:</b></p> <ol style="list-style-type: none"> <li>1. Press PLUS (+) or MINUS (-) to toggle between the options.</li> </ol>

Table 9 • Printer Parameters (Page 4 of 19)

Parameter	Action/Explanation
<div style="border: 1px solid black; padding: 5px; text-align: center;">           PRINT WIDTH            - MM +         </div>	<p><b>Set Print Width</b></p> <p>Determines the printable area across the width of the label given the resolution of the printer.</p> <p> <b>Note</b> • Setting the width too narrow can result in portions of the label not being printed on the media. Setting the width too wide wastes formatting memory and can cause printing off the label and on the platen roller. This setting can affect the horizontal position of the label format if the image was inverted using the ^POI ZPL II command.</p> <p><b>To change the value shown:</b></p> <ol style="list-style-type: none"> <li>1. Press MINUS (-) to move the cursor.</li> <li>2. Press PLUS (+) to increase the value of the digit.</li> </ol> <p><b>To change the unit of measurement:</b></p> <ol style="list-style-type: none"> <li>1. Press MINUS (-) until the unit of measurement is active.</li> <li>2. Press PLUS (+) to toggle to a different unit of measure (mm, inches, or dots).</li> </ol>

Table 9 • Printer Parameters (Page 5 of 19)

Parameter	Action/Explanation						
<b>MAXIMUM LENGTH</b> <b>-39.0 IN     988 MM</b>	<p><b>Set Maximum Label Length</b></p> <p>This parameter is used during the media portion of the calibration process. Always set maximum label length to a value that is at least 1.0 in. (25.4 mm) greater than the actual label length (Figure 25). If the value is set to a smaller value than the label length, the printer assumes that continuous media is loaded, and the printer cannot calibrate.</p> <p>For example, if the label length is 5.0 inches (126 mm) including the interlabel gap, set the parameter for 6.0 inches (152 mm). If the label length is 7.5 inches (190 mm), set the parameter for 9.0 inches (229 mm).</p> <p style="text-align: center;"><b>Figure 25 • Label Length</b></p> <table border="1" style="margin-left: auto; margin-right: auto;"> <tr> <td style="text-align: center;"><b>1</b></td> <td>Label length (including interlabel gap)</td> </tr> <tr> <td style="text-align: center;"><b>2</b></td> <td>Interlabel gap</td> </tr> <tr> <td style="text-align: center;"><b>3</b></td> <td>Set maximum label length to approximately this value</td> </tr> </table> <p><b>Default:</b> 39.0 inches (988 mm).  <b>Range:</b> Values are adjustable in one-inch (25.4 mm) increments.</p> <p><b>To change the value shown:</b></p> <ol style="list-style-type: none"> <li>1. Press PLUS (+) to increase the value.</li> <li>2. Press MINUS (-) to decrease the value.</li> </ol>	<b>1</b>	Label length (including interlabel gap)	<b>2</b>	Interlabel gap	<b>3</b>	Set maximum label length to approximately this value
<b>1</b>	Label length (including interlabel gap)						
<b>2</b>	Interlabel gap						
<b>3</b>	Set maximum label length to approximately this value						

Table 9 • Printer Parameters (Page 6 of 19)

Parameter	Action/Explanation
<div style="border: 1px solid black; padding: 5px; width: fit-content;">                     LIST FONTS PRINT                 </div>	<p><b>List Fonts</b> This option prints a label that lists the available fonts in the printer, including standard printer fonts plus any optional fonts. Fonts may be stored in RAM, Flash memory, optional PCMCIA font cards, or CompactFlash® cards.</p> <p><b>To print a list of the available fonts:</b></p> <ol style="list-style-type: none"> <li>1. Press PLUS (+) to select <b>PRINT</b>.</li> </ol>
<div style="border: 1px solid black; padding: 5px; width: fit-content;">                     LIST BAR CODES PRINT                 </div>	<p><b>List Bar Codes</b> This option prints a label that lists the available bar codes in the printer. Bar codes may be stored in RAM, Flash memory, optional PCMCIA cards, or Compact Flash cards.</p> <p><b>To print a list of the available bar codes:</b></p> <ol style="list-style-type: none"> <li>1. Press PLUS (+) to select <b>PRINT</b>.</li> </ol>
<div style="border: 1px solid black; padding: 5px; width: fit-content;">                     LIST IMAGES PRINT                 </div>	<p><b>List Images</b> This option prints a label that lists the available images stored in the printer's RAM, Flash memory, optional memory card, PCMCIA cards, or Compact Flash cards.</p> <p><b>To print a list of the available images:</b></p> <ol style="list-style-type: none"> <li>1. Press PLUS (+) to select <b>PRINT</b>.</li> </ol>
<div style="border: 1px solid black; padding: 5px; width: fit-content;">                     LIST FORMATS PRINT                 </div>	<p><b>List Formats</b> This option prints a label that lists the available formats stored in the printer's RAM, Flash memory, optional EPROM, or optional memory card.</p> <p><b>To print a list of the available formats:</b></p> <ol style="list-style-type: none"> <li>1. Press PLUS (+) to select <b>PRINT</b>.</li> </ol>
<div style="border: 1px solid black; padding: 5px; width: fit-content;">                     LIST SETUP PRINT                 </div>	<p><b>List Setup</b> This option prints a configuration label (see <a href="#">Figure 22 on page 77</a>), which lists the current printer configuration.</p> <p><b>To print a configuration label:</b></p> <ol style="list-style-type: none"> <li>1. Press PLUS (+) to select <b>PRINT</b>.</li> </ol>
<div style="border: 1px solid black; padding: 5px; width: fit-content;">                     LIST NETWORK PRINT                 </div>	<p><b>List Network Settings</b> This option prints a network configuration label (see <a href="#">Figure 23 on page 78</a>), which lists the settings for any print server that is installed.</p> <p><b>To print a network configuration label:</b></p> <ol style="list-style-type: none"> <li>1. Press PLUS (+) to select <b>PRINT</b>.</li> </ol>

Table 9 • Printer Parameters (Page 7 of 19)

Parameter	Action/Explanation
<div style="border: 1px solid black; padding: 5px; display: flex; justify-content: space-between;"> <span>LIST ALL</span> <span>PRINT</span> </div>	<p><b>List All</b> This option prints labels that list the available fonts, bar codes, images, formats, and the current printer and network configurations.</p> <p><b>To print labels for all settings:</b></p> <ol style="list-style-type: none"> <li>1. Press PLUS (+) to select <b>PRINT</b>.</li> </ol>
<div style="border: 1px solid black; padding: 5px; display: flex; justify-content: space-between;"> <span>FORMAT CARD:</span> <span>B:</span> </div> <div style="border: 1px solid black; padding: 5px; display: flex; justify-content: space-between;"> <span>A:</span> <span></span> </div>	<p><b>Format Memory Card</b> This option erases all previously stored information from the optional PCMCIA card or Compact Flash card.</p> <p><b>Caution</b> • This option completely erases the selected card.</p> <p><b>To format a memory card:</b></p> <ol style="list-style-type: none"> <li>1. Press MINUS (-) to select <b>A:</b> or PLUS (+) to select <b>B:</b> . If your printer is set to require a password, you are prompted to enter the password.</li> <li>2. Enter the password. For instructions, see <i>Change Password-Protected Parameters on page 76</i>.</li> <li>3. Press the appropriate button again to select the desired card. The display shows <b>ARE YOU SURE?</b>.</li> <li>4. Do you wish to continue? <ul style="list-style-type: none"> <li>• Press MINUS (-) to select <b>NO</b> to cancel the request and return to <b>FORMAT CARD</b> prompt.</li> <li>• Press PLUS (+) to select <b>YES</b> and begin initialization. When initialization is complete, the printer automatically exits Setup mode, and the control panel displays <b>PRINTER READY</b>. If you exit Setup mode while initialization is still in process, the control panel display flashes between the phrases <b>CHECKING B: MEMORY</b> and <b>PRINTER IDLE</b>.</li> </ul> </li> </ol> <p> <b>Note</b> • Depending on the amount of memory in the memory card, initialization may take up to 5 minutes to complete.</p>

Table 9 • Printer Parameters (Page 8 of 19)

Parameter	Action/Explanation
<div style="border: 1px solid black; padding: 5px; text-align: center;"> <b>INIT FLASH MEM.</b>  <b>YES</b> </div>	<p><b>Initialize Flash Memory</b>            This option erases all previously stored information from Flash memory.  <b>Caution</b> • This option completely erases the Flash memory.</p> <p><b>To initialize Flash memory:</b></p> <ol style="list-style-type: none"> <li>1. Press PLUS (+) to select <b>YES</b>.              If your printer is set to require a password, you are prompted to enter the password.</li> <li>2. Enter the password. For instructions, see <i>Change Password-Protected Parameters on page 76</i>.              The display shows <b>INITIALIZE FLASH?</b></li> <li>3. Press PLUS (+) to select <b>YES</b>.              The display shows <b>ARE YOU SURE?</b></li> <li>4. Do you wish to continue?             <ul style="list-style-type: none"> <li>• Press MINUS (-) to select <b>NO</b> to cancel the request and return to the <b>INITIALIZE FLASH</b> prompt.</li> <li>• Press PLUS (+) to select <b>YES</b> and begin initialization.                When initialization is complete, the printer automatically exits Setup mode, and the control panel displays <b>PRINTER READY</b>. If you exit Setup mode while initialization is still in process, the control panel display flashes between the phrases <b>CHECKING E: MEMORY</b> and <b>PRINTER IDLE</b>.</li> </ul> </li> </ol> <p> <b>Note</b> • Depending on the amount of free FLASH memory, initialization may take up to 1 minute to complete.</p>

Table 9 • Printer Parameters (Page 9 of 19)



Parameter	Action/Explanation
<b>SENSOR PROFILE PRINT</b>	<p><b>Print Sensor Profile</b></p> <p>A sensor profile shows sensor settings compared to actual sensor readings. This label (which will extend across several actual labels or tags) can be used to troubleshoot printing problems. To interpret the results of the sensor profile, see <a href="#">Sensor Profile on page 140</a>.</p> <p style="text-align: center;"><b>Figure 26 • Sensor Profile</b></p>  <p><b>To print a sensor profile:</b></p> <ol style="list-style-type: none"> <li>1. Press PLUS (+) to start this standard calibration procedure and print a media sensor profile.</li> <li>2. If the sensitivity of the sensors must be adjusted, perform <a href="#">Calibrate Media and Ribbon Sensor Sensitivity on page 88</a>.</li> </ol>

Table 9 • Printer Parameters (Page 10 of 19)

Parameter	Action/Explanation
<div style="border: 2px solid black; padding: 5px; text-align: center;"> <b>MEDIA AND RIBBON CALIBRATE</b> </div>	<p><b>Calibrate Media and Ribbon Sensor Sensitivity</b> Use this procedure to adjust sensitivity of media and ribbon sensors.</p> <p> <b>Important</b> • Follow this procedure exactly as presented. All of the steps must be performed even if only one of the sensors requires adjustment. You may press MINUS (-) at any step in this procedure to cancel the process.</p> <p><b>To perform a media and ribbon sensor calibration:</b></p> <ol style="list-style-type: none"> <li>1. Press PLUS (+) to start the calibration procedure. The <b>LOAD BACKING</b> prompt displays.</li> <li>2. Open the printhead.</li> <li>3. Remove approximately 8 in. (203 mm) of labels from the backing, and pull the media into the printer so that only the backing is between the media sensors.</li> <li>4. Leave the printhead open.</li> <li>5. Press PLUS (+) to continue. The <b>REMOVE RIBBON</b> prompt displays.</li> <li>6. Remove the ribbon (if used).</li> <li>7. Close the printhead.</li> <li>8. Press PLUS (+) to continue. The message <b>CALIBRATING PLEASE WAIT</b> displays. The printer adjusts the scale (gain) of the signals that it receives from the media and ribbon sensors based on the specific media and ribbon combination being used. On the sensor profile, this essentially corresponds to moving the peak of the graph up or down to optimize the readings for your application. When calibration is complete, <b>RELOAD ALL</b> displays.</li> <li>9. Open the printhead and pull the media forward until a label is positioned under the media sensor.</li> <li>10. Reload the ribbon (if used).</li> <li>11. Close the printhead.</li> <li>12. Press PLUS (+) to continue. The printer performs an auto-calibration. During this process, the printer checks the readings for the media and ribbon based on the new scale established, determines the label length, and determines the print mode. To see the new readings on the new scale, print a sensor profile.</li> </ol>

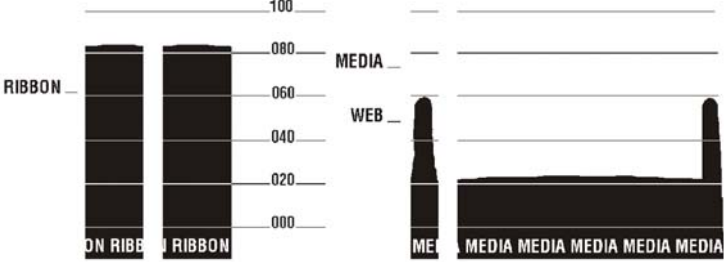

**Table 9 • Printer Parameters (Page 11 of 19)**



Parameter	Action/Explanation
<b>PARALLEL COMM.</b> <b>-BIDIRECTIONAL</b> +	<p><b>Set Parallel Communications</b></p> <p>Select the communications port that matches the one being used by the host computer.</p> <p><b>Default:</b> BIDIRECTIONAL</p> <p><b>Selections:</b> BIDIRECTIONAL, TWINAX/COAX, UNIDIRECTIONAL</p> <p><b>To change the value shown:</b></p> <ol style="list-style-type: none"> <li>1. Press PLUS (+) or MINUS (-) to scroll through the options.</li> </ol>
<b>SERIAL COMM</b> <b>-RS232</b> +	<p><b>Set Serial Communications</b></p> <p>Select the communications port that matches the one being used by the host computer. This setting applies only when the serial port is used.</p> <p> <b>Important</b> • Do not change this parameter from the default. The printer supports only RS-232. This parameter will be eliminated in a future version of the firmware.</p> <p><b>Default:</b> RS232</p> <p><b>Selections:</b> RS232, RS422/485, RS485 MULTIDROP</p> <p><b>To change the value shown:</b></p> <ol style="list-style-type: none"> <li>1. Press PLUS (+) or MINUS (-) to scroll through the options.</li> </ol>
<b>BAUD</b> <b>-9600</b> +	<p><b>Set Baud</b></p> <p>This setting applies only when the serial port is used. The baud setting of the printer must match the baud setting of the host computer for accurate communications to take place. Select the value that matches the one being used by the host computer.</p> <p><b>Default:</b> 9600</p> <p><b>Selections:</b> 110, 300, 600, 1200, 2400, 4800, 9600, 14400, 19200, 28800, 38400, 57600, 115200</p> <p><b>To change the value shown:</b></p> <ol style="list-style-type: none"> <li>1. Press PLUS (+) or MINUS (-) to scroll through the options.</li> </ol>
<b>DATA BITS</b> <b>- 8 BITS</b>	<p><b>Set Data Bits</b></p> <p>This setting applies only when the serial port is used. The data bits of the printer must match the data bits of the host computer for accurate communications to take place. Set the data bits to match the setting being used by the host computer.</p> <p> <b>Note</b> • Code Page 850 requires the data bits to be set to 8 bits. See the <i>ZPL II Programming Guide</i> for more information.</p> <p><b>Default:</b> 8 BITS</p> <p><b>Selections:</b> 7 BITS, 8 BITS</p> <p><b>To change the value shown:</b></p> <ol style="list-style-type: none"> <li>1. Press PLUS (+) or MINUS (-) to toggle between the options.</li> </ol>

Table 9 • Printer Parameters (Page 12 of 19)

Parameter	Action/Explanation
<div style="border: 1px solid black; padding: 5px;">           PARITY            -        NONE        +         </div>	<p><b>Set Parity</b></p> <p>This setting applies only when the serial port is used. The parity of the printer must match the parity of the host computer for accurate communications to take place. Select the parity that matches the one being used by the host computer.</p> <p><b>Default:</b> NONE <b>Selections:</b> EVEN, ODD, NONE</p> <p><b>To change the value shown:</b></p> <ol style="list-style-type: none"> <li>1. Press PLUS (+) or MINUS (-) to scroll through the options.</li> </ol>
<div style="border: 1px solid black; padding: 5px;">           HOST HANDSHAKE            -        XON/XOFF        +         </div>	<p><b>Set Host Handshake</b></p> <p>This setting applies only when the serial port is used. The handshake protocol of the printer must match the handshake protocol of the host computer for communication to take place. Select the handshake protocol that matches the one being used by the host computer.</p> <p><b>Default:</b> XON/XOFF <b>Selections:</b> XON/XOFF, DTR/DSR, RTS/CTS</p> <p><b>To change the value shown:</b></p> <ol style="list-style-type: none"> <li>1. Press PLUS (+) or MINUS (-) to scroll through the options.</li> </ol>
<div style="border: 1px solid black; padding: 5px;">           PROTOCOL            -        NONE        +         </div>	<p><b>Set Protocol</b></p> <p>Protocol is a type of error checking system. Depending on the selection, an indicator may be sent from the printer to the host computer signifying that data has been received. Select the protocol that is requested by the host computer. Further details on protocol can be found in the <i>ZPL II Programming Guide</i>.</p> <p><b>Default:</b> NONE <b>Selections:</b> NONE, ZEBRA, ACK_NAK</p> <p> <b>Note • ZEBRA</b> is the same as <b>ACK_NAK</b>, except that <b>ZEBRA</b> response messages are sequenced. If <b>ZEBRA</b> is selected, the printer must use <b>DTR/DSR</b> for host handshake protocol.</p> <p><b>To change the value shown:</b></p> <ol style="list-style-type: none"> <li>1. Press PLUS (+) or MINUS (-) to scroll through the options.</li> </ol>
<div style="border: 1px solid black; padding: 5px;">           NETWORK ID            -        000        +         </div>	<p><b>Set Network ID</b></p> <p>Network ID is used to assign a unique number to a printer. This gives the host computer the means to address a specific printer. This does not affect TCP/IP or IPX networks.</p> <p><b>Default:</b> 000 <b>Range:</b> 000 to 999</p> <p><b>To change the value shown:</b></p> <ol style="list-style-type: none"> <li>1. Press MINUS (-) to move to the next digit position.</li> <li>2. Press PLUS (+) to increase the value of the digit.</li> </ol>

Table 9 • Printer Parameters (Page 13 of 19)



Parameter	Action/Explanation
<div style="border: 1px solid black; padding: 5px;">           COMMUNICATIONS            - NORMAL MODE      +         </div>	<p><b>Set Communications Mode</b></p> <p>The communication diagnostics mode is a troubleshooting tool for checking the interconnection between the printer and the host computer. For more information, see <i>Communications Diagnostics Test</i> on page 139.</p> <p><b>Default:</b> NORMAL MODE  <b>Selections:</b> NORMAL MODE, DIAGNOSTICS</p> <p><b>To select communication diagnostics mode:</b></p> <ol style="list-style-type: none"> <li>1. Press PLUS (+) or MINUS (-) to toggle between the options.</li> </ol>
<div style="border: 1px solid black; padding: 5px;">           CONTROL PREFIX            -      &lt;■&gt;7EH      +         </div>	<p><b>Set Control Prefix Character</b></p> <p>The printer looks for this two-digit hex character to indicate the start of a ZPL/ZPL II control instruction. The “H” that is displayed indicates Hexadecimal and is not part of the value.</p> <p> <b>Note</b> • Do not use the same hex value for the control, format, and delimiter character. The printer must see different characters to work properly.</p> <p><b>Default:</b> 7E (tilde—displayed as a black square)  <b>Range:</b> 00 to FF</p> <p><b>To change the value shown:</b></p> <ol style="list-style-type: none"> <li>1. Press MINUS (-) to move to the next digit position.</li> <li>2. Press PLUS (+) to increase the value of the digit.</li> </ol>
<div style="border: 1px solid black; padding: 5px;">           FORMAT PREFIX            -      &lt;^&gt;5EH      +         </div>	<p><b>Set Format Prefix Character</b></p> <p>The format prefix is a two-digit hex value used as a parameter place marker in ZPL/ZPL II format instructions. The “H” that is displayed indicates Hexadecimal and is not part of the value. The printer looks for this hex character to indicate the start of a ZPL/ZPL II format instruction. See the <i>ZPL II Programming Guide Volume I</i> for more information.</p> <p> <b>Note</b> • Do not use the same hex value for the control, format, and delimiter character. The printer must see different characters to work properly.</p> <p><b>Default:</b> 5E (caret)  <b>Range:</b> 00 to FF</p> <p><b>To change the value shown:</b></p> <ol style="list-style-type: none"> <li>1. Press MINUS (-) to move to the next digit position.</li> <li>2. Press PLUS (+) to increase the value of the digit.</li> </ol>

Table 9 • Printer Parameters (Page 14 of 19)

Parameter	Action/Explanation
<div style="border: 1px solid black; padding: 5px;">                     DELIMITER CHAR                      -      &lt;, &gt;2CH      +                 </div>	<p><b>Set Delimiter Character</b></p> <p>The delimiter character is a two-digit hex value used as a parameter place marker in ZPL/ZPL II format instructions. See the <i>ZPL II Programming Guide Volume I</i> for more information.</p> <p> <b>Note</b> • Do not use the same hex value for the control, format, and delimiter character. The printer must see different characters to work properly.</p> <p><b>Default:</b> 2C (comma)</p> <p><b>Range:</b> 00 to FF</p> <p><b>To change the value shown:</b></p> <ol style="list-style-type: none"> <li>1. Press MINUS (-) to move to the next digit position.</li> <li>2. Press PLUS (+) to increase the value of the digit.</li> </ol>
<div style="border: 1px solid black; padding: 5px;">                     ZPL MODE                      -      ZPL II      +                 </div>	<p><b>Select ZPL Mode</b></p> <p>The printer remains in the selected mode until it is changed by this parameter or by using a ZPL/ZPL II command. The printer accepts label formats written in either ZPL or ZPL II, eliminating the need to rewrite any ZPL formats that already exist. See the <i>ZPL II Programming Guide</i> for more information on the differences between ZPL and ZPL II.</p> <p><b>Default:</b> ZPL II</p> <p><b>Selections:</b> ZPL II, ZPL</p> <p><b>To change the value shown:</b></p> <ol style="list-style-type: none"> <li>1. Press PLUS (+) or MINUS (-) to toggle between the options.</li> </ol>
<div style="border: 1px solid black; padding: 5px;">                     MEDIA POWER UP                      - CALIBRATION      +                 </div>	<p><b>Select Media Power-Up Option</b></p> <p>This parameter sets the action of the media when you turn on the printer.</p> <p><b>Default:</b> CALIBRATION</p> <p><b>Selections:</b> FEED, CALIBRATION, LENGTH, SHORT CAL, and NO MOTION</p> <ul style="list-style-type: none"> <li>• <b>Feed</b>—feeds the labels to the first registration point.</li> <li>• <b>Calibration</b>—determines the length of the label and adjusts the sensor settings.</li> <li>• <b>Length</b>—In continuous mode, feeds the last stored label length. In noncontinuous mode, calibrates based on the maximum label length setting (see <i>Set Maximum Label Length on page 83</i>).</li> <li>• <b>Short Cal</b>—calibrates label length using the current sensor settings.</li> <li>• <b>No Motion</b>—the media does not move. You must press FEED to cause the printer to resynch to the start of the next label.</li> </ul> <p><b>To change the value shown:</b></p> <ol style="list-style-type: none"> <li>1. Press PLUS (+) or MINUS (-) to scroll through the options.</li> </ol>

Table 9 • Printer Parameters (Page 15 of 19)

Parameter	Action/Explanation
<div style="border: 1px solid black; padding: 5px; width: fit-content;">                     HEAD CLOSE - CALIBRATION      +                 </div>	<p><b>Select Head Close Option</b> This parameter sets the action of the media when you close the printhead. <b>Default:</b> CALIBRATION <b>Selections:</b> FEED, CALIBRATION, LENGTH, SHORT CAL, and NO MOTION</p> <ul style="list-style-type: none"> <li>• <b>Feed</b>—feeds the labels to the first registration point.</li> <li>• <b>Calibration</b>—determines the length of the label and adjusts the sensor settings.</li> <li>• <b>Length</b>—In continuous mode, feeds the last stored label length. In noncontinuous mode, calibrates based on the maximum label length setting (see <a href="#">Set Maximum Label Length on page 83</a>).</li> <li>• <b>Short Cal</b>—calibrates label length using the current sensor settings.</li> <li>• <b>No Motion</b>—the media does not move. You must press FEED to cause the printer to resynch to the start of the next label.</li> </ul> <p><b>To change the value shown:</b></p> <ol style="list-style-type: none"> <li>1. Press PLUS (+) or MINUS (-) to scroll through the options.</li> </ol>
<div style="border: 1px solid black; padding: 5px; width: fit-content;">                     BACKFEED -      DEFAULT      +                 </div>	<p><b>Select Backfeed Sequence</b> This parameter sets when label backfeed occurs after a label is removed in some print modes. It has no effect in Rewind mode. This setting is superseded by ~JS when received as part of a label format (see <i>ZPL II Programming Guide Volume I</i>). <b>Default:</b> DEFAULT (90%) <b>Selections:</b> DEFAULT, AFTER, BEFORE, 10%, 20%, 30%, 40%, 50%, 60%, 70%, 80%, OFF</p> <p><b>To change the value shown:</b></p> <ol style="list-style-type: none"> <li>1. Press PLUS (+) or MINUS (-) to scroll through the options.</li> </ol>
<div style="border: 1px solid black; padding: 5px; width: fit-content;">                     LABEL TOP +000 -■■■■■■■■      +                 </div>	<p><b>Adjust Label Top Position</b> This parameter adjusts the print position vertically on the label. Positive numbers adjust the label top position farther down the label (away from the printhead); negative numbers adjust the position up the label (toward the printhead). The displayed value represents dots. <b>Default:</b> +000 <b>Range:</b> -120 to +120 dots</p> <p><b>To change the value shown:</b></p> <ol style="list-style-type: none"> <li>1. Press PLUS (+) to increase the value.</li> <li>2. Press MINUS (-) to decrease the value.</li> </ol>

Table 9 • Printer Parameters (Page 16 of 19)

Parameter	Action/Explanation
<div style="border: 1px solid black; padding: 5px; width: fit-content;"> <p>LEFT POSITION -      ±0000      +</p> </div>	<p><b>Adjust Left Position</b></p> <p>This parameter establishes how far from the left edge of a label the format begins to print by adjusting horizontal positioning on the label. Positive numbers adjust the printing away from the main frame by the number of dots selected; negative numbers shift printing toward the main frame. The displayed value represents dots.</p> <p><b>Default:</b> 0000</p> <p><b>Range:</b> -9999 to +9999 dots</p> <p><b>To change the value shown:</b></p> <ol style="list-style-type: none"> <li>1. Press MINUS (-) to move the cursor.</li> <li>2. Press PLUS (+) to change between +/- and to increase the value of the digit.</li> <li>3. For a negative value, enter the value before changing to the minus sign.</li> </ol>

Table 9 • Printer Parameters (Page 17 of 19)

Parameter	Action/Explanation
<div style="border: 1px solid black; padding: 5px; display: inline-block;">                     HEAD RESISTOR                      - 0500 OHMS +                 </div>	<p><b>Set the Printhead Resistor Value</b></p> <p><b>Caution</b> • This parameter should be changed only by qualified service personnel. Do not set the value higher than that shown on the printhead. Setting a higher value may damage the printhead.</p> <p> <b>Note</b> • Depending on the printer model that you have, this parameter may not be available. For printers with model numbers 10500-2XXX-XXXX and 10500-3XXX-XXXX, the head resistor value is set automatically.</p> <p>This value is preset at the factory to match the resistance value of the printhead. It does not need to be changed unless the printhead or the main logic board is replaced.</p> <p><b>Initial Value:</b> Factory-set to match the printhead shipped with your printer.  <b>Default Value:</b> 0500  <b>Range:</b> 0500 to 1175</p> <p><b>To set the printhead resistor value:</b></p> <ol style="list-style-type: none"> <li>1. Before replacing the printhead, look for the label that shows the resistance value (<math>\Omega</math> value) of the new printhead. Make note of this setting before installing the new printhead (Figure 27).</li> </ol> <div style="text-align: center; margin: 20px 0;"> <p><b>Figure 27 • Head Resistance Value</b></p>  </div> <ol style="list-style-type: none"> <li>2. Press MINUS (-) to move to the next digit position.</li> <li>3. Press PLUS (+) to increase the value of the digit.</li> </ol>

Table 9 • Printer Parameters (Page 18 of 19)

Parameter	Action/Explanation
<div style="border: 1px solid black; padding: 2px;">           WEB S.      073            - ■■■■■■      +         </div>	<p>These parameters are automatically set during the calibration procedure and should be changed only by a qualified service technician. Refer to the <i>ZPL II Programming Guide</i> for information on these parameters.</p> <p><b>To skip these parameters:</b></p> <ol style="list-style-type: none"> <li>1. Press PLUS (+) repeatedly.</li> </ol>
<div style="border: 1px solid black; padding: 2px;">           MEDIA S.      075            - ■■■■■■      +         </div>	
<div style="border: 1px solid black; padding: 2px;">           RIBBON S.      071            - ■■■■■■      +         </div>	
<div style="border: 1px solid black; padding: 2px;">           - ■■■■■■      +         </div>	
<div style="border: 1px solid black; padding: 2px;">           MARK S.      000            - ■              +         </div>	
<div style="border: 1px solid black; padding: 2px;">           MARK MED S. 000            - ■              +         </div>	
<div style="border: 1px solid black; padding: 2px;">           MEDIA LED    082            - ■              +         </div>	
<div style="border: 1px solid black; padding: 2px;">           RIBBON LED   008            - ■              +         </div>	
<div style="border: 1px solid black; padding: 2px;">           MARK LED     005            - ■              +         </div>	
<div style="border: 1px solid black; padding: 2px;">           LCD ADJUST   +10            - ■              +         </div>	<p><b>Adjust LCD Display</b></p> <p>This parameter allows you to adjust the brightness of your LCD if it is difficult to read.</p> <p><b>Default:</b> 10</p> <p><b>Range:</b> 00 to 19</p> <p><b>To change the value shown:</b></p> <ol style="list-style-type: none"> <li>1. Press PLUS (+) to increase the value (increase brightness).</li> <li>2. Press MINUS (-) to decrease the value (reduce brightness).</li> </ol>
<div style="border: 1px solid black; padding: 2px;">           FORMAT CONVERT            - NONE              +         </div>	<p><b>Select Format Convert</b></p> <p>Selects the bitmap scaling factor. The first number is the original dots per inch (dpi) value; the second, the dpi to which you would like to scale.</p> <p><b>Default:</b> NONE</p> <p><b>Selections:</b> NONE, 150 → 300, 150 → 600, 200 → 600, 300 → 600</p> <p><b>To change the value shown:</b></p> <ol style="list-style-type: none"> <li>1. Press PLUS (+) or MINUS (-) to scroll through the options.</li> </ol>

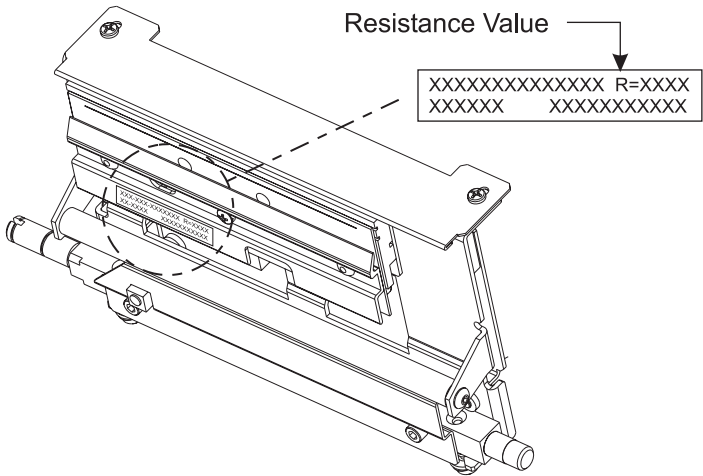

Table 9 • Printer Parameters (Page 19 of 19)

Parameter	Action/Explanation
<div style="border: 1px solid black; padding: 5px;">                     RTC DATE                      - 01/31/01      +                 </div>	<p><b>Set Real-Time Clock (RTC) Date</b>                      This parameter allows you to set the date following the convention selected in <b>IDLE DISPLAY</b>.</p> <p><b>To change the value shown:</b></p> <ol style="list-style-type: none"> <li>1. Press MINUS (-) to move to the next digit position.</li> <li>2. Press PLUS (+) to change the value of the digit.</li> </ol>
<div style="border: 1px solid black; padding: 5px;">                     RTC TIME                      - 14:55      +                 </div>	<p><b>Set RTC Time</b>                      This parameter allows you to set the time following the convention selected in <b>IDLE DISPLAY</b>.</p> <p><b>To change the value shown:</b></p> <ol style="list-style-type: none"> <li>1. Press MINUS (-) to move to the next digit position.</li> <li>2. Press PLUS (+) to change the value of the digit.</li> </ol>
<div style="border: 1px solid black; padding: 5px;">                     LANGUAGE                      ← ENGLISH →                 </div>	<p><b>Select the Display Language</b>                      This parameter changes the language displayed on the LCD.</p> <p><b>Default:</b> ENGLISH</p> <p><b>Selections:</b> ENGLISH, SPANISH, FRENCH, GERMAN, ITALIAN, NORWEGIAN, PORTUGUESE, SWEDISH, DANISH, SPANISH 2, DUTCH, FINNISH, JAPAN</p> <p><b>To change the value shown:</b></p> <ol style="list-style-type: none"> <li>1. Press PLUS (+) or MINUS (-) to scroll through the options.</li> </ol>

## Print Server LCD Displays

The menu options shown in Table 10 display only if you have a print server installed.

**Table 10 • Print Server Parameters (Page 1 of 4)**

Parameter	Action/Explanation
LOAD LAN FROM? PRINTER	<p><b>Load LAN Source<sup>1</sup></b> This parameter, which serves the same function as the ^NP ZPL command, specifies whether to use the printer's or the print server's IP settings at bootup.</p> <p><b>Default:</b> PRINTER <b>Selections:</b> PRINTER, PRINTSERVER</p> <p><b>To change the value shown:</b></p> <ol style="list-style-type: none"> <li>1. Press PLUS ( ) or MINUS (–) to toggle between the options.</li> </ol>
WIRED PS CHECK? NO	<p><b>Check for Wired PrintServer<sup>1</sup></b> This parameter, which serves the same function as the ^NB ZPL command, tells the printer whether to search for a wired print server at bootup.</p> <p><b>Default:</b> NO <b>Selections:</b> YES, NO</p> <p><b>To change the value shown:</b></p> <ol style="list-style-type: none"> <li>1. Press PLUS ( ) or MINUS (–) to toggle between the options.</li> </ol>
IP PROTOCOL ALL	<p><b>Specify IP Protocol<sup>2</sup></b> Allows either the user (permanent) or the server (dynamic) to select the IP address. If a dynamic option is chosen, this selection determines the method(s) by which the print server (wired or wireless) receives the IP address from the server.</p> <p><b>Default:</b> ALL <b>Selections:</b> ALL, GLEANING ONLY, RARP, BOOTP, DHCP, DHCP AND BOOTP, PERMANENT</p> <p> <b>Note</b> • Use of GLEANING ONLY is not recommended when the Wireless Print Server is installed.</p> <p><b>To change the value shown:</b></p> <ol style="list-style-type: none"> <li>1. Press PLUS ( ) or MINUS (–) to scroll through the options.</li> </ol>

<sup>1</sup> Appears only when the ZebraNet Wireless Print Server is installed.

<sup>2</sup> These parameters appear after the system recognizes the existence of a ZebraNet print server (wired or wireless). After the print server is recognized, all zeroes (000.000.000.000) will display until the printer obtains an IP address or defaults to address 192.168.254.254.



<sup>3</sup> If a wireless password is set, you must enter the wireless password (not the printer password) to access this parameter.

Table 10 • Print Server Parameters (Page 2 of 4)

Parameter	Action/Explanation
<div style="border: 1px solid black; padding: 5px;"> <b>IP ADDRESS</b>                      000.000.000.000                 </div>	<p><b>Specify IP Address<sup>2</sup></b>                      This parameter allows you to select the IP address if PERMANENT was chosen in IP PROTOCOL. (If a dynamic option was chosen, the user cannot select the address.)</p> <p><b>To change the value shown:</b></p> <ol style="list-style-type: none"> <li>1. Press MINUS (–) to move the cursor.</li> <li>2. Press PLUS ( ) to increase the value of the digit.</li> </ol>
<div style="border: 1px solid black; padding: 5px;"> <b>SUBNET MASK</b>                      000.000.000.000                 </div>	<p><b>Specify Subnet Mask<sup>2</sup></b>                      This parameter selects the part of the IP address that is considered to be part of the local network. It can be reached without going through the default gateway.</p> <p><b>To change the value shown:</b></p> <ol style="list-style-type: none"> <li>1. Press MINUS (–) to move the cursor.</li> <li>2. Press PLUS ( ) to increase the value of the digit.</li> </ol>
<div style="border: 1px solid black; padding: 5px;"> <b>DEFAULT GATEWAY</b>                      000.000.000.000                 </div>	<p><b>Specify Default Gateway<sup>2</sup></b>                      This parameter allows you to select the IP address that the network traffic is routed through if the destination address is not part of the local network.</p> <p><b>To change the value shown:</b></p> <ol style="list-style-type: none"> <li>1. Press MINUS (–) to move the cursor.</li> <li>2. Press PLUS (+) to increase the value of the digit.</li> </ol>
<div style="border: 1px solid black; padding: 5px;"> <b>MAC ADDRESS</b>                      000000000000                 </div>	<p><b>View MAC Address<sup>1,3</sup></b>                      Displays the MAC address of the wireless card. This parameter cannot be changed through the control panel.</p>
<div style="border: 1px solid black; padding: 5px;"> <b>ESSID</b>                      125                 </div>	<p><b>View ESSID<sup>1,3</sup></b>                      This parameter cannot be changed through the control panel. Use the ^WS ZPL command to change the value. For more information, see the <i>Wireless Print Server User Guide</i>.</p>
<div style="border: 1px solid black; padding: 5px;"> <b>AUTH. TYPE</b>                      OPEN                 </div>	<p><b>Select Authentication Type<sup>1,3</sup></b>                      If encryption is on, specify whether to use open or shared authentication.  <b>Default:</b> OPEN  <b>Selections:</b> OPEN, SHARED</p> <p><b>To change the value shown:</b></p> <ol style="list-style-type: none"> <li>1. Press PLUS (+) or MINUS (–) to toggle between the options.</li> </ol>

1 Appears only when the ZebraNet Wireless Print Server is installed.  
 2 These parameters appear after the system recognizes the existence of a ZebraNet print server (wired or wireless). After the print server is recognized, all zeroes (000.000.000.000) will display until the printer obtains an IP address or defaults to address 192.168.254.254.  
 3 If a wireless password is set, you must enter the wireless password (not the printer password) to access this parameter.

Table 10 • Print Server Parameters (Page 3 of 4)

Parameter	Action/Explanation
LEAP MODE OFF	<p><b>Enable LEAP Mode<sup>3,4</sup></b></p> <p>LEAP is an encryption method that is available with some wireless cards. Set the LEAP user name and password through the printer web pages.</p> <p>This parameter appears 1) when no wireless card is inserted or 2) when the wireless card is associated to the WLAN and the card supports LEAP.</p> <p><b>Default:</b> OFF</p> <p><b>Selections:</b> ON, OFF</p> <p><b>To change the value shown:</b></p> <ol style="list-style-type: none"> <li>1. Press PLUS (+) or MINUS (-) to toggle between the options.</li> </ol>
ENCRYPTION MODE OFF	<p><b>Select Encryption Mode<sup>1,3</sup></b></p> <p>Select whether to use 40-bit encryption, 128-bit encryption, or no encryption.</p> <p> <b>Important</b> • If using encryption, use the ^WE ZPL command to set the value for the active encryption key. Failure to do so can disable the wireless system. For more information, see the <i>Wireless Print Server User Guide</i>.</p> <p><b>Default:</b> OFF</p> <p><b>Selections:</b> OFF, 40-BIT, 128-BIT</p> <p><b>To change the value shown:</b></p> <ol style="list-style-type: none"> <li>1. Press PLUS (+) or MINUS (-) to scroll through the options.</li> </ol>
ENCRYPT. INDEX 1	<p><b>Select Encryption Index<sup>1,3</sup></b></p> <p>Use this parameter to tell the printer which encryption key to use.</p> <p> <b>Important</b> • Use the ^WE ZPL command to set the value for the active encryption key. Failure to do so can disable the wireless system. For more information, see the <i>Wireless Print Server User Guide</i>.</p> <p><b>Default:</b> 1</p> <p><b>Selections:</b> 1, 2, 3, 4</p> <p><b>To change the value shown:</b></p> <ol style="list-style-type: none"> <li>1. Press PLUS (+) or MINUS (-) to scroll through the options.</li> </ol>

1 Appears only when the ZebraNet Wireless Print Server is installed.

2 These parameters appear after the system recognizes the existence of a ZebraNet print server (wired or wireless). After the print server is recognized, all zeroes (000.000.000.000) will display until the printer obtains an IP address or defaults to address 192.168.254.254.

3 If a wireless password is set, you must enter the wireless password (not the printer password) to access this parameter.

**Table 10 • Print Server Parameters (Page 4 of 4)**

Parameter	Action/Explanation
<b>RESET NETWORK YES</b>	<p><b>Reset Network<sup>2,3</sup></b></p> <p>This option resets the wireless card and the print server when the wireless option is running. Selecting this option has no effect when the wireless option is not running, when there is no card inserted, or when the wireless password is anything other than the default (zero).</p> <ol style="list-style-type: none"> <li>1. Press PLUS (+) to select <b>YES</b>. The LCD prompts <b>ARE YOU SURE?</b></li> <li>2. Do you wish to reset the network parameters? <ul style="list-style-type: none"> <li>• If no, press MINUS (-) to select <b>NO</b> and cancel the request.</li> <li>• If yes, press PLUS (+) to select <b>YES</b> and reset the network.</li> </ul> </li> </ol>

- 1 Appears only when the ZebraNet Wireless Print Server is installed.
- 2 These parameters appear after the system recognizes the existence of a ZebraNet print server (wired or wireless). After the print server is recognized, all zeroes (000.000.000.000) will display until the printer obtains an IP address or defaults to address 192.168.254.254.
- 3 If a wireless password is set, you must enter the wireless password (not the printer password) to access this parameter.



**Notes •** \_\_\_\_\_

\_\_\_\_\_

\_\_\_\_\_

\_\_\_\_\_

\_\_\_\_\_

\_\_\_\_\_

\_\_\_\_\_

\_\_\_\_\_

\_\_\_\_\_

\_\_\_\_\_

\_\_\_\_\_



---

# PC and Memory Cards

This section describes the optional cards that can be used with the printer and gives instructions for installation.

## Contents

PCMCIA PC Cards.....	104
----------------------	-----

## PCMCIA PC Cards

The printer can use Type I- or Type II-compliant PCMCIA PC cards. These cards may hold extra memory or font options for the printer, or they may be wireless radio frequency (RF) cards that allow the printer to communicate over a network (ZebraNet Wireless Print Server option required).



**Caution** • Observe proper electrostatic safety precautions when handling any static-sensitive components such as circuit boards and printheads.



**Note** • PCMCIA cards are hot-swappable (they can be installed while the printer is on).

### To install the PCMCIA card, complete these steps:

1. See [Figure 28](#). Remove the card shield from the rear of the printer.

Figure 28 • PCMCIA Card Installation

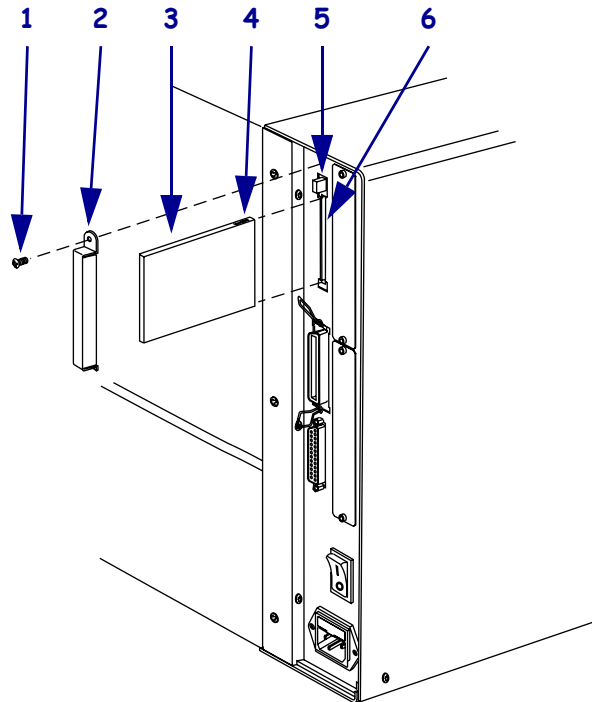

1	Screw
2	Card shield
3	PCMCIA card
4	Notch
5	Card-eject button
6	PCMCIA card slot



2. Insert the PCMCIA card into the card slot with the notch up. Insert it far enough to make the card-eject button pop out.
3. Reinstall the card shield over the PCMCIA card and card slot.



**Note •** The PCMCIA card may take a few minutes to initialize. The PAUSE light flashes while the card initializes. If the card is already initialized, the PAUSE light flashes only once or twice after the card is installed.

The printer is ready to operate with the additional memory, font option, or wireless capability. To be sure that a memory or font card has successfully initialized, print a configuration label as instructed in *Print a Configuration Label on page 77*, and review it to see if the new card information is listed. For wireless cards, follow the instructions in *Print a Network Configuration Label on page 78*.



**Notes •** \_\_\_\_\_

\_\_\_\_\_

\_\_\_\_\_

\_\_\_\_\_

\_\_\_\_\_

\_\_\_\_\_

\_\_\_\_\_

\_\_\_\_\_

\_\_\_\_\_

\_\_\_\_\_

\_\_\_\_\_



---

# Routine Maintenance

This section provides routine cleaning and maintenance procedures.

## Contents

Lubrication . . . . .	108
Cleaning Schedule . . . . .	108
Clean the Exterior . . . . .	109
Clean the Printhead and Platen Roller . . . . .	109
Clean the Media Compartment and Sensors . . . . .	112
Clean the Snap Plate . . . . .	114
Clean the Cutter . . . . .	115
Replace the Fuse . . . . .	116

## Lubrication



**Caution** • No lubricating agents other than Zebra-supplied, silicon-only lubricants should be used on the spindle felt clutches of this printer. Other commercially available lubricants damage the finish and mechanical parts.

## Cleaning Schedule

Cleaning your printer regularly maintains print quality and may extend the life of the printer. The recommended cleaning schedule is shown in [Table 11](#). See the following pages for specific procedures.

**Caution** • Use only the cleaning agents indicated. Zebra is not responsible for damage caused by any other fluids being used on this printer.

**Table 11 • Recommended Printer Cleaning Schedule**

Area	Method	Interval
Printhead	Solvent*	Perform these procedures at the following times: <ul style="list-style-type: none"> <li>• When <b>CLEAN HEAD NOW</b> appears.</li> <li>• <b>Direct Thermal Print Mode:</b> After every roll of labels or 500 ft (150 m) of fanfold labels.</li> <li>• <b>Thermal Transfer Print Mode:</b> After every roll (1500 ft or 450 m) of ribbon.</li> </ul>
Platen roller	Solvent*	
Transmissive (media) sensor	Air blow	
Black mark sensor	Air blow	
Media path	Solvent*	
Ribbon sensor	Air blow	
Label-available sensors	Air blow	Monthly
Tear-off/peel-off bar	Solvent*	As needed
Snap plate	Solvent*	
Cutter	Solvent*	

\* Zebra recommends using Preventive Maintenance Kit (part number 47362). In place of this kit, you may use a clean swab dipped in a solution of isopropyl alcohol (minimum 90%) and deionized water (maximum 10%).

## Clean the Exterior

Clean the outside surfaces of the printer with a lint-free cloth. Use a mild detergent solution or desktop cleaner sparingly, as needed.

---

**Caution** • Do not use harsh or abrasive cleaning agents or solvents.

---

## Clean the Printhead and Platen Roller

After every roll of ribbon, clean the printhead. Clean the printhead more often if you see inconsistent print quality, such as voids in the bar code or graphics.



**Note** • You do not need to turn off the printer before cleaning the printhead. If power is turned off, all label formats and images, as well as any temporarily saved parameter settings stored in the printer's internal memory, are lost. When power is turned back on, these items must be reloaded.

If print quality does not improve after you perform this procedure, clean the printhead with *Save-a-Printhead* cleaning film. This specially coated material removes contamination buildup without damaging the printhead. Call your authorized Zebra reseller or distributor for more information.



---

**Caution** • The printhead is hot and can cause severe burns. Allow the printhead to cool.

---





---

**Caution** • Before touching the printhead assembly, discharge any built-up static electricity by touching the metal printer frame or by using an anti-static wriststrap and mat.

---

### To clean the printhead and platen roller, complete these steps:

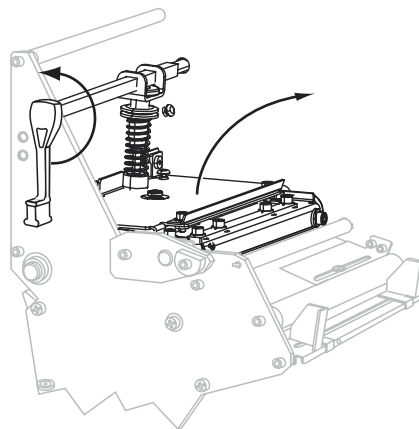
1. Open the printhead assembly by rotating the printhead-open lever counterclockwise.



2. Remove the media and ribbon.

3. See [Figure 29](#). Using the swab from the Preventive Maintenance Kit (part number 47362), wipe along the brown strip on the printhead assembly from end to end. In place of the Preventive Maintenance Kit, you may use a clean swab dipped in a solution of isopropyl alcohol (minimum 90%) and deionized water (maximum 10%). Allow the solvent to evaporate.

**Figure 29 • Printhead and Platen Roller Cleaning**

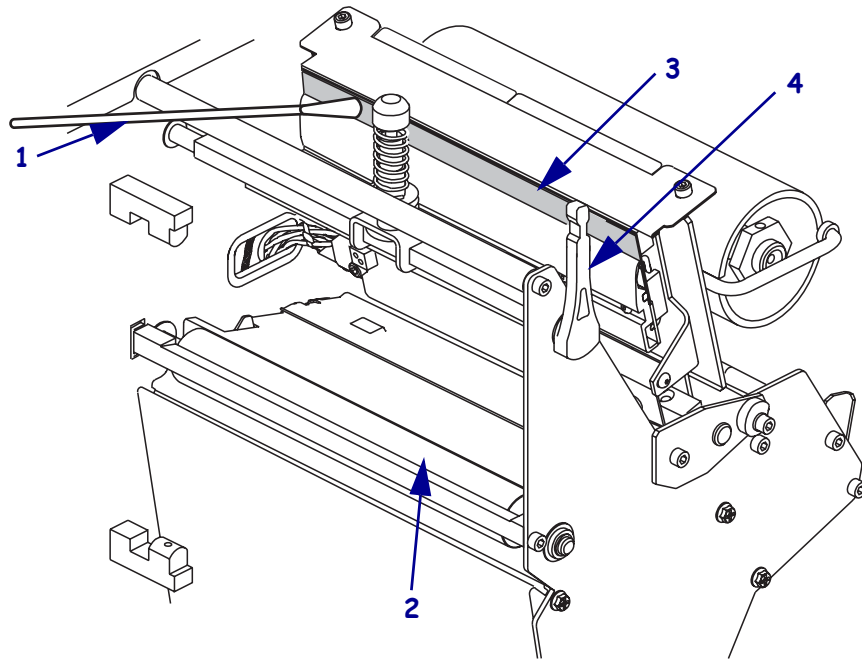

<b>1</b>	Swab
<b>2</b>	Platen roller
<b>3</b>	Printhead print elements
<b>4</b>	Printhead-open lever

4. While manually rotating the platen roller, clean it thoroughly with the swab. Allow the solvent to evaporate.
5. Reload the media and the ribbon (if required).

6. Push the printhead assembly down (1), and then rotate the printhead-open lever clockwise until it locks into place (2).

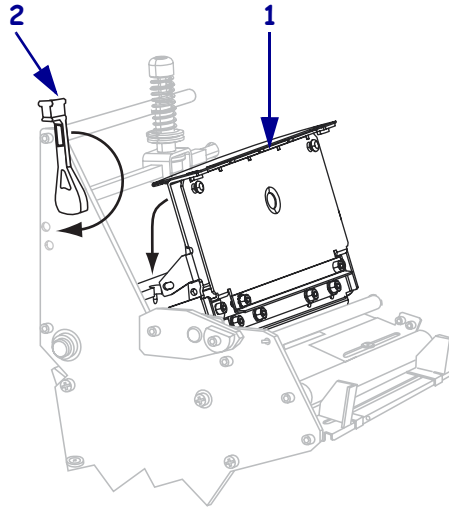

## Clean the Media Compartment and Sensors

After every four rolls of media, inspect the media compartment. Use a soft bristle brush or a vacuum cleaner to remove any dirt and lint from the interior of the printer.

The sensors should be cleaned on a regular basis to ensure proper operation of the printer. Brush or vacuum any accumulated paper lint and dust off of these sensors.

### To clean the media compartment and sensors, complete these steps:

1. Brush or vacuum any accumulated paper lint and dust away from the media and ribbon paths.
2. Brush or vacuum any paper lint and dust away from the sensors.

**Figure 30 • Upper Media Sensor Assembly**

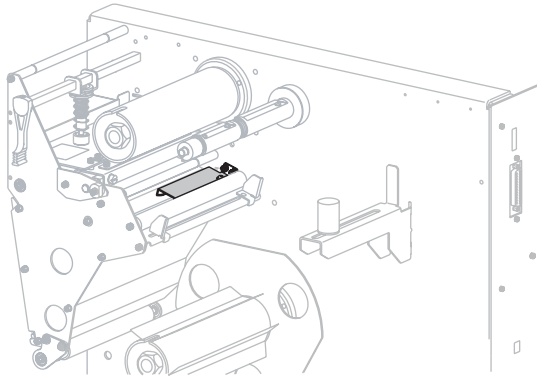

**Figure 31 • Lower Media Sensor Assembly**

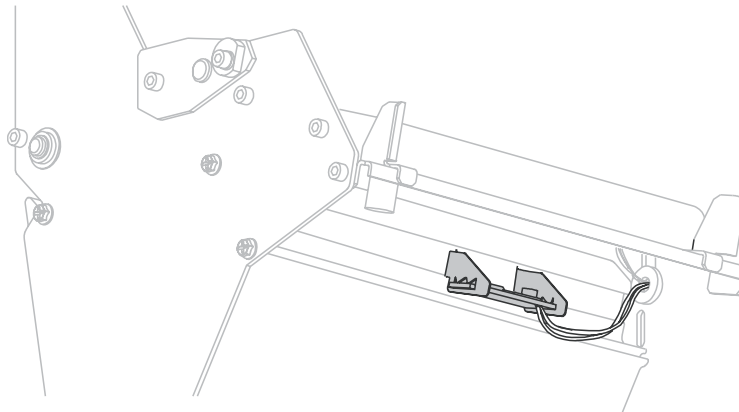
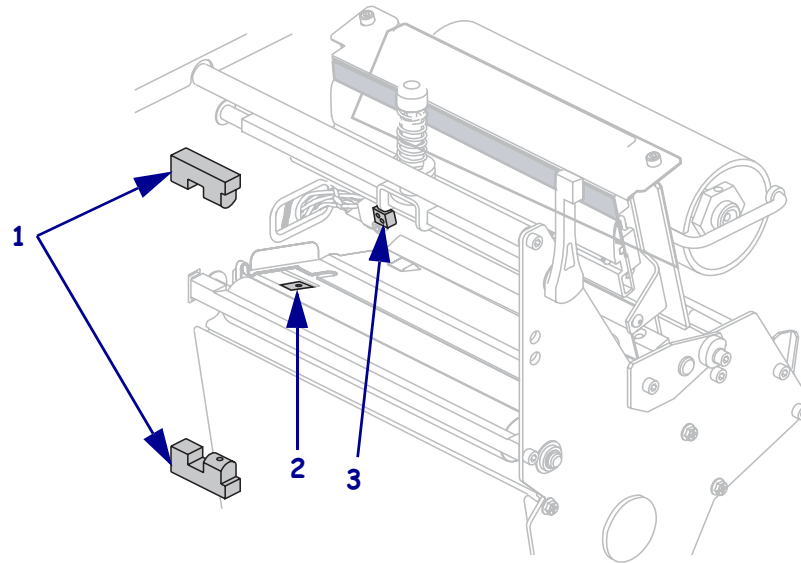



Figure 32 • Take-Label Sensors, Black Mark Sensor, and Ribbon Sensor



1	Take-label sensors
2	Black mark sensor
3	Ribbon sensor

## Clean the Snap Plate

Clean the snap plate to remove label adhesive or a label that has adhered to the underside of the snap plate.

### To clean the snap plate, complete these steps:

1. **Caution** • Do not bend, twist, or deform the loops in the snap plate. If the snap plate is damaged in any way, a new one may be required for proper ribbon sensing.

Insert a small-blade screwdriver or similar tool into the loop on the left side of the snap plate. Lift the snap plate.

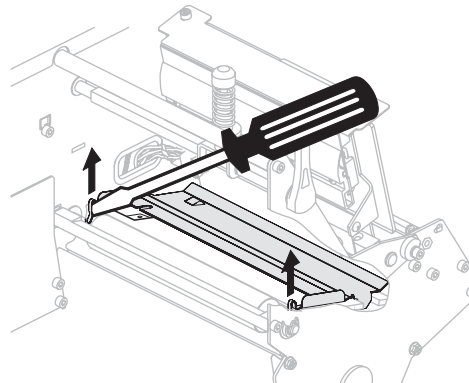

2. Repeat step 1 on the right side of the snap plate.
3. Remove the snap plate from the printer.
4. Using the swab from the Preventive Maintenance Kit (part number 47362), clean the snap plate. In place of the Preventive Maintenance Kit, you may use a clean swab dipped in a solution of isopropyl alcohol (minimum 90%) and deionized water (maximum 10%). Allow the solvent to evaporate.
5. To reinstall the snap plate, insert the two tabs on the bottom of the snap plate (1) into the two slots of the media pathway (2).

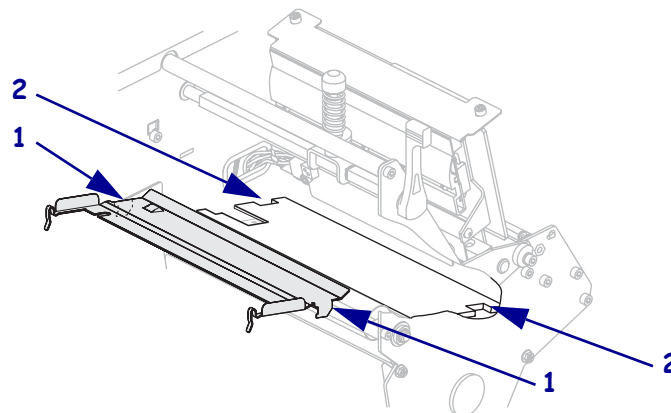

6. Slide the snap plate toward you.
7. Press down on the loops to lock the snap plate into place.

## Clean the Cutter

If the cutter is not cutting the labels cleanly or if it jams with labels, clean the cutter.



---

**Caution** • For personnel safety, always power off and unplug the printer before performing this procedure.

---

### To clean the cutter, complete these steps:

1. Turn off (O) the printer.
2. Unplug the power cord.



3. **Caution** • The cutter blade is sharp. Do not touch or rub the blade with your fingers.
- 

Using the swab from the Preventive Maintenance Kit (part number 47362), clean the stationary cutter blade with solvent. In place of the Preventive Maintenance Kit, you may use a clean swab dipped in a solution of isopropyl alcohol (minimum 90%) and deionized water (maximum 10%). Allow the solvent to evaporate.

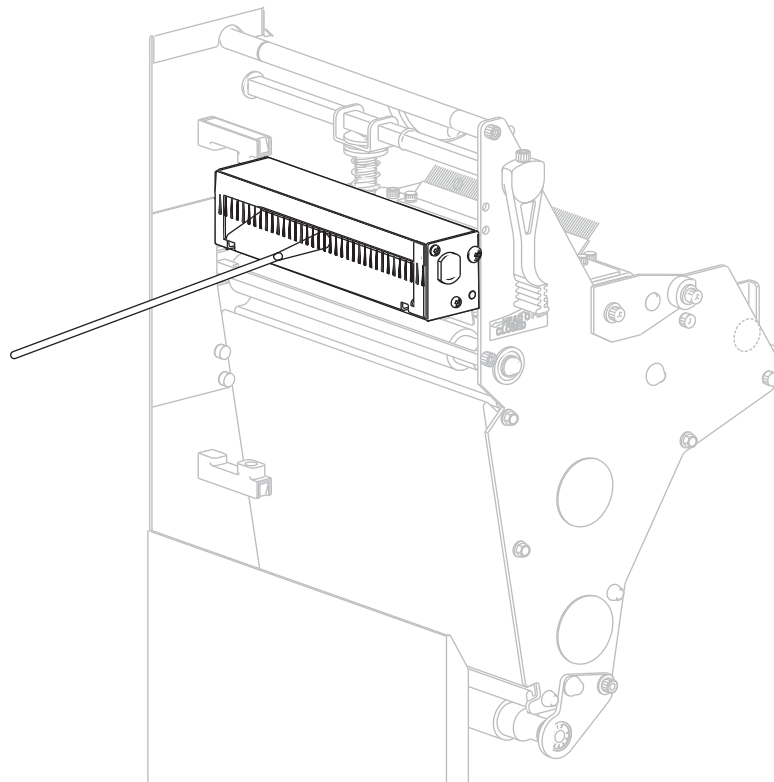

If this does not remove label fragments and adhesive, contact an authorized service technician.

4. Turn on (I) the printer.

## Replace the Fuse

The printer uses a metric-style fuse (5 × 20 mm IEC) rated at F5A, 250 V. The end caps of the fuse must bear the certification mark of a known international safety organization (see [Figure 10 on page 24](#)).

Depending on your printer model, the fuse may be user-replaceable (see [Figure 33](#)). In a model that has a user-replaceable fuse, the fuse holder is part of the AC power entry module at the rear of the printer. In these models, the AC power entry module comes with two approved fuses in the fuse holder: one fuse is in-circuit, and the second is provided as a spare.

Figure 33 • User-Replaceable Fuse

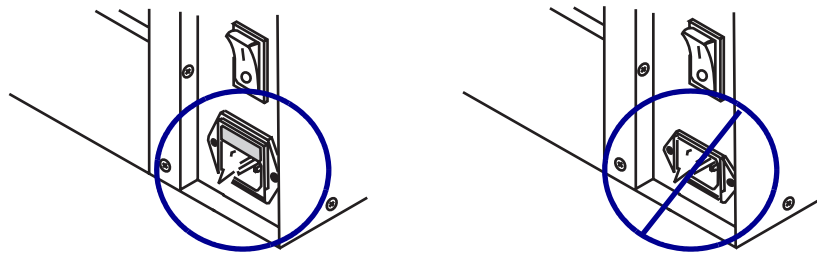

---

**Caution** • Turn off (O) the printer and remove the power cord before performing this procedure.

---

### To replace a faulty fuse, complete these steps:

1. Turn off (O) the printer, and remove the power cord.
2. Use a small-blade screwdriver (1) to remove the fuse holder (2) from the power entry module.

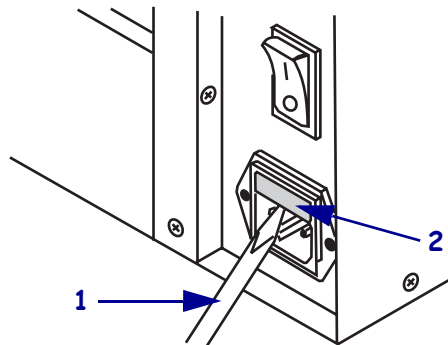

3. Remove the faulty fuse and install a new fuse in the in-circuit position.



**Important** • If you use the spare fuse, order a replacement fuse from an authorized Zebra distributor. The spare fuse should be the exact type and rating as the original in-circuit fuse.



---

# Troubleshooting

This section provides information about errors that you might need to troubleshoot. Assorted diagnostic tests are included.

## Contents

Troubleshooting Checklists .....	118
LCD Error Messages .....	119
Print Quality Problems .....	122
Calibration Problems .....	125
Communications Problems .....	126
Ribbon Problems .....	127
Miscellaneous Printer Problems .....	128
Printer Diagnostics .....	130
Power-On Self Test .....	130
CANCEL Self Test .....	131
PAUSE Self Test .....	133
FEED Self Test .....	134
FEED and PAUSE Self Test .....	138
Communications Diagnostics Test .....	139
Sensor Profile .....	140

## Troubleshooting Checklists

### If an error condition exists with the printer, review this checklist:

- Is there an error message on the LCD? If yes, see [LCD Error Messages on page 119](#).
- Are noncontinuous labels being treated as continuous labels? If yes, see [Calibrate Media and Ribbon Sensor Sensitivity on page 88](#).
- Is the CHECK RIBBON light on when ribbon is loaded properly, or are noncontinuous labels being treated as continuous labels? If yes, see [Calibrate Media and Ribbon Sensor Sensitivity on page 88](#).
- Are you experiencing problems with print quality? If yes, see [Print Quality Problems on page 122](#).
- Are you experiencing communications problems? If yes, see [Communications Problems on page 126](#).

### If the labels are not printing or advancing correctly, review this checklist:

- Are you using the correct type of labels? Review the types of label in [Types of Media on page 25](#).
- Are you using a label that is narrower than the maximum print width? See [Set Print Width on page 82](#).
- Does the printhead need to be adjusted? See [Adjust Printhead Balance and Pressure on page 68](#) for more information.
- Do the sensors need to be calibrated? See [Calibrate Media and Ribbon Sensor Sensitivity on page 88](#) for more information.

### If none of the above suggestions correct the problem, review this checklist:

- Perform one or more of the self-tests given in [Printer Diagnostics on page 130](#). Use the results to help identify the problem.
- If you are still having problems, see [Contacts on page 3](#) for customer support information.

## LCD Error Messages

The LCD displays messages when there is an error. See [Table 12](#) for LCD errors, the possible causes, and the recommended solutions.

**Table 12 • LCD Error Messages**

LCD Display/ Printer Condition	Possible Cause	Recommended Solution
<div style="border: 2px solid black; padding: 5px; text-align: center; width: fit-content; margin-bottom: 10px;"> <b>ERROR CONDITION RIBBON OUT</b> </div> <p>The printer stops; RIBBON light ON, ERROR light flashes.</p>	In thermal transfer mode, ribbon is not loaded or incorrectly loaded.	Load ribbon correctly.
	In thermal transfer mode, the ribbon sensor is not detecting ribbon that is loaded incorrectly.	<ol style="list-style-type: none"> <li>1. Load ribbon correctly.</li> <li>2. Calibrate the sensors. See <a href="#">Calibrate Media and Ribbon Sensor Sensitivity</a> on page 88.</li> </ol>
	In thermal transfer mode, media is blocking the ribbon sensor.	<ol style="list-style-type: none"> <li>1. Load media correctly.</li> <li>2. Calibrate the sensors. See <a href="#">Calibrate Media and Ribbon Sensor Sensitivity</a> on page 88.</li> </ol>
	In thermal transfer mode, the printer did not detect the ribbon even though it is loaded correctly.	<ol style="list-style-type: none"> <li>1. Print a sensor profile. See <a href="#">Print Sensor Profile</a> on page 87. The ribbon out threshold (marked by the word RIBBON) is likely too high, above the black area that indicates where the ribbon is detected. <div style="text-align: center; margin: 10px 0;">  <p>The diagram shows a vertical scale from 000 to 100 in increments of 20. Two black bars are shown: one labeled 'ON RIBBON' at the bottom and one labeled 'RIBBON' above it. The 'RIBBON' bar is positioned higher on the scale, indicating a high threshold.</p> </div> </li> <li>2. Calibrate the sensors or load printer defaults. See <a href="#">Calibrate Media and Ribbon Sensor Sensitivity</a> on page 88 or <a href="#">LOAD DEFAULTS</a> on page 75.</li> </ol>
	If you are using direct thermal media, the printer is waiting for ribbon to be loaded because it is incorrectly set for thermal transfer mode.	Set the printer for Direct Thermal mode. See <a href="#">Select Print Method</a> on page 81.

Table 12 • LCD Error Messages (Continued)



LCD Display/ Printer Condition	Possible Cause	Recommended Solution
<div style="border: 1px solid black; padding: 5px; text-align: center;"> <b>WARNING RIBBON IN</b> </div> <p>RIBBON light ON, ERROR light flashes.</p>	Ribbon is loaded, but the printer is set for direct thermal mode.	Ribbon is not required with direct thermal media. If you are using direct thermal media, remove ribbon unless you are using it to protect the printhead. This error message will not affect printing.
		If you are using thermal transfer media, which requires ribbon, set the printer for Thermal Transfer mode. See <a href="#">Select Print Method on page 81</a> .
<div style="border: 1px solid black; padding: 5px; text-align: center;"> <b>ERROR CONDITION PAPER OUT</b> </div> <p>The printer stops; MEDIA light ON, ERROR light flashes.</p>	Media is not loaded or is loaded incorrectly.	Load media correctly.
	Misaligned media sensor.	Check position of the media sensor.
	The printer is set for noncontinuous media, but continuous media is loaded.	Install proper media type, or reset printer for current media type and perform calibration.
<div style="border: 1px solid black; padding: 5px; text-align: center;"> <b>ERROR CONDITION HEAD OPEN</b> </div> <p>The printer stops and the ERROR light flashes.</p>	The printhead is not fully closed.	Close printhead completely.
	The head open sensor is not working properly.	Call a service technician.
<div style="border: 1px solid black; padding: 5px; text-align: center;"> <b>WARNING HEAD TOO HOT</b> </div> <p>The printer stops and the ERROR light flashes.</p>	 <b>Caution</b> • The printhead may be hot enough to cause severe burns. Allow the printhead to cool.	
	The printhead is over temperature.	Allow the printer to cool. Printing automatically resumes when the printhead elements cool to an acceptable operating temperature.

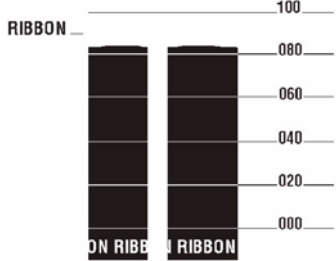

Table 12 • LCD Error Messages (Continued)

LCD Display/ Printer Condition	Possible Cause	Recommended Solution
<div style="border: 2px solid black; padding: 5px; text-align: center;"> <b>WARNING HEAD COLD</b> </div> <p>The printer stops and the ERROR light flashes.</p>	 <p><b>Caution</b> • An improperly connected printhead data or power cable can cause this error message. The printhead may be hot enough to cause severe burns. Allow the printhead to cool.</p>	
	<p>The printhead is under temperature.</p>	<p>Continue printing while the printhead reaches the correct operating temperature. If the error remains, the environment may be too cold for proper printing. Relocate the printer to a warmer area.</p>
	<p>The printhead data cable is not properly connected.</p>	 <p><b>Caution</b> • Turn the printer off (O) before performing this procedure. Failure to do so can damage the printhead.</p> <ol style="list-style-type: none"> <li>1. Turn off (O) the printer.</li> <li>2. Disconnect and reconnect the data cable to the printhead.</li> <li>3. Ensure that the cable connector is fully inserted into the printhead connector.</li> <li>4. Turn on (I) the printer.</li> </ol>
<div style="border: 2px solid black; padding: 5px; text-align: center;"> <b>OUT OF MEMORY (function)</b> </div>	<p>There is not enough memory to perform the function specified on the second line of the error message.</p>	<p>Free up some of the printer's memory by adjusting the label format or printer parameters. One way to free up memory is to adjust the print width to the actual width of the label instead of leaving the print width set to the default. See <a href="#">Set Print Width on page 82</a>.</p>
		<p>Ensure that the device, such as FLASH memory or PCMCIA card, is installed and not write protected or full.</p>
		<p>Ensure that the data is not directed to a device that is not installed or available.</p>
		<p>Refer to the <i>Maintenance Manual</i> for more information about the specified function.</p>

## Print Quality Problems

Table 13 identifies problems with print quality, the possible causes, and the recommended solutions.

**Table 13 • Print Quality Problems**

Problem	Possible Cause	Recommended Solution
<b>General print quality issues</b>	The printer is set at the incorrect print speed.	For optimal print quality, set the print speed to the lowest possible setting for your application via the driver or the software. You may wish to perform the <i>FEED Self Test</i> on page 134.
	You are using an incorrect combination of labels and ribbon for your application.	<ol style="list-style-type: none"> <li>1. Switch to a different type of media or ribbon to try to find a compatible combination.</li> <li>2. If necessary, consult your authorized Zebra reseller or distributor for information and advice.</li> </ol>
	The printer is set at an incorrect darkness level.	For optimal print quality, set the darkness to the lowest possible setting for your application via the control panel, the driver, or the software. See <i>Adjust Print Darkness</i> on page 79. You may wish to perform the <i>FEED Self Test</i> on page 134 to determine the ideal darkness setting.
	The printhead is dirty.	See <i>Clean the Printhead and Platen Roller</i> on page 109.
<b>Wrinkled ribbon</b>	Ribbon fed through the machine incorrectly.	See <i>Load Ribbon</i> on page 61.
	Incorrect burn temperature.	Set the darkness to the lowest possible setting for good print quality. See <i>Adjust Print Darkness</i> on page 79.
	Incorrect or uneven pressure.	Set the pressure to the minimum needed for good print quality. See <i>Adjust Printhead Balance and Pressure</i> on page 68.
	Media not feeding properly; “walking” from side to side.	Make sure that media is snug by adjusting the media guide, or call a service technician.
	The strip plate needs adjusting.	Call a service technician.
	The printhead needs vertical adjustment.	Call a service technician.
	The printhead and platen roller need to be realigned.	Call a service technician.
<b>Long tracks of missing print on several labels</b>	Print element damaged.	Call a service technician.
	Wrinkled ribbon.	See wrinkled ribbon causes and solutions in this table.

**Table 13 • Print Quality Problems (Continued)**

<b>Problem</b>	<b>Possible Cause</b>	<b>Recommended Solution</b>
<b>Fine, angular gray lines on blank labels</b>	Wrinkled ribbon.	See wrinkled ribbon causes and solutions in this table.
<b>Printing too light or too dark over the entire label</b>	Media or ribbon is not designed for high-speed operation.	Replace supplies with those recommended for high-speed operation.
	You are using an incorrect combination of labels and ribbon for your application.	<ol style="list-style-type: none"> <li>1. Switch to a different type of media or ribbon to try to find a compatible combination.</li> <li>2. If necessary, consult your authorized Zebra reseller or distributor for information and advice.</li> </ol>
	You are using ribbon with direct thermal media.	<p>Direct thermal media does not require ribbon. To check if you are using direct thermal media, perform the label scratch test in <i>When to Use Ribbon</i> on page 27.</p> <p>If you are using ribbon intentionally with direct thermal media, increase the darkness level, but note that high darkness levels may decrease printhead life. You may wish to perform the <i>FEED Self Test</i> on page 134 to determine the ideal darkness setting.</p>
	Incorrect or uneven printhead pressure.	Set the pressure to the minimum needed. See <i>Printhead Pressure Adjustment</i> on page 70.
<b>Smudge marks on labels</b>	Media or ribbon is not designed for high-speed operation.	Replace supplies with those recommended for high-speed operation.
<b>Misregistration/skips labels</b>	The printer is not calibrated.	Recalibrate the printer.
	Media sensor is not positioned correctly.	Perform media sensor position adjustment.
	Improper label format.	Use correct label format.
<b>Misregistration and misprint of one to three labels</b>	The platen roller is dirty.	See <i>Clean the Printhead and Platen Roller</i> on page 109.
	Media sensor is not positioned correctly.	Place media sensor in proper position.
	Media does not meet specifications.	Use media that meets specifications.

Table 13 • Print Quality Problems (Continued)

Problem	Possible Cause	Recommended Solution
<b>Vertical drift in top-of-form position</b>	Normal tolerances of mechanical parts and printer modes.   <b>Note</b> • A vertical drift of $\pm 4$ to 6 dot rows (approximately 0.5 mm) is within normal tolerances.	1. Calibrate the printer. 2. Adjust the label top position setting. See <a href="#">Adjust Label Top Position on page 93</a> .
	The printer is out of calibration.	Recalibrate the printer.
	The platen roller is dirty.	See <a href="#">Clean the Printhead and Platen Roller on page 109</a> .
<b>Vertical image or label drift</b>	The printer is using noncontinuous labels but is configured in continuous mode.	Configure the printer for non-continuous and run calibration routine, if necessary.
	Incorrectly positioned media sensor.	Ensure the media sensor is properly positioned to read a single/consistent interlabel gap.
	Improperly calibrated media sensor.	See <a href="#">Calibrate Media and Ribbon Sensor Sensitivity on page 88</a> .
	The platen roller is dirty.	Clean the platen roller. See <a href="#">Clean the Printhead and Platen Roller on page 109</a> .
	Improper printhead pressure settings (toggles).	Adjust the printhead pressure to ensure proper functionality.
	Improperly loaded ribbon or media.	Verify that the printer is loaded properly.
	Incompatible media.	Ensure that the interlabel gaps or notches are 2 to 4 mm and consistently placed. Media must not exceed minimum specifications for mode of operation.
<b>The bar code printed on a label does not scan.</b>	The bar code is not within specifications because the print is too light or too dark.	Perform the <a href="#">FEED Self Test on page 134</a> . Adjust the darkness or print speed settings as necessary.
	Not enough blank space around the bar code.	Leave at least 1/8 in. (3.2 mm) between the bar code and other printed areas on the label and between the bar code and the edge of the label.

## Calibration Problems

Table 14 identifies problems with calibration, the possible causes, and the recommended solutions.

**Table 14 • Calibration Problems**

<b>Problem</b>	<b>Possible Cause</b>	<b>Recommended Solution</b>
<b>Loss of printing registration on labels. Excessive vertical drift in top-of-form registration.</b>	Improperly positioned media guides.	Ensure that the media guides are properly positioned.
	Media type set incorrectly.	Set the printer for the correct media type (non-continuous or continuous). See <a href="#">Set Media Type on page 81</a> .
	Media loaded incorrectly or media sensor positioned improperly.	Reload the media and ensure that the sensor in use is properly positioned (see <a href="#">Adjust Media Sensors on page 66</a> ).
	Dirty platen roller.	Clean the platen roller according to the instructions in <a href="#">Clean the Printhead and Platen Roller on page 109</a> .
<b>Auto Calibrate failed.</b>	Improperly loaded media or ribbon.	Ensure that media and ribbon are loaded correctly.
	The sensors could not detect the media or ribbon.	Manually calibrate the printer (see <a href="#">Calibrate Media and Ribbon Sensor Sensitivity on page 88</a> ).
	Sensors dirty or improperly positioned.	Ensure that the sensors are clean and properly positioned.

## Communications Problems

Table 15 identifies problems with communications, the possible causes, and the recommended solutions.

**Table 15 • Communications Problems**

Problem	Possible Cause	Recommended Solution
<b>A label format was sent to the printer but was not recognized. The DATA light does not flash.</b>	The communication parameters are incorrect.	Check the printer driver or software communications settings (if applicable).
		If you are using serial communication, check the serial port setting in the control panel menu. See <a href="#">Set Serial Communications on page 89</a> .
		If you are using serial communication, make sure you are using the correct communication cable. See <a href="#">RS-232 Serial on page 20</a> for basic cabling information.
		Using the control panel controls, check the protocol setting. It should be set to <b>NONE</b> . See <a href="#">Set Protocol on page 90</a> .
		If a driver is used, check the driver communication settings for your connection.
<b>A label format was sent to the printer. Several labels print, then the printer skips, misplaces, misses, or distorts the image on the label.</b>	The serial communication settings are incorrect.	Ensure that the flow control settings match.
		Check the communication cable length. See <a href="#">RS-232 Serial on page 20</a> for requirements.
		Check the printer driver or software communications settings (if applicable).
<b>A label format was sent to the printer but was not recognized. The DATA light flashes but no printing occurs.</b>	The prefix and delimiter characters set in the printer do not match the ones in the label format.	Verify the prefix and delimiter characters. See <a href="#">Set Format Prefix Character on page 91</a> and <a href="#">Set Delimiter Character on page 92</a> for the requirements.
		Incorrect data is being sent to the printer.
	Check the communication settings on the computer. Ensure that they match the printer settings.	
	If the problem continues, check the ZPL II format for changed ^CC, ^CT, and ^CD.	

## Ribbon Problems

Table 16 identifies problems that may occur with ribbon, the possible causes, and the recommended solutions.

**Table 16 • Ribbon Problems**

<b>Problem</b>	<b>Possible Cause</b>	<b>Recommended Solution</b>
<b>Broken or melted ribbon</b>	Darkness setting too high.	<ol style="list-style-type: none"> <li>1. Reduce the darkness setting.</li> <li>2. Clean the printhead thoroughly.</li> </ol>
<b>The printer does not detect when the ribbon runs out.</b>  <b>In thermal transfer mode, the printer did not detect the ribbon even though it is loaded correctly.</b>	The printer was calibrated without ribbon. Later, ribbon was inserted without the user recalibrating the printer or loading printer defaults.	Calibrate the printer, this time using ribbon, or load printer defaults. See <a href="#">Calibrate Media and Ribbon Sensor Sensitivity on page 88</a> or <a href="#">LOAD DEFAULTS on page 75</a> .
<b>The ribbon light is on even though ribbon is loaded correctly.</b>	The printer was not calibrated for the label and ribbon being used.	Perform the calibration procedure in <a href="#">Calibrate Media and Ribbon Sensor Sensitivity on page 88</a> .

## Miscellaneous Printer Problems

Table 17 identifies miscellaneous problems with the printer, the possible causes, and the recommended solutions.

**Table 17 • Miscellaneous Printer Problems**

<b>Problem</b>	<b>Possible Cause</b>	<b>Recommended Solution</b>
<b>The LCD displays a language that I cannot read</b>	The language parameter was changed through the control panel or a ZPL command.	<ol style="list-style-type: none"> <li>1. Press <b>SETUP/EXIT</b> to enter configuration mode.</li> <li>2. Press <b>MINUS (-)</b>. The printer displays the <b>LANGUAGE</b> parameter in the current language. Even if you cannot recognize the characters displayed, you can still scroll to another language.</li> <li>3. Press <b>PLUS (+)</b> or <b>MINUS (-)</b> to scroll through the choices.</li> <li>4. Press <b>SETUP/EXIT</b>. The LCD displays <b>SAVE CHANGES</b> in the original language.</li> <li>5. Press <b>NEXT/SAVE</b> to exit configuration mode and save the changes (if the language does not change, you may need to scroll to a different save option by pressing <b>PLUS (+)</b> or <b>MINUS (-)</b> in the previous step).</li> <li>6. Repeat this process, if necessary, until you reach the desired language.</li> </ol>
<b>The LCD is missing characters or parts of characters</b>	The LCD may need replacing.	Call a service technician.
<b>Changes in parameter settings did not take effect</b>	Parameters are set incorrectly.	<ol style="list-style-type: none"> <li>1. Set parameters and save permanently.</li> <li>2. Turn the printer off (<b>O</b>) and then on (<b>I</b>).</li> </ol>
	A ZPL command turned off the ability to change the parameter.	Refer to the <i>ZPL Programming Guide</i> , or call a service technician.
	A ZPL command changed the parameter back to the previous setting.	Refer to the <i>ZPL Programming Guide</i> , or call a service technician.
	If the problem continues, there may be a problem with the main logic board.	Call a service technician.



**Table 17 • Miscellaneous Printer Problems (Continued)**

<b>Problem</b>	<b>Possible Cause</b>	<b>Recommended Solution</b>
<b>The printer fails to calibrate or detect the top of the label.</b>	The printer was not calibrated for the label being used.	Perform the calibration procedure in <i>Calibrate Media and Ribbon Sensor Sensitivity</i> on page 88.
	The printer is configured for continuous media.	Set the media type to noncontinuous media. See <i>Set Media Type</i> on page 81.
	The driver or software configuration is not set correctly.	Driver or software settings produce ZPL commands that can overwrite the printer configuration. Check the driver or software media-related setting.
<b>Non-continuous labels are being treated as continuous labels.</b>	The printer is configured for continuous media.	Set the media type to noncontinuous media. See <i>Set Media Type</i> on page 81.
	The printer was not calibrated for the media being used.	Perform the calibration procedure in <i>Calibrate Media and Ribbon Sensor Sensitivity</i> on page 88.
<b>All lights are on, but nothing displays on the LCD, and the printer locks up.</b>	Internal electronic or firmware failure.	Call a service technician.
<b>The printer locks up while running the Power-On Self Test.</b>	Main logic board failure.	Call a service technician.

## Printer Diagnostics

Self tests and other diagnostics provide specific information about the condition of the printer. The self tests produce sample printouts and provide specific information that helps determine the operating conditions for the printer. The most commonly used are the Power-On and the CANCEL self tests.



**Important** • Use full-width media when performing self tests. If your media is not wide enough, the test labels may print on the platen roller. To prevent this from happening, check the print width using [Set Print Width on page 82](#), and ensure that the width is correct for the media that you are using.

Each self test is enabled by pressing a specific control panel key or combination of keys while turning on (I) the printer power. Keep the key(s) pressed until the first indicator light turns off. The selected self test automatically starts at the end of the Power-On Self Test.



**Note** •

- When performing these self tests, do not send data to the printer from the host.
- If your media is shorter than the label to be printed, the test label continues on the next label.
- When canceling a self test prior to its actual completion, always reset the printer by turning it off (O) and then on (I).

## Power-On Self Test

A Power-On Self Test (POST) is performed each time the printer is turned on (I). During this test, the control panel lights (LEDs) turn on and off to ensure proper operation. At the end of this self test, only the POWER LED remains lit. When the Power-On Self Test is complete, the media is advanced to the proper position.

### To initiate the Power-On Self Test, complete these steps:

The POWER LED illuminates. The other control panel LEDs and the LCD monitor the progress and indicate the results of the individual tests. All messages during the POST display in English; however, if the test fails, the resulting messages cycle through the international languages as well.

## CANCEL Self Test

The CANCEL self test prints a configuration label (Figure 34).

### To perform the CANCEL Self Test, complete these steps:

1. Turn off (O) the printer.
2. Press and hold CANCEL while turning on (I) the printer. Hold CANCEL until the first control panel light turns off.  
 A printer configuration label prints (Figure 34).

Figure 34 • Configuration Label

PRINTER CONFIGURATION	
Zebra Technologies	
ZTC 105SL-200dpi	
ZBR11362166	
+10.....	DARKNESS
+000.....	TEAR OFF
TEAR OFF.....	PRINT MODE
NON-CONTINUOUS.....	MEDIA TYPE
WEB.....	SENSOR TYPE
THERMAL-TRANS.....	PRINT METHOD
104 0/8 MM.....	PRINT WIDTH
1239.....	LABEL LENGTH
39.0IN 988MM.....	MAXIMUM LENGTH
BIDIRECTIONAL.....	PARALLEL COMM.
RS232.....	SERIAL COMM.
9600.....	BAUD
8 BITS.....	DATA BITS
NONE.....	PARITY
XON/XOFF.....	HOST HANDSHAKE
NONE.....	PROTOCOL
000.....	NETWORK ID
NORMAL MODE.....	COMMUNICATIONS
<~> 7EH.....	CONTROL PREFIX
<^> 5EH.....	FORMAT PREFIX
<.> 2CH.....	DELIMITER CHAR
ZPL II.....	ZPL MODE
CALIBRATION.....	MEDIA POWER UP
CALIBRATION.....	HEAD CLOSE
DEFAULT.....	BACKFEED
+000.....	LABEL TOP
+0000.....	LEFT POSITION
047.....	WEB S.
079.....	MEDIA S.
065.....	RIBBON S.
050.....	TAKE LABEL
050.....	MARK S.
000.....	MARK MED S.
063.....	MEDIA LED
009.....	RIBBON LED
000.....	MARK LED
+10.....	LCD ADJUST
DPSWFXM.....	MODES ENABLED
.....	MODES DISABLED
832 8/MM FULL.....	RESOLUTION
V60.13.0.OP15 <-.....	FIRMWARE
V30 SW3 56.....	HARDWARE ID
CUSTOMIZED.....	CONFIGURATION
NONE.....A:	COMPACT FLASH
3584k.....R:	RAM
NONE.....B:	MEMORY CARD
0448k.....E:	ONBOARD FLASH
NONE.....	FORMAT CONVERT
005 DISPLAY.....	P32 INTERFACE
.....	TWINAX/COAX ID
2004-05-28 09:55:13	TIME STAMP

FIRMWARE IN THIS PRINTER IS COPYRIGHTED

PRINTER CONFIGURATION	
Zebra Technologies	
ZTC 105SL-200dpi	
ZBR11362166	
+10.....	DARKNESS
+000.....	TEAR OFF
TEAR OFF.....	PRINT MODE
NON-CONTINUOUS.....	MEDIA TYPE
WEB.....	SENSOR TYPE
THERMAL-TRANS.....	PRINT METHOD
104 0/8 MM.....	PRINT WIDTH
1239.....	LABEL LENGTH
39.0IN 988MM.....	MAXIMUM LENGTH
BIDIRECTIONAL.....	PARALLEL COMM.
RS232.....	SERIAL COMM.
9600.....	BAUD
8 BITS.....	DATA BITS
NONE.....	PARITY
XON/XOFF.....	HOST HANDSHAKE
NONE.....	PROTOCOL
000.....	NETWORK ID
NORMAL MODE.....	COMMUNICATIONS
<~> 7EH.....	CONTROL PREFIX
<^> 5EH.....	FORMAT PREFIX
<.> 2CH.....	DELIMITER CHAR
ZPL II.....	ZPL MODE
CALIBRATION.....	MEDIA POWER UP
CALIBRATION.....	HEAD CLOSE
DEFAULT.....	BACKFEED
+000.....	LABEL TOP
+0000.....	LEFT POSITION
047.....	WEB S.
079.....	MEDIA S.
065.....	RIBBON S.
050.....	TAKE LABEL
050.....	MARK S.
000.....	MARK MED S.
063.....	MEDIA LED
009.....	RIBBON LED
000.....	MARK LED
+10.....	LCD ADJUST
DPSWFXM.....	MODES ENABLED
.....	MODES DISABLED
832 8/MM FULL.....	RESOLUTION
V60.13.0.OP15 <-.....	FIRMWARE
V30 SW3 56.....	HARDWARE ID
CUSTOMIZED.....	CONFIGURATION
NONE.....	A: COMPACT FLASH
3584k.....	R: RAM
NONE.....	B: MEMORY CARD
0448k.....	E: ONBOARD FLASH
NONE.....	FORMAT CONVERT
005 DISPLAY.....	P32 INTERFACE
.....	TWINAX/COAX ID
2004-05-28 09:55:13	TIME STAMP

FIRMWARE IN THIS PRINTER IS COPYRIGHTED

## PAUSE Self Test

This self test can be used to provide the test labels required when making adjustments to the printer's mechanical assemblies or to determine if any printhead elements are not working. Figure 35 shows a sample printout.

### To perform a PAUSE self test, complete these steps:

1. Turn off (O) the printer.
2. Press and hold PAUSE while turning on (I) the printer. Hold PAUSE until the first control panel light turns off.
  - The initial self test prints 15 labels at the printer's slowest speed, and then automatically pauses the printer. Each time PAUSE is pressed, an additional 15 labels print. Figure 35 shows a sample of the labels.

Figure 35 • PAUSE Test Label



- While the printer is paused, pressing CANCEL alters the self test. Each time PAUSE is pressed, 15 labels print at 6 in. (152 mm) per second.
- While the printer is paused, pressing CANCEL again alters the self test a second time. Each time PAUSE is pressed, 50 labels print at the printer's slowest speed
- While the printer is paused, pressing CANCEL again alters the self test a third time. Each time PAUSE is pressed, 50 labels print at 6 in. (152 mm) per second.
- While the printer is paused, pressing CANCEL again alters the self test a fourth time. Each time PAUSE is pressed, 15 labels print at the printer's maximum speed.
- To exit this self test at any time, press and hold CANCEL.

## FEED Self Test

Different types of media may require different darkness settings. This section contains a simple but effective method for determining the ideal darkness for printing bar codes that are within specifications.

During the FEED self test, labels are printed at different darkness settings at two different print speeds. The relative darkness and the print speed are printed on each label. The bar codes on these labels may be ANSI-graded to check print quality.

The darkness value starts at three settings lower than the printer's current darkness value (relative darkness of -3) and increase until the darkness is three settings higher than the current darkness value (relative darkness of +3).

The speed at which labels are printed during this print quality test depend on the dot density of the printhead.

- 300 dpi printers: 7 labels are printed at the 2 ips and 8 ips print speeds.
- 203 dpi printers: 7 labels are printed at the 2 ips and 12 ips print speeds.

### To perform a FEED self test, complete these steps:

1. Print a configuration label to show the printer's current settings.
2. Turn off (O) the printer.
3. Press and hold FEED while turning on (I) the printer. Hold FEED until the first control panel light turns off.

The printer prints a series of labels (Figure 36) at various speeds and at darkness settings higher and lower than the darkness value shown on the configuration label.

Figure 36 • FEED Test Label



4. See [Figure 37](#) and [Table 18](#). Inspect the test labels and determine which one has the best print quality for your application. If you have a bar code verifier, use it to measure bars/spaces and calculate the print contrast. If you do not have a bar code verifier, use your eyes or the system scanner to choose the optimal darkness setting based on the labels printed in this self test.

Figure 37 • Bar Code Darkness Comparison

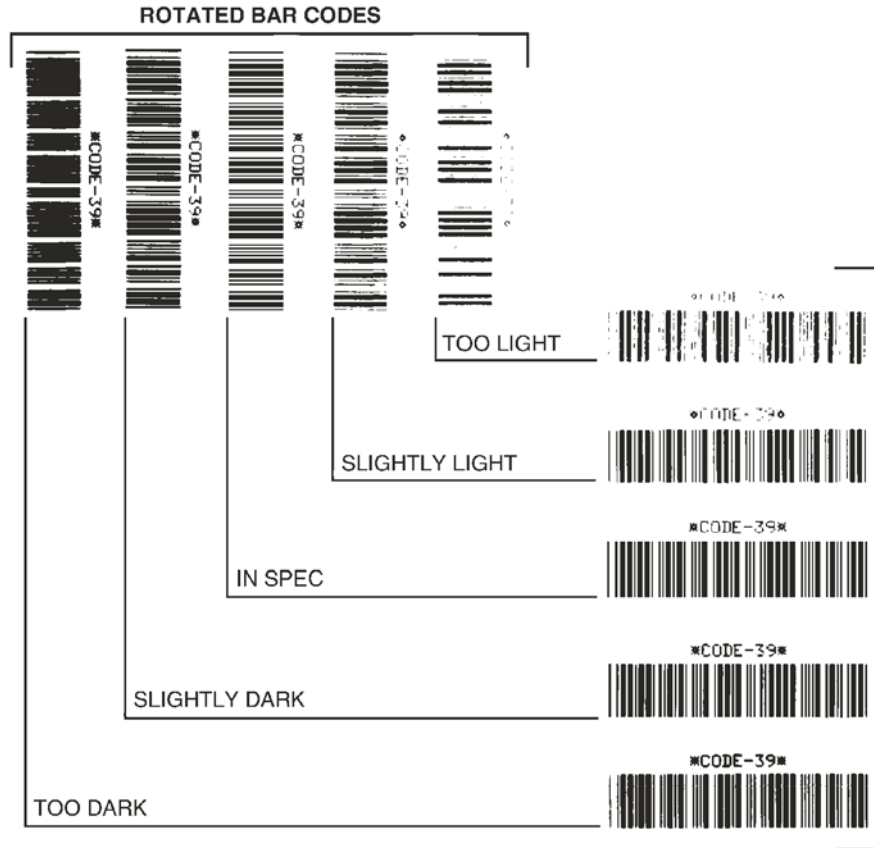

Table 18 • Judging Bar Code Quality

Print Quality	Description
<b>Too dark</b>	<p>Labels that are too dark are fairly obvious. They may be readable but not “in-spec.”</p> <ul style="list-style-type: none"> <li>• The normal bar code bars increase in size.</li> <li>• The openings in small alphanumeric characters may fill in with ink.</li> <li>• Rotated bar code bars and spaces run together.</li> </ul>
<b>Slightly dark</b>	<p>Slightly dark labels are not as obvious.</p> <ul style="list-style-type: none"> <li>• The normal bar code will be “in-spec.”</li> <li>• Small character alpha numerics will be bold and could be slightly filled in.</li> <li>• The rotated bar code spaces are small when compared to the “in-spec” code, possibly making the code unreadable.</li> </ul>



**Table 18 • Judging Bar Code Quality (Continued)**

Print Quality	Description
<b>“In-spec”</b>	The “in-spec” bar code can only be confirmed by a verifier, but it should exhibit some visible characteristics. <ul style="list-style-type: none"> <li>• The normal bar code will have complete, even bars and clear, distinct spaces.</li> <li>• The rotated bar code will have complete, even bars and clear, distinct spaces. Although it may not look as good as a slightly dark bar code, the bar code will be “in-spec.”</li> <li>• In both normal and rotated styles, small alphanumeric characters look complete.</li> </ul>
<b>Slightly light</b>	Slightly light labels are, in some cases, preferred to slightly dark ones for “in-spec” bar codes. <ul style="list-style-type: none"> <li>• Both normal and rotated bar codes will be in spec, but small alphanumeric characters may not be complete.</li> </ul>
<b>Too light</b>	Labels that are too light are obvious. <ul style="list-style-type: none"> <li>• Both normal and rotated bar codes have incomplete bars and spaces.</li> <li>• Small alphanumeric characters are unreadable.</li> </ul>

5. Note the relative darkness value printed on the best test label.
6. Add or subtract the relative darkness value from the darkness value specified on the configuration label. The resulting numeric value (0 to 30) is the best darkness value for that specific label/ribbon combination and print speed.
7. If necessary, change the darkness value to the darkness value on the best test label. See [Adjust Print Darkness on page 79](#).

## FEED and PAUSE Self Test

Performing this self test temporarily resets the printer configuration to the factory default values. These values are active only until power is turned off unless you save them permanently in memory. If the factory default values are permanently saved, a media calibration procedure must be performed.

### To perform a FEED and PAUSE self test, complete these steps:

1. Turn off (O) the printer.
2. Press and hold FEED and PAUSE while turning on (I) the printer.
3. Hold FEED and PAUSE until the first control panel light turns off.

The printer configuration is temporarily reset to the factory default values. No labels print at the end of this test.

## Communications Diagnostics Test

The communication diagnostics test is a troubleshooting tool for checking the interconnection between the printer and the host computer.

When the printer is in diagnostics mode, it prints all data received from the host computer as straight ASCII characters with the hex values below the ASCII text. The printer prints all characters received, including control codes such as CR (carriage return). [Figure 38](#) shows a typical test label from this test.



**Note** • The test label prints upside-down.

**Figure 38 • Communications Diagnostics Test Label**

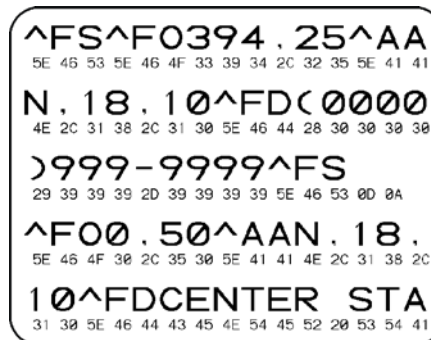

### To use communications diagnostics mode, complete these steps:

1. Set the print width equal to or less than the label width being used for the test. See [Set Print Width on page 82](#) for more information.
2. Set the printer to **DIAGNOSTICS**. For instructions, see [Set Communications Mode on page 91](#).

The printer enters diagnostics mode and prints any data received from the host computer on a test label.

3. Check the test label for error codes. For any errors, check that your communication parameters are correct.

Errors show on the test label as follows:

- FE indicates a framing error.
- OE indicates an overrun error.
- PE indicates a parity error.
- NE indicates noise.

4. Turn the printer off (**O**) and then back on (**I**) to exit this self test and return to normal operation.

## Sensor Profile

Use the sensor profile label to troubleshoot the following types of problems:

- If the media sensor experiences difficulty in determining gaps (web) between labels.
- If the media sensor incorrectly identifies preprinted areas on a label as gaps (web).
- If the ribbon sensor cannot detect ribbon.

For instructions on printing a sensor profile, see [Print Sensor Profile on page 87](#). If the sensitivity of the sensors must be adjusted, perform [Calibrate Media and Ribbon Sensor Sensitivity on page 88](#).

**Ribbon Sensor Profile (Figure 39)** The bars (1) on the sensor profile indicate the ribbon sensor readings. The ribbon sensor threshold setting is indicated by the word RIBBON (2). If the ribbon readings are below the threshold value, the printer does not acknowledge that ribbon is loaded.

Figure 39 • Sensor Profile (Ribbon Section)

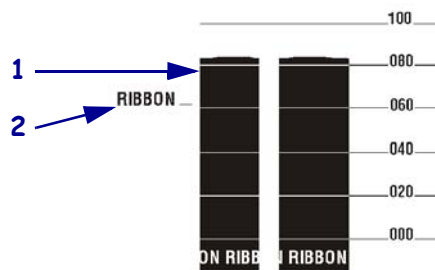

**Media Sensor Profile (Figure 40)** The media sensor readings are shown as bars and flat areas on the sensor profile. The bars (1) indicate gaps between labels (the web), and the low areas (2) indicate where labels are located. If you compare the sensor profile printout to a blank length of your media, the bars should be the same distance apart as the gaps on the media. If the distances are not the same, the printer may be having difficulty determining where the gaps are located.

The media sensor threshold settings are shown by the words MEDIA (3) for the media threshold and WEB (4) for the web threshold. Use the numbers to the left of the sensor readings to compare the numeric readings to the sensor settings.

Figure 40 • Sensor Profile (Media Section)

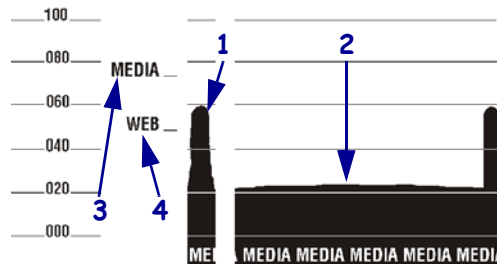



---

# Specifications

This section provides the features of and specifications for the printer.

## Contents

General Specifications .....	142
Agency Approvals .....	144
Printing Specifications .....	145
Ribbon Specifications.....	145
Media Specifications .....	146
Zebra Programming Language (ZPL II) .....	147
Bar Codes .....	147

## General Specifications

### Physical

<b>Height</b>	15.5 in. (394 mm)
<b>Width</b>	11.2 in. (283 mm)
<b>Depth</b>	19.5 in. (495 mm)
<b>Weight</b>	55 lb (25 kg)

### Environmental Conditions for Operation and Storage

Environment	Mode	Temperature	Relative Humidity
<b>Operation</b>	Thermal Transfer	41° to 104°F (5° to 40° C)	20 to 85% non-condensing
	Direct Thermal	32° to 104°F (0° to 40° C)	
<b>Storage</b>	Thermal Transfer or Direct Thermal	-40° to 140°F (-40° to 60° C)	5 to 85% non-condensing

### Electrical Specifications

<b>Power Supply</b>	Universal Power Supply with power-factor correcting 90–264 VAC, 47–63 Hz
<b>Power Consumption</b>	
Idle	19 W
Printing	180 W (printing PAUSE test label at speed A)
<b>Fuses</b>	5 Amp, 250 VAC, 5 × 20 mm IEC style, as supplied with the printer

## Communications Specifications

<b>Serial</b>	High-speed RS-232C DB9 pin (standard)
<b>Parallel</b>	<ul style="list-style-type: none"> <li>• Bi-directional high-speed (36-pin connector)</li> <li>• IEEE 1284-compliant software protocol (standard)</li> </ul>
<b>Optional Print Servers</b>	<ul style="list-style-type: none"> <li>• ZebraNet 10/100 Print Server—Supports 10Base-T, 100Base-TX, and fast Ethernet 10/100 auto-switching networks and enables use of ZebraLink Webview Alert features (internal or external).</li> <li>• ZebraNet 10/100 External Print Server—Class B digital device, approved for residential, commercial, or light industrial environment use only. Degradation in performance could occur if used in a heavy industrial environment.</li> <li>• ZebraNet Wireless Print Server —Provides an internally integrated 802.11b wireless option and supports Symbol and Cisco radio cards.</li> <li>• ZebraNet PrintServer II (PS2)</li> </ul>

### Other Standard Features

- Fast 32 bit 133 MHz RISC processor
- 6 MB SDRAM memory (3 MB available to user)
- Flash memory including 2 MB non-volatile memory storage for downloadable objects
- Zebra printer driver for windows 3.X and 95/98/NT 2000 operating systems

### Additional Options

- Printhead 300 dpi (12 dots/mm)
- Cutter
- Cutter catch tray (not compatible with rewind and peel options)
- Rewind
- Label peel and liner rewind
- Internal fanfold media supply bin (not compatible with rewind and peel options)
- Black mark media sensing option
- APL-I firmware
- APL-D firmware
- Twinax or coax interface option
- PCMCIA Flash memory slot
- 64 MB on-board flash memory

## Agency Approvals

<b>Agency Approvals</b>	<ul style="list-style-type: none"><li>• IEC 60950-1</li><li>• EN55022, Class B</li><li>• EN55024</li><li>• EN61000-3-2, -3-3</li></ul>
<b>Product Markings</b>	<ul style="list-style-type: none"><li>• cULus</li><li>• CE</li><li>• FCC - B</li><li>• ICES-003</li><li>• VCCI</li><li>• C-Tick</li><li>• CCC</li><li>• NOM</li><li>• Gost-R</li><li>• S Mark (Argentina)</li><li>• MIC</li><li>• BSMI</li><li>• ZIK</li></ul>



## Printing Specifications

Printing Specifications			
Resolution		203 dots/inch (8 dots/mm) or 300 dots/inch (12 dots/mm)	
Dot size (width × length)	203 dpi	0.0049 in. × 0.0049 in. (0.125 mm × 0.125 mm)	
	300 dpi	0.0033 in. × 0.0039 in. (0.084 mm × 0.10 mm)	
First dot location measured from inside media edge		0.10 in. ± 0.035 in. (2.5 mm ± 0.89 mm)	
Maximum print width for roll media		4.49 in. (114 mm)	
Maximum print width for fanfold media		4.1 in. (104 mm)	
Print Length (maximum)	Continuous printing	203 dpi	90 in. (2286 mm)
		300 dpi	41 in. (1041 mm)
Media registration toleration* (non-continuous media)		Vertical	±0.050 in. (1.3 mm)
		Horizontal	±0.050 in. (1.3 mm)
Programmable print speeds		203 dpi	2.4 in. (61 mm) through 8.0 in. (203 mm) per second in 1 in. (25.4 mm) increments
		300 dpi	2.4 in. (61 mm) through 8.0 in. (203 mm) per second in 1 in. (25.4 mm) increments
Bar code modulus (“X”) dimension	Ladder (rotated) orientation	203 dpi	4.9 mil to 49 mil
		300 dpi	3.9 mil to 39 mil
	Picket fence (nonrotated) orientation	203 dpi	4.9 mil to 49 mil
		300 dpi	3.3 mil to 33 mil
Thin film printhead with Element Energy Equalizer (E <sup>3</sup> ) <sup>®</sup>		Yes	

\* Media registration and minimum label length are affected by media type and width, ribbon type, and print speed. Performance improves as these factors are optimized. Zebra recommends always qualifying any application with thorough testing.

## Ribbon Specifications

Ribbon Specifications		
Ribbon must be wound with the coated side out.		
Ribbon width	Minimum	0.79 in. (20 mm)
	Maximum	4.49 in. (114 mm)
Standard lengths	2:1 media to ribbon roll ratio	984 ft. (300 m)
	3:1 media to ribbon roll ratio	1476 ft. (450 m)
Ribbon core inside diameter		1.0 in. (25.4 mm)
Maximum ribbon roll outside diameter		3.2 in. (81.3 mm)

## Media Specifications

Media Specifications				
Minimum label length*	Tear-Off		0.7 in. (18 mm)	
	Peel-Off		0.5 in. (13 mm)	
	Cutter		1.5 in. (38 mm)	
	Rewind		0.25 in. (6 mm)	
Total media width (label + liner, if any)	Minimum		0.79 in. (20 mm)	
	Maximum		4.52 in. (115 mm)	
Total thickness (includes liner, if any)	Minimum		0.003 in. (0.076 mm)	
	Maximum		0.012 in. (0.305 mm)	
Cutter maximum full-width media thickness			0.009 in. (0.229 mm)	
Roll media core inside diameter			3 in. (76 mm)	
Maximum roll diameter			8.0 in. (203 mm)	
Inter-label gap	Minimum		0.079 in. (2 mm)	
	Preferred		0.118 in. (3 mm)	
	Maximum		Maximum inter-label gap = 2 × (label length for which you have calibrated the printer) + 1 in. (25.4 mm)	
Maximum internal fanfold media pack size (label + liner) L × W × H			8.0 in. × 4.5 in. × 4.5 in. (203 mm × 114 mm × 114 mm)	
Ticket/tag sensing notch L × W			0.12 in. × 0.25 in. (3 mm × 6 mm)	
Ticket/tag sensing hole diameter			0.125 in. (3 mm)	
Additional specifications for black mark sensing	Mark length (measuring parallel to label/tag edge)	Minimum	0.12 in. (3 mm)	
		Maximum	0.43 in. (11 mm)	
	Mark width (measuring to perpendicular label/tag edge)	Minimum	≥ 0.43 in. (≥ 11 mm)	
		Maximum	Full media width	
	Mark location		Marks must be located within 0.040 in. (1 mm) of the inside media edge.	
	Mark density		>1.0 Optical Density Unit (ODU)	
Maximum density of back of media on which black mark is printed		0.5 ODU		

\* Media registration and minimum label length are affected by media type and width, ribbon type, print speed, and printer mode of operation. Performance improves as these factors are optimized. Zebra recommends always qualifying any application with thorough testing.

## Zebra Programming Language (ZPL II)

<ul style="list-style-type: none"> <li>• Communicates in printable ASCII characters</li> <li>• Controlled via mainframe, mini, or PC</li> <li>• Downloadable graphics, scalable and bitmap fonts, label templates and formats</li> <li>• Object copying between memory areas (RAM and PC memory card)</li> <li>• Adjustable print cache</li> <li>• Data compression</li> <li>• Automatic memory allocation for “format while printing”</li> </ul>	<ul style="list-style-type: none"> <li>• Status messages to host upon request</li> <li>• Format inversion (white on black)</li> <li>• Mirror image printing</li> <li>• Four-position field rotation (normal/0°, 90°, 180°, and 270°)</li> <li>• Slew command</li> <li>• Programmable label quantities with print and pause control</li> <li>• Automatic serialization of fields</li> <li>• User-programmable password</li> </ul>
---	--

## Bar Codes

<p><b>Bar code modulus “X” dimensions</b></p> <ul style="list-style-type: none"> <li>• Picket fence (non-rotated) orientation:             <ul style="list-style-type: none"> <li>• 203 dpi = 0.0049 in. mil to 0.049 in.</li> <li>• 300 dpi = 0.0033 in. mil to 0.033 in.</li> </ul> </li> <li>• Ladder (rotated) orientation:             <ul style="list-style-type: none"> <li>• 203 dpi = 0.0049 in. mil to 0.049 in.</li> <li>• 300 dpi = 0.0039 in. mil to 0.039 in.</li> </ul> </li> </ul>	<p><b>Linear bar codes</b></p> <ul style="list-style-type: none"> <li>• Code 11</li> <li>• Code 39</li> <li>• Code 93</li> <li>• Code 128 with subsets A/B C and UCC Case Codes</li> <li>• ISBT-128</li> <li>• UPC-A</li> <li>• UPC-E</li> <li>• EAN-8</li> <li>• EAN-13</li> <li>• UPC and EAN 2 or 5 digit extensions</li> <li>• Plessey</li> <li>• Postnet</li> <li>• Standard 2 of 5</li> <li>• Industrial 2 of 5</li> <li>• Interleaved 2 of 5</li> <li>• LOGMARS</li> <li>• MSI</li> <li>• Codabar</li> <li>• RSS-14</li> </ul>
<p><b>Two-dimensional bar codes</b></p> <ul style="list-style-type: none"> <li>• Code 49</li> <li>• Maxi Code</li> <li>• PDF-417</li> <li>• QR Code</li> <li>• Codablock</li> <li>• DataMatrix</li> <li>• Micro-PDF417</li> </ul>	
<p><b>Bar code ratios</b></p> <ul style="list-style-type: none"> <li>• 2:1</li> <li>• 7:3</li> <li>• 5:2</li> <li>• 3:1</li> </ul>	



**Notes •** \_\_\_\_\_

\_\_\_\_\_

\_\_\_\_\_

\_\_\_\_\_

\_\_\_\_\_

\_\_\_\_\_

\_\_\_\_\_

\_\_\_\_\_

\_\_\_\_\_

\_\_\_\_\_

\_\_\_\_\_

---

# Glossary



**alphanumeric** Indicating letters, numerals, and characters such as punctuation marks.

**backfeed** When the printer pulls the media and ribbon (if used) backward into the printer so that the beginning of the label to be printed is properly positioned behind the printhead. Backfeed occurs when operating the printer in Tear-Off and Applicator modes.

**bar code** A code by which alphanumeric characters can be represented by a series of adjacent stripes of different widths. Many different code schemes exist, such as the universal product code (UPC) or Code 39.

**black mark** A registration mark found on the underside of the print media that acts as a start-of-label indication for the printer. (See [continuous media](#).)

**calibration (of a printer)** A process in which the printer determines some basic information needed to print accurately with a particular media and ribbon combination. To do this, the printer feeds some media and ribbon (if used) through the printer and senses whether to use the direct thermal or thermal transfer print method, and (if using non-continuous media) the length of individual labels or tags.

**character set** The set of all letters, numerals, punctuation marks, and other characters that can be expressed by a particular font or bar code.

**check digit** A character added to a bar code symbol that indicates to the scanner that it has read the symbol correctly.

**configuration** The printer configuration is a group of operating parameters specific to the printer application. Some parameters are user selectable, while others are dependent on the installed options and mode of operation. Parameters may be switch selectable, control panel programmable, or downloaded as ZPL II commands. A configuration label listing all the current printer parameters may be printed for reference.

**continuous media** Label or tag-stock media that has no notch, gap, or web (media liner only) to separate the labels or tags. The media is one long piece of material.

**core diameter** The inside diameter of the cardboard core at the center of a roll of media or ribbon.

**diagnostics** Information about which printer functions are not working that is used for troubleshooting printer problems.

**die-cut media** A type of label stock that has individual labels stuck to a media liner. The labels may be either lined up against each other or separated by a small distance. Typically the material surrounding the labels has been removed. (See *non-continuous media*.)

**direct thermal** A printing method in which the printhead presses directly against the media. Heating the printhead elements causes a discoloration of the heat-sensitive coating on the media. By selectively heating the printhead elements as the media moves past, an image is printed onto the media. No ribbon is used with this printing method. Contrast this with *thermal transfer*.

**direct thermal media** Media that is coated with a substance that reacts to the application of direct heat from the printhead to produce an image.

**dynamic RAM** The memory devices used to store the label formats in electronic form while they are being printed. The amount of DRAM memory available in the printer determines the maximum size and number of label formats that can be printed. This is volatile memory that loses the stored information when power is turned off.

**fanfold media** Media that comes folded in a rectangular stack. Contrast this with *roll media*.

**firmware** This is the term used to specify the printer's operating program. This program is downloaded to the printer from a host computer and stored in FLASH memory. Each time the printer power is turned on, this operating program starts. This program controls when to feed the media forward or backward and when to print a dot on the label stock.

**FLASH memory** FLASH memory is non-volatile and maintains the stored information intact when power is off. This memory area is used to store the printer's operating program. In addition, this memory can be used to store optional printer fonts, graphic formats, and complete label formats.

**Font** A complete set of alphanumeric characters in one style of type. Examples include CG Times™, CG Triumvirate Bold Condensed™.

**ips (inches-per-second)** The speed at which the label or tag is printed. Zebra printers can print from 1 ips to 12 ips.

**label** An adhesive-backed piece of paper, plastic, or other material on which information is printed.

**label backing (liner)** The material on which labels are affixed during manufacture and which is discarded or recycled by the end-users.

**liquid crystal display (LCD)** The LCD is a back-lit display that provides the user with either operating status during normal operation or option menus when configuring the printer to a specific application.

**light emitting diode (LED)** Indicators of specific printer status conditions. Each LED is either off, on, or blinking depending on the feature being monitored.

**lock-up** This is the term generally used to describe a fault condition that, for no apparent reason, causes the printer to stop working.

**media** Material onto which data is printed by the printer. Types of media include: tag stock, die-cut labels, continuous labels (with and without media liner), non-continuous media, fanfold media, and roll media.

**media sensor** This sensor is located behind the printhead to detect the presence of media and, for non-continuous media, the position of the web, hole, or notch used to indicate the start of each label.

**media supply hanger** The stationary arm that supports the media roll.

**non-continuous media** Media that contains an indication of where one label/printed format ends and the next one begins. Examples are die-cut labels, notched tag-stock, and stock with black mark registration marks.

**non-volatile memory** Electronic memory that retains data even when the power to the printer is turned off.

**notched media** A type of tag stock containing a cutout area that can be sensed as a start-of-label indicator by the printer. This is typically a heavier, cardboard-like material that is either cut or torn away from the next tag. (See *non-continuous media*.)

**peel-off** A mode of operation in which the printer pauses to allow the user to peel a printed label away from the backing before another label is printed. Printing pauses until the label is removed.

**print speed** The speed at which printing occurs. For thermal transfer printers, this speed is expressed in terms of ips (inches per second). Zebra offers printers that can print from 1 ips to 12 ips.

**printhead wear** The degradation of the surface of the printhead and/or the print elements over time. Heat and abrasion can cause printhead wear. Therefore, to maximize the life of the printhead, use the lowest print darkness setting (sometimes called burn temperature or head temperature) and the lowest printhead pressure necessary to produce good print quality. In the thermal transfer printing method, use ribbon that is as wide or wider than the media to protect the printhead from the rough media surface.

**registration** Alignment of printing with respect to the top of a label or tag.

**ribbon** A band of material consisting of a base film coated with wax or resin “ink.” The inked side of the material is pressed by the printhead against the media. The ribbon transfers ink onto the media when heated by the small elements within the printhead. Zebra ribbons have a coating on the back that protects the printhead from wear.

**ribbon wrinkle** A wrinkling of the ribbon caused by improper alignment or improper printhead pressure. This wrinkle can cause voids in the print and/or the used ribbon to rewind unevenly. This condition should be corrected by performing adjustment procedures.

**roll media** Media that comes supplied rolled onto a core (usually cardboard). Contrast this with *fanfold media*.

**supplies** A general term for media and ribbon.

**symbology** The term generally used when referring to a bar code.

**tag** A type of media having no adhesive backing but featuring a hole or notch by which the tag can be hung on something. Tags are usually made of cardboard or other durable material.

**tear-off** A mode of operation in which the user tears the label or tag stock away from the remaining media by hand.

**thermal transfer** A printing method in which the printhead presses an ink or resin coated ribbon against the media. Heating the printhead elements causes the ink or resin to transfer onto the media. By selectively heating the printhead elements as the media and ribbon move past, an image is printed onto the media. Contrast this with *direct thermal*.

**void** A space on which printing should have occurred, but did not due to an error condition such as wrinkled ribbon or faulty print elements. A void can cause a printed bar code symbol to be read incorrectly or not at all.



---

# End User License Agreement



Please read the terms of this “End User License Agreement” (the “Agreement”) carefully. The Agreement is a legal agreement between you (either an individual or a single entity) and Zebra Technologies International, LLC (“Zebra”) for the Zebra computer software and/or firmware accompanying this End User License Agreement, and any associated media, printed materials and any “online” or electronic documentation (collectively, “Software”). By installing or using the Software, you agree to be bound by the terms of this Agreement. If you do not agree to the terms of this Agreement, you may not install or use the Software.

**1. Grant of License.** The Software is protected by copyright and other intellectual property laws and international treaties. The Software is licensed to you, and not sold, subject to the terms of this Agreement. Subject to the terms of this Agreement, Zebra hereby grants you a limited, personal, non-exclusive license during the term of this Agreement to use the Software solely and exclusively for your internal use for the operation of your associated Zebra printer(s) and for no other purpose. To the extent that any portion of the Software is provided to you in a manner that is designed to be installed by you, you may install one copy of the installable Software on one hard disk or other storage device for one printer, computer, workstation, terminal, or other digital electronic device, as applicable (an “Electronic Device”), and you may access and use that Software as installed on that Electronic Device so long as only one copy of such Software is in operation. If you are an organization rather than an individual, you may authorize personnel associated with your business to use the Software, but only one person at a time on one Electronic Device at a time. You agree not to duplicate or copy the Software, except that you may make one back-up copy for archive purposes. The primary user of the Electronic Device on which installable Software is installed may also make a copy for his or her exclusive use on a portable computer, so long as such Software is being used only on one Electronic Device at a time.

**2. Storage/Network Use.** In the alternative, you may install a copy of the Software on a storage device, such as a network server, used only to access and use the Software on your Electronic Devices over an internal network; however, you must acquire and dedicate a license for each separate Electronic Device on which the Software is accessed and used from the storage device. A license for the Software may not be shared or used concurrently on different Electronic Devices.

**3. Documentation.** If the Software contains documentation which is provided only in electronic form, you may print one copy of such electronic documentation. You may not copy the printed materials accompanying the Software.

**4. Limitations of Reverse Engineering, Decompilation and Disassembly.** You may not reverse engineer, decompile, or disassemble the Software, except and only to the extent that such activity is permitted by applicable law notwithstanding this limitation.

**5. Transfer/Sublicense.** You may not transfer, sublicense, distribute, rent, lease, supply, market or lend the Software to any other party.

**6. Confidentiality.** You acknowledge that the Software embodies confidential information owned by Zebra and/or its suppliers and licensors. To the extent you have access to any such information, you agree to use such information only for the authorized use of the Software. You further agree not to disclose such confidential information to any other party and to use at least the same degree of care to maintain the confidential nature of such information as you use to maintain the confidentiality of your own confidential information.

**7. Intellectual Property.** All title, copyrights and other intellectual property rights in and to the Software (including but not limited to copyrights, patents, trade secrets and trademarks) are owned by Zebra or its suppliers and licensors. You must maintain all copyright notices on all copies of the Software. All rights not expressly granted are reserved by Zebra. Without prejudice to any rights or remedies Zebra may have for your violation of this Software License, Zebra shall own all changes or modifications to the Software.

**8. Termination.** Without prejudice to any other rights or remedies Zebra may have, Zebra may terminate this Agreement if you fail to comply with the terms and conditions of this Agreement. Zebra may terminate this Agreement by offering you a superseding Agreement for the Software or any replacement or modified version of or upgrade to the Software and conditioning your continued use of the Software or such replacement, modified or upgraded version on your acceptance of such superseding Agreement. In addition, either party may terminate this Agreement at any time. Subject to the foregoing, termination shall be effective upon notice to the other party. In the event that this Agreement terminates for any reason, your license to use the Software will terminate, and you must immediately stop using the Software, destroy all copies of the Software and all of its component parts, and, upon request, provide an affidavit certifying your compliance with the foregoing. The provisions of Sections 4, 5, 6, 7, 12, 13, 14, 15, 16, 17, 18, 19 and 20 shall survive termination of this Agreement.

**9. U.S. Government Restricted Rights.** All Software provided to the U.S. Government pursuant to solicitations issued on or after December 1, 1995 is provided with the commercial rights and restrictions described elsewhere herein. All Software provided to the U.S. Government pursuant to solicitations issued prior to December 1, 1995 is provided with RESTRICTED RIGHTS as provided for in FAR, 48 CFR 52.227-19 (JUNE 1987) or DFARs, 48 CFR 252.227-7013 (OCT 1988), as applicable.

**10. Export Restrictions.** You agree that you will not export or re-export the Software, any part thereof, or any process or service that is the direct product of the Software (the foregoing collectively referred to as the “Restricted Components”), to any country, person or entity subject to U.S. export restrictions. You specifically agree not to export or re-export any of the Restricted Components: (i) to any country to which the U.S. has embargoed or restricted the export of goods or services, which currently include but are not necessarily limited to Cuba, Iran, Iraq, North Korea, Sudan and Syria, or to any national of any such country, wherever located, who intends to transmit or transport the Restricted Components back to such country; (ii) to any person or entity who you know or have reason to know will utilize the Restricted Components in the design, development or production of nuclear, chemical or biological weapons; or (iii) to any person or entity who has been prohibited from participating in U.S. export transactions by any federal agency of the U.S. government. You warrant and represent that neither the U.S. Commerce Department, Bureau of Export Administration nor any other U.S. federal agency has suspended, revoked or denied your export privileges. Contractor/Manufacturer is Zebra Technologies Corporation, 333 Corporate Woods Parkway, Vernon Hills, Illinois 60061.

**11. Accessing Services Using the Software.** Your use of any service accessible using the Software is not covered by this EULA and may be governed by separate terms of use, conditions or notices. Zebra and its suppliers and licensors hereby disclaim any such liability for any such services accessed.

**12. Disclaimer.** ZEBRA SUPPLIES THE SOFTWARE AS IS AND WITH ALL FAULTS AND DOES NOT MAKE ANY WARRANTIES WHATSOEVER, EXPRESS OR IMPLIED, INCLUDING BUT NOT LIMITED TO WARRANTIES CONCERNING THE SOFTWARE OR ANY APPLICATION, OPERATION OR USE THEREOF, THE OUTPUT OR THE DATA GENERATED BY THE OPERATION OR USE THEREOF, OR ANY SUPPORT SERVICES RENDERED WITH RESPECT THERETO. ZEBRA HEREBY EXCLUDES ALL IMPLIED WARRANTIES TO THE MAXIMUM EXTENT AUTHORIZED BY LAW, INCLUDING, SPECIFICALLY, ANY IMPLIED WARRANTY ARISING BY STATUTE OR OTHERWISE IN LAW OR FROM A COURSE OF DEALING OR USAGE OF TRADE, ALL IMPLIED WARRANTIES OF MERCHANTABILITY, OR OF MERCHANTABLE QUALITY, OR OF FITNESS FOR ANY PURPOSE, PARTICULAR, SPECIFIC OR OTHERWISE, OR OF TITLE, OR OF NONINFRINGEMENT. SOME JURISDICTIONS DO NOT ALLOW THE EXCLUSION OR LIMITATION OF IMPLIED WARRANTIES, SO THE ABOVE LIMITATION OR EXCLUSION MAY NOT APPLY TO YOU. WHEN THE IMPLIED WARRANTIES ARE NOT ALLOWED TO BE EXCLUDED IN THEIR ENTIRETY, THEY WILL BE LIMITED TO THE DURATION OF NINETY (90) DAYS. WITHOUT LIMITING THE GENERALITY OF THE FOREGOING, ZEBRA DOES NOT WARRANT THAT THE OPERATION OF THE SOFTWARE WILL BE UNINTERRUPTED OR ERROR FREE. To the extent that the Software covered by this EULA includes emulation libraries, such emulation libraries do not work 100% correctly or cover 100% of the functionality of the printer language being emulated, are offered “as is” AND WITH ALL FAULTS, AND ALL THE DISCLAIMERS AND LIMITATIONS CONTAINED IN THIS PARAGRAPH AND THIS AGREEMENT APPLY TO SUCH EMULATION LIBRARIES.

**13. Limitation of Liability and Damages.** ZEBRA DOES NOT ASSUME RESPONSIBILITY FOR ANY SPECIFIC APPLICATION OF THE SOFTWARE OR FOR COMPATIBILITY WITH OTHER SOFTWARE OR EQUIPMENT. TO THE FULL EXTENT ALLOWED BY LAW, ZEBRA EXCLUDES FOR ITSELF AND ITS LICENSORS AND SUPPLIERS ANY LIABILITY FOR ANY DAMAGES, INCLUDING WITHOUT LIMITATION DIRECT, CONSEQUENTIAL, INCIDENTAL, INDIRECT, SPECIAL, EXEMPLARY OR PUNITIVE DAMAGES OF ANY KIND, OR FOR LOSS OF REVENUE OR PROFITS, LOSS OF BUSINESS, DAMAGE TO GOODWILL, LOSS OF INFORMATION OR DATA, OR OTHER FINANCIAL LOSS ARISING OUT OF OR IN CONNECTION WITH THE SALE, INSTALLATION, MAINTENANCE, USE, PERFORMANCE, FAILURE, OR INTERRUPTION OF ANY PRODUCTS, PARTS OR SOFTWARE, WHETHER BASED ON CONTRACT, TORT, NEGLIGENCE, STRICT LIABILITY OR OTHERWISE, EVEN IF ZEBRA OR ANY LICENSOR OR SUPPLIER HAS BEEN ADVISED OF THE POSSIBILITY OF SUCH DAMAGES. TO THE MAXIMUM EXTENT AUTHORIZED BY LAW, THIS DISCLAIMER OF LIABILITY FOR DAMAGES WILL NOT BE AFFECTED IF ANY REMEDY PROVIDED HEREIN SHALL FAIL OF ITS ESSENTIAL PURPOSE. SOME JURISDICTIONS DO NOT ALLOW THE EXCLUSION OR LIMITATION OF DIRECT, INCIDENTAL, CONSEQUENTIAL OR OTHER DAMAGES, SO THE ABOVE LIMITATION OR EXCLUSION MAY NOT APPLY TO YOU. WHEN LIABILITY FOR DAMAGES IS NOT ALLOWED TO BE LIMITED OR EXCLUDED IN ITS ENTIRETY, ZEBRA LIMITS ITS LIABILITY TO REPAIR, REPLACEMENT, OR, AT ZEBRA'S OPTION, REFUND OF THE PRICE OF THE SOFTWARE.

**14. Zebra Suppliers and Licensors.** Any release, disclaimer or limitation of Zebra's liability or damages pursuant to this Agreement shall be construed, in addition to Zebra's benefit, also to the benefit of Zebra's suppliers, licensors, employees, and contractors and, without limiting any other defenses that such suppliers, licensors, employees and contractors may have, you agree to release such parties from liability or damages in accordance with such release, disclaimer, or limitation of liability or damages to the same extent that such provisions apply to Zebra.

**15. Governing Law.** To the maximum extent permitted by law, the laws of the State of Illinois, U.S.A., without reference to its conflict of laws provisions, will apply to this Agreement. You irrevocably agree to submit to the exclusive jurisdiction and venue of the state or federal courts in the State of Illinois in the event of any litigation involving this Agreement or the Software. You agree that you shall not assert any claim that you are not subject to the jurisdiction of such courts, that the venue is improper, that the forum is inconvenient or any similar objection, claim or argument. Zebra may, in its sole discretion, choose to resolve any controversy or dispute between you and Zebra concerning this Agreement, or the existence, validity, breach or termination thereof, whether during or after the term by binding arbitration in accordance with the Commercial Arbitration Rules of the American Arbitration Association ("AAA"), as modified or supplemented under this Section 15, by providing notice to you. In the event that Zebra provides such notice, you hereby waive any right to institute a court or other dispute resolution proceeding with respect to such controversy or dispute and acknowledge arbitration in accordance with this Section 15 as the sole and exclusive means of resolving such controversy or dispute. The arbitration proceeding will take place in Chicago, Illinois and be conducted in the English language. The arbitration panel will consist of 3 arbitrators, one arbitrator appointed by each party and a third neutral arbitrator appointed by the two arbitrators designated by the parties. Any communication

between a party and any arbitrator will be directed to the AAA for transmittal to the arbitrator. The parties expressly agree that the arbitrators will be empowered to, at either party's request, grant injunctive relief. The arbitral award will be the exclusive remedy of the parties for all claims, counterclaims, issues or accountings presented or pleaded to the arbitrators. Judgment upon the arbitral award may be entered in any court that has jurisdiction thereof. Any additional costs, fees or expenses incurred in enforcing the arbitral award will be charged against the party that resists its enforcement. Nothing in this Section will prevent Zebra from seeking interim injunctive relief against you or filing an action against you to collect unpaid and past due amounts in any court of competent jurisdiction.

**16. Injunctive Relief.** You acknowledge that, in the event you breach any provision of this Agreement, Zebra will not have an adequate remedy in money or damages. Zebra shall therefore be entitled to obtain an injunction against such breach from any court of competent jurisdiction immediately upon request without posting bond. Zebra's right to obtain injunctive relief shall not limit its right to seek further remedies.

**17. Entire Agreement.** This Agreement constitutes the entire understanding and agreement of the parties and supersedes any and all prior or contemporaneous representations, understandings and agreements between the parties with respect to the subject matter of this Agreement. If any provision of this Agreement is held invalid, the remainder of this Agreement shall continue in full force and effect.

**18. Assignment.** You may not assign this Agreement or any of your rights or obligations hereunder (by operation of law or otherwise) without the prior written consent of Zebra. Zebra may assign this Agreement and its rights and obligations without your consent. Subject to the foregoing, this Agreement shall be binding upon and inure to the benefit of the parties to it and their respective legal representatives, successors and permitted assigns.

**19. Modification.** No modification of this Agreement shall be binding unless it is in writing and is signed by an authorized representative of the party against whom enforcement of the modification is sought.

**20. Waiver.** The failure by a party to exercise any right hereunder shall not operate as a waiver of such party's right to exercise such right or any other right in the future.

**21. QUESTIONS.** Should you have any questions, or if you desire to contact Zebra for any reason, please contact the Zebra subsidiary serving your country, or write:

Zebra Technologies International, LLC  
333 Corporate Woods Parkway  
Vernon Hills, Illinois 60061

**Effective February 2006.**



**Notes •** \_\_\_\_\_  
\_\_\_\_\_  
\_\_\_\_\_  
\_\_\_\_\_  
\_\_\_\_\_  
\_\_\_\_\_  
\_\_\_\_\_  
\_\_\_\_\_  
\_\_\_\_\_  
\_\_\_\_\_

---

# Index



## A

- active control panel buttons, 10
- adhesive test for ribbon coating, 28
- adjustments
  - black mark sensor, 66
  - LCD, 96
  - left position, 94
  - lower media sensor, 67
  - print darkness, 79
  - printhead balance, 68
  - printhead pressure, 70
  - sensors, 66
  - tear-off position, 80
  - upper media sensor, 66
- agency approvals, 144
- authentication type, 99
- auto-calibration, 71

## B

- backfeed setting, 93
- backing removal, 47, 55
- bar codes
  - list available codes, 84
  - specifications, 147
- baud setting, 89
- before you begin setup, 16
- bitmap scaling factor, 96
- black mark media
  - described, 25
  - sensor adjustment, 66
  - when to clean sensor, 108

## C

- cable requirements, 22
- calibration
  - media and ribbon sensor, 88
  - methods, 71
  - setting for head close, 93
  - setting for media power up, 92
  - troubleshooting problems, 125
- Canadian DOC compliance, iv
- CANCEL button
  - CANCEL self test, 131
  - function, 10
- checklist
  - before you begin, 16
  - troubleshooting, 118
- cleaning
  - cutter, 115
  - exterior of printer, 109
  - printhead and platen roller, 109
  - recommended schedule, 108
  - sensors, 112
  - snap plate, 114
- communication interfaces
  - overview and location, 19
  - types of connections, 20
- communications diagnostics test
  - overview, 139
  - selecting, 91
- communications problems, 126
- CompactFlash card
  - initialization, 85
- components of printer, 13

- configuration
  - changing parameters, 79
  - enter Setup mode, 74
  - exit Setup mode, 75
  - software or printer driver, 79
- configuration label
  - printing using CANCEL self test, 131
  - printing using List Setup command, 84
- connect to power source, 23
- contacts, 3
- continuous media
  - described, 26
  - setting media type, 81
- control panel
  - buttons, 10
  - enter Setup mode, 74
  - exit Setup mode, 75
  - LCD error messages, 119
  - LCD functions, 10
  - lights, 11
  - location, 8
  - overview, 9
  - parameters, 79
- control prefix setting, 91
- customer service, 3
- cutter
  - cleaning, 115
  - loading media in Cutter mode, 57
  - selecting Cutter mode, 80
  - when to clean, 108

**D**

- darkness setting, 79
- data bits setting, 89
- data cable requirements, 22
- data source
  - connections, 19
  - site selection, 18
- date setting, 97
- default gateway, 99
- default password, 76
- delimiter character setting, 92
- diagnostics, 130
- direct thermal mode
  - media scratch test, 27
  - setting, 81
- disable password protection, 76
- display language
  - changing from unreadable language, 128
  - selection, 97
- disposal of printer, 17
- dpi format conversion, 96

**E**

- electrical noise, 22
- electrical specifications, 142
- electronics cover, 8
- encryption settings, 100
- enter Setup mode, 74
- environmental specifications, 142
- error messages, 119
- Error mode, 10
- ESSID setting, 99
- exit Setup mode, 75
- exterior cleaning, 109
- external view of printer, 8

**F**

- factory defaults
  - reload parameters, 75
  - restore network settings, 75
- fanfold media, 26
- FCC compliance, iv
- FEED button
  - FEED and PAUSE self test, 138
  - FEED self test, 134
  - function, 10
- Flash memory, 86
- font list, 84
- fonts
  - using PCMCIA memory card, 104
- format convert setting, 96
- format list, 84
- format memory card, 85
- format prefix setting, 91
- fuse replacement, 116
- fuses
  - specifications, 142

**G**

- gleaning, 98

**H**

- HEAD COLD message, 121
- HEAD TOO HOT message, 120
- host handshake setting, 90
- humidity requirements, 18



**I**

- images list, 84
- initialize Flash memory, 86
- initialize memory card, 85
- inspect for shipping damage, 17
- interfaces
  - IEEE 1284 bidirectional parallel, 21
  - print servers, 22
  - RS-232 serial, 20
- international safety organization marks, 24
- IP settings
  - default gateway, 99
  - IP address, 99
  - protocol, 98
  - subnet mask, 99

**L**

- label backing removal, 47, 55
- label length maximum setting, 83
- label top
  - printer cannot detect, 129
  - setting, 93
- label-available sensor
  - when to clean, 108
- labels did not print, 126
- language
  - changing from unreadable language, 128
  - selection, 97
- LCD error messages, 119
- LCD messages
  - adjust LCD settings, 96
  - language selection, 97
  - Setup mode, 79
- liability, ii
- list settings
  - all settings, 85
  - bar codes, 84
  - fonts, 84
  - formats, 84
  - images, 84
  - network, 84
  - setup, 84
- load factory defaults, 75
- loading
  - ribbon, 61
- long calibration, 71
- lower media sensor adjustment, 67
- lubrication, 108

**M**

- MAC address, 99
- mark LED setting, 96
- Mark Med S. setting, 96
- maximum label length setting, 83
- media
  - continuous roll media, 26
  - fanfold, 26
  - loading, 30
  - media LED setting, 96
  - non-continuous roll media, 25
  - ordering, 3
  - setting media type, 81
  - types of media, 25
- media and ribbon sensor calibration procedure, 88
- media compartment, 13
- media door, 8
- media loading
  - Cutter mode, 57
  - Peel-Off mode, 38
  - Rewind mode, 49
  - Tear-Off mode, 34
- media path cleaning, 108
- media power up setting, 92
- Media S. setting, 96
- media scratch test, 27
- media sensor
  - print sensor profile, 87
  - sensor sensitivity calibration, 72
- media specifications, 146
- memory card installation
  - PCMCIA memory card, 104
- memory options, 143
- MINUS button function, 11

**N**

- network configuration label
  - printing, 78
  - printing using List Network command, 84
- network ID setting, 90
- NEXT/SAVE button function, 10
- non-continuous media
  - described, 25
  - setting media type, 81

**O**

- operating conditions, 18
- Operating mode, 10
- optional print servers, 22
- ordering ribbon and media, 3
- OUT OF MEMORY** message, 121

**P**

- PAPER OUT** message, 120
- parallel port
  - overview, 21
  - setting parallel communications, 89
- parity setting, 90
- passwords
  - default, 76
  - disable, 76
  - entering, 76
- PAUSE button
  - FEED and PAUSE self test, 138
  - function, 10
  - PAUSE self test, 133
- Pause mode, 10
- PCMCIA card
  - installing card, 104
- PCMCIA card initialization, 85
- peel-off bar cleaning, 108
- Peel-Off mode
  - loading media, 38
  - selecting, 80
- physical specifications, 142
- platen roller
  - cleaning, 109
  - when to clean, 108
- PLUS button function, 11
- power
  - connect to power source, 23
  - electrical specifications, 142
  - power cord specifications, 24
  - site selection, 18
- Power-On Self Test (POST), 130
- PREVIOUS button function, 10
- print configuration label
  - CANCEL self test, 131
  - List Setup command, 84
- print darkness setting, 79
- print modes
  - load media for different modes, 30
  - selecting, 80
- print network configuration label, 78, 84
- print quality
  - effect of printhead toggle pressure, 68
  - troubleshooting, 122
- print server options, 22
- print server settings, 98
  - default gateway, 99
  - IP address, 99
  - IP protocol, 98
  - subnet mask, 99
- print width setting, 82
- printer components, 13
- printer diagnostics, 130
- printer interior, 13
- printer memory, 143
- printer modes, 10
- printer options, 143
- printer settings
  - backfeed, 93
  - baud, 89
  - calibration methods, 71
  - control prefix, 91
  - data bits, 89
  - date, 97
  - delimiter character, 92
  - format convert, 96
  - format prefix, 91
  - head resistor, 95
  - host handshake, 90
  - IP settings, 98
  - label top, 93
  - language, 97
  - LCD, 96
  - left position, 94
  - maximum label length, 83
  - media type, 81
  - network configuration label as baseline, 78
  - network ID, 90
  - parallel communications, 89
  - parity, 90
  - print darkness, 79
  - print method, 81
  - print server settings, 98
  - print width, 82
  - protocol, 90
  - saving, 75
  - serial communications, 89
  - setting through control panel, 74
  - time, 97
  - ZPL mode, 92
- printhead
  - adjust balance, 68
  - cleaning, 109
  - head close setting, 93
  - head resistor value setting, 95
  - pressure adjustment, 70
  - when to clean, 108
- printing specifications, 145
- product markings, 144
- protocol setting, 90

**R**

- recycling the printer, 17
- registration problems, 125
- relative humidity requirements, 18
- remove backing from rewind spindle, 47, 55
- replace fuse, 116
- report shipping damage, 17
- reset network option, 101
- restore
  - factory default settings, 75
  - network settings, 75
- Rewind mode
  - loading media, 49
  - selecting, 80
- rewind spindle, 47, 55
- ribbon
  - adhesive test, 28
  - determining coated side, 27
  - loading, 61
  - ordering, 3
  - removal, 65
  - ribbon LED setting, 96
  - scratch test, 28
  - specifications, 145
  - when to use, 27
- RIBBON IN** message, 120
- RIBBON OUT** message, 119
- Ribbon S. setting, 96
- ribbon sensor
  - calibration procedure, 88
  - cleaning, 112
  - sensitivity calibration, 72
  - when to clean, 108
- roll media
  - described, 25
- RS-232 serial interface, 20
- RTC (real-time clock) setting
  - date, 97
  - time, 97

**S**

- sales, 3
- schedule for cleaning, 108
- scratch test
  - media type, 27
  - ribbon coated side, 28
- self tests, 130
  - CANCEL, 131
  - communications diagnostics, 139
  - FEED, 134
  - FEED and PAUSE, 138
  - PAUSE, 133
  - Power-On Self Test (POST), 130
- sensor profile calibration
  - description, 72
  - interpreting results, 140
  - selecting through control panel, 87
- sensors
  - adjusting, 66
  - calibration methods, 71
  - cleaning, 112
  - lower media sensor adjustment, 67
  - print sensor profile, 87
  - upper media sensor adjustment, 66
- serial port
  - setting serial communications, 89
- setup
  - checklist, 16
  - unpack the printer, 17
- Setup mode
  - defined, 10
  - enter Setup mode, 74
  - exit Setup mode, 75
  - LCD messages, 79
  - passwords, 76
- SETUP/EXIT button function, 10
- shipping
  - report damage, 17
  - reshipping the printer, 17
- short calibration, 71
- snap plate
  - cleaning, 114
  - when to clean, 108
- spacing requirements, 18

- specifications
  - agency approvals and markings, 144
  - bar codes, 147
  - communications options, 143
  - electrical, 142
  - environmental, 142
  - fuses, 142
  - media, 146
  - physical, 142
  - power cord, 24
  - printing, 145
  - ribbon, 145
  - Zebra Programming Language (ZPL II), 147
- standard features, 143
- storing the printer, 17
- subnet mask, 99
- surface for the printer, 18

## T

- tag stock
  - described, 25
  - loading media, 31
- Tear-Off mode
  - loading media, 34
  - selecting, 80
  - tear-off bar cleaning, 108
  - tear-off position adjustment, 80
- technical support, 3
- temperature requirements, 18
- thermal transfer mode
  - media scratch test, 27
  - setting, 81
- time setting, 97
- toggle adjustment, 68
- top of label
  - printer cannot detect, 129
  - setting, 93

- transmissive sensor
  - adjustment, 66
  - when to clean, 108
- troubleshooting
  - checklist, 118
  - communications problems, 126
  - diagnostic tests, 130
  - LCD error messages, 119
  - print quality problems, 122
- types of media
  - continuous roll media, 26
  - fanfold media, 26
  - non-continuous roll media, 25

## U

- unpack the printer, 17
- upper media sensor adjustment, 66

## W

- web media, 25
- Web S. setting, 96
- wireless PCMCIA card installation, 104
- Wireless Print Server settings
  - authentication type, 99
  - default gateway, 99
  - encryption, 100
  - ESSID, 99
  - IP address, 99
  - IP protocol, 98
  - MAC address, 99
  - reset network, 101
  - subnet mask, 99

## Z

- Zebra Programming Language (ZPL)
  - specifications, 147
  - ZPL mode setting, 92





**Zebra Technologies Corporation**

333 Corporate Woods Parkway  
Vernon Hills, Illinois 60061.3109 U.S.A.  
Telephone: +1 847.793.2600  
Facsimile: +1 847.913.8766

**Zebra Technologies Europe Limited**

Zebra House  
The Valley Centre, Gordon Road  
High Wycombe  
Buckinghamshire HP13 6EQ, UK  
Telephone: +44 (0) 1494 472872  
Facsimile: +44 (0) 1494 450103

**Zebra Technologies Asia Pacific, LLC**

16 New Industrial Road  
#05-03 Hudson TechnoCentre  
Singapore 536204  
Telephone: +65 6858 0722  
Facsimile: +65 6885 0838

Part Number: 11342L-001 Rev. A  
© 2006 ZIH Corp.

## Free Manuals Download Website

<http://myh66.com>

<http://usermanuals.us>

<http://www.somanuals.com>

<http://www.4manuals.cc>

<http://www.manual-lib.com>

<http://www.404manual.com>

<http://www.luxmanual.com>

<http://aubethermostatmanual.com>

Golf course search by state

<http://golfingnear.com>

Email search by domain

<http://emailbydomain.com>

Auto manuals search

<http://auto.somanuals.com>

TV manuals search

<http://tv.somanuals.com>