

# Zebra 170PAX2™ -Series User's Guide

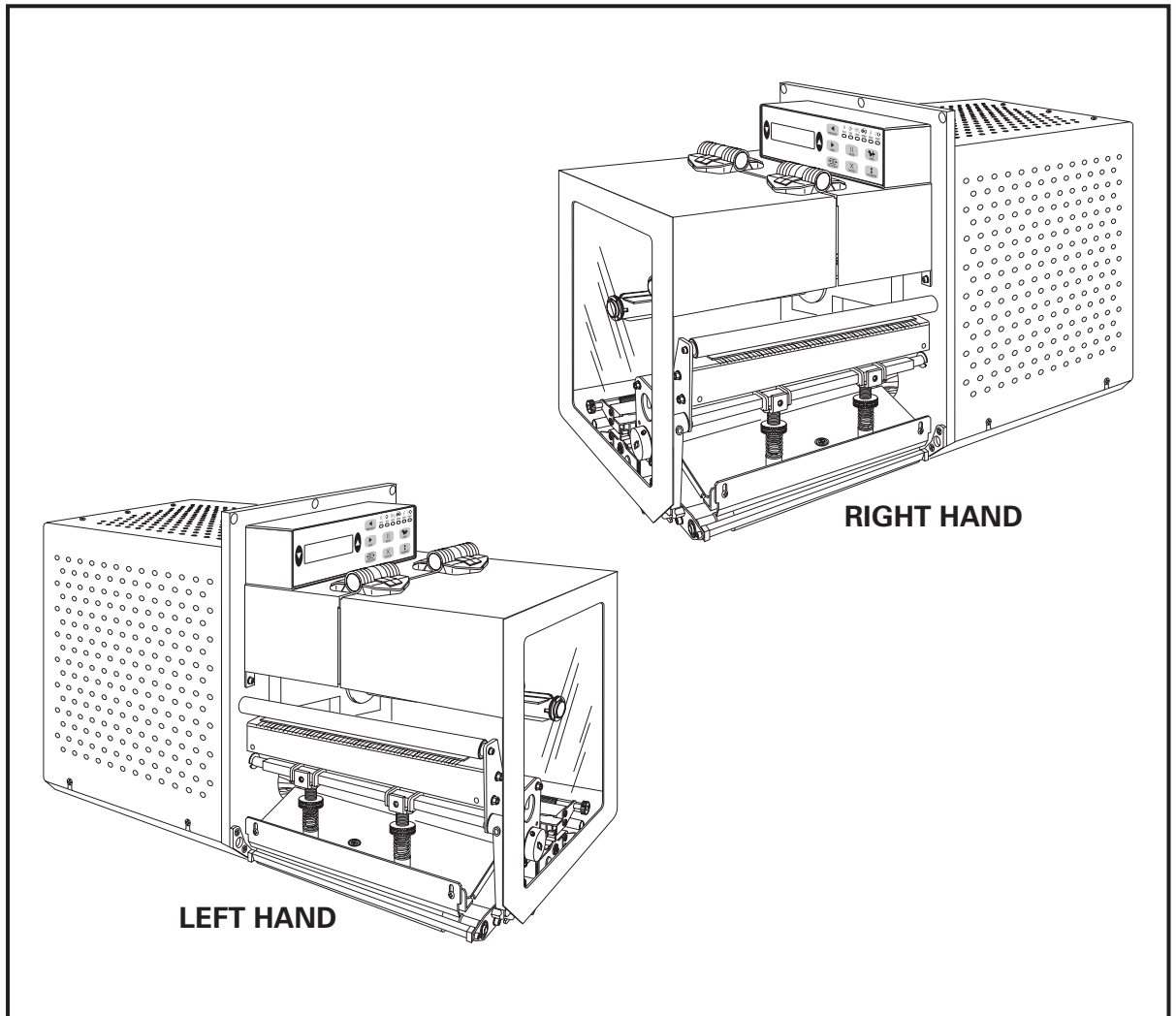

## Proprietary Statement

This manual contains proprietary information of Zebra Technologies Corporation. It is intended solely for the information and use of parties operating and maintaining the equipment described herein. Such proprietary information may not be used, reproduced, or disclosed to third parties for any other purpose without the expressed written permission of Zebra Technologies Corporation.

## Product Improvements

Continuous improvement of products is a policy of Zebra Technologies Corporation. All specifications and signs are subject to change without notice.

## FCC Compliance Statement

This equipment has been tested and found to comply with the limits for a Class A digital Device, pursuant to Part 15 of the FCC Rules. These limits are designed to provide reasonable protection against harmful interference when the equipment is operated in a commercial environment. This equipment generates, uses and can radiate radio frequency energy and, if not installed and used in accordance with the instructions manual, may cause harmful interference to radio communications. Operation of this equipment in a residential area is likely to cause harmful interference in which case the user will be required to correct the interference at his own expense.

In order to insure compliance, this printer must be used with a Shielded Power Cord and Shielded Communication Cables.

“The user is cautioned that any changes or modifications not expressly approved by Zebra Technologies Corporation could void the user’s authority to operate the equipment.”

## Canadian DOC Compliance Statement

This digital apparatus does not exceed the Class A limits for radio noise emissions from digital apparatus as set out in the radio interference regulations of the Canadian Department of Communications.

## Liability Disclaimer

Zebra Technologies Corporation takes steps to assure that its published Engineering Specifications and Manuals are correct; however, errors do occur. Zebra Technologies Corporation reserves the right to correct any such errors and disclaims liability resulting therefrom.

## No Liability for Consequential Damage

In no event shall Zebra Technologies Corporation or anyone else involved in the creation, production, or delivery of the accompanying product (including hardware and software) be liable for any damages whatsoever (including, without limitation, damages for loss of business profits, business interruption, loss of business information, or other pecuniary loss) arising out of the use of or the results of use of or inability to use such product, even if Zebra Technologies Corporation has been advised of the possibility of such damages. Because some states do not allow the exclusion or limitation of liability for consequential or incidental damages, the above limitation may not apply to you.

## Copyrights

The copyrights in this manual and the label printer described therein are owned by Zebra Technologies Corporation. All rights are reserved. Unauthorized reproduction of this manual or the software in the label printer may result in imprisonment of up to one year and fines of up to \$10,000 (17 U.S.C.506). Copyright violators may be subject to civil liability.

Zebra 170PAX™, 174PAX™, 175PAX™, ZebraNet™, ProPlus™, Platinum™, and Z-Tools™ are trademarks and ZPL® , ZPL II® , and BAR-ONE® are registered trademarks of Zebra Technologies Corporation.

Centronics® is a registered trademark of Genicom Corporation.

IBM® is a registered trademark of IBM Corporation.

© 1999 Zebra Technologies Corporation. All rights reserved.

## Introduction

Zebra 170PAX2 Print Engine . . . . .	1
Getting Started . . . . .	1
Print Engine Mounting . . . . .	1
Communications . . . . .	1
Printer Power . . . . .	2

## Media & Ribbon Loading

Media Loading . . . . .	3
Ribbon Loading . . . . .	5
Removing Used Ribbon . . . . .	6

## Media Sensor Position

Reflective Media Sensor . . . . .	7
Transmissive Media Sensor . . . . .	7

## Printer Operation

Power On/Off Switch . . . . .	9
Front Panel Keys . . . . .	9
Liquid Crystal Display . . . . .	10
Control Panel Keys . . . . .	10
Front Panel Indicator Lights (LEDs) . . . . .	10

## Configuration and Calibration

Introduction . . . . .	11
Configuration Process . . . . .	12
Setting Print Parameters . . . . .	12
Listing Printer Information . . . . .	16
Media and Ribbon Sensor Calibration . . . . .	18
Setting Communication Parameters . . . . .	20
Selecting Prefix and Delimiter Characters . . . . .	23
Selecting ZPL Mode . . . . .	24
Setting Ribbon Tension . . . . .	24
Power Up and Head Close Parameters . . . . .	24
Label Positioning Parameters . . . . .	25
Head Test Function . . . . .	28
Head Resistance . . . . .	28
Verifier Port . . . . .	28
Applicator Port . . . . .	29
Printing Controls . . . . .	30
Sensor Values . . . . .	31
LCD Adjust . . . . .	32
Printer Language . . . . .	32

# Contents

---

## Care & Adjustments

Cleaning . . . . .	33
Toggle Positioning. . . . .	35
Printhead Pressure Adjustment . . . . .	35

## Troubleshooting

Power On Self Test . . . . .	37
Power On Troubleshooting . . . . .	38
Printer Troubleshooting . . . . .	38
Printer Self Tests. . . . .	42

## Options

Single In-line Memory Module (SIMM) . . . . .	47
Personal Computer Memory Card Interface Association (PCMCIA) Memory Card . . . . .	47
Communication Interfaces. . . . .	47
ZebraNet™ Micro Print Server (MPS) . . . . .	47

## Printer Specifications

### Appendix A

AC Power Cord Requirements . . . . .	53
Power Fuse Replacement . . . . .	53
Shipping . . . . .	54

### Appendix B

Printer Communications Interface Technical Information . . . . .	55
RS-232/RS-422/RS-485 Serial Data Port . . . . .	56
Centronics-Compatible Parallel Data Port . . . . .	59
Cabling Requirements . . . . .	60
Applicator Interface Connector . . . . .	60

### Appendix C

ASCII Code Chart . . . . .	63
----------------------------	----

### Appendix D

Adjusting Darkness For “In-Spec” Bar Codes . . . . .	65
------------------------------------------------------	----

### Appendix E

Installation Information . . . . .	67
------------------------------------	----

## Glossary

## Index

# Introduction

---

Congratulations! You have just purchased a high-quality thermal demand print engine manufactured by the industry leader in quality, service, and value. For over 25 years, Zebra Technologies Corporation has provided customers with the highest caliber of products and support.

To create and print label formats, refer to the *ZPL II Programming Guide* (part # 46530L). This guide is available by contacting your distributor or Zebra Technologies Corporation. It is also available as a file to download from Zebra's web site "support.zebra.com". In addition, label preparation software is available. Contact your distributor or Zebra Technologies Corporation for further information.

The *Zebra 170PAX™-Series Maintenance Manual* (part # 49803L) contains the information you may need to properly maintain the print engine.

## Zebra 170PAX2 Print Engine

This user's guide contains information specific to the 172PAX2 (203 dot/inch) and the 173PAX2 (300 dot/inch) print engines manufactured by Zebra Technologies Corporation. Each of these print engines is available in either a right hand configuration (media moves from left to right) or a left hand configuration (media moves from right to left.)

## Getting Started

### *Unpacking*

Save the carton and all packing materials in case shipping is required.

Inspect the print engine for possible shipping damage:

- Check all exterior surfaces for damage.
- Raise the front cover and inspect for damage.

### *Reporting Damage*

If you discover shipping damage:

- Immediately notify the shipping company and file a damage report.
- Retain the carton and all packing material for inspection.
- Notify your local Zebra distributor of the damage.

Zebra Technologies Corporation is not responsible for any damage incurred during shipment of the print engine and will not cover the repair of this damage under its warranty policy. Any damage claim should be filed with the shipping company.

For shipping information, refer to Appendix A.

## Print Engine Mounting

For specific information on mounting the print engine into an applicator, refer to Appendix E.

## Communications

Refer to Figure 1. The 170PAX2™-Series printer comes standard with both an Electronics Industries Association (EIA) RS-232 serial interface (DB-25 Connector) and a Centronics®-compatible parallel interface. The serial interface is also configured for both RS-422/RS-485 single drop and RS-485 multi-drop serial interfaces.

Any of these four interface methods may be used to send commands and label formats from a host to the print engine. Only the RS-232 serial interface may be used to send printer status back to the host.

# Introduction

A DB-15 Applicator Interface Connector provides communication between the print engine and the associated applicator hardware. In some applications, control signal timing may be a critical element in the performance of the print engine. Refer to Appendix B for control signal descriptions.



**WARNING!!** Connecting a data communications cable while the power is ON may damage the PAX2 print engine.



**NOTE:** You must supply the interface cables for your application. Refer to Appendix B for specific cable requirements.

## Printer Power

The Power Supply in the PAX2-Series printer automatically detects the applied line voltage and works in the 90 to 264 VAC, 48 to 62 Hz range.

Refer to Figure 1. The AC Power Cord must have a three-prong female connector on one end which plugs into the mating connector at the rear of the printer. If a power cable was not included with your printer, refer to Appendix A at the back of this guide.



**WARNING!!** For personnel and equipment safety, always use a three-prong plug with an earth ground connection to the AC Power Source.

Refer to Figure 7 and insure that the front panel AC Power ON/OFF Switch is in the OFF (O) position before connecting the AC Power cord to a nearby electrical outlet.

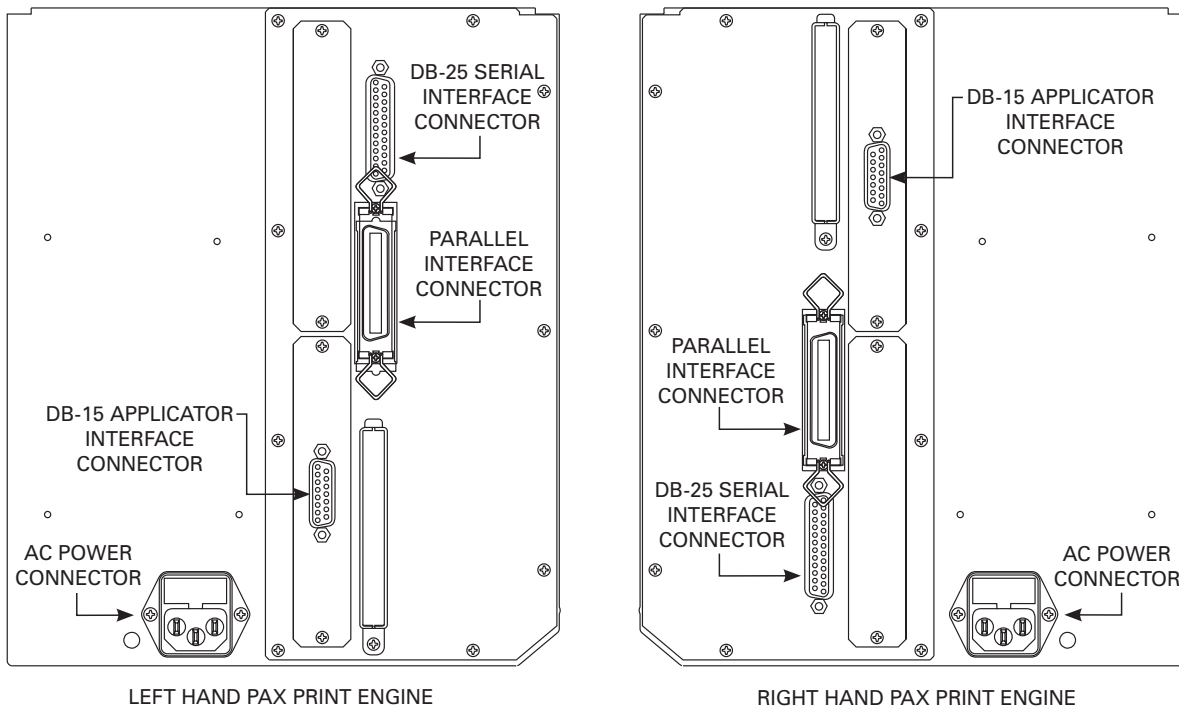

Figure 1. Cable Connections

# Media & Ribbon Loading

## Media Loading

If your print engine is a right hand unit (printed labels are presented on the right hand side of the unit), refer to Figure 2 while performing the procedure shown below. If your print engine is a left hand configuration (printed labels are presented on the left hand side of the unit), refer to Figure 3.

1. Load the media on the media supply hanger of the applicator (refer to the applicator's user's manual).
2. Grasp the thumb nut (A) and slide the outer media edge guide (B) as far out from the printer frame as possible. (The thumb nut does not have to be loosened.)
3. Open the printhead assembly (C) by unlatching the printhead lock lever (D) from the locking pin (E).
4. Raise the pinch roller (F) by pressing down on the pinch roller assembly latch (G). Thread the media under the upper guide post (H), between the pinch roller and the associated rubber pinch roller, and under the printhead assembly (C) until approximately 30" (75 cm) of media extends out of the print engine.

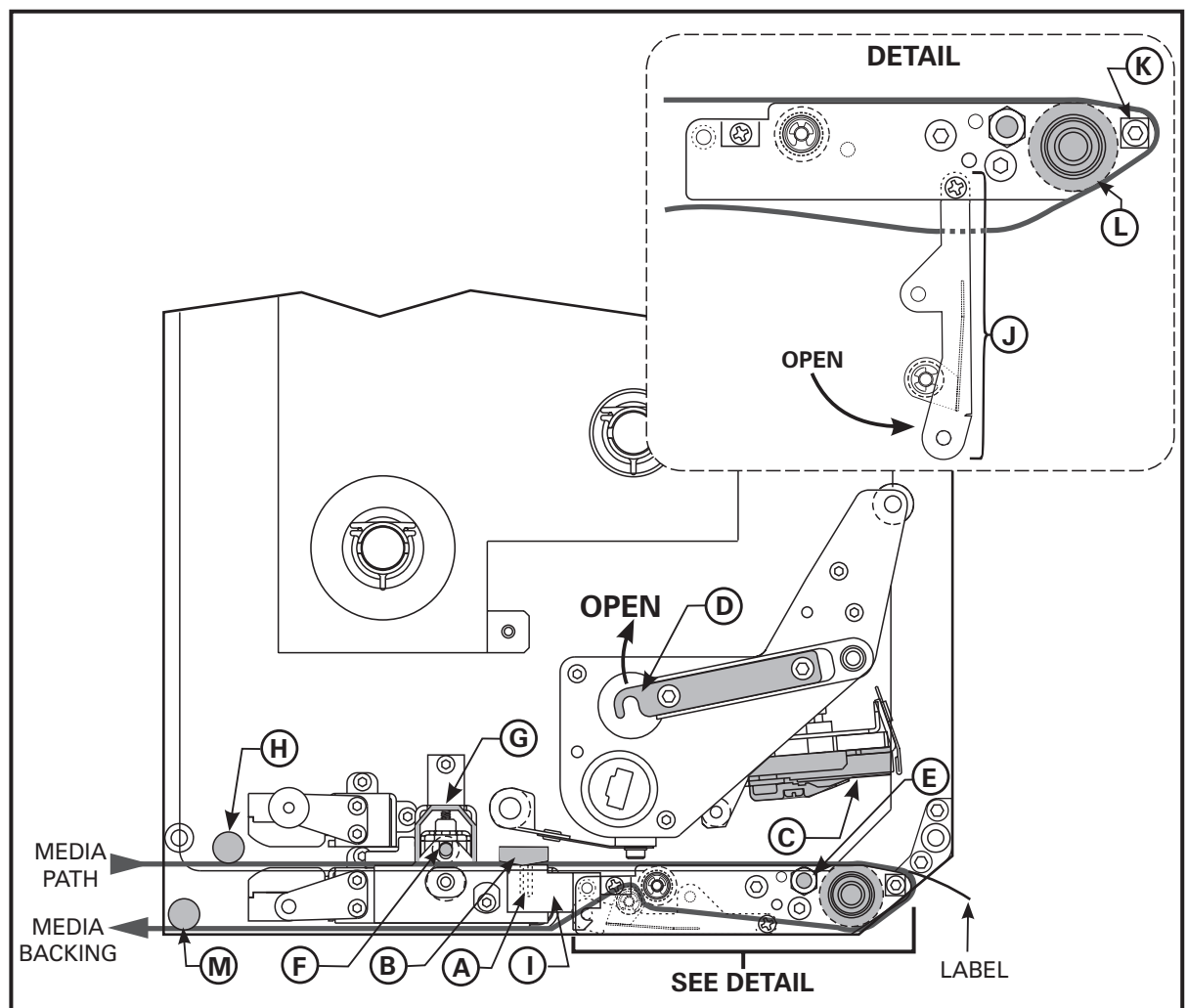

Figure 2. Media Loading (Right-Hand Units)

# Media & Ribbon Loading

5. Ensure the media is aligned within the print path then close the printhead assembly (C) by rotating the printhead lock lever (D) until it latches onto the locking pin (E).
6. Secure the pinch roller (F) in position by pressing down on the top of the pinch roller latch (G) until the assembly snaps closed.
7. Position the outer media edge guide (B) so it just touches the outer edge of the media.
8. Raise the peel roller latch (I) and the peel roller assembly (J) will pivot down to a vertical position.
9. Thread the backing material around the peel bar (K), under the platen roller (L), and through the peel roller assembly (J). (See DETAIL.)



**NOTE:** If the applicator has an air tube, route the media between the air tube and the peel bar. Do not thread the media over this tube!

10. Rotate the peel roller assembly (J) up until it latches closed.
11. Thread the backing material under the lower guide post (M) and around the take-up spindle of the applicator (refer to the applicator's user's manual).

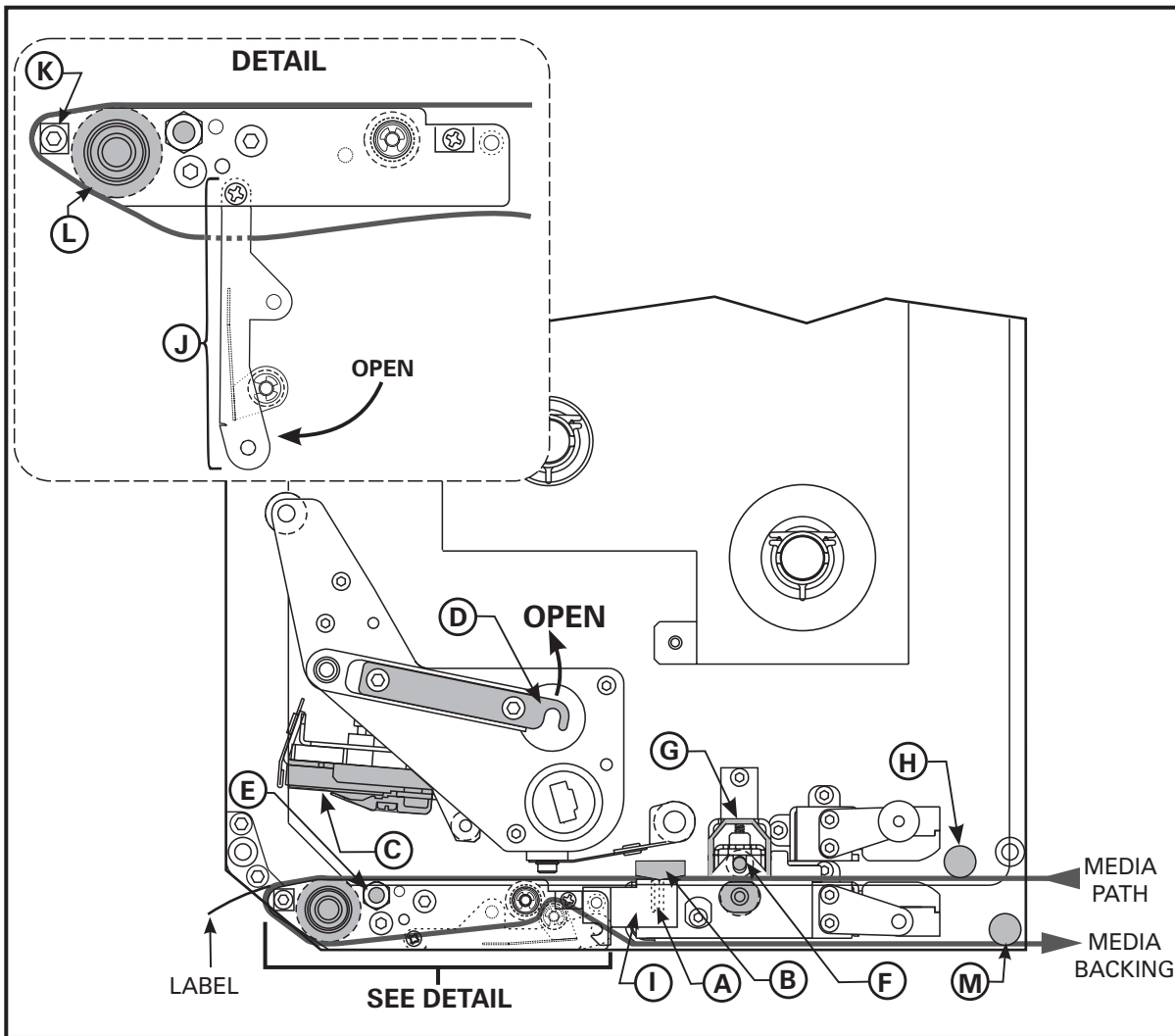

Figure 3. Media Loading (Left-Hand Units)



## Ribbon Loading

To load ribbon, refer to Figure 4 (for right-hand units) or Figure 5 (for left-hand units).



**NOTE:** *Do not* load ribbon if the printer is to be used in the direct thermal mode.



**CAUTION:** When installing the ribbon roll on the ribbon supply spindle, make sure it is pushed up against the stop and that the ribbon is aligned squarely with its core. *Do not* use ribbon that is narrower than the media. If the printhead is not protected by the smooth backing of the ribbon, premature printhead failure may result due to excessive abrasion.

### Right Hand Units

1. Push the ribbon roll onto the supply spindle (N) as far as it will go, so the ribbon feeds as shown in Figure 4.
2. Install an empty ribbon core onto the ribbon take-up spindle (O).
3. Open the printhead assembly (C) by unlatching the printhead lock lever (D) from the locking pin (E).
4. Thread the ribbon below the lower ribbon guide roller (P), under the printhead assembly (C), and up and over the upper ribbon guide roller (Q) as shown in Figure 4. *Use caution not to crease or wrinkle the ribbon!*
5. Attach the ribbon to the take-up spindle core (use a label if needed) and wind for several turns in the direction shown in Figure 4.
6. Close the printhead assembly (C) by latching the printhead lock lever (D) onto the locking pin (E).
7. Insure the ribbon is located between the Ribbon Sensor and the Sensor Reflector positioned above it.

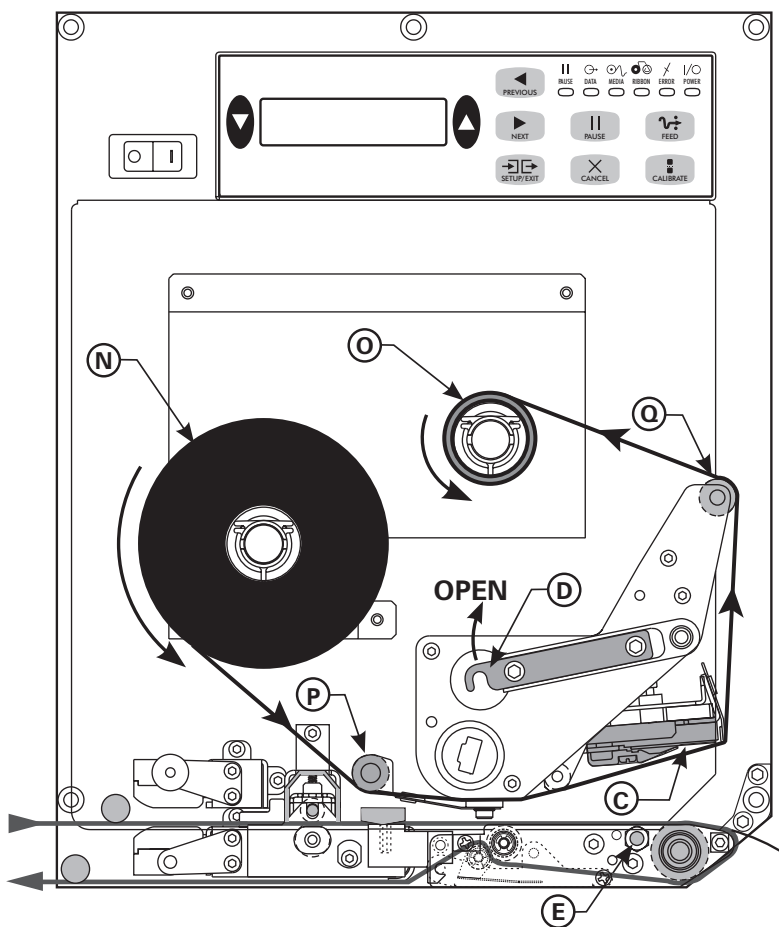

Figure 4. Ribbon Loading (Right-Hand Units)

# Media & Ribbon Loading

## Left Hand Units

1. Push the ribbon roll onto the supply spindle (N) as far as it will go, so the ribbon feeds as shown in Figure 4.
2. Install an empty ribbon core onto the ribbon take-up spindle (O).
3. Open the printhead assembly (C) by unlatching the printhead lock lever (D) from the locking pin (E).
4. Thread the ribbon below the lower ribbon guide roller (P), under the printhead assembly (C), and up and over the upper ribbon guide roller (Q) as shown in Figure 5. *Use caution not to crease or wrinkle the ribbon!*
5. Attach the ribbon to the take-up spindle core (use a label if needed) and wind for several turns in the direction shown in Figure 5.
6. Close the printhead assembly (C) by latching the printhead lock lever (D) onto the locking pin (E).
7. Insure the ribbon is located between the Ribbon Sensor and the Sensor Reflector positioned above it.

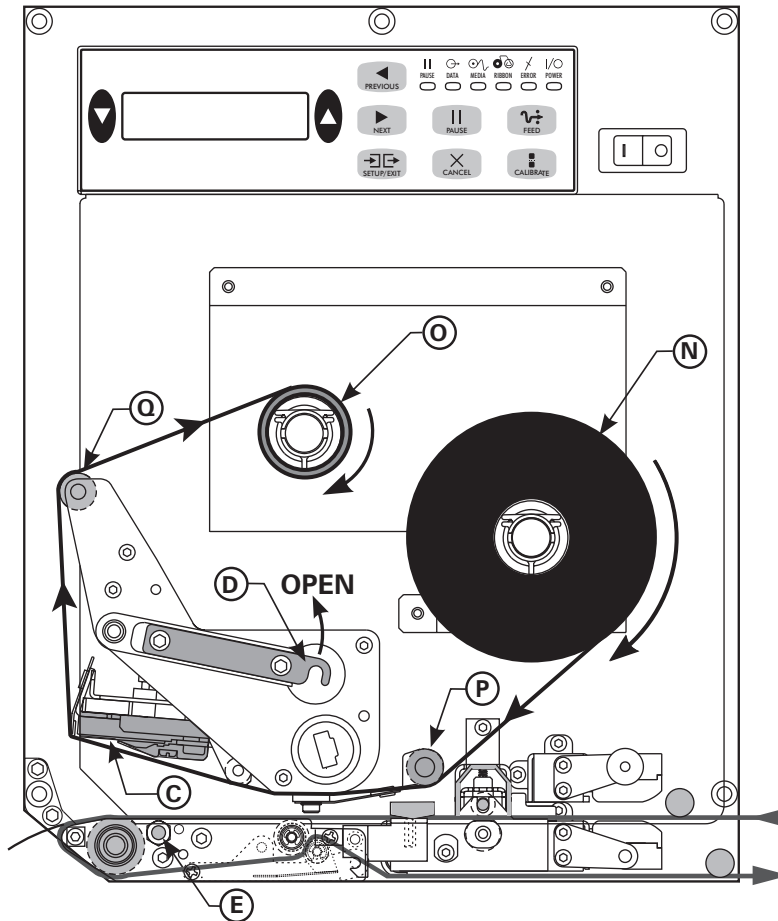

Figure 5. Ribbon Loading (Left-Hand Units)

## Removing Used Ribbon

To remove used ribbon:

1. Open the printhead assembly (C) by unlatching the lock lever (D) from the locking pin (E).
2. Cut the ribbon between the upper ribbon guide roller (Q) and the ribbon take-up spindle (O).
3. Remove the used ribbon and the core together from the ribbon take-up spindle (O).
4. Remove the empty ribbon core from the ribbon supply spindle (N).
5. To load the new ribbon, refer to the previous "Ribbon Loading" topic.

# Media Sensor Position

## Reflective Media Sensor

Some types of media have black marks printed on the underside of the backing material that act as “Start of Label” indicators. These black marks are sensed by the reflective media sensor mounted on the printer frame. The position of this sensor is not adjustable. If you will use this type of media, refer to the “Specifications” section of this guide for information about black mark requirements.

## Transmissive Media Sensor

The transmissive media sensor is used to find “start of label” indicators such as a notch or hole in the media or an interlabel gap (backing only) between labels. This sensor consists of a light source (positioned below the media) and a light sensor (positioned above the media). To properly align the position of this sensor, refer to Figure 6 and turn the adjustment knob (R) on the media guide shelf assembly until the sensor (S) is aligned with the notch or hole in the media. If your media uses an interlabel gap, position the media sensor approximately at the center of the media width.

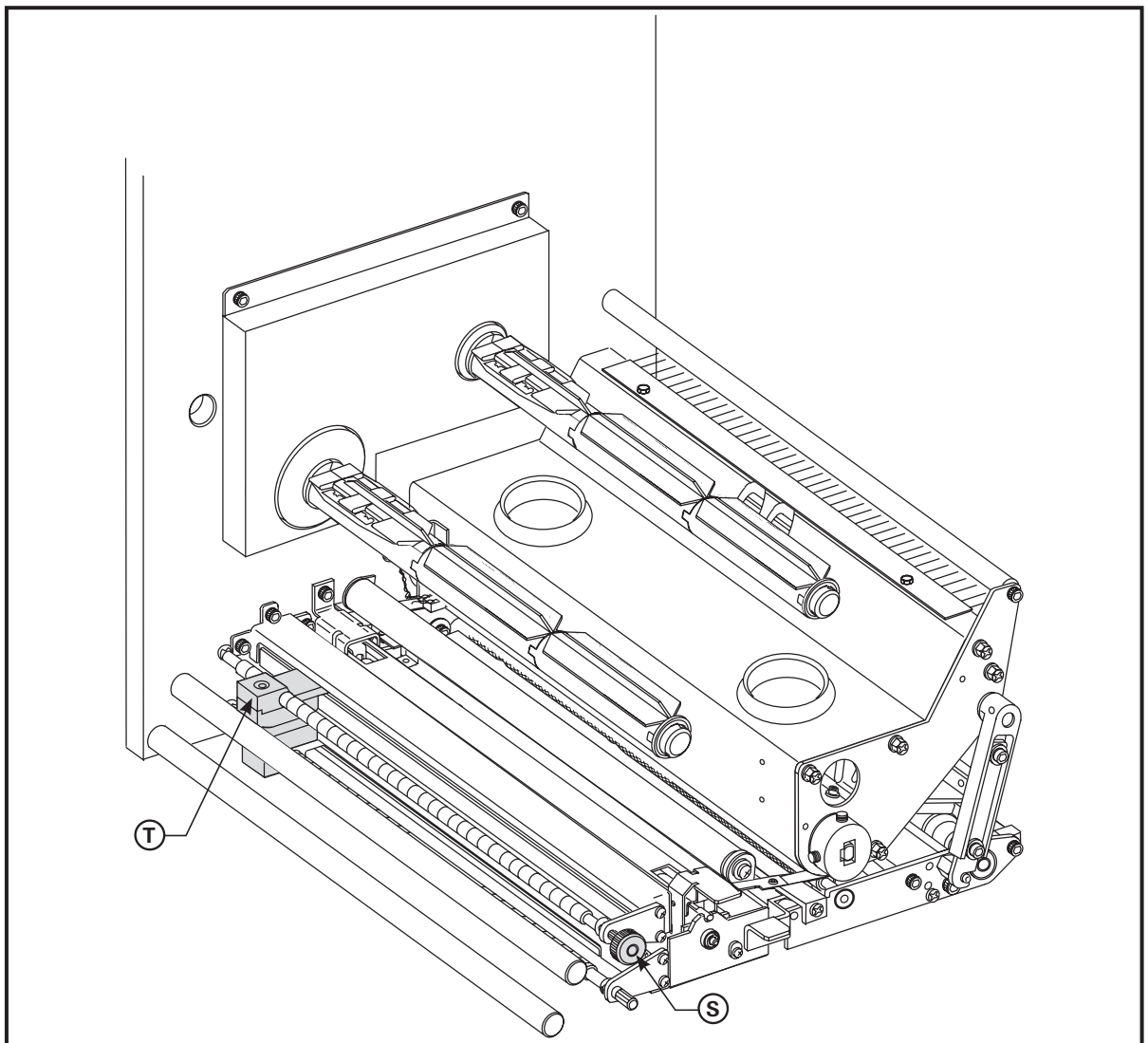

Figure 6. Media Sensor Adjustment (Right-Hand Unit Shown)



# Printer Operation

## Power On/Off Switch

The Power On/Off Switch is located just to the left (or right) of the printer's control panel. When this switch is placed in the ON (I) position, the POWER light goes ON and the printer automatically performs a Power On Self Test (POST). The Liquid Crystal Display validates the steps in the self test.



**NOTE:** Refer to the “Troubleshooting section of this manual if the printer stops due to failing a test in the Power On Self Test.

## Front Panel Keys

Four keys are used to control the various printer operations.

**FEED Key** — If you press the FEED key while the printer is idle or paused, a blank label is fed immediately. If you press the FEED key while the printer is printing, one blank label is fed after the completion of the current batch of labels. Once the blank label has been fed, pressing the FEED key again will feed a second label.

**PAUSE Key** — The PAUSE key stops and restarts the printing process. When the printer is paused, the PAUSE light will be ON. The first time you press the PAUSE key, any partially printed label is completed; then the printing process is stopped. If the printer is idle when you press the PAUSE key, no new print requests are accepted. Press the PAUSE key a second time to resume the printing process. Press this key to remove any error messages and clear the Liquid Crystal Display.

The PAUSE mode can also be activated through pin 5 of the Applicator Port or by sending a ZPL II<sup>®</sup> command to the printer.

**CANCEL Key** — The CANCEL key only functions when the printer is paused. When you press the CANCEL key, the label format that is currently printing is canceled. If no label format is printing, then the next one to be printed is canceled. If there are no label formats stored in the printer and waiting to be printed, the CANCEL key is ignored. *To clear the printer's entire label format memory, press and hold this key for several seconds until the DATA light turns OFF. The printer discards all of the label format data it has received and returns to the idle state.*

**CALIBRATE Key** — The CALIBRATE key functions only in the PAUSE mode. Press once to recalibrate for proper media length, set media type, and set print method.

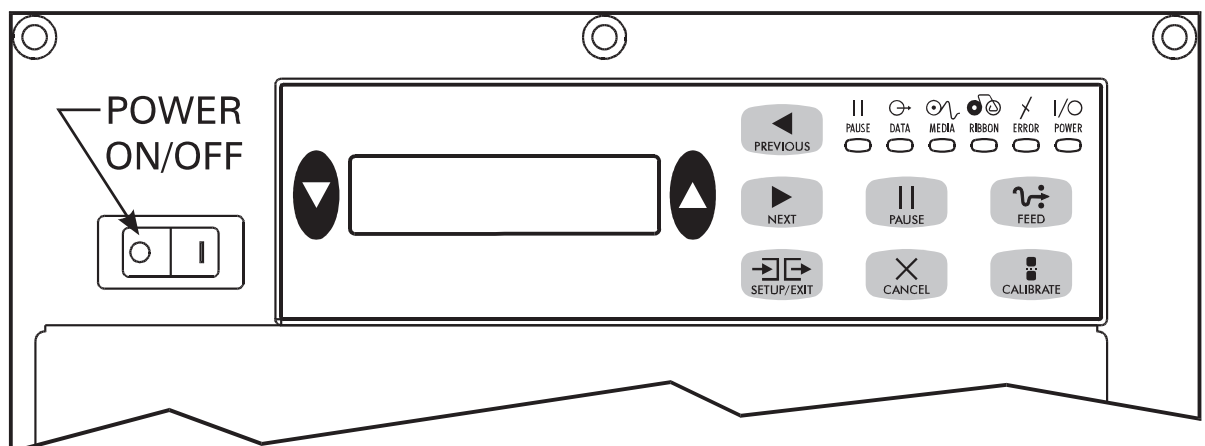

Figure 7. Control Panel

# Printer Operation

## Liquid Crystal Display

The control panel shown in Figure 7 contains a backlit Liquid Crystal Display. It shows operational status as well as programming modes and feature parameters.

## Control Panel Keys

Five keys are used to set print and communication parameters.

**BLACK OVAL KEYS** — These two keys are used to change parameter values; the actual use depends on the parameter being displayed. Common uses include increasing or decreasing a value, answering yes or no, indicating ON or OFF, and scrolling through several choices.

**PREVIOUS** — Scrolls the display to the previous parameter.

**NEXT** — Scrolls the display to the next parameter.

**SETUP/EXIT** — Enters and exits the configuration mode.

Specific uses of these keys are explained with each parameter setting description in the “Configuration and Calibration” section of this guide.

## Front Panel Indicator Lights (LEDs)

LEDs on the front panel are a quick indication of the printer’s status.

LED	OFF	ON	FLASHING
POWER (Green)	Printer OFF or no power to printer.	Power switch ON and power being supplied to printer.	---
PAUSE (Yellow)	Normal operation.	Printer is paused (Printhead, ribbon or paper error detected. <i>or</i> PAUSE key was pressed. <i>or</i> A Pause was requested from the Applicator Port. <i>or</i> A pause was received as part of the label format).	---
DATA (Green)	No data being received or processed.	Data processing or printing taking place. No data is being received.	Printer is receiving data. Flashing slows when the printer cannot accept more data, but returns to normal once data is again being received.
MEDIA (Yellow)	Normal operation. Media properly loaded.	Out of media. (Printer paused, LCD displays error message, and PAUSE light is ON).	---
RIBBON (Yellow)	Normal operation. Ribbon properly loaded.	Ribbon in (printer in direct thermal mode) or no ribbon loaded (printer in thermal transfer mode). Printer is paused, LCD displays error message, and PAUSE light is ON.	---
ERROR (Orange)	No printer errors.	---	Printer error exists. Check LCD display for status.

# Configuration and Calibration

After you have installed the media and ribbon, plugged in and turned on the AC Power, and the printer has completed the Power On Self Test (POST), you may configure the printer parameters for your application using the Liquid Crystal Display and the control panel keys. *Not all choices pertain to all applications. Choose only those settings that apply to your particular application.*



**NOTE:** To restore the printer's factory defaults, see "Leaving the Program Mode" below or refer to "FEED Key and PAUSE Key" in the "Troubleshooting" section of this guide.

## Introduction

### Entering the Program Mode

To enter the Program Mode, press the SETUP/EXIT key when **PRINTER READY** is displayed. Press either the NEXT key or the PREVIOUS key to scroll to the parameter you wish to set.



### Changing Password-Protected Parameters

Certain parameters, indicated by an illustration of a key  after the title, are password protected. The first attempt to change one of these parameters (pressing one of the black oval keys) will require a password to be entered. This is done via the **ENTER PASSWORD** display.

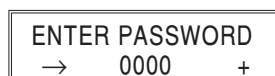

The left oval key changes the digit position. The right oval key increases the digit value. After entering the password, press the NEXT key. The parameter you were trying to change will be displayed. If the password was entered correctly, you can now change the value.

The default password value is 1234. A new password can be configured by sending an appropriate **^KP** (Define Password) ZPL II instruction to the printer.



**NOTE:** Once the password has been entered correctly, it will not have to be entered again until leaving and re-entering the programming mode using the SETUP/EXIT key.

### Leaving the Program Mode

Press the SETUP/EXIT key to leave the Program Mode. The display will show **SAVE SETTINGS**. There are five choices: Permanent, Temporary, Cancel, Load Defaults, and Load Last Save.



Pressing the left or right oval key changes the choices. Pressing the NEXT key activates the displayed choice. Pressing PREVIOUS returns you to the last prompt.

**Permanent** — saved values are permanently stored in the printer even when the power is OFF.

**Temporary** — saves the new changes until changed again or until the power is turned OFF.



# Configuration and Calibration

---

**Cancel** — cancels all changes since pressing the SETUP/EXIT key except Darkness and Tear Off (if they were changed).

**Load Defaults** — loads factory defaults as the printer's operating parameters. These are reflected on the following pages. (Loading factory defaults requires that a new printer calibration process be performed and resetting of the printhead resistance, verifier port, and applicator port values.)

**Load Last Save** — reloads the values from the last permanent save as the printer's operating parameters.

## Configuration Process

The following sequences of parameters are shown in the order displayed when pressing the NEXT key. Throughout this process, press the NEXT key to proceed to the next parameter; press PREVIOUS to return to the prior parameter in the cycle. As you change a parameter, an asterisk (\*) in the upper left-hand corner of the display indicates that the value displayed is different from the one that is currently active in the printer.

If you want the prompts displayed in a language other than English, press the PREVIOUS key and go to page 32 to select the Printer Language. Exit the Program Mode, Save Permanent, then re-enter the Program Mode. The Front Panel Display will now use the language selected.

## Setting Print Parameters

### Setting Darkness

Darkness (burn duration) settings are dependent upon a variety of factors, including ribbon type, media, and the condition of the printhead. You may adjust the darkness for consistent high-quality printing.



**NOTE:** The FEED Key Self Test described in “Troubleshooting” can also be used to determine the best darkness setting.



**CAUTION:** Set the darkness to the lowest setting possible for the desired print quality. Darkness set too high for a given ribbon may cause ink smearing and/or the printhead to burn through the ribbon.

---

If printing is too light, you should increase the darkness. If printing is too dark, or if there is spreading or bleeding of printed areas, you should decrease the darkness. (If there are voids in printed areas, adjust the toggle pressure.)



**NOTE:** The darkness setting takes effect right away. If labels are being printed, results can be seen immediately.



Press the right oval key to increase darkness, or press the left oval key to decrease darkness.

**Default:** +10

**Range:** 0 to +30

Press the NEXT key to display **TEAR OFF**.



# Configuration and Calibration

## Setting the Tear Off Position

The Tear Off Position adjusts the position of the media over the peel bar after printing. The label and backing can be torn off or cut between labels. This also affects the dispense position in Peel Off, Applicator, and Cutter modes.



Press the right oval key to increase the value or the left oval key to decrease the value. Each press of the key moves the tear off position by four dot rows (positive values move the media farther out over the peel bar).

**Default:** +0

**Range:** -120 to +120

Press the NEXT key to display **PRINT MODE**.

## Selecting the Print Mode

Print Mode settings tell the printer the method of media delivery that you wish to use. Be sure to select a print mode your hardware configuration supports, since some selections displayed are optional. *“Applicator” is the recommended mode for an applicator.*



Press the right or left oval key to display other selections.

**Default:** Tear Off

**Selections:** Tear Off, Applicator, Rewind

Press the NEXT key to display **MEDIA TYPE**.

## Selecting the Media Type

The Media Type parameter specifies the kind of media being used. “Continuous” media requires that a label length instruction (^LLxxx) be included in your ZPL or ZPL II label format.

With “non-continuous,” the printer feeds media to calculate label length (the distance between two detections of the inter-label webbing, or alignment notch, or hole). *“Non-Continuous” is the recommended mode for an applicator.*



Press the right or left oval key to display other selections.

**Default:** Non-Continuous

**Selections:** Non-Continuous, Continuous

Press the NEXT key to display **SENSOR TYPE**.

## Selecting the Sensor Type

The Sensor Type parameter selects the appropriate sensor for the type of media being used.



# Configuration and Calibration

---

Press the right or left oval key to display other selections.

**Default:** Web (used to sense notches or holes in media or liner between labels)

**Selections:** Web, Mark (used to sense black marks on the back of the media or liner)

Press the NEXT key to display **PRINT METHOD**.

## **Selecting the Print Method**

The Print Method parameter specifies the method of printing: direct thermal (no ribbon) or thermal transfer (using thermal-transfer media and ribbon).



**WARNING:** Selecting direct thermal when using thermal transfer media and ribbon will create a warning condition. Verify that ribbon is correctly installed or not installed in the printer, as required!

PRINT METHOD  
THERMAL-TRANS.

Press the right or left oval key to display other selections.

**Selections:** Thermal Transfer, Direct Thermal

Press the NEXT key to display **PRINT WIDTH**.

## **Setting the Print Width**

Print Width selects the media width. Setting the width too narrow may result in portions of your label not being printed on the label material. In addition, this setting can affect the horizontal position of the label format if you invert the image via the ^POI ZPL command. Setting the width too wide wastes formatting memory and, in the case of right hand printers, can cause printing to occur on the platen to the left of the actual label.

The units of measure can be changed from millimeters to inches to dots. Inches and millimeters are shown as fractions of the dots per inch (for example, 4-101/203 IN is the value for 4 1/2").

PRINT WIDTH  
168 00/12 MM +

Press the right oval key to increase the value or change the unit of measure and press the left oval key to change the selected character position. Select a print width that is at least as wide as your media.

**Default:** 6.62" (168 mm)

**Range:** 1 dot (1/8 mm or 1/12 mm) to 6.62" (168 mm)

Press the NEXT key to display **MAXIMUM LENGTH**.

## **Setting the Maximum Label Length**

Maximum Label Length specifies the distance from the leading edge of one label to the leading edge of the next label. Refer to Figure 8. The interlabel gap is considered part of the label length. Setting this parameter serves two functions:

- The value of this setting determines the maximum label length value to be used during the media portion of the calibration process.
- Only a few labels are required to set the media sensors.

Always set the length to a value that is one step above the actual length of the label you are using. For example, if the label length is 5 inches (126 mm), set the parameter for 6 inches (152 mm). If the label length is 7.5 inches (190 mm), set the parameter for 8.0 inches (202 mm).

# Configuration and Calibration



**NOTE:** Before you begin the media and ribbon calibration procedure, be sure the Maximum Length is set to a value one step greater than the actual media. If the Maximum Length is set to a lower value, the printer will assume that continuous media is loaded.



**NOTE:** If the Maximum Label Length is changed to a value that is lower than the length of the media being used, the printer will not calibrate.

MAXIMUM LENGTH - 39.0IN 988MM +
------------------------------------

Press the left oval key to decrease the value or press the right oval key to increase the value.

**Default:** 39.0 inches (988 mm)

**Range:** 2.0 inches (50 mm) to 39.0 inches (988 mm) in 1.0 inch (25.4 mm) increments.

Press the NEXT key to display **LIST FONTS**.

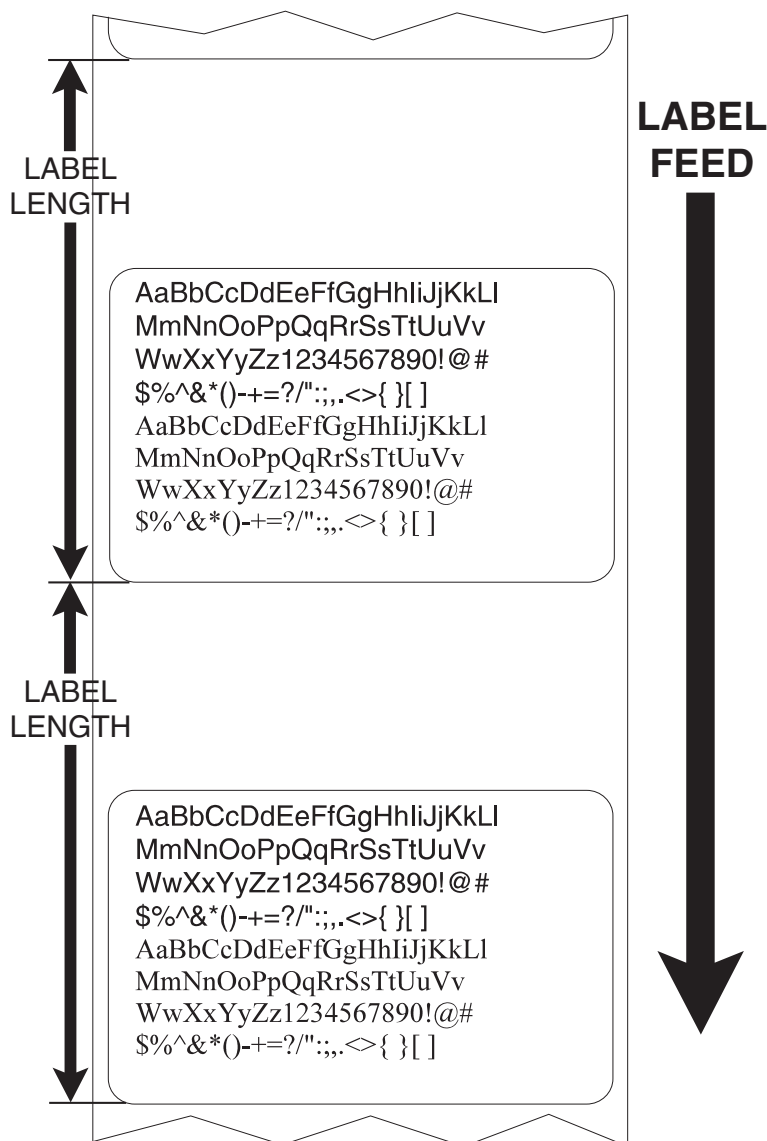

Figure 8. Maximum Label Length

# Configuration and Calibration

---

## Listing Printer Information

### **List Fonts**

This selection is used to print a label that lists all of the fonts currently available in the printer. Fonts may be stored in optional font EPROMs and as part of firmware EPROMs, on an optional PCMCIA memory card, or downloaded and stored in formatting memory (RAM).



Press the right oval key to print a label listing all of the fonts.

Press the NEXT key to display **LIST BAR CODES**.

### **List Bar Codes**

This selection is used to print a label that lists all of the bar codes currently available in the printer.



Press the right oval key to print a label listing all of the bar codes.

Press the NEXT key to display **LIST IMAGES**.

### **List Images**

This selection is used to print a label that lists all of the graphic images currently stored in the printer's DRAM, optional EPROM, or on an optional memory card.



Press the right oval key to print a label listing all of the images.

Press the NEXT key to display **LIST FORMATS**.

### **List Formats**

This selection is used to print a label that lists all of the formats currently stored in the printer's DRAM, optional EPROM, or on an optional memory card. Press the right oval key to print the label.



Press the right oval key to print a label listing all of the formats.

Press the NEXT key to display **LIST SETUP**.

### **List Setup**

This selection is used to print a label that lists the current printer configuration information (same as the CANCEL Key Self Test). Press the right oval key to print a label listing the current printer configuration.



Press the right oval key to print a label listing the current printer configuration.

Press the NEXT key to display **INITIALIZE CARD**.

# Configuration and Calibration

## Initialize Card

This selection initializes the optional memory card.



**CAUTION:** Perform this operation **only** when it is necessary to erase all previously stored information in the optional memory card. Otherwise, press the NEXT key to bypass this function and display **SENSOR PROFILE**.

INITIALIZE CARD  
YES

1. Press the right oval key to select “YES”. If your printer is set to require a password, you will now be prompted to enter the password. Enter the password then press the NEXT key.

INITIALIZE CARD  
YES

2. The display will ask “INITIALIZE CARD?” Press the right oval key to select “YES”. The front panel LCD will ask “ARE YOU SURE?”

ARE YOU SURE?  
NO YES

3. Press the right oval key to select “YES” and begin the initialization. or  
Press the left oval key “NO” to cancel the request and return to the “INITIALIZE CARD” prompt.
4. Press the SETUP/EXIT key followed by the NEXT key.

If initialization is still in process, the front panel display will flash back and forth between the two phrases “CHECKING B: MEMORY” and “PRINTER IDLE.”

When initialization is complete, the printer will automatically exit the configuration mode and the front panel will display “PRINTER READY”.



**NOTE:** Depending on the amount of memory in the memory card, initialization may take up to five minutes to complete.

# Configuration and Calibration

## Media and Ribbon Sensor Calibration

When the print engine is first put into service, the following calibration process must be performed. This allows the printer to establish the proper settings for the specific media and ribbon being used in your application. *If you have not reached this point by starting on page 11, you will have to enter the "Program Mode" by pressing the SETUP/EXIT key when the PRINTER READY is displayed on the LCD. Then press the NEXT key multiple times until the LCD displays the words "SENSOR PROFILE."* Now continue below to perform the Media and Ribbon Sensor Calibration.



**NOTE:** Ensure that the "Media Type" and "Maximum Length" values have been configured prior to performing this calibration process.

There are two different types of "Calibration" which can be performed on the print engine.

- When the front panel CALIBRATE key is pressed, the print engine determines the label length of noncontinuous media by sensing the time it takes for the media to feed from one "Start of Label" indicator (web, notch, hole, black mark) to the next. This process also determines if the application is using the direct thermal or thermal transfer print method by sensing the presence or absence of ribbon.
- The full Media and Ribbon Sensor Calibration discussed here, performs the same functions as the CALIBRATE key plus sensitivity adjustments on both the media and ribbon sensors. These adjustments set parameters for the specific media and ribbon currently installed in the printer.

If a different type of media and/or ribbon is used in the printer, the full calibration must be performed (not just the front panel key). Press the NEXT key and perform the "Media and Ribbon Calibration" procedure on the next page.

### Sensor Profile

Press the right oval key to print a graphic representation (Media Sensor Profile) of the changes in density between the media and the web (backing). The Sensor Profile may be used to help troubleshoot media registration problems.



Refer to Figure 9. The Media Sensor Profile shows three conditions. The black area along the bottom of the profile illustrates media passing by the media sensor. When the level goes above the point labeled "WEB" (black spikes), the backing material only is passing by the sensor. When a notch or hole in the media passes by the sensor, the level will go above the point labeled "MEDIA". If the level remains above the "MEDIA" point for longer than .5 seconds, this signifies a Media Out condition. The Ribbon Profile indicates Ribbon IN if the black level is above the point labeled "RIBBON".

Press the NEXT key to display **MEDIA AND RIBBON**.

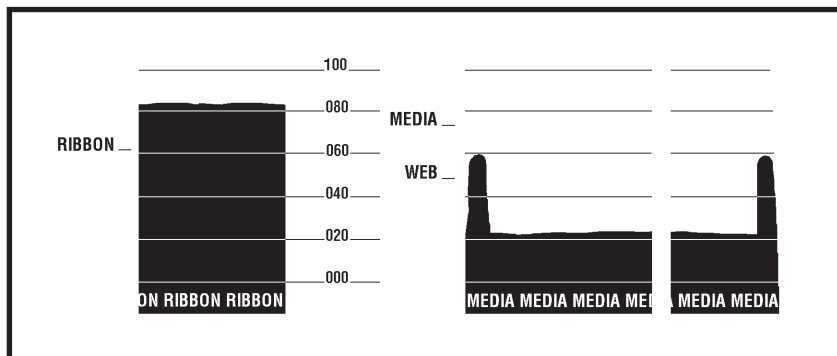

Figure 9. Sensor Profile Sample Label

# Configuration and Calibration

## **Media and Ribbon Calibration**

Changing the type of ribbon and/or media may require adjustments to the sensitivity of the media and ribbon sensors. Indications that the sensitivity may need to be adjusted would be a RIBBON light ON with the ribbon properly installed or non-continuous media being treated as continuous media.

The following procedure is used to adjust the sensitivity of both the media and ribbon sensors. To be sure this procedure is required, first read the information presented on the previous page.

*This procedure must be followed exactly as presented.* To bypass this procedure, press the NEXT key.

MEDIA AND RIBBON  
CALIBRATE

1. Press the right oval key to start the calibration procedure. **LOAD BACKING** will be displayed.

LOAD BACKING  
CANCEL CONTINUE

2. Press the left oval key to cancel the operation or do the following:

Open the printhead. Remove a sufficient number of labels from the backing material to ensure that only backing material is threaded through the entire media path.

3. Press the right oval key to continue. **REMOVE RIBBON** will be displayed.

REMOVE RIBBON  
CANCEL CONTINUE

4. Press the left oval key to cancel the operation or press NEXT to display **HOST PORT**, or remove the ribbon (sliding it away from the mainframe will have the same effect as removing it).
5. Close the printhead.
6. Press the right oval key to continue (start the calibration process) or the left oval key to cancel the operation. If you choose to continue, **CALIBRATING...PLEASE WAIT** will be displayed.

CALIBRATING  
PLEASE WAIT

The sensitivity adjustments for the media and ribbon sensors are now being made. This process takes only a few seconds.

RELOAD ALL  
CONTINUE

7. When **RELOAD ALL** is displayed, open the printhead and pull the media forward until a label is positioned under the media sensor. Move the ribbon back to its proper position.
8. Close the printhead.
9. Press the right oval key to continue the calibration procedure. Label Length will be calibrated and **MEDIA AND RIBBON** will be displayed.

MEDIA AND RIBBON  
CALIBRATE

The sensitivity adjustments for the media and ribbon sensors are now completed.

Press the NEXT key to display **HOST PORT**, or turn to page 11 to exit the programming mode.

# Configuration and Calibration

## Setting Communication Parameters

Communication parameters must be set correctly for the printer to receive data from the host. These parameters ensure that the printer and host are “speaking the same language.”

All communications parameters are password-protected. See page 11.

### Setting the Host Port

Select the communications port that matches the one being used by the host computer.

HOST PORT  
← MAIN RS232 →

Press the right or left oval key to display other selections.

**Default:** Main RS232

**Selections:** Main RS232, RS422/485, RS485 Multidrop, Parallel

Press the NEXT key to display **BAUD**. (If Parallel was selected, go to “Setting the Protocol”.)

### Setting the Baud Rate

The baud rate of the printer must match the baud rate of the host for communications to take place. Select the baud rate that matches the one being used by the host.

BAUD  
- 9600 +

Press the right oval key to increase the value, or press the left oval key to decrease the value.

**Default:** 9600

**Selections:** 110, 300, 600, 1200, 2400, 4800, 9600, 19200, 28800, 57600

Press the NEXT key to display **DATA BITS**.

### Setting the Data Bits

The data bits of the printer must match the data bits of the host for communications to take place. Select the data bits that match the ones being used by the host.



**NOTE:** This parameter must be set to 8 data bits to use the Code Page 850 character set. See the ZPL II Programming Guide for further information.

DATA BITS  
- 7 BITS +

Press the right or left oval key to display other selections.

**Default:** 7 Bits

**Selections:** 7 Bits, 8 Bits

Press the NEXT key to display **PARITY**.



# Configuration and Calibration

## Setting the Parity

The parity of the printer must match the parity of the host for communications to take place. Select the parity that matches the one being used by the host.

PARITY  
- EVEN +

Press the right or left oval key to display other selections.

**Default:** Even

**Selections:** Even, None, Odd

Press the NEXT key to display **STOP BITS**.

## Setting the Stop Bits

The stop bits of the printer must match the stop bits of the host for communications to take place. Select the number of stop bits that match the quantity being used by the host.

STOP BITS  
- 1 STOP BIT +

Press the right or left oval key to display other selections.

**Default:** 1 Stop Bit

**Selections:** 1 Stop Bit, 2 Stop Bits

Press the NEXT key to display **HOST HANDSHAKE**.

## Setting the Host Handshake

The handshake protocol of the printer must match the handshake protocol of the host for communications to take place. Select the handshake protocol that matches the one being used by the host.

HOST HANDSHAKE  
← XON/XOFF →

Press the right or left oval key to display other selections.

**Default:** XON/XOFF

**Selections:** XON/XOFF, DSR/DTR

Press the NEXT key to display **PROTOCOL**.

## Setting the Protocol

The serial port supports Error Detection Protocol which sends and receives data in packets. The selected protocol must be compatible with your host computer and your application software. Select the protocol that is required by the host.



**NOTE: Do not** enable Error Detection unless your Host is programmed to use it. For more information, refer to the ZPL II Programming Guide.

PROTOCOL  
← NONE →

Press the right or left oval key to display other selections.

**Default:** None (Always select “None” if you are not using error checking software.)

**Selections:** None, Zebra Protocol, ACK/NACK Protocol

# Configuration and Calibration



**NOTE:** Zebra Protocol is the same as ACK/NACK Protocol, except the response messages are sequenced.



**NOTE:** If Zebra Protocol is selected, the printer must use “DSR/DTR” Host Handshake Protocol.

Press the NEXT key to display **NETWORK ID**.

## Setting the Network ID

Network ID is used to assign a unique number to a printer used in a selective calling network. This gives the host the means to address a specific printer. *A Network ID is not required when connected in an Ethernet Network.*

```
NETWORK ID
→ 000  +
```

Press the left oval key to move to the next digit position, and press the right oval key to increase the value of the selected digit.

**Default:** 000

**Range:** 000 - 999

Press the NEXT key to display **COMMUNICATIONS**.

## Setting the Communications Mode

The Communications Diagnostics Mode is a tool to check the interconnection between the printer and the host. When DIAGNOSTICS is selected, all data sent from the host to the printer will be printed as an ASCII hex printout. The printer prints all ASCII characters received, including ASCII control codes (for example, CR [Carriage Return]). A sample printout is shown in Figure 10.

```
COMMUNICATIONS
←NORMAL MODE→
```

Press the right or left oval key to display other selections.

**Default:** Normal Mode

**Selections:** Normal Mode, Diagnostics

**NOTES** on diagnostic printouts:

An FE indicates a framing error.

An OE indicates an overrun error.

A PE indicates a parity error.

An NE indicates noise.

For any errors, check that your communication parameters are correct. Set the print width *equal to or less than* the label width used for the test.

```
^FS^F0394,25^AA
5E 46 53 5E 46 4F 33 39 34 2C 32 35 5E 41 41
N,18,10^FD(0000
4E 2C 31 38 2C 31 30 5E 46 44 28 30 30 30 30
)999-9999^FS
29 39 39 39 2D 39 39 39 39 5E 46 53 0D 0A
^F00,50^AAN,18,
5E 46 4F 30 2C 35 30 5E 41 41 4E 2C 31 38 2C
10^FDCENTER STA
31 30 5E 46 44 43 45 4E 54 45 52 20 53 54 41
```

**Figure 10. Diagnostics Sample Label**

Press the NEXT key to display **CONTROL PREFIX**.

# Configuration and Calibration

## Selecting Prefix and Delimiter Characters

Prefix and delimiter characters are two-digit hex values used within the ZPL/ZPL II formats sent to the printer. See “Appendix C” for an ASCII Code chart.

The printer uses the most recently configured prefix and delimiter characters, whether included as part of a ZPL II instruction or input from the front panel.



**NOTE:** DO NOT use the same hex value as the control, format, and delimiter characters. The printer requires different characters to function properly.

### *The Control Prefix Character*

The control prefix character is a two-digit hex value. Once configured, this character will signify the start of a ZPL/ZPL II control instruction.

CONTROL PREFIX → <■> 7EH +
-------------------------------

Press the left oval key to move to the next digit position, and press the right oval key to increase the value of the digit. (The “H” is displayed but not entered as part of the value.)

**Default:** 7E (tilde)

**Range:** 00 - FF (exclude the values indicated on the ASCII Code Chart in “Appendix C”)

Press the NEXT key to display **FORMAT PREFIX**.

### *The Format Prefix Character*

The format prefix character is a two-digit hex value. Once configured, this character will signify the start of a ZPL or ZPL II format instruction.

FORMAT PREFIX → <^> 5EH +
------------------------------

Press the left oval key to move to the next digit position, and press the right oval key to increase the value of the digit. (The “H” is displayed but not entered as part of the value.)

**Default:** 5E (caret)

**Range:** 00 - FF (exclude the values indicated on the ASCII Code Chart in “Appendix C”)

Press the NEXT key to display **DELIMITER CHAR**.

### *The Delimiter Character*

The delimiter character is a two-digit hex value. Once configured, this character acts as a parameter place marker in ZPL/ZPL II. Refer to the “ZPL II Programming Guide” for more information.

DELIMITER CHAR → <, > 2CH +
--------------------------------

Press the left oval key to move to the next digit position, and press the right oval key to increase the value of the digit. (The “H” is displayed but not entered as part of the value.)

**Default:** 2C (comma)

**Range:** 00 - FF (exclude the values indicated on the ASCII Code Chart in “Appendix C”)

Press the NEXT key to display **MODE**.

# Configuration and Calibration

## Selecting ZPL Mode

The printer accepts label formats written in either ZPL or ZPL II. Refer to the “ZPL II Programming Guide” for more information on the differences between ZPL and ZPL II.

The printer will remain in the selected mode until changed by this front panel instruction or by sending a ZPL/ZPL II command to the printer.



Press the right or left oval key to display other selections.

**Default:** ZPL II

**Selections:** ZPL II, ZPL

Press the NEXT key to display **RIBBON TENSION**.

## Setting Ribbon Tension

This parameter sets the tension applied to the Ribbon Supply Spindle. A setting of Low, Medium, or High is determined by the combination of ribbon width and length. Use the tables below to determine the recommended setting for your specific application. If ribbon wrinkle, or smudging or scuffing of ink on the label material is evident, reduce the tension to the next lower setting.



Ribbon Width	Ribbon Tension Setting			
	300 Meter Roll	450 Meter Roll	600 Meter Roll	900 Meter Roll
3" to 5"	LOW	LOW	LOW	LOW
4" to 6"	LOW	LOW - MEDIUM	LOW - MEDIUM	MEDIUM
5" to 7"	LOW - MEDIUM	MEDIUM	MEDIUM - HIGH	HIGH

Press the right or left oval key to display other selections.

**Default:** High

**Selections:** Low, Medium, High

Press the NEXT key to display **MEDIA POWER UP**.

## Power Up and Head Close Parameters

### Media Power Up

Determines the action of the media when the printer is turned ON. “Calibration” recalibrates the media sensors, “Feed” feeds the label to the first web, “Length” calculates the length of the label, and “No Motion” means the media does not move. “No Motion” is the recommended mode for an applicator.



# Configuration and Calibration

Press the right or left oval key to display other selections.

**Default:** Feed

**Selections:** Feed, Calibration, Length, No Motion

Press the NEXT key to display **HEAD CLOSE**.

## **Head Close**

Determines the action of the media after the printhead has been opened and then closed.

“Calibration” recalibrates the media sensors, “Feed” feeds the label to the first web, “Length” calculates the length of the label, and “No Motion” means the media does not move.

“Feed” is the recommended mode for an applicator.



Press the right or left oval key to display other selections.

**Default:** Feed

**Selections:** Feed, Calibration, Length, No Motion

Press the NEXT key to display **BACKFEED**.

## **Label Positioning Parameters**

### **Backfeed Sequence**

Determines when and how much label backfeed occurs in the Applicator mode. It has no effect in Rewind or Tear-Off modes.

This parameter setting can be superseded by a ZPL/ZPL II instruction when received as part of a label format. Refer to the “ZPL II Programming Guide.”



Press the right oval key for the next choice, or press the left oval key for the previous choice.

**Default:** 90% of the backfeed occurs after the label is dispensed; the remaining 10% takes place before the next label is printed.

**Selections:** Default; After, Before, 10%, 20%, 30%, 40%, 50%, 60%, 70%, 80%, or 90%



**NOTE:** The difference between the value entered and 100% establishes how much backfeed occurs before the next label is printed. For example, a value of 40 means that 40% of the backfeed takes place after the label is dispensed. The remaining 60% takes place before the next label prints. A value of “Before” means that all backfeed will take place before the next label is printed.

Press the NEXT key to display **LABEL TOP**.

# Configuration and Calibration

## Setting the Label Top Position

The Label Top Position controls the initial vertical print position on the label (viewed as the label exits the printer). The Default position is referenced to the leading edge of the label which follows the one to be printed. Refer to Figure 11. If there is a lengthy web between labels, the label format may begin printing on the backing material. To set the position where the format begins printing, change the Label Top Position value.



Press the right oval key to increase the value, or press the left oval key to decrease the value. Each positive number moves the label top position down by one dot row; each negative number moves the position up by one dot row.

**Default:** +0

**Range:** -120 to +120

Press the NEXT key to display LEFT POSITION.

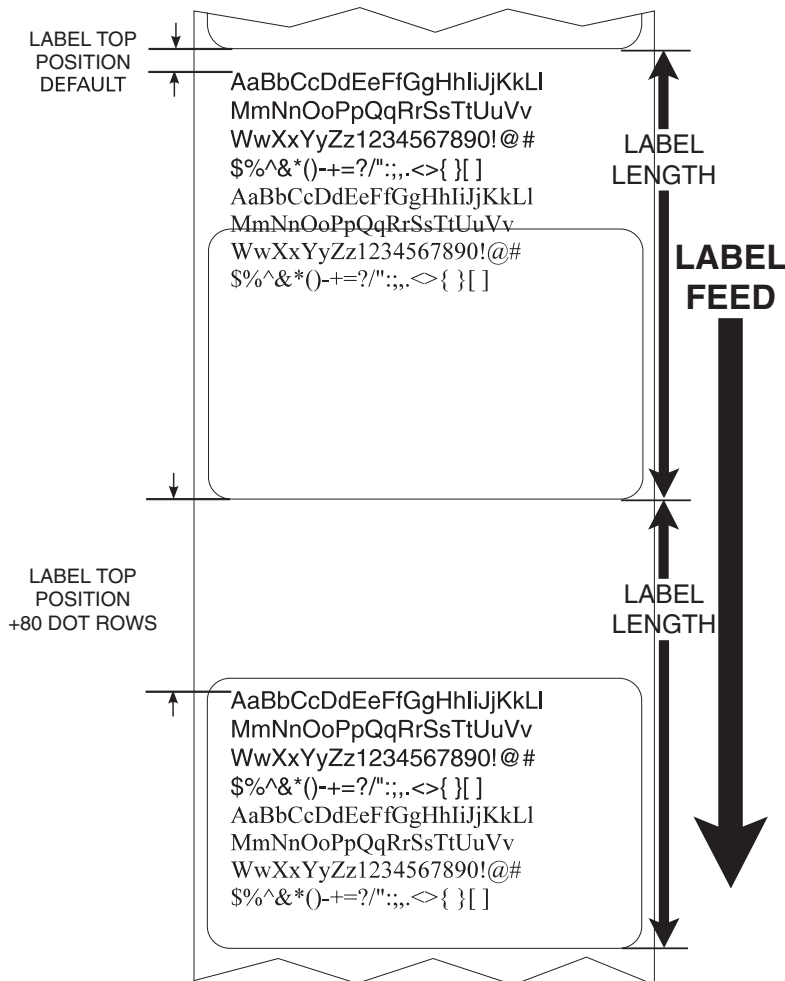

Figure 11. Label Top Position

# Configuration and Calibration

## Setting the Left Position

The Left Position controls the initial print position from the left edge of a label (viewed as the label exits the printer). The Default position is referenced to the left edge of the media. Refer to Figure 12. Depending on the width of the media, the label format may begin printing on the backing material or on the platen. To set the position where the format begins printing, change the Left Position value.

LEFT POSITION		
→	+ 0000	+

Press the left oval key to move the cursor to the next digit, and press the right oval key to change the +/- value and increase the value of the digit (“+” shifts to the left; “-” shifts to the right.) The displayed value represents the number of dot positions the format will shift right or left.

**Default:** 0000

**Range:** -9999 to +9999 (If a negative value is required, enter the numeric value first, then change the plus to a minus sign.)

Press the NEXT key to display **HEAD TEST COUNT**.

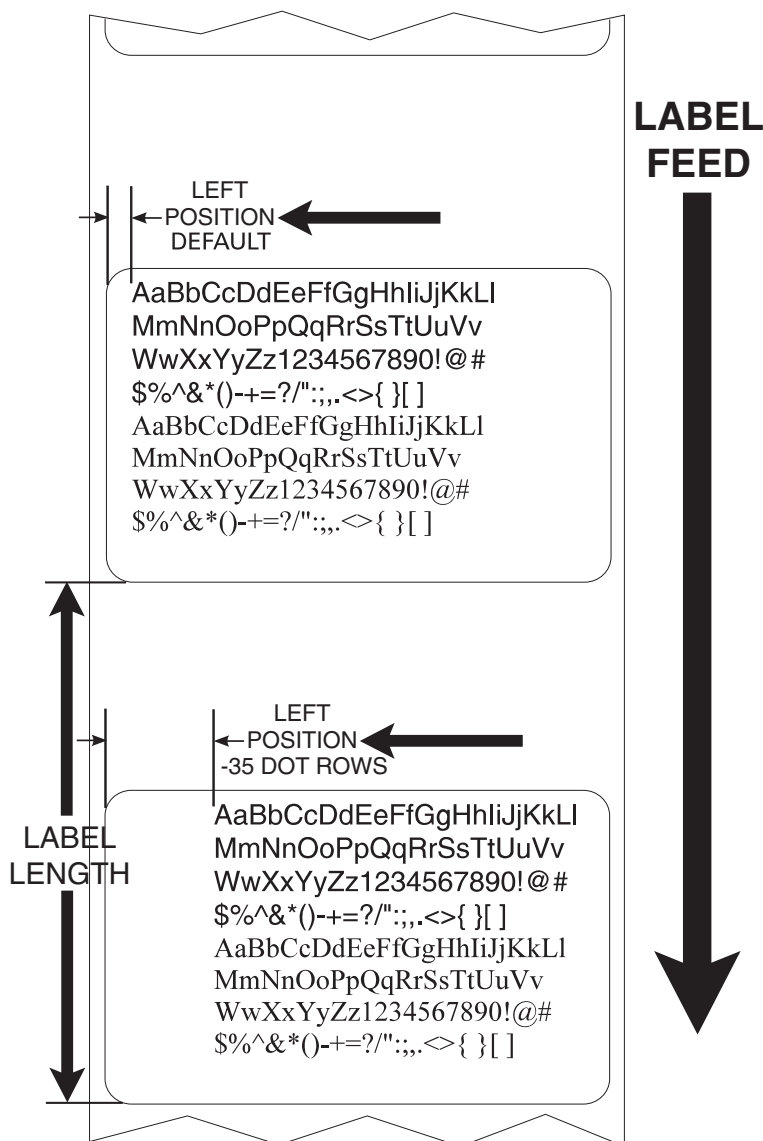

Figure 12. Left Position

# Configuration and Calibration

---

## Head Test Function

Periodically a Head Test is automatically performed to ensure that the printhead elements are working correctly. This parameter determines how many labels are printed between these internal printhead tests.

### Setting the Head Test Count

The Head Test Count is used to select the head test interval (the number of labels printed between head tests).

HEAD TEST COUNT
→ 0000 +

Press the left oval key to move to the next digit position, and press the right oval key to change the value of the digit. The displayed value represents the number of labels printed between tests.

**Default:** 0000 (disables the head test)

**Range:** 0000 to 9999

Press the NEXT key to display **HEAD RESISTOR**.

## Head Resistance

### Setting the Head Resistance Value

This value has been pre-set at the factory to match the resistance value of the printhead. It will not need to be changed, unless:

1. The printhead is replaced.
2. The printer is set to the factory defaults. (The factory default value is usually lower than the actual head resistance value.)

Before replacing a printhead, look on the bottom of the new printhead for the label that shows the resistance (ohm –  $\Omega$ ) value.



**CAUTION:** DO NOT set the value higher than that shown on the printhead. Setting a higher value may damage the printhead.

---

HEAD RESISTOR
→ 0500 OHMS +

Press the left oval key to move to the next digit position, and press the right oval key to increase the value of the digit.

**Initial Value:** Factory set

**Range:** 0500 - 1175

Press the NEXT key to display **VERIFIER PORT**.

## Verifier Port

### Setting the Verifier Port

The Verifier Port determines how the optional verifier will interface with a Zebra printer.

*This setting is factory set and should not be changed unless the factory defaults have been reloaded. Please make a note of it! While other choices are valid, the printer must be returned to its designated setting in order for it to work properly.*



# Configuration and Calibration

**OFF** - The verifier port is off.

**1 ERR** — Label reprinted if verifier detects an error. If the bar code is near the upper edge of the label, the label will feed out far enough to be verified and then backfed to allow the next label to be printed and verified.

**2 VER-THRUPUT** — Allows for the greatest throughput but may not indicate a verification error immediately upon detection. May print from one to three labels before an error is recognized and printing stops.



Press the right or left oval key to display other selections.

**Default:** Off

**Selections:** Off, 1 VER-RPRNT ERR, 2 VER-THRUPUT

Press the NEXT key to display **APPLICATOR PORT**.

## Applicator Port

### Setting the Applicator Port

The Applicator Port is used to determine how the printer will interface with the applicator.

*This is set by the applicator manufacturer and should not be changed unless the factory defaults have been reloaded. Please make a note of it! While other choices are valid, the printer must be returned to its designated setting in order for it to work properly.*

Refer to Table 5 in “Appendix B” for more applicator cable information.

**OFF** — Applicator interface is off.

**MODE 1** — Asserts the END PRINT signal LOW while the printer is moving the label forward.

**MODE 2** — Asserts the END PRINT signal HIGH while the printer is moving the label forward.

**MODE 3** — Asserts the END PRINT signal LOW for 20 milliseconds when a label has been completed and positioned. Not asserted during continuous printing modes.

**MODE 4** — Asserts the END PRINT signal HIGH for 20 milliseconds when a label has been completed and positioned. Not asserted during continuous printing modes.



Press the right or left oval key to display other selections.

**Default:** Off

**Selections:** Off, MODE 1, MODE 2, MODE 3, MODE 4

Press the NEXT key to display **START PRINT SIG**.

## Printing Controls

### Setting the Start Print Signal

This parameter determines how the printer will react to the Start Print Signal input on pin 3 of the applicator interface connector at the rear of the printer.

*This is set by the applicator manufacturer and should not be changed unless the factory defaults have been reloaded. Please make a note of it! While other choices are valid, the printer must be returned to its designated setting in order for it to work properly.*

Refer to Table 5 in “Appendix B” for more applicator cable information.

**PULSE MODE** — A label will print when the signal transitions from HIGH to LOW.

**LEVEL MODE** — Labels will print as long as the signal is asserted LOW.



Press the right or left oval key to display other selections.

**Default:** Pulse Mode

**Selections:** Pulse Mode, Level Mode

Press the NEXT key to display **RESYNCH MODE**.

### Setting the Resync Mode

This parameter determines how the printer will react if the label synchronization is lost and the label top is not where expected.

*This is set by the applicator manufacturer and should not be changed unless the factory defaults have been reloaded. Please make a note of it! While other choices are valid, the printer must be returned to its designated setting in order for it to work properly.*

**FEED MODE** — If the label top is not where expected, the printer will feed a blank label to find the label top position.

**ERROR MODE** — If the label top is not where expected, the printer will stop, enter the PAUSED mode, display the message “Error Condition Feed Label”, flash the ERROR LED, and assert the “Service Required” signal (pin 10 on the Applicator Interface Connector).

To resync the media to the top of the label in this mode, the user must press the PAUSE key to exit the PAUSED state. The ERROR LED will then stop flashing and the “Service Required” signal will be de-asserted. The action of the printer is then determined by the “Head Close” configuration selection:

- “Calibration” – the printer feeds labels and recalibrates the media sensors.
- “Feed” – the printer feeds the labels to the next web.
- “Length” – the printer feeds labels and calculates the label length.
- “No Motion” – the media does not move. The user must press the FEED key to cause the printer to resync to the start of the next label.



Press the right or left oval key to display other selections.

**Default:** Feed Mode

**Selections:** Feed Mode, Error Mode

Press the NEXT key to display **RIBBON LOW**.

# Configuration and Calibration

## Selecting the Ribbon Low Feature

When the Ribbon Low feature is enabled, the “Ribbon Low” output signal (Pin 9) on the applicator port is functional. When the amount of ribbon on the supply spindle reaches a specific low level, the output signal will assert HIGH to provide a “Ribbon Low” warning.

When the Ribbon Low feature is disabled, the output signal (Pin 9) will not function, the “Low Ribbon” warning is not displayed, and the printer will continue to print until it runs out of ribbon.

RIBBON LOW MODE  
← ENABLED →

Press the right or left oval key to display other selections.

**Default:** Enabled

**Selections:** Enabled, Disabled

Press the NEXT key to display **REPRINT MODE**.

## Reprint Mode

When the Reprint feature is enabled, the “Reprint” input signal (Pin 6) on the applicator port is functional. When the input signal is asserted, the last label printed will be printed again. (This includes non-printing labels.) When the Reprint feature is disabled, the “Reprint” input signal is ignored.



**NOTE:** The **^SP** command is ignored when the Reprint feature is enabled. When the Reprint feature is disabled, the **^SP** command can be used. In addition, when a received label format is canceled prior to printing, the “reprint” function for the previous label is also canceled.

REPRINT MODE  
← DISABLED →

Press the right or left oval key to display other selections.

**Default:** Disabled

**Selections:** Disabled, Enabled

Press the NEXT key to display **WEB SENSOR**

## Sensor Values

The following eight parameters — Web Sensor, Media Sensor, Ribbon Sensor, Mark Sensor, Mark Media Sensor, Media LED, Ribbon LED, and Mark LED — are automatically calculated during the calibration procedure and typically do not require adjustment. Additional information about these values can be found in the *170PAX-Series Maintenance Manual* (P/N 49803L).

Press the NEXT key to display **LCD ADJUST**.

# Configuration and Calibration

---

## LCD Adjust

Adjusts the brightness of the Liquid Crystal Display.

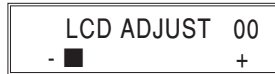

Press the left oval key to decrease the brightness; the right oval key to increase the brightness.

**Default:** 00

**Range:** 00 to 19

Press the NEXT key to display LANGUAGE

## Printer Language

### *Selecting the Liquid Crystal Display (LCD) Language.*

Allows you to specify the language for the LCD prompts and error messages language. The selected language will also be print on the following labels: setup/configuration, and the font, bar code, graphic, and format listings.



**NOTE:** At the beginning of the programming process on page 12, it is recommended that the user press the PREVIOUS key to display this parameter and allow for international language selection. If you want the prompts displayed in a language other than English, select the Printer Language, exit the Program Mode, Save Permanent, then re-enter the Program Mode. The Front Panel Display will now use the language selected. This allows the user to read the programming prompts in the desired language.

Press the right oval key to select a language.

**Default:** English

**Selections:** English, Spanish, French, German, Italian, Norwegian, Portuguese, Swedish, Spanish2, Dutch, Finnish, Custom

If this is the last configuration parameter, press the SETUP/EXIT key, select the desired Save Mode (typically "Permanent"), then press the NEXT key to end the configuration process. Refer to "Leaving the Program Mode" on page 11.

# Care & Adjustments

## Cleaning



**CAUTION:** Use only the cleaning agents indicated. Zebra Technologies Corporation will not be responsible for damage caused by any other cleaning materials used on the 170PAX2-Series print engine.

Table 1 provides a recommended cleaning schedule. Cleaning swabs saturated with 70% Isopropyl Alcohol are available from your Zebra distributor as a Preventive Maintenance Kit (part # 01429).

AREA	METHOD	INTERVAL
<b>See Figures 13 and 14 for parts locations.</b>		
Printhead (1)	Alcohol	After every roll of ribbon when printing in the thermal transfer mode. After every roll of media when printing in the direct thermal mode.
Platen Roller (2)	Alcohol	
Media Path	Alcohol	
Transmissive Media Sensor (3)	Air blow	
Reflective Media Sensor (4)	Air blow	
Ribbon Sensor (5)	Air blow	
Door-Open Sensor (6)	Air blow	
Peel Bar (7)	Alcohol	After every roll of media or more often if needed.

**Table 1. Recommended Cleaning Schedule**

### ***Cleaning the Exterior***

The exterior surfaces of the printer may be cleaned with a lint free cloth. *Do not use harsh or abrasive cleaning agents or solvents!* If necessary, a mild detergent solution or desktop cleaner may be used sparingly.

### ***Cleaning the Interior***

Remove any accumulated dirt and lint from the interior of the printer using a soft bristle brush and/or vacuum cleaner. This area should be inspected after every roll of ribbon.

### ***Cleaning the Sensors***

To ensure proper operation of the printer, all sensors should be cleaned on a regular basis. To locate the position of these sensors, refer to Figure 13.

# Care & Adjustments

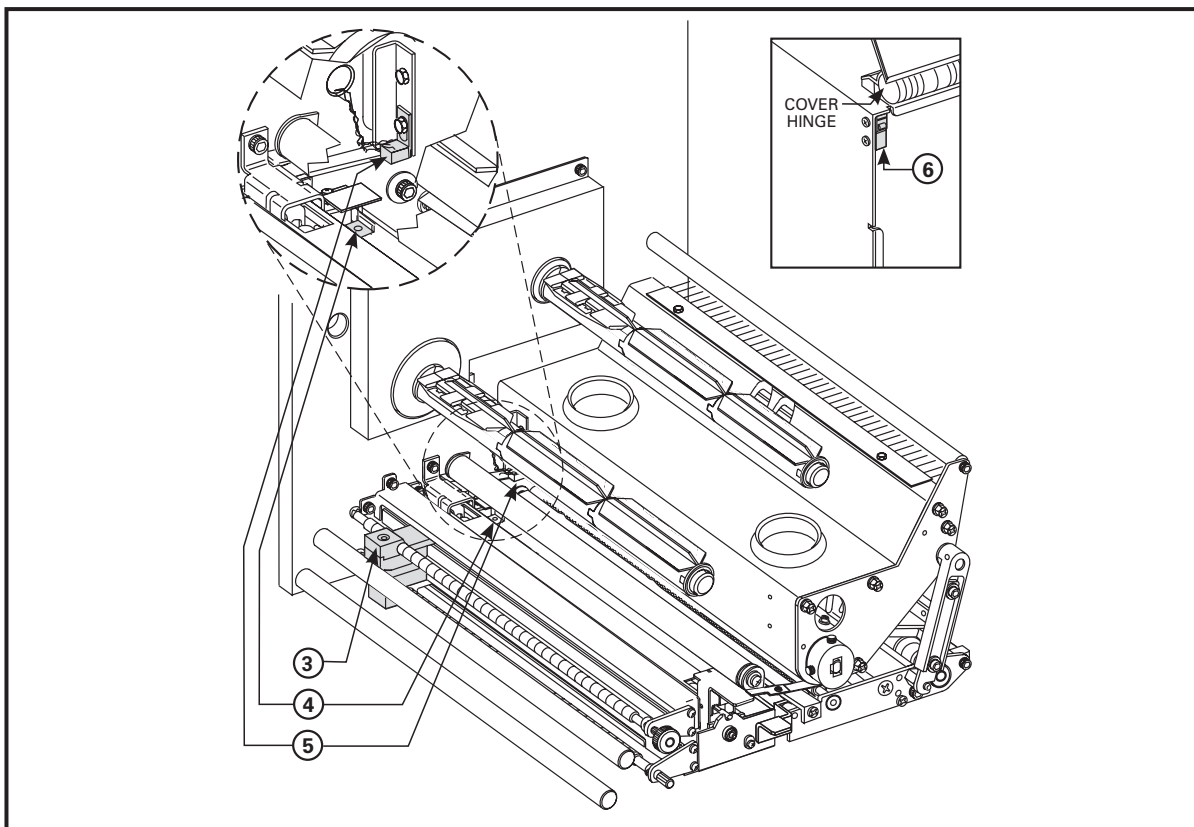

Figure 13. Sensor Locations (Right-Hand Unit Shown)

## ***Cleaning the Printhead and Platen Roller***

Inconsistent print quality, such as voids in the bar code or graphics, or light print may indicate a dirty printhead. Media movement problems may indicate a dirty platen. For optimum print quality, perform the following cleaning procedure after every roll of ribbon.



**NOTE:** If print quality has degraded and you have not changed to a different type of media or ribbon, it should not be necessary to change the burn temperature or the toggle pressure.

To clean the printhead and platen roller, refer to Figure 14 and perform the following steps:

1. Open the printhead assembly (C) by lifting the printhead lock lever (D) upward away from the locking pin (E), and remove the media and ribbon.
2. Brush, vacuum, or air blow any accumulated lint and paper dust away from the rollers. *It is good practice to clean the various media, ribbon, and door-open sensors at this time. See Figure 13.*
3. Use a cleaning swab saturated with alcohol and wipe the print elements from end to end. *The print elements form the grayish/black strip (1) just behind the chrome strip on the underside of the printhead.* Allow a few seconds for the solvent to evaporate.
4. Use a lint-free cloth moistened with alcohol to clean the platen roller (2) and other rollers. Rotate the rollers while cleaning.
5. Reload the ribbon and/or media, latch the printhead, and continue printing. (Turn the printer ON if previously turned OFF.)

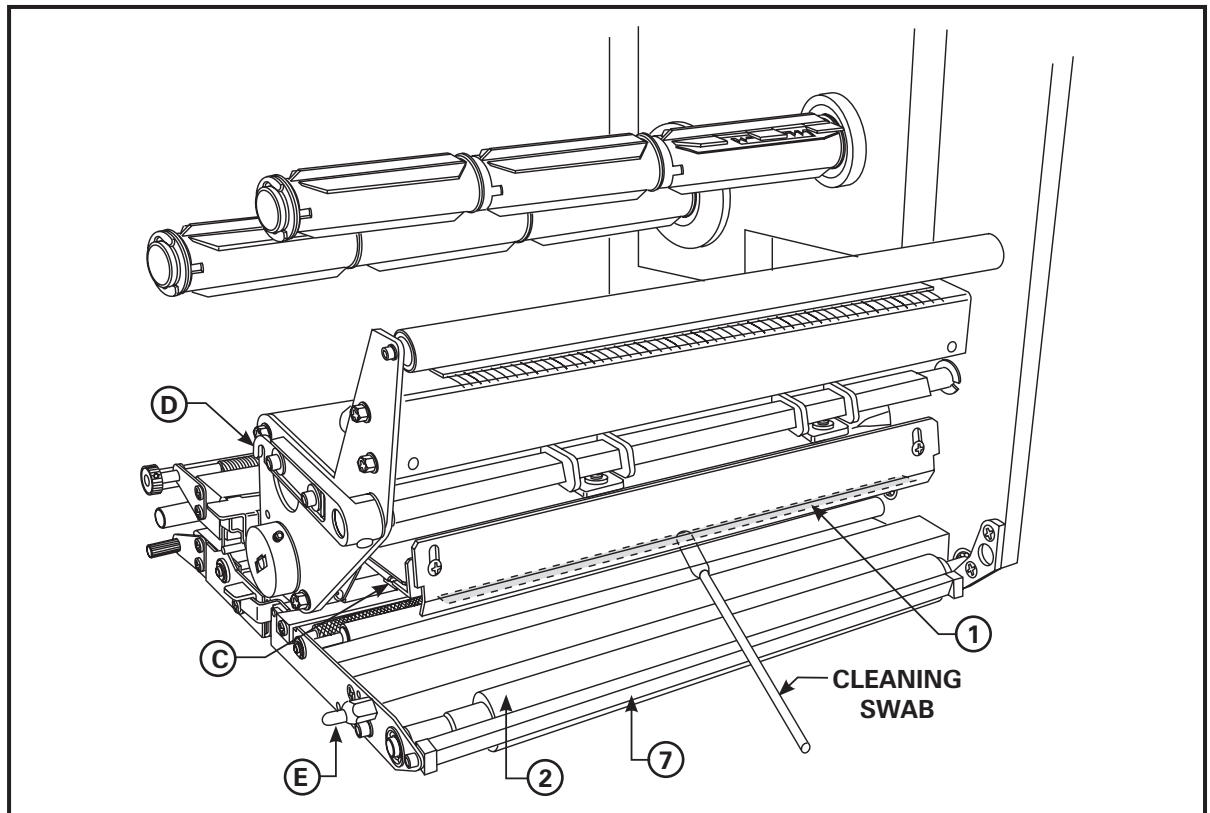

Figure 14. Printer Cleaning (Right-Hand Unit Shown)



**NOTE:** If print quality has not improved, try cleaning the printhead with the Save-a-Printhead cleaning film. This specially coated material removes contamination buildup without damaging the printhead. Call your authorized Zebra distributor to order the Save-a-Printhead cleaning kit for the 170PAX2 printer (part # 38902M).

## Toggle Positioning

Proper Toggle positioning is important for proper print quality. The toggles should be positioned 1/4 of the width in from the media edges (see Figure 15 inset).

To position the toggles, loosen the set screws (T) with a 1.5 mm Allen wrench and slide them to the desired position on the toggle pivot shaft (U); then, **tighten the set screws 1/2 turn past contact.**



**NOTE:** Perform the Printhead Pressure Adjustment which follows, and make sure the toggle pressure is even, otherwise the media may drift or the ribbon may wrinkle.

## Printhead Pressure Adjustment

If printing is too light, or if thick or thin media is used, printhead pressure may need to be adjusted. During this adjustment procedure, refer to Figure 15. (Use the lowest pressure possible that provides the desired print quality.)

1. Refer to the Configuration process starting on page 11 and lower the darkness setting (burn duration) to a value of "2" or "3".
2. Refer to the PAUSE Key Self Test on page 43 and print test labels at 2" (50.8 mm) per second.
3. Loosen the locking nuts (R) on the threaded shafts of both toggle assemblies.



# Care & Adjustments

4. Use the adjusting nuts (S) to increase or decrease the spring pressure until the left and right edges of the printed area are equally dark.
5. Increase darkness to the optimum level for the media being used.
6. Hold the adjusting nuts (S) in position, and tighten the locking nuts (R) against them.



**NOTE:** Printhead and drive system (belts and bearings) life can be maximized by using the lowest pressure that produces the desired print quality.

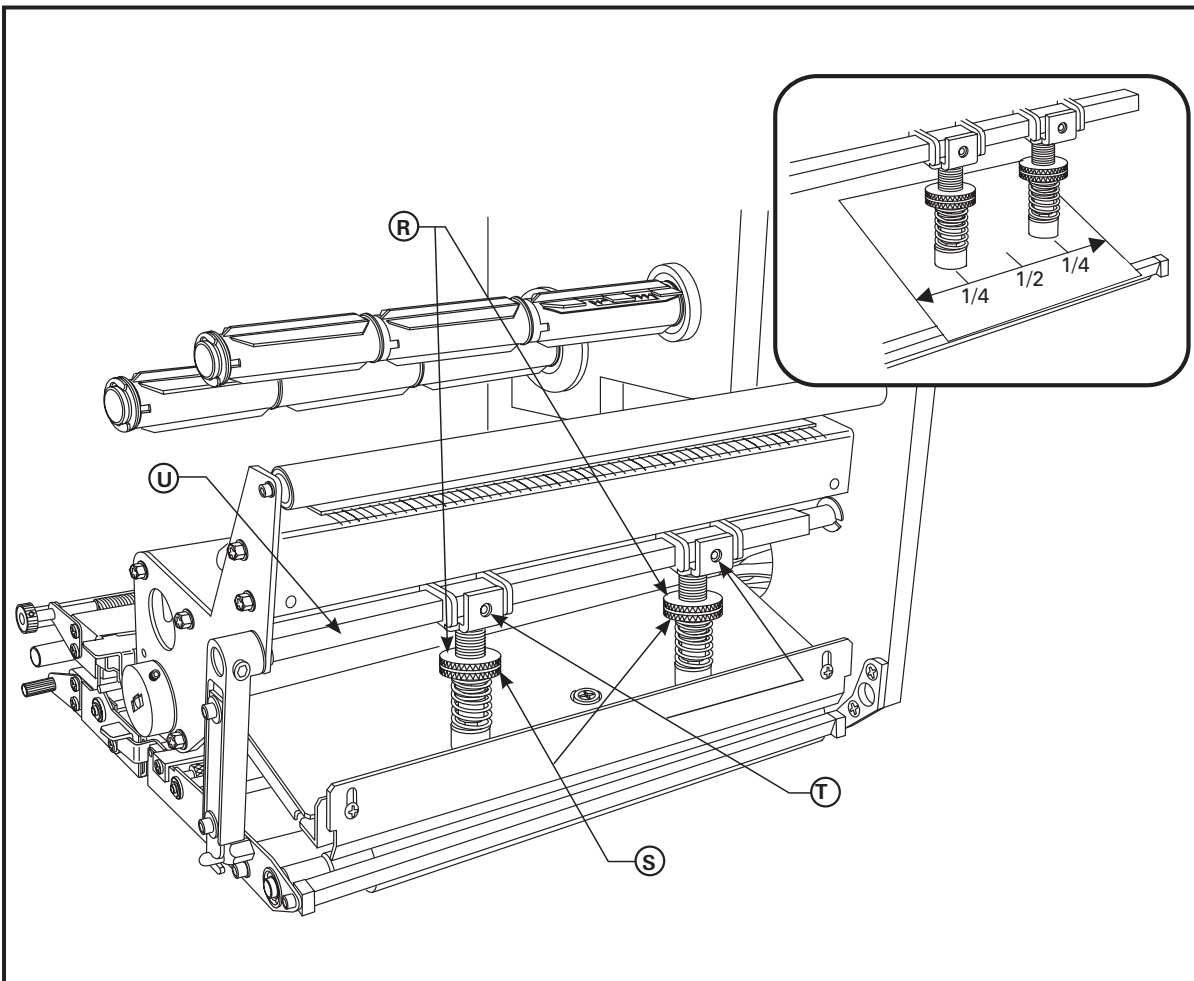

Figure 15. Printhead Pressure (Right-Hand Unit Shown)



# Troubleshooting

## Power On Self Test

A Power On Self Test (POST) is performed each time the printer is turned ON. During this test, the front panel lights (LEDs) will turn ON and OFF to ensure proper operation. At the end of this self test, only the POWER LED will remain lit. Once the Power On Self Test is complete, the media is advanced to the proper resting position, as determined by the programmed Media Feed setting.

To initiate the Power On Self Test, turn the printer ON using the power switch on the control panel. The POWER LED will go ON. The other control panel LEDs and the LCD monitor the progress and indicate the results of the individual tests. All displayed prompts occur in English; however when a test fails, the prompt will also rotate through the international languages.

The normal self test sequence, which occurs each time the printer is turned on, is as follows:

1.		All lights turn on simultaneously and then turn off in sequence through the following steps.
2.	SRAM Test	SRAM functionality test performed.
3.	Option ROM Test	Option ROM functionality test performed. The words "Not Installed" will be added to the display if optional ROM is not used.
4.	Printhead Test	Printhead is checked for proper operation.
5.	Processor Test	Processor functionality test performed. The word "Failed" will be added to the display if the test fails.
6.	E-Cubed Test	E-cubed functionality test performed. The word "Failed" will be added to the display if the test fails.
7.	EEPROM Test	EEPROM/PROM functionality test performed. The word "Failed" will be added to the display if the test fails.
8.	Memory Card Test	Optional PCMCIA Memory Card functionality test performed. The words "Not Installed" will be added to the display if no card is present.
9.		Depending on how the <b>^MF</b> (Media Feed) instruction is set, the printer will feed to the first web or label length, calibrate ribbon and media sensors, or set label length and feed one or more labels.
10.	PRINTER READY x.x MB VXX.X.X	Printer is ready for operation. Refer to "Configuration and Calibration" to set specific parameters. Designate prompt language with the <b>^KL</b> command or from the menu.

# Troubleshooting

The following tables provide trouble symptoms, a diagnosis of specific causes, and a recommended action which should result in proper printer operation.

If you are in need of technical assistance, contact your equipment supplier.

## Power On Troubleshooting

SYMPTOM	DIAGNOSIS	ACTION
All lights on, but nothing displays on the LCD, and the printer locks up.	Internal electronic or firmware failure.	Call a service technician.
Printer locks up while running the Power On Self Test.	Main Logic Board failure.	Call a service technician.
EEPROM TEST FAILED	EEPROM checksum is incorrect.	Call a service technician.

## Printer Troubleshooting

SYMPTOM	DIAGNOSIS	ACTION
ERROR CONDITION RIBBON OUT	<b>For Thermal Transfer:</b> Ribbon not loaded or incorrectly loaded.	Load ribbon correctly. See "Ribbon Loading" on page 5.
Printer stops; RIBBON light ON, ERROR light flashes.	Ribbon Sensor not detecting ribbon that is loaded correctly.	Perform "Media and Ribbon Sensor Calibration" on page 18.
WARNING RIBBON IN	<b>For Direct Thermal:</b> Ribbon loaded.	Remove ribbon. Load media correctly. Perform "Media and Ribbon Sensor Calibration" on page 18.
RIBBON light ON, ERROR light flashes.	Media blocking the Ribbon Sensor.	
ERROR CONDITION PAPER OUT	No media loaded or incorrectly loaded.	Load media correctly. See "Media Loading" on page 3.
Printer stops; MEDIA light ON, ERROR light flashes.	Misadjusted Media Sensor.	Check position of the Media Sensor.
	Printer set for non-continuous media, but continuous media is loaded.	Install proper media or reset printer for current media type and perform calibration.
ERROR CONDITION HEAD OPEN	Printhead is not fully closed.	Close printhead completely.
Printer stops and ERROR light flashes.	Head Open Sensor not working properly.	Call a service technician.
WARNING HEAD TOO HOT	Printhead is overheated.	Allow printer to cool. Printing resumes when the printhead elements cool to operating temperature.
Printer stops and ERROR light flashes.		

SYMPTOM	DIAGNOSIS	ACTION
<div style="border: 1px solid black; padding: 2px; width: fit-content; margin-bottom: 5px;">WARNING HEAD COLD</div> ERROR light flashes.	Printhead is not hot enough to print properly.	Printing continues while printhead heats up. If error remains, environment may be too cold for proper printing. Relocate printer to warmer area. Verify print quality.
<div style="border: 1px solid black; padding: 2px; width: fit-content; margin-bottom: 5px;">ERROR CONDITION HEAD ELEMENT BAD</div> Experiencing print quality problems.	Printhead element is bad or going bad.	To <b>correct</b> the situation, call a service technician to replace the printhead. To <b>override</b> this error message, turn off the Head Test in the Printer Configuration.
Printer stops and PAUSE light goes ON. The LCD displays:	Not enough memory to perform function shown on the second line.  <b>Explanation of Errors:</b>	You may do any of the following:
<div style="border: 1px solid black; padding: 2px; width: fit-content; margin-bottom: 5px;">OUT OF MEMORY CREATING BITMAP</div>	<b>1. Creating Bitmap -</b> Bitmap size (label length/width) does not fit in available memory.	A. With PAUSE on, send a ~HM command to the printer to display the amount of free memory. <i>Then either:</i>
<div style="border: 1px solid black; padding: 2px; width: fit-content; margin-bottom: 5px;">OUT OF MEMORY STORING BITMAP</div>	<b>2. Storing Bitmap -</b> Not enough memory available to store the bitmap created.	Redesign graphic/format to fit available memory or remove items from memory to create more space. <i>or</i>
<div style="border: 1px solid black; padding: 2px; width: fit-content; margin-bottom: 5px;">OUT OF MEMORY BUILDING FORMAT</div>	<b>3. Building Format -</b> Label is too complex.	Press PAUSE to skip the formatting step in process and proceed to the next step.
<div style="border: 1px solid black; padding: 2px; width: fit-content; margin-bottom: 5px;">OUT OF MEMORY STORING FORMAT</div>	<b>4. Storing Format -</b> Format is too large to fit in available memory.	B. With PAUSE on, press CANCEL. The printer skips the current label formatting process and goes on to the next label.
<div style="border: 1px solid black; padding: 2px; width: fit-content; margin-bottom: 5px;">OUT OF MEMORY STORING GRAPHIC</div>	<b>5. Storing Graphic -</b> Graphic image is too large to fit in available memory.	C. Turn power OFF and then ON to clear printer memory and start over.
<div style="border: 1px solid black; padding: 2px; width: fit-content; margin-bottom: 5px;">OUT OF MEMORY STORING FONT</div>	<b>6. Storing Font -</b> Not enough memory available to store the font.	D. Upgrade the printer to a larger memory size.
Long tracks of missing print on several labels.	Wrinkled ribbon.	See "Wrinkled Ribbon" later in this section.
	Print element damaged.	Call a service technician.
Fine, angular gray lines on blank labels.	Wrinkled ribbon.	See "Wrinkled Ribbon" later in this section.

# Troubleshooting

SYMPTOM	DIAGNOSIS	ACTION
Wrinkled ribbon.	Ribbon fed through the machine incorrectly.	See "Ribbon Loading" on page 5.
	Incorrect burn temperature.	Set the burn temperature to the lowest possible setting for good print quality.
	Incorrect or uneven printhead pressure.	Set the pressure to the minimum needed. See "Printhead Pressure" adjustment on page 35.
	Media not feeding properly; "walking" from side to side.	Make sure that the media is snug by adjusting the Media Guide, or call a service tech.
	Strip Plate needs adjusting.	Call a service technician.
	Printhead needs vertical adjustment.	Call a service technician.
	Printhead and Platen Roller need to be realigned.	Call a service technician.
	Ribbon Supply Spindle motor is inoperative.	Call a service technician.
Broken or melted ribbon.	Darkness setting too high.	Reduce setting for best print quality, and clean the printhead thoroughly.
Light printing or no printing on the left or right side of the label.	Printhead pressure needs adjustment or printhead out of alignment.	See "Printhead Pressure" adjustment on page 35.
		Call a service technician.
Misregistration/skips labels.	Media Sensor is not positioned correctly.	Perform Media Sensor position adjustment.
	Printer not calibrated.	Recalibrate printer.
	Improper label format.	Use correct label format.
Misregistration and misprint of one to three labels.	Media Sensor is not positioned correctly.	Place Media Sensor in proper position.
	Dirty Platen.	Clean the Platen.
	Media does not meet specifications.	Use media that meets specifications.
Vertical drift in top-of-form registration.	A plus or minus 4-6 dot row (approximately 0.5 mm) vertical drift is acceptable due to the different tolerances of the mechanical parts and printer modes.	First calibrate the printer, then use the "Label Top Position" setting to correct. See "Configuration and Calibration."
	Printer out of Calibration.	Recalibrate printer.
	Platen dirty.	Clean Platen.
Missing LCD characters or parts of characters.	Liquid Crystal Display may be bad and need replacing.	Call a service technician.
Changes in parameter settings did not take effect.	Parameters are set incorrectly.	Set parameters and save permanently. Cycle the printer power OFF and back ON.
	If problem continues, there may be a problem with the main logic board.	Call a service technician.

# Troubleshooting

SYMPTOM	DIAGNOSIS	ACTION
ZPL II was sent to the printer, but not recognized.  DATA light always OFF.  or  DATA light always flashing.	Communications parameters are incorrect.	Print a Communications Diagnostic Label. Check for format or overrun errors. Reset communication parameters. See page 22.
	Incorrect Communications Cable in use.	Verify proper cable and replace if necessary.
	Prefix and delimiter characters set in printer do not match the ones used in ZPL II format sent to the printer.	Set the characters in the printer to match ZPL II format. See "Selecting Prefix and Delimiter Characters" on page 23.
	Incorrect/incomplete ZPL format sent to the printer.	If problem continues, check the ZPL II format for changed <b>^CC</b> , <b>^CT</b> , and <b>^CD</b> .
Vertical image or label drift.	Printer using non-continuous labels but configured in continuous mode.	Configure the printer for non-continuous and run calibration routine, if necessary.
	Incorrectly-positioned media sensor.	Assure the media sensor is properly positioned to read a single/consistent inter-label gap.
	Improperly-calibrated media sensor.	Perform "Media and Ribbon Sensor Calibration" on page 18.
	Platen roller dirty.	Clean the Platen roller.
	Improper printhead pressure settings (toggles).	Adjust the printhead pressure to assure proper functionality.
	Improperly-loaded ribbon or media.	Verify that the ribbon and media are properly loaded.
	Incompatible media.	Assure the inter-label gaps or notches are 2 mm - 4 mm and constantly placed. Also, media must not exceed minimum specifications for mode of operation.

# Troubleshooting

## Printer Self Tests

### Introduction

These self tests, illustrated on the following pages, produce sample labels and provide specific information that help determine the operating conditions for the printer.

Each self test is enabled by pressing a specific control panel key or combination of keys while turning the power switch ON. Keep the key pressed until the first indicator light turns OFF. The selected self test will automatically start at the end of the Power On Self Test.

**NOTE:** When performing these self tests, do not send data to the printer from the Host.

**NOTE:** Full width media should be used when performing Printer Self Tests. If your media is not wide enough, the test labels may print on the label *and* the platen roller, or in the case of narrow media, not on the label at all. To prevent this from happening, check the configuration parameter “Setting the Print Width”, and insure it is correct for the media you are using.



**NOTE:** If your media is too short, the test label will continue on the next label.

**NOTE:** When canceling a self test prior to its actual completion, always reset the printer by turning the printer power OFF and then ON.

**NOTE:** When performing these self tests, the operator must manually remove the labels as they become available.

### CANCEL Key Self Test

Press and hold the CANCEL key while turning the printer power ON. Release the key anytime after the first front panel LED turns OFF.

This self test prints a label that contains a listing of the printer’s current configuration parameters stored in configuration (EEPROM) memory (refer to Figure 16). To enable this test, press the CANCEL key while turning on the power switch.

The configuration may be changed either temporarily (for specific label formats or ribbon and label stock) or permanently (by saving the new parameters in EEPROM memory). Saving new parameters occurs whenever a printer calibration procedure is performed. Refer to “Configuration and Calibration” for further details.

```
PRINTER CONFIGURATION
+10..... DARKNESS
+000..... TEAR OFF
APPLICATOR..... PRINT MODE
NON-CONTINUOUS..... MEDIA TYPE
WEB..... SENSOR TYPE
THERMAL-TRANS..... PRINT METHOD
050 00/12 MM..... PRINT WIDTH
1831..... LABEL LENGTH
7.0IN..... 177MM..... MAXIMUM LENGTH
MAIN RS232..... HOST PORT
2400..... BAUD
8 BITS..... DATA BITS
NONE..... PARITY
1 STOP BIT..... STOP BITS
XON/XOFF..... HOST HANDSHAKE
NONE..... PROTOCOL
000..... NETWORK ID
NORMAL MODE..... COMMUNICATIONS
<> 7EH..... CONTROL PREFIX
<> 5EH..... FORMAT PREFIX
<> 2CH..... DELIMITER CHAR
ZPL I..... ZPL MODE
HIGH..... RIBBON TENSION
FEED..... MEDIA POWER UP
FEED..... HEAD CLOSE
AFTER..... BACKFEED
+000..... LABEL TOP
+0000..... LEFT POSITION
000 TEST COUNT
1000..... HEAD RESISTOR
OFF..... VERIFIER PORT
MODE 2..... APPLICATOR PORT
PULSE MODE..... START PRINT SIG
FEED MODE..... RESYNCH MODE
ENABLED..... RIBBON LOW MODE
DISABLED..... REPRINT MODE
000..... WEB S.
075..... MEDIA S.
071..... RIBBON S.
000..... MARK S.
000..... MARK MED S.
027..... MEDIA LED
011..... RIBBON LED
007..... MARK LED
+15..... LCD ADJUST
DPCSWFXM..... MODES ENABLED
..... MODES DISABLED
1984 12/MM FULL..... RESOLUTION
..... SOCKET 1 ID
V29.8.0P11 ->..... FIRMWARE
CUSTOMIZED..... CONFIGURATION
S216k..... MEMORY
NONE..... B: MEMORY
007 POWER SUPPLY..... J12 INTERFACE
004 DISPLAY..... J11 INTERFACE
017 RIBBON SYSTEM..... J10 INTERFACE
*** NONE..... J9 INTERFACE
*** APPLICATOR..... J8 INTERFACE
*** NONE..... J7 INTERFACE
..... TWINAX/COAX ID
FIRMWARE IN THIS PRINTER IS COPYRIGHTED
```

Figure 16. CANCEL Key Self Test

## ***PAUSE Key Self Test***

Press and hold the PAUSE key while turning the printer power ON. Release the key anytime after the first front panel LED turns OFF.

This self test is actually comprised of four individual test features:

1. The initial self test prints 15 labels at 2" (5.08 cm) per second, then automatically pauses the printer. Each time the PAUSE key is pressed, an additional 15 labels print.
2. While the printer is paused, alter the self test by pressing the CANCEL key once. Now each time the PAUSE key is pressed, the printer prints 15 labels at 6" (15.24 cm) per second.
3. While the printer is paused, alter the self test a second time by pressing the CANCEL key once. Now each time the PAUSE key is pressed, the printer prints 50 labels at 2" (5.08 cm) per second.
4. While the printer is paused, alter the self test a third time by pressing the CANCEL key once. Now each time the PAUSE key is pressed, the printer prints 50 labels at 6" (15.24 cm) per second.
5. While the printer is paused, alter the self test a fourth time by pressing the CANCEL key once. Now each time the PAUSE key is pressed, the printer prints 15 labels at the maximum speed of the printer.

This self test can be used to provide the test labels required when making adjustments to the printer's mechanical assemblies. See Figure 17.



**Figure 17. Pause Key Test Sample Printout**







## FEED Key and PAUSE Key

Press and hold these two keys while turning the printer power ON. The printer configuration will be *temporarily* reset to the factory default values. These values will be active until power is turned OFF. **If the factory default values are permanently saved, a media calibration procedure must be performed. You must also reset the head resistance value, and the verifier and applicator port settings to their required values (see “Configuration and Calibration”).**

The following chart indicates which printer function controls each of the configuration parameters:

Parameter	Controlled by
Darkness	Configuration and ZPL
Tear Off	Configuration and ZPL
Print Mode	Configuration and ZPL
Media Type	Calibration, Configuration, and ZPL
Sensor Type	Configuration and ZPL
Print Method	Calibration, Configuration, and ZPL
Print Width	Configuration and ZPL
Label Length	Calibration, Configuration, and ZPL
Maximum Length	Configuration and Memory Size
Host Port	Configuration
Baud	Configuration
Data Bits	Configuration
Parity	Configuration
Stop Bits	Configuration
Host Handshake	Configuration
Protocol	Configuration
Network ID	Configuration and ZPL
Communications	Configuration and ZPL
Control Prefix	Configuration and ZPL
Format Prefix	Configuration and ZPL
Delimiter Character	Configuration and ZPL
ZPL Mode	Configuration and ZPL
Ribbon Tension	Configuration and ZPL
Media Power Up	Configuration and ZPL
Head Close	Configuration and ZPL
Backfeed	Configuration and ZPL
Label Top	Configuration and ZPL
Left Position	Configuration and ZPL
Head Test Count	Configuration and ZPL
Head Resistance	Configuration (must match head resistance label value) or ZPL
Verifier Port	Configuration and ZPL
Applicator Port	Configuration and ZPL
Start Print Signal	Configuration and ZPL
Resynch Mode	Configuration and ZPL
Ribbon Low Mode	Configuration and ZPL
Reprint Mode	Configuration and ZPL
Web Sensor	Configuration and ZPL
Media Sensor	Configuration and ZPL
Ribbon Sensor	Configuration and ZPL
Mark Sensor	Configuration and ZPL
Mark Media Sensor	Configuration and ZPL
Media LED	Configuration and ZPL
Ribbon LED	Configuration and ZPL
Mark LED	Configuration and ZPL

# Troubleshooting

Parameter	Controlled by
LCD Adjust	Configuration
Modes Enabled	ZPL
Modes Disabled	ZPL
Resolution	Fixed (head type switch)
Socket 1 ID	Fixed (option EPROMS)
Firmware	Fixed (code EPROMS)
Configuration	Configuration
Memory	Fixed (SIMM size and 1 MB standard)
B: Memory	Fixed (option card)
J12 Interface	Fixed
J11 Interface	Fixed
J10 Interface	Fixed
J9 Interface	Fixed
J8 Interface	Fixed
J7 Interface	Fixed
Twinax/Coax ID	ZPL

## Communications Diagnostics Test

The following test cannot be performed until **all** configuration and calibration parameters have been set. For information, refer to “Configuration and Calibration.”

This test is performed via the control panel. Refer to “Setting the Communications Mode” in “Configuration and Calibration.” A typical printout from this test is shown in Figure 19.



**NOTE:** This label will be inverted when printed.

```

^FS^F0394 , 25^AA
 5E 46 53 5E 46 4F 33 39 34 2C 32 35 5E 41 41
N , 18 , 10^FDC(0000
 4E 2C 31 38 2C 31 30 5E 46 44 28 30 30 30 30
)999-9999^FS
 29 39 39 39 2D 39 39 39 39 5E 46 53 0D 0A
^F00 , 50^AAN , 18 ,
 5E 46 4F 30 2C 35 30 5E 41 41 4E 2C 31 38 2C
10^FDCENTER STA
 31 30 5E 46 44 43 45 4E 54 45 52 20 53 54 41
  
```

Figure 19. Results of Communications Diagnostic Test

Your print engine can be equipped with the following options. Contact your equipment supplier for further information and pricing.

## **Single In-line Memory Module (SIMM)**

An optional 8 MByte SIMM increases the graphic and font storage capacity of the printer and/or increases the print length. As this is volatile memory, contents will be lost when the printer is turned off.

## **Personal Computer Memory Card Interface Association (PCMCIA) Memory Card**

The Type I or Type II PCMCIA memory card is used for graphic, font, and label format storage. This card is an 8 MByte, non-volatile memory device, so the contents are not lost when the printer is turned OFF.

## **Communication Interfaces**

### ***IBM® Twinax Interface***

This interface emulates IBM System 3/X and AS/400 (5224, 5225, 5256, and 4214) printers. This option comes with an auto-terminating one-foot “Y” connector cable.

### ***IBM Coax Interface***

This interface emulates an IBM System 3287 printer used in the IBM 3270 environment. This option comes with a BNC connector to interface to your host mainframe’s controller.

## **ZebraNet™ Micro Print Server (MPS)**

Allows you to connect a Zebra printer to your Ethernet network. Available for 10BaseT networks.



# Printer Specifications

## Printing Considerations

Media Type (continuous, die-cut, or black mark)	172 PAX2	173 PAX2
<b>Resolution</b>	203 dots per inch (8 dots per mm)	300 dots per inch (12 dots per mm)
<b>Dot size</b>	0.0049" x 0.0049" (0.125 mm x 0.125 mm)	0.0033" x 0.0039" (0.084 mm x 0.100 mm)
<b>First dot location</b> (from inside media edge)	0.093" ±0.035" (2.4 mm ±0.89 mm)	0.093" ±0.035" (2.4 mm ±0.89 mm)
<b>Maximum print width</b>	6.6" (168 mm)	6.6" (168 mm)
<b>Maximum print length</b> (with full width media)		
Non-continuous (1 MB Memory)	20" (508 mm)	8" (203 mm)
Non-continuous (9 MB Memory)	39" (990 mm)	39" (990 mm)
Continuous (1 MB Memory)	20" (508 mm)	8" (203 mm)
Continuous (9 MB Memory)	266" (6756 mm)	117" (2971 mm)

## Print Speeds

172PAX2 (203 DPI) – Programmable constant printing speeds (per second) of 2.4" (61 mm), 3" (76 mm), 4" (102 mm), 5" (127 mm), 6" (152 mm), 7" (178 mm), 8" (203 mm), 9" (229 mm), 10" (254 mm), 11" (279 mm), and 12" (305 mm).

173PAX2 (300 DPI) – Programmable constant printing speeds (per second) of 2.4" (61 mm), 3" (76 mm), 4" (102 mm), 5" (127 mm), 6" (152 mm), 7" (178 mm), and 8" (203 mm).

## Media Specifications

<b>Media width</b> (label and liner)	3" (76 mm) to 7.1" (180 mm)
<b>Minimum label length</b> <i>Applicator mode</i> <i>Rewind mode</i> <i>Tear-off mode</i>	3.0" (76.2 mm); 1.0" (25.4 mm) with backfeed off 1.0" (25.4 mm); no backfeed 3.0" (76.2 mm); 1.0" (25.4 mm) with backfeed off
<b>Media registration tolerance</b> Vertical (concurrent labels) Horizontal	±0.040" (±1.0 mm) (in Applicator mode) ±0.040" (±1.0 mm)
<b>Total thickness (including liner)</b>	0.003" to 0.012" (0.076 mm to 0.305 mm)
<b>Interlabel Gap</b> (Transmissive Sensor) <i>Minimum</i> <i>Preferred</i> <i>Maximum</i>	0.079" (2 mm) 0.118" (3 mm) Refer to page 14 for Interlabel Gap and Label Length discussion.
<b>Black Mark</b> (Reflective Sensor) Length (parallel to inside media edge) Width (perpendicular to inside media edge)	.12" (3 mm) to .43" (11 mm) ≥0.43" (≥11 mm)
<b>Print Line to Peel Bar Distance</b>	.63" (16 mm)

## Ribbon Specifications

<b>Width</b> (wound coated side out)	3.0" (76 mm) to 7.1" (180 mm)
<b>Standard length</b>	984' (300 m), 1476' (450 m), 1969' (600 m), and 2955' (900 m)
<b>Roll size</b> <i>Inner core diameter / Maximum roll size</i>	1.0" (25.4 mm) / 4.0" (101.6 mm)

# Printer Specifications

---

## ***Zebra Programming Language (ZPL II)***

- Communicates in printable ASCII characters
- Controlled via mainframe, mini, or PC
- Downloadable graphics, scalable and bit-map fonts, label templates, and formats
- Object copying between memory areas (RAM and PC memory card)
- Adjustable print cache
- Data compression
- Automatic memory allocation for “format while printing”
- Format inversion (white on black)
- Mirror image printing
- Four-position field rotation (normal - 0°, 90°, 180°, and 270°)
- Slew command
- Programmable label quantities with print and pause control
- Automatic serialization of fields
- User-programmable password
- Status messages to host upon request

## ***Bar Codes***

- Bar code modulus “X” dimensions:
  - Picket fence (non-rotated) orientation:  
203 dpi = 0.0049” mil to 0.049”  
300 dpi = 0.0033” mil to 0.033”
  - Ladder (rotated) orientation:  
203 dpi = 0.0049” mil to 0.049”  
300 dpi = 0.0039” mil to 0.039”
- 2-dimensional bar codes:  
Code 49, Maxi Code, PDF-417, QR Code, Codablock, DataMatrix, Micro-PDF417
- Linear bar codes:  
Code 11, Code 39, Code 93, Code 128 with subsets A/B/C and UCC Case Codes, ISBT-128, UPC-A, UPC-E, EAN-8, EAN-13, UPC and EAN 2 or 5 digit extensions, Plessey, Postnet, Standard 2 of 5, Industrial 2 of 5, Interleaved 2 of 5, LOGMARS, MSI, and Codabar
- Bar code ratios: 2:1, 7:3, 5:2, and 3:1

## ***Communications Specifications***

- High-speed parallel interface, Centronics® compatible
- High-speed serial interfaces:
  - RS-232C and RS422 with DB25S (Female) connector
  - RS-485 multi-drop capability
  - Configurable baud rate (110 - 57.6 K bits/sec.), parity, data bits, and stop bits
  - Software (XON/XOFF) or hardware (DTR/DSR) communications handshake protocols
- ZebraNet™ MPS ethernet network print server (10Base-T)
- IBM® Twinax interface - emulates IBM® System 3X and AS/400 printers
- IBM® Coax interface - emulates IBM® System 3270 printers
- Applicator interface with DB15S (Female) connector

# Printer Specifications

## Standard Printer Fonts

Font Matrices for 12 dot/mm (300 DPI) Printhead										
Font	Matrix (in dots)			Type*	Character Size					
	Height	Width	Inter-character Gap		Inches			Millimeters		
					Height	Width	Char./inch	Height	Width	Char./mm
A	9	5	1	U-L-D	0.030	0.020	50.00	0.76	0.51	1.97
B	11	7	2	U	0.037	0.030	33.33	0.93	0.76	1.31
C, D	18	10	2	U-L-D	0.060	0.040	25.00	1.53	1.02	0.98
E	41	20	6	OCR-B	0.137	0.087	11.54	3.47	2.20	0.45
F	26	13	3	U-L-D	0.087	0.053	18.75	2.20	1.36	0.74
G	60	40	8	U-L-D	0.200	0.160	6.25	5.08	4.07	0.25
H	30	19	9	OCR-A	0.100	0.093	10.71	2.54	2.37	0.42
GS	24	24	0	SYMBOL	0.080	0.080	12.50	2.03	2.03	0.49
Ø	Default: 15 X 12			U-L-D	Scalable					
* U = Uppercase, L = Lowercase, D = Descenders										

Font Matrices for 8 dot/mm (203 DPI) Printhead										
Font	Matrix (in dots)			Type*	Character Size					
	Height	Width	Inter-character gap		Inches			Millimeters		
					Height	Width	Char./inch	Height	Width	Char./mm
A	9	5	1	U-L-D	0.044	0.029	33.90	1.13	0.75	1.33
B	11	7	2	U	0.054	0.044	22.60	1.38	1.13	0.89
C, D	18	10	2	U-L-D	0.088	0.059	16.95	2.25	1.50	0.67
E	28	15	5	OCR-B	0.138	0.098	10.17	3.50	2.50	0.40
F	26	13	3	U-L-D	0.128	0.079	12.71	3.25	2.00	0.50
G	60	40	8	U-L-D	0.295	0.236	4.24	7.50	6.00	0.17
H	21	13	6	OCR-A	0.103	0.093	10.71	2.63	2.38	0.42
GS	24	24	0	SYMBOL	0.118	0.118	8.48	3.00	3.00	0.33
Ø	Default: 15 X 12			U-L-D	Scalable					
* U = Uppercase, L = Lowercase, D = Descenders										

- Bitmap fonts A through H and GS symbols are expandable up to 10 times, height and width independent
- Smooth, scalable font Ø (CG Triumvirate™ Bold Condensed) is expandable dot by dot, height and width independent
- IBM® Code Page 850 International Characters

# Printer Specifications

---

## Memory

- 1 MByte RAM standard  
Optional 8 MByte SIMM Option available for longer labels or additional storage of fonts, graphics, logos, and label formats
- Type II Series C & D PC Card Interface (memory only) standard  
Optional 8 MByte PC Memory Card - available for additional storage of fonts, graphics, logos, templates, and label formats.  
Also available pre-programmed with optional and international scalable fonts.
- Additional fonts available on Optional EPROMs

## Physical

<b>Height</b>	11.8" (300 mm)
<b>Width</b>	9.6" (245 mm)
<b>Depth</b>	17.0" (432 mm)
<b>Weight</b>	32 lbs. (14.5 kg)

- For installation information, refer to Appendix E.

## Electrical

- Dual 32-bit RISC and CISC microprocessors
- Universal Power Supply with power-factor correcting  
90-264 VAC, 48-62 Hz
- Power consumption: Idle = 19 W  
Printing = 220 W (printing Pause  
Test label at speed A)
- Agency approvals: UL 1950 3rd edition, CSA 22.2 950-95,  
EN60950 (IE 950), FCC (Class A), DOC (Class A), EN55022  
(CISPR) (Class A), EN50082-2, AS/NZS 3548
- CE, and FCC Class "A" approved

## Fuses

- 5 Amp, 250 VAC, 5 x 20 mm IEC style, as supplied with the printer

## Environmental Operating Range

<b>Operating temperature</b> <i>Thermal transfer</i> <i>Direct thermal</i>	41° F to 104° F (5° C to 40° C) 32° F to 104° F (0° C to 40° C)
<b>Non-condensing relative humidity</b> <i>Operation</i> <i>Storage</i>	20% to 85% 5% to 85%
<b>Storage temperature</b>	-40° F to 140° F (-40° C to 60° C)

\* Media registration and minimum label length are affected by media type and width, ribbon type, and print speed. Performance improves as these factors are optimized. Zebra recommends always qualifying any application with thorough testing.



## AC Power Cord Requirements

Since many areas of the world have specific power requirements, an AC Power Cord may not be included with your printer. Refer to Figure 20. A power cord must be provided by you that meets your local electrical requirements.



**WARNING!!** For personnel and equipment safety, always use a three-prong plug with an earth ground connection to the AC Power Source.

### AC Power Cord Specifications:

- The overall length must be less than 9.8 feet (3 m).
- It must be rated for at least 5 Amp, 250 VAC.
- The chassis ground (earth) **must** be connected to assure safety and reduce electro-magnetic interference. This is done by the third wire (earth) in the power cord.
- The AC power plug and IEC320 connector should bear the certification mark of at least one of the known international safety organization shown in Figure 20.

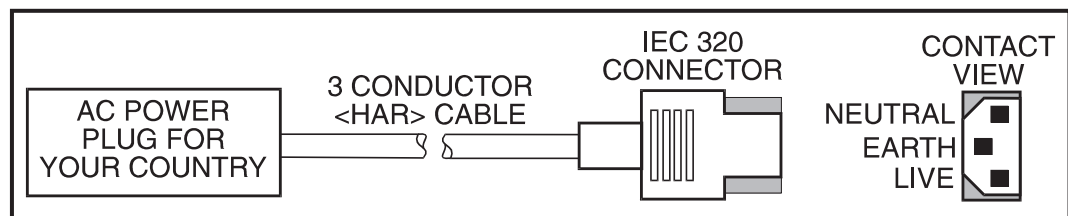

Figure 20. VAC Power Cord

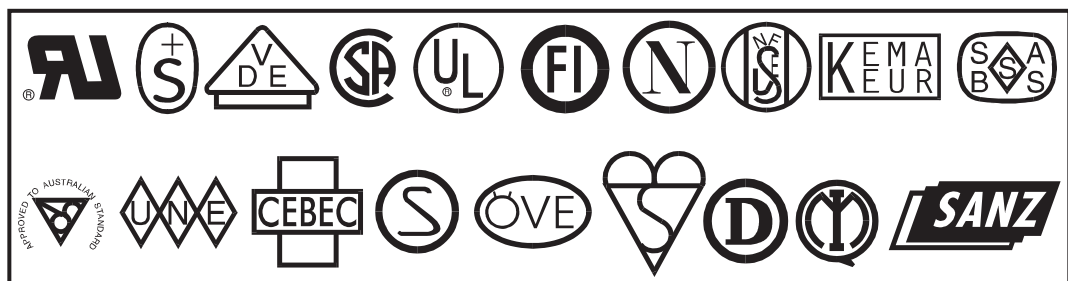

Figure 21. Safety Organization Logos

## Power Fuse Replacement

The printer uses a metric-style fuse (5 x 20 mm IEC) rated for 5 Amps at 250 Volts that bears the certification mark of a known international safety organization (see Figure 21).

The power entry module comes with two approved fuses in the fuse holder; one is “in-circuit” and one is provided as a “spare.”

# Appendix A

---

To replace a fuse, follow this procedure and refer to Figure 22:

1. Turn off the printer and unplug the power cord from the back of the printer.
2. Using a small-blade screwdriver, remove the fuse holder from the power entry module at the rear of the printer.
3. Carefully remove the fuse from the “in circuit” location. To remove the fuse from the “spare” location, insert the point of a pencil through one of the two holes in the fuse holder; gently push. Repeat this procedure through the other hole.
4. Insert this fuse in the “in circuit” location. (Remember to replace an approved 250 VAC, 5 Amp fuse in the “spare” location!)
5. Reinstall the fuse holder into the power entry module at the rear of the printer.
6. Reconnect the power cord and turn the printer on.

The printer should now be ready for operation and the POWER light should be on.



**NOTE:** If power is not restored, an internal component failure may have occurred and the printer requires servicing. Refer to “Troubleshooting.”

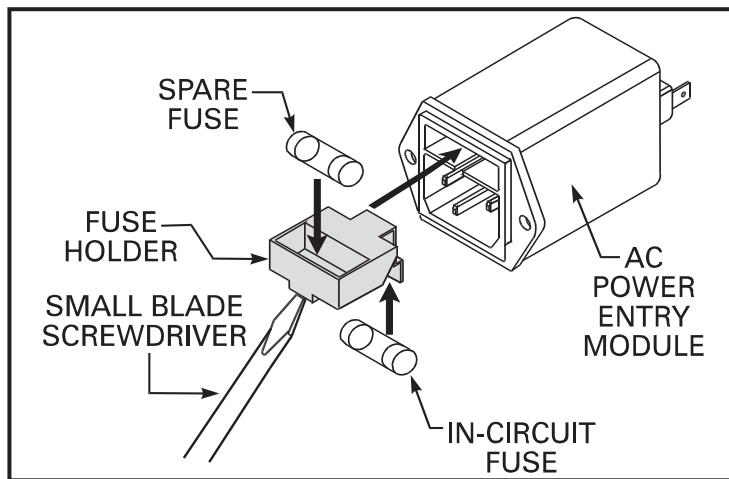

**Figure 22. Installing a Fuse**

## Shipping

To ship the Zebra 170PAX2-Series print engine, remove all ribbon and media. Carefully pack the print engine in a suitable container to avoid damage during transit. Whenever possible, use the original “carton within a carton” packing materials from the factory. A shipping container can be purchased from Zebra Technologies Corporation if the original packaging is lost or destroyed. Contact your distributor or Zebra Technologies Corporation to order the 170PAX2-Series Packing Materials Kit.

If you use a different container, package the print engine carefully to avoid damage.



**CAUTION:** When packaging the printer in a rigid container, use shock mounts or shock-absorbing packing material.

---

## Printer Communications Interface Technical Information

### ***System Considerations***

**Communications Code** — The printer sends and receives American Standard Code for Information Interchange (ASCII). This code consists of 128 characters (256 for Code Page 850) including upper- and lower-case letters, numbers, punctuation marks, and various control codes.

**Interfaces** — The method of interfacing the printer to a data source depends on the communication options installed in the printer and the host. The standard interfaces are an RS-232/RS-422/RS-485 serial data port and a Centronics-compatible parallel port. Optional IBM Twinax, IBM Coax and Ethernet options are available for those applications which require them.

**Data Specifications** — When communicating via an asynchronous serial data port (RS-232/RS-422/RS-485), the baud rate, number of data and stop bits, the parity, and the XON/XOFF or DTR control are user-selectable and should be set to match those of the host computer. When communicating via the Centronics-compatible parallel port, the previously mentioned parameters are not considered. Refer to “Configuration and Calibration” to configure the communication parameters for the printer.

### ***Interface Considerations***

**RS-232** – A serial communication method consisting of data and control signals; available as a standard feature on most PCs and other hosts.

*Advantages:* Cables and connectors are readily available from computer equipment stores and suppliers; easy to connect; two-way communication between the host and the printer.

*Disadvantages:* Slower than the parallel connection; limited to 50 feet (15.24 meters) of cable.

**RS-422** – A single-user current loop serial communication method.

*Advantages:* Longer cable length up to 4000 feet (1219.2 m); greater immunity to data corruption caused by industrial motors and fluorescent lights; two-way communication between the host and the printer.

*Disadvantages:* Not commonly available on standard PCs without additional hardware; slower than the parallel connection.

**RS-485** – A multiple-user current loop serial communication method that is used to support multiple printers connected to a single host.

*Advantages:* Longer cable length up to 4000 feet (1219.2 m); greater immunity to data corruption caused by industrial motors and fluorescent lights; two-way communication between the host and the printer.

*Disadvantages:* Not commonly available on standard PCs without additional hardware; slower than the parallel connection.

**Centronics-compatible Parallel** – This is a common communication method available on most PCs and other hosts.

*Advantages:* Fastest of the four communication interfaces; cables and connectors are readily available from computer equipment stores and suppliers; easy to connect.

*Disadvantages:* One-way communication (the serial port is used to send printer status to the host); shorter recommended cable length of 6 feet (1.83 m).

# Appendix B



**WARNING:** Connecting a data communications cable while the power is ON may damage the PAX2 print engine.

## RS-232/RS-422/RS-485 Serial Data Port

The connections for these standard interfaces are made through the DB25 Female connector on the rear panel. Refer to Table 2. For all RS-232 input and output signals, the printer follows both the Electronics Industries Association's (EIA) RS-232 and the Consultative Committee for International Telegraph and Telephone (CCITT) V.24 standard signal level specifications.

PIN NO.	DESCRIPTION
1	Frame ground for cable shield
2	TXD (RS-232 transmit data) output from printer
3	RXD (RS-232 receive data) input to printer
4	RTS (RS-232 request to send) output from printer
6	DSR (data set ready) input to printer
7	Signal ground for RS-232
9	+5 VDC source output (750 mA maximum)
11	Signal ground reference for RS-422/RS-485
13	RS-422/RS-485 data input B (-)
14	RS-422/RS-485 data output B (-)
16	RS-422/RS-485 data input A (+)
19	RS-422/RS-485 data output A (+)
20	DTR (RS-232 data terminal ready) output from printer

**NOTE:** Pins 5, 8, 10, 12, 15, 17-18, 21-25 are not used and are unterminated.

Table 2. RS-232/RS-422/RS-485 Pinouts

**RS-232 Interconnections** — The printer is configured as Data Terminal Equipment (DTE). Figure 23 illustrates the connections required to interconnect the printer with the standard 9-pin serial port connector on a PC. Figure 24 illustrates the internal connections of the printer's RS-232 connector.

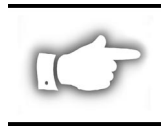

**NOTE:** If using a 9-pin to 25-pin adapter plug attached to the computer, use a null modem cable between the adapter plug and the printer. To connect the printer to other DTE devices with DB25 connectors (such as an optional serial port of a PC), an RS-232 null modem (crossover) cable should be used.

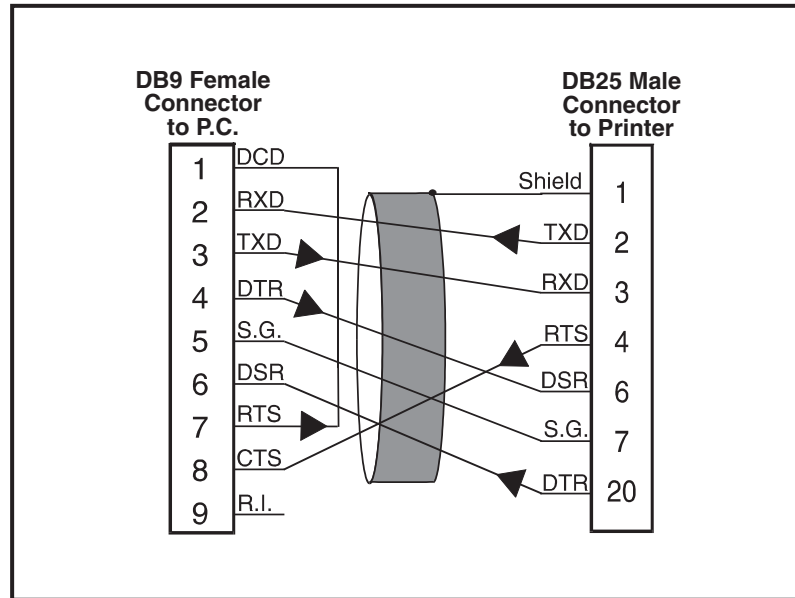

**Figure 23. 9-Pin to 25-Pin Interconnecting Cable**

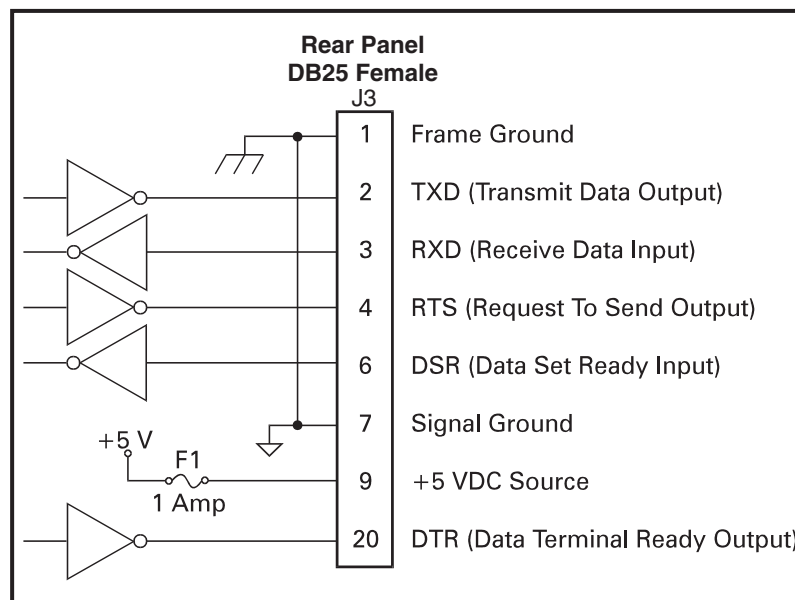

**Figure 24. RS-232 Connections**

# Appendix B

**RS-422/RS-485 Interconnections** — The printer may be connected to a host by a RS-422/RS-485 interface. The DB25 Female connector on the rear of the printer uses specific pins for this purpose. Figure 25 illustrates the required cable wiring for interconnecting to the printer's DB25 connector. Figure 26 illustrates the internal connections of the printer's RS-422/RS-485 connector.

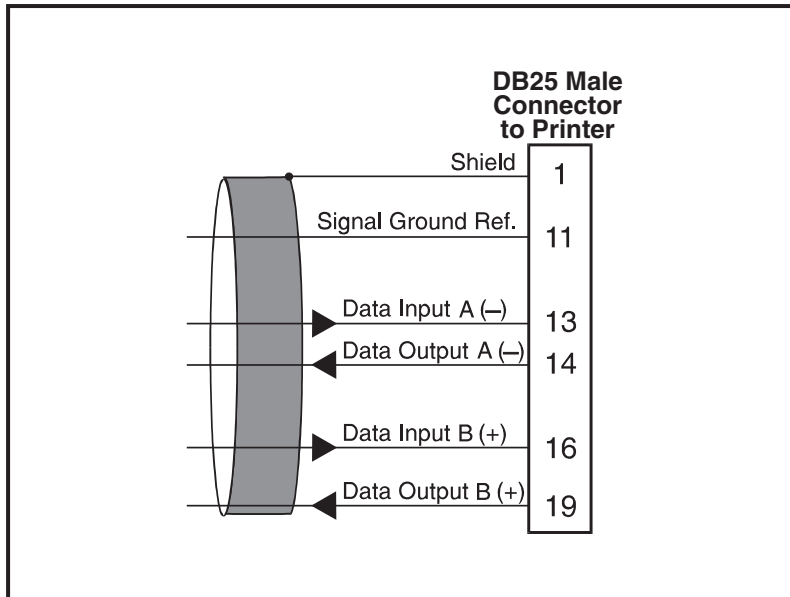

Figure 25. RS-422/RS-485 Interconnecting Cable

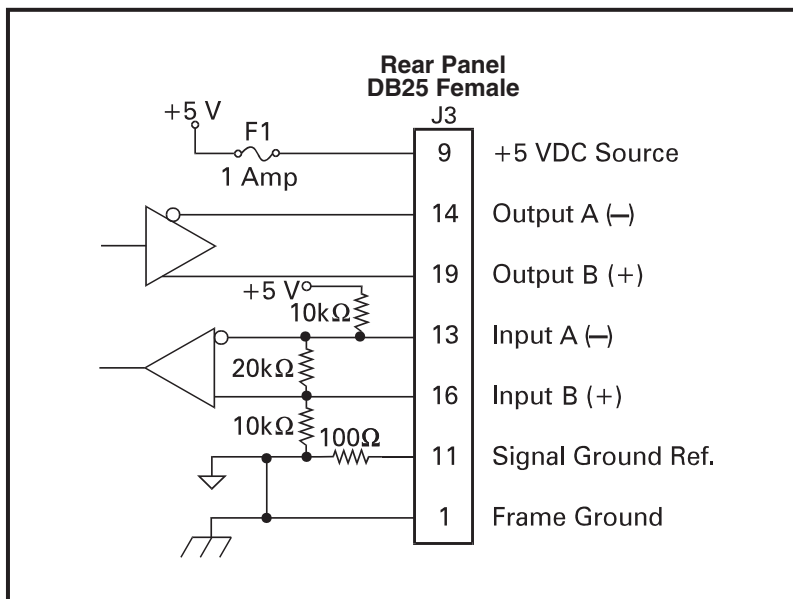

Figure 26. RS-422/RS-485 Connections

## Centronics-Compatible Parallel Data Port

A standard 36-pin Centronics-compatible parallel connector is available at the rear of the printer for connection to the data source. The standard RS-232 port will not accept data when the parallel port is enabled. The parallel interface receives data from the data source but cannot send back printer status information over this port. However, if the printer receives a “Printer Status Request” command over the parallel interface, it will send back this information over the RS-232 port.

**Parallel Port Interconnections** — Table 3 shows the pin configuration and function of a standard computer-to-printer Centronics-compatible parallel cable:

PIN NO.	DESCRIPTION
1	STROBE — The high to low transition of this input signal will latch the data at the eight data inputs into the printer.
2-9	DATA BITS 0-7 — Parallel data inputs to the printer. They have TTL input characteristics where a HIGH (+5 V) level corresponds with a logic 1 and a LOW (0 V) level is a logic 0.
10	ACKNOWLEDGE — This output of the printer is an active LOW pulse indicating that the printer has received the previous character and is ready to accept another data character.
11	BUSY — This printer output is active HIGH whenever it cannot accept data.
12	ERROR — This output signal is active HIGH whenever the printer is out of paper or ribbon.
13	SELECT — The function of this output signal is determined by a Printer Configuration Option. In the default condition, SELECT is active HIGH whenever the parallel port is powered up and enabled.
14	AUTOFEED — This input is unused by the printer.
15, 33, 34	Not used
16, 19-30	SIGNAL GROUNDS — The logic GROUNDS and returns for all input and output signals.
17	Chassis ground (for cable shield connections)
18	+5 V fused output, 750 mA maximum
31	INITIALIZE (reset) — This input is unused by the printer.
32	FAULT — This output from the printer is active LOW whenever any of the following error conditions are present: Printhead Open, Printhead Over Temperature, Paper Out, Ribbon Out, Rewind Full (if Rewind is used).
35	+5 V resistive
36	SEL IN — Connected but not used by the printer.

**Table 3. Centronics-Compatible Connector Pinouts**

# Appendix B

## Cabling Requirements

Data cables must be fully shielded and fitted with metal or metalized connector shells. Shielded cables and connectors are required to prevent radiation and reception of electrical noise. To minimize electrical noise pickup in the cable:

- Keep data cables as short as possible.
- Do not bundle the data cables tightly with the power cords.
- Do not tie the data cables to power wire conduits.



**NOTE:** Printers comply with FCC “Rules and Regulations,” Part 15, Subpart “J,” for Class “A” equipment, using fully-shielded 6-foot data cables. Use of longer cables or unshielded cables may increase radiated emissions above the Class “A” limits.



**NOTE:** RS-422 and RS-485 applications should use shielded twisted pairs with 120 ohm controlled impedance as recommended in the Appendix of the ITA/EIA-485 specification.

## Applicator Interface Connector

Refer to Table 4. An external DB-15 connector is present on the rear panel of the print engine for communication with the applicator. (An optional DB-15 to DB-9 adapter cable is available to accommodate existing DB-9 interfaces.)

PIN #	SIGNAL NAME	SIGNAL TYPE	FUNCTIONAL DESCRIPTION
1	SIGNAL GROUND (+5V Return)	Ground	JP1 IN – Ground return for Internal +5v power source and is available here for remote opto-isolators, if required. (JP2 IN)  JP1 OUT – Ground return for External +5v power source. (JP2 OUT)
2	+5V (Fused at 750mA)	Power	JP2 IN – Internal +5v power source supplies power to internal opto-isolators and is available here for remote opto-isolators, if required. (JP1 IN)  JP2 OUT – External +5v power source must be connected here to supply power to internal opto-isolators. (JP1 OUT)
3	START PRINT	Input	PULSE MODE – The label printing process begins on the HIGH to LOW transition of this signal, if a format is ready. De-assert this signal HIGH to inhibit printing of a new label.  LEVEL MODE – Assert LOW to enable the printer to begin printing, if a format is ready. The printer will print new labels as long as the signal is asserted. When de-asserted, the currently printing label will be completed and the printer will stop and wait for this input to be reasserted LOW.
4	FEED	Input	When the printer is in an Idle state or has been PAUSED, assert this input LOW to trigger repeated feeding of blank labels. De-assert HIGH to stop feeding blank labels and register to the top of the next label.

Table 4. DB-15 Connector (Printer to Applicator)



PIN #	SIGNAL NAME	SIGNAL TYPE	FUNCTIONAL DESCRIPTION
5	PAUSE	Input	To toggle the current PAUSE state, this input must be asserted LOW for 200 milliseconds, or until the SERVICE REQUIRED output (pin 10) changes state.
6	REPRINT	Input	If the REPRINT feature is enabled – this input must be asserted LOW to cause the printer to reprint the last label. (See the Configuration and Calibration section.)  If the REPRINT feature is disabled – this Input is ignored.
7	+28V (Fused at 1.5A)	Power	Interface Power Supply – supplies power to external sensors as required.
8	POWER GROUND (+28V Return)	Ground	Interface Power Ground.
9	RIBBON LOW	Output	If the RIBBON LOW feature is enabled, and the amount of ribbon remaining on the supply spool is below a specific threshold level – this output will be asserted HIGH.  If the RIBBON LOW feature is disabled – this output lead is disabled. (See the Configuration and Calibration section.)
10	SERVICE REQUIRED	Output	While either the media cover is open, the printhead is open, the ribbon is out, the media is out, the printer is paused, or an operational fault has occurred, this output will be asserted LOW..  If the applicator RESYNCH mode is set to ERROR mode, this signal will also assert LOW for a RESYNCH error.
11	END PRINT	Output	MODE 0: The Applicator Port is OFF. MODE 1: Asserted LOW only while the printer is moving the label forward; otherwise deasserted HIGH MODE 2: Asserted HIGH only while the printer is moving the label forward; otherwise deasserted LOW. MODE 3: (Default) Asserted LOW for 20 milliseconds when a label has been completed and positioned. Not asserted during continuous printing. MODE 4: Asserted HIGH for 20 milliseconds when a label has been completed and positioned. Not asserted during continuous printing.
12	MEDIA OUT	Output	Asserted LOW while there is no media in the printer.
13	RIBBON OUT	Output	Asserted LOW while there is no ribbon in the printer.
14	DATA READY	Output	Asserted LOW when sufficient data has been received to begin printing the next label.  De-asserted HIGH whenever printing stops after the current label, due to either a PAUSE condition or the absence of a label format.
15	SPARE	Output	To Be Determined

**Table 4. DB-15 Connector (Printer to Applicator)**

# Appendix B

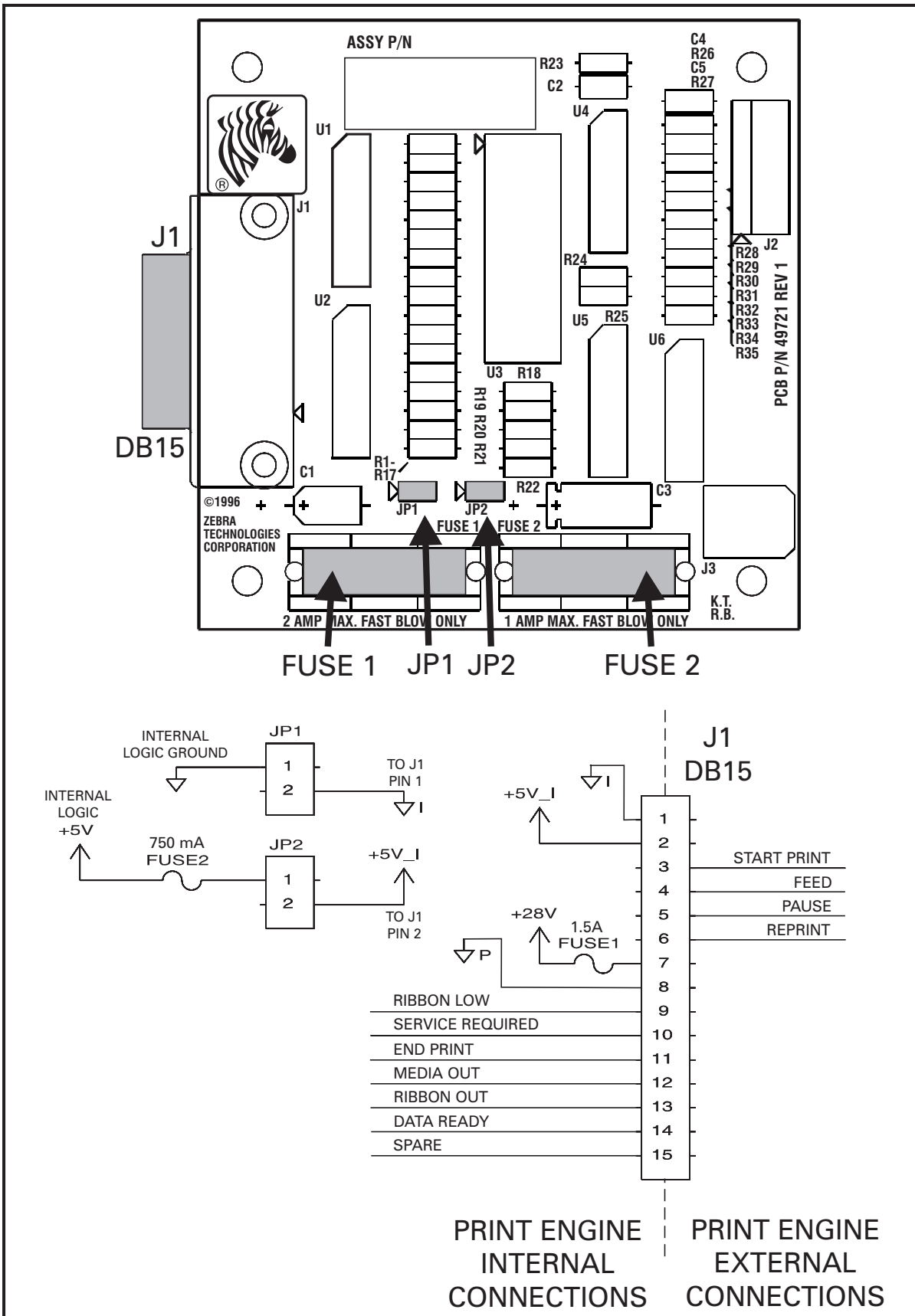

Figure 27. Applicator Interface Connections

## ASCII Code Chart

HEX	CHAR	HEX	CHAR	HEX	CHAR	HEX	CHAR
00	NUL	20	space	40	@	60	'
01	SOH	21	!	41	A	61	a
02	STX	22	"	42	B	62	b
03	ETX	23	#	43	C	63	c
04	EOT	24	\$	44	D	64	d
05	ENQ	25	%	45	E	65	e
06	ACK	26	&	46	F	66	f
07	BEL	27	'	47	G	67	g
08	BS	28	(	48	H	68	h
09	HT	29	)	49	I	69	i
0A	LF	2A	*	4A	J	6A	j
0B	VT	2B	++	4B	K	6B	k
0C	FF	2C	,	4C	L	6C	l
0D	CR	2D	-	4D	M	6D	m
0E	SO	2E	.	4E	N	6E	n
0F	SI	2F	/	4F	O	6F	o
10	DLE	30	0	50	P	70	p
11	DC1	31	1	51	Q	71	q
12	DC2	32	2	52	R	72	r
13	DC3	33	3	53	S	73	s
14	DC4	34	4	54	T	74	t
15	NAK	35	5	55	U	75	u
16	SYN	36	6	56	V	76	v
17	ETB	37	7	57	W	77	w
18	CAN	38	8	58	X	78	x
19	EM	39	9	59	Y	79	y
1A	SUB	3A	:	5A	Z	7A	z
1B	ESC	3B	;	5B	[	7B	{
1C	FS	3C	<	5C	\	7C	
1D	GS	3D	=	5D	]	7D	}
1E	RS	3E	>	5E	^^	7E	~
1F	US	3F	?	5F	_	7F	DEL

Shaded values NOT recommended for command prefix, format prefix, or delimiter characters.

**NOTE:** DLE always represents the command prefix.  
 RS always represents the format prefix.  
 US always represents the delimiter prefix.



## Adjusting Darkness For “In-Spec” Bar Codes

All direct thermal and thermal transfer materials do not require the same darkness setting. The best way to check for proper darkness is to use a bar code verifier that actually measures bars/spaces and will calculate the print contrast. Without the assistance of a verifier, your eyes and/or the system scanner are the best bet for choosing the optimal darkness setting. What follows is a simple yet effective method for adjusting the darkness to print “in-spec” bar codes.

1. Load media according to the appropriate media loading and ribbon loading instructions in “Getting Ready to Print.” Insure the proper print method has been selected (see “Configuration and Calibration”).
2. To print a label for evaluation, turn the power off; then, press and hold the FEED key. Next, turn the printer power on and release the FEED key. The printer will begin printing test labels.
3. Print a label, then press the PAUSE key. The label will contain two bar codes, as well as other printer information. Normal bar codes are printed in a horizontal (“picket fence”) format as they feed out of the printer. Rotated bar codes are printed in a vertical (“stepladder”) format.
4. Compare the test label printed to the bar codes in Figure 28. If the test label appears too dark or too light, refer to “Configuration and Calibration” and increase or decrease the darkness setting accordingly.
5. Resume printing by pressing the PAUSE key again. Print a few labels at the new setting and verify that proper “in-spec” bar codes are being printed. Repeat steps 3, 4 and 5 until satisfied.
6. To terminate the printing of the test labels, first press the PAUSE key and then press the CANCEL key.

### ***Too Dark***

Labels that are too dark are fairly obvious. The normal bar code bars increase in size, and the openings in small alphanumeric characters may fill in with ink. It may be readable but not “in-spec.” Rotated bar code bars and spaces will run together.

### ***Slightly Dark***

Slightly dark labels are not as obvious. The normal bar code will be “in-spec.” Small character alphanumerics will be bold and could be slightly filled in. The rotated bar code spaces are small when compared to the “in-spec” code, possibly making the code unreadable.

### ***Slightly Light***

Slightly light labels are, in some cases, preferred to slightly dark ones for “in-spec” bar codes. Both normal and rotated bar codes will be in spec, but small alphanumeric characters may not be complete.

### ***Too Light***

Labels that are too light are obvious. Both normal and rotated bar codes have incomplete bars and spaces. Small alphanumeric characters are unreadable.

# Appendix D

## "In-Spec"

The "in-spec" bar code can only be confirmed by a verifier, but it should exhibit some very visible characteristics. The normal bar code will have complete, even bars and clear, distinct spaces. The rotated bar code will also have complete bars and clear distinct spaces. Although it may not look as good as a slightly dark bar code, it will be "in-spec." In both normal and rotated styles, small alphanumeric characters will look complete.

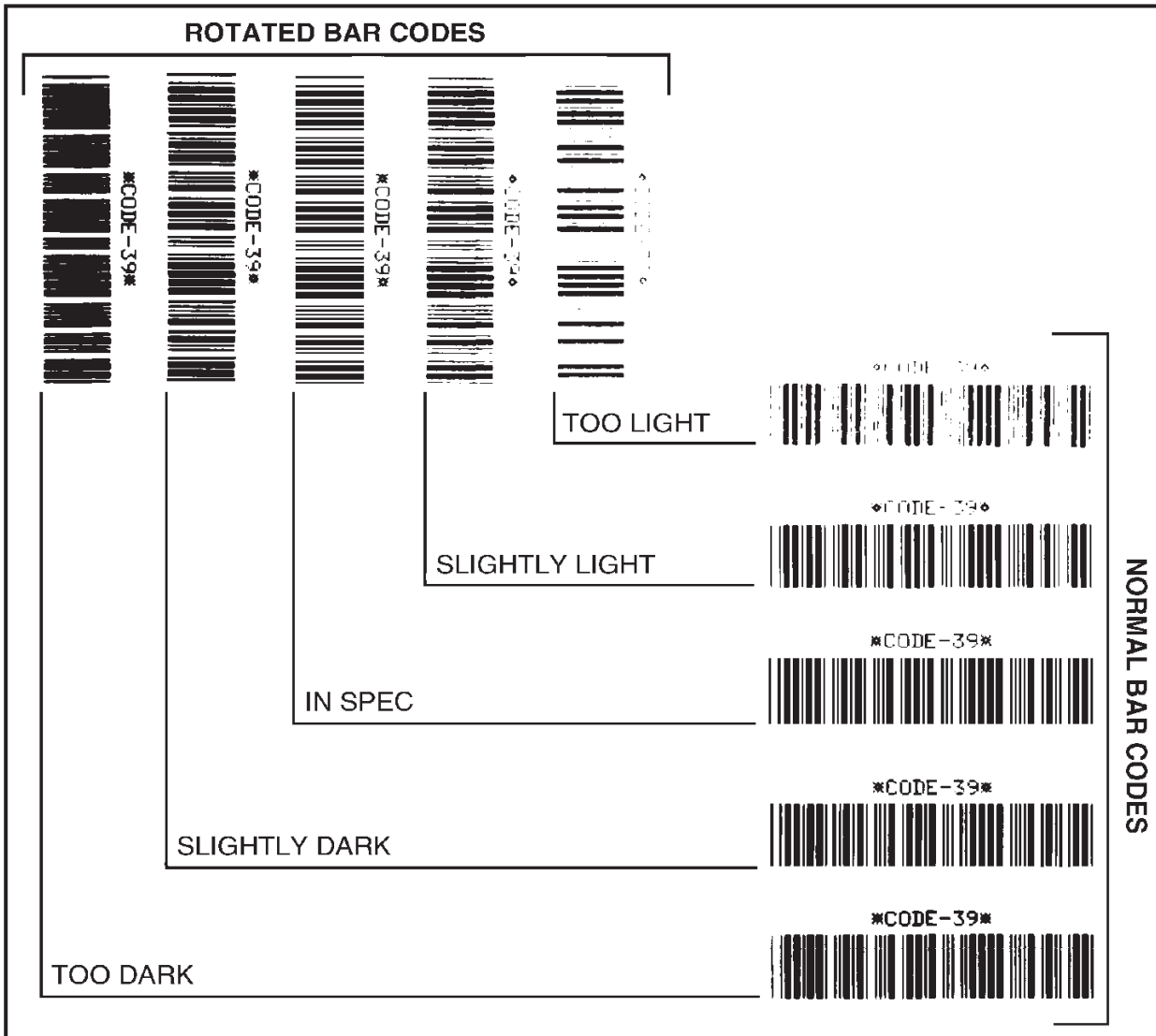

Figure 28. Bar Code Darkness Comparison

## Installation Information

Ventilation openings of the printer mounting enclosure shall be provided by the installer to remove heat and ensure uninterrupted, trouble-free operation of the printer. Ambient air temperature surrounding the printer **must not exceed** 40 degrees Centigrade or 104 degrees Fahrenheit.

When the printer is mounted, consideration must be given to the stability of the complete assembly so that when a full roll of media is loaded, the equipment does not become physically unstable.

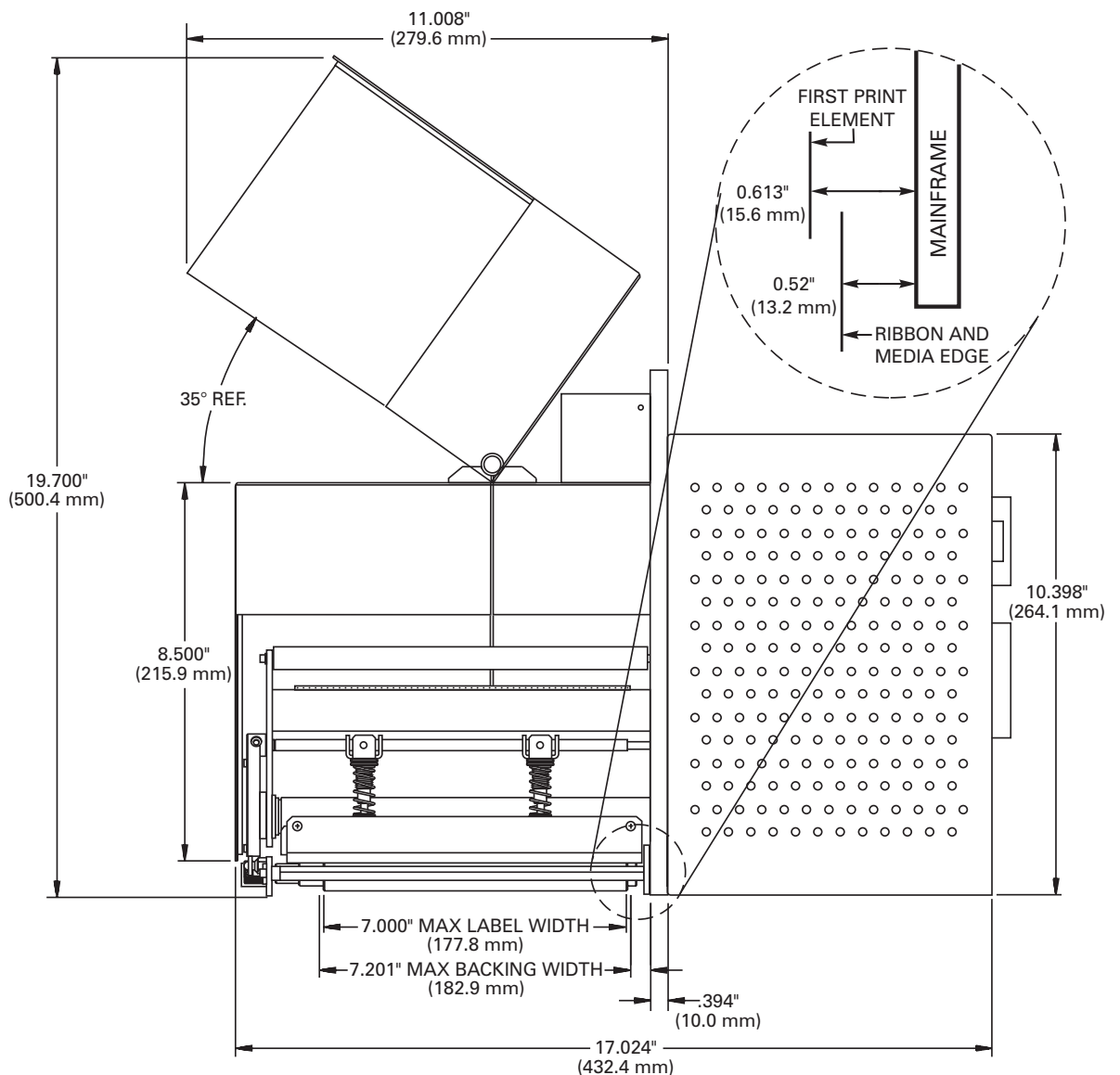

Figure 29. Right Side View of Right Hand Printer

# Appendix E

Consideration must be given to the current rating of the printer during installation so that when power is applied to the printer and the enclosing equipment, an overload condition is not effected on enclosing equipment circuits or supply wiring.

Reliable earthing of the printer must be maintained. Particular attention must be given to the AC power supply connections so that earth ground is maintained through the AC power input connector.

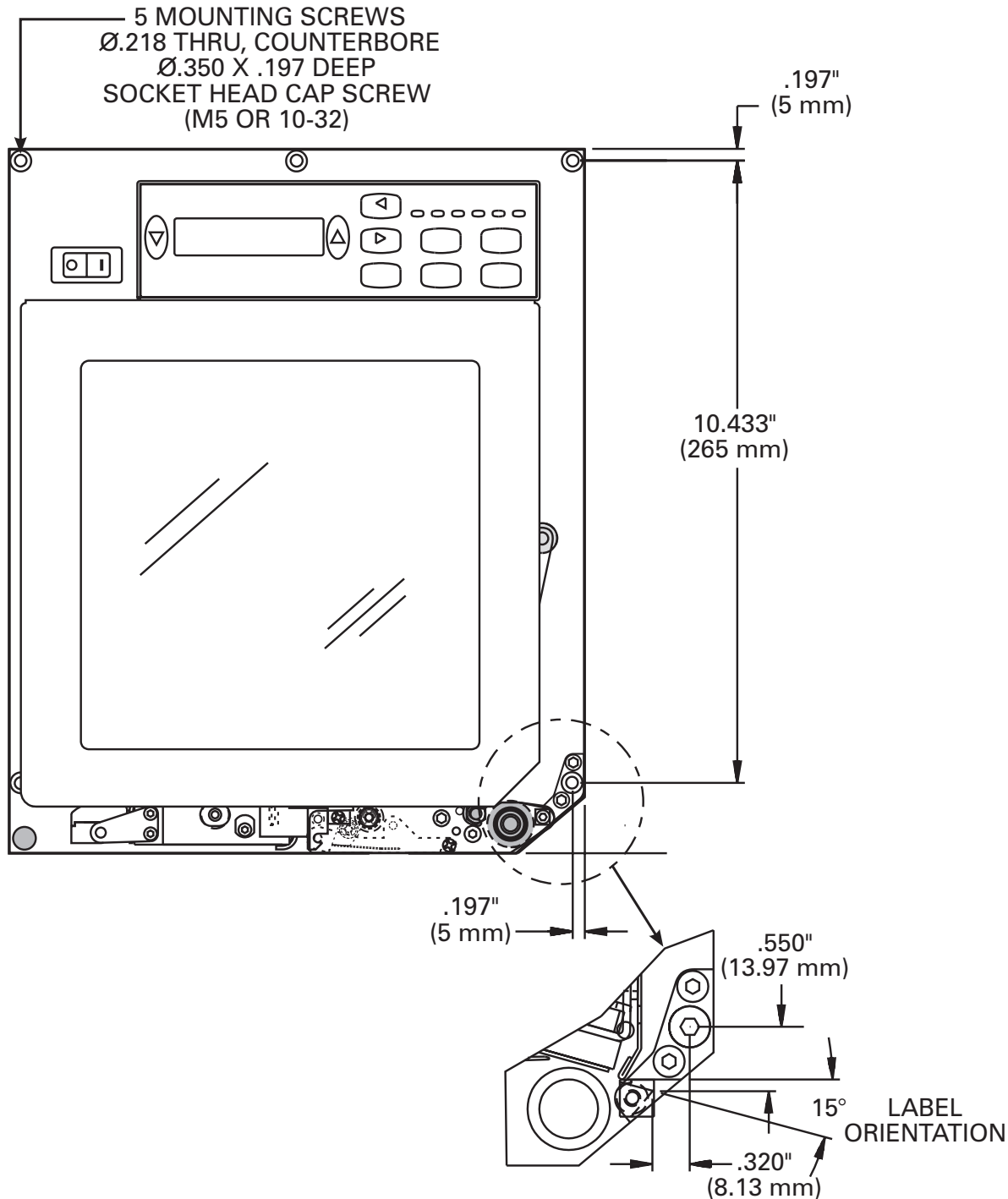

Figure 30. Front View of Right Hand Printer





**NOTE:** Mounting hole locations are identical for both the right hand and left hand print engines.

Clearance at the rear panel of the electronics enclosure must provide ample space for electronic connectors and dressing of the following cables: IEC power cord, serial and/or parallel host communication cable, optional host communication cable (Coax, Twinax, Ethernet), and the discrete signal (applicator) interface cable.

The IEC power cord does not have a strain relief on the printer. If the operating characteristics of the applicator include vibration or strain on the power cord, then the installation shall provide an appropriate clamping mechanism to avoid unintentional disconnection of the power cord from the printer.

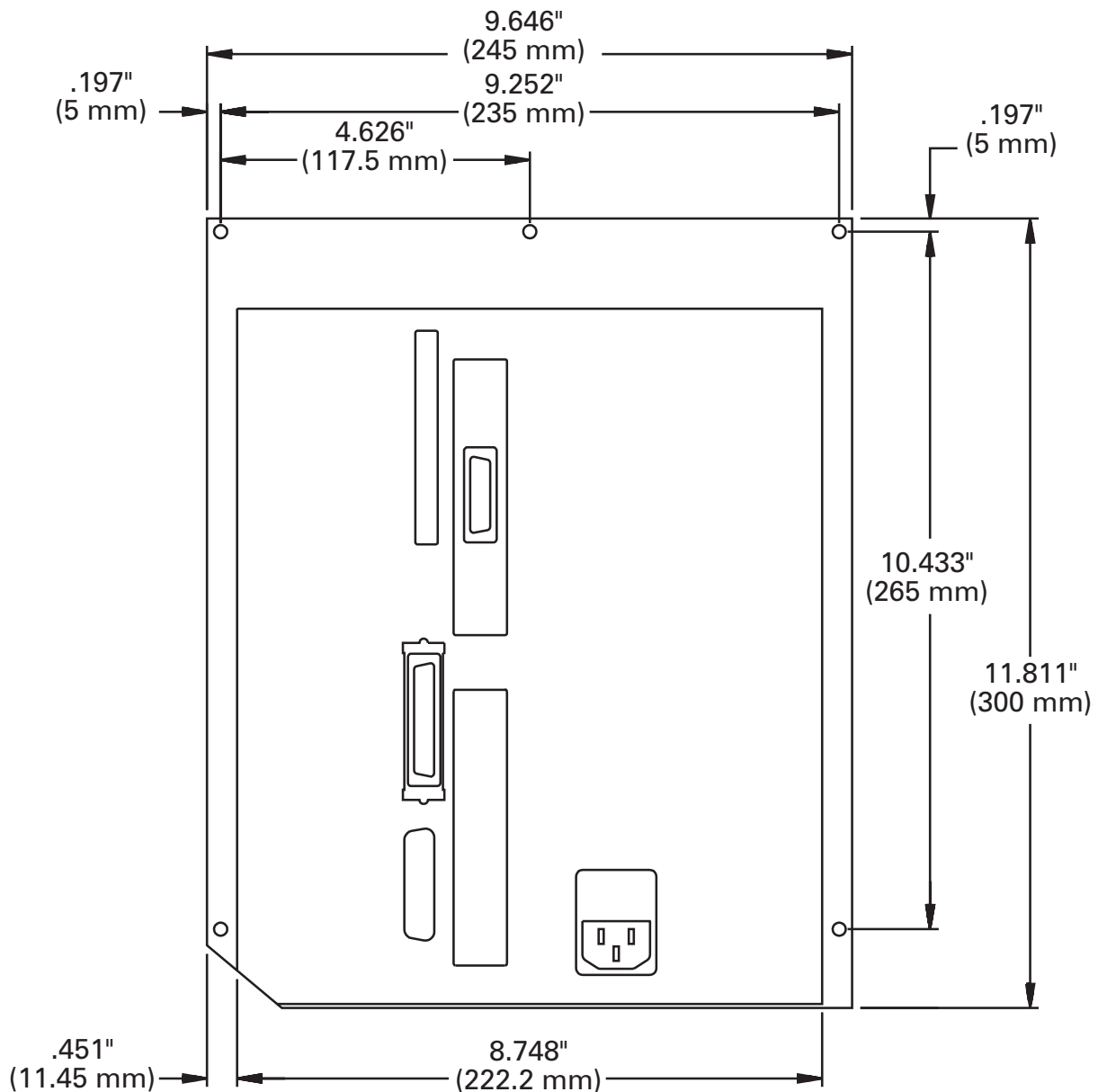

**Figure 31. Rear View of Right Hand Printer**



- alphanumeric** Indicating letters, numerals, and characters such as punctuation marks.
- backfeed** When the printer pulls the media and ribbon (if used) backward into the printer so that the beginning of the label to be printed is properly positioned behind the printhead. Backfeed occurs when operating the printer in tear-off, peel-off, or cutter mode.
- bar code** A code by which alphanumeric characters can be represented by a series of adjacent stripes of different widths. Many different code schemes exist, such as the universal product code (UPC) or Code 39.
- black mark** A registration mark found on the underside of the print media which acts as a start-of-label indication for the printer. (See non-continuous media.)
- calibration (of a printer)** A process in which the printer determines some basic information needed to print accurately with a particular media and ribbon combination. To do this, the printer feeds some media and ribbon (if used) through the printer and senses whether to use the direct thermal or thermal transfer print method, and (if using non-continuous media) the length of individual labels or tags.
- character set** The set of all letters, numerals, punctuation marks, and other characters that can be expressed by a particular font or barcode.
- check digit** A character added to a barcode symbol that indicates to the scanner that it has read the symbol correctly.
- configuration** The printer configuration is a group of operating parameters which are specific to the printer application. Some parameters are user selectable while others are dependent on the installed options and mode of operation. Parameters may be switch selectable, front panel programmable or downloaded as ZPL II commands. A Configuration Label listing all the current printer parameters may be printed for reference.
- continuous media** Label or tag-stock media that has no notch, gap, or web (backing material only) to separate the labels or tags. The media is one long piece of material.
- core diameter** The inside diameter of the cardboard core at the center of a roll of media or ribbon.
- cutter** An optional mechanical device that cuts the media into individual labels or tags immediately after it is printed.
- diagnostics** Information about which printer functions are not working that is used for troubleshooting printer problems.
- die-cut media** A type of label stock where individual labels are stuck to a backing material. The labels may be either lined up against each other or separated by a small distance. Typically the material surrounding the labels has been removed. (See non-continuous media.)
- direct thermal** A printing method in which the printhead presses directly against the media. Heating the printhead elements causes a discoloration of the heat-sensitive coating on the media. By selectively heating the printhead elements as the media moves past, an image is printed onto the media. No ribbon is used with this printing method. Contrast this with *thermal transfer*.
- direct thermal media** Media that is coated with a substance which reacts to the application of direct heat from the printhead to produce an image.
- dynamic ram** DRAM is the term used to describe the memory devices used to store the label formats in electronic form while they are being printed. The amount of DRAM memory available in the printer determines the maximum size and number of label formats that can be printed. This is volatile memory which loses the stored information when power is turned off.

# Glossary

---

**fanfold media** Media that comes folded in a rectangular stack. Contrast this with *roll media*.

**firmware** This is the term used to specify the printer's operating program. This program is downloaded to the printer from a host computer and stored in FLASH memory. Each time the printer power is turned on, this operating program starts. This program controls when to feed the media forward or backward, when to print a dot on the label stock, when to activate the cutter, etc.

**flash memory** FLASH memory is non-volatile and will maintain the stored information intact when power is off. This memory area is used to store the printer's operating program. In addition this memory can be used to store optional printer fonts, graphic formats, and complete label formats.

**font** A complete set of alphanumeric characters in one style of type. Ex: CG Times™, CG Triumvirate Bold Condensed™.

**ips "inches-per-second"** The speed at which the label or tag is printed. Zebra offers printers that can print from 2 ips to 12 ips.

**label** An adhesive-backed piece of paper, plastic, or other material on which information is printed.

**label available sensor** For printers equipped with the Peel-Off Option, this sensor detects a printed label waiting to be taken or "picked" by the operator. While it detects this label, the printer will not print additional labels. Once the label has been removed from the printer, the next label is printed. Also called the "take-label sensor".

**label backing (label liner)** The material on which labels are affixed during manufacture and which is discarded or recycled by the end-users.

**liquid crystal display** The LCD is a back-lit display which provides the user with either operating status during normal operation or option menus when configuring the printer to a specific application.

**light emitting diode** LEDs are used as indicators of specific printer status conditions. Each LED will be either off, on, or blinking depending on the feature being monitored.

**lock-up** This is the term generally used to describe a fault condition that, for apparently unknown reasons, causes the printer to stop working.

**media** Material onto which data is printed by the printer. Types of media include: tag-stock, die-cut labels, continuous (with and without backing material), fanfold, and roll.

**media sensor** This sensor is located behind the printhead to detect the presence of media and, for non-continuous media, the position of the web, hole, or notch used to indicate the start of each label.

**media supply hanger** The stationary arm that supports the media roll.

**non-continuous media** Consumable printing stock which contains an indication of where one label/printed format ends and the next one begins. Examples are die-cut labels, notched tag-stock, and stock with black mark registration marks

**non-volatile memory** Electronic memory that retains data even when the power to the printer is turned OFF.

**notched media** A type of tag stock containing a cutout area that can be sensed as a start-of-label indicator by the printer. This is typically a heavier, cardboard-like material which is either cut or torn away from the next tag. (See non-continuous media.)

**peel-off** A mode of operation in which the label is separated from the backing material by a mechanical process. The backing material may be rewound onto a spindle or allowed to fall freely from the printer. A peel-off option must be installed to operate in this mode.

**print speed** The speed at which printing occurs. For thermal transfer printers, this speed is expressed in terms of ips (inches per second). Zebra offers printers that can print from 2 ips to 12 ips.

**printer configuration** (See configuration.)

**printhead wear** The degradation of the surface of the printhead and/or the print elements over time. Heat and abrasion can cause printhead wear. Therefore, to maximize the life of the printhead, use the lowest print darkness setting (sometimes called burn temperature or head temperature) and the lowest printhead pressure necessary to produce good print quality. In the thermal transfer printing method, use ribbon that is as wide or wider than the media, to protect the printhead from the rough media surface.

**registration** Alignment of printing with respect to the top of a label or tag.

**rewind** A mode of operation in which the label and backing material are wound onto a spindle within the printer and then dispensed for use in a separate process. The rewind option must be installed to operate in this mode.

**ribbon** A band of material consisting of a base film coated with wax or resin “ink”. The inked side of the material is pressed by the printhead against the media. The ribbon transfers ink onto the media when heated by the small elements within the printhead. Zebra ribbons have a coating on the back that protects the printhead from wear.

**ribbon wrinkle** A wrinkling of the ribbon caused by improper alignment or improper printhead pressure. This wrinkle can cause voids in the print and/or the used ribbon to rewind unevenly. This condition should be corrected by performing adjustment procedures.

**roll media** Media that comes supplied rolled onto a core (usually cardboard). Contrast this with *fanfold media*.

**supplies** A general term for media and ribbon.

**symbology** The term generally used when referring to a bar code.

**tag** A type of media having no adhesive backing but featuring a hole or notch by which the tag can be hung on something. Tags are usually made of cardboard or other durable material.

**take label sensor** (See label available sensor.)

**tear-off** A mode of operation in which the user tears the label or tag stock away from the remaining media by hand.

**thermal direct** (See direct thermal.)

**thermal transfer** A printing method in which the printhead presses an ink or resin coated ribbon against the media. Heating the printhead elements causes the ink or resin to transfer onto the media. By selectively heating the printhead elements as the media and ribbon move past, an image is printed onto the media. Contrast this with *direct thermal*.

**void** A space where printing should have occurred, but did not due to an error condition such as wrinkled ribbon or faulty print elements. A void can cause a printed bar code symbol to be read incorrectly or not at all.



## A

AC Power . . . . .	2
Adjustments	
Printhead pressure. . . . .	35
Toggle positioning . . . . .	35
Applicator Interface Connector . . . . .	60
Applicator Port, setting . . . . .	29
ASCII Code Chart. . . . .	63

## B

Backfeed Sequence . . . . .	25
Bar Codes	
List of available. . . . .	50
Printing a list . . . . .	16
Baud Rate . . . . .	20

## C

CANCEL Key Self Test. . . . .	42
Cleaning	
Cleaning supplies . . . . .	33
Exterior surfaces . . . . .	33
Printhead and platen roller . . . . .	34
Sensors . . . . .	34
Communication Parameters	
Baud rate . . . . .	20
Communications mode . . . . .	22
Data bits. . . . .	20
Host handshake . . . . .	21
Host port . . . . .	20
Network ID . . . . .	22
Parity . . . . .	21
Protocol . . . . .	21
Stop bits . . . . .	21
Communications . . . . .	1
Communications Diagnostics Test . . . . .	46
Communications Mode, setting . . . . .	22

Control Panel	
Indicator lights . . . . .	10
Keys. . . . .	10
Liquid Crystal Display . . . . .	10
Control Prefix Character, selecting . . . . .	23

## D

Damage Report . . . . .	1
Darkness, setting . . . . .	12
Data Bits, setting . . . . .	20
Delimiter Character, setting . . . . .	23
Designating the Display Screen Language . . . . .	32

## E

Electrical Specifications. . . . .	52
------------------------------------	----

## F

FEED Key and PAUSE Key . . . . .	45
FEED Key Self Test. . . . .	44
Fonts (specifications) . . . . .	51
Fonts, printing a list . . . . .	16
Format Prefix Character, selecting . . . . .	23
Formats, printing a list . . . . .	16

## G

Glossary . . . . .	71
--------------------	----

## H

Head Close . . . . .	25
Head Resistance . . . . .	28
Head Resistance, setting the value . . . . .	28
Head Test Count, setting . . . . .	28
Head Test function	
Head test count . . . . .	28
Head Test Function . . . . .	28
Host Handshake, setting. . . . .	21
Host Port, setting . . . . .	20

## I

IBM Coax Interface . . . . .	47
IBM Twinax Interface . . . . .	47
Images, printing a list . . . . .	16
Initializing the Card . . . . .	17
In-Spec Bar Codes, adjusting darkness . . . . .	65

## L

Label Positioning Parameters . . . . .	25
Backfeed sequence . . . . .	25
Label top position . . . . .	26
Left position . . . . .	27
LCD, adjusting brightness/darkness . . . . .	32

## M

Maintenance . . . . .	1
Maximum Length, setting . . . . .	14
Media (specifications) . . . . .	49
Media and Ribbon Sensor Calibration . . . . .	18
Media and Ribbon Sensor Sensitivity . . . . .	19
Media Loading . . . . .	3
Media Power Up . . . . .	24
Media Type, setting . . . . .	13
Memory (specifications) . . . . .	52

## N

Network ID, setting . . . . .	22
-------------------------------	----

## O

Options	
Communication interfaces . . . . .	47
ZebraNet Micro Print Server . . . . .	47

## P

Parity, setting . . . . .	21
Passwords . . . . .	11
PAUSE Key Self Test . . . . .	43
Options . . . . .	47
Physical Specifications . . . . .	52
Power Cord . . . . .	53
Power Fuse, replacement . . . . .	53

Power On Self Test . . . . .	37
Power Up and Head Close Parameters . . . . .	24
Prefix and Delimiter characters	
Delimiter character . . . . .	23
Prefix and Delimiter Characters	
Control prefix character . . . . .	23
Format prefix character . . . . .	23
Print Method, selecting . . . . .	14
Print Mode, setting . . . . .	13
Print Parameters	
Darkness . . . . .	12
Maximum length . . . . .	14
Media . . . . .	13
Print method . . . . .	14
Print mode . . . . .	13
Print width . . . . .	14
Sensor . . . . .	13
Tear Off position . . . . .	13
Print Speeds (specifications) . . . . .	49
Print Width, setting . . . . .	14
Printer Information	
Bar codes . . . . .	16
Fonts . . . . .	16
Formats . . . . .	16
Images . . . . .	16
Initializing the card . . . . .	17
Setup . . . . .	16
Printer Interface Technical Information . . . . .	55
Applicator interface connector . . . . .	60
Cabling Requirements . . . . .	60
RS-232/RS-422/RS-485 Serial Data Port	56
System considerations . . . . .	55
Printer Language	
Designating the display screen language	32
Printer Power . . . . .	2
Printer Self Tests	
CANCEL key . . . . .	42
Communications diagnostics . . . . .	46
FEED key and PAUSE key . . . . .	45
FEED key self test . . . . .	44
Introduction . . . . .	42
PAUSE key self test . . . . .	43



Printing considerations (specifications) . . .	49
Program Mode	
Entering . . . . .	11
Leaving . . . . .	11
Passwords . . . . .	11
Protocol, setting . . . . .	21

## R

Reporting Damage . . . . .	1
Ribbon	
Loading . . . . .	5
Removal . . . . .	6

## S

Selecting the ZPL Mode. . . . .	24
Self Tests	
Power on . . . . .	37
Sensor Calibration	
Media/Ribbon . . . . .	18
Sensor profile . . . . .	18
Sensor Profile . . . . .	18
Sensor Type, setting . . . . .	13
Sensor Values	
LCD brightness . . . . .	32
Setting the Applicator Port . . . . .	29
Setting the Verifier Port . . . . .	28
Setup, current printer configuration. . . .	16
Shipping Damage. . . . .	1
Options . . . . .	47
Stop Bits, setting . . . . .	21

## T

Tear Off Position, setting . . . . .	13
Temperature, operating range . . . . .	52
Toggle Positioning. . . . .	35
Troubleshooting	
Power on . . . . .	38
Table . . . . .	38

## U

Unpacking . . . . .	1
---------------------	---

## V

Verifier Port, setting . . . . .	28
----------------------------------	----

## W

Warning	
AC Power . . . . .	2
Earth Ground . . . . .	2
Equipment Safety . . . . .	2
Personnel Safety . . . . .	2

## Z

Zebra Programming Language (specs) . . .	50
ZebraNet Micro Print Server . . . . .	47





**Zebra Technologies Corporation**

333 Corporate Woods Parkway  
Vernon Hills, Illinois 60061-3109 U.S.A.

Phone Number: +1 847. 634.6700

Fax Number: +1 847. 913.8766

**Zebra Technologies Europe Limited**

Zebra House  
The Valley Centre, Gordon Road  
High Wycombe, Buckinghamshire  
HP13 6EQ, UK

Phone Number: +44 (0) 1494 472872

Fax Number: +44 (0) 1494 450103

Customer Order # 49861L Rev. 1  
Manufacturer Order # 49861LB  
© Zebra Technologies Corporation

## Free Manuals Download Website

<http://myh66.com>

<http://usermanuals.us>

<http://www.somanuals.com>

<http://www.4manuals.cc>

<http://www.manual-lib.com>

<http://www.404manual.com>

<http://www.luxmanual.com>

<http://aubethermostatmanual.com>

Golf course search by state

<http://golfingnear.com>

Email search by domain

<http://emailbydomain.com>

Auto manuals search

<http://auto.somanuals.com>

TV manuals search

<http://tv.somanuals.com>