

# Zebra<sup>®</sup> Snapdragon<sup>™</sup> Sierra<sup>™</sup>

Water & Fines Removal Equipment  
for Straight Oils

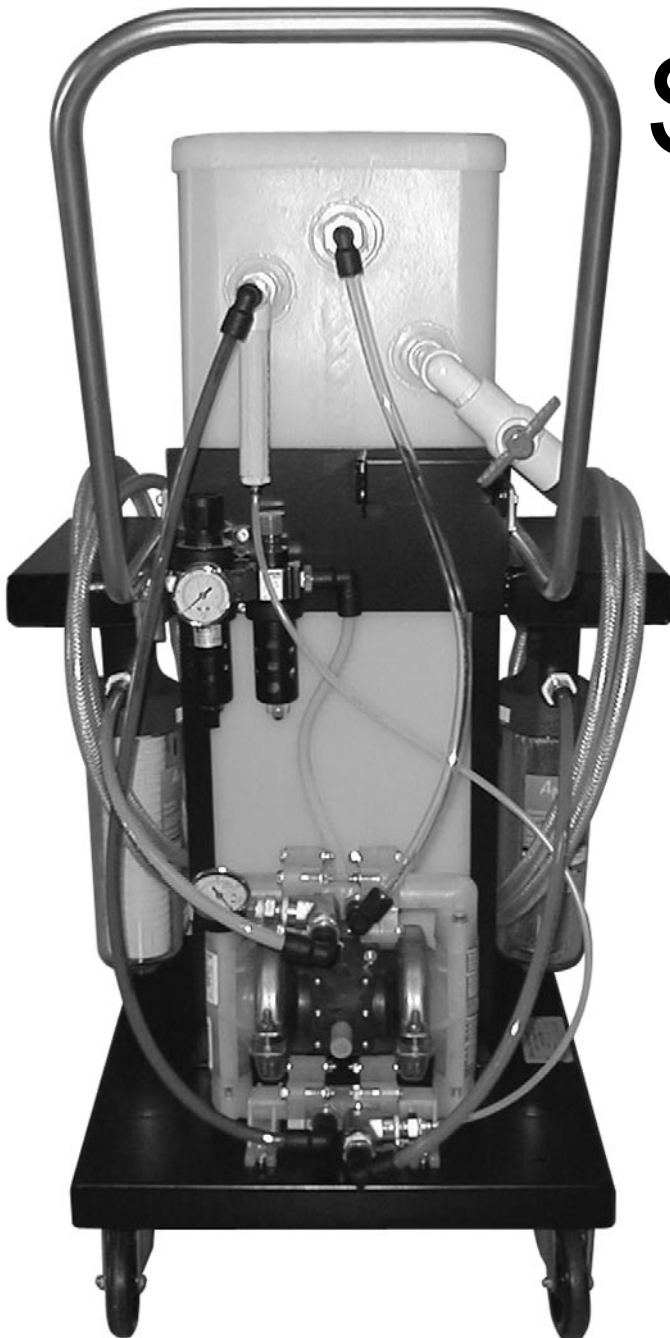

## WARNING

This manual must be read and understood before operating this piece of machinery.  
Warning! Failure to do so will void all warranties.



Copyright 2007 © ZSC  
Zebra Skimmers Corp.  
PO Box 833  
Chagrin Falls, OH 44022  
888-249-4855  
[www.ZebraSkimmers.com](http://www.ZebraSkimmers.com)

Printed in the USA • Revised April 2007

# Table of Contents

## Chapter One: Introduction to your Snapdragon Coalescer

1.0 Introduction to your Snapdragon Coalescer .....	page 3
1.1 Limited Warranty Information .....	page 3
1.2 Contacting Customer Support .....	page 3

## Chapter Two: Precautionary Safety Measures

2.0 Precautionary Safety Measures .....	page 4
---	--------

## Chapter Three: Coalescing System Review

3.0 Component Review .....	page 5-6
3.1 Fluid Movement through the System .....	page 7
3.2 System Flow Schematic .....	page 7

## Chapter Four: Coalescing System Operation & Maintenance Guidelines

4.0 Installation & Usage Guidelines .....	page 8
4.1 Oil Accumulation & Waste Discharge .....	page 8
4.2 Finishing Up .....	page 8
4.3 Emptying the Coalescing Tank .....	page 9
4.4 Storing the System .....	page 9
4.5 Cleaning the System .....	page 9

## Appendix: Third Party Equipment

Parker Pneumatic Filter Regulator .....	page 10-12
All Flo Diaphragm Pump .....	page 13-14

### Calling Customer Support

If you have difficulty assembling this product or have any questions regarding the controls, operation, or maintenance of this unit, please call the Customer Support Line at 888-249-4855.

For the latest details about the Zebra Snapdragon™ you can also visit our web site at [www.ZebraSkimmers.com](http://www.ZebraSkimmers.com).

# Chapter 1

## 1.0 Introduction to Your Snapdragon Coalescer

Thank you for purchasing the Zebra® Snapdragon™ Sierra™ Coalescer System to meet your oil maintenance challenges.

This system is designed to be utilized on straight oil applications to filter out fine particulate and separate any water-based liquid content. The oils will accumulate inside the tank, and then be drawn through the ultra filter to remove particulate. The filtered oil will then be delivered against pressure to your holding vessel.

The water-based liquid content of your solution, if any, will remain at the bottom the tank for manual discharge to your waste container. Please make sure to discharge the water portion on a timely basis so that oils are always being fed to the ultra filter. If no oils are in the holding tank of this unit, it will circulate the water portion instead.

Please assemble, install, operate, and maintain this system in accordance with the guidelines provided in this manual. This will help to insure that the unit performs properly to your satisfaction.

### 1.1 Limited Warranty information

The Zebra® Snapdragon™ Coalescer is warranted for one year from date of purchase against manufacturing or material defects, except for disposable elements. Individual warranties may apply to third party components, above and beyond this expressed warranty. This warranty will be void, in full or in part, for any use not in keeping with general safe operating procedures or any of those principles outlined in this manual.

THE ABOVE WARRANTY IS EXCLUSIVE AND IN LIEU OF ALL OTHER WARRANTIES, WHETHER EXPRESSED OR IMPLIED, INCLUDING THE IMPLIED WARRANTIES OF MERCHANTABILITY, FITNESS FOR A PARTICULAR PURPOSE AND NON-INFRINGEMENT. THIS WARRANTY GIVES YOU SPECIFIC LEGAL RIGHTS. YOU MAY HAVE OTHER RIGHTS, WHICH VARY FROM STATE TO STATE.

Zebra Skimmers Corp. (ZSC) has made every attempt

in earnest and good faith to make this manual as comprehensive, complete and detailed as possible. However, all information contained herein is subject to change without notice at the sole discretion of ZSC, or at the discretion of third party vendors whose information has been reprinted herein with their permission. ZSC is not liable for any damages which may or may not be caused by improper use of this equipment, as explicitly stated within this operator's manual. Furthermore, ZSC is not liable for the quality of information that may be contained in, or unintentionally omitted from this manual. ZSC will repair or replace such defective components at its sole discretion. Customer must pay for shipping any parts or the entire Zebra Snapdragon™ to or from ZSC repair facilities, at the sole discretion of ZSC. Zebra Snapdragon™, ADAPT™, Sierra™, Zebra Sumpster™, and Zebra Hammerhead™ are wholly owned trademarks of the Zebra Skimmers Corporation.

### 1.2 Customer Support

If you would like any assistance in assembly or installation of this system, or have any questions on its use or maintenance, please contact customer support at 888-249-4855. We would be glad to help you and welcome your feedback.

For the latest product details, please visit our web site [www.ZebraSkimmers.com](http://www.ZebraSkimmers.com).

# Chapter 2

## 2.0 Precautionary Safety Measures



**WARNING:** Read, understand, and follow all instructions contained in this manual before starting. Keep this manual in a safe, yet convenient, place for future reference.



**WARNING:** Failure to comply with all installation, operating, and maintenance guidelines will void all warranties, may cause damage to the unit, or cause personal injury.



**WARNING:** It is the responsibility of the user to only allow individuals familiar with, and with full knowledge of, this unit to install, operate, and maintain it. Zebra Skimmers Corp. will not be liable for any damages due to lack of proper use of this equipment.



**WARNING:** Make sure you have the MSDS for your coolant on file, and measures related to its mixing, measuring, maintenance, and disposal are read and understood. If you have any questions regarding your specific coolant, contact your coolant supplier's technical support service.



**WARNING:** Care must be taken at all times when handling coolant and waste oils. This includes utilizing safety glasses with side shield protection, gloves, longsleeved shirts and long-legged pants. Sturdy shoes should also be worn, preferably with reinforced toes. Any liquids that come into contact with the skin should be washed off with mild soap as soon as possible. Liquid that comes into contact with the eyes should be washed out immediately with water only.



**WARNING:** Tramp oils floating on coolant promote growth of anaerobic bacteria. These bacteria create noxious gases, such as hydrogen sulfide (H<sub>2</sub>S) and hydrochloric acid (HCl). Hydrogen sulfide causes unpleasant odors. Hydrochloric acid, however, can cause skin, eye, and lung irritation. If these symptoms are present, consult a physician. Use the Zebra Muscle Coalescer in a well-ventilated area to prevent these symptoms, should these gases be present.



**WARNING:** Waste oil is hazardous and should be handled accordingly. Observe all proper national and local disposal laws and regulations.



**WARNING:** Do not operate this equipment while under the influence of drugs or alcohol.



**WARNING:** Do not put hands or feet in the barrel of this unit.



**WARNING:** While moving this equipment, slow down before turning corners to prevent tipping. To prevent spillage, do not move the unit over hoses, mats, or other floor obstructions.

# Chapter 3

## 3.0 Component Review

### Sumpster™ Skimmer

This free-standing skimmer intake attachment can be mounted on the provided rod or on the sump wall with a magnet, depending upon your tank depth. Position the Sumpster so the top of the box is 1/4" ABOVE the maximum fluid level in the tank. It can handle a 3" fluid level drop once installed.



The chip screen will prevent large floating chips, such as aluminum and plastic, from clogging the intake hose or damaging the pump diaphragms and other internal pump components. Periodically clean the debris to maintain the 1 gpm flow rate of the system and to maximize the pump life.

### Oil Wand™ Skimmer

This manual attachment is used to clean machine ways and other hard to access machine and sump areas, which also tend to accumulate oil.

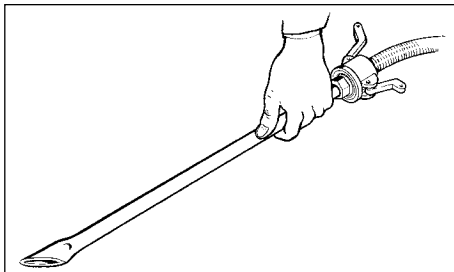

Just connect it to the intake hose when ready to use.

### Cam Lock Quick-Connectors

We supply these connectors standard with the Sierra. The female is permanently fixed to the oil intake hose and the male to the end of the intake attachment.

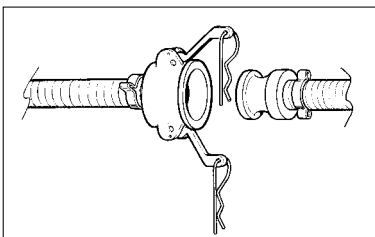

Before making the connection, verify that the interiors of these connectors are free of chips, debris, and oil residue to maintain a tight seal.

### Hoses

The 1/2", clear braided hose is industrial strength and will withstand use with water, coolants, and oils. Over time, however, they may become stiff, depending upon your overall tank conditions.



You may contact your distributor for replacement hose or choose your own. If choosing your own, please select a grade that has a wall thickness comparable to our standard to prevent wall collapse and thus poor system performance. Periodically inspect them for any blockages caused by debris to maintain system performance and maximize pump life.

### Push-to-Connect Fittings

Zebra uses Department of Transportation-rated push-to-connect fittings for vacuum loss prevention

### Pump Prefilter

The pump prefilter is made of stainless steel with 500µ pores to prevent debris from damaging the pump.



It may be cleaned and reused as long as the mesh integrity is maintained. After cleaning and reinstallation, verify that the filter housing and o-ring is free of debris to prevent vacuum loss.

### Pressure Limiter

Zebra incorporates a pressure limiter to prevent over-pressurization of the pump diaphragms, which leads to immediate pump failure.



If more than 85psi is needed to draw fluid through the system, thorough inspection of the intake attachment, connectors, hoses, and fittings is needed. It is likely that there is a vacuum leak caused by an improper seal of one of the above components or there is a debris blockage in the system.

### Pressure Regulator and Lubricator Package

Use the adjustment knob of the pressure regulator to adjust the air pressure going through the pump. It must be pulled up before adjusting.

Check the oil atomizer, located near the air line and behind the regulator, to verify that it is running at approximately one drop every 2-3 minutes. This atomizer feeds lubrication to the air line and should be refilled with ISO 32 SAE10 Airline Lubricating (mineral) Oil when necessary. Use of the wrong oil may cause o-ring failure. If there is oil leaking from the muffler, adjust the oil atomizer valve.

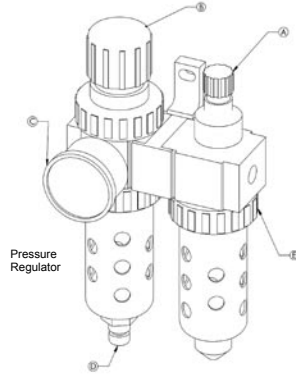

- A Lubricator adjustment knob
- B Air pressure adjustment knob
- C Pressure gauge
- D Filter drain
- E Unscrew to fill lubricator

### Air-Diaphragm Pump

The 1/2" air diaphragm pump is the heart of the system and should be well maintained. Zebra has chosen this particular brand pump for its durability and ease of maintenance.

In normal operation, it will emit a thumping sound. The faster the sound, the faster fluid is moving through the system.

The pump can handle lifting fluids 15 feet on the intake side. However, it develops great pressures on the output side, and care must be taken to never try to restrict the fluid flow in any way.

For more information on the pump, please refer to the Third Party Information in the Appendix of this manual.



### Coalescing Tank

The coalescing tank is made of polyethylene to withstand oils and coolant. It is not made to withstand punctures or shock, so care must be taken to prevent damage.

It can hold approximately 19 gallons of liquid. You will need to prefill the tank with oil only in the event that your application requires no oil to be "removed" from the tank in service.

### Baffled Anti-Turbulence System (BATS)

The BATS is made of PVC and acts to remove air bubbles from the incoming fluid. In so, turbulence is lessened in the coalescing tank, aiding in the separation of oil and water-based fluids.

### Pressurized Filtered Oil Return System

The oil return piping system will remove oil from the coalescing tank, circulating it through the pump to the ultrafilter. After ultrafiltration, it is then pumped under pressure to your holding vessel.

### Ultrafilter

The Sierra is equipped with a 5µ ultrafilter, standard. This filter cartridge is made of cellulose and should not be reused, but replaced, when necessary. Reuse of this filter may cause damage to the pump and void all warranties.



Periodically inspect the cartridge to determine whether it needs replacement. Another good indication for replacement is if the system requires more than 40psi to maintain the proper flow rate. Also verify that the o-ring is free of debris before reinstallation.

### Overfill Prevention Line

This line, which is the 1/4" clear hose, recirculates up to 10% of the fluid back through the right side of the pump to prevent the coalescing tank from overflowing.

### Ball Valve for Waste Fluid Discharge

The waste fluid, whether it's water or coolant, will settle on the bottom of the coalescing tank. It will be necessary to manually discharge this fluid to a waste container before its level reaches that of the oil return piping. NOTE: Waste waters will recirculate through the ultrafilter and into your holding vessel if not regularly discharged.

### 3.1 Fluid Movement through the System

- Intake attachment
- Intake hose
- Prefilter, 500 $\mu$  stainless steel
- Pump, right side
- BATS
- Coalescing tank
- Overfill prevention line (10% of fluid only)
- Pump, left side
- Ultrafilter, 5 $\mu$  cellulose
- Pressurized oil return hose
- Wasterwaters will accumulate in the coalescing tank until manually discharged

### 3.2 System Flow Schematic

Please review the flow schematic of the Snapdragon Sierra before attempting to install and utilize the system. Understanding the system will aid in accident prevention, provide for ease of use, and help keep you satisfied with its performance.

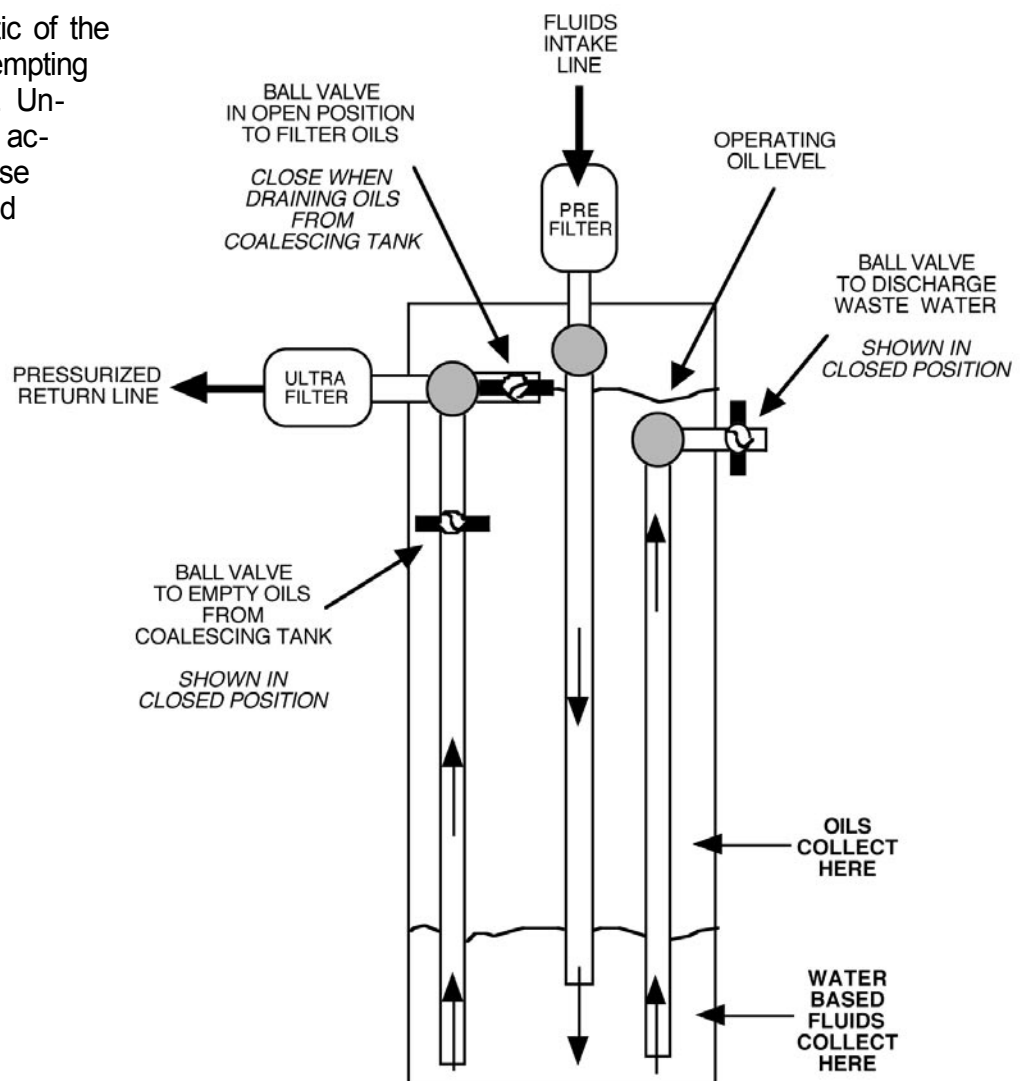

# Chapter 4 System Operation & Maintenance

## 4.0 Installation & Usage Guidelines

1. Inspect the unit to make sure it is in good operating condition.
2. Fill the coalescing tank with 3 gallons of water to fill the waste discharge pipe column. NOTE: If the coalescer tank is not pre-filled, oils will enter this column and your first waste discharge may contain oil until this column fills with water-based fluid.
3. Secure the filtered oil return hose to your preferred holding vessel using the magnet, provided.
4. Install your preferred fluid intake attachment, according to the guidelines in Section 3.0, quick-connecting it to the fluid intake hose.
5. Connect your air hose to the air connection fitting.
6. Lift the air regulator knob and adjust until the pressure is approximately 10-20 psi. NOTE: You will need to adjust this pressure higher as the filters fill with debris, if there is a blockage in a line or fitting, or there is a loss of vacuum pressure due to an improper seal. In each of the previous cases, it is recommended to correct the problem and not use excessive pressure to operate the system. This will ensure a proper flow rate for maximum oil/water separation.

## 4.1 Oil Accumulation for Ultrafiltration & Waste Discharge

Once the fluid is drawn into the coalescing tank, it will begin to separate into two main layers. The oil component will float towards the top of the tank and water-based fluids will accumulate near the bottom of the coalescing tank. The degree of this separation will be strictly determined by these factors:

- The strength of the water-based fluids anti-emulsification components (as in metalworking fluid, aka coolants)
- The age and quality of the water-based fluid to be manually discharged
- The age and quality of the oil to be ultrafiltered
- Chemical instabilities caused by other additives entering fluid pool
- The flow rate of the coalescing system

Maintain a regulated flow rate so it provides for a proper hold time for all fluids to separate, usually 1-2 gallons per minute.

If there is not a complete separation of the oil and water portions, then a slower flow rate may be necessary, as your fluids have lost the ability to gravity separate within 10-20 minutes. You may notice a third layer which does not completely separate at all. These are called inverse layers, and are generally caused by high-pressure systems which further emulsify oils into one another. Consider this layer as waste and discharge it regularly.

The Snapdragon Sierra is not guaranteed to separate a straight oil from another straight oil and/or tramp oils. Before reusing any straight oil, verify its integrity.

Manually discharge the wastewater portion to a waste container, via the ball valve, so as not to recirculate it through the ultrafilter and into your preferred holding vessel. NOTE: We recommend maintaining a waste water level of about a third of the tank height to maintain the separated fluid layers. ALWAYS discharge the waste fluid while the pump is running to prevent vacuum loss in the waste discharge pipe.



## 4.2 Finishing Up

1. Once the oils have been removed from the tank being skimmed, disconnect the intake hose from the intake attachment via the quick connection.
2. Before shutting off the pump, lift the intake hose out of the tank for about 10 seconds. This will ensure that no liquid is still in the intake line.
3. Shut the pump off by adjusting the regulator.  
NOTE: See Section 4.3 for details on emptying the tank, if necessary, before proceeding further.
4. Disconnect your air line from the air intake fitting.
5. Remove the return line from the tank being skimmed by lifting it near its connection to the coalescing tank to free it of liquid.

## 4.3 Emptying the Coalescing Tank

1. Open waste water ball valve to manually drain any wastewater to your waste container, then close (refer to flow schematic in Section 3.2).
2. Tilt, in an upward position, the prefilter and ultrafilter housings.
3. Close ball valve for the oil ultrafiltration line (refer to flow schematic in Section 3.2).
4. Open ball valve for oils to be emptied from tank (refer to flow schematic in Section 3.2).
5. Place the oil return line into your preferred oil holding vessel. Make sure that it can hold the remaining amount of oil left in the coalescing tank.  
CAUTION: Fluid is returned under pressure.
6. Adjust the air regulator of the pump to 10psi.

## 4.4 Storing the System

It is recommended to empty the coalescing tank before storing the system for more than 1 or 2 days. Holding liquid in the tank can contribute to bacterial contamination of the coalescer, and thus your equipment. We recommend utilizing an Oxygenator™ when storing fluids in the coalescing tank to minimize bacterial growth.

## 4.5 Cleaning the System

1. Empty and clear the coalescing tank and both hoses of all fluids (refer to Section 4.3)
2. Discard the cellulose ultrafilter.
3. Mix a 10% solution of a mild degreasing agent, such as Red Thunder™, provided, to clean the coalescing tank and stainless steel prefilter. A pressure washer works well, or just clean by hand with the brush, provided.
4. Rinse thoroughly with straight water.
5. Dispose of wash and rinse baths in accordance to federal, state, and local environmental laws and regulations.
6. Replace filters, making sure o-rings are free of debris and seated correctly.
7. Double-check all hoses, fittings, and attachments for cracks and obstructions.

# Appendix: Third Party Equipment

## Contents

Parker Pneumatic Filter/Regulator ..... 10-11  
 Parker Pneumatic 14E Mini Filter/Regulator ..... 11-12  
 ALL-FLOW PUMP ..... 13-14

## Parker Pneumatic Filter/Regulator

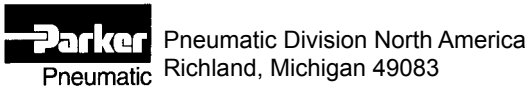

**WARNING**

To avoid unpredictable system behavior that can cause personal injury and property damage:

- Disconnect air supply and depressurize all air lines connected to this product before installation, servicing, or conversion.
- Operate within the manufacturer's specified pressure, temperature, and other conditions listed on these instructions.
- Medium must be moisture-free if ambient temperature is below freezing.
- Service according to procedures listed in these instructions.
- Installation, service, and conversion of these products must be performed by knowledgeable personnel who understand how pneumatic products are to be applied.
- After installation, servicing, or conversion, air supply should be connected and the product tested for proper function and leakage. If audible leakage is present, or the product does not operate properly, do not put into use.
- Warnings and specifications on the product should not be covered by paint, etc. If masking is not possible, contact your local representative for replacement labels.

### Introduction

Follow these instructions when installing, operating, or servicing the product.

### Application Limits

These products are intended for use in general purpose compressed air systems only

### Operating Inlet Pressure:

	kPa	PSIG	bar
with Polycarbonate Bowl	1000	150	10.3
with Metal Bowl	1700	250	17.0

Note: The maximum recommended pressure drop for a particulate filter is 70 kPa (10 psig, 0.7 bar).

### Ambient Temperature Range:

- with Polycarbonate Bowl: 0°C to 52°C (32°F to 125°F)
- with Metal Bowl: 0°C to 52°C (32°F to 175°F)

### Symbols

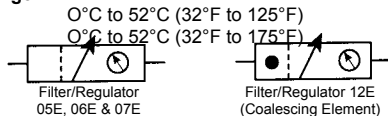

### Installation

1. The filter/regulator should be installed with reasonable accessibility for service whenever possible - repair service kits are available. Keep pipe or tubing lengths to a minimum with inside clean and free of dirt and chips. Pipe joint compound should be used sparingly and applied only to the male pipe - never into the female port. Do not use Teflon<sup>®</sup> tape to seal pipe joints - pieces have a tendency to break off and lodge inside the unit, possibly causing malfunction. Also, new pipe or hose should be installed between the filter/regulator and equipment being protected.
2. The upstream pipe work must be clear of accumulated dirt and liquids.
3. Select a filter/regulator location as close as possible to the equipment being protected.
4. Install filter/regulator so that air flows in the direction of arrow on body.
5. Install filter/regulator vertically with the bowl drain mechanism at the bottom. Free moisture will thus drain into the sump ("quiet zone") at the bottom of the bowl.
6. Gauge ports are located on both sides of the filter/regulator body for your convenience. It is necessary to install a gauge or socket pipe plugs into each port during installation.

### Operation

1. Both free moisture and solids are removed automatically by the filter. Units with coalescing elements (e.g. 12E series) also remove oil. For coalescing units, a 5 micrometer pre-filter is recommended to protect and prolong the life of the coalescent filter element.
2. Manual drain filters must be drained regularly before the separated moisture and oil reaches the bottom of the baffle or end cap.
3. The filter element should be removed and replaced when pressure differential across the filter is 69 kPa (10 psig).
4. Before turning on the air supply, turn the knob counterclockwise until compression is released from the pressure control spring. Then turn knob clockwise and adjust

regulator to desired downstream pressure. This permits pressure to build up slowly in the downstream line.

5. To decrease regulated pressure settings, always reset from a pressure lower than the final setting required. Example, lowering the secondary pressure from 550 to 410 kPa (80 to 60 psig) is best accomplished by dropping the secondary pressure to 350 kPa (50 psig), then adjusting upward to 410 kPa (60 psig).

6. When desired secondary pressure settings have been reached, push the knob down to lock this pressure setting.

### Service

Caution: Disconnect or shut off air supply and exhaust the primary and secondary pressures before servicing unit. Turning the adjusting knob counterclockwise does not vent downstream pressure on non-relieving regulators. Downstream pressure must be vented before servicing regulator.

Note: Grease packets are supplied with kits for lubrication of seals. Use only mineral based grease or oils. Do not use synthetic oils such as esters. Do not use silicones.

Note: After servicing unit, turn on air supply and adjust regulator to the desired downstream pressure. Check unit for leaks. If leakage occurs, do not operate - conduct repairs and retest.

### Servicing Filter Element

A. 05E, 06E, & 07E Units (Refer to Figure 1.)

1. Unscrew the bottom threaded collar and remove bowl.
2. Unscrew the baffle and then remove element.
3. Clean all internal parts and bowl before reassembling. See polycarbonate bowl cleaning section. IMPORTANT: The 05E & 06E Filter/Regulator will not operate properly if the deflector (or rubber spacer if using an 06E adsorber) is not installed properly. The deflector (or rubber spacer) must be installed between the filter stem and the filter body
4. Install new element.
5. Attach baffle and finger tighten firmly.
6. Replace bowl seal. Lightly lubricate new seal to assist with retaining it in position.
7. Install bowl into body and tighten collar; hand tight, plus 1/4 turn.

WARNING FAILURE OR IMPROPER SELECTION OR IMPROPER USE OF THE PRODUCTS AND/OR SYSTEMS DESCRIBED HEREIN OR RELATED ITEMS CAN CAUSE DEATH, PERSONAL INJURY AND PROPERTY DAMAGE.

This document and other information from Parker Hannifin Corporation, its subsidiaries and authorized distributors provide product and/or system options for further investigation by users having technical expertise. It is important that you analyze all aspects of your application, including consequences of any failure and review the information concerning the product or system in the current product catalog. Due to the variety of operating conditions and applications for these products or systems, the user, through its own analysis and testing, is solely responsible for making the final selection of the products and systems and assuring that all performance, safety and warning requirements of the application are met.

The products described herein, including without limitation, product features, specifications, designs, availability and pricing, are subject to change by Parker Hannifin Corporation and its subsidiaries at any time without notice.

### 05E, 06E, 07E, & 12E Filter/Regulator Series

B. 12E Units (Refer to Figure 2.)

1. Hold bowl collar stationary while unscrewing and removing bowl.
2. Unscrew end cap and then remove element. (Do not remove threaded rod.)
3. Clean all internal parts and bowl before reassembling.
4. Install new element.
5. Attach end cap and finger tighten firmly,
6. Replace bowl seal. Lightly lubricate new seal to assist with retaining it in position.
7. Thread bowl into collar; hand tighten until bowl stops against collar.

### Servicing Regulator

A. 05E, 06E, & 07E Units - (Refer to Figure 1.)

1. Disengage the adjusting knob by pulling upward. Turn adjusting knob counterclockwise until the compression is released from the pressure control spring.
2. Remove the bonnet and bowl assemblies by unscrewing the two threaded collars.
3. Remove diaphragm assembly from bonnet assembly.
4. Remove filter stem, filter element, poppet assembly, poppet return spring, (seat) insert and its o-rings.
5. Clean and carefully inspect parts for wear or damage. If replacement is necessary, use parts from service kits. Clean bowl. See polycarbonate bowl cleaning section.
6. Lubricate o-ring and vee packing seals with grease found in service kits.
7. Install poppet return spring, poppet assembly, (seat) insert and its o-rings, and filter stem. IMPORTANT: The 05E & 06E Filter/Regulator will not operate properly if the deflector (or rubber spacer if using an 06E adsorber) is not installed properly. The deflector (or rubber spacer) must be installed between the filter stem and filter body.
8. Install filter element and firmly tighten baffle onto the filter stem.
9. Install diaphragm assembly into bonnet assembly. Assemble bonnet assembly to body and tighten threaded collar from 5.4 to 5.9 N•m (48 to 52 in-lbs).
10. Install bowl into body and tighten collar; hand tight, plus 1/4 turn,

B. 12E Units - (Refer to Figure 2.)

1. Disengage the adjusting knob by pulling upward. Turn adjusting knob counterclockwise until the compression is released from the pressure control spring.
2. Remove the bonnet assembly by unscrewing its threaded collar.

3. Remove the bottom collar and bowl as an integral unit. Note: The reverse flow adapter and element assembly should remain in proper alignment with the collar; they are held in place by the o-ring between the adapter and the collar.

4. Remove diaphragm assembly from bonnet assembly.

5. Remove poppet assembly, poppet return spring, (seat) insert and its o-rings.

6. Clean and carefully inspect parts for wear or damage. If replacement is necessary, use parts from service kits.

7. Lubricate o-ring and vee packing seals with grease found in service kits.

8. Install poppet return spring, poppet assembly, (seat) insert and its o-rings.

9. Install diaphragm assembly into bonnet assembly. Assemble bonnet assembly to body and tighten threaded collar from 5.4 to 5.9 N·m (48 to 52 in-lbs).

10. Install bottom collar and bowl subassembly into body. Tighten collar hand tight, plus 1/4 turn.

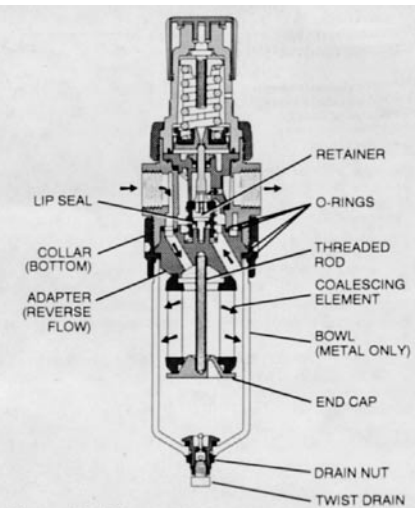

Figure 2: 12E

**Safety: Polycarbonate Bowls**

Bowl guards are recommended for added protection of polycarbonate bowls where chemical attack may occur.

**WARNING** To avoid polycarbonate bowl rupture that can cause personal injury or property damage, do not exceed bowl pressure of temperature ratings. Polycarbonate bowls have a 150 psig (1030 kPa) pressure rating and a maximum temperature rating of 52°C (125°F).

MAINTENANCE SERVICE KITS	05E 1/8", 1/4" & 3/8"	06E 1/4", 3/8" & 1/2"	07E 3/8", 1/2" & 3/4"	12E 3/8", 1/2" & 3/4"
Element Kits				
5 Micron	PS902P	PS702P	PS802P	N/A
40 Micron	PS901P	PS701P	PS801P	N/A
Grade 6	N/A	N/A	N/A	PS884P
Grade 10	N/A	N/A	N/A	PS885P
Relieving Regulator				
Repair Kit	PS908P	PS710P	PS810P	PS886P
Non-Relieving				
Regulator Repair Kit	PS909P	PS711P	PS811P	PS887P

EXTRA COPIES OF THESE INSTRUCTIONS ARE AVAILABLE FOR INCLUSION IN EQUIPMENT/ MAINTENANCE MANUALS THAT UTILIZE THESE PRODUCTS. CONTACT YOUR LOCAL REPRESENTATIVE.

**Parker Pneumatic 14E Mini Filter/Regulator**

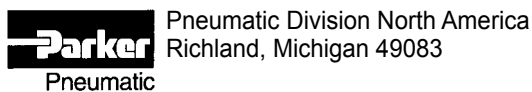

**WARNING**

To avoid unpredictable system behavior that can cause personal injury and property damage:

- Disconnect electrical supply (when necessary) before installation, servicing, or conversion.
- Disconnect air supply and depressurize air lines connected to this product before installation, servicing, or conversion.
- Operate within the manufacturer's specified pressure, temperature, and other conditions listed in these instructions.
- Medium must be moisture-free if ambient temperature is below freezing.
- Service according to procedures listed in these instructions.
- Installation, service, and conversion of these products must be performed by knowledgeable personnel who understand how pneumatic products are to be applied.
- After installation, servicing, or conversion, air and electrical supplies (when necessary) should be connected and the product tested for proper function and leakage. If audible leakage is present, or the product does not operate properly, do not put into use.
- Warnings and specifications on the product should not be covered by paint, etc. If masking is not possible, contact your local representative for replacement labels.

**Introduction**

Follow these instructions when installing, operating, or servicing the product.

**Application Limits**

These products are intended for use in general purpose compressed air systems only. Compliance with the rated pressure and temperature is necessary.

Maximum Operating (Inlet) Pressure:	kPa	psig	bar
P3A-RN, 8AR (Plastic Body)	827	120	8.3
14E (with Plastic Bowl)	1030	150	10.3
14E (with Metal Bowl)	1720	250	17.2
14R (Metal Body)	2000	300	20.0
15R (Metal Body)	1720	250	17.2

**Ambient Temperature Range:** 0°C to 52°C (32°F to 125°F)

**Symbols**

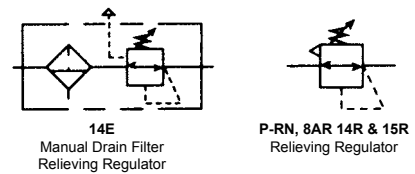

**Installation**

1. This unit should be installed with reasonable accessibility for service whenever possible - repair service kits are available. Keep pipe and tubing lengths to a minimum with inside clean and free of dirt and chips. Pipe joint compounds should be used sparingly and applied only to the male pipe - never into the female port. Do not use PTFE tape to seal pipe joints - pieces have a tendency to break off and lodge inside the unit, possibly causing malfunction.

2. Install unit so that air flow is in the direction of arrow. Installation must be upstream of and close to devices it is to service (valve, cylinder, tool etc.). Mounting of regulators may be in any position; mounting of filter/regulators must be vertical as shown in figure.

3. Gauge ports are located on both sides of the regulator body for your convenience. It is necessary to install a gauge or pipe plug into each port during installation.

4. To protect regulator units against rust, pipe scale, and other foreign matter, install a filter on the upstream (high pressure) side as close to the regulator as possible.

**Caution:** For proper assembly of P3A-RN and 8AR fittings, they must be installed hand-tight and then tightened by wrench 1/2 turn. To prevent leakage past threads, apply thread sealant to fitting. Prestolok fittings are recommended. Use of hard pipe is not recommended.

**EXCESSIVE TURNING OF FITTINGS BY WRENCH MAY RESULT IN PERMANENT DAMAGE AND RENDER THE REGULATOR INOPERABLE.**

**Operation of Regulator**

1. Before turning on air supply, turn adjusting handle counterclockwise until compression is released from control spring. Then turn on air supply and adjust regulator to desired secondary pressure by turning adjusting handle clockwise. This permits pressure to build up slowly, preventing any unexpected operation of the valve, cylinders, tools, etc., attached to the line. Adjustment to desired secondary pressure can be made only with primary pressure applied to the regulator.

2. To decrease regulator pressure setting, always reset from a pressure lower than the final setting desired. For example, lowering the secondary pressure from 550 to 410 kPa (80 to 60 psig) is best accomplished by dropping the secondary pressure to 350 kPa (50 psig), then adjusting upward to 410 kPa (60 psig).

**Operation of Filter/Regulator**

1. Both free moisture and solids are removed automatically by the Filter/Regulator.
2. Manual drain filters must be drained regularly before the separated moisture and oil reaches the bottom of the element holder. Automatic drain models (pulse drain) will collect and dump liquids automatically. They are actuated when a pressure drop occurs within the filter.
3. The filter element should be removed and replaced when the pressure differential across the filter is excessive.

**Service**

**Caution:** SHUT OFF AIR SUPPLY and exhaust the primary and secondary pressure before disassembling unit. (Units may be serviced without removing them from the air line.)

**Servicing Regulator:**

Note: See Figure 1, 2, 3 & 4 to aid with this procedure.  
1. Unlock the adjusting knob by pulling upward (with the unit in an upright position.) Then turn adjusting knob counterclockwise until compression of the control spring has been removed.

2. Remove the bonnet from body. Then remove o-ring (7), piston, lip seal (9), and control spring to service the bonnet subassembly. Unscrew seat (8) to service the poppet (17), return spring (5), and/or poppet seal (6), o-rings (25 & 27), and washer (26).

Note: On filter/regulator units, the poppet assembly & poppet return spring may be accessed by removing filter element.

3. Clean old grease from unit and inspect seals for sign of wear (nicks, cuts, and scratches). Repair kits are available which contain the parts which are typically replaced.

4. Apply a light film of grease to all seals and sliding surfaces using the grease packet supplied with repair kit.

Note: Refer to Figures to determine the correct position and orientation of the

various parts during assembly.

5. On relieving 15R units, gently and firmly press vent seal into piston using a blunt instrument.

6. Install lip seal onto piston with the lips of the seal facing away from the support flange. Then insert control spring and piston assembly into bonnet.

7. On 15R units, place balancing o-ring (27) and washer (26) into body's bore. Then insert poppet return spring and poppet assembly, followed by seat o-ring (25) and seat. On 14E, P3A-RN, 8AR & 14R units, place poppet return spring and poppet assembly into bore, followed by poppet seal and seat.

8. On 15R units, tighten seat from 0.6 to 0.8 Nm (5 to 7 in-lbs). On 14E, P3A-RN, 8AR & 14R units, tighten seat to body from 0.9 to 1.1 Nm (8 to 10 in-lbs) of torque. Tighten bonnet onto body from 5.6 to 7.3 Nm (50 to 65 in-lbs) of torque.

9. Make sure that the control spring is still uncompressed before turning on the air supply. Turn on air supply, then slowly adjust the knob clockwise to increase downstream pressure until the desired pressure has been reached.

10. To decrease regulator pressure setting, always reset from a pressure lower than the final setting desired. For example, lowering the secondary pressure from 550 to 410 kPa (80 to 60 psig) is best accomplished by dropping the secondary pressure to 350 kPa (50 psig), then adjusting upward to 410 kPa (60 psig).

11. When the desired secondary pressure setting has been reached, push the adjusting knob down to lock it.

12. Check for leaks. If leaks occur, shut off the air supply, exhaust system air pressure, and make necessary adjustments to eliminate leakage.

**Servicing Filter Element:**

Note: See Figure 1 to aid with this procedure.

1. Unscrew threaded bowl and element holder. Then remove filter element, deflector, and gaskets.

2. Clean all internal parts, bowl, and body before re-assembling unit. See Polycarbonate bowl cleaning section.

3. Install deflector, filter element, and gaskets.

4. Attach element holder. Torque 0.9 to 1.4 Nm (8 to 12 in-lbs).

5. To assist with retaining bowl's o-ring while installing bowl, lubricate the o-ring (with a mineral based oil or grease). Then place it on the bowl.

6. Screw bowl into body until it is stopped by body; then back off bowl 1/8 turn.

7. Apply pressure to the system and check for leaks. If leaks occur, shut off the air supply, de-pressurize the system and make necessary adjustments to eliminate leakage. If you have questions concerning how to service this unit, contact your local authorized dealer or your customer service representative.

**Parts Identification List**

- Item# Description
- 1 Bowl (14E)
- 2 Filter Element (14E)
- 3 Deflector (14E)
- 4 O-ring (14E) - bowl to body
- 5 Poppet Return Spring
- 6 Poppet Seal
- 7 O-ring - body to bonnet
- 8 Seat
- 9 Lip Seal - piston to bonnet
- 10 O-ring (14E, P3A-RN, 8AR & 14R relieving units) - piston to poppet
- 11 Piston (relieving shown)
- 12 Control Spring
- 13 Knob
- 14 Hex Nut
- 15 Adjusting Screw
- 16 Bonnet Assembly
- 17 Poppet (14E, P3A-RN, 8AR & 14R) & Poppet Assembly (15R)
- 18 Body
- 19 Gasket (14E) - deflector to body
- 20 Gasket (14E) - element holder to filter element
- 21 Element Holder (14E)
- 22 O-ring (14E) - body to drain
- 23 Twist Drain (14E)
- 24 Vent Seal (15R, relieving units) - poppet assembly to piston
- 25 O-ring (15R) - seat to body
- 26 Washer (balanced units)
- 27 O-ring (balanced units) - poppet assembly to body

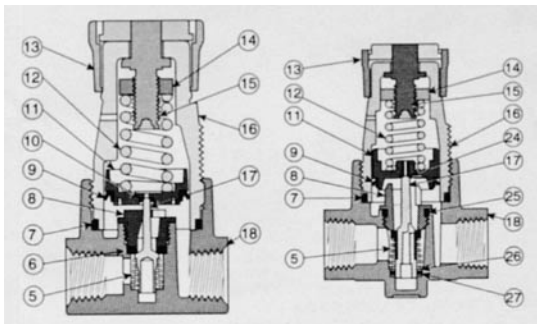
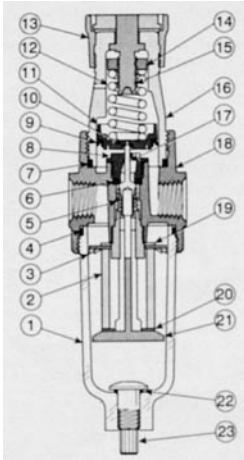
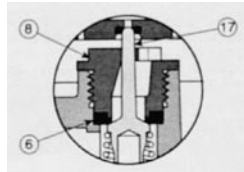

**Service Kits Available**

The following service kits contain the appropriate seals and parts necessary for ordinary field service.

Description	14E	P3A-RN, 8AR & 14R	15R
Poppet Kit - Balanced	N/A	N/A	PS455BP
Piston Kit - Non-Relieving	N/A	N/A	PS422P
Piston Kit - Relieving	N/A	N/A	PS423P
Piston & Poppet Kit - Unbal. Rel.	PS426P	PS426P	N/A
Piston & Poppet Kit - Bal. Rel.	PS427P	PS427P	N/A
Piston & Poppet Kit - Unbal. Non-Rel	PS428P	PS428P	N/A
Piston & Poppet Kit - Bal. Non-Rel	PS429P	PS429P	N/A
Bonnet Assembly	L01369	L01369	L01369
Mounting Bracket Kit (plastic ring)	PS417BP	PS417BP	PS417BP
Mounting Bracket Kit (aluminum ring)	PS466P	PS466P	PS466P
Knob Tamperproof Clip	P01265	P01265	P01265
5 Micron Element Kit	PS403P	N/A	N/A
40 Micron Element Kit	PS401P	N/A	N/A
Polycarbonate Bowl w/Manual Drain	PS404P	N/A	N/A
Polycarbonate Bowl w/Automatic Drain	PS408P	N/A	N/A
Metal Bowl w/Manual Drain	PS447BP	N/A	N/A
Metal Bowl w/Automatic Drain	PS451P	N/A	N/A

**SAFETY: Transparent Bowls**

▲ Caution: Polycarbonate bowls, being transparent and tough, are ideal for use with Filters and Lubricators. They are suitable for use in normal industrial environments, but should not be located in areas where they could be subject to direct sunlight, an impact blow, nor temperatures outside of the rated range. As with most plastics, some chemicals can cause damage. Polycarbonate bowls should not be exposed to chlorinated hydrocarbons, ketones, esters and certain alcohols. They should not be used in air systems where compressors are lubricated with fire resistant fluids such as phosphate ester and di-ester types.

Metal bowls are recommended where ambient and/or media conditions are not compatible with Polycarbonate bowls. Metal bowls resist the action of most such solvents, but should not be used where strong acids or bases are present or in at laden atmospheres. Consult the factory for specific recommendations where these conditions exist.

TO CLEAN POLYCARBONATE BOWLS USE MILD SOAP AND WATER ONLY!  
DO NOT use cleansing agents such as acetone, benzene, carbon tetrachloride, gasoline, toluene, etc., which are damaging to this plastic.

**ALL-FLO Pump Service and Operating Manual**

**ALL-FLO PUMP**

ALL-FLO Pump Co., Inc.  
 9321 Pineneedle Drive  
 Mentor, OH 44060  
 Ph: 440-354-1700  
 Fax: 440-354-9466  
 Email: email@all-flo.com

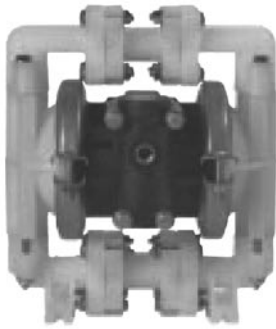

**Specifications**

- Capacity:**  
 Adjustable 0 to 14 GPM (53,2 liters/min.)
- Maximum Temperature:**  
 KN-5 Model 200°F (93°C)  
 Other Plastic Models 150°F (66°C)
- Maximum Air Pressure:**  
 All Models 100 PSI (6.8 bar)
- Minimum Air Pressure:**  
 All Models 20 PSI (1.3 bar)
- Dry Lift Capacity @ 100 PSI (6.8 bar):**  
 Models w/PTFE balls 10 ft. (3 meters)  
 Other Models 15 ft. (4.5 meters)
- Maximum Solids:** 1/8" (3.2 mm)
- Air Supply:**  
 Inlet 1/4" NPT Female  
 • Air flow control valve supplied, 1/4" NPT or 1/2" BSP Female  
 Outlet 3/8" NPT Female  
 • Muffler supplied
- Fluid Inlet/Discharge:**  
 All Models 1/2" NPS Female  
 (BSP or NPT Compatible)

**Performance Curve**

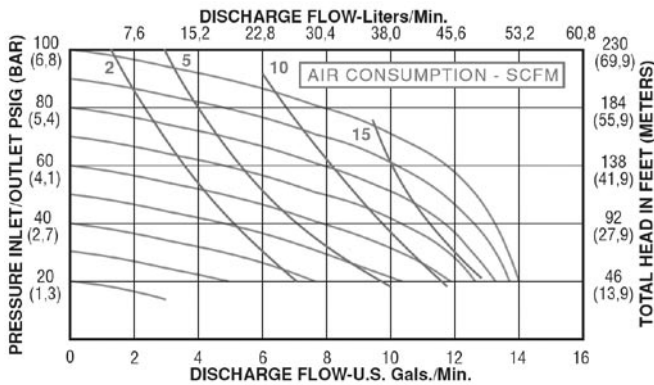

**AIR DRIVEN, DOUBLE DIAPHRAGM PUMP MANUAL**

Congratulations on purchasing one of the most durable and versatile pumps made anywhere. With the proper installation and maintenance the pump will provide years of great performance.

READ THESE WARNINGS AND SAFETY PRECAUTIONS PRIOR TO INSTALLATION OR OPERATION. FAILURE TO COMPLY WITH THESE INSTRUCTIONS COULD RESULT IN PERSONAL INJURY AND OR PROPERTY DAMAGE. RETAIN THESE INSTRUCTIONS FOR FUTURE REFERENCE.

- ⚠️WARNING** Before placing the pump in service make certain it is compatible with the fluid being pumped. Changes of temperature, concentrations or combinations of chemicals may vary resistance of material. Always consult Material Safety Data Sheets and Engineering Resistance Tables for chemical compatibility.
- Be certain all operators of this equipment have been trained for safe working practices.

**HAZARDOUS MATERIAL:** Protective eye wear and clothing should be used whenever pumping hazardous or toxic fluids.

- If a diaphragm ruptures, the pumped product can enter the air side of the pump and exit through the air exhaust. When the fluid is hazardous pipe exhaust away from the work area and personnel.
- When the fluid source is at a higher level than the pump (flooded suction), the exhaust should be piped to a higher level than the fluid source to prevent spills caused by siphoning if a diaphragm rupture should occur.

**HAZARDOUS PRESSURE:** Do not clean or service pump, hoses or dispensing valves when the system is pressurized - serious injury may result.

- Disconnect air supply line and relieve pressure from the system prior to disassembly.

**⚠️DANGER** **STATIC WARNING:** Pumping of flammable materials may cause a build-up of a static charge within the electrically non conductive pumps. Static spark can cause explosion resulting in severe injury or death. Ground pump and pumping systems when pumping flammable products or when used in a location where surrounding atmosphere is conductive to spontaneous combustion. Optional conductive non-metallic models are available when grounding is necessary. Use grounding lugs and always connect to a good ground source.

- Secure pump, connections and all contact points to avoid vibrations and generation of contact or static spark. Periodically verify continuity of electrical path to ground with an ohmmeter from each component.
- Consult local building codes and electrical codes for specific grounding requirements.
- Use hoses incorporating a static wire.
- Use proper ventilation
- Keep flammables away from heat, open flames and sparks.
- Keep containers closed when not in use.

**⚠️WARNING** Maximum temperatures are based on mechanical stress only. Certain chemicals will significantly reduce maximum safe operating temperature. Consult engineering guides for chemical compatibility and temperature limits.

- Always use minimum air pressure when pumping at elevated temperatures.

**⚠️WARNING** Excessive air pressure can cause pump damage, personal injury or property damage.

**⚠️WARNING** Pump must be reassembled properly after maintenance.

**⚠️CAUTION** Do not use the pump for the structural support of the piping system. Be certain the system components are supported to prevent stress on the pump parts.

- Flexible connections will avoid damage to piping due to vibration.

**Installation**

**NOTICE:** Re-torque fasteners prior to use. Refer to torque requirements listed in maintenance manual and attached to pump.

1. A lube-free, clean, dry, compressed air source (or any nonflammable, compressed gas) is recommended. Use a filter that is capable of filtering out particles larger than 50 microns.
2. All pumps should be mounted in an upright position with the exception of the 1/4" models which may be rotated 360° to suit the application.
3. When particles exceed the maximum particle specification of the pump or are sharp enough to cut elastomers install a particle fluid filter on the fluid suction line.
4. Fluid suction lines and air exhaust lines should never be smaller than specified pipe size of pump.
5. Apply PTFE tape to threads upon assembly to prevent leakage.
6. Never use pipe dope on air line connections.
7. Never use collapsible tube on fluid inlet.
8. Do not exceed 10 ft-pounds of torque on plastic pipe threads.
9. If changing to a different application reconfirm compatibility of fluid.

**GENERAL MAINTENANCE**

1. Check periodically for product or air leakage. Tighten any joint where leakage is occurring.
2. When pumping hazardous or toxic materials, diaphragms should be replaced at regularly scheduled intervals based upon pump usage.
3. In freezing temperatures, the pump must be completely drained when idle.
4. When pumping highly abrasive fluids reduce discharge flow rate or reduce air pressure to prolong diaphragm life.
5. If you are pumping a material that will settle or compact the pump must be flushed before shut down.

**Trouble Shooting**

**AIR IS APPLIED TO PUMP BUT PUMP IS NOT STARTING**

1. Clean filters and debris from all fluid lines
2. Make sure all valves on fluid lines are open.
3. Inspect diaphragms for rupture.
4. Air pressure must not be below 20 psi (1,3 bar)

**PUMP IS PUMPING BUT NOT PRIMING**

1. Check all suction line connections for leakage.
2. Inspect check valves for wear or debris.
3. Suction lift specifications may be exceeded.
4. If fluid is viscous use larger suction lines.

**LEAKAGE**

1. Retorque all fasteners to specified torque requirements.
2. Replace o-rings.
3. Inspect diaphragms for rupture

**LOW FLOW RATE**

1. Confirm air pressure and air capacity at the air valve as required.
2. Check for leaks in suction line or obstructions in lines.
3. If fluid is viscous use larger suction lines.
4. Viscosity of fluid may have increased if temperature is lower.

**AIR IN DISCHARGE LINES**

1. Check for leaks in suction lines.
2. Inspect diaphragms for rupture.

**ERRATIC CYCLING**

1. Inspect check valve seats for debris.
2. Inspect fluid lines for debris.
3. Automatic valves must be properly functioning.
4. Viscosity of product may be changing.

**PREMATURE DESTRUCTION OF WETTED COMPONENTS**

1. If fluid is abrasive slow down pump or increase size of pump
2. Filter fluid for sharp objects.
3. Make sure fluid is compatible with wetted materials.

**1/2" MODELS**

**MAINTENANCE MANUAL**

**Check Valve And O-ring Maintenance**

1. Flush and neutralize the pump to be certain all corrosives or hazardous materials are removed prior to any maintenance. This procedure should always be followed when returning pumps for factory service also.
2. Remove the nuts (19) and washers (10) from the four long pumping cap screws (35). Suction check valve seats and check balls (26, 27) are located inside of the bottom of the outer chamber (28). Gently remove and inspect for excessive wear, pitting or other signs of degradation. Inspect valve seat o-rings (38). Replace if necessary. Discharge check valves are located inside of the bottom of the discharge elbows (28). Repeat procedure for inspection of discharge check valves.
3. To inspect the manifold o-rings remove the eight sets of nuts, washers and bolts (10, 19, 20) from each manifold assembly and replace if necessary. Then reassemble, lightly tighten fasteners. Tighten all external fasteners to final torque requirement after pump is completely assembled. The check ball should fit into the curved portion of the valve seat and be facing upward when reinserted into the valve seat location.

NOTE: When using pumps built with PTFE o-rings always replace with new PTFE o-rings, since the original o-rings will not reseal the pump.

**Diaphragm And Pilot Sleeve Assembly Maintenance**

4. To inspect diaphragms remove the band clamps (16) from the outer pumping chambers (28). If replacement is necessary due to abrasion or rupture unscrew the outer diaphragm plates (29). Models that are built with PTFE elastomers will have a PTFE overlay (30) that faces the outer pumping chamber and a back-up diaphragm (31) on the air side of pump. Pumps without PTFE will contain only the back-up diaphragms.
5. If there has been a diaphragm rupture and corrosive or viscous fluid has entered the air side of pump the complete air system should be inspected. After removing diaphragms and inner diaphragm plate (33), the pilot sleeve assembly (14, 40, 42, 45-47) and diaphragm rod assembly (13, 15) may be removed by removing the retaining plates (41) (you may only need to remove one retaining plate) and pushing the entire unit out through the bore in the intermediate (34). Diaphragm rod assembly must be unscrewed to remove pilot sleeve.

NOTE: To aid in reassembly use a non-synthetic, petroleum based lubricating grease without EP additives. Carleton-Stuart MagnaLube G is recommended.

6. Clean or replace any components that have excessive wear, dirt build-up, or chemical attack. Lube all components prior to reassembling. Reassemble pilot sleeve spacers, o-rings and lip seals (40) within bore of intermediate. Make sure that the open side of the lip seals is facing outward toward the diaphragms. Also make sure that the end pilot spacers (14) are at the end on either side of the pilot sleeve assembly and all inner spacers (47) are separated by o-rings. Next carefully insert the diaphragm rod assembly with pilot sleeve inside the assembly in the bore. Reattach retaining plates. Do not overtighten self-tapping screws (24).
7. Take one diaphragm and invert (reverse the natural bow of the material) and with the curved side of the inner diaphragm plate facing the diaphragm assemble onto outer diaphragm plate stud and then screw assembly into diaphragm rod. Push diaphragm rod to opposite side of intermediate and add the opposite diaphragm assembly. Tighten the outer diaphragm plates to 70 in-lbs (7,91 NM) of torque.

NOTE: Inverting the first diaphragm aids reassembly.

8. Position outer diaphragm chambers onto intermediate making sure that witness lines are matching.

NOTE: If air valve has been removed, proper orientation of air system with fluid chambers must be observed. The top of the intermediate has a single vertical air passage slot on the air valve mounting face while the outer chamber check ball cavity should be pointing downward.

9. When positioning band clamps use soapy water or a compatible lubricating spray on the inside of band clamps to aid assembly. Tap with a mallet on the outside of clamp to help position the clamp while tightening the fasteners. The band clamp fasteners are stainless steel. To prevent galling always apply an anti-seize compound to the thread. Tighten all external fasteners to final torque requirement after pump is completely assembled.

10. Position the reassembled manifolds making sure of the proper orientation in relation to the air valve for your application. Also make sure that the valve seat o-rings do not shift from their grooves during reassembly. Flat washers should be placed under the head of each cap screw and nut. Tighten all external fasteners to final torque requirement after pump is completely assembled.

**External Fastener Torque Requirements**

NOTE: When reassembling loosely tighten all external fasteners adjusting and gradually, in an alternating fashion, tighten to torque requirements listed below.

- AIR VALVE CAP SCREWS 40 in-lbs (4,52 NM)
- BAND CLAMPS 13.3 ft-lbs (18,08 NM)
- MANIFOLD BOLTS, 20 in-lbs (2,26 NM)
- OUTER CHAMBER CAP SCREWS, 28 in-oz (0,02 NM) (Plastic Pumps)
- OUTER CHAMBER CAP SCREWS, 30 in-lbs (3,39 NM) (Metal Pumps)

**Air Valve Maintenance**

11. To evaluate air valve components, remove the four cap screws (11), washers, (25, 10) and nuts from the air valve body (7). The valve plate (5) and shuttle (6) may be inspected by removing them from their location in the slot in the back of the air valve. Inspect for scratches or surface irregularities. Replace if necessary. To remove the plug (1) at the bottom of the air valve, point the bottom of the air valve safely away from people, direct compressed air through one of the lower holes in the back of the air valve body and the plug will shoot out. Next push the air valve spool (2) out of the air valve body. Gently reach in and pull lip seals (43) out of inside bore of the air valve body. Check for cracks, splitting or scratches. Clean components if replacement is not necessary. Inspect plug oring (44) for any damage and replace if necessary and reinsert in o-ring groove.

NOTE: Make sure that the open side of the two lip seals face each other when reassembling air valve. Lube all components with suggested maintenance grease as an aid in reassembly.

12. Reinsert air valve spool inside of air valve body. Place shuttle on middle rib of air valve spool through the square slot in back of air valve. If using original valve plate lubricate side of plate that was facing the shuttle (or if new valve plate is used lubricate the lapped and polished side of plate) and place the lubricated side next to the shuttle in the slot. Press valve plug into air valve body, chamfered end first.

13. Check that gaskets (3, 4) are not cracked. If damaged replace.
14. After gaskets are pressed back into position align air valve onto intermediate and reinsert the four capscrews with lock washer and flat washers. Apply 40 in-lbs (4,52 NM) of torque to fasteners.

**1/2" MODEL**  
Plastic  
Serial Numbers 35000 and Above

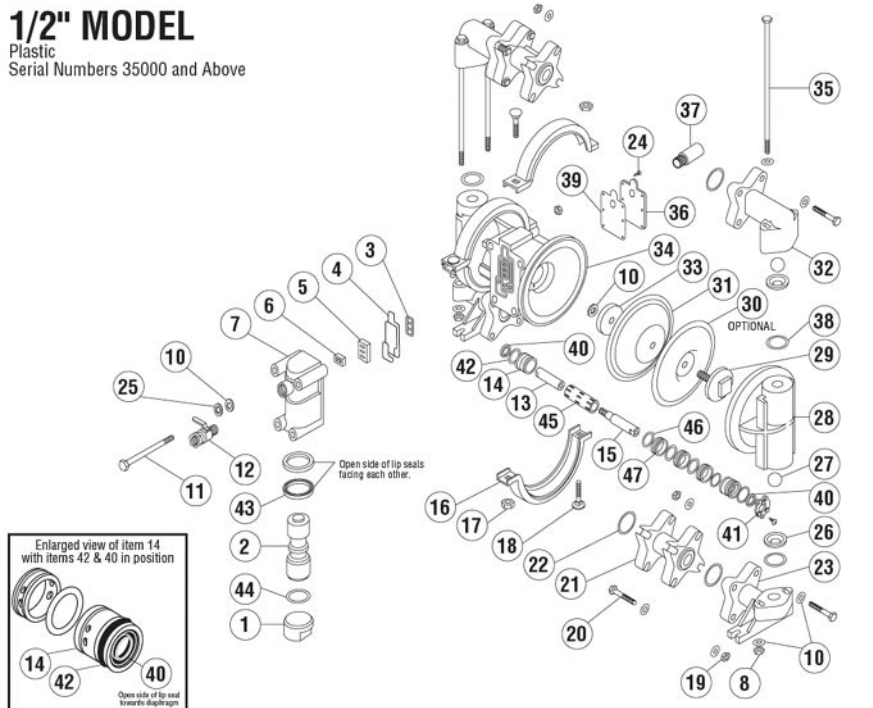





Copyright 2007 © ZSC  
Zebra Skimmers Corp.  
PO Box 833  
Chagrin Falls, OH 44022  
888-249-4855  
[www.ZebraSkimmers.com](http://www.ZebraSkimmers.com)  
[www.CoolantMaintenance.com](http://www.CoolantMaintenance.com)



## Free Manuals Download Website

<http://myh66.com>

<http://usermanuals.us>

<http://www.somanuals.com>

<http://www.4manuals.cc>

<http://www.manual-lib.com>

<http://www.404manual.com>

<http://www.luxmanual.com>

<http://aubethermostatmanual.com>

Golf course search by state

<http://golfingnear.com>

Email search by domain

<http://emailbydomain.com>

Auto manuals search

<http://auto.somanuals.com>

TV manuals search

<http://tv.somanuals.com>