



Lenovo S710 All-In-One Hardware Maintenance Manual

Machine Types:10152/F0AG



Lenovo S710 All-In-One Hardware Maintenance Manual

Machine Types:10152/F0AG

Note: Before using this information and the product it supports, be sure to read and understand Chapter 2 “Safety information” on page 3 and Appendix A “Notices” on page 107.

First Edition (August 2013)

© Copyright Lenovo 2013.

LIMITED AND RESTRICTED RIGHTS NOTICE: If data or software are delivered pursuant a General Services Administration “GSA” contract, use, reproduction, or disclosure is subject to restrictions set forth in Contract No. GS-35F-05925.

Contents

Chapter 1. About this manual 1

Important Safety Information 1

Chapter 2. Safety information 3

General safety 3

Electrical safety 3

Safety inspection guide 5

Handling electrostatic discharge-sensitive devices 5

Grounding requirements 6

Safety notices (multi-lingual translations) 6

Chapter 3. General information 29

Specifications 29

Lenovo Support Web site 29

Chapter 4. General Checkout 31

Problem determination tips 31

Chapter 5. Troubleshooting and diagnostics 33

Basic troubleshooting 33

Accessing Control Panel on the Windows 8 operating system 34

Troubleshooting procedure 34

Troubleshooting 35

 Audio problems 35

 CD problems 37

 DVD problems 38

 Intermittent problems 39

 Keyboard, mouse, or pointing device problems 39

 Monitor problems 41

 Networking problems 43

 Option problems 45

 Performance and lockup problems 46

 Printer problems 48

 Serial port problems 48

 Software problems 49

 USB problems 50

Chapter 6. Using the Setup Utility program 51

Starting the Setup Utility program 51

Viewing and changing settings 51

Using passwords 51

 Password considerations 51

 Power-On Password 52

 Administrator Password 52

 Setting, changing, and deleting a password 52

Enabling or disabling a device 52

Selecting a startup device 53

 Selecting a temporary startup device 53

 Selecting or changing the startup device sequence 53

Changing the BIOS settings before installing a new operating system 53

Exiting the Setup Utility program 54

Chapter 7. Symptom-to-FRU Index 55

Hard disk drive boot error 55

Power Supply Problems 55

Beep symptoms 55

POST error codes 56

Miscellaneous error conditions 57

Undetermined problems 59

Chapter 8. Locations 61

Locating connectors, controls, and indicators on the front of your computer 61

Locating connectors, controls, and indicators on the rear of your computer 62

Locating major FRUs and CRUs 63

Looking up FRU information 65

Locating parts on the system board 66

Chapter 9. Replacing FRUs 67

Removing and reinstalling the system stand hinge cover 67

Removing and reinstalling the system stand 68

Removing the computer cover 71

Removing and reinstalling the VESA mount bracket 71

Replacing the hard disk drive 72

Replacing the optical drive 74

Removing and reinstalling the system board shield 76

Replacing the microprocessor fan 77

Replacing the heat sink assembly 78

Replacing the microprocessor 80

Replacing the battery 83

Replacing the inverter 84

Installing or replacing a memory module 85

Replacing the internal speakers 87

Replacing the integrated camera 88

Replacing the system board 89

Replacing the LCD panel.	91
Replacing the Wi-Fi card.	94
Replacing the USB keyboard or mouse	96
Completing the parts replacement	96

Chapter 10. FRU lists-S710 99

Chapter 11. Additional Service Information 103

Security features	103
Hardware controlled Passwords	103
Operating system password	103
BIOS levels	103
Flash update procedures	103
Updating (flashing) the BIOS from a disc.	103

Updating (flashing) the BIOS from your operating system	104
Recovering from a POST/BIOS update failure	105
Power management	105
Automatic configuration and power interface (ACPI) BIOS	106
Automatic Power-on features	106

Appendix A. Notices. 107

Television output notice	108
European conformance CE mark	108
Trademarks	108

Index. 109

Chapter 1. About this manual

This manual provides service and reference information for Lenovo® S710 All-In-One computers listed on the front cover. This manual is intended only for trained service personnel who are familiar with Lenovo® computer products.

Before servicing a Lenovo computer product, be sure to read “Important Safety Information” on page 1.

Chapter 7 “Symptom-to-FRU Index” on page 55 and Chapter 11 “Additional Service Information” on page 103 are not specific to any machine type and are applicable to all Lenovo All-In-One computers.

For major Field Replaceable Units (FRU) locations and Customer Replaceable Unit (CRU) identification, see Chapter 8 “Locations” on page 61.

For FRU replacement instructions, see Chapter 9 “Replacing FRUs” on page 67.

For FRU part numbers, go to:
<http://www.lenovo.com/serviceparts-lookup>

Important Safety Information

Be sure to read all caution and danger statements in this book before performing any of the instructions.

Veillez lire toutes les consignes de type DANGER et ATTENTION du présent document avant d'exécuter les instructions.

Lesen Sie unbedingt alle Hinweise vom Typ "ACHTUNG" oder "VORSICHT" in dieser Dokumentation, bevor Sie irgendwelche Vorgänge durchführen

Leggere le istruzioni introdotte da ATTENZIONE e PERICOLO presenti nel manuale prima di eseguire una qualsiasi delle istruzioni

Certifique-se de ler todas as instruções de cuidado e perigo neste manual antes de executar qualquer uma das instruções

Es importante que lea todas las declaraciones de precaución y de peligro de este manual antes de seguir las instrucciones.

تأكد من قراءة كل التحذيرات الموجودة في هذا الكتاب قبل اتباع هذه التعليمات .

执行任何说明之前，请确保已阅读本书中的所有警告和危险声明。

執行任何指示前，請確實閱讀本書中的所有警告及危險聲明。

ודאו שקראתם את כל הודעות האזהרה והסכנה במסמך זה לפני שתבצעו פעולה כלשהי.

본 사용 설명서에 기재된 내용을 실행하기 전에 모든 주의사항 및 위험사항을 숙지하십시오.

Chapter 2. Safety information

This chapter contains the safety information that you need to be familiar with before servicing a computer.

General safety

Follow these rules to ensure general safety:

- Observe good housekeeping in the area of the machines during and after maintenance.
- When lifting any heavy object:
 1. Ensure you can stand safely without slipping.
 2. Distribute the weight of the object equally between your feet.
 3. Use a slow lifting force. Never move suddenly or twist when you attempt to lift.
 4. Lift by standing or by pushing up with your leg muscles; this action removes the strain from the muscles in your back.
Do not attempt to lift any objects that weigh more than 16 kg (35 lb) or objects that you think are too heavy for you.
- Do not perform any action that causes hazards to the customer, or that makes the equipment unsafe.
- Before you start the machine, ensure that other service representatives and the customer's personnel are not in a hazardous position.
- Place removed covers and other parts in a safe place, away from all personnel, while you are servicing the machine.
- Keep your tool case away from walk areas so that other people will not trip over it.
- Do not wear loose clothing that can be trapped in the moving parts of a machine. Ensure that your sleeves are fastened or rolled up above your elbows. If your hair is long, fasten it.
- Insert the ends of your necktie or scarf inside clothing or fasten it with a nonconductive clip, approximately 8 centimeters (3 inches) from the end.
- Do not wear jewelry, chains, metal-frame eyeglasses, or metal fasteners for your clothing.
Remember: Metal objects are good electrical conductors.
- Wear safety glasses when you are: hammering, drilling, soldering, cutting wire, attaching springs, using solvents, or working in any other conditions that might be hazardous to your eyes.
- After service, reinstall all safety shields, guards, labels, and ground wires. Replace any safety device that is worn or defective.
- Reinstall all covers correctly before returning the machine to the customer.

Electrical safety



CAUTION:

Electrical current from power, telephone, and communication cables can be hazardous. To avoid personal injury or equipment damage, disconnect the attached power cords, telecommunication systems, networks, and modems before you open the computer covers, unless instructed otherwise in the installation and configuration procedures.

Observe the following rules when working on electrical equipment.

Important: Use only approved tools and test equipment. Some hand tools have handles covered with a soft material that does not insulate you when working with live electrical currents. Many customers have, near their equipment, rubber floor mats that contain small conductive fibers to decrease electrostatic discharges. Do not use this type of mat to protect yourself from electrical shock.

- Find the room emergency power-off (EPO) switch, disconnecting switch, or electrical outlet. If an electrical accident occurs, you can then operate the switch or unplug the power cord quickly.
- Do not work alone under hazardous conditions or near equipment that has hazardous voltages.
- Disconnect all power before:
 - Performing a mechanical inspection
 - Working near power supplies
 - Removing or installing Field Replaceable Units (FRUs)
- Before you start to work on the machine, unplug the power cord. If you cannot unplug it, ask the customer to power-off the wall box that supplies power to the machine and to lock the wall box in the off position.
- If you need to work on a machine that has exposed electrical circuits, observe the following precautions:
 - Ensure that another person, familiar with the power-off controls, is near you.
Remember: Another person must be there to switch off the power, if necessary.
 - Use only one hand when working with powered-on electrical equipment; keep the other hand in your pocket or behind your back.
Remember: There must be a complete circuit to cause electrical shock. By observing the above rule, you may prevent a current from passing through your body.
 - When using a tester, set the controls correctly and use the approved probe leads and accessories for that tester.
 - Stand on suitable rubber mats (obtained locally, if necessary) to insulate you from grounds such as metal floor strips and machine frames.

Observe the special safety precautions when you work with very high voltages; these instructions are in the safety sections of maintenance information. Use extreme care when measuring high voltages.

- Regularly inspect and maintain your electrical hand tools for safe operational condition.
- Do not use worn or broken tools and testers.
- *Never assume* that power has been disconnected from a circuit. First, *check* that it has been powered-off.
- Always look carefully for possible hazards in your work area. Examples of these hazards are moist floors, nongrounded power extension cables, power surges, and missing safety grounds.
- Do not touch live electrical circuits with the reflective surface of a plastic dental mirror. The surface is conductive; such touching can cause personal injury and machine damage.
- Do not service the following parts with the power on when they are removed from their normal operating places in a machine:
 - Power supply units
 - Pumps
 - Blowers and fans
 - Motor generatorsand similar units. (This practice ensures correct grounding of the units.)
- If an electrical accident occurs:
 - Use caution; do not become a victim yourself.
 - Switch off power.
 - Send another person to get medical aid.

Safety inspection guide

The intent of this inspection guide is to assist you in identifying potentially unsafe conditions on these products. Each machine, as it was designed and built, had required safety items installed to protect users and service personnel from injury. This guide addresses only those items. However, good judgment should be used to identify potential safety hazards due to attachment of features or options not covered by this inspection guide.

If any unsafe conditions are present, you must determine how serious the apparent hazard could be and whether you can continue without first correcting the problem.

Consider these conditions and the safety hazards they present:

- Electrical hazards, especially primary power (primary voltage on the frame can cause serious or fatal electrical shock).
- Explosive hazards, such as a damaged CRT face or bulging capacitor
- Mechanical hazards, such as loose or missing hardware

The guide consists of a series of steps presented in a checklist. Begin the checks with the power off, and the power cord disconnected.

Checklist:

1. Check exterior covers for damage (loose, broken, or sharp edges).
2. Power-off the computer. Disconnect the power cord.
3. Check the power cord for:
 - a. A third-wire ground connector in good condition. Use a meter to measure third-wire ground continuity for 0.1 ohm or less between the external ground pin and frame ground.
 - b. The power cord should be the appropriate type as specified in the parts listings.
 - c. Insulation must not be frayed or worn.
4. Remove the cover.
5. Check for any obvious alterations. Use good judgment as to the safety of any alterations.
6. Check inside the unit for any obvious unsafe conditions, such as metal filings, contamination, water or other liquids, or signs of fire or smoke damage.
7. Check for worn, frayed, or pinched cables.
8. Check that the power-supply cover fasteners (screws or rivets) have not been removed or tampered with.

Handling electrostatic discharge-sensitive devices

Any computer part containing transistors or integrated circuits (ICs) should be considered sensitive to electrostatic discharge (ESD). ESD damage can occur when there is a difference in charge between objects. Protect against ESD damage by equalizing the charge so that the machine, the part, the work mat, and the person handling the part are all at the same charge.

Notes:

1. Use product-specific ESD procedures when they exceed the requirements noted here.
2. Make sure that the ESD protective devices you use have been certified (ISO 9000) as fully effective.

When handling ESD-sensitive parts:

- Keep the parts in protective packages until they are inserted into the product.
- Avoid contact with other people while handling the part.

- Wear a grounded wrist strap against your skin to eliminate static on your body.
- Prevent the part from touching your clothing. Most clothing is insulative and retains a charge even when you are wearing a wrist strap.
- Use the black side of a grounded work mat to provide a static-free work surface. The mat is especially useful when handling ESD-sensitive devices.
- Select a grounding system, such as those listed below, to provide protection that meets the specific service requirement.

Note: The use of a grounding system is desirable but not required to protect against ESD damage.

- Attach the ESD ground clip to any frame ground, ground braid, or green-wire ground.
- Use an ESD common ground or reference point when working on a double-insulated or battery-operated system. You can use coax or connector-outside shells on these systems.
- Use the round ground-prong of the ac plug on ac-operated computers.

Grounding requirements

Electrical grounding of the computer is required for operator safety and correct system function. Proper grounding of the electrical outlet can be verified by a certified electrician.

Safety notices (multi-lingual translations)

The caution and danger safety notices in this section are provided in the following languages:

- English
- Arabic
- Brazilian/Portuguese
- Chinese (simplified)
- Chinese (traditional)
- French
- German
- Hebrew
- Italian
- Korean
- Spanish



DANGER

Electrical current from power, telephone and communication cables is hazardous.

To avoid a shock hazard:

- **Do not connect or disconnect any cables or perform installation, maintenance, or reconfiguration of this product during an electrical storm.**
- **Connect all power cords to a properly wired and grounded electrical outlet.**

- Connect to properly wired outlets any equipment that will be attached to this product.
- When possible, use one hand only to connect or disconnect signal cables.
- Never turn on any equipment when there is evidence of fire, water, or structural damage.
- Disconnect the attached power cords, telecommunications systems, networks, and modems before you open the device covers, unless instructed otherwise in the installation and configuration procedures.
- Connect and disconnect cables as described in the following tables when installing, moving, or opening covers on this product or attached devices.

To Connect	To Disconnect
<ol style="list-style-type: none"> 1. Turn everything OFF. 2. First, attach all cables to devices. 3. Attach signal cables to connectors. 4. Attach power cords to outlet. 5. Turn device ON. 	<ol style="list-style-type: none"> 1. Turn everything OFF. 2. First, remove power cords from outlet. 3. Remove signal cables from connectors. 4. Remove all cables from devices.



CAUTION:

When replacing the lithium battery, use only Part Number 45C1566 or an equivalent type battery recommended by the manufacturer. If your system has a module containing a lithium battery, replace it only with the same module type made by the same manufacturer. The battery contains lithium and can explode if not properly used, handled, or disposed of. *Do not:*

- Throw or immerse into water
- Heat to more than 100°C (212°F)
- Repair or disassemble

Dispose of the battery as required by local ordinances or regulations.



CAUTION:

When laser products (such as CD-ROMs, DVD-ROM drives, fiber optic devices, or transmitters) are installed, note the following:

- Do not remove the covers. Removing the covers of the laser product could result in exposure to hazardous laser radiation. There are no serviceable parts inside the device.
- Use of controls or adjustments or performance of procedures other than those specified herein might result in hazardous radiation exposure.



DANGER

Some laser products contain an embedded Class 3A or Class 3B laser diode. Note the following:

Laser radiation when open. Do not stare into the beam, do not view directly with optical instruments, and avoid direct exposure to the beam.

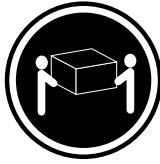

≥18 kg (37 lbs)



≥32 kg (70.5 lbs)



≥55 kg (121.2 lbs)

CAUTION:

Use safe practices when lifting.



CAUTION:

The power control button on the device and the power switch on the power supply do not turn off the electrical current supplied to the device. The device also might have more than one power cord. To remove all electrical current from the device, ensure that all power cords are disconnected from the power source.



التيار الكهربائي الموجود بمصدر الطاقة أو أجهزة التلفون أو أسلاك الاتصالات يشكل خطورة.

لتفادي مخاطر الصدمات الكهربائية:

لا تحاول توصيل أو فصل أي أسلاك أو القيام بعمليات تركيب أو صيانة أو إعادة توصيف لهذا المنتج أثناء وجود عاصفة كهربائية.

يجب توصيل كل أسلاك الكهرباء في مخارج كهرباء ذات توصيلات أسلاك وتوصيلات أرضية صحيحة
يجب توصيل أي جهاز سيتم الحاقه بهذا المنتج في مخارج كهرباء ذات توصيلات أسلاك صحيحة.

وإن أمكن يجب استخدام يد واحدة فقط في توصيل أو فصل أسلاك الإشارة.

لا تحاول تشغيل أي جهاز إذا كان هناك أثر لحرق أو مياه أو تلف بالمكونات

يجب فصل أسلاك الكهرباء وأنظمة الاتصالات وشبكات الاتصال وأجهزة المودم الملحقة قبل فتح أغطية الجهاز، ما لم يتم طلب خلاف ذلك في التعليمات الخاصة بالتركيب والتوصيف.
قم بتوصيل وفصل الأسلاك كما هو موضح في الجدول التالي وذلك عند القيام بعمليات التركيب أو النقل أو فتح أغطية هذا المنتج أو الأجهزة الملحقة.

للفصل:

- قم بإيقاف كل شيء.
- أولاً، قم بفصل كل أسلاك الكهرباء من المخرج.
- قم بفصل أسلاك الإشارة من الموصلات.
- قم بفصل كل الأسلاك من الأجهزة.

للتوصيل:

- قم بإيقاف كل شيء.
- أولاً، قم بتوصيل كل الأسلاك بالأجهزة.
- قم بتوصيل أسلاك الإشارة في لموصلات.
- قم بتوصيل أسلاك الكهرباء في المخارج.
- قم بتشغيل الجهاز.



تنبيه :

عند استبدال البطارية الليثيوم، استخدم فقط رقم الجزء الخاص **Part Number 45C1566**

أو نوع آخر يكون على نفس مستوى الكفاءة يحدده لك المصنع.

إذا كان النظام الخاص يستخدم معه بطارية ليثيوم قم باستبدالها بنفس النوع الذي تم صناعته من خلال نفس المصنع. تحتوي البطارية على مادة الليثيوم ويمكن أن تنفجر في حالة عدم استخدامها أو التعامل معها بطريقة صحيحة أو عند التخلص منها بطريقة خطأ.

لا تقم بـ:

- القاء البطارية أو غمرها في الماء
- تسخينها أعلى من ١٠٠ درجة مئوية و(٢١٢ ° فهرنهايت)
- بتصليحها أو فكها

تخلص من البطارية طبقاً للقانون أو النظام المحلي .



تنبيه :
أثناء تركيب منتجات ليزر (مثل CD-ROMs أو وحدة تشغيل DVD أو أجهزة Fiber Optic أو وحدات الإرسال) يجب مراعاة الآتي:

لا تنزع الأغطية. قد ينتج عن نزع أغطية منتج الليزر انفجار أشعة الليزر شديدة الخطورة.
لا يوجد أجزاء يمكن تغييرها داخل الجهاز. قد ينتج عن استخدام تحكيمات أو تعديلات أو عمل أي تصرفات أخرى تخالف ما هو محدد هنا إلى انفجار أشعة شديدة الخطورة.



خطر

تحتوي بعض منتجات الليزر على الفئة دايود ليزر مدمج من الفئة Class 3A أو Class 3B. يجب مراعاة الآتي .

أشعة الليزر عند الفتح. لا تحدد إلى الإشعاع و لا تنظر إليه مباشرة بواسطة أي أجهزة مرئية وتجنب التعرض المباشر للإشعاع .

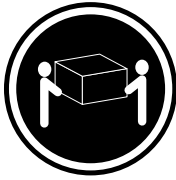

≥18 kg (37 lbs)



≥32 kg (70.5 lbs)

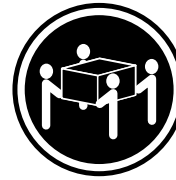

≥55 kg (121.2 lbs)

تنبيه :
يجب استخدام ممارسات أمانة عند الرفع



تنبيه :
لا يقر التحكم في التشغيل الموجود على الجهاز والمفتاح الكهربائي الموجود على لوحة التحكم بإيقاف التيار الكهربائي المار بالجهاز. قد يكون للجهاز أكثر من سلك كهربائي واحد. لإيقاف التيار الكهربائي المار بالجهاز، تأكد من فصل جميع أسلاك الكهرباء من مصدر الكهرباء .

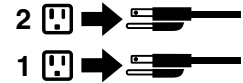

PERIGO

A corrente elétrica proveniente de cabos de alimentação, de telefone e de comunicações é perigosa.

Para evitar risco de choque elétrico:

- Não conecte nem desconecte nenhum cabo ou execute instalação, manutenção ou reconfiguração deste produto durante uma tempestade com raios.
- Conecte todos os cabos de alimentação a tomadas elétricas corretamente instaladas e aterradas.
- Todo equipamento que for conectado a este produto deve ser conectado a tomadas corretamente instaladas.
- Quando possível, utilize apenas uma das mãos para conectar ou desconectar cabos de sinal.
- Nunca ligue nenhum equipamento quando houver evidência de fogo, água ou danos estruturais.
- Antes de abrir tampas de dispositivos, desconecte cabos de alimentação, sistemas de telecomunicação, redes e modems conectados, a menos que especificado de maneira diferente nos procedimentos de instalação e configuração.
- Conecte e desconecte os cabos conforme descrito na tabela apresentada a seguir ao instalar, mover ou abrir tampas deste produto ou de dispositivos conectados.

Para Conectar:	Para Desconectar:
<ol style="list-style-type: none">1. DESLIGUE Tudo.2. Primeiramente, conecte todos os cabos aos dispositivos.3. Conecte os cabos de sinal aos conectores.4. Conecte os cabos de alimentação às tomadas.5. LIGUE os dispositivos.	<ol style="list-style-type: none">1. DESLIGUE Tudo.2. Primeiramente, remova os cabos de alimentação das tomadas.3. Remova os cabos de sinal dos conectores.4. Remova todos os cabos dos dispositivos.



CUIDADO:

Ao substituir a bateria de lítio, utilize apenas uma bateria com Número de Peça 45C1566 ou um tipo de bateria equivalente recomendado pelo Se o seu sistema possui um módulo com uma bateria de lítio, substitua-o apenas por um módulo do mesmo tipo e do mesmo fabricante. A bateria contém lítio e pode explodir se não for utilizada, manuseada ou descartada de maneira correta.

Não:

- Jogue ou coloque na água
- Aqueça a mais de 100°C (212°F)
- Conserte nem desmonte

Descarte a bateria conforme requerido pelas leis ou regulamentos locais.



PRECAUCIÓN:

Quando produtos a laser (como unidades de CD-ROMs, unidades de DVD-ROM, dispositivos de fibra ótica ou transmissores) estiverem instalados, observe o seguinte:

- Não remova as tampas. A remoção das tampas de um produto a laser pode resultar em exposição prejudicial à radiação de laser. Não existem peças que podem ser consertadas no interior do dispositivo.

- A utilização de controles ou ajustes ou a execução de procedimentos diferentes dos especificados aqui pode resultar em exposição prejudicial à radiação.

PERIGO

Alguns produtos a laser contêm diodo de laser integrado da Classe 3A ou da Classe 3B. Observe o seguinte:

Radiação a laser quando aberto. Não olhe diretamente para o feixe a olho nu ou com instrumentos ópticos e evite exposição direta ao feixe.



≥18 kg (37 lbs)



≥32 kg (70.5 lbs)



≥55 kg (121.2 lbs)

CUIDADO:

Utilize procedimentos de segurança para levantar equipamentos.



CUIDADO:

O botão de controle de alimentação do dispositivo e o botão para ligar/desligar da fonte de alimentação não desligam a corrente elétrica fornecida ao dispositivo. O dispositivo também pode ter mais de um cabo de alimentação. Para remover toda a corrente elétrica do dispositivo, assegure que todos os cabos de alimentação estejam desconectados da fonte de alimentação.

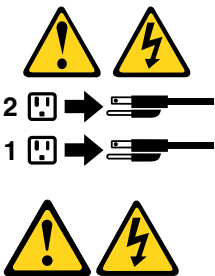

危险

电源、电话和通信电缆中的电流是危险的。

为避免电击危险：

- 请勿在雷电期间连接或断开任何电缆的连接，或者对本产品进行安装、维护或重新配置。
- 将所有电源线连接到正确连线和妥善接地的电源插座。
- 将所有要连接到该产品的设备连接到正确连线的插座。
- 如果可能，请仅使用一只手来连接或断开信号电缆的连接。
- 切勿在有火、水、结构损坏迹象的情况下开启任何设备。
- 在打开设备外盖之前请断开已连接的电源线、远程通信系统、网络和调制解调器，除非在安装和配置过程中另有说明。
- 当安装、移动或打开该产品或连接设备的外盖时，请按照下表所述来连接或断开电缆的连接。

要连接	要断开连接
<ol style="list-style-type: none">1. 切断所有电源。2. 首先将所有电缆连接到设备。3. 将信号电缆连接到接口。4. 将电源线连接到插座。5. 开启设备。	<ol style="list-style-type: none">1. 切断所有电源。2. 首先从插座上拔出电源线。3. 从接口上拔出信号电缆。4. 从设备上拔出所有电缆。



警告：
更换锂电池时，请仅使用部件号为 45C1566 的电池或制造商推荐的同类电池。如果您的系统有包含锂电池的模块，请仅使用同一制造商生产的相同模块类型来替换该模块。该电池中含有锂，如果使用、操作或处理不当，可能会发生爆炸。

切勿：

- 投入或浸入水中
- 加热到 100°C (212°F) 以上
- 维修或拆卸

请按照当地法令或条例的要求处理电池。



警告：
安装激光产品（例如 CD-ROM、DVD-ROM 驱动器、光纤设备或发射设备）时，请注意以下声明：

- 请勿卸下外盖。卸下激光产品的外盖可能导致遭受激光辐射的危险。该设备内没有可维修的部件。
- 如果不按照此处指定的过程进行控制、调整或操作，则有可能导致遭受辐射的危险。



危險

某些激光产品包含嵌入式 3A 类或 3B 类激光二极管。请注意以下声明：

打开后有激光辐射。请勿注视光束，请勿直接用光学仪器查看，并请避免直接暴露在光束中。



≥18 千克 (37 磅) ≥32 千克 (70.5 磅) ≥55 千克 (121.2 磅)

警告：
抬起时请采取安全措施。



警告：
设备上的电源控制按钮和电源上的电源开关不会切断供给该设备的电流。该设备还可能有多条电源线。要切断该设备的所有电流，请确保所有电源线都与电源断开连接。

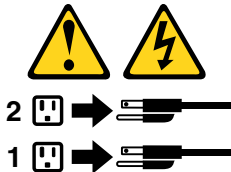

危險

電源、電話及通訊纜線上的電流都具有危險性。

若要避免觸電危險：

- 請勿在雷雨期間，連接或拔除纜線、執行安裝、維護或重新配置本產品。
- 將所有電源線連接到正確配線及接地的電源插座。
- 任何與本產品連接的設備都必須連接到配線妥當的電源插座。
- 請盡可能用單手連接或拔除信號線。
- 發生火災、水災或結構損害時，絕對不要開啟任何設備。
- 除非在安裝及配置程序中另有指示，否則在開啟裝置機蓋之前，請拔掉連接的電源線、電信系統、網路及數據機。
- 安裝、移動或開啟本產品或附屬裝置的機蓋時，請遵循下列說明連接及拔掉纜線。

連線	切斷連線
<ol style="list-style-type: none"> 1. 關閉所有開關。 2. 首先，連接所有接線到裝置。 3. 連接信號線到接頭。 4. 連接電源線到插座。 5. 開啟裝置。 	<ol style="list-style-type: none"> 1. 關閉所有開關。 2. 首先，拔掉插座上的電源線。 3. 拔掉接頭上的信號線。 4. 拔掉裝置上所有接線。



警告：

更換鋰電池時，請僅使用產品編號 **45C1566** 或製造商所建議的同類型電池。
如果您的系統中含有鋰電池模組，請僅使用同一家製造商所生產的相同模組進行更換。
如果未以正確方式使用、處理或棄置含鋰的電池，會有爆炸的危險。
請勿：

- 沾溼或浸入水中
 - 置於 **100°C (212°F)** 以上的高溫環境
 - 修理或拆開
- 請按照各地區有關廢棄電池的法令和規定處理舊電池。



警告：

- 請勿移除機蓋。移除雷射產品的機蓋，可能會導致暴露在危險的雷射輻射中。裝置內部並無可自行維修的零件。
- 利用或執行非本文中指定的控制、調整及執行程序，可能會導致危險的輻射外洩。



危險

部分雷射產品含有內嵌式 **Class 3A** 或 **Class 3B** 雷射二極體。請注意下列事項：
在開啟光碟機時，會發生雷射輻射。請勿直視光束或用光學儀器直接檢視，並避免直接暴露在光束中。



≥ 18 公斤 (37 磅)



≥ 32 公斤 (70.5 磅)



≥ 55 公斤 (121.2 磅)

警告：

搬運時請注意安全。



警告：

裝置上的電源控制按鈕及電源供應器上的電源開關，無法關閉裝置所產生的電流。
該裝置可能有多條電源線。若要除去裝置流出的所有電流，請確認已切斷所有電源線的電源。



DANGER

Le courant électrique provenant de l'alimentation, du téléphone et des câbles de transmission peut présenter un danger.

Pour éviter tout risque de choc électrique :

- Ne manipulez aucun câble et n'effectuez aucune opération d'installation, d'entretien ou de reconfiguration de ce produit au cours d'un orage.
- Branchez tous les cordons d'alimentation sur un socle de prise de courant correctement câblé et mis à la terre.
- Branchez sur des socles de prise de courant correctement câblés tout équipement connecté à ce produit.
- Lorsque cela est possible, n'utilisez qu'une seule main pour connecter ou déconnecter les câbles d'interface.
- Ne mettez jamais un équipement sous tension en cas d'incendie ou d'inondation, ou en présence de dommages matériels.
- Avant de retirer les carters de l'unité, mettez celle-ci hors tension et déconnectez ses cordons d'alimentation, ainsi que les câbles qui la relient aux réseaux, aux systèmes de télécommunication et aux modems (sauf instruction contraire mentionnée dans les procédures d'installation et de configuration).
- Lorsque vous installez, que vous déplacez, ou que vous manipulez le présent produit ou des périphériques qui lui sont raccordés, reportez-vous aux instructions ci-dessous pour connecter et déconnecter les différents cordons.

Connexion	Déconnexion
<ol style="list-style-type: none">1. Mettez les unités HORS TENSION.2. Commencez par brancher tous les cordons sur les unités.3. Branchez les câbles d'interface sur des connecteurs.4. Branchez les cordons d'alimentation sur des prises.5. Mettez les unités SOUS TENSION.	<ol style="list-style-type: none">1. Mettez les unités HORS TENSION.2. Débranchez les cordons d'alimentation des prises.3. Débranchez les câbles d'interface des connecteurs.4. Débranchez tous les câbles des unités.



ATTENTION:

Remplacer la pile au lithium usagée par une pile de référence identique exclusivement, (référence 45C1566), ou suivre les instructions du fabricant qui en définit les équivalences. Si votre système est doté d'un module contenant une pile au lithium, vous devez le remplacer uniquement par un module identique, produit par le même fabricant. La pile contient du lithium et peut exploser en cas de mauvaise utilisation, de mauvaise manipulation ou de mise au rebut inappropriée.

Ne pas :

- la jeter à l'eau,
- l'exposer à des températures supérieures à 100°C,
- chercher à la réparer ou à la démonter.

Ne pas mettre la pile à la poubelle. Pour la mise au rebut, se reporter à la réglementation en vigueur.



ATTENTION:

Si des produits à laser (tels que des unités de CD-ROM, de DVD-ROM, des unités à fibres optiques, ou des émetteurs) sont installés, prenez connaissance des informations suivantes :

- Ne retirez pas le carter. En ouvrant l'unité de CD-ROM ou de DVD-ROM, vous vous exposez au rayonnement dangereux du laser. Aucune pièce de l'unité n'est réparable.
- Pour éviter tout risque d'exposition au rayon laser, respectez les consignes de réglage et d'utilisation des commandes, ainsi que les procédures décrites dans le présent manuel.



DANGER

Certains produits à laser contiennent une diode à laser intégrée de classe 3A ou 3B. Prenez connaissance des informations suivantes:

Rayonnement laser lorsque le carter est ouvert. Evitez toute exposition directe au rayon laser. Evitez de regarder fixement le faisceau ou de l'observer à l'aide d'instruments optiques.

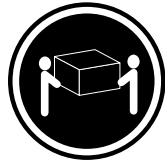

≥18 kg (37 lbs)



≥32 kg (70.5 lbs)



≥55 kg (121.2 lbs)

ATTENTION:

Soulevez la machine avec précaution.



ATTENTION:

L'interrupteur de contrôle d'alimentation de l'unité et l'interrupteur dubloc d'alimentation ne coupent pas le courant électrique alimentant l'unité. En outre, le système peut être équipé de plusieurs cordons d'alimentation. Pour mettre l'unité hors tension, vous devez déconnecter tous les cordons de la source d'alimentation.

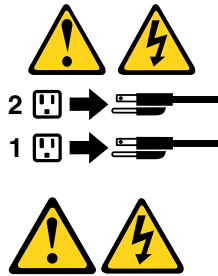

VORSICHT

An Netz-, Telefon- und Datenleitungen können gefährliche Spannungen anliegen.

Aus Sicherheitsgründen:

- Bei Gewitter an diesem Gerät keine Kabel anschließen oder lösen. Ferner keine Installations-, Wartungs- oder Rekonfigurationsarbeiten durchführen.
- Gerät nur an eine Schutzkontaktsteckdose mit ordnungsgemäß geerdetem Schutzkontakt anschließen.
- Alle angeschlossenen Geräte ebenfalls an Schutzkontaktsteckdosen mit ordnungsgemäß geerdetem Schutzkontakt anschließen.
- Die Signalkabel nach Möglichkeit einhändig anschließen oder lösen, um einen Stromschlag durch Berühren von Oberflächen mit unterschiedlichem elektrischem Potenzial zu vermeiden.
- Geräte niemals einschalten, wenn Hinweise auf Feuer, Wasser oder Gebäudeschäden vorliegen.
- Die Verbindung zu den angeschlossenen Netzkabeln, Telekommunikationssystemen, Netzwerken und Modems ist vor dem Öffnen des Gehäuses zu unterbrechen, sofern in den Installations- und Konfigurationsprozeduren keine anders lautenden Anweisungen enthalten sind.
- Zum Installieren, Transportieren und Öffnen der Abdeckungen des Computers oder der angeschlossenen Einheiten die Kabel gemäß der folgenden Tabelle anschließen und abziehen.

Zum Anschließen der Kabel gehen Sie wie folgt vor	Zum Abziehen der Kabel gehen Sie wie folgt vor
<ol style="list-style-type: none"> 1. Schalten Sie alle Einheiten AUS. 2. Schließen Sie erst alle Kabel an die Einheiten an. 3. Schließen Sie die Signalkabel an die Buchsen an. 4. Schließen Sie die Netzkabel an die Steckdose an. 5. Schalten Sie die Einheit EIN. 	<ol style="list-style-type: none"> 1. Schalten Sie alle Einheiten AUS. 2. Ziehen Sie zuerst alle Netzkabel aus den Netzsteckdosen. 3. Ziehen Sie die Signalkabel aus den Buchsen. 4. Ziehen Sie alle Kabel von den Einheiten ab.



CAUTION:

Eine verbrauchte Lithiumbatterie nur durch eine Batterie mit der Teilenummer 45C1566 oder eine gleichwertige, vom Hersteller empfohlene Batterie ersetzen. Enthält das System ein Modul mit einer Lithiumbatterie, dieses nur durch ein Modul desselben Typs und von demselben Hersteller ersetzen. Die Batterie enthält Lithium und kann bei unsachgemäßer Verwendung, Handhabung oder Entsorgung explodieren.

Die Batterie nicht:

- mit Wasser in Berührung bringen.

- über 100 C erhitzen.
- reparieren oder zerlegen.

Die örtlichen Bestimmungen für die Entsorgung von Sondermüll beachten.



ACHTUNG:

Bei der Installation von Lasergeräten (wie CD-ROM-Laufwerken, DVD- aufwerken, Einheiten mit Lichtwellenleitertechnik oder Sendern) Folgendes beachten:

- Die Abdeckungen nicht entfernen. Durch Entfernen der Abdeckungen des Lasergeräts können gefährliche Laserstrahlungen freigesetzt werden. Das Gerät enthält keine zu wartenden Teile.
- Werden Steuerelemente, Einstellungen oder Durchführungen von Prozeduren anders als hier angegeben verwendet, kann gefährliche Laserstrahlung auftreten.



VORSICHT

Einige Lasergeräte enthalten eine Laserdiode der Klasse 3A oder 3B. Beachten Sie Folgendes:

Laserstrahlung bei geöffneter Verkleidung. Nicht in den Strahl blicken. Keine Lupen oder Spiegel verwenden. Strahlungsbereich meiden.



≥18 kg



≥32 kg

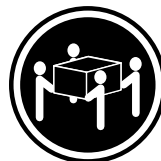

≥55 kg

ACHTUNG:

Arbeitsschutzrichtlinien beim Anheben der Maschine beachten.



ACHTUNG:

Mit dem Netzschalter an der Einheit und am Netzteil wird die Stromversorgung für die Einheit nicht unterbrochen. Die Einheit kann auch mit mehreren Netzkabeln ausgestattet sein. Um die Stromversorgung für die Einheit vollständig zu unterbrechen, müssen alle zum Gerät führenden Netzkabel vom Netz getrennt werden.

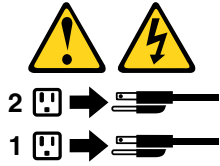

סכנה

זרם חשמלי המועבר בכבלי חשמל, טלפון ותקשורת הוא מסוכן.

כדי להימנע מסכנת התחשמלות:

- אל תחברו או תנתקו כבלים, ואל תבצעו פעולת התקנה, תחזוקה או שינוי תצורה במוצר זה במהלך סופת ברקים.
- חברו את כל כבלי החשמל לשקע חשמל מחווט ומוארק כהלכה.
- חברו כל ציוד שיחובר למוצר זה לשקעי חשמל מחוטים כהלכה.
- במידת האפשר, השתמשו ביד אחת בלבד לחיבור או לניתוק של כבלי אותות.
- לעולם אל תפעילו ציוד כלשהו כאשר יש עדות לנזק מבני או לנזק כתוצאה מאש או ממים.
- נתקו את כבלי החשמל, מערכות התקשורת, התקני הרשת והמודמים המחוברים לפני פתיחת כיסויי ההתקן, אלא אם הליכי ההתקנה וקביעת התצורה מורים אחרת.
- בעת התקנה, העברה או פתיחת כיסויים במוצר זה או בהתקנים המחוברים, חברו ונתקו את הכבלים כמתואר בטבלה שלהלן.

כדי לחבר	כדי לנתק
1. כבו הכל.	1. כבו הכל.
2. ראשית, חברו את כל הכבלים להתקנים.	2. ראשית, נתקו את כבלי החשמל מהשקעים.
3. חברו את כבלי האותות למחברים.	3. נתקו את כבלי האותות מהמחברים.
4. חברו את כבלי החשמל לשקעים.	4. הסירו את כל הכבלים מההתקנים.
5. הפעילו את ההתקן.	



זהירות:

בעת החלפת סוללת הליתיום, השתמשו רק בסוללה בעלת מק"ט 45C1566 או בסוג תואם שהומלץ על ידי היצרן. אם המערכת כוללת מודול המכיל סוללת ליתיום, החליפו אותה רק במודול מאותו סוג ומתוצרת אותו יצרן. הסוללה מכילה ליתיום, ועלולה להתפוצץ אם לא משתמשים ומטפלים בה או משליכים אותה כיארות.

לעולם:

- אל תטבלו במים
 - אל תחממו לטמפרטורה הגבוהה מ-100°C (212°F)
 - אל תתקנו או תפרקו
- השליכו את הסוללה כנדרש לפי התקנות והחוקים המקומיים.



זהירות:

בעת התקנת מוצרי ליזר (כגון כונני תקליטורים ו-DVD, התקני סיב אופטי או משדרים), שימו לב לאזהרות הבאות:

- אל תסירו את הכיסויים. הסרת הכיסויים של מוצר הלייזר עלולה לגרום לחשיפה לקרינת לייזר מסוכנת. אין חלקים ברי טיפול בתוך ההתקן.
- שינויים, שימוש בבקרות או ביצוע הליכים אחרים מאלה המתוארים כאן, עלולים לגרום לחשיפה לקרינה מסוכנת.



סכנה

מוצרי לייזר מסוימים מכילים דיודת לייזר מסוג Class 3A או Class 3B. שימו לב לאזהרה הבאה:
כאשר הוא פתוח, המוצר פולט קרינת לייזר. אל תביטו ישירות בקרן, אל תביטו ישירות בעזרת ציוד אופטי, והימנעו מחשיפה לקרן.



≤ 18 ק"ג (37 ליב')

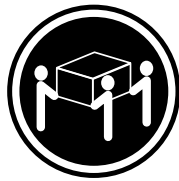

≤ 32 ק"ג (70.5 ליב')

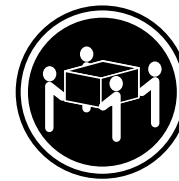

≤ 55 ק"ג (121.2 ליב')

זהירות:
השתמשו בהליכים הנאותים בעת הרמת הציוד.



זהירות:

לחצן ההפעלה של ההתקן ומתג ההפעלה של ספק החשמל אינם מפסיקים את זרם החשמל המסופק להתקן. בנוסף, ההתקן עשוי לכלול יותר מכבל חשמל אחד. כדי לסלק את כל הזרם החשמלי מההתקן, ודאו שכל כבלי החשמל מנותקים ממקור החשמל.

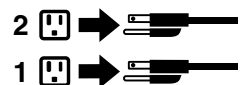



PERICOLO

La corrente elettrica proveniente dai cavi di alimentazione, del telefono e di comunicazione può essere pericolosa.

Per evitare il rischio di scosse elettriche:

- **Non collegare o scollegare qualsiasi cavo oppure effettuare l'installazione, la manutenzione o la riconfigurazione del prodotto durante un temporale.**
- **Collegare tutti i fili elettrici a una presa di alimentazione correttamente cablata e dotata di messa a terra.**
- **Collegare alle prese elettriche appropriate tutte le apparecchiature che verranno utilizzate per questo prodotto.**
- **Se possibile, utilizzare solo una mano per collegare o scollegare i cavi di segnale.**
- **Non accendere assolutamente apparecchiature in presenza di incendi, perdite d'acqua o danno strutturale.**
- **Scollegare i cavi di alimentazione, i sistemi di telecomunicazione, le reti e il modem prima di aprire i coperchi del dispositivo, salvo istruzioni contrarie relative alle procedure di installazione e configurazione.**
- **Collegare e scollegare i cavi come descritto nella seguente tabella quando vengono effettuate operazioni di installazione, spostamento o apertura dei coperchi di questo prodotto o delle unità collegate.**

Per collegarsi	Per scollegarsi
<ol style="list-style-type: none">1. SPEGNERE le apparecchiature.2. Innanzitutto, collegare tutti i cavi alle unità.3. Collegare i cavi di segnale ai connettori.4. Collegare i cavi di alimentazione alla presa.5. Accendere l'unità.	<ol style="list-style-type: none">1. SPEGNERE le apparecchiature.2. Innanzitutto, rimuovere i cavi di alimentazione dalla presa.3. Rimuovere i cavi di segnale dai connettori.4. Rimuovere tutti i cavi dalle unità.



ATTENZIONE:

Quando si sostituisce la batteria al litio, utilizzare solo il Numero parte 45C1566 o un tipo di batteria equivalente consigliato dal produttore. Se sul sistema è presente un modulo che contiene una batteria al litio, sostituirlo solo con un tipo di modulo dello stesso tipo della stessa casa di produzione. La batteria contiene litio e può esplodere se usata, maneggiata o smaltita in modo non corretto.

Non:

- **Gettare o immergere la batteria nell'acqua**
- **Riscaldarla ad una temperatura superiore ai 100 gradi C (212 gradi F)**
- **Smontarla, ricaricarla o tentare di ripararla**

Le batterie usate vanno smaltite in accordo alla normativa in vigore (DPR 915/82 e successive disposizioni e disposizioni locali).



ATTENZIONE:

Quando vengono installati prodotti laser (quali CD-ROM, unità DVD-ROM, unità a fibre ottiche o trasmettenti), tener presente quanto segue:

- Non rimuovere gli sportelli. L'apertura di un'unità laser può determinare l'esposizione a radiazioni laser pericolose. All'interno dell'unità non vi sono parti su cui effettuare l'assistenza tecnica.
- L'utilizzo di controlli, regolazioni o l'esecuzione di procedure non descritti nel presente manuale possono provocare l'esposizione a radiazioni pericolose.



PERICOLO

Alcune unità laser contengono un diodo laser di Classe 3A o Classe 3B. Tener presente quanto segue:

Aperto l'unità vengono emesse radiazioni laser. Non fissare il fascio, non guardarlo direttamente con strumenti ottici ed evitare l'esposizione al fascio.



≥18 kg



≥32 kg



≥55 kg

ATTENZIONE:

Prestare attenzione nel sollevare l'apparecchiatura.



ATTENZIONE:

Il pulsante di controllo dell'alimentazione presente sull'unità e l'interruttore dell'alimentatore non disattivano l'alimentazione corrente fornita all'unità. E' possibile che l'unità disponga di più cavi di alimentazione. Per disattivare l'alimentazione dall'unità, accertarsi che tutti i cavi di alimentazione siano scollegati dalla fonte di alimentazione.

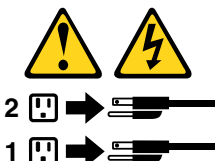



위험

전원, 전화, 통신 케이블의 전류는 위험합니다.

감전의 위험을 피하려면 다음과 같이 하십시오.

- 번개가 치는 날에는 케이블을 연결 또는 분리하거나 본 제품을 설치, 보수, 재구성하지 마십시오.
- 모든 전원 코드는 올바르게 접지된 전기 콘센트에 연결하십시오.
- 본 제품에 연결될 장치는 올바르게 배선된 콘센트에 연결하십시오.
- 신호 케이블을 연결 또는 분리할 때 가능하면 한 손만을 사용하십시오.
- 불 또는 물로 인한 손상이나 구조적인 손상이 있을 경우 장치의 전원을 절대 켜지 마십시오.
- 설치 및 구성 과정에 별도의 지시 사항이 없는 경우, 장치의 덮개를 열기 전에 연결된 전원 코드, 원격 통신 시스템, 네트워크, 모뎀을 분리하십시오.
- 본 제품이나 연결된 장치를 설치, 이동하거나 덮개를 열 때 다음 표와 같은 순서로 케이블을 연결하거나 분리하십시오.

연결할 때:	분리할 때:
<ol style="list-style-type: none"> 1. 모든 장치의 전원을 끄십시오. 2. 먼저 모든 케이블을 장치에 연결하십시오. 3. 커넥터에 신호 케이블을 연결하십시오. 4. 콘센트에 전원 코드를 연결하십시오. 5. 장치의 전원을 켜십시오. 	<ol style="list-style-type: none"> 1. 모든 장치의 전원을 끄십시오. 2. 먼저 콘센트에서 전원 코드를 분리하십시오. 3. 커넥터에서 신호 케이블을 분리하십시오. 4. 장치에서 모든 케이블을 분리하십시오.



주의:

배터리를 교환할 때는 Part Number 45C1566 또는 제조업체에서 지정한 동일한 종류의 제품을 사용하십시오. 사용자의 시스템이 리튬 배터리를 포함하는 모듈일 경우, 동일한 제조업체에서 동일한 모듈 유형으로 생산된 제품으로 교체하십시오. 배터리에는 리튬이 함유되어 있어 잘못 사용, 취급 또는 폐기할 경우 폭발의 위험이 있습니다.

사고를 방지하려면 다음 사항을 준수하십시오.

- 배터리를 물 속에 던지거나 침수시키지 마십시오.
- 100°C (212°F) 이상 가열하지 마십시오.
- 수리하거나 분해하지 마십시오.

배터리를 폐기할 때는 법령 또는 회사의 안전 수칙에 따라 폐기하십시오.



주의:

CD-ROM, DVD-ROM 장치, 광섬유 장치 또는 송신 장치와 같은 레이저 제품을 설치할 때, 다음과 같은 취급 주의사항을 참고하십시오.

- 덮개를 열지 마십시오. 덮개를 열면 레이저 복사 에너지에 노출될 위험이 있습니다. 장치 내부에는 사용자가 조정하거나 수리할 수 있는 부품이 없습니다.
- 규정된 것 이외의 절차 수행, 제어 조정 등의 행위로 인해 해로운 레이저 복사에 노출될 수 있습니다.



위험

일부 장비에는 임베디드 클래스 3A 또는 클래스 3B 레이저 다이오드가 있습니다. 다음 주의사항에 유의하십시오.

드라이브가 열리면 레이저 복사 에너지가 방출됩니다. 광선이 눈에 직접 쏘이지 않도록 하십시오. 나안 또는 광학 기구를 착용한 상태에서 광선을 직접 바라보지 않도록 하십시오.

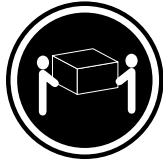

≥ 18 kg (37 lbs)



≥ 32 kg (70.5 lbs)



≥ 55 kg (121.2 lbs)

주의:
제품을 들어 올릴 때
안전 규제를 따르십시오.



주의:
장치의 전원 제어 버튼 및 전원 공급 장치의 전원 스위치를 사용하여 장치에 공급되는 전기를 차단하지 마십시오.
장치는 둘 이상의 코드를 가지고 있을 수 있습니다. 장치에서 모든 전원을 차단하려면 콘센트에서 코드가 모두 분리되어 있는지 확인하십시오.

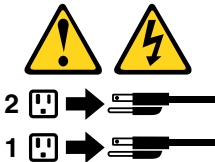

PELIGRO

La corriente eléctrica procedente de cables de alimentación, teléfonos y cables de comunicación puede ser peligrosa.

Para evitar el riesgo de descarga eléctrica:

- No conecte ni desconecte los cables ni realice ninguna tarea de instalación, mantenimiento o reconfiguración de este producto durante una tormenta eléctrica.
- Conecte todos los cables de alimentación a tomas de corriente debidamente cableadas y conectadas a tierra.
- Cualquier equipo que se conecte a este producto también debe conectarse a tomas de corriente debidamente cableadas.
- Siempre que sea posible, utilice una sola mano para conectar o desconectar los cables de señal.

- No encienda nunca un equipo cuando hay señales de fuego, agua o daños estructurales.
- Desconecte los cables de alimentación, los sistemas de telecomunicaciones, las redes y los módems conectados antes de abrir las cubiertas de los dispositivos, a menos que se indique lo contrario en los procedimientos de instalación y configuración.
- Conecte y desconecte los cables, como se describe en la tabla siguiente, cuando instale, mueva o abra las cubiertas de este producto o de los dispositivos conectados.

Para conectar	Para desconectar
1. APÁGUELO todo. 2. En primer lugar, conecte todos los cables a los dispositivos. 3. Conecte los cables de señal a los conectores. 4. Enchufe los cables de alimentación a las tomas de corriente. 5. Encienda el dispositivo.	1. APÁGUELO todo. 2. En primer lugar, desenchufe los cables de alimentación de las tomas de corriente. 3. Desconecte los cables de señal de los conectores. 4. Desconecte todos los cables de los dispositivos.



PRECAUCIÓN:

Quando sustituya una batería de litio, utilice solamente una batería número de pieza 45C1566 u otra de tipo equivalente recomendada por el fabricante. Si su sistema dispone de un módulo que contiene una batería de litio, reemplácelo sólo con el mismo tipo de módulo, del mismo fabricante. La batería contiene litio y puede explotar si no se utiliza, manipula o desecha correctamente.

No debe:

- Arrojarla al agua o sumergirla en ella
- Exponerla a temperaturas superiores a 100°C (212°F)
- Repararla o desmontarla

Deshágase de la batería según especifiquen las leyes o normas locales.



PRECAUCIÓN:

Quando haya productos láser (como unidades de CD-ROM, unidades de DVD, dispositivos de fibra óptica o transmisores) instalados, tenga en cuenta lo siguiente:

- No quite las cubiertas. Si quita las cubiertas del producto láser, podría quedar expuesto a radiación láser peligrosa. Dentro del dispositivo no existe ninguna pieza que requiera servicio técnico.
- Si usa controles o ajustes o realiza procedimientos que no sean los especificados aquí, podría exponerse a radiaciones peligrosas.



PELIGRO

Algunos productos láser tienen incorporado un diodo láser de clase 3A o clase 3B. Tenga en cuenta lo siguiente:

Cuando se abre, queda expuesto a radiación láser. No mire directamente al rayo láser, ni siquiera con instrumentos ópticos, y evite exponerse directamente al rayo láser.



≥18 kg



≥32 kg

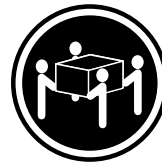

≥55 kg

PRECAUCIÓN:

Adopte procedimientos seguros al levantar el equipo.



PRECAUCIÓN:

El botón de control de alimentación del dispositivo y el interruptor de alimentación de la fuente de alimentación no desconectan la corriente eléctrica suministrada al dispositivo. Además, el dispositivo podría tener más de un cable de alimentación. Para suprimir toda la corriente eléctrica del dispositivo, asegúrese de que todos los cables de alimentación estén desconectados de la toma de corriente.

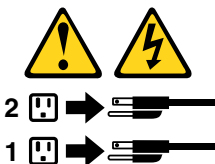

Chapter 3. General information

This chapter provides general information that applies to all machine types supported by this publication.

Specifications

This section lists the physical specifications for your computer.

Dimensions

Width: 469.7 mm (18.49 inches)

Height: 368.3 mm (14.5 inches)

Depth: 59.5 mm (2.34 inches)

Weight

Maximum configuration as shipped: 5 kg (11.02 lb) (without package)

Maximum configuration as shipped: 8.3 kg (18.3 lb) (with package)

Environment

- Air temperature:

Operating: 10°C to 35°C (50°F to 95°F)

Storage: -40°C to 60°C (-40°F to 140°F) in original shipping package

Storage: -10°C to 60°C (14°F to 140°F) without package

- Humidity:

Operating: 20% to 80% (non-condensing)

Storage: 20% to 90% (non-condensing)

- Altitude:

Operating: -50 to 10 000 ft (-15.2 to 3048 m)

Storage: -50 to 35 000 ft (-15.2 to 10 668 m)

Electrical input

- Input voltage:

- Low range:

Minimum: 100 V ac

Maximum: 127 V ac

Input frequency range: 50 to 60 Hz

- High range:

Minimum: 200 V ac

Maximum: 240 V ac

Input frequency range: 50 to 60 Hz

Lenovo Support Web site

Technical support information is available on the Lenovo Support Web site at:
<http://www.lenovo.com/support>

This Web site is updated with the latest support information such as the following:

- Drivers and software
- Diagnostic solutions
- Product and service warranty
- Product and parts details
- User guides and manuals
- Knowledge base and frequently asked questions

Chapter 4. General Checkout

Attention

The drives in the computer you are servicing might have been rearranged or the drive startup sequence changed. Be extremely careful during write operations such as copying, saving, or formatting. Data or programs can be overwritten if you select an incorrect drive.

General error messages appear if a problem or conflict is found by an application program, the operating system, or both. For an explanation of these messages, refer to the information supplied with that software package.

Before replacing any FRUs, ensure that the latest level of BIOS is installed on the system. A down-level BIOS might cause false errors and unnecessary replacement of the system board. For more information on how to determine and obtain the latest level BIOS, see “BIOS levels” on page 103.

Use the following procedure to help determine the cause of the problem:

1. Power-off the computer and all external devices.
2. Check all cables and power cords.
3. Set all display controls to the middle position.
4. Power-on all external devices.
5. Power-on the computer.
 - Look for displayed error codes
 - Listen for beep codes
 - Look for readable instructions or a main menu on the display.If you *did not* receive the correct response, proceed to step 6 on page 31.
If you *do* receive the correct response, proceed to step 7 on page 31.
6. Look at the following conditions and follow the instructions:
 - If you hear beep codes during POST, go to “Beep symptoms” on page 55.
 - If the computer displays a POST error, go to “POST error codes” on page 56.
 - If the computer hangs and no error is displayed, continue at step 7 on page 31.
7. If these actions do not correct the problem, and you need technical assistance, see “Lenovo Support Web site” on page 29.

Problem determination tips

Due to the variety of hardware and software combinations that can be encountered, use the following information to assist you in problem determination. If possible, have this information available when requesting assistance from Service Support and Engineering functions.

- Machine type and model
- Processor or hard disk drive upgrades
- Failure symptom
 - Do diagnostics indicate a failure?
 - What, when, where, single, or multiple systems?
 - Is the failure repeatable?
 - Has this configuration ever worked?
 - If it has been working, what changes were made prior to it failing?

- Is this the original reported failure?
- Diagnostics version
 - Type and version level
- Hardware configuration
 - Print (print screen) configuration currently in use
 - BIOS level
- Operating system software
 - Type and version level

Notes: To eliminate confusion, identical systems are considered identical only if they:

1. Are the exact machine type and models
2. Have the same BIOS level
3. Have the same adapters/attachments in the same locations
4. Have the same address jumpers/terminators/cabling
5. Have the same software versions and levels
6. Have the same Diagnostic Diskettes (version)
7. Have the same configuration options set in the system
8. Have the same setup for the operating system control files

Comparing the configuration and software set-up between “working and non-working” systems will often lead to problem resolution.

Chapter 5. Troubleshooting and diagnostics

This chapter describes some basic troubleshooting and diagnostic programs.

Basic troubleshooting

The following table provides information to help you troubleshoot your computer problems.

Note: If you cannot correct the problem, have the computer serviced. For a list of service and support telephone numbers, refer to the *Safety, Warranty, and Setup Guide* that comes with your computer or go to the Lenovo Support Web site at <http://www.lenovo.com/support/phone>.

Symptom	Action
The computer does not start when you press the power switch.	Verify that: <ul style="list-style-type: none">• The power cord is correctly connected to the rear of the computer and to a working electrical outlet.• If your computer has a secondary power switch on the rear of the computer, make sure that it is switched on.• The power indicator on the front of the computer is on.• The computer voltage matches the voltage available at the electrical outlet for your country or region.
The monitor screen is blank.	Verify that: <ul style="list-style-type: none">• The monitor power cord is correctly connected to the monitor and to a working electrical outlet.• The monitor is turned on and the brightness and contrast controls are set correctly.• The computer voltage matches the voltage available at the electrical outlet for your country or region.
The keyboard does not work.	Verify that: <ul style="list-style-type: none">• The computer is turned on.• The keyboard is securely connected to a USB connector on the computer.• No keys are stuck.
The mouse does not work.	Verify that: <ul style="list-style-type: none">• The computer is turned on.• The mouse is securely connected to a USB connector on the computer.• The mouse is clean.

Symptom	Action
The wireless keyboard or mouse does not work.	Verify that: <ul style="list-style-type: none"> • The computer is turned on. • The battery or batteries installed in the wireless keyboard or mouse are in good condition. • The wireless configurations are all set correctly. You might need to refer to the documentation that come with the wireless keyboard or mouse, or refer to your Windows Help and Support information system for wireless related instructions. If your wireless mouse has a dongle, make sure the dongle is correctly connected to one of the USB connectors on the computer. • For the wireless keyboard, no keys are stuck. • The wireless mouse is clean.
The operating system does not start.	Verify that: <ul style="list-style-type: none"> • The startup sequence includes the device where the operating system resides. Usually, the operating system is on the hard disk drive. For more information, see “Selecting a startup device” on page 53.
The computer beeps multiple times before the operating system starts.	Verify that no keys are stuck.

Accessing Control Panel on the Windows 8 operating system

On the Windows operating system, you can view and change computer settings through Control Panel. To access Control Panel on the Windows 8 operating system, do one of the following:

- From the desktop
 1. Move the cursor to the top-right or bottom-right corner of the screen to display the charms.
 2. Click **Settings**.
 3. Click **Control Panel**.
- From the Start screen
 1. Move the cursor to the top-right or bottom-right corner of the screen to display the charms.
 2. Click **Search**.
 3. On the Apps screen, scroll to the right side, and click **Control Panel** in the **Windows System** section.

Troubleshooting procedure

Use the following procedure as a starting point for diagnosing problems you are experiencing with your computer:

1. Verify that the cables for all attached devices are connected correctly and securely.
2. Verify that all attached devices that require ac power are connected to properly grounded, functioning electrical outlets.
3. Verify that all attached devices are enabled in the BIOS settings of your computer. For more information about accessing and changing the BIOS settings, refer to your Chapter 6 “Using the Setup Utility program” on page 51.
4. Go to the “Troubleshooting” on page 35 and follow the instructions for the type of problem you are experiencing. If the Troubleshooting information does not help you resolve a problem, continue with the next step.
5. Try using a previously captured configuration to see if a recent change to hardware or software settings has caused a problem. Before restoring a previous configuration, capture your current configuration in

case the older configuration settings do not solve the problem or have adverse affects. To restore a captured configuration, do the following:

- For Windows 7: Click **Start → Control Panel → System and Security → System → System Protection → System Restore**.
- For Windows 8: Open **Control Panel**, and then click **System and Security → System → System Protection → System Restore**.

If this does not correct the problem, continue with the next step.

6. Use an antivirus program to see if your computer has been infected by a virus. If the program detects a virus, remove the virus.
7. If none of these actions solve the problem, seek technical assistance. See “Lenovo Support Web site” on page 29 for more information.

Troubleshooting

Use the troubleshooting information to find solutions to problems that have definite symptoms.

If the symptom your computer is experiencing occurred immediately after a new hardware option or new software installed, do the following before referring to the troubleshooting information:

1. Remove the new hardware option or software. If you must remove the computer cover to remove a hardware option, have the computer serviced. For your safety, do not operate the computer with the cover removed.
2. Run the diagnostic programs to ensure your computer is operating correctly.
3. Reinstall the new hardware option or software.

Select the problem your computer is experiencing from the following list:

- “Audio problems” on page 35
- “CD problems” on page 37
- “DVD problems” on page 38
- “Intermittent problems” on page 39
- “Keyboard, mouse, or pointing device problems” on page 39
- “Monitor problems” on page 41
- “Networking problems” on page 43
- “Option problems” on page 45
- “Performance and lockup problems” on page 46
- “Printer problems” on page 48
- “Serial port problems” on page 48
- “Software problems” on page 49
- “USB problems” on page 50

Audio problems

Select your symptom from the following list:

- “No audio in Windows” on page 36
- “An audio disc or AutoPlay-enabled disc does not automatically play when it is inserted into a drive” on page 36
- “Sound comes from one external speaker only” on page 36

- “No audio in DOS applications or games” on page 36

No audio in Windows

Symptom: No audio in Windows

Actions:

- If you are using powered external speakers that have an On/Off control, verify that the On/Off control is set to the **On** position and the speaker power cable is connected to a properly grounded, functional ac electrical outlet.
- If your external speakers have a volume control, verify that the volume control is not set too low.
- Double-click the speaker icon in the Windows notification area. A master volume-control window opens. Verify that the **Mute** settings are not checked and none of the volume settings is set too low.
- Some models have a front audio panel you can use to adjust volume. If you have a front audio panel, verify that the volume is not set too low.
- Verify that your external speakers (and headphones, if used) are connected to the correct audio connector on the computer. Most speaker cables are color-coded to match the connector.

Note: When external-speaker or headphone cables are attached to the audio connector, the internal speaker, if present, is disabled. In most cases, if an audio adapter is installed in one of the expansion slots, the audio function built into the system board is disabled; use the audio jacks on the adapter.

- Make sure that the program you are running is designed for use in the Microsoft Windows operating system. If the program is designed to run in DOS, the program does not use the Windows sound feature and must be configured to use SoundBlaster Pro or SoundBlaster emulation.
- Verify that the audio device drivers are correctly installed. See Microsoft Windows help system for more information.

If these actions do not correct the problem, and you need technical assistance, see “Lenovo Support Web site” on page 29.

An audio disc or AutoPlay-enabled disc does not automatically play when it is inserted into a drive

Symptom: An audio disc or AutoPlay-enabled disc does not automatically play when it is inserted into a drive

Action: See “CD problems” on page 37.

Sound comes from one external speaker only

Symptom: Sound comes from one external speaker only.

Actions:

- Ensure that the speaker cable is inserted completely into the connector on the computer.
- Make sure the cable that attaches the left speaker to the right speaker is securely connected.
- Double-click the speaker icon in the Windows notification area. A master volume-control window opens. Verify that the Balance settings are set correctly.

If these actions do not correct the problem, you might have a failing speaker. Have the speaker serviced. If you need technical assistance, see “Lenovo Support Web site” on page 29.

No audio in DOS applications or games

Symptom: No audio in DOS applications or games

Actions:

- Make sure the DOS application or game is configured to use SoundBlaster Pro or SoundBlaster emulation. Refer to the documentation that comes with the application or game for instructions on setting sound-card settings.
- If these actions do not correct the problem, and you need technical assistance, see “Lenovo Support Web site” on page 29.

CD problems

Select your symptom from the following list:

- “An audio disc or AutoPlay-enabled disc does not automatically play when it is inserted into a CD drive” on page 37
- “A CD or DVD does not work” on page 37
- “Unable to use a startable (bootable) recovery medium, such as the Product Recovery CD, to start your computer” on page 37

An audio disc or AutoPlay-enabled disc does not automatically play when it is inserted into a CD drive

Symptom: An audio disc or AutoPlay-enabled disc does not automatically play when it is inserted into a CD drive.

Actions:

- If you have multiple CD or DVD drives installed (or a combination of CD and DVD drives), try inserting the disc into the other drive. In some cases, only one of the drives is connected to the audio subsystem.
- If you are using the Windows 7 operating system, follow the action for “A CD or DVD does not work” on page 37.

If this does not correct the problem, follow the action for “A CD or DVD does not work” on page 37.

A CD or DVD does not work

Symptom: A CD or DVD does not work.

Actions:

- Verify that the disc is inserted correctly, with its label up.
- Make sure that the disc you are using is clean. To remove dust or fingerprints, wipe the disc clean with a soft cloth from the center to the outside. Wiping a disc in a circular motion might cause loss of data.
- Verify that the disc you are using is not scratched or damaged. Try inserting another disc that you know is good. If you cannot read from a known-good disc, you might have a problem with your CD or DVD drive or the cabling to your CD or DVD drive. Make sure that the power cable and signal cable are securely connected to the drive.

Unable to use a startable (bootable) recovery medium, such as the Product Recovery CD, to start your computer

Symptom: Unable to use a startable (bootable) recovery medium, such as the Product Recovery CD, to start your computer.

Action: Make sure that the CD or DVD drive is in the startup sequence before the hard disk drive. Refer to your “Selecting or changing the startup device sequence” on page 53 for information on viewing and changing the startup sequence. Note that on some models the startup sequence is permanently set and cannot be changed.

If these actions do not correct the problem, and you need technical assistance, see “Lenovo Support Web site” on page 29.

DVD problems

Select your symptom from the following list:

- “Black screen instead of DVD video” on page 38
- “DVD movie will not play” on page 38
- “No audio or intermittent audio while playing DVD movie” on page 38
- “Playback is very slow or choppy” on page 38
- “Invalid disc or no disc found message” on page 39

Black screen instead of DVD video

Symptom: Black screen instead of DVD video

Actions:

- Restart the DVD player program.
- Close any open files, turn off the computer, and then restart the computer.
- Try a lower screen resolution or color depth.

If these actions do not correct the problem, and you need technical assistance, see “Lenovo Support Web site” on page 29.

DVD movie will not play

Symptom: DVD movie will not play.

Actions:

- Make sure that the disc surface is clean and not scratched.
- Check the disc or package for regional coding. You might need to purchase a disc with coding for the region where you are using your computer.

If these actions do not correct the problem, and you need technical assistance, see “Lenovo Support Web site” on page 29.

No audio or intermittent audio while playing DVD movie

Symptom: No audio or intermittent audio while playing DVD movie.

Actions:

- Check the volume control settings on your computer and on your speakers.
- Make sure that the disc surface is clean and not scratched.
- Check all cable connections to and from the speakers.
- Use the DVD menu for the video to select a different audio track.

If these actions do not correct the problem, and you need technical assistance, see “Lenovo Support Web site” on page 29.

Playback is very slow or choppy

Symptom: Playback is very slow or choppy.

Actions:

- Disable any background programs, such as AntiVirus or Desktop Themes.
- Ensure that video resolution is set to less than 1152 x 864.

If these actions do not correct the problem, and you need technical assistance, see “Lenovo Support Web site” on page 29.

Invalid disc or no disc found message

Symptom: Invalid disc or no disc found message

Actions:

- Ensure that a DVD disc is in the drive with the shiny side of the disc facing down.
- Ensure that video resolution is set to less than 1152 x 864.
- On computers that have a CD-ROM or CD-RW drive in addition to a DVD-ROM drive, make sure that the DVD disc is in the drive labeled “DVD”.

If these actions do not correct the problem, and you need technical assistance, see “Lenovo Support Web site” on page 29.

Intermittent problems

Symptom: A problem occurs only occasionally and is difficult to repeat.

Actions:

- Verify that all cables and cords are securely connected to the computer and attached devices.
- Verify that when the computer is on, the fan is not blocked (there is air flow around the fan), and the fan is working. If airflow is blocked or the fan is not working, the computer might overheat.
- If SCSI devices are installed, verify that the last external device in each SCSI chain is terminated correctly. (See your SCSI documentation.)

If these actions do not correct the problem, and you need technical assistance, see “Lenovo Support Web site” on page 29.

Keyboard, mouse, or pointing device problems

Select your symptom from the following list:

- “All or some keys on the keyboard do not work” on page 39
- “The mouse or pointing device does not work” on page 40
- “The pointer on the screen does not move smoothly with the mouse” on page 40
- “The fingerprint reader does not work” on page 40
- “The wireless keyboard does not work” on page 41

All or some keys on the keyboard do not work

Symptom: All or some keys on the keyboard do not work.

Actions:

- Verify that the keyboard cable is securely connected to the correct connector on the computer.
- If you are using an Enhanced Performance USB keyboard and one or more of the Rapid Access buttons are the only keys that are not working, these buttons might have been disabled or have not been assigned

to a function. Use the help system in the Enhanced Performance Customization Keyboard program to help diagnose problems with the Rapid Access buttons.

To open the Enhanced Performance Customization Keyboard program, do one of the following:

- On the Windows 7 operating system, do the following:
 1. Click **Start → Control Panel**.
 2. Click **Hardware and Sound**.
 3. Click **Devices and Printers**.
 4. Double-click **USB Enhanced Performance Keyboard**. The USB Enhanced Performance Keyboard Customization program starts.
- On the Windows 8 operating system, do the following:
 1. Open Control Panel.
 2. Click **Hardware and Sound**.
 3. Click **Devices and Printers**.
 4. Double-click **USB Enhanced Performance Keyboard**. The USB Enhanced Performance Keyboard Customization program starts.

If these actions do not correct the problem, have the computer and keyboard serviced. See “Lenovo Support Web site” on page 29 for details.

The mouse or pointing device does not work

Symptom: The mouse or pointing device does not work.

Actions:

- Verify that the mouse or pointing-device cable is securely attached to the correct connector on the computer. Depending on the type of mouse you have, the mouse cable will connect to either the mouse, serial, or USB connector. Some keyboards have integrated USB connectors that can be used for a USB mouse or pointing device.
- Verify that the device drivers for the mouse or pointing device are installed correctly.
- If you are using a USB keyboard or mouse, verify that the USB connectors are enabled in the BIOS settings. See “Enabling or disabling a device” on page 52.

If these actions do not correct the problem, and you need technical assistance, see “Lenovo Support Web site” on page 29.

The pointer on the screen does not move smoothly with the mouse

Symptom: The pointer on the screen does not move smoothly with the mouse.

Action: Erratic movement of the mouse pointer is generally caused by a buildup of dirt, oils, and other contaminants on the ball inside the mouse. Clean the mouse.

The fingerprint reader does not work

Symptom: The fingerprint reader does not work.

Action: The following could cause the fingerprint reader not to operate properly:

- Not enrolling your fingerprint correctly.
- Scratching the surface of the reader with a hard, pointed object.
- Scraping the surface of the reader with your nail or anything hard.

- Using or touching the reader with a dirty finger.
- The surface of your finger is very different from when you enrolled your fingerprint.

The wireless keyboard does not work

Symptom: The wireless keyboard does not work.

Action: If the Transceiver Communications LED is on and the wireless Keyboard does not work, restart your computer. If restarting your computer does not solve the problem, verify that the following conditions are met:

- The batteries are properly installed.
- The batteries still retain their current.
- The wireless keyboard is located less than ten meters away from the transceiver.
- The transceiver is fully installed.

Action: If the transceiver communications LED is not on, reconnect the transceiver and the keyboard.

Monitor problems

Note: Many monitors have status-indicator lights and built-in controls for adjusting brightness, contrast, width, height, and other picture adjustments. However, the controls vary from monitor type to monitor type.

Select your symptom from the following list:

- “Wrong characters appear on the screen” on page 41
- “The monitor works when you turn on the computer, but goes blank after some period of computer inactivity” on page 41
- “The monitor works when you turn on the computer, but goes blank when you start some application programs” on page 41
- “The image appears to be flickering” on page 42
- “The image is discolored” on page 42

Wrong characters appear on the screen

Symptom: Wrong characters appear on the screen.

Action: Have the computer serviced. For details, see “Lenovo Support Web site” on page 29.

The monitor works when you turn on the computer, but goes blank after some period of computer inactivity

Symptom: The monitor works when you turn on the computer, but goes blank after some period of computer inactivity.

Action: The computer is probably set for energy savings with the power-management feature. If the power-management feature is enabled, disabling it or changing the settings might solve the problem.

If these actions do not correct the problem, and you need technical assistance, see “Lenovo Support Web site” on page 29.

The monitor works when you turn on the computer, but goes blank when you start some application programs

Symptom: The monitor works when you turn on the computer, but goes blank when you start some application programs.

Action:

Verify that the necessary device drivers for the application programs are installed. Refer to the documentation for the affected application program to see if device drivers are required.

If these actions do not correct the problem, and you need technical assistance, see “Lenovo Support Web site” on page 29.

The image appears to be flickering

Symptom: The image appears to be flickering.

Actions:

- The monitor might be operating in a low-refresh rate display mode. Set the monitor to the highest, noninterlaced refresh rate supported by your monitor and the video controller in your computer.

Attention: Using a resolution or refresh rate that is not supported by your monitor might damage it. Check the documentation that comes with your monitor to verify the supported refresh rates.

- The monitor might be affected by interference from nearby equipment. Magnetic fields around other devices, such as transformers, appliances, fluorescent lights, and other monitors might be causing the problem. Move fluorescent desk lighting or any equipment that produces magnetic fields farther away from the monitor. If this does not correct the problem, do the following:
 1. Turn off the monitor. (Moving a color monitor while it is turned on might cause screen discoloration.)
 2. Adjust the placement of the monitor and other devices so that they are at least 305 mm (12 inches) apart.
 3. Turn on the monitor.
- You can reset the refresh rate through your operating system Control Panel:

On the Windows 7 operating system, click **Start → Control Panel → Hardware and Sound → Adjust screen resolution → Advanced Settings**. Then click the **Monitor** tab and select a new refresh rate.

On the Windows 8 operating system, open Control Panel and click **Hardware and Sound → Adjust screen resolution → Advanced Settings**. Then click the **Monitor** tab and select a new refresh rate.
- See your operating system documentation or help for further information on monitor settings.

If these actions do not correct the problem, your monitor might need service. See “Lenovo Support Web site” on page 29 for details.

The image is discolored

Symptom: The image is discolored.

Action: The monitor might be affected by interference from nearby equipment. Magnetic fields around other devices, such as transformers, appliances, fluorescent lights, and other monitors might be causing the problem. Move fluorescent desk lighting or any equipment that produces magnetic fields further away from the monitor. If this does not correct the problem, do the following:

1. Turn off the monitor. (Moving a color monitor while it is turned on might cause screen discoloration.)
2. Adjust the placement of the monitor and other devices so that they are at least 305 mm (12 inches) apart.
3. Turn on the monitor.

If these actions do not correct the problem, your monitor might need service. See “Lenovo Support Web site” on page 29 for details.

Networking problems

The following are the most common networking problems. Select your networking problem from the following list:

- “Ethernet problems” on page 43
- “A wireless LAN problem” on page 44
- “A wireless WAN problem” on page 45
- “Bluetooth problems” on page 45

Ethernet problems

For Ethernet problems, select your symptom from the following list:

- “Your computer cannot connect to the network” on page 43
- “The adapter stops working for no apparent reason” on page 44
- “If your computer is a Gigabit Ethernet model and you use a speed of 1000 Mbps, the connection fails or errors occur” on page 44
- “If your computer is a Gigabit Ethernet model, it cannot connect to the network at 1000 Mbps. Instead, it connects at 100 Mbps” on page 44

Your computer cannot connect to the network

Symptom: Your computer cannot connect to the network.

Actions: Ensure that:

- The cable is installed properly.

The network cable must be securely connected to both the Ethernet connector of your computer and the RJ45 connector of the hub. The maximum allowable distance from the computer to hub is 100 meters. If the cable is connected and the distance is within acceptable limits but the problem persists, try a different cable.

- The cable is installed properly.
- You are using the correct device driver.

On the Windows 7 operating system, do the following:

1. Click **Start** → **Control Panel**.
2. Click **Hardware and Sound**.
3. Click **Device Manager**. If you are prompted for an administrator password or confirmation, type the password or provide confirmation.
4. If an exclamation mark is displayed next to an adapter name under **Network adapters**, you might not be using the correct driver or the driver is not enabled. To update the driver, right-click the highlighted adapter.
5. Click **Update Driver Software**, and then follow the instructions on the screen.

On the Windows 8 operating system, do the following:

1. Open Control Panel.
2. Click **Hardware and Sound**.
3. Click **Device Manager**. If you are prompted for an administrator password or confirmation, type the password or provide confirmation.
4. If an exclamation mark is displayed next to an adapter name under **Network adapters**, you might not be using the correct driver or the driver is not enabled. To update the driver, right-click the highlighted adapter.

5. Click **Update Driver Software**, and then follow the instructions on the screen.

- The switch port and the adapter have the same duplex setting.

If you configured the adapter for full duplex, ensure that the switch port is also configured for full duplex. Setting the wrong duplex mode can degrade performance, cause data loss, or result in lost connections.

- You have installed all networking software that is necessary for your network environment.

Check with your LAN administrator for the necessary networking software.

The adapter stops working for no apparent reason

Symptom: The adapter stops working for no apparent reason.

Action: The network driver files may be corrupt or missing. Update the driver by referring to the “Solution” description for the procedure to make sure that the correct device driver is installed.

The Wake on LAN feature is not working

Symptom: The Wake on LAN (WOL) feature is not working.

Actions:

- Make sure that WOL is enabled in the BIOS Setup Utility program.
- If it is, check with your LAN administrator for the necessary settings.

If your computer is a Gigabit Ethernet model and you use a speed of 1000 Mbps, the connection fails or errors occur

Symptom: If your computer is a Gigabit Ethernet model and you use a speed of 1000 Mbps, the connection fails or errors occur.

Actions:

- Use Category 5 wiring and make sure that the network cable is securely connected.
- Connect to a 1000 BASE-T hub/switch (not 1000 BASE-X).

If your computer is a Gigabit Ethernet model, it cannot connect to the network at 1000 Mbps. Instead, it connects at 100 Mbps

Symptom: If your computer is a Gigabit Ethernet model, it cannot connect to the network at 1000 Mbps. Instead, it connects at 100 Mbps.

Actions:

- Try another cable.
- Make sure that the link partner is set to auto-negotiate.
- Make sure that the switch is 802.3ab-compliant (gigabit over copper).

A wireless LAN problem

Symptom: You cannot connect using the built-in wireless networking card.

Actions:

- Make sure that your wireless LAN driver is the latest version. Check the Web site and verify the driver version supported by Access Connections is the latest documented in the readme file.
- Make sure that your computer is within range of a wireless access point.
- Make sure that the wireless radio is enabled by double-clicking the Access Connections icon in the Windows notification area.

Note: If your computer is preinstalled with the Windows 7 operating system, click **Show hidden icons** in the Windows notification area. The Access Connections icon is displayed. For more information about the icon, see the Help in Access Connections.

- Check Network Name (SSID), and your encryption information. Use Access Connections to verify this case-sensitive information.

A wireless WAN problem

Message: Unauthorized WAN card is plugged in - Power off and remove the WAN card.

Action: Seek technical assistance for help to remove the unauthorized WAN card. See “Lenovo Support Web site” on page 29 for more information.

Note: Some computer models do not have a wireless WAN.

Bluetooth problems

Bluetooth is available with some certain computer models.

For Bluetooth problems, select your symptom from the following list:

- “Sound does not come from the Bluetooth headphone” on page 45
- “PIM items sent from the Windows 7 operating system cannot be received correctly” on page 45

Sound does not come from the Bluetooth headphone

Symptom: Sound does not come from the Bluetooth headset/headphone but comes from the local speaker even though the headset/headphone is connected using Headset profile or AV profile.

Action: Do the following:

1. Exit the application that uses the sound device (for example, Windows Media Player).
2. Open the Control Panel by clicking **Start → Control Panel**.
3. Click **Hardware and Sound → Sound**.
4. Select the **Playback** tab.
5. If you are using Headset profile, select **Bluetooth Hands-free Audio** and click the **Set Default** button. If you are using AV profile, select **Stereo Audio** and click the **Set Default** button.
6. Click **OK** to close the Sound window.

PIM items sent from the Windows 7 operating system cannot be received correctly

Symptom: Personal Information Manager (PIM) items sent from the Windows 7 operating system cannot be received correctly into the address book of any other Bluetooth-enabled device.

Action: The Windows 7 operating system sends PIM items in XML format, but most Bluetooth-enabled devices handle PIM items in vCard format. If another Bluetooth-enabled device can receive a file through Bluetooth, a PIM item sent from the Windows 7 operating system system might be saved as a file with the extension contact.

Option problems

Use this information to diagnose problems with Lenovo hardware options that do not have their own troubleshooting information.

Select your symptom from the following list:

- “An option that was just installed does not work” on page 46

- “An option that previously worked does not work now” on page 46

An option that was just installed does not work

Symptom: An option that was just installed does not work.

Action: Verify that:

- The option is designed for your computer.
- You followed the installation instructions supplied with the option and the installation instructions provided with your computer, and all option files (such as device drivers, if required) are installed correctly.
- You have not loosened other installed options or cables.
- If the option is an adapter, you have provided enough hardware resources for the adapter to function correctly. See the documentation supplied with the adapter (as well as the documentation for any other installed adapters) to determine the resources required for each adapter.

If these actions do not correct the problem, and you need technical assistance, see “Lenovo Support Web site” on page 29.

An option that previously worked does not work now

Symptom: An option that previously worked does not work now.

Actions:

- Verify that all option hardware and cable connections are secure.
- If the option comes with its own test instructions, use those instructions to test the option.
- If the failing option is a SCSI option, verify that:
 - The cables for all external SCSI options are connected correctly.
 - The last option in each SCSI chain, or the end of the SCSI cable, is terminated correctly.
 - All external SCSI options are turned on. External SCSI options must be turned on before the computer is turned on. For more information, see your SCSI documentation.
- Verify that the option and any required device drivers are installed correctly.

If these actions do not correct the problem, and you need technical assistance, see “Lenovo Support Web site” on page 29.

Performance and lockup problems

Poor performance and lockup problems can be a result of any of the following:

- “Insufficient free hard disk drive space” on page 46
- “Excessive number of fragmented files” on page 47

Make a selection from the above list to find out more about the corrective actions you can take.

Insufficient free hard disk drive space

Symptom: Insufficient free hard disk drive space

The Windows operating system will slow down and might produce errors if the hard disk drive gets too full.

To check the amount of free space on the Windows 7 operating system, do the following:

1. Click **Start → Computer**.

2. Right-click your C drive entry and then click **Properties**. The amount of free disk space is displayed.

To check the amount of free space on the Windows 8 operating system, do the following:

1. Open the Windows Explorer and click **Computer**.
2. Right-click your C drive entry and then click **Properties**. The amount of free disk space is displayed.

To free up disk space, do any of the following:

- Procedure 1
 1. On the Windows 7 operating system, click **Start → Computer**. On the Windows 8 operating system, open the Windows Explorer and click **Computer**.
 2. Right-click your C drive entry and then click **Properties**.
 3. Click **Disk Cleanup**.
 4. A list of unnecessary file categories is displayed. Select each file category you want to delete, and then click **OK**.
- Procedure 2
 1. Open Control Panel.
 2. Click **Programs**.
 3. Click **Turn Windows features on or off**.
 4. A list of optional Windows components is displayed. Follow the instructions on the screen.
- Procedure 3
 1. On the Windows 7 operating system, click **Start → Computer**. On the Windows 8 operating system, open the Windows Explorer and click **Computer**.
 2. Right-click your C drive entry and then click **Properties**.
 3. Click **Disk Cleanup**.
 4. Click **Clean up system files**.
 5. Click the **More Options** tab.
 6. In the **Programs and Features** area, click the **Clean up** button.
 7. A list of installed programs is displayed. Select the program that you want to remove. Click **Uninstall/Change**.
- Clean out your Inbox, Sent Items, and Deleted Items folders from your e-mail application. The folder names and procedures vary depending on your e-mail application. If you need assistance, see the help system for your e-mail application.

Excessive number of fragmented files

Symptom: Excessive number of fragmented files

Action: Run the Windows Disk Defragmenter program.

Note: Depending on the size of the hard disk drive and amount of data currently stored on the hard disk drive, the disk-defragmentation process might take up to several hours to complete.

On the Windows 7 operating system, do the following:

1. Close any programs that are currently running and close any open windows.
2. Click **Start → Computer**.
3. Right-click your C drive entry and then click **Properties**.
4. Click the **Tools** tab.

5. Click **Defragment Now**, then click **Continue**.
6. Click **Defragment Now** again to start a disk-defragmentation process.

On the Windows 8 operating system, do the following:

1. Close any programs that are currently running and close any open windows.
2. Open the Windows Explorer and click **Computer**.
3. Right-click your C drive entry and then click **Properties**.
4. Click the **Tools** tab.
5. Click **Optimize**.
6. Click **Optimize** again to start a disk-defragmentation process.

Printer problems

Printer is supported by some certain computer models.

Symptom: The printer does not work.

Actions: Verify that:

1. The printer is turned on and is online.
2. Paper is loaded correctly.
3. The printer signal cable is securely connected to the correct parallel, serial, or USB connector on the computer.

Note: Non-IEEE-approved printer signal cables might cause unpredictable problems.

1. Any device drivers and other software that came with the printer are correctly installed.
2. You have assigned the printer port correctly in your operating system, application program, or BIOS settings. For more information about BIOS settings, see Chapter 6 “Using the Setup Utility program” on page 51.

If the problem persists, run the tests described in the documentation that comes with your printer. If you cannot correct the problem, have the computer serviced. See “Lenovo Support Web site” on page 29.

Serial port problems

Serial port is available with some certain computer models.

Use this information to troubleshoot the serial port and devices attached to the serial port.

Symptom: Serial port cannot be accessed.

Actions:

- Make sure the serial cable is securely connected to the serial port on the computer and to the serial device. If the serial device has its own power cord, make sure it is attached to a properly grounded electrical outlet.
- If the serial device has its own On/Off switch, make sure it is in the On position.
- If the serial device has an Online switch, make sure it is in the Online position.
- If the serial device is a printer, make sure paper is loaded correctly.
- Verify that any software supplied with the serial device is correctly installed. Refer to the documentation for the serial-device option.
- Make sure that the serial-port adapter, if you added one, is properly installed and firmly seated.

If these actions do not correct the problem, and you need technical assistance, see “Lenovo Support Web site” on page 29.

Software problems

Select your symptom from the following list:

- “When using a sort feature, dates do not sort in the correct order” on page 49
- “Software does not work as expected” on page 49

When using a sort feature, dates do not sort in the correct order

Symptom: When using a sort feature, dates do not sort in the correct order.

Action: Some software developed before the year 2000 used only the last two digits of a year to sort dates, always assuming the first two digits were 19. Consequently, these programs sort dates out of order. Check with your software manufacturer to see if any updates are available. Many software manufacturers make updates available from the World Wide Web.

Software does not work as expected

Symptom: Software does not work as expected.

Actions:

- Most software programs have built-in help systems that provide instructions for most tasks. If you are having difficulty performing a specific task within a software program, refer to the help system for that program. Help systems are typically accessible from a menu or button in the program, and frequently from the F1 key.
- If you are having difficulty with the Windows operating system or one of its components, refer to the Windows help system. It is accessible from the Windows **Start** menu.
- To determine if problems are caused by newly installed software, verify that:
 - Your computer has the minimum memory requirements needed to use the software. See the information supplied with the software to verify memory requirements. (If you just installed an adapter or memory, you might have a memory-address conflict.)
 - The software is designed to operate on your computer.
 - Other software works on your computer.
 - The software you are using works correctly on another computer.
- If you received any error messages while using the software program, see the printed documentation supplied with the software or the help system for that software for a description of the messages and solutions to the problem.
- Check with your software manufacturer to see if any updates are available. Many software manufacturers make updates available from the World Wide Web.
- If the software program used to work correctly, but does not work correctly now, do the following:
 - On the Windows 7 operating system, click **Start → Control Panel → System and Security → System → System Protection → System Restore**. Then, follow the instructions on the screen.
 - On the Windows 8 operating system, open Control Panel and click **System and Security → System → System Protection → System Restore**. Then, follow the instructions on the screen.
- If you are unable to resolve the problem through other methods, uninstall the software program and reinstall it.

If these actions do not correct the problem, you might need technical assistance. Contact your software manufacturer or see “Lenovo Support Web site” on page 29 for details.

USB problems

Symptom: The USB connectors cannot be accessed.

Actions:

- Make sure the USB cable is securely connected to the USB connector and to the USB device. If the USB device has its own power cord, make sure it is attached to a properly grounded electrical outlet.
- If the USB device has its own On/Off switch, make sure it is in the On position.
- If the USB device has an Online switch, make sure it is in the Online position.
- If the USB device is a printer, make sure paper is loaded correctly.
- Make sure any device drivers or other software supplied with the USB device is correctly installed. Refer to the documentation for the USB device.
- Reset the device by detaching and reattaching the USB connector.

If these actions do not correct the problem, and you need technical assistance, see “Lenovo Support Web site” on page 29.

Chapter 6. Using the Setup Utility program

The Setup Utility program is used to view and change the configuration settings of your computer, regardless of which operating system you are using. However, the operating system settings might override any similar settings in the Setup Utility program.

Starting the Setup Utility program

To start the Setup Utility program, do the following:

1. Make sure your computer is turned off.
2. Repeatedly press and release the F1 key when turning on the computer. When you hear multiple beeps or see a logo screen, release the F1 key.

Note: If a Power-On Password or an Administrator Password has been set, the Setup Utility program menu will not be displayed until you type the correct password. For more information, see “Using passwords” on page 51.

When the POST detects that the hard disk drive has been removed from your computer or the memory module size has decreased, an error message will be displayed when you start the computer and you will be prompted to do one of the following:

- Press F1 to enter the Setup Utility program.

Note: After you enter the Setup Utility program, select **Save Changes and Exit** at the bottom of the screen. The error message will not be displayed again.

- Press F2 to bypass the error message and log in to the operating system.

Viewing and changing settings

The Setup Utility program menu lists various items about the system configuration. To view or change settings, start the Setup Utility program. See “Starting the Setup Utility program” on page 51. Then, follow the instructions on the screen.

You can use the keyboard to navigate through BIOS menu choices. The keys used to perform various tasks are displayed at the bottom of each screen.

Using passwords

By using the Setup Utility program, you can set passwords to prevent unauthorized access to your computer and data. The following types of passwords are available:

- Power-On Password
- Administrator Password

You do not have to set any passwords to use your computer. However, using passwords improves computing security. If you decide to set any passwords, read the following sections.

Password considerations

A password can be any combination of up to 64 alphabetic and numeric characters. For security reasons, it is recommended to use a strong password that cannot be easily compromised. To set a strong password, use the following guidelines:

- Have at least eight characters in length
- Contain at least one alphabetic character and one numeric character
- Setup Utility program is not case sensitive
- Not be your name or your user name
- Not be a common word or a common name
- Be significantly different from your previous passwords

Power-On Password

When a Power-On Password is set, you are prompted to type a valid password each time the computer is turned on. The computer cannot be used until the valid password is typed in.

Administrator Password

Setting an Administrator Password deters unauthorized users from changing configuration settings. If you are responsible for maintaining the configuration settings of several computers, you might want to set an Administrator Password.

When an Administrator Password is set, you are prompted to type a valid password each time you try to access the Setup Utility program. The Setup Utility program cannot be accessed until a valid password is typed in.

If both the Power-On Password and Administrator Password are set, you can type either password. However, you must use your Administrator Password to change any configuration settings.

Setting, changing, and deleting a password

To set, change, or delete a password, do the following:

1. Start the Setup Utility program. See “Starting the Setup Utility program” on page 51.
2. From the Setup Utility program main menu, select **Security**.
3. Depending on the password type, select **Set Power-On Password** or **Set Administrator Password**.
4. Follow the instructions on the right side of the screen to set, change, or delete a password.

Note: A password can be any combination of up to 64 alphabetic and numeric characters. For more information, see “Password considerations” on page 51.

Enabling or disabling a device

This section provides information on how to enable or disable user access to the following devices:

USB Setup	Use this option to enable or disable a USB connector. When a USB connector is disabled, the device connected to the USB connector cannot be used.
SATA Controller	When this feature is set to Disable , all devices connected to the SATA connectors (such as hard disk drives or the optical drive) are disabled and cannot be accessed.

To enable or disable a device, do the following:

1. Start the Setup Utility program. See “Starting the Setup Utility program” on page 51.
2. From the Setup Utility program main menu, select **Devices**.
3. Depending on the device you want to enable or disable, do one of the following:
 - Select **USB Setup** to enable or disable a USB device.

- Select **ATA Drive Setup** to enable or disable a SATA device.
4. Select the desired settings and press Enter.
 5. Press F10 to save changes and exit the Setup Utility program. See “Exiting the Setup Utility program” on page 54.

Selecting a startup device

If your computer does not start up from a device such as the disc or hard disk drive as expected, do one of the following to select the startup device you want.

Selecting a temporary startup device

Use this procedure to select a temporary startup device.

Note: Not all discs and hard disk drives are bootable.

1. Turn off your computer.
2. Repeatedly press and release the F12 key when turning on the computer. When the Startup Device Menu window displays, release the F12 key.
3. Select the desired startup device and press Enter. The computer will start up from the device you selected.

Note: Selecting a startup device from the Startup Device Menu window does not permanently change the startup sequence.

Selecting or changing the startup device sequence

To view or permanently change the configured startup device sequence, do the following:

1. Start the Setup Utility program. See “Starting the Setup Utility program” on page 51.
2. From the Setup Utility program main menu, select **Startup**.
3. Select the devices for the Primary Startup Sequence, the Automatic Startup Sequence, and the Error Startup Sequence. Read the information displayed on the right side of the screen.
4. Press F10 to save changes and exit the Setup Utility program. See “Exiting the Setup Utility program” on page 54.

Changing the BIOS settings before installing a new operating system

BIOS settings vary by operating system. Change the BIOS settings before installing a new operating system.

To change the BIOS settings, do the following:

1. Start the Setup Utility program. See “Starting the Setup Utility program” on page 51.
2. From the Setup Utility program main menu, select **Exit → OS Optimized Default**.
3. Depending on the operating system to be installed, do one of the following:
 - To install the Windows 8 (64-bit) operating system, select **Enabled**.
 - To install an operating system other than Windows 8 (64-bit), select **Disabled**.
4. Select **Yes** in the window displayed and press Enter to confirm your selection.
5. Press F10 to save changes and exit the Setup Utility program. See “Exiting the Setup Utility program” on page 54.

Exiting the Setup Utility program

After you finish viewing or changing settings, press Esc to return to the Setup Utility program main menu. You might have to press Esc several times. Do one of the following:

- If you want to save the new settings, press F10 to save changes and exit the Setup Utility program.
- If you do not want to save the settings, select **Exit → Discard Changes and Exit**, and then press Enter. When the Reset Without Saving window shows, select **Yes**, and then press Enter to exit the Setup Utility program.
- If you want to return to the default settings, press F9 to load the default settings, and then press F10 to save and exit the Setup Utility program.

Chapter 7. Symptom-to-FRU Index

The Symptom-to-FRU index lists error symptoms and possible causes. The most likely cause is listed first. Always begin with Chapter 4 “General Checkout” on page 31. This index can also be used to help you decide which FRUs to have available when servicing a computer. If you are unable to correct the problem using this index, go to “Undetermined problems” on page 59.

Notes:

- If you have both an error message and an incorrect audio response, diagnose the error message first.
- If you cannot run the diagnostic tests or you get a diagnostic error code when running a test, but did receive a POST error message, diagnose the POST error message first.
- If you did not receive any error message, look for a description of your error symptoms in the first part of this index.

Hard disk drive boot error

A hard disk drive boot error can have the following causes.

Error	FRU/Action
The start-up drive is not in the boot sequence in configuration.	Check the configuration and ensure the start-up drive is in the boot sequence.
No operating system installed on the boot drive.	Install an operating system on the boot drive.
The boot sector on the startup drive is corrupted.	The drive must be formatted. Do the following: <ol style="list-style-type: none">1. Attempt to back up the data on the failing hard disk drive.2. Using the operating system programs, format the hard disk drive.
The drive is defective.	Replace the hard disk drive.

Power Supply Problems

If you suspect a power problem, use the following procedures.

Check/Verify	FRU/Action
Check the following for proper installation. <ul style="list-style-type: none">• Power cord• On/Off switch connector• On/Off switch power supply connector• System board power supply connectors• Microprocessor(s) connection	Reseat connectors
Check the power cord for continuity.	Power cord
Check the power-on switch for continuity.	Power-on switch

Beep symptoms

Beep symptoms are tones or a series of tones separated by pauses (intervals without sound) during POST.

The following table describes the beep symptoms.

Beep Symptom	FRU/Action
2 short beeps CMOS setting error	Common error code, see the detail failure information in "POST error codes" on page 56.
3 short and 1 long beeps DRAM memory error	Perform the following actions in order. <ol style="list-style-type: none"> 1. Make sure the memory module(s) are properly seated in the connector(s). 2. Replace the memory module(s). 3. Replace the system board.

POST error codes

Each time you power-on the system, it performs a series of tests that check the operation of the system and some options. This series of tests is called the *Power-On Self-Test*, or *POST*. POST does the following operations.

- Checks some basic system-board operations
- Checks the memory operation
- Starts the video operation
- Verifies that the boot drive is working

If the POST detects a problem, an error message appears on the screen. A single problem can cause several error messages to appear. When you correct the cause of the first error message, the other error messages probably will not appear on the screen the next time you turn on the system.

Error code	POST Error Message	Description/Action
0135	Fan failure	The system might be overheating. Press F10 to exit. Note: If the problem is caused by the microprocessor fan, press F10 will not solve the problem.
0211	Keyboard not found	When there is no keyboard detected, the error message will be displayed.
0164	Memory size decreased	Press F10 to exit.
1762	Configuration change has occurred	This error message is displayed when a hard disk drive or optical drive change has been made. Press F10 to exit.
0662	Configuration change has occurred	This error message is displayed when a floppy drive change has been made. Press F10 to exit.

Error code	POST Error Message	Description/Action
1820	More than one external fingerprint reader are attached. Power off and remove all but the reader that you set up within your main operating system.	If more than one external fingerprint reader are connected to a computer, this error message will be displayed to inform you to remove all of the fingerprint keyboards except the one compatible with the fingerprint application on your computer.
1962	No operating system found. Press any key to repeat boot sequence.	This error occurs only after the POST is completed. Press any key to repeat boot sequence.

Miscellaneous error conditions

Message/Symptom	FRU/Action
Changing display colors	Display/Monitor
Computer will <i>not</i> power-off. See "Hard disk drive boot error" on page 55.	<ol style="list-style-type: none"> 1. Power Switch 2. System Board 3. Riser card, if installed.
Computer will <i>not</i> RPL from server	<ol style="list-style-type: none"> 1. Ensure that network is in startup sequence as first device or first device after diskette. 2. Ensure that network adapter is enabled for RPL. 3. Network adapter (Advise network administrator of new MAC address)
Computer will <i>not</i> perform a Wake On LAN® (if applicable)	<ol style="list-style-type: none"> 1. Check power supply and signal cable connections to network adapter. 2. Ensure that the operating system settings are set to enable Wake on LAN. 3. Ensure Wake On LAN feature is enabled in Setup/Configuration (see "Starting the Setup Utility program" on page 51) 4. Ensure network administrator is using correct MAC address. 5. Ensure no interrupt or I/O address conflicts. 6. Network adapter (advise network administrator of new MAC address)
Dead computer. See "Hard disk drive boot error" on page 55.	<ol style="list-style-type: none"> 1. Power Supply 2. System Board
Diskette drive in-use light remains on or does not light when drive is active.	<ol style="list-style-type: none"> 1. Diskette Drive 2. System Board 3. Diskette Drive Cable
Blank screen except for flashing cursor.	<ol style="list-style-type: none"> 1. System Board 2. Primary Hard Disk Drive 3. Hard Disk Drive Cable

Message/Symptom	FRU/Action
Incorrect memory size during POST	<ol style="list-style-type: none"> 1. Run the Memory tests. 2. Memory Module 3. System Board
"Insert a Diskette" icon appears with a known-good diagnostics diskette in the first 3.5-inch diskette drive.	<ol style="list-style-type: none"> 1. System Board 2. Diskette Drive Cable 3. Network Adapter
Intensity or color varies from left to right of characters and color bars	<ol style="list-style-type: none"> 1. Display 2. Video adapter (if present) 3. System Board
No power or fan not running	<ol style="list-style-type: none"> 1. See "Hard disk drive boot error" on page 55.
Non-system disk or disk error-type message with a known-good diagnostic diskette.	<ol style="list-style-type: none"> 1. Diskette Drive 2. System Board 3. Diskette Drive Cable
Other display symptoms not listed above (including blank or illegible display)	<ol style="list-style-type: none"> 1. Display 2. System Board
Power-on indicator or hard disk drive in-use light not on, but computer works correctly	<ol style="list-style-type: none"> 1. Power switch/LED assembly 2. System Board
Printer problems	<ol style="list-style-type: none"> 1. Printer 2. System Board
Program loads from the hard disk with a known-good diagnostics diskette in the first 3.5-inch diskette drive	<ol style="list-style-type: none"> 1. Run the Setup Utility program and check Startup sequence. 2. Diskette Drive 3. Diskette Drive Cable 4. System Board 5. Power Supply
RPL computer cannot access programs from its own hard disk.	<ol style="list-style-type: none"> 1. If network administrator is using LCCM Hybrid RPL, check startup sequence: <ol style="list-style-type: none"> a. First device - network b. Second device - hard disk 2. Hard disk drive
RPL computer does not RPL from server	<ol style="list-style-type: none"> 1. Check startup sequence. 2. Check the network adapter LED status.
Serial or parallel port device failure (system board port)	<ol style="list-style-type: none"> 1. External Device Self-Test OK? 2. External Device 3. Cable 4. System Board

Message/Symptom	FRU/Action
Serial or parallel port device failure (adapter port)	<ol style="list-style-type: none"> 1. External Device Self-Test OK? 2. External Device 3. Cable 4. Alternate Adapter 5. System Board
Some or all keys on the keyboard do not work	<ol style="list-style-type: none"> 1. Keyboard 2. Keyboard Cable 3. System Board

Undetermined problems

This section provides instructions on how to find out the failing devices or adapters.

1. Power-off the computer.
2. Remove or disconnect the following components (if installed) one at a time.
 - a. External devices (modem, printer, or mouse)
 - b. Any adapters
 - c. Memory modules
 - d. Extended video memory
 - e. External Cache
 - f. External Cache RAM
 - g. Hard disk drive
 - h. Diskette drive
3. Power-on the computer to re-test the system.
4. Repeat steps 1 through 3 until you find the failing device or adapter.

If all devices and adapters have been removed, and the problem continues, replace the system board.

Chapter 8. Locations

This chapter introduces the locations of the computer hardware components.

Locating connectors, controls, and indicators on the front of your computer

Figure 1 “Front connector, control, and indicator locations” on page 61 shows the locations of the connectors, controls, and indicators on the front of your computer.

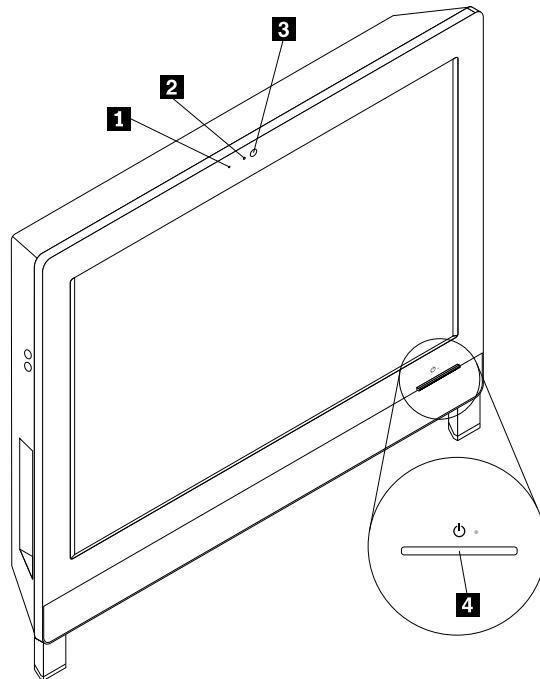

Figure 1. Front connector, control, and indicator locations

- | | |
|--------------------------------------|----------------------------|
| 1 Integrated microphone | 3 Integrated camera |
| 2 Integrated camera indicator | 4 Power switch |

Locating connectors, controls, and indicators on the rear of your computer

Figure 2 “Rear connector locations” on page 62 shows the locations of the connectors on the rear of your computer. Some connectors on the rear of your computer are color-coded to help you determine where to connect the cables on your computer.

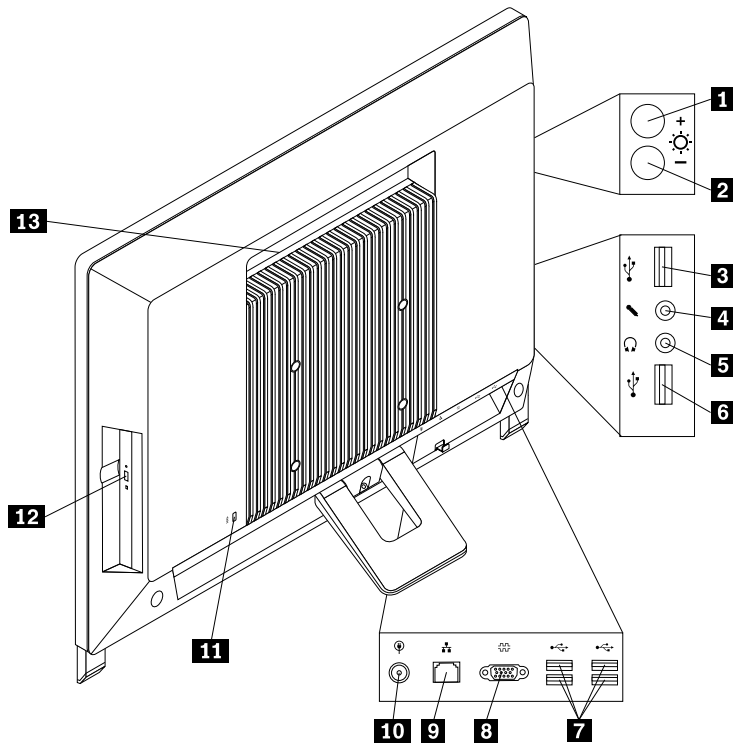

Figure 2. Rear connector locations

- | | |
|--|--|
| 1 Brightness-up control (computer mode) | 8 Serial port |
| 2 Brightness-down control (computer mode) | 9 Ethernet connector |
| 3 USB connector 1 | 10 Power connector |
| 4 Microphone connector | 11 Integrated cable lock (Kensington lock) slot |
| 5 Headphone connector | 12 Optical drive eject/close button |
| 6 USB connector 2 | 13 Ventilation slots |
| 7 USB connectors (USB ports 3 to 6) | |

Attention: Never block or cover the ventilation slots, especially the ventilation slots beneath the computer handle. Blocking the ventilation slots will cause the computer to overheat.

Locating major FRUs and CRUs

Figure 3 “Locating major FRUs and CRUs” on page 64 shows the locations of the major FRUs and CRUs in the computer. To remove the computer cover, see “Removing the computer cover” on page 71.

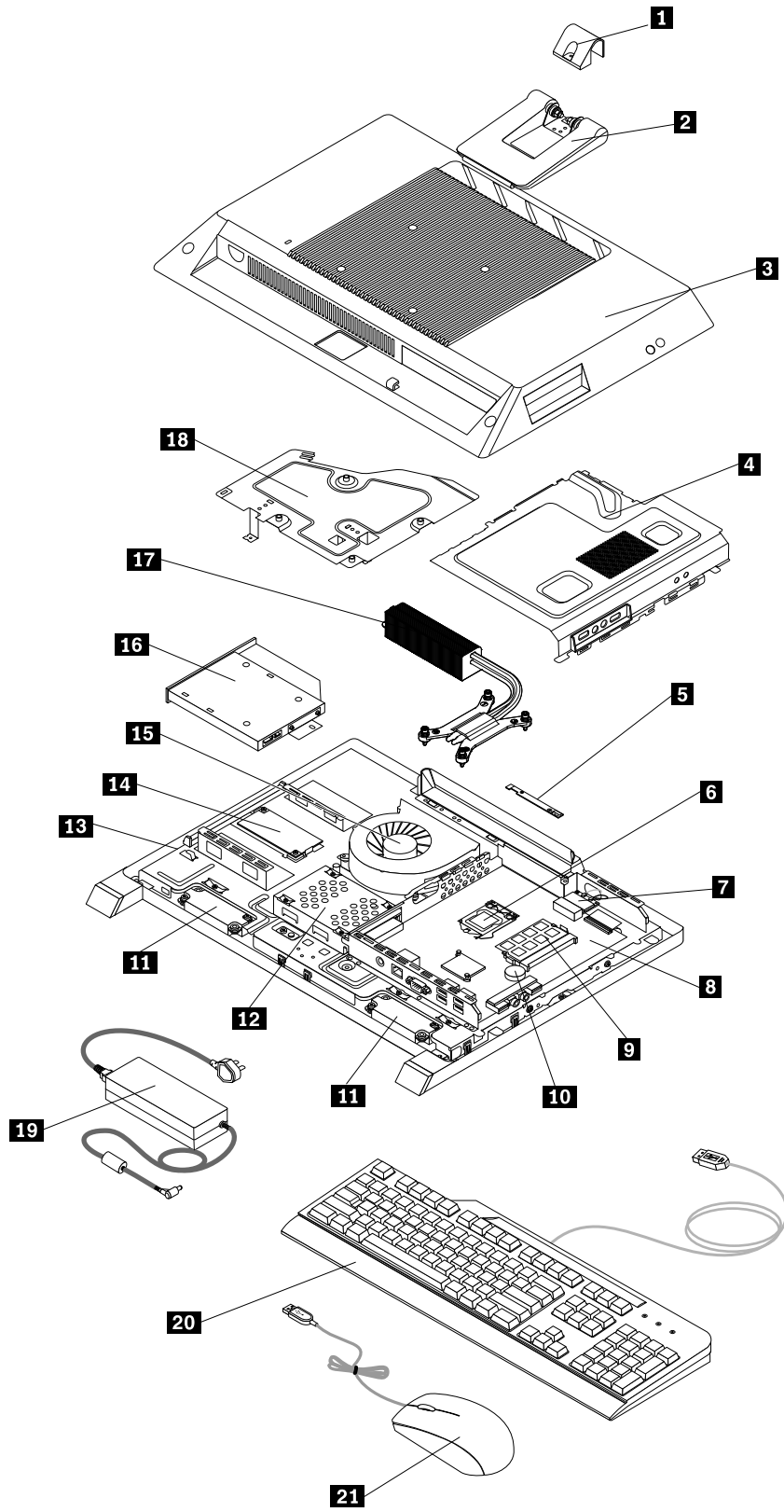

Figure 3. Locating major FRUs and CRUs

The following table lists the major FRUs shown in Figure 3 “Locating major FRUs and CRUs” on page 64 and identifies which FRUs are also self-service CRUs or optional-service CRUs.

Notes:

- Self-service CRUs: These CRUs unplug or are secured by no more than two screws. Examples of these types of CRUs include the keyboard, the mouse, any USB device, and the power cord. Other self-service CRUs depending on product design might include memory modules, adapter cards, hard disk drives, and optical drives.
- Optional-service CRUs: These CRUs are isolated parts within the computer and are concealed by an access panel that is typically secured by more than two screws. Once the access panel is removed, the specific CRU is visible.

Number	FRU description	Self-service CRU	Optional-service CRU
1	System stand hinge cover	Yes	No
2	System stand	No	Yes
3	Computer cover	No	No
4	System board shield	No	No
5	Integrated camera	No	No
6	Microprocessor	No	No
7	Wi-Fi card	No	No
8	System board	No	No
9	Memory module	No	No
10	Battery	No	No
11	Internal speaker	No	No
12	Hard disk drive	No	No
13	LCD panel	No	No
14	Inverter	No	No
15	Microprocessor fan	No	No
16	Optical drive	No	No
17	Heat sink assembly	No	No
18	VESA mount bracket	No	No
19	External power adaptor	Yes	No
20	Keyboard	Yes	No
21	Mouse	Yes	No

Looking up FRU information

For detailed FRU information, such as the FRU part numbers and supported computer models, go to:
<http://www.lenovo.com/serviceparts-lookup>

Locating parts on the system board

Figure 4 “Locations of the parts and connectors on the system board” on page 66 shows the locations of the parts and connectors on the system board.

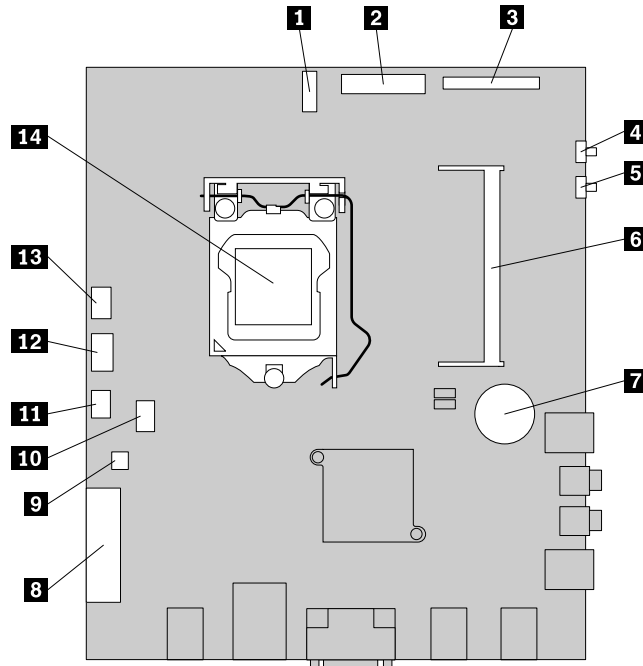

Figure 4. Locations of the parts and connectors on the system board

- | | |
|--|---|
| 1 Integrated camera cable connector | 8 SATA connector/Hard disk drive power connector |
| 2 Wi-Fi connector | 9 Optical drive power connector |
| 3 LCD panel connector | 10 Internal speaker cable connector |
| 4 Volume up button | 11 Power switch connector |
| 5 Volume down button | 12 Inverter connector |
| 6 Control button connector | 13 Microprocessor fan connector |
| 7 Battery | 14 Microprocessor |

Chapter 9. Replacing FRUs

This chapter provides instructions about removing or replacing major FRUs. Not all FRUs are documented.

Important

Before you replace any FRU, read Chapter 2 “Safety information” on page 3. These precautions and guidelines will help you work safely.

FRU replacements are to be done by trained service technicians only.

Removing and reinstalling the system stand hinge cover

Attention

Do not open your computer or attempt any repair before reading and understanding the “Important safety information” in the *Safety, Warranty, and Setup Guide* that came with your computer. To obtain a copy of the *Safety, Warranty, and Setup Guide*, go to:

<http://www.lenovo.com/support>

This section provides instructions on how to remove and reinstall the system stand hinge cover.

CAUTION:



Turn off the computer and wait three to five minutes to let the computer cool before removing the system stand hinge cover.

To remove and reinstall the system stand hinge cover, do the following:

1. Remove any media from the drives and turn off all attached devices and the computer.
2. Disconnect all power cords from electrical outlets.
3. Disconnect the power cords, Input/Output cables, and any other cables that are connected to the computer. See “Locating connectors, controls, and indicators on the front of your computer” on page 61 and “Locating connectors, controls, and indicators on the rear of your computer” on page 62.
4. Place a soft, clean towel or cloth on the desk or surface. Hold the sides of your computer and gently lay it down so that the screen is against the surface and the cover is facing up.
5. Remove the screw that secures the system stand hinge cover, and then lift the system stand hinge cover up and remove it from the computer.

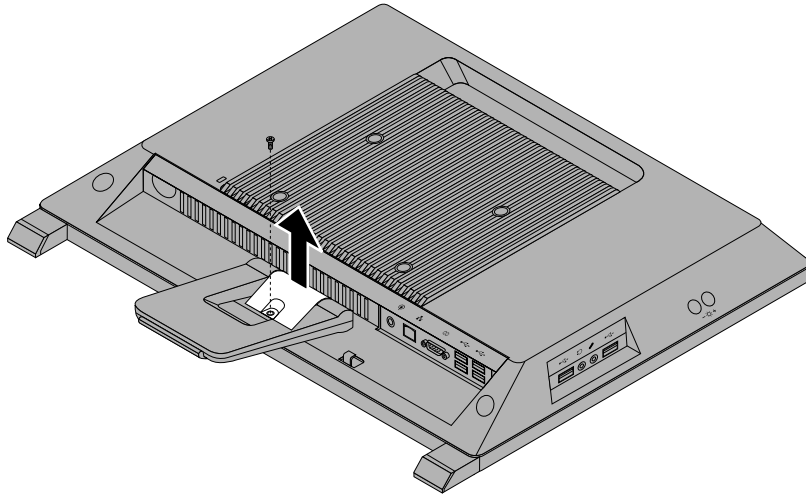

Figure 5. Removing the system stand hinge cover

6. To reinstall the system stand hinge cover, place the system stand hinge cover on the computer so that the plastic tab on the hinge cover aligns with the corresponding hole in the computer.
7. Reinstall the screw to secure the system stand hinge cover to the computer.

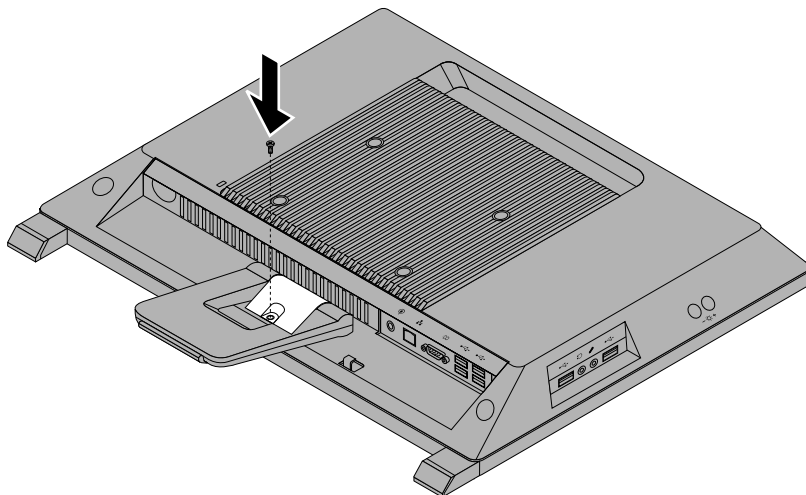

Figure 6. Reinstalling the screw to secure the system stand hinge cover to the computer

Removing and reinstalling the system stand

Attention

Do not open your computer or attempt any repair before reading and understanding the “Important safety information” in the *Safety, Warranty, and Setup Guide* that came with your computer. To obtain a copy of the *Safety, Warranty, and Setup Guide*, go to:
<http://www.lenovo.com/support>

This section provides instructions on how to remove and reinstall the system stand.

To remove and reinstall the system stand, do the following:

1. Turn off the computer and disconnect all power cords from electrical outlets.
2. Remove the system stand hinge cover. See “Removing and reinstalling the system stand hinge cover” on page 67.
3. Remove the two screws that secure the system stand, and then lift the system stand up and remove it from the computer.

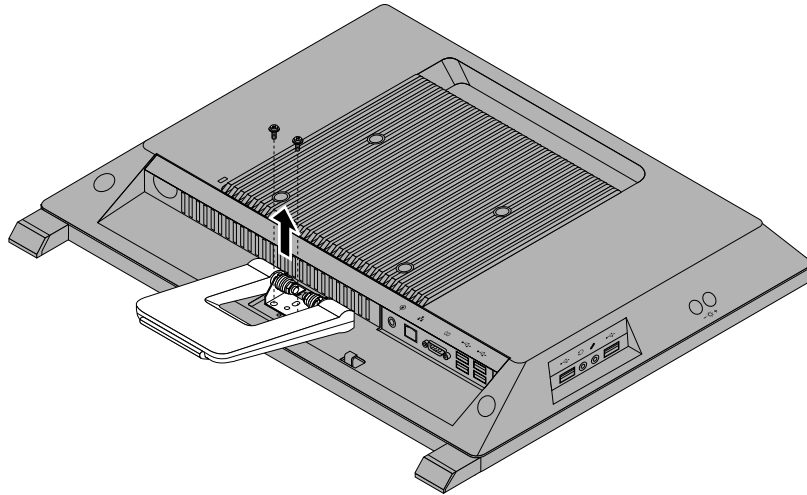

Figure 7. Removing the system stand

4. To reinstall the system stand, insert the two metal tabs **1** on the system stand into the two holes in the chassis. Then, align the two screw holes with the corresponding holes in the chassis, and install the two screws to secure the system stand to the computer.

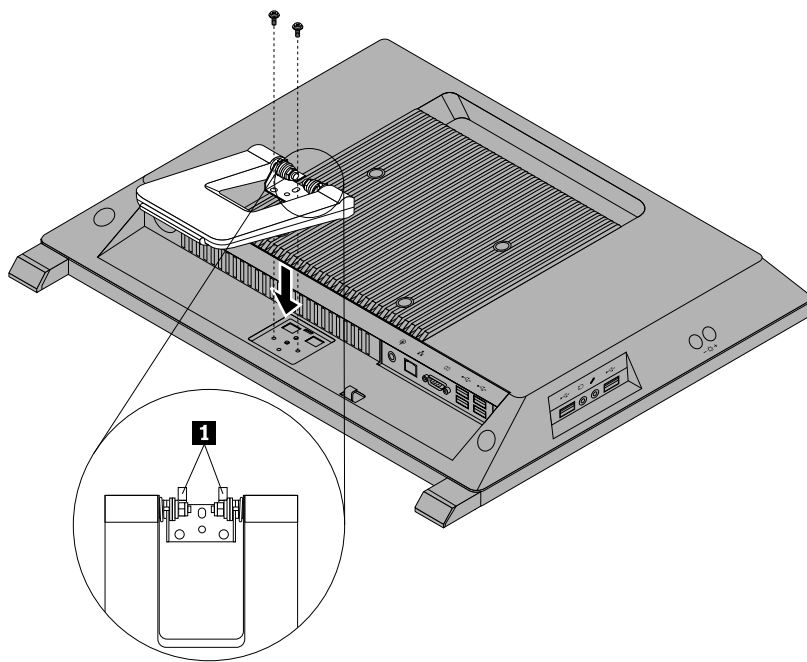

Figure 8. Reinstalling the system stand

5. Reinstall the system stand hinge cover. See “Removing and reinstalling the system stand hinge cover” on page 67.

Removing the computer cover

Attention

Do not open your computer or attempt any repair before reading and understanding the “Important safety information” in the *Safety, Warranty, and Setup Guide* that came with your computer. To obtain a copy of the *Safety, Warranty, and Setup Guide*, go to: <http://www.lenovo.com/support>

This section provides instructions on how to remove the computer cover.

CAUTION:



Turn off the computer and wait three to five minutes to let the computer cool before removing the computer cover.

To remove the computer cover, do the following:

1. Remove all media from the drives and turn off all attached devices and the computer. Then, disconnect all power cords from electrical outlets and disconnect all cables that are connected to the computer.
2. Place a soft, clean towel or cloth on the desk or other flat surface. Hold the sides of your computer and gently lay it down so that the screen is against the surface and the cover is facing up.
3. Remove any locking device that secures the computer cover, such as an integrated cable lock.
4. Remove the system stand. See “Removing and reinstalling the system stand” on page 68.
5. Loosen the two screws **1** at the bottom of the computer. Put your index finger or thumb in the finger slot **2**, and then lift the computer cover up to remove it from the computer.

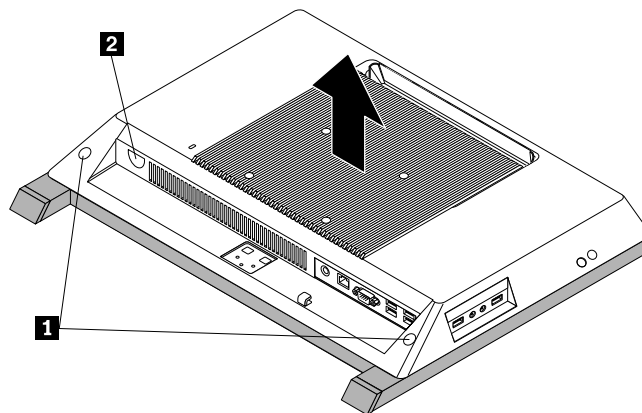

Figure 9. Removing the computer cover

Removing and reinstalling the VESA mount bracket

Attention

Do not open your computer or attempt any repair before reading and understanding the “Important safety information” in the *Safety, Warranty, and Setup Guide* that came with your computer. To obtain a copy of the *Safety, Warranty, and Setup Guide*, go to: <http://www.lenovo.com/support>

This section provides instructions on how to remove the VESA mount bracket.

To remove the VESA mount bracket, do the following:

1. Remove all media from the drives and turn off all attached devices and the computer. Then, disconnect all power cords from electrical outlets and disconnect all cables that are connected to the computer.
2. Place a soft, clean towel or cloth on the desk or other flat surface. Hold the sides of your computer and gently lay it down so that the screen is against the surface and the cover is facing up.
3. Remove the computer cover. See “Removing the computer cover” on page 71.
4. Locate the VESA mount bracket. See “Locating major FRUs and CRUs” on page 63.
5. Remove the four screws **1** that secure the VESA mount bracket and lift the VESA mount bracket out of the computer.

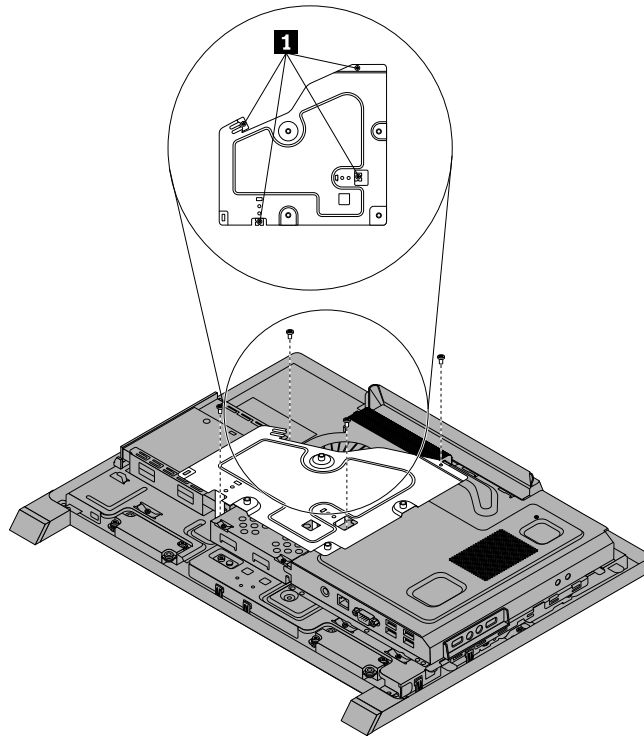

Figure 10. Removing the VESA mount bracket

6. To reinstall the VESA mount bracket, position the VESA mount bracket into the computer so that the screw holes align with those in the computer. Reinstall the four screws to secure the VESA mount bracket.
7. Go to “Completing the parts replacement” on page 96.

Replacing the hard disk drive

Attention

Do not open your computer or attempt any repair before reading and understanding the “Important safety information” in the *Safety, Warranty, and Setup Guide* that came with your computer. To obtain a copy of the *Safety, Warranty, and Setup Guide*, go to:

<http://www.lenovo.com/support>

This section provides instructions on how to replace the hard disk drive.

To replace the hard disk drive, do the following:

1. Remove all media from the drives and turn off all attached devices and the computer. Then, disconnect all power cords from electrical outlets and disconnect all cables that are connected to the computer.
2. Remove the computer cover. See “Removing the computer cover” on page 71.
3. Remove the VESA mount bracket. See “Removing and reinstalling the VESA mount bracket” on page 71.
4. Locate the hard disk drive in the computer. See “Locating major FRUs and CRUs” on page 63.
5. Remove the screw **1** that secures the hard disk drive, slide the hard disk drive out to disconnect the connector, and then lift the hard disk drive to remove it from the chassis.

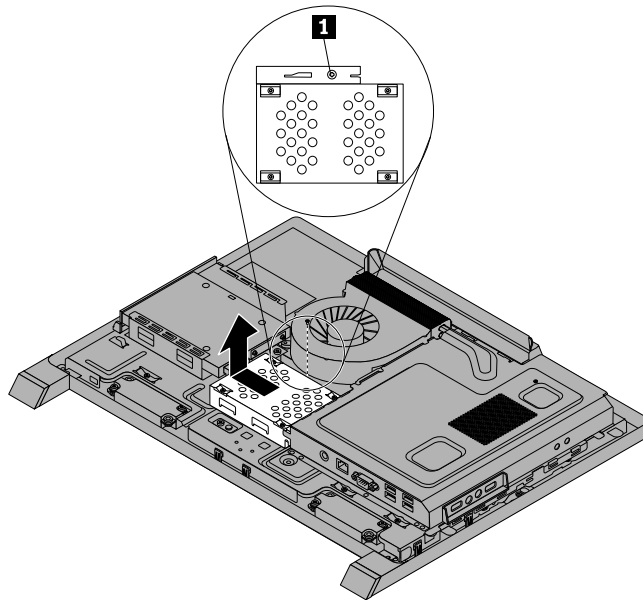

Figure 11. Removing the hard disk drive

6. Remove the four screws on the hard disk drive bracket, and then slide the hard disk drive out of the bracket. Do not touch the circuit board on the bottom of the hard disk drive.

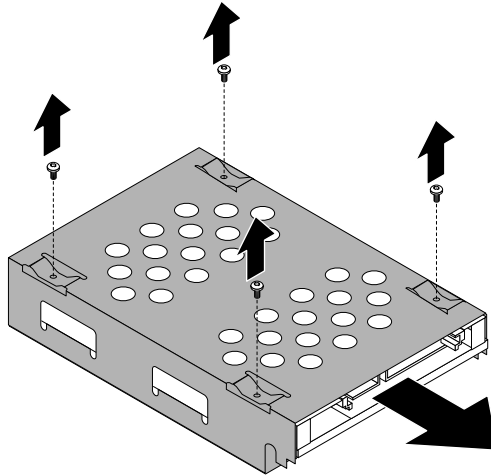

Figure 12. Removing the hard disk drive from the bracket

7. To install the new hard disk drive into the bracket, slide the hard disk drive in and align the four screw holes with those in the bracket.
8. Install the four screws that secure the hard disk drive to the hard disk drive bracket.
9. Align the slots in the hard disk drive bracket with the tabs in the chassis. Then, slide the hard disk drive with the bracket in to connect the hard disk drive connector.

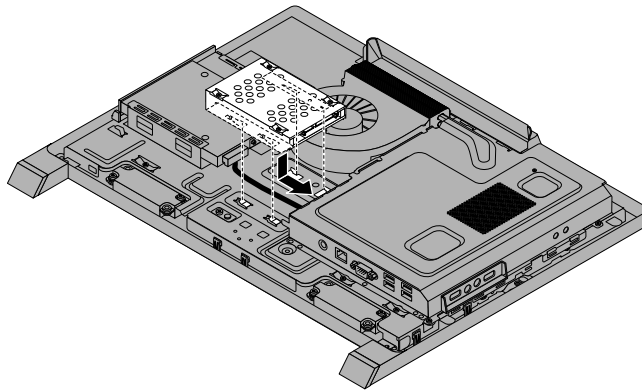

Figure 13. Installing the hard disk drive

10. Install the screw to secure the hard disk drive bracket to the chassis.
11. Go to “Completing the parts replacement” on page 96.

Replacing the optical drive

Attention

Do not open your computer or attempt any repair before reading and understanding the “Important safety information” in the *Safety, Warranty, and Setup Guide* that came with your computer. To obtain a copy of the *Safety, Warranty, and Setup Guide*, go to:
<http://www.lenovo.com/support>

This section provides instructions on how to replace the optical drive.

Note: The optical drive is available only in some models.

To replace the optical drive, do the following:

1. Remove all media from the drives and turn off all attached devices and the computer. Then, disconnect all power cords from electrical outlets and disconnect all cables that are connected to the computer.
2. Place a soft, clean towel or cloth on the desk or other flat surface. Hold the sides of your computer and gently lay it down so that the screen is against the surface and the cover is facing up.
3. Remove the computer cover. See “Removing the computer cover” on page 71.
4. Remove the VESA mount bracket. See “Removing and reinstalling the VESA mount bracket” on page 71.
5. Locate the optical drive. See “Locating major FRUs and CRUs” on page 63.
6. Disconnect the optical drive cable from the optical drive, and remove the screw that secures the optical drive. Then, slide the optical drive to remove it from the optical drive bay.

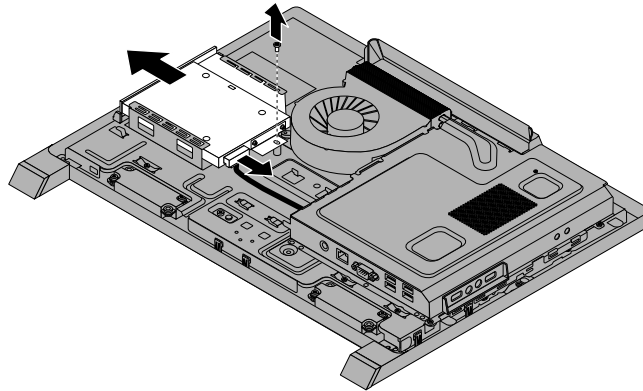

Figure 14. Removing the optical drive

7. To install a new optical drive, slide the new optical drive into the optical drive bay until the screw hole in the metal tab is aligned with that in the chassis.

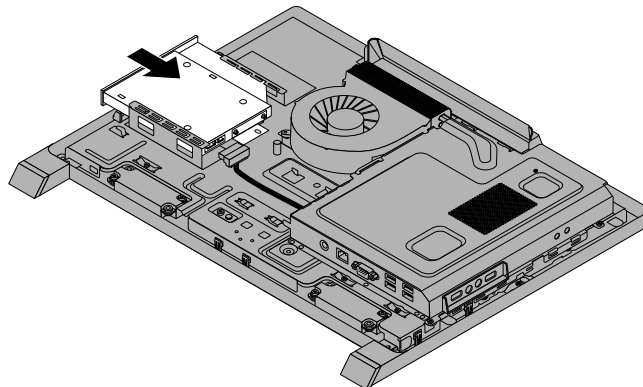

Figure 15. Installing the optical drive

8. Connect the optical drive cable to the optical drive, and install the screw to secure the optical drive.

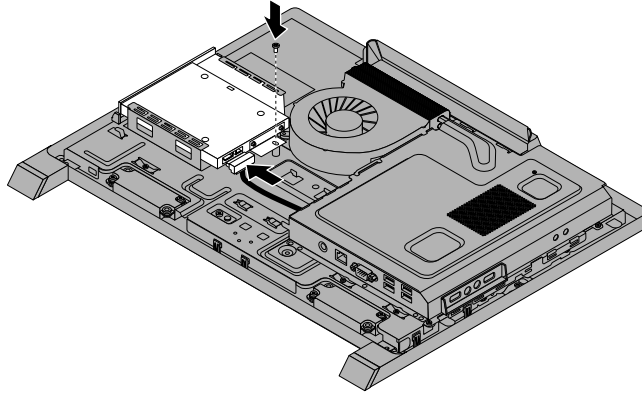

Figure 16. Connecting the cable and installing the screw

9. Go to “Completing the parts replacement” on page 96.

Removing and reinstalling the system board shield

Attention

Do not open your computer or attempt any repair before reading and understanding the “Important safety information” in the *Safety, Warranty, and Setup Guide* that came with your computer. To obtain a copy of the *Safety, Warranty, and Setup Guide*, go to:
<http://www.lenovo.com/support>

This section provides instructions on how to remove and reinstall the system board shield.

To remove and reinstall the system board shield, do the following:

1. Remove all media from the drives and turn off all attached devices and the computer. Then, disconnect all power cords from electrical outlets and disconnect all cables that are connected to the computer.
2. Place a soft, clean towel or cloth on the desk or other flat surface. Hold the sides of your computer and gently lay it down so that the screen is against the surface and the cover is facing up.
3. Remove the computer cover. See “Removing the computer cover” on page 71.
4. Remove the VESA mount bracket. See “Removing and reinstalling the VESA mount bracket” on page 71.
5. Locate the system board shield in the computer. See “Locating major FRUs and CRUs” on page 63.

- Remove the two screws that secure the system board shield, and then slide the system board shield out of the computer.

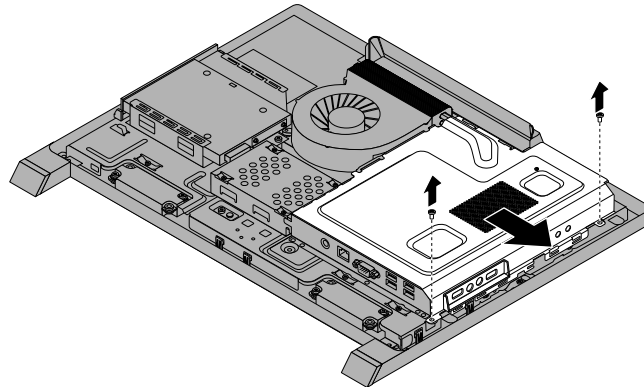

Figure 17. Removing the system board shield

- To reinstall the system board shield, align the tabs in the system board shield with the slots in the computer. Then, slide the system board shield in so that the screw holes align with those in the computer.

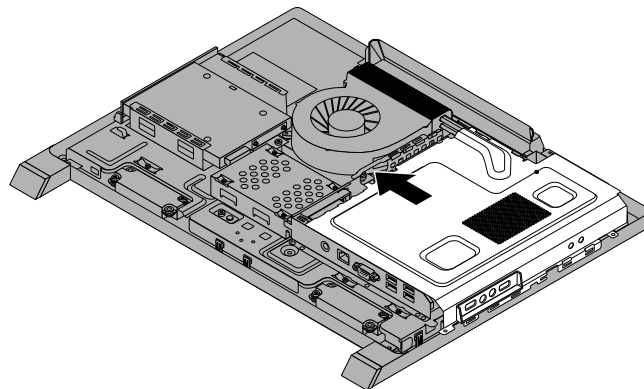

Figure 18. Installing the system board shield

- Reinstall the screws to secure the system board shield to the computer.
- Go to “Completing the parts replacement” on page 96.

Replacing the microprocessor fan

Attention

Do not open your computer or attempt any repair before reading and understanding the “Important safety information” in the *Safety, Warranty, and Setup Guide* that came with your computer. To obtain a copy of the *Safety, Warranty, and Setup Guide*, go to:
<http://www.lenovo.com/support>

This section provides instructions on how to replace the microprocessor fan.

To replace the microprocessor fan, do the following:

1. Remove all media from the drives and turn off all attached devices and the computer. Then, disconnect all power cords from electrical outlets and disconnect all cables that are connected to the computer.
2. Place a soft, clean towel or cloth on the desk or other flat surface. Hold the sides of your computer and gently lay it down so that the screen is against the surface and the cover is facing up.
3. Remove the computer cover. See “Removing the computer cover” on page 71.
4. Remove the VESA mount bracket. See “Removing and reinstalling the VESA mount bracket” on page 71.
5. Locate the microprocessor fan in the computer. See “Locating major FRUs and CRUs” on page 63.
6. Remove the microprocessor board shield. See “Removing and reinstalling the system board shield” on page 76.
7. Note the routing of the microprocessor fan cable, and then disconnect the microprocessor fan cable from the system board. See “Locating parts on the system board” on page 66.
8. Remove the two screws **1** that secure the microprocessor fan to the main bracket. Then, lift the microprocessor fan off the main bracket.

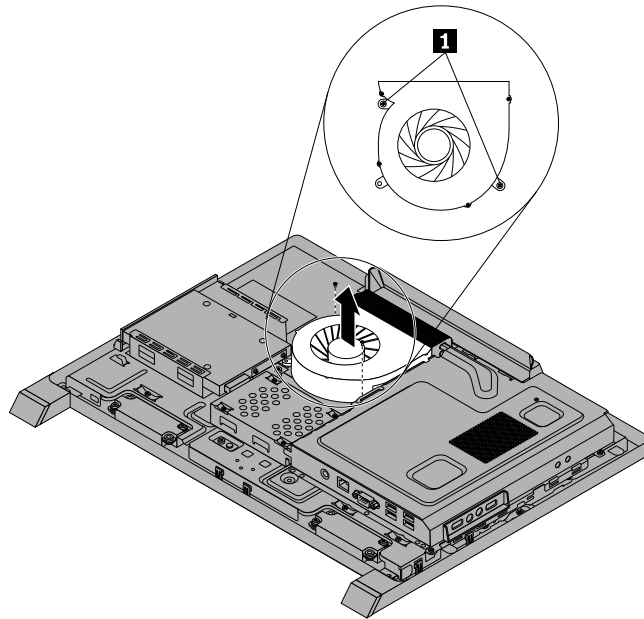

Figure 19. Removing the microprocessor fan

9. To reinstall the microprocessor fan, position the new microprocessor fan on the main bracket and align the screw holes in the new microprocessor fan with those in the main bracket. Reinstall the two screws that secure the microprocessor fan to the main bracket.
10. Connect the new microprocessor fan cable to the system board. See “Locating parts on the system board” on page 66.
11. Reinstall the system board shield. See “Removing and reinstalling the system board shield” on page 76.
12. Go to “Completing the parts replacement” on page 96.

Replacing the heat sink assembly

Attention

Do not open your computer or attempt any repair before reading and understanding the “Important safety information” in the *Safety, Warranty, and Setup Guide* that came with your computer. To obtain a copy of the

Safety, Warranty, and Setup Guide, go to:
<http://www.lenovo.com/support>

This section provides instructions on how to replace the heat sink assembly.

CAUTION:



The heat sink and fan assembly might be very hot. Turn off the computer and wait three to five minutes to let the computer cool before removing the computer cover.

To replace the heat sink assembly, do the following:

1. Remove all media from the drives and turn off all attached devices and the computer. Then, disconnect all power cords from electrical outlets and disconnect all cables that are connected to the computer.
2. Place a soft, clean towel or cloth on the desk or other flat surface. Hold the sides of your computer and gently lay it down so that the screen is against the surface and the cover is facing up.
3. Remove the computer cover. See “Removing the computer cover” on page 71.
4. Remove the VESA mount bracket. See “Removing and reinstalling the VESA mount bracket” on page 71.
5. Locate the heat sink assembly on the system board. See “Locating major FRUs and CRUs” on page 63.
6. Remove the system board shield. See “Removing and reinstalling the system board shield” on page 76.
7. Remove the screw **5**, and then follow the sequence **1**, **2**, **3**, **4** on the heat sink assembly to loose the four screws that secure the heat sink assembly to the system board.

Note: Carefully loose the four screws from the system board to avoid any possible damage to the system board. The four screws cannot be removed from the heat sink assembly.

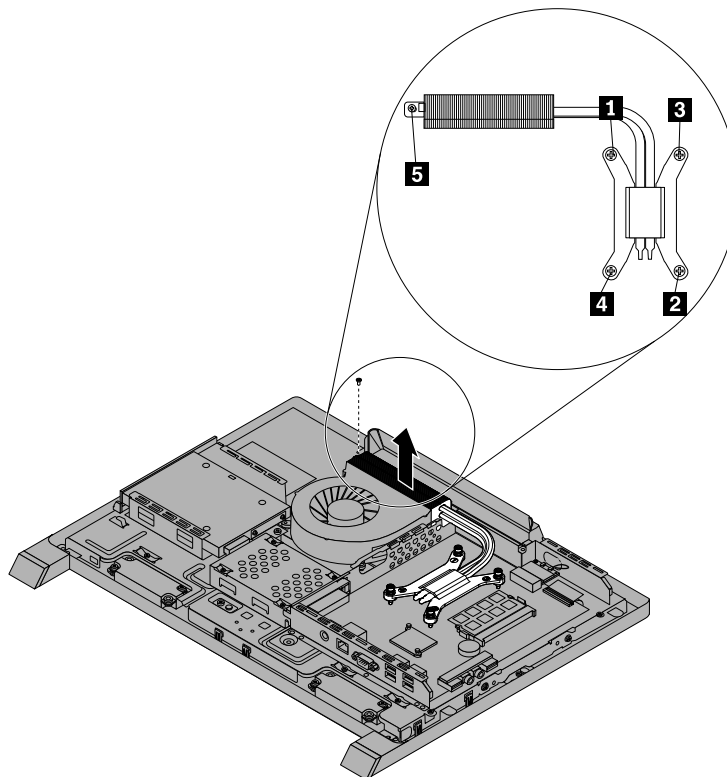

Figure 20. Loosing the screws that secure the heat sink assembly to the system board

- Lift the failing heat sink assembly off the system board.

Notes:

- You might have to gently twist the heat sink assembly to free it from the microprocessor.
 - Do not touch the thermal grease while handling the heat sink assembly.
- To reinstall the heat sink assembly, position the new heat sink assembly on the system board so that the five screws are aligned with the corresponding holes in the system board and computer main bracket.
 - Follow the sequence **1**, **2**, **3**, **4** on the heat sink assembly to tighten the four screws and install the screw **5** to secure the heat sink assembly to the system board, as shown in Figure 20 “Loosing the screws that secure the heat sink assembly to the system board” on page 79.
 - Reinstall the system board shield. See “Removing and reinstalling the system board shield” on page 76.
 - Go to “Completing the parts replacement” on page 96.

Replacing the microprocessor

Attention

Do not open your computer or attempt any repair before reading and understanding the “Important safety information” in the *Safety, Warranty, and Setup Guide* that came with your computer. To obtain a copy of the *Safety, Warranty, and Setup Guide*, go to:
<http://www.lenovo.com/support>

This section provides instructions on how to replace the microprocessor.

CAUTION:



The heat sink and fan assembly might be very hot. Turn off the computer and wait three to five minutes to let the computer cool before removing the computer cover.

To replace the microprocessor, do the following:

- Remove all media from the drives and turn off all attached devices and the computer. Then, disconnect all power cords from electrical outlets and disconnect all cables that are connected to the computer.
- Place a soft, clean towel or cloth on the desk or other flat surface. Hold the sides of your computer and gently lay it down so that the screen is against the surface and the cover is facing up.
- Remove the computer cover. See “Removing the computer cover” on page 71.
- Remove the VESA mount bracket. See “Removing and reinstalling the VESA mount bracket” on page 71.
- Locate the microprocessor on the system board. See “Locating major FRUs and CRUs” on page 63.
- Remove the system board shield. See “Removing and reinstalling the system board shield” on page 76.
- Remove the heat sink assembly to gain access to the microprocessor. See “Replacing the heat sink assembly” on page 78.
- Press the small handle **1** to open the retainer **2** to access the microprocessor **3**.

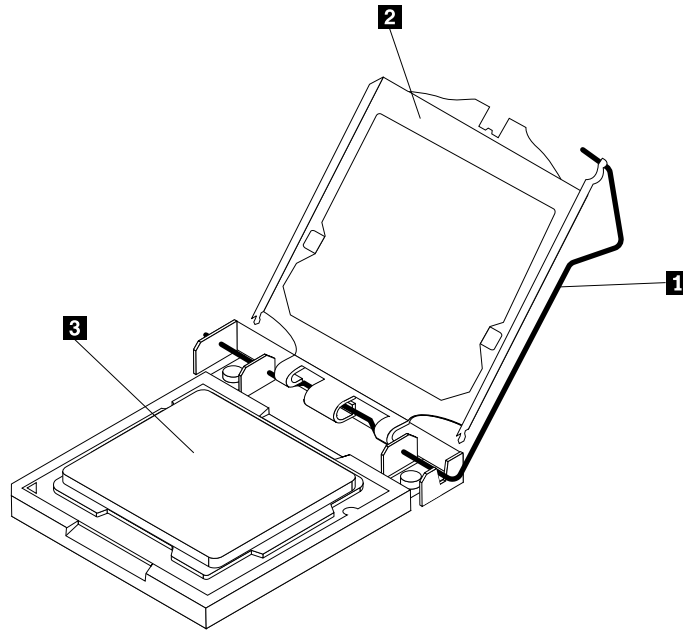

Figure 21. Opening the retainer to access the microprocessor

9. Lift the microprocessor straight up and out of the socket.

Notes:

- a. Your microprocessor and socket might look different from the one illustrated.
- b. Note the orientation of the microprocessor in the socket. You can either look for the small triangle **1** on one corner of the microprocessor or note the orientation of the notches **2** on the microprocessor. This is important when installing a new microprocessor on the system board.

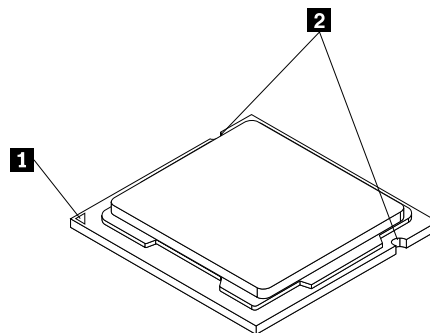

Figure 22. Noting the orientation of the microprocessor in the socket

- c. Touch only the sides of the microprocessor. Do not touch the gold contacts on the bottom.
- d. Do not drop anything onto the microprocessor socket while it is exposed. The socket pins must be kept as clean as possible.

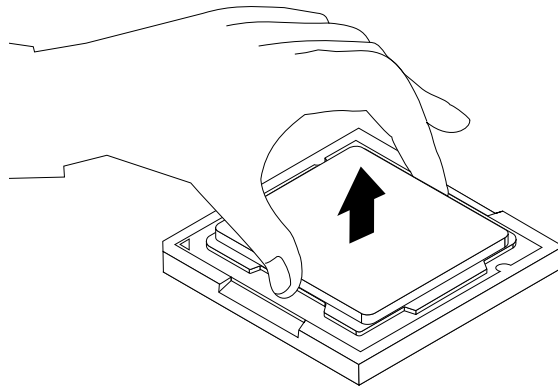

Figure 23. Removing the microprocessor

10. Make sure that the small handle is in the raised position and the microprocessor retainer is fully open.
11. Hold the new microprocessor and align the notches **2** on it with the alignment keys in the microprocessor socket, or align the small triangle **1** on one corner of the new microprocessor with the corresponding beveled corner of the microprocessor socket.

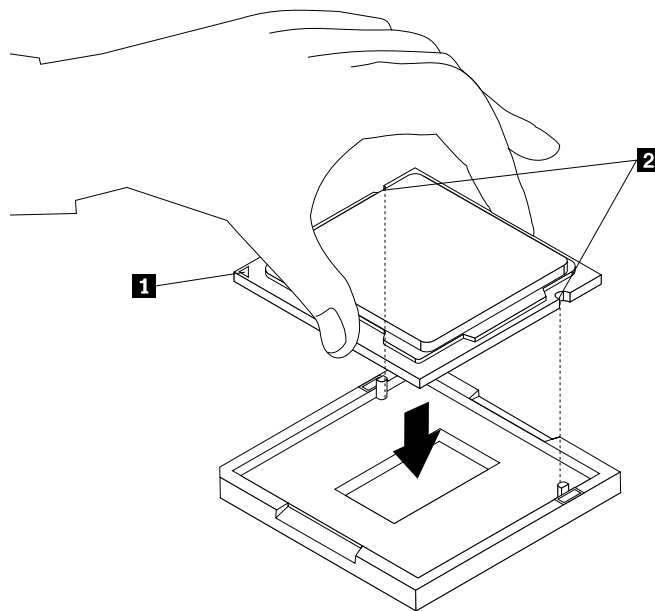

Figure 24. Installing the microprocessor

12. Lower the new microprocessor straight down into the microprocessor socket on the system board.
13. Close the microprocessor retainer and lock it into position with the small handle to secure the new microprocessor in the socket.
14. Reinstall the heat sink assembly. See “Replacing the heat sink assembly” on page 78.
15. Reinstall the system board shield. See “Removing and reinstalling the system board shield” on page 76.
16. Go to “Completing the parts replacement” on page 96.

Replacing the battery

Attention

Do not open your computer or attempt any repair before reading and understanding the “Important safety information” in the *Safety, Warranty, and Setup Guide* that came with your computer. To obtain a copy of the *Safety, Warranty, and Setup Guide*, go to:
<http://www.lenovo.com/support>

This section provides instructions on how to replace the battery.

Your computer has a special type of memory that maintains the date, time, and settings for built-in features, such as parallel-port assignments (configuration). A battery keeps the information active when you turn off the computer.

The battery normally requires no charging or maintenance throughout its life. However, if the battery fails, the date, time, and configuration information (including passwords) are lost. An error message will be displayed when you turn on the computer.

Refer to “Lithium battery notice” in the *Safety, Warranty, and Setup Guide* for information about replacing and disposing of the battery.

To replace the battery, do the following:

1. Remove all media from the drives and turn off all attached devices and the computer. Then, disconnect all power cords from electrical outlets and disconnect all cables that are connected to the computer.
2. Place a soft, clean towel or cloth on the desk or other flat surface. Hold the sides of your computer and gently lay it down so that the screen is against the surface and the cover is facing up.
3. Remove the computer cover. See “Removing the computer cover” on page 71.
4. Remove the VESA mount bracket. See “Removing and reinstalling the VESA mount bracket” on page 71.
5. Locate the battery on the system board. See “Locating major FRUs and CRUs” on page 63.
6. Remove the system board shield to get access to the battery. See “Removing and reinstalling the system board shield” on page 76.
7. Remove the battery.

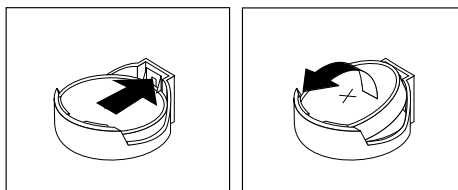

Figure 25. Removing the battery

8. Install a new battery.

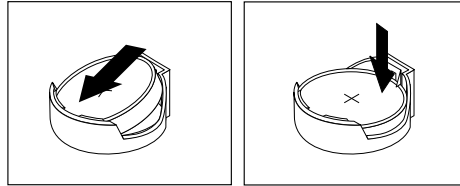

Figure 26. Installing a new battery

9. Reinstall the system board shield. See “Removing and reinstalling the system board shield” on page 76.
10. Reinstall the computer cover. See “Completing the parts replacement” on page 96.
11. Turn on the computer and all attached devices.

Note: When you turn on the computer for the first time after replacing the battery, an error message might be displayed. This is normal after replacing the battery.

12. Use the Setup Utility program to set the date, time, and any passwords. See Chapter 6 “Using the Setup Utility program” on page 51.

Replacing the inverter

Attention

Do not open your computer or attempt any repair before reading and understanding the “Important safety information” in the *Safety, Warranty, and Setup Guide* that came with your computer. To obtain a copy of the *Safety, Warranty, and Setup Guide*, go to:
<http://www.lenovo.com/support>

This section provides instructions on how to replace the inverter.

To replace the inverter, do the following:

1. Remove all media from the drives and turn off all attached devices and the computer. Then, disconnect all power cords from electrical outlets and disconnect all cables that are connected to the computer.
2. Place a soft, clean towel or cloth on the desk or surface. Hold the sides of your computer and gently lay it down so that the screen is against the surface and the cover is facing up.
3. Remove the computer cover. See “Removing the computer cover” on page 71.
4. Remove the VESA mount bracket. See “Removing and reinstalling the VESA mount bracket” on page 71.
5. Remove the optical drive. See “Replacing the optical drive” on page 74.
6. Locate the inverter in the computer. See “Locating major FRUs and CRUs” on page 63.
7. Remove the two screws that secure the inverter to the main bracket.

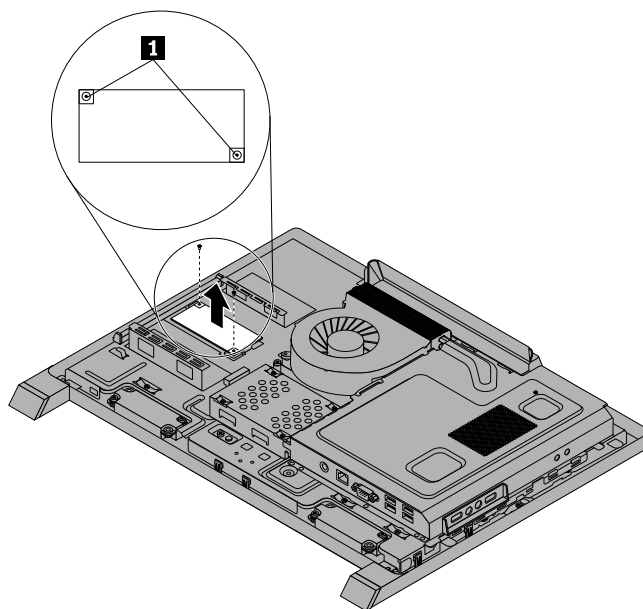

Figure 27. Removing the screws that secure the inverter

8. Disconnect the three cables from the inverter.
9. Lift the inverter off the computer.
10. To reinstall the new inverter, connect the three cables to the new inverter. Position the new inverter and align the two screw holes in the new inverter with those in the computer.
11. Install the two screws to secure the new inverter to the main bracket.
12. Reinstall the optical drive. See “Replacing the optical drive” on page 74.
13. Go to “Completing the parts replacement” on page 96.

Installing or replacing a memory module

Attention:

Do not open your computer or attempt any repair before reading and understanding the “Important safety information” in the *Safety, Warranty, and Setup Guide* that came with your computer. To obtain a copy of the *Safety, Warranty, and Setup Guide*, go to:
<http://www.lenovo.com/support>

This section provides instructions on how to install or replace a memory module.

Your computer has one memory slot for installing or replacing DDR3 SODIMM (small outline dual inline memory module). When installing or replacing a memory module, use a 2 GB, 4 GB or 8 GB DDR3 SODIMM.

To install or replace a memory module, do the following:

1. Remove all media from the drives and turn off all attached devices and the computer. Then, disconnect all power cords from electrical outlets and disconnect all cables that are connected to the computer.
2. Place a soft, clean towel or cloth on the desk or other flat surface. Hold the sides of your computer and gently lay it down so that the screen is against the surface and the cover is facing up.
3. Remove the computer cover. See “Removing the computer cover” on page 71.
4. Remove the VESA mount bracket. See “Removing and reinstalling the VESA mount bracket” on page 71.

5. Locate the memory slots on the system board. See “Locating major FRUs and CRUs” on page 63.
6. Remove the system board shield to get access to the battery. See “Removing and reinstalling the system board shield” on page 76.
7. Remove any parts and disconnect any cables that might prevent your access to the memory slots.
8. Do one of the following:
 - If you are replacing a memory module, open the retaining clips and remove the old memory module that is currently installed.

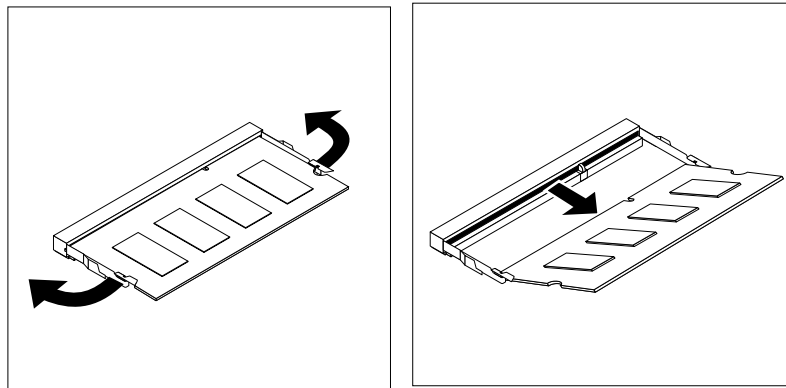

Figure 28. Removing a memory module

- If you are installing a memory module, open the retaining clips of the memory slot into which you want to install the memory module.
9. Insert the notched end **1** of the new memory module into the slot. Press the memory module firmly and pivot the memory module until it snaps into place. Make sure that the memory module is secured in the slot and does not move easily.

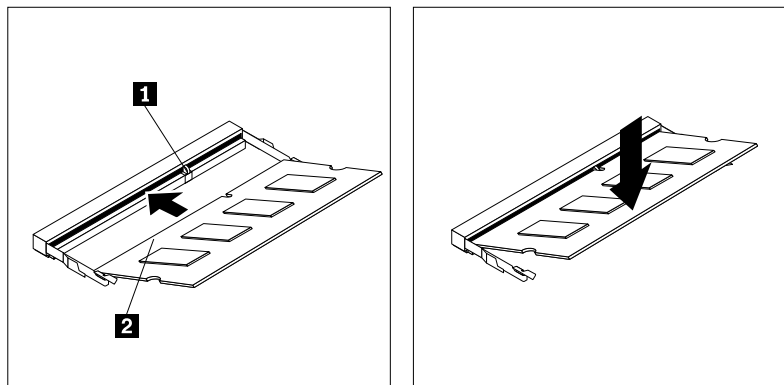

Figure 29. Installing a memory module

10. Reinstall the system board shield. See “Removing and reinstalling the system board shield” on page 76.
11. Go to “Completing the parts replacement” on page 96.

Replacing the internal speakers

Attention

Do not open your computer or attempt any repair before reading and understanding the “Important safety information” in the *Safety, Warranty, and Setup Guide* that came with your computer. To obtain a copy of the *Safety, Warranty, and Setup Guide*, go to: <http://www.lenovo.com/support>

This section provides instructions on how to replace the internal speakers.

To replace the internal speakers, do the following:

1. Remove all media from the drives and turn off all attached devices and the computer. Then, disconnect all power cords from electrical outlets and disconnect all cables that are connected to the computer.
2. Place a soft, clean towel or cloth on the desk or other flat surface. Hold the sides of your computer and gently lay it down so that the screen is against the surface and the cover is facing up.
3. Remove the computer cover. See “Removing the computer cover” on page 71.
4. Remove the VESA mount bracket. See “Removing and reinstalling the VESA mount bracket” on page 71.
5. Locate the internal speakers in the computer. See “Locating major FRUs and CRUs” on page 63.
6. Remove the system board shield. See “Removing and reinstalling the system board shield” on page 76.
7. Note the location of the internal speaker cable connection and the routing of the internal speaker cables. Disconnect the internal speaker cables from the system board.
8. Remove the two screws that secure each internal speaker to the front bezel, and then remove the internal speakers from the computer.

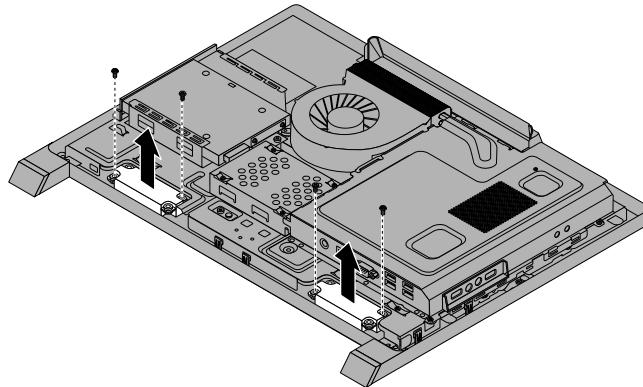

Figure 30. Removing the internal speakers

9. Route the new internal speaker cables, and then position the new internal speakers on the front bezel so that the two screw holes in each internal speaker align with those in the front bezel.
10. Reinstall the two screws to secure each of the internal speakers to the front bezel.
11. Connect the internal speaker cables to the system board. See “Locating parts on the system board” on page 66.
12. Reinstall the system board shield. See “Removing and reinstalling the system board shield” on page 76.
13. Go to “Completing the parts replacement” on page 96.

Replacing the integrated camera

Attention

Do not open your computer or attempt any repair before reading and understanding the “Important safety information” in the *Safety, Warranty, and Setup Guide* that came with your computer. To obtain a copy of the *Safety, Warranty, and Setup Guide*, go to:
<http://www.lenovo.com/support>

This section provides instructions on how to replace the integrated camera.

Note: The integrated camera is available only in some models.

To replace the integrated camera, do the following:

1. Remove all media from the drives and turn off all attached devices and the computer. Then, disconnect all power cords from electrical outlets and disconnect all cables that are connected to the computer.
2. Place a soft, clean towel or cloth on the desk or other flat surface. Hold the sides of your computer and gently lay it down so that the screen is against the surface and the cover is facing up.
3. Remove the computer cover. See “Removing the computer cover” on page 71.
4. Remove the VESA mount bracket. See “Removing and reinstalling the VESA mount bracket” on page 71.
5. Locate the integrated camera in the computer. See “Locating major FRUs and CRUs” on page 63.
6. Remove the system board shield. See “Removing and reinstalling the system board shield” on page 76.
7. Note the routing of the integrated camera cable, and then disconnect the cable from the system board. See “Locating parts on the system board” on page 66.
8. Remove the two screws that secure the integrated camera to the front bezel to remove the integrated camera from the computer.

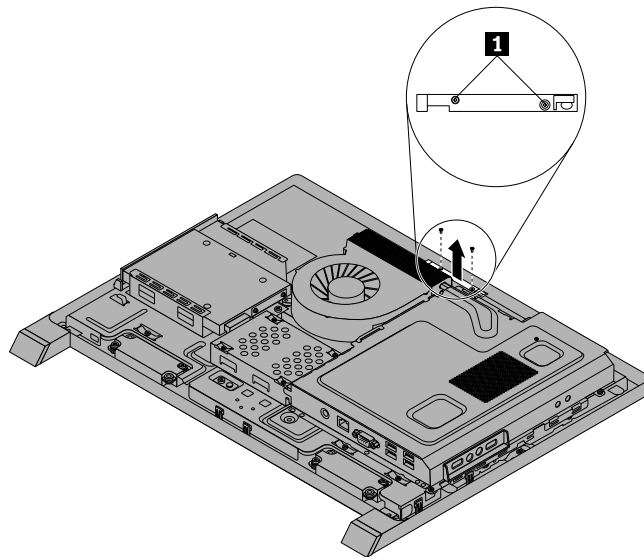

Figure 31. Removing the integrated camera

9. To reinstall the integrated camera, position the new integrated camera and align the two screw holes in the new integrated camera with those in the front bezel.
10. Install the two screws to secure the new integrated camera to the front bezel.

11. Route the new integrated camera cable, and then connect the integrated camera cable to the system board. See “Locating parts on the system board” on page 66.
12. Reinstall the system board shield. See “Removing and reinstalling the system board shield” on page 76.
13. Go to “Completing the parts replacement” on page 96.

Replacing the system board

Attention

Do not open your computer or attempt any repair before reading and understanding the “Important safety information” in the *Safety, Warranty, and Setup Guide* that came with your computer. To obtain a copy of the *Safety, Warranty, and Setup Guide*, go to:
<http://www.lenovo.com/support>

This section provides instructions on how to replace the system board.

To replace the system board, do the following:

1. Remove all media from the drives and turn off all attached devices and the computer. Then, disconnect all power cords from electrical outlets and disconnect all cables that are connected to the computer.
2. Place a soft, clean towel or cloth on the desk or other flat surface. Hold the sides of your computer and gently lay it down so that the screen is against the surface and the cover is facing up.
3. Remove the computer cover. See “Removing the computer cover” on page 71.
4. Remove the VESA mount bracket. See “Removing and reinstalling the VESA mount bracket” on page 71.
5. Remove the system board shield. See “Removing and reinstalling the system board shield” on page 76.
6. Locate the system board in the computer. See “Locating major FRUs and CRUs” on page 63.
7. Remove the heat sink assembly. See “Replacing the heat sink assembly” on page 78.
8. Remove the microprocessor. See “Replacing the microprocessor” on page 80.
9. Remove the memory modules. See “Installing or replacing a memory module” on page 85.
10. Remove the battery. See “Replacing the battery” on page 83.
11. Note the locations of all cable connections on the system board and disconnect all cables. See “Locating parts on the system board” on page 66.
12. Remove the six screws that secure the system board to the main bracket. Carefully lift the system board out of the chassis.

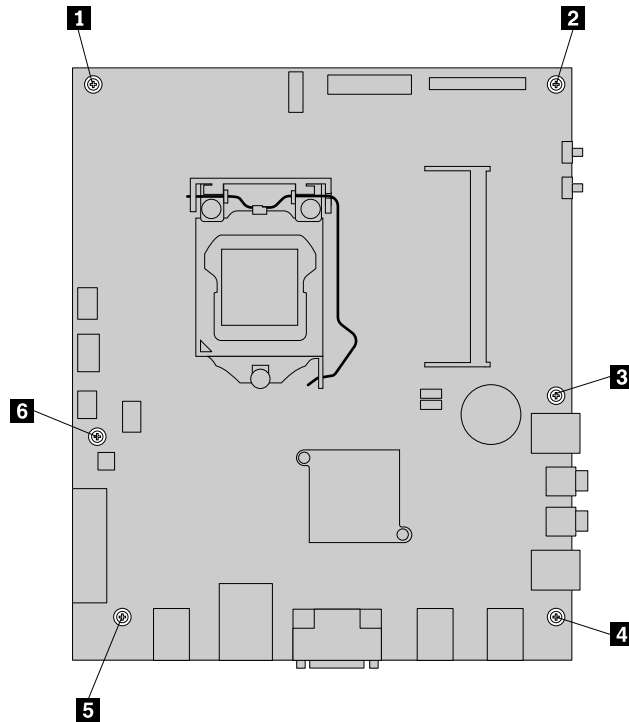

Figure 32. Removing the six screws that secure the system board to the main bracket

13. Place the new system board into the chassis and align the screw holes with those in the chassis.
14. Reinstall the six screws that secure the system board to the main bracket.
15. Reinstall the battery. See “Replacing the battery” on page 83.
16. Reinstall the memory modules. See “Installing or replacing a memory module” on page 85.
17. Reinstall the microprocessor. See “Replacing the microprocessor” on page 80.
18. Reinstall the heat sink assembly. See “Replacing the heat sink assembly” on page 78.
19. Reinstall the system board shield. See “Removing and reinstalling the system board shield” on page 76.
20. Reconnect all cables that were disconnected from the system board. See “Locating parts on the system board” on page 66.
21. Go to “Completing the parts replacement” on page 96.

The failing system board must be returned with a microprocessor socket cover to protect the pins during shipping and handling.

To install the microprocessor socket cover, do the following:

1. Release the lever securing the microprocessor retainer and open the retainer to access the microprocessor.
2. Grasp the microprocessor on the sides and lift it straight up and out of the socket. Do not touch the contacts on the microprocessor socket.
3. Note the orientation of the socket cover. Align the notches on the microprocessor socket cover with the alignment keys on the microprocessor socket. Install one side of the socket cover into the microprocessor socket.

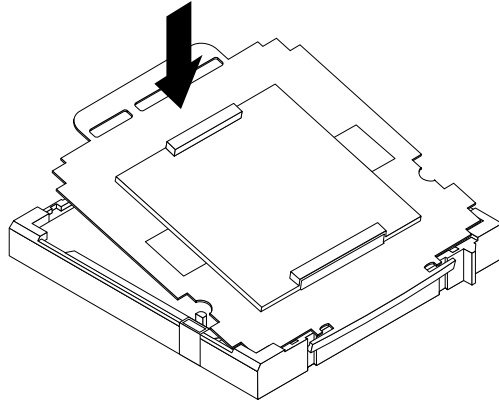

Figure 33. Installing one side of the socket cover into the microprocessor socket

Note: Your microprocessor socket and cover might look slightly different from the illustration.

4. Carefully press the other side of the socket cover downwards until the socket cover snaps into place.
5. Carefully check the four corners of the socket cover to make sure that the cover is secured in the microprocessor socket.
6. Lower the microprocessor retainer, and then lower the lever to secure the retainer. Make sure the lever is locked into position.
7. Follow any additional instructions included with the replacement part you received.

Note: If your system board has two microprocessor sockets, be sure to install a socket cover for each microprocessor socket.

Replacing the LCD panel

Attention

Do not open your computer or attempt any repair before reading and understanding the “Important safety information” in the *Safety, Warranty, and Setup Guide* that came with your computer. To obtain a copy of the *Safety, Warranty, and Setup Guide*, go to:
<http://www.lenovo.com/support>

This section provides instructions on how to replace the LCD panel.

To replace the LCD panel, do the following:

1. Remove all media from the drives and turn off all attached devices and the computer. Then, disconnect all power cords from electrical outlets and disconnect all cables that are connected to the computer.
2. Place a soft, clean towel or cloth on the desk or other flat surface. Hold the sides of your computer and gently lay it down so that the screen is against the surface and the cover is facing up.
3. Remove the computer cover. See “Removing the computer cover” on page 71.
4. Remove the VESA mount bracket. See “Removing and reinstalling the VESA mount bracket” on page 71.
5. Locate the LCD panel in the computer. See “Locating major FRUs and CRUs” on page 63.
6. Remove the optical drive. See “Replacing the optical drive” on page 74.
7. Remove the inverter. See “Replacing the inverter” on page 84.
8. Remove the system board shield. See “Removing and reinstalling the system board shield” on page 76.

9. Disconnect the LCD panel cable from the system board. See “Locating parts on the system board” on page 66.

Figure 34. Disconnect the LCD panel cable from the system board

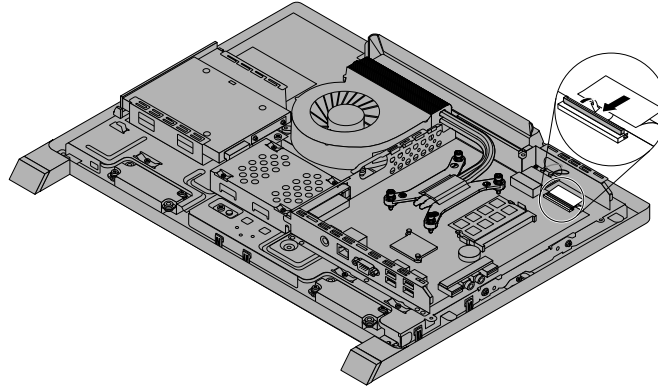

10. Remove all the 10 screws that secure the computer main bracket to the front bezel.

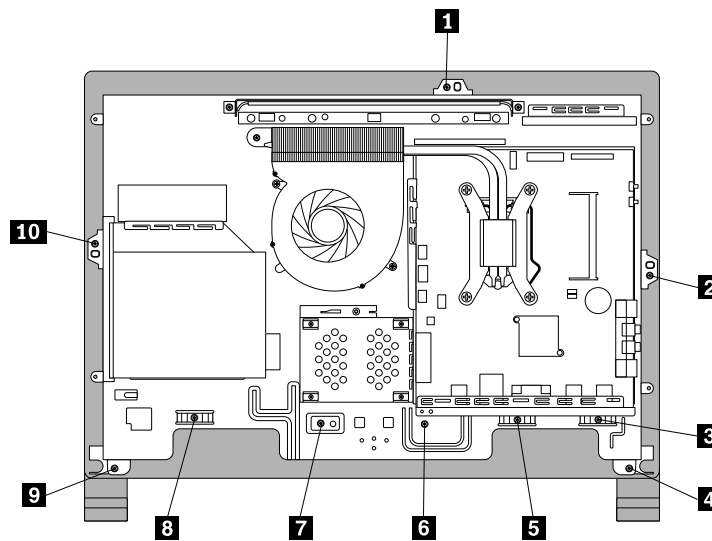

Figure 35. Removing the 10 screws that secure the computer main bracket to the front bezel

11. Note the locations of all cable connections that prevent you from lifting the computer main bracket, and disconnect all cables. See “Locating parts on the system board” on page 66.
12. Remove the integrated camera. See “Replacing the integrated camera” on page 88
13. Lift the computer main bracket off the front bezel.

14. Remove the four screws that secure the chassis to the LCD panel, and then lift the chassis out of the computer to get access to the LCD panel.

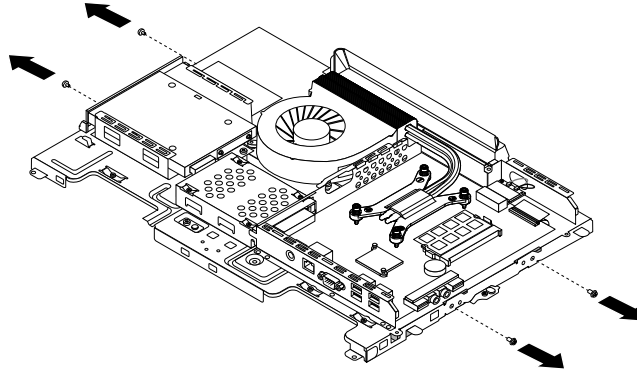

Figure 36. Removing the four screws that secure the LCD panel

15. Place the computer chassis over the new LCD panel so that the four screw holes align with those in the chassis. Reinstall the four screws to secure the LCD panel to the chassis.
16. Position the computer main bracket over the LCD panel. Make sure the screw holes in the computer main bracket align with those in the front bezel.
17. Reinstall all of the 10 screws that secure the computer main bracket to the front bezel.

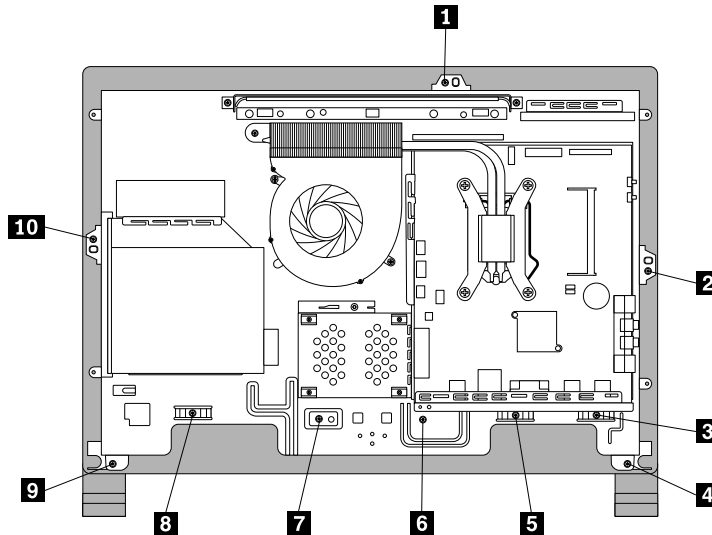

Figure 37. Reinstalling the 10 screws that secure the computer main bracket to the front bezel

18. Reconnect the LCD panel cable to the system board. See “Locating parts on the system board” on page 66.

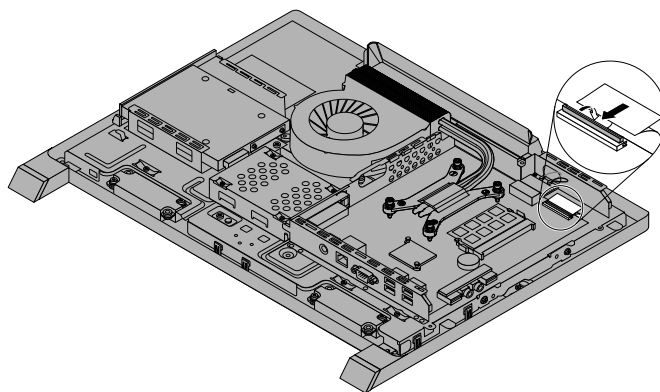

Figure 38. Reconnect the LCD panel cable to the system board

19. Reinstall the integrated camera. See “Replacing the integrated camera” on page 88.
20. Connect all the cables that were disconnected. See “Locating parts on the system board” on page 66.
21. Reinstall the system board shield. See “Removing and reinstalling the system board shield” on page 76.
22. Go to “Completing the parts replacement” on page 96.

Replacing the Wi-Fi card

Attention

Do not open your computer or attempt any repair before reading and understanding the “Important safety information” in the *Safety, Warranty, and Setup Guide* that came with your computer. To obtain a copy of the *Safety, Warranty, and Setup Guide*, go to:
<http://www.lenovo.com/support>

This section provides instructions on how to replace the Wi-Fi card.

Note: The Wi-Fi card is available only in some models.

To replace the Wi-Fi card, do the following:

1. Remove all media from the drives and turn off all attached devices and the computer. Then, disconnect all power cords from electrical outlets and disconnect all cables that are connected to the computer.
2. Place a soft, clean towel or cloth on the desk or other flat surface. Hold the sides of your computer and gently lay it down so that the screen is against the surface and the cover is facing up.
3. Remove the computer cover. See “Removing the computer cover” on page 71.
4. Remove the VESA mount bracket. See “Removing and reinstalling the VESA mount bracket” on page 71.
5. Remove the system board shield. See “Removing and reinstalling the system board shield” on page 76.
6. Locate the Wi-Fi card on the system board. See “Locating major FRUs and CRUs” on page 63.
7. Disconnect the two cables from the Wi-Fi card, and then carefully remove the screw that secures the Wi-Fi card.

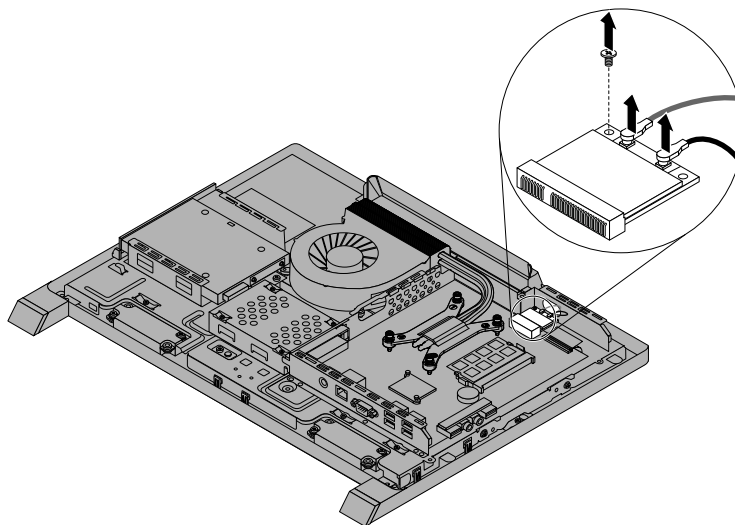

Figure 39. Removing the screw that secures the Wi-Fi card

8. Pivot the Wi-Fi card upward and lift the Wi-Fi card out of the mini PCI Express slot.

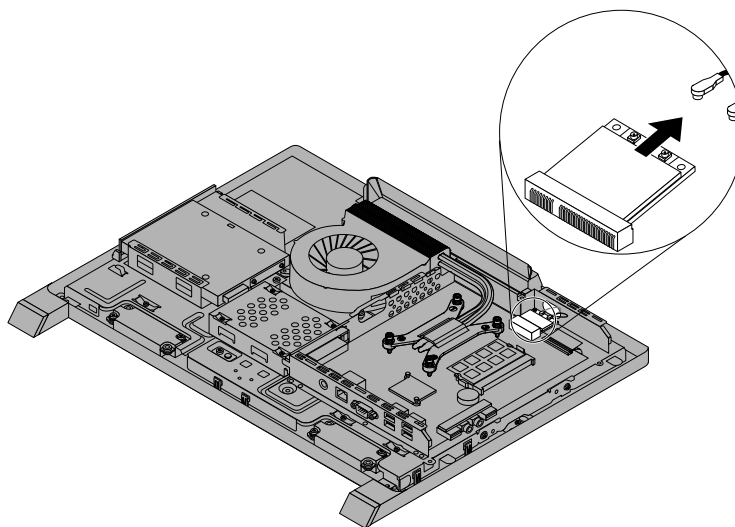

Figure 40. Removing the Wi-Fi card

9. Insert the notched end of the new Wi-Fi card into the mini PCI Express slot. Press the new Wi-Fi card firmly, and then pivot the Wi-Fi card to align the screw hole in the new Wi-Fi card with that in the computer main bracket.
10. Install the screw to secure the new Wi-Fi card.
11. Connect the two cables to the new Wi-Fi card.
12. Reinstall the system board shield. See “Removing and reinstalling the system board shield” on page 76.
13. Go to “Completing the parts replacement” on page 96.

Replacing the USB keyboard or mouse

Attention

Do not open your computer or attempt any repair before reading and understanding the “Important safety information” in the *Safety, Warranty, and Setup Guide* that came with your computer. To obtain a copy of the *Safety, Warranty, and Setup Guide*, go to:
<http://www.lenovo.com/support>

This section provides instructions on how to replace the USB keyboard or mouse.

To replace the USB keyboard or mouse, do the following:

1. Disconnect the old keyboard cable or mouse cable from the computer.
2. Connect a new keyboard or mouse to one of the USB connectors on the computer. Depending on where you want to connect the new keyboard or mouse, see “Locating connectors, controls, and indicators on the rear of your computer” on page 62.

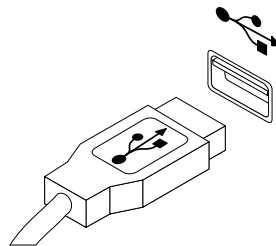

Figure 41. Connecting the USB keyboard or mouse

Completing the parts replacement

After completing the installation or replacement for all parts, you need to reinstall the computer cover and reconnect cables.

To reinstall the computer cover and reconnect cables, do the following:

1. Make sure that all components have been reassembled correctly and that no tools or loose screws are left inside your computer. See “Locating major FRUs and CRUs” on page 63 for the locations of various components in your computer.
2. Make sure that the cables are routed correctly before reinstalling the computer cover. Keep cables clear of the hinges and sides of the computer chassis to avoid interference with reinstalling the computer cover.
3. Reinstall the VESA mount bracket. See “Removing and reinstalling the VESA mount bracket” on page 71.

4. Lower and position the computer cover into place and then tighten the two screws **1** to secure the computer cover.

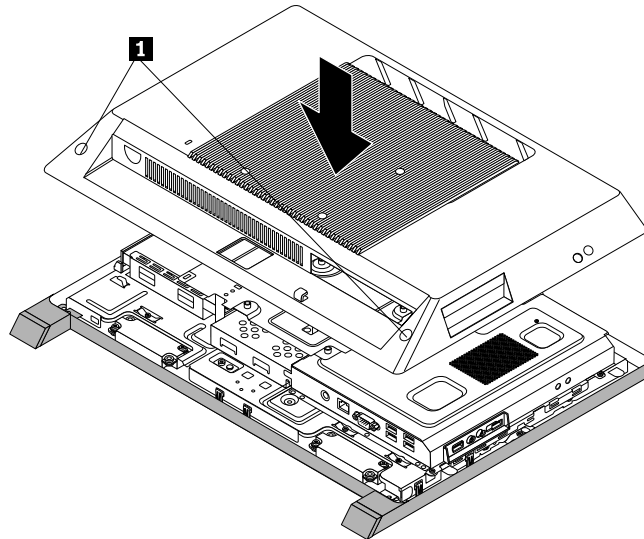

Figure 42. Installing the computer cover

5. Reinstall the system stand and system stand hinge cover. See “Removing and reinstalling the system stand” on page 68 and “Removing and reinstalling the system stand hinge cover” on page 67.
6. Lock the computer cover if you have an integrated cable lock.
7. Reconnect the external cables and power cord to the computer.
8. Depending on the parts you installed or replaced, you might need to confirm the updated information in the Setup Utility program. Refer to Chapter 6 “Using the Setup Utility program” on page 51.

Note: In most areas of the world, Lenovo requires the return of the defective Customer Replaceable Unit (CRU). Information about this will come with the CRU or will come a few days after the CRU arrives.

Chapter 10. FRU lists-S710

This chapter lists the information on the field replaceable units (FRUs) for Lenovo S710 All-In-One desktop computer.

Attention: Be sure to read and understand all the safety information before replacing any FRUs.

Notes: FRUs that have a 1 or 2 in the CRU column are Customer Replaceable Units (CRUs).

- **1**– identifies parts that are fairly simple to replace, requiring few or no tools.
- **2**– identifies parts that are slightly more difficult to replace.
- **N**– identifies parts that are not to be replaced by the customer.

#	Description	Service part number (FRU)	CRU ID
1	Processor		
	i3-3250 3.5/1600/3/1155 55 CPU(R)	1100878	N
	G2030 3.0/1333/3/1155 55 CPU	1100857	N
	ICP G1620 2.7/1333/2/1155/55 P0 CPU®	1100697	N
	IPP G2130 3.2/1600/3/1155/55 P0 CPU®	1100695	N
	I3-3210 3.2/1600/3/1155 55 P0 CPU®	1100694	N
	G1610 2.6/1333/2/1155 55 CPU	1100689	N
	I G2020 2.9/1333/3/1155 55 CPU	1100688	N
	IPP G2120 3.1/1600/3/1155/55 P0 CPU®	1100589	N
	I3-3220 3.3/1600/3/1155 55 L1 CPU®	1100456	N
	I3-3225 3.3/1600/3/1155 55 L1 CPU®	1100455	N
	I3-3240 3.4/1600/3/1155 55 L1 CPU®	1100454	N
	i5-3475S 2.9G/1600/6/1155/65 CPU®	1100415	N
	i5-3470S 2.9G/1600/6/1155/65 CPU®	1100413	N
	i5-3570S 3.1G/1600/6/1155/65 CPU®	1100395	N
	I5-3330S 2.7/1600/6/1155 65 E1 CPU	1100394	N
2	System Board		
	Tahoe NOK_H61_DIS MB	90004849	N
	Tahoe W8P_H61_DIS MB	90004850	N
	Tahoe W8S_H61_DIS MB	90004851	N
3	Hard Drive		

	WDXL500A WD5000AAKX-08U6AA0 500G HDD-LH	16200544	N
	3.5inch SATA6G 7.2K Grenada BP 1.5 1TB	16200528	N
	TSB Mars 4K 1TB DT01ACA100 -LH	16200513	N
	TSB Mars 4K 500G DT01ACA050 -LH	16200512	N
	SGT Grenada BP ST1000DM003 1TB HDD-LH	16200293	N
	WD XL1000S WD10EZEX-08RKKAA0 1TB HDD-LH	16200292	N
	SGT Pharaoh 4K ST500DM002 500G HDD-LH	16200178	N
4	Memory		
	HMT425S6AFR6A-PB 2GB D3L-1600S MEMORY	1100643	N
	M471B5773DH0-YK0 2GB D3L-1600S MEMORY	1100642	N
	Elp_R J4208EBBG-GN-F 4G D3L-1600S MEMORY	1100640	N
	MT8KTF51264HZ-1G6J1 4G D3L-1600S MEMORY	1100639	N
	HMT451S6AFR8A-PB 4G D3L-1600S MEMORY	1100638	N
	M471B5273DH0-YK0 4G D3L-1600S MEMORY	1100637	N
	Elp_R J4208EBBG-GN-F 8G D3L-1600SMEMORY	1100636	N
	MT16KTF1G64HZ-1G6E1 8G D3L-1600S MEMORY	1100635	N
	HMT41GS6AFR8A-PB 8GB D3L-1600S MEMORY	1100634	N
	M471B1G73BH0-YK0 8GB D3L-1600S MEMORY	1100633	N
	Elp_R J2108EDBG-GN-F 2G D3L-1600SMEMORY	1100750	N
	MT8KTF25664HZ-1G6M1 2GB D3L-1600SMEMORY	1100228	N
5	Optical Drive		
	PSN UJ8D1 Slim Tray Rambo with bezel	25210755	N
	HLDS DT80N Slim Tray DVDROM-LH	25210281	N
	HLDS GT80N Slim SATA Rambo with bezel-LH	25209233	N
	PLDS DS-8D9SH Slim Tray DVDROM-LH	25205802	N
	PLDS DS-8A9SH Slim Tray Rambo-LH	25205801	N
6	Power Supply		
	HKF1802-3A 92plus internal 180w psu	36200054	N
	FSP150-20AI ES5.0 internal 150W psu	36200053	N
	Liteon PS-2181-01VA 180w Pt gold psu(R)	36002087	N
	Acbel APA004-EL0G 180w Pt gold PSU(R)	36002086	N
	Acbel APA005-EL0G 150w ES5.0 PSU(R)	36002085	N
	huntkey HK1502-3B 150w ES5.0 psu(R)	36002084	N
7	Converter board		
	Tahoe H61 converter	31504197	N
	Tahoe H61 converter	31504196	N
8	Power cord		
	LX(ASAP) 1.8M C13 EU power cord	31049522	1
	LW BLK1.8m VDE Power Cord®	31026355	1
	VL BLK1.8m VDE Power Cord®	31026144	1

9	Thermal Module		
	70x70x12mm System fan for Tahoe Delta	31049422	N
	110x25mm CPU Fan for Tahoe,DLT	31049420	N
	110x25mm CPU Fan for Tahoe,AVC	31049419	N
	I 1155 66W CPU HT for Tahoe,TSL	31049418	N
	I 1155 66W CPU HT for Tahoe, AVC	31049417	N
	BLOWER 7012 TAHOE DELTA	31051082	N
10	Keyboard & mouse		
	Primax Edge 2.4G KB+MC(RU) CALC8	25214494	1
	Chicony KU0989 (RU)NewF5 USB KB Win8	25214483	1
	Liteon SK8821 (RU)NewF5 USB KB Win8	25214482	1
	Sunrex JME-2209U(RU)NewF5 USB KB Win8	25214481	1
	Logitech LXB-M-U0025-O(Silver) USB Mouse	25011476	1
	Primax LXB-MOEUUO(Silver) USB Mouse	25011475	1
11	Speaker		
	SPEAKER X08029N-054	25200490	N
12	Wireless LAN Card		
	Cbt BCM43227 MOW M PCIE NB HMC WLAN	20002506	N
	Intel Jackson Peak 1 Wifi card	20200078	N
13	Camera		
	Tahoe 2M camera (Bison 5B3)(R)	20002573	N
	Tahoe 2M camera (Chicony 2031)(R)	20002572	N
14	LCD module		
	Tahoe LCD Module w/o touch	90400223	N
15	Boards & Cables		
	PIB65F/TAHOE REAR IO-1 CHINA DIP +BKT	11200216	N
	SWITCH BOARD TAHOE 8NS-TAHO00-W31R	11200244	N
	C.A. WEBCAM TAHOE	31051395	N
	C.A. SATA TAHOE	31051071	N
	Tahoe Switch board cable	90204278	N
16	Mechanicals		
	BRKT_ODD_TAHOE	31051063	N
	CVR_STAND_CHANGSHA	31051079	N
	HLDR WEBCAM TAHOE	31052614	N
	ASSY HINGE TAHOE	31051077	N
	ASSY HDD BRKT TAHOE	31051059	N
	ASSY REAR CVR TAHOE	31051080	N
	ASSY FRONTCOVER TAHOE	90204279	N
	ASSY VESA BKT TAHOE	31051070	N
	ASSY MB SHIELDING_2 TAHOE	31051062	N

	FOOT HOLDER PCAK W/RUBBER	31051069	N
	ANTENNA PACK MAIN/AUX	31051066	N
	Tahoe Middleframe w/o switch board&cable	90204279	N

Chapter 11. Additional Service Information

This chapter provides additional information that the service representative might find helpful.

Security features

Security features in this section include the following:

- Passwords
- Vital Product Data
- Management Information Format (MIF)

Hardware controlled Passwords

Hardware controlled passwords are set using the Setup Utility program. For more information about passwords, see “Using passwords” on page 51.

Operating system password

An operating system password is very similar to a power-on password and denies access to the computer by an unauthorized user when the password is activated. The computer is unusable until the password is entered and recognized by the computer.

BIOS levels

An incorrect level of BIOS can cause false errors and unnecessary FRU replacement. Use the following information to determine the current level of BIOS installed in the computer, the latest BIOS available for the computer, and where to obtain the latest level of BIOS.

- To determine the current Level of BIOS:
 - Start the Setup Utility.
 - Select Standard CMOS Features.
- Sources for obtaining the latest level BIOS available
 1. Lenovo support web site: <http://www.lenovo.com/support/>
 2. Lenovo Customer Support Center
 3. Levels 1 and 2 Support

To update (flash) the BIOS, see “Flash update procedures” on page 103.

Note: BIOS settings vary by operating system. Change the BIOS settings before installing a new operating system. See “Changing the BIOS settings before installing a new operating system” on page 53.

Flash update procedures

This section details how to flash (update) the BIOS.

Updating (flashing) the BIOS from a disc

This section provides instructions on how to update (flash) the BIOS from a disc on the Windows 8 (64-bit) operating system and on other operating systems.

Note: You can download a self-starting bootable disc image (known as an ISO image) with the system program updates to create a system-program-update disc. Go to <http://www.lenovo.com/support>.

To update (flash) the BIOS from a disc on the Windows 8 (64-bit) operating system, do the following:

1. Start the Setup Utility program. See “Starting the Setup Utility program” on page 51.
2. From the Setup Utility program main menu, select **Exit → OS Optimized Default → Disabled**.
3. Select **Yes** in the window displayed and press Enter to confirm your selection.
4. Press F10 to save changes and exit the Setup Utility program. See “Exiting the Setup Utility program” on page 54.
5. Repeatedly press and release F12 when turning on the computer. When the Startup Device Menu window opens, release F12.
6. From the Startup Device Menu window, select the desired optical drive as the startup device. Then, insert the disc into this optical drive and press Enter. The update begins.
7. When prompted to change the serial number, it is suggested that you do not make this change by pressing N. However, if you do want to change the serial number, press Y, and then type in the serial number and press Enter.
8. When prompted to change the machine type and model, it is suggested that you do not make this change by pressing N. However, if you do want to change the machine type and model, press Y, and then type in the machine type and model and press Enter.
9. Follow the instructions on the screen to complete the update. After the update is completed, remove the disc from the optical drive.
10. Restart your computer and start the Setup Utility program. See “Starting the Setup Utility program” on page 51.
11. From the Setup Utility program main menu, select **Exit → OS Optimized Default → Enabled**.
12. Select **Yes** in the window displayed and press Enter to confirm your selection.
13. Press F10 to save changes and exit the Setup Utility program. See “Exiting the Setup Utility program” on page 54.

To update (flash) the BIOS from a disc on other operating systems, do the following:

1. Turn off your computer.
2. Repeatedly press and release F12 when turning on the computer. When the Startup Device Menu window opens, release F12.
3. From the Startup Device Menu window, select the desired optical drive as the startup device. Then, insert the disc into this optical drive and press Enter. The update begins.
4. When prompted to change the serial number, it is suggested that you do not make this change by pressing N. However, if you do want to change the serial number, press Y, and then type in the serial number and press Enter.
5. When prompted to change the machine type and model, it is suggested that you do not make this change by pressing N. However, if you do want to change the machine type and model, press Y, and then type in the machine type and model and press Enter.
6. Follow the instructions on the screen to complete the update. After the update is completed, remove the disc from the optical drive.

Updating (flashing) the BIOS from your operating system

Note: Because Lenovo makes constant improvements to its Web sites, the Web page contents are subject to change without notice, including the contents referenced in the following procedure.

To update (flash) the BIOS from your operating system, do the following:

1. Go to <http://www.lenovo.com/support>.
2. Do the following to locate the downloadable files for your machine type:
 - a. In the **Enter a product number** field, type your machine type and click **Go**.
 - b. Click **Downloads and drivers**.
 - c. Select **BIOS** from the **Refine results** drop-down list box to easily locate all the BIOS related links.
 - d. Click the BIOS update link.
3. Click the TXT file that contains the instructions for updating (flashing) the BIOS from your operating system.
4. Print these instructions. This is very important because these instructions will not be displayed on the screen after the download begins.
5. Follow the printed instructions to download, extract, and install the update.

Recovering from a POST/BIOS update failure

If the power to your computer is interrupted while the POST/BIOS is being updated (flash update), your computer might not restart correctly. If this happens, perform the following procedure commonly called Boot-block Recovery.

1. Remove all media from the drives and turn off all attached devices and the computer. Then, disconnect all power cords from electrical outlets and disconnect all cables that are connected to the computer.
2. Remove the computer cover. See “Removing the computer cover” on page 71.
3. Locate the Clear CMOS /Recovery jumper on the system board. See “Locating parts on the system board” on page 66.
4. Move the jumper from the standard position (pin 1 and pin 2) to the maintenance position (pin 2 and pin 3).
5. Install the computer cover and reconnect all cables and power cords that were disconnected. See “Completing the parts replacement” on page 96.
6. Repeatedly press and release the F12 key when turning on the computer. When the **Startup Device Menu** opens, release the F12 key.
7. Insert the POST/BIOS update (flash) disc into the optical drive. Then, select the optical drive as the startup device and press Enter. The recovery session begins.

Note: The recovery session will take two to three minutes. During this time you will hear a series of beeps.
8. After the recovery session is completed, the series of beeps will end, and the system will automatically turn off. Remove the disc from the optical drive before the system completely turns off.
9. Repeat steps 1 through 3.
10. Move the Clear CMOS /Recovery jumper back to the standard position (pin 1 and pin 2).
11. Install the computer cover and reconnect all cables and power cords that were disconnected. See “Completing the parts replacement” on page 96.
12. Turn on the computer to restart the operating system.

Power management

Power management reduces the power consumption of certain components of the computer such as the system power supply, processor, hard disk drives, and some monitors.

Automatic configuration and power interface (ACPI) BIOS

Being an ACPI BIOS system, the operating system is allowed to control the power management features of the computer and the setting for Advanced Power Management (APM) BIOS mode is ignored. Not all operating systems support ACPI BIOS mode.

Automatic Power-on features

The Automatic Power-On features within the Power Management menu allow you to enable and disable features that turn on the computer automatically.

- **Wake Up on Alarm:** You can specify a date and time at which the computer will be turned on automatically. This can be either a single event or a daily event.
- **Wake on LAN:** If the computer has a properly configured token-ring or Ethernet LAN adapter card that is Wake on LAN-enabled and there is remote network management software, you can use the Wake on LAN feature. When you set Wake on LAN to **Enabled**, the computer will turn on when it receives a specific signal from another computer on the local area network (LAN).

To enable the Wake on LAN function or the Wake Up on Alarm function on the Windows 8 operating system, do the following:

1. Open Control Panel.
2. Click **Hardware and Sound → Power Options**.
3. In the left panel, click **Choose what the power buttons do**.
4. In the **Shutdown setting** section, clear **Turn on fast startup**.

Note: If the settings are unavailable, click **Change settings that are currently unavailable**.

5. Click **Save changes**.

Appendix A. Notices

Lenovo may not offer the products, services, or features discussed in this document in all countries. Consult your local Lenovo representative for information on the products and services currently available in your area. Any reference to a Lenovo product, program, or service is not intended to state or imply that only that Lenovo product, program, or service may be used. Any functionally equivalent product, program, or service that does not infringe any Lenovo intellectual property right may be used instead. However, it is the user's responsibility to evaluate and verify the operation of any other product, program, or service.

Lenovo may have patents or pending patent applications covering subject matter described in this document. The furnishing of this document does not give you any license to these patents. You can send license inquiries, in writing, to:

*Lenovo (United States), Inc.
1009 Think Place - Building One
Morrisville, NC 27560
U.S.A.
Attention: Lenovo Director of Licensing*

LENOVO PROVIDES THIS PUBLICATION "AS IS" WITHOUT WARRANTY OF ANY KIND, EITHER EXPRESS OR IMPLIED, INCLUDING, BUT NOT LIMITED TO, THE IMPLIED WARRANTIES OF NON-INFRINGEMENT, MERCHANTABILITY OR FITNESS FOR A PARTICULAR PURPOSE. Some jurisdictions do not allow disclaimer of express or implied warranties in certain transactions, therefore, this statement may not apply to you.

This information could include technical inaccuracies or typographical errors. Changes are periodically made to the information herein; these changes will be incorporated in new editions of the publication. Lenovo may make improvements and/or changes in the product(s) and/or the program(s) described in this publication at any time without notice.

The products described in this document are not intended for use in implantation or other life support applications where malfunction may result in injury or death to persons. The information contained in this document does not affect or change Lenovo product specifications or warranties. Nothing in this document shall operate as an express or implied license or indemnity under the intellectual property rights of Lenovo or third parties. All information contained in this document was obtained in specific environments and is presented as an illustration. The result obtained in other operating environments may vary.

Lenovo may use or distribute any of the information you supply in any way it believes appropriate without incurring any obligation to you.

Any references in this publication to non-Lenovo Web sites are provided for convenience only and do not in any manner serve as an endorsement of those Web sites. The materials at those Web sites are not part of the materials for this Lenovo product, and use of those Web sites is at your own risk.

Any performance data contained herein was determined in a controlled environment. Therefore, the result obtained in other operating environments may vary significantly. Some measurements may have been made on development-level systems and there is no guarantee that these measurements will be the same on generally available systems. Furthermore, some measurements may have been estimated through extrapolation. Actual results may vary. Users of this document should verify the applicable data for their specific environment.

Television output notice

The following notice applies to models that have the factory-installed television-output feature.

This product incorporates copyright protection technology that is protected by method claims of certain U.S. patents and other intellectual property rights owned by Macrovision Corporation and other rights owners. Use of this copyright protection technology must be authorized by Macrovision Corporation, and is intended for home and other limited viewing uses only unless otherwise authorized by Macrovision Corporation. Reverse engineering or disassembly is prohibited.

European conformance CE mark



Trademarks

The following terms are trademarks of Lenovo in the United States, other countries, or both:

- Lenovo
- The Lenovo logo
- Rescue and Recovery

Microsoft and Windows are trademarks of the Microsoft group of companies.

Intel is a trademark of Intel Corporation in the United States, other countries, or both.

Linux is a trademark of Linus Torvalds in the United States, other countries, or both.

Other company, product, or service names may be trademarks or service marks of others.

Index

A

Administrator, password 52

B

basic troubleshooting 33
battery, replacing 83
BIOS settings, changing 53
boot-block recovery 105

C

changing
 password 52
 startup device sequence 53
components, internal 63
computer cover
 removing 71
computer cover, reinstalling 96
connectors
 rear 62
connectors, controls, indicators
 front 61
considerations, passwords 51
CRU
 completing the installation 96
CRUs (Customer Replaceable Units), returning defective 63

D

deleting a password 52
diagnostics, troubleshooting 33

E

environment, operating 29
exiting, Setup Utility 54

F

flashing the BIOS 103
front
 connectors, controls, indicators 61
FRU locations 63
FRU part numbers 1, 61, 65
FRUs, replacing 67

H

hard disk drive, replacing 72
heat sink assembly, replacing 78

I

Identifying FRUs 63
installing
 operating system 53
installing, replacing
 memory module 85
integrated camera, replacing 88
internal speakers, replacing 87
inverter, replacing 84

K

keyboard, replacing 96

L

LCD panel, replacing 91
locating components 63
looking up part numbers 1, 61, 65

M

memory module 85
 installing, replacing 85
microprocessor fan, replacing 77
mouse, replacing 96

N

notice, television output 108
notices 107

O

optical drive, replacing 74
Optional-service CRUs 63

P

part numbers 1, 61, 65
parts replacement, completing 96
password
 Administrator 52
 considerations 51
 Power-On Password 52
 setting, changing, deleting 52
passwords, using 51
physical specifications 29
Power-On, Password 52

R

rear connectors 62
recovering

- a POST/BIOS update failure 105
- recovery
 - boot-block 105
- removing
 - system board shield 76
 - VESA mount bracket 71
- removing computer cover 71
- removing the system stand hinge cover 67
- replacing
 - battery 83
 - hard disk drive 72
 - heat sink assembly 78
 - integrated camera 88
 - internal speakers 87
 - inverter 84
 - LCD panel 91
 - microprocessor fan 77
 - system board 89
 - Wi-Fi card 94

S

- security
 - enabling or disabling 52
- selecting
 - startup device 53
 - temporary startup device 53
- Self-service CRUs 63
- setting
 - password 52
- settings
 - changing 51
 - viewing 51
- Setup Utility 51
- Setup Utility program, starting 51
- Setup Utility, exiting 54
- starting the Setup Utility program 51
- startup device 53
 - sequence, changing 53
 - temporary, selecting 53
- support web site
 - support 29
- support, web site 29
- system board
 - locating parts 66
- system board shield, removing 76
- system board, replacing 89
- system stand
 - l, removing 68
- system stand hinge cover
 - reinstalling 67
 - removing 67
- system stand, reinstalling 68

T

- television output notice 108
- temporary startup device 53
- the BIOS, updating (flashing) 103–104

- trademarks 108
- troubleshooting, basic 33
- troubleshooting, diagnostics 33

U

- updating
 - (flashing) the BIOS 103
- updating (flashing) the BIOS 104
- using
 - passwords 51
 - Setup Utility 51

V

- VESA mount bracket, removing 71
- viewing and changing settings 51

W

- Wi-Fi card, replacing 94

lenovo[®]

Free Manuals Download Website

<http://myh66.com>

<http://usermanuals.us>

<http://www.somanuals.com>

<http://www.4manuals.cc>

<http://www.manual-lib.com>

<http://www.404manual.com>

<http://www.luxmanual.com>

<http://aubethermostatmanual.com>

Golf course search by state

<http://golfingnear.com>

Email search by domain

<http://emailbydomain.com>

Auto manuals search

<http://auto.somanuals.com>

TV manuals search

<http://tv.somanuals.com>