

MVME5100
Single Board Computer

Installation and Use

V5100A/IH4

July 2003 Edition

© Copyright 2003 Motorola, Inc.

All rights reserved.

Printed in the United States of America.

Motorola and the Motorola logo are registered trademarks and AltiVec is a trademark of Motorola, Inc.

PowerPC and the PowerPC logo are registered trademarks; and PowerPC 750 is a trademark of International Business Machines Corporation and are used by Motorola, Inc. under license from International Business Machines Corporation.

All other products mentioned in this document are trademarks or registered trademarks of their respective holders.

Safety Summary

The following general safety precautions must be observed during all phases of operation, service, and repair of this equipment. Failure to comply with these precautions or with specific warnings elsewhere in this manual could result in personal injury or damage to the equipment.

The safety precautions listed below represent warnings of certain dangers of which Motorola is aware. You, as the user of the product, should follow these warnings and all other safety precautions necessary for the safe operation of the equipment in your operating environment.

Ground the Instrument.

To minimize shock hazard, the equipment chassis and enclosure must be connected to an electrical ground. If the equipment is supplied with a three-conductor AC power cable, the power cable must be plugged into an approved three-contact electrical outlet, with the grounding wire (green/yellow) reliably connected to an electrical ground (safety ground) at the power outlet. The power jack and mating plug of the power cable meet International Electrotechnical Commission (IEC) safety standards and local electrical regulatory codes.

Do Not Operate in an Explosive Atmosphere.

Do not operate the equipment in any explosive atmosphere such as in the presence of flammable gases or fumes. Operation of any electrical equipment in such an environment could result in an explosion and cause injury or damage.

Keep Away From Live Circuits Inside the Equipment.

Operating personnel must not remove equipment covers. Only Factory Authorized Service Personnel or other qualified service personnel may remove equipment covers for internal subassembly or component replacement or any internal adjustment. Service personnel should not replace components with power cable connected. Under certain conditions, dangerous voltages may exist even with the power cable removed. To avoid injuries, such personnel should always disconnect power and discharge circuits before touching components.

Use Caution When Exposing or Handling a CRT.

Breakage of a Cathode-Ray Tube (CRT) causes a high-velocity scattering of glass fragments (implosion). To prevent CRT implosion, do not handle the CRT and avoid rough handling or jarring of the equipment. Handling of a CRT should be done only by qualified service personnel using approved safety mask and gloves.

Do Not Substitute Parts or Modify Equipment.

Do not install substitute parts or perform any unauthorized modification of the equipment. Contact your local Motorola representative for service and repair to ensure that all safety features are maintained.

Observe Warnings in Manual.

Warnings, such as the example below, precede potentially dangerous procedures throughout this manual. Instructions contained in the warnings must be followed. You should also employ all other safety precautions which you deem necessary for the operation of the equipment in your operating environment.



To prevent serious injury or death from dangerous voltages, use extreme caution when handling, testing, and adjusting this equipment and its components.

Flammability

All Motorola PWBs (printed wiring boards) are manufactured with a flammability rating of 94V-0 by UL-recognized manufacturers.

EMI Caution



This equipment generates, uses and can radiate electromagnetic energy. It may cause or be susceptible to electromagnetic interference (EMI) if not installed and used with adequate EMI protection.

Lithium Battery Caution

This product contains a lithium battery to power the clock and calendar circuitry.



Danger of explosion if battery is replaced incorrectly. Replace battery only with the same or equivalent type recommended by the equipment manufacturer. Dispose of used batteries according to the manufacturer's instructions.



Il y a danger d'explosion s'il y a remplacement incorrect de la batterie. Remplacer uniquement avec une batterie du même type ou d'un type équivalent recommandé par le constructeur. Mettre au rebut les batteries usagées conformément aux instructions du fabricant.



Explosionsgefahr bei unsachgemäßem Austausch der Batterie. Ersatz nur durch denselben oder einen vom Hersteller empfohlenen Typ. Entsorgung gebrauchter Batterien nach Angaben des Herstellers.

CE Notice (European Community)

Motorola Computer Group products with the CE marking comply with the EMC Directive (89/336/EEC). Compliance with this directive implies conformity to the following European Norms:

EN55022 “Limits and Methods of Measurement of Radio Interference Characteristics of Information Technology Equipment”; this product tested to Equipment Class B

EN55024 “Information technology equipment—Immunity characteristics—Limits and methods of measurement”

Board products are tested in a representative system to show compliance with the above mentioned requirements. A proper installation in a CE-marked system will maintain the required EMC performance.

In accordance with European Community directives, a “Declaration of Conformity” has been made and is available on request. Please contact your sales representative.

Notice

While reasonable efforts have been made to assure the accuracy of this document, Motorola, Inc. assumes no liability resulting from any omissions in this document, or from the use of the information obtained therein. Motorola reserves the right to revise this document and to make changes from time to time in the content hereof without obligation of Motorola to notify any person of such revision or changes.

Electronic versions of this material may be read online, downloaded for personal use, or referenced in another document as a URL to the Motorola Computer Group website. The text itself may not be published commercially in print or electronic form, edited, translated, or otherwise altered without the permission of Motorola, Inc.

It is possible that this publication may contain reference to or information about Motorola products (machines and programs), programming, or services that are not available in your country. Such references or information must not be construed to mean that Motorola intends to announce such Motorola products, programming, or services in your country.

Limited and Restricted Rights Legend

If the documentation contained herein is supplied, directly or indirectly, to the U.S. Government, the following notice shall apply unless otherwise agreed to in writing by Motorola, Inc.

Use, duplication, or disclosure by the Government is subject to restrictions as set forth in subparagraph (b)(3) of the Rights in Technical Data clause at DFARS 252.227-7013 (Nov. 1995) and of the Rights in Noncommercial Computer Software and Documentation clause at DFARS 252.227-7014 (Jun. 1995).

Motorola, Inc.
Computer Group
2900 South Diablo Way
Tempe, Arizona 85282

Contents

About This Manual

- Summary of Changes xvii
- Overview of Contents xvii
- Comments and Suggestions xix
- Conventions Used in This Manual xix
 - Terminology xx

CHAPTER 1 Hardware Preparation and Installation

- Introduction 1-1
- Getting Started 1-1
 - Overview and Equipment Requirements 1-1
 - Unpacking Instructions 1-2
- Preparation 1-3
 - Hardware Configuration 1-3
 - Jumper Settings 1-5
 - PMC/SBC (761/IPMC) Mode Selection 1-6
 - Installation Considerations 1-6
- Installation 1-8
 - PMC Modules 1-10
 - Primary PMCspan 1-12
 - Secondary PMCspan 1-14
 - MVME5100 1-16

CHAPTER 2 Operation

- Introduction 2-1
- Switches and Indicators 2-1
 - ABT/RST Switch 2-1
 - Abort Function 2-1
 - Reset Function 2-1
 - Status Indicators 2-2
 - RST Indicator (DS1) 2-2
 - CPU Indicator (DS2) 2-2
- Connectors 2-2
 - 10/100 BASE T Ports 2-3

DEBUG Port	2-3
System Powerup	2-3
Initialization Process	2-4

CHAPTER 3 PPCBug Firmware

Introduction	3-1
PPCBug Overview.....	3-1
Implementation and Memory Requirements	3-3
Using PPCBug.....	3-3
Hardware and Firmware Initialization	3-4
Default Settings	3-6
CNFG - Configure Board Information Block	3-7
ENV - Set Environment	3-7
Configuring the PPCBug Parameters.....	3-8
LED/Serial Startup Diagnostic Codes	3-16
Configuring the VMEbus Interface.....	3-17
Firmware Command Buffer	3-21
Standard Commands.....	3-22
Diagnostics.....	3-26

CHAPTER 4 Functional Description

Introduction	4-1
Features Summary	4-1
Features Descriptions	4-3
General	4-3
Processor	4-5
System Memory Controller and PCI Host Bridge.....	4-5
Memory	4-5
Flash Memory	4-5
ECC SDRAM Memory	4-6
P2 Input/Output (I/O) Modes	4-7
Input/Output Interfaces.....	4-7
Ethernet Interface	4-7
VMEbus Interface	4-8
Asynchronous Communications	4-8
Real-Time Clock & NVRAM & Watchdog Timer.....	4-8
Timers	4-8
Interrupt Routing.....	4-8
IDSEL Routing.....	4-9

CHAPTER 5 Pin Assignments

Introduction	5-1
Summary	5-1
Jumper Settings	5-2
Connectors	5-3
IPMC761 Connector (J3) Pin Assignments	5-3
Memory Expansion Connector (J8) Pin Assignments	5-4
PCI Expansion Connector (J25) Pin Assignments	5-7
PCI Mezzanine Card (PMC) Connectors	5-10
VMEbus Connectors P1 & P2 Pin Assignments (PMC mode)	5-23
VMEbus P1 & P2 Connector Pin Assignments (SBC Mode)	5-25
10 BaseT/100 BaseTx Connector Pin Assignments	5-29
COM1 and COM2 Connector Pin Assignments	5-30

CHAPTER 6 Programming the MVME51xx

Introduction	6-1
Memory Maps	6-1
Processor Bus Memory Map	6-2
Default Processor Memory Map	6-2
Processor Memory Map	6-3
PCI Memory Map	6-5
VME Memory Map	6-5
PCI Local Bus Memory Map	6-5
VMEbus Memory Map	6-6
Programming Considerations	6-6
PCI Arbitration	6-6
Interrupt Handling	6-9
DMA Channels	6-11
Sources of Reset	6-11
Endian Issues	6-13
Processor/Memory Domain	6-13
PCI Domain	6-13
VMEbus Domain	6-14

APPENDIX A Specifications

General Specifications	A-1
Power Requirements	A-2
Cooling Requirements	A-3

EMC Compliance	A-3
----------------------	-----

APPENDIX B Troubleshooting

Solving Startup Problems	B-1
--------------------------------	-----

APPENDIX C Related Documentation

Motorola Computer Group Documents	C-1
Manufacturers' Documents	C-2
Related Specifications	C-4

APPENDIX D RAM500 Memory Expansion Module

Overview	D-1
Features.....	D-1
Functional Description	D-2
RAM500 Description	D-2
SRAM.....	D-5
Host Clock Logic.....	D-5
RAM500 Module Installation.....	D-5
RAM500 Connectors	D-7
Bottom Side Memory Expansion Connector (P1).....	D-7
Top Side Memory Expansion Connector (J1)	D-10
RAM500 Programming Issues	D-13
Serial Presence Detect (SPD) Data	D-13

APPENDIX E Thermal Analysis

Thermally Significant Components.....	E-1
Component Temperature Measurement.....	E-6
Preparation.....	E-6
Measuring Junction Temperature	E-6
Measuring Case Temperature	E-6
Measuring Local Air Temperature	E-9

List of Figures

Figure 1-1. MVME5100 Layout	1-9
Figure 1-2. MVME5100 Installation and Removal From a VMEbus Chassis	1-11
Figure 1-3. Typical PMC Module Placement on an MVME5100	1-11
Figure 1-4. PMCspan-002 Installation on an MVME510	1-13
Figure 1-5. PMCspan-010 Installation on a PMCspan-002/MVME5100	1-15
Figure 2-1. Boot-Up Sequence	2-5
Figure 4-1. MVME5100 Block Diagram.....	4-4
Figure 6-1. VMEbus Master Mapping.....	6-8
Figure 6-2. MVME510x Interrupt Architecture	6-10
Figure D-1. RAM500 Block Diagram	D-4
Figure D-2. RAM500 Module Placement on MVME5100	D-6
Figure E-1. Thermally Significant Components on the MVME5100 Single Board Computer - Primary Side	E-4
Figure E-2. Thermally Significant Components on the IPMC761 Module - Primary Side	E-5
Figure E-3. Mounting a Thermocouple Under a Heatsink	E-8
Figure E-4. Measuring Local Air Temperature	E-9

List of Tables

Table 1-1. Manually Configured Headers/Jumpers	1-4
Table 3-1. Debugger Commands	3-22
Table 3-2. Diagnostic Test Groups.....	3-27
Table 4-1. MVME5100 General Features.....	4-1
Table 5-1. Jumper Switches and Settings.....	5-2
Table 5-2. IPMC761 Connector Pin Assignments	5-3
Table 5-3. Memory Expansion Connector Pin Assignments	5-4
Table 5-4. PCI Expansion Connector Pin Assignments.....	5-7
Table 5-5. PMC Slot 1 Connector (J11) Pin Assignments.....	5-10
Table 5-6. PMC Slot 1 Connector (J12) Pin Assignments.....	5-12
Table 5-7. PMC Slot 1 Connector (J13) Pin Assignments.....	5-13
Table 5-8. PMC Slot 1 Connector (J14) Pin Assignments.....	5-15
Table 5-9. PMC Slot 2 Connector (J21) Pin Assignments.....	5-17
Table 5-10. PMC Slot 2 Connector (J22) Pin Assignments.....	5-18
Table 5-11. PMC Slot 2 Connector (J23) Pin Assignments.....	5-20
Table 5-12. PMC Slot 2 Connector (J24) Pin Assignments.....	5-21
Table 5-13. VMEbus Connector P2 Pin Assignments (PMC Mode)	5-23
Table 5-14. VMEbus P2 Connector Pinouts with IPMC761- SBC Mode.....	5-25
Table 5-15. VMEbus Connector P2 Pinout with IPMC712.....	5-27
Table 5-16. 10 BaseT/100 BaseTx Connector Pin Assignment.....	5-29
Table 5-17. COM1 (J19) Connector Pin Assignments	5-30
Table 5-18. COM2 (J5) Connector Pin Assignments	5-30
Table 6-1. Default Processor Memory Map.....	6-2
Table 6-2. Suggested CHRP Memory Map	6-3
Table 6-3. Hawk PPC Register Values for Suggested Memory Map.....	6-4
Table 6-4. PCI Arbitration Assignments.....	6-9
Table A-1. MVME5100 Specifications	A-1
Table A-2. Power Consumption	A-2
Table B-1. Troubleshooting Problems	B-1
Table C-1. Motorola Computer Group Documents	C-1
Table C-2. Manufacturers' Documents	C-2

Table C-3. Related Specifications	C-4
Table D-1. RAM500 Feature Summary	D-1
Table D-2. RAM500 SDRAM Memory Size Options	D-3
Table D-3. RAM500 Bottom Side Connector (P1) Pin Assignments	D-8
Table D-4. RAM500 Top Side Connector (J1) Pin Assignments	D-10
Table E-1. Thermally Significant Components on the MVME5100 Single Board Computer	E-2
Table E-2. Thermally Significant Components on the IPMC761 Module	E-3

About This Manual

The *MVME51xx Single Board Computer Installation and Use* provides the information you will need to install and configure your MVME51xx Single Board Computer. It provides specific preparation and installation information and data applicable to the board.

The MVME51xx is a high-performance VME single board computer featuring the Motorola Computer Group (MCG) PowerPlus II architecture with a choice of processors—either Motorola’s MPC7410 with AltiVec™ technology for algorithmic intensive computations or the low-power MPC755 or MPC750.

As of the printing date of this manual, the MVME51xx is available in the configurations shown below. Note: all models of the MVME51xx are available with either VME Scanbe front panel (-xxx) or IEEE 1101 compatible front panel (-xxx3) handles.

Part Number	Description
450 MHz MPC750 Commercial Models	
MVME5100-016x	450 MHz MPC750, 512MB ECC SDRAM, 17MB Flash and 1MB L2 cache
400 MHz MPC755 Extended Temperature Models	
MVME5106-114x	400 MHz MPC755, 128MB ECC SDRAM, 17MB Flash and 1MB L2 cache
MVME5106-115x	400 MHz MPC755, 256MB ECC SDRAM, 17MB Flash and 1MB L2 cache
MVME5106-116x	400 MHz MPC755, 512MB ECC SDRAM, 17MB Flash and 1MB L2 cache
400 and 500 MHz MPC7410 Commercial Models	
MVME5110-216x	400 MHz MPC7410, 512MB ECC SDRAM, 17MB Flash and 2MB L2 cache
MVME5110-226x	500 MHz MPC7410, 512MB ECC SDRAM, 17MB Flash and 2MB L2 cache
500 MHz MPC7410 Extended Temperature Models	
MVME5107-214x	500 MHz MPC7410, 128MB ECC SDRAM, 17MB Flash and 2MB L2 cache
MVME5107-215x	500 MHz MPC7410, 256MB ECC SDRAM, 17MB Flash and 2MB L2 cache
MVME5107-216x	500 MHz MPC7410, 512MB ECC SDRAM, 17MB Flash and 2MB L2 cache
MVME712M Compatible I/O	
IPMC712-001	Multifunction rear I/O PMC module; 8-bit SCSI, Ultra Wide SCSI, one parallel port, three async and one sync/async serial port

Part Number	Description
MVME712M	Transition module connectors: One DB-25 sync/async serial port, three DB-25 async serial ports, one AUI connector, one D-36 parallel port, and one 50-pin 8-bit SCSI; includes 3-row DIN P2 adapter module and cable.
MVME761 Compatible I/O	
IPMC761-001	Multifunction rear I/O PMC module; 8-bit SCSI, one parallel port, two async and two sync/async serial ports
MVME761-001	Transition module: Two DB-9 async serial port connectors, two HD-26 sync/async serial port connectors, one HD-36 parallel port connector, and one RJ-45 10/100 Ethernet connector; includes 3-row DIN P2 adapter module and cable (for 8-bit SCSI).
MVME761-011	Transition module: Two DB-9 async serial port connectors, two HD-26 sync/async serial port connectors, one HD-36 parallel port connector, and one RJ-45 10/100 Ethernet connector; includes 5-row DIN P2 adapter module and cable (for 16-bit SCSI); requires backplane with 5-row DIN connectors.
SIM232DCE or DTE	EIA-232 DCE or DTE Serial Interface Module
SIM530DCE or DTE	EIA-530 DCE or DTE Serial Interface Module
SIMV35DCE or DTE	V.35 DCE or DTE Module
SIMX21DCE or DTE	X.21 DCE or DTE Serial Interface Module
Related Products	
PMCSAN1-002	PMCSAN-002 with original VME Scanbe ejector handles
PMCSAN1-010	PMCSAN-010 with original VME Scanbe ejector handles
RAM500-004	Stackable (top) 64MB ECC SDRAM mezzanine
RAM500-006	Stackable (top) 256MB ECC SDRAM mezzanine
RAM500-016	Stackable (bottom) 256MB ECC SDRAM mezzanine

Summary of Changes

The following changes were made for the 4th revision of this manual.

Date	Doc. Rev	Changes
08/2001	V5100A/IH2	A correction was made on page 1-5 to change the explanation of the jumper settings for Flash Bank A and B. Flash Bank B (0) is the factory setting. Memory Map information was also added to <i>Chapter 6, Programming Information. Appendix B, Specifications</i> was updated, and <i>Appendix D, RAM500 Memory Expansion Module</i> was added. Other corrections were made throughout the manual. This section titled " <i>About this Manual</i> " was also added.
02/2003	V5100A/IH3	Changes were made to pages 1-4 and 5-2 respectively to clarify the explanation for J16 to state that the setting of jumpers 2 and 3 only write protect the upper 64KB of Flash memory. Additional corrections were made to Table 5-15 to duplicate information in Rows Z and D from Table 5-14 and to add note below Table 5-15.
07/2003	V5100A/IH4	Changes were made to this section to update model numbers and descriptions to coincide with the MVME5100 Datasheet. Changes were also made to correct the address of the DS1621 from \$A6 to \$96. Changes were also made to specifications for additional power ratings and additions were made to a new thermal rating chart.

Overview of Contents

The following paragraphs briefly describe the contents of each chapter.

[Chapter 1, *Hardware Preparation and Installation*](#), provides a description of the MVME5100 and its main integrated PMC and IPMC boards. The remainder of the chapter includes an explanation of the installation procedure, including preparation and jumper setting information.

[Chapter 2, *Operation*](#), provides a description of the operational functions of the MVME5100 including tips on applying power, a description of the switch settings, the status indicators, I/O connectors, and system power up information.

[Chapter 3, *PPC Bug Firmware*](#), provides an explanation of the debugger firmware, PPC Bug, on the MVME5100. The chapter includes an overview of the firmware, a section on how to use PPC Bug, a listing of the initialization steps, a brief explanation of the two main configuration commands CNFG and ENV, and a description of the standard configuration parameters. A listing of the basic commands are also provided.

[Chapter 4, *Functional Description*](#), provides a summary of the MVME5100 features, a block diagram, and a description of the major functional areas.

[Chapter 5, *Pin Assignments*](#), provides a listing of all connector and header pin assignments for the MVME5100.

[Chapter 6, *Programming the MVME51xx*](#), provides a description of the memory maps on the MVME5100 including tables of default processor memory maps, suggested CHRP memory maps, and Hawk PPC register values for suggested memory maps. The remainder of the chapter provides some programming considerations.

[Appendix A, *Specifications*](#), provides the standard specifications for the MVME5100, as well as some general information on cooling.

[Appendix B, *Troubleshooting*](#), provides a brief explanation of the possible resolutions for basic error conditions.

[Appendix C, *Related Documentation*](#), provides a listing of related documentation for the MVME5100, including vendor documentation and industry related specifications.

[Appendix D, *RAM500 Memory Expansion Module*](#), provides a description of the RAM500 Memory Expansion Module, a list of features, a block diagram of the module, a table of memory size allocations, an installation procedure, and pinouts of the module's top and bottom side connectors.

Comments and Suggestions

Motorola welcomes and appreciates your comments on its documentation. We want to know what you think about our manuals and how we can make them better. Mail comments to:

Motorola Computer Group
Reader Comments DW164
2900 S. Diablo Way
Tempe, Arizona 85282

You can also submit comments to the following e-mail address:
reader-comments@mcg.mot.com

In all your correspondence, please list your name, position, and company. Be sure to include the title and part number of the manual and tell how you used it. Then tell us your feelings about its strengths and weaknesses and any recommendations for improvements.

Conventions Used in This Manual

The following typographical conventions are used in this document:

bold

is used for user input that you type just as it appears; it is also used for commands, options and arguments to commands, and names of programs, directories and files.

italic

is used for names of variables to which you assign values. Italic is also used for comments in screen displays and examples, and to introduce new terms.

`courier`

is used for system output (for example, screen displays, reports), examples, and system prompts.

<**Enter**>, <**Return**> or <**CR**>

<CR> represents the carriage return or Enter key.

CTRL

represents the Control key. Execute control characters by pressing the Ctrl key and the letter simultaneously, for example, **Ctrl-d**.

Terminology

A character precedes a data or address parameter to specify the numeric format, as follows (if not specified, the format is hexadecimal):

0x	Specifies a hexadecimal number
%	Specifies a binary number
&	Specifies a decimal number

An asterisk (*) following a signal name for signals that are *level significant* denotes that the signal is *true* or valid when the signal is low.

An asterisk (*) following a signal name for signals that are *edge significant* denotes that the actions initiated by that signal occur on high to low transition.

In this manual, *assertion* and *negation* are used to specify forcing a signal to a particular state. In particular, *assertion* and *assert* refer to a signal that is active or true; *negation* and *negate* indicate a signal that is inactive or false. These terms are used independently of the voltage level (high or low) that they represent. Data and address sizes are defined as follows:

Byte	8 bits, numbered 0 through 7, with bit 0 being the least significant.
Half word	16 bits, numbered 0 through 15, with bit 0 being the least significant.
Word	32 bits, numbered 0 through 31, with bit 0 being the least significant.
Double word	64 bits, numbered 0 through 63, with bit 0 being the least significant.

Hardware Preparation and Installation

1

Introduction

This chapter provides information on hardware preparation and installation for the MVME5100 Series of Single Board Computers.

Note Unless otherwise specified, the designation “MVME5100” refers to all models of the MVME5100-series Single Board Computers.

Getting Started

The following subsections include information helpful in preparing your equipment. It includes an overview of the MVME5100, any equipment needed to complete the installation, and unpacking instructions.

Overview and Equipment Requirements

The MVME5100 interfaces to a VMEbus system via its P1 and P2 connectors and contains two IEEE 1386.1 PCI Mezzanine Card (PMC) Slots. The PMC Slots are 64-bit and support both front and rear I/O.

Additionally, the MVME5100 is user configurable by setting on-board jumpers. Two I/O modes are possible: PMC mode or SBC mode (also called 761 or IPMC mode). The SBC mode uses the IPMC712 I/O PMC and the MVME712M Transition Module, or the IPMC761 I/O PMC and the MVME761 Transition Module. The SBC mode is backwards compatible with the MVME761 transition card and the P2 adapter card (excluding PMC I/O routing) used on the MVME2600/2700 product. This mode is accomplished by configuring the on-board jumpers and by attaching an IPMC761 PMC in PMC slot 1. Secondary Ethernet is configured to the rear.

PMC mode is backwards compatible with the MVME2300/MVME2400 and is accomplished by simply configuring the on-board jumpers.

The following equipment list is appropriate for use in an MVME5100 system:

- ❑ PMCspan PCI expansion mezzanine module (mates with MVME5100)
- ❑ Peripheral Component Interconnect (PCI) Mezzanine Cards (PMCs) (installed on an MVME5100 board)
- ❑ RAM500 memory mezzanine modules (installed on an MVME5100 board)
- ❑ VME system enclosure
- ❑ System console terminal
- ❑ Disk drives (and/or other I/O) and controllers
- ❑ Operating system (and/or application software)

Unpacking Instructions



Avoid touching areas of integrated circuitry; static discharge can damage these circuits.

Note If the shipping carton(s) is/are damaged upon receipt, request that the carrier's agent be present during the unpacking and inspection of the equipment.

Use ESD

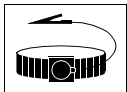

Wrist Strap

Motorola strongly recommends that you use an antistatic wrist strap and a conductive foam pad when installing or upgrading a system.

Electronic components, such as disk drives, computer boards, and memory modules, can be extremely sensitive to electrostatic discharge (ESD). After removing the component from its protective wrapper or from the system, place the component on a grounded, static-free, and adequately

protected working surface. Do not slide the component over any surface. In the case of a Printed Circuit Board (PCB), place the board with the component side facing up.

If an ESD station is not available, you can avoid damage resulting from ESD by wearing an antistatic wrist strap (available locally) that is attached to an active electrical ground.

Note A system chassis may not be a suitable grounding source if it is unplugged.

Preparation

This section includes subsections on hardware configuration that may need to be performed immediately before and after board installation. It includes a brief reminder on setting bits in control registers, setting jumpers for the appropriate configuration, and other VME data considerations.

Hardware Configuration

To produce the desired board configuration and to ensure proper operation of the MVME5100, it may be necessary to perform certain modifications before and after installation. The following paragraphs discuss the preparation of the MVME5100 hardware components prior to installing them into a chassis and connecting them.

The MVME5100 provides software control over most of its options by setting bits in control registers. After installing it in a system, you can modify its configuration. For additional information on the board's control registers, refer to the *MVME5100 Single Board Computer Programmer's Reference Guide* listed in [Appendix C, Related Documentation](#).

It is important to note that some options are not software-programmable. These specific options are controlled through manual installation or removal of jumpers, and in some cases, the addition of other interface modules on the MVME5100. The following table lists the manually configured jumpers on the MVME5100, and their default settings.

If you are resetting the board jumpers from their default settings, it is important to verify that all settings are reset properly. For example, the SBC mode requires setting jumpers 4, 10 and 17 for rear Ethernet functions, but it also requires resetting jumpers J6 and J20. Neglecting to reset J6 and J20 could damage or destroy subsequent PMCs or PrPMCs installed on the base board at power-up.

Table 1-1. Manually Configured Headers/Jumpers

Jumper	Description	Setting	Default
J1	RISCWatch Header	None (Factory Use Only)	N/A
J2	PAL Programming Header	None (Lab Use Only)	N/A
J4	Ethernet Port 2 Selection (see also J10/J17)	For P2 Ethernet Port 2: Pins 1,2; 3,4; 5,6; 7,8 (set when in SBC mode, also called 761 mode)	No Jumper Installed (front panel)
		For Front Panel Ethernet Port 2: No Jumpers Installed	
J6, J20	Operation Mode (Set Both Jumpers)	Pins 1, 2 for PMC Mode	PMC Mode
		Pins 2, 3 for SBC Mode*	
J7	Flash Memory Selection	Pins 1, 2 for Soldered Bank A	Socketed Bank B
		Pins 2, 3 for Socketed Bank B	
J10, J17	Ethernet Port 2 Selection (see also J4)	For Front Panel Ethernet Port 2: Pins 1, 3 and 2,4 on Both Jumpers	Front Panel Ethernet Port 2
		For P2 Ethernet Port 2: Pins 3, 5 and 4, 6 on Both Jumpers (set for SBC mode)	

Table 1-1. Manually Configured Headers/Jumpers (Continued)

Jumper	Description	Setting	Default
J15	System Controller (VME)	Pins 1, 2 for No SCON	Auto SCON
		Pins 2, 3 for Auto SCON	
		No Jumper for ALWAYS SCON	
J16	Soldered Flash Protection	Pins 1, 2 Enables Programming of Flash	Flash Prog. Enabled ¹
		Pins 2, 3 Disables Programming of the upper 64KB of Flash	

Refer to the section titled Jumper Settings on the next page for additional information.

Note 1. Write protects only outer two 8K boot sectors. Refer to *Flash Memory* on page 4-5 for an complete explanation.

Jumper Settings

Prior to performing the installation instructions, you must ensure that the jumpers are set properly for your particular configuration. For example, if you are using an IPMC761/MVME761 or IPMC712/MVME712 combination in conjunction with the MVME5100, you must reset the jumpers for the SBC mode (jumpers J4, J6, J10, J17 and J20). These are factory configured for the PMC mode. Verify all settings according to the previous table and follow the instructions below if applicable.

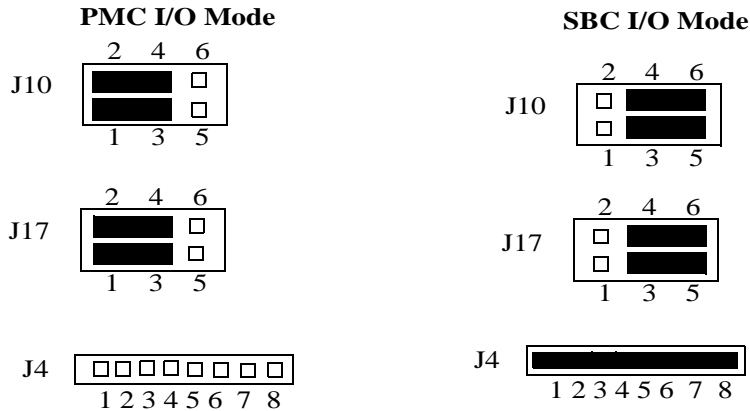

For rear panel LAN, jumper entire 8 pin header on J4

PMC/SBC (761/IPMC) Mode Selection

There are five headers associated with the selection of the PMC or SBC mode: J4, J6, J10, J17 and J20. Three of these headers are responsible for secondary Ethernet I/O (J4, J10 and J17) to either the front panel (PMC mode), or to the P2 connector via J4 (SBC mode). The other two headers (J6 and J20) ensure proper routing of +/- 12V signal routing. The MVME5100 is set at the factory for front panel I/O: PMC mode (see Table 1-1). The SBC mode should only be selected when using one of the IPMC-7xx modules in conjunction with the corresponding MVME7xx transition module.

Installation Considerations

The MVME5100 draws power from the VMEbus backplane connectors P1 and P2. Connector P2 is also used for the upper 16 bits of data in 32-bit transfers, and for the upper 8 address lines in extended addressing mode. The MVME5100 will not function properly without its main board connected to VMEbus backplane connectors P1 and P2.

Whether the MVME5100 operates as a VMEbus master or as a VMEbus slave, it is configured for 32 bits of address and 32 bits of data (A32/D32). However, it handles A16 or A24 devices in the appropriate address ranges. D8 and/or D16 devices in the system must be handled by the processor software.

If the MVME5100 tries to access off-board resources in a nonexistent location and if the system does not have a global bus time-out, the MVME5100 waits indefinitely for the VMEbus cycle to complete. This will cause the system to lock up. There is only one situation in which the system might lack this global bus time-out; that is when the MVME5100 is not the system controller and there is no global bus time-out elsewhere in the system.

Note Software can also disable the bus timer by setting the appropriate bits in the Universe II VMEbus interface.

Multiple MVME5100 boards may be installed in a single VME chassis; however, each must have a unique VMEbus address. Other MPUs on the VMEbus can interrupt, disable, communicate with, and determine the operational status of the processor(s).

Installation

This section discusses the installation of PMCs onto the MVME5100, installation of PMCspan modules onto the MVME5100, and the installation of the MVME5100 into a VME chassis.

Note If you have ordered one or more of the optional RAM500 memory mezzanine boards for the MVME5100, ensure that they are installed on the board prior to proceeding. If they have not been installed by the factory, and you are installing them yourself, please refer to [Appendix D, *RAM500 Memory Expansion Module*](#), for installation instructions. It is recommended that the memory mezzanine modules be installed prior to installing other board accessories, such as PMCs, IPMCs, or transition modules.

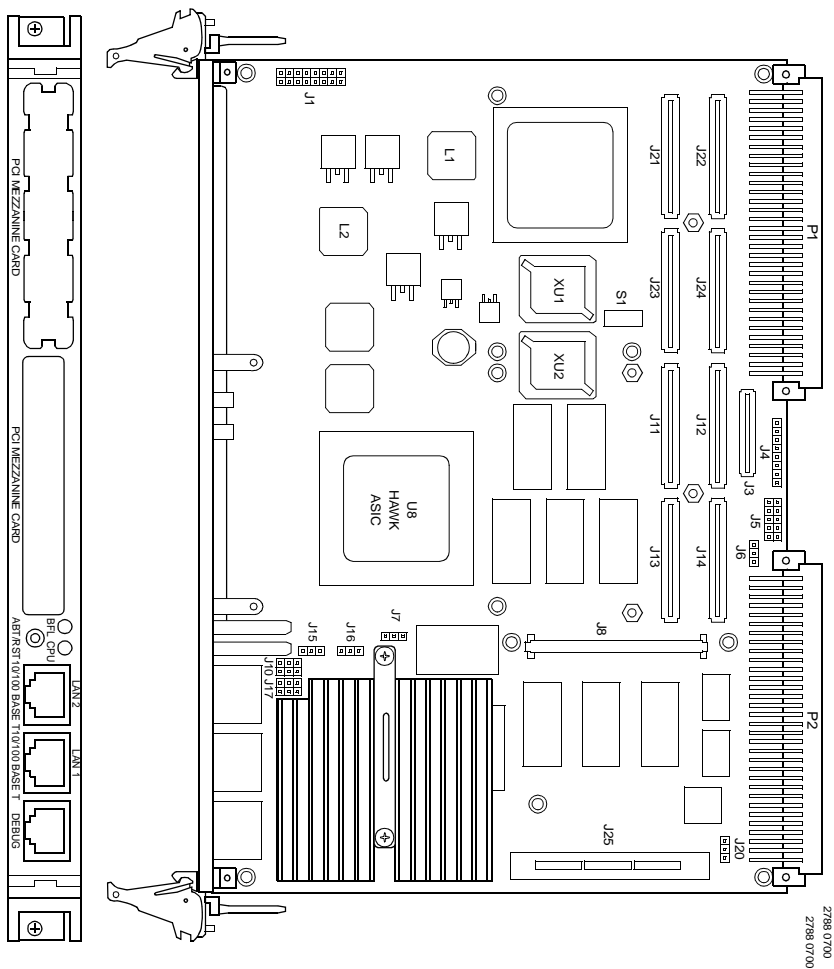

Figure 1-1. MVME5100 Layout

PMC Modules

PMC modules mount on top of the MVME5100. Perform the following steps to install a PMC module on your MVME5100.



Dangerous voltages, capable of causing death, are present in this equipment. Use extreme caution when handling, testing, and adjusting.



Inserting or removing modules with power applied may result in damage to module components. Avoid touching areas of integrated circuitry, static discharge can damage these circuits.

Note This procedure assumes that you have read the user's manual that came with your PMCs.

1. Attach an ESD strap to your wrist. Attach the other end of the ESD strap to an electrical ground. Note that the system chassis may not be grounded if it is unplugged. The ESD strap must be secured to your wrist and to ground throughout the procedure.
2. Perform an operating system shutdown. Turn the AC or DC power off and remove the AC cord or DC power lines from the system. Remove chassis or system cover(s) as necessary for access to the VME modules.
3. If the MVME5100 has already been installed in a VMEbus card slot, carefully remove it as shown in [Figure 1-2](#) and place it with connectors P1 and P2 facing you.
4. Remove the filler plate(s) from the front panel of the MVME5100.
5. Align the PMC module's mating connectors to the MVME5100's mating connectors and press firmly into place.
6. Insert the appropriate number of Phillips screws (typically 4) from the bottom of the MVME5100 into the standoffs on the PMC module and tighten the screws (refer to [Figure 1-3](#)).

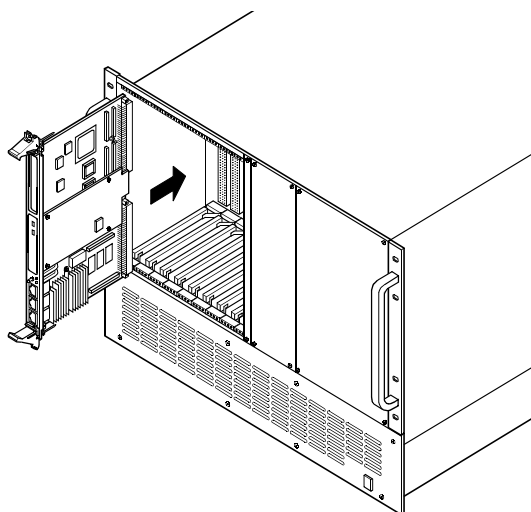

Figure 1-2. MVME5100 Installation and Removal From a VMEbus Chassis

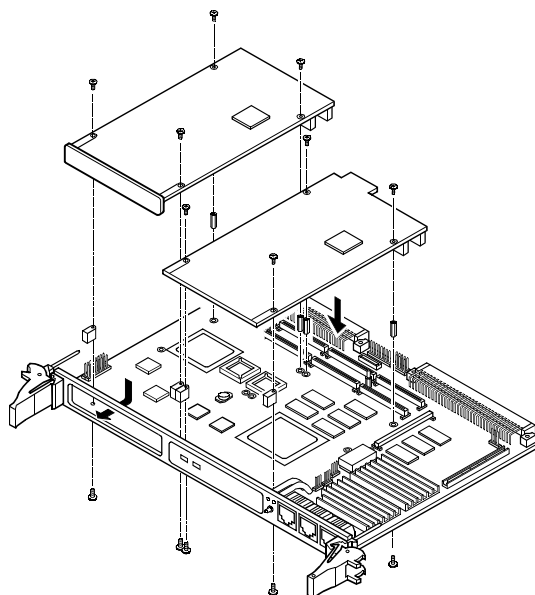

Figure 1-3. Typical PMC Module Placement on an MVME5100

Primary PMCspan

To install a PMCspan-002 PCI expansion module on your MVME5100, perform the following steps while referring to the figure on the next page:



Dangerous voltages, capable of causing death, are present in this equipment. Use extreme caution when handling, testing, and adjusting.



Inserting or removing modules with power applied may result in damage to module components. Avoid touching areas of integrated circuitry, static discharge can damage these circuits.

Note This procedure assumes that you have read the user's manual that was furnished with your PMCspan and that you have installed the selected PMC modules on to your PMCspan according to the instructions provided in the PMCspan and PMC manuals.

1. Attach an ESD strap to your wrist. Attach the other end of the ESD strap to an electrical ground. Note that the system chassis may not be grounded if it is unplugged. The ESD strap must be secured to your wrist and to ground throughout the procedure.
2. Perform an operating system shutdown. Turn the AC or DC power off and remove the AC cord or DC power lines from the system. Remove chassis or system cover(s) as necessary for access to the VME modules.
3. If the MVME5100 has already been installed in a VMEbus card slot, carefully remove it as shown in [Figure 1-2](#) and place it with connectors P1 and P2 facing you.
4. Attach the four standoffs to the MVME5100. For each standoff:
 - Insert the threaded end into the standoff hole at each corner of the MVME5100.
 - Thread the locking nuts into the standoff tips and tighten.

5. Place the PMCspan on top of the MVME5100. Align the mounting holes in each corner to the standoffs and align PMCspan connector P4 with MVME5100 connector J25.

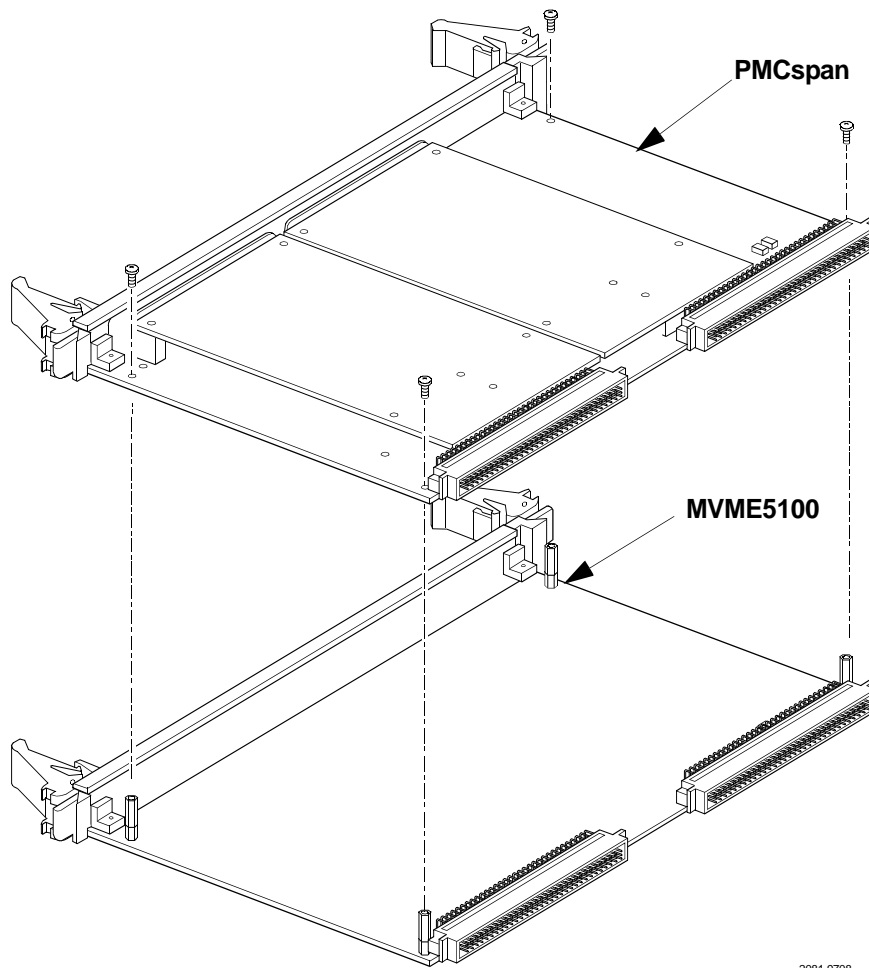

Figure 1-4. PMCspan-002 Installation on an MVME5100

6. Gently press the PMCspan and MVME5100 together and verify that P4 is fully seated in J25.

7. Insert four short screws (Phillips type) through the holes at the corners of the PMCspan and into the standoffs on the MVME5100. Tighten screws securely.

Secondary PMCspan

The PMCspan-010 PCI expansion module mounts on top of a PMCspan-002 PCI expansion module. To install a PMCspan-010 on your MVME5100, perform the following steps while referring to the figure on the next page:



Dangerous voltages, capable of causing death, are present in this equipment. Use extreme caution when handling, testing, and adjusting.



Inserting or removing modules with power applied may result in damage to module components. Avoid touching areas of integrated circuitry, static discharge can damage these circuits.

Note This procedure assumes that you have read the user's manual that was furnished with the PMCspan, and that you have installed the selected PMC modules on your PMCspan according to the instructions provided in the PMCspan and PMC manuals.

1. Attach an ESD strap to your wrist. Attach the other end of the ESD strap to an electrical ground. Note that the system chassis may not be grounded if it is unplugged. The ESD strap must be secured to your wrist and to ground throughout the procedure.
2. Perform an operating system shutdown. Turn the AC or DC power off and remove the AC cord or DC power lines from the system. Remove chassis or system cover(s) as necessary for access to the VME module
3. If the Primary PMC Carrier Module and MVME5100 assembly is already installed in the VME chassis, carefully remove it as shown in [Figure 1-2](#) and place it with connectors P1 and P2 facing you.

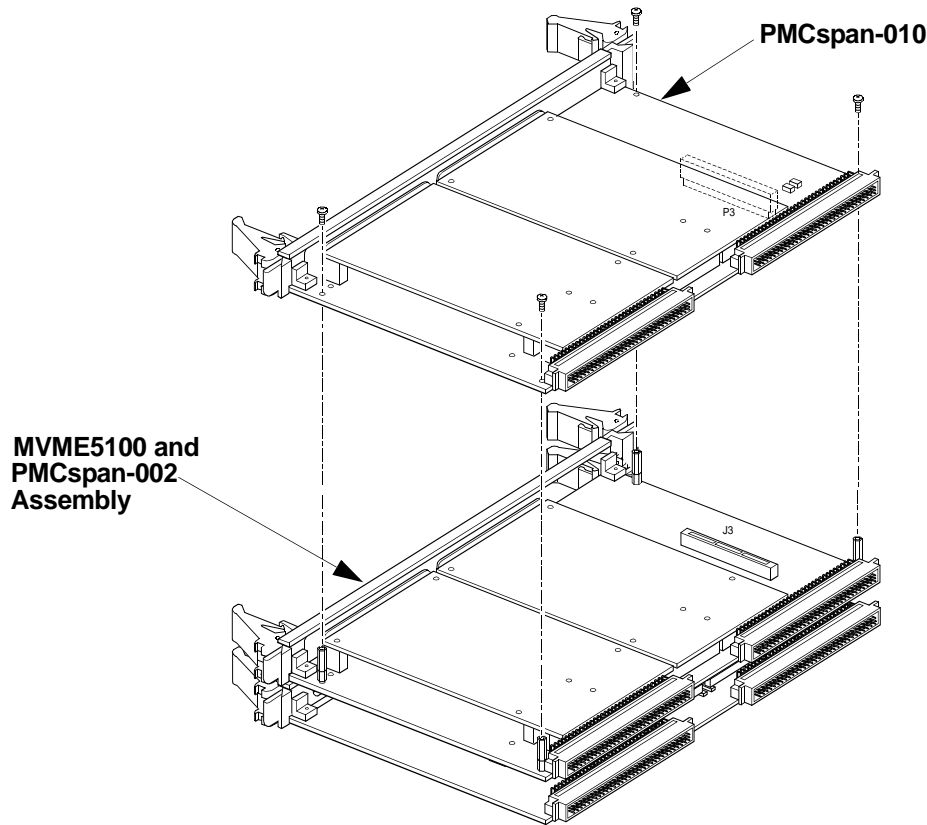

Figure 1-5. PMCspan-010 Installation on a PMCspan-002/MVME5100

4. Remove four screws (Phillips type) from the standoffs in each corner of the primary PCI expansion module.
5. Attach the four standoffs from the PMCspan-010 mounting kit to the PMCspan-002 by screwing the threaded male portion of the standoffs in the locations where the screws were removed in the previous step.
6. Place the PMCspan-010 on top of the PMCspan-002. Align the mounting holes in each corner to the standoffs and align PMCspan-010 connector P3 with PMCspan-002 connector J3.

7. Gently press the two PMCspan modules together and verify that P3 is fully seated in J3.
8. Insert the four screws (Phillips type) through the holes at the corners of PMCspan-010 and into the standoffs on the primary PMCspan-002. Tighten screws securely.

Note The screws have two different head diameters. Use the screws with the smaller heads on the standoffs next to VMEbus connectors P1 and P2.

MVME5100

Before installing the MVME5100 into your VME chassis, ensure that the jumpers are configured properly. This procedure assumes that you have already installed the PMCspan(s) and any PMCs that you have selected.

Perform the following steps to install the MVME5100 in your VME chassis:



Dangerous voltages, capable of causing death, are present in this equipment. Use extreme caution when handling, testing, and adjusting.



Inserting or removing modules with power applied may result in damage to module components. Avoid touching areas of integrated circuitry, static discharge can damage these circuits

1. Attach an ESD strap to your wrist. Attach the other end of the ESD strap to an electrical ground. Note that the system chassis may not be grounded if it is unplugged. The ESD strap must be secured to your wrist and to ground throughout the procedure
2. Perform an operating system shutdown. Turn the AC or DC power off and remove the AC cord or DC power lines from the system. Remove chassis or system cover(s) as necessary for access to the VME module

3. Remove the filler panel from the VMEbus chassis card slot where you are going to install the MVME5100. If you have installed one or more PMCspan PCI expansion modules onto your MVME5100, you will need to remove filler panels from one additional card slot for each PMCspan, above the card slot for the MVME5100.
 - If you intend to use the MVME5100 as system controller, it must occupy the left-most card slot (slot 1). The system controller must be in slot 1 to correctly initiate the bus-grant daisy-chain and to ensure proper operation of the IACK daisy-chain driver.
 - If you do not intend to use the MVME5100 as system controller, it can occupy any unused card slot.
4. Slide the MVME5100 (and PMCspans if used) into the selected card slot(s). Verify that the module or module(s) seated properly in the P1 and P2 connectors on the chassis backplane. Do not damage or bend connector pins.
5. Secure the MVME5100 (and PMCspans if used) in the chassis with the screws in the top and bottom of its front panel and verify proper contact with the transverse mounting rails to minimize RF emissions.

Note Some VME backplanes (such as those used in Motorola Modular Chassis systems) have an auto-jumpering feature for automatic propagation of the IACK and BG signals. The step immediately below does not apply to such backplane designs.

6. On the chassis backplane, remove the INTERRUPT ACKNOWLEDGE (IACK) and BUS GRANT (BG) jumpers from the header for the card slots occupied by the MVME5100 and any PMCspan modules.
7. If you intend to use PPCbug interactively, connect the terminal that is to be used as the PPCbug system console to the DEBUG port on the front panel of the MVME5100.

Note In normal operation, the host CPU controls MVME5100 operation via the VMEbus Universe registers.

8. Replace the chassis or system cover(s) and cable peripherals to the panel connectors as required.
9. Reconnect the system to the AC or DC power source and turn the system power on.
10. The MVME5100's *green* **CPU** LED indicates activity as a set of confidence tests is run, and the debugger prompt `PPC6-Bug>` appears.

Introduction

This chapter provides operating instructions for the MVME5100 Single Board Computer. It includes necessary information about powering up the system along with the functionality of the switches, status indicators, and I/O ports on the front panels of the board.

Switches and Indicators

The front panel of the MVME5100 as shown in [Figure 1-1](#), incorporates one dual function toggle switch (**ABT/RST**) and two Light-Emitting Diode (LED) status indicators (**BFL**, **CPU**) located on the front panel.

ABT/RST Switch

The **ABT/RST** switch operates in the following manner: if pressed for less than 5 seconds, the ABORT function is selected, if pressed for more than 5 seconds, the RESET function is selected. Each function is described below.

Abort Function

When toggled to **ABT**, the switch generates an interrupt signal to the processor. The interrupt is normally used to abort program execution and return control to the debugger firmware located in the processor and flash memory.

The interrupt signal reaches the processor via ISA bus interrupt line IRQ8. The interrupter connected to the ABORT switch is an edge-sensitive circuit, filtered to remove switch bounce.

Reset Function

When toggled to **RST**, the switch resets all onboard devices. To generate a reset, the switch must be depressed for more than five seconds.

The on-board Universe ASIC includes both a global and a local reset driver. When the ASIC operates as the System Controller, the reset driver provides a global system reset by asserting the **SYSRESET#** signal.

Additionally, when the MVME5100 is configured as a System Controller (SCON), a **SYSRESET#** signal may be generated by toggling the **ABT/RST** switch to **RST**, or by a power-up reset, or by a watchdog timeout, or by a control bit in the Miscellaneous Control Register (**MISC_CTL**) in the Universe ASIC.

Note **SYSRESET#** remains asserted for at least 200 ms, as required by the VMEbus specification.

Status Indicators

There are two Light-Emitting Diode (LED) status indicators located on the MVME5100 front panel. They are labeled **BFL** and **CPU**.

RST Indicator (DS1)

The *yellow* **BFL** LED indicates board failure; this indicator is also illuminated during reset as an LED test. The **BFL** is set if the **MODFAIL** Register or **FUSE** Register is set. Refer to the *MVME5100 Single Board Computer Programmer's Reference Guide* (V5100A/PG) for information on these registers.

CPU Indicator (DS2)

The *green* **CPU** LED indicates CPU activity.

Connectors

There are three connectors on the front panel of the MVME5100. Two are bottom-labeled **10/100BASE T** and one is labeled **DEBUG**.

10/100 BASE T Ports

The two RJ-45 ports labeled **10/100 BASE T** provide the 10BaseT/100BaseTX Ethernet LAN interface. These connectors are top-labeled with the designation **LAN1** and **LAN2**.

DEBUG Port

The RJ-45 port labeled **DEBUG** provides an RS232 serial communications interface, based on TL16C550 Universal Asynchronous Receiver/Transmitter (UART) controller chip. It is asynchronous only. For additional information on pin assignments, refer to [Chapter 5, Pin Assignments](#).

The **DEBUG** port may be used for connecting a terminal to the MVME5100 to serve as the firmware console for the factory installed debugger, PPCBug. The port is configured as follows:

- ❑ 8 bits per character
- ❑ 1 stop bit per character
- ❑ Parity disabled (no parity)
- ❑ Baud rate = 9600 baud (default baud rate at power-up)

After power-up, the baud rate of the **DEBUG** port can be reconfigured by using the debugger's Port Format (**PF**) command.

System Powerup

After you have verified that all necessary hardware preparation is done, that all connections were made correctly, and that the installation is complete, you can power up the system.

Initialization Process

The MPU, hardware, and firmware initialization process is performed by the PPCBug firmware upon system powerup or system reset. The firmware initializes the devices on the MVME5100 in preparation for booting an operating system.

The firmware is shipped from the factory with an appropriate set of defaults. Depending on your system and specific application, there may or may not be a need to modify the firmware configuration before you boot the operating system. If it is necessary, refer to [Chapter 3, *PPCBug Firmware*](#) for additional information on modifying firmware default parameters.

The following flowchart in [Figure 2-1](#) shows the basic initialization process that takes place during MVME5100 system start-ups.

For further information on PPCBug, refer to the following:

- ❑ [Chapter 3, *PPCBug Firmware*](#)
- ❑ [Appendix B, *Troubleshooting*](#)
- ❑ [Appendix C, *Related Documentation*](#)

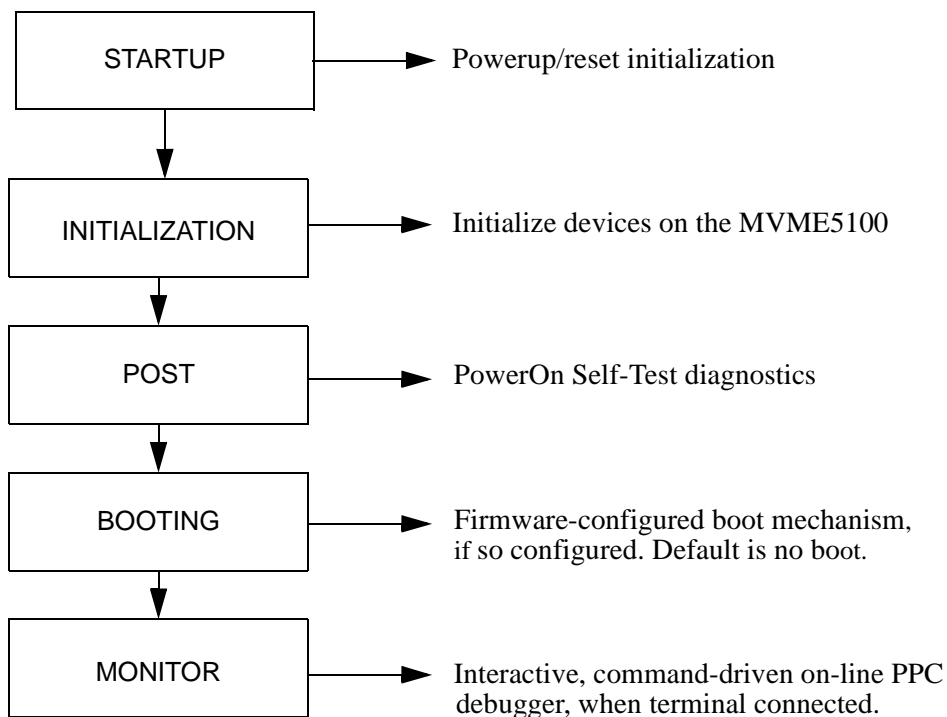

Figure 2-1. Boot-Up Sequence

Introduction

The PPCBug firmware is the layer of software just above the hardware. The firmware provides the proper initialization for the devices on the MVME5100 upon powerup or reset.

This chapter describes the basics of the PPCBug and its architecture. It also describes the monitor (interactive command portion of the firmware), and provides information on using the PPCBug debugger and the special commands. A complete list of PPCBug commands is also provided.

For full user information about PPCBug, refer to the *PPCBug Firmware Package User's Manual* and the *PPCBug Diagnostics Manual*, listed in [Appendix C, Related Documentation](#).

PPCBug Overview

The PPCBug debugger firmware is a powerful evaluation and debugging tool for systems built around Motorola microprocessor. Facilities are available for loading and executing user programs under complete operator control for system evaluation. The PPCBug provides a high degree of functionality, user friendliness, portability, and ease of maintenance.

The PPCBug also achieves its portability because it was written entirely in the C programming language, except where necessary to use assembler functions.

PPCBug includes commands for:

- ❑ Display and modification of memory
- ❑ Breakpoint and tracing capabilities
- ❑ A powerful assembler and disassembler useful for patching programs

- ❑ A self-test at powerup feature which verifies the integrity of the system

PPCBug consists of three parts:

- ❑ A command-driven, user-interactive software debugger, described in the *PPCBug Firmware Package User's Manual*, listed in [Appendix C, Related Documentation](#) (hereafter referred to as “debugger” or “PPCBug”).
- ❑ A command-driven diagnostics package for the MVME5100 hardware (hereafter referred to as “diagnostics”). The diagnostics package is described in the *PPCBug Diagnostics Manual*, listed in [Appendix C, Related Documentation](#).
- ❑ A user interface or debug/diagnostics monitor that accepts commands from the system console terminal.

When using PPCBug, you operate out of either the *debugger directory* or the *diagnostic directory*.

- ❑ If you are in the debugger directory, the debugger prompt `PPC6-Bug>` is displayed and you have all of the debugger commands at your disposal.
- ❑ If you are in the diagnostic directory, the diagnostic prompt `PPC6-Diag>` is displayed and you have all of the diagnostic commands at your disposal as well as all of the debugger commands.

Because PPCBug is command-driven, it performs its various operations in response to user commands entered at the keyboard. When you enter a command, PPCBug executes the command and the prompt reappears. However, if you enter a command that causes execution of user target code (for example, **GO**), then control may or may not return to PPCBug, depending on the outcome of the user program.

Implementation and Memory Requirements

PPCBug is written largely in the C programming language, providing benefits of portability and maintainability. Where necessary, assembly language has been used in the form of separately compiled program modules containing only assembler code.

Physically, PPCBug is contained in two socketed 32-pin PLCC Flash devices that together provide 1MB of storage. The executable code is checksummed at every power-on or reset firmware entry. The result (which includes a precalculated checksum contained in the flash devices), is verified against the expected checksum.

PPCBug requires a maximum of 768KB of read/write memory. The debugger allocates this space from the top of memory. For example, a system containing 64MB (0x04000000) of read/write memory will place the PPCBug memory locations 0x03F40000 to 0x3FFFFFFF. Additionally, the first 1MB of DRAM is reserved for the exception vector table and stack.

Using PPCBug

PPCBug is command-driven; it performs its various operations in response to commands that you enter at the keyboard. When the `PPC6-Bug>` prompt appears on the screen, the debugger is ready to accept debugger commands. When the `PPC6-Diag>` prompt appears on the screen, the debugger is ready to accept diagnostics commands. To switch from one mode to the other, enter **SD**.

What you enter is stored in an internal buffer. Execution begins only after you press the **Return** or **Enter** key. This allows you to correct entry errors, if necessary, with the control characters described in the *PPCBug Firmware Package User's Manual*, listed in [Appendix C, Related Documentation](#).

After the debugger executes the command, the prompt reappears. However, depending on what the user program does, if the command causes execution of a user target code (that is, **GO**), then control may or may not return to the debugger.

For example, if a breakpoint has been specified, then control returns to the debugger when the breakpoint is encountered during execution of the user program. Alternately, the user program could return to the debugger by means of the System Call Handler routine **RETURN** (described in the *PPCBug Firmware Package User's Manual*). For more about this, refer to the **GD**, **GO**, and **GT** command descriptions in the *PPCBug Firmware Package User's Manual*, listed in [Appendix C, Related Documentation](#) .

A debugger command is made up of the following parts:

- ❑ The command name, either uppercase or lowercase (for example, **MD** or **md**)
- ❑ Any required arguments, as specified by command
- ❑ At least one space before the first argument. Precede all other arguments with either a space or comma.
- ❑ One or more options. Precede an option or a string of options with a semicolon (;). If no option is entered, the command's default option conditions are used.

Hardware and Firmware Initialization

The debugger performs the hardware and firmware initialization process. This process occurs each time the MVME5100 is reset or powered up. The steps listed below are a high-level outline; be aware that not all of the detailed steps are listed.

1. Sets MPU.MSR to known value.
2. Invalidates the MPU's data/instruction caches.
3. Clears all segment registers of the MPU.
4. Clears all block address translation registers of the MPU.
5. Initializes the MPU-bus-to-PCI-bus bridge device.
6. Initializes the PCI-bus-to-ISA-bus bridge device.
7. Calculates the external bus clock speed of the MPU.

8. Delays for 750 milliseconds.
9. Determines the CPU base board type.
10. Sizes the local read/write memory (that is, DRAM).
11. Initializes the read/write memory controller. Sets base address of memory to 0x00000000.
12. Retrieves the speed of read/write memory.
13. Initializes the read/write memory controller with the speed of read/write memory.
14. Retrieves the speed of read only memory (that is, Flash).
15. Initializes the read only memory controller with the speed of read only memory.
16. Enables the MPU's instruction cache.
17. Copies the MPU's exception vector table from 0xFFFF0000 to 0x00000000.
18. Verifies MPU type.
19. Enables the superscalar feature of the MPU (superscalar processor boards only).
20. Verifies the external bus clock speed of the MPU.
21. Determines the debugger's console/host ports and initializes the PC16550A.
22. Displays the debugger's copyright message.
23. Displays any hardware initialization errors that may have occurred.
24. Checksums the debugger object and displays a warning message if the checksum failed to verify.
25. Displays the amount of local read/write memory found.
26. Verifies the configuration data that is resident in NVRAM and displays a warning message if the verification failed.

27. Calculates and displays the MPU clock speed, verifies that the MPU clock speed matches the configuration data, and displays a warning message if the verification fails.
28. Displays the BUS clock speed, verifies that the BUS clock speed matches the configuration data, and displays a warning message if the verification fails.
29. Probes PCI bus for supported network devices.
30. Probes PCI bus for supported mass storage devices.
31. Initializes the memory/IO addresses for the supported PCI bus devices.
32. Executes Self-Test, if so configured. (Default is no Self-Test).
33. Extinguishes the board fail LED, if Self-Test passed, and outputs any warning messages.
34. Executes boot program, if so configured. (Default is no boot.)
35. Executes the debugger monitor (that is, issues the `PPC6-Bug>` prompt).

Default Settings

The following sections provide information pertaining to the firmware settings of the MVME5100. Default (factory set) Environment (**ENV**) commands are provided to inform you on how the MVME5100 was configured at the time it left the factory.

CNFG - Configure Board Information Block

Use this command to display and configure the Board Information Block, which is resident within the NVRAM. This data block contains various elements detailing specific operational parameters of the MVME5100. The structure for the board is shown in the following example:

```
Board (PWA) Serial Number    = MOT00xxxxxxx
Board Identifier              = MVME5100
Artwork (PWA) Identifier     = 01-W3518FxxB
MPU Clock Speed              = 450
Bus Clock Speed              = 100
Ethernet Address              = 0001AF2A0A57
Primary SCSI Identifier       = 07
System Serial Number         = nnnnnnnnn
System Identifier             = Motorola MVME5100
License Identifier            = nnnnnnnnn
```

The Board Information Block parameters shown above are left-justified character (ASCII) strings padded with space characters.

The Board Information Block is factory-configured before shipment. There is no need to modify block parameters unless the NVRAM is corrupted.

Refer to the *PPCBug Firmware Package User's Manual*, listed in [Appendix C, Related Documentation](#) for a description of **CNFG** and examples.

ENV - Set Environment

Use the **ENV** command to view and/or configure interactively all PPCBug operational parameters that are kept in Non-Volatile RAM (NVRAM).

Refer to the *PPC Bug Firmware Package User's Manual* for a description of the use of **ENV**. Additional information on registers in the Universe ASIC that affect these parameters is contained in your *MVME5100 Programmer's Reference Guide*, listed in [Appendix C, Related Documentation](#).

Listed and described below are the parameters that you can configure using **ENV**. The default values shown were those in effect when this publication went to print.

Configuring the PPC Bug Parameters

The parameters that can be configured using **ENV** are:

Bug or System environment [B/S] = B?

- B** Bug is the mode where no system type of support is displayed. However, system-related items are still available. (Default)
- S** System is the standard mode of operation, and is the default mode if NVRAM should fail. System mode is defined in the *PPC Bug Firmware Package User's Manual* listed in [Appendix C, Related Documentation](#).

Maximum Memory Usage (MB, 0=AUTO) = 1?

This parameter specifies the maximum number of megabytes the bug is allowed to use. Allocation begins at the top of physical memory and expands downward as more memory is required until the maximum value is reached.

If a value of zero is specified, memory will continue to be increased as needed until half of the available memory is consumed (that is, 32MB in a 64MB system). This mode is useful for determining the full memory required for a specific configuration. Once this is determined, a hard value may be given to the parameter and it is guaranteed that no memory will be used over this amount.

The default value for this parameter is one.

Note: The bug does not automatically acquire all of the memory it is allowed. It accumulates memory as necessary in one megabyte blocks.

Field Service Menu Enable [Y/N] = N?

- Y** Display the field service menu.
- N** Do not display the field service menu. (Default)

Remote Start Method Switch [G/M/B/N] = B?

The Remote Start Method Switch is used when the MVME5100 is cross-loaded from another VME-based CPU in order to start execution of the cross-loaded program.

- G** Use the Global Control and Status Register to pass and start execution of the cross-loaded program.
- M** Use the Multiprocessor Control Register (MPCR) in shared RAM to pass and start execution of the cross-loaded program.
- B** Use both the GCSR and the MPCR methods to pass and start execution of the cross-loaded program. (Default)
- N** Do not use any Remote Start Method.

Probe System for Supported I/O Controllers [Y/N] = Y?

- Y** Accesses will be made to the appropriate system buses (for example, VMEbus, local MPU bus) to determine the presence of supported controllers. (Default)
- N** Accesses will not be made to the VMEbus to determine the presence of supported controllers.

Auto-Initialize of NVRAM Header Enable [Y/N] = Y?

- Y** NVRAM (PreP partition) header space will be initialized automatically during board initialization, but only if the PreP partition fails a sanity check. (Default)
- N** NVRAM header space will not be initialized automatically during board initialization.

Network PreP-Boot Mode Enable [Y/N] = N?

- Y** Enable PreP-style network booting (same boot image from a network interface as from a mass storage device).
- N** Do not enable PreP-style network booting. (Default)

Negate VMEbus SYSFAIL* Always [Y/N] = N?

- Y** Negate the VMEbus SYSFAIL* signal during board initialization.
- N** Negate the VMEbus SYSFAIL* signal after successful completion or entrance into the bug command monitor. (Default)

SCSI Bus Reset on Debugger Startup [Y/N] = N?

- Y** Local SCSI bus is reset on debugger setup.
- N** Local SCSI bus is not reset on debugger setup. (Default)

Primary SCSI Bus Negotiations Type [A/S/N] = A?

- A** Asynchronous SCSI bus negotiation. (Default)
- S** Synchronous SCSI bus negotiation.
- N** None.

Primary SCSI Data Bus Width [W/N] = N?

- W** Wide SCSI (16-bit bus).
- N** Narrow SCSI (8-bit bus). (Default)

Secondary SCSI identifier = 07?

Select the identifier. (Default = 07.)

NVRAM Bootlist (GEV.fw-boot-path) Boot Enable [Y/N] = N?

- Y** Give boot priority to devices defined in the *fw-boot-path* global environment variable (GEV).
- N** Do not give boot priority to devices listed in the *fw-boot-path* GEV. (Default)

Note When enabled, the GEV boot takes priority over all other boots, including Autoboot and Network Boot.

NVRAM Bootlist (GEV.fw-boot-path) Boot at power-up only [Y/N] = N?

- Y** Give boot priority to devices defined in the *fw-boot-path* GEV at powerup reset only.
- N** Give powerup boot priority to devices listed in the *fw-boot-path* GEV at any reset. (Default)

NVRAM Bootlist (GEV.fw-boot-path) Boot Abort Delay = 5?

The time (in seconds) that a boot from the NVRAM boot list will delay before starting the boot. The purpose for the delay is to allow you the option of stopping the boot by use of the **BREAK** key. The time value is from 0-255 seconds. (Default = 5 seconds)

Auto Boot Enable [Y/N] = N?

- Y** The Autoboot function is enabled.
- N** The Autoboot function is disabled. (Default)

Auto Boot at powerup only [Y/N] = N?

- Y** Autoboot is attempted at powerup reset only.
- N** Autoboot is attempted at any reset. (Default)

Auto Boot Scan Enable [Y/N] = Y?

- Y** If Autoboot is enabled, the Autoboot process attempts to boot from devices specified in the scan list (for example, FDISK/CDROM/TAPE/HDISK). (Default)
- N** If Autoboot is enabled, the Autoboot process uses the Controller LUN and Device LUN to boot.

Auto Boot Scan Device Type List = FDISK/CDROM/TAPE/HDISK?

This is the listing of boot devices displayed if the Autoboot Scan option is enabled. If you modify the list, follow the format shown above (uppercase letters, using forward slash as separator).

Auto Boot Controller LUN = 00?

Refer to the *PPCBug Firmware Package User's Manual* for a listing of disk/tape controller modules currently supported by PPCBug. (Default = 0x00)

Auto Boot Device LUN = 00?

Refer to the *PPCBug Firmware Package User's Manual* listed in [Appendix C, Related Documentation](#) for a listing of disk/tape devices currently supported by PPCBug. (Default = 0x00)

Auto Boot Partition Number = 00?

Identifies which disk “partition” is to be booted, as specified in the PowerPC Reference Platform (PReP) specification. If set to zero, the firmware will search the partitions in order (1, 2, 3, 4) until it finds the first “bootable” partition. That is then the partition that will be booted. Other acceptable values are 1, 2, 3, or 4. In these four cases, the partition specified will be booted without searching.

Auto Boot Abort Delay = 7?

The time in seconds that the Autoboot sequence will delay before starting the boot. The purpose for the delay is to allow you the option of stopping the boot by use of the **BREAK** key. The time value is from 0-255 seconds. (Default = 7 seconds)

Auto Boot Default String [NULL for an empty string] = ?

You may specify a string (filename) which is passed on to the code being booted. The maximum length of this string is 16 characters. (Default = null string)

ROM Boot Enable [Y/N] = N?

- Y** The ROMboot function is enabled.
- N** The ROMboot function is disabled. (Default)

ROM Boot at power-up only [Y/N] = Y?

- Y** ROMboot is attempted at power-up only. (Default)
- N** ROMboot is attempted at any reset.

ROM Boot Enable search of VMEbus [Y/N] = N?

- Y** VMEbus address space, in addition to the usual areas of memory, will be searched for a ROMboot module.
- N** VMEbus address space will not be accessed by ROMboot. (Default)

ROM Boot Abort Delay = 5?

The time (in seconds) that the ROMboot sequence will delay before starting the boot. The purpose for the delay is to allow you the option of stopping the boot by use of the **BREAK** key. The time value is from 0-255 seconds. (Default = 5 seconds)

ROM Boot Direct Starting Address = FFF00000?

The first location tested when PPCBug searches for a ROMboot module. (Default = 0xFFFF0000)

ROM Boot Direct Ending Address = FFFFFFFC?

The last location tested when PPCbug searches for a ROMboot module. (Default = 0xFFFFFFFF)

Network Auto Boot Enable [Y/N] = N?

Y The Network Auto Boot (NETboot) function is enabled.

N The NETboot function is disabled. (Default)

Network Auto Boot at power-up only [Y/N] = N?

Y NETboot is attempted at powerup reset only.

N NETboot is attempted at any reset. (Default)

Network Auto Boot Controller LUN = 00?

Refer to the *PPCbug Firmware Package User's Manual*, listed in [Appendix C, Related Documentation](#) for a listing of network controller modules currently supported by PPCbug. (Default = 0x00)

Network Auto Boot Device LUN = 00?

Refer to the *PPCbug Firmware Package User's Manual*, listed in [Appendix C, Related Documentation](#) for a listing of network controller modules currently supported by PPCbug. (Default = 0x00)

Network Auto Boot Abort Delay = 5?

The time in seconds that the NETboot sequence will delay before starting the boot. The purpose for the delay is to allow you the option of stopping the boot by use of the **BREAK** key. The time value is from 0-255 seconds. (Default = 5 seconds)

Network Auto Boot Configuration Parameters Offset (NVRAM) = 00001000?

The address where the network interface configuration parameters are to be saved/retained in NVRAM; these parameters are the necessary parameters to perform an unattended network boot. A typical offset might be 0x1000, but this value is application-specific. (Default = 0x00001000)



If you use the **NIOT** debugger command, these parameters need to be saved somewhere in the offset range 0x00001000 through 0x000016F7. The **NIOT** parameters do not exceed 128 bytes in size. The setting of this **ENV** pointer determines their location. If you have used the same space for your own program information or commands, they will be overwritten and lost.

You can relocate the network interface configuration parameters in this space by using the **ENV** command to change the Network Auto Boot Configuration Parameters Offset from its default of 0x00001000 to the value you need to be clear of your data within NVRAM.

Memory Size Enable [Y/N] = Y?

- Y** Memory will be sized for SelfTest diagnostics.
(Default)
- N** Memory will not be sized for SelfTest diagnostics.

Memory Size Starting Address = 00000000?

The default Starting Address is 0x00000000.

Memory Size Ending Address = 02000000?

The default Ending Address is the calculated size of local memory. If the memory start is changed from 0x0x00000000, this value will also need to be adjusted.

DRAM Speed in NANO Seconds = 15?

The default setting for this parameter will vary depending on the speed of the DRAM memory parts installed on the board. The default is set to the slowest speed found on the available banks of DRAM memory.

ROM Bank A Access Speed (ns) = 80?

This defines the minimum access speed for the Bank A Flash Device(s) in nanoseconds.

ROM Bank B Access Speed (ns) = 70?

This defines the minimum access speed for the Bank B Flash Device(s) in nanoseconds.

DRAM Parity Enable [On-Detection/Always/Never - O/A/N] = O?

- O DRAM parity is enabled upon detection. (Default)
- A DRAM parity is always enabled.
- N DRAM parity is never enabled.

Note This parameter also applies to enabling ECC for DRAM.

L2 Cache Parity Enable [On-Detection/Always/Never - O/A/N] = O?

- O L2 Cache parity is enabled upon detection. (Default)
- A L2 Cache parity is always enabled.
- N L2 Cache parity is never enabled.

PCI Interrupts Route Control Registers (PIRQ0/1/2/3) = 0A0B0E0F?

Initializes the PIRQx (PCI Interrupts) route control registers in the IBC (PCI/ISA bus bridge controller). The **ENV** parameter is a 32-bit value that is divided by 4 fields to specify the values for route control registers PIRQ0/1/2/3. The default is determined by system type as shown: PIRQ0=0A, PIRQ1=0B, PIRQ2=0E, PIRQ3=0F.

LED/Serial Startup Diagnostic Codes

These codes can be displayed at key points in the initialization of the hardware devices. The codes are enabled by an **ENV** parameter.

Serial Startup Code Master Enable [Y/N]=N?

Should the debugger fail to come up to a prompt, the last code displayed will indicate how far the initialization sequence had progressed before stalling.

Serial Startup Code LF Enable [Y/N]=N?

A line feed can be inserted after each code is displayed to prevent it from being overwritten by the next code. This is also enabled by an **ENV** parameter:

The list of LED/serial codes is included in the section on *MPU, Hardware, and Firmware Initialization* found in Chapter 1 of the *PPC Bug Firmware Package User's Manual*, listed in [Appendix C, Related Documentation](#).

Configuring the VMEbus Interface

ENV asks the following series of questions to set up the VMEbus interface for the MVME5100. To perform this configuration, you should have a working knowledge of the Universe ASIC as described in your *MVME5100 Programmer's Reference Guide*. Also, refer to the *Tundra Universe II Users Manual*, as listed in [Appendix C, Related Documentation](#) for a detailed description of VMEbus addressing. In general, the PCI slave images describe the VME master addresses, while the VMEbus slave describes the VME slave addresses.

VME3PCI Master Master Enable [Y/N] = Y?

- Y** Set up and enable the VMEbus Interface. (Default)
- N** Do not set up or enable the VMEbus Interface.

PCI Slave Image 0 Control = 00000000?

The configured value is written into the LSI0_CTL register of the Universe chip.

PCI Slave Image 0 Base Address Register = 00000000?

The configured value is written into the LSI0_BS register of the Universe chip.

PCI Slave Image 0 Bound Address Register = 00000000?

The configured value is written into the LSI0_BD register of the Universe chip.

PCI Slave Image 0 Translation Offset = 00000000?

The configured value is written into the LSI0_TO register of the Universe chip.

PCI Slave Image 1 Control = C0820000?

The configured value is written into the LSI1_CTL register of the Universe chip.

PCI Slave Image 1 Base Address Register = 81000000?

The configured value is written into the LSI1_BS register of the Universe chip.

PCI Slave Image 1 Bound Address Register = A0000000?

The configured value is written into the LSI1_BD register of the Universe chip.

PCI Slave Image 1 Translation Offset = 80000000?

The configured value is written into the LSI1_TO register of the Universe chip.

PCI Slave Image 2 Control = C0410000?

The configured value is written into the LSI2_CTL register of the Universe chip.

PCI Slave Image 2 Base Address Register = A0000000?

The configured value is written into the LSI2_BS register of the Universe chip.

PCI Slave Image 2 Bound Address Register = A2000000?

The configured value is written into the LSI2_BD register of the Universe chip.

PCI Slave Image 2 Translation Offset = 500000000?

The configured value is written into the LSI2_TO register of the Universe chip.

PCI Slave Image 3 Control = C0400000?

The configured value is written into the LSI3_CTL register of the Universe chip.

PCI Slave Image 3 Base Address Register = AFFF0000?

The configured value is written into the LSI3_BS register of the Universe chip.

PCI Slave Image 3 Bound Address Register = B0000000?

The configured value is written into the LSI3_BD register of the Universe chip.

PCI Slave Image 3 Translation Offset = 50000000?

The configured value is written into the LSI3_TO register of the Universe chip.

VMEbus Slave Image 0 Control = E0F20000?

The configured value is written into the VSI0_CTL register of the Universe chip.

VMEbus Slave Image 0 Base Address Register = 00000000?

The configured value is written into the VSI0_BS register of the Universe chip.

VMEbus Slave Image 0 Bound Address Register = (Local DRAM Size)?

The configured value is written into the VSI0_BD register of the Universe chip. The value is the same as the Local Memory Found number already displayed.

VMEbus Slave Image 0 Translation Offset = 00000000?

The configured value is written into the VSI0_TO register of the Universe chip.

VMEbus Slave Image 1 Control = 00000000?

The configured value is written into the VSI1_CTL register of the Universe chip.

VMEbus Slave Image 1 Base Address Register = 00000000?

The configured value is written into the VSI1_BS register of the Universe chip.

VMEbus Slave Image 1 Bound Address Register = 00000000?

The configured value is written into the VSI1_BD register of the Universe chip.

VMEbus Slave Image 1 Translation Offset = 00000000?

The configured value is written into the VSI1_TO register of the Universe chip.

VMEbus Slave Image 2 Control = 00000000?

The configured value is written into the VSI2_CTL register of the Universe chip.

VMEbus Slave Image 2 Base Address Register = 00000000?

The configured value is written into the VSI2_BS register of the Universe chip.

VMEbus Slave Image 2 Bound Address Register = 00000000?

The configured value is written into the VSI2_BD register of the Universe chip.

VMEbus Slave Image 2 Translation Offset = 00000000?

The configured value is written into the VSI2_TO register of the Universe chip.

VMEbus Slave Image 3 Control = 00000000?

The configured value is written into the VSI3_CTL register of the Universe chip.

VMEbus Slave Image 3 Base Address Register = 00000000?

The configured value is written into the VSI3_BS register of the Universe chip.

VMEbus Slave Image 3 Bound Address Register = 00000000?

The configured value is written into the VSI3_BD register of the Universe chip.

VMEbus Slave Image 3 Translation Offset = 00000000?

The configured value is written into the VSI3_TO register of the Universe chip.

PCI Miscellaneous Register = 10000000?

The configured value is written into the LMISC register of the Universe chip.

Special PCI Slave Image Register = 00000000?

The configured value is written into the SLSI register of the Universe chip.

Master Control Register = 80C00000?

The configured value is written into the MAST_CTL register of the Universe chip.

Miscellaneous Control Register = 52060000?

The configured value is written into the MISC_CTL register of the Universe chip.

User AM Codes = 00000000?

The configured value is written into the USER_AM register of the Universe chip.

Firmware Command Buffer

Firmware Command Buffer Enable = N?

- Y** Enables Firmware Command Buffer execution.
- N** Disables Firmware Command Buffer execution (Default).

Firmware Command Buffer Delay = 5?

Defines the number of seconds to wait before firmware begins executing the startup commands in the startup command buffer. During this delay, you may press any key to prevent the execution of the startup command buffer.

The default value of this parameter causes a startup delay of 5 seconds.

Firmware Command Buffer:

['NULL' terminates entry]?

The Firmware Command Buffer contents contain the **BUG** commands which are executed upon firmware startup.

BUG commands you place into the command buffer should be typed just as you enter the commands from the command line.

The string 'NULL' on a new line terminates the command line entries.

All PPC Bug commands, except for the following, may be used within the command buffer: **DU, ECHO, LO, TA, VE**.

Note Interactive editing of the startup command buffer is not supported. If changes are needed to an existing set of startup commands, a new set of commands with changes must be reentered.

Standard Commands

The individual debugger commands are listed in the following table. The commands are described in detail in the *PPC Bug Firmware Package User's Manual*, listed in [Appendix C, Related Documentation](#).

Note You can list all the available debugger commands by entering the Help (**HE**) command alone. You can view the syntax for a particular command by entering **HE** and the command mnemonic, as listed below.

Table 3-1. Debugger Commands

Command	Description
AS	Assembler
BC	Block of Memory Compare
BF	Block of Memory Fill
BI	Block of Memory Initialize
BM	Block of Memory Move
BS	Block of Memory Search
BR	Breakpoint Insert
BV	Block of Memory Verify
CACHE	Modify Cache State
CM	Concurrent Mode

Table 3-1. Debugger Commands (Continued)

Command	Description
CNFG	Configure Board Information Block
CS	Checksum a Block of data
CSAR	PCI Configuration Space READ Access
CSAW	PCI Configuration Space WRITE Access
DC	Data Conversion and Expression Evaluation
DE	Detect Errors
DS	Disassembler
DU	Dump S-Records
ECHO	Echo String
ENV	Set Environment to Bug/Operating System
FORK	Fork Idle MPU at Address
FORKWR	Fork Idle MPU with Registers
G	“Alias” for “GO” Command
GD	Go Direct (Ignore Breakpoints)
GEVBOOT	Global Environment Variable Boot - Bootstrap Operating System
GEVDEL	Global Environment Variable Delete
GEVDUMP	Global Environment Variable(s) Dump (NVRAM Header + Data)
GEVEDIT	Global Environment Variable Edit
GEVINIT	Global Environment Variable Initialize (NVRAM Header)
GEVSHOW	Global Environment Variable Show
GN	Go to Next Instruction
GO	Go Execute User Program
GT	Go to Temporary Breakpoint
HE	Help on Command(s)
IBM	Indirect Block Move
IDLE	Idle Master MPU
IOC	I/O Control for Disk

Table 3-1. Debugger Commands (Continued)

Command	Description
IOI	I/O Inquiry
IOP	I/O Physical to Disk
IOT	I/O “Teach” for Configuring Disk Controller
IRD	Idle MPU Register Display
IRM	Idle MPU Register Modify
IRS	Idle MPU Register Set
LO	Load S-Records from Host
M	“Alias” for “MM” Command
MA	Macro Define/Display
MAE	Macro Edit
MAL	Enable Macro Expansion Listing
MAR	Macro Load
MAW	Macro Save
MD	Memory Display
MDS	Memory Display (Sector)
MENU	System Menu
MM	Memory Modify
MMD	Memory Map Diagnostic
MMGR	Access Memory Manager
MS	Memory Set
MW	Memory Write
NAB	Automatic Network Bootstrap Operating System
NAP	Nap MPU
NBH	Network Bootstrap Operating System and Halt
NBO	Network Bootstrap Operating System
NIOC	Network I/O Control
NIOP	Network I/O Physical
NIOT	I/O “Teach” for Configuring Network Controller
NOBR	Breakpoint Delete

Table 3-1. Debugger Commands (Continued)

Command	Description
NOCM	No Concurrent Mode
NOMA	Macro Delete
NOMAL	Disable Macro Expansion Listing
NOPA	Printer Detach
NOPF	Port Detach
NORB	No ROM Boot
NOSYM	Detach Symbol Table
NPING	Network Ping
OF	Offset Registers Display/Modify
PA	Printer Attach
PBOOT	Bootstrap Operating System
PF	Port Format
PFLASH	Program FLASH Memory
PS	Put RTC into Power Save Mode
RB	ROMboot Enable
RD	Register Display
REMOTE	Remote
RESET	Cold/Warm Reset
RL	Read Loop
RM	Register Modify
RS	Register Set
RUN	MPU Execution/Status
SD	Switch Directories
SET	Set Time and Date
SROM	SROM Examine/Modify
ST	Self Test
SYM	Symbol Table Attach
SYMS	Symbol Table Display/Search
T	Trace

Table 3-1. Debugger Commands (Continued)

Command	Description
TA	Terminal Attach
TIME	Display Time and Date
TM	Transparent Mode
TT	Trace to Temporary Breakpoint
VE	Verify S-Records Against Memory
VER	Revision/Version Display
WL	Write Loop

**Caution**

Although a command (PFLASH) to allow the erasing and reprogramming of Flash memory is available to you, keep in mind that reprogramming any portion of Flash memory will erase everything currently contained in Flash, including the PPCBug debugger, if the target address addresses the bank in which it resides.

Diagnostics

The PPCBug hardware diagnostics are intended for testing and troubleshooting the MVME5100.

In order to use the diagnostics, you must switch to the diagnostic directory. You may switch between directories by using the **SD** (Switch Directories) command. You may view a list of the commands in the directory that you are currently in by using the **HE** (Help) command.

If you are in the debugger directory, the debugger prompt `PPC6-Bug>` is displayed, and all of the debugger commands are available. Diagnostics commands cannot be entered at the `PPC6-Bug>` prompt.

If you are in the diagnostic directory, the diagnostic prompt `PPC6-Diag>` is displayed, and all of the debugger and diagnostic commands are available.

PPCBug's diagnostic test groups are listed in [Table 3-2](#). Note that not all tests are performed on the MVME5100. Using the **HE** command, you can list the diagnostic routines available in each test group. Refer to the

PPC Bug Diagnostics Manual, listed in [Appendix C, Related Documentation](#) for complete descriptions of the diagnostic routines and instructions on how to invoke them.

Table 3-2. Diagnostic Test Groups

Test Group	Description
EPIC	EPIC Timers Test
PHB	PCI Bridge Revision Test
RAM	RAM Tests (various)
HOSDMA	DMA Transfer Test
RTC	MK48Txx Real Time Clock Tests
UART	Serial Input/Output Tests (Register, IRQ, Baud, & Loopback)
Z8536	Z8536 Counter/Timer Tests*
SCC	Serial Communications Controller (Z85C230) Tests*
PAR8730x	Parallel Interface (PC8730x) Test*
KBD8730x	PC8730x Keyboard/Mouse Tests*
ISABRDGE	PCI/ISA Bridge Tests (Register Access & IRQ)
VME3	VME3 Tests (Register Read & Register Walking Bit)
DEC	DEC21x43 Ethernet Controller Tests
CL1283	Parallel Interface (CL1283) Tests*

- Notes**
1. You may enter command names in either uppercase or lowercase.
 2. Some diagnostics depend on restart defaults that are set up only in a particular restart mode. Refer to the documentation on a particular diagnostic for the correct mode.
 3. Test Sets marked with an asterisk (*) are not available on the MVME5100 (unless an IPMC712 or IPMC761 is mounted). The ISABRDGE test is only performed if an IPMC761 is mounted on the MVME5100. If the MVME5100 is operating in PMC mode (IPMC761 is not mounted), then the test suite is bypassed.

Introduction

This chapter provides a functional description for the MVME5100 Single Board Computer. The MVME5100 is a high-performance product featuring Motorola's PowerPlus II architecture with a choice of PowerPC processors—either Motorola's MPC7410 with AltiVec™ technology for algorithmic intensive computations or the low-power MPC755 or MPC750.

The MVME5100 incorporates a highly optimized PCI interface and memory controller enabling up to 582MB memory read bandwidth and 640MB burst write bandwidth.

The optimization of the memory bus is as important as optimization of the system bus in order to achieve maximum system performance. The MVME5100's advanced PowerPlus II Architecture supports full PCI throughput of 264MB without starving the CPU of its memory.

Additional features of the MVME5100 include dual Ethernet ports, dual serial ports, and up to 17MB of Flash.

Features Summary

The table below lists the general features for the MVME5100. Refer to [Appendix A, Specifications](#), for additional product specifications and information.

Table 4-1. MVME5100 General Features

Feature	Specification
Microprocessors and Bus Clock Frequency	MPC7410 @400 or 500 MHz Internal Clock Frequency MPC755 @400 MHz Internal Clock Frequency MPC750 @450 MHz Internal Clock Frequency Bus Clock Frequency up to 100 MHz

Table 4-1. MVME5100 General Features (Continued)

Feature	Specification
L2 Cache (Optional)	1MB (MPC750 or MPC755) or 2MB (MPC7410) using burst-mode SRAM modules.
Memory	EEPROM, on-board programmable 1MB via two 32-pin PLCC/CLCC sockets; 16MB Surface Mount
Main Memory (SDRAM)	PC100 ECC SDRAM with 100 MHz bus 32MB to 512MB on board, expandable to 1GB via RAM500 memory mezzanine
NVRAM	32KB (4KB available for users)
Memory Controller	Hawk System Memory Controller (SMC)
PCI Host Bridge	Hawk PCI Host Bridge (PHB)
Interrupt Controller	Hawk Multi-Processor Interrupt Controller (MPIC)
Peripheral Support	Dual 16550-Compatible Asynchronous Serial Port's Routed to the Front Panel RJ45 Connector (COM1) and On-Board Header (COM2) Dual Ethernet Interfaces, one routed to the Front Panel RJ45, One Routed to the Front Panel RJ45 or Optionally Routed to P2, RJ45 on MVME761
VMEbus	Tundra Universe Controller, 64-bit PCI Programmable Interrupter & Interrupt Handler Programmable DMA Controller With Link List Support Full System Controller Functions
PCI/PMC/Expansion	Two 32/64-bit PMC Slots With Front-Panel I/O Plus, P2 Rear I/O (MVME2300 Routing) One PCI Expansion Connector (for the PMCSpan)
Miscellaneous	Combined RESET and ABORT Switch Status LEDs
Form Factor	6U VME

Features Descriptions

General

As stated earlier, the MVME5100 is a high-performance VME based Single Board Computer featuring Motorola's PowerPlus II architecture with a choice of processors. The board can be equipped with either the Motorola MPC7410 processor with AltiVec™ technology for algorithmic intensive computations or with the low-power MPC755 or MPC750 for low-power or field applications.

Designed to meet the needs of OEMs servicing the military and aerospace, industrial automation, and semiconductor process equipment market segments, the MVME5100 is available in both commercial grade (0° to 55° C) and industrial grade (-20° to 71° C) temperatures.

The MVME5100 has two Input/Output (I/O) modes of operation: PMC and SBC (also called 761 mode or IPMC mode). In PMC mode, it is fully backwards compatible with previous generation dual PMC products such as the MVME2300 and MVME2400.

In the SBC mode, the MVME5100 is backwards compatible with the corresponding Motorola MVME712 or MVME761 transition board originated for use with previous generation single-board computer products, such as the MVME2600 and MVME2700.

It is important to note that MVME712 and MVME761 compatibility is accomplished with the addition of the corresponding IPMC712 or IPMC761 (an optional add-on PMC card). The IPMC712 and IPMC761 provides rear I/O support for one single-ended ultra-wide SCSI device, one parallel port, four serial ports (two synchronous for 761 and one for 712, and two asynchronous/synchronous for 761 and three for 712), and I²C functionality through the Hawk ASIC. This multi-function PMC card is offered with the MVME5100 as a factory bundled configuration.

The following diagram illustrates the architecture of the MVME5100 Single Board Computer.

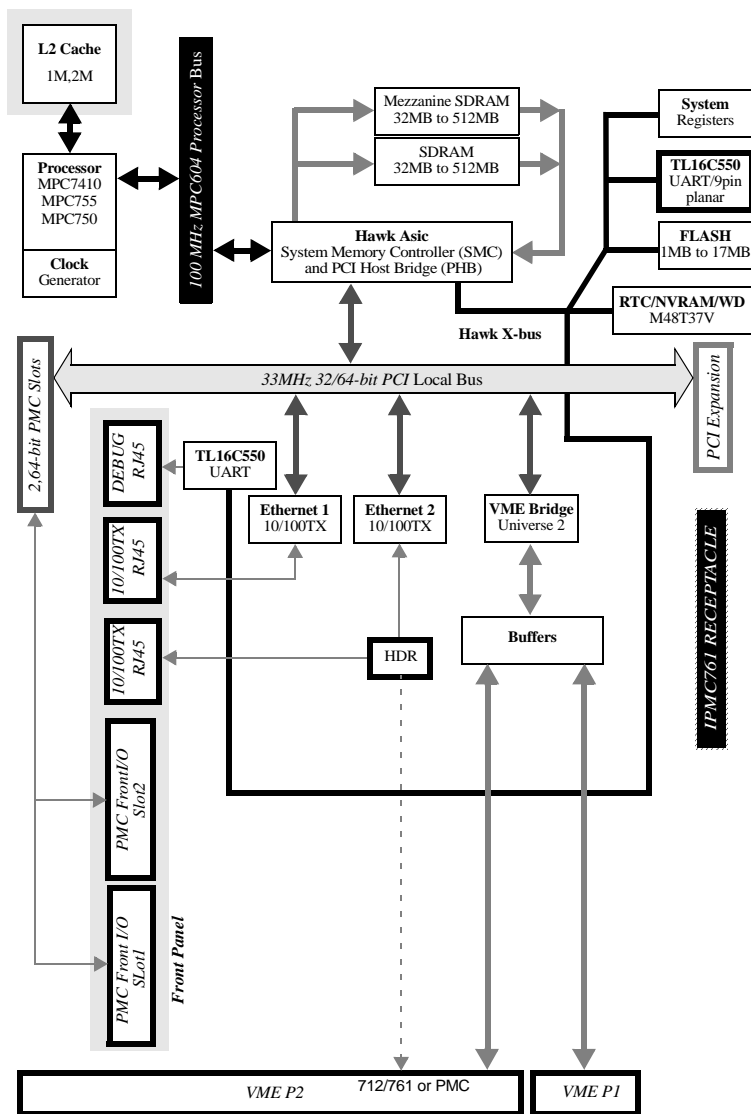

Figure 4-1. MVME5100 Block Diagram

Processor

The MVME5100 incorporates a *BGA* foot print that supports both the MCP7410 and the MCP75x processors. The maximum external processor bus speed is 100 MHz.

Note The MCP7410 is configured to operate only with the PowerPC 60xbus interface.

4

System Memory Controller and PCI Host Bridge

The on-board Hawk ASIC provides the bridge function between the processor's bus and the PCI bus. It provides 32-bit addressing and 64-bit data; however, 64-bit addressing (dual address cycle) is not supported. The ASIC also supports various processor external bus frequencies up to 100 MHz.

There are four programmable map decoders for each direction to provide flexible address mappings between the processor and the PCI bus. The ASIC also provides an Multi-Processor Interrupt Controller (MPIC) to handle various interrupt sources. They are: four MPIC timer interrupts, interrupts from all PCI devices, and two software interrupts.

Memory

The following subsections describe various memory capabilities on the MVME5100 including Flash memory and ECC SDRAM memory.

Flash Memory

The MVME5100 contains two banks of Flash memory. Bank B consists of two 32-pin devices which can be populated with 1MB of Flash memory (only 8-bit writes are supported for this bank). Refer to the application note following for more write-protect information on this product.

Bank A has 4 16-bit Smart Voltage FLASH SMT devices. With 32Mbit flash devices, the flash memory size is 16MB. Note that only 32-bit writes are supported for this bank of flash memory.

Application Note: For Am29DL322C or Am29DL323C, 32Megabit (4M x 8-Bit/2M x 16-bit) CMOS 3.0 Volt-only Flash Memory.

The Write Protect function provides a hardware method of protecting certain boot sectors. If the system asserts V_{IL} (low signal) on the WP#/ACC pin, the device disables the program and erase capability, independently of whether those sectors were protected or unprotected using the method described in the Sector/Sector Block Protection and Unprotection of the AMD datasheet. The two outermost 8Kbyte boot sectors are the two sectors containing the lowest addresses in a bottom-boot-configured device, or the two sectors containing the highest addresses in a top-boot-configured device.

The aforementioned Motorola implemented device (at the time of this printing is the only Motorola qualified Flash device used on this product) is a top-boot device, and as such, the write protected area is in the upper 16KB of each device. And, since Motorola is using 4 devices for the soldered Flash bank, the write protected region corresponds to the upper 64KB of the soldered Flash memory map. Thus the address range of \$F4FF 0000 to F4FF FFFF is the write protected region when the J16 header is jumpered across pins 2 and 3.

If PPCBug tries to write to those write-protected address areas when pins 2-3 on J16 are set, the command will simply not finish (i.e., erase sector function stops at \$F4FF 0000).

ECC SDRAM Memory

The MVME5100's on-board memory and optional memory mezzanines allow for a variety of memory size options. Memory size can be 64 or 512MB for a total of 1GB on-board and mezzanine ECC memory. The memory is controlled by the hardware which provides single-bit error correction and double-bit error detection (ECC is calculated over 72-bits).

Either 1 or 2 mezzanines can be installed. Each mezzanine will add 1 bank of SDRAM memory of 256MB. A total of 512MB of mezzanine memory can be added. Refer to [Appendix D, RAM500 Memory Expansion Module](#) for more information.

P2 Input/Output (I/O) Modes

The MVME5100 has two P2 I/O modes (SBC and PMC) that are user-configurable with jumpers on the board (J6 and J20). The jumpers route the on-board Ethernet port 2 to row C of the P2 connector. Ethernet jumpers (J4, J10, and J17) should also be configured.

The SBC mode (also called 761 or IPMC mode) are backwards compatible with the corresponding MVME712 and MVME761 transition cards and the P2 adapter card (excluding PMC I/O routing) used on the MVME2600/2700. The SBC mode is accomplished by configuring the on-board jumpers and attaching an IPMC712 or IPMC761 PMC in PMC slot 1 of the MVME5100.

PMC mode is backwards compatible with the MVME2300/MVME2400. PMC mode is accomplished by simply configuring the on-board jumpers.

Note Refer to [Chapter 5, Pin Assignments](#) for P2 Input/Output Mode jumper settings.

Input/Output Interfaces

The following subsections describe the major I/O interfaces on the MVME5100 including Ethernet, VMEbus, asynchronous communications ports, real-time clock/NVRAM/Watchdog Timer, other timer interfaces, interrupt routing capabilities and IDSEL routing capabilities.

Ethernet Interface

The MVME5100 incorporates dual Ethernet interfaces (Port 1 and Port 2) via two Fast Ethernet PCI controller chips.

The Port 1 10BaseT/100BaseTX interface is routed to the front panel. The Port 2 Ethernet interface is routed to either the front panel or the P2 connector as configured by jumpers. The front panel connectors are of the RJ45 type.

Every board is assigned two Ethernet Station Addresses. The address is \$0001AFXXXXX where XXXXX is the unique number assigned to each interface. Each Ethernet Station Address is displayed on a label attached to the PMC front-panel keep-out area.

In addition, LAN 1 Ethernet address is stored in the configuration area of the NVRAM specified by the Boot ROM and in SROM.

VMEbus Interface

The VMEbus interface is provided by the Universe II ASIC. Refer to the *Universe II User's Manual*, as listed in [Appendix C, Related Documentation](#), for additional information.

Asynchronous Communications

The MVME5100 provides dual asynchronous debug ports. The serial signals COM1 and COM2 are routed through appropriate EIA-232 drivers and receivers to an RJ45 connector on the front panel (COM1) and an on-board connector (COM2). The external signals are ESD protected.

Real-Time Clock & NVRAM & Watchdog Timer

The MVME5100's design incorporates 32KB of non-volatile static RAM, along with a real-time clock and a watchdog function an integrated device. Refer to the *M48T37V CMOS 32Kx8 Timekeeper SRAM Data Sheet*, as referenced in [Appendix C, Related Documentation](#) for additional programming and engineering information.

Timers

Timers and counters on the MVME5100 are provided by the board's hardware (Hawk ASIC). There are four 32-bit timers on the board that may be used for system timing or to generate periodic interrupts.

Interrupt Routing

Legacy interrupt assignment for the PCI/ISA Bridge is maintained to ensure software compatibility between the MVME5100 and the MVME2700 while in SBC mode.

This is accomplished by using the corresponding on-board IPMC712 or IPMC761 connector to route the PCI/ISA Bridge interrupt signal to the external interrupt 0 of the Hawk ASIC (MPIC).

Note The SCSI device on either the IPMC712 or IPMC761 uses the standard INTA# pin J11-04 of PMC Slot 1.

IDSEL Routing

Legacy IDSEL assignment for the PCI/ISA Bridge is also maintained to ensure software compatibility between MVME5100 and the MVME2700 while in SBC mode (also called 761 or IPMC mode).

This is accomplished by using either the on-board IPMC712 or IPMC761 connector to route IDSEL (AD11) to the PCI/ISA Bridge on the IPMC712 or IPMC761.

Note The SCSI device on the IPMC712 and IPMC761 uses the standard IDSEL pin J12-25 connected to AD16.

When a standard PMC card (not the IPMC712 or IPMC761) is plugged into slot 1, its IDSEL assignment corresponds to the standard IDSEL pin J12-25 and shall be connected to AD16.

Introduction

This chapter provides information on pin assignments for various jumpers and connectors on the MVME5100 Single Board Computer.

Summary

The following tables summarize all of the jumpers and connectors:

Jumper	Description
J1	RISCWatch Header
J2	PAL Programming Header
J4	Ethernet Port 2 Configuration
J6, J20	Operation Mode Jumpers
J7	Flash Memory Selection
J10, J17	Ethernet Port Selection
J15	System Controller (VME)
J16	Soldered Flash Protection

Connector	Description
J3	IPMC761 Interface
J8	Memory Expansion
J25	PCI Expansion Interface
J11 - J14	PMC Interface (Slot 1)
J21 - J24	PMC Interface (Slot 2)
P1, P2	VMEbus Interface
J9	Ethernet Interface (LAN1)
J18	Ethernet Interface (LAN2)
J19	COM1 Interface
J5	COM2 Interface

Jumper Settings

The following table provides information about the jumper settings associated with the MVME5100 Single Board Computer. The table below provides a brief description of each jumper and the appropriate setting(s) for proper board operation.

Table 5-1. Jumper Switches and Settings

Jumper	Description	Setting	Default
J1	RISCWatch Header	None (Factory Use Only)	N/A
J2	PAL Programming Header	None (Lab Use Only)	N/A
J4	Ethernet Port 2 Selection (set in conjunction with jumpers J10 and J17)	For "P2" Ethernet Port 2: Pins 1,2; 3,4; 5,6; 7,8 (set for 712/761)	No Jumper Installed (front panel)
		For "Front Panel" Ethernet Port 2: No Jumpers Installed	
J6, J20	Operation Mode (Set Both Jumpers)	Pins 1,2 for PMC Mode	PMC Mode
		Pins 2,3 for SBC Mode (761 Mode)	
J7	Flash Memory Selection at Boot	Pins 1,2 for Soldered Bank A	Socketed Bank B
		Pins 2,3 for Socketed Bank B	
J10, J17	Ethernet Port 2 Selection (set in conjunction with jumper J4)	For "Front Panel" Ethernet Port 2: Pins 1,3 and 2,4 on Both Jumpers	Front Panel Ethernet Port 2
		For "P2" Ethernet Port 2: Pins 3,5 and 4,6 on Both Jumpers (set for 712/761)	
J15	System Controller (VME)	Pins 1,2 for No SCON	Auto SCON
		Pins 2,3 for Auto SCON	
		No Jumper for ALWAYS SCON	
J16	Soldered Flash Protection	Pins 1,2 Enables Programming of Flash	Flash Prog. Enabled
		Pins 2,3 Disables Programming of the upper 64KB of Flash	

Connectors

IPMC761 Connector (J3) Pin Assignments

This connector is used to provide an interface to the IPMC761 module signals and is located near J11. The pin assignments for this connector are as follows:

Table 5-2. IPMC761 Connector Pin Assignments

Pin	Assignment		Pin
1	I2CSCL	I2CSDA	2
3	GND	GND	4
5	DB8#	GND	6
7	GND	DB9#	8
9	DB10#	+3.3V	10
11	+3.3V	DB11#	12
13	DB12#	GND	14
15	GND	DB13#	16
17	DB14#	+3.3V	18
19	+3.3V	DB15#	20
21	DBP1#	GND	22
23	GND	LANINT2_L	24
25	PIB_INT	+3.3V	26
27	+3.3V	PIB_PMCREQ#	28
29	PIB_PMCGNT#	GND	30
31	GND	+3.3V	32
33	+5.0V	+5.0V	34
35	GND	GND	36
37	+5.0V	+5.0V	38
39	GND	GND	40

Memory Expansion Connector (J8) Pin Assignments

This connector is used to provide memory expansion capability. A single memory mezzanine card provides a maximum of 256MB of memory. Attaching another memory mezzanine to the first mezzanine provides an additional 512MB of expansion memory. The pin assignments for this connector are as follows:

Table 5-3. Memory Expansion Connector Pin Assignments

Pin	Assignment		Pin
1	GND	GND	2
3	DQ00	DQ01	4
5	DQ02	DQ03	6
7	DQ04	DQ05	8
9	DQ06	DQ07	10
11	+3.3V	+3.3V	12
13	DQ08	DQ09	14
15	DQ10	DQ11	16
17	DQ12	DQ13	18
19	DQ14	DQ15	20
21	GND	GND	22
23	DQ16	DQ17	24
25	DQ18	DQ19	26
27	DQ20	DQ21	28
29	DQ22	DQ23	30
31	+3.3V	+3.3V	32
33	DQ24	DQ25	34
35	DQ26	DQ27	36
37	DQ28	DQ29	38
39	DQ30	DQ31	40
41	GND	GND	42
43	DQ32	DQ33	44
45	DQ34	DQ35	46

Table 5-3. Memory Expansion Connector Pin Assignments (Continued)

Pin	Assignment		Pin
47	DQ36	DQ37	48
49	DQ38	DQ39	50
51	+3.3V	+3.3V	52
53	DQ40	DQ41	54
55	DQ42	DQ43	56
57	DQ44	DQ45	58
59	DQ46	DQ47	60
61	GND	GND	62
63	DQ48	DQ49	64
65	DQ50	DQ51	66
67	DQ52	DQ53	68
69	+3.3V	+3.3V	70
71	DQ54	DQ55	72
73	DQ56	DQ57	74
75	DQ58	DQ59	76
77	DQ60	DQ61	78
79	GND	GND	80
81	DQ62	DQ63	82
83	CKD00	CKD01	84
85	CKD02	CKD03	86
87	CKD04	CKD05	88
89	+3.3V	+3.3V	90
91	CKD06	CKD07	92
93	BA1	BA0	94
95	A12	A11	96
97	A10	A09	98
99	GND	GND	100
101	A08	A07	102
103	A06	A05	104

Table 5-3. Memory Expansion Connector Pin Assignments (Continued)

Pin	Assignment		Pin
105	A04	A03	106
107	A02	A01	108
109	+3.3V	+3.3V	110
111	A00	CS_C0_L	112
113	CS_E0_L	GND	114
115	CS_C1_L	CS_E1_L	116
117	WE_L	RAS_L	118
119	GND	GND	120
121	CAS_L	+3.3V	122
123	+3.3V	DQMB0	124
125	DQMB1	SCL	126
127	SDA	A1_SPD	128
129	A0_SPD	MEZZ1_L	130
131	MEZZ2_L	GND	132
133	GND	SDRAMCLK1	134
135	SDRAMCLK3	+3.3V	136
137	SDRAMCLK4	SDRAMCLK2	138
139	GND	GND	140

Note PIN 130, 131, MEZZ1_L, MEZZ2_L, configures the board's local bus frequency. If a single mezzanine is attached to the board, MEZZ1_L will be pulled down on the board. If a second mezzanine is attached on-top to the first, MEZZ2_L will be pulled down on the board. This may cause the clock generation logic to set the local bus frequency to 83.33 MHz if necessary.

PCI Expansion Connector (J25) Pin Assignments

This connector is used to provide PCI/PMC expansion capability. The pin assignments for this connector are as follows:

Table 5-4. PCI Expansion Connector Pin Assignments

Pin	Assignment		Pin	
1	+3.3V	GND	+3.3V	2
3	PCICLK		PMCINTA#	4
5	GND		PMCINTB#	6
7	PURST#		PMCINTC#	8
9	HRESET#		PMCINTD#	10
11	TDO		TDI	12
13	TMS		TCK	14
15	TRST#		PCIXP#	16
17	PCIXGNT#		PCIXREQ#	18
19	+12V		-12V	20
21	PERR#		SERR#	22
23	LOCK#		SDONE	24
25	DEVSEL#		SBO#	26
27	GND		GND	28
29	TRDY#		IRDY#	30
31	STOP#		FRAME#	32
33	GND		GND	34
35	ACK64#		Reserved	36
37	REQ64#		Reserved	38

**Table 5-4. PCI Expansion Connector
Pin Assignments (Continued)**

Pin	Assignment		Pin
39	PAR	+5V	PCIRST#
41	C/BE1#		C/BE0#
43	C/BE3#		C/BE2#
45	AD1		AD0
47	AD3		AD2
49	AD5		AD4
51	AD7		AD6
53	AD9		AD8
55	AD11		AD10
57	AD13		AD12
59	AD15		AD14
61	AD17		AD16
63	AD19		AD18
65	AD21		AD20
67	AD23		AD22
69	AD25		AD24
71	AD27		AD26
73	AD29		AD28
75	AD31		AD30

**Table 5-4. PCI Expansion Connector
Pin Assignments (Continued)**

Pin	Assignment		Pin	
77	PAR64	GND	Reserved	78
79	C/BE5#		C/BE4#	80
81	C/BE7#		C/BE6#	82
83	AD33		AD32	84
85	AD35		AD34	86
87	AD37		AD36	88
89	AD39		AD38	90
91	AD41		AD40	92
93	AD43		AD42	94
95	AD45		AD44	96
97	AD47		AD46	98
99	AD49		AD48	100
101	AD51		AD50	102
103	AD53		AD52	104
105	AD55		AD54	106
107	AD57		AD56	108
109	AD59		AD58	110
111	AD61		AD60	112
113	AD63		AD62	114

PCI Mezzanine Card (PMC) Connectors

These connectors provide 32/64-bit PCI interfaces and P2 I/O for two optional add-on PCI Mezzanine Cards (PMC). The pin assignments for these connectors are as follows.

Table 5-5. PMC Slot 1 Connector (J11) Pin Assignments

Pin	Assignment		Pin
1	TCK	-12V	2
3	GND	INTA#	4
5	INTB#	INTC#	6
7	PMCPRSNT1#	+5V	8
9	INTD#	Not Used	10
11	GND	Not Used	12
13	CLK	GND	14
15	GND	PMCGNT1#	16
17	PMCREQ1#	+5V	18
19	+5V (Vio)	AD31	20
21	AD28	AD27	22
23	AD25	GND	24
25	GND	C/BE3#	26
27	AD22	AD21	28
29	AD19	+5V	30
31	+5V (Vio)	AD17	32
33	FRAME#	GND	34
35	GND	IRDY#	36
37	DEVSEL#	+5V	38
39	GND	LOCK#	40
41	SDONE#	SBO#	42
43	PAR	GND	44
45	+5V (Vio)	AD15	46
47	AD12	AD11	48

Table 5-5. PMC Slot 1 Connector (J11) Pin Assignments (Continued)

Pin	Assignment		Pin
49	AD09	+5V	50
51	GND	C/BE0#	52
53	AD06	AD05	54
55	AD04	GND	56
57	+5V (Vio)	AD03	58
59	AD02	AD01	60
61	AD00	+5V	62
63	GND	REQ64#	64

Table 5-6. PMC Slot 1 Connector (J12) Pin Assignments

Pin	Assignment		Pin
1	+12V	TRST#	2
3	TMS	TDO	4
5	TDI	GND	6
7	GND	Not Used	8
9	Not Used	Not Used	10
11	Pull-up to +3.3V	+3.3V	12
13	RST#	Pull-down to GND	14
15	+3.3V	Pull-down to GND	16
17	Not Used	GND	18
19	AD30	AD29	20
21	GND	AD26	22
23	AD24	+3.3V	24
25	IDSEL1	AD23	26
27	+3.3V	AD20	28
29	AD18	GND	30
31	AD16	C/BE2#	32
33	GND	Not Used	34
35	TDRY#	+3.3V	36
37	GND	STOP#	38
39	PERR#	GND	40
41	+3.3V	SERR#	42
43	C/BE1#	GND	44
45	AD14	AD13	46
47	GND	AD10	48
49	AD08	+3.3V	50
51	AD07	Not Used	52
53	+3.3V	Not Used	54
55	Not Used	GND	56
57	Not Used	Not Used	58

Table 5-6. PMC Slot 1 Connector (J12) Pin Assignments (Continued)

Pin	Assignment		Pin
59	GND	Not Used	60
61	ACK64#	+3.3V	62
63	GND	Not Used	64

Table 5-7. PMC Slot 1 Connector (J13) Pin Assignments

Pin	Assignment		Pin
1	Reserved	GND	2
3	GND	C/BE7#	4
5	C/BE6#	C/BE5#	6
7	C/BE4#	GND	8
9	+5V (Vio)	PAR64	10
11	AD63	AD62	12
13	AD61	GND	14
15	GND	AD60	16
17	AD59	AD58	18
19	AD57	GND	20
21	+5V (Vio)	AD56	22
23	AD55	AD54	24
25	AD53	GND	26
27	GND	AD52	28
29	AD51	AD50	30
31	AD49	GND	32
33	GND	AD48	34

Table 5-7. PMC Slot 1 Connector (J13) Pin Assignments (Continued)

Pin	Assignment		Pin
35	AD47	AD46	36
37	AD45	GND	38
39	+5V (Vio)	AD44	40
41	AD43	AD42	42
43	AD41	GND	44
45	GND	AD40	46
47	AD39	AD38	48
49	AD37	GND	50
51	GND	AD36	52
53	AD35	AD34	54
55	AD33	GND	56
57	+5V (Vio)	AD32	58
59	Reserved	Reserved	60
61	Reserved	GND	62
63	GND	Reserved	64

**Table 5-8. PMC Slot 1 Connector (J14)
Pin Assignments**

Pin	Assignment		Pin
1	Jumper Configurable	PMC1_2 (P2-A1)	2
3	Jumper Configurable	PMC1_4 (P2-A2)	4
5	Jumper Configurable	PMC1_6 (P2-A3)	6
7	Jumper Configurable	PMC1_8 (P2-A4)	8
9	PMC1_9 (P2-C5)	PMC1_10 (P2-A5)	10
11	PMC1_11 (P2-C6)	PMC1_12 (P2-A6)	12
13	PMC1_13 (P2-C7)	PMC1_14 (P2-A7)	14
15	PMC1_15 (P2-C8)	PMC1_16 (P2-A8)	16
17	PMC1_17 (P2-C9)	PMC1_18 (P2-A9)	18
19	PMC1_19 (P2-C10)	PMC1_20 (P2-A10)	20
21	PMC1_21 (P2-C11)	PMC1_22 (P2-A11)	22
23	PMC1_23 (P2-C12)	PMC1_24 (P2-A12)	24
25	PMC1_25 (P2-C13)	PMC1_26 (P2-A13)	26
27	PMC1_27 (P2-C14)	PMC1_28 (P2-A14)	28
29	PMC1_29 (P2-C15)	PMC1_30 (P2-A15)	30
31	PMC1_31 (P2-C16)	PMC1_32 (P2-A16)	32
33	PMC1_33 (P2-C17)	PMC1_34 (P2-A17)	34
35	PMC1_35 (P2-C18)	PMC1_36 (P2-A18)	36
37	PMC1_37 (P2-C19)	PMC1_38 (P2-A19)	38
39	PMC1_39 (P2-C20)	PMC1_40 (P2-A20)	40
41	PMC1_41 (P2-C21)	PMC1_42 (P2-A21)	42
43	PMC1_43 (P2-C22)	PMC1_44 (P2-A22)	44
45	PMC1_45 (P2-C23)	PMC1_46 (P2-A23)	46
47	PMC1_47 (P2-C24)	PMC1_48 (P2-A24)	48
49	PMC1_49 (P2-C25)	PMC1_50 (P2-A25)	50
51	PMC1_51 (P2-C26)	PMC1_52 (P2-A26)	52

**Table 5-8. PMC Slot 1 Connector (J14)
Pin Assignments (Continued)**

Pin	Assignment		Pin
53	PMC1_53 (P2-C27)	PMC1_54 (P2-A27)	54
55	PMC1_55 (P2-C28)	PMC1_56 (P2-A28)	56
57	PMC1_57 (P2-C29)	PMC1_58 (P2-A29)	58
59	PMC1_59 (P2-C30)	PMC1_60 (P2-A30)	60
61	PMC1_61 (P2-C31)	PMC1_62 (P2-A31)	62
63	PMC1_63 (P2-C32)	PMC1_64 (P2-A32)	64

Jumper configuration is dependent upon P2 I/O mode chosen (PMC or SBC Mode, also known as 761 or IPMC mode).

Table 5-9. PMC Slot 2 Connector (J21) Pin Assignments

Pin	Assignment		Pin
1	TCK	-12V	2
3	GND	INTA#	4
5	INTB#	INTC#	6
7	PMCPRSNT2#	+5V	8
9	INTD#	Not Used	10
11	GND	Not Used	12
13	CLK	GND	14
15	GND	PMCGNT2#	16
17	PMCREQ2#	+5V	18
19	+5V (Vio)	AD31	20
21	AD28	AD27	22
23	AD25	GND	24
25	GND	C/BE3#	26
27	AD22	AD21	28
29	AD19	+5V	30
31	+5V (Vio)	AD17	32
33	FRAME#	GND	34
35	GND	IRDY#	36
37	DEVSEL#	+5V	38
39	GND	LOCK#	40
41	SDONE#	SBO#	42
43	PAR	GND	44
45	+5V (Vio)	AD15	46
47	AD12	AD11	48

Table 5-9. PMC Slot 2 Connector (J21) Pin Assignments (Continued)

Pin	Assignment		Pin
49	AD09	+5V	50
51	GND	C/BE0#	52
53	AD06	AD05	54
55	AD04	GND	56
57	+5V (V _{io})	AD03	58
59	AD02	AD01	60
61	AD00	+5V	62
63	GND	REQ64#	64

Table 5-10. PMC Slot 2 Connector (J22) Pin Assignments

Pin	Assignment		Pin
1	+12V	TRST#	2
3	TMS	TDO	4
5	TDI	GND	6
7	GND	Not Used	8
9	Not Used	Not Used	10
11	Pull-up to +3.3V	+3.3V	12
13	RST#	Pull-down to GND	14
15	+3.3V	Pull-down to GND	16
17	Not Used	GND	18
19	AD30	AD29	20
21	GND	AD26	22

Table 5-10. PMC Slot 2 Connector (J22) Pin Assignments (Continued)

Pin	Assignment		Pin
23	AD24	+3.3V	24
25	IDSEL2	AD23	26
27	+3.3V	AD20	28
29	AD18	GND	30
31	AD16	C/BE2#	32
33	GND	Not Used	34
35	TDRY#	+3.3V	36
37	GND	STOP#	38
39	PERR#	GND	40
41	+3.3V	SERR#	42
43	C/BE1#	GND	44
45	AD14	AD13	46
47	GND	AD10	48
49	AD08	+3.3V	50
51	AD07	Not Used	52
53	+3.3V	Not Used	54
55	Not Used	GND	56
57	Not Used	Not Used	58
59	GND	Not Used	60
61	ACK64#	+3.3V	62
63	GND	Not Used	64

Table 5-11. PMC Slot 2 Connector (J23) Pin Assignments

Pin	Assignment		Pin
1	Reserved	GND	2
3	GND	C/BE7#	4
5	C/BE6#	C/BE5#	6
7	C/BE4#	GND	8
9	+5V (Vio)	PAR64	10
11	AD63	AD62	12
13	AD61	GND	14
15	GND	AD60	16
17	AD59	AD58	18
19	AD57	GND	20
21	+5V (Vio)	AD56	22
23	AD55	AD54	24
25	AD53	GND	26
27	GND	AD52	28
29	AD51	AD50	30
31	AD49	GND	32
33	GND	AD48	34
35	AD47	AD46	36
37	AD45	GND	38
39	+5V (Vio)	AD44	40
41	AD43	AD42	42
43	AD41	GND	44
45	GND	AD40	46

Table 5-11. PMC Slot 2 Connector (J23) Pin Assignments (Continued)

Pin	Assignment		Pin
47	AD39	AD38	48
49	AD37	GND	50
51	GND	AD36	52
53	AD35	AD34	54
55	AD33	GND	56
57	+5V (Vio)	AD32	58
59	Reserved	Reserved	60
61	Reserved	GND	62
63	GND	Reserved	64

5

Table 5-12. PMC Slot 2 Connector (J24) Pin Assignments

Pin	Assignment		Pin
1	PMC2_1 (P2-D1)	PMC2_2 (P2-Z1)	2
3	PMC2_3 (P2-D2)	PMC2_4 (P2-D3)	4
5	PMC2_5 (P2-Z3)	PMC2_6 (P2-D4)	6
7	PMC2_7 (P2-D5)	PMC2_8 (P2-Z5)	8
9	PMC2_9 (P2-D6)	PMC2_10 (P2-D7)	10
11	PMC2_11 (P2-Z7)	PMC2_12 (P2-D8)	12
13	PMC2_13 (P2-D9)	PMC2_14 (P2-Z9)	14
15	PMC2_15 (P2-D10)	PMC2_16 (P2-D11)	16
17	PMC2_17 (P2-Z11)	PMC2_18 (P2-D12)	18
19	PMC2_19 (P2-D13)	PMC2_20 (P2-Z13)	20
21	PMC2_21 (P2-D14)	PMC2_22 (P2-D15)	22
23	PMC2_23 (P2-Z15)	PMC2_24 (P2-D16)	24

Table 5-12. PMC Slot 2 Connector (J24) Pin Assignments (Continued)

Pin	Assignment		Pin
25	PMC2_25 (P2-D17)	PMC2_26 (P2-Z17)	26
27	PMC2_27 (P2-D18)	PMC2_28 (P2-D19)	28
29	PMC2_29 (P2-Z19)	PMC2_30 (P2-D20)	30
31	PMC2_31 (P2-D21)	PMC2_32 (P2-Z21)	32
33	PMC2_33 (P2-D22)	PMC2_34 (P2-D23)	34
35	PMC2_35 (P2-Z23)	PMC2_36 (P2-D24)	36
37	PMC2_37 (P2-D25)	PMC2_38 (P2-Z25)	38
39	PMC2_39 (P2-D26)	PMC2_40 (P2-D27)	40
41	PMC2_41 (P2-Z27)	PMC2_42 (P2-D28)	42
43	PMC2_43 (P2-D29)	PMC2_44 (P2-Z29)	44
45	PMC2_45 (P2-D30)	PMC2_46 (P2-Z31)	46
47	Not Used	Not Used	48
49	Not Used	Not Used	50
51	Not Used	Not Used	52
53	Not Used	Not Used	54
55	Not Used	Not Used	56
57	Not Used	Not Used	58
59	Not Used	Not Used	60
61	Not Used	Not Used	62
63	Not Used	Not Used	64

VMEbus Connectors P1 & P2 Pin Assignments (PMC mode)

The VMEbus connector P1 provides power and VME signals for 24-bit address and 16-bit data. The pin assignments for the connector are specified by the IEEE P1014-1987 VMEbus Specification and the VME64 Extension Standard.

Row B of connector P2 provides power to the MVME5100, and to the upper eight VMEbus address lines, and additional 16 VMEbus data lines. Rows A, C, Z, and D provide power and interface signals to the MVME762 transition module. The pin assignments for connector P2 in PMC mode are as follows:

Table 5-13. VMEbus Connector P2 Pin Assignments (PMC Mode)

Pin	Row Z	Row A	Row B	Row C	Row D
1	PMC2_2 (J24-2)	PMC1_2 (J14-2)	+5V	PMC1_1 (J14-1)	PMC2_1 (J24-1)
2	GND	PMC1_4 (J14-4)	GND	PMC1_3 (J14-3)	PMC2_3 (J24-3)
3	PMC2_5 (J24-5)	PMC1_6 (J14-6)	RETRY#	PMC1_5 (J14-5)	PMC2_4 (J24-4)
4	GND	PMC1_8 (J14-8)	VA24	PMC1_7 (J14-7)	PMC2_6 (J24-6)
5	PMC2_8 (J24-8)	PMC1_10 (J14-10)	VA25	PMC1_9 (J14-9)	PMC2_7 (J24-7)
6	GND	PMC1_12 (J14-12)	VA26	PMC1_11 (J14-11)	PMC2_9 (J24-9)
7	PMC2_11(J24-11)	PMC1_14 (J14-14)	VA27	PMC1_13 (J14-13)	PMC2_10 (J24-10)
8	GND	PMC1_16 (J14-16)	VA28	PMC1_15 (J14-15)	PMC2_12 (J24-12)
9	PMC2_14 (J24-14)	PMC1_18 (J14-18)	VA29	PMC1_17 (J14-17)	PMC2_13 (J24-13)
10	GND	PMC1_20 (J14-20)	VA30	PMC1_19 (J14-19)	PMC2_15 (J24-15)
11	PMC2_17 (J24-17)	PMC1_22 (J14-22)	VA31	PMC1_21 (J14-21)	PMC2_16 (J24-16)
12	GND	PMC1_24 (J14-24)	GND	PMC1_23 (J14-23)	PMC2_18 (J24-18)
13	PMC2_20 (J24-20)	PMC1_26 (J14-26)	+5V	PMC1_25 (J14-25)	PMC2_19 (J24-19)

**Table 5-13. VMEbus Connector P2 Pin Assignments
(PMC Mode) (Continued)**

Pin	Row Z	Row A	Row B	Row C	Row D
14	GND	PMC1_28 (J14-28)	VD16	PMC1_27 (J14-27)	PMC2_21 (J24-21)
15	PMC2_23 (J24-23)	PMC1_30 (J14-30)	VD17	PMC1_29 (J14-29)	PMC2_22 (J24-22)
16	GND	PMC1_32 (J14-32)	VD18	PMC1_31 (J14-31)	PMC2_24 (J24-24)
17	PMC2_26 (J24-26)	PMC1_34 (J14-34)	VD19	PMC1_33 (J14-33)	PMC2_25 (J24-25)
18	GND	PMC1_36 (J14-36)	VD20	PMC1_35 (J14-35)	PMC2_27 (J24-27)
19	PMC2_29 (J24-29)	PMC1_38 (J14-38)	VD21	PMC1_37 (J14-37)	PMC2_28 (J24-28)
20	GND	PMC1_40 (J14-40)	VD22	PMC1_39 (J14-39)	PMC2_30 (J24-30)
21	PMC2_32 (J24-32)	PMC1_42 (J14-42)	VD23	PMC1_41 (J14-41)	PMC2_31 (J24-31)
22	GND	PMC1_44 (J14-44)	GND	PMC1_43 (J14-43)	PMC2_33 (J24-33)
23	PMC2_35 (J24-35)	PMC1_46 (J14-46)	VD24	PMC1_45 (J14-45)	PMC2_34 (J24-34)
24	GND	PMC1_48 (J14-48)	VD25	PMC1_47 (J14-47)	PMC2_36 (J24-36)
25	PMC2_38 (J24-38)	PMC1_50 (J14-50)	VD26	PMC1_49 (J14-49)	PMC2_37 (J24-37)
26	GND	PMC1_52 (J14-52)	VD27	PMC1_51 (J14-51)	PMC2_39 (J24-39)
27	PMC2_41 (J24-41)	PMC1_54 (J14-54)	VD28	PMC1_53 (J14-53)	PMC2_40 (J24-40)
28	GND	PMC1_56 (J14-56)	VD29	PMC1_55 (J14-55)	PMC2_42 (J24-42)
29	PMC2_44 (J24-44)	PMC1_58 (J14-58)	VD30	PMC1_57 (J14-57)	PMC2_43 (J24-43)
30	GND	PMC1_60 (J14-60)	VD31	PMC1_59 (J14-59)	PMC2_45 (J24-45)
31	PMC2_46 (J24-46)	PMC1_62 (J14-62)	GND	PMC1_61 (J14-61)	GND
32	GND	PMC1_64 (J14-64)	+5V	PMC1_63 (J14-63)	VPC

VMEbus P1 & P2 Connector Pin Assignments (SBC Mode)

The VMEbus connector P1 provides power and VME signals for 24-bit address and 16-bit data. The pin assignments for the connector are specified by the IEEE P1014-1987 VMEbus Specification and the VME64 Extension Standard.

Row B of connector P2 provides power to the MVME5100 and to the upper 8 VMEbus address lines and additional 16 VMEbus data lines. Rows A, C, Z, and D provide power and interface signals to the MVME712 or MVME761 transition module in SBC mode (also called 761 mode and IPMC mode).

It is important to note that the PMC I/O routing to row D and Z are not the same as MVME2600/2700. The PMC I/O routing for row D and row Z is the same as the PMC mode with the exception of pins Z1, 3, 5, 7, 9, 11, 13, 15, and 17 which are used for extended SCSI.

Note A PMC card installed in slot 2 of an MVME5100 in SBC mode **MUST NOT** connect to J24-2, 5, 8, 11, 14, 17, 20, 23, and 26 since they are connected to the extended SCSI signals of the MVME5100.

The pin assignments for the P2 connector using the IPMC761 or the IPMC712 are listed in the following two tables:

Table 5-14. VMEbus P2 Connector Pinouts with IPMC761-SBC Mode

Pin	Row Z	Row A	Row B	Row C	Row D
1	DB8#	DB0#	+5V	RD- (10/100)	PMC2_1 (J24-1)
2	GND	DB1#	GND	RD+ (10/100)	PMC2_3 (J24-3)
3	DB9#	DB2#	RETRY#	TD- (10/100)	PMC2_4 (J24-4)
4	GND	DB3#	VA24	TD+ (10/100)	PMC2_6 (J24-6)
5	DB10#	DB4#	VA25	Not Used	PMC2_7 (J24-7)
6	GND	DB5#	VA26	Not Used	PMC2_9 (J24-9)

Table 5-14. VMEbus P2 Connector Pinouts with IPMC761-SBC Mode (Continued)

Pin	Row Z	Row A	Row B	Row C	Row D
7	DB11#	DB6#	VA27	+12VF	PMC2_10 (J24-10)
8	GND	DB7#	VA28	PRSTB#	PMC2_12 (J24-12)
9	DB12#	DBP#	VA29	PRD0	PMC2_13 (J24-13)
10	GND	ATN#	VA30	PRD1	PMC2_15 (J24-15)
11	DB13#	BSY#	VA31	PRD2	PMC2_16 (J24-16)
12	GND	ACK#	GND	PRD3	PMC2_18 (J24-18)
13	DB14#	RST#	+5V	PRD4	PMC2_19 (J24-19)
14	GND	MSG#	VD16	PRD5	PMC2_21 (J24-21)
15	DB15#	SEL#	VD17	PRD6	PMC2_22 (J24-22)
16	GND	D/C#	VD18	PRD7	PMC2_24 (J24-24)
17	DBP1#	REQ#	VD19	PRACK#	PMC2_25 (J24-25)
18	GND	O/I#	VD20	PRBSY	PMC2_27 (J24-27)
19	PMC2_29 (J24-29)	AFD#	VD21	PRPE	PMC2_28 (J24-28)
20	GND	SLIN#	VD22	PRSEL	PMC2_30 (J24-30)
21	PMC2_32 (J24-32)	TXD3	VD23	INIT#	PMC2_31 (J24-31)
22	GND	RXD3	GND	PRFLT#	PMC2_33 (J24-33)
23	PMC2_35 (J24-35)	RTXC3	VD24	TXD1_232	PMC2_34 (J24-34)
24	GND	TRXC3	VD25	RXD1_232	PMC2_36 (J24-36)
25	PMC2_38 (J24-38)	TXD3	VD26	RTS1_232	PMC2_37 (J24-37)
26	GND	RXD3	VD27	CTS1_232	PMC2_39 (J24-39)
27	PMC2_41 (J24-41)	RTXC4	VD28	TXD2_232	PMC2_40 (J24-40)
28	GND	TRXC4	VD29	RXD2_232	PMC2_42 (J24-42)
29	PMC2_44 (J24-44)		VD30	RTS2_232	PMC2_43 (J24-43)
30	GND	-12VF	VD31	CTS2_232	PMC2_45 (J24-45)
31	PMC2_46 (J24-46)	MSYNC#	GND	MDO	GND
32	GND	MCLK	+5V	MDI	VPC

Note Rows A and C and Z's (Z1, 3, 5, 7, 9, 11, 13, 15, and 17) functionality is provided by the IPMC761 in slot 1 and the MVME5100 Ethernet port 2.

Table 5-15. VMEbus Connector P2 Pinout with IPMC712

Pin	Row Z	Row A	Row B	Row C	Row D
1	DB8#	DB0#	+5V	C- (10/100)	PMC2_1 (J24-1)
2	GND	DB1#	GND	C+ (10/100)	PMC2_3 (J24-3)
3	DB9#	DB2#	N/C	T- (10/100)	PMC2_4 (J24-4)
4	GND	DB3#	VA24	T+ (10/100)	PMC2_6 (J24-6)
5	DB10#	DB4#	VA25	R-	PMC2_7 (J24-7)
6	GND	DB5#	VA26	R+	PMC2_9 (J24-9)
7	DB11#	DB6#	VA27	+12V (LAN)	PMC2_10 (J24-10)
8	GND	DB7#	VA28	PRSTB#	PMC2_12 (J24-12)
9	DB12#	DBP#	VA29	P DB0	PMC2_13 (J24-13)
10	GND	ATN#	VA30	P DB1	PMC2_15 (J24-15)
11	DB13#	BSY#	VA31	P DB2	PMC2_16 (J24-16)
12	GND	ACK#	GND	P DB3	PMC2_18 (J24-18)
13	DB14#	RST#	+5V	P DB4	PMC2_19 (J24-19)
14	GND	MSG#	VD16	P DB5	PMC2_21 (J24-21)
15	DB15#	SEL#	VD17	P DB6	PMC2_22 (J24-22)
16	GND	D/C#	VD18	P DB7	PMC2_24 (J24-24)
17	DBP1#	REQ#	VD19	P ACK#	PMC2_25 (J24-25)
18	GND	I/O#	VD20	P BSY	PMC2_27 (J24-27)
19	PMC2_29 (J24-29)	TXD#	VD21	P PE	PMC2_28 (J24-28)
20	GND	RXD3#	VD22	P SEL	PMC2_30 (J24-30)
21	PMC2_32 (J24-32)	RTS3	VD23	P IME	PMC2_31 (J24-31)
22	GND	CTS3	GND	P FAULT#	PMC2_33 (J24-33)
23	PMC2_35 (J24-35)	DTR3	VD24	TXD1_232	PMC2_34 (J24-34)
24	GND	DCD3	VD25	RXD1	PMC2_36 (J24-36)

Table 5-15. VMEbus Connector P2 Pinout with IPMC712 (Continued)

Pin	Row Z	Row A	Row B	Row C	Row D
25	PMC2_38 (J24-38)	TXD4	VD26	RTS1	PMC2_37 (J24-37)
26	GND	RXD4	VD27	CTS1	PMC2_39 (J24-39)
27	PMC2_41 (J24-41)	RTS4	VD28	TXD2	PMC2_40 (J24-40)
28	GND	TRXC4	VD29	RXD2	PMC2_42 (J24-42)
29	PMC2_44 (J24-44)	CTS4	VD30	RTS2	PMC2_43 (J24-43)
30	GND	DTR4	VD31	CTS2	PMC2_45 (J24-45)
31	PMC2_46 (J24-46)	DCD4	GND	DTR2	GND
32	GND	RTXC4	+5V	DCD2	VPC

Note Since the P2 adaptor card for the MVME712M is a three (3) row connector, signals on Rows Z and D are not routed to the MVME712M. Thus

(a) although the IPMC712 controller is capable of 16-bit (wide) SCSI operations only 8-bit (narrow) transfers are supported through the MVME712M

(b) PMC I/O from site two (2) is not available through the MVME712M

(c) Please remember the caution stated on page 5-25 that a PMC located at site two (2) may not connect to pins J24-2, 5, 8, 11, 14, 17, 20, 23 and 26.

10 BaseT/100 BaseTx Connector Pin Assignments

The board's dual 10 BaseT/100 BaseTx RJ45 connectors (J9 and J18) are located on the front plate. The connections provide two LAN connections (LAN1-J18 and LAN2-J9). The pin assignments for these connector's are as follows:

Table 5-16. 10 BaseT/100 BaseTx Connector Pin Assignment

Pin	Assignment
1	TD+
2	TD-
3	RD+
4	AC Terminated
5	AC Terminated
6	RD-
7	AC Terminated
8	AC Terminated

COM1 and COM2 Connector Pin Assignments

A standard RJ45 connector located on the front panel and a 9-pin header located near the bottom edge of the MVME5100 provides the interface to the serial debug ports. The RJ45 connector is for COM1 and the 9-pin header is for COM2.

The pin assignments for these connectors are as follows:

5

Table 5-17. COM1 (J19) Connector Pin Assignments

Pin	Assignment
1	DCD
2	RTS
3	GNDC
4	TXD
5	RXD
6	GNDC
7	CTS
8	DTR

Table 5-18. COM2 (J5) Connector Pin Assignments

Pin	Assignment
1	DCD
2	DSR
3	RXD
4	RTS
5	TXD
6	CTS
7	DTR
8	RI
9	GND

Introduction

This chapter provides basic information useful in programming the MVME51xx. This includes a description of memory maps, control and status registers, PCI arbitration, interrupt handling, sources of reset, and big/little-endian issues.

For additional programming information about the MVME510x, refer to the *MVME5100-Series Single Board Computer Programmer's Reference Guide*.

For programming information about the PMCs, refer to the applicable user's manual furnished with the PMCs.

Memory Maps

There are multiple buses on the MVME510x and each bus domain has its own view of the memory map. The following sections describe the MVME510x memory organization from the following three points of view:

- ❑ The mapping of all resources as viewed by the MPU (processor bus memory map)
- ❑ The mapping of onboard resources as viewed by PCI local bus masters (PCI bus memory map)
- ❑ The mapping of onboard resources as viewed by VMEbus masters (VMEbus memory map)

Additional, more detailed memory maps can be found in the *MVME5100-Series Single Board Computer Programmer's Reference Guide*.

Processor Bus Memory Map

The processor memory map configuration is under the control of the PHB and SMC portions of the Hawk ASIC. The Hawk adjusts system mapping to suit a given application via programmable map decoder registers. At system power-up or reset, a default processor memory map takes over.

Default Processor Memory Map

The default processor memory map that is valid at power-up or reset remains in effect until reprogrammed for specific applications. [Table 6-1](#) defines the entire default map (\$00000000 to \$FFFFFFF).

Table 6-1. Default Processor Memory Map

Processor Address		Size	Definition
Start	End		
0000 0000	7FFF FFFF	2GB	Not Mapped
8000 0000	8080 FFFF	8M+64K	Zero-based PCI/ISA I/O Space
8081 0000	FEF7 FFFF	2GB-24MB-576KB	Not Mapped
FEF8 0000	FEF8 FFFF	64KB	System Memory Controller Registers
FEF9 0000	FEFE FFFF	384KB	Not Mapped
FEFF 0000	FEFF FFFF	64KB	PCI Host Bridge (PHB) Registers
FF00 0000	FFEF FFFF	15MB	Not Mapped
FFF0 0000	FFFF FFFF	1MB	ROM/FLASH Bank A or Bank B (See Note)

Note The first 1MB of ROM/FLASH Bank A (soldered Flash up to 8MB) appears in this range after a reset if the **rom_b_rv** control bit in the SMC's ROM B Base/Size register is cleared. If the **rom_b_rv** control bit is set, this address range maps to ROM/FLASH Bank B (socketed 1MB Flash).

For an example of the CHRP memory map, refer to the following table. For detailed processor memory maps, including suggested CHRP- and PREP-compatible memory maps, refer to the *MVME5100-Series Single Board Computer Programmer's Reference Guide*.

Processor Memory Map

The following table describes a suggested CHRP Memory Map from the point of view of the processor. This memory map is an alternative to the PREP memory map. Note: in all recommended CHRP maps, the beginning of PCI Memory Space is determined by the end of DRAM rounded up to the nearest 256MB-boundary as required by CHRP. For example, if memory was 1G on the baseboard and 192MB on a mezzanine, the beginning of PCI memory would be rounded up to address 0x50000000 (1G + 256M).

Table 6-2. Suggested CHRP Memory Map

Processor Address		Size	Definition	Notes
Start	End			
0000 0000	top_dram	dram_size	System Memory (onboard DRAM)	1
top_dram	8000 0000	variable	PCI Memory Space	1, 5
8100 0000	9FFF FFFF	512MB	A32/D32 space mapped to VMEbus starting address of 0100 0000	
A000 0000	A1FF FFFF	32MB	A24/D16 space mapped to VMEbus starting address of F000 0000	
AFFF 0000	AFFF FFFF	64KB	A16/D16 space mapped to VMEbus starting address of FFFF 0000	
F400 0000	F7FF FFFF	64MB	FLASH Bank A (optional)	1, 2
F800 0000	FBFF FFFF	64MB	FLASH Bank B (optional)	1, 2
FC00 0000	FDFE FFFF	32MB	Reserved	
FE00 0000	FE7F FFFF	8MB	PCI/ISA I/O Space	1
FE80 0000	FEF7 FFFF	7.5MB	Reserved	
FEF8 0000	FEF8 FFFF	64KB	System Memory Controller Registers	
FEF9 0000	FEFE FFFF	384KB	Reserved	
FEFF 0000	FEFF FFFF	64KB	Processor Host Bridge Registers	4

Table 6-2. Suggested CHRP Memory Map (Continued)

Processor Address		Size	Definition	Notes
Start	End			
FF00 0000	FF7F FFFF	8MB	FLASH Bank A (preferred)	1, 2
FF80 0000	FF8F FFFF	1MB	FLASH Bank B (preferred)	1, 2
FF90 0000	FFEF FFFF	6MB	Reserved	
FFF0 0000	FFFF FFFF	1MB	Boot ROM	3

Notes

1. Programmable via Hawk ASIC.
2. The actual Power Plus II size of each ROM/FLASH bank may vary.
3. The first 1MB of ROM/FLASH Bank A appears at this range after a reset if the *rom_b_rv* control bit is cleared. If the *rom_b_rv* control bit is set, this address maps to ROM/FLASH Bank B.
4. The only method to generate a PCI Interrupt Acknowledge cycle (8259 IACK) is to perform a read access to the Hawks PIACK Register at 0xFEFF0030.
5. VME should be placed at the top of PCI memory space.

The following table shows the programmed values for the associated Hawk PCI Host Bridge Registers for the suggested Processor Memory Map.

Table 6-3. Hawk PPC Register Values for Suggested Memory Map

Address	Register Name	Register Name
FEFF 0040	MSADD0	X000 F3FF [X:1..8]
FEFF 0044	MSOFF0 & MSATT0	0000 00C2
FEFF 0048	MSADD1	FE00 FE7F
FEFF 004C	MSOFF1 & MSATT1	0200 00C0

Table 6-3. Hawk PPC Register Values for Suggested Memory Map (Continued)

Address	Register Name	Register Name
FEFF 0050	MSADD2	0000 0000
FEFF 0054	MSOFF2 & MSATT2	0000 0000
FEFF 0058	MSADD3	0000 0000
FEFF 005C	MSOFF3 & MSATT3	0000 0000

PCI Memory Map

Following a reset, the Hawk ASIC disables all PCI slave map decoders. The MVME5100 is fully capable of supporting both PREP and CHRP PCI Memory Maps with RAM size limited to 2GB.

6

VME Memory Map

The MVME5100 is fully capable of supporting both the PREP and the CHRP VME Memory Maps examples with RAM size limited to 2GB.

PCI Local Bus Memory Map

The PCI memory map is controlled by the MPU/PCI bus bridge controller portion of the Hawk ASIC and by the Universe PCI/VME bus bridge ASIC. The Hawk and Universe devices adjust system mapping to suit a given application via programmable map decoder registers.

No default PCI memory map exists. Resetting the system turns the PCI map decoders off, and they must be reprogrammed in software for the intended application.

For detailed PCI memory maps, including suggested CHRP- and PREP-compatible memory maps, refer to the *MVME5100-Series Single Board Computer Programmer's Reference Guide*.

VMEbus Memory Map

The VMEbus is programmable. Like other parts of the MVME510x memory map, the mapping of local resources as viewed by VMEbus masters varies among applications.

The Universe PCI/VME bus bridge ASIC includes a user-programmable map decoder for the VMEbus-to-local-bus interface. The address translation capabilities of the Universe enable the processor to access any range of addresses on the VMEbus.

Recommendations for VMEbus mapping, including suggested CHRP- and PREP-compatible memory maps, can be found in the *MVME5100-Series Single Board Computer Programmer's Reference Guide*. [Figure 6-1](#) shows the overall mapping approach from the standpoint of a VMEbus master.

Programming Considerations

Good programming practice dictates that only one MPU at a time have control of the MVME510x control registers. Of particular note are:

- ❑ Registers that modify the address map
- ❑ Registers that require two cycles to access
- ❑ VMEbus interrupt request registers

PCI Arbitration

There are seven potential PCI bus masters on the MVME510x:

- ❑ Hawk ASIC (MPU/PCI bus bridge controller)
- ❑ Winbond W83C554 PIB (PCI/ISA bus bridge controller)
- ❑ DECchip 21143 Ethernet controller
- ❑ Universe II ASIC (PCI/VME bus bridge controller)
- ❑ PMC Slot 1 (PCI mezzanine card)

- ❑ PMC Slot 2 (PCI mezzanine card)
- ❑ PCI Expansion Slot

The Winbond W83C554 PIB device supplies the PCI arbitration support for these seven types of devices. The PIB supports flexible arbitration modes of fixed priority, rotating priority, and mixed priority, as appropriate in a given application. Details on PCI arbitration can be found in the *MVME5100-Series Single Board Computer Programmer's Reference Guide*.

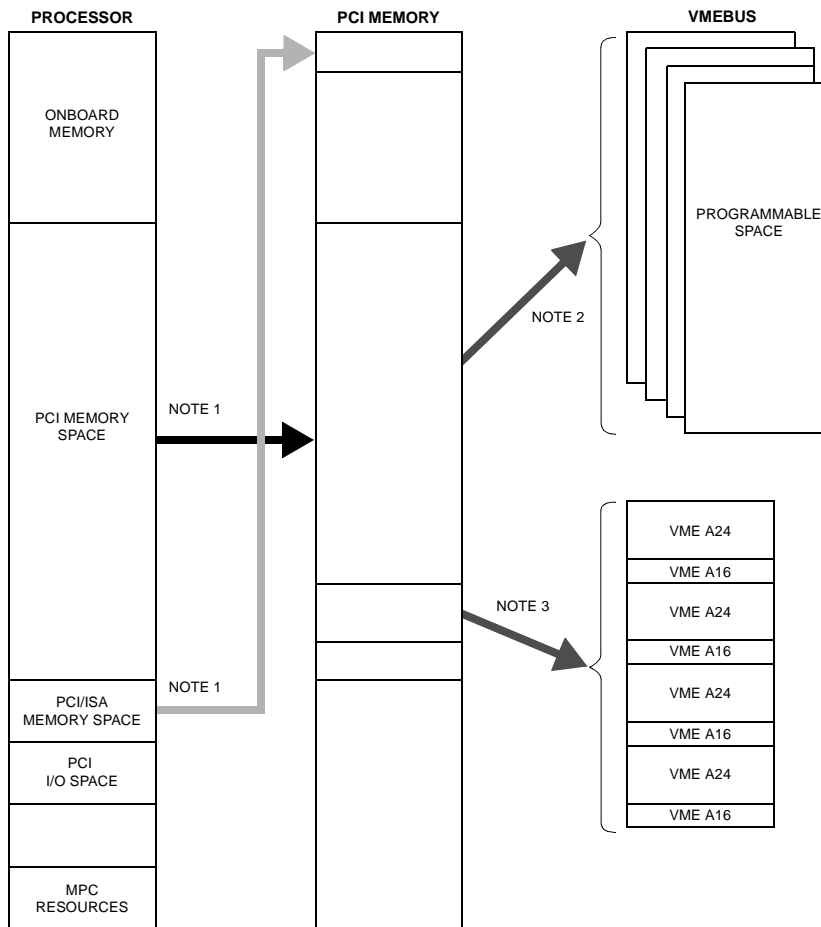

- NOTES: 1. Programmable mapping done by Hawk ASIC.
 2. Programmable mapping performed via PCI Slave images in Universe ASIC.
 3. Programmable mapping performed via Special Slave image (SLSI) in Universe ASIC.

11553.00 9609

Figure 6-1. VMEbus Master Mapping

The arbitration assignments for the MVME510x are shown in [Table 6-4](#).

Table 6-4. PCI Arbitration Assignments

PCI Bus Request	PCI Master(s)
PIB (Internal)	PIB
CPU	Hawk ASIC
Request 0	PMC Slot 2
Request 1	PMC Slot 1
Request 2	PCI Expansion Slot
Request 3	Ethernet
Request 4	Universe ASIC (VMEbus)

Interrupt Handling

The Hawk ASIC, which controls the PHB (PCI Host Bridge) and the MPU/local bus interface functions on the MVME510x, performs interrupt handling as well. Sources of interrupts may be any of the following:

- ❑ The Hawk ASIC itself (timer interrupts, transfer error interrupts, or memory error interrupts)
- ❑ The processor (processor self-interrupts)
- ❑ The PCI bus (interrupts from PCI devices)
- ❑ The ISA bus (interrupts from ISA devices)

[Figure 6-2](#) illustrates interrupt architecture on the MVME510x. For details on interrupt handling, refer to the *MVME5100-Series Single Board Computer Programmer's Reference Guide*.

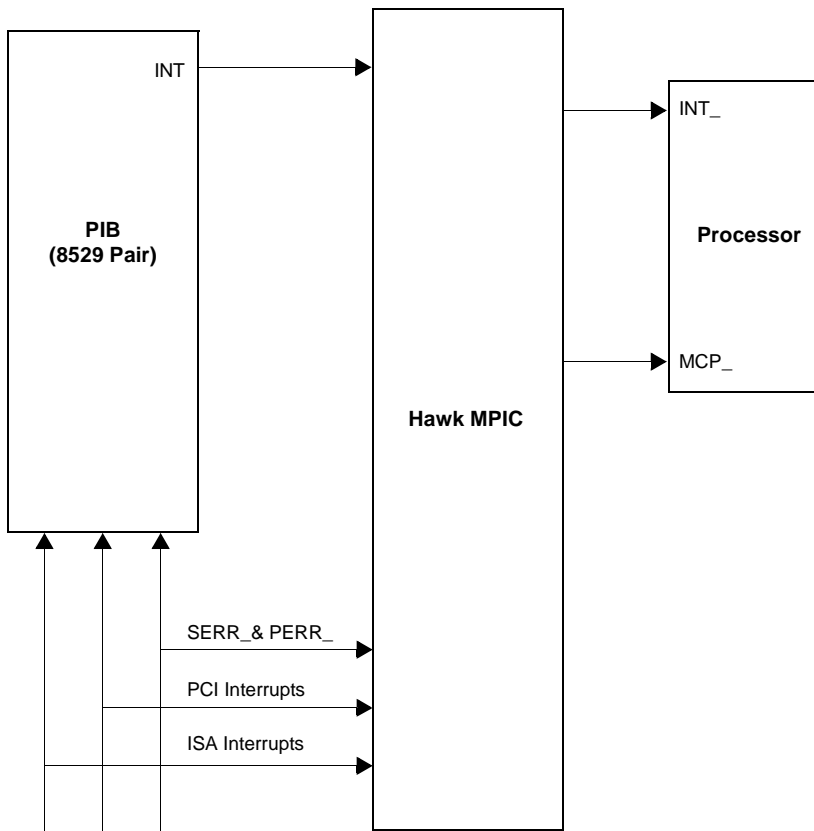

11559.00 9609

Figure 6-2. MVME510x Interrupt Architecture

The MVME510x routes the interrupts from the PMCs and PCI expansion slots as follows:

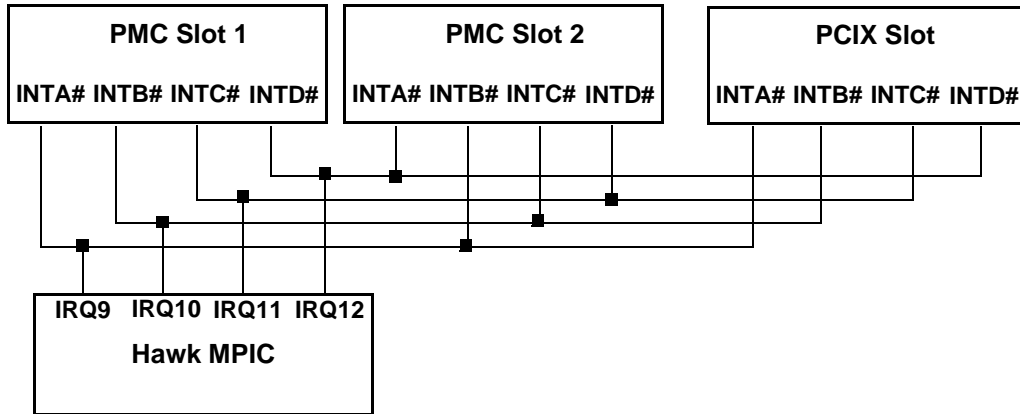

DMA Channels

The PIB supports seven DMA channels. They are not functional on the MVME510x.

Sources of Reset

The MVME510x has nine potential sources of reset:

1. Power-on reset
2. **RST** switch (resets the VMEbus when the MVME510x is system controller)
3. Watchdog timer Reset function controlled by the SGS-Thomson MK48T559 timekeeper device (resets the VMEbus when the MVME510x is system controller)
4. ALT_RST* function controlled by the Port 92 register in the PIB (resets the VMEbus when the MVME510x is system controller)

5. PCI/ISA I/O Reset function controlled by the Clock Divisor register in the PIB
6. The VMEbus SYSRESET* signal
7. VMEbus Reset sources from the Universe ASIC (PCI/VME bus bridge controller): the System Software reset, Local Software Reset, and VME CSR Reset functions.

Note On the MVME5100, Watchdog Timer 2 is a source of reset *only* if component R206 is installed on the board. Consult your local Motorola Computer Group (MCG) sales representative if this feature needs to be enabled.

Table 6-5 shows which devices are affected by the various types of resets. For details on using resets, refer to the *MVME5100-Series Single Board Computer Programmer's Reference Guide*.

Device Affected	Processor	Hawk ASIC	PCI Devices	ISA Devices	VMEbus (as system controller)
Reset Source					
Power-On reset	√	√	√	√	√
Reset switch	√	√	√	√	√
Watchdog reset	√	√	√	√	√
VME SYSRESET*signal	√	√	√	√	√
VME System SW reset	√	√	√	√	√
VME Local SW reset	√	√	√	√	
VME CSR reset	√	√	√	√	
Hot reset (Port 92)	√	√	√	√	
PCI/ISA reset			√	√	

Endian Issues

The MVME510x supports both little-endian (e.g., Windows NT) and big-endian (e.g., AIX) software. The PowerPC processor and the VMEbus are inherently big-endian, while the PCI bus is inherently little-endian. The following sections summarize how the MVME510x handles software and hardware differences in big- and little-endian operations. For further details on endian considerations, refer to the *MVME5100-Series Single Board Computer Programmer's Reference Guide*.

Processor/Memory Domain

The MPC750 processor can operate in both big-endian and little-endian mode. However, it always treats the external processor/memory bus as big-endian by performing *address rearrangement and reordering* when running in little-endian mode. The MPC registers in the Hawk MPU/PCI bus bridge controller, SMC memory controller, as well as DRAM, Flash, and system registers, always appear as big-endian.

Role of the Hawk ASIC

Because the PCI bus is little-endian, the PHB portion of the Hawk performs byte swapping in both directions (from PCI to memory and from the processor to PCI) to maintain address invariance while programmed to operate in big-endian mode with the processor and the memory subsystem.

In little-endian mode, the PHB *reverse-rearranges* the address for PCI-bound accesses and *rearranges* the address for memory-bound accesses (from PCI). In this case, no byte swapping is done.

PCI Domain

The PCI bus is inherently little-endian. All devices connected directly to the PCI bus operate in little-endian mode, regardless of the mode of operation in the processor's domain.

PCI and Ethernet

Ethernet is byte-stream-oriented; the byte having the lowest address in memory is the first one to be transferred regardless of the endian mode. Since the PHB maintains address invariance in both little-endian and big-

endian mode, no endian issues should arise for Ethernet data. Big-endian software must still take the byte-swapping effect into account when accessing the registers of the PCI/Ethernet device, however.

Role of the Universe ASIC

Because the PCI bus is little-endian while the VMEbus is big-endian, the Universe PCI/VME bus bridge ASIC performs byte swapping in both directions (from PCI to VMEbus and from VMEbus to PCI) to maintain address invariance, regardless of the mode of operation in the processor's domain.

6

VMEbus Domain

The VMEbus is inherently big-endian. All devices connected directly to the VMEbus must operate in big-endian mode, regardless of the mode of operation in the processor's domain.

In big-endian mode, byte-swapping is performed first by the Universe ASIC and then by the PHB. The result is transparent to big-endian software (a desirable effect).

In little-endian mode, however, software must take the byte-swapping effect of the Universe ASIC and the address *reverse-rearranging* effect of the PHB into account.

For further details on endian considerations, refer to the *MVME5100-Series Single Board Computer Programmer's Reference Guide*.

Specifications

A

This appendix lists general specifications and power characteristics for the MVME5100 Single Board Computer. It also provides information on cooling requirements.

A complete functional description of the MVME5100 Single Board Computer appears in [Chapter 4, *Functional Description*](#). Specifications for the optional PMC modules can be found in the documentation for those modules.

General Specifications

The following table lists general specifications for MVME5100 Single Board Computer.

Table A-1. MVME5100 Specifications

Characteristic	Specification
Operating Temperature	0° C to 55° C (commercial) and - 20° C to 71° C (industrial) inlet air temperature with forced air cooling. 400 LFM (Linear Feet per Minute) of forced air cooling is recommended for operation in the upper temperature range.
Storage Temperature	- 40° C to +85° C
Relative Humidity	5% to 90% Non-Condensing
Physical Dimensions	
Height	233.4 mm (9.2 in.)
Depth	160 mm (6.3 in.)
Front Panel Height	261.8 mm (10.3 in.)
Width	19.8 mm (0.8 in.)
Max. Component Height	14.8 mm (0.58 in.)

Power Requirements

Power requirements for the MVME5100 Single Board Computer depend on the configuration of the board. The table below lists the typical and maximum power consumption of the board using an MVME761 Transition Module.

Table A-2. Power Consumption

Model	+5V +/-5%	+12V +/-10%	-12V +/-10%
MVME5100	3.8A max 3.0A typ.	8.0 mA typ.	2.0 mA typ.
MVME5106	3.8A max 2.6A typ	8.0 mA typ	2.0 mA typ.
MVME5107	4.7 A max. 3.5 A typ.	8.0 mA typ	2.0 mA typ
MVME5110-21xx	3.8 A max. 3.1 A typ.	8.0 mA typ.	2.0 mA typ
MVME5110-22xx	4.7 A max. 3.5 A typ.	8.0 mA typ.	2.0 mA typ.

Note The power requirements for the MVME5100 include the power requirements for a PMC or IMPC Modules. The PMC specification allows for 7.5 watts per PMC slot. The 15 watts total can be drawn from any combination of the three voltage sources provided by the MVME5100: +5V, +12V, and -12V.

Cooling Requirements

Refer to Appendix E, "Thermal Requirements" for more information.

EMC Compliance

The MVME5100 was tested in an EMC-compliant chassis and meets the requirements for EN55022 Class B equipment. Compliance was achieved under the following conditions:

- ❑ Shielded cables on all external I/O ports
- ❑ Cable shields connected to earth ground via metal shell connectors bonded to a conductive module front panel
- ❑ Conductive chassis rails connected to earth ground. This provides the path for connecting shields to earth ground.
- ❑ Front panel screws properly tightened.

For minimum RF emissions, it is essential that the conditions above be implemented. Failure to do so could compromise the EMC compliance of the equipment containing the module.

Solving Startup Problems

In the event of difficulty with your MVME5100, perform the simple troubleshooting steps listed in the table below before calling for help or sending the board back for repair.

Some of the procedures will return the board to the factory debugger environment. It is important to note that the Board was tested under these conditions before it left the factory. The self-tests may not run in all user-customized environments.

Table B-1. Troubleshooting Problems

Condition	Possible Problem	Possible Resolution:
I. Nothing works; no display on the terminal.	A. If the LEDs are not lit, the board may not be getting power.	<ol style="list-style-type: none">1. Make sure the system is plugged in.2. Check that the board is securely installed in its backplane or chassis.3. Check that all necessary cables are connected to the board.4. Review the Installation and Startup procedures in this manual. They include a step-by-step powerup routine.
	B. If the LEDs are lit, the board may be in the wrong slot.	<ol style="list-style-type: none">1. The MVME5100 should be in the first (leftmost) slot.2. Check if the “system controller” function on the board is enabled per the instructions this manual.
	C. The “system console” terminal may be configured incorrectly.	Configure the system console terminal per the instructions this manual.

Table B-1. Troubleshooting Problems (Continued)

Condition	Possible Problem	Possible Resolution:
II. There is a display on the terminal; however, keyboard and/or mouse input has no effect.	A. The keyboard or mouse may be connected incorrectly.	Recheck the keyboard connections and power. Verify correct configuration of RS232 interface.
	B. Board jumpers may be configured incorrectly.	Check the board jumpers per the instructions in this manual.
	C. You may have invoked flow control by pressing a HOLD or PAUSE key, or by typing: <CTRL>-S	Press the HOLD or PAUSE key again. If this does not free up the keyboard, type in: <CTRL>-Q
III. Debug prompt PPC6-Bug> does not appear at powerup; the board does not autoboot.	A. Debugger Flash may be missing	1. Disconnect <i>all</i> power from your system. 2. Check that the proper debugger devices are installed. 3. Reconnect power. 4. Restart the system using the ABT/RST switch (press and hold switch down, approximately 3 - 5 seconds). 5. If the debug prompt appears, go to step IV or step V, as indicated. If the debug prompt does not appear, go to step VI.
	B. The board may need to be reset.	
IV. Debug prompt PPC6-Bug> appears at powerup; the board does not autoboot.	A. The initial debugger environment parameters may be set incorrectly.	1. Start the onboard calendar clock and timer. Type: set mmdyyhhmm <CR> where the characters indicate the month, day, year, hour, and minute. The date and time will be displayed. CAUTION: Performing the next step (env;d) will change some parameters that may affect your system's operation.
	B. There may be some fault in the board hardware.	

Table B-1. Troubleshooting Problems (Continued)

Condition	Possible Problem	Possible Resolution:
<p>IV. Debug prompt PPC6-Bug> appears at powerup; the board does not autoboot (Continued)</p>		<ol style="list-style-type: none"> 2. At the command line prompt, type in: env;d <CR> (this sets up the default parameters for the debugger environment). 3. When prompted to Update Non-Volatile RAM, type in: y <CR> 4. When prompted to Reset Local System, type in: y <CR> 5. After clock speed is displayed, immediately (within five seconds) press the Return key: <CR> -or- BREAK to exit to the System Menu. Then enter a 3 for “Go to System Debugger” and Return: 3 <CR> Now the prompt should be: PPC6-Diag> 6. You may need to use the cnfg command (see your board Debugger Manual) to change clock speed and/or Ethernet Address, and then later return to: env <CR> and step 3. 7. Run the selftests by typing in: st <CR> The tests take as much as 10 minutes, depending on RAM size. They are complete when the prompt returns. (The onboard selftest is a valuable tool in isolating defects.) 8. The system may indicate that it has passed all the selftests. Or, it may indicate a test that failed. If neither happens, enter: de <CR> Any errors should now be displayed. If there are any errors, go to step VI. If there are no errors, go to step V.

Table B-1. Troubleshooting Problems (Continued)

Condition	Possible Problem	Possible Resolution:
V. The debugger is in system mode; the board autoboots, or the board has passed self tests.	A. No apparent problems — troubleshooting is done.	No further troubleshooting steps are required.
VI. The board has failed one or more of the tests listed above; cannot be corrected using the steps given.	A. There may be some fault in the board hardware or the on-board debugging and diagnostic firmware.	1. Document the problem and return the board for service. 2. Phone 1-800-222-5640.
TROUBLESHOOTING PROCEDURE COMPLETE		

Motorola Computer Group Documents

The Motorola publications listed below are referenced in this manual. You can obtain paper or electronic copies of Motorola Computer Group publications by:

- ❑ Contacting your local Motorola sales office
- ❑ Visiting Motorola Computer Group's World Wide Web literature site, <http://www.motorola.com/computer/literature>

Table C-1. Motorola Computer Group Documents

Document Title	Motorola Publication Number
MVME5100 Single Board Computer Programmer's Reference Guide	V5100A/PG
MVME761 Transition Module Installation and Use	VME761A/IH
MVME762 6-Channel Serial Transition Module Installation and Use	VME762A/UM
MVME762 6-Channel Serial Transition Module Installation and Use Supplement	VME762A/UM1A1
IPMC712/761 I/O Module Installation and Use	VIPMCA/IH
PMCspan PMC Adapter Carrier Module Installation and Use	PMCSPANA/IH
PPCbug Firmware Package User's Manual, Part 1 of 2	PPCBUGA1/UM
PPCbug Firmware Package User's Manual, Part 2 of 2	PPCBUGA2/UM
PPCbug Diagnostics Manual	PPCDIAA/UM

To obtain the most up-to-date product information in PDF or HTML format, visit <http://www.motorola.com/computer/literature>.

Manufacturers' Documents

C

For additional information, refer to the following table for manufacturers' data sheets or user's manuals. As an additional help, a source for the listed document is provided. Please note that while these sources have been verified, the information is subject to change without notice.

Table C-2. Manufacturers' Documents

Document Title	Publication Number
MPC750 RISC Microprocessor Users Manual Motorola Literature Distribution Center Telephone: (800) 441-2447 or (303) 675-2140	MPC750UM/AD
MPC7400 RISC Microprocessor Users Manual Motorola Literature Distribution Center Telephone: (800) 441-2447 or (303) 675-2140	MPC7400UM/D
Universe II User Manual Tundra Semiconductor Corporation 603 March Road, Kanata, ON, Canada K2K 2M5 1-800-267-7231, (613) 592-0714, Fax: (613) 592-1320	9000000.MD303.01
Dallas Semiconductor DS1621 Digital Thermometer and Thermostat Dallas Semiconductor http://www.dalsemi.com	DS1621
LEVEL ONE LXT970 Fast Ethernet Transceiver Data Sheet LEVEL ONE 9750 Goethe Road Sacramento, CA 95827	LXT970
Texas Instruments TL16C550C UART Data Sheet Texas Instruments P.O. Box 655303 Dallas, TX 75265	TL16550
M48T37V CMOS 32Kx8 Timekeeper SRAM Data Sheet SGS Thomson Microelectronics tap//.us.st.com	M48T37V

Table C-2. Manufacturers' Documents (Continued)

Document Title	Publication Number
2-Wire Serial CMOS EEPROM Data Sheet Atmel Corporation San Jose, CA	AT24C04
Intel GD82559ER Fast Ethernet PCI Controller Datasheet Intel Corporation	714682-001 Rev. 1.0 March 1999

C

Related Specifications

C

For additional information, refer to the following table for related specifications. As an additional help, a source for the listed document is provided. Please note that, while these sources have been verified, the information is subject to change without notice.

Table C-3. Related Specifications

Document Title and Source	Publication Number
Peripheral Component Interconnect (PCI) Interface Specification, Revision 2.1 PCI Special Interest Group P.O. Box 14070 Portland, Oregon 97214-4070 Marketing/Help Line: Telephone: (503) 696-6111 Document/Specification Ordering: Telephone: 1-800-433-5177 or (503) 797-4207 FAX: (503) 234-6762	PCI Local Bus Specification
Common Mezzanine Card Specification IEEE Standards Department 445 Hoes Lane, P.O. Box 1331 Piscataway, NJ 08855-1331	P1386 Draft 2.0
PCI Mezzanine Card Specification IEEE Standards Department 445 Hoes Lane, P.O. Box 1331 Piscataway, NJ 08855-1331	P1386.1 Draft 2.0

RAM500 Memory Expansion Module

D

Overview

The RAM500 memory expansion module can be used on the MVME5100 as an option for additional memory capability. Each expansion module is a single bank of SDRAM with up to 256MB of available ECC memory. Currently, two expansion modules can be used in tandem to produce an additional expanded memory capability of 512MB. There are two configurations of the board to accommodate tandem usage. The bottom expansion module has both a bottom and top connector: one to plug into the base board, and one to mate with the second RAM500 module. The top expansion module is designed with just a bottom connector to plug into the lower RAM500 module. The RAM500 incorporates a Serial ROM for system memory Serial Presence Detect (SPD) data.

A maximum of two expansion modules are allowed: one bottom and one top. If only one module is used, the RAM500 module with the top configuration is recommended.

Features

The following table lists the features of the RAM500 memory expansion module:

Table D-1. RAM500 Feature Summary

Form Factor	Dual sided mezzanine, with screw/post attachment to host board
SROM	Single 256x8 I ² C SROM for Serial Presence Detect Data
SDRAM	Double-Bit-Error detect, Single-Bit-Error correct across 72 bits 64MB or 256MB mezzanine memory @ 100MHz as a goal
Memory Expansion Flexibility	Any RAM500 memory size can be attached to the host board followed by any secondary RAM500 memory size for maximum memory expansion flexibility.

Functional Description

The following sections describe the physical and electrical structure of the RAM500 memory expansion module.

D

RAM500 Description

The RAM500 is a memory expansion module that is used on the MVME5100 Single Board Computer, and will be used on other Motorola products in the future. The RAM500 is based on a single memory mezzanine board design with the flexibility of being populated with different sized SDRAM components and SPD options to provide a variety of memory configurations. The design of the RAM500 allows any memory size module to connect to and operate with any other available memory size module.

The optional RAM500 memory expansion module is currently available in two sizes: 64MB and 256MB, with a total added capacity of 512MB. The SDRAM memory is controlled by the Hawk ASIC, which provides single-bit error correction and double-bit error detection. ECC is calculated over 72-bits. Refer to the *MVME5100 Single Board Computer Programmer's Reference Guide (V5100A/PG)* for more information.

The RAM500 consists of a single bank/block of memory. The memory block size is dependent upon the SDRAM devices installed. Refer to [Table D-2](#) for memory options.

The RAM500 memory expansion module is connected to the host board with a 140-pin AMP 0.6mm Free Height plug connector. If the expansion module is designed to accommodate another RAM500 module, the bottom expansion module will have two 140-pin AMP connectors installed: one on the bottom side of the module, and one on the top side of the module. The RAM500 memory expansion module draws +3.3V through this connector.

When populated, the optional RAM500 memory expansion memory blocks should appear as Block C and Block E to the Hawk ASIC. Block C and E are used because each of the module's SPD is defined to correspond to two banks of memory each: C and D for the first SPD and E and F for the second SPD.

The RAM500 SPD uses the SPD JEDEC standard definition and is accessed at address \$AA or \$AC. Refer to the following section on SROM for more details.

D

Table D-2. RAM500 SDRAM Memory Size Options

RAM500 Memory Size	Device Size	Device Organization	Number of Devices
32 Mbytes	64 Mbit	4Mx16	5*
64 Mbytes	128 Mbit	8Mx16	5*
128 Mbytes	256 Mbit	16Mx16	5*
64 Mbytes	64 Mbit	8Mx8	9
128 Mbytes	128 Mbit	16Mx8	9
256 Mbytes	256 Mbit	32Mx8	9

D

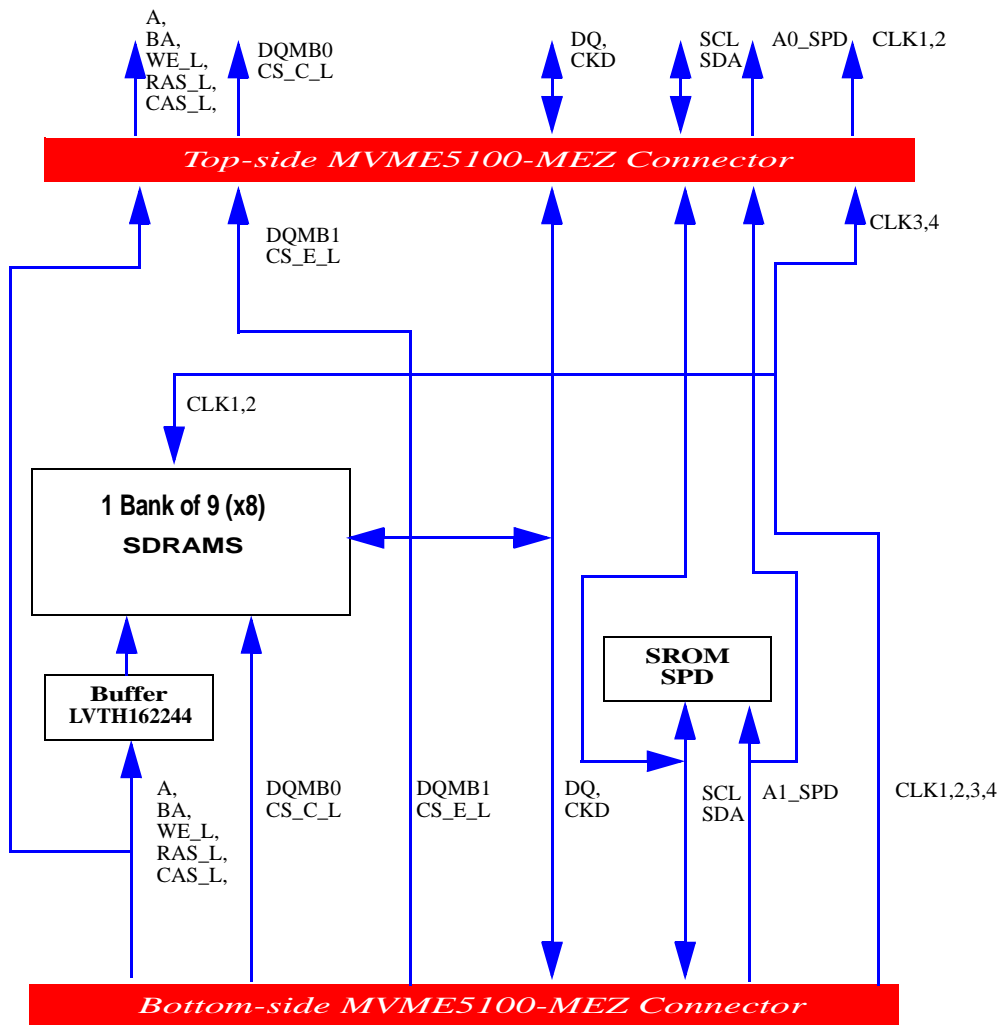

Note: DQMB1, CS_E_L, A1_SPD, CLK3,4 from Bottom Connector is routed to Top connector at the DQMB0, CS_C_L and A0_SPD, CLK1,2 pins.

Figure D-1. RAM500 Block Diagram

SROM

The RAM500 memory expansion module contains a single 3.3V, 256 x 8, Serial EEPROM device (AT24C02). The Serial EEPROM provides Serial Presence Detect (SPD) storage of the module memory subsystem configuration. The RAM500 SPD is software addressable by a unique address as follows: The first RAM500 attached to the host board has its SPD addressable at \$AA. The second RAM500 attached to the host board has its SPD addressable at \$AC. This dynamic address relocation of the RAM500 SPD shall be done using the bottom-side connector signal A1_SPD and A0_SPD.

D

Host Clock Logic

The host board provides four SDRAM clocks to the memory expansion connector. The frequency of the RAM500 CLKS is the same as the host board.

RAM500 Module Installation

One or more RAM500 memory expansion modules can be mounted on top of the MVME5100 for additional memory capacity. To upgrade or install a RAM500 module, refer to [Figure D-2](#) and proceed as follows:

1. Attach an ESD strap to your wrist. Attach the other end of the ESD strap to the chassis as a ground. The ESD strap must be secured to your wrist and to ground throughout the procedure.
2. Perform an operating system shutdown. Turn the AC or DC power off and remove the AC cord or DC power lines from the system. Remove the chassis or system cover(s) as necessary for access to the CompactPCI boards.
3. Carefully remove the MVME5100 from its VME card slot and lay it flat, with connectors P1 and P2 facing you.
4. Inspect the RAM500 module that is being installed on the MVME5100 host board (bottom configuration if two are being installed, top configuration if only one is being installed) to ensure

that standoffs are installed in the three mounting holes on the module.

5. With standoffs installed in the three mounting holes on the RAM500 module, align the standoffs and the P1 connector on the module with the three holes and the J16 connector on the MVME5100 host board and press the two connectors together until they are firmly seated in place.

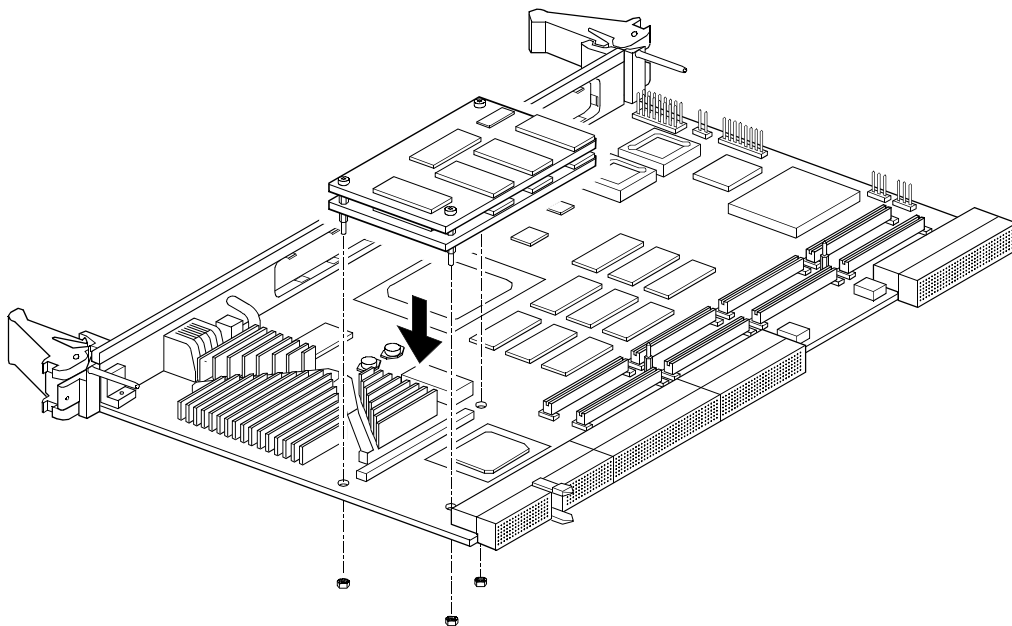

Figure D-2. RAM500 Module Placement on MVME5100

6. (Optional step) If a second RAM500 module is being used, align the top connector on the bottom RAM500 module with the bottom connector on the top RAM500 module and press the two connectors together until the connectors are seated in place.
7. Insert the three short Phillips screws through the holes at the corners of the RAM500 and screw them into the standoffs.

8. Turn the entire assembly over, and fasten the three nuts provided to the standoff posts on the bottom of the MVME5100 host board.
9. Reinstall the MVME5100 assembly in its proper card slot. Be sure the host board is well seated in the backplane connectors. Do not damage or bend connector pins.
10. Replace the chassis or system cover(s), reconnect the system to the AC or DC power source, and turn the equipment power on.

D

RAM500 Connectors

RAM500 memory expansion modules are populated with one or two connectors. If the module is to be used in tandem with a second RAM500 module, the “bottom” module will have two connectors: one to mate with the MVME5100 host board (P1), and one to mate with the “top” RAM500 module (J1). The “top” RAM500 module has only one connector, since it needs to mate only with the RAM500 module directly underneath it and because an added connector on a tandem RAM500 configuration would exceed the height limitations in some backplanes. If only one RAM500 module is being used, a top module, single connector configuration is used.

A 4H plug and receptacle are used on both boards to provide a 4 millimeter stacking height between dual RAM500 cards and the host board.

The following subsections specify the pin assignments for the connectors on the RAM500.

Bottom Side Memory Expansion Connector (P1)

The bottom side connector on the RAM500 is a 140-pin AMP 0.6mm Free Height mating plug. This plug includes common ground contacts that mate with standard AMP receptacle assemblies or AMP GIGA assemblies with ground plates. A single memory expansion module will have 1 bank of SDRAM for a maximum of 256Mbytes of memory. Attaching a second memory module to the first module will provide 2 banks of SDRAM with a maximum of 512Mbytes.

**Table D-3. RAM500 Bottom Side Connector (P1)
Pin Assignments**

1	GND*	GND*	2
3	DQ00	DQ01	4
5	DQ02	DQ03	6
7	DQ04	DQ05	8
9	DQ06	DQ07	10
11	+3.3V	+3.3V	12
13	DQ08	DQ09	14
15	DQ10	DQ11	16
17	DQ12	DQ13	18
19	DQ14	DQ15	20
21	GND*	GND*	22
23	DQ16	DQ17	24
25	DQ18	DQ19	26
27	DQ20	DQ21	28
29	DQ22	DQ23	30
31	+3.3V	+3.3V	32
33	DQ24	DQ25	34
35	DQ26	DQ27	36
37	DQ28	DQ29	38
39	DQ30	DQ31	40
41	GND*	GND*	42
43	DQ32	DQ33	44
45	DQ34	DQ35	46
47	DQ36	DQ37	48
49	DQ38	DQ39	50
51	+3.3V	+3.3V	52
53	DQ40	DQ41	54
55	DQ42	DQ43	56
57	DQ44	DQ45	58
59	DQ46	DQ47	60
61	GND*	GND*	62

D

**Table D-3. RAM500 Bottom Side Connector (P1)
Pin Assignments (Continued)**

63	DQ48	DQ49	64
65	DQ50	DQ51	66
67	DQ52	DQ53	68
69	+3.3V	+3.3V	70
71	DQ54	DQ55	72
73	DQ56	DQ57	74
75	DQ58	DQ59	76
77	DQ60	DQ61	78
79	GND*	GND*	80
81	DQ62	DQ63	82
83	CKD00	CKD01	84
85	CKD02	CKD03	86
87	CKD04	CKD05	88
89	+3.3V	+3.3V	90
91	CKD06	CKD07	92
93	BA1	BA0	94
95	A12	A11	96
97	A10	A09	98
99	GND*	GND*	100
101	A08	A07	102
103	A06	A05	104
105	A04	A03	106
107	A02	A01	108
109	+3.3V	+3.3V	110
111	A00	CS_C0_L	112
113	CS_E0_L	GND*	114
115	CS_C1_L	CS_E1_L	116
117	WE_L	RAS_L	118
119	GND*	GND*	120
121	CAS_L	+3.3V	122
123	+3.3V	DQMB0	124

D

**Table D-3. RAM500 Bottom Side Connector (P1)
Pin Assignments (Continued)**

125	DQMB1	SCL	126
127	SDA	A1_SPD	128
129	A0_SPD	MEZZ1_L	130
131	MEZZ2_L	GND	132
133	GND	SDRAMCLK1	134
135	SDRAMCLK3	+3.3V	136
137	SDRAMCLK4	SDRAMCLK2	138
139	GND*	GND*	140

*Common GND pins mate to a GIGA assembly with a ground plate. The GIGA assembly is an enhanced electrical performance receptacle and plug from AMP that includes receptacles loaded with contacts for grounding circuits at 9 or 10 signal circuits. These ground contacts mate with grounding plates on both sides of the plug assemblies.

Top Side Memory Expansion Connector (J1)

The top side memory expansion connector is a 140-pin AMP 0.6mm Free Height receptacle. This receptacle includes common ground contacts that mate with standard AMP plug assemblies or AMP GIGA assemblies with ground plates. A single memory module will have one bank of SDRAM for a maximum of 256MB of memory. The pin assignments for this connector are as follows:

**Table D-4. RAM500 Top Side Connector (J1)
Pin Assignments**

1	GND*	GND*	2
3	DQ00	DQ01	4
5	DQ02	DQ03	6
7	DQ04	DQ05	8
9	DQ06	DQ07	10
11	+3.3V	+3.3V	12

**Table D-4. RAM500 Top Side Connector (J1)
Pin Assignments (Continued)**

13	DQ08	DQ09	14
15	DQ10	DQ11	16
17	DQ12	DQ13	18
19	DQ14	DQ15	20
21	GND*	GND*	22
23	DQ16	DQ17	24
25	DQ18	DQ19	26
27	DQ20	DQ21	28
29	DQ22	DQ23	30
31	+3.3V	+3.3V	32
33	DQ24	DQ25	34
35	DQ26	DQ27	36
37	DQ28	DQ29	38
39	DQ30	DQ31	40
41	GND*	GND*	42
43	DQ32	DQ33	44
45	DQ34	DQ35	46
47	DQ36	DQ37	48
49	DQ38	DQ39	50
51	+3.3V	+3.3V	52
53	DQ40	DQ41	54
55	DQ42	DQ43	56
57	DQ44	DQ45	58
59	DQ46	DQ47	60
61	GND*	GND*	62
63	DQ48	DQ49	64
65	DQ50	DQ51	66
67	DQ52	DQ53	68
69	+3.3V	+3.3V	70
71	DQ54	DQ55	72
73	DQ56	DQ57	74

D

**Table D-4. RAM500 Top Side Connector (J1)
Pin Assignments (Continued)**

75	DQ58	DQ59	76
77	DQ60	DQ61	78
79	GND*	GND*	80
81	DQ62	DQ63	82
83	CKD00	CKD01	84
85	CKD02	CKD03	86
87	CKD04	CKD05	88
89	+3.3V	+3.3V	90
91	CKD06	CKD07	92
93	BA1	BA0	94
95	A12	A11	96
97	A10	A09	98
99	GND*	GND*	100
101	A08	A07	102
103	A06	A05	104
105	A04	A03	106
107	A02	A01	108
109	+3.3V	+3.3V	110
111	A00	CS_E0_L	112
113		GND*	114
115	CS_E1_L		116
117	WE_L	RAS_L	118
119	GND*	GND*	120
121	CAS_L	+3.3V	122
123	+3.3V	DQMB1	124
125		SCL	126
127	SDA		128
129	A1_SPD	MEZZ2_L	130
131		GND	132

D

**Table D-4. RAM500 Top Side Connector (J1)
Pin Assignments (Continued)**

133	GND	SDRAMCLK3	134
135		+3.3V	136
137		SDRAMCLK4	138
139	GND*	GND*	140

*Common GND pins mate to GIGA assemblies with ground plates.

D

RAM500 Programming Issues

The RAM500 contains no user programmable registers, other than the Serial Presence Detect (SPD) Data.

Serial Presence Detect (SPD) Data

This register is partially described for the RAM500 within the *MVME5100 Single Board Computer Programmer's Reference Guide*. The register is accessed through the I²C interface of the Hawk ASIC on the host board (MVME5100). The RAM500 SPD is software addressable by a unique address as follows: The first RAM500 attached to the host board has an SPD address of \$AA. The second RAM500 attached to the top of the first RAM500 has an SPD address of \$AC.

Ambient temperature, air flow, board electrical operation, and software operation affect board component temperatures. To evaluate the thermal performance of a circuit board assembly, you should test the board under actual operating conditions. These operating conditions vary depending on system design.

Motorola Computer Group performs thermal analysis in a representative system to verify operation within specified ranges. Refer to Specifications, [Table A-1](#). You should evaluate the thermal performance of the board in your application.

This appendix gives systems integrators the information necessary to conduct thermal evaluations of the board in their specific system configuration. It identifies thermally significant components and lists the corresponding maximum allowable component operating temperatures. It also provides example procedures for component-level temperature measurements.

Thermally Significant Components

[Table E-1](#) summarizes components that show significant temperature rises. You should monitor these components to assess thermal performance. [Table E-1](#) also supplies the component reference designator and the maximum allowable operating temperature.

You can find components on the board by their reference designators. Refer to [Figure E-1](#) and [Figure E-2](#).

The preferred temperature measurement location for a component may be:

- ❑ junction - refers to the temperature measured by an on-chip thermal device
- ❑ case - refers to the temperature at the top, center surface of the component
- ❑ air - refers to the ambient temperature near the component

E

Table E-1. Thermally Significant Components on the MVME5100 Single Board Computer

Reference Designator?	Generic Description	Maximum Allowable Component Temperature (degrees C) ¹	Measurement Location
U8	Hawk ASIC	105	Junction
U9	ECC DRAM (NEC D4564841G5)	70	Ambient
U4	Intel 82559ER	85	Case
U5	Intel 82559ER	85	Case
U3	Universe 2	125	Junction
U29	L2 cache 512K (MCM69P7377P)	70	Ambient
U30	L2 cache 512K (MCM69P7377P)	70	Ambient
U31	MPC952	125	Junction
U32	MPC972	125	Junction
U21	ECC DRAM (NEC D4564841G5)	70	Ambient
U16	ECC DRAM (NEC D4564841G5)	70	Ambient
U19	PPC7400@400 MHz (Max)	105	Junction
U53	Pulse H0009.2 9942-C	85	Ambient
¹ maximum temperature for reliable operation specified by the component manufacturer.			

Table E-2. Thermally Significant Components on the IPMC761 Module

Reference Designator?	Generic Description	Maximum Allowable Component Temperature (degrees C) ¹	Measurement Location
U6	Super I/O National Semiconductor	70	Ambient
U3	Zilog (Z0853606 VSC)	70	Ambient
U11	LSI Symbios LSA0564 609-0393602	70	Ambient
U12	Winbond W83C554F	70	Ambient
U14	Lattice ispLSI 1032E 70LT D935B14	125	Case
¹ maximum temperature for reliable operation specified by the component manufacturer.			

Note An MVME5100 Single Board Computer and an IPMC761 I/O board was tested in a Motorola lab environment, and it was verified that the reliability of the components would not be compromised when operating in a maximum ambient temperature of 55 degrees C, if the required airflow of 400 LFM is provided. Customer findings may differ based on specific environmental and operational characteristics.

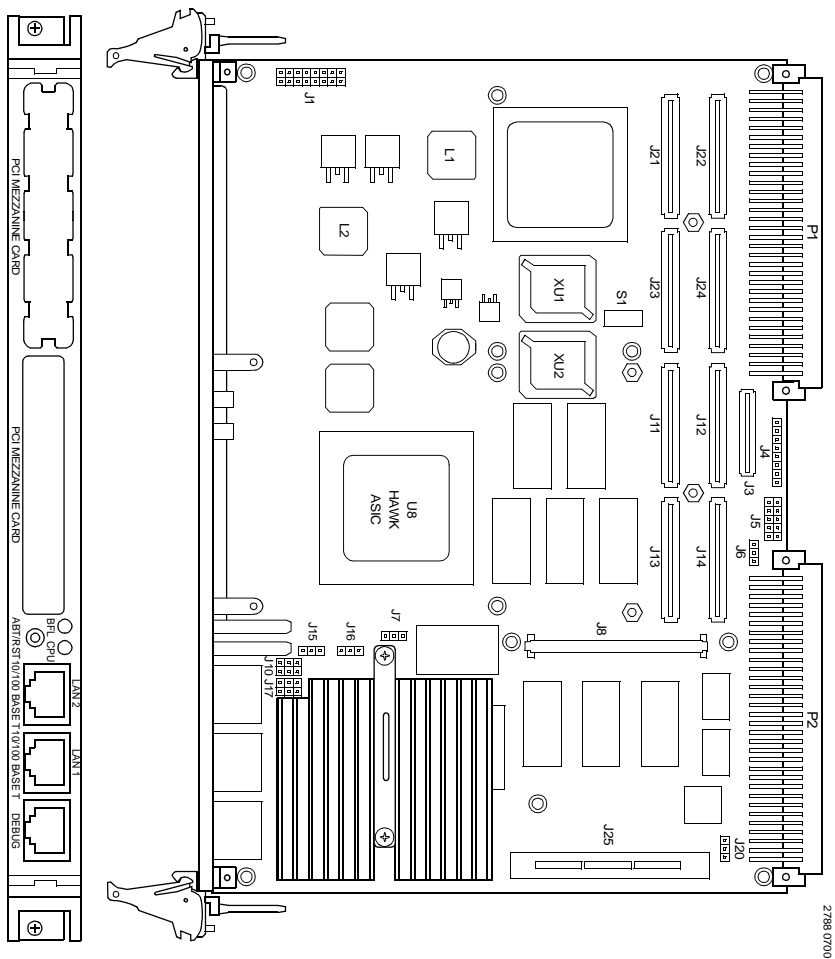
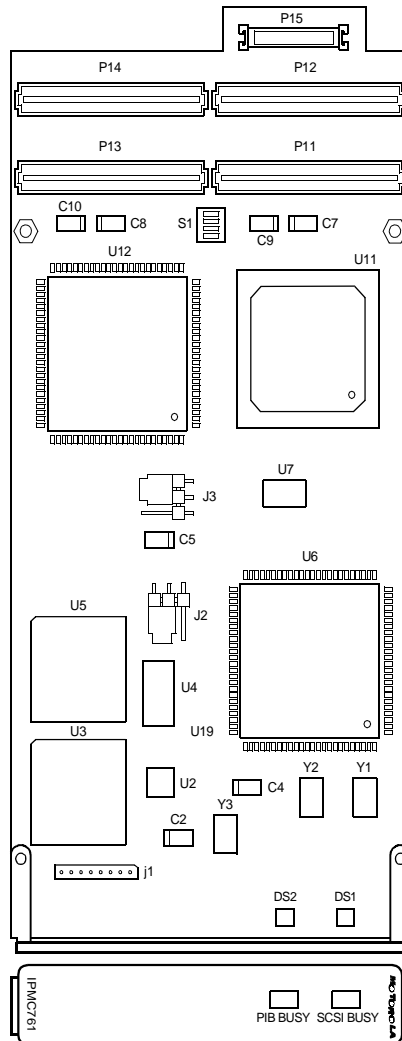

Figure E-1. Thermally Significant Components on the MVME5100 Single Board Computer - Primary Side

E



2844 1100

IPMC761

Figure E-2. Thermally Significant Components on the IPMC761 Module - Primary Side

Component Temperature Measurement

This section outlines general temperature measurement methods. For the specific types of measurements required for thermal evaluation of this board, see [Table E-1](#).

Preparation

E

We recommend 40-gage thermocouples for all thermal measurements. Larger gage thermocouples can wick heat away from the components and disturb air flowing past the board.

Allow the board to reach thermal equilibrium before taking measurements. Most circuit boards reach thermal equilibrium within 30 minutes. After the warm up period, monitor a small number of components over time to assure that equilibrium is reached.

Measuring Junction Temperature

Some components have an on-chip thermal measuring device such as a thermal diode. For instructions on measuring temperatures using the on-board device, refer to the MVME5100 component manufacturer's documentation listed in [Appendix C, Related Documentation](#).

Measuring Case Temperature

Measure the case temperature at the center of the top of the component. Make sure there is good thermal contact between the thermocouple junction and the component. We recommend you use a thermally conductive adhesive such as Loctite 384.

If components are covered by mechanical parts such as heatsinks, you need to machine these parts to route the thermocouple wire. Make sure that the thermocouple junction contacts *only* the electrical component. Also make sure that heatsinks lay flat on electrical components. [Figure E-3](#) shows one method of machining a heatsink base to provide a thermocouple routing path.

Note Machining a heatsink base reduces the contact area between the heatsink and the electrical component. You can partially compensate for this effect by filling the machined areas with thermal grease. The grease should not contact the thermocouple junction.

E

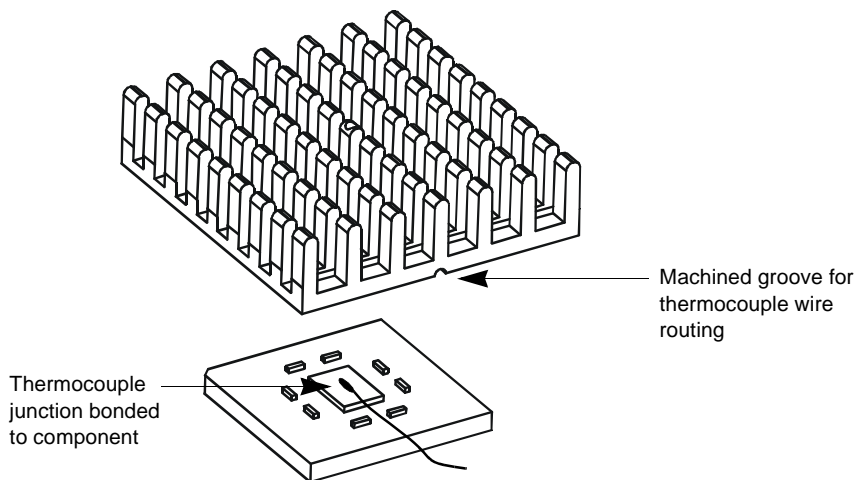

ISOMETRIC VIEW

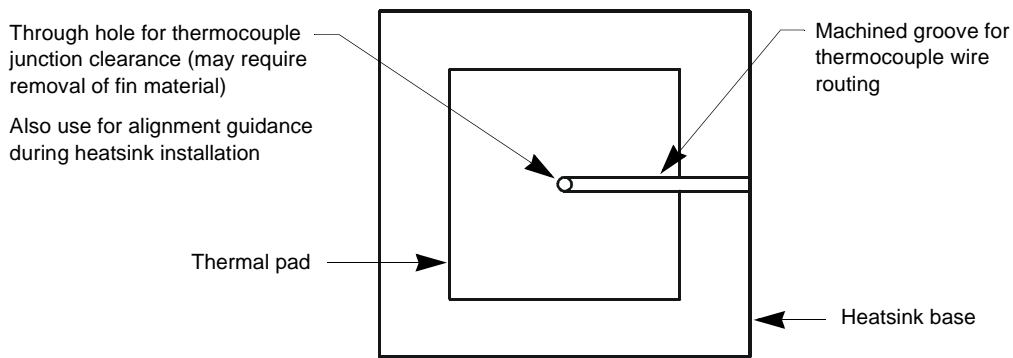

HEATSINK BOTTOM VIEW

Figure E-3. Mounting a Thermocouple Under a Heatsink

Measuring Local Air Temperature

Measure local component ambient temperature by placing the thermocouple downstream of the component. This method is conservative since it includes heating of the air by the component. Figure E-4 shows one method of mounting the thermocouple.

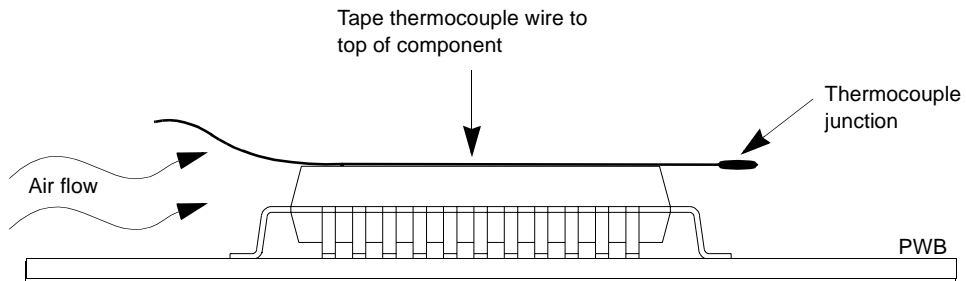

Figure E-4. Measuring Local Air Temperature

E

A

- Abort (interrupt) signal [2-1](#)
- ABT switch (S1) [2-1](#)
- AltiVec™ technology [4-3](#)
- assembly language [3-3](#)
- Asynchronous Communications [4-8](#)
- Auto Boot Abort Delay [3-13](#)
- Auto Boot Controller [3-12](#)
- Auto Boot Default String [3-13](#)
- Auto Boot Device [3-12](#)
- Auto Boot Partition Number [3-12](#)
- Autoboot enable [3-11](#), [3-12](#)

B

- backplane
 - connectors, P1 and P2
 - as power source [1-6](#)
 - jumpers [1-17](#)
- baud rate [2-3](#)
- BFL
 - LED [2-2](#)
- BG and IACK signals [1-17](#)
- bit size
 - data/address (MVME5100) [1-7](#)
- bits per character [2-3](#)
- board information block [3-6](#), [3-7](#)
- board placement [1-17](#)
- board structure [3-6](#), [3-7](#)
- Boot ROM [4-8](#)
- bridge function
 - as provided by Hawk ASIC [4-5](#)
- bug
 - basics [3-1](#)

- Bus Clock Frequency [4-1](#)
- buses, standard [6-1](#)

C

- case temperature
 - measuring [E-6](#)
- CNFG [3-6](#), [3-7](#)
- COM1 Interface [5-1](#)
- COM2 Interface [5-1](#)
- commands
 - PPCBug [3-3](#)
- commands, debugger [3-22](#)
- component temperature measurement [E-6](#)
- configurable items, MVME510x base board
 - [1-4](#)
- configurations
 - MVME51xx [xv](#)
- configure
 - PPC1Bug parameters [3-8](#)
 - VMEbus interface [3-17](#)
- configuring the hardware [1-3](#)
- connector
 - on RAM500 [D-2](#)
- cooling requirements [A-3](#)
- CPU
 - LED [2-2](#)

D

- DEBUG port [1-17](#)
- debugger
 - directory [3-26](#)
 - prompt [3-2](#)
- debugger commands [3-22](#)

DECchip 21143 LAN controller 6-6

diagnostics

- directory 3-26
- hardware 3-26
- prompt 3-2
- test groups 3-27

dimensions, MVME5100 A-1

directories, debugger and diagnostic 3-26

DMA channels 6-11

DRAM speed 3-15

E

ECC memory 4-6

ECC SDRAM Memor 4-6

EEPROM 4-2

endian issues

- function of Hawk ASIC 6-13
- function of Universe ASIC 6-14
- PCI domain 6-13
- processor/memory domain 6-13
- VMEbus domain 6-14

ENV

- Auto Boot Abort Delay 3-13
- Auto Boot Controller 3-12
- Auto Boot Default String 3-13
- Auto Boot Device 3-12
- Auto Boot Partition Number 3-12
- L2 Cache Parity Enable 3-16
- Memory Size 3-15
- Negate VMEbus SYSFAIL* Always 3-10
- Network Auto Boot Controller 3-14
- NVRAM Bootlist 3-11
- Primary SCSI Bus Negotiations 3-10
- Primary SCSI Data Bus Width 3-11
- ROM Boot Enable 3-13
- SCSI bus reset on debugger startup 3-10
- Secondary SCSI identifier 3-11

ENV command

- parameters 3-7

equipment, required 1-2

Ethernet controller 6-6

Ethernet Interface 4-7, 5-1

Ethernet Interfaces 4-2

Ethernet PCI controller chips 4-7

Ethernet Port 2 Configuration 5-1

Ethernet Port Selection 5-1

Ethernet ports 4-1

expansion memory

- RAM500 D-1

F

Features Description 4-3

firmware initialization 3-3

firmware, PPCBug 3-1

Flash

- ap note 4-6

FLASH Memory 4-2

Flash memory 4-5

Flash Memory Selection 5-1

FLASH SMT devices 4-5

Form Factor 4-2

front panel

- controls 2-1

front panels, using 2-1

G

global bus timeout 1-7

H

hardware

- configuration 1-3
- diagnostics 3-26
- initialization 3-3

Hawk

- as MPU/PCI bus bridge controller ASIC 6-6, 6-9, 6-13, 6-14

Hawk ASIC

- as bridge 4-5
- PHB/SMC parts 6-2

Hawk System Memory Controller 4-2

HE (Help) command 3-26

help command 3-26

humidity A-1

I

- I/O modes
 - described (PMC and SBC) 4-3
 - IACK and BG signals 1-17
 - IDSEL routing 4-9
 - initialization
 - performed by PPCBug 2-4
 - initialization process
 - as performed by firmware 3-4
 - Input/Output Interface 4-7
 - installation
 - RAM500 D-5
 - installation considerations 1-5
 - installing
 - multiple MVME510x boards 1-7
 - MVME510x 1-16
 - MVME510x hardware 1-8
 - MVME510x into chassis 1-16
 - PCI mezzanine cards 1-10
 - PMCs 1-10
 - PMCSpan 1-12, 1-14
 - primary PMCSpan 1-12
 - secondary PMCSpan 1-14
 - Internal Clock Frequency 4-1
 - interrupt
 - from ABORT switch 2-1
 - interrupt architecture, MVME510x 6-10
 - Interrupt Controller 4-2
 - interrupt routing 4-8
 - interrupt signals 2-1
 - interrupt support 6-9
 - IPMC761
 - pin assignments (J3) 5-3
 - IPMC761 Interface 5-1
 - ISA bus 2-1, 6-6, 6-9
- ## J
- jumper headers 1-4
 - jumper settings
 - MVME5100 5-2
 - jumpers and connectors 5-1
 - jumpers, backplane 1-17

- junction temperature
 - measuring E-6

L

- L2 Cache 4-2
- L2 Cache Parity Enable 3-16
- LED/serial startup diagnostic codes 3-16
- LEDs (light-emitting diodes), MVME510x 2-1
- local air temperature
 - measuring E-9
- lowercase 3-27

M

- Main Memory 4-2
- Memory 4-5
- memory
 - Flash and SDRAM 4-5
 - RAM500 D-1
- Memory Controller 4-2
- Memory Expansion 5-1
- memory map
 - CHRP 6-3
 - PCI local bus 6-2, 6-5
 - processor (default) 6-2
- memory maps
 - MVME510x 6-1
 - VMEbus 6-6
- memory size 3-15
- Memory Size Enable 3-15
- Miscellaneous 4-2
- MPU initialization 3-3
- mvme5100
 - description 1-1
- MVME510x
 - installing 1-16
 - programming 6-1

N

- Negate VMEbus SYSFAIL* Always 3-10
- NETboot enable 3-14
- Network Auto Boot Controller 3-14

Network Auto Boot enable [3-14](#)

NIOT debugger command

using [3-15](#)

Non-Volatile RAM (NVRAM) [3-7](#)

non-volatile static RAM [4-8](#)

NVRAM [4-2](#)

NVRAM Bootlist [3-11](#)

O

operation

parameter (Auto Boot Abort Delay) [3-13](#)

parameter (Auto Boot Controller) [3-12](#)

parameter (Auto Boot Default String)
[3-13](#)

parameter (Auto Boot Device) [3-12](#)

parameter (Auto Boot Partition Number)
[3-12](#)

parameter (L2 Cache Parity Enable)
[3-16](#)

parameter (Memory Size) [3-15](#)

parameter (Negate VMEbus SYSFAIL*
Always) [3-10](#)

parameter (Network Auto Boot Control-
ler) [3-14](#)

parameter (NVRAM Bootlist) [3-11](#)

parameter (Primary SCSI Bus Negotia-
tions) [3-10](#)

parameter (Primary SCSI Data Bus
Width) [3-11](#)

parameter (ROM Boot Enable) [3-13](#)

parameter (SCSI bus reset on debugger
startup) [3-10](#)

parameter (Secondary SCSI identifier)
[3-11](#)

Operation Mode Jumpers [5-1](#)

P

P1 and P2 [1-6](#)

P2 Input/Output (I/O) Mod [4-7](#)

Pal Programming Header [5-1](#)

parallel port [6-11](#)

parity [2-3](#)

PC100 ECC [4-2](#)

PC16550 [2-3](#)

PCI bus [6-5](#), [6-9](#)

PCI Expansion Connector [4-2](#)

PCI Expansion Interface [5-1](#)

PCI expansion slot

arbiter [6-7](#)

PCI Host Bridge [4-2](#)

PCI throughput [4-1](#)

PCI/PMC/Expansion [4-2](#)

Peripheral Support [4-2](#)

PHB/SMC

of Hawk ASIC [6-2](#)

PIB controller [6-6](#)

pin assignments

IPMC761 (J3) [5-3](#)

pinouts

J1/P1, RAM500 [D-7](#)

PMC

slot 1 arbiter [6-6](#)

slot 2 arbiter [6-7](#)

PMC Carrier Board Placement on
MVME510x [1-15](#)

PMC Interface (Slot 1) [5-1](#)

PMC Interface (Slot 2) [5-1](#)

PMC mode [4-3](#), [4-7](#)

jumper settings [1-6](#)

PMC Module Placement on MVME510x
[1-11](#)

PMC power requirements [A-2](#)

PMC slots [2-5](#)

PMCs

installing [1-10](#)

PMCSpan-002 Installation on an
MVME510x [1-13](#)

power

requirements [A-2](#)

power needs

mvme5100 [1-6](#)

power requirements

exclusions [A-2](#)

PowerPlus II architecture [4-1](#)

PPC6-Bug> 3-2, 3-26
PPC6-Diag> 3-2, 3-26
PPCbug
 as initialization firmware 2-4
 basics 3-1
 commands 3-3
 location/size requirements 3-3
 overview 3-1
 prompt 3-2
PPCbug commands
 uses of 3-1
primary PMCspan
 installing 1-12
Primary SCSI Bus Negotiations 3-10
Primary SCSI Data Bus Width 3-11
Processor 4-5
product specifications 4-1
programming the MVME510x 6-1
prompt, debugger 3-26
prompts
 PPCbug 3-2

R

RAM500
 bottom side connector D-7
 connectors D-2, D-7
 described D-2
 expansion module D-1
 features D-1
 install instructions D-5
 memory blocks D-3
 SPD addresses D-5
 top side connector D-10
Real-Time Clock & NVRAM & Watchdog
 Timer 4-8
required equipment 1-2
reset 6-11
RESET and ABORT Switc 4-2
resetting the system 2-1, 6-11
restart mode 3-27
Riscwatch Header 5-1
rogrammable DMA Controller 4-2

ROM Boot Enable 3-13
ROMboot enable 3-13, 3-16

S

SBC mode 4-3
 jumper settings 1-6
SCSI bus 3-10
SCSI bus reset on debugger startup 3-10
SD command 3-26
SDRAM clocks for RAM500 D-5
secondary PMCspan
 installing 1-14
Secondary SCSI identifier 3-11
set environment to bug/operating system
 (ENV) 3-7
setup terminal 1-17
SGS-Thomson MK48T559 timekeeper de-
 vice 6-11
Soldered Flash Protection 5-1
sources of reset 6-11
SPD D-13
SPD addresses
 for RAM500 D-5
specifications
 MBX board A-1
 MVME510x A-1
SRO 4-8
stop bit per character 2-3
switch
 abort 2-1
 reset 2-1
switches 2-1
switches, MVME510x front panel 2-1
SYSFAIL* 3-10
system console, connecting 1-17
system controller 1-17
System Controller (VME) 5-1
system controller function 2-2
System Memory Controller and PCI Host
 Bridge 4-5
system reset signal 2-1

T

temperature
 operating [A-1](#)
 storage [A-1](#)
terminal setup [1-17](#)
testing the hardware [3-26](#)
thermal analysis [E-1](#)
thermally significant components [E-2](#), [E-3](#)
timeout, global [1-7](#)
timers [4-8](#)
transition modules
 compatible with MVME5100 [4-3](#)
troubleshooting procedures [B-1](#)
troubleshooting the MVME510x [3-26](#)
Tundra Universe Controller [4-2](#)
Typical Single-width PMC Module Place-
 ment on MVME510x [1-11](#)

U

Universe VMEbus interface ASIC [2-2](#), [6-5](#),
 [6-6](#), [6-12](#), [6-14](#)
uppercase [3-27](#)
using the front panels [2-1](#)

V

VMEbus [4-2](#)
 memory map [6-6](#)
 memory maps [6-6](#)
VMEbus Interface [4-8](#), [5-1](#)
VMEbus interface [3-17](#)

W

Winbond PCI/ISA bus bridge controller [6-6](#)
Winbond W83C553
 as PCI arbiter support [6-7](#)

Free Manuals Download Website

<http://myh66.com>

<http://usermanuals.us>

<http://www.somanuals.com>

<http://www.4manuals.cc>

<http://www.manual-lib.com>

<http://www.404manual.com>

<http://www.luxmanual.com>

<http://aubethermostatmanual.com>

Golf course search by state

<http://golfingnear.com>

Email search by domain

<http://emailbydomain.com>

Auto manuals search

<http://auto.somanuals.com>

TV manuals search

<http://tv.somanuals.com>