



# **CPCI-6115 CompactPCI Single Board Computer**

**Installation and Use**

**6806800A68D**

March 2008

© Copyright 2008, 2007, 2006 Motorola, Inc.

All rights reserved.

Printed in the United States of America.

## Trademarks

Motorola® and the Motorola symbol are registered trademarks of Motorola, Inc.

CompactPCI® is a registered trademark of PCI Industrial Computer Manufacturers Group.

All other product or service names mentioned in this document are trademarks or registered trademarks of their respective holders.

## Notice

While reasonable efforts have been made to assure the accuracy of this document, Motorola, Inc. assumes no liability resulting from any omissions in this document, or from the use of the information obtained therein. Motorola reserves the right to revise this document and to make changes from time to time in the content hereof without obligation of Motorola to notify any person of such revision or changes.

Electronic versions of this material may be read online, downloaded for personal use, or referenced in another document as a URL to the Motorola Computer Group Web site. The text itself may not be published commercially in print or electronic form, edited, translated, or otherwise altered without the permission of Motorola, Inc.

It is possible that this publication may contain reference to or information about Motorola products (machines and programs), programming, or services that are not available in your country. Such references or information must not be construed to mean that Motorola intends to announce such Motorola products, programming, or services in your country.

## Limited and Restricted Rights Legend

If the documentation contained herein is supplied, directly or indirectly, to the U.S. Government, the following notice shall apply unless otherwise agreed to in writing by Motorola, Inc.

Use, duplication, or disclosure by the Government is subject to restrictions as set forth in subparagraph (b)(3) of the Rights in Technical Data clause at DFARS 252.227-7013 (Nov. 1995) and of the Rights in Noncommercial Computer Software and Documentation clause at DFARS 252.227-7014 (Jun. 1995).

Motorola, Inc.

Embedded Communications Computing

2900 South Diablo Way, Suite 190

Tempe, Arizona 85282

# Contents

---

<b>About this Manual</b> .....	<b>11</b>
<b>Safety Notes</b> .....	<b>17</b>
<b>Sicherheitshinweise</b> .....	<b>21</b>
<b>1 Introduction</b> .....	<b>25</b>
1.1 Features .....	25
1.2 Standard Compliances .....	26
1.3 Ordering Information .....	27
<b>2 Hardware Preparation and Installation</b> .....	<b>29</b>
2.1 Overview .....	29
2.2 Unpacking and Inspecting the Board .....	29
2.3 Environmental, Power, and Thermal Requirements .....	30
2.3.1 Environmental Requirements .....	30
2.3.2 Power Requirements .....	32
2.3.3 Thermal Requirements .....	32
2.4 Getting Started .....	35
2.4.1 Overview of Start-up Procedure .....	35
2.4.2 Equipment Required .....	36
2.5 Baseboard Preparation .....	36
2.5.1 Configuring the Hardware .....	36
2.5.2 Setting Switches and Jumpers .....	37
2.5.3 J6, Bus Mode Selection .....	38
2.5.4 J9, Standalone Operating Mode .....	39
2.5.5 J10, Flash Bank Selection .....	39
2.5.6 J15, +/-12 V Present Header .....	40
2.5.7 J20, Safe Start Header .....	40
2.5.8 J25, SROM Initialization Enable Header .....	41
2.5.9 J99, Flash Bank A Programming Enable Header .....	41
2.5.10 SW2, Geographic Address .....	42
2.6 Operating Modes .....	42
2.7 Installing Hardware .....	42
2.7.1 Installing PMC Modules on the CPCI-6115 .....	43
2.7.2 Installing the CPCI-6115 Baseboard .....	46
2.8 Connecting to a Console Port .....	47
2.9 Applying Power .....	47

<b>3</b>	<b>Controls, LEDs, and Connectors</b>	<b>49</b>
3.1	Overview	49
3.2	Board Layout	50
3.3	Front Panel Connectors and LEDs	50
3.4	ABORT/Reset Switch	52
3.5	On-Board Connectors and Headers	52
3.5.1	J19, Front Panel Asynchronous Serial Port	52
3.5.2	J95, Front Panel 10/100/1000 Megabits/s Ethernet Connector	53
3.5.3	CompactPCI J1/J2 Connectors	53
3.5.4	CompactPCI Bus Connector	54
3.5.5	CompactPCI Bus Connector	54
3.5.6	CompactPCI User I/O Connector	55
3.5.7	CompactPCI Connector	56
3.5.8	CompactPCI User I/O Connector	57
3.5.9	PCI Mezzanine Card (PMC) Connectors	59
3.5.10	Boundary Scan JTAG Header	63
3.5.11	Processor JTAG/COP Header	63
3.5.12	Stand-Alone Operation Select Header	64
3.5.13	Flash Boot Bank Select Header	64
3.5.14	Safe Start Header	65
3.5.15	Bus Mode Select Header	65
3.5.16	SROM Initialization Enable Header	65
3.5.17	Flash Bank A Write Protect Header	66
3.5.18	+/-12 V Present Header	66
<b>4</b>	<b>Functional Description</b>	<b>67</b>
4.1	Overview	67
4.2	Block Diagram	68
4.3	General Description	69
4.3.1	Processor Bus Resources	69
4.3.2	Processor	70
4.3.3	L3 Cache	70
4.3.4	MV64360 System Controller	70
4.3.4.1	MV64360 CPU Bus Interface	71
4.3.4.2	MV64360 DDR SDRAM Interface	71
4.3.4.3	MV64360 32-bit Interface to Devices	72
4.3.4.4	MV64360 Dual PCI/PCI-X Interfaces	72
4.3.4.5	MV64360 Integrated Gigabit Ethernet MACs	72
4.3.4.6	MV64360 Integrated 2 Megabit SRAM	73
4.3.4.7	MV64360 General-Purpose 32-bit Timer/Counters	73
4.3.4.8	MV64360 Watchdog Timer	73
4.3.4.9	MV64360 I2O Message Unit	73
4.3.4.10	MV64360 Four-Channel Independent DMA Controller	73
4.3.4.11	MV64360 I2C Interface	73
4.3.4.12	Interrupt Controller	74

4.3.4.13	PCI Bus Arbitration	74
4.3.4.14	Board Reset Logic	75
4.3.4.15	MV64360 MPP Configuration	75
4.3.4.16	MV64360 Reset Configuration	76
4.3.5	System Memory	79
4.3.6	Flash Memory	80
4.3.7	NVRAM, Real-Time Clock, Watchdog Timer	80
4.3.8	TL16C550C UART Devices	81
4.3.9	System Registers	81
4.3.10	Serial EEPROM Devices	81
4.3.11	PCI Bus 0.0	81
4.3.12	PCI Bus 1.0	81
4.3.13	IDE Controller	82
4.3.14	Intel 21555 PCI-to-PCI Bridge	82
4.3.15	CompactPCI Bus	82
4.3.16	PMC Slots	82
4.4	Miscellaneous	84
4.4.1	Clock Generation	84
4.4.2	Interrupt Handling	84
4.4.2.1	MV64360 Interrupt Controller	85
4.4.2.2	Sources of Reset	86
4.4.2.3	Machine Check	86
4.4.2.4	Soft Reset	86
4.4.2.5	SMI	86
4.4.2.6	Other Software Considerations	86
4.4.3	Onboard Power Supplies	87
4.4.4	Hot Swap Support	87
4.4.5	Hot Swap Process	87
4.4.6	Intel 21555 Hot Swap Support	87
<b>5</b>	<b>Transition Module Preparation and Installation</b>	<b>89</b>
5.1	Overview	89
5.2	Block Diagram	90
5.3	Preparing the Transition Module	91
5.4	Rear Panel Connectors	92
5.5	On-Board Connectors and Headers	92
5.5.1	IDE CompactFlash Connector	93
5.5.2	PMC I/O Module Connectors	93
5.5.2.1	Host IO Connectors	94
5.5.2.2	PMC I/O Connectors	96
5.5.3	CompactPCI User I/O Connector	97
5.5.4	CompactPCI User I/O Connector	98
5.5.5	10/100/1000BaseTx Connectors	100
5.5.6	COM1 And COM2 Connectors (MXP Version)	100
5.5.7	RJ-45 to DB-9 Adapter for COM1 to PC COM1	101

5.6	Jumper Settings	102
5.6.1	CompactFlash Jumper	102
5.6.2	COM1 and COM2 Asynchronous Serial Ports Jumpers	102
5.7	Functional Description	103
5.7.1	IDE Flash	103
5.7.2	Ethernet Interface (CompactPCI Version)	104
5.7.3	Hot-Swap Support	104
5.7.4	Serial EEPROM	104
5.7.5	PMC I/O Modules	104
5.7.6	Asynchronous Serial Ports	104
5.7.6.1	I/O Signal Multiplexing (IOMX)	105
5.7.6.2	Serial Port Redirection	107
5.7.6.3	Asynchronous Serial Port Diagrams	107
5.7.6.4	Port Configuration Diagrams	108
5.7.7	PMC I/O Module	108
5.7.8	PMC I/O Module Form Factor	109
5.7.9	PMC I/O Connector	110
5.7.10	Host I/O Connector	110
5.7.11	PMC I/O Module Presence Detection and Identification	110
5.8	Installing the PIM	111
5.9	Installing the Transition Module	113
5.10	Removing the Transition Module in a Hot-Swap Chassis	114
<b>6</b>	<b>Remote Start via the PCI Bus</b>	<b>115</b>
6.1	Overview	115
6.2	Register Description	115
6.3	Command/Response Register Description	116
<b>7</b>	<b>MOTLoad Firmware</b>	<b>117</b>
7.1	Overview	117
7.2	MOTLoad Description	117
7.3	MOTLoad Implementation and Memory Requirements	117
7.4	MOTLoad Commands	118
7.5	MOTLoad Utility Applications	118
7.6	MOTLoad Tests	118
7.7	Using MOTLoad	119
7.7.1	Command Line Interface	119
7.7.2	Command Line Help	120
7.7.3	Command Line Rules	120
7.8	MOTLoad Command List	121
<b>8</b>	<b>Memory Maps</b>	<b>125</b>
8.1	Overview	125
8.2	Memory Maps	125

---

8.2.1	Default Processor Memory Map .....	125
8.2.2	Processor Memory Map .....	126
8.2.3	Default PCI Memory Map .....	127
8.2.4	Suggested PCI Memory Map .....	128
8.2.5	System I/O Memory Map .....	129
8.2.6	PCI Local Bus Memory Map .....	129
8.2.7	CompactPCI Memory Map .....	129
8.2.8	Address Decoding with the 21555 .....	130
8.2.9	L1, L2 and L3 Cache .....	130
8.2.10	System Memory .....	130
<b>A</b>	<b>Related Documentation .....</b>	<b>131</b>
A.1	Embedded Communications Computing Documents .....	131
A.2	Manufacturers' Documents .....	131
A.3	Related Specifications .....	132





# List of Tables

---

Table 1-1	CPCI-6115 Features	25
Table 1-2	Board Standard Compliances	26
Table 1-3	Board Variant Order Numbers	27
Table 1-4	Related Product Order Numbers	27
Table 2-1	CPCI-6115 Specifications	30
Table 2-2	Power Requirements	32
Table 2-3	Thermally Significant Components	33
Table 2-4	Startup Overview	35
Table 2-5	CPCI-6115 Jumper Map	37
Table 3-1	Front Panel LEDs	50
Table 3-2	COM1 Pin Assignments, J19	52
Table 3-3	10/100/1000 Megabit/s Ethernet Connector, J95	53
Table 3-4	CompactPCI Connector, J1	54
Table 3-5	CompactPCI Connector, J2	54
Table 3-6	User I/O Connector Pinout, J3	55
Table 3-7	User I/O Connector Pinout, J5	57
Table 3-8	PMC Connector Pin Assignments, J11/J21	59
Table 3-9	PMC Connector Pin Assignments, J12/J22	60
Table 3-10	PMC Connector Pin Assignments, J13/J23	61
Table 3-11	PMC Connector Pin Assignments, J14/J24	62
Table 3-12	Boundary Scan JTAG Header Pin Assignments, J16	63
Table 3-13	Processor JTAG/COP Header Pin Assignments, J17	63
Table 3-14	Stand-Alone Operation Select Header Pin Assignments, J9	64
Table 3-15	Flash Boot Bank Select Header Pin Assignments, J10	64
Table 3-16	Safe Start ENV Header Pin Assignments, J20	65
Table 3-17	Bus Mode Select Header Pin Assignments, J6	65
Table 3-18	SROM Initialization Enable Header Pin Assignments, J25	65
Table 3-19	Bank A Write Protect Header Pin Assignments, J99	66
Table 3-20	+/-12 V Present Header Pin Assignments, J15	66
Table 4-1	Device Bus Parameters	72
Table 4-2	MV64360 MPP Pin Function Assignments	75
Table 4-3	MV64360 Power-Up Configuration Settings	77
Table 4-4	System Memory Options	79
Table 4-5	Bank A Flash Options	80
Table 4-6	Processor PMC Support	83
Table 4-7	MV64360 Interrupt Assignments	85
Table 5-1	CPCI-6115-MCPTM Rear Panel Connectors	92
Table 5-2	On-Board Connectors and Headers	92
Table 5-3	CompactFlash IDE Connector Pin Assignments, J1	93
Table 5-4	PMC I/O Module 1 - Host I/O Connector Pin Assignments, J10	94

## List of Tables

---

Table 5-5	PMC I/O Module 2 - Host I/O Connector Pin Assignments, J20	95
Table 5-6	PMC I/O Modules 1 and 2 - PMC I/O Connector Pin Assignments, J14/24	96
Table 5-7	User I/O Connector Pinout, J3	97
Table 5-8	User I/O Connector Pinout, J5	98
Table 5-9	10BaseT/100BaseTx Connector Pin Assignments	100
Table 5-10	COM1, COM2 Connector Pin Assignments	100
Table 5-11	Wire Interconnection List RJ-45 to DB-9	101
Table 5-12	Multiplexing Sequence of the IOMX Function	105
Table 7-1	MOTLoad Commands	121
Table 8-1	Default Processor Memory Map	125
Table 8-2	Suggested PPC Memory Map	127
Table 8-3	Default PCI Address Map	127
Table 8-4	Suggested PCI Memory Map	128
Table 8-5	Device Bank 1 I/O Memory Map	129
Table 8-6	Apollo L3CR Register Assignments	130
Table A-1	Motorola ECC Documents	131
Table A-2	Manufacturers' Documents	131
Table A-3	Related Specifications	132

# List of Figures

---

Figure 2-1	CPCI-6115 Thermally Significant Components (Primary Side)	34
Figure 2-2	CPCI-6115 Thermally Significant Components (Secondary Side)	35
Figure 2-3	Switch and Jumper Locations	38
Figure 2-4	Jumper Setting for J6	38
Figure 2-5	Jumper Settings for J9	39
Figure 2-6	Jumper Settings for J10	39
Figure 2-7	Jumper Settings for J15	40
Figure 2-8	Jumper Setting for J20	40
Figure 2-9	Jumper Setting for J25	41
Figure 2-10	Jumper Setting for J99	41
Figure 2-11	MOTLoad System Startup	48
Figure 3-1	Component Layout	50
Figure 3-2	Front Panel Connector Cutouts, Connectors, and LED Indicators	51
Figure 4-1	CPCI-6115 Baseboard Block Diagram	68
Figure 5-1	CPCI-6115-MCPTM Block Diagram	90
Figure 5-2	Connector and Header Locations (MXP Version)	91
Figure 5-3	CompactFlash Jumper Settings (J2)	102
Figure 5-4	COM1 and COM2 Serial Port Jumpers (J6/J11)	103
Figure 5-5	Signal Multiplexing Diagram	105
Figure 5-6	P2MX Signal Timings	106
Figure 5-7	CPCI-6115-MCPTM Serial Ports 1 and 2	108
Figure 5-8	PMC I/O Module Physical Representation (MXP Version)	109
Figure 5-9	Installing the PIM	112
Figure 5-10	CPCI-6115-MCPTM Mating Configuration	114



# About this Manual

---

## Overview of Contents

This manual, *CPCI-6115 CompactPCI Single Board Computer Installation and Use*, provides general information, hardware preparation and installation instructions, operating instructions, firmware information, functional descriptions and pin assignments for the CPCI-6115 Single Board Computer (SBC).

This manual is divided into the following chapters and appendices:

[Safety Notes](#), contains the warnings, cautions, and notices that precede potentially dangerous procedures, alert the user to practices that could cause minor injury, or possibly damage the product.

[Sicherheitshinweise](#), contains the German translation of these warnings, cautions, and notices.

[Chapter 1, Introduction](#), describes the features of the CPCI-6115, standard compliances, and ordering information.

[Chapter 2, Hardware Preparation and Installation](#), provides an overview of basic operating and configuring issues such as the MOTLoad firmware, and environmental, power, and thermal requirements. The remainder of the chapter provides information on hardware preparation and installation instructions, including peripheral boards such as the CPCI-6115-MCPTM transition module.

[Chapter 3, Controls, LEDs, and Connectors, on page 49](#) describes face plate and on-board connectors and their pin assignment. On-board headers and their settings are also discussed.

[Chapter 4, Functional Description](#), provides a description of the major components and functionality of the MCPN905.

[Chapter 5, Transition Module Preparation and Installation](#), provides information on the transition module that is compatible with the CPCI-6115. Information includes a brief overview, unpacking instructions, board preparation and installation instructions, face plate and on-board connector descriptions and pin assignments. Other sections describe the functionality, the PIMs that are installed on the transition module, along with installation and removal instructions.

[Chapter 6, Remote Start via the PCI Bus](#), describes the remote interface provided by the firmware to the host CPU via the CompactPCI bus. This interface facilitates the host obtaining information about the board, downloading code and/or data, and execution of the downloaded program.

[Chapter 7, MOTLoad Firmware](#), provides an overview and description of basic MOTLoad use including implementation issues, a list of the initialization sequence, and a description of basic commands.

[Chapter 8, Memory Maps](#), provides an overview of the memory maps, interrupts, arbitration, sources of reset and endian issues.

Appendix A, *Related Documentation*, provides a list of related documents including those produced by Motorola, as well as third parties. It also provides a list of industry related specifications.

## Abbreviations

This document uses the following abbreviations:

Abbreviation	Description
AC	Alternating Current
AMC	Alarm Management Controller
AMP	Amphere
ASIC	Application-Specific Integrated Circuit
ATA	Advanced Technology Attachment
BFL	Board Fail
CBGA	Ceramic Ball Grid Array
CHRP	Computer Hardware Reference Platform
CMC	Common Mezzanine Card
CPCI	CompactPCI
CPU	Central Processing Unit
CSR	Control and Status Register
DC	Direct Current
DDR	Double Data Rate
DMA	Direct Memory Access
DRAM	Dynamic Random Access Memory
DTE	Data Terminal Equipment
DTR	Data Terminal Ready
EIA	Electronic Industries Alliance
EIDE	Enhanced Integrated Drive Electronics
EMC	Electromagnetic Compatibility
ESD	Electrostatic Discharge
ETSI	European Telecommunications Standards Institute
FAT	File Allocation Table
FCC	Federal Communications Commission
GPP	General Purpose Port
HS	Hot Swap
I/O	In/Out
IDE	Integrated Drive Electronics
IDMA	Internal Direct Memory Access

Abbreviation	Description
IEEE	Institute of Electrical and Electronics Engineers, Inc.
IOMUX	I/O Signal Multiplexing
IP	Internet Protocol
LED	Light Emitting Diode
LOO	LED On/OFF
MAC	Media Access Control
MPP	Multipurpose Port
MPU	Microprocessing Unit
MPX	Multiplex/Multiplexer Multiprocessor eXtension
MXP	Multi-Service Packet Transport Platform
NC	Not Connected
NEBS	Network Equipment Building Systems
NVRAM	Nonvolatile Random Access Memory
OS	Operating System
PC	Payload Card
PCB	Printed Circuit Board
PCI	Peripheral Component Interconnect
PCI-X	Peripheral Component Interconnect eXtended
PF	Port Format
PICMG	PCI Industrial Computer Manufacturer's Group
PIM	PMC I/O Module
PLD	Programmable Logic Device
PMC	Peripheral Management Controller
PMCIO	PMC User I/O
PPC	PowerPC
PRP	PowerPC Reference Platform
PrPMC	Processor PMC
RAM	Random Access Memory
RF	Radio Frequency
RISC	Reduced Instruction Set Computer
ROM	Read Only Memory
RTC	Real Time Clock
RTM	Rear Transition Module
RTOS	Real Time Operating system
RoHS	Restriction of the Use of Certain Harzardous Substances
SBC	Single Board Computer





Abbreviation	Description
SDMA	Space-Division Multiple Access
SDRAM	Synchronous Dynamic Random Access Memory
SELV	Safety Extra Low Voltage
SPD	Serial Presence Detect
SRAM	Static Random Access Memory
SROM	Serial Read Only Memory
TFTP	Trivial File Transfer Protocol
TPE	Twisted Pair Ethernet
UART	Universal Asynchronous Receiver Transmitter
UL	Underwriters Laboratory
VCCI	Voluntary Control Council for Interference
VITA	VMEBUS International Trade Association
VME	Versa Module Eurocard
VPD	Vital Product Data

## Conventions

The following table describes the conventions used throughout this manual.

Notation	Description
0x00000000	Typical notation for hexadecimal numbers (digits are 0 through F), for example used for addresses and offsets
0b0000	Same for binary numbers (digits are 0 and 1)
<b>bold</b>	Used to emphasize a word
Screen	Used for on-screen output and code related elements or commands in body text
<b>Courier + Bold</b>	Used to characterize user input and to separate it from system output
<i>Reference</i>	Used for references and for table and figure descriptions
File > Exit	Notation for selecting a submenu
<text>	Notation for variables and keys
[text]	Notation for software buttons to click on the screen and parameter description
...	Repeated item for example node 1, node 2, ..., node 12
.	Omission of information from example/command that is not necessary at the time being



Notation	Description
..	Ranges, for example: 0..4 means one of the integers 0,1,2,3, and 4 (used in registers)
	Logical OR
 <div style="background-color: #f96; padding: 2px; text-align: center; border: 1px solid black;">  <b>WARNING</b> </div> <p>XX XX</p>	Indicates a hazardous situation which, if not avoided, could result in death or serious injury
 <div style="background-color: #f9e79f; padding: 2px; text-align: center; border: 1px solid black;">  <b>CAUTION</b> </div> <p>XX XX</p>	Indicates a hazardous situation which, if not avoided, may result in minor or moderate injury
<div style="background-color: #2e75b6; color: white; padding: 2px; text-align: center; border: 1px solid black;"> <b>NOTICE</b> </div> <p>XX XX</p>	Indicates a property damage message
 <p>XX XX</p>	No danger encountered. Pay attention to important information

# Summary of Changes

The following changes have been made to this manual.

Date	Description	Replaces
March 2008	Corrected description for Bank B flash memory to soldered (not socketed).	6806800A68C
December 2007	Added Remote Start section. Corrected default setting for J99. Added ability for search and copy/paste text. Applied new documentation style standards throughout.	6806800A68B
March 2007	Corrected default setting for J99	6806800A68A

## Comments and Suggestions

Motorola welcomes and appreciates your comments on its documentation. We want to know what you think about our manuals and how we can make them better. Mail comments to:

- Embedded Communications Computing  
Reader Comments DW164  
2900 S. Diablo Way, Suite 190  
Tempe, Arizona 85282
- [eccrc@motorola.com](mailto:eccrc@motorola.com)

In all your correspondence, please list your name, position, and company. Be sure to include the title and part number of the manual and tell how you used it. Then tell us your feelings about its strengths and weaknesses and any recommendations for improvements.

# Safety Notes

---

This section provides warnings that precede potentially dangerous procedures throughout this manual. Instructions contained in the warnings must be followed during all phases of operation, service, and repair of this equipment. You should also employ all other safety precautions necessary for the operation of the equipment in your operating environment. Failure to comply with these precautions or with specific warnings elsewhere in this manual could result in personal injury or damage to the equipment.

Motorola intends to provide all necessary information to install and handle the product in this manual. Because of the complexity of this product and its various uses, we do not guarantee that the given information is complete. If you need additional information, ask your Motorola representative.

The product has been designed to meet the standard industrial safety requirements. It must not be used except in its specific area of office telecommunication industry and industrial control.

Only personnel trained by Motorola or persons qualified in electronics or electrical engineering are authorized to install, remove or maintain the product.

The information given in this manual is meant to complete the knowledge of a specialist and must not be used as replacement for qualified personnel.

Keep away from live circuits inside the equipment. Operating personnel must not remove equipment covers. Only Factory Authorized Service Personnel or other qualified service personnel may remove equipment covers for internal subassembly or component replacement or any internal adjustment.

Do not install substitute parts or perform any unauthorized modification of the equipment or the warranty may be voided. Contact your local Motorola representative for service and repair to make sure that all safety features are maintained.

## EMC

This equipment has been tested and found to comply with the limits for a Class A digital device, pursuant to Part 15 of the FCC Rules. These limits are designed to provide reasonable protection against harmful interference when the equipment is operated in a commercial environment. This equipment generates, uses, and can radiate radio frequency energy and, if not installed and used in accordance with the instruction manual, may cause harmful interference to radio communications.

Operation of this equipment in a residential area is likely to cause harmful interference in which case the user will be required to correct the interference at his own expense. Changes or modifications not expressly approved by Motorola Embedded Communications Computing could void the user's authority to operate the equipment.

Board products are tested in a representative system to show compliance with the above mentioned requirements. A proper installation in a compliant system will maintain the required performance. Use only shielded cables when connecting peripherals to assure that appropriate radio frequency emissions compliance is maintained.

## Operation

### Damage of the Product

#### Surface of the Product

High humidity and condensation on the product surface causes short circuits.

Do not operate the product outside the specified environmental limits. Make sure the product is completely dry and there is no moisture on any surface before applying power.

Do not operate the product below 0°C.

### Overheating and Damage of the Product

Operating the product without forced air cooling may lead to overheating and thus damage of the product.

When operating the product, make sure that forced air cooling is available in the shelf.

## Configuration Switches/Jumpers

### Malfunction of the Product

Switches marked as "Reserved" might carry production-related functions and can cause the product to malfunction if their setting is changed.

Do not change settings of switches marked as "reserved".

### Damage of the Product

Setting/resetting the switches during operation can cause damage of the product.

Check and change switch settings before you install the product.

## Installation

### Personal Injury or Death

This product operates with dangerous voltages that can cause injury or death.

To prevent serious injury or death from dangerous voltages use extreme caution when handling, testing, and adjusting this equipment and its components.

### Damage of the Product and Additional Devices and Modules

Incorrect installation or removal of additional devices or modules may damage the product or the additional devices or modules.

Before installing or removing additional devices or modules, read the respective documentation.

**Damage of Circuits**

Electrostatic discharge and incorrect installation and removal of the product can damage circuits or shorten their life.

Before touching the product or electronic components, make sure that you are working in an ESD-safe environment.

**Product Damage**

Inserting or removing modules in a non-hot-swap chassis with power applied may result in damage to module components. The CPCI-6115 is a hot-swappable board and may be inserted in a hot-swap chassis, such as a CPX2000, CPX8000 or MXP3000 series chassis with power applied.

Check to make sure your chassis is hot swap compliant.

**Damage to the Product, Backplane, or System Components**

Bent pins or loose components can cause damage to the product, the backplane, or other system components.

Carefully inspect the product and the backplane for both pin and component integrity before installation.

Motorola Embedded Communications Computing (ECC) and our suppliers take significant steps to ensure there are no bent pins on the backplane or connector damage to the boards prior to leaving the factory. Bent pins caused by improper installation or by inserting boards with damaged connectors could void the ECC warranty for the backplane or boards.

**Damage of the Product**

Incorrect installation of the product can cause board damage,

Only use handles for when installing/removing the product to avoid damage to the face plate and/or PCB.

**Product Damage**

Inserting or removing modules in a non-hot-swap chassis with the power applied may result in damage to the module components. The CPCI-6115-MCPTM is not a hot-swap board, but it may be installed in a hot-swap chassis with power applied.

Remove the corresponding CPCI-6115 before the CPCI-6115-MCPTM is installed.

## Cabling and Connectors

**Damage of the Product**

The RJ-45 connector(s) on the face plate are either twisted-pair Ethernet (TPE) or E1/T1/J1 interfaces. Connecting an E1/T1/J1 line to an Ethernet connector may damage the product.

- Make sure that TPE connectors near your working area are clearly marked as network connectors.
  - Verify that the length of an electric cable connected to a TPE bushing does not exceed 100 m.
  - Make sure the TPE bushing of the product is connected only to safety extra low voltage circuits (SELV circuits)
- If in doubt, ask your system administrator.

## Environment

Always dispose of used boards, system components and RTMs according to your country's legislation and manufacturer's instructions.

## Battery

### Board/System Damage

Danger of explosion if battery is replaced incorrectly. Replace battery only with the same or equivalent type recommended by the equipment manufacturer. Dispose of used batteries according to the manufacturer's instructions.

Il y a danger d'explosion s'il y a remplacement incorrect de la batterie. Remplacer uniquement avec une batterie du même type ou d'un type équivalent recommandé par le constructeur. Mettre au rebut les batteries usagées conformément aux instructions du fabricant.

# Sicherheitshinweise

---

Dieses Kapitel enthält Hinweise, die potentiell gefährlichen Prozeduren innerhalb dieses Handbuchs vorrangestellt sind. Beachten Sie unbedingt in allen Phasen des Betriebs, der Wartung und der Reparatur des Systems die Anweisungen, die diesen Hinweisen enthalten sind. Sie sollten außerdem alle anderen Vorsichtsmaßnahmen treffen, die für den Betrieb des Produktes innerhalb Ihrer Betriebsumgebung notwendig sind. Wenn Sie diese Vorsichtsmaßnahmen oder Sicherheitshinweise, die an anderer Stelle dieses Handbuchs enthalten sind, nicht beachten, kann das Verletzungen oder Schäden am Produkt zur Folge haben.

Motorola ist darauf bedacht, alle notwendigen Informationen zum Einbau und zum Umgang mit dem Produkt in diesem Handbuch bereit zu stellen. Da es sich jedoch um ein komplexes Produkt mit vielfältigen Einsatzmöglichkeiten handelt, können wir die Vollständigkeit der im Handbuch enthaltenen Informationen nicht garantieren. Falls Sie weitere Informationen benötigen sollten, wenden Sie sich bitte an die für Sie zuständige Geschäftsstelle von Motorola.

Das System erfüllt die für die Industrie geforderten Sicherheitsvorschriften und darf ausschließlich für Anwendungen in der Telekommunikationsindustrie und im Zusammenhang mit Industriesteuerungen verwendet werden.

Einbau, Wartung und Betrieb dürfen nur von durch Motorola ausgebildetem oder im Bereich Elektronik oder Elektrotechnik qualifiziertem Personal durchgeführt werden. Die in diesem Handbuch enthaltenen Informationen dienen ausschließlich dazu, das Wissen von Fachpersonal zu ergänzen, können dieses jedoch nicht ersetzen.

Halten Sie sich von stromführenden Leitungen innerhalb des Produktes fern. Entfernen Sie auf keinen Fall Abdeckungen am Produkt. Nur werksseitig zugelassenes Wartungspersonal oder anderweitig qualifiziertes Wartungspersonal darf Abdeckungen entfernen, um Komponenten zu ersetzen oder andere Anpassungen vorzunehmen.

Installieren Sie keine Ersatzteile oder führen Sie keine unerlaubten Veränderungen am Produkt durch, sonst verfällt die Garantie. Wenden Sie sich für Wartung oder Reparatur bitte an die für Sie zuständige Geschäftsstelle von Motorola. So stellen Sie sicher, dass alle sicherheitsrelevanten Aspekte beachtet werden.

## EMV

Das Produkt wurde in einem Motorola Standardsystem getestet. Es erfüllt die für digitale Geräte der Klasse A gültigen Grenzwerte in einem solchen System gemäß den FCC-Richtlinien Abschnitt 15 bzw. EN 55022 Klasse A. Diese Grenzwerte sollen einen angemessenen Schutz vor Störstrahlung beim Betrieb des Produktes in Gewerbe- sowie Industriegebieten gewährleisten.

Das Produkt arbeitet im Hochfrequenzbereich und erzeugt Störstrahlung. Bei unsachgemäßem Einbau und anderem als in diesem Handbuch beschriebenen Betrieb können Störungen im Hochfrequenzbereich auftreten.

Wird das Produkt in einem Wohngebiet betrieben, so kann dies mit grosser Wahrscheinlichkeit zu starken Störungen führen, welche dann auf Kosten des Produktanwenders beseitigt werden müssen. Änderungen oder Modifikationen am Produkt, welche ohne ausdrückliche Genehmigung von Motorola ECC durchgeführt werden, können dazu führen, dass der Anwender die Genehmigung zum Betrieb des Produktes verliert. Boardprodukte werden in einem repräsentativen System getestet, um zu zeigen, dass das Board den oben aufgeführten EMV-Richtlinien entspricht. Eine ordnungsgemässe Installation in einem System, welches die EMV-Richtlinien erfüllt, stellt sicher, dass das Produkt gemäss den EMV-Richtlinien betrieben wird. Verwenden Sie nur abgeschirmte Kabel zum Anschluss von Zusatzmodulen. So ist sichergestellt, dass sich die Aussendung von Hochfrequenzstrahlung im Rahmen der erlaubten Grenzwerte bewegt.

Warnung! Dies ist eine Einrichtung der Klasse A. Diese Einrichtung kann im Wohnbereich Funkstörungen verursachen. In diesem Fall kann vom Betreiber verlangt werden, angemessene Maßnahmen durchzuführen.

## Operation

### Beschädigung des Produktes

Hohe Luftfeuchtigkeit und Kondensat auf der Oberfläche des Produktes können zu Kurzschlüssen führen.

Betreiben Sie das Produkt nur innerhalb der angegebenen Grenzwerte für die relative Luftfeuchtigkeit und Temperatur. Stellen Sie vor dem Einschalten des Stroms sicher, dass sich auf dem Produkt kein Kondensat befindet und betreiben Sie das Produkt nicht unter 0°C.

### Überhitzung und Beschädigung des Produktes

Betreiben Sie das Produkt ohne Zwangsbelüftung, kann das Produkt überhitzt und schließlich beschädigt werden.

Bevor Sie das Produkt betreiben, müssen Sie sicher stellen, dass das Shelf über eine Zwangskühlung verfügt.

## Schaltereinstellungen/Jumper

### Fehlfunktion des Produktes

Schalter, die mit 'Reserved' gekennzeichnet sind, können mit produktionsrelevanten Funktionen belegt sein. Das Ändern dieser Schalter kann im normalen Betrieb Störungen auslösen.

Verstellen Sie nur solche Schalter, die nicht mit 'Reserved' gekennzeichnet sind. Prüfen und ggf. ändern Sie die Einstellungen der nicht mit 'Reserved' gekennzeichneten Schalter, bevor Sie das Produkt installieren.



#### **Beschädigung des Produktes**

Das Verstellen von Schaltern während des laufenden Betriebes kann zur Beschädigung des Produktes führen.

Prüfen und ändern Sie die Schaltereinstellungen, bevor Sie das Produkt installieren.

## **Installation**

#### **Schwere Verletzungen oder Tod**

Dieses System wird mit gefährlichen Spannungen betrieben, die schwere Verletzungen oder Tod Verursachen können.

Gehen Sie deshalb extrem vorsichtig vor, wenn Sie mit dem System oder seinen Komponenten umgehen, es testen oder anpassen.

#### **Beschädigung des Produktes und von Zusatzmodulen**

Fehlerhafte Installation von Zusatzmodulen, kann zur Beschädigung des Produktes und der Zusatzmodule führen.

Lesen Sie daher vor der Installation von Zusatzmodulen die zugehörige Dokumentation.

#### **Beschädigung von Schaltkreisen**

Elektrostatische Entladung und unsachgemäßer Ein- und Ausbau des Produktes kann Schaltkreise beschädigen oder ihre Lebensdauer verkürzen.

Bevor Sie das Produkt oder elektronische Komponenten berühren, vergewissern Sie sich, daß Sie in einem ESD-geschützten Bereich arbeiten.

#### **Beschädigung des Produktes**

Fehlerhafte Installation des Produktes kann zu einer Beschädigung des Produktes führen.

Verwenden Sie die Handles, um das Produkt zu installieren/deinstallieren. Auf diese Weise vermeiden Sie, dass das Face Plate oder die Platine deformiert oder zerstört wird.

#### **Beschädigung des Produktes**

Wird das Modul in ein Chassis installiert oder aus einem Chassis entfernt, dessen Spannungsversorgung eingeschaltet ist und das nicht Hot-Swap-fähig ist, kann das Modul beschädigt werden.

Das CPCI-6115 ist ein Hot-Swap-fähiges Board und kann in ein Hot-Swap-fähiges Chassis, dessen Spannungsversorgung eingeschaltet ist, installiert werden. Beispiele für derartige Chassis sind solche aus der Serie CPX2000, CPX8000 oder MXP3000.

Prüfen Sie und stellen Sie sicher, dass Ihr Chassis Hot-Swap-fähig ist.

**Beschädigung des Produktes, der Backplane oder von System Komponenten**  
Verbogene Pins oder lose Komponenten können zu einer Beschädigung des Produktes, der Backplane oder von Systemkomponenten führen.  
Überprüfen Sie daher das Produkt sowie die Backplane vor der Installation sorgfältig und stellen Sie sicher, dass sich beide in einwandfreien Zustand befinden und keine Pins verbogen sind.

Motorola Embedded Communications Computing (ECC) und unsere Zulieferer unternehmen größte Anstrengungen um sicherzustellen, dass sich Pins und Stecker von Boards vor dem Verlassung der Produktionsstätte in einwandfreiem Zustand befinden. Verbogene Pins, verursacht durch fehlerhafte Installation oder durch Installation von Boards mit beschädigten Steckern kann die durch ECC gewährte Garantie für Boards und Backplanes erlöschen lassen.

## Kabel und Stecker

### Beschädigung des Produktes

Bei den RJ-45-Steckern, die sich an dem Produkt befinden, handelt es sich entweder um Twisted-Pair-Ethernet (TPE) oder um E1/T1/J1-Stecker. Beachten Sie, dass ein versehentliches Anschließen einer E1/T1/J1-Leitung an einen TPE-Stecker das Produkt zerstören kann.

- Kennzeichnen Sie deshalb TPE-Anschlüsse in der Nähe Ihres Arbeitsplatzes deutlich als Netzwerkanschlüsse.
- Stellen Sie sicher, dass die Länge eines mit Ihrem Produkt verbundenen TPE-Kabels 100 m nicht überschreitet.
- Das Produkt darf über die TPE-Stecker nur mit einem Sicherheits-Kleinspannungs-Stromkreis (SELV) verbunden werden.

Bei Fragen wenden Sie sich an Ihren Systemverwalter.

## Umweltschutz

Entsorgen Sie alte Batterien und/oder Boards/Systemkomponenten/RTMs stets gemäß der in Ihrem Land gültigen Gesetzgebung und den Empfehlungen des Herstellers.

## Batterie

### Beschädigung des Produktes

Explosionsgefahr bei unsachgemäßem Austausch der Batterie. Ersatz nur durch denselben oder einen vom Hersteller empfohlenen Typ. Entsorgung gebrauchter Batterien nach Angaben des Herstellers.

## 1.1 Features

The following table summarizes the features of the CPCI-6115 Single Board Computer (SBC). The CPCI-6115 was formerly offered as the MCPN905 SBC.

*Table 1-1 CPCI-6115 Features*

Feature	Description
Processor	Single MPC7457 Processor Core Frequency to 1.0 GHz Bus Clock Frequency of 133 MHz Integrated L1 and L2 cache Address and data bus parity
L3 Cache	1 MB or 2 MB DDR back side L3 Cache @ 266 MHz Data bus parity
Flash	Bank A: 32 MB soldered flash using two Intel StrataFlash devices. Bank B: 8 MB soldered flash using two Intel StrataFlash devices. Bank A/B Reset vector jumper selectable
SDRAM	Double-Bit-Error detect, Single-Bit-Error correct across 72 bits. Up to 1.5 GB of DDR266 (133 MHz) SDRAM onboard memory
Memory Controllers	Provided by Marvell MV64360 System Memory Controller.
PCI Host Bridges	Provided by Marvell MV64360 System Memory Controller.
Interrupt Controller	Provided by Marvell MV64360 System Memory Controller.
PCI Interfaces	One local PCI/PCI-X bus supporting 32/64-bit, 33/66 MHz PCI or 66/133 MHz PCI-X to PMC2. One local PCI bus supporting 32-bit, 33 MHz PCI to PMC 1, the 21555 PCI bridge, and IDE controller.
Ethernet Interface	Three Gigabit Ethernet channels provided by the Marvell MV64360 Two to J3 for PICMG 2.16 compliance One to front panel
SEEPROM	Two 8 KB dual-address I2C SEEPROM devices for Vital Product Data and user configuration data Industry standard SPD for onboard and mezzanine board memory.
CompactPCI Interface	Intel 21555 PCI-to-PCI Bridge 64-bit, 33/66 MHz PCI to CompactPCI bus Peripheral Slot operation
Form Factor	Single slot 6U CompactPCI
RTC/NVRAM	32KB NVRAM/RTC/WDT provided by M48T37V

Table 1-1 CPCI-6115 Features (continued)

Feature	Description
Watchdog Timers	Four programmable timer/counters in the Marvel MV64360 One watchdog timer in the Marvell MV64360 One watchdog timer in the M48T37V
Peripheral Support	Three Gigabit Ethernet interfaces IDE channel to support CompactFlash on transition module Two async serial ports (two rear I/O or one front panel, one rear I/O).
PMC Slots	PMC 2: 64-bit, 33/66 MHz PCI or 66/133 MHz PCI-X with front-panel I/O plus rear I/O PMC 1: 32-bit, 33 MHz PCI Both slots support non-Monarch Processor PMC modules
Front Panel	One asynchronous debug port via RJ-45 connector Recessed ABORT/RESET switch CPU Activity and Board Fail LEDs Switch and blue LED in handle to support hot-swap Ethernet RJ-45 connector with Status LEDs
Debug Support	Serial port with RS-232 interface Processor JTAG interface RESET and ABORT signals Boundary Scan Header

## 1.2 Standard Compliances

The CPCI-6115 is designed to be CE compliant and to meet the following standard requirements.

Table 1-2 Board Standard Compliances

Standard	Description
UL 60950-1 EN 60950-1 IEC 60950-1 CAN/CSA C22.2 No 60950-1	Safety Requirements (legal)
CISPR 22 CISPR 24 EN 55022 EN 55024 FCC Part 15 Industry Canada ICES-003 VCCI Japan AS/NZS CISPR 22 EN 300 386 NEBS Standard GR-1089 CORE	EMC requirements (legal) on system level (predefined Motorola system)

Table 1-2 Board Standard Compliances (continued)

Standard	Description
NEBS Standard GR-63-CORE ETSI EN 300 019 series	Environmental Requirements
Directive 2002/95/EC	Directive on the restriction of the use of certain hazardous substances in electrical and electronic equipment (RoHS)

## 1.3 Ordering Information

When ordering board variants or board accessories, use the order numbers given in the following tables.

Currently, the following configurations are available:

Table 1-3 Board Variant Order Numbers

Description	Part Numbers
CPCI-6115-220	867 MHz, MPC7457, 512 MB DRAM, three Ethernet ports
CPCI-6115-240	1 GHz, MPC7457, 512 MB DRAM
CPCI-6115-270	1 GHz, MPC7457, 2 GB DRAM, three Ethernet ports

Table 1-4 Related Product Order Numbers

Related Products	
CPCI-6115-MCPTM-02	Transition module/PIM carrier, two RJ-45 Ethernet connectors, one RJ-45 asynchronous serial port connector, COM2 accessible via PIM slots, one CompactFlash socket, two PIM slots.
CFLASH5E-xxx	CompactFlash memory card (where xxx = number of MB)



## 2.1 Overview

This chapter provides a brief product description and preparation and installation instructions for the CPCI-6115 CompactPCI CPU board. These instructions include hardware preparation instructions, including jumper settings, system considerations, and installation instructions for the baseboard, as well as the PMCs and transition module associated with this board.

The CPCI-6115 can be used in both a CompactPCI or a PICMG 2.16 compatible chassis. It can be used only in a peripheral (nonsystem) slot. The board employs an Intel 21555 PCI-to-PCI bridge for accessing additional components on adjacent PCI buses.

A fully implemented CPCI-6115 consists of the baseboard, PMC cards, and an optional transition module for rear I/O.

## 2.2 Unpacking and Inspecting the Board

Read all notices and cautions prior to unpacking the product.

### **NOTICE**

#### **Damage of Circuits**

**Electrostatic discharge and incorrect installation and removal can damage circuits or shorten their life.**

**Before touching the AMC or electronic components, make sure that you are working in an ESD-safe environment.**

### Shipment Inspection

To inspect the shipment, perform the following steps:

1. Verify that you have received all items of your shipment.
2. Check for damage and report any damage or differences to customer service.
3. Remove the desiccant bag shipped together with the board and dispose of it according to your country's legislation.



The product is thoroughly inspected before shipment. If any damage occurred during transportation or any items are missing, contact customer service immediately.

## 2.3 Environmental, Power, and Thermal Requirements

The next sections describe the environmental, power, and thermal requirements for the CPCI-6115.

### 2.3.1 Environmental Requirements

The following table lists the currently available specifications for the environmental and mechanical characteristics of the CPCI-6115. A complete functional description of the CPCI-6115 baseboard appears in [Chapter 4, Functional Description](#). Specifications for the optional PCI mezzanines can be found in the documentation for those modules.

You must make sure that the board, when operated in your particular system configuration, meets the environmental requirements specified below.



Operating temperatures refer to the temperature of the air circulating around the board and not to the component temperature.

Table 2-1 CPCI-6115 Specifications

Characteristics	Specifications
PMC I/O Signal Impedance	42 to 75 ohms (nominal impedance)
Operating temperature	0°C to +55°C (32°F to 131°F) entry air with forced-air cooling



Table 2-1 CPCI-6115 Specifications (continued)

Characteristics	Specifications
Storage temperature	-40°C to +70° C (104°F to 158°F)
Relative humidity	5% to 90% (operating) 5% to 95% (nonoperating)
Vibration	1.0G sine sweep, 5-200 Hz, .25 octaves/min, all 3 axis (operating) .5 G sine sweep, 5 - 50 Hz, .1 octaves/min 3.0 G sine sweep, 50 - 500 Hz, .25 octaves/min, all 3 axis (nonoperating)
Physical dimensions	6U Eurocard
Baseboard only	
Height	9.2 in. (233 mm)
Depth	6.3 in. (160 mm)
Baseboard with front panel and connectors	
Height	10.3 in. (262 mm)
Depth	7.4 in. (188 mm)
Front panel width	0.8 in (20 mm)

## NOTICE

### Product Damage

**High humidity and condensation on the board surface causes short circuits.**

**Do not operate the board outside the specified environmental limits.**

**Make sure the board is completely dry and there is no moisture on any surface before applying power.**

## 2.3.2 Power Requirements

The board's power requirements depend on the installed hardware accessories. The following table gives examples of typical power requirements for +5 V and +3.3 V for a processor running at 600 MHz without any accessories. If you want to install any accessories, the load of the respective accessory has to be added to the load of the used board variant. For information on the accessories' power requirements, refer to the documentation delivered with the respective accessory or ask your local representative.

Table 2-2 Power Requirements

Characteristic	Value
Power Requirements (not transition module or PMC)	CPCI-6115-260 +5 V@4.5 A, typical +3.3 V@2.4 A, typical +12 V@1 mA, typical -12 V@2 mA, typical CPCI-6115-220 +5 V@4.1 A, typical +3.3 V@2.4 A, typical +12 V@1 mA, typical -12 V@2 mA, typical
Power available for PMCs/ transition modules (see note after table)	+5 V@5.5 A, typical +3.3 V@7.5 A, typical +12 V@1.0 A, typical -12 V@1.0 A, typical



The power available for PMCs/transition module values represent the available current on each power rail and do not guarantee that thermal or cooling needs are met. You must evaluate to ensure adequate cooling.

## 2.3.3 Thermal Requirements

Board component temperatures are affected by ambient temperature, air flow, board electrical operation and software operation. In order to evaluate the thermal performance of a circuit board assembly, it is necessary to test the board under actual operating conditions. These operating conditions vary depending on system design.

While Motorola performs thermal analysis in a representative system to verify operation within specified ranges (see [Table 2-3 on page 33](#)), you should evaluate the thermal performance of the board in your application.

This section provides systems integrators with information that can be used to conduct thermal evaluations of the board in their specific system configuration. It identifies thermally significant components and lists the corresponding maximum allowable component operating temperatures. It also provides sample procedures for component-level temperature measurements.

[Table 2-3 on page 33](#) summarizes components that exhibit significant temperature rises. These are the components that should be monitored in order to assess thermal performance. The table also supplies the component reference designator and the maximum allowable operating temperature.

You can find components on the board by their reference designators as shown in [Figure 2-1 on page 34](#). Versions of the board that are not fully populated may not contain some of these components.

The preferred measurement location for a component may be junction, case or air as specified in the table. Junction temperature refers to the temperature measured by an on-chip thermal device. Case temperature refers to the temperature at the top, center surface of the component. Air temperature refers to the ambient temperature near the component.

*Table 2-3 Thermally Significant Components*

Component Location	General Description	Maximum Allowable Temperature (Degrees C)	Measurement Location (Junction, Case or Air)
U40	Ultra DMA PCI-IDE	70° C (158° F)	Air
U36	21555BB PCI Bridge	70° C (158° F)	Air
U32	MPC7457 Processor	103° C (217.4° F)	Case
U23, U89	DDR Clock Generator	85° C (185° F)	Air
U22	MV64360	110° C (230° F)	Case
U159, U160	32 megabit flash	85° C (185° F)	Air
U146	Clock Buffer	105° C (221° F)	Case
U13, U14	Cache	115° C (239° F)	Case
U2-U10, U74-U82	DDR SDRAM	70° C (158° F)	Air
U101, U102, U96	Ethernet PHY	120° C (248° F)	Case

Figure 2-1 CPCI-6115 Thermally Significant Components (Primary Side)

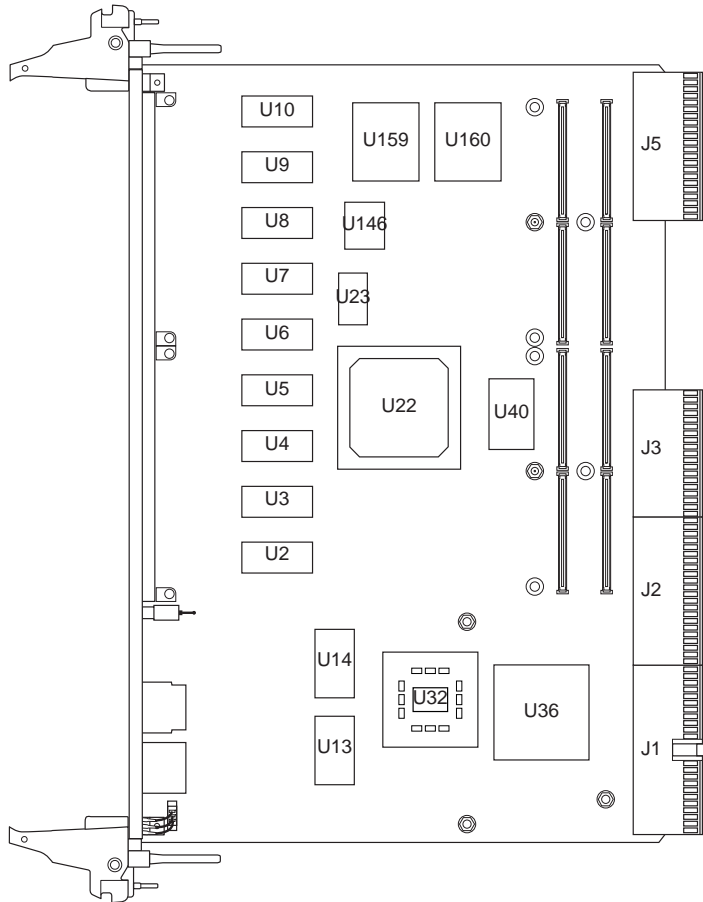
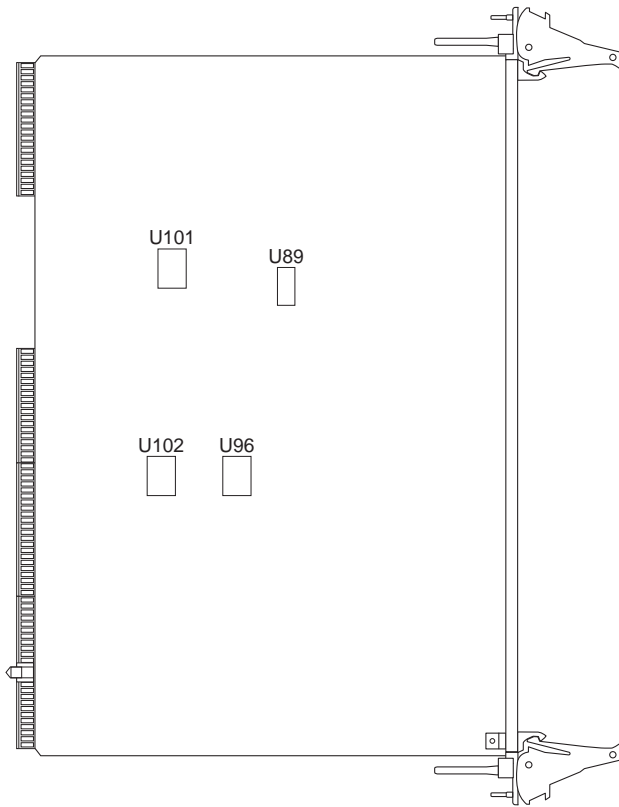

Figure 2-2 CPCI-6115 Thermally Significant Components (Secondary Side)



## 2.4 Getting Started

This section provides an overview of the steps necessary to install and power up the CPCI-6115, any additional equipment requirements, and a brief section on unpacking and ESD precautions. As identified in the following table, several steps can be omitted if your board has been shipped with PMCs already installed.

### 2.4.1 Overview of Start-up Procedure

The following table lists the things you will need to do before you can use this board and tells where to find the information you need to perform each step. Be sure to read this entire chapter, including all Caution and Warning notes, before you begin.

Table 2-4 Startup Overview

Task	Section or Manual Reference	Page
Unpack the hardware	<a href="#">Unpacking and Inspecting the Board</a>	37
Configure the hardware by setting jumpers on the baseboard and transition module.	<a href="#">Setting Switches and Jumpers (CPCI-6115)</a> <a href="#">Jumper Settings (CPCI-6115-MCPTM)</a>	37 126

Table 2-4 Startup Overview (continued)

Task	Section or Manual Reference	Page
Install the PMC Module (if required)	<a href="#">Installing PMC Modules on the CPCI-6115</a>	43
Install the CPCI-6115 in the chassis.	<a href="#">Installing the CPCI-6115 Baseboard</a>	46
Install the transition module.	<a href="#">Appendix A, Transition Module Preparation and Installation</a>	113
Connect any other equipment you will be using.	<a href="#">Connecting to a Console Port</a>	47
Power up the system	<a href="#">Applying Power</a>	47

## 2.4.2 Equipment Required

The following equipment is required to complete an CPCI-6115 system:

- CompactPCI or compatible system enclosure
- System console terminal
- Operating system (and/or application software)
- Disk drives (and/or other I/O) and controllers

The CPCI-6115 baseboards are factory-configured for I/O handling via its front panel, installed PMCs or a rear transition module that is specifically designed for the CPCI-6115 product family.

## 2.5 Baseboard Preparation

This section discusses certain hardware and software tasks that may need to be performed prior to installing the board in a CompactPCI or PICMG 2.9 compliant chassis.

### 2.5.1 Configuring the Hardware

To produce the desired configuration and ensure proper operation of the CPCI-6115, you may need to carry out certain hardware modifications before installing the module.

Most options on the CPCI-6115 are software configurable. Configuration changes are made by setting bits in control registers after the board is installed in a system. The control registers are described in the *CPCI-6115 CompactPCI Single Board Computer Programmer's Reference Guide*, and other vendor publications.

Jumpers are used to control those options that are not software configurable. These jumper settings are described further on in this section.

## 2.5.2 Setting Switches and Jumpers

Figure 2-2 on page 35 illustrates the placement of the switches, jumper headers, connectors and LED indicators on the CPCI-6115. Use this figure to help identify the approximate location of the jumpers on the CPCI-6115. There are seven manually configured headers on the baseboard. They are described in the following table:

Table 2-5 CPCI-6115 Jumper Map

Reference	Function	Comment
J6	Bus Mode Select Header	Jumper pins 1-2 for 60x mode Jumper pins 2-3 for MPX mode
J9	Stand-Alone Operation Header	Jumper pins 1-2 for Stand-Alone operation (no CPCI bus)
J10	Flash Boot Bank Select Header	No jumper or jumper pins 1-2 for Bank A (32 MB) Jumper pins 2-3 for Bank B (8 MB)
J15	+/-12 V Present Header	Jumper pins 1-2 allows board operation without +/- 12 V power
J20	Safe Start ENV Header	No jumper or jumper pins 1-2 for normal ENV settings Jumper pins 2-3 for safe ENV settings
J25	SROM Initialization Enable Header	Jumper pins 1-2 to enable SROM init No jumper or jumper pins 2-3 to disable SROM init
J99	Flash Bank A Write Protect Header	Jumper pins 1-2 to enable Bank A Flash Write No jumper to disable Flash Writes
SW2	Manual Geographic Address -	OFF (default) - GA from CompactPCI backplane ON - generate address locally

### NOTICE

#### Damage of the Product

**Setting/resetting the switches during operation can cause damage of the product. Check and change switch settings before you install the product.**

Figure 2-3 Switch and Jumper Locations

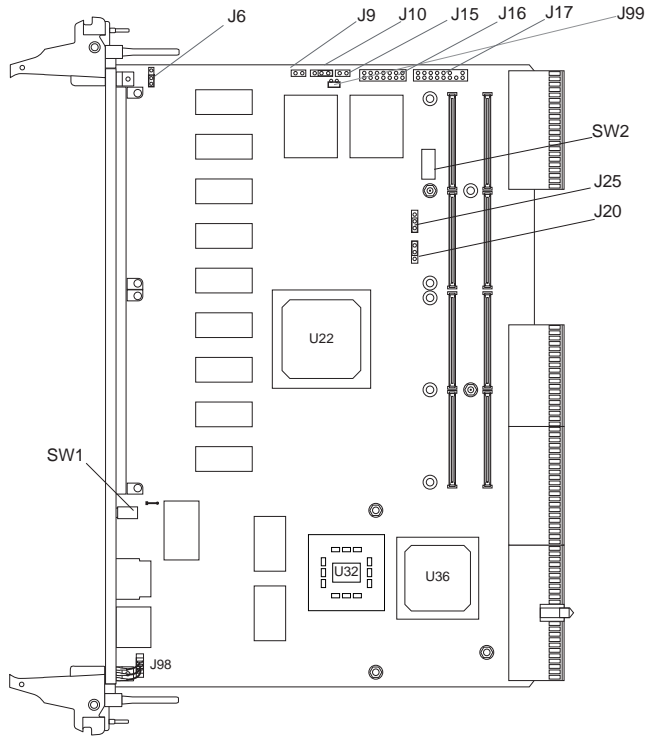

### 2.5.3 J6, Bus Mode Selection

A three-pin header is located on the board to select the correct bus mode operation (60x or MPX). No jumper or a jumper between pins 2 and 3 allows the board to be in MPX mode. A jumper placed between pins 1 and 2 enables 60x mode.

Figure 2-4 Jumper Setting for J6

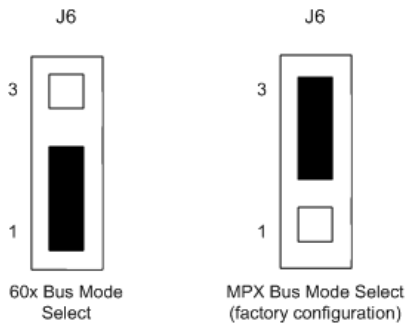



## 2.5.4 J9, Standalone Operating Mode

The CPCI-6115 has a standalone operating mode that allows the CPCI-6115 to function without a system slot controller board. Installing a jumper across pins 1 and 2 of J9 enables the standalone mode. The J9 jumper must be removed for normal operation.

Figure 2-5 Jumper Settings for J9

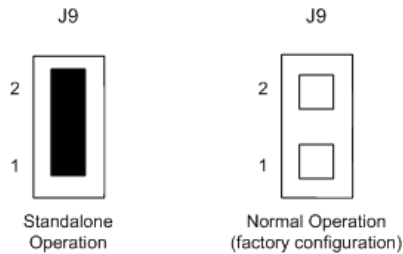

An CPCI-6115 configured for standalone mode should not be installed in a chassis with a system slot controller board. This will result in unpredictable system operation.

## 2.5.5 J10, Flash Bank Selection

The flash memory is organized in two banks (A and B). Both banks are 32 bits wide and form a 32-bit flash bank. Bank B offers a minimum of 8MB of soldered flash memory. Bank A offers 32MB of soldered flash memory.

To enable Flash Bank A, place a jumper across header pins 1 and 2. This will route the BOOTCS\* signal to Flash Bank A and device CS0\* to Flash Bank B. To enable Flash Bank B place a jumper across header pins 2 and 3. This routes the BOOTCS\* signal to Flash Bank B and the CS0\* signal to Flash Bank A.

Figure 2-6 Jumper Settings for J10

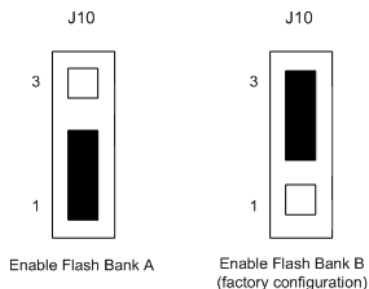

## 2.5.6 J15, +/-12 V Present Header

A 2-pin header on the board is used to allow operation with or without +12 V or -12 V supplies. A jumper placed between pins 1 and 2 allows board operation without +/-12 V supplies. No jumper implies that +12 V and -12 V are present at the backplane.

Figure 2-7 Jumper Settings for J15

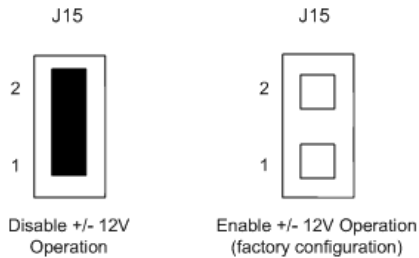

## 2.5.7 J20, Safe Start Header

A 3-pin header is used to select programmed or safe start settings. No jumper or a jumper placed between pins 1 and 2 allows programmed settings (e.g., VPD, SPD) to be used during boot. A jumper placed between pins 2 and 3 allows the safe start settings (Safe VPD, SPD parameters, GEVs ignored) to be used.

Figure 2-8 Jumper Setting for J20

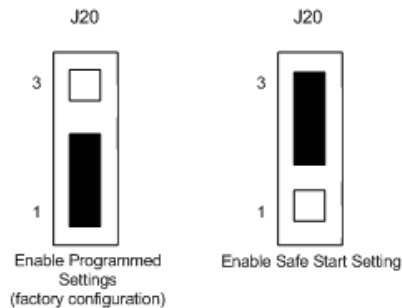

## 2.5.8 J25, SROM Initialization Enable Header

A 3-pin header is used to enable or disable the SROM initialization. A jumper placed between pins 1 and 2 enables the device initialization via the I<sup>2</sup>C SROM. No jumper or a jumper placed between pins 2 and 3 disables the initialization sequence.

Figure 2-9 Jumper Setting for J25

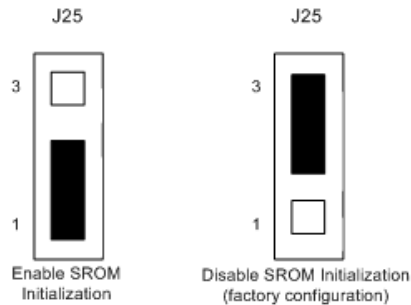

## 2.5.9 J99, Flash Bank A Programming Enable Header

To protect the contents of Flash Bank A a 2-pin header is used to enable or disable the programming of Flash Bank A. A jumper across pins 1 and 2 enables writes to array blocks, programming data, or configuring lock-bits. No jumper installed disables all Flash Bank A programming.

Figure 2-10 Jumper Setting for J99

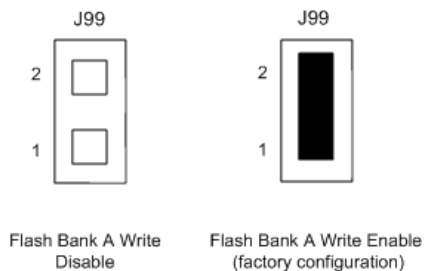

## 2.5.10 SW2, Geographic Address

SW2 allows user to set the CPCI-6115's Geographic Address when installed in a chassis that does not supply this information. Setting ON grounds signal, OFF pulls up.

Switch Setting	Address
SW2:1	GA0
SW2:2	GA1
SW2:3	GA2
SW2:4	GA3
SW2:5	GA4
SW2:6	RESERVED
SW2:7	RESERVED

## 2.6 Operating Modes

An CPCI-6115 configured for standalone mode should not be installed in a chassis with a system slot controller board. This results in unpredictable system operation. In this mode, the CPCI-6115 cannot communicate over the CompactPCI backplane.

In the standalone mode, a jumper must be set (J9) on the CPCI-6115 to obtain clock signals from other on-board devices. This routes an on-board PCI clock to the 21555 primary side clock input and allows the CPCI-6115 to operate in a chassis with no system slot controller board installed.

An CPCI-6115 configured for the standard operating mode must be used in a chassis with a system slot board which provides the clock and arbitration signals to the CPCI-6115.

The chassis must provide +5 V, +3.3 V and VIO to the CPCI-6115, and the BD\_SEL pin (P1-D15) in the chassis must be grounded.

## 2.7 Installing Hardware

The following sections discuss the placement of PMC mezzanine cards on the CPCI-6115 baseboard and the installation of the complete CPCI-6115 assembly into a CompactPCI chassis. Before installing the CPCI-6115, ensure that all header jumpers are configured as desired according to the previous sections of this chapter.

It is critical that two prerequisite steps be performed prior to installing your board into the CompactPCI backplane to prevent possible backplane pin damage.

1. Visually inspect the board connectors to ensure they are not damaged by previous insertions or accidental mishandling. If any board connector damage is observed, do not install board into the backplane. This may cause a bent pin on the connector, resulting in an expensive repair.
2. Visually inspect the backplane pins for any bent pins from previous board installations in the slot where the board will be installed.

When it is determined that there are no bent pins on the board connectors or backplane, carefully slide the board into the backplane slots until the board ejector handles come in contact with the system chassis. **Do not force the board into the backplane slot.** As the handles engage, apply forward pressure while pushing the ejector handles toward each other. Pushing the handles towards each other seats the board into the backplane.

In most cases, PMC modules ordered with the baseboard are installed on the CPCI-6115 at the factory and the order is shipped as a single unit. The user-configured jumpers on the PMCs are accessible with the modules installed.

If you need to install PMCs on the baseboard, refer to [Installing PMC Modules on the CPCI-6115 on page 43](#) for the installation procedure. The procedure assumes the CPCI-6115 has already been installed in the chassis.

## 2.7.1 Installing PMC Modules on the CPCI-6115

One dual-wide, one single-wide or two single-wide PCI mezzanine (PMC) modules can be mounted on the CPCI-6115 baseboard. Each PMC slot has four connectors that provide a PCI interface to two PMC slots that provide a user I/O to the backplane. Refer to [Power Requirements on page 32](#) for the total current available to PMCs and transition module.

### Procedure

To install a PMC module follow these steps.

#### NOTICE

##### Damage of Circuits

**Electrostatic discharge and incorrect installation and removal can damage circuits or shorten their life.**

**Before touching the AMC or electronic components, make sure that you are working in an ESD-safe environment.**

#### NOTICE

##### Product Damage

**Inserting or removing modules in a non-hot-swap chassis with power applied may result in damage to module components. The CPCI-6115 is a hot-swappable board and may be inserted in a hot-swap chassis, such as a CPX2000, CPX8000 or MXP3000 series chassis with power applied.**

**Check to make sure your chassis is hot swap compliant.**

1. Attach an ESD strap to your wrist. Attach the other end of the ESD strap to the chassis as a ground. The ESD strap must be secured to your wrist and to ground throughout the procedure.
2. Remove chassis or system cover(s) as necessary for access to the board.

	<b>! WARNING</b>
	<b>Personal Injury or Death</b> Dangerous voltages, capable of causing death, are present in this equipment. Use extreme caution when handling, testing and adjusting.

3. Carefully remove the CPCI-6115 from the card slot and lay it flat, with connectors J1 through J5 facing you.
4. Remove the PMC filler plate from the front panel of the CPCI-6115.

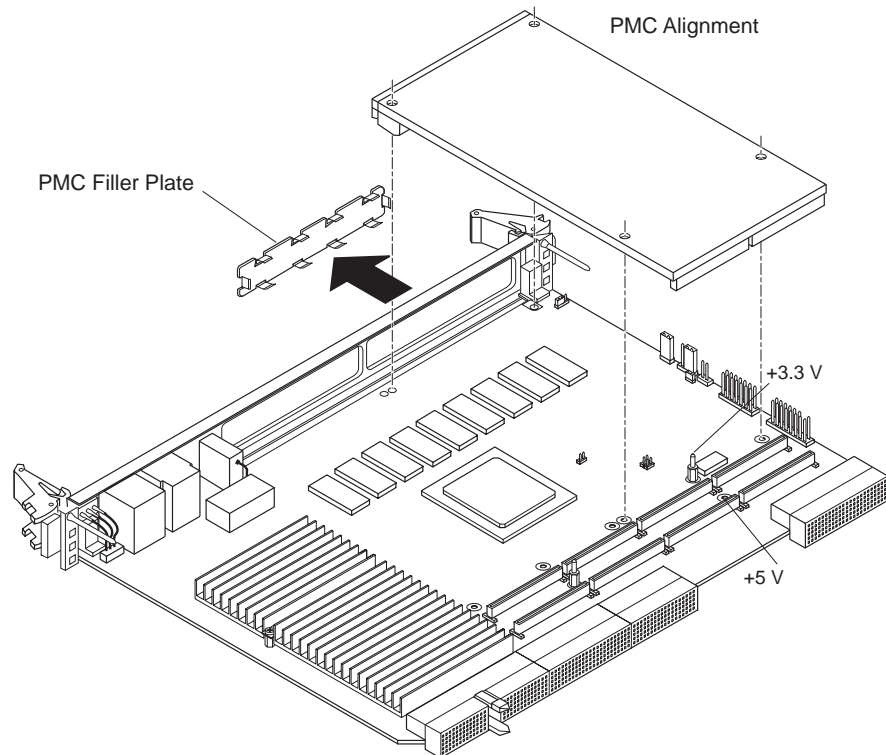

5. Set the PMC 2 voltage key to the desired position. (The PMC 1 I/O voltage key is factory-installed at the +5 V position since the IDE controller regulates +5 V I/O. Do not move the PMC 1 voltage key.)

The PMC 2 I/O voltage key should be installed in the appropriate position for the PMC to be used. If installed in the +5 V position, PMC 2 is set to +5 V I/O. If installed in the +3.3 V position, PMC 2 is set to +3.3 V I/O. If the PMC accepts either key, install the key in the +3.3 V position (factory default). +3.3 V I/O voltage is required for any PCI/PCI-X operation faster than 33 MHz.

6. Slide the edge connector of the PMC module into the front panel opening from behind and place the PMC module on top of the baseboard. The four connectors on the underside of the PMC module should then connect smoothly with the corresponding connectors (J11/12/13/14) or (J21/22/23/24) on the CPCI-6115.
7. Insert the four short Phillips screws, provided with the PMC, through the holes on the bottom side of the CPCI-6115 into the PMC front bezel and rear standoffs. Tighten the screws.
8. Reinstall the CPCI-6115 assembly in its proper card slot. Be sure the module is well seated in the backplane connectors. Do not damage or bend connector pins.
9. Replace the chassis or system cover(s), reconnect the system to the AC or DC power source, and turn the equipment power on.

If the PMC provides rear I/O, refer to [Chapter 3, Controls, LEDs, and Connectors](#) for the pin assignments. Connectors on the CPCI-6115-MCPTM transition module provide rear panel access to these signals.

## 2.7.2 Installing the CPCI-6115 Baseboard

### Procedure

With PMC modules installed (if applicable) and headers properly configured, proceed as follows to install the CPCI-6115 in the CompactPCI chassis:

1. Attach an ESD strap to your wrist. Attach the other end of the ESD strap to the chassis as a ground. The ESD strap must be secured to your wrist and to ground throughout the procedure.
2. In a non-hot-swap system, perform an operating system shutdown. Turn the AC or DC power off and remove the AC cord or DC power lines from the system. Remove chassis or system cover(s) as necessary for access to the CompactPCI modules.

### NOTICE

#### Product Damage

**Inserting or removing modules in a non-hot-swap chassis with power applied may result in damage to module components. The CPCI-6115 is a hot-swappable board and may be inserted in a hot-swap chassis, such as a CPX2000, CPX8000 or MXP3000 series chassis with power applied.**

**Check to make sure your chassis is hot swap compliant.**



### WARNING

#### Personal Injury or Death

**Dangerous voltages, capable of causing death, are present in this equipment. Use extreme caution when handling, testing and adjusting.**

3. Remove the filler panel from the appropriate card slot.
4. Set the VIO on the backplane to either +3.3 V or +5 V (the CPCI-6115 is a universal board), depending upon your CompactPCI system signaling requirements and ensure the backplane does not bus J3 or J5 signals.
5. Slide the CPCI-6115 into the appropriate slot. Grasping the top and bottom injector handles, be sure the module is well seated in the P1 through P5 connectors on the backplane. Do not damage or bend connector pins.
6. Secure the CPCI-6115 in the chassis with the screws provided, making good contact with the transverse mounting rails to minimize RF emissions.
7. Replace the chassis or system cover(s), making sure no cables are pinched. Cable the peripherals to the panel connectors, reconnect the system to the AC or DC power source and turn the equipment power on.



## 2.8 Connecting to a Console Port

On the CPCI-6115 baseboard, the standard serial console port (COM1) serves as the MOTLoad debugger console port. The firmware console should be set up as follows:

- Eight bits per character
- One stop bit per character
- Parity disabled (no parity)
- Baud rate of 9600

9600 baud is the power-up default for serial ports on CPCI-6115 boards. After power-up you can reconfigure the baud rate if you wish, using the MOTLoad PF (Port Format) command via the command line interface. Whatever the baud rate, some type of hardware handshaking — either XON/OFF or via the RTS/CTS line — is desirable if the system supports it.

## 2.9 Applying Power

After you have verified that all necessary hardware preparation has been done, that all connections have been made correctly and that the installation is complete, you can power up the system. The MPU, hardware and firmware initialization process is performed by the MOTLoad power-up or system reset. The firmware initializes the devices on the SBC module in preparation for booting the operating system.

The firmware is shipped from the factory with an appropriate set of defaults. In most cases there is no need to modify the firmware configuration before you boot the operating system.

The following flowchart shows the basic initialization process that takes place during PowerPC system startup.

For further information on MOTLoad, refer to [Chapter 7, MOTLoad Firmware](#) in this manual, or to the *MOTLoad Firmware Package User's Manual* referenced in [Appendix A, Related Documentation](#).

Figure 2-11 MOTLoad System Startup

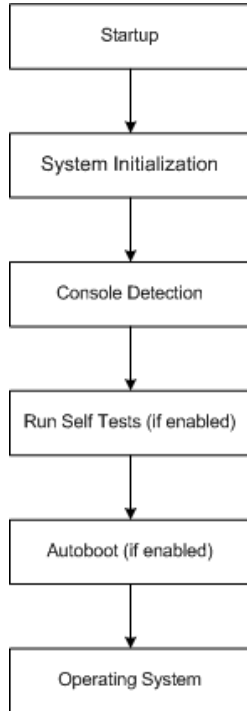

The CPCI-6115 front panel has one ABORT/RESET switch and three LED (light-emitting diode) status indicators (BFL, CPU, and HOT SWAP STATUS). For more information on front panel operation, refer to [Chapter 4, Functional Description](#).

The CPCI-6115 also has status LEDs for SPEED/LINK and ACTIVITY for Ethernet 2 on the front panel.

---

## 3.1 Overview

This chapter illustrates the placement of the on-board jumper headers and connectors as well as the front panel connectors and LED indicators on the CPCI-6115. Also included are the pin assignments for the connectors and headers on the CPCI-6115 CompactPCI Single Board Computer. Pinout listings can be found in [Front Panel Connectors and LEDs on page 50](#) and [On-Board Connectors and Headers on page 52](#).

## 3.2 Board Layout

This figure provides the location and reference designators for major components, switches, and connectors on the base board.

Figure 3-1 Component Layout

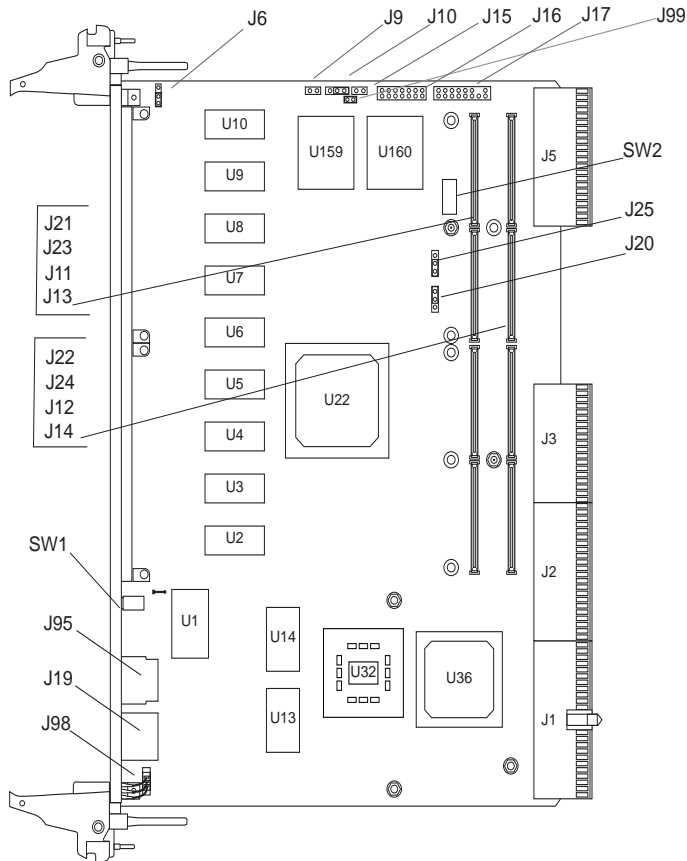

## 3.3 Front Panel Connectors and LEDs

The CPCI-6115 CPU board provides these status LEDs visible on the front panel of the CPCI-6115.

Table 3-1 Front Panel LEDs

LED	Indicator Color	Status
CPU	Green	Glows solid: TS# signal of the processor bus is active (hardware control).
BFL	Yellow	Glows solid: board fail bit in the Miscellaneous Control and Status register is active (software controller).

Table 3-1 Front Panel LEDs (continued)

LED	Indicator Color	Status
HS	Blue	Glow solid when the board is ready to extract.
SPD/LNK	Green/Yellow	Shows link status of the Ethernet link (Ethernet 2). Glow solid green: a valid 1000 megabit link. Glow solid yellow: a valid 10/100 megabit link. Off: No link.
ALT	Green	Glow solid: activity is present on the Ethernet link.

The CPCI-6115 front panel provides also provides a recessed Abort/Reset push-button switch, an RJ-45 Ethernet connector with status LEDs, an RJ-45 asynchronous serial port connector and, two PMC cutouts.

Figure 3-2 Front Panel Connector Cutouts, Connectors, and LED Indicators

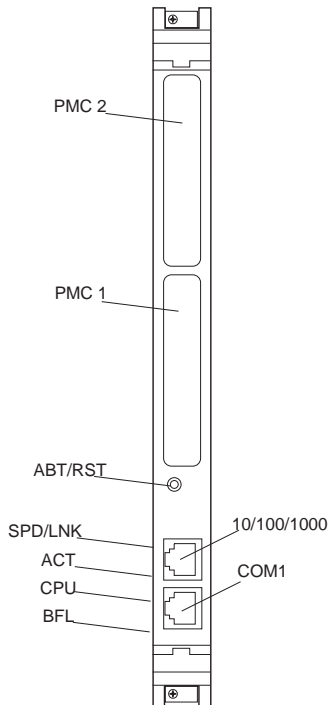

Connector/Header	Pin Assignment
CPCI-6115 Front Panel Asynchronous Serial Port (J19)	<a href="#">Table 3-2 on page 52</a>
CPCI-6115 Front Panel 10/100/1000 Mb/s Ethernet Connector (J95)	<a href="#">Table 3-3 on page 53</a>

## 3.4 ABORT/Reset Switch

The CPCI-6115 contains a single push button switch that provides both ABORT and RESET functions. When the switch is depressed for less than 3 seconds, an ABORT interrupt is generated to the processor. If the switch is held for more than 3 seconds, a board hard reset is generated.

## 3.5 On-Board Connectors and Headers

The CPCI-6115 CPU board provides the on-board connectors and jumper headers listed in the next table. Use the links in the Location column to go to the description and pin assignment for each connector.

Connector/Header	Location
CPCI-6115 CompactPCI Connectors ( J1/J2 )	<a href="#">Table 3-4 on page 54</a>
CPCI-6115 CompactPCI User I/O Connector (J3)	<a href="#">Table 3-5 on page 54</a>
CPCI-6115 CompactPCI Connector (J4)	N/A
CPCI-6115 CompactPCI User I/O Connector (J5)	<a href="#">Table 3-7 on page 57</a>
CPCI-6115 PCI Mezzanine Card (PMC) Connectors (J11/J21)	<a href="#">Table 3-8 on page 59</a>
CPCI-6115 PCI Mezzanine Card (PMC) Connectors (J12/J22)	<a href="#">Table 3-9 on page 60</a>
CPCI-6115 PCI Mezzanine Card (PMC) Connectors (J13/J23)	<a href="#">Table 3-10 on page 61</a>
CPCI-6115 PCI Mezzanine Card (PMC) Connectors (J14/J24)	<a href="#">Table 3-11 on page 62</a>
Boundary Scan JTAG Header (J16)	<a href="#">Table 3-12 on page 63</a>
CPCI-6115 Riscwatch Header (J17)	<a href="#">Table 3-13 on page 63</a>
Standalone Operation Select Header (J9)	<a href="#">Table 3-14 on page 64</a>
CPCI-6115 Flash Boot Bank Select Header (J10)	<a href="#">Table 3-15 on page 64</a>
Safe Start Header (J20)	<a href="#">Table 3-16 on page 65</a>
Bus Mode Select Header (J6)	<a href="#">Table 3-17 on page 65</a>
SROM Init Enable Header (J25)	<a href="#">Table 3-18 on page 65</a>
Flash Bank A Write Protect Header (J99)	<a href="#">Table 3-19 on page 66</a>
+/-12 V Present Header (J15)	<a href="#">Table 3-20 on page 66</a>

### 3.5.1 J19, Front Panel Asynchronous Serial Port

An RJ-45 receptacle is located on the front panel of the CPCI-6115 CPU board to provide the interface to the COM1 serial port. This port is configured as DTE. The pin assignments for this connector are as follows:

Table 3-2 COM1 Pin Assignments, J19

Pin #	Signal	Direction
1	DCD	INPUT

Table 3-2 COM1 Pin Assignments, J19 (continued)

Pin #	Signal	Direction
2	RTS	OUTPUT
3	GNDC	N/A
4	TXD	OUTPUT
5	RXD	INPUT
6	GNDC	N/A
7	CTS	INPUT
8	DTR	OUTPUT

### 3.5.2 J95, Front Panel 10/100/1000 Megabits/s Ethernet Connector

The CPCI-6115 has one front panel 10/100/1000 megabit/s Gigabit Ethernet connector. It is an industry standard RJ-45 connector with the following pin assignments:

Table 3-3 10/100/1000 Megabit/s Ethernet Connector, J95

Pin #	1000 Megabit/S	10/100 Megabit/S
1	MDIO0+	TD+
2	MDIO0-	TD-
3	MDIO1+	RD+
4	MDIO2+	Not Used
5	MDIO2-	Not Used
6	MDIO1-	RD-
7	MDIO3+	Not Used
MDIO3-	8	Not Used

### 3.5.3 CompactPCI J1/J2 Connectors

The CPCI-6115 CPU board implements a 64-bit CompactPCI interface on connectors J1 and J2. J1 is a 110 pin AMP Z-pack 2mm hard metric type A connector with either +3.3 V or +5 V signaling. J2 is a 110 pin AMP Z-pack 2mm hard metric type B connector. Each of these connectors conform to the CompactPCI specification. The pinout for connectors J1 and J2 are implemented as defined in the CompactPCI specification for a 64-bit peripheral slot board. Note that no reserved or bussed reserved pins are used by CPCI-6115.

### 3.5.4 CompactPCI Bus Connector

Pinouts for the J1 CompactPCI Bus connector on the CPCI-6115 are as follows:

Table 3-4 CompactPCI Connector, J1

Pin	Row A	Row B	Row C	Row D	Row E
25	+5.0 V	REQ64#	ENUM#	+3.3 V	+5.0 V
24	AD[1]	+5.0 V	V(IO)1	AD[0]	ACK64#
23	+3.3 V	AD[4]	AD[3]	+5.0 V1	AD[2]
22	AD[7]	GND	+3.3 V1	AD[6]	AD[5]
21	+3.3 V	AD[9]	AD[8]	M66EN	C/BE[0]#
20	AD[12]	GND	V(IO)	AD[11]	AD[10]
19	+3.3 V	AD[15]	AD[14]	GND1	AD[13]
18	SERR#	GND	+3.3 V	PAR	C/BE[1]#
17	+3.3 V	IPMB0_SCL	IPMB0_SDA	GND1	PERR#
16	DEVSEL#	PCIXCAP	V(IO)	STOP#	LOCK#
15	+3.3 V	FRAME#	IRDY#	BD_SEL#	TRDY#
KEY AREA (Pins 12 - 14)					
11	AD[18]	AD[17]	AD[16]	GND1	C/BE[2]#
10	AD[21]	GND	+3.3 V	AD[20]	AD[19]
9	C/BE[3]#	IDSEL	AD[23]	GND1	AD[22]
8	AD[26]	GND	V(IO)	AD[25]	AD[24]
7	AD[30]	AD[29]	AD[28]	GND1	AD[27]
6	REQ#	GND	+3.3 V1	CLK	AD[31]
5	BRSVR1A5	BRSVR1B5	RST#	GND1	GNT#
4	IPMB_PWR	HEALTHY#	V(IO)1	INTP	INTS
3	INTA#	INTB#	INTC#	+5.0 V1	INTD#
2	TCK	+5.0 V	TMS	TDO	TDI
1	+5.0 V	-12 V	TRST#	+12 V	+5.0 V

### 3.5.5 CompactPCI Bus Connector

Pinouts for the J2 CompactPCI Bus connector on the CPCI-6115 are as follows:

Table 3-5 CompactPCI Connector, J2

Pin	Row A	Row B	Row C	Row D	Row E
22	GA4	GA3	GA2	GA1	GA0
21	RSV	GND	RSV	RSV	RSV
20	RSV	GND	RSV	GND	RSV



Table 3-5 CompactPCI Connector, J2 (continued)

Pin	Row A	Row B	Row C	Row D	Row E
19	GND	GND	RSV	RSV	RSV
18	BRSVP2A18	BRSVP2B18	BRSVP2C18	GND	BRSVP2E18
17	BRSVP2A17	GND	RSV	RSV	RSV
16	BRSVP2A16	BRSVP2B16	RSV	GND	BRSVP2E16
15	BRSVP2A15	GND	RSV	RSV	RSV
14	AD[35]	AD[34]	AD[33]	GND	AD[32]
13	AD[38]	GND	V(IO)	AD[37]	AD[36]
12	AD[42]	AD[41]	AD[40]	GND	AD[39]
11	AD[45]	GND	V(IO)	AD[44]	AD[43]
10	AD[49]	AD[48]	AD[47]	GND	AD[46]
9	AD[52]	GND	V(IO)	AD[51]	AD[50]
8	AD[56]	AD[55]	AD[54]	GND	AD[53]
7	AD[59]	GND	V(IO)	AD[58]	AD[57]
6	AD[63]	AD[62]	AD[61]	GND	AD[60]
5	C/BE[5]#	64EN#	V(IO)	C/BE[4]#	PAR64
4	V(IO)	BRSVP2B4	C/BE[7]#	GND	C/BE[6]#
3	RSV	GND	RSV	RSV	RSV
2	RSV	RSV	SYSEN# <sup>a</sup>	RSV	RSV
1	RSV	GND	RSV	RSV	RSV

a. Defined as SYSEN#. This OV allows the CPCI-6115 to ensure that it is installed into a peripheral slot.

### 3.5.6 CompactPCI User I/O Connector

Connector J3 is a 110 pin AMP Z-pack 2mm hard metric type B connector. This connector routes the I/O signals for one of the PMC slots and two 10/100/1000Base-T Ethernet channels compliant with the CompactPCI Packet Switching Backplane Specification. The pin assignments for J3 are as follows:

(Note that outer row F is assigned and used as ground pins but is not shown in the table).

Table 3-6 User I/O Connector Pinout, J3

Pin	Row A	Row B	Row C	Row D	Row E	Pin
19	GND	+12 V	-12 V	GND	GND	19
18	LPa_DA+ (TX1+)	LPa_DA- (TX1-)	GND	LPa_DC+	LPa_DC-	18
17	LPa_DB+ (RX1+)	LPa_DB- (RX1-)	GND	LPa_DD+	LPa_DD-	17
16	LPb_DA+ (TX2+)	LPb_DA- (TX1-)	GND	LPb_DC+	LPb_DC-	16
15	LPb_DB+ (RX2+)	LPb_DB- (RX2-)	GND	LPb_DD+	LPb_DD-	15

Table 3-6 User I/O Connector Pinout, J3 (continued)

Pin	Row A	Row B	Row C	Row D	Row E	Pin
14	+3.3 V	+3.3 V	+3.3 V	+5 V	+5 V	14
13	PMCIO5	PMCIO4	PMCIO3	PMCIO2	PMCIO1	13
12	PMCIO10	PMCIO9	PMCIO8	PMCIO7	PMCIO6	12
11	PMCIO15	PMCIO14	PMCIO13	PMCIO12	PMCIO11	11
10	PMCIO20	PMCIO19	PMCIO18	PMCIO17	PMCIO16	10
9	PMCIO25	PMCIO24	PMCIO23	PMCIO22	PMCIO21	9
8	PMCIO30	PMCIO29	PMCIO28	PMCIO27	PMCIO26	8
7	PMCIO35	PMCIO34	PMCIO33	PMCIO32	PMCIO31	7
6	PMCIO40	PMCIO39	PMCIO38	PMCIO37	PMCIO36	6
5	PMCIO45	PMCIO44	PMCIO43	PMCIO42	PMCIO41	5
4	PMCIO50	PMCIO49	PMCIO48	PMCIO47	PMCIO46	4
3	PMCIO55	PMCIO54	PMCIO53	PMCIO52	PMCIO51	3
2	PMCIO60	PMCIO59	PMCIO58	PMCIO57	PMCIO56	2
1	IPMI_PWR	PMCIO64	PMCIO63	PMCIO62	PMCIO61	1

**Signal Descriptions**

10/100/1000Base-T Ethernet signals:

LPa\_Dx

CH1 10/100/1000Base-T Ethernet

LPb\_Dx

CH2 10/100/1000Base-T Ethernet

PMC User I/O:

PMCIO(64:1)

PMC I/O

### 3.5.7 CompactPCI Connector

There are no electrical connections from the CompactPCI J4 connector to the CPCI-6115. This connector is depopulated.

### 3.5.8 CompactPCI User I/O Connector

Connector J5 is a 110-pin AMP Z-pack 2mm hard metric type B connector. This connector routes the I/O signals for one PMC site, an IDE channel, two asynchronous serial ports and the I2C clock and data signals to the CompactPCI backplane. The pin assignments for J5 are as follows: (Note that outer row F is assigned and used as ground pins but is not shown in the table).

Table 3-7 User I/O Connector Pinout, J5

Pin	Row A	Row B	Row C	Row D	Row E	Pin
22	DRESET#	NC	NC	COM2_TXD	COM1_TXD	22
21	INTRQ	NC	NC	COM2_RXD	COM1_RXD	21
20	CS1FX# (CS0)	CS3FX# (CS1)	DA2	MXDI	MXDO	20
19	DMACK#	DIORDY	DA1	MXCLK	MXSYNC#	19
18	DIOW#	DA0	TMCOM1#	I2C_CLK	I2C_DATA	18
17	GND	DD14	DD15	DIOR#	DMARQ	17
16	DD9	DD10	DD11	DD12	DD13	16
15	DD5	DD6	GND	DD7	DD8	15
14	DD0	DD1	DD2	DD3	DD4	14
13	PMCIO5	PMCIO4	PMCIO3	PMCIO2	PMCIO1	13
12	PMCIO10	PMCIO9	PMCIO8	PMCIO7	PMCIO6	12
11	PMCIO15	PMCIO14	PMCIO13	PMCIO12	PMCIO11	11
10	PMCIO20	PMCIO19	PMCIO18	PMCIO17	PMCIO16	10
9	PMCIO25	PMCIO24	PMCIO23	PMCIO22	PMCIO21	9
8	PMCIO30	PMCIO29	PMCIO28	PMCIO27	PMCIO26	8
7	PMCIO35	PMCIO34	PMCIO33	PMCIO32	PMCIO31	7
6	PMCIO40	PMCIO39	PMCIO38	PMCIO37	PMCIO36	6
5	PMCIO45	PMCIO44	PMCIO43	PMCIO42	PMCIO41	5
4	PMCIO50	PMCIO49	PMCIO48	PMCIO47	PMCIO46	4
3	PMCIO55	PMCIO54	PMCIO53	PMCIO52	PMCIO51	3
2	PMCIO60	PMCIO59	PMCIO58	PMCIO57	PMCIO56	2
1	TM_PRSENT#	PMCIO64	PMCIO63	PMCIO62	PMCIO61	1

#### Signal Descriptions

##### IDE Port, TTL Levels:

DMARQ	DMA request
DMACK_L	DMA acknowledge
DIOR_L	I/O read

**Signal Descriptions****IDE Port, TTL Levels:**

DLOW_L	I/O write
IORDY	indicates drive ready for I/O
DD(15:0)	data lines
DRESET_L	reset signal to drive
CS1FX_L	chip select drive 0 or command register block select
CS3FX_L	chip select drive 1 or command register block select
DA(2:0)	drive register and data port address lines
INTRQ	drive interrupt request

**Asynchronous Serial Ports 1-2, TTL Levels:**

<b>Signal</b>	<b>Description</b>
COMxRD	receive data
COMxTD	transmit data
MXCLK	clock for multiplexed data containing sync port control signals
MXDI	multiplexed data input
MXDO	multiplexed data output
MXSYNC#	multiplexed data sync
TMCOM1	enable COM1 Front panel RS232 transceiver

**PMC User I/O**

PMCIO(64:1)	PMC I/O
-------------	---------

**Miscellaneous**

TM_PRSENT#	Transition Module Present
I2C_CLK	I2C Clock signal from ZirconPM I2C port
I2C_DATA	I2C Data signal from ZirconPM I2C port
No Connect	NC

### 3.5.9 PCI Mezzanine Card (PMC) Connectors

There are four 64-pin EIA E700 AAAB SMT connectors for each PMC slot on the CPCI-6115 to provide the two 32/64-bit PCI interface and optional I/O interface to the PMC.

When the front-panel Gigabit Ethernet is populated, PMC 1 has a 32-bit interface. In this case, these pins are not connected on J13. (factory configuration)

Table 3-8 PMC Connector Pin Assignments, J11/J21

Pin	J11/J21		Pin
1	TCK	-12 V	2
3	GND	INTA#	4
5	INTB#	INTC#	6
7	PRESENT#	+5 V	8
9	INTD#	PCI_RSVD	10
11	GND	+3.3 Vaux	12
13	CLK	GND	14
15	GND	GNT#/XREQ0#	16
17	REQ#/XGNT0#	+5 V	18
19	VIO	AD31	20
21	AD28	AD27	22
23	AD25	GND	24
25	GND	C/BE3#	26
27	AD22	AD21	28
29	AD19	+5 V	30
31	VIO	AD17	32
33	FRAME#	GND	34
35	GND	IRDY#	36
37	DEVSEL#	+5 V	38
39	PCIXCAP	LOCK#	40
41	PCI_RSVD	PCI_RSVD	42
43	PAR	GND	44
45	VIO	AD15	46
47	AD12	AD11	48
49	AD09	+5 V	50
51	GND	C/BE0#	52
53	AD06	AD05	54
55	AD04	GND	56
57	VIO	AD03	58
59	AD02	AD01	60

Table 3-8 PMC Connector Pin Assignments, J11/J21 (continued)

Pin	J11/J21		Pin
61	AD00	+5 V	62
63	GND	REQ64#	64

PCI\_RSVD = PCI Reserved pin.

Table 3-9 PMC Connector Pin Assignments, J12/J22

Pin	J12	J22	Pin
1	+12 V	TRST#	2
3	TMS	TDO	4
5	TDI	GND	6
7	GND	PCI_RSVD	8
9	PCI_RSVD	PCI_RSVD	10
11	MOT_RSVD	+3.3 V	12
13	RST#	MOT_RSVD	14
15	+3.3 V	MOT_RSVD	16
17	PME#*	GND	18
19	AD30	AD29	20
21	GND	AD26	22
23	AD24	+3.3 V	24
25	IDSEL	AD23	26
27	+3.3 V	AD20	28
29	AD18	GND	30
31	AD16	C/BE2#	32
33	GND	IDSELB	34
35	TRDY#	+3.3 V	36
37	GND	STOP#	38
39	PERR#	GND	40
41	+3.3 V	SERR#	42
43	C/BE1#	GND	44
45	AD14	AD13	46
47	M66EN	AD10	48
49	AD08	+3.3 V	50
51	AD07	REQB_L	52
53	+3.3 V	GNTB_L	54
55	MOT_RSVD	GND	56
57	MOT_RSVD	EREADY	58

Table 3-9 PMC Connector Pin Assignments, J12/J22 (continued)

Pin	J12	J22	Pin
59	GND	NC (RESETOUT_L)	60
61	ACK64#	+3.3 V	62
63	GND	NC (MONARCH#)	64

MOT\_RSVD = Motorola Reserved pin  
 PCI\_RSVD = PCI Reserved pin

Table 3-10 PMC Connector Pin Assignments, J13/J23

Pin	J13/J23		Pin
1	PCI_RSVD	GND	2
3	GND	C/BE7# (Note 1)	4
5	C/BE6# (Note 1)	C/BE5# (Note 1)	6
7	C/BE4# (Note 1)	GND	8
9	VIO	PAR64 (Note 1)	10
11	AD63 (Note 1)	AD62 (Note 1)	12
13	AD61 (Note 1)	GND	14
15	GND	AD60 (Note 1)	16
17	AD59 (Note 1)	AD58 (Note 1)	18
19	AD57 (Note 1)	GND	20
21	VIO	AD56 (Note 1)	22
23	AD55 (Note 1)	AD54 (Note 1)	24
25	AD53 (Note 1)	GND	26
27	GND	AD52 (Note 1)	28
29	AD51 (Note 1)	AD50 (Note 1)	30
31	AD49 (Note 1)	GND	32
33	GND	AD48 (Note 1)	34
35	AD47 (Note 1)	AD46 (Note 1)	36
37	AD45 (Note 1)	GND	38
39	VIO	AD44 (Note 1)	40
41	AD43 (Note 1)	AD42 (Note 1)	42
43	AD41 (Note 1)	GND	44
45	GND	AD40 (Note 1)	46
47	AD39 (Note 1)	AD38 (Note 1)	48
49	AD37 (Note 1)	GND	50

Table 3-10 PMC Connector Pin Assignments, J13/J23 (continued)

Pin	J13/J23		Pin
51	GND	AD36 (Note 1)	52
53	AD35 (Note 1)	AD34 (Note 1)	54
55	AD33 (Note 1)	GND	56
57	VIO	AD32 (Note 1)	58
59	PCI_RSVD	PCI_RSVD	60
61	PCI_RSVD	GND	62
63	GND	PCI_RSVD	64

Table 3-11 PMC Connector Pin Assignments , J14/J24

Pin	J14/J24		Pin
1	PMCIO1	PMCIO2	2
3	PMCIO3	PMCIO4	4
5	PMCIO5	PMCIO6	6
7	PMCIO7	PMCIO8	8
9	PMCIO9	PMCIO10	10
11	PMCIO11	PMCIO12	12
13	PMCIO13	PMCIO14	14
15	PMCIO15	PMCIO16	16
17	PMCIO17	PMCIO18	18
19	PMCIO19	PMCIO20	20
21	PMCIO21	PMCIO22	22
23	PMCIO23	PMCIO24	24
25	PMCIO25	PMCIO26	26
27	PMCIO27	PMCIO28	28
29	PMCIO29	PMCIO30	30
31	PMCIO31	PMCIO32	32
33	PMCIO33	PMCIO34	34
35	PMCIO35	PMCIO36	36
37	PMCIO37	PMCIO38	38
39	PMCIO39	PMCIO40	40
41	PMCIO41	PMCIO42	42
43	PMCIO43	PMCIO44	44
45	PMCIO45	PMCIO46	46
47	PMCIO47	PMCIO48	48
49	PMCIO49	PMCIO50	50



Table 3-11 PMC Connector Pin Assignments , J14/J24 (continued)

Pin	J14/J24		Pin
51	PMCIO51	PMCIO52	52
53	PMCIO53	PMCIO54	54
55	PMCIO55	PMCIO56	56
57	PMCIO57	PMCIO58	58
59	PMCIO59	PMCIO60	60
61	PMCIO61	PMCIO62	62
63	PMCIO63	PMCIO64	64

### 3.5.10 Boundary Scan JTAG Header

This 2x7 0.1" header is used to provide boundary scan testing of all onboard JTAG devices in a single scan chain. The pin assignments for this header are as follows:

J16 pin 12 is grounded in the JTAG test cable. When the cable is attached, the CPU\_BSCAN\_L signal is grounded, which automatically configures the boundary scan chain to include the CPU.

Table 3-12 Boundary Scan JTAG Header Pin Assignments, J16

Pin	Signal		Pin
1	TRST_L	GND	2
3	TDO	GND	4
5	TDI	GND	6
7	TMS	GND	8
9	TCK	GND	10
11	NC	CPU_BSCAN_L	12
13	AUTOWR_L	GND	14

### 3.5.11 Processor JTAG/COP Header

The processor has a 2x8 0.1" JTAG/COP header for use with third party MPC745x JTAG/COP controllers. The pin assignments for this header are as follows:

With no JTAG cable attached to J16, the CPU JTAG signals are routed to J17 as shown.

Table 3-13 Processor JTAG/COP Header Pin Assignments, J17

Pin	Signal	Pin	Signal
1	CPUTDO	2	QACK_L
3	CPUTDI	4	CPUTRST_L
5	QREQ_L	6	+1.8 V
7	CPUTCK	8	CHKSTPI_L

Table 3-13 Processor JTAG/COP Header Pin Assignments, J17 (continued)

Pin	Signal	Pin	Signal
9	CPUTMS	10	NC
11	SRESET_L	12	NC
13	CPURST_L	14	KEY (no pin)
15	CHKSTPO_L	16	GND

### 3.5.12 Stand-Alone Operation Select Header

There is a 0.1", 2-pin header located on the CPCI-6115 to control standalone operation. Standalone operation is selected when the jumper is installed and normal operation occurs when the jumper is not installed. The pin assignments for this header are as follows:

Table 3-14 Stand-Alone Operation Select Header Pin Assignments, J9

Pin	Signal
1	STAND_ALONE_L
2	GND

### 3.5.13 Flash Boot Bank Select Header

There is a 0.1", 3-pin header on the CPCI-6115 to select the boot flash bank. No jumper or a jumper installed between pins 1 and 2 will route the BOOTCS\* signal to Flash Bank A and device CS0\* to Flash Bank B. A jumper installed between pins 2 and 3 routes BOOTCS\* to Flash Bank B and CS0\* to Flash Bank A. The pin assignments for this header are as follows:

Table 3-15 Flash Boot Bank Select Header Pin Assignments, J10

Pin	Signal	Function
1	GND	1-2 Boot from Bank A
2	BANK_SEL	
3	+3.3 V	2-3 Boot from Bank B

### 3.5.14 Safe Start Header

A 3-pin 2 mm header is located on the board to select programmed or safe start ENV settings. No jumper or a jumper between pins 1 and 2 indicates that the programmed (e.g., VPD, SPD) settings should be used during boot. A jumper between pins 2 and 3 indicates that the safe start settings should be used. The pin assignments for this header are as follows:

*Table 3-16 Safe Start ENV Header Pin Assignments, J20*

Pin	Signal	Function
1	GND	1-2 for ENV parameters
2	SAFE_START	
3	+3.3 V	2-3 for SAFE start

### 3.5.15 Bus Mode Select Header

A 3-pin 2 mm header is located on the board to select the processor bus operating mode. No jumper or a jumper from pins 1 to 2 selects the 60x bus mode while a jumper between pins 2 and 3 selects the MPX bus mode. The pin assignments for this header are as follows:

*Table 3-17 Bus Mode Select Header Pin Assignments, J6*

Pin	Signal	Function
1	GND	1-2 for 60x mode
2	BMODE_SEL	
3	+3.3 V	2-3 for MPX mode

### 3.5.16 SRAM Initialization Enable Header

A 3-pin 2 mm header is located on the board to enable/disable the MV64360 SRAM initialization. A jumper from pins 1 to 2 enables the MV64360 device initialization via I2C SRAM while no jumper or a jumper between pins 2 and 3 will disable this initialization sequence. The pin assignments for this header are as follows:

*Table 3-18 SRAM Initialization Enable Header Pin Assignments, J25*

Pin	Signal	Function
1	+3.3 V	1-2 for I2C Init
2	SRAM_INIT	
3	GND	2-3 for No I2C Init

### 3.5.17 Flash Bank A Write Protect Header

A 2-pin 2 mm header is located on the board to enable/disable programming of Flash Bank A to protect the contents from being corrupted. No jumper installed disables all Flash Bank A programming by driving the FLASH VPEN pin to a logic low. The jumper must be installed for erasing array blocks, programming data or configuring lock-bits. The pin assignments for this header are as follows:

*Table 3-19 Bank A Write Protect Header Pin Assignments, J99*

Pin	Signal
1	+3.3 V
2	VPEN

### 3.5.18 +/-12 V Present Header

A 2-pin 0.1" header is located on the board to inform the CPCI-6115 whether the +/-12 V power supplies are present on the backplane. If so, then these power supplies are monitored for inclusion in the HLT<sub>Y</sub># status. If no jumper is installed, the CPCI-6115 will assume that the +/-12 V supplies are present. With a jumper installed, the +/-12 V power supplies are not monitored. The pin assignments for this header are as follows:

*Table 3-20 +/-12 V Present Header Pin Assignments, J15*

Pin	Signal
1	PWR12V_EN
2	GND

## 4.1 Overview

This chapter describes the CPCI-6115 single-board computer on a block diagram level. The General Description section provides an overview of the CPCI-6115, followed by a detailed description of several blocks of circuitry. [Figure 4-1](#) shows a block diagram of the overall board architecture.

Detailed descriptions of other CPCI-6115 blocks, including programmable registers in the ASICs and peripheral chips, can be found in the *MCPN905 CompactPCI Single Board Computer Programmer's Reference Guide* and the Marvell MV64360 Reference Guide, both are listed in [Appendix A, Related Documentation](#).

## 4.2 Block Diagram

The block diagram below illustrates the architecture of the CPC1-6115 baseboard.

Figure 4-1 CPC1-6115 Baseboard Block Diagram

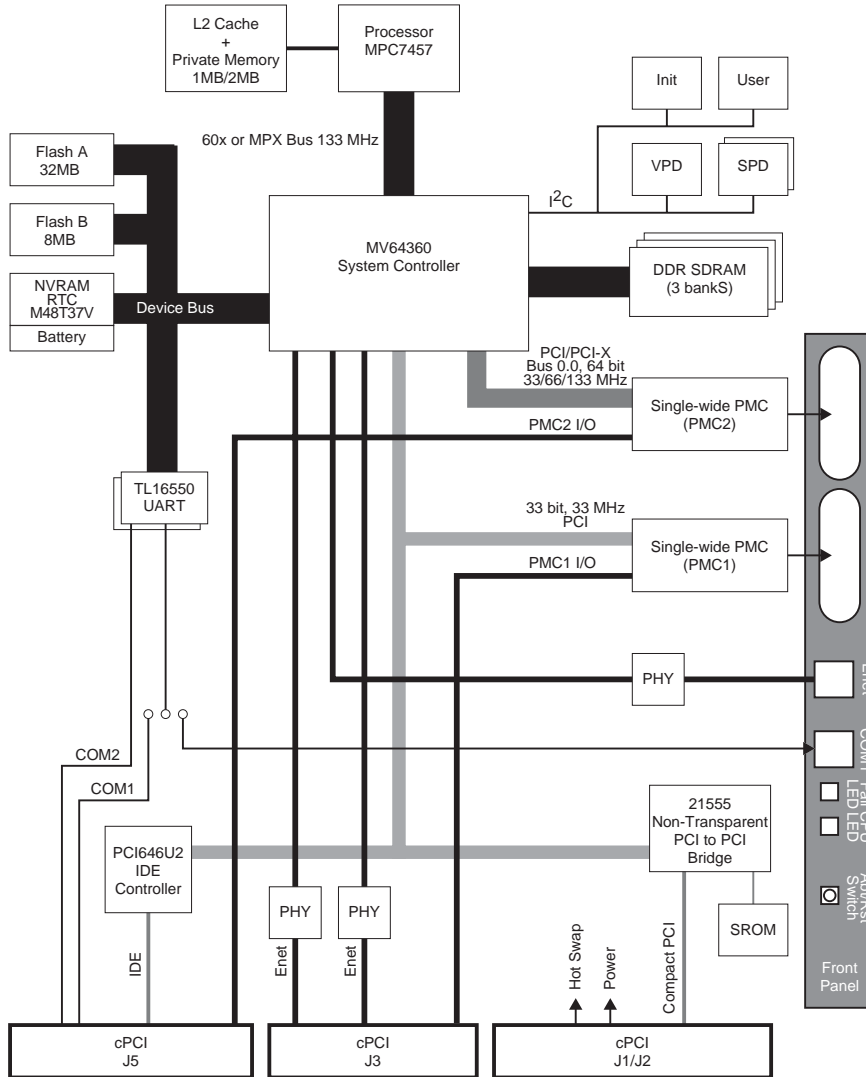

## 4.3 General Description

The CPCI-6115 is a peripheral slot CompactPCI CPU board based on the MPC7457 processor family and MV64360 PCI-Host bridge/system memory controller and the Intel 21555 PCI-to-PCI bridge. The CPCI-6115 supports up to 1.5 GB of DDR SDRAM, two PMC sites, 8MB of boot flash, 32MB of soldered flash, three Gigabit Ethernet ports and one IDE port. The CPCI-6115 also supports the CompactPCI Packet Switching Backplane (PICMG 2.16) specification.

The CPCI-6115 has two planar PCI busses (PCI\_0 and PCI\_1). In order to support a more generic PCI bus hierarchy nomenclature, the MV64360 PCI busses are referred to in this document as PCI Bus 0.0 (root bridge instance 0, bus 0) and PCI Bus 1.0 (root bridge instance 1, bus 0). PCI Bus 0.0 connects to PMC 2. This PMC slot has PCI/PCI-X speed capability and supports non-Monarch PrPMC modules. PCI Bus 1.0 connects to PMC1, the 21555 PCI-to-PCI bridge and the IDE controller. This interface operates at 33 MHz PCI speed. Both PCI Planar busses are controlled by the MV64360 System Controller.

The MV64360 Device Controller can support up to 5 banks of devices. On the CPCI-6115, it supports the onboard flash, NVRAM/RTC, UART and programming registers. Each bank supports up to 512 MB of address space.

The MV64360 must acquire some knowledge about the system before it is configured by the software. This is done through jumper-controlled initialization. The jumper setting selects either a planar configuration resistor initialization, or an I<sup>2</sup>C interface SROM initialization.

The CPCI-6115 board interfaces to the CompactPCI bus via the J1 and J2 connectors as specified in the PICMG 2.0 specification. It draws +3.3 V and +5 V power, and optionally +/-12 V power, from the CompactPCI backplane through these two connectors. All other required voltages are regulated onboard from the +3.3 V or +5 V power.

Front panel connectors on the CPCI-6115 board include: one RJ-45 connector for the Gigabit Ethernet; one RJ-45 connector for the asynchronous serial port; a combined reset and abort switch; and two status LEDs. One additional asynchronous serial port is provided and routed to the J5 connector for rear I/O access. Two Gigabit Ethernet ports are routed to the J3 connector for PICMG 2.16 connectivity or other rear I/O access.

The CPCI-6115 contains two IEEE1386.1 PCI Mezzanine Card (PMC) slots. PMC 2 is a 32/64-bit capable and supports both front and rear I/O. PMC 1 is 32-bit capable and supports both front and rear I/O. All I/O pins of PMC 2 are routed to the J5 connector. All I/O pins of PMC 1 are routed to the J3 connector.

The CPCI-6115 board also provides access to the processor JTAG port via a standard 16-pin header.

### 4.3.1 Processor Bus Resources

Devices resident on the processor bus of the CPCI-6115 are a single processor, the MV64360 System Controller and a debug connector (unpopulated). The bus is capable of operation in either 60x or MPX modes (jumper selectable) and runs at 133 MHz. Processor address and data bus parity generation and checking is supported.

The MPC7457 processor uses +2.5 V signal levels on the processor bus. Care should be taken that probe boards attached to the debug connector do not pull up or drive signals in violation of this.

The JTAG port is tolerant of +3.3 V signals.

Arbitration on the processor bus is provided by the MV64360 chip.

### 4.3.2 Processor

The CPCI-6115 has the 360-pin CBGA foot print that supports the MPC7457 family of processors. The MPC7457 processors have integrated L1 and L2 caches and has a L3 cache interface with on-chip tags to support up to 2MB of off-chip cache. The CPCI-6115 initially supports processor core frequencies of 866 MHz and 1 GHz and an external processor bus speed of 133 MHz. The common processor configuration will support variable core voltages between +0.8 V and +1.6V.

### 4.3.3 L3 Cache

The CPCI-6115 external L3 cache/private memory is implemented using two 8 megabit DDR SRAM devices. The MPC7457 allows a maximum of 2 MB of memory on the L3 cache bus, which may be allocated as L3 cache, private memory or a combination of both.

The L3 cache bus is 72-bits wide (64 bits of data and 8 bits of parity). The MPC7457 has an on-chip, 8-way, set-associative tag memory. The external SRAMs are accessed through a dedicated L3 cache port which supports one bank of SRAM. The L3 cache normally operates in copyback mode and supports system cache coherency through snooping. Parity generation and checking may be disabled by programming the L3CR register of the Apollo (MPC7457) device. Refer to the *PowerPC Apollo Microprocessor Implementation Definition Book IV*, listed in [Appendix A, Related Documentation](#), for more information (Addendum to SC-Vger Book IV Version - 1.0 04/21/00).

### 4.3.4 MV64360 System Controller

The MV64360 is an integrated system controller for high performance embedded control applications. The following features of the MV64360 are supported by the CPCI-6115. The MV64360 has a five bus architecture comprised of:

- 72-bit interface to the CPU bus (with parity)
- 72-bit interface to DDR SDRAM (with ECC)
- 32-bit interface to devices
- Two 64-bit PCI/PCI-X interfaces

In addition to the above the MV64360 integrates the following:

- Three gigabit Ethernet MACs
- Interrupt controller
- Four general-purpose 32-bit timers/counters



- One I<sup>2</sup>C interface
- One four-channel Independent DMA controller

All of the above interfaces are connected through a cross-bar fabric. The cross-bar enables concurrent transactions between units. For example, the cross-bar can simultaneously control the:

- Gigabit Ethernet MAC fetching a descriptor from the integrated SRAM
- CPU reading from the DRAM
- DMA moving data from the device bus to the PCI bus

#### 4.3.4.1 MV64360 CPU Bus Interface

The CPU interface (master and slave) operates at 133 MHz using either the 60x or MPX bus modes. The bus mode is jumper selectable. The CPU bus has 36-bit address and 64-bit data busses. The MV64360 fully supports PowerPC cache coherency. The MV64360 supports up to eight pipelined transactions per processor. There are 21 address windows supported in the CPU interface:

- Four for DDR SDRAM chip selects
- Five for device chip selects
- Five for PCI\_0 interface (4 memory + one I/O)
- Five for PCI\_1 interface (4 memory + one I/O)
- One for the MV64360 integrated SRAM
- One for the MV64360 internal registers SRAM

Each window is defined by Base and Size registers and can decode up to 4 GB space (except for the integrated SRAM which is fixed at 256 KB). Refer to the MV64360 Data Sheet for additional information and programming details.

#### 4.3.4.2 MV64360 DDR SDRAM Interface

The CPCI-6115 supports three banks of DDR SDRAM using 256 megabit, 512 megabit or 1 gigabit DDR SDRAM devices onboard. A 133 MHz (DDR266) operation is used when two or three banks are populated. The SDRAM supports ECC. The SDRAM controller contains four transaction queues - two write buffers and two read buffers. The SDRAM controller does not necessarily issue SDRAM transactions in the same order that it receives the transactions. The MV64360 supports full PowerPC cache coherency between CPU L1/L2 and L3 caches and SDRAM. Each access to the SDRAM may result in snoop transaction initiated by the MV64360 on the CPU bus. The SDRAM controller supports a wide range of SDRAM timing parameters to meet the needs of current and future DDR SDRAM devices. These parameters can be configured through the SDRAM Mode register and the SDRAM Timing Parameters register. Refer to the MV64360 Data Sheet for additional information and programming details.

### 4.3.4.3 MV64360 32-bit Interface to Devices

The device controller supports up to five banks of devices, of which three are used for Flash Bank A and B, NVRAM/RTC, and serial ports on the CPCI-6115. Each bank supports up to 512 MB of address space, resulting in total device space of 1.5 GB. Each bank has its own parameters register as shown in the following table.

Table 4-1 Device Bus Parameters

Device	Device ID	Parameter Description
Flash Bank A	Device Bus Bank 0	Bank width 32-bit, parity disabled
Flash Bank B	Device Bus Boot Bank	Bank width 32-bit, parity disabled
Real Time Clock Board Specific Register Serial Ports	Device Bus Bank 1	Bank width 8-bit, parity disabled

### 4.3.4.4 MV64360 Dual PCI/PCI-X Interfaces

The MV64360 supports two PCI/PCI-X busses capable of operating up to 133 MHz in PCI-X mode, and up to 66 MHz in conventional PCI mode, subject to routing and loading considerations.

On the CPCI-6115, PCI Bus 0.0 is connected to PMC 2 and supports 32/64-bit transfers at 66/133 MHz PCI-X or 33/66 MHz PCI.

On the CPCI-6115, PCI Bus 1.0 is connected to PMC 1, the 21555 PCI-to-PCI bridge and the IDE controller. The upper 32 bits of PCI Bus 1.0 on the MV64360 are multiplexed with the third Gigabit Ethernet port (which may be routed to the front panel on the CPCI-6115), so PCI Bus 1.0 is only 32 bits wide when the third Gigabit Ethernet port is populated.

The IDE controller is a 33 MHz-only PCI device, so PCI Bus 1.0 is limited to 33 MHz PCI transfers when the IDE controller is populated.

The MV64360 PCI interfaces are fully PCI Rev. 2.2 and PCI-X compliant. The MV64360 contains all the required PCI configuration registers. All internal registers, including the PCI configuration registers, are accessible from the CPU bus or the PCI bus.

### 4.3.4.5 MV64360 Integrated Gigabit Ethernet MACs

The CPCI-6115 supports two 10/100/1000Base-T full duplex Ethernet ports connected to the J3 connector for support of PICMG 2.16 I/O. The CPCI-6115 also routes the third Gigabit Ethernet port to an RJ-45 connector on the front panel. The CPCI-6115 supports ports configured to the 10/100 megabits/s MII interface and the 1 Gbps GMII interface. Receive and transmit buffer management is based on buffer-descriptor linked list. Descriptors and data transfers are performed by the port dedicated SDMA. Each board is assigned two Ethernet Station Addresses.

The MV64360 does not integrate a Physical Layer for the Ethernet interfaces, so external PHYs are required. On the CPCI-6115, the PHY device is a BroadCom BCM5421S 10/100/1000Base-T Gigabit Transceiver with SERDES Interface. This device was chosen for its small footprint (8mm x 14mm) and low power (1 watt).

#### 4.3.4.6 MV64360 Integrated 2 Megabit SRAM

The MV64360 integrates 2 megabit (144-bit wide and 2 KB deep) of general purpose SRAM. It is accessible from the CPU or any of the other interfaces. It can be used as fast CPU access memory (6 cycles latency) and for off-loading DRAM traffic. A typical usage of the SRAM could be as a descriptor RAM for the Gigabit Ethernet port.

#### 4.3.4.7 MV64360 General-Purpose 32-bit Timer/Counters

There are four 32-bit timers/counters within the MV64360. Each timer/counter can be selected to operate as a timer or as a counter. The timing reference is based on the MV64360 Tclk input which is set at 133 MHz. Each counter/timer is capable of generating an interrupt. Refer to the MV64360 Data Sheet for additional information and programming details.

#### 4.3.4.8 MV64360 Watchdog Timer

The MV64360 internal watchdog timer is a 32-bit down counter that can be used to generate a non-maskable interrupt or reset the system in the event of unpredictable software behavior. After the watchdog timer is enabled, it becomes a free running counter that must be serviced periodically to keep it from expiring. Following reset, the watchdog timer is initially disabled but it is enabled during the MV64360 I<sup>2</sup>C device initialization. The watchdog timer has two output pins, WDNMI# and WDE#. The WDNMI# is asserted after the timer is enabled and the 24-bit NMI\_VAL count is reached. The WDNMI# pin is connected to one of the MV64360 interrupt input pins so that an interrupt is generated when the NMI\_VAL count is reached. The WDE# pin is asserted after the watchdog timer is enabled and the 32-bit watchdog count expires. The MV64360 holds WDE# asserted for the duration of 16 system cycles after reset assertion. The WDE# pin is connected to the board reset logic so that a board reset will be generated when WDE# is asserted. For additional details refer to the MV64360 Data Sheet.

#### 4.3.4.9 MV64360 I2O Message Unit

I2O compliant messaging for the CPCI-6115 board is provided by an I2O messaging unit integrated into the MV64360. The MV64360 messaging unit includes hardware hooks for message transfers between PCI devices and the CPU. This includes all of the registers required for implementing the I2O messaging, as defined in the Intelligent I/O (I2O) Standard specification. For additional details regarding the I2O messaging unit, refer to the MV64360 Data Sheet.

#### 4.3.4.10 MV64360 Four-Channel Independent DMA Controller

The MV64360 incorporates four Independent DMA (IDMA) engines. Each IDMA engine has the capability to transfer data between any interface. Refer to the MV64360 Data Sheet for additional information and programming details.

#### 4.3.4.11 MV64360 I<sup>2</sup>C Interface

A two-wire serial interface for the CPCI-6115 board is provided by a master/slave capable I<sup>2</sup>C serial controller integrated into the MV64360 device. The I<sup>2</sup>C serial controller provides two basic functions. The first function is to optionally provide MV64360 register initialization following a reset. The MV64360 can be configured (by jumper setting) to automatically read data out of a serial EEPROM following a reset and initialize any number of internal registers. In

the second function, the controller is used by the system software to read the contents of the VPD EEPROM contained on the CPCI-6115 board, along with the SPD EEPROMs for the onboard memory banks, to further initialize the memory controller and other interfaces. See the programming model section of this document for more information including I<sup>2</sup>C bus device addressing.

The CPCI-6115 board has the following I<sup>2</sup>C serial devices connected to this I<sup>2</sup>C bus:

- 8 KB EEPROM for user defined MV64360 initialization
- 8 KB EEPROM for VPD
- 8 KB EEPROM for user data
- Two 256-byte EEPROMs for SPD
- DS1621 Temperature Sensor

The 8 KB devices are Atmel AT24C04N Serial EEPROMs.

#### 4.3.4.12 Interrupt Controller

The CPCI-6115 uses the interrupt controller integrated into MV64360 to manage the MV64360 internal interrupts, as well as external interrupt requests. The interrupts are routed to the MV64360 MPP pins from onboard resources as shown in [Figure 4-2 on page 75](#). The external interrupt sources include the following:

- Onboard PCI device interrupts
- PMC slot interrupts
- RTC interrupt
- Watchdog timer interrupts
- ABORT switch interrupt
- External UART interrupts
- CompactPCI interrupts
- Ethernet PHY interrupts

For added information on external interrupt assignments, refer to the *MCPN905 CompactPCI Single Board Computer Programmer's Reference Guide*.

#### 4.3.4.13 PCI Bus Arbitration

PCI arbitration is performed by the MV64360 chip. The MV64360 integrates two PCI arbiters, one for each PCI interface (PCI Bus 0.0/1.0). Each arbiter can handle up to six external agents plus one internal agent (PCI Bus 0.0/1.0 master). The internal PCI arbiter REQ#/GNT# signals are multiplexed on the MV64360 MPP pins. The internal PCI arbiter is disabled by default (the MPP pins function as general purpose inputs). Software will configure the MPP pins to function as request/grant pairs for the internal PCI arbiter. The arbitration pairs for the CPCI-6115 are assigned to the MPP pins as shown in the following table.

#### 4.3.4.14 Board Reset Logic

The board reset logic is implemented in a programmable logic device (PLD) in order to provide maximum flexibility of the circuit. Refer to [Sources of Reset on page 86](#) for a summary of potential reset sources.

#### 4.3.4.15 MV64360 MPP Configuration

The MV64360 contains a 32-bit multi-purpose port (MPP). The MPP pins can be configured as general purpose I/O pins, as external interrupt inputs, or as specific control/status pins for one of the MV64360 internal devices. After reset, all MPP pins default to general purpose inputs. Software must then configure each of the pins for the desired function. The following table defines the function assigned to each MPP pin on the CPCI-6115 board.

Table 4-2 MV64360 MPP Pin Function Assignments

MPP Pin Number	Input/Output	Function
0	I	COM1 /COM2 interrupts (ORed)
1	I	Unused (optionally 21555 interrupt can be routed here)
2	I	Abort interrupt
3	I	RTC and Temperature Sensor interrupts (ORed)
4	I	Unused
5	I	Unused
6	I	MV64360 WDNMI# interrupt
7	I	BCM5421S PHY interrupts (ORed)
MPP[7:0] Interrupts		
8	O	PCI Bus 1.0 - 21555 Bridge grant
9	I	PCI Bus 1.0 - 21555 Bridge request
10	O	PCI Bus 1.0 - PMC 1 secondary grant (GNTB#)
11	I	PCI Bus 1.0 - PMC 1 secondary request (REQB#)
12	O	PCI Bus 1.0 - PCI646U2 IDE Controller grant
13	I	PCI Bus 1.0 - PCI646U2 IDE Controller request
14	O	PCI Bus 1.0 - PMC 1 grant
15	I	PCI Bus 1.0 - PMC 1 request
MPP[15:8] PCI_1 Arbitration Request-Grant Pairs		
16	I	PCI Bus 1.0 Interrupts - PMC1 INTA#, PMC1 INTC#, 21555
17	I	PCI Bus 1.0 Interrupts - PMC1 INTB#, PMC1 INTD#, IDE
18	I	PCI Bus 0.0 Interrupts - PMC2 INTA#, PMC2 INTC#
19	I	PCI Bus 0.0 Interrupts - PMC2 INTB#, PMC2 INTD#
20	I	CompactPCI Bus Interrupts - INTA#
21	I	CompactPCI Bus Interrupts - INTB#

Table 4-2 MV64360 MPP Pin Function Assignments (continued)

MPP Pin Number	Input/Output	Function
22	I	CompactPCI Bus Interrupts - INTC#
23	I	CompactPCI Bus Interrupts - INTD#
MPP[17:16] PCI_1 Interrupts MPP[19:18] PCI_0 Interrupts, MPP[23:20] CompactPCI Interrupts		
24	O	MV64360 SROM initialization active (InitAct)
25	O	Watchdog Timer Expired output (WDE#)
26	O	Watchdog Timer NMI output (WDNMI#)
27	I	Unused
28	O	PCI Bus 0.0 - PMC 2 secondary grant (GNTB#)
29	I	PCI Bus 0.0 - PMC 2 secondary request (REQB#)
30	O	PCI Bus 0.0 - PMC 2 grant
31	I	PCI Bus 0.0 - PMC 2 request
MPP[27:24] Miscellaneous MPP[31:28] PCI_0 Arbitration Request-Grant Pairs		

#### 4.3.4.16 MV64360 Reset Configuration

The MV64360 supports two methods of device initialization following reset:

- Pins sampled on the deassertion of reset
- Partial pin sample on deassertion of reset plus serial ROM initialization via the I<sup>2</sup>C bus for user defined initialization.

The CPCI-6115 board supports both options. An onboard jumper setting is used to select the option. If the pin sample only method is selected, then states of the various pins on the device AD bus are sampled when reset is deasserted to determine the desired operating modes. The following table describes the configuration options. Combinations of pullups, pulldowns and jumpers are used to set the options. Some options are fixed and some are selectable at build time by installing the proper pullup/pulldown resistor. Finally, some options may be selected using an onboard jumper. Each option is described in the following table.

Using the SROM initialization method, any of the MV64360 internal registers or other system components (that is, devices on the PCI bus) can be initialized. Initialization takes place by sequentially reading 8 byte address/data pairs from the SROM and writing the 32-bit data to the decoded 32-bit address until the data pattern matching the last serial data item register is read from the SROM (default value 0xffffffff). An 8 KB EEPROM is provided onboard for this user defined initialization of the MV64360.

The default settings are indicated by bold cell ruling.

Table 4-3 MV64360 Power-Up Configuration Settings

Device AD Bus Signal	Select Option	Default Power-Up Setting	Description	State of Bit vs. Function	
AD[0]	Jumper	X	SRAM Initialization	0	No SRAM initialization
				1	SRAM initialization enabled
AD[1]	Resistor	1	DRAM Pads Calibration	0	Calibration Disabled
				1	Calibration Enabled
AD[3:2]	Resistors	10	SRAM Device Address	00	1010000 (\$A0)
				01	1010001 (\$A2)
				10	1010010 (\$A4)
				11	1010011 (\$A6)
AD[4]	Fixed	1	Internal 60x Bus Arbiter	0	Internal arbiter disabled
				1	Internal arbiter enabled
AD[5]	Resistor	1	Internal Space Default Address	0	0x1400.0000
				1	0xf100.0000
AD[7:6]	Jumpers	01	CPU Bus Configuration	00	60x bus mode
				01	MPX bus mode
				10	Reserved
				11	Reserved
AD[8]	Resistor	1	CPU Pads Calibration	0	Calibration Disabled
				1	Calibration Enabled
AD[9]	Fixed	0	Multiple MV64360 Support	0	Not supported
				1	Supported
AD[12]	Resistor	1	PCI_0 Pads Calibration	0	Calibration Disabled
				1	Calibration Enabled
AD[13]	Resistor	1	PCI_1 Pads Calibration	0	Calibration Disabled
				1	Calibration Enabled
AD[15:14]	Resistors	10	BootCS* Device Width	00	8 bits
				01	16 bits
				10	32 bits
				11	Reserved
AD[16]	Resistor	1	PCI Retry	0	Disable
				1	Enable
AD[17]	Fixed	1		1	Must pull high

Table 4-3 MV64360 Power-Up Configuration Settings (continued)

Device AD Bus Signal	Select Option	Default Power-Up Setting	Description	State of Bit vs. Function	
AD[18]	Resistor	1	DRAM Clock Select	0	DRAM is running at a higher frequency than the core clock
				1	DRAM is running at a same frequency as the core clock
AD[19]	Resistor	0	DRAM Address/Control Delay	0	DRAM address and control signals toggle on falling edge of DRAM clock
				1	DRAM address and control signals toggle on rising edge of DRAM clock
AD[21:20]	Resistors	11	DRAM control path pipeline select	00	Reserved
				01	Reserved
				10	Two pipe stages
				11	Three pipe stages
AD[24:22]	Resistors	000	DRAM read path control	000	DRAM running in sync mode
				100	
				001	DRAM running in async mode
				111	
AD[25]	Fixed	0	Gigabit port2 Enable	0	Disable
				1	Enable
AD[28:26]	Resistors	000	PCI_1 DLL control	000	DLL disable
				001	Conventional PCI mode at 66MHz
				101	PCI-X mode at 133 MHz
				110	PCI-X mode at 66 MHz
AD[31:29]	PLD	101	PCI_0 DLL control	000	DLL disable
				001	Conventional PCI mode at 66MHz
				101	PCI-X mode at 133 MHz
				110	PCI-X mode at 66 MHz
TxD0[0]	Resistor	0	Gigabit port0 GMII/PCS Select	0	MII/GMII
				1	PCS
TxD1[0]	Resistor	0	Gigabit port1 GMII/PCS Select	0	MII/GMII
				1	PCS
TxD2[0]	Resistor	0	Gigabit port2 GMII/PCS Select	0	MII/GMII
				1	PCS



Table 4-3 MV64360 Power-Up Configuration Settings (continued)

Device AD Bus Signal	Select Option	Default Power-Up Setting	Description	State of Bit vs. Function	
WE[3:0], DP[3:0]	X	X	DRAM PLL N Divider [7:4], [3:0]	X	Not used in sync mode
BADR[0]	Resistor	1	DRAM PLL NP	X	Not used in sync mode
BADR[1]	Resistor	1	DRAM PLL HIKVCO	X	Not used in sync mode
BADR[2]	Resistor	1	DRAM PLL NP	0	PLL power down
				1	PLL power up (normal operation)
TxD0[6:1]	X	X	DRAM PLL M Divider	X	Not used in sync mode
TxD0[7]	Resistor	0	JTAG Pad Calib Bypass	0	Normal Operation
				1	Bypass pad calibration
TxD1[1]	Resistor	0	Core PLL Bypass	0	Normal Operation
				1	Bypass the core's PLL
TxD1[4:2]	Resistors	000	Core PLL Control	000	Tuning of the core PLL clock tree.

### 4.3.5 System Memory

The CPCI-6115 consists of up to three banks of Double-Data-Rate SDRAMs. DDR SDRAM supports two data transfers per clock cycle. The base memory device is a standard monolithic DDR SDRAM, 8-bits wide, in a 66-pin TSOPII package. The CPCI-6115 can be populated with up to three banks of memory onboard (nine devices per bank). One or two banks can be populated with standard single DDR devices. If three banks are populated, chip-stacking technology is used on the top side to accommodate two banks in a single-bank footprint. When using the stacked parts, the two stacked banks (0 and 2) are identical, so a single SPD EEPROM is used for them.

All memory configurations operate at DDR226 (133 MHz CLK).

Table 4-4 System Memory Options

Organization	Memory Device	Device Size	Bank Size
32 MB x 8	K4H560838F-TCB3 (133 MHz, CL=2.5)	256 MB	256 MB
64 MB x 8	K4H510838B-TCB3 (133 MHz, CL=2.5)	512 MB	512 MB
128 MB x 8	K4H1G0738M-TCB0 (133 MHz, CL=2.5)	1 GB	Two banks of 512 MB
	K4H1G0838M-TCB0 (133 MHz, CL=2.5)		

### 4.3.6 Flash Memory

The CPCI-6115 contains two banks of flash memory accessed via the device controller bus contained within the MV64360 chip. Bank B consists of two Intel StrataFlash +3.3 V devices, configured to operate in 16-bit mode, to form a 32-bit flash bank. Bank B provides a minimum of 8 MB of flash memory.

Bank A consists of two Intel StrataFlash +3.3 V devices, configured to operate in 16-bit mode, to form a 32-bit flash bank. The following table defines the flash type and size options for Bank A. The CPCI-6115 standard product is built with the 128 megabit devices. These Intel StrataFlash devices support page read mode operations with a 8-byte page size per device.

*Table 4-5 Bank A Flash Options*

Flash Bank Size	Intel Part Number	Device Size
8 MB	28F320J3D	32 megabit
16 MB	28F640J3D	64 megabit
32 MB	28F128J3D	128 megabit
64 MB	28F256P3	256 megabit

Since the StrataFlash initial access time is 150ns, onboard hardware is used to guarantee initial access timing using the Device port READY# signal.

A flash write protect header is provided on the CPCI-6115 to enable write protection of the entire Bank A flash via the device VPEN pins when the jumper is not installed. Bank A write protection can also be enabled by software using the System Register 2 FLASH\_WP bit in the MV64360 when the jumper is installed.

There is a boot bank select jumper on the CPCI-6115 that selects either Flash Bank A or Bank B as the boot bank. This jumper effectively routes the MV64360 BOOTCS# pin to either Bank A/Bank B and chip select CS0# to the other bank (Bank B/Bank A).

### 4.3.7 NVRAM, Real-Time Clock, Watchdog Timer

An SGS-Thompson M48T37V device is connected to the MV64360 device controller bus. This device provides 32 KB of nonvolatile static RAM, a real-time clock and a watchdog function. Refer to the M48T37V Data Sheet for programming information. The M48T37V consists of two parts:

- One 44-pin 330mil SO device that contains the RTC, the oscillator, the power fail detection, the watchdog timer logic, 32 KB of SRAM and gold-plated sockets for the SNAPHAT battery.
- One SNAPHAT that houses the battery and the crystal.

The SNAPHAT package is mounted on top of the SO MT48T37V device after the completion of the surface mount process.

The watchdog timer can generate a timeout period of 62.5 msec to 128 seconds. The output of the watchdog timer can be programmed to generate an interrupt or reset the board if enabled.

## 4.3.8 TL16C550C UART Devices

The CPCI-6115 board contains two Texas Instruments TL16C550C UART devices connected to the MV64360 device controller bus to provide asynchronous serial communication ports. Serial port COM1 can be routed to connector J5 for rear-panel I/O, or through EIA-232 drivers and receivers to an RJ-45 connector on the front panel. When used with a rear transition module (RTM), the routing is selectable via a jumper on the RTM. When routed to J5, the COM1 signals are TTL-level signals. The TTL-level signals for serial port COM2 are routed only to connector J5. Both ports are wired as DTE and have a maximum data rate of 115 Kbaud. A 1.8432 MHz oscillator provides the reference clock for the UARTs. The external (front-panel) signals for COM1 are ESD protected.

## 4.3.9 System Registers

The CPCI-6115 provides all of the system registers specified in the *MCPN905 CompactPCI Single Board Computer Programmer's Reference Guide*, listed in [Appendix A, Related Documentation](#). Refer to that document for additional details.

## 4.3.10 Serial EEPROM Devices

The CPCI-6115 board contains three 8 KB serial EEPROM devices onboard: one provides Vital Product Data (VPD) storage of the module hardware configuration, one provides storage for user configuration data, and the third (optional) provides initialization information for the MV64360 device.

The CPCI-6115 also has up to two 256-byte serial EEPROM devices onboard. These 256-byte devices provide for Serial Presence Detect (SPD) configuration information for the banks of DDR SDRAM. One SPD device is used to define the characteristics of banks 0 and 2 since these (stacked) banks must be identical. A separate SPD devices is used for bank 1. The contents of the 256-byte devices are accessed using standard one-byte addressing.

## 4.3.11 PCI Bus 0.0

On the CPCI-6115, PCI Bus 0.0 is connected only to PMC 2 and will support 32/64-bit transfers at 66/133 MHz PCI-X or 33/66 MHz PCI.

PCI bus 0.0 is compliant to PCI-X Revision 1.0a and PCI Revision 2.2. VIO is user-selectable between +3.3 V and +5 V by positioning the PMC2 keying pin at the +3.3 V or +5 V site.

## 4.3.12 PCI Bus 1.0

On the CPCI-6115, PCI Bus 1.0 is connected to PMC 1, the CMD PCI646U2 IDE controller and the Intel 21555 PCI-to-PCI bridge.

This bus is limited to 32-bit operation. This is because the upper address/data lines of PCI Bus 1.0 are multiplexed with the third Ethernet port on the MV64360 device.

This bus is limited to 33 MHz PCI because the IDE controller is a 33 MHz-only device. PCI Bus 1.0 is compliant to PCI Revision 2.1. VIO is limited to +5 V only. Do not alter the location of PMC1 keying pin.

### 4.3.13 IDE Controller

The CPCI-6115 uses the CMD Technology PCI646U2 IDE Controller to provide a single IDE channel for external storage devices. The IDE Controller supports ATA/33 transfer rates. This IDE channel is routed to connector J5 for rear-panel I/O or to a transition module. The transition module allows connection of an IDE hard disk or CompactFlash module.

The PCI646U2 PCI-IDE Controller is a 32-bit/33 MHz PCI device and is the limiting device when determining the operating frequency of PCI bus 1.0.

### 4.3.14 Intel 21555 PCI-to-PCI Bridge

The CPCI-6115 uses the Intel 21555 PCI-to-PCI bridge, which is connected to PCI bus 1.0. The 21555 bridge is compliant to PCI Revision 2.2. The following are key features of the 21555:

- Non-transparent PCI-to-PCI bridge
- Mixed-frequency bus operation (33/66 MHz PCI on either primary or secondary)
- CompactPCI hot-swap compliant
- Secondary bus arbiter (not used on CPCI-6115)
- +3.3 V I/O, +5 V tolerant

The 21555 provides a MicroWire serial ROM interface. On power-up or reset, the 21555 can load its configuration registers from a serial EEPROM on this interface. A 512-byte (93LC66A) device is present on the CPCI-6115 for this purpose.

### 4.3.15 CompactPCI Bus

The CompactPCI bus interface is implemented using the 21555 bridge with a 32-bit secondary data bus (local side - PCI bus 1.0) and a 64-bit primary data bus (CompactPCI side). The 21555 supports +3.3 V or +5 V signalling at the CompactPCI bus, allowing the CPCI-6115 to operate in a +3.3 V or +5 V chassis.

The CPCI-6115 is designed for use in a CompactPCI peripheral slot, so the 21555 non-transparent bridge is used. The CPCI-6115 receives the CompactPCI clock, reset and bus grant signals, and generates bus requests and interrupts as a peripheral board.

The CPCI-6115 supports a 33/66 MHz PCI interface to the CompactPCI backplane.

### 4.3.16 PMC Slots

The CPCI-6115 CPU board contains four EIA-E700 AAAB connectors for each PMC slot. These connectors provide a PCI interface to two IEEE P1386.1-compliant PMC slots. Connectors J11-J13 and J21-J23 provide the PCI interface while J14 and J24 provide a user I/O path from the PMC slots to the CompactPCI backplane. PMC user I/O signals are routed

from the PMC J14 connector to the CompactPCI J3 I/O connector while the PMC J24 connector signals are routed to the CompactPCI J5 I/O connector. Both PMC I/O connectors are routed to their respective CompactPCI I/O connector following the PIM differential signalling recommendations. The CPCI-6115 front panel allows for front I/O through the PMC faceplate.

PMC slot 1 supports:

- Mezzanine Type: PMC = PCI Mezzanine Card
- Mezzanine Size: S1B = Single width and standard depth (75mm x 150mm) with front panel
- PMC Connectors: J11, J12, J13, and J14
- Signaling Voltage: +5 V
- Supported modes: 32-bit, 33 MHz PCI
- I/O: front panel and CompactPCI J3 rear panel

PMC slot 2 supports:

- Mezzanine Type: PMC = PCI Mezzanine Card
- Mezzanine Size: S1B = Single width and standard depth (75mm x 150mm) with front panel
- PMC Connectors: J21, J22, J23, and J24
- Signaling Voltage: Vio = +3.3 V (+5 V tolerant) or +5 V, selected by keying pin
- Supported modes: 32/64-bit 33/66 MHz PCI or 66/133 MHz PCI-X
- I/O: front panel and CompactPCI J5 rear panel

In addition, the PMC connectors are located such that a double width PMC may be installed in place of two single PMCs.

In this case, the CPCI-6115 supports:

- Mezzanine Type: PMC = Mezzanine Card
- Mezzanine Size: double width and standard depth (150mm x 150mm) with front panel
- PMC Connectors: J11, J12, J13, J14, J21, J22, J23, J24
- Signaling Voltage: +5 V
- Supported modes: 32-bit 33 MHz PCI
- I/O: front panel and CompactPCI J3 rear panel

The following special-function processor PMC pins, as defined by the draft Processor PMC Standard VITA 32-199x, are implemented on the CPCI-6115 as described in the following sections.

*Table 4-6 Processor PMC Support*

PrPMC Signal	Support
PRESENT#	The PRESENT# signal from each PMC slot is used to detect the presence of a PMC. The state of this bit is readable in the board Presence Detect Register.

Table 4-6 Processor PMC Support (continued)

PrPMC Signal	Support
MONARCH#	The CPCI-6115 leaves the MONARCH# pin floating, causing any installed processor PMC to operate as a slave module. Processor PMC monarch mode is not supported.
IDSELB	These IDSELB pins are resistively coupled to the appropriate PCI AD pins.
REQB#	These REQB# pins are routed to the appropriate PCI bus arbiters.
GNTB#	These GNTB# pins are routed to the appropriate PCI bus arbiters.
M66EN	The CPCI-6115 has a weak pull-up on this signal. If this signal is grounded, as it is when a 33 MHz PMC module is installed, it will force the corresponding PCI bus to 33 MHz operation. If the signal remains high, this will allow 66 MHz operation.
RESETOUT_L	The CPCI-6115 does not make any connection to RESETOUT_L.
EReady	The EREADY signals from each PMC are routed board Presence Detect Register for software readability.

## 4.4 Miscellaneous

The following described functions and features are also part of the CPCI-6115.

### 4.4.1 Clock Generation

The CPCI-6115 synchronizes its CompactPCI bus interface to the received PCI clock from the J1-D6 connector pin. Onboard logic determines the CompactPCI operating mode by looking at the state of the CompactPCI M66EN and PCIXCAP signals at the end of reset. The onboard clock generator is then configured to provide the necessary clocks for the CompactPCI interface. All other clocks for onboard resources are generated locally.

### 4.4.2 Interrupt Handling

The following sections further describe CPCI-6115 interrupt-related topics.

### 4.4.2.1 MV64360 Interrupt Controller

The CPC1-6115 uses the MV64360 interrupt controller to route internal and external interrupt requests to the CPU and the PCI bus. The MV64360 interrupt controller registers are implemented as part of the CPU interface unit in order to have minimum read latency from CPU interrupt handler. The external interrupt sources use the GPP interface to register external interrupts. The following table shows the CPC1-6115 interrupt assignment to MV64360 GPP pins:

Table 4-7 MV64360 Interrupt Assignments

GPP Group	MV64360	Edge/L evel	Polarity	Interrupt Source	Notes
0	GPP[0]	Level	High	COM1    COM2	3
	GPP[1]	Level	Low	Unused	
	GPP[2]	Level	Low	ABORT#	
	GPP[3]	Level	Low	RTC    Thermostat output	6
	GPP[4]	Level	Low	Unused	
	GPP[5]	Level	Low	Unused	
	GPP[6]	Level	Low	MV64360 WDNMI# interrupt	
	GPP[7]	Level	Low	BCM5421S PHY 1 INTR#    BCM5421S PHY 2 INTR#    BCM5421S PHY 3 INTR#	
2	GPP[16]	Level	Low	PCI Bus 1.0 - PMC1 INTA#, PMC1 INTC#, 21555	2
	GPP[17]	Level	Low	PCI Bus 1.0 - PMC1 INTB#, PMC1 INTD#, IDE	2
	GPP[18]	Level	Low	PCI Bus 0.0 - PMC2 INTA#, PMC2 INTC#	1
	GPP[19]	Level	Low	PCI Bus 0.0 - PMC2 INTB#, PMC2 INTD#	1
	GPP[20]	Level	Low	CompactPCI Bus - INTA#	5
	GPP[21]	Level	Low	CompactPCI Bus - INTB#	5
	GPP[22]	Level	Low	CompactPCI Bus - INTC#	5
	GPP[23]	Level	Low	CompactPCI Bus - INTD#	5
3	GPP[24]			Reserved for SROM initialization active InitAct output	
	GPP[25]			Reserved for Watchdog Timer WDE# output	
	GPP[26]			Reserved for Watchdog Timer WDNMI# output	
	GPP[27]			Reserved for future device interrupt	

These notes apply to [Table 4-7](#).

1. The interrupting device is addressed from the MV64360 PCI Bus 0.0.
2. The interrupting device is addressed from the MV64360 PCI Bus 1.0

3. The interrupting device is addressed from the MC64360 Device Bus.
4. The interrupting device is addressed from the MV64360 I<sup>2</sup>C Bus.
5. The interrupting device is addressed from the MV64360 PCI Bus 1.0 through the 21555 PCI-to-PCI bridge.
6. The DS1621 Digital Thermometer and Thermostat provides 9-bit temperature readings which indicate the temperature of the device. The thermal alarm output, TOUT, is active when the temperature of the device exceeds a user defined temperature TH.

#### 4.4.2.2 Sources of Reset

The CPCI-6115 SBC provides reset control from a programmable logic device (PLD) to provide maximum flexibility of the circuit design. A hard reset is defined as a reset of all onboard circuitry including the PowerPC hard reset and reset of all onboard peripheral devices. A soft reset is defined as a reset of the PowerPC. The CPCI-6115 has these listed sources of reset:

- Power-On/undervoltage reset
- Front panel reset switch
- CompactPCI RESET# signal
- MV64360 Watchdog Timer
- M48T37V Watchdog Timer
- System Control Register bit

The Processor RiscWatch HRESET# signal can cause a CPU-only reset.

#### 4.4.2.3 Machine Check

The processor MCP# signal is pulled high (inactive).

#### 4.4.2.4 Soft Reset

The processor SRESET# signal is connected only to the RiscWatch header.

#### 4.4.2.5 SMI

The processor SMI# is pulled high (inactive).

#### 4.4.2.6 Other Software Considerations

The following issues also apply to this board.

The MV64360 supports a big endian CPU bus. The endianness of the local memory (DDR and SRAM) is also big endian. Data transferred to/from the local memory is NEVER swapped. The internal registers of the MV64360 are always programmed in Little Endian. On a CPU access to the internal registers, data is byte swapped.

Data swapping on a CPU access to the PCI is controlled via PCISwap bits of each PCI Low Address register. This configurable setting allows a CPU access to PCI agents with a different endianness convention.



For software compatibility with the GT-64120/130 devices, the MV64360 maintains MByteSwap and MWordSwap bits in the PCI Command register. If the PCI Command register's MSwapEn bit is set to "1", the MV64360 PCI master performs data swapping according to PCISwap bits setting. If set to "0" (default), it works according to MByteSwap and MWordSwap bits setting, as in the GT-64120/130 devices.

Refer to the MV64360 data sheet for additional information and programming details.

### 4.4.3 Onboard Power Supplies

The CPCI-6115 CPU board requires +5 V and +3.3 V input power. The +/-12 V input voltages are optional and are routed to the PMC slots. All other required voltages are generated onboard from the +3.3 V or +5 V power. The processor core voltage regulator has a variable output which is set using feedback resistors. In addition to the processor core voltage regulator, there are regulators for +1.8 V, +2.5 V, CPU\_VIO, +1.25 V and L3\_VIO.

### 4.4.4 Hot Swap Support

The CPCI-6115 provides hardware to support the physical connection process and the hardware connection process of the full hot swap system model defined in the *CompactPCI Hot-Swap Specification PICMG 2.1 R2.0*. Hot swap support is only applicable when the CPCI-6115 is installed into a CompactPCI peripheral slot.

### 4.4.5 Hot Swap Process

The CPCI-6115 may be safely inserted and extracted from a hot-swap system chassis while power is applied. Hot-swap circuitry protects the board from electrical damage.

The BD\_SEL# signal from CPCI bus J1 pin D15 must be driven true (low) for the back end power supplies to switch on. When BD\_SEL# is not asserted only a small portion of the CPCI-6115 circuitry is powered.

For a system without +/-12 V, the HLT# signal is driven true (low) to the CPCI bus J1 pin B4 when the +5.0 V and +3.3 V input power supplies are within tolerance. For a system with +/-12 V, these supply voltages can also be monitored and included into the HLT# signal generation. A jumper selects whether the +/-12 V should be monitored in this way. The HLT# signal can be used as a status indicator.

### 4.4.6 Intel 21555 Hot Swap Support

The 21555 Bridge contains a CompactPCI Hot Swap Control Register which includes the following functions:

- The 21555 drives the ENUM# signal during a hot-swap event if the ENUM# Interrupt Mask (ENUM\_MASK) bit in the CompactPCI Hot-Swap Control Register is cleared.
- The 21555 supports the LED On/OFF (LOO) status/control bit in the CompactPCI Hot Swap Control Register which enables the host to determine the status of the blue Hot Swap LED and/or force the LED on.

- The 21555 contains an Removal Status bit (REM\_STAT) in the CompactPCI Hot Swap Control Register to indicate an impending hot swap event.
- The 21555 contains an Insertion Status bit (INS\_STAT) in the CompactPCI Hot Swap Control Register to indicate that the serial preload is complete and the Primary Lockout bit has been cleared, indicating that the card is ready for host initialization.

## 5.1 Overview

This chapter provides hardware preparation and installation instructions for the CPCI-6115-MCPTM transition module. Refer to [Chapter 3, Controls, LEDs, and Connectors](#) for pin assignments.

The CPCI-6115-MCPTM transition module provides additional I/O capabilities to the CPCI-6115 SBC. The transition module is installed directly in the CompactPCI backplane in the rear transition board bay of the chassis and interfaces with the CPCI-6115 SBC through the J3 and J5 connectors.

Rear panel connectors on the CPCI-6115-MCPTM include one of two configurations: two RJ-45 connectors for 10/100/1000BaseTx Ethernet and one RJ-45 connector for asynchronous serial port, COM1 (CompactPCI version); or four RJ-45 connectors for asynchronous serial ports, COM1, COM2, COM3 and COM4 (MXP version). **Only COM1 and COM2, however, are available on the CPCI-6115 SBC for use with the transition module.** An additional two serial ports and the one EIDE channel are available on J3 and J5 from the baseboard.

The transition module supports two single-wide (74mm wide by 69mm long) PMC I/O modules. PMC I/O pins 1 through 64 of each PMC slot on the CPCI-6115 SBC are routed from the J3 and J5 connectors to the PMC I/O (PIM1 and PIM2) on the transition module. For a detailed description of PMC I/O modules refer to the section titled [PMC I/O Modules on page 104](#).

Before installing your transition module, ensure that you have performed all tasks as described in [Chapter 2, Hardware Preparation and Installation](#) for installing the CPCI-6115 prior to configuring and installing the transition module.

## 5.2 Block Diagram

The block diagram for the CPCI-6115-MCPTM is shown in the following figure.

Figure 5-1 CPCI-6115-MCPTM Block Diagram

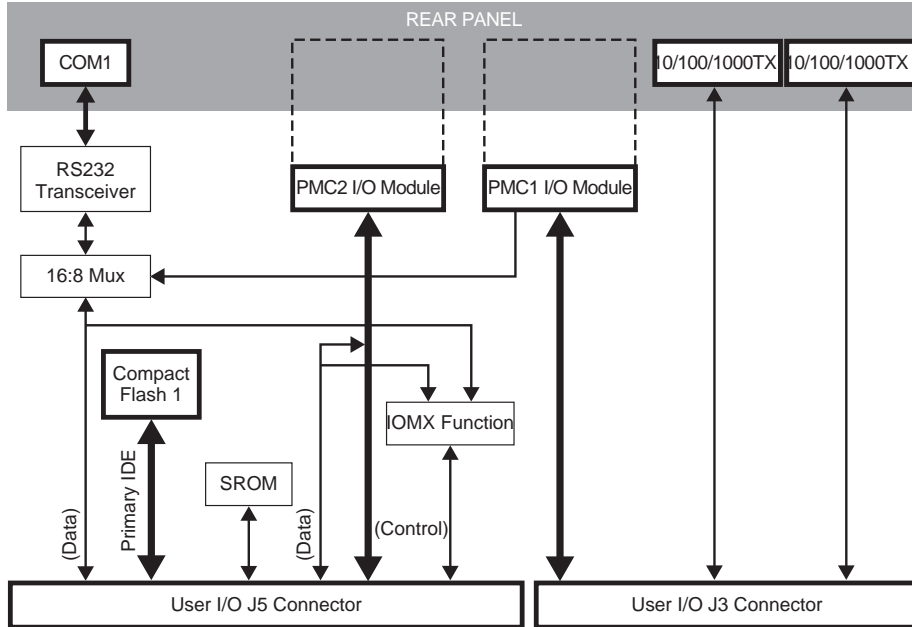

## 5.3 Preparing the Transition Module

The CPCI-6115-MCPTM (refer to [Figure 5-2](#)) is used in conjunction with the CPCI-6115 baseboard. It includes the following features (IP version):

*Figure 5-2 Connector and Header Locations (MXP Version)*

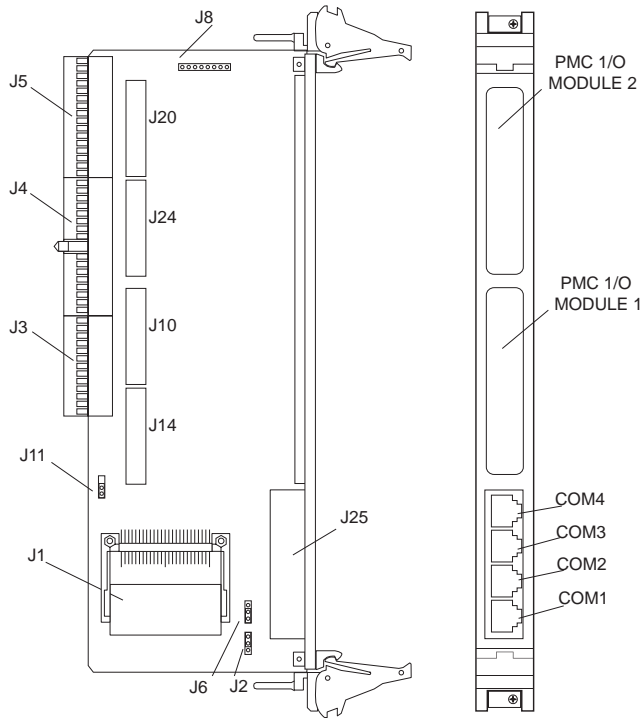

- One 50-pin Type II connector for IDE CompactFlash cards or microdrives
- Two PMC I/O modules (PIM)
- Four asynchronous serial ports (COM1, COM2, COM3 and COM4)
- I/O signal multiplexing (IOMUX)

## 5.4 Rear Panel Connectors

The rear panel port connectors on the CPCI-6115-MCPTM are listed in [Table 5-1](#) and shown in [Figure 5-2 on page 91](#). Refer to [Table 5-10 on page 100](#) for connector pinout information.

*Table 5-1 CPCI-6115-MCPTM Rear Panel Connectors*

Type	Number	Description
Serial Ports	J25	Routed to four RJ-45 connectors for COM1, COM2, COM3, and COM4 connections (MXP version). Note: COM3 and COM4 are not used.

## 5.5 On-Board Connectors and Headers

The following table lists the connectors and headers on the CPCI-6115-MCPTM. Use the links in the Location column to find the connector descriptions and pin assignments or jumper settings.

*Table 5-2 On-Board Connectors and Headers*

Connector/Header	Location
CPCI-6115-MCPTM IDE CompactFlash Connector (J1)	<a href="#">Table 5-3 on page 93</a>
CPCI-6115-MCPTM PMC I/O Module 1 - Host I/O Connector (J10)	<a href="#">Table 5-4 on page 94</a>
CPCI-6115-MCPTM PMC I/O Module 2 - Host I/O Connector (J20)	<a href="#">Table 5-5 on page 95</a>
CPCI-6115-MCPTM PMC I/O Modules 1 & 2 - PMC I/O (J14/J24)	<a href="#">Table 5-6 on page 96</a>
CPCI-6115-MCPTM CompactPCI User I/O Connector (J3)	<a href="#">Table 5-7 on page 97</a>
CPCI-6115-MCPTM CompactPCI User I/O Connector (J5)	<a href="#">Table 5-8 on page 98</a>
CPCI-6115-MCPTM 10/100/1000BaseTx Connectors	<a href="#">Table 5-9 on page 100</a>
COM1 Header (J6)	<a href="#">COM1 and COM2 Asynchronous Serial Ports Jumpers on page 102</a>
COM2 Header (J11)	<a href="#">COM1 and COM2 Asynchronous Serial Ports Jumpers on page 102</a>
CompactFlash Selection Header (J2)	<a href="#">CompactFlash Jumper on page 102</a>

## 5.5.1 IDE CompactFlash Connector

One 50-pin Type II CompactFlash card header connector located on both standard and MXP versions of the CPCI-6115-MCPTM transition module provides the IDE interface to one CompactFlash plug-in module. This CompactFlash interface is connected to the primary IDE channel. The pin assignments for these connectors are as follows:

Table 5-3 CompactFlash IDE Connector Pin Assignments, J1

Pin	J1		Pin
1	GND	NO CONNECT	26
2	DD3	DD11	27
3	DD4	DD12	28
4	DD5	DD13	29
5	DD6	DD14	30
6	DD7	DD15	31
7	CS1FX1_L	CS3FX1_L	32
8	GND	NO CONNECT	33
9	GND	DIOR_L	34
10	GND	DIOW_L	35
11	GND	+5 V	36
12	GND	INTRQ1	37
13	+5 V	+5 V	38
14	GND	MASTER/SLAVE	39
15	GND	NO CONNECT	40
16	GND	DRESET_L	41
17	GND	DIORDY	42
18	DA2	NO CONNECT	43
19	DA1	+5 V	44
20	DA0	DASP	45
21	DD0	PDIAG	46
22	DD1	DD8	47
23	DD2	DD9	48
24	NO CONNECT	DD10	49
25	NO CONNECT	GND	50

## 5.5.2 PMC I/O Module Connectors

There are two pairs of 64-pin surface mount connectors on both the standard and MXP version of the CPCI-6115-MCPTM to provide an interface for two optional add-on PMC I/O modules. Each module has an identical PMC I/O connector and a unique Host I/O connector. All serial port signals are at TTL levels. The pin assignments are as follows:

On the host I/O connectors, a PMC I/O module only uses power, ground and the OUT-going serial port pins. A host I/O module could potentially use all pins except the OUT-going serial port.



**On the PMC I/O connector, pin meaning is defined entirely by the PMC residing on the host. A host I/O module would not use any pins on this connector.**

### 5.5.2.1 Host IO Connectors

Table 5-4 PMC I/O Module 1 - Host I/O Connector Pin Assignments, J10

Pin	J10		Pin
1	IN1_DCD	+12 V	2
3	IN1_RXD	IN1_TXD	4
5	+5 V	IN1_DTR	6
7	IN1_DSR	IN1_RTS	8
9	IN1_CTS	+3.3 V	10
11	IN1_RI	IN2_DCD	12
13	GND	IN2_RXD	14
15	IN2_TXD	IN2_DTR	16
17	IN2_DSR	GND	18
19	IN2_RTS	IN2_CTS	20
21	+5 V	IN2_RI	22
23	Not Connected	Not Connected	24
25	Not Connected	+3.3 V	26
27	Not Connected	Not Connected	28
29	GND	Not Connected	30
31	Not Connected	Not Connected	32
33	Not Connected	GND	34
35	Not Connected	Not Connected	36
37	+5 V	Not Connected	38
39	Not Connected	Not Connected	40
41	Not Connected	+3.3 V	42
43	Not Connected	Not Connected	44
45	GND	Not Connected	46



Table 5-4 PMC I/O Module 1 - Host I/O Connector Pin Assignments, J10 (continued)

Pin	J10		Pin
47	Not Connected	Not Connected	48
49	Not Connected	GND	50
51	Not Connected	Not Connected	52
53	+5 V	OUT_DCD	54
55	OUT_DTR	Not Connected	56
57	OUT_CTS	+3.3 V	58
59	OUT_RTS	OUT_RXD	60
61	-12 V	OUT_TXD	62
63	I2C_CLK	I2C_DATA	64

Table 5-5 PMC I/O Module 2 - Host I/O Connector Pin Assignments, J20

Pin	J20		Pin
1	Not Connected	+12 V	2
3	DD3	DD11	4
5	+5 V	DD4	6
7	DD12	DD5	8
9	DD13	+3.3 V	10
11	DD6	DD14	12
13	GND	DD7	14
15	DD15	CS1FX1_L	16
17	CS3FX1_L	GND	18
19	DIOR_L	DIOW_L	20
21	+5 V	DINTRQ1	22
23	MASTER/SLAVE	DRESET_L	24
25	IORDY	+3.3 V	26
27	DA2	DA1	28
29	GND	DA0	30
31	DASP	DD0	32
33	PDIAG	GND	34
35	DD1	DD8	36
37	+5 V	DD2	38
39	DD9	DD10	40
41	Not Connected	+3.3 V	42
43	Not Connected	Not Connected	44
45	GND	Not Connected	46

Table 5-5 PMC I/O Module 2 - Host I/O Connector Pin Assignments, J20 (continued)

Pin	J20		Pin
47	Not Connected	Not Connected	48
49	Not Connected	GND	50
51	Not Connected	Not Connected	52
53	+5 V	OUT_DCD	54
55	OUT_DTR	Not Connected	56
57	OUT_CTS	+3.3 V	58
59	OUT_RTS	OUT_RXD	60
61	-12 V	OUT_TXD	62
63	I2C_CLK	I2C_DATA	64

### 5.5.2.2 PMC I/O Connectors

Table 5-6 PMC I/O Modules 1 and 2 - PMC I/O Connector Pin Assignments, J14/J24

Pin	J14/J24		Pin
1	PMC IO1	PMC IO2	2
3	PMC IO3	PMC IO4	4
5	PMC IO5	PMC IO6	6
7	PMC IO7	PMC IO8	8
9	PMC IO9	PMC IO10	10
11	PMC IO11	PMC IO12	12
13	PMC IO13	PMC IO14	14
15	PMC IO15	PMC IO16	16
17	PMC IO17	PMC IO18	18
19	PMC IO19	PMC IO20	20
21	PMC IO21	PMC IO22	22
23	PMC IO23	PMC IO24	24
25	PMC IO25	PMC IO26	26
27	PMC IO27	PMC IO28	28
29	PMC IO29	PMC IO30	30
31	PMC IO31	PMC IO32	32
33	PMC IO33	PMC IO34	34
35	PMC IO35	PMC IO36	36
37	PMC IO37	PMC IO38	38
39	PMC IO39	PMC IO40	40

Table 5-6 PMC I/O Modules 1 and 2 - PMC I/O Connector Pin Assignments, J14/J24 (continued)

Pin	J14/J24		Pin
41	PMC IO41	PMC IO42	42
43	PMC IO43	PMC IO44	44
45	PMC IO45	PMC IO46	46
47	PMC IO47	PMC IO48	48
49	PMC IO49	PMC IO50	50
51	PMC IO51	PMC IO52	52
53	PMC IO53	PMC IO54	54
55	PMC IO55	PMC IO56	56
57	PMC IO57	PMC IO58	58
59	PMC IO59	PMC IO60	60
61	PMC IO61	PMC IO62	62
63	PMC IO63	PMC IO64	64

### 5.5.3 CompactPCI User I/O Connector

Connector J3 is a 95-pin AMP Z-pack 2mm hard metric type AB connector. This connector routes the I/O signals for the PMC1 I/O, and two 10/100/1000Base-T ethernet ports. The pin assignments for J3 on the processor board and on the CPCI-6115-MCPTM are as follows:

(Outer row F is assigned and used as ground pins but is not shown in the table).

Table 5-7 User I/O Connector Pinout, J3

Pin	Row A	Row B	Row C	Row D	Row E	Pin
19	GND	+12 V	-12 V	GND	GND	19
18	LPa_DA+ (TX1+)*	LPa_DA-(TX1-)*	GND	LPa_DC+*	LPa_DC-*	18
17	LPa_DB+ (RX1+)*	LPa_DB-(RX1-)*	GND	LPa_DD+*	LPa_DD-*	17
16	LPb_DA+ (TX2+)*	LPb_DA-(TX1-)*	GND	LPb_DC+*	LPb_DC-*	16
15	LPb_DB+(RX2+)*	LPb_DB-(RX2-)*	GND	LPb_DD+*	LPb_DD-*	15
14	+3.3 V	+3.3 V	+3.3 V	+5 V	+5 V	14
13	PMC1IO5	PMC1IO4	PMC1IO3	PMC1IO2	PMC1IO1	13
12	PMC1IO10	PMC1IO9	PMC1IO8	PMC1IO7	PMC1IO6	12
11	PMC1IO15	PMC1IO14	PMC1IO13	PMC1IO12	PMC1IO11	11
10	PMC1IO20	PMC1IO19	PMC1IO18	PMC1IO17	PMC1IO16	10
9	PMC1IO25	PMC1IO24	PMC1IO23	PMC1IO22	PMC1IO21	9
8	PMC1IO30	PMC1IO29	PMC1IO28	PMC1IO27	PMC1IO26	8
7	PMC1IO35	PMC1IO34	PMC1IO33	PMC1IO32	PMC1IO31	7
6	PMC1IO40	PMC1IO39	PMC1IO38	PMC1IO37	PMC1IO36	6

Table 5-7 User I/O Connector Pinout, J3 (continued)

Pin	Row A	Row B	Row C	Row D	Row E	Pin
5	PMC1IO45	PMC1IO44	PMC1IO43	PMC1IO42	PMC1IO41	5
4	PMC1IO50	PMC1IO49	PMC1IO48	PMC1IO47	PMC1IO46	4
3	PMC1IO55	PMC1IO54	PMC1IO53	PMC1IO52	PMC1IO51	3
2	PMC1IO60	PMC1IO59	PMC1IO58	PMC1IO57	PMC1IO56	2
1	IPMI_PWR	PMC1IO64	PMC1IO63	PMC1IO62	PMC1IO61	1

\*Not connected on MXP version

#### Signal Description

##### PMCIO:

PMC1IO(64:1)                      PMC1 I/O signals 1 through 64

##### Ethernet:

PORTn\_TXP                      high side of differential transmit data

PORTn\_TXN                      low side of differential transmit data

PORTn\_RXP                      high side of differential receive data

PORTn\_RXN                      low side of differential receive data

## 5.5.4 CompactPCI User I/O Connector

Connector J5 is a 110 pin AMP Z-pack 2mm hard metric type B connector. This connector routes the I/O signals for the PMC2 I/O signals, the IDE port, four asynchronous serial ports and I2C. The pin assignments for J5 on the processor board and the CPC1-6115-MCPTM are as follows:

(Outer row F is assigned and used as ground pins but is not shown in the table).

Table 5-8 User I/O Connector Pinout, J5

Pin	Row A	Row B	Row C	Row D	Row E	Pin
22	DRESET_L	COM4_TXD	COM3_TXD	COM2_TXD	COM1_TXD	22
21	INTRQA	COM4_RXD	COM3_RXD	COM2_RXD	COM1_RXD	21
20	CS1FXA_L	CS3FXA_L	DA2	MXDI	MXDO	20
19	Not Connected	DIORDYA	DA1	MXCLK	MXSYNC#	19
18	DIOWA_L	DA0	TMCOM1_L	I2C_CLK	I2C_DATA	18
17	GND	DD14	DD15	DIORA_L	Not Connected	17
16	DD9	DD10	DD11	DD12	DD13	16
15	DD5	DD6	GND	DD7	DD8	15
14	DD0	DD1	DD2	DD3	DD4	14
13	PMC2IO5	PMC2IO4	PMC2IO3	PMC2IO2	PMC2IO1	13

Table 5-8 User I/O Connector Pinout, J5 (continued)

Pin	Row A	Row B	Row C	Row D	Row E	Pin
12	PMC2IO10	PMC2IO9	PMC2IO8	PMC2IO7	PMC2IO6	12
11	PMC2IO15	PMC2IO14	PMC2IO13	PMC2IO12	PMC2IO11	11
10	PMC2IO20	PMC2IO19	PMC2IO18	PMC2IO17	PMC2IO16	10
9	PMC2IO25	PMC2IO24	PMC2IO23	PMC2IO22	PMC2IO21	9
8	PMC2IO30	PMC2IO29	PMC2IO28	PMC2IO27	PMC2IO26	8
7	PMC2IO35	PMC2IO34	PMC2IO33	PMC2IO32	PMC2IO31	7
6	PMC2IO40	PMC2IO39	PMC2IO38	PMC2IO37	PMC2IO36	6
5	PMC2IO45	PMC2IO44	PMC2IO43	PMC2IO42	PMC2IO41	5
4	PMC2IO50	PMC2IO49	PMC2IO48	PMC2IO47	PMC2IO46	4
3	PMC2IO55	PMC2IO54	PMC2IO53	PMC2IO52	PMC2IO51	3
2	PMC2IO60	PMC2IO59	PMC2IO58	PMC2IO57	PMC2IO56	2
1	TMPRSNT_L	PMC2IO64	PMC2IO63	PMC2IO62	PMC2IO61	1

**Signal Descriptions****PMCIO:**

PMC2IO(1:64)                      PMC 2 I/O signals 1 through 64

**EIDE Primary Port (ATA-2):**

DIORA\_L -                      I/O read  
 DIOWA\_L -                      I/O write  
 DIORDYA -                      indicates drive ready for I/O  
 DD(15:0) -                      IDE data lines  
 CS1FXA\_L -                      chip select drive 0 or command register block select  
 CS3FXA\_L -                      chip select drive 1 or command register block select  
 DA(2:0) -                      drive register and data port address lines  
 DRESET\_L -                      drive reset

**Serial COM Ports 1-4:**

COMn\_TD -                      COM Port n Transmit Data Output  
 COMn\_RD -                      COM Port n Receive Data Input

**Miscellaneous:**

TMPRSNT\_L -                      indicates that the MCxx805TM is installed  
 TMCOM1\_L -                      used to select COM1 active on processor board or on transition module  
 MXCLK -                      multiplexed I/O signal clock, 10 MHz  
 MXSYNC\_L -                      multiplexed I/O sync signal  
 MXDI -                      multiplexed I/O data-in signal from transition module  
 MXDO -                      multiplexed I/O data-out signal to transition module

**Signal Descriptions**

I2C_CLK -	I2C Serial Clock for transition module EEPROM
I2C_DATA -	I2C Serial Data for transition module EEPROM

**5.5.5 10/100/1000BaseTx Connectors**

Two 10/100/1000BaseTx RJ-45 connectors are located on the rear panel of the standard version of the CPCI-6115-MCPTM to support Ethernet I/O from the CPCI-6115 SBC. The pin assignments for these connectors are as follows:

*Table 5-9 10BaseT/100BaseTx Connector Pin Assignments*

Pin	Signal
1	MDIO0+
2	MDIO0-
3	MDIO1+
4	MDIO2+
5	MDIO2-
6	MDIO1-
7	MDIO3+
8	MDIO3-

**5.5.6 COM1 And COM2 Connectors (MXP Version)**

Four RJ-45 connectors are located on the panel of the MXP version of the CPCI-6115-MCPTM to provide the interface to the COM1 and COM2 serial ports originating from the CPCI-6115 SBC. The CPCI-6115 only supports two serial ports, COM1 and COM2.

The COM1DIR jumper is a two position (three pin) jumper which controls the origin of the serial port. In one position, COM1 from the CPCI-6115 is enabled (and thereby disabling it on the CPCI-6115 front panel connector). In the other position, the connector is redirected to the PMC I/O module 1. The COM2DIR jumper is a two position (three pin) jumper which controls the origin of the serial port. In one position, COM2 from the CPCI-6115 is enabled. In the other position, the connector is redirected to the PMC I/O module 2.

The pin assignments for this connector is as follows:

*Table 5-10 COM1, COM2 Connector Pin Assignments*

Pin	Signal
1	DCD
2	RTS
3	GND
4	TXD

Table 5-10 COM1, COM2 Connector Pin Assignments (continued)

Pin	Signal
5	RXD
6	GND
7	CTS
8	DTR

## 5.5.7 RJ-45 to DB-9 Adapter for COM1 to PC COM1

The following information is provided for those users wishing to attach a console to an CPCI-6115 COM1 port for the purpose of terminal emulation.

A prewired, completely shielded RJ-45 to DB-9 female adapter assembly with 8 position RJ-45 socket on one end to DB-9 socket on the other end is available through Motorola. This can be ordered through Motorola by requesting the following part number: MRJ45DB9ADP-01 (works with either a Motorola or Intel CPU).

Connecting an CPCI-6115 to a PC terminal requires that the adapter described above be attached to a standard RJ-45-to-RJ-45 shielded cable with straight through signaling.

The pinout information for this adapter is in the following table:

Table 5-11 Wire Interconnection List RJ-45 to DB-9

RF-45 Signal	RJ-45 Pin	DB-9 Pin	DB-9 Signal
DCD	1	4	DTR
RTS	2	8	CTS
GND	3	5	GND
TxD	4	2	RxD
RxD	5	3	TxD
GND	6	OPEN	
CTS	7	7	RTS
DTR	8	6	DSR

## 5.6 Jumper Settings

This section describes the jumper settings that are required for proper operation prior to installing the CPCI-6115-MCPTM transition module into a chassis backplane. Many boards are already factory configured based on customer requirements, but the jumper settings should be verified before installation.

### NOTICE

#### Damage of the Product

**Setting/resetting the switches during operation can cause damage of the product. Check and change switch settings before you install the product.**

### 5.6.1 CompactFlash Jumper

Jumper J2 controls the Master/Slave relationship between the planar socket (CompactFlash connector) and the PIM socket. By setting a jumper across pins 1 and 2 on jumper J2, the CompactFlash device becomes the Master, and the PIM device becomes the Slave. By setting a jumper across pins 2 and 3 on jumper J2, the PIM device becomes the Master, and the CompactFlash device becomes the Slave. If no jumper is installed, the board will default to the CompactFlash as the Master device.

Figure 5-3 CompactFlash Jumper Settings (J2)

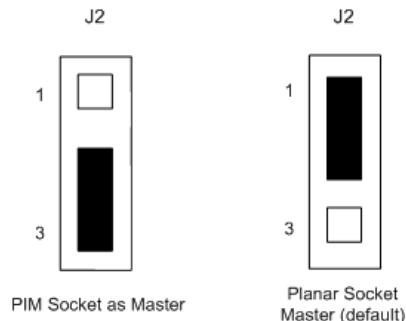

### 5.6.2 COM1 and COM2 Asynchronous Serial Ports Jumpers

The asynchronous serial ports (COM1 and COM2) are configured permanently as data circuit terminating equipment (DTE). The COM1 port is also routed to an RJ-45 connector on the front panel of the processor board. A terminal for COM1 may be connected to either the processor board or the transition module, but not both. If it is configured for the transition module, front panel access to COM1 is disabled.



Jumper J6 on the transition module controls the routing of the COM1 port to either the processor board front panel or through the PIM 1 socket on the transition module. When pins 1 and 2 are jumpered on J6, the COM1 signal is routed to the PIM1 socket on the transition module. When pins 2 and 3 are jumpered on J6 the COM1 signal is routed to the processor board front panel. Jumper J11 on the transition module controls the routing of the COM2 port to either the processor board front panel or through the PIM2 socket on the transition module. When pins 1 and 2 are jumpered on J11, the COM2 signal is routed to PIM2 on the transition module. When pins 2 and 3 are jumpered on J11, the COM2 signal is routed to the processor board front panel.

Figure 5-4 COM1 and COM2 Serial Port Jumpers (J6/J11)

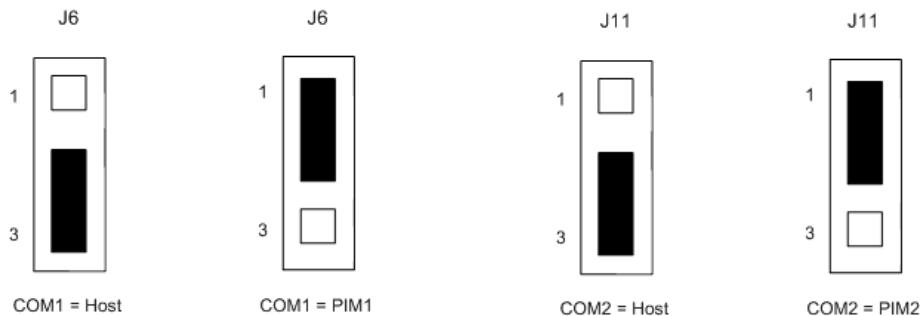

## 5.7 Functional Description

The following subsections describe the major functional components of the CPCI-6115-MCPTM transition module. There are certain differences between the IP version and the CompactPCI model that are explained in the subsections where those differences apply.

### 5.7.1 IDE Flash

The CPCI-6115 SBC supports a single IDE channel routed to the J5 User I/O connector. The CPCI-6115-MCPTM contains one 50-pin Type II connector which supports a removable IDE CompactFlash memory card on the primary IDE channel. Refer to the [CompactFlash Jumper on page 102](#) for the definition of this connector. The CompactFlash connector is not accessible through the rear panel. The CPCI-6115 transition module must be removed in order to install a CompactFlash memory card.

Since the transition module receives its power from the host board through power pins on the backplane, it cannot be removed in a hot-swap chassis without first removing the associated host board, or by powering off the slot in some other way, via software or by toggling the lower lever of the associated host board, so the blue LED illuminates. Since the CompactFlash is an active component, and some PIMs are as well, damage to these active components may occur if the transition module is not properly powered down.

The CPCI-6115-MCPTM also routes the IDE signals to the host I/O connector of PMC I/O module 2. Refer to [Jumper Settings on page 102](#) for more details.

Currently available CompactFlash memory cards provide from 2MB to 512MB. Once configured, this memory appears as a standard ATA (IDE) disk drive.

## 5.7.2 Ethernet Interface (CompactPCI Version)

The CPCI-6115 SBC provides three 10/100/1000Base-T Ethernet interfaces. Two of them are routed to the transition module and one is routed to the front panel.

The Ethernet Station Addresses are determined by the CPCI-6115 SBC and are not affected by the CPCI-6115-MCPTM.

## 5.7.3 Hot-Swap Support

The CPCI-6115-MCPTM is considered to be part of the CPCI-6115 SBC. Therefore, the CPCI-6115-MCPTM cannot be swapped without first removing or powering down the CPCI-6115 SBC. All power for the CPCI-6115-MCPTM is provided from the CPCI-6115 SBC through pins on the J3 I/O connector.

## 5.7.4 Serial EEPROM

The CPCI-6115-MCPTM contains a 512 x 8 Serial EEPROM. The Serial EEPROM provides for storage of the transition module configuration information. The default I2C address for this EEPROM is \$A8, but optional resistors can be used allowing population options to configure this part to respond to any standard I2C address.

## 5.7.5 PMC I/O Modules

CPCI-6115 SBC supports two single-wide PMC sites. Each site provides four 64-pin EIA-E700 AAAB connectors to interface to a 32/64-bit IEEE P1386.1 PMC. One of the four connectors is dedicated to user I/O. Two PMC I/O modules are supported on the CPCI-6115-MCPTM, one per PMC site on the CPCI-6115 SBC. The CPCI-6115 SBC maps the PMC user I/O pins onto the CompactPCI J3 and J5 connectors. The CPCI-6115-MCPTM reverses the mapping and brings the signals to a 64-pin EIA-E700 AAAB connector to interface with the PMC I/O module. This causes a one-to-one correspondence in the pinout between the PMC on the CPCI-6115 SBC and the PMC I/O module on the CPCI-6115-MCPTM. Refer to the section titled PMC I/O Module for a detailed description of PMC I/O modules.

## 5.7.6 Asynchronous Serial Ports

The CPCI-6115 SBC contains two asynchronous serial ports that are routed to the J5 user I/O connector. Serial port 1 (COM1) is also wired as an RS-232 interface to an RJ-45 connector on the front panel. A jumper (J6) on the CPCI-6115-MCPTM enables the COM1 port either on the CPCI-6115 SBC or the transition module. One version of the CPCI-6115-MCPTM employs four RJ-45 connectors on the rear panel of the transition module for COM1, COM2, COM3 and COM4 respectively. Note: only COM1 and COM2 can be used.

Due to pin limitations of the J5 connector, the CPCI-6115 SBC multiplexes the serial channel control signals between the CPCI-6115 SBC and the CPCI-6115-MCPTM. This hardware function is transparent to software. The block diagram for the signal multiplexing on the transition module is shown in the following figure:

Figure 5-5 Signal Multiplexing Diagram

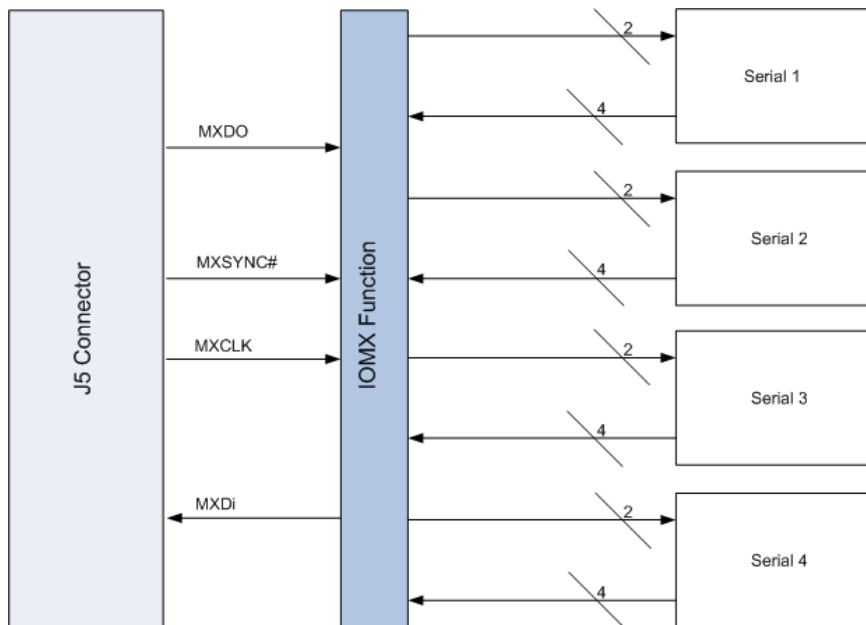

### 5.7.6.1 I/O Signal Multiplexing (IOMUX)

The CPCI-6115-MCPTM uses a PLD to generate the IOMUX function. The CPCI-6115 SBC uses a similar device. There are four pins that are used for the IOMUX function: MXCLK, MXSYNC#, MXDO and MXDI. MXCLK is the 10 MHz bit clock for the time-multiplexed data lines MXDO and MXDI. MXSYNC# is asserted for one bit time at Time Slot 15 by the CPCI-6115 SBC. MXSYNC# is used by the CPCI-6115-MCPTM to synchronize with the CPCI-6115 SBC. MXDO is the time-multiplexed output line from the CPCI-6115 and MXDI is the time-multiplexed line from the CPCI-6115-MCPTM. A 16-to-1 multiplexing scheme is used with a 10 MHz bit rate. Sixteen time slots are defined and allocated as follows:

Table 5-12 Multiplexing Sequence of the IOMUX Function

MXDO (From CPCI-6115 SBC)		MXDI (From CPCI-6115-MCPTM or CPCI-6106)	
Time Slot	Signal Name	Time Slot	Signal Name
0	RTS3	0	CTS3
1	DTR3	1	DSR3
2	RTS1	2	DCD3
3	RTS2	3	CTS1

Table 5-12 Multiplexing Sequence of the IOMX Function (continued)

MXDO (From CPCI-6115 SBC)		MXDI (From CPCI-6115-MCPTM or CPCI-6106)	
Time Slot	Signal Name	Time Slot	Signal Name
4	RTS4	4	RI3
5	DTR4	5	CTS4
6	Reserved	6	DSR4
7	Reserved	7	DCD4
8	Reserved	8	CTS2
9	DTR1	9	RI4
10	DTR2	10	RI1
11	Reserved	11	DSR1
12	Reserved	12	DCD1
13	Reserved	13	RI2
14	Reserved	14	DSR2
15	Reserved	15	DCD2

MXSYNC# is clocked out using the falling edge of MXCLK and MDXO is clocked out with the rising edge of the MXCLK. MXDI is sampled at the rising edge of MXCLK (the CPCI-6115-MCPTM synchronizes MXDI with MXCLK's rising edge). The timing relationships among MXCLK, MXSYNC#, MXDO, and MXDI are illustrated by the following figure:

Figure 5-6 P2MX Signal Timings

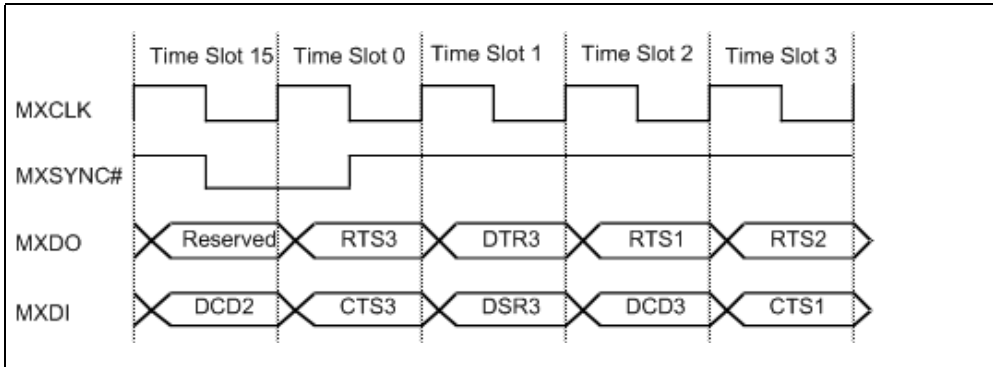

**Serial Port Signal Descriptions**

- CTS<sub>n</sub> clear to send
- DCD<sub>n</sub> data carrier detected
- DSR<sub>n</sub> data set ready
- DTR<sub>n</sub> data terminal ready

**Serial Port Signal Descriptions**

RIn	ring indicator
RTSn	request to send

**5.7.6.2 Serial Port Redirection**

It is expected that many PMCs will include a serial debug port in addition to their other I/O. The CPCI-6115-MCPTM allows the COM1 and COM2 connectors to be redirected by means of 16:8 multiplexers to the PMC I/O modules so the PMC I/O module faceplate area does not have to be used to provide a connector to access the debug port. A jumper on the CPCI-6115-MCPTM switches the COM1 connector between either the serial port originating on CPCI-6115 SBC or the serial port originating on PMC I/O module 1 (if any). Likewise for COM2 and PMC I/O module 2.

The redirected serial channels are routed to pins reserved on the host I/O connector. A serial port (if any) originating on the PMC located on the CPCI-6115 SBC is connected to the PMC I/O module through the standard 64 bits of PMC user I/O. The PMC I/O module must then loop the serial port back out on its host I/O connector.

This approach allows the serial debug port to be assigned to any of the 64 PMC user I/O lines. The mating PMC I/O module maps those lines onto the CPCI-6115-MCPTM serial channels. It is expected that future transition modules will reserve the same pins on the host I/O connector for this serial port function.

**5.7.6.3 Asynchronous Serial Port Diagrams**

The two asynchronous port configuration diagrams are shown on the following pages. The asynchronous serial ports are configured through jumper settings. Serial ports 1 and 2 are routed through connector J5.

Synchronous Port	Board Connector	Jumper Header
Port 1	J5	J6
Port 2	J5	J11

The next two figures illustrate the CPCI-6115 baseboard and CPCI-6115-MCPTM with the interconnections and jumper settings for DCE/DTE configuration on each serial port.

### 5.7.6.4 Port Configuration Diagrams

The following interface configuration diagrams describe the interface between the CPCI-6115 SBC and the CPCI-6115-MCPTM.

Figure 5-7 CPCI-6115-MCPTM Serial Ports 1 and 2

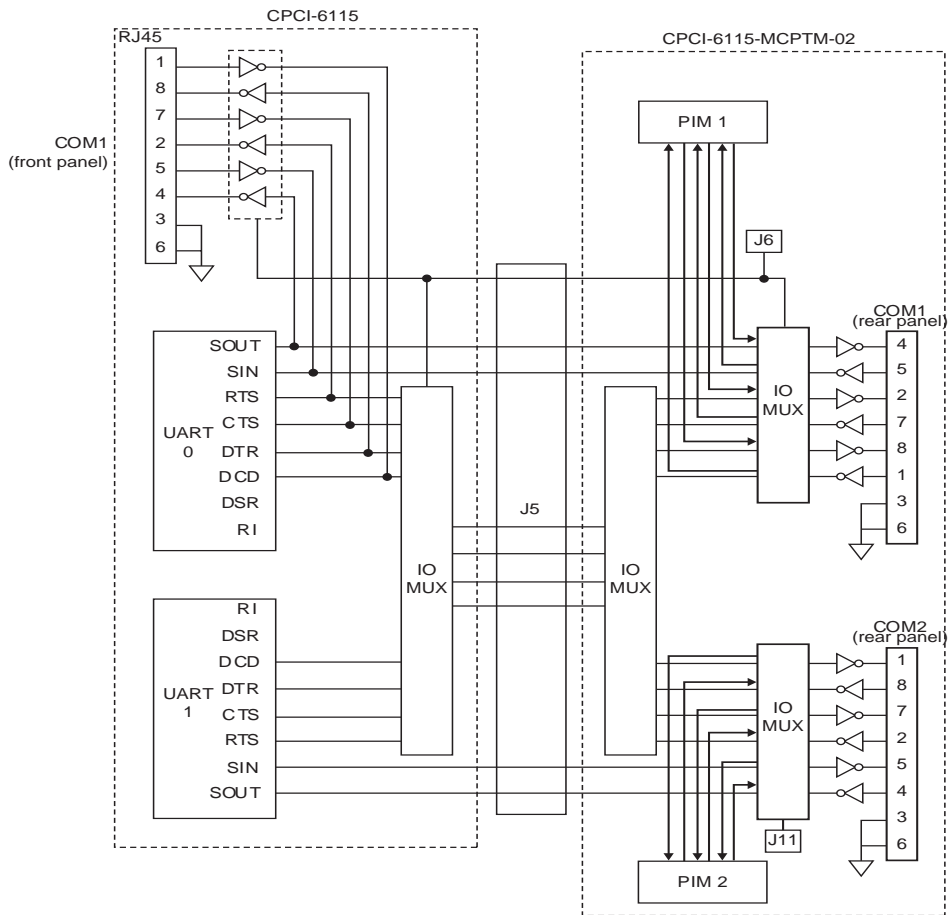

### 5.7.7 PMC I/O Module

The CPCI-6115-MCPTM provides additional I/O capabilities for the CPCI-6115 SBC. There are three distinct groups of I/O passed from the CPCI-6115 SBC to the CPCI-6115-MCPTM through the CompactPCI J3 and J5 connectors; MCxx905 SBC host I/O, PMC1 I/O and PMC2 I/O. CPCI-6115 SBC host I/O functions are designed into the CPCI-6115 SBC and their presence or absence is determined when that board is built. This I/O cannot be configured at

the system integration level. PMC I/O depends entirely upon which, if any, PMC is installed in one or both of the CPCI-6115 SBC PMC sites. To accommodate the pluggable nature of a PMC, a custom form factor pluggable I/O module is presented here. A physical representation of the CPCI-6115-MCPTM and I/O modules is shown below.

Figure 5-8 PMC I/O Module Physical Representation (MXP Version)

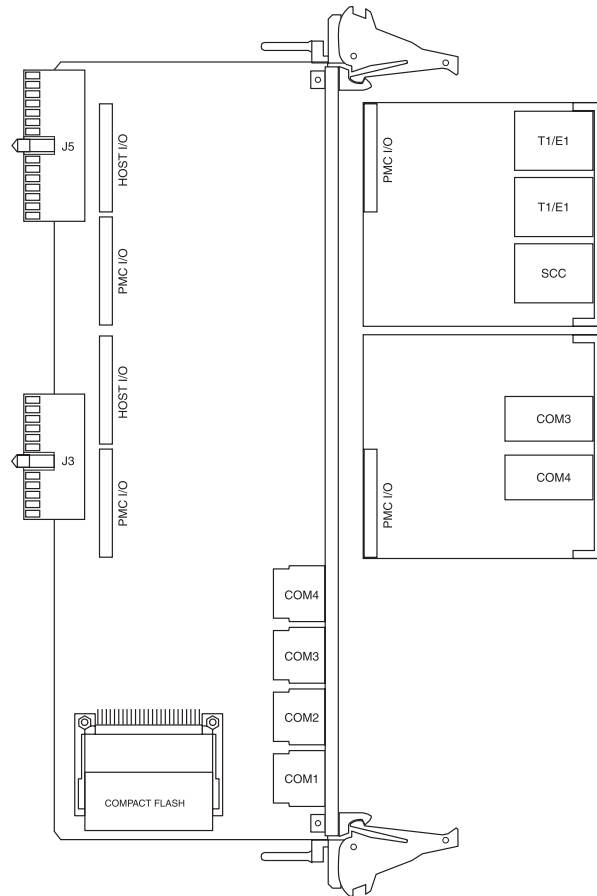

### 5.7.8 PMC I/O Module Form Factor

The PMC I/O module form factor is identical to the single-wide PMC form factor with the following differences:

- Shorter by 80mm
- Deletes the +5 V and +3.3 V keys
- Pn1 and Pn3 are deleted

The 80mm is “cut out of the middle” of the PMC I/O module. This means that features in the front half of the module keep their positioning relative to the front edge of the board while features in the back half of the board keep their positioning relative to the back edge of the board.

### 5.7.9 PMC I/O Connector

The mapping used by the CPCI-6115 SBC of the PMC I/O connectors onto the CompactPCI user I/O connectors is reversed by the CPCI-6115-MCPTM. This allows the designer of a PMC to create a PMC I/O module without knowledge of how the CPCI-6115 SBC maps signals through the backplane. There is nothing to tie the PMC I/O module to the CPCI-6115 SBC platform and in this sense the module is “universal”.

### 5.7.10 Host I/O Connector

The second connector on the PMC I/O module is used to provide power and ground to the module. In addition, the remaining pins may be used for host I/O signals. Any host I/O functionality for which there is no space available, or which the cost of does not justify its presence on the standard board, may be implemented in a “host I/O module”. This functionality is special to the host (in this case the CPCI-6115 SBC) and so the host I/O module is not a “universal” module. However, if the host I/O connector pinout is reused on future transition modules, the host I/O module may be reused.

If possible, optional host I/O routed to the host I/O connector will be terminated in such a fashion that the host does not incorrectly determine that a device is connected to that I/O when no module is present. This termination must not interfere with normal operation of the I/O when a module is present.

### 5.7.11 PMC I/O Module Presence Detection and Identification

Presence detection and identification of PMC I/O modules is currently an open issue. It is anticipated that PMCs and PMC I/O modules will be designed as pairs. Any and all of the 64 bits of PMC user I/O are available to the designers to use as they wish to detect and identify an installed PMC I/O module. No standard exists, or is likely to exist, so hopefully the method chosen will be sufficiently robust to prevent accidental misidentification of modules.

Host I/O modules also need to be detected and identified. To this end the I2C bus provided from the CPCI-6115 SBC is connected to both PMC I/O module sites. The addresses and content of the I2C devices to reside on the Host I/O module remain an open issue.



## 5.8 Installing the PIM

### Procedure

If a PIM has already been installed on the CPCI-6115-MCPTM, or you are installing a transition module as it has been shipped from the factory, disregard this section, and proceed to the main installation section titled *Installing the Transition Module* on page 113. For PIM installation, perform the following steps:

1. Attach an ESD strap to your wrist. Attach the other end of the ESD strap to the chassis as a ground. The ESD strap must be secured to your wrist and to ground throughout the procedure.
2. Perform an operating system shutdown. Turn the AC or DC power off and remove the AC cord or DC power lines from the system.
3. Remove chassis or system cover(s) as necessary for access to the CompactPCI.

### NOTICE

#### Product Damage

Inserting or removing modules in a non-hot-swap chassis with the power applied may result in damage to the module components. The CPCI-6115-MCPTM is not a hot-swap board, but it may be installed in a hot-swap chassis with power applied. Remove the corresponding CPCI-6115 before the CPCI-6115-MCPTM is installed.



### WARNING

#### Personal Injury or Death

Dangerous voltages, capable of causing death, are present in this equipment. Use extreme caution when handling, testing and adjusting.

4. Carefully remove the transition module from its CompactPCI card slot and lay it flat on a stable surface.
5. Remove the PIM filler from the front panel of the transition module.

- Slide the face plate (front bezel) of the PIM module into the front panel opening from behind and place the PIM module on top of the transition module, aligned with the appropriate two PIM connectors (P0 and P4). The two connectors on the underside of the PIM module should then connect smoothly with the corresponding connectors on the transition module (J10 and J14). Refer to the following figure for proper screw/board alignment.

Figure 5-9 Installing the PIM

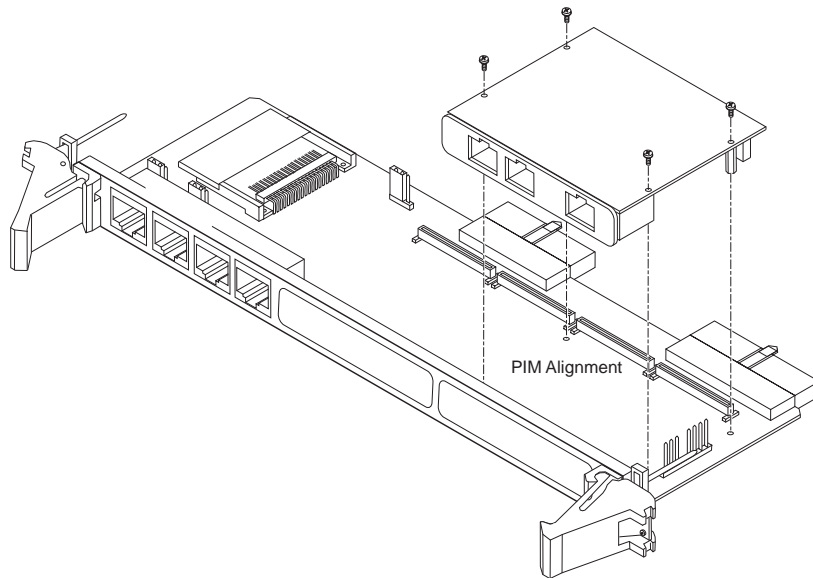

- Insert the four short Phillips screws, provided with the PIM, through the holes on the bottom side of the transition module into the PIM front bezel and rear standoffs. Tighten the screws.
- With the CPCI-6115-MCPTM in the correct vertical position that matches the pin positioning of the backplane, carefully slide the transition module into the appropriate slot and seat tightly into the backplane.
- Secure in place with the screws provided, making good contact with the transverse mounting rails to minimize RF emissions.
- Replace the chassis or system cover(s), reconnect the system to the AC or DC power source, and turn the equipment power on, or if hot-swapping, you may now install the CPCI-6115.

## 5.9 Installing the Transition Module

After all peripheral modules have been installed and all of the appropriate jumpers have been set, you are ready to install the transition module in its chassis slot. At this point, follow the steps below:

### Procedure

To install the rear transition module, follow these steps:

1. Attach an ESD strap to your wrist. Attach the other end of the strap to the chassis as a ground. The ESD strap must be secured to your wrist and to ground throughout the procedure.
2. Perform an operating system shutdown. Turn the AC or DC power off and remove the AC cord or DC power lines from the system. Remove the chassis or system cover(s) as necessary for access to the chassis backplane.

	<b>! WARNING</b>
	<b>Personal Injury or Death</b> Dangerous voltages, capable of causing death, are present in this equipment. Use extreme caution when handling, testing and adjusting.

<b>NOTICE</b>
<b>Damage of Circuits</b> Electrostatic discharge and incorrect installation and removal of the product can damage circuits or shorten their life. Before touching the product or electronic components, make sure that you are working in an ESD-safe environment.

3. With the CPCI-6115-MCPTM in the correct vertical position that matches the pin positioning of the backplane, carefully slide the transition module into the appropriate slot and seat tightly into the backplane. Refer to [Figure 5-10 on page 114](#) for the correct board/connector orientation.
4. Secure in place with the screws provided, making good contact with the transverse mounting rails to minimize RF emissions.
5. Replace the chassis or system cover(s), reconnect the system to the AC or DC power source and turn the equipment power on, or if hot-swapping, you may now install the CPCI-6106.

## 5.10 Removing the Transition Module in a Hot-Swap Chassis

Although the CPCI-6115 SBC can be removed and inserted while power is applied in a hot-swap capable backplane, the CPCI-6115-MCPTMs are not hot-swap capable. Inserting or removing the transition module while the CPU board is active may affect the normal operation of the CPU board. Even in a hot-swap capable chassis, the CPU back end power should be switched off (or the chassis power shut down) prior to inserting or removing its corresponding transition module.

Figure 5-10 CPCI-6115-MCPTM Mating Configuration

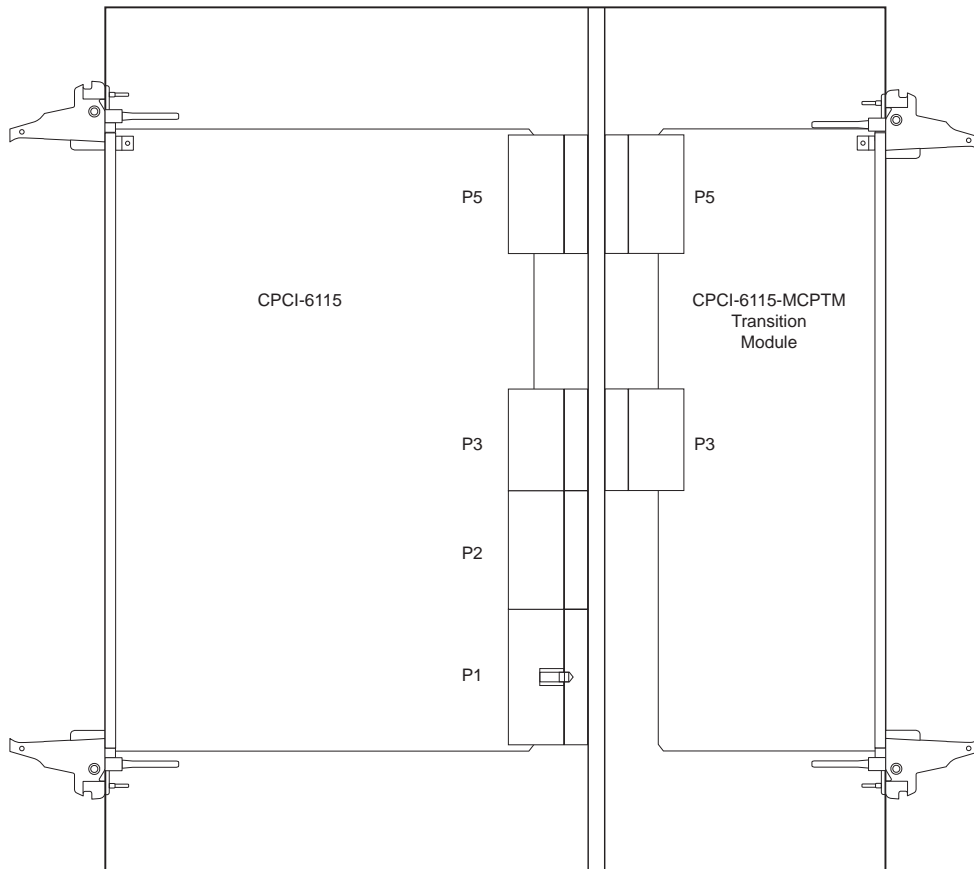

## 6.1 Overview

This chapter describes the remote interface provided by the firmware to the host CPU via the CompactPCI bus. This interface facilitates the host obtaining information about the board, downloading code and/or data, and execution of the downloaded program.

For boards where the 21555 is disabled, the remote start function, as described in the *MOTLoad Firmware Package User's Manual* will not work.

Applications may also be downloaded to the CPCI-6115 via one of the PCI bus windows provided by the PCI-to-PCI bridge. This method is faster than using the MOTLoad remote interface and may be preferable to use for large downloads.

## 6.2 Register Description

MOTLoad uses one of the scratch pad registers of the Intel 2155x PCI-to-PCI bridge as the interboard communication channel. This scratch pad register is logically divided into five sections:

- An ownership flag. When set, indicates that the host 'owns' the register and is free to write a new command into it. It also indicates that the previous command, if any, has been completed and the results, if any, have been returned to the register. When the host writes a new command to the register, it must clear the ownership flag to indicate the register contains a command to be processed.
- A 'command opcode'. This field is a numeric field that specifies the command the host wants performed.
- An error flag, which is used to provide command completion status to the host CPU.
- A 'command options field'. This field further qualifies the specifics of the command to be performed. The meaning of the option field is specific to each command opcode.
- A command data and result field. This field provides the data, if any, needed by the command and provides the response from MOTLoad upon command completion. The meaning of the bits in this field are specific to each command opcode.

Additionally, certain commands require more information than can be contained within the data and result fields of the scratch pad register. To provide this information, the interface provides four 'virtual' registers. The contents of these registers are used in certain commands. The contents of the registers can be accessed via commands issued through the scratch register. These registers are identified as VR0, VR1, VR2 and VR3.

During reset startup, the command/response register is written with a specific reset pattern. This indicates that the local CPU has been reset and is ready to accept commands through the command/response register.

MOTLoad uses certain areas of memory and I/O devices for its own operation. This interface allows the host CPU to write and read any location on the local CPU bus including those in use by the firmware. Host CPUs should interrogate the firmware via the memory size query command (as described in Opcode 0x05: Memory size Query in Appendix B of the *MOTLoad Firmware Package User's Manual*) and avoid overwriting memory which is in-use by firmware; otherwise, erratic behavior may result.

## 6.3 Command/Response Register Description

The Intel 2155x SCRATCH7 register is used as the command/response register. In this register description, and the following command descriptions, references to the upper half of the register refer to bits 0 through 15, and references to the lower half of the register refer to bits 16 through 31.

Format of command/response register (Intel 2155x SCRATCH7):

<b>0</b>	<b>1</b>	<b>2</b>	<b>3</b>	<b>4</b>	<b>5</b>	<b>6</b>	<b>7</b>	<b>8</b>	<b>9</b>	<b>10</b>	<b>11</b>	<b>12</b>	<b>13</b>	<b>14</b>	<b>15</b>	<b>16</b>	<b>17</b>	<b>18</b>	<b>19</b>	<b>20</b>	<b>21</b>	<b>22</b>	<b>23</b>	<b>24</b>	<b>25</b>	<b>26</b>	<b>27</b>	<b>28</b>	<b>29</b>	<b>30</b>	<b>31</b>
O Command opcode								E Command Options								Command Data/Result															
W								R																							
N								R																							

At reset, hardware clears this register. After reset, firmware writes this register with the value 0x80525354. This value indicates that a reset event has occurred and the interface is ready to accept commands.

Bit Number	Description
Bit 0	The ownership flag (OWN). A value of 1 indicates the 'host' owns the register. A value of 0 indicates that the local CPU owns the register.
Bits 1 to 7	7 bit command opcode field. Each command is described in more detail in the <i>MOTLoad Firmware Package User's Manual</i> .
Bit 8	Global error status flag (ERR). If the command completed successfully, then this bit is written with the value 0 at command completion. If the command fails, it will be written with the value 1. Additional command specific error status may be returned in other fields of the register.
Bits 9 to 15	7 bit command option field. Each command specifies the particular meaning of each of the command option bits. Option bits that are unused are considered reserved and should be written to 0 to ensure compatibility with future implementations of this interface.  For most commands, bit 9 is used to specify verbose/non-verbose mode target command processing. In verbose mode, command related information is printed on the target console as the host command is processed. Verbose mode is selected when bit 9=0, non-verbose mode is set when bit 9=1.
Bits 16 to 31	16 bit data/result field. The meaning of this field is specific to each command opcode. Refer to the <i>MOTLoad Firmware Package User's Manual</i> for error codes.

## 7.1 Overview

This chapter describes the basic features of the MOTLoad firmware product, designed by Motorola as the next generation initialization, debugger and diagnostic tool for high-performance embedded board products using state-of-the-art system memory controllers and bridge chips, such as the MV64360.

In addition to an overview of the product, this chapter includes a list of standard MOTLoad commands and the default CompactPCI settings that are changeable by the user, as allowed by the firmware.

## 7.2 MOTLoad Description

The MOTLoad firmware package serves as a board power-up and initialization package, as well as a vehicle from which user applications can be booted. A secondary function of the MOTLoad firmware is to serve in some respects as a test suite providing individual tests for certain devices.

MOTLoad is controlled through an easy-to-use, UNIX-like, command line interface. The MOTLoad software package is similar to many end-user applications designed for the embedded market, such as the real time operating systems currently available.

Refer to the *MOTLoad Firmware Package User's Manual*, listed in [Appendix A, Related Documentation](#), for more details.

## 7.3 MOTLoad Implementation and Memory Requirements

The implementation of CPCI-6115 CompactPCI Single Board Computer and its memory requirements are product specific. The CPCI-6115 single-board computer (SBC) is offered with a wide range of memory (for example, DRAM, external cache, flash). Typically, the smallest amount of on-board DRAM that a Motorola SBC has is 32MB. Each supported Motorola product line has its own unique CPCI-6115 CompactPCI Single Board Computer binary image(s). Currently the largest CPCI-6115 CompactPCI Single Board Computer compressed image is less than 1MB in size.

## 7.4 MOTLoad Commands

CPCI-6115 CompactPCI Single Board Computer supports two types of commands (applications): utilities and tests. Both types of commands are invoked from the CPCI-6115 CompactPCI Single Board Computer command line in a similar fashion. Beyond that, CPCI-6115 CompactPCI Single Board Computer utilities and CPCI-6115 CompactPCI Single Board Computer tests are distinctly different.

## 7.5 MOTLoad Utility Applications

The definition of a MOTLoad utility application is very broad. Simply stated, it is considered a MOTLoad command, if it is not a MOTLoad test. Typically, MOTLoad utility applications are applications that aid the user in some way (that is, they do something useful). From the perspective of MOTLoad, examples of utility applications are: configuration, data/status displays, data manipulation, help routines, data/status monitors, etc.

Operationally, MOTLoad utility applications differ from MOTLoad test applications in several ways:

- Only one utility application operates at any given time (that is, multiple utility applications can not be executing concurrently).
- Utility applications may interact with the user. Most test applications do not.

## 7.6 MOTLoad Tests

A MOTLoad test application determines whether or not the hardware meets a given standard. Test applications are validation tests. Validation is conformance to a specification. Most MOTLoad tests are designed to directly validate the functionality of a specific SBC subsystem or component. These tests validate the operation of such SBC modules as: dynamic memory, external cache, NVRAM, real time clock, etc.

All MOTLoad tests are designed to validate functionality with minimum user interaction. Once launched, most MOTLoad tests operate automatically without any user interaction. There are a few tests where the functionality being validated requires user interaction (that is, switch tests, interactive plug-in hardware modules, etc.). Most MOTLoad test results (error-data/status-data) are logged, not printed. All MOTLoad tests/commands have complete and separate descriptions. Refer to the *MOTLoad Firmware Package User's Manual* for this information.

All devices that are available to MOTLoad for validation/verification testing are represented by a unique device path string. Most MOTLoad tests require the operator to specify a test device at the MOTLoad command line when invoking the test.

A listing of all device path strings can be displayed through the `devshow` command. If an SBC device does not have a device path string, it is not supported by MOTLoad and cannot be directly tested. There are a few exceptions to the device path string requirement, like testing RAM, which is not considered a true device and can be directly tested without a device path string. Refer to the `devshow` command description page in the *MOTLoad Firmware Package User's Manual*.



Most MOTLoad tests can be organized to execute as a group of related tests (a testSuite) through the use of the `testSuite` command. The expert operator can customize their testing by defining and creating a custom testSuite(s). The list of built-in and user-defined MOTLoad testSuites, and their test contents, can be obtained by entering `testSuite -dtestSuite` at the MOTLoad prompt. All testSuites that are included as part of a product specific MOTLoad firmware package are product specific. For more information, refer to the command description page in the *MOTLoad Firmware Package User's Manual*.

Test results and test status are obtained through the `testStatus`, `errorDisplay` and `taskActive` commands. Refer to the appropriate command description page in the *MOTLoad Firmware Package User's Manual* for more information.

## 7.7 Using MOTLoad

Interaction with MOTLoad is performed via a command line interface through a serial port on the SBC, which is connected to an X-terminal or other terminal emulator (for example, Window's Hypercomm). The default MOTLoad serial port settings are: 9600 baud, 8 bits, no parity.

### 7.7.1 Command Line Interface

The MOTLoad command line interface is similar to a UNIX command line shell interface. Commands are initiated by entering a valid MOTLoad command (a text string) at the MOTLoad command line prompt and pressing the carriage-return key to signify the end of input. MOTLoad then performs the specified action. An example of a MOTLoad command line prompt is shown below. The MOTLoad prompt changes according to what product it is used on (for example, HXEB100, CPCI-6115, MVME5500).

Example:

```
CPCI-6115>
```

If an invalid MOTLoad command is entered at the MOTLoad command line prompt, MOTLoad displays a message that the command was not found.

Example:

```
CPCI-6115> mytest
"mytest" not found
CPCI-6115>
```

If the user enters a partial MOTLoad command string that can be resolved to a unique valid MOTLoad command and presses the carriage-return key, the command will be executed as if the entire command string had been entered. This feature is a user-input shortcut that minimizes the required amount of command line input. MOTLoad is an ever changing firmware package, so user-input shortcuts may change as command additions are made.

Example:

```
CPCI-6115> version
Copyright: Motorola Inc.1999-2002, All Rights Reserved
MOTLoad RTOS Version 2.0
PAL Version 0.1 (Motorola CPCI-6115)
```

Example:

```
CPCI-6115> ver
Copyright: Motorola Inc. 1999-2002, All Rights Reserved
MOTLoad RTOS Version 2.0
PAL Version 0.1 (Motorola CPCI-6115)
```

If the partial command string cannot be resolved to a single unique command, MOTLoad will inform the user that the command was ambiguous.

Example:

```
CPCI-6115> te
"te" ambiguous
CPCI-6115>
```

## 7.7.2 Command Line Help

Each MOTLoad firmware package has an extensive, product-specific help facility that can be accessed through the `help` command. The user can enter `help` at the MOTLoad command line to display a complete listing of all available tests and utilities.

Example

```
CPCI-6115>help
```

For help with a specific test or utility the user can enter the following at the MOTLoad prompt:

```
help <command_name>
```

The `help` command also supports a limited form of pattern matching. Refer to the `help` command page.

Example

```
CPCI-6115>help testRam
Usage: testRam [-aPh] [-bPh] [-iPd] [-nPh] [-tPd] [-v]
Description: RAM Test [Directory]
Argument/Option Description
-a Ph: Address to Start (Default = Dynamic Allocation)
-b Ph: Block Size (Default = 16KB)
-i Pd: Iterations (Default = 1)
-n Ph: Number of Bytes (Default = 1MB)
-t Ph: Time Delay Between Blocks in OS Ticks (Default = 1)
-v O : Verbose Output
CPCI-6115>
```

## 7.7.3 Command Line Rules

There are a few things to remember when entering a MOTLoad command:

- Multiple commands are permitted on a single command line, provided they are separated by a single semicolon(";").
- Spaces separate the various fields on the command line (command/arguments/options).

- The argument/option identifier character is always preceded by a hyphen (“-”) character.
- Options are identified by a single character.
- Option arguments immediately follow (no spaces) the option.
- All commands, command options, device tree strings, etc., are case sensitive.

Example:

```
CPCI-6115> flashProgram -d/dev/flash0 -n00100000
```

For more information on MOTLoad operation and function, refer to the *MOTLoad Firmware Package User's Manual*.

## 7.8 MOTLoad Command List

The following table provides a list of all current MOTLoad commands. Products supported by MOTLoad may or may not employ the full command set. Typing help at the MOTLoad command prompt displays all commands supported by MOTLoad for a given product.

Table 7-1 MOTLoad Commands

Command	Description
as	One-Line Instruction Assembler
bc bch bcw	Block Compare Byte/Halfword/Word
bdTempShow	Display Current Board Temperature
bfb bfh bfw	Block Fill Byte/Halfword/Word
blkCp	Block Copy
blkFmt	Block Format
blkRd	Block Read
blkShow	Block Show Device Configuration Data
blkVe	Block Verify
blkWr	Block Write
bmb bmh bmw	Block Move Byte/Halfword/Word
br	Assign/Delete/Display User-Program Break-Points
bsb bsh bsw	Block Search Byte/Halfword/Word
bvb bv h bvw	Block Verify Byte/Halfword/Word
cdDir	ISO9660 File System Directory Listing
cdGet	ISO9660 File System File Load
clear	Clear the Specified Status/History Table(s)
cm	Turns on Concurrent Mode

Table 7-1 MOTLoad Commands (continued)

Command	Description
csb , csh , csw	Checksum Byte/Halfword/Word
devShow	Display (Show) Device/Node Table
diskBoot	Disk Boot (Direct-Access Mass-Storage Device)
downLoad	Down Load S-Record from Host
ds	One-Line Instruction Disassembler
echo	Echo a Line of Text
elfLoader	ELF Object File Loader
errorDisplay	Display the Contents of the Test Error Status Table
eval	Evaluate Expression
execProgram	Execute Program
fatDir	FAT File System Directory Listing
fatGet	FAT File System File Load
fdShow	Display (Show) File Descriptor
flashProgram	Flash Memory Program
flashShow	Display Flash Memory Device Configuration Data
gd	Go Execute User-Program Direct (Ignore Break-Points)
gevDelete	Global Environment Variable Delete
gevDump	Global Environment Variable(s) Dump (NVRAM Header + Data)
gevEdit	Global Environment Variable Edit
gevInit	Global Environment Variable Area Initialize (NVRAM Header)
gevList	Global Environment Variable Labels (Names) Listing
gevShow	Global Environment Variable Show
gn	Go Execute User-Program to Next Instruction
go	Go Execute User-Program
gt	Go Execute User-Program to Temporary Break-Point
hbd	Display History Buffer
hbx	Execute History Buffer Entry
help	Display Command/Test Help Strings
l2CacheShow	Display state of L2 Cache and L2CR register contents
l3CacheShow	Display state of L3 Cache and L3CR register contents
mdb mdh mdw	Memory Display Bytes/Halfwords/Words
memShow	Display Memory Allocation

Table 7-1 MOTLoad Commands (continued)

Command	Description
mmb mmh mmw	Memory Modify Bytes/Halfwords/Words
mpuFork	Execute program from idle processor
mpuShow	Display multi-processor control structure
mpuSwitch	Resets board switching master MPU
netBoot	Network Boot (BOOT/TFTP)
netShow	Display Network Interface Configuration Data
netShut	Disable (Shutdown) Network Interface
netStats	Display Network Interface Statistics Data
noCm	Turns off Concurrent Mode
pciDataRd	Read PCI Device Configuration Header Register
pciDataWr	Write PCI Device Configuration Header Register
pciDump	Dump PCI Device Configuration Header Register
pciShow	Display PCI Device Configuration Header Register
pciSpace	Display PCI Device Address Space Allocation
ping	Ping Network Host
portSet	Port Set
portShow	Display Port Device Configuration Data
rd	User Program Register Display
reset	Reset System
rs	User Program Register Set
set	Set Date and Time
sromRead	SROM Read
sromWrite	SROM Write
sta	Symbol Table Attach
stl	Symbol Table Lookup
stop	Stop Date and Time (Power-Save Mode)
taskActive	Display the Contents of the Active Task Table
tc	Trace (Single-Step) User Program
td	Trace (Single-Step) User Program to Address
testDisk	Test Disk
testEnetPtP	Ethernet Point-to-Point
testNvramRd	NVRAM Read
testNvramRdWr	NVRAM Read/Write (Destructive)
testRam	RAM Test (Directory)
testRamAddr	RAM Addressing
testRamAlt	RAM Alternating

Table 7-1 MOTLoad Commands (continued)

Command	Description
testRamBitToggle	RAM Bit Toggle
testRamBounce	RAM Bounce
testRamCodeCopy	RAM Code Copy and Execute
testRamEccMonitor	Monitor for ECC Errors
testRamMarch	RAM March
testRamPatterns	RAM Patterns
testRamPerm	RAM Permutations
testRamQuick	RAM Quick
testRamRandom	RAM Random Data Patterns
testRtcAlarm	RTC Alarm
testRtcReset	RTC Reset
testRtcRollOver	RTC Rollover
testRtcTick	RTC Tick
testSerialExtLoop	Serial External Loopback
testSerialIntLoop	Serial Internal Loopback
testStatus	Display the Contents of the Test Status Table
testSuite	Execute Test Suite
testSuiteMake	Make (Create) Test Suite
testThermoOp	Thermometer Temperature Limit Operational Test
testThermoQ	Thermometer Temperature Limit Quick Test
testThermoRange	Test That Board Temperature Is Within Range
testWatchdogTimer	Tests the accuracy of the watchdog timer device.
tftpGet	TFTP Get
tftpPut	TFTP Put
time	Display Date and Time
transparentMode	Transparent Mode (Connect to Host)
tsShow	Display Task Status
upLoad	Up Load Binary-Data from Target
version	Display Version String(s)
vmeCfg	Manages user specified VME configuration parameters
vpdDisplay	VPD Display
vpdEdit	VPD Edit
waitProbe	Wait for I/O Probe to Complete

## 8.1 Overview

This chapter supplies information for use of the CPCI-6115 family of Single Board Computers in a system configuration. Here you will find descriptions of the memory maps and software initialization.

## 8.2 Memory Maps

There are three points of view for memory maps:

- Mapping of all resources as viewed by the processor (MPU bus memory map)
- Mapping of onboard resources as viewed by PCI local bus masters (PCI bus memory map)
- Mapping of onboard resources as viewed by the CompactPCI bus

The following sections give a general description of the CPCI-6115 memory organization from the above three points of view. Detailed memory maps can be found in the *MCPN905 CompactPCI Single Board Computer Programmer's Reference Guide* (MCPN905A/PG).

### 8.2.1 Default Processor Memory Map

The MV64360 presents a default CPU memory map following RESET negation. The following table shows the default Memory Map from the point of view of the Processor. Address bits [35:32] are only relevant for the MPC7457 extended address mode and are not shown in the following tables.

Table 8-1 Default Processor Memory Map

Processor Address		Size	Definition	Notes
Start	End			
0000 0000	007F FFFF	8 MB	DRAM Bank 0	
0080 0000	00FF FFFF	8 MB	DRAM Bank 1	
0100 0000	017F FFFF	8 MB	DRAM Bank 2	
0180 0000	01FF FFFF	8 MB	DRAM Bank 3	
0200 0000	0FFF FFFF	224 MB	Unassigned	
1000 0000	11FF FFFF	32 MB	PCI Bus 0 I/O Space	
1200 0000	13FF FFFF	32 MB	PCI Bus 0 Memory Space 0	
1400 0000	1BFF FFFF	128 MB	Unassigned	
1C00 0000	1C7F FFFF	8 MB	Device CS0*	

Table 8-1 Default Processor Memory Map (continued)

Processor Address		Size	Definition	Notes
Start	End			
1C80 0000	1CFF FFFF	8 MB	Device CS1*	
1D00 0000	1DFF FFFF	16 MB	Device CS2*	
1E00 0000	1FFF FFFF	32 MB	Unassigned	
2000 0000	21FF FFFF	32 MB	PCI Bus 1 I/O	
2200 0000	23FF FFFF	32 MB	PCI Bus 1 Memory Space 0	
2400 0000	25FF FFFF	32 MB	PCI Bus 1 Memory Space 1	
2600 0000	27FF FFFF	32 MB	PCI Bus 1 Memory Space 2	
2800 0000	29FF FFFF	32 MB	PCI Bus 1 Memory Space 3	
2A00 0000	41FF FFFF	384 MB	Unassigned	
4200 0000	4303 FFFF	256 KB	MV64360 Integrated SRAM	
4304 0000	F0FF FFFF	2783 MB	Unassigned	
F100 0000	F100 FFFF	64 KB Aliased	Internal Registers	1
F101 0000	F1FF FFFF	16 MB-64 KB	Unassigned	
F200 0000	F3FF FFFF	32 MB	PCI Bus 0 Memory Space 1	
F400 0000	F5FF FFFF	32 MB	PCI Bus 0 Memory Space 2	
F600 0000	F7FF FFFF	32 MB	PCI Bus 0 Memory Space 3	
F800 0000	FEFF FFFF	112 MB	Unassigned	
FF00 0000	FF7F FFFF	8 MB	Device CS3*	
FF80 0000	FFFF FFFF	8 MB	Boot Flash	2

1.Set by configuration resistors.

2.This may be Flash Bank A or B, depending on the setting of the Flash Boot Bank Select jumper.

## 8.2.2 Processor Memory Map

The following table describes a suggested Memory Map from the point of view of the Processor. The beginning of PCI Memory Space is determined by the end of DRAM rounded up to the nearest 256 MB boundary. For example, if memory was 1G on the baseboard and 192 MB on a mezzanine, the beginning of PCI memory would be rounded up to address 0x50000000 (1 GB + 256 MB).



This is a suggested map only. Motorola developed firmware and software adheres to the following mapping, but end user applications are free to select an alternate mapping.

Table 8-2 Suggested PPC Memory Map

Processor Address		Size	Definition	Notes
Start	End			
0000 0000	top_dram-1	dram_size	System Memory (onboard DRAM)	
8000 0000	9FFF FFFF	512 MB	PCI Bus 0 Memory Space	
B000 0000	CFFF FFFF	512 MB	PCI Bus 1 Memory Space	
F000 0000	F07F FFFF	8 MB	PCI Bus 0 I/O Space	
F080 0000	F0FF FFFF	8 MB	PCI Bus 1 I/O Space	
F100 0000	F10F FFFF	1 MB	MV64360 Internal Registers	1
F110 0000	F11F FFFF	1 MB	Device CS1* I/O System Regs/NVRAM/RTC/UART	
F200 0000	F5FF FFFF	64 MB	Flash Bank A	
FF800 0000	FFFF FFFF	8 MB	Flash Bank B	

1. The internal registers only occupy the first 64 KB but minimum address decoding resolution is 1 MB.

### 8.2.3 Default PCI Memory Map

The MV64360 presents the following default PCI memory map after RESET negation.

Table 8-3 Default PCI Address Map

PCI Address		Size	Definition	Notes
Start	End			
0000 0000	007F FFFF	8 MB	DRAM Bank 0	
0080 0000	00FF FFFF	8 MB	DRAM Bank 1	
0100 0000	017F FFFF	8 MB	DRAM Bank 2	
0180 0000	01FF FFFF	8 MB	DRAM Bank 3	
0200 0000	0FFF FFFF	224 MB	Unassigned	
1000 0000	11FF FFFF	32 MB	PCI Bus 1 P2P I/O Space	
1200 0000	13FF FFFF	32 MB	PCI Bus 1 P2P Memory Space 0	
1400 0000	1400 FFFF	64 KB	Internal Registers	
1401 0000	1BFF FFFF	128 MB- 64 KB	Unassigned	
1C00 0000	1C7F FFFF	8 MB	Device CS0*	
1C80 0000	1CFF FFFF	8 MB	Device CS1*	
1D00 0000	1DFF FFFF	16 MB	Device CS2*	

Table 8-3 Default PCI Address Map (continued)

PCI Address		Size	Definition	Notes
Start	End			
1E00 0000	1FFF FFFF	32 MB	Unassigned	
2000 0000	21FF FFFF	32 MB	PCI Bus 0 P2P I/O Space	
2200 0000	23FF FFFF	32 MB	PCI Bus 0 P2P Memory Space 0	
2400 0000	25FF FFFF	32 MB	PCI Bus 0 P2P Memory Space 1	
2600 0000	41FF FFFF	448 MB	Unassigned	
4200 0000	4303 FFFF	256 KB	MV64360 Integrated SRAM	
4304 0000	F1FF FFFF	2800 MB	Unassigned	
F200 0000	F3FF FFFF	32 MB	PCI Bus 1 P2P Memory Space 1	
F400 0000	FEFF FFFF	176 MB	Unassigned	
FF00 0000	FF7F FFFF	8 MB	Device CS3*	
FF80 0000	FFFF FFFF	8 MB	Boot Flash	1

1. This may be Flash Bank A or B depending on Flash Boot Bank Select jumper.

## 8.2.4 Suggested PCI Memory Map

The following table is the suggested PCI memory map for each PCI bus. This table reflects the address map followed by the board level firmware at release time.

Table 8-4 Suggested PCI Memory Map

PCI Address		Size	Definition
Start	End		
0000 0000	top_dram	dram_size	System Memory (onboard DRAM)
8000 0000	9FFF FFFF	512 MB	PCI Bus 0 Memory Space
B000 0000	CFFF FFFF	512 MB	PCI Bus 1 Memory Space P2P Memory Space
F000 0000	F07F FFFF	8 MB	PCI Bus 0 I/O Space
F080 0000	F0FF FFFF	8 MB	PCI Bus 1 I/O Space
F100 0000	F10F FFFF	1 MB	MV64360 Internal Registers
F110 0000	F11F FFFF	1 MB	Device CS1* based I/O System Regs/NVRAM/RTC/UART
F200 0000	F5FF FFFF	64 MB	Flash Bank A
FF800 0000	FFFF FFFF	8 MB	Flash Bank B

## 8.2.5 System I/O Memory Map

System resources including system control and status registers, NVRAM/RTC and the 16550 UART are mapped into a 1 MB address range assigned to Device Bank 1. The memory map is defined in the following table:

Table 8-5 Device Bank 1 I/O Memory Map

Address	Definition
F110 0000	System Control/Status Register 1
F110 0001	System Control/Status Register 2
F110 0002	System Control/Status Register 3
F110 0003	Geographic Address Register (CompactPCI)
F110 0004	PCI Presence Detect Register
F110 0005	Software Readable Header/Switch
F110 0006	Timebase Enable Register
F110 0008	System Interrupt Status Register
F110 0009 - F110 FFFF	Reserved for onboard registers
F111 0000 - FF11 7FFF	M48T37V NVRAM/RTC
F112 0000 - FF12 0FFF	COM1 16550 UART
F112 1000 - FF12 1FFF	COM2 16550 UART

All register descriptions follow a fixed convention. The possible operations for each bit within a register are as follows:

R - The bit is a read only status bit.

R/W - The bit is readable and writable.

R/C - The bit is cleared by writing a one to itself.

W - The bit is a write only bit.

## 8.2.6 PCI Local Bus Memory Map

There are two PCI local buses on the CPCI-6115: PCI Bus 0.0 and PCI Bus 1.0. The only device on PCI Bus 0.0 is PMC 2. The PCI devices on PCI Bus 1.0 are PMC 1, the CMD 646U2 IDE controller and the Intel 21555 PCI-to-PCI bridge.

## 8.2.7 CompactPCI Memory Map

The CPCI-6115 uses the 21555 non-transparent PCI-to-PCI bridge to interface between the local PCI bus and the CompactPCI bus. The 21555 is different from traditional PCI-to-PCI bridges in that it uses address translation instead of a flat address map between primary and secondary PCI buses. In the CPCI-6115 configuration, the primary bus is the CompactPCI bus and the secondary bus is the CPCI-6115 local bus. Downstream transactions are those that are initiated on the primary bus and are forwarded to the secondary bus. Upstream transactions are those initiated on the secondary bus and forwarded to the primary bus.

## 8.2.8 Address Decoding with the 21555

The 21555 implements multiple base address registers on both the primary and secondary interfaces that denote separate address ranges for both downstream and upstream transactions. It also has base registers for access to its Control and Status Register (CSR) space. Consequently, on the primary interface (CompactPCI bus) the 21555 responds only to those transactions which are in the address range defined by one of the base address ranges. All other addresses are ignored. The same is true for transactions on the secondary interface (local PCI bus).

The address ranges defined by the primary base address registers reside in the primary or system address map. The address ranges defined by the secondary base address registers reside in the secondary or local address map. Each of these address maps is independent of each other. The 21555 provides address translation between these two address maps when forwarding transactions upstream or downstream.

Recommendations for CompactPCI mapping can be found in the MCPN905 CompactPCI Single Board Computer Programmer's Reference Guide (MCPN905A/PG).

## 8.2.9 L1, L2 and L3 Cache

The CPC1-6115 supports the MPC7457 processor on-chip L1 and L2 caches with 2 MB of external L3 cache installed. The CPC1-6115 L3 memory consists of two 8 megabit (256Kx36, 300 MHz, 1.9 ns access) devices providing a total of 2 MB of memory. Data parity checking should be enabled. The following settings assume a processor speed of 1000 MHz and L3 clock speed of 200 MHz.

Table 8-6 Apollo L3CR Register Assignments

Apollo L3CR Register	Description	Value
L3SIZ	L3 size, 1 MB	0b
L3RT	L3 SRAM type, DDR SRAM	00b
L3PE	L3 data parity checking enable, on	1b
L3CLK	L3 Clk speed; 266 MHz, divide by 5	111b
L3CKSP	L3 clock sample point, 4 clocks	10b
L3PSP	L3 P-clock sample point, 3 clocks	011b

Refer to the *PowerPC™ Apollo Microprocessor Implementation Definition Book IV* for more information (Addendum to SC-Vger Book IV Version - 1.0 04/21/00).

## 8.2.10 System Memory

The CPC1-6115 system memory capability is controlled through an I<sup>2</sup>C compatible serial controller integrated into the MV64360 system controller.



## A.1 Embedded Communications Computing Documents

The Motorola publications listed below are referenced in this manual, or apply to systems that use this product. You can obtain paper or electronic copies of Embedded Communications Computing publications by:

- Contacting your local Motorola sales office, or
- Visiting the Embedded Communications Computing World Wide Web literature site, <http://www.motorola.com/computer literature>.

Table A-1 Motorola ECC Documents

Document Title	Publication Number
MCPN905 CompactPCI Single Board Computer Programmer's Reference Guide	MCPN905A/PG
MOTLoad Firmware Package User's Manual	MOTLODA/UM

## A.2 Manufacturers' Documents

For additional information, refer to the following table for manufacturers' data sheets or user's manuals. As an additional help, a source for the listed document is provided. Please note that, while these sources have been verified, the information is subject to change without notice.

Table A-2 Manufacturers' Documents

Document Title and Source	Publication Number or Search Term
Freescale Semiconductor <a href="http://www.freescale.com">http://www.freescale.com</a>	
PowerPC Microprocessor Family: The Programming Environments	MPCFPE32B/AD
MPC7457 RISC Microprocessor Hardware Specification WebSite:	MPC7457EC/D Rev 4, 11/2003
IBM Microelectronics <a href="http://www.ibm.com/us/">http://www.ibm.com/us/</a>	
Programming Environments for 32-Bit Microprocessors	G522-0290-01
Marvell <a href="http://www.marvell.com">http://www.marvell.com</a>	
MV64360 System Controller	MV64360
Intel <a href="http://www.intel.com">http://www.intel.com</a>	
3 Volt Intel Strata Flash Memory, 28F128J3A	298130xx 290667

Table A-2 Manufacturers' Documents (continued)

Document Title and Source	Publication Number or Search Term
Intel 21555 Non-Transport PCI-to-PCI Bridge	278320xx
Texas Instruments <a href="http://www.ti.com">http://www.ti.com</a>	
TL 16C550C UART	SLLS177C
ATMEL <a href="http://www.atmel.com/atmel/support">http://www.atmel.com/atmel/support</a>	
ATMEL Nonvolatile Memory Data Book	AT24Cxx AT93CV6
Broadcom <a href="http://www.broadcom.com">http://www.broadcom.com</a>	
BCM5421S 10/100/1000Base-T Gigabit Transceiver with SERDES Interface	5421S-DS02R 09/25/01
CMD <a href="http://www.cmd.com">http://www.cmd.com</a>	
CMD PCI 646U2 5V Ultra ATA/33 PCI-IDE Controller Users Manual	Man-064602-000 PCI0646U2.pdf

## A.3 Related Specifications

The following table lists the product's related specifications. The appropriate source for the listed document is also provided. Please note that in many cases, the information is preliminary and the revision levels of the documents are subject to change without notice.

Table A-3 Related Specifications

Document Title and Source	Publication Number
IEEE <a href="http://standards.ieee.org/catalog/">http://standards.ieee.org/catalog/</a>	
IEEE Standard for Local Area Networks: Carrier Sense Multiple Access with Collision Detection (CSMA/CD) Access Method and Physical Layer Specifications Institute of Electrical and Electronics Engineers, Inc.	IEEE 802.3
IEEE - PCI Mezzanine Card Specification (PMC) Institute of Electrical and Electronics Engineers, Inc.	P1386.1 Draft 2.0
IEEE - Common Mezzanine Card Specification (CMC) Institute of Electrical and Electronics Engineers, Inc.	P1386 Draft 2.0
Peripheral Component Interconnect (PCI) Local Bus Specification, Revision 2.0, 2.1, 2.2 <a href="http://www.pcisig.com">http://www.pcisig.com</a> (PCI Special Interest Group)	PCI Local Bus Specification
Interface Between Data Terminal Equipment and Data Circuit-Terminating Equipment Employing Serial Binary Data Interchange; Electronic Industries Alliance; <a href="http://global.ihs.com/index.cfm">http://global.ihs.com/index.cfm</a> (for publications)	TIA/EIA-232 Standard

Table A-3 Related Specifications (continued)

Document Title and Source	Publication Number
PowerPC Reference Platform (PRP) Specification, Third Edition, Version 1.0, Volumes I and II International Business Machines Corporation <a href="http://www.ibm.com">http://www.ibm.com</a>	MPR-PPC-RPU-02
PCI-X Addendum to the PCI Local Bus Specification <a href="http://www.pcisig.com">http://www.pcisig.com</a> (PCI Special Interest Group)	Rev. 1.0a 7/24/00
PowerPC Microprocessor Common Hardware Reference Platform: A System Architecture (CHRP), Version 1.0 Morgan Kaufmann Publishers, Inc. Telephone: (415) 392-2665 Telephone: 1-800-745-7323 <a href="http://www.mkp.com">http://www.mkp.com</a>	ISBN 1-55860-394-8
Compact PCI Specification PCI Industrial Manufacturers Group (PICMG) <a href="http://www.picmg.com">http://www.picmg.com</a>	PICMG 2.0 R3.0 10/1/99
CompactPCI Hot-Swap Specification PCI Industrial Manufacturers Group (PICMG) <a href="http://www.picmg.com">http://www.picmg.com</a>	PICMG 2.1 R2.0 1/17/01
CompactPCI Packet Switching Backplane Specification PCI Industrial Manufacturers Group (PICMG) <a href="http://www.picmg.com">http://www.picmg.com</a>	PICMG 2.16
CompactPCI System Management Specification PCI Industrial Manufacturers Group (PICMG) <a href="http://www.picmg.com">http://www.picmg.com</a>	PICMG 2.9
VITA-32-199x Processor PMC Standard for Processor PMC Mezzanine Cards VITA Standards Organization <a href="http://www.vita.com/">http://www.vita.com/</a>	VITA32 Draft 0.2





## Numerics

21555  
dual address mapping role 130

## A

address decoding  
with 21555 130  
applying power 47  
asynchronous serial ports  
pin assignments 52

## C

COM1  
pin assignments (905) 52  
command line rules  
MOTLoad 120  
comments, sending 16  
CompactPCI bus  
21555 limited address selection 130  
CompactPCI Memory Map 129  
compliances 26  
Control and Status Register 130  
CPCI-6115  
block diagram 68  
described 69  
features 25

## D

damage reporting 30  
disposal of product 27, 30

## E

EMC requirements 26  
environmental requirements 26, 29  
equipment required  
to complete CPCI-6115 system 36

## F

features  
CPCI-6115 25  
field defined  
command options (Remote Start) 115  
firmware  
as initialization agent 47

## H

hardware configuration 36  
hardware management components 115  
help command  
MOTLoad 120

## I

inspecting shipment 29

## J

J10  
jumper settings 39  
J3 connector (905)  
pin assignments 55  
J5 connector (905)  
pin assignments 57  
jumper settings  
baseboard 37

## L

list of commands  
MOTLoad 121

## M

manufacturer's documents 131  
memory maps 125  
MOTLoad  
command characteristics 119  
command line help 120  
command line rules 120  
command types 118  
command versus test 118  
described 117  
how employed 117  
interface 119  
list of commands 121  
memory requirements 117  
prompt explained 119  
test suites 119  
tests described 118

## O

OpenHPI description 115  
operational differences  
baseboard 42  
ordering product 27

## P

PCI Local Bus  
Memory Map 129  
pin assignments  
COM1 (905) 52  
connector listing 49  
front panel Ethernet connectors (905) 53  
J1 connector (905) 54  
J1 connector (TM) 93  
J1/J2 connectors (905) 53

---

- J10 connector (TM) [93](#)
- J10 header (905) [64](#)
- J11/J21 connectors (905) [59](#)
- J12/J22 connectors (905) [60](#)
- J13/J23 connectors (905) [61](#)
- J14/J24 connectors (905) [62](#)
- J14/J24 connectors (TM) [96](#)
- J15 header (905) [66](#)
- J16 header (905) [63](#)
- J17 header (905) [63](#)
- J2 connector (905) [54](#)
- J20 connector (TM) [95](#)
- J20 header (905) [65](#)
- J25 (MXP version) connector (TM) [100](#)
- J25 connector (TM) [100](#)
- J25 header (905) [65](#)
- J3 connector (905) [55](#)
- J3 connector (TM) [97](#)
- J5 connector (905) [57](#)
- J5 connector (TM) [98](#)
- J6 header (905) [65](#)
- J9 header (905) [64](#)
- J99 header (905) [66](#)
- power requirements [29](#)
- preparation
  - baseboard [36](#)
- product, how to order [27](#)

## R

- related specifications [132](#)
- Remote Start
  - command options field [115](#)
- reset sources [86](#)

## S

- software
  - OpenHPI [115](#)
- specification
  - compliance [26](#)
- specifications
  - CPCI-6115 [30](#)
- Stand-Alone Operating Mode (J10) [39](#)
- standard compliance [26](#)
- start-up procedure
  - overview [35](#)
- suggestions, submitting [16](#)
- system memory
  - device assignments [130](#)
- system startup sequence [48](#)

## T

- thermal requirements [29](#)
- transition module
  - features [91](#)
  - overview [89](#)
- transition modules
  - PMC support [89](#)

## Free Manuals Download Website

<http://myh66.com>

<http://usermanuals.us>

<http://www.somanuals.com>

<http://www.4manuals.cc>

<http://www.manual-lib.com>

<http://www.404manual.com>

<http://www.luxmanual.com>

<http://aubethermostatmanual.com>

Golf course search by state

<http://golfingnear.com>

Email search by domain

<http://emailbydomain.com>

Auto manuals search

<http://auto.somanuals.com>

TV manuals search

<http://tv.somanuals.com>