

MOCK-UP DRAFT

7 May 09



Panasonic®

Operating Instructions CD Stereo System

Model No. **SC-AK580**

Dear Customer

Thank you for purchasing this product.

For optimum performance and safety, please read these instructions thoroughly before connecting, operating or adjusting this product.

Please keep this manual for future reference.

These operating instructions are applicable to the following system.

System	SC-AK580
Main unit	SA-AK580
Speakers	SB-AK780

Supplied Accessories

Please check and identify the supplied accessories.

1 x AC mains lead

1 x FM indoor antenna

2 x Remote control
batteries

1 x AM loop antenna

1 x Remote Control

(N2QAYB000424)



Operations in these instructions are described mainly using the remote control, but you can perform the operations on the main unit if the controls are the same.

Your unit may not look exactly the same as illustrated.

GN

RQTX0271-B



CAUTION!

THIS PRODUCT UTILIZES A LASER.
USE OF CONTROLS OR ADJUSTMENTS OR PERFORMANCE OF PROCEDURES OTHER THAN THOSE SPECIFIED HEREIN MAY RESULT IN HAZARDOUS RADIATION EXPOSURE. DO NOT OPEN COVERS AND DO NOT REPAIR YOURSELF. REFER SERVICING TO QUALIFIED PERSONNEL.

CAUTION	- CLASS 1M INVISIBLE LASER RADIATION WHEN OPEN. DO NOT VIEW DIRECTLY WITH OPTICAL INSTRUMENTS. IEC60825-1 +A2 Class 1M
VARNING	- KLASS 1M OSYNLIG LASERSTRÅLING NÄR DENNA DEL ÄR ÖPPNAD. BETRÄKTA EJ STRÅLEN DIREKT GENOM OPTISKT INSTRUMENT.
FORSIGTIG	- USYNLIG LASERSTRÅLING KLASSE 1M. NÄR LÅGET ER ÅBENT. UNDGÅ AT SELUGE PÅ MED OPTISKE INSTRUMENTER.
VARO!	- AVATTAASSA OLET ALTIIN LUKOKAN 1M NÄKYMÄTÖNTÄ LASERSÄTELYÄ. ÄLÄ KATSO OPTISELLÄ LAITTEELLA SUORAAN SÄTEESEEN.
VORSICHT	- UNSICHTBARE LASERSTRÄHLUNG KLASSE 1M. WENN ABDECKUNG GEÖFFNET. NICHT DIREKT MIT OPTISCHEN INSTRUMENTEN BETRACHTEN.
ATTENTION	- RAYONNEMENT LASER INVISIBLE. CLASSE 1M EN CAS D'OUVERTURE. NE PAS REGARDER DIRECTEMENT AL ADRE D'INSTRUMENTS D'OPTIQUE.
PRECAUCIÓN	- RADIACIÓN LASER INVISIBLE DE CLASE 1M AL ESTAR ABIERTO. NO VEA DIRECTAMENTE CON INSTRUMENTOS ÓPTICOS.
注意	- ここを開くと不可視レーザー光が出ます。ビームを見たり、触れたりしないでください。
注意	- 打开时有不可见激光辐射。避免光照射。

Inside of product

WARNING:

TO REDUCE THE RISK OF FIRE, ELECTRIC SHOCK OR PRODUCT DAMAGE,

- DO NOT EXPOSE THIS APPARATUS TO RAIN, MOISTURE, DRIPPING OR SPLASHING AND THAT NO OBJECTS FILLED WITH LIQUIDS, SUCH AS VASES, SHALL BE PLACED ON THE APPARATUS.
- USE ONLY THE RECOMMENDED ACCESSORIES.
- DO NOT REMOVE THE COVER (OR BACK); THERE ARE NO USER SERVICEABLE PARTS INSIDE. REFER SERVICING TO QUALIFIED SERVICE PERSONNEL.

- If you see this symbol -

Information on Disposal in other Countries outside the European Union



This symbol is only valid in the European Union. If you wish to discard this product, please contact your local authorities or dealer and ask for the correct method of disposal.

CAUTION!

- DO NOT INSTALL OR PLACE THIS UNIT IN A BOOKCASE, BUILT-IN CABINET OR IN ANOTHER CONFINED SPACE. ENSURE THE UNIT IS WELL VENTILATED. TO PREVENT RISK OF ELECTRIC SHOCK OR FIRE HAZARD DUE TO OVERHEATING, ENSURE THAT CURTAINS AND ANY OTHER MATERIALS DO NOT OBSTRUCT THE VENTILATION VENTS.
- DO NOT OBSTRUCT THE UNIT'S VENTILATION OPENINGS WITH NEWSPAPERS, TABLECLOTHS, CURTAINS, AND SIMILAR ITEMS.
- DO NOT PLACE SOURCES OF NAKED FLAMES, SUCH AS LIGHTED CANDLES, ON THE UNIT.
- DISPOSE OF BATTERIES IN AN ENVIRONMENTALLY FRIENDLY MANNER.

The socket outlet shall be installed near the equipment and easily accessible.

The mains plug of the power supply cord shall remain readily operable.

To completely disconnect this apparatus from the AC Mains, disconnect the power supply cord plug from AC receptacle.

This product may receive radio interference caused by mobile telephones during use. If such interference is apparent, please increase separation between the product and the mobile telephone.

THIS UNIT IS INTENDED FOR USE IN MODERATE CLIMATES.

Safety precautions

Placement

Set the unit up on an even surface away from direct sunlight, high temperatures, high humidity, and excessive vibration. These conditions can damage the cabinet and other components, thereby shortening the unit's service life.

Place it at least 15 cm away from wall surfaces to avoid distortion and unwanted acoustical effects.

Do not place heavy items on the unit.

Voltage

Do not use high voltage power sources. This can overload the unit and cause a fire.

Do not use a DC power source. Check the source carefully when setting the unit up on a ship or other places where DC is used.

AC mains lead protection

Ensure the AC mains lead is connected correctly and not damaged. Poor connection and lead damage can cause fire or electric shock. Do not pull, bend, or place heavy items on the lead.

Grasp the plug firmly when unplugging the lead. Pulling the AC mains lead can cause electric shock.

Do not handle the plug with wet hands. This can cause electric shock.

Foreign matter

Do not let metal objects fall inside the unit. This can cause electric shock or malfunction.

Do not let liquids get into the unit. This can cause electric shock or malfunction. If this occurs, immediately disconnect the unit from the power supply and contact your dealer.

Do not spray insecticides onto or into the unit. They contain flammable gases which can ignite if sprayed into the unit.

Service

Do not attempt to repair this unit by yourself. If sound is interrupted, indicators fail to light, smoke appears, or any other problem that is not covered in these instructions occurs, disconnect the AC mains lead and contact your dealer or an authorized service centre. Electric shock or damage to the unit can occur if the unit is repaired, disassembled or reconstructed by unqualified persons.

Extend operating life by disconnecting the unit from the power source if it is not to be used for a long time.

Table of contents

Safety precautions	3
Placement of speakers.....	4
Preparing the remote control	4
Making the connections.....	5
DEMO function.....	6
Handling of the disc trays and discs	6
Overview of controls	7
Discs	9
Using the FM/AM radio.....	11
USB	12
Using the timers	15
Using sound effects	16
Using the microphone.....	16
Using other equipments	17
Troubleshooting guide	18
Maintenance.....	19
When moving the unit	19
Specifications	20

Placement of speakers

Speakers are designed identically so that no left or right channel orientation is necessary.

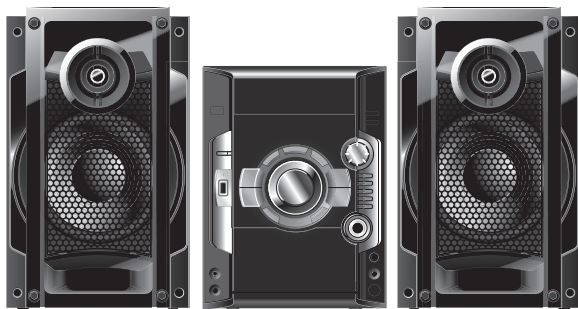

You cannot take the front net off the speakers.

Use only the supplied speakers.

The combination of the main unit and speakers provide the best sound. Using other speakers can damage the unit and sound quality will be negatively affected.

Note:

- Keep your speakers at least 10mm away from the system for proper ventilation.
- These speakers do not have magnetic shielding. Do not place them near televisions, personal computers or other devices easily influenced by magnetism.
- You can damage your speakers and shorten their useful life if you play sound at high levels over extended periods.
- Reduce the volume in the following cases to avoid damage.
 - When playing distorted sound.
 - When adjusting the sound quality.

Caution

- **Use the speakers only with the recommended system. Failure to do so can damage the amplifier and speakers, and can cause fire. Consult a qualified service person if damage occurs or if a sudden change in performance is apparent.**
- **Do not attach these speakers to walls or ceilings.**

Preparing the remote control

Use alkaline or manganese batteries.

Insert so the poles (+ and -) match those in the remote control.

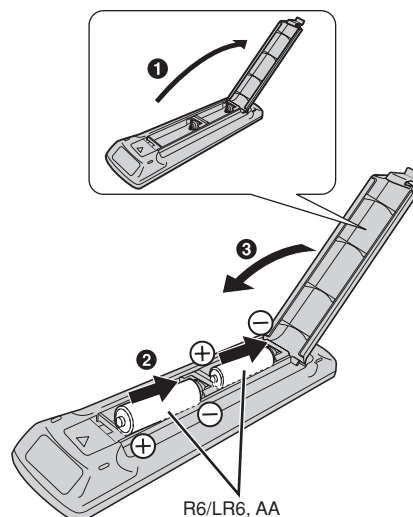

Aim at the remote control signal sensor (→ page 7), avoiding obstacles, at a maximum range of 7 m directly in front of the unit.

Note on using the remote control

- Do not mix old and new batteries.
- Do not use different types of batteries at the same time.
- Do not take apart or short circuit the batteries.
- Do not attempt to recharge alkaline or manganese batteries.
- Do not use batteries if the covering has been peeled off.
- Do not heat or expose to flame.
- Do not leave the battery(ies) in an automobile exposed to direct sunlight for a long period of time with doors and windows closed.
- Mishandling of batteries in the remote control can cause electrolyte leakage, which may cause a fire.
- Remove the batteries if the remote control is not going to be used for a long period of time. Store in a cool, dark place.

CAUTION

Danger of explosion if battery is incorrectly replaced. Replace only with the same or equivalent type recommended by the manufacturer. Dispose of used batteries according to the manufacturer's instructions.

Making the connections

Connect the AC mains lead only after all the other connections have been made.

Antenna connections

Place the antenna where reception is best.

FM indoor antenna

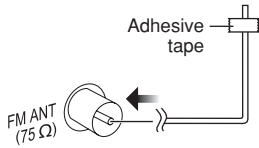

AM loop antenna

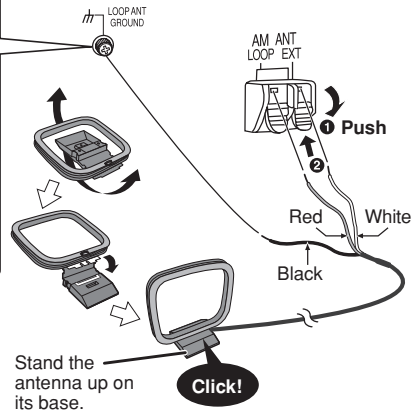
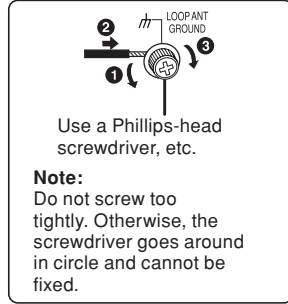

Please refer to "Connecting to other external unit" on page 17 for more information on the AUX connection.

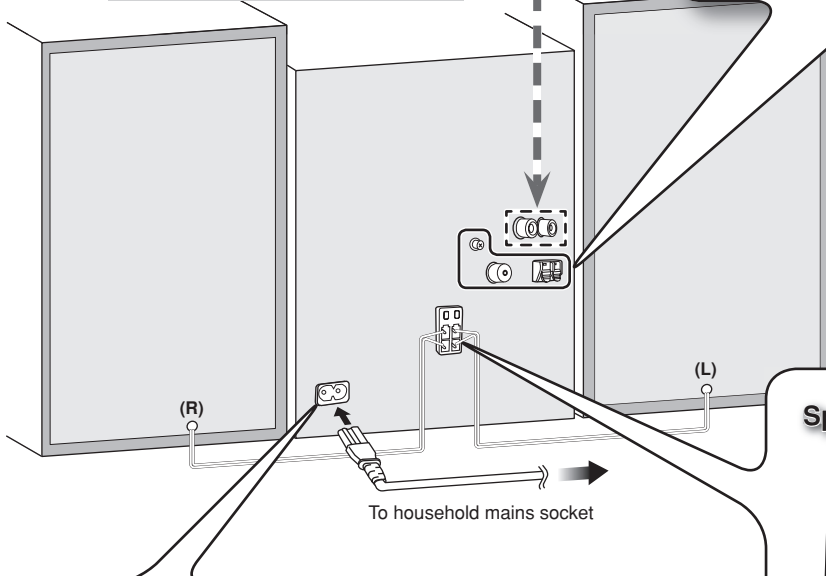

Speaker connections

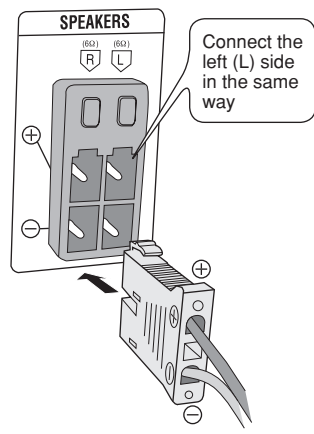

AC mains lead connection

Insertion of connector

Even when the connector is perfectly inserted, depending on the type of inlet used, the front part of the connector may jut out as shown in the drawing. However there is no problem using the unit.

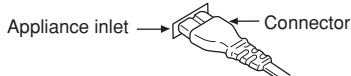

For your reference

To save power when the unit is not to be used for a long time, unplug it from the household mains socket. You will need to reset some memory items after plugging in the unit.

Note:

- The included AC mains lead is for use with this unit only. Do not use it with other equipment.
- Do not use an AC mains lead from other equipment.

RQTX0271

Making the connections (continued)

Optional antenna connections

Use an outdoor antenna if radio reception is poor.

Note:

Disconnect the outdoor antenna when the unit is not in use.
Do not use the outdoor antenna during a lightning storm.

FM outdoor antenna

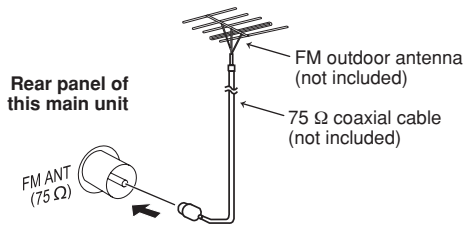

- Disconnect the FM indoor antenna.
- The antenna should be installed by a competent technician.

AM outdoor antenna

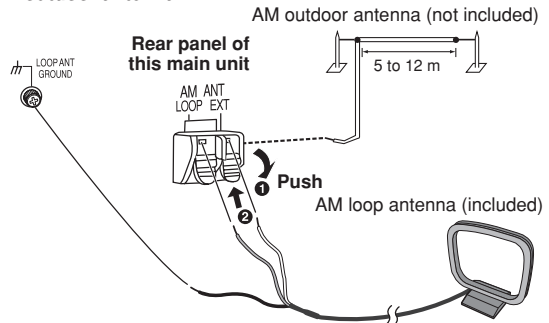

- Run a piece of vinyl wire horizontally across a window or other convenient location.
- Leave the loop antenna connected.

DEMO function

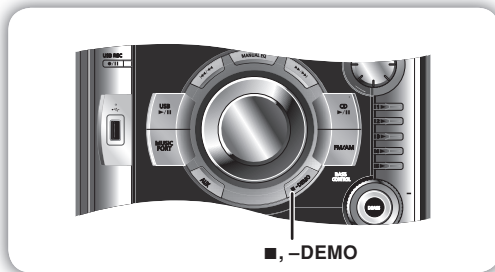

When the unit is first plugged in, a demonstration of its functions may be shown on the display.

If the demo setting is off, you can show a demonstration by selecting "DEMO ON".

Press and hold [■, -DEMO] (demo) on the main unit.

The display changes each time you press and hold the button.
DEMO OFF (off) ↔ DEMO ON (on)

While in standby mode, select "DEMO OFF" to reduce power consumption.

Note:

DEMO function cannot be turned on when dimmer function is on.

Handling of the disc trays and discs

Not doing the following will cause damage to the unit.

Removing the mains plug

Press [⏻/I] to turn off the unit and remove the mains plug only after all the displays have disappeared.

Inserting a disc

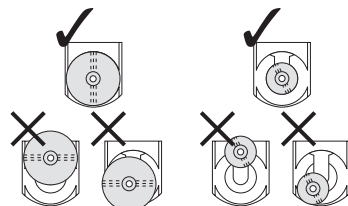

Tray caution

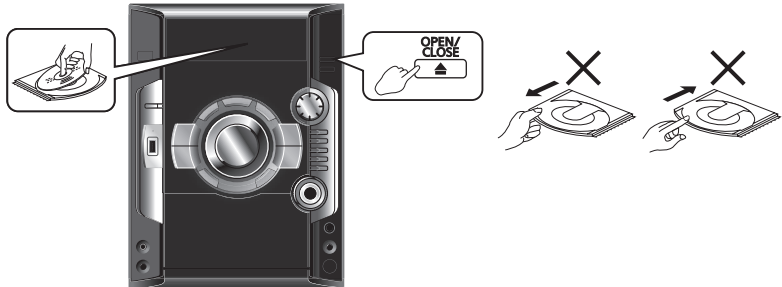

- Place the disc correctly with the label facing up as shown in the diagram.
- Insert one disc into the tray.

- Always press [▲, OPEN/CLOSE] to insert or remove a disc.
- Do not push or pull out the tray by hand as this will cause an accident.

Overview of controls

Main unit

Refer to the numbers in parentheses for page reference. Buttons labelled such as ❶ function in exactly the same way as the controls on the remote control (➔ page 8).

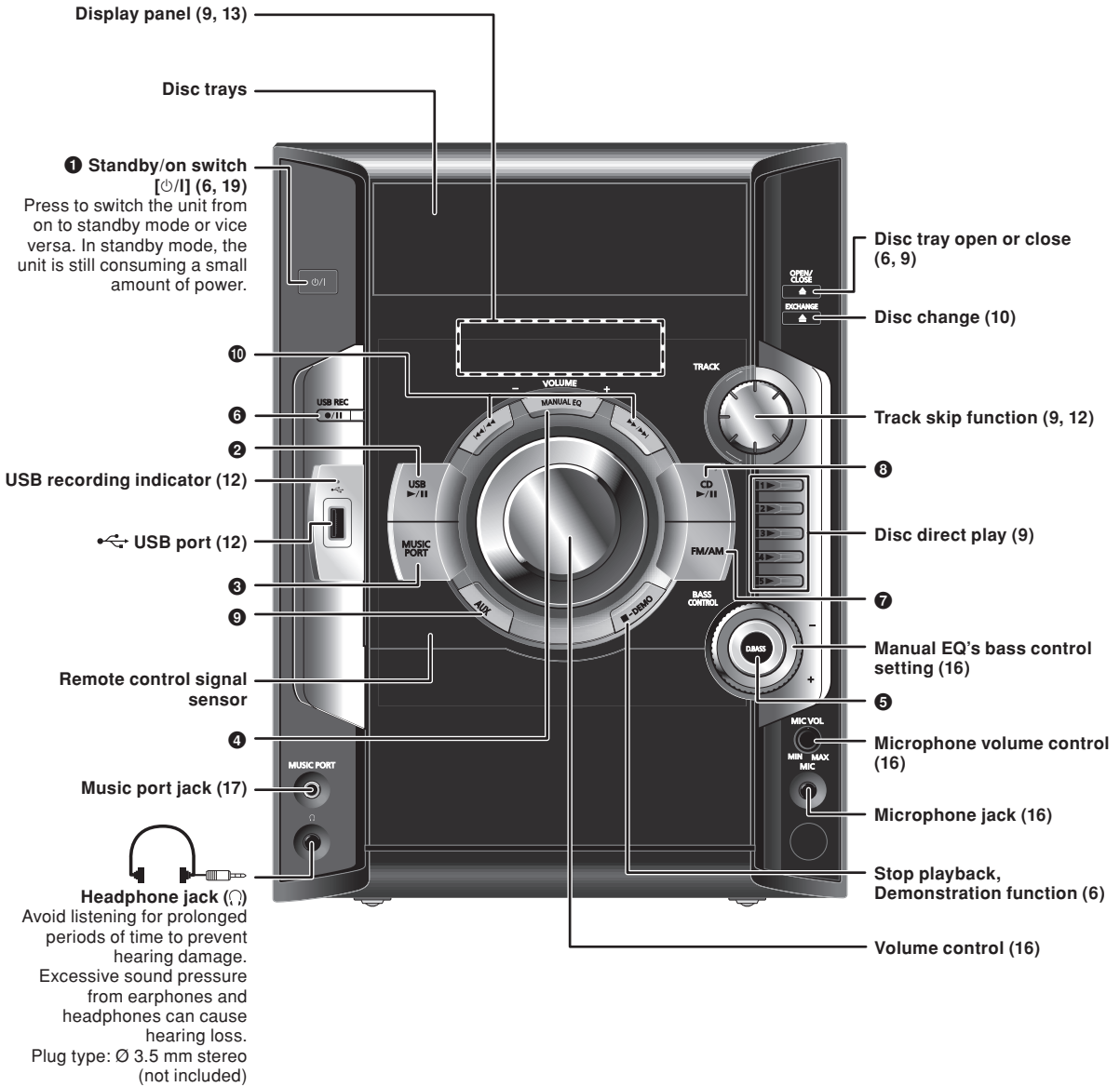

Overview of controls (continued)

Remote control

Buttons labelled such as ❶ function in exactly the same way as the controls on the main unit (➔ page 7).

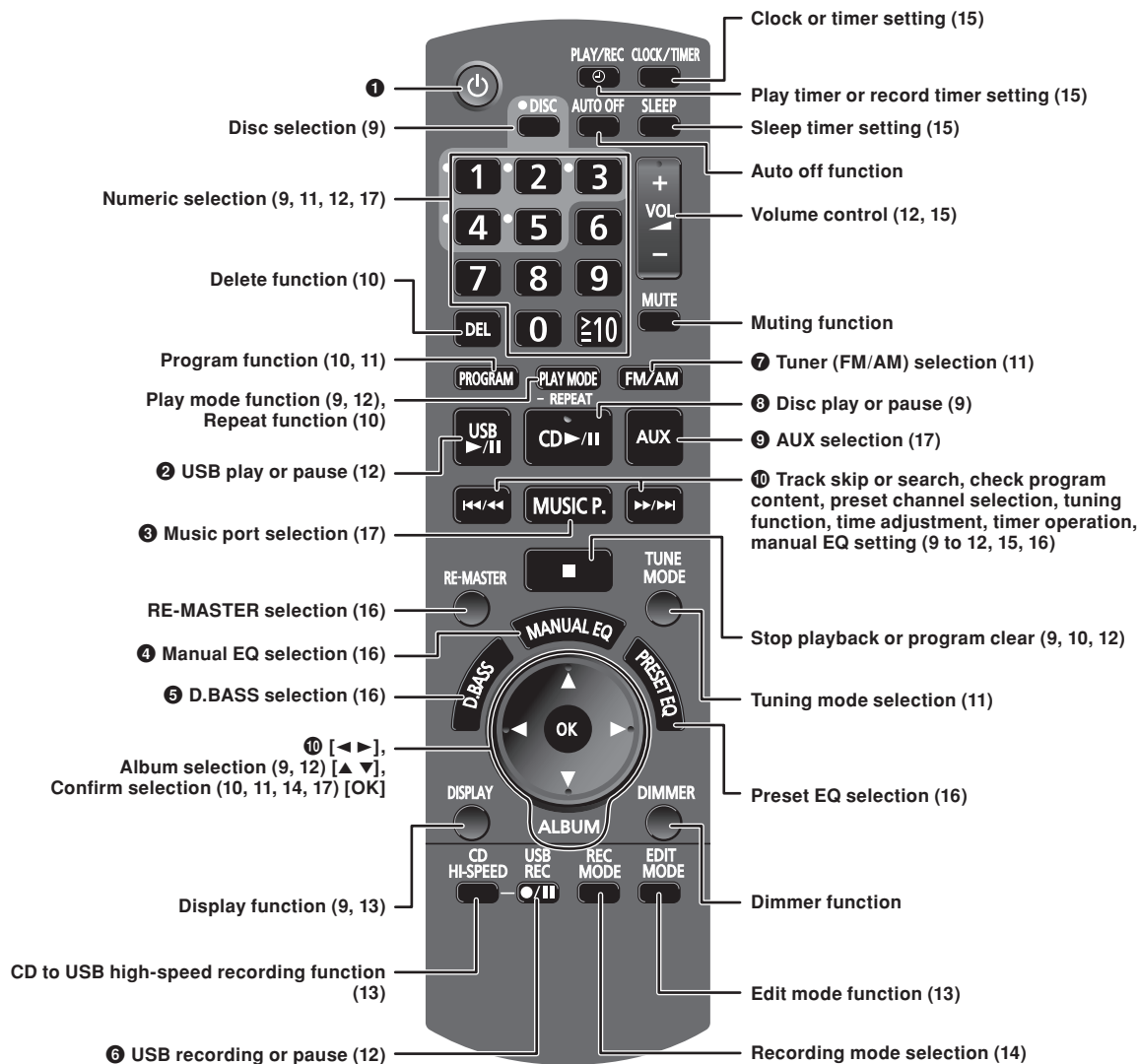

<p style="text-align: center;">AUTO OFF</p> <p style="text-align: center;"></p> <p>This auto off function allows you to turn off the unit in disc or USB mode only after left unused for 10 minutes.</p> <ul style="list-style-type: none"> • Press the button to activate the function. • Press the button again to cancel. • The setting is maintained even if the unit is turned off. 	<p style="text-align: center;">DIMMER</p> <p style="text-align: center;"></p> <p>To dim the display panel.</p> <ul style="list-style-type: none"> • Press the button to activate the function. • Press the button again to cancel. 	<p style="text-align: center;">MUTE</p> <p style="text-align: center;"></p> <p>To mute the sound.</p> <ul style="list-style-type: none"> • Press the button to activate the function. • Press the button again or adjust the volume to cancel.
---	---	---

RQTX0271

Discs







Basic play

- Press [▲, OPEN/CLOSE] on the main unit to open the tray. The unit turns on, load a disc in the current tray with the label facing up. Press [▲, OPEN/CLOSE] to close the tray.
- Press [▶/⏸, CD] to start play. You can also press [▶, 1] ~ [▶, 5] or [● DISC] and then [* 1] ~ [* 5] to select and play the other loaded discs.

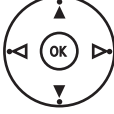

Current disc indicator

<p>Stop playback</p> 	<p>Press [■] (stop) during play.</p> <p>MP3 Display when in the stop mode: Example: "MP3" indicates the disc contains MP3 files.</p> <p>Total number of albums Total number of tracks</p> 
<p>Pause play</p> 	<p>Press [▶/⏸, CD] during play. Press again to resume play.</p>
<p>Skip album</p> 	<p>MP3 Press [▲/▼, ALBUM] to select the desired album during play or when in stop mode.</p> <ul style="list-style-type: none"> This function does not work during 1-DISC RANDOM mode.
<p>Skip tracks</p> 	<p><u>During play</u> Press [◀◀/▶▶] or [▶▶/▶▶], or turn [TRACK] to skip to your desired track.</p> <p><u>While in stop mode</u> Press [◀◀/▶▶] or [▶▶/▶▶] followed by [▶/⏸, CD] to skip and play your desired track. Alternatively, turn [TRACK] to skip and play your desired track.</p> <ul style="list-style-type: none"> During random play (→ see right, "Play Mode function"), you cannot skip to tracks which have been played. <p>MP3 During 1-ALBUM and 1-ALBUM RANDOM mode, track skipping can only be done within the current album.</p>
<p>Search through tracks</p> 	<p>CD Press and hold [◀◀/▶▶] or [▶▶/▶▶] during play or pause to search.</p> <ul style="list-style-type: none"> During program play (→ page 10), or random play (→ see right, "Play Mode function"), you can search only within the track.

PLAY MODE

- REPEAT

Play Mode function



CD **MP3**

You can listen to specific discs and tracks.

Preparation

Select and play your desired disc.

Press [PLAY MODE] to select the desired mode.

<p>1-DISC 1 DISC</p>	<p>Play one selected disc.</p>
<p>ALL-DISC ALL DISC</p>	<p>Play all loaded discs in succession from the selected disc to the final disc. Example: 4 → 5 → 1 → 2 → 3.</p>
<p>1-TRACK 1-TR</p>	<p>Play one selected track on the selected disc. Press the numeric buttons to select the track in the current disc.</p>
<p>1-ALBUM 1-ALB</p> 	<p>MP3 Play one selected album on the selected disc. Press [▲/▼, ALBUM] to select the album.</p>
<p>1-DISC RANDOM 1 DISC RND</p>	<p>Play one selected disc randomly.</p>
<p>1- ALBUM RANDOM 1-ALB RND</p> 	<p>MP3 Play all tracks in one selected album randomly. Press [▲/▼, ALBUM] to select the album.</p>
<p>ALL-DISC RANDOM ALL DISC RND</p>	<p>CD Play all loaded discs randomly.</p>

When playback ends

The current play mode will be retained in memory until it is changed even if the unit is turned off.

Note:

You cannot use program mode together with "Play Mode function".

DISPLAY

Checking the track information

You can view the information of the current track from the display panel.

Press [DISPLAY] repeatedly during play or pause.

CD

Elapsed play time ↔ Remaining play time

MP3

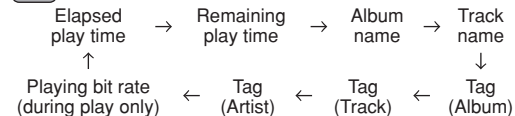

Note:

MP3

- "NO TAG" is displayed if titles with tags have not been entered.
- This unit can display album, track and artist name with MP3 ID3 tags (version 1.0 and 1.1).
- Titles containing text data that the unit does not support may be differently displayed.
- ID3 is a tag embedded in MP3 track to provide information about the track.
- Titles entered with 2-byte code cannot be displayed correctly on this unit.

Discs (continued)

EXCHANGE



Changing multiple discs

By main unit only

Press [**▲**, EXCHANGE] repeatedly to check and change multiple discs.

Note:

- The tray with a disc being played will not open.
- If the player is stopped, all trays will open. To close the remaining trays simultaneously, press [**▲**, OPEN/CLOSE].

Advanced play

PROGRAM

Program play

This function allows you to program up to 24 tracks.

CD

- 1 Press [**▶/⏸**, CD] and then [**■**] (stop).
- 2 Press [PROGRAM].
"PGM" appears.
- 3 Press [**●** DISC] and then [* 1] ~ [* 5] to select the disc.
- 4 Press the numeric buttons to select your desired track.
Repeat steps 3 and 4 to program other tracks.
- 5 Press [**▶/⏸**, CD] to start play.

MP3

- 1 Press [**●** DISC] and then [* 1] ~ [* 5] to select the disc.
- 2 Press [**■**] (stop).
- 3 Press [PROGRAM].
- 4 Press [**▲/▼**, ALBUM] to select your desired album.
- 5 Press [**◀/▶**] or [**▶▶/▶▶**] to select the track.
To select a track directly, press the numeric buttons after press [**◀/▶**] or [**▶▶/▶▶**].
- 6 Press [OK].
Repeat steps 4 to 6 to program other tracks.
- 7 Press [**▶/⏸**, CD] to start play.

For two-digit track, press [≥ 10] once then the two digits.
For three-digit track, press [≥ 10] twice then the three digits.

Cancel program mode	Press [PROGRAM] in the stop mode.
Replay the program	Press [PROGRAM] then [▶/⏸ , CD] in the stop mode.
Add to the program	<p>CD</p> <p>Repeat steps 3 and 4 in the stop mode.</p> <p>MP3</p> <p>Repeat steps 4 to 6 in the stop mode.</p>
Check program contents	<p>Press [◀/▶] or [▶▶/▶▶] when "PGM" is displayed in the stop mode.</p> <p>CD</p> <p>The track number, program order and disc number are displayed:</p> <div style="text-align: center;"> <p>Track number Program order</p> </div> <p>MP3</p> <p>The program order is displayed followed by the album number and track number.</p>

Clear the last track	Press [DEL] in the stop mode.
Clear all programmed tracks	Press [■] (clear) in the stop mode. "CLEAR ALL" is displayed.

Note:

- You cannot program CD-DA together with MP3 tracks.
- The program memory is cleared when you change a disc or open the disc tray.

MP3

- You cannot program more than one disc.

PLAY MODE

- REPEAT

Repeat play

CD MP3

You can repeat program play or other selected play mode.

Press and hold [- REPEAT].

"REPEAT ON" and "**⏮**" are displayed.

To cancel

Press and hold [- REPEAT] again.

"REPEAT OFF" is displayed and "**⏮**" is cleared.

Note:

You can use repeat mode with "Program play" (→ see left) and "Play Mode function" (→ page 9).

NOTE about using a DualDisc

The digital audio content side of a DualDisc does not meet the technical specifications of the Compact Disc Digital Audio (CD-DA) format so playback may not be possible.

NOTE on CDs

- This unit can access up to 99 tracks.
- This unit can play MP3 files and CD-DA format audio CD-R/RW that have been finalised.
- It may not be able to play some CD-R/RW due to the condition of the recording.
- Do not use irregularly shaped disc.
- Do not use disc with labels and stickers that are coming off or with adhesive exuding from under labels and stickers.
- Do not attach extra labels or stickers on the disc.
- Do not write anything on the disc.

NOTE on MP3

- Files are treated as tracks and folders are treated as albums.
- This unit can access up to 999 tracks, 255 albums and 20 sessions.
- Disc must conform to ISO9660 level 1 or 2 (except for extended formats).
- To play in a certain order, prefix the folder and file names with 3-digits numbers in the order you want to play them.

When "PLAYERERROR" appears on the display, an unsupported MP3 format is being played. The unit will skip that track and play the next one.

Limitations on MP3 play

- If you have recorded MP3 on the same disc as CD-DA, only the format recorded in the first session can be played.
- Some MP3s may not be played due to the condition of the disc or recording.
- Recordings will not necessarily be played in the order you recorded them.

Using the FM/AM radio



- 1** Press [FM/AM] to select “FM” or “AM”.
- 2** Press [TUNE MODE] to select “MANUAL”.
- 3** Press [◀◀/▶▶] or [▶▶/▶▶] to select the frequency of the required station.
“ST” is displayed when a stereo FM broadcast is being received.

To tune automatically

Press and hold [◀◀/▶▶] or [▶▶/▶▶] until the frequency starts changing rapidly. The unit begins auto tuning, stopping when it finds a station.

- Auto tuning may be interrupted when there is excessive interference.
- To cancel auto tuning, press [◀◀/▶▶] or [▶▶/▶▶] once again.

TUNE MODE



To improve the sound quality

When “FM” is selected

Press and hold [TUNE MODE] to display “MONO”.

To cancel

Press and hold [TUNE MODE] again until “MONO” disappears.

- MONO is also cancelled if the frequency is changed.
- Turn off “MONO” for normal listening.

When “AM” is selected

Press and hold [TUNE MODE].

Each time you press button: BP2 ↔ BP1



30 FM and 15 AM stations can be preset.

Preparation

Press [FM/AM] to select “FM” or “AM”.



- 1** Press [OK] repeatedly to select either “CURRENT” or “LOWEST”.

CURRENT	Tuning begins from the current frequency.
LOWEST	Tuning begins from the lowest frequency.

- 2** Press and hold [PROGRAM] to start presetting.



The tuner presets all the stations it can receive into the channels in ascending order. When finished, the first station memorised is tuned in.

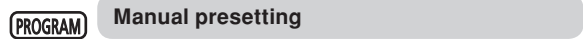

- 1** Press [TUNE MODE] to select “MANUAL”.
- 2** Press [◀◀/▶▶] or [▶▶/▶▶] to tune to the required station.
- 3** Press [PROGRAM].
- 4** Press the numeric buttons to select a channel.
The station occupying a channel is erased if another station is preset to that channel.
- 5** Repeat steps 2 to 4 to preset more stations.

TUNE MODE



Selecting a preset station

Press the numeric buttons to select the channel.

For channels 10 to 30 press [≥10], then the two digits.



OR

- 1** Press [TUNE MODE] to select “PRESET”.
- 2** Press [◀◀/▶▶] or [▶▶/▶▶] to select the channel.

USB

The USB connectivity enables you to record sound or music tracks from various sources to MP3 format and store into the USB mass storage device which can be played back. Typically, USB memory devices (bulk only transfer).

Connecting a USB mass storage device

Preparation

Before connecting any USB mass storage device to the unit, ensure that the data stored therein has been backed up.

It is not recommended to use a USB extension cable. The device connected via the cable will not be recognised by this unit.

USB enabled device
(not included)







Playing a USB mass storage device

MP3

1 Reduce the volume and connect the USB mass storage device to the USB port.

2 Press [▶/II, USB] to start play.

<p>Stop playback</p> 	<p>Press [■] (stop) during play. The current track will be memorised. Press [▶/II, USB] to resume play. OR Press [■] (stop) again to clear the position.</p>
<p>Pause play</p> 	<p>Press [▶/II, USB] during play. Press again to resume play.</p>
<p>Skip tracks</p> 	<p>Press [◀◀/▶▶] or [▶▶/▶▶], or turn [TRACK] (⇒ page 9, "Basic play"). OR Press the numeric buttons.</p>
<p>Skip album</p>  <p>ALBUM</p>	<p>Press [▲/▼, ALBUM] to select the desired album during play or when in stop mode.</p>

DISPLAY



Checking the USB status

You can check the available recording time of the USB device.

1 Press [▶/II, USB] and then [■] (stop).

2 Press [DISPLAY].

Shows the time is 10 minutes and 15 seconds



Shows the time 20 hours and 15 minutes



Recording to a USB mass storage device

Panasonic will not be held responsible on the consumer's action to record copyrighted music in the form of various audio files which results in copyright infringement.

Note:

- This function does not work during any "RANDOM" mode selection.
- Repeat mode will turn off when recording starts.
- A new album is created each time you perform a recording. Depending on the memory, the album's sequence may change once the recording has completed.
- The recorded sound or music tracks are stored in a folder named "REC_DATA".
- All tracks are recorded to .mp3 format.



Basic recording

1 Connect the USB device.

2 Select the source to be recorded.

Radio recording:

Tune in the station (⇒ page 11).

CD recording:

- 1) Insert the disc(s) you want to record. Press [▶/II, CD] and then [■] (stop).
- 2) Prepare the desired disc recording mode.

Record programmed tracks	Program the tracks you want (⇒ page 10).
Record specific tracks	Press [PLAY MODE] to select the desired mode (⇒ page 9).

Ensure the disc has stopped.

MUSIC PORT or AUX recording:

Connect and play the equipment (⇒ page 17).

3 Press [●/II, USB REC] to start recording.

"REC" is displayed and USB recording indicator blinks. "REXXXXXX MAKING" is displayed, where "REXXXXXX" is the folder's name.

Stop recording	Press [■] (stop). "WRITING" is displayed for a few second.
Pause recording	Press [●/II, USB REC]. "REC" blinks. Press again to resume recording. Note: Pause can only be performed during recording from the radio, music port or AUX source (except in SYNCHRO mode). A track mark (⇒ page 14) is inserted every time you pause.
Erase a recorded track	(⇒ page 14)

Note:

"RENAME" and "ALBUM" will be displayed when the system rearranges and renames the folders in ascending order.



Recording of MP3 tracks

You can record MP3 tracks stored in an album from disc to a USB device.

- 1 Insert the disc you want to record.
- 2 Press [▶/II, CD] and then [■] (stop).
- 3 Press [▲/▼, ALBUM] to select the desired album.
- 4 Press [●/II, USB REC] to start recording.

Example:

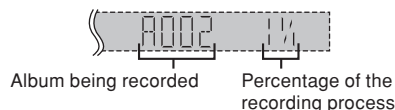

Stop recording	Press [■] (stop). Recording stops at the last completed track in the album. "NO. FXXX" which is the folder name will be displayed. Example: If recording stops amidst the fourth track, only the first three tracks will be stored. "NO FILE RECORDED" is displayed if recording stops amidst the first track.
Erased a recorded track	(⇒ page 14)

Note:

- Some files may take longer to record.
- Depending on the condition of the disc or file, some MP3 files may not be able to record.

DISPLAY



Checking the track information

While performing basic recording function (⇒ page 12), you can view the information of the current track from the display panel.

Press [DISPLAY] repeatedly during recording.

Example: display during CD recording

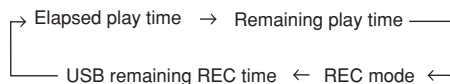

Advanced recording functions

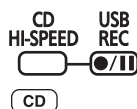

High-speed recording

Recording speed:
 CD to USB device : Four times (maximum of 4x) the normal speed.
 CD-RW to USB device : Two times (2x) the normal speed.

- 1 Insert the CD you want to record.
- 2 Press [▶/II, CD] and then [■] (stop).
- 3 Press [PLAY MODE] to select 1-TRACK, 1-DISC or ALL DISC.
- 4 Press [CD HI-SPEED] and [●/II, USB REC] simultaneously to start recording.

Note:

- Depending on the condition of the disc, it may not be possible to record at four times the normal speed or perform high-speed recording. Record the CD at normal speed.
- The sound is muted during high-speed recording.



Recording from CD using analogue format



You can change your recording mode from the default digital recording to analogue recording.

- 1 Press [▶/II, CD] and then [■] (stop).
- 2 Press and hold [EDIT MODE] to select "ANALOG-REC".
Each time you press and hold the button:

ANALOG-REC (analogue recording) ↔ DIGITAL-REC (digital recording)

Note:

- The recording mode returns to the default "DIGITAL-REC" after completing the analogue recording.
- High-speed recording is not applicable while using analogue mode.

USB (continued)



Recording mode

You can select the desired recording mode before you start the basic recording (➔ page 12).

Press [REC MODE] repeatedly to select your desired setting.

128 KBPS → 192 KBPS → 320 KBPS

Recording mode	Effect
128 KBPS	Long play mode
192 KBPS	Normal mode
320 KBPS	High quality sound mode

During recording

Press [DISPLAY] repeatedly to display the current recording mode.

Note:

You cannot change the recording mode during recording.



Adding track marks

When recording from analogue source such as radio, music port or AUX, you may want to separate the sound or music track at desired point during recording.

You can perform this separation by adding track marks using the various listed modes.

Before recording

Press [EDIT MODE] repeatedly to select your desired track mark mode.

Radio:

→ MANUAL → TIME MARK

MUSIC PORT or AUX:

→ MANUAL → SYNCHRO
TIME MARK ←

Edit mode	Action
MANUAL	Track marks are inserted manually. Press [OK] to add track mark during recording.
TIME MARK	Track marks are inserted automatically every five minutes.
SYNCHRO	Recording automatically starts when the other equipment starts to play. Recording pause when detects silence for approximately three seconds.

Note:

- If you press [OK] or pause recording while using TIME MARK mode during recording, the five-minute counter will be reset.
- You cannot insert track marks manually in SYNCHRO mode.



Erasing the recorded tracks

This function allows you to erase unwanted tracks quickly and easily.

- 1 Press [▶/||, USB] and then [■] (stop).
- 2 Press [▲, ▼, ◀, ▶] to select your desired album or track.
- 3 Press [EDIT MODE] repeatedly to select your desired erasing mode.

TRACKDEL → ALBUMDEL → FORMAT
Original display ←

Edit mode	Action
TRACKDEL	Erase single track
ALBUMDEL	Erase one album
FORMAT	Erase all albums (format the USB device)

- 4 Press [OK].
Within 2 seconds or so, the selected track to be erased is displayed followed by the "PRESS OK" display.

Example:



- 5 Press [OK] again.

- 6 Press [◀, ▶] to select "YES" then press [OK] to confirm the erasure.

"WRITING" is displayed.

OR

Press [◀, ▶] to select "NO" then press [OK] to cancel the erasure.

Example:

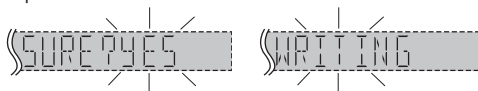

Note:

For "ALBUMDEL", only 999 tracks in albums which contain more than 999 tracks will be erased. To erase the selected album, repeat steps 2 to 6.

NOTE on USB

Compatible devices

Devices which are defined as USB mass storage class:

- USB devices that support bulk only transfer.
- USB devices that support USB 2.0 full speed.

Supported format

- Folders are defined as album.
- Files are defined as track.
- Track must have the extension ".mp3" or ".MP3".
- CBI (Control/Bulk/Interrupt) is not supported.
- A device using NTFS file system is not supported.
[Only FAT 12/16/32 (File Allocation Table 12/16/32) file system is supported.]
- Depending on the sector size, some files may not work.
- Maximum album: 255 albums
- Maximum track: 2500 tracks
- Maximum track in one album: 999 tracks

When you connect your digital audio player to the USB port, it charges all the time except standby mode.

Using the timers

CLOCK/TIMER

Setting the clock

This is a 24-hour clock.

- Press [CLOCK/TIMER] to select "CLOCK".
Each time you press the button:

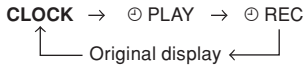

- (Within 8 seconds or so)**

Press [◀◀/▶▶] or [▶▶/▶▶] to set the time.

- Press [CLOCK/TIMER] to finish setting the time.

Displaying the clock

Press [CLOCK/TIMER] once when the unit is on or in standby mode.

The time is displayed for a few seconds.

Note:

Reset the clock regularly to maintain accuracy.

PLAY/REC



Using the play or record timer

You can set the timer to come on at a certain time to wake you up (play timer) or to record from the radio or the other equipments (record timer).

Play timer and record timer cannot be used together.

Turn the unit on and set the clock.

Play timer	Prepare the music source you want to listen to; disc number (1 to 5), radio, USB device or other equipments and set the volume.
Record timer	Insert the USB device and tune to the radio station (➔ page 11) or select the music port or AUX source (➔ page 17).

- Press [CLOCK/TIMER] repeatedly to select the timer function.

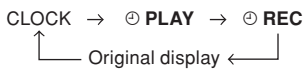

ⓄPLAY : to set the play timer

ⓄREC : to set the record timer

(Proceed to the next step **within 8 seconds**)

- Press [◀◀/▶▶] or [▶▶/▶▶] to set the starting time.

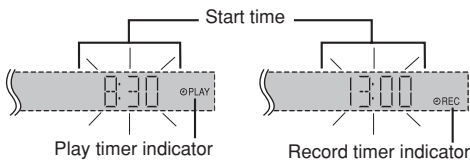

- Press [CLOCK/TIMER] to confirm.

- Repeat steps 2 and 3 to set the finishing time.

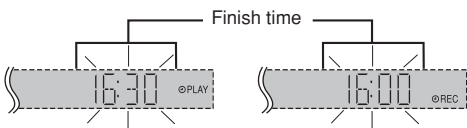

To activate the timer

- Press [ⓄPLAY/REC] repeatedly to turn on your desired timer.

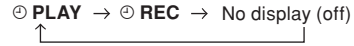

- Press [Ⓞ] to turn off the unit.

The unit must be turned off for the timers to operate.

Change the settings	Repeat steps 1 to 4 and 6 (➔ see left and above).
Change the source or volume	1) Press [ⓄPLAY/REC] to clear the timer indicator from the display. 2) Make changes to the source or volume. 3) Perform steps 5 and 6 (➔ see above).
Check the settings	Press [CLOCK/TIMER] repeatedly to select ⓄPLAY or ⓄREC.
Cancel	Press [ⓄPLAY/REC] to clear the timer indicators from the display.

If you use the unit after the timers are set

After using, check that the correct disc is loaded before turning the unit off.

Note:

- The play timer will start at the preset time with volume increasing gradually to preset level.
- The record timer will start 30 seconds before the set time with the volume muted.
- The timer comes on at the set time every day if the timer is on.
- The unit must be in the standby mode for the timer to function.
- If you turn the unit off and on again while a timer is functioning, the finish time setting will not be activated.

SLEEP



Using the sleep timer

This function enables you to turn off the unit automatically after the set time.

Press [SLEEP] repeatedly to select your desired time.

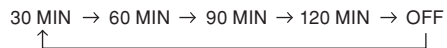

Sleep timer indicator

To cancel

Press [SLEEP] repeatedly to select "OFF".

Changing the remaining time

Press [SLEEP] to show the remaining time and press [SLEEP] again to select your desired time.

Note:

- The play and sleep timer or the record and sleep timer can be used together.
- The sleep timer always has priority. Be sure not to overlap timer settings.

Using other equipments

Note:

All peripheral components and cables are sold separately.



Avoid interfering with other Panasonic equipment

Other Panasonic audio or video equipment may start functioning when you operate the unit using the supplied remote control.

You can operate this unit in another mode by setting the remote control operating mode to "REMOTE 2".

The main unit and remote control must be set to the same mode.

1 Press and hold [MUSIC PORT] on the main unit and [2] on the remote control until the main unit's display shows "REMOTE 2".

2 Press and hold [OK] and [2] on the remote control for at least 2 seconds.

To change the mode back to "REMOTE 1", repeat both steps above by replacing [2] with [1].

Connecting to a portable audio equipment

This feature enables you to enjoy music from a portable audio equipment.

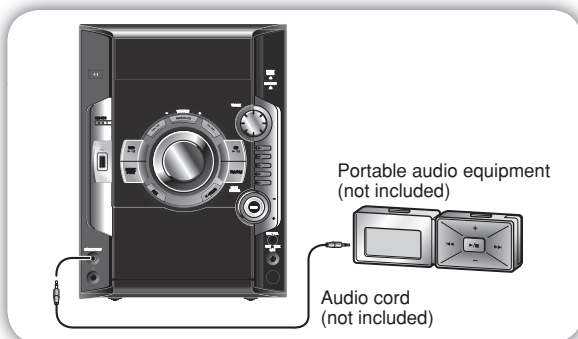

MUSIC P. Playing a portable audio equipment

Switch off the equaliser function (if there is any) of the portable audio equipment before you plug into the MUSIC PORT jack. Otherwise, sound from the speaker may be distorted.

- 1** Plug the audio cord into the MUSIC PORT jack.
- 2** Press [MUSIC P.] (main unit: [MUSIC PORT]) to select "MUSIC PORT".
- 3** Play the portable audio equipment. (See the portable audio equipment's instruction manual.)

Connecting to other external unit

You can connect to an analogue player with a built-in phone equaliser.

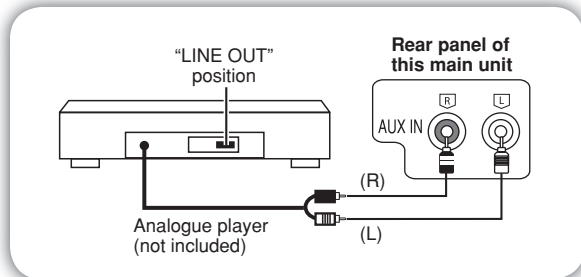

AUX Playing an external unit

- 1** Press [AUX] to select "AUX".
- 2** Start playback from the external source.

Note:

- For details, refer to the instruction manual of the unit which is to be connected.
- When units other than those described above are to be connected, please consult your audio dealer.
- Sound distortion may occur when you use an adaptor other than the one supplied.

Troubleshooting guide

Before requesting service, make the following checks. If you are in doubt about some of the check points, or if the solutions indicated in the chart do not solve the problem, consult your dealer for instructions.

■ Common problems		Page
When the unit is in standby mode, the display lights up and changes continuously.	<ul style="list-style-type: none"> Turn off the demo function. 	6
No response from the unit even though it has been turned on.	<ul style="list-style-type: none"> Press [⏻/] for more than 10 seconds to turn off the unit. Alternatively, unplug the AC mains lead and plug it in after a lapse of a few seconds. Turn the unit on again. 	—
No response when remote control buttons are pressed.	<ul style="list-style-type: none"> Check that the batteries are installed correctly. 	4
Distorted sound or no sound.	<ul style="list-style-type: none"> Turn the volume up. Turn off the unit, determine and correct the cause, then turn the unit on again. It may be caused by straining of the speakers through excessive volume or power, and using the unit in a hot environment. 	— —
A “humming” sound can be heard during play.	<ul style="list-style-type: none"> An AC mains lead or fluorescent light is near the unit. Keep other appliances and cords away from the unit. 	—

■ Discs		
Incorrect display or play will not start.	<ul style="list-style-type: none"> You have not inserted the disc correctly; insert it correctly. Disc may be dirty. Wipe it clean. Replace the disc if it is scratched, warped, or non-standard. Condensation has formed: Wait 1 to 2 hours for it to evaporate. 	6 — — —
The total number of tracks displayed is incorrect. The disc cannot be read. Distorted sound is heard.	<ul style="list-style-type: none"> You have inserted a disc the unit cannot play; insert one it can. You have inserted a disc that has not been finalised or completely formatted. 	— —
Disc tray(s) cannot open.	<ul style="list-style-type: none"> Press [⏻/] to release the jammed tray(s) as the unit will switch off. Turn it on again and the tray(s) will initialise to the previous tray(s) condition. If this still does not fix the problem, please consult the dealer. 	— —

■ Radio		
Distorted sound or noise is heard. The stereo indicator flickers or does not light.	<ul style="list-style-type: none"> Use an outdoor antenna. 	6
A beat sound is heard.	<ul style="list-style-type: none"> Turn the television off or move it away from the unit. Switch to either BP 1 or BP 2 when in AM tuner mode. 	— 11
A low hum is heard during AM broadcast.	<ul style="list-style-type: none"> Separate the antenna from other cables and cords. 	—

■ USB		
The USB drive or its contents cannot be read.	<ul style="list-style-type: none"> The USB drive format or its contents is/are not compatible with the system. The USB host function of this product may not work with some USB devices. USB devices with storage capacity of more than 32 gigabytes may not work in some instances. 	14 — —
Slow operation of the USB device.	<ul style="list-style-type: none"> Large file size or high memory USB flash drive takes longer time to read. 	—

■ Unit displays

Page

"NO PLAY"	<ul style="list-style-type: none"> • Check the content. • Only MP3 format files can be played. • Disconnect the USB device. Turn the unit off and then turn back on. Alternatively, format the USB device and record the desired tracks again and playback the device. 	— — 14
"F61"	<ul style="list-style-type: none"> • Check and correct the speaker cords connection. If this does not fix the problem, consult the dealer. • Disconnect the USB device. Turn the unit off and then turn back on. 	5 —
"ERROR"	<ul style="list-style-type: none"> • Incorrect operation performed. Read the instructions and try again. 	—
"ERROR" (during recording)	<ul style="list-style-type: none"> • You are not able to select other playback source (example: radio, USB and etc.) or press [◀◀/◀◀] or [▶▶/▶▶] during recording. Stop the recording function. • You are not able to open the disc tray when recording from AM source. • Select a suitable recording mode (128 KBPS or 192 KBPS) and resume recording. 	12 — 14
"VBR—"	<ul style="list-style-type: none"> • The unit cannot display the remaining play time for variable bit rate (VBR) tracks. 	—
"- -: - -" (during standby mode)	<ul style="list-style-type: none"> • You plugged the AC mains lead in for the first time or there was a power failure recently. • Set the time. 	— 15
"USB OVER CURRENT ERROR"	<ul style="list-style-type: none"> • The USB device is drawing too much power. Disconnect the USB device. Turn the unit off and then back on. 	—
"HI-SPEED CAN'T REC"	<ul style="list-style-type: none"> • You cannot use high-speed recording while using analogue mode. Change to digital mode or use normal recording. 	13
"DEVICE FULL"	<ul style="list-style-type: none"> • You cannot perform recording because the total USB remaining REC (recording) time of the USB device is less than the total time of the music source. Change to a USB device which has the appropriate recording time and perform the recording again. 	12

Memory reset (Initialisation)

When the following situations occur, refer to the instructions below to reset the memory:

- There is no response when buttons are pressed.
- You want to clear and reset the memory contents.

To reset memory

- 1 **Disconnect the AC mains lead. (Wait at least 3 minutes before proceeding to step 2.)**
- 2 **While pressing and holding down [⏻/⏻] on the main unit, reconnect the AC mains lead.** "-----" appears on the display panel.
- 3 **Release [⏻/⏻].**
All the settings are returned to the factory preset.
You will need to reset the memory items.

Maintenance

If the surfaces are dirty

To clean this unit, wipe with a soft, dry cloth.

- Never use alcohol, paint thinner or benzene to clean this unit.
- Before using chemically treated cloth, read the instructions that came with the cloth carefully.

When moving the unit

- 1 **Remove all discs.**
- 2 **Press [⏻/⏻] to turn the unit off.**
- 3 **Disconnect the AC mains lead.**

Specifications

AMPLIFIER SECTION

RMS output power stereo mode

Front Ch (both channels driven)	250 W per channel (6 Ω), 1 kHz
Total RMS stereo mode power	500 W

FM/AM TUNER, TERMINALS SECTION

Preset station	FM 30 stations AM 15 stations
----------------	----------------------------------

Frequency Modulation (FM)

Frequency range	87.50 MHz to 108.00 MHz (50 kHz step)
Antenna terminal	75 Ω (unbalanced)

Amplitude Modulation (AM)

Frequency range	522 kHz to 1629 kHz (9 kHz step)
-----------------	----------------------------------

AUX input

RCA pin jack

Music Port (front) jack

Sensitivity	100 mV, 4.7 kΩ
Terminal	Stereo, 3.5 mm jack

Headphone jack

Terminal	Stereo, 3.5 mm jack
Output level (CD, 1 kHz, -20 dB)	32 Ω (Max)

Mic jack

Sensitivity	0.7 mV, 1.2 kΩ
Terminal	Mono, 3.5 mm jack (1 system)

DISC SECTION

Disc played (8 cm or 12 cm)

- (1) CD-Audio (CD-DA)
- (2) CD-R/RW (CD-DA, MP3* formatted disc)
- (3) MP3*

*MPEG-1 Layer 3, MPEG-2 Layer 3

Pick up

Wavelength	795 nm
------------	--------

Audio output (Disc)

Number of channels	2 (FL, FR)
FL	= Front left channel
FR	= Front right channel

USB SECTION

USB port

USB Standard	USB 2.0 full speed
Media file format support	MP3 (*.mp3)
USB device file system	FAT 12, FAT 16, FAT 32
USB port power	500 mA (Max)
Bit rate	16 kbps to 320 kbps (P.B)

USB recording

Recording file format	MP3 (*.mp3)
Bit rate	128 kbps / 192 kbps / 320 kbps
USB recording speed	1x, max 4x (CD only)

SPEAKER SECTION

Type 2 way, 2 speaker system (Bass reflex)

Speaker(s)

Tweeter	6 cm cone type
Woofer	20 cm cone type

Impedance 6 Ω

Input power (IEC) 250 W (Max)

Output sound pressure 87 dB/W (1.0 m)

Frequency range 49 Hz to 21 kHz (-16 dB)

68 Hz to 20 kHz (-10 dB)

Dimensions (WxHxD) 250 mm x 414 mm x 298 mm

Mass 5.3 kg

GENERAL

Power supply AC 220 to 240 V, 50 Hz

Power consumption 112 W

Dimensions (WxHxD) 250 mm x 333 mm x 326 mm

Mass 4.6 kg

Operating temperature range 0°C to +40°C

Operating humidity range 35% to 80% RH (no condensation)

Power consumption in standby mode:

0.5 W (approximate)

Note:

- 1) Specifications are subject to change without notice. Mass and dimensions are approximate.
- 2) Total harmonic distortion is measured by the digital spectrum analyzer.

Free Manuals Download Website

<http://myh66.com>

<http://usermanuals.us>

<http://www.somanuals.com>

<http://www.4manuals.cc>

<http://www.manual-lib.com>

<http://www.404manual.com>

<http://www.luxmanual.com>

<http://aubethermostatmanual.com>

Golf course search by state

<http://golfingnear.com>

Email search by domain

<http://emailbydomain.com>

Auto manuals search

<http://auto.somanuals.com>

TV manuals search

<http://tv.somanuals.com>