

Operating Instructions

Compact Audio System SA-HD52

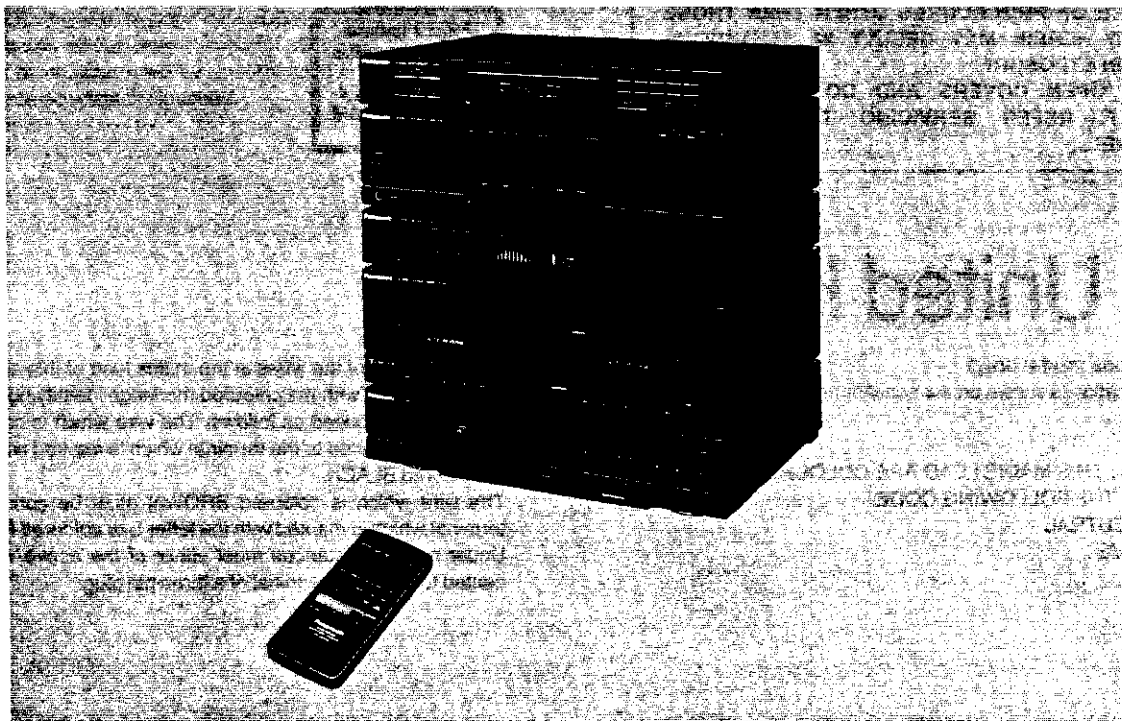

Notes:

- Specifications differ according to the area code.
- The "EB" area code, for example, indicates United Kingdom specifications.
- The "EB" indication is shown on the packing case and serial number tag.

Panasonic

Before operating this unit, please read these instructions completely.

EB GN

Dear Stereo Fan

We want to thank you for selecting this product and to welcome you to the growing family of satisfied Panasonic product owners around the world. We feel certain you will get maximum enjoyment

from this new addition to your home. Please read these operating instructions carefully, and be sure to keep them handy for convenient reference.

Contents

•For United Kingdom	2	•Listening to Compact Discs	22
•Suggestion for safety	3	•Listening to Other Source	27
•Accessories	4	•Changing the Tone Quality	28
•Remote-Control Transmitter	5	•Recording	32
•Connections	6	•Edit-Recording from Compact Discs	34
•Antenna Connections	7	•Edit-Recording	36
•Front Panel Controls and Functions	8	•Remote-Control Operation	37
•Memory Presettings	14	•About Cassette Tapes	38
•Standard Operations	16	•About Compact Discs	38
•Listening to Radio Broadcasts	18	•Maintenance	39
•Listening to Tapes	20	•Troubleshooting Guide	40
		•Technical Specifications	42

CAUTION!

THIS PRODUCT UTILIZES A LASER.
USE OF CONTROLS OR ADJUSTMENTS OR PERFORMANCE OF PROCEDURES OTHER THAN THOSE SPECIFIED HEREIN MAY RESULT IN HAZARDOUS RADIATION EXPOSURE.
DO NOT OPEN COVERS AND DO NOT REPAIR YOURSELF. REFER SERVICING TO QUALIFIED PERSONNEL.

**DANGER-Invisible
laser radiation when
open.
AVOID DIRECT EX-
POSURE TO BEAM.**

(inside of product)

For United Kingdom

("EB" area code model only)

The "EB" indication is shown on the serial number tag.

Important

THE WIRES IN THIS MAINS LEAD ARE COLOURED IN ACCORDANCE WITH THE FOLLOWING CODE.

BLUE: NEUTRAL

BROWN: LIVE

As the colours of the wires in the mains lead of this apparatus may not correspond with the coloured markings identifying the terminals in your plug proceed as follows. The wire which is coloured BLUE must be connected to the terminal which is marked with the letter N or coloured BLACK.

The wire which is coloured BROWN must be connected to the terminal which is marked with the letter L or coloured RED.

Under no circumstances must either of the above wires be connected to the earth terminal of a three pin plug.

Suggestions for Safety

■ Use a standard AC wall outlet

1. **Use from an AC power source of high voltage, such as for an air conditioner, is very dangerous.**

There is the possibility that a fire might be caused by making such a connection.

2. **A DC power source cannot be used.**

Be sure to check the power source carefully, especially on a ship or other place where DC is used.

■ Grasp the plug when disconnecting the power supply cord

1. **Wet hands are dangerous.**

A dangerous electric shock may result if the plug is touched by wet hands.

2. **Never place heavy items on top of the power supply cord, and never force it to bend sharply.**

■ Place the unit where it will be well ventilated

Place this unit at least 10 cm (4") away from wall surfaces, etc.

■ Avoid places such as the following:

In direct sunlight or in other places where the temperature is high.

In places where there is excessive vibration or humidity.

Such conditions might damage the cabinet and/or other component parts and thereby shorten the unit's service life.

■ Be sure to place the unit on a flat, level surface

If the surface is inclined, a malfunction may result.

■ Never attempt to repair or reconstruct this unit

A serious electric shock might occur if this unit is repaired, disassembled or reconstructed by unauthorized persons, or if the internal parts are accidentally touched.

■ Take particular care if children are present

Never permit children to put anything, especially metal, inside this unit. A serious electric shock or malfunction could occur if articles such as coins, needles, screwdrivers, etc. are inserted through the ventilation holes, etc. of this unit.

■ If water is spilled on the unit

Be extremely careful if water is spilled on the unit, because a fire or serious electric shock might occur. Immediately disconnect the power cord plug, and consult with your dealer.

■ Avoid spray-type insecticides

Insecticides might cause cracks or "cloudiness" in the cabinet and plastic parts of this unit. The gas used in such sprays might, moreover, be ignited suddenly.

■ Never use alcohol or paint thinner

These and similar chemicals should never be used, because they might cause flaking or cloudiness of the cabinet finish.







■ Disconnect the power supply cord if the unit will not be used for a long time

If the unit is left for a long time with the power ON, this will not only shorten its useful operation life, but may also cause other troubles.

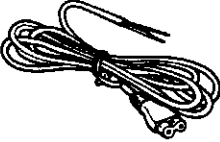
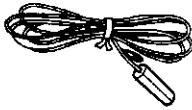
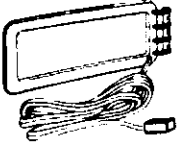
■ If trouble occurs

If, during operation, the sound is interrupted or indicators no longer illuminate, or if abnormal odor or smoke is detected, immediately disconnect the power cord plug, and contact your dealer or an Authorized Service Center.

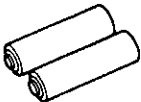
Accessories

•AC power supply cord 1	•FM indoor antenna 1	•AM loop antenna 1
		
•AM antenna holder1	•Screws 2	•Remote-control transmitter 1
		
•Batteries2	•Attachment plug 1 (For United Kingdom)	
		

Note: Configuration of AC power supply cord and FM indoor antenna differs according to area.

THIS MUSIC SYSTEM IS CAPABLE OF RECEIVING THE NEW AM STEREO BROADCASTS FROM THE AM BAND RADIO STATIONS. HOWEVER LIKE MANY MUSIC SYSTEM CURRENTLY AVAILABLE ON THE MARKET IT WILL REPRODUCE THIS AM STEREO SIGNAL ONLY IN AM MONO, WHICH, IN EFFECT, IS OF NO LESSER QUALITY THAN YOUR EXISTING AM MONO MUSIC SYSTEM.

Remote-Control Transmitter

Insertion of remote-control transmitter batteries

1. Open the cover.
2. Insert the batteries.
 - Be sure to insert according to the (+) and (-) indications in the battery compartment.
 - Use two UM-4 "AAA" (R03 1.5 V) size batteries.
3. Close the cover.

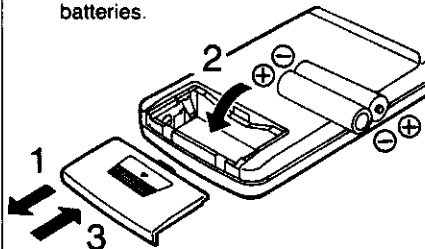

■ Battery life

Battery life is about one year. (Battery life may vary depending upon the frequency of use and other conditions of use.)

The batteries should be replaced if the unit cannot be operated even when the remote-control transmitter is brought close to the unit.

■ Battery notes

- Be sure that batteries are inserted so that they are placed correctly with respect to the (+) and (-) indications in the battery compartment. If the batteries are not inserted correctly, they may leak and damage the remote-control transmitter.
- Do not use rechargeable (nickel-cadmium) type batteries.

- Do not mix old and new batteries, or batteries of different types (carbon and alkaline, etc.).
- If the remote-control transmitter is not to be used for a long period of time, take out the batteries and store them in a cool, dark place.
- Remove and dispose of worn-out batteries.
- Never attempt to recharge or short-circuit the batteries, and do not disassemble them or expose them to excessive heat or throw them into a fire.
- If a battery leaks, remove both batteries and dispose of them, and then thoroughly clean the battery compartment before inserting new batteries.

Remote-control transmitter operation notes

Use the remote-control transmitter within 6 meters (20 ft.).

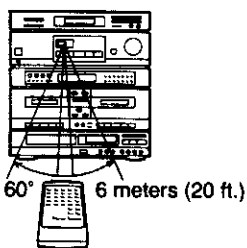

Face it towards the remote-control signal receptor of this unit.

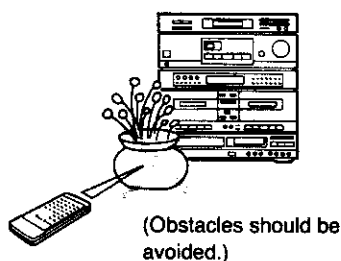

(Obstacles should be avoided.)

Be sure the transmitter part of the remote-control transmitter and the receptor part of this unit are free from dust.

Excessive dust might prevent reception.

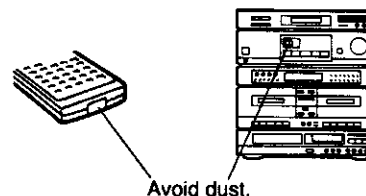

Other notes

1. Do not expose the receptor (on this unit) to direct sunlight or other strong light, because to do so might result in incorrect operation.
2. Do not use a remote-control transmitter for a TV set, a VCR or other video component at the same time as this remote-control transmitter is being used, because to do so might result in incorrect operation.
3. If this unit is installed in a rack with glass doors, the glass doors' thickness or color might make it necessary to use the remote-control transmitter a shorter distance from the unit.
4. The control panel of the remote-control transmitter may be covered by a clear plastic protective sheet. This sheet can be removed if desired.

Connections

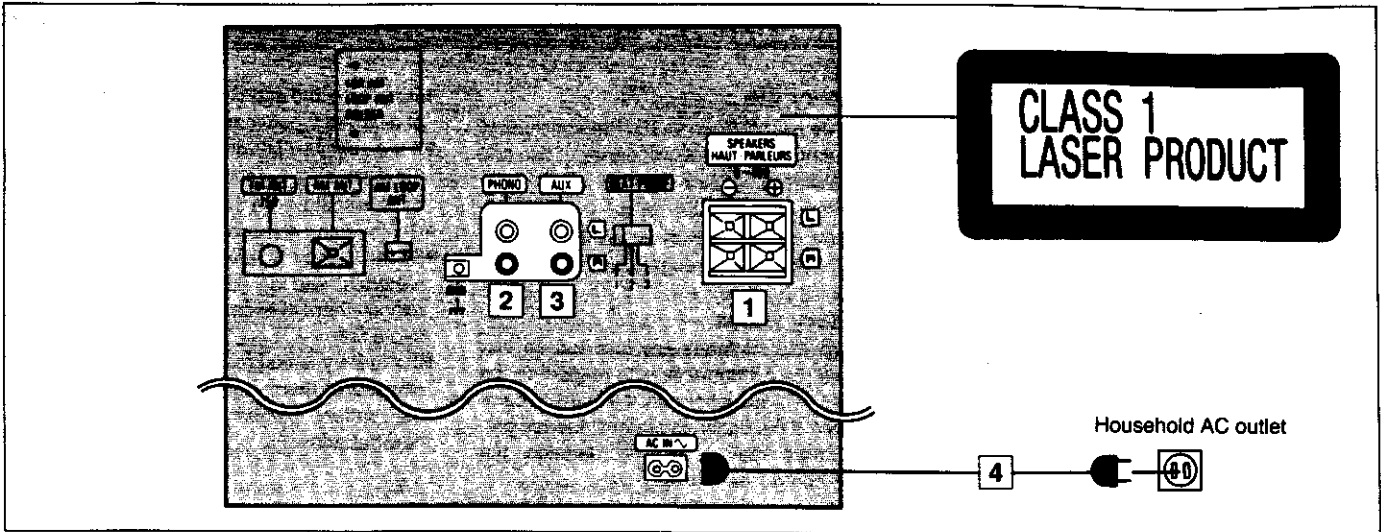

1 "SPEAKERS" terminals

The impedance of any speaker used with this unit must be 8–16 ohms.
Be sure to connect the striped cords to the negative terminals.

Connection of speaker cords

- Strip off the outer covering, and twist the center conductor.
- Tilt the lever back and insert the cord.
- Close the lever and pull the cord gently to be sure that it is secured.

Notes:

- To prevent damage to circuitry, never short-circuit positive (+) and negative (-) speaker terminals.
- Be sure to only connect positive (+) cords to positive (+) terminals, and negative (-) cords to negative (-) terminals.
- Connections of speaker cords should be made before connecting the AC power supply cord.

2 "PHONO" terminals

Connect the turntable which was specially designed for use with this system, to these terminals.

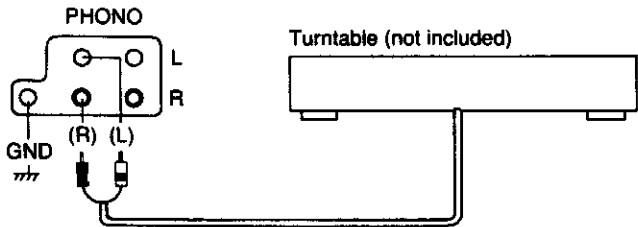

■ **"GND" terminal**
This terminal is for use with turntables which have a ground wire.

3 "AUX" terminals

Connect a second tape deck (for playback only) etc.

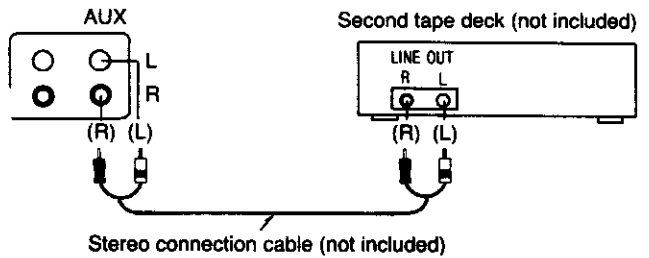

4 AC power supply cord

- Connect this cord only after all other cables have been connected.
Note: Configuration of the AC outlet and AC power supply cord differ according to area.
- For United Kingdom**

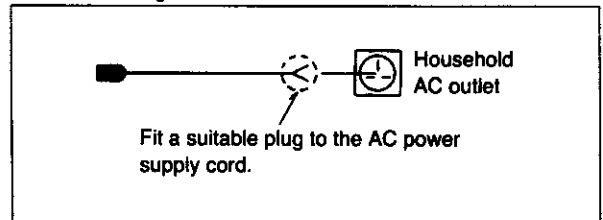

Antenna Connections

The indication AM used here includes both MW and LW.

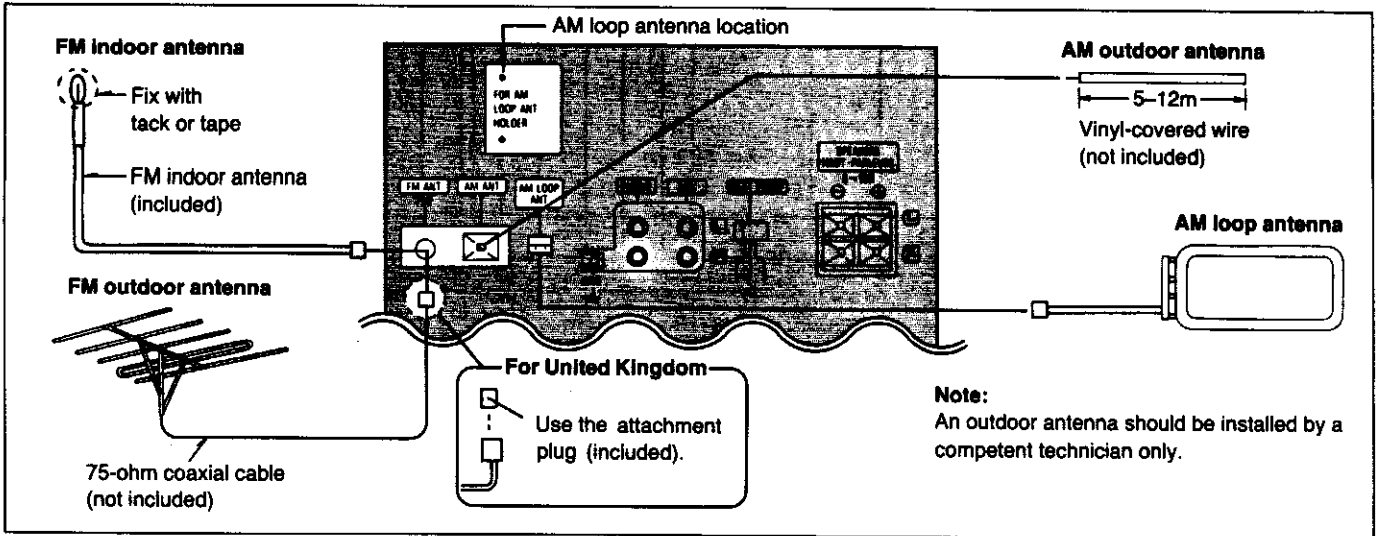



FM antenna

FM indoor antenna (included)
 Attach to a wall (using tack or tape) facing in the direction of best reception.
For best reception sound quality:
 An FM outdoor antenna is recommended.
Notes:
 •The tack should not contact the internal antenna wire.
 •Disconnect this antenna if an FM outdoor antenna is installed.

FM outdoor antenna (not included)
 If the FM indoor antenna does not provide satisfactory reception of FM broadcasts, an outdoor antenna should be used. The outdoor antenna may be required in a mountainous region, or if this unit is located inside a reinforced-concrete building, etc.

If FM antenna terminal is as shown below

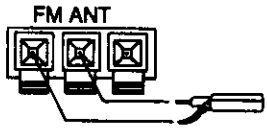
- Remove a piece of the outer vinyl sheath from the end. 
- Bundle the shield braid, and remove a piece of the inner vinyl sheath covering the core wire. 
- Tilt the lever back and insert the core wire and the shield braid. 
- Close the lever and pull the cable gently to be sure that it is secured.

AM antenna

AM loop antenna (included)
 Connect the AM loop antenna to the AM antenna terminal, and attach it to a column, rack or this unit (facing in the direction of best reception).
Notes:
 •If this antenna is not properly installed, AM broadcasts will not be received.
 •Be sure to connect the AM loop antenna even when an outdoor antenna is used.
Pay attention to the following points when attaching the antenna.
 •Do not attach it horizontally (to do so would impair reception).
 •Do not attach it close to power cords, speaker wires or metal surfaces (to do so would result in noise).

When attaching the antenna to the unit
 This type of installation may cause impaired reception or result in signal noise. If possible, attach the antenna to a rack, a wall, or a column. Move the antenna toward the right or left to find the point of best reception.

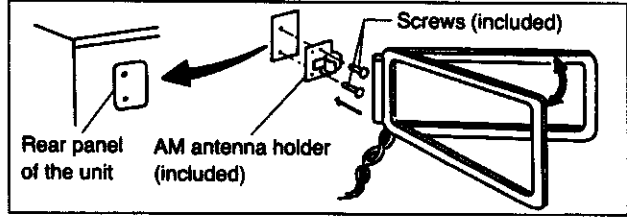

AM outdoor antenna (not included)
 The outdoor antenna may be required in a mountainous region, or if this unit is located inside a reinforced-concrete building, etc. Use 5–12m (16–40 ft.) of vinyl-covered wire horizontally at the window.

Front Panel Controls and Functions

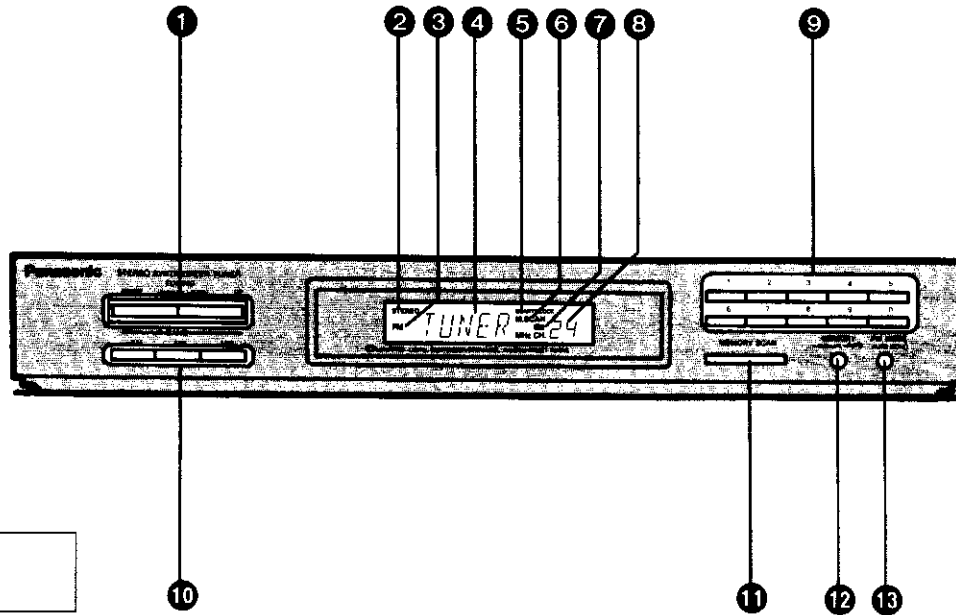
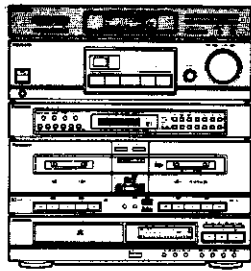

The indication AM used here includes both MW and LW.

Tuner section

- 1 Tuning buttons (TUNING)**
These buttons are used for tuning to the desired broadcast station.
- 2 FM stereo indicator (STEREO)**
This indicator automatically illuminates when an FM stereo broadcast is being received. It will not illuminate if the FM mode selector is set to the monaural mode.
- 3 Band indicator (FM, LW, MW)**
This indicator indicates the band selected by using the band selector.
- 4 Digital frequency/input display**
This display shows the sound source selected by pressing one of the input selectors. If the "TUNER" input selector is pressed, there will be a change to the frequency after the source is indicated.
- 5 Quartz-lock indicator (QUARTZ LOCK)**
This indicator illuminates when the tuner is precisely tuned to a broadcast station.
- 6 Memory scan indicator (M.SCAN)**
This illuminates when the memory scanning is activated.
- 7 Memory indicator (M)**
This indicator illuminates when the memory button is pressed.
- 8 Channel display**
This display shows the channel number selected by one of the preset-tuning buttons.
- 9 Preset-tuning buttons (1-0) (24 CHANNEL RANDOM PRESET TUNING)**
These buttons are used to preset broadcast frequencies into the memory of this unit, and are also pressed to recall the desired preset stations. (Refer to pages 14, 15 and 18.)
- 10 Band selectors (BAND)**
These selectors are used to select the band.
- 11 Memory scan button (MEMORY SCAN)**
This button can be used to locate a desired broadcast station; each broadcast station is selected for about four seconds.
- 12 Memory button (MEMORY)**
This button can be used when presetting broadcast station frequencies to the memory. (Refer to pages 14 and 15.)
- 13 FM mode selector (FM MODE)**
This unit automatically switches to the stereo mode when an FM stereo broadcast is received. This selector is used to select the mode (stereo or monaural) of FM broadcast signals. (Refer to page 18.)

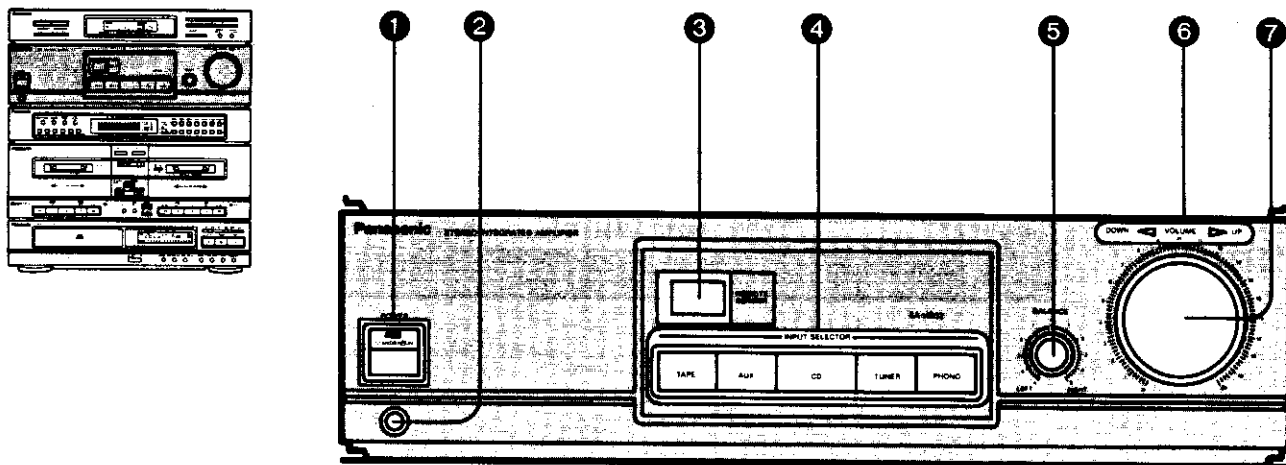

Amplifier section

1 Power "STANDBY \odot /ON" switch and indicator

(POWER/STANDBY \odot /ON)

This switch switches ON and OFF the secondary circuit power only. The unit is in the "standby" condition when this switch is set to the STANDBY \odot position. Regardless of the switch setting, the primary circuit is always "live" as long as the power cord is connected to an electrical outlet.

•The indicator will illuminate when the unit is in "STANDBY" condition.

2 Headphones jack (PHONES)

3 Remote-control signal receptor (REMOTE SENSOR)

Receives the signals from the remote-control transmitter.

4 Input selectors (INPUT SELECTOR)

These selectors are used to select the sound source to be heard, such as a phono disc, radio broadcast, etc.

5 Balance control (BALANCE)

This control can be used to adjust the balance of sound heard from the left and right speaker systems.

6 Volume-level adjustment indicators

One of these indicators flashes continually to indicate when the sound volume level is being adjusted by using the volume controls on the remote-control transmitter.

UP (\triangleright): When increasing the volume level.

DOWN (\triangleleft): When reducing the volume level.

7 Volume control (VOLUME)

Front Panel Controls and Functions

(continued)

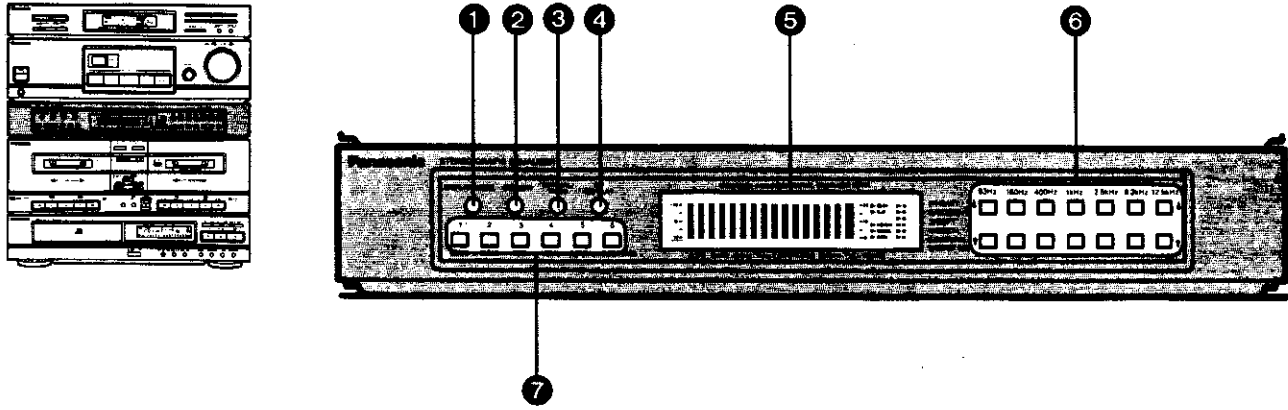

Graphic equalizer section

- 1 Display mode button (DISPLAY MODE)**
This button can be used to change any of five types of spectrum display modes. (Refer to page 17.)
- 2 Memory button (MEMORY)**
This button is used to program the equalization curve into the memory.
- 3 Memory mode-select button (MANUAL/FIXED)**
This button is used to select the equalization memory mode to be used.
MANUAL: Select this mode to program a desired curve to the unit's memory or to retrieve a curve that you have programmed.
FIXED: Select this mode to retrieve a curve that was originally pre-programmed to the unit's memory.
- 4 Equalization mode-select button (EQ ON/FLAT)**
This button is used to switch the equalization correction function "EQ ON" and "FLAT". Each time a button is pressed, the mode changes alternately to one or the other of the following modes.
EQ ON: Select this mode to make an equalization correction.
FLAT: Select this mode if no equalization correction is desired.
Note that the "EQ ON" mode is automatically selected if a preset-memory button or an equalizer level-control button is pressed while this button is set to the "FLAT" mode.

5 Display section

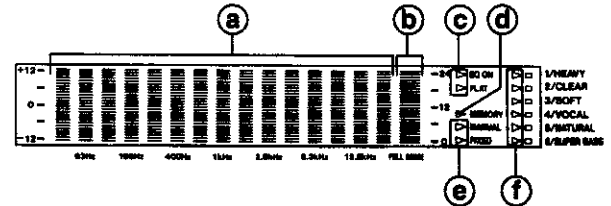

- a Spectrum/Equalization display**
 - **Spectrum displays**
The 5 types of display can be shown. (Refer to page 17.)
 - **Equalization-level display**
The amount of correction is displayed by a series of lines (=) for each sound range (frequency range).
-
- This will be shown for 3 seconds when any of the operation buttons of graphic equalizer (except the display mode button) is pressed.
- b Full range display**
This shows the full range level.
 - c Equalization-mode indicators**
 - EQ ON:** Indicates that the equalization effect has been switched ON.
 - FLAT:** Indicates that the equalization effect has been switched OFF.

Graphic equalizer section (continued)

Ⓓ **Equalization-memory indicator (MEMORY)**

This indicator illuminates when the memory button is pressed, thus indicating that an equalization curve can be programmed into the memory.

Ⓔ **Memory-mode indicators**

MANUAL: Indicates that an equalization curve that you programmed into the memory can be retrieved.

FIXED: Indicates that one of the equalization curves that were originally programmed into the memory can be retrieved.

Ⓕ **Equalization-preset indicators (1-6)**

The indicator corresponding to the pressed preset-memory button will illuminate.

MANUAL: Indicates an equalization curve that you programmed into the memory.

FIXED: Indicates one of the six equalization curves that were originally programmed into the memory.

Ⓖ **Equalizer level-control buttons (EQUALIZER LEVEL CONTROL)**

These buttons are used for adjustment of the equalization level.

Upper row: These buttons are used to increase the level of each sound range (frequency range).

Lower row: These buttons are used to reduce the level of each sound range (frequency range).

Ⓙ **Preset-memory buttons (1-6)**

These buttons are used to program an equalization curve into the memory, or to retrieve a curve originally programmed into the unit's memory.

Front Panel Controls and Functions

(continued)

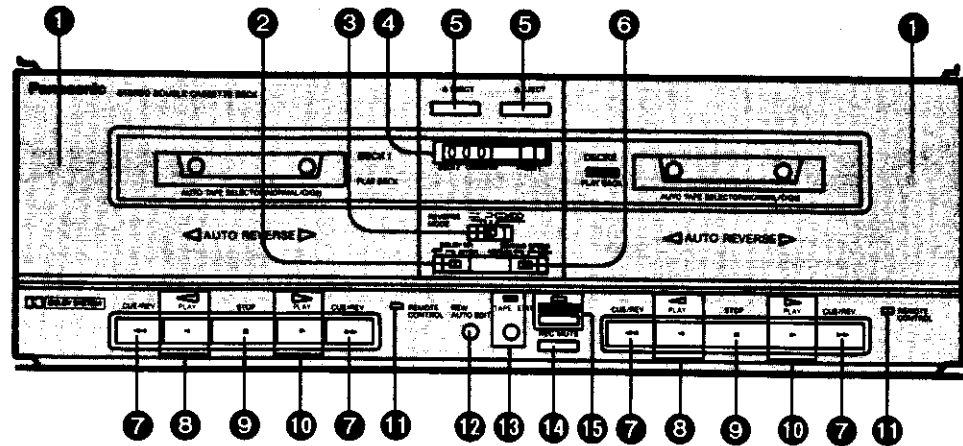
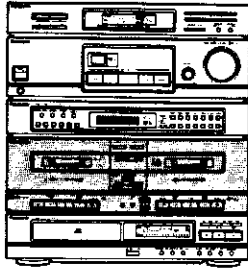

Cassette deck section

- 1 Cassette holder**
- 2 Dolby noise-reduction switch (DOLBY NR)**
This switch can be used to reduce the amount of the characteristic "hissing" noise heard from the tape. (Refer to page 21.)
- 3 Reverse-mode selector (REVERSE MODE)**
This selector is used for the selection of the desired reverse mode for recording or playback.
- 4 Tape deck 2 counter/reset button (DECK 2 COUNTER/RESET)**
This tape counter shows the amount of tape movement of the tape in deck 2.
The reset button can be used to reset the tape counter reading to "000".
Note:
To reset the tape counter, be sure to press the reset button completely. Otherwise, the tape counter may not operate correctly.
- 5 Eject button (▲ EJECT)**
This button is used to open the cassette holder.
- 6 Edit-recording tape-speed selector (EDITING SPEED)**
This selector is used to select the recording speed when a tape-to-tape recording is made.
- 7 Fast-forward/cue, rewind/review buttons (◀◀ CUE/REV ▶▶)**
These buttons are used to advance or review the tape. During playback these buttons are used to cue or review while listening to the contents at high speed. (Refer to page 20.)
- 8 Reverse-side playback button/indicator (◀ PLAY)**
This button is used to start the playback or recording (of deck 2 only) of side "B" of the cassette.
The indicator illuminates during playback or recording, and flashes in the recording stand-by mode.
(The tape will move in the right-to-left direction.)
- 9 Stop button (■ STOP)**
This button is used to stop the tape movement.
- 10 Forward-side playback button/indicator (▶ PLAY)**
This button is used to start the playback or recording (of deck 2 only) of side "A" of the cassette.
The indicator illuminates during playback or recording, and flashes in the recording stand-by mode. (The tape will move in the left-to-right direction.)
- 11 Remote-control indicator (REMOTE CONTROL)**
This indicator illuminates to indicate that this unit can now be controlled by the remote-control transmitter.
- 12 Rewind auto edit button (REW AUTO EDIT)**
This button is used to rewind the tape to the beginning and start a tape-to-tape automatic recording.
- 13 Tape edit button/indicator (TAPE EDIT)**
This button is used to start a tape-to-tape recording, simultaneously starting tape deck 1 (the playback deck) and tape deck 2 (the recording deck). The indicator illuminates in this mode.
- 14 Record-muting button (REC MUTE)**
This button is used while recording a tape on deck 2 to insert a silent interval on the tape. (Refer to page 33.)
- 15 Recording pause button/indicator (REC PAUSE)**
This button is used to activate the recording pause mode. The indicator will illuminate when in this mode. (Refer to page 33.)

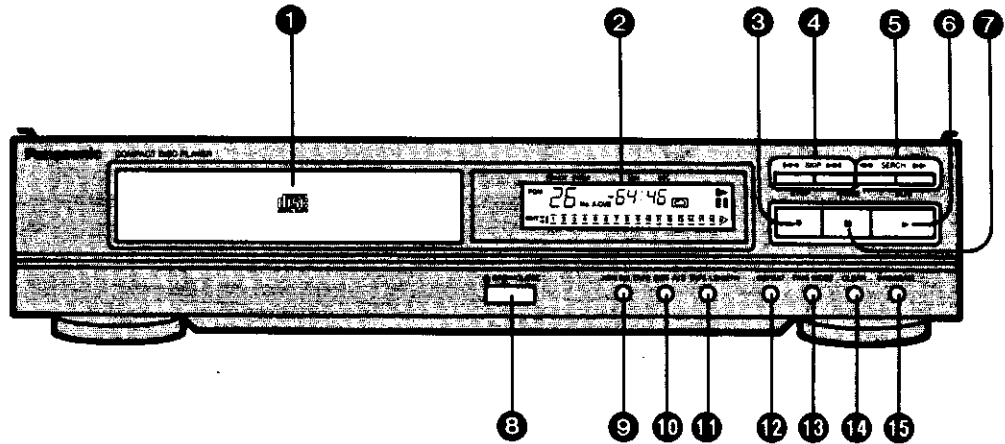
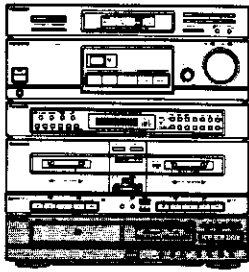

Compact disc section

1 Disc holder

2 Display section

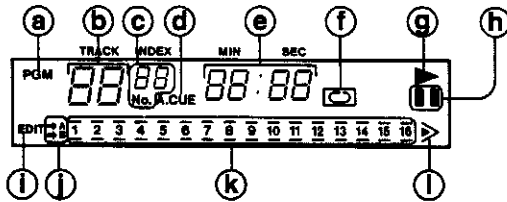

- a Program play indicator (PGM)
 - b Track number display (TRACK)
 - c Programmed order number display (No.)
 - d Auto cue indicator (A. CUE)
 - e Time display
 - f Repeat play indicator (↻)
 - g Play indicator (▶)
 - h Pause indicator (⏸)
 - i Compact disc edit indicator (EDIT)
 - j Tape side Indicator (→ A, → B)
 - k Track number indicator (1-16)
 - l "Over" mark (▶)
- This indicator lights if the total number of tracks on the disc is 17 or more.

3 Stop button (■ STOP)

This button can be used to stop disc play, as well as to cancel the various play modes.

4 Skip buttons (◀◀ SKIP ▶▶)

These buttons can be used to skip by track in the forward or reverse direction.

5 Search buttons (◀◀ SEARCH ▶▶)

These buttons can be used to move rapidly forward or backward on the disc during play. The search speed is slow when the button is pressed at first and becomes faster if the button is pressed and held continuously.

6 Play button (▶ PLAY)

7 Pause button (⏸ PAUSE)

8 Disc holder open/close button (▲ OPEN/CLOSE)

9 Auto cue button (AUTO CUE)

Pressing this button enables the unit to stop at the beginning of every track and switch to the play standby mode.

10 Tape-side select button (SIDE A/B)

When recording compact discs to tape, this button can be used to check the number of tracks and amount of tape left over for side A or B.

11 Edit tape length button (TAPE LENGTH)

When compact discs are to be recorded to tape, this button can be used to calculate the number of tracks that can be recorded on each side of the tape, depending on the length of the cassette tape used, so that as little tape as possible is wasted.

12 Repeat button (REPEAT)

13 Time mode select button (TIME MODE)

14 Clear button (CLEAR)

Each pressing this button makes one track cleared from the programmed sequence.

15 Program button (PROGRAM)

Pressing this button initiates the program play mode. You can then enter specific tracks using the numeric buttons at the remote control transmitter.

Memory Presettings

The indication AM used here includes both MW and LW.

When broadcast frequencies have been preset to the memory, any of those broadcast frequencies can thereafter be easily selected by simply pressing one of the preset-tuning buttons. There are two methods for presetting broadcast frequencies in the memory: the automatic method (see below) and the manual method (refer to page 15.); select whichever method you prefer.

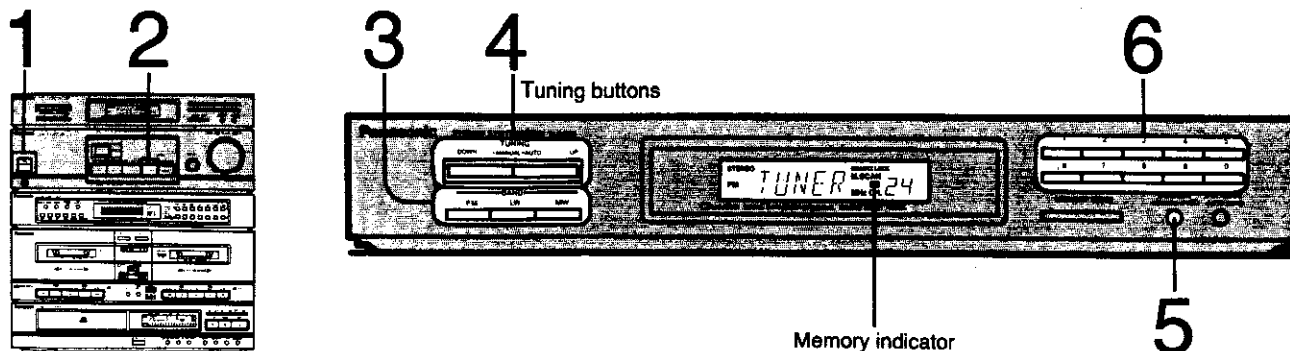

Automatic memory presetting

When this method is used, the frequencies of the selected broadcast stations are automatically preset (in sequence to higher frequencies) into the memory: "channels" 1 to 24 are available for the presetting of FM stations, "channels" 13 to 24 are available for MW stations, and "channels" 19 to 24 are available for LW stations. When a presetting is made to a channel that has already been preset, the prior presetting will be erased.

1 **POWER**
Switch ON the power "STANDBY /ON" switch.

2 **INPUT SELECTOR**
Press the "TUNER" button. 

3 **BAND**
Press the desired band selector ("FM", "LW" or "MW").

4 **TUNING**
Set to the frequency from which you want to start automatic memory presetting. (Refer to "Frequency tuning", below.)

5 **MEMORY**
Press and hold the memory button; release it when the display frequency begins to change. (The memory indicator will flash, and the automatic memory presetting is activated.)

6 **1-0**
Confirm the stations which are preset to each channel, and write them in the station log (page 18). (Refer to "How to designate preset channels", at the bottom of the next page.)

■ Notes

- For automatic presetting in areas where there are fewer than 24 FM stations, the remaining channels (through channel 24) will be left unoccupied. The unoccupied channels can be filled by using manual memory presettings.
- For AM broadcasts with extremely strong signal transmissions, the frequency memorized may be slightly different than the correct frequency. If this occurs, make a manual presetting.

Frequency tuning ("TUNING" buttons)

DOWN Press to change the frequency downward.

UP Press to change the frequency upward.

1. Press and hold one of the tuning buttons, then release the button when the displayed frequency begins to change.

2. When the displayed frequency approaches the desired frequency, press one of the tuning buttons momentarily. (The displayed frequency will stop changing.)

Note:

The changing of the displayed frequency will be automatically stopped (by the automatic tuning function) if a broadcast station frequency is located during the tuning process. If the frequency at which it stops is not the desired frequency, repeat step 1 at the left.

3. After stopping at step 2, tap one of the tuning buttons a few times until the desired frequency is reached.

Note:

If a new broadcast station is preset into a channel, the broadcast station which was previously entered in that channel will be automatically erased.

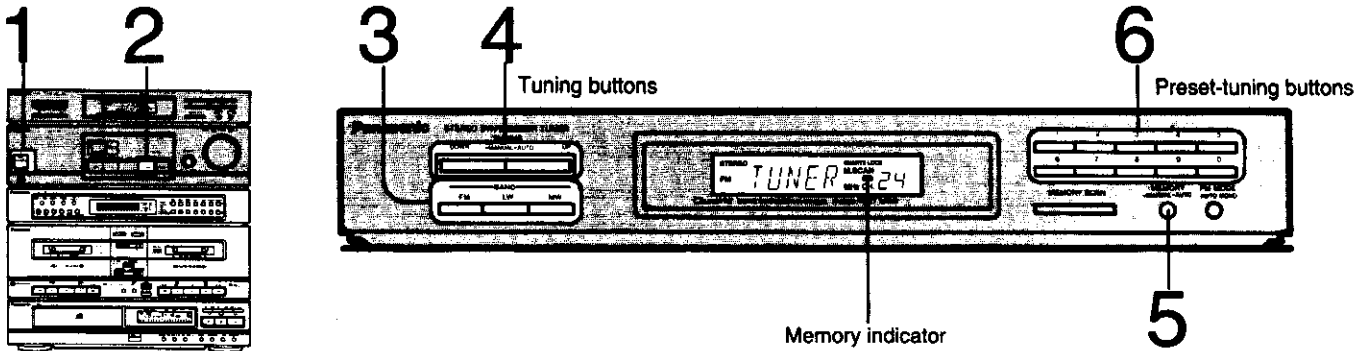

Manual memory presetting

Stations can be freely preset to any desired channel. A maximum of 24 broadcast stations can be memorized.

- 1** **POWER**
Switch ON the power "STANDBY /ON" switch.
- 2** **INPUT SELECTOR**
Press the "TUNER" button.
- 3** **BAND**
Press the desired band selector ("FM", "LW" or "MW").
- 4** **DOWN UP**
Press the appropriate tuning button to tune to the desired broadcast.
(Refer to "Frequency tuning" at the bottom of the previous page.)

- 5** **MEMORY**
Press the memory button momentarily.
(The memory indicator will illuminate.)
Note:
If the memory button is pressed continuously, the automatic memory presetting is activated. To stop the automatic memory presetting, press the tuning button. Then begin again from step 4.

- 6** **1-0**
Select the desired "channel".
(Refer to "How to designate preset channels", below.)

- 7** Repeat the above procedures to make memory presettings; write the presettings in the station log (page 18).

How to designate preset channels

- To designate channels 1-9: Press the appropriate (1-9) preset-channel button.
- To designate channels 10-24:
 - ① Press the button for the left digit (1 or 2).
 - ② Press the button for the right digit (0-9) within 2 seconds after pressing the first button.**Example:** To designate channel 12
Press the "1" button and then the "2" button.



Note:
If the interval between pressing the first button and pressing the second button is more than about 2 seconds, the setting may not be made correctly. If this happens, make the setting once again.

Standard Operations

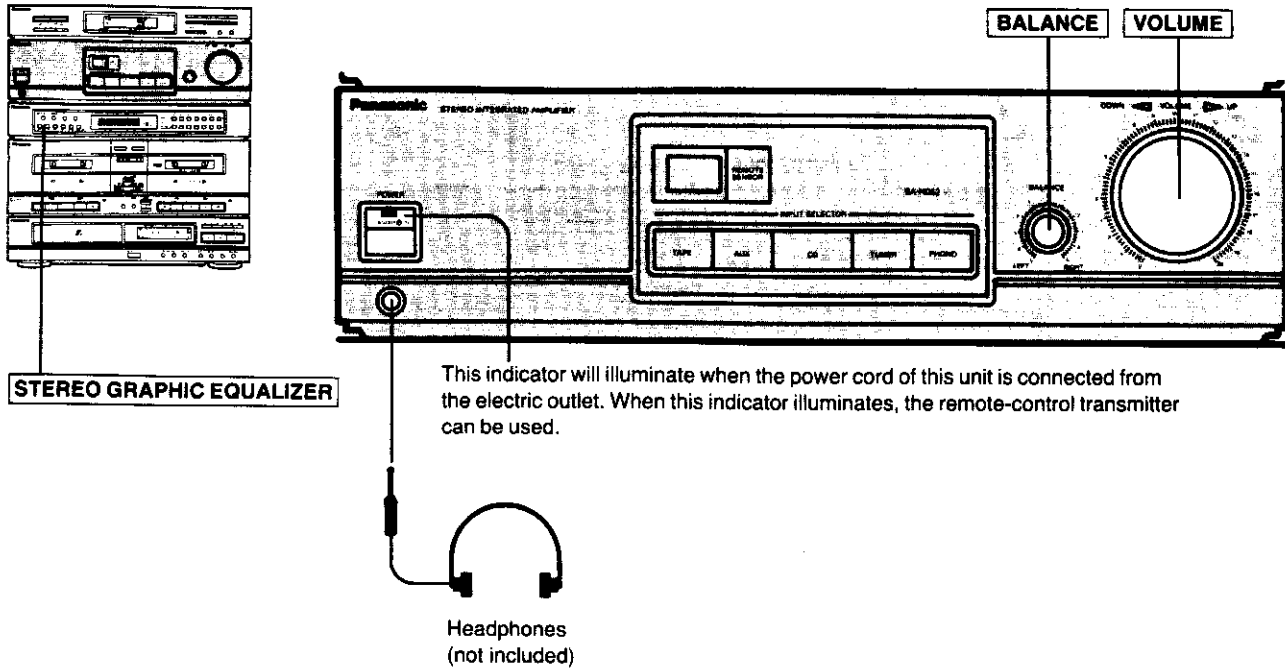

This indicator will illuminate when the power cord of this unit is connected from the electric outlet. When this indicator illuminates, the remote-control transmitter can be used.

Headphones
(not included)

To listen through headphones

PHONES

Connect headphones (not included) to the headphones jack.

Notes:

- Reduce the volume level before connecting headphones.
- Sound from the speakers will not be heard when headphones are connected to this jack.
- Avoid listening for a long time at a volume level so high that it irritates the ears.

After record play or radio broadcast, etc. has started

VOLUME

Adjust the volume level.

BALANCE

Adjust the left/right volume balance.

While listening to an AM broadcast or a monaural FM broadcast, balance the sound so that it seems to be heard from the center, between the speakers.

STEREO GRAPHIC EQUALIZER

Change the tone quality.

(See the page 28.)

After listening is finished

Be sure to reduce the volume level, and switch this unit to standby mode using its "STANDBY \odot /ON" switch or an "ON/OFF" switch on the remote-control transmitter.

Note:

The input selection and equalizer settings will be retained (as they were at the time when the power is switched to standby mode) by the memory back-up function.

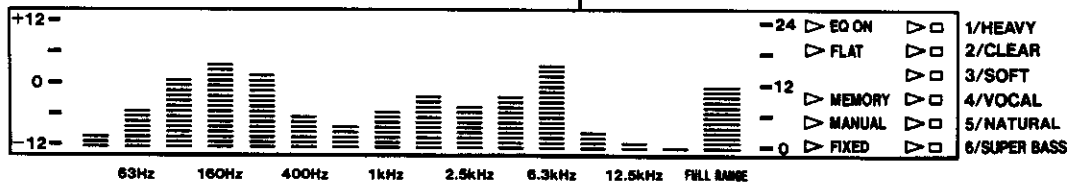
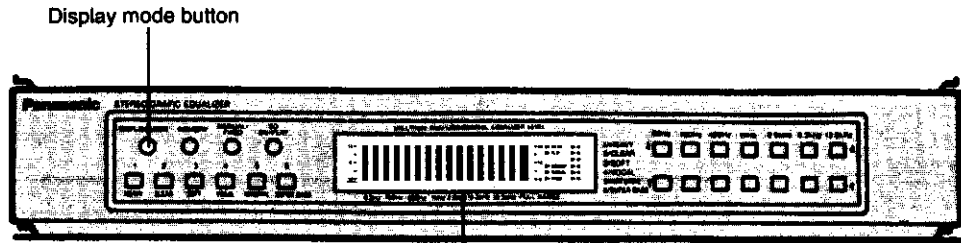
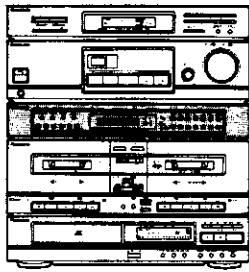

Spectrum display

The following 5 types of display are possible.
The display can be changed by pressing the display mode button.

1 Bar-type display

This display can be used to show the output strength for each sound range (frequency range), and to show the output strength of sound for all ranges (full range) by a bar-type display. Every time the unit is set to "ON", this type display will always appear.

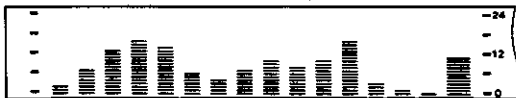

2 Peak-hold display

The peak sound value of each sound range is held on the display for about two seconds after it occurs.

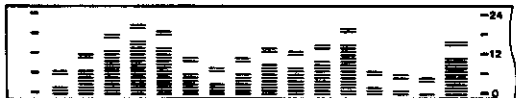

3 Dot display

Only the upper two parts of the bar display are shown, thus making the strength of the sound for each sound range even easier to see.

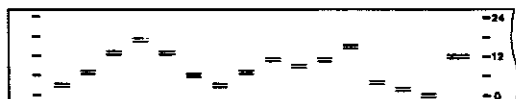

4 Hustler mode

The peak sound value of each sound range is displayed in augmented form.

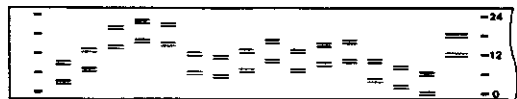

5 Aurora mode

The peak sound value of each sound range is displayed in inverted form.



Note:

If an equalization level-control or the memory-mode selector or a preset-memory button is pressed during any display other than the equalization-level display, the equalization-level display will be shown for about 3 seconds, after which the former display will return.

Listening to Radio Broadcasts

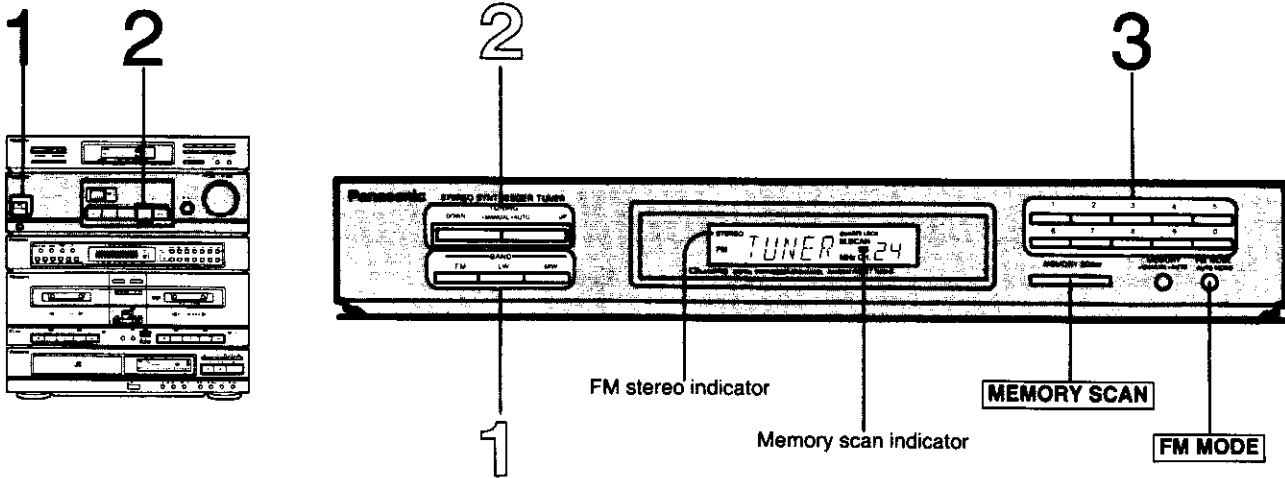

Have you completed the steps (on page 14 or 15) of "Memory Presettings"?

If not, follow the appropriate steps (on page 14 or 15), and then select the desired station by following the steps below, or tune by using the tuning buttons. (Refer to "Manual tuning", at the right.)

1 **POWER**
Switch ON the power "STANDBY /ON" switch.

2 **INPUT SELECTOR**
Press the "TUNER" button.

3 **1-0**
Press the button for the desired channel (1-24).
(Refer to "How to designate preset channels" at the bottom of page 15.)
The FM stereo indicator automatically illuminates when an FM stereo broadcast is being received.

Note:

If, for channels 10-24, the interval between pressing the first button and pressing the second button is more than about 2 seconds, the setting may not be made correctly. If this happens, make the setting once again.

4 Adjust the volume level and the tone quality as desired.
(Refer to pages 16 and 28.)

Manual tuning

Follow the steps at the left, except that, for step 3, follow the steps below.

1 **BAND**
Press the desired band selector ("FM", "LW" or "MW").

2 **DOWN UP**
Select the desired broadcast station by using one of the tuning buttons.
(Refer to "Frequency tuning", at the bottom of page 14.)

If noise is excessive in FM broadcasts

FM MODE

Press the FM mode selector.

This unit automatically switches to the stereo mode when a stereo broadcast is received.

Press this button for monaural reception, regardless of the strength of the incoming FM signal or whether it is stereo or mono.

Station Log

CH. 1	CH. 2	CH. 3	CH. 4	CH. 5	CH. 6
CH. 7	CH. 8	CH. 9	CH. 10	CH. 11	CH. 12
CH. 13	CH. 14	CH. 15	CH. 16	CH. 17	CH. 18
CH. 19	CH. 20	CH. 21	CH. 22	CH. 23	CH. 24

Memory scanning

This feature is convenient for use when trying to locate a certain broadcast, or to listen to each station briefly to hear what is being broadcast, because each frequency can be heard (in sequence) for about four seconds.

MEMORY SCAN Press the memory scan button.

Each frequency will then be heard (in sequence) for about four seconds.

(The memory scan indicator will flash on and off during scanning.)

When a preset channel is being received:

Scanning will begin from that channel, and will then continue in sequence to higher channels. When the highest channel is reached, scanning will then continue, repeating from the lowest channel.

When a manually tuned channel is being received:

Scanning will begin from preset channel "1", and continue in sequence.

■ **When a broadcast you want to listen to is found**

MEMORY SCAN (at this unit) or **TUNER PRESET** (at the remote-control transmitter)

Press the memory scan button or the tuner preset button (at the remote-control transmitter).

(The broadcast will continue, even after four seconds have passed.)

Back-up memory

The back-up function maintains the preset memory and the most-recent memory (see below) when the power is switched OFF, in the event of a power failure, or if the power cord is disconnected.

The memory will be maintained for as long as approximately one week.

Most-recent memory

The most-recent memory system "remembers" the broadcast station last tuned to when the unit was switched to standby mode. That station will be automatically tuned to when the power is switched ON.

■ **If frequency presettings are accidentally erased**

1. Switch ON the power "STANDBY /ON" switch.
2. Make the frequency presettings (on page 14 or 15) once again.

Listening to Tapes

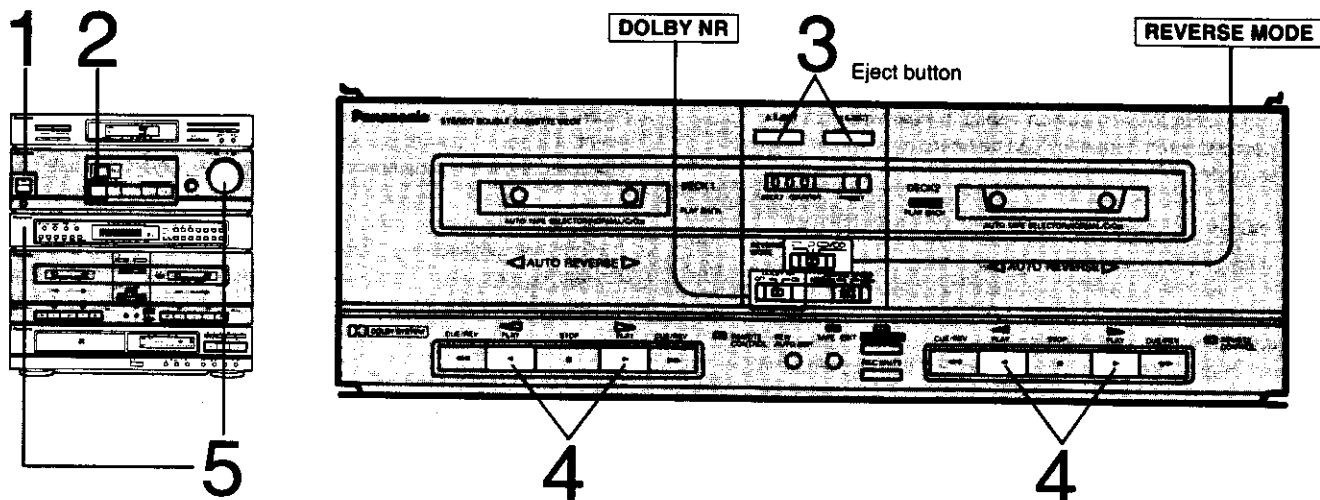

Either tape deck 1 or tape deck 2 can be used for tape playback by following the same steps.

- 1 POWER**
Switch ON the power "STANDBY /ON" switch.
- 2 INPUT SELECTOR**
Press the "TAPE" button.
- 3 EJECT**
Press the eject button, and then insert the cassette to be used for playback.

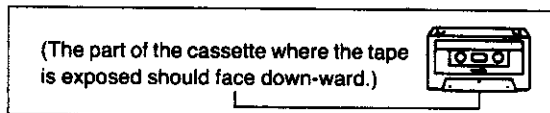

- 4 PLAY**
Press the forward- (or reverse-) side playback button to select the side ("A" or "B").
(The playback indicator will illuminate, and playback will begin.)
PLAY/▶ : Plays side "A" (side facing outward).
PLAY/◀ : Plays side "B".

- 5 Adjust the volume level and the tone quality as desired.** (Refer to pages 16 and 28.)

Notes

- Tape deck 1 and tape deck 2 cannot be used for playback at the same time.
- If the playback button of one of the decks is pressed while the other deck is in the play mode, playback of the first deck will stop.
- If the volume level is too high during "cue" and "review" operation, the tweeters in the speaker systems may be damaged.

STOP Press the stop button.
(The playback indicator will switch OFF.)

To fast forward or rewind the tape
CUE/REV Press one of the fast-forward/cue, rewind/review buttons to advance in the forward or reverse direction.

To cue or review the tape
CUE/REV During playback, press and hold the fast-forward/cue or rewind/review button.
The recorded sound on the tape can be monitored at a fast speed.
When the button is released, playback will resume.

Full automatic-stop system

When the tape reaches its end, it will stop automatically.

Playing tapes recorded with Dolby NR

DOLBY NR

Set the Dolby noise-reduction switch to "ON".

■ Dolby noise-reduction system

The Dolby noise-reduction system is a system designed to effectively reduce the annoying high-frequency "hissing" noise, typically heard from tapes if this system is not used. During recording, the system functions to increase the level of the high-frequency part of the sound, and then, during playback, that same portion is weakened and returned to the previous level. This unit is equipped with the B-type Dolby noise-reduction system.

Dolby noise reduction manufactured under license from Dolby Laboratories Licensing Corporation. "DOLBY" and the double-D symbol  are trademarks of Dolby Laboratories Licensing Corporation.

Various playback functions

REVERSE MODE

The reverse-mode selector can be used to select either or three different playback functions.

 ; Select this mode to playback only one side of a cassette tape.

When the playback has finished, tape movement will stop automatically.

 ; Select this mode to playback both sides of the tape only once.

When the both sides playback has finished, tape movement will stop automatically.

If playback starts from the reverse side, only that side will be played and stop.

 : When tape is loaded into deck 1 or 2 only.

Select this mode to playback both sides of a cassette tape continuously.

This playback will continue until the stop button is pressed.

 : When tapes are loaded into both deck 1 and 2.

Select this mode to playback both sides (from side "A" to "B") of the cassette tapes continuously.

(This is called "series playback".)

This mode is convenient for enjoyment of a long period of uninterrupted background music.

This series playback can start from any of decks.

This playback will continue until the stop button is pressed.

Automatic-tape select function

This unit is equipped with the automatic-tape-select feature; it automatically detects the type of tape being used, and then makes the suitable adjustment accordingly of the bias for recording and equalization.

Listening to Compact Discs

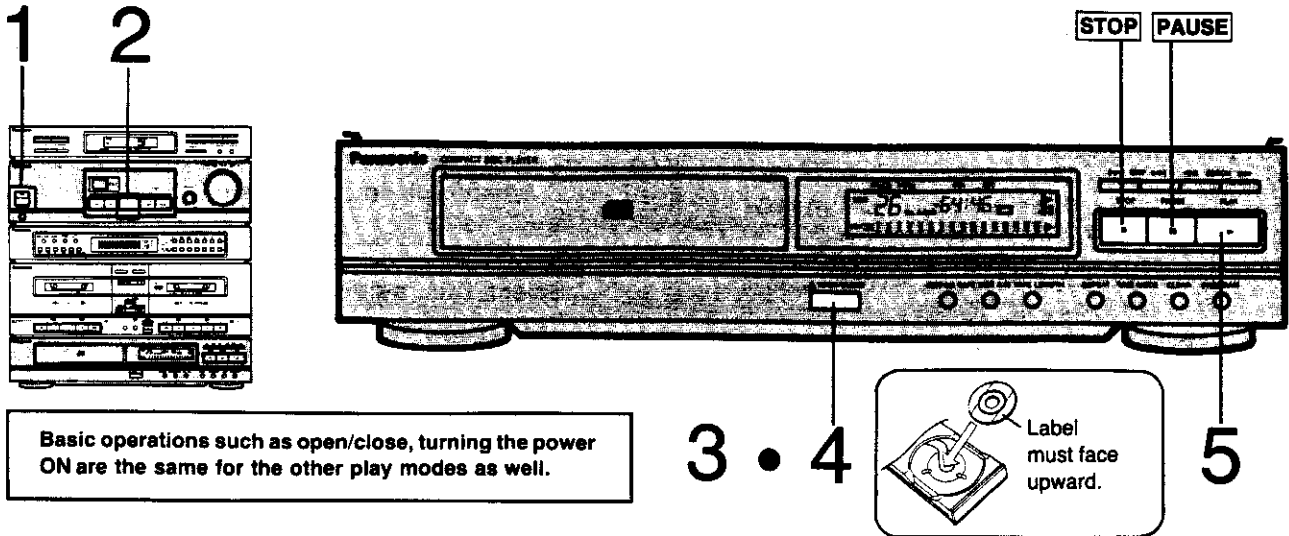

Basic operations such as open/close, turning the power ON are the same for the other play modes as well.

Normal play

Playing an entire disc from the first track to the last.

1 POWER
Switch ON the power "STANDBY /ON" switch.

Turn down your amplifier volume first. If, inadvertently, the volume is set too loud, damage to your speakers could result.

2 INPUT SELECTOR
Press the "CD" button.

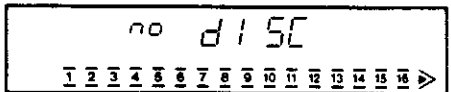

3 OPEN/CLOSE
Press the open/close button to open the disc holder and insert a disc.

4 OPEN/CLOSE
Press the open/close button again to close the disc holder.

Do not stick your finger through the hole in the middle of the disc holder. (It could get caught when the holder closes.)

The total number of tracks on the disc and the total playing time are displayed.

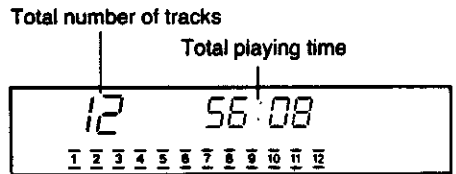

5 PLAY
Press the play button.
Disc play begins from the first track on the disc.

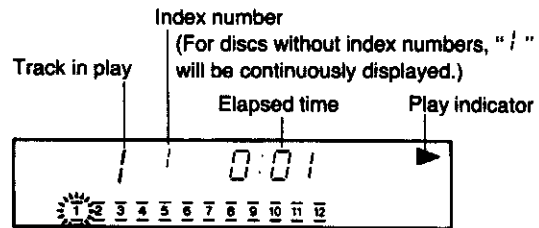

The bars above and below the number of the track in play flash. They go out when play finishes.

•The unit stops automatically when the last track on the disc finishes playing. (The display returns to the total number of tracks and total playing time indications.)

To stop disc play
STOP Press the stop button.

The unit switches to the stop mode and the total number of tracks and total playing time are displayed.

To temporarily stop disc play
PAUSE Press the pause button.

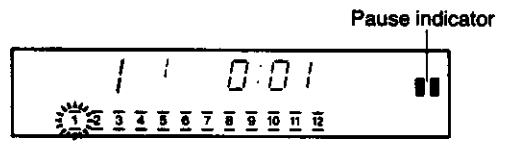

•Press the play button to play again.

Notes:

- Attempting to change discs while the disc holder is in the process of opening can scratch or damage your discs.
- The total playing time displayed includes the silent sections between tracks. For this reason, it may differ by a few seconds from the playing time printed in the disc's liner notes.

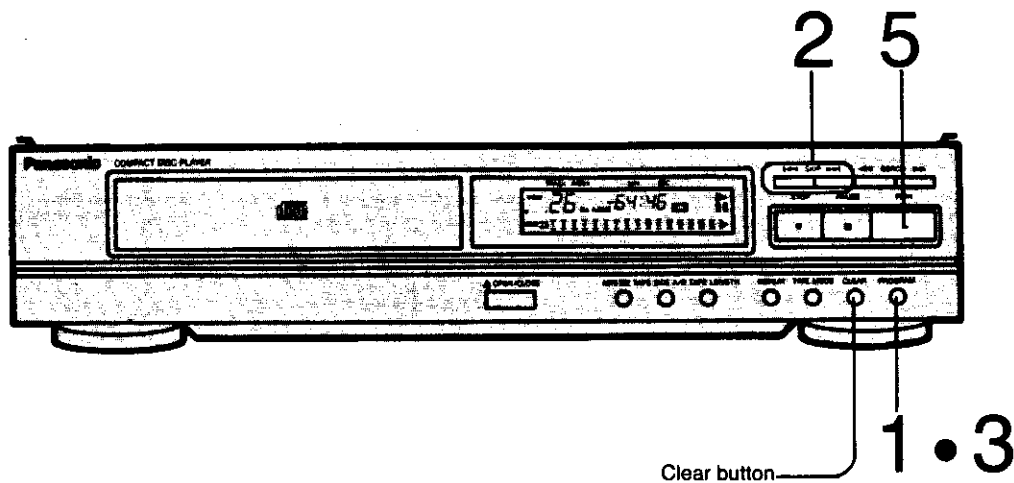

Program play

This function allows you to program up to 20 tracks on the disc in any order you choose.

- 1** **PROGRAM**
Press the program button.

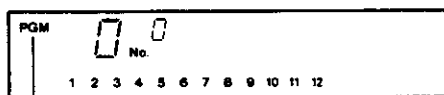

Program indicator

- 2** **SKIP**
Press the skip button to select the desired track.

For example; to select 3.
Press the ►► button three times.

- 3** **PROGRAM**
Press the program button again to enter the desired track.

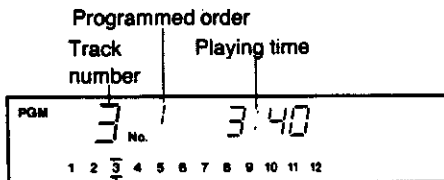

The bars above and below the number 3 illuminate, indicating that track has been programmed.

- 4** Repeat the steps 2 and 3 to add the tracks.

- If you continue adding track numbers by repeating the above step, the programmed order counter counts up and the playing time for each new track is added to the total playing time. If the total playing time exceeds 99 minutes or the track number 21 (or higher) has been specified, the display reads "-----".
- To specify the same track number successively, press the skip button (►► or ◀◀) to move to the other track than the desired one. Then press the skip button again to return to the desired track.
- When the 21st program has been performed, "F" (full) appears on the display, indicating that no more tracks can be added to the programmed sequence.
- Track numbers not actually on the disc can not be programmed.
- To clear the program track, press the clear button. Each time the clear button is pressed, the last track in the programmed sequence will be cancelled.

- 5** **PLAY**
Press the play button.

- The programmed sequence is played beginning from the first track you entered.
- If pressing the numeric button at the remote control transmitter, you can add tracks to the programmed sequence during disc play.
 - The unit stops automatically when all the programmed tracks have finished playing.

- To cancel program play, press the program button.

Pressing the stop button in the stop mode can also cancel program play.

Listening to Compact Discs (continued)

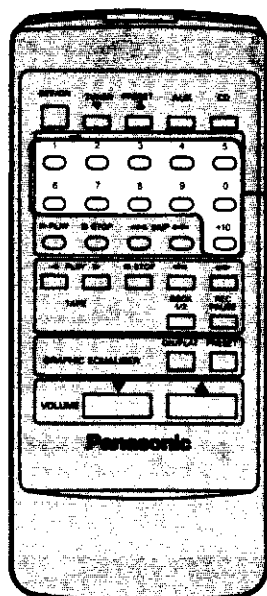

NUMERIC BUTTONS

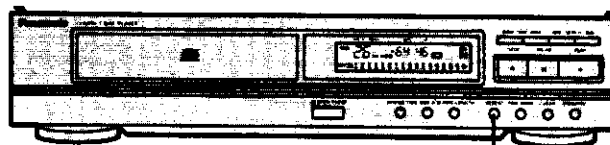

REPEAT

Direct access play (by remote control transmitter only)

1 ~ +10

To listen to a disc from track 3, press the numeric button 3. Play begins directly from track 3.

Choosing a specific track

- Tracks 1-9: Press the appropriate numeric button 1-9 directly.
- Tracks 10 and up: First press +10, then 1-9. (Press +10 twice and 0 for 20, +10 three times and 0 for 30, and so on.)

- Playback begins from the track selected and continues from subsequent tracks until the end of the disc is reached.
- The unit stops automatically when the last track on the disc finishes playing.
- During play, you can skip to the specific track directly by using the numeric button.

Repeat play

REPEAT

Press the repeat button.

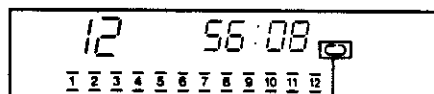

Repeat play indicator

- Pressing the repeat button again cancels the repeat play.

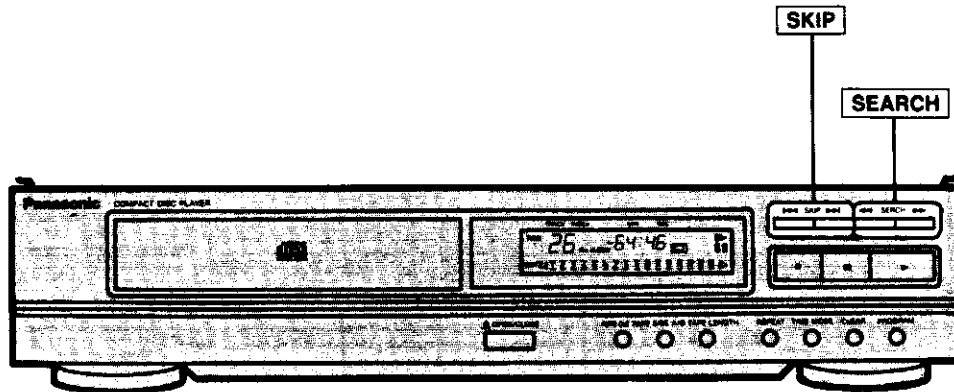

Skip play



This function allows you to skip to the beginnings of tracks preceding or following the track in play and begins play immediately. It is a good idea to keep an eye on the track number display when using this function.

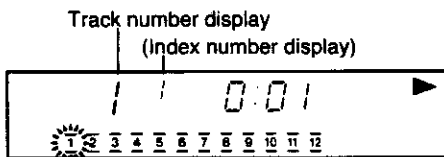

- **To skip forward, press the skip button (▶▶).**
The unit skip ahead one track each time the button is pressed.

For example, to skip from track 3 to track 5:

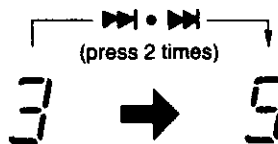

- **To skip backward, press the skip button (◀◀).**
The first time the button is pressed, the unit skips back to the beginning of the track in play. Then it skips back one track for each additional press.

For example, to skip from track 5 to track 3 during play:

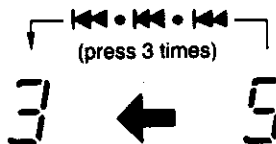

- You can also skip tracks when the unit is in the pause mode. The unit skips to the track selected and remains in the pause mode.

Search play



This function allows you to search rapidly forward or backward on the disc for specific sections.

- **To search forward, press the search button (▶▶).**

The unit begins searching in a forward direction.

- **To search backward, press the search button (◀◀).**

The unit begins searching in a reverse direction.

- Sound from the disc can be heard as the pickup moves. The output level at this time is decreased by 12 dB (1/4) compared with the normal level.
- The search speed is slow when the button is pressed at first and becomes faster if you keep it pressed down. Release the button when you reach the desired point on the disc.
- Search play can also be activated in the pause mode. As one of the search buttons is released the unit will return to the pause mode.

Listening to Compact Discs (continued)

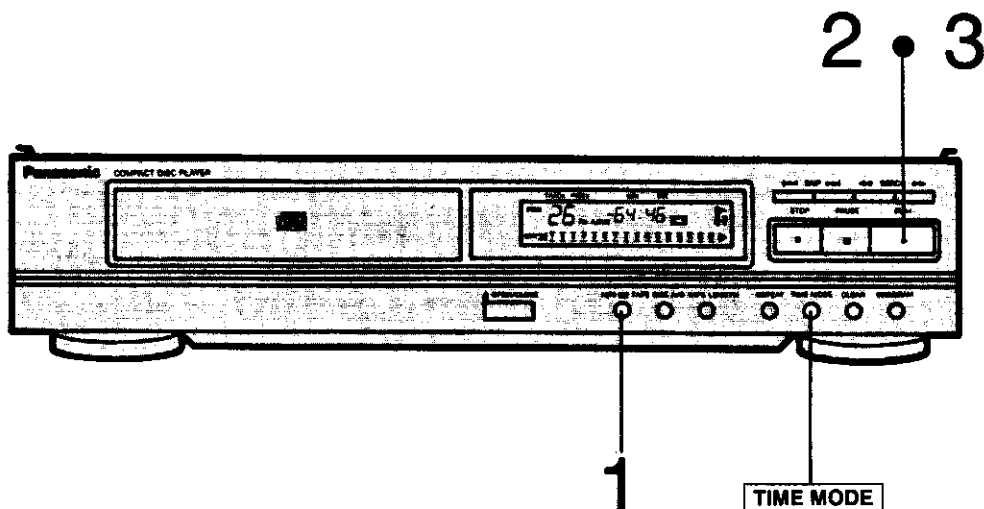

Auto cue

AUTO CUE

The auto cue function allows the unit to wait in the standby condition at the beginning of each tune so as to start play right when you are ready. When each tune finishes playing, the unit skips to the beginning of the next tune and switches to the play standby mode. This function is especially convenient when used together with programmed play.

1 Press the auto cue button.

2 Press the play button.
The unit switches to the play standby mode.

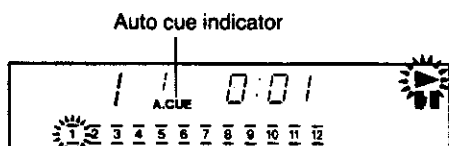

3 Press the play button again to start play.

•Pressing the auto cue button again cancels auto cue.

Note:

The auto cue function may not function at the beginning of tune properly if a selection begins with a very soft passage or if there is a lot of background noise.

Time mode display

TIME MODE

Each time the time mode select button is pressed during play or when the unit is in the pause mode, the display changes as follows.

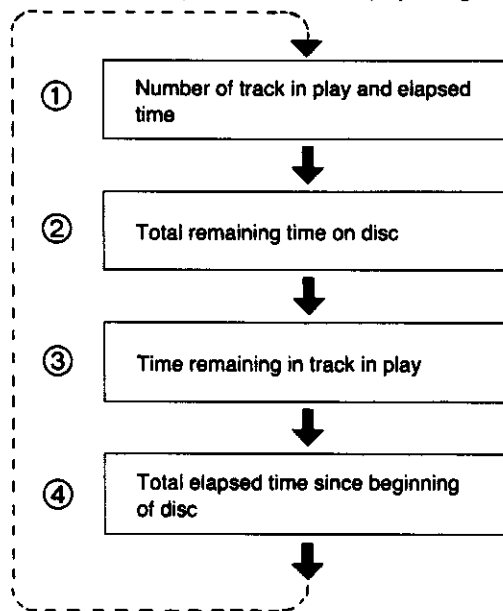

•While the track number 21 or higher is playing:
The "----" indication will be shown on display ③.

Listening to Other Source

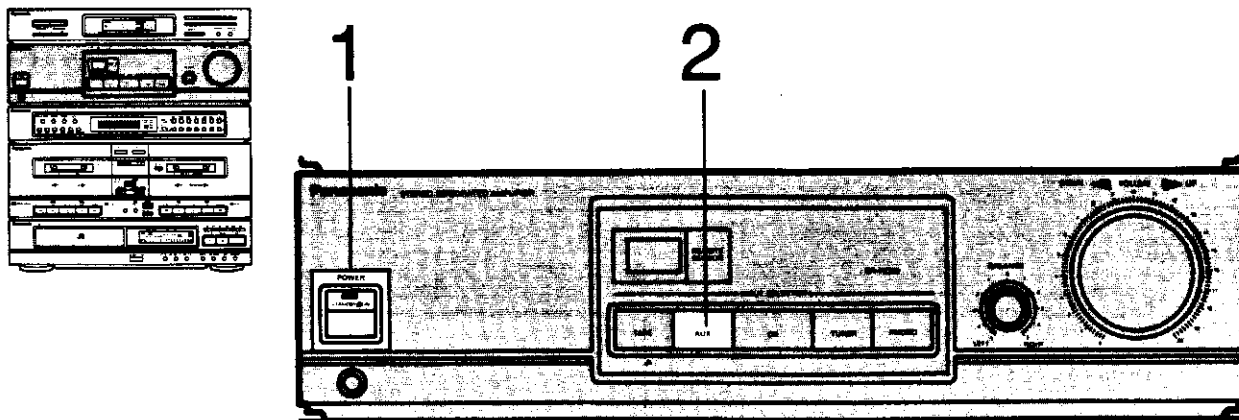

1 **POWER**
Switch ON the power "STANDBY /ON" switch.

2 **INPUT SELECTOR**
Press the "AUX" button.
AUX: Press to listen to sound from equipment connected to the "AUX" terminals of this unit.

AUX

3 **Begin the operation of that unit.**
(Refer to the operating instructions of each component.)

4 **Adjust the volume level and the tone quality as desired.**
(Refer to pages 16 and 28.)

Changing the Tone Quality

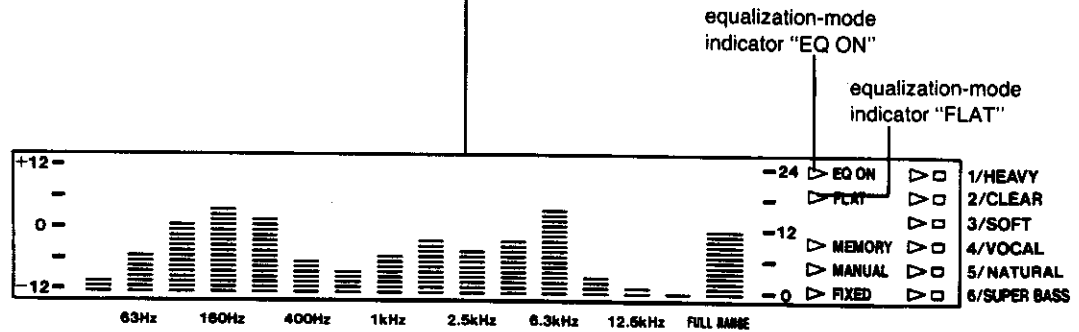
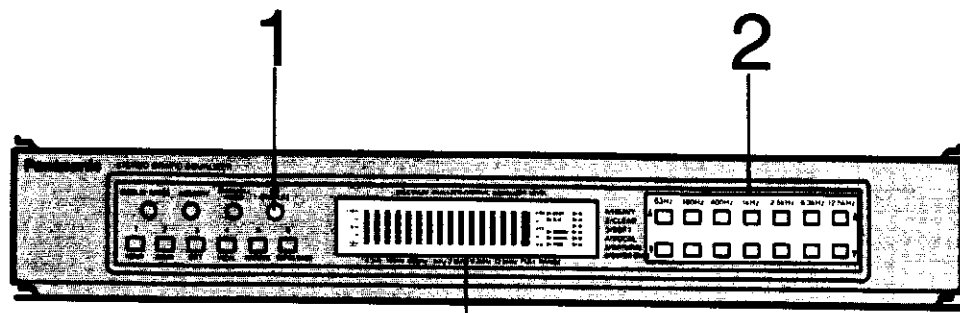
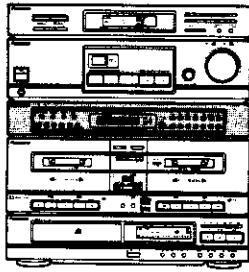

To adjust the desired tone quality

While listening to the music, adjust the sound to suit your taste.

- EQ ON/FLAT**
Press the equalizer on/flat button to set the equalizer on mode.
 (The equalization-mode indicator, "EQ ON" will illuminate.)

- ▲▼**
Press the equalizer level control buttons to adjust the level of each frequency range.
 ▲...for increasing
 ▼...for decreasing
 ●If pressed, the equalization-level will be shown.
 It will return to previous display mode 3 seconds after released.

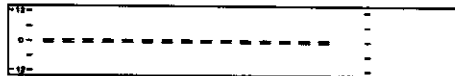

■ When the equalizer effect is not necessary.

Press the equalizer on/flat button to set the flat mode.
 (The "FLAT" indicator will illuminate.)

Characteristics of each frequency range

- 63 Hz:** The deep bass range
- 160 Hz:** The bass range
- 400 Hz:** The fundamental tonal range of music
- 1 kHz:** The tonal range which adds tension to the sound
- 2.5 kHz:** The tonal range where strings and winds are most prominent
- 6.3 kHz:** The tonal range which adds gloss to the sound
- 12.5 kHz:** The tonal range which adds glitter to the sound

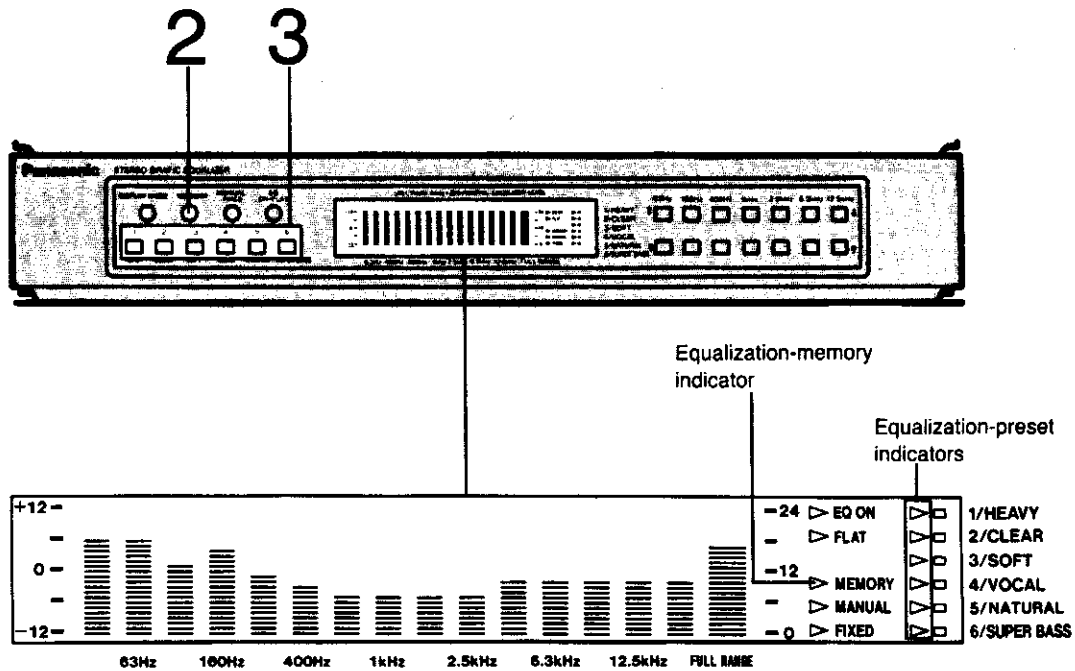

To program an equalization curve into the memory

As many as six curves can be programmed into and retained by the memory of this unit. It is convenient to program those curves that are frequently used.

1 Adjust to the desired equalization curve.
(Adjust by following the steps in "To adjust the desired tone quality" on page 28.)

2 **MEMORY**
Press the "MEMORY" button.
(The equalization-memory indicator will illuminate.)
•To cancel memory programming, press the memory button once again.

3 **1~6**
Press one of the preset-memory buttons (1-6), whichever is to be used to make the programming to the memory.
(The corresponding equalization-preset indicator will illuminate, and the programming will be made.)

Note:

If a new curve is programmed for a number for which a curve is already programmed in the memory, the previously programmed curve will be erased.

Changing the Tone Quality (continued)

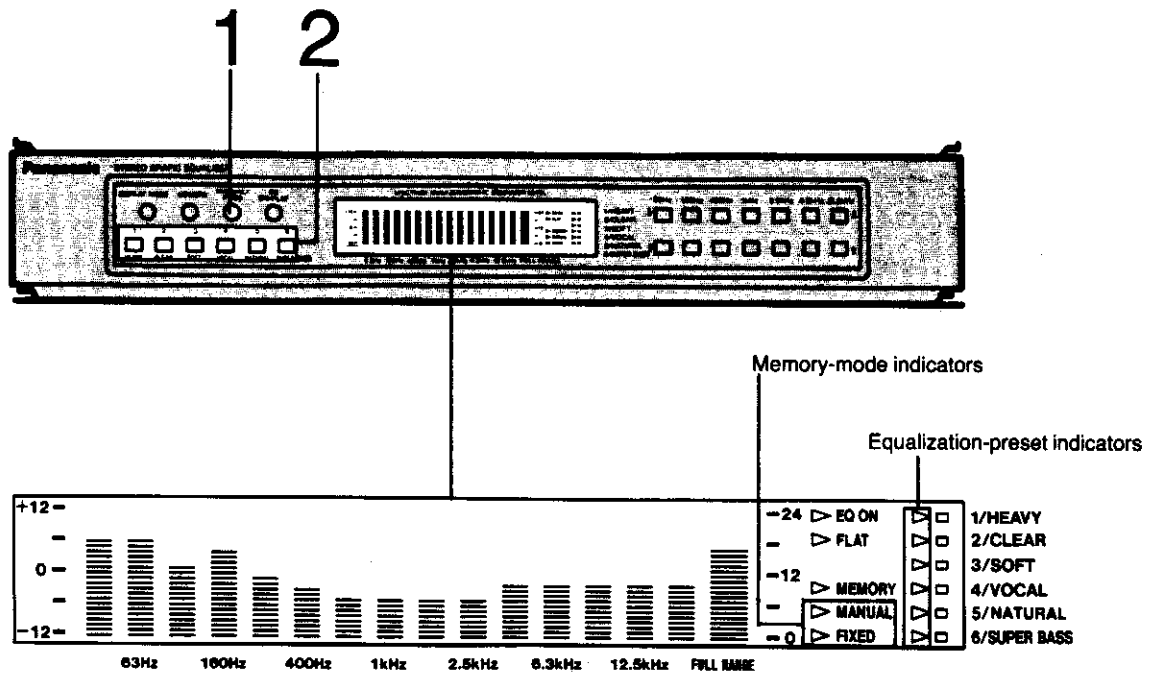

To retrieve equalization curves from the memory

This unit has been pre-programmed with six types of typical equalization curves which are applicable to certain styles of music.

- 1 **MANUAL/FIXED**
Press the "memory mode-select" button.
MANUAL: Select this mode when you want to retrieve a equalization curve that you have programmed into memory.
FIXED: Select this mode when you want to retrieve a equalization curve that was originally programmed into memory as a permanent ("FIXED") curve.
 (The memory-mode indicator will indicate the selection made.)

- 2 **1~6**
Press one of the preset-memory buttons, whichever corresponds to the curve to be retrieved.
 (The corresponding equalization-preset indicator will illuminate.)

•While in the "FIXED" mode, if one of the equalizer level-control buttons is pressed, the unit will automatically switch to the "MANUAL" mode.

Note:

Curves programmed into the memory will be retained for about a few days if the AC power supply cord is unplugged. If curves are erased, they must be programmed again. Note, however, that curves originally programmed beforehand into the unit's memory as permanent curves (the "FIXED" curves) will not be erased.

■ "MOST RECENT" memory

If, after the buttons and equalization levels of this unit have been set, the power is switched to "STANDBY" and then switched ON, the setting of each button and the equalization levels will be entered into the memory, and these settings will return when the power is switched ON.

Equalization curves pre-programmed to this unit

1/ HEAVY

This curve can be used to add "punch" to rock and other music.

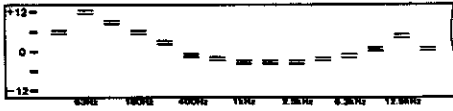

2/ CLEAR

This curve can be used to clarify the treble range of jazz, etc.

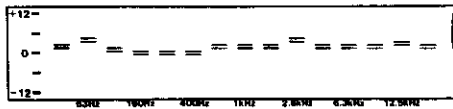

3/ SOFT

This curve can be used to listen to background music, etc. at a low volume level.



4/ VOCAL

This curve can be used to clarify vocal music.

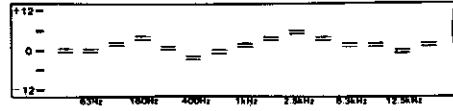

5/ NATURAL

This curve can be used to listen to the natural tone.

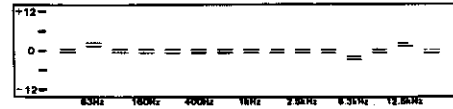

6/ SUPER BASS

This curve can be used to boost the dynamic low sound.

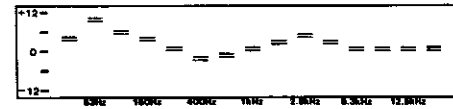

Recording (tape deck 2 only)

Your attention is drawn to the fact that recording pre-recorded tapes or discs on other published or broadcast material may infringe copyright laws.

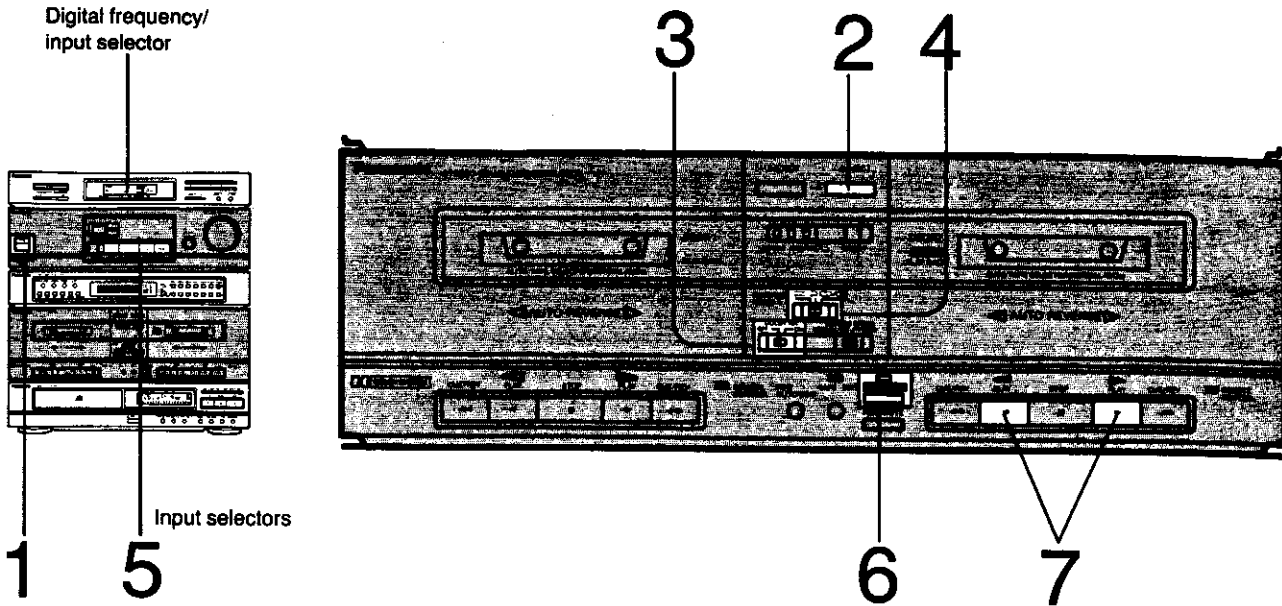

To record from a sound source

1 **POWER**
Switch ON the power "STANDBY  /ON" switch.

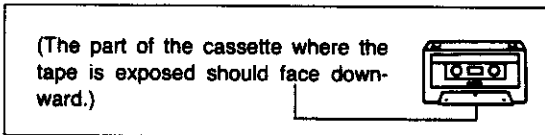

2 **EJECT**
Press the eject button, and then insert the cassette to be used for recording into tape deck 2.



Note:
The normal or chromium type of tape is recommended.



3 **DOLBY NR**
To record with the Dolby noise-reduction effect, set the Dolby noise-reduction switch to "ON".

4 **REVERSE MODE**
Select the side(s) of the tape (one side only or both sides) upon which the recording is to be made.

-  ; Select this setting to record on one side only. At this setting, the recording will stop at the end of one side of the tape.
-  ; Select this setting to record on both sides. The recording will be made on side "B" after recording on side "A"; the tape will stop at the end of side "B".

5 **INPUT SELECTOR**
Press the input selector corresponding to the sound source (compact-disc player, phono disc, etc.) from which you want to make the recording. (The selected source will be shown by the digital frequency/input display.)

6 **REC PAUSE**
Press the recording pause button. (The recording pause indicator will illuminate, and the playback indicators start flashing. The tape deck will be in the recording stand-by mode.)

7 **PLAY**
Press the playback button (The recording will begin.), then begin the sound source to be recorded.
 •If only one side of the tape (reverse mode position: ) is to be recorded, press the playback button that corresponds to that side.
 •To record on both sides of the tape (reverse mode position: ), press the "A" side playback button ().
 (The playback indicator will illuminate steadily, and the recording will begin.)
 This unit has been set for the optimum recording level.

Edit-Recording from Compact Discs

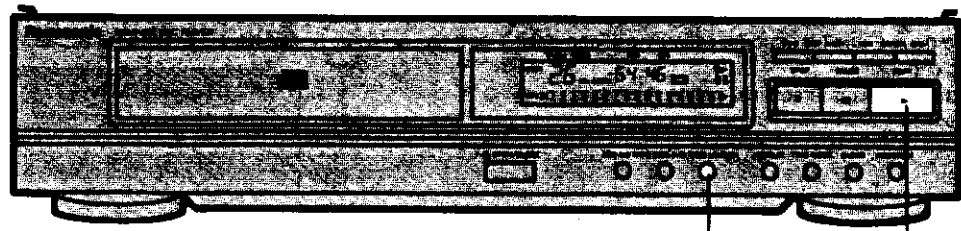
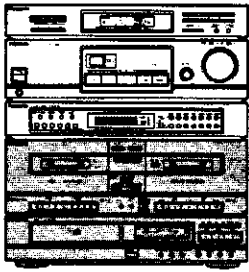

1 Prepare for recording on cassette deck.

2

3

Automatic edit

This unit automatically calculates how many tracks will fit on a given tape side and programs them. The recording can be started by simply pressing the play button.

1 Carry out the steps 1 to 6 of "To record from a sound source" on page 32.

- When you want to record programmed tracks, first program tracks in memory using the program play procedure (see page 23). Then press the edit tape length button.
- Recording will take place automatically from the forward side to the reverse side of the tape, so insert the tape with the side from which you intend to record first facing toward you, then set the reverse mode selector to "↔".

2 **TAPE LENGTH**
Press the edit tape length button to select the tape length.

Each time the button is pressed the tape length indicator changes as follows. Choose the length of the tape you will use.

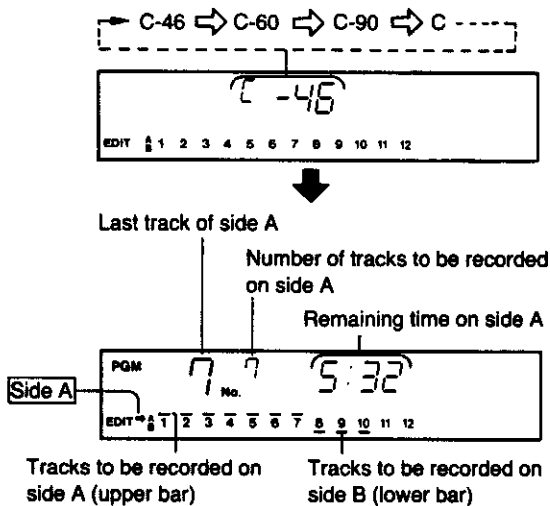

•To see the data of side B, press the tape-side select button.

3 **PLAY**
Press the play button.
Recording will begin from side A.

- When the tracks programmed for tape side A have finished playing, the unit searches for the beginning of the first track to be recorded on side B and switches to the pause mode. When the auto reverse mechanism of the cassette deck works at the end of side A and the tape switches to side B, recording for side B starts automatically.
 - During recording, silent gaps of approximately 3 seconds are inserted between tracks automatically (auto space function).
- Note:**
According to the discs, the little sound of the beginning of the next track may be recorded onto the end of the track.

Notes:

- The maximum allowable playing time for editing is 99 minutes.
- When the track number 21 (or higher) is specified, the edit function does not work.

To select your desired recording time

Press the edit tape length button 4 times to select "C---". Press the skip button repeatedly until the desired tape's playing time in minutes (1-99) will appear.

Using the remote control transmitter

Press the numeric button to select the time.

For example:

"C-52": First press [5] then press [2].

- If you make a mistake, select "C---" once again and enter the correct tape length.

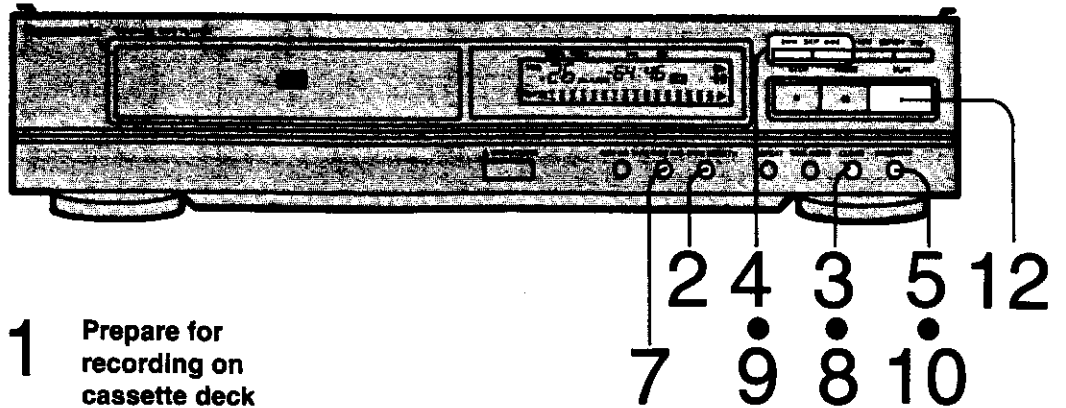
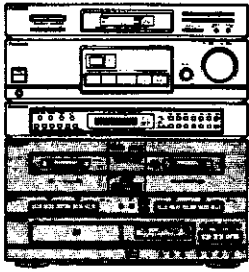

1 Prepare for recording on cassette deck

Manual edit

This function allows you to add selections one by one to each tape side and check the time remaining after each entry in order to minimize wasted tape.

1 Carry out the steps 1 to 6 of "To record from a sound source" on page 32.

2 **TAPE LENGTH**
Press the edit tape length button to select the tape length.

The automatic editing functions and the tracks are programmed on the both tape side A and B.

3 **CLEAR**
Press the clear button until "0" appears in the track number display.

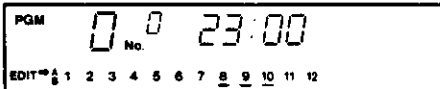

4 **SKIP**
Press the skip button to select the desired track for side A.

5 **PROGRAM**
Press the program button to enter the desired track.

Number of tracks to be recorded Remaining time

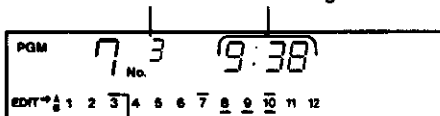

Bars for tracks reserved for side A illuminate

6 Repeat step 4 and 5 to add the track and complete the program for side A.

•If the remaining tape is not sufficient to hold the last track programmed, a negative number will be displayed.

In this case, press the clear button to cancel the last track in the sequence from memory and enter a track which better matches the remaining time.

•3-second silent gaps which are automatically inserted between tracks are included in the remaining time.

7 **SIDE A/B**
Press the tape-side select button to switch to tape side B.

8 **CLEAR**
Press the clear button until "0" appears in the track number display.

9 **SKIP**
Press the skip button to select the desired track for side B.

10 **PROGRAM**
Press the program button to enter the desired track.

11 Repeat the 9 and 10 steps to add the track and complete the program for side B.

12 **PLAY**
Press the play button.
Recording will begin from side A.

Notes:

- The maximum allowable playing time for editing is 99 minutes.
- More than 20 programs cannot be edited.
- When the track number 21 (or higher) is specified, the edit function does not work.

Edit-Recording

"Edit-recording" is recording from one tape to another.

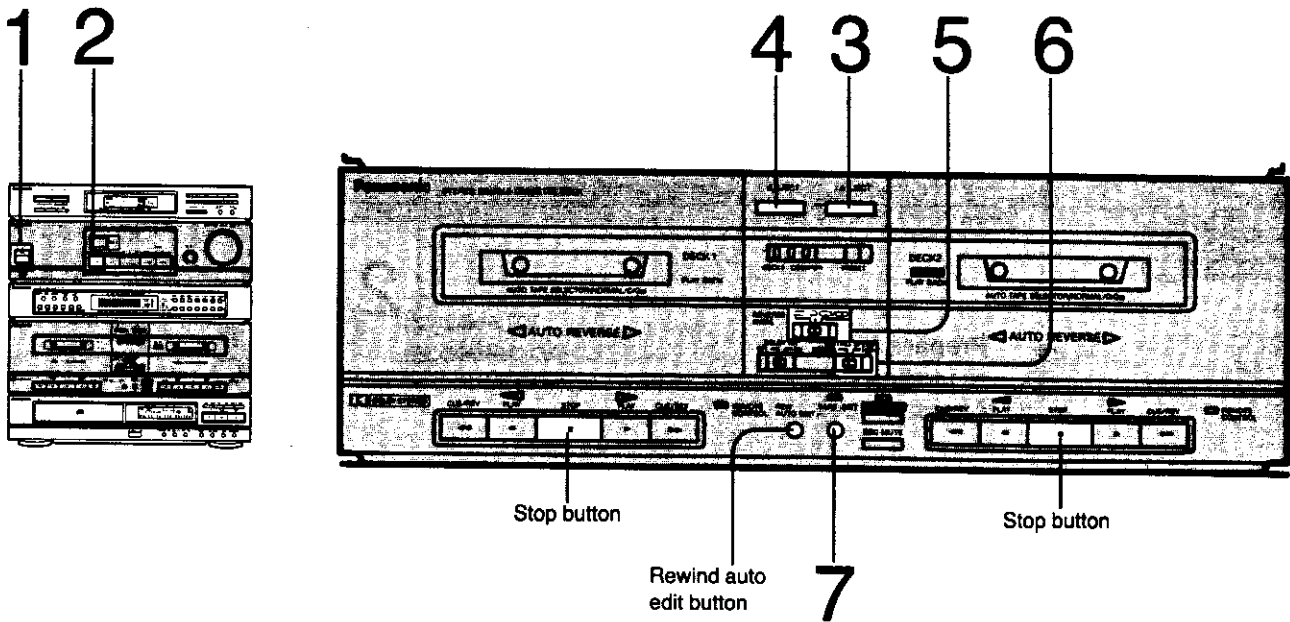

1 **POWER**
Switch ON the power "STANDBY $\text{\textcircled{O}}$ /ON" switch.

2 **INPUT SELECTOR**
Press the "TAPE" button. TAPE

3 **EJECT**
Press the eject button on deck 2, and insert the tape upon which the recording will be made.

(The part of the cassette where the tape is exposed should face downward.)



Note:
The normal or chromium type of tape is recommended.

4 **EJECT**
Press the eject button on deck 1, and insert the tape to be played back.

5 **REVERSE MODE**
Select the side(s) of the tape (one side only or both sides) upon which the recording is to be made.

- $\text{\textcircled{A}}$; Select this setting to record on one side only.
At this setting, the recording will stop at the end of one side of the tape.
- $\text{\textcircled{B}}$; Select this setting to record on both sides.
The recording will be made on side "B" after recording on side "A"; the tape will stop at the end of side "B".
(When the playback in the "B" side by deck 1 has finished, tape movement in deck 1 will stop and deck 2 will stop.)

6 **EDITING SPEED**
Select the speed at which the recording will be made.
NORMAL; For operation at the normal tape speed.
HIGH; For operation at the high tape speed.

7 **TAPE EDIT**
Press the tape edit button.
The indicator will illuminate.
By pressing the tape edit button at this time, recording will begin immediately at the present tape locations. (Playback of deck 1/Recording onto deck 2.)

Pressing the rewind auto edit button will cause both tapes to rewind to their beginning, at which point recording will start.

■ To stop edit-recording
Press any of the stop button.
(Both of the tapes in the deck will stop.)

- Notes:**
- Do not change the editing tape-speed setting while a recording is being made. (To do so will cause a momentary sound distortion in the recording.)
 - The recording level as well as the equalizer effects and the Dolby noise-reduction effects will be recorded on the tape in tape deck 2 exactly as they were originally recorded on the tape in the tape deck 1.
 - The monitor sound in Dolby recording can be played back accurately if the Dolby noise reduction switch is set to "ON".
 - While an edit-recording is in progress, you can enjoy some other sources. Select the desired sound source by using the input selectors, and start the performance.
Then again, when you want to listen to the tape on edit-recording, press the "TAPE" button of the input selectors of this unit.
 - When performing the edit-recording, be sure to turn off the power for the video or TV product. (To do so will cause the distortion sound may be recorded.)

Remote-Control Operation

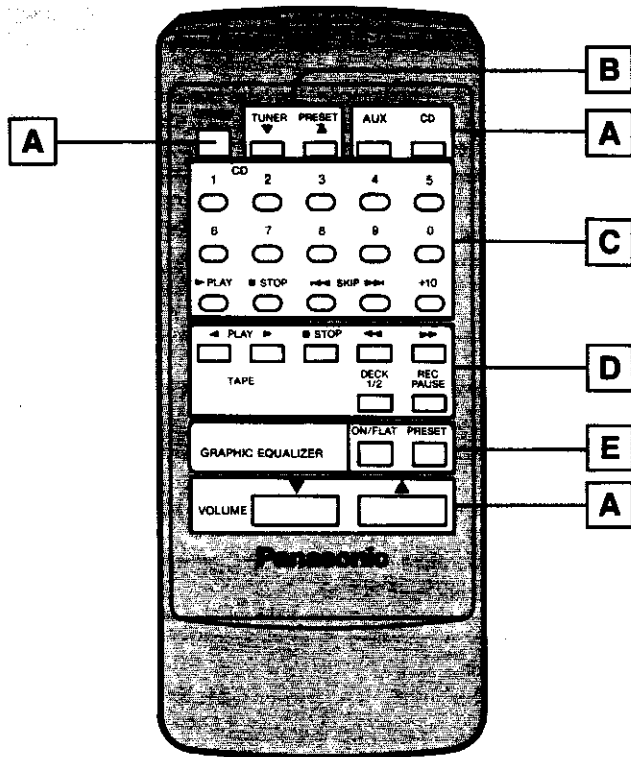

For detailed information concerning operation steps, etc., please refer to the appropriate page for each unit and the respective operation instructions. For this system, you can listen to tapes or compact discs, etc., by operating the remote-control transmitter without using the input selectors.

A Amplifier controls

OFF/ON

Press this button to switch the unit ON or to the stand-by condition. Note that there is no need to press this button if the unit's power is ON. (If it is pressed, the unit will be switched to the stand-by mode.)

AUX, CD

These buttons are used to select the program source (AUX, CD)

AUX: Press to listen to sound from equipment connected to the "AUX" terminals of this unit.

CD: Press to listen to compact discs.

VOLUME

For adjustment of the volume level.

▲: To increase the volume level.

▼: To decrease the volume level.

B Tuner controls

▼-TUNER PRESET-▲

To select a preset channel. (Refer to page 18.)

(There will be an automatically change of the input selector.)

▲: Press to change to a higher channel.

▼: Press to change to a lower channel.

(If either button is pressed and held, the channel will change continuously.)

C Compact-disc controls

1-0, +10

These buttons are used to specify the desired track number.

•The play begins automatically from the selected track when a track is selected while the unit is in the stop mode.

To select the specific track number

•Tracks 1-9: Press the appropriate numeric button [1]-[9] directly.

•Tracks 10 and up: First press [+10], then [1] - [0]. (Press [+10] twice and [0] for 20, [+10] three times and [0] for 30, and so on.)

▶ PLAY

Press this button to start disc play.

■ STOP

Press this button to stop disc play.

◀◀ SKIP ▶▶

Press one of these buttons to select the desired track.

◀◀: for a prior track

▶▶: for a track ahead

D Cassette tape deck controls

◀ PLAY ▶

Press this button to start the tape.

▶: "A" side (side facing outward)

◀: "B" side

(There will be an automatic change of the input selector.)

STOP

Press this button to stop the tape.

◀◀ ▶▶

Press one of these buttons to forward or rewind the tape. Hold one of these buttons to cue or review the tape.

DECK 1/2

Press to select the deck ("DECK 1" or "DECK 2") to be used.

REC PAUSE

Press to change to the recording stand-by mode.

E Graphic equalizer controls

ON/FLAT

Press to select the equalizer effect on or off.

PRESET

First press and hold to select the manual or fixed program mode, and then press to select the preset channel of the equalization curve.

About Cassette Tapes

Avoid the following types of tapes

•120-minute (or longer) tapes

Because this tape is very thin, it might stretch during use, become tangled with rotating parts in this unit, and/or tape movement might not be stable.

•Fe-Cr tape (TYPE III)

The high range will be emphasized and a flat frequency response characteristic cannot be obtained.

•Metal tape

In particular, recordings will be very distorted.

Notes about the handling of cassettes

If the tape in the cassette is loose, the tape can easily break during use or otherwise be damaged. Never touch the tape itself, or attempt to pull it out of the cassette.

Use a pencil or similar object to take up the slack.



Avoid tape storage in the following places

Tape can be damaged if it is stored in places such as described below.

- Where the temperature is high (95°F/35°C or higher) or where the humidity is high (80% or higher).
- Where there is a strong magnetic field (near a speaker, on top of a TV, etc.).
- In direct sunlight.

About Compact Discs

Handling precautions

Only compact discs having this mark can be used with this unit.



Observe the following precautions to enjoy the same outstanding sonic performance from your Compact Discs for many years.

- Hold compact discs by the edges so the surface is not soiled with fingerprints.

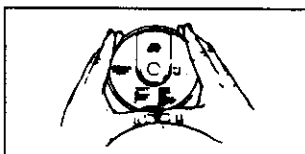

- Be careful not to scratch the surface with fingernails or other sharp objects, particularly when inserting and removing discs from their cases.
- Do not bend the disc.
- Do not use record cleaning sprays or static electricity prevention liquids.
- Do not wipe with benzene, thinner or any other solvent. If the surface is soiled, wipe gently with a soft, damp (water only) cloth.

- When wiping discs, always move the cloth directly outward from the center of the disc, not in a circular motion as with standard phonograph records.

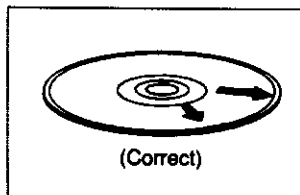

(Correct)

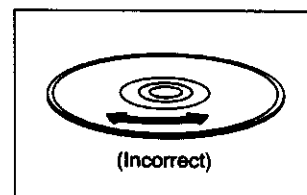

(Incorrect)

(In compact discs, circular scratches along a line of pits are more likely to cause errors than straight scratches across many lines of pits.)

- If the disc is brought from a cold environment into a warm room, moisture may form on the disc. Wipe this off with a soft, dry, lint-free cloth before using the disc.
- Do not dry discs with a hair dryer.
- Do not write on the label side with a ball-point pen, hard pencil or other writing utensil.
- Handle compact discs with care. Fingerprints, dirt and scratches can cause skipping and distortion.

Storage precautions

- Be sure to store discs in their cases to protect them from dust, scratches and warping.
- Do not place or store discs in the following places:
 - 1) Locations exposed to direct sunlight.
 - 2) Humid or dusty locations.
 - 3) Locations directly exposed to a heat outlet or heating appliance.
 - 4) In the glove compartment or rear ledge of an automobile.

Maintenance

Head care

To assure good sound quality for recording and playback, be sure to clean the heads after approximately every 10 hours of use.

1. Switch the power of this unit to standby mode.
2. Press the eject button to open the cassette holder.
3. Clean the heads, pinch roller and the capstan shaft of each deck with a cotton swab (or with a soft, lint-free cloth) slightly moistened with alcohol.

Do not use any solution other than alcohol for head cleaning.

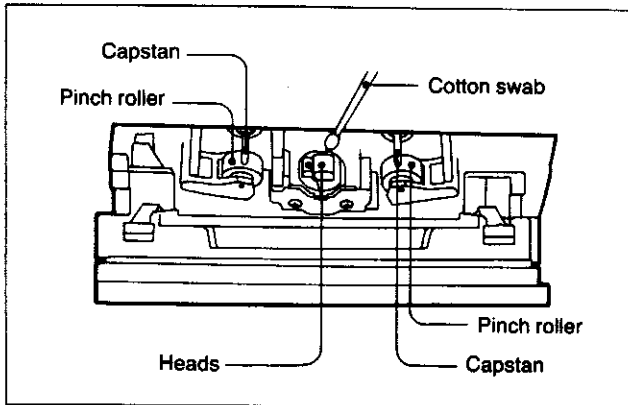

Head demagnetization

In order to maintain good sound quality during recording and playback, it is recommended that the heads should be demagnetized if distortion or poor sound quality persist after cleaning the heads.

If the heads become magnetized, they could create noise in recordings, loss of high-frequency response, or erasure of valuable recordings. Several types of head demagnetizers are available and may be purchased at local electronics supply stores. Follow the instructions that are supplied with the device.

•Do not bring any type of metal objects or tools such as magnetic screwdrivers in contact with the head assembly.

Maintenance of external surfaces

To clean this unit, use a soft, dry cloth.

For very dirty surfaces, dip a soft cloth in a weak soap-and-water solution and wring well. After cleaning, wipe with a soft, dry cloth.

Never use alcohol, paint thinner, benzene, or a chemically treated cloth to clean this unit.

Such chemicals may damage the unit's finish.

Troubleshooting Guide

Before requesting service for this unit, check the chart below for a possible cause of the problem you are experiencing. Some simple checks or a minor adjustment on your part may eliminate the problem and restore proper operation. If you are in doubt about some of the check points, or if the remedies indicated in the chart do not solve the problem, refer to the directory of Authorized Service Center (enclosed with this unit) to locate a convenient service center.

Problem	Probable cause(s)	Suggested remedy
While listening to FM broadcasts		
An unusual hissing noise is heard when listening to the broadcast in stereo, but not heard when listening monaurally.	Due to the differences between a monaural and a stereo signal, a higher level of signal strength is required for proper stereo reception. If the signal level is low, a hissing noise may be produced on the stereo channel.	<ul style="list-style-type: none"> •Try reducing the treble sound by using the equalizer controls. •Set for monaural reception to reduce the hiss. Note, however, that the broadcast will not be heard as stereo.
Noise is excessive in both stereo and monaural broadcasts.	Poor location and/or direction of the antenna.	<ul style="list-style-type: none"> •Try changing the location, height and/or direction of the antenna. •If an indoor antenna is being used, change to an outdoor antenna. •Try using an antenna with more elements.
	Transmitting station is too far away.	
Excessive distortion in the sound of stereo broadcasts.	Nearby building or mountain. [Multipath distortion is being caused by the mutual interference of broadcast signals received directly from the transmitting station (direct waves) and signals being reflected from nearby buildings or mountains (reflected waves).]	<ul style="list-style-type: none"> •Try changing the location, height and/or direction of the antenna. •If an indoor antenna is being used, change to an outdoor antenna. •Try using an antenna with more elements.
Sound is distorted, "popping" noise is heard, and/or the volume level becomes low.	Broadcast signals are being disturbed by nearby automobile traffic or airplanes.	<ul style="list-style-type: none"> •Relocate the antenna and the connection wires to a place farther away from where automobiles pass.
While listening to AM broadcasts		
An unusual "beat" sound is heard.	Unit is being used at the same time as the television set.	<ul style="list-style-type: none"> •Switch OFF the television set, or use this unit farther away from it.
	Interference from adjacent broadcast signals.	<ul style="list-style-type: none"> •Try reducing the treble sound by using the equalizer controls.
While using the tape deck		
Previously recorded sound has not been erased.	Erase head is dirty.	<ul style="list-style-type: none"> •Clean the head.
Sound output is hoarse or unsteady.	Heads are dirty.	<ul style="list-style-type: none"> •Clean the heads.
	Tape is damaged.	<ul style="list-style-type: none"> •Try operation with a new cassette; if there is no problem with the new cassette, discard the damaged cassette.
Sound is low, poor tone, intermittent sound, noise.	Heads, capstan and/or pinch roller are dirty or tape is damaged.	<ul style="list-style-type: none"> •Clean the heads, capstan and/or pinch roller, or try a new cassette.
Recording is not possible.	Erase-prevention tabs have been removed.	<ul style="list-style-type: none"> •Attach tape to cover the space left by removal of the erase-prevention tabs.
While listening to a compact disc		
The tray does not close when a disc is loaded and the open/close button is pressed.	The disc is not sitting correctly in the disc tray.	Re-insert the disc.
The total number of tracks and total time are not displayed when a disc is loaded. The disc does not start being played when the play button is pressed.	The disc is loaded upside down.	Re-load the disc.
	The disc is dirty.	Wipe the disc with a soft cloth.
	The disc is scratched.	Replace the disc with a new one.
	The disc is badly warped.	
	The disc used is a non-standard one.	Replace the disc with a different one.
The moisture has condensed inside the CD player.	Switch ON the power, then wait for 60 minutes before using it.	
A certain part of the disc cannot be played.	The disc is dirty.	Clean the disc with a soft cloth.
	The disc is scratched.	Skip the scratched part of the disc (skip play).

Problem	Probable cause(s)	Suggested remedy
Problems noted at all times		
No sound is heard when a tape or disc is played.	The incorrect input selector has been pressed.	•Check to be sure that the correct selector is pressed.
When listening to stereo sound, the sound lacks depth (i.e. weak bass, tinny sound).	One of the speakers is connected out of phase [(+) → (-), (-) → (+)].	•Re-connect the speakers maintaining proper polarity [i.e., (+) → (+), (-) → (-)].
A low-pitched noise ("hum" or "buzz") is heard.	The power cord or a fluorescent light, etc., is near the connection cords.	•Try moving this unit as far as possible from the electric appliance.
Sound is not heard from the speaker system on one side.	The speaker cords are disconnected.	•Check and correct the connections of the speaker cords.
	The balance control is set too far to one side.	•Set the control so that sounds are heard at the center, between the speaker systems.
Sound stops during a performance, or no sound is heard when the power is switched ON.	The protection circuitry has functioned because the positive and negative speaker connection wires are "shorted".	•Check and correct the connections of the speaker cords.
	The impedance of the speaker system being used is less than the rating.	•Switch OFF power and then ON again, and listen at a low volume level, or use speaker systems of the proper impedance rating.
When listening to stereo sound, the left and right sounds are reversed.	The left and right speaker connections or source connections are reversed.	•Check all connections and correct them if necessary.

While using the remote control transmitter		
The remote control transmitter does not function.	Batteries are installed incorrectly.	•Insert the batteries so that the positive (+) and negative (-) polarities are correct.
	The remote control transmitter batteries are consumed.	•Replace them with new batteries.
	There is an obstruction between the remote control transmitter and this unit.	•Remove the obstruction.
	The remote control transmitter is not correctly facing the remote control signal receptor of each unit.	•Face the remote control transmitter correctly toward the remote control signal receptor of each unit.

About moisture for compact disc player

Moisture may form on the lens in the following cases...

- Immediately after a heater has been turned on.
- In a steamy or very humid room.
- When the unit is suddenly moved from a cold environment to a warm one.

If moisture forms inside this unit, it may not operate properly. To correct this problem, turn on the power and wait about one hour for the moisture to evaporate.

Technical Specifications

■ AMPLIFIER SECTION

40 Hz~16 kHz continuous power output both channels driven	2×45 W (THD 1%, 8Ω)
1 kHz continuous power output both channels driven	2×50 W (THD 1%, 8Ω)
MPO	2×90 W (THD 10%, 8Ω)
PMPO	360 W (THD 10%, 8Ω)
Total harmonic distortion half power at 1 kHz	0.03% (8Ω)
Power bandwidth both channels driven, -3 dB	20 Hz~40 kHz (8Ω)
Frequency response	
PHONO	30 Hz~15 kHz RIAA standard curve ±1 dB
AUX	20 Hz~30 kHz (-3 dB)
Input sensitivity and impedance	
PHONO	2.5 mV/47 kΩ
AUX	150 mV/12 kΩ
Graphic equalizer	±10 dB (63 Hz, 160 Hz, 400 Hz, 1 kHz, 2.5 kHz, 6.3 kHz, 12.5 kHz)
Damping factor	20 (8Ω)
Load impedance	8~16Ω

■ FM TUNER SECTION

Frequency range	87.50~108.00 MHz
Sensitivity	25.2 dBf, (5 μV, IHF'58)
S/N 26 dB	3.8 μV (40 kHz mod., 75Ω)
Total harmonic distortion	
MONO	0.3%
STEREO	0.5%
S/N	
MONO	60 dB (65 dB, IHF)
Image rejection at 98 MHz	35 dB
Stereo separation	
1 kHz	35 dB
Antenna terminals	75Ω (unbalanced)

■ AM TUNER SECTION

Frequency range	
MW	522~1611 kHz
LW	144~288 kHz
Sensitivity (for 500 mW)	
MW (at 999 kHz)	200 μV/m
LW (at 254 kHz)	500 μV/m

■ CASSETTE DECK SECTION

Track system	4-track, 2-channel
Heads	
playback	Solid Permalloy Head (Rotary head)
record/playback	Solid Permalloy Head (Rotary head)
erasure	Double gap ferrite head
Motor	DC servo motor
Recording system	AC bias, 85 kHz
Erase system	AC erase, 85 kHz
Tape speed	4.8 cm/sec (1 7/8 ips)
Frequency response	
NORMAL	40 Hz~14 kHz, ±3 dB
CrO ₂	40 Hz~15 kHz, ±3 dB
S/N (CrO ₂ type tape)	
Dolby NR off	53 dB (A-WTD)
Dolby NR on	62 dB (CCIR)
Wow and flutter	0.1% (WRMS)
Fast forward and rewind time	Approx. 110 seconds with C-60 cassette tape

■ CD SECTION

S/N ratio	95 dB or more
T.H.D	0.03% or less
Wow. & flutter	below measurement threshold
Sampling frequency	44.1 kHz
D-A conversion	multi stage noise shaping
Beam source	semi conductor laser (wave length 780 nm)
No. of channels	2-channels, stereo
No. of memory	20-tracks random programming

■ GENERAL

Power consumption	265 W
Power supply	AC 50 Hz, 230~240 V
Dimensions (W×H×D)	360×381.5×270.8 mm
Weight	10.0 kg.

This apparatus was produced to BS 800.

Notes:

- Specifications are subject to change without notice. Weight and dimensions are approximate.
- Total harmonic distortion is measured by the digital spectrum analyzer.

Matsushita Electric Industrial Co., Ltd.
Central P.O. Box 288, Osaka 530-91, Japan

Printed in Singapore

RQT0866-B
F0391U0

Free Manuals Download Website

<http://myh66.com>

<http://usermanuals.us>

<http://www.somanuals.com>

<http://www.4manuals.cc>

<http://www.manual-lib.com>

<http://www.404manual.com>

<http://www.luxmanual.com>

<http://aubethermostatmanual.com>

Golf course search by state

<http://golfingnear.com>

Email search by domain

<http://emailbydomain.com>

Auto manuals search

<http://auto.somanuals.com>

TV manuals search

<http://tv.somanuals.com>