

CD Stereo System

Operating Instructions

Model No. **SC-AK310**
SC-AK210
SC-AK110



The illustrations show SC-AK310.

COMPACT
disc
DIGITAL AUDIO

Panasonic

SC-AK310 is for Australia, New Zealand, Russia and Ukraine only. SC-AK210 is for United Kingdom and Continental Europe only. SC-AK110 is for Australia and New Zealand only.

Note:

“EB” on the packaging indicates the United Kingdom.

Before connecting, operating or adjusting this product, please read these instructions completely. Please keep this manual for future reference.

E EB EE GN

RQT6713-2B

Dear customer

Thank you for purchasing this product.
For optimum performance and safety, please read these instructions carefully.

These operating instructions are applicable to the following systems.

Unless otherwise indicated, illustrations in these operating instructions are of SC-AK310.

System	SC-AK310	SC-AK210	SC-AK110
Main unit	SA-AK310	SA-AK210	SA-AK110
Speakers	SB-AK310	SB-AK210	SB-AK110

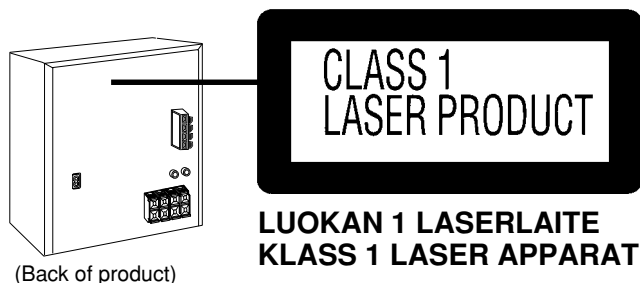

For Russia, Ukraine, Australia and New Zealand

CAUTION	INVISIBLE LASER RADIATION WHEN OPEN. AVOID EXPOSURE TO BEAM. (IEC60825-1)
ATTENTION	RADIATION LASER LORSQUE OUVERT. ÉVITER TOUTE EXPOSITION AU FAISCEAU.
ADVARSEL	USYNLIG LASERSTRÅLING VED ÅBNING, NÅR SIKKERHEDSAFBRYDERE ER UDE AF FUNKTION. UNDGÅ UDSÆTTELSE FOR STRÅLING.
VARO!	AVAITAESSA JA SUOJALUKITUS OHITETTAESSA OLET ALTIINNA NÄKYMÄTÖNTÄ LASERSÄTELYLLE. ÄLÄ KATSO SÄTEESEEN.
WARNING	OSYNLIG LASERSTRÅLING NÅR DENNA DEL ÄR ÖPPNAD OCH SPÄRREN ÄR URKOPPLAD. BETRakta EJ STRÅLEN.
ADVARSEL	USYNLIG LASERSTRÅLING NÅR DEKSEL ÅPNES OG SIKKERHEDSLÅS BRYTES. UNNGÅ EKSPONERING FOR STRÅLEN.
VORSICHT	UNSIHTBARE LASERSTRÄHLUNG, WENN ABDECKUNG GEÖFFNET. NICHT DEM STRAHL AUSSETZEN.

Inside of product
Tuotteen sisällä
Produktets innsida

For Continental Europe and United Kingdom

DANGER	INVISIBLE LASER RADIATION WHEN OPEN. AVOID DIRECT EXPOSURE TO BEAM.
ADVARSEL	USYNLIG LASERSTRÅLING VED ÅBNING, NÅR SIKKERHEDSAFBRYDERE ER UDE AF FUNKTION. UNDGÅ UDSÆTTELSE FOR STRÅLING.
VARO!	AVAITAESSA JA SUOJALUKITUS OHITETTAESSA OLET ALTIINNA NÄKYMÄTÖNTÄ LASERSÄTELYLLE. ÄLÄ KATSO SÄTEESEEN.
WARNING	OSYNLIG LASERSTRÅLING NÅR DENNA DEL ÄR ÖPPNAD OCH SPÄRREN ÄR URKOPPLAD. BETRakta EJ STRÅLEN.
ADVARSEL	USYNLIG LASERSTRÅLING NÅR DEKSEL ÅPNES OG SIKKERHEDSLÅS BRYTES. UNNGÅ EKSPONERING FOR STRÅLEN.
VORSICHT	UNSIHTBARE LASERSTRÄHLUNG, WENN ABDECKUNG GEÖFFNET. NICHT DEM STRAHL AUSSETZEN.

Inside of product
Tuotteen sisällä
Produktets innsida

This product may receive radio interference caused by mobile telephones during use. If such interference is apparent, please increase separation between the product and the mobile telephone.

THIS UNIT IS INTENDED FOR USE IN MODERATE CLIMATES.

TÄMÄ LAITE ON TARKOITETTU KÄYTETTÄVÄKSI LEUDOSSA ILMASTOSSA.

DETTE APPARATET ER BEREGNET TIL BRUK UNDER MODERATE KLIMAFORHOLD.

Caution for AC Mains Lead	3
Safety precautions	4
Supplied accessories	4
Placement of speakers	5
The remote control	5
Set-up	6
Front panel controls	7
CDs	8
The radio: manual tuning	10
The radio: preset tuning	10
Cassettes	11
Sound quality/sound field	11
Recording	11
Optional antenna connections	12
External unit connections	12
Using an external unit	12
Using headphones (not included)	12
Turning the demo function off	13
Convenient functions	13
Auto-off function	13
Setting the time	13
Using the timers	14
Troubleshooting guide	15
Maintenance	15
Specifications	Back cover

CAUTION!

THIS PRODUCT UTILIZES A LASER.
USE OF CONTROLS OR ADJUSTMENTS OR PERFORMANCE OF PROCEDURES OTHER THAN THOSE SPECIFIED HEREIN MAY RESULT IN HAZARDOUS RADIATION EXPOSURE.
DO NOT OPEN COVERS AND DO NOT REPAIR YOURSELF. REFER SERVICING TO QUALIFIED PERSONNEL.

CAUTION!

- DO NOT INSTALL, OR PLACE THIS UNIT, IN A BOOKCASE, BUILT-IN CABINET OR IN ANOTHER CONFINED SPACE. ENSURE THE UNIT IS WELL VENTILATED. TO PREVENT RISK OF ELECTRIC SHOCK OR FIRE HAZARD DUE TO OVERHEATING, ENSURE THAT CURTAINS AND ANY OTHER MATERIALS DO NOT OBSTRUCT THE VENTILATION VENTS.
- DO NOT OBSTRUCT THE UNIT'S VENTILATION OPENINGS WITH NEWSPAPERS, TABLECLOTHS, CURTAINS, AND SIMILAR ITEMS.
- DO NOT PLACE SOURCES OF NAKED FLAMES, SUCH AS LIGHTED CANDLES, ON THE UNIT.
- DISPOSE OF BATTERIES IN AN ENVIRONMENTALLY FRIENDLY MANNER.

WARNING:

TO REDUCE THE RISK OF FIRE, ELECTRIC SHOCK OR PRODUCT DAMAGE, DO NOT EXPOSE THIS APPARATUS TO RAIN, MOISTURE, DRIPPING OR SPLASHING AND THAT NO OBJECTS FILLED WITH LIQUIDS, SUCH AS VASES, SHALL BE PLACED ON THE APPARATUS.

SUOMI

VAROITUS!

LAITTEEN KÄYTTÄMINEN MUULLA KUIN TÄSSÄ KÄYTTÖOHJEESSA MAINITULLA TAVALLA SAATTAÄ ALTISTAA KÄYTTÄJÄN TURVALLISUUSLUOKAN 1 YLITTÄVÄLLE NÄKYMÄTTÖMÄLLE LASERSÄTEILYLLE.

VAROITUS!

- ÄLÄ ASENNATA TAI LAITETA TÄTÄ LAITETTA KABINETTITYYPPISEEN KIRJAKAAPPIIN TAI MUUHUN SULJETTUUN TILAAN, JOTTA TUULETUS ONNISTUISI. VARMISTA, ETTÄ VERHO TAI MIKÄÄN MUU MATERIAALI EI HUONONNA TUULETUSTA, JOTTA VÄLTETTÄISIIN YLIKUUMEMISESTA JOHTUVA SÄHKÖISKU- TAI TULIPALOVAARA.
- ÄLÄ PEITÄ LAITTEEN TUULETUSAUKKOJA SANOMALEHDellä, PÖYTÄLIINALLA, VERHOLLA TAI MUULLA VASTAAVALLA ESINEELLÄ.
- ÄLÄ ASETA PALAVAA KYNTTILÄÄ TAI MUUTA AVOTULEN LÄHDETTÄ LAITTEEN PÄÄLLE.
- HÄVITÄ PARISTOT LUONTOA VAHINGOITTAMATTOMALLA TAVALLA.

VAROITUS:

TULIPALO-, SÄHKÖISKUAARAN TAI TUOTETTA KOHTAAVAN MUUN VAHINGON VÄHENTÄMISEKSI EI LAITETTA SAA ALTISTAA SATEELLE, KOSTEUELLE, VESIPISAROILLE TAI ROISKEELLE, EIKÄ NESTETTÄ SISÄLTÄVIÄ ESINEITÄ, KUTEN ESIMERKIKSI MALJAKOITA, SAA ASETTAA LAITTEEN PÄÄLLE.

NORSK

ADVARSEL!

DETTE PRODUKTET ANVENDER EN LASER. BETJENING AV KONTROLLER, JUSTERINGER ELLER ANDRE INNGREP ENN DE SOM ER BESKREVENT I DENNE BRUKSANVISNING, KAN FØRE TIL FARLIG BESTRÅLING. DEKSLER MÅ IKKE ÅPNES, OG FORSØK ALDRI Å REPARERE APPARATET PÅ EGENHÅND. ALT SERVICE OG REPARASJONSARBEID MÅ UTFØRES AV KVALIFISERT PERSONELL.

ADVARSEL!

- APPARATET MÅ IKKE Plasseres i en bokhylle, et innebygget kabinett eller et annet lukket sted hvor ventilasjonsforholdene er utilstrekkelige. Sørg for at gardiner eller lignende ikke forverrer ventilasjonsforholdene, så risiko for elektrisk sjokk eller brann forårsaket av overheting unngås.
- APPARATETS VENTILASJONSÅPNINGER MÅ IKKE DEKKES TIL MED AVISER, BORDDUKER, GARDINER OG LIGNENDE.
- Plasser ikke åpen ild, slik som levende lys, oppå apparatet.
- Brukte batterier må kasseres uten fare for miljøet.

ADVARSEL:

FOR Å REDUSERE FAREN FOR BRANN, ELEKTRISK STØT ELLER SKADER PÅ PRODUKTET, MÅ DETTE APPARATET IKKE UTSETTES FOR REGN, FUKTIGHET, VANNDRÅPER ELLER VANNSPRUT. DET MÅ HELLER IKKE Plasseres gjenstander fylt med vann, slik som blomstervaser, oppå apparatet.

Caution for AC Mains Lead

(For United Kingdom)



("EB" area code model only)

For your safety, please read the following text carefully.

This appliance is supplied with a moulded three pin mains plug for your safety and convenience.

A 5-ampere fuse is fitted in this plug.

Should the fuse need to be replaced please ensure that the replacement fuse has a rating of 5-ampere and that it is approved by ASTA or BSI to BS1362.

Check for the ASTA mark  or the BSI mark  on the body of the fuse.

If the plug contains a removable fuse cover you must ensure that it is refitted when the fuse is replaced.

If you lose the fuse cover the plug must not be used until a replacement cover is obtained.

A replacement fuse cover can be purchased from your local dealer.

CAUTION!

IF THE FITTED MOULDED PLUG IS UNSUITABLE FOR THE SOCKET OUTLET IN YOUR HOME THEN THE FUSE SHOULD BE REMOVED AND THE PLUG CUT OFF AND DISPOSED OF SAFELY.

THERE IS A DANGER OF SEVERE ELECTRICAL SHOCK IF THE CUT OFF PLUG IS INSERTED INTO ANY 13-AMPERE SOCKET.

If a new plug is to be fitted please observe the wiring code as stated below.

If in any doubt please consult a qualified electrician.

IMPORTANT

The wires in this mains lead are coloured in accordance with the following code:

Blue: Neutral, Brown: Live.

As these colours may not correspond with the coloured markings identifying the terminals in your plug, proceed as follows:

The wire which is coloured Blue must be connected to the terminal which is marked with the letter N or coloured Black or Blue.

The wire which is coloured Brown must be connected to the terminal which is marked with the letter L or coloured Brown or Red.

WARNING: DO NOT CONNECT EITHER WIRE TO THE EARTH TERMINAL WHICH IS MARKED WITH THE LETTER E, BY THE EARTH SYMBOL \perp OR COLOURED GREEN OR GREEN/YELLOW.

THIS PLUG IS NOT WATERPROOF—KEEP DRY.

Before use

Remove the connector cover.

How to replace the fuse

The location of the fuse differ according to the type of AC mains plug (figures A and B). Confirm the AC mains plug fitted and follow the instructions below.

Illustrations may differ from actual AC mains plug.

1. Open the fuse cover with a screwdriver.

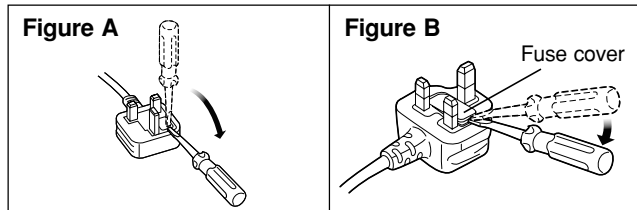

2. Replace the fuse and close or attach the fuse cover.

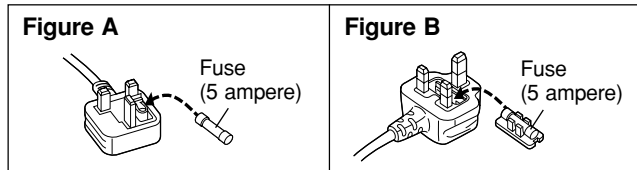

Safety precautions

Placement

Set the unit up on an even surface away from direct sunlight, high temperatures, high humidity, and excessive vibration. These conditions can damage the cabinet and other components, thereby shortening the unit's service life.

Place it at least 15 cm away from wall surfaces to avoid distortion and unwanted acoustical effects.

Do not place heavy items on the unit.

Voltage

Do not use high voltage power sources. This can overload the unit and cause a fire.

Do not use a DC power source. Check the source carefully when setting the unit up on a ship or other place where DC is used.

AC mains lead protection

Ensure the AC mains lead is connected correctly and not damaged. Poor connection and lead damage can cause fire or electric shock. Do not pull, bend, or place heavy items on the lead.

Grasp the plug firmly when unplugging the lead. Pulling the AC mains lead can cause electric shock.

Do not handle the plug with wet hands. This can cause electric shock.

Foreign matter

Do not let metal objects fall inside the unit. This can cause electric shock or malfunction.

Do not let liquids get into the unit. This can cause electric shock or malfunction. If this occurs, immediately disconnect the unit from the power supply and contact your dealer.

Do not spray insecticides onto or into the unit. They contain flammable gases which can ignite if sprayed into the unit.

Service

Do not attempt to repair this unit by yourself. If sound is interrupted, indicators fail to light, smoke appears, or any other problem that is not covered in these instructions occurs, disconnect the AC mains lead and contact your dealer or an authorized service center. Electric shock or damage to the unit can occur if the unit is repaired, disassembled or reconstructed by unqualified persons.

Extend operating life by disconnecting the unit from the power source if it is not to be used for a long time.

Supplied accessories

Please check and identify the supplied accessories.



AC mains lead 1 pc.

For United Kingdom (RJA0044-3C)

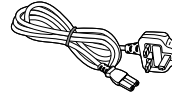

For Continental Europe (RJA0043-1C)

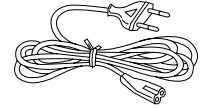

For Russia and Ukraine (RJA0019-2K)



For Australia and New Zealand (RJA0035-X)

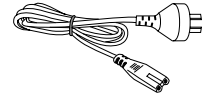

Remote control transmitter 1 pc.

SC-AK310

For Russia and Ukraine
 • Black: (N2QAGB000025)
 • Silver: (N2QAGB000029)

SC-AK210

(N2QAGB000028)

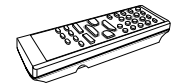

For Australia and New Zealand (N2QAGB000029)

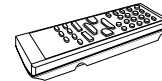

SC-AK110

(N2QAGB000029)

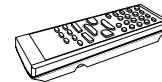

Batteries for remote control 2 pcs. R6, AA, UM-3

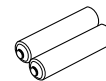

FM indoor antenna 1 pc.

For Europe (RSA0007)



For Australia and New Zealand (RSA0006-J)



AM loop antenna (N1DADYY00002) 1 pc.

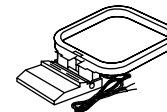

Antenna plug adaptor (for United Kingdom only) (SJP9009) 1 pc.



Use numbers indicated in parentheses when asking for replacement parts.

For United Kingdom and Republic of Ireland

shop@ **Panasonic**

www.panasonic.co.uk (for UK customers only)

- Order accessory and consumable items for your product with ease and confidence by telephoning our Customer Care Centre Mon–Friday 9:00 am–5:30 pm. (Excluding public holidays.)
- Or go on line through our Internet Accessory ordering application.
- Most major credit and debit cards accepted.
- All enquiries transactions and distribution facilities are provided directly by Panasonic UK Ltd.
- It couldn't be simpler!

Customer Care Centre
For UK customers: 08705 357357
For Republic of Ireland customers: 01 289 8333

Technical Support
For UK customers: 0870 1 505610
This Technical Support Hot Line number is for Panasonic PC software related products only.
For Republic of Ireland, please use the Customer Care Centre number listed above for all enquiries.
For all other product related enquiries, please use the Customer Care Centre numbers listed above.

Placement of speakers

SC-AK310

Place the speakers so that the super tweeter is on the outside.

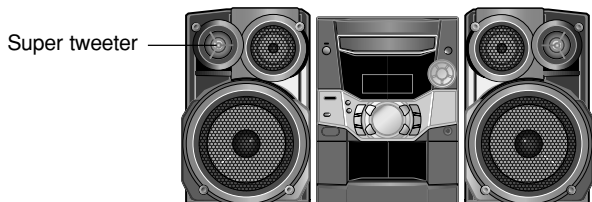

SC-AK210

Speakers are designed identically so that no left or right channel orientation is necessary.



SC-AK110

Speakers are designed identically so that no left or right channel orientation is necessary.



Notes

- Keep your speakers at least 10 mm away from the system for proper ventilation.
- These speakers do not have magnetic shielding. Do not place them near televisions, personal computers or other devices easily influenced by magnetism.
- You cannot take the front net off the speakers.

Caution

- Use the speakers only with the recommended system. Failure to do so may lead to damage to the amplifier and/or the speakers, and may result in the risk of fire. Consult a qualified service person if damage has occurred or if you experience a sudden change in performance.
- Do not attach these speakers to walls or ceilings.

The remote control

Batteries

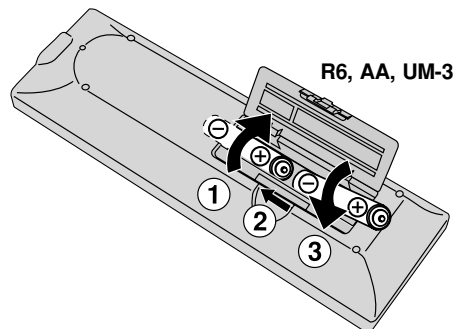

- Insert so the poles (+ and –) match those in the remote control.
- Do not use rechargeable type batteries.

Do not:

- mix old and new batteries.
 - use different types at the same time.
 - heat or expose to flame.
 - take apart or short-circuit.
 - attempt to recharge alkaline or manganese batteries.
 - use batteries if the covering has been peeled off.
 - keep together with metallic objects such as necklaces.
- Mishandling of batteries can cause electrolyte leakage which can damage items the fluid contacts and may cause a fire. If electrolyte leaks from the batteries, consult your dealer. Wash thoroughly with water if electrolyte comes in contact with any part of your body.

Remove if the remote control is not going to be used for a long period of time. Store in a cool, dark place. Replace if the unit does not respond to the remote control even when held close to the front panel.

Use

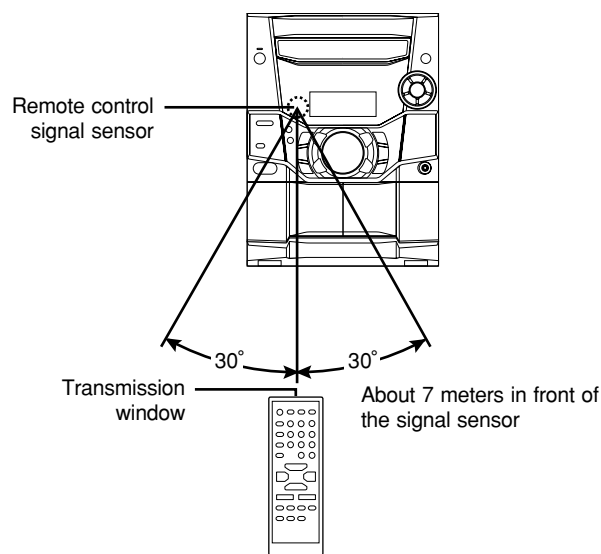

Aim at the sensor, avoiding obstacles, at a maximum range of 7 meters directly in front of the unit.

- Keep the transmission window and the unit's sensor free from dust.
- Operation can be affected by strong light sources, such as direct sunlight, and the glass doors on cabinets.

Do not:

- put heavy objects on the remote control.
- take the remote control apart.
- spill liquids onto the remote control.

Set-up

Connect the AC mains lead only after all other connections have been made.

Preparation

Twist and pull off the vinyl tip of the antenna wires and speaker cords.



2 AM loop antenna

Stand the antenna up on its base.

For Australia and New Zealand

For Europe

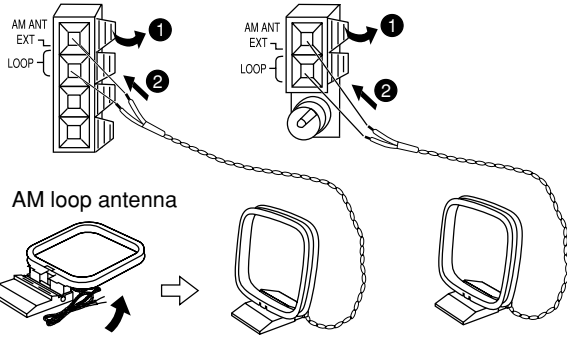

1 FM indoor antenna

Tape the antenna where reception is best.

For Australia and New Zealand

For Europe

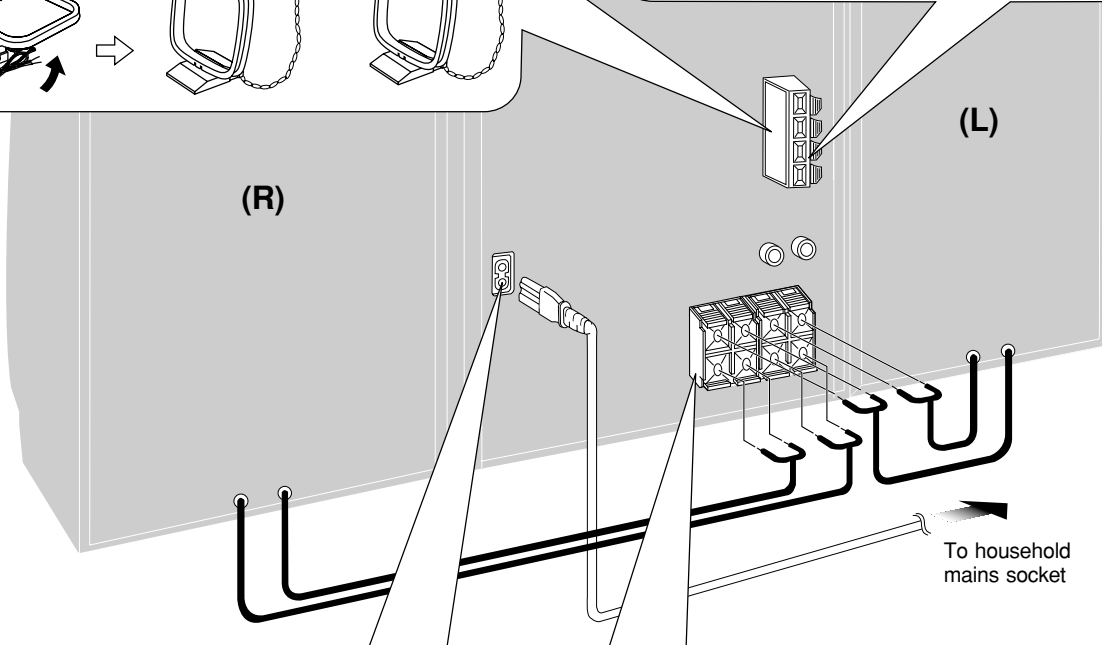
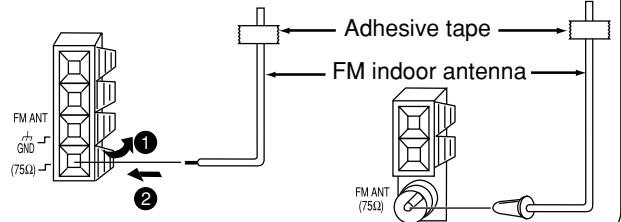

4 AC mains lead

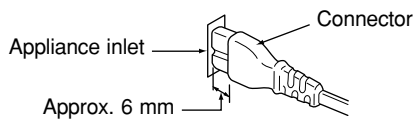

FOR UNITED KINGDOM ONLY
READ THE CAUTION FOR THE AC MAINS LEAD ON PAGE 3 BEFORE CONNECTION.

Insertion of connector

Even when the connector is perfectly inserted, depending on the type of inlet used, the front part of the connector may jut out as shown in the drawing. However there is no problem using the unit.

Note

The included AC mains lead is for use with this unit only. Do not use it with other equipment.

For your reference

Information you enter into the unit's memory, except for time, remains intact for up to a week after the AC mains lead is disconnected.

3 Speaker cords

SC-AK310

SC-AK210

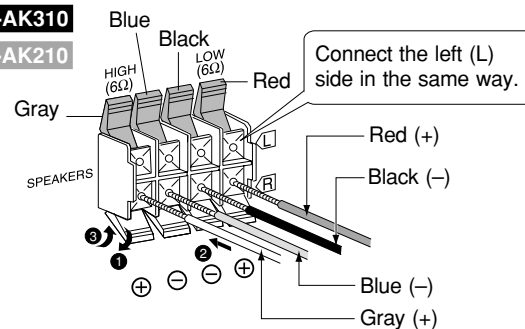

SC-AK110

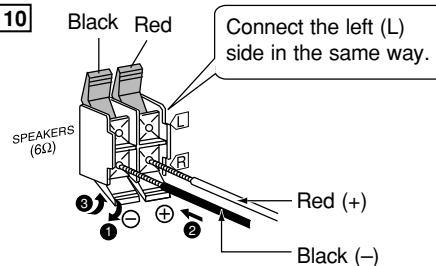

Use only the supplied speakers.

The combination of the main unit and speakers provide the best sound. Using other speakers can damage the unit and sound quality will be negatively affected.

Front panel controls

Main unit

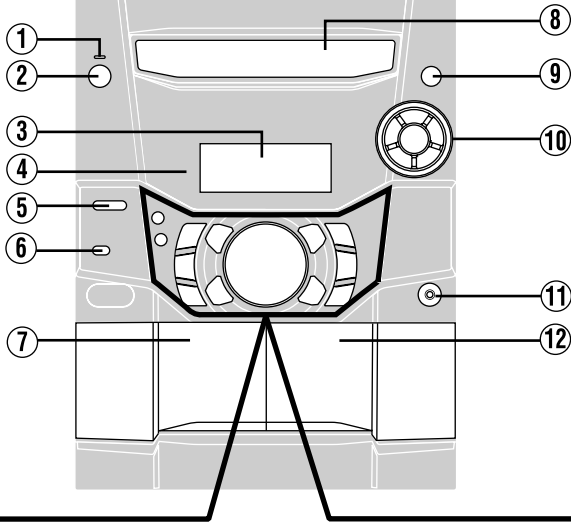

- ① **AC supply indicator (AC IN)**
This indicator lights when the unit is connected to the AC mains supply.
- ② **Standby/on switch (⏻/⏻)**
Press to switch the unit from on to standby mode or vice versa. In standby mode, the unit is still consuming a small amount of power.
- ③ **Display**
- ④ **Remote control signal sensor** 5
- ⑤ **Super sound EQ button (SUPER SOUND EQ)**..... 11
- ⑥ **Preset EQ select button (PRESET EQ)** 11
- ⑦ **Deck 1 cassette holder** 11
- ⑧ **Disc tray**
- ⑨ **CD tray open/close button (⏻, OPEN/CLOSE)** 8
- ⑩ **Disc direct play buttons (1 ~ 5)** 8
- ⑪ **Headphones jack (PHONES)** 12
- ⑫ **Deck 2 cassette holder** 11

Center console

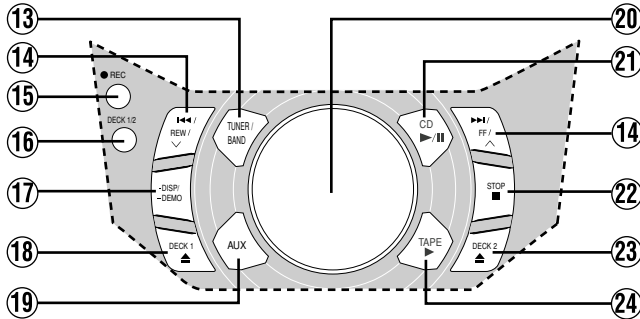

- ⑬ **Tuner/band select button (TUNER/BAND)** 10
- ⑭ **CD skip/search, tape fast-forward/rewind, tune/preset channel select, time adjust buttons (⏮/REW/∇, ⏭/FF/∧)** 8, 9, 10, 11, 13
- ⑮ **Record button (● REC)** 11
- ⑯ **Deck select button (DECK 1/2)** 11
- ⑰ **Display, demonstration button (-DISP/-DEMO)** 13
- ⑱ **Deck 1 open button (⏻, DECK 1)** 11
- ⑲ **AUX button (AUX)** 12
- ⑳ **Volume control (VOLUME DOWN, UP)** 13
- ㉑ **CD play/pause button (▶/⏻, CD)** 8
- ㉒ **Stop/program clear button (■, STOP)** 8, 11, 12
- ㉓ **Deck 2 open button (⏻, DECK 2)** 11
- ㉔ **Tape play button (▶, TAPE)** 11, 12

Remote control

This illustration is of SC-AK310.

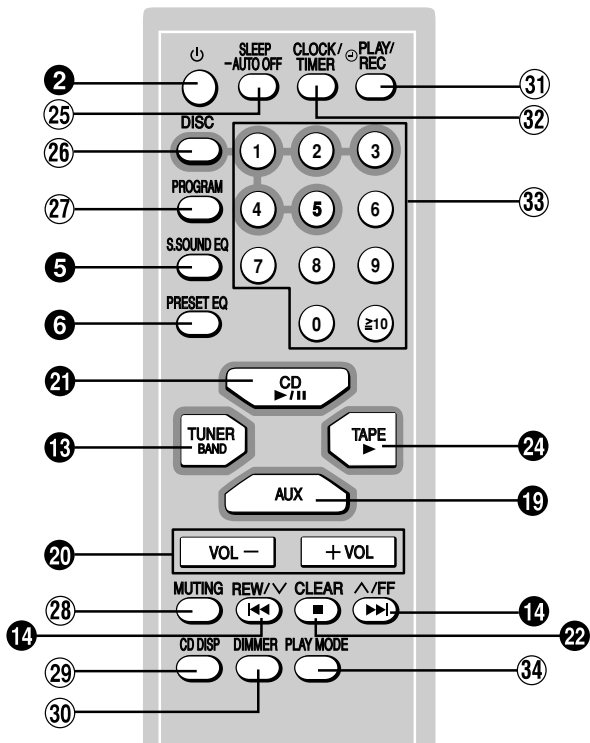

Buttons such as ② function in exactly the same way as the buttons on the main unit.

- ㉕ **Sleep timer/auto off button (SLEEP, -AUTO OFF)** 13, 14
- ㉖ **Disc button (DISC)** 9
- ㉗ **Program button (PROGRAM)** 9
- ㉘ **Muting button (MUTING)** 13
- ㉙ **SC-AK310 SC-AK110**
CD display button (CD DISP) 8
- SC-AK210**
CD display/RDS display button (CD/RDS DISP) 8, 10
- ㉚ **Dimmer button (DIMMER)** 13
- ㉛ **Play timer/record timer button (⏻ PLAY/REC)** 14
- ㉜ **Clock/timer button (CLOCK/TIMER)** 13, 14
- ㉝ **Numbered buttons (≥10, 1-9, 0)** 9, 10
- ㉞ **Play mode select button (PLAY MODE)** 9, 10, 12

CD selection

Choose CDs with this mark:



Do not:

- use irregularly shaped CDs.
- attach extra labels and stickers.
- use CDs with labels and stickers that are coming off or with adhesive exuding from under labels and stickers.
- attach scratch proof covers or any other kind of accessory.
- write anything on the CD.
- clean CDs with liquids. (Wipe with a soft, dry cloth.)
- use CDs printed with label printers available on the market.

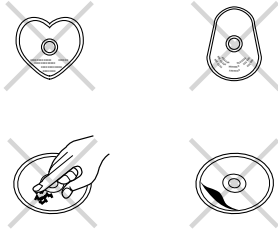

To prevent damage

Always observe the following points:

- Load only 1 CD on the tray.

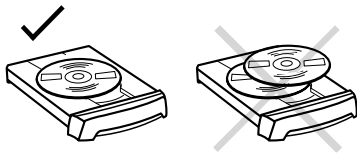

- Load CDs as shown in the figure. An adaptor is not needed with 8 cm CDs (singles).

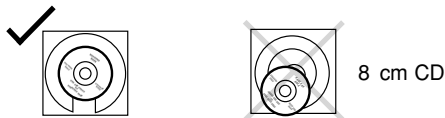

- Set the system on a flat, level surface.
- Always unload all CDs before moving the unit.

Do not:

- set the unit on top of magazines, inclined surfaces, etc.
- move the unit while a tray is opening/closing, or when loaded.
- put anything except a CD in the tray.
- use cleaning CDs or CDs which are badly warped or cracked.
- disconnect the AC mains lead from the household mains socket during disc changing operation.

This unit can play CD-DA (digital audio) format audio CD-R and CD-RW that have been finalized (a process that enables CD-R/CD-RW players to play audio CD-R and CD-RW) upon completion of recording. It may not be able to play some CD-R or CD-RW due to the condition of the recording.

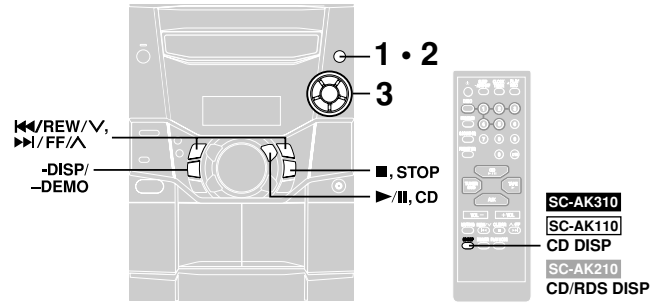

- 1 Press [**▲**, OPEN/CLOSE] to open the tray. The unit comes on.
- 2 Set a CD in the tray. (Label must face upward.) To continue loading CDs in the other trays Press [1]–[5] to select the required tray and press [**▲**, OPEN/CLOSE] to open the tray. Press [**▲**, OPEN/CLOSE] to close the tray.
- 3 Press [1]–[5] to play your desired disc. (Alternatively, you can press [**▶**/II, CD] if the current disc is your desired CD.) The track number and its elapsed playing time are shown.

Display during play

(example):

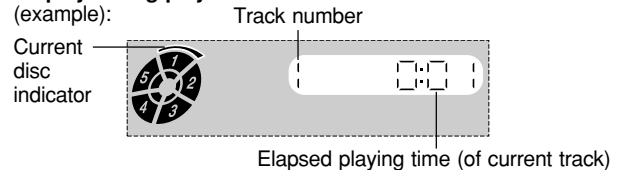

Use the CD Play Mode function's ALL-DISC mode to play CDs in succession. (→ page 9)

To stop the disc play

Press [**■**, STOP].

The total number of tracks and total playing time are shown.

“▶▶” (SC-AK110: “▶”) indication

It indicates current disc has 16 or more tracks.

One touch play

During standby mode and when a CD is loaded, press [**▶**/II, CD] or [1]–[5].

The unit comes on and play starts.

To pause	Press [▶ /II, CD] during play. Press again to resume play.
To search forward/backward	Hold down [◀ /REW/V] (backward) or [▶ /FF/A] (forward) during play or pause.
To skip forward/backward	Press [◀ /REW/V] (backward) or [▶ /FF/A] (forward) during play or pause.

Notes

- During 1-RANDOM or A-RANDOM play (→ page 9), you cannot skip to tracks already played.
- During program play (→ page 9), 1-RANDOM or A-RANDOM play, you can search only within the track.
- Always stop the changer before loading or changing CDs. You cannot change CDs while a disc is playing.

CD display

You can display the remaining play time of the current track.

SC-AK310

Remote control only

Press [CD DISP] during play or pause.

SC-AK210

Remote control only

Press [CD/RDS DISP] during play or pause.

SC-AK110

Press [-DISP/–DEMO] during play or pause.

Remote control: Press [CD DISP].

Every time you press the button:

Elapsed play time ↔ Remaining play time

Note

When track number 25 or greater is playing, remaining play time display shows “--:--”.

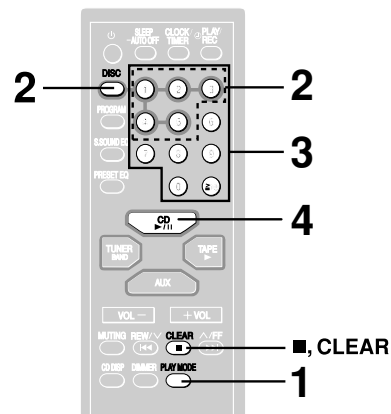
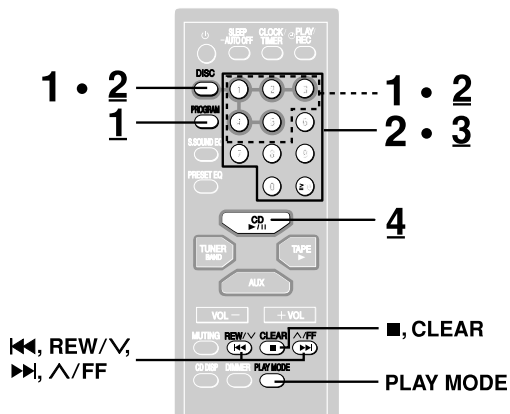

Starting play from a specific track

Remote control only

- 1 Press [DISC] and (within 10 seconds) [1]–[5] to select the disc.
- 2 Select the track with the numbered buttons.
To select track 10 or over, press [≥ 10] then the two digits.
Play starts from the selected track.

Note

You cannot use this function with 1-RANDOM or A-RANDOM mode.

Program play

You can program up to 24 tracks.

Remote control only

Preparation: Press [▶/II, CD] and then [■, CLEAR].

- 1 Press [PROGRAM].
“PGM” appears.
- 2 Press [DISC] and (within 10 seconds) [1]–[5] to select the disc.
- 3 Select the tracks with the numbered buttons.
To select track 10 or over, press [≥ 10] then the two digits.
Repeat steps 2 and 3 to program other tracks.
- 4 Press [▶/II, CD] to start play.

To exit program mode

Press [PROGRAM] in the stop mode. (You can replay your program by pressing [PROGRAM] then [▶/II, CD].)

To cancel

Press [■, CLEAR] in the stop mode. “CLEAR” is displayed.

To check program contents

Press [◀◀, REW/V] or [▶▶, ▲/FF] while “P” is displayed.
Every time you press the button, the track number and program order are displayed.

To add to the program

Do steps 2 and 3 while “P” is displayed.

Note

You can use repeat mode with program play.

Repeat play

Remote control only

Hold down [PLAY MODE] during play.

“C” is displayed.

To cancel repeat play

Hold down [PLAY MODE] to clear “C”.

To listen to specific CDs and tracks (CD Play Mode function)

Remote control only

Preparation: Press [▶/II, CD] and then [■, CLEAR].

- 1 Press [PLAY MODE] to select the desired mode.

Every time you press the button:

ALL-DISC → 1-SONG → 1-RANDOM → A-RANDOM

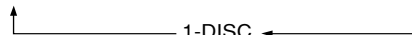

ALL-DISC: Plays **all** loaded **discs** in succession from the selected disc to the final disc ※.

1-SONG: Plays **one** selected **track** on the selected disc.

1-RANDOM: Plays **one** selected **disc** in **random** order.

A-RANDOM: Plays **all** loaded **discs** in **random** order.

1-DISC: Plays **one** selected **disc**.

(The original display is restored in about 2 seconds.)

Proceed to step 4 when you selected A-RANDOM in step 1.

- 2 Press [DISC] and (within 10 seconds) [1]–[5] to select the disc.
The CD starts.
- 3 Only when you selected “1-SONG” in step 1
Select the track with the numbered buttons.
To select a track 10 or over, press [≥ 10] then the two digits.
Play starts from the selected track.
- 4 Only when you selected “A-RANDOM” in step 1
Press [▶/II, CD] to start play.

To stop play

Press [■, CLEAR].

When playback ends

The current play mode will be retained.

※ Final disc

For example, if play starts from disc 4, disc 3 will be the “final disc”.
Order of progression: Disc 4→5→1→2→3

Note

You can use repeat mode with CD Play Mode function.

The radio: manual tuning

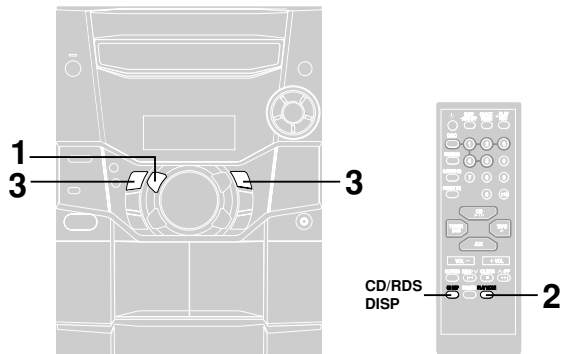

- Press [TUNER/BAND] to select band.**
The unit comes on.
Every time you press the button:
FM ↔ AM
- Press [PLAY MODE] on the remote control to select "MANUAL".**
Every time you press the button:
MANUAL ↔ PRESET
- Hold down [◀◀/REW/V] or [▶▶/FF/∧] for a moment to search for a station.**
The frequency stops when it finds a clear station.
To stop during the process, press [◀◀/REW/V] or [▶▶/FF/∧].
Under excessive interference, a station may not be found.
Press [◀◀/REW/V] or [▶▶/FF/∧] repeatedly to tune step-by-step.

"TUNED" is displayed when a radio station is tuned.
"ST" is displayed when a stereo FM broadcast is being received.

RDS broadcasting SC-AK210 only

Remote control only

This unit can display the text data transmitted by the radio data system (RDS) available in some areas.

If the station you are listening to is transmitting RDS signals, "RDS" will light up on the display.

Displaying the name of a broadcasting station or a program type

Press [CD/RDS DISP].

Every time you press the button:

Frequency display → Station Name (PS) → Program type (PTY)

Program type displays			
NEWS	VARIED	FINANCE	COUNTRY
AFFAIRS	POP M	CHILDREN	NATIONAL
INFO	ROCK M	SOCIAL A	OLDIES
SPORT	M.O.R M*	RELIGION	FOLK M
EDUCATE	LIGHT M	PHONE IN	DOCUMENT
DRAMA	CLASSICS	TRAVEL	TEST
CULTURE	OTHER M	LEISURE	ALARM
SCIENCE	WEATHER	JAZZ	

* "M.O.R M" = "Middle of the road music"

Notes

- RDS displays may not be available if reception is poor.
- Sound is momentarily interrupted if you load/unload tapes while listening to an AM broadcast.

If noise is excessive in FM

Remote control only

Hold down [PLAY MODE] to display "MONO".

Monaural sound is selected and noise reduces when reception is weak.

Hold down [PLAY MODE] again to cancel the mode.

"MONO" is also cancelled if the frequency is changed.

The radio: preset tuning

Remote control only

There are two methods of pre-setting stations.

Automatic presetting : All the stations the tuner can receive are preset.

Manual presetting : You can select the stations to preset and the order they are preset in.

Up to 15 stations each can be set in the FM and AM bands.

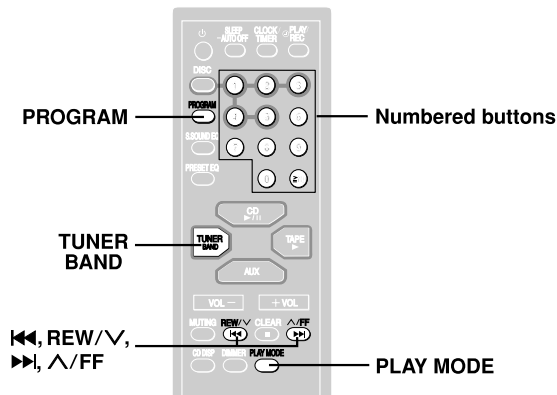

Preparation:

Press [TUNER BAND] to select "FM" or "AM".

Automatic presetting

Do the following once each for FM and AM.

Preparation: Tune to the frequency where pre-setting is to begin.

Hold down [PROGRAM] until the frequency changes.

The tuner presets all the stations it can receive into the channels in ascending order. When finished, the last station memorized is tuned in.

SC-AK310 SC-AK210

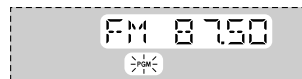

SC-AK110



Manual presetting

Pre-set the stations one at a time.

- Press [PROGRAM] then press [◀◀, REW/V] or [▶▶, ∧/FF] to tune to the desired station.
- Press [PROGRAM] then press [◀◀, REW/V] or [▶▶, ∧/FF] to select a channel.
- Press [PROGRAM].

The station occupying a channel is erased if another station is preset in that channel.

Selecting channels

Press the numbered buttons to select the channel.

To enter channel 10 or over, press [≥10], then the two digits.

SC-AK310 SC-AK210

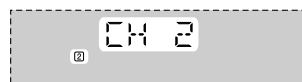

SC-AK110



OR

- Press [PLAY MODE] to select "PRESET".
- Press [◀◀, REW/V] or [▶▶, ∧/FF] to select the channel.

Cassettes

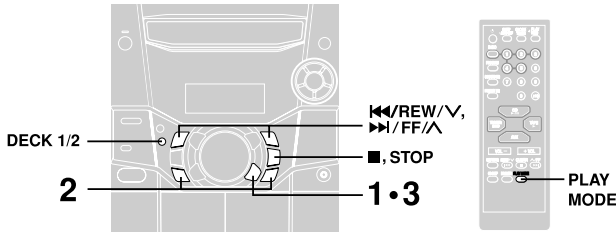

You can use either deck 1 or deck 2 for tape playback.

Use normal position tapes.

High position and metal position tapes can be played, but the unit will not be able to do full justice to the characteristics of these tapes.

1 Press [▶, TAPE].

The unit comes on.

If a cassette was loaded, play starts automatically (One touch play).

2 Press [▲, DECK 1] or [▲, DECK 2] and insert the cassette.

Insert with the side to be played facing towards you and the exposed tape facing down. Close the holder by hand.

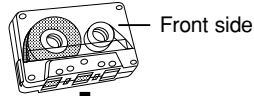

3 Press [▶, TAPE] to start playback.

To play on the other side of the tape, turn the tape over and press [▶, TAPE].

To stop tape playback

Press [■, STOP].

To fast-forward or rewind

Press [I◀◀/REW/V] (rewind) or [▶▶I/FF/△] (fast-forward).

To select between loaded decks

Press [DECK 1/2] (remote control: [PLAY MODE]).

Notes

- Tape playback is momentarily interrupted if you open the other deck.
- Tapes exceeding 100 minutes are thin and can break or get caught in the mechanism.
- Tape slack can get caught up in the mechanism and should be taken up before the tape is played.
- Endless tapes can get caught up in the deck's moving parts if used incorrectly.

Sound quality/sound field

Using the built-in sound quality/sound field settings

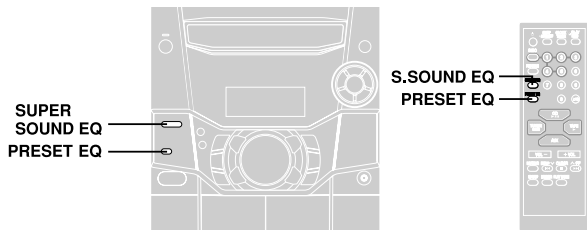

Press [PRESET EQ] to select a setting.

Every time you press the button:

HEAVY → SOFT → CLEAR → DISCO → LIVE → HALL
 ↑ EQ-OFF (cancelled) ↓

HEAVY (sound quality) : Adds punch to rock

SOFT (sound quality) : For background music

CLEAR (sound quality) : Clarifies higher sounds

DISCO (sound field) : Produces sound with the same kind of lengthy reverberations heard at a disco

LIVE (sound field) : Makes vocals more alive

HALL (sound field) : Adds an expansiveness to the sound to produce the atmosphere of a great concert hall.

Note

You cannot use PRESET EQ and SUPER SOUND EQ together.

Sound quality/sound field

Enhancing the sound quality

You can enhance the bass and treble effect of the sound.

Press [SUPER SOUND EQ].

Remote control: Press [S.SOUND EQ].

The button light comes on.

Press the button again to cancel.

The button light goes out.

Recording

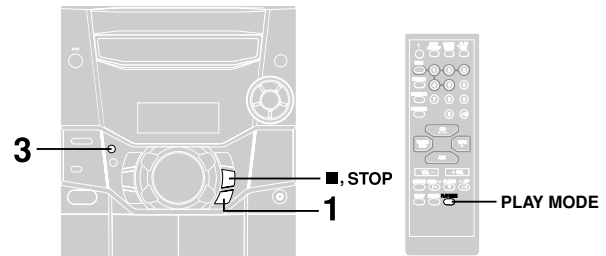

Selection of tapes for recording

Use normal position tapes.

High position and metal position tapes can be used, but this unit will not be able to record or erase them correctly.

Preparation:

Wind up the leader tape so recording can begin immediately.

1 Press [▲, DECK 2] and insert the cassette to be recorded.

Insert with the side to be recorded facing towards you and the exposed tape facing down.

2 Select the source to be recorded.

Radio recording:

Tune in the station. (→ page 10)

CD recording:

① Insert the CD(s) you want to record.

Press [▶/||, CD] and then [■, STOP].

② Prepare the desired CD recording mode.

- To record programmed tracks (→ "Program play" on page 9: steps 1-3).

- To record specific CDs/tracks

1-DISC/ALL-DISC recording

Do steps 1 to 2 on page 9: "To listen to specific CDs and tracks (CD Play Mode function)".

Ensure CD is stopped.

1-SONG recording

1. Do steps 1 to 2 on page 9: "To listen to specific CDs and tracks (CD Play Mode function)".

Ensure CD is stopped.

2. Press [I◀◀/REW/V] or [▶▶I/FF/△] to select the track.

Tape-to-tape recording:

① Press [▶, TAPE] and then [■, STOP].

② Press [▲, DECK 1] and insert the cassette you want to record.

3 Press [● REC] to start recording.

Your attention is drawn to the fact that recording pre-recorded tapes or discs or other published or broadcast material may infringe copyright laws.

To stop recording

Press [■, STOP].

If the tape finishes before the CD

The CD continues playing. Press [■, STOP] to stop it.

To record on the other side of the tape

Turn the tape over and press [● REC].

Recording

Reducing noise when recording AM

Remote control only

Hold down [PLAY MODE] while recording.

Every time you hold down the button: BP1 ↔ BP2

Choose the setting with the least noise.

Notes

- Changes to volume and sound/field quality do not affect recording.
- You cannot open deck 1 while recording.
- You cannot fast-forward or rewind one deck while recording with the other.
- When recording an AM broadcast, sound is momentarily interrupted when you start and stop the recording.

Erasure prevention

Use a screwdriver or similar object to break out the tab.

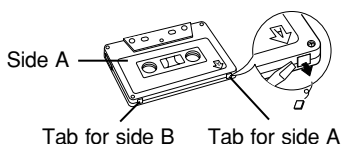

To re-record on a protected cassette

Cover the hole with adhesive tape.

To erase a tape

1. Press [▶, TAPE] and then [■, STOP].
2. Insert the recorded tape into deck 2.
Ensure there is no tape in deck 1.
3. Press [● REC].

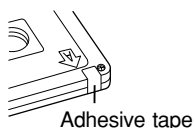

Optional antenna connections

Use outdoor antenna if radio reception is poor.

FM outdoor antenna

For Europe

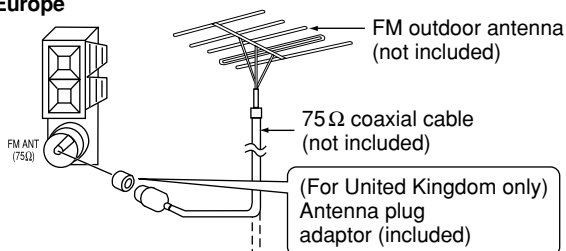

For Australia and New Zealand

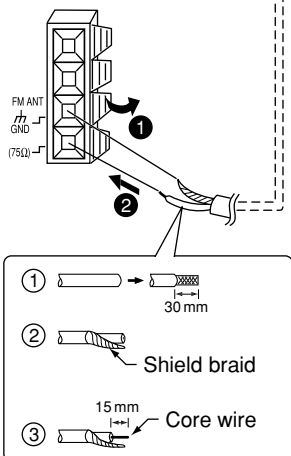

- Disconnect the FM indoor antenna.
- The antenna should be installed by a competent technician.

Optional antenna connections

AM outdoor antenna

For Europe

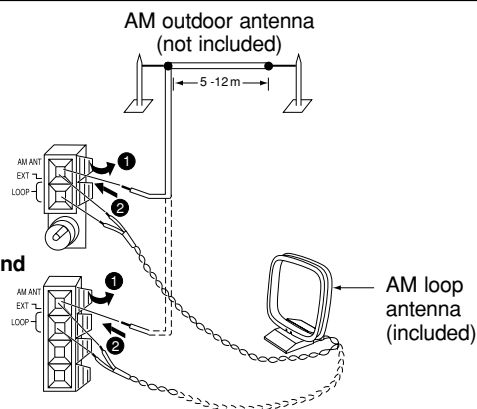

For Australia and New Zealand

Run a piece of vinyl wire horizontally across a window or other convenient location.

Leave the loop antenna connected.

Note

Disconnect the outdoor antenna when the unit is not in use. Do not use the outdoor antenna during a lightning storm.

External unit connections

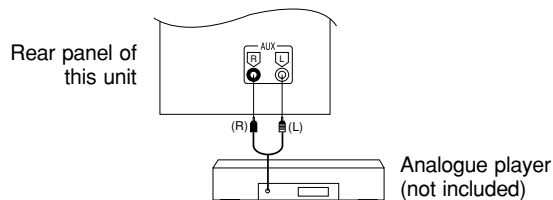

- An analogue player with a built-in phono equalizer can be connected.
- For details, refer to the instruction manual of the units which are to be connected.
- When units other than those described above are to be connected, please consult your audio dealer.

Using an external unit

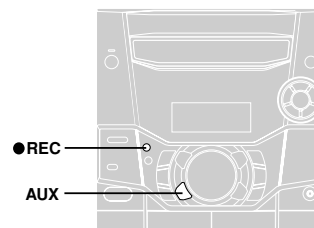

(See above for external unit connection)

1. Press [AUX].
The unit comes on.
2. **For listening** : Proceed to step 3
For recording : Press [● REC] (recording starts).
3. Start playback from the external source. (For details, refer to the external unit's instruction manual.)

Using headphones (not included)

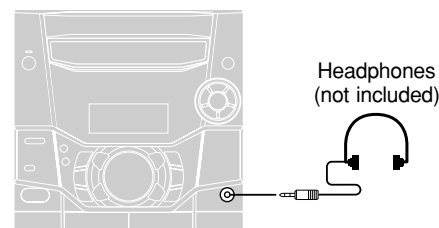

Reduce the volume level and connect the headphones. Plug type: 3.5 mm stereo

Note

Avoid listening for prolonged periods of time to prevent hearing damage.

Turning the demo function off

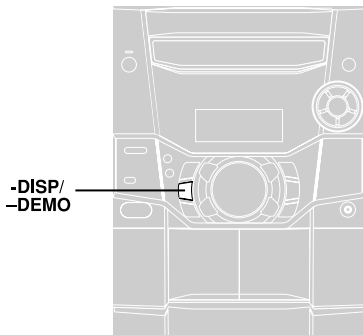

A demonstration of the display is shown if you have not set the clock. You can reduce the power consumed in standby mode by turning it off.

During standby mode

Hold down [-DISP/-DEMO] until “NO DEMO” is displayed.

Every time you hold down the button:

NO DEMO (off) ↔ DEMO ON (on)

To show a demonstration of the display

Hold down [-DISP/-DEMO] until “DEMO ON” is displayed.

Note

DEMO function cannot be turned on when Dimmer is on.

Convenient functions

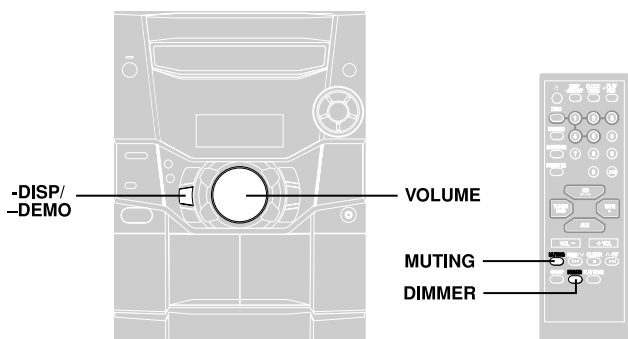

To dim the display panel

Remote control only

Press [DIMMER].

The display is dimmed and the indicator is turned off.

(The AC supply indicator remains on.)

Press [DIMMER] again to restore the display.

Switching displays (SC-AK310 and SC-AK210 only)

Press [-DISP/-DEMO] to select the desired spectrum analyzer.

Every time you press the button:

Normal → Peak hold → Aurora

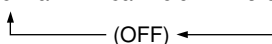

To mute the volume

Remote control only

Press [MUTING].

Press the button again to cancel.

“MUTING” goes out.

To cancel from the unit, turn [VOLUME] to minimum (–dB), then raise it to the required level.

Muting is also cancelled when the unit is turned off.

Auto-off function

Remote control only

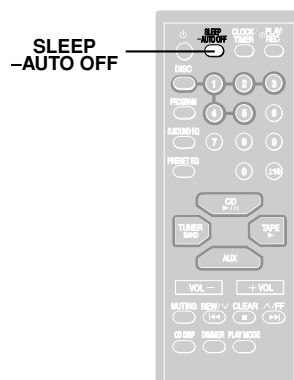

When CD or tape is selected as the source

To save power, the unit turns off if it is left unused for ten minutes.

This function does not work if the source is tuner or AUX.

Hold down [-AUTO OFF].

“AUTO OFF” is shown on the display.

The setting is maintained even if the unit is turned off.

If you select tuner or AUX as the source, “AUTO OFF” goes out. It comes on again when you select CD or tape.

To cancel

Hold down [-AUTO OFF] again.

Setting the time

Remote control only

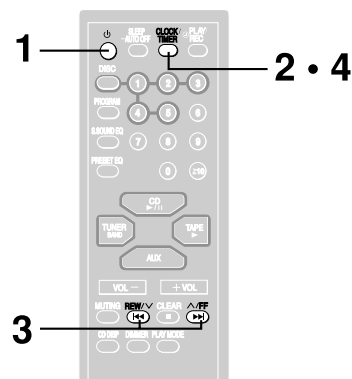

This is a 24-hour clock.

- 1 Switch on the unit.**
- 2 Press [CLOCK/TIMER] to select “CLOCK”.**
Every time you press the button:
CLOCK → ◉PLAY → ◉REC
↑ Previous display ↓
- 3 (within 7 seconds or so)**
Press [◀◀, REW/V] or [▶▶, ^/FF] to set the time.
- 4 Press [CLOCK/TIMER] to finish setting the time.**
The display will return to whatever was displayed before you set the time.

To display the time

Press [CLOCK/TIMER] once when the unit is on or at standby mode.

The time is shown for about 5 seconds.

Note

Reset the clock regularly to maintain accuracy.

Using the timers

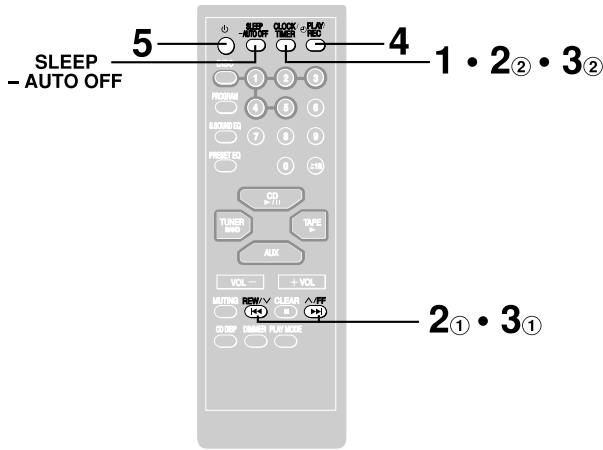

Using the play/record timer

Remote control only

You can set the timer to come on at a certain time to wake you up (play timer) or to record a radio station or from the aux source (record timer).

The play and record timers cannot be used together.

Preparations:

- Turn the unit on and set the clock (→ page 13).
- **For the play timer**, prepare the desired music source (tape/CD/radio/aux), and set the volume.
- **For the record timer**, check the cassette's erasure prevention tabs (→ page 12) and insert the tape in deck 2 (→ page 11). Tune to the radio station (→ page 10) or select the aux source (→ page 12).

1 Press [CLOCK/TIMER] to select the timer function.

Every time you press the button:

CLOCK → ⊙PLAY → ⊙REC

↑ Previous display ↓

⊙PLAY: to set the play timer

⊙REC: to set the record timer

2 ON time setting

① (Within 8 seconds or so)

Press [←, REW/V] or [→, FF] to set the start time.

② Press [CLOCK/TIMER].

3 OFF time setting

① Press [←, REW/V] or [→, FF] to set the finish time.

② Press [CLOCK/TIMER].

The start and finish times are now set.

4 Press [⊙PLAY/REC] to display the timer indicator.

Every time you press the button:

⊙PLAY → ⊙REC

↑ (off) ↓

⊙PLAY: to turn the play timer on

⊙REC: to turn the record timer on

(The indicator doesn't appear if the start and finish times or the clock hasn't been set.)

5 Press [⊕] to turn the unit off.

The unit must be off for the timers to operate.

- **Play timer:** Play will start in the set condition at the set time with volume increasing gradually to the set level.
- **Record timer:** The unit comes on 30 seconds before the set time with the volume muted.

To cancel the timer

Press [⊙PLAY/REC] to clear the timer indicator from the display. (The timer comes on at the set time everyday if the timer is on.)

To change the settings (when the unit is on)

To change the play/record times

Do steps 1, 2, 3 and 5.

To change the source or volume

1. Press [⊙PLAY/REC] to clear the timer indicator from the display.
2. Make changes to the source or volume.
3. Do steps 4 to 5.

To change the timer

Press [⊙PLAY/REC] to select the desired timer.

Every time the button is pressed:

⊙PLAY → ⊙REC

↑ (off) ↓

To check the settings

Press [CLOCK/TIMER] while the unit is on to select "⊙PLAY" or "⊙REC".

The settings are shown in the following order:

Play timer: start time→finish time→source→volume

Record timer: start time→finish time→source

To check the settings while the unit is off, press [CLOCK/TIMER] twice.

If you use the unit after the timers are set

After using, check that the correct tape/CD are loaded before turning the unit off.

Notes

- If you turn the unit off and on again while a timer is functioning, the finish time setting will not be activated.
- If you selected AUX as the source, when the timer comes on, the unit turns on and engages "AUX" as the source. If you want to playback or record from a connected unit, set that unit's timer to the same time. (See the connected unit's instruction manual.)

Using the sleep timer

Remote control only

This timer turns the unit off after a set time.

While enjoying the desired source:

Press [SLEEP] to select the time (minutes).

Every time you press the button:

→ SLEEP 30 → SLEEP 60 → SLEEP 90 → SLEEP 120 → SLEEP OFF →

To cancel the sleep timer

Press [SLEEP] to select "SLEEP OFF".

To confirm the remaining time

Press [SLEEP] once.

The remaining time is shown for about 5 seconds.

To change the setting

Press [SLEEP] to select the new setting.

You can use the sleep timer in combination with the play/record timer. Make sure the unit is off before the play/record timer's start time.

Note

The sleep timer will be turned off when you start recording from a CD.

Troubleshooting guide

Before requesting service, make the checks below. If you can't fix the system as described below, or if something not listed here occurs, refer to the enclosed directory to locate an Authorized Service Center convenient to you or contact your dealer.

Reference pages are shown as black circled numbers ⑥.

Common Problems

No sound. Sound stops.	Turn the volume up. Switch off the unit, determine and correct the cause, then switch the unit on. Causes include shorting of the positive and negative speaker wires, straining of the speakers through excessive volume or power, and using the unit in a hot environment.
Sound is unfixed, reversed or comes from one speaker only.	Check the speaker connections. ⑥
Humming heard during play.	An AC mains lead or fluorescent light is near the cables. Keep other appliances and cords away from this unit's cables.
"ERROR" is displayed.	Incorrect operation performed. Read the instructions and try again.
"- -: -" appears on the display at standby mode.	You plugged the AC mains lead in for the first time or there was a power failure recently. Set the time. ⑬
"F61" is displayed.	Check and correct the speaker cords connection. ⑥ If this does not fix the problem, there is a power supply problem. Consult the dealer.

Listening to the radio

Noise is heard. The stereo indicator flickers or doesn't light. Sound is distorted.	Use an outdoor antenna. ⑫
A beat sound is heard.	Turn the TV off or separate it from the unit.
A low hum is heard during AM broadcasts.	Separate the antenna from other cables and cords.

When there is a television set nearby

The picture on the TV disappears or stripes appear on the screen.	The location and orientation of the antenna are incorrect. If you are using an indoor antenna, change to an outdoor antenna. The TV antenna wire is too close to the unit. Separate the antenna wire of the TV set from the unit.
--	--

Using the cassette deck

Poor quality sound.	Clean the heads. See below
Recording is not possible.	If the erasure prevention tabs have been removed, cover the holes with adhesive tape. ⑫

Playing discs

The display is wrong or play won't start.	The disc may be upside down. ⑥ Wipe the disc. Replace the disc if it is scratched, warped, or non-standard. Condensation may have formed inside the unit due to a sudden change in temperature. Wait about an hour for it to clear and try again.
CD-RW cannot be read.	The disc was incompletely formatted. Use the recording equipment to fully format the disc before recording.
"TAKE OUT/DISC" appears on the display.	There is a problem with the disc mechanism. (A power failure may have occurred.) The tray will open automatically. Remove the disc from the tray, and after ensuring there is no disc in the tray, close it. The unit will make the disc changing noises for a few moments and then it should operate normally.

Remote control

Remote control doesn't work.	Check that the batteries are inserted correctly. ⑤ Replace the batteries if they are worn.
-------------------------------------	---

Maintenance

If the surfaces are dirty

To clean this unit, wipe with a soft, dry cloth.

- Never use alcohol, paint thinner or benzine to clean this unit.
- Before using a chemically treated cloth, read the instructions that came with the cloth carefully.

For a cleaner, crisper sound

Clean the heads regularly to assure good quality playback and recording.

Use a cleaning tape (not included).

Specifications

AMPLIFIER SECTION **SC-AK310**

RMS Power output	
10% Total harmonic distortion	
1kHz, both channels driven	
(Low channel)	55 W per channel (6Ω)
10 kHz, both channels driven	
(High channel)	55 W per channel (6Ω)
Total Bi-Amp power	110 W per channel
Input sensitivity	
AUX	250 mV
Input impedance	
AUX	13.3 kΩ

AMPLIFIER SECTION **SC-AK210**

RMS Power output	
10% Total harmonic distortion	
1 kHz, both channels driven	
(Low channel)	55 W per channel (6Ω)
10 kHz, both channels driven	
(High channel)	55 W per channel (6Ω)
Total Bi-Amp power	110 W per channel
Input sensitivity	
AUX	250 mV
Input Impedance	
AUX	13.3 kΩ

AMPLIFIER SECTION **SC-AK110**

Power output	
10% Total harmonic distortion	
1 kHz, both channels driven	
(Low channel)	80 W per channel (6Ω)
Total power	80 W per channel
Input sensitivity	
AUX	250 mV
Input Impedance	
AUX	13.3 kΩ

FM TUNER SECTION

Frequency range	87.50 – 108.00 MHz (50 kHz steps)
(For Europe)	
Sensitivity	1.8 μV (IHF)
S/N 26 dB	1.5 μV
(For Australia and New Zealand)	
Sensitivity	2.5 μV (IHF)
S/N 26 dB	2.2 μV
Antenna terminal(s)	75 Ω (unbalanced)

AM TUNER SECTION

Frequency range	522 – 1629 kHz (9 kHz steps)
Sensitivity	
S/N 20 dB (at 999 kHz)	560 μV/m

CASSETTE DECK SECTION

Track system	4 track, 2 channel
Heads	
Record/playback	Solid permalloy head
Erasure	Double gap ferrite head
Motor	DC servo motor
Recording system	AC bias 100 kHz
Erasing system	AC erase 100 kHz
Tape speed	4.8 cm/s
Overall frequency response	
(+3 dB, –6 dB at DECK OUT)	
NORMAL (TYPE I)	35 Hz – 14 kHz
S/N	50 dB (A weighted)
Wow and flutter	0.18% (WRMS)
Fast forward and rewind time	Approx. 120 seconds with C-60 cassette tape

CD SECTION

Sampling frequency	44.1 kHz
Decoding	16 bit linear
Pickup	
Beam source/wavelength	Semiconductor laser/780 nm
(For Norge)	
Bølgelengde	780 nm
Laserstyrke	Ingen farlig stråling sendes ut
Number of channels	Stereo
Frequency response	20 Hz–20 kHz (+1, –2 dB)
Wow and flutter	Below measurable limit
Digital filter	8 fs
D/A converter	MASH (1 bit DAC)

SPEAKER SECTION **SB-AK310**

Type	3 way, 3 speaker system
Speaker(s)	
Woofer	16 cm cone type
Tweeter	6 cm cone type
Super tweeter	2.5 cm Piezo type
Impedance	
HIGH	6 Ω
LOW	6 Ω
Input power	
HIGH	110 W (Music)
LOW	110 W (Music)
Output sound pressure level	86.5 dB/W (1.0 m)
Cross over frequency	3.5 kHz, 10 kHz
Frequency range	35 Hz–25 kHz (–16 dB)
	47 Hz–24 kHz (–10 dB)
Dimensions (WxHxD)	227 x 344 x 243 mm
Mass	3.3 kg

SPEAKER SECTION **SB-AK210**

Type	2 way, 2 speaker system
Speaker(s)	
Woofer	16 cm cone type
Tweeter	6 cm cone type
Impedance	
HIGH	6 Ω
LOW	6 Ω
Input power	
HIGH	110 W (Music)
LOW	110 W (Music)
Output sound pressure level	86.8 dB/W (1.0 m)
Cross over frequency	3.5 kHz
Frequency range	45 Hz–25 kHz (–16 dB)
	60 Hz–24 kHz (–10 dB)
Dimensions (WxHxD)	220 x 330 x 227 mm
Mass	3.1 kg

SPEAKER SECTION **SB-AK110**

Type	2 way, 2 speaker system
Speaker(s)	
Woofer	16 cm cone type
Tweeter	6 cm cone type
Impedance	6 Ω
Input power	160 W (Music)
Output sound pressure level	86.8 dB/W (1.0 m)
Cross over frequency	4 kHz
Frequency range	45 Hz–30 kHz (–16 dB)
	60 Hz–26 kHz (–10 dB)
Dimensions (WxHxD)	220 x 330 x 227 mm
Mass	3.0 kg

GENERAL

Power supply	AC 230-240 V, 50 Hz
Power consumption	
SC-AK310	170 W
SC-AK210	170 W
SC-AK110	174 W
Dimensions (WxHxD)	250 x 330 x 370 mm
Mass	
SC-AK310	7.0 kg
SC-AK210	7.0 kg
SC-AK110	7.2 kg

Power consumption in standby mode:
Approx. 0.5 W

Notes

- Specifications are subject to change without notice.
Mass and dimensions are approximate.
- Total harmonic distortion is measured by the digital spectrum analyzer.
- Except SB-AK110**
The labels "HIGH" and "LOW" on the rear of the speakers refer to High frequency and Low frequency.

Free Manuals Download Website

<http://myh66.com>

<http://usermanuals.us>

<http://www.somanuals.com>

<http://www.4manuals.cc>

<http://www.manual-lib.com>

<http://www.404manual.com>

<http://www.luxmanual.com>

<http://aubethermostatmanual.com>

Golf course search by state

<http://golfingnear.com>

Email search by domain

<http://emailbydomain.com>

Auto manuals search

<http://auto.somanuals.com>

TV manuals search

<http://tv.somanuals.com>