

CD Stereo System

Operating Instructions

Model No. **SC-AK52**
SC-AK44
SC-AK22

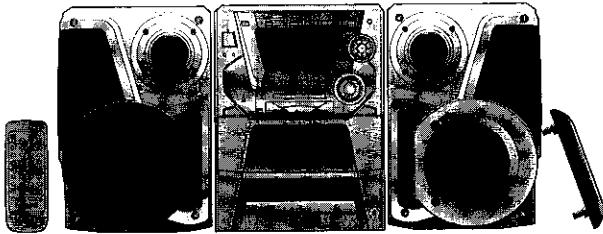

The illustrations show SC-AK44.

COMPACT
disc
DIGITAL AUDIO



E EB EE GN

Panasonic®

Note:
"EB" on the packaging indicates the United Kingdom.

Before connecting, operating or adjusting this product, please read these instructions completely. Please keep this manual for future reference.

RQT5666-B

Dear customer

Thank you for purchasing this product.
For optimum performance and safety, please read these instructions carefully.

These operating instructions are applicable to the following system.
These operating instructions, however, fundamentally explain the operation of system SC-AK44.

System	SC-AK52	SC-AK44	SC-AK22
Main unit	SA-AK52	SA-AK44	SA-AK22
Speakers	SB-AK52	SB-AK44	SB-AK22



LUOKAN 1 LASERLAITE KLASS 1 LASER APPARAT

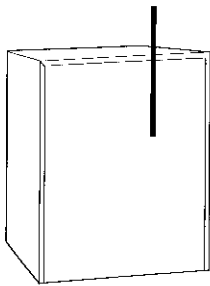

(Back of product)

DANGER	IRVIG SILE LASER RADIATION WHEN OPEN AVOID DIRECT EXPOSURE TO BEAM.
ADVARSEL	USYNLIG LASERSTRÅLING VED ÅBNING, NÅR SIKKERHEDSÅBRYDRE ER I LØB AF FUNKTION. UNDGÅ UDSEJTELSE FOR STRÅLING.
VARO!	AVAITTAESSA JA SUOJALUKITUS OIHITETTAFSSA OLET ALTIITINA NÄKYMÄTÖNTÄ LÄSHÄSATEILYLLE ÄLÄ KATSO SÄTEESEEN.
VARNING	OSYNLIG LASERSTRÅLING NÄR DENNA DEL ÄR ÖPPNAD OCH SPÅRREHÄR UTKÖPPNAD. BEHÅRKTÄ EJ STRÅLEN.
ADVARSEL	USYNLIG LASERSTRÅLING NÄR DEKSEL ÅPNES OG SIKKERHEDSKÅS BRYTES. UNDGÅ EKSPONERING FOR STRÅLEN.
VORSICHT	UNGSICHTBARE LASERSTRÄHLUNG, WENN ABDECKUNG GEÖFFNET NICHT DEM STRAHL AUSSETZEN.

(Inside of product)

(Indersiden at apparatet)

(Tuotteen sisällä)

(Apparatens insida)

(Produktets insido)

(Im Inneren des Gerätes)

Supplied accessories

Please check and identify the supplied accessories.

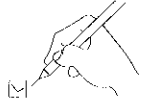

AC mains lead 1 pc.

For United Kingdom
(RJA0044-3C)

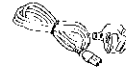

For Europe
(RJA0043-1C)

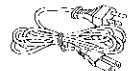

For Russia and
Ukraine (RJA0019-2K)



For Australia and
New Zealand (RJA0035-X)

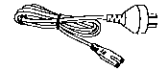

Remote control transmitter 1 pc.

SC-AK22

United Kingdom and Europe : N2QAGB000006 (Silver)
(Except Russia and Ukraine) N2QAGB000011 (Black)



Russia and Ukraine : N2QAGB000005 (Silver)
: N2QAGB000012 (Black)



Australia and New Zealand : N2QAGB000002



SC-AK52 and **SC-AK44**

United Kingdom and Europe : N2QAGB000001



SC-AK44

Australia and New Zealand : N2QAGB000004



Batteries for remote control 2 pcs.

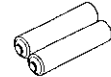

FM indoor antenna 1 pc.

For United Kingdom and
Europe (RSA0007)



For Australia and
New Zealand (RSA0006-J)



AM loop antenna (RSA0029-L) 1 pc.



Antenna plug adaptor (SJP9009) 1 pc. (United Kingdom only)



Use numbers indicated in parentheses when asking for replacement parts.



Table of contents

Before using

Supplied accessories	2
Safety precautions	3
Caution for AC Mains Lead	4
Concerning the remote control	5
Battery installation	5
Correct method of use	5
Placement of speakers	5
Connections	6
Basic connections (for supplied accessories)	6
Optional antenna connections	7
External unit connection	7
Front panel controls	8
Turning the demo function off	10
Auto-off function	10
Setting the time	11
Convenient functions	11

Radio operations

Listening to radio broadcasts	12
Presetting radio broadcasts	13

Compact disc operations

Concerning compact discs	14
Listening to compact discs	15
Direct access play	16
Repeat play	16
Random play	16
Program play	17
To listen to special CDs and tracks (CD Manager function)	18

Cassette deck operations

Listening to tapes	19
--------------------------	----

Recording operations

Before recording (Deck 2 only)	20
Tape-to-tape recording	21
Recording from radio broadcasts	22
Recording from compact discs	23
To record special CDs and tracks (CD Manager function)	24

Sound quality/sound field operations

Using the built-in sound quality/sound field settings	25
Enhancing the sound quality	25
Boosting the super woofer	25
Varying the sound quality with the manual equalizer	26
Varying the sound quality with the acoustic image (AI) equalizer	26

Timer operations

Using the timer	27
Using the play/record timer	27
Using the sleep timer	29

Reference

Using an external unit	29
Troubleshooting guide	30
Maintenance	30
Specifications	31

Safety precautions

Placement

Set the system up on an even surface away from direct sunlight, high temperatures, high humidity, and excessive vibration. These conditions can damage the cabinet and other components, thereby shortening the unit's service life.

Place it at least 15 cm away from wall surfaces to avoid distortion and unwanted acoustical effects.

Do not place heavy items on the unit.

Voltage

Do not use high voltage power sources. This can overload the unit and cause a fire.

Do not use a DC power source. Check the source carefully when setting the unit up on a ship or other place where DC is used.

AC mains lead protection

Ensure the AC mains lead is connected correctly and not damaged. Poor connection and lead damage can cause fire or electric shock. Do not pull, bend, or place heavy items on the lead.

Grasp the plug firmly when unplugging the lead. Pulling the AC mains lead can cause electric shock.

Do not handle the plug with wet hands. This can cause electric shock.

Foreign matter

Do not let metal objects fall inside the unit. This can cause electric shock or malfunction.

Do not let liquids get into the unit. This can cause electric shock or malfunction. If this occurs, immediately disconnect the unit from the power supply and contact your dealer.

Do not spray insecticides onto or into the unit. They contain flammable gases which can ignite if sprayed into the unit.

Service

Do not attempt to repair this unit by yourself. If sound is interrupted, indicators fail to light, smoke appears, or any other problem that is not covered in these instructions occurs, disconnect the AC mains lead and contact your dealer or an authorized service center. Electric shock or damage to the unit can occur if the unit is repaired, disassembled or reconstructed by unqualified persons.

Extend operating life by disconnecting the unit from the power source if it is not to be used for a long time.

Caution for AC Mains Lead

(For United Kingdom)



("EB" area code model only)

For your safety, please read the following text carefully.

This appliance is supplied with a moulded three pin mains plug for your safety and convenience.

A 5-ampere fuse is fitted in this plug.

Should the fuse need to be replaced please ensure that the replacement fuse has a rating of 5-ampere and that it is approved by ASTA or BSI to BS1362.

Check for the ASTA mark  or the BSI mark  on the body of the fuse.

If the plug contains a removable fuse cover you must ensure that it is refitted when the fuse is replaced.

If you lose the fuse cover the plug must not be used until a replacement cover is obtained.

A replacement fuse cover can be purchased from your local dealer.

CAUTION!

IF THE FITTED MOULDED PLUG IS UNSUITABLE FOR THE SOCKET OUTLET IN YOUR HOME THEN THE FUSE SHOULD BE REMOVED AND THE PLUG CUT OFF AND DISPOSED OF SAFELY.

THERE IS A DANGER OF SEVERE ELECTRICAL SHOCK IF THE CUT OFF PLUG IS INSERTED INTO ANY 13-AMPERE SOCKET.

If a new plug is to be fitted please observe the wiring code as stated below.

If in any doubt please consult a qualified electrician.

IMPORTANT

The wires in this mains lead are coloured in accordance with the following code:

Blue: Neutral, Brown: Live.

As these colours may not correspond with the coloured markings identifying the terminals in your plug, proceed as follows:

The wire which is coloured Blue must be connected to the terminal which is marked with the letter N or coloured Black or Blue.

The wire which is coloured Brown must be connected to the terminal which is marked with the letter L or coloured Brown or Red.

WARNING: DO NOT CONNECT EITHER WIRE TO THE EARTH TERMINAL WHICH IS MARKED WITH THE LETTER E, BY THE EARTH SYMBOL  OR COLOURED GREEN OR GREEN/YELLOW.

THIS PLUG IS NOT WATERPROOF—KEEP DRY.

Before use

Remove the connector cover.

How to replace the fuse

The location of the fuse differ according to the type of AC mains plug (figures A and B). Confirm the AC mains plug fitted and follow the instructions below.

Illustrations may differ from actual AC mains plug.

1. Open the fuse cover with a screwdriver.

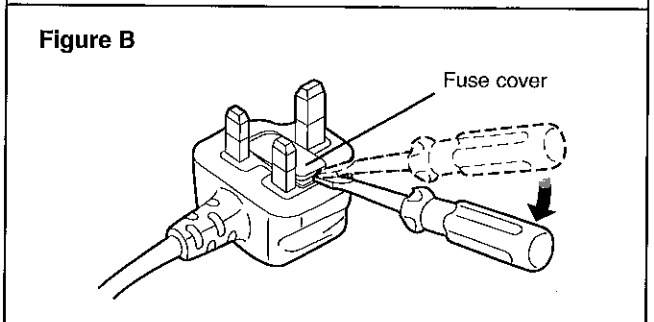
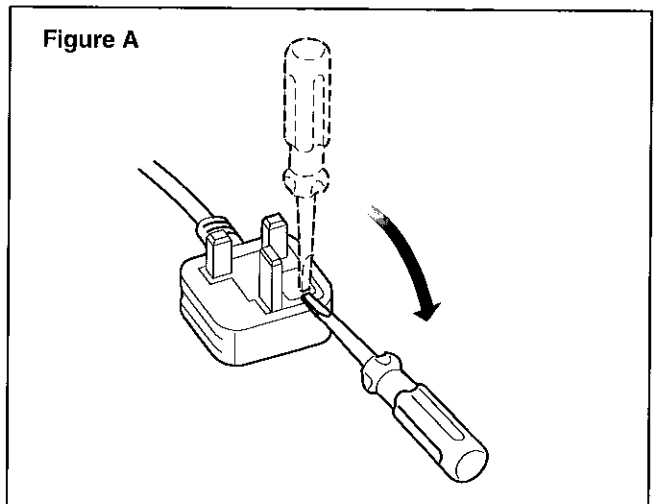

2. Replace the fuse and close or attach the fuse cover.

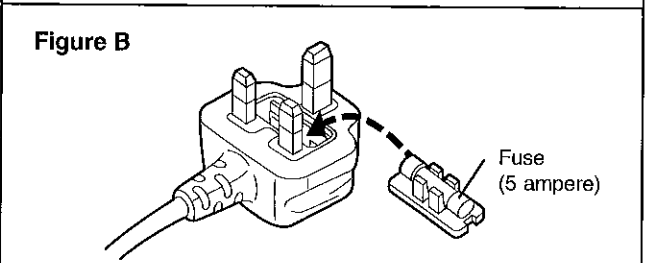
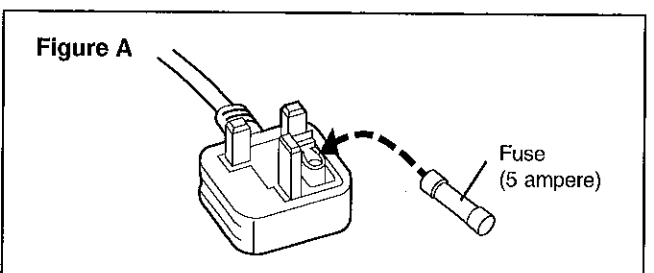

Concerning the remote control

- A** For model SC-AK44 : Australia and New Zealand
For model SC-AK22 : Russia and Ukraina

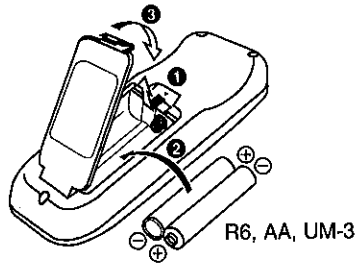

For others

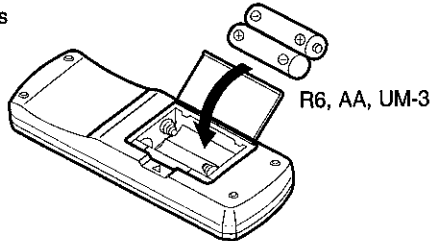

A Battery installation

Use of batteries

- Align the poles (+ and -) properly when inserting the batteries.
- Do not mix old and new batteries or different types of batteries.
- Do not recharge ordinary dry cell batteries.
- Do not heat or disassemble the batteries. Do not allow them to contact flame or water.
- Remove the batteries if the unit is not to be used for a long time.
- Do not keep together with metallic objects such as necklaces.
- Do not use rechargeable type batteries.
- Do not use batteries if the covering has been peeled off.

Mishandling of batteries can cause electrolyte leakage which can damage items the fluid contacts and may cause a fire. If electrolyte leaks from the batteries, consult your dealer. Wash thoroughly with water if electrolyte comes in contact with any part of your body.

B Correct method of use

Operation notes

- Do not place obstacles between the remote control signal sensor and remote control unit.
- Do not expose the remote control signal sensor to direct sunlight or to the bright light of a fluorescent light.
- Take care to keep the remote control signal sensor and end of the remote control unit free from dust.
- If this system is installed in a rack with glass doors, the glass doors' thickness or colour might make it necessary to use the remote control a shorter distance from the system.

To prevent damage

- Never place heavy items on top of the unit.
- Do not disassemble or reconstruct the unit.
- Do not spill water or other liquids into the unit.

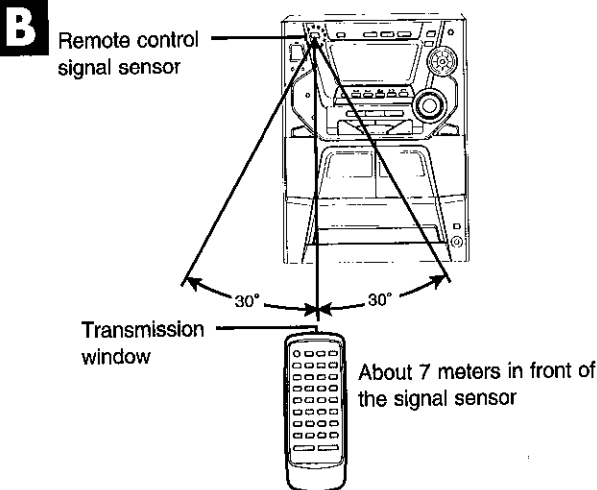

C Placement of speakers

SC-AK52 SC-AK44

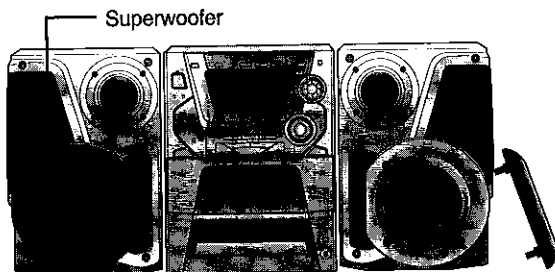

SC-AK22

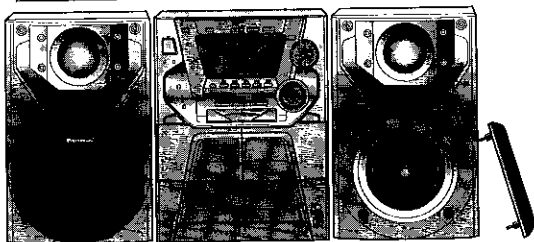

SC-AK52 SC-AK44

Place the speakers so that the super woofer is on the outside.

SC-AK22

Speakers are designed identically so that no left or right channel orientation is necessary.

Notes

- Keep your speakers at least 10 mm away from the system for proper ventilation.
- These speakers do not have magnetic shielding. Do not place them near televisions, personal computers or other devices easily influenced by magnetism.
- To avoid damage to the speakers, do not touch the speaker cones if you have taken the nets off.

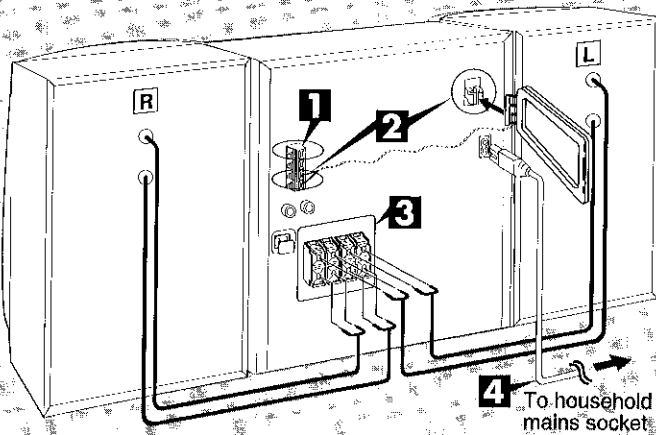

1 For Australia and New Zealand **For United Kingdom and Europe**

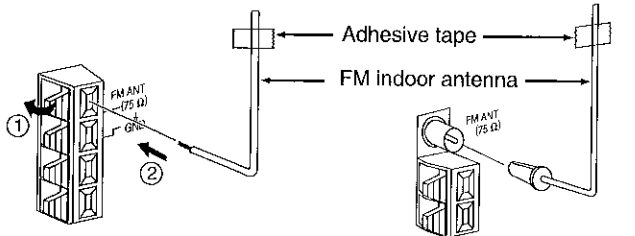

2 For Australia and New Zealand **For United Kingdom and Europe**

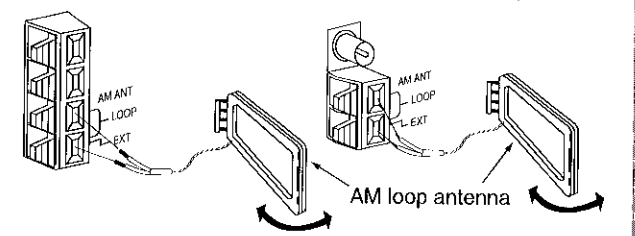

3

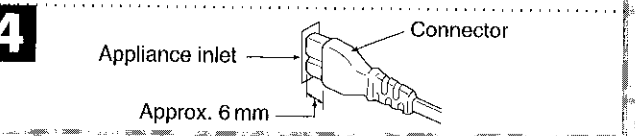
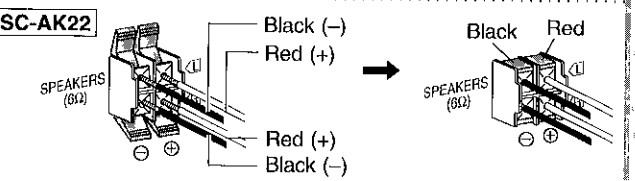
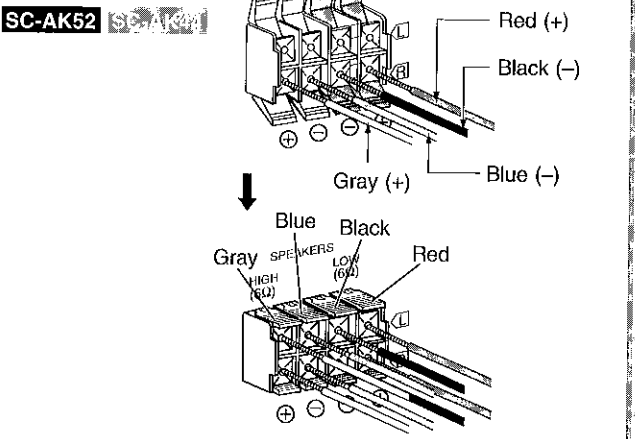

Connections

Basic connections (for supplied accessories)

- Plug the AC mains lead into a household mains socket only after all other connections have been made.
- To prepare the antenna wires and speaker cords, twist the vinyl cover tip and pull off.

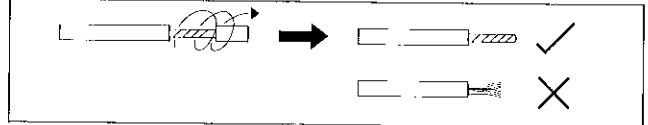

1 Connect the FM indoor antenna.
Tape the antenna to a wall or column, in a position where radio signals are received with the least amount of interference.

Note

For best reception sound quality:
An FM outdoor antenna is recommended. (See page 7.)

2 Connect the AM loop antenna.
After attaching the antenna, turn on the system and tune in a broadcast station. Then, turn the antenna to the angle of best reception and least interference.

3 Connect the speaker cables.
Connect each end of the speaker cables to the terminal lever of the same colour so (+) and (-) are correct. Never allow the exposed wires to contact each other when connected. **Incorrect connection can damage the unit.**

Caution

- **Use only the supplied speakers.**
The combination of the main unit and speakers provide the best sound. Using other speakers can damage the unit and sound quality will be negatively affected.

Caution

• **Use the speakers only with the recommended system.**
Failure to do so may lead to damage to the amplifier and/or the speakers, and may result in the risk of fire.
Consult a qualified service person if damage has occurred or if you experience a sudden change in performance.

- **Do not attach these speakers to walls or ceilings.**

4 Connect the AC mains lead.

(FOR UNITED KINGDOM ONLY)
BE SURE TO READ THE CAUTION FOR THE AC MAINS LEAD ON PAGE 4 BEFORE CONNECTION.

Insertion of connector

Even when the connector is perfectly inserted, depending on the type of inlet used, the front part of the connector may jut out as shown in the drawing. However there is no problem using the unit.

Note

The included AC mains lead is for use with this unit only. Do not use it with other equipment.

Optional antenna connections

You may need an outdoor antenna if you use this system in a mountainous region or inside a reinforced-concrete building, etc.

A FM outdoor antenna

Disconnect the FM indoor antenna if an FM outdoor antenna is installed.

- ① Remove a piece of the outer vinyl insulator.
- ② Twist the shield braid.
- ③ Expose the core wire.

Note

An outdoor antenna should be installed by a qualified technician only.

B AM outdoor antenna

Connect the outdoor antenna without removing the AM loop antenna. Run 5 to 12 m of vinyl-covered wire horizontally along a window or other convenient location.

Note

When the unit is not in use, disconnect the outdoor antenna to prevent possible damage that may be caused by lightning. Never use an outdoor antenna during an electrical storm.

External unit connection

- Make sure that the power supply for all components has been turned off before making any connections.
- For details, refer to the operating instructions of the unit which are to be connected.
- All peripheral components and cables sold separately.

C Connecting analogue equipment

An analogue player with a built-in phono equalizer can be connected. When units other than those described are to be connected, please consult your audio dealer.

D Connecting digital equipment to the optical fiber out terminal (For United Kingdom and Europe: model SC-AK52 and SC-AK44 only)

Remove the dust-protection cap and connect this unit to other digital equipment with an optical fibre terminal, such as a receiver or digital surround processor.

- Leave the cap attached when this terminal is not being used.

For your reference

If you have DTS format CDs, you can enjoy six channel playback by connecting this unit to a receiver or digital surround processor that has a DTS decoder.

Note

Use only the optical fibre terminal when playing back DTS format discs. DTS signals can only be correctly output through the digital terminal.

- DTS is a trademark of Digital Theater Systems, L.P.

A For Australia and New Zealand

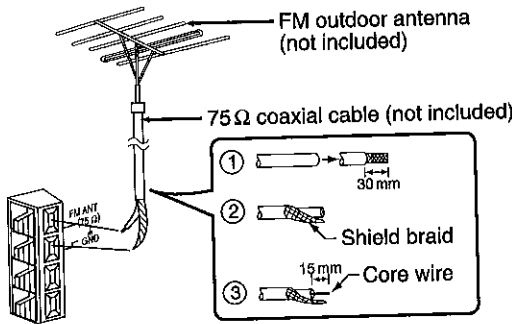

For United Kingdom and Europe

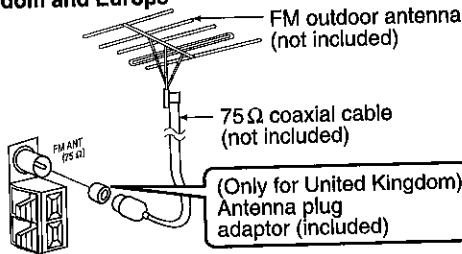

B For Australia and New Zealand

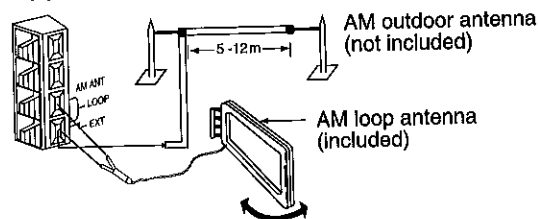

For United Kingdom and Europe

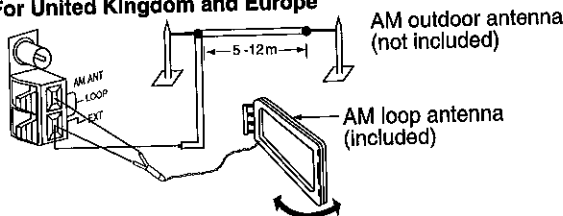

C Rear panel of this unit

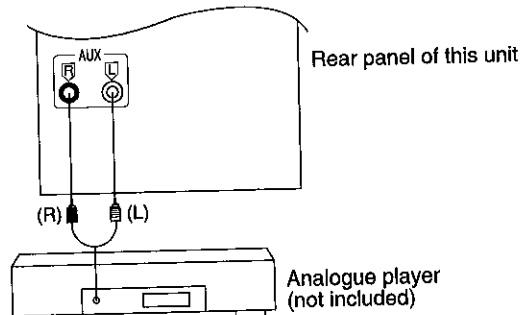

D Rear panel of this unit

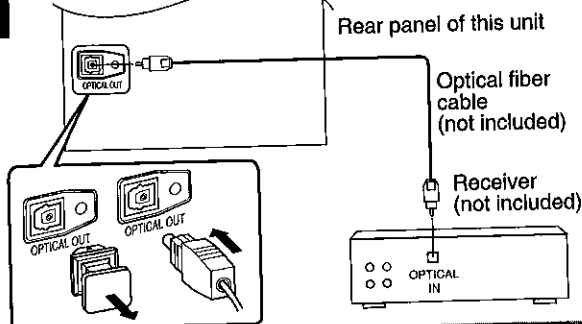

Before using

Front panel controls

A Main unit

No.	Name	Ref. page
①	AC supply indicator (AC IN) This indicator lights when the unit is connected to the AC mains supply.	
②	For Australia and New Zealand Standby/on switch (⏻/⏻, POWER) 11 Press to switch the unit from on to standby mode or vice versa. In standby mode, the unit is still consuming a small amount of power.	11
	For United Kingdom and Europe Standby/on switch (⏻/⏻) 11 Press to switch the unit from on to standby mode or vice versa. In standby mode, the unit is still consuming a small amount of power.	11
③	Play timer/record timer button (⏻/⏻) 27	27
④	Clock/timer button (CLOCK/TIMER) 11, 27, 28	11, 27, 28
⑤	Deck 1 open button (⏻ DECK 1 OPEN) 19	19
⑥	Deck 1 cassette holder 19	19
⑦	Disc tray	
⑧	SC-AK52 and SC-AK44 only Super woofer on/off button (S.WOOFER) 25	25
⑨	Deck 2 open button (⏻ DECK 2 OPEN) 19	19
⑩	Deck 2 cassette holder 19	19
⑪	CD open/close button (⏻, OPEN/CLOSE) 15	15
⑫	Headphone jack (PHONES) 29	29

B Center console

⑬	Remote control signal sensor 5	5
⑭	AUX button (AUX) 29	29
⑮	Tuner/band select button (TUNER, BAND) 12	12
⑯	Tape/deck select button (TAPE, DECK 1/2) 19	19
⑰	CD button (CD) 18	18
⑱	Display	
⑲	Disc direct play buttons and indicators (CD 1 ~ CD 5) 15	15
⑳	For United Kingdom and Europe only RDS button (RDS DISPLAY) 12	12
㉑	CD manager button (CD MANAGER) 18, 24	18, 24
㉒	SC-AK52, SC-AK44 and SC-AK22: Russia and Ukraine only Reverse mode select button (REV MODE) 19	19
㉓	Display select/demonstration button (-DISPLAY/-DEMO) 10, 11	10, 11
㉔	Tape edit button (TAPE EDIT) 21	21
㉕	Basic operating buttons Functions change according to the source.	
㉖	SC-AK52 and SC-AK44 only 3D AI button (3D AI) 26	26
㉗	Super sound EQ button (SUPER SOUND EQ) 25	25
㉘	Jog control (SOUND EQ) 25	25
㉙	SC-AK52 and SC-AK44 only Joy stick (SOUND EQ) 26	26
㉚	Volume control (VOL) 12	12
㉛	Recording start/stop button (● REC/STOP) 22	22

A

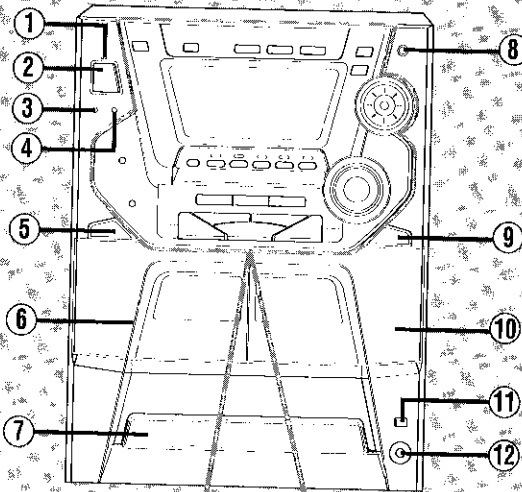

B

SC-AK52 SC-AK44 SC-AK22: Russia and Ukraine

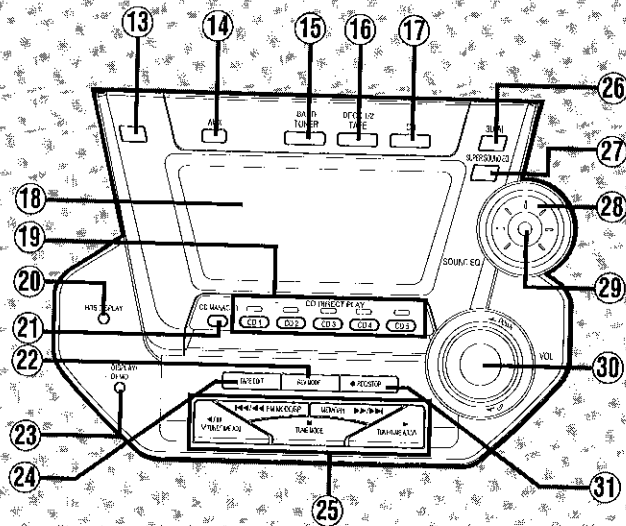

SC-AK22: Except Russia and Ukraine

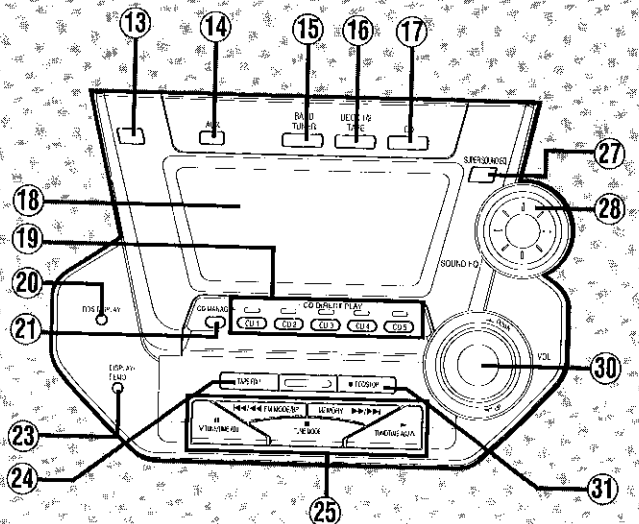

Before using

(For Australia and New Zealand: model: SC-AK44)
 (For Russia and Ukraine: model: SC-AK22)

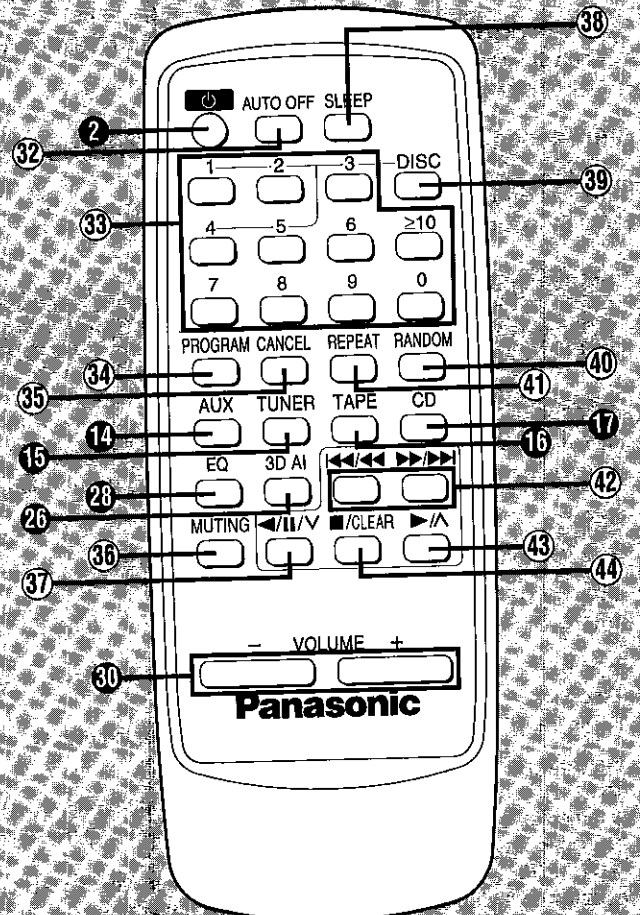

Front panel controls

Remote control

Buttons such as 2 functions in exactly the same way as the buttons on the main unit.

No.	Name	Ref. page
32	Auto off button (AUTO OFF)	10
33	Numeric buttons (≥ 10 , 1-9, 0)	13, 16
34	Program button (PROGRAM)	17
35	Cancel button (CANCEL)	17
36	Muting button (MUTING)	11
37	SC-AK52 , SC-AK44 and SC-AK22: Russia and Ukraine only Reverse side playback/pause/preset channel select button ($\blacktriangleleft/\blacktriangleright$)	13, 15, 19
	SC-AK22: except Russia and Ukraine Pause/preset channel select button ($\blacksquare/\blacktriangleright$)	13, 15
38	Sleep button (SLEEP)	29
39	Disc button (DISC)	16
40	Random button (RANDOM)	16
41	Repeat button (REPEAT)	16
42	Skip/search buttons ($\blacktriangleleft/\blacktriangleleft, \blacktriangleright/\blacktriangleright$)	15, 20
43	Play/preset channel select button ($\blacktriangleright/\blacktriangle$)	13, 15, 19
44	Stop/program clear button ($\blacksquare/\text{CLEAR}$)	15, 17, 19

(For others)

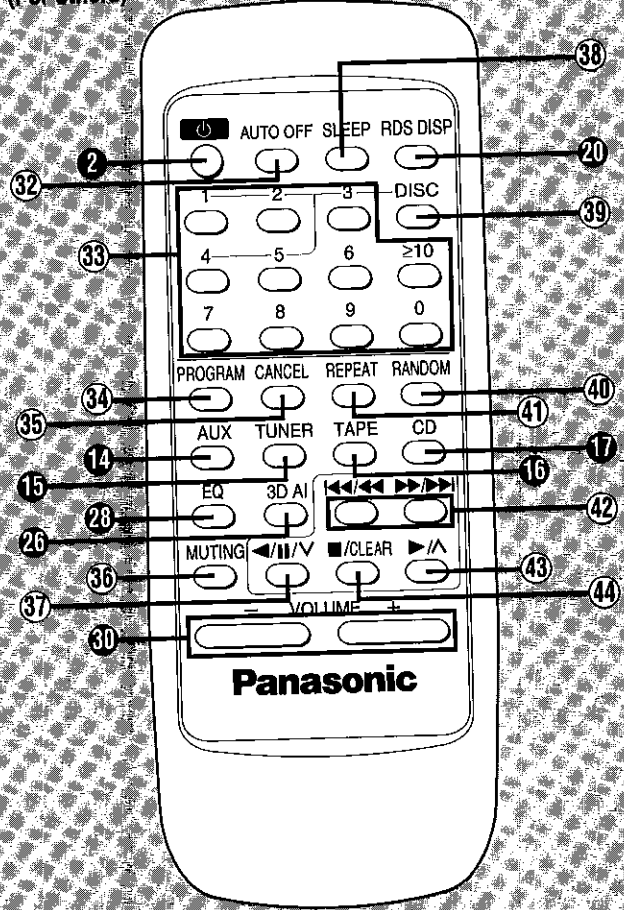

Before using

A

- DISPLAY /
- DEMO

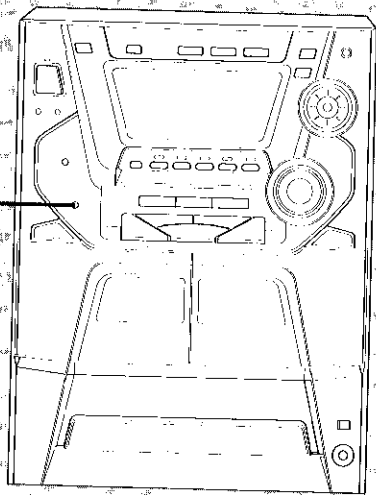

A Turning the demo function off

If the clock has not been set, a demonstration of the display is shown when the unit is switched to standby. This function is set to on at the time of purchase.

Press and hold [-DISPLAY/-DEMO] until "NO DEMO" is displayed.

The display changes each time the button is held down. NO DEMO (off) ↔ DEMO (on)

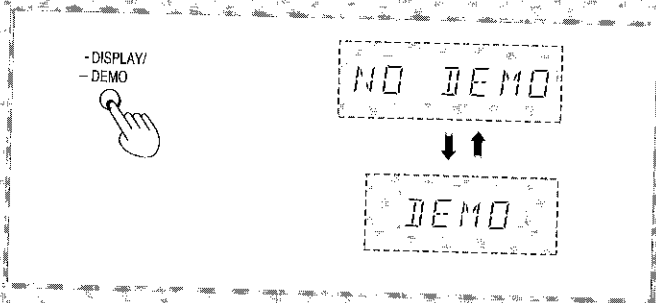

B Auto-off function

by remote control only

When CD or tape is selected as the source To save power, the unit turns off if it is left unused for ten minutes.

Note

This function does not work if the source is tuner or AUX.

Press [AUTO OFF].

"AUTO OFF" is shown on the display.

B

AUTO OFF

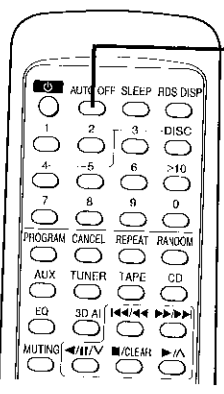

To cancel

Press [AUTO OFF] again to clear "AUTO OFF" from the display.

For your reference

The setting is maintained even if the unit is turned off. When the unit is turned on again, "AUTO OFF" is displayed and the unit functions as described above.

"AUTO OFF" disappears from the display if either tuner or AUX is selected as the source but continues to function normally.

"AUTO OFF" remains displayed if CD or tape is selected as the source.

Setting the time

This is a 24-hour display clock.
This example in the figure shows how to set the time for 16:25.

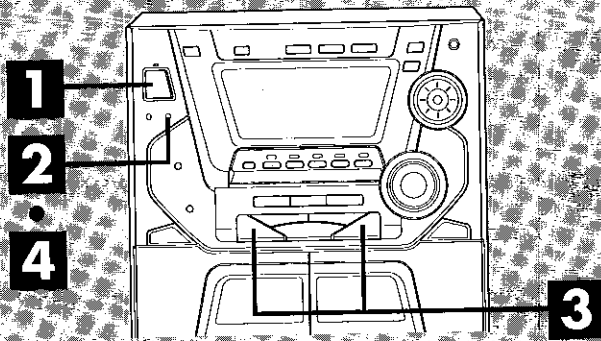

- 1** For Australia and New Zealand For United Kingdom and Europe

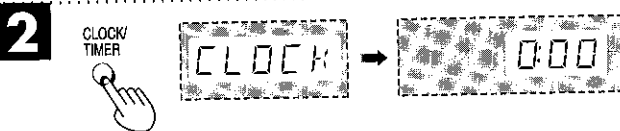
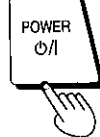

- 3** SC-AK52 SC-AK44 SC-AK22: Russia and Ukraina

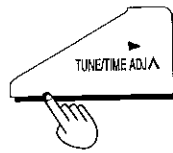
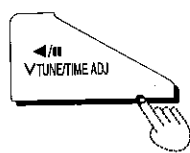

- SC-AK22: except Russia and Ukraina

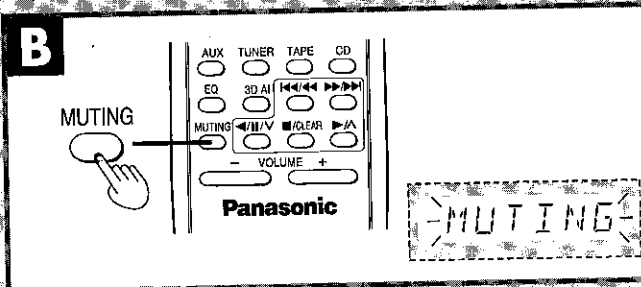
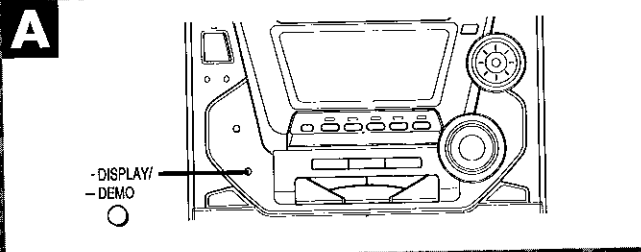
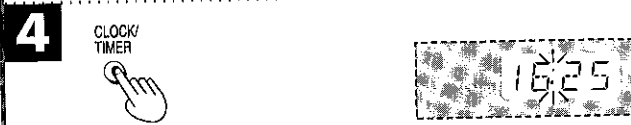
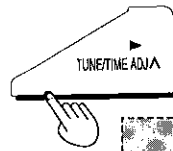
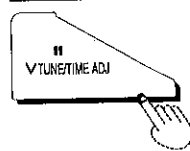

- 1** Switch on the unit.

- 2** Press [CLOCK/TIMER] to select "CLOCK".
Every time you press the button:

CLOCK → O/PLAY → O/REC
↑ Previous display ↓

- 3** (within 7 seconds or so)
Press [TUNE/TIME ADJ (V) or (A)] to show the present time.

- 4** Press [CLOCK/TIMER] to finish setting the time.
The display will return to whatever was displayed before you set the time.

To display the time when system is ON
Press [CLOCK/TIMER] to select "CLOCK".

To display the time when system is OFF
Press [CLOCK/TIMER].

The time will be displayed for about 5 seconds and then the display will return to whatever was previously displayed.

Note

The clock may lose or gain some time over a period. Readjust if necessary.

Convenient functions

A Switching displays

Press [-DISPLAY/-DEMO] to select the desired spectrum analyzer.

Every time you press the button:

Normal → Peak hold → Aurora
└── (OFF) ──┘

B To mute the volume

by remote control only

This feature is convenient when you have a telephone call, etc.

Press [MUTING].

Press the button again to cancel.

"MUTING" goes out.

Muting can also be canceled by lowering the volume all the way (--dB).

When the system is turned off, the muting operation will be automatically canceled.

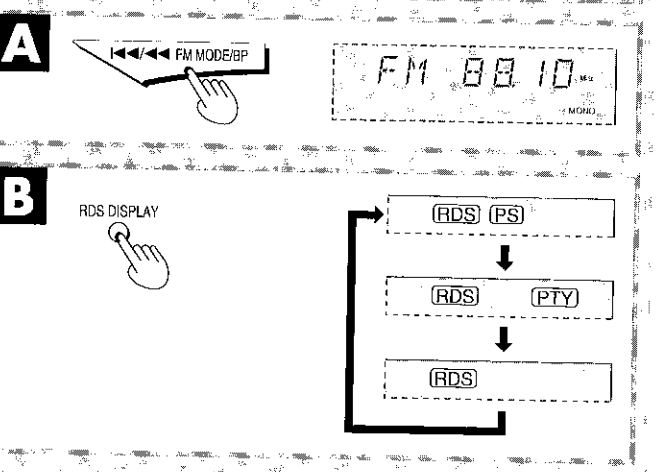
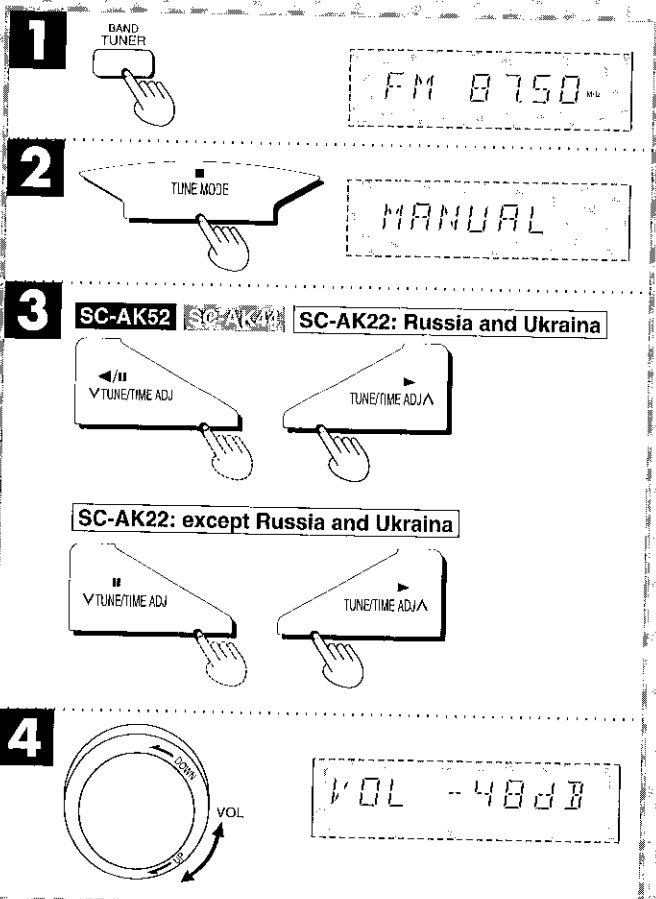
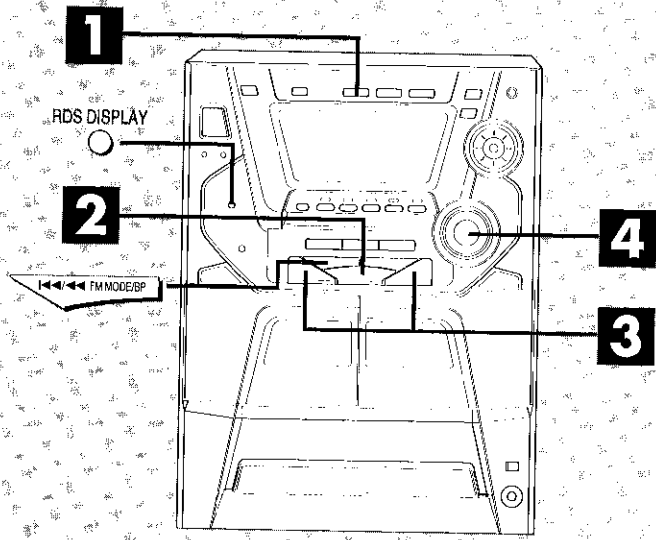

Listening to radio broadcasts

- 1** Press [TUNER, BAND] to select band.
The unit comes on automatically.
Every time you press the button:
FM ↔ AM
- 2** Press [■, TUNE MODE] to select "MANUAL".
Every time you press the button:
MANUAL ↔ PRESET.
- 3** Press [TUNE/TIME ADJ (V) or (Λ)] to select the frequency of the required station.
"TUNED" is displayed when a radio station is tuned.
"STEREO" ("ST" for SC-AK22) is displayed when a stereo FM broadcast is being received.
- 4** Adjust the volume.

Auto tuning

Press and hold [TUNE/TIME ADJ (V) or (Λ)] for a moment until the frequency starts changing rapidly. The unit begins auto tuning, stopping when it finds a station.

- Auto tuning may not function when there is excessive interference.
- To cancel auto tuning, press [TUNE/TIME ADJ (V) or (Λ)] once again.

A If noise is excessive in FM

Press [◀◀/▶▶ FM MODE/BP] to display "MONO". This mode improves sound quality if reception is weak, but broadcasts will be heard in monaural.
Press [◀◀/▶▶ FM MODE/BP] again to cancel the mode. "MONO" goes out. MONO is also canceled if the frequency is changed.
Turn off "MONO" for normal listening. Stereo and monaural broadcasts are automatically played as they are received.

B (Only for United Kingdom and Europe) RDS broadcasting

This unit can display the text data transmitted by the radio data system (RDS) available in some areas.

If the station you are listening to is transmitting RDS signals, "RDS" will light up on the display.

Displaying the name of a broadcasting station or a program type

Press [RDS DISPLAY].
Every time you press the button:

Frequency display → Station Name (PS) → Program type (PTY)

Program type displays			
NEWS	VARIED	FINANCE	COUNTRY
AFFAIRS	POP M	CHILDREN	NATIONAL
INFO	ROCK M	SOCIAL A	OLDIES
SPORTS	M.O.R M*	RELIGION	FOLK M
EDUCATE	LIGHT M	PHONE IN	DOCUMENT
DRAMA	CLASSICS	TRAVEL	TEST
CULTURE	OTHER M	LEISURE	ALARM
SCIENCE	WEATHER	JAZZ	

Note

- RDS displays may not be available if reception is poor.
- *"M.O.R M"="Middle of the road music"
- Sound is momentarily interrupted if you load/unload tapes while listening to an AM broadcast.

Presetting radio broadcasts

There are two methods of presetting stations.

Automatic presetting : All the stations the tuner can receive are preset.

Manual presetting : You can select the stations to preset and the order they are preset in.

Up to 12 stations each can be set in the FM and AM bands.

A Automatic presetting

Do the following once each for FM and AM.

Preparation:

- Tune to the frequency where presetting is to begin (→ page 12).

Press and hold [MEMORY ►►►►].

Release the button when frequency begins to change.

The tuner presets all the stations it can receive into the channels in ascending order. When finished, the last station memorized is tuned in.

Manual presetting

Preset the stations one at a time.

- 1 Press [TUNER, BAND] to select the "FM" or "AM".
- 2 Press [MEMORY ►►►►] then press [TUNE/TIME ADJ (V) or (^)] to tune to the required station.
- 3 Press [MEMORY ►►►►] then press [TUNE/TIME ADJ (V) or (^)] to tune to select a channel.
- 4 Press [MEMORY ►►►►].

The station occupying a channel is erased if another station is preset in that channel.

B Selecting channels

by remote control

- 1 Press [TUNER] to select "FM" or "AM".
The unit comes on automatically.
Every time you press the button:
FM ↔ AM

- 2 Press the numbered buttons to select the channel.
• To select channel 10 or over
Press [≥10] then the two digits.

- 3 Adjust the volume.

On the main unit

- 1 Press [TUNER, BAND] to select "FM" or "AM".
- 2 Press [PRESET] to select "PRESET".
- 3 Press [TUNE/TIME ADJ (V) or (^)] to select the preset channel.

A

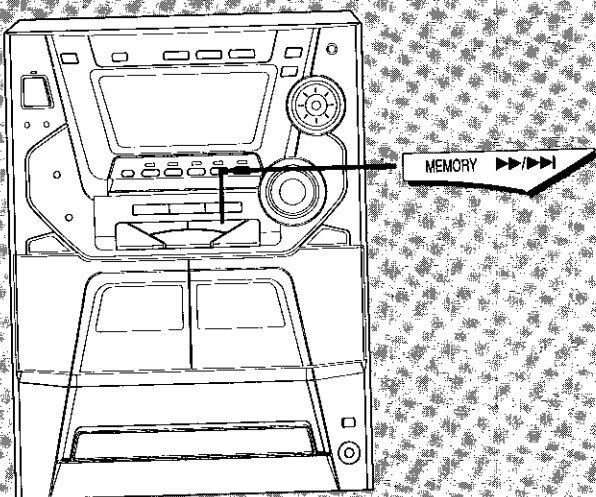

B

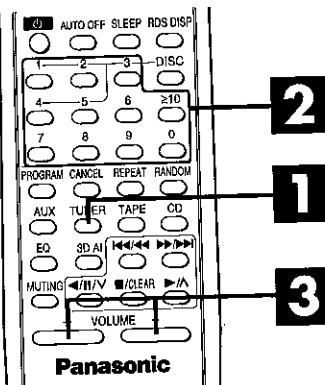

1

TUNER



2

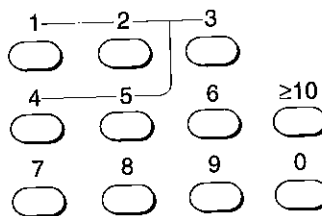

Preset channel



3

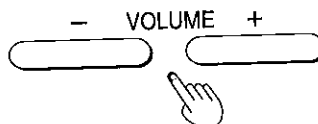

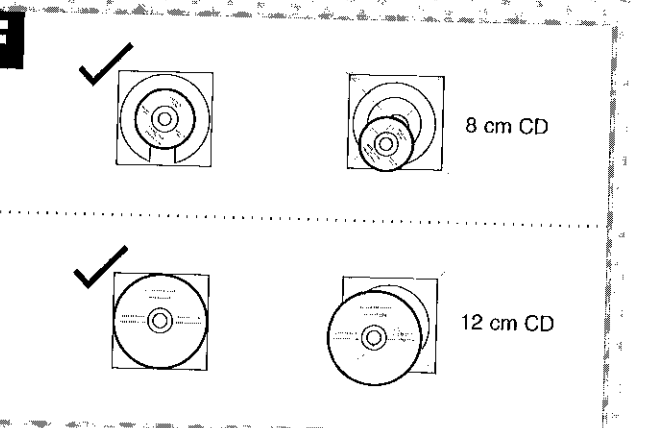
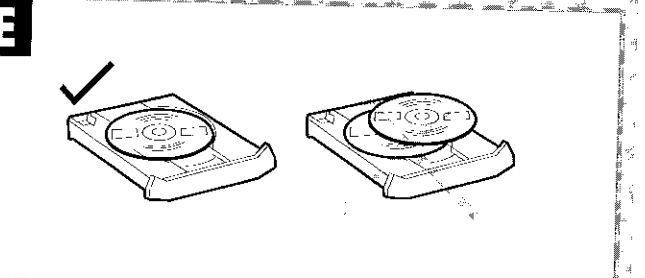
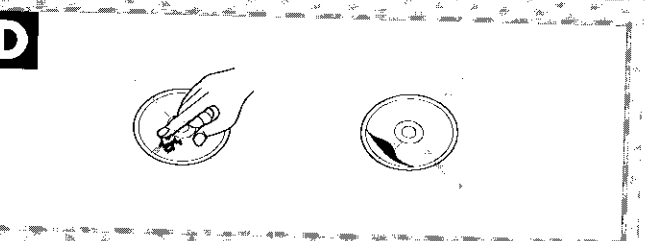
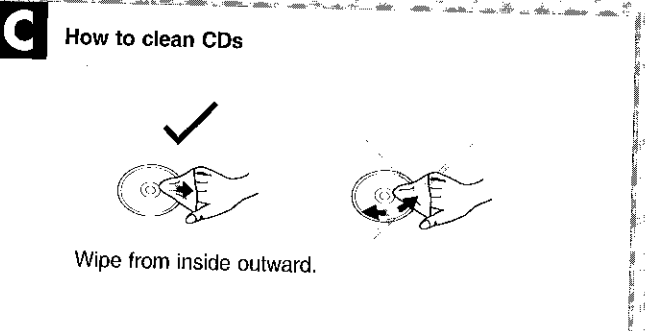
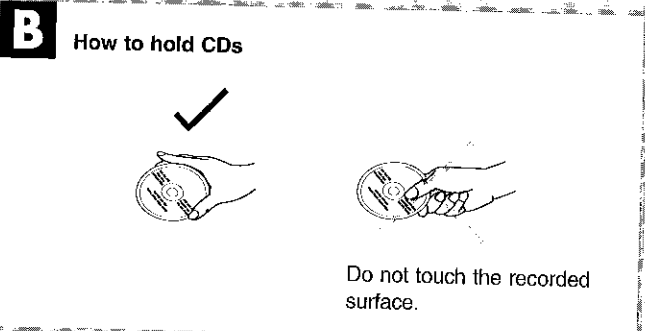
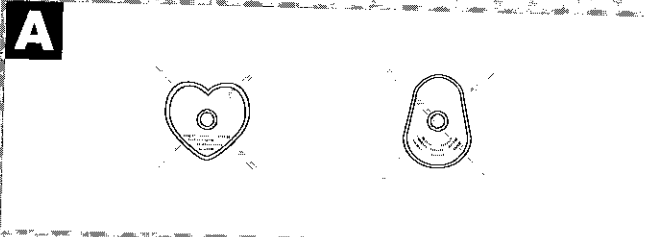

Concerning compact discs

With this system, you can only play compact discs having this mark.



A However, do not use irregular shaped CDs. CDs of the sort can damage the unit.

B ~ D Handling precautions

- If you are taking the disc from a cold to a warm environment, moisture may form on the disc. Wipe this off with a soft, dry, lint-free cloth before using the disc.
- Do not write on the label side with a ball-point pen or other writing instrument.
- Do not use record cleaning sprays, benzene, thinner, static electricity prevention liquids or any other solvent.
- Do not attach labels or stickers to CDs. (Do not use CDs with exposed adhesive from tape or left over peeled off stickers.)
- Do not use scratch-proof protectors or covers other than those specified for use with this system.
- Do not use CDs printed with label printers available on the market.

Storage precautions

Be sure to store discs in their cases to protect them from dust, scratches, and warping.

Do not place or store discs in the following places

- Locations exposed to direct sunlight
- Humid or dusty locations
- Locations directly exposed to a heat vent or heating appliance
- In the glove compartment or on the rear deck of an automobile

To prevent damage

Always observe the following points.

- **E** Load only 1 CD on the tray.
- **F** Load CDs as shown in the figure. The adapter is not needed with 8 cm CDs (singles).
- Set the system on a flat, level surface. Do not set it on top of magazines, inclined surfaces, etc.
- Do not move the system while tray is opening/closing, or when loaded. Always unload all CDs before moving the system.
- Do not put anything except CD in tray.
- Do not use cleaning CDs or CDs which are badly warped or cracked.
- Do not disconnect the power cord from the household AC outlet during disc changing operation.

Listening to compact discs

This unit can play CD-DA format audio CD-R and CD-RW that have been finalized* upon completion of recording. It may not be able to play some CD-R or CD-RW due to the condition of the recording.

* Finalizing is a process that enables CD-R/CD-RW players to play audio CD-R and CD-RW.

- 1** Press [**▲**, OPEN/CLOSE] button.
The unit will come on automatically and the tray opens.
- 2** Set CD in the tray.
To continue loading CDs in the other trays
Press another [(CD 1) ~ (CD 5)] to select the required tray and press [**▲**, OPEN/CLOSE] to open the tray.
The current tray closes and the selected tray automatically opens.
Press [**▲**, OPEN/CLOSE] to close the tray.
- 3** Press [(CD 1) ~ (CD 5)] to play your desired disc.
(If the desired CD is indicated on the display panel, the same operation can be accomplished by pressing [**▶**].)
Play will start from the first track on the disc and will continue until the last track of the final disc is played (see below).
- 4** Adjust the volume.

SC-AK52

SC-AK44

SC-AK22:
Russia and
Ukraine

SC-AK22:
except
Russia and
Ukraine

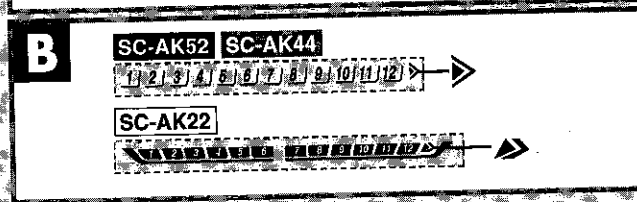
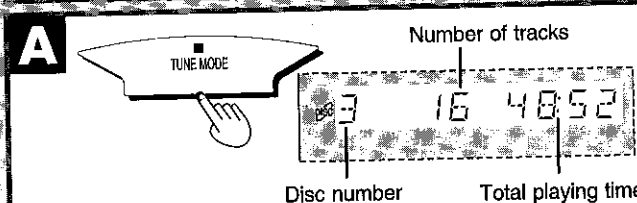
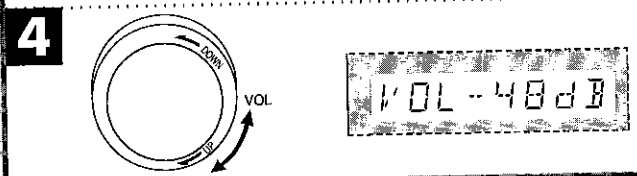
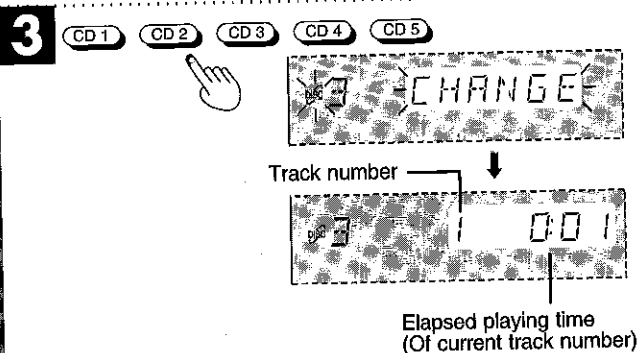
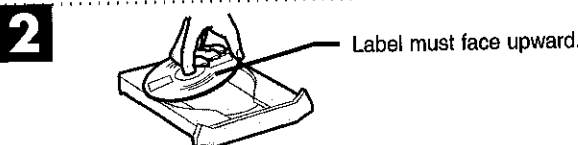
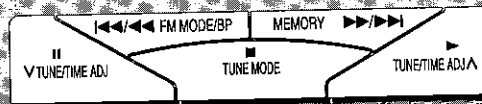
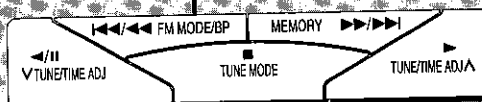
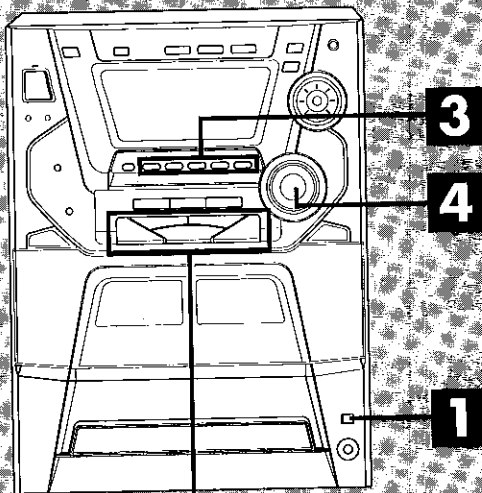

A To stop the disc play

Press [**■**].

B When "≥" appears on the display

It indicates there are 13 or more tracks on the disc in the playing position.

Disc indicators

The disc indicators light whenever the tray is in the playing position whether it is loaded or not.

What is meant by "final disc"?

For example, if play starts from disc 4, disc 3 will be the "final disc".

Order of progression:

Disc 4→5→1→2→3

One touch play

If the unit is in standby mode and a CD is loaded, press [CD] or [(CD 1) ~ (CD 5)].

The unit will come on automatically and play will start.

To pause	(For SC-AK52, SC-AK44 and SC-AK22: Russia and Ukraine) Press [⏸] during playback. To resume playback, press [▶]. (For SC-AK22: except Russia and Ukraine) Press [⏸] during playback. To resume playback, press [▶].
To search forward/backward	Hold down [⏮] (backward) or [⏭] (forward) during playback or pause mode.
To skip forward/backward	Press [⏪] (backward) or [⏩] (forward) during playback or pause mode.

Notes

- During random play (→ page 16), you cannot skip to tracks which have already been played.
- During program play (→ page 17) or random play, you can search forward or backward only within the current track.
- During program play, skipping is always in the programmed order, whether forward or backward.
- Always stop the changer before loading or changing CDs. You cannot change CDs while a disc is playing.

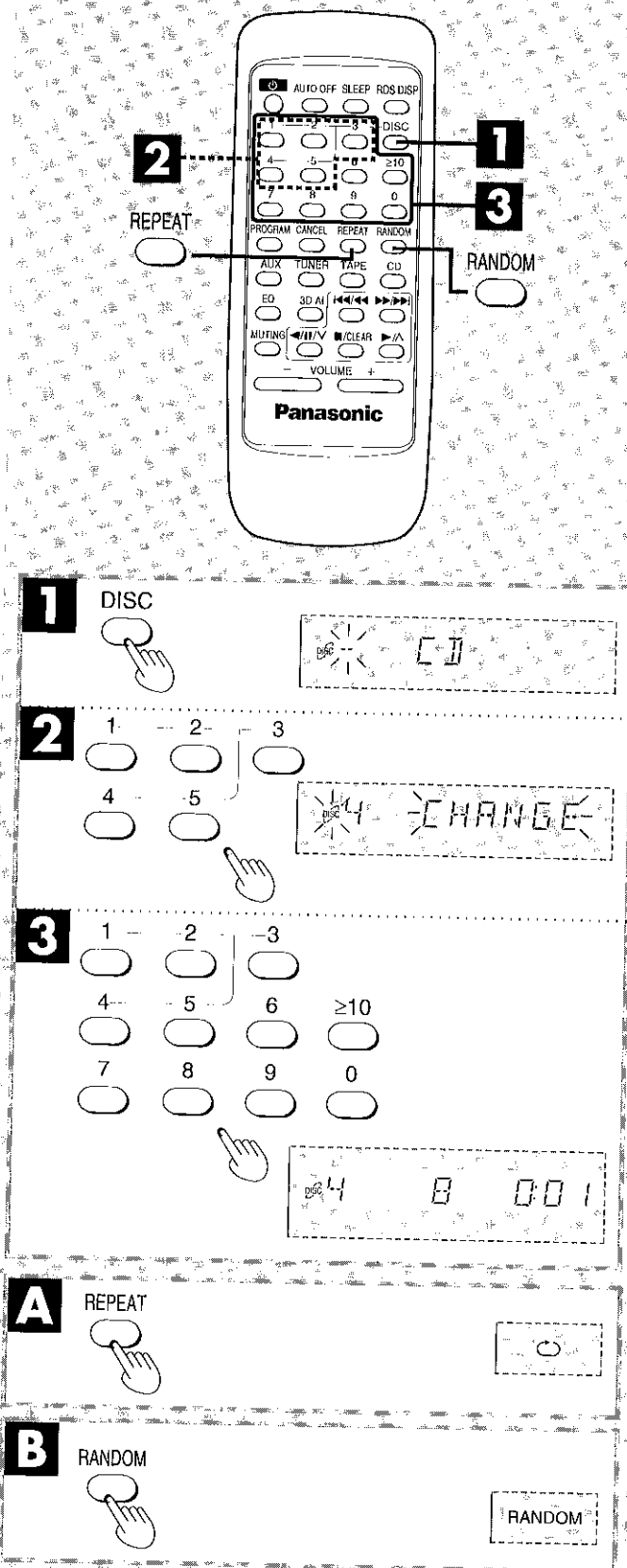

Listening to compact discs

Direct access play

by remote control only

- 1** Press [DISC].
- 2** (within 10 seconds or so)
Press [1] – [5] to select the disc you want.
- 3** Press the numeric button to select the desired track number.
The CD will be played from the selected track to the last track of the final disc (→ page 15).

To select a two-digit track

Press [≥10] and then the two numbers you want within 10 seconds or so.

For example

Track no. 20: [≥10] → [2] → [0]

Track no. 35: [≥10] → [3] → [5]

Repeat play

by remote control only

- A** Press [REPEAT] before or during play.
All tracks on the loaded CDs are repeated.

To cancel repeat play

Press [REPEAT] once again.

To repeat your favorite tracks

1. Program the tracks you want (perform steps **1** ~ **6** on page 17).
2. Press [REPEAT] and make sure "C" is displayed.
3. Press [▶/▲]. Playback will start.

To repeat just one track

Set the 1-TRACK mode (→ page 18), press [REPEAT] before or during playback, and make sure "C" is displayed.

Random play

by remote control only

- B** Press [RANDOM].

Every time you press the button:

1-DISC → ALL-DISC
 ↑ Previous display ↓

To random play just one disc

Select the CD you want to random play with [(CD 1) ~ (CD 5)] and press [RANDOM] to select "1-DISC".

To random play all the loaded CDs

Press [RANDOM] to select "ALL-DISC".

All tracks on the CD(s) will be played in random order. Playback will stop automatically when all tracks have been played.

To cancel random play

Press [RANDOM] to clear "RANDOM" display.

Note

You can use random play with your program. Only the programmed tracks will be played, but in random order.

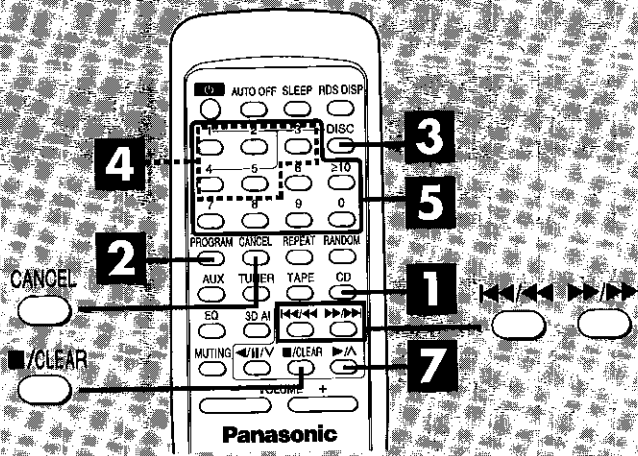

Program play

by remote control only

You can program up to 24 tracks.

- 1** Press [CD].
Ensure CD is stopped.
- 2** Press [PROGRAM].
- 3** Press [DISC].
- 4** (within 10 seconds or so)
Press [1] - [5] to select the disc you want.
- 5** Press the numeric button to select the desired track.
- 6** Repeat steps **3** through **5** until you have programmed all the tracks you want.
- 7** Press [▶/▲].
Play will start in the programmed sequence.

To cancel program play mode

Press [PROGRAM] in the stop mode.

Programmed contents will be saved in memory.

Pressing [■/CLEAR] will cancel program play, but it will also erase the entire program.

To select a two-digit track

Press [≥10] and then the two numbers you want.

A When "CD FULL" appears

The number of programmed tracks is limited to 24. No further tracks can be programmed.

B You can do the following during program mode

- Check program contents.
Press [◀◀/▶▶] or [▶▶/▶▶].
Every time you press one of the buttons, the track and program No. are shown on the display.
- Add to the program.
Repeat steps **3** through **5**.
- Cancel entries.

From the last programmed track	Press [CANCEL].
A specified track only	Select the track with [◀◀/▶▶] or [▶▶/▶▶], and press [CANCEL] within 3 seconds.
All tracks	Press [■/CLEAR].

Memory retention

Your program is retained in memory for about 2 weeks while the system is unplugged.

To replay your program

If you turned OFF your program with [PROGRAM], you can play it again as explained below.

1. Press [PROGRAM].
2. Press [▶/▲].

If you program a track not on your CDs

The track is initially programmed, but during program play, the player will skip that track and will continue playing from the next programmed item.

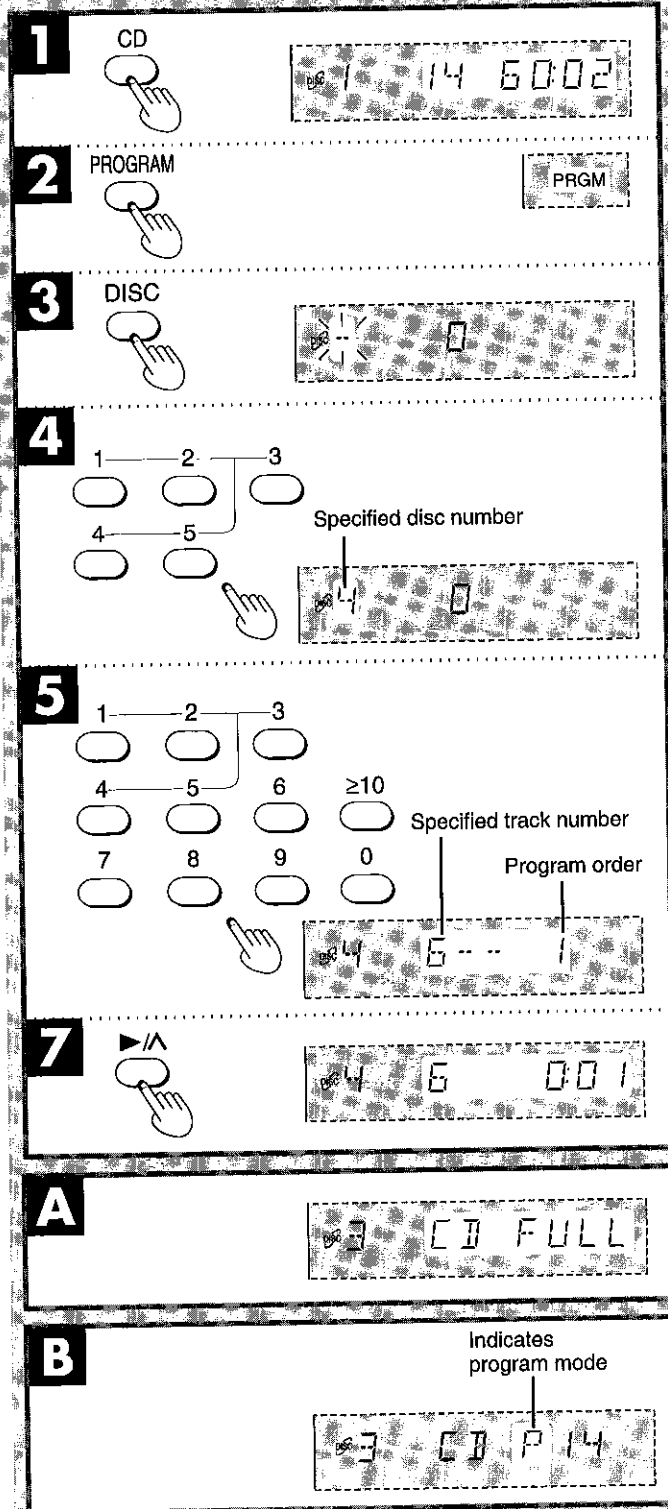

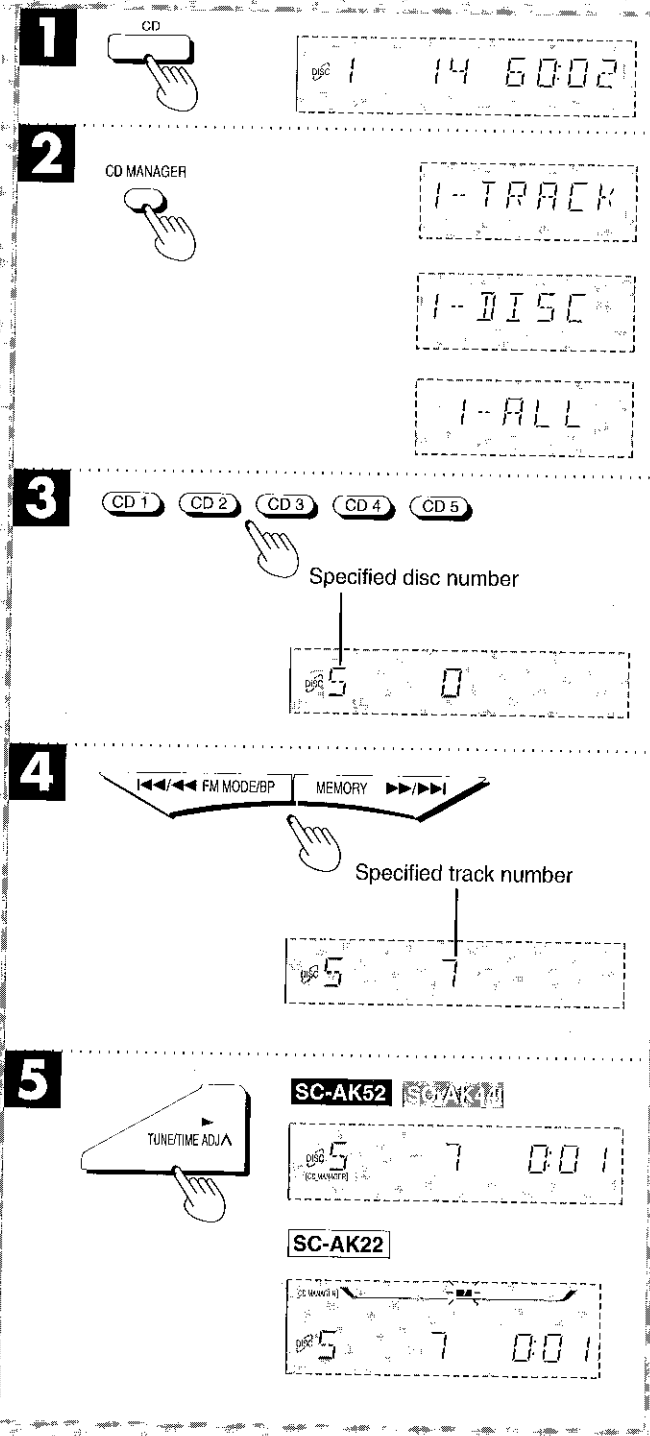
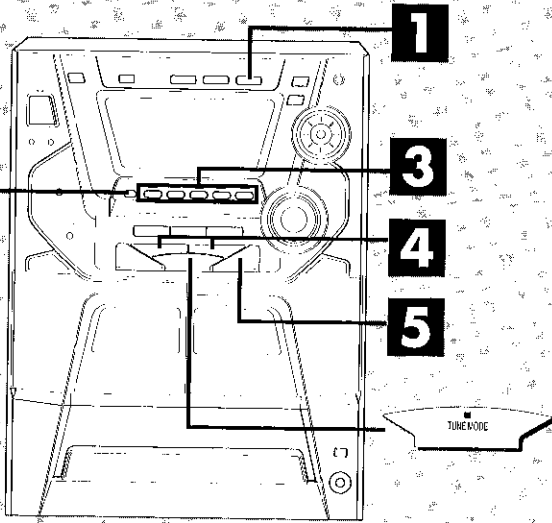

Listening to compact discs

To listen to special CDs and tracks (CD Manager function)

This function makes it easier for you to select special CDs and tracks from amongst those loaded in the player.

You can use this function to make recordings as well.

There are 3 CD/track selection modes.

- For playing back 1 track only from all loaded CDs
1-Track mode (1-TRACK)
- For playing back 1 CD only from all loaded CDs
1-Disc mode (1-DISC)
- For playing back 1 track on all loaded CDs
1-Track All-Disc mode (1-ALL)

1 Press [CD].
Ensure CD is stopped.

2 Press [CD MANAGER] to select the desired mode.
Every time you press the button:

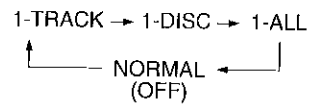

- 1-TRACK: Only one particular track is played.
 - 1-DISC: The tracks on only one particular disc are played.
 - 1-ALL: The same track numbers on each of the CDs are played in succession.
- (NORMAL: The original display is restored in about 3 seconds.)

3 Press [(CD 1) ~ (CD 5)] to select the disc you want.
Note
This step is not required if 1-ALL was selected in step 2.

4 Press [◀◀/▶▶] or [▶▶/▶▶] to select the desired track.
Note
This step is not required if 1-DISC was selected in step 2.

5 Press [▶].
The selected track will start.

To stop play
Press [■].

When playback ends
"NORMAL" will appear on the display for about 3 seconds, then the CD MANAGER function will turn OFF automatically.

During play in the 1-ALL mode:

- It is not possible to skip back to a CD whose track has already been played.
- If a CD does not have the designated track number, it is skipped and play continues.

Notes

- You can use the CD Manager function together with repeat play.
- CD Manager function will be canceled when you press the [RANDOM] button.

Listening to tapes

You can use either deck 1 or deck 2 for tape playback.

SC-AK52 SC-AK44 SC-AK22: Russia and Ukraina

The unit can play normal, high and metal position tapes. It identifies the type automatically.

SC-AK22: except Russia and Ukraina

Use normal position tapes.

High position and metal position tapes can be played, but the unit will not be able to do full justice to the characteristics of these tapes.

1 Press [TAPE, DECK 1/2].

The unit will come on automatically.

If the unit was off and a cassette was loaded, play will start automatically (One touch play function).

2 Press [▲ DECK 1 OPEN] or [▲ DECK 2 OPEN] and insert the tape.

Insert the tape with the exposed tape facing down. Close the holder by hand.

3 **SC-AK52, SC-AK44 and SC-AK22: Russia and Ukraina only**
Press [REV MODE] to select the reverse mode.

Every time you press the button:

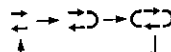

→ : One side is played.

↔ : Both sides are played.

↻ : Both sides are played 8 times each.

To listen to 2 tapes consecutively

Load a tape into each deck and select "↻". Both tapes will be played 8 times each.

4 **SC-AK52 SC-AK44 SC-AK22: Russia and Ukraina**

Press [◀/II] or [▶] to start playback.

[▶] : The forward side (front side) will play.

[◀/II] : The reverse side will play.

SC-AK22: except Russia and Ukraina

Press [▶] to start playback.

One side is played, then playback stops automatically.

To play on the other side of the tape, turn the tape over and press [▶].

5 Adjust the volume.

To stop tape playback

Press [■].

A To change the deck to be used

Press [TAPE, DECK 1/2] to select the deck you want to use when you load cassettes into both decks.

Notes

- Playback is momentarily interrupted while playing back tapes, if you open the other deck.
- Tapes exceeding 100 minutes are thin and can break or get caught in the mechanism.
- Tape slack can get caught up in the mechanism and should be taken up before the tape is played.

SC-AK52 SC-AK44 SC-AK22: Russia and Ukraina

Endless tapes can get caught up in the deck's moving parts if used incorrectly. Use tapes appropriate to this unit's auto-reverse mechanism.

SC-AK22: except Russia and Ukraina

Failure to operate these tapes correctly may cause the tape to wind around the revolving parts. Always read the instructions provided with your tapes.

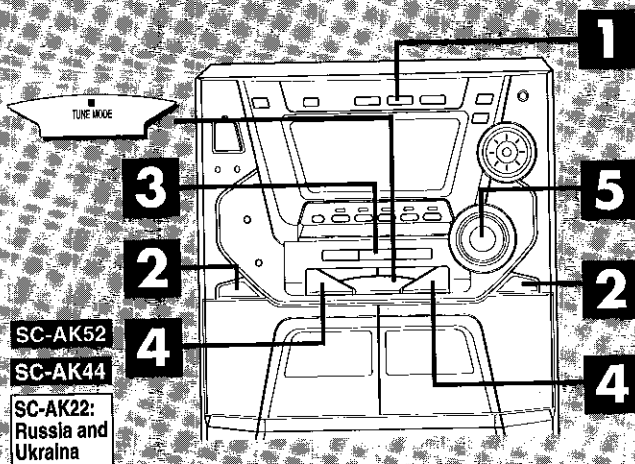

SC-AK52
SC-AK44
SC-AK22:
Russia and
Ukraina

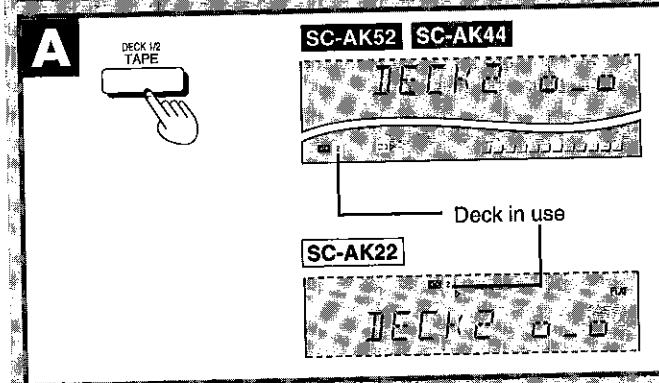
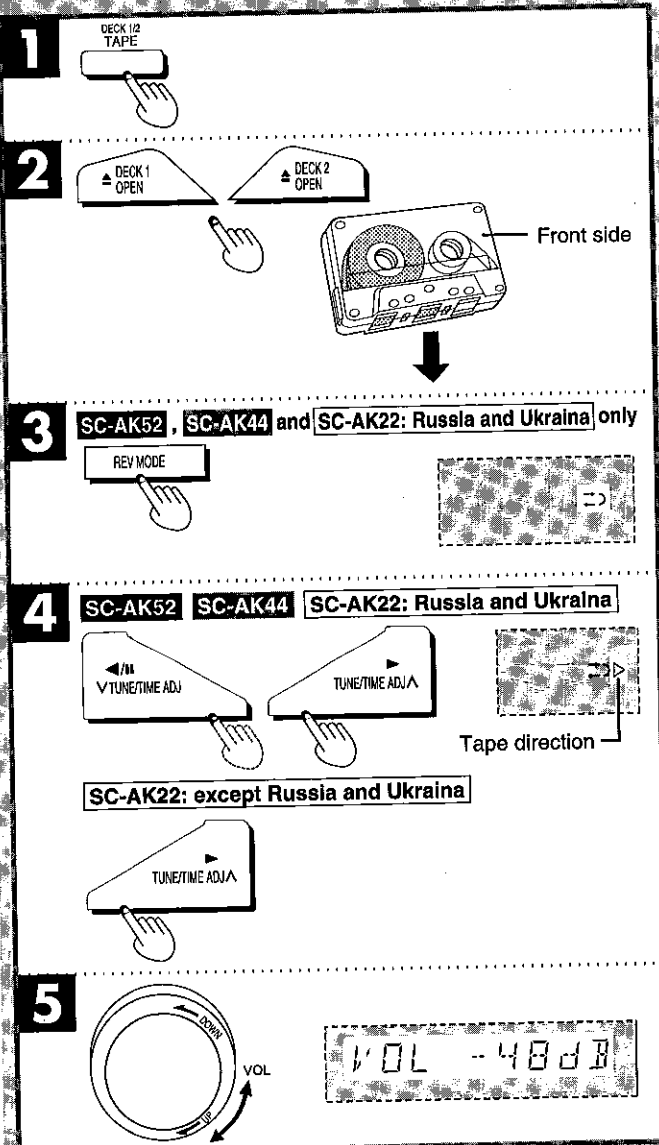

A

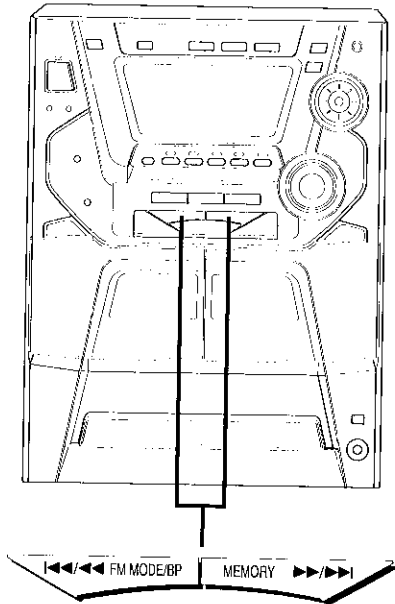

B

To protect tapes against further recording

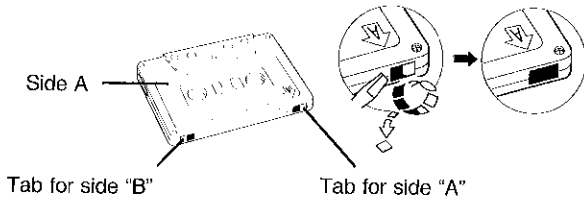

To re-record

SC-AK52, **SC-AK44** and **SC-AK22: Russia and Ukraine** only

Normal position tape

Hi-position tape

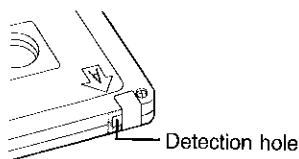
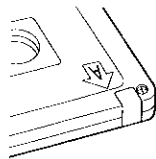

C

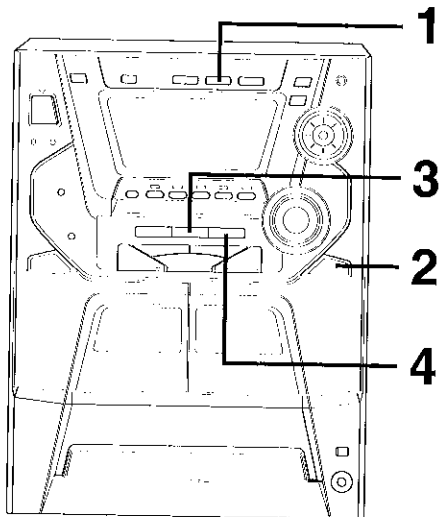

Listening to tapes

A To fast-forward or rewind the tape

Press [**◀◀/▶▶**] or [**▶▶/▶▶**] in the stop mode.

SC-AK52, **SC-AK44** **SC-AK22: Russia and Ukraine**

Tape direction	To rewind	To fast-forward
"▶"	[◀◀/▶▶]	[▶▶/▶▶]
"◀"	[▶▶/▶▶]	[◀◀/▶▶]

SC-AK22: except Russia and Ukraine

To rewind	To fast-forward
[◀◀/▶▶]	[▶▶/▶▶]

A To find the beginning of a program (TPS: Tape Program Sensor)

TPS finds the beginning of a track and resumes play from there. Each press increases the number of tracks skipped, up to a maximum of 9.

Press [**◀◀/▶▶**] or [**▶▶/▶▶**] during play.

Note

- TPS may not operate correctly in the following situations:
If the interval between tracks is less than 4 seconds.
If there is noise between tracks.
If there are silent parts within tracks.

Before recording (Deck 2 only)

Your attention is drawn to the fact that recording pre-recorded tapes or discs or other published or broadcast material may infringe copyright laws.

Types of tapes which can be recorded correctly

SC-AK52, **SC-AK44** **SC-AK22: Russia and Ukraine**

Use normal and high position tapes. Metal position tapes can be used, but the unit will not be able to record or erase them correctly. The unit automatically identifies the type of tape.

SC-AK22: except Russia and Ukraine

Use normal position tapes. High position and metal position tapes can be used, but this unit will not be able to record or erase them correctly.

B Erasure prevention

The illustration shows how to remove the tabs to prevent recording. To record on the tape again, cover as shown, being careful not to cover the high position discrimination hole.

How volume, sound quality/field affect recording

The tape you are recording is not affected whatsoever by changes in volume, sound quality/field.

C To erase a recorded sound

1. Press [TAPE, DECK 1/2].
2. Insert the recorded tape into deck 2.
3. **SC-AK52**, **SC-AK44** and **SC-AK22: Russia and Ukraine** only
Press [REV MODE] to select reverse mode.
4. Press [● REC/STOP].

Notes

- You cannot open deck 1 while recording.
- You cannot fast-forward or rewind one deck while recording with the other.

Tape-to-tape recording

The recording level will be recorded as it is on the tape being played back.

1 Press [TAPE, DECK 1/2].

2 Press [▲ OPEN] on both decks and insert the tapes.
 For playback: Into deck 1
 For recording: Into deck 2
 Close the holders by hand.

3 **SC-AK52, SC-AK44** and **SC-AK22: Russia and Ukraine only**
 Press [REV MODE] to select the reverse mode.

Every time you press the button:

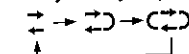

→ : One side records only.

↔ : Both sides record (front → reverse).

“↔” automatically changes to “↔” when [TAPE EDIT] is pressed.

4 Press [TAPE EDIT] to start recording.

To stop recording

Press [■].

Both decks will stop.

To record from a specific point on a tape

Before recording, advance the tape to the point from where you want to start recording.

SC-AK52 SC-AK44 SC-AK22: Russia and Ukraine

To start recording on the reverse side

Load a tape and change the tape direction as follows:

1. Press [TAPE, DECK 1/2] and select tape deck 2.

2. Press [◀/II] and immediately thereafter [■]. The tape direction will be shown as “<”.

SC-AK22: except Russia and Ukraine

To record on the other side of the tape

Turn the tape over and press [TAPE EDIT].

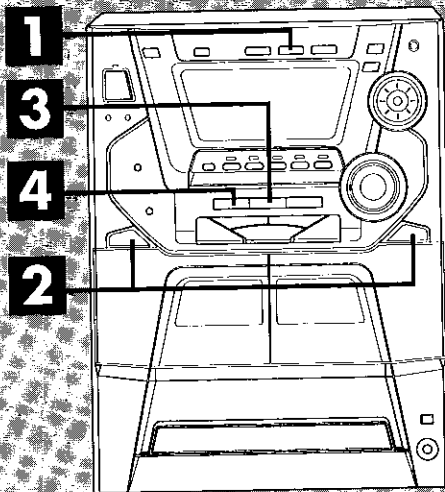

1 DECK 1/2 TAPE

2 DECK 1 OPEN DECK 2 OPEN

SC-AK52 SC-AK44

SC-AK22

3 **SC-AK52, SC-AK44** and **SC-AK22: Russia and Ukraine only**

REV MODE

4 TAPE EDIT

SC-AK52 SC-AK44

Tape direction of the tape you are recording onto

SC-AK22

Recording from radio broadcasts

Wind up the leader tape so recording can begin immediately.

- 1 Press [▲ DECK 2 OPEN] and insert the tape. Close the holder by hand.

- 2 **SC-AK52**, **SC-AK41** and **SC-AK22: Russia and Ukraine** only
Press [REV MODE] to select the reverse mode. Every time you press the button:

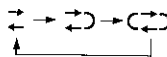

- : One side, only, records.
- ↔ : Both sides record (front side → reverse side).
- ← : "↔" automatically changes to "←" when [● REC/STOP] is pressed.

- 3 Select a radio station. Perform steps 1 through 3 on page 12.

- 4 Press [● REC/STOP] to start recording.

To stop recording

Press [● REC/STOP] again. Recording can also be stopped by pressing [■].

To record from a specific point on a tape

Before recording, advance the tape to the point from where you want to start recording.

To cut an unnecessary part while recording

1. Press [● REC/STOP] during the unnecessary part. The cassette deck will go into the stop mode.
2. Press [● REC/STOP] to resume recording again. Recording will continue in the same direction as before.

SC-AK52, **SC-AK41**, **SC-AK22: Russia and Ukraine**

To start recording on the reverse side

Load a tape and change the tape direction as follows:

1. Press [TAPE, DECK 1/2] and select tape deck 2.
2. Press [◀/||] and immediately thereafter [■]. The tape direction will be shown as "◀".

SC-AK22: except Russia and Ukraine

To record on the other side of the tape

Turn the tape over and press [● REC/STOP].

Note

When recording an AM broadcast, sound is momentarily interrupted when you start and stop the recording.

A To reduce noise while AM recording (Beat proof function)

Press [◀◀/▶▶, FM MODE/BP] while recording.

Each time you press the button, "BP1" and "BP2" will be displayed alternately.

Select the position where there is less noise.

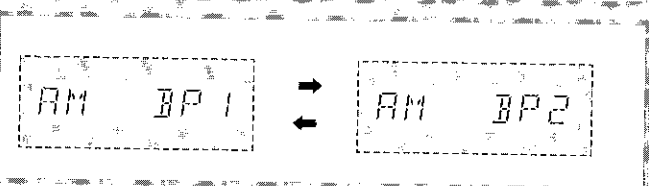
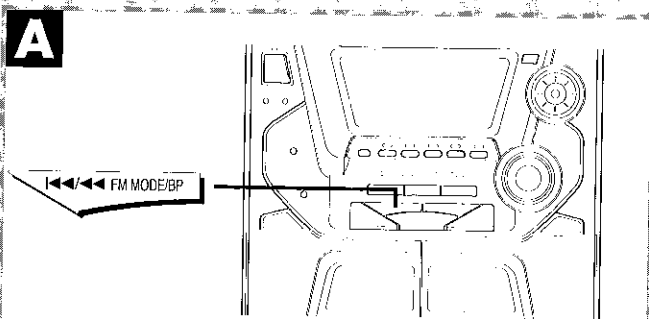
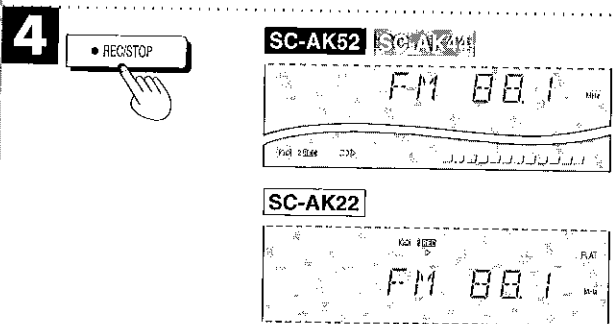
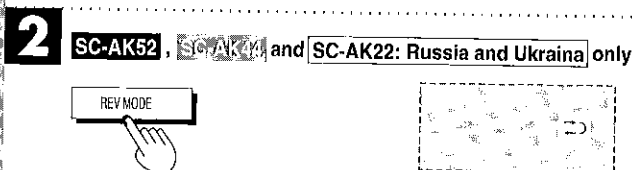
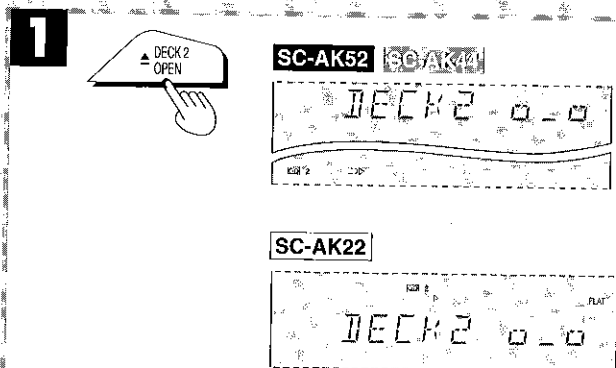
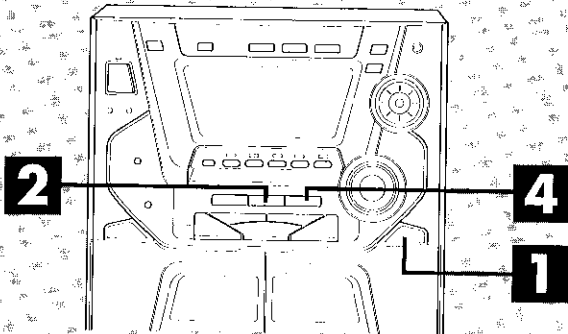

Recording from compact discs

Wind up the leader tape so recording can begin immediately.

1 Press [**▲** DECK 2 OPEN], and insert the tape. Close the holder by hand.

2 **SC-AK52**, **SC-AK44** and **SC-AK22: Russia and Ukraine** only
Press [**REV MODE**] to select the reverse mode. Every time you press the button:

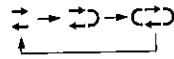

→ : One side only records.

↔, ↔ : Both sides (front → reverse) record.

“↔” automatically changes to “↔” when [**●** REC/STOP] is pressed.

3 Press [CD].

4 Insert CD in the tray.
(Perform steps **1** ~ **2** on page 15).

5 Press [(CD 1) ~ (CD 5)] to select the disc you want. Pressing [■] will stop playback.

6 Press [**●** REC/STOP] to start recording.

- The recording will proceed from the first track on the selected CD and will continue on through the last track of the final disc (page 15).
- The tape deck stops automatically when the CD is finished.

To stop recording

- To add a 4 second silent interval before stopping Press [■]. The CD will stop automatically too.
- To stop recording without a silent interval Press [**●** REC/STOP]. The CD will stop automatically too.

To record programmed tracks

1. After step **4**, program the track you want (perform steps **2** ~ **6** on page 17).
2. Press [**●** REC/STOP] to start recording.

SC-AK52 SC-AK44 SC-AK22: Russia and Ukraine

To start recording on the reverse side

Load a tape and change the tape direction as follows:

1. Press [TAPE, DECK 1/2] and select tape deck 2.
2. Press [◀/||] and immediately thereafter [■]. The tape direction will be shown as “◀”.

SC-AK22: except Russia and Ukraine

To record on the other side of the tape

Turn the tape over and press [**●** REC/STOP].

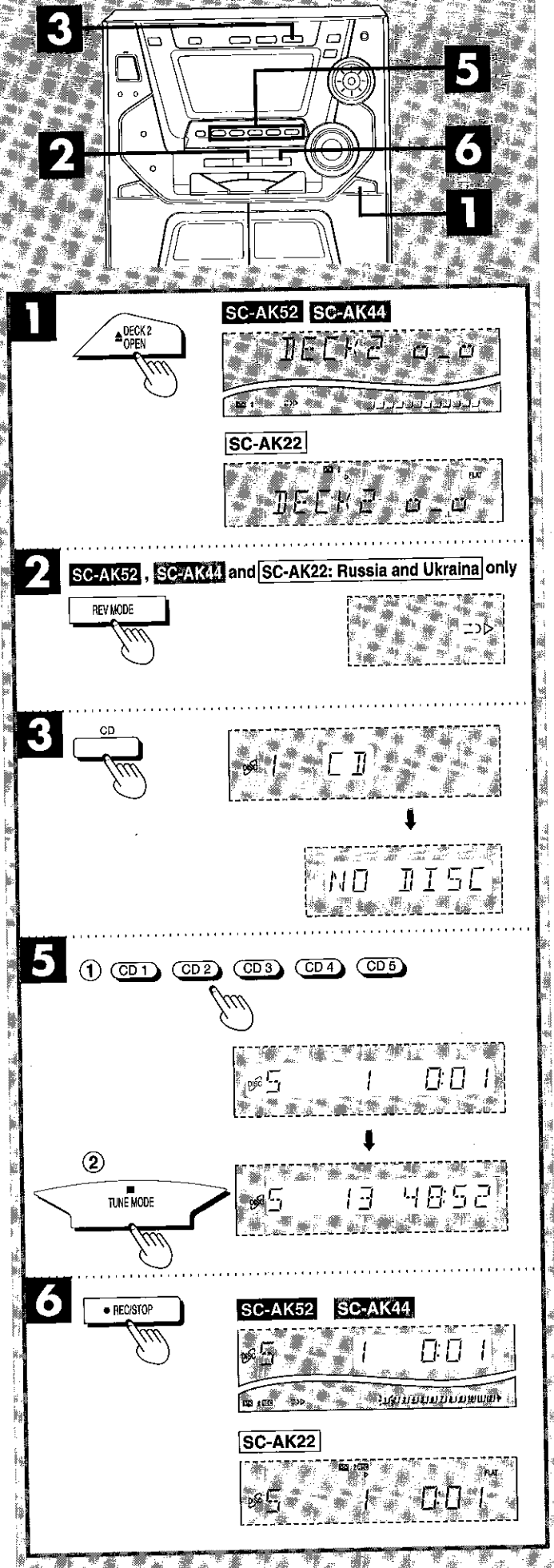

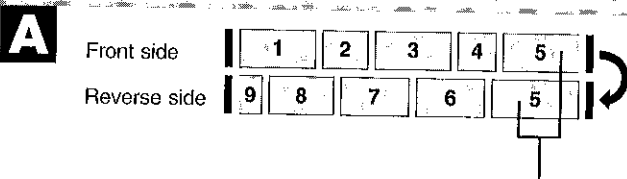
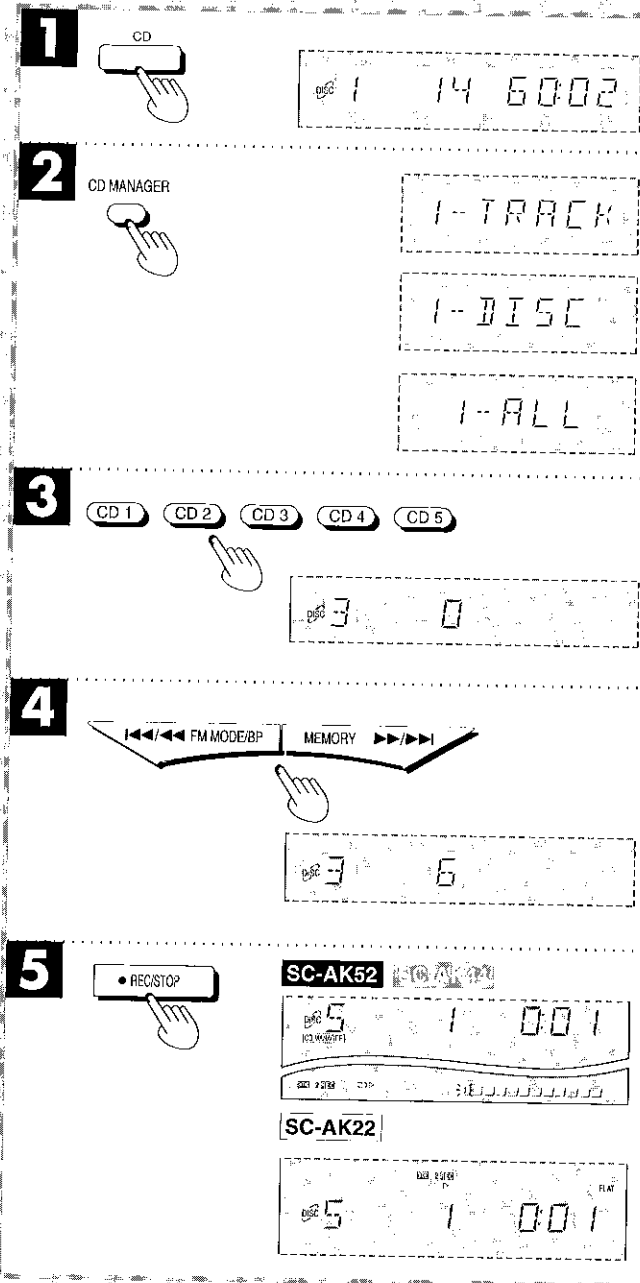
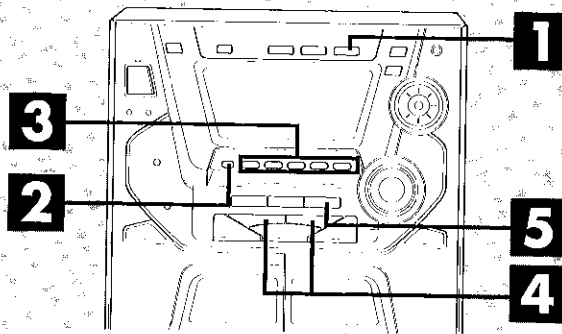

The interrupted track is re-recorded in its entirety on the reverse side.

Recording from compact discs

To record special CDs and tracks (CD Manager function)

This function makes it easier for you to select special CDs and tracks from amongst those loaded in the player.

Preparation

Press [▶] [DECK 2 OPEN] and insert the tape. Wind up the leader tape so recording can begin immediately.

1 Press [CD].

2 Press [CD MANAGER] to select the desired mode. Every time you press the button:

1-TRACK → 1-DISC → 1-ALL
 ↑ ↓
 NORMAL (OFF)

1-TRACK: Only one particular track is recorded.

1-DISC: The tracks on only one particular disc are recorded.

1-ALL: The same track numbers on each of the CDs are recorded in succession.

(NORMAL: The original display is restored in about 3 seconds.)

3 Press [(CD 1) ~ (CD 5)] to select the disc you want.

Note

This step is not required if 1-ALL was selected in step **2**.

4 Press [◀◀/▶▶] or [▶▶/▶▶] to select the desired track.

Note

This step is not required if 1-DISC was selected in step **2**.

5 Press [● REC/STOP] to start recording.

To stop recording

- To add a 4 second silent interval before stopping Press [■]. The CD will stop automatically too.
- To stop recording without a silent interval Press [● REC/STOP]. The CD will stop automatically too.

SC-AK52 SC-AK44 SC-AK22: Russia and Ukraina

- A** While recording, if a track is cut off in the middle at the end of the front side, it is re-recorded from the beginning, on the reverse side.
- At the end of the reverse side recording stops and the current track will be interrupted.

SC-AK22: except Russia and Ukraina

If the tape finishes before the CD

The CD continues playing. Press [■] to stop it. (CD Manager function will also be canceled.)

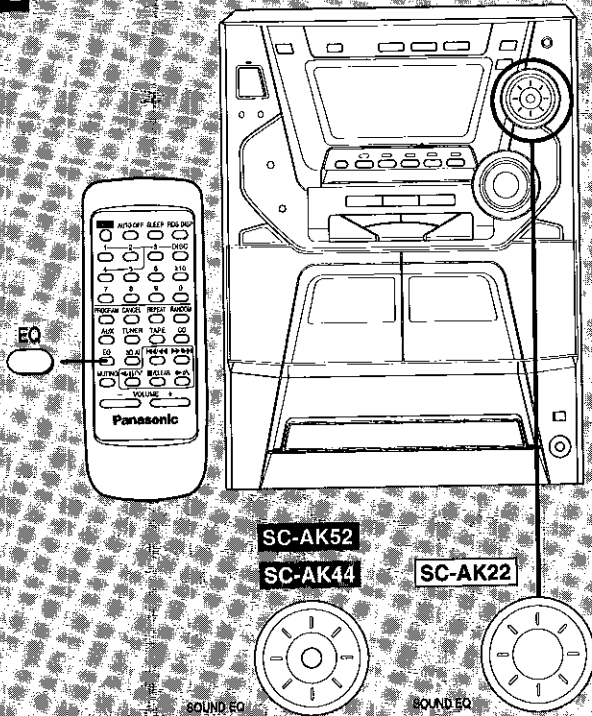
A**A Using the built-in sound quality/sound field settings**

Dial [SOUND EQ] to select the sound quality or sound field. When it is turned clockwise, the settings are selected in the following sequence.

- ① **HEAVY (sound quality)**
Select this when playing rock or other kinds of music that sound better with an added punch.
- ② **CLEAR (sound quality)**
Select this for jazz or other kinds of music for which clarity in the treble range is desired.
- ③ **SOFT (sound quality)**
Select this when listening to background music.
- ④ **DISCO (sound field)**
Select this to produce sound with the same kind of lengthy reverberations heard at a disco.
- ⑤ **LIVE (sound field)**
Select this to make vocals more alive.
- ⑥ **HALL (sound field)**
Select this to add an expansiveness to the sound to produce the atmosphere of a great concert hall.
- ⑦ **SC-AK52 and SC-AK44 only**
MANUAL (see page 26)
- ⑧ **SC-AK52 and SC-AK44 only**
AI-EQ (see page 26)

The original display is restored on the display panel in about 5 seconds.

To release the equalizer
Dial [SOUND EQ] to display "FLAT".

When using the remote control to perform the operations described above
Press [EQ].
Each time this button is pressed, the setting is changed in the sequence described above.

Note
All recordings are performed at the flat setting even if an alternative sound quality/sound field setting has been selected.

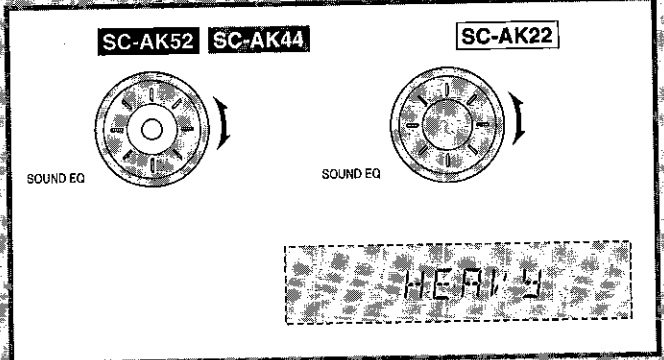
**B Enhancing the sound quality**

This feature enhances the bass and treble effect of the sound.

Press [SUPER SOUND EQ].
Press the button again to cancel.
The button light goes out.

B Boosting the super woofer

- SC-AK52 and SC-AK44 only**
Press [S.WOOFER].
- When listening to the sound through the speakers
MID (medium) → MAX (high) → Light off (OFF)
 - When listening to the sound through the headphones
Light on (ON) = Light off (OFF)

Note
You cannot record super woofer effect, but you can use it for playback sound.

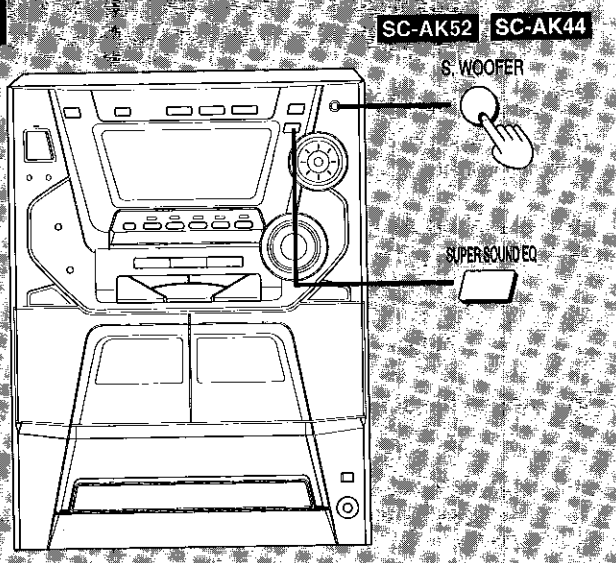
B
Sound quality/sound field operations

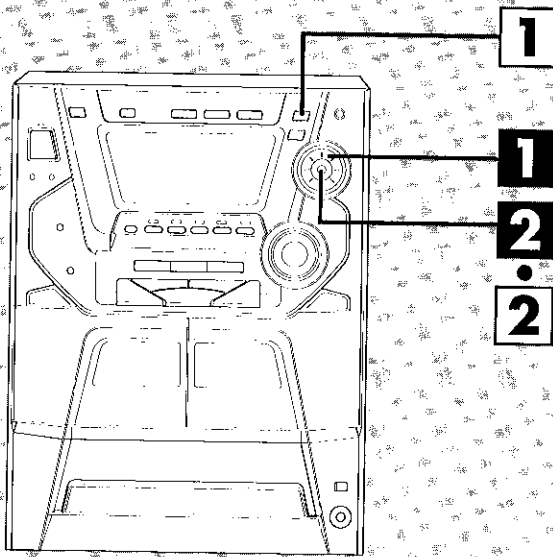

Varying the sound quality with the manual equalizer

SC-AK52 and **SC-AK44** only

- 1** Dial [SOUND EQ] to display "MANUAL".
When it is turned clockwise, the settings are selected in the following sequence.

- ① HEAVY
- ② CLEAR
- ③ SOFT
- ④ DISCO
- ⑤ LIVE
- ⑥ HALL
- ⑦ **MANUAL**
- ⑧ AI-EQ
- ⑨ FLAT

- 2** Adjust the sound quality.

- ① ← → direction: For selecting the range of the sound to be adjusted

Characteristics of each sound range

- Under 100 Hz: Super woofer range
- Around 330 Hz: Bass to midrange
- Around 1 kHz: Midrange
- Around 3.3 kHz: Midrange to treble
- Above 10 kHz: Treble

- ② ↓ ↑ direction: For adjusting the level (7 steps)
When the level is in the center, the dot flashes rapidly.

Repeat steps ① and ② to set the desired sound quality.
The original display is restored on the display panel in about 5 seconds.

To release the equalizer

Dial [SOUND EQ] to display "FLAT".

Notes

- The sound quality setting is stored automatically. It is recalled when "MANUAL" is next selected.
- All recordings are performed at the flat setting even if an alternative sound quality setting has been selected.

Varying the sound quality with the acoustic image (AI) equalizer

SC-AK52 and **SC-AK44** only

The AI equalizer uses the SOFT, SHARP, HEAVY and LIGHT sound quality coordinates to achieve subtle sound quality settings with ease.

- 1** Press [3D AI] to adjust the surround level.
Every time you press the button:

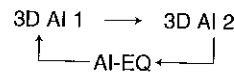

- 2** Adjust the sound quality.

- ① ← → direction: SOFT-SHARP setting

- ② ↓ ↑ direction: LIGHT-HEAVY setting

Repeat steps ① and ② to set the desired sound quality.

The original display is restored on the display panel in about 5 seconds.

To release the equalizer

Dial [SOUND EQ] to display "FLAT".

Notes

- The sound quality setting is stored automatically. It is recalled when "AI-EQ" is next selected.
- All recordings are performed at the flat setting even if an alternative sound quality setting has been selected.

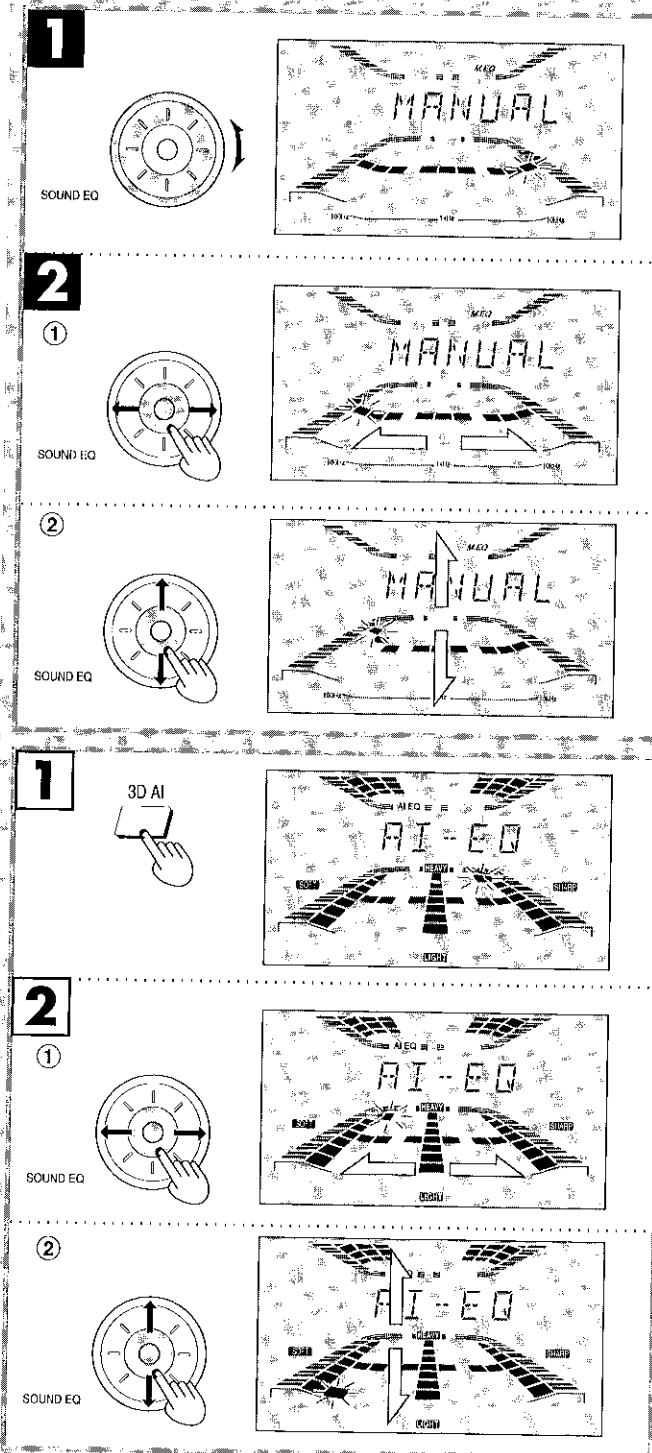

Using the timer

Using the play/record timer

The timer has two functions. It can be set to on at a certain time to wake you up, or it can be set to record the radio or from the aux source.

The play timer cannot be used in combination with the record timer.

Preparations

- Turn the unit on and set the clock (→ page 11).
- **For the play timer**, prepare the music source you want to listen to; tape, CD, radio or aux, and set the volume.
- **For the record timer**, check the cassette's erasure prevention tabs (→ page 20: **B**), insert the tape in deck 2, select the reverse mode (For SC-AK52, SC-AK44 and SC-AK22: Russia and Ukraina only) (→ page 22) and tune to the radio station (→ page 12) or select the aux source (→ page 29).

1 Press [CLOCK/TIMER] to select the timer function.

Every time you press the button:

CLOCK → \odot PLAY → \odot REC

← Previous display ←

\odot PLAY : to set the play timer

\odot REC : to set the record timer

Setting the start and finish times

2 ① (Within 8 seconds or so) Press [TUNE/TIME ADJ (V) or (^)] to select the starting time.

② Press [CLOCK/TIMER].

3 ① Press [TUNE/TIME ADJ (V) or (^)] to select the finishing time.

② Press [CLOCK/TIMER].

The start and finish times are now set.

Turning the timer on

4 Press [\odot PLAY/ \odot REC] to display the timer indicator.

Every time you press the button:

\odot PLAY → \odot REC

← (OFF) ←

\odot PLAY : to turn the play timer on

\odot REC : to turn the record timer on

(The indicator doesn't appear if the start and finish times or the clock haven't been set.)

5 Press [\odot /I] to turn the unit off.

The unit must be off for the timers to operate.

• For play timer

The timer play will start at the preset time with volume increasing gradually up to the volume level you preset.

• For record timer

The record timer comes on about 30 seconds earlier than the set time.

To cancel the timer

Press [\odot PLAY/ \odot REC] to clear the timer indicators from the display. (The timer comes on at the set time everyday if the timer is on.)

To change the settings (when unit is on)

• To change the play/record times

Do steps **1**, **2**, **3** and **5**.

• To change the source or volume

1. Press [\odot PLAY/ \odot REC] to clear the timer indicator from the display.
2. Make changes to the source or volume.
3. Do steps **4** to **5**.

(Continued on next page)

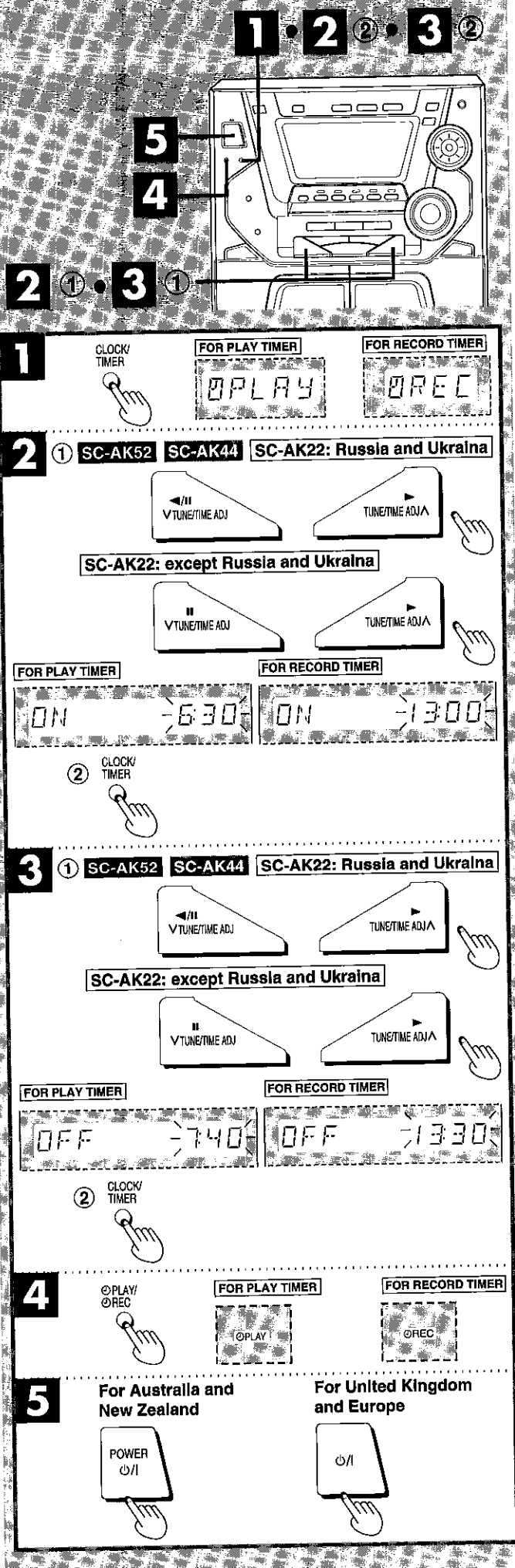

For Australia and New Zealand For United Kingdom and Europe

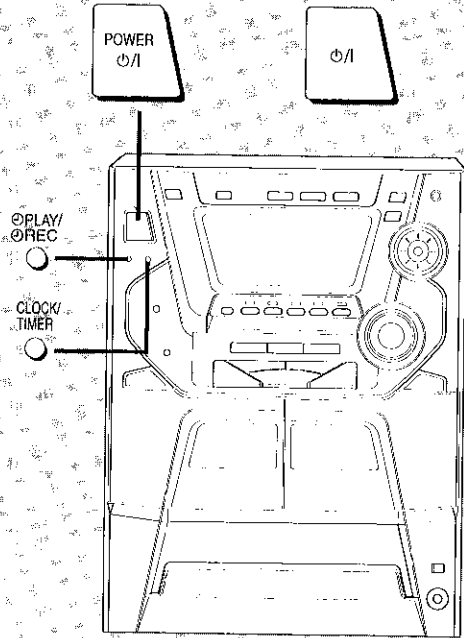

Using the timer

Using the play/record timer

To change the timer

Press [PLAY/REC] to select the desired timer.

Every time the button is pressed the setting changes as follows.

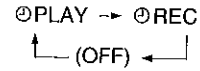

To check settings

While the unit is on and the "PLAY" (or "REC") indicator is on, press [CLOCK/TIMER] so "PLAY" (or "REC") appears on the display.

Two seconds after "PLAY" (or "REC") appear, the settings are displayed in the following order:

- | | |
|--------------------|-------------------------|
| • For play timer | • For record timer |
| ① Play start time | ① Recording start time |
| ② Play finish time | ② Recording finish time |
| ③ Play source | ③ Recording source |
| ④ Playback volume | |

You can check the settings even when the system is OFF by pressing [CLOCK/TIMER] twice.

To enjoy the desired source after the timer setting is completed

The volume level (for play timer) and music source are stored in the timer memory and the timer will start in these preset conditions. However, the Disc numbers and reverse mode do not get stored in the timer memory.

- After step 4, start playing the desired source.
- Reset the Disc numbers and reverse mode (For SC-AK52, SC-AK44 and SC-AK22: Russia and Ukraine only) if you have changed any of them, confirm that a Disc or cassette is inserted, then press [P/A] to put the unit on standby.

Notes

- If you switch the system to the standby mode while the play/record timer is functioning, the OFF time setting will not be activated.
- If AUX is selected as the source, when the timer comes ON, the system will turn ON and will engage "AUX" as the source. If you want to playback or record from a connected component, set the component's timer to the same time. (See the instruction manual that came with the component.)

Using the timer

A Using the sleep timer

by remote control only

This timer turns your system OFF at the set time (Max. 2 hours, settable at 30-minute intervals). It lets you fall asleep listening to music.

Preparation

Switch on the unit.

The figure shows how to set the system to standby mode after 30 minutes.

While enjoying the desired source:
Press [SLEEP] to select the desired time.

Every time you press the button:

→ SLEEP 30 → SLEEP 60 → SLEEP 90 → SLEEP 120 → SLEEP OFF

The system is turned off after the set time has elapsed.

To cancel the sleep timer:

Press [SLEEP] to select "SLEEP OFF".

To confirm the remaining time:

(only while system is ON)

Press [SLEEP].

To change the time remaining during operation:

Press [SLEEP] to show the remaining time then press [SLEEP] to select the desired time.

Notes

- The sleep timer turns OFF automatically the moment you attempt to edit-record a CD using CD Manager function.
- The sleep timer can be used in combination with the play/record timer.
The sleep timer always has priority.
Be sure not to overlap timer settings.

B Using an external unit

Listening to an external source

(See page 7 for external unit connection)

1. Press [AUX].
The system will come on automatically.
2. Start playback from the external source. (For details, refer to the owner's manual of the equipment.)

Recording from an external source

1. Press [AUX].
2. Press [● REC/STOP] (recording starts).
3. Start playback from the external source. (For details, refer to the owner's manual of the equipment.)

C Listening with headphones

Reduce the volume level, and connect the headphones.
Plug type: 3.5 mm stereo

Note

Avoid listening for prolonged periods of time to prevent hearing damage.

A

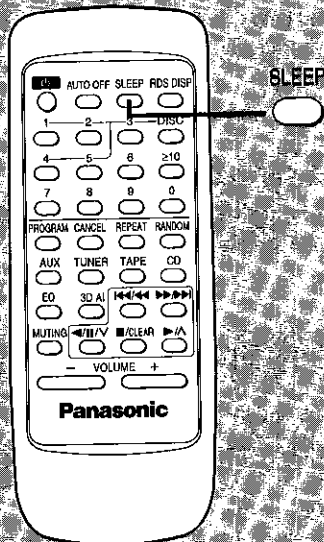

B

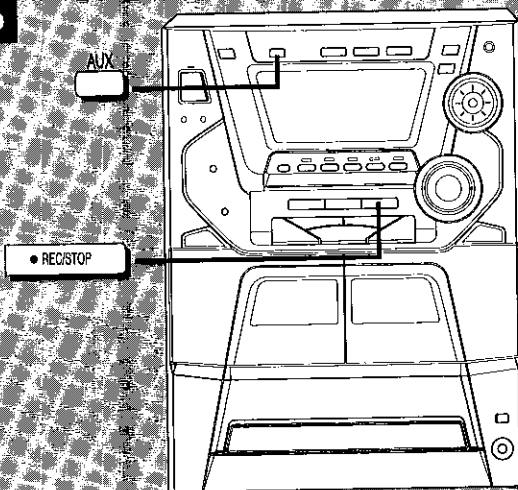

C

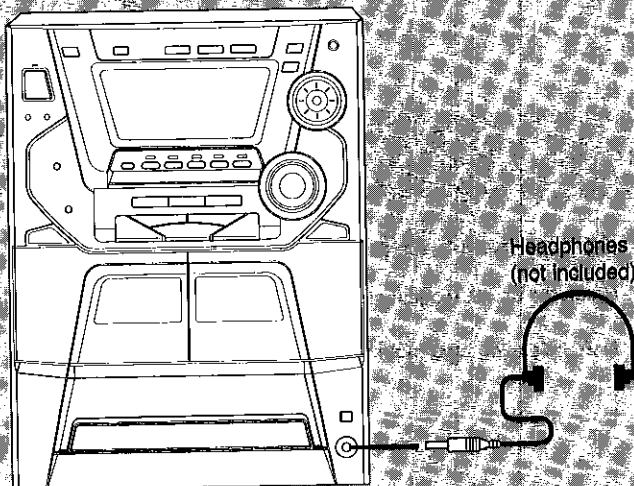

Troubleshooting guide

Before requesting service, make the checks below. If you can't fix the system as described below, or if something not listed here occurs, refer to the enclosed directory to locate an Authorized Service Center convenient to you or contact your dealer.

Reference pages are shown as black circled numbers ⑤.

Common Problems

<p>No sound.</p> <p>Sound is unfixed, reversed or comes from one speaker only.</p> <p>Humming heard during play.</p> <p>"ERROR" is displayed.</p> <p>"- - -" appears on the display.</p> <p>"F61" is displayed.</p>	<p>Turn the volume up.</p> <p>The speaker cables may be shorted. Turn the unit off, check and correct the connections and turn the unit on. ⑥</p> <p>Check the speaker connections. ⑥</p> <p>An AC mains lead or fluorescent light is near the cables. Keep other appliances and cords away from this unit's cables.</p> <p>Incorrect operation performed. Read the instructions and try again.</p> <p>You plugged the mains lead in for the first time or there was a power failure recently. Set the time. ①</p> <p>Check and correct the speaker cords connection. ⑥</p> <p>If this does not fix the problem, there is a power supply problem. Consult the dealer.</p>
---	---

Listening to the radio

<p>Noise is heard.</p> <p>The stereo indicator flickers or doesn't light.</p> <p>Sound is distorted.</p> <p>A beat sound is heard.</p> <p>A low hum is heard during AM broadcasts.</p>	<p>Use an outdoor antenna. ⑦</p> <p>Turn the TV off or separate it from the unit.</p> <p>Separate the antenna from other cables and cords.</p>
--	--

When there is a television set nearby

<p>The picture on the TV disappears or stripes appear on the screen.</p>	<p>The location and orientation of the antenna are incorrect. If you are using an indoor antenna, change to an outdoor antenna.</p> <p>The TV antenna wire is too close to the unit. Separate the antenna wire of the TV set from the unit.</p>
--	---

Using the cassette deck

<p>Poor quality sound.</p> <p>Recording is not possible.</p>	<p>Clean the heads.</p> <p>If the erasure prevention tabs have been removed, cover the holes with adhesive tape. ⑩</p>
--	--

Playing discs

<p>The display is wrong or play won't start.</p> <p>"TAKE OUT/DISC" appears on the display.</p>	<p>The disc may be upside down. ⑮</p> <p>Wipe the disc.</p> <p>Replace the disc if it is scratched, warped, or non-standard.</p> <p>Condensation may have formed inside the unit due to a sudden change in temperature. Wait about an hour for it to clear and try again.</p> <p>There is a problem with the disc mechanism. (A power failure may have occurred.)</p> <p>The tray will open automatically. Remove the disc from the tray, and after ensuring there is no disc in the tray, close it. The unit will make the disc changing noises for a few moments and then it should operate normally.</p>
---	---

Remote control

<p>Remote control doesn't work.</p>	<p>Check the batteries are inserted correctly. ⑤</p> <p>Replace the batteries if they are worn.</p>
-------------------------------------	---

Maintenance

If the surfaces are dirty

To clean this unit, wipe with a soft, dry cloth. If the surfaces are extremely dirty, use a soft cloth dipped in a soap-and-water solution or a weak detergent solution.

- Never use alcohol, paint thinner or benzine to clean this unit.
- Before using a chemically treated cloth, carefully read the instructions that came with the cloth.

For a cleaner, crisper sound

Clean the heads regularly to assure good quality playback and recording. Use a cleaning tape (not included).

Specifications

AMPLIFIER SECTION

SC-AK52 SC-AK44

RMS Power output

10% Total harmonic distortion
 80 Hz, both channels driven
 (Low channel) 115 W per channel (6Ω)
 1 kHz, both channels driven
 (High channel) 45 W per channel (6Ω)
 Total BI-Amp power 160 W per channel

Input sensitivity

AUX 250 mV

Input Impedance

AUX 13 kΩ

AMPLIFIER SECTION

SC-AK22

RMS Power output

10% Total harmonic distortion,
 both channels driven
 80 W per channel (6Ω)

Input sensitivity

AUX 250 mV

Input Impedance

AUX 13 kΩ

FM TUNER SECTION

Frequency range

87.50 – 108.00 MHz (50 kHz steps)

(For United Kingdom and Europe)

Sensitivity

1.8 μV (IHF)

S/N 26 dB

1.5 μV

(For Australia and New Zealand)

Sensitivity

2.5 μV (IHF)

S/N 26 dB

2.2 μV

Antenna terminal(s)

75 Ω (unbalanced)

AM TUNER SECTION

Frequency range

522 – 1629 kHz (9 kHz steps)

Sensitivity

S/N 20 dB (at 999 kHz) 560 μV/m

CASSETTE DECK SECTION

Track system 4 track, 2 channel

Heads

Record/playback Solid permalloy head

Erasure Double gap ferrite head

Motor

DC servo motor

Recording system

AC bias 100 kHz

Erasing system

AC erase 100 kHz

Tape speed

4.8 cm/s

Frequency response

(+3 dB, -6 dB at DECK OUT)

NORMAL (TYPE I) 35 Hz – 14 kHz

(For SC-AK52, SC-AK44 and SC-AK22:
 Russia and Ukraina only)

HIGH (TYPE II) 35 Hz – 14 kHz

S/N

50 dB (A weighted)

Wow and flutter

0.18% (WRMS)

Fast forward and rewind time

Approx. 120 seconds with

C-60 cassette tape

CD SECTION

Sampling frequency

44.1 kHz

Decoding

16 bit linear

Beam source/wavelength

Semiconductor laser/780 nm

Bølgelengde

780 nm

Laser-styrke

Ingen farlig stråling

sendes ut

Number of channels

Stereo

Frequency response

20 Hz–20 kHz (+1, -2 dB)

Wow and flutter

Below measurable limit

Digital filter

8 fs

D/A converter

MASH (1 bit DAC)

SPEAKER SECTION

SB-AK52 SB-AK44

Type

3 way speaker system

Speaker(s)

Super Woofer 17 cm cone type

Woofer 12 cm cone type

Tweeter 6 cm cone type

Impedance

HIGH 6 Ω

LOW 6 Ω

Input power

HIGH 60 W (Music)

LOW 140 W (Music)

Output sound pressure level

87 dB/W (1.0 m)

Cross over frequency

150 Hz, 5 kHz

Frequency range

45 Hz–22 kHz (-16 dB)

55 Hz–20 kHz (-10 dB)

Dimensions (WxHxD)

230 x 332 x 291 mm

Mass

4.3 kg

SPEAKER SECTION

SB-AK22

Type

2 way speaker system

Speaker(s)

Woofer 12 cm cone type

Tweeter 6 cm cone type

Impedance

6 Ω

Input power

100 W (Music)

Output sound pressure level

85 dB/W (1.0 m)

Cross over frequency

5 kHz

Frequency range

45 Hz–22 kHz (-16 dB)

55 Hz–20 kHz (-10 dB)

Dimensions (WxHxD)

211 x 332 x 250 mm

Mass

2.8 kg

GENERAL

Power supply

(For United Kingdom, Australia
 and New Zealand)

AC 230-240 V, 50 Hz

(For others)

AC 230 V, 50 Hz

Power consumption

(SC-AK52) 185 W

(SC-AK44) 185 W

(SC-AK22) 170 W

Standby

0.4 W

Dimensions (WxHxD)

250 x 332 x 316 mm

Mass

(SC-AK52) 8.5 kg

(SC-AK44) 8.5 kg

(SC-AK22) 8.2 kg

Notes:

- Specifications are subject to change without notice.
 Mass and dimensions are approximate.
- Total harmonic distortion is measured by the digital spectrum analyzer.
- (For SB-AK52 and SB-AK44)
 The labels "HIGH" and "LOW" on the rear of the speakers refer to High frequency and Low frequency.

CAUTION!

THIS PRODUCT UTILIZES A LASER.
USE OF CONTROLS OR ADJUSTMENTS OR PERFORMANCE
OF PROCEDURES OTHER THAN THOSE SPECIFIED HEREIN
MAY RESULT IN HAZARDOUS RADIATION EXPOSURE.
DO NOT OPEN COVERS AND DO NOT REPAIR YOURSELF.
REFER SERVICING TO QUALIFIED PERSONNEL.

CAUTION!

DO NOT INSTALL OR PLACE THIS UNIT IN A BOOKCASE,
BUILT IN CABINET OR IN ANOTHER CONFINED SPACE. EN-
SURE THE UNIT IS WELL VENTILATED. ENSURE THAT CUR-
TAINS AND ANY OTHER MATERIALS DO NOT OBSTRUCT THE
VENTILATION TO PREVENT RISK OF ELECTRIC SHOCK OR
FIRE HAZARD DUE TO OVERHEATING.

WARNING:

TO REDUCE THE RISK OF FIRE, ELECTRIC SHOCK OR
PRODUCT DAMAGE, DO NOT EXPOSE THIS APPLIANCE TO
RAIN, SPLASHING, DRIPPING OR MOISTURE.

SUOMI**VAROITUS!**

LAITTEEN KÄYTTÄMINEN MUULLA KUIN TÄSSÄ
KÄYTTÖOHJEESSA MAINITULLA TAVALLA SAATTAA
ALTISTAA KÄYTTÄJÄN TURVALLISUUSLUOKAN 1
YLITTÄVÄLLE NÄKYMÄTTÖMÄLLE LASERSÄTEILYLLE.

VAROITUS!

ÄLÄ ASENNATA TAI LAITA TÄTÄ LAITETTA KABINETTI-
TYYPPISEEN KIRJAKAAPPIIN TAI MUUHUN SULJETTUUN
TILAAN, JOTTA TUULETUS ONNISTUISI. VARMISTA, ETTÄ
VERHO TAI MIKÄÄN MUU MATERIAALI EI HUONONNA
TUULETUSTA, JOTTA VÄLTETTÄISIIN YLIKUUMENEMISESTA
JOHTUVA SÄHKÖISKU- TAI TULIPALOVAARA.

VAROITUS:

TULIPALO-, SÄHKÖISKUVAARAN TAI MUUN VAHINGON
VÄHENTÄMISEKSI EI LAITETTA SAA ALTISTAA SATEELLE,
ROISKEELLE, VESIPISAROILLE TAI KOSTEUELLE.

NORSK**ADVARSEL!**

DETTE PRODUKTET ANVENDER EN LASER.
BETJENING AV KONTROLLER, JUSTERINGER ELLER ANDRE
INNGREP ENN DE SOM ER BESKREVENT I DENNE
BRUKSANVISNING, KAN FØRE TIL FARLIG BESTRÅLING.
DEKSLER MÅ IKKE ÅPNES, OG FORSØK ALDRI Å REPARERE
APPARATET PÅ EGENHÅND. ALT SERVICE OG
REPARASJONSARBEID MÅ UTFØRES AV KVALIFISERT
PERSONELL.

ADVARSEL!

APPARATET MÅ IKKE Plasseres i en bokhylle, et
innebygget kabinett eller et annet lukket sted
hvor ventilasjonsforholdene er utilstrekkelige.
SØRG FOR AT GARDINER ELLER LIGNENDE IKKE
FORVERRER VENTILASJONSFORHOLDENE, SÅ RISIKO FOR
ELEKTRISK SJOKK ELLER BRANN FORÅRSAKET AV
OVERHETING UNNGÅS.

ADVARSEL:

FOR Å REDUSERE FAREN FOR BRANN, STRØMSJOKK
ELLER SKADER PÅ PRODUKTET, MÅ DETTE APPARATET
IKKE UTSETTES FOR REGN, VANNSPRUT, VANNDRÅPER
ELLER FUKTIGHET.

Environment friendly printed on chlorine free bleached paper.

Matsushita Electric Industrial Co., Ltd.
Osaka 542-8588, Japan

En

RQT5666-B
P1100GL0

Free Manuals Download Website

<http://myh66.com>

<http://usermanuals.us>

<http://www.somanuals.com>

<http://www.4manuals.cc>

<http://www.manual-lib.com>

<http://www.404manual.com>

<http://www.luxmanual.com>

<http://aubethermostatmanual.com>

Golf course search by state

<http://golfingnear.com>

Email search by domain

<http://emailbydomain.com>

Auto manuals search

<http://auto.somanuals.com>

TV manuals search

<http://tv.somanuals.com>