

DVD Home Theater Sound System

Operating Instructions

Model No. **SC-HT500**

Panasonic®

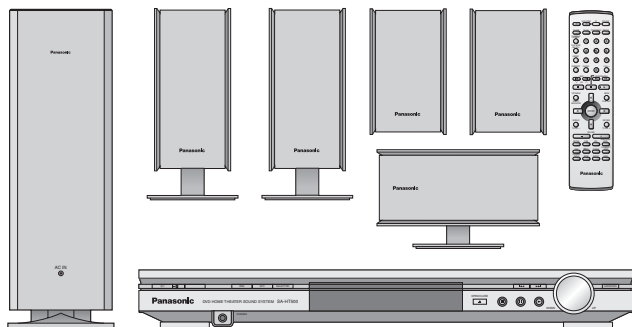

The illustration shows the model for the United Kingdom and Continental Europe.



Region number supported by this unit

Region numbers are allocated to this unit and software according to where they are sold.

For the United Kingdom and Continental Europe

- The region number of this unit is "2".
- The unit will play DVD-Video marked with labels containing "2" or "ALL".

Example:



For Australia and N.Z.

- The region number of this unit is "4".
- The unit will play DVD-Video marked with labels containing "4" or "ALL".

Example:



Before connecting, operating or adjusting this product, please read these instructions completely. Please keep this manual for future reference.

Note

"EB" on the packaging indicates the United Kingdom.

Dear customer

Thank you for purchasing this product.
For optimum performance and safety, please read these instructions carefully.

- Operations in these instructions are described mainly with the remote control, but you can do the operations on the main unit if the controls are the same.
- Unless otherwise indicated, illustrations in these operating instructions are of the unit for the United Kingdom and Continental Europe.

	For the United Kingdom and Continental Europe	For Australia and N.Z.
System	SC-HT500	SC-HT500
Main unit	SA-HT500	SA-HT500
Front speakers	SB-FS700	SB-FS803A
Center speaker	SB-PC700	SB-PC703
Surround speakers	SB-FS803A	SB-FS803A
Active subwoofer	SB-WA330	SB-WA330

Getting started

CAUTION!

THIS PRODUCT UTILIZES A LASER. USE OF CONTROLS OR ADJUSTMENTS OR PERFORMANCE OF PROCEDURES OTHER THAN THOSE SPECIFIED HEREIN MAY RESULT IN HAZARDOUS RADIATION EXPOSURE. DO NOT OPEN COVERS AND DO NOT REPAIR YOURSELF. REFER SERVICING TO QUALIFIED PERSONNEL.

WARNING:

TO REDUCE THE RISK OF FIRE, ELECTRIC SHOCK OR PRODUCT DAMAGE, DO NOT EXPOSE THIS APPARATUS TO RAIN, MOISTURE, DRIPPING OR SPLASHING AND THAT NO OBJECTS FILLED WITH LIQUIDS, SUCH AS VASES, SHALL BE PLACED ON THE APPARATUS.

CAUTION!

- DO NOT INSTALL OR PLACE THIS UNIT IN A BOOKCASE, BUILT-IN CABINET OR IN ANOTHER CONFINED SPACE. ENSURE THE UNIT IS WELL VENTILATED. TO PREVENT RISK OF ELECTRIC SHOCK OR FIRE HAZARD DUE TO OVERHEATING, ENSURE THAT CURTAINS AND ANY OTHER MATERIALS DO NOT OBSTRUCT THE VENTILATION VENTS.
- DO NOT OBSTRUCT THE UNIT'S VENTILATION OPENINGS WITH NEWSPAPERS, TABLECLOTHS, CURTAINS, AND SIMILAR ITEMS.
- DO NOT PLACE SOURCES OF NAKED FLAMES, SUCH AS LIGHTED CANDLES, ON THE UNIT.
- DISPOSE OF BATTERIES IN AN ENVIRONMENTALLY FRIENDLY MANNER.

THIS UNIT IS INTENDED FOR USE IN MODERATE CLIMATES.

This product may receive radio interference caused by mobile telephones during use. If such interference is apparent, please increase separation between the product and the mobile telephone.

CAUTION	- LASER RADIATION WHEN OPEN. DO NOT STARE INTO BEAM. FDA 21 CFR / Class II
CAUTION	- VISIBLE AND INVISIBLE LASER RADIATION WHEN OPEN. AVOID EXPOSURE TO BEAM. IEC60825-1 / Class 3b
WARNING	- SYNLIG OCH USYNLIG LASERSTRÅLNING NÄR DENNA DEL ÄR ÖPPNAD. BETRÄKTA EJ STRÅLEN.
ADVARSEL	- SYNLIG OG USYNLIG LASERSTRÅLING VED ÅBNING. UNDGÅ UDSÆTTELSE FOR STRÅLING.
ADVARSEL	- SYNLIG OG USYNLIG LASERSTRÅLING NÄR DEKSEL ÄPNES. UNDGÅ EXPOSITION FÖR STRÅLEN.
VARO!	- HUOMI! KÄYTTÄESSÄ OLET ALTISTINA NÄKYVÄÄ JA NÄKYMÄTÖN LASERSÄTEILYLLE. ÄLÄ KATSO SÄTEELSEEN.
VORSICHT	- SICHTBARE UND UNSICHTBARE LASERSTRÄHLUNG. WENN ABDECKUNG GEÖFFNET, NICHT DEM STRAHL AUSSETZEN.
ATTENTION	- RAYONNEMENT LASER VISIBLE ET INVISIBLE EN CAS D'OUVERTURE. EXPOSITION DANGEREUSE AU FAISCEAU.
注意	- 打開時及び使用中もレーザー光線が放射されます。直射光線を見たり、触れたりしないで下さい。ROHS0054

(Inside of product)
(Tuotteen sisällä)
(Produktets innside)



LUOKAN 1 LASERLAITE KLASS 1 LASER APPARAT

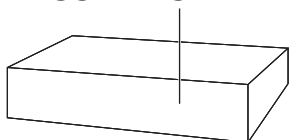

(Back of product)

SUOMI

VAROITUS!

LAITTEEN KÄYTTÄMINEN MUULLA KUIN TÄSSÄ KÄYTTÖOHJEESSA MAINITULLA TAVALLA SAATAA ALTISTAA KÄYTTÄJÄN TURVALLISUUSLUOKAN 1 YLITTÄVÄLLE NÄKYMÄTTÖMÄLLE LASERSÄTEILYLLE.

VAROITUS:

TULIPALO-, SÄHKÖISKUVAARAN TAI TUOTETTA KOHTAAVAN MUUN VAHINGON VÄHENTÄMISEKSI EI LAITETTA SAA ALTISTAA SATEELLE, KOSTEUDELLE, VESIPISAROILLE TAI ROISKEELLE, EIKÄ NESTETTÄ SISÄLTÄVIÄ ESINEITÄ, KUTEN ESIMERKIKSI MALJAKOITA, SAA ASETTAA LAITTEEN PÄÄLLE.

VAROITUS!

- ÄLÄ ASENNATA TAI LAITA TÄTÄ LAITETTA KABINETTITYYPPISEEN KIRJAKAAPPIN TAI MUUHUN SULJETTUUN TILAAN, JOTTA TUULETUS ONNISTUISI. VARMISTA, ETTÄ VERHO TAI MIKÄÄN MUU MATERIAALI EI HUONONNA TUULETUSTA, JOTTA VÄLTETTÄISIN YLIKUUMENEMISESTÄ JOHTUVA SÄHKÖISKU- TAI TULIPALOVAARA.
- ÄLÄ PEITÄ LAITTEEN TUULETUSAUKKOJA SANOMALEHDELLÄ, PÖYTÄLIINALLA, VERHOLLA TAI MUULLA VASTAVALLLA ESINEELLÄ.
- ÄLÄ ASETA PALAVAA KYNTTILÄÄ TAI MUUTA AVOTULEN LÄHDETTÄ LAITTEEN PÄÄLLE.
- HÄVITÄ PARISTOT LUONTOA VAHINGOITTAMATTOMALLA TAVALLA.

TÄMÄ LAITE ON TARKOITETTU KÄYTETTÄVÄKSI LEUDOSSA ILMASTOSSA.

NORSK

ADVARSEL!

DETTE PRODUKTET ANVENDER EN LASER. BETJENING AV KONTROLLER, JUSTERINGER ELLER ANDRE INNGREP ENN DE SOM ER BESKREVET I DENNE BRUKSANVISNING, KAN FØRE TIL FARLIG BESTRÅLING. DEKSLER MÅ IKKE ÅPNES, OG FORSØK ALDRI Å REPARERE APPARATET PÅ EGENHÅND. ALT SERVICE OG REPARASJONSARBEID MÅ UTFØRES AV KVALIFISERT PERSONELL.

ADVARSEL:

FOR Å REDUSERE FAREN FOR BRANN, ELEKTRISK STØT ELLER SKADER PÅ PRODUKTET, MÅ DETTE APPARATET IKKE UTSETTES FOR REGN, FUKTIGHET, VANNDRÅPER ELLER VANNSPRUT. DET MÅ HELLER IKKE PLOSSERES GJENSTANDER FYLT MED VANN, SLIK SOM BLOMSTERVASER, OPPÅ APPARATET.

ADVARSEL!

- APPARATET MÅ IKKE PLOSSERES I EN BOKHYLLE, ET INNEBYGGET KABINETT ELLER ET ANNET LUKKET STED HVOR VENTILASJONSFORHOLDENE ER UTILSTREKKELEGE. SØRG FOR AT GARDINER ELLER LIGNENDE IKKE FORVERRER VENTILASJONSFORHOLDENE, SÅ RISIKO FOR ELEKTRISK SJOKK ELLER BRANN FORÅRSAKET AV OVERHETING UNNGÅS.
- APPARATETS VENTILASJONSÅPNINGER MÅ IKKE DEKKES TIL MED AVISER, BORDDUKER, GARDINER OG LIGNENDE.
- PLOSSER IKKE ÅPEN ILD, SLIK SOM LEVENDE LYS, OPPÅ APPARATET.
- BRUKTE BATTERIER MÅ KASSERES UTEN FARE FOR MILJØET.

DETTE APPARATET ER BEREGNET TIL BRUK UNDER MODERATE KLIMAFORHOLD.

Accessories



Please check and identify the supplied accessories. Use numbers indicated in parentheses when asking for replacement parts.

- 1 Remote control**
(EUR7623XA0)

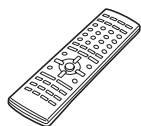

- 2 Batteries**
for remote control

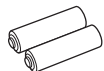

- 1 AC mains lead**
For the United Kingdom
(RJA0053-2X)



For Continental Europe
(RJA0019-2X)

- For Australia and N.Z.**
(RJA0035-X)

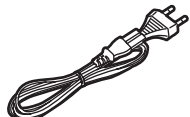
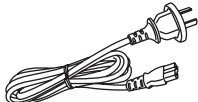

- 1 AM loop antenna**
(N1DAAAA00001)



- 1 FM indoor antenna**
(RSA0007-J)

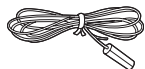

- 1 Video cable**
(RJL1P016B15A)



- 1 System cable**
(K1HA25HA0001)

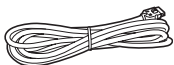

- 5 Speaker cables**
(RFA2163-J)
3×4-m cables
2×10-m cables



- For the United Kingdom only**
1 Antenna plug adaptor
(SJP9009)



- 1 Sheet of speaker-cable stickers**



Note

The included AC mains lead is for use with this unit only. Do not use it with other equipment.

For the United Kingdom and Republic of Ireland

shop@ Panasonic

www.panasonic.co.uk (for UK customers only)

- Order accessory and consumable items for your product with ease and confidence by telephoning our Customer Care Centre Mon–Friday 9:00am–5:30pm. (Excluding public holidays.)
- Or go on line through our Internet Accessory ordering application.
- Most major credit and debit cards accepted.
- All enquiries transactions and distribution facilities are provided directly by Panasonic UK Ltd.
- It couldn't be simpler!

Customer Care Centre
For UK customers: 08705 357357
For Republic of Ireland customers: 01 289 8333

Technical Support
For UK customers: 0870 1 505610

This Technical Support Hot Line number is for Panasonic PC software related products only.

For Republic of Ireland, please use the Customer Care Centre number listed above for all enquiries.

For all other product related enquiries, please use the Customer Care Centre numbers listed above.

Table of contents



Getting started	
Accessories	3
Caution for AC Mains Lead	4
Disc information	5
Simple setup	
STEP1 Locating	6
STEP2 Speakers	7
STEP3 Television	8
STEP4 Connecting the subwoofer, antennas, and AC mains lead	9
STEP5 The remote control	9
Other speaker setup options	10
STEP6 QUICK SETUP	11
Control reference guide	12
Disc operations	
Discs—Basic play	13
Starting play from a selected item	14
Position Memory function	14
Skipping items/Fast forward and rewind—SEARCH	15
Slow-motion play/Frame-by-frame viewing	15
Selecting groups to play	15
Discs—Convenient functions	16
Repeat play/A-B repeat play	16
All group play/Program play/Random play	17
Marking places to play again	18
Variable Zoom function	18
Soundtracks/Subtitles	19
WMA/MP3 and CD text navigation menus	20
Playing the programs or play lists on DVD-RAM	22
Selecting a program to play—DIRECT NAVIGATOR	22
Using the play list menu	22
Using GUI (Graphical User Interface) screens	23
Common procedures/Progress indicator	23
Disc information/Unit information	24
Radio operations	
The radio	26
Manual tuning/Preset tuning	26
RDS broadcasting	27
Sound field/sound quality operations	
Sound field	27
Dolby Digital and DTS	27
Dolby Pro Logic/Speaker level adjustments	28
Super Surround	28
Sound Field Control/Center Focus	29
Custom Sound Memory—Store the sound settings	29
Sound quality	29
Adjusting the bass	29
Re-master—Enjoying more natural sound	29
Other functions	
Convenient functions	30
Muting the volume/Dimming the display	30
The sleep timer/Using headphones	30
Changing settings	31
Operating a television or video cassette recorder	34
Optimal antenna connections	35
Reference	
Troubleshooting guide	36
Maintenance	37
Glossary	38
Safety precautions	38
Specifications	39

(For United Kingdom)

("EB" area code model only)

For your safety, please read the following text carefully.

This appliance is supplied with a moulded three pin mains plug for your safety and convenience. A 5-ampere fuse is fitted in this plug.

Should the fuse need to be replaced please ensure that the replacement fuse has a rating of 5-ampere and that it is approved by ASTA or BSI to BS1362. Check for the ASTA mark  or the BSI mark  on the body of the fuse.

If the plug contains a removable fuse cover you must ensure that it is refitted when the fuse is replaced. If you lose the fuse cover the plug must not be used until a replacement cover is obtained. A replacement fuse cover can be purchased from your local dealer.

CAUTION!

IF THE FITTED MOULDED PLUG IS UNSUITABLE FOR THE SOCKET OUTLET IN YOUR HOME THEN THE FUSE SHOULD BE REMOVED AND THE PLUG CUT OFF AND DISPOSED OF SAFELY. THERE IS A DANGER OF SEVERE ELECTRICAL SHOCK IF THE CUT OFF PLUG IS INSERTED INTO ANY 13-AMPERE SOCKET.

If a new plug is to be fitted please observe the wiring code as stated below. If in any doubt please consult a qualified electrician.

IMPORTANT

The wires in this mains lead are coloured in accordance with the following code:

Blue: Neutral, Brown: Live.

As these colours may not correspond with the coloured markings identifying the terminals in your plug, proceed as follows:

The wire which is coloured Blue must be connected to the terminal which is marked with the letter N or coloured Black or Blue.

The wire which is coloured Brown must be connected to the terminal which is marked with the letter L or coloured Brown or Red.

WARNING: DO NOT CONNECT EITHER WIRE TO THE EARTH TERMINAL WHICH IS MARKED WITH THE LETTER E, BY THE EARTH SYMBOL  OR COLOURED GREEN OR GREEN/YELLOW.

THIS PLUG IS NOT WATERPROOF—KEEP DRY.

Before use

Remove the connector cover.

How to replace the fuse

The location of the fuse differ according to the type of AC mains plug (figures A and B). Confirm the AC mains plug fitted and follow the instructions below. Illustrations may differ from actual AC mains plug.

1. Open the fuse cover with a screwdriver.

Figure A

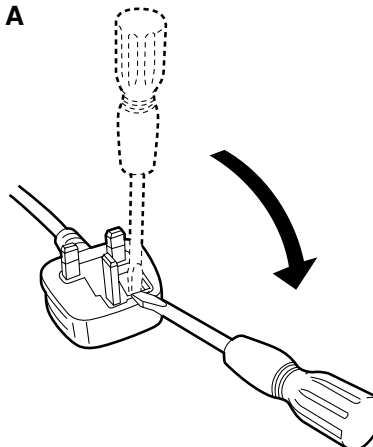
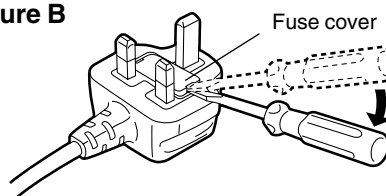

Figure B



2. Replace the fuse and close or attach the fuse cover.

Figure A

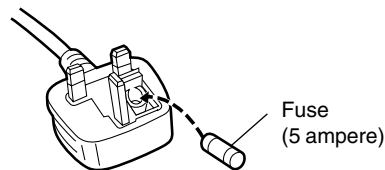
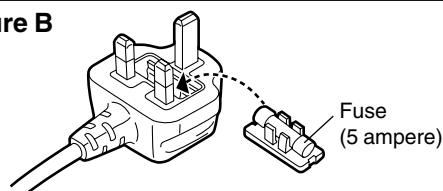









Figure B



■ Discs that can be played

Disc type	Logo	Indication used in instructions
DVD-RAM		RAM
DVD-Audio		DVD-A
DVD-Video	 	DVD-V
DVD-R		
Video CD		VCD
CD	 	CD Including CD text
CD-R/RW	—	WMA MP3

- Use discs with the above logos and that conform to specifications. The unit cannot play other discs correctly.
- Do not use irregularly shaped discs (e.g. heart-shaped), as these can damage the unit.

■ Discs that cannot be played

DVD-ROM, CD-ROM, CDV, CD-G, +RW, DVD-RW, CVD, SVCD, SACD, Divx Video Discs and Photo CD.

■ Disc structure

Disc structure and the labels given to the items on discs depend on the disc type.

- Track:** the smallest division on DVD-Audio, CDs and Video CDs, or a single WMA/MP3 file.
- Chapter:** the smallest division on DVD-Video.
- Group:** collections of tracks on DVD-Audio and equivalent to folders or albums on data discs.
- Title:** the largest division on DVD-Video, usually an entire movie.
- Program:** the division on DVD-RAM equivalent to a single recording.
- Play list:** a group of scenes on DVD-RAM.
- Scene:** DVD-RAM program sections specified and grouped into play lists on a DVD video recorder.

Playing DVDs and Video CDs

The producer of these discs can control how they are played so you may not always be able to control play as described in these operating instructions (for example if the play time is not displayed or if a Video CD has menus). Read the disc's instructions carefully.

■ CD-R and CD-RW discs

This unit can play CD-R/RW (audio recording disc) recorded with CD-DA, video CD, WMA or MP3. Finalize* the disc after recording.

■ DVD-R discs

Panasonic DVD-R recorded and finalized* on a Panasonic DVD video recorder are played as DVD-Video on this unit.

*A process that allows play on compatible equipment.

■ DVD-RAM discs

DVD-RAM discs must meet the following conditions for this unit to be able to play them.

Type	<ul style="list-style-type: none"> • Non-cartridge discs • Discs that can be removed from their cartridges (TYPE 2 and 4)
Capacity	<ul style="list-style-type: none"> • 12 cm 9.4 GB (double-sided) and 4.7 GB (single-sided) • 8 cm 2.8 GB (double-sided)
Recording format	Discs recorded with DVD video recorders, DVD video cameras, personal computers, etc., using Version 1.1 of the Video Recording Format (a unified video recording standard).

- Remove TYPE 2 and 4 discs from their cartridges before use, then return them when you are finished. Read the instructions for the disc carefully.
- Do not allow the disc to become dirty or scratched. Store discs in their cartridges and ensure the disc label and cartridge label face the same way.
- Some parts of the disc, for example where one program ends and another begins, may not play smoothly.

Note

It may not be possible to play CD-R, CD-RW, DVD-R and DVD-RAM in all cases due to the type of disc or condition of the recording.

■ Video systems

This unit can play both the PAL and NTSC video systems. To view PAL or NTSC, however, your television must match the system used on the disc.

PAL discs cannot be correctly viewed on an NTSC television. NTSC can be correctly viewed on a PAL television by converting the video signal to PAL 60 (→ page 31, Video—NTSC Disc Output).

■ To clean discs

DVD-Audio, DVD-Video, Video CD, CD

Wipe with a damp cloth and then wipe dry.

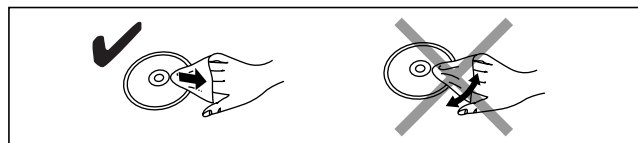

DVD-RAM, DVD-R

- Clean with an optional DVD-RAM/PD disc cleaner (LF-K200DCA1, where available).
- Never use cloths or cleaners for CDs etc.

■ Handling precautions

- Do not write on the label side with a ball-point pen or other writing instrument.
- Do not use record cleaning sprays, benzene, thinner, static electricity prevention liquids or any other solvent.
- Do not attach labels or stickers to discs. (Do not use discs with exposed adhesive from tape or left over peeled-off stickers.)
- Do not use scratch-proof protectors or covers.
- Do not use discs printed with label printers available on the market.

Simple setup

STEP 1 Locating

For the United Kingdom and Continental Europe

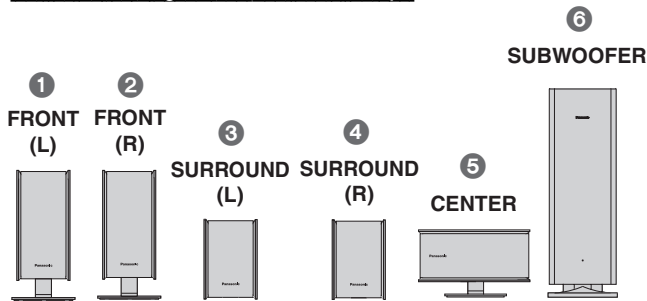

Setup example

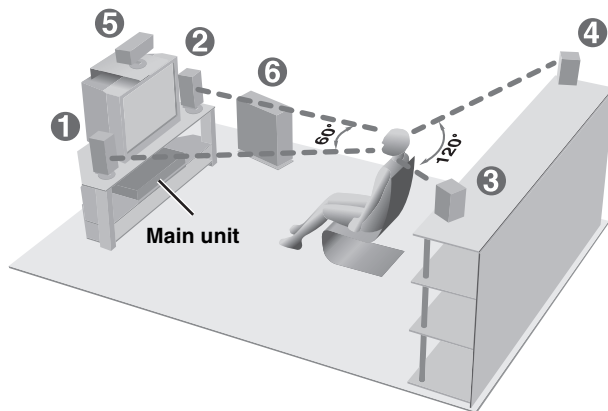

For Australia and N.Z.

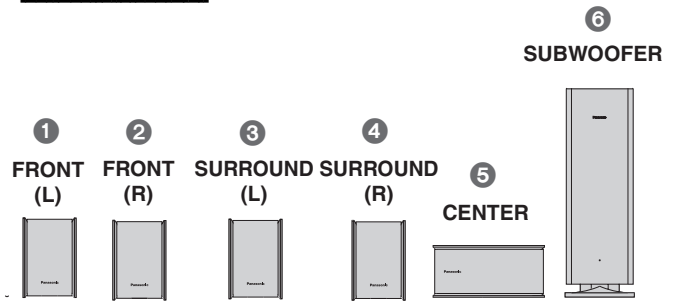

Setup example

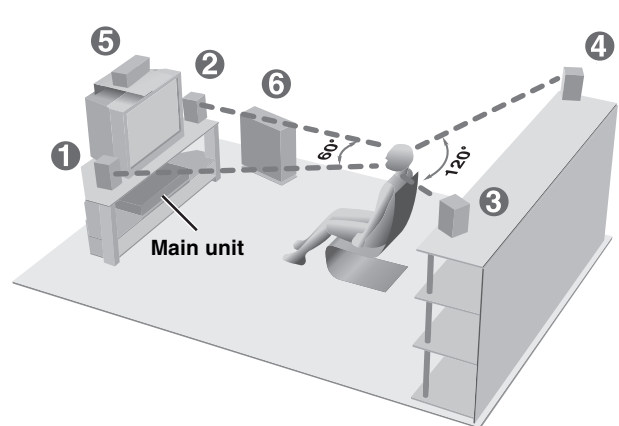

- The front and surround speakers are the same. Use those you have connected the short cords to as front speakers and those you have connected the long cords to as surround speakers.

- Place the front, center, and surround speakers at approximately the same distance from the seating position. The angles in the diagram are approximate.

Use only supplied speakers

Using other speakers can damage the unit and sound quality will be negatively affected.

- Set the speakers up on an even surface to prevent them from falling. Take proper precautions to prevent the speakers from falling if you cannot set them up on an even surface.

Positioning for best effect

How you set up your speakers can affect the bass and the sound field. Note the following points.

- Place speakers on flat secure bases.
- Placing speakers too close to floors, walls, and corners can result in excessive bass. Cover walls and windows with thick curtain.

Main unit

Keep your speakers at least 10 mm away from the system for proper ventilation.

Center speaker

- You can also put this speaker directly under the television.
- Vibration caused by the center speaker can disrupt the picture if it is placed directly on the television. Put the center speaker on a rack or shelf.

Subwoofer

Place to the right of the television, on the floor or a sturdy shelf so that it won't cause vibration.

Leave 10 cm on the right for the woofer to be effective. Leave 10 cm at the rear for ventilation.

Caution

Hold the speakers by the sides. Applying pressure to the front net can damage the speaker.

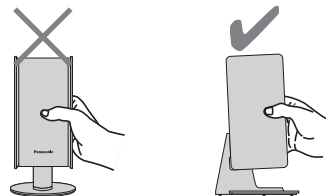

STEP 2 Speakers

- Speaker cables**
- 3 × 4-m cables
 - 2 × 10-m cables



Sheet of speaker-cable stickers

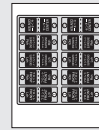

1 Attaching the stickers to the speaker cables

Attach the speaker-cable stickers to make connection easier.

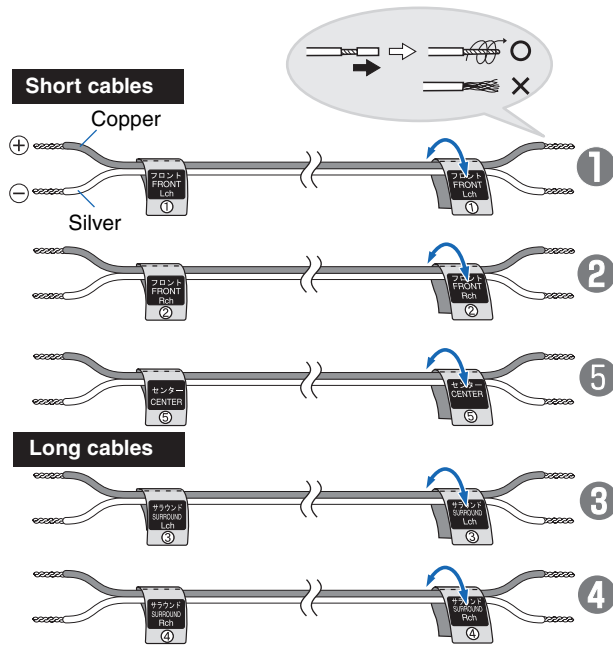

2 Connecting the speakers

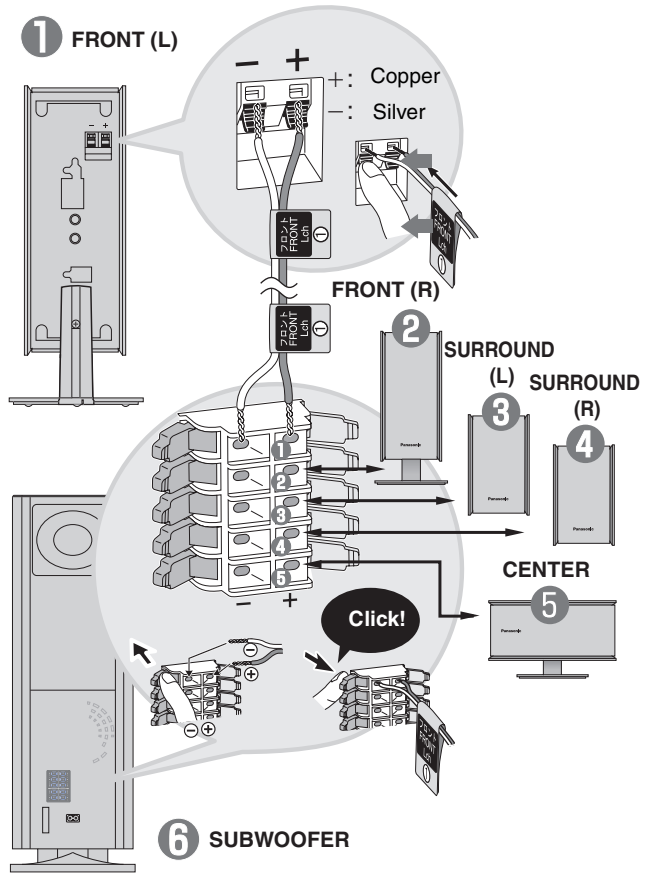

For the United Kingdom and Continental Europe

Keeping the cables out of the way (Front speakers and center speaker)

Pass the cables through the holes in the stand to keep them out of the way.

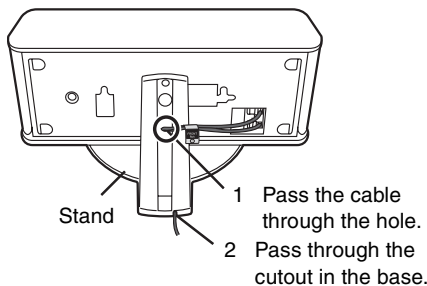

Note

- Never short-circuit positive (+) and negative (-) speaker wires.
- Be sure to connect only positive (copper) wires to positive (+) terminals and negative (silver) wires to negative (-) terminals. Incorrect connection can damage the speakers.

STEP 3 Television

■ Connecting a television with a VIDEO IN terminal

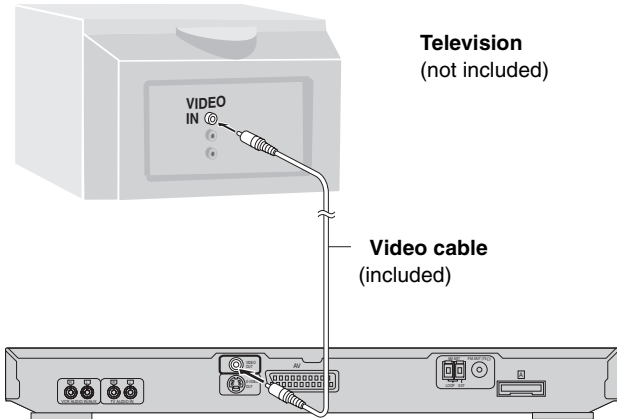

Video cable



Connect directly to your television.

Do not connect the unit through a video cassette recorder, because the picture may not be played correctly due to the copy guard.

For the United Kingdom and Continental Europe

■ Connecting a television with SCART terminal

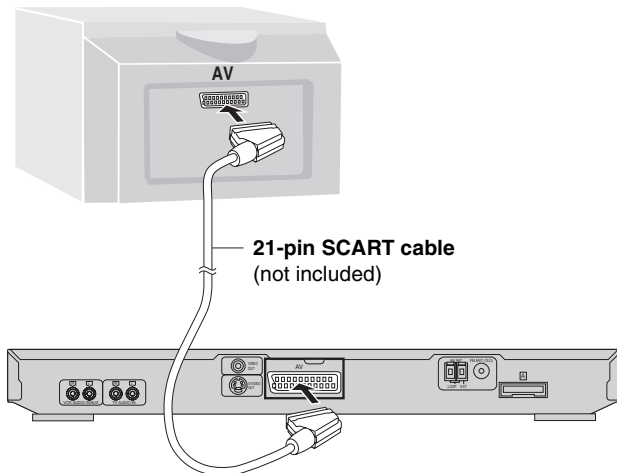

SCART terminal

To improve picture quality, you can change the video signal output from the AV terminal from "Video" to either "S-Video" or "RGB" to suit the type of television you are using (➔ page 11, QUICK SETUP or page 31, Video—AV Output).

■ Connecting a television with an S-VIDEO IN terminal

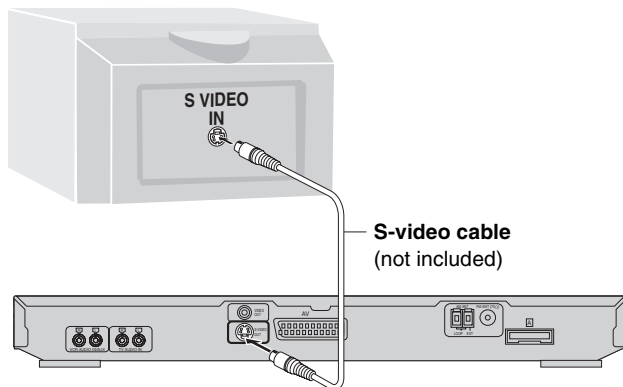

S VIDEO OUT terminal

The S video terminal achieves a more vivid picture than the VIDEO OUT terminal by separating the chrominance (C) and luminance (Y) signals. (Actual results depend on the television.)

STEP 4

Connecting the subwoofer, antennas, and AC mains lead

System cable

AM loop antenna

FM indoor antenna

AC mains lead

For the United Kingdom

For Australia and N.Z.

For Continental Europe

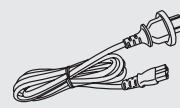
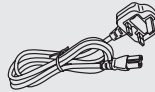
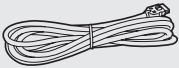

Connect the AC mains lead after all other connections are complete.

For the United Kingdom only
BE SURE TO READ THE CAUTION FOR THE AC MAINS LEAD ON PAGE 4 BEFORE CONNECTION.

Stand the antenna up on its base. Keep loose antenna cord away from other wires and cords.

AM loop antenna

FM indoor antenna

Subwoofer

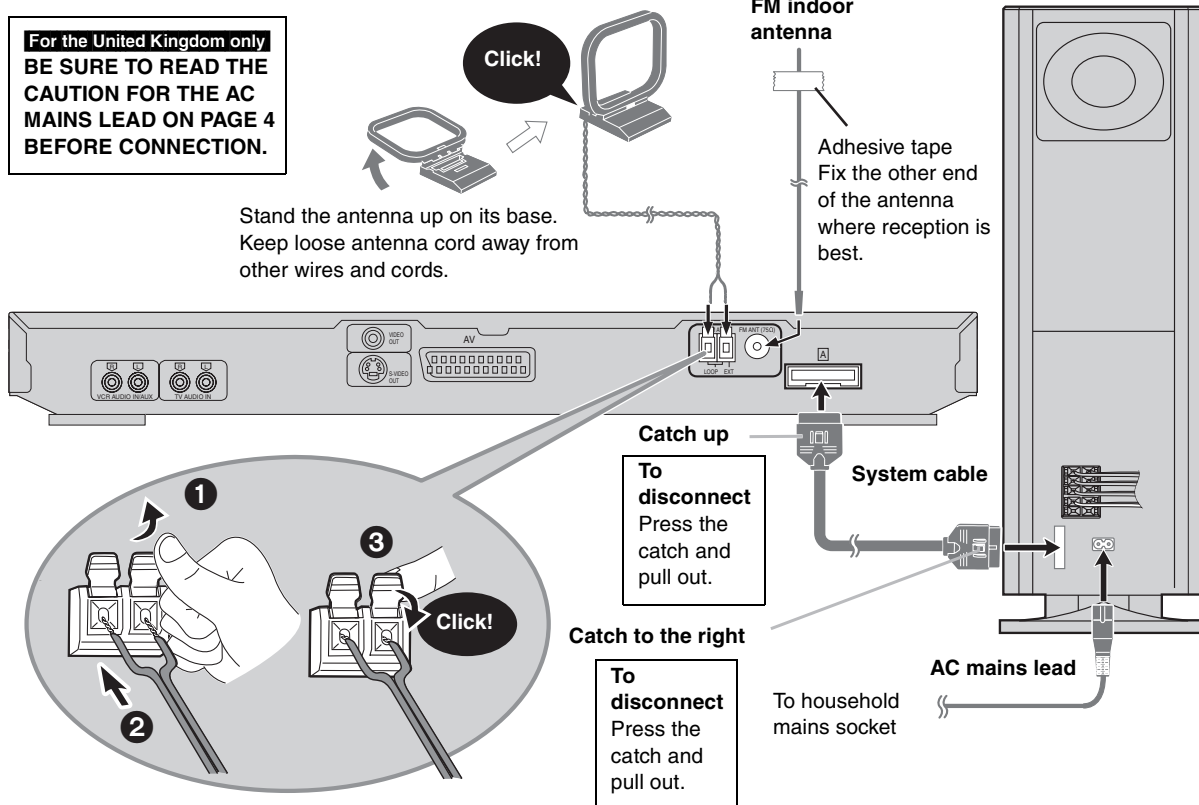

Conserving power

The unit consumes power [approx. 0.7 W (Subwoofer)] even when it is turned off with [Power Off]. To save power when the unit is not to be used for a long time, unplug it from the household mains socket.

Remember to reset the radio stations and any other memory items before using the unit again.

Information you enter into the unit's memory remains intact for up to 2 weeks after the AC mains lead is disconnected.

STEP 5

The remote control

Remote control

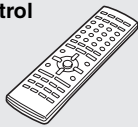

Batteries

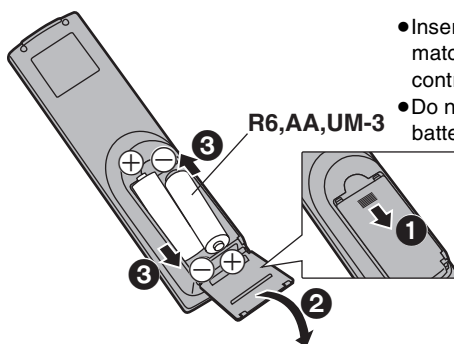

- Insert so the poles (+ and -) match those in the remote control.
- Do not use rechargeable type batteries.

Do not;

- mix old and new batteries.
- use different types at the same time.
- heat or expose to flame.
- take apart or short circuit.
- attempt to recharge alkaline or manganese batteries.
- use batteries if the covering has been peeled off.

Mishandling of batteries can cause electrolyte leakage which can damage items the fluid contacts and may cause a fire.

Remove if the remote control is not going to be used for a long period of time. Store in a cool, dark place.

Use

Aim at the sensor, avoiding obstacles, at a maximum range of 7 m directly in front of the unit.

Other speaker setup options

Attaching to a wall

Note

The wall or pillar on which the speakers are to be attached should be capable of supporting 10 kg per screw.

1

For the United Kingdom and Continental Europe

Remove the stand before attaching the front and center speakers.

BEFORE REMOVING THE STAND

- Take the speaker cable out of the stand's hole if it is threaded through.
- Lay the speaker on a soft cloth.

Unscrew the screw with a Phillips-head screwdriver.

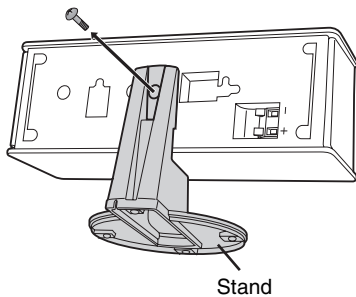

2 Screw a screw (not included) into the wall.

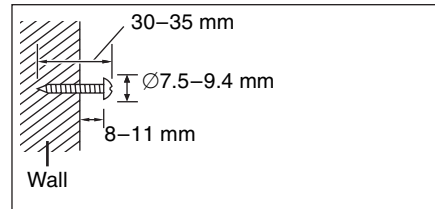

3 Fit the speaker securely onto the screw with the hole or holes.

Vertical

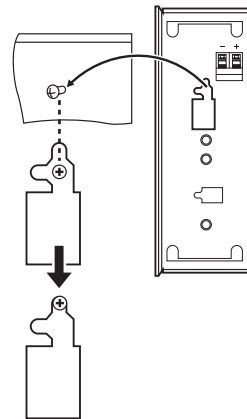

Horizontal

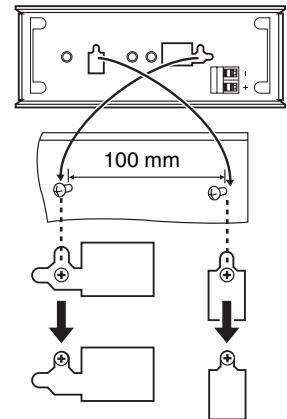

Fitting speaker stands (optional)

Preparation

Remove the stand (→ step 1 above).

Ensure the stands meet these conditions before purchasing them.

- Observe the diameter and length of the screws and the distance between screws as shown in the diagram.
- The stands must be able to support over 10 kg.
- The stands must be stable even if the speakers are in a high position.

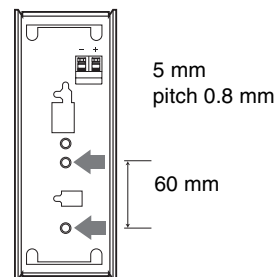

Notes on speaker use

- You can damage your speakers and shorten their useful life if you play sound at high levels over extended periods.
- Reduce the volume in the following cases to avoid damage.
 - When playing distorted sound.
 - When the speakers are receiving howling from a record player, noise from FM broadcasts, or continuous signals from an oscillator, test disc, or electronic instrument.
 - When adjusting the sound quality.
 - When turning the unit on or off.

If irregular coloring occurs on your television

These speakers are designed to be used close to a television, but the picture may be affected with some televisions and set-up combinations.

If this occurs, turn the television off for about 30 minutes.

The television's demagnetizing function should correct the problem. If it persists, move the speakers further away from the television.

Caution

- Use the speakers only with the recommended system. Failure to do so may lead to damage to the amplifier and/or the speakers, and may result in the risk of fire. Consult a qualified service person if damage has occurred or if you experience a sudden change in performance.
- Do not attempt to attach these speakers to walls using methods other than those described in this manual.

STEP 6 QUICK SETUP

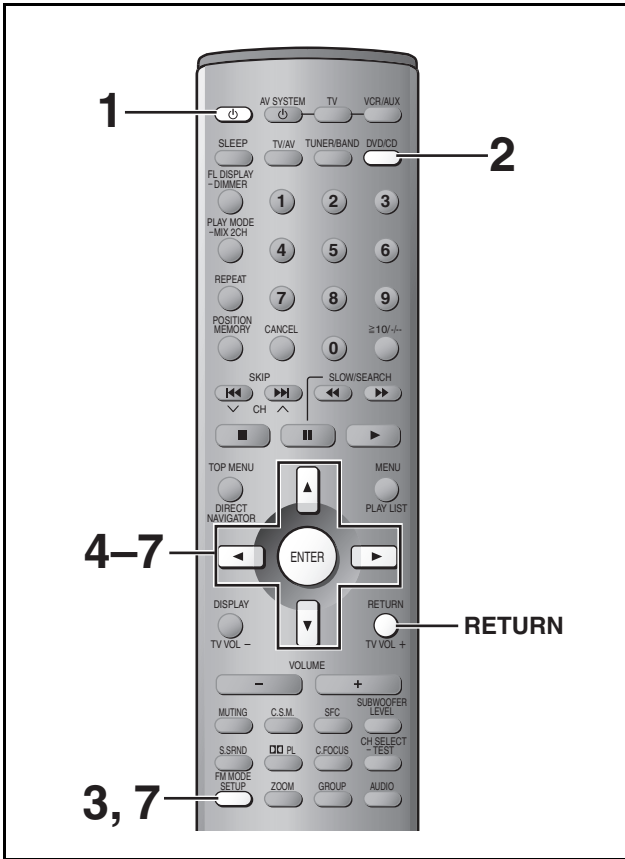

The **QUICK SETUP** screen appears when you press [SETUP] the first time after purchase and assists you to make necessary settings. You can access this screen again later if you need to (⇒ page 31, Others—QUICK SETUP).

Preparation

Turn on the television and select the appropriate video input on the television to suit the connections for the unit.

- 1 Press [POWER] to turn on the unit.
- 2 Press [DVD/CD] to select “DVD/CD” as the source.
- 3 Press [SETUP] to show the **QUICK SETUP** screen.

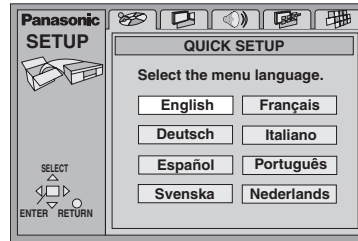

- 4 Press [▲, ▼] to select the menu language and press [ENTER].
 - 5 Press [▲, ▼] to select “Yes” to continue and press [ENTER].
 - 6 Press [▲, ▼, ◀, ▶] to select the item and press [ENTER].
 - Audio Language (⇒ page 31)
 - Subtitle Language (⇒ page 31)
 - TV Type (⇒ below)
 - TV Aspect (⇒ below)
- For the United Kingdom and Continental Europe**
- AV Output (⇒ page 31)
- 7 Press [ENTER] and then [SETUP] to end the settings.

To return to the previous screen

Press [RETURN].

■ TV Type

Select to suit the type of television.

- Standard (Direct View TV) (factory preset)
- CRT Projector
- LCD TV/Projector
- Projection TV
- Plasma TV

■ TV Aspect

Select “4:3” (regular) or “16:9” (widescreen) to suit your television.

If you have a regular 4:3 television, you can also select how video on some discs is shown (⇒ page 31, Video—TV Aspect).

- 4:3 Pan&Scan (factory preset)
Widescreen software is expanded to fill the screen of a 4:3 aspect television (unless prohibited by the producer of the disc).
- 4:3 Letterbox
Widescreen software is shown in the letterbox style on a 4:3 aspect television.



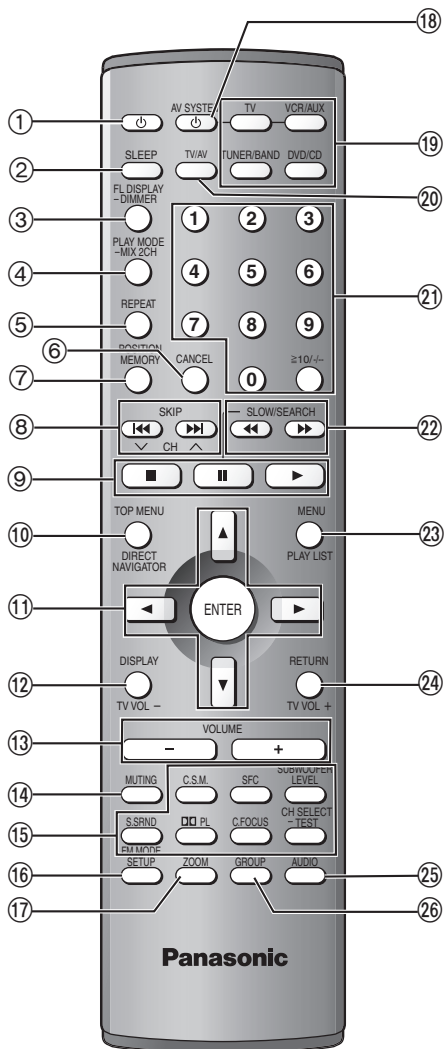

Remote control

- ① Standby/on switch [⏻]11
- ② Sleep button [SLEEP]30
- ③ FL display, Dimmer button [FL DISPLAY, -DIMMER]...27, 30
- ④ Play mode, Mix 2ch button [PLAY MODE, -MIX 2CH]17, 27
- ⑤ Repeat button [REPEAT]16
- ⑥ Cancel button [CANCEL]17
- ⑦ Position memory button [POSITION MEMORY]14
- ⑧ Skip, Preset channel, TV channel buttons [◀◀ ▶▶], [SKIP, √ CH ^]15, 26, 34
- ⑨ Basic operation buttons13
- ⑩ Top menu, Direct navigator button [TOP MENU, DIRECT NAVIGATOR]13, 22
- ⑪ Cursor buttons [▲, ▼, ◀, ▶], Enter button [ENTER]11
- ⑫ Display, TV volume down button [DISPLAY, TV VOL-]23, 34
- ⑬ Volume buttons [-, +, VOLUME]13
- ⑭ Muting button [MUTING]30
- ⑮ Sound field, sound quality buttons28, 29
- ⑯ FM mode, Setup button [FM MODE, SETUP]11, 26
- ⑰ Zoom button [ZOOM]18
- ⑱ AV system standby/on button [⏻, AV SYSTEM]34
- ⑲ Source select buttons
 - Face towards this unit to change the source.
 - Press [TV] or [VCR/AUX] first to operate a Panasonic television or video cassette recorder (➡ page 34).
- ⑳ TV/AV button [TV/AV]34
- ㉑ Numbered buttons [1-9, 0, ≧10/-/-]13
- ㉒ Slow/search, Tuning buttons [◀◀ ▶▶ SLOW/SEARCH]15, 26
- ㉓ Menu, Play list button [MENU, PLAY LIST]13, 22
- ㉔ Return, TV volume up button [RETURN, TV VOL+]11, 34
- ㉕ Audio button [AUDIO]19
- ㉖ Group button [GROUP]15

Main unit

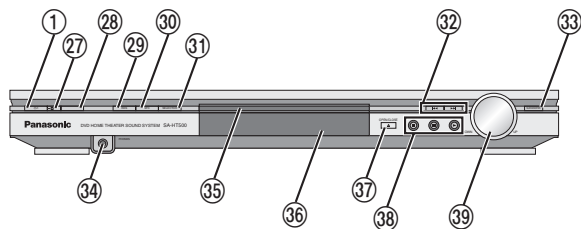

- ① Standby/on switch [⏻/⏿]11
Press to switch the unit from on to standby mode or vice versa. In standby mode, the unit is still consuming a small amount of power.
- ⑲ Standby/on indicator
When the unit is connected to the AC mains supply, this indicator lights up in standby mode and goes out when the unit is turned on.
- ⑳ Remote control signal sensor
- ㉑ RDS button [RDS]27
- ㉒ SFC button [SFC]29
- ㉓ Source select button [SELECTOR]
DVD/CD→FM→AM→TV→VCR/AUX
- ㉔ Skip, Preset channel buttons [◀◀ ▶▶]15, 26
- ㉕ Subwoofer level button [SUBWOOFER]29
- ㉖ Headphone jack [PHONES]30
- ㉗ Disc tray13
- ㉘ Display
- ㉙ Open/close button [▲, OPEN/CLOSE]13
- ㉚ Basic operation buttons13
- ㉛ Volume control [VOLUME, DOWN, UP]13

Subwoofer

- ⑳ AC supply indicator [AC IN]
This indicator lights when the unit is connected to the AC mains supply.



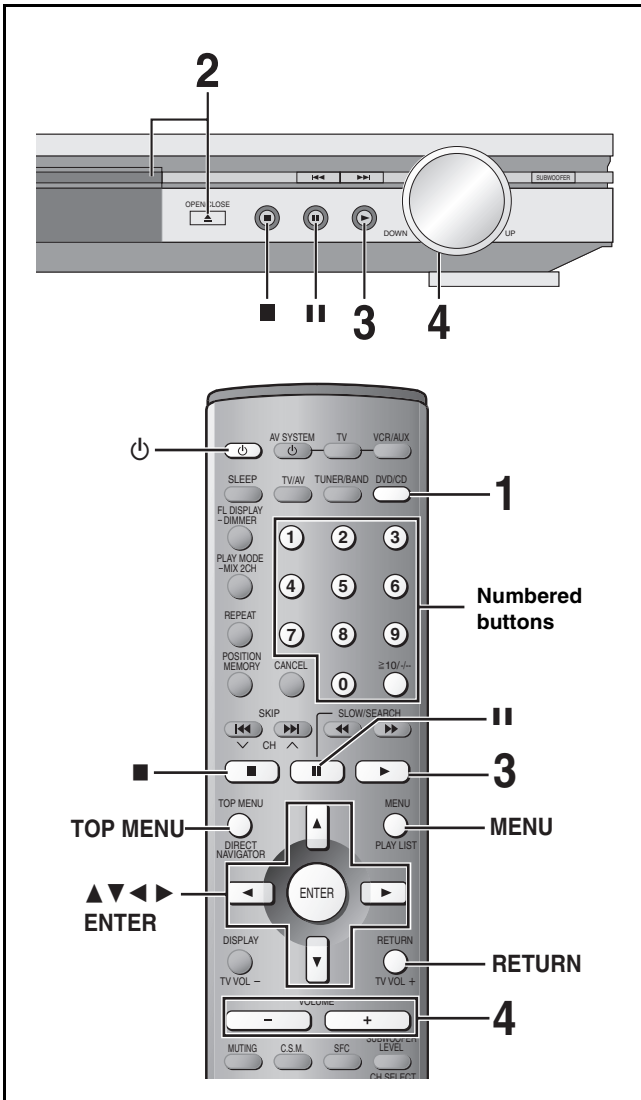

RAM DVD-A DVD-V VCD CD WMA MP3

Preparation

- Press [⏻] to turn on the unit.
- Turn on the television and select the appropriate video input on the television to suit the connections for the unit.

1 Press [DVD/CD] to select “DVD/CD” as the source.

2 Press [▲] to open the disc tray and place the disc.

- Remove TYPE 2 and 4 discs from their cartridges before use. **RAM**

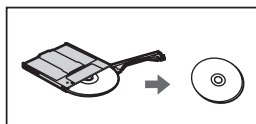

- Label-up (With double-sided discs, load so the label for the side you want to play is facing up.)

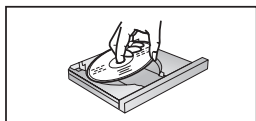

3 Press [▶] (play).

The disc tray closes and play begins.

WMA **MP3** **CD** (CD text only)

Group and track names are displayed on the television.

- To turn the display on or off → page 24, Disc information ⑤
- You can also use the navigation menus to control play (→ page 20).

4 Adjust the volume.

-- dB ▲ 0 dB

(Minimum) (Maximum)

■ To pause play

Press [⏸] during play.

Press [▶] (play) to restart play.

■ To stop play

Press [■] (→ page 14, Resume function).

Note

- If “⊘” appears on the television

The operation is prohibited by the unit or disc.

- It may take some time for play to start but this is normal.

When a menu appears on the television

DVD-A **DVD-V** **VCD**

Press the numbered buttons to select an item.

To select a 2-digit number

Example: To select item 23, press [≥10] → [2] → [3].

- When playing DVDs, you can also use [▲, ▼, ◀, ▶] to select items. Press [ENTER] to confirm your selection.

To return to the menu screen

DVD-A **DVD-V** [TOP MENU]: Shows the first menu screen.

DVD-V [MENU]: Shows the menu screen.

VCD [RETURN]: Shows the menu screen.

Note

- The disc continues to rotate while the menu is displayed even after you finish playing an item. Press [■] when you finish to preserve the unit's motor and your television screen.

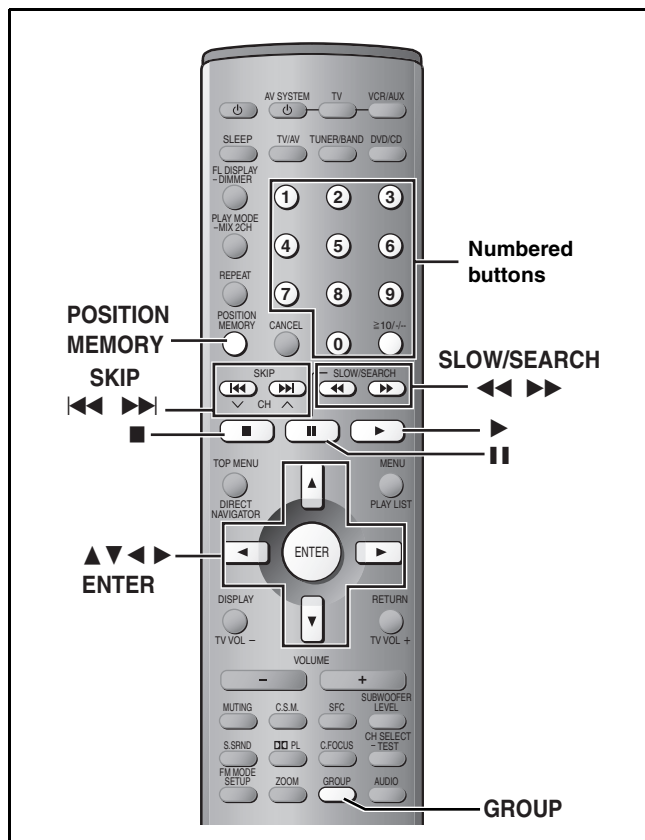

Starting play from a selected item

RAM DVD-A DVD-V VCD CD WMA MP3

Press the numbered buttons to select the item.

Play starts from the selected item.

To select a 2-digit number

Example: To select track 23, press [≧10] → [2] → [3].

WMA MP3 [2] → [3] → [ENTER]

Note

This works only when stopped with some discs.

Position Memory function

RAM DVD-A DVD-V VCD CD WMA MP3

During play

Press [POSITION MEMORY] to memorize a position.

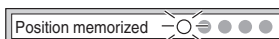

Press again to replace the position.

This position is saved even if you turn the unit off, change the source or open the disc tray. When you turn the unit on, reselect "DVD/CD" or reinsert the disc whose position you memorized, "RESUME" lights on the display. Press [▶] (play) to start play from the memorized position. The position is cleared.

- You can memorize positions on up to five different discs at a time. When you memorize another position, the earliest position is replaced.

Resume function

"RESUME" lights on the display when the unit has recorded the position at which you stopped play.

Press [▶] (play) to start play from that position.

- The position is cleared when you:
 - Turn the unit off.
 - Select another source or open the disc tray.
- Press [■] to clear the position.

Chapter Review

DVD-V

The following message appears immediately after you press [▶] (play) when "RESUME" is displayed.

Press PLAY to Chapter Review

Press [▶] (play) while the message is displayed and the beginning portions of each chapter up to the current one are played.

Full play resumes from the point where you pressed [■] or [POSITION MEMORY].

(This feature works only within a title.)

If you do not press [▶] (play), the message disappears and play starts from where you pressed [■] or [POSITION MEMORY].

Skipping items

RAM DVD-A DVD-V VCD CD WMA MP3

During play or while paused

Press [**⏮**] or [**⏭**].

- Each press increases the number of skips.

DVD-A DVD-V VCD CD WMA MP3

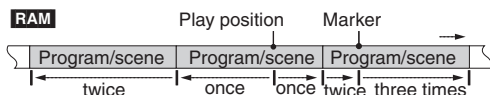
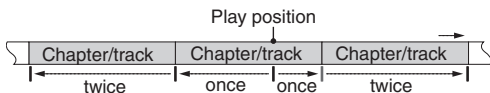

Fast forward and rewind—SEARCH

RAM DVD-A DVD-V VCD CD WMA MP3

During play

Press [**⏮**] or [**⏭**].

- Audio will be heard during search for most discs. You can turn this audio off if you want to (⇒ page 31, Audio—Audio during Search).
- **DVD-V** You can slow down or speed up play (⇒ page 23).

Slow-motion play

RAM DVD-V VCD

DVD-A (Motion picture parts only)

While paused

Press [**⏮**] or [**⏭**].

Frame-by-frame viewing

RAM DVD-V VCD

DVD-A (Motion picture parts only)

While paused

Press [**⏪**] or [**⏩**].

The frame changes each time you press the button.

- The frames change in succession if you press and hold the button.
- Pressing [**⏪**] also activates forward frame-by-frame.

Notes

- The speed of search and slow-motion increases up to 5 steps.
- Press [**▶**] (play) to restart play.
- You cannot move backwards with Video CD during frame-by-frame and slow-motion.

When playing Video CDs with playback control

Pressing buttons to perform skip, search or slow-motion may take you to a menu screen.

Selecting groups to play

DVD-A WMA MP3

1 During play

Press [**GROUP**].

Example MP3

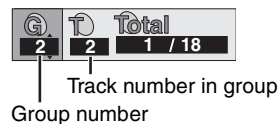

Group number

2 Press the numbered buttons to select the group and press [**ENTER**].

3 Press the numbered buttons to select the track number and press [**ENTER**].

DVD-A

Playing all the groups in succession (⇒ page 17, All group play)

Playing bonus groups

Some discs contain bonus groups. If a password screen appears after selecting a group, enter the password with the numbered buttons. Refer also to the disc's jacket.

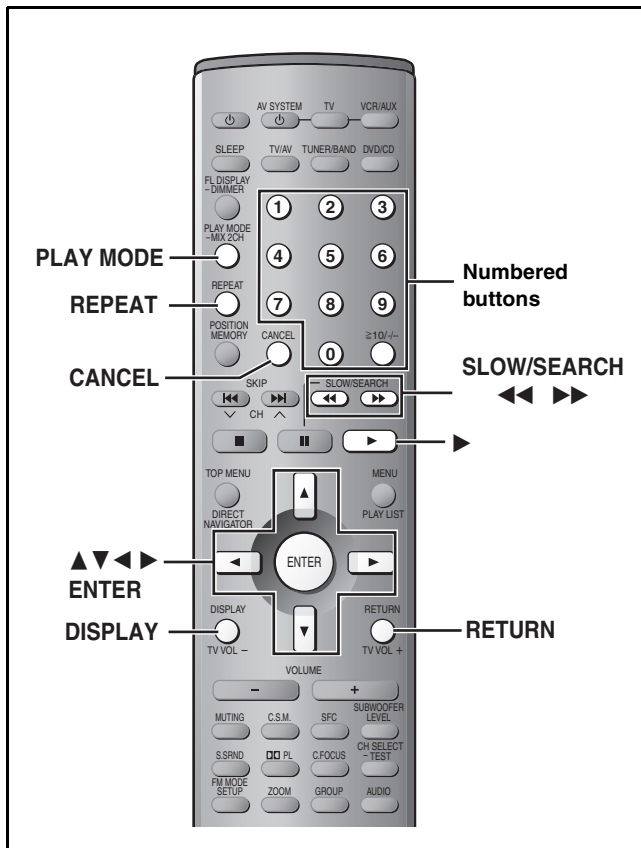

Repeat play

RAM **DVD-A** **DVD-V** **VCD** **CD** **WMA** **MP3**

During play
Press [**REPEAT**].

Each time you press the button:

RAM

Program → All (Entire disc) → Off

• During play list play

Scene → Playlist → Off

DVD-V

Chapter → Title* → Off

VCD **CD**

Track → All (Entire disc) → Off

DVD-A **WMA** **MP3**

Track → Group* → Off

※ During all group (**DVD-A**), program and random play
“All” is displayed.

■ To repeat only your favorite tracks/chapters

Start program play (→ page 17) and press [**REPEAT**] to select the repeat mode.

A-B repeat play

RAM **DVD-A** **DVD-V** **VCD** **CD** **WMA** **MP3**

You can repeat a section between points A and B within a program, title or track.

- 1 During play
Press [**DISPLAY**] until the unit information screen is displayed (→ page 24).
- 2 Press [**▲**, **▼**] to select the play menu.



A-B Repeat

- 3 Press [**◀**, **▶**] to select “A-B Repeat” and
 - ① Press [**ENTER**] at the starting point (A).
 - ② Press [**ENTER**] at the finishing point (B).



A-B repeat starts.

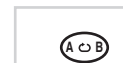

To return to the normal play
Press [**ENTER**] again.

To clear the menus
Press [**RETURN**] until the menu disappears.

Common procedures for all group, program and random play

While stopped

Press [PLAY MODE].

Each time you press the button:

All group (DVD-A) → Program → Random
 ↑ Off (Normal play) ↓

DVD-A

If you select bonus groups, you will have to enter a password (→ page 15).

All group play

DVD-A

Press [▶] (play).

ALL

Program play

You can select up to 32 items to play in the order you choose.

Example DVD-V

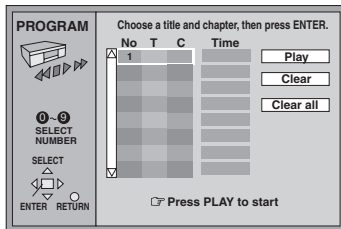

1 Press the numbered buttons to select a title, chapter, group or track (WMA MP3 then press [ENTER]).

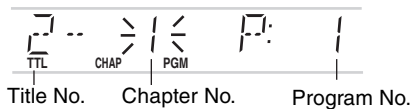

- **To select a 2-digit number**

Example: To select item 25, press [≥10] ⇒ [2] ⇒ [5].

WMA MP3: [2] ⇒ [5] ⇒ [ENTER].

- Repeat this step to program other items.

- **To select an item using the cursor buttons**

Press [ENTER] and [▲, ▼] to select an item, then press [ENTER] again to register the number.

All the items in the selected disc, title or group are selected when you select "ALL".

2 Press [▶] (play).

To add or change the program

Press [▲, ▼] to select an available item, then repeat step 1.

To move to the page before or after the one shown

Press [◀, ▶].

To clear an item

- 1 Select the item you want to clear with [▲, ▼].
- 2 Press [CANCEL], or select "Clear" with [▲, ▼, ◀, ▶] and press [ENTER].

To clear the whole program

Select "Clear all" with [▲, ▼, ◀, ▶] and press [ENTER].

Note

- DVD-V WMA MP3

Times are not displayed while programming.

- The program is cleared when you switch the unit to standby, open the disc tray, select another source, or exit the program mode by pressing [PLAY MODE].

Random play

1

DVD-A DVD-V

Press the numbered buttons to select a title or a group.

Example DVD-V

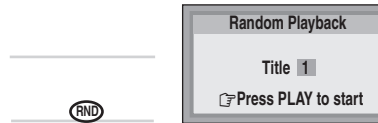

DVD-A

- You can select more than one group.
- To enter all groups, select "All" using [◀, ▶] and press [ENTER].
- To deselect a group, press the numbered buttons corresponding to the group you want to clear.

2 Press [▶] (play).

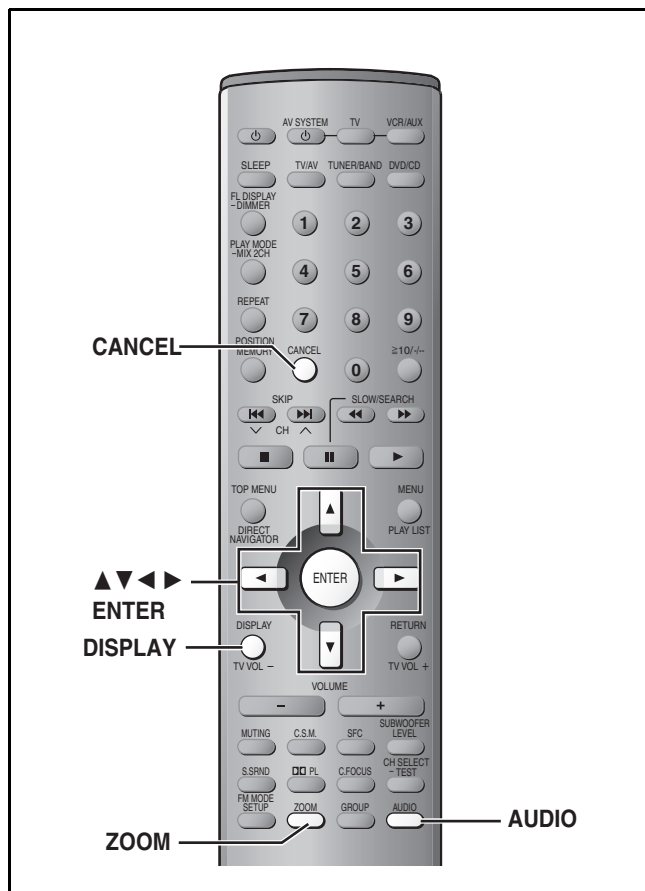

Marking places to play again

RAM **DVD-A** **DVD-V** **VCD** **CD** **WMA** **MP3**

You can mark a position so you can return to it easily at a later time.

- 1** During play
Press **[DISPLAY]** until the unit information screen is displayed (⇒ page 24).
- 2** Press **[▲, ▼]** to select the play menu.
Example **DVD-V**

- 3** Press **[◀, ▶]** to select “Marker” and press **[ENTER]**.
RAM
Press **[▶]** to select an asterisk (*).
- 4** Press **[ENTER]** at the point you want to mark.

To mark another position

Up to 5 points (**RAM** only: up to 999 points)

- Press **[▶]** to select “*”.
- Press **[ENTER]** at the point.

To recall or erase a marker

- Press **[◀, ▶]** to select a marker.
- Press **[ENTER]** to recall or press **[CANCEL]** to erase.

RAM

To mark the eleventh point and beyond

- Press **[◀, ▶]** to select the marker pin icon.

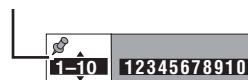

- Press **[▲, ▼]** to select “11–20”.

You can select the next group when the current group is full.

Note

Markers added with this unit clear when you switch the unit to standby, change the source, or open the disc tray.

Variable Zoom function

RAM **DVD-V** **VCD**

DVD-A (Motion picture parts only)

Change the zoom ratio so the picture expands to the optimum size to fill the screen.

Preparation

Change the setting “TV Aspect” to suit your television (⇒ page 31).

During play

Press **[ZOOM]** to select the aspect ratio.

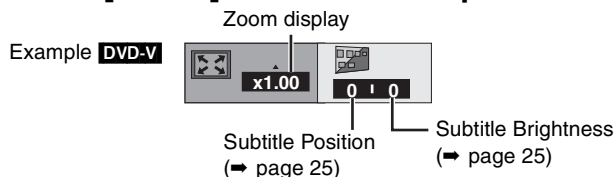

Each time you press the button:

4:3 Standard → **European Vista** → **16:9 Standard**

↑ **Cinemascope2** ← **Cinemascope1** ← **American Vista** ↓

• Refer to the disc’s instructions and “Screen size” below for the aspect ratio of the picture.

To restore the original ratio

Press **[ZOOM]** until the ratio returns to 1.00.

- The ratio also returns to 1.00 when you open the disc tray, change the source or switch the unit to standby.
- The ratio may return to 1.00 when a menu is displayed.

Making fine adjustments to the zoom ratio

While the ZOOM icon is displayed

Press **[▲, ▼]**.

The ratio changes in 0.01 units between 1.00 and 1.60 and in 0.02 units between 1.60 and 2.00.

Screen size

Movies are made using a variety of screen sizes.

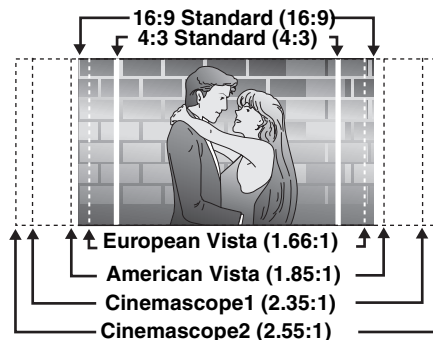

- “_” or “_” is displayed instead of the language number in circumstances such as when no language is recorded on the disc.

Soundtracks

RAM DVD-A DVD-V VCD

(Discs with multiple soundtracks)

During play

Press [AUDIO].

The number changes each time you press the button.

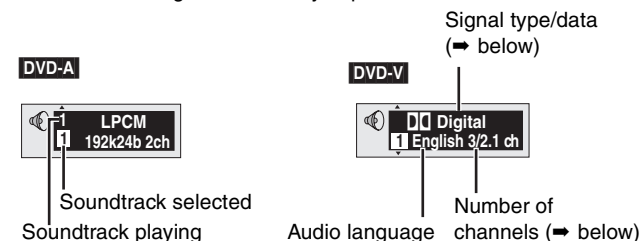

RAM VCD

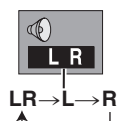

- You can also use this button to turn the vocals on and off on karaoke discs. Read the disc's instructions for details.

DVD-A

- Play restarts from the beginning of the soundtrack when changing soundtracks that are accompanied by still pictures.
- Even if a second soundtrack isn't recorded, two soundtrack numbers will normally be shown when you press [AUDIO]. The soundtrack currently playing is number 1.

Signal type/data

LPCM/PPCM/□□ Digital/DTS: Signal type

k (kHz): Sampling frequency

b (bit): Number of bits ch (channel): Number of channels

Example:

3/2 .1ch

.1: Low frequency effect
(not displayed if there is no signal)

0: No surround

1: Mono surround

2: Stereo surround (left/right)

1: Center

2: Front left+Front right

3: Front left+Front right+Center

Subtitles

DVD-A (Motion picture parts only)

DVD-V

(Discs with multiple subtitle languages)

You can change the subtitle language and turn the subtitles on and off.

RAM

You can turn the subtitles on and off.

1 During play

Press [DISPLAY] until the disc information screen is displayed.



Subtitle Number

2 Press [◀, ▶] to select “Subtitle Number”.



3 Press [▲, ▼] to select the language.



- In some cases, the subtitle language is not changed to the selected one immediately.
- Refer to “Audio/Subtitle language” (→ page 24) for language abbreviations.

To clear/display the subtitles

1 Press [◀, ▶] to highlight the following icon.

DVD-A DVD-V RAM



2 Press [▲, ▼] to select “OFF” or “ON”.

■ Changing the position and brightness of the subtitles (→ page 25)

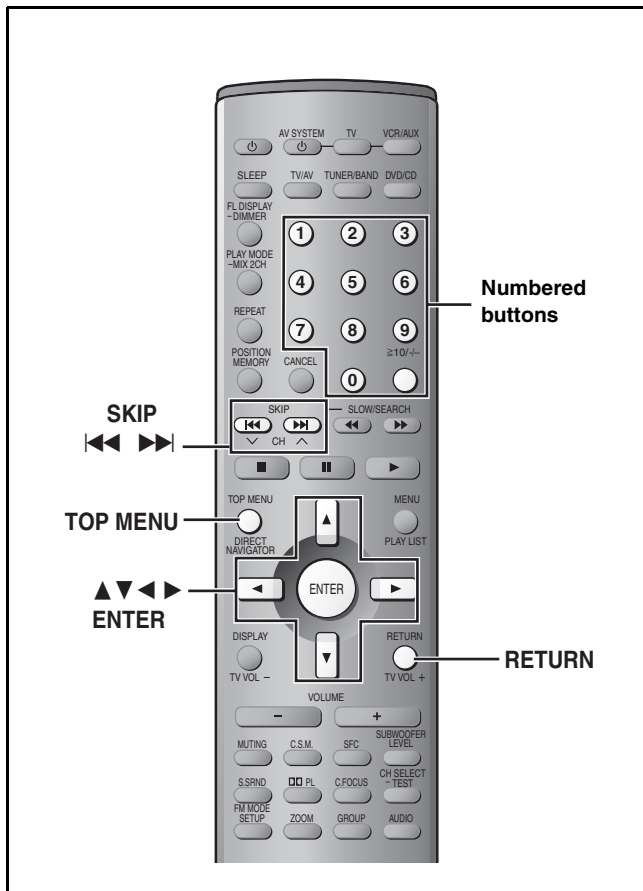

WMA **MP3** **CD** (CD text only)

Various numbers help you find items you want to start play.

1 Press [TOP MENU].

Example **MP3** navigation menu
Group name

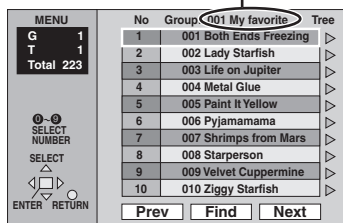

2 Press [▲, ▼] to select a track, and press [ENTER].

"" indicates the track currently playing.

To show other pages

Press [▲, ▼, ◀, ▶] to select "Prev" or "Next" and press [ENTER]. After listing all the tracks in one group, the list for the next group appears.

To exit the navigation menu

Press [TOP MENU].

Track title search

Example: finding a track including the word "LOVE"

1 Press [▲, ▼] to select "Find" and press [ENTER].

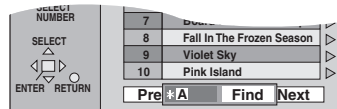

2 Press [▲, ▼] to select "L" and press [ENTER].

Characters change in alphanumeric order each time you press [▲].

Repeat this step to enter "O", "V", and "E".

- Press [◀▶] to skip between A, E, I, O, and U.
- Only uppercase appear but the search also includes lower case.
- Press [◀] to erase a character.
- You can erase the asterisk (*) to search for the first word in a title.
- You can enter numbers with the numbered buttons.

3 Press [▶] to select "Find" and press [ENTER].

The search results screen appears.

4 Press [▲, ▼] to select the track and press [ENTER].

To return to the navigation menu

Press [RETURN].

To use the tree screen to find a group **WMA** **MP3**

1 Press [▶] while a track is highlighted to display a tree screen.

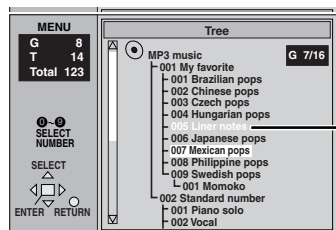

You cannot select groups that contain no compatible files.

2 Press [▲, ▼, ◀, ▶] to select a group and press [ENTER].

The navigation menu for the group appears.

To return to the navigation menu

Press [RETURN].

To use the contents screen to find a track

CD (CD text only)

You can use the text information recorded on these discs to find a track to play.

1 Press [▶] while a track is highlighted to display the contents screen.

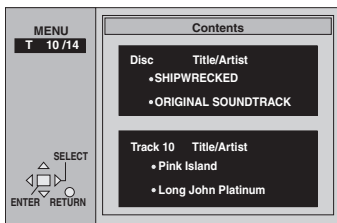

2 Press [◀, ▶] to move through the tracks and press [ENTER].

Note

- Discs must conform to ISO9660 level 1 or 2 (except for extended formats).
- This unit is compatible with multi-session but if there are a lot of sessions it takes more time for play to start. Keep the number of sessions to a minimum to avoid this.
- The order tracks appear in the menus may differ to the order shown on your computer.

WMA

- Noise may occur when playing WMA files.
- You cannot play WMA files that are copy protected.

MP3

- This unit is not compatible with ID3 tags.
- If you play an MP3 track that includes still picture data, it will take some time before the music itself starts playing and the elapsed time will not be displayed during this time. Even after the track starts, the correct play time will not be displayed.

Order of play

WMA **MP3**

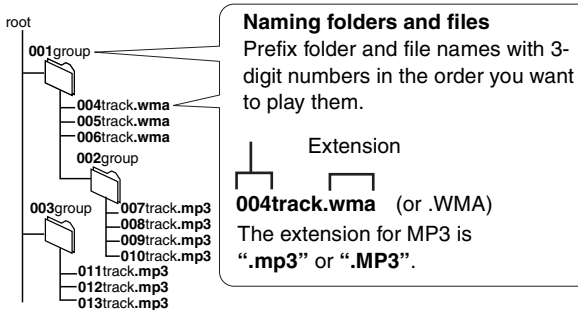

CD (CD text only)

When making your own CD text discs

The unit plays the tracks in the order you record them so you do not have to prefix the titles with numbers.

Windows Media, and the Windows logo are trademarks, or registered trademarks of Microsoft Corporation in the United States and/or other countries.



WMA is a compression format developed by Microsoft Corporation. It achieves the same sound quality as MP3 with a file size that is smaller than that of MP3.

MPEG Layer-3 audio decoding technology licensed from Fraunhofer IIS and Thomson multimedia.

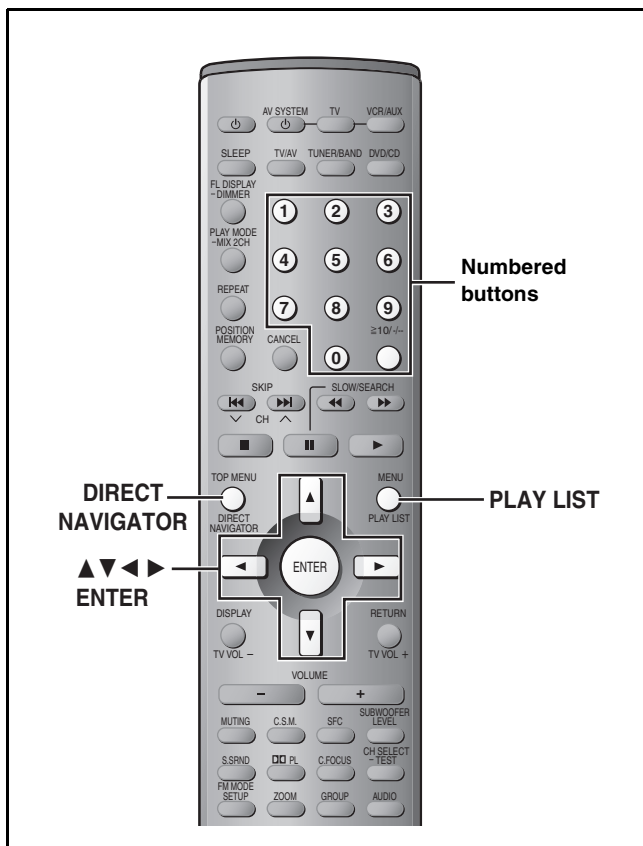

Using the play list menu

You can play a group of scenes, a play list, created on other equipment such as a DVD video recorder.

1 Press [PLAY LIST].

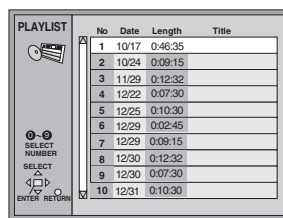

2 Press [▲, ▼] to select the play list.

• You can select play lists with the numbered buttons.

To select a 2-digit number

Example 23: [≥10] → [2] → [3]

3 Press [ENTER] to start play.

To clear the play list screen

Press [PLAY LIST].

RAM

Selecting a program to play —DIRECT NAVIGATOR

Use the program list to find programs to play.

1 Press [DIRECT NAVIGATOR].

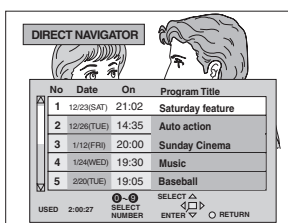

2 Press [▲, ▼] to select the program.

The selected program plays in the background.

• You can select programs with the numbered buttons.

To select a 2-digit number

Example 23: [≥10] → [2] → [3]

3 Press [ENTER].

The program being played in the background continues.

To clear the program list

Press [DIRECT NAVIGATOR].

Note

- Titles appear only if you have entered them.
- You cannot change program and disc titles.

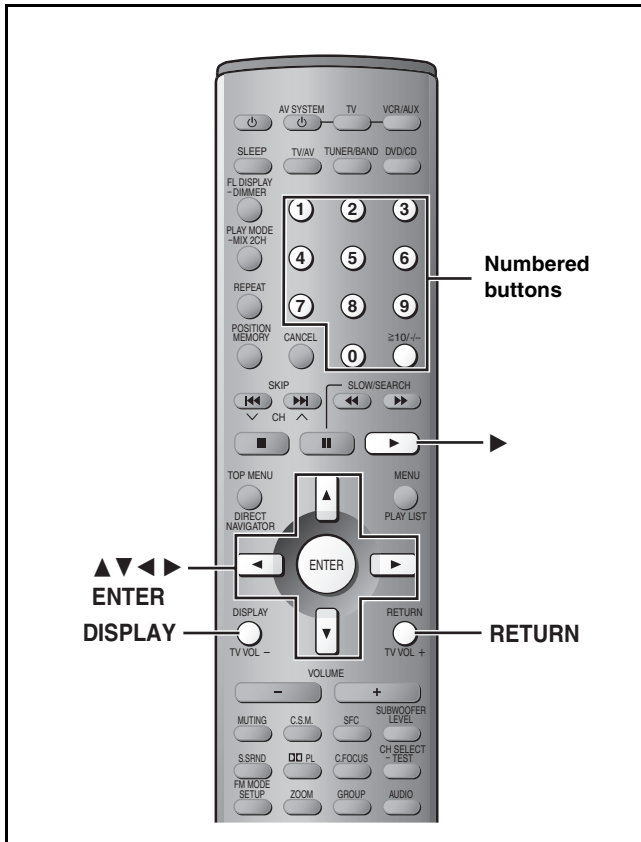

RAM DVD-A DVD-V VCD CD WMA MP3

GUI screens are menus that contain information about the disc or unit. These menus allow you to perform operations by changing this information.

Common procedures

1 Press [DISPLAY].

Each time you press the button:

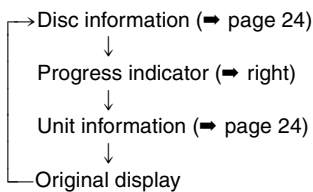

2

Unit information only

While the leftmost icon is highlighted

Press [▲, ▼] to select the menu.

Each time you press the button:

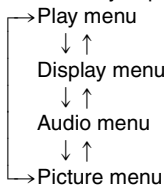

3 Press [◀, ▶] to select the item.

4 Press [▲, ▼] to select the setting.

- Items with “▲” or “▼” above and below can be changed by [▲, ▼].
- Press [ENTER] if the setting does not change after pressing [▲, ▼].
- Some items require different operations. Read the explanations on the following pages.

For your reference

- Depending on the condition of the unit (playing, stopped, etc.) and the type of software you are playing, there are some items that you cannot select or change.
- When numbers are displayed (e.g. title No.), the numbered buttons are also effective for setting. After entering the numbers, press [ENTER] to register the setting.

To clear the menus

Press [RETURN] until the menus disappear.

■ To change the position of the icons

- 1 Press [◀, ▶] to select the rightmost icon.
 - 2 Press [▲, ▼] to move the icons. 
- (There are 5 positions.)

Progress indicator

Indicates how far you have played through an item.

Example **DVD-V**

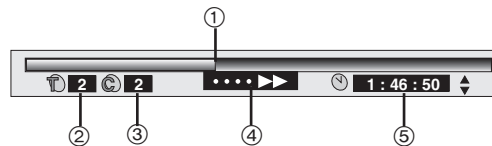

① **Current position** RAM DVD-A DVD-V VCD CD WMA MP3

② **PG: Program number** RAM

PL: Play list number RAM

T: Title number DVD-V

Track number VCD CD

G: Group number DVD-A WMA MP3

③ **T: Track number in group** DVD-A WMA MP3

C: Chapter number DVD-V

④ **Condition – play, pause, or slow/search**

RAM DVD-A DVD-V VCD CD WMA MP3

Play speed (⇒ below)

⑤ **Changing the time display** RAM DVD-A DVD-V VCD CD

Press [▲, ▼] to show the elapsed play time or remaining time for the program, play list, track or title (or chapter during program and random play).

Elapsed play time WMA MP3

(display only, cannot be changed)

Changing play speed

DVD-V (Dolby Digital only)

You can slow down or speed up play.

During play

Press [◀] (slower) or [▶] (faster).

There are five speeds:

×0.8 ↔ ×0.9 ↔ ×1.0 (normal speed) ↔ ×1.2 ↔ ×1.4

After you change the speed, output is in stereo.

Sound is stereo as long as “×1.0” is orange.

To return to normal play (surround sound), press [▶] (play) or [ENTER].

Normal play is also restored when you return the speed to x1.0 and clear the progress indicator.

Unless otherwise indicated, select items with [◀, ▶] and change with [▲, ▼].

Disc information

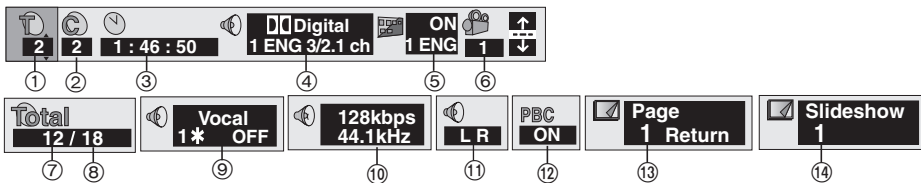

Disc operations

①	PG: Program number RAM PL: Play list number RAM G: Group number DVD-A WMA MP3 T: Title number DVD-V Track number VCD CD	[▲, ▼] ↓ [ENTER]
②	T: Track number in group DVD-A WMA MP3 C: Chapter number DVD-V	
③	Time RAM DVD-A DVD-V Select a position to start play by specifying a time.	Numbered buttons ↓ [ENTER]
	Changing the time display RAM DVD-A DVD-V VCD CD (WMA MP3 Display only) → Elapsed play time for the program, play list, title or track ↓ ↑ Remaining time for the group (DVD-A) or disc (VCD CD) ↓ ↑ → Remaining time for the program, play list, title or track	
④	Soundtrack RAM DVD-A DVD-V (⇒ page 19)	
⑤	Subtitle language DVD-A DVD-V (⇒ page 19) Subtitles on/off RAM DVD-A DVD-V Track information on/off WMA MP3 CD (CD text only)	
⑥	Angle number DVD-A DVD-V	

⑦	Track number in disc WMA MP3	[▲, ▼] ↓ [ENTER]
⑧	Total number of tracks on disc WMA MP3	Display only
⑨	Karaoke vocal on/off DVD-V (Karaoke DVD only) If a DVD title is a duet, select V1 or V2 to duet with the unit.	
⑩	Current bitrate (kbps) Current sampling frequency (kHz) WMA MP3	Display only
⑪	Audio mode RAM VCD LR ↔ L ↔ R ↑ ↔ ↓	
⑫	Menu play VCD (with playback control only)	Display only
⑬	Still picture number DVD-A ● To return to page 1 [◀, ▶] → Select "Return" → [ENTER]	
⑭	Slideshow DVD-A Picture number	Display only

Audio/Subtitle language

ENG: English	SVE: Swedish	CHI: Chinese
FRA: French	NOR: Norwegian	KOR: Korean
DEU: German	DAN: Danish	MAL: Malay
ITA: Italian	POR: Portuguese	VIE: Vietnamese
ESP: Spanish	RUS: Russian	THA: Thai
NLD: Dutch	JPN: Japanese	*: Others

Unit information

Play menu

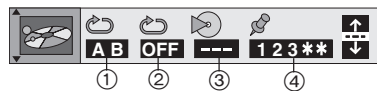

①	A-B repeat (⇒ page 16) RAM DVD-A DVD-V VCD CD WMA MP3	[ENTER]
②	Repeat mode (⇒ page 16) RAM DVD-A DVD-V VCD CD WMA MP3	
③	Play mode (⇒ page 17) DVD-A DVD-V VCD CD WMA MP3 ---: Normal play PGM: Program play RND: Random play ALL: All group play (DVD-A)	Display only
④	Marker RAM DVD-A DVD-V VCD CD WMA MP3	⇒ Page 18

Audio menu

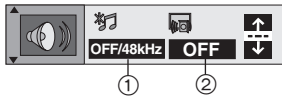

①	Re-master (→ page 29) RAM DVD-A DVD-V CD WMA MP3
②	Dialogue Enhancer on/off DVD-V (Discs where the dialogue is recorded in the center channel) This makes the dialogue in movies easier to hear.

Display menu

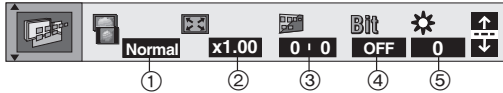

①	4:3 Aspect RAM DVD-A DVD-V VCD Select how to show images made for 4:3 aspect screens on a 16:9 aspect television. <ul style="list-style-type: none"> •Normal: laterally stretches images made for a 4:3 screen. •Auto: expands suitable 4:3 letterbox images to fill more of the screen. Other images appear in full in the center of the screen. •Shrink: images appear in the center of the screen. •Zoom: expands all images to fill the screen. If your television has a similar feature, use it instead for a better effect.
②	Zoom (→ page 18) RAM DVD-A DVD-V VCD <div style="text-align: center;"> [ENTER] ↓ [◀, ▶] ↓ [ENTER] </div> Making fine adjustments to the zoom ratio
③	Subtitle position/Subtitle brightness DVD-A DVD-V <ul style="list-style-type: none"> •Position (0 to -60): in 2 unit steps •Brightness (Auto*/0 to -9) *The brightness adjusts automatically against the background.
④	Bitrate display on/off RAM DVD-A DVD-V VCD During play: shows the bitrate (approximate values) of the video being played While paused: shows the data volume of the frame and type of picture (→ page 38, Glossary—I/P/B) <div style="text-align: center;"> </div> Current bitrate Average bitrate A record of bitrates for a sampling period.
⑤	OSD brightness (-3 to +3) Adjust the brightness of the on-screen displays.

Picture menu **RAM DVD-A DVD-V VCD**

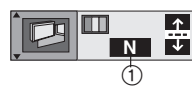

①	Picture mode <ul style="list-style-type: none"> •N: Normal mode •S: Soft mode (Soft picture with fewer video artifacts) •F: Fine mode (Details are sharper) •C1: Mellows images and enhances detail in dark scenes •C2: Sharpens images and enhances detail in dark scenes •U1/U2: User mode (→ below)
---	--

To change the user mode

- 1 Select User mode and press [▶] to highlight the number.
- 2 Press [▲, ▼] to select "1" or "2".



U1: MPEG D.N.R. (Digital Noise Reduction)

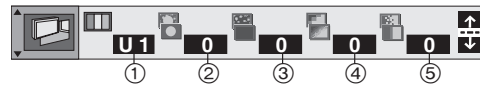

②	Depth Enhancer (0 to +4) Reduces the rough noise in the background to give a greater feeling of depth.
③	3D-NR (0 to +4)/ Dot NR (On) Reduces overall noise/Reduces the dot noise that occurs at the borders between colors.
④	Block NR (0 to +3) Smooths block noise.
⑤	Mosquito NR (0 to +3) Reduces the smudging that appears around contrasting sections of the picture.

U2

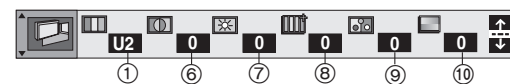

⑥	Contrast (-7 to +7) Increases the contrast between light and dark parts of the picture.
⑦	Brightness (0 to +15) Brightens the picture.
⑧	Sharpness (-7 to +7) Adjusts the sharpness of the edges of the horizontal lines.
⑨	Color (-7 to +7) Adjust the shade of the picture's color.
⑩	Gamma (0 to +5) Emphasis of outlines.

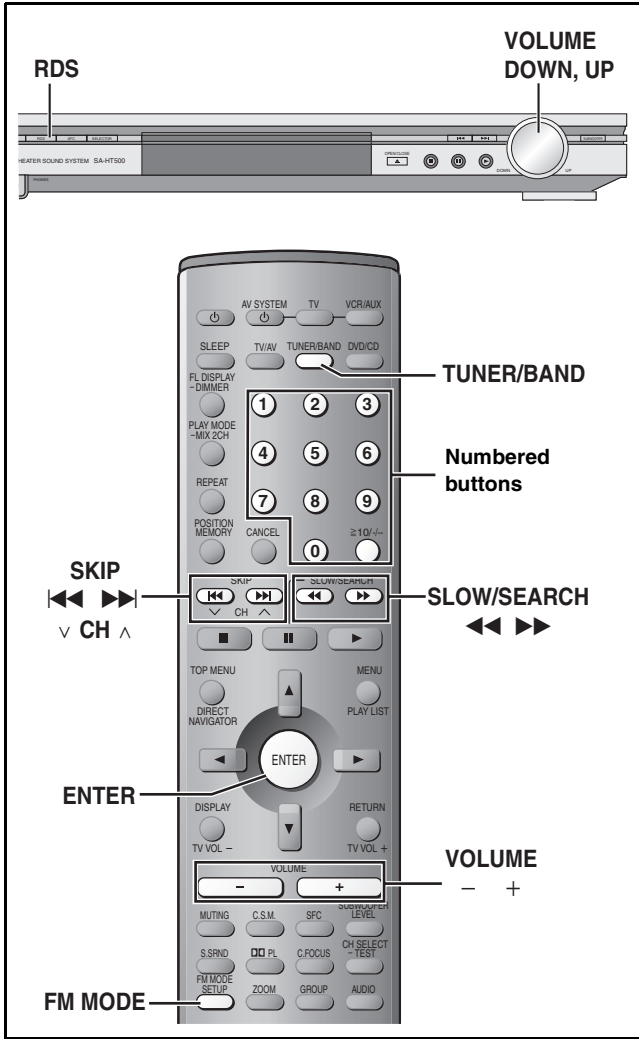

Manual tuning

- 1 Press [TUNER/BAND] to select “FM” or “AM”.
- 2 Press [◀◀] or [▶▶] to select the frequency of the required station.
 TUNED: Displayed when a radio station is tuned.
 ST: Displayed when a stereo FM broadcast is being received.
 Press and hold [◀◀] or [▶▶] until the frequency starts scrolling to start automatic tuning. Tuning stops when a station is found.
- 3 Adjust the volume.

■ If noise is excessive in FM
 Press [FM MODE] to display “MONO”.

Press [FM MODE] again to cancel the mode.
 The mode is also canceled when you changed the frequency.

Preset tuning

Preset channels to make selection simple.
 Up to 15 stations can each be set in the FM and AM bands.

Automatic presetting

- 1 Tune to “FM 87.50 MHz” (⇒ left).
- 2 Press and hold [ENTER].
 Release the button when “FM AUTO” is displayed.
 The tuner presets all the stations it can receive into the channels in ascending order.
 “SET OK” is displayed when the stations are set. The last station to be set is then played.
- 3 Tune to “AM 522 kHz”.
- 4 Press and hold [ENTER].

■ “ERROR” is displayed
 Presetting was unsuccessful. Preset manually.

Manual presetting

- 1 Tune to the station (⇒ left).
- 2 Press [ENTER].
- 3 While “PGM” is flashing
 Press the numbered buttons to select a channel.
 Alternatively, press [◀◀, √ CH] or [▶▶, CH ^] then press [ENTER].



The station occupying a channel is erased if another station is preset in that channel.

Selecting channels

- 1 Press [TUNER/BAND] to select “FM” or “AM”.
- 2 Press the numbered buttons or [◀◀, √ CH] or [▶▶, CH ^] to select the channel.



To select a 2-digit number
 Example: To select channel 12, press [≥10] ⇒ [1] ⇒ [2]

RDS broadcasting

For the United Kingdom and Continental Europe

Main unit only

The unit can display the text data transmitted by the radio data system (RDS) available in some areas. If the station you are listening to is transmitting RDS signals, "RDS" will light up on the display.

Displaying the text data

Press [RDS].

Each time you press the button:
 PS → PTY → Frequency display

PTY displays			
NEWS	VARIED	FINANCE	COUNTRY
AFFAIRS	POP M	CHILDREN	NATIONAL
INFO	ROCK M	SOCIAL A	OLDIES
SPORT	M.O.R. M*	RELIGION	FOLK M
EDUCATE	LIGHT M	PHONE IN	DOCUMENT
DRAMA	CLASSICS	TRAVEL	TEST
CULTURE	OTHER M	LEISURE	ALARM
SCIENCE	WEATHER	JAZZ	

*"M.O.R. M"= Middle of the road music

Note

RDS displays may not be available if reception is poor.

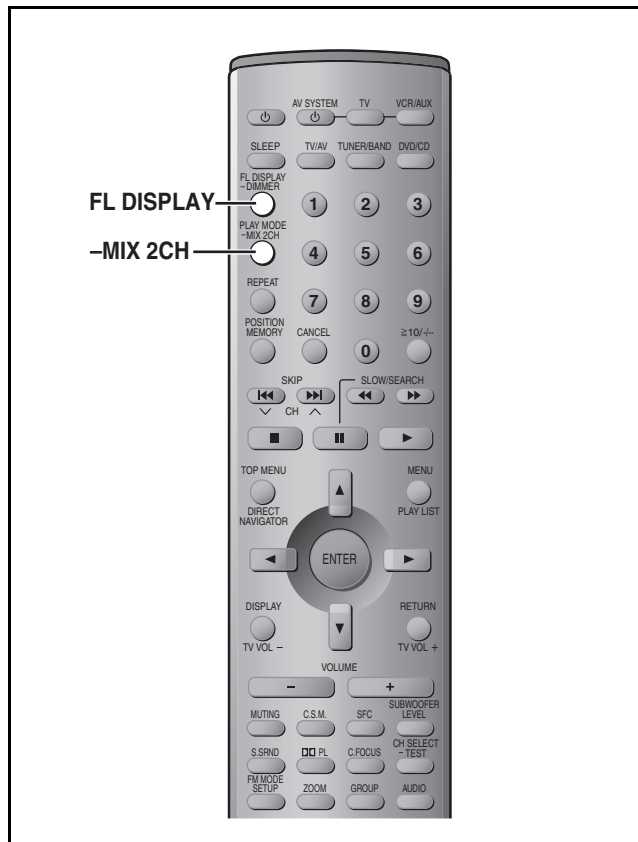

- Dolby Pro Logic, Super Surround, Center Focus and Subwoofer Level adjusting (→ page 29) cannot be used if headphones are connected ("ERROR" appears on the display).
- You may experience a reduction in sound quality when these sound field systems are used with some sources. If this occurs, turn the sound field system off.

Dolby Digital and DTS

- Dolby Digital and DTS are digital encoding systems used on DVD to carry surround sound. Both were originally developed for use in cinemas.
- This unit automatically recognizes and decodes these systems.

Software encoded with Dolby Digital can be identified with this mark.



Software encoded with DTS can be identified with this mark.



Play a Dolby Digital or DTS source.

The Dolby Digital or DTS indicator lights.



To down-mix Dolby Digital or DTS (multiple-channel) signals to 2 channels

Press and hold [-MIX 2CH].

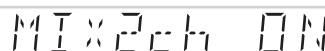

To cancel, press and hold [-MIX 2CH] again.

To check the current setting

Press [FL DISPLAY].

When "D.MIX" flashes on the display DVD-A

The DVD-Audio contains multiple-channel signals that cannot be down-mixed.

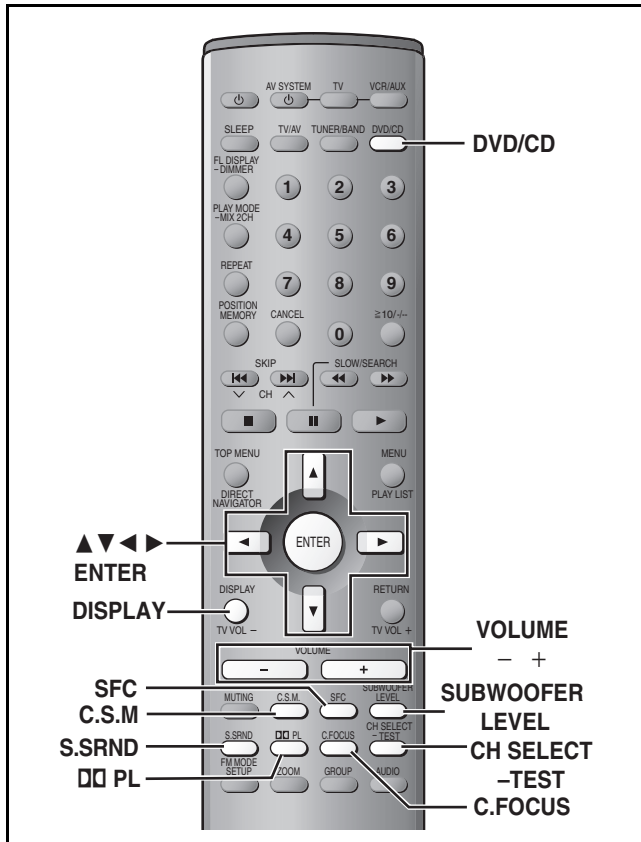

Dolby Pro Logic

Dolby Pro Logic is a decoding system that was developed to get a better sense of presence from sources encoded with Dolby Surround. The feeling of position has been improved by the addition of a separate center speaker channel.

Software encoded with Dolby Surround can be identified with this mark (DVD, CD, Video CD, Laser Disc, Video tape).



1 Press [DOLBY PL].



2 Play a Dolby Surround source.

To cancel

Press [DOLBY PL] again.

Note

This does not work when playing multi-channel Dolby Digital.

Speaker level adjustments

If the level of the speakers appears to be different while listening to a source, adjust the level of the speakers to the same apparent level.

Preparation

● Press [DVD/CD].

1 Press and hold [–TEST] to output a test signal.

- Lch: Front left
- Cch: Center
- Rch: Front right
- RSch: Right surround
- LSch: Left surround

2 Press [VOLUME, +] or [–] to set the volume level normally used for enjoying the source.

3 Press [▲] (to increase) or [▼] (to decrease).

- L, R: –16 dB to 0 dB
- C, RS, LS: –10 dB to +6 dB

To stop the test signal, press and hold [–TEST] again.

To adjust speaker level during play

1 Press [CH SELECT] to select the speaker.

- Lch → Cch → Rch → RSch → LSch → SWch

SWch: Subwoofer

● You can only adjust SWch if the disc includes a subwoofer channel.

2 Press [▲] (to increase) or [▼] (to decrease).

- L, R: –16 dB to 0 dB
- C, RS, LS: –10 dB to +6 dB
- SW: –10 dB to +10 dB

Super Surround

Add surround effects to stereo sound.

Press [S.SRND].

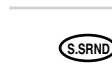

Each time you press the button:

- MUSIC → MOVIE → OFF

● You can adjust the volume of the surround speakers to get the best surround effect (➡ above, Speaker level adjustments).

Note

- Turn Super Surround off when playing a DVD recorded with Dolby Digital or DTS. The surround effects will not be reproduced correctly if this is left on.
- Dolby Pro Logic (➡ left) switches off.

Sound Field Control

Press [SFC] to select a setting.



Each time you press the button:

- HEAVY:** Adds punch to rock.
- CLEAR:** Clarifies higher sounds.
- SOFT:** For background music.
- DISCO:** Reverberates sound to make you feel like you were in a disco.
- LIVE:** Makes vocals more alive.
- HALL:** Expands sound to make you feel like you were in a hall.
- FLAT:** Canceled (no effect is added) (factory preset).

To check the current setting

Press [SFC].

Center Focus

You can make the sound of the center speaker seem like it is coming from within the television.

Press [C.FOCUS].



Each time you press the button:

CENTER FOCUS 1 (Normal) → CENTER FOCUS 2 (Enhanced)
 ← OFF →

- This does not work when Super Surround is turned on.
- This will have less effect when Dolby Pro Logic is turned on.

Custom Sound Memory—Store the sound settings

DVD-A DVD-V VCD CD

Store the sound settings for a disc so the unit recalls them the next time you play it.

- Number of discs: 30
- Settings: Dolby Pro Logic, Subwoofer level, Center Focus, Sound Field Control, Super Surround

Store the settings

- 1 Make the settings.
- 2 Press and hold [C.S.M].



Recall the settings

The unit recalls the settings when you play the disc again.

- The settings are replaced if you change them.
- When you store settings for a 31st disc, the earliest settings disappear.
- Press [C.S.M] while “CSM” is lit and the settings return to those that were on before the settings are recalled.
- Press [C.S.M] while “CSM” is out and you are playing a disc for which you stored settings and those settings are recalled.

Adjusting the bass

Press [SUBWOOFER LEVEL].



Each time you press the button:

SUB W 1 → SUB W 2 → SUB W 3 → SUB W 4 (factory preset)
 ↑

Re-master—Enjoying more natural sound

RAM DVD-A DVD-V CD

Discs recorded with 2-channel LPCM at 44.1 kHz or 48 kHz

This feature gives you a more natural sound by adding the higher frequency signals not recorded on the disc.

WMA MP3

Discs recorded at 44.1 kHz or 48 kHz

This feature reproduces the frequencies lost during recording to give you a sound closer to the original.

- 1 During play
Press [DISPLAY] until the unit information screen is displayed (→ page 25).

- 2 Press [▲, ▼] to select the audio menu.



Re-master

- 3 Press [◀, ▶] to select “Re-master”.
- 4 Press [▲, ▼].

Each time you press the button:

Setting	RAM DVD-A DVD-V CD Type of music	WMA MP3 Effect level
1	High tempo (e.g., pops and rock)	Light
2	Various tempos (e.g., jazz)	Medium
3	Low tempo (e.g., classical)	Strong
OFF	Off	Off

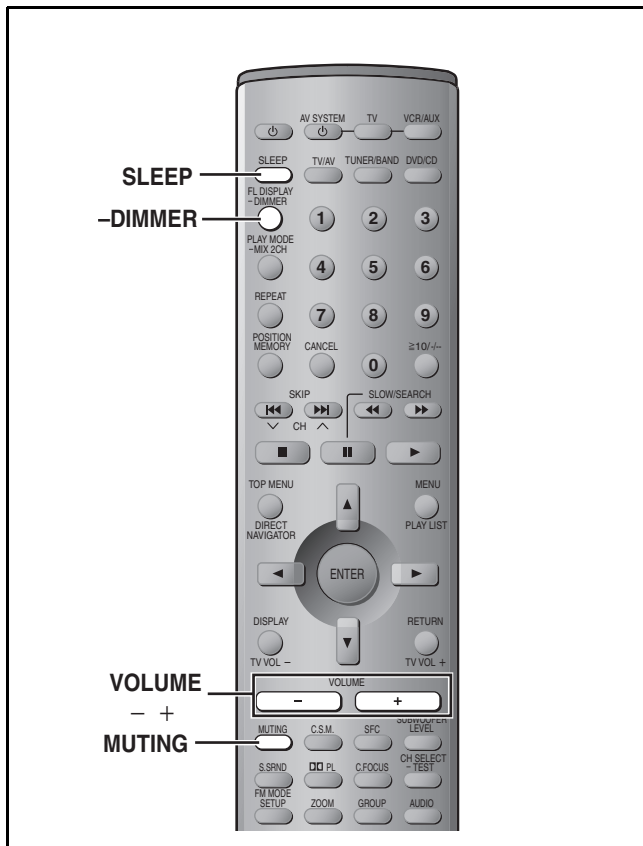

Muting the volume

Press [MUTING].



Volume is reduced to minimum.

To cancel

Press [MUTING] again or reduce the volume to minimum (--- dB), then raise it to the required level. Muting is also canceled when you switch the unit to standby.

Dimming the display

Press and hold [-DIMMER].

To return to the original brightness, press and hold [-DIMMER] again.

The display also returns to the original brightness when you switch the unit to standby.

The sleep timer

This timer turns the unit off after a set time.

Press [SLEEP] to select the time (minutes).

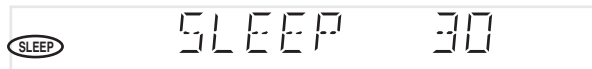

Each time you press the button:

SLEEP 30 → SLEEP 60 → SLEEP 90
 ↑ SLEEP OFF ← SLEEP 120 ←

To cancel the timer

Press [SLEEP] to select "SLEEP OFF".

To check the SLEEP setting

Press [SLEEP] once.

- The time remaining appears.

To change the setting

Press [SLEEP] to display the remaining time, then press again to select the required time.

Using headphones

- 1 Reduce the volume and connect the headphones (not included).

Headphone plug type: 3.5 mm stereo

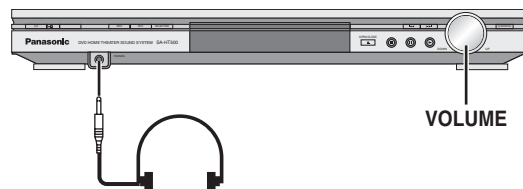

- 2 Adjust headphone volume with [VOLUME].

Audio is automatically switched to stereo (2-channel).





Note

Avoid listening for prolonged periods of time to prevent hearing damage.

Changing settings

This chart shows the settings for this unit. Change the settings to suit your preferences and to suit the unit to the environment in which it is being used. These settings are retained in memory until they are changed, even if the unit is turned off. See page 32 for details on menu operation.

• Underlined items are the factory preset.

Menus	Items	Options
Disc 	Audio Choose the preferred audio language.	<u>English</u> French German Italian Spanish Portuguese Swedish Dutch Original Other **** Original: The original language of each disc will be selected. Other ****: Input a code number with the numbered buttons (⇒ page 33).
	Subtitle Choose the preferred subtitle language.	<u>Automatic</u> English French German Italian Spanish Portuguese Swedish Dutch Other **** Automatic: If the language selected for "Audio" is not available, subtitles of that language will automatically appear if available on that disc.
	Menus Choose the preferred language for disc menus.	<u>English</u> French German Italian Spanish Portuguese Swedish Dutch Other ****
	Ratings (⇒ page 33) Set a ratings level to limit DVD-Video play. • The password screen is shown if you choose levels 0 to 7 or if you choose "Ratings" when levels 0 to 7 have been selected. • Select "Level 0" to prevent play of discs that do not have ratings levels recorded on them.	Setting ratings (When level 8 is selected) <u>8 No Limit</u> : All DVD-Video can be played. 1 to 7: Prohibits play of DVD-Video with corresponding ratings recorded on them. 0 Lock All: Prohibits play of all DVD-Video. Changing ratings (When level 0–7 is selected) Unlock Player Change Level Change Password Temporary Unlock
Video 	TV Aspect (⇒ page 11) Choose the setting to suit your television and preference.	<u>4:3 Pan&Scan</u> 4:3 Letterbox 16:9
	TV Type (⇒ page 11) Select to suit the type of television.	<u>Standard (Direct View TV)</u> CRT Projector LCD TV/Projector Projection TV Plasma TV
	AV Output *1 (⇒ page 8) Choose the video signal format to be output from the SCART terminal.	<u>Video</u> S-Video RGB
	Still Mode Specify the type of picture shown when paused.	<u>Automatic</u> Field Frame
	NTSC Disc Output Choose whether PAL 60 or NTSC signals are output during playback of NTSC discs (⇒ page 5).	<u>PAL60</u> : when connected to a PAL television. NTSC: when connected to an NTSC television.
Audio 	Speaker Setting (⇒ page 33) Set the delay time for your center and surround speakers.	Multi-channel Center: 0/1.3/2.6/3.9/5.3 ms Surround (L/R): 0/5.3/10.6/15.9 ms
	Dynamic Range Compression (Dolby Digital only) Change the dynamic range for late night viewing.	<u>Off</u> On: For clear dialog when listening at low volume.
	Audio during Search Choose whether to have sound during search.	<u>On</u> Off • This feature doesn't work for some discs.
Display 	Menu Language Choose the preferred language for these menus and the on-screen messages.	<u>English</u> Français Deutsch Italiano Español Português Svenska Nederlands
	On-Screen Messages Choose whether to show on-screen messages or not.	<u>On</u> Off
Others 	DVD-Video Mode Select how to play pictures contained on some DVD-Audio. The setting returns to "Off" when you remove the disc, turn the unit off or change the source.	<u>Off</u> : DVD-Audio are played as DVD-Audio. On: DVD-Video contents found on DVD-Audio can be played.
	QUICK SETUP (⇒ page 11) Answer questions to make basic settings.	Yes (Menu language, Audio language, Subtitle language, TV type, TV aspect, AV Output*1) <u>No</u>

*1 For the United Kingdom and Continental Europe

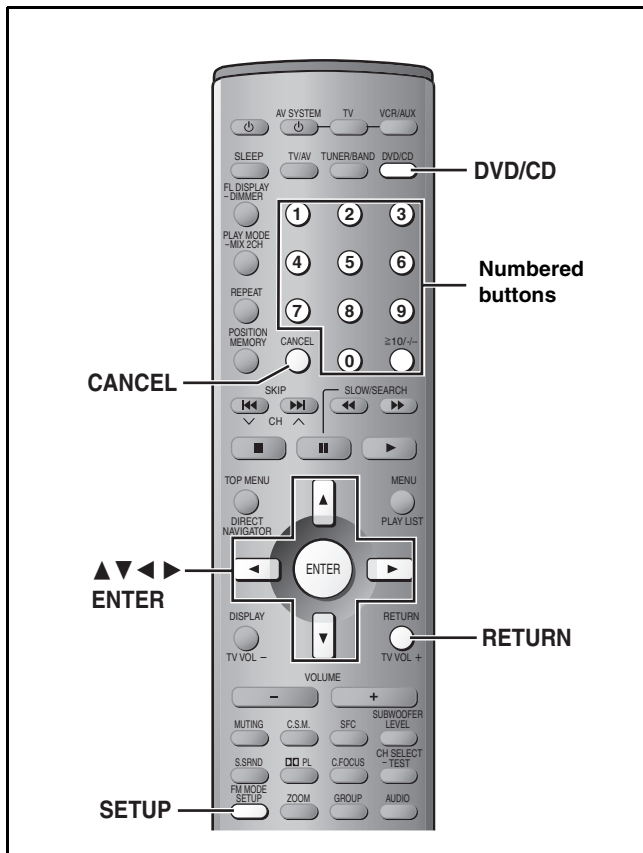

Common procedures

See page 31 for menu and option details.

Preparation

Press [DVD/CD].

1 Press [SETUP] to show the menus.

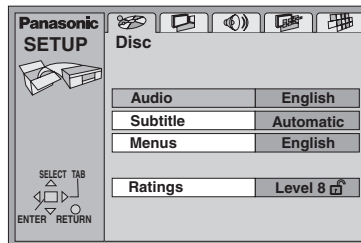

2 Press [◀, ▶] to select the menu's tab.

The screen changes to display the menu.

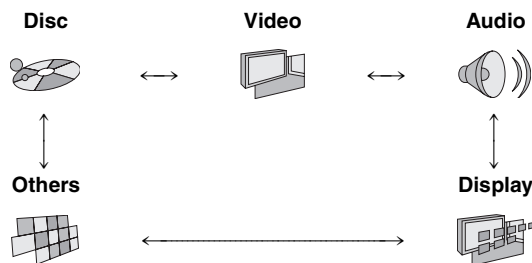

3 Press [▲, ▼] to select the item you want to change and press [ENTER].

4 Press [▲, ▼, ▶, ◀] to select the option and press [ENTER].

The screen now shows the menu again.

To return to the previous screen

Press [RETURN].

When you are finished

Press [SETUP].

Entering a password (Ratings)

DVD-V

The password screen is shown when you select levels 0 to 7.

- Input a 4-digit password with the numbered buttons and press [ENTER].
 - If you enter a wrong number, press [CANCEL] to erase it before you press [ENTER].
 - The lock symbol appears closed to show the rating is locked.
 - Do not forget your password.**
- Press [ENTER] to confirm the 4 digits.

Now, when you insert a DVD-Video that exceeds the ratings limit you set, a message appears on the television. Follow the on-screen instructions.

Changing the delay time (Speaker Setting)

DVD-V

(center and surround speakers only)

For optimum listening with 5.1-channel sound, all the speakers, except for the subwoofer, should be the same distance from the seating position. If you have to place the center or surround speakers closer to the seating position, adjust the delay time to make up for the difference.

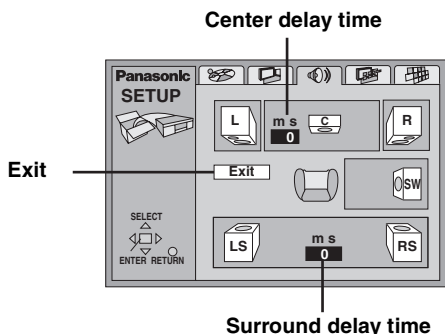

- Press [▲, ▼, ◀, ▶] to select the delay time box and press [ENTER].
- Press [▲, ▼] to adjust the delay time and press [ENTER].

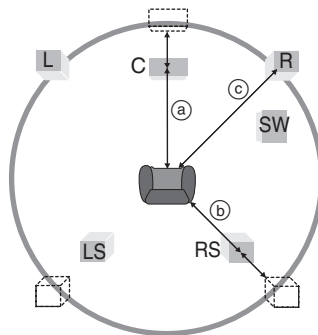

Values

If distance (a) or (b) is greater than or equal to distance (c), set to "0".
If distance (a) or (b) is less than distance (c), set as follows.

(a) Center speaker

Difference	Setting
Approx. 50 cm	1.3 ms
Approx. 100 cm	2.6 ms
Approx. 150 cm	3.9 ms
Approx. 200 cm	5.3 ms

(b) Surround speakers

Difference	Setting
Approx. 200 cm	5.3 ms
Approx. 400 cm	10.6 ms
Approx. 600 cm	15.9 ms

When you are finished

Press [▲, ▼, ◀, ▶] to select "Exit" and press [ENTER].

Language code list

Abkhazian: 6566	Chinese: 9072	Hausa: 7265	Lithuanian: 7684	Romanian: 8279	Telugu: 8469
Afar: 6565	Corsican: 6779	Hebrew: 7387	Macedonian: 7775	Russian: 8285	Thai: 8472
Afrikaans: 6570	Croatian: 7282	Hindi: 7273	Malagasy: 7771	Samoan: 8377	Tibetan: 6679
Albanian: 8381	Czech: 6783	Hungarian: 7285	Malay: 7783	Sanskrit: 8365	Tigrinya: 8473
Ameharic: 6577	Danish: 6865	Icelandic: 7383	Malayalam: 7776	Scots Gaelic: 7168	Tonga: 8479
Arabic: 6582	Dutch: 7876	Indonesian: 7378	Maltese: 7784	Serbian: 8382	Turkish: 8482
Armenian: 7289	English: 6978	Interlingua: 7365	Maori: 7773	Serbo-Croatian: 8372	Turkmen: 8475
Assamese: 6583	Esperanto: 6979	Irish: 7165	Marathi: 7782	Shona: 8378	Twi: 8487
Aymara: 6588	Estonian: 6984	Italian: 7384	Moldavian: 7779	Sindhi: 8368	Ukrainian: 8575
Azerbaijani: 6590	Faroese: 7079	Japanese: 7465	Mongolian: 7778	Singhalese: 8373	Urdu: 8582
Bashkir: 6665	Finnish: 7073	Javanese: 7487	Nauru: 7865	Slovak: 8375	Uzbek: 8590
Basque: 6985	French: 7082	Kannada: 7578	Nepali: 7869	Slovenian: 8376	Vietnamese: 8673
Bengali; Bangla: 6678	Frisian: 7089	Kashmiri: 7583	Norwegian: 7879	Somali: 8379	Volapük: 8679
Bhutani: 6890	Galician: 7176	Kazakh: 7575	Oriya: 7982	Spanish: 6983	Welsh: 6789
Bihari: 6672	Georgian: 7565	Kirghiz: 7589	Pashto, Pushto: 8083	Sundanese: 8385	Wolof: 8779
Breton: 6682	German: 6869	Korean: 7579	Persian: 7065	Swahili: 8387	Xhosa: 8872
Bulgarian: 6671	Greek: 6976	Kurdish: 7585	Polish: 8076	Swedish: 8386	Yiddish: 7473
Burmese: 7789	Greenlandic: 7576	Laotian: 7679	Portuguese: 8084	Tagalog: 8476	Yoruba: 8979
Byelorussian: 6669	Guarani: 7178	Latin: 7665	Punjabi: 8065	Tajik: 8471	Zulu: 9085
Cambodian: 7577	Gujarati: 7185	Latvian, Lettish: 7686	Quechua: 8185	Tamil: 8465	
Catalan: 6765		Lingala: 7678	Rhaeto-Romance: 8277	Tatar: 8484	

Operating a television or video cassette recorder

You can use the remote control to operate a Panasonic television or a video cassette recorder. (Some models cannot be operated by this remote control.)

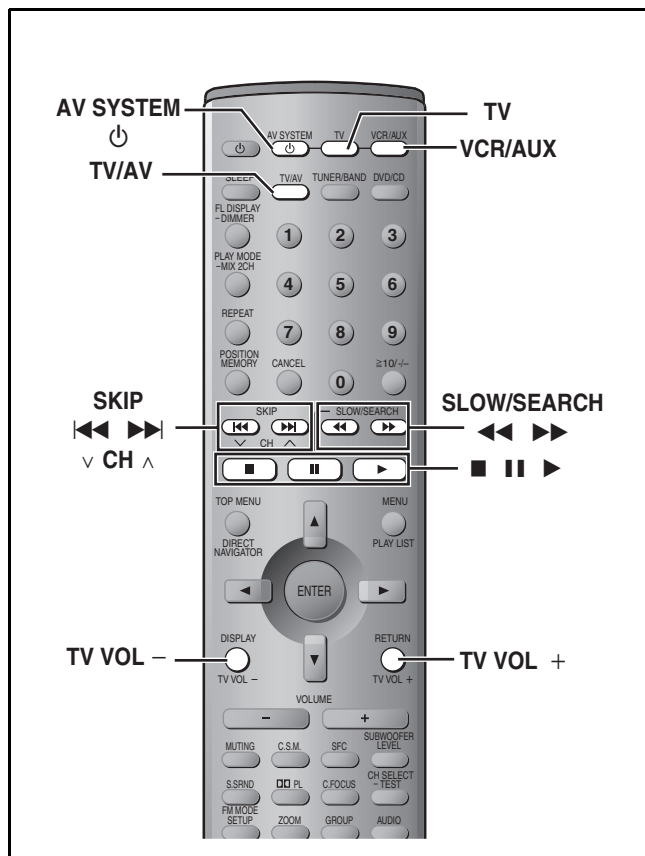

Operating a video cassette recorder

Connection example

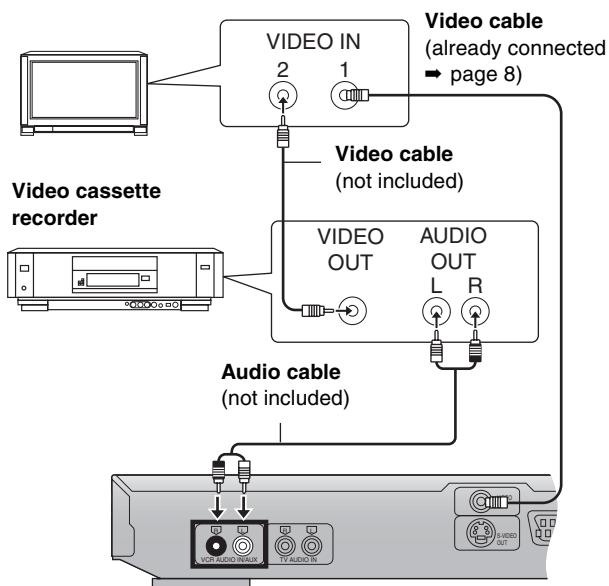

Preparation

- Face the remote control at this unit and press [VCR/AUX]. The button lights and "VCR/AUX" appears on the unit's display. You can operate the video cassette recorder.
- Change the video input mode on the television ("VIDEO 2" in the example).
- Face the remote control at the video cassette recorder for the following operations.

Turning the video cassette recorder on/off

Press [⏻ AV SYSTEM].

Play, pause and stop

Press [▶], [⏸] or [■].

Fast forward and rewind

Press [⏩] or [⏪].

You can connect a laser disc or record player instead of a video cassette recorder.

Connect as shown above and select "VCR/AUX" as the source.

When connecting a record player

We recommend using a record player with a built-in phono equalizer. If your player doesn't have a built-in equalizer, connect it first to a separate equalizer and then connect that to this unit.

Operating a television

Preparation

- Face the remote control at this unit and press [TV]. The button lights and "TV" appears on the unit's display. You can now operate the television.
- Face the remote control at the television for the following operations.

Turning the television on/off

Press [⏻ AV SYSTEM].

Switching the television's video input mode

Press [TV/AV].

Changing channels

Press [◀◀, √ CH] or [▶▶, CH ▲].

Adjusting the volume

Press [TV VOL+] or [TV VOL-].

Playing the television through this unit's speakers

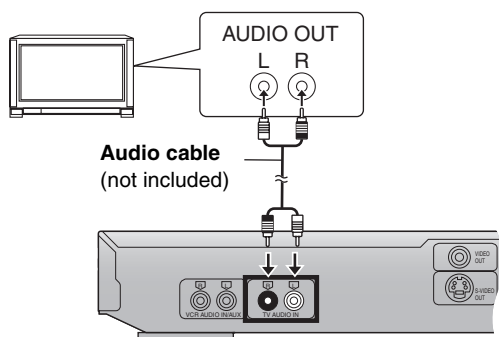

Optional antenna connections

Use outdoor antennas if radio reception is poor.

Note

Disconnect the antenna when the unit is not in use.
Do not use the outdoor antenna during an electrical storm.

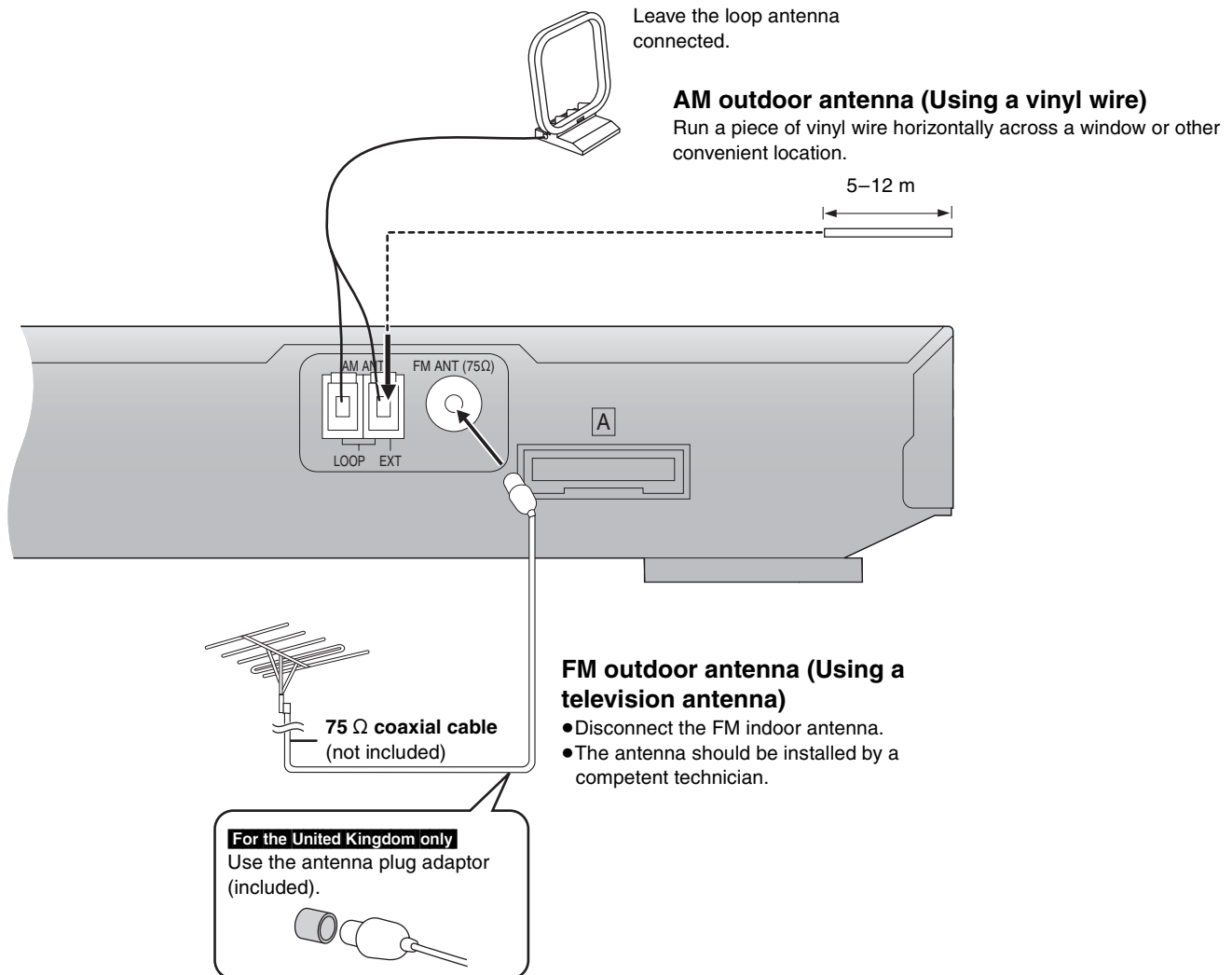

Troubleshooting guide

Before requesting service, make the below checks. If you are in doubt about some of the check points, or if the remedies indicated in the chart do not solve the problem, consult your dealer for instructions.

Power

		Page
No power.	● Insert the AC mains lead and system cable securely.	9
The unit is automatically switched to the standby mode.	● The unit was switched to standby by the sleep timer.	30

Operation

No response when buttons pressed.	<ul style="list-style-type: none"> ● Some operations may be prohibited by the disc. ● The unit may not be operating properly due to lightning, static electricity or some other external factor. <p>Reset procedure: Press [⏻] to switch the unit to the standby mode and then back to ON. Alternatively, press [⏻] to switch the unit to the standby mode, disconnect the AC mains lead, and then reconnect it.</p>	— —
No operations can be performed with the remote control.	<ul style="list-style-type: none"> ● Check that the batteries are installed correctly. ● The batteries are depleted: Replace them with new ones. ● Point the remote control at the remote control sensor and operate. 	9 9 —
Cannot switch on the television with the remote control.	<ul style="list-style-type: none"> ● Press [TV] first to operate the television. 	—
Play doesn't start (or stops immediately) when you press [▶] (play).	<ul style="list-style-type: none"> ● Condensation has formed: Wait 1 to 2 hours for it to evaporate. ● This unit cannot play discs other than the ones listed in these operating instructions. ● You can only play DVD-Video if their region number is the same or includes the same region number as the unit or if the DVD-Video is marked "ALL". Confirm the region number for the unit on the rear panel. ● The disc may be dirty and may require cleaning. ● Ensure that the disc is installed with the label of the side to be played facing upwards. ● Check that the DVD-RAM has something recorded on it. 	— 5 Cover 5 13 —
Cannot select alternative languages.	<ul style="list-style-type: none"> ● This function is dependent on software availability. ● Try selecting from the disc's menu if one is available. 	— 13
No menu play.	<ul style="list-style-type: none"> ● This function is dependent on software availability. 	—
No subtitles.	<ul style="list-style-type: none"> ● This function is dependent on software availability. ● Subtitles are cleared from the television. Display the subtitles. 	— 19
The position of the subtitles is incorrect.	<ul style="list-style-type: none"> ● Change the position of the subtitles with "Subtitle Position" in the GUI screen. 	25
Soundtrack and/or subtitle language is not the one selected with the SETUP menus.	<ul style="list-style-type: none"> ● This function is dependent on software availability. 	—
Cannot change angle.	<ul style="list-style-type: none"> ● This function is dependent on software availability. Even if a disc has a number of angles recorded, these angles may be recorded for specific scenes only. 	—
The SETUP menu cannot be accessed.	<ul style="list-style-type: none"> ● Select "DVD/CD" as the source. ● Cancel all group, program and random play. 	— 17
Cannot add markers.	<ul style="list-style-type: none"> ● You cannot add markers while playing a play list or if the disc's play time doesn't appear on the unit's display. 	—
There are already markers. RAM	<ul style="list-style-type: none"> ● The unit reads and displays the markers added with a DVD video recorder. You can clear them but reappear when you switch the unit to standby, change the source, or open the disc tray. 	—
Marker numbers I added are different when I call them up. RAM	<ul style="list-style-type: none"> ● The unit numbers markers by time so they change when you add and delete them. 	—
Cannot select random or program play.	<ul style="list-style-type: none"> ● You cannot select random or program play with some DVD-Video. 	—
Folders deeper than the eighth layer on a data CD are not displayed correctly.	<ul style="list-style-type: none"> ● Folders deeper than the eighth layer are displayed as the eighth layer. 	—
You have forgotten your ratings password. Reset all the SETUP settings to Factory Preset.	<ul style="list-style-type: none"> ● While stopped and "DVD/CD" is the source, press and hold [■] on the unit and [≥10] on the remote control for about 3 seconds until "Initialized" disappears from the television. Turn the unit off and on again. All settings will return to the default values. 	—

Sound

No sound.	<ul style="list-style-type: none"> ● Check the connections. 	7
Distorted sound.	<ul style="list-style-type: none"> ● Turn the volume up. ● Turn muting off. ● Switch off the unit, determine and correct the cause, then switch the unit on. Causes include: <ul style="list-style-type: none"> – Shorting (bare wires touching) of positive and negative speaker wires. – Using speakers with an impedance lower than that rated for this unit. – Straining of the speakers through excessive volume or power. – Using the unit in a hot environment without proper ventilation. 	— 30 —
Humming heard during play.	<ul style="list-style-type: none"> ● An AC mains lead or fluorescent light is near the subwoofer. Keep other appliances and cords away from the subwoofer. 	—

Picture

Picture distorted.	<ul style="list-style-type: none"> Some distortion is normal during SEARCH. 	—
No picture.	<ul style="list-style-type: none"> Check the connection. Make sure the television is on. Ensure the television's video input setting (e.g., VIDEO 1) is correct. 	8 — —
The picture shown on the television is not normal. (The sides of the picture are cut off, the picture is stretched horizontally, or black bands appear at the top and bottom of the screen.)	<ul style="list-style-type: none"> Go to Video in the SETUP menus, and change "TV Aspect" to suit your television. Use the television to change the aspect to the correct one. If your television cannot change the aspect, try changing 4:3 Aspect with the GUI screen. Ensure that the unit is connected directly to the television, and is not connected through a video cassette recorder. Change the size with the variable zoom function. 	31 25 — 18
Picture quality is poor.	<ul style="list-style-type: none"> Check the settings in the GUI screen's Picture Menu. 	25
The picture on the television disappears or stripes appear on the screen.	<ul style="list-style-type: none"> The location and orientation of the antenna are incorrect. If you are using an indoor antenna, change to an outdoor antenna. The television antenna wire is too close to the unit. Separate the antenna wire of the television from the unit. 	35 —
Menus not displayed correctly.	<ul style="list-style-type: none"> Change the zoom ratio to "×1.00". With the GUI screen, change "Subtitle Position" to "0" or change "4:3 Aspect" to "Normal". 	18 25

Listening to the radio

Noise is heard. "ST" flickers or doesn't light. Sound is distorted.	<ul style="list-style-type: none"> Adjust the position of the FM or AM antenna. Use an outdoor antenna. 	— 35
A beat sound is heard.	<ul style="list-style-type: none"> Turn the television off or separate it from the unit. 	—
A low hum is heard during AM broadcasts.	<ul style="list-style-type: none"> Separate the antenna from other cables and cords. 	—

Unit displays

The display is dark.	<ul style="list-style-type: none"> Press and hold [–DIMMER] to brighten the display. 	30
"NO PLAY"	<ul style="list-style-type: none"> You inserted a disc the unit cannot play; insert one it can. You inserted a blank DVD-RAM. 	5 —
"NO DISC"	<ul style="list-style-type: none"> You haven't inserted a disc; insert one. You haven't inserted the disc correctly; insert it correctly. 	— 13
"F61"	<ul style="list-style-type: none"> Check and correct the speaker cord connections. If this does not fix the problem, there is a power supply problem. Consult the dealer. 	7
"DVD U11"	<ul style="list-style-type: none"> Disc is dirty. Wipe it clean. 	5
"ERROR"	<ul style="list-style-type: none"> Incorrect operation performed. Read the instructions and try again. 	—
"DVD H□□" □□ stands for a number.	<ul style="list-style-type: none"> Trouble may have occurred. The number following "H" depends on the status of the unit. Reset procedure: Press [⏻] to switch the unit to the standby mode and then back to ON. Alternatively, press [⏻] to switch the unit to the standby mode, disconnect the AC mains lead, and then reconnect it. If the service numbers fail to clear, note the service number and contact a qualified service person. 	— —

Television displays

No on-screen display.	<ul style="list-style-type: none"> Go to Display in the SETUP menus, and select "On" for "On-Screen Messages". 	31
GUI screen not displayed or only partially displayed on the television.	<ul style="list-style-type: none"> Press [▲, ▼] while the rightmost icon is highlighted to move them down. 	23
The disc's menu is displayed in a different language.	<ul style="list-style-type: none"> Go to Disc in the SETUP menus, and select the preferred language for "Menus". 	31

Maintenance

To clean this unit, wipe with a soft, dry cloth.

- Never use alcohol, paint thinner or benzine to clean this unit.
- Before using chemically treated cloth, read the instructions that came with the cloth carefully.

Before moving the unit, ensure the disc tray is empty.

Failure to do so will risk severely damaging the disc and the unit.

Decoder

A decoder restores the coded audio signals on DVDs to normal. This is called decoding.

Dolby Digital

This is a method of coding digital signals developed by Dolby Laboratories. Apart from stereo (2-channel) audio, these signals can also be multi-channel audio. A large amount of audio information can be recorded on one disc using this method.

Dolby Pro Logic

A surround system where a 4-channel audio track is recorded as 2 channels and then is restored to 4 channels for play. The surround channel is monaural and can reproduce up to 7 kHz.

DTS (Digital Theater Systems)

This surround system is used in many movie theaters around the world. There is good separation between the channels, so realistic sound effects are possible.

Dynamic range

Dynamic range is the difference between the lowest level of sound that can be heard above the noise of the equipment and the highest level of sound before distortion occurs.

Frame still and field still

Frames are the still pictures that go together to make a moving picture. There are about 30 frames shown each second. One frame is made up of two fields. A regular television shows these fields one after the other to create frames. A still is shown when you pause a moving picture. A frame still is made up of two alternating fields, so the picture may appear blurred, but overall quality is high. A field still is not blurred, but it has only half the information of a frame still so picture quality is lower.

I/P/B

MPEG 2, the video compression standard adopted for use with DVD-Video, codes frames using these 3 picture types.

I: Intra coded picture

This picture has the best quality and is the best to use when adjusting the picture.

P: Predictive coded picture

This picture is calculated based on past I or P-pictures.

B: Bidirectionally-predictive coded picture

This picture is calculated by comparing past and future I and P-pictures so it has the lowest volume of information.

Linear PCM (pulse code modulation)

These are uncompressed digital signals, similar to those found on CDs.

Playback control (PBC)

If a Video CD has playback control, you can select scenes and information with menus.

Placement

Set the unit up on an even surface away from direct sunlight, high temperatures, high humidity, and excessive vibration. These conditions can damage the cabinet and other components, thereby shortening the unit's service life.

Do not place heavy items on the unit.

Voltage

Do not use high voltage power sources. This can overload the unit and cause a fire.

Do not use a DC power source. Check the source carefully when setting the unit up on a ship or other place where DC is used.

AC mains lead protection

Ensure the AC mains lead is connected correctly and not damaged. Poor connection and lead damage can cause fire or electric shock. Do not pull, bend, or place heavy items on the lead.

Grasp the plug firmly when unplugging the lead. Pulling the AC mains lead can cause electric shock.

Do not handle the plug with wet hands. This can cause electric shock.

Foreign matter

Do not let metal objects fall inside the unit. This can cause electric shock or malfunction.

Do not let liquids get into the unit. This can cause electric shock or malfunction. If this occurs, immediately disconnect the unit from the power supply and contact your dealer.

Do not spray insecticides onto or into the unit. They contain flammable gases which can ignite if sprayed into the unit.

Service

Do not attempt to repair this unit by yourself. If sound is interrupted, indicators fail to light, smoke appears, or any other problem that is not covered in these instructions occurs, disconnect the AC mains lead and contact your dealer or an authorized service center. Electric shock or damage to the unit can occur if the unit is repaired, disassembled or reconstructed by unqualified persons.

Extend operating life by disconnecting the unit from the power source if it is not to be used for a long time.

AMPLIFIER SECTION

RMS Output Power : Dolby Digital Mode, 10 % Total Harmonic Distortion	
1 kHz Front CH	50 W per channel (6 Ω)
1 kHz Surround CH	50 W per channel (6 Ω)
1 kHz Center CH	100 W per channel (6 Ω)
100 Hz Subwoofer CH	200 W per channel (4 Ω)
Total RMS Dolby Digital Mode Power	500 W
RMS Output Power Stereo Mode :	
1 kHz Front CH	40 W per channel (6 Ω)
100 Hz Subwoofer CH	200 W per channel (4 Ω)
Total RMS Stereo Mode Power	280 W
DIN Output Power : Dolby Digital Mode, 1 % Total Harmonic Distortion	
1 kHz Front CH	35 W per channel (6 Ω)
1 kHz Surround CH	35 W per channel (6 Ω)
1 kHz Center CH	80 W per channel (6 Ω)
45 Hz–120 Hz Subwoofer CH	130 W per channel (4 Ω)
Total DIN Dolby Digital Mode Power	350 W
DIN Output Power Stereo Mode:	
120 Hz–20 kHz Front CH	30 W per channel (6 Ω)
45 Hz–120 Hz Subwoofer CH	130 W per channel (4 Ω)
Total DIN Stereo Mode Power	190 W
Input sensitivity/Input impedance	
AUX	350 mV, 10 kΩ

FM TUNER SECTION

Frequency range	87.50–108.00 MHz (50-kHz step)
Sensitivity	2.5 μV(IHF)
S/N 26dB	2.2 μV
Antenna terminals	75 Ω (unbalanced)
Preset station	15

AM TUNER SECTION

Frequency range	522–1629 kHz (9-kHz step)
AM Sensitivity S/N 20 dB at 1000 kHz	560 μV/m
Preset station	15

DISC SECTION

Disc played	(one layer per side)
DVD-Audio/Video	8cm/12cm, single/double-sided, single/double-layer
DVD-RAM/R (DVD-Video formatted discs)	
CD (CD-DA), Video-CD	
CD/VCD/MP3/WMA	8cm/12cm, CD-R/RW
Video	
Signal system	NTSC/PAL (depend on disc format)
Output level	Composite video 1 Vp-p (75 Ω) S-video Y 1 Vp-p (75 Ω) S-video C 0.3 Vp-p (75 Ω) (PAL) 0.286 Vp-p (75 Ω) (NTSC)
Audio	
Sampling frequency	
CD	44.1 kHz
MP3	32 kHz, 44.1 kHz, 48 kHz
DVD	48 kHz, 96 kHz, 192 kHz
Bitrate	
MP3	32–320 kbps
Decoding	16/20/24 bit linear
Pick up	
Beam Source	Semiconductor Laser
Wavelength	
CD/VCD	780 nm
DVD	658 nm

NORSK	
Bølgelengde	
CD/VCD	780 nm
DVD	658 nm
Laserstyrke	Ingen farlig stråling sendes ut
Number of channels	5.1 (FL, FR, SL, SR, C, SW)
Frequency response	20 Hz–20 kHz (+1, –2 dB)
Wow and flutter	Less than possible measurement data
Digital filter	8 fs
D/A converter	Delta signal DAC

SPEAKER SECTION

Front speakers SB-FS700	
Type	1 way, 1 Speaker, Bass-ref.
Speaker unit	
Full range	6.5 cm Cone type 6 Ω
Input power	60 W (Music) DIN
Output sound pressure level	79 dB/W (1.0 m)
Frequency range	95 Hz–25 kHz (–16 dB) 110 Hz–22 kHz (–10 dB)
Dimensions (W×H×D)	135×295×145 mm
Mass	1.11 kg

Center speaker SB-PC700	
Type	1 way, 2 Speaker, Bass-ref.
Speaker unit	
Full range	6.5 cm Cone type 6 Ω
Input power	220 W (Music) DIN
Output sound pressure level	82 dB/W (1.0 m)
Frequency range	110 Hz–25 kHz (–16 dB) 130 Hz–22 kHz (–10 dB)
Dimensions (W×H×D)	250×140×145 mm
Mass	1.6 kg

Surround speakers SB-FS803A	
Type	1 way, 1 Speaker, Bass-ref.
Speaker unit	
Full range	6.5 cm Cone type 6 Ω
Input power	60 W (Music) DIN
Output sound pressure level	79 dB/W (1.0 m)
Frequency range	110 Hz–25 kHz (–16 dB) 130 Hz–22 kHz (–10 dB)
Dimensions (W×H×D)	92×183×90 mm
Mass	0.86 kg

Subwoofer SB-WA330	
Type	1 way, 1 Speaker, Bass-ref.
Speaker unit	
Woofer	17 cm Cone type 4 Ω
Input power	200 W (Music)
Output sound pressure level	80 dB/W (1.0 m)
Frequency range	40 Hz–220 Hz (–16 dB) 45 Hz–180 Hz (–10 dB)
Dimensions (W×H×D)	160×450×424 mm
Mass	12 kg

GENERAL

Power supply	
For the United Kingdom	AC 230–240 V, 50 Hz
For Continental Europe	AC 230 V, 50 Hz
Power consumption	
SA-HT500	25 W
SB-WA330	210 W
Dimensions (W×H×D)	430×52×390 mm
Mass	3.3 kg

Power consumption in standby mode (Subwoofer)	0.7 W
--	-------

Note

- Specifications are subject to change without notice. Mass and dimensions are approximate.
- Total harmonic distortion is measured by the digital spectrum analyzer.

Manufactured under license from Dolby Laboratories.
“Dolby”, “Pro Logic” and the double-D symbol are trademarks of
Dolby Laboratories.

Manufactured under license from Digital Theater Systems, Inc.
US Pat. No. 5,451,942, 5,956,674, 5,974,380, 5,978,762 and
other world-wide patents issued and pending. “DTS” and “DTS
Digital Surround” are registered trademarks of Digital Theater
Systems, Inc. © 1996, 2000 Digital Theater Systems, Inc. All
rights reserved.

This product incorporates copyright protection technology that is protected by method claims of certain U.S. patents and other intellectual property rights owned by Macrovision Corporation and other rights owners. Use of this copyright protection technology must be authorized by Macrovision Corporation, and is intended for home and other limited viewing uses only unless otherwise authorized by Macrovision Corporation. Reverse engineering or disassembly is prohibited.

Free Manuals Download Website

<http://myh66.com>

<http://usermanuals.us>

<http://www.somanuals.com>

<http://www.4manuals.cc>

<http://www.manual-lib.com>

<http://www.404manual.com>

<http://www.luxmanual.com>

<http://aubethermostatmanual.com>

Golf course search by state

<http://golfingnear.com>

Email search by domain

<http://emailbydomain.com>

Auto manuals search

<http://auto.somanuals.com>

TV manuals search

<http://tv.somanuals.com>