



**Mini Hi-Fi System**



**Toll Free Help Line**  
Ligne d'assistance en service libre  
Línea de ayuda telefónica sin cargo  
**800-531-0039**



*Let's make things better.*



**PHILIPS**





## Return your Warranty Registration card today to ensure you receive all the benefits you're entitled to.

- Once your Philips purchase is registered, you're eligible to receive all the privileges of owning a Philips product.
- So complete and return the Warranty Registration Card enclosed with your purchase at once. And take advantage of these important benefits.

### Warranty Verification

Registering your product within 10 days confirms your right to maximum protection under the terms and conditions of your Philips warranty.

### Owner Confirmation

Your completed Warranty Registration Card serves as verification of ownership in the event of product theft or loss.

### Model Registration

Returning your Warranty Registration Card right away guarantees you'll receive all the information and special offers which you qualify for as the owner of your model.

# PHILIPS



**Congratulations on your purchase, and welcome to the "family!"**

Dear Philips product owner:

Thank you for your confidence in Philips. You've selected one of the best-built, best-backed products available today. And we'll do everything in our power to keep you happy with your purchase for many years to come.

As a member of the Philips "family," you're entitled to protection by one of the most comprehensive warranties and outstanding service networks in the industry.

What's more, your purchase guarantees you'll receive all the information and special offers for which you qualify, plus easy access to accessories from our convenient home shopping network.

And most importantly you can count on our uncompromising commitment to your total satisfaction.

All of this is our way of saying welcome—and thanks for investing in a Philips product.

Sincerely,

Robert Minkhorst  
President and Chief Executive Officer

**P.S. Remember, to get the most from your Philips product, you must return your Warranty Registration Card within 10 days. So please mail it to us right now!**

Know these safety symbols



This "bolt of lightning" indicates uninsulated material within your unit may cause an electrical shock. For the safety of everyone in your household, please do not remove product covering.

The "exclamation point" calls attention features for which you should read the enclosed literature closely to prevent operating and maintenance problems.

**WARNING:** TO PREVENT FIRE OR SHOCK HAZARD, DO NOT EXPOSE THIS EQUIPMENT TO RAIN OR MOISTURE.

**CAUTION:** To prevent electric shock, match wide blade of plug to wide slot, and fully insert.

#### For Customer Use

Enter below the Serial No. which is located on the rear of the cabinet. Retain this information for future reference.

Model No. \_\_\_\_\_

Serial No. \_\_\_\_\_

HA CS097

**PHILIPS** Visit our World Wide Web Site at <http://www.philipsusa.com>

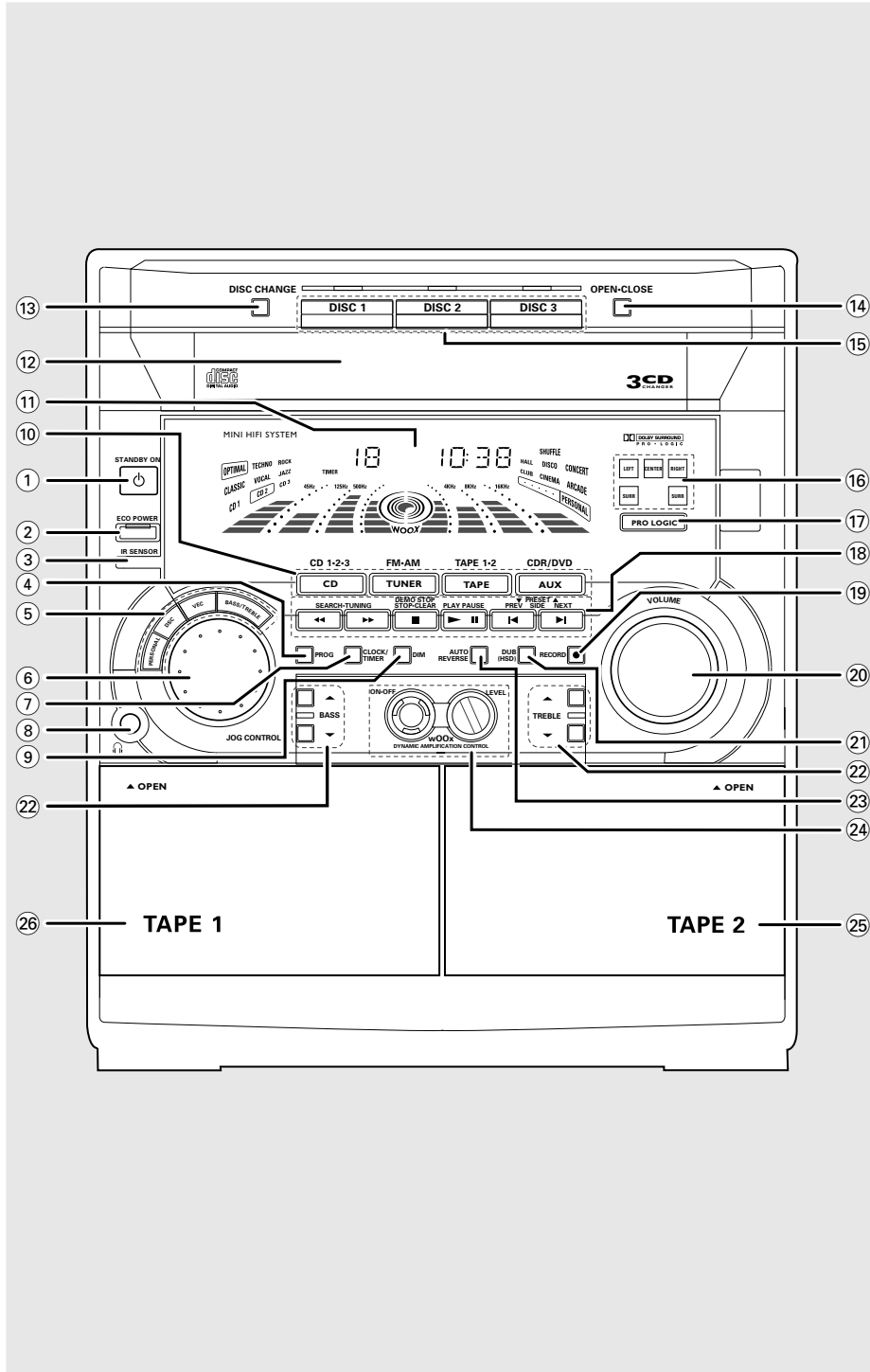

3



# IMPORTANT SAFETY INSTRUCTIONS

## – Read before operating equipment

This product was designed and manufactured to meet strict quality and safety standards. There are, however, some installation and operation precautions which you should be particularly aware of.

1. **Read these instructions** – All the safety and operating instructions should be read before the appliance is operated.
2. **Keep these instructions** – The safety and operating instructions should be retained for future reference.
3. **Heed all warnings** – All warnings on the appliance and in the operating instructions should be adhered to.
4. **Follow all instructions** – All operating and use instructions should be followed.
5. **Do not use this apparatus near water** – for example, near a bathtub, washbowl, kitchen sink, laundry tub, in a wet basement, or near a swimming pool, etc.
6. **Clean only with a damp cloth.** The appliance should be cleaned only as recommended by the manufacturer.
7. **Install in accordance with the manufacturer's instructions. Do not block any of the ventilation openings.** For example, the appliance should not be situated on a bed, sofa, rug, or similar surface or placed in a built-in installation, such as a bookcase or cabinet that may impede the flow of air through the ventilation openings.
8. **Do not install near any heat sources** such as radiators, heat registers, stoves, or other apparatus (including amplifiers) that produce heat.
9. **Do not defeat the safety purpose** of the polarized or grounding-type plug.



A polarized plug has two blades with one wider than the other. A grounding type plug has two blades and a third grounding prong. The wide blade or the third prong are provided for your safety. When the provided plug does not fit into your outlet, consult an electrician for replacement of the obsolete outlet.

10. **Protect the power cord** from being walked on or pinched particularly at plugs, convenience receptacles, and the point where they exit from the apparatus.
11. **Only use attachments/accessories** specified by the manufacturer.
12.  **Use only with a cart, stand, tripod, bracket, or table** specified by the manufacturer, or sold with the apparatus. When a cart is used, use caution when moving the cart/apparatus combination to avoid injury from tip-over.
13. **Unplug this apparatus** during lightning storms or when unused for long periods of time.
14. **Refer all servicing** to qualified service personnel. Servicing is required when the apparatus has been damaged in any way, such as power-supply cord or plug is damaged, liquid has been spilled or objects have fallen into the apparatus, the apparatus has been exposed to rain or moisture, does not operate normally, or has been dropped.
15. **Battery usage CAUTION** – To prevent battery leakage which may result in bodily injury or damage to the unit:
  - Install **all** batteries correctly, + and - as marked on the unit.
  - Do not mix batteries (**old** and **new** or **carbon** and **alkaline**, etc.).
  - Remove batteries when the unit is not used for a long time.

EL 6475-E001: 00/8



## Index

English ..... 7

Français ..... 35

Español ..... 63

English

Français

Español

### Canada

#### English:

This digital apparatus does not exceed the Class B limits for radio noise emissions from digital apparatus as set out in the Radio Interference Regulations of the Canadian Department of Communications.

#### Français:

Cet appareil numérique n'émet pas de bruits radioélectriques dépassant les limites applicables aux appareils numériques de Class B prescrites dans le Règlement sur le Brouillage Radioélectrique édicté par le Ministère des Communications du Canada.

### CAUTION

*Use of controls or adjustments or performance of procedures other than herein may result in hazardous radiation exposure or other unsafe operation.*

### ATTENTION

*L'utilisation des commandes ou réglages ou le non-respect des procédures ci-inclues peuvent se traduire par une exposition dangereuse à l'irradiation.*

### ATENCIÓN

*El uso de mando o ajustes o la ejecución de métodos que no sean los aquí descritos puede ocasionar peligro de exposición a radiación.*

**This warning label is located on the rear side and inside this laser product.**

**CAUTION:** INVISIBLE LASER RADIATION WHEN OPEN. DO NOT STARE INTO BEAM.

**DANGER:** INVISIBLE LASER RADIATION WHEN OPEN. AVOID DIRECT EXPOSURE TO BEAM.

**VARO!** AVATTAESSA JA SUOJALLUKITUS OHITETTAESSA OLET ALTTIINANÄKYMÄTTÖMÄALLE LASERSATEILYLLE. ÄLÄ KATSO SATEESEEN.

**WARNING!** OSYNLIG LASERSTRÅLNING NÄR DENNA DEL ÄR ÖPPNAD. OCH SPÄRREN ÄR URKOPPLAD. BETRÄKTA EJ STRÅLEN.

or

**DANGER -** Invisible laser radiation when open. AVOID DIRECT EXPOSURE TO BEAM.



## Read this first!

Congratulations on your purchase of this Philips product!  
Everything you need to get started is in this box.

If you have any problems, Philips Representatives can help you get the most from your new product by explaining:

- Hookup
- First Time Setup
- Feature Operation

**Do not attempt to return this product to the store.**

For Fast Help, Call Us First!

**1-800-531-0039**

Thank you for making Philips part of your home!

## DEMO MODE

**To turn ON**

Press & HOLD button  
for **5 seconds**

**To turn OFF**

Press & HOLD button  
for **5 seconds**



## Lisez d'abord ceci!

Nous vous félicitons pour l'achat de cet appareil Philips!  
Tout ce dont vous avez besoin pour sa mise en service se trouve dans cet emballage.

Si vous avez le moindre problème, les représentants de Philips peuvent vous aider à tirer entière satisfaction de votre nouvel achat en vous expliquant:

- Les connexions
- La première installation
- L'utilisation des fonctions

**Ne cherchez pas à retourner ce produit au magasin.**

Pour une assistance rapide, appelez-nous d'abord!

**1-800-531-0039**

Nous vous remercions d'avoir fait entrer Philips dans votre maison!

## MODE DE DEMONSTRATION

**ACTIVER**

Maintenez enfoncé le bouton   
pendant **5 secondes**

**DÉSACTIVER**

Maintenez enfoncé le bouton   
pendant **5 secondes**



## ¡Antes de todo lea esto!

¡Se le felicita por su compra de este producto Philips!  
Esta caja contiene todo lo que necesita para empezar.

Si tiene algún problema, los representantes de Philips pueden ayudarle a obtener el máximo rendimiento de su producto explicándole lo siguiente:

- La conexión
- La primera configuración
- La utilización de las funciones

**No intente devolver este producto a la tienda.**

¡Para obtener ayuda rápida, antes de todo llámenos!

**1-800-531-0039**

¡Gracias por hacer que Philips forme parte de su hogar!

## MODO DE DEMOSTRACIÓN

**ACTIVARLO**

Mantenga apretado el botón   
durante **5 segundos**

**DESACTIVARLO**

Mantenga apretado el botón   
durante **5 segundos**



# Contents

English

## General Information

Environmental Information .....	8
Acknowledgement .....	8
Supplied Accessories .....	8
Safety Information .....	8

## Preparations

Rear Connections .....	9–10
Optional Connections .....	10
Inserting batteries into the remote control .....	10

## Dolby Pro Logic

Setting up the Dolby Pro Logic system .....	11
Test Tone .....	11–12
Switching the Dolby Pro Logic .....	12

## Controls

Controls on the system and remote control .....	13–14
---	-------

## Basic Functions

Demonstration mode .....	15
Easy Set .....	15
Switching the system on .....	16
Switching the system to Standby mode .....	16
Switching the system to Eco Power Standby mode .....	16
Power Saving Automatic Standby .....	16
Dim mode .....	16
Volume Control .....	17
Interactive Sound Control .....	17–18

## CD Operation

Discs for Playback .....	19
Loading Discs .....	19
Disc Playback .....	20
Programming the disc tracks .....	20–21
Repeat .....	21
Shuffle .....	21

## Radio Reception

Storing Preset Radio Stations .....	22–23
Tuning to Preset Radio Stations .....	23

## External Sources

Listening to External Sources .....	23
-------------------------------------	----

## Tape Operation/Recording

Tape Playback .....	24–25
General Information on Recording .....	25
Preparation for Recording .....	25–26
One Touch Recording .....	26
CD Synchro Recording .....	26
Dubbing Tapes .....	26
Digital Recording via Digital Out .....	26

## Clock/Timer

View Clock .....	27
Clock Setting .....	27
Timer Setting .....	27–28
Sleep Timer Setting .....	28

## Specifications

.....	29
-------	----

## Maintenance

.....	30
-------	----

## Troubleshooting

.....	30–31
-------	-------





## General Information

**This system complies with the FCC rules, Part 15 and with 21 CFR 1040.10.**

**Operation is subject to the following two conditions:**

- **This device may not cause harmful interference, and**
- **This device must accept any interference received, including interference that may cause undesired operation.**

### Environmental Information

All unnecessary packaging has been omitted. We have tried to make the packaging easy to separate into three materials: cardboard (box), polystyrene foam (buffer) and polyethylene (bags, protective foam sheet).

Your system consists of materials which can be recycled and reused if disassembled by a specialized company. Please observe the local regulations regarding the disposal of packaging materials, exhausted batteries and old equipment.

### Acknowledgement

#### Energy Star

As an ENERGY STAR® Partner, Philips has determined that this product meets the ENERGY STAR® guidelines for energy efficiency.



#### Dolby

Manufactured under license from Dolby Laboratories. "PRO-LOGIC" and the double-D symbol  are trademarks of Dolby Laboratories. Confidential unpublished works. © 1992-1997 Dolby Laboratories. All rights reserved.



### Supplied accessories

- Remote control
- Batteries (two AA size) for remote control
- AM loop antenna
- FM wire antenna
- AC power cord
- CS-900 speaker package (includes one pair of surround speakers and one center speaker)

### Safety Information

- Before operating the system, check that the operating voltage indicated on the typeplate (or the voltage indication beside the voltage selector) of your system is identical with the voltage of your local power supply. If not, please consult your dealer.
- Place the system on a flat, hard and stable surface.
- Place the system in a location with adequate ventilation to prevent internal heat build-up in your system. Allow at least 10 cm (4 inches) clearance from the rear and the top of the unit and 5 cm (2 inches) from each side.
- Do not expose the system, batteries or discs to excessive moisture, rain, sand or heat sources caused by heating equipment or direct sunlight.
- If the system is brought directly from a cold to a warm location, or is placed in a very damp room, moisture may condense on the lens of the disc unit inside the system. Should this occur; the CD player would not operate normally. Leave the power on for about one hour with no disc in the system until normal playback is possible.
- The mechanical parts of the set contain self-lubricating bearings and must not be oiled or lubricated.
- **When the system is switched to Standby mode, it is still consuming some power. To disconnect the system from the power supply completely, remove the AC power plug from the wall socket.**





## Preparations

English

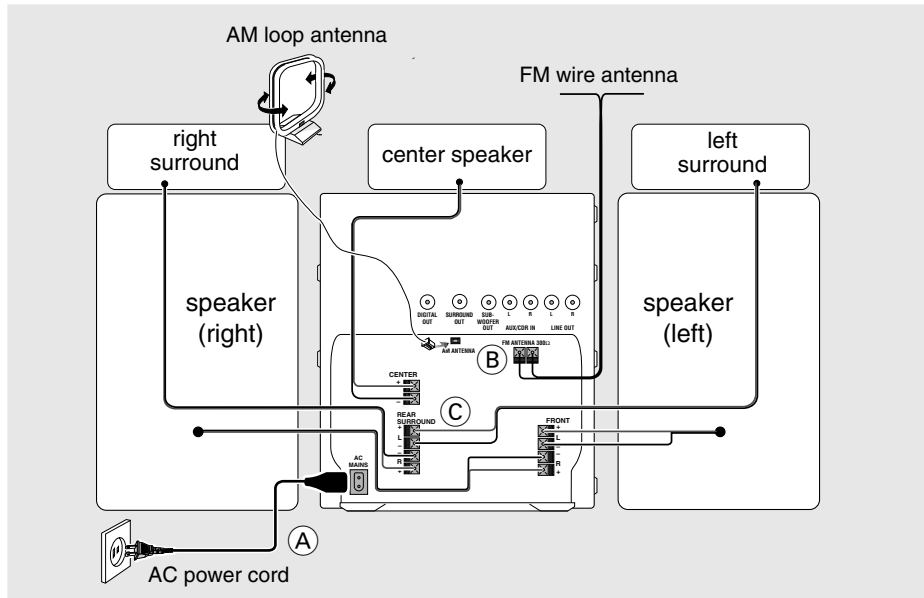

### Rear Connections

The type plate is located at the rear of the system.

#### A Power

Before connecting the AC power cord to the wall outlet, ensure that all other connections have been made.

#### WARNING!

- For optimal performance, use only the original power cable.
- Never make or change any connections with the power switched on.

To avoid overheating of the system, a safety circuit has been built in. Therefore, your system may switch to Standby mode automatically under extreme conditions. If this happens, let the system cool down before reusing it (not available for all versions).

#### B Antennas Connection

Connect the supplied AM loop antenna and FM antenna to the respective terminals. Adjust the position of the antenna for optimal reception.

##### AM Antenna

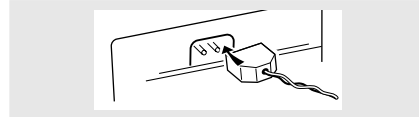

- Position the antenna as far as possible from a TV, VCR or other radiation source.

##### FM Antenna

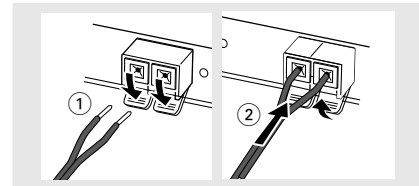

- For better FM stereo reception, connect an outdoor FM antenna to the FM ANTENNA terminal.



## Preparations

### Speakers Connection

#### Front Speakers

Connect the speaker wires to the SPEAKERS (FRONT) terminals, right speaker to "R" and left speaker to "L", colored (marked) wire to "+" and black (unmarked) wire to "-".

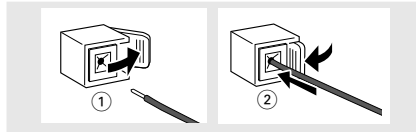

- Clip the stripped portion of the speaker wire as shown.

#### Rear Surround Speakers

Connect the speaker wires to the REAR SURROUND terminals, right speaker to "R" and left speaker to "L", colored (marked) wire to "+" and black (unmarked) wire to "-".

#### Center Speaker

Connect the speaker wires to the CENTER terminal, colored (marked) wire to "+" and black (unmarked) wire to "-".

#### Notes:

- For optimal sound performance, use the supplied speakers.
- Do not connect more than one speaker to any one pair of + / - speaker terminals.
- Do not connect speakers with an impedance lower than the speakers supplied. Please refer to the SPECIFICATIONS section of this manual.

### Optional Connections

The optional equipment and connecting cords are not supplied. Refer to the operating instructions of the connected equipment for details.

#### Line Out Connection

Connect this output to any analog audio equipment for playback or recording (CD recorder, tape recorder or amplifier for example). Use a cinch cable to connect the **LINE OUT** terminals to the analog audio in terminals of the equipment.

#### Connecting other equipment to your system

Connect the audio left and right OUT terminals of a TV, VCR, Laser Disc player, DVD player or CD Recorder to the **AUX/CDR IN** terminals.

#### Notes:

- Do not connect equipment to both the **LINE OUT** and **AUX/CDR IN** terminals at the same time. Otherwise, noise will be generated and malfunction might occur.
- If you are connecting equipment with a mono output (a single audio out terminal), connect it to the **AUX/CDR IN** left terminal. Alternatively, you can use a "single to double" cinch cable (still be mono sound).

#### Subwoofer Out Connection

Connect the subwoofer to the **SUBWOOFER OUT** terminal. The subwoofer reproduces just the low bass sound effect (explosions or the rumble of spaceships, for example).

#### Wireless Surround Out Connection

Connect the transmitter unit of wireless rear speakers to the **SURROUND OUT** terminal.

#### Note:

- The availability of a wireless transmitter and its peripherals are subjected to the approval of local authorities. Please check with your respective local safety or approving authority.

#### Digital Out Connection

Connect this digital output when recording on any audio equipment with digital input (CD Recorder, Digital Audio Tape [DAT] deck, Digital to Analog Converter and Digital Signal Processor, for example). Use a cinch cable to connect the **DIGITAL OUT** terminal to the digital input terminal of the equipment.

### Inserting batteries into the Remote Control

Insert two batteries (Type R06 or AA) into the remote control with the correct polarity as indicated by the + and - symbols inside the battery compartment.

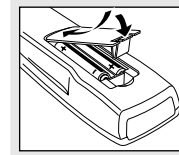

#### CAUTION!

- Remove batteries if they are exhausted or not to be used for a long time.
- Do not use old and new or different types of batteries in combination.
- Batteries contain chemical substances, so dispose of them properly.



## Dolby Pro Logic

Dolby ProLogic Surround Sound provides the current industry standard for home cinema sound from VCR and TV broadcasts. The front left and right speakers deliver detailed, directional sound as the center speaker "steers" dialogue/ vocal sound and center screen action toward the TV screen. Both surround speakers add a greater sense of depth with special effects.

Audio and video tapes and discs with the **DOLBY SURROUND** mark are encoded for multi channel Dolby Surround sound. The DOLBY PRO LOGIC sound setting allows you to listen to audio tracks as they were recorded through the left, right, center, and rear channels.

### IMPORTANT!

- **Dolby Pro Logic Surround sound can only be reproduced if the program is broadcast in Dolby Surround Sound.**
- **For the best Dolby Pro Logic sound, switch on DPL with DSC set to "Classic" and with VEC off.**
- **Dolby Pro Logic mode will automatically switch to normal Stereo mode when headphones is connected.**
- **When recording, switch to normal stereo mode.**

### Setting up the Dolby Pro Logic system

You must set up the system properly in order to experience and enjoy a Home Cinema sound ambience.

#### Connecting the Speakers

**5-Speakers Connection** (refer to "Preparations - Rear Connections")

- **Front speakers:** Connect the front speakers.
- **Center speaker:** Connect the center speaker.
- **Rear (surround) speakers:** Connect either the wired rear surround speakers or a pair of wireless rear speakers (not supplied) to the SURROUND OUT terminals.

### Positioning the Speakers

To get the best surround sound effect, place the speakers as follows.

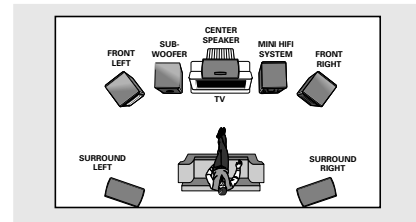

#### Front Left and Right Speakers

For the best sound, place the left and right speakers at an angle of approximately 45 degrees to the listener:

#### Note:

- *To avoid magnetic interference with the picture on your TV, do not position the front speakers too close to the TV.*

#### Rear (surround) Speakers

The surround speakers should be placed at normal listening ear level or mounted on the wall at the back of the room. Most importantly, experiment when placing the surround speakers to obtain the best sound.

#### Center Speaker

For the best sound, place the center speaker at the same height as the left and right speakers. Place the center speaker directly above or beneath the television.

### Test Tone

This feature enables you to adjust the Front Left, Front Right, Center and Surround Sound levels of the respective speakers in Dolby Pro Logic mode.

**You must sit at the ideal sitting position and use the remote control to perform this operation.**

- 1 Press **CD, TUNER, TAPE** or **AUX** to switch on the system.
- 2 Press **TEST TONE** on the remote control.

→ A test signal is generated; it will move through the Left, Center, Right, and Surround speakers.

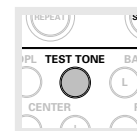

## Dolby Pro Logic

- "TEST TONE" followed by "ADAPT BALANCE, CENTER AND REAR LEVEL" will be displayed.
- The test signal will last for about 90 seconds.

### Adjust the sound level

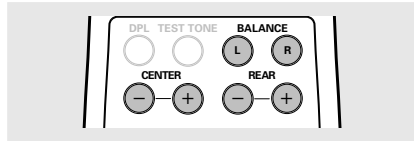

#### Front speakers

- Press **BALANCE L** on the remote control for left speaker and press **BALANCE R** on the remote control for right speaker.
  - "BAL L +XX" or "BAL R +XX" will be displayed.

#### Center speaker

- Press **CENTER +** or **-** on the remote control.
  - "CENT +XX" or "CENT -XX" will be displayed.

#### Surround speakers

- Press **REAR +** or **-** on the remote control.
  - "REAR +XX" or "REAR -XX" will be displayed.

#### To switch off the TEST TONE

- Press **TEST TONE**.

#### Notes:

- It is advisable to set the speakers' level at normal listening level.
- "XX" denotes the sound level.

### Switching the Dolby Pro Logic

- Press **DPL (PRO LOGIC)** repeatedly to select and cycle through the various sound modes.
  - The Dolby Pro Logic display panel will light up with the selection.

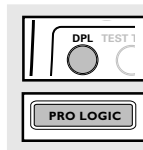

**Dolby Surround → Dolby Center Phantom  
→ Dolby 3 Stereo → Stereo → Dolby Surround ...**

#### Dolby Surround

This setting is for a full Dolby Surround Pro Logic mode.

- "DOLBY SURROUND" will be displayed.

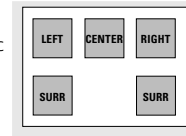

#### Dolby Center Phantom

This setting is for use without the center speaker. It redistributes the center speaker sound to the left and right speakers, providing conventional stereo across the front.

- "DOLBY CENTER PHANTOM" will be displayed.

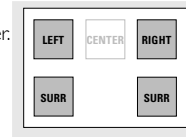

#### Dolby 3 Stereo

Use this setting when full surround is not required, but a wide stereo sound is desired. It requires only the left, right and center speakers.

- "DOLBY 3 STEREO" will be displayed.

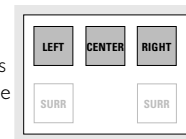

#### Normal Stereo

This setting is for normal stereo sound without Dolby Pro Logic. It requires only the left and right speakers.

- "STEREO" will be displayed.

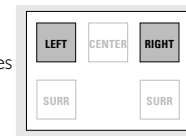



## Controls (main system's illustration on page 3)

### Controls on the system and remote control

- ① **STANDBY ON**
- to switch the system on or to Standby mode.
  - to start EASY SET operation.
- ② **ECO POWER**
- to activate or deactivate Eco Power Standby mode.
- ③ **iR SENSOR**
- infrared sensor for remote control.
- ④ **PROG (PROGRAM)**
- for CD ..... to program disc tracks.
  - for TUNER ..... to program preset radio stations.
  - for CLOCK ..... (on the system only) to select 12- or 24-hour clock mode.
- ⑤ **INTERACTIVE SOUND CONTROLS**
- to select the desired sound feature : PERSONAL (PER.), DSC, VEC or BASS/TREBLE (BTC).
- ⑥ **JOG CONTROL**
- to select the desired sound effect for the selected sound feature.
- PERSONAL** ..... PERSONAL 1-6, six personal preferred Spectrum Analyzer settings.
- DSC** ..... OPTIMAL, CLASSIC, TECHNO, VOCAL, ROCK or JAZZ.
- VEC** ..... HALL, CLUB, DISCO, CINEMA, CONCERT or ARCADE.
- ⑦ **CLOCK/TIMER**
- to view the clock, set the clock or set the timer.
- ⑧
- to connect headphones.
- ⑨ **DIM**
- to select brightness of the display screen : DIM 1, DIM 2, DIM 3 or DIM OFF.
- ⑩ **SOURCE** – to select the following:
- CD / (CD 1•2•3)**
- to select disc tray 1, 2 or 3.
- TUNER / (FM•AM)**
- to select waveband : FM or AM.
- TAPE / (TAPE 1• 2)**
- to select tape deck 1 or 2.
- AUX / (CDR/DVD)**
- to select a connected external source : CDR/DVD or AUX (auxiliary) mode.
- TV/AV** (on the remote control only)
- to select TV or Video mode.
- ⑪ **DISPLAY SCREEN**
- to view the current status of the system.
- ⑫ **DISC TRAY**
- ⑬ **DISC CHANGE**
- to change disc(s).
- ⑭ **OPEN•CLOSE**
- to open or close the disc tray.
- ⑮ **DISC 1 / DISC 2 / DISC 3 (CD DIRECT)**
- to select a disc tray for playback.
- ⑯ **DPL DISPLAY PANEL**
- to view the selected Dolby Pro Logic setting.
- ⑰ **DOLBY PRO LOGIC (DPL)**
- to select Dolby Surround, Dolby Center Phantom, Dolby 3 Stereo or Stereo mode.
- ⑱ **Mode Selection**
- SEARCH•TUNING ◀◀ ▶▶**
- for CD ..... to search backward/forward.
  - for TUNER ..... to tune to a lower or higher radio frequency.
  - for TAPE ..... to rewind or fast forward.
  - for CLOCK ..... (on the system only) to set the hour.
  - for TV VOL ..... to adjust the TV volume (if the remote operates your TV).
- STOP•CLEAR ■ (DEMO STOP)**
- for CD ..... to stop playback or to clear a program.
  - for TUNER ..... to stop programming.
  - for TAPE ..... to stop playback or recording.
  - for DEMO ..... (on the system only) to activate/deactivate the demonstration.
- PLAY PAUSE ▶ II**
- for CD ..... to start or interrupt playback.
  - for TAPE ..... to start playback.
- ◀ PREV / SIDE / NEXT ▶ (PRESET ▼ ▲)**
- for CD ..... to skip to the beginning of the current, previous, or next track.
  - for TUNER ..... to select a preset radio station.
  - for TAPE ..... to select tape side (back or front) in tape deck 2 only.
  - for CLOCK ..... (on the system only) to set the minute.
- ⑲ **RECORD**
- to start recording on tape deck 2.
- ⑳ **VOLUME**
- to increase or decrease the volume.
- ㉑ **DUB (HSD) (HIGH SPEED DUBBING)**
- to dub a tape in normal or fast speed.





## Controls

- ②② **BASS/TREBLE CONTROL** – to adjust the BASS/TREBLE level :  
**BASS** ▲ ▼  
 – to increase or decrease the low tone.  
**TREBLE** ▲ ▼  
 – to increase or decrease the high tone.
- ②③ **AUTO REVERSE**  
 – to select the desired playback modes in tape deck 2 only.
- ②④ **wOOx ON•OFF**  
 – to select enhanced or normal wOOx sound effect.  
**wOOx LEVEL**  
 – to select desired wOOx level : WOOX 1, WOOX 2 or WOOX 3.
- ②⑤ **TAPE DECK 2**
- ②⑥ **TAPE DECK 1**
- ②⑦ **CLOCK**  
 – to view the clock display.
- ②⑧ **REPEAT**  
 – to playback track(s)/disc(s)/program repeatedly.
- ②⑨ **TEST TONE**  
 – to check the sound level of the Front Left, Front Right, Center and Surround speakers.
- ③① **CENTER +/–**  
 – to adjust the sound level of the center speaker.
- ③① **TIMER ON/OFF**  
 – to activate or deactivate the timer.
- ③② **SLEEP**  
 – to activate, deactivate or set the sleep timer.
- ③③ **REAR +/–**  
 – to adjust the sound level of the surround speakers.
- ③④ **BALANCE L/R**  
 – to balance the sound level of the front left and right speakers.
- ③⑤ **SHUFFLE**  
 – to playback all available discs and their tracks/program in random order.
- ③⑥ **DIGITS 0 – 9**  
*(numbers consisting of more than two figures must be keyed in within 2 seconds.)*  
 for CD ..... to key in a CD track for playback or programming.  
 for TUNER ..... to key in a preset radio station.
- ③⑦   
 – to switch the system to Standby mode or Eco Power Standby mode.

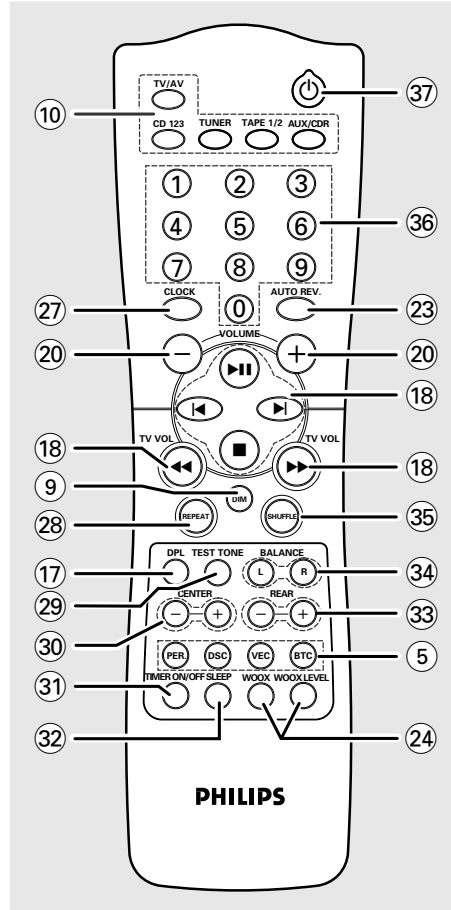

### Notes for remote control:

- **First, select the source you wish to control by pressing one of the source select keys on the remote control (CD 123 or TUNER, for example).**
- **Then select the desired function (▶, ◀, ▶|, for example).**



## Basic Functions

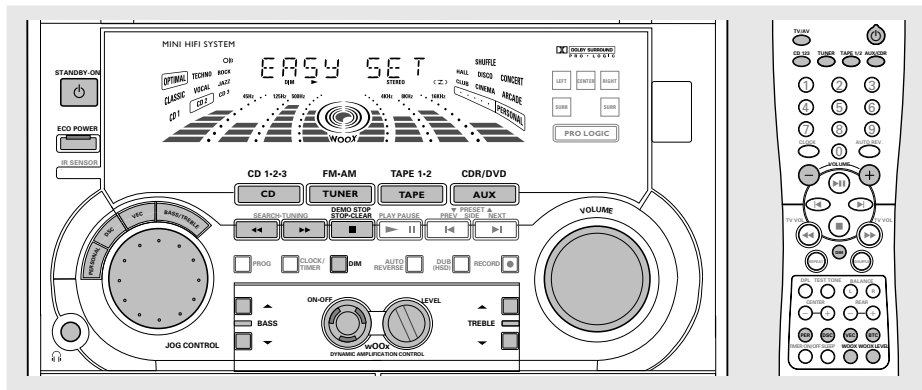

English

### IMPORTANT!

**Before you operate the system, complete the preparation procedures.**

### Demonstration mode

The system has a demonstration mode that shows the various features offered by the system.

#### To activate the demonstration

- In Standby mode, press and hold **DEMO STOP** ■ on the system until "DEMO ON" is displayed.
  - The demonstration will begin.

#### To deactivate the demonstration

- Press and hold **DEMO STOP** ■ on the system until "DEMO OFF" is displayed.
  - The system will switch to Standby mode.

#### Notes:

- Even if you remove the AC power cord and reconnect it to the wall socket, the demonstration will remain off until you activate it again.
- When the power is turned on, the disc tray may open and close to initialize the system.

### Easy Set

EASY SET allows you to store all available radio stations automatically.

- In Standby or Demonstration mode, press and hold **STANDBY ON** until "EASY SET" is displayed.
  - The system will search for all radio stations on the FM band, then the AM band.
  - All available radio stations with sufficient signal strength will be stored automatically.
  - The system will stop searching when all the available radio stations are stored or when the memory for 40 preset radio stations is used.
  - The last preset radio station will play when Easy Set completed.

#### Note:

- When EASY SET is used, all previously stored radio stations will be replaced.



## Basic Functions

### Switching the system on

#### In Standby mode

- Press **STANDBY ON** or **CD/TUNER/TAPE/AUX** on the system.  
→ The system will switch to the last selected source or the selected source.
- Press any one of the **DISC DIRECT PLAY** buttons or **OPEN•CLOSE**.  
→ The system will switch to CD mode.

#### In Eco Power Standby mode

- Press **CD 123, TUNER, TAPE 1/2** or **AUX/CDR** on the remote control.  
→ The system will switch to the selected source.

### Switching the system to Standby mode

#### In Demonstration mode

- Press and hold **DEMO STOP** ■ on the system.

#### In Eco Power Standby mode

- Press **ECO POWER**.

#### In any other source mode

- Press **STANDBY ON** (or  on the remote control).  
→ The clock will appear on the display when the system is in Standby mode.

### Switching the system to Eco Power Standby mode

- Press **ECO POWER** (or press and hold  on the remote control).  
→ "LOW POWER STANDBY ON" will be displayed, then the display screen will go blank.  
→ The low power STANDBY ON LED will be lighted.

#### Note:

- If you have not deactivated the demonstration, it will resume five seconds after the system switches to Eco Power Standby or Standby mode.

### Power Saving Automatic Standby

As a power-saving feature, the system will automatically switch to Standby mode if you do not press any buttons within 30 minutes after a disc or tape has stopped playing.

### Dim mode

You can select the desired brightness for the display.

- Press **DIM** repeatedly to select DIM 1, DIM 2, DIM 3 or DIM OFF.  
→ **DIM** appears on the display, except for DIM OFF mode.

#### DIM OFF - normal brightness with Spectrum Analyzer On



#### DIM 1 - normal brightness with Spectrum Analyzer Off



#### DIM 2 - half brightness with Spectrum Analyzer On



#### DIM 3 - half brightness with Spectrum Analyzer Off and all LEDs on the system will be switched off.







## Basic Functions

### Volume Control

Adjust **VOLUME** to increase (turn knob clockwise or press **VOLUME +**) or decrease (turn knob counter-clockwise or press **VOLUME -**) the sound level.

### To listen through the headphones

- Connect the headphones plug to the socket at the front of the system.  
→ The speakers will be muted.

### Interactive Sound Control

**For optimal sound listening, select only one of the following interactive sound controls at a time : PERSONAL, DSC, VEC or BASS/ TREBLE.**

#### Personal Sound

- 1 Press **PERSONAL**.
- 2 Adjust the **JOG CONTROL** (or press **PER.** on the remote control repeatedly) to select the desired Personal setting.  
→ The selected Personal setting number will appear on the display.  
→ If no name has been stored previously, "PERSONAL x" will be displayed. "x" is the setting number.

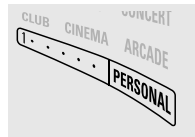

#### Personal Setting

You can use the **JOG CONTROL** to adjust the Personal setting to your desired level. Up to six Personal settings can be stored.

- 1 Press and hold **PERSONAL** on the system until "SELECT PRESET NUMBER" is displayed.
- 2 Adjust the **JOG CONTROL** to select the desired Personal setting number and press **▶▶** on the system to confirm the selection.  
→ "ADAPT LOW FREQ LEVEL" will be displayed.
- 3 Adjust the **JOG CONTROL** to select the desired Spectrum Analyzer band level for low frequency.  
→ The level will increase or decrease between **+3** and **-3**.

- 4 Press **▶▶** to confirm the selection.  
→ "ADAPT MID FREQ LEVEL" will be displayed, followed by "ADAPT HIGH FREQ LEVEL".
- Repeat **steps 3-4** to select the desired middle and high frequency Spectrum Analyzer band levels.
- 5 You can edit the name for the personal setting.  
→ The first character of the setting name will be flashing.
- 6 Adjust the **JOG CONTROL** to select the desired letter; number or symbol.  
→ "A to Z", "0 to 9" or "\*, -, +, \, /, \_".
- 7 Press **▶▶** to confirm the selection.  
→ The next character for editing will be flashing.
- Repeat **steps 6-7** to store up to 10 characters.
- 8 To store the setting, press **PERSONAL** on the system again.

### To change any previous setting before storing

- Press **◀◀** on the system to retrace the steps in reverse order and make the changes accordingly.

### To exit without storing the setting

- Press **■** on the system.

#### Notes:

- During personal setting, if no button is pressed within 90 seconds, the system will exit the Personal setting mode automatically.
- The **wOOx** level cannot be stored as part of the Personal setting.
- When making a Personal setting, it is not possible to adjust the Bass/Treble level, "USE JOG" will be displayed.

### Digital Sound Control (DSC)

The DSC feature enables you to adjust the system to suit your type of music.

- 1 Press **DSC**.
- 2 Adjust the **JOG CONTROL** (or press **DSC** on the remote control



repeatedly) to select the desired Digital Sound Control effect : OPTIMAL, CLASSIC, TECHNO, VOCAL, ROCK or JAZZ.  
→ The selected DSC will be encircled.

#### Note:

- For a neutral sound effect, select **CLASSIC**.

## Basic Functions

### Virtual Environment Control (VEC)

The VEC feature enables you to adjust the system to select a type of environment.

- 1 Press **VEC**.
- 2 Adjust the **JOG CONTROL** (or press **VEC** on the remote control repeatedly) to select the desired Virtual Environment Control effect : HALL, CLUB, DISCO, CINEMA, CONCERT or ARCADE.  
→ The selected VEC will be encircled.



### BASS/TREBLE

The BASS/TREBLE feature enables you to define the sound-processor settings for Bass and Treble.

- 1 Press **BASS/TREBLE (BTC)**.  
→ The BASS and TREBLE LEDs will be lighted.  
→ "ADAPT BASS AND TREBLE LEVELS" will be displayed.
- 2 Use the BASS/TREBLE controls to select the desired BASS or TREBLE levels respectively.  
→ The BASS/TREBLE level will increase or decrease between level +3 and -3.
  - Press **BASS** ▲ or ▼ repeatedly to select the low tone level.  
→ "BASS -x" or "BASS +x" will be displayed.
  - Press **TREBLE** ▲ or ▼ repeatedly to select the high tone level.  
→ "TREBLE -x" or "TREBLE +x" will be displayed.

#### Note:

- "x" denotes the sound level.

### Automatic DSC-wOOx / VEC-wOOx selection

The best wOOx setting is generated automatically for each DSC or VEC selection. You can manually select the wOOx setting that best suits your listening environment.

### wOOx

There are three wOOx settings to enhance the bass response.

- 1 Press **wOOx ON-OFF** (or **wOOx** on the remote control) to switch ON (enhanced) or OFF (normal) the wOOx sound effect.
  - When wOOx is switched on;  
→ The **wOOx** will appear on the display.
  - When wOOx is switched off;  
→ The display will show "wOOx NORM" and **wOOx** will disappear from the display.
- 2 When wOOx is switched on, adjust **wOOx LEVEL** to select the desired wOOx settings: WOOX 1, WOOX 2 or WOOX 3.



#### Notes:

- When Personal or Bass/Treble sound control is selected, wOOx will be switched off automatically.
- Some discs or tapes might be recorded in high modulation, which causes a distortion at high volume. If this occurs, deactivate wOOx or reduce the volume.



## CD Operation

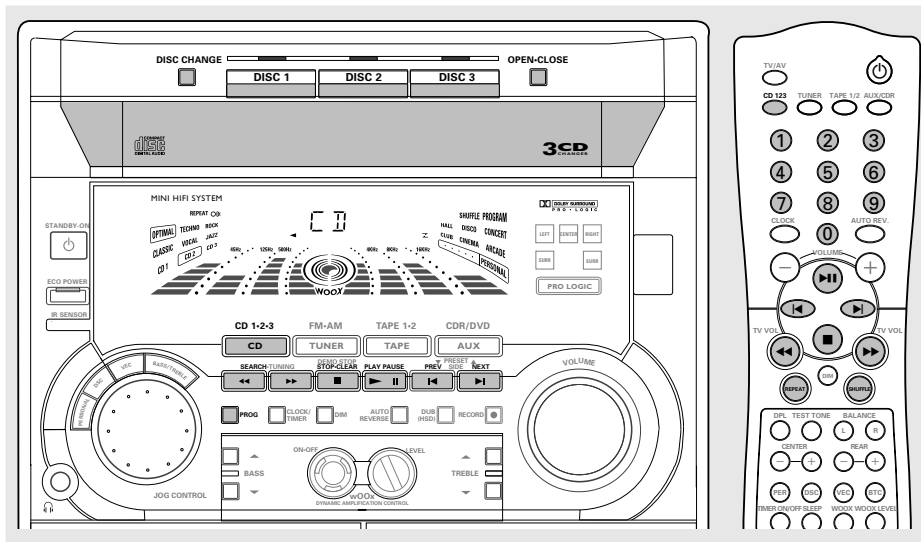

English

### IMPORTANT!

- This system is designed for regular discs. Therefore, do not use any accessories such as disc stabilizer rings or disc treatment sheets, etc., as offered on the market, because they may jam the changer mechanism.
- Do not load more than one disc into each tray.

### Discs for Playback

This system can playback all digital audio CD, finalized digital audio CD-Recordable (CDR) discs and finalized digital audio CD-Rewritable (CDRW) discs.



### Loading Discs

- 1 Press **CD** to select CD mode.
- 2 Press **OPEN•CLOSE** to open the disc tray.
- 3 Load up to two discs on the individual disc trays.  
To load the third disc, press **DISC CHANGE**.  
→ The disc tray will rotate until the empty tray is ready for loading.

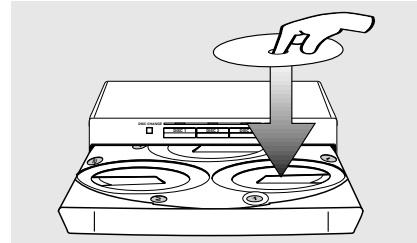

- 4 Press **OPEN•CLOSE** to close the disc tray.  
→ "READING" will be displayed. The selected disc, total number of tracks and the playing time will appear on the display.  
→ A lighted button indicates that a disc is loaded on the disc tray.

#### Notes:

- Load the discs with the label side facing up.
- To ensure good system performance, wait until the disc tray completely reads the disc(s) before proceeding.

## CD Operation

### Disc Playback

#### To playback all discs on the disc tray

- Press **PLAY ►II**.
  - All the available discs will playback once, then stop.
  - During playback, the selected disc tray, track number and elapsed playing time of the current track will appear on the display.

#### To playback one disc only

- Press the DISC DIRECT PLAY button : **DISC 1**, **DISC 2** or **DISC 3**.
  - The selected disc will playback once, then stop.

#### To interrupt playback

- Press **PAUSE ►II**
- To resume playback, press **PLAY ►II** again.

#### To stop playback

- Press **■**.

#### To search for a particular passage during playback

- Press and hold **◀◀** or **▶▶** and release it when the desired passage is located.
  - During searching, the volume will be reduced.

#### To select a desired track

- Press **◀** or **▶** repeatedly (or **Digits 0-9** on the remote control) until the desired track appears on the display.
- If playback is stopped, press **PLAY ►II** to start playback.

#### Note:

- In *Shuffle mode*, pressing **◀** will cause the player to skip only to the beginning of the current track.

#### To skip to the beginning of the current track during playback

- Press **◀** **once**.

### Replace discs during playback

- 1 Press **DISC CHANGE**.
- 2 To change the inner disc, press **DISC CHANGE** again.
  - "DISC CHANGE" will be displayed and the disc will stop playing.
  - The disc tray will close to retrieve the inner disc, then reopen with the inner disc accessible.

### Programming the disc tracks

Programming tracks is possible when playback is stopped. Up to 40 tracks can be stored in the memory in any order.

- 1 Load the desired discs on the disc tray (refer to "Loading Discs").
- 2 Press **PROG** to start programming.
  - **PROGRAM** will start flashing.
- 3 Press **CD** (CD 1•2•3) or **DISC 1/2/3** button to select a disc.
- 4 Press **◀** or **▶** (or **Digits 0-9** on the remote control) to select the desired track.
- 5 Press **PROG** to store the track.
  - Repeat **steps 3-5** to store other discs and tracks.
- 6 Press **PLAY ►II** to start program playback.
  - "PLAY PROGRAM" will be displayed.
  - To end programming without starting playback, press **■** **once**.
    - The total number of tracks programmed and the total playing time will appear on the display.

#### Notes:

- If the total playing time is more than "99:59" or if one of the programmed tracks has a number greater than 30, then "- - - -" will appear on the display instead of the total playing time.
- If you attempt to program more than 40 tracks, "PROGRAM FULL" will be displayed.
- If you press any of the DISC DIRECT PLAY buttons, the system will playback the selected disc or track, and the stored program will be ignored temporarily. The **PROGRAM** symbol also will disappear temporarily from the display. It will reappear when playback of the selected disc ends.
- During programming, if no button is pressed within 20 seconds, the system will exit the Program mode automatically.



## CD Operation

### To review the program

- Stop playback and press ◀ or ▶ repeatedly.
- To exit review mode, press ■.

### To erase the entire program

- Press ■ **once** when playback is stopped or **twice** during playback.
  - "PROGRAM CLEAR" will be displayed.
  - PROGRAM will disappear from the display.

#### Note:

- The program will be erased when the system is disconnected from the power supply or when the disc tray is opened.

### Repeat

The current track, a disc, all available discs or all programmed tracks can be played repeatedly.

- 1 Press **REPEAT** on the remote control repeatedly to select various repeat modes.
- **In normal playback**
  - "TRACK" – to repeat the current track.
  - "DISC" – to repeat the entire disc.
  - "ALL DISC" – to repeat all available discs.
  - REPEAT appears on the display.
- **In program playback**
  - "TRACK" – to repeat the current programmed track.
  - "PROGRAM" – to repeat all programmed tracks.
  - REPEAT and PROGRAM will appear on the display.
- The selected track/disc(s)/program will now be played repeatedly until you press ■.
- 2 To resume normal playback, press **REPEAT** until the "OFF" mode is displayed.
  - REPEAT will disappear from the display.

#### Note:

- Selecting SHUFFLE during repeat playback will cancel all repeat modes.

### Shuffle

All the available discs and their tracks or all the programmed tracks can be played in random order:

- 1 Press **SHUFFLE** on the remote control.
  - "SHUFFLE" and SHUFFLE will appear on the display.
- The discs and the tracks will be played in random order until you press ■.
- 2 To resume normal playback, press **SHUFFLE** again.
  - SHUFFLE will disappear from the display.

### When REPEAT is selected during shuffling

- **In normal shuffled playback**
  - "TRACK" and "ALL DISC" repeat modes are available for selection.
  - REPEAT and SHUFFLE will appear on the display.
- **In program shuffled playback**
  - "TRACK" or "PROGRAM" repeat modes are available for selection.
  - REPEAT, PROGRAM and SHUFFLE will appear on the display.

**For Recording, please refer to "Tape Operation/Recording".**



## Radio Reception

English

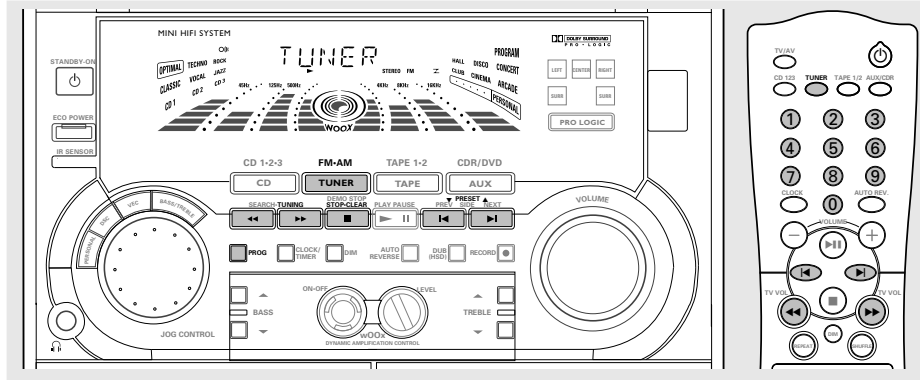

### Storing Preset Radio Stations

You can store up to 40 preset radio stations in the memory.

#### Automatic Preset Programming

- EASY SET setting (refer to "Basic Functions - EAST SET").  
OR
- 1 Press **TUNER** (FM•AM) to select TUNER mode.  
→ "TUNER" will be displayed. A few seconds later; the current radio frequency will be displayed.
- To begin automatic preset from a desired preset number**
- Press **◀** or **▶** (or **Digits 0-9** on the remote control) to select the desired preset number:  
→ For those radio stations that had been stored in one of the preset will not be restored again to another preset number.
- 2 Press and hold **PROG** until "AUTO" appears on the display.  
→ **PROGRAM** will start flashing.  
→ The system will start searching for all radio stations on the FM band and then the AM band.  
→ All available radio stations with sufficient signal strength will be stored automatically.  
→ The system will stop searching when all the available radio stations are stored or when the memory for 40 preset radio stations is used.  
→ The last preset radio station will then be played when completed.

### To stop storing the automatic preset

- Press **PROG** or **■** on the system.

#### Note:

– If no preset number is selected, automatic preset will begin from preset (1) and all your former presets will be overridden.

### Manual Preset Programming

- 1 Press **TUNER** (FM•AM) repeatedly to select the desired waveband : FM or AM.
- 2 Press **PROG**.  
→ **PROGRAM** will start flashing.  
→ The next available preset number will be displayed for selection.
- 3 Press and hold **◀** or **▶** until the frequency indication starts to change, then release.  
→ The display will show "SEARCH" until a radio station with sufficient signal strength is found.
- To store the radio station to another preset number**
- Press **◀** or **▶** (or **Digits 0-9** on the remote control) to select the desired preset number.
- 4 Press **PROG** again to store the radio station.  
→ **PROGRAM** will disappear from the display.
- Repeat **steps 2-4** to store other preset radio stations.

### Tuning to a weak radio station

- Press **◀** or **▶** briefly and repeatedly until the optimal reception is found.

### To stop storing the manual preset

- Press **■** on the system.



## Radio Reception

### Notes:

- If you attempt to store more than 40 preset radio stations, "PROGRAM FULL" will be displayed.
- During programming, if no button is pressed within 20 seconds, the system will exit the Program mode automatically.

### Tuning to Preset Radio Stations

- Press **◀** or **▶** (or **Digits 0–9** on the remote control) to select the desired preset number.
  - The preset number, radio frequency, and waveband will appear on the display.

**For Recording, please refer to "Tape Operation/Recording".**

## External Sources

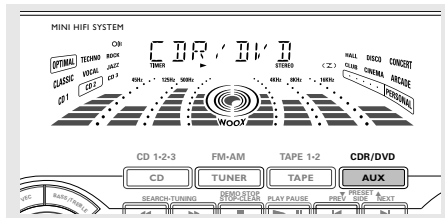

- If the sound from the external source is distorted, select CDR/DVD mode for listening.

### Notes:

- You are advised not to listen to and record from the same source simultaneously.
- All the interactive sound control features (DSC or VEC, for example) are available for selection.
- Refer to the operating instructions for the connected equipment for details.

### Listening to External Sources

- 1 Connect the audio out terminals of the external equipment (TV/VCR, Laser Disc player, DVD player or CD Recorder) to the AUX/CDR IN terminals of your system.
  - 2 Press **AUX** (CDR/DVD) repeatedly to select CDR/DVD or normal AUX mode.
    - "CDR/DVD" or "AUX" will be displayed.
- When CDR/DVD mode is selected, any audio equipment connected to the LINE OUT terminals of this mini system will be muted. You will not be able to record or listen to the sound from the LINE OUT source.

**For Recording, please refer to "Tape Operation/Recording".**



English

## Tape Operation/Recording

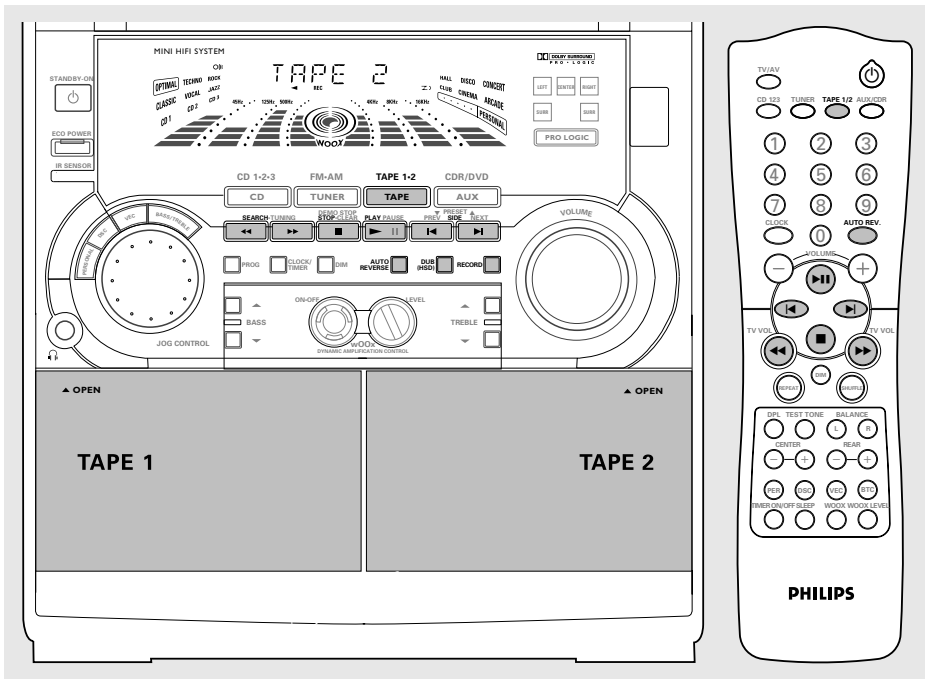

### IMPORTANT!

- Before playing a tape, check and tighten slack tape with a pencil. Slack tape may get jammed or may burst in the mechanism.
- C-120 tape is extremely thin and is easily deformed or damaged. It is not recommended for use in this system.
- Store the tapes at room temperature and do not put them too close to a magnetic field (for example, a transformer, TV or speaker).

### Tape Playback

- 1 Press **▲ OPEN** to open the tape deck door.
- 2 Insert a recorded tape and close the tape door.
- Load the tape with the open side down and the full spool to the left.

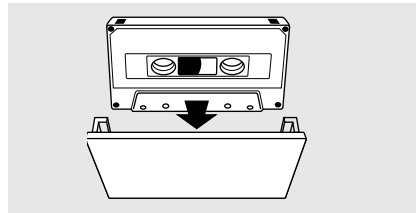

- 3 Press **TAPE (TAPE 1•2)** repeatedly to select tape deck 1 or tape deck 2.  
→ The selected tape deck number is displayed.
- 4 Press **PLAY ► II** to start playback.

### To stop playback

- Press **■**.





## Tape Operation/Recording

### To change the playback side on tape deck 2 only

- Press ◀ or ▶.
- The ◀ (BACK) or ▶ (FRONT) will appear on the display, depending on the tape side selected.

### To change the playback mode on tape deck 2 only

- Press **AUTO REVERSE** repeatedly to select the different playback modes.
  - ☐ : playback on one side of the tape only.
  - ☐☐ : both sides are played once.
  - ☐☐☐ : both sides are played repeatedly, up to 10 times each side unless you press ■.

### To rewind or fast forward during playback

- Press and hold ◀◀ or ▶▶ until the desired passage is reached, then release.
  - The tape continues playing.
- The tape will stop automatically at the end of the rewinding or fast forwarding.
  - During searching, the sound is reduced to a low volume.

### To rewind or fast forward when playback is stopped

- 1 Press ◀◀ or ▶▶.
- 2 Press ■ when you reached the desired passage.

#### Note:

– During rewinding or fast forwarding of a tape, it is also possible to select another source (CD, TUNER or AUX, for example).

### General Information on Recording

- For recording, use only tape of IEC type I (normal tape) or IEC type II (CrO<sub>2</sub>).
- The recording level is set automatically, regardless of the position of the Volume, VEC, DSC and so forth.
- The tape is secured at both ends with leader tape. At the beginning and end of the tape, nothing will be recorded for six to seven seconds.
- To prevent accidental recording, break out the tab on the left shoulder of the tape side you want to protect.

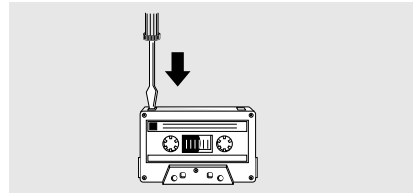

- If "CHECK TAPE" is displayed, the protection tab has been broken. Put a piece of clear adhesive tape over the opening. Do not cover the CrO<sub>2</sub> tape detection hole when covering the tab opening.

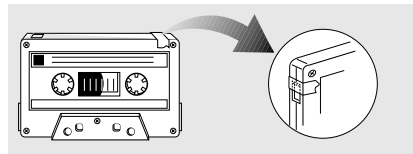

#### IMPORTANT!

- Recording is permissible if copyright or other rights of third parties are not infringed upon.
- Recording is possible only on tape deck 2.
- Switch off Dolby Pro Logic when recording.

### Preparation for Recording

- 1 Press **TAPE** (TAPE 1•2) to select TAPE 2.
- 2 Load a recordable tape into tape deck 2.
- 3 Press ◀ or ▶ to select the recording tape side.
  - ◀ appears on the display for the reverse side.
  - ▶ appears on the display for the forward side.



## Tape Operation/Recording

- 4 Press **AUTO REVERSE** repeatedly to select a recording mode.
  - for recording on one side only.
  - for recording on both sides.
- 5 Prepare the source to be recorded.
  - CD** – load the disc(s).
  - TUNER** – tune to the desired radio station.
  - TAPE** – load the prerecorded tape into tape deck 1 with the full spool to the left.
  - AUX** – connect external equipment.

### When recording is in progress

- **REC** starts flashing.
- It is not possible to change tape side.
- It is not possible to listen to another source except for dubbing tapes.
- It is not possible to activate the timer function.

### One Touch Recording

- 1 Press **CD**, **TUNER** or **AUX** to select the source.
- 2 Start playback of the selected source.
- 3 Press **RECORD** to start recording.

### To stop recording

- Press .

#### Note:

- *One Touch Recording is not possible in TAPE mode, "SELECT SOURCE" will be displayed.*

### CD Synchro Recording

- 1 Press **CD 1•2•3** to select the disc.
  - Press or (or **Digits 0–9** on the remote control) to select the desired track to start recording.
  - You can program the tracks in the order you want them to be recorded (refer to "CD Operation - Programming the disc tracks").
- 2 Press **RECORD** to start recording.
  - The disc will start playback automatically.

### To select another track during recording

- 1 Press **PAUSE ►II** to interrupt recording.
- 2 Press or (or **Digits 0–9** on the remote control) to select the desired track.
- 3 Press **PLAY ►II** to resume recording.

### To stop recording

- Press .
- Recording and disc playback will stop simultaneously.

### Dubbing Tapes

- 1 Load the prerecorded tape in tape deck 1.
  - You can set the tape to the desired passage where recording will start.
- 2 Press **DUB (HSD) once** for normal speed dubbing or **twice** (within 2 seconds) for high speed dubbing.
  - Playing and recording will start simultaneously.
  - "NORMAL" (normal speed) or "FAST" (high speed) will be displayed, followed by "DUB" with an indication on the selected tape side direction.
  - During high speed dubbing, the volume will be reduced and **HSD** will appear on the display.
- Dubbing of tapes is possible on one side of the tape only. To continue record on the reverse side, at the end of side A, flip the tapes to side B and repeat the procedure.

### To stop dubbing

- Press .

#### Notes:

- *Only mode is available during dubbing.*
- *Dubbing of tapes is possible only from tape deck 1 to tape deck 2.*
- *To ensure good dubbing, use tapes of the same length.*
- *You can listen to another source while dubbing.*

### Digital Recording via Digital Out

For CD digital recording, please refer to the instruction manuals for the CD recorder, digital audio equipment and so forth.



## Clock/Timer

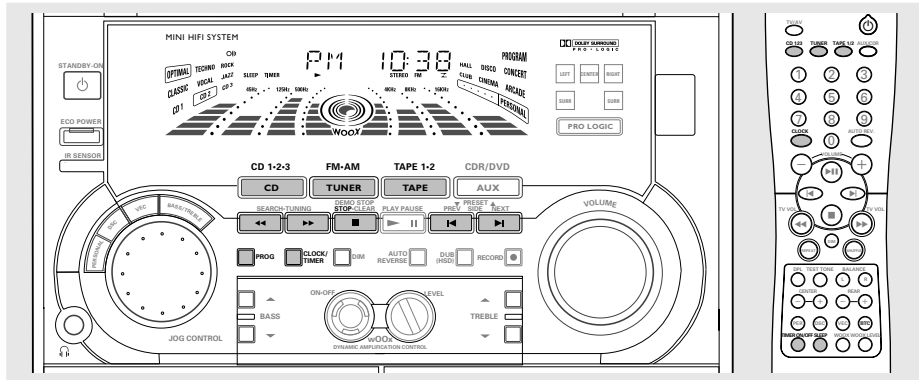

English

### View Clock

The clock (if it is set) will be shown in Standby mode.

#### To view the clock in any source mode (CD or TUNER, for example)

- Press **CLOCK/TIMER** briefly (or **CLOCK** on the remote control).
  - The clock will be displayed for a few seconds.
  - If the clock has not been set, "--:--" will be displayed.

#### Note:

- When in Eco Power Standby mode, the clock will not be displayed.

### Clock Setting

The clock can be set in either 12-hour or 24-hour mode ("PM 12:00" or "00:00" for example)

- 1 Press **CLOCK/TIMER** twice.
- 2 Press **PROG** on the system repeatedly to select clock mode.
  - If 12-hour mode is selected, "PM 12:00" will start flashing.
  - If 24-hour mode is selected, "00:00" will start flashing.
- 3 Press **◀** or **▶** on the system repeatedly to set the hour.
- 4 Press **⏪** or **⏩** on the system repeatedly to set the minute.
- 5 Press **CLOCK/TIMER** again to store the setting.
  - The clock will start working.

#### To exit without storing the setting

- Press **■** on the system.

#### Notes:

- The clock setting will be cancelled when the power cord is disconnected or if a power failure occurs.
- When in Eco Power Standby mode, the clock/timer function will not operate.
- During clock setting, if no button is pressed within 90 seconds, the system will exit clock setting mode automatically.

### Timer Setting

The system can switch on to CD, TUNER, or TAPE 2 mode automatically at a preset time, serving as an alarm to wake you up.

#### IMPORTANT!

- Before setting the timer, ensure that the clock is set correctly.
- The timer will always be switched on after it has been set.
- The timer will not start if a recording is in progress.
- The volume of the timer will increase gradually from the minimum level until it reaches the last tuned volume level.

- 1 Press and hold **CLOCK/TIMER** for more than **two seconds** to select timer mode.
  - "PM 12:00" or "00:00" or the last timer setting will start flashing.
  - **TIMER** will start flashing.
  - The selected source will be lighted while other available sources are flashing.





## Clock/Timer

- 2 Press **CD**, **TUNER** or **TAPE** to select the desired source.
  - Make sure the music source has been prepared.
    - CD** – Load the disc(s). To start from a specific track, make a program (refer to "CD Operation - Programming the disc tracks").
    - TUNER** – tune to the desired radio station.
    - TAPE** – load the prerecorded tape into tape deck 2.
- 3 Press ◀◀ or ▶▶ on the system repeatedly to set the hour for the timer to start.
- 4 Press ◀ or ▶ on the system repeatedly to set the minute for the timer to start.
- 5 Press **CLOCK/TIMER** to store the start time.
  - The timer is now set and activated.
  - **TIMER** will remain on the display.
- At the preset time, the selected source will play.

### To exit without storing the setting

- Press ■ on the system.

### Notes:

- If the selected source (CD) is not available when preset timer is reached, TUNER will be selected automatically.
- If the source selected is TAPE, and if the preset time is reached during dubbing, TUNER will be selected automatically.
- During timer setting, if no button is pressed within 90 seconds, the system will exit timer setting mode automatically.

### To deactivate the TIMER

- Press **TIMER ON/OFF** on the remote control.
  - The display will show "CANCEL" and **TIMER** will disappear from the display.

### To activate the TIMER

- Press **TIMER ON/OFF** on the remote control.
  - The last set timer information will be shown for a few seconds and **TIMER** will appear on the display.

### Sleep Timer Setting

The sleep timer enables the system to switch to Standby mode automatically at a preset time.

- 1 Set the clock (refer to "Clock Setting").
- 2 Press **SLEEP** on the remote control repeatedly to select a preset time.
  - The selections are as follows (time in minutes):  
60 → 45 → 30 → 15 → OFF → 60 ...
  - "SLEEP xx" or "OFF" will be displayed. "xx" is the time in minutes.
- 3 When you reach the desired length of time, stop pressing the **SLEEP** button.
  - The Sleep Timer is now set. After this amount of time passes, the system will switch to Standby mode.

### To deactivate the Sleep Timer

- Press **SLEEP** repeatedly until "OFF" is displayed, or press the **STANDBY ON** button.



## Specifications

English

### AMPLIFIER

Output power	
Total power .....	400 W
DPL Mode	
Left/Right Channel .....	2 x 150 W RMS <sup>(1)</sup>
Center Channel .....	50 W RMS, 12 $\Omega$
Surround Channel .....	2 x 25 W RMS, 6 $\Omega$
Stereo Mode .....	2 x 150 W RMS <sup>(1)</sup> / 2 x 120 W FTC <sup>(1)</sup>
Signal-to-noise ratio .....	$\geq$ 75 dBA (IEC)
Frequency response .....	40 – 20000 Hz, $\pm$ 3 dB
Input sensitivity	
AUX In / CDR/DVD In .....	500 mV / 1V
Output	
Speakers .....	$\geq$ 6 $\Omega$
Center Speaker .....	$\geq$ 12 $\Omega$
Surround Speakers .....	$\geq$ 6 $\Omega$
Headphones .....	32 $\Omega$ – 1000 $\Omega$
Subwoofer Out .....	1.5 V $\pm$ 2dB, > 22000 $\Omega$
Line Out .....	500 mV $\pm$ 2dB, > 22000 $\Omega$
Digital Out .....	IEC 958, 44.1 kHz
Surround Out (wireless) .....	350 mV

(1) 6  $\Omega$ , 60 Hz – 12.5 kHz, 10% THD)

### CD PLAYER

Number of programmable tracks .....	40
Frequency response .....	40 – 20000 Hz
Signal-to-noise ratio .....	$\geq$ 76 dBA
Channel separation .....	$\geq$ 79 dB (1 kHz)
Total harmonic distortion .....	< 0.02% (1 kHz)

### TUNER

FM wave range .....	87.5 – 108 MHz
AM wave range .....	530 – 1700 kHz
Number of presets .....	40
Antenna	
FM .....	300 $\Omega$ dipole wire
AM .....	Loop antenna

### TAPE PLAYER

Frequency response	
CrO <sub>2</sub> tape (type II) .....	60 – 15000 Hz (5 dB)
Normal tape (type I) .....	60 – 15000 Hz (5 dB)
Signal-to-noise ratio	
CrO <sub>2</sub> tape (type II) .....	$\geq$ 50 dBA
Normal tape (type I) .....	$\geq$ 47 dBA
Wow and flutter .....	$\leq$ 0.4% DIN

### SPEAKERS

<b>Front left/right</b>	
System .....	3-way; Bass reflex system with top firing wOOx
Impedance .....	6 $\Omega$
wOOx .....	1 x 6.5" top firing wOOx driver
Woofer .....	1 x 6.5" full range
Tweeter .....	1 x 2.5" Ferrofluid Polydome Tweeter
Dimensions (w x h x d) .....	240 x 335 x 347 (mm) 9.45 x 13.19 x 13.66 (inch)
Weight .....	4.81 kg each 10.58 pounds each

### Surround speakers

System .....	closed satellite
Impedance .....	6 $\Omega$
Speaker Driver .....	1 x 4" full range
Dimensions (w x h x d) .....	235 x 135 x 155 (mm) 9.25 x 5.31 x 6.10 (inch)
Weight .....	1.07 kg each / 2.36 pounds each

### Center speaker

System .....	shielded bass reflex
Impedance .....	12 $\Omega$
Speaker Driver .....	1 x 4" full range
Dimensions (w x h x d) .....	235 x 135 x 155 (mm) 9.25 x 5.31 x 6.10 (inch)
Weight .....	1.21 kg / 2.67 pounds

### GENERAL

Material/finish .....	Polystyrene/Metal
AC Power .....	120 V / 60 Hz
Power Consumption	
Active .....	180 W
Standby .....	< 20 W
Eco Power Standby .....	< 2 W
Dimensions (w x h x d) .....	265 x 310 x 390 (mm) 10.43 x 12.20 x 15.35 (inch)
Weight (without speakers) .....	9.7 kg / 21.34 pounds

**Specifications and external appearance are subject to change without notice.**



## Maintenance

### Cleaning the Cabinet

- Use a soft cloth slightly moistened with a mild detergent solution. Do not use a solution containing alcohol, spirits, ammonia or abrasives.

### Cleaning Discs

- When a disc becomes dirty, clean it with a cleaning cloth. Wipe the disc from the center out. Do not wipe in a circular motion.
- Do not use solvents such as benzene, thinner, commercially available cleaners, or antistatic spray intended for analog records.



### Cleaning the disc lens

- After prolonged use, dirt or dust may accumulate at the disc lens. To ensure good playback quality, clean the disc lens with Philips CD Lens Cleaner or any commercially available cleaner. Follow the instructions supplied with cleaner:

### Cleaning the Heads and the Tape Paths

- To ensure good recording and playback quality, clean the heads (A), the capstan(s) (B), and pressure roller(s) (C) after every 50 hours of tape operation.
- Use a cotton swab slightly moistened with cleaning fluid or alcohol.
- You also can clean the heads by playing a cleaning tape once.

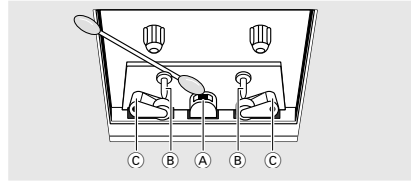

### Demagnetizing the heads

- Use a demagnetizing tape available at your dealer.

## Troubleshooting

### WARNING

**Under no circumstances should you try to repair the system yourself, as this will invalidate the warranty. Do not open the system as there is a risk of electric shock.**

**If a fault occurs, first check the points listed below before taking the system for repair. If you are unable to remedy a problem by following these hints, consult your dealer or service center.**

Problem	Solution
<b>CD OPERATION</b>	
"NO DISC" is displayed.	<ul style="list-style-type: none"> <li>- Insert a disc.</li> <li>- Check if the disc is inserted upside down.</li> <li>- Wait until the moisture condensation at the lens has cleared.</li> <li>- Replace or clean the disc, see "Maintenance".</li> </ul>
"DISC NOT FINALIZED" is displayed.	<ul style="list-style-type: none"> <li>- Use a finalized CD-R(W) or CD-R.</li> </ul>



## Troubleshooting

### RADIO RECEPTION

#### Radio reception is poor.

- If the signal is too weak, adjust the antenna or connect an external antenna for better reception.
- Increase the distance between the Mini HiFi System and your TV or VCR.

### TAPE OPERATION/RECORDING

#### Recording or playback cannot be made.

- Clean deck parts, see "Maintenance".
- Use only NORMAL (IEC I) or IEC type II (CrO<sub>2</sub>) tape.
- Apply a piece of adhesive tape over the missing tab space.

#### The tape deck door cannot open.

- Remove and reconnect the AC power plug and switch on the system again.

#### Recorded material sounds strange.

- Switch off Dolby Pro Logic mode when recording.

### GENERAL

#### The system does not react when buttons are pressed.

- Remove and reconnect the AC power plug and switch on the system again.

#### Sound cannot be heard or is of poor quality.

- Adjust the volume.
- Disconnect the headphones.
- Check that the speakers are connected correctly.
- Check if the stripped speaker wire is clamped.

#### The left and right sound outputs are reversed.

- Check the speaker connections and location.

#### The remote control does not function properly.

- Select the source (CD or TUNER, for example) before pressing the function button (▶, ◀, ▶).
- Reduce the distance between the remote control and the system.
- Insert the batteries with their polarities (+/- signs) aligned as indicated.
- Replace the batteries.
- Point the remote control in the direction of the system's IR sensor.

#### The timer is not working.

- Set the clock correctly.
- Press the TIMER ON/OFF to switch on the timer.
- If recording is in progress, stop recording.

#### Not all lighted buttons are showing light.

- Press DIM to select DIM OFF display mode.

#### The Clock/Timer setting is erased.

- Power has been interrupted or the power cord has been disconnected. Reset the clock/timer.

#### The system displays features automatically and buttons start flashing.

- Press and hold DEMO STOP ■ on the system to switch off the demonstration.



# LIMITED WARRANTY

## AUDIO SYSTEM

One Year Free Labor

One Year Free Service on Parts

This product must be carried in for repair.

### WHO IS COVERED?

You must have proof of purchase to receive warranty service. A sales receipt or other document showing that you purchased the product is considered proof of purchase.

### WHAT IS COVERED?

Warranty coverage begins the day you buy your product. For one year thereafter, all parts will be repaired or replaced, and labor is free. After one year from the day of purchase, you pay for the replacement or repair of all parts, and for all labor charges. All parts, including repaired and replaced parts, are covered only for the original warranty period. When the warranty on the product expires, the warranty on all replaced and repaired parts also expires.

### WHAT IS EXCLUDED?

Your warranty does not cover:

- labor charges for installation or setup of the product, adjustment of customer controls on the product, and installation or repair of antenna systems outside of the product.
- product repair and/or part replacement because of misuse, accident, unauthorized repair or other cause not within the control of Philips Consumer Electronics Company.
- reception problems caused by signal conditions or cable or antenna systems outside the unit.
- a product that requires modification or adaptation to enable it to operate in any country other than the country for which it was designed, manufactured, approved and/or authorized, or repair of products damaged by these modifications.
- incidental or consequential damages resulting from the product. (Some states do not allow the exclusion of incidental or consequential damages, so the above exclusion may not apply to you. This includes, but is not limited to, prerecorded material, whether copyrighted or not copyrighted.)
- a product that is used for commercial or institutional purposes.

### WHERE IS SERVICE AVAILABLE?

Warranty service is available in all countries where the product is officially distributed by Philips Consumer Electronics Company. In countries where Philips Consumer Electronics Company does not distribute the product, the local Philips service organization will attempt to provide service (although there may be a delay if the appropriate spare parts and technical manual(s) are not readily available).

### MAKE SURE YOU KEEP...

Please keep your sales receipt or other document showing proof of purchase. Attach it to this owner's manual and keep both nearby. Also keep the original box and packing material in case you need to return your product.

### BEFORE REQUESTING SERVICE...

Please check your owner's manual before requesting service. Adjustments of the controls discussed there may save you a service call.

### TO GET WARRANTY SERVICE IN U.S.A., PUERTO RICO OR U.S. VIRGIN ISLANDS...

Take the product to a Philips factory service center (see enclosed list) or authorized service center for repair. When the product has been repaired, you must pick up the unit at the center. Centers may keep defective parts. (In U.S.A., Puerto Rico and U.S. Virgin Islands, all implied warranties, including implied warranties of merchantability and fitness for a particular purpose, are limited in duration to the duration of this express warranty. But, because some states do not allow limitations on how long an implied warranty may last, this limitation may not apply to you.)

### TO GET WARRANTY SERVICE IN CANADA...

Please contact Philips at:

1-800-661-6162 (French Speaking)  
1-800-363 7278 (English Speaking)

(In Canada, this warranty is given in lieu of all other warranties. No other warranties are expressed or implied, including any implied warranties of merchantability or fitness for a particular purpose. Philips is not liable under any circumstances for any direct, indirect, special, incidental or consequential damages, howsoever incurred, even if notified of the possibility of such damages.)

### REMEMBER...

Please record the model and serial numbers found on the product below. Also, please fill out and mail your warranty registration card promptly. It will be easier for us to notify you if necessary.

MODEL # \_\_\_\_\_

SERIAL # \_\_\_\_\_

This warranty gives you specific legal rights. You may have other rights which vary from state/province to state/province.

Philips Service Solutions Group, P.O. Box 2976, Longview, Texas 75606, USA, (903) 242-4800

EL4965E006 / MAC 4110 / 12-98



## Free Manuals Download Website

<http://myh66.com>

<http://usermanuals.us>

<http://www.somanuals.com>

<http://www.4manuals.cc>

<http://www.manual-lib.com>

<http://www.404manual.com>

<http://www.luxmanual.com>

<http://aubethermostatmanual.com>

Golf course search by state

<http://golfingnear.com>

Email search by domain

<http://emailbydomain.com>

Auto manuals search

<http://auto.somanuals.com>

TV manuals search

<http://tv.somanuals.com>