

Pioneer

50-DISC MAGAZINE

DRM-AF751

Operating instructions

Thank you for buying this Pioneer product. Please read through these operating instructions so you will know how to operate your model properly.

This product is an optional unit designed for exclusive use as the 700-disc changers, models DRM-7000. This means that this unit cannot be used alone or connected to other equipment than specified.

WARNING: TO PREVENT FIRE OR SHOCK HAZARD, DO NOT EXPOSE THIS APPLIANCE TO RAIN OR MOISTURE.

The export of this product or devices in which this product has been installed from Japan is regulated by Japanese government. The export of this product may be prohibited without governmental license. To export or re-export of this product from a country other than Japan may also be prohibited without an export license from the country involved.

IMPORTANT NOTICE:

RECORD THE MODEL NUMBER AND SERIAL NUMBER OF THIS EQUIPMENT BELOW. THE NUMBERS ARE ON THE TOP PANEL.

MODEL NO. DRM-AF751

SERIAL NO. _____

KEEP THESE NUMBERS FOR FUTURE USE.

IMPORTANT



The lightning flash with arrowhead symbol, within an equilateral triangle, is intended to alert the user to the presence of uninsulated "dangerous voltage" within the product's enclosure that may be of sufficient magnitude to constitute a risk of electric shock to persons.

CAUTION

**RISK OF ELECTRIC SHOCK
DO NOT OPEN**

CAUTION:

TO PREVENT THE RISK OF ELECTRIC SHOCK, DO NOT REMOVE COVER (OR BACK). NO USER-SERVICEABLE PARTS INSIDE. REFER SERVICING TO QUALIFIED SERVICE PERSONNEL.



The exclamation point within an equilateral triangle is intended to alert the user to the presence of important operating and maintenance (servicing) instructions in the literature accompanying the appliance.

This equipment has been tested and found to comply with the limits for a Class A digital device, pursuant to Part 15 of the FCC Rules. These limits are designed to provide reasonable protection against harmful interference when the equipment is operated in a commercial environment. This equipment generates, uses, and can radiate radio frequency energy and, if not installed and used in accordance with the instruction manual, may cause harmful interference to radio communications. Operation of this equipment in a residential area is likely to cause harmful interference in which case the user will be required to correct the interference at his own expense.

[For Canadian model]

This Class A digital apparatus complies with Canadian ICES-003.

[Pour le modèle Canadien]

Cet appareil numérique de la Classe A est conforme à la norme NMB-003 du Canada.

Information to User

Alteration or modifications carried out without appropriate authorization may invalidate the user's right to operate the equipment.

Handling the discs

- Avoid touching the signal surface when you use a disc.
- To hold it, place your fingers on the edge of the disc or the edge of the center hole and the disc edge.
- DO NOT use non-standard discs, as these may adversely influence this unit and other equipment.
- DO NOT play a CD having other shape than a circular disc, such as heart shaped disc, or malfunction may occur.



- Do not attach paper or stickers to the label side of the disc. Handle discs carefully and avoid damaging the label.



- Discs rotate at high speed in the changer. Do not use defective discs (e.g., cracked or considerably warped). Such discs may damage the changer.



Do not use the following types of discs for they may cause malfunction of the unit or damage to the discs:

- Disc which has a molding flash (projected fin) left on the periphery as shown in the illustration.
- Disc with its edges are rounded or tapered as shown in the figure.

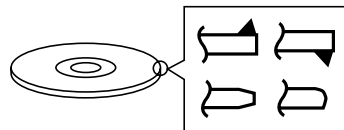

FEATURES

- **Able to accommodate 50 discs**
- **Disc holder lock/release mechanism**
- **Memory**

Disc magazines are equipped with memory which makes it possible to read IDs to identify individual magazines and make the management of offline media easier.

A HARDWARE TOUR

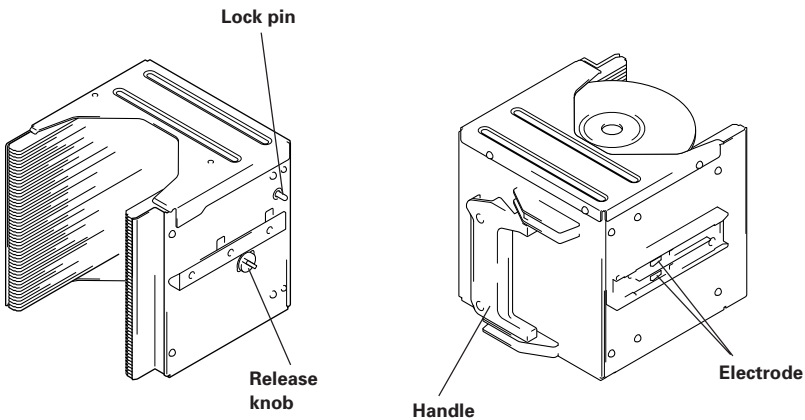

NOTES:

- *Electrodes are highly susceptible to damage from static electricity, and for this reason you should always be careful not to allow your hands to come into contact with the electrodes.*
- *Always be sure to place disc magazines into the provided dust covers when storing magazines.*

TO INSTALL THE DISC MAGAZINE

For instructions on how to open the access doors, see the operating instructions for the DRM-7000 disc changer.

1. Insert discs into a disc magazine.

- ① Turn the release knob to the vertical direction to unlock.
- ② Insert discs.
- ③ Turn the release knob to the horizontal direction to lock the discs into place.

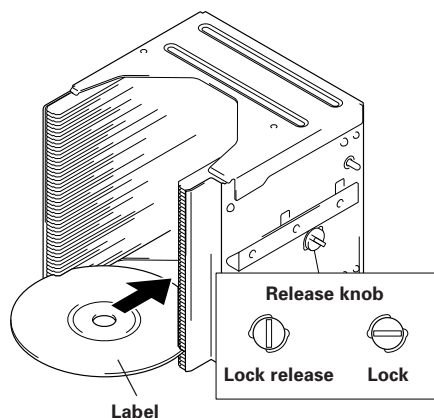

NOTES:

- Insert with label facing upward.
- Insert discs horizontally. Otherwise it may result in damage to the discs.
- Take care not to scratch or do other damage to the recording faces of discs.
- Do not turn a disc magazine upside down while the lock is disengaged. Otherwise it may result in discs falling out of the magazine.
- Discs may not be inserted or removed when the magazine is locked, and the use of excessive force when trying to do so may result in damage to discs or to the disc magazine.

2. Insert magazine into changer.

Holding the handle of the disc magazine, insert the disc magazine into the changer following the changer guide rails until it runs against the stopper.

And turn the handle to the left with pushing the magazine in so that the lock pin on the left of the magazine slides into the corresponding hole along the side of the changer.

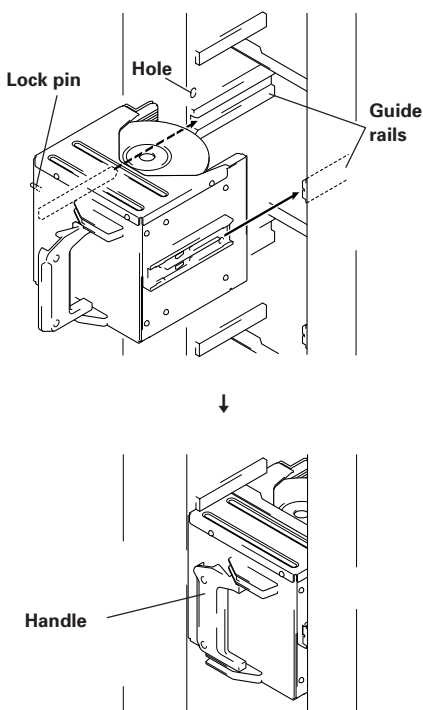

Shown above is the insertion to the front magazine bay. Though the insertion to the rear magazine bay is almost same but note that the proper installation position is in the place where it is very secluded.

To remove a disc magazine from the changer, pull the handle towards you and pull the magazine from the changer.

SPECIFICATIONS

Maximum number of discs	50 discs
Operating temperature	+5°C +35°C
Operating humidity	5 - 85% (no condensation)
Storage temperature	-40°C + 60°C
Weight	1,5 kg
External dimensions	184.8 (W) x 156.3 (H) x 173 (D)

NOTE:

Specifications and design subject to possible modifications without notice, due to improvements.

AFTER-SALES SERVICE FOR PIONEER PRODUCTS

Please contact the dealer or distributor from where you purchased the product for its after-sales service (including warranty conditions) or any other information. In case the necessary information is not available, please contact the Pioneer's subsidiaries (regional service headquarters) listed below:

PLEASE DO NOT SHIP YOUR PRODUCT TO THE COMPANIES

at the addresses listed below for repair without advance contact, for these companies are not repair locations.

AMERICA

PIONEER ELECTRONICS SERVICE, INC.
CUSTOMER SUPPORT DIVISION
P.O. BOX 1760, LONG BEACH, CA 90801-1760, U.S.A.

EUROPE

PIONEER ELECTRONIC (EUROPE) N.V.
EUROPEAN SERVICE DIVISION
HAVEN 1087, KEETBERGLAAN 1, 9120 MELSELE, BELGIUM

ASEAN

PIONEER ELECTRONICS ASIACENTRE PET. LTD.
SERVICE DEPARTMENT
501 ORCHARD ROAD, #10-00
WHEELLOCK PLACE, SINGAPORE 238880

JAPAN AND OTHERS

PIONEER ELECTRONIC CORPORATION (HEAD OFFICE)
CUSTOMER SUPPORT CENTER
4-1, MEGURO 1-CHOME, MEGURO-KU, TOKYO 153-8654 JAPAN



この取扱説明書はエコマーク認定
の再生紙を使用しています。

© 1999 パイオニア株式会社 禁無断転載

France : tapez 36 15 PIONEER

Published by Pioneer Electronic Corporation.
Copyright © 1999 Pioneer Electronic Corporation.
All rights reserved.

パイオニア株式会社 ☎ 153-8654 東京都目黒区目黒 1 丁目 4 番 1 号

PIONEER ELECTRONIC CORPORATION 4-1, Meguro 1-Chome, Meguro-ku, Tokyo 153-8654, Japan

Business System Company: 15-5, Ohmorinishi 4-Chome, Ohta-ku, Tokyo 143-8564 Japan TEL: 81-3-3763-2369

PIONEER NEW MEDIA TECHNOLOGIES, INC.

Laser Optical Systems Division: 2265 East 220th Street, Long Beach, CA 90810, U.S.A. TEL: 1-310-952-2111

PIONEER ELECTRONIC [EUROPE] N.V.

PIONEER House, Hollybush Hill, STOKE POGES, SLOUCH SL2 4QP U.K. TEL: 44-1753-789-789

PIONEER ELECTRONICS OF CANADA, INC.

Industrial Products Department: 300 Allstate Parkway, Markham, Ontario L3R 0P2, Canada TEL: 905-479-4411

PIONEER ELECTRONICS AUSTRALIA PTY. LTD.

178-184 Boundary Road, Braeside, Victoria 3195, Australia TEL: 61-3-9586-6300

PIONEER ELECTRONICS ASIACENTRE PTE. LTD.

501 Orchard Road, #10-00, Wheelock Place, Singapore 238880 TEL: 65-735-9011

Free Manuals Download Website

<http://myh66.com>

<http://usermanuals.us>

<http://www.somanuals.com>

<http://www.4manuals.cc>

<http://www.manual-lib.com>

<http://www.404manual.com>

<http://www.luxmanual.com>

<http://aubethermostatmanual.com>

Golf course search by state

<http://golfingnear.com>

Email search by domain

<http://emailbydomain.com>

Auto manuals search

<http://auto.somanuals.com>

TV manuals search

<http://tv.somanuals.com>