

PRO·FORM[®]

640

Model No. PFBE64080

Serial No. _____

Write the serial number in the space above for reference.

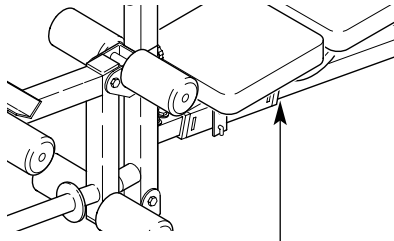

Serial Number Decal (under seat)

QUESTIONS?

As a manufacturer, we are committed to providing complete customer satisfaction. If you have questions, or find that there are missing or damaged parts, we will guarantee you complete satisfaction through direct assistance from our factory.

TO AVOID UNNECESSARY DELAYS, PLEASE CALL DIRECT TO OUR TOLL-FREE CUSTOMER HOT LINE. The trained technicians on our customer hot line will provide immediate assistance, free of charge to you.

CUSTOMER HOT LINE:

1-800-999-3756

Mon.–Fri., 6 a.m.–6 p.m. MST

CAUTION

Read all precautions and instructions in this manual before using this equipment. Save this manual for future reference.

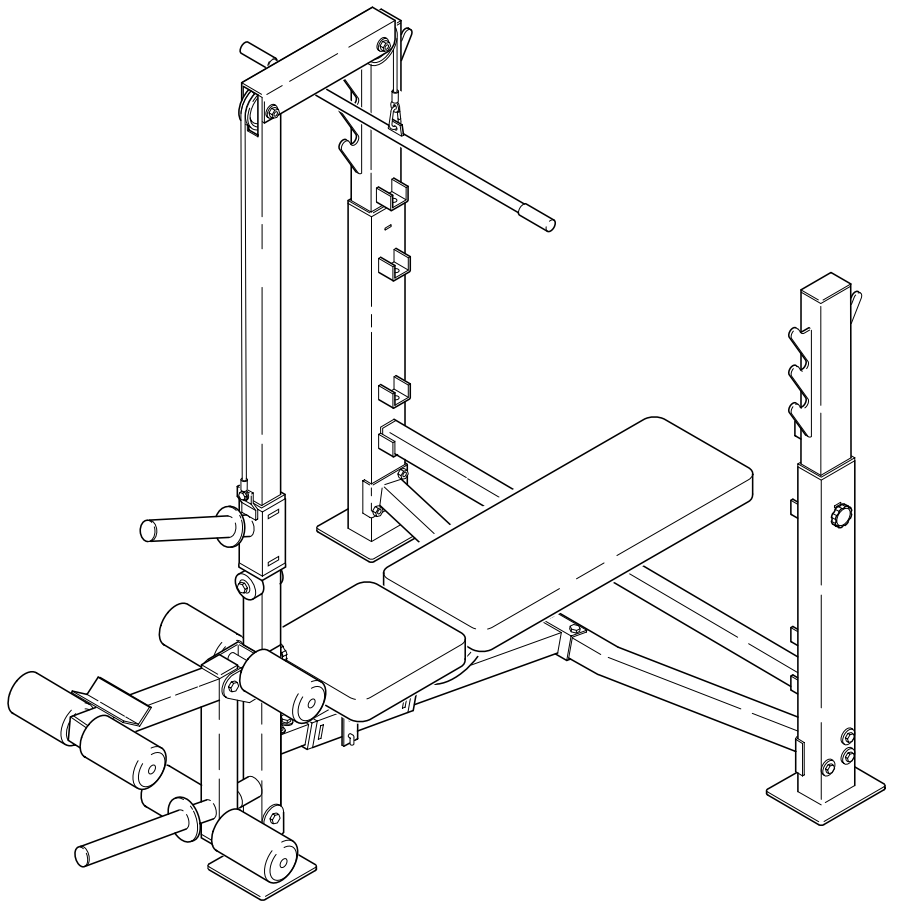

USER'S MANUAL

PATENT PENDING

Table of Contents

Warning Decal Placement	2
Important Precautions	3
Before You Begin	4
Part Identification Chart	5
Assembly	6
Adjusting the Weight Bench	13
Exercise Guidelines	17
Ordering Replacement Parts	Back Cover
Limited Warranty	Back Cover

Note: A Part List/Exploded Drawing is attached to the center of this manual. Remove the Part List/Exploded Drawing before beginning assembly.

Warning Decal Placement

The decal shown below has been placed on the weight bench. If the decal is missing, or if it is not legible, please call our Customer Service Department toll-free at 1-800-999-3756, Monday through Friday, 6 a.m. until 6 p.m. Mountain Time, to order a replacement decal. Apply the replacement decal to the location shown.

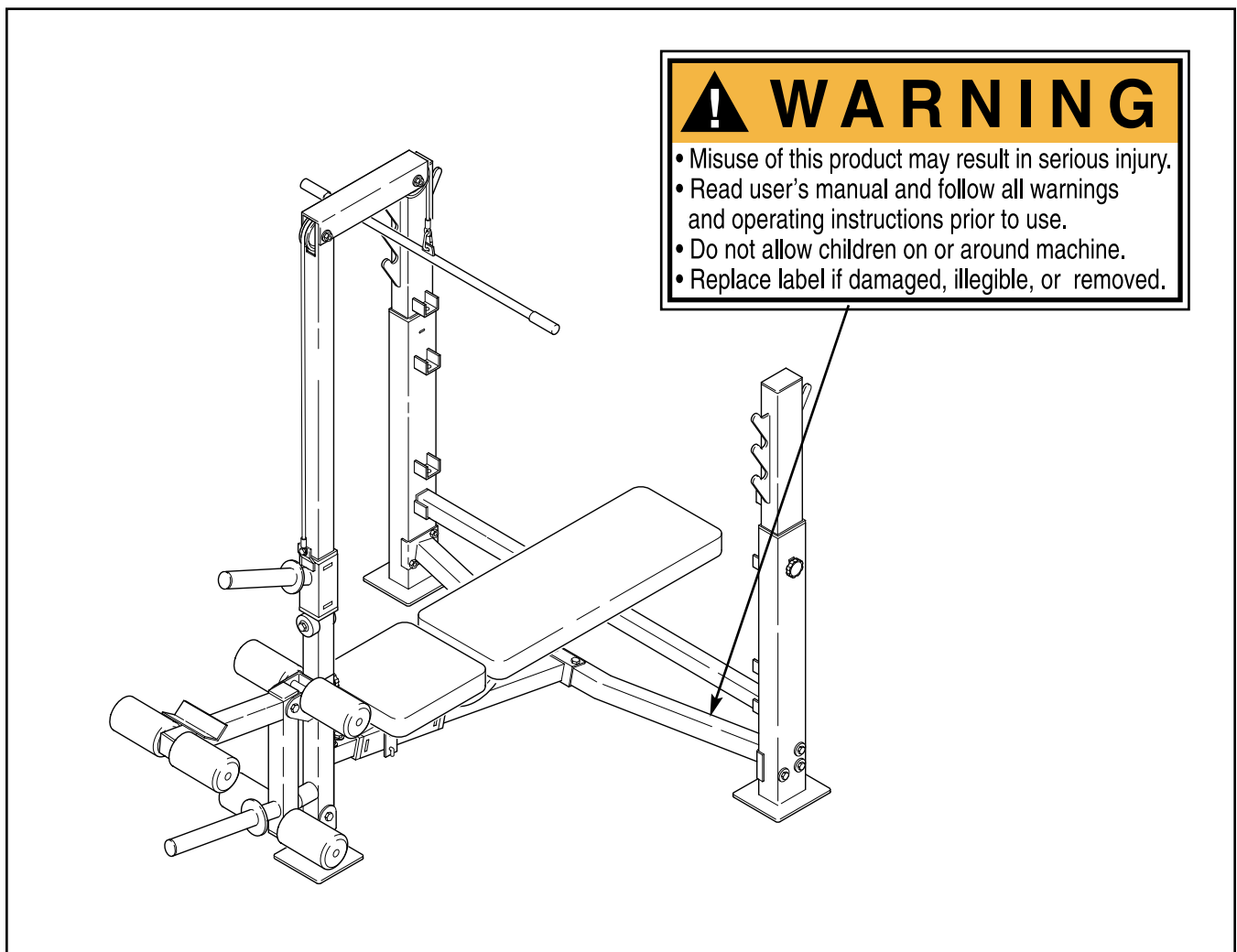

Important Precautions

WARNING: To reduce the risk of serious injury, read the following important precautions before using the weight bench.

1. Read all instructions in this manual before using the weight bench. Use the weight bench only as described in this manual.
2. It is the responsibility of the owner to ensure that all users of the weight bench are adequately informed of all precautions.
3. The weight bench is intended for home use only. Do not use the weight bench in any commercial, rental or institutional setting.
4. Use the weight bench only on a level surface. Cover the floor beneath the weight bench for protection.
5. Inspect and tighten all parts each time you use the weight bench. Replace any worn parts immediately.
6. Keep children under 12 and pets away from the weight bench at all times.
7. Keep hands and feet away from moving parts.
8. Always wear athletic shoes for foot protection while exercising.
9. Do not use a barbell (not included) longer than six feet with the weight bench.
10. Always make sure there is an equal amount of weight on each side of your barbell.
11. The weight bench is designed to support a maximum of 560 pounds, including the user, a barbell and weights. Do not place more than 310 pounds, including a barbell and weights, on the weight rests. Do not place more than 150 pounds on the weight carriage. Do not place more than 150 pounds on the leg lever for normal use.
12. Always place 50 pounds on the leg lever to balance the bench when performing squat exercises (see page 15).
13. Always fold the backrest out of the way when performing squat exercises (see page 15). Do not sit on the seat when the backrest is folded.
14. Do not stand with your back to the weight bench when performing squat exercises (see page 15). You should be able to see the weight rests while exercising so that you can safely return the barbell to the weight rests when you finish the exercise.
15. When using the backrest, make sure the adjustment tube is fully inserted into the adjustment brackets on the uprights.
16. Always remove the lat tower or curl post from the front leg before performing leg curl or leg extension exercises with the leg lever (see page 14).
17. When performing an exercise during which you are sitting on the bench with your back to the lat tower, make sure there is plenty of space between your back and the weight carriage. Always lower the weight carriage in a controlled manner. Never let the weight carriage drop.
18. Always set both weight rests at the same height. The adjustment knob must always be inserted through both the weight rest and upright and firmly tightened. Never tighten the adjustment knob into an upright and then set a weight rest in the upright on top of the adjustment knob.
19. Always exercise with a partner. When you are performing bench press exercises, squat exercises or toe raise exercises, your partner should stand behind you to catch the barbell if you cannot complete a repetition.
20. If you feel pain or dizziness at any time while exercising, stop immediately and begin cooling down.

WARNING: Before beginning this or any exercise program, consult your physician. This is especially important for persons over the age of 35 or persons with pre-existing health problems. Read all instructions before using. ICON assumes no responsibility for personal injury or property damage sustained by or through the use of this product.

Before You Begin

Thank you for selecting the versatile PROFORM® 640 Weight Bench. The PROFORM® 640 is designed to help you develop every major muscle group of the body. Whether your goal is a shapely figure, dramatic muscle size and strength or a healthier cardiovascular system, the PROFORM® 640 Weight Bench will help you achieve the specific results you want.

For your benefit, read this manual carefully before using the PROFORM® 640 Weight Bench. If you have additional questions, please call our Customer Service Department toll-free at 1-800-999-3756,

Monday through Friday, 6 a.m. until 6 p.m. Mountain Time (excluding holidays). To help us assist you, please note the product model number and serial number before calling. The model number is PFBE64080. The serial number can be found on a decal attached to the Weight Bench (see the front cover of this manual).

Before reading further, please review the drawing below and familiarize yourself with the parts that are labeled.

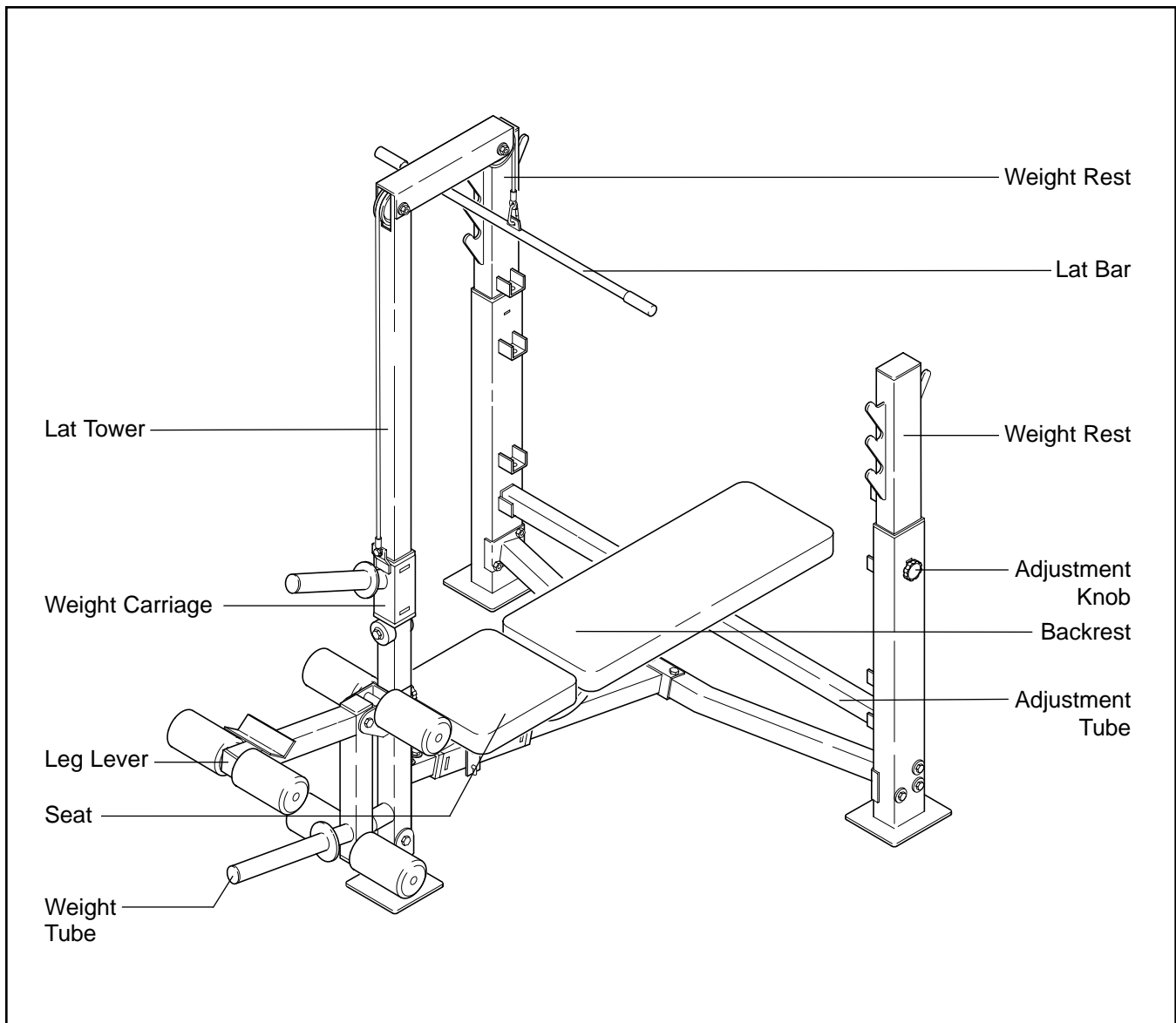

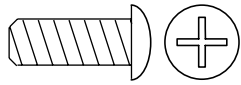

M6 x 16mm Screw (3)

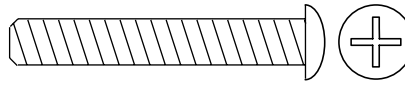

M6 x 38mm Screw (4)

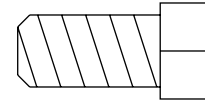

M10 x 19mm Bolt (8)



M10 x 136mm Bolt (22)

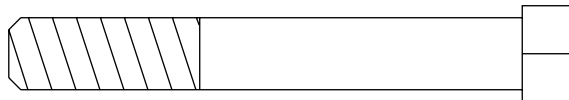

M10 x 68mm Bolt (33)

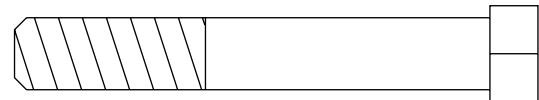

M10 x 63mm Bolt (43)

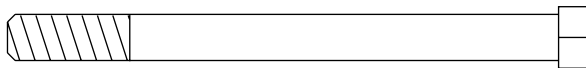

M6 x 73mm Bolt (7)

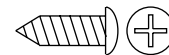

M4 x 12mm Tapping Screw (64)

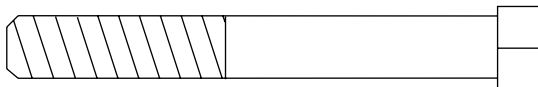

M8 x 65mm Bolt (52)



M10 x 68mm Bolt (33)

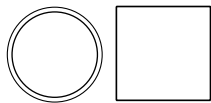

Pulley Spacer (61)

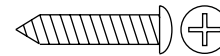

M4 x 19mm Tapping Screw (38)

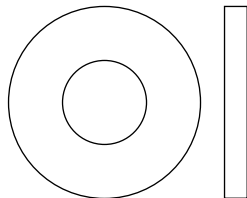

Plastic Washer (21)

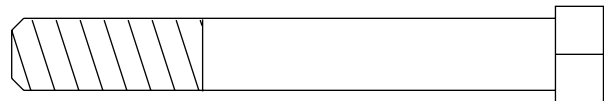

M10 x 72mm Bolt (59)

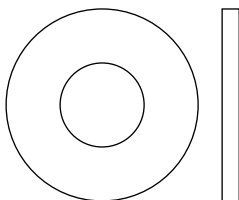

M10 Washer (6)

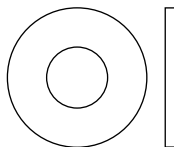

M8 Washer (23)

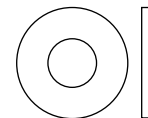

M6 Washer (50)



M6 Nylon Locknut (2)



M8 Nylon Locknut (13)



M10 Nylon Locknut (1)

Assembly

Before beginning assembly, carefully read the following information and instructions:

Make Things Easier for Yourself!





Everything in this manual is designed to ensure that the assembly of our products can be completed successfully by anyone. However, it is important to recognize that your new equipment is a sophisticated product with many small parts and consequently, the assembly process will take time. Most people find that by setting aside plenty of time, and by deciding to make the task enjoyable, assembly will go smoothly.

- Assembly requires two people.
- Place all parts in a cleared area and remove the packing materials. Do not dispose of the packing materials until assembly is completed.
- Tighten all parts as you assemble them, unless instructed to do otherwise.

• For help identifying the small parts, use the PART IDENTIFICATION CHART on page 5.

• As you assemble the weight bench, make sure all parts are oriented as shown in the drawings.

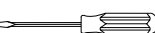
The following tools (not included) are required for assembly:

- **Two (2) adjustable wrenches** 
- **One (1) rubber mallet** 
- **One (1) standard screwdriver** 
- **One (1) phillips screwdriver** 
- **Lubricant, such as grease or petroleum jelly plus soapy water.**

Assembly will be more convenient if you have the following tools: A socket set, a set of open-end or closed-end wrenches or a set of ratchet wrenches.

1. **Before assembling this product, make sure you have read and understand the information in the box above.**

Identify the Left Upright (25) and the Right Upright (26) by looking at the three holes for the M10 x 68mm Bolts (33). The upper hole (A) on each Upright must be oriented as shown in the drawing.

Attach the Crossbar (20) to the Left Upright (25) with three M10 x 68mm Bolts (33), three M10 Washers (6) and three M10 Nylon Locknuts (1).

Attach the Crossbar (20) to the Right Upright (26) in the same manner.

Do not tighten the Nylon Locknuts yet.

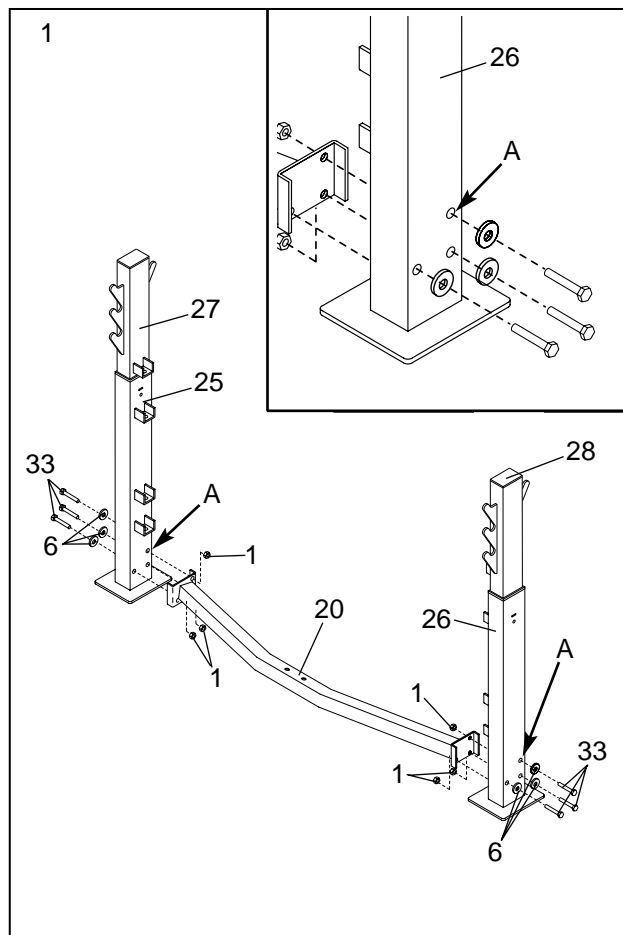

- Slide the Decline Carriage (11) onto the Bench Frame (5). To do this, you will have to pull out on the Seat Adjustment Knob (47). If the Knob does not pull out, unscrew it until it is loose.

Make sure the Bench Frame (5) is oriented as shown. The end with no bracket is cut in an angle, and the pointed edge must be on the top side (see inset drawing).

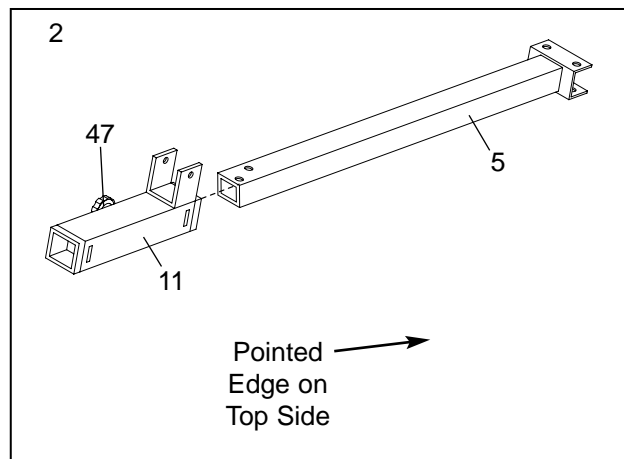

- Attach the Bench Frame (5) to the bracket (B) on the Front Leg (19) with two M10 x 63mm Bolts (43), four M10 Washers (6) and two M10 Nylon Locknuts (1).

Make sure you tighten the Nylon Locknuts so there is no play between the Bench Frame (5) and the Front Leg (19).

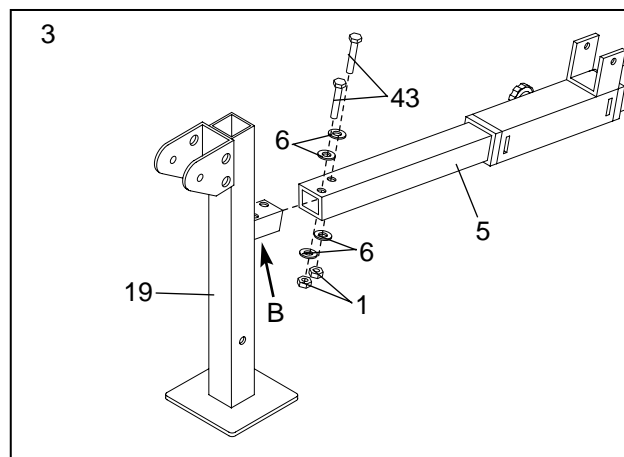

- Attach the Bench Frame (5) to the Crossbar (20) with two M10 x 68mm Bolts (33) and two M10 Nylon Locknuts (1).

Tighten the Nylon Locknuts used in steps 1, 2 and 4 now.

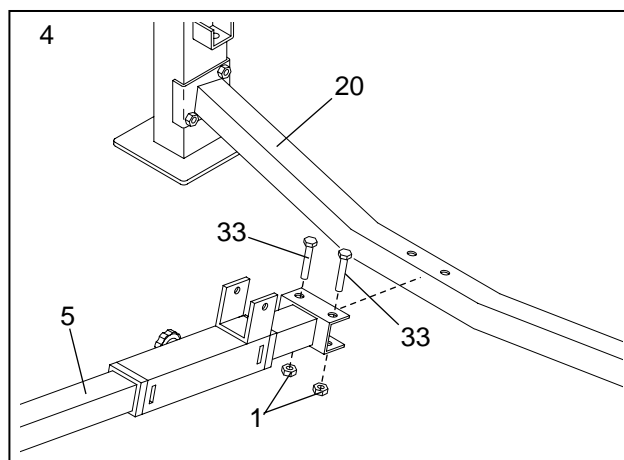

- Attach the Lock (55) to the Front Leg (19) with the M8 x 65mm Bolt (52), two M8 Washers (23) and an M8 Nylon Locknut (13).

Attach the Leg Lever Bumper (39) to the Front Leg (19) with the M4 x 19mm Tapping Screw (38).

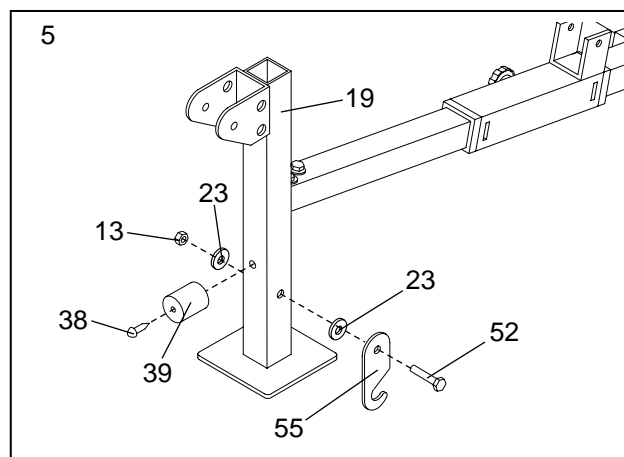

- Press a 30mm Square Inner Cap (24) into each end of the Adjustment Tube (29).

Note: The Inner Caps (24) and many of the end-caps used in the following steps may have been pre-assembled from the factory.

Place the Adjustment Tube (29) in one set of adjustment brackets (C) on the Uprights (25, 26). **Make sure the pins on the Adjustment Tube lock into the slot in the adjustment brackets.**

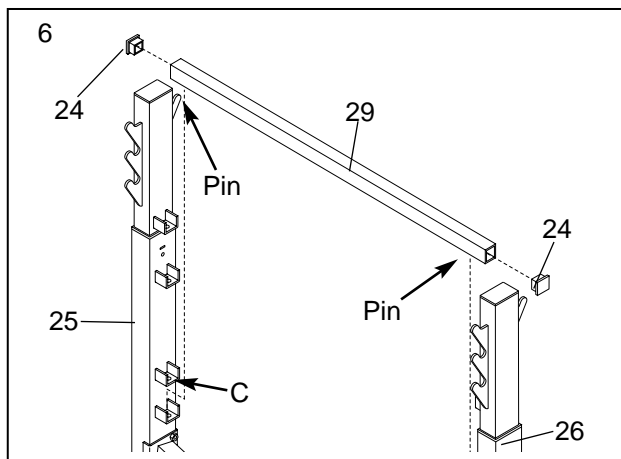

- Align the adjustment holes in the Right Weight Rest (28) with the adjustment hole in the Right Upright (26). Insert the Adjustment Knob (36) through both the Upright and the Weight Rest and tighten it into the welded nut in the Upright.

Repeat this procedure for the Left Weight Rest (27). **Make sure that you fully tighten the Adjustment Knobs and that both Weight Rests are set at the same height.**

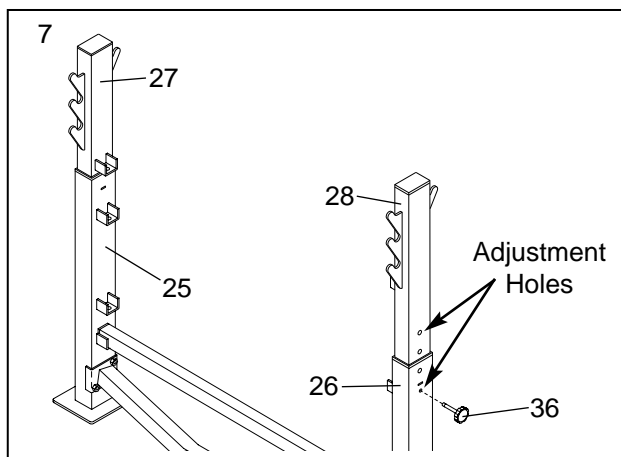

- Press a 1" x 2" Inner Cap (58) into each end of the Seat Carriage (16).

Attach the Seat (14) to the bracket (D) on the Seat Carriage (16) with two M6 x 16mm Screws (3). Attach the other end of the Seat to the Seat Carriage with an M6 x 38mm Screw (4) and an M6 Washer (50).

Press a 1" Square Inner Cap (57) into each end of the two Backrest Tubes (53). Orient the Backrest Tubes as shown in the drawing and place one on each side of the Bench Frame (5).

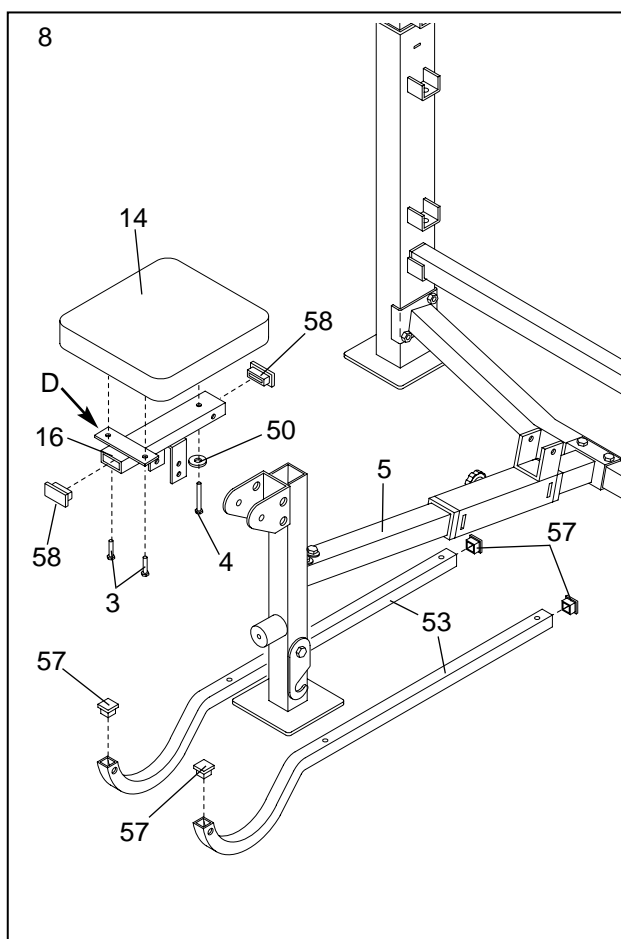

- Lubricate the M10 x 136mm Bolt (22) and slide an M10 Washer (6) onto it. Push the Bolt through the indicated hole in the left Backrest Tube (53).

Slide a Plastic Washer (21) onto the M10 x 136mm Bolt (22). Insert the Bolt into the hole in the left side of the "U"-bracket (E) on the Decline Carriage (11).

Slide a Plastic Washer (21) onto the M10 x 136mm Bolt (22) and pull it back until it barely sticks through the "U"-bracket (E).

Place the Seat (14) so that the Seat Carriage (16) is between the legs of the "U"-bracket. Push the M10 x 136mm Bolt (22) through the holes in the Seat Carriage. **Note: It may be easier to perform this step if you tilt the Seat to a vertical position.**

Push a Plastic Washer (21) in between the Seat Carriage (16) and the right side of the "U"-bracket (E). Line up the Washer and the holes, then push the M10 x 136mm Bolt (22) through the Washer and the "U"-Bracket.

Slide a Plastic Washer (21) onto the M10 x 136mm Bolt (22). **Refer to the inset drawing and make sure you have all parts in the right sequence.**

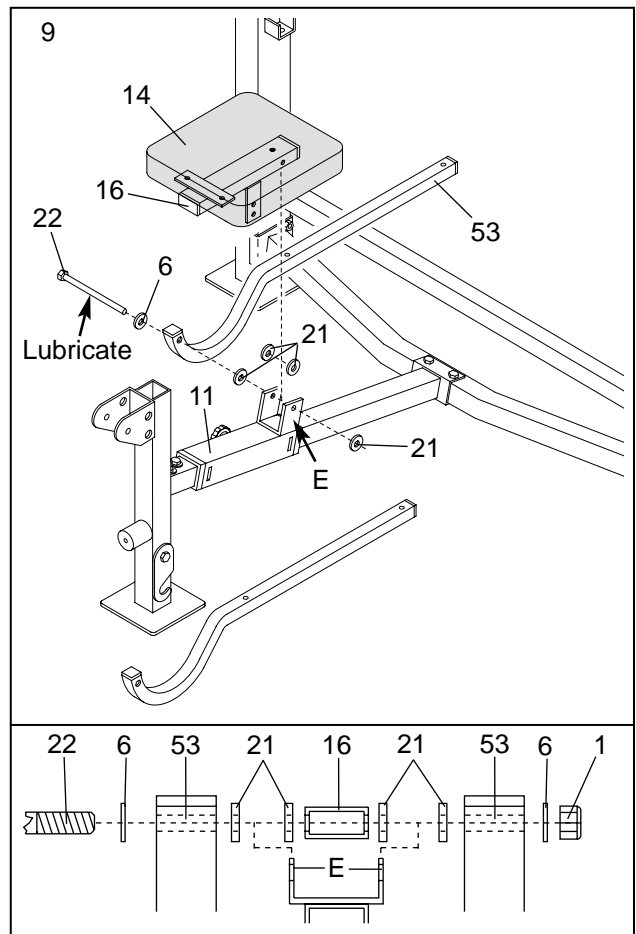

- Slide the indicated hole in the right Backrest Tube (53) onto the M10 x 136mm Bolt (22).

Slide an M10 Washer (6) onto the M10 x 136mm Bolt (22) and secure it with an M10 Nylon Locknut (1). **Do not overtighten the Nylon Locknut. You must be able to freely pivot the Seat and Backrest Tubes.**

Insert the "L"-Pin (63) through one of the holes in the bracket (F) on the Seat Carriage (16). The "L"-Pin should be on top of the Decline Carriage (11).

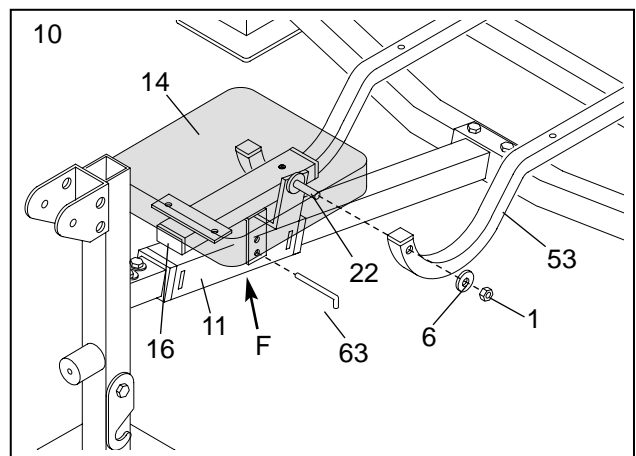

- Attach the Backrest (15) to the Backrest Tubes (53) with four M6 x 38mm Screws (4) and four M6 Washers (50).

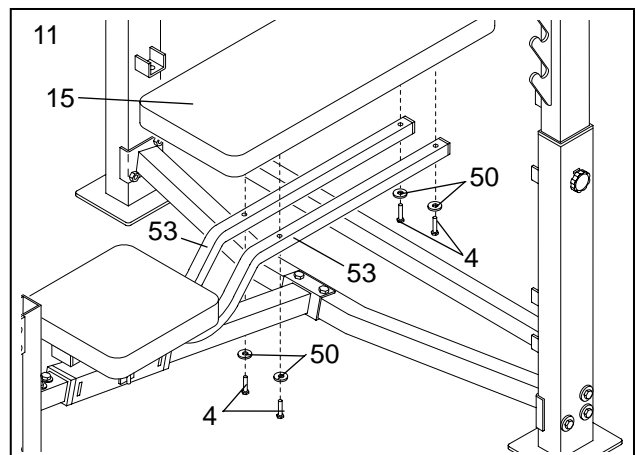

12. Press a 2" Square Inner Cap (17) into each end of the Leg lever (18).

Press a 48mm Round Inner Cap (12) into the end of the weight tube (G).

Note: The above steps may have been pre-assembled by the factory.

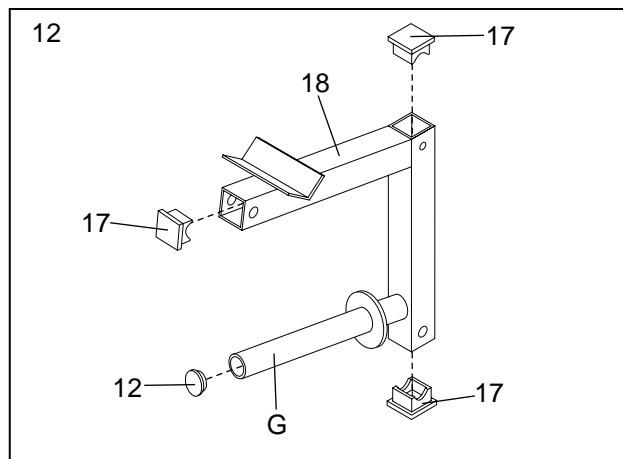

13. Lubricate the M10 x 72mm Bolt (59).

Attach the Leg Lever (18) to the bracket (H) on the Front Leg (19) with the M10 x 72mm Bolt (59) and an M10 Nylon Locknut (1).

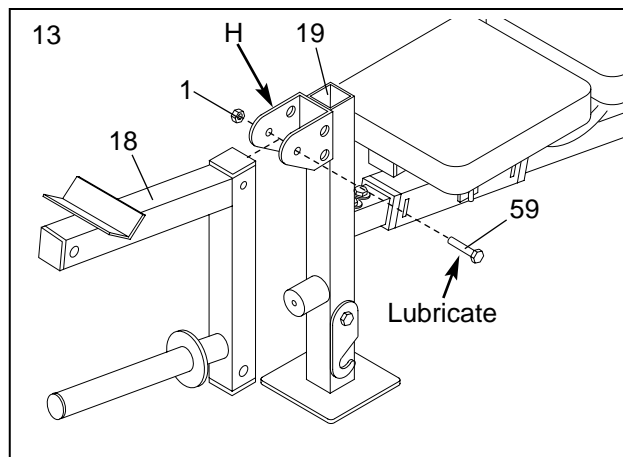

14. Press a 3/4" Round Inner Cap (54) into each end of the three Pad Tubes (46 and 48).

Insert a Short Pad Tube (48) through the upper hole in the Leg Lever (18). Slide two Foam Pads (10) onto the Pad Tube.

Insert the Long Pad Tube (46) through the lower hole in the Leg Lever (18). Slide two Foam Pads (10) onto the Pad Tube.

Insert a Short Pad Tube (48) through one set of holes in the bracket (H) on the Front Leg (19). Slide two Foam Pads (10) onto the Pad Tube.

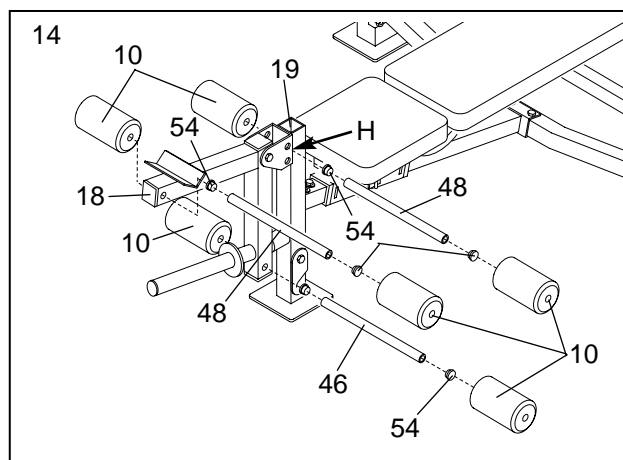

15. Attach the Cable (45) to the Weight Carriage (37) with the M10 x 19mm Bolt (8) and an M10 Nylon Locknut (1).

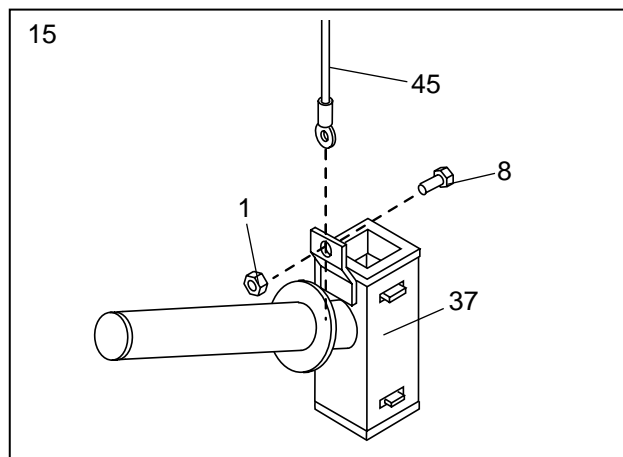

16. Slide the Weight Carriage (37) onto the Lat Tower (9).
Make sure the Weight Carriage is oriented as shown.

Attach two Carriage Bumpers (34) to the Lat Tower (9) with the M6 x 73mm Bolt (7), two M6 Washers (50) and an M6 Nylon Locknut (2). **Note: Make sure that the recessed sides of the Carriage Bumpers (34) are facing away from the Lat Tower (9).** Use the two included socket tools to tighten the M6 x 73mm Bolt (7) and the M6 Nylon Locknut (2). **Note: Insert a small screwdriver through each socket tool to turn the socket tool.**

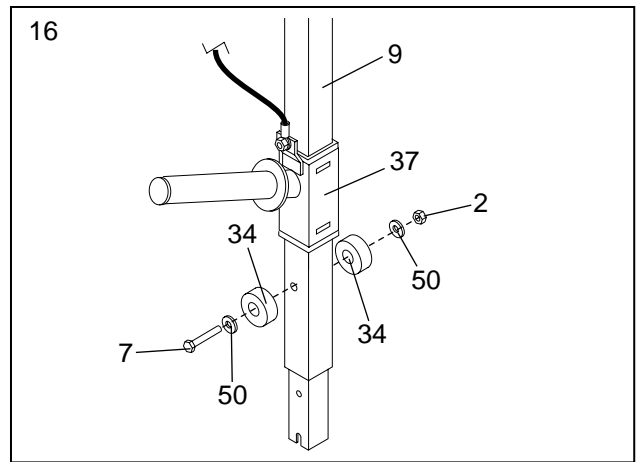

17. Attach the Pulley Bracket (60) to the Lat Tower (9) with two M10 x 65mm Bolts (43), four M10 Washers (6) and two M10 Nylon Locknuts (1).

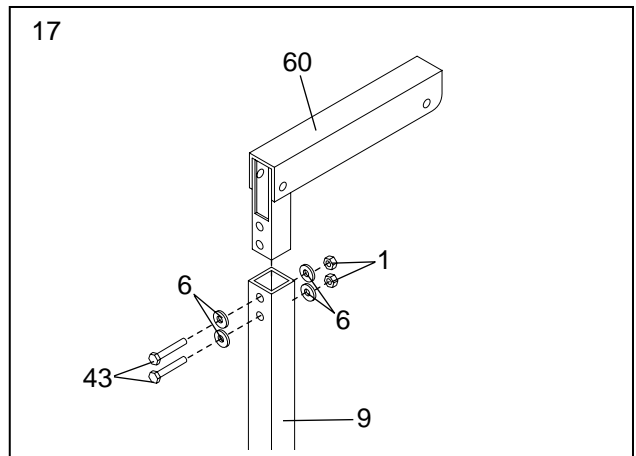

18. Feed the free end of the Cable (45) through the indicated slot in the Pulley Bracket (60).

Rest the Cable (45) in the groove of a Pulley (35). Attach the Pulley to the Pulley Bracket (60) with an M10 x 63mm Bolt (43), two M10 Washers (6), two Pulley Spacers (61) and an M10 Nylon Locknut (1).

Rest the Cable (45) in the groove of the second Pulley (35). Attach the Pulley to the Pulley Bracket (60) with an M10 x 63mm Bolt (43), two M10 Washers (6), two Pulley Spacers (61) and an M10 Nylon Locknut (1).

Make sure the Cable (45) runs smoothly over both Pulleys (35).

Attach the Cable Clip (40) to the loop on the Cable (45).

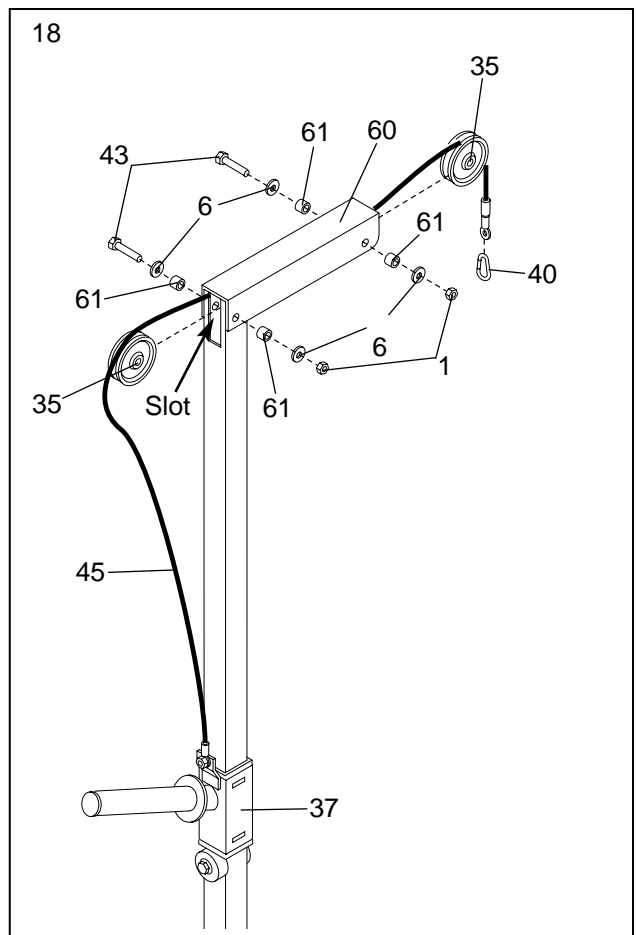

19. Insert the Lat Tower (9) into the Front Leg (19). **The Lat Tower must be turned as shown.** Secure the Lat Tower with the Adjustment Knob (36).

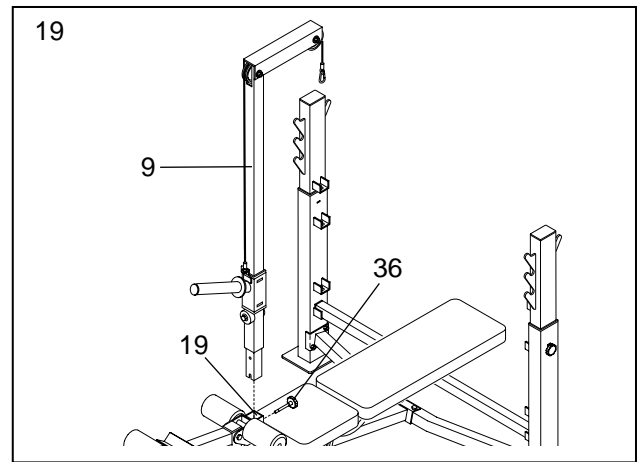

20. Attach the Curl Pad (44) to the Curl Post (42) with two M6 x 16mm Screws (3).

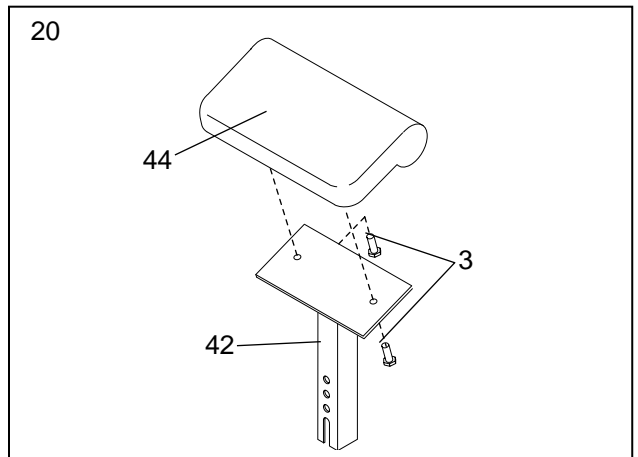

21. Press three 48mm Round Inner Caps (12) into the three welded tubes on the Weight Stand Upright (62). Press a 2" Square Inner Cap (17) into the top of the Weight Stand Upright.

Press a 2" Square Inner Cap (17) into each end of the Weight Stand Base (49).

Attach the Weight Stand Upright (62) to the Weight Stand Base (49) with two M10 x 68mm Bolts (33) and two M10 Nylon Locknuts (1). **Note: The Weight Stand Base (49) must be turned so the two indicated holes are closer to the top of the Weight Stand Base (49) than the bottom.**

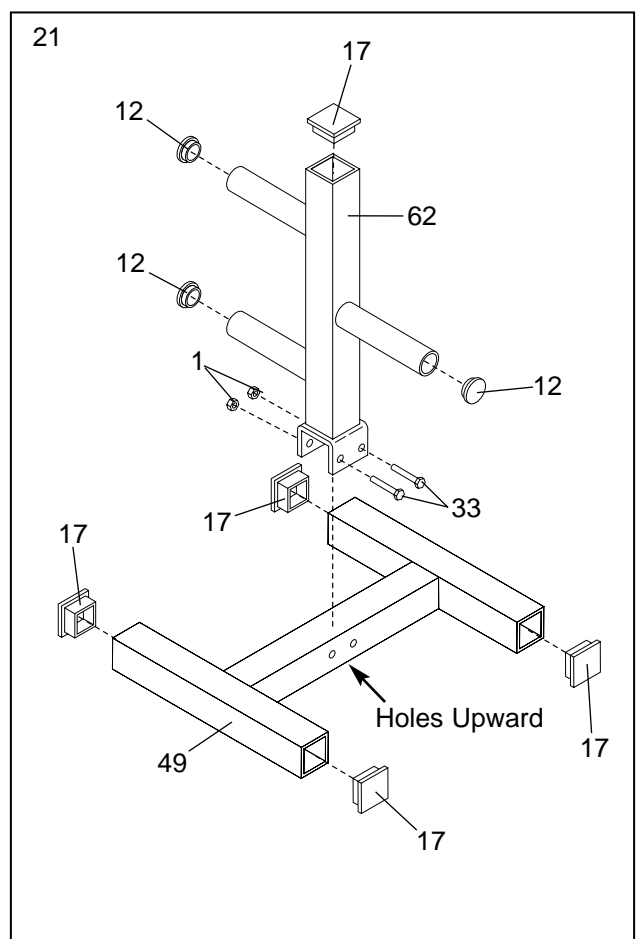

Adjusting the Weight Bench

This section explains how to adjust the weight bench. See the EXERCISE GUIDELINES on page 17 for important information on how to get the most benefit from your exercise program. Also, refer to the accompanying exercise poster to see the correct form for each exercise.

Inspect and tighten all parts each time you use the weight bench. Replace any worn parts immediately. The weight bench can be cleaned with a damp cloth and a mild, non-abrasive detergent. Do not use solvents.

ADJUSTING THE BACKREST

The Backrest (15) can be set to four different positions: a level position, a decline position and two incline positions.

To change the position of the Backrest (15), move the Adjustment Tube (29) to a different set of adjustment brackets (C) on the Uprights (25, 26) or on the Weight Rests (27, 28).

Make sure the Adjustment Tube (29) is securely seated in the adjustment brackets (C).

The Backrest (15) must always be positioned so that the Backrest Tubes (53, not shown), and not the backrest pad, are resting on the Adjustment Tube (29).

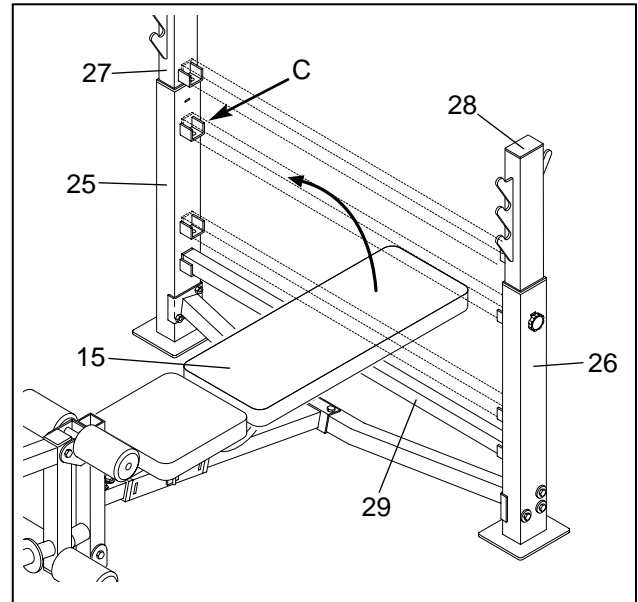

ADJUSTING THE WEIGHT RESTS

To change the height of the Weight Rests (27, 28), **first remove your barbell from the Weight Rests.** Then remove the Adjustment Knob (36) from the Weight Rest in one Upright. Position the Weight Rest at the desired height and align the holes in the Weight Rest and the Upright. Secure the Weight Rest with the Adjustment Knob. **Make sure that you fully tighten the Adjustment Knob.**

Position the other Weight Rest in the same manner. **Both Weight Rests must be set at the same height.**

WARNING: Always set both weight rests at the same height. The adjustment knob must always be inserted through both the weight rest and upright and firmly tightened. Never tighten the adjustment knob into an upright and then set a weight rest in the upright on top of the adjustment knob.

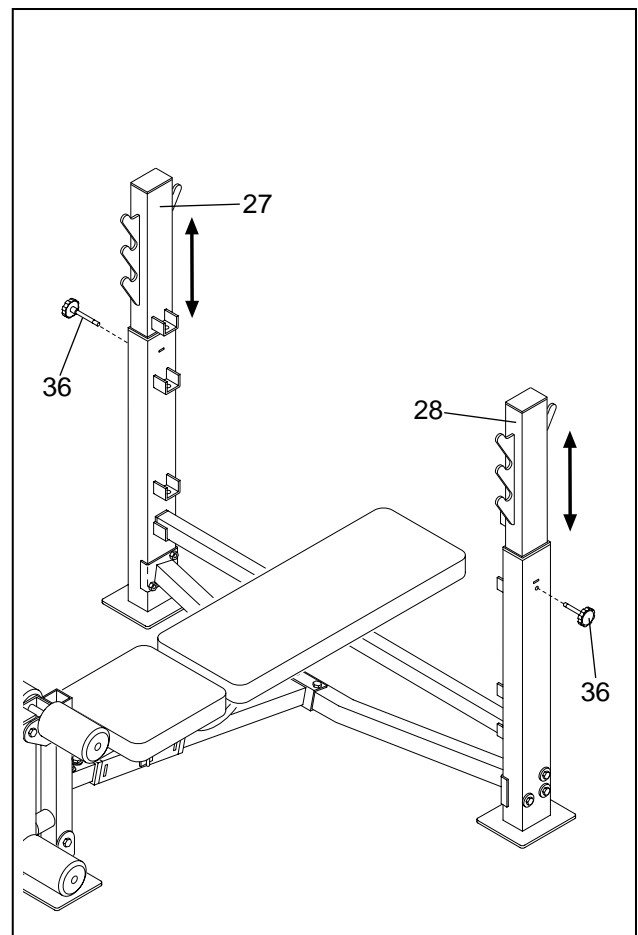

ATTACHING THE CURL POST OR LAT TOWER

For some exercises, the Curl Post (42) must be attached to the weight bench.

Insert the Curl Post (42) into the indicated hole in the Front Leg (19). Align the holes in the Front Leg and the Curl Post. Secure the Curl Post with the Adjustment Knob (36). **Make sure that you fully tighten the Adjustment Knob.**

For other exercises, the Lat Tower (9) must be attached to the weight bench.

Insert the Lat Tower (9) into the indicated hole in the Front Leg (19). Align the holes in the Front Leg and the Lat Tower. Secure the Lat Tower with the Adjustment Knob (36). **Make sure that you fully tighten the Adjustment Knob.**

When the Lat Tower or Curl Post are not in use, store them so far away from the weight bench that they do not interfere with your exercise program.

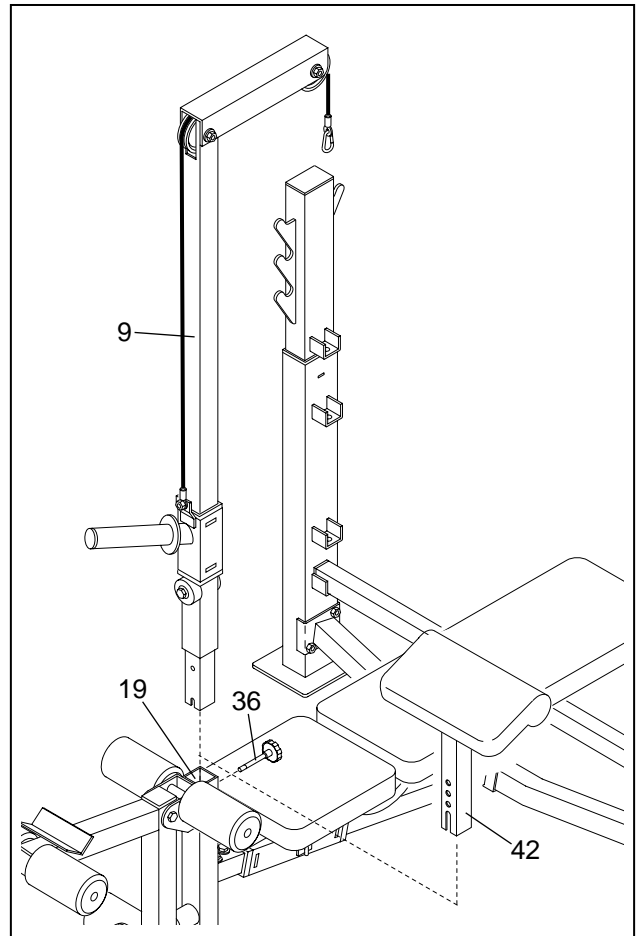

ADJUSTING THE PAD TUBE

The Short Pad Tube (48) that is inserted in the bracket (H) on the Front leg (19) can be adjusted to either a high or low position.

To adjust the Pad Tube (48), remove one Foam Pad (10). Slide the Pad Tube out of the bracket (H) on the Front Leg (19) and re-insert it through another set of holes in the bracket. Slide the Foam Pad back onto the Pad Tube.

Note: The bracket (H) may have three sets of adjustment holes on your particular weight bench.

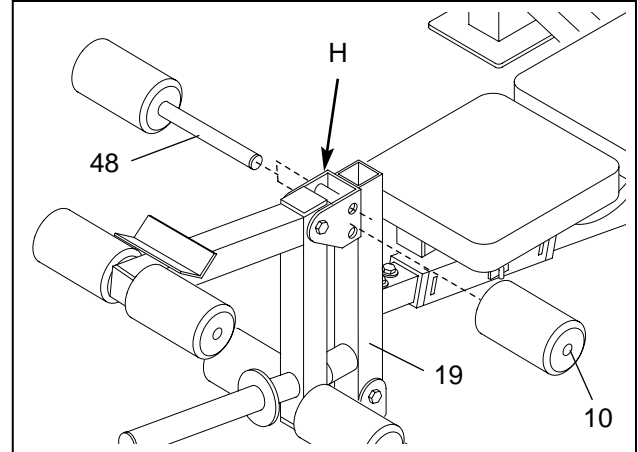

ADJUSTING THE SEAT INCLINE

Some exercises can be performed more comfortably when the Seat (14) has a slight incline. To give the Seat an incline, pull out the "L"-Pin (63). Lift up one end of the Seat and insert the "L"-Pin through the lower holes in the bracket (F) on the Seat Carriage (16).

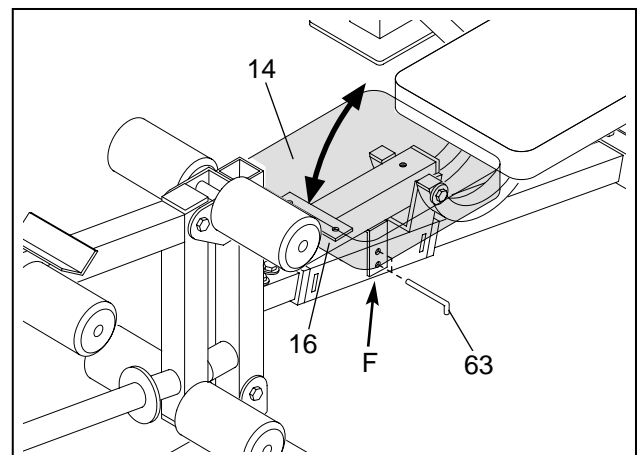

ADJUSTING THE SEAT POSITION

To adjust the position of the Seat (14) and Backrest (15), unscrew the Seat Adjustment Knob (47) until it is loose. Pull out on the Knob and move the Seat to the desired position by sliding the Seat Carriage (16) on the Bench Frame (5). Then release the Seat Adjustment Knob and let it snap into one of the holes in the Bench Frame. Finally, tighten the Seat Adjustment Knob.

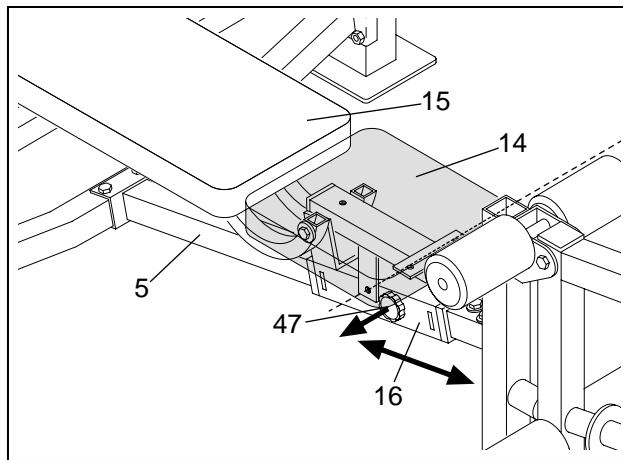

ADJUSTING THE BENCH FOR SQUAT EXERCISES

To perform squat or toe raise exercises, fold the Backrest (15) into the upright position by lifting and pulling it forward as far as it will go.

Remove the Adjustment Tube (29) from the Uprights (25, 26).

Raise the Weight Rests (27, 28) to the highest position (see ADJUSTING THE WEIGHT RESTS earlier in this section).

WARNING: Always fold the backrest out of the way when performing squat exercises. Do not sit on the seat when the backrest is folded.

WARNING: Always place 50 pounds on the leg lever when performing squat exercises to balance the bench.

WARNING: Do not stand with your back to the weight bench when performing squat exercises. You should be able to see the weight rests while exercising so that you can safely return the barbell when you finish the exercise.

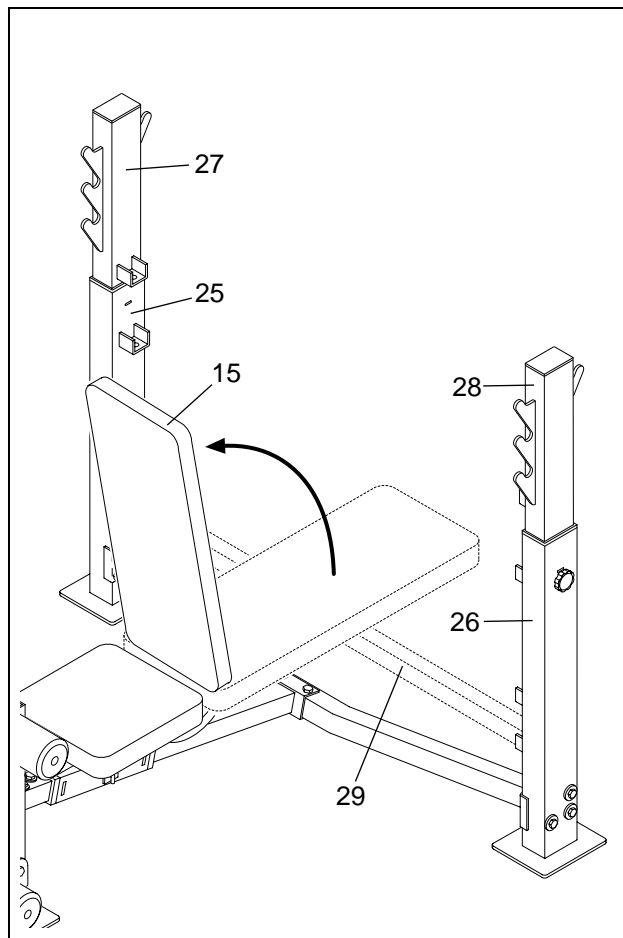

USING THE WEIGHT STAND

The weight stand gives you a convenient way to store weights (not included) when they are not in use. Simply slide the weights onto the round tubes on the weight stand.

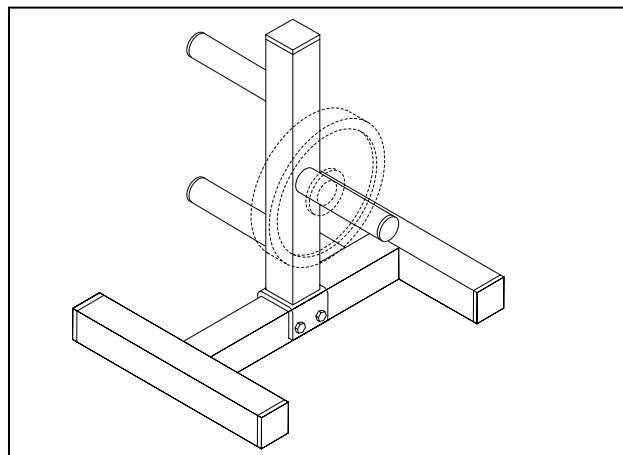

ATTACHING THE LAT BAR TO THE LAT TOWER

To use the Lat Tower (9), attach the Lat Bar (51) to the Cable (45) with a Cable Clip (40).

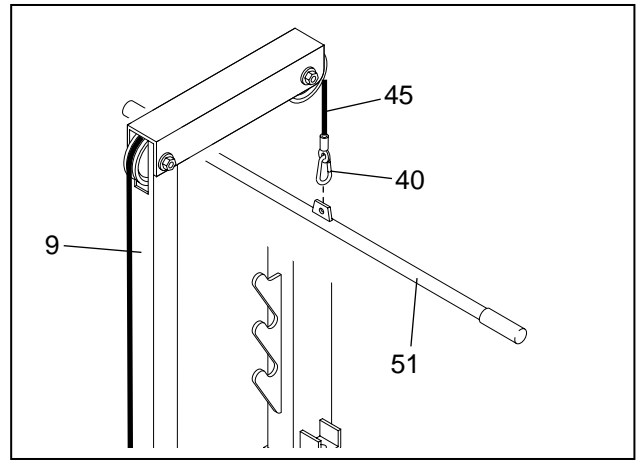

LOCKING THE LEG LEVER

Some exercises, such as sit-ups, can be performed more comfortably with the Leg Lever (18) locked.

To lock the Leg Lever (18), turn the Lock (55) until it engages the Long Pad Tube (46).

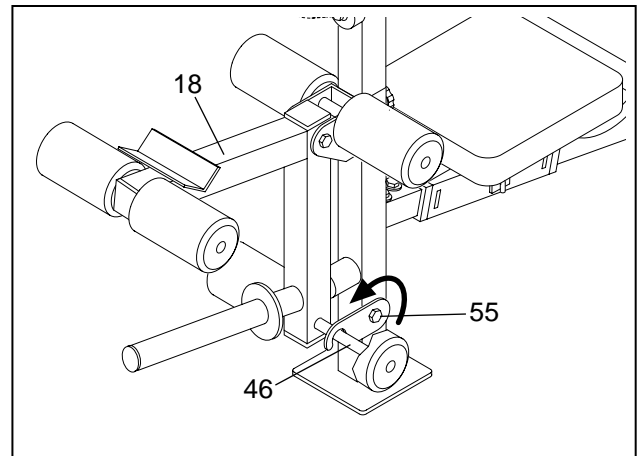

ATTACHING WEIGHTS TO THE WEIGHT CARRIAGE

To use the Lat Tower (9), slide the desired amount of weight (not included) onto the weight tube (G) on the Weight Carriage (37).

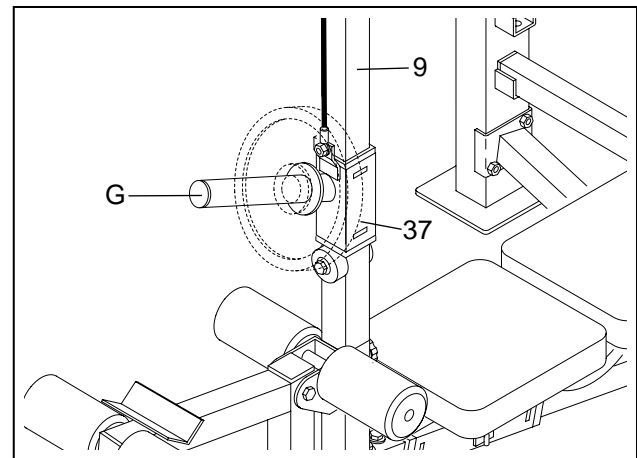

WARNING: Do not place more than 150 pounds on the weight carriage.

ATTACHING WEIGHTS TO THE LEG LEVER

To use the Leg Lever, slide the desired amount of weight onto the Weight Tube (F).

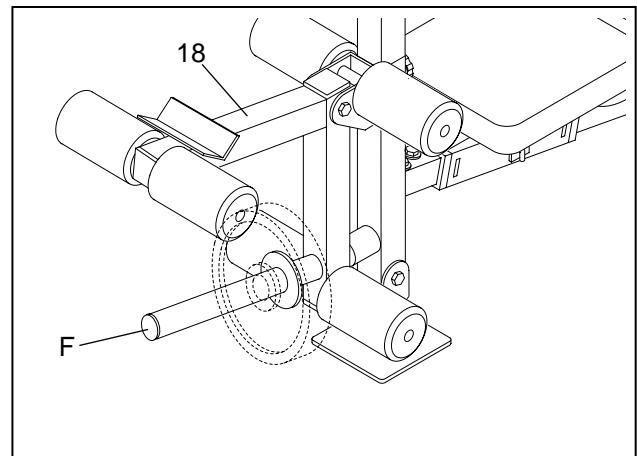

WARNING: Do not place more than 150 pounds on the leg lever.

Exercise Guidelines

THE FOUR BASIC TYPES OF WORKOUTS

Muscle Building

The only way to increase the size and strength of your muscles is to push them close to their maximum capacity. When you progressively increase the intensity of your exercise, your muscles will continually adapt and grow. You can tailor the individual exercise to the proper intensity level in two ways:

- by changing the amount of weight used
- by changing the number of repetitions or sets performed (A “repetition” is one complete cycle of an exercise, such as one sit-up. A “set” is a series of repetitions).

The proper amount of weight for each exercise obviously depends upon the individual user. You must gauge your limits and select the amount of weight that is right for you. Begin with 3 sets of 8 repetitions for each exercise you perform. Rest for 3 minutes after each set. When you can complete 3 sets of 12 repetitions without difficulty, increase the amount of weight.

Toning

You can tone your muscles by pushing them to a moderate percentage of their capacity. Select a moderate amount of weight and increase the number of repetitions in each set. Complete as many sets of 15 to 20 repetitions as possible without discomfort. Rest for 1 minute after each set. Work your muscles by completing more sets rather than by using high amounts of weight.

Weight Loss

To lose weight, use a low amount of weight and increase the number of repetitions in each set. Exercise for 20 to 30 minutes, resting for a maximum of 30 seconds between sets.

Cross Training

Many people desire a complete and well-balanced fitness program, and cross training is a very efficient way to accomplish this. One example of a balanced program is:

- Plan weight training workouts on Monday, Wednesday and Friday.
- Plan 20 to 30 minutes of aerobic exercise, such as cycling, running or swimming on Tuesday and Thursday.
- Rest from both weight training and aerobic exercise for at least one full day each week to give your body time to regenerate.

The combination of weight training and aerobic exercise will reshape and strengthen your body plus develop your heart and lungs.

PERSONALIZING YOUR EXERCISE PROGRAM

Specifying the exact length of time for each workout, as well as the number of repetitions or sets for each exercise, is a highly individual matter. It is very important to avoid overdoing it during the first few months of your exercise program. You should progress at your own pace and be sensitive to your body's signals. If you experience pain or dizziness at any time while exercising, stop immediately and begin cooling down. Find out what is wrong before continuing. Remember that adequate rest and a proper diet are important factors in any exercise program.

WARMING UP

Begin each workout with 5 to 10 minutes of stretching and light exercise to warm up. Warming up prepares your body for more strenuous exercise by increasing circulation, raising your body temperature and delivering more oxygen to your muscles.

WORKING OUT

Each workout should include 6 to 10 different exercises. Select exercises for every major muscle group with emphasis on the areas that you want to develop the most. To give balance and variety to your workouts, vary the exercises from session to session.

Schedule your workouts for the time of day when your energy level is the highest. Each workout should be followed by at least one day of rest. Once you find the schedule that is right for you, stick with it.

EXERCISE FORM

You will gain the greatest benefits from exercising by maintaining proper form. This requires moving through the full range of motion for each exercise and moving only the appropriate parts of the body. Exercising in an uncontrolled manner will leave you feeling exhausted. On the exercise poster accompanying this manual, you will find photographs showing the correct form for several exercises. A description of each exercise is also provided, along with a list of the muscles affected. Refer to the muscle chart on page 18 to find the locations of the muscles.

The repetitions in each set should be performed smoothly and without pausing. The exertion stage of each repetition should last about half as long as the return stage. Proper breathing is important. Exhale during the exertion stage of each repetition and inhale during the return stroke. Never hold your breath!

You should rest for a short period of time after each set. The ideal resting periods are:

- Rest three minutes after each set for a muscle building workout
- Rest one minute after each set for a toning workout
- Rest 30 seconds after each set for a weight loss workout

Plan to spend the first couple of weeks familiarizing yourself with the equipment and learning the proper form for each exercise.

COOLING DOWN

End each workout with 5 to 10 minutes of stretching. Include stretches for both your arms and legs. Move slowly as you stretch and do not bounce. Ease into each stretch gradually and go only as far as you can

without strain. Stretching at the end of each workout is very effective for increasing flexibility.

STAYING MOTIVATED

For motivation, keep a record of each workout. The chart on page 19 of this manual can be photocopied and used to schedule and record your workouts. List the date, the exercises performed, the weight plus the numbers of sets and repetitions completed. Record your weight and key body measurements at the end of every month.

Remember, the key to achieving the greatest results is to make exercise a regular and enjoyable part of your everyday life.

MUSCLE CHART

- A. Sternomastoid (neck)
- B. Pectoralis Major (chest)
- C. Biceps (front of arm)
- D. Obliques (waist)
- E. Brachioradials (forearm)
- F. Hip Flexors (upper thigh)
- G. Abductor (outer thigh)
- H. Quadriceps (front of thigh)
- I. Sartorius (front of thigh)
- J. Tibialis Anterior (front of calf)
- K. Soleus (front of calf)
- L. Rectus Abdominus (stomach)
- M. Adductor (inner thigh)
- N. Trapezius (upper back)
- O. Rhomboideus (upper back)
- P. Deltoid (shoulder)
- Q. Triceps (back of arm)
- R. Latissimus Dorsi (mid back)
- S. Spinae Erectors (lower back)
- T. Gluteus Medius (hip)
- U. Gluteus Maximus (buttocks)
- V. Hamstring (back of leg)
- W. Gastrocnemius (back of calf)

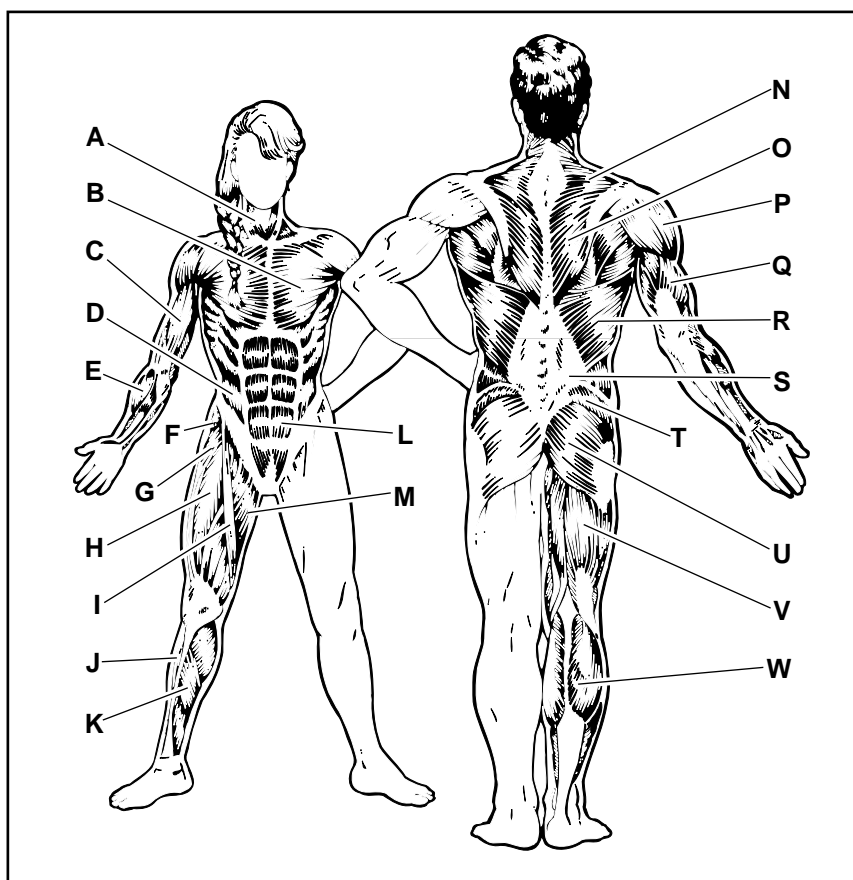

MONDAY Date: _ / _ / _	EXERCISE	WEIGHT	SETS	REPS

TUESDAY **AEROBIC EXERCISE**
Date:
_ / _ / _

WEDNESDAY Date: _ / _ / _	EXERCISE	WEIGHT	SETS	REPS

THURSDAY **AEROBIC EXERCISE**
Date:
_ / _ / _

FRIDAY Date: _ / _ / _	EXERCISE	WEIGHT	SETS	REPS

Make photocopies of this page for scheduling and recording your workouts.

Ordering Replacement Parts

To order replacement parts, simply call our Customer Service Department toll-free at 1-800-999-3756, Monday through Friday, 6 a.m. until 6 p.m. Mountain Time (excluding holidays). To help us assist you, please be prepared to give the following information when calling:

1. The MODEL NUMBER of the product (PFBE64080).
2. The NAME of the product (PROFORM® 640 Weight Bench).
3. The SERIAL NUMBER of the product (see the front cover of this manual).
4. The KEY NUMBER and DESCRIPTION of the desired part(s) (see the PART LIST and the EXPLODED DRAWING at the center of this manual).

Limited Warranty

ICON Health & Fitness, Inc. (ICON), warrants this product to be free from defects in workmanship and material, under normal use and service conditions, for a period of ninety (90) days from the date of purchase. This warranty extends only to the original purchaser. ICON's obligation under this warranty is limited to replacing or repairing, at ICON's option, the product at one of its authorized service centers. All products for which warranty claim is made must be received by ICON at one of its authorized service centers with all freight and other transportation charges prepaid, accompanied by sufficient proof of purchase. All returns must be pre-authorized by ICON. This warranty does not extend to any product or damage to a product caused by or attributable to freight damage, abuse, misuse, improper or abnormal usage or repairs not provided by an ICON authorized service center, products used for commercial or rental purposes, or products used as store display models. No other warranty beyond that specifically set forth above is authorized by ICON.

ICON is not responsible or liable for indirect, special or consequential damages arising out of or in connection with the use or performance of the product or damages with respect to any economic loss, loss of property, loss of revenues or profits, loss of enjoyment or use, costs of removal, installation or other consequential damages of whatsoever nature. Some states do not allow the exclusion or limitation of incidental or consequential damages. Accordingly, the above limitation may not apply to you.

The warranty extended hereunder is in lieu of any and all other warranties and any implied warranties of merchantability or fitness for a particular purpose is limited in its scope and duration to the terms set forth herein. Some states do not allow limitations on how long an implied warranty lasts. Accordingly, the above limitation may not apply to you.

This warranty gives you specific legal rights. You may also have other rights which vary from state to state.

ICON HEALTH & FITNESS, INC., 1500 S. 1000 W., LOGAN, UT 84321-9813

PROFORM is a registered trademark of ICON Health & Fitness, Inc.

**REMOVE THIS PART LIST/EXPLODED
DRAWING FROM THE MANUAL**

SAVE THIS PART LIST/EXPLODED DRAWING FOR FUTURE REFERENCE

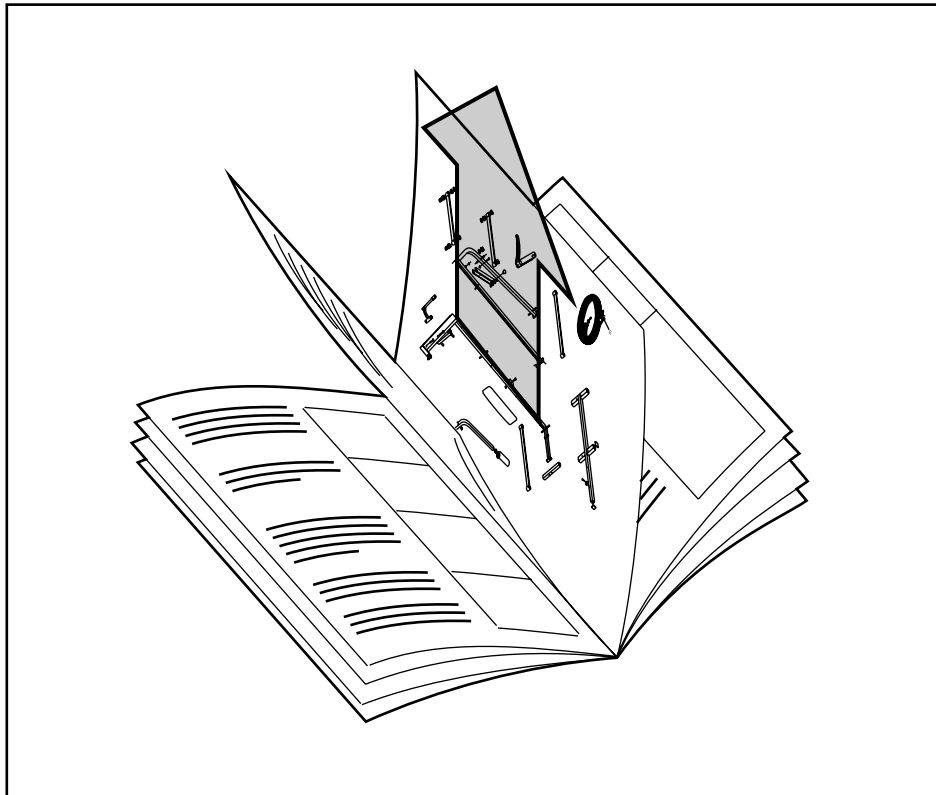

Part List - Model No. PFBE64080

R0998A

Key No.	Qty.	Description	Key No.	Qty.	Description
1	19	M10 Nylon Locknut	35	2	3" Pulley
2	1	M6 Nylon Locknut	36	3	Adjustment Knob
3	4	M6 x 16mm Screw	37	1	Weight Carriage
4	5	M6 x 38mm Screw	38	1	M4 x 19mm Tapping Screw
5	1	Bench Frame	39	1	Leg Lever Bumper
6	20	M10 Washer	40	1	Cable Clip
7	1	M6 x 73mm Bolt	41	2	Grip
8	1	M10 x 19mm Bolt	42	1	Curl Post
9	1	Lat Tower	43	6	M10 x 65mm Bolt
10	6	Foam Pad	44	1	Curl Pad
11	1	Decline Carriage	45	1	Cable
12	5	48mm Round Inner cap	46	1	Long Pad Tube
13	1	M8 Nylon Locknut	47	1	Seat Adjustment Knob
14	1	Seat	48	2	Short Pad Tube
15	1	Backrest	49	1	Weight Stand Base
16	1	Seat Carriage	50	7	M6 Washer
17	8	2" Square Inner Cap	51	1	Lat Bar
18	1	Leg Lever	52	1	M8 x 65mm Bolt
19	1	Front Leg	53	2	Backrest Tube
20	1	Crossbar	54	6	3/4" Round Inner Cap
21	4	Plastic Washer	55	1	Lock
22	1	M10 x 136mm Bolt	56	4	Carriage Bushing
23	2	M8 Washer	57	4	1" Square Inner Cap
24	2	30mm Square Inner Cap	58	2	1" x 2" Inner Cap
25	1	Left Upright	59	1	M10 x 72 Bolt
26	1	Right Upright	60	1	Pulley Bracket
27	1	Left Weight Rest	61	4	Pulley Spacer
28	1	Right Weight Rest	62	1	Weight Stand Upright
29	1	Adjustment Tube	63	1	"L" Pin
30	2	38mm x 63.5mm Inner Cap	64	2	M4 x 12mm Tapping Screw
31	2	Upright Bushing	#	2	Socket Tool
32	2	Weight Rest Bushing	#	1	User's Manual
33	10	M10 x 68mm Bolt	#	1	Exercise Guide
34	2	Carriage Bumper			

Note: "#" indicates a non-illustrated part. Specifications are subject to change without notice. See the back cover of the user's manual for information about ordering replacement parts.

Exploded Drawing - Model No. PFBE64080

R0998A

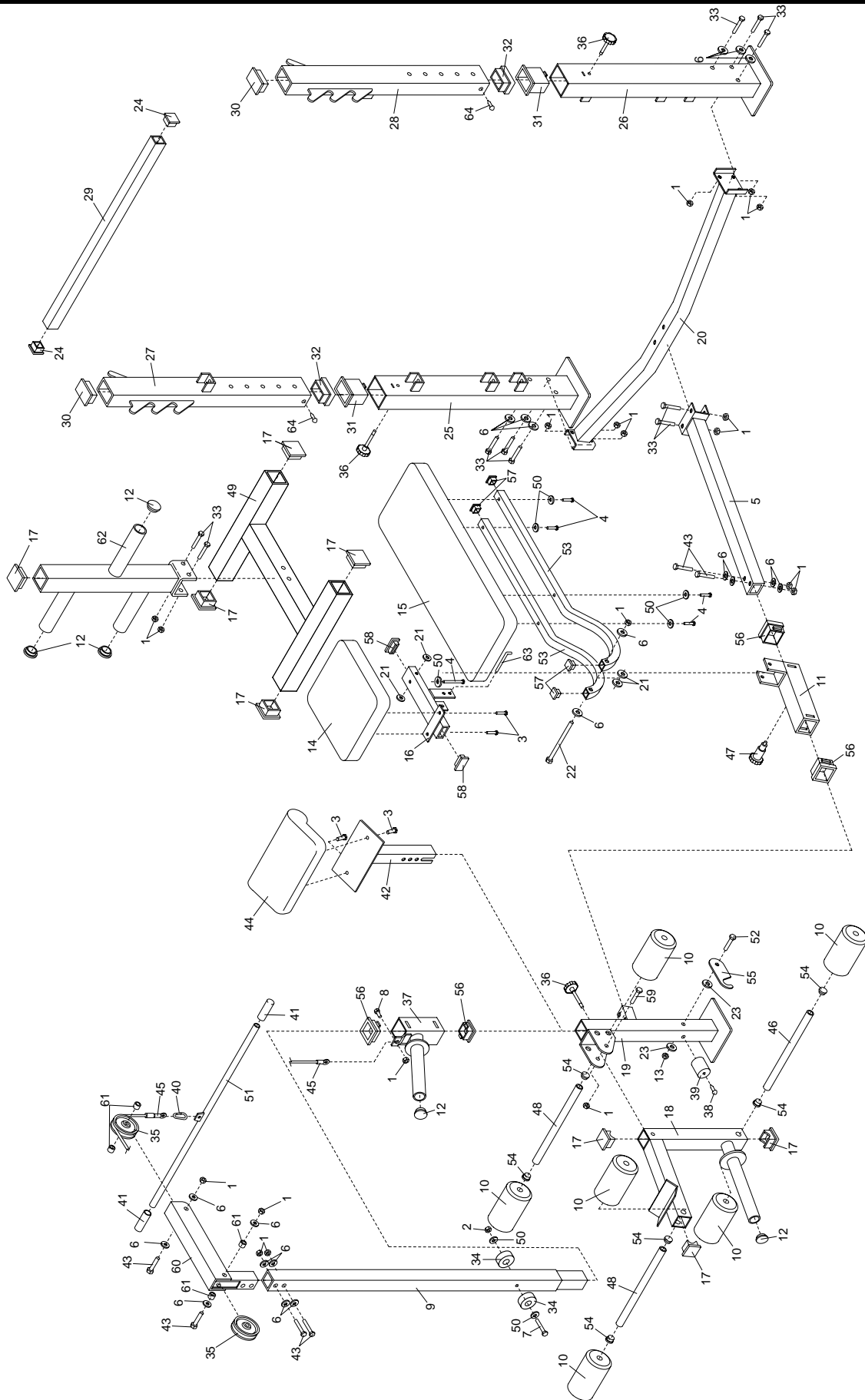

Free Manuals Download Website

<http://myh66.com>

<http://usermanuals.us>

<http://www.somanuals.com>

<http://www.4manuals.cc>

<http://www.manual-lib.com>

<http://www.404manual.com>

<http://www.luxmanual.com>

<http://aubethermostatmanual.com>

Golf course search by state

<http://golfingnear.com>

Email search by domain

<http://emailbydomain.com>

Auto manuals search

<http://auto.somanuals.com>

TV manuals search

<http://tv.somanuals.com>