

TOSHIBA

MULTIFUNCTIONAL DIGITAL COLOUR SYSTEMS

Operator's Manual for Basic Function

e-STUDIO281c/351c/451c

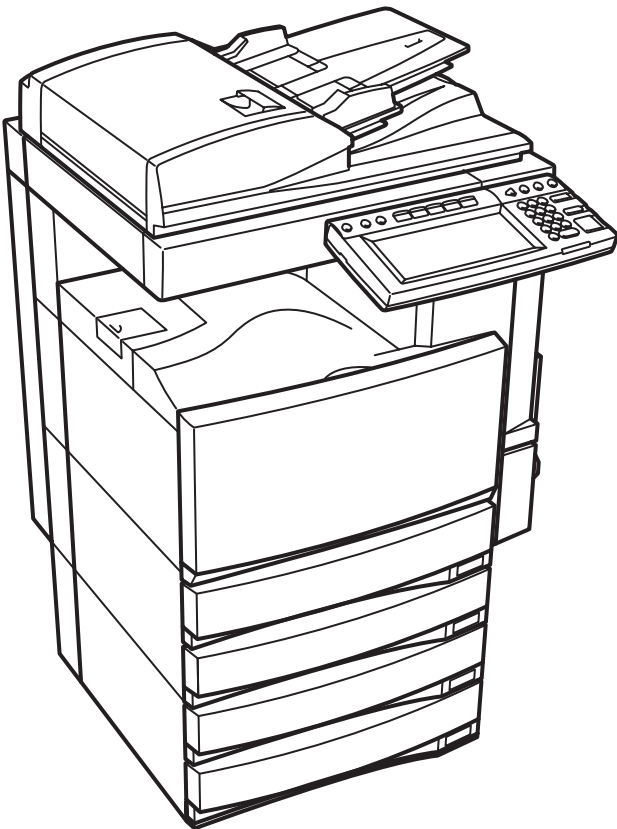



EPA ENERGY STAR® (MFD)

The United States Environmental Protection Agency (EPA) has introduced a voluntary programme, the ENERGY STAR programme, to encourage the widespread and voluntary use of energy-efficient technologies that enhance the workplace, improve product performance and prevent pollution. As an ENERGY STAR Partner, the TOSHIBA TEC CORPORATION has determined that this copier model meets the ENERGY STAR guidelines for energy efficiency.

ENERGY STAR guidelines for this class of copier require ENERGY STAR copiers to have a 'Sleep Mode' feature that automatically makes the copier enter the sleep mode after a period of inactivity. The copier must also automatically change to a 'Low Power Mode' (Automatic Energy Save) after a period of time since the last usage. Specifically, this copier complies with the following requirements.

e-STUDIO281c/351c/451c Copier/Printer + Fax model (Multifunction model)

'Automatic Energy Save'-

The copier consumes less than 157 W (e-STUDIO281c)/184 W (e-STUDIO351c)/223 W (e-STUDIO451c) during Energy Save.

'Automatic Energy Save' Default Time-

The default time for the 'Automatic Energy Save' is 15 minutes.

'Sleep Mode'

The copier consumes less than 69 W (e-STUDIO281c)/80 W (e-STUDIO351c)/95 W (e-STUDIO451c) in the 'Sleep Mode'.

'Sleep Mode' Default Time-

The default time for the 'Sleep Mode' is 90 minutes.

Note1- The default setting for the 'Sleep Mode' and 'Automatic Energy Save' can be changed. See the User Functions Guide to change the default settings noted above.

Note2- If the Fax or printer data is received in the sleep mode, the copier starts warming itself up and prints out the data when it becomes ready. Also, when the start button or the energy saver button on the control panel is pressed, the copier starts warming itself up.

In accordance with EPA ENERGY STAR programme guidelines, Toshiba recommends the following recycled paper.

Great White MultiUse 20 paper

If you have any questions regarding the use of recycled paper or some recommended types of recycled paper, please contact your authorized Toshiba dealer.

ENERGY STAR is a U.S. registered mark.

CONTENTS

Notice to Users	5
TOSHIBA Quality is Second to None	7
Preface	9
Features of the e-STUDIO281c/351c/451c	10
General Precautions	11
• When installing or moving	11
• When using the Multifunctional Digital Colour Systems	14
• During maintenance or inspection	17
• When handling supplies	18
Disclaimer Notice	19
Forgery Prevention Function/Storage of Colour Copies	20
1. BEFORE USING EQUIPMENT	21
1. Description of Each Component	22
• Main components	22
• Configuration of options	23
• Control panel	26
• Adjustment of the angle of the control panel	28
• Touch panel	30
2. Turning Power On / Shutdown	34
• Turning power on	34
• When department or user management is used	35
• Turning power off (Shutdown)	39
3. Energy Saving Mode	42
4. Setting Copy Paper	43
• About the “width” and the “length” of the original and the copy paper	43
• Acceptable copy paper	44
• Setting copy paper (size change)	46
• Placing paper in the Large Capacity Feeder (optional)	51
• Drawer for special uses	52
2. HOW TO MAKE COPIES	55
1. Setting Originals	56
• Acceptable originals	56
• Placing originals on the glass	58
• Using the Reversing Automatic Document Feeder (optional)	60
2. Making Copies	63
• Initial (Default) settings	63
• Copying procedure	64
• Scanning the next originals during copying (Auto job start)	68
• Interrupt copying in progress and make other copies (Interrupt copying)	70
3. Bypass Copying	71
• Bypass copying	71
• Bypass copying on standard size paper	72
• Bypass copying on non-standard size paper	76
4. Proof Copy	80
3. SETTING OF BASIC COPY MODES	83
1. Paper Selection	84
• Automatic Paper Selection (APS)	84
• Manual paper selection	86
• Copying mixed-size originals in one go (mixed original size)	87
2. Switching Colour Mode	89
3. Enlargement and Reduction Copying	90
4. Selecting Finishing Modes	96
• Type of finishing mode	96
• Name of each part in the Finisher (optional)	97
• Sort/Group copying	98
• Rotate sort mode	100
• Staple sort mode	101
• Magazine sort & saddle stitch mode (booklet mode)	103
• Hole punch mode (optional)	106
• Manual stapling (MJ-1101 only)	108
5. Duplex Copying	110
6. Original Mode	119
7. Copy Density Adjustment	121

4. IMAGE ADJUSTMENT	123
1. Colour Balance (YMCK Adjustment).....	124
2. RGB Adjustment	125
3. One-Touch Adjustment	126
4. Background Adjustment.....	127
5. Sharpness.....	128
6. Twin Colour (2-Colour) Copy	129
5. USING THE EDITING FUNCTIONS.....	133
1. IMAGE SHIFT	134
2. EDGE ERASE.....	140
3. BOOK CENTRE ERASE.....	141
4. DUAL PAGE	143
5. 2IN1 / 4IN1.....	145
6. MAGAZINE SORT	148
7. EDITING	150
• Trimming / Masking	150
• Mirror image.....	153
• Negative/Positive reversal	154
8. XY ZOOM	155
9. COVER SHEET	157
10. SHEET INSERTION	160
11. TIME STAMP	163
12. PAGE NUMBER	164
13. JOB BUILD	166
14. IMAGE DIRECTION.....	170
15. BOOK - TABLET	172
16. ADF / SADF	174
6. e-FILING.....	177
1. e-Filing	178
2. Creating User Boxes.....	180
3. Changing Data of User Boxes	182
4. Deleting User Boxes	185
5. Storing Documents in e-Filing.....	187
6. Printing Stored Documents.....	191
7. Deleting Folders or Documents	196
8. Appendix.....	198
• Storing documents in the shared folder	198
7. TEMPLATE	203
1. Template	204
2. Registering User Groups and Templates.....	206
3. Changing Data of User Groups and Templates.....	218
4. Recalling Templates	226
5. Deleting User Groups or Templates	231
8. JOB STATUS.....	235
1. Job Status.....	236
2. Confirming Print Job Status	237
• Print jobs.....	238
• Proof print jobs.....	241
• Private print jobs.....	244
• When using department codes	247
3. Confirming Scan Job Status	250
4. Log List	251
• Confirming job history in log list.....	252
• Registering into address book from log lists.....	256
• Printing journals (send/receive log list).....	258
5. Print Status Display.....	259
6. Error Code	262

9. BLINKING GRAPHIC SYMBOLS	273
1. Blinking Graphic Symbols	274
2. Drawer Display on the Touch Panel	275
3. Replace Toner Cartridge Symbol	276
4. Replace Toner Bag Symbol	283
5. Jam Symbols	285
6. Call Service Symbol	306
10.WHEN THIS MESSAGE APPEARS.....	307
1. "Check staple cartridge"	308
2. "Check staple cartridge in the Saddle Stitch Unit"	314
3. "Examine stapler"	316
4. "READY (CHECK STAPLER)"	322
5. "Examine stapler in the Saddle Stitch Unit"	323
6. "READY (CHECK SADDLE STITCH STAPLER)"	326
7. "READY (HOLE PUNCH DUST BIN IS FULL)"	327
8. "POWER FAILURE"	329
9. "Time for periodic maintenance"	330
10. "Check paper size setting on control panel for drawer N"	331
11. "Cannot print this paper size Select the other drawer"	338
12. "Reboot the machine"	339
11.MAINTENANCE.....	341
1. Daily Inspection	342
2. Simple Troubleshooting	343
12.SPECIFICATIONS & OPTIONS	347
1. e-STUDIO281c/351c/451c Specifications	348
2. Specifications of Options	351
3. Packing List	358
4. Copying Function Combination Matrix	359
• Combination Matrix 1/2	359
• Combination Matrix 2/2	360
5. Image Quality Adjustment Combination Matrix	361

Notice to Users

After a suitable place has been selected for the installation of the e-STUDIO281c/351c/451c, please do not change it. Avoid excessive heat, dust, vibration and direct sunlight. Also, provide proper ventilation as the copier emits a small amount of ozone.

Warning:

This is a Class A product. In a domestic environment this product may cause radio interference in which case the user may be required to take adequate measures.

Working environment

This product and original electric accessories are designed to fulfill the EMC (Electromagnetic Compatibility) requirements for "commercial and light industry environments".

TOSHIBA TEC does not approve the use of this product in working environments other than "commercial and light industry environments". As example, the following environments are not approved:

- Industrial Environments (e.g. environments where a mains voltage of 380 V three-phase is being used).
- Medical Environments: This product is not certified as a medical product according to the Medical Product Directive 93/42/EEC.
- Residential Environments (e.g. a private living room with TV / Radio sets in the nearby surrounding area)

Any consequences resulting from the use of this product in working environments that are not approved or the use is restricted are not the responsibility of TOSHIBA TEC.

The consequences of the use of this product in those working environments may be an electromagnetic interference with other devices or machines in the nearby surrounding area.

This can result into malfunction including data loss / data error pertaining to this product or the other devices / machines involved in the electromagnetic interference.

Furthermore, for general safety reasons, the use of this product in environments with explosive atmospheres is not permitted.

1. Do not touch the connector terminal when disconnecting the cables of peripheral equipment.
2. Before opening any covers or removing any units from the copier, discharge the static electricity from your body by touching a metal part of the copier.

CE compliance

This product is labelled with the CE mark in accordance with the provisions of the applicable European Directives, notably the Low Voltage Directive 73/23/EEC, the Electromagnetic Compatibility Directive 2004/108/EEC for this product and the electric accessories, the Radio Equipment and Telecommunications Terminal Equipment Directive 99/5/EEC for the telecommunication accessories.

CE marking is the responsibility of TOSHIBA TEC GERMANY IMAGING SYSTEMS GmbH, Carl-Schurz-Str. 7, 41460 Neuss, Germany, phone +49-(0)-2131-1245-0.

For a copy of the related CE Declaration of Conformity please contact your dealer or TOSHIBA TEC.

For Germany only

Machine Noise Information

Ordinance 3. GPSGV: The maximum sound pressure level is equal or less than 70 dB(A) according to EN ISO 7779

Following information is for EU-member states only:



This product is marked according to the requirement in EU-Directive 2002/96/EC.
(Directive on Waste electrical and electronic equipment - WEEE)

The use of the symbol indicates that this product may not be disposed as unsorted municipal waste and has to be collected separately. By ensuring this product is disposed of correctly, you will help prevent potential negative consequences for the environment and human health, which could otherwise be caused by inappropriate waste handling of this product.

For more detailed information about the take-back and recycling of this product please contact your supplier where you purchased the product.

TOSHIBA Quality is Second to None

e-STUDIO281c/351c/451c Toner Cartridges.

It is recommended that genuine TOSHIBA supplies and parts be used to obtain optimum results.

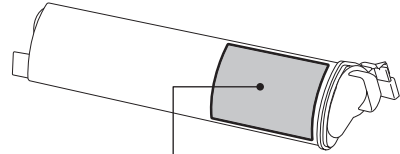
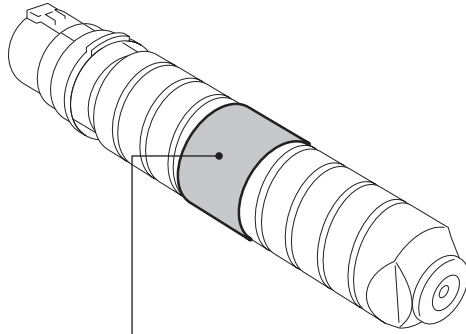

TOSHIBA						
T-281CE-Y	FOR e-STUDIO281c/351c/451c NET 220 g					
ORIGINAL & GENUINE TOSHIBA TONER						
<ul style="list-style-type: none"> ■ HANDLE WITH CARE ■ STORE IN A DRY PLACE BELOW 35°C(95°F) ■ READ THE OPERATING INSTRUCTIONS OF THE MACHINE BEFORE USING ■ SHAKE WELL BEFORE USING ■ MANIPULER AVEC PRECAUTION ■ GARDER DANS UN ENDROIT SANS HUMIDITE OU LA TEMPERATURE AMBIANTE EST MOINS DE 35°C ■ LIRE LE MANUEL D'EMPLOI DE L'APPAREIL AVANT D'EN FAIRE USAGE ■ AGITER AVANT EMPLOI 	<table border="1"> <tr><td>YELLOW</td></tr> <tr><td>JAUNE</td></tr> <tr><td>GELB</td></tr> <tr><td>AMARILLO</td></tr> <tr><td>GIALLO</td></tr> </table>	YELLOW	JAUNE	GELB	AMARILLO	GIALLO
YELLOW						
JAUNE						
GELB						
AMARILLO						
GIALLO						
<small>COMPONENTS: Polyester resin, Organic pigment, Wax, Polypropylene, Silica</small>						
TOSHIBA TEC CORPORATION <small>2-172, Higashi-1-chome, Shinagawa-ku, Tokyo, 141-8604, Japan PHONE: (81-3)66262733</small>						
<small>MADE IN CHINA / FABRIQUE EN CHINE HERGESTELLT IN CHINA HECHO EN CHINA / FATTO IN CHINA PAT. P.</small>						

TOSHIBA	ORIGINAL & GENUINE TOSHIBA TONER		<table border="1"> <tr><td>BLACK</td></tr> <tr><td>NOIR</td></tr> <tr><td>SCHWARZ</td></tr> <tr><td>NEGRO</td></tr> <tr><td>NERO</td></tr> </table>	BLACK	NOIR	SCHWARZ	NEGRO	NERO
BLACK								
NOIR								
SCHWARZ								
NEGRO								
NERO								
T-281CE-K NET 675 g	<ul style="list-style-type: none"> ● SHAKE WELL BEFORE USING. ● AGITER AVANT EMPLOI. ● VOR GEBRAUCH GUT SCHÜTTELN. ● AGITARE BENE PRIMA DELL'USO. ● SACUDIR BIEN ANTES DE USAR. ● TAP THE BOTTLE REPEATEDLY. ● TAPER DE FAÇON REPÉTÉE SUR LA BOUTEILLE. ● ENIGE MALE WIEDERHOLT AUF DIE TONERFLASCHE KLOPFEN. ● DARE ROPETUTAMENTE DEI COLPETTI ALLA BOTTIGLIA. ● GOLPEE SUAVEMENTE LA BASE DEL CARTUCHO DE TONER. 	<small>MADE IN U.S.A. / FABRIQUE AUX ETATS-UNIS HERGESTELLT IN U.S.A. HECHO EN U.S.A. / FATTO IN U.S.A.</small>	<small>PAT. P.</small>					
<small>FOR e-STUDIO281c/351c/451c</small> <small>COMPONENTS: Polyester resin, Carbon black(1333-86-4), Wax, Polypropylene, Silica</small>	<small>TOSHIBA AMERICA BUSINESS SOLUTIONS, INC. 2 Music, Irvine, California 92618-1631 (949)462-6000</small>							

Supplies / Parts

- **Dependability**
Genuine Toshiba supplies are subjected to the strictest of inspections so that every supply you receive will perform at optimal levels.
- **High Productivity**
Genuine Toshiba supplies are created to meet the demands of our competitive world and provide high-speed reliable copies when you need them.
- **Stable Image Quality**
Genuine Toshiba supplies are designed to provide consistently stable image output.
- **Copier Friendly Supplies**
Genuine Toshiba supplies are designed to help to keep the copier and all its parts in trouble-free working order.
Reduction of machine wear is due to Toshiba's intimate knowledge of the copier's characteristics ensuring the highest standard of care.
- **Perfectly Suited Supplies**
From the beginning Toshiba supplies and machines were made for each other. Whenever Toshiba designs a new machine, it also designs a new toner that is made just for that machine. By using genuine Toshiba supplies with Toshiba copiers, you are guaranteed optimum performance.

Toner

- **Optimum Image Quality**
Toshiba toner is manufactured using ultra-fine quality materials under precisely controlled conditions to ensure that your Toshiba copiers will continually generate sharp high-quality images.
- **Cost Advantage**
Genuine Toshiba toner provides value. Only the proper amount of toner is used during the reproduction process, thereby enabling the machine to continue to operate until all the toner has been used. In this way you get the full value from each cartridge used.
- **Environmental Harmony**
Genuine Toshiba toner is manufactured with the environment in mind. To protect our planet for the benefit of future generations, we use embossed or plastic labels making our toner cartridges fully recyclable. In addition, dust and ozone levels have been reduced to improve the working environment.
- **User Friendly**
Before approving our toners for sale, we test them to be sure that they pass the strictest of health standards. This takes all the worry out of handling the toner.

General

- **Service and Support Benefits**
Toshiba's Service technicians are certified to keep your copier performing at optimum levels. To ensure continuous image quality, utilize an authorized Toshiba Service provider to care for and perform periodical maintenance on your copier.

Preface

Thank you for purchasing the Toshiba Multifunctional Digital Colour Systems e-STUDIO281c/351c/451c. This Operator's Manual describes the following:

- How to use the Multifunctional Digital Colour Systems.
- How to inspect and carry out maintenance on the Multifunctional Digital Colour Systems.
- How to remedy mechanical and copying problems.

Before using the Multifunctional Digital Colour Systems, thoroughly read and understand this Operator's Manual. To ensure that clean copies are made at all times and to keep your Multifunctional Digital Colour Systems in optimum working order, this Operator's Manual should be readily available for future reference.

To ensure correct and safe use of the Toshiba Multifunctional Digital Colour Systems e-STUDIO281c/351c/451c, this Operator's Manual describes safety precautions according to the following three levels of warning:

Before reading this Operator's Manual, you should fully understand the meaning and importance of these signal words.

- **Warning**
Indicates a potentially hazardous situation which, if not avoided, could result in death, serious injury, or serious damage, or fire in the equipment or surrounding assets.
- **Caution**
Indicates a potentially hazardous situation which, if not avoided, may result in minor or moderate injury, partial damage of the equipment or surrounding assets, or loss of data.
- **Note**
Indicates a procedure you should follow to ensure the optimal performance of the Multifunctional Digital Colour Systems and problem-free copying.
- **Tip**
Describes handy information that is useful to know when operating the Multifunctional Digital Colour Systems.

©2005 TOSHIBA TEC CORPORATION All rights reserved

Under the copyright laws, this manual cannot be reproduced in any form without prior written permission of TOSHIBA TEC CORPORATION. No patent liability is assumed, however, with respect to the use of the information contained herein.

Features of the e-STUDIO281c/351c/451c

The e-STUDIO281c/351c/451c is a Multifunctional Digital Colour System that combines black-and-white and colour copy modes and is capable of using each function via networks. The e-STUDIO281c/351c/451c also has various optional paper handling devices to meet the needs of your office.

The e-STUDIO281c/351c/451c offers the following convenient features, functions and options.

- The black-and-white copying speed is 28 copies per minute for e-STUDIO281c, 35 copies per minute for e-STUDIO351c, 45 copies per minute for the e-STUDIO451c *¹. The colour copying speed is 11 copies for all (when 1-sided A4 landscape continuous copying is performed in the non-sort mode without the Reversing Automatic Document Feeder being used).
- Warm-up time has been drastically shortened to approximately 40 seconds *².
- An all-in-one controller, as standard equipment, is installed to perform the effective network functions.
- A 1/2 VGA wide panel improves operability and efficiency.
- A universal design is adopted for the control panel whose angle can be changed.
- The e-Filing function allows you to scan, save, reuse, and re-edit the original data via client PCs from the scanning section.
- Received Fax documents can be stored in e-Filing without printing them.
- Scanned originals can be sent via Fax (optional) and E-mail simultaneously.
- Electronic sorting improves both colour and black-and-white copying productivity.
- Comes with rich editing functions such as trimming, masking and mirror.
- Loading the page memory and hard disk as standard equipment enables 2in1 / 4in1, Electronic sorting and magazine sorting, etc.
- A fixing system that uses less oil reduces the amount adhering to the paper.
- By simply replacing the cartridge, you can add toner without dirtying your hands.
- A wide variety of media from thick paper (up to 209 g/m²), sticker labels, OHP films, etc. is acceptable.
- The image quality technology offers up to 999 successive stable copy images.
- Installing an optional finisher offers quick automatic sorting, stapling and hole punching (optional) of copies.
- Installing a finisher with an optional saddle stitching function attached allows you to select the saddle stitching mode which will automatically staple the centre of the documents just like a book.
- Two energy-saving features are available: 1. ENERGY SAVER MODE: Unnecessary electricity at READY status is cut off, 2. SLEEP MODE: The minimum power consumption is kept if the equipment is not used for a specified period.
- Improved security-related features ensure users of a safe and pleasant working environment.
- The built-in wireless LAN unit and Bluetooth-compliant options are introduced to respond to users' wide-ranging needs.

*1 44 copies per minute with the IMAGE SMOOTHING mode

*2 Options not installed

General Precautions

When installing or moving

Warning

- This Multifunctional Digital Colour Systems requires 220 to 240 V AC, 8 A 50/60 Hz electric power. Do not use a power supply with a voltage other than that specified. Avoid multiple connections in the same outlet. This could cause a fire or give you an electric shock. If you are considering increasing the number of outlets, contact an electrician.
- Always connect this Multifunctional Digital Colour Systems to an outlet with a ground connection to avoid the danger of fire or electric shock in case of short-circuiting. Contact your service representative for the details. Be sure to use a 3-conductor, grounded wall outlet.
In areas, where a 2-pin plug is used, the Multifunctional Digital Colour Systems must be grounded for safety. Never ground it to a gas pipe, a water pipe, or any other object not suitable for grounding.
- Plug the power cord securely into the outlet. If it is not plugged in properly, it could heat up and cause a fire or give you an electric shock.
- Do not damage, break or attempt to repair the power cord.
The following things should not be done to the power cord.
 - Twisting it
 - Bending it
 - Pulling it
 - Placing anything on it
 - Making it hot
 - Situating it near radiators or other heat sourcesThis could cause a fire or give you an electric shock. If the power cord is damaged, contact your service representative.
- Do not install the equipment by yourself or try to move it once it has been installed. This could result in an injury or damage to the device. Contact your service representative if the equipment needs to be installed or moved.
- The socket outlet should be near the equipment and be easily accessible.
- Pull out the plug from the outlet more than once a year to clean around the prongs. Accumulating dust and dirt could cause a fire due to the heat released by electric leakage.

Caution

- Avoid placing the Multifunctional Digital Colour Systems in a place unsuitable for its weight and also make sure the surface is level.
Remember that if the Multifunctional Digital Colour Systems falls over, serious injuries could result.
Weight of the Multifunctional Digital Colour Systems: approx. 113 kg.
- There are 4 adjusters (stoppers) on both sides (2 adjusters each) and 2 safety stoppers in front at the bottom of the Paper Feed Pedestal and the large capacity feeder. After moving/installing the equipment, be sure to turn and lower the adjusters, and then fix them firmly on the floor. After regulating the adjuster, fix the safety stopper as well.
Before moving the equipment, turn and raise the safety stoppers and adjusters.

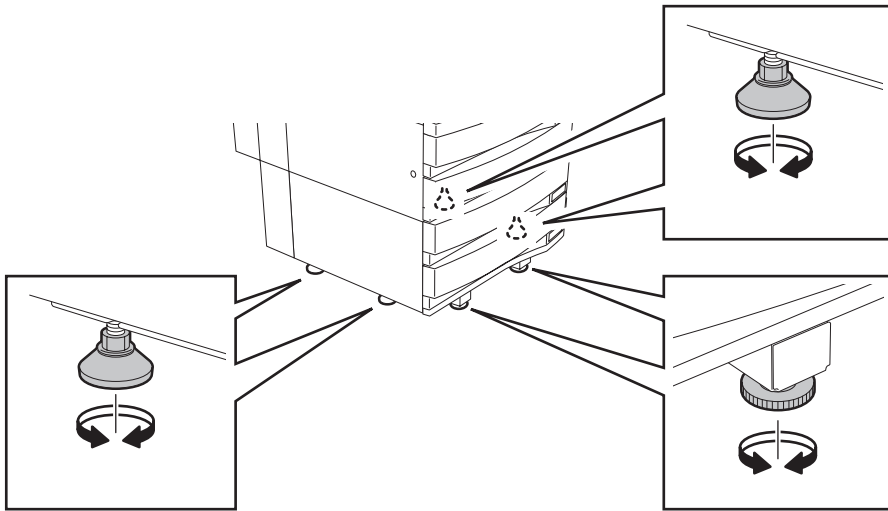

- When removing the plug from the outlet, do not pull the power cord. Always hold the plug when removing it from the outlet. If the power cord is pulled, the wires may become broken and this could cause a fire or give you an electric shock.
- Make sure that the ventilation holes are not blocked up.
If the temperature within the Multifunctional Digital Colour Systems becomes too high, a fire could result.
- When connecting the optional equipment and interface cable to the Multifunctional Digital Colour Systems, be sure to turn the power OFF. If the power is not turned off, you could get an electric shock.
To turn the power OFF, see P.39 "Turning power off (Shutdown)".

Caution

Do not install the equipment by yourself or try to move it once it has been installed. This could result in an injury or damage to the device. Contact your service representative if the equipment needs to be installed or moved.

Other points

- Make sure that there is enough space around the system to facilitate changing of parts, maintenance and clearing paper jam.
If there is insufficient space, some operations, such as bypass feeding, will become difficult and the Multifunctional Digital Colour Systems could even break down.
To insure optimal operation, allow clearances of at least 80 cm on the right, and 10 cm on the left and behind.

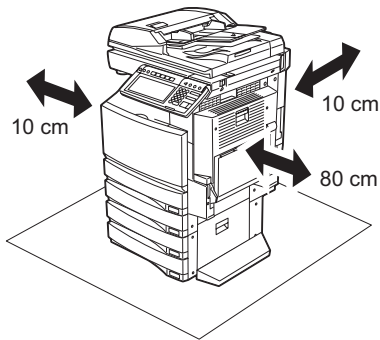

- Be sure to fix the power cable securely so that no one trips over it.
- Adverse environmental conditions may affect the safe operation and performance of the Multifunctional Digital Colour Systems, and the Multifunctional Digital Colour Systems could break down.
 - Avoid locations near windows or with exposure to direct sunlight.
 - Avoid locations with drastic temperature fluctuations.
 - Avoid too much dust.
 - Avoid location that suffer from vibration.
- Allow the air to flow freely and make sure there is a ventilator.
With inadequate ventilation, the unpleasant odor released by ozone will begin to dominate the atmosphere.

When using the Multifunctional Digital Colour Systems

Warning

- Do not take off the cover of the equipment; otherwise you could be injured or get an electric shock.
- Do not remove or connect the plug with wet hands, as this could give you an electric shock.
- Do not place any container with liquid (flower vases, coffee cups, etc.) on or near the equipment. This could cause a fire or give you an electric shock.
- Keep paper clips and staples away from the air vent. If not, a fire could result or you could get an electric shock.
- If the Multifunctional Digital Colour Systems becomes excessively hot, smoke comes out of it or there is an odd smell or noise, proceed as follows.
Turn the main switch OFF and remove the plug from the outlet, then contact your service representative.
- If the Multifunctional Digital Colour Systems will not be used for more than one month, remove the plug from the outlet for safety purposes during that time.
If an insulation failure occurs, this could cause a fire or give you an electric shock.

Caution

- Do not place heavy objects (4 kg or more) on the original glass and do not press on it with force. Breaking the glass could cause personal injury.
- Do not place heavy objects (4 kg or more) on the Multifunctional Digital Colour Systems. If the objects fall off, this could cause injury.
- Do not touch the fuser unit or the metal area around it. Since they are very hot, you could be burned or the shock could cause you to get your hand injured in the machine.
- When changing the angle of the control panel, be careful not to catch your hands in the gap between the equipment and the control panel. This could cause personal injury.
- Be careful not to let your fingers be caught when closing the drawer. This could injure you.
- Be careful not to let your fingers be caught between the equipment and the finisher (optional). This could injure you.
- Be careful not to let your fingers be caught between the equipment and the automatic duplexing unit. This could injure you.
- Do not place 3 kg or more of objects on an optional work table. Breaking the work table could cause personal injury.
- Do not touch the metal portion of the guide plate in the automatic duplexing unit as it could burn you.
- Do not touch the hinge (= a connecting part) on the rear side of the Reversing Automatic Document Feeder (optional). This could catch and injure your fingers when you open or close the Reversing Automatic Document Feeder (optional).

Position of Certification label, etc.

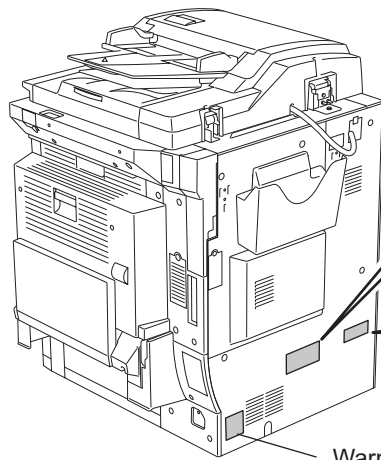

Explanatory label



Identification label

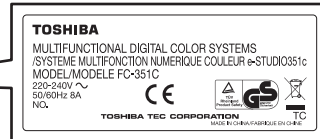

Warning for grounding wire

Warning label

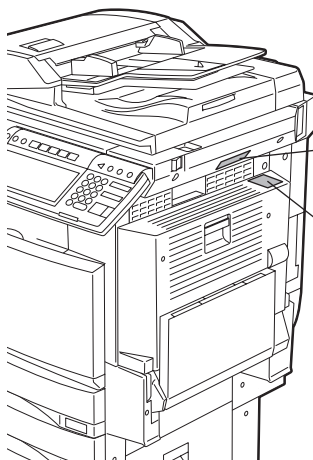
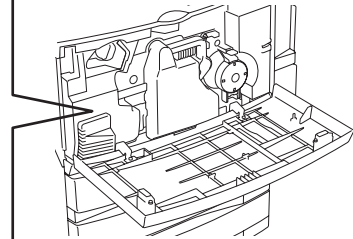
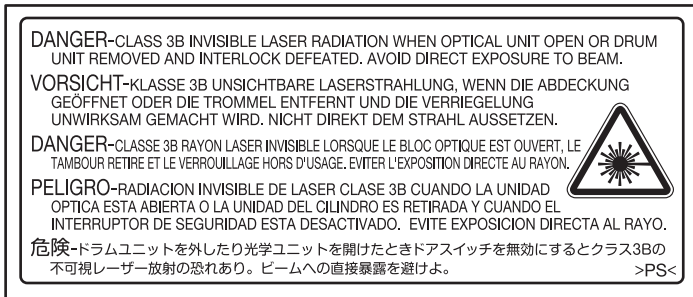

Warning for high temperature area (fuser unit)

Warning for high temperature area (ventilation holes)

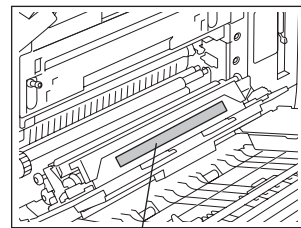

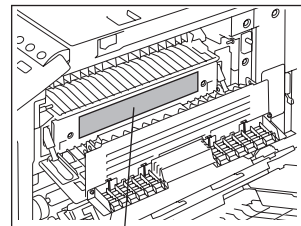

Warning for handling transfer belt



Warning for high temperature area

Other points



- Be very careful to treat the touch panel gently and never hit it. Breaking the surface could cause malfunctions.
- Do not turn the power OFF with jammed paper left inside the Multifunctional Digital Colour Systems. This could cause malfunctions when the main switch is turned ON next time. To turn the power OFF, see  P.39 "Turning power off (Shutdown)".
- Be sure to turn the power OFF when leaving the office or if there is a power outage. However, Do not turn the power OFF if the weekly timer is in use. To turn the power OFF, see  P.39 "Turning power off (Shutdown)".
- Be careful because the paper exit area and paper just after exiting are hot.
- Do not place anything other than paper on the receiving tray. This could disturb a normal operation and cause malfunctions.
- Do not touch the photoconductive drum surface or the transfer charger. This could cause image problems.

During maintenance or inspection

Warning

- Never attempt to repair, disassemble or modify the Multifunctional Digital Colour Systems by yourself. You could cause a fire or get an electric shock. Always contact your Service representative for maintenance or repair of the Multifunctional Digital Colour Systems.
- Do not let liquids such as water and oil get into the system when cleaning the floor. This could cause a fire and give you an electric shock.

Caution

- Always keep the plug and outlet clean. Prevent them from accumulating dust and dirt. This could cause a fire and give you an electric shock due to the heat released by electric leakage.
- Do not touch the stapling area. The actual needle point could cause you personal injury.
Saddle Stitch Finisher (optional)  P.323
Finisher (optional)  P.316

Other points

- Do not use such solvents as thinner or alcohol when cleaning the surface of the Multifunctional Digital Colour Systems.
 - This could warp the shape of the surface or leave it discoloured.
 - When using a chemical cleaning pad to clean it, pay attention to any cautionary points.

When handling supplies

Caution

- Never attempt to incinerate toner cartridges and toner bags. This could cause an explosion. Do not dispose of used toner cartridges and toner bags. Contact your service representative. (📖 P.276 "3.Replace Toner Cartridge Symbol", 📖 P.283 "4.Replace Toner Bag Symbol")

Disclaimer Notice

The following notice sets out the exclusions and limitations of liability of TOSHIBA TEC CORPORATION (including its employees, agents and sub-contractors) to any purchaser or user ('User') of the e-STUDIO281c/351c/451c, including its accessories, options and bundled software ('Product').

1. The exclusion and limitations of liability referred to in this notice shall be effective to the fullest extent permissible at law. For the avoidance of doubt, nothing in this notice shall be taken to exclude or limit TOSHIBA TEC CORPORATION's liability for death or personal injury caused by TOSHIBA TEC CORPORATION's negligence or TOSHIBA TEC CORPORATION's fraudulent misrepresentation.
2. All warranties, conditions and other terms implied by law are, to the fullest extent permitted by law, excluded and no such implied warranties are given or apply in relation to the Products.
3. TOSHIBA TEC CORPORATION shall not be liable for any loss, cost, expense, claim or damage whatsoever caused by any of the following:
 - (a) use or handling of the Product otherwise than in accordance with the manuals, including but not limited to Operator's Manual, User's Guide, and/or incorrect or careless handling or use of the Product;
 - (b) any cause which prevents the Product from operating or functioning correctly which arises from or is attributable to either acts, omissions, events or accidents beyond the reasonable control of TOSHIBA TEC CORPORATION including without limitation acts of God, war, riot, civil commotion, malicious or deliberate damage, fire, flood, or storm, natural calamity, earthquakes, abnormal voltage or other disasters;
 - (c) additions, modifications, disassembly, transportation, or repairs by any person other than service technicians authorized by TOSHIBA TEC CORPORATION; or
 - (d) use of paper, supplies or parts other than those recommended by TOSHIBA TEC CORPORATION.
4. Subject to paragraph 1, TOSHIBA TEC CORPORATION shall not be liable to Customer for:
 - (a) loss of profits; loss of sales or turnover; loss of or damage to reputation; loss of production; loss of anticipated savings; loss of goodwill or business opportunities; loss of customers; loss of, or loss of use of, any software or data; loss under or in relation to any contract; or
 - (b) any special, incidental, consequential or indirect loss or damage, costs, expenses, financial loss or claims for consequential compensation;

whatsoever and howsoever caused which arise out of or in connection with the Product or the use or handling of the Product even if TOSHIBA TEC CORPORATION is advised of the possibility of such damages.

TOSHIBA TEC CORPORATION shall not be liable for any loss, cost, expense, claim or damage caused by any inability to use (including, but not limited to failure, malfunction, hang-up, virus infection or other problems) which arises from use of the Product with hardware, goods or software which TOSHIBA TEC CORPORATION has not directly or indirectly supplied

Forgery Prevention Function/Storage of Colour Copies

Forgery prevention function

This copier has a forgery prevention function. Please ensure that your digital full-colour copier is not used for making copies of prohibited items.

Storage of colour copies

- The copies should be kept in a place which is not exposed to light to prevent fading when they are stored for a long time.
- If copies are kept pressed between plastics made of chloroethylene for a long time, the toner may melt and stick to the plastic due to high pressure and high temperature. Keep them in polyethylene binders.
- When a colour copy is folded, the toner at the fold can become separated.
- The toner on the copies may melt if it touches solvent. If the ink on the copies has not completely dried, the toner may also melt. Keep copies away from solvent.
- When copies are kept near an extremely high temperature such as a heater, the toner may melt. Keep them at room temperature and do not allow this to vary very much.

1. BEFORE USING EQUIPMENT

1. Description of Each Component	22
• Main components	22
• Configuration of options	23
• Control panel	26
• Adjustment of the angle of the control panel	28
• Touch panel	30
2. Turning Power On / Shutdown	34
• Turning power on	34
• When department or user management is used	35
• Turning power off (Shutdown)	39
3. Energy Saving Mode	42
4. Setting Copy Paper	43
• About the “width” and the “length” of the original and the copy paper	43
• Acceptable copy paper	44
• Setting copy paper (size change)	46
• Placing paper in the Large Capacity Feeder (optional)	51
• Drawer for special uses	52

1. Description of Each Component

Main components

1

1. Front cover
 2. Drawers
 3. Operator's Manual pocket (Back side)
 4. Power switch
 5. Automatic duplexing unit
 6. Bypass tray
 7. Paper size indicator
 8. Original scale
 9. Scanning area
 10. Receiving tray
 11. Colour toner cartridge (Cyan/Magenta/Yellow)
 12. Original glass
 13. Touch panel
 14. Control panel
 15. Black toner cartridge
 16. Toner bag
 17. Touch panel contrast adjustment volume
- A and B: Options

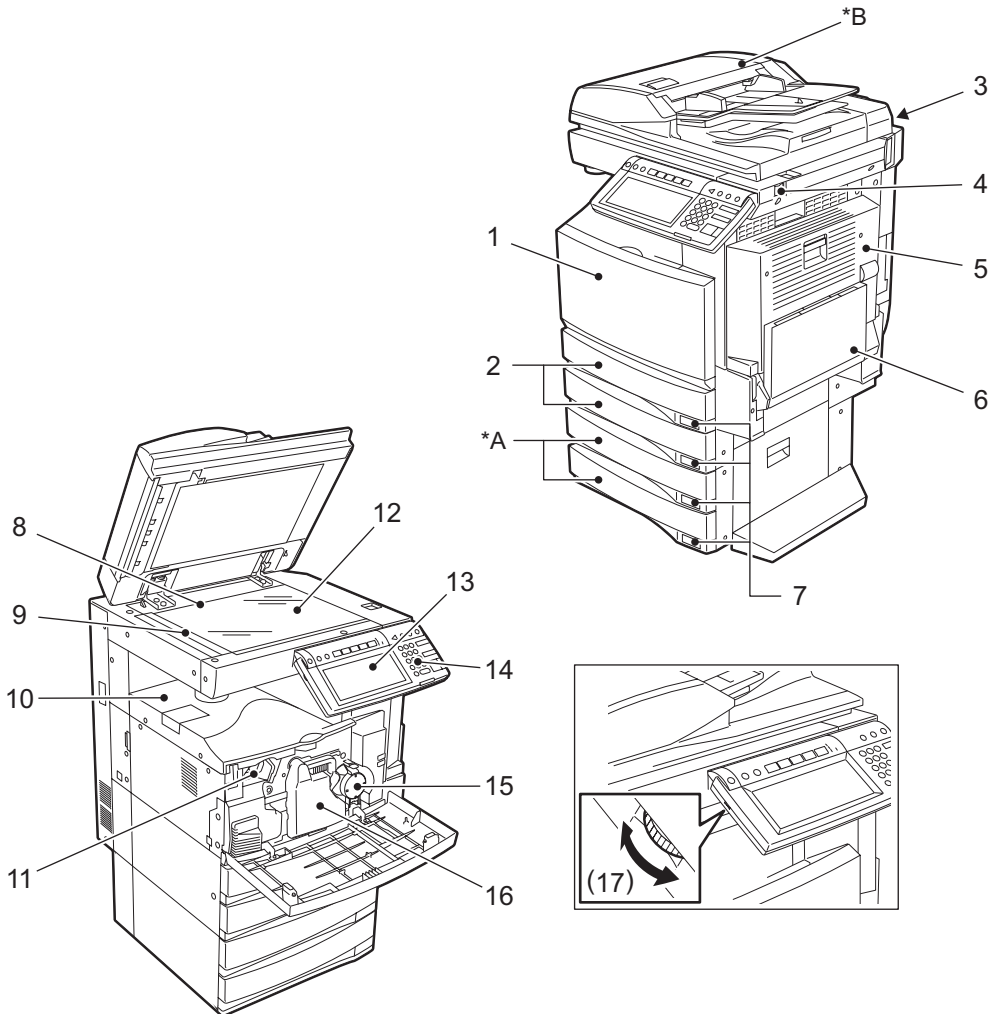

Configuration of options

1

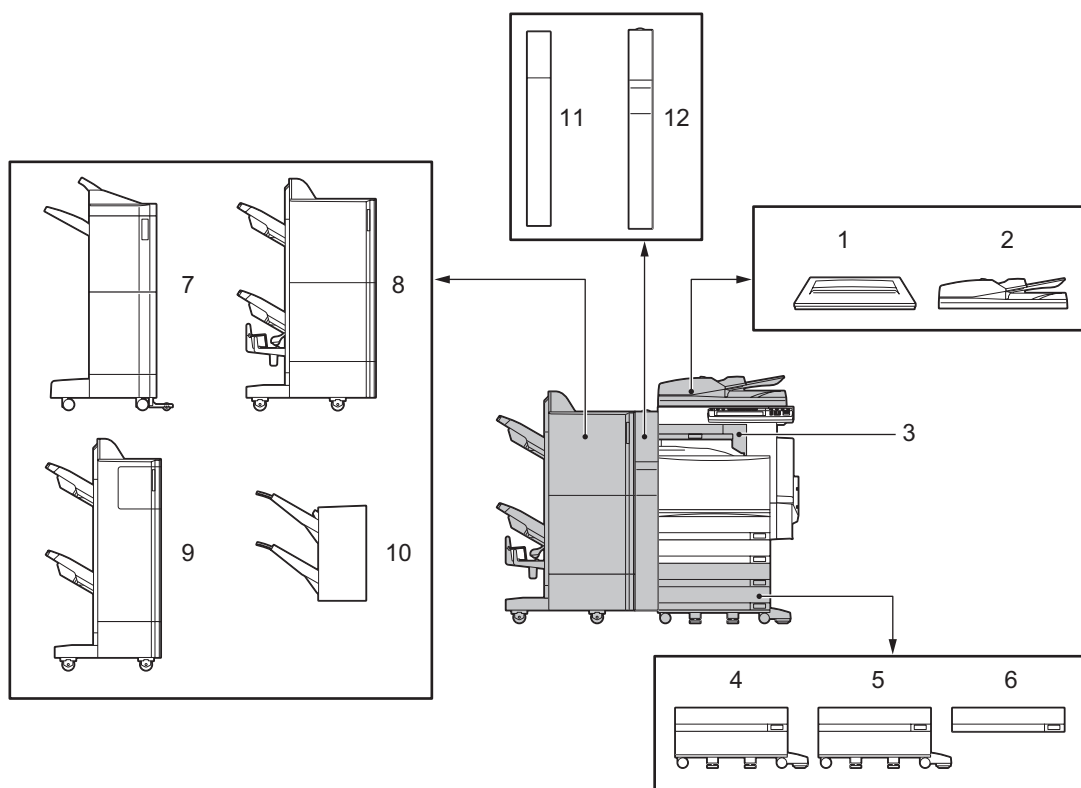

- 1. Original Cover (KA-3511PC)**
Holds an original.
- 2. Reversing Automatic Document Feeder (MR-3018)**
Automatically feeds a placed stack of originals one by one to have them copied.
- 3. Bridge Unit (KN-3511A)**
Acts as a relay for the finisher and this equipment.
- 4. Large Capacity Feeder (KD-1012)**
This feeder enables you to feed up to 2500 sheets (80 g/m²) of A4 paper.
- 5. Paper Feed Pedestal (KD-1011)**
Adds one drawer to the equipment.
- 6. Additional Drawer Module (MY-1021)**
Enables one drawer to be added to the Paper Feed Pedestal.
- 7. Finisher (MJ-1101)**
This finisher enables sort/group finishing and stapling. The Hole Punch Unit (optional, MJ-6101) can be installed to this finisher. The Bridge Unit (optional, KN-3511A) is required for the installation of this finisher.

8. Saddle Stitch Finisher (MJ-1024)

This finisher enables saddle stitching, in addition to sort/group finishing and stapling. The Hole Punch Unit (optional, MJ-6004) can be installed to this finisher. The Bridge Unit (optional, KN-3511A) is required for the installation of this finisher.

9. Multi Position Staple Finisher (MJ-1023)

This finisher enables sort/group finishing and stapling. The Hole Punch Unit (optional, MJ-6004) can be installed to this finisher. The Bridge Unit (optional, KN-3511A) is required for the installation of this finisher.

10. Hanging Finisher (MJ-1022) (for e-STUDIO281c/351c only)

This finisher enables sort/group finishing and stapling. The Bridge Unit (optional, KN-3511A) is required for the installation of this finisher.

11. Hole Punch Unit (MJ-6101)

This unit enables you to punch holes on printouts. It can be used by installing it on the Finisher (MJ-1101).

12. Hole Punch Unit (MJ-6004)

This unit enables you to punch holes on printouts. It can be used by installing it to the Saddle Stitch Finisher (MJ-1024) and Multi Position Staple Finisher (MJ-1023).

Other options available are as follows. Contact your service technician or Toshiba product distributors for details.

Work Table (KK-3511)

This is a small table for placing originals while the equipment is operated.

- Cannot be installed with e-BRIDGE ID Gate at the same time

FAX Unit (GD-1200)

This is a unit for using the equipment as a Fax.

2nd Line for Fax Unit (GD-1160)

This unit enables to add a line to the Fax to make it 2nd line.

- The Fax Unit (GD-1200) is necessary.

Desk (MH-1700)

This is a desk for the equipment.

Data Overwrite Kit (GP-1060)

This is a kit to erase the data stored temporarily when copying, printing, scanning, Fax, internet Fax or network Fax is performed. It overwrites temporarily stored data with random data.

Scrambler Board (GP-1040)

This board enhances the security of the equipment. Data are encrypted when they are written into the hard disk of the equipment and decrypted when they are read.

Parallel Board (GF-1140)

This kit is used when the equipment is connected in parallel with a computer.

- The PCI slot (GO-1060) is necessary.

Expansion Memory (GC-1181, GC-1230)

GC-1181 is a page memory for storing data temporarily when scanning or printing. GC-1230 is a main memory used for the equipment programs or operations. Both of them are necessary for the memory expansion. High resolution scanning (Colour/Auto colour: 600/400 dpi, Image Smoothing: 600 dpi) and high resolution colour printing (1200 dpi equiv. x 600 dpi) functions are enhanced.

Wireless LAN Module (GN-1041)

This module enables the equipment to be used in a wireless LAN environment.

- The Antenna (GN-3010) is necessary.
- The equipment cannot be connected to the wireless and wired LAN at the same time.

Bluetooth Module (GN-2010)

This module enables the Bluetooth printing.

- The Antenna (GN-3010) is necessary.

Antenna (GN-3010)

This is used when the Wireless LAN Module and Bluetooth Module are installed.

Control panel

Use the buttons on the control panel for various operations and settings through the equipment.

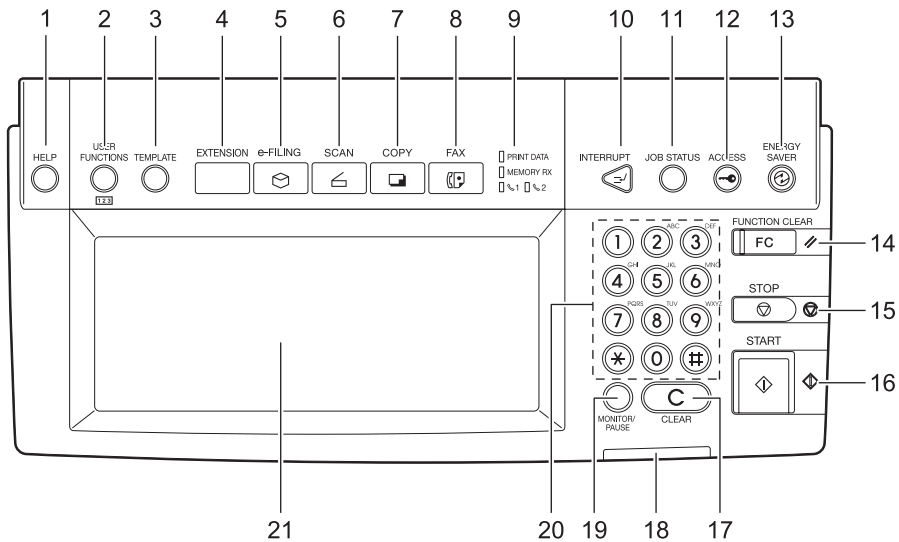

1. **[HELP] button**
Use this button to display a desired operation procedure.
2. **[USER FUNCTIONS] button**
Use this button for paper size or media type setting of drawers, and registration of the copy, scan and FAX settings (including a default setting change.) See the User Functions Guide for the functions enabled by this button.
3. **[TEMPLATE] button**
Use this button to store and recall frequently used copy, scan, and FAX settings.
4. **[EXTENSION] button**
Any operation with this button is invalid at present. This button is to extend functions in the future.
5. **[e-FILING] button**
Use this button to access saved image data.
6. **[SCAN] button**
Use this button to use the scanning function.
7. **[COPY] button**
Use this button to use the copier function.
8. **[FAX] button**
Use this button to use the FAX / Internet FAX function.
9. **PRINT DATA / MEMORY RX / FAX communication lamps**
These lamps show the status of FAX data reception and FAX communication.
10. **[INTERRUPT] button**
Use this button to interrupt the copy job in process and perform another one. The interrupted job is resumed by your pressing this button again.

11. [JOB STATUS] button

Use this button to confirm each job status, printing status, and FAX transmission/reception status of a print job, scan job and FAX job. (📖 P.236 “1.Job Status”)

12. [ACCESS] button

Use this button when the department code or user information has been set. If this button is pressed after copying, the next user cannot use functions such as copying without keying in the department code or user information. See the User Functions Guide for the department and user management.

13. [ENERGY SAVER] button

Use this button when you want to shut down the equipment or when you want the equipment enter into the energy saving mode. When you press this button, the menu for the energy saving mode appears. Press the [SLEEP] button on this menu to enter into the energy saving mode and press the [SHUT-DOWN] button to shut down the equipment.

14. [FUNCTION CLEAR] button

When this button is pressed, all selected functions are cleared and returned to the default settings.

15. [STOP] button

Use this button to stop any scanning and copying operations in progress.

16. [START] button

Use this button to start copying, scanning and FAX operations.

17. [CLEAR] button

Use this button to correct numbers keyed in, such as the copy quantity.

18. ERROR lamp

This lamp lights when an error occurs and the equipment needs some actions to be taken.

19. [MONITOR/PAUSE] button

Use this button only when a FAX Unit (optional) is installed. (See the Operator's Manual for Facsimile Function for details.)

20. Digital keys

Use these keys to enter any numbers such as the copy quantity.

21. Touch panel

Use this panel for the various settings of each function of the copier, scanner and FAX. This panel also indicates the status of the equipment, such as when you run out of paper or there is a paper jam.

Adjustment of the angle of the control panel

1

When adjusting the angle of the control panel

The angle of the control panel is adjustable at any angle between 7 and 45 degrees from the horizontal position.

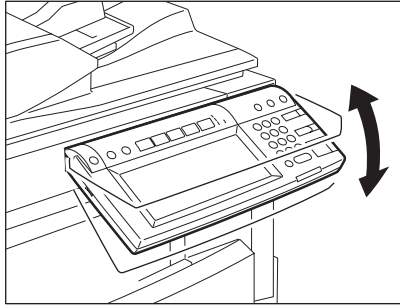

Caution

When changing the angle of the control panel, be careful not to catch your hands in the gap between the equipment and the control panel. This could injure you.

When fixing the angle of the control panel

The angle of the control panel can be fixed by using the stopper on the backside of the control panel (at 7 degrees from the horizontal position). The stopper is located on A when the equipment is set up. Move it from the position A to B before fixing it.

A: The position where the angle is adjustable.

B: The position where the angle is fixed.

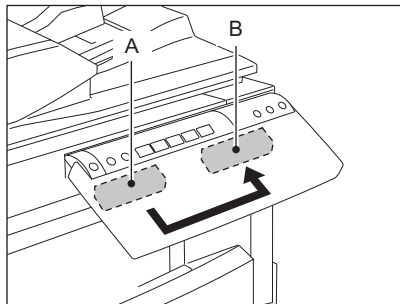

- 1 Slide the stopper (in the position A) slightly to the right, and then pull it out.

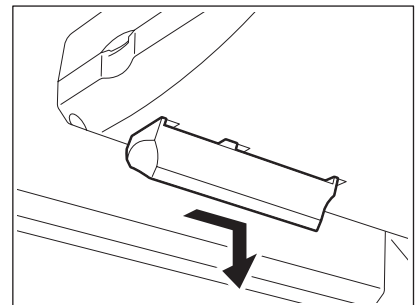

- 2** Fit the latches of the stopper in the hole of the position B and insert them turning the stopper itself.

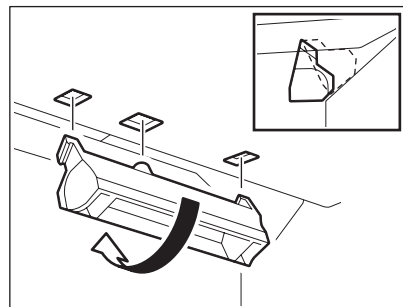

- 3** Shift the stopper to the left until it clicks.

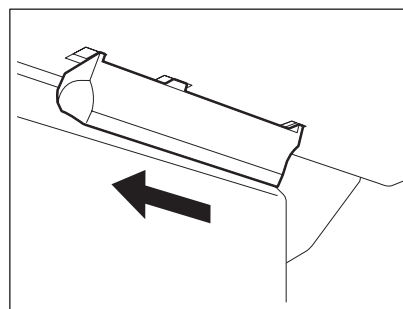

- The angle of the control panel is fixed at 7 degrees.

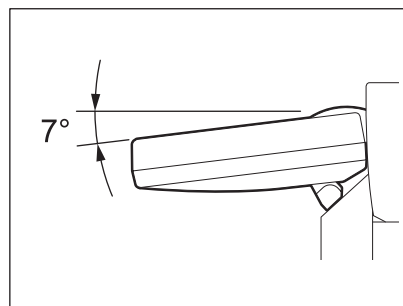

Touch panel

1

When the power is turned on, the basic menu for the copier function appears on this touch panel. The status of the equipment is also displayed on the touch panel with messages and illustrations.

- | | |
|--|--------------------------------------|
| 1. Message | 10. Original mode button |
| 2. Reproduction ratio | 11. [PROOF COPY] button |
| 3. Number of copy sets | 12. Density adjustment buttons |
| 4. APS/AMS* or currently selected paper size | 13. Simplex / duplex button |
| 5. Remaining paper level | 14. Colour mode button |
| 6. Date and time | 15. Paper source selection buttons |
| 7. [SETTINGS] button | 16. Equipment status indication area |
| 8. Finisher button | 17. Function setting area |
| 9. Enlargement/Reduction ([Zoom...]) button | 18. Index buttons |

* APS : Automatic paper selection , AMS : Automatic magnification selection

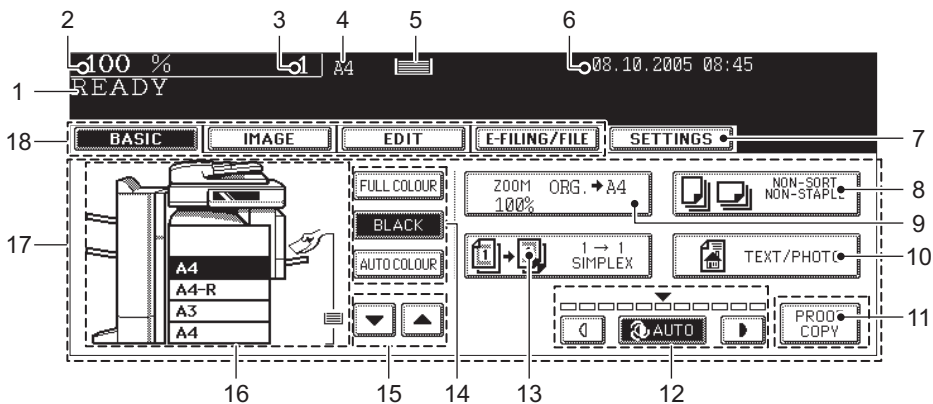

Message display

The following information appears at the top of the touch panel:

Equipment status, operational instructions, cautionary messages, reproduction ratios, number of copy sets, paper size of a selected drawer, amount of paper in a selected drawer and date and time.

Touch-buttons

Press these buttons on the touch panel lightly to set various functions.

Index buttons

Press these buttons to switch menus. The type and number of the index buttons vary depending on the function of the copier, scanner and e-Filing.

Function setting area

This area includes buttons for selecting and setting each function.

[SETTINGS] button

Press this button to confirm currently set functions.
(An example is shown below.)

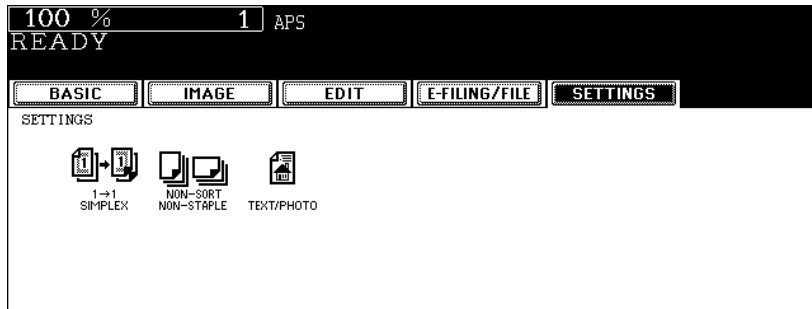

Buttons appearing on the various menus are as follows (some buttons may not appear on the menu):

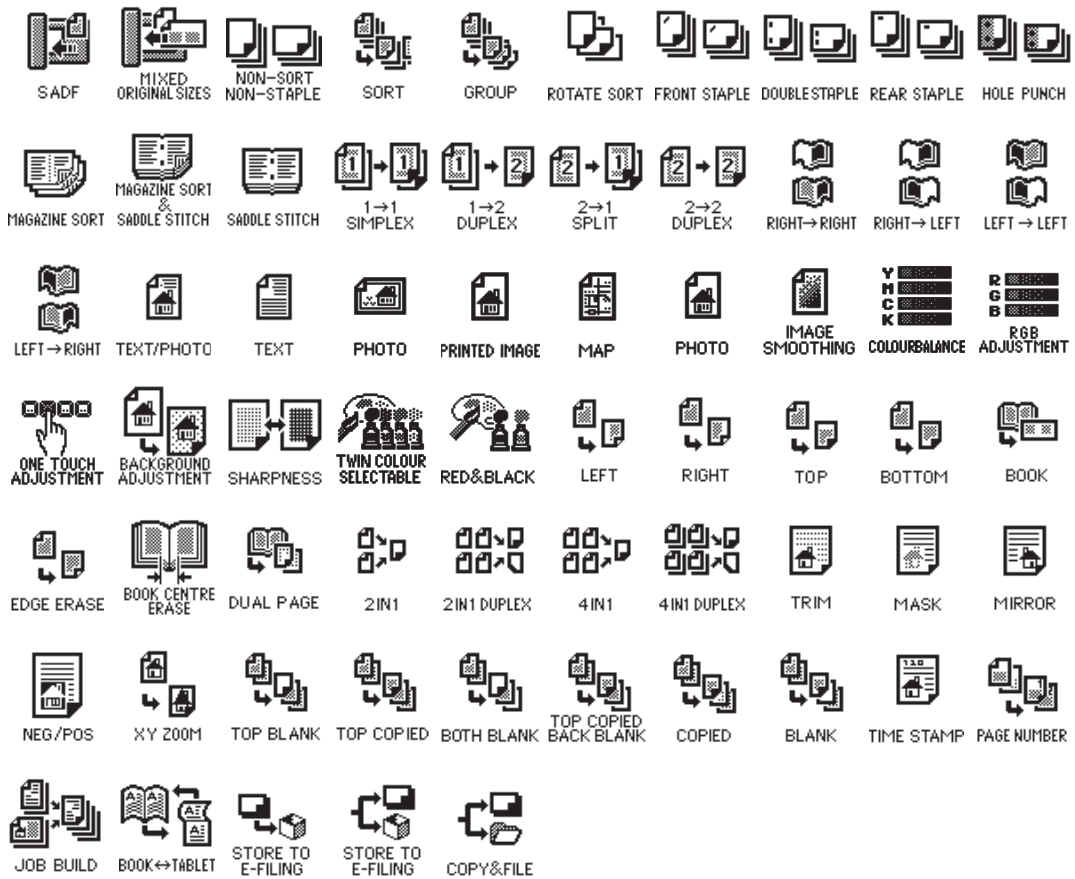

1

Clearing functions selected

When you press the selected button, the function which has been selected is cleared. Or the selected setting is cleared automatically by the automatic function clear* when the equipment has been left inactive for a specified period of time.

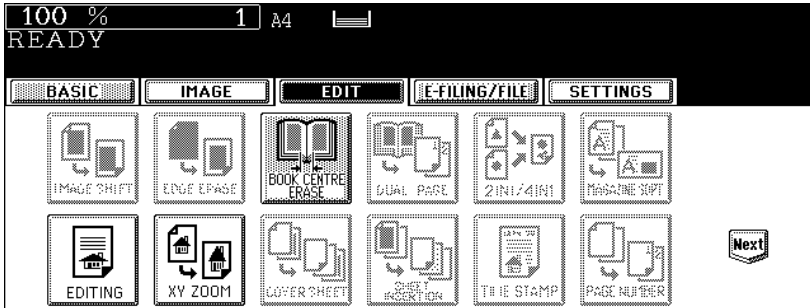

* Automatic function clear:

This function works when a specified period of time has passed since the last paper exit or the last entry of any button. This function returns all the function settings to default without the need to press the [FUNCTION CLEAR] button. When the department or user management function is being used, the display returns to the department code or user information input menu. When these functions are not being used, the display returns to the basic menu of the copier function.

The period for the automatic function clear is set at 45 seconds by default at the time of installation of the equipment. See the User Functions Guide for change of this setting.

Adjusting the contrast of the touch panel

Turn this adjustment volume on the left side of the control panel to adjust the contrast of the touch panel.

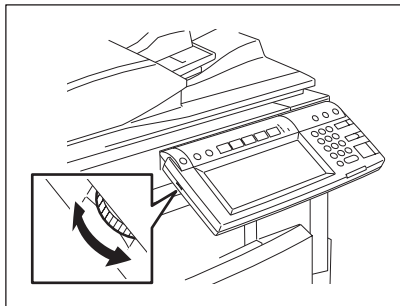

Setting letters

The following menu appears when any letter entry is required for the operations of scanning, e-Filing, template and Internet FAX.

Use the buttons on the touch panel for letter entry and use the digital keys on the control panel for number entry.

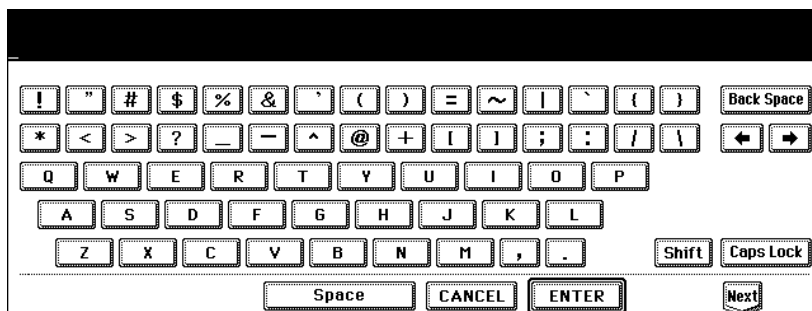

The following buttons are used for letter entry.

- [Space]: Press this to enter a space.
- [CANCEL]: Press this to cancel the entry of letters.
- [ENTER]: Press this to fix all entered letters.
- [Back Space]: Press this to delete the letter before the cursor.
- [←][→]: Press them to move the cursor.
- [Shift]: Press this to enter capital letters.
- [Caps Lock]: Press this to switch capital letters and small letters.
- [Next]: Press this to access the special keys.

2. Turning Power On / Shutdown

Turning power on

1

Open the switch cover, and then turn the power switch on.

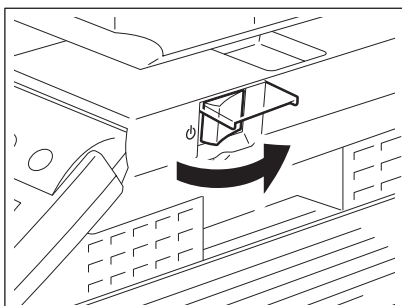

- The equipment starts warming-up. “Wait Warming Up” appears during warming-up.
- While the equipment is warming up, you can use the auto job start function. (📖 P.68 “Scanning the next originals during copying (Auto job start)”)

The equipment will be ready for copying after about 40 seconds and “READY” appears.

When you turn the power of the equipment OFF, do not simply turn the power switch to turn it off but be sure to shut it down. (📖 P.39 “Turning power off (Shutdown)”)

When “ERASING DATA” appears

This message appears when the Data Overwrite Kit (optional) has been installed. It appears immediately after the power is turned ON or after the equipment has been operated. You can operate the equipment even if it is displayed.

- When the use of the equipment is managed under department management or user management function, you need to enter the department code or user information before making a copy. For details, see 📖 P.35 “When department or user management is used”.
-

When department or user management is used

When the use of the equipment is managed under department management or user management function, each user needs to enter the department code or user information.

1

Department management

You can restrict users or manage copy volumes made by an individual group or department in your company using the department codes. When the copy volume is controlled under the department code, enter the code after turning the power on. See the User Functions Guide for setting and registration of the department codes.

When the power is turned on, the following menu appears.

- This menu also appears when the [ACCESS] button is pressed or the automatic function clear has worked.

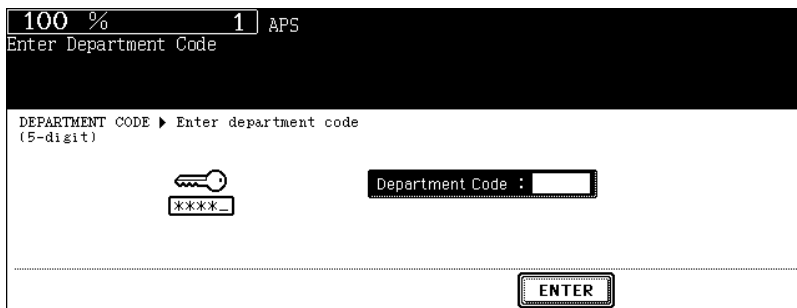

Key in a department code (5 digits) previously registered and press the [ENTER] button. The menu will switch and the equipment will be ready to be used.

- If the department code keyed in is incorrect, the menu does not change. In this case, press the [FUNCTION CLEAR] button and then key in the correct code.

When copying is finished

When you finish all operations, press the [ACCESS] button to prevent unauthorized use of the equipment. The display returns to the department code input menu.

1

User management

Users of the equipment can be limited and the available functions and past record of each user can be controlled by using the user management function. When the equipment is managed under this function, turn the power of the equipment ON and enter the information required (e.g. user name, password) to use the equipment. The menu for entering user information also appears when you pressed the [ACCESS] button on the control panel or automatic function clear has worked. Enter the information following the procedure below.

1 The menu for user authentication appears.

MFP local authentication, LDAP authentication

100 % 1 APS
READY

USER AUTHENTICATION ▶ Key in the user name and password. Press ENTER

USER NAME

PASSWORD

ENTER

Windows Domain Authentication

100 % 1 APS
READY

USER AUTHENTICATION ▶ Key in the user name and password. Press ENTER

USER NAME

PASSWORD

DOMAIN Dept01

ENTER

- The domain name previously set by the network administrator is displayed in [DOMAIN].

Tip

If the domain name belonging to your organization is not displayed, press the [DOMAIN] button and select it.

DOMAIN1 Dept01

DOMAIN2 Dept02

DOMAIN3 Dept03

CANCEL

2 Press the [USER NAME] button.

1

100 % 1 APS
READY

USER AUTHENTICATION ▶ Key in the user name and password. Press ENTER

USER NAME

PASSWORD

DOMAIN Dept01

ENTER

3 Enter the user name (maximum 128 letters) and then press the [ENTER] button.

User01_

! " # \$ % & ' () = ~ | \ { } Back Space

* < > ? _ - ^ @ + | | ; : / \ ← →

Q W E R T Y U I O P

A S D F G H J K L

Z X C V B N M , . Shift Caps Lock

Space CANCEL ENTER Next

4 Press the [PASSWORD] button.

100 % 1 APS
READY

USER AUTHENTICATION ▶ Key in the user name and password. Press ENTER

USER NAME User01

PASSWORD

DOMAIN Dept01

ENTER

1

5 Enter the password (maximum 64 letters) and then press the [ENTER] button.

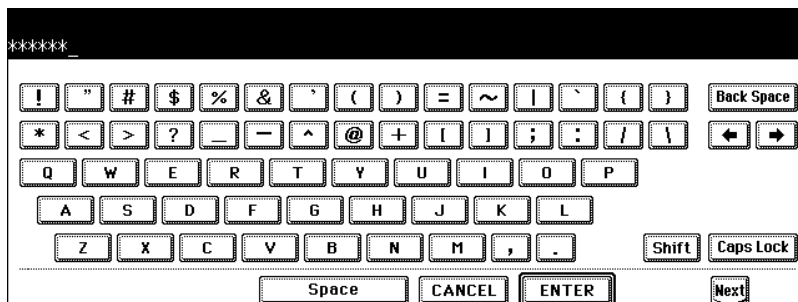

6 Press the [ENTER] button.

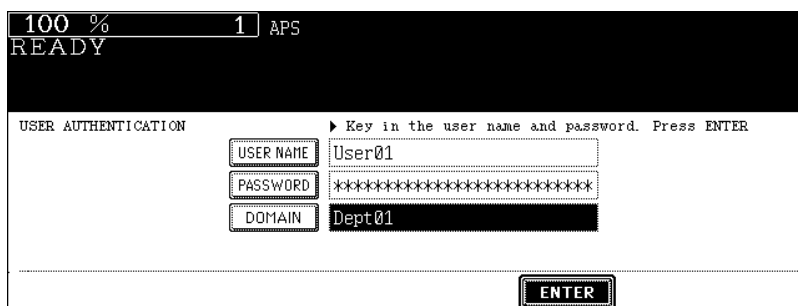

The menu will switch and the equipment will be ready to be used.

- If the user information is incorrectly entered, the menu will not switch. In this case, press the [FUNCTION CLEAR] button and then enter it again.

Displaying the available number of copies

The amount is determined by how many copies the user (👤) or the department (👥) has remaining and the smaller of the two numbers is displayed.

The number appears for 5 seconds on the upper right of the screen.

COLOUR: Available number of copies for colour copying

BLACK: Available number of copies for black-and-white copying

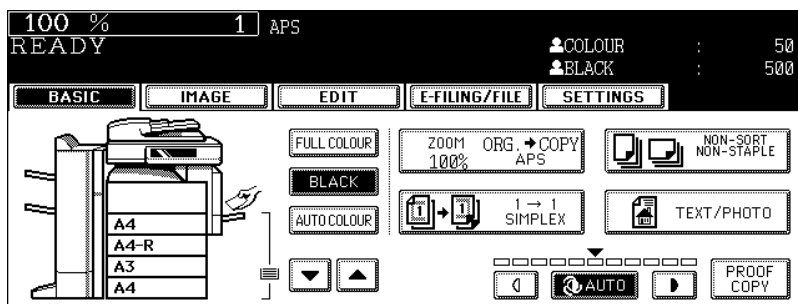

- The display differs depending on the management setting of this equipment.

When copying is finished

When you finish all operations, press the [ACCESS] button to prevent unauthorized use of the equipment. The display returns to the one for entering user information.

Turning power off (Shutdown)

When turning OFF the power of the equipment, be sure to shut it down following the procedure below. Make sure to check the following three points before shutdown.

- No jobs should be left in the print job list. (P.236 “1.Job Status”)
- None of the PRINT DATA, MEMORY RX and FAX communication lamps should be blinking. (If the equipment is shut down while any of the above lamps is blinking, jobs in progress such as FAX reception will be aborted.)
- No PC should access the equipment via the network.

Note

- Do not press the power switch to turn the power OFF, otherwise the stored data may be lost or the hard disk may be damaged.
- When the equipment is shut down, the job in progress is cleared.

- 1 Press the [USER FUNCTIONS] button on the control panel.**

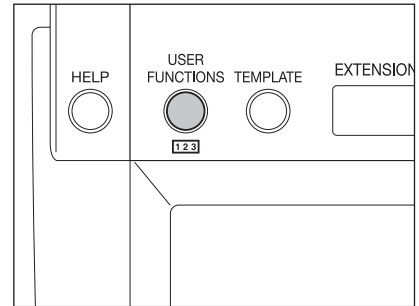

- 2 Press the [USER] button on the touch panel to enter the user setting menu, and then press the [SHUTDOWN] button.**

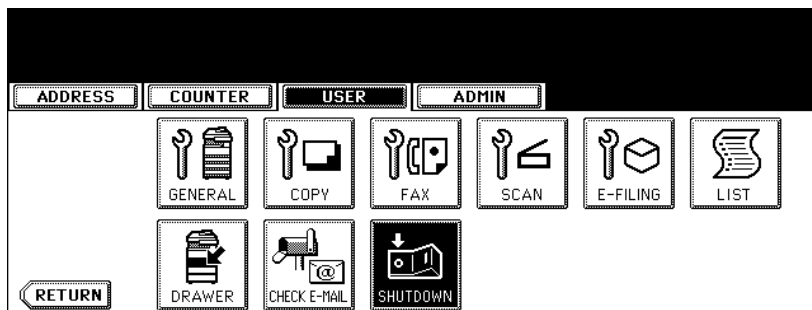

1

- 3** “Processing job will be deleted. Are you sure you want to shutdown?” appears on the menu. Press the [YES] button.

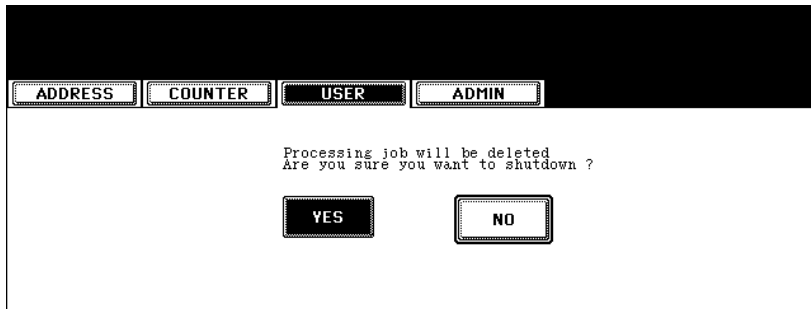

- To cancel the shutdown operation, press the [NO] button.

- 4** “Shutdown in progress” appears on the menu. After a while, the equipment is shut down and the power is turned OFF.

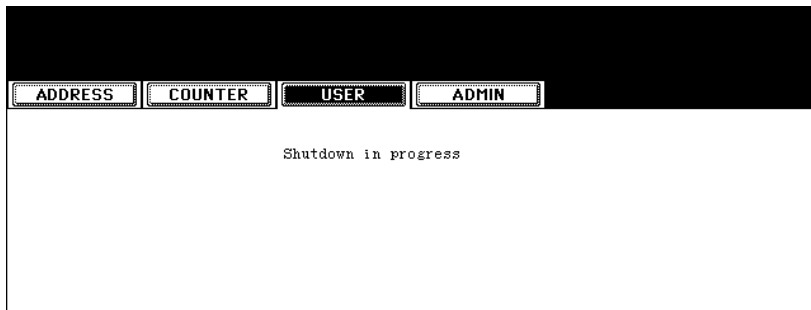

- The power switch automatically returns to the OFF position.

Shutting down with the [ENERGY SAVER] button

The equipment can also be shut down by following the procedure below.

- 1** Press the [ENERGY SAVER] button on the control panel.

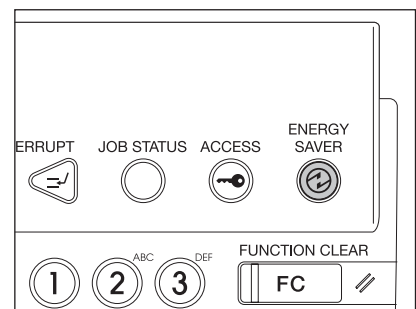

2 Press the [SHUTDOWN] button on the touch panel.

1

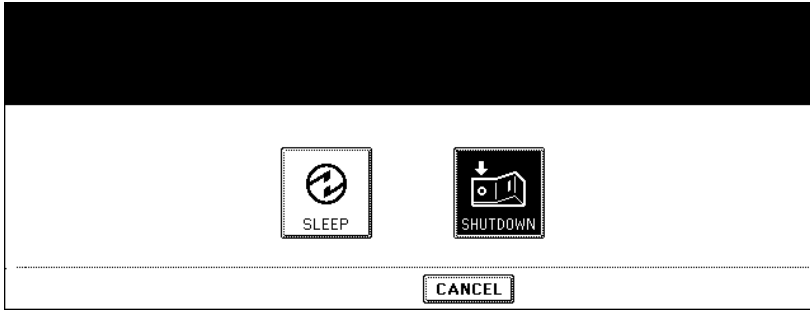

- To cancel the shutdown operation, press the [CANCEL] button.

3 “Shutdown in progress” appears on the menu. After a while, the equipment is shut down and the power is turned OFF.

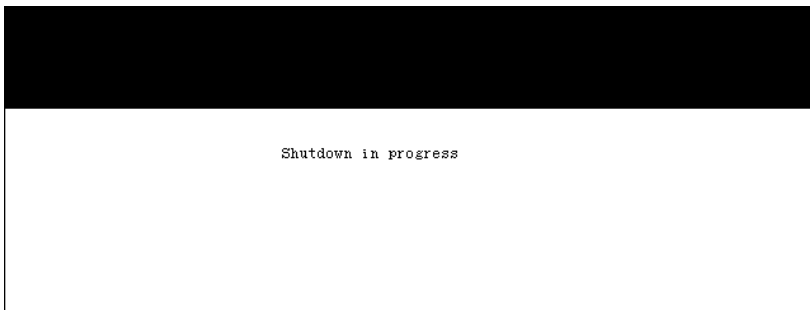

- The power switch automatically returns to the OFF position.

3. Energy Saving Mode

1

This equipment supports two energy saving modes; the Automatic Energy Save mode and the Sleep Mode.

Automatic Energy Save

The equipment enters the Automatic Energy Save mode automatically after a specified period of time ^{*1} since its last use. During this mode, "Saving energy – Press START button" appears on the touch panel.

Sleep Mode

The equipment enters the Sleep Mode automatically after a specified period of time ^{*2} since its last use. During this mode, the message of the Automatic Energy Save mode disappears and the [ENERGY SAVER] button lights in green.

These modes are automatically cleared upon the reception of print data, Fax data, Internet Fax data or E-mails. They are also cleared by pressing the [START] button.

*1 This period is set at 15 minutes by factory default.

*2 This period is set at 60 minutes for the e-STUDIO281c/351c and 90 minutes for the e-STUDIO451c by factory default.

See the User Functions Guide to change the default settings noted above.

The equipment can also be made to enter the sleep mode manually by means of the following procedure.

1 Press the [ENERGY SAVER] button on the control panel.

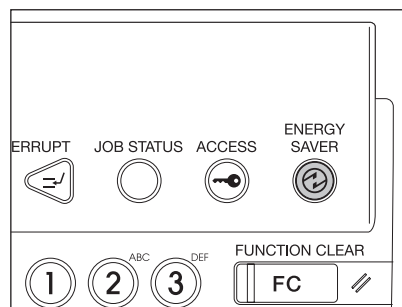

2 Press the [SLEEP] button on the touch panel.

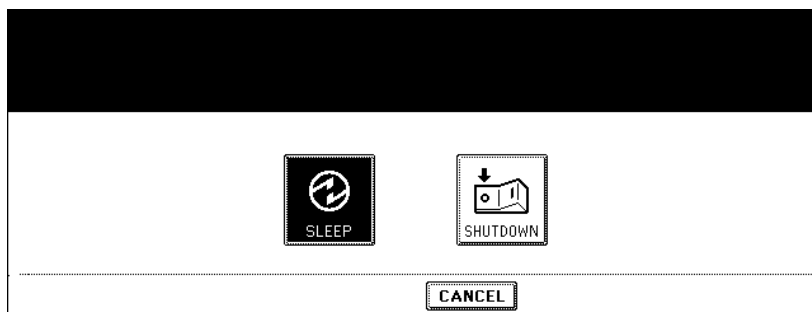

- The equipment enters into the sleep mode. During this mode, the display on the touch panel disappears and the [ENERGY SAVER] button lights in green.

To canceling the energy saving mode

Press the [START] button on the control panel. The sleep mode is cleared and the equipment will be ready for copying.

The sleep mode is also cleared by pressing any button of [ENERGY SAVER], [COPY], [SCAN], [FAX] and [e-FILING].

4. Setting Copy Paper

About the “width” and the “length” of the original and the copy paper

Originals and copy paper whose size is A4/B5 can be set in both portrait and landscape directions. In the size descriptions of original and copy paper throughout this manual, “A” in the figure below is called “length” and “B” is called “width”. (In the figure below, the operator is standing in front of the equipment.)

1

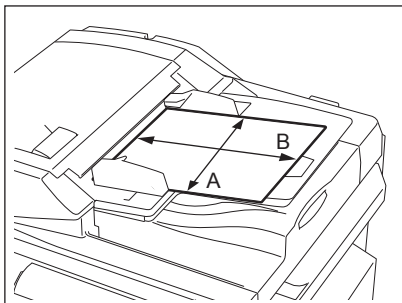

When “B” is shorter than “A”, it is called “placing the original in a portrait direction.”

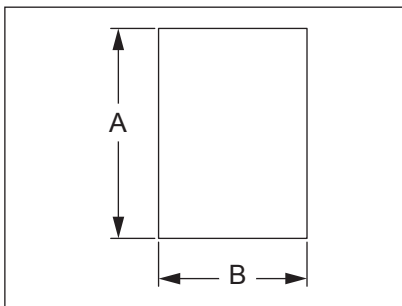

When “B” is longer than “A”, it is called “placing the original in a landscape direction.”

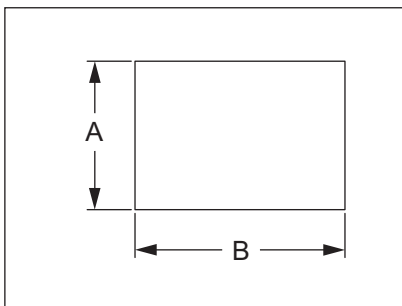

In this manual, when an original or copy paper which can be set in both in portrait and landscape directions is placed horizontally, its paper size is identified by adding “-R” at the end. (e.g. “A4-R”, “B5-R”)

Acceptable copy paper

1

Feeder	Paper type	Paper size	Maximum sheet capacity
Drawers (Including optional drawers)	Plain paper (64 - 80 g/m ²)	(Standard size) A/B format: A3, A4, A4-R, A5-R, B4, B5, B5-R, FOLIO	600 sheets (64 g/m ²) 550 sheets (80 g/m ²)
	Thick 1 (- 105 g/m ²)	LT format: LD, LG, LT, LT-R, ST-R, COMP, 13"LG, 8.5"SQ K format: 8K, 16K, 16K-R	450 sheets
Large Capacity Feeder (optional)	Plain paper (64 - 80 g/m ²)	(Standard size) A4, LT	3000 sheets (64 g/m ²) 2500 sheets (80 g/m ²)
	Thick 1 (- 105 g/m ²)		2000 sheets
Bypass tray	Plain paper (64 - 80 g/m ²)	(Standard size) A/B format: A3, A4, A4-R, A5-R, A6-R, B4, B5, B5-R, FOLIO,	100 sheets (64 g/m ²) 100 sheets (80 g/m ²)
	Thick 1 (- 105 g/m ²)	305 x 457 WIDE LT format: LD, LG, LT, LT-R, ST-R, COMP, 13"LG, 8.5"SQ,	80 sheets (- 105 g/m ²)
	Thick 2 (- 163 g/m ²)	12" x 18" FULL K format: 8K, 16K, 16K-R	40 sheets *1 (- 163 g/m ²)
	Thick 3 (- 209 g/m ²)	(Non-Standard size) Length: 100 - 297 mm, Width: 148 - 432 mm	30 sheets *1 (- 209 g/m ²)
	Sticker labels	(Standard size) A4 only	*1, *2
	OHP film		30 sheets *1

*1 Automatic duplex copying is not available.

*2 Use Thick 3 mode for sticker labels.

- Multiple paper sizes cannot be set in one drawer.
- "Maximum sheet capacity" refers to the maximum number of sheets when Toshiba-recommended paper is set.
- Be sure that the paper height does not exceed the line indicated inside of the guide.
- "LT format" is the standard size for only use in North America.
- "K format" is a Chinese standard size.

Abbreviations for paper sizes:

LT: Letter, LD: Ledger, LG: Legal, ST: Statement, COMP: Computer, SQ: Square

Recommended paper

To make copies with a fine colour image, the following types of paper are recommended. If you wish to use copy paper other than the recommended types, consult your service technician.

Paper type	Toshiba recommendations/Manufacturer	Mode	
Plain paper	TGIS Paper/Neusiedler (80 g/m ²)	PLAIN	
Thick	Colour Copy/Neusiedler	(90 g/m ²)	THICK1
		(100 g/m ²)	THICK1
		(120 g/m ²)	THICK2
		(160 g/m ²)	THICK2
		(200 g/m ²)	THICK3
Sticker labels	3478/Zweckform-Avery	THICK3	
OHP film *1	BG78/FOLEX	OHP FILM	

*1 Only Toshiba-recommended OHP film should be used. Using any other film may cause a malfunction.

Handling and storing paper

Pay attention to the following points:

- Avoid using paper that is specially treated or previously printed on another machine, and also avoid performing double copying on the same side of the paper, since this may cause a malfunction.
- Do not use paper with creases, wrinkles or curls, paper prone to curling, smooth or rough paper; this may cause paper misfeeds.
- Paper should be wrapped in its wrapping and stored in a damp-free place.
- To prevent paper from being folded or bent, store it evenly on a flat surface.

Setting copy paper (size change)

When you set or add copy paper in the drawer, follow the procedure below.

1

Placing paper in the drawer

- 1 Turn the power on.
- 2 Pull out the drawer carefully until it comes to a stop.
- 3 Push the lower part of the end guide in the direction of the arrow to remove it, then reinstall it at the desired paper size (indicated on the bottom inner surface on the drawer).
- 4 Push the arrow part (right side) of the side guide to unlock it.

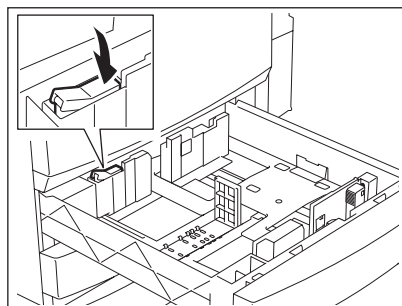
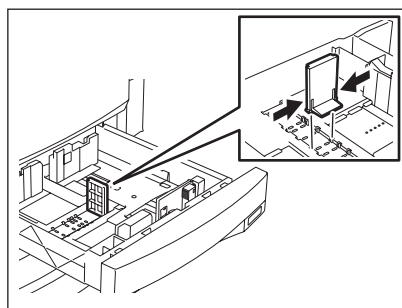
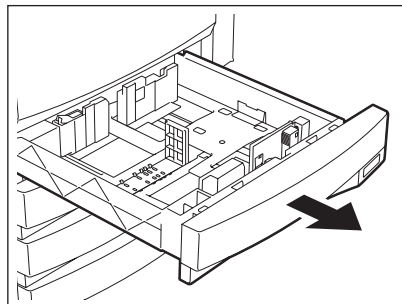

5 While pushing the green lever of the side guide in the direction of the arrow, set the side guide to the desired paper size.

- Adjust the side guides with both hands.

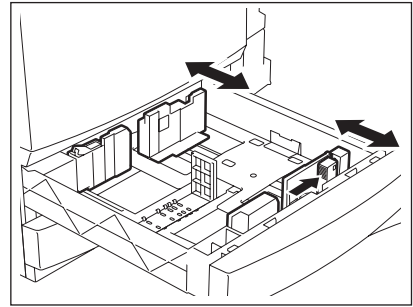

1

6 Push the arrow part (left side) to lock the side guide.

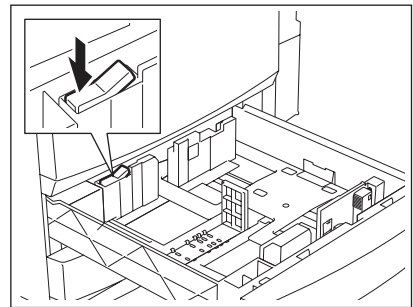

7 Place paper in the drawer(s).

- Place paper with its copy side up. (The copy side may be described on the wrapping paper.)
- For the maximum number of sheets that can be set, see P.44 "Acceptable copy paper".
- Fan the paper well before placing it in the drawer.
- Be sure that the paper height does not exceed the line indicated inside of the guide.
- Do not use creased, folded, wrinkled or damp sheets of paper.

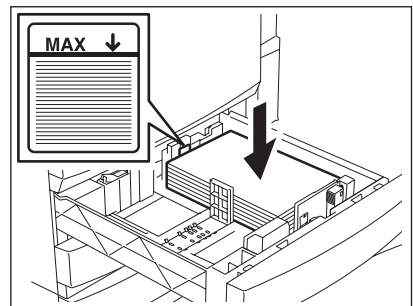

Note

Make sure that a gap of 0.5 mm (1.0 mm or less in total) is left between the paper and the side guide for plain paper, and approx. 0.5 mm to 1.0 mm (approx. 1.0 mm to 2.0 mm in total) for thick paper. If the gap is insufficient, it could cause paper misfeeding.

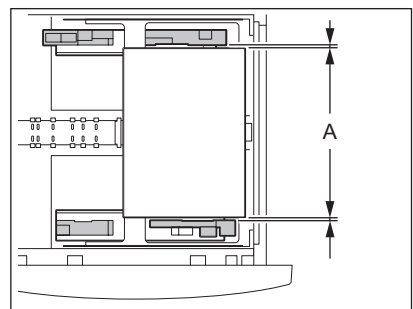

1

8 Push the drawer straight into the equipment until it comes to a stop.

- Be sure to close the drawer securely and carefully.

Caution

Be careful not to let your fingers be caught when closing the drawer. This could injure you.

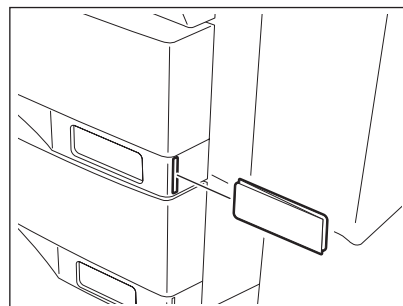
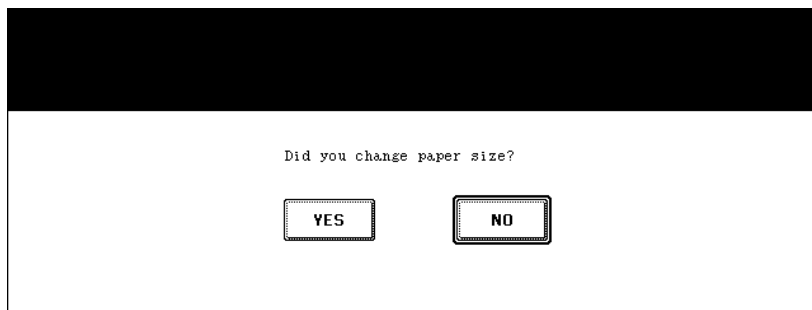
9 When the paper size is different from the one in the drawer, change the paper size indicator to match with the size of paper which has been set.**10 When the paper size is different from the one in the drawer, press the [YES] button. When the paper is the same size as the one in the drawer, press the [NO] button. (When you press the [NO] button, you do not need to continue with step 11 and subsequent steps.)****Tip**

This menu may not be displayed under a certain equipment setup. In this case, see the procedure in [P.50](#) "Changing the setting of paper size" to change the paper size setting when a paper size different from the one which had been placed in the drawer is set.

- Contact the administrator in your office when the display setting of this menu needs to be changed.

- 11** Press the paper size button corresponding to the paper that has been set in the drawer.

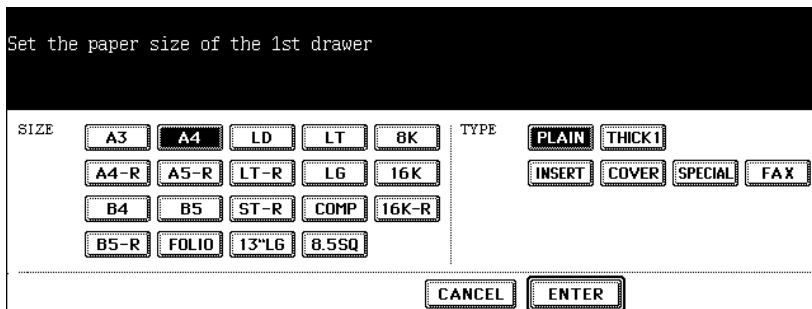

- 12** When you want to change the setting of the drawer for special uses (📖 P.52), press the paper type button.

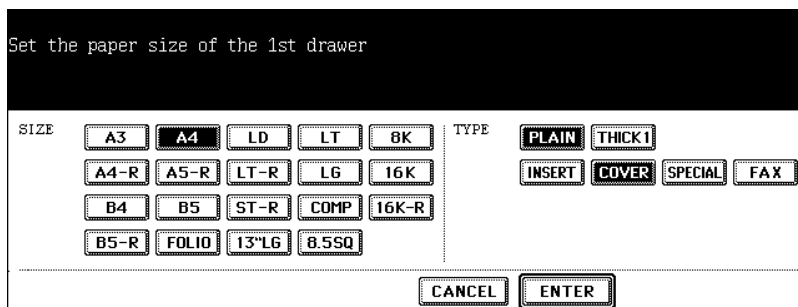

- 13** Press the [ENTER] button.

1

Changing the setting of paper size

If the setting of the paper size registered in the equipment does not correspond to the one in the drawer, it could cause a paper jam. In this case, change the setting of the paper size according to the following procedure.

- 1 Press the [USER FUNCTIONS] button on the control panel.

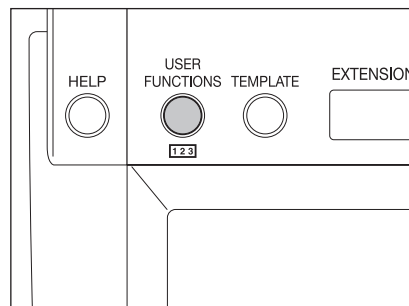

- 2 Press the [USER] button on the touch panel to enter the user setting menu and then press the [DRAWER] button.

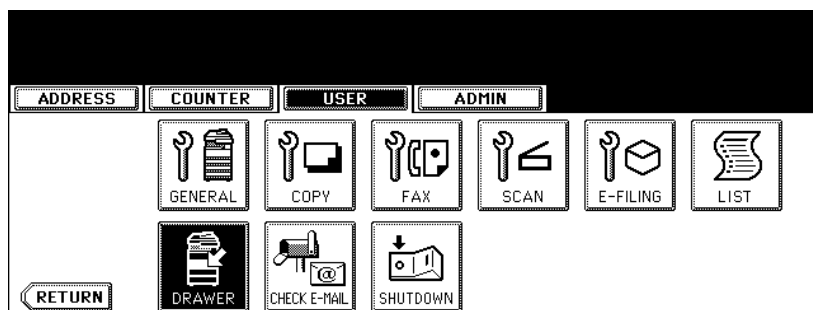

- 3 Press the drawer on the touch panel corresponding to the one in which the paper size has been set, and then press the button indicating the new one.

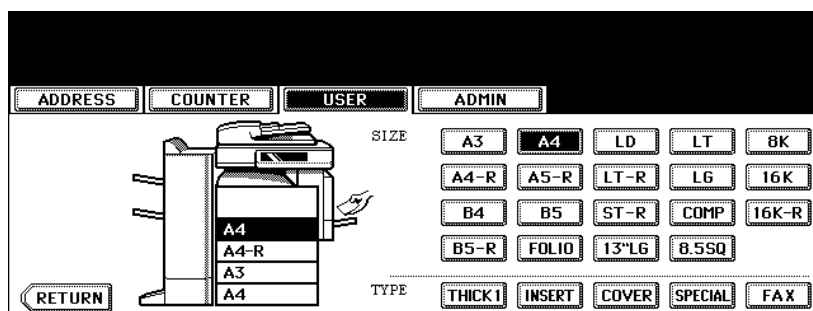

Placing paper in the Large Capacity Feeder (optional)

1 Pull out the Large Capacity Feeder carefully.

- Pull out the drawer until it comes to a stop.

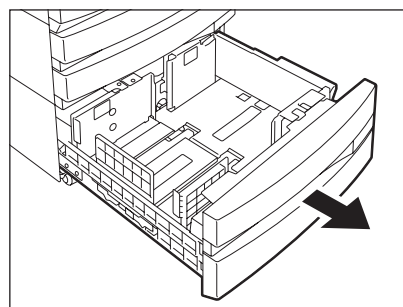

1

2 Place paper in A and B.

- Place paper with its copy side up. (The copy side may be described on the wrapping paper.)
- For the maximum number of sheets that can be set, see  P.44 "Acceptable copy paper".
- Be sure that the paper height does not exceed the line indicated on the side guide.
- Fan and jog the paper well before placing it on the drawer. Set the paper for A to the right side, and set that for B to the left side. (The paper can be set neatly if you pile it up gradually and alternately in A and B.) Be sure that the centre lever is not open (see the labels attached in the Large Capacity Feeder).
- Paper starts being fed out of the elevator tray (A) at first. When the paper on A has run out, the paper on B moves to the position of A and starts being fed.
- Do not use wrinkled, folded or damp sheets of paper.

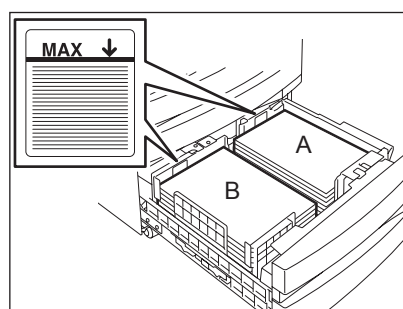

3 Push the drawer of the Large Capacity Feeder straight into the equipment until it comes to a stop.

- Close the drawer completely. The elevator tray automatically moves up to the paper feeding position.

Caution





Be careful not to let your fingers be caught when closing the drawer. This could injure you.

Drawer for special uses

1

When you set paper for special uses other than normal copying (e.g. sheets for cover copying) in the drawer, you need to set this drawer for the special use in advance. If the drawer has been set for a special use, its indication will change on the touch panel. A drawer with this setting will not be used for normal copying.

The following paper types are selectable according to each purpose.

Paper type	Purpose	Indication	Reference
Cover sheet	Sheet used in the cover copying mode	"COVER"	 P.157 "9.COVER SHEET"
Insertion sheet	Sheet used in the sheet insertion mode (Up to 2 drawers can be set for this mode. First, set Insert source 1, then press the drawer for the paper type of Insert source 2, and then press the [INSERT] button.)	"INSERT 1" (or "INSERT 2")	 P.160 "10.SHEET INSERTION"
FAX paper	Fax paper (Fax Unit (optional) is required for the Fax function.)	F	(See the manual of each option.)
Special paper	Special types of paper (e.g. Paper with a watermark)	*	-
Thick 1	Sheet used when its weight is between 81 g/m ² and 105 g/m ² . It can be set with other paper types.	 ₁	 P.44 "Acceptable copy paper"

Setting the drawer for special uses

1 Place paper in the drawer(s).

- Place paper with its copy side up.
- Set the paper size as required. ( P.50 "Changing the setting of paper size")

2 Press the [USER FUNCTIONS] button on the control panel.

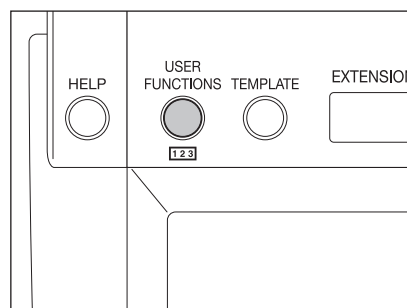

- 3** Press the [USER] button on the touch panel to enter the user setting menu, then press the [DRAWER] button.

1

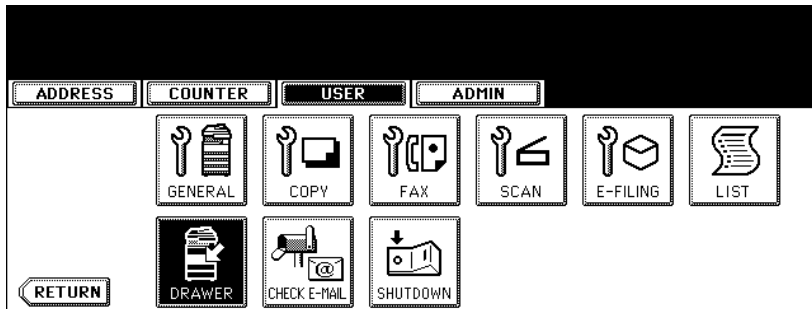

- 4** Press the desired drawer and paper type button on the touch panel.
E. g.: When “Cover sheet” is set in the 1st drawer.

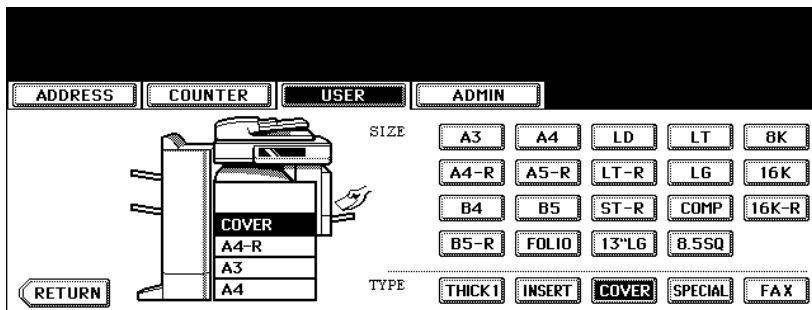

Press the [RETURN] button twice or the [COPY] button on the control panel to return to the basic menu.

1

Clearing the drawer for special uses

- 1 Follow steps 1 to 3 of “Setting the drawer for special uses” (📖 P.52).
- 2 Press the drawer on the touch panel corresponding to the one whose setting you want to clear, and then press the button indicating the paper type in this drawer.

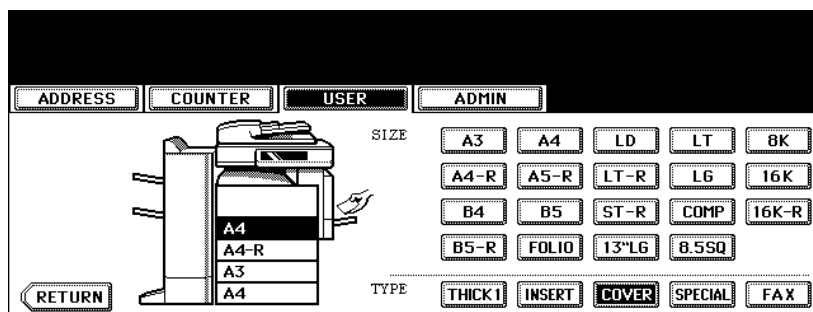

- The paper type setting is cleared and the indication of drawer returns to the original state.

Tip

When both Insertion sheet 1 and 2 have been set and only the setting of Insertion sheet 1 is cleared, the drawer for Insertion sheet 2 changes to the one for Insertion sheet 1.

2. HOW TO MAKE COPIES

1. Setting Originals.....	56
• Acceptable originals.....	56
• Placing originals on the glass.....	58
• Using the Reversing Automatic Document Feeder (optional).....	60
2. Making Copies.....	63
• Initial (Default) settings.....	63
• Copying procedure.....	64
• Scanning the next originals during copying (Auto job start).....	68
• Interrupt copying in progress and make other copies (Interrupt copying).....	70
3. Bypass Copying.....	71
• Bypass copying.....	71
• Bypass copying on standard size paper.....	72
• Bypass copying on non-standard size paper.....	76
4. Proof Copy.....	80

1. Setting Originals

Acceptable originals

Acceptable originals are as follows.

Setting position	Type of original	Maximum size	Acceptable sizes for automatic size detection
Original glass *1	Sheets 3-dimensional object Books	Length: 297 mm Width: 432 mm	(Standard size) A3, A4, A4-R, A5-R, B4, B5, B5-R
Reversing Automatic Document Feeder (optional) *2 *3	Plain paper Recycled paper 1-sided originals: 35 - 157 g/m ² 2-sided originals: 50 - 157 g/m ²	Length: 297 mm Width: 432 mm	(Standard size) A3, A4, A4-R, A5-R, B4, B5, B5-R, FOLIO (210 mm x 330 mm)

*1 Do not place any heavy objects (4 kg or over) on the glass.

*2 Some originals cannot be used depending on their paper quality.

*3 Be sure to place A5-size originals in the landscape direction.

Automatic size detection does not work properly when LT or K format paper is used for printing. (LT format is a standard paper size for North America. K format is a standard paper size for China.)

Tips

- Originals up to 100 sheets (35 to 80 g/m²) or 16 mm in height can be placed on the Reversing Automatic Document Feeder (optional), regardless of their sizes.
- When you copy a large number of landscape originals using the Reversing Automatic Document Feeder (optional), use the original stopper to prevent them from being scattered.

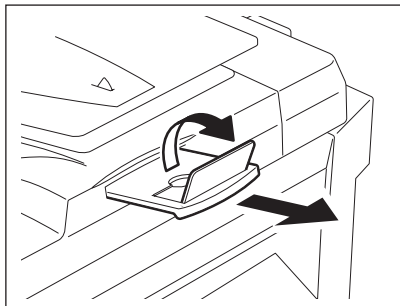

Maximum number of sheets for scanning

A maximum of 1000 A4 sheets, or up until the memory becomes full can be accepted per 1 copy job. When the number of scanned sheets has exceeded the above limit, a message "The number of originals exceeds the limits. Will you copy stored originals?" appears. If you want to print out the data of originals stored (scanned) up till then, press the [YES] button on the touch panel. If you want to delete the stored data, press the [NO] button.

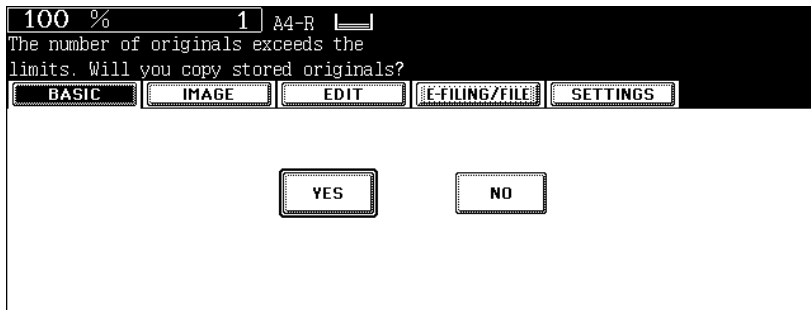

Placing originals on the glass

Sheet originals

Caution

2

Do not place heavy objects (4 kg or more) on the original glass and do not press on it with force. Breaking the glass could injure you.

1 Raise the original cover or Reversing Automatic Document Feeder (optional).

- Raise it 60 degrees or more for detecting the original.

2 Place the original with its face down on the original glass and align it against the left rear corner of the glass.

A: Original

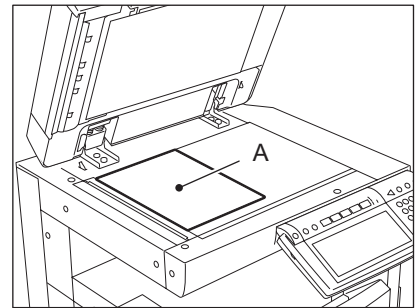

3 Lower the original cover or Reversing Automatic Document Feeder (optional) carefully.

- When you want to copy originals with high transparency such as OHP films or tracing paper, place a blank sheet of paper, the same size as the original or larger, over the original.

A: Original

B: Blank sheet

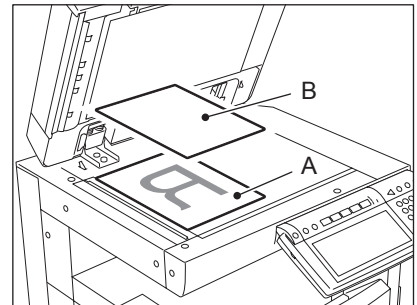

Book-type originals



Caution

Do not place heavy objects (4 kg or more) on the original glass and do not press on it with force. Breaking the glass could injure you.

2

1 Raise the original cover or Reversing Automatic Document Feeder (optional).

2 Open the desired page of the original and place it face down. Align it against the left rear corner of the glass.

- When you want to use the 2-sided copying function or the dual-page function on the book-type originals, align the centre of the original on the yellow indicator line of the glass.
( P.115 "Book-type original -> 2-sided copy")
( P.143 "4.DUAL PAGE")

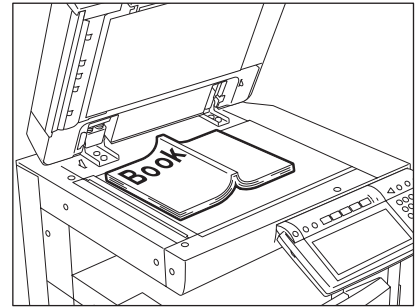

3 Lower the original cover or Reversing Automatic Document Feeder (optional) carefully.

- Do not lower the Reversing Automatic Document Feeder forcibly when the original is very thick. There will be no problem in copying even if the Reversing Automatic Document Feeder is not fully lowered.
- Do not look fully at the original glass because intensive light may leak out during copying.

Using the Reversing Automatic Document Feeder (optional)

Precautions

Do not use the types of original 1 to 8 shown below because such types may cause misfeeding or damage to the equipment.

1. Badly wrinkled, folded or curled originals
2. Original with carbon paper
3. Taped, pasted or cut-out originals
4. Clipped or stapled originals
5. Originals with holes or tears
6. Damp originals
7. OHP films or tracing paper
8. Coating paper (coated with wax, etc.)

Use types of original 9 and 10 shown below with extra care.

9. Originals which cannot be moved with the fingers, or surface-treated originals
(The sheets of such originals may not be able to be separated.)
10. Folded or curled originals should be smoothed out before being used.

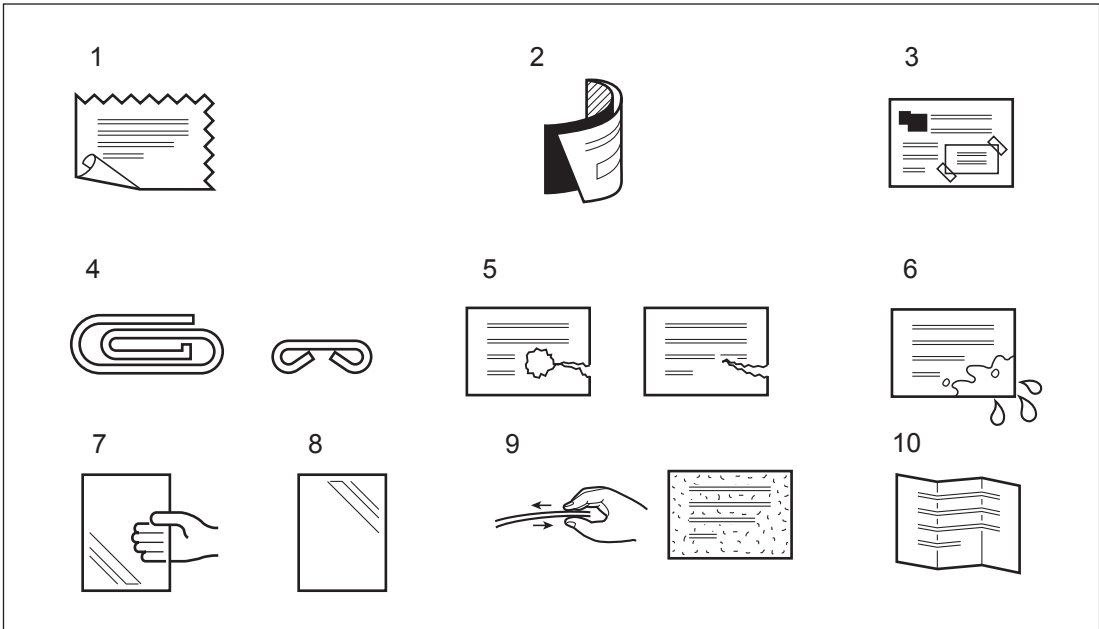

Tip

If the scanning area or the guide area is dirty, image trouble such as black streaks may occur in the print-out. Weekly cleaning of these areas is recommended. (P.342 "1.Daily Inspection")

Continuous feed mode

1 Align all the originals. Then place them face up and align the side guides to the original length.

- Place the originals straight along the side guides.
- Collate the originals in the order that you want them to be copied. The top sheet of the originals will be fed first.
- This mode is also available for one-sheet originals.
- Regardless of their sizes, originals are acceptable up to 100 sheets (35 to 80 g/m²) or 16 mm in height.
- For mixed-size originals, see  P.87 "Copying mixed-size originals in one go (mixed original size)".

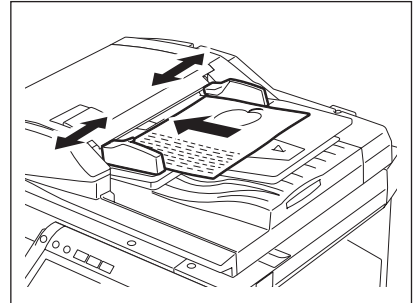

- Use the original stopper as required.
- To replace the original stopper, lift it slightly and push it in.

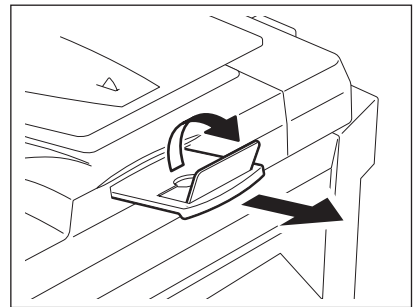

Tip

When the number of originals is too large to be set at one time, you can previously divide the originals into several sets to copy them continuously. To do so, place the first set of the originals and press the [CONTINUE] button on the touch panel while the data of this set are being scanned. When this scanning has finished, set the next set of the originals and press the [START] button on the control panel.

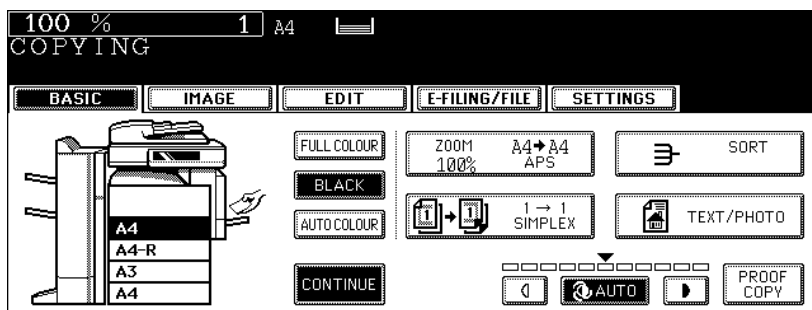

Single feed mode

To switch over between the continuous feed mode and the single feed mode, see  P.174 "16.ADF / SADF".

2

1 Align the side guides to the original width.

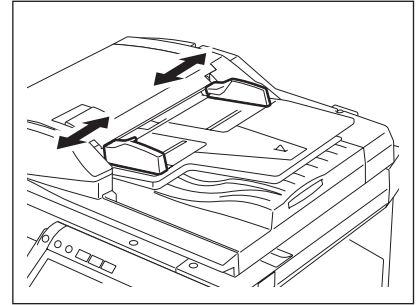

2 Insert the original with its face up and straight along the side guides.

- The original will be pulled in automatically. Be sure to let go of it when it starts being pulled.
- The menu of step 3 will be displayed.

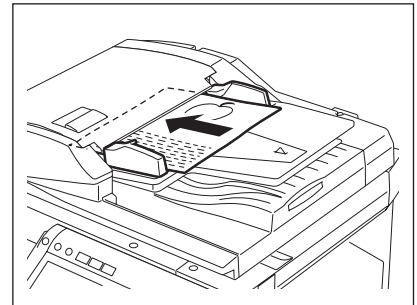

3 If there are more originals, set them in the same way.



- The same operation is performed whether or not you press the [YES] button.

4 After all originals have finished being fed, press the [FINISHED] button.

Tip

If the [FINISHED] button is not pressed, copying is started when the automatic function clear is operated.
 P.32 "Clearing functions selected"

2. Making Copies

Initial (Default) settings

When the power is turned on, when the energy saving mode is cleared, and when the [FUNCTION CLEAR] button on the control panel is pressed, various setting items are automatically set. These items are called the initial (default) settings. Set originals after placing paper or confirming that there is paper in the drawers. When the [START] button on the control panel is pressed with any of the settings unchanged, copies are made in the initial (default) settings. You can make copies as desired by setting various copy modes.

The table below lists the various items of the initial settings at the time of installation of this equipment.

Item	Initial (Default) setting
Reproduction ratio	100%
Copy quantity	1
Paper selection	Automatic Paper Selection (APS)
Original -> Copy	1-Sided -> 1-Sided
Density adjustment	Automatic copy density adjustment
Colour mode	Black
Original mode	TEXT/PHOTO
Finishing mode	Placing originals on the original glass: Non-sort/ Non-staple mode Placing originals on the Reversing Automatic Document Feeder (optional): Sort mode
Feeding mode when originals are placed on the Reversing Automatic Document Feeder (optional)	Continuous feed mode

- These initial settings can be changed as desired. See the User Functions Guide for details.

Copying procedure

Placing originals on the Reversing Automatic Document Feeder (optional)

1 Place paper in the drawer(s).

- For the types and sizes of paper selectable, see P.44 “Acceptable copy paper”.

Tip

When the desired size or type of paper is not in any of the drawers or the Large Capacity Feeder, see the following pages.

- P.46 “Setting copy paper (size change)”
- P.51 “Placing paper in the Large Capacity Feeder (optional)”
- P.71 “3.Bypass Copying”

2 Place the original(s).

- See the following pages to set the originals.
 - P.56 “Acceptable originals”
 - P.60 “Using the Reversing Automatic Document Feeder (optional)”

The originals are copied in the order of being scanned.

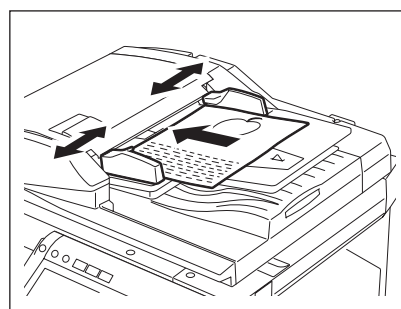

3 Select the copy modes as required. When you want to copy more than one set, key in the desired number of copies.

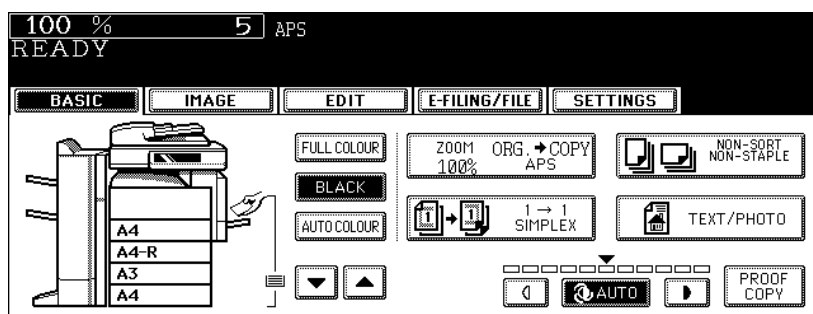

- Press the [CLEAR] button on the control panel to correct the number keyed in.
- Note that some combinations of copy modes are restricted. (P.359 “4.Copying Function Combination Matrix”, P.361 “5.Image Quality Adjustment Combination Matrix”)
- Once the [START] button on the control panel has pressed, any change in copy modes (including setting of the previously divided sets of originals) cannot be applied afterward.

4 Press the [START] button.

- Copying starts. The paper exits with its copied side down.
- When the drawer runs out of paper during copying, the corresponding drawer on the touch panel and the [JOB STATUS] button on the control panel blink. Add paper to this drawer or select another one with the same paper size.
- Be careful because the paper exit area and paper just after exiting are hot.

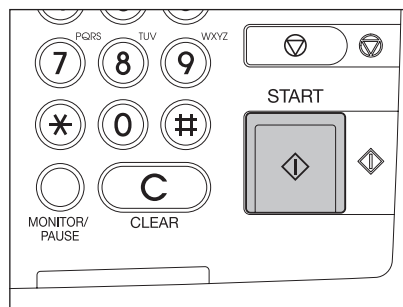

Placing an original on the original glass

1 Place paper in the drawer(s).

- For the types and sizes of paper selectable, see [P.44](#) "Acceptable copy paper".

Tip

When the desired size or type of paper is not in any of the drawers or the Large Capacity Feeder, see the following pages.

- [P.46](#) "Setting copy paper (size change)"
- [P.51](#) "Placing paper in the Large Capacity Feeder (optional)"
- [P.71](#) "3.Bypass Copying"

2 Place the original(s).

- See the following pages to set the originals.
 - [P.56](#) "Acceptable originals"
 - [P.60](#) "Using the Reversing Automatic Document Feeder (optional)"

The originals are copied in the order of being scanned.

3 Select the copy modes as required. When you want to copy more than one set, key in the desired number of copies.

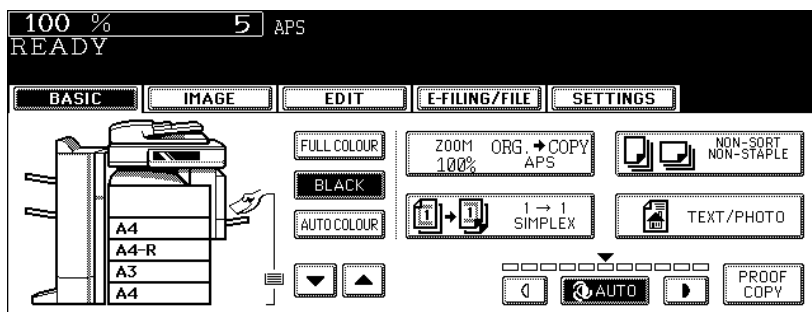

- Press the [CLEAR] button on the control panel to correct the number keyed in.
- Note that some combinations of copy modes are restricted. ([P.359](#) "4.Copying Function Combination Matrix", [P.361](#) "5.Image Quality Adjustment Matrix")
- Once the [START] button on the control panel has pressed, any change in copy modes (including setting of the previously divided sets of originals) cannot be applied afterward.

4 Press the [START] button.

- Copying starts.

Tip

When you copy by placing originals on the original glass (e.g. using the sort mode, or making 1-sided original 2-sided copies), the data of these originals are scanned into the memory. In this case, proceed to steps 5 and 6.

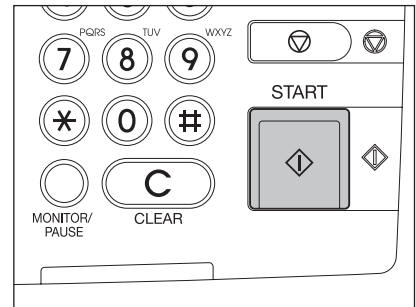

5 Place the next original, and press the [START] button.

- Data scanning of this original starts.
- The next original will also be scanned in the same manner when you press the [YES] button on the touch panel, and then press the [START] button on the control panel.
- Repeat the above procedure until the scanning of the last page of the original finishes.

6 When scanning of all pages has finished, press the [FINISHED] button on the touch panel.



- Copying starts. The paper exits with its copied side down.
- When the drawer runs out of paper during copying, the corresponding drawer on the touch panel and the [JOB STATUS] button on the control panel blink. Add paper to this drawer or select another one with the same paper size.
- Be careful because the paper exit area and paper just after exiting are hot.

Stopping the copying operation

Press the [STOP] button on the control panel to stop scanning or continuous copying.

- 1 Press the [STOP] button on the control panel during scanning (or continuous copying).



2

- 2 When the following menu is displayed, press the [MEMORY CLEAR] button on the touch panel.

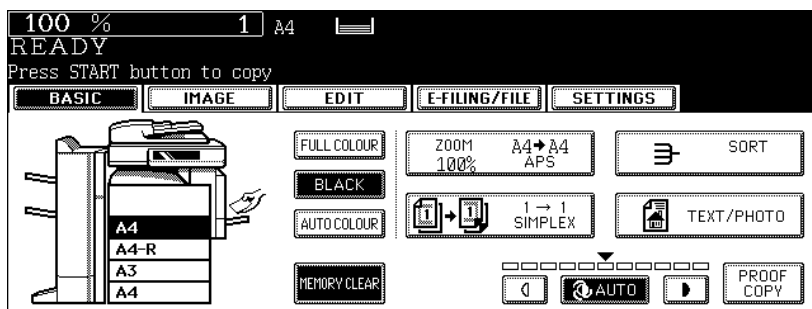

- During scanning: The data scanned up to then are deleted.
- During continuous copying: Copying stops and the data scanned up to then are deleted.

Tip

If there is any copy job waiting, this job will start.

Scanning the next originals during copying (Auto job start)

You can reserve a copy job by scanning the original during continuous copying or while “READY (WARMING UP)” appears.

2

- 1 Place the original(s).
- 2 Select the copy mode and set the number of copies.

Tip

Note that the job starts in the copy modes of the previous job unless you set new ones particularly for this job.

- 3 Press the [START] button on the control panel.

- Up to 10 jobs can be stored in the memory. When an 11th job is placed on the original glass or the Reversing Automatic Document Feeder (optional) and the [START] button is pressed, “Auto Start” appears on the touch panel.
- A maximum of 1000 A4 sheets, or up until the memory becomes full can be accepted per 1 copy job. (☞ P.57 “Maximum number of sheets for scanning”)

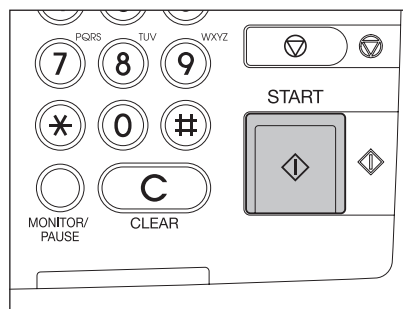

Confirming and canceling auto job

Confirming auto job and canceling job in waiting

Press the [JOB STATUS] button on the control panel to display the job list for confirming the set auto job and canceling a job waiting to be copied. To cancel auto jobs, see [P.238](#) “Deleting print jobs”.

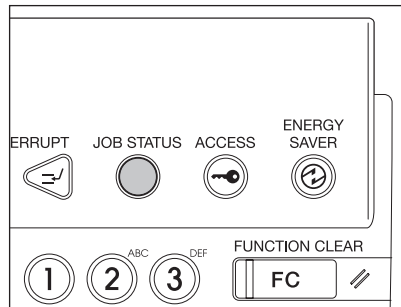

Canceling auto job

Press the [STOP] button on the control panel to stop a job while originals are being scanned. To restart the job, press the [START] button. To clear the job, press the [FUNCTION CLEAR] button. (However, the originals which have been scanned before the job is stopped are copied even though the [FUNCTION CLEAR] button is pressed.)

To cancel the 11th auto job, press the [STOP] button.



Interrupt copying in progress and make other copies (Interrupt copying)

While continuous copying is in progress, you can interrupt this job with another copy job.

The following features cannot be used together with interrupt copying:

- Cover sheet copying
- Sheet insertion copying
- Scan to e-Filing / Save as file
- Job build

2

1 Press the [INTERRUPT] button on the control panel.

- The [INTERRUPT] button blinks first, then lights after “Job interrupted job 1 saved” appears.

Tip

When the [INTERRUPT] button is pressed while originals are being scanned, the [INTERRUPT] button blinks first. Then the button lights after “Job interrupted job 1 saved” appears when the scanning is finished.

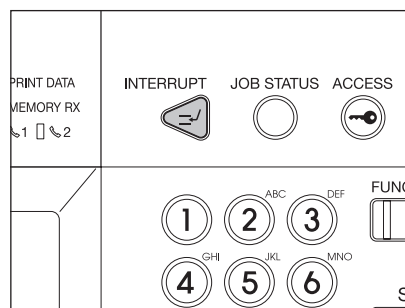

2 Replace the original with a new one.

- Set other copy modes as required.

3 Press the [START] button on the control panel.

4 After you have finished the interrupt copying, press the [INTERRUPT] button again.

- The message “READY to resume job 1” appears and the interrupted job resumes.

Tip

Interrupt copying is automatically canceled after a certain period by automatic function clearing without the need to press the [INTERRUPT] button again. The interrupted job (= Job 1) resumes after this automatic function clearing.

3. Bypass Copying

Bypass copying

When you want to make copies on OHP film, sticker labels, or non-standard size paper, place the sheets of paper on the bypass tray. Bypass copying is also recommended for copying on standard size paper which is not in any of the drawers.



Tip

If you select the paper size, you can utilize various functions such as the automatic paper selection (APS) or the automatic magnification selection (AMS). For the details, see  P.359 “4.Copying Function Combination Matrix”.

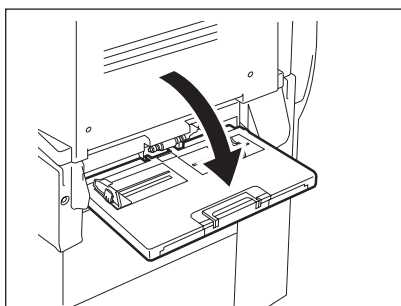
To carry out bypass copying, open the bypass tray.



The operating procedure of bypass copying differs depending on the paper size used. See the corresponding page for the operating procedure of each size. The table below shows these pages.

Paper size		Procedure
Standard size	A3, A4, B4, B5	 P.72
	Other than the above	 P.74
Others (Non-standard size)		 P.76

Tips

- Bypass copying stops when the paper placed on the bypass tray runs out during copying, even if the same size paper is in any of the drawers. Copying is resumed when paper is supplied to the bypass tray.
- When bypass copying has completed, the [FUNCTION CLEAR] button on the control panel blinks. Press this button to switch it to default copying using the drawers. (Bypass copying is automatically canceled after a certain period by automatic function clearing without the need to press the [FUNCTION CLEAR] button. The bypass copying returns to default copying using the drawers after this automatic function clearing.)

Bypass copying on standard size paper

Copying on A3, A4, B4 and B5 size paper

2

1 Place some sheets of paper with their copy side down on the bypass tray. Align the side guides to the paper length while holding A.

- The message "Ready for bypass feeding" appears.
- Rear side of the side guides of the bypass tray has an indicator for paper height. The height of the sheets must not exceed this indicator.
- When you use more than one sheet, fan the sheets well before setting them on the tray.
- Do not push the sheets into the entrance of the bypass feeder; this may cause a paper jam.

Tip

When the paper size is larger, draw out the three-stage paper holder. Raise B when you use A3 or a larger size of paper.

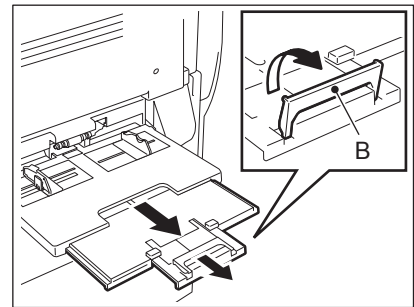
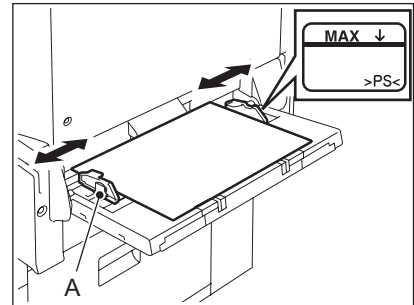

2 Place the original(s).

3 Press the button of the same size as the one of the paper you have set on the tray.

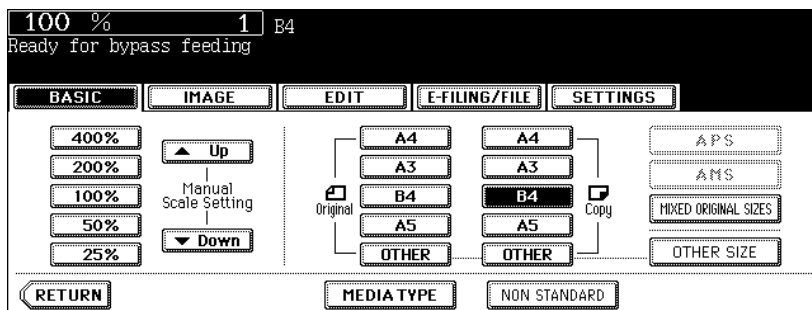

- If the paper size is not specified here, some operations may slow down the copying.

- 4 Press the [MEDIA TYPE] button on the touch panel if the media type of the paper you have set on the tray is other than plain paper.

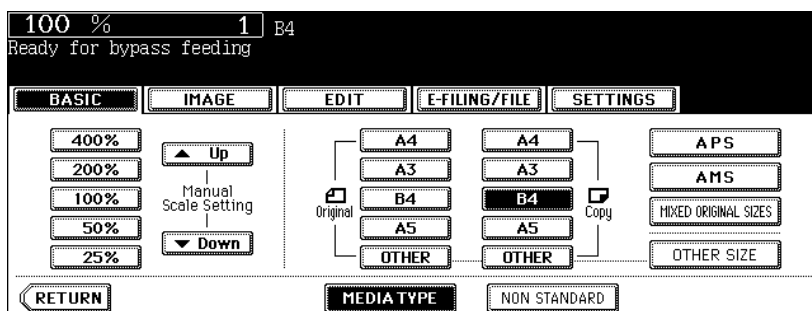

- 5 Press the button of the same media type as the one of the paper you have set on the tray, and then press the [ENTER] button on the touch panel.

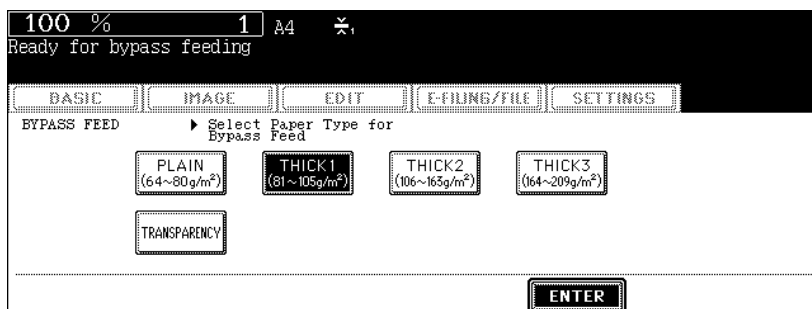

- Set other copy modes as required.
- If a media type which is not same as the one you have set is selected here, this may cause a paper jam or significant image trouble.

- 6 Press the [START] button on the control panel.

Tip

When you copy on OHP films, remove the copied OHP films, which have exited on to the receiving tray one by one. When the films pile up, they may become curled and may not be projected properly.

Copying on standard size paper other than A3, A4, B4 and B5

- 1 Place paper and original(s) by following step 1 and 2 in “Copying on A3, A4, B4 and B5 size paper” (P.72).
- 2 Press the [OTHER SIZE] button on the touch panel.

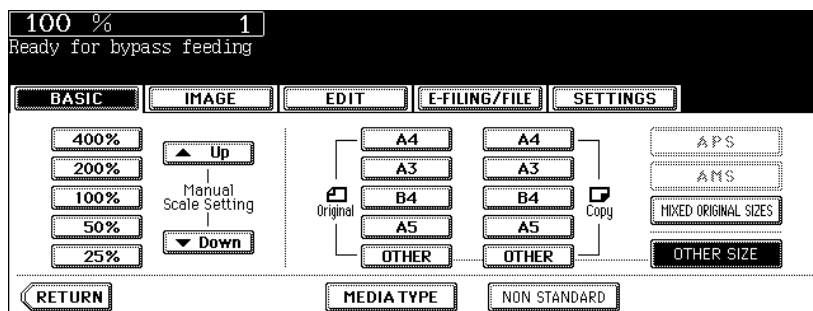

- 3 Press the button of the same size as the one of the paper you have set on the tray.

E.g.: When COMP-size paper is set

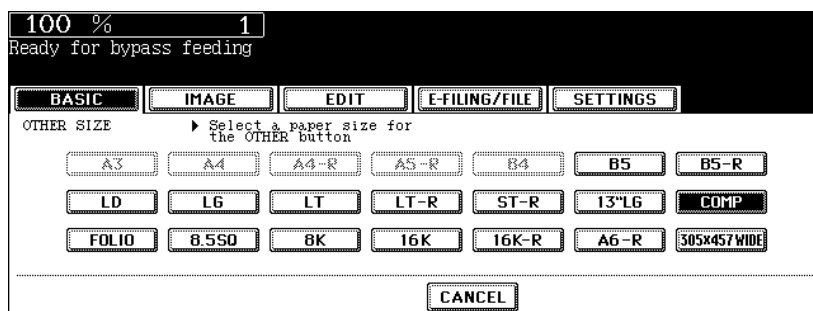

- 4 Press the [OTHER] button for the media type.

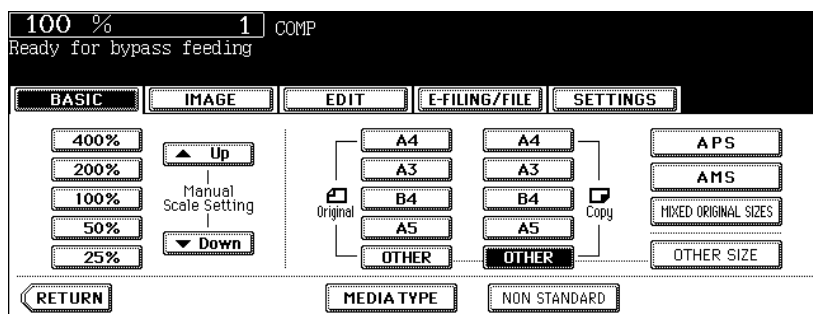

- If the paper size is not specified here, some operations may slow down the copying.

- 5** Press the [MEDIA TYPE] button on the touch panel if the media type of the paper you have set on the tray is other than plain paper.

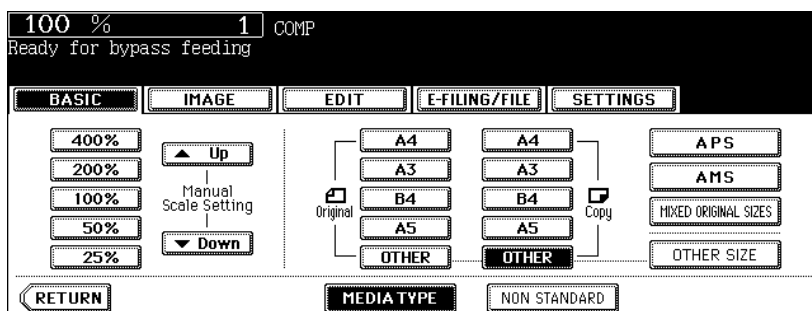

- 6** Press the button of the same media type as the one of the paper you have set on the tray, and then press the [ENTER] button on the touch panel.

E.g.: When Thick 1 paper is set

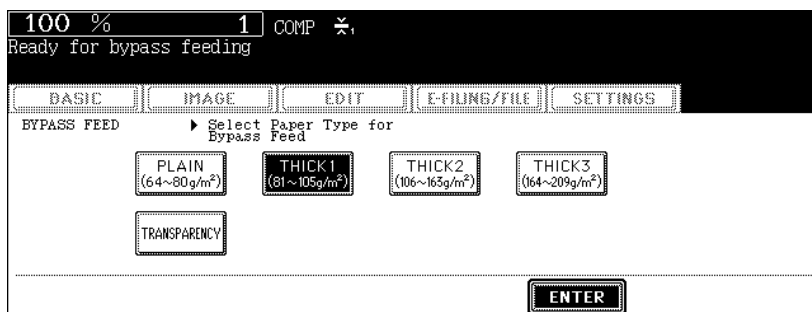

- Set other copy modes as required.
- If a media type which is not same as the one you have set is selected here, this may cause a paper jam or significant image trouble.

- 7** Press the [START] button on the control panel.

Tip

When you copy on OHP films, remove the copied OHP films, which have exited on to the receiving tray one by one. When the films pile up, they may become curled and may not be projected properly.

Bypass copying on non-standard size paper

Non-standard size paper should be within the following ranges:
A (Length): 100 to 297 mm, B (Width): 148 to 432 mm

2

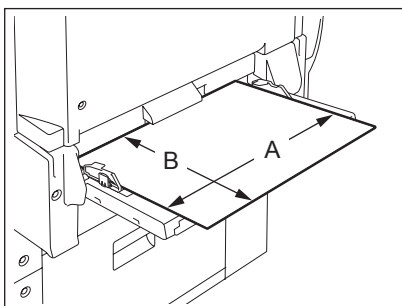

1 Place some sheets of paper with their copy side down on the bypass tray. Align the side guides to the paper length while holding A.

- The message "Ready for bypass feeding" appears.
- Rear side of the side guides of the bypass tray has an indicator for paper height. The height of the sheets must not exceed this indicator.
- When you use more than one sheet, fan the sheets well before setting them on the tray.
- Do not push the sheets into the entrance of the bypass feeder; it may cause a paper jam.

Tip

When the paper size is larger, draw out the three-stage paper holder. Raise B when you use A3 or a larger size of paper.

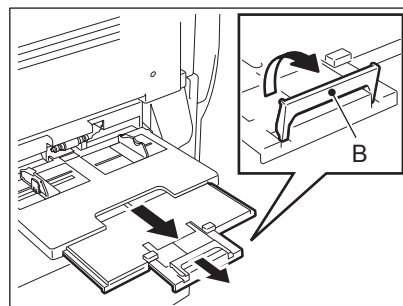
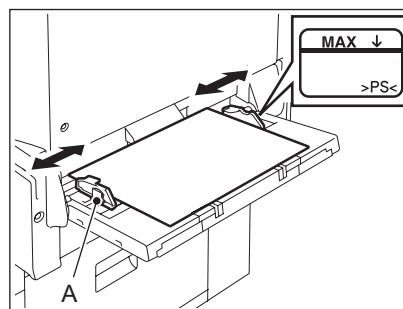

2 Place the original on the original glass.

3 Press the [NON STANDARD] button on the touch panel.

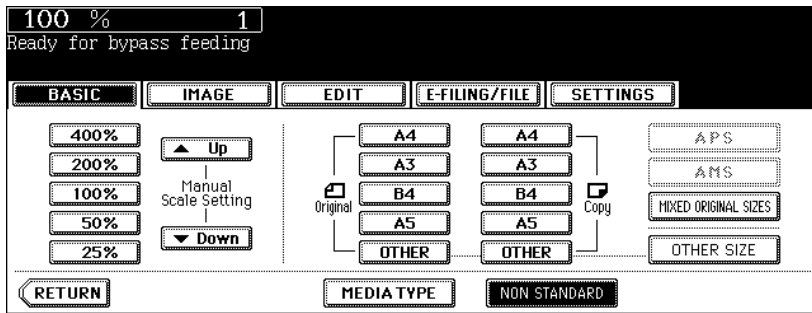

2

4 Set each dimension following the procedure below.

The [Length] and [Width] are indicated as follows:

A: [Length]

B: [Width]

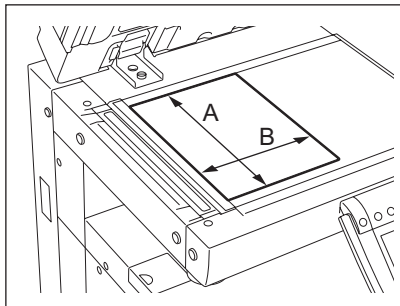

Using the digital keys

Key in the value in [Length] and press the [SET] button on the touch panel. Set the width in the same way and press the [ENTER] button.

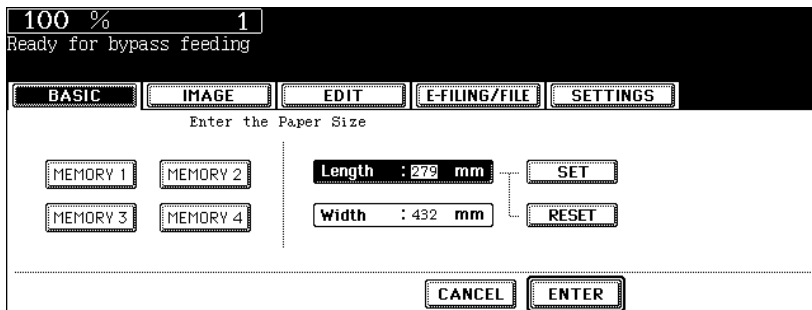

Recalling dimensions registered in the memory

Press the desired memory number button from [MEMORY 1] to [MEMORY 4] to recall the dimension data registered previously, and then press the [ENTER] button.

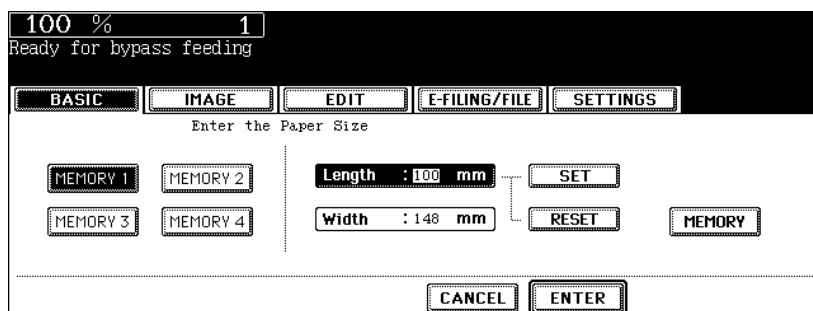

- Paper size that can be set is as follows:
Length: 100 mm to 297 mm
Width: 148 mm to 432 mm
- To register the dimension data in the memory, see P.78 “Registering non-standard size in the memory”.
- Set other copy modes as required.

5 Press the [START] button on the control panel.**Registering non-standard size in the memory**

1 Follow steps 1 to 3 on “Bypass copying on non-standard size paper” (P.76).

2 Press the memory number button (from [MEMORY 1] to [MEMORY 4]) you want to register the dimension.

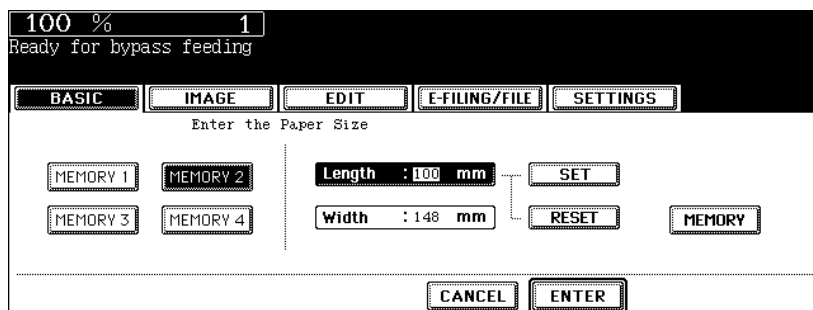

3 Key in each dimension, and press the [MEMORY] button on the touch panel.

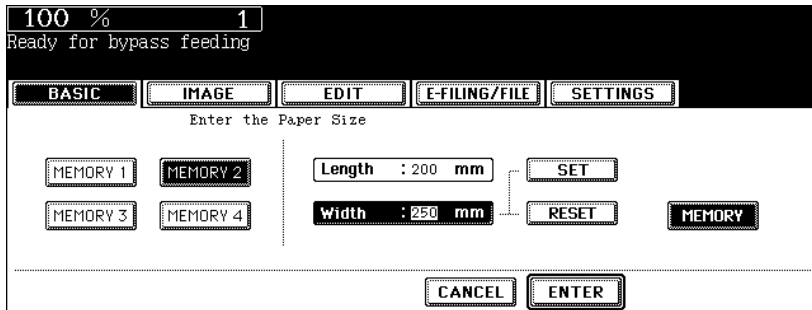

- Key in its length in [Length] and press the [SET] button on the touch panel. Set its width in the same manner.
- Paper size that can be set is as follows:
Length: 100 mm to 297 mm
Width: 148 mm to 432 mm

4. Proof Copy

This function allows you to check that the copy density, zoom and margin width, etc. are properly set by making only one set of copies.

You can prevent miscopying by using this function before committing yourself to mass-copying.

2

Note

- The setting of the number of copy sets, time stamp and stapling (when the optional Finisher has been installed) can be changed after having made the proof copy.
- Press the [MEMORY CLEAR] button to clear the proof copy before changing the setting of the zoom or copy density, etc. When you make copies again after changing the settings, the data of the originals need to be scanned.

1 Place paper in the drawer(s).

2 Place the original(s).

3 Select the copy modes as required.

4 Press the [PROOF COPY] button.

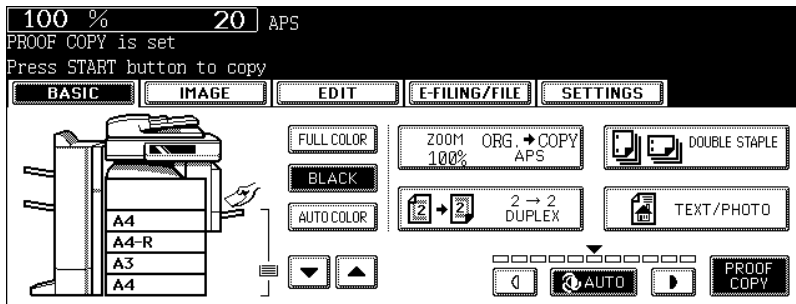

- "PROOF COPY is set Press START button to copy" appears. (for approx. 2 sec.)
- Copy modes except for some such as sort/group can be set.

5 Press the [START] button.

- The data scanning of the originals is started and one set of copies is made.

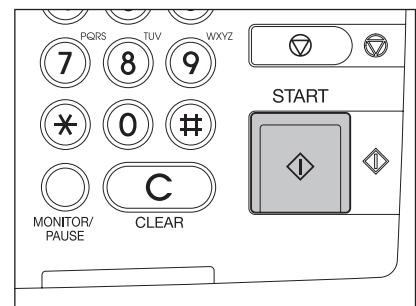

6 Change the settings as required.

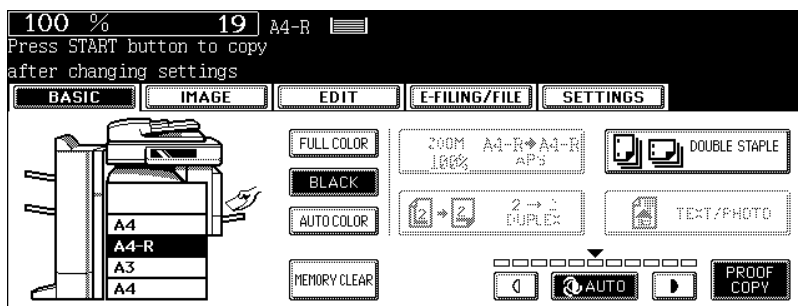

- The setting of the number of copy sets, time stamp, stapling (when the optional Finisher has been installed) and sort can be changed.
- If you want to change the setting of the copy density, original mode, zoom or simplex/duplex, press the [MEMORY CLEAR] button to clear the proof copy. After the change, perform the instructions from step 1 again.

7 Press the [START] button.

- If the number of copy sets is not changed in step 6, one less than the previously specified number is copied. However, if "1" is specified for the number of copy sets, one set of copies is made.



2

3. SETTING OF BASIC COPY MODES

1. Paper Selection.....	84
• Automatic Paper Selection (APS).....	84
• Manual paper selection.....	86
• Copying mixed-size originals in one go (mixed original size).....	87
2. Switching Colour Mode.....	89
3. Enlargement and Reduction Copying.....	90
4. Selecting Finishing Modes.....	96
• Type of finishing mode.....	96
• Name of each part in the Finisher (optional).....	97
• Sort/Group copying.....	98
• Rotate sort mode.....	100
• Staple sort mode.....	101
• Magazine sort & saddle stitch mode (booklet mode).....	103
• Hole punch mode (optional).....	106
5. Duplex Copying.....	110
6. Original Mode.....	119
7. Copy Density Adjustment.....	121

1. Paper Selection

Automatic Paper Selection (APS)

When you place standard size originals on the original glass or the Reversing Automatic Document Feeder (optional), the size of the originals is automatically detected, which helps the equipment select paper that is the same size as the originals.

- The automatic paper selection may not work correctly depending on the type of the originals. In that case, select the paper size manually. (P.86 “Manual paper selection”)
- For original sizes available for automatic paper selection, see P.56 “Acceptable originals”.

3 1 Place paper in the drawer(s).

2 Place the original(s).

3 Confirm that automatic paper selection has been selected on the basic menu.

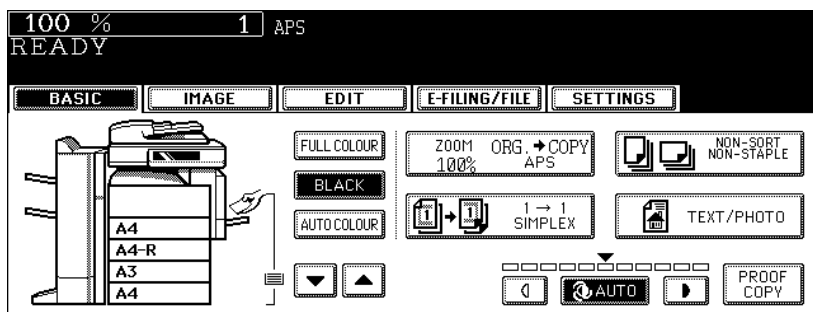

- Automatic paper selection is selected by default at the installation of the equipment.
- If “Change direction of original” or “CHANGE DRAWER TO CORRECT PAPER SIZE” appears, perform the action accordingly.
- Set other copy modes as required.

Tip

Even if the direction of the paper set in the selected drawer differs from that of the original, the equipment rotates the data of the original by 90 degrees to make copies as long as their sizes are the same. (This works on A4 paper only.) For example, when an A4 original is set vertically and A4-R paper is placed in the drawer, the data of A4 original will be rotated and copied correctly on A4-R paper.

When automatic paper selection is not selected

(1) Press the Enlargement/Reduction ([ZOOM...]) button.

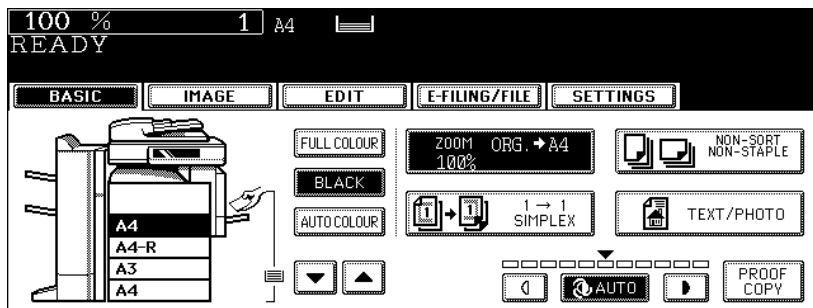

(2) Press the [APS] button.

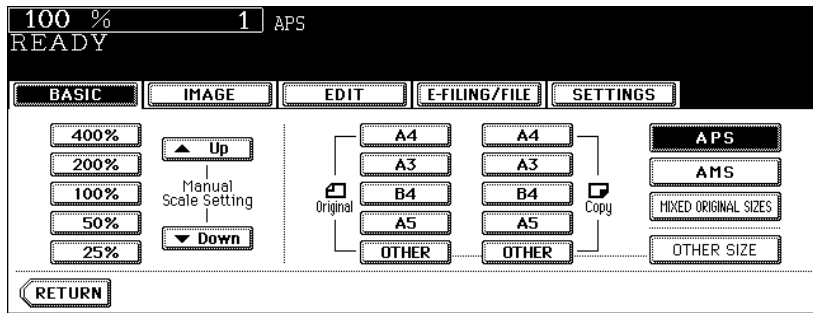

3

4 Press the [START] button.

Manual paper selection

Automatic paper selection cannot be selected for the following originals because their sizes are not detected correctly. Select the paper size manually for these originals.

- Highly transparent originals (e.g. OHP film, tracing paper)
- Wholly dark originals or originals with dark borders
- Non-standard size originals (e.g. newspapers, magazines)

Tip

3

When the desired size of paper is not set in any of the drawers, place this size of paper in the selected drawer or place the paper on the bypass tray manually.

([P.46](#) "Placing paper in the drawer", [P.71](#) "3.Bypass Copying")

1 Place paper in the drawer(s).

- When using the bypass tray, be sure to specify the paper size.

2 Place the original(s).

3 Press the drawer button representing the desired paper size on the touch panel.

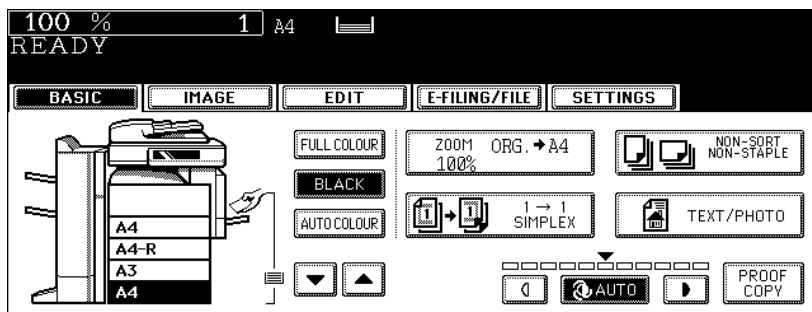

- You can use the paper source selection (▼/▲) buttons to select the desired drawer.
- Set other copy modes as required.

4 Press the [START] button.

Copying mixed-size originals in one go (mixed original size)

You can copy a set of originals whose sizes are individually different, using the Reversing Automatic Document Feeder (optional), by pressing the [MIXED ORIGINAL SIZE] button.

- This mixed original size setting is available only in the following combinations.
A3, A4, A4-R, B4, B5, FOLIO
- Note that the copied image may be dislocated depending on the combination.

1 Place paper in the drawer(s).

- Bypass copying is not available.

2 Adjust the side guides to the widest original, and then align the original against the guide at the front side.

- Place the originals face up.

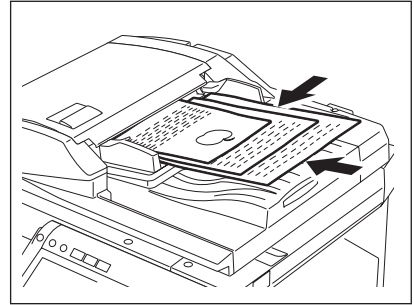

3 Press the Enlargement/Reduction ([ZOOM...]) button to enter the setting menu of the original or paper size.

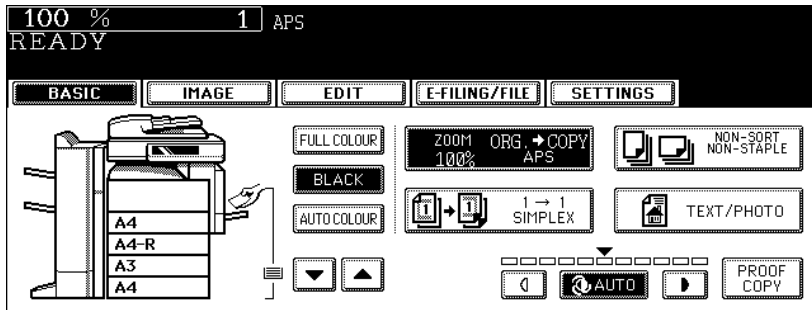

4 Press the [MIXED ORIGINAL SIZES] button.

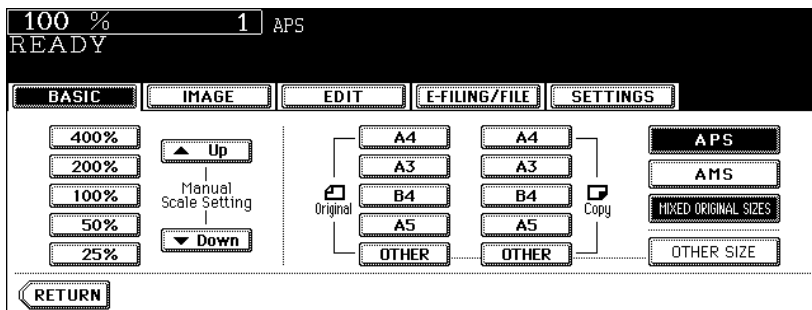

5 Select either automatic paper selection (APS) or automatic magnification selection (AMS).

Automatic paper selection: Copies on the same size of paper as that of originals (📖 P.84).

Automatic magnification selection: Copies all in one size (📖 P.90).

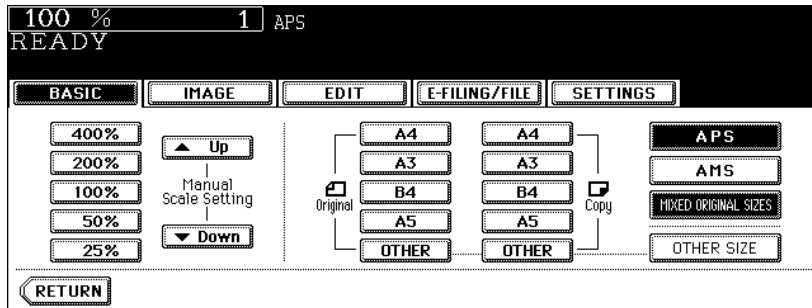

- Before you use automatic paper selection, be sure that all paper sizes corresponding to the original sizes have been set in the drawers.
- In automatic magnification selection, the copies cannot be enlarged from, A4 (portrait)/B5 (portrait) to A3 (landscape)/B4 (landscape).
- If “Change direction of original” appears when [AMS] is used with [MIXED ORIGINAL SIZES], change the direction according to the message.
- Set other copy modes as required.

6 Press the [START] button.

2. Switching Colour Mode

This function allows you to switch colour modes. There are three types of colour modes as follows:

FULL COLOUR: All originals are copied in full colour regardless of the type of each original.

BLACK: All originals are copied in black regardless of the type of each original. (Default setting)

AUTO COLOUR: The equipment automatically judges the type of each original. Coloured originals are copied in full colour and black-and-white originals are copied in black.

1 Press the [FULL COLOUR], [BLACK] or [AUTO COLOUR] button.

3

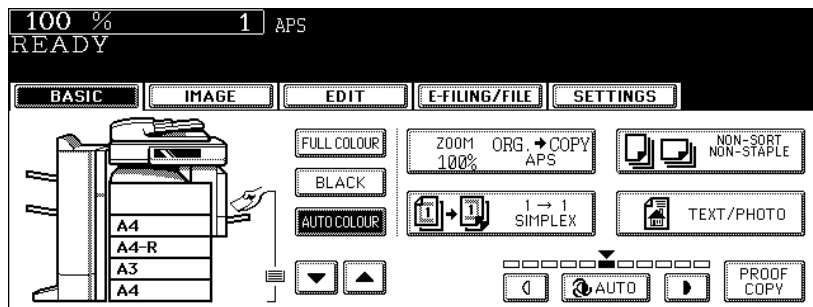

Tip

When you use "AUTO COLOUR", note the following points:

When the coloured area in an original is extremely small, when the colours of the original are close to black, or when the colours of an original are too light, these originals may be automatically copied in black even though they are coloured. Also yellowed originals or originals with a coloured background may be automatically copied in full colour even though they are black-and-white. Select the full colour mode or the black mode depending on the state of the original to reproduce exact colours.

3. Enlargement and Reduction Copying

You can enlarge or reduce the size of copies by means of the following procedures.

- Specifying the copy paper size in advance so that the equipment will detect the original size and automatically select the most appropriate reproduction ratio for the copy paper size (= automatic magnification selection)
- Specifying both original size and copy paper size separately
- Using the zoom buttons or the one-touch zoom buttons

Tip

The enlargement/reduction ratio available differs depending on whether the originals have been set on the original glass or on the Reversing Automatic Document Feeder (optional).

On the original glass: 25 to 400%

On the Reversing Automatic Document Feeder: 25 to 200%

Automatic Magnification Selection (AMS)

- The automatic magnification selection cannot be selected for the following originals. Set their reproduction ratios in other ways.
 - Highly transparent originals (e.g. OHP film, tracing paper)
 - Wholly dark originals or originals with dark borders
 - Non-standard size originals (e.g. newspapers, magazines)
- For the original sizes available for this automatic magnification selection, see P.56 “Acceptable originals”.

1 Place paper in the drawer(s).

2 Press the Enlargement/Reduction ([ZOOM...]) button.

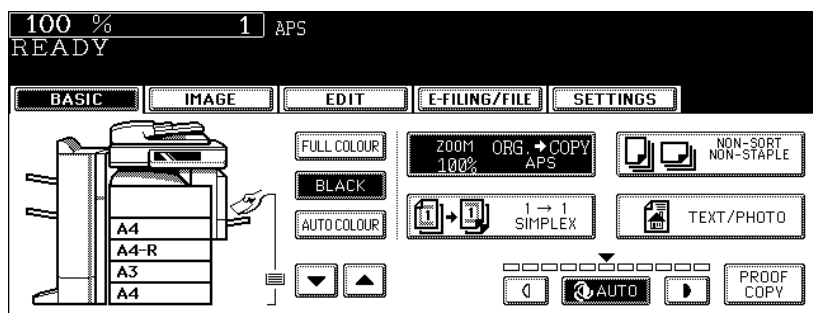

3 Press the button representing the desired copy paper size.

E.g.: When A3-size paper is selected

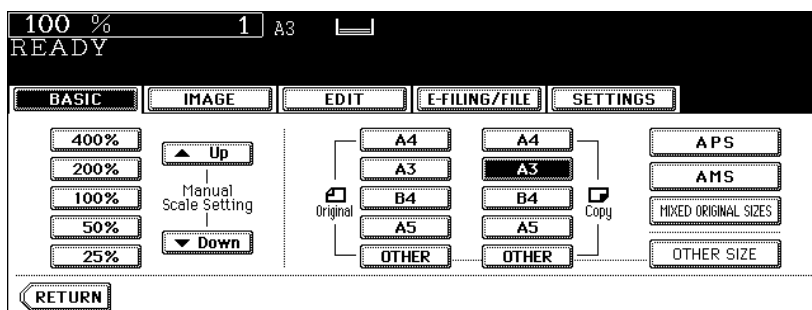

- The copy paper size can also be set by pressing the drawer button on the touch panel.

4 Press the [AMS] button.

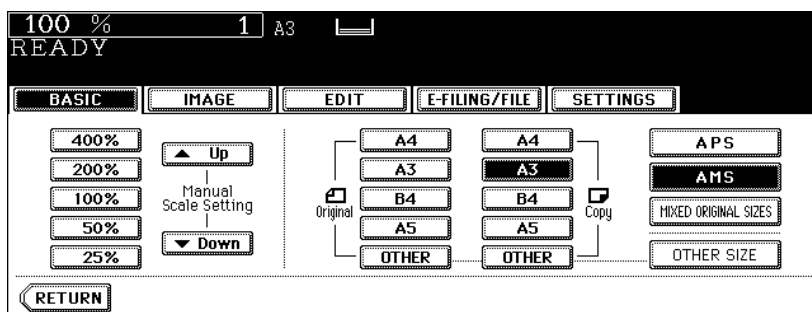

5 Place the original(s).

- When the original is placed, the equipment detects the original size, then computes and displays the most appropriate reproduction ratio for the specified copy paper size.
- If "Change direction of original" appears, make the change accordingly.
- Set other copy modes as required.

6 Press the [START] button.

Specifying both original size and copy size separately

- 1 Place paper in the drawer(s).
- 2 Place the original(s).
- 3 Press the Enlargement/Reduction ([ZOOM...]) button.

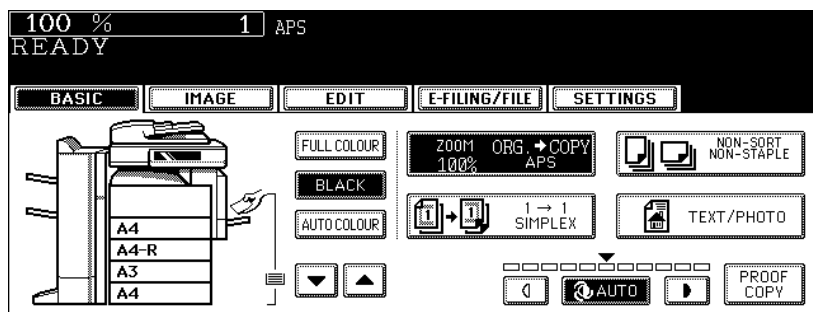

4 Specify the original size and copy paper size.

Original size: Press the size button representing the same size as that of the set original.

Copy paper size: Press the size button representing the desired copy paper size.

E.g.: When A4 for the original size and A3 for the copy paper size are selected

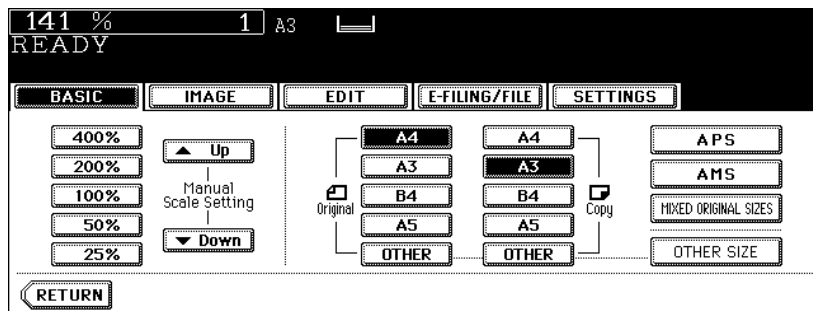

- The copy paper size can also be set by pressing the drawer button on the touch panel.
- When the original size and copy paper size have been specified, the enlargement/reduction ratio is computed and displayed on the touch panel.
- Set other copy modes as required.

Tip

When the original or copy paper is a standard size other than A3, A4, B4 or B5, you need to register this paper size in the selections of the [OTHER] button in advance. See "When a standard size paper other than A3, A4, B4 and B5 is set" below for the registration.

5 Press the [START] button.

When a standard size paper other than A3, A4, B4 and B5 is set

Register the size of the placed paper to the [OTHER] button with the following procedure. The registered paper size is automatically selected when the [OTHER] button is pressed.

1 Press the [OTHER SIZE] button.

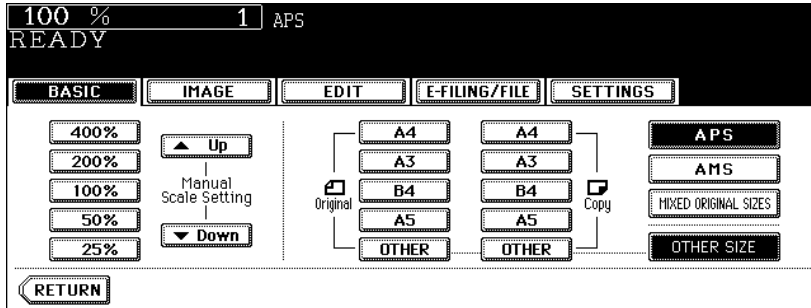

2 Press the paper size button corresponding to the paper that has been set.

E.g.: When COMP-size paper is set

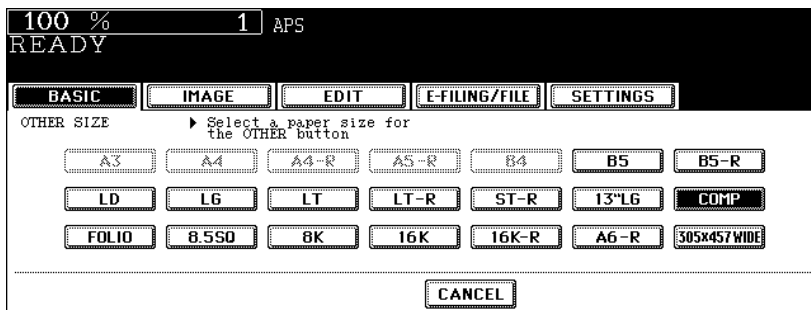

3 Press the [OTHER] button.

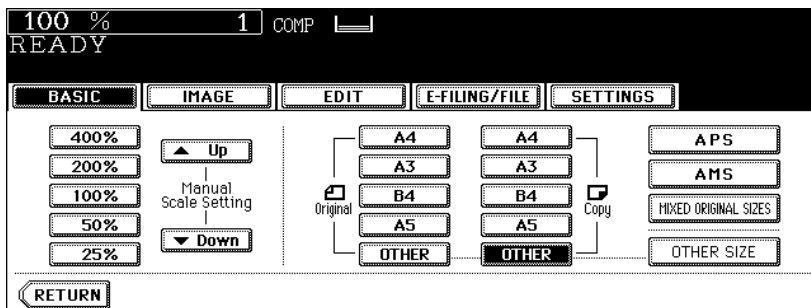

Using the zoom buttons or the one-touch zoom buttons

- 1 Place paper in the drawer(s).
- 2 Place the original(s).
- 3 Press the Enlargement/Reduction ([ZOOM...]) button.

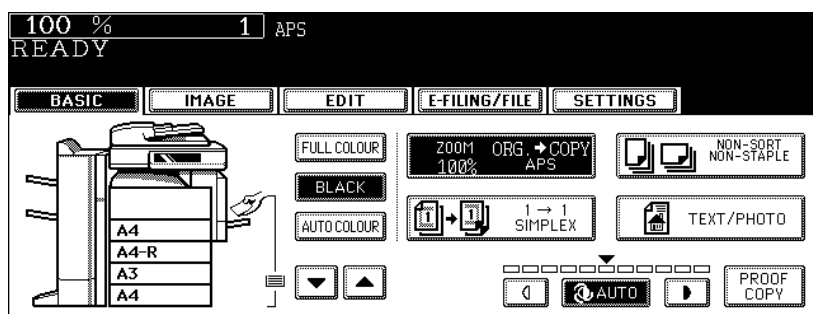

4 Press the following buttons to set the desired reproduction ratio.

A: Zoom ([▲ Up] and [▼ Down]) buttons

The reproduction ratio changes by 1% every time it is pressed. When you hold down either of them, the ratio goes up or down automatically.

B: One-touch zoom buttons

You can select the ratio from [400%], [200%], [100%], [50%] and [25%].

- The maximum ratio when the Reversing Automatic Document Feeder (optional) is used is 200%.

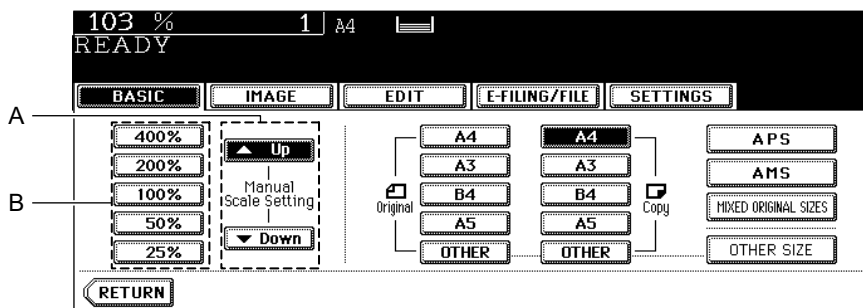

5 Press the button representing the desired copy paper size.

E.g.: When A4-size paper is selected

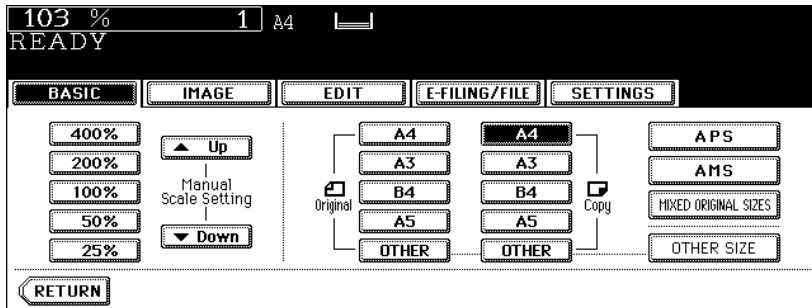

- The copy paper size can also be set by pressing the drawer button on the touch panel.
- Set other copy modes as required.

6 Press the [START] button.

4. Selecting Finishing Modes

Type of finishing mode

The available finishing modes differ depending on the type of finishing device installed (MJ-1024, MJ-1023, MJ-1022, MJ-1101, MJ-6004 or MJ-6101). Check the available finishing modes with the table below.

Yes: Available
No: Not available

Finishing device	Type of finishing mode						
	Sort/Group	Rotate sort	Staple sort	Magazine sort	Magazine sort & Saddle stitch	Saddle stitch	Hole punch
MJ-1024 + MJ-6004	Yes	Yes	Yes	Yes	Yes	Yes	Yes
MJ-1024	Yes	Yes	Yes	Yes	Yes	Yes	No
MJ-1023 + MJ-6004	Yes	Yes	Yes	Yes	No	No	Yes
MJ-1023	Yes	Yes	Yes	Yes	No	No	No
MJ-1022	Yes	Yes	Yes	Yes	No	No	No
MJ-1101 + MJ-6101	Yes	Yes	Yes	Yes	No	No	Yes
MJ-1101	Yes	Yes	Yes	Yes	No	No	No
No finishing device	Yes	Yes	No	Yes	No	No	No

MJ-1024: Saddle Stitch Finisher

MJ-1023: Multi Position Staple Finisher

MJ-1022: Hanging Finisher (for e-STUDIO281c/351c only)

MJ-1101: Finisher

MJ-6004: The Hole Punch Unit for MJ-1024 and MJ-1023

MJ-6101: Hole Punch Unit for MJ-1101

Name of each part in the Finisher (optional)

1. Tray
2. Sub-tray
3. Upper cover
4. Front cover
5. Hole Punch Unit (MJ-6101)
6. Hole Punch Unit (MJ-6004)
7. Saddle stitch tray
8. Fixed tray

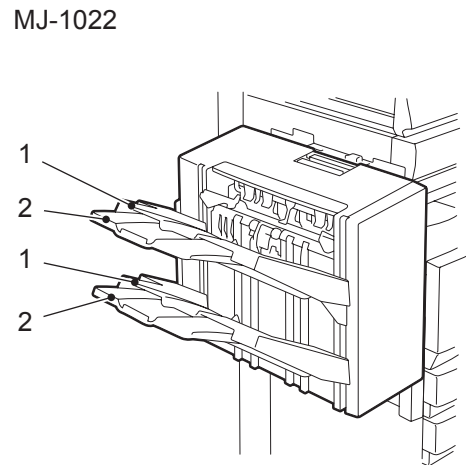
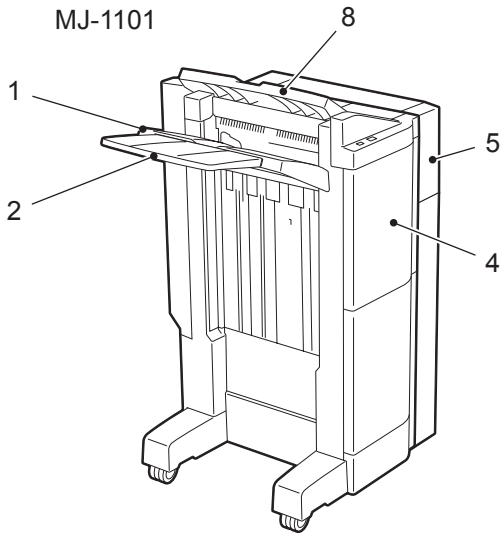
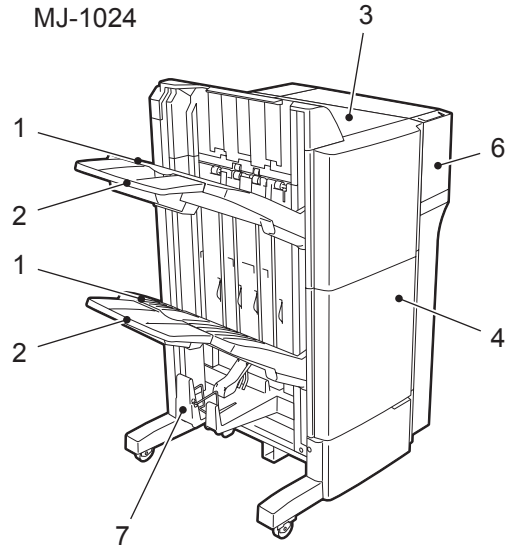
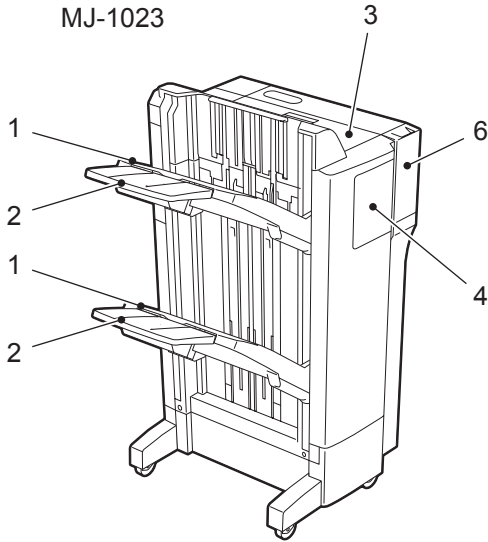

Sort/Group copying

To make multiple copies, select the sort mode or the group mode as required.

(Example of making 5 sets of copies from 5 original sheets)

1. Sort copying
2. Group copying

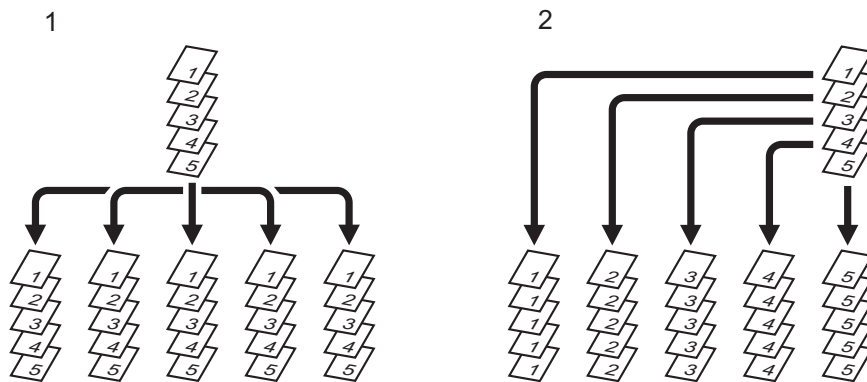

Tip

When you use the A3 or B4 size copy paper, pull out the sub-tray in advance. The copied paper may fall or may not be sorted properly without the sub-tray.

1 Place paper in the drawer(s).

2 Place the original(s).

3 Press the finisher button on the basic menu.

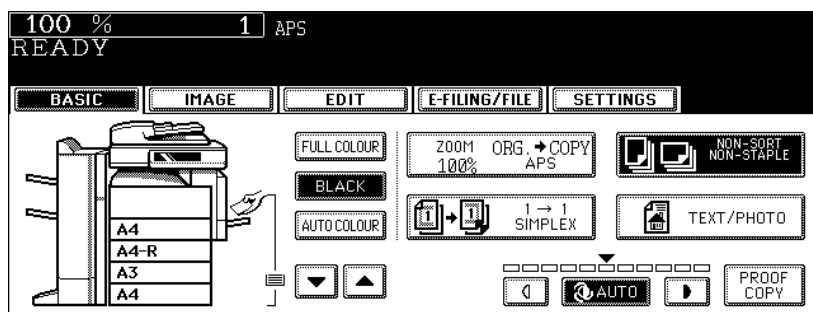

Tip

When the original is placed in the Reversing Automatic Document Feeder (optional), the sort mode is automatically selected.

4 Press the [SORT] (or [GROUP]) button.

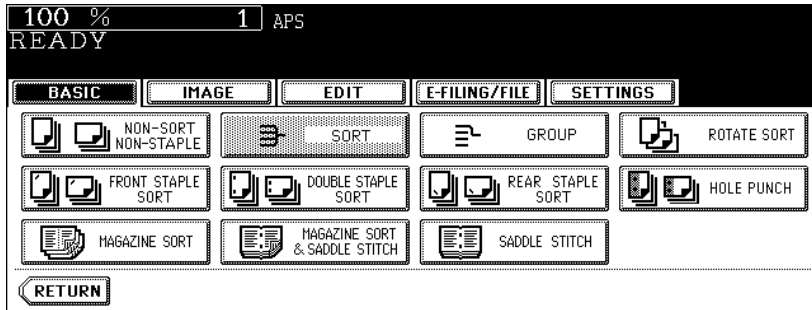

- Set other copy modes as required.

5 Press the [START] button.

Rotate sort mode

In the rotate sort mode, one set of copies is made to exit on another set of copies, being alternated lengthwise or crosswise.

The available paper sizes for this mode is A4/A4-R. Set the A4/A4-R size paper in the drawers in advance. Paper exits to the receiving tray in this mode.

- This mode cannot be used with automatic paper selection.

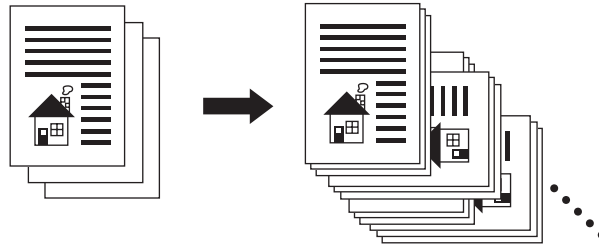

- 1 Place paper in the drawer(s).
- 2 Place the original(s).
- 3 Press the finisher button on the basic menu.

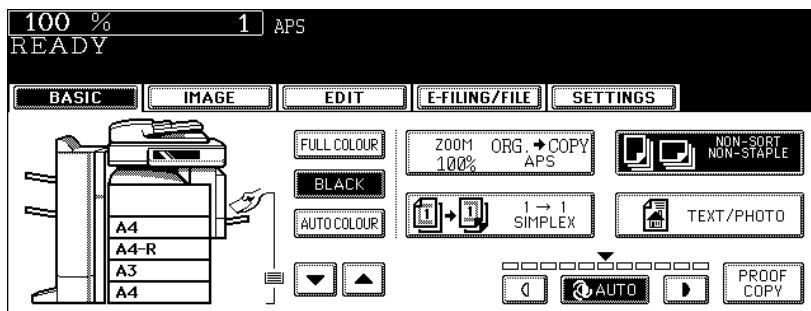

- 4 Press the [ROTATE SORT] button.

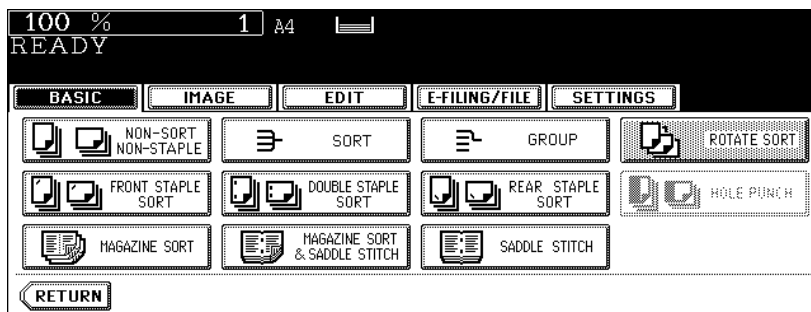

- Set other copy modes as required.

- 5 Press the [START] button.

Staple sort mode

When the Finisher (optional) is installed, automatic stapling is enabled. You can select the stapling position from three types.

- The paper quantity and weight applicable for this mode differ depending on the Finisher installed in this equipment. See [P.102](#) "Maximum number of sheets for stapling".
- Special paper such as OHP films or sticker label cannot be used for stapling.
- Copies in different size cannot be stapled. (When the lengths of the copies are the same, they can be stapled even if their sizes are different.)

(Example of selecting the [FRONT STAPLE SORT] button)

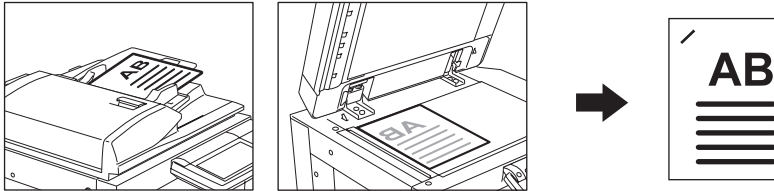

1 Place paper in the drawer(s).

- When using this mode in bypass copying, specify the paper size in advance. ([P.71](#) "3.Bypass Copying")

2 Place the original(s).

3 Press the finisher button on the basic menu.

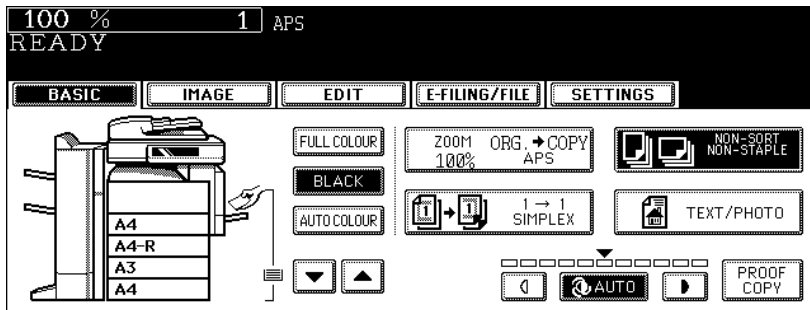

4 Press the [FRONT STAPLE SORT] (or [DOUBLE STAPLE SORT] or [REAR STAPLE SORT]) button.

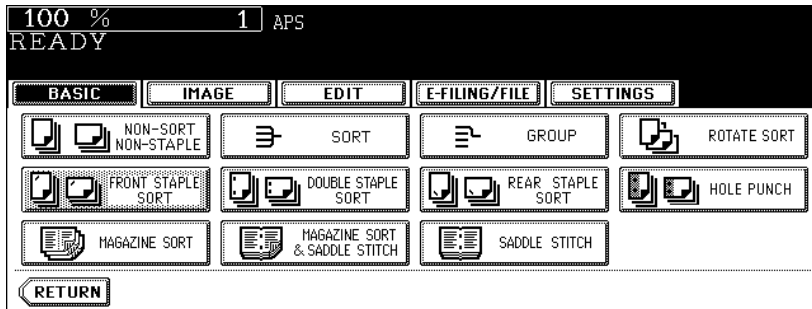

- For the Hanging Finisher (MJ-1022), only the [FRONT STAPLE SORT] button can be selected.
- Set other copy modes as required.

5 Press the [START] button.

Tip

If the paper quantity exceeds the maximum number of sheets that can be stapled, the Finisher automatically enters the sort mode.

Maximum number of sheets for stapling

- For the tray loading capacity, see P.351 "2.Specifications of Options"
- Two covers of 64 to 209 g/m² can be added. In this case, the covers are included in the maximum number of sheets that can be stapled.

Saddle Stitch Finisher (MJ-1024)/Multi Position Staple Finisher (MJ-1023)/Finisher (MJ-1101)

Paper size	Paper type (weight)	Qty. ^{*1}
A4, B5	Plain paper (64 - 80 g/m ²)	50 sheets
	Thick 1 (81 - 105 g/m ²)	30 sheets
A3, A4-R, B4, FOLIO	Plain paper (64 - 80 g/m ²)	30 sheets
	Thick 1 (81 - 105 g/m ²)	15 sheets

*1 Maximum number of sheets for stapling when plain paper and thick 1 are mixed is the same as that of thick 1.

Hanging Finisher (MJ-1022)

Only plain paper (64 to 80 g/m²) can be used.

Paper size	Qty.
A4, A4-R, B5	30 sheets
B4	20 sheets
A3, FOLIO	15 sheets

Magazine sort & saddle stitch mode (booklet mode)

In the magazine sort mode, more than one original can be copied and bound like magazines or booklets. Also, a set of copied sheets can be automatically folded and stapled at its centre when the Saddle Stitch Finisher (optional) is installed. The available copy paper sizes for these modes are A3, A4-R and B4.

- Special paper such as OHP films or sticker label cannot be used for saddle stitching.
- The paper weight applicable for this mode is 64 to 105 g/m².

Tip

When placing portrait originals horizontal to you in the magazine sort mode, set the Image Direction in the edit menu. Otherwise the originals will not be copied in the proper page order. (📖 P.170 “14.IMAGE DIRECTION”)

1. When [MAGAZINE SORT] is selected

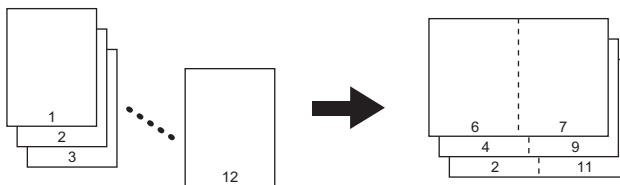

2. When [MAGAZINE SORT & SADDLE STITCH] is selected

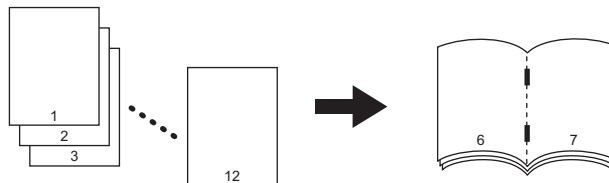

3. When [SADDLE STITCH] is selected

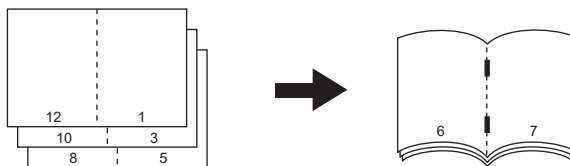

You can select the magazine sort mode from the edit menu, as well as from the basic menu. When this mode is selected from the edit menu, you can adjust the binding margin of the copy. To select this mode from the edit menu, see 📖 P.148 “6.MAGAZINE SORT”.

1 Place paper in the drawer(s).

2 Select the paper size.

- Available copy paper sizes are A3, A4-R and B4.
- For bypass copying, see  P.71 "3.Bypass Copying".

3

Tip

To use the saddle stitch mode for A3 or B4-size paper, lift the stopper of the saddle stitch tray.

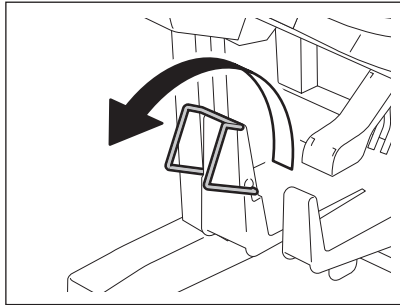

3 Place the original(s).

- When placing originals on the Reversing Automatic Document Feeder, see the illustrations ( P.103) for the proper page order of the copies.
- When placing originals on the original glass, follow the procedure below.
 - When [MAGAZINE SORT] or [MAGAZINE SORT & SADDLE STITCH] is selected: Place the first page of the originals first.
 - When [SADDLE STITCH] is selected: In case of 12-page originals, set them in the order of pages 12-1, 2-11, 10-3, 4-9, 8-5, then 6-7.

4 Press the finisher button on the basic menu.

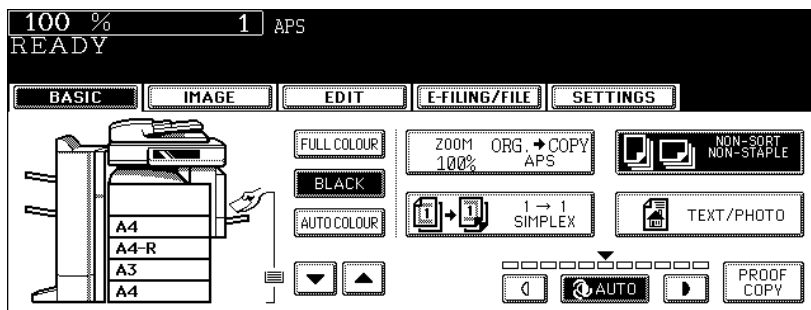

5 Press the [MAGAZINE SORT] (or [MAGAZINE SORT & SADDLE STITCH] or [SADDLE STITCH] button.

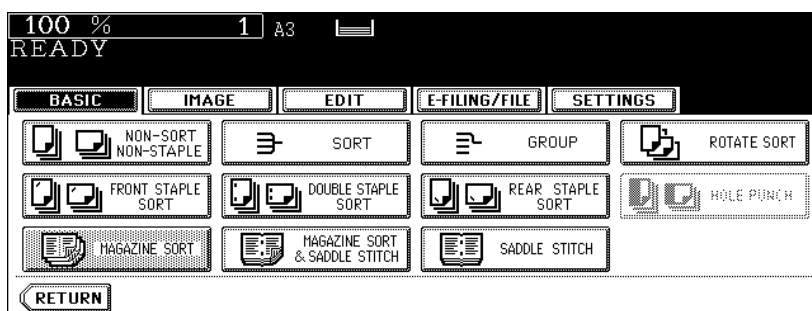

- The [MAGAZINE SORT & SADDLE STITCH] button and the [SADDLE STITCH] button are selectable only when the Saddle Stitch Finisher is installed.
- Set other copy modes as required.

6 Press the [START] button.

- When placing the originals on the original glass, follow the procedure in P.58 “Placing originals on the glass”.

Available conditions for saddle stitching

Available paper sizes are A3, A4-R and B4.

Paper weight	Saddle stitch tray loading capacity		
	11 - 15 sheets	6 - 10 sheets	5 sheets or less
64 g/m ²	10 sets	20 sets	25 sets
80 g/m ²	10 sets	20 sets	25 sets
90 g/m ² *1	-	15 sets	25 sets
105 g/m ² *1	-	15 sets	25 sets

*1 When the cover is added, the tray loading capacity is always 5 sets.

- One cover of 64 to 209 g/m² can be added. In this case, this cover is included in the maximum number of sheets that can have saddle stitching.
- When paper of a different weight is loaded, count the number of sheets for saddle stitching as applied to the paper with the highest weight.

Hole punch mode (optional)

When the Hole Punch Unit (optional) is installed to the finisher (optional), you can punch holes in the copies.

- The available copy paper sizes for this mode are A3, A4, A4-R, B4, B5, B5-R and FOLIO.
- The paper weight applicable for this mode is 64 to 209 g/m².
- Special paper such as OHP films or sticker label cannot be used for hole punching.

3

1 Place paper in the drawer(s).

- When using this mode in bypass copying, specify the paper size in advance. (P.71 “3.Bypass Copying”)

2 Place the original(s).

3 Press the finisher button on the basic menu.

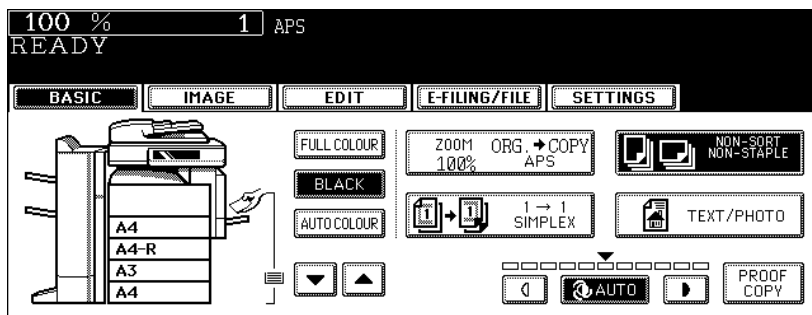

4 Press the [HOLE PUNCH] button.

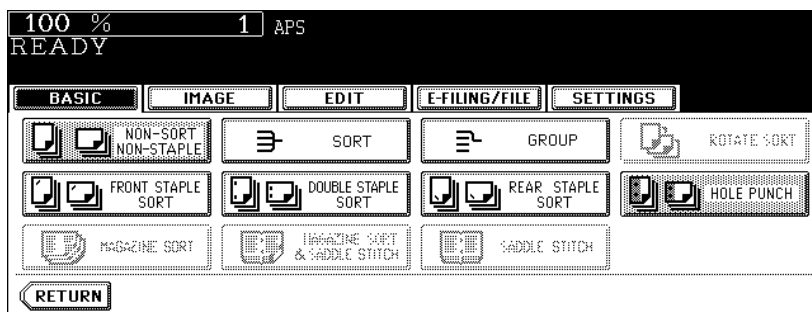

- Set other copy modes as required.

5 Press the [START] button.

Number of punch holes and available paper sizes

Since the number of punch holes and the distance between the holes vary depending on the country/region, purchase a hole punch unit that meets your requirements. (For details, consult your service technician.)

	Number of punch holes and hole diameter	Available paper sizes
MJ-6004E, MJ-6101E (Japan and most of Europe)	2 holes (6.5 mm dia.)	A3, A4, A4-R, B4, B5, B5-R, FOLIO, LD, LG, LT, LT-R, COMP
MJ-6004N, MJ-6101N (North America)	2/3 holes switchable (8.0 mm dia.)	2 holes: A4-R, LG, LT-R 3 holes: A3, A4, LD, LT
MJ-6004F, MJ-6101F (France)	4 holes (6.5 mm dia.; 80 mm pitch)	A3, A4, LD, LT
MJ-6004S, MJ-6101S (Sweden)	4 holes (6.5 mm dia.; 70 mm and 21 mm pitch)	A3, A4, A4-R, B4, B5, B5-R, FOLIO, LD, LG, LT-R, COMP

Manual stapling (MJ-1101 only)

The manual stapling function which enables you to use the staple function without making copies is available in the Finisher (MJ-1101, optional). This function is useful when copies are made without stapling being set or when you want to staple originals.

A: Stapling position lamps C: Manual-stapling lamp
B: [Stapling position] button D: [Manual-stapling] button

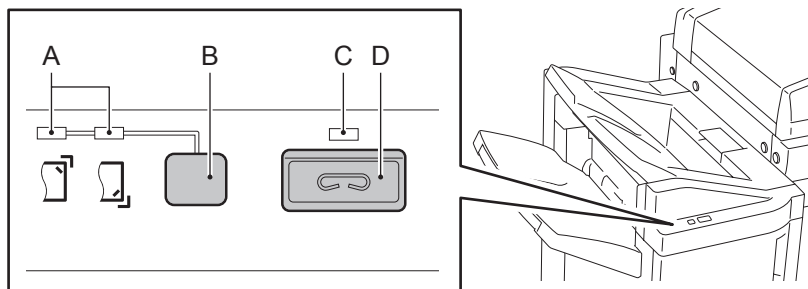

3

1 Press the [Manual-stapling] button.

The shutter in the paper exit area is opened.

2 Press the [Stapling position] button to switch the stapling position.

Stapling positions are the front and the other end.

The stapling position lamp corresponding to the selected stapling position lights in green.

3 Place paper in the lower tray of the finisher.

Jog the paper well and place it with its face down.

Place the paper in front to have it stapled in the front, and in the other end to have it stapled in the other end.

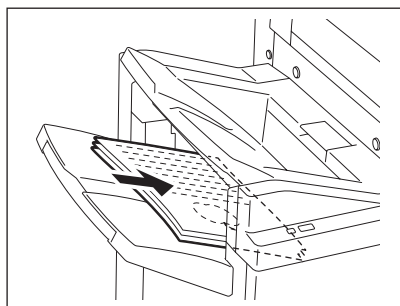
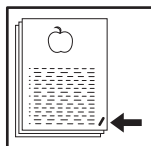
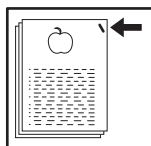

Tip

Check that the manual-stapling lamp lights in green. If not, place the paper again.

4 Release the paper and press the [Manual-stapling] button.

The stapling position lamp blinks when the stapling is completed. Remove the paper.

Note

Be sure to release the paper before the manual stapling.

Tips

- Operation can be continued while the manual-stapling lamp lights. If no operation is performed for approx. 15 min., the manual stapling operation is stopped.
- If you want to stop the manual stapling operation during setting, remove paper and press the [Manual-stapling] button. The shutter in the paper exit area is closed and the operation of the manual stapling is finished.

Specification

Acceptable paper size	A3, A4, A4-R, B4, LD, LG, LT, LT-R, COMP, 13" LG, 8.5" SQ, 8K, 16K
Maximum number of sheets for stapling	50 sheets (A4, LT, 8.5" SQ, 16K: 64 - 80 g/m ²) 30 sheets (A3, A4-R, B4, FOLIO, LD, LG, LT-R, COMP, 13" LG, 8K: 64 - 80 g/m ²) 30 sheets (A4, LT, 8.5" SQ, 16K: 81 - 105 g/m ²) 15 sheets (A3, A4-R, B4, FOLIO, LD, LG, LT-R, COMP, 13" LG, 8K: 81 - 105 g/m ²)
Stapling position	Front, Rear

5. Duplex Copying

The following 5 combinations are available for duplex copying.

1. 1-sided original -> 1-sided copy (default setting at installation)
2. 1-sided original -> 2-sided copy
3. 2-sided original -> 2-sided copy
4. 2-sided original -> 1-sided copy
5. Book-type original -> 2-sided copy

- Duplex copying is available for plain paper (64 to 80 g/m²) and thick 1 paper (- 105 g/m²).

3

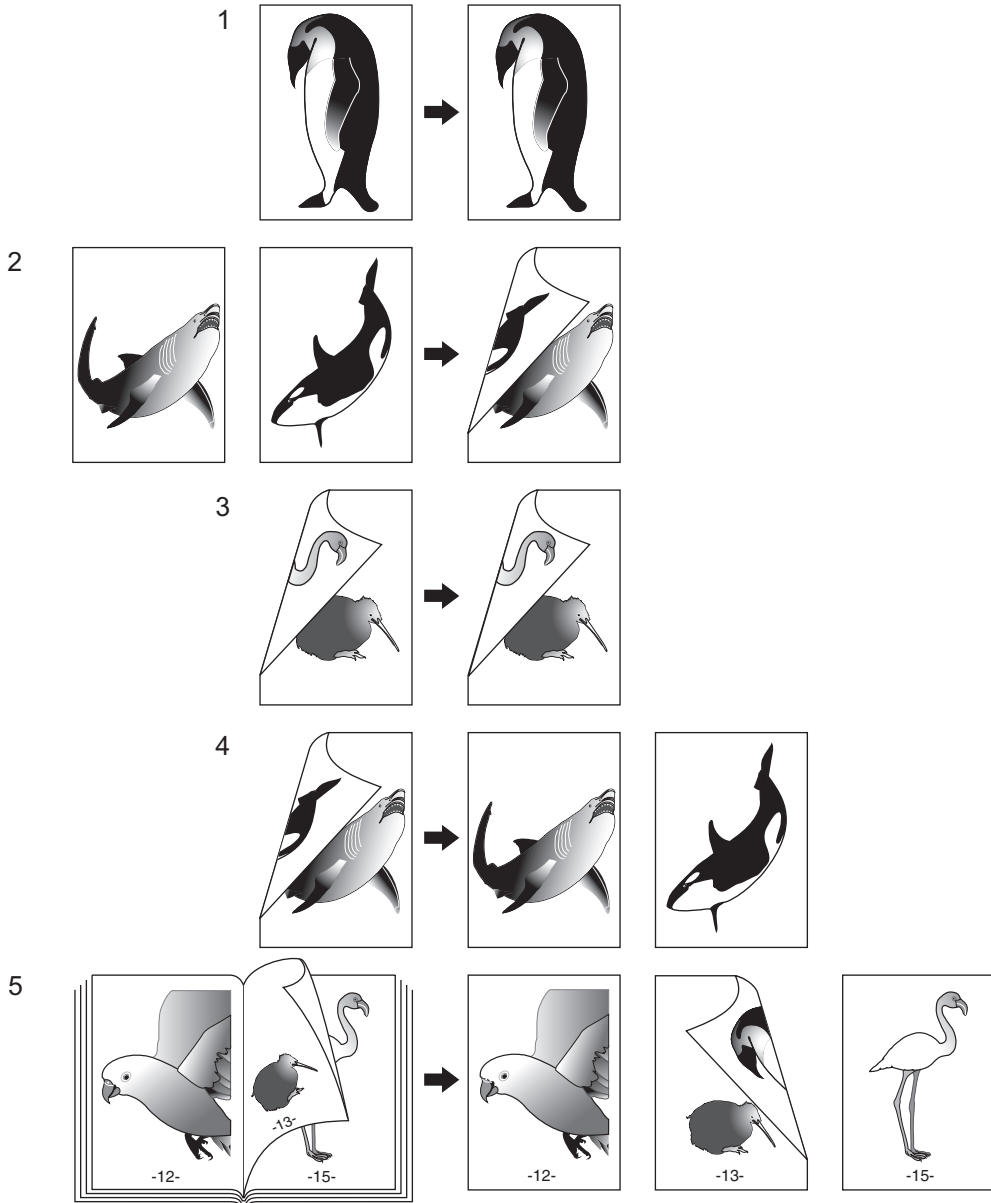

1-sided original -> 1-sided copy (default setting at installation)

- 1 Place paper in the drawer(s).
- 2 Place the original(s).
- 3 Confirm that the simplex/duplex button on the basic menu is [1 -> 1 SIMPLEX].

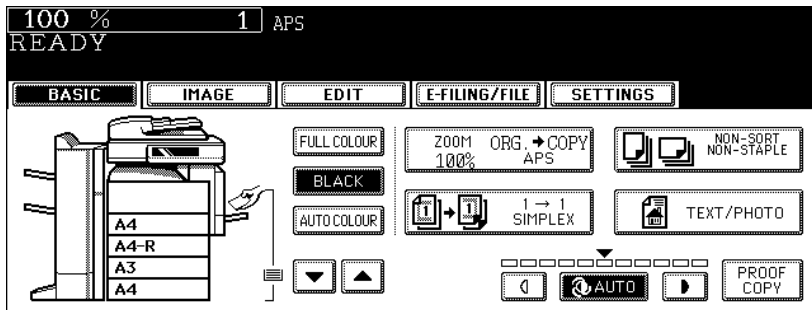

- If [1 -> 1 SIMPLEX] is not shown, press the simplex/duplex button to display the next menu, and then press the [1 -> 1 SIMPLEX] button on that menu.

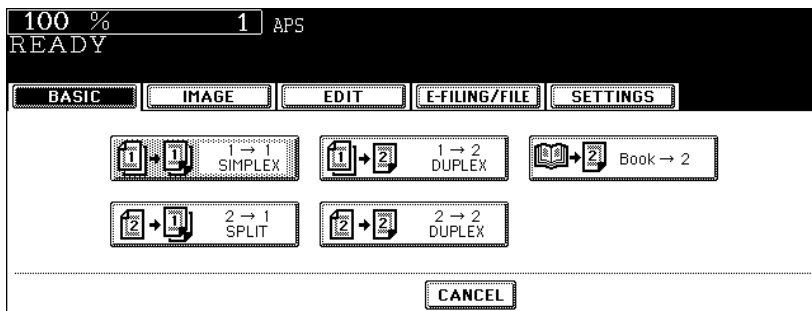

- Set other copy modes as required.

- 4 Press the [START] button.

1-sided original -> 2-sided copy

When you copy 1-sided portrait originals to 2-sided copies, you can make a booklet-type copy in the direction of "open to left" opening, using the image direction mode in the edit menu.

([P.170](#) "14.IMAGE DIRECTION")

1 Place paper in the drawer(s).

- When using this mode in bypass copying, specify the paper size in advance. ([P.71](#) "3.Bypass Copying")

2 Place the original(s).

3 Press the simplex/duplex button on the basic menu.

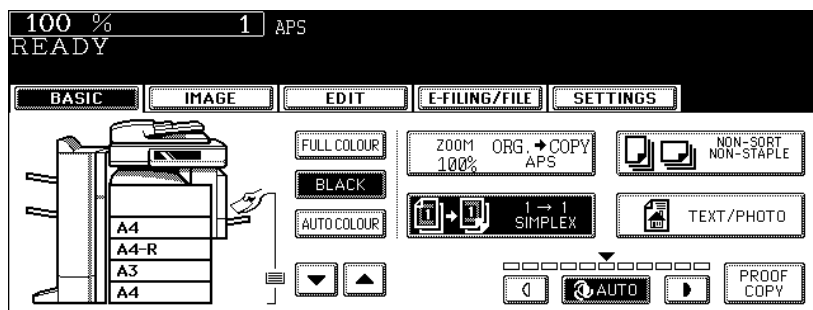

4 Press the [1 -> 2 DUPLEX] button.

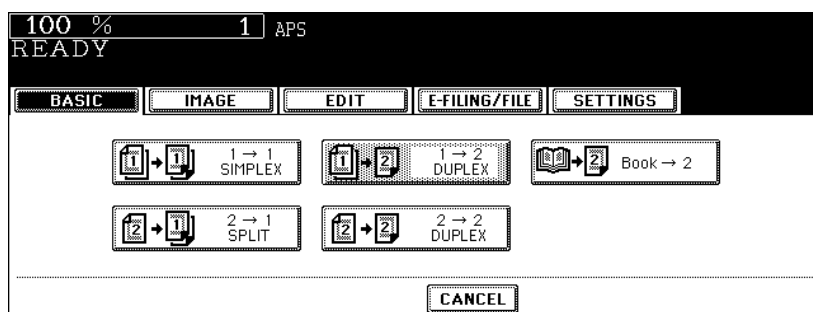

- Set other copy modes as required.

5 Press the [START] button.

- When placing an original on the original glass, follow steps 5 to 6 of [P.65](#) "Placing an original on the original glass" continuously.

2-sided original -> 2-sided copy

1 Place paper in the drawer(s).

- When using this mode in bypass copying, specify the paper size in advance. (P.71 "3.Bypass Copying")

2 Place the original(s).

3 Press the simplex/duplex button on the basic menu.

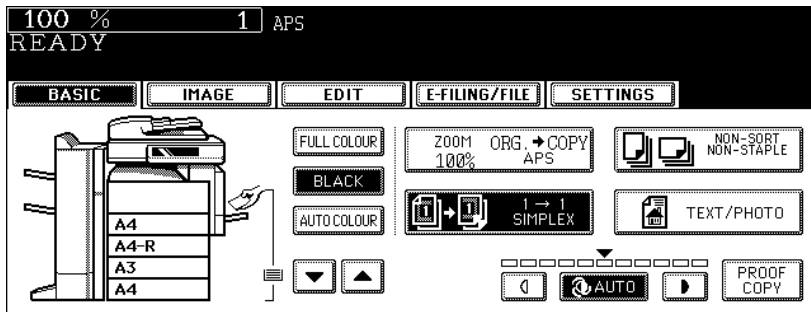

4 Press the [2 -> 2 DUPLEX] button.

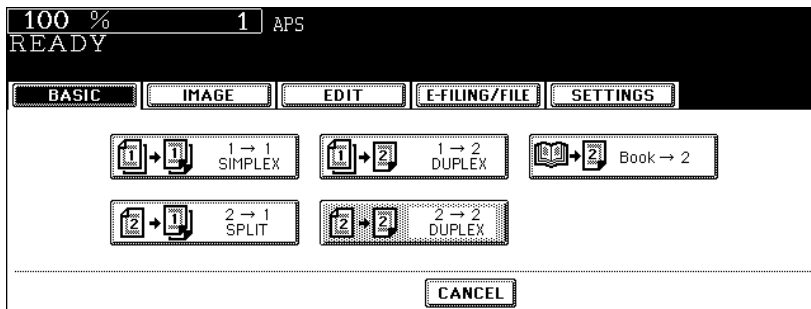

- Set other copy modes as required.

5 Press the [START] button.

- When placing an original on the original glass, follow steps 5 to 6 of P.65 "Placing an original on the original glass" continuously.

2-sided original -> 1-sided copy

When a 2-sided 'open to left' (Book) portrait original is copied using the image direction mode in the edit menu with [2-Sided Originals to 1-Sided Copies], copies can be adjusted to the same direction. (P.170 "14.IMAGE DIRECTION")

- 1** Place paper in the drawer(s).
- 2** Place the original(s).
- 3** Press the simplex/duplex button on the basic menu.

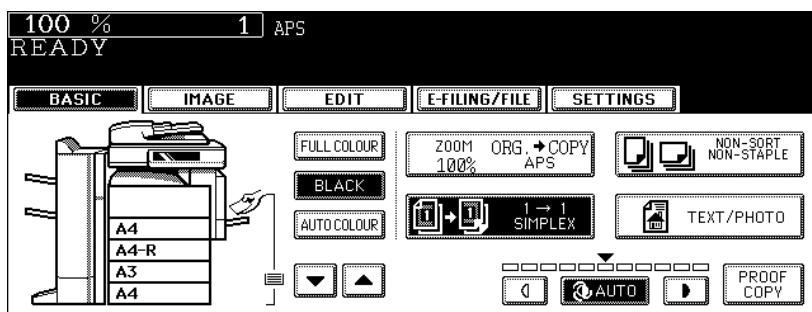

- 4** Press the [2 -> 1 SPLIT] button.

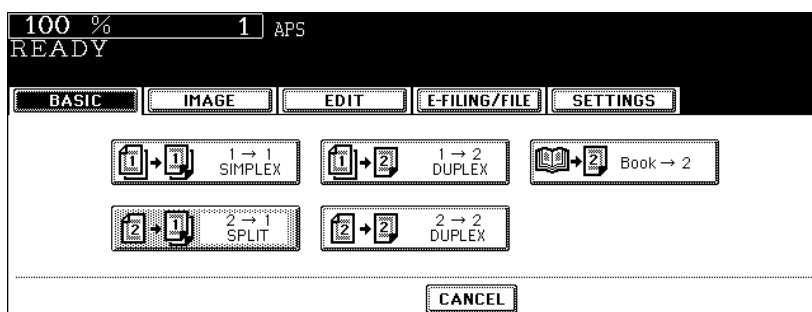

- Set other copy modes as required.

- 5** Press the [START] button.

Book-type original -> 2-sided copy

You can make a booklet-type copy in the same page configuration in which the original is.

- The acceptable paper size for this function is A4 or B5 only.

1 Place paper in the drawer(s).

- When using this mode in bypass copying, specify the paper size in advance. (P.71 "3.Bypass Copying")

2 Press the simplex/duplex button on the basic menu.

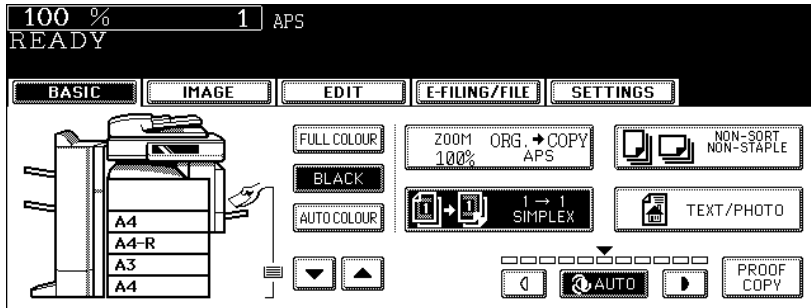

3 Press the [BOOK -> 2] button.

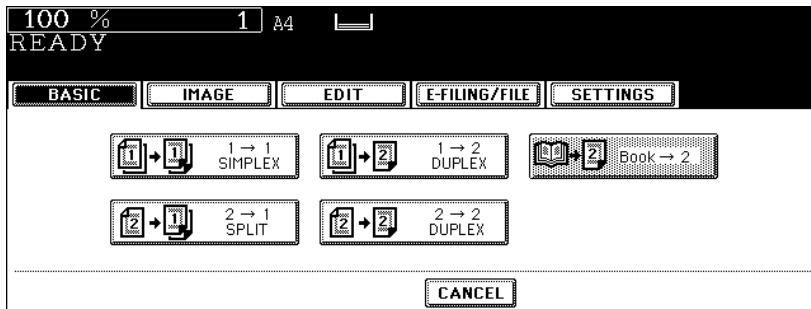

4 Select the book copying type.

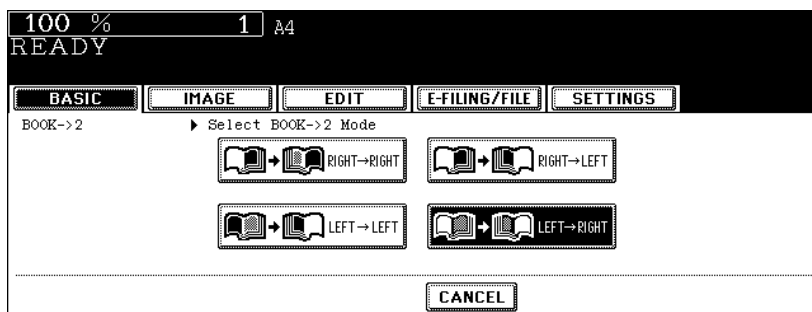

- Press the [RIGHT -> RIGHT] button (= default setting at the installation) if copying should start at a right-hand page and end at a right-hand page. Other copying types are selectable by pressing any of the [RIGHT -> LEFT], [LEFT -> LEFT] and [LEFT -> RIGHT] buttons.

e.g.: If pages 2 to 6 of a book which opens to the left are to be copied, select [LEFT -> RIGHT].

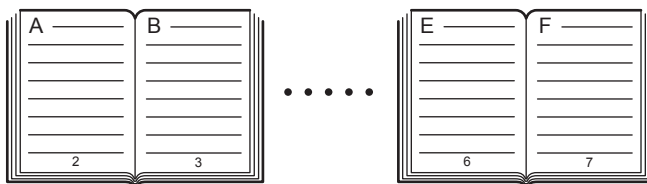

- The yellow indicator line for booklet copying moves to the centre of the original glass.

5 Select A4 or B5 copy size.

- Only A4 or B5 size is available. Press the drawer button on the touch panel, or use the paper source selection (▼/▲) buttons to select A4 or B5 size.

E.g.: When A4-size paper is selected

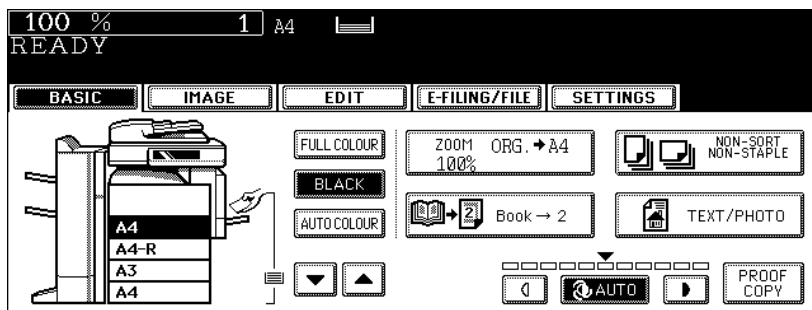

- If you need a binding space, select the book margin mode. (P.134 "1.IMAGE SHIFT")
- Set other copy modes as required.

6 Open and place the first page(s) on the original glass.

- Centre the booklet on the yellow indicator line with its bottom toward you.

Caution

Do not place heavy objects (4 kg or more) on the original glass and do not press on it with force. Breaking the glass could injure you.

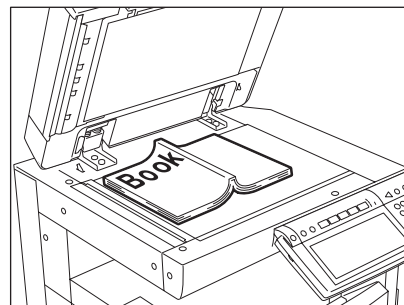

7 Press the [START] button. When the data of the opened pages have been scanned, open the next page and set the booklet on the original glass again.

- Repeat the procedures above until all the desired pages have been scanned. If the last copy is only a single page, press the [COPY FINAL PAGE] button on the touch panel before the scanning of this page is started.

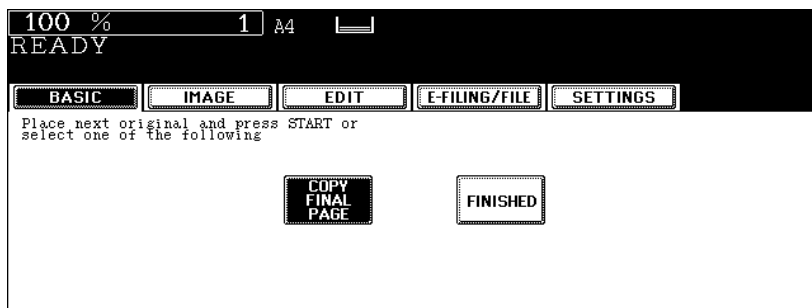

8 When all the pages have been scanned, press the [FINISHED] button on the touch panel.

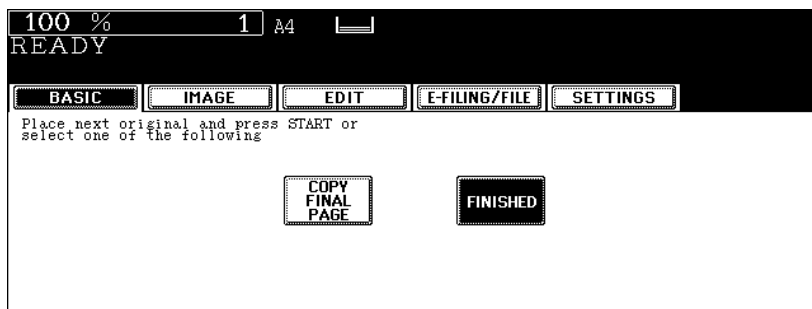

- The scanned pages will be copied.
- For setting image shift, see P.138 "Creating a bookbinding margin".

6. Original Mode

You can make copies with optimal image quality by selecting the following modes for your original. The selectable original mode differs depending on the colour mode (P.89). Switch the colour mode first, and then select the original mode.

Full colour

TEXT/PHOTO:	Originals with text and photographs mixed (Default setting)
TEXT:	Originals with text (or text and line art) only
PRINTED IMAGE:	Originals with general photographs on photographic printing paper
PHOTO:	Originals with photogravure (e.g. Magazine, brochure)
MAP:	Originals with fine illustrations or text

Black

TEXT/PHOTO:	Originals with text and photographs mixed (Default setting)
TEXT:	Originals with text (or text and line art) only
PHOTO:	Originals with photographs
IMAGE SMOOTHING:	Originals with text and photographs mixed, especially originals requiring higher reproducibility on photos

Auto colour

TEXT/PHOTO:	Originals with text and photographs mixed
-------------	---

1 Place paper in the drawer(s).

2 Place the original(s).

3 Press the original mode button on the basic menu.

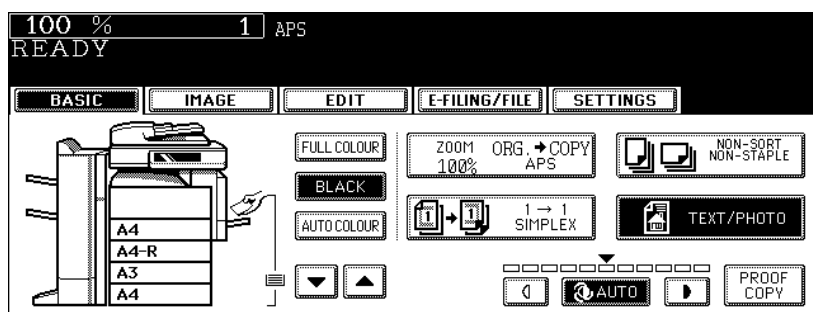

4 Select and press the button for the most appropriate original mode for your original.

The selectable original mode differs depending on the colour mode as follows.

Full colour

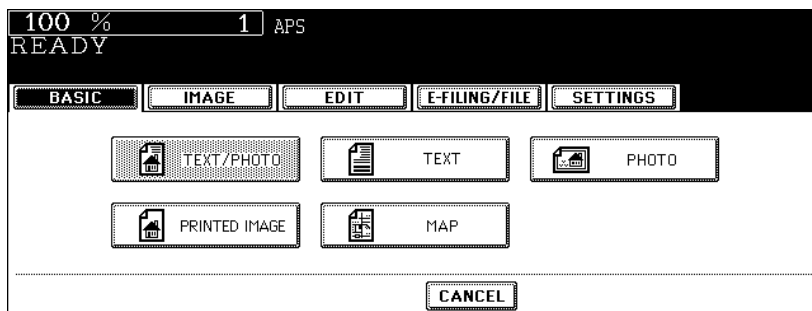

Black

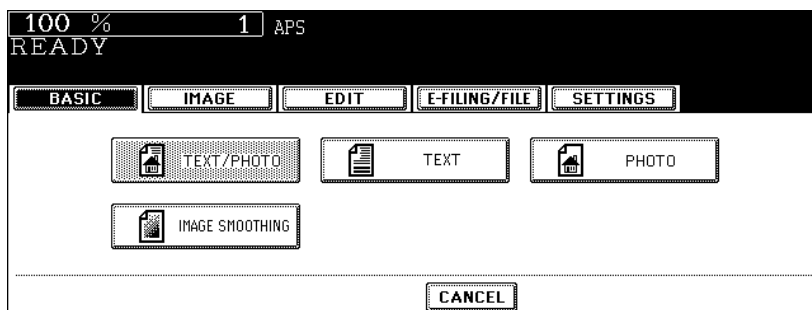

Auto colour

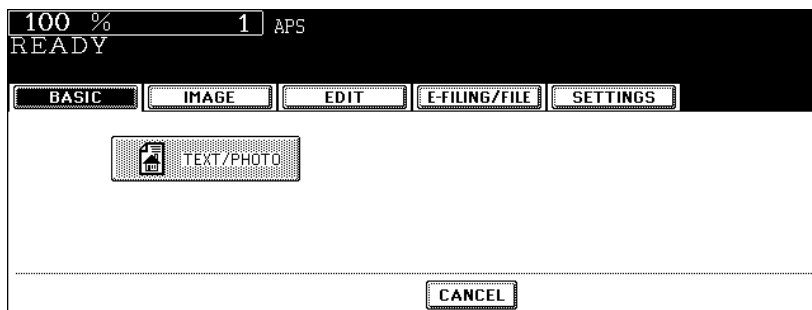

- Set other copy modes as required.

5 Press the [START] button.

7. Copy Density Adjustment

There are 2 types of copy density adjustment: the automatic copy density mode and the manual copy density mode. In the automatic copy density mode, the equipment automatically selects the most appropriate copy density by detecting the density of the original. In the manual copy density mode, you can adjust the copy density manually according to the conditions of the original.

- Default setting: Manual density mode for "FULL COLOUR" / "AUTO COLOUR", Automatic density mode for "BLACK"

Automatic copy density mode

- 1 Place paper in the drawer(s).
- 2 Place the original(s).
- 3 Confirm that the [AUTO] button on the basic menu is selected. If it is not, press the button.

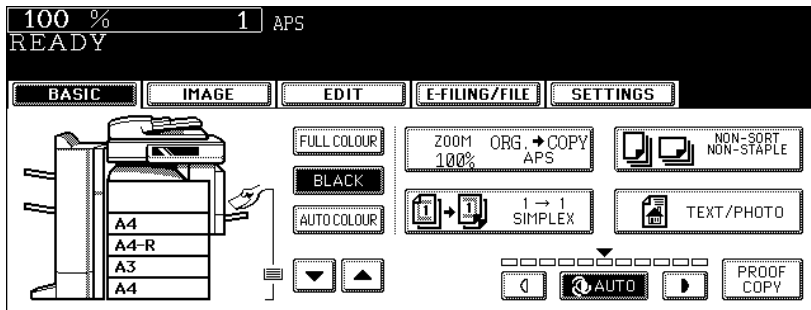

- Set other copy modes as required.

- 4 Press the [START] button.

Manual copy density mode

- 1 Place paper in the drawer(s).
- 2 Place the original(s).
- 3 Press either the ◀ or ▶ button to adjust the copy density to the desired level.

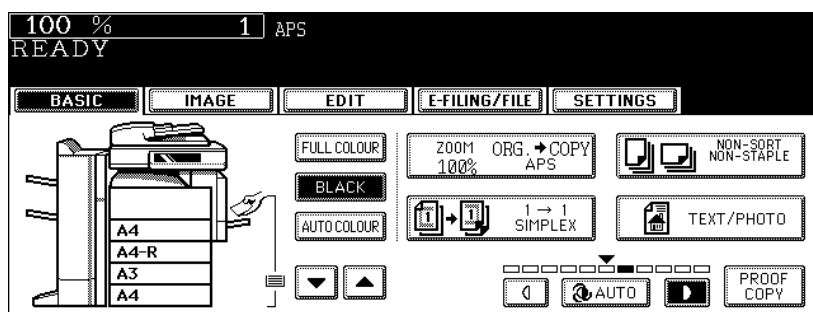

- The copied image becomes lighter as you press the ◀ button and darker as you press the ▶ button.
- Set other copy modes as required.

- 4 Press the [START] button.

4. IMAGE ADJUSTMENT

1. Colour Balance (YMCK Adjustment).....	124
2. RGB Adjustment	125
3. One-Touch Adjustment	126
4. Background Adjustment.....	127
5. Sharpness.....	128
6. Twin Colour (2-Colour) Copy	129

1. Colour Balance (YMCK Adjustment)

This function allows you to adjust an overall colour balance of the copied image by changing each toner amount of yellow (Y), magenta (M), cyan (C) and black (K).

- This function is available only in the full colour mode.

1 Place paper in the drawer(s).

2 Place the original(s).

3 Press the [IMAGE] button to enter the image menu, and then press the [COLOUR BALANCE] button.

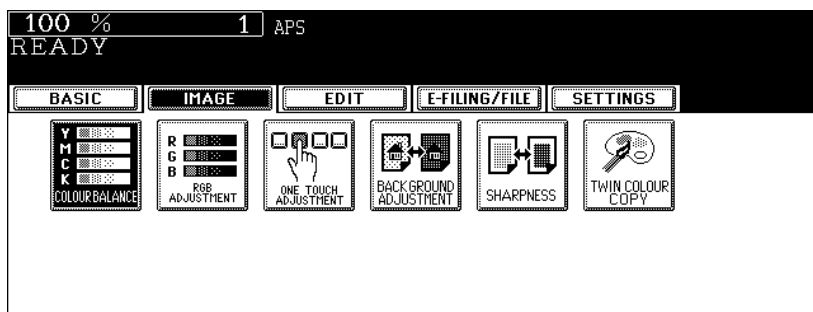

4 Press the **+** or **-** button of the colour to obtain the desired colour balance. Then press the [ENTER] button.

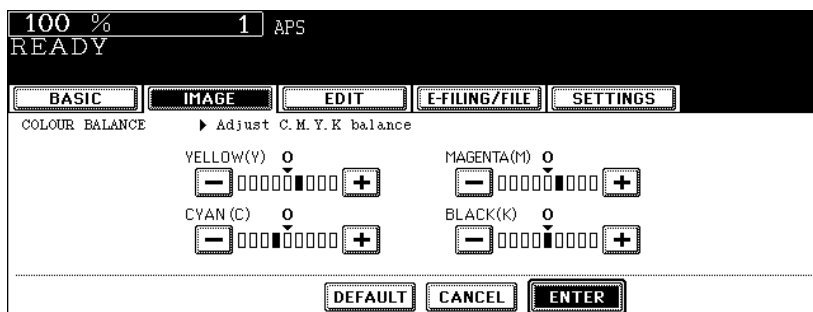

- "0" is the standard setting.
- Pressing the **+** button strengthens the adjusted colour, and pressing the **-** button weakens it.
- Select other copy modes as required.

5 Press the [START] button.

Canceling the colour balance adjustment

Move the indicator of the colour whose adjustment you want to cancel its adjustment to 0 by your pressing the **+** or **-** button, and then press the [ENTER] button.

If you want to cancel the adjustment of all colours, press the [DEFAULT] button, and then press the [ENTER] button.

2. RGB Adjustment

This function allows you to adjust an overall colour balance of the copied image by changing the strength of red (R), green (G) and blue (B) at the time of scanning.

- This function is available only in the full colour mode.

1 Place paper in the drawer(s).

2 Place the original(s).

3 Press the [IMAGE] button to enter the image menu, and then press the [RGB ADJUSTMENT] button.

4

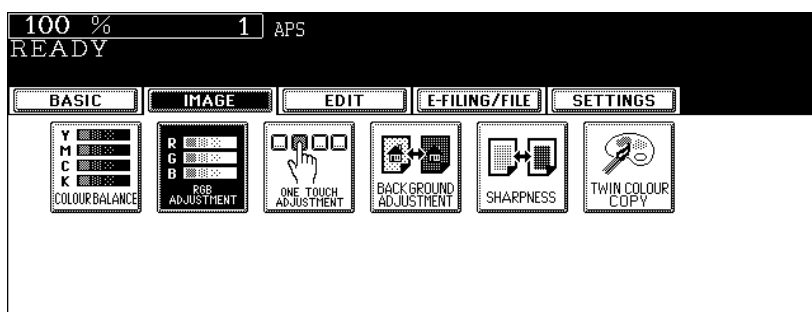

4 Press the **+** or **-** button of the colour to obtain the desired colour balance. Then press the [ENTER] button.

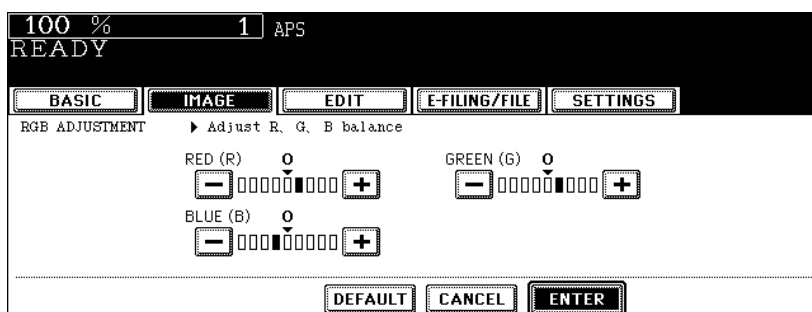

- "0" is the standard setting.
- Pressing the **+** button strengthens the adjusted colour, and pressing the **-** button weakens it.
- Select other copy modes as required.

5 Press the [START] button.

Canceling RGB adjustment

Move the indicator of the colour whose adjustment you want to cancel its adjustment to 0 by your pressing the **+** or **-** button, and then press the [ENTER] button.

If you want to cancel the adjustment of all colours, press the [DEFAULT] button, and then press the [ENTER] button.

3. One-Touch Adjustment

This function allows you to obtain the desired image quality. You can select among 4 modes; “WARM”, “COOL”, “VIVID” or “CLEAR” in a one-touch operation.

- See Colour Guide for the adjustment results.
- This function is available only in the full colour mode.

1 Place paper in the drawer(s).

2 Place the original(s).

3 Press the [IMAGE] button to enter the image menu, and then press the [ONE TOUCH ADJUSTMENT] button.

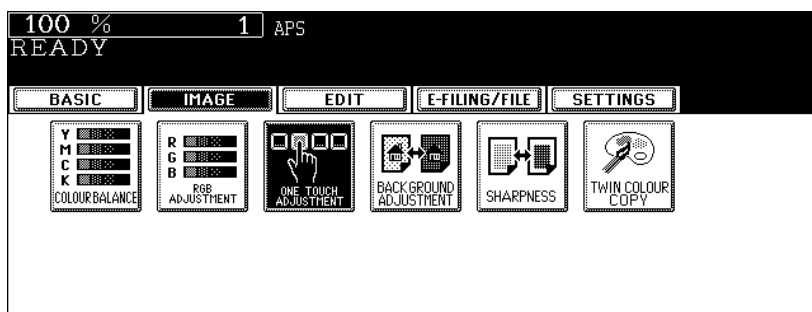

4 Press the [WARM], [COOL], [VIVID] or [CLEAR] button.

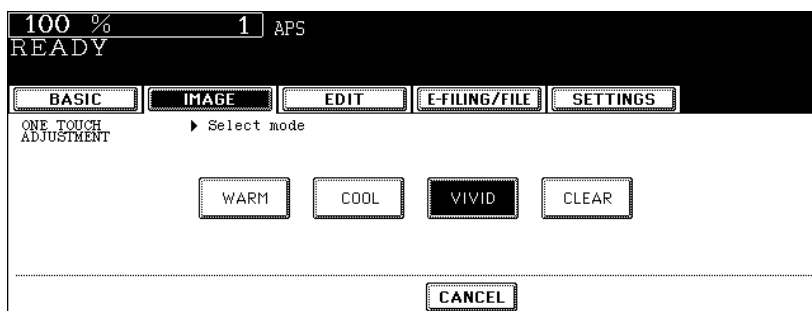

- Select other copy modes as required.

5 Press the [START] button.

4. Background Adjustment

This function allows you to adjust the density of the original's background. It avoids the back side of 2-sided originals becoming visible on the front side of the original through the copy.

- This mode cannot be used with the automatic copy density mode. (P.121)

1 Place paper in the drawer(s).

2 Place the original(s).

3 Press the [IMAGE] button to enter the image menu, and then press the [BACKGROUND ADJUSTMENT] button.

4

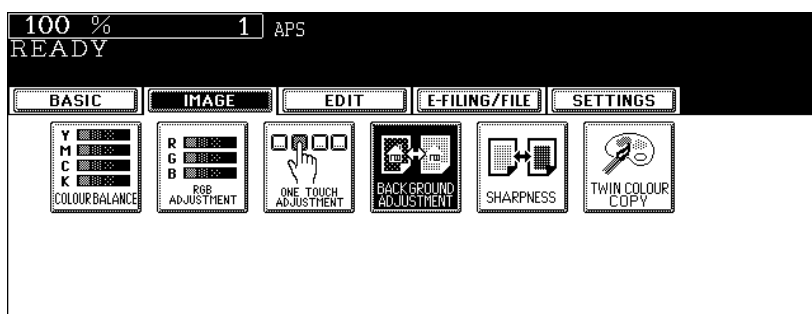

4 Press the [LIGHT] (or [DARK]) button to adjust the density, and then press the [ENTER] button.

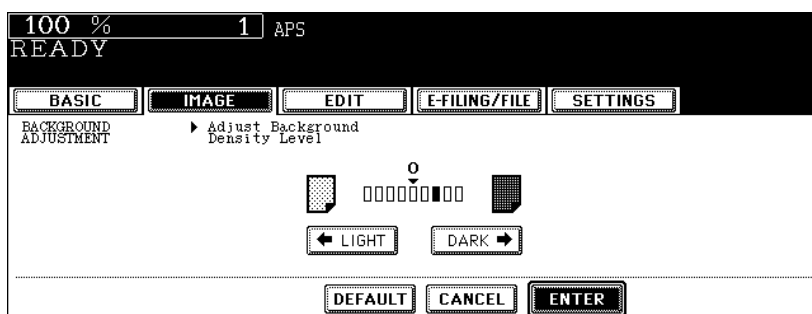

- Select other copy modes as required.

5 Press the [START] button.

Canceling the background adjustment

- Press the [DEFAULT] button and then the [ENTER] button.
- Adjust the background level to "0", and then press the [ENTER] button.

5. Sharpness

This function allows you to emphasize or blur the outline of the image. When the sharpness level is adjusted to the [SOFT] side, the moire fringes are suppressed. If it is adjusted to the [SHARP] side, the letters and fine lines become sharper.

1 Place paper in the drawer(s).

2 Place the original(s).

3 Press the [IMAGE] button to enter the image menu, and then press the [SHARPNESS] button.

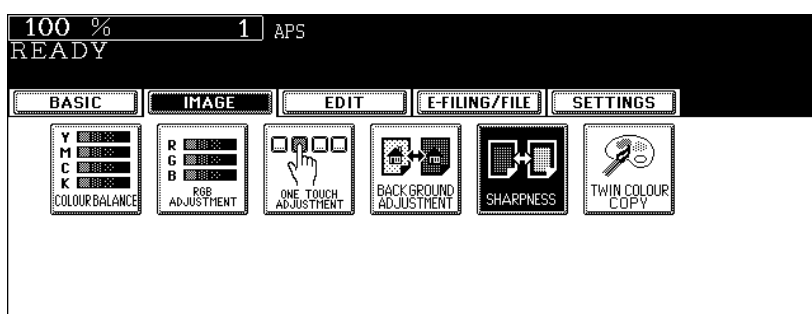

4 Press the [SOFT] (or [SHARP]) button to adjust the sharpness, and then press the [ENTER] button.

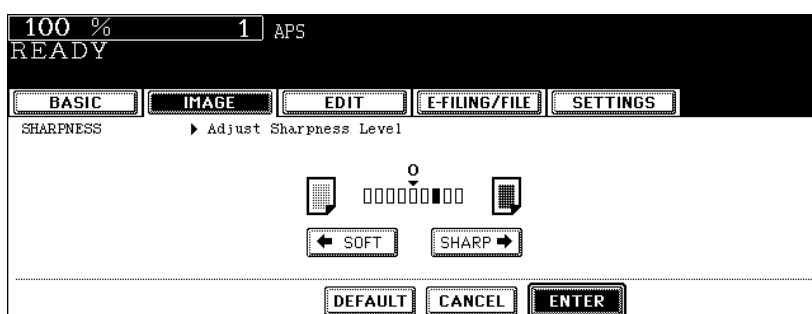

- When the sharpness level is adjusted to the [SOFT] side, the moire fringes are suppressed. If it is adjusted to the [SHARP] side, the letters and fine lines become sharper.
- Select other copy modes as required.

5 Press the [START] button.

Canceling the sharpness adjustment

- Press the [DEFAULT] button and then the [ENTER] button.
- Adjust the sharpness level to "0", and then press the [ENTER] button.

6. Twin Colour (2-Colour) Copy

This function allows you to copy a coloured original in 2 specified colours. There are 2 types of twin colour copy as follows:

TWIN COLOUR SELECTABLE: The black part and the parts other than black in the original are copied separately in 2 colours which have been manually specified.

RED & BLACK: The red part in the original is copied in red and the parts other than red are copied in black and white.

- The colour may not be correctly reproduced depending on originals. In that case, copy them in the full colour mode.

TWIN COLOUR SELECTABLE

4

- 1 Place paper in the drawer(s).
- 2 Place the original(s).
- 3 Press the [IMAGE] button to enter the image menu, and then press the [TWIN COLOUR COPY] button.

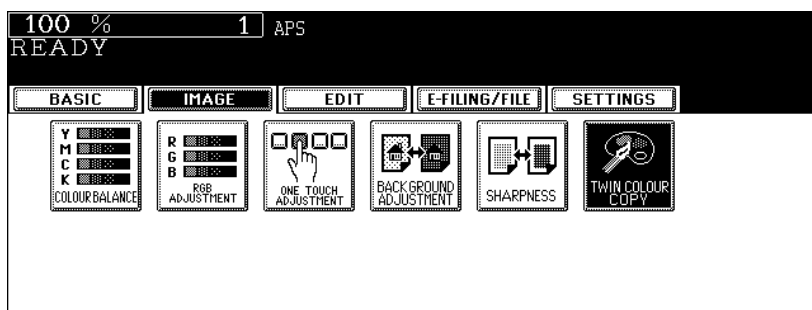

- 4 Press the [TWIN COLOUR SELECTABLE] button.

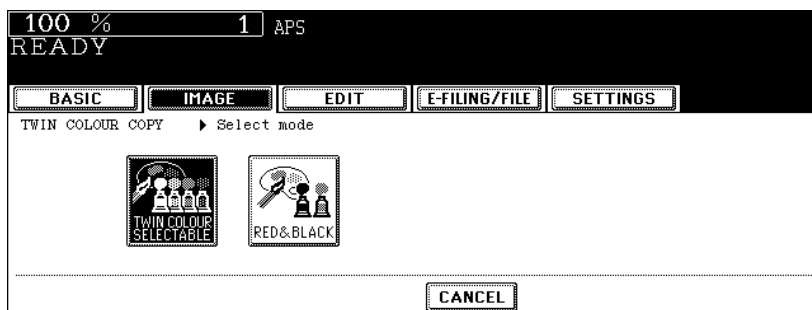

- 5** Select a colour for the black part in the original. Press the [CHANGE BLACK TO] button, and then select the desired colour.

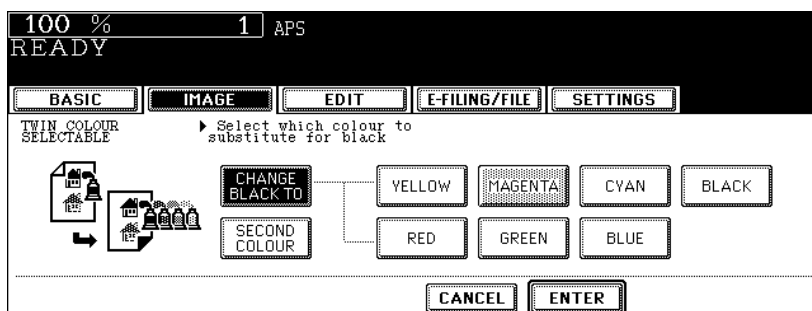

- 6** Select a colour for the parts other than black in the original. Press the [SECOND COLOUR] button, and then select the desired colour.

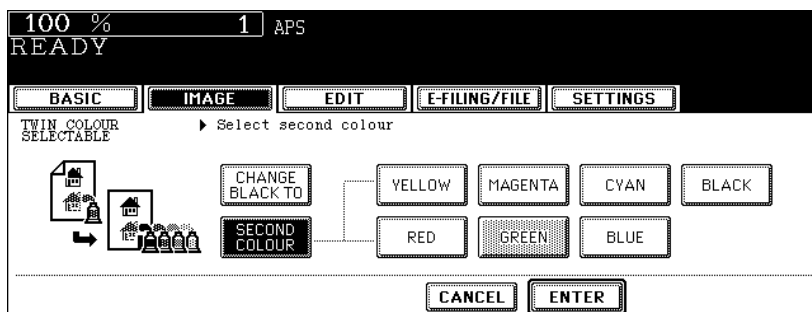

- 7** Press the [ENTER] button.

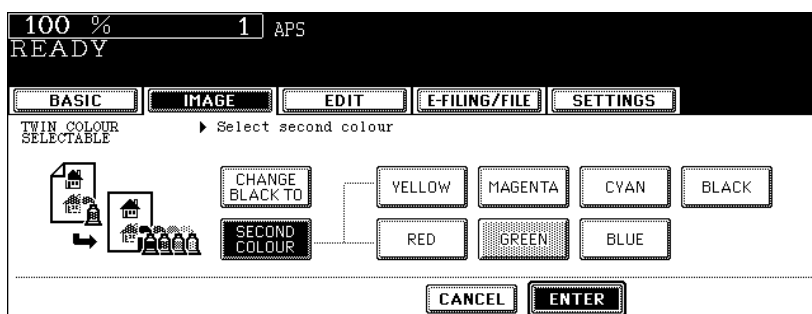

- Select other copy modes as required.

- 8** Press the [START] button.

RED & BLACK

- 1 Place paper in the drawer(s).
- 2 Place the original(s).
- 3 Press the [IMAGE] button to enter the image menu, and then press the [TWIN COLOUR COPY] button.

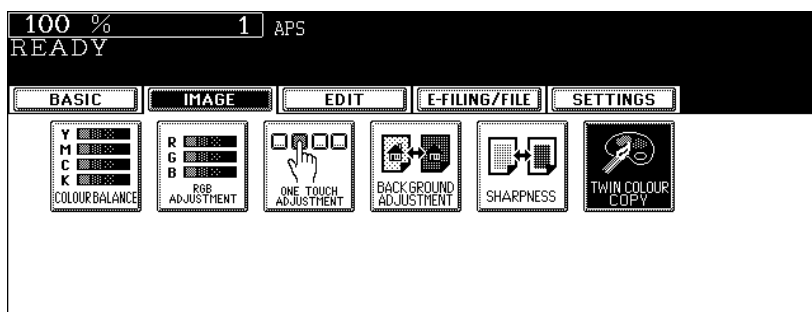

- 4 Press the [RED & BLACK] button.

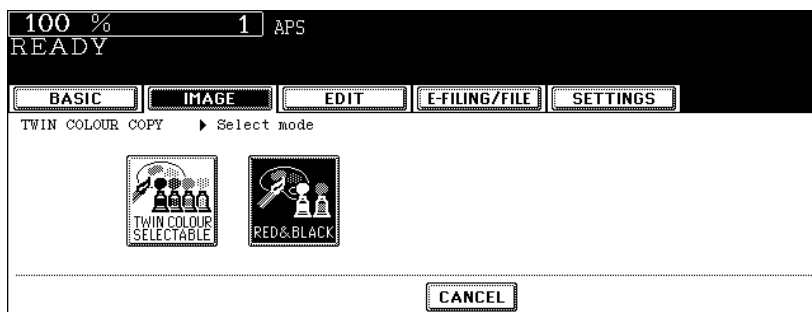

- 5 To adjust the red colour, press the [ADJUST] button. If you do not change the colour balance, press the [ENTER] button and proceed to step 7.

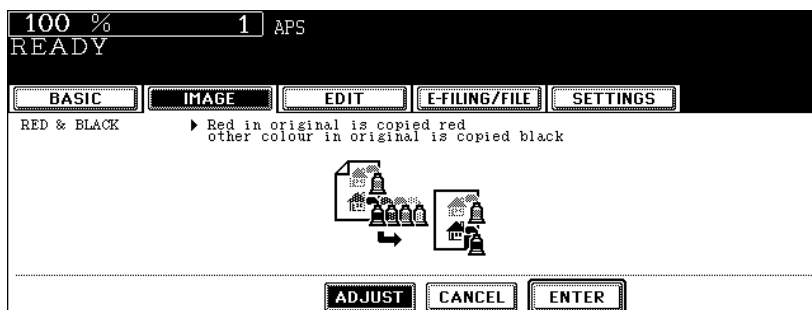

- 6** Press the **+** or **-** button of the colour to obtain the desired colour balance. Then press the **[ENTER]** button.

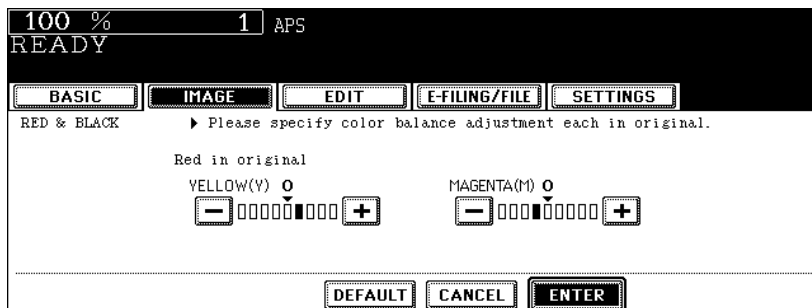

- 7** Select other copy modes as required and then, press the **[START]** button.

5. USING THE EDITING FUNCTIONS

1. IMAGE SHIFT	134
2. EDGE ERASE.....	140
3. BOOK CENTRE ERASE.....	141
4. DUAL PAGE.....	143
5. 2IN1 / 4IN1.....	145
6. MAGAZINE SORT	148
7. EDITING	150
• Trimming / Masking.....	150
• Mirror image.....	153
• Negative/Positive reversal.....	154
8. XY ZOOM	155
9. COVER SHEET	157
10.SHEET INSERTION.....	160
11. TIME STAMP	163
12.PAGE NUMBER.....	164
13.JOB BUILD	166
14.IMAGE DIRECTION.....	170
15.BOOK - TABLET	172
16.ADF / SADF	174

1. IMAGE SHIFT

A margin for binding can be created. The following types are available.

1. Created by shifting the original image to either the right or left side (Right or Left margin)
2. Created by shifting the original image to either the upper or lower side (Top or Bottom margin)
3. Created binding margins in the centre (inner margin) (Bookbinding margin)
Select this setting when using "Book-type original -> 2-sided copy" (📖 P.115).

Tips

- The 'Top or Bottom margin' can be used in combination with the 'Right or Left margin' or the 'Bookbinding margin'.
- The margin width can be adjusted in 1 mm increments.

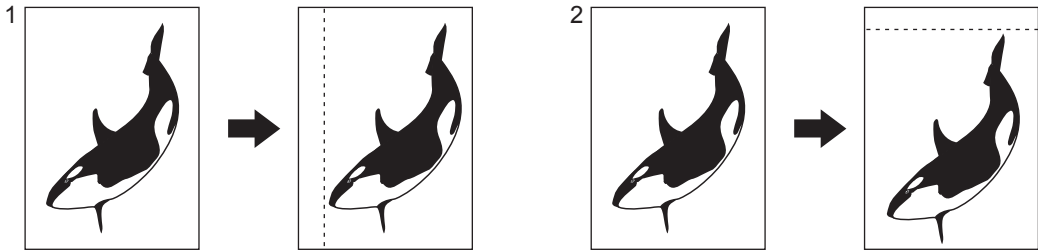

5

Creating a right or left margin

1 Place paper in the drawer(s).

- When using this mode in bypass copying (📖 P.71), be sure to specify the paper size.

2 Place the original(s).

3 Press the [EDIT] button to enter the edit menu, and then press the [IMAGE SHIFT] button.

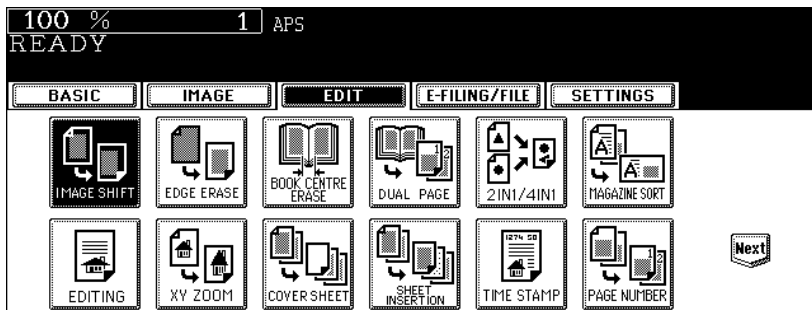

4 Press the [LEFT] (or [RIGHT]) button.

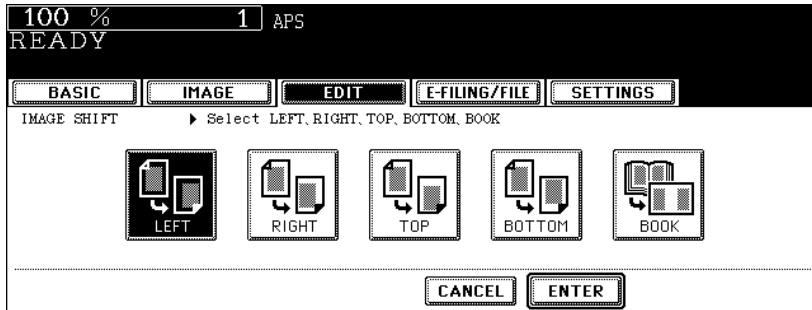

5 Adjust the margin width by pressing the [2 mm] or [100 mm] button, and then press the [ENTER] button.

5

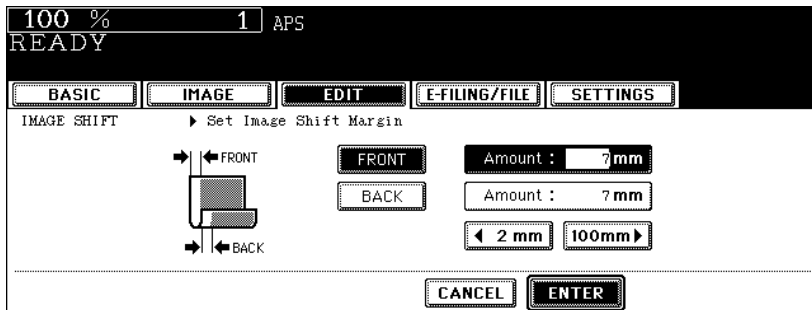

- The default width of the margin is 7 mm.
- In duplex copying, margins on the back are created on the other side of those in the front. (P.110 “5.Duplex Copying”)

6 Press the [ENTER] button.

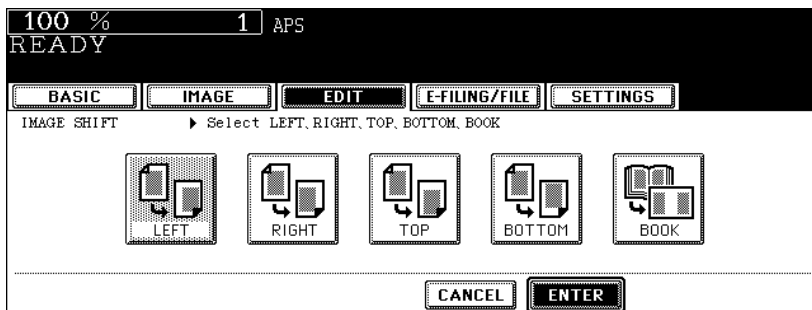

- Select other copy modes as required.

7 Press the [START] button.

Creating a top or bottom margin

1 Place paper in the drawer(s).

- When using this mode in bypass copying (P.71), be sure to specify the paper size.

2 Place the original(s).

3 Press the [EDIT] button to enter the edit menu, and then press the [IMAGE SHIFT] button.

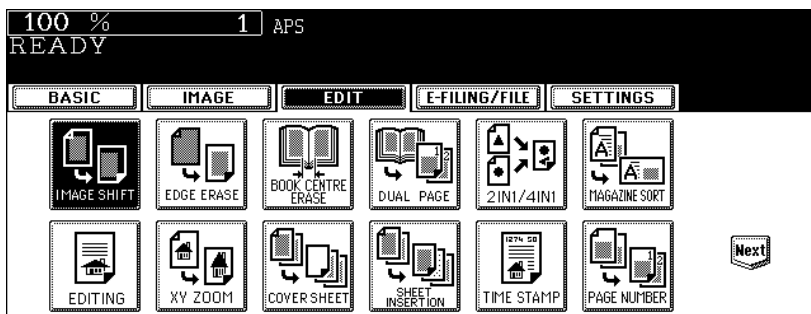

4 Press the [TOP] (or [BOTTOM]) button.

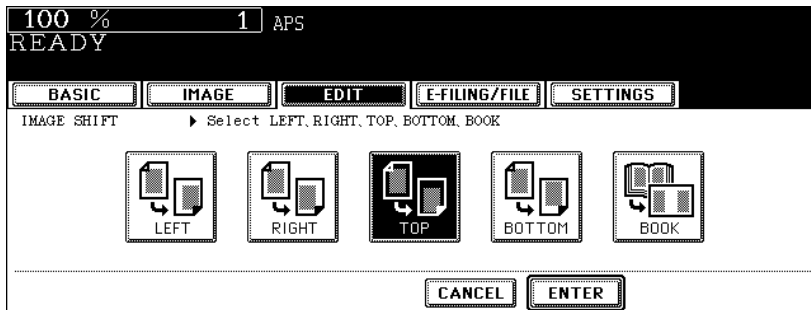

5 Adjust the margin width by pressing the [2 mm] or [100 mm] button, and then press the [ENTER] button.

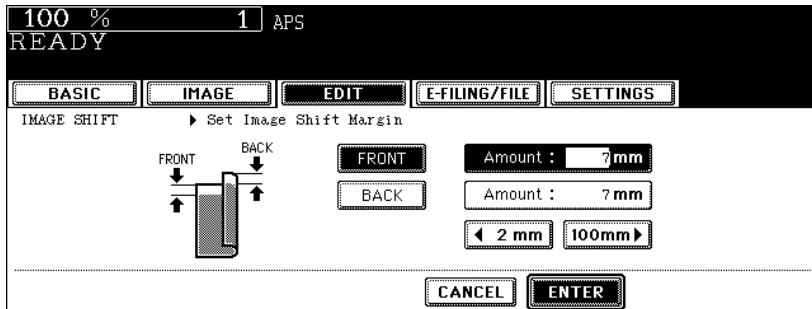

- The default width of the margin is 7 mm.
- In duplex copying, margins on the back are created on the other side of those in the front. (☞ P.110 “5.Duplex Copying”)

5

6 Press the [ENTER] button.

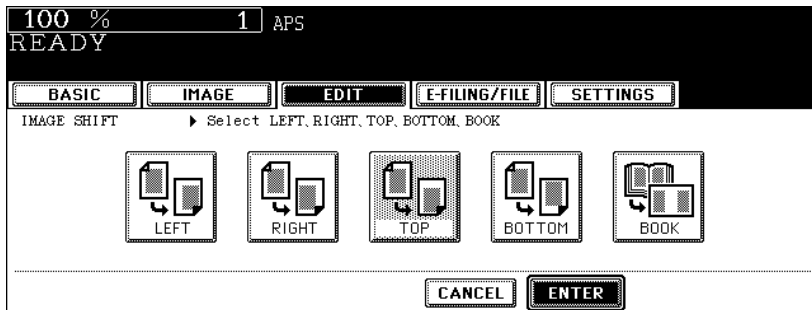

- Select other copy modes as required.

7 Press the [START] button.

Creating a bookbinding margin

This is used when setting "Book-type original -> 2-sided copy" (📖 P.115) in duplex copying. The margin is created in the centre (inner margin).

- Acceptable paper sizes for this function is A4 and B5 only.

- 1 Press the [EDIT] button to enter the edit menu, and then press the [IMAGE SHIFT] button.

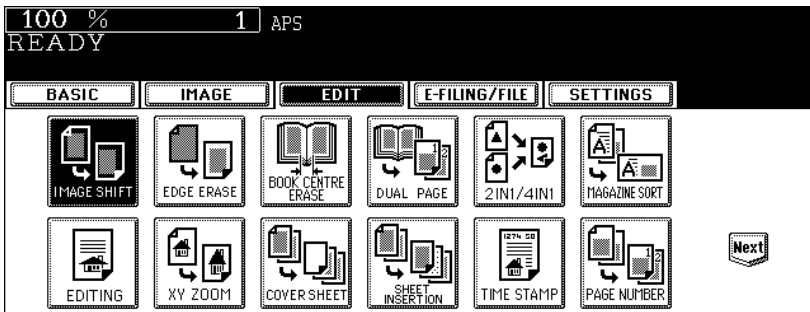

- 2 Press the [BOOK] button.

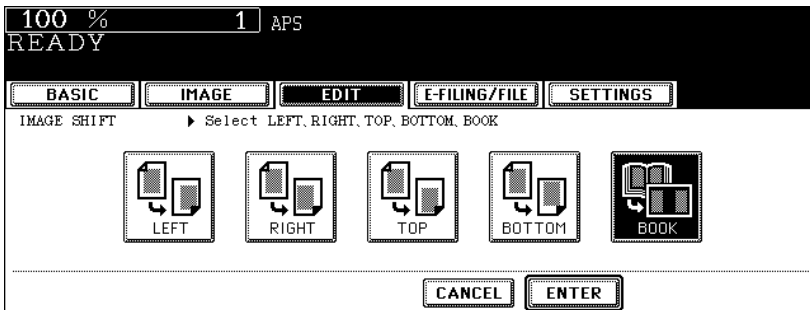

- 3 Adjust the margin width by pressing the [2 mm] or [30 mm] button, and then press the [ENTER] button.

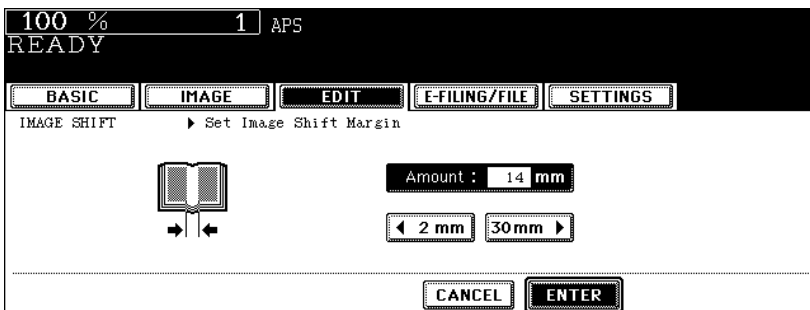

- The default width of the margin is 14 mm.

4 Press the [ENTER] button.

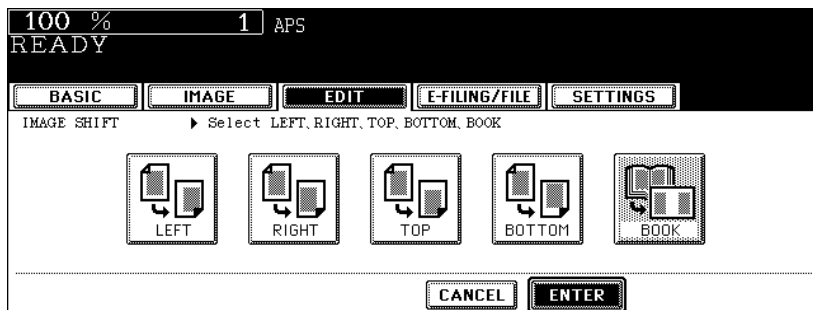

- Set "Book-type original -> 2-sided copy" (📖 P.115) in duplex copying as well.

2. EDGE ERASE

If the original has a dirty or torn edge, it may be reproduced as a black stain on the copy. In that case, set the edge erase. A white border is created along the edges of the copy, eliminating those black stains.

- This function is available only in the case of standard-size originals.
- The width of the edge erase margin can be adjusted in 1 mm increments.

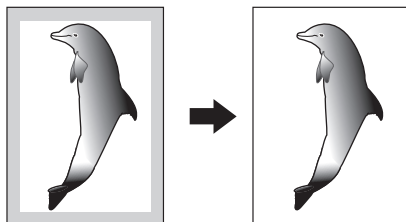

5 1 Place paper in the drawer(s).

- When using this mode in bypass copying (P.71), be sure to specify the paper size.

2 Place the original(s).

3 Press the [EDIT] button to enter the edit menu, and then press the [EDGE ERASE] button.

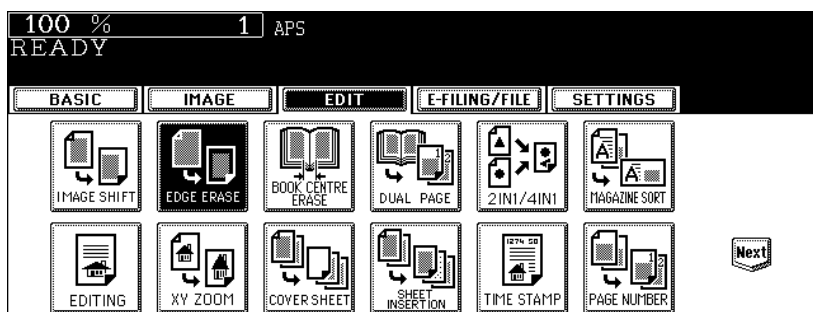

4 Adjust the width by pressing the [2 mm] or [50 mm] button, and then press the [ENTER] button.

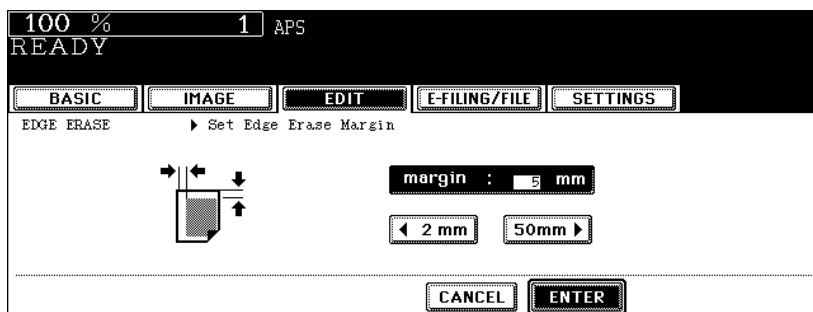

- The default width of the white border is 5 mm.
- Select other copy modes as required.

5 Press the [START] button.

3. BOOK CENTRE ERASE

This function allows you to erase the shadow in the centre of a book original.

1. Before book centre erase is set
2. After book centre erase is set
The width of the book centre erase margin can be adjusted in 1 mm increments.

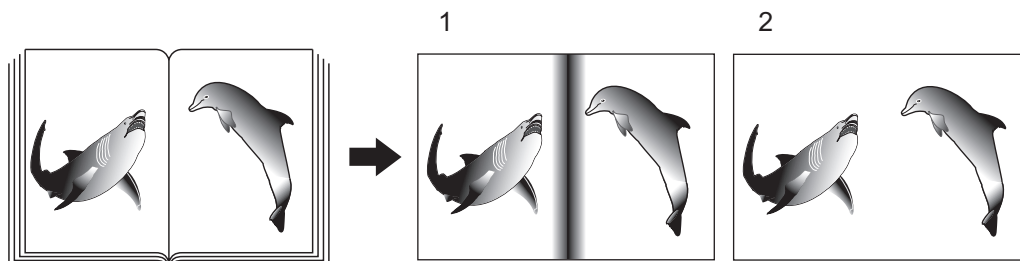

1 Place paper in the drawer(s).

- When using this mode in bypass copying (P.71), be sure to specify the paper size.

2 Press the drawer button representing the desired paper size on the touch panel.

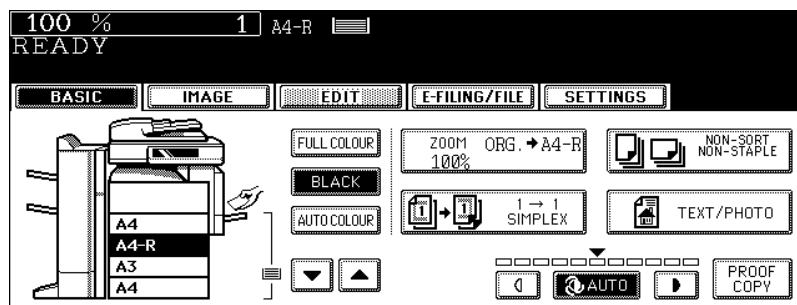

3 Press the [EDIT] button to enter the edit menu, and then press the [BOOK CENTRE ERASE] button.

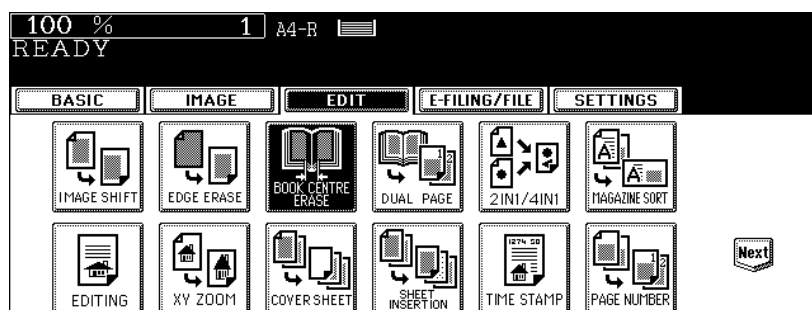

4 Adjust the width by pressing the [2 mm] or [50 mm] button, and then press the [ENTER] button.

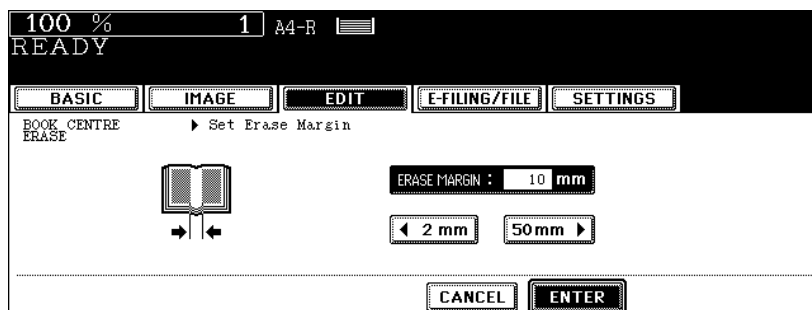

- The default width of the erase margin is 10 mm.
- Select other copy modes as required.

5 Place a book original on the original glass. Align its center with the yellow guide line near the centre of the original glass.

Caution

Do not place heavy objects (4 kg or more) on the original glass and do not press on it with force. Breaking the glass could injure you.

6 Press the [START] button.

4. DUAL PAGE

This function allows the facing pages of a book or magazine to be copied page by page onto 2 separate sheets of paper or duplex-copied on one sheet. It is not necessary to move the original on the glass. You can also place a pair of A4 or B5 sized originals side by side and copy them on separate sheets of paper.

- Acceptable paper sizes for this function is A4 and B5 only.

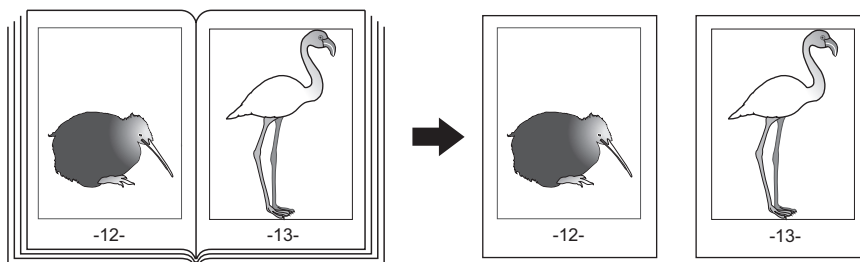

5

1 Place paper in the drawer(s).

2 Press the [EDIT] button to enter the edit menu, and then the [DUAL PAGE] button.

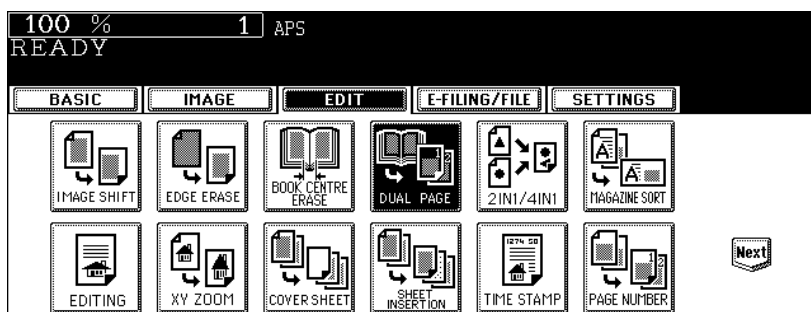

3 Press the [1 SIDE] (or [2 SIDE]) button.

- 1 SIDE: Making copies of the facing pages on 2 separate sheets of paper page by page
- 2 SIDE: Making duplex copies of them on one sheet

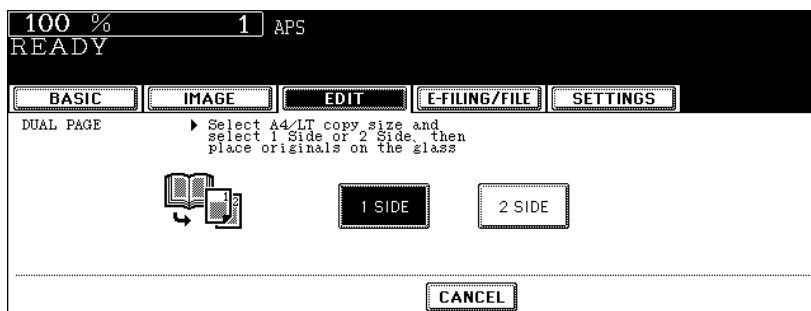

- The yellow indicator line for placing a book moves near the centre of the original glass.
- If you need a binding margin, set the right or left margin. (P.134 "Creating a right or left margin")

4 Press the [BASIC] button to enter the basic menu, and then select the copy size (A4 or B5).

- When using this mode in bypass copying (☞ P.71), be sure to specify the paper size.
- Select other copy modes as required.

5 Place the first page(s) to be copied on the glass, and then press the [START] button.

- Centre the book on the yellow indicator line with the bottom toward you. (☞ P.59 "Book-type originals")

Caution

Do not place heavy objects (4 kg or more) on the original glass and do not press on it with force. Breaking the glass could injure you.

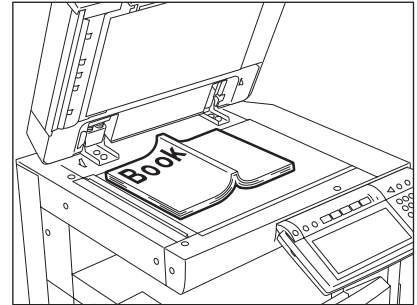

6 Turn to the next page, set the book again, and then press the [START] button.

- Repeat this step until all the originals have finished being scanned.

7 After all the originals have finished being scanned, press the [FINISHED] button.

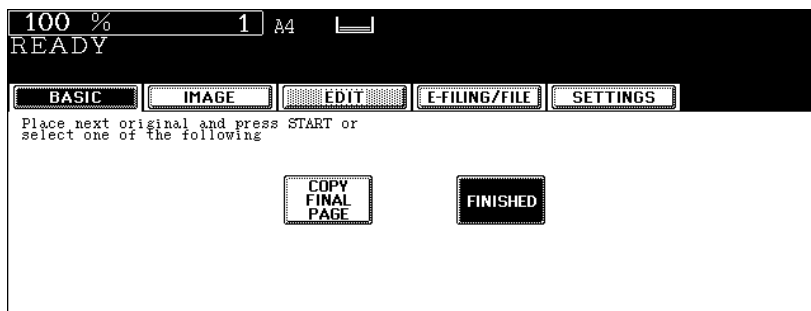

- Press the [COPY FINAL PAGE] button if the last original is a 1-sided page.

5. 2IN1 / 4IN1

This feature allows multiple originals to be reduced and copied onto a single sheet of paper. There are 2 modes: 2IN1 copying, where 2 originals are copied onto a single sheet, and 4IN1 copying, where 4 originals are copied onto a single sheet. In addition, duplex 2IN1 / 4IN1 modes are available, where four/eight originals can be copied to 2 sides of a single sheet of paper.

2IN1

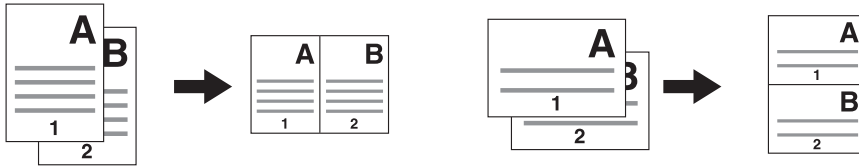

4IN1

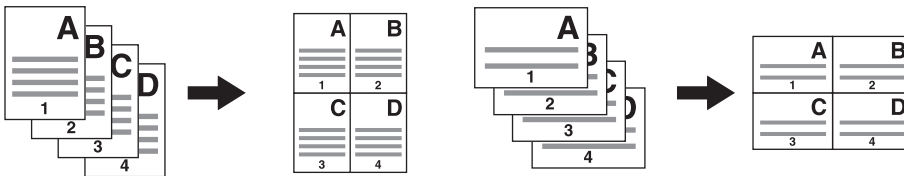

2IN1 DUPLEX (a: Side 1, b: Side 2)

- When a copy is turned with the line as a pivot, originals are printed on Side 2 (back face) as shown.

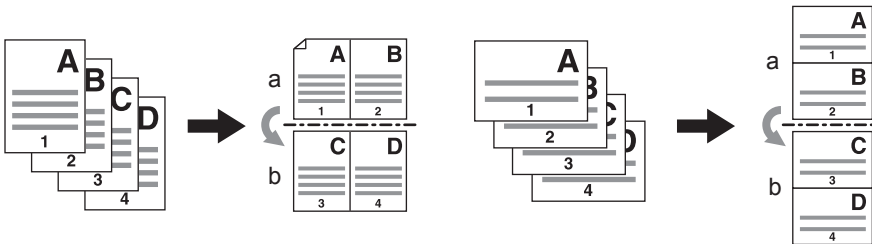

4IN1 DUPLEX (a: Side 1, b: Side 2)

- When a copy is turned with the line as a pivot, originals are printed on Side 2 (back face) as shown.

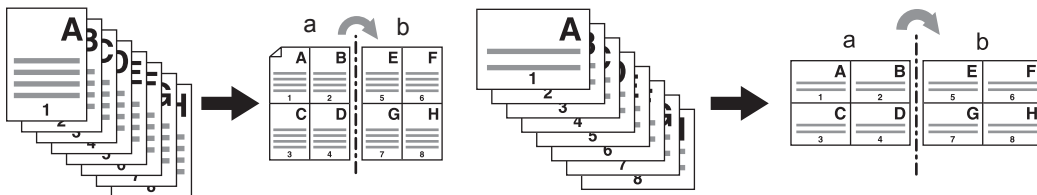

1 Place paper in the drawer(s).

Tips

- When using this mode in bypass copying (P.71), be sure to specify the paper size.
- If the paper size is not changed, paper of the same size as the original is selected.
- To make copies on paper which is not the same size as the original, press the [ZOOM] button on the basic menu to enter the following menu, select the desired paper size and press the [AMS] button.

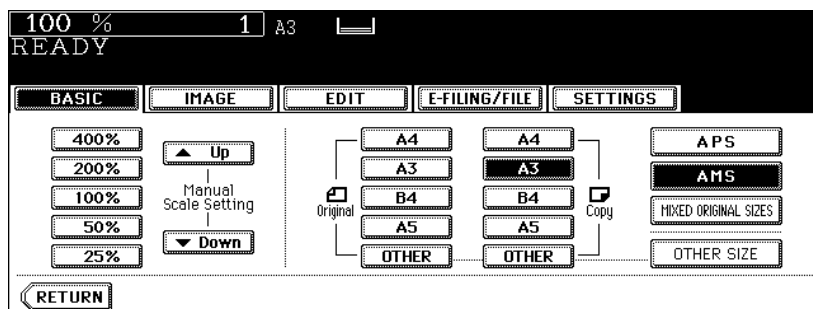

2 Place the original(s).

3 Press the [EDIT] button to enter the edit menu, and then press the [2IN1 / 4IN1] button.

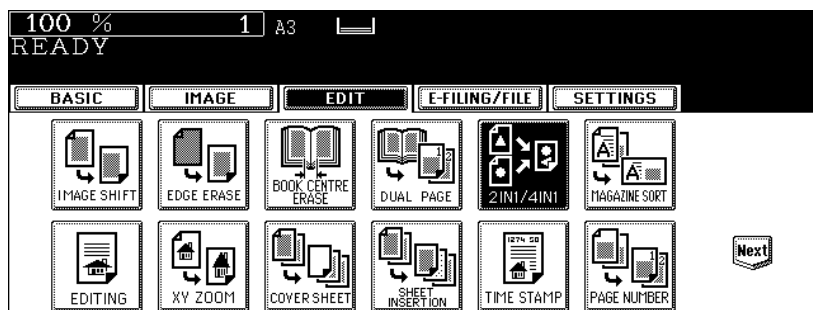

4 Select the type of image combination.

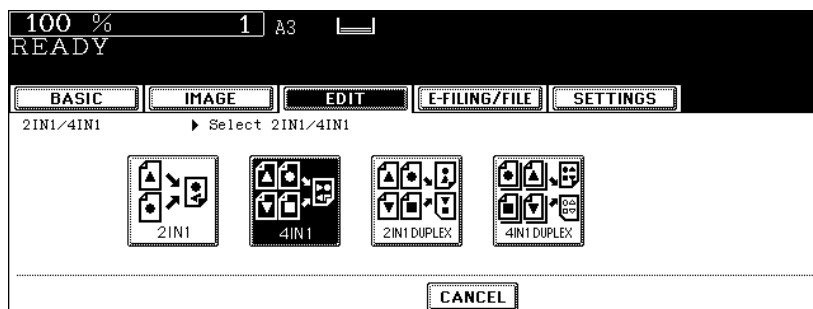

5 Press the [1 SIDE] (or [2 SIDE]) button.

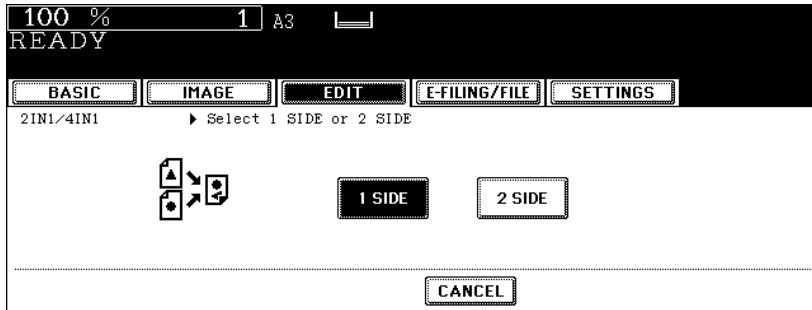

- Select other copy modes as required.

6 Press the [START] button.

5

6. MAGAZINE SORT

This function allows 1-sided originals to be copied and sorted so that they can be folded and bound along a centre line like typical magazines or booklets.

Example of copying a 12-page document

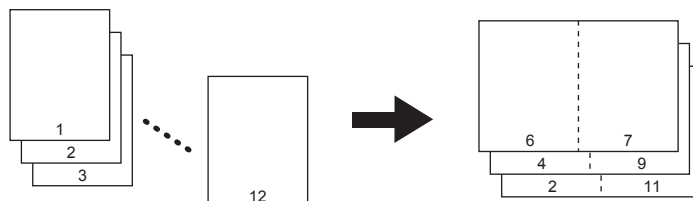

Tip

5

When placing a portrait originals horizontal to you in the magazine sort mode, be sure to set the correct direction of the originals. (P.170 "14.IMAGE DIRECTION")

Using this function in combination with the Saddle Stitch Finisher (optional) makes copies automatically folded in half and stapled along their centre line.

Example of copying with the Saddle Stitch Finisher (optional)

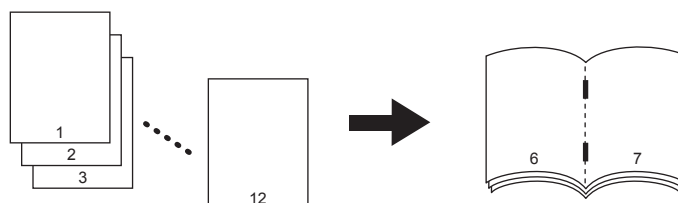

The Magazine sort function has 2 procedures; operating from the basic menu and operating from the edit menu. When operating from the edit menu, the margin width can be adjusted.

To operate from the basic menu, see P.103 "Magazine sort & saddle stitch mode (booklet mode)".

1 Place paper in the drawer(s).

- When using the Saddle Stitch Finisher, A3, A4-R, B4, LD, LG and LT-R are available.

2 Select the paper type.

- For drawer feeding, see P.86 "Manual paper selection".
- For bypass feeding, see P.71 "3.Bypass Copying".

3 Place the original(s).

- 4** Press the [EDIT] button to enter the edit menu, and then press the [MAGAZINE SORT] button.

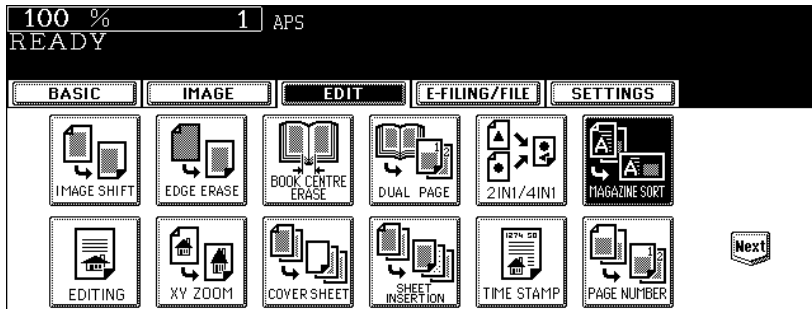

- 5** Set the saddle-stitch and the binding margin and press the [ENTER] button.

5

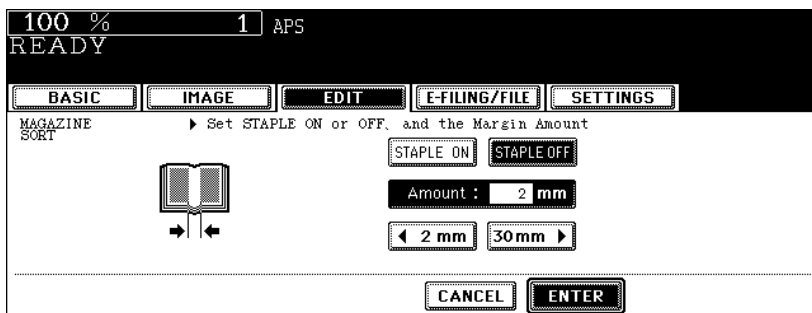

- To staple the centre line using the Saddle Stitch Finisher (optional), press the [STAPLE ON] button. For the maximum number of sheets that can be stapled, see P.105 “Available conditions for saddle stitching”.
- To adjust the width, press the [2 mm] or [30 mm] button.
- The default width of the margin is 2 mm.
- The margin width can be adjusted in 1 mm increments.
- Select other copy modes as required.

- 6** Press the [START] button.

7. EDITING

Trimming / Masking

This function allows you to copy only the inside of the specified area on an original (trimming) or copy with the specified area masked (masking). Up to 4 rectangular areas can be specified on an original.

- Image editing is only available with standard-size originals.
- If the original and copy paper sizes are set incorrectly, the image in the specified range may not be copied correctly.
 1. An example of trimming
 2. An example of masking

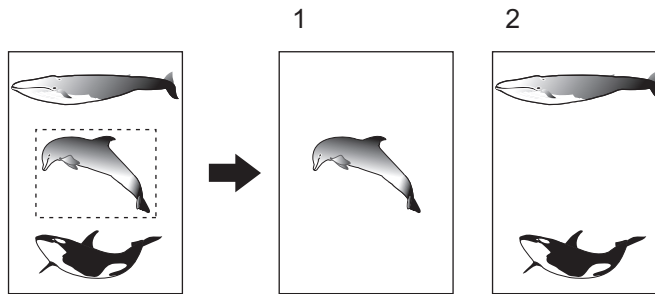

5

1 Place paper in the drawer(s).

- When using this mode in bypass copying, be sure to specify the paper size (☞ P.84 “1.Paper Selection”).

2 Press the [EDIT] button to enter the edit menu, and then press the [EDITING] button.

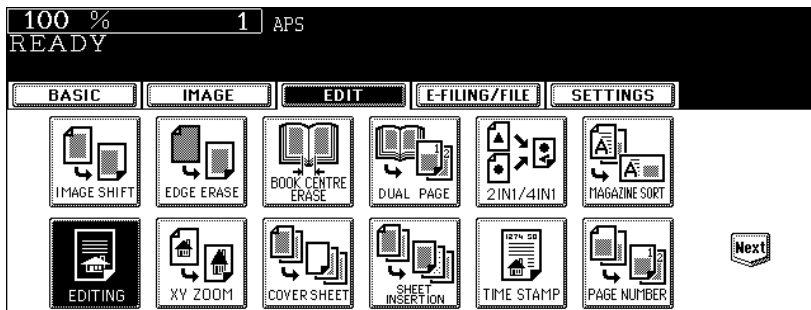

3 Press the [TRIM] (or [MASK]) button.

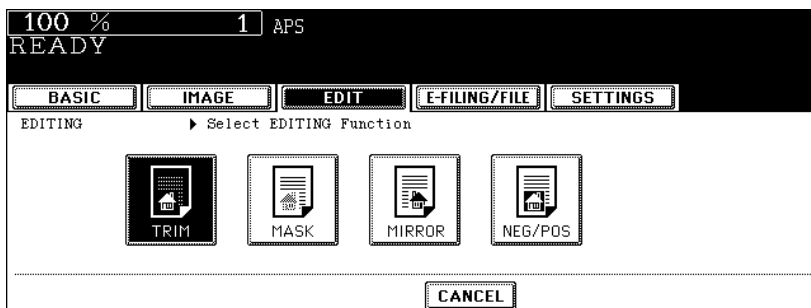

4 Place the original with its face up on the original glass.

- Set the original face up with its bottom toward you and fit its top left corner against the top left corner of the original glass, and align it with the original scales.

Caution

Do not place heavy objects (4 kg or more) on the original glass and do not press on it with force. Breaking the glass could injure you.

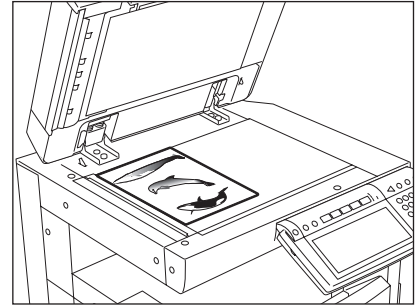

5 Specify the area. Using the original scale on the left and the inner (top) scale, read the following 4 values:

X1: Distance from the top left to the left edge of the specified area

X2: Distance from the top left to the right edge of the specified area

Y1: Distance from the top left to the upper edge of the specified area

Y2: Distance from the top left to the lower edge of the specified area

- The marks of the original scale have a 2 mm pitch.

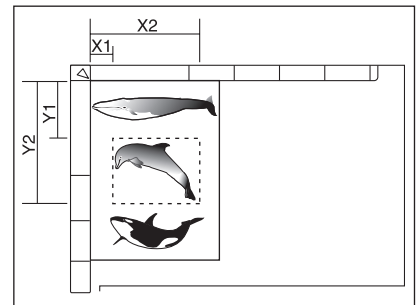

5

6 Enter the values read in step 5 for the specified area, and then press the [SET] button. Set 4 values in order.

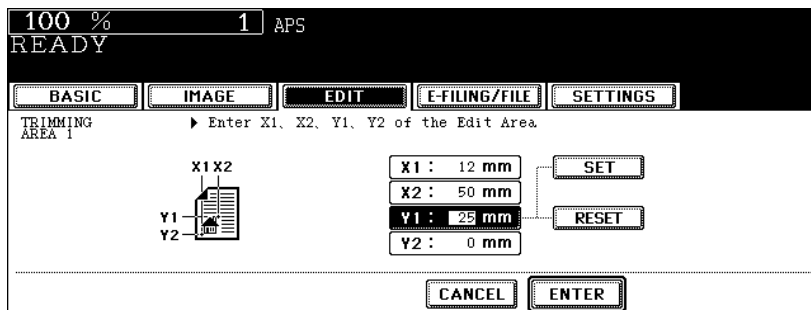

- After the setting of 4 values is finished, the next edit area menu is displayed. Repeat steps 5 and 6 when you specify other areas. Up to 4 areas can be specified on an original.
- To correct the value which has been set, press the [RESET] button. Pressing it once makes the highlighted field move one position upward. Highlight the field in which you want to rectify the value, and then key in the correct one.

7 Press the [ENTER] button after specifying the area.

8 Place the original(s) with its face down.

- Set the original face down with its bottom toward you and fit its top left corner against the top left corner of the original glass.
- Select other copy modes as required.

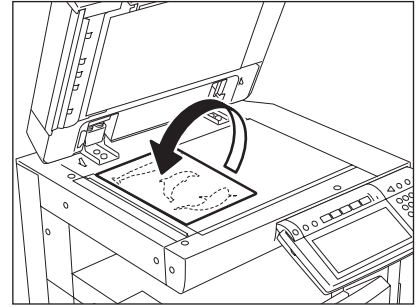

9 Press the [START] button.

5

Mirror image

This function allows you to make copies with images completely reversed (right and left).

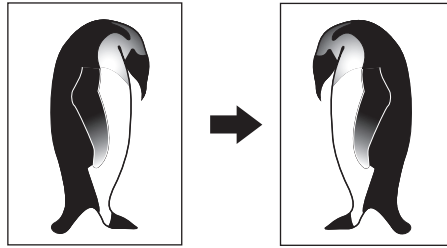

1 Place paper in the drawer(s).

- When using this mode in bypass copying, be sure to specify the paper size (☞ P.84 “1.Paper Selection”).

2 Place the original(s).

3 Press the [EDIT] button to enter the edit menu, and then press the [EDITING] button.

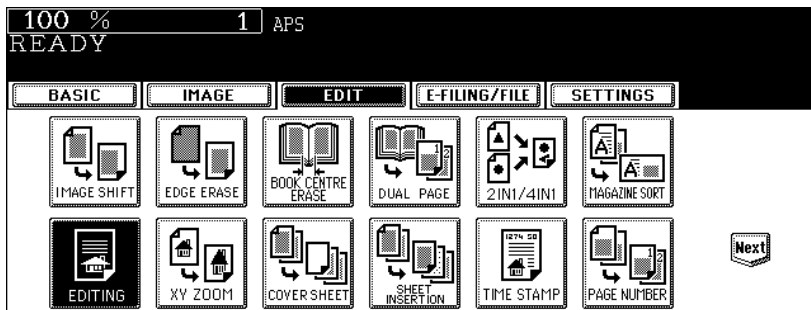

4 Press the [MIRROR] button.

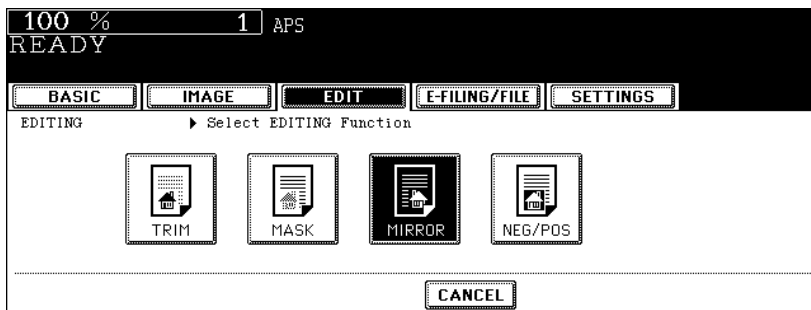

- Select other copy modes as required.

5 Press the [START] button.

Negative/Positive reversal

This function allows you to make copies reversing the contrasting density on the whole face of original.

- This function can be used only when the colour mode is "BLACK" or "FULL COLOUR".

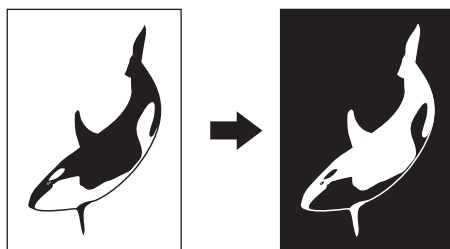

1 Place paper in the drawer(s).

- When using this mode in bypass copying, be sure to specify the paper size (☞ P.84 "1.Paper Selection").

2 Place the original(s).

3 Press the [EDIT] button to enter the edit menu, and then press the [EDITING] button.

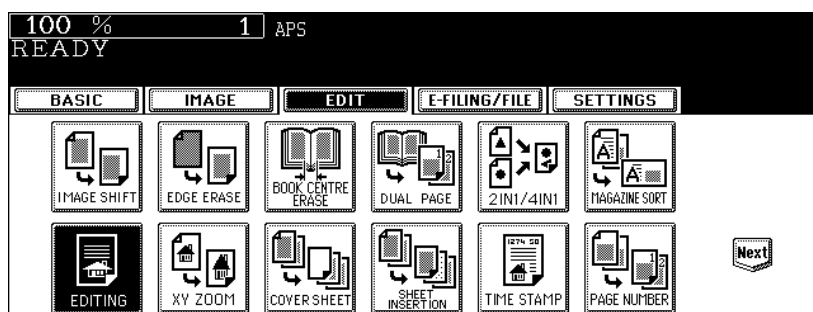

4 Press the [NEG/POS] button.

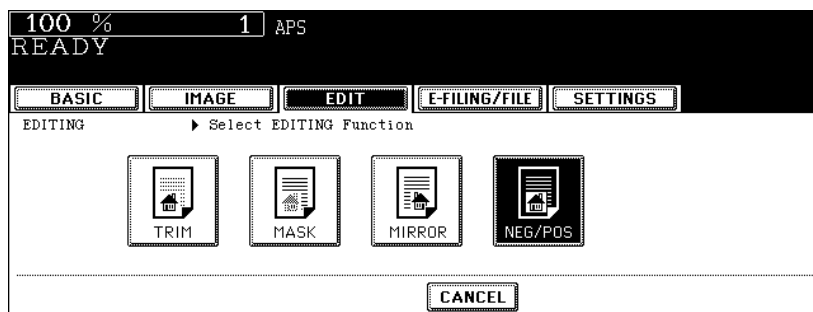

- Select other copy modes as required.

5 Press the [START] button.

8. XY ZOOM

This function allows you to make copies with different reproduction ratios set for the X (horizontal) and Y (vertical) direction.

The reproduction ratio is in the range of 25 to 400%. However, in the following cases, it is in the range of 25 to 200%.

- When the colour mode is “FULL COLOUR” or “AUTO COLOUR”
- When the original mode is “IMAGE SMOOTHING”
- When “TWIN COLOUR COPY” is used
- When the original is set on the Reversing Automatic Document Feeder (optional)



5

1 Place paper in the drawer(s).

- When using this mode in bypass copying (P.71), be sure to specify the paper size.

2 Place the original(s).

3 Press the [EDIT] button to enter the edit menu, and then press the [XY ZOOM] button.

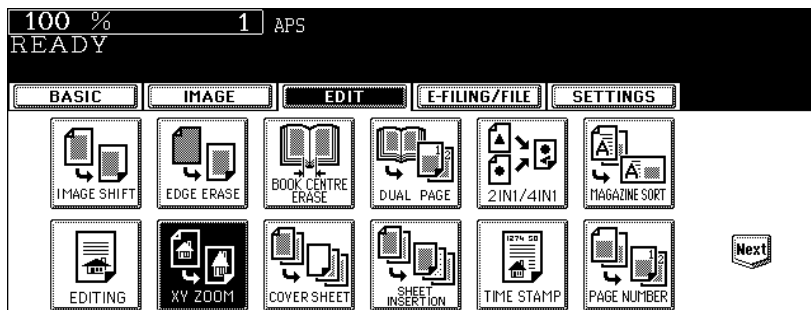

- 4** Using the [25%] and [400%] buttons, set the reproduction ratio for X and press the [SET] button. Then set the reproduction ratio for Y.

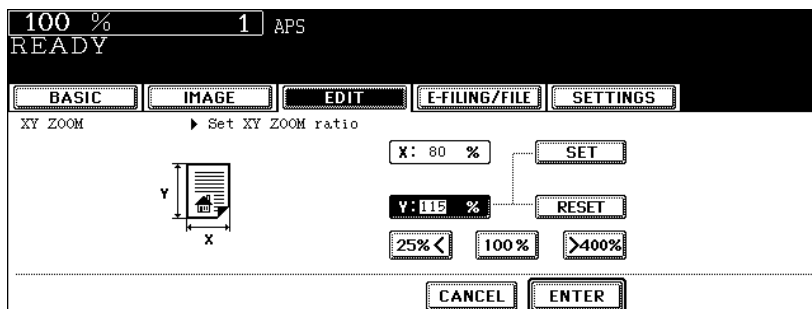

- 5** Press the [ENTER] button.

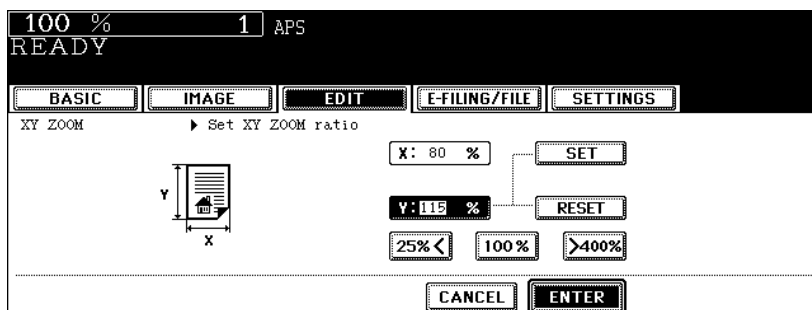

- Select other copy modes as required.

- 6** Press the [START] button.

9. COVER SHEET

This function allows you to insert special sheets of paper (such as colour paper) into a set of copies as cover sheets. A copied front cover sheet can be inserted. The back cover sheet is inserted blank. There are 4 types of sheet insertion modes:

1. Adding a blank front cover sheet ([TOP BLANK])
2. Adding a copied front cover sheet ([TOP COPIED])
3. Adding a blank front and blank back cover sheets ([BOTH BLANK])
4. Adding a copied front and blank back cover sheets ([TOP COPIED BACK BLANK])

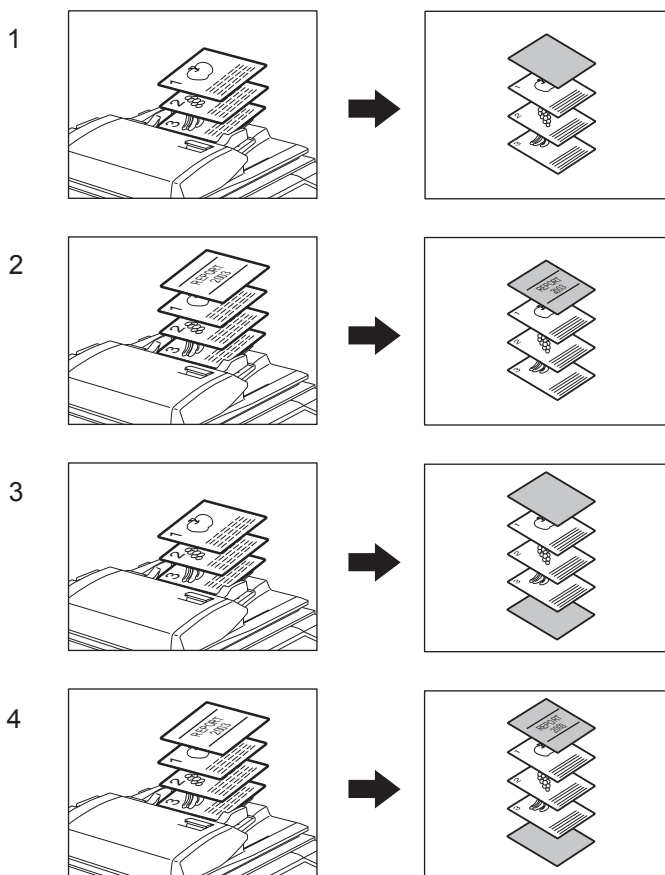

1 Place the cover sheet.

- Place the cover sheet in the drawer selected for cover sheets or on the bypass tray.
- When it is placed in the drawer for the cover sheets, you must set the paper type (cover sheet), size and thickness. (P.52 "Drawer for special uses")
- When it is placed on the bypass tray, you must set the paper size and thickness. (P.71 "3.Bypass Copying")
- Make sure the cover sheet and the sheets other than the cover sheet are placed in the same direction and of the same size.

2 Place paper (other than cover paper) in the drawer(s).

3 Place the original(s).

- Originals should be placed from the first page on the original glass.

4 Press the [EDIT] button to enter the edit menu and then the [COVER SHEET] button.

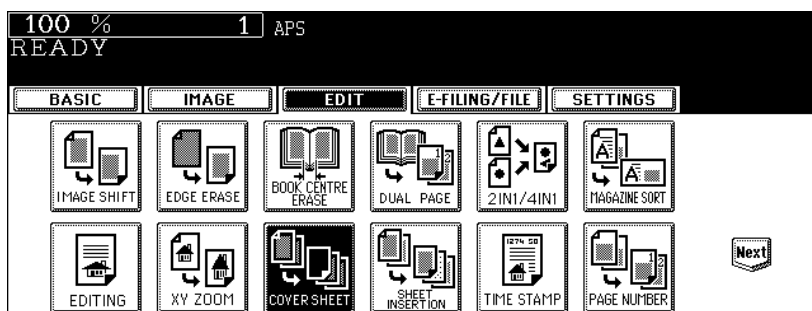

5 Press the desired cover sheet button.

TOP BLANK: To add a blank front cover sheet

TOP COPIED: To add a copied front cover sheet

BOTH BLANK: To add blank front and back cover sheets

TOP COPIED BACK BLANK: To add copied front and blank back cover sheets

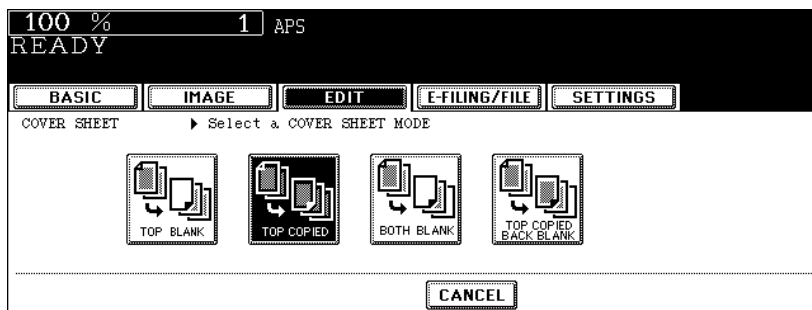

Tip

When "1-Sided Original to 2-Sided Copy" with the [TOP COPIED] or [TOP COPIED BACK BLANK] button pressed is performed, a 1-sided copy is made for a cover sheet.

6 Press the [BASIC] button to enter the basic menu, and then select a paper source of the same size and direction as the cover sheet.

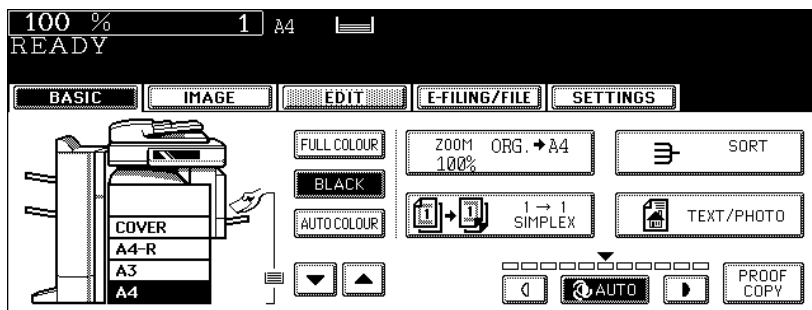

- Select other copy modes as required.

7 Press the [START] button.

- When the Reversing Automatic Document Feeder (optional) is used, the original is scanned and copying starts.
- When the original is placed on the original glass, perform steps 8 and 9.

8 Press the [YES] button and place the next original. Then press the [START] button.

- Repeat this step until all the originals have finished being scanned.

9 After all the originals have finished being scanned, press the [FINISHED] button.

- Copying starts.

10. SHEET INSERTION

This function allows you to insert special sheets of paper (such as colour paper) into the specified pages. 2 kinds of sheets for insertion are available. Up to 50 pages can be specified for [INSERT SOURCE 1] and [INSERT SOURCE 2], respectively. There are 2 types of sheet insertion modes:

1. Inserting a copied sheet into the specified page ([COPIED])
2. Inserting a blank sheet into the page previous to the specified one ([BLANK])

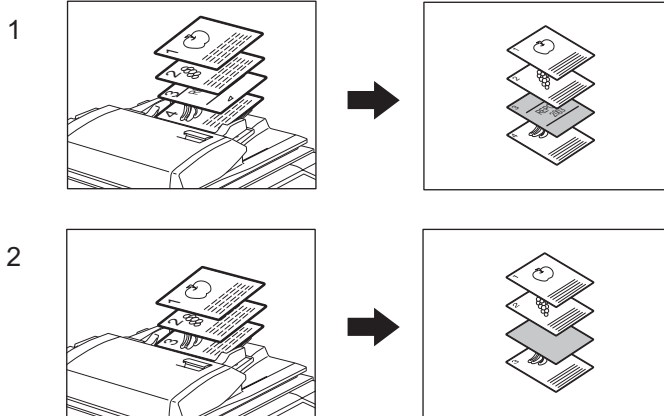

5

1 Place the special sheets of paper.

📖 P.52 “Drawer for special uses”

- Place the special sheets of paper on the bypass tray or in the drawer selected for sheet insertion.
- Both special sheets of paper and plain paper should be placed in the same direction and be of the same size.

2 Place plain paper in the drawer(s).

3 Place the original(s).

- Originals should be placed from the first page on the original glass.

4 Press the [EDIT] button to enter the edit menu, and then press the [SHEET INSERTION] button.

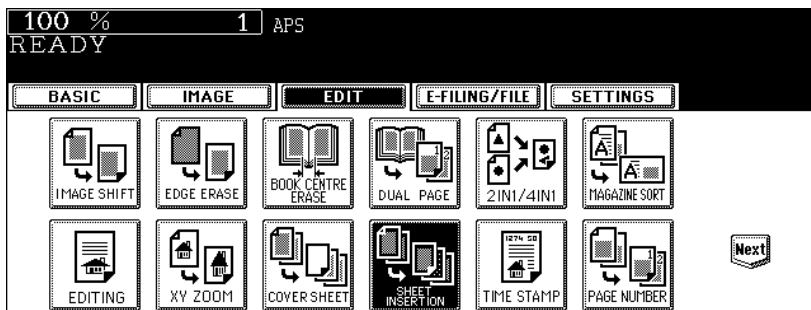

5 Press the [COPIED] (or [BLANK]) button.

COPIED: To insert a copied sheet into the specified page

BLANK: To insert a blank sheet into the page previous to the specified one

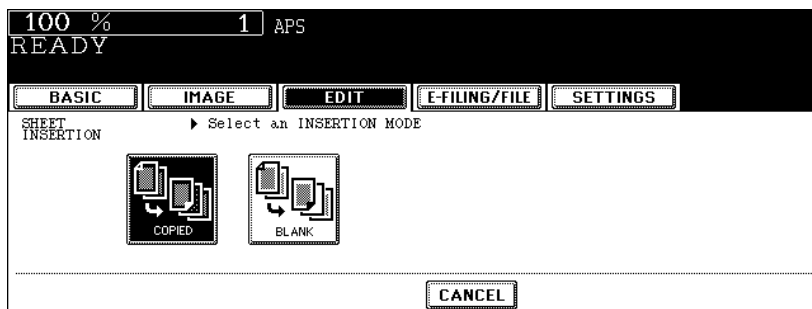

6 Press the [INSERT SOURCE 1] (or [INSERT SOURCE 2]) button.

5

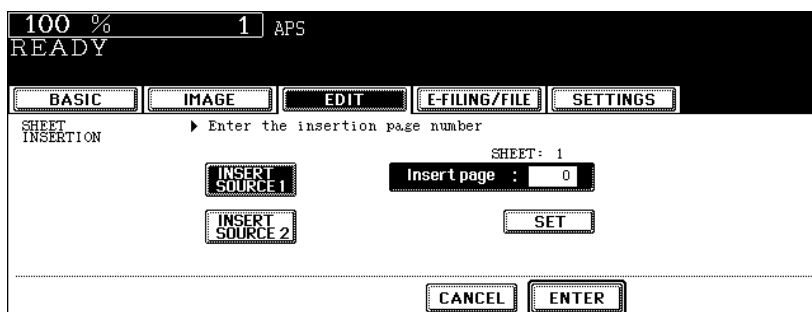

7 Key in the desired page number (3 digits or less) for insertion and press the [SET] button.

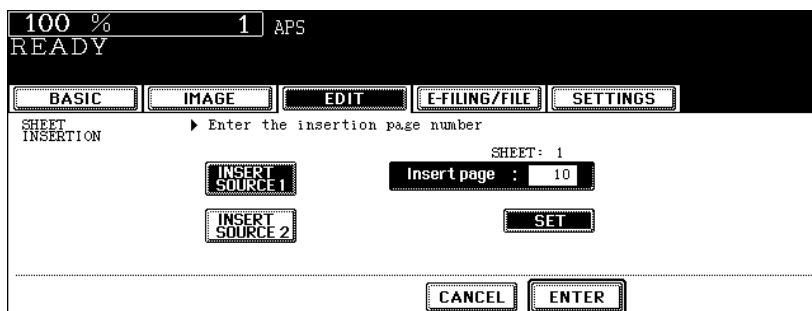

- When [COPIED] is selected on step 5, a copied sheet is inserted into the specified page. When [BLANK] is selected, a blank sheet is inserted into the page previous to the specified one.
- Up to 50 pages can be specified for [INSERT SOURCE 1] and [INSERT SOURCE 2]. When inserting multiple sheets one by one at specified pages, repeat steps 6 and 7.

- 8** After the specifying of all insertion pages is finished, press the [ENTER] button.

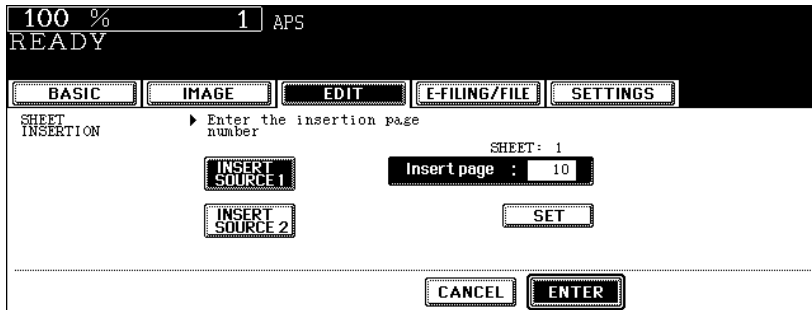

5

- 9** Press the [BASIC] button to enter the basic menu, and then select a paper source of the same size and direction as the sheet insertion.

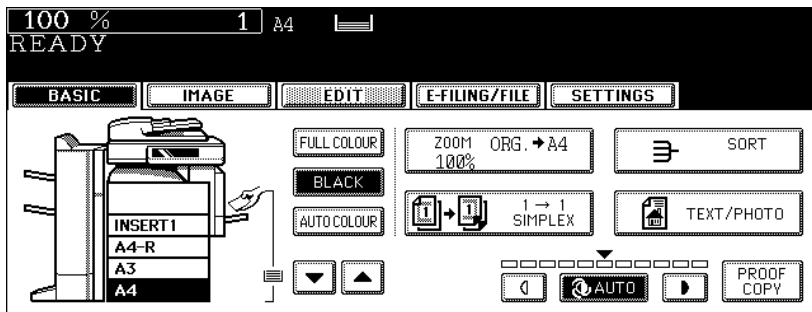

- Select other copy modes as required.

- 10** Press the [START] button.

- When the Reversing Automatic Document Feeder (optional) is used, the original is scanned and copying starts.
- When the original is placed on the original glass, perform steps 11 and 12.

- 11** Press the [YES] button and place the next original. Then press the [START] button.

- Repeat this step until all the originals have finished being scanned.

- 12** After all the originals have finished being scanned, press the [FINISHED] button.

- Copying starts.

11. TIME STAMP

This function allows you to add the time and date of the scanning to the copies.

1. Printed at the bottom of a portrait copy
2. Printed at the top of a landscape copy

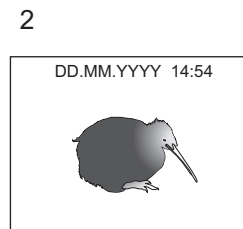
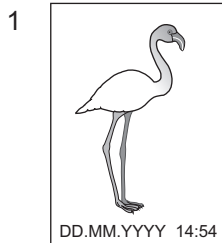

1 Place paper in the drawer(s).

2 Place the original(s).

3 Press the [EDIT] button to enter the edit menu, and then press the [TIME STAMP] button.

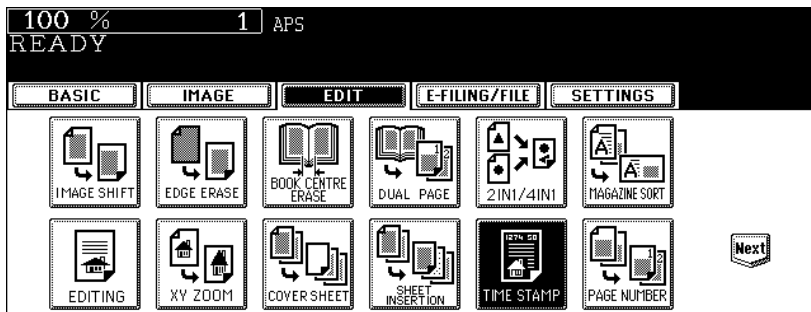

4 Select the orientation ([Short edge] or [Long edge]) and position ([UPPER] or [LOWER]) of the date and time to be printed, and then press the [ENTER] button.

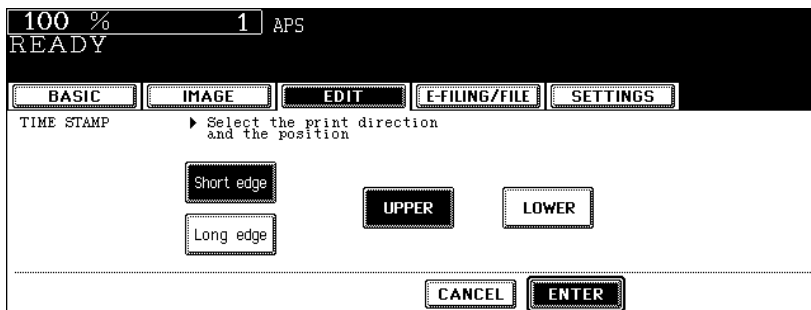

- Select other copy modes as required.

5 Press the [START] button.

12. PAGE NUMBER

This function allows you to add page numbers to the copies.

1. Printed at the bottom centre of a portrait copy
2. Printed at the top right of a landscape copy

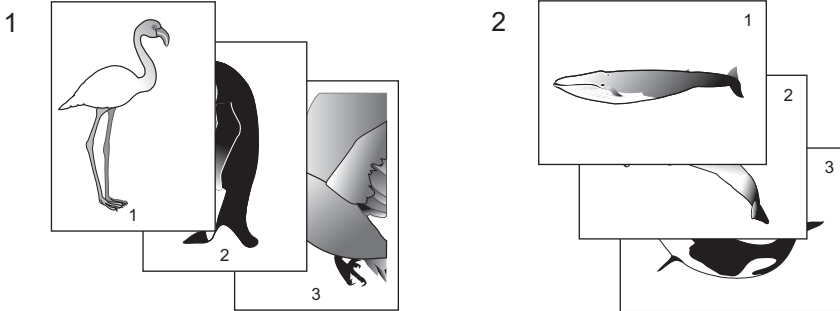

5

1 Place paper in the drawer(s).

2 Place the original(s).

3 Press the [EDIT] button to enter the edit menu, and then press the [PAGE NUMBER] button.

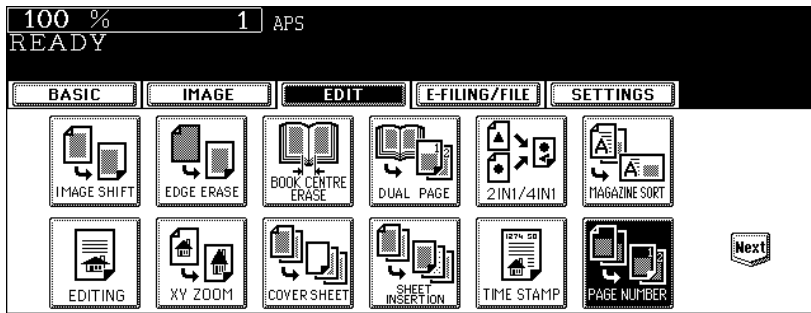

- 4** Select the orientation ([Short edge] or [Long edge]) and position ([TOP LEFT], [TOP CENTRE], [TOP RIGHT], [BOTTOM LEFT], [BOTTOM CENTRE] or [BOTTOM RIGHT]) of the page number to be printed, and then press the [ENTER] button.

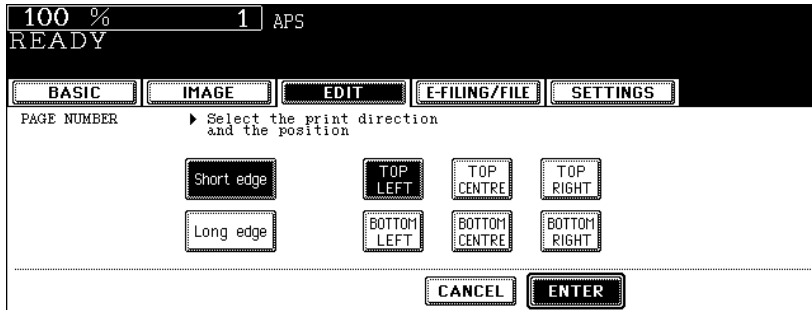

5

- 5** Key in the starting page number and then press the [ENTER] button.

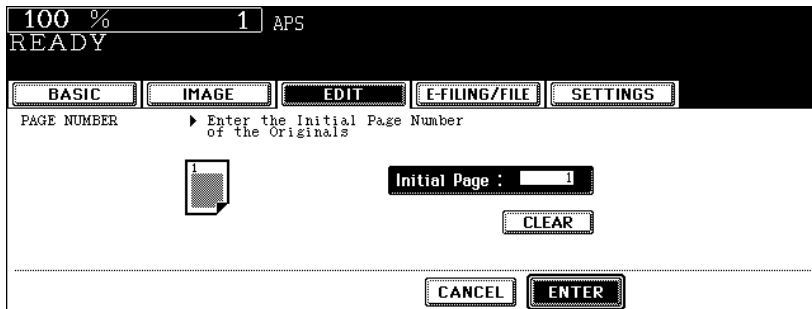

- Select other copy modes as required.

- 6** Press the [START] button.

13. JOB BUILD

This function allows you to copy different kinds of originals at one time.

Scanning is performed by setting the optimal original mode and image adjustment for each original (it is called a job). After all the originals have finished being scanned, they can be copied at one time.

Also, the original scanning source (Reversing Automatic Document Feeder or original glass) of originals can be switched per job, and so, for example, after originals such as multiple A3 texts, news clips, photographs in magazines and multiple A4 photographs with the appropriate settings have finished being scanned, they can be copied in the scanned order in one go. And the scanned data can be stored in e-Filing.

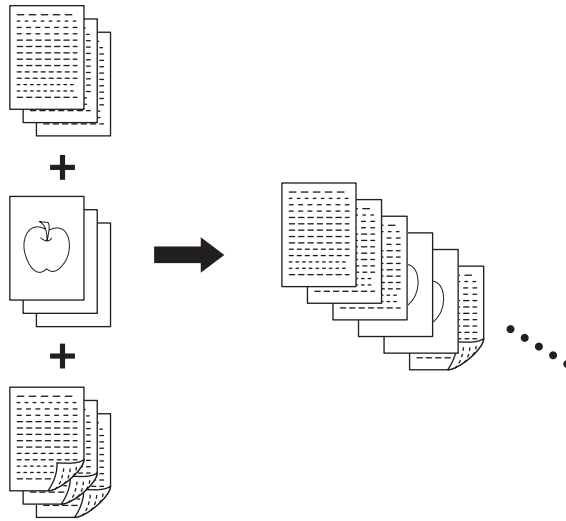

5

- Up to 1000 pages of originals are possible.
- Any number of jobs can be set until the total number of scanned original pages reaches 1000.

There are restrictions on the settings for JOB BUILD: Settings not available for JOB BUILD, common settings which are set before scanning the first job and applied to all jobs, and changeable settings for each job. See the following table to perform the setting.

Settings not available for JOB BUILD	Common settings for all jobs	Changeable settings per each job
Automatic Paper Selection (APS) Book to 2 Twin colour copy Image editing XY zoom Cover copying Sheet insertion mode Magazine sort Magazine sort & Saddle stitch 2IN1 / 4IN1	e-Filing/file Mixed-size original Paper size to be copied Sort mode Image shift Book centre erase Time stamp Page number Image direction in 2-sided copying Book <-> tablet	Reproduction ratio Automatic magnification selection (Default setting for JOB BUILD) Original size Original mode Colour mode 1-sided -> 1-sided / 2-sided -> 1-sided (or 1-sided -> 2-sided / 2-sided -> 2-sided) copying Background adjustment Sharpness Edge erase Dual-page ADF / SADP

1 Place the originals of the 1st job.

Tips

- When an original is placed on the original glass, one page is regarded as one job.
- To copy mixed-size originals using the Reversing Automatic Document Feeder, see [P.87](#) “Copying mixed-size originals in one go (mixed original size)”.
- Select the drawer if you want to specify it.

2 Press the [EDIT] button to enter the edit menu, and then press the [JOB BUILD] button.

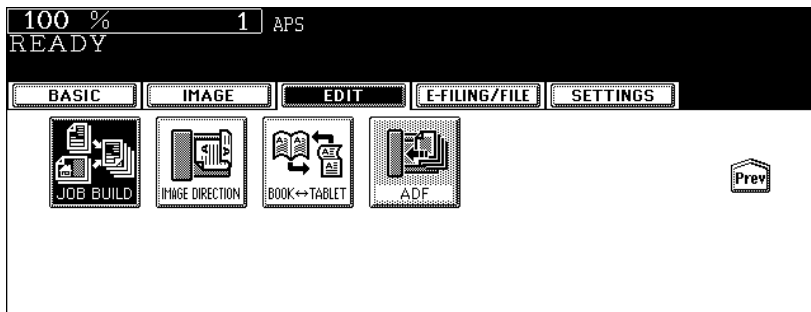

- If the desired function button is not displayed, press the [Prev] or [Next] button to switch the menu.

3 Press the [ENTER] button.

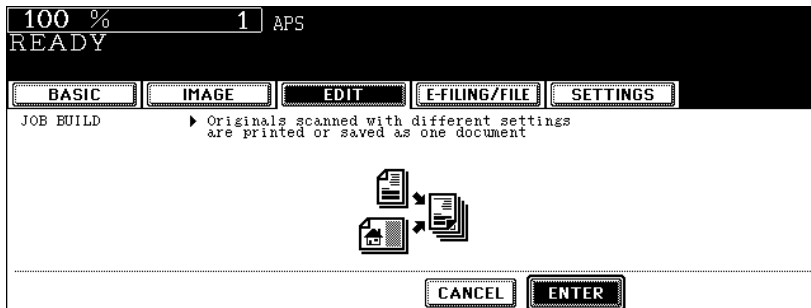

- Read the brief description of JOB BUILD on the touch panel.
- JOB BUILD is set and the basic menu is displayed.

- 4** After “Press START button to copy after changing settings.” appears, perform the settings for the 1st job and the common settings for all jobs.

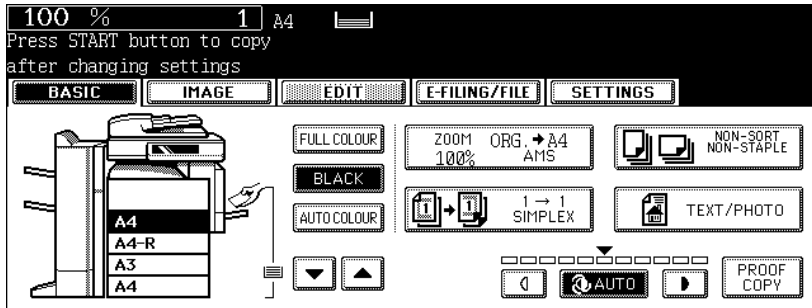

- Press the [SETTINGS] button to confirm the settings.
- To change the settings, press the [FUNCTION CLEAR] button, and then start the procedure again from step 1.

- 5** Press the [START] button.

- The scanning of the originals for the 1st job starts.

- 6** After “Press START button to copy after changing settings.” appears, place the originals of the 2nd job. Perform the settings for the 2nd job.

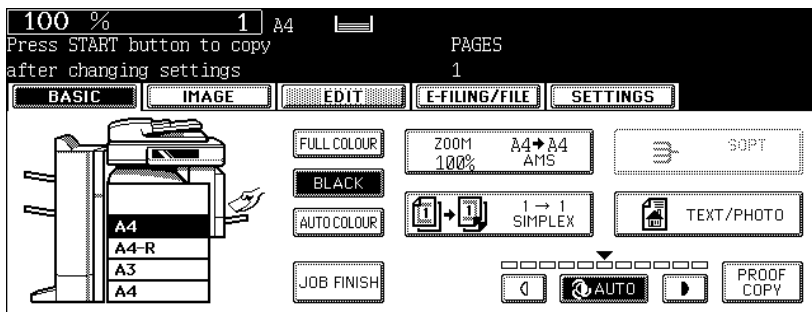

- Note that copying will be performed in the same modes as those of the 1st job if the settings are not changed.
- Press the [SETTINGS] button to confirm the settings.

- 7** Press the [START] button.

- The scanning of the originals for the 2nd job starts.
- Repeat steps 6 to 7 until all the originals have finished being scanned.

- 8** After all the originals have finished being scanned, confirm the number of copies on the menu and change if needed.

9 Press the [JOB FINISH] button on the basic menu.

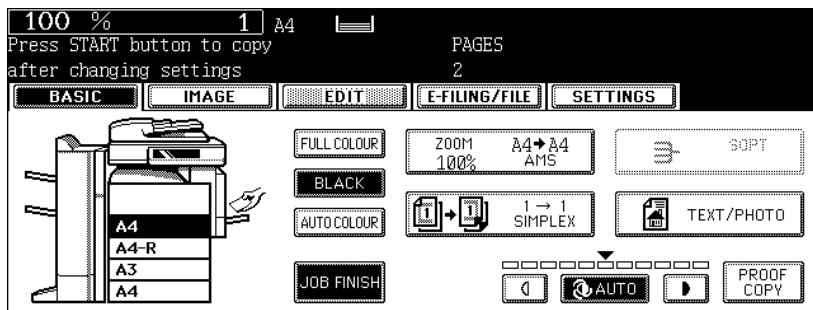

- The copying of the originals starts.
- When copy and e-Filing/file functions are set, storing starts.

14. IMAGE DIRECTION

This function allows you to adjust the direction to 'open to left' when a lengthwise A3, A4, A5, B4, B5 originals, etc. is copied under the mode of 1-Sided Originals to 2-Sided Copies (or 2-Sided Originals to 1-Sided Copies).

- This function is not necessary for copying in the direction of 'open to top'.

When a 2-sided 'open to left' (Book) portrait A3, A4, A5, B4, B5 originals, etc. is copied using this function with [2-Sided Originals to 1-Sided Copies], copies can be adjusted to the same direction.

[IMAGE DIRECTION]:

1. Set
2. No setting

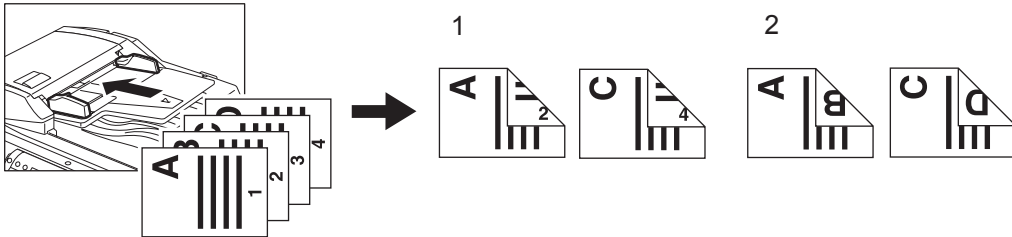

1 Place paper in the drawer(s).

2 Place the original(s).

3 Perform the setting of [1 -> 2 DUPLEX] (or [2 -> 1 SPLIT]).

P.110 "5.Duplex Copying"

4 Press the [EDIT] button to enter the edit menu, and then press the [IMAGE DIRECTION] button.

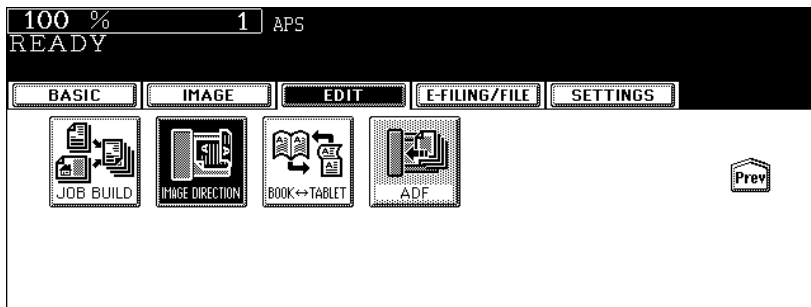

- The direction of the copy is adjusted by this operation.
- If the desired function button is not displayed, press the [Prev] or [Next] button to switch the menu.

5 Press the [ENTER] button.

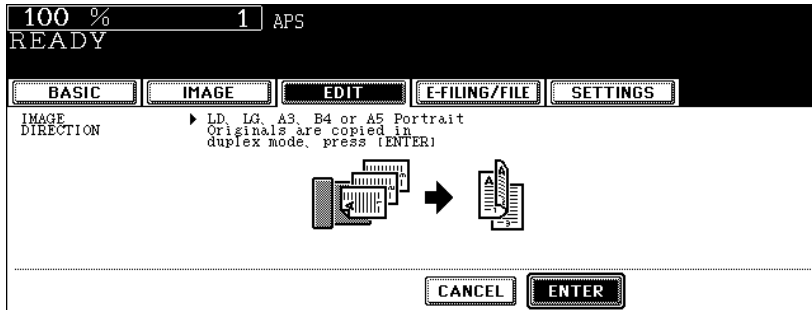

- Select other copy modes as required.

6 Press the [START] button.

5

15. BOOK - TABLET

When copying under the mode of 2-Sided Originals to 2-Sided-Copies, this function allows you to rotate the back side of the original to be copied by 180°. It is useful when 'open to left' (Book) originals need to be copied in 'open to top' (Tablet), and the opposite condition is available.

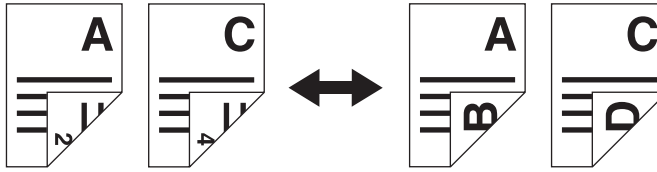

1 Place paper in the drawer(s).

5

2 Place the original(s).

3 Perform the setting of [2 -> 2 DUPLEX].

📖 P.110 "5.Duplex Copying"

4 Press the [EDIT] button to enter the edit menu, and then press the [BOOK <-> TABLET] button.

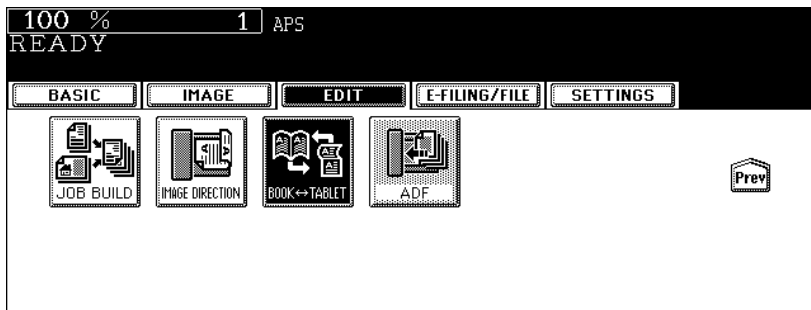

- 'Open to left' originals are copied in 'open to top' and 'open to top' originals are copied in 'open to left' by this operation.
- If the desired function button is not displayed, press the [Prev] or [Next] button to switch the menu.

5 Press the [ENTER] button.

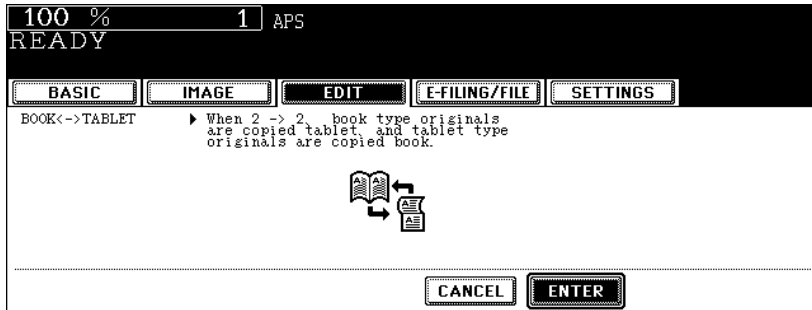

- Select other copy modes as required.

6 Press the [START] button.

16. ADF / SADF

You can select the paper feeding mode when using the Reversing Automatic Document Feeder (optional). There are two ways to feed originals.

Continuous feed mode: Originals placed on the Reversing Automatic Document Feeder are continuously fed in after the [START] button is pressed. It is useful to select this mode for copying multiple originals at one time. (This is the initial setting at the time of the installation of the equipment.)

Single feed mode: An original is automatically pulled in as soon as it is placed. It is recommended to select this mode for copying originals one by one.

- In the single feed mode, set the originals one after another. Setting more than one original could cause a tilted image or a paper jam.
- To set different size originals, see  P.87 “Copying mixed-size originals in one go (mixed original size)”.

5

Continuous feed mode

1 Place paper in the drawer(s).

2 Press the [EDIT] button to enter the edit menu, and then press the [SADF] button.

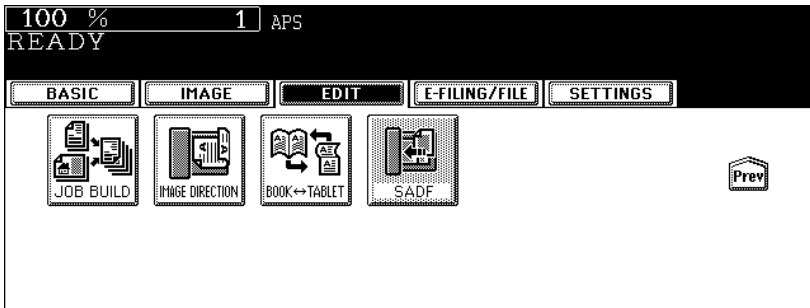

- If the [ADF] button is already displayed, the continuous feed mode is set. In this case, skip to step 5.
- If the desired function button is not displayed, press the [Prev] or [Next] button to switch the menu.

3 Press the [ADF] button.

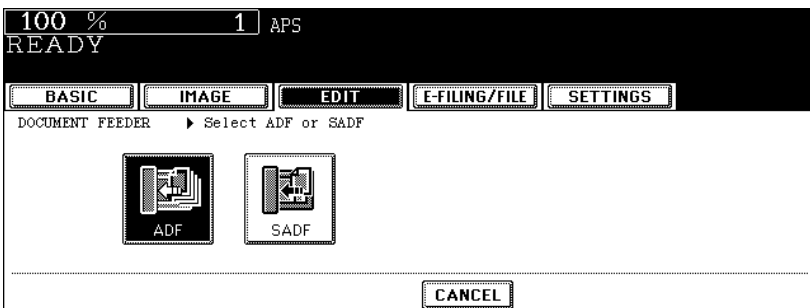

- Select other copy modes as required.

4 Place the original(s) on the Reversing Automatic Document Feeder (optional).

P.60 “Using the Reversing Automatic Document Feeder (optional)”

5 Press the [START] button.

Single feed mode

1 Place paper in the drawer(s).

2 Press the [EDIT] button to enter the edit menu, and then press the [ADF] button.

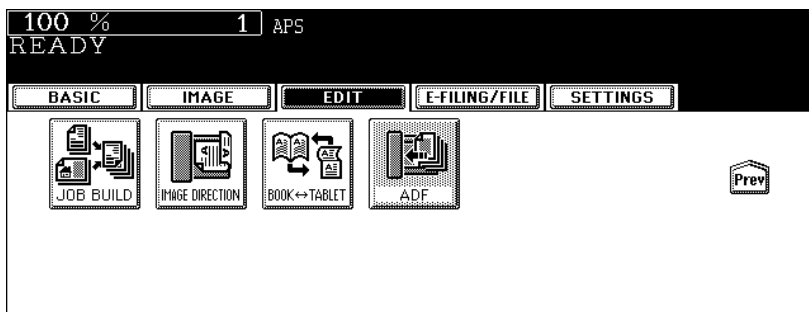

- If the [SADF] button is already displayed, the single feed mode is set. In this case, skip to step 4.
- If the desired function button is not displayed, press the [Prev] or [Next] button to switch the menu.

3 Press the [SADF] button.

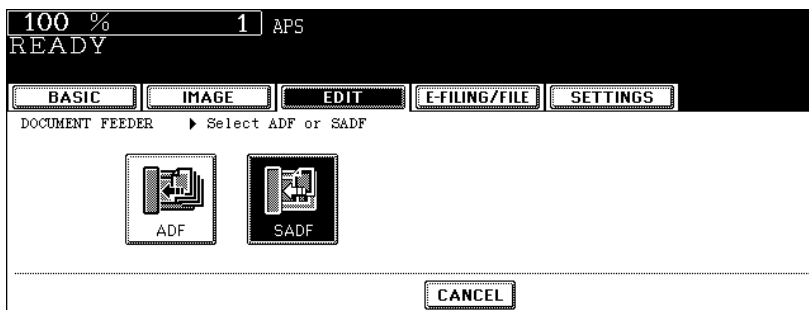

- Select other copy modes as required.

4 Place the originals one by one.

- The original is automatically pulled in and the following menu is displayed.

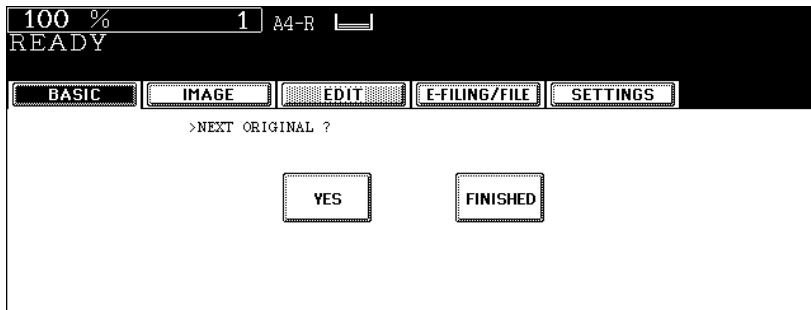

- If there are more originals, set them in the same way. (The same operation is performed whether or not you press the [YES] button.)

5 After all originals have finished being fed, press the [FINISHED] button.

5

6. e-FILING

1. e-Filing	178
2. Creating User Boxes	180
3. Changing Data of User Boxes.....	182
4. Deleting User Boxes	185
5. Storing Documents in e-Filing	187
6. Printing Stored Documents	191
7. Deleting Folders or Documents.....	196

1. e-Filing

This feature allows you to store, print and manage documents obtained by copying, printing from a PC, scanning, receiving Fax and receiving Internet Fax. The document is stored into the hard disk embedded in this equipment.

- To use documents received by Fax in e-Filing, a Fax Unit is required.
- When the Data Overwrite Kit (optional) is installed, it may take time before e-Filing can be used after the power is turned ON. This depends on the number of files in e-Filing.
- Delete the documents in e-Filing when they are no longer needed.
- The e-Filing box in which highly confidential documents are stored must be password protected.

There are two kinds of e-Filing as follows.

Public box:

This is prepared as a default setting. This is used to store a shared document that can be accessed by any users without restrictions.

User box:

Up to 200 boxes can be created. Passwords can be set for each user box.

- Up to 100 folders per one box can be created. A maximum of 400 documents can be stored in one folder. The maximum number of original pages is 200. (However, it may be restricted depending on the amount of free space on the hard disk embedded in this equipment.)

6

An outline of e-Filing is as follows.

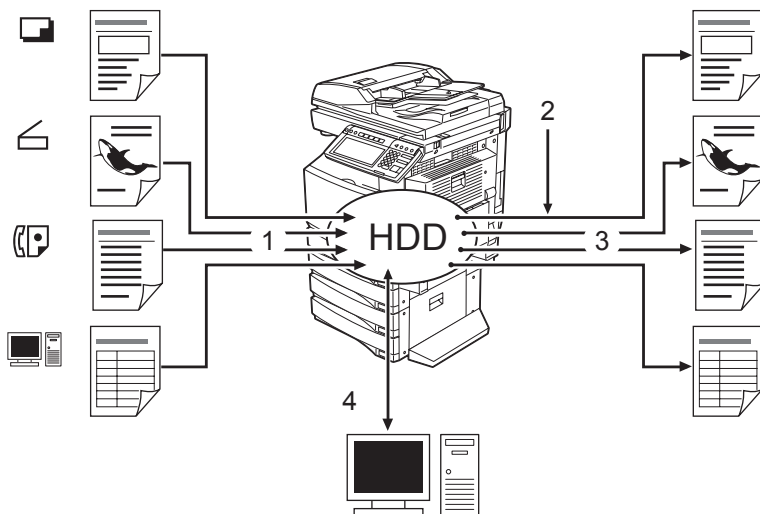

1. Store a document into e-Filing.
2. Add a printing setting to the stored document as required.
3. Print the document.
4. Use the document on the PC. (See the e-Filing Guide for details.)
 - The stored document in e-Filing can be downloaded to a client PC by using the "File Downloader".
 - The stored document in e-Filing can be imported as an image into the TWAIN-compatible application by the TWAIN driver.
 - You can edit and back up the document, create a folder, etc. in the e-Filing using "TopAccess".

Tips

- The available settings differ between when the operation is performed from the touch panel of this equipment or using “TopAccess” from a client PC. See the e-Filing Guide for details.
- When the preservation period for documents in e-Filing is specified, the stored documents will be deleted after this period has passed. You need to print the documents or download them into a client PC using the “File Downloader”. See the e-Filing Guide for details. (For setting the storing period of the documents in e-Filing, ask the network administrator.)
- Be sure to back up the data stored in e-Filing regularly in case of a hard disk failure. See the e-Filing Guide for details.

This chapter explains about when copied original data are stored to e-Filing. See the e-Filing Guide for storing, printing and managing the document obtained by printing from a PC, scanning, receiving fax and receiving Internet Fax (except for copying) and operating e-Filing via network.

2. Creating User Boxes

Up to 200 user boxes can be created. To prepare user boxes for different purposes enables you to have efficient document management.

Folders can be created in each user box. Also, password can be set to each user box.

- You can create folders using “TopAccess” from a client PC. See the e-Filing Guide for details.

Set up a user box following the procedure below.

- 1 Press the [e-FILING] button on the control panel.**

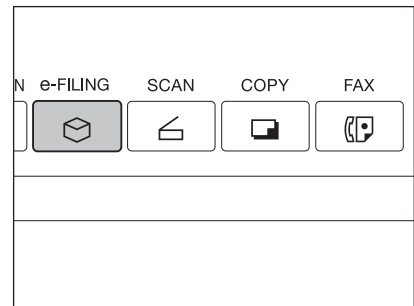

- 2 Select a blank box number between “001” and “200”, and then press the [SETUP] button.**

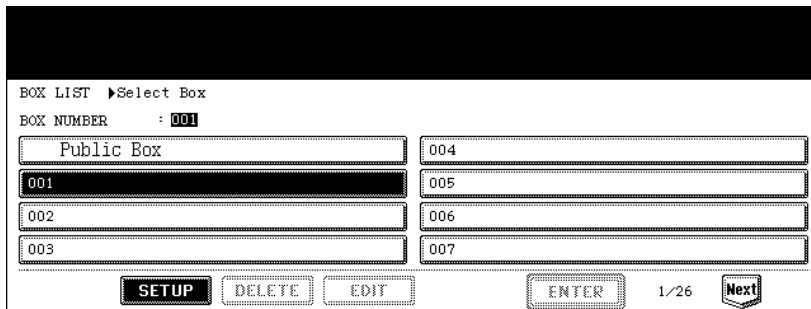

- If the desired box is not displayed, press the [Prev] or [Next] button to switch the menu.
- To display the applicable menu immediately, key in the box number.

- 3 Press the [BOX NAME] button, and then enter the box name.**

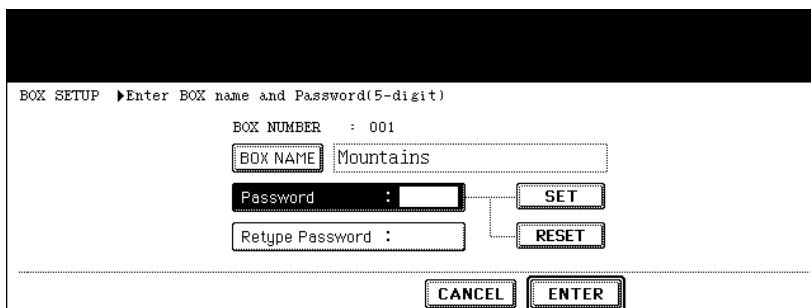

- When the [BOX NAME] button is pressed, the letter entry menu (P.33) is displayed. Up to 32 letters can be entered.

4 Key in the password in “Password” as required, and then press the [SET] button to fix it.

BOX SETUP ▶Enter BOX name and Password(5-digit)

BOX NUMBER : 001

BOX NAME Mountains

Password : *****

Retype Password :

SET

RESET

CANCEL ENTER

Detailed description: This screenshot shows a terminal-style interface for setting up a box. The title is 'BOX SETUP ▶Enter BOX name and Password(5-digit)'. Below this, it shows 'BOX NUMBER : 001'. There are two input fields: 'BOX NAME' containing 'Mountains' and 'Password' containing five asterisks. To the right of the 'Password' field is a 'SET' button, and to the right of the 'Retype Password' field is a 'RESET' button. At the bottom of the screen are 'CANCEL' and 'ENTER' buttons. The 'Password' field is highlighted with a thick black border.

- Be sure to key in the 5-digit password.
- * (asterisk) is displayed in “Password” when the password is entered.
- To correct the entered password, press the [CLEAR] button on the control panel.
- When the [SET] button is pressed, “Retype Password” becomes highlighted.

5 Key in the password in “Retype Password”.

BOX SETUP ▶Enter BOX name and Password(5-digit)

BOX NUMBER : 001

BOX NAME Mountains

Password : *****

Retype Password : *****

SET

RESET

CANCEL ENTER

Detailed description: This screenshot is identical to the previous one, but now the 'Retype Password' field is highlighted with a thick black border. The 'Password' field is no longer highlighted.

- * (asterisk) is displayed in “Retype Password” when the password is entered.
- To correct the entered password, press the [CLEAR] button on the control panel.

6 Press the [ENTER] button.

BOX SETUP ▶Enter BOX name and Password(5-digit)

BOX NUMBER : 001

BOX NAME Mountains

Password : *****

Retype Password : *****

SET

RESET

CANCEL ENTER

Detailed description: This screenshot is identical to the previous ones, but now the 'ENTER' button at the bottom right is highlighted with a thick black border.

- The user box is created.

3. Changing Data of User Boxes

Created user boxes and passwords can be changed.

- You cannot change the folder name using the control panel of this equipment. It can be changed using “TopAccess” from a client PC. See the e-Filing Guide for details.

1 Press the [e-FILING] button on the control panel.

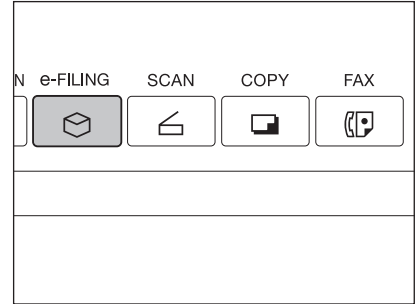

2 Select the desired box, and then press the [EDIT] button.

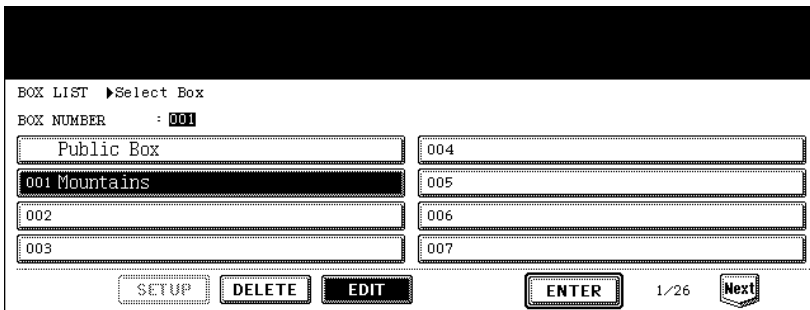

- If the desired box is not displayed, press the [Prev] or [Next] button to switch the menu.
- To display the applicable menu immediately, key in the box number.

3 Key in the password (5 digits) for the selected box, and then press the [ENTER] button.

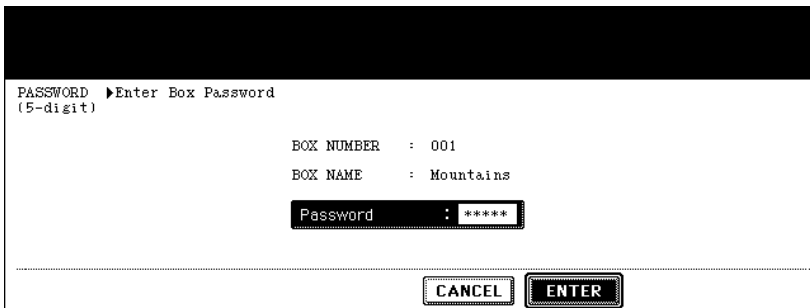

- If no password was set when the box was created, skip to step 4.

4 Press the [BOX NAME] button, and then enter the new box name.

BOX MODIFY ▶Enter BOX Name and Password(5-digit)

BOX NUMBER : 001

BOX NAME River

Password :

Retype Password :

SET

RESET

CANCEL ENTER

- When [BOX NAME] is pressed, the letter entry menu (P.33) is displayed. A box name can contain up to 32 letters.

5 Key in the new password in “Password”, and then press the [SET] button to fix it.

BOX MODIFY ▶Enter BOX Name and Password(5-digit)

BOX NUMBER : 001

BOX NAME River

Password : *****

Retype Password :

SET

RESET

CANCEL ENTER

- Be sure to key in the 5-digit password.
- * (asterisk) is displayed in “Password” when the password is entered.
- To correct the entered password, press the [CLEAR] button on the control panel.
- When the [SET] button is pressed, “Retype Password” becomes highlighted.

6 Key in the password in “Retype Password”.

BOX MODIFY ▶Enter BOX Name and Password(5-digit)

BOX NUMBER : 001

BOX NAME River

Password : *****

Retype Password : *****

SET

RESET

CANCEL ENTER

- * (asterisk) is displayed in “Retype Password” when the password is entered.
- To correct the entered password, press the [CLEAR] button on the control panel.

7 Press the [ENTER] button.

BOX MODIFY ▶Enter BOX Name and Password(5-digit)

BOX NUMBER : 001

BOX NAME : River

Password : *****

Retype Password : *****

SET

RESET

CANCEL ENTER

- The box settings are updated.

4. Deleting User Boxes

Unnecessary user boxes can be deleted. All folders and documents in the user boxes are also deleted.

- Public box cannot be deleted.

1 Press the [e-FILING] button on the control panel.

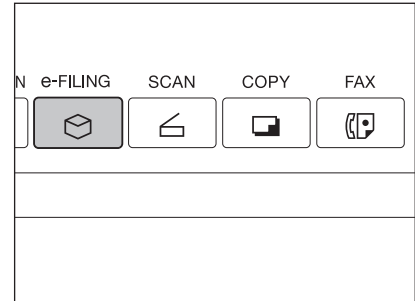

2 Select the box you want to delete, and then press the [DELETE] button.

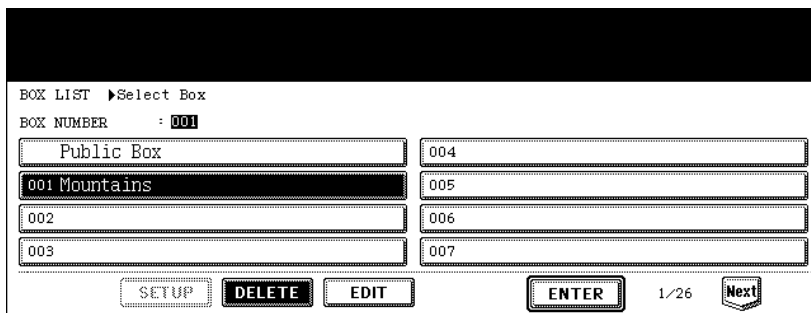

- If the desired box is not displayed on the menu, press the [Prev] or [Next] button to switch the menu.
- To display the applicable menu immediately, key in the box number.

3 Key in the password (5 digits) for the selected box, and then press the [ENTER] button.

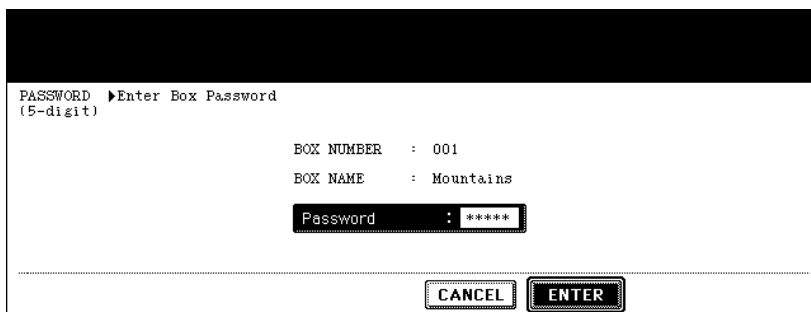

- If no password was set when the box was created, skip to step 4.

4 “Are you sure you want to delete this box?” appears. Press the [Yes] button to delete the box.

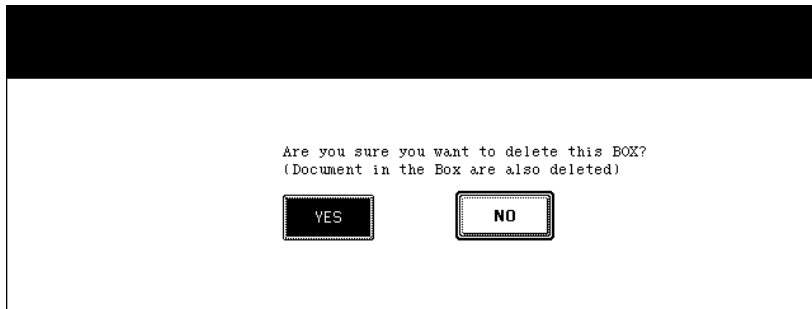

- The box is deleted.

5. Storing Documents in e-Filing

Scanned original data can be stored in e-Filing. The copy mode settings will be saved with the e-Filing document. You can copy originals and store the data at one time. After storing the original data, you can print them out at any time.

- There are two types of e-Filing, public box and user boxes. To store the data in a user box, you need to set it up in advance. (P.180 “2.Creating User Boxes”)
- The data scanned with the scanning function can be also stored in e-Filing. The stored data can be downloaded to the client PC as a JPEG, PDF or TIFF file. For details, refer to the Scanning Guide.

1 Place the original(s).

- Up to 100 folders can be created in one e-Filing, and a maximum of 400 documents can be stored in one folder. The maximum number of original pages is 200. (However this may be restricted depending on the amount of free space of the hard disk in this equipment.)
- Set the copy mode as required.
- Twin colour images cannot be saved in e-Filing.

2 Press the [E-FILING/FILE] button to enter the e-Filing/file menu.

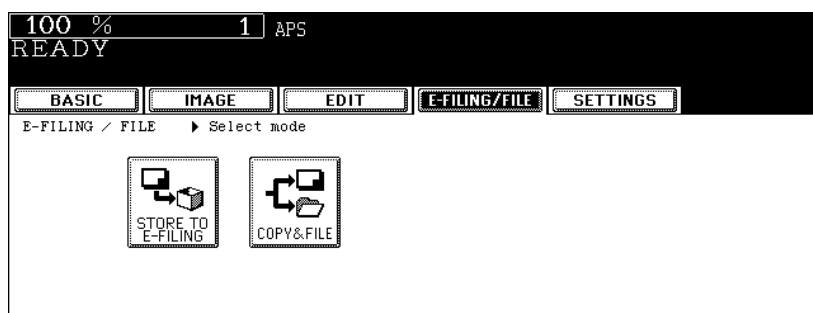

3 Press the [STORE TO E-FILING] button.

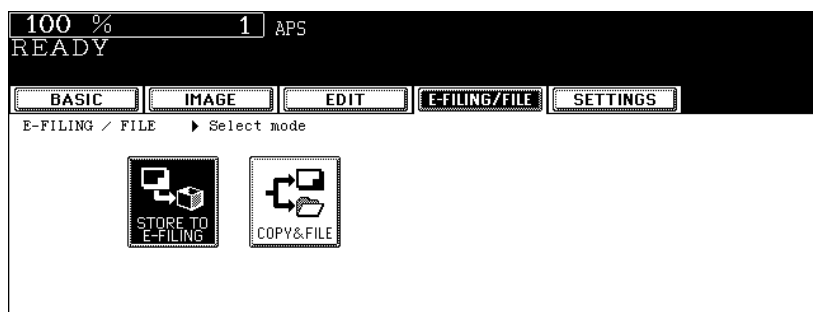

4 Press the [BOX/FOLDER] button.

100 % 1 APS
READY

BASIC IMAGE EDIT **E-FILING/FILE** SETTINGS

STORE TO E-FILING ▶ Select box and folder

BOX/FOLDER BOX NUMBER :
BOX NAME :
FOLDER NAME :

DOCUMENT NAME DOC031002

CANCEL ENTER

5 Select the box in which you want to store the document, and then press the [ENTER] button.

6

BOX LIST ▶ Select Box

BOX NUMBER : 001

Public Box	004
001 Mountains	005
002	006
003	007

CANCEL ENTER 1/26 Next

- If the desired box is not displayed on the menu, press the [Prev] or [Next] button to switch the menu.
- To display the applicable menu immediately, key in the box number.

When the password entry menu is displayed

When the password entry menu is displayed, the password is set in the selected user box. Key in the password and press the [ENTER] button.

PASSWORD ▶ Enter Box Password
(5-digit)

BOX NUMBER : 001
BOX NAME : Mountains

Password : *****

CANCEL ENTER

6 The document list in the selected box is displayed. Press the [ENTER] button to store in this box.

STORE TO E-FILING ▶ Select Storage Location				
	Document/Folder Name	Date,Time	Paper	Pages
	HAKKODA	21,17:09	A4	1
	HAKKODA-001	21,17:10	A4	1
	New	21,17:19		

Buttons: OPEN FOLDER, CANCEL, ENTER, 1/1

To store the document in the folder

To store the document in the folder, select the folder to be stored, press the [OPEN FOLDER] button. The document list in the selected folder is displayed. Press the [ENTER] button to store in this folder.

STORE TO E-FILING ▶ Select Storage Location				
	Document Name	Date,Time	Paper	Pages
	HAKKODA-002	21,17:20	A4	1

Buttons: CLOSE FOLDER, CANCEL, ENTER, 1/1

- If you want to close the folder and go back to the box above, press the [CLOSE FOLDER] button.
- Creating the folder can be performed from the client PC using "TopAccess". For details, see e-Filing Guide.

7 Press the [DOCUMENT NAME] button, and then enter the document name.

100 % 1 APS
READY

BASIC IMAGE EDIT E-FILING/FILE SETTINGS

STORE TO E-FILING ▶ Select box and folder

BOX/FOLDER BOX NUMBER : 001

BOX NAME : Mountains

FOLDER NAME :

DOCUMENT NAME TANIGAWA

Buttons: CANCEL, ENTER

- When the [DOCUMENT NAME] button is pressed, the letter entry menu (P.33) is displayed. Up to 64 letters can be entered.

8 Press the [ENTER] button.

100 % 1 APS
READY

BASIC IMAGE EDIT **E-FILING/FILE** SETTINGS

STORE TO E-FILING ▶ Select box and folder

BOX/FOLDER BOX NUMBER : 001
BOX NAME : Mountains
FOLDER NAME :
DOCUMENT NAME : TANIG&WA

CANCEL ENTER

9 “PRINT THIS DOCUMENT?” appears. Press the [YES] button to store and print it out at one time.

100 % 1 APS
READY

BASIC IMAGE EDIT **E-FILING/FILE** SETTINGS

>PRINT THIS DOCUMENT ?

YES NO

CANCEL

- If you want to store the document without printing it, press the [NO] button.

10 Press the [START] button.

- The reading and storing of the documents starts.

Tip

When the original is placed on the original glass or on the Reversing Automatic Document Feeder (optional) in the Single original feeding mode, the following menu is displayed. Setting the original on the original glass: When the next original is placed, the [YES] button and then the [START] button are pressed, storing of the document starts. Setting the original on the Reversing Automatic Document Feeder in the single original feeding mode: When the next original is placed on the Reversing Automatic Document Feeder, storing of the document starts. After the last page has finished being scanned, press the [FINISHED] button.

100 % 1 A4-R

READY

BASIC IMAGE EDIT **E-FILING/FILE** SETTINGS

>NEXT ORIGINAL ?

YES FINISHED

6. Printing Stored Documents

Stored documents can be printed out. You can also print out a part of a document and change the setting in the finishing mode or the like before printing the documents.

Printing the whole document

All pages of the document are printed. If printing multiple copies is desired, see  P.194 "Printing the stored document after changing the settings".

- 1 Press the [e-FILING] button on the control panel.

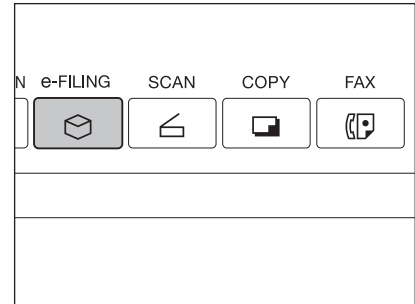

- 2 Select the box in which the desired printing document is stored, and then press the [ENTER] button.

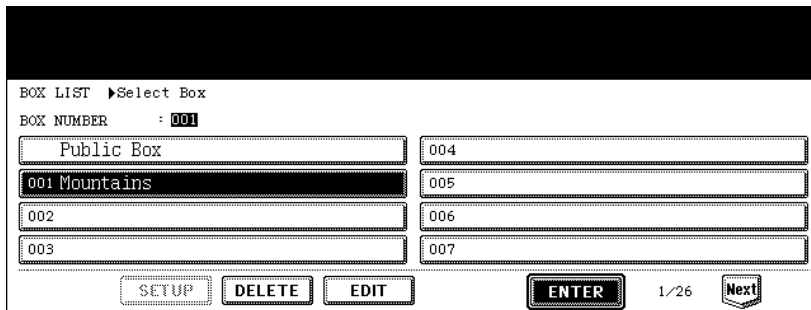

- If the desired box is not displayed on the menu, press the [Prev] or [Next] button to switch the menu.
- To display the applicable menu immediately, key in the box number.

- 3 Key in the password (5 digits) for the selected box, and then press the [ENTER] button.

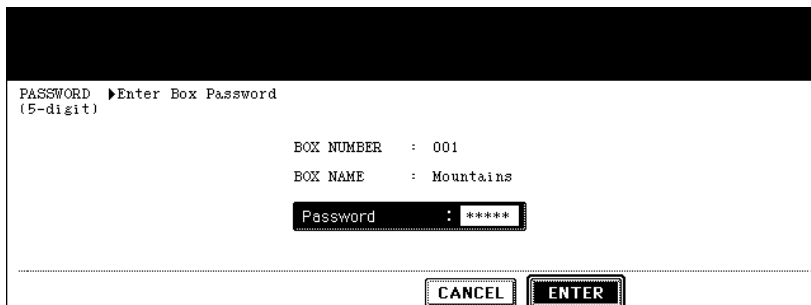

- If no password was set when the box was registered, skip to step 4.

4 Select the document to be printed.

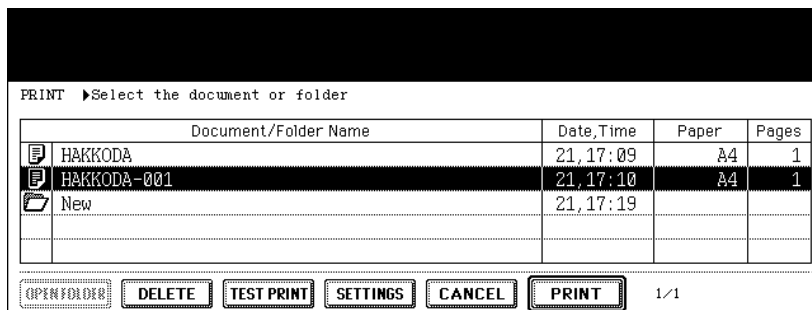

- To print a document in the folder, select the folder in which you want to print the document out and press the [OPEN FOLDER] button. Select the desired document on the menu.

5 Press the [PRINT] button.

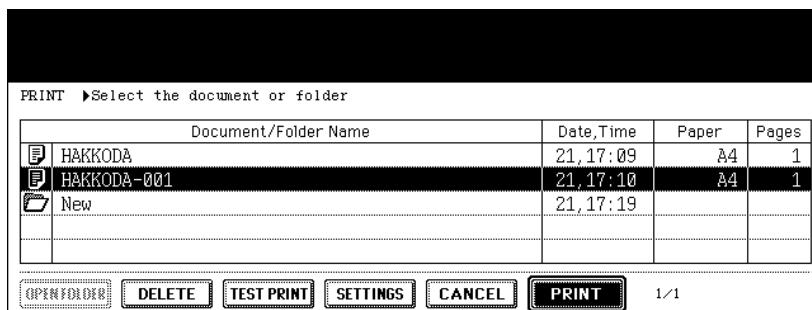

- Printing starts.

To stop printing a stored document during the operation

Select the job you want to stop from the print job menu or scan job menu, and then press the [DELETE] button. For details, see P.235 "8.JOB STATUS".

Test printing

A part of a document of several pages can be printed out.

- 1 Select the document to be printed according to steps 1 to 4 of  P.191 “Printing the whole document”.
- 2 Press the [TEST PRINT] button.

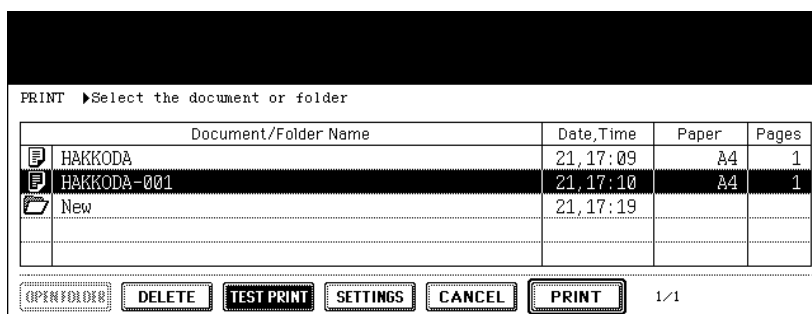

- 3 Key in the number of the last page and press the [SET] button. Then key in the number of the first page.

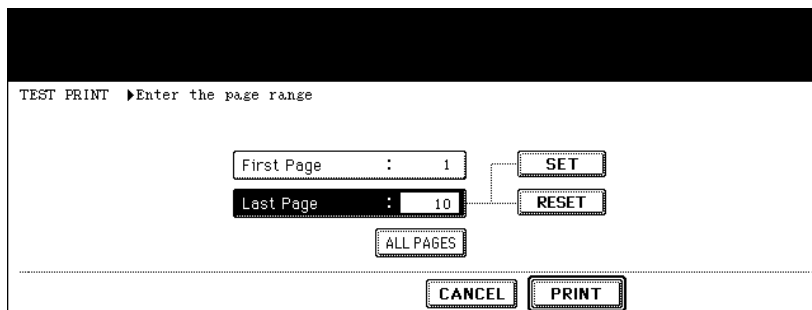

- To correct the pages, press the [CLEAR] button on the control panel.
- To print all pages, press the [ALL PAGES] button.

4 Press the [PRINT] button.

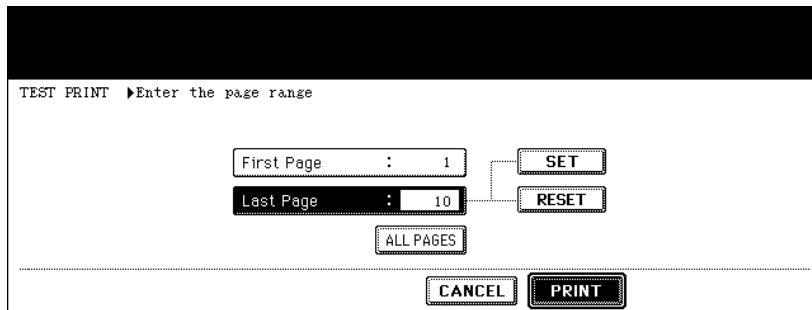

- Printing of the set pages starts.

To stop printing a stored document during this operation

Select the job you want to stop from the print job menu or scan job menu, and then press the [DELETE] button. For details, see [P.235 "8.JOB STATUS"](#).

6

Printing the stored document after changing the settings

The following settings are available before the stored document is printed.

1. Paper source (Press the drawer icon to be set as a paper source. However, the paper in the drawer selected for the paper source is used only when its size and type correspond to those of the documents in the box.)
2. Number of printings (Key them in.)
3. Simplex printing / duplex printing
4. Finishing mode (Selecting the mode is limited depending on the installed optional equipment.)
5. Paper exit (Available when the finisher (optional) is installed)
6. Image shift position
7. Added date and time position
8. Page number position

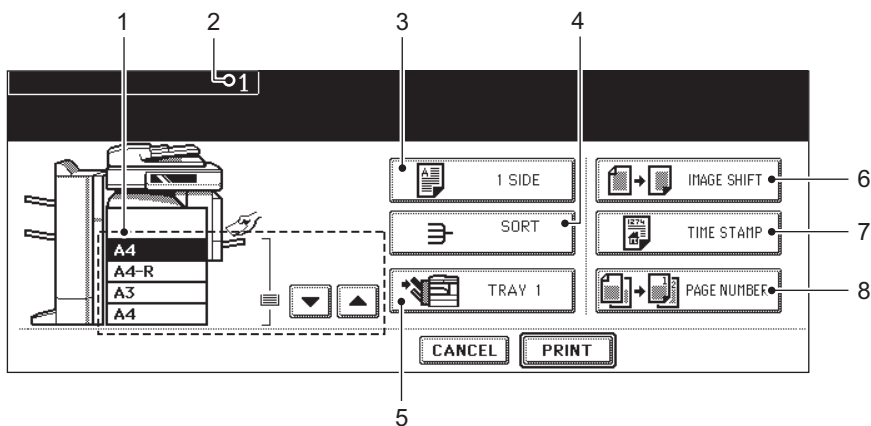

1 Select the document to be printed according to steps 1 to 4 of  P.191 “Printing the whole document”.

2 Press the [SETTINGS] button.

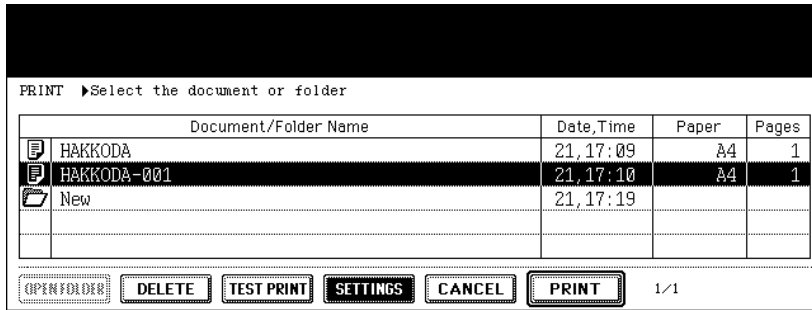

3 Set the printing modes as required.

- See the eight items mentioned above for the setting mode. To set items 3 to 8, press the button and set the required setting on the menu.

4 Press the [PRINT] button.

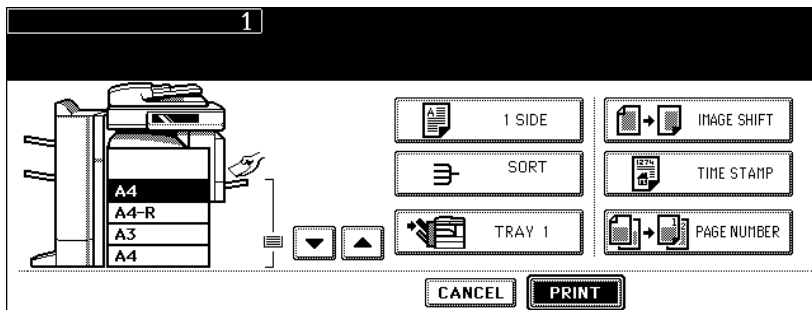

- Printing starts.

To stop printing a stored document during this operation

Select the job you want to stop from the print job menu or scan job menu, and then press the [DELETE] button. For details, see  P.235 “8.JOB STATUS”.

7. Deleting Folders or Documents

Unnecessary folders or documents can be deleted. If a folder is deleted, all documents in the folder are also deleted.

1 Press the [e-FILING] button on the control panel.

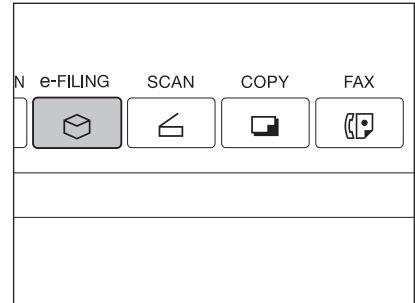

2 Select the box in which you want to delete the folder or document, and then press the [ENTER] button.

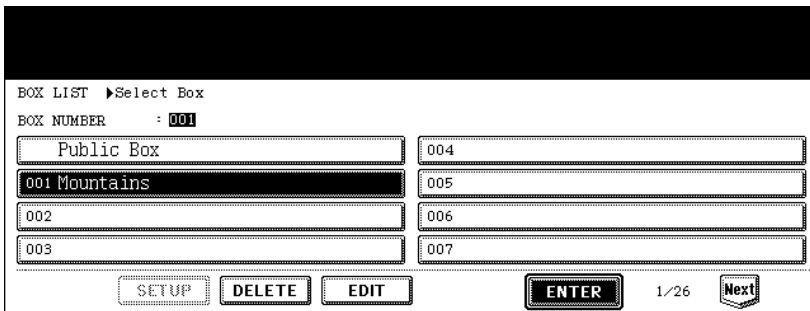

- If the desired box is not displayed on the menu, press the [Prev] or [Next] button to switch the menu.
- To display the applicable menu immediately, key in the box number.

3 Key in the password (5 digits) for the selected box, and then press the [ENTER] button.

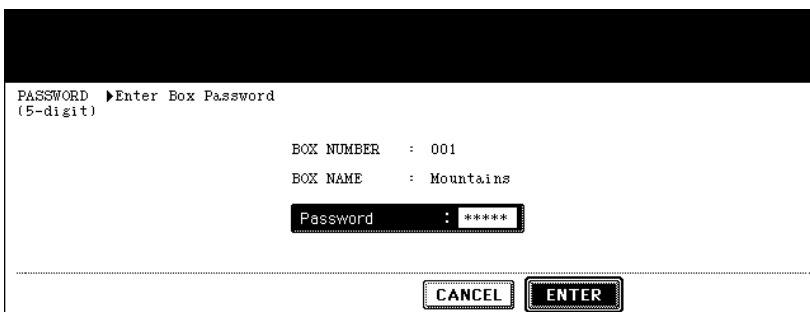

- If no password was set when the box was created, skip to step 4.

4 Select the folder or document to be deleted, and then press the [DELETE] button.

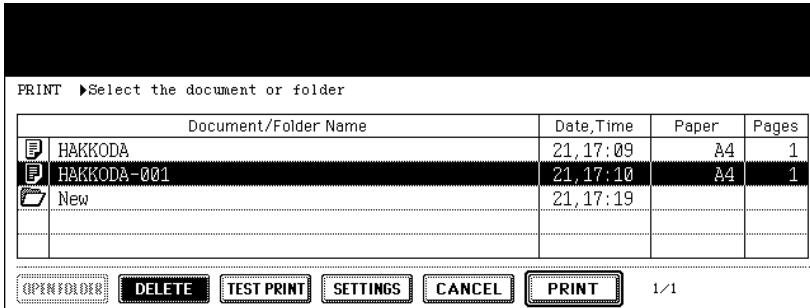

To delete a document in the folder

To delete a document in the folder, select the folder in which you want to delete the document and press the [OPEN FOLDER] button. Select the desired document and press the [DELETE] button.

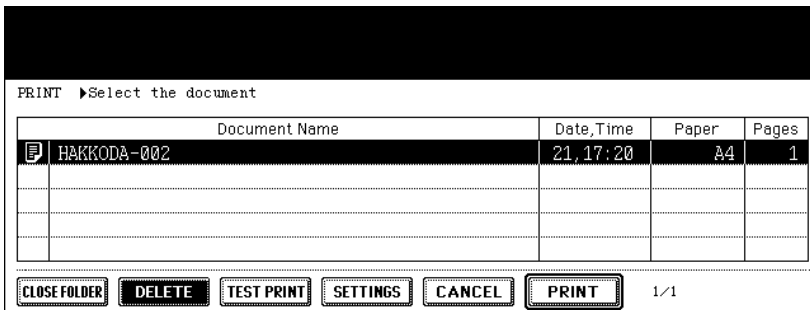

5 “Are you sure you want to delete this folder?” or “Are you sure you want to delete this document?” appears. Press the [Yes] button to perform deletion.

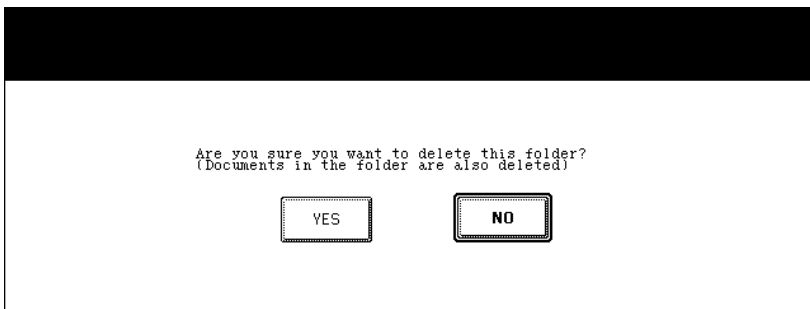

- The folder or document is deleted.
- If a folder is deleted, all the documents in the folder are also deleted.

8. Appendix

Storing documents in the shared folder

Scanned original data can be stored in the shared folder. You can copy originals and store the data at the same time.

Tips

- Data can be stored in the TIFF or PDF format.
- Colour originals are stored in the black mode. They can be stored in the colour mode using the scanning function.
- Data can be stored in the [MFP LOCAL] (hard disk in the equipment) as well as [REMOTE 1] and [REMOTE 2] (hard disk of a computer connected with the equipment in the network). See “6. Copy & File” in the Scanning Guide for details.

1 Place the original(s).

2 Press the [E-FILING/FILE] button on the basic menu to enter the e-Filing/file menu.

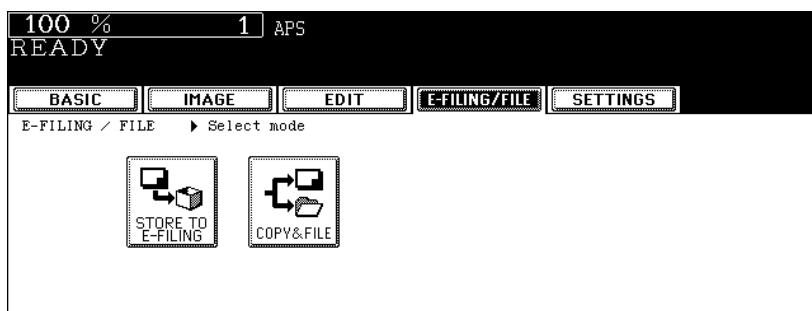

3 Press the [COPY & FILE] button.

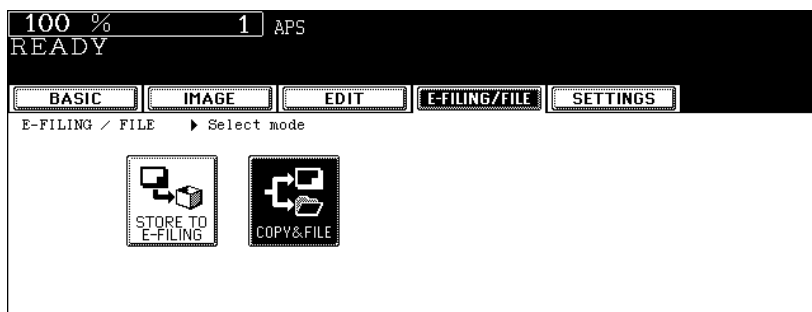

4 Press the [FILE NAME] button.

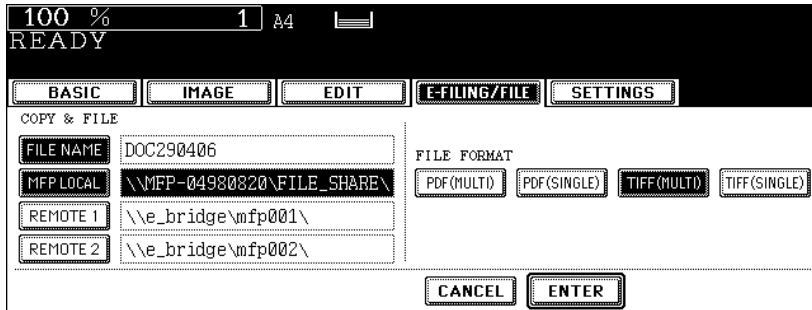

When the [FILE NAME] button is pressed, the letter entry menu (P.33 “Setting letters”) is displayed. Up to 45 letters can be entered.

5 Select the destination you want to store the data.

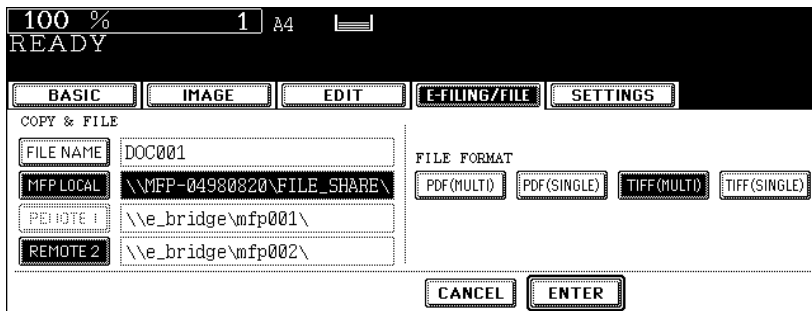

- Any two of the destinations [MFP LOCAL], [REMOTE 1] and [REMOTE 2] can be selected at one time.
- If you press the [REMOTE 1] or [REMOTE 2] button, you may need to specify the computer in which you want to store the data. See “3. SCAN TO FILE” in the Scanning Guide for details.

6 Select the format in which the data are stored.

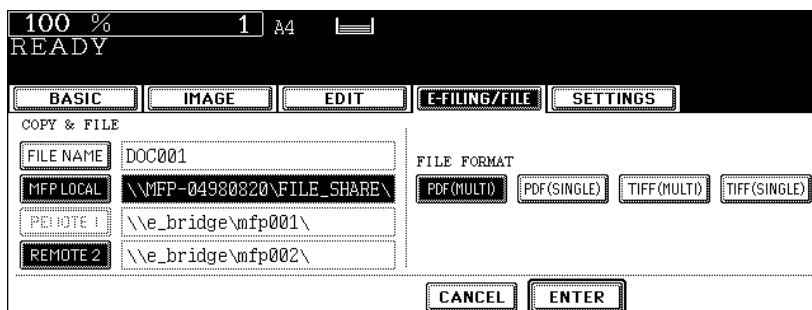

PDF (MULTI)

Scanned originals are stored as one PDF file.

PDF (SINGLE)

A folder is created and each page of the scanned original is stored into this folder separately as a PDF file.

E.g.: A three-page original is stored as three PDF files.

TIFF (MULTI)

Scanned originals are stored as one TIFF file.

TIFF (SINGLE)

A folder is created and each page of the scanned original is stored into this folder separately as a PDF file.

E.g.: A three-page original is stored as three TIFF files.

7 Press the [ENTER] button.

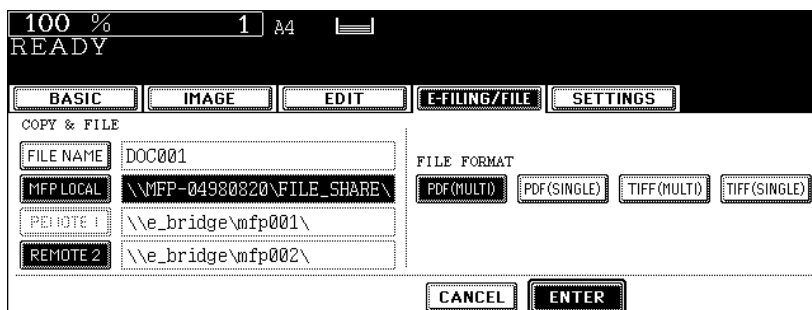

8 Press the [START] button.

- The scanning, storing and copying of the documents starts.
- All the documents are stored and copied in the black mode.

Tip

When the original is placed on the original glass or on the Reversing Automatic Document Feeder (optional) in the single original feeding mode, the following menu is displayed. Setting the original on the original glass: When the next original is placed, the [YES] button and then the [START] button are pressed, storing of the document starts.

Setting the original on the Reversing Automatic Document Feeder in the single original feeding mode: When the next original is placed on the Reversing Automatic Document Feeder, storing of the document starts. After the last page has finished being scanned, press the [FINISHED] button.

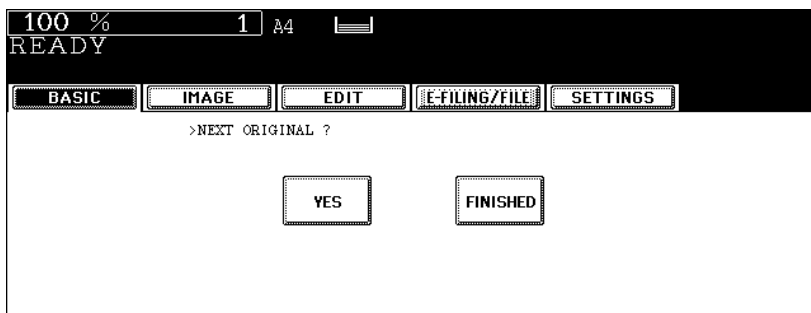



7. TEMPLATE

1. Template	204
2. Registering User Groups and Templates	206
3. Changing Data of User Groups and Templates	218
4. Recalling Templates	226
5. Deleting User Groups or Templates	231

1. Template

A combination of functions frequently used can be registered as a template and recalled as required. Templates can be used with the copy, scanning and Fax functions.

- To use Fax functions, the optional Fax Unit is required.

The following illustration shows the outline of a template function.

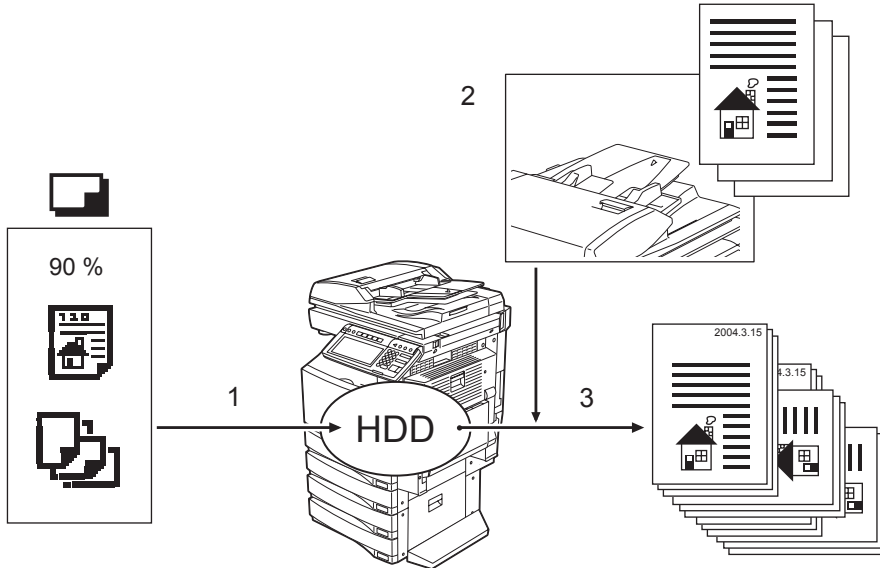

1. Register the combination of the functions to the template.
2. Place the original.
3. Recall the desired template, and then make a copy.



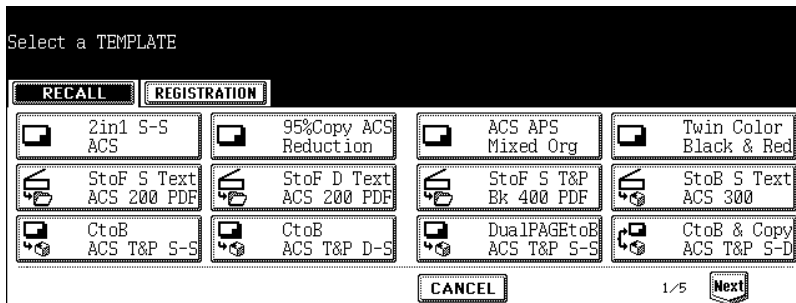

Template in “Useful Template”

In this equipment, 12 templates are included by default. They are registered to be available in the user group number 001 “Useful Template”.





- To recall the template, see [P.228](#) “When recalling a template in a user group”.







Template using the copying function

Button	Function *1
 2in1 S-S ACS	"1-sided original -> 1-sided copy" is performed in the auto colour and 2IN1 mode.
 95% Copy ACS Reduction	Reduction copy by 95% is performed in the auto colour mode.
 ACS APS Mixed Org	Mixed-size originals are copied in the auto colour mode.
 Twin Color Black & Red	Twin colour (RED&BLACK) copy is made.

Template using the scanning function

Button	Function *1
 StoF S Text ACS 200 PDF	A 1-sided original is scanned in the auto colour and text mode at 200 dpi resolution, then stored in the shared folder of this equipment as a PDF file.
 StoF D Text ACS 200 PDF	A 2-sided original is scanned in the auto colour and text mode at 200 dpi resolution, then stored in the shared folder of this equipment as a PDF file.
 StoF S T&P Bk 400 PDF	A 1-sided original is scanned in the black and text/photo mode at 400 dpi resolution, then stored in the shared folder of this equipment as a PDF file.
 StoB S Text ACS 300	A 1-sided original is scanned in the auto colour and text mode at 300 dpi resolution, then stored in the e-Filing box as a TIFF file (default setting).

Template using the e-Filing function

Button	Function *1
 CtoB ACS T&P S-S	Data are read in the auto colour and text/photo mode and with "1-sided original -> 1-sided copy", then stored in the e-Filing box. Data are not copied.
 CtoB ACS T&P D-S	Data are read in the auto colour and text/photo mode and with "2-sided original -> 1-sided copy", then stored in the e-Filing box. Data are not copied.
 DualPAGEtoB ACS T&P S-S	Data are read in the auto colour and text/photo mode and with "1-sided original -> 1-sided copy" using the dual-page mode, then stored in the e-Filing box.
 CtoB & Copy ACS T&P S-D	"1-sided original -> 2-sided copy" is performed in the auto colour and text/photo mode, then the data are stored in the e-Filing box.

*1 The functions not described in the "Function" field are set by default.

2. Registering User Groups and Templates

A template can be registered either in “PUBLIC TEMPLATE GROUP” or “USER GROUP” depending on your purpose. Passwords can be set to restrict the unauthorized use of a template.

PUBLIC TEMPLATE GROUP:

This is prepared as a default setting. Anyone can use a template registered in this group.

It is useful if the setting combinations of functions frequently used throughout the company or organization are registered in this group. Up to 60 templates can be registered.

- When registering a template in the public template group, keying in the Admin Password is required.

USER GROUP:

Up to 200 groups can be registered. It is useful if you register each department, section or person as a user group. Up to 60 templates can be registered in each group. Passwords can be set for the user groups.

- “Useful Template” is registered to be available in user group number 001.

Registering a template in the public template group

1 Set every function you want to include in the combination.

- e.g.: Setting “Image shift”, “90% reduction” and “10 sets of copies” of the copy function.

2 Press the [TEMPLATE] button on the control panel.

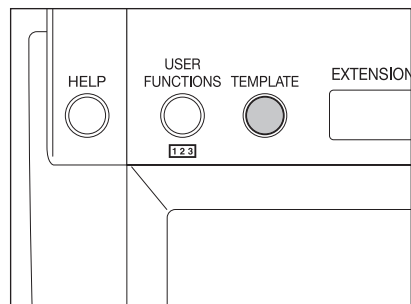

3 Press the [REGISTRATION] button on the touch panel.

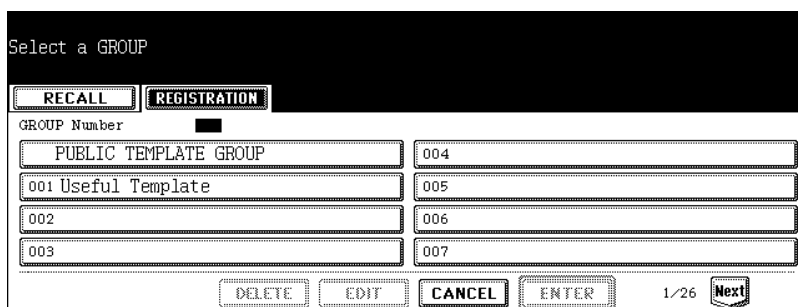

4 Press the [PUBLIC TEMPLATE GROUP], and then press the [ENTER] button.

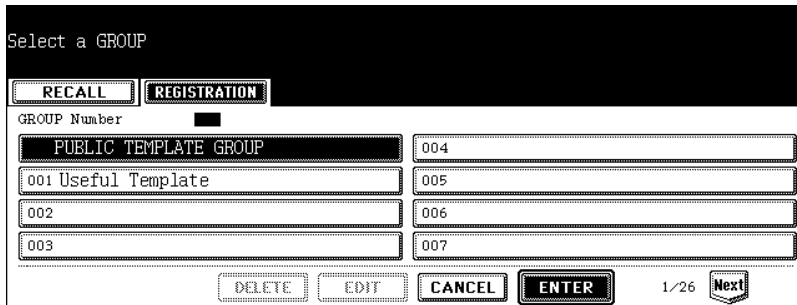

5 Press the [PASSWORD] button.

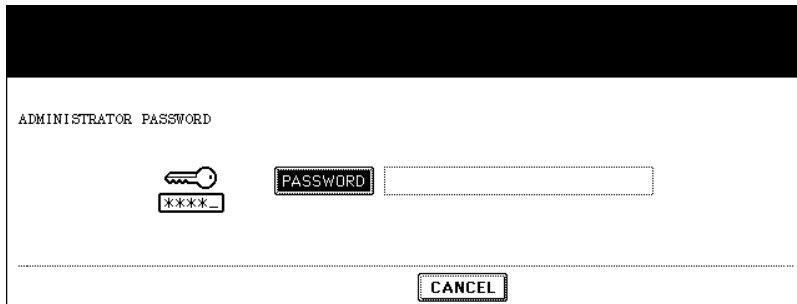

- The letter entry menu is displayed.

6 Key in the Admin Password (6 to 10 digits) with the keys on the letter entry menu and the digital keys, and then press the [ENTER] button.

- If an incorrect Admin Password is entered three times in a row, this equipment will not be able to be operated for approx. 30 sec. In that case, wait until it becomes available and then enter the correct Admin Password again.



- The corresponding buttons of the template registered in the public template group are displayed.

10 Key in the password in “Password” as required, and then press the [SET] button to fix it.

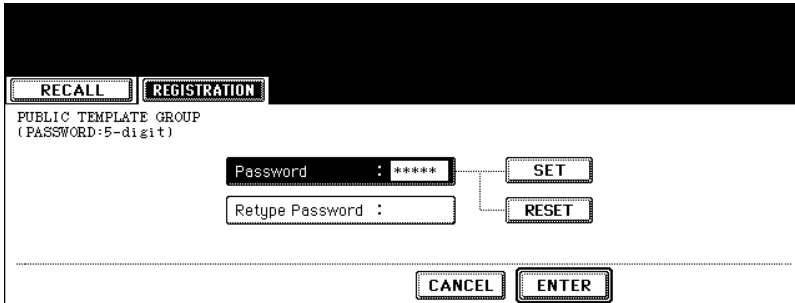

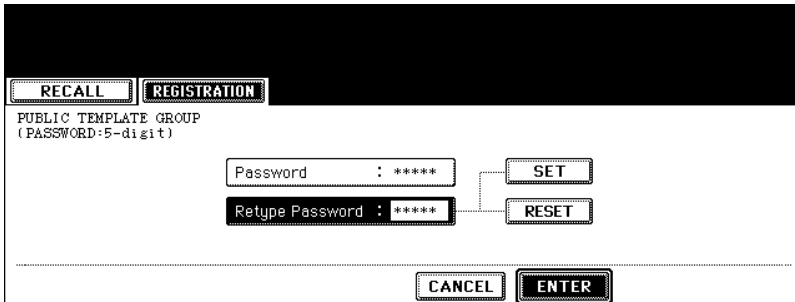

- Be sure to key in the 5-digit password.
- * (asterisk) is displayed in “Password” when the password is entered.
- To correct the entered password, press the [CLEAR] button on the control panel.
- When the [SET] button is pressed, “Retype Password” becomes highlighted.

11 Key in the password in “Retype Password”, and then press the [ENTER] button to fix it.



- * (asterisk) is displayed in “Retype Password” when the password is entered.
- To correct the entered password, press the [CLEAR] button on the control panel.

12 Select whether to enable “AUTOMATIC START” or not when the template is recalled.

- Press the [ENABLE] or [DISABLE] button.
- When [ENABLE] is selected, the  icon is added to the template button. (The operation of the setting functions is automatically started by pressing the template button with the  icon when the template is recalled. However, if a password is set for the template, you need to key it in when an operation with the function set to the template is performed, though automatic start is enabled.)

13 Press the [SAVE] button.

- The screen returns to the one of step 1, which is the menu before the [TEMPLATE] button on the control panel is pressed.

Registering the new user group

1 Press the [TEMPLATE] button on the control panel.

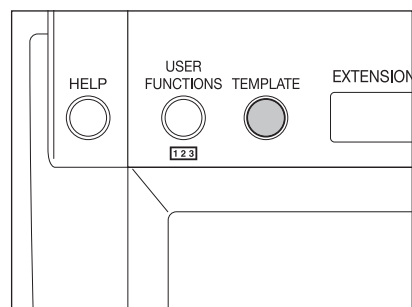

2 Press the [REGISTRATION] button on the touch panel.

Select a GROUP

RECALL REGISTRATION

GROUP Number

PUBLIC TEMPLATE GROUP	004
001 Useful Template	005
002	006
003	007

DELETE EDIT CANCEL ENTER 1/26 Next

3 Select an unregistered user group between “002” and “200”, and then press the [ENTER] button.

Select a GROUP

RECALL REGISTRATION

GROUP Number 002

PUBLIC TEMPLATE GROUP	004
001 Useful Template	005
002	006
003	007

DELETE EDIT CANCEL ENTER 1/26 Next

- If the desired user group is not displayed on the menu, press the [Prev] or [Next] button to switch the menu.
- To display the applicable menu immediately, key in the user group number.

4 Press the [NAME] button, and then enter the user group name.

RECALL REGISTRATION

TEMPLATE GROUP :

NAME	COMMON
USER NAME	
PASSWORD	

CANCEL ENTER

- When the [NAME] button is pressed, the letter entry menu (P.33) is displayed. Up to 20 letters can be entered.

5 Press the [USER NAME] button, and then enter the user name of the user group as required.

The screenshot shows a control panel with two tabs: 'RECALL' and 'REGISTRATION'. Under the 'REGISTRATION' tab, the text 'TEMPLATE GROUP :' is displayed. Below this, there are three input fields: 'NAME' with the value 'COMMON', 'USER NAME' with the value 'USER01', and 'PASSWORD' which is empty. At the bottom of the screen, there are two buttons: 'CANCEL' and 'ENTER'.

- When the [USER NAME] button is pressed, the letter entry menu (P.33) is displayed. Up to 30 letters can be entered.

6 Key in the password in “Password” as required, and then press the [SET] button to fix it.

The screenshot shows the same control panel as in step 5. The 'PASSWORD' field is now active, and the text 'Password : *****' is displayed. Below it, the text 'Retype Password :' is shown. To the right of the 'Password' field is a 'SET' button, and to the right of the 'Retype Password' field is a 'RESET' button. At the bottom, the 'CANCEL' and 'ENTER' buttons are still present.

- Be sure to key in the 5-digit password.
- * (asterisk) is displayed in “Password” when the password is entered.
- To correct the entered password, press the [CLEAR] button on the control panel.
- When the [SET] button is pressed, “Retype Password” becomes highlighted.

7 Key in the password in “Retype Password”, and then press the [ENTER] button to fix it.

The screenshot shows the same control panel as in step 6. The 'Retype Password' field is now active, and the text 'Retype Password : *****' is displayed. The 'Password' field is now inactive. The 'SET' and 'RESET' buttons remain to the right. At the bottom, the 'CANCEL' and 'ENTER' buttons are still present.

- * (asterisk) is displayed in “Retype Password” when the password is entered.
- To correct the entered password, press the [CLEAR] button on the control panel.

8 Press the [ENTER] button.

The screenshot shows a registration screen with two tabs: 'RECALL' and 'REGISTRATION'. The 'REGISTRATION' tab is active. Below the tabs, it says 'TEMPLATE GROUP :'. There are three input fields: 'NAME' with the value 'COMMON', 'USER NAME' with the value 'USER01', and 'PASSWORD' with the value '*****'. At the bottom right, there are two buttons: 'CANCEL' and 'ENTER'.

- The user group is registered.

Registering a template in the user group

1 Set every function you want to include in the combination.

- e.g.: Setting "Image shift", "90% reduction" and "10 sets of copies" of the copy function.

2 Press the [TEMPLATE] button on the control panel.

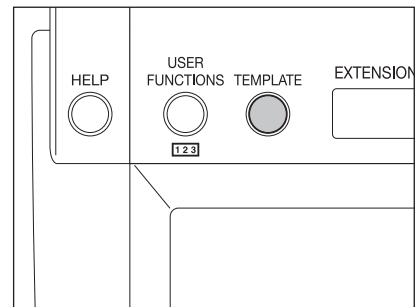

7

3 Press the [REGISTRATION] button on the touch panel.

The screenshot shows a screen titled 'Select a GROUP'. It has two tabs: 'RECALL' and 'REGISTRATION'. Below the tabs, it says 'GROUP Number'. There is a list of template groups with their corresponding numbers:

GROUP Name	GROUP Number
PUBLIC TEMPLATE GROUP	004
001 Useful Template	005
002 COMMON	006
003	007

At the bottom, there are buttons for 'DELETE', 'EDIT', 'CANCEL', and 'ENTER'. The page number '1/26' and a 'Next' button are also visible.

4 Select the desired user group, and then press the [ENTER] button.

Select a GROUP

RECALL REGISTRATION

GROUP Number 002

PUBLIC TEMPLATE GROUP	004
001 Useful Template	005
002 COMMON	006
003	007

DELETE EDIT CANCEL ENTER 1/26 Next

- If the desired user group is not displayed, press the [Prev] or [Next] button to switch the menu.

5 Key in the password (5 digits) for the selected user group, and then press the [ENTER] button.

PASSWORD
(5-digit)

NAME : COMMON
USER NAME : USER01

Password : *****

CANCEL ENTER

- If no password was set when the user group was registered, skip to step 6.

6 The corresponding buttons of the template registered in the user group are displayed. Press the blank key, and then press the [SAVE] button.

Select a TEMPLATE

RECALL REGISTRATION

<input checked="" type="checkbox"/> COPY MODE 001			

DELETE EDIT CANCEL SAVE 1/5 Next

7 Press the [NAME1] button and the [NAME2] button, and then enter the template name.

The screenshot shows the REGISTRATION menu with the following fields and options:

- Buttons: **RECALL**, **REGISTRATION**
- TEMPLATE GROUP : COMMON
- NAME 1: COPY MODE
- NAME 2: 002
- USER NAME: [Empty]
- PASSWORD: [Empty]
- AUTOMATIC START: **ENABLE**, **DISABLE**
- Text: This icon is indicated when an automatic start is enabled.
- Icon: A small icon of a device with a downward arrow.
- Buttons: **CANCEL**, **SAVE**

- [NAME 1] is displayed in the upper side and [NAME 2] is displayed in the lower side of the template button. Enter [NAME 1] and/or [NAME 2]. When both are entered, [NAME 1] is displayed in the upper side and [NAME 2] is displayed in the lower side of the button.
- When the [NAME 1] or [NAME 2] button is pressed, the letter entry menu (P.33) is displayed. Up to 11 letters can be entered.
- The following symbols cannot be used for [NAME 1] and [NAME 2].
["], [=], [], [*], [<], [>], [?], [+], [], [], [], [], [], [], [], [], [], []

8 Press the [USER NAME] button, and then enter the user name of the template as required.

7

The screenshot shows the REGISTRATION menu with the following fields and options:

- Buttons: **RECALL**, **REGISTRATION**
- TEMPLATE GROUP : COMMON
- NAME 1: COPY MODE
- NAME 2: 002
- USER NAME: GUEST01
- PASSWORD: [Empty]
- AUTOMATIC START: **ENABLE**, **DISABLE**
- Text: This icon is indicated when an automatic start is enabled.
- Icon: A small icon of a device with a downward arrow.
- Buttons: **CANCEL**, **SAVE**

- When the [USER NAME] button is pressed, the letter entry menu (P.33) is displayed. Up to 30 letters can be entered.

9 Key in the password in “Password” as required, and then press the [SET] button to fix it.

The screenshot shows a control panel with two tabs: **RECALL** and **REGISTRATION**. Below the tabs, the text reads: **TEMPLATE GROUP : COMMON** and **(PASSWORD:5-digit)**. There are two input fields: **Password : ******* and **Retype Password :**. The **Password** field is highlighted with a thick border. To the right of the **Password** field is a **SET** button, and to the right of the **Retype Password** field is a **RESET** button. At the bottom of the panel are **CANCEL** and **ENTER** buttons.

- Be sure to key in the 5-digit password.
- * (asterisk) is displayed in “Password” when the password is entered.
- To correct the entered password, press the [CLEAR] button on the control panel.
- When the [SET] button is pressed, “Retype Password” becomes highlighted.



10 Key in the password in “Retype Password”, and then press the [ENTER] button to fix it.

The screenshot shows the same control panel as in step 9. The **REGISTRATION** tab is active. The text **TEMPLATE GROUP : COMMON** and **(PASSWORD:5-digit)** is present. The **Retype Password : ******* field is now highlighted with a thick border. The **SET** button is now disabled and faded, while the **RESET** button is active. The **ENTER** button at the bottom is also active.

- * (asterisk) is displayed in “Retype Password” when the password is entered.
- To correct the entered password, press the [CLEAR] button on the control panel.

11 Select whether to enable “AUTOMATIC START” or not when the template is recalled.

The screenshot shows a menu with two tabs: 'RECALL' and 'REGISTRATION'. The 'REGISTRATION' tab is active. Below the tabs, it says 'TEMPLATE GROUP : COMMON'. There are four input fields: 'NAME 1' with 'COPY MODE', 'NAME 2' with '002', 'USER NAME' with 'GUEST01', and 'PASSWORD' with '****'. To the right, under 'AUTOMATIC START', there are two buttons: 'ENABLE' (which is highlighted) and 'DISABLE'. Below these buttons is a small icon of a document with a checkmark and the text 'This icon is indicated when an automatic start is enabled.' At the bottom, there are 'CANCEL' and 'SAVE' buttons.

- Press the [ENABLE] or [DISABLE] button.
- When [ENABLE] is selected, the  icon is added to the template button. (The operation of the setting functions is automatically started by pressing the template button with the  icon when the template is recalled. However, if a password is set for the template, you need to key it in when an operation with the function set to the template is performed, though automatic start is enabled.)

12 Press the [SAVE] button.

This screenshot is identical to the one above, but the 'SAVE' button at the bottom right is now highlighted, indicating it is the next step in the process.

- The screen returns to the one of step 1, which is the menu before the [TEMPLATE] button on the control panel is pressed.

3. Changing Data of User Groups and Templates

Registered names, user names and passwords of user groups or templates, and the automatic start setting of a template can be changed.

- The data of a public group cannot be changed from the control panel, but from “TopAccess”. For details, see the TopAccess Guide.

Changing the data of a user group

- 1 Press the [TEMPLATE] button on the control panel.

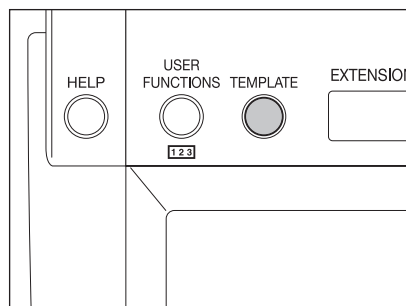

- 2 Press the [REGISTRATION] button on the touch panel.

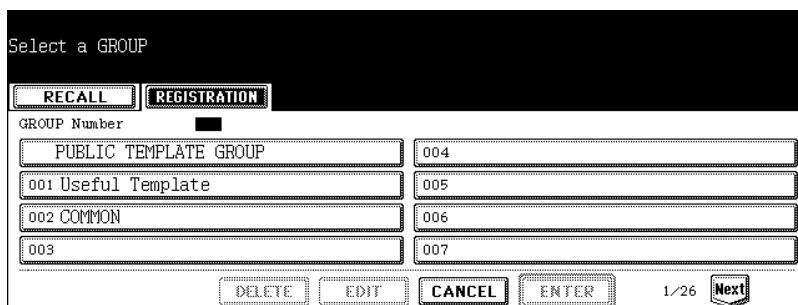

- 3 Select the user group you want to change, and then press the [EDIT] button.

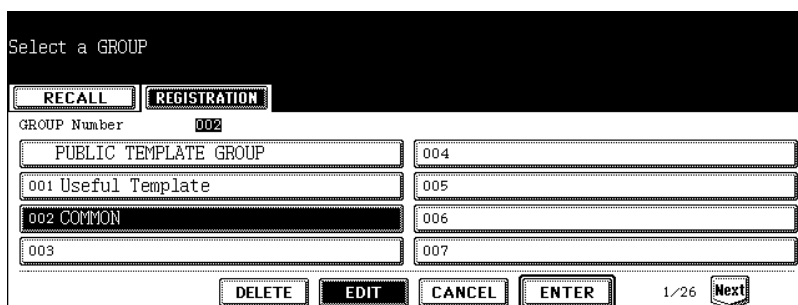

- If the desired user group is not displayed on the menu, press the [Prev] or [Next] button to switch the menu.
- To display the applicable menu immediately, key in the user group number.

4 Key in the password (5 digits) for the selected user group, and then press the [ENTER] button.

```
PASSWORD
(5-digit)

NAME      : COMMON
USER NAME : USER01

Password  : *****

CANCEL   ENTER
```

- If no password was set when the user group was registered, skip to step 5.

5 Press the [NAME] button, and then enter the new name of the user group.

```
RECALL  REGISTRATION
TEMPLATE GROUP : COMMON

NAME    LOCAL
USER NAME
PASSWORD

CANCEL   ENTER
```

- When the [NAME] button is pressed, the letter entry menu (P.33) is displayed. Up to 20 letters can be entered.

6 Press the [USER NAME] button, and then enter the new user name of the user group.

```
RECALL  REGISTRATION
TEMPLATE GROUP : COMMON

NAME    LOCAL
USER NAME USER02
PASSWORD

CANCEL   ENTER
```

- When the [USER NAME] button is pressed, the letter entry menu (P.33) is displayed. Up to 30 letters can be entered.

7 Key in the new password in “Password”, and then press the [SET] button to fix it.

RECALL REGISTRATION

TEMPLATE GROUP : COMMON
(PASSWORD:5-digit)

Password : *****

Retype Password :

SET

RESET

CANCEL ENTER

- Be sure to key in the 5-digit password.
- * (asterisk) is displayed in “Password” when the password is entered.
- To correct the entered password, press the [CLEAR] button on the control panel.
- When the [SET] button is pressed, “Retype Password” becomes highlighted.

8 Key in the password in “Retype Password”, and then press the [ENTER] button to fix it.

RECALL REGISTRATION

TEMPLATE GROUP : COMMON
(PASSWORD:5-digit)

Password : *****

Retype Password : *****

SET

RESET

CANCEL ENTER

- * (asterisk) is displayed in “Retype Password” when the password is entered.
- To correct the entered password, press the [CLEAR] button on the control panel.

9 Press the [ENTER] button.

RECALL REGISTRATION

TEMPLATE GROUP : COMMON

NAME LOCAL

USER NAME USER02

PASSWORD *****

CANCEL ENTER

- The data of the user group are changed.

Changing the data of a template

- 1 Press the [TEMPLATE] button on the control panel.

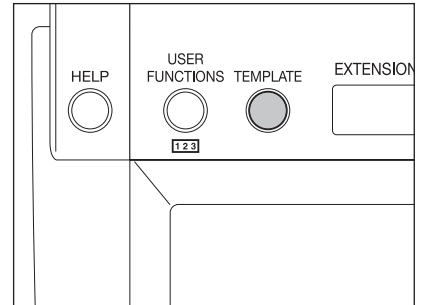

- 2 Press the [REGISTRATION] button on the touch panel.

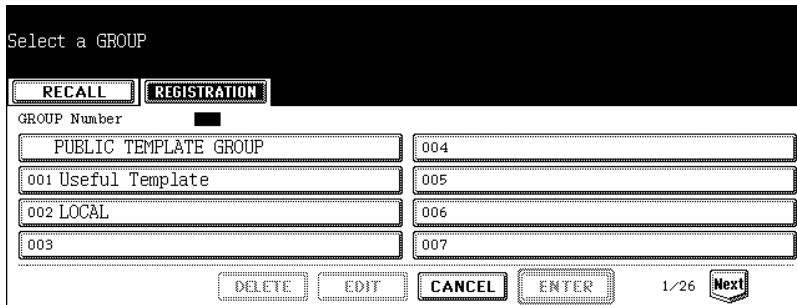

- 3 Select the group in which the template to be changed was registered, and then press the [ENTER] button.

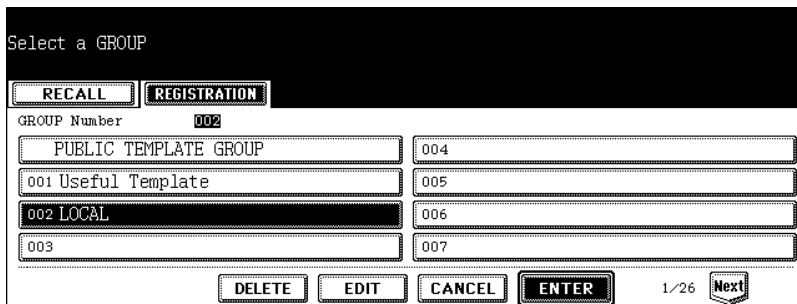

- If the desired user group is not displayed on the menu, press the [Prev] or [Next] button to switch the menu.
- To display the applicable menu immediately, key in the user group number.

4 Enter the following password, and then press the [ENTER] button.

When the public group is selected:

Press the [PASSWORD] button, and then key in the Admin Password (6 to 10 digits) with the keys on the letter entry menu and the digital keys.

- If an incorrect Admin Password is entered three times in a row, this equipment will not be able to be operated for approx. 30 sec. In that case, wait until it becomes available and then enter the correct Admin Password again.

When the user group is selected:

Key in the password (5 digits) for the selected user group. (If no password was set when the user group was registered, skip to step 5.)

SCREENSHOT: A screen titled 'PASSWORD (5-digit)' showing user information: NAME : LOCAL, USER NAME : USER02. A password field contains '*****'. At the bottom are 'CANCEL' and 'ENTER' buttons.

7

5 Select the template to be changed, and then press the [EDIT] button.

SCREENSHOT: A screen titled 'Select a TEMPLATE' with 'RECALL' and 'REGISTRATION' tabs. It shows a grid of templates, with 'COPY MODE 002' selected. At the bottom are 'DELETE', 'EDIT', 'CANCEL', 'SAVE', '1/5', and 'Next' buttons.

- If the desired template is not displayed on the menu, press the [Prev] or [Next] button to switch the menu.

6 Key in the password (5 digits) for the selected template, and then press the [ENTER] button.

SCREENSHOT: A screen titled 'PASSWORD (5-digit)' showing template information: NAME : COPY MODE 002, USER NAME : GUEST01. A password field contains '*****'. At the bottom are 'CANCEL' and 'ENTER' buttons.

- If no password was set when the template was registered, skip to step 7.

7 Press the [NAME1] button and the [NAME2] button, and then enter the new name of the template.

The screenshot shows a menu with two tabs: 'RECALL' and 'REGISTRATION'. Under 'REGISTRATION', the 'TEMPLATE GROUP' is set to 'LOCAL'. There are four input fields: 'NAME 1' (containing 'COPY MODE'), 'NAME 2' (containing '005'), 'USER NAME' (empty), and 'PASSWORD' (empty). To the right, there is an 'AUTOMATIC START' section with 'ENABLE' and 'DISABLE' buttons. Below this is a small icon of a device with a downward arrow and the text 'This icon is indicated when an automatic start is enabled.' At the bottom are 'CANCEL' and 'ENTER' buttons.

- When the [NAME 1] or [NAME 2] button is pressed, the letter entry menu (P.33) is displayed. Up to 11 letters can be entered.
- The following symbols cannot be used for [NAME 1] and [NAME 2].
[], [=], [], [*], [<], [>], [?], [+], [[], []], [:], [;], [/], [\], [,], [.]

8 Press the [USER NAME] button, and then enter the new user name of the template.

This screenshot is identical to the one above, but the 'USER NAME' field now contains the text 'USER05'. The 'COPY MODE' button remains highlighted.

- When the [USER NAME] button is pressed, the letter entry menu (P.33) is displayed. Up to 30 letters can be entered.

9 Key in the new password in “Password”, and then press the [SET] button to fix it.

RECALL REGISTRATION

TEMPLATE GROUP : LOCAL
(PASSWORD:5-digit)

Password : *****

Retype Password :

SET

RESET

CANCEL ENTER

- Be sure to key in the 5-digit password.
- * (asterisk) is displayed in “Password” when the password is entered.
- To correct the entered password, press the [CLEAR] button on the control panel.
- When the [SET] button is pressed, “Retype Password” becomes highlighted.

10 Key in the password in “Retype Password”, and then press the [ENTER] button to fix it.

RECALL REGISTRATION

TEMPLATE GROUP : LOCAL
(PASSWORD:5-digit)

Password : *****

Retype Password : *****

SET



RESET

CANCEL ENTER

- * (asterisk) is displayed in “Retype Password” when the password is entered.
- To correct the entered password, press the [CLEAR] button on the control panel.

11 Change the setting of “AUTOMATIC START” for recalling the template.

The screenshot shows a menu with two tabs: 'RECALL' and 'REGISTRATION'. The 'REGISTRATION' tab is active. Below the tabs, it says 'TEMPLATE GROUP : LOCAL'. There are four input fields: 'NAME 1' with 'COPY MODE', 'NAME 2' with '005', 'USER NAME' with 'USER05', and 'PASSWORD' with '*****'. To the right, under 'AUTOMATIC START', there are two buttons: 'ENABLE' (which is highlighted) and 'DISABLE'. Below these buttons is a small icon of a document with a checkmark and the text 'This icon is indicated when an automatic start is enabled.' At the bottom are 'CANCEL' and 'ENTER' buttons.

- Press the [ENABLE] or [DISABLE] button.
- When [ENABLE] is selected, the  icon is added to the template button. (The operation of the setting functions is automatically started by pressing the template button with the  icon when the template is recalled. However, if a password is set for the template, you need to key it in when an operation with the function set to the template is performed, though automatic start is enabled.)

12 Press the [ENTER] button.

This screenshot is identical to the previous one, but the 'ENTER' button at the bottom right is now highlighted with a thick border, indicating it is the next step in the process.

- The data of the template are changed.

4. Recalling Templates

When a template is recalled, the registered setting functions of the template are reflected in the equipment.

If [ENABLE] is selected for "AUTOMATIC START" when the template is registered, operation of the setting functions is automatically started by pressing the template button.

When recalling a template in a public group

- 1 Place paper in the drawer(s).
- 2 Place the original(s).
- 3 Press the [TEMPLATE] button on the control panel.

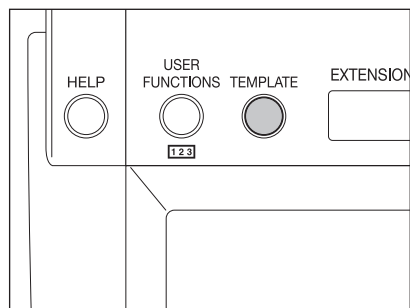

- 4 Press the [PUBLIC TEMPLATE GROUP].

The screenshot shows a menu titled "Select a GROUP". At the top, there are two tabs: "RECALL" and "REGISTRATION". Below the tabs, there is a "GROUP Number" field with a small black square next to it. The menu lists several options:

PUBLIC TEMPLATE GROUP	004
001 Useful Template	005
002 LOCAL	006
003	007

At the bottom of the menu, there is a "CANCEL" button, a page indicator "1/26", and a "Next" button.

5 Press the desired template button.

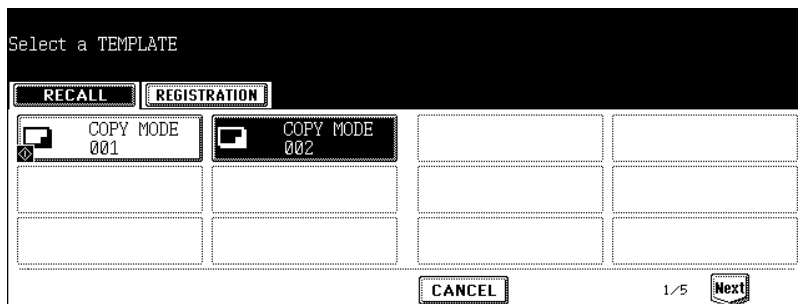

- If the desired template is not displayed on the menu, press the [Prev] or [Next] button to switch the menu.
- If you press the template button with the  icon, the operation of the registered setting functions is automatically started.

6 Key in the password (5 digits) for the selected template, and then press the [ENTER] button.

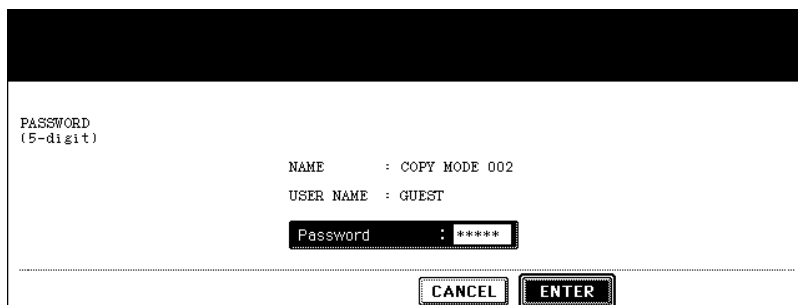

- If no password was set when the template was registered, skip to step 7.

7 Confirm that “Updated the template setting” appears on the menu.

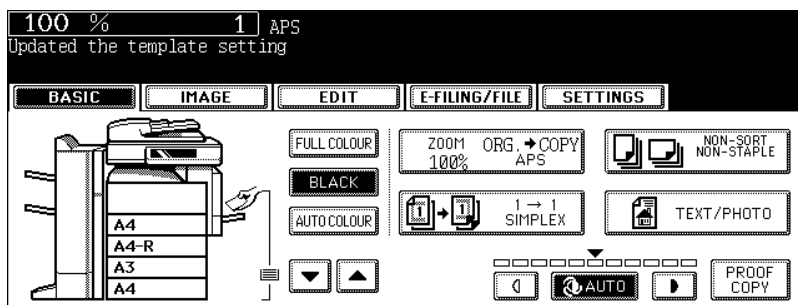

- Select other copy modes as required.

8 Press the [START] button.

When recalling a template in a user group

- 1 Place paper in the drawer(s).
- 2 Place the original(s).
- 3 Press the [TEMPLATE] button on the control panel.

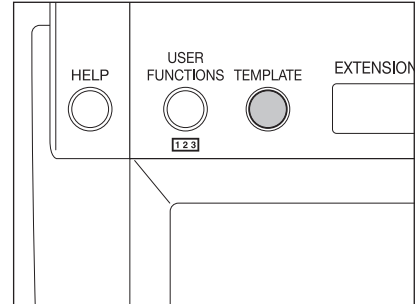

7

- 4 Select the user group in which the template to be recalled is registered.

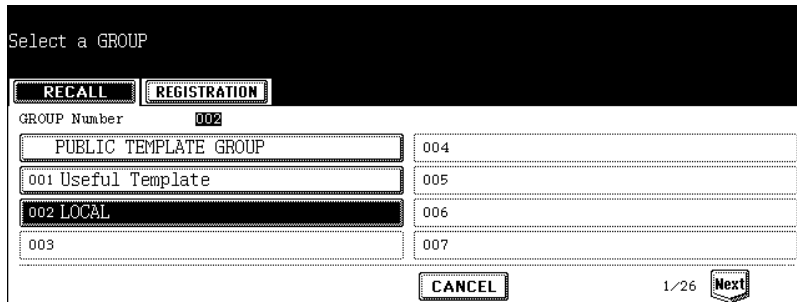

- If the desired user group is not displayed on the menu, press the [Prev] or [Next] button to switch the menu.
- To display the applicable menu immediately, key in the user group number.

5 Key in the password (5 digits) for the selected user group, and then press the [ENTER] button.

PASSWORD
(5-digit)

NAME : LOCAL
USER NAME : USER02

Password : *****

CANCEL ENTER

- If no password was set when the user group was registered, skip to step 6.

6 Press the desired template button.

Select a TEMPLATE

RECALL REGISTRATION

COPY MODE 001 COPY MODE 005

CANCEL 1/5 Next

- If the desired template is not displayed on the menu, press the [Prev] or [Next] button to switch the menu.
- If you press the template button with the  icon, the operation of the registered setting functions is automatically started.

7 Key in the password (5 digits) for the selected template, and then press the [ENTER] button.

PASSWORD
(5-digit)

NAME : COPY MODE 005
USER NAME : USER05

Password : *****

CANCEL ENTER

- If no password was set when the template was registered, skip to step 8.

8 Confirm that “Updated the template setting” appears on the menu.

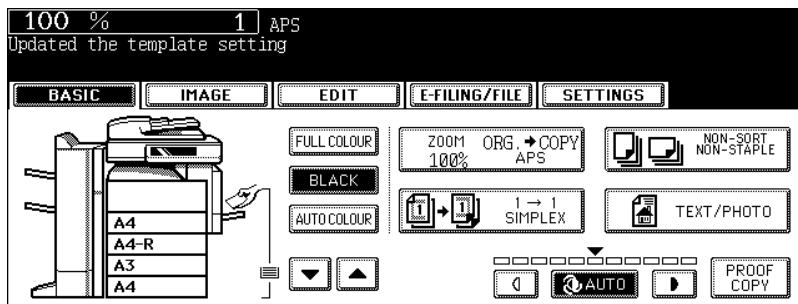

- Select other copy modes as required.

9 Press the [START] button.

5. Deleting User Groups or Templates

Unnecessary user groups and templates can be deleted. If a user group is deleted, all templates in the user group are also deleted.

Deleting a user group

- 1 Press the [TEMPLATE] button on the control panel.

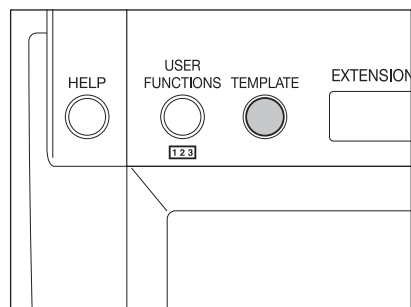

- 2 Press the [REGISTRATION] button on the touch panel.

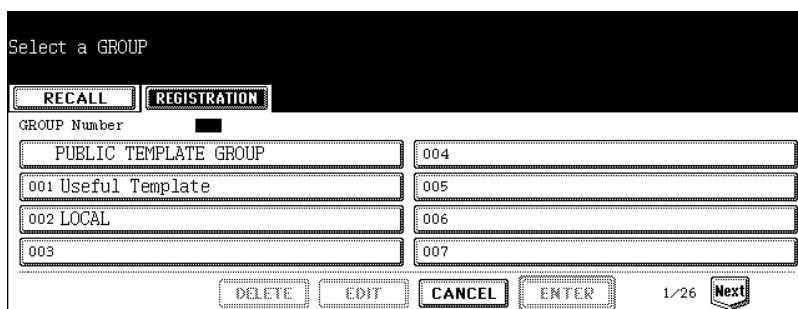

- 3 Select the user group you want to delete, and then press the [DELETE] button.

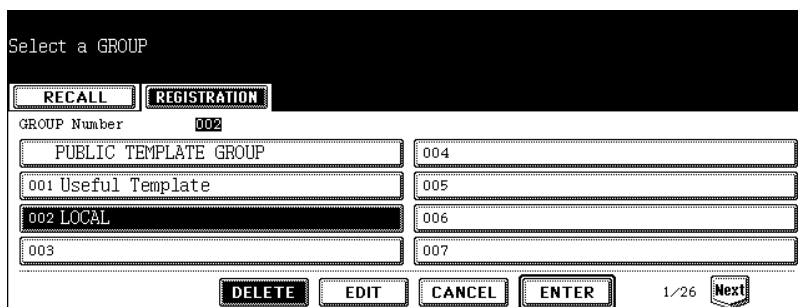

- If the desired user group is not displayed on the menu, press the [Prev] or [Next] button to switch the menu.
- To display the applicable menu immediately, key in the user group number.

4 Key in the password (5 digits) for the selected user group, and then press the [ENTER] button.

```

PASSWORD
(5-digit)

NAME      : LOCAL
USER NAME : USER02

Password  : *****

-----
          CANCEL  ENTER
  
```

- If no password was set when the user group was registered, skip to step 5.

5 “DELETE OK?” appears. Press the [DELETE] button.

```

DELETE OK?

DELETE  CANCEL
  
```

- The selected user group is deleted.

Deleting a template

1 Press the [TEMPLATE] button on the control panel.

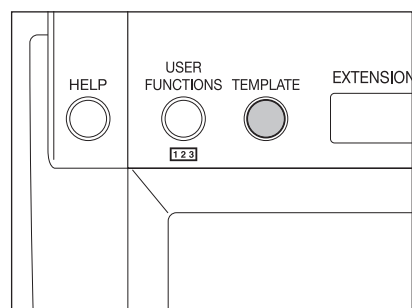

2 Press the [REGISTRATION] button on the touch panel.

Select a GROUP

RECALL REGISTRATION

GROUP Number

PUBLIC TEMPLATE GROUP	004
001 Useful Template	005
002 LOCAL	006
003	007

DELETE EDIT CANCEL ENTER 1/26 Next

3 Select the group in which the template to be deleted is registered, and then press the [ENTER] button.

Select a GROUP

RECALL REGISTRATION

GROUP Number 002

PUBLIC TEMPLATE GROUP	004
001 Useful Template	005
002 LOCAL	006
003	007

DELETE EDIT CANCEL ENTER 1/26 Next

- If the desired user group is not displayed on the menu, press the [Prev] or [Next] button to switch the menu.
- To display the applicable menu immediately, key in the user group number.

4 Enter the following password, and then press the [ENTER] button.

When the public group is selected:

Press the [PASSWORD] button, and then key in the Admin Password (6 to 10 digits) with the keys on the letter entry menu and the digital keys.

- If an incorrect Admin Password is entered three times in a row, this equipment will not be able to be operated for approx. 30 sec. In that case, wait until it becomes available and then enter the correct Admin Password again.

When the user group is selected:

Key in the password (5 digits) for the selected user group. (If no password was set when the user group was registered, skip to step 5.)

PASSWORD
(5-digit)

NAME : LOCAL
USER NAME : USER02

Password : *****

CANCEL ENTER

5 Select the template you want to delete, and then press the [DELETE] button.

Select a TEMPLATE

RECALL REGISTRATION

<input type="checkbox"/> COPY MODE 001	<input checked="" type="checkbox"/> COPY MODE 005		

DELETE EDIT CANCEL SAVE 1/5 Next

- If the desired template is not displayed on the menu, press the [Prev] or [Next] button to switch the menu.

6 Key in the password (5 digits) for the selected template, and then press the [ENTER] button.

PASSWORD
(5-digit)

NAME : COPY MODE 005
USER NAME : USER05

Password : *****

CANCEL ENTER

- If no password was set when the template was registered, skip to step 7.

7 “DELETE OK?” appears. Press the [DELETE] button.

DELETE OK?

DELETE CANCEL

- The selected template is deleted.

8. JOB STATUS

1. Job Status	236
2. Confirming Print Job Status	237
• Print jobs	238
• Proof print jobs	241
• Private print jobs	244
• When using department codes	247
3. Confirming Scan Job Status.....	250
4. Log List	251
• Confirming job history in log list	252
• Registering into address book from log lists	256
• Printing journals (send/receive log list)	258
5. Print Status Display	259
6. Error Code	262

1. Job Status

When you press the [JOB STATUS] button on the control panel, the job status menu is displayed. The following information can be confirmed on this menu.

- Status of jobs (print, Fax, Internet Fax and scan) in waiting
- Log list of jobs (print, sending/receiving, scan) performed
- Print status

You can also start, pause, release, delete and move the job in waiting.

- For the status confirmation of the Fax job, see the Operator's Manual for Facsimile Function. (The FAX Unit (optional) is necessary for the Fax function.)

Tip

When the equipment is managed under the user management function (📖 P.36), enter the user information (e.g. user name, password) before pressing the [JOB STATUS] button.

2. Confirming Print Job Status

You can confirm the status of the print job. The following information is displayed in a list.

Printing A4 PRINTING
Press JOB STATUS to return

PRINT **FAX** **SCAN** **LOG** **STATUS**

PRINT JOB

User Name	Date,Time	Paper	Pages	Sets	Status
User 01	10,10:12	A4	1	1	Printing
User 02	10,10:13	A4	2	2	Wait
User 03	10,10:13	A4	1	2	Wait

PRINT **PROOF** **PRIVATE** **INVALID**

RETURN **DELETE** **PAUSE** **MOVE** **EDIT** **RELEASE** 1/1

- User Name: Name of user for whom the job was registered
Date, Time: Date and time the job was registered
Paper: Paper size to be printed
Pages: Number of pages to be printed
Sets: Number of sets to be printed
Status: Status of jobs ("Scheduled" is displayed for the scheduled print.)

Tip

4 jobs are displayed in 1 page. Up to 250 pages (1000 jobs) can be displayed. When you want to confirm the 5th and following jobs, press the [Next] button, and when you want to return to the previous page, press the [Prev] button.

Print jobs

Copying and printing of the document, and printing of an E-mail, etc. are called print jobs. Print jobs can be deleted, paused and released, moved, and printed on the print job list.

Displaying print job list

1 Press the [JOB STATUS] button on the control panel.

- The print job list is displayed.

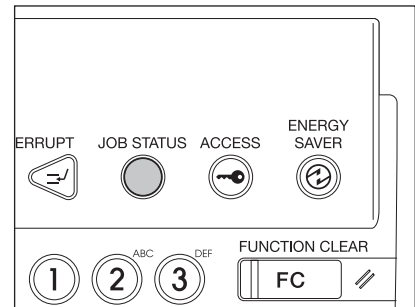

Deleting print jobs

1 Select the job you want to delete on the print job list, then press the [DELETE] button.

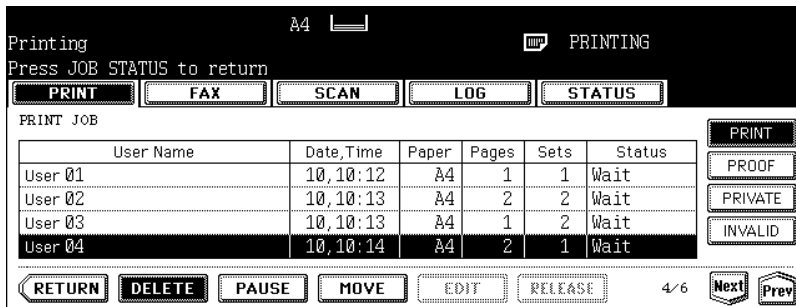

- If the subject job is not displayed on the page, press the [Prev] or [Next] button to switch the page.

2 “Delete OK?” appears. Press the [DELETE] button.

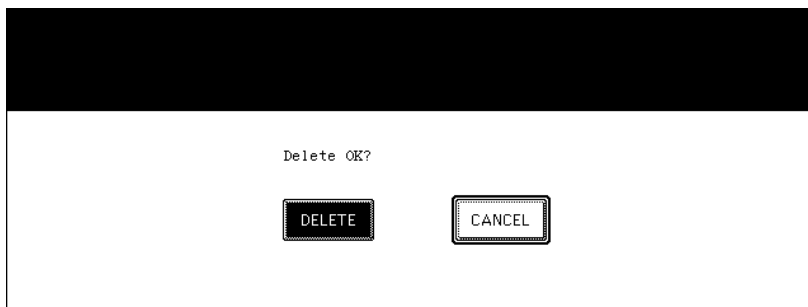

- The job is deleted.

Pausing print jobs

The 11th job or later counting from the one in progress can be paused.

- 1 Select the job you want to pause on the print job list, then press the [PAUSE] button.

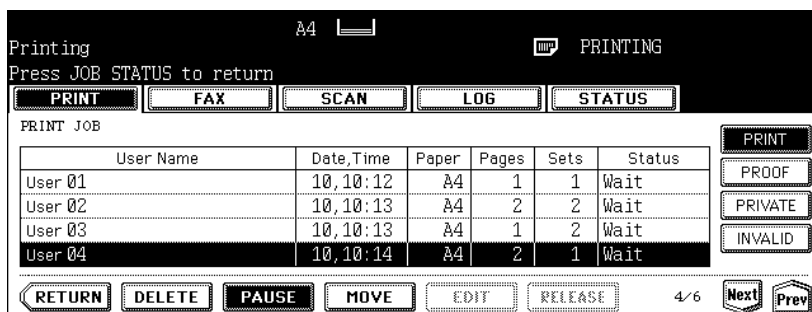

- When the [PAUSE] button is pressed, the display of this button changes to [RESUME].
- When the job is paused, the next job is started.

Releasing print job

Press the [RESUME] button. A job once paused will not be printed out unless the [RESUME] button is pressed.

Moving print jobs

The 11th job or later counting from the one in progress can be moved.

- 1 Select the job you want to move on the print job list, then press the [MOVE] button.

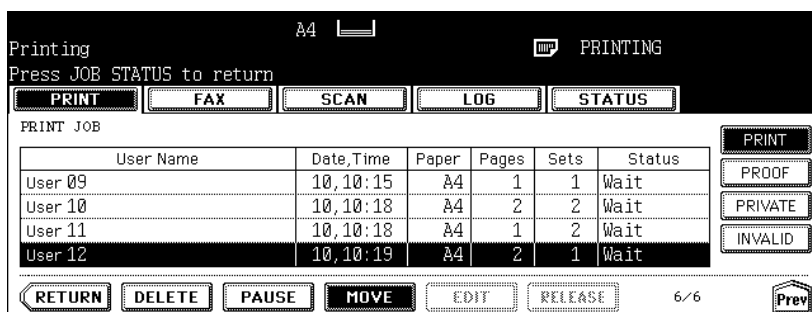

- If the corresponding job is not displayed on the page, press the [Prev] or [Next] button to switch the page.

2 Select the position where you want to move the job. (The job comes right under the job you selected on the list.)

Printing A4 MP PRINTING
 Press JOB STATUS to return

PRINT FAX SCAN LOG STATUS

PRINT JOB

User Name	Date,Time	Paper	Pages	Sets	Status
User 01	10,10:12	A4	1	1	Wait
User 02	10,10:13	A4	2	2	Wait
User 03	10,10:13	A4	1	2	Wait
User 04	10,10:14	A4	2	1	Wait

PRINT PROOF PRIVATE INVALID

RETURN DELETE PAUSE **MOVE** EDIT RELEASE 4/6 Next Prev



Printing A4 MP PRINTING
 Press JOB STATUS to return

PRINT FAX SCAN LOG STATUS

PRINT JOB

User Name	Date,Time	Paper	Pages	Sets	Status
User 01	10,10:12	A4	1	1	Wait
User 12	10,10:19	A4	2	1	Wait
User 02	10,10:13	A4	2	2	Wait
User 03	10,10:13	A4	1	2	Wait

PRINT PROOF PRIVATE INVALID

RETURN DELETE PAUSE **MOVE** EDIT RELEASE 4/6 Next Prev

Proof print jobs

“Proof print” is a function to print only 1 set as a proof print when you print more than one set of documents from a client PC on the network before you print out all the sets of the documents.

You can check this proof print and then select whether you print the rest of the documents or quit printing to change the setting on the proof print job list. If you want to print the rest, you can change the number of printouts.

- For details of proof print, see the Printing Guide.

Displaying proof print job list

1 Press the [JOB STATUS] button on the control panel.

- The print job list is displayed.

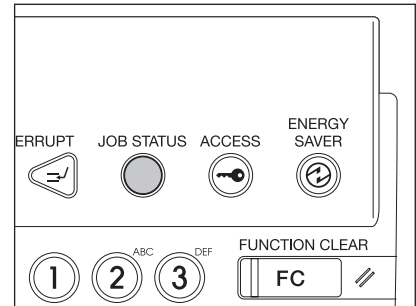

2 Press the [PROOF] button.

The screenshot shows the printer's menu interface. At the top are buttons for 'PRINT', 'FAX', 'SCAN', 'LOG', and 'STATUS'. Below is a 'PRINT JOB' section with a table. To the right of the table are buttons for 'PRINT', 'PROOF', 'PRIVATE', and 'INVALID'. At the bottom are buttons for 'RETURN', 'DELETE', 'PAUSE', 'MOVE', 'EDIT', 'RELEASE', and a page indicator '1/1'.

User Name	Date,Time	Paper	Pages	Sets	Status

- The proof print job list is displayed.

Continuing printing after proof printing

1 Select the job you want to print on the proof print job list.

User Name	Date, Time	Paper	Pages	Sets
User 01	10, 10:12	A4	1	1

Buttons: PRINT, FAX, SCAN, LOG, STATUS, PRINT, PROOF, PRIVATE, INVALID, RETURN, DELETE, PAUSE, MOVE, EDIT, RELEASE 1/1

- If the corresponding job is not displayed on the page, press the [Prev] or [Next] button to switch the page.

2 Press the [RELEASE] button.

User Name	Date, Time	Paper	Pages	Sets
User 01	10, 10:12	A4	1	1

Buttons: PRINT, FAX, SCAN, LOG, STATUS, PRINT, PROOF, PRIVATE, INVALID, RETURN, DELETE, PAUSE, MOVE, EDIT, RELEASE 1/1

- Printing starts.
- The printing status can be confirmed on the print job list.

When you want to change the number of sets

When you want to change the number of sets, press the [EDIT] button and key in the desired number. Then press the [RELEASE] button to start printing.

Filename : Project-01.txt
 Owner : User01
 Pages : 1
 Sets : 5

Buttons: RETURN, RELEASE

Deleting proof print jobs

- 1 Select the job you want to delete on the proof print job list, and then press the [DELETE] button.

The screenshot shows a control panel for 'PROOF PRINT JOB'. At the top, there are buttons for PRINT, FAX, SCAN, LOG, and STATUS. Below these is a table with the following data:

User Name	Date,Time	Paper	Pages	Sets
User 01	10,10:12	A4	1	1

At the bottom of the interface, there are buttons for RETURN, DELETE, PAUSE, MOVE, EDIT, and RELEASE. On the right side, there are buttons for PRINT, PROOF, PRIVATE, and INVALID. A '1/1' indicator is visible at the bottom right.

- If the corresponding job is not displayed on the page, press the [Prev] or [Next] button to switch the page.

- 2 “Delete OK?” appears. Press the [DELETE] button.

The screenshot shows a dialog box with the text "Delete OK?" centered at the top. Below the text are two buttons: "DELETE" on the left and "CANCEL" on the right.

- The job is deleted.

Private print jobs

“Private print” is a function to print a document from a client PC on the network only when a previously set password is keyed in from the control panel of this equipment. This function is useful when you want to print confidential documents.

- For details of private print jobs, see the Printing Guide.

Displaying private print job list

1 Press the [JOB STATUS] button on the control panel.

- The print job list is displayed.

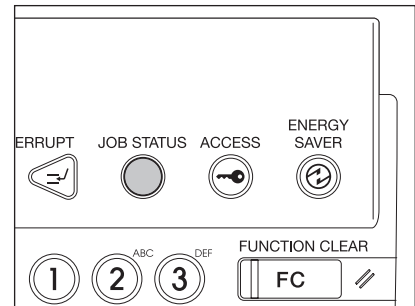

2 Press the [PRIVATE] button.

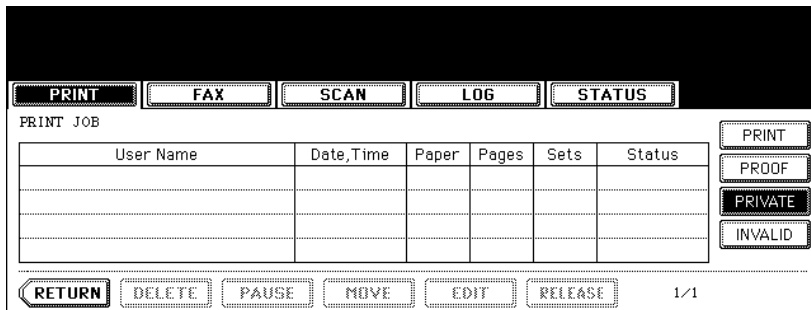

3 Select the appropriate user name.

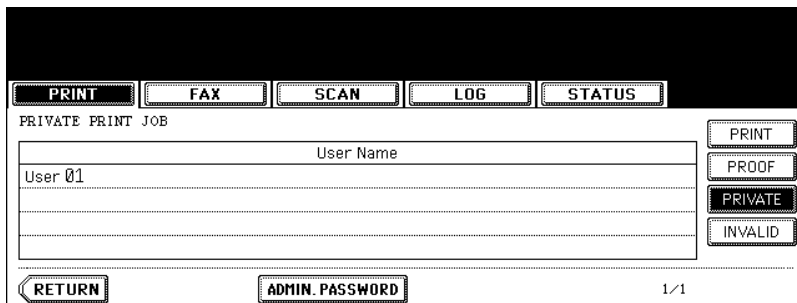

- When you perform the operation as an administrator, do not press the user name but press the [ADMIN. PASSWORD] button. The letter entry menu (P.33 “Setting letters”) appears and you can enter the Admin Password (6 to 10 digits). In this case, jobs can be deleted but not printed. (If an incorrect Admin Password is entered three times in a row, this equipment will not be able to be operated for approx. 30 sec. In that case, wait until it becomes available and then enter the correct Admin Password again.)

4 Press the [PASSWORD] button.

PRIVATE PRINT JOB

User Name
User 01

Buttons: PRINT, FAX, SCAN, LOG, STATUS, PRINT, PROOF, PRIVATE, INVALID, RETURN, PASSWORD, 1/1

- The letter entry menu (P.33 "Setting letters") is displayed. Key in the password, which has previously been set from the client PC, and then press the [ENTER] button.
- The private print job list is displayed.

Tip

A list of private print jobs for which the same password has been set appears.

PRIVATE PRINT JOB

Document Name	Date_Time	Paper	Pages	Sets
01.txt -	30,14:38	A4	1	1
02.txt -	30,14:39	A4	1	1

Buttons: PRINT, FAX, SCAN, LOG, STATUS, PRINT, PROOF, PRIVATE, INVALID, RETURN, DELETE, ALL CLEAR, SELECT ALL, EDIT, RELEASE, 1/1

Printing private print jobs

1 Select the job you want to print on the private print job list.

PRIVATE PRINT JOB

Document Name	Date_Time	Paper	Pages	Sets
Project-01.txt	10,10:12	A4	1	1

Buttons: PRINT, FAX, SCAN, LOG, STATUS, PRINT, PROOF, PRIVATE, INVALID, RETURN, DELETE, ALL CLEAR, SELECT ALL, EDIT, RELEASE, 1/1

- If the corresponding job is not displayed on the page, press the [Prev] or [Next] button to switch the page.
- To select all jobs on the private print job list, press the [SELECT ALL] button. To clear the selection, press the [ALL CLEAR] button.

2 Press the [RELEASE] button.

PRIVATE PRINT JOB

Document Name	Date,Time	Paper	Pages	Sets
Project-01.txt	10,10:12	A4	1	1

Buttons: PRINT, FAX, SCAN, LOG, STATUS, PRINT, PROOF, PRIVATE, INVALID, RETURN, DELETE, ALL CLEAR, SELECT ALL, EDIT, RELEASE, 1/1

- Printing starts.
- The printing status can be confirmed on the print job list.

Deleting private print jobs

1 Select the job you want to delete on the private print job list, and then press the [DELETE] button.

PRIVATE PRINT JOB

Document Name	Date,Time	Paper	Pages	Sets
Project-01.txt	10,10:12	A4	1	1

Buttons: PRINT, FAX, SCAN, LOG, STATUS, PRINT, PROOF, PRIVATE, INVALID, RETURN, DELETE, ALL CLEAR, SELECT ALL, EDIT, RELEASE, 1/1

- If the corresponding job is not displayed on the page, press the [Prev] or [Next] button to switch the page.
- To select all jobs on the private print job list, press the [SELECT ALL] button. To clear the selection, press the [ALL CLEAR] button.

2 “Delete OK?” appears. Press the [DELETE] button.

Delete OK?

Buttons: DELETE, CANCEL

- The job is deleted.

When using department codes

If the department code keyed in at printing is not correct, this job will be stored in the invalid queue (= the list of jobs with an incorrect department code or with no department code), and will not be printed out. However, the jobs stored in the invalid queue can be printed when the correct department code is newly keyed in.

A print job, whose number of pages exceeds that specified for a particular department code, will not be printed out either. In this case, contact the administrator in your office.

Displaying invalid queues

1 Press the [JOB STATUS] button on the control panel.

- The print job list is displayed.

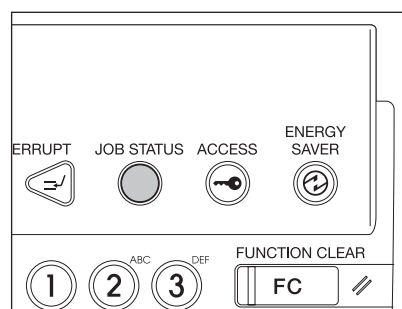

2 Press the [INVALID] button.

The screenshot shows a printer's menu interface. At the top, there are buttons for 'PRINT', 'FAX', 'SCAN', 'LOG', and 'STATUS'. Below these is a 'PRINT JOB' section with a table. The table has columns for 'User Name', 'Date,Time', 'Paper', 'Pages', 'Sets', and 'Status'. To the right of the table are buttons for 'PRINT', 'PROOF', 'PRIVATE', and 'INVALID'. The 'INVALID' button is highlighted. At the bottom, there are buttons for 'RETURN', 'DELETE', 'PAUSE', 'MOVE', 'EDIT', and 'RELEASE'. The page number '1/1' is shown in the bottom right corner.

User Name	Date,Time	Paper	Pages	Sets	Status

- The menu for the invalid queue is displayed.

Keying in correct department code to print

When an incorrect department code has been keyed in at printing, you can key in the correct department code again to print the subject job.

1 Select the job you want to print on the menu for the invalid queue.

User Name	Date, Time	Paper	Pages	Sets
User 01	10, 10:12	A4	1	1

Buttons: PRINT, FAX, SCAN, LOG, STATUS, PRINT, PROOF, PRIVATE, INVALID, RETURN, DELETE, PAUSE, MOVE, EDIT, RELEASE 1/1

- If the corresponding is not displayed on the page, press the [Prev] or [Next] button to switch the page.

2 Press the [RELEASE] button.

User Name	Date, Time	Paper	Pages	Sets
User 01	10, 10:12	A4	1	1

Buttons: PRINT, FAX, SCAN, LOG, STATUS, PRINT, PROOF, PRIVATE, INVALID, RETURN, DELETE, PAUSE, MOVE, EDIT, RELEASE 1/1

3 Key in the correct department code, and then press the [ENTER] button.

DEPARTMENT CODE ▶ Enter department code (5-digit)

Department Code : ****_

Buttons: CANCEL, ENTER

- Printing starts.
- The printing status can be confirmed on the print job list.

Deleting invalid print jobs

- 1 Select the job you want to delete on the menu for the invalid queue, then press the [DELETE] button.

The screenshot shows a printer control panel menu. At the top, there are five buttons: PRINT, FAX, SCAN, LOG, and STATUS. Below these is the text "INVALID DEPARTMENT CODE PRINT JOB". A table displays job details:

User Name	Date,Time	Paper	Pages	Sets
User 01	10,10:12	A4	1	1

Below the table are several buttons: RETURN, DELETE, PAUSE, MOVE, EDIT, and RELEASE. On the right side, there are four buttons: PRINT, PROOF, PRIVATE, and INVALID. The page number "1/1" is shown at the bottom right.

- If the corresponding job is not displayed on the page, press the [Prev] or [Next] button to switch the page.

- 2 "Delete OK?" appears. Press the [DELETE] button.

The screenshot shows a confirmation dialog box with the text "Delete OK?". Below the text are two buttons: DELETE and CANCEL.

- The job is deleted.

3. Confirming Scan Job Status

You can confirm the scan job status and delete a scan job. For details, refer to the Scanning Guide.

Press the [JOB STATUS] button on the control panel. Then press the [SCAN] button on the touch panel to display the scan job list.

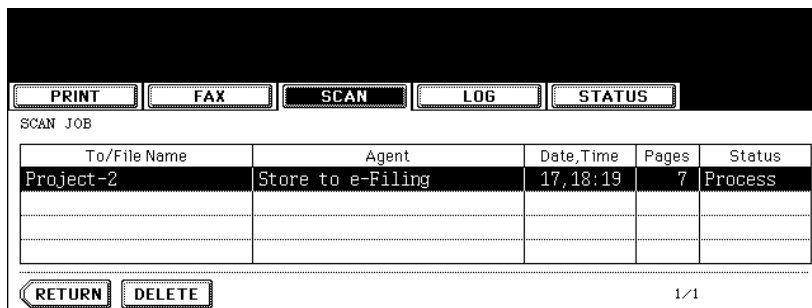

To/File Name	Agent	Date,Time	Pages	Status
Project-2	Store to e-Filing	17,18:19	7	Process

1/1

The following information is displayed.

To/File Name: Name of the file created or the E-mail address of the recipient
Agent: Function selected for the scan job
Date, Time: Date and time of the scan job
Pages: Number of pages scanned or sent via E-mail
Status: Status of jobs

Tip

4 jobs are displayed in 1 page. Up to 250 pages (1000 jobs) can be displayed. When you want to confirm the 5th and the following jobs, press the [Next] button, and when you want to return to the previous page, press the [Prev] button.

Deleting scan job

Select the job you want to delete on the scan job list, and then press the [DELETE] button.

4. Log List

You can confirm the history of each copy, print, scan, and sending and receiving of Fax, Internet Fax and E-mail job on the log list.

You can also register unregistered Fax numbers or E-mail addresses into the address book from the log list of the Fax and Internet Fax, or the log list of scan jobs.

- The FAX Unit (optional) is necessary for the Fax function.

When you press the [JOB STATUS] button on the control panel and the [LOG] button on the touch panel, the log menu is displayed.

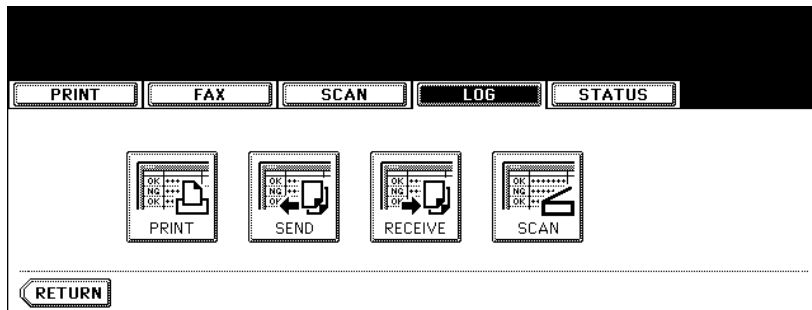

Confirming job history in log list

Print log

When you press the [PRINT] button on the log menu, the history of copy jobs and print jobs is displayed.

PRINT LOG					
User Name	Date, Time	Paper	Pages	Sets	
COPY	02, 19:53	A4	2	1	
COPY	02, 19:52	A4	1	1	
COPY	02, 19:50	A4	2	1	
COPY	02, 18:23	A4	1	1	

1/3

The following information is displayed.

User Name: Name of the senders of the copy/print job
 Date, Time: Date and time the job was printed
 Paper: Paper size printed
 Pages: Number of pages of the copy/print job
 Sets: Number of sets printed

Tip

8

4 jobs are displayed in 1 page. Up to 30 pages (120 jobs) can be displayed. When you want to confirm the 5th and the following jobs, press the [Next] button, and when you want to return to the previous page, press the [Prev] button.

The following button is displayed.

[RETURN]: Press this button to return to the log menu.

Send log

When you press the [SEND] button on the log menu, the sending history of Fax jobs and Internet Fax jobs is displayed. (The Fax function is optional.)

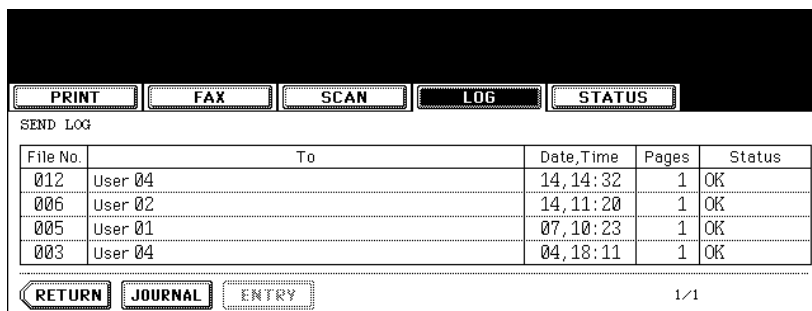

File No.	To	Date, Time	Pages	Status
012	User 04	14, 14:32	1	OK
006	User 02	14, 11:20	1	OK
005	User 01	07, 10:23	1	OK
003	User 04	04, 18:11	1	OK

The following information is displayed.

File No.: Order of job registered
To: Recipient's Fax number or E-mail address of Internet Fax
Date, Time: Date and time the Fax or Internet Fax was sent
Pages: Number of pages of the Fax or Internet Fax sent
Status: Result is displayed as "OK" or in error codes.
(For the error codes, see [P.262](#) "6.Error Code".)

Tip

4 jobs are displayed in 1 page. Up to 10 pages (40 jobs) can be displayed. When you want to confirm the 5th and the following jobs, press the [Next] button, and when you want to return to the previous page, press the [Prev] button.

The following buttons are displayed.

[JOURNAL]: Press this button to print the history of sent jobs (= journal). (For details, see [P.258](#) "Printing journals (send/receive log list)".)
[ENTRY]: Press this button to register unregistered Fax numbers or E-mail addresses on the send log list into the address book. (For details, see [P.256](#) "Registering into address book from log lists".)
[RETURN]: Press this button to return to the log menu.

Receive log

When you press the [RECEIVE] button on the log menu, the receiving history of Fax jobs, Internet Fax jobs and E-mail jobs is displayed. (The Fax function is optional.)

PRINT FAX SCAN LOG STATUS				
RECEIVE LOG				
File No.	From	Date,Time	Pages	Status
014	User 01	17,09:52	1	OK
013	User 02	15,12:27	0	3C12
011	User 04	11,18:10	0	3C12
009	User 02	10,18:07	0	3C12

RETURN JOURNAL ENTRY
1/1

The following information is displayed.

- File No.: Order of job registered
 From: Sender's Fax number or E-mail address of Internet Fax
 (The recipient's name in the address book is displayed, if registered.)
 Date, Time: Date and time the Fax, Internet Fax or E-mail was received
 Pages: Number of pages of the Fax, Internet Fax or E-mail received
 Status: Result is displayed as "OK" or in error codes.
 (For the error codes, see [P.262](#) "6.Error Code".)

8

Tip

4 jobs are displayed in 1 page. Up to 10 pages (40 jobs) can be displayed. When you want to confirm the 5th and the following jobs, press the [Next] button, and when you want to return to the previous page, press the [Prev] button.

The following buttons are displayed.

- [JOURNAL]: Press this button to print the history of received jobs (= journal). (For details, see [P.258](#) "Printing journals (send/receive log list)".)
 [ENTRY]: Press this button to register unregistered Fax numbers or E-mail addresses on the receive log list into the address book. (For details, see [P.256](#) "Registering into address book from log lists".)
 [RETURN]: Press this button to return to the log menu.

Scan log

When you press the [SCAN] button on the log menu, the histories of the following items are displayed.

Job history of the following functions using the copying functions:

- Storing job in e-filing
- Storing job in a shared folder

Job history of the following functions using the scanning functions:

- Storing job in e-filing
- Storing job in a shared folder
- Sending E-mails

Job history of the following function using the printing functions:

- Storing job in e-filing

Job history of the following function using the e-Filing functions:

- Sending E-mails

Job history of the following function using the Fax functions:

- Storing job in a shared folder

Job history of the following functions using the “Received Fax Forward” function:

- Storing job in e-filing
- Storing job in a shared folder
- Sending E-mails

Job history of the following functions using the “Received Internet Fax Forward” function:

- Storing job in e-filing
- Storing job in a shared folder
- Sending E-mails

To/File Name	Agent	Date, Time	Pages	Status
HAKKODÀ-001	Store to e-Filing	10,10:13	1	OK
HAKKODÀ	Store to e-Filing	10,10:12	1	OK

The following information is displayed.

- To/File Name: Name of the file created or the E-mail address of the recipient
 Agent: Function selected for the scan job
 Date, Time: Date and time of the scan job
 Pages: Number of pages scanned or sent via E-mail
 Status: Result is displayed as “OK” or in error codes.
 (For the error codes, see [P.262](#) “6.Error Code”.)

Tip

4 jobs are displayed in 1 page. Up to 30 pages (120 jobs) can be displayed. When you want to confirm the 5th and the following jobs, press the [Next] button, and when you want to return to the previous page, press the [Prev] button.

The following buttons are displayed.

- [ENTRY]: Press this button to register unregistered E-mail addresses on the scan log list into the address book. (For details, see [P.256](#) “Registering into address book from log lists”.)
 [RETURN]: Press this button to return to the log menu.

Registering into address book from log lists

You can register the information such as the remote Fax numbers and E-mail addresses in the address book from the send/receive log screen.

The following information can be registered from the Send log:

- Remote FAX number which was dialed by direct entry using the digital keys, or which was searched for by the LDAP server
- E-mail address which was manually entered, or which was searched for by the LDAP server

The following information can be registered from the Receive log:

- Remote FAX number which was dialed by direct entry using the digital keys, or which was searched for by the LDAP server for a Polling Reception
- E-mail address of the sender

The following information can be registered from the Scan log:

- E-mail address which was manually entered

1 Press the [SEND] (or [RECEIVE] or [SCAN]) button on the log menu.

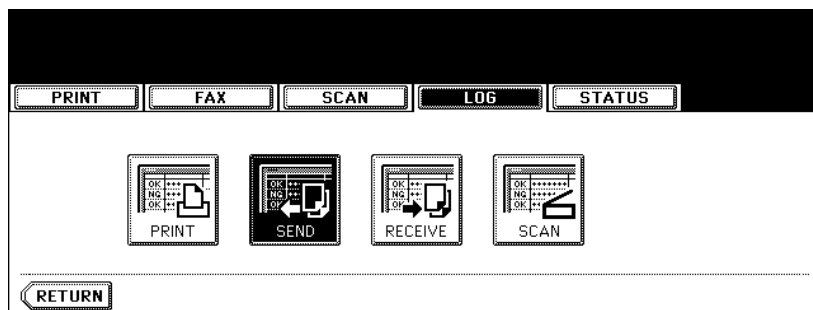

- The send (or receive or scan) log list is displayed.

2 Select the job which includes the Fax number or E-mail address you want to register into the address book.

File No.	To	Date, Time	Pages	Status
005	055-000-0000	10,10:14	1	OK
002	045-000-0000	10,10:13	1	OK
001	044-000-0000	10,10:11	1	OK

3 Press the [ENTRY] button.

SEND LOG

File No.	To	Date,Time	Pages	Status
005	055-000-0000	10,10:14	1	OK
002	045-000-0000	10,10:13	1	OK
001	044-000-0000	10,10:11	1	OK

Buttons: RETURN, JOURNAL, ENTRY

1/1

4 Enter the following information. (You need to enter at least either of [FIRST NAME] or [LAST NAME], and either of [FAX NO.] or [E-MAIL].)

ADDRESS ENTRY ID NO. :0041

FIRST NAME	User 01	E-MAIL	
LAST NAME	User	CORP.	
FAX NO.	045-000-0000	DEPT.	
2ND FAX		KEYWORD	

Buttons: OPTION, CANCEL, ENTER

- **FIRST NAME:** Enter the first name. The entered first name is displayed in the address book list on the touch panel.
- **LAST NAME:** Enter the last name. The entered last name is displayed in the address book list on the touch panel.
- **FAX NO.:** Enter the Fax number.
- **2ND FAX:** Enter the second Fax number.
- **E-MAIL:** Enter the E-mail address.
- **CORP.:** Enter the company name.
- **DEPT.:** Enter the department name.
- **KEYWORD:** Enter a keyword with which you can search for the desired contact.

Tip

When you press any of the above, the letter entry menu (P.33) is displayed. Enter the information with the buttons on this menu and the digital keys on the control panel.

5 Press the [ENTER] button.

- The information has been registered in the address book.
- For details of the address book, see the User Functions Guide.

Printing journals (send/receive log list)

You can print the send and receive log lists of the Fax job. The 40 latest send-and-receive logs (1 page), or the 120 latest send-and-receive logs (3 pages) can be printed out. You can also select and print only 1 log.

- For details, see the Operator's Manual for Facsimile Function.

1 Press the [SEND] (or [RECEIVE]) button on the log menu.

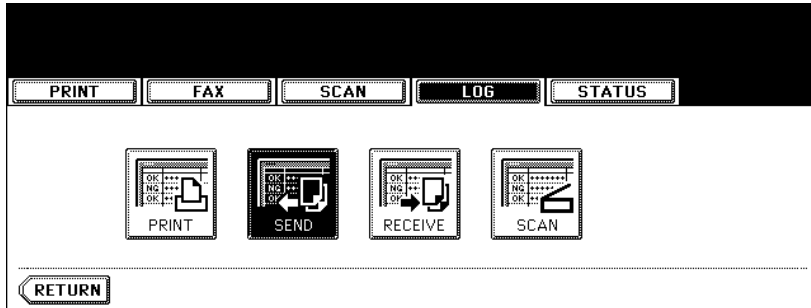

- The send (receive) log list is displayed.

2 Press the [JOURNAL] button.

File No.	To	Date,Time	Pages	Status
005	055-000-0000	10,10:14	1	OK
002	045-000-0000	10,10:13	1	OK
001	044-000-0000	10,10:11	1	OK

- The send (receive) log list is printed.

5. Print Status Display

When you press the [STATUS] button on the touch panel while no operation is in progress, the size of the paper set in the drawer is displayed. When you press the [STATUS] button during printing, the drawer button being used for the feeding of this printing is highlighted.

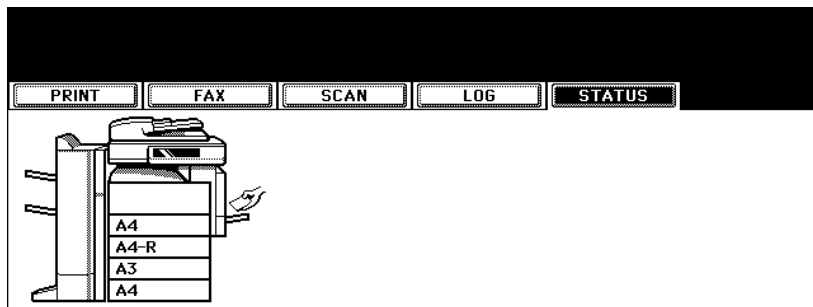

Releasing print job errors

If the specified size of paper is not in the drawer when printing is to be performed from a client PC, a print job error occurs. The [JOB STATUS] button blinks and the following menu is displayed.

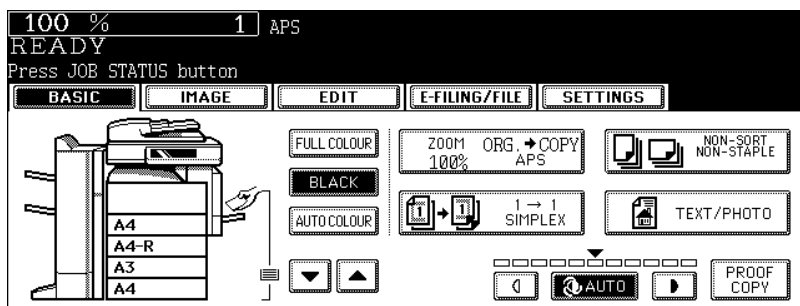

Follow the procedure below to release the error.

Printing by placing sheets of paper on the bypass tray

1 Press the blinking [JOB STATUS] button.

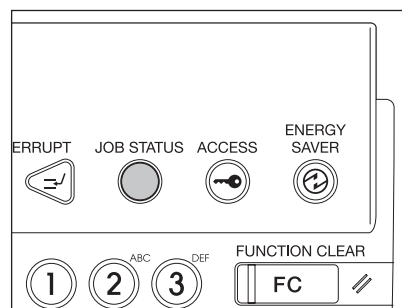

2 Place the specified size of paper on the bypass tray, and then press the [START] button.

- Printing is performed. Press the [JOB STATUS] button when printing is completed.

Printing by placing appropriate size of sheets in the drawer

1 Press the blinking [JOB STATUS] button.

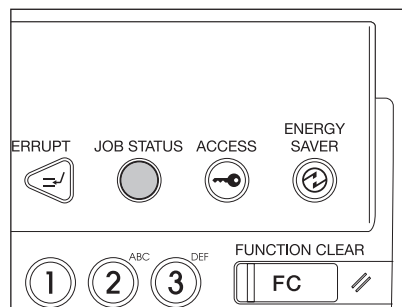

2 Press the drawer button whose size you want to change on the touch panel.

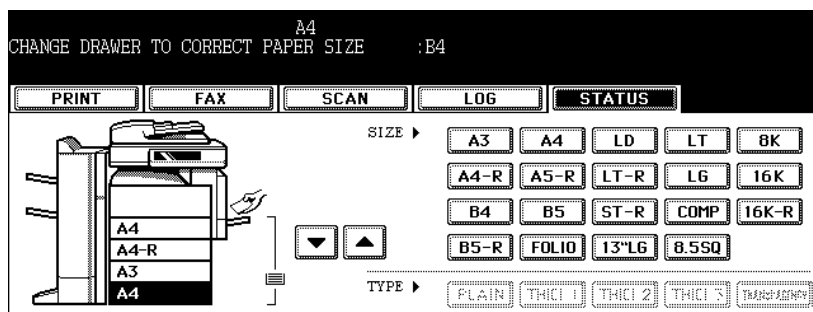

- You can select the desired drawer with the paper source selection (▼/▲) buttons.

3 Place paper in the corresponding drawer.

4 Press the paper size button corresponding to the one you have placed.

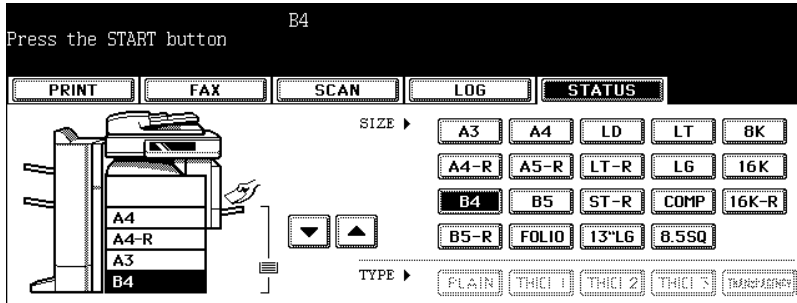

5 Press the [START] button.

- Printing is performed. Press the [JOB STATUS] button when printing is completed.

Printing by selecting a paper size already placed in another drawer

When the specified size of paper is not in the drawer, you can release the error by selecting another size of paper already placed in another drawer, instead of placing the specified size of paper in the drawer. However, a part of the image may not be printed if the size of the paper placed in the drawer is smaller than the specified one.

Press the drawer button whose size you want to use on the touch panel. Then press the [START] button.

6. Error Code

If an error occurs while using the printer, optional Fax, optional Internet Fax or optional scan, the error code is displayed in the status of each log. Take an appropriate action with reference to the following.

Fax / Internet Fax

Error code	Problem	What to do
Fax		
0012	Original jam	Clear the jammed original.
0013	Door open	Firmly close the open door.
0020	Power interruption	Check the power interruption report.
0030	Reset	Transmission is cancelled. (The transmission is terminated by the jammed printing paper during the Direct Transmission.)
0033	Polling error	Check polling options setup (Security code, etc.), and check if the polling document exists.
0042	Memory full	Make sure that there is sufficient memory before making the call again.
0050	Line busy	Retry communications.
0053	Security mismatch in relay or mailbox transmission	Confirm the remote party's security code, system password, and your setup.
00B0 - 00B5 00C0 - 00C4 00D0 - 00D2 00F0, 00F1	Signal error or line condition error	Retry communications. Frequent failures may indicate a phone line problem. If possible, move the unit to another line and try your communications again.
00E8	HDD error	Retry communications.
Internet Fax		
1C10	System access abnormality	Turn the power OFF and then back ON. Perform the job in error again. If the error still occurs, contact your service representative.
1C11	Insufficient memory	When there are running jobs, perform the job in error again after the completion of the running jobs. If the error still occurs, turn the power OFF and then back ON, and perform the job again.
1C12	Message reception error	Turn the power OFF and then back ON. Perform the job in error again.
1C13	Message transmission error	Turn the power OFF and then back ON. Perform the job in error again.
1C14	Invalid parameter	When a template is used, form the template again. If the error still occurs, turn the power OFF and then back ON, and perform the job again.
1C15	Exceeding file capacity	Ask your administrator to change the "Fragment Page Size" setting for the Internet Fax setting, or reduce the number of pages and perform the job again.
1C20	System management module access abnormality	Turn the power OFF and then back ON. Perform the job in error again. If the recovery is still not completed, contact your service representative.
1C21-1C22	Job control module access abnormality	Turn the power OFF and then back ON. Perform the job in error again. If the recovery is still not completed, contact your service representative.

Error code	Problem	What to do
1C30	Directory creation failure	Check if the access privilege to the storage directory is writable. Check if the server or local disk has a sufficient space in disk capacity.
1C31	File creation failure	Check if the access privilege to the storage directory is writable. Check if the server or local disk has a sufficient space in disk capacity.
1C32	File deletion failure	Check if the access privilege to the storage directory is writable. Check if the server or local disk has a sufficient space in disk capacity.
1C33	File access failure	Check if the access privilege to the storage directory is writable. Check if the server or local disk has a sufficient space in disk capacity.
1C40	Image conversion abnormality	Turn the power OFF and then back ON. Perform the job in error again. If the error still occurs, contact your service representative.
1C60	HDD full failure during processing	Reduce the number of pages of the job in error and perform the job again. Check if the server or local disk has a sufficient space in disk capacity.
1C61	Address book reading failure	Turn the power OFF and then back ON. Perform the job in error again. Reset the data in the Address book and perform the job again. If the error still occurs, contact your service representative.
1C62	Memory acquiring failure	Turn the power OFF and then back ON. Perform the job in error again. If the error still occurs, contact your service representative.
1C63	Terminal IP address unset	Ask your administrator to set the IP address of the equipment.
1C64	Terminal mail address unset	Ask your administrator to set the E-mail address of the equipment.
1C65	SMTP address unset	Ask your administrator to set the SMTP server address.
1C66	Server time time out error	Check if the SMTP server is operating properly.
1C69	SMTP server connection error	Ask your administrator to set the login name or password of SMTP server and perform the job again. Check if the SMTP server is operating properly.
1C6A	HOST NAME error	Ask your administrator to check if there is an illegal character in the device name. Delete the illegal character and reset the appropriate device name.
1C6B	Terminal mail address error	Ask your administrator to check if there is an illegal character in the E-mail address of the equipment. Delete the illegal character and reset the appropriate E-mail address, then perform the job again.
1C6C	Destination mail address error	Check if there is an illegal character in the Destination E-mail address. Delete the illegal character and reset the appropriate Destination E-mail address, then perform the job again.
1C6D	System error	Turn the power OFF and then back ON. Perform the job in error again. If the error still occurs, contact your service representative.

Error code	Problem	What to do
1C70	SMTP client OFF	Ask your administrator to enable the SMTP Client and perform the job again.
1C71	SMTP authentication error	Check if the SMTP authentication method, login name and password are correct. If the SSL setting is enabled, check if the setting and the port number of SSL correspond to those of the server.
1C72	POP Before SMTP error	Check if the settings of POP Before SMTP and POP3 are correct.
1C80	Internet Fax transmission failure when processing E-mail job received	Confirm the "Received Internet Fax Forward" settings.
1C81	Onramp Gateway transmission failure	Confirm the mailbox settings.
1C82	Internet Fax transmission failure when processing Fax job received	Confirm the "Received Fax Forward" setting.
1CC0	Job canceling	Job was canceled.
1CC1	Power failure	Check if the power cable is connected properly and it is inserted securely. Check if the power voltage is unstable.
3A10-3A12	MIME format error	Ask the sender to resend the E-mail in the MIME1.0 format.
3A20-3A22	E-mail process error	Ask the sender to resend the E-mail.
3A30	Partial E-mail timeout error	Ask the sender to resend the E-mail, or change the Partial Wait time setting.
3A40	Invalid partial E-mail received	Ask the sender to resend the partial E-mail in the RFC2046 format.
3A50-3A52	HDD full error	Ask the sender to resend the E-mail by separating it to several E-mails. If this error occurs because the paper empty occurs and too much waiting jobs are stored in the hard disk, add the paper to activate other jobs.
3A60-3A62	HDD full alert	Ask the sender to resend the E-mail by separating it to several E-mails. If this error occurs because the paper empty occurs and too much waiting jobs are stored in the hard disk, add the paper to activate other jobs.
3A70	Interrupt partial E-mail reception	Ask your administrator to enable the Enable Partial E-mail setting and ask the sender to resend the E-mail.
3A80-3A82	Partial E-mail disabled	Ask your administrator to enable the Enable Partial E-mail setting and ask the sender to resend the E-mail.
3B10-3B12	E-mail format error	Ask your administrator to enable the Enable Partial E-mail setting and ask the sender to resend the E-mail.
3B20-3B22	Context-type error	Ask the sender to resend the E-mail with attached files that are the TIFF format.
3B30-3B32	Invalid character set	Ask the sender to resend the E-mail in the ISO-8559-1/2 format.
3B40-3B42	E-mail decode error	Ask the sender to resend the E-mail.

Error code	Problem	What to do
3C10-3C13	TIFF analysis error	Ask the sender to resend the E-mail with attached files that are the TIFF format.
3C20-3C22	TIFF compression error	Ask the sender to resend the E-mail with attached TIFF files in the MH, MR, MMR, or JPEG compression.
3C30-3C32	TIFF resolution error	Ask the sender to resend the E-mail with attached TIFF files whose resolution is either 200 x 100, 200 x 200, 200 x 400, 300 x 300, or 400 x 400 dpi.
3C40-3C42	TIFF paper size error	Ask the sender to resend the E-mail with attached TIFF files that can be printed on the paper available for this equipment.
3C50-3C52	Offramp transmission error	Ask the sender to specify the correct fax numbers and resend the E-mail.
3C60-3C62	Offramp security error	Confirm the fax numbers that are specified in the received offramp gateway job and ask the sender to resend the E-mail with correct fax numbers.
3C70	Power failure	Confirm the job is recovered or not. If not, ask the sender to resend the E-mail.
3D10	Destination address error	Ask your administrator whether the DNS and mail server settings are correctly set. If they are correctly set, ask the sender to confirm the destination address is correct.
3D20	Exceeding maximum offramp destinations	Ask the sender to specify up to 40 destinations for one offramp gateway job. The equipment cannot perform the offramp gateway transmission for more than 40 destinations.
3D30	Fax unit is not installed	Make sure the Fax unit is installed, or connected correctly.
3E10	POP3 server communication error	Ask your administrator that the POP3 server address is correctly set, or the POP3 server works properly. Check if the setting and the port number of SSL correspond to those of the server.
3E20	POP3 server communication timeout	Ask your administrator that the POP3 server works properly and the LAN cable is connected to the server.
3E30	POP3 login error	Ask your administrator that the POP3 user name and password is set correctly.
3E40	POP3 login type error	Ask your administrator if the login types (Auto, POP3, APOP) to the POP3 server are correct.
3F00, 3F10, 3F20, 3F30, 3F40	File I/O error	Ask the sender to resend the E-mail. If the error still occurs, contact your service representative.

Scan Job

Error code	Problem	What to do
Remote Scan		
2A20	Failed to acquire resource	Perform the job in error again. If the error still occurs, turn the power OFF and then back ON. Perform the job in error again.
2A40	System fatal error	Turn the power OFF and then back ON. Perform the job in error again.
2A50	Job cancelling	Job was cancelled.
2A51	Power failure	Check if the power cable is connected properly and it is inserted securely. Check if the power voltage is unstable.
Scan to E-mail		
2C10, 2C12, 2C13, 2C20-2C22	Illegal job status	A system error has occurred during sending an E-mail. Retry it. If the error still occurs, contact your service representative.
2C11, 2C62	Not enough memory	Scan job exceeded the limit or maximum size. Send your documents separately.
2C14	Invalid parameter specified	Make sure you specify the settings correctly and try again.
2C15	Message size exceeded limit or maximum size	Fragment the message into several smaller-sized ones and send them again.
2C30	Failed to create directory	Make sure that the access privilege to the storage directory is writable and the server or local disk has a sufficient space. Then retry the scan.
2C31, 2C33	Failed to create file	Make sure that the access privilege to the storage directory is writable and the server or local disk has a sufficient space. Then retry the scan.
2C32	Failed to delete file	Make sure that the access privilege to the storage directory is writable and the server or local disk has a sufficient space. Then retry the scan.
2C40	Failed to convert image file format	Turn the power OFF and then back ON. Retry the scan. If the error still occurs, contact your service representative.
2C61	Failed to read Address book	Turn the power OFF and then back ON. Retry the job in error. Reset the data in the Address book and retry it. If the error still occurs, contact your service representative.
2C63, 2C64	Invalid domain address	Ask your administrator to set the IP address.
2C65, 2C66, 2C69	Failed to connect to SMTP server	Make sure the SMTP server is correctly working, or the SMTP server address has been set correctly. Then retry the scan.
2C6A	Failed to send E-mail message	Turn the power OFF and then back ON. Retry the scan. If the error still occurs, contact your service representative.
2C6B	Invalid address specified in From: field	Ask your administrator to check if there is an illegal character in the E-mail address of the equipment. Delete the illegal character and reset the appropriate E-mail address, then perform the job again.

Error code	Problem	What to do
2C6C	Invalid address specified in To: field	Check if there is an illegal character in the Destination E-mail address. Delete the illegal character and reset the appropriate Destination E-mail address, then perform the job again.
2C6D	NIC system error	Turn the power OFF and then back ON. Retry the job in error. If the error still occurs, contact your service representative.
2C70	SMTP service is not available	Ask your administrator to enable the SMTP setting.
2C71	SMTP authentication error	Check if the SMTP authentication method, login name and password are correct. If the SSL setting is enabled, check if the setting and the port number of SSL correspond to those of the server.
2C72	POP Before SMTP error	Check if the settings of POP Before SMTP and POP3 are correct.
2C80	Failed to process received E-mail job	Ask your administrator to confirm whether the Received Internet Fax Forward is set.
2C81	Failed to process received Fax job	Ask your administrator to confirm whether the Received Fax Forward is set.
2CC0	Job canceled	Job was canceled.
2CC1	Power failure occurred	Make sure that the power cable is connected properly and it is inserted securely. Resend the job.
Save as File		
2D10, 2D12, 2D13, 2D20-2D22	Illegal job status	Turn the power OFF and then back ON. Retry sending. If the error still occurs, contact your service representative.
2D11	Not enough memory for saving the scan job	Wait for a while and retry the job. If the error still occurs, turn the power OFF and then back ON and retry it.
2D14	An internal error occurred	Turn the power OFF and then back ON, and retry the job. If the error still occurs, contact your service representative.
2D15	Exceeding maximum file capacity	Divide the file into several files, or retry in a single-page format.
2D30	Failed to create directory	Make sure that the access privilege to the storage directory is writable and also the disk in the directory has enough space, and then retry the job. If more than one job is performed simultaneously, the error may occur because the disk temporarily runs out of space. In this case, wait for a while and retry the job. If the error still occurs, turn the power OFF and then back ON, and then retry it.
2D31, 2D33	Failed to create file	Make sure that the access privilege to the storage directory is writable and also the disk in the directory has enough space, and then retry the job. If more than one job is performed simultaneously, the error may occur because the disk temporarily runs out of space. In this case, wait for a while and retry the job. If the error still occurs, turn the power OFF and then back ON, and then retry it.
2D32	Failed to delete file	Make sure that the access privilege to the storage directory is writable and the server or local disk has a sufficient space. Then retry the scan.

Error code	Problem	What to do
2D40	Failed to convert image file format	Turn the power OFF and then back ON. Retry the scan. If the error still occurs, contact your service representative.
2D60	Failed to copy file	Turn the power OFF and then back ON. Retry the scan. If the error still occurs, contact your service representative.
2D62	Failed to connect to network destination. Check destination path.	Check destination path. Make sure that the network path is correct, and retry the scan. If the error still occurs, ask your administrator to confirm whether the IP address or path of the server is correct. Also make sure that the server is operating properly.
2D63	Specified network path is invalid. Check destination path.	Make sure you specify correct network folder and retry the scan.
2D64	Logon to file server failed. Check username and password.	Make sure you specify correct user name and password to logon the file server and retry the scan.
2D65	There are too many documents in the folder. Failed in creating new document.	Delete the data in the local storage folder in the equipment and retry the scan.
2D66	Failed to process your job. Insufficient storage space.	Delete the data in the local storage folder in the equipment and retry the scan.
2D67	FTP service is not available.	Ask your administrator whether the FTP service is configured correctly.
2D68	File sharing service is not available.	Ask your administrator whether the SMB protocol is enabled.
2DA8	The HDD is running out of capacity for the shared folder.	Delete the unnecessary data in HDD.
2DC0	Job canceled.	Job was canceled.
2DC1	Power failure occurred.	Make sure that the power cable is connected properly and it is inserted securely. Resend the job.
Store to e-Filing		
2B10	There was no applicable job.	Turn the power OFF and then back ON. Retry the scan. If the error still occurs, contact your service representative.
2B11	Job status failed.	Turn the power OFF and then back ON. Retry the scan. If the error still occurs, contact your service representative.
2B20	Failed to access file	Turn the power OFF and then back ON. Retry the scan. If the error still occurs, contact your service representative.
2B21	Message size exceeded limit or maximum size	Fragment the message into several smaller-sized ones and send them again.
2B30	Insufficient disk space	Delete unnecessary documents in e-Filing and try again.

Error code	Problem	What to do
2B31	Failed to access e-Filing	Make sure that the specified e-Filing or folder exists. (If not, this error would not occur.). Turn the power OFF and then back ON. Delete the specified e-Filing or folder and reset them. Retry the job in error. If the specified e-Filing or folder cannot be deleted, contact your service representative.
2B32	Failed to print e-Filing document	Make sure that the specified document exists. (If not, this error would not occur.). Turn the power OFF and then back ON. Delete the specified document. If the specified document cannot be deleted, contact your service representative.
2B50	Failed to process image	Turn the power OFF and then back ON. Retry the scan. If the error still occurs, contact your service representative.
2B51	Failed to process print image	Make sure that the Function List can be printed out. Retry the print. If the error still occurs, contact your service representative.
2B90	Insufficient memory	Turn the power OFF and then back ON. Retry the scan. If the error still occurs, contact your service representative.
2BA0	Invalid box password specified	Make sure that the password is correct and retry the scan, or reset the password and retry the scan. When this error occurs for the print of the data in the e-Filing, perform the print with the administrator's password. If the recovery is still not completed or in case of invalid password for the operation other than printing (opening the file, etc.), contact your service representative.
2BB0	Job canceled.	Job was canceled by the user.
2BB1	Power failure occurred.	Make sure that the power cable is connected properly and it is inserted securely.
2BC0	System fatal error	Turn the power OFF and then back ON. Retry the print. If the error still occurs, contact your service representative.
2BC1	Failed to acquire resource	Turn the power OFF and then back ON. Retry the print. If the error still occurs, contact your service representative.
2B60	The folder was renamed. A folder of the same name already existed.	Check the folder to be made.
2B70	The document was renamed. A document of the same name already existed.	Check the data to be stored.
2B71	The storage period of e-Filing documents will expire.	Check the storage period.
2B80	The HDD for storing e-Filing data is running out of space.	Delete the unnecessary data in HDD.
2BA1	Incorrect paper size	This size is not supported by e-Filing. Check the paper size.
2BD0	Power failure occurred during restoring.	Check the power cable.
2BE0	Failed to obtain the machine parameters.	Turn the power OFF and then back ON to print again.

Error code	Problem	What to do
2BF0	Reached the maximum number of pages.	Reduce the pages to be inserted, and print them.
2BF1	Reached the maximum number of documents.	Delete unnecessary documents in the box or folder.
2BF2	Reached the maximum number of folders.	Delete unnecessary folders in the box.
Printer		
4031	HDD full for printing	Too many jobs of Private print and department code print are stored in HDD.
4032	Private-print-only error	Jobs other than Private print cannot be printed. Perform Private printing.
4033	Printing data storing limitation error	Printing with its data being stored to the HDD temporarily (Proof print, Private print, Scheduled print, etc.) cannot be performed. Perform normal printing.
4034	e-Filing storing limitation error	Printing with its data being stored to the HDD (print and e-Filing, print to e-Filing, etc.) cannot be performed. Perform normal printing.
4035	Local file storing limitation error	Network Fax or Internet Fax cannot be sent when "Local" is selected for the destination of the file to save. Select "Remote" (SMB/FTP) for the destination.
4036	User authentication error	The user performing the printing has not been authenticated or user-registered. Perform user authentication or user registration.
4040	No authority to execute a job	Ask your administrator about it.
4050	The connection with the LDAP server or its authority setting has something wrong.	Ask your LDAP server administrator about it.
A221	Print job cancel	Print job is canceled. Retry the print.
A222	Print Job power interruption	Power failure occurred. Retry the print.
A290	Limit over error (Black and White)	Number of prints has exceeded the one specified with the department code and user code at the same time. Clear the limit counter.
A291	Limit over error (Black and White)	Number of prints has exceeded the one specified with the user code. Clear the limit counter.
A292	Limit over error (Black and White)	Number of prints has exceeded the one specified with the department code. Clear the limit counter.
A2A0	Limit over error (Colour)	Number of prints has exceeded the one specified with the department code and user code at the same time. Clear the limit counter.
A2A1	Limit over error (Colour)	Number of prints has exceeded the one specified with the user code. Clear the limit counter.
A2A2	Limit over error (Colour)	Number of prints has exceeded the one specified with the department code. Clear the limit counter.

RFC related

Error code	Problem	What to do
2500	Syntax error, command unrecognized: HOST NAME error (RFC: 500), Destination mail address error (RFC: 500), Terminal mail address error (RFC: 500)	Check if the Terminal mail address and Destination mail address are correct. Check if the mail server is operating properly. Turn the power OFF and then back ON, and perform the job in error again.
2501	Syntax error in parameters or arguments: HOST NAME error (RFC: 501), Destination mail address error (RFC: 501), Terminal mail address error (RFC: 501)	Check if the Terminal mail address and Destination mail address are correct. Check if the mail server is operating properly. Turn the power OFF and then back ON, and perform the job in error again.
2503	Destination mail address error (RFC: 503)	Check if the mail server is operating properly. Turn the power OFF and then back ON, and perform the job in error again. If the error still occurs, contact your service representative.
2504	HOST NAME error (RFC: 504)	Check if the mail server is operating properly. Turn the power OFF and then back ON, and perform the job in error again. If the error still occurs, contact your service representative.
2550	Destination mail address error (RFC: 550)	Check if the Destination mail address is correct. Check the status of mailbox access restriction, etc. on the mail server.
2551	Destination mail address error (RFC: 551)	Check the Destination mail address. Check if the mail server is operating properly.
2552	Terminal/Destination mail address error (RFC: 552)	Check if the Destination mail address is correct. Check the restriction of the capacity in the mailbox of the mail server.
2553	Terminal/Destination mail address error (RFC: 553)	Check if there is an illegal character in the mailbox in the mail server.



9. BLINKING GRAPHIC SYMBOLS

1. Blinking Graphic Symbols	274
2. Drawer Display on the Touch Panel.....	275
3. Replace Toner Cartridge Symbol	276
4. Replace Toner Bag Symbol	283
5. Jam Symbols	285
6. Call Service Symbol.....	306

1. Blinking Graphic Symbols

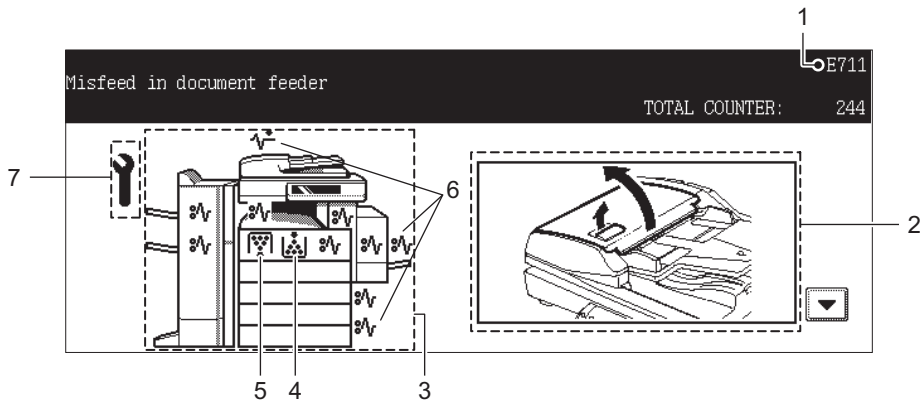

1. Error code
2. Guidance display area
3. Illustration of the equipment
4. Replace toner cartridge symbol (📖 P.276 "3.Replace Toner Cartridge Symbol")
5. Replace toner bag symbol (📖 P.283 "4.Replace Toner Bag Symbol")
6. Jam symbol (📖 P.285 "5.Jam Symbols")
7. Call service symbol (📖 P.306 "6.Call Service Symbol")

When one of the graphic symbols 4 to 7 blinks, take the appropriate action referring to the indicated pages.

2. Drawer Display on the Touch Panel

When the drawer runs out of paper, the drawer display on the touch panel starts blinking. Add paper to the drawer.

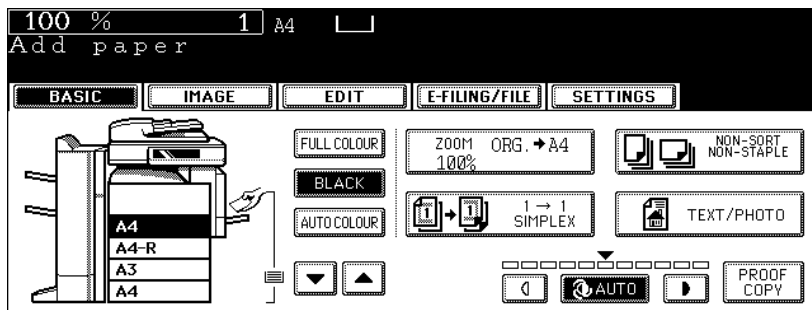

3. Replace Toner Cartridge Symbol

When the toner in the cartridge runs out, the Replace toner cartridge symbol blinks and the following message appears.

When the black toner runs out:

“Install new Black toner cartridge” appears.

When the yellow, magenta or cyan toner runs out:

“Install new ***** toner cartridge. Press *** button.”

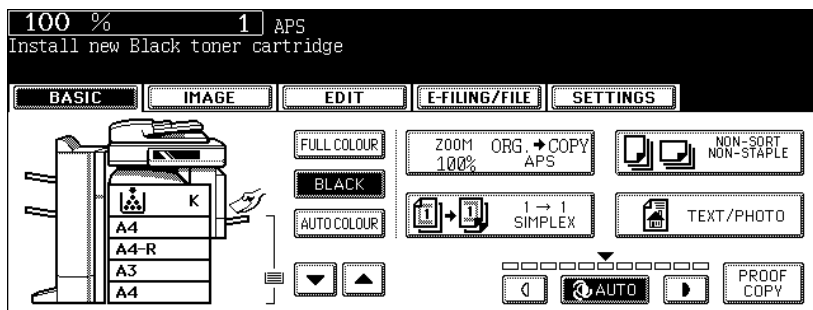

Caution

Never attempt to incinerate toner cartridges. This could cause an explosion. Do not dispose of used toner cartridges. Contact your service representative.

Then replace the cartridge in the following procedures.

Recommendation for original toner

At Toshiba we strive to provide you with the highest quality images. Please use genuine Toshiba toner to ensure that you continue to receive quality output that is environmentally safe.

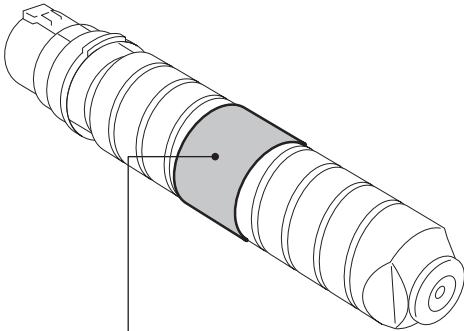

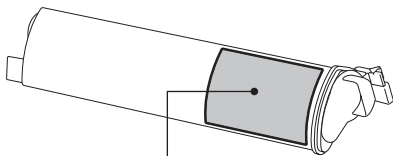

TOSHIBA

T-281CE-K

NET 675 g

FOR e-STUDIO281c/351c/451c

COMPONENTS: Polyester resin, Carbon black(1333-86-4), Wax, Polypropylene, Silica

TOSHIBA

T-281CE-Y

FOR e-STUDIO281c/351c/451c

NET 220 g

ORIGINAL & GENUINE TOSHIBA TONER

- HANDLE WITH CARE
- STORE IN A DRY PLACE BELOW 35°C(95°F)
- READ THE OPERATING INSTRUCTIONS OF THE MACHINE BEFORE USING
- SHAKE WELL BEFORE USING
- MANIPULER AVEC PRECAUTION
- GARDER DANS UN ENDROIT SANS HUMIDITE OU LA TEMPERATURE AMBIANTE EST MOINS DE 35°C
- USER LE MANUEL D'EMPLOI DE L'APPAREIL AVANT D'EN FAIRE USAGE
- AGITER AVANT EMPLOI

COMPONENTS:
Polyester resin, Organic pigment, Wax, Polypropylene, Silica

TOSHIBA TEC CORPORATION

2-172, Higashi-cho, 5-chome-2-1, Bunkyo-ku, Tokyo, 114-8605, Japan
PHONE: +81-3-5442-7753

MADE IN CHINA / FABRIQUE EN CHINE
HERGESTELLT IN CHINA
HECHO EN CHINA / FATTO IN CHINA

YELLOW
JAUNE
GELB
AMARILLO
GIALLO

TOSHIBA

T-281CE-K

NET 675 g

FOR e-STUDIO281c/351c/451c

COMPONENTS: Polyester resin, Carbon black(1333-86-4), Wax, Polypropylene, Silica

TOSHIBA

T-281CE-Y

FOR e-STUDIO281c/351c/451c

NET 220 g

ORIGINAL & GENUINE TOSHIBA TONER

- SHAKE WELL BEFORE USING.
- AGITER AVANT EMPLOI.
- VOR GEBRAUCH GUT SCHÜTTELN.
- AGITARE BENE PRIMA DELL'USO.
- SACUDIR BIEN ANTES DE USER.
- TAP THE BOTTLE REPEATEDLY.
- TAPER DE FAÇON REPÉTÉE SUR LA BOUTEILLE.
- EINIGE MALE WIEDERHOLT AUF DIE TONERFLASCHE KLOPFEN.
- DARE ROPETUTAMENTE DEI COLPETTI ALLA BOTTIGLIA.
- GOLPEE SUAVEMENTE LA BASE DEL CARTUCHO DE TONER.

TOSHIBA AMERICA BUSINESS SOLUTIONS, INC.
2 Music, Irvine, California 92618-1631
(949)462-8000

MADE IN U.S.A. / FABRIQUE AUX ETATS-UNIS
HERGESTELLT IN U.S.A.
HECHO EN U.S.A. / FATTO IN U.S.A.

BLACK
NOIR
SCHWARZ
NEGRO
NERO



Replacing the Black (K) toner cartridge

Tip

When you want to replace a cartridge before the Replace toner cartridge symbol blinks, see the procedure of "Replacing the Toner Cartridge" in Chapter 3 SETTING ITEMS (USER) in the User Functions Guide.

1 Open the front cover.

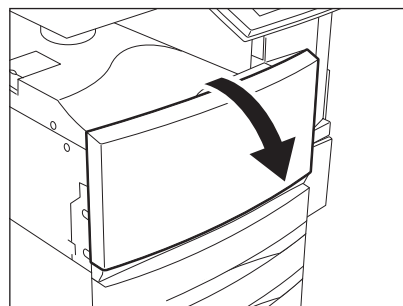

2 While pushing on the latch, lower the cartridge holder toward you.

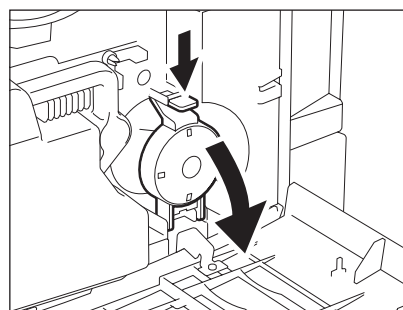

3 Pull the cartridge out carefully.

- If you cannot pull it straight out, pull it out rotating it clockwise.

Tip

If it cannot be pulled out, close the front cover, turn the power OFF and then ON again. When "Install new Black toner cartridge" appears, start the procedure again from step 1.

Caution

Never attempt to incinerate toner cartridges. This could cause an explosion. Do not dispose of used toner cartridges. Contact your service representative.

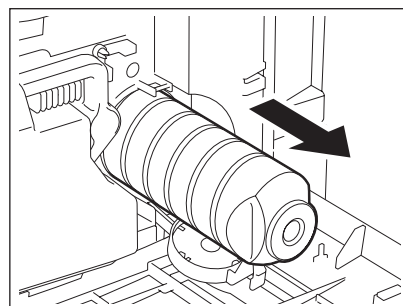

4 Tap and shake the new toner cartridge well to loosen the toner inside.

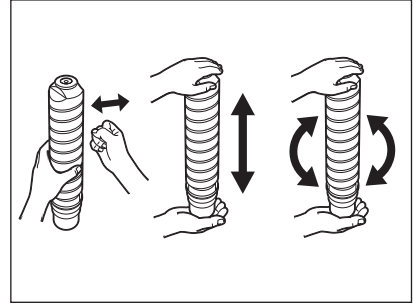

5 Stand the toner cartridge upright, and pull out the seal in the direction of the arrow.

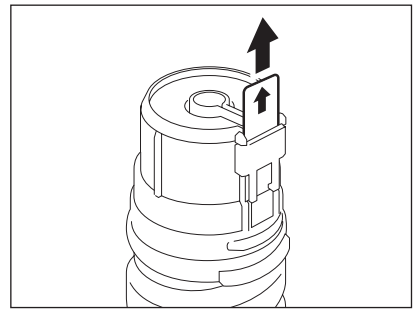

6 Insert the cartridge completely.

- Match the label (orange) on the equipment with the shutter (orange) on the toner cartridge, then insert it.
- If the inside of the equipment becomes dirty with toner, clean it before inserting the cartridge.

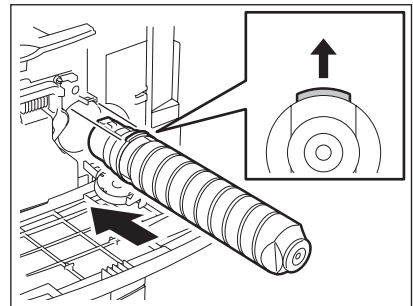

7 Return the cartridge holder to its original position.

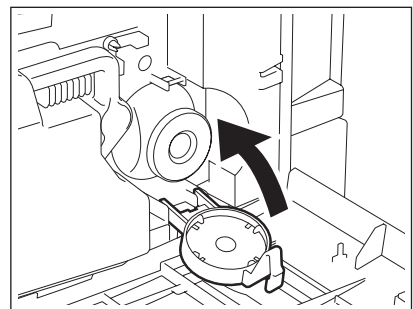

8 Close the front cover.

- “Wait adding toner” appears. The equipment automatically starts supplying toner.

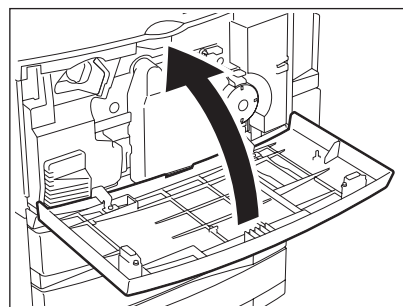

Replacing the Yellow (Y), Magenta (M), Cyan (C) toner cartridge

Follow the procedure on the touch panel shown at the replacement of the colour toner cartridge.

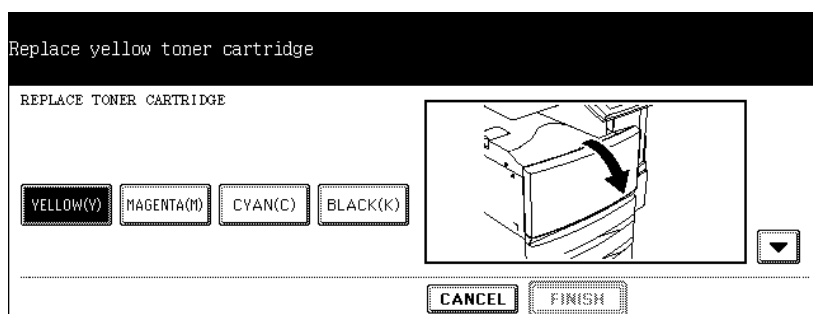

Tip

When you want to replace a cartridge before the Replace toner cartridge symbol blinks, see the procedure of “Replacing the Toner Cartridge” in Chapter 3 SETTING ITEMS (USER) in the User Functions Guide.

1 When the colour toner in the cartridge has run out, the following menu appears. Press the button corresponding to the colour to be replaced.

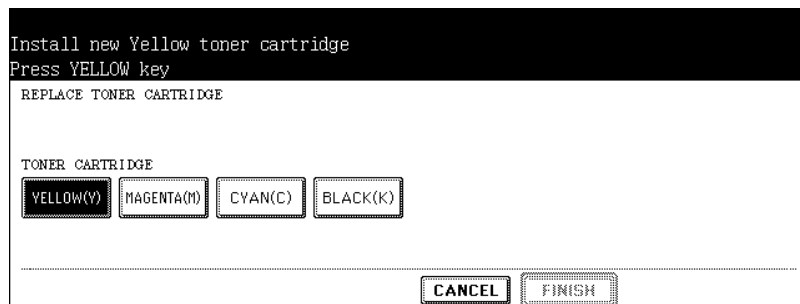

Tips

- The menu above appears every time after the period of time specified in the automatic function clear setting has passed while the empty cartridge is left without being replaced.
- You can print in the black mode if necessary while the colour toner cartridge is empty.

2 The cartridge is moved to the appropriate position to be replaced.



3 Open the front cover.

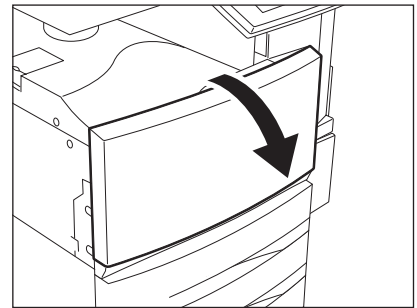

4 Push on the latch, and then pull out the cartridge.

Caution

Never attempt to incinerate toner cartridges. This could cause an explosion. Do not dispose of used toner cartridges. Contact your service representative.

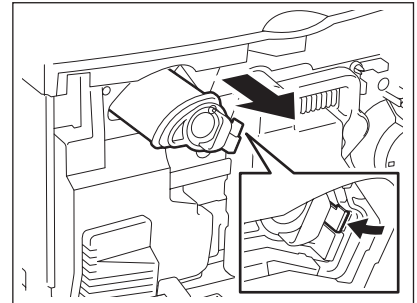

5 Shake the new toner cartridge well to loosen the toner inside.

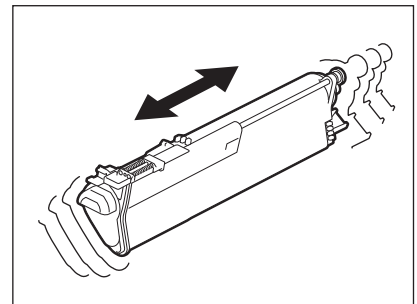

6 Holding the new toner cartridge, pull out the seal in the direction of the arrow.

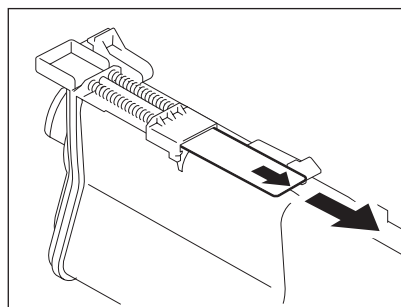

7 Insert the cartridge completely.

- Insert the cartridge until there is a click.

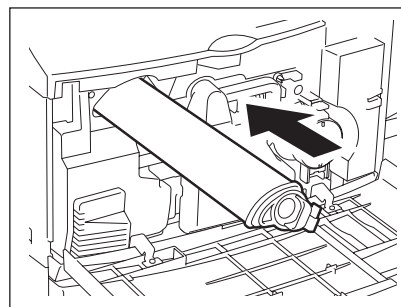

8 Close the front cover.

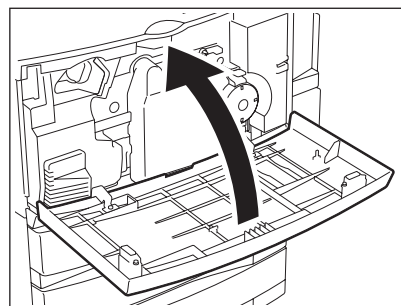

9 Press the [FINISH] button.

- When you are replacing two or more cartridges at a time, repeat the procedure from steps 1 to 8, replace the desired cartridges, and then press the [FINISH] button.
- "Wait adding toner" appears. The equipment automatically starts supplying toner.

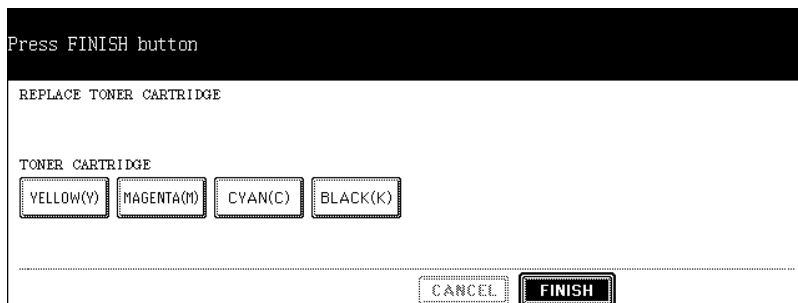

4. Replace Toner Bag Symbol

When the toner bag becomes full of used toner, the replace toner bag symbol blinks and “Dispose of used toner” appears.

Replace the toner bag following the procedure below.

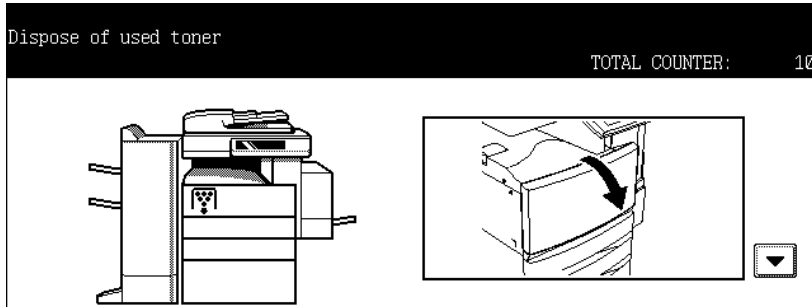

Caution

Never attempt to incinerate toner bags. This could cause an explosion. Do not dispose of used toner bags. Contact your service representative.

1 Open the front cover.

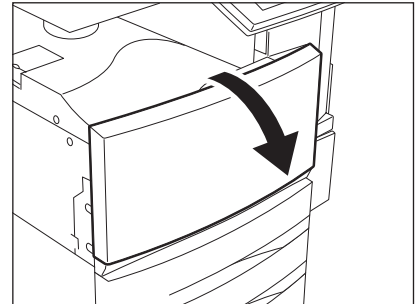

2 Pull the toner bag out carefully.

Caution

Never attempt to incinerate toner bags. This could cause an explosion. Do not dispose of used toner bags. Contact your service representative.

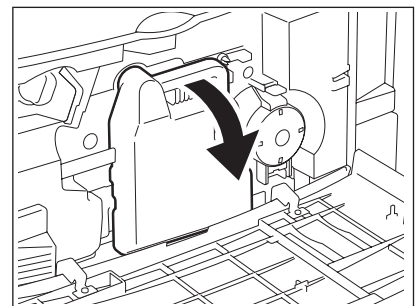

3 Put the lid on the toner bag.

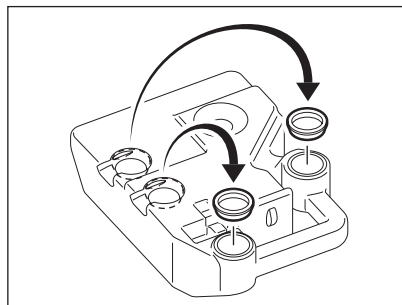

4 Set a new toner bag, and then close the front cover.

Tip

Check that the model name "TB-281C" is written on the toner bag.

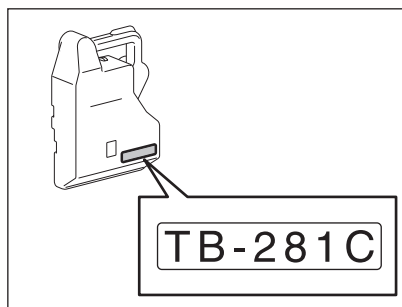

5. Jam Symbols

When a paper misfeed occurs in the equipment, the jam symbol blinks in the positions where the paper is misfed. Follow the guidance on the touch panel to remove the misfed paper properly.

- The misfed paper may not be in the correct position as shown in the illustration depending on the timing of the misfeeding.

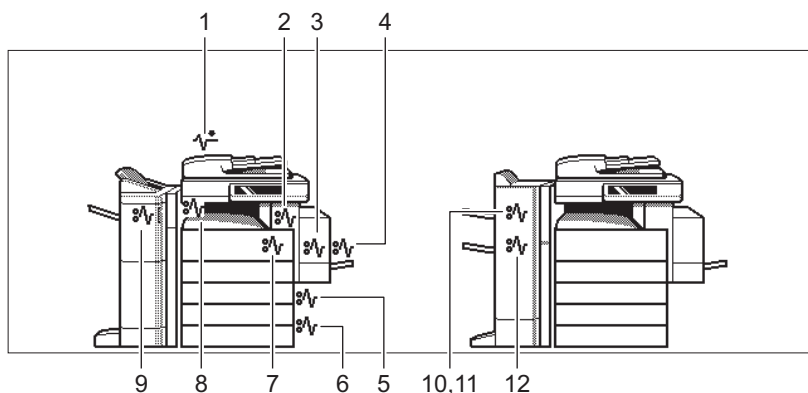

1. Reversing Automatic Document Feeder (optional) (📖 P.285)
2. Fuser Unit (📖 P.292)
3. Automatic Duplexing Unit (📖 P.291)
4. Bypass tray (📖 P.290)
5. Drawer feeding area (📖 P.288)
6. Large Capacity Feeder (optional: KD-1012) (📖 P.289) or Paper Feed Pedestal (optional: KD-1011) (📖 P.290)
7. Jam releasing cover (📖 P.292)
8. Bridge Unit (optional) (📖 P.294)
9. Finisher (optional, MJ-1101) and Hole Punch Unit (optional: MJ-6101) (📖 P.295)
10. Finisher (optional, MJ-1024/1023) and Hole Punch Unit (optional: MJ-6004) (📖 P.301)
11. Hanging Finisher (optional: MJ-1022) (📖 P.302)
12. Saddle Stitch Unit of Saddle Stitch Finisher (optional) (📖 P.303)

Releasing a paper misfeed in the Reversing Automatic Document Feeder (optional)

- 1** Raise the lever, and then open the upper cover.

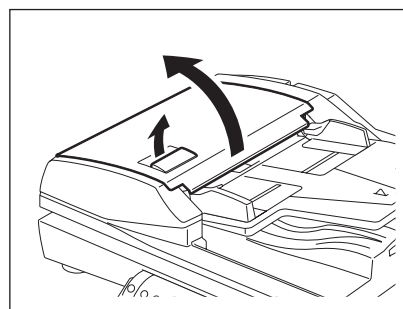

2 Remove any misfed originals.

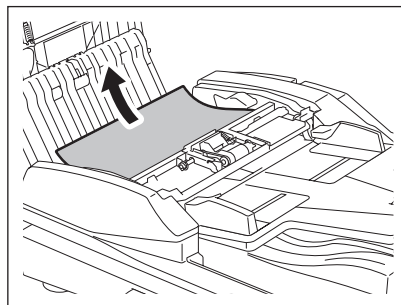

3 Turn the dial to remove the misfed original.

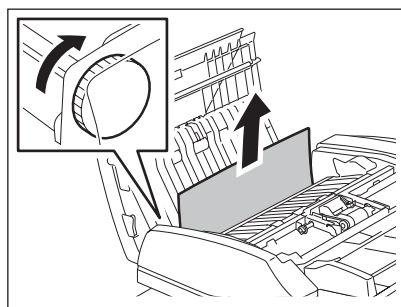

4 Open the transport guide.

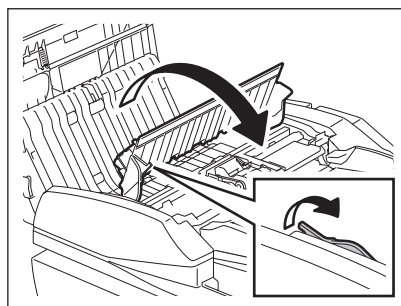

5 Raise the guide plate under the transport guide, and then remove the original under the guide plate.

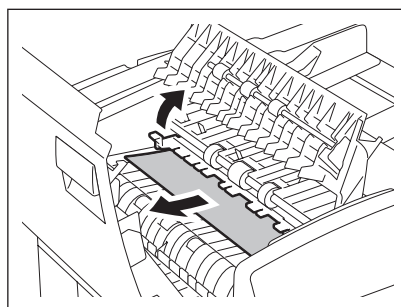

6 Close the transport guide, and then the upper cover.

7 Open the Reversing Automatic Document Feeder.

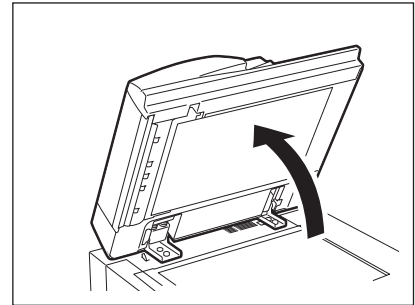

8 Open the reverse cover, and then remove the original.

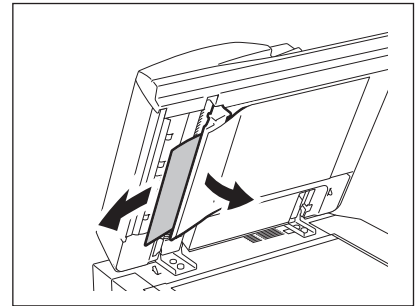

9 Close the Reversing Automatic Document Feeder.

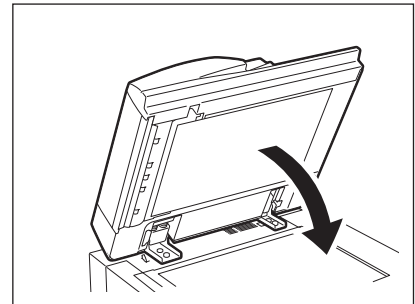

9

10 Raise the lever, and then open the upper cover.

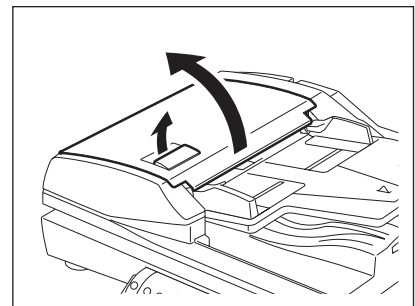

-
- 11** Raise the original feeding tray, and then remove the original under the tray.

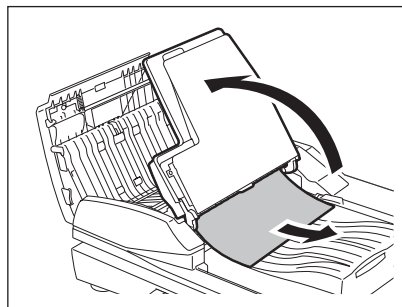

- 12** Lower the original feeding tray.

- 13** Close the upper cover.

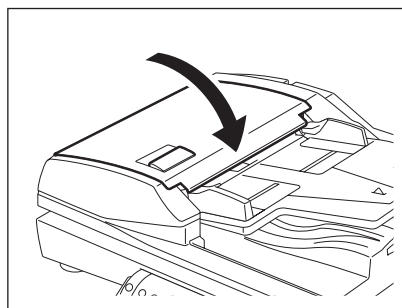

9

Releasing a paper misfeed in drawer feeding area

- 1** Open the cover.

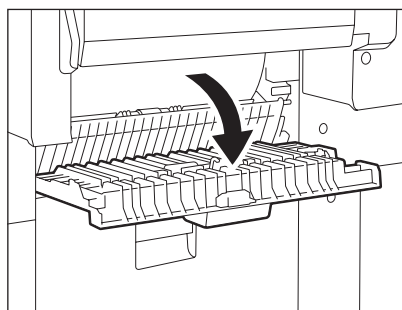

2 Remove any misfed paper.

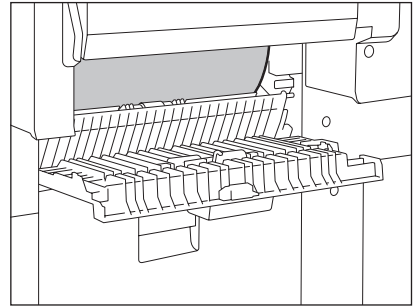

3 Close the cover.

Releasing a paper misfeed in the Large Capacity Feeder (optional)

1 Open the cover of the Large Capacity Feeder.

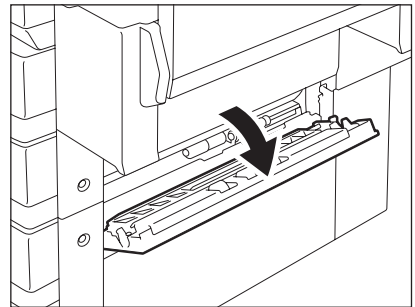

2 Remove any misfed paper.

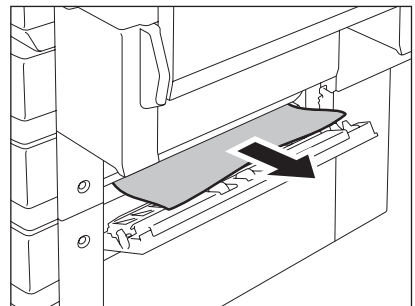

3 Close the cover.

Releasing a paper misfeed in the Paper Feed Pedestal (optional)

- 1** Open the cover of the Paper Feed Pedestal.

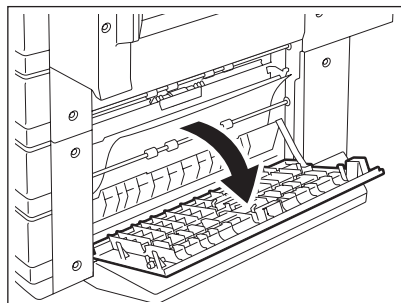

- 2** Remove any misfed paper.

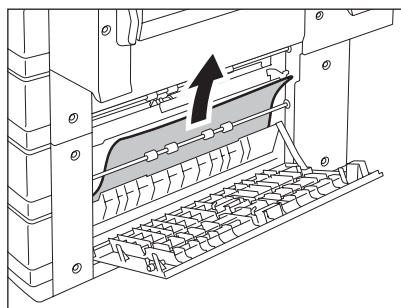

- 3** Close the cover.

9

Releasing a paper misfeed on the bypass tray

- 1** Pull out misfed paper on the bypass tray.

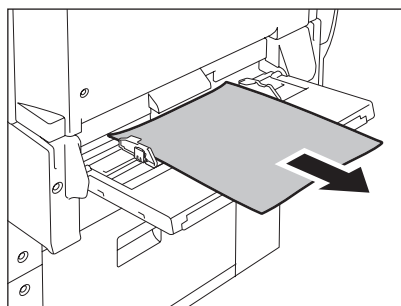

Releasing a paper misfeed in the automatic duplexing unit

Caution

- Be careful not to let your fingers be caught between the equipment and the automatic duplexing unit. This could injure you.
- Do not touch the metal portion of a guide plate as it could burn you.

1 Make sure that the bypass tray is opened, and then open the automatic duplexing unit.

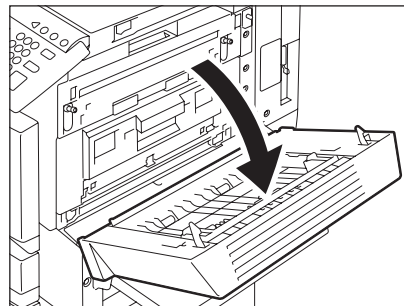

2 Lift the paper guide as indicated by the arrow and remove any misfed paper.

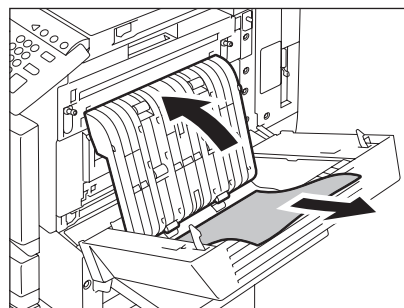

3 Lower the paper guide and return the automatic duplexing unit to the original position.

- Be sure to close both sides of the automatic duplexing unit firmly.

Releasing a paper misfeed in the jam releasing cover

- 1 Make sure that the bypass tray and the automatic duplexing unit are open. Put your fingers into A, push it up to release the lock and open the jam releasing cover.

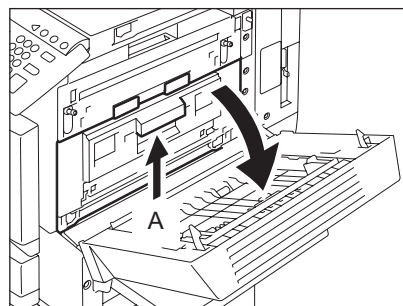

- 2 Rotate the green knob as indicated by the arrow toward the inside and remove any misfed paper.

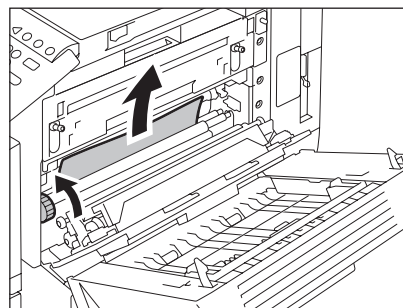

- 3 Return the jam releasing cover, the automatic duplexing unit and the bypass tray to the original positions.

- Be sure to close both sides of the automatic duplexing unit firmly.

9

Releasing a paper misfeed in the fuser unit

Caution

Do not touch the fuser unit or the metal area around it. Since they are very hot, you could be burned or the shock could cause an injury to your hand.

- 1 Make sure that the bypass tray, the automatic duplexing unit and the jam releasing cover are open, and push down the 2 fuser pressure release levers until they come to a stop.

Tip

Be sure to perform step 1 without fail.

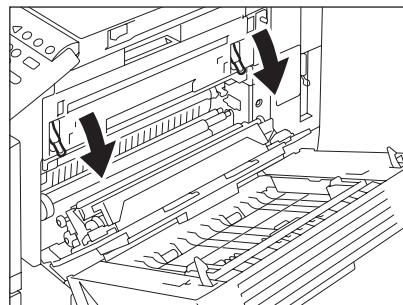

2 Open the fuser unit cover.

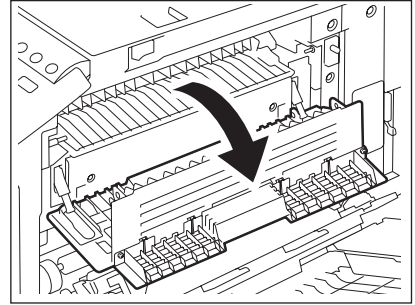

3 Holding the knob, open the transport guide.

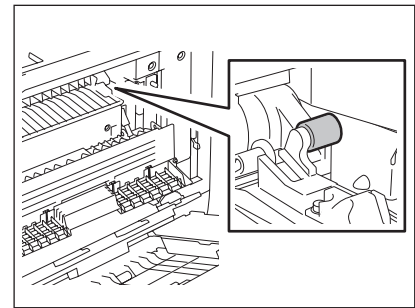

4 Remove any misfed paper inside the fuser unit.

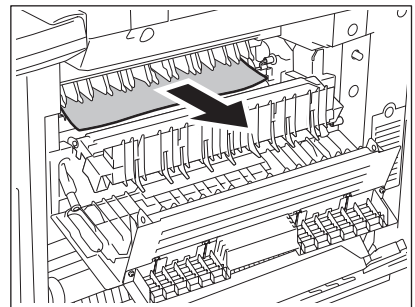
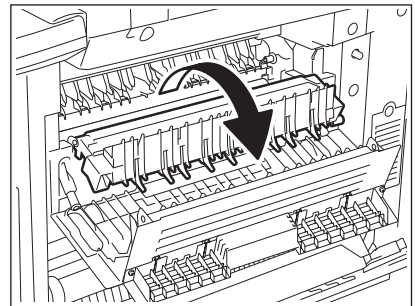

- 5** Pull the lever toward you to loose the misfed paper. Hook a finger under the loose part of it, and then pull it out.

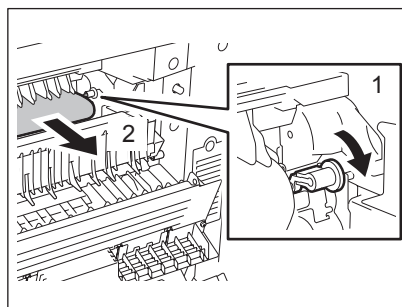

- 6** Pull it out with both hands to remove it.

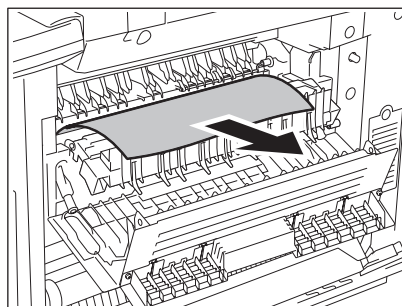

- 7** Close the transport guide and the fuser unit cover. Push up the fuser pressure release lever to return the jam releasing cover, the automatic duplexing unit and the bypass tray to the original positions.

9

Releasing a paper misfeed in the Bridge Unit (optional)

- 1** Holding the cover handle of the Bridge Unit, open the cover.

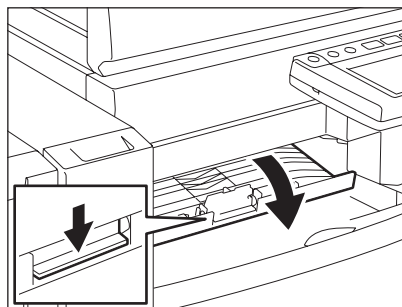

2 Remove any misfed paper that is inside the Bridge Unit.

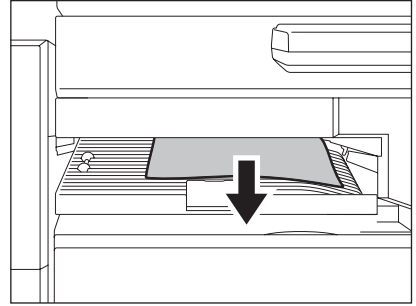

- Remove the misfed paper from the fuser unit side if it is easier.

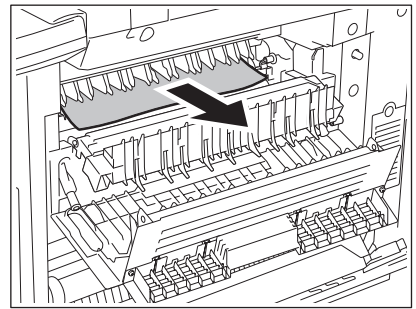

3 Close the Bridge unit cover.

Releasing a paper misfeed in the Finisher and the Hole Punch Unit (optional: MJ-1101/6101)

A paper misfeed at the upper tray

1 Raise the lever, and then open the upper tray.

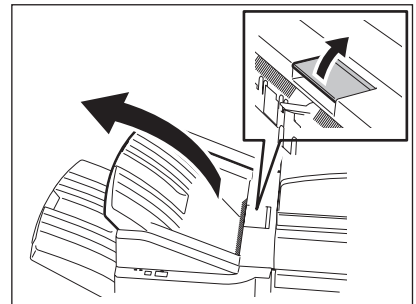

2 Remove any misfed paper.

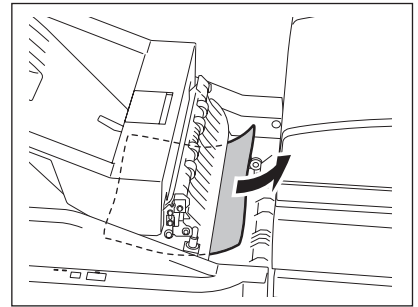
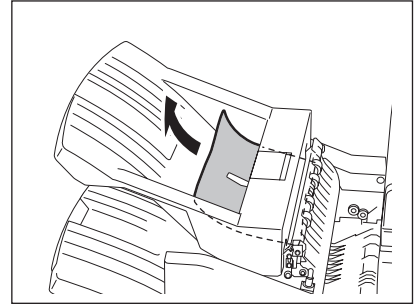

3 Holding the cover handle of the Bridge Unit, open the cover.

- When the Hole Punch Unit (optional: MJ-6101) is installed, proceed to step 5.

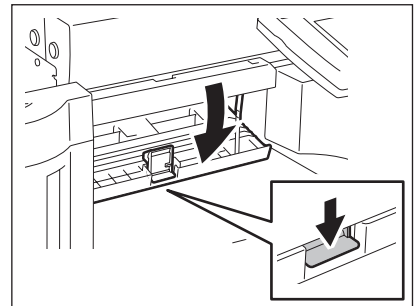

4 Remove any misfed paper.

- Proceed to step 8.

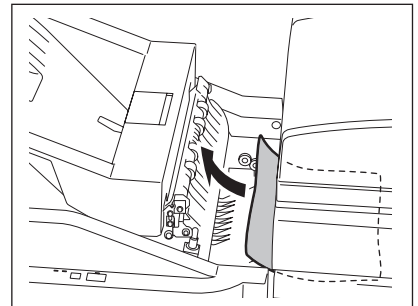

When installing the Hole Punch Unit (optional: MJ-6101)

5 Open the cover of the Hole Punch Unit.

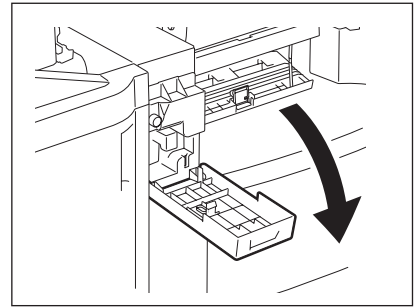

6 Turn the knob anticlockwise to remove any misfed paper.

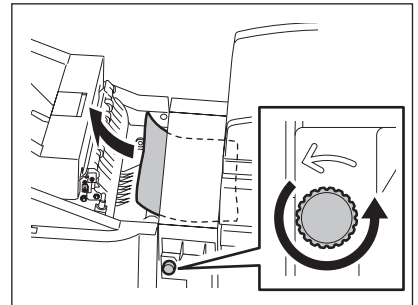

7 Close the cover of the Hole Punch Unit.

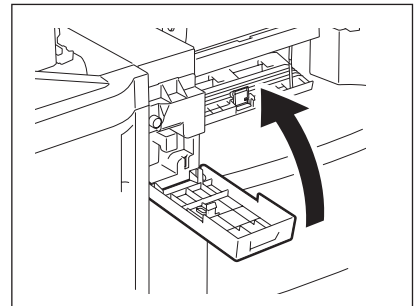

8 Close the cover of the Bridge Unit.

9 Close the upper tray.

- Place both hands at the shaded area of the upper tray, and then push and close the upper tray until it locks.

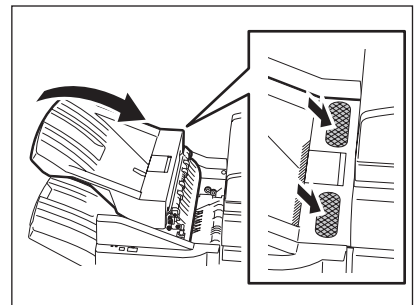

- The upper tray can be closed by pressing the right side of the latch.

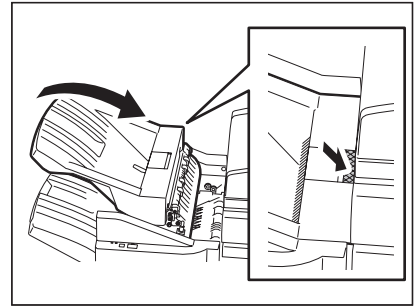

A paper misfed at the lower tray

1 Raise the lever, and then open the upper tray.

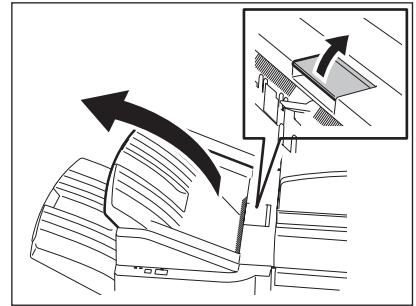

2 Remove any misfed paper.

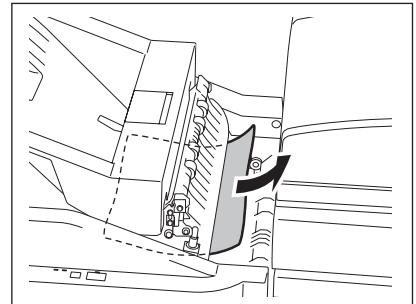

3 Lower the shutter of the paper exit.

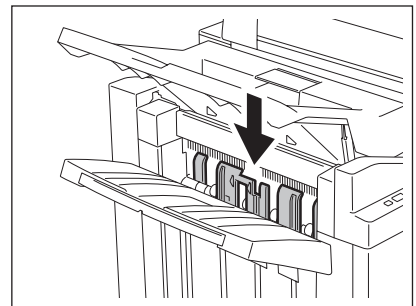

4 Remove any misfed paper.

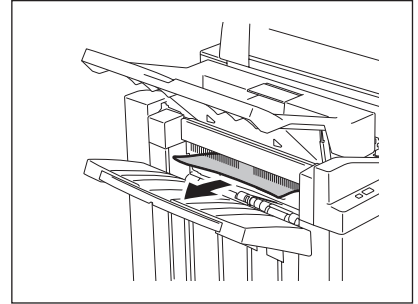

5 Holding the cover handle of the Bridge Unit, open the cover.

- When the Hole Punch Unit (optional: MJ-6101) is installed, proceed to step 7.

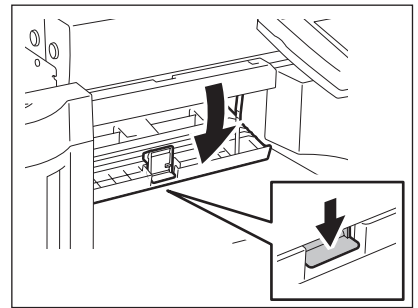

6 Remove any misfed paper.

- Proceed to step 10.

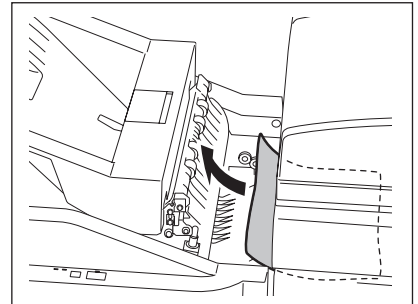

9

When installing the Hole Punch Unit (optional: MJ-6101)

7 Open the cover of the Hole Punch Unit.

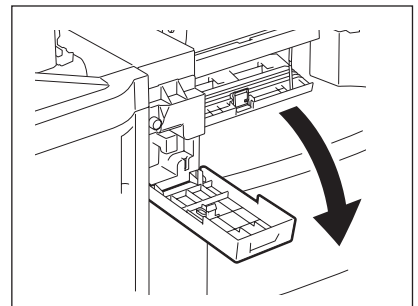

8 Turn the knob anticlockwise to remove any misfed paper.

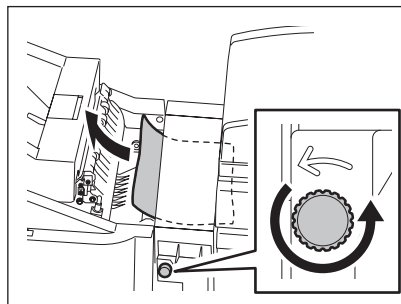

9 Close the cover of the Hole Punch Unit.

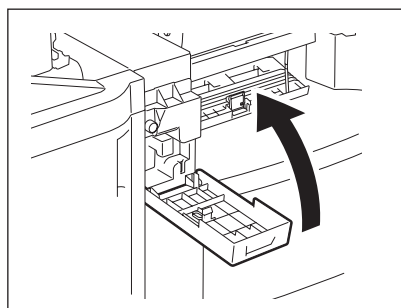

10 Close the cover of the Bridge Unit.

11 Close the upper tray.

- Place both hands at the shaded area of the upper tray, and then push and close the upper tray until it locks.

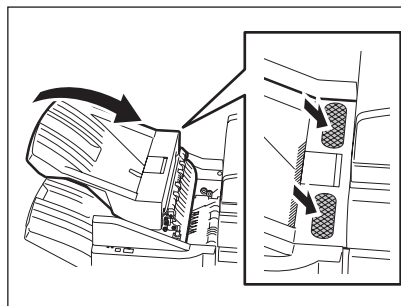

- The upper tray can be closed by pressing the right side of the latch.

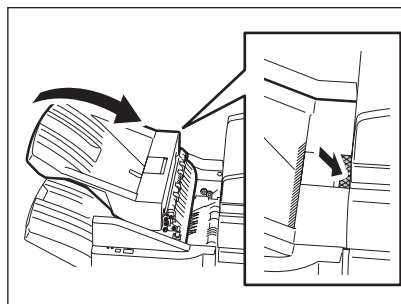

Releasing a paper misfed in the Finisher and the Hole Punch Unit (optional: MJ-1024/1023, MJ-6004)

1 Hold up the guide and remove any misfed paper in the paper exit area.

- When the Hole Punch Unit (optional: MJ-6004) is installed, proceed to step 2. If not installed, proceed to step 6.

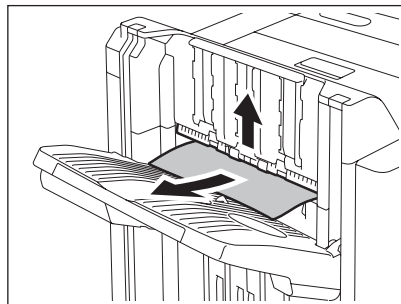

2 Open the front cover of the Hole Punch Unit.

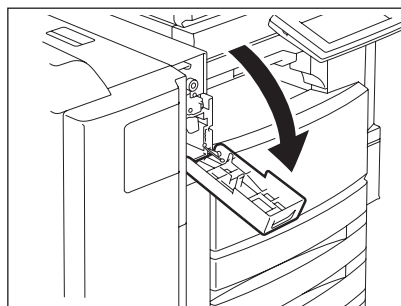

3 Turn the green knob to locate the triangle mark within the area indicated on the label.

- Under this condition, the punchers are up.

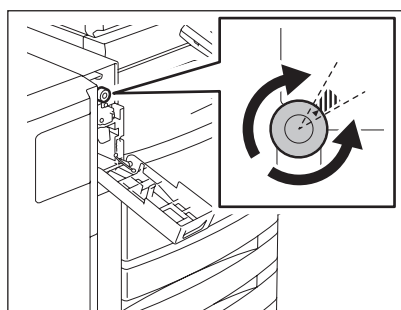

9

4 Raise the Hole Punch Unit, and remove any misfed paper.

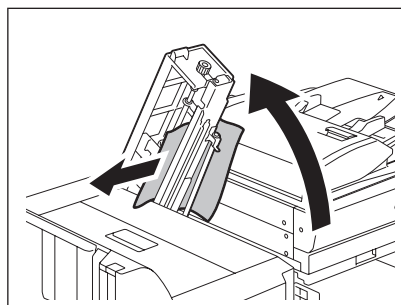

5 Return the Hole Punch Unit to the original position and close the front cover.

6 Open the upper cover of the Finisher until it locks.

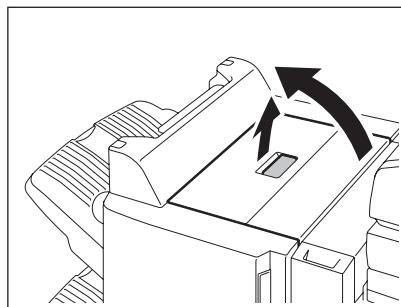

7 Remove any misfed paper.

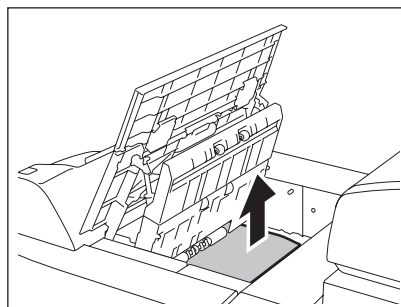

8 Close the upper cover.

Releasing a paper misfeed in the Hanging Finisher (optional: MJ-1022)

1 Pull the lever and move the finisher carefully away from the equipment.

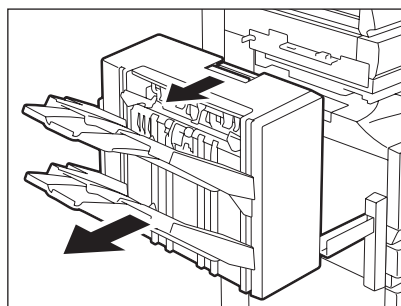

-
- 2** Lift the green lever and remove any misfed paper.

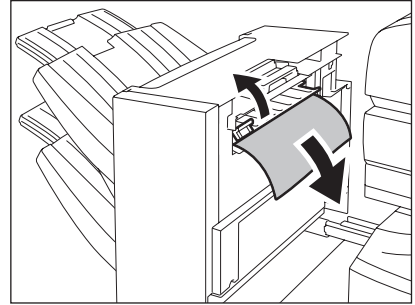

- 3** Remove any misfed paper in the paper exit area.

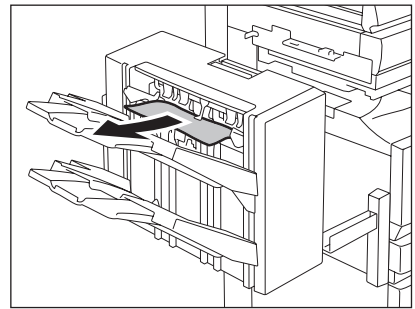

- 4** Install the finisher to the equipment.

Caution

Be careful not to let your fingers be caught between the equipment and the finisher (optional). This could injure you.

Releasing a paper misfeed in the Saddle Stitch Unit (optional)

- 1** Open the front cover of the Saddle Stitch Finisher.

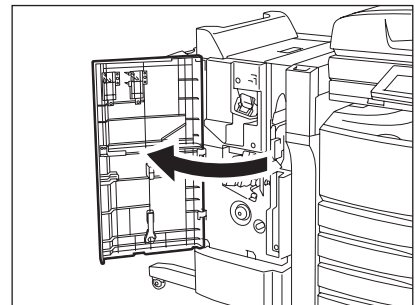

- 2 Slide the green handle toward the right and remove the misfed paper.**

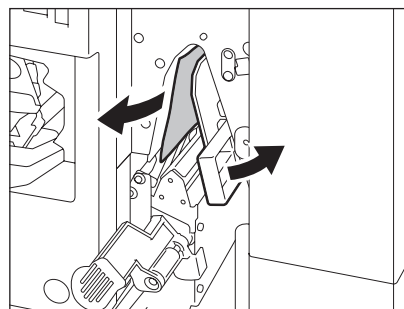

- 3 Move the green handle to the right-hand side.**

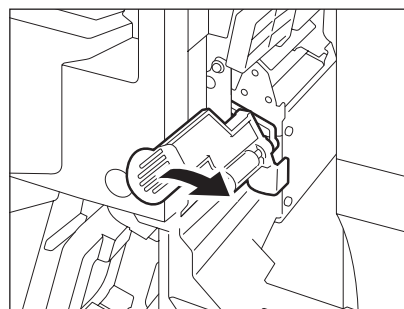

- 4 Remove any misfed paper and return the handle to its original position.**

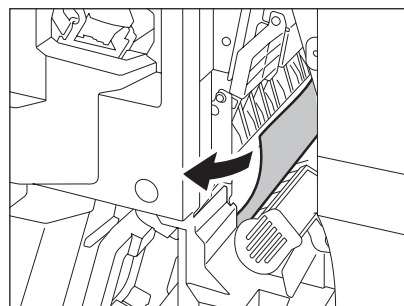

- 5 Turn the right-hand knob anticlockwise.**

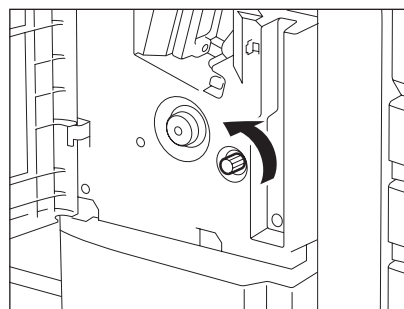

- 6** Turn the left-hand knob clockwise while you are pushing it.

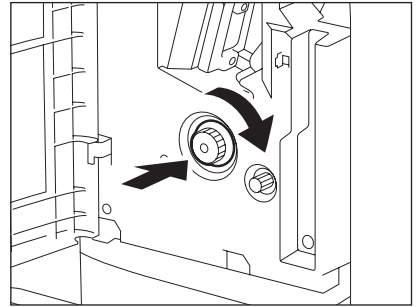

- 7** Remove any misfed paper on the exit side of the Saddle Stitch Unit.

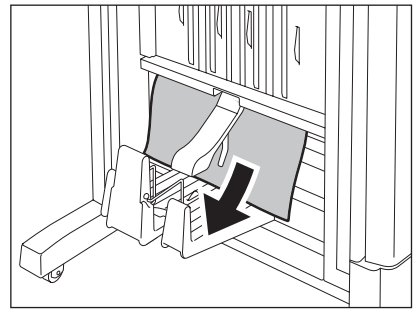

- 8** Raise the lever and open the exit cover of the Saddle Stitch Unit.

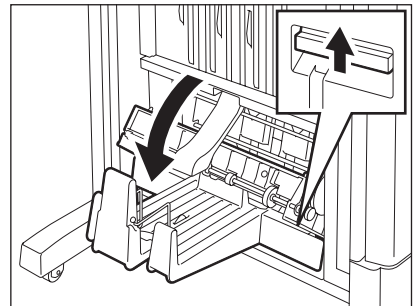

- 9** Remove any misfed paper.

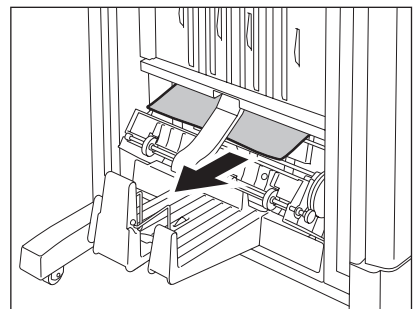

9

- 10** Close the exit cover and the front cover.

6. Call Service Symbol



1. Call service symbol
2. Error code

Warning

Never attempt to repair, disassemble or modify the equipment by yourself. You could cause a fire or get an electric shock.

Always contact your service representative for maintenance or repair of the internal parts of the equipment.

When the call service symbol blinks and "Misfeed in copier Press HELP" appears, output is no longer possible. Contact your service representative with the information of the displayed error code.

10. WHEN THIS MESSAGE APPEARS

1. “Check staple cartridge”	308
2. “Check staple cartridge in the Saddle Stitch Unit”	314
3. “Examine stapler”	316
4. “READY (CHECK STAPLER)”	322
5. “Examine stapler in the Saddle Stitch Unit”	323
6. “READY (CHECK SADDLE STITCH STAPLER)”	326
7. “READY (HOLE PUNCH DUST BIN IS FULL)”	327
8. “POWER FAILURE”	329
9. “Time for periodic maintenance”	330
10. “Check paper size setting on control panel for drawer N”	331
11. “Cannot print this paper size Select the other drawer”	338
12. “Reboot the machine”	339

1. “Check staple cartridge”

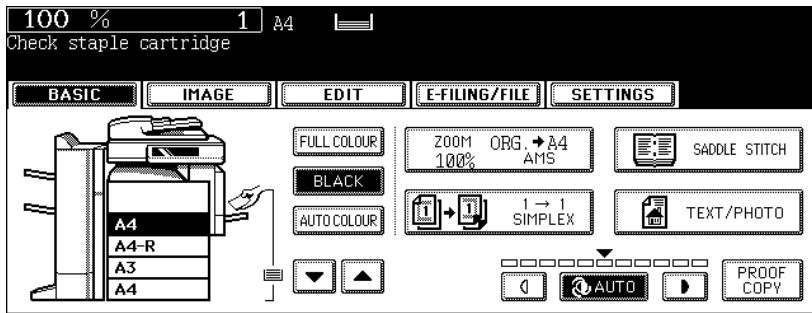

This message will be shown only if the finisher (optional) is installed. When the staples in the stapler of the finisher run out, this message appears. Add staples to the cartridge according to the following procedure.

Finisher (optional: MJ-1024/1023)

1 Open the front cover of the finisher.

<MJ-1024>

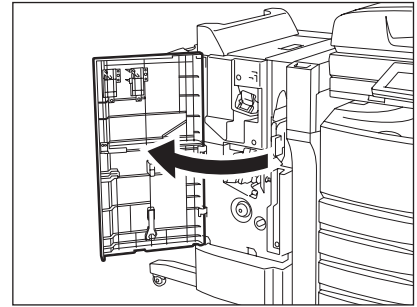

<MJ-1023>

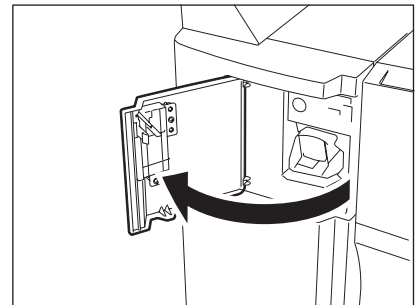

2 Take off the staple cartridge.

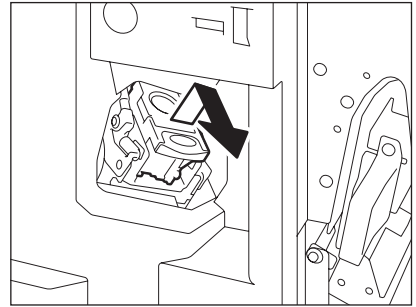

3 Take the empty staple case out of the staple cartridge.

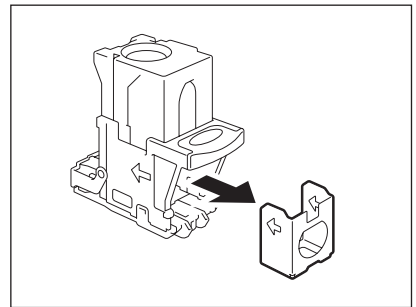

4 Remove the seal bundling the staples.

- Be careful that the staples are not misaligned.

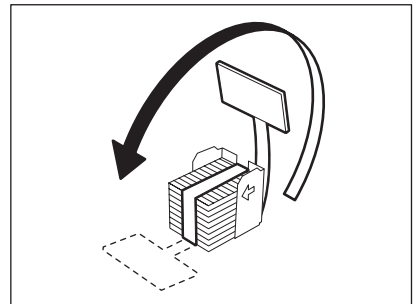

5 Install a new staple case into the staple cartridge.

- Insert the new case into the cartridge until you hear a click sound.

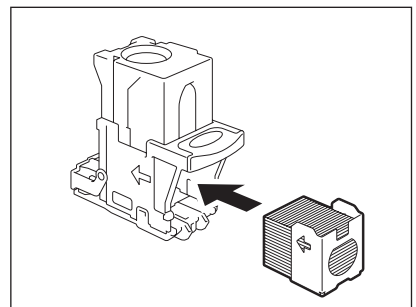

6 Install the staple cartridge onto the stapler.

- Insert the cartridge until it is caught by the latch and fixed with a click sound.

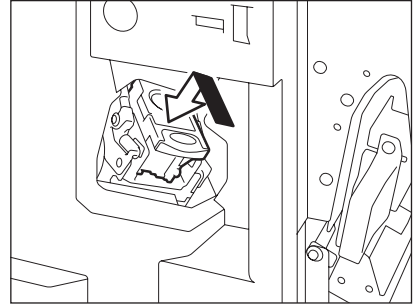

7 Close the front cover of finisher.

Note

If "Check staple cartridge" remains, repeat the above procedure from steps 1 to 7.

Hanging Finisher (optional: MJ-1022)

1 Pull the lever and move the finisher away carefully from the equipment.

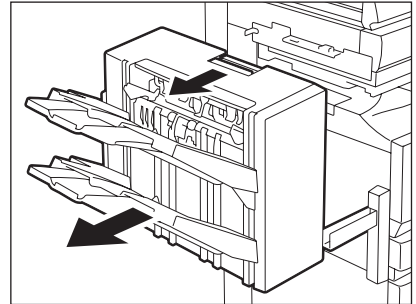

2 Take off the staple cartridge.

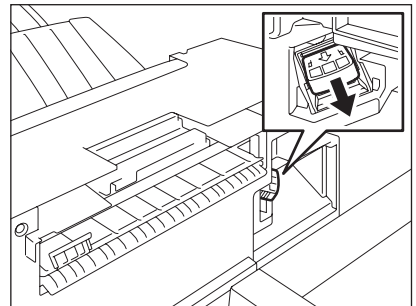

3 Take the empty staple case out of the staple cartridge.

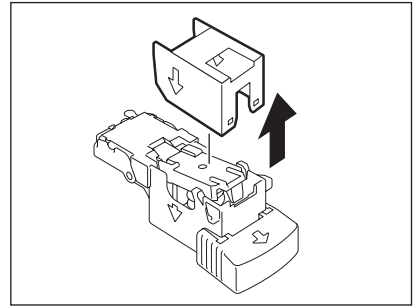

4 Install a new staple case into the staple cartridge.

- Insert the new case into the cartridge until you hear a click sound.
- Do not remove the seal bundling the staples until the new staple case is installed into the cartridge.

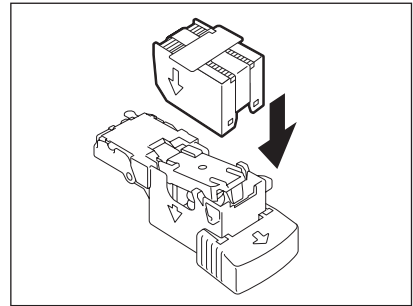

5 Remove the seal bundling the staples and then pull out the seal straight upward.

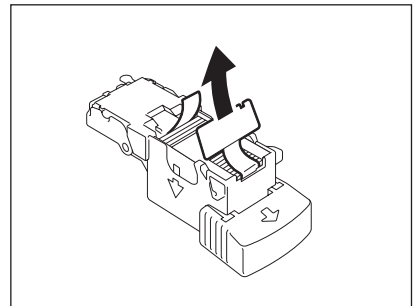

6 Install the staple cartridge into the stapler.

- Insert the cartridge until it is caught by the latch and fixed with a click sound.

Tip

If "Check staple cartridge" remains, repeat the above procedure from steps 1 to 6.

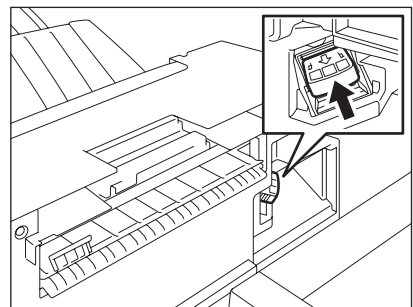

7 Install the finisher to the equipment.

Caution

Be careful not to let your fingers be caught between the equipment and the finisher (optional). This could injure you.

Finisher (optional: MJ-1101)

1 Open the front cover of the finisher.

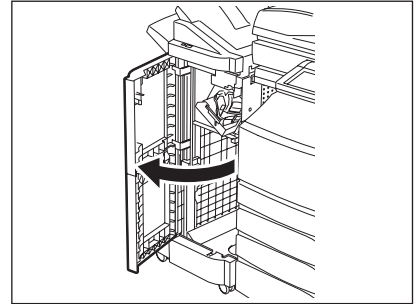

2 Take off the staple cartridge.

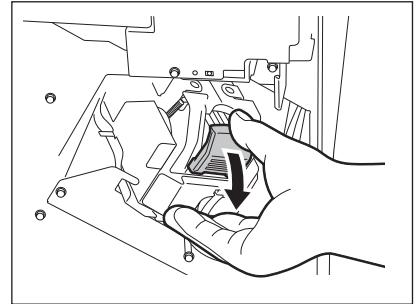

3 Take the empty staple case out of the staple cartridge.

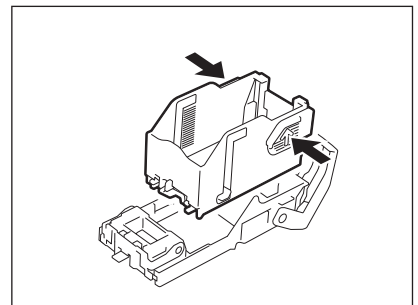

4 Install a new staple case into the staple cartridge.

- Insert the new case into the cartridge until you hear a click sound.

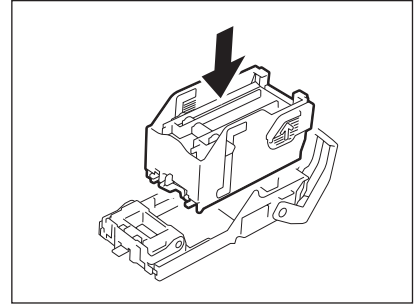

5 Install the staple cartridge onto the stapler.

- When installing the staple cartridge, hold the mint-green colour label portion of the bracket securely so that it will not move.
- Insert the cartridge until it is caught by the latch and fixed with a click sound.

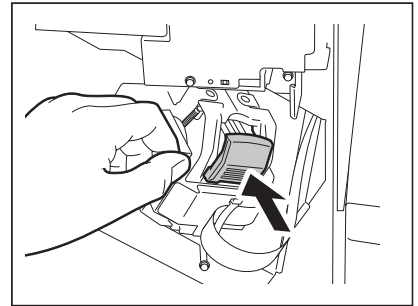

6 Close the front cover of finisher.

Note

If "Check staple cartridge" remains, repeat the above procedure from steps 1 to 6.

2. "Check staple cartridge in the Saddle Stitch Unit"

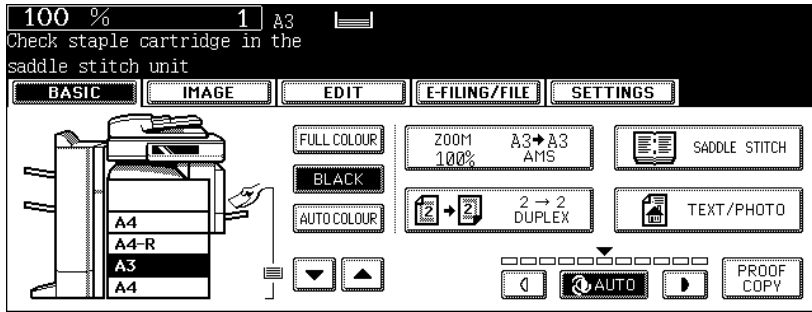

This message will be shown only if the Saddle Stitch Finisher (optional) is installed. When the staples in the stapler of the Saddle Stitch Finisher run out, this message appears. Replace the staple cartridge according to the following procedure.

1 Open the front cover of the finisher.

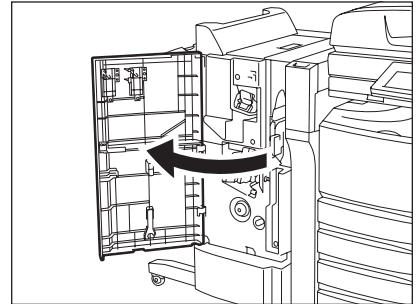

2 Slide the Saddle Stitch Unit carefully toward the front.

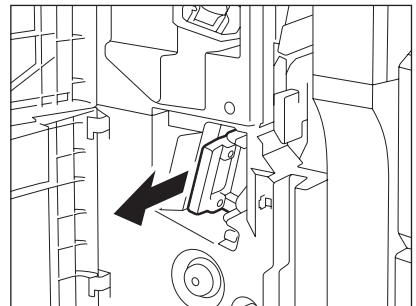

3 Pull the handle of the stapler of the Saddle Stitch Unit toward you to unlock it. Then turn the stapler clockwise for about 60 degrees.

- The stapler will be locked and will not be turned any further when it becomes almost horizontal.

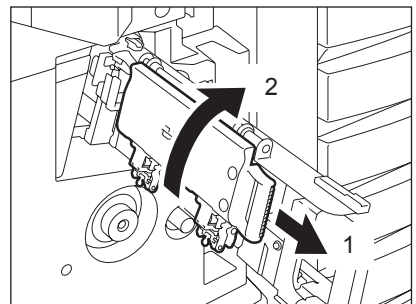

4 Take off the empty staple cartridge, and then install a new one.

- Replace both cartridges at a time.

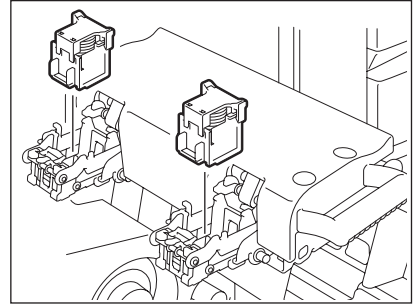

5 Pull the handle of the stapler of the Saddle Stitch Unit toward you to unlock it. Then lower the stapler to its original position.

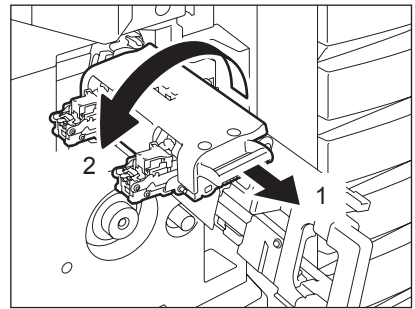

6 Insert the Saddle Stitch Unit into the finisher carefully.

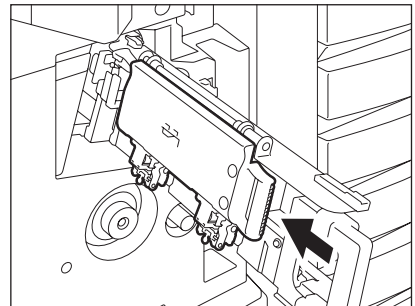

7 Close the front cover of the finisher.

3. "Examine stapler"

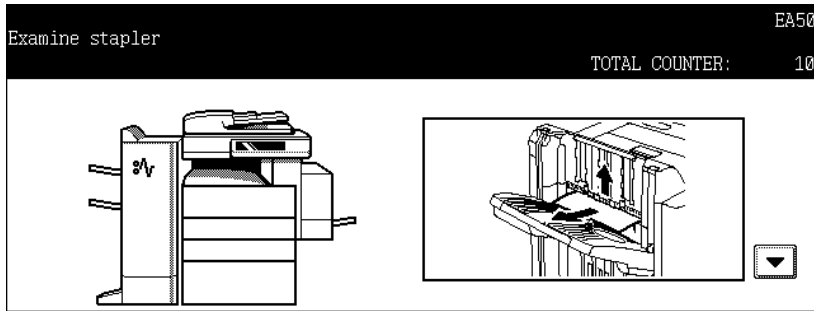

This message appears when the staples in the finisher (optional) are jammed. To remove them, follow the procedure below.

Finisher (optional: MJ-1024/1023)

- 1 Open the front cover of the finisher.
<MJ-1024>

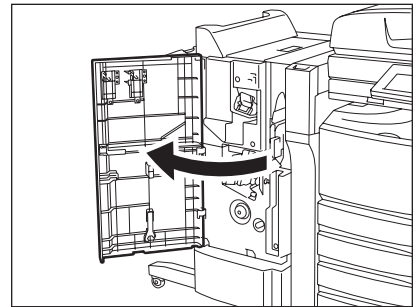

<MJ-1023>

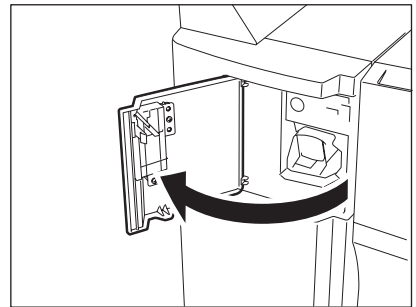

2 Take off the staple cartridge.

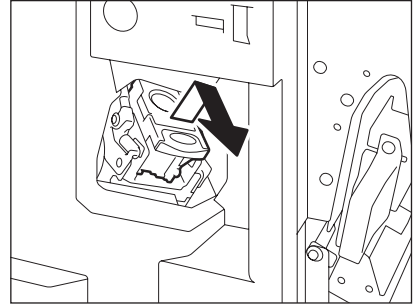

3 Lower the guide while holding the knob.

A: Stapling area

Caution

Do not touch the stapling area. The stapler could injure you.

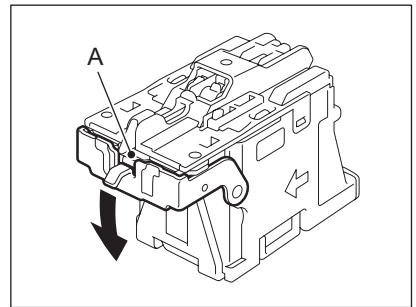

4 Remove any jammed staples.

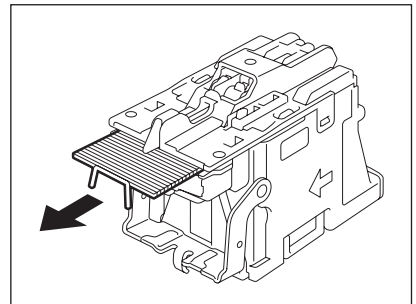

5 Hold the knob and raise the guide, and then return the guide to its original position.

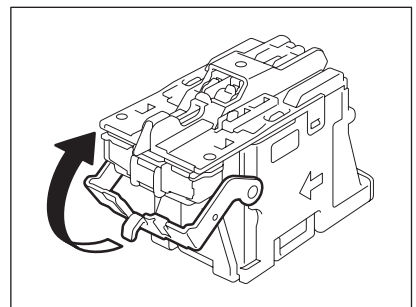

6 Install the staple cartridge into the stapler.

- Insert the cartridge until it is caught by the latch and fixed with a click sound.

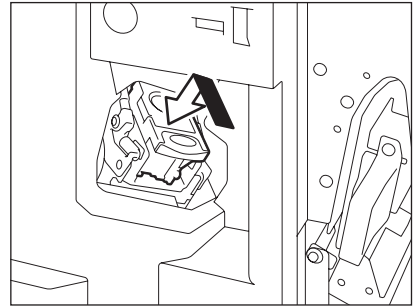

7 Close the front cover of the finisher.

Hanging Finisher (optional: MJ-1022)

1 Pull the lever and move the finisher away carefully from the equipment.

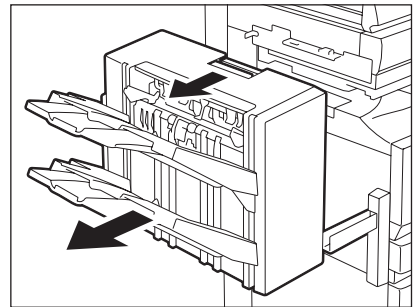

2 Take off the staple cartridge.

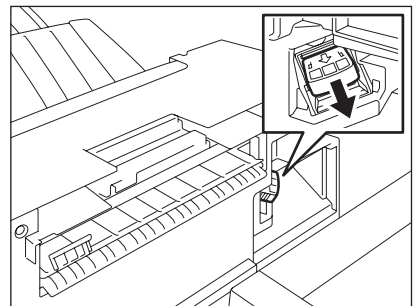

3 Lower the guide while holding the knob.

A: Stapling area

Caution

Do not touch the stapling area. The stapler could injure you.

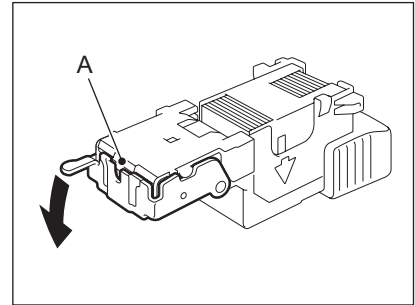

4 Remove any jammed staples.

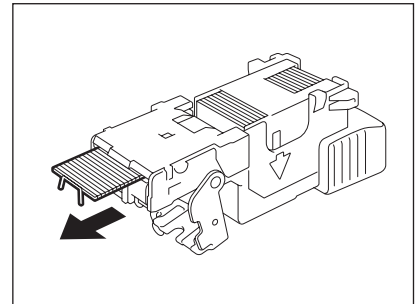

5 Hold the knob and raise the guide, and then return the guide to its original position.

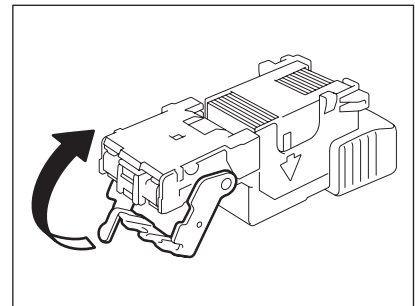

6 Install the staple cartridge into the stapler.

- Insert the cartridge until it is caught by the latch and fixed with a click sound.

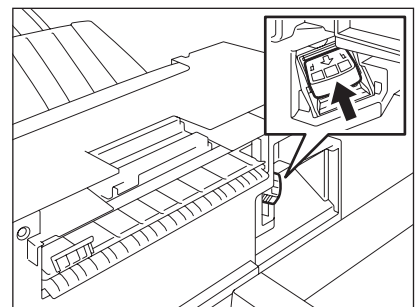

7 Install the finisher to the equipment.

Caution

Be careful not to let your fingers be caught between the equipment and the finisher (optional). This could injure you.

Finisher (optional: MJ-1101)

1 Open the front cover of the finisher.

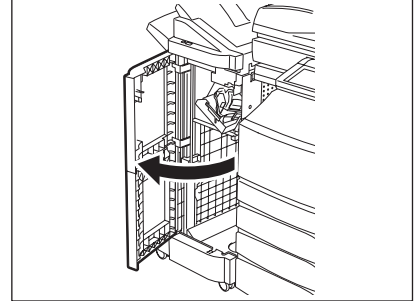

2 Take off the staple cartridge.

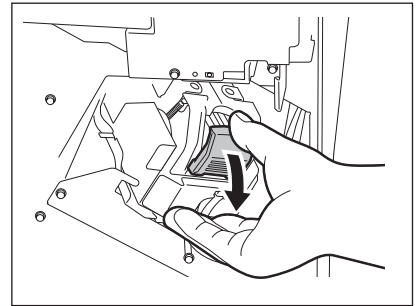

3 Lower the guide while holding the knob.

A: Stapling area

Caution

Do not touch the stapling area. The stapler could injure you.

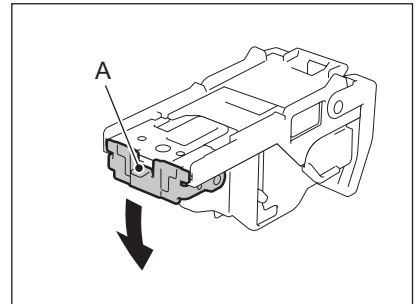

4 Remove any jammed staples.

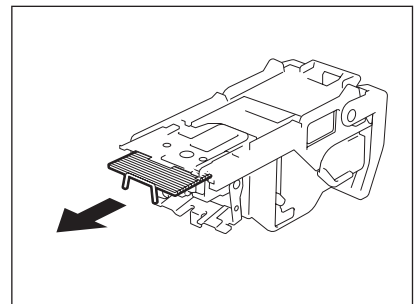

5 Hold the knob and raise the guide, and then return the guide to its original position.

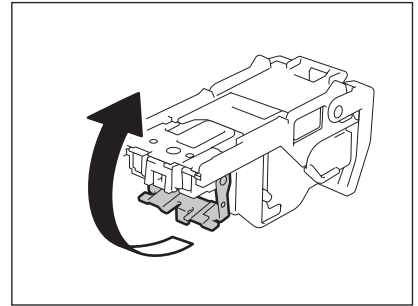

6 Install the staple cartridge into the stapler.

- When installing the staple cartridge, hold the mint-green colour label portion of the bracket securely so that it will not move.
- Insert the cartridge until it is caught by the latch and fixed with a click sound.

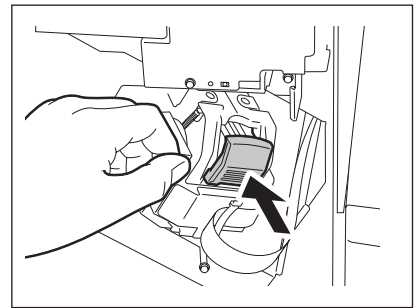

7 Close the front cover of the finisher.

4. “READY (CHECK STAPLER)”

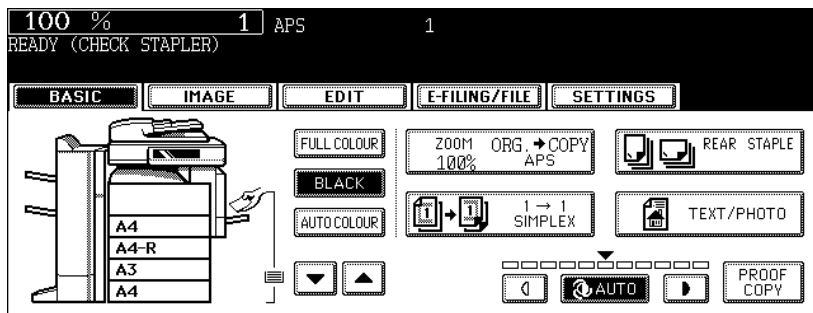

This message will be shown only when the finisher (optional) is installed. It appears when the staples in the stapler of the finisher run out or when the staples in the finisher are jammed. Clear the error according to the procedure in [P.308](#) “1. “Check staple cartridge”” or [P.316](#) “3. “Examine stapler””.

5. “Examine stapler in the Saddle Stitch Unit”

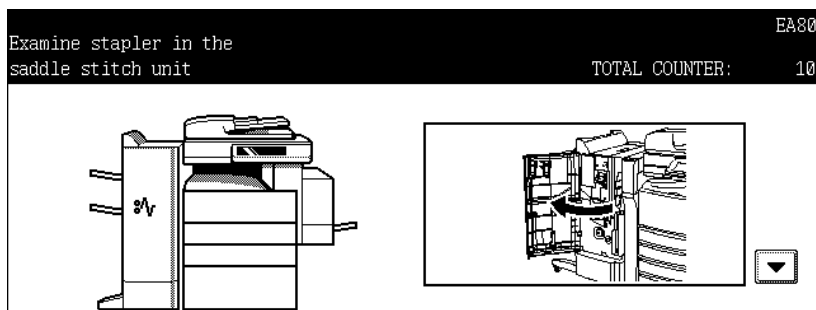

This message appears when the staples in the Saddle Stitch Unit of the Saddle Stitch Finisher (optional) are jammed. To remove them, follow the procedure below.

1 Open the front cover of the finisher.

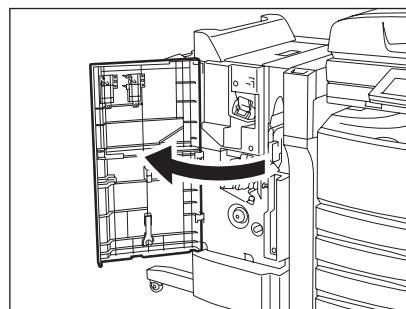

2 Slide the Saddle Stitch Unit carefully toward the front.

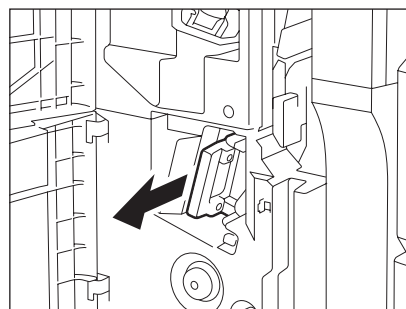

3 Pull the handle of the stapler of the Saddle Stitch Unit toward you to unlock it. Then turn the stapler clockwise for about 60 degrees.

- The stapler will be locked and will not be turned any further when it becomes almost horizontal.

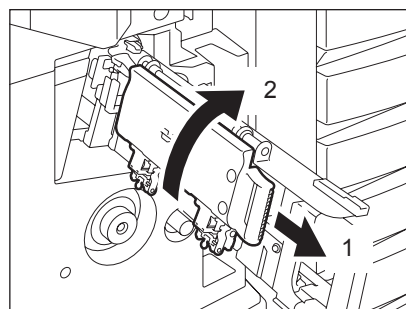

4 Take off the staple cartridge.

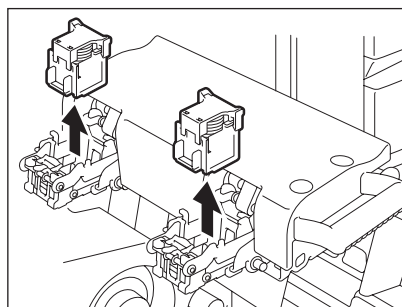

5 While pushing the lever (1) downward, pull up the shutter with the knob (2).

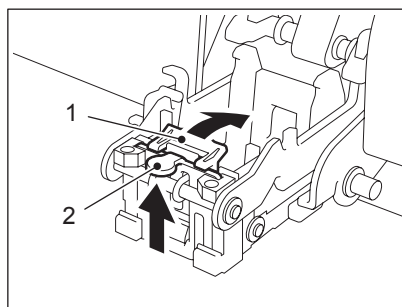

6 Remove any jammed staples.

A: Stapling area

Caution

Do not touch the stapling area. The stapler could injure you.

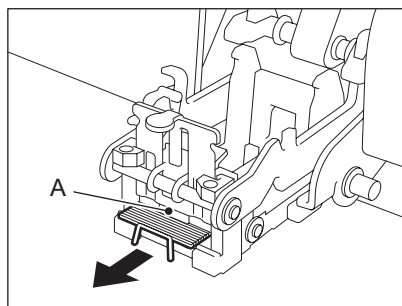

7 Push the knob (2) to return it to its original position.

- Confirm if the lever (1) is latched onto the shutter.

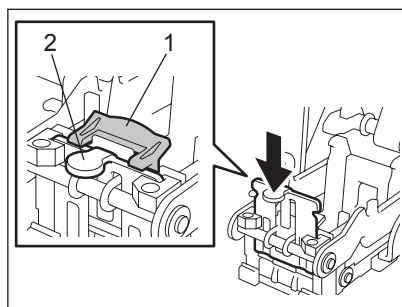

8 Install the staple cartridge.

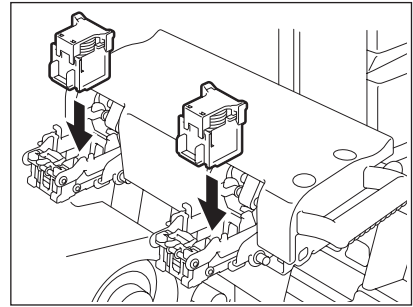

9 Pull the handle of the stapler of the Saddle Stitch Unit toward you to unlock it. Then return the stapler to its original position.

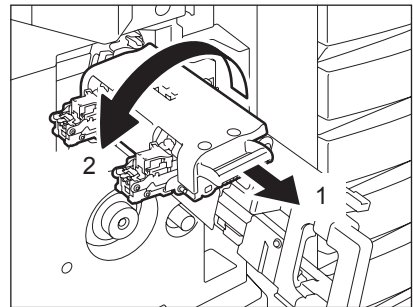

10 Insert the Saddle Stitch Unit into the finisher carefully.

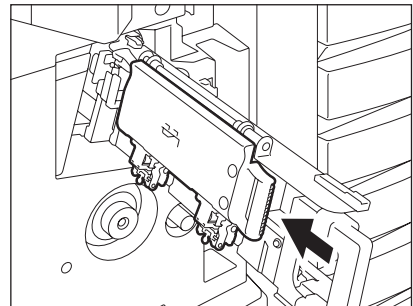

10

11 Check the following 2 items before test stapling.

- Check if the finisher is securely installed on the equipment.
- Check if any of A3, A4-R or B4 paper is set in the drawer.

12 Close the front cover of the finisher.

- Test stapling is automatically performed.

Tip

Test stapling will not be performed if the conditions mentioned in step 11 are not met. Be sure to check the items mentioned in step 11 and open the front cover of the finisher and then close it again before performing test stapling. Test stapling is necessary to prevent void stapling.

6. “READY (CHECK SADDLE STITCH STAPLER)”

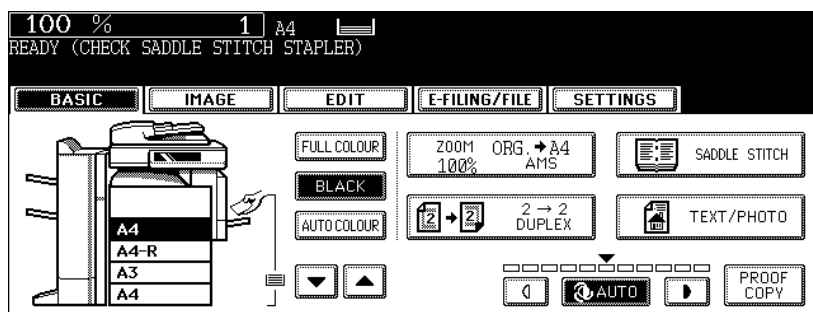

This message will be shown only when the Saddle Stitch Finisher (optional) is installed. It appears when the staples in the stapler of the Saddle Stitch Finisher run out or when the staples in the Saddle Stitch Finisher are jammed.

Remove the jammed staples according to the procedure in [P.323](#) “5. “Examine stapler in the Saddle Stitch Unit””.

If the staples run out, follow the procedure below as well as the procedure in [P.314](#) “2. “Check staple cartridge in the Saddle Stitch Unit””.

1 Follow steps 1 to 6 of [P.314](#) “2. “Check staple cartridge in the Saddle Stitch Unit””.

- Do not close the front cover of the Saddle Stitch Finisher.

2 Check the following 2 items to perform test stapling.

- Whether the Saddle Stitch Finisher is securely installed in the equipment.
- Whether any A3, A4-R or B4 paper is set in the equipment.

3 Close the front cover of the Saddle Stitch Finisher.

- Test stapling is automatically performed.

Tip

If the front cover of the Saddle Stitch Finisher is closed without satisfying the condition of step 2, test stapling is not performed. Test stapling is necessary to prevent void stapling. After satisfying the condition of step 2 and opening/closing the front cover of the Saddle Stitch Finisher again, be sure to perform the test stapling.

7. "READY (HOLE PUNCH DUST BIN IS FULL)"

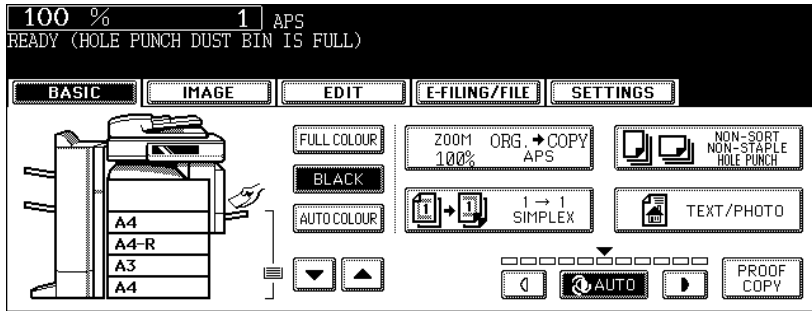

This message appears when the hole punch dustbin in the Hole Punch Unit (optional) becomes full. To dispose of the paper bits, follow the procedure below.

Hole Punch Unit (optional: MJ-6004)

1 Open the cover of the Hole Punch Unit.

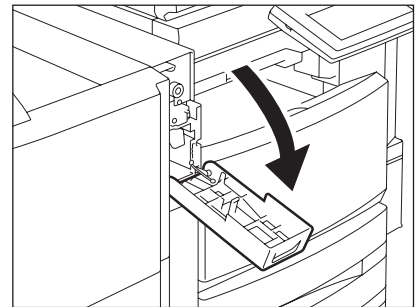

2 Pull out the hole punch dustbin.

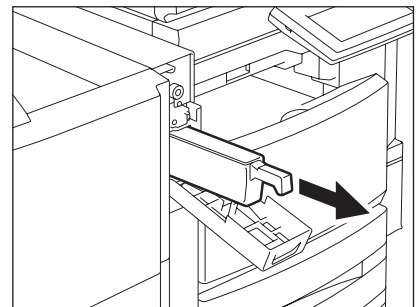

10

3 Dispose of the punched paper bits.

4 Attach the hole punch dustbin.

5 Close the cover of the Hole Punch Unit.

Hole Punch Unit (optional: MJ-6101)

1 Open the cover of the Hole Punch Unit.

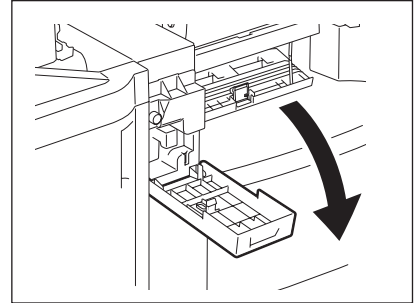

2 Pull out the hole punch dustbin.

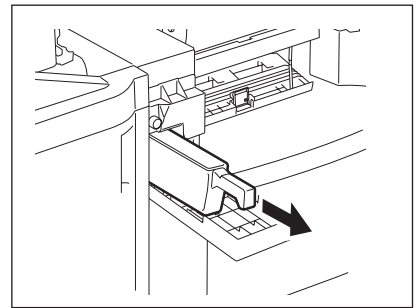

3 Dispose of the punched paper bits.

4 Attach the hole punch dustbin.

5 Close the cover of the Hole Punch Unit.

10

8. "POWER FAILURE"

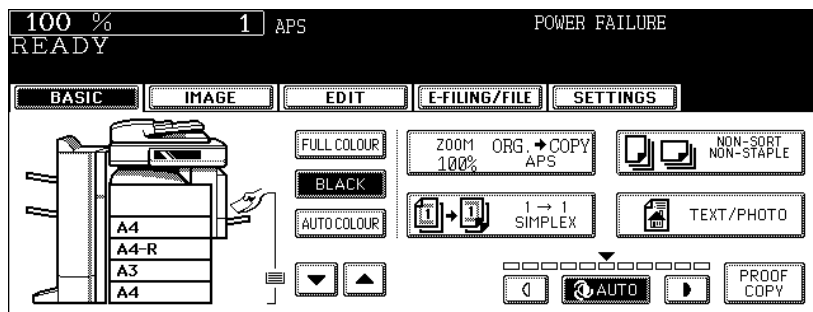

This message appears when a job is interrupted due to a power failure, etc. The print or Fax job in progress at the time of a power failure may not be completed. Confirm the job status by pressing the [JOB STATUS] button. To clear this message, press the [FUNCTION CLEAR] button twice.

9. "Time for periodic maintenance"

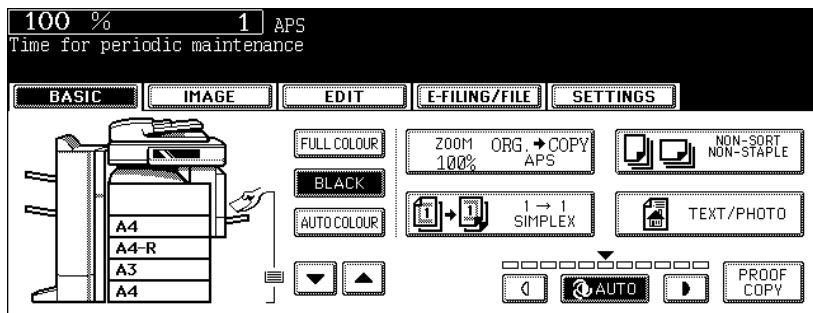

This message appears when assistance from a qualified service technician is required. Contact your service representative.

10. “Check paper size setting on control panel for drawer N”

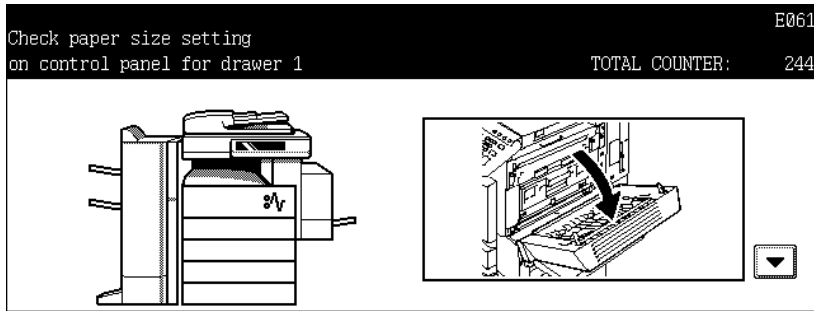

This message appears when the size of the paper actually placed in the drawer or on the bypass tray differs from the one registered in the equipment for the corresponding drawer or the bypass tray. There are 5 messages of this type as shown below.

“Check paper size setting on control panel for drawer 1”

“Check paper size setting on control panel for drawer 2”

“Check paper size setting on control panel for drawer 3”

(Only when the Paper Feed Pedestal (optional) is installed)

“Check paper size setting on control panel for drawer 4”

(Only when the Paper Feed Pedestal and the Additional Drawer Module (optional) are installed)

“Check paper size setting on control panel for Bypass”

In case that a paper misfeed occurs and one of the above messages consequently appears, another paper misfeed will occur if you just remove the jammed paper. Instead, be sure to follow the procedure below.

- Make a note of the position of the jammed paper and the number of the drawer displayed in the message in advance because guidance for removing the jammed paper is not displayed while you are working on the procedure.

This countermeasure differs depending on when the paper misfeeding has occurred – during copying or during printing from the Fax or the Printer.

During copying (using a drawer)

1 Turn the power of the equipment OFF.

- You cannot shut down the equipment.

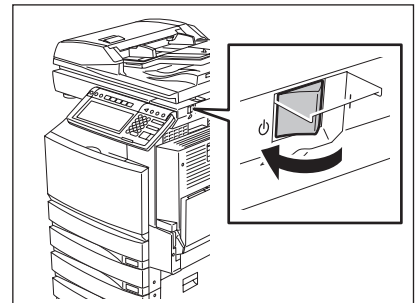

2 Remove the jammed paper.

📖 P.285 “5.Jam Symbols”

3 Pull out the drawer mentioned in the message. Then remove all the paper in it.

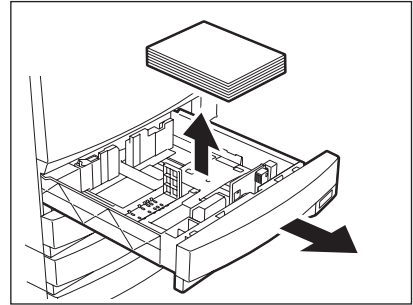

4 Close the drawer and then turn the power ON.

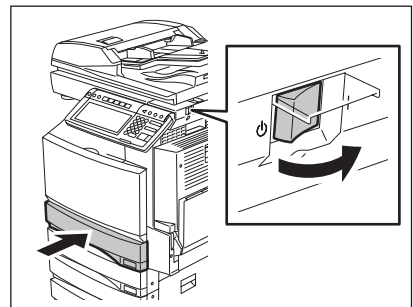

5 Press the [USER FUNCTIONS] button on the control panel.

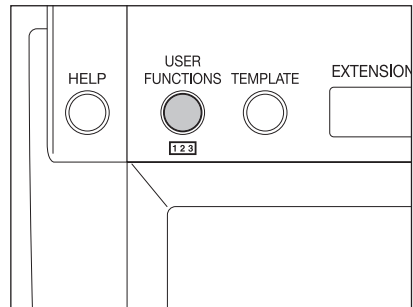

6 Press the [USER] button on the touch panel to display the USER menu, and then press the [DRAWER] button.

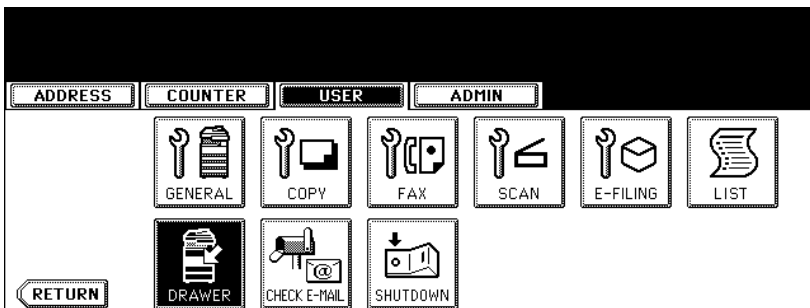

7 Press the drawer button corresponding to the one mentioned in the message on the touch panel.

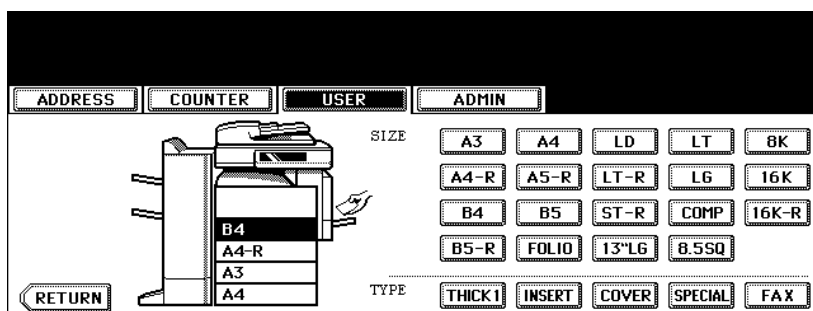

8 Press the paper size button corresponding to the one placed in the drawer.

📖 P.43 "4.Setting Copy Paper"

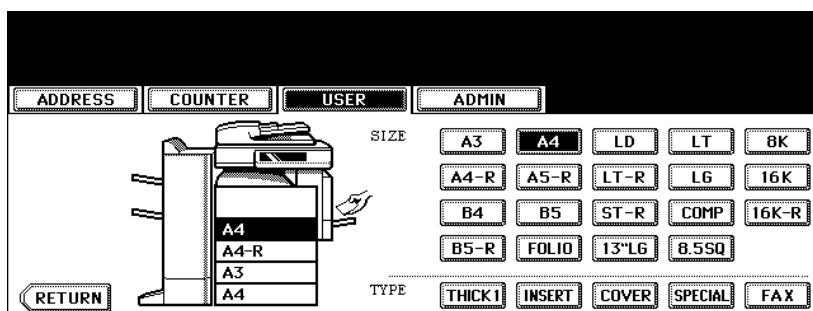

9 Place the removed paper and the original, and then try to copy again.

- When "POWER FAILURE" appears, press the [FUNCTION CLEAR] button twice to clear the message. See 📖 P.329 "8."POWER FAILURE"" for details.

10

During copying (using the bypass tray)

1 Turn the power of the equipment OFF.

- You cannot shut down the equipment.

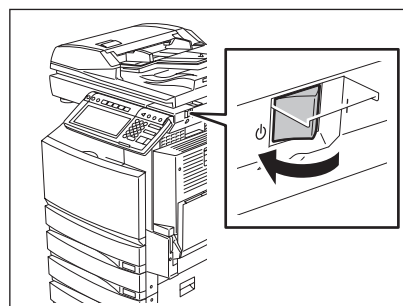

2 Remove the jammed paper.

📖 P.285 "5.Jam Symbols"

3 Remove all the paper from the bypass tray.

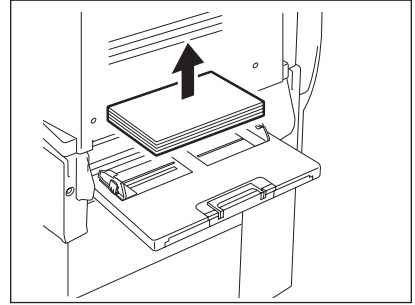

4 Turn the power ON.

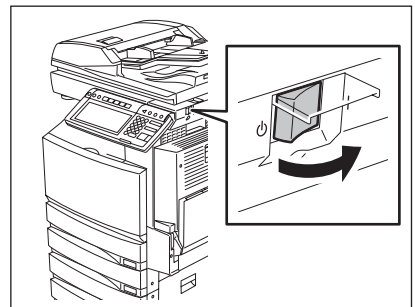

5 Place paper on the bypass tray and select the paper size.

📖 P.71 "3.Bypass Copying"

6 Place the original and try to copy again.

- When "POWER FAILURE" appears, press the [FUNCTION CLEAR] button twice to clear the message.
See 📖 P.329 "8."POWER FAILURE"" for details.

10

During printing from the FAX or Printer (using a drawer)

1 Turn the power of the equipment OFF.

- You cannot shut down the equipment.

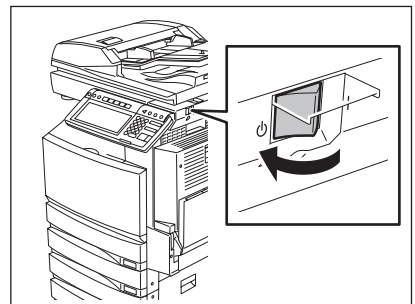

2 Remove the jammed paper.

📖 P.285 "5.Jam Symbols"

- 3** Pull out the drawer mentioned in the message. Then remove all the paper in it.

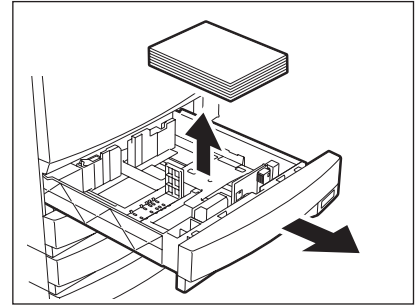

- 4** Close the drawer and then turn the power ON.

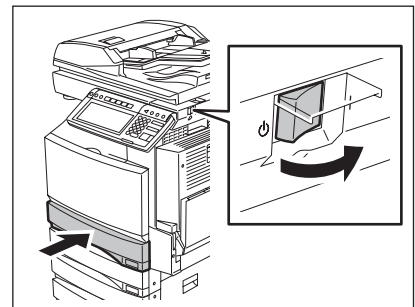

- 5** See the size indication on the touch panel to check the paper size registered for the drawer mentioned in the message.

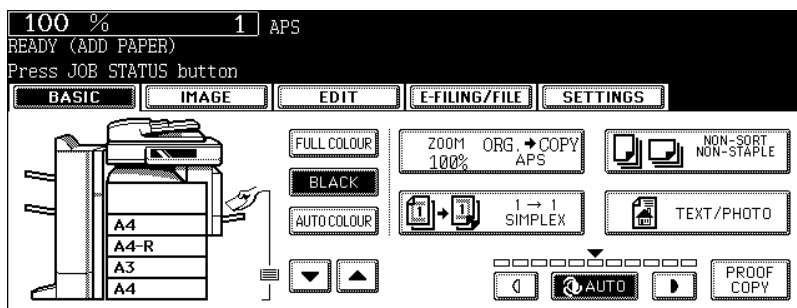

- 6** Place the paper, whose size is same as the one you have checked at step 5, in the drawer mentioned in the message.

📖 P.43 “4.Setting Copy Paper”

- 7** The job is resumed.

- If you change the paper size again after the completion of the job, check that the paper size placed in the drawer is the same as the one registered in the equipment for the corresponding drawer.

During printing from the Printer (using the bypass tray)

- Paper will not be fed out of the bypass tray during a FAX reception.

1 Turn the power of the equipment OFF.

- You cannot shut down the equipment.

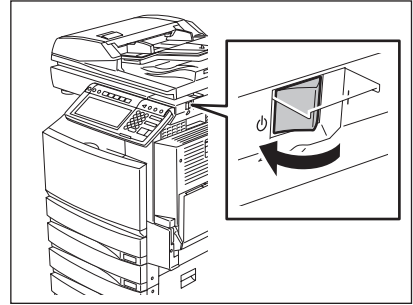

2 Remove the jammed paper.

 P.285 "5.Jam Symbols"

3 Remove all the paper from the bypass tray.

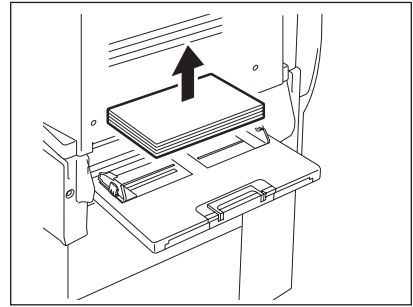

4 Turn the power ON.

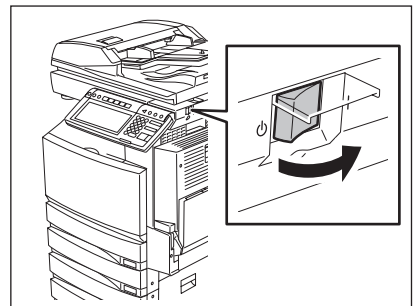

- 5** Press the [JOB STATUS] button on the control panel.

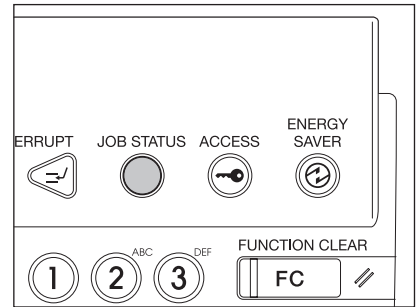

- 6** Place the paper of the size corresponding to the one shown next to the message “Place Paper in the Bypass tray :” on the bypass tray.

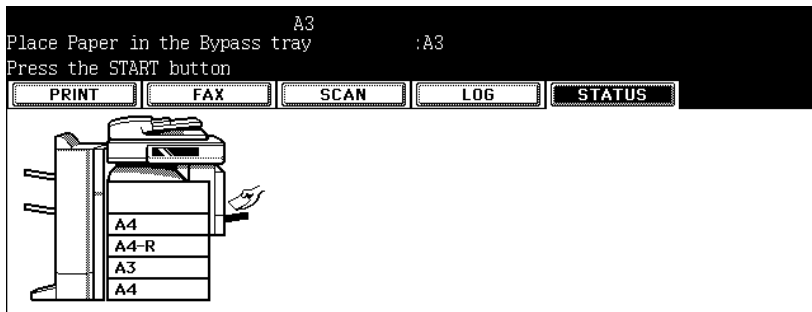

- 7** Press the [START] button.

11. “Cannot print this paper size Select the other drawer”

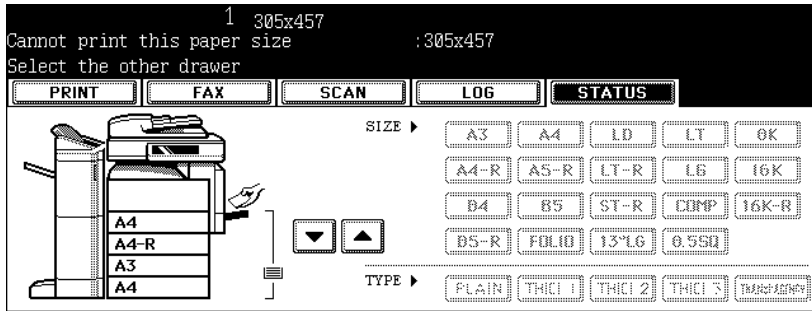

When the finisher is installed, A3-Wide paper cannot exit to the receiving tray.

When this message appears, delete the print job, change the paper size you set for printing or specify the finisher as an exit tray, and tray again.

Tips

Printing can be performed without deleting the print job in the following two ways. However, some parts of the original image may be missing because the paper size smaller than A3-Wide will be used in both cases.

- Select a drawer button to be set as a paper source on the touch panel, and press the [START] button.
- Place paper other than A3-Wide size on the bypass tray and press the [START] button.

Caution

Be sure to specify the paper size.

12. “Reboot the machine”

Reboot the machine	CBF0
TOTAL COUNTER:	244

This message appears when the equipment cannot be operated normally because an error occurs but it may be released by rebooting the equipment. Since the equipment cannot be shut down with the control panel, reboot it with the power switch.

11. MAINTENANCE

- 1. Daily Inspection.....342
- 2. Simple Troubleshooting343

1. Daily Inspection

We recommend you to clean the following items weekly, so that the originals can be scanned in unsoiled conditions.

Be careful not to scratch the parts that you are cleaning.

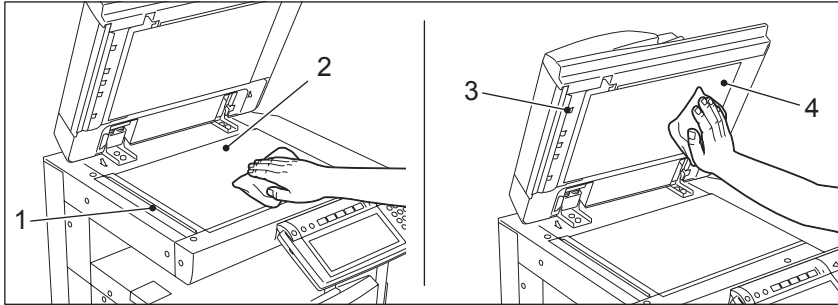

1. Scanning area

Clean the surface with a dry soft cloth or a cloth lightly moistened with water.
Do not use solvents such as alcohol.

2. Original glass

3. Guide

4. Platen sheet

Clean the surface as follows depending on the staining.

- Clean it with a soft cloth.
- Clean it with a soft cloth lightly moistened with water.
- Clean it with a soft cloth lightly moistened with alcohol, and then wipe it with a dry cloth.
- Clean it with a soft cloth lightly moistened with watered-down neutral detergent, and then wipe it with a dry cloth.

Caution

- Do not use solvents such as thinner or benzine when cleaning the surface of the equipment. This could warp the shape of the surface or leave it discoloured.
- When using a chemical cleaning pad to clean it, follow the instructions.





2. Simple Troubleshooting

Check the following items and, if the problem still occurs, call your service representative for assistance.

Equipment does not start

Item to be checked	Countermeasure	Reference page
Is the power cord plug securely inserted in the outlet?	Insert the power cord plug until it comes to a stop.	-
Is the front cover firmly closed?	Close the cover properly.	 P.22 "1.Description of Each Component"

Paper jamming occurs frequently

Item to be checked	Countermeasure	Reference page
Does the message: "Check paper size setting on control panel for drawer N (Bypass)" appear?	Match the size of the paper placed in the drawer or on the bypass tray and the one registered to the equipment.	 P.331 "10."Check paper size setting on control panel for drawer N""
Does the paper placed exceed the line indicated inside of the side guide?	Remove some of the sheets of paper and place them with the paper height not exceeding the line indicated.	 P.46 "Placing paper in the drawer"
Is the space between the side guide of the drawer or the bypass tray and the paper too narrow/wide?	Keep an appropriate space between the side guide and paper, and then place paper straight along the side guide.	 P.46 "Placing paper in the drawer"
Has all of the jammed paper removed?	Since the jammed paper may not be easily found, follow the guidance shown on the touch panel.	 P.285 "5.Jam Symbols"

Display does not change when buttons or icons are pressed

Item to be checked	Countermeasure	Reference page
Is the equipment in the energy saving mode (Automatic energy saving mode)?	Press the [ENERGY SAVER] or [START] button on the control panel to clear the mode. (It takes a while for the equipment to become ready.)	📖 P.42 “3.Energy Saving Mode”
Is the power OFF because the weekly timer functions?	Press the [START] button to return the power ON.	See the [User Function Guide]
When the use of the equipment is managed under department management, is the correct code entered?	Key in the correct department code.	📖 P.35 “When department or user management is used”
When the use of the equipment is managed under user management, is the correct information entered?	Enter the user information correctly.	📖 P.35 “When department or user management is used”
Is the “Warming up” message displayed?	Wait until the equipment becomes ready.	📖 P.34 “Turning power on”

Functions cannot be set

Item to be checked	Countermeasure	Reference page
Are there functions that cannot be combined set together?	See the copying function combination and image quality adjustment combination matrices, and then set them again.	📖 P.359 “4.Copying Function Combination Matrix”, 📖 P.361 “5.Image Quality Adjustment Combination Matrix”

Image density is too low

Item to be checked	Countermeasure	Reference page
Is the message to replace the toner cartridge displayed on the touch panel?	Replace the toner cartridge.	📖 P.276 “3.Replace Toner Cartridge Symbol”
Is the level of the colour adjustment set suitably?	Use the manual density buttons or the background adjustment function to adjust the image density properly.	📖 P.121 “7.Copy Density Adjustment”, 📖 P.127 “4.Background Adjustment”

Image density is too high

Item to be checked	Countermeasure	Reference page
Is the level of the colour adjustment set suitably?	Use the manual density buttons or the background adjustment function to adjust the image density properly.	📖 P.121 “7.Copy Density Adjustment”, 📖 P.127 “4.Background Adjustment”

Images are stained

Item to be checked	Countermeasure	Reference page
Is the Reversing Automatic Document Feeder (optional) securely closed?	Close the cover or feeder properly to shut out any outer light.	📖 P.56 “1.Setting Originals”
Are the platen sheet, Original Cover and scanning area dirty?	Clean them up.	📖 P.342 “1.Daily Inspection”
Is the image density set properly?	Adjust the image density properly with the [AUTO] button or manual density buttons.	📖 P.121 “7.Copy Density Adjustment”
Are 2-sided originals used?	As the other side of the originals can be seen, adjust the image density properly (lighter) with the background adjustment function.	📖 P.127 “4.Background Adjustment”
Are originals with high transparency used?	Place a blank sheet of paper with originals of the same size or larger over the original.	📖 P.58 “Sheet originals”

Images are blurred

Item to be checked	Countermeasure	Reference page
Does the entire original lie properly on the surface of the glass?	Place the original on the glass, and then close the Reversing Automatic Document Feeder (optional) firmly.	-
Is the paper moist?	Replace it with new paper.	-

Copy images are partially missing

Item to be checked	Countermeasure	Reference page
Are the original size, direction and the reproduction ratio suitable for the paper size?	Select copy paper of the same size as the original, or set the reproduction ratio suitable for the paper size.	P.84 "Automatic Paper Selection (APS)", P.90 "3.Enlargement and Reduction Copying"
Is the margin on the copy set properly?	Adjust the image shift value.	P.134 "1.IMAGE SHIFT"

12. SPECIFICATIONS & OPTIONS

1. e-STUDIO281c/351c/451c Specifications	348
2. Specifications of Options.....	351
3. Packing List.....	358
4. Copying Function Combination Matrix	359
• Combination Matrix 1/2	359
• Combination Matrix 2/2	360
5. Image Quality Adjustment Combination Matrix.....	361

1. e-STUDIO281c/351c/451c Specifications

Model name		FC-281C/FC-351C/FC-451C
Type		Desktop type
Original glass		Fixed
Printing (copying) system		Indirect electrophotographic method
Developing system		2-component magnetic brush developing
Fixing method		Heat roller + belt fusing (Twin separated IH coil)
Photosensor type		OPC
Original scanning system		Flat surface scanning system (When the Reversing Automatic Document Feeder is installed: Fixed scanning system by feeding the original)
Original scanning sensor		Linear CCD sensor
Scanning light source		Xenon lamp
Resolution	Scanning	600 dpi x 600 dpi
	Writing	Black-and-white: 2400 dpi x 600 dpi (Smoothing process), 1 bit Colour, Image smoothing: 600 dpi x 600 dpi, 8 bits
Acceptable originals		Sheets, books and 3-dimensional objects
Acceptable original size		Max. A3
Acceptable copy paper size	Drawer	A3, A4, A4-R, A5-R, B4, B5, B5-R, FOLIO, LD, LG, LT, LT-R, ST-R, COMP, 13" LG, 8.5" SQ, 8K, 16K, 16K-R
	Bypass	Paper size within 100 - 305 mm (Length), 148 - 457 mm (Width)
Acceptable copy paper weight	Drawer	64 - 105 g/m ²
	Bypass	64 - 209 g/m ²
Warm-up time		Approx. 40 seconds
First copy time (A4 portrait)		Black-and-white: Approx. 6.8, Colour: 16.2 seconds or less
Continuous copy speed		See  P.350 "Continuous copying speed".
Multiple copying		Up to 999 copies (digital key entry)
Excluded image width	Black-and-white	Leading edge: 3.0±2.0 mm, Trailing edge: 3.0±2.0 mm, Both edge: 2.0±2.0 mm
	Colour	Leading edge: 5.0±2.0 mm, Trailing edge: 5.0±2.0 mm, Both edge: 2.0±2.0 mm
	Printer (Black-and-white/Colour)	Leading edge: 5.0±2.0 mm, Trailing edge: 5.0±2.0 mm, Both edge: 5.0±2.0 mm
Reproduction ratio	Actual size	100±0.5%
	Zoom	25 - 400% (in 1% increments) For the Reversing Automatic Document Feeder 25 - 200% (in 1% increments)
Paper supply	Drawer	550 sheets (80 g/m ²)
	Bypass	100 sheets (80 g/m ²)
Toner density adjustment		Black (K): Magnetic auto-toner system Yellow (Y)/Magenta (M)/Cyan (C): Optical auto-toner system
Exposure control		Automatic plus manual selection from 11 exposure step

Environment (for normal use)	Temperature: 10 - 30 °C, Humidity: 20 - 85% (No Condensation)
Power requirements	AC 220 - 240 V±10%, 8 A (50/60 Hz)
Power consumption	1.7 kW or less (including optional equipments)
Dimensions (equipment only)	660 mm (W) x 758 mm (D) x 739 mm (H)
Weight	Approx. 113 kg (equipment including developer and drum)
Space occupied (equipment only)	1028 mm (W) x 819 mm (D)
Storage capacity	Max. 1000 sheets or until the memory is full (Toshiba's own chart)

- This specification varies depending on the copying conditions and the environment.
- Specifications and appearance are subject to change without notice in the interest of product improvement.

Continuous copying speed

sheets/min.

Paper type	Paper size	Feeder	e-STUDIO281c		e-STUDIO351c		e-STUDIO451c	
			Black-and-white	Twin colour/Colour	Black-and-white	Twin colour/Colour	Black-and-white	Twin colour/Colour
Plain paper (64 - 80 g/m ²)	A4, A5-R, B5, LT, ST-R, 8.5" SQ	Drawer	28	11	35	11	45 *1	11
		Bypass	28	11	35	11	45 *1	11
	A4-R, B5-R, LT-R	Drawer	21	5.4	28	5.4	32	5.4
		Bypass	21	5.4	28	5.4	32	5.4
	B4, FOLIO, LG, COMP, 13" LG	Drawer	18	5.4	24	5.4	26	5.4
		Bypass	18	5.4	24	5.4	26	5.4
	A3, LD	Drawer	16	5.4	21	5.4	22	5.4
		Bypass	16	5.4	21	5.4	22	5.4
Thick 1 (- 105 g/m ²)	A4, A5-R, B5, LT, ST-R, 8.5" SQ	Drawer	28	11	30	11	30	11
		Bypass	28	11	30	11	30	11
	A4-R, B5-R, LT-R	Drawer	20	5.4	23	5.4	23	5.4
		Bypass	20	5.4	23	5.4	23	5.4
	B4, FOLIO, LG, COMP, 13" LG	Drawer	18	5.4	19	5.4	19	5.4
		Bypass	18	5.4	19	5.4	19	5.4
	A3, LD	Drawer	16	5.4	16	5.4	16	5.4
		Bypass	16	5.4	16	5.4	16	5.4
Thick 2 (- 163 g/m ²)	A4, A5-R, B5, LT, ST-R, 8.5" SQ	Bypass	20	6.7	20	6.7	20	6.7
	A4-R, B5-R, LT-R	Bypass	14	3.1	14	3.1	14	3.1
	FOLIO, LG, COMP, 13" LG, B4	Bypass	11	3.0	11	3.0	11	3.0
	A3, LD	Bypass	10	2.9	10	2.9	10	2.9
Thick 3 (- 209 g/m ²)	A4, A5-R, B5, LT, ST-R, 8.5" SQ	Bypass	20	2.8	20	2.8	20	2.8
	A4-R, B5-R, LT-R	Bypass	14	2.7	14	2.7	14	2.7
	FOLIO, LG, COMP, 13" LG, B4	Bypass	11	2.7	11	2.7	11	2.7
	A3, LD	Bypass	10	2.5	10	2.5	10	2.5

*1 When the [IMAGE SMOOTHING] is selected for the original mode, the copying speed will be 44 sheets/min.

- The bypass copying speed is as listed above when specifying the paper size.
- The values above are measured when originals are set on the original glass, 1-sided, 100% and non-sort multiple copies are made.
- This specification varies depending on the copying conditions and the environment.
- Toshiba-recommended paper is used for the values of this specification above.

2. Specifications of Options

Reversing Automatic Document Feeder

Model name	MR-3018
Copy sides	1-side, Duplex
Number of originals (A4)	100 originals (35 - 80 g/m ²) or 16 mm or less in height (more than 80 g/m ²)
Feeding speed	Black-and-white: 105 - 420 mm/s Colour: 52.5 - 210 mm/s
Acceptable originals	A3, A4, A4-R, A5-R, B4, B5, B5-R, FOLIO, LD, LG, LT, LT-R, ST-R, COMP (A5 and ST size are not acceptable.)
Paper weight	1-sided original: 35 - 157 g/m ² , 2-sided original: 50 - 157 g/m ²
Power source	Power supplied from the equipment
Dimensions	600 mm (W) x 523 mm (D) x 135 mm (H)
Weight	Approx. 12.5 kg
Power consumption	49.5 W max.

Large Capacity Feeder

Model name	KD-1012
Acceptable paper size	A4
Paper weight	64 - 105 g/m ²
Maximum capacity	2500 sheets (80 g/m ²) (Height: approx. 137 mm x 2)
Power source	DC 5 V, DC 24 V (supplied from the copier)
Dimensions	623 mm (W) x 657 mm (D) x 307.5 mm (H) (incl. Stabilizer)
Weight	Approx. 27 kg

Paper Feed Pedestal (1 drawer type)

Model name	KD-1011
Acceptable paper size	A3, A4, A4-R, A5-R, B4, B5, B5-R, FOLIO, LD, LG, LT, LT-R, ST-R, COMP (A5, ST and non-standard size are not acceptable.)
Paper weight	64 - 105 g/m ²
Maximum capacity	550 sheets (80 g/m ²)
Power source	DC 5 V, DC 24 V (supplied from the copier)
Dimensions	623 mm (W) x 657 mm (D) x 320 mm (H)
Weight	Approx. 21.5 kg

Additional Drawer Module

Model name	MY-1021
Acceptable paper size	A3, A4, A4-R, A5-R, B4, B5, B5-R, FOLIO, LD, LG, LT, LT-R, ST-R, COMP (A5, ST and non-standard size are not acceptable.)
Paper weight	64 - 105 g/m ²
Maximum capacity	550 sheets (80 g/m ²)
Weight	Approx. 3.8 kg

Finisher (MJ-1101)

Model name	MJ-1101			
Type	Floor type (Console type)			
Acceptable paper size	A3, A3-Wide, A4, A4-R, A5-R, B4, B5, B5-R, FOLIO, LD, LG, LT, LT-R, ST-R, COMP, 8.5"SQ, 13"LG			
Acceptable paper weight	64 - 209 g/m ²			
Number of copies stapled at a time (Including 2 covers (64 - 209 g/m ²))	Paper size	64 - 80 g/m ²	81 - 90 g/m ²	91 - 105 g/m ²
	A4, B5, LT, 8.5"SQ	50 sheets	30 sheets	30 sheets
	A3, A4-R, B4, FOLIO, LD, LG, LT-R, COMP, 13"LG	30 sheets	15 sheets	15 sheets
Stapling position	Front, Rear, Double			
Power source	Supplied from the equipment			
Dimensions	535 mm (W) x 598 mm (D) x 1092 mm (H)			
Weight	Approx. 34 kg			
Power consumption	70 W max.			

Tray loading capacity of Finisher (MJ-1101)Unit: mm (with allowable error of ± 7 mm)Values in parentheses: Number of sheets (80 g/m²)**Upper Tray**

MJ-1101 with mixed paper not loaded	
Mode	Non-Sort
A4, A5-R, B5, LT, ST-R, 8.5"SQ	36.75 mm (250)
A3, A3-Wide, A4-R, B4, B5-R, FOLIO, LD, LG, LT-R, COMP, 13"LG	18.4 mm (125)

Lower Tray

MJ-1101 with mixed paper not loaded			
Mode	Non-Sort	Sort/Group	Staples loaded
A4, B5, LT, 8.5"SQ	250 mm (2000)	250 mm (2000)	Whichever of 250 mm, 2000 sheets or 30 copies is reached first
A3, A4-R, B4, FOLIO, LD, LG, LT-R, COMP, 13"LG	140 mm (1000)	140 mm (1000)	Whichever of 140 mm, 1000 sheets or 30 copies is reached first

When mixed-size paper is loaded, the tray loading capacity should follow the specifications for larger paper sizes in the above tables.

Saddle Stitch Finisher (MJ-1024)

Model name	MJ-1024			
Type	Floor type (Console type)			
Acceptable paper size	A3, A3-Wide, A4, A4-R, A5-R, B4, B5, B5-R, FOLIO, LD, LG, LT, LT-R, ST-R, COMP			
Acceptable paper weight	64 - 209 g/m ²			
Number of copies stapled at a time (Including 2 covers (64 - 209 g/m ²))	Paper size	80 g/m ²	90 g/m ²	105 g/m ²
	A4, B5, LT	50 sheets	30 sheets	30 sheets
	A3, A4-R, B4, FOLIO, LD, LG, LT-R, COMP	30 sheets	15 sheets	15 sheets
Stapling position	Front, Rear, Double			
Stitching capacity (Including 2 covers (64 - 209 g/m ²))	Paper size	80 g/m ²	90 g/m ²	105 g/m ²
	A3, A4-R, B4, LD, LT-R	15 sheets	10 sheets	10 sheets
Power source	Supplied from the equipment			
Dimensions	649 mm (W) x 657 mm (D) x 1086 mm (H)			
Weight	Approx. 70 kg			
Power consumption	170 W max.			

Tray loading capacity of Saddle Stitch Finisher (MJ-1024) (MJ-1024 with mixed paper not loaded)

Unit: mm (with allowable error of ±7 mm)

Values in parentheses: Number of sheets (80 g/m²)

Mode Tray No.	Non-Sort		Sort/Group		Staples loaded	
	1	2	1	2	1	2
A4, A5-R, B5, LT, ST-R	147 (1000)		147 (1000)		Whichever of 147 mm, 1000 sheets or 30 copies is reached first	Whichever of 147 mm, 1000 sheets or 30 copies is reached first
A3, A4-R, B4, B5-R, FOLIO, LD, LG, LT-R, COMP	73.5 (500)		73.5 (500)		Whichever of 73.5 mm, 500 sheets or 30 copies is reached first	Whichever of 73.5 mm, 500 sheets or 30 copies is reached first

- Sort/Group/Staple is not available with A5-R, B5-R, ST-R.
- See  P.105 "Available conditions for saddle stitching" for tray loading capacity of saddle stitch tray.
- If copied paper remains on the receiving tray and the next copying job is performed, the loading capacity is the same as that for mixed paper.

(MJ-1024 with mixed paper loaded)

Unit: mm (with allowable error of ±7 mm)

Values in parentheses: Number of sheets (80 g/m²)

Mode Tray No.	Non-Sort		Sort/Group		Staples loaded	
	1	2	1	2	1	2
A3 and A4	73.5 (500)		73.5 (500)		Whichever of 73.5 mm, 500 sheets or 30 copies is reached first	Whichever of 73.5 mm, 500 sheets or 30 copies is reached first
B4 and B5						
FOLIO and A4-R						
LD and LT						
LG and LT-R						

Multi Position Staple Finisher (MJ-1023)

Model name	MJ-1023			
Type	Floor type (Console type)			
Acceptable paper size	A3, A3-Wide, A4, A4-R, A5-R, B4, B5, B5-R, FOLIO, LD, LG, LT, LT-R, ST-R, COMP			
Acceptable paper weight	64 - 209 g/m ²			
Number of copies stapled at a time (Including 2 covers (64 - 209 g/m ²))	Paper size	80 g/m ²	90 g/m ²	105 g/m ²
	A4, B5, LT	50 sheets	30 sheets	30 sheets
	A3, A4-R, B4, FOLIO, LD, LG, LT-R, COMP	30 sheets	15 sheets	15 sheets
Stapling position	Front, Rear, Double			
Power source	Supplied from the equipment			
Dimensions	536 mm (W) x 657 mm (D) x 1086 mm (H)			
Weight	Approx. 39 kg			
Power consumption	70 W max.			

**Tray loading capacity of Multi Position Staple Finisher (MJ-1023)
(MJ-1023 with mixed paper not loaded)**Unit: mm (with allowable error of ± 7 mm)Values in parentheses: Number of sheets (80 g/m²)

Mode Tray No.	Non-Sort		Sort/Group		Staples loaded	
	1	2	1	2	1	2
A4, A5-R, B5, LT, ST-R	147 (1000)		147 (1000)		Whichever of 147 mm, 1000 sheets or 30 copies is reached first	Whichever of 147 mm, 1000 sheets or 30 copies is reached first
A3, A4-R, B4, B5-R, FOLIO, LD, LG, LT-R, COMP	73.5 (500)		73.5 (500)		Whichever of 73.5 mm, 500 sheets or 30 copies is reached first	Whichever of 73.5 mm, 500 sheets or 30 copies is reached first

- Sort/Group/Staple is not available with A5-R, B5-R, ST-R.
- If copied paper remains on the receiving tray and the next copying job is performed, the loading capacity is the same as that for mixed paper.

(MJ-1023 with mixed paper loaded)Unit: mm (with allowable error of ± 7 mm)Values in parentheses: Number of sheets (80 g/m²)

Mode Tray No.	Non-Sort		Sort/Group		Staples loaded	
	1	2	1	2	1	2
A3 and A4	73.5 (500)		73.5 (500)		Whichever of 73.5 mm, 500 sheets or 30 copies is reached first	Whichever of 73.5 mm, 500 sheets or 30 copies is reached first
B4 and B5						
FOLIO and A4-R						
LD and LT						
LG and LT-R						

Hanging Finisher (MJ-1022)

Model name	MJ-1022	
Type	Hanging-type	
Acceptable paper size	A3, A4, A4-R, A5-R, B4, B5, B5-R, FOLIO, LD, LG, LT, LT-R, ST-R, COMP	
Acceptable paper weight	64 - 209 g/m ²	
Number of copies stapled at a time (Acceptable weight for staple: 64 - 80 g/m ²)	A4, A4-R, B5, LT, LT-R	30 sheets
	B4, LG	20 sheets
	A3, FOLIO, LD, COMP	15 sheets
Stapling position	Rear	
Power source	Supplied from the copier	
Dimensions	451 mm (W) x 539 mm (D) x 590 mm (H)	
Weight	Approx. 17 kg	
Power consumption	40 W max.	

Tray loading capacity of Hanging Finisher (MJ-1022) (MJ-1022 with mixed paper not loaded)

Unit: mm (with allowable error of ±7 mm)

Values in parentheses: Number of sheets (80 g/m²)

Mode Tray No.	Non-Sort		Sort/Group		Staples loaded	
	1	2	1	2	1	2
A5-R, B5-R, ST-R	30 (200)	99 (700)	-	-	-	-
A4, A4-R, B5, LT, LT-R	30 (200)	99 (700)	30 (200)	99 (700)	Whichever of 170 sheets or 30 copies is reached first	Whichever of 600 sheets or 50 copies is reached first
B4, LG	20 (140)	70 (490)	20 (140)	70 (490)	Whichever of 110 sheets or 30 copies is reached first	Whichever of 400 sheets or 50 copies is reached first
A3, FOLIO, LD, COMP	15 (100)	49 (350)	15 (100)	49 (350)	Whichever of 80 sheets or 30 copies is reached first	Whichever of 300 sheets or 50 copies is reached first

(MJ-1022 with mixed paper loaded)Unit: mm (with allowable error of ± 7 mm)Values in parentheses: Number of sheets (80 g/m²)

Mode Tray No.	Non-Sort		Sort/Group		Staples loaded	
	1	2	1	2	1	2
Combination of different width paper	15 (100)	49 (350)	-	-	-	-
A3 and A4	15 (100)	49 (350)	15 (100)	49 (350)	Whichever of 100 sheets or 15 copies is reached first	Whichever of 350 sheets or 15 copies is reached first
B4 and B5	15 (100)	49 (350)	15 (100)	49 (350)	Whichever of 100 sheets or 15 copies is reached first	Whichever of 350 sheets or 15 copies is reached first
LD and LT	15 (100)	49 (350)	15 (100)	49 (350)	Whichever of 100 sheets or 15 copies is reached first	Whichever of 350 sheets or 15 copies is reached first
LG and LT-R	15 (100)	49 (350)	15 (100)	49 (350)	Whichever of 100 sheets or 15 copies is reached first	Whichever of 350 sheets or 15 copies is reached first

Hole Punch Unit (MJ-6101 Series)

Model name	MJ-6101 Series
Acceptable paper size	A3, A4, A4-R, B4, B5, B5-R, FOLIO, LD, LG, LT, LT-R, COMP, 8.5"SQ, 13"LG
Acceptable paper weight	64 - 209 g/m ² (OHP film and specially treated paper are not available.)
Dimensions	112 mm (W) x 617 mm (D) x 378 mm (H) (excl. Lower cover)
Weight	Approx. 9 kg

	Number of punching holes and hole diameter	Available paper size
Japan and most of Europe (MJ-6101E)	2 holes (6.5 mm dia.)	A3, A4, A4-R, B4, B5, B5-R, FOLIO, LD, LG, LT, LT-R, COMP
North America (MJ-6101N)	2/3 holes switchable (8.0 mm dia.)	2 holes: A4-R, LG, LT-R 3 holes: A3, A4, LD, LT
France (MJ-6101F)	4 holes (6.5 mm dia.; 80 mm pitch)	A3, A4, LD, LT
Sweden (MJ-6101S)	4 holes (6.5 mm dia.; 70 mm and 21 mm pitch)	A3, A4, A4-R, B4, B5, B5-R, FOLIO, LD, LG, LT-R, COMP

Hole Punch Unit (MJ-6004 Series)

Model name	MJ-6004 Series
Acceptable paper size	A3, A4, A4-R, B4, B5, B5-R, FOLIO, LD, LG, LT, LT-R, COMP
Acceptable paper weight	64 - 209 g/m ² (OHP film and specially treated paper are not available.)
Dimensions	112 mm (W) x 617 mm (D) x 378 mm (H)
Weight	Approx. 9 kg

	Number of punching holes and hole diameter	Available paper size
Japan and most of Europe (MJ-6004E)	2 holes (6.5 mm dia.)	A3, A4, A4-R, B4, B5, B5-R, FOLIO, LD, LG, LT, LT-R, COMP
North America (MJ-6004N)	2/3 holes switchable (8.0 mm dia.)	2 holes: A4-R, LG, LT-R 3 holes: A3, A4, LD, LT
France (MJ-6004F)	4 holes (6.5 mm dia.; 80 mm pitch)	A3, A4, LD, LT
Sweden (MJ-6004S)	4 holes (6.5 mm dia.; 70 mm and 21 mm pitch)	A3, A4, A4-R, B4, B5, B5-R, FOLIO, LD, LG, LT-R, COMP

Bridge Unit

Model name	KN-3511A
------------	----------

- Toshiba-recommended paper is used for the values above. Specifications and appearance are subject to change without notice in the interest of product improvement.

3. Packing List

Packing list	Setup instructions
	Operator's Manual
	Photoconductive drum
	Operator's Manual pocket
	Setup report
	CD-ROM (2 pcs.)
	Stopper (for control panel)

4. Copying Function Combination Matrix

Combination Matrix 1/2

	Store to e-Filing	Copy & File	Job build	Template	Sheet insertion			Cover sheet			Editing			Dual page XY zoom	Book centre erase	2IN1/4IN1	Image shift
					Copied	Blank	Top copied back blank	Both blank	Top copied	Top blank	Negar/Pos	Mask	Trim				
Bypass copy	*1	*1	Yes	Yes	*1	*1	*1	*1	*1	*1	*1	*1	*1	Yes	*1	*1	*1
1 - 1 Simplex	Yes	Yes	Yes	Yes	Yes	Yes	Yes	Yes	Yes	Yes	Yes	Yes	Yes	Yes	Yes	Yes	Yes
1 - 2 Duplex	Yes	*2	Yes	Yes	Yes	Yes	Yes	Yes	Yes	Yes	Yes	Yes	Yes	Yes	Yes	*3	Yes
2 - 1 Split	Yes	Yes	Yes	Yes	Yes	Yes	Yes	Yes	Yes	Yes	Yes	Yes	Yes	Yes	No	*3	Yes
2 - 2 Duplex	Yes	*2	Yes	Yes	Yes	Yes	Yes	Yes	Yes	Yes	Yes	Yes	Yes	Yes	No	*3	Yes
Book - 2	Yes	Yes	No	Yes	No	No	No	No	No	No	No	No	No	No	No	No	Yes
Non-sort/Non-staple	*3	Yes	*4	Yes	*3	*3	*3	*3	*3	*3	*3	*3	*3	Yes	Yes	Yes	Yes
Sort	Yes	Yes	*4	Yes	Yes	Yes	Yes	Yes	Yes	Yes	Yes	Yes	Yes	Yes	Yes	Yes	Yes
Group	Yes	Yes	*4	Yes	No	No	No	No	No	No	No	No	No	Yes	Yes	Yes	Yes
Staple sort	Yes	Yes	*4	Yes	Yes	Yes	Yes	Yes	Yes	Yes	Yes	Yes	Yes	Yes	Yes	Yes	Yes
Magazine sort	*3	*3	No	Yes	No	No	No	No	No	No	No	No	No	Yes	Yes	Yes	Yes
Magazine sort & Saddle stitch	*3	*3	No	Yes	No	No	No	No	No	No	No	No	No	Yes	Yes	No	No
Hole punch	Yes	Yes	*4	Yes	Yes	Yes	Yes	Yes	Yes	Yes	Yes	Yes	Yes	Yes	Yes	Yes	Yes
Saddle stitch	Yes	Yes	*4	Yes	No	No	No	No	No	No	No	No	No	Yes	Yes	No	No
Rotate sort	Yes	Yes	*4	Yes	No	No	No	No	No	No	No	No	No	Yes	Yes	No	No
Mixed original sizes	Yes	Yes	*4	Yes	No	No	No	No	No	No	No	No	No	Yes	Yes	No	No
SADF	Yes	Yes	Yes	Yes	Yes	Yes	Yes	Yes	Yes	Yes	Yes	Yes	Yes	Yes	Yes	--	Yes
Image direction	Yes	Yes	*4	Yes	Yes	Yes	Yes	Yes	Yes	Yes	Yes	Yes	Yes	Yes	Yes	Yes	Yes
Book - Tablet	Yes	Yes	*4	Yes	Yes	Yes	Yes	Yes	Yes	Yes	Yes	Yes	Yes	Yes	Yes	Yes	No
Edge erase	Yes	Yes	Yes	Yes	Yes	Yes	Yes	Yes	Yes	Yes	Yes	Yes	Yes	Yes	Yes	Yes	No
Image shift	*3	*3	*4	Yes	Yes	Yes	Yes	Yes	Yes	Yes	Yes	Yes	Yes	Yes	Yes	Yes	Yes
2IN1/4IN1	*3	*3	No	Yes	No	No	No	No	No	No	No	No	No	Yes	Yes	Yes	Yes
Book centre erase	Yes	Yes	*4	Yes	No	No	No	No	No	No	No	No	No	Yes	Yes	No	No
XY zoom	Yes	Yes	No	Yes	Yes	Yes	Yes	Yes	Yes	Yes	Yes	Yes	Yes	Yes	Yes	Yes	Yes
Dual page	Yes	*2	Yes	Yes	No	No	No	No	No	No	No	No	No	Yes	Yes	Yes	Yes
Mirror	Yes	Yes	No	Yes	Yes	Yes	Yes	Yes	Yes	Yes	Yes	Yes	Yes	Yes	Yes	Yes	Yes
Trim	Yes	Yes	No	Yes	Yes	Yes	Yes	Yes	Yes	Yes	Yes	Yes	Yes	Yes	Yes	Yes	Yes
Mask	Yes	Yes	No	Yes	Yes	Yes	Yes	Yes	Yes	Yes	Yes	Yes	Yes	Yes	Yes	Yes	Yes
Negar/Pos	Yes	Yes	No	Yes	Yes	Yes	Yes	Yes	Yes	Yes	Yes	Yes	Yes	Yes	Yes	Yes	Yes
Top blank	*3	*3	No	Yes	Yes	Yes	Yes	Yes	Yes	Yes	Yes	Yes	Yes	Yes	Yes	Yes	Yes
Top copied	*3	*3	No	Yes	Yes	Yes	Yes	Yes	Yes	Yes	Yes	Yes	Yes	Yes	Yes	Yes	Yes
Both blank	*3	*3	No	Yes	Yes	Yes	Yes	Yes	Yes	Yes	Yes	Yes	Yes	Yes	Yes	Yes	Yes
Top copied back blank	*3	*3	No	Yes	Yes	Yes	Yes	Yes	Yes	Yes	Yes	Yes	Yes	Yes	Yes	Yes	Yes
Blank	*3	*3	No	Yes	Yes	Yes	Yes	Yes	Yes	Yes	Yes	Yes	Yes	Yes	Yes	Yes	Yes
Copied	*3	*3	No	Yes	Yes	Yes	Yes	Yes	Yes	Yes	Yes	Yes	Yes	Yes	Yes	Yes	Yes
Sheet insertion	Yes	Yes	Yes	Yes	Yes	Yes	Yes	Yes	Yes	Yes	Yes	Yes	Yes	Yes	Yes	Yes	Yes
Template	Yes	Yes	Yes	Yes	Yes	Yes	Yes	Yes	Yes	Yes	Yes	Yes	Yes	Yes	Yes	Yes	Yes
Job build	*4	*4	No	Yes	Yes	Yes	Yes	Yes	Yes	Yes	Yes	Yes	Yes	Yes	Yes	Yes	Yes
Copy & File	No	No	No	Yes	Yes	Yes	Yes	Yes	Yes	Yes	Yes	Yes	Yes	Yes	Yes	Yes	Yes
Store to e-Filing	No	No	No	Yes	Yes	Yes	Yes	Yes	Yes	Yes	Yes	Yes	Yes	Yes	Yes	Yes	Yes

- *1 Size selection is required.
- *2 The data stored into the file are the same as the ones for simplex copying.
- *3 The function set later will be valid.
- *4 The setting cannot be changed from 2nd job or later.
- *5 Up to 15 pages can be registered.
- *6 Bookbinding margin is not available.
- *7 Available when the paper width is the same

Combination Matrix 2/2

	Edge erase	Book - Tablet	Image direction	SADF	Mixed original sizes	Rotate sort	Saddle stitch	Hole punch	Magazine sort & Saddle stitch	Magazine sort	Staple sort	Group	Sort	Non-sort/ Non-staple	Book - 2	2 - 2 Duplex	2 - 1 Split	1 - 2 Duplex	1 - 1 Simplex	Bypass copy
Bypass copy	*1	*1	Yes	Yes	*1	*1	*1	*1	*1	*1	*1	Yes	Yes	Yes	*1	Yes	Yes	*1	Yes	
1 - 1 Simplex	Yes	*3	Yes	Yes	Yes	Yes	*3	Yes	*3	*3	Yes	Yes	Yes	Yes	-	-	-	-		
1 - 2 Duplex	Yes	*3	Yes	Yes	Yes	Yes	*3	Yes	Yes	Yes	Yes	Yes	Yes	Yes	-	-	-	-		
2 - 1 Split	Yes	*3	Yes	Yes	Yes	Yes	*3	Yes	No	No	Yes	Yes	Yes	Yes	-	-	-	-		
2 - 2 Duplex	Yes	Yes	Yes	Yes	Yes	Yes	Yes	Yes	Yes	No	Yes	Yes	Yes	Yes	-	-	-	-		
Book - 2	Yes	No	Yes	--	No	No	*3	Yes	No	No	Yes	Yes	Yes	Yes	-	-	-	-		
Non-sort/Non-staple	Yes	Yes	Yes	Yes	Yes	*3	--	Yes	--	--	--	--	--	--						
Sort	Yes	Yes	Yes	Yes	Yes	*3	--	Yes	--	--	--	--	--	--						
Group	Yes	Yes	Yes	Yes	Yes	*3	--	Yes	--	--	--	--	--	--						
Staple sort	Yes	Yes	Yes	Yes	*7	*3	--	Yes	--	--	--	--	--	--						
Magazine sort	Yes	No	Yes	Yes	No	*3	--	No	--	--	--	--	--	--						
Magazine sort & Saddle stitch	Yes	No	Yes	Yes	No	*3	--	No	--	--	--	--	--	--						
Hole punch	Yes	Yes	Yes	Yes	Yes	No	No	No	No	No	No	No	No	No						
Saddle stitch	Yes	No	Yes	Yes	No	*3	No	Yes	No	No	No	No	No	No						
Rotate sort	Yes	Yes	Yes	Yes	Yes	Yes	Yes	Yes	Yes	Yes	Yes	Yes	Yes	Yes						
Mixed original sizes	No	Yes	Yes	Yes	Yes	Yes	Yes	Yes	Yes	Yes	Yes	Yes	Yes	Yes						
SADF	Yes	Yes	Yes	Yes	Yes	Yes	Yes	Yes	Yes	Yes	Yes	Yes	Yes	Yes						
Image direction	Yes	Yes	Yes	Yes	Yes	Yes	Yes	Yes	Yes	Yes	Yes	Yes	Yes	Yes						
Book - Tablet	Yes	Yes	Yes	Yes	Yes	Yes	Yes	Yes	Yes	Yes	Yes	Yes	Yes	Yes						
Edge erase	Yes	Yes	Yes	Yes	Yes	Yes	Yes	Yes	Yes	Yes	Yes	Yes	Yes	Yes						
Image shift																				
2IN1/4IN1																				
Book centre erase																				
XY zoom																				
Dual page																				
Editing	Mirror																			
	Trim																			
	Mask																			
Cover sheet	Negat/Pos																			
	Top blank																			
	Top copied																			
Sheet insertion	Both blank																			
	Top copied back blank																			
	Blank																			
Template																				
Job build																				
Copy & File																				
Store to e-Filing																				

- *1 Size selection is required.
- *2 The data stored into the file are the same as the ones for simplex copying.
- *3 The function set later will be valid.
- *4 The setting cannot be changed from 2nd job or later.
- *5 Up to 15 pages can be registered.
- *6 Bookbinding margin is not available.
- *7 Available when the paper width is the same

5. Image Quality Adjustment Combination Matrix

	Twin colour	Sharp-ness	Back-ground adjustment	One-touch adjustment			RGB adjustment	Colour balance	Original mode			Colour mode		Density Manual / Auto	
				Clear	Vivid	Cool			Warm	Image smoothing	Map	Photo	Printed image		Text
Density Manual / Auto	Yes	Yes	*1	Yes	Yes	Yes	Yes	Yes	Yes	Yes	Yes	Yes	Yes	Yes	
Colour mode	Auto colour	*2	Yes	No	No	Yes	No	No	Yes	Yes	No	Yes	Yes	*2	
	Full colour	*2	Yes	Yes	Yes	Yes	Yes	Yes	No	No	Yes	Yes	Yes	*2	
	Black	*2	Yes	No	No	No	No	No	No	No	Yes	Yes	Yes		
Original mode	Text / Photo	Yes	Yes	Yes	Yes	Yes	Yes	Yes	*2	*2	*2	*2	Yes		
	Text	*2	Yes	Yes	Yes	Yes	Yes	Yes	*2	*2	*2	*2	Yes		
	Printed image	*2	Yes	Yes	Yes	Yes	Yes	Yes	*2	*2	*2	*2	Yes		
	Photo	*2	Yes	Yes	Yes	Yes	Yes	Yes	*2	*2	*2	*2	Yes		
	Map	*2	Yes	Yes	Yes	Yes	Yes	Yes	*2	*2	*2	*2	Yes		
Image smoothing		Yes	Yes	Yes	Yes	Yes	Yes	Yes	Yes	Yes	Yes	Yes	Yes		
Colour balance		Yes	Yes	No	No	No	No	No	No	No	No	No	No		
RGB adjustment	No	Yes	Yes	Yes	Yes	Yes	Yes	Yes	Yes	Yes	Yes	Yes	Yes		
One-touch adjustment	Warm	No	No	No	--	--	No	No	No	No	No	No	No		
	Cool	No	No	No	--	--	No	No	No	No	No	No	No		
	Vivid	No	No	No	--	--	No	No	No	No	No	No	No		
	Clear	No	No	No	--	--	No	No	No	No	No	No	No		
Background adjustment	No	Yes	No	No	No	No	No	No	No	No	No	No	No		
Sharpness	Yes	Yes	Yes	Yes	Yes	Yes	Yes	Yes	Yes	Yes	Yes	Yes	Yes		
Twin colour	Yes	Yes	Yes	Yes	Yes	Yes	Yes	Yes	Yes	Yes	Yes	Yes	Yes		

*1 Available for manual adjustment only
 *2 The function is determined by that set last.



INDEX

Numerics

- 1-sided original -> 1-sided copy 110, 111
- 1-sided original -> 2-sided copy 110, 112
- 2-colour copy 129
- 2IN1 / 4IN1 145
- 2-sided original -> 1-sided copy 110, 114
- 2-sided original -> 2-sided copy 110, 113

A

- Acceptable copy paper 44
- ACCESS button 27
- Additional Drawer Module 23, 351
- ADF 174
- Adjusting the contrast of the touch panel 32
- AMS 90
- APS 84
- APS/AMS or currently selected paper size 30
- Automatic copy density mode 121
- Automatic duplexing unit 22, 291
- Automatic function clear 32
- Automatic Magnification Selection (AMS) 90
- Automatic Paper Selection (APS) 84
- AUTOMATIC START 210, 217

B

- Background adjustment 127
- Black toner cartridge 22, 276
- BLANK 160
- Blinking graphic symbols 274
- BOOK - TABLET 172
- BOOK CENTRE ERASE 141
- Book-type original -> 2-sided copy 110, 115
- Book-type originals 59
- BOTH BLANK 157
- Bottom margin 134
- Bridge Unit 23, 294, 357
- Bypass copying
 - Bypass copying 71
 - Non-standard size paper 76
 - Standard size paper 72
- Bypass tray 22, 71, 290

C

- Call service symbol 306
- Canceling the colour balance adjustment 124
- Canceling the energy saving mode 42
- Caution 12
- Changing data of user boxes 182
- Changing the data of a template 221
- Changing the data of a user group 218
- Changing the setting of paper size 50
- Cleaning 342
- CLEAR button 27
- Clearing functions selected 32
- Clearing the drawer for special uses 54
- Colour balance 124
- Colour mode 89

- Colour mode button 30
- Colour toner cartridge 22, 276
- Configuration of options 23
- Confirming and canceling auto job 69
- Confirming job history in log list 252
- Confirming print job status 237
- Confirming scan job status 250
- Continuing printing after proof printing 242
- Continuous feed mode 61, 174
- Control panel 22, 26
- COPIED 160
- COPY button 26
- Copy density adjustment 121
- Copying function combination matrix 359
- Copying mixed-size originals in one go 87
- Copying procedure 64
- COVER SHEET 157
- Creating user boxes 180

D

- Daily inspection 342
- Date and time 30
- Deleting a template 232
- Deleting a user group 231
- Deleting folders or documents 196
- Deleting invalid print jobs 249
- Deleting print jobs 238
- Deleting private print jobs 246
- Deleting proof print jobs 243
- Deleting user boxes 185
- Density adjustment buttons 30
- Department codes 247
- Department management 35
- Description of each component 22
- Digital keys 27
- Disclaimer notice 19
- Displaying invalid queues 247
- Displaying private print job list 244
- Displaying proof print job list 241
- Drawer 22, 46, 275, 331
- Drawer feeding area 288
- Drawer for special uses 52
- DUAL PAGE 143
- Duplex copying 110

E

- EDGE ERASE 140
- EDITING 150
- e-Filing 178
- e-FILING button 26
- ENERGY SAVER button 27, 40, 42
- Energy saving mode 42
- Enlargement and reduction copying 90
- Enlargement/Reduction (Zoom...) button 30
- Equipment status indication area 30
- Error code 262, 274

ERROR lamp	27	LDAP authentication	36
EXTENSION button	26	Left margin	134
F		Log list	251
FAX button	26	M	
Features of the e-STUDIO281c/351c/451c	10	Magazine sort	96, 148
File Downloader	178	Magazine sort & Saddle stitch	96, 103
Finisher		Maintenance	342
Finisher	96, 308, 316	Making Copies	63
Name of each part in the Finisher	97	Manual copy density mode	122
Removing jammed staples	316	Manual paper selection	86
Finisher button	30	Margin	134, 136, 138
Folder	196	Masking	150
Front cover	22	Maximum number of sheets for scanning	57
FUNCTION CLEAR button	27	Maximum number of sheets for stapling	102
Function setting area	30	Message	30
Fuser unit	292	Message display	30
G		MFP local authentication	36
General precautions		Mirror image	153
During maintenance or inspection	17	MONITOR/PAUSE button	27
General precautions	11	Moving print jobs	239
When handling supplies	18	Multi Position Staple Finisher	24, 96, 354
When installing or moving	11	N	
When using the Multifunctional digital colour systems	14	Negative/Positive reversal	154
Group copying	96, 98	Notice to users	5
H		Number of copy sets	30
Handling and storing paper	45	O	
Hanging Finisher	24, 96, 302, 310, 318, 355	One-touch adjustment	126
HELP button	26	One-touch zoom buttons	94
Hole punch	96, 106	Operator's Manual pocket	22
Hole Punch Unit	24, 357	Original Cover	23
I		Original glass	22
IMAGE DIRECTION	170	Original mode	119
Image quality adjustment combination matrix	361	Original mode button	30
IMAGE SHIFT	134	Original scale	22
Index buttons	30	Original stopper	56
Initial (default) settings	63	P	
INTERRUPT button	26	Packing list	358
Interrupt copying in progress and make other copies (Interrupt copying)	70	PAGE NUMBER	164
J		Paper Feed Pedestal	23, 351
Jam releasing cover	292	Paper selection	84
Jam symbols	285	Paper size indicator	22, 48
JOB BUILD	166	Paper source selection buttons	30
Job status	236	Paper type	52
JOB STATUS button	27	Pausing print jobs	239
K		Placing originals on the glass	58
K format	56	Placing paper in the drawer	46
Keying in correct department code to print	248	Power switch	22
L		Preface	9
Large Capacity Feeder	23, 289, 351	PRINT DATA / MEMORY RX / FAX communication lamps	26
		Print jobs	238
		Print log	252
		Print status display	259

Printing journals	258
Printing private print jobs	245
Printing stored documents	191
Private print jobs	244
Proof Copy	80
PROOF COPY button	30
Proof print jobs	241
Public box	178
Public group	226
Public template group	206

R

Recalling templates	226
Receive log	254
Receiving tray	22
Recommended paper	45
Registering a template in the public template group	206
Registering a template in the user group	213
Registering into address book from log lists ...	256
Registering non-standard size in the memory ..	78
Registering the new user group	210
Releasing print job errors	259
Remaining paper level	30
Replace toner bag symbol	283
Replace toner cartridge symbol	276
Reproduction ratio	30
Reversing Automatic Document Feeder	23, 60, 285, 351
RGB adjustment	125
Right margin	134
Rotate sort	96, 100

S

Saddle stitch	
Available conditions	105
Saddle stitch	96, 303, 314
Saddle Stitch Finisher	24, 96, 353
SADF	174
SCAN button	26
Scan log	255
Scanning area	22
Scanning the next originals during copying (Auto job start)	68
Send log	253
Setting copy paper	43
Setting letters	33
Setting originals	56
SETTINGS button	30
Sharpness	128
SHEET INSERTION	160
Sheet originals	58
Simplex / duplex button	30
Single feed mode	62, 175
Sort copying	96, 98

Specifications

e-STUDIO281c/351c/451c	348
Options	351
Specifying both original size and copy size separately	92
Staple sort	96, 101
Stapler	308, 314, 316, 322, 323
START button	27
STOP button	27
Stopping the copying operation	67
Storage of colour copies	20
Storing documents in e-Filing	187
Sub-tray	97
Switching colour mode	89

T

Template	204
TEMPLATE button	26
Test printing	193
TIME STAMP	163
Toner bag	22, 283
TOP BLANK	157
TOP COPIED	157
TOP COPIED BACK BLANK	157
Top margin	134
TopAccess	178
Touch panel	22, 27, 30
Touch panel contrast adjustment volume	22
Touch-buttons	30
Tray	97
Trimming	150
Troubleshooting	
Copy images are partially missing	346
Display does not change when buttons or icons are pressed	344
Equipment does not start	343
Functions cannot be set	344
Image density is too high	345
Image density is too low	344
Images are blurred	345
Images are stained	345
Paper jamming occurs frequently	343
Turning power off (Shutdown)	39
Turning power on	34
TWAIN driver	178
Twin colour copy	129
Type of finishing mode	96

U

Upper cover	97
Useful template	204
User box	178, 180
USER FUNCTIONS button	26
User group	213, 228
User management	36, 236

W

Warning 11
Windows Domain Authentication 36

X

XY ZOOM 155

Z

Zoom buttons 94

MULTIFUNCTIONAL DIGITAL COLOUR SYSTEMS
Operator's Manual for Basic Function

e-STUDIO281c/351c/451c

TOSHIBA TEC CORPORATION

2-17-2, HIGASHIGOTANDA, SHINAGAWA-KU, TOKYO, 141-8664, JAPAN



R05022083503-TTEC 
Ver03 2006-06

Free Manuals Download Website

<http://myh66.com>

<http://usermanuals.us>

<http://www.somanuals.com>

<http://www.4manuals.cc>

<http://www.manual-lib.com>

<http://www.404manual.com>

<http://www.luxmanual.com>

<http://aubethermostatmanual.com>

Golf course search by state

<http://golfingnear.com>

Email search by domain

<http://emailbydomain.com>

Auto manuals search

<http://auto.somanuals.com>

TV manuals search

<http://tv.somanuals.com>