

# GENERAL PRECAUTIONS REGARDING THE INSTALLATION AND SERVICE FOR THE COPIER FC-22

The installation and service should be done by a qualified service technician.

## 1. Transportation/Installation

- When transporting/installing the copier, move it by the casters while lifting the stoppers.  
The copier is quite heavy and weighs approximately 200 kg (441 lb), therefore pay full attention when handling it.
- Be sure to use a dedicated outlet with AC 115V or 120V/20A (220V, 230V, 240V/10A) or more for its power source.
- The copier must be grounded for safety.  
Never ground it to a gas pipe or a water pipe.
- Select a suitable place for installation.  
Avoid excessive heat, high humidity, dust, vibration and direct sunlight.
- Also provide proper ventilation as the copier emits a slight amount of ozone.
- To insure adequate working space for the copying operation, keep a minimum clearance of 80 cm (32") on the left, 80 cm (32") on the right and 10 cm (4") in the rear.

## 2. Service of Machines

- Basically, be sure to turn the main switch off and unplug the power cord during service.
- Be sure not to touch high-temperature sections such as the exposure lamp, the fuser unit, the damp heater and their periphery.
- Be sure not to touch high-voltage sections such as the chargers, the transfer belt and the high-voltage transformer.
- Be sure not to touch rotating/operating sections such as gears, belts, pulleys, fan, etc.
- When servicing the machines with the main switch turned on, be sure not to touch live sections and rotating/operating sections. Avoid exposure to laser radiation.
- Use suitable measuring instruments and tools.
- Avoid exposure to laser radiation during servicing.
  - Avoid direct exposure to the beam.
  - Do not insert tools, parts, etc. that are reflective into the path of the laser beam.
  - Remove all watches, rings, bracelets, etc. that are reflective.

## 3. Main Service Parts for Safety

- The breaker, door switch, fuse, thermostat, thermofuse, thermistor, etc. are particularly important for safety. Be sure to handle/install them properly.

## 4. Cautionary Labels

- During servicing, be sure to check the rating plate and the cautionary labels such as "Unplug the power cord during service", "Hot area", "Laser warning label" etc. to see if there is any dirt on their surface and whether they are properly stuck to the copier.

**5. Disposition of Consumable Parts/Packing Materials**

- Regarding the recovery and disposal of the copier, supplies, consumable parts and packing materials, it is recommended to follow the relevant local regulations or rules.

**6. When parts are disassembled, reassembly is basically the reverse of disassembly unless otherwise noted in this manual or other related documents. Be careful not to reassemble small parts such as screws, washers, pins, E-rings, star washers in the wrong places.**

**7. Basically, the machine should not be operated with any parts removed or disassembled.**

**8. Precautions Against Static Electricity**

- The PC board must be stored in an anti-electrostatic bag and handled carefully using a wristband, because the ICs on it may become damaged due to static electricity.

**Caution: Before using the wristband, pull out the power cord plug of the copier and make sure that there are no uninsulated charged objects in the vicinity.**

**Caution** : Dispose of used RAM-ICs (including lithium battery) according to the manufacturer's instructions.

**Vorsicht** : Entsorgung des gebrauchten RAM-ICs (inklusive der Lithium-Batterie) nach Angaben des Herstellers.

**1. ADJUSTMENT ITEMS**

**2. PREVENTIVE MAINTENANCE  
(PM)**

**3. PRECAUTIONS FOR STORING  
& HANDLING SUPPLIES**

**4. TROUBLESHOOTING**

**5. FIRMWARE UPDATING**

**6. WIRE HARNESS CONNECTION  
DIAGRAMS**

## CONTENTS

<b>1. ADJUSTMENT ITEMS</b> .....	<b>1-1</b>
1.1 Error Code List .....	1-1
1.2 Self Diagnostic Mode .....	1-6
1.2.1 Input check (Test mode 03) .....	1-8
1.2.2 Output check (Test mode 03) .....	1-15
1.2.3 Test print mode (04) .....	1-19
1.2.4 Adjustment mode (05) .....	1-20
1.2.5 Setting mode (08) .....	1-33
1.2.6 Registering/changing ID codes .....	1-43
1.3 Adjustment Order (Copy Image Related Adjustment) .....	1-45
1.4 Automatic Adjustment of the Auto-Toner Circuit .....	1-46
1.5 Automatic Initialization of Image Quality Control .....	1-50
1.6 Copy Image Dimensional Adjustment .....	1-51
1.6.1 Paper alignment (paper buckle) at the main registration roller .....	1-53
1.6.2 Feed motor speed adjustment .....	1-54
1.6.3 Printer related adjustment .....	1-55
1.6.4 Scanner related adjustment .....	1-58
1.7 Automatic Adjustment of Gamma Correction .....	1-66
1.8 Density Adjustment .....	1-68
1.9 Color Balance Adjustment .....	1-69
1.10 Offset Amount for Processing Background .....	1-70
1.11 Judgment Threshold for ACS .....	1-71
1.12 AI Mode Setting .....	1-72
1.13 Sharpness Adjustment .....	1-73
1.14 High-Voltage Transformer Setting .....	1-74
1.14.1 Overview .....	1-74
1.14.2 Settings after replacing main high-voltage transformers .....	1-74
1.14.3 Settings after replacing transfer transformer .....	1-75
1.15 Adjusting Doctor-to-Sleeve Gap .....	1-76
1.16 Adjusting the Scanner Section .....	1-77
1.16.1 Adjusting the carriage .....	1-77
1.16.2 Lens unit .....	1-80
1.17 Adjusting the Cassette for Sidewise Deviation .....	1-83
1.18 Key Copy Counter (MU-8, MU-10) .....	1-84
<b>2. PREVENTIVE MAINTENANCE (PM)</b> .....	<b>2-1</b>
2.1 Types of Preventive Maintenance .....	2-1
2.2 Maintenance to be Performed Every 30,000, 60,000, 90,000 and 120,000 Copies .....	2-2
2.3 Preventive Maintenance Checklist .....	2-2
2.4 PM Kit .....	2-12

2.5	List of Adjustment Tools .....	2-13
<b>3.</b>	<b>PRECAUTIONS FOR STORING &amp; HANDLING SUPPLIES .....</b>	<b>3-1</b>
3.1	Precautions for Storing TOSHIBA Supplies .....	3-1
3.2	Checking and Cleaning of the Photoconductive Drum .....	3-1
3.3	Checking and Cleaning of the Drum Cleaning Blade and Transfer Belt Cleaning Blade .....	3-2
3.4	Checking and Replacing the Oil Roller and Cleaning Roller of Fuser Section .....	3-3
3.5	Checking and Cleaning of the Fuser Rollers .....	3-3
3.6	Checking and Replacing the Transfer Belt .....	3-4
3.7	Checking and Replacing the Transfer Roller .....	3-4
<b>4.</b>	<b>TROUBLESHOOTING .....</b>	<b>4-1</b>
4.1	Troubleshooting Based on Error Code .....	4-1
4.1.1	Paper transport jam inside the copier .....	4-1
4.1.2	Paper feeding jam .....	4-3
4.1.3	Paper transport jam (Paper not reaching the registration sensor after feeding) .....	4-5
4.1.4	Cover open jam .....	4-6
4.1.5	Paper jam in ADU and reversing area .....	4-8
4.1.6	Original jam in the RADF .....	4-10
4.1.7	Paper jam in the sorter .....	4-12
4.1.8	Special sheet jam .....	4-15
4.1.9	Drive system related service call .....	4-16
4.1.10	Paper feeding system related service call .....	4-20
4.1.11	Scanner related service call .....	4-23
4.1.12	Copy process related service call .....	4-25
4.1.13	Fuser unit related service call .....	4-30
4.1.14	Communications related service call .....	4-33
4.1.15	ADF related service call .....	4-36
4.1.16	Other service calls .....	4-37
4.1.17	Laser optical unit related service call .....	4-38
4.1.18	Sorter related service call .....	4-40
4.1.19	Image quality related service call .....	4-45
4.1.20	Options related service call .....	4-52
4.1.21	Image processing options related service call .....	4-53
4.2	Troubleshooting of Image .....	4-54
<b>5.</b>	<b>FIRMWARE UPDATING .....</b>	<b>5-1</b>
5.1	[3] [9] Mode Operation .....	5-1
5.1.1	Outline .....	5-1
5.1.2	Preparation of PC .....	5-1
5.1.3	Firmware update operation .....	5-4

5.1.4	Screen details .....	5-10
5.2	Installation Instructions for Firmware Update through PC .....	5-14
5.2.1	Outline .....	5-14
5.2.2	System configuration .....	5-14
5.2.3	Preparation of PC to use a network .....	5-15
5.2.4	Installation of FTP server .....	5-25
<b>6.</b>	<b>WIRE HARNESS CONNECTION DIAGRAMS .....</b>	<b>6-1</b>
6.1	AC Wire Harness .....	6-1
6.2	DC Wire Harness .....	Appendix

In this manual, colors are sometimes described using abbreviations as listed below:

Yellow : Y      Magenta : M      Cyan : C      Black : K

## 1. ADJUSTMENT ITEMS

### 1.1 Error Code List

While the “CLEAR PAPER” or “CALL SERVICE” symbol is flashing, pressing the [CLEAR] key and the [8] key on the digital keys at the same time shows one of the following error codes on the copy-quantity indicator as long as those keys are pressed.

Classification	Error code	Content
Paper transport jam inside the copier	E01	Paper leading edge not reaching the exit sensor
	E02	Paper trailing edge not passing the exit sensor
	E03	Paper remaining inside the copier at power ON
	<i>EB7</i>	<i>Restart time out error</i>
Paper feeding jam	E11	Paper misfeed from the ADU
	E12	Paper misfeed from the bypass
	E13	Paper misfeed from the 1st cassette
	E14	Paper misfeed from the 2nd cassette
	E15	Paper misfeed from the 3rd cassette
	E16	Paper misfeed from the 4th cassette
	E19	Paper misfeed from the LCF
Paper transport jam (Paper not reaching the registration sensor after feeding)	E21	Paper transport jam from the LCF
	E22	Paper transport jam from the 1st cassette
	E23	Paper transport jam from the 2nd cassette
	E24	Paper transport jam from the 3rd cassette
	E25	Paper transport jam from the 4th cassette
Cover open jam	E41	Front cover opened during copying
	E42	Side door opened during copying
	E43	ADU unit pulled out during copying
	E45	LCF jam access cover opened during copying
	E46	Bypass unit opened during copying
Paper jam in ADU and reversing area	E50	Paper not reaching the ADU
	E51	Paper not restarting from the ADU stack
	E52	Paper not reaching the ADU path sensor
	E54	ADU paper transport jam



Classification	Error code	Content
<i>Original jam in the ADF</i>	<i>E71</i>	<i>Original not reaching the aligning sensor</i>
	<i>E72</i>	<i>Original not reaching the exit sensor</i>
	<i>E73</i>	<i>Original not passing the exit sensor</i>
	<i>E75</i>	<i>Second original not reaching the aligning sensor in 2-in-1 mode</i>
	<i>E79</i>	<i>Original pre-feeding jam</i>
Paper jam in the sorter	EA1	Paper transport delay jam
	EA2	Paper transport stop jam
	EA3	Paper remaining on the sorter transport path at power on
	EA4	Sorter front door opened during copying
	EA5	Staple jam
Paper jam in the sorter	EA6	Finisher/sorter early-arrival jam (P30) (internal)
	EA8	Finisher saddle staple jam
	EA9	Finisher saddle door open
	EAA	Finisher saddle power ON jam
	EAB	Finisher saddle delivery delay
	EAC	Finisher saddle delivery failure
Special sheet jam	EC2	OHP sheets used except from bypass and 2nd cassette
	EC3	OHP sheet used in non-OHP mode
Drive system related service call Paper feeding system related service call	C05	ADU motor rotation abnormal
	C09	Black developer motor rotation abnormal
	C0A	Color developer motor rotation abnormal
	C0B	Drum motor K rotation abnormal
	C0C	Drum motor C rotation abnormal
	C0D	Drum motor M rotation abnormal
	C0E	Drum motor Y rotation abnormal
	C11	ADU paper side guide function abnormal
	C12	ADU paper end guide function abnormal
	C13	1st cassette tray function abnormal
	C14	2nd cassette tray function abnormal
	C15	3rd cassette tray function abnormal
	C16	4th cassette tray function abnormal
	C18	LCF tray function abnormal
<i>Scanner related service call</i>	<i>C27</i>	<i>Carriage home position sensor not turning OFF within a fixed time</i>
	<i>C28</i>	<i>Carriage home position sensor not turning ON within a fixed time</i>
	<i>C29</i>	<i>Exposure lamp disconnection detected</i>





Classification	Error code	Content
Copy process related service call	C31	Used toner transport motor rotation abnormal
	C33	Developer removal shutter function abnormal
	C35	Transfer belt unit contact/release function abnormal
	C37	Transfer belt moter rotation abnormal
	C38	Auto toner initializing error (K)
	C39	Auto toner initializing error (C)
	C3A	Auto toner initializing error (M)
	C3B	Auto toner initializing error (Y)
	C3C	Main charger wire abnormal (K)
	C3D	Main charger wire abnormal (C)
	C3E	Main charger wire abnormal (M)
	C3F	Main charger wire abnormal (Y)

Classification	Error code	Content
Fuser unit related service call	C41	Thermistor or heater abnormal when warming-up is started
	C42	Thermistor abnormal after the copier becomes ready
	C43	Thermistor abnormal during warming-up after abnormality judgment
	C44	Heater abnormal during warming-up after abnormality judgment
	C46	Heater abnormal (low temperature) after the copier has become ready
	C47	Rear thermistor abnormal after the copier has become ready
	C48	Heater abnormal (high temperature)
	C7	Error C7
Communications related service call	C57	Communications error between Main-CPU and Sorter-CPU
	C5A	Communications error between Main-CPU and printer controller
	C5B	Main-CPU signal transmission error to IMC-CPU
	C5C	Main-CPU signal reception error from IMC-CPU
<i>ADF related service call</i>	<i>C72</i>	<i>Error of aligning sensor automatic adjustment</i>
	<i>C73</i>	<i>EEPROM initializing error</i>
	<i>C74</i>	<i>Error of paper exit sensor automatic adjustment</i>
<i>Other service calls</i>	<i>C94</i>	<i>Main-CPU abnormal</i>
	<i>C9A</i>	<i>Main memory abnormal</i>
	<i>C9E</i>	<i>IMC board connection abnormal</i>
Laser optical unit related service call	CA1	Polygonal motor rotation abnormal
	CA2	H-SYNC abnormal
	CD1	Laser calibration error (K)
	CD2	Laser calibration error (C)
	CD3	Laser calibration error (M)
	CD4	Laser calibration error (Y)



Classification	Error code	Content
Sorter related service call	CB1	Delivery motor abnormal
	CB2	Paper exit motor abnormal
	CB3	Tray-up motor abnormal
	CB4	Alignment motor abnormal
	CB5	Staple motor abnormal
	CB6	Staple unit shift motor abnormal
	CB7	Stack detection sensor abnormal
	CB8	Backup RAM data abnormal
	CB9	Saddle push motor abnormal
	CBA	Saddle outer staple motor abnormal
	CBB	Saddle inner staple motor abnormal
	CBC	Saddle alignment motor abnormal
	CBD	Saddle guide motor abnormal
	CBE	Saddle folding motor abnormal
	CBF	Saddle positioning plate motor abnormal
	CC0	Sensor connector connection abnormal
	CC2	Micro-switch abnormal
Sorter related service call	<i>CC1</i>	<i>Transport motor rotation abnormal</i>
	<i>CC3</i>	<i>Bin shift motor rotation abnormal</i>
	<i>CC4</i>	<i>Guide bar swing motor rotation abnormal</i>
	<i>CC5</i>	<i>Staple-unit swing motor rotation abnormal</i>
	<i>CCA</i>	<i>Automatic adjustment error of bin inside paper sensor</i>
	CCC	No power being supplied
Image quality related service call	CE1	Image quality sensor abnormal (OFF level)
	CE2	Image quality sensor abnormal (no pattern level)
	CE3	Abnormal image caused by poor charger
	CE4	Image quality control test pattern abnormal
	CE5	Temperature/humidity sensor upper-limit abnormal
	CF1	Color registration control abnormal





Classification	Error code	Content
Options related service call	F07	Communications error between System-CPU and Main-CPU
	F11	Communications error between System-CPU and Scanner-CPU
<i>Image processing options related service call</i>	F51	Communications error between System-CPU and AI-board during pre-scanning

<<Error history>>

Under code 253 in the setting mode (08), the latest eight groups of error data will be displayed.

Display example

EA1	<u>99 08 26 17 57 32</u>	<u>64</u>	<u>64</u>	<u>236210000000</u>
Error code	YY MM DD HH MM SS	MMM	NNN	ABCDEFGHIJLOP
3 digits	12 digits	3 digits	3 digits	12 digits



A	Paper source 0:Not fixed 1:Bypass feed 2:LCF 3:1st 4:2nd 5:3rd 6:4th 7:ADU feed
B	Paper size code 0:A5/ST 1:A5-R 2:ST-R 3:LT 4:A4 5:B5-R 6:LT-R 7:A4-R 8:OTHER/UNIV 9:B5 A:FOL/COM B:LG C:B4 D:LD E:A3 Z:Not selected
C	Sort mode 0:Not selected 1:Group 2:Sort 6:Staple sort
D	DF mode 0:Unused 1:AUTO FEED (SADF) 2:STACK FEED
E	APS/AMS mode 0:Not selected 1:APS 2:AMS
F	Duplex mode 0:Not selected 1:BOOK 2:Two-sided/Single-sided 4:Two-sided/Duplexed 8:Single-sided/Duplexed
G	Unused
H	Binding space 0:Unused 1:BOOK 2:LEFT 4:RIGHT
I	Editing 0:Unused 1:Masking 2:Trimming 3:Mirror image 4:Negative/Positive
J	Edge erase/Dual-page 0:Unused 1:Edge erase 2:Dual-page 3:Edge erase & Dual-page
K	Unused
L	Function 0:Copying 1:Unused (Extended copying) 2:Unused (Fax input) 3:Unused (Fax printing) 4:Printing 5:Unused (DSS)
MMM	Primary-scanning reproduction ratio (Display in hexadecimal) (Mx256)+(Mx16)+M
NNN	Secondary-scanning reproduction ration (Display in hexadecimal) (Nx256)+(Nx16)+N
O	Color mode 0:Auto color 1:Full color 2:Black 3:Monocolor
P	AI board 0:Unused 1:Used



## 1.2 Self Diagnostic Mode

Mode	Input method	Meaning	Clearing
Whole control panel lighting mode	[0]+[1]+[POWER]	All control-panel LEDs are lit, and all LCD pixels are turned on/off repeatedly.	[C] or [POWER] OFF/ON
Test mode	[0]+[3]+[POWER]	Input/output signals are checked	[POWER] OFF/ON
Test print mode	[0]+[4]+[POWER]	A test pattern print is made.	[POWER] OFF/ON
Adjustment mode	[0]+[5]+[POWER]	Adjustment of various items	[POWER] OFF/ON
Setting mode	[0]+[8]+[POWER]	Setting of various items	[POWER] OFF/ON

**Note:** Input method for various modes:

While pressing simultaneously the two digital keys corresponding to the mode you want to set (for example, [0] and [5]), turn on the main switch [POWER].

<Operation procedure>

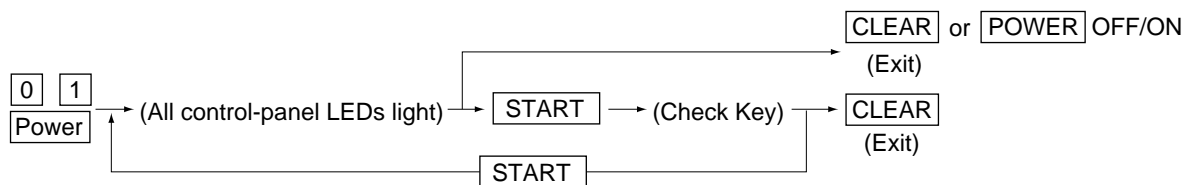

- Whole control-panel lighting mode (01) :

Notes: 1. During the “Check keys” mode, [CLEAR] alone can do.

During the “Whole control-panel lighting mode”, [CLEAR] can clear the mode.

2. Check keys : Any key with LED (when it is pressed, the LED goes out.)

Any key without LED (When it is pressed, an indication is made in the message area.)

- Test mode (03) : Refer to Sec. 1.2.1 and 1.2.2 for test modes.
- Test print mode (04) : Refer to Sec. 1.2.3 for test print modes.
- Adjustment mode (05) : Refer to Sec. 1.2.4 for adjustment modes.
- Setting mode (08) : Refer to Sec. 1.2.5 for setting modes.

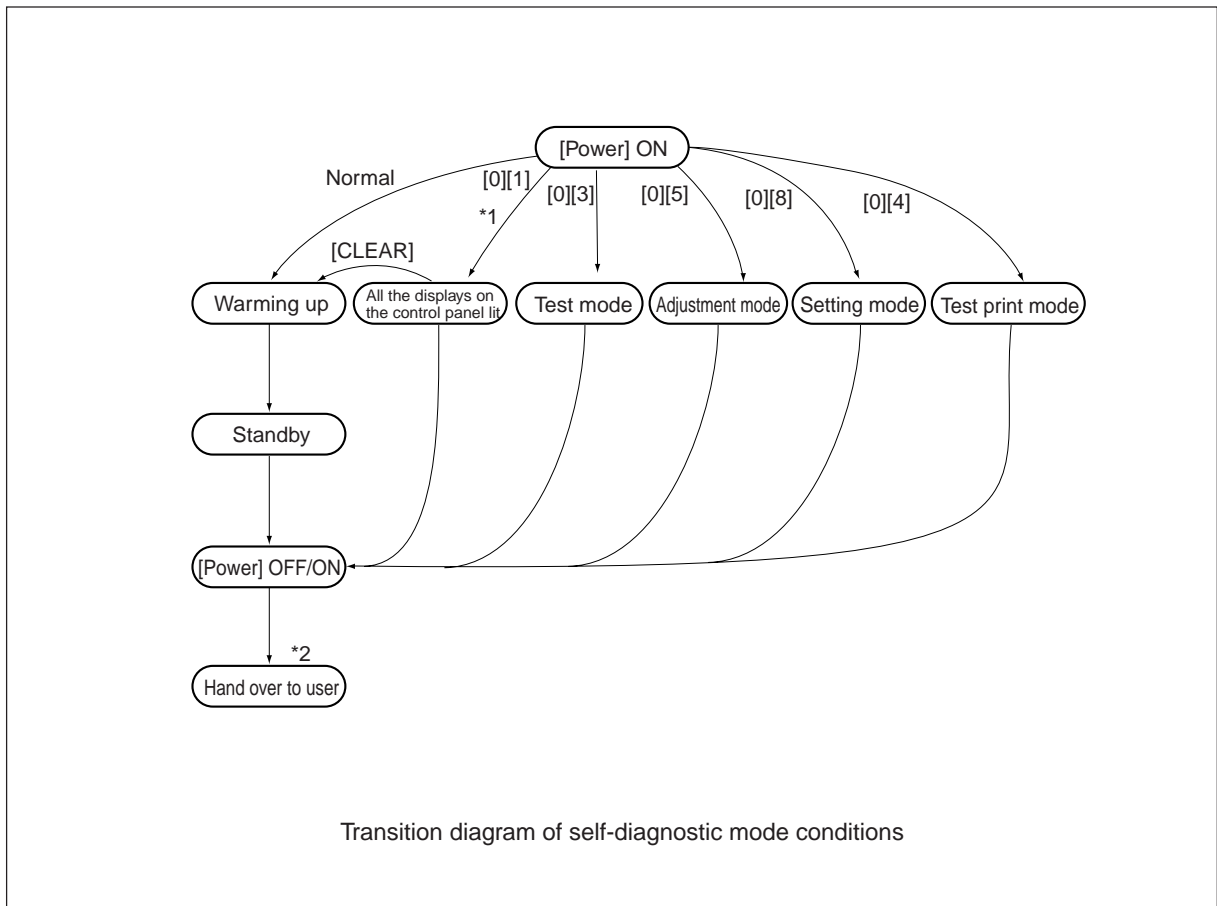

\*1 : During the “Whole control-panel lighting mode”, copying is not possible. But after pressing [CLEAR] to make the copier ready, you can make copies.

\*2 : After having used the self-diagnostic mode, be sure to turn OFF and then ON the power before returning the copier to the customer.

## 1. 2. 1 Input check (Test mode 03)

The status of each item can be checked by setting ON/OFF of each [FULL COLOR], [AUTO COLOR], [ENERGY SAVER], and then pressing each of the corresponding digital key in this test mode 03.

**Note:** When icon is displayed with black letter on white background, it indicates the value is 0, while in reverse black and white, it indicates the value is 1.

[FULL COLOR]key: OFF, [AUTO COLOR]key: OFF, [ENERGY SAVER]key: OFF

Digital key	Icon	Item	Condition
1	A	Paper size switch 0 (1st cassette : Lower)	0: Switch is ON
	B	Paper size switch 1 (1st cassette : Middle lower)	0: Switch is ON
	C	Paper size switch 2 (1st cassette : Middle upper)	0: Switch is ON
	D	Paper size switch 3 (1st cassette : Upper)	0: Switch is ON
	E	Cassette paper empty sensor (1st cassette)	1: No paper
	F	Cassette tray-up limit sensor (1st cassette)	1: Tray is upper limit
	G	Cassette-feed jam sensor (1st cassette)	1: Paper exist
	H	—	
2	A	Paper size switch 0 (2nd cassette : Lower)	0: Switch is ON
	B	Paper size switch 1 (2nd cassette : Middle lower)	0: Switch is ON
	C	Paper size switch 2 (2nd cassette : Middle upper)	0: Switch is ON
	D	Paper size switch 3 (2nd cassette : Upper)	0: Switch is ON
	E	Cassette paper empty sensor (2nd cassette)	1: No paper
	F	Cassette tray-up limit sensor (2nd cassette)	1: Tray is upper limit
	G	Cassette-feed jam sensor (2nd cassette)	1: Paper exist
	H	—	
3	A	Paper size switch 0 (3rd cassette : Lower)	0: Switch is ON
	B	Paper size switch 1 (3rd cassette : Middle lower)	0: Switch is ON
	C	Paper size switch 2 (3rd cassette : Middle upper)	0: Switch is ON
	D	Paper size switch 3 (3rd cassette : Upper)	0: Switch is ON
	E	Cassette paper empty sensor (3rd cassette)	1: No paper
	F	Cassette tray-up limit sensor (3rd cassette)	1: Tray is upper limit
	G	Cassette-feed jam sensor (3rd cassette)	1: Paper exist
	H	—	
4	A	Paper size switch 0 (4th cassette : Lower)	0: Switch is ON
	B	Paper size switch 1 (4th cassette : Middle lower)	0: Switch is ON
	C	Paper size switch 2 (4th cassette : Middle upper)	0: Switch is ON
	D	Paper size switch 3 (4th cassette : Upper)	0: Switch is ON
	E	Cassette paper empty sensor (4th cassette)	1: No paper
	F	Cassette tray-up limit sensor (4th cassette)	1: Tray is upper limit
	G	Cassette-feed jam sensor (4th cassette)	1: Paper exists
	H	—	



Digital key	Icon	Item	Condition
5	A	Bypass paper-width sensor 0	Refer to Table 1.
	B	Bypass paper-width sensor 1	Refer to Table 1.
	C	Bypass paper-width sensor 2	Refer to Table 1.
	D	Bypass paper-width size sensor 3	Refer to Table 1.
	E	Bypass paper sensor	1: No paper
	F	Bypass unit open/close switch	1: Unit is open
	G	Side door open/close switch	1: Side door is open
	H	Bypass unit is installed or not	0: Unit is installed
6	A	LCF paper empty sensor	1: No paper
	B	LCF lower-limit sensor	1: Tray limit (lower)
	C	LCF tray-up sensor	1: Tray limit (upper)
	D	LCF tray-down switch	0: Switch is ON
	E	LCF paper supply door switch	1: Door is open
	F	LCF is installed or not	0: LCF is installed
	G	ADU motor rotation status (Motor is rotating by 03 Output mode)	0: Normal rotation
	H	ADU unit is installed or not	0: ADU unit is installed
7	A	ADU paper jam switch	1: Paper exist
	B	ADU paper empty switch	0: No paper
	C	ADU end switch	1: End guide is positioned at home position
	D	ADU side switch	1: Side guide is positioned at home position
	E	—	
	F	Total counter is installed or not	0: Total counter is installed
	G	Key copy counter is installed or not	0: Key copy counter is installed
	H	—	
8	A	Developer removal shutter home position sensor	0: Shatter is closed
	B	—	
	C	Transfer belt unit is installed or not	0: Unit is installed
	D	—	
	E	Color developer motor rotation status (Motor is rotating by 03 Output mode)	0: Normal rotation
	F	Black developer motor rotation status (Motor is rotating by 03 Output mode)	0: Normal rotation
	G	Transfer belt limit switch	0: Transfer belt is black mode position
	H	Transfer belt home position switch	0: Transfer belt is color mode position

Digital key	Icon	Item	Condition
9	A	External printer controller power ON/OFF	0: Controller power ON
	B	—	
	C	—	
	D	Front-cover switch	1: Front cover is open
	E	OHP center sensor	0: Opaque paper is installed
	F	—	
	G	Registration sensor	1: Paper exist
	H	IPC-IF board (Sorter installation kit) is installed or not	0: Board installed
0	A	ADU path sensor	1: Paper exist
	B	—	
	C	Exit sensor	1: Paper exist
	D	Paper-exit unit open/close switch	1: Paper-exit unit is open
	E	Toner bag limit sensor	1: Used toner full
	F	—	
	G	—	
	H	—	

Table 1. Relation between bypass paper-width sensor status and paper width size.

Bypass paper-width sensor				Paper-width size
3	2	1	0	
0	1	1	1	A3/LD
1	0	1	1	A4-R/LT-R
1	1	0	1	A5-R/ST-R
1	1	1	0	Card size
0	0	1	1	B4-R/LG
1	0	0	1	B5-R

[FULL COLOR]key: OFF, [AUTO COLOR]key: OFF, [ENERGY SAVER]key: ON

Digital key	Icon	Item	Condition
1	A	—	
	B	—	
	C	—	
	D	—	
	E	—	
	F	—	
	G	—	
	H	—	
2	A	Developer cartridge Y is installed or not	0: Cartiridge is installed
	B	Developer cartridge M is installed or not	0: Cartiridge is installed
	C	Developer cartridge C is installed or not	0: Cartiridge is installed
	D	Developer cartridge K is installed or not	0: Cartiridge is installed
	E	Processing unit is installed or not	0: Unit is installed
	F	Fuser unit is installed or not	0: Unit is installed
	G	—	
	H	—	
3	A	Wire cleaner home position switch Y	0: Cleaning pad is positioned at home position.
	B	Wire cleaner home position switch M	0: Cleaning pad is positioned at home position.
	C	Wire cleaner home position switch C	0: Cleaning pad is positioned at home position.
	D	Wire cleaner home position switch K	0: Cleaning pad is positioned at home position.
	E	Wire cleaner limit switch Y	0: Cleaning pad is positioned at limit position.
	F	Wire cleaner limit switch M	0: Cleaning pad is positioned at limit position.
	G	Wire cleaner limit switch C	0: Cleaning pad is positioned at limit position.
	H	Wire cleaner limit switch K	0: Cleaning pad is positioned at limit position.
4	A	—	
	B	—	
	C	—	
	D	—	
	E	—	
	F	—	
	G	—	
	H	—	

Digital key	Icon	Item	Condition
5	A	—	
	B	—	
	C	—	
	D	—	
	E	—	
	F	—	
	G	—	
	H	—	
6	A	—	
	B	—	
	C	—	
	D	—	
	E	—	
	F	—	
	G	Front cover, paper-exit unit open/close check	1: Cover/unit open
	H	Polygonal motor rotation status (Motor is rotating by 03 Output mode)	0: Normal rotation
7	—	—	
8	—	Upper fuser roller thermistor (center) check	Thermistor output value is displayed with 8 bit.
9	—	Upper fuser roller thermistor (rear) check	Thermistor output value is displayed with 8 bit.
0	—	Lower fuser roller thermistor (center) check	Thermistor output value is displayed with 8 bit.

[FULL COLOR]key: OFF, [AUTO COLOR]key: ON, [ENERGY SAVER]key: OFF

Digital key	Icon	Item	Condition
1	—	Lower fuser roller thermistor (rear) check	Thermistor output value is displayed with 8 bit.
2	—	Temperature sensor check	Sensor output value is displayed with 8 bit.
3	—	Humidity sensor check	Sensor output value is displayed with 8 bit.
4	—	Drum thermistor Y check	Thermistor output value is displayed with 8 bit.
5	—	Drum thermistor M check	Thermistor output value is displayed with 8 bit.
6	—	Drum thermistor C check	Thermistor output value is displayed with 8 bit.
7	—	Drum thermistor K check	Thermistor output value is displayed with 8 bit.
8	—	—	
9	—	—	
0	—	—	

[FULL COLOR]key: OFF, [AUTO COLOR]key: ON, [ENERGY SAVER]key: ON

Digital key	Icon	Item	Condition	
1	—	—		
2	—	Color registration sensor (front)	Sensor output value is displayed with 8 bit.	
3	—	Color registration sensor (rear)	Sensor output value is displayed with 8 bit.	
4	—	Image quality sensor	Sensor output value is displayed with 10 bit.	
5	—	—		
★ FC15/22 ONLY	6	A	ADF aligning sensor	1: Original exist
		B	ADF exit sensor	1: Original exist
		C	ADF open/close sensor	1: ADF is open
		D	ADF empty sensor	1: Original exist
		E	ADF size sensor 1	
		F	—	
		G	ADF size sensor 2	
		H	ADF unit is installed or not	1: ADF unit is installed
★ FC15/22 ONLY	7	A	—	
		B	Direct control-panel connection detection	
		C	Connection	
		D	Installation	
		E	—	
		F	Carriage home position sensor	1: Carriage is home position
		G	Direct control-panel SW-F key (during debugging)	
		H	Platen sensor	1: Platen cover is closed
★ FC15/22 ONLY	8	A	—	
		B	—	
		C	—	
		D	APS sensor (APS-R)	1: Original exist
		E	APS sensor (APS-C)	1: Original exist
		F	APS sensor (APS-3)	1: Original exist
		G	APS sensor (APS-2) (for A4 series)	1: Original exist
		H	APS sensor (APS-1)	1: Original exist
★ FC15/22 ONLY	9	—	Scanner SCM board input 24V check	Output value is displayed with 8 bit.
★ FC15/22 ONLY	0	—	Thermistor check	—

[FULL COLOR]key: ON, [AUTO COLOR]key: OFF, [ENERGY SAVER]key: OFF

Digital key	Icon	Item	Condition
1	—	Auto-toner sensor Y	Sensor output value is displayed with 8 bit.
2	—	Auto-toner sensor M	Sensor output value is displayed with 8 bit.
3	—	Auto-toner sensor C	Sensor output value is displayed with 8 bit.
4	—	Auto-toner sensor K	Sensor output value is displayed with 8 bit.
5	—	—	
6	—	—	
7	—	—	
8	—	—	
9	—	—	
0	—	—	

<Operation procedure>

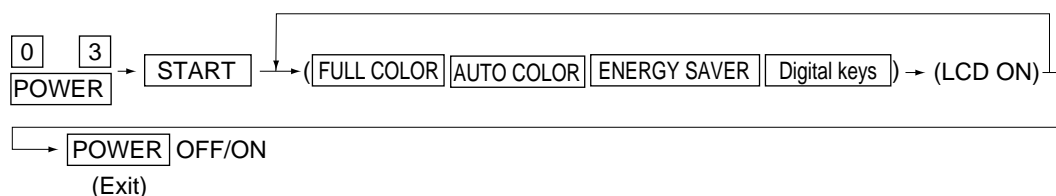

**Note:** After initialization, the copier goes into the test mode.

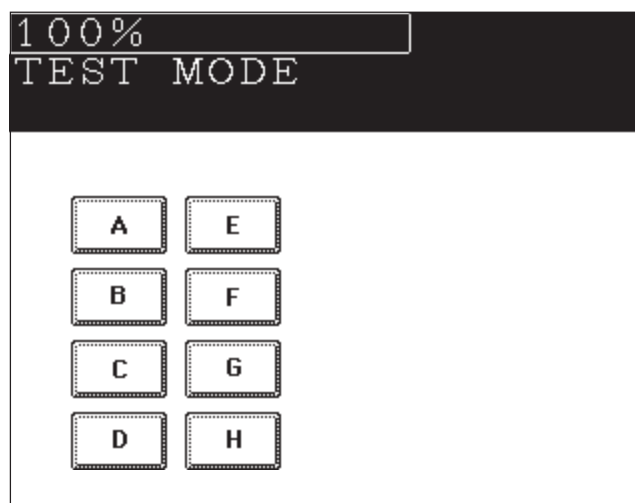

**Note:** When icon is displayed with white letter on black background on the control panel, it indicates the value is 1.

## 1. 2. 2 Output check (Test mode 03)

Output signal status can be checked by inputting the following code according to this test mode 03.

Code	Function	Code	Function	Procedure
		150	All output OFF	1
101	Drum motor and transfer belt motor rotation with normal running speed ON	151	Code No. 101 function OFF	1
102	Drum motor and transfer belt motor rotation with OHP copying speed (low) ON	152	Code No. 102 function OFF	1
103	Paper feed motor ON	153	Code No. 103 function OFF	1
104	Fuser motor ON	154	Code No. 104 function OFF	1
105	Color developer motor ON	155	Code No. 105 function OFF	1
106	Black developer motor ON	156	Code No. 106 function OFF	1
107	Registration clutch ON	157	Code No. 107 function OFF	1
108	Used-toner transport motor ON	158	Code No. 108 function OFF	1
109	ADU motor ON	159	Code No. 109 function OFF	1
110	Toner motor (Y) ON	160	Code No. 110 function OFF	1
111	Toner motor (M) ON	161	Code No. 111 function OFF	1
112	Toner motor (C) ON	162	Code No. 112 function OFF	1
113	Toner motor (K) ON	163	Code No. 113 function OFF	1
114	Image quality sensor shutter solenoid ON	164	Code No. 114 function OFF	1
130	Polygonal motor standby speed ON	180	Code No. 130 function OFF	1
131	Polygonal motor normal speed ON	181	Code No. 131 function OFF	1
132	Image quality sensor LED ON	182	Code No. 132 function OFF	1
133	Color registration sensor LED (front) ON	183	Code No. 133 function OFF	1
134	Color registration sensor LED (rear) ON	184	Code No. 134 function OFF	1
135	Image quality sensor mode switching ON (Black mode)	185	Code No. 135 function OFF (Color mode)	1
201	1st cassette feed clutch ON/OFF			3
202	2nd cassette feed clutch ON/OFF			3
203	3rd cassette feed clutch ON/OFF			3
204	4th cassette feed clutch ON/OFF			3
205	Feed path clutch ON/OFF			2
206	Bypass feed clutch ON/OFF			3
207	1st cassette tray-up motor ON (tray goes up)			2
208	2nd cassette tray-up motor ON (tray goes up)			2
209	3rd cassette tray-up motor ON (tray goes up)			2
210	4th cassette tray-up motor ON (tray goes up)			2
211	Paper-exit gate solenoid ON/OFF			3
212	Total counter count up			2
213	Ozone exhaust fan motor ON/OFF			3
214	Fuser exhaust fan motor speed Low/High			3

Code	Function	Procedure
215	SIC fan motor speed Low/High	3
216	Charger wire cleaner drive motor (Y) CW/CCW (continuous reciprocating)	2
217	Charger wire cleaner drive motor (M) CW/CCW (continuous reciprocating)	2
218	Charger wire cleaner drive motor (C) CW/CCW (continuous reciprocating)	2
219	Charger wire cleaner drive motor (K) CW/CCW (continuous reciprocating)	2
220	Transfer-belt contact/release motor CW/CCW (continuous reciprocating)	2
221	Developer removal shutter open/close motor CW/CCW (continuous reciprocating)	2
223	LCF paper-feed motor ON/OFF	3
224	LCF tray motor ON/OFF	2
225	ADU feed clutch ON/OFF	3
226	ADU gate solenoid ON/OFF	3
227	ADU side motor ON/OFF	3
228	ADU end motor ON/OFF	3
235	Main charger (Y) ON/OFF	3
236	Main charger (M) ON/OFF	3
237	Main charger (C) ON/OFF	3
238	Main charger (K) ON/OFF	3
239	Developer bias (Y) DC (+) ON/OFF	3
240	Developer bias (M) DC (+) ON/OFF	3
241	Developer bias (C) DC (+) ON/OFF	3
242	Developer bias (K) DC (+) ON/OFF	3
243	Developer bias (Y) DC (-) ON/OFF	3
244	Developer bias (M) DC (-) ON/OFF	3
245	Developer bias (C) DC (-) ON/OFF	3
246	Developer bias (K) DC (-) ON/OFF	3
247	Developer bias (Y) AC ON/OFF	3
248	Developer bias (M) AC ON/OFF	3
249	Developer bias (C) AC ON/OFF	3
250	Developer bias (K) AC ON/OFF	3
251	Cleaning blade bias (Y) AC + DC ON/OFF	3
252	Cleaning blade bias (M) AC + DC ON/OFF	3
253	Cleaning blade bias (C) AC + DC ON/OFF	3
254	Cleaning blade bias (K) AC + DC ON/OFF	3
255	Transfer roller bias (Y) ON/OFF	3
256	Transfer roller bias (M) ON/OFF	3
257	Transfer roller bias (C) ON/OFF	3
258	Transfer roller bias (K) ON/OFF	3
259	Paper suction charger ON/OFF	3
260	Discharge LED (Y) ON/OFF	3





Code	Function	Procedure
261	Discharge LED (M) ON/OFF	3
262	Discharge LED (C) ON/OFF	3
263	Discharge LED (K) ON/OFF	3
280	Laser (Y) ON/OFF	3
281	Laser (M) ON/OFF	3
282	Laser (C) ON/OFF	3
283	Laser (K) ON/OFF	3
300	<i>Carriage fan motor rotation when standby (low speed) ON/OFF</i>	3
301	<i>Carriage fan motor rotation when running (high speed) ON/OFF</i>	3
302	<i>SCM fan motor rotation speed Low/High</i>	3
304	<i>Scanner exposure lamp ON/OFF</i>	4
331	<i>ADF pick-up roller rotation ON/OFF</i>	3
332	<i>ADF aligning roller rotation ON/OFF</i>	3
333	<i>ADF transport-belt CW rotation ON/OFF</i>	3
334	<i>ADF transport-belt CCW rotation ON/OFF</i>	3
351	<i>Scan motor (carriage 1 reciprocating)</i>	3
352	<i>Document motor (indicator 1 reciprocating)</i>	3
353	<i>ADF single-sided original feeding</i>	3
354	<i>ADF two-sided original feeding</i>	3
355	<i>ADF original exiting</i>	3
356	<i>ADF 2 in 1 original feeding</i>	3

<Operation procedure>

Group 1

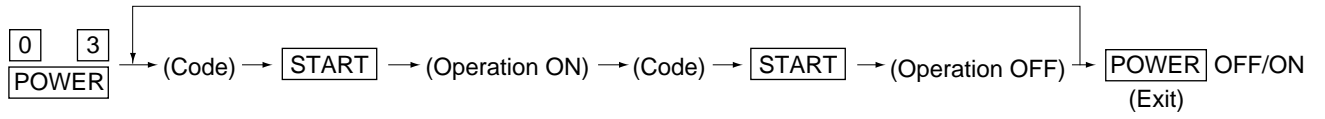

Group 2

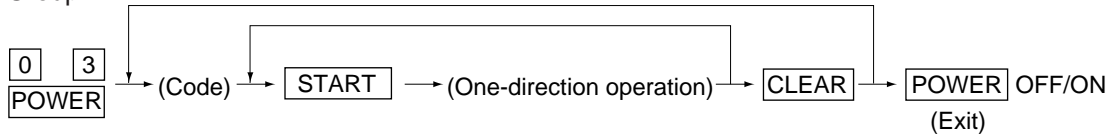

Group 3

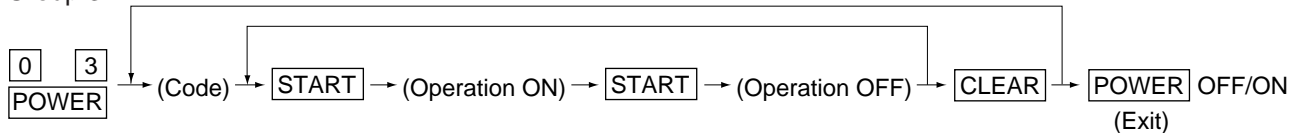

Group 4

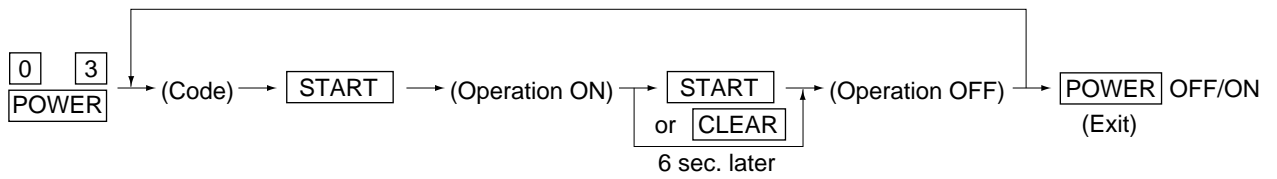

### 1. 2. 3 Test print mode (04)

In the 04 test print mode, you can print the test patterns matching with each item if you input the following codes.



Code	Types of test pattern	Remarks	Paper size
11	2-pixel modulation pattern for creating $\gamma$ table		A3
12	3-pixel modulation pattern for creating $\gamma$ table		A3
13	1-pixel modulation pattern for checking $\gamma$ table		A3
14	2-pixel modulation pattern for checking $\gamma$ table		A3
15	3-pixel modulation pattern for checking $\gamma$ table		A3
24	Gray 2-pixel modulation pattern for checking $\gamma$ table		A3
25	Gray 3-pixel modulation pattern for checking $\gamma$ table		A3
204	Grid pattern (Printer reproduction ratio/Registration adjustment pattern)	Pattern width: 1 dot, Pitch: 5mm (same as the adjustment pattern by [05] mode [1][SETTINGS])	A3/LD
219	6% test pattern		
220	8% test pattern		None
230	Gradation check pattern (2 Pixels standard)	Pattern width: 10mm, 32 gradation steps	A3/LD
231	Gradation check pattern (3 Pixels standard)	Pattern width: 10mm, 32 gradation steps	A3/LD
234	Half tone		A3/LD
256	Density check pattern		A3/LD
291	2-pixel modulation pattern 1 for selecting pulse width		A3
292	2-pixel modulation pattern 2 for selecting pulse width		A3



**Note:** Full color (YMCK) mode is not available in 230, 231 and 234.

<Operation procedure>

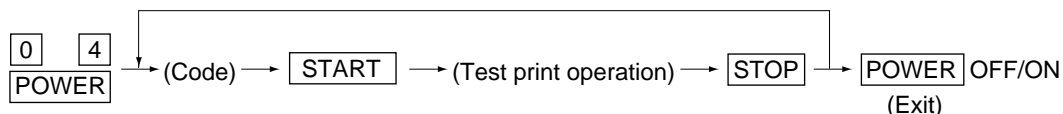

- Note:**
1. When an error has occurred, it is indicated, but the recovery operation is not performed. So, turn the power OFF and then back ON to clear the error.
  2. During test printing, when "Wait adding toner" is displayed, the [STOP] key is disabled.

## 1. 2. 4 Adjustment mode (05)

In the adjustment mode 05, the following adjustment items can be corrected, changed, or checked.

\*In code No. column, number after hyphen means sub-code.



Code	Description/Mode	Default	Acceptable Value	Contents	Operation procedure group	
104	Scanner (secondary scanning) copy length reproduction ratio adjustment.	128	1~255	When the value increases by 1, the reproduction ratio in the secondary scanning direction (vertical paper feeding direction) increases by approx. 0.1522%.	1	
105	Scanner (secondary scanning) start position deviation	128	85~171	When the value increases by 1, the image shifts by approx. 0.1213mm toward the trailing edge of the paper.	1	
106	CCD primary scanning start position deviation	For regular copy mode	180	5~251	When the value increases by 1, the image shifts by approx. 0.042mm toward the front side of the paper (machine).	1
108		For whole-area copy mode	133	5~251	When you input a value, which is 47steps (equivalent to 2mm) smaller than the set value of [106], the rear original edge and the front copy edge match (0.042mm/step).	1
135	RADF original stop position (single-sided)	8	0~15	Changes the position where the original stops. When the value increases by 1, the original stop position shifts by 1 mm away from the original stopper.	1	
136	RADF original stop position (reverse side of two-sided original)	8	0~15		1	
137	RADF sensor automatic adjustment and EPROM Initialization	–	–	By pressing the START key, WAIT is displayed while the automatic adjustment is performed. Perform RADF EPROM Initialization when EPROM, RADF logic PWA or sensors are replaced.	6	
142	RADF 2-in-1 gap adjustment	8	0~15	When the value increases by 1, the gap between two originals extend by 1 mm.	1	

Code	Description/Mode		Default	Acceptable Value	Contents	Operation procedure group	
200	Automatic filling of developer material and automatic adjustment of the auto-toner circuit	All (Y, M, C, K)	–	0~255	After filling the developer from the developer cartridge (approx. 2.5min.), auto-toner sensor output is adjusted (approx. 2min.) to set in the range of 4.00-4.33V. (As the value increases, the sensor output increases.)	5	
201		Y	–	0~255		5	
202		M	–	0~255		5	
203		C	–	0~255		5	
204		K	–	0~255		5	
221		Color (Y, M, C)	–	0~255		5	
213	Auto toner output value		0	0~1023	Auto toner output value is displayed.	10	
223	Developer bias DC (–) output adjustment	Y	130	0~255	As the value increases, the transformer output increases. The adjustment value becomes effective only when the setting mode (08-400, 401, 409) is 0 (disabled).	1	
224		M	130	0~255		1	
225		C	130	0~255		1	
226		K	125	0~255		1	
241	Main charger grid bias output adjustment	Y	120	0~255	As the value increases, the transformer output increases. The adjustment value becomes effective only when the setting mode (08-400, 401, 409) is 0 (disabled).	1	
242		M	120	0~255		1	
243		C	120	0~255		1	
244		K	116	0~255		1	
245	Automatic adjustment of the auto-toner circuit (Without automatic filling of developer material)	All	–	0~255	Auto-toner sensor output is adjusted (approx. 2 min.) to set in the range of 4.00~4.33V. (As the value increases, the sensor output increases.)	5	
		(C, M, Y, K)					
246		Y	–	0~255			
247		M	–	0~255			
248		C	–	0~255			
249		K	–	0~255			
250		Color (Y, M, C)	–	0~255			
252-0	Main charger bias output voltage 1 (lower)	Y	250	0~999	Actual output voltage of main charger grid bias. After replacing the main high-voltage transformer, input the value according to the supplementary data sheet.	4	
252-1		M	250	0~999		4	
252-2		C	250	0~999		4	
252-3		K	250	0~999		4	
253-0	Main charger bias output voltage 2 (upper)	Y	900	0~999		4	
253-1		M	900	0~999		4	
253-2		C	900	0~999		4	
253-3		K	900	0~999		4	
257-0	Developer bias DC (–) output voltage 1 (lower)	Y	100	0~999	Actual output voltage of developer bias. After replacing the main high-voltage transformer, input the value according to the supplementary data sheet.	4	
257-1		M	100	0~999		4	
257-2		C	100	0~999		4	
257-3		K	100	0~999		4	
258-0	Developer bias DC (–) output voltage 2 (upper)	Y	700	0~999		4	
258-1		M	700	0~999		4	
258-2		C	700	0~999		4	
258-3		K	700	0~999		4	

Code	Description/Mode			Default	Acceptable Value	Contents	Operation procedure group	
318	Transfer bias output adjustment	<i>Full color</i>	Normal paper mode (Top face)/thick paper 1 mode	Y	67	0~255	The bias value of the transfer roller is set. The higher the value, the larger the transformer output becomes. The adjustment value becomes effective only when the setting mode (08-400, 401, 409) is 0 (disabled).	1
319				M	67	0~255		1
320				C	72	0~255		1
321				K	67	0~255		1
326			Normal paper mode (Reverse face)	Y	67	0~255		1
327				M	67	0~255		1
328				C	72	0~255		1
329				K	67	0~255		1
330			<i>OHP mode</i>	Y	61	0~255		1
331				M	101	0~255		1
332				C	111	0~255		1
333				K	141	0~255		1
334			Thick paper 2 mode	Y	67	0~255		1
335				M	67	0~255		1
336				C	72	0~255		1
337				K	67	0~255		1
361	<i>Black</i>	Normal paper mode (Top face)/Thick paper 1 mode	K	56	0~255	1		
363			Normal paper mode (Reverse face)	K	56	0~255	1	
364				<i>OHP mode</i>	K	82	0~255	1
365				<i>Thick paper2 mode</i>	K	56	0~255	1
367-0	Transfer bias output voltage 1 (lower)	Y		589	0~5000	Actual output voltage of transfer roller bias. After replacing the transfer transformer, input the value according to the supplementary data sheet.	4	
367-1		M	589	0~5000	4			
367-2		C	589	0~5000	4			
367-3		K	589	0~5000	4			
368-0	Transfer bias output voltage 2 (upper)	Y	3929	0~5000		4		
368-1		M	3929	0~5000		4		
368-2		C	3929	0~5000		4		
368-3		K	4715	0~5000		4		
381	Transfer bias output adjustment	<i>Full color</i>	Thick paper 3 mode	Y	72	0~255	The bias value of the transfer roller is set. The higher the value, the larger the transformer output becomes. The adjustment value becomes effective only when the setting mode (08-400, 401, 409) is 0 (disabled).	1
382				M	72	0~255		1
383				C	72	0~255		1
384				K	72	0~255		1
385		<i>Black</i>	<i>Thick paper3 mode</i>	K	72	0~255		1

Code	Description/Mode	Default	Acceptable Value	Contents	Operation procedure group
390	Automatic removing of developer material	All (Y, M, C, K)	–	The developer material in the developer unit is removed into the toner bag.	6
391		Color (Y, M, C)	–		6
392		K	–		6
400	Reproduction ratio adjustment of primary scanning direction (Fine adjustment of polygonal motor rotation speed)	1222	1209~1235	When the value increases by 1, the reproduction ratio in the primary scanning direction (horizontal paper feeding direction) decreases by approx. 0.082%. (If the values of this code 400 is changed, the values of code 05-401, 402, 403, 404 and 474 are optimized.)	1
401	Reproduction ratio adjustment of secondary scanning direction (Fine adjustment of transfer belt motor rotation speed)	1355	1327~1382	When the value increases by 1, the reproduction ratio in the secondary scanning direction (vertical paper feeding direction) decreases by approx. 0.074%. (If the values of this code 401 is changed, the values of code 05-401, 402, 403, 404 and 474 are optimized.)	1
402	<i>Fine adjustment of fuser motor rotation speed</i>	3794	0~65535	When the value increases by 1, the rotation speed of fuser motor decreases by 0.026%.	1
403	<i>Fine adjustment of drum motor rotation speed</i>	1700	0~65535	When the value increases by 1, the rotation speed of the drum motors (Y,M,C,K) decreases by 0.059%.	1
404	<i>Fine adjustment of feed motor rotation speed</i>	4289	0~65535	When the value increases by 1, the rotation speed of the paper feed motor decreases by 0.023%.	1
406	<i>Feed motor speed adjustment</i>	–	–	The paper transport speed of registration roller in relation to the image printing speed is set at the optimum value. (If the value of this code 406 is performed, the value of code 05-404 is optimized.)	6
407	<i>Color registration control forced performing</i>	–	–	Performs the color registration control.	6
408	Correction of fuser motor rotation speed in the thick paper 3 mode	0	0~20	In this thick paper 3 mode, when the value is increased by 1, the fuser motor rotation speed is decreased by 0.026%.	1

Code	Description/Mode		Default	Acceptable Value	Contents	Operation procedure group	
427	Right margin		160	0~255	Printed page right edge void (margin) adjustment. When the value increases by 1, the void in the right side of paper feed direction (rear side) decreases by approx. 0.042mm.	1	
428	Bottom margin		160	0~255	Printed page trailing edge void (margin) adjustment. When the value increases by 1mm, the void in the trailing edge of paper feed direction decreases by approx. 0.042mm.	1	
439	Paper alignment (paper buckle) at the main registration roller	1st cassette	Long size	25	0~40	When the value increases by 1, the aligning (paper buckle) increases by approx. 0.8mm.  * Long size: Paper length 330 mm and longer (A3/LD/A3 wide) Short size: Paper length 220 mm to 329 mm	1
440			Short size	25	0~40		1
441		2nd cassette	Long size	25	0~40		1
442			Short size	25	0~40		1
443		3rd cassette	Long size	25	0~40		1
444			Short size	25	0~40		1
445		4th cassette	Long size	25	0~40		1
446			Short size	25	0~40		1
447		ADU	Long size	25	0~40		1
448			Short size	25	0~40		1
449		LCF		18	0~40		1
450		Bypass feed		35	0~40		1
451		Thick paper 2 mode		35	0~50		1
452		Thick paper 3 mode		35	0~50		1
461	Color registration status display		0	0~255	The value of Y (0) shows the status of color registration sensor error. 0 or 16 or above: Normal 1-14: Data abnormal (sensor normal) 15: Color registration pattern reading error	10	
470	Primary-scanning data write start position adjustment	K	100	0~255	When the value increases by 1, the image shifts by approx. 0.042mm toward the right side of paper feed direction.	1	
474	Secondary-scanning data write start position adjustment (Printer and Test print mode)		8	1~15	When the value increases by 1, the image shifts by approx. 0.6mm toward the leading edge of paper feed direction.	1	





Code	Description/Mode	Default	Acceptable Value	Contents	Operation procedure group	
482	Primary-scanning reproduction ratio (scanner)	127	112~142	When the value increases by 1, the reproduction ratio of the primary scanning direction (paper feeding in horizontal direction) decreases by 0.082%.	1	
484	Secondary-scanning data write start position adjustment (Copier)	1st cassette	Y 6	0~15	When the value increases by 1, the image shifts by approx. 0.6 mm toward the trailing edge of paper feed direction.	1
485		2nd cassette	Y 6	0~15		1
486		3rd cassette	Y 6	0~15		1
487		4th cassette	Y 7	0~15		1
488		Bypass feed	Y 6	0~15		1
489		LCF	Y 7	0~15		1
490		ADU	Y 7	0~15		1
492	Paper aligning amount adjustable for the main registration roller in OHP mode when feeding from the bypass.	40	0~50	When the value increases by 1, the aligning increases by approx. 0.8 mm.	1	
493	Paper restarting amount adjustable for the bypass feed roller in OHP mode when restarting its roller.	9	0~14	Default 9: 68 msec. When the value increases by 1, the aligning increases by approx. 7 msec.	1	
500	Modulation mode switching, type A	0	0~255		1	
501	Modulation mode switching, type B	0	0~255		1	
502	Modulation mode switching, type C	0	0~255		1	
503	Modulation mode switching, type D	0	0~255		1	
504	Highlight processing ON/OFF	0	0~255		1	
505	Screen angle change (Y)	0	0~255		1	
506	Screen angle change (M)	0	0~255		1	
507	Screen angle change (C)	0	0~255		1	
508	Screen angle change (K)	0	0~255		1	
509	Modulation data results indication	0	8bit*4*4*5		10	
511	Density adjustment; density curve input, full color	0	0~255		4	
512	Density adjustment; density curve selection, full color	0	0~255		1	
513	Density adjustment; density curve selection, full color	0	0~255		1	
514	Density adjustment; density curve selection, full color	0	0~255		1	
515	Density adjustment; density curve selection, full color	0	0~255		1	
516	Density adjustment; density curve selection, full color	0	0~255		1	
517	Density adjustment; density curve input, monochrome	0	0~255		1	



Code	Description/Mode	Default	Acceptable Value	Contents	Operation procedure group
518	Density adjustment; density curve selection, monochrome	0	0~255		1
519	Density adjustment; density curve selection, monochrome	0	0~255		1
520	Density adjustment; density curve selection, monochrome	0	0~255		1
521	Density adjustment; density curve selection, monochrome	0	0~255		1
522	Density adjustment; density curve selection, monochrome	0	0~255		1
523	Color mode black text $\gamma$ curve set selection	0	0~255		1
524	Color mode black text $\gamma$ curve set selection	0	0~255		1
525	Color mode black text $\gamma$ curve set selection	0	0~255		1
526	Monochrome mode black text $\gamma$ curve set selection	0	0~255		1
527	Monochrome mode black text $\gamma$ curve set selection	0~255			1
528	Monochrome mode black text $\gamma$ curve set selection	0~255			1
529	Monitor patch output ON/OFF switching	0~255			1
530	Filter coefficient set selection table	–	(0~99)*62		4
531	Scanner characteristic R for filter selection	0~8			1
532	Scanner characteristic G for filter selection	0~8			1
533	Scanner characteristic B for filter selection	0~8			1
534	Scanner correction color conversion matrix selection	0~15			
535	Basic color conversion matrix selection, type A	0~255			1
536	Basic color conversion matrix selection, type B	0~255			1
537	Basic color conversion matrix selection, type C	0~255			1
538	Basic color conversion matrix selection, type D	0~255			1
539	Operation of pre-scan unit only	–			1
540	Operation equivalent to normal copying	–			1
544	Automatic adjustment of scanner correction color conversion matrix	–			–
545	Selection of scanner correction color conversion matrix type	0		0:3 x 4 1:3 x 3	0
546	Indication of scanner correction color conversion patch read data	–			–
547	Indication of scanner correction color conversion matrix calculation results	–	32bit*3*10*9		–



Code	Description/Mode			Default	Acceptable Value	Contents	Operation procedure group
550	<i>"Manual density" fine adjustment (Center setting)</i>	<i>Full color</i>	<i>Text/Photo</i>	128	0~255	<i>When the value increases, images made at center density become darker.</i>	1
551			<i>Text</i>	128	0~255		1
552			<i>Printed image</i>	128	0~255		1
553			<i>Photo</i>	128	0~255		1
554			<i>Map</i>	128	0~255		1
555		<i>Black</i>	<i>Text/Photo</i>	128	0~255		1
556			<i>Text</i>	128	0~255		1
557			<i>Printed image</i>	128	0~255		1
558			<i>Photo</i>	128	0~255		1
559			<i>Map</i>	128	0~255		1
560		<i>"Manual density" fine adjustment (Darker setting)</i>	<i>Full color</i>	<i>Text/Photo</i>	20		0~255
561	<i>Text</i>			20	0~255	1	
562	<i>Printed image</i>			20	0~255	1	
563	<i>Photo</i>			20	0~255	1	
564	<i>Map</i>			20	0~255	1	
565	<i>Black</i>		<i>Text/Photo</i>	20	0~255	1	
566			<i>Text</i>	20	0~255	1	
567			<i>Printed image</i>	20	0~255	1	
568			<i>Photo</i>	20	0~255	1	
569			<i>Map</i>	20	0~255	1	



Code	Description/Mode			Default	Acceptable Value	Contents	Operation procedure group
570	"Manual density"	Full color	Text/Photo	20	0~255	When the value increases, images made at the "light" side become lighter.	1
571	fine adjustment		Text	20	0~255		1
572	(Lighter setting)		Printed image	20	0~255		1
573			Photo	20	0~255		1
574			Map	20	0~255		1
575		Black	Text/Photo	20	0~255		1
576			Text	20	0~255		1
577			Printed image	20	0~255		1
578			Photo	20	0~255		1
579			Map	20	0~255		1
580	"Automatic density" fine adjustment	Full color	Text/Photo	128	0~255	When the value increases, images become darker.	1
581			Text	128	0~255		1
582			Printed image	128	0~255		1
583			Photo	128	0~255		1
584			Map	128	0~255		1
585		Black	Text/Photo	128	0~255		1
586			Text	128	0~255		1
587			Printed image	128	0~255		1
588			Photo	128	0~255		1
589			Map	128	0~255		1
604	Indication of calculation results for color conversion matrix (within design) type A			–	32bit*3*4		10
605	Indication of calculation results for color conversion matrix (within design) type B			–	32bit*3*10*9		10
606	Indication of calculation results for color conversion matrix (within design) type C			–	32bit*3*10*9		10
607	Indication of calculation results for color conversion matrix (within design) type D			–	32bit*3*10*9		10
611	Indication of scanner automatic color correction results			–	32bit*3*10*9		10
612	For paper size : Maximum value adjustment for plain paper			255	0~255		1
613	For paper size : Maximum value adjustment for thick paper 1			249	0~255		1
614	For paper size : Maximum value adjustment for thick paper 2			249	0~255		1
615	For paper size : Maximum value adjustment for thick paper 3			240	0~255		1



Code	Description/Mode	Default	Acceptable Value	Contents	Operation procedure group
616	For paper size : Maximum value adjustment for OHP	255	0~255		1
617	For ID : Full color non-text area (Y)	255	0~255		1
618	For ID : Full color non-text area (M)	255	0~255		1
619	For ID : Full color non-text area (C)	255	0~255		1
620	For ID : Full color non-text area (K)	255	0~255		1
621	Calculation results indication for $\gamma$ correction table for 2 pixels (For user automatic gradation correction)	–	8bit*256*4 (CMYK)		4
622	Calculation results indication for $\gamma$ correction table for 3 pixels (For user automatic gradation correction)	–	8bit*256*4 (CMYK)		4
634	Calculation results indication : Pulse width selection for 1 pixel	–	8bit*16*4 (CMYK)		4
635	Calculation results indication : Pulse width selection for 2 pixels	–	8bit*16*4 (CMYK)		4
636	Calculation results indication : Pulse width selection for 3 pixels	–	8bit*16*4 (CMYK)		4
643	Automatic adjustment of gamma correction	–	–	Auto-correction of gradation reproduction for each color Y, M, C, K	13
646	Calculation results indication : $\gamma$ correction table creation for 1 pixel	–	(8bit*65*4 (CMYK))		10
647	Calculation results indication : $\gamma$ correction table creation for 2 pixels	–	(8bit*65*4 (CMYK))		10
648	Calculation results indication : $\gamma$ correction table creation for 3 pixels	–	(8bit*65*4 (CMYK))		10
649	Calculation results indication : $\gamma$ correction table creation for 1 pixel	–	8bit*256*4		4
650	Calculation results indication : $\gamma$ correction table creation for 2 pixels	–	8bit*256*4		4
651	Calculation results indication : $\gamma$ correction table creation for 3 pixels	–	8bit*256*4		4
652	Achromatic axis equalization selection	0	0~1		1
653	Achromatic axis equalization selection	0	0~1		1
654	Achromatic axis equalization selection	0	0~1		1
655	Achromatic axis equalization selection	0	0~1		1
656	Achromatic axis equalization selection	0	0~1		1
657	Total hue adjustment	128	0~255		1



Code	Description/Mode	Default	Acceptable Value	Contents	Operation procedure group
658	Total hue adjustment	128	0~255		1
659	Total hue adjustment	128	0~255		1
660	Total hue adjustment	128	0~255		1
661	Total hue adjustment	128	0~255		1
662	Total luminance adjustment	128	0~255		1
663	Total luminance adjustment	128	0~255		1
664	Total luminance adjustment	128	0~255		1
665	Total luminance adjustment	128	0~255		1
666	Total luminance adjustment	128	0~255		1
667	Total saturation adjustment	100	0~255		1
668	Total saturation adjustment	100	0~255		1
669	Total saturation adjustment	100	0~255		1
670	Total saturation adjustment	100	0~255		1
671	Total saturation adjustment	100	0~255		1
672	Differential threshold (R-G) for ACS	0	0~255		1
673	Differential threshold (G-B) for ACS	0	0~255		1
674	Differential threshold (B-R) for ACS	0	0~255		1
675	Judgement threshold for ACS 104	0	0~255	When the value increases, originals tend to be judged as monochrome, and when the value decreases, they tend to be judged as color in auto-color mode.	1
676	Indication of results for ACS	–			2
677	Outputting of results for ACS	0	0~1		1
678	AI mode setting Discrimination setting	0	0~4	Operation mode of discrimination is changed in AI mode. 0: Standard (for regular) 1: Photograph priority 2: Only judgement of original type 3: Only judgement of original type with photograph priority 4: Discrimination is not performed in AI mode.	
679	Macro recognition : Pre-process text threshold adjustment	0	0~255		1
681	Macro recognition : Patch area recognition ON/OFF	0	0~255		1



Code	Description/Mode		Default	Acceptable Value	Contents	Operation procedure group		
682	<i>AI mode setting</i>	<i>Time-out setting</i>	63	11~99	<i>Maximum amount of processing time is set for image discrimination. 2 digits are designated, 1st digit is for setting A4/LT original, 2nd digit is for setting A3/LD original. (unit: second)</i>	1		
683	<i>Macro recognition : Pre-process text threshold adjustment</i>		0	0~7		1		
684	<i>Macro recognition : Pre-process background threshold adjustment</i>		0	0~7		1		
685	<i>Macro recognition : Pre-process shading threshold adjustment</i>		0	0~7		1		
687	<i>Background processing : Indication of results</i>		–			2		
698	<i>Offset amount for processing background (Background density adjustment)</i>	<i>Full color</i>	<i>Text/Photo</i>	128	0~255	<i>When the value increases, the background becomes denser.</i>	1	
699			<i>Text</i>	128	0~255			
700			<i>Printed image</i>	128	0~255			
701			<i>Photo</i>	128	0~255			
702			<i>Map</i>	128	0~255			
703		<i>Black</i>	<i>Text/Photo</i>	128	0~255			
704			<i>Text</i>	128	0~255			1
705			<i>Printed image</i>	128	0~255			1
706			<i>Photo</i>	128	0~255			1
707			<i>Map</i>	128	0~255			1
708	<i>Offset amount for processing background (Text density adjustment)</i>	<i>Full color</i>	<i>Text/Photo</i>	128	0~255	<i>When the value increases, the text becomes denser.</i>	1	
709			<i>Text</i>	128	0~255			
710			<i>Printed image</i>	128	0~255			
711			<i>Photo</i>	128	0~255			
712			<i>Map</i>	128	0~255			
713		<i>Black</i>	<i>Text/Photo</i>	128	0~255			
714			<i>Text</i>	128	0~255			1
715			<i>Printed image</i>	128	0~255			1
716			<i>Photo</i>	128	0~255			1
717			<i>Map</i>	128	0~255			1
718	<i>Micro recognition : Achromatic threshold, low</i>		0	0~8191		1		
719	<i>Micro recognition : Achromatic threshold, high</i>		0	0~8191		1		
720	<i>Micro recognition : Adjustment (text&lt;-&gt;photo), color</i>		0	0~255		1		
721	<i>Micro recognition : Adjustment (text&lt;-&gt;photo), monochrome</i>		0	0~255		1		



Code	Description/Mode	Default	Acceptable Value	Contents	Operation procedure group	
722	Micro recognition : Text emphasis adjustment, color	0	0~127		1	
723	Micro recognition : Text emphasis adjustment, monochrome	0	0~127		1	
724	Micro recognition : Black lowest level threshold, color	0	0~99		1	
725	Micro recognition : Black lowest level threshold, monochrome	0	0~99		1	
726	Micro recognition : Logo text inside threshold Macro recognition available	0	0~100		1	
727	Micro recognition : Recognition expansion / threshold adjustment	0	0~255		1	
728	Micro recognition : Recognition results output, color	0	0~1999		1	
729	Micro recognition : Recognition results output, monochrome	0	0~1999		1	
730	Sharpness adjustment	Full color Text/Photo (text area)	0	0~31	When the value increases, the image becomes sharper. When the value decreases, the image becomes softer. The smaller the value, the fewer the moire becomes. * 0 in default is equivalent to 16 (center value).	1
731		Text/Photo (photo area)	0	0~31		1
732		AI (text area)	0	0~31		1
733		AI (photo area)	0	0~31		1
734		Text	0	0~31		1
735		Printed image	0	0~31		1
736		Photo	0	0~31		1
737		Map	0	0~31		1





Code	Description/Mode			Default	Acceptable Value	Contents	Operation procedure group
738	Sharpness adjustment	Black	Text/Photo (text area)	0	0~31	When the value increases, the image becomes sharper. When the value decreases, the image becomes softer. The smaller the value, the fewer the moire becomes. * 0 in default is equivalent to 16 (center value).	1
739			Text/Photo (photo area)	0	0~31		1
740			AI (text area)	0	0~31		1
741			AI (photo area)	0	0~31		1
742			Text	0	0~31		1
743			Printed image	0	0~31		1
744			Photo	0	0~31		1
745			Map	0	0~31		1
746	HPF coefficient			0	0~99		1
747	HPF coefficient			0	0~99		1
748	HPF coefficient			0	0~99		1
749	HPF coefficient			0	0~99		1
750	HPF coefficient			0	0~99		1
751	LPF coefficient			0	0~99		1
752	LPF coefficient			0	0~99		1
753	LPF coefficient			0	0~99		1
754	LPF coefficient			0	0~99		1
755	LPF coefficient			0	0~99		1
756	Enlargement/reduction random interpolation ON/OFF			0	0~63		1
757	Fixed "black" ratio adjustment, type A			0	0~255		1
758	Fixed "black" ratio adjustment, type B			0	0~255		1
759	Fixed "black" ratio adjustment, type C			0	0~255		1
760	Fixed "black" ratio adjustment, type D			0	0~255		1
761	"Black" table adjustment, type A			0	0~77		1
762	"Black" table adjustment, type B			0	0~77		1
763	"Black" table adjustment, type C			0	0~77		1
764	"Black" table adjustment, type D			0	0~77		1
765	"Black" calculation reference amount specification, type A			1		0: Difference between maximum and minimum; 1: Minimum	1
766	"Black" calculation reference amount specification, type A			1		0: Difference between maximum and minimum; 1: Minimum	1
767	"Black" calculation reference amount specification, type A			1		0: Difference between maximum and minimum; 1: Minimum	1
768	"Black" calculation reference amount specification, type A			1		0: Difference between maximum and minimum; 1: Minimum	1



Code	Description/Mode		Default	Acceptable Value	Contents	Operation procedure group		
769	"Black" substitution method specification, type A		0		0:GCR 1:UCR	1		
770	"Black" substitution method specification, type B		0		0:GCR 1:UCR	1		
771	"Black" substitution method specification, type C		0		0:GCR 1:UCR	1		
772	"Black" substitution method specification, type D		0		0:GCR 1:UCR	1		
773	Color mode, black text $\gamma$ adjustment		128	0~255		1		
774	Color mode, black text $\gamma$ adjustment		128	0~255		1		
775	Color mode, black text $\gamma$ adjustment		128	0~255		1		
776	Monochrome mode, black text $\gamma$ adjustment		128	0~255		1		
777	Monochrome mode, black text $\gamma$ adjustment		128	0~255		1		
778	Monochrome mode, black text $\gamma$ adjustment		128	0~255		1		
779-0	Color balance adjustment	Y Text/Photo	Low density	128	0~255	When the value increases, the color and mode become denser.	4	
779-1			Medium density	128	0~255		4	
779-2			High density	128	0~255		4	
780-0		Text	Low density	128	0~255		4	
780-1			Medium density	128	0~255		4	
780-2			High density	128	0~255		4	
781-0		Printed image	Low density	128	0~255		4	
781-1			Medium density	128	0~255		4	
781-2			High density	128	0~255		4	
782-0		Photo	Low density	128	0~255		4	
782-1			Medium density	128	0~255		4	
782-2			High density	128	0~255		4	
783-0		Map	Low density	128	0~255		4	
783-1			Medium density	128	0~255		4	
783-2			High density	128	0~255		4	
784-0		M	Text/Photo	Low density	128		0~255	4
784-1				Medium density	128		0~255	4
784-2				High density	128		0~255	4
785-0			Text	Low density	128		0~255	4
785-1				Medium density	128		0~255	4
785-2				High density	128		0~255	4
786-0	Printed image		Low density	128	0~255	4		
786-1			Medium density	128	0~255	4		
786-2			High density	128	0~255	4		
787-0	Photo		Low density	128	0~255	4		
787-1			Medium density	128	0~255	4		
787-2			High density	128	0~255	4		
788-0	Map		Low density	128	0~255	4		
788-1			Medium density	128	0~255	4		
788-2			High density	128	0~255	4		



Code	Description/Mode			Default	Acceptable Value	Contents	Operation procedure group	
789-0	Color balance adjustment	C	Text/Photo	Low density	128	0~255	When the value increases, the color and mode become denser.	4
789-1				Medium density	128	0~255		4
789-2				High density	128	0~255		4
790-0			Text	Low density	128	0~255		4
790-1				Medium density	128	0~255		4
790-2				High density	128	0~255		4
791-0			Printed image	Low density	128	0~255		4
791-1				Medium density	128	0~255		4
791-2				High density	128	0~255		4
792-0		Photo	Low density	128	0~255	4		
792-1			Medium density	128	0~255	4		
792-2			High density	128	0~255	4		
793-0		Map	Low density	128	0~255	4		
793-1			Medium density	128	0~255	4		
793-2			High density	128	0~255	4		
794-0		K	Text/Photo	Low density	128	0~255		4
794-1				Medium density	128	0~255		4
794-2				High density	128	0~255		4
795-0			Text	Low density	128	0~255		4
795-1				Medium density	128	0~255		4
795-2	High density			128	0~255	4		
796-0	Printed image		Low density	128	0~255	4		
796-1			Medium density	128	0~255	4		
796-2			High density	128	0~255	4		
797-0	Photo		Low density	128	0~255	4		
797-1			Medium density	128	0~255	4		
797-2			High density	128	0~255	4		
798-0	Map		Low density	128	0~255	4		
798-1			Medium density	128	0~255	4		
798-2			High density	128	0~255	4		

Code	Description/Mode		Default	Acceptable Value	Contents	Operation procedure group
817	Output value indication of image quality sensor	When the light source is OFF	—	0~1023	Displays the output value of image quality sensor when the sensor light source is OFF.	2
818		Transfer belt surface	—	0~1023	Displays the output value of image quality sensor when there is no test pattern on the transfer belt.	2
819		Low density pattern	—	0~1023	Displays the output value of image quality sensor when a low-density test pattern is written.	10
820		High density pattern	—	0~1023	Displays the output value of image quality sensor when a high-density test pattern is written.	10
821	Light amount adjustment results of image quality sensor		—	0~255	The sensor's LED light amount adjustment value, for setting the reflected light amount from the belt surface as the reference value.	2
878	Forced performing of image quality control		—	—	Perform the image quality control	6
879	Automatic initialization of image quality control		—	—	Perform the image quality control and restore the initial value.	6

<Procedure>

Group 1

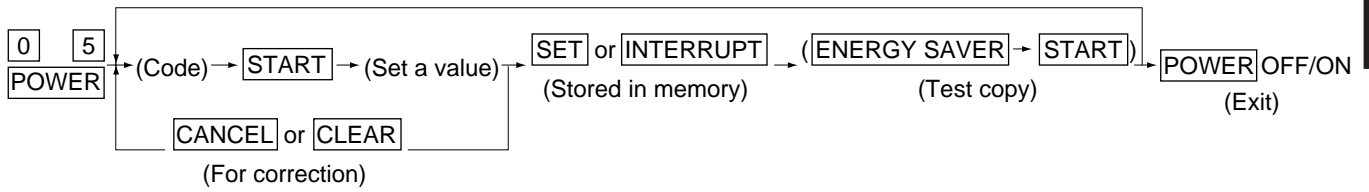

Group 2

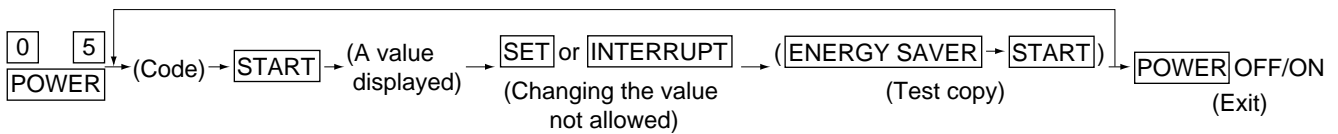

Group 4

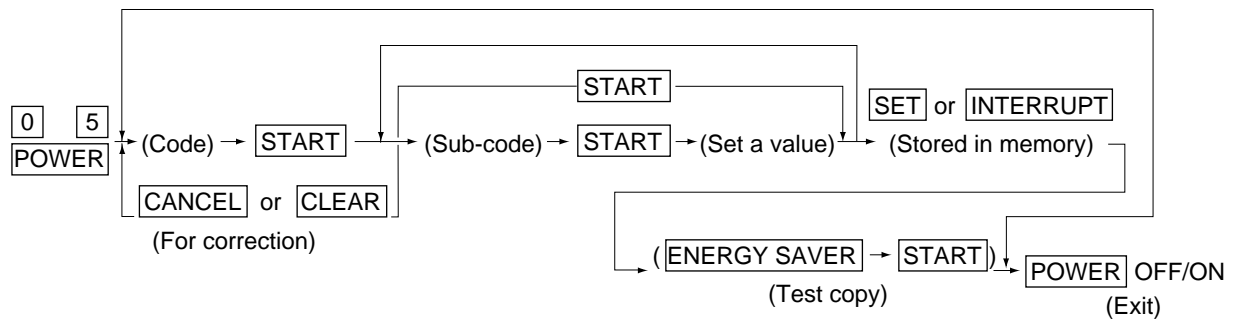

Group 5

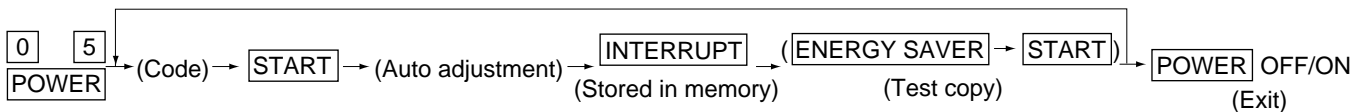

Group 6

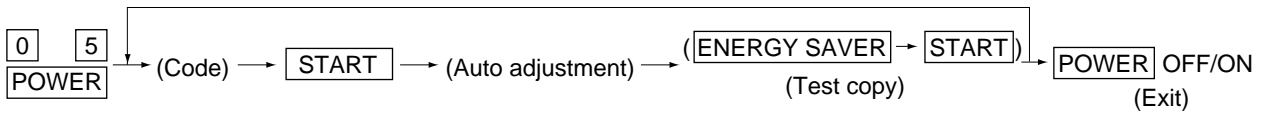

Group 10

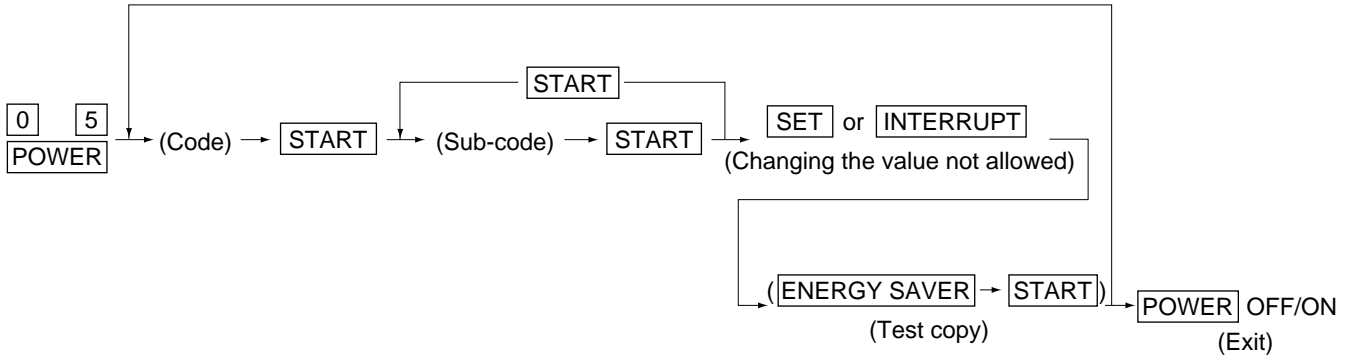

Group 13

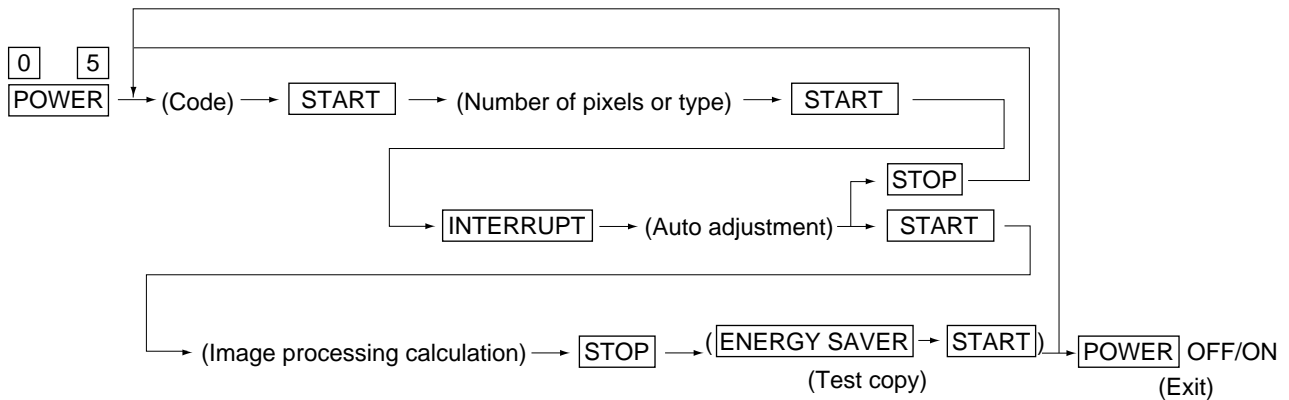

Group 15

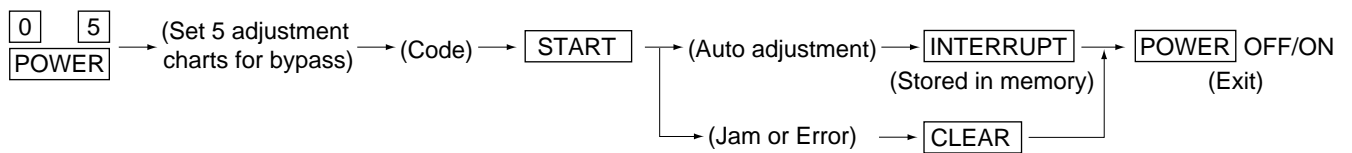

## 1. 2. 5 Setting mode (08)

The following items can be set or changed in this mode 08.

Code	Name	Default	Allowable input value	Contents	Operation procedure group
200	Date and time setting	–	13 digits	Year/month/date/day/hour/minute/second Example: 99:08:07:5:11:30:48	1
201	Destination selection	2	0-3:FC15/22 0-1:FC25P	0: Europe (A4/A3/Folio) 1: USA/Canada (Letter/Ledger) 2: Japan (A4/B4) 3:Others	1
202	<i>Externally installed copy counter/ controller device</i>	0	0-3	0: No external copy counter/controller device 1: Coin controller 2: Copy key card 3: Key copy counter	1
204	Auto clear time setting	3:FC22 0:FC25P	0-10	Time-out for cleaning control panel settings and returning to the default settings. 0: Disabled 1 to 10: Set number x 15 second	1
205	Energy saver timer setting	0	0-15:FC15/22 0-19:FC25P	Timer for switching from Ready mode to Energy Saver selected code 618. 0: Disabled 1: 30sec. 2: 60sec. 3: 90sec. 4: 120sec. 5: 150sec. 6: 3min 7: 4min 8: 5min 9: 7min 10: 10min 11: 15min 12: 20min 13: 30min 14: 45min 15: 60min 16: 90min 17: 120min 18: 180min 19: 240min	1
206	<i>Auto-power shut off setting</i>	20	0-20	<i>Timer for switching from Ready mode to Auto-Power Shut OFF. US Energy Star Compliance</i> 0: 3min 1: 5min 2: 10min 3: 15min 4: 20min 5: 25min 6: 30min 7: 40min 8: 50min 9: 60min 10: 70min 11: 80min 12: 90min 13: 100min 14: 110min 15: 120min 16: 150min 17: 180min 18: 210min 19: 240min 20: Disabled	1





Code	Name	Default	Allowable input value	Contents	Operation procedure group
209	Timer for Print job start up time from copy mode when auto-clear is disabled	1	1-10	Set number x 15 seconds	1
212	Bypass paper default type	0		0: Plain paper; 1: OHP; 2: A3 wide; 3: Thick paper 1; 4: Thick paper 2; 5: Thick paper 3	1
217	Cassette loading status	15	0~15	1: 1st and 2nd cassette 2: 1st, 2nd, 3rd cassette 3: 1st, 2nd, 3rd, 4th cassette 4: 1st cassette (Auto cassette detection is not available) 5: 1st cassette (Auto cassette detection is available) 15: Auto cassette detection 6, 5~14: Change value to "3" forcibly. (1st, 2nd, 3rd, 4th cassette)	1
220	Message language selection	0	0-2	0: Language 1 1: Language 2 2: Language 3	1
222	All clearing by key copy counter removal	0	0-1	0: Disabled 1: Enabled	1
224	Judgement setting during DF-ACS	0		0: Always full color; 1: Detection for each original	1
250	Telephone number for "Call for service"	0	14 digits	A telephone number up to 14 digits can be entered. Use the HELP key to enter hyphens (-).	1
253	Error code history display.	-	-		2
256	LCF paper size	0	0-1	0: A4 1: LT	1
258	FSMS function	1	0-1	0: impossible 1: possible	1
259	Large size setting	0	0-1	0: A3, LD, A3W, unspecified bypass -> Large size 1: A3, LD, A3W, B4, LG, FOLIO, COMP, unspecified bypass -> Large size	1
260	STR history indication	-			2
267	C9B error code history display	-	-	-	2
268	Black display/white display switching	0		0: Black; 1: White	1







Code	Name	Default	Allowable input value	Contents	Operation procedure group
269	Forced performing of image quality control before the use-level calibration	0	0-1	0: Disabled 1: Enabled	1
300	Maximum number of copies allowed	0	0-2	0:999 1:99 2:9	1
302	Resettable Copy and Original counter display	UC: 0 EUR: 3	0-3	0: Off 1: Resettable Copy counter 2: Resettable Original counter 3: Resettable Copy and Original counters	1
350	Manually placed original detection	0		0: Not present; 1: Present	1
352	Shooting correction process setting	0		0: Valid; 2: Invalid	1
353	SALT log table setting	0		0: Normal operation; 1: Forced setting on log table (for ACS/full color); 2: Forced setting on log table (for single color/monochrome); 3: Forced setting on log table (for CCV)	1
354	HDEN control	0		0: Normal operation; 1: HDEN control operation	1
355	Sharpness availability setting	1		0: Unavailable; 1: Available	1
360	Switch back	0	0-1	RADF reversing of transport belt during original transporting, to align originals against the original scale. 0: Disabled 1: Enabled	1
361	RADF Non-standard size original detection	0	0-1	When non-standard originals are used; 0: Non-standard - Machine will stop and prompt operator to select copy size. 1: Standard - Machine continues the current job without stopping	1
400	Image quality control 1	1	0-1	Auto-performing of image quality control 0: Disabled 1: Enabled (Performing 08-410,413)	1

Code	Name	Default	Allowable input value	Contents	Operation procedure group
407	Image quality control auto-start (continuous print)	0	0-1	When operating continuous printing, image quality control is started for every print volume set for continuous print (08-453). 0: Disabled 1: Enabled (Set value of 08-453)	1
408	Image quality control auto-start (accumulated print volume)	1	0-1	When the accumulated print volume since the last image quality control, set in 08-455, is attained, new image quality control automatically starts after the current printing job. 0: Disabled 1: Enabled (Setting value of 08-455)	1
409	Image quality control 3	1	0-1	Auto-performing of image quality control 0: Disabled 1: Enabled (Performing 08-410,413)	1
410	Drum temperature compensation control	1	0-1	Performing drum temperature compensation for image quality control. 0: Disabled 1: Enabled * When 'Image quality controls 1 and 3 (08-400,409)' are 1(Enabled), this is reflected.	1
413	Transfer bias temperature and humidity correction control	1	0-1	Performing transfer bias correction by temperature and humidity for image quality control. 0: Disabled 1: Enabled * When 'Image quality controls 1 and 3 (08-400,409)' are 1(Enabled), this is reflected.	1
415	Abnormal detection counter Y (display/0 clearing)	0	0-16	Accumulated total of CE1, CE2, CE4 (Max.16) * Enabled when 'Image quality control 3 (08-401)' is 1(Enabled).	1
416	Abnormal detection counter M (display/0 clearing)	0	0-16	Accumulated total of CE1, CE2, CE4 (Max.16) * Enabled when 'Image quality control 3 (08-401)' is 1 (Enabled).	1
417	Abnormal detection counter C (display/0 clearing)	0	0-16	Accumulated total of CE1, CE2, CE4 (Max.16) * Enabled when 'Image quality control 3 (08-401)' is 1 (Enabled).	1

Code	Name	Default	Allowable input value	Contents	Operation procedure group
418	Abnormal detection counter K (display/0 clearing)	0	0-16	Accumulated total of CE1, CE2, CE4 (Max.16) * Enabled when 'Image quality control 3 (08-401)' is 1 (Enabled).	1
452	Image quality control auto-start time setting (ready)	4	0-24	Setting time (hour) of Image quality control auto-start (ready)	1
453	Image quality control auto-start print volume setting (continuous printing)	300	0-999	Setting print volume (number of sheets) to automatically start Image quality control (continuous printing)	1
455	Image quality control auto-start print volume setting (accumulated print volume)	10	0-30	Setting print volume (x 100 sheets) to automatically start Image quality control (accumulated print volume)	1
480	<i>Paper source priority</i>	<i>0</i>	<i>0-5</i>	<i>0: A4/LT 1: LCF 2: 1st cassette 3: 2nd cassette 4: 3rd cassette 5: 4th cassette</i>	<i>1</i>
481	<i>Automatic paper source change</i>	<i>1</i>	<i>0-1</i>	<i>0: OFF 1:Normal When 1 is set, a paper source becomes empty and the same size paper is present in another source, the machine will automatically switch to that source of paper.</i>	<i>1</i>
485	Pre-running rotation of polygonal motor	0	0-1	Setting of pre-running rotation of polygonal motor 0: Low speed rotation (Pre-running rotation) 1: Stop	1
491	<i>Out of specified paper size printing</i>	<i>0</i>	<i>0-1</i>	<i>0: Disabled 1: Enabled</i>	<i>1</i>
505	<i>Paper (plain paper, OHP, thick paper). Switched according to image processing</i>	<i>1</i>		<i>0: Compatible paper not present; 1: Compatible paper present</i>	<i>1</i>
507	<i>Filter setting selection in Fiery scanning</i>	<i>0</i>	<i>0-1</i>	<i>0: non-filter mode (OFF) 1: filter mode (ON)</i>	<i>1</i>
558	<i>Start setting of developer material counter image quality control</i>	<i>1</i>	<i>0-1</i>	<i>0: Disabled 1: Image quality control is started on each setting counter (08-559).</i>	<i>1</i>
559	<i>Start count setting of developer material counter image quality control</i>	<i>100</i>	<i>0-999</i>	<i>Image quality control start count is set when (08-558) is used</i>	<i>1</i>





Code	Name	Default	Allowable input value	Contents	Operation procedure group
601	<i>Secondary scanning reproduction ratio adjustment</i>	0		0: 100%; 1: 101%	1
603	<i>Automatic duplexing mode</i>	0	0-3	0: Disabled 1: Single-sided to Duplexed 2: Two-sided to Duplexed 3: User selection	1
604	<i>APS (Automatic Paper Selection) AMS (Automatic Magnification Selection) Mode priority at power on</i>	0	0-2	0: APS mode 1: AMS mode 2: None	1
605	SAPS mode	1		0: All originals detected; 1 First original only	1
606	Edge erase default setting	0		0: Invalid; 1: Valid	1



Code	Name	Default	Allowable input value	Contents	Operation procedure group
607	RADF priority mode	0	0-1	0: Continuous feeding by START key 1: SADF (Automatic feeding by setting originals)	1
608	Function clearing immediately after copying		0	0: Invalid; 1: Valid	1
611	Book duplexing copy priority (left/right page)	0	0-1	0: Left page to right page 1: Right page to left page	1
612	Image repeat gap	5	0-10mm		1
613	Universal cassette size	UC:12 EUR:13	0-13	0: A3 1: A4 2: A4-R 3: A5-R 4: B4 5: B5 6: B5-R 7: LT 8: LT-R 9: LD 10: LG 11: ST 12: COMPUTER 13: FOLIO	1
614	Function clearing LED flashing	1		0: Invalid; 1: Valid	1
615	Free size definition X	210	0 – 432 not used	0: Invalid; Other than 0: Valid	1
616	Free size definition Y	297	0 – 307 not used	0: Invalid; Other than 0: Valid	1
617	RADF image shifting	0	0-1	0: Without shift 1: With shift	1
618	Energy saver mode	0	0-1	0: Energy saver mode with priority aim of energy saving (Refer to 08-712) 1: Energy saver mode with priority aim of returning to copying (Refer to 08-713)	1
619	Initial value setting of center void width	10	0-50		1
620	APS forced start setting /selection	0	0-2	0: Single press of key 1: Double press of key 2: Disabled	1
624	Cut width for all-area copying	0		0 – 2 mm (unit: 0.1)	1
625	Blank paper prevention mode	0		0: Invalid; 1: Valid	1
628	Macro recognition function	1		0: Invalid; 1: Valid	1
629	Macro recognition function during ADF	1		0: Invalid; 1: Valid	1
630	Automatic bypass-tray/cassette change	0	0-1	0: Disabled 1: Enabled	1
631	Color release control for DF-ACS	0	0-1	0: Disabled 1: Enabled	1
632	Gradation correction disclosure level	1	0-2	0: Service technician 1: Administrator 2: User	1
633	By-department control: Black copies free	0		0: Invalid; 1: Valid	1
634	Initial value setting of image repeat frequency	2	2-8		1
635	RADF mixed size original priority	0	0-1	0: Same original size 1: Mixed original size	1





Code	Name	Default	Allowable input value	Contents	Operation procedure group
636	APS thick paper compatibility	0		0: Plain paper; 1: Thick paper; 2: Mixed	1
641	Automatic sorting mode priority from the RADF	0	0-3	0: OFF 1: STAPLE 2: SORT 3: GROUP	1
642	Sorter mode priority at power ON (for AC)	0	0-3	0: NON SORT 1: STAPLE 2: SORT 3: GROUP	1
649	Monochrome copying when empty of color toner	1		0: Prohibited; 1: Allowed	1
653	Machine administrator's password	0000	0000-9999		1
655	Off-level setting for auto off-mode	0		0: Power shutoff; 1: Low power	1
656	Execution mode for self diagnostic image processing	0	0 – 255	0: Normal; 1: Pulse; 2: $\gamma$ ; 3: Scanner correction 8 color conversion; 16: Other	1
664	Switching of aging ADF operation	0		0: Single-side; 1: Both-side	1
668	All clearing of ID codes	-			3
669	All clearing of image processing 05 adjustment values	-			3
670	All clearing of halfway results of color conversion	-			3
671	All clearing of pulse width selection adjustment results	-			3
672	All clearing of $\gamma$ correction table adjustment results	-			3
678	Mode memory initialization	-			3
679	Weekly timer initialization	-			3
681	Support for cascading exit	0~1		0: Invalid; 1: Valid	1
682	(Auto job start: Magazine-sort setting)	0		0: Left-hand opening; 1: Right-hand opening	0
700	Fuser thermistor status counter (C7 counter)	0	0-9	2: 2nd-time abnormality of thermistor/ heater at warming-up start 3: Unused 6: Thermistor abnormal after "ready" is attained. 9: Heater abnormal after "ready" is attained (high temp.)	1
712	Upper and lower fuser roller temperature for energy saver mode with priority aim of energy saving	2	0-6	0: OFF 1: 60°C 2: 70°C 3: 80°C 4: 115°C 5: 125°C 6: 135°C	1

Code	Name	Default	Allowable input value	Contents	Operation procedure group
713	Upper and lower fuser roller temperature for energy saver mode with priority aim of returning to copying	5	0-6	0:OFF 1:60°C 2:70°C 3:80°C 4:115°C 5:125°C 6:135°C	1
742	Color registration control	0	0-1	0: Automatic 1: Manual	1
743		1	0-1	0: Disabled 1: Enabled	1
* 801	Electronic total copy/print counter Color registration control for warming-up	0	0-999999	Electronic counter counts all copies and prints including all test mode copies. * The mechanical counter only counts the customers' copies and prints, not test mode copies or prints.	1
* 802	Large paper size double count	0	0-2	0: Disabled 1: Double count - A3, LD, A3 wide 2: Double count - A3, LD, A3 wide, B4, LG, FOLIO, COMP	1
803	Short-size counter (postcard -A4/LT)	0	0-999999	Display of counter value	1
804	Long-size counter (B4 - A3 wide)	0	0-999999	Display of counter value	1
* 805	<i>Full-color print counter (Copier)</i>	<i>0</i>	<i>0-999999</i>	<i>Display of counter value (Code 08-802 is reflected)</i>	<i>1</i>
* 806	<i>Black print counter (Copier)</i>	<i>0</i>	<i>0-999999</i>	<i>Display of counter value (Code 08-802 is reflected)</i>	<i>1</i>
* 807	<i>Mono-color print counter (Copier)</i>	<i>0</i>	<i>0-999999</i>	<i>Display of counter value (Code 08-802 is reflected)</i>	<i>1</i>
808	Bypass counter	0	0-999999	Display of counter value (Single count for every paper size)	1
809	LCF counter	0	0-999999	Display of counter value (Single count for every paper size)	1
* 810	Full-color print counter (Printer)	0	0-999999	Display of counter value (Code 08-802 is reflected)	1
* 811	Black print counter (Printer)	0	0-999999	Display of counter value (Code 08-802 is reflected)	1
* 812	Mono-color print counter (Printer)	0	0-999999	Display of counter value (Code 08-802 is reflected)	1
* 813	Test print counter	0	0-999999	In case of Test print, only this counter is counted. Display of counter value	1
814	Single-sided print counter	0	0-999999	Display of counter value (Single count for every paper size)	1

\* Refer to "Counter function and maintenance check list"





Code	Name	Default	Allowable input value	Contents	Operation procedure group
815	Duplexed print counter	0	0-999999	Display of counter value (Single count for every paper size)	1
817	Bypass jam counter	0	0-999999	Accumulated total of E12	1
818	Registration jam counter	0	0-999999	Jam on paper trailing edge by registration roller	1
820	Paper exit jam counter	0	0-999999	Accumulated total of E01, E02	1
822	ADU counter	0	0-999999	ADU feed counter Display of counter value (Single count for every paper size)	1
824	<i>RADF original counter</i>	<i>0</i>	<i>0-999999</i>	<i>RADF feed counter</i> <i>Display of counter value (Single count for every paper size)</i>	<i>1</i>
825	LCF jam counter	0	0-999999	Accumulated total of E19, E21	1
826	ADU paper-feed jam counter	0	0-999999	Accumulated total of E11, E54	1
827	ADU stack jam counter	0	0-999999	Accumulated total of E50, E51, E52	1
831	Key copy counter function	1	0-3	1: PPC 2: Printer 3: PPC/Printer	1
832	1st cassette counter	0	0-999999	Paper feed counter of 1st cassette Display of counter value (Single count for every paper size)	1
833	2nd cassette counter	0	0-999999	Paper feed counter of 2nd cassette Display of counter value (Single count for every paper size)	1
834	3rd cassette counter	0	0-999999	Paper feed counter of 3rd cassette Display of counter value (Single count for every paper size)	1
835	4th cassette counter	0	0-999999	Paper feed counter of 4th cassette Display of counter value (Single count for every paper size)	1
836	1st cassette jam counter	0	0-999999	Accumulated total of E13, E22	1
837	2nd cassette jam counter	0	0-999999	Accumulated total of E14, E23	1
838	3rd cassette jam counter	0	0-999999	Accumulated total of E15, E24	1
839	4th cassette jam counter	0	0-999999	Accumulated total of E16, E25	1
* 840	Drum Y life counter (display/0 clearing)	0	0-65535	Number of printed sheets Display of counter value (Code 08-858 is reflected)/0 clearing	1
* 841	Drum M life counter (display/0 clearing)	0	0-65535	Number of printed sheets Display of counter value (Code 08-858 is reflected)/0 clearing	1

\* Refer to "Counter function and maintenance check list"



Code	Name	Default	Allowable input value	Contents	Operation procedure group
* 842	Drum C life counter (display/0 clearing)	0	0-65535	Number of printed sheets Display of counter value (Code 08-858 is reflected)/0 clearing	1
* 843	Drum K life counter (display/0 clearing)	0	0-65535	Number of printed sheets Display of counter value (Code 08-858 is reflected)/0 clearing	1
* 844	Developer Y counter (display/0 clearing)	0	0-999999	Number of printed sheets Display of counter value (Code 08-858 is reflected)/0 clearing	1
* 845	Developer M counter (display/0 clearing)	0	0-999999	Number of printed sheets Display of counter value (Code 08-858 is reflected)/0 clearing	1
* 846	Developer C counter (display/0 clearing)	0	0-999999	Number of printed sheets Display of counter value (Code 08-858 is reflected)/0 clearing	1
* 847	Developer K counter (display/0 clearing)	0	0-999999	Number of printed sheets Display of counter value (Code 08-858 is reflected)/0 clearing	1
* 851	"Color" charger wire cleaner counter (display/0 clearing)	0	0-65535	Frequency that Y, M and C wire cleaning pads reciprocate	1
* 852	"Black" charger wire cleaner (display/0 clearing)	0	0-65535	Frequency that K wire cleaning pad reciprocates	1
* 853	Transfer-belt unit counter (display/0 clearing)	0	0-999999	Number of printed sheets Display of counter value (Code 08-858 is reflected)/0 clearing	1
* 854	Fuser unit counter (display/0 clearing)	0	0-999999	Number of printed sheets Display of counter value (Code 08-858 is reflected)/0 clearing	1
* 855	Fuser oil-roller counter (display/0 clearing)	0	0-999999	Number of printed sheets Display of counter value (Code 08-858 is reflected)/0 clearing	1
* 856	Fuser oil-roller time counter (display/0 clearing)	0	0-999999	Rotation time of fuser motor (sec.) Display of counter value/0 clearing	1
* 857	Counter setting for PM	0	0-999999	Counter value (number or sheets)	1
* 858	OHP/thick-paper double count	1	0-1	0: Disabled: Double count - A3 wide, A3, LD, B4, LG, FOLIO, COMP 1: Enabled: Quadruple count - A3 wide, A3, LD, B4, LG, FOLIO, COMP Double count - A4, A4-R, LT, LT-R, B5, B5-R, ST-R, A5, A6-R	1

\* Refer to "Counter function and maintenance check list"

Code	Name	Default	Allowable input value	Contents	Operation procedure group	
* 867	Drum Y drive counter (display/0 clearing)	0	0-999999	Rotation time of Y drum drive motor (sec.) Display of counter value/0 clearing	1	
* 868	Drum M drive counter (display/0 clearing)	0	0-999999	Rotation time of M drum drive motor (sec.) Display of counter value/0 clearing	1	
* 869	Drum C drive counter (display/0 clearing)	0	0-999999	Rotation time of C drum drive motor (sec.) Display of counter value/0 clearing	1	
* 870	Drum K drive counter (display/0 clearing)	0	0-999999	Rotation time of K drum drive motor (sec.) Display of counter value/0 clearing	1	
* 871	Developer Y time counter (display/0 clearing)	0	0-999999	Rotation time of color development motor (sec.) Display of counter value/0 clearing	1	
* 872	Developer M time counter (display/0 clearing)	0	0-999999	Rotation time of color development motor (sec.) Display of counter value/0 clearing	1	
* 873	Developer C time counter (display/0 clearing)	0	0-999999	Rotation time of color development motor (sec.) Display of counter value/0 clearing	1	
* 874	Developer K time counter (display/0 clearing)	0	0-999999	Rotation time of black development motor (sec.) Display of counter value/0 clearing	1	
 876	<i>Full color, large size copy counter</i>	<i>0</i>	<i>0 – 999999</i>		<i>1</i>	
877	<i>Full color, small size copy counter</i>	<i>0</i>	<i>0 – 999999</i>		<i>1</i>	
878	<i>Black, large size copy counter</i>	<i>0</i>	<i>0 – 999999</i>		<i>1</i>	
879	<i>Black, small size copy counter</i>	<i>0</i>	<i>0 – 999999</i>		<i>1</i>	
880	<i>Mono-color, large size copy counter</i>	<i>0</i>	<i>0 – 999999</i>		<i>1</i>	
881	<i>Mono-color, small size copy counter</i>	<i>0</i>	<i>0 – 999999</i>		<i>1</i>	
882	<i>Printer counter</i>	<i>Full-color</i>	<i>Long size</i>	<i>0</i>	<i>0 – 999999</i>	<i>1</i>
883			<i>Short size</i>	<i>0</i>	<i>0 – 999999</i>	<i>1</i>
884	<i>(Printer)</i>	<i>Black</i>	<i>Long size</i>	<i>0</i>	<i>0 – 999999</i>	<i>1</i>
885			<i>Short size</i>	<i>0</i>	<i>0 – 999999</i>	<i>1</i>
888	<i>Long size setting of Setting code (08-876~885)</i>		<i>2</i>	<i>1 – 2</i>	<i>1: A3, LD, A3W 2: A3, LD, A3W, B4, LG, FOLIO, COMP</i>	<i>1</i>
* 892	Current counter value for PM (display/0 clearing)	0	0-999999	Total number of sheets (Copier+printer) for life related (double count) Display of counter value (Code 08-858 are reflected.)/0 clearing	1	

\* Refer to "Counter function and maintenance check list"

Code	Name	Default	Allowable input value	Contents	Operation procedure group
* 894	Drum drive total counter for color PM time counter (display/0 clearing)	0	0-999999999	Rotation time(sec.) of Y, M and C drum drive motor Display of counter value/0 clearing	1
* 896	Current counter value for color PM (display/0 clearing)	0	0-9999999	Number of color printed sheets Display of counter value (Code 08-858 are reflected.)/0 clearing	1
* 897	Counter setting for color PM	0	0-9999999	Counter value (number of sheets)	1
* 898	Drum drive total counter for PM life-time counter (display/0 clearing)	0	0-999999999	Rotation time(sec.) of K drum drive motor Display of counter value/0 clearing	1
900	Firmware version (Basic part ROM)	-	-		2
902	Engine ROM version (LGC)	-	-		2
903	Engine ROM version (IMC)	-	-		2
904	SCAN ROM version	-	-		2
906	<i>Macro recognition, control version</i>	-			2
917	<i>Waiting time for requesting scanner resource acquisition</i>	3		<i>0: Invalid; 1 – 9: Set value x 5 seconds</i>	1
918	<i>Auto clearing if no copy paper is available during MFP</i>	0	When no copy paper is available, printing:	<i>0: Does not start; 1: Starts 0: Invalid; 1: Valid</i>	1
919	<i>Automatic printer restart during auto job start</i>	1		<i>0: Invalid; 1: Valid</i>	1
956	<i>Setting FC key when default cassette is empty of paper</i>	0		<i>0: Invalid; 1: Valid</i>	1
957	Position aligning icon displaying	0		0: Invalid; 1: Valid	1
958	Time setting icon displaying	0		0: Invalid; 1: Valid	1
961	<i>Scanning order in dual-page copying</i>	0		<i>0: From right; 1: From left</i>	1
997	<i>Long/Short size counter</i>	-	-	<i>List display of Money collection counter (08-876~885)</i>	2



\* Refer to "Counter function and maintenance check list"

<Operation procedure>

Group 1

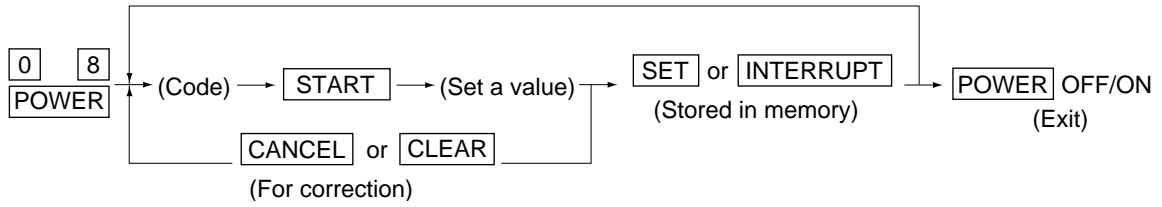

Group 2

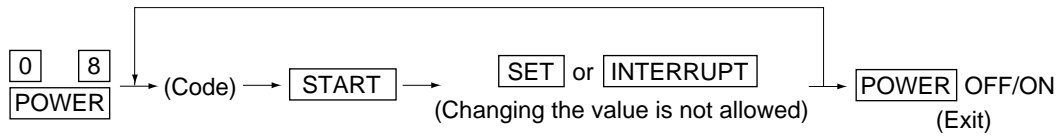

Group 3

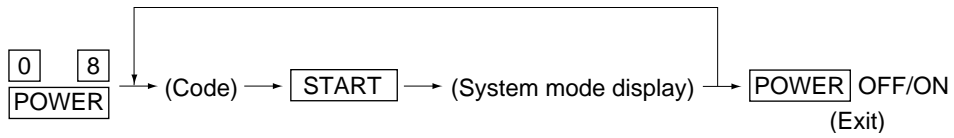



### 1. 2. 6 Registering/changing ID codes

When ID codes are registered, copy count will be classified according to each ID code. Copies cannot be made without entering one of the ID codes registered with digital keys.

Procedure for using the ID code mode:

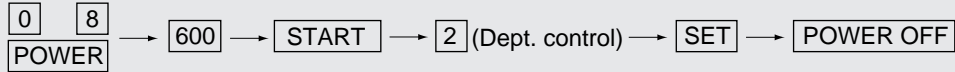

Procedure for registering ID codes:

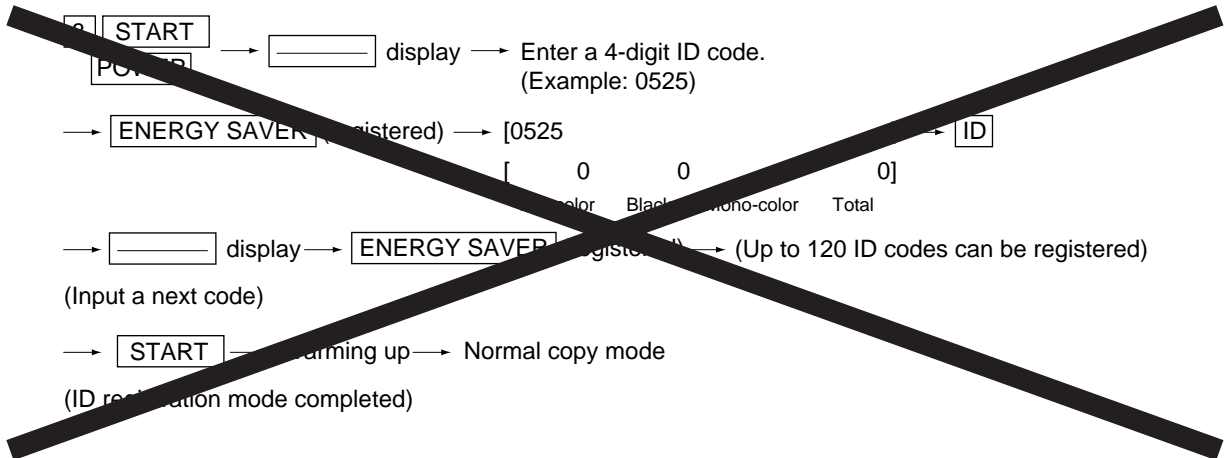

*Correcting ID code*

⑧ [START] → [0525] → ①  
[POWER] [ 0 0 0 0 ]

*Erasing an ID code:*

① → [CLEAR] → [ ] display → [ENERGY SAVER] (registered)

*Displaying the next ID code:*

① → [ID] → (Next ID code displayed)

*Adding an ID code*

① → While [ ] displayed → (Input an ID code) → [ENERGY SAVER] (registered)

*Changing the "full-color" counter:*

① → [HELP] → (Input a counter value) → [ENERGY SAVER] (registered)

*Changing the "black" counter:*

① → Press [HELP] twice → (Input a counter value) → [ENERGY SAVER] (registered)

*Changing the "mono-color" counter:*

① → Press [HELP] 3 times → (Input a counter value) → [ENERGY SAVER] (registered)

*To finish the registration mode and return to normal copy mode:*

① → [START] → Warming up → Normal copy mode

### 1.3 Adjustment Order (Copy Image Related Adjustment)

The diagram below explains the main procedures for image related adjustment.

When replacing components which have other specified instructions for adjustment, those specified instructions are to be obeyed in priority.

In the following diagram, the solid lines with arrow lead to essential adjustments, while the dotted lines lead to adjustments to be performed if necessary.

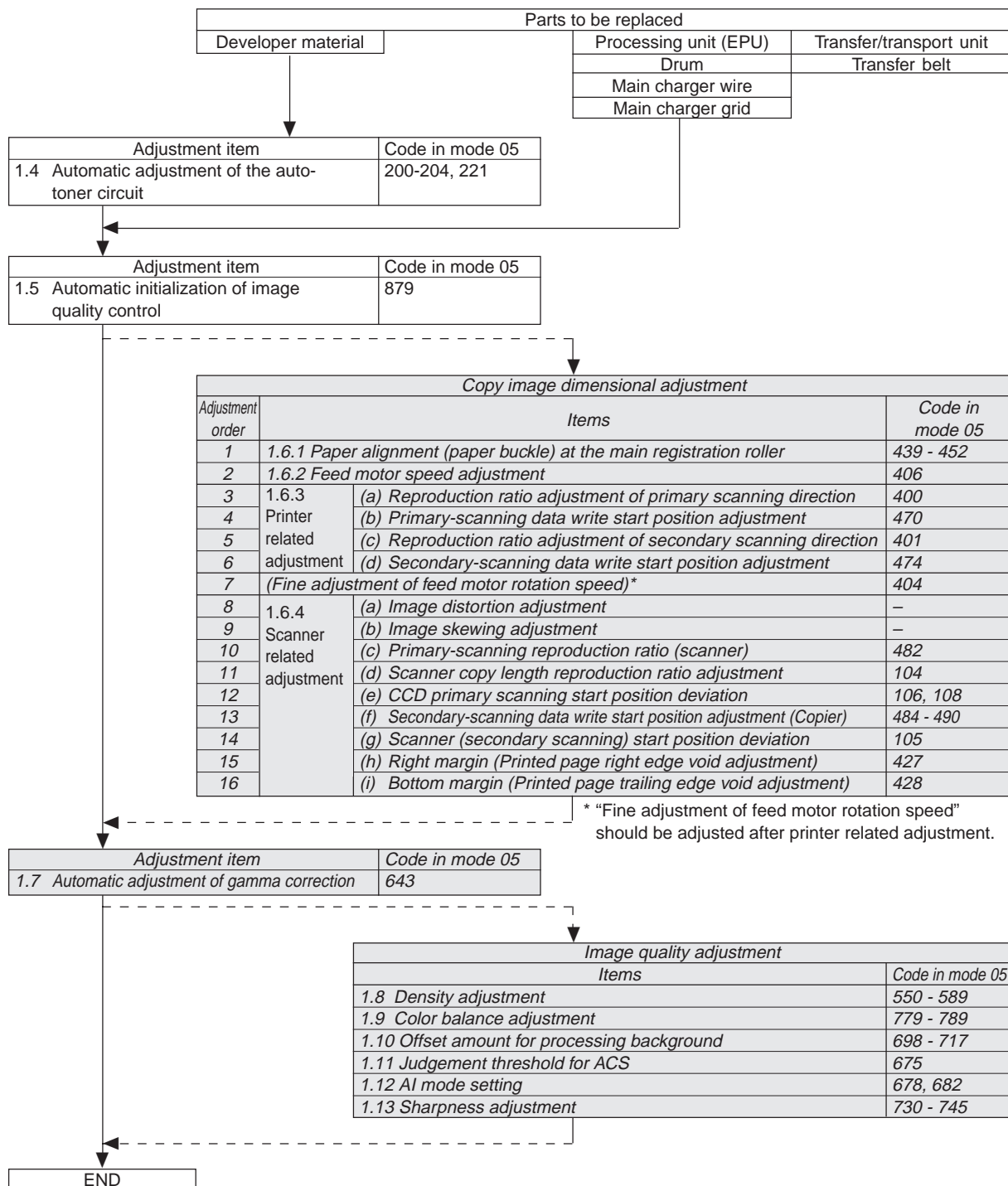

## 1.4 Automatic Adjustment of the Auto-Toner Circuit

With this copier, the filling and removing of developer material is automatically performed by operation from the control panel. In addition, the auto-toner sensor is automatically adjusted successively after the automatic filling of developer material.

<Operation procedure>

**Note:** At the time of unpacking, if developer material is not filled, the steps (3) and (4) below do not need to be performed.

- (1) Remove the toner cartridges.
- (2) While pressing [0] and [5] simultaneously, turn the power ON. The following appears on the display:

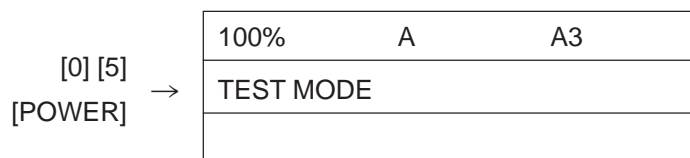

- (3) Input a code with digital keys and press the [START] key.→The developer material is removed.

Code 390 : All developer materials are removed (developer materials Y, M, C and K).

391 : All color developer materials are removed (developer materials Y, M and C).

392 : Only developer material K is removed.

- (4) After all developer materials are removed, press the [INTERRUPT] key.

Time required for removing All developer materials : Approx. 10 min.

Color developer materials only : Approx. 6 min.

Developer material K only : Approx. 3 min.

- (5) Open the front cover, install the developer cartridge(s) and then close the cover.

\* When installing or uninstalling the developer cartridge(s), it is necessary to open and close the front cover.

- (6) Input a code with digital keys and press the [START] key.

Code 200 : All developer materials                      221 : Color developer materials only

204 : Developer material K only

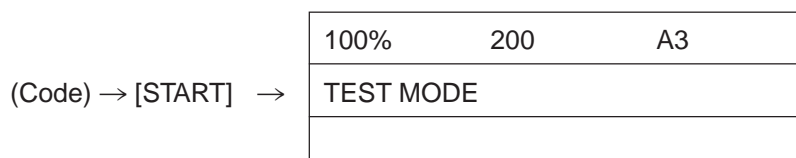



- (7) When the copier starts operating, a message “WAIT” is shown and the developer material filling starts (approx. 2 minutes and 30 seconds).

WAIT

- (8) Approx. 2 minutes after the developer material filling is finished, the following display appears:

Ⓑ →	Y:6.30V M:6.38V C:6.38V K:6.38V
Ⓒ →	61%
Ⓐ →	Y:4.00V M:4.00V C:4.00V K:4.00V

Upper line Ⓑ : Current sensor voltages (V)

Middle line Ⓒ : Humidity (%)

Lower line Ⓐ : Target values (V) for adjustment reference voltages

**Note:**

- The current sensor voltages (V) shown in Ⓑ automatically changes, gradually approaching the target values for adjustment reference voltages shown in Ⓐ.
- Values are displayed only for the developer materials being filled.

- (9) In 30 to 60 seconds, the current sensor voltages (V) in Ⓑ are converged to those in Ⓐ. The humidity shown in Ⓒ disappears, and the sensor output control values (bit values) are shown instead.

Ⓑ →	Y:4.00V M:4.00V C:4.00V K:4.00V
Ⓒ →	Y: 135 M: 135 C: 135 K: 135
Ⓐ →	Y:4.00V M:4.00V C:4.00V K:4.00V

**Note:** Be careful that the values in Ⓐ, Ⓑ and Ⓒ vary with humidity.

Ⓐ : Target value (V) for adjustment reference voltage

Humidity (%)	Y	M	C	K
~59.9	4.00	4.00	4.00	4.00
60.0~74.9	4.14	4.14	4.14	4.12
75.0~	4.35	4.35	4.35	4.31

Ⓑ : Current sensor voltage (V)

Humidity (%)	Y	M	C	K
~59.9	3.95~4.05	3.95~4.05	3.95~4.05	3.95~4.05
60.0~74.9	4.09~4.19	4.09~4.19	4.09~4.19	4.07~4.17
75.0~	4.30~4.40	4.30~4.40	4.30~4.40	4.26~4.36

(10) If an adjustment error occurs, values of the color in problem displayed in A, B or C are replaced with “\*\*\*”.

As for properly adjusted colors, press the [INTERRUPT] key to store their adjustment results in memory.

(11) Press the [INTERRUPT] key to store the adjustment results in memory. The screen returns to the initial display.

[INTERRUPT] →

100%	A	A3
TEST MODE		

(12) Remove the developer cartridge(s).

(13) Install the toner cartridge(s).

<Troubleshooting in auto-toner sensor adjustment> (measures against adjustment error)

Check which color is in adjustment error.

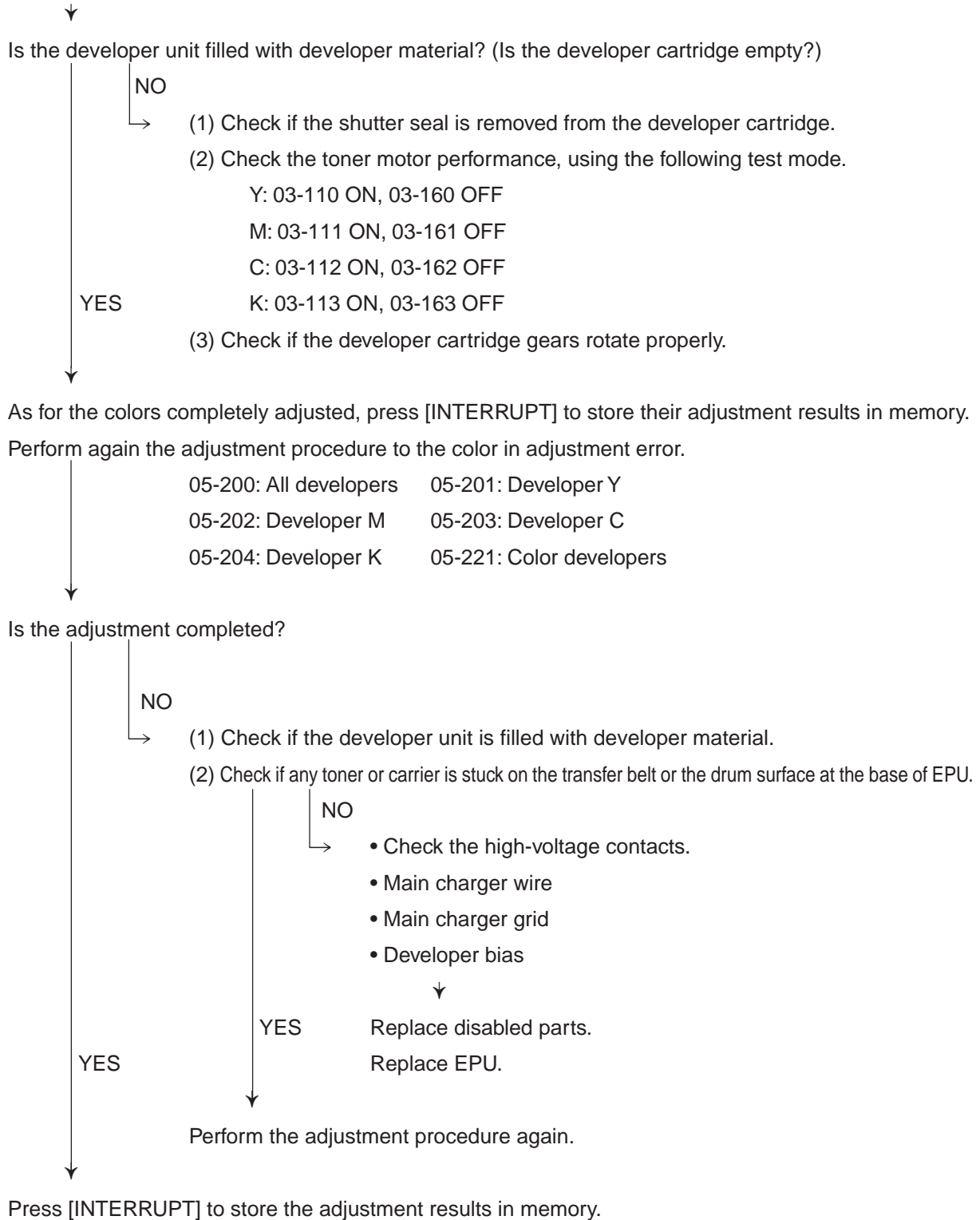

## 1.5 Automatic Initialization of Image Quality Control

(1) At the time of unpacking

Prior to copy-image dimensional adjustment, perform the 05-879 “Automatic initialization of image quality control” procedure.

(2) When any of the following parts is replaced, be sure to perform the 05-879 “Automatic initialization of image quality control” procedure.

- Processing unit
- Transfer belt unit
- Photoconductive drum
- Laser optical unit
- Image quality sensor
- Developer material

**Note:** When performing automatic adjustment of gamma correction in addition, “Automatic initialization of image quality control” should be done first.

(3) When performing automatic adjustment of gamma correction in cases other than the above ones, do the 05-878 “Forced performing of image quality control” procedure before automatic gamma value correction.

Code	Adjustment item	Content
878	Forced performing of image quality control	<p>&lt;Procedure&gt;</p> <p>(1) While pressing [0] and [5] simultaneously, turn the power ON. → Adjustment mode</p> <p>(2) Input [878] with digital keys and press [START].</p> <p>(3) When the adjustment finishes normally, the copier will return to the adjustment mode's initial state.</p> <p>If an abnormal condition has occurred, take appropriate action by referring to “4. TROUBLESHOOTING”.</p>
879	Automatic initialization of image quality control	<p>&lt;Procedure&gt;</p> <p>(1) While pressing [0] and [5] simultaneously, turn the power ON. → Adjustment mode</p> <p>(2) Input [879] with digital keys and press [START].</p> <p>(3) When the adjustment finishes normally, the copier will return to the adjustment mode's initial state.</p> <p>If an abnormal condition has occurred, take appropriate action by referring to “4. TROUBLESHOOTING”.</p>

## 1.6 Copy Image Dimensional Adjustment

There are several adjustment items in the copy image dimensional adjustment, as listed below. Prior to this image dimensional adjustment, perform the automatic initialization of image quality control (code [879] in adjustment mode 05). When adjusting these items, the following adjustment order should strictly be observed.

Adjustment items		Code in mode 05
① Paper alignment (paper buckle) at the main registration roller		439 – 452
② Feed motor speed adjustment		406
③ Printer related adjustment	(a) Reproduction ratio adjustment of primary scanning direction (Fine-adjustment of polygonal motor rotation speed)	400
	(b) Primary-scanning data write start position adjustment	470
	(c) Reproduction ratio adjustment of secondary scanning direction (Fine-adjustment of transfer belt motor rotation speed)	401
	(d) Secondary-scanning data write start position adjustment	474
④ Fine adjustment of feed motor rotation speed)*		404
⑤ Scanner related adjustment	(a) <i>Image distortion adjustment</i>	–
	(b) <i>Image skewing adjustment</i>	–
	(c) <i>Primary-scanning reproduction ratio (scanner)</i>	482
	(d) <i>Scanner copy length reproduction ratio adjustment</i>	104
	(e) <i>CCD primary-scanning start position deviation</i>	106, 108
	(f) <i>Secondary scanning data write start position adjustment (Copier)</i>	484 – 490
	(g) <i>Scanner (secondary scanning) start position deviation</i>	105
	(h) <i>Right margin (Printed page right edge void adjustment)</i>	427
	(i) <i>Bottom margin (Printed page trailing edge void adjustment)</i>	428



\* "Fine adjustment of feed motor rotation speed" should be adjusted after printer related adjustment.

[Procedure for inputting adjustment values]

In accordance with the procedure described below, make adjustment of each adjustment item so that the measured values obtained from test copies satisfy the specification. By pressing the [ENERGY SAVER] key, immediately after starting the adjustment mode "05", single-sided test copying can be performed (normal copy mode).

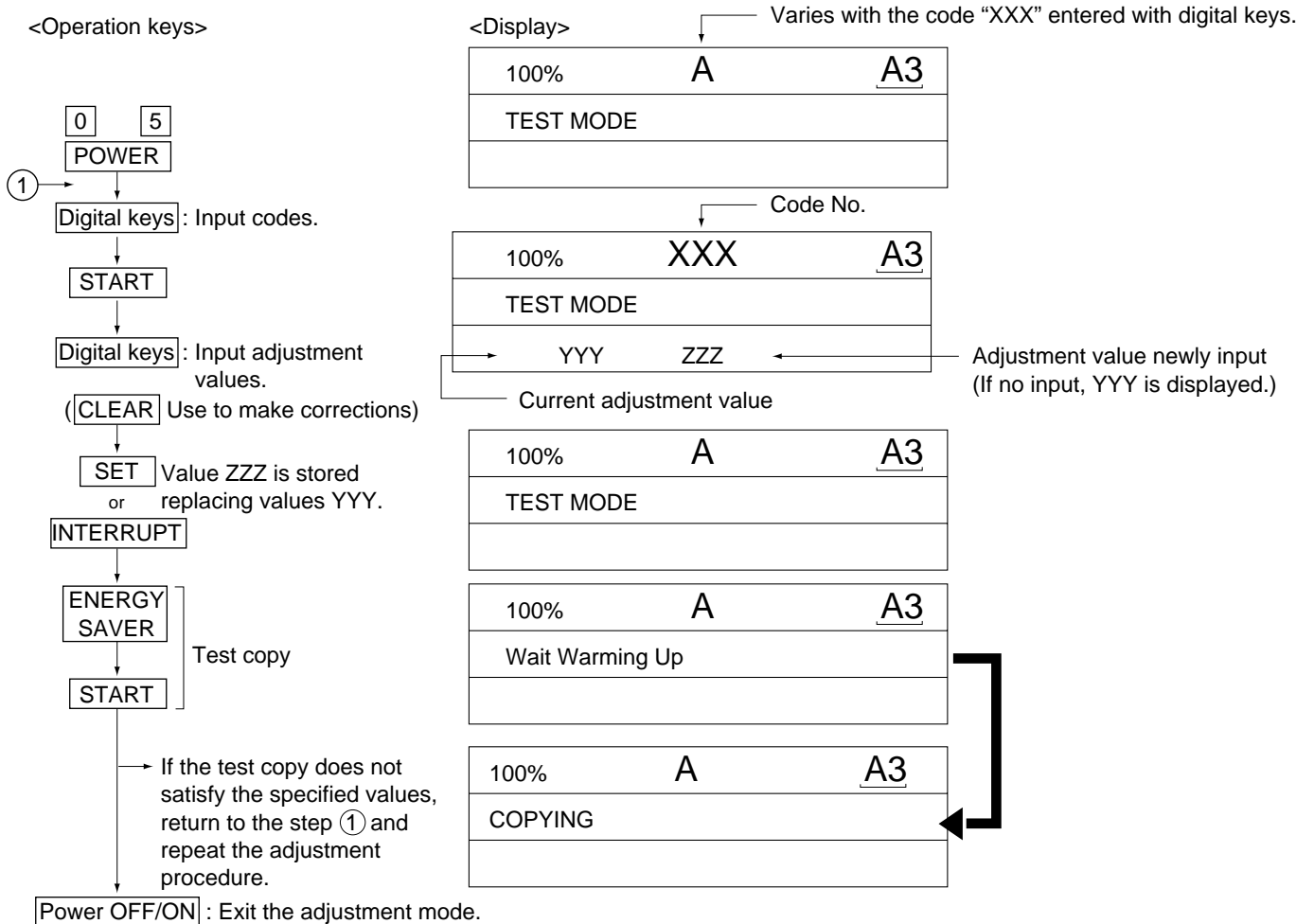

### 1. 6. 1 Paper alignment (paper buckle) at the main registration roller

If the paper feed roller has prematurely become defective, it is possible to extend its service life, if necessary, by increasing the aligning amount, as a temporary measure until a replacement becomes available.

<Operation procedure> (Use codes 439 to 452 in adjustment mode "05".)

	Copier cassettes				ADU	LCF	Bypass feeding	Thick paper2	Thick paper3
	1st cassette	2nd cassette	3rd cassette	4th cassette					
Long size	439	441	443	445	447				
Short size	440	442	444	446	448	449	450	451	452

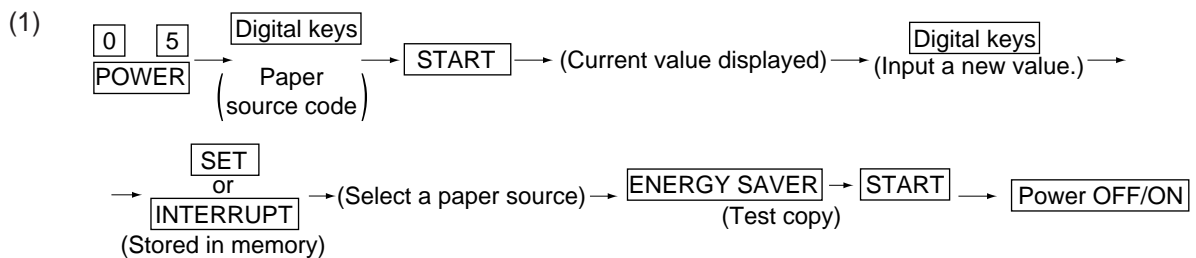

- (2) Check for any transfer void or "Z" fold. If a transfer problem is present, try the values in descending order as "31" → "30" → "29"... until the transfer void disappears. At the same time, confirm that any paper jam has not occurred. Also, when the aligning amount has been increased, this may increase the scraping sound which occurs when the paper scrapes on the mylar sheet as it is transferred by the registration roller. If this scraping sound is irritating, try reducing the aligning amount.
- (3) Do the same for ADU, LCF, bypass feeding, thick paper 2 and thick paper 3.

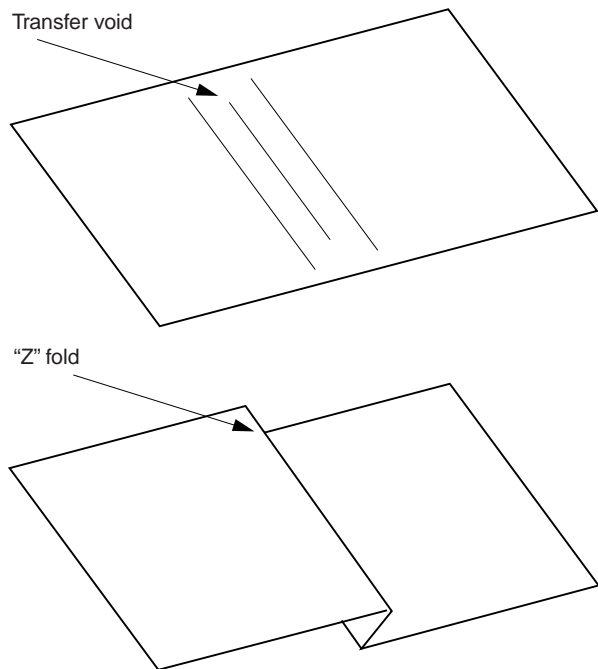

**Note:**

When paper thinner than specified is used, paper jams may occur frequently at the registration section. In this case, it is advisable to change (or reduce) the aligning amount. However, if the aligning amount is reduced too much, this could cause the leading edge void to vary adversely. So, when adjusting the aligning amount, try to choose the appropriate amount while checking the leading edge void at the same time.

### 1.6.2 Feed motor speed adjustment

The paper transport speed of the registration roller vis-a-vis the image print speed can be set to the optimum value.

<Procedure>

- (1) While pressing the digital keys [0] and [5] simultaneously, turn the power ON. (Adjustment mode)
- (2) Set five sheets of A4-R (LT-R) paper into the bypass tray.
- (3) Input [10] and press the [SETTINGS] key to perform the continuous printing of five "adjustment charts" from the bypass tray.
- (4) Since the printed sheets of "adjustment charts" are slightly shrunk after being fused, it is required to wait one or two minutes to cool them for precise adjustment. Then, set those five sheets again into the bypass tray in the same print direction, with the chart face upward.
- (5) Without changing the mode [05], enter [406] and press [START].  
While the "adjustment chart" sheets are fed and transported, the pitches in the black belt zone are read.
- (6) The step (5) is to be repeated five times automatically.  
The displayed set value does not change until the fourth printing round and at the final fifth round, a newly set value is displayed.
- (7) When a newly set value for aligning is displayed at the fifth round, press the [INTERRUPT] key to update the set value.  
If ERROR is displayed at the second paper feeding, press the [CLEAR] key and return to the step (2).



### 1. 6. 3 Printer related adjustment

(a) Reproduction ratio adjustment of primary scanning direction (Fine adjustment of polygonal motor rotation speed)

1. While pressing the digital keys [0] and [5] simultaneously, turn ON the power.→(Adjustment mode)
2. Press [1]→[SETTINGS]. (A grid pattern with 10 mm squares illustrated later is printed out. Use A3 (LD) from the 2nd cassette.)
3. Measure the distance A from the first grid line at the rear to the 21st of the grid pattern.
4. Check if the distance A is within  $200 \pm 0.5$  mm or not.
5. If it is not, use the following procedure to change values and repeat the steps 2. to 4. above.

<Procedure> (Adjustment mode)→(Input code [400] with digital keys)→[START]  
→(Input a value (acceptable values: 1209 to 1235) with digital keys)  
→[SET] icon or [INTERRUPT] key (Stored in memory)  
→(Input code [407] with digital keys)→[START]  
→Color registration control forced performing

\*The larger the adjustment value, the shorter the distance A becomes  
(0.082 %/step = 0.164 mm/step).

(b) Primary-scanning data write start position adjustment

1. While pressing the digital keys [0] and [5] simultaneously, turn ON the power.→(Adjustment mode)
2. Press [1]→[SETTINGS]. (A grid pattern with 10 mm squares is printed out. Use A3 (LD) from the 2nd cassette.)
3. Measure the distance B from the front edge of the paper to the 1st grid line from the front of the grid pattern.
4. Check if the distance B is within  $5 \pm 0.5$  mm or not.
5. If it is not, use the following procedure to change values and repeat the steps 2 to 4 above.

<Procedure> (Adjustment mode)→(Input code [470] with digital keys)→[START]  
→(Input a value (acceptable values: 0 to 255) with digital keys)  
→[SET] icon or [INTERRUPT] key (Stored in memory).  
→(Input code [407] with digital keys)→[START]  
→Color registration control forced performing

\*The larger the adjustment value, the longer the distance B becomes  
(0.0423 mm/step).

(c) Reproduction ratio adjustment of secondary scanning direction (Fine adjustment of transfer belt motor rotation speed)

1. While pressing the digital keys [0] and [5] simultaneously, turn ON the power.→(Adjustment mode)
2. Press [1]→[SETTINGS]. (A grid pattern illustrated later is printed out. Use A3 (LD) from the 2nd cassette.)
3. Measure the distance C from the 6th to 26th grid lines of the grid pattern.
4. Check if the distance C is within  $200 \pm 0.5$  mm or not.
5. If it is not, use the following procedure to change values and repeat the steps 2 to 4 above.

<Procedure> (Adjustment mode)→(Input code [401] with digital keys)→[START]→(Input a value (acceptable values: 1327 to 1382) with digital keys)→[SET] icon or [INTERRUPT] key (Stored in memory).→(Input code [407] with digital keys)→[START]→Color registration control forced performing

\*The larger the adjustment value, the shorter the distance C becomes ( $0.074 \text{ \%/step} = 0.15 \text{ mm/step}$ ).

(d) Secondary-scanning data write start position adjustment

1. While pressing the digital keys [0] and [5] simultaneously, turn ON the power.→(Adjustment mode)
2. Press [1]→[SETTINGS]. (The following grid pattern is printed out. Use A3 (LD) from the 2nd cassette.)
3. Measure the distance D from the leading edge of the paper to the 6th grid line of the grid pattern.
4. Check if the distance D is within  $55 \pm 0.5$  mm or not.
5. If it is not, use the following procedure to change values and repeat the steps 2. to 4. above.

<Procedure> (Adjustment mode)→(Input code [474] with digital keys)→[START]→(Input a value (acceptable values: 0 to 15) with digital keys)→[SET] icon or [INTERRUPT] key (Stored in memory).→(Input code [407] with digital keys)→[START]→Color registration control forced performing

\*The larger the adjustment value, the shorter the distance D becomes ( $0.6 \text{ mm/step}$ ).

**Note:** The reproduction ratio adjustment and the data write start position adjustment in the primary and secondary scanning directions have a connection as shown below.

1. When [05-400] is adjusted, [05-401, 402, 403, 404 and 474] are automatically adjusted.
2. When [05-401] is adjusted, [05-402, 403, 404 and 474] are automatically adjusted.
3. When [05-406] is adjusted, [05-404] is automatically adjusted.

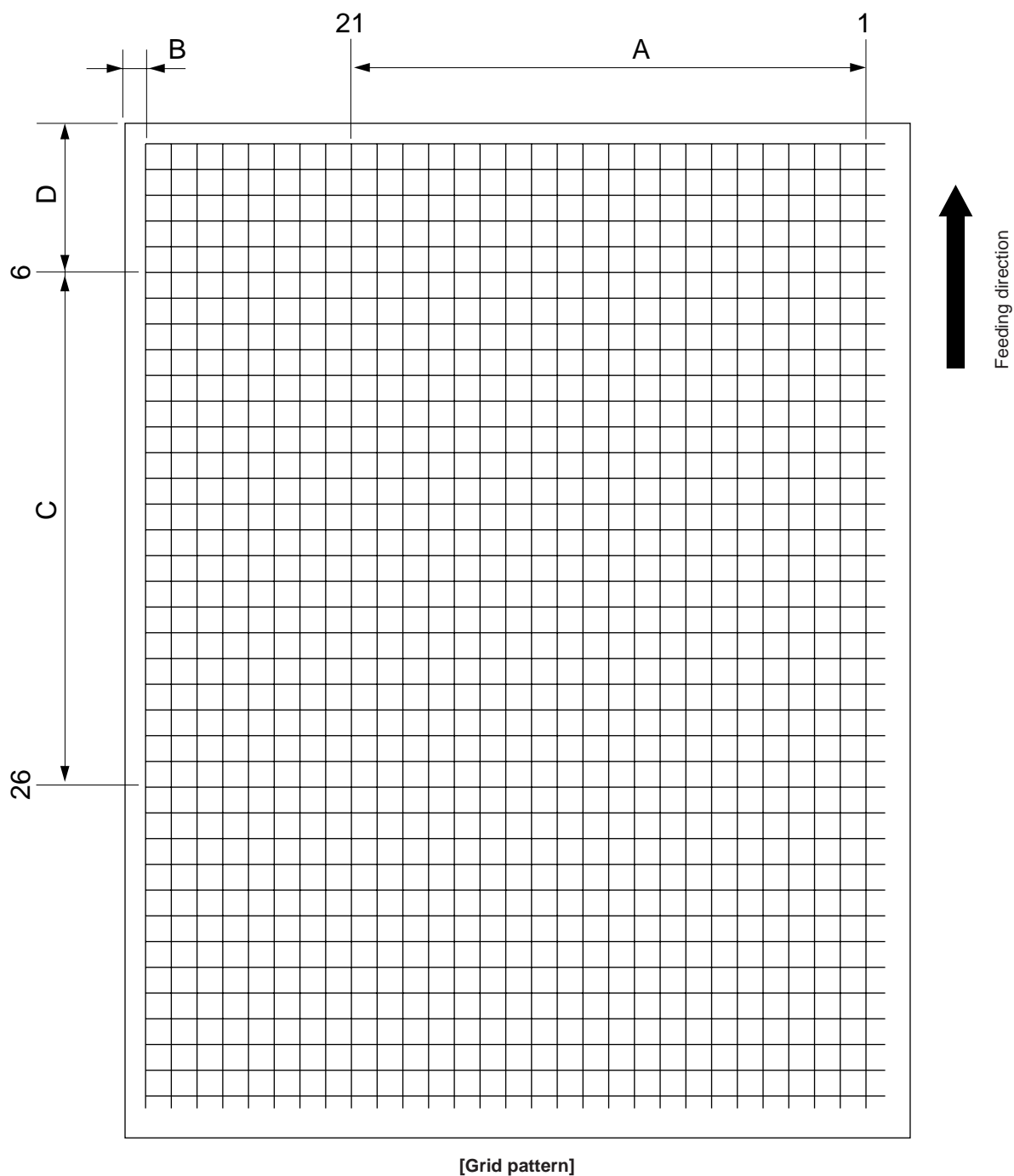

<Adjustment order>

[0] [5] [power ON] → [1] → [SETTINGS] (2nd cassette, A3/LD)

A: 05-400 → 200±0.5 mm (0.164 mm/step) → 05-407

B: 05-470 → 5±0.5 mm (0.042 mm/step) → 05-407

C: 05-401 → 200±0.5 mm (0.15 mm/step) → 05-407

D: 05-474 → 55±0.5 mm (0.6 mm/step) → 05-407

## 1.6.4 Scanner related adjustment

### (a) Image distortion adjustment

**Note:** The screws on the rear side of the mirrors 1 and 3 must not be adjusted.

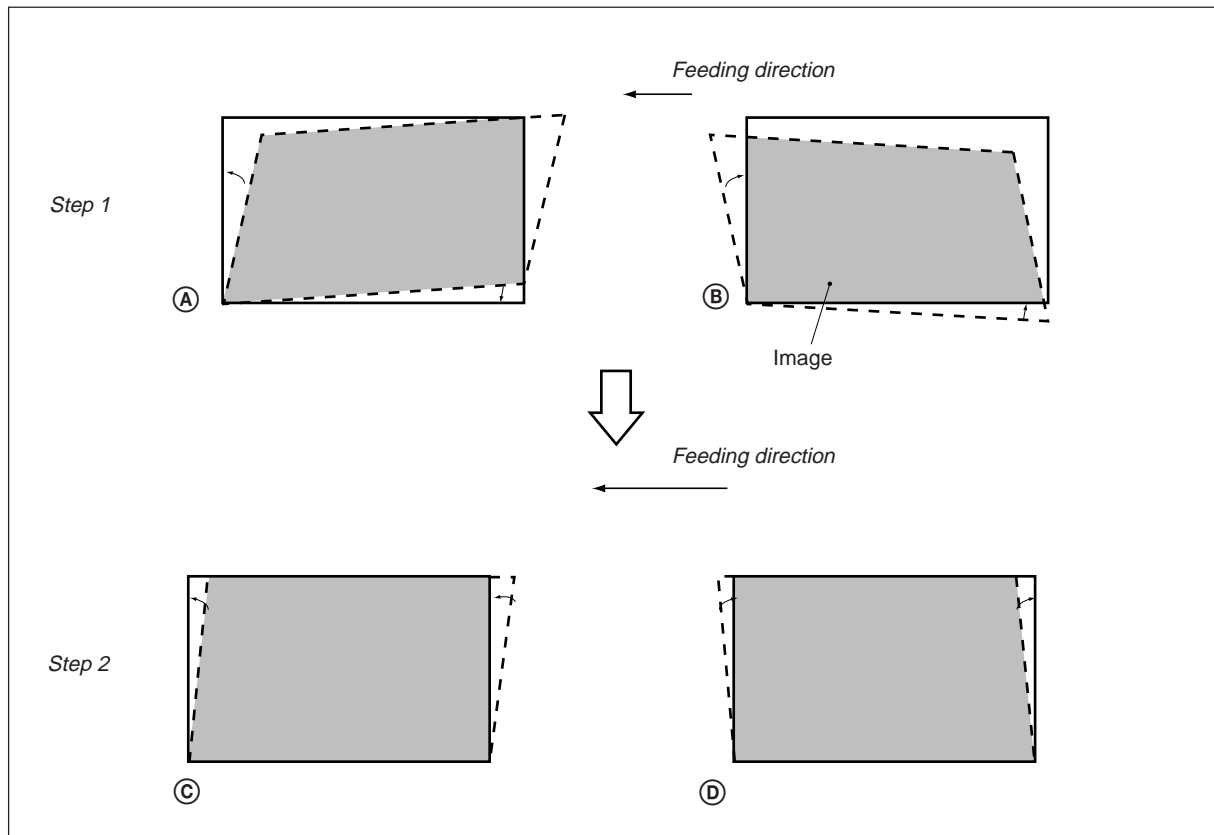

#### <Procedure>

Remove the original glass and the left top cover, and then move the carriage 1 toward the paper exit side until it stops. Insert a plus type screwdriver into the hole of the indicator unit and adjust the screws, following the step 1 to step 2.

#### Step 1

In case of (A):

Tighten the mirror-2 adjustment screw (CW).

→ Go to (C)

In case of (B):

Loosen the mirror-2 adjustment screw (CCW).

→ Go to (D)

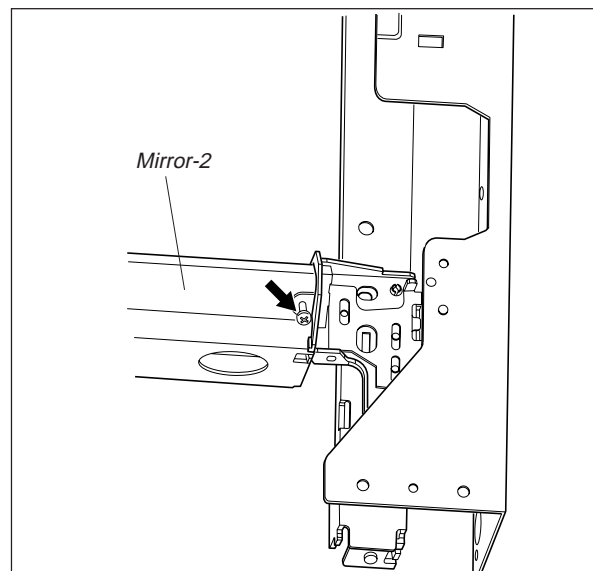

## Step 2

In case of ©:

Tighten the mirror-1 adjustment screw (CW).

→ Normal image

In case of Ⓓ:

Loosen the mirror-1 adjustment screw (CCW).

→ Normal image

**Note:** After the image distortion adjustment, when the adjustment screws of the mirror 1 and 2 are turned, lock the adjustment screws using the screw locking agent "BOND-1324".

### [Application Method of the Adhesive for the Screw Locking]

- (1) Adjust the image distortion.
- (2) Remove the original glass and the indicator unit.
- (3) Move the carriage 1 toward the paper exit side.
- (4) Apply the adhesive (BOND-1324) to the adjustment screws of carriage 1 and 2.

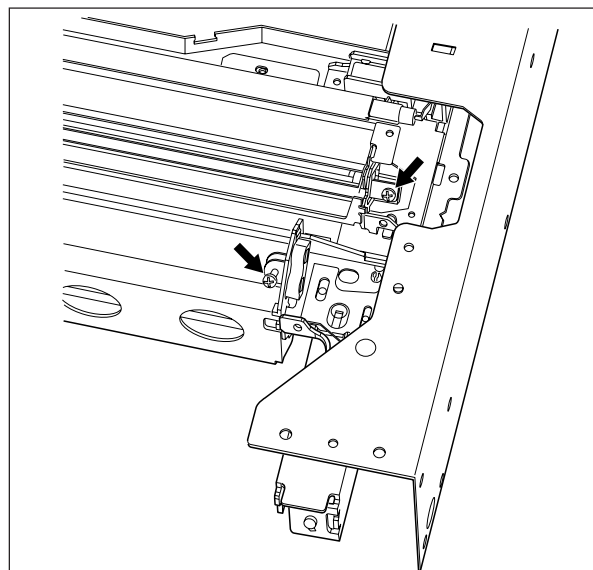
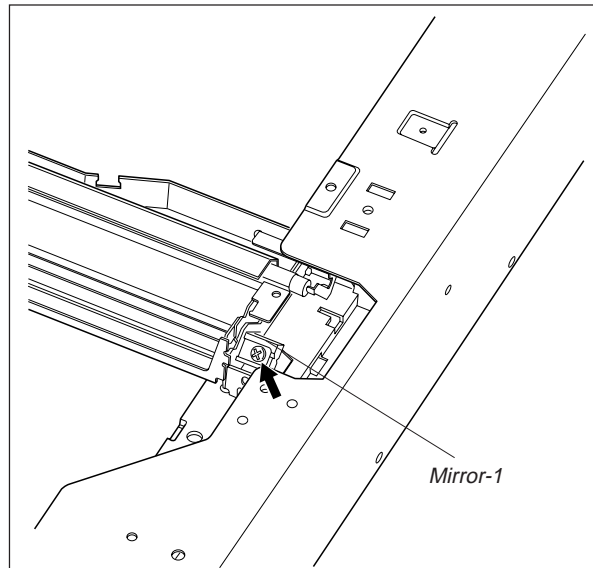

### **Note:** Application Method

\*Apply good quantity of the adhesive to the "Application area".

\*The adhesive needs 12 hours to harden completely.

- (5) Confirm that there is no dust or stain on the mirror 1, 2 or 3 or the shading correction plate.
- (6) Install the indicator unit and the original glass.

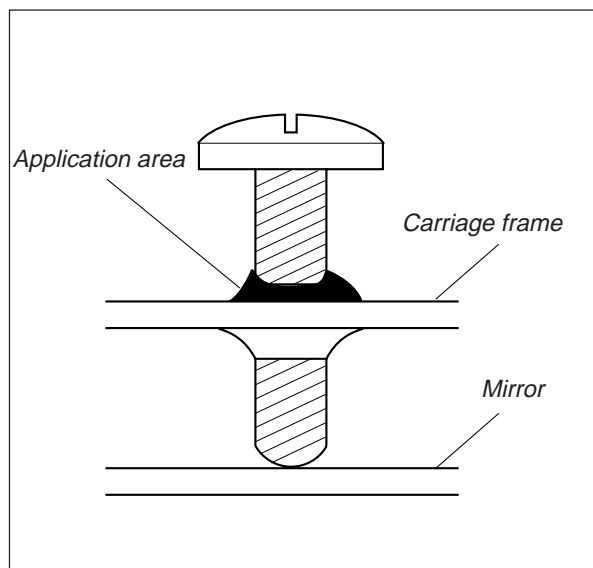

(b) Image skewing adjustment

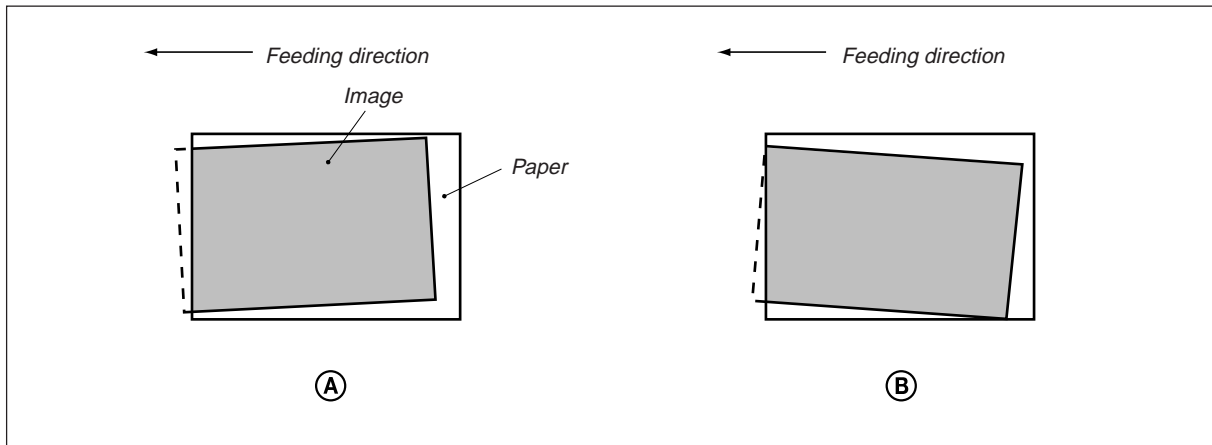

If the copy image is tilted even when the original is placed precisely against the original scale, adjust the original scale to correct this problem.

When the image is tilted as in (A):

- Adjust the original scale in the direction of the arrow A →.

When the image is tilted as in (B):

- Adjust the original scale in the direction of the arrow B ←.

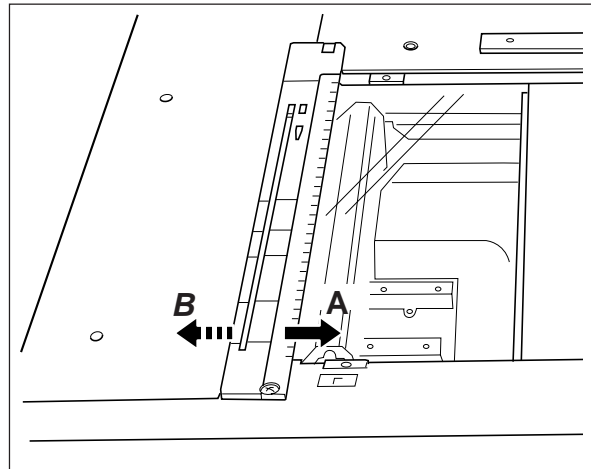

The following adjustments (c) to (i) should be conducted using Test Chart No. TCC-1. (Refer to page 1-64.)

(c) Primary-scanning reproduction ratio (Scanner)

1. While pressing the digital keys [0] and [5] simultaneously, turn the power ON. → (Adjustment mode)
2. Place Test Chart No. TCC-1 on the original glass (with the arrow positioned at the left rear side).
3. Press [ENERGY SAVER] → [START] to make a copy in the mode of A4 (LT), 100%, full color and text/photo.
4. Measure the distance A between M1 and M2 on the copy with a ruler.
5. Check if the distance A is within a range of  $200 \pm 0.5$  mm or not.
6. If it is not, change values using the following procedure, and repeat the steps 3. to 5. above.

<Procedure> (Adjustment mode) → (Input code [482] with digital keys) → [START] → (Input a value (acceptable values : 0 to 255) with digital keys) → [INTERRUPT] (Stored in memory) (Input code [407] with digital keys) → [START] → Color registration control forced performing

\* The larger the adjustment value, the shorter the distance A becomes (0.2 mm/step).

(d) Scanner copy length reproduction ratio adjustment

1. While pressing the digital keys [0] and [5] simultaneously, turn the power ON. → (Adjustment mode)
2. Place Test Chart No. TCC-1 on the original glass (with the arrow positioned at the left rear side).
3. Press [ENERGY SAVER] → [START] to make a copy in the mode of A4 (LT), 100%, full color and text/photo.
4. Measure the distance B between M3 and M4 on the copy with a ruler.
5. Check if the distance B is within a range of  $150 \pm 0.5$  mm or not.
6. If it is not, change values using the following procedure, and repeat steps 3. to 5. above.

<Procedure> (Adjustment mode) → (Input code [104] with digital keys) → [START] → (Input a value (acceptable values : 0 to 255) with digital keys) → [INTERRUPT] (Stored in memory) (Input code [407] with digital keys) → [START] → Color registration control forced performing

\* The larger the adjustment value, the longer the distance B becomes. (0.23 mm/step)

(e) CCD primary-scanning start position deviation

1. While pressing the digital keys [0] and [5] simultaneously, turn the power ON. → (Adjustment mode)
2. Place Test Chart No. TCC-1 on the original glass (with the arrow positioned at the left rear side).
3. Press [ENERGY SAVER] → [START] to make a copy in the mode of A4 (LT), 100%, full color and text/photo.
4. Measure the distance C from the left edge of the paper to the left-edge mark (5 mm) on the copy with a ruler.

5. Check if the distance C is within a range of  $5 \pm 0.5$  mm or not.
6. If it is not, change values using the following procedure, and repeat the steps 3. to 5. above.

<Procedure> (Adjustment mode) → (Input code [106] with digital keys) → [START] → (Input a value (acceptable values : 5 to 251) with digital keys) → [INTERRUPT] (Stored in memory)  
 \* The larger the adjustment value, the shorter the distance C becomes (0.042 mm/step).

7. When the distance C is within the acceptable range, perform the following procedure.

<Procedure> (Adjustment mode) → (Input code [108] with digital keys) → [START] → (Input a setting value with digital keys, deducting 47 from the value set in the code [106] adjustment mode 05) → [INTERRUPT] (Stored in memory)

(f) Secondary-scanning data write start position adjustment (Copier)

1. While pressing the digital keys [0] and [5] simultaneously, turn the power ON. → (Adjustment mode)
2. Place Test Chart No. TCC-1 on the original glass (with the arrow positioned at the left rear side).
3. Press [ENERGY SAVER] → [START] to make a copy in the mode of A4 (LT), 100%, full color and text/photo.
4. Measure the distance D from the upper paper edge to the upper write-start position on the copy with a ruler.
5. Check if the distance D is within a range of  $5 \pm 0.5$  mm or not.
6. If it is not, change values using the following procedure, and repeat the steps 3. to 5. above.

\* This adjustment should be done for each of the cassettes.

The adjustment order is : 2nd cassette → 1st cassette → 3rd cassette → 4th cassette → Bypass tray → LCF → ADU.

The adjustment code for each cassette is as follows:

1st cassette	: 484	2nd cassette	: 485	3rd cassette	: 486
4th cassette	: 487	Bypass tray	: 488	LCF	: 489
ADU	: 490				

<Procedure> (Adjustment mode) → (Input a code [485 to 490] with digital keys) → [START] → (Input a value (acceptable values : 0 to 15) with digital keys) → [INTERRUPT] (Stored in memory)

\* The larger the adjustment value, the longer the distance D becomes (0.6 mm/step).

(g) Scanner (secondary scanning) start position deviation

1. While pressing the digital keys [0] and [5] simultaneously, turn the power ON. → (Adjustment mode)
2. Place Test Chart No. TCC-1 on the original glass (with the arrow positioned at the left rear side).



3. Press [ENERGY SAVER] → [START] to make a copy in the mode of A4 (LT), 100%, full color and text/photo.
4. Measure the distance E from the upper paper edge to the upper mark (10 mm) on the copy with a ruler.
5. Check if the distance E is within a range of  $10 \pm 0.5$  mm or not.
6. If it is not, change values using the following procedure, and repeat the steps 3. to 5. above.

<Procedure> (Adjustment mode) → (Input code [105] with digital keys) → [START] → (Input a value (acceptable values : 128 to 135) with digital keys) → [INTERRUPT] (Stored in memory)  
 \* The larger the adjustment value, the longer the distance E becomes (0.12 mm/step).

(h) Right margin (Printed page right edge void adjustment)

1. While pressing the digital keys [0] and [5] simultaneously, turn the power ON. → (Adjustment mode)
2. Place Test Chart No. TCC-1 on the original glass (with the arrow positioned at the left rear side).
3. Press [ENERGY SAVER] → [START] to make a copy in the mode of A4 (LT), 100%, full color and text/photo.
4. Measure the blank area F to the right of the copy image with a ruler.
5. Check if the blank area F is within a range of  $2 \pm 0.5$  mm or not.
6. If it is not, change values using the following procedure, and repeat the steps 3. to 5. above.

<Procedure> (Adjustment mode) → (Input code [427] with digital keys) → [START] → (Input a value (acceptable values : 0 to 255) with digital keys) → [INTERRUPT] (Stored in memory)  
 \* The larger the adjustment value, the larger the blank area becomes (0.042 mm/step).

(i) Bottom margin (Printed page trailing edge void adjustment)

1. While pressing the digital keys [0] and [5] simultaneously, turn the power ON. → (Adjustment mode)
2. Place Test Chart No. TCC-1 on the original glass (with the arrow positioned at the left rear side).
3. Press [ENERGY SAVER] → [START] to make a copy in the mode of A4 (LT), 100%, full color and text/photo.
4. Measure the blank area G beneath the copy image with a ruler.
5. Check if the blank area G is within a range of  $2.5 \pm 0.5$  mm or not.
6. If it is not, change values using the following procedure, and repeat the steps 2 to 4 above.

<Procedure> (Adjustment mode) → (Input code [428] with digital keys) → [START] → (Input a value (acceptable values : 0 to 255) with digital keys) → [INTERRUPT] (Stored in memory)  
 \* The larger the adjustment value, the larger the blank area becomes (0.042 mm/step).

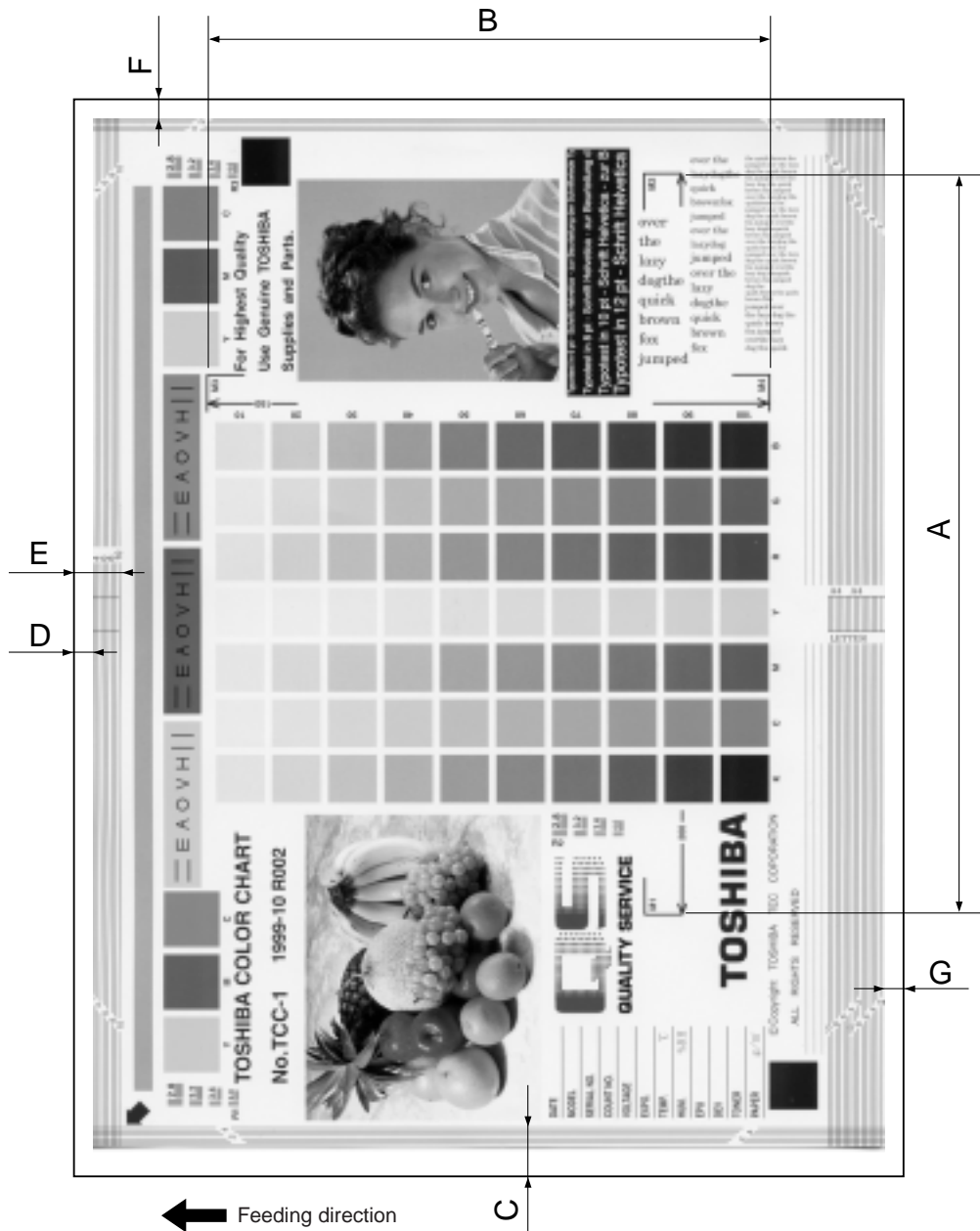

[Chart TCC-1]

<Adjustment order>

[0][5][Power ON] → (Chart TCC-1) → [ENERGY SAVER] → [START] (A4/LT, 100%, full color and text/photo)

A: 05-482 → 200±0.5 mm (0.2 mm/step) → 05-407

B: 05-104 → 150±0.5 mm (0.23 mm/step) → 05-407

C: 05-106 → 5±0.5 mm (0.042 mm/step)

D: 05-485(2nd), 484(1st), 486(3rd), 487(4th), 488(bypass), 489(LCF) and 490(ADU) → 5±0.5 mm (0.6 mm/step)

E: 05-105 → 10±0.5 mm (0.12 mm/step)

F: 05-427 → 2±0.5 mm (0.042 mm/step)

G: 05-428 → 2.5±0.5 mm (0.042 mm/step)

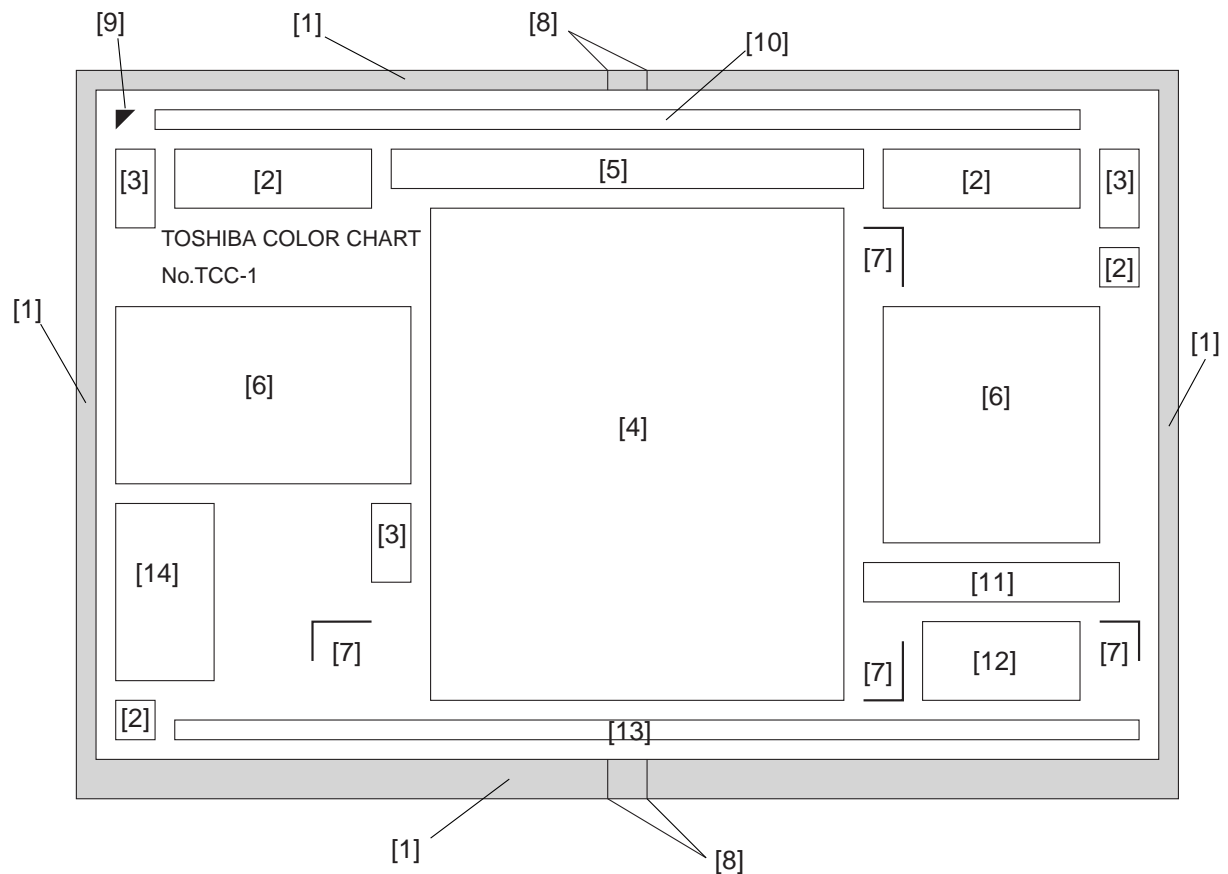

- |                                    |   |
|------------------------------------|---|
| [1] Grid lines                     | : For adjusting margin (void) and scanner section   |
| [2] YMCK patches                   | : For checking uniformity   |
| [3] Resolution pattern             | : For checking resolution   |
| [4] Gradation pattern              | : Gradation pattern of seven colors (Y, M, C, R, G, B and K)<br>Coverage ratio: 10-100%<br>For adjusting the halftone reproduction and gray balance |
| [5] Color registration pattern     | : For checking color registration   |
| [6] Pictures                       | : For checking color reproduction and moire   |
| [7] Magnification lines            | : For checking the magnification error of primary and secondary scanning directions   |
| [8] Center lines                   | : Center lines for A4/LT sizes  |
| [9] Arrow                          | : A mark for placing the chart properly onto the original glass (place it to the left rear corner of the original glass).                           |
| [10] Halftone band                 | : For checking uniformity   |
| [11] White text on the black solid | : For checking the reproduction of white text on black solid  |
| [12] Text                          | : For checking reproduction of text   |
| [13] Thin lines                    | : For checking reproduction of the thin lines (line width: 100µm).  |
| [14] Note area                     | : For recording the date, conditions, etc.  |

## 1.7 Automatic Adjustment of Gamma Correction

(1) At the time of unpacking:

When the reproduction of gradation is not appropriate, the gradation reproducibility of all colors Y, M, C and K can be corrected by performing this automatic adjustment of gamma correction. Check the image, and if the gradation reproduction is not satisfactory, make this adjustment as described below.

(2) When any of the following parts has been replaced, be sure to make this adjustment:

- Laser optical unit
- Drum
- Developer material

(3) When any of the following parts are replaced or adjusted, make a copy and check the image to determine if the adjustment is necessary:

- Main charger
- Transfer belt

**Note:** Be sure that this adjustment be made after performing the copy image adjustment in "1.5 Automatic Initialization of Image Quality Control" and "1.6 Copy Image Dimensional Adjustment".

Code	Adjustment item	Content
643	Automatic adjustment of gamma correction	<p>&lt;Procedure&gt; Adjustment of Text or Map mode</p> <p>(1) While pressing [0] and [5] simultaneously, turn the power ON. → Adjustment mode</p> <p>(2) Press [4] → [SETTINGS] and output a "Patch chart for gamma adjustment".</p> <p>(3) Place the "Patch chart for gamma adjustment" produced in step (2), face down onto the original glass, with the side, on which a black band is present, precisely against the original scale.</p> <p>(4) Input code [643] with digital keys and press [START].</p> <p>(5) Input [2] with digital keys, and press [START] and then [INTER-RUPT] → The scanner reads the original automatically and performs automatic gamma adjustment calculation (approx. 30 sec.).</p> <p>(6) When the adjustment ends normally, "SCAN COMPLETE" is shown. Press [START] to have the adjustment results reflected. (To cancel the reflection of adjustment results, press [STOP].) When "COMPLETE" is shown, press [STOP] to return to the standby state.</p> <p>In the case of an abnormal ending, "ADJUSTMENT ERROR" is shown. Press [STOP] to clear the error display. When it is cleared, the control panel display will return to the standby state. Then, check if the gradation pattern image on the original glass is oriented in the wrong direction or if it is placed inclined on the original glass, and then repeat step (3) and afterward.</p>

		<p><i>&lt;Adjustment of other modes&gt;</i></p> <ol style="list-style-type: none"> <li><i>(1) While pressing [0] and [5] simultaneously, turn the power ON. → Adjustment mode</i></li> <li><i>(2) Press [5] → [SETTINGS] to output a "Patch chart for gamma adjustment".</i></li> <li><i>(3) Place the "Patch chart for gamma adjustment" produced in step (2), face down onto the original glass, with the side, on which a black band is present, precisely against the original scale.</i></li> <li><i>(4) Input code [643] with digital keys and press [START].</i></li> <li><i>(5) Input [3] with digital keys, and press [START] and then [INTER-RUPT]. → The scanner reads the original automatically and performs automatic gamma adjustment calculation (approx. 30 sec.).</i></li> <li><i>(6) When the adjustment ends normally, "SCAN COMPLETE" is shown. Press [START] to have the adjustment results reflected. (To cancel the reflection of adjustment results, press [STOP].) When "COMPLETE" is shown, press [STOP] to return to the standby state.</i></li> </ol> <p><i>In the case of an abnormal ending, "ADJUSTMENT ERROR" is shown. Press [STOP] to clear the error display. When it is cleared, the control panel display will return to the standby state. Then, check if the gradation pattern image on the original glass is oriented in the wrong direction or if it is placed inclined on the original glass, and then repeat step (3) and afterward.</i></p>
--	--	--

## 1.8 Density Adjustment

The center density and the density variation controlled by density adjustment keys can be adjusted as follows.

Color mode	Copy mode					Items to be adjusted	Remarks
	Text/photo	Text	Printed image	Photo	Map		
Full color	550	551	552	553	554	Manual-density center value	The larger the value, the darker the image becomes.
	560	561	562	563	564	Manual-density "dark" step value	The larger the value, the darker the "dark" side becomes.
	570	571	572	573	574	Manual-density "light" step value	The larger the value, the lighter the "light" side becomes.
	580	581	582	583	584	Automatic density	The larger the value, the darker the image becomes.
Black	555	556	557	558	559	Manual-density center value	The larger the value, the darker the image becomes.
	565	566	567	568	569	Manual-density "dark" step value	The larger the value, the darker the "dark" side becomes.
	575	576	577	578	579	Manual-density "light" step value	The larger the value, the lighter the "light" side becomes.
	585	586	587	588	589	Automatic density	The larger the value, the darker the image becomes.

Make a test copy and compare the image obtained with the current settings; if necessary, make adjustment using the following procedure.

### <Procedure>

- (1) While pressing [0] and [5] simultaneously, turn the power ON.
- (2) Input the code of required mode (color mode, copy mode, item to be adjusted) with digital keys and press the [START] key.
- (3) Input an adjustment value with digital keys (acceptable values: 0 to 255).  
(To correct an input value, press the [CLEAR] key.)
- (4) Press the [SET] icon or [INTERRUPT] key to store the value. → The copier goes back to the standby state.
- (5) Press the [ENERGY SAVER] key and then press the [START] key to make a test copy.
- (6) If the desired image density has not been attained, repeat the steps (2) to (5).

## 1.9 Color Balance Adjustment

	Copy mode					Item to be adjusted	Remarks
	Text/ photo	Text	Printed image	Photo	Map		
Adjustment code	779	780	781	782	783	Yellow	The larger the value, the darker the color to be adjusted becomes. Acceptable values: 0 to 255
Sub code	0	0	0	0	0	Low density	
	1	1	1	1	1	Medium density	
	2	2	2	2	2	High density	
Adjustment code	784	785	786	787	788	Magenta	
Sub code	0	0	0	0	0	Low density	
	1	1	1	1	1	Medium density	
	2	2	2	2	2	High density	
Adjustment code	789	790	791	792	793	Cyan	
Sub code	0	0	0	0	0	Low density	
	1	1	1	1	1	Medium density	
	2	2	2	2	2	High density	
Adjustment code	794	795	796	797	798	Black	
Sub code	0	0	0	0	0	Low density	
	1	1	1	1	1	Medium density	
	2	2	2	2	2	High density	

Make a test copy and compare the image obtained with the current settings; if necessary, make adjustment using the following procedure.

**Note:** Be sure that this adjustment be made after performing "1.7 Automatic Adjustment of Gamma Correction".

<Procedure>

- (1) While pressing [0] and [5] simultaneously, turn the power ON.
- (2) Input the code of required mode (color mode, copy mode, item to be adjusted) with digital keys and press the [START] key.
- (3) Select the density area to be adjusted with digital keys (0, 1 or 2), and press the [START] key.  
0 : Low density (L)   1 : Medium density (M)   2 : High density (H)
- (4) Input an adjustment value with digital keys.  
(To correct an input value, press the [CLEAR] key.)
- (5) Press the [SET] icon to have the value memorized. → Returns to the display in (3).
- (6) For resetting the value, repeat the steps (3) to (5).
- (7) Press the [SET] icon or [INTERRUPT] key to store the value in memory. → The copier goes back to the standby state.
- (8) Press the [ENERGY SAVER] key and then press the [START] key to make a test copy.
- (9) If the desired image density has not been attained, repeat the steps (2) to (8).

## 1. 10 Offset Amount for Processing Background

The density of background and text can be adjusted as follows.

Color mode	Copy mode					Item to be adjusted	Remarks
	Text/photo	Text	Printed image	Photo	Map		
Full color	698	699	700	701	702	Offset value for background	The larger the value, the darker the background becomes.
	708	709	710	711	712	Offset value for text	The smaller the value, the darker the text becomes.
Black	703	704	705	706	707	Offset value for background	The larger the value, the darker the background becomes.
	713	714	715	716	717	Offset value for text	The smaller the value, the darker the text becomes.

Make a test copy and compare the image obtained with the current settings; if necessary, make adjustment using the following procedure.

### <Procedure>

- (1) While pressing [0] and [5] simultaneously, turn the power ON.
- (2) Input the code of required mode (color mode, copy mode, item to be adjusted) with digital keys and press the [START] key.
- (3) Input an adjustment value with digital keys.  
(To correct an input value, press the [CLEAR] key.)
- (4) Press the [SET] icon or [INTERRUPT] key to store the value in memory.→The copier goes back to the standby screen.
- (5) Press the [ENERGY SAVER] key and then press the [START] key to make a test copy.
- (6) If the desired image density has not been attained, repeat the steps (2) to (5).



### **1. 11 Judgment Threshold for ACS**

*The judgment level is adjusted for the automatic identification of whether the original set on the glass is monochrome or color. Namely, this is to adjust the judgment level used when "Auto color" is selected in the color mode.*

<i>Code</i>	<i>Adjustment item</i>	<i>Content</i>
675	Judgment threshold for ACS	<i>The larger the value, the more an original tends to be judged to be monochrome, and the smaller the value, the more it tends to be judged to be color.</i>

## 1. 12 AI Mode Setting

### (a) AI mode discrimination setting

Select the discrimination level in the AI mode as follows:

Code	Adjustment item	Content
678	AI mode Discrimination setting	<p>&lt;Procedure&gt;</p> <p>(1) While pressing [0] and [5] simultaneously, turn ON the power.</p> <p>(2) Input code [678] with digital keys.</p> <p>(3) Input an appropriate setting value:</p> <ul style="list-style-type: none"><li>0 : Standard (for regular)</li><li>1 : Photograph priority</li><li>2 : Only judgement of original type</li><li>3 : Only judgement of original type with photograph priority</li><li>4 : No AI discrimination</li></ul> <p>(4) Press [SET] icon or the [INTERRUPT] key to store the adjustment value.</p>

### (b) AI mode time-out setting

Set the maximum processing time allowable during the AI mode. Two kinds of setting are made, one for originals of A4 or smaller sizes, and the other for originals larger than A4.

**Note:** In case discrimination does not finish, stop AI mode discrimination and copy in the selected copy mode.

Code	Adjustment item	Content
682	AI mode Time-out setting	<p>&lt;Procedure&gt;</p> <p>(1) While pressing [0] and [5] simultaneously, turn ON the power.</p> <p>(2) Input code [682] with digital keys.</p> <p>(3) Input an appropriate setting value:</p> <p>The setting value should be two digits; the lower digit is the time-out period (seconds) for A4 original size, and should be in the range of 1 to 9. The upper digit is the time-out period for A3 original size, and should be in the range of 1 to 9. However, time is set in proportion to original sizes for originals larger than A4, based on A4 or A3 setting value.</p> <p>(4) Press [SET] icon or the [INTERRUPT] key to store the setting value.</p>

## 1. 13 Sharpness Adjustment

If you want to make copy images look softer or sharper, perform the following adjustment. The adjustment can be made for each of the color modes and image modes independently.

Code	Color mode	Copy mode	Content
730	Full color	Text/photo (text area)	<ul style="list-style-type: none"> <li>The larger the value, the sharper the image becomes; while the smaller the value, the softer the image becomes.</li> <li>The smaller the value, the less moire tends to appear.</li> <li>The permissible range of values : 0 to 31. The center value is 16. However, 0 is equivalent to the center value.</li> </ul>
731		Text/photo (photo area)	
732		AI (text area)	
733		AI (photo area)	
734		Text	
735		Printed image	
736		Photo	
737		Map	
738	Black	Text/photo (text area)	<p><b>Note:</b> In the text/photo and AI modes, you can make adjustment for text area and photo area independently, but in the other modes, you have to make adjustment by compromising between moire and sharpness.</p>
789		Text/photo (photo area)	
740		AI (text area)	
741		AI (photo area)	
742		Text	
743		Printed image	
744		Photo	
745		Map	

Make a test copy and compare the image obtained with the current settings; if necessary, make adjustment using the following procedure.

### <Procedure>

- (1) While pressing [0] and [5] simultaneously, turn the power ON.
- (2) Input the code of required mode (color mode, copy mode, items to be adjusted) with digital keys and press the [START] key.
- (3) Input an adjustment value with digital keys.  
(To correct an input value, press the [CLEAR] key.)
- (4) Press the [SET] icon or [INTERRUPT] key to store the value in memory.→The copier goes back to the standby state.
- (5) Press the [ENERGY SAVER] key and then press the [START] key to make a test copy.
- (6) If the desired image density has not been attained, repeat the steps (2) to (5).

## 1.14 High-Voltage Transformer Settings

### 1.14.1 Overview

This machine uses four main high-voltage transformers for charging/development/discharging and one transfer transformer for transfer/suction.

The main high-voltage transformers (PS-HVT-M-310) are used each for one of the colors Y, M, C and K, giving a total of four units.

The transfer transformer (PS-HVT-TB-310) supplies high-voltage for the transfer rollers Y, M, C and K and the suction charger to be used in black mode.

The main high-voltage transformers have the following high-voltage outputs.

- CH1: main charger wire
- CH2: main charger grid bias
- CH3: developer bias
- CH4: cleaning blade bias

The transfer transformer has the following high-voltage outputs.

- CH1: transfer roller bias (Y)
  - CH2: transfer roller bias (M)
  - CH3: transfer roller bias (C)
  - CH4: transfer roller bias (K)
  - CH5: suction charger
- \* CH5 is used in black mode only.

The main high-voltage transformer and transfer transformer for service parts are supplied with the data sheets to be used for the following setup. Be careful not to lose them.

Output adjustment is performed when the devices are shipped, so under any circumstances, do not move the resistors fixed to the board.

### 1.14.2 Settings after replacing main high-voltage transformers

After replacing a main high-voltage transformer, input the data stated on the supplementary data sheet (main charger grid bias, developer bias) according to the procedure below without fail.

<Settings for main charger grid bias>

- (1) Turn the power ON while pressing [0] and [5] simultaneously.
- (2) Input code 252 and press [START] key.
  - The lower limit value for main charger grid bias is displayed for each Y, M, C and K.
- (3) Input the sub-code (0: Y, 1: M, 2: C, 3: K) and press [START] key.
- (4) Input a value according to the supplementary data sheet and press either [SET] or [INTERRUPT] key.
- (5) Input code [253] and press [START] key.
  - The upper limit value for main charger grid bias is displayed for each Y, M, C and K.
- (6) Input the sub-code (0: Y, 1: M, 2: C, 3: K) and press [START] key.

- (7) Input a value according to the supplementary data sheet and press either [SET] or [INTERRUPT] key.
- (8) Turn the power OFF.

< Settings for developer bias >

- (1) Turn the power ON while pressing [0] and [5] simultaneously.
- (2) Input code [257] and press [START] key.
  - The lower limit value for developer bias is displayed for each Y, M, C and K.
- (3) Input sub-code (0: Y, 1: M, 2: C, 3: K) and press [START] key.
- (4) Input a value according to the supplementary data sheet and press either [SET] or [INTERRUPT] key.
- (5) Input code [258] and press [START] key.
  - The upper limit value for developer bias is displayed for each Y, M, C and K.
- (6) Input the sub-code (0: Y, 1: M, 2: C, 3: K) and press [START] key.
- (7) Input a value according to the supplementary data sheet and press either [SET] or [INTERRUPT] key.
- (8) Turn the power OFF.

### 1.14.3 Settings after replacing transfer transformer

After replacing a transfer transformer, input the data shown on the supplementary data sheet (transfer bias) according to the procedure below without fail.

<Settings for transfer roller bias>

- (1) Turn the power ON while pressing [0] and [5] simultaneously.
- (2) Input code [367] and press [START] key.
  - The lower limit value for transfer bias is displayed for each Y, M, C and K.
- (3) Input the sub-code (0: Y, 1: M, 2: C, 3: K) and press [START] key.
- (4) Input a value according to the supplementary data sheet, and press either [SET] or [INTERRUPT] key.
  - \* Perform the operation in (3) and (4) for each of Y, M, C and K.
- (5) Input code [368] and press [START] key.
  - The upper limit value for transfer bias is displayed for each Y, M, C and K.
- (6) Input the sub-code (0: Y, 1: M, 2: C, 3: K) and press [START] key.
- (7) Input a value according to the supplementary data sheet, and press either [SET] or [INTERRUPT] key.
  - \* Perform the operation in (6) and (7) for each of Y, M, C and K.
- (8) Turn the power OFF.

## 1.15 Adjusting Doctor-to-Sleeve Gap

Adjustment tool to use : Doctor-sleeve jig

Adjusting procedure :

- (1) Remove the developer unit from the processing unit (EPU), and then remove the developer unit cover and toner-scattering prevention seal holder from the developer unit.

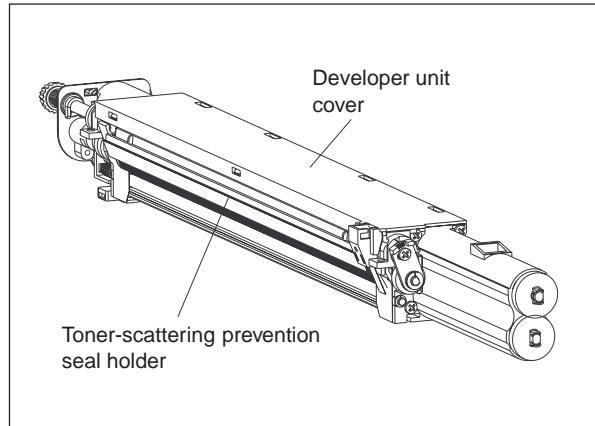

- (2) Loosen the 2 screws for fixing the doctor blade (M3), and insert the gauge "0.60" of the jig into the gap between the developer sleeve and the doctor blade to adjust the gap. Fasten the screws for fixing the doctor blade after adjusting.

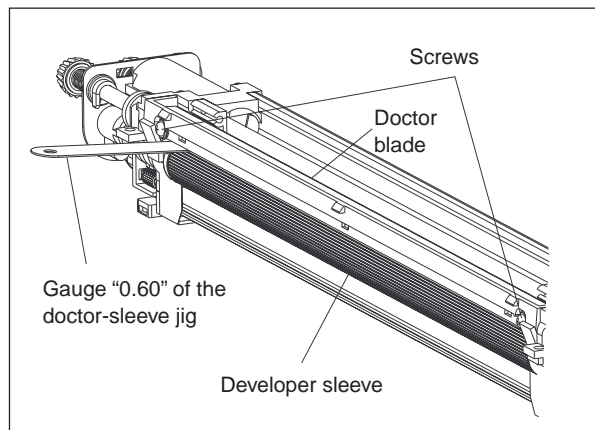

- (3) Insert the gauge "0.55" of the jig into the gap between the sleeve and the doctor, and make sure that the gauge can move smoothly in the front↔rear direction. In addition, confirm that the gauge "0.65" cannot be inserted into the gap.

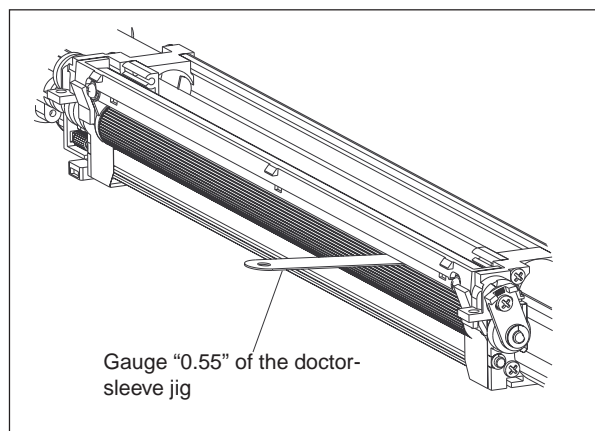

### Note :

1. When confirming and adjusting the gap between the developer sleeve and the doctor blade, insert the gauges into the gap after rotating the developer sleeve so that its marking faces the doctor blade.
2. While reinstalling the toner-scattering prevention seal holder, make the slide hooks inserted securely.
3. After reinstalling the toner-scattering prevention seal holder, make sure that each of the side mylar sheets (one each on the front and rear) is between the 2 urethane rubber sheets.
4. While reinstalling the developer unit cover, make the latches fitted securely.

## 1.16 Adjusting the Scanner Section

### 1.16.1 Adjusting the Carriages

#### (a) Installing carriage drive wires

When replacing the carriage drive wires with new wires, proceed as illustrated below:

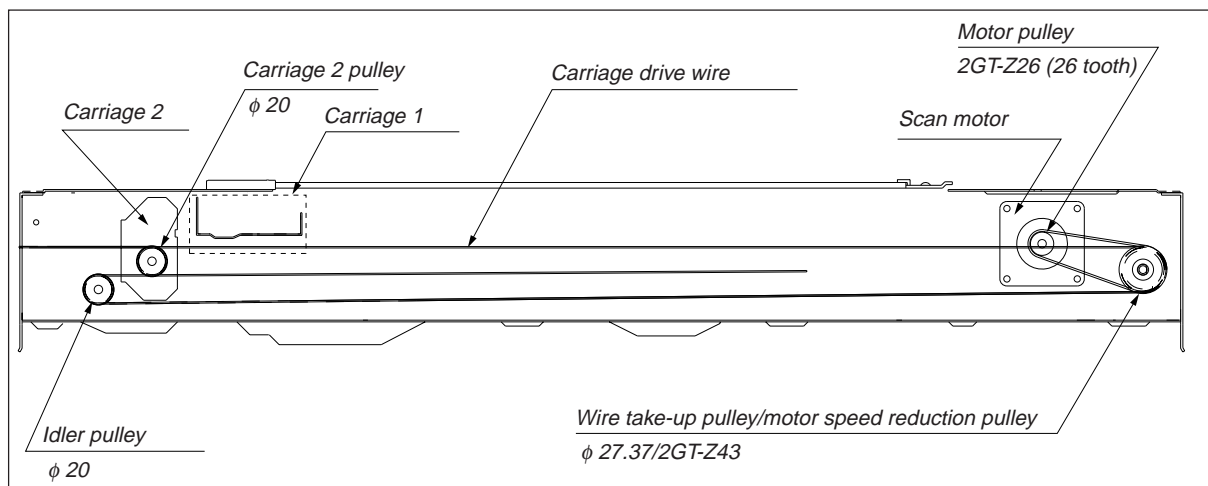

#### (b) Adjusting the carriage drive wires

Since the wires are applied with proper tension by tension springs, there is no need for tension adjustment.

**Note:**

Check that the wire tension is identical for both front and rear wires and is properly applied.

#### (c) Adjusting the positions of carriages 1 and 2

1. Loosen 2 screws (one each on the front and rear) which are fixing carriage 1 to the wires, and another 1 screw (on the front) which are fixing carriage 2 to the wires.
2. Move carriage 2 to the exit side. Insert the carriage jigs into the jig-insertion holes, one each on the front and rear sides of carriage 2, and fasten the screw on the front side of carriage 2.
3. While placing the protruding parts of carriage 1 against the carriage jigs, fasten carriage 1 to the wire on both front and rear sides.
4. Pull out the carriage jigs.

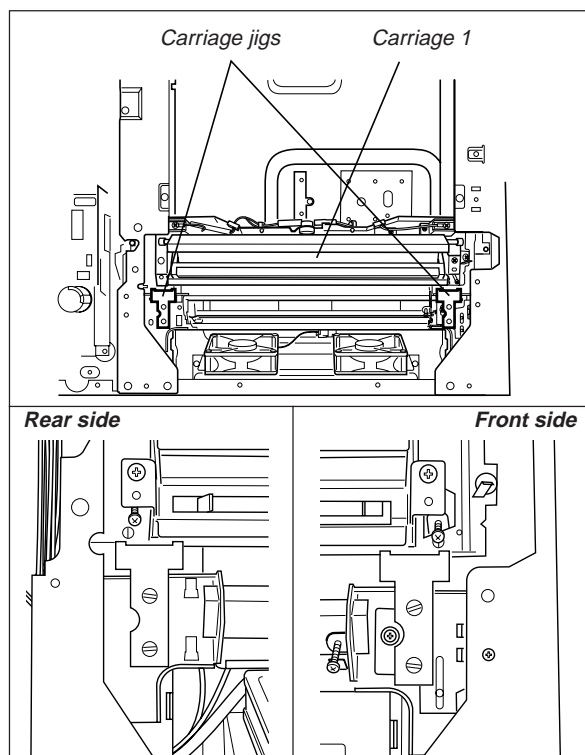

(d) Installing the carriage drive wires to the wire pulleys

Winding the wire to the wire pulleys:

1. Fit the 3-mm ball terminal in the center of the wire into the hole in the wire pulley. The wire should be positioned so that the part of the wire with a hook on its crimped side be on the upper side.

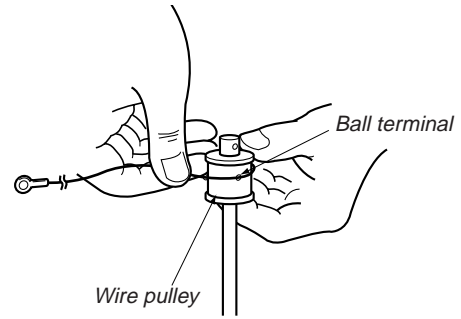

2. Wind the wires onto the wire pulleys on the front and rear. The number of turns to be wound are as follows (see the illustrations below):

- One turn on the inside of the boss.
- Six turns on the outside of the boss.

After winding the wires on the pulleys, hold the wires with wire holder jigs to prevent them from unwinding.

[Rear side]

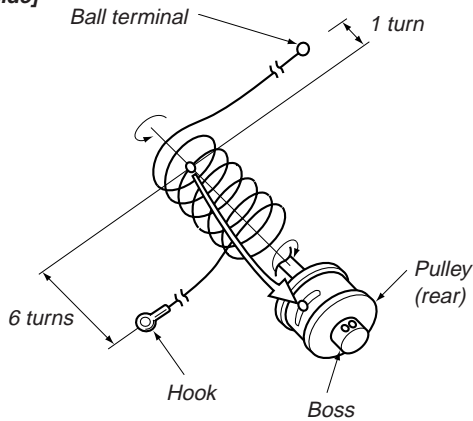

[Front side]

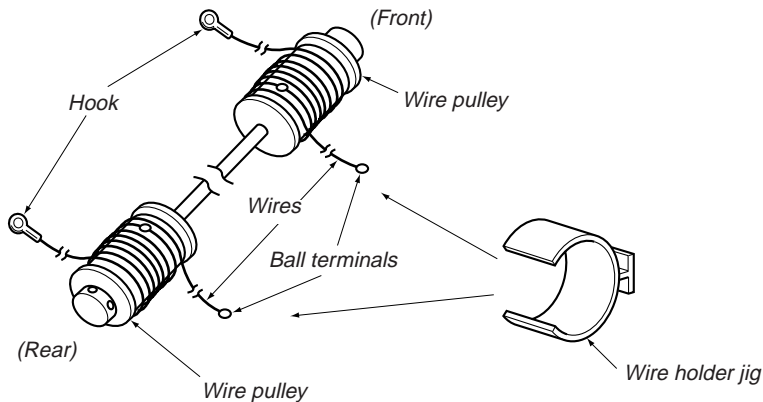
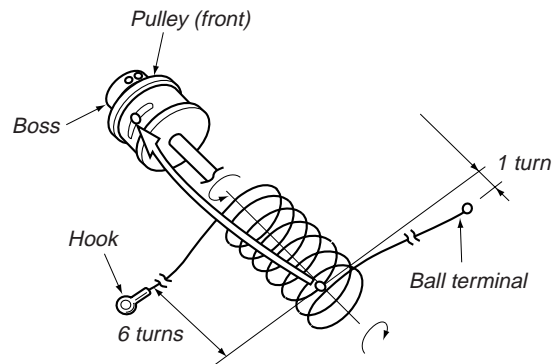



**Note :**

1. When winding the wires on the pulleys, take the following precautions:
  - Do not wind the wire on the pulley with the wire twisted.
  - Wind the wire strongly so that all the turns of the wire are in firm contact with the surface of the pulley.
  - Each time you wind a turn on the pulley, push it to the preceding turn so that all the turns are closely wound.
2. When fitting wire holder jigs, take care so that the turns wound on the pulleys do not move or unwind.

No gap should exist.

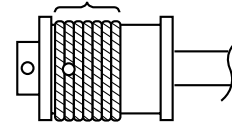

e.g. Front side

<Relationship between wound turns and wire holder jigs>

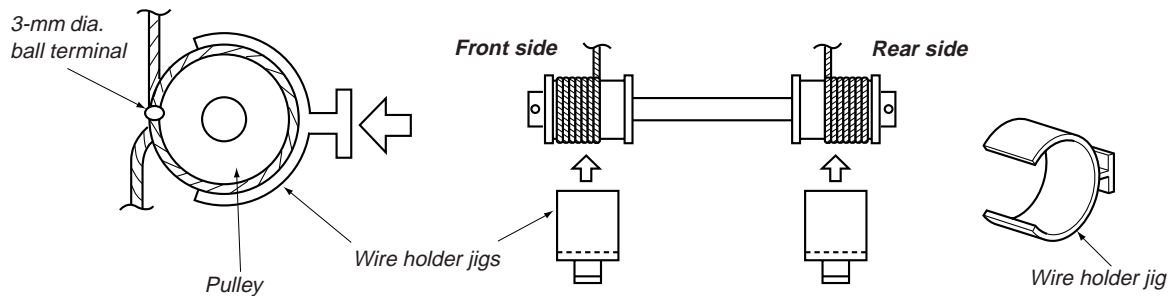

### 1.16.2 Lens Unit

#### (a) Replacing the lens unit

- Since the lens unit was precisely adjusted at the factory, it must not be readjusted in the field or some of its components must not be replaced. If necessary, the lens unit should be replaced as a unit.
- While replacing with a new lens unit, never loosen or remove the six screws indicated with arrows below. They are locked with special paint.

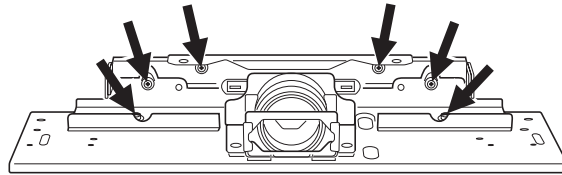

- Use sufficient care when handling the lens unit. Never hold the precision-adjusted area of the lens unit.

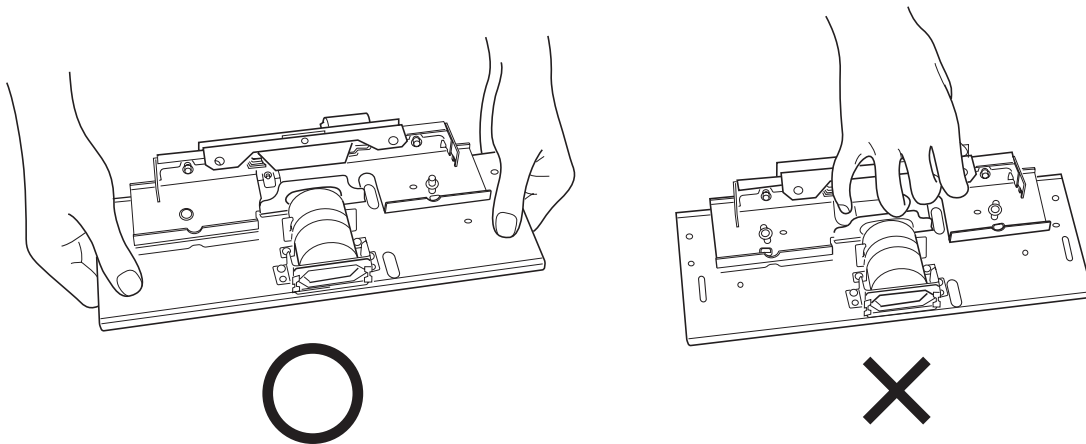

(4) Adjusting the magnification ratio of the lens

**Note:**

1. The lens magnification ratio adjustment should be performed only when the lens unit is removed or replaced in the field.
2. Before this adjustment, check that the primary scanning reproduction ratio of the printer is corrected.

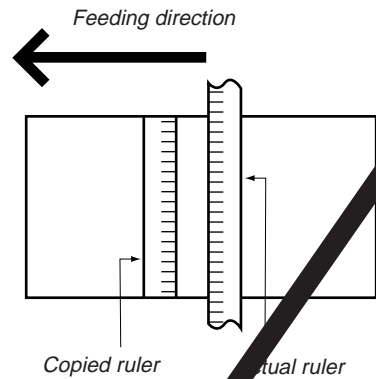

1. Place a suitable ruler on the original glass and make a copy of it on A4(LT)-size paper at 100% reproduction ratio.
2. Compare the copied ruler with the actual ruler to measure the error in the reproduction ratio.
3. Make adjustment so that the distance between each mark of both rulers becomes equal, using the following procedure.

**Note:**

After this adjustment, be sure to perform CCD primary scanning deviation adjustment.

<Adjustment procedure>

- (1) Remove the original glass, lens cover, damp blower unit and lens shield bracket.
- (2) Screw the 2 pins for lens magnification ratio adjustment into the 2 elongated holes in the lens base.

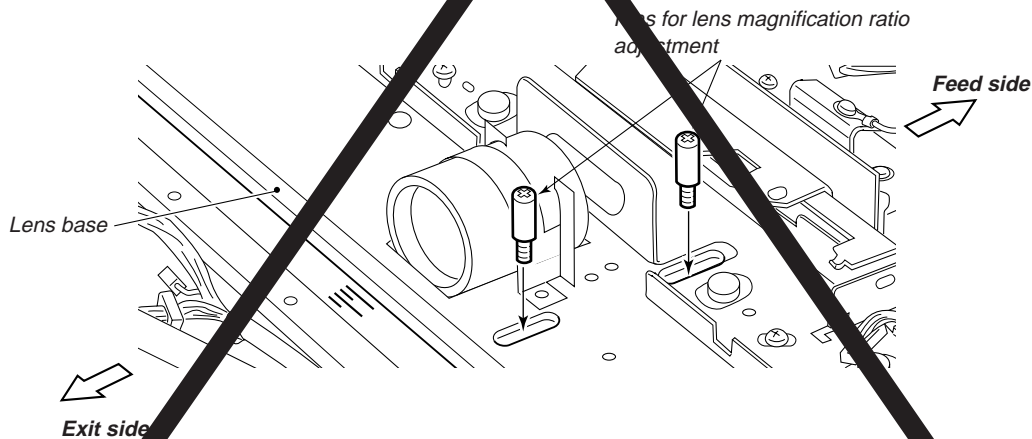

- (3) Loosen 2 screws for fixing the lens unit.

(4) Using the marks on the scanner base as a guide, adjust the lens unit in either forward or backward direction.

The following table shows the error in the reproduction ratio between the copies and actual rulers compared to be measured, and the amount of adjustment of the lens unit.

Reproduction ratio error	Amount of adjustment
0.1 %	0.5 mm
0.2 %	0.9 mm
0.3 %	1.4 mm
0.4 %	1.9 mm
0.5 %	2.4 mm
0.6 %	2.9 mm
0.7 %	3.3 mm
0.8 %	3.8 mm
0.9 %	4.3 mm
1.0 %	4.8 mm

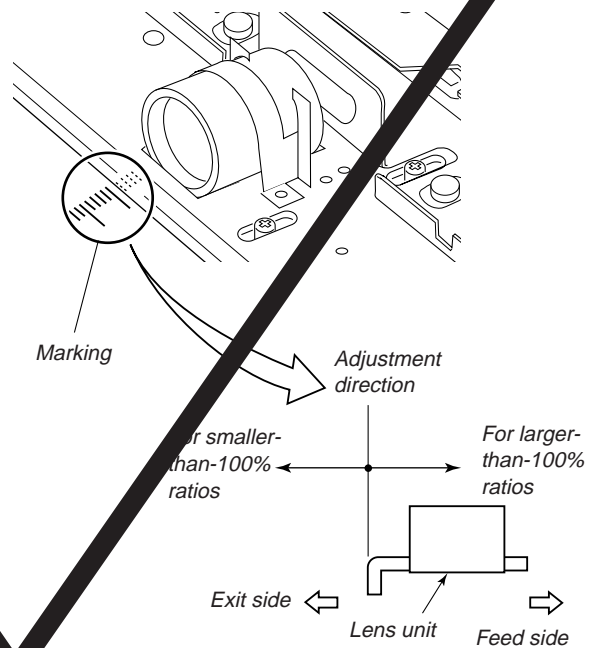

**Note:**

If the adjustment finer than that in the above table is required, perform "Fine adjustment of polygonal motor rotation speed".

- (5) Install the lens cover and original glass, and then make a copy to confirm the reproduction ratio.
- (6) Remove the original glass and lens cover again, and then tighten the 2 screws for the lens unit to fix its position.
- (7) Remove the 2 pins used for adjusting the lens magnification ratio.
- (8) Reinstall the damp heater unit, lens shield bracket, lens cover and original glass.

(C) Fixing the lens unit

(1) Insert the positioning pins (front and rear) into the hole of the lens unit, and install to the scanner unit.

**note)** As the shape of the front and rear differ, pay attention to this point when installing parts.

(2) Fix the two oblong holes by two screws. (B: two points)

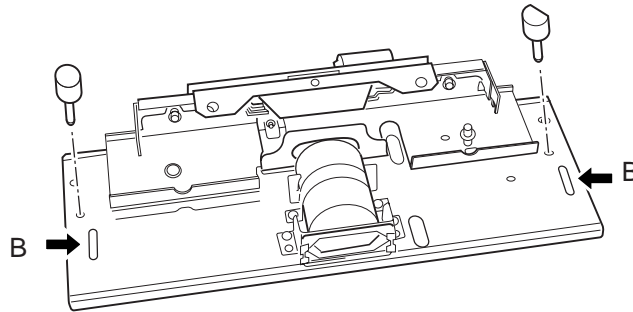

## 1.17 Adjusting the Cassette for Sidewise Deviation

- (1) Loosen 5 screws for fixing the cassette front cover, and the sidewise deviation can be adjusted toward the front or the rear by a maximum of 3 mm.
- (2) If the copy image is shifted toward the rear of copy paper, adjust the front cover of the cassette toward the front by the amount of the shift, and fasten the screws.
- (3) If the copy image is shifted toward the front of copy paper, adjust the front cover of the cassette toward the rear by the amount of the shift, and fasten the screws.

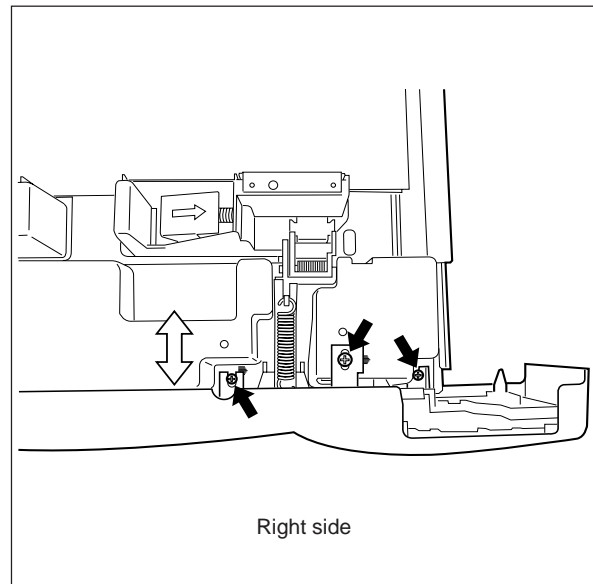
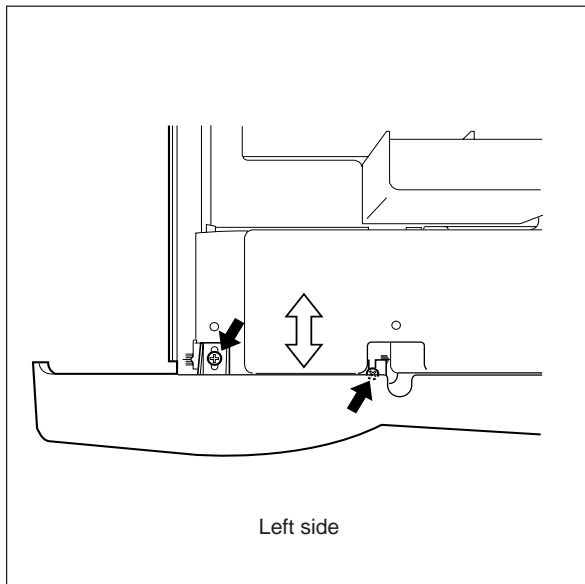

## 1.18 Key Copy Counter (MU-8, MU-10)

To make a key copy counter available, the following 2 components must be installed to the machine.

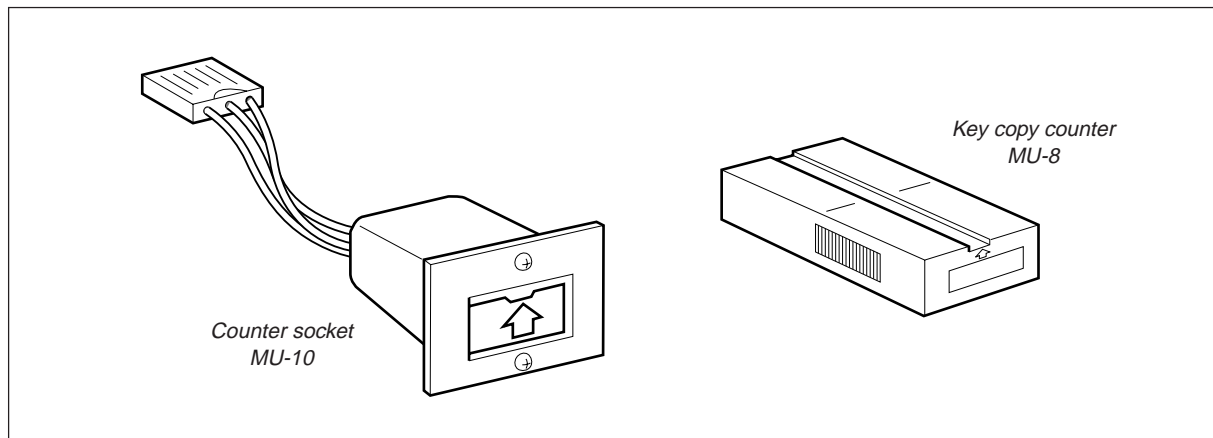

### <Installation procedure>

- (1) Remove the rear cover.
- (2) Remove the feed-side upper cover, and cut open the window for the key copy counter.
- (3) Pull out the harness connector from the hole in the machine frame, and cut the shorting harness of the connector. (Treat the cut harness properly to avoid it causing a short-circuit with the machine frame.) Then, disconnect the dummy connector.

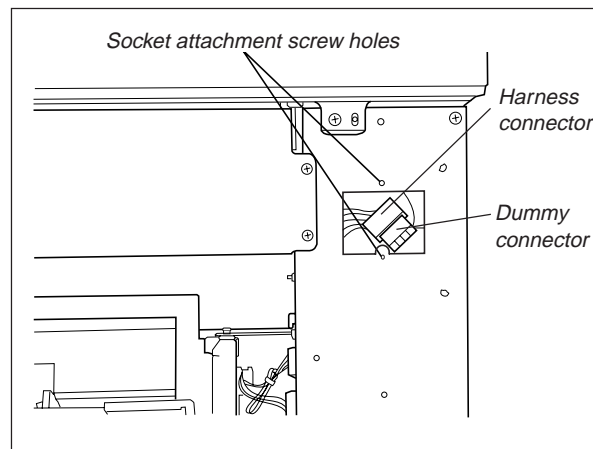

- (4) Connect the connector of the counter socket to the harness connector of the machine.
- (5) Install the counter socket to the machine frame with two M3 screws.
- (6) Reinstall the feed-side upper cover and the rear cover.

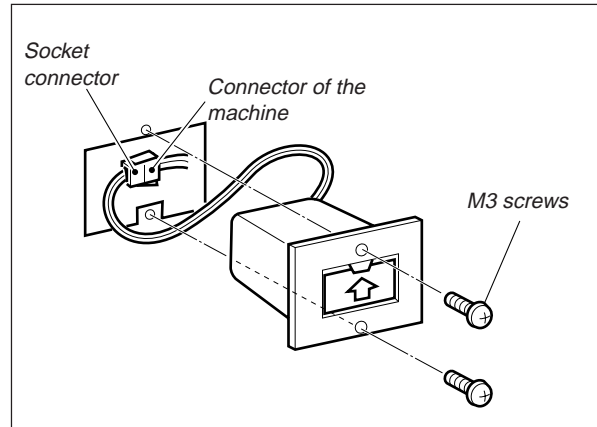

- (7) Insert the key copy counter with its arrow mark facing up and pointing toward the machine.

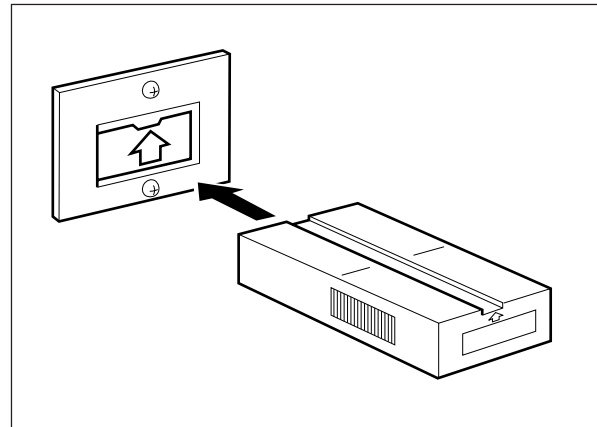

- (8) In the "08" setting mode, enter "3" under code 202.



## 2. PREVENTIVE MAINTENANCE (PM)

### 2.1 Types of Preventive Maintenance

The following two types of preventive maintenance should be performed:

(1) General maintenance

General maintenance should be performed based on the value of the PM counter (08-857).

This maintenance, which covers the black developer unit as well as the entire machine, should be conducted in conjunction with the replacement cycle (For FC-22: every 30K Copies, For FC-15: every 20K Copies) of the black developer material.

(2) Color maintenance

Color maintenance should be performed based on the value of the color PM counter (08-897).

This maintenance, which is performed with a focus on the color developer units, should be conducted in conjunction with the replacement cycle of the color developer materials.

FC-22: every 30K copies

FC-15: every 20K copies

The replacement cycle (counter value) of color maintenance is determined by the ratio of color copy to black copy, as shown by the following table, "Variation in PM cycles due to color/black output ratios".

Variation in PM cycles due to color/black output ratios

Color modes	Monochrome modes	FC-15		FC-22	
		PM (copies)	Color PM (copies)	PM (copies)	Color PM (copies)
100%	0%	20.0K	20.0K	30.0K	30.0K
90%	10%	20.0K	22.2K	30.0K	33.3K
80%	20%	20.0K	25.0K	30.0K	37.5K
70%	30%	20.0K	28.5K	30.0K	42.9K
60%	40%	20.0K	33.3K	30.0K	50.0K
50%	50%	20.0K	40.0K	30.0K	60.0K

\* Therefore, replacing parts, cleaning and coating oil for the paper feeding unit, scanner unit, transfer/transport unit, fuser unit, all should be checked and maintained in conjunction with the replacement cycle of the black developer material.

e.g. ) Replacing fuser rollers : At the 3rd cycle of replacing black developer material  
( $30K \times 3 = 90K$  copies)

Replacing the transfer belt : At the 4th cycle of replacing black developer material  
( $30K \times 4 = 120K$  copies)

\* For the details of maintenance items, refer to the checklist described later.

\* Yields are based on factory defaults.

## 2.2 Maintenance to be Performed

**FC-22: Every 30,000, 60,000, 90,000 and 120,000 Copies**

**FC-15: Every 20,000, 40,000, 60,000 and 120,000 Copies**

### (1) Preparation

- ① Discuss current machine conditions with the key operator and note them down.
- ② Before starting maintenance, make a few sample copies by TCC-1 chart and save them for later reference purposes.
- ③ Turn OFF the power switch, and be sure to unplug the copier.

### (2) Perform preventive maintenance following the checklist shown below. During maintenance, refer to the illustrations attached and the Service Manual as required.

### (3) After having finished the maintenance, plug in the copier, turn ON the power switch, and make a few copies to confirm that the copier is working normally.

## 2.3 Preventive Maintenance Checklist

### Symbols used in the checklist (For FC-22)

Cleaning	Coating	Replacing	Operation check	Date
A Cleaning with alcohol	W White grease	30 Every 30K copies	○ After cleaning or replacing, check for no abnormality.	User's name
○ Cleaning with soft pad, cloth or vacuum cleaner	(Molycoat)	60 Every 60K copies		Serial No.
	AV Alvania No.2	90 Every 90K copies		Inspector's name
		120 Every 120K copies		Remarks
		△ Replace if deformed or damaged		

### Symbols used in the checklist (For FC-15)

Cleaning	Coating	Replacing	Operation check	Date
A Cleaning with alcohol	W White grease	20 Every 20K copies	○ After cleaning or replacing, check for no abnormality.	User's name
○ Cleaning with soft pad, cloth or vacuum cleaner	(Molycoat)	40 Every 40K copies		Serial No.
	AV Alvania No.2	60 Every 60K copies		Inspector's name
		120 Every 120K copies		Remarks
		△ Replace if deformed or damaged		

General Maintenance Checklist

FC-22

Section	Item to inspect	Cleaning	Coating	Replace every 1K copies	Operation check	Remarks <P-1>
Processing unit (EPU) (Only Black related parts)	1. Developer material			30		*9
	2. Doctor blade	○(30/60)		△		*1
	3. Developer unit drum seal	○(60)		△		*10
	4. Front/rear sides of developer unit	○(60)				*2
	5. Oil seal portion		AV			
	6. Cleaning blade			60		*3 <P23-I13>
	7. Recovery blade	○(60)		△		*4
	8. Felt seals on both ends of the cleaning blade	○(60)		△		
	9. Entire developer/cleaner unit	○(60)				*8
	10. Main charger case	○(60)				*7
	11. Discharge LED	○(60)				
	12. Wire cleaning pad			60	○	<P22-I21>
	13. Main charger wire			60		*7 <P22-I15>
	14. Main charger grid			60		<P22-I24>
	15. Main charger contact	○(60)				
	16. Drum			60		*5 <P22-I38>
	17. Drum shaft	○(60)				
	18. Drum thermister	○(60)				
	19. Toner recovery auger drive	○(60)		W		
Around-EPU area	20. Toner cartridge drive gear		W			
	21. Ozone filter			60		*6 <P6-I37>
	22. Toner bag			30		Key-operator's item <P33-I33>
Fuser unit	23. Upper fuser roller			90		*11 <P27-I17>
	24. Lower fuser roller			90		*12 <P27-I4>
	25. Separation fingers			90		*14 <P28-I31>
	26. Upper oil roller			30		*13 <P28-I56>
	27. Upper cleaning roller			30		*13 <P28-I57>
	28. Lower oil roller			90		*13 <P28-I11>
	29. Lower cleaning roller			90		*13 <P28-I12>
	30. Upper thermistors	A(30)		△		
	31. Lower thermistors	A(30)		△		
	32. Fuser roller inlet guide	A(90)				
	33. Fuser roller exit guide	A(90)				
	34. Paper exit roller	A				

Section	Item to inspect	Cleaning	Coating	Replace every 1K copies	Operation check	Remarks <P-1>
Image quality control	35. Image quality sensor's area	○(60)				
Color registration	36. Color registration sensor	○(60)				
Laser unit	37. Slit glass	○(60)				
Paper feeding system	38. Pick-up roller			90		<P14-I13>
	39. Feed roller			△		
	40. Separation roller			△		
	41. Bypass pick-up roller			90		<P17-I32>
	42. Bypass feed roller					
	43. Bypass separation pad	A		90△		<P17-I10>
	44. Registration roller	A		△		
	45. Paper guide	○(60)		△		
	46. Paper dust brush	○(60)		△		
	47. Paper feeding system drive gears (tooth face)		W			
48. Registration unit support bushings		W				
Scanner	49. Original glass	○(60)or A				
	50. Platen cover	○(60)or A				
	51. Mirror 1	○(60)				
	52. Mirror 2	○(60)				
	53. Mirror 3	○(60)				
	54. Reflector	○(60)				
	55. Lens	○(60)				
	56. Exposure lamp			△	○	
	57. Original-width indicator				○	
	58. Automatic original detection unit				○	
	59. Slide sheet			△		
	60. Air filter	○(60)		△		
Transfer/ transport unit (TBU)	61. Transfer belt			120		<P30-I2>
	62. Transfer roller (Y, M, C, K)			120		<P30-I22>
	63. Drive roller cleaning felt			120		<P30-I27>
	64. Transfer belt cleaning blade			120		<P30-I46>
	65. Transfer belt recovery blade	○(120)				
	66. Transfer belt drive roller	○(60)		△		
	67. Transfer belt driven roller	○(60)		△		



**Notes:** 1. <P-I> in the "Remarks" column indicates a page item in the Parts List.

2. The replacement cycle of each supply item of a particular paper feeding system corresponds with the maximum number of sheets specified for the paper feed source.

**Color Maintenance Checklist**

**FC-22**

Section	Item to inspect	Cleaning	Coating	Replace every 1K copies	Operation check	Remarks <P-I>
Processing unit (EPU) (Color (Y, M, C) related parts)	1. Developer material (Y, M, C)			30		*9
	2. Doctor blade	○(30/60)		△		*1
	3. Developer unit drum seal	○(60)		△		*10
	4. Front/rear sides of developer unit	○(60)				*2
	5. Oil seal portion		AV			
	6. Cleaning blade			60		*3 <P23-I13>
	7. Recovery blade	○(60)		△		*4
	8. Felt seals on both ends of the cleaning blade	○(60)		△		
	9. Entire developer/cleaner unit	○(60)				*8
	10. Main charger case	○(60)				*7
	11. Discharge LED	○(60)				
	12. Wire cleaning pad			60	○	<P22-I21>
	13. Main charger wire			60		*7 <P22-I15>
	14. Main charger grid			60		<P22-I24>
	15. Main charger contact	○(60)				
	16. Drum			60		*5 <P22-I38>
	17. Drum shaft	○(60)				
	18. Drum thermister	○(60)				
	19. Toner recovery auger drive	○(60)		W		
Image quality control	35. Image quality sensor's area	○(60)				
Color registration	36. Color registration sensor	○(60)				
Laser unit	37. Slit glass	○(60)				

**Note:** 1. <P-I> in the "Remarks" column indicates a page item in the Parts List.

General Maintenance Checklist

FC-15

Section	Item to inspect	Cleaning	Coating	Replace every 1K copies	Operation check	Remarks <P-1>
Processing unit (EPU) (Only Black related parts)	1. Developer material (Y, M, C)			20		*9
	2. Doctor blade	○(20/40)		△		*1
	3. Developer unit drum seal	○(40)		△		*10
	4. Front/rear sides of developer unit	○(40)				*2
	5. Oil seal portion		AV			
	6. Cleaning blade			40		*3 <P23-I13>
	7. Recovery blade	○(40)		△		*4
	8. Felt seals on both ends of the cleaning blade	○(40)		△		
	9. Entire developer/cleaner unit	○(40)				*8
	10. Main charger case	○(40)				*7
	11. Discharge LED	○(40)				
	12. Wire cleaning pad			40	○	<P22-I21>
	13. Main charger wire			40		*7 <P22-I15>
	14. Main charger grid			40		<P22-I24>
	15. Main charger contact	○(40)				
	16. Drum			40		*5 <P22-I38>
	17. Drum shaft	○(40)				
	18. Drum thermister	○(40)				
	19. Toner recovery auger drive	○(40)		W		
Processing unit Around EPU area	20. Toner cartridge drive gear		W			
	21. Ozone filter			40		*6 <P6-I37>
	22. Toner bag			30		Key-operator's item <P33-I33>
Fuser unit	23. Upper fuser roller			60		*11 <P27-I17>
	24. Lower fuser roller			60		*12 <P27-I4>
	25. Separation fingers			60		*14 <P28-I31>
	26. Upper oil roller			20		*13 <P28-I56>
	27. Upper cleaning roller			20		*13 <P28-I57>
	28. Lower oil roller			60		*13 <P28-I11>
	29. Lower cleaning roller			60		*13 <P28-I12>
	30. Upper thermistors	A(20)		△		
	31. Lower thermistors	A(20)		△		
	32. Fuser roller inlet guide	A(60)				
	33. Fuser roller exit guide	A(60)				
	34. Paper exit roller	A				

Section	Item to inspect	Cleaning	Coating	Replace every 1K copies	Operation check	Remarks <P-1>
Image quality control	35. Image quality sensor's area	○(40)				
Color registration	36. Color registration sensor	○(40)				
Laser unit	37. Slit glass	○(40)				
Paper feeding system	38. Pick-up roller			90		<P14-I13>
	39. Feed roller			△		
	40. Separation roller			△		
	41. Bypass pick-up roller			90		<P17-I32>
	42. Bypass feed roller					
	43. Bypass separation pad	A		90△		<P17-I10>
	44. Registration roller	A		△		
	45. Paper guide	○(40)		△		
	46. Paper dust brush	○(20)		△		
	47. Paper feeding system drive gears (tooth face)		W			
48. Registration unit support bushings		W				
Scanner	49. Original glass	○(40)or A				
	50. Platen cover	○(40)or A				
	51. Mirror 1	○(40)				
	52. Mirror 2	○(40)				
	53. Mirror 3	○(40)				
	54. Reflector	○(40)				
	55. Lens	○(40)				
	56. Exposure lamp			△	○	
	57. Original-width indicator				○	
	58. Automatic original detection unit				○	
	59. Slide sheet			△		
60. Air filter	○(40)		△			
Transfer/ transport unit (TBU)	61. Transfer belt			120		<P30-I2>
	62. Transfer roller (Y, M, C, K)			120		<P30-I22>
	63. Drive roller cleaning felt			120		<P30-I27>
	64. Transfer belt cleaning blade			120		<P30-I46>
	65. Transfer belt recovery blade	○(120)		△		
	66. Transfer belt drive roller	○(60)		△		
	67. Transfer belt driven roller	○(60)		△		

**Notes:** 1. <P-I> in the "Remarks" column indicates a page item in the Parts List.

2. The replacement cycle of each supply item of a particular paper feeding system corresponds with the maximum number of sheets specified for the paper feed source.

## Color Maintenance Checklist

FC-15

Section	Item to inspect	Cleaning	Coating	Replace every 1K copies	Operation check	Remarks <P-1>
Processing unit (EPU) (Color (Y, M, C) related parts)	1. Developer material (Y, M, C)			20		*9
	2. Doctor blade	○(20/40)		△		*1
	3. Developer unit drum seal	○(40)		△		*10
	4. Front/rear sides of developer unit	○(40)				*2
	5. Oil seal portion		AV			
	6. Cleaning blade			40		*3 <P23-I13>
	7. Recovery blade	○(40)		△		*4
	8. Felt seals on both ends of the cleaning blade	○(40)		△		
	9. Entire developer/cleaner unit	○(40)				*8
	10. Main charger case	○(40)				*7
	11. Discharge LED	○(40)				
	12. Wire cleaning pad			40	○	<P22-I21>
	13. Main charger wire			40		*7 <P22-I15>
	14. Main charger grid			40		<P22-I24>
	15. Main charger contact	○(40)				
	16. Drum			40		*5 <P22-I38>
	17. Drum shaft	○(40)				
	18. Drum thermister	○(40)				
	19. Toner recovery auger drive	○(40)		W		
Image quality control	35. Image quality sensor's area	○(40)				
Color registration	36. Color registration sensor	○(40)				
Laser unit	37. Slit glass	○(40)				

**Note:** 1. <P-I> in the "Remarks" column indicates a page item in the Parts List.



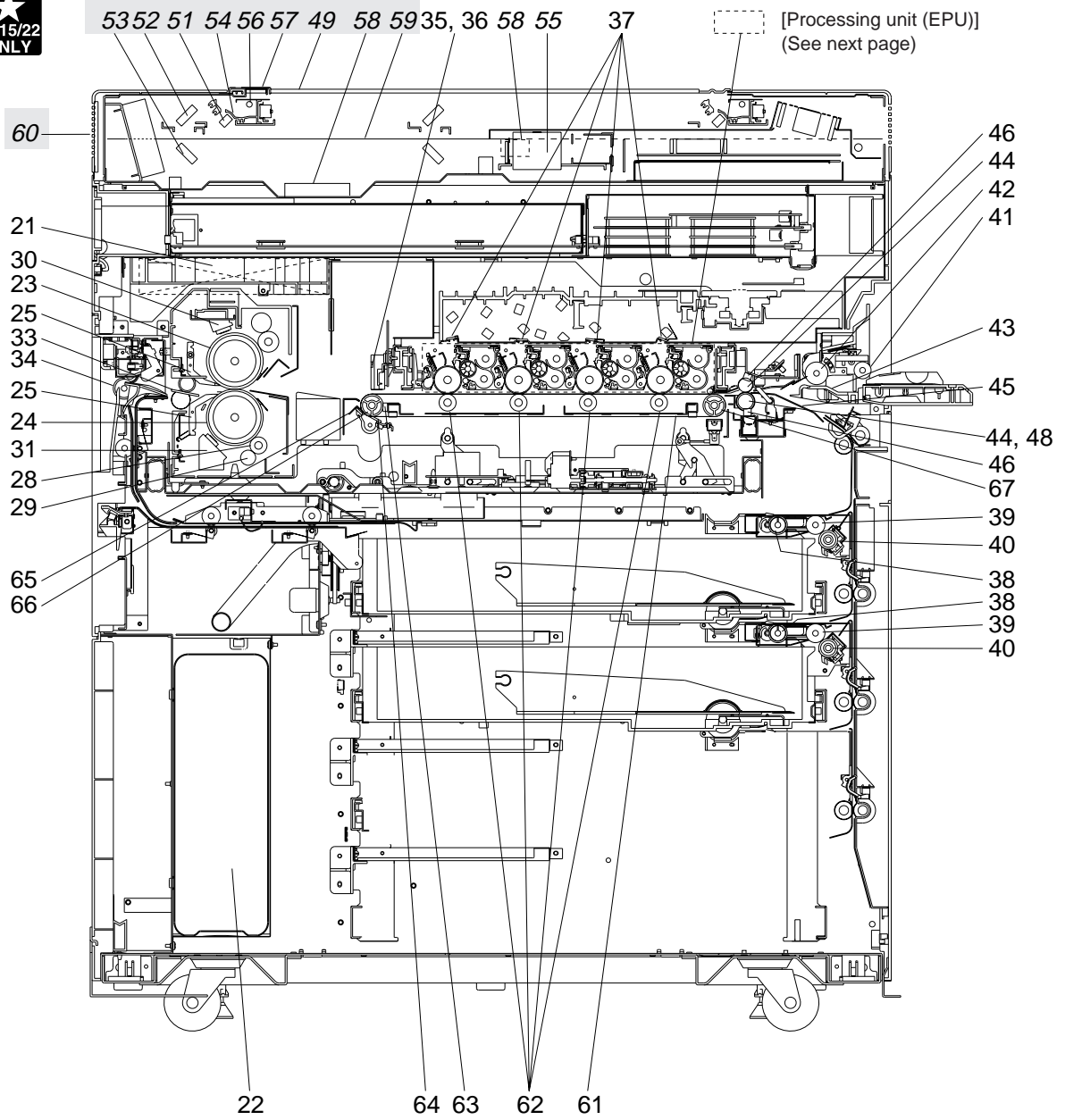

[Front sectional view]

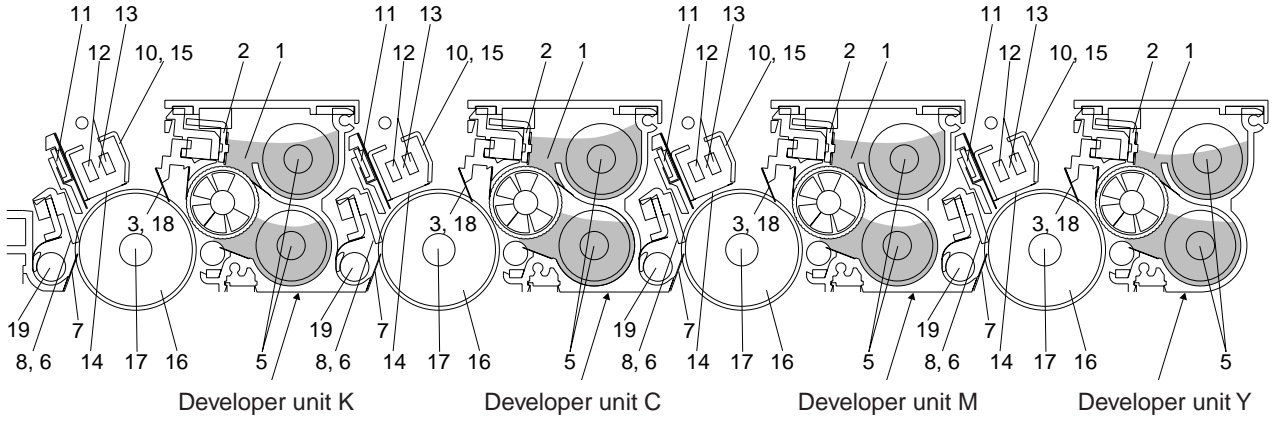

[Processing unit (EPU)]

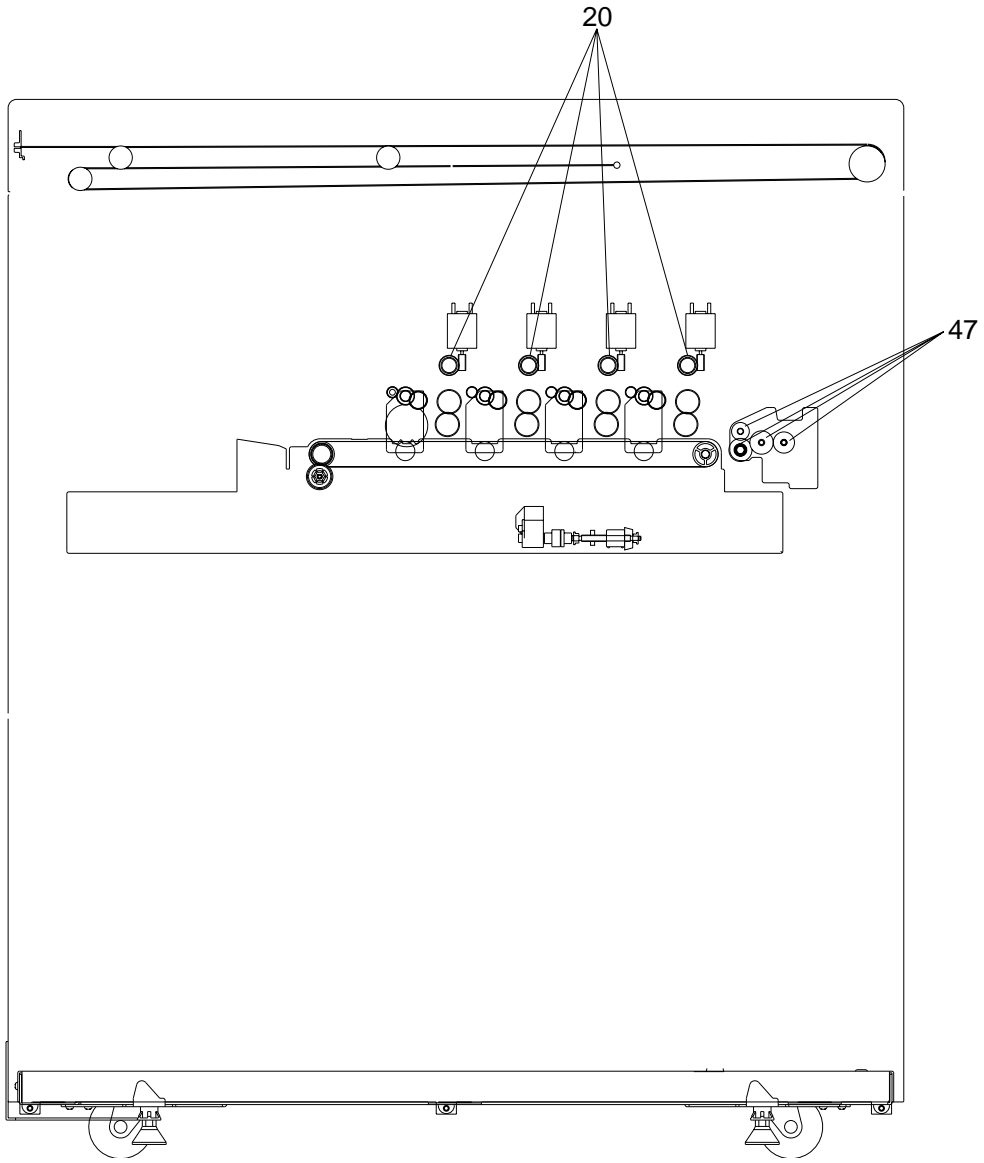

[Front-side drive system]

## \* Notes on the Preventive Maintenance Checklist

### \* 1. Doctor blade cleaning

#### (a) Cleaning every 30K

**Note:** This cleaning should be done prior to “automatic removing of developer material”.

(1) Open the front covers, and turn the lever to the right to make the transfer belt unit move down.

(2) Remove the toner cartridges (Y, M, C, K).

(3) Remove the processing unit (EPU) and place it on a flat table.

**Note:** Make sure there are no projections or parts such as screws on the table.

(4) Pull out the drum thermistor.

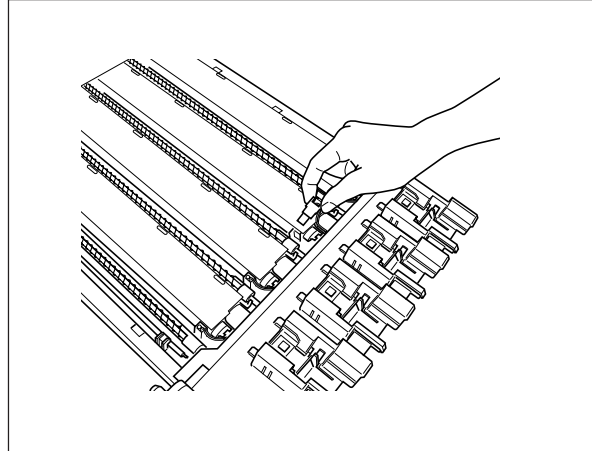

(5) Disengage 4 latches of the developer unit cover gently and lift the cover up slowly.

**Note:** Be careful not to allow the developer material deposited on the back of the cover to drop into different-color developer units. (To avoid this problem, put paper over the other developer units not being cleaned now.)

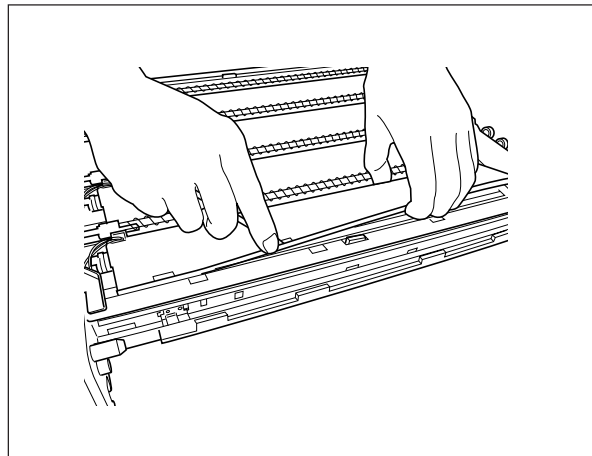

(6) Insert the doctor blade cleaning jig between the doctor blade and the sleeve, and move the jig along the blade edge back and forth; make 3 return movements to clean the doctor blade.

(7) Reinstall the developer unit cover and the drum thermistor.

(8) Do steps (4) to (7) for developer unit K or units Y, M and C.

(9) Reinstall the EPU into the machine, and raise the transfer belt unit.

(10) Perform the automatic removing of developer material (adjustment mode 05-392:K, 391: Y, M, C).

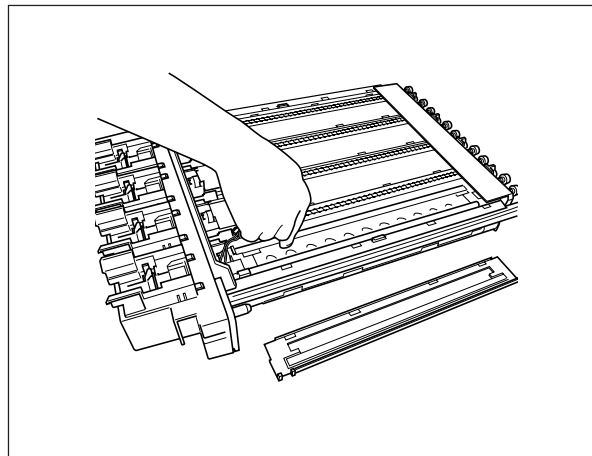

(b) Cleaning every 60K (which should be give priority when coincides with every-30K cleaning)

**Note:** This cleaning should be done subsequent to “automatic removing of developer material”.

- (1) Move the developer removal shutter lever in the direction of the arrow shown to close the developer removal opening.
- (2) Remove the developer unit from the EPU.

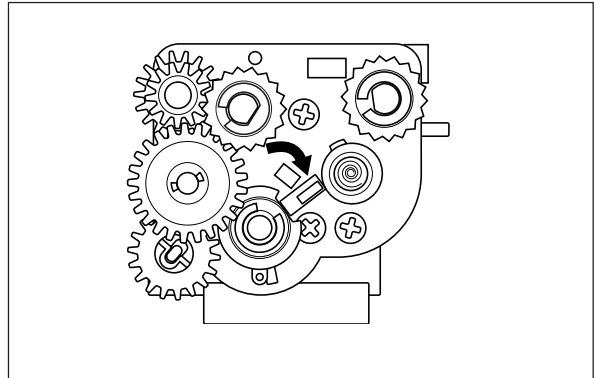

- (3) Remove the developer unit cover. Insert the doctor blade cleaning jig between the doctor blade and the sleeve and move the jig back and forth; make 3 return movements to clean the doctor blade.
- (4) After the cleaning, return the developer removal shutter lever to open the developer removal opening (move the lever in a direction reverse to (1)).

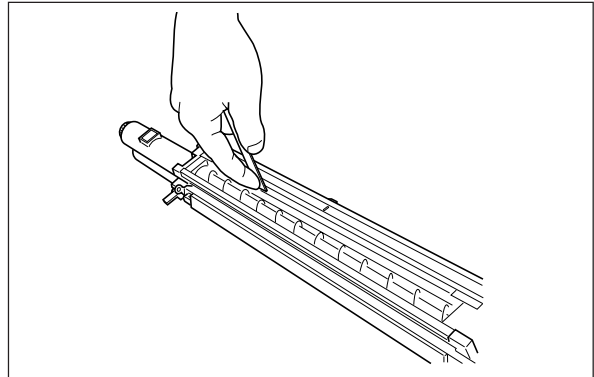

- (5) Making the developer removal opening point downward, remove the developer material remaining in the developer unit. (Shake the developer unit to the right and left, and rotate the mixer and the sleeve alternately.)

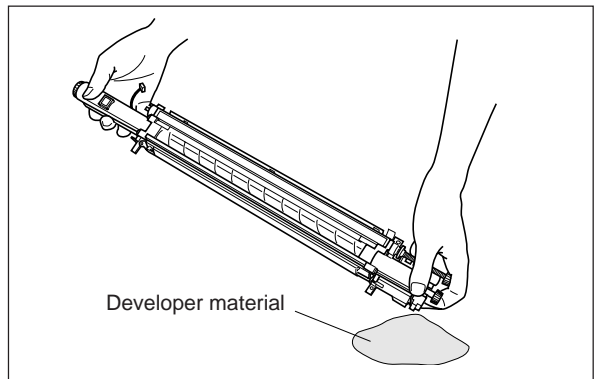

\*2 Front/rear sides of developer unit

Clean off any toner accumulating on the developer sleeve ends indicated with arrows and in the area beneath the scattered toner recovery roller.

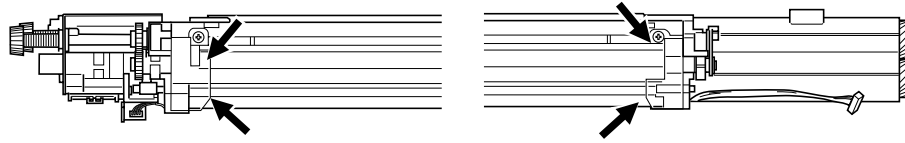

\*3 Cleaning blade

If poor cleaning has occurred due to such causes as adhesion of paper dust, etc. prior to the specified number of copies for replacement, replace the cleaning blade as required because the blade edge may have been damaged.

\*4 Recovery blade

If the blade edge has been marred, replace the blade regardless of the number of copies that have been made so far.

\*5 Drum

Refer to "3.2 Checking and Cleaning of the Photoconductive Drums".

\*6 Ozone filter

If the ozone filter is heavily dirty, replace it.

\*7 Main charger case and charger wire

To clean the inside of the main charger case and the charger wire, use a cloth which should be soaked in water and then wrung lightly.

\*8 Developer unit and cleaner unit

Check if the outside surfaces including the bottom surfaces are dirty, and clean if necessary.

\*9 Developer material

When the developer material is replaced, be sure to perform "automatic adjustment of the auto-toner circuit" (adjustment mode 05-200, 204, 221).

\*10 Drum seal

Use a cloth which should be soaked in water and then wrung strongly to clean the front seal.

\*11 Upper fuser roller )  
\*12 Lower fuser roller ) Refer to "3.5 Checking and Cleaning of the Fuser rollers".

\*13 Oil roller and cleaning roller

Refer to "3.4 Checking and Replacing of the Oil Roller and Cleaning Roller of fuser section".

\*14 Separation fingers

Replace any finger if its tip is damaged, regardless of the specified number of copies for replacement. If toner is fused tightly on the tip of fingers, the tip may be damaged if you try to scrape the toner off forcefully. So, replace any fingers that are heavily dirty with toner.

## 2.4 PM Kit

FC-22

Kit name	Classification of kits	Part name	Q'ty	No. of copies for replacement cycle
DEV-KIT-FC22 (30K kit)	1. Developer material (Y)	PS-ZDFC22Y	1	30K
	1. Developer material (M)	PS-ZDFC22M	1	
	1. Developer material (C)	PS-ZDFC22C	1	
	1. Developer material (K)	PS-ZDFC22K	1	
	26. Upper oil roller (fuser unit)	SR-FC22H	1	
	27. Upper cleaning roller (fuser unit)	B-FC22H	1	
	– Doctor blade cleaning jig	JIG-CLEAN-DOC	1	
EPU-KIT-FC22 (60K kit)	6. Cleaning blade	BL-FC22D	4	60K
	12. Charger wire cleaning pad	WIRE-CH-310	4	
	13. Main charger wire	K-PAD-WIRE	4	
	14. Main charger grid	GRID-CH-310	4	
	21. Ozone filter	K-FILTER-OZN	1	
FU-KIT-FC22 (90K kit)	23. Upper fuser roller	HR-FC22-U	1	90K
	24. Lower fuser roller	HR-FC22-L	1	
	25. Separation finger	SCRAPER-PR	9	
	28. Lower oil roller	SR-FC22L	1	
	29. Lower cleaning roller	B-FC22L	1	
	38. Pick-up roller (cassette feed section)	K-ROL-PICK-310	1	
TBU-KIT-FC22 (120K kit)	61. Transfer belt	BT-FC22TR	1	120K
	62. Transfer roller	CR-FC22TR	4	
	63. Drive roller cleaning felt	FP-FC22TR	1	
	64. Transfer belt cleaning blade	BL-FC22TR	1	

\* The numbers in the “Classification of kits” column above correspond with the numbers in the Preventive Maintenance Checklist.

**PM Kit**

**FC-15**

Kit name	Classification of kits	Part name	Q'ty	No. of copies for replacement cycle
DEV-KIT-FC22 (20K kit)	1. Developer material (Y)	PS-ZDFC22Y	1	20K
	1. Developer material (M)	PS-ZDFC22M	1	
	1. Developer material (C)	PS-ZDFC22C	1	
	1. Developer material (K)	PS-ZDFC22K	1	
	26. Upper oil roller (fuser unit)	SR-FC22H	1	
	27. Upper cleaning roller (fuser unit)	B-FC22H	1	
	– Doctor blade cleaning jig	JIG-CLEAN-DOC	1	
EPU-KIT-FC22 (40K kit)	6. Cleaning blade	BL-FC22D	4	40K
	12. Charger wire cleaning pad	WIRE-CH-310	4	
	13. Main charger wire	K-PAD-WIRE	4	
	14. Main charger grid	GRID-CH-310	4	
	21. Ozone filter	K-FILTER-OZN	1	
FU-KIT-FC22 (60K kit)	23. Upper fuser roller	HR-FC22-U	1	60K
	24. Lower fuser roller	HR-FC22-L	1	
	25. Separation finger	SCRAPER-PR	9	
	28. Lower oil roller	SR-FC22L	1	
	29. Lower cleaning roller	B-FC22L	1	
	39. Pick-up roller (cassette feed section)	K-ROL-PICK-310	1	
TBU-KIT-FC22 (120K kit)	61. Transfer belt	BT-FC22TR	1	120K
	62. Transfer roller	CR-FC22TR	4	
	63. Drive roller cleaning felt	FP-FC22TR	1	
	64. Transfer belt cleaning blade	BL-FC22TR	1	

\* The numbers in the “Classification of kits” column above correspond with the numbers in the Preventive Maintenance Checklist.





## 2.5 List of Adjustment Tools

Name	Parts List	
	Page	Item
Door switch keep-on jig	100	1
Wire holder jig	100	2
ROM writer adapter 1	100	4
ROM writer adapter 2	100	8
Area sheet (grid-patterned sheet which facilitates the reading of values on X-Y coordinates in trimming and masking modes)	100	5
Doctor blade - sleeve gap adjustment jig	100	3
Doctor blade cleaning jig	100	7
Cleaning brush	100	6
<i>Test chart (No. TCC-1)</i>	<i>100</i>	<i>9</i>
<i>Scanner carriage jig</i>	<i>100</i>	<i>10</i>

## 3. PRECAUTIONS FOR STORING & HANDLING SUPPLIES

### 3.1 Precautions for Storing TOSHIBA Supplies

#### A. Toner and Developer

Toner and developer should be stored in a shaded place where the ambient temperature is between 10 to 35°C (no condensation), and should also be protected against direct sunlight during transportation.

#### B. Photoconductive Drum

Like toner and developer, Photoconductive drums should be stored in a dark place where the ambient temperature is between 10 to 35°C (no condensation). Be sure to avoid places where drums may be subjected to high humidity, chemicals and/or chemical gas.

#### C. Drum Cleaning Blade

This item should be stored “horizontally” on a flat surface where the ambient temperature is between 10 to 35°C, and should also be protected against high humidity, chemicals and/or chemical gas.

#### D. Fuser Roller

Avoid places where the fuser rollers may be subjected to high humidity, chemicals and/or chemical gas.

#### E. Cleaning Roller

Avoid places where the felt roller may be subjected to high humidity, chemicals and/or chemical gas. It should also be stored “horizontally” on a flat surface.

#### F. Copy Paper

Avoid storing copy paper in places where it may be subjected to high humidity.

After a package is opened, be sure to place and store it in a storage bag.

### 3.2 Checking and Cleaning of the Photoconductive Drum

#### (1) Use of Gloves

If fingerprints or oil stain the OPC drum surface, the characteristics of the photoconductor may degrade, affecting the quality of the copy image. So, do not touch the drum surface with your bare hands.

#### (2) Handling Precautions

As the OPC drum surface is very delicate, be sure to handle the drum carefully when installing and removing it so as not to damage its surface.

When the drum is replaced with a new one, be sure to apply “patting powder” (lubricant) to the entire surface of the new drum before installing. After installing, the drum counter must be cleared to 0 (zero) by operating the setting mode 840 – 843 and 867 – 870.

#### Note:

1. Application of the patting powder is for reducing the friction between the drum and the cleaning blade. If the application of patting powder is neglected, the drum and the cleaning blade may be damaged.
2. When some fibers adhere to the cleaning blade edge, they may reduce the cleaning efficiency and, in addition, may damage the blade and the drum. Be sure to remove any fibers found adhering to the blade.

### (3) Installation of the Copier and Storage of the Drum

Avoid installing the copier where it may be subjected to high temperature, high humidity, chemicals and/or chemical gas.

Do not leave drums in a brightly lit place for a long time. Otherwise, the drum will be fatigued, producing some background fog on the copy after being installed in the machine. However, this effect will decrease as time elapses.

### (4) Cleaning the Drum

At periodic maintenance calls, wipe softly the entire surface of the drum using the designated cleaning cotton (dry soft pad). Use sufficiently thick cleaning cotton so as not to touch the drum surface inadvertently with your fingertips or nails. Also, remove your rings and wristwatch before starting cleaning work to prevent accidental damage to the drum.

Do not use organic solvents such as alcohol or silicone oil as they will have an adverse effect on the drum. Never use selenium refresher, either.

### (5) Scratches on Photoconductive Drum Surface

If the surface is scratched to such a degree that the aluminum base is exposed, black spots or streaks will be produced on copy images and can also damage the cleaning blade. So, replace the drum with a new one.

### (6) Collecting Used Photoconductive Drums

Regarding the recovery and disposal of used OPC drums, you should follow your relevant local regulations and rules.

## **3.3 Checking and Cleaning of the Drum Cleaning Blade and Transfer Belt Cleaning Blade**

### (1) Handling Precautions

Since the edge of the cleaning blade performs the cleaning operation, pay special attention when handling it:

- ① Do not allow any hard object to hit or rub against the blade edge. Do not rub the edge with a cloth or soft pad.
- ② Do not stain the edge with any oil or fingerprints, etc.
- ③ Do not allow solvents such as paint thinner to touch the blade.
- ④ Do not leave any lint or dirt on the blade edge.
- ⑤ Do not place the blade near a heat source.

### (2) Cleaning Procedure

Clean the blade edge lightly with a cloth moistened with water.

### 3.4 Checking and Replacing the Oil Roller and Cleaning Roller of Fuser Section

#### (1) Handling Precautions

Never allow solvents such as paint thinner to touch to the cleaning roller.

#### (2) Defective Cleaning and Corrective Treatment

Judgement should be made depending on how much toner has been deposited on the fuser roller surface. When its surface is stained with toner, examine the oil roller and cleaning roller. If toner is heavily adhered on the oil/cleaning rollers, it means the cleaning performance is declined and the oil/cleaning rollers should be replaced with new ones.

The oil/cleaning rollers will be gradually degraded due to subjection to the heat from the fuser roller over a long period of time. Replace them preferably after a fixed amount of copies have been made.

### 3.5 Checking and Cleaning of the Fuser Rollers

#### (1) Handling Precautions

Upper and lower fuser rollers

- ① Do not leave any oil (fingerprints, etc.) on the upper and lower fuser rollers.
- ② Be careful not to allow any hard object to hit or rub against the fuser rollers, or they may be damaged, possibly resulting in defective cleaning.

#### (2) Checking

- ① Check for stain and damage on the fuser rollers and clean if necessary.
- ② Clean the separation claws and check for chipped claw tips.
- ③ Check the cleaning effect of the cleaning roller.
- ④ Check the thermistor for proper contact with the fuser roller.
- ⑤ Check the fused condition of the toner image.
- ⑥ Check the gap between the inlet guide and lower fuser roller.
- ⑦ Check the fuser rollers for proper rotation.

#### (3) Cleaning Procedure for Fuser Rollers

When fuser rollers become dirty, they will cause jamming. If this happens, wipe the roller surface clean with a suitable cloth. For easier cleaning, clean the rollers while they are still warm.

#### **Note:**

Be careful not to rub the fuser roller surface with your fingernails or hard objects because it can be easily damaged. Do not use silicone oil on the fuser rollers.

### **3.6 Checking and Replacing the Transfer Belt**

#### **(1) Handling Precautions**

- ① Do not touch the belt surface with your bare hands.
- ② Prevent oil or other foreign matter from staining the belt surface.
- ③ Do not allow alcohol or any other organic solvent to come into contact with the transfer belt.
- ④ Do not apply external pressure that might scratch the transfer belt.

### **3.7 Checking and Replacing the Transfer Roller**

#### **(1) Handling Precautions**

- ① Do not touch the transfer roller surface with your bare hands.
- ② Be careful not to leave any scratch or dent on the transfer roller surface.

## 4. TROUBLESHOOTING

### <CAUTION IN REPLACING PC BOARDS>

The ID for each machine is registered on the LGC board, the IMC board and the SIC board. So, if their replacement is required, be sure to replace only one board at a time.

If more than one of the LGC board, the IMC board and the SIC board require replacement, replace them in the following procedure.

1. First, replace one of the boards to be replaced.
2. Turn the power ON and confirm that "READY" is displayed.
3. Turn the power OFF.
4. Replace another board that requires replacement.
5. Repeat the steps 2. to 3.

\* If more than one of the LGC board, the IMC board and the SIC board are replaced at the same time, the error code "C9E" might be displayed.

### 4.1 Troubleshooting Based on Error Code

#### 4.1.1 Paper transport jam inside the copier

**E01** Paper leading edge not reaching the exit sensor

**E02** Paper trailing edge not passing the exit sensor

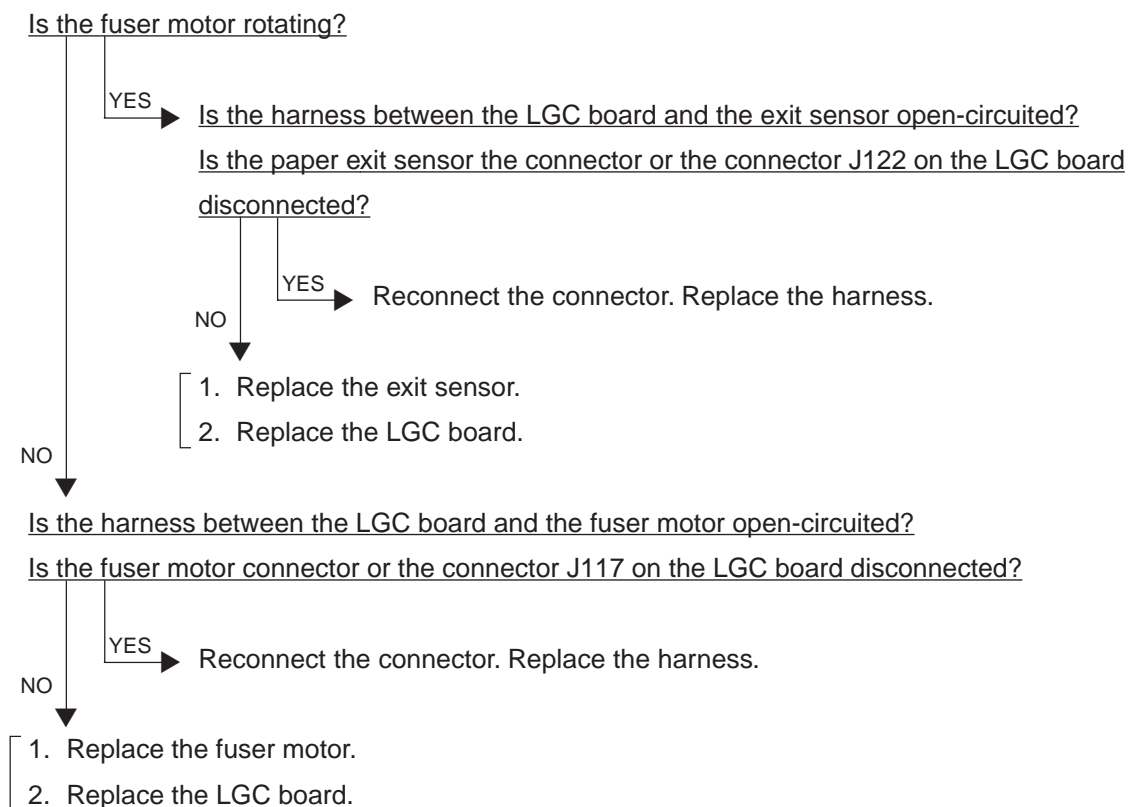

Where was the paper stopped?

Near the exit sensor (paper not damaged)

Is the registration sensor functioning properly? (Does its actuator return smoothly?)

YES

1. Check the test mode 03 and see if the registration sensor is valid.
2. Reconnect the registration sensor connector.

NO

Repair if the actuator is displaced.

Before reaching the fuser unit

Did the paper stop, curling upward excessively?

YES

Replace the paper in the cassette.

From on the transfer belt up to the exit sensor

Do the size of paper and the size plate indication match?

NO

Make the sizes match.

YES

Is the transfer belt moving?

(To C37)

### E03 Paper remaining inside the copier at power ON

Is any paper remaining inside the copier?

YES

Remove the paper.

NO

Refer to E01, E02 and E11 to E26.



## 4.1.2 Paper feeding jam

### E11 Paper misfeed from the ADU

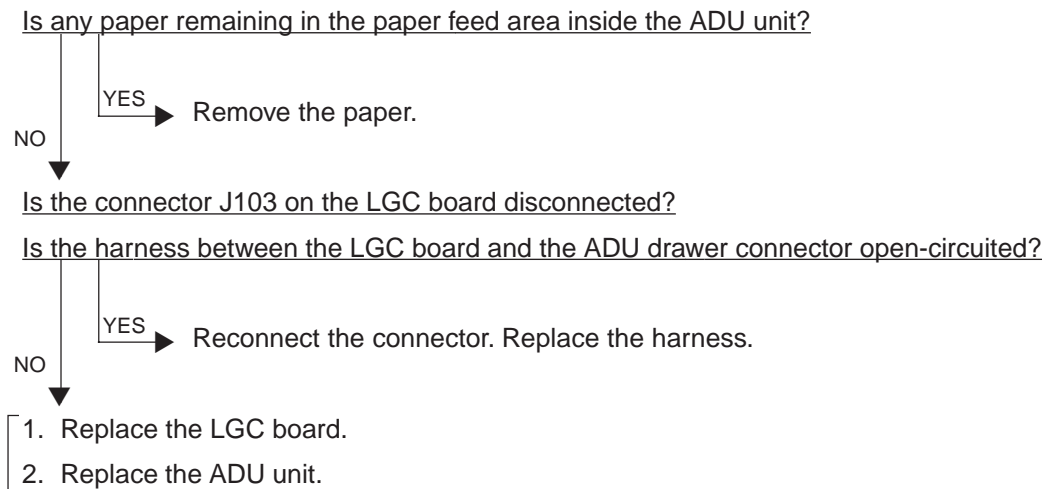

### E12 Paper misfeed from the bypass

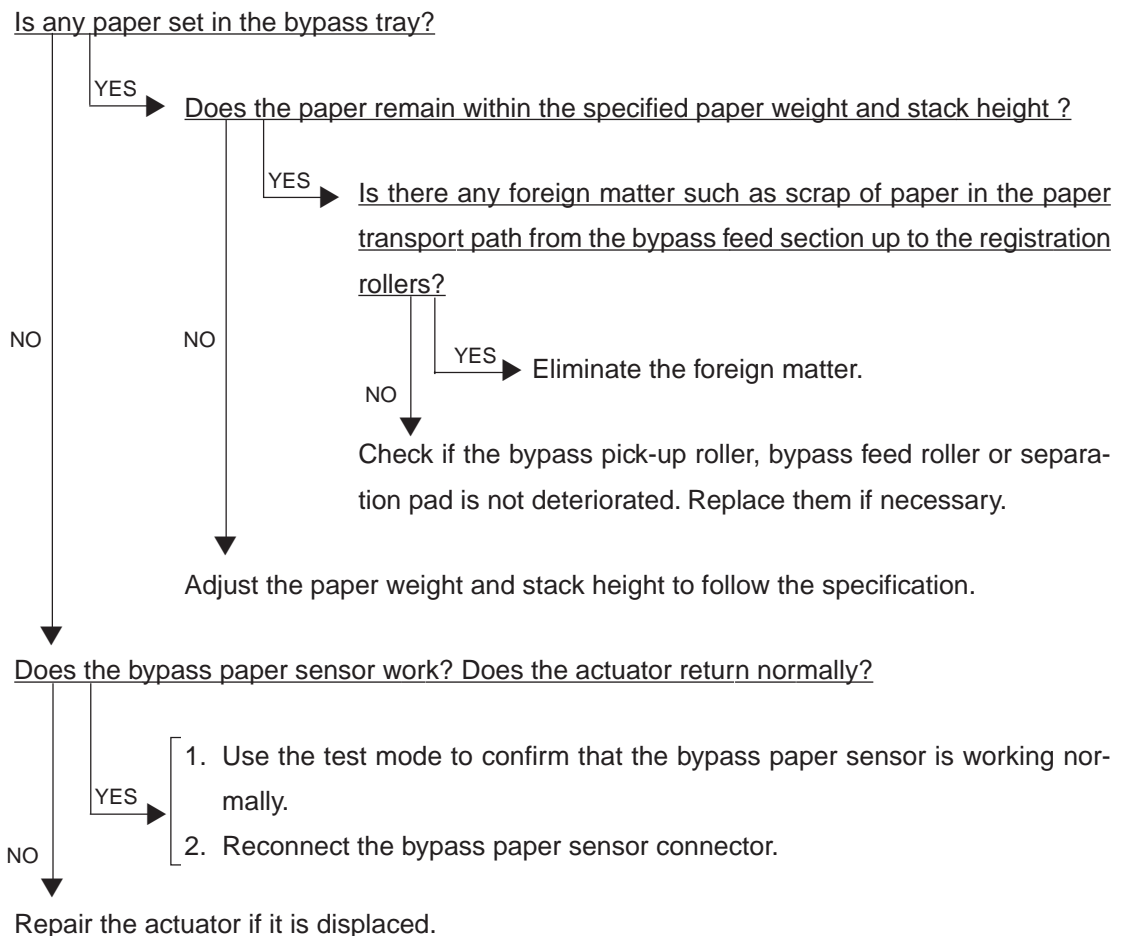

**E13** Paper misfeed from the 1st cassette

**E14** Paper misfeed from the 2nd cassette

**E15** Paper misfeed from the 3rd cassette

**E16** Paper misfeed from the 4th cassette

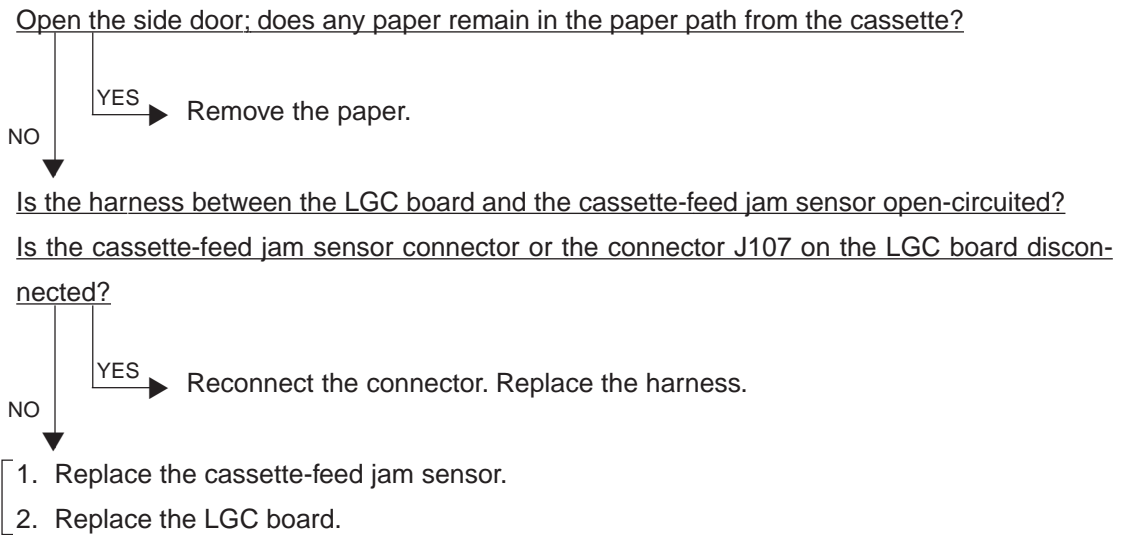

**E19** Paper misfeed from the LCF

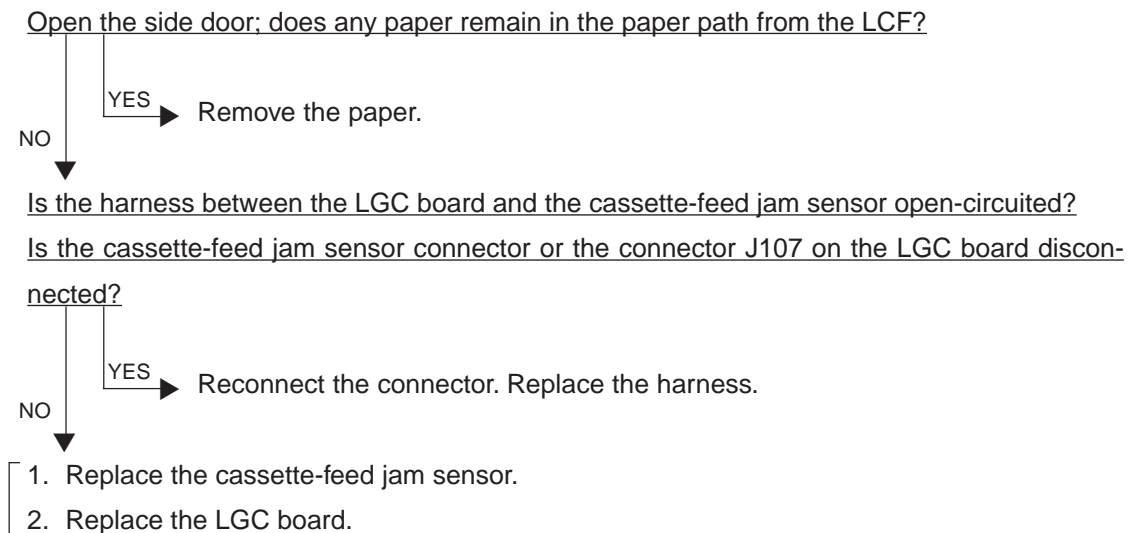

### 4.1.3 Paper transport jam (Paper not reaching the registration sensor after feeding)

- E21** Paper transport jam from the LCF
- E22** Paper transport jam from the 1st cassette
- E23** Paper transport jam from the 2nd cassette
- E24** Paper transport jam from the 3rd cassette
- E25** Paper transport jam from the 4th cassette

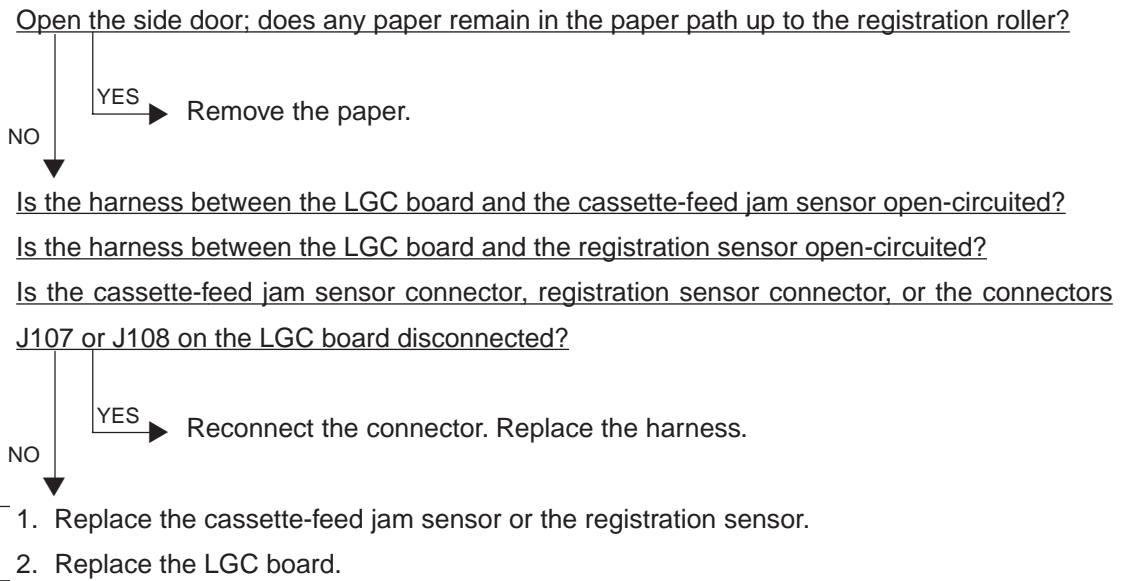

#### 4.1.4 Cover open jam

##### **E41** Front cover opened during copying

\* To avoid electrical hazards, the following checks must be made after unplugging the power cord.

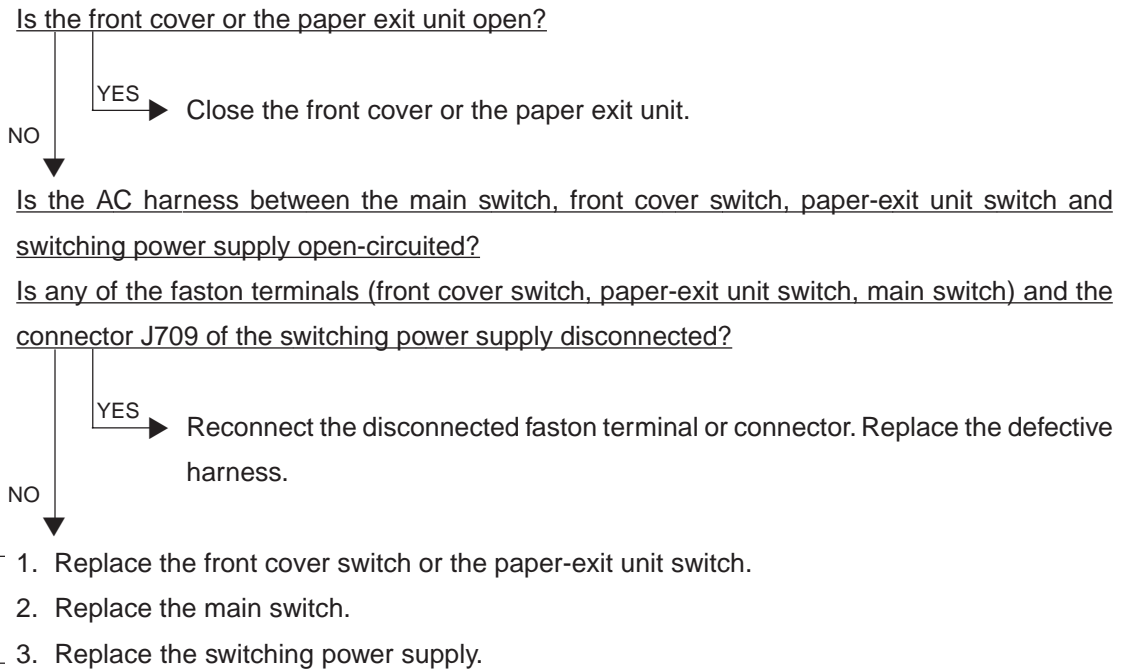

##### **E42** Side door opened during copying

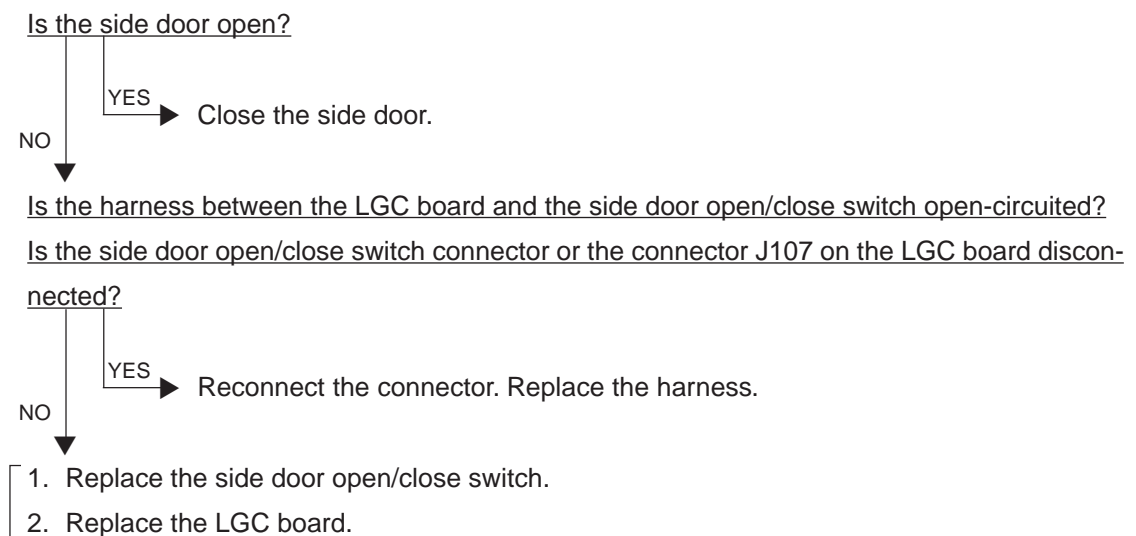

**E43** ADU unit pulled out during copying

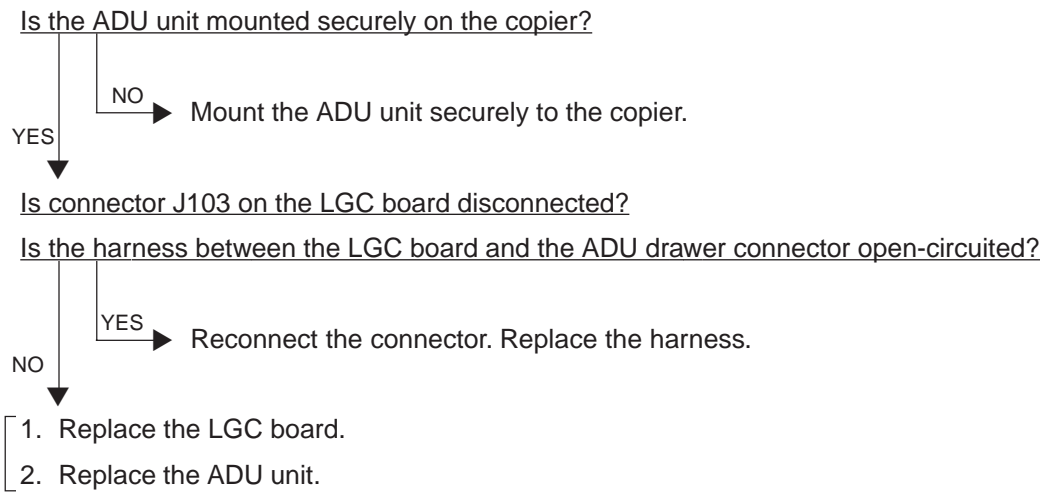

**E45** LCF jam access cover opened during copying

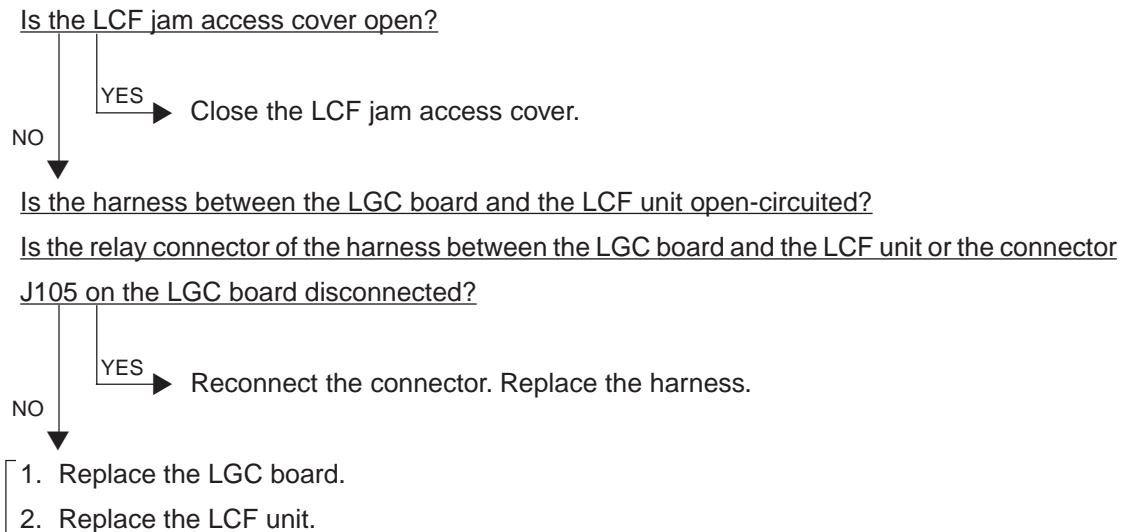

**E46 Bypass unit opened during copying**

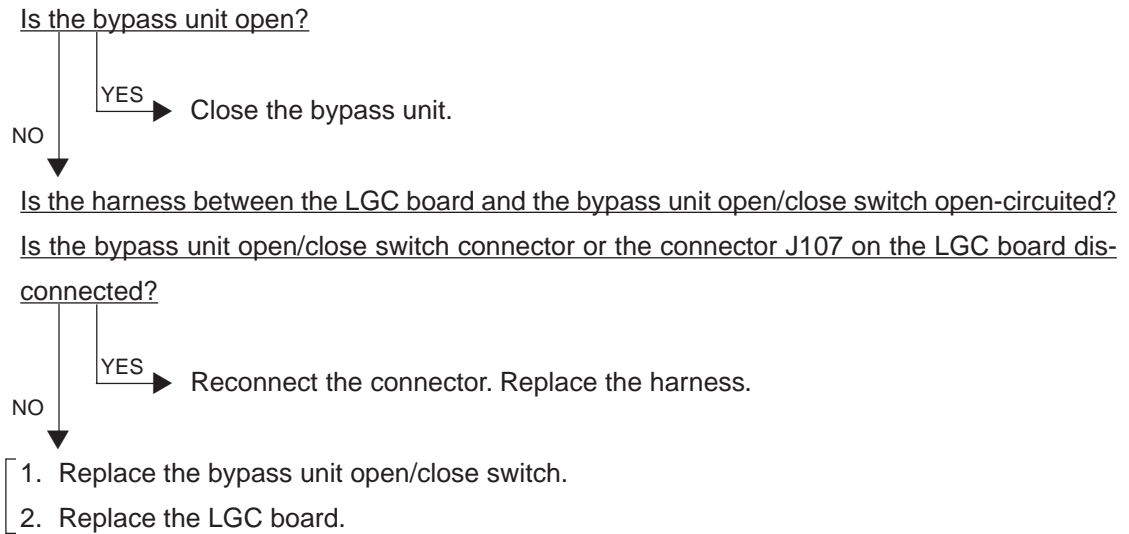

**4.1.5 Paper jam in ADU and reversing area**

**E50 Paper not reaching the ADU**

**E51 Paper not restarting from the ADU stack**

**E54 ADU paper transport jam**

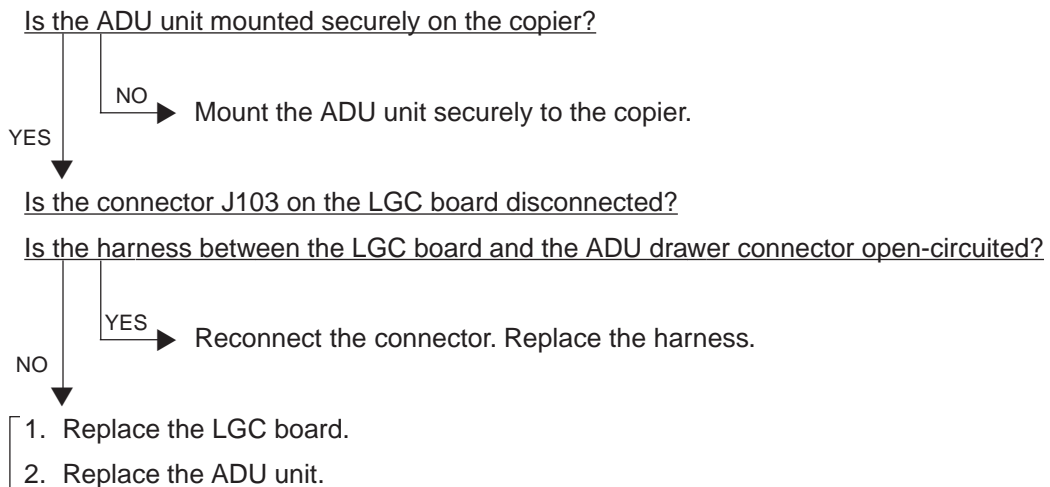

**E52** Paper not reaching the ADU path sensor

Is the harness between the LGC board and the ADU path sensor open-circuited?

Is the ADU path sensor connector or the connector J122 on the LGC board disconnected?

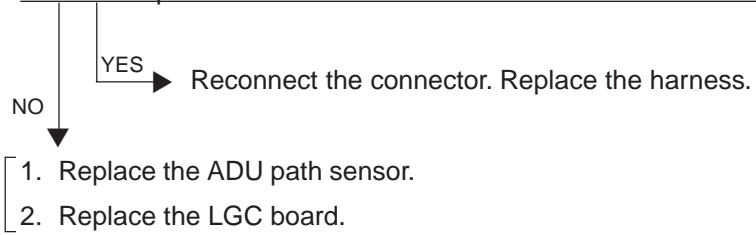

#### 4.1.6 Original jam in the RADF

- E71** Original not reaching the aligning sensor
- E72** Original not reaching the exit sensor
- E73** Original not passing the exit sensor
- E75** Second original not reaching the aligning sensor in 2-in-1 mode
- E79** Prefeed jam

**[Two or more originals are fed simultaneously.]**

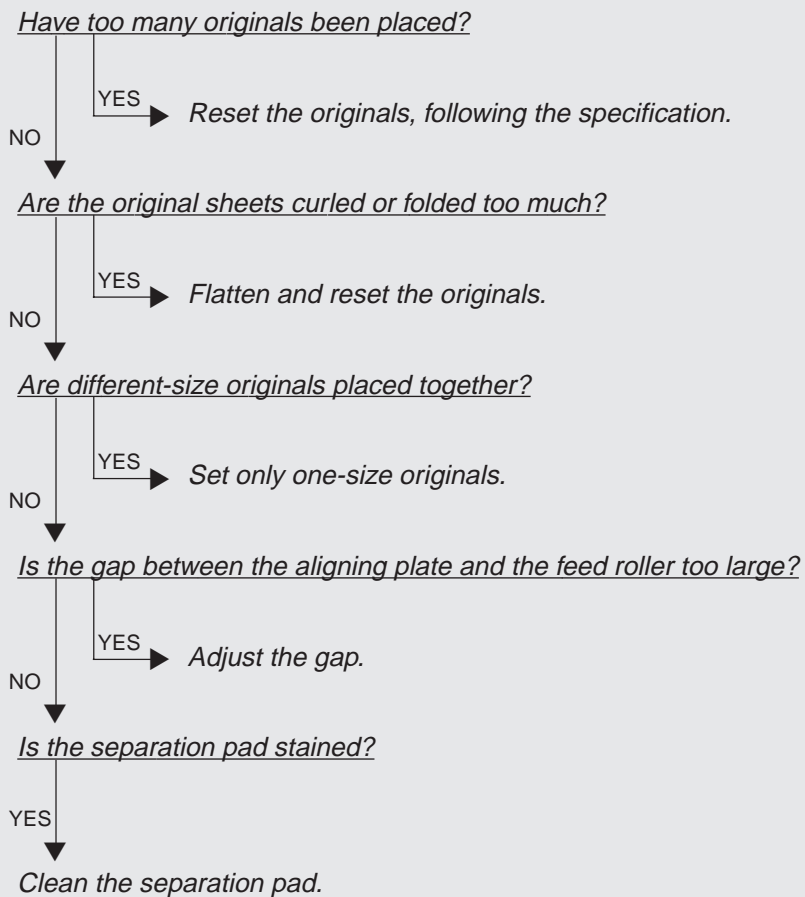



**[The original does not reach the aligning roller.]**

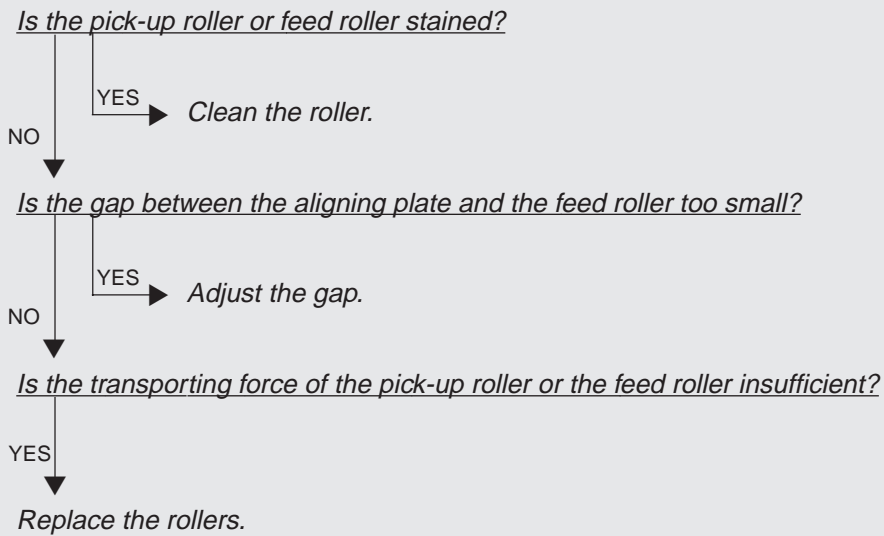

**[The original stops, skewed on the original glass.]**

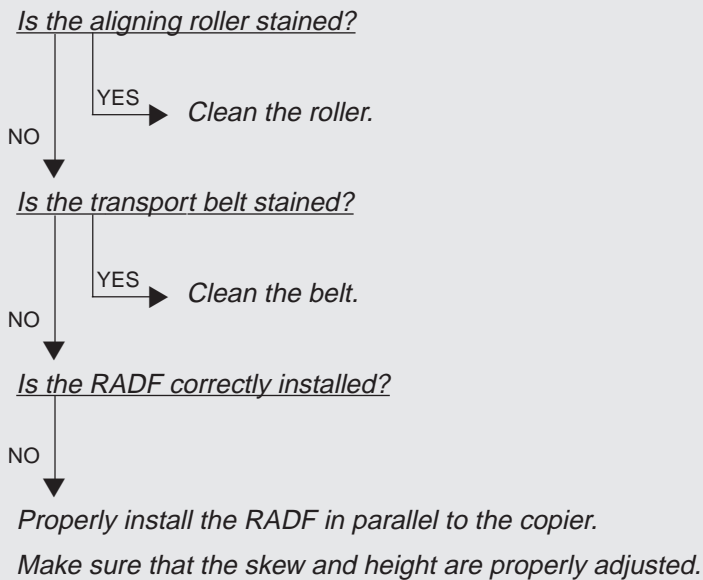

**[The side edges of the original are out of alignment with the side edges of the copy.]**

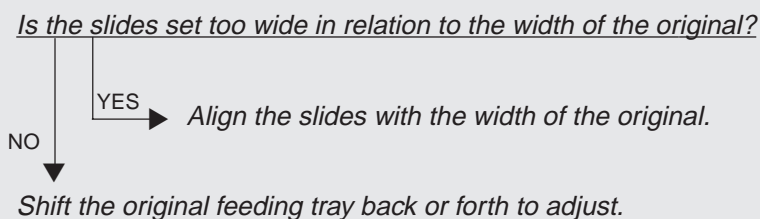

#### 4.1.7 Paper jam in the sorter

##### **EA1** Paper transport delay jam

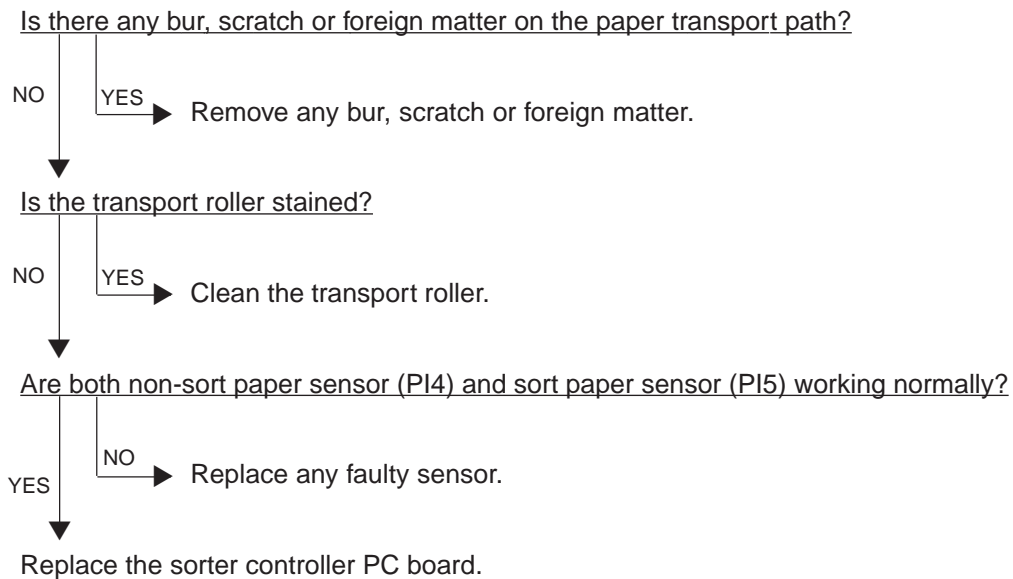

##### **EA2** Paper transport stop jam

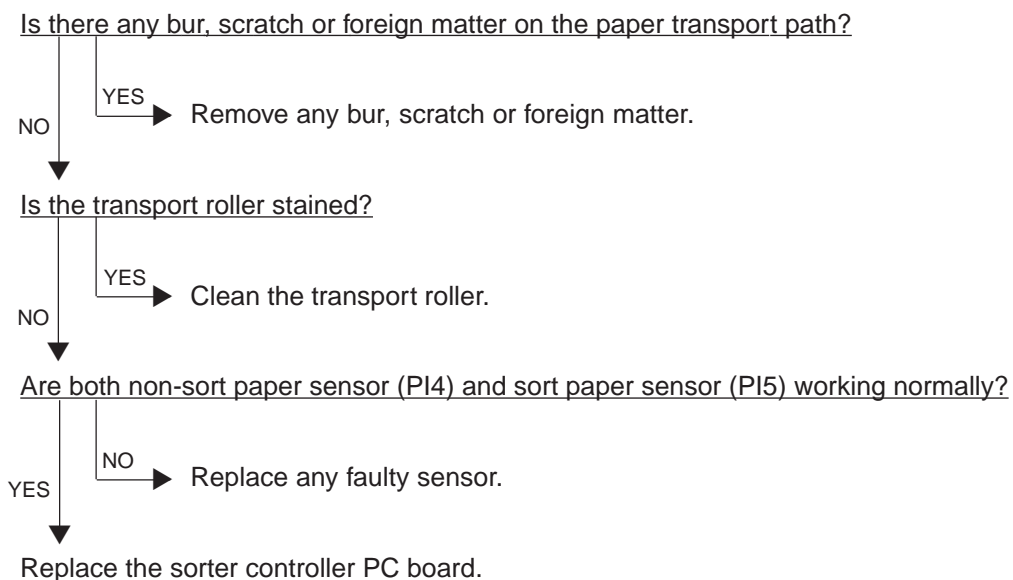

**EA3 Paper remaining on the sorter transport path at power ON**

Is there any dirt or foreign matter around the non-sort paper sensor (PI4) or the sort paper sensor (PI5)?

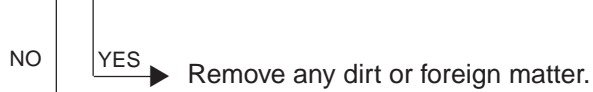

Are both non-sort paper sensor (PI4) and sort paper sensor (PI5) working normally?



Replace the sorter controller PC board.

**EA4 Sorter front door opened during copying**

Is the stapler unit cover securely closed?

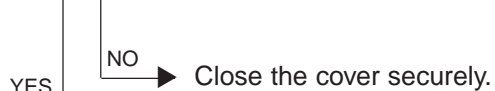

Is the sorter securely mounted on the copier?

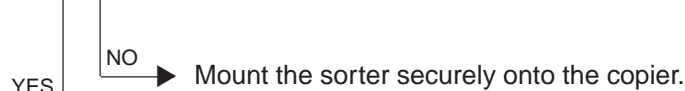

Is the feed guide securely closed?

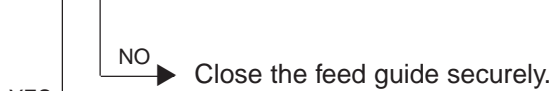

Are the stapler cover open/close switch (MS5), joint switch (MS1) and feed guide open/close switch (MS10) all working normally?



Replace the sorter controller PC board.

**EA5** Staple jam

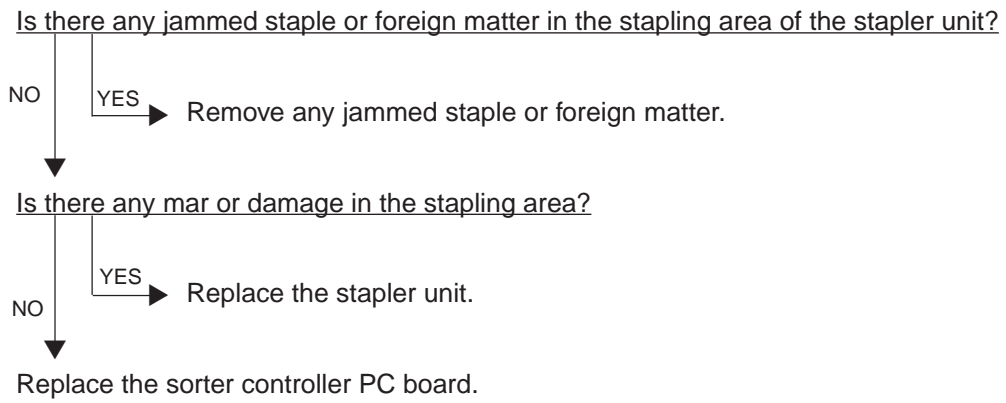

#### 4.1.8 Special sheet jam

##### **EC2** OHP sheets used except from bypass and 2nd cassette

Use the 2nd cassette or the bypass as the feeding source of OHP sheets.

##### **EC3** OHP sheet used in non-OHP mode

Set the specified type of paper as selected on the control panel in the paper source.

#### 4.1.9 Drive system related service call

##### **C05** ADU motor rotation abnormal

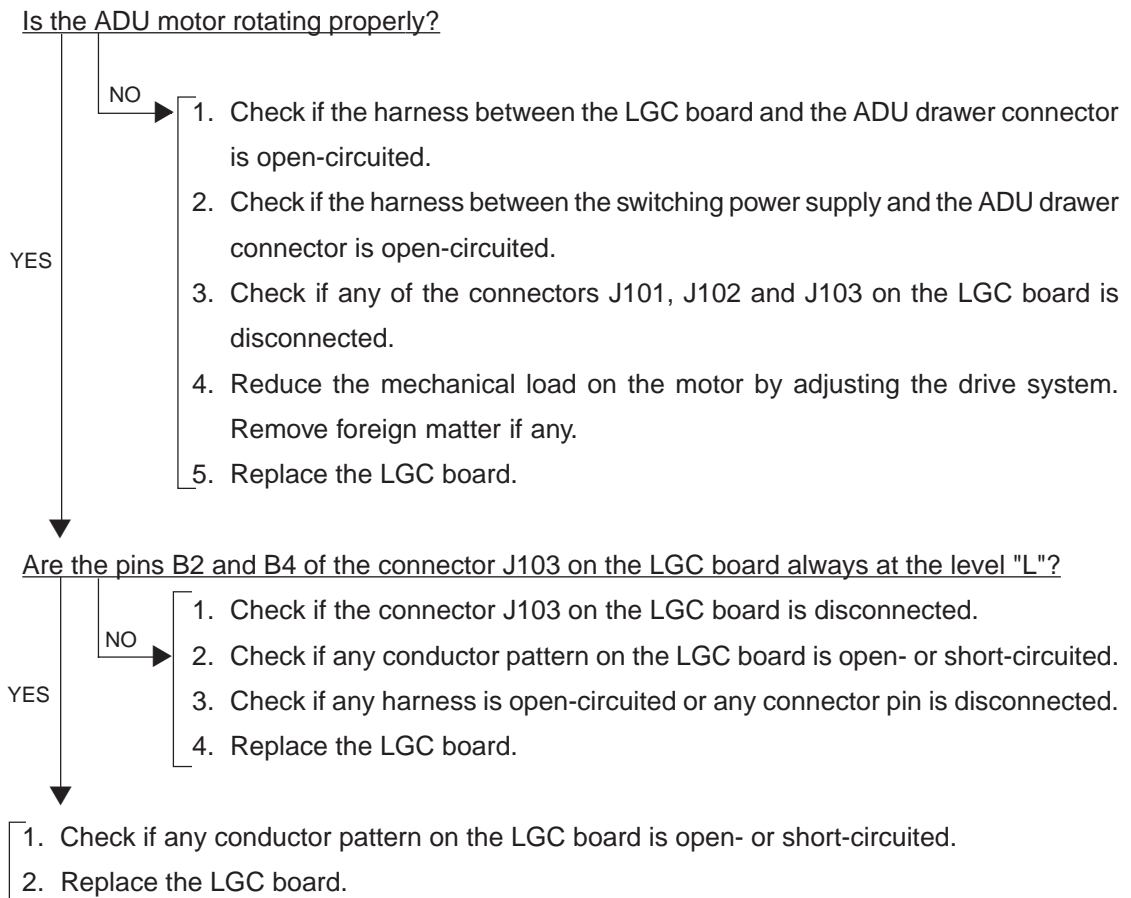

**C09** Black developer motor rotation abnormal

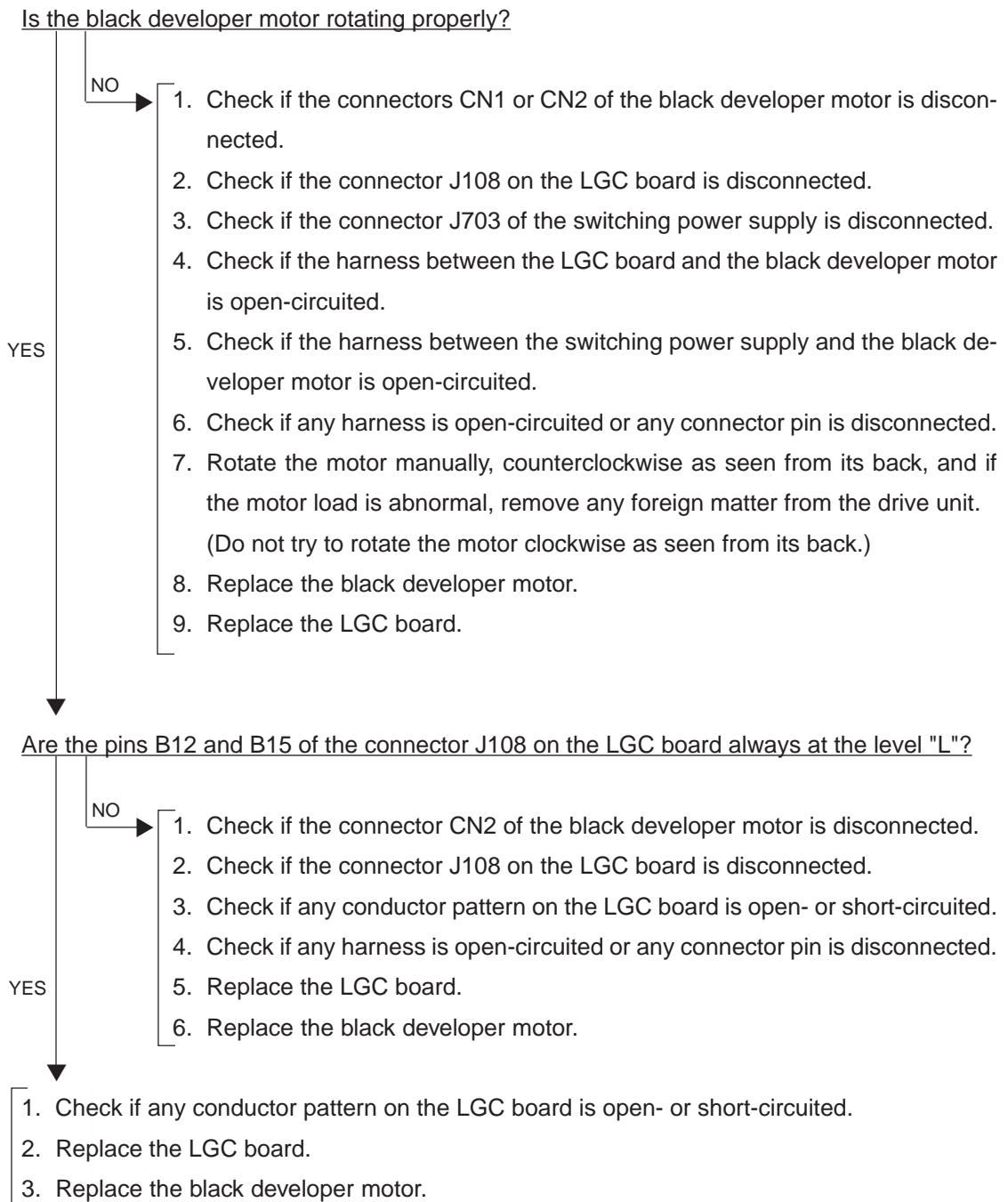

**C0A** Color developer motor rotation abnormal

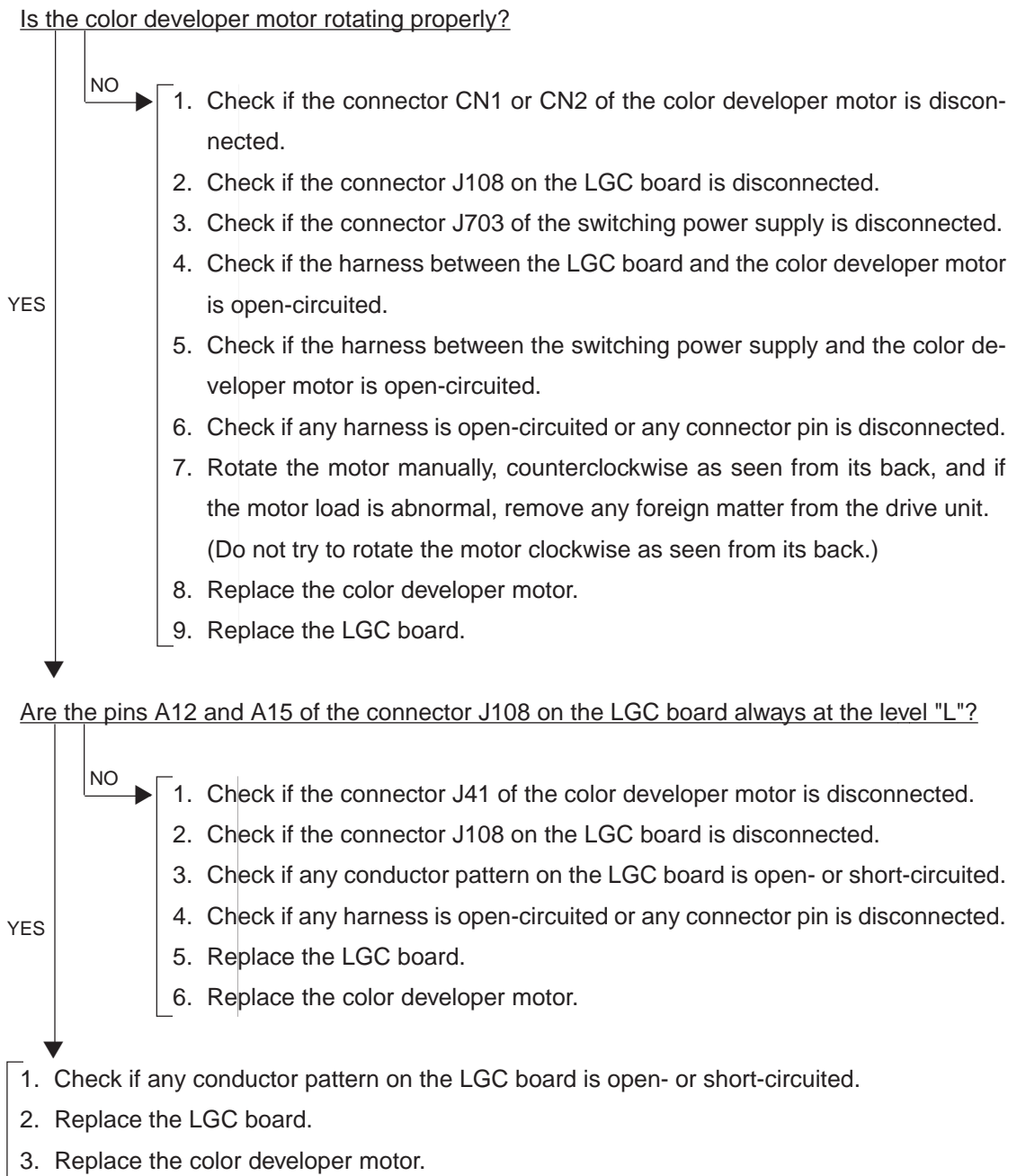



- C0B** Drum motor K rotation abnormal
- C0C** Drum motor C rotation abnormal
- C0D** Drum motor M rotation abnormal
- C0E** Drum motor Y rotation abnormal

\* Before performing the following checks, be sure to place the transfer belt unit in a lowered position; otherwise, the drums and the transfer belt would be damaged when you rotate the drum motor.

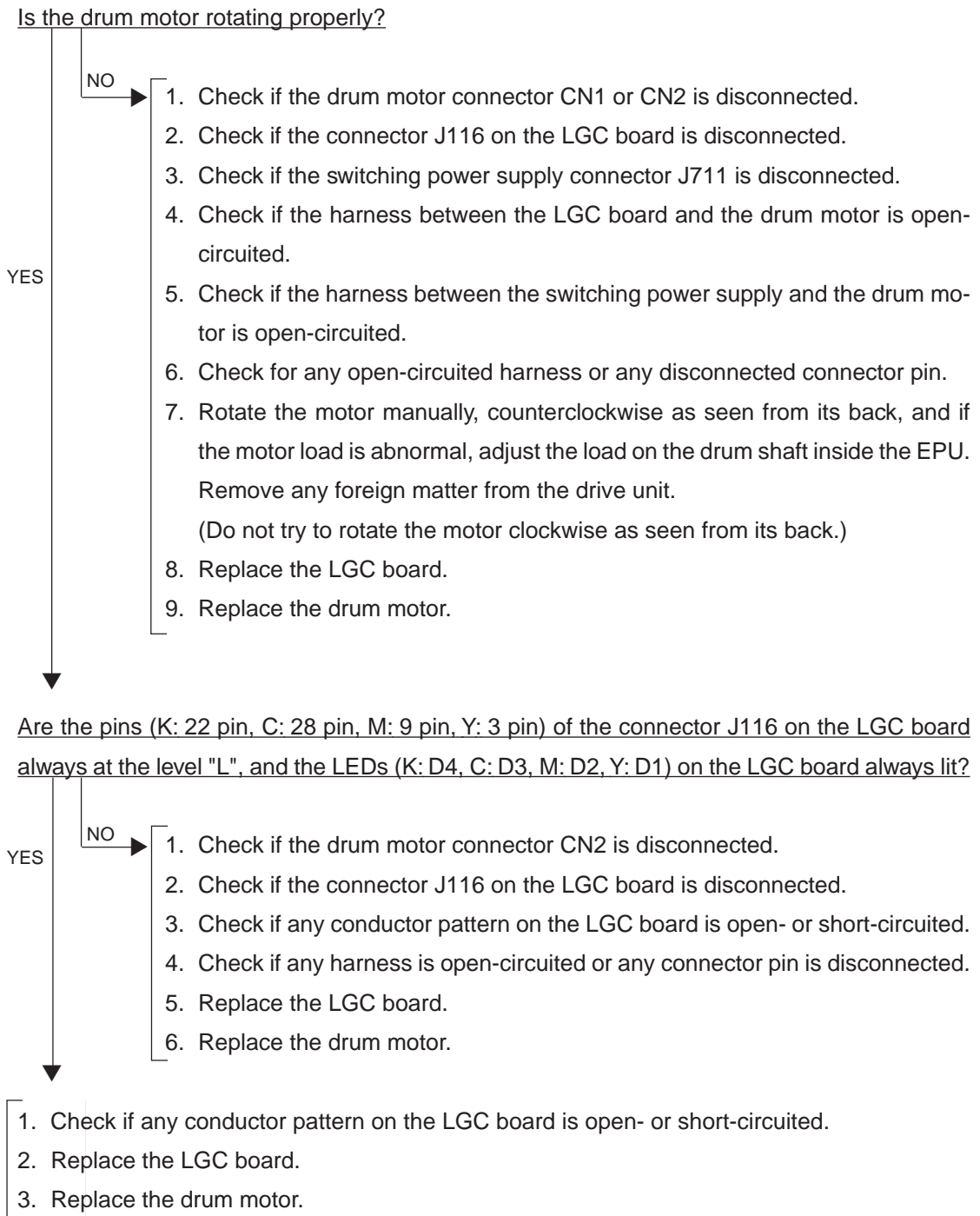

#### 4.1.10 Paper feeding system related service call

##### **C11** ADU paper side guide function abnormal

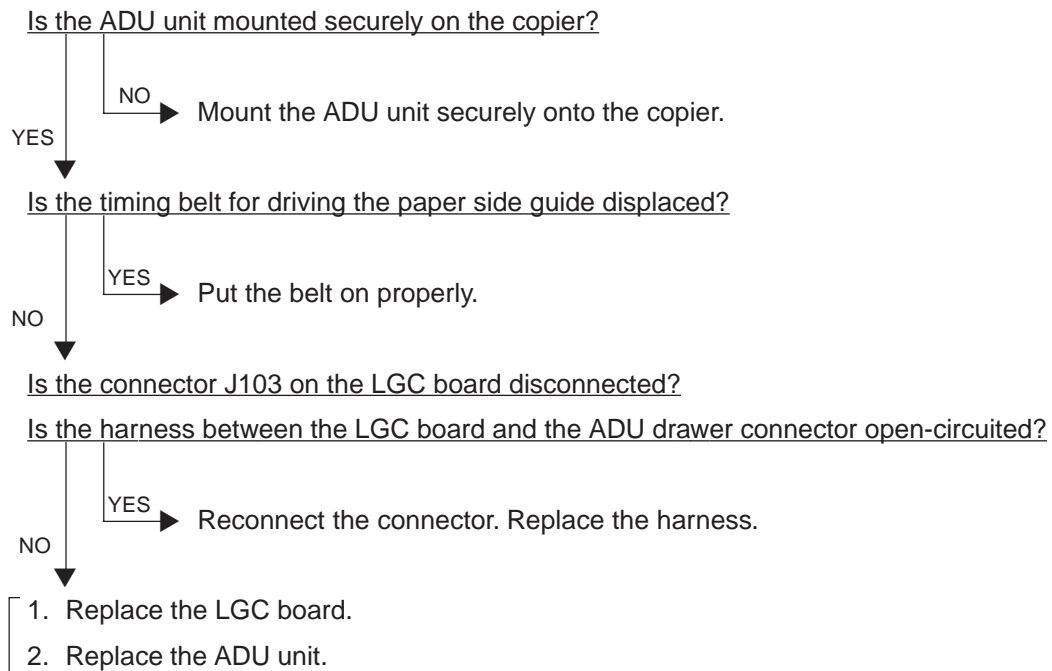

##### **C12** ADU paper end guide function abnormal

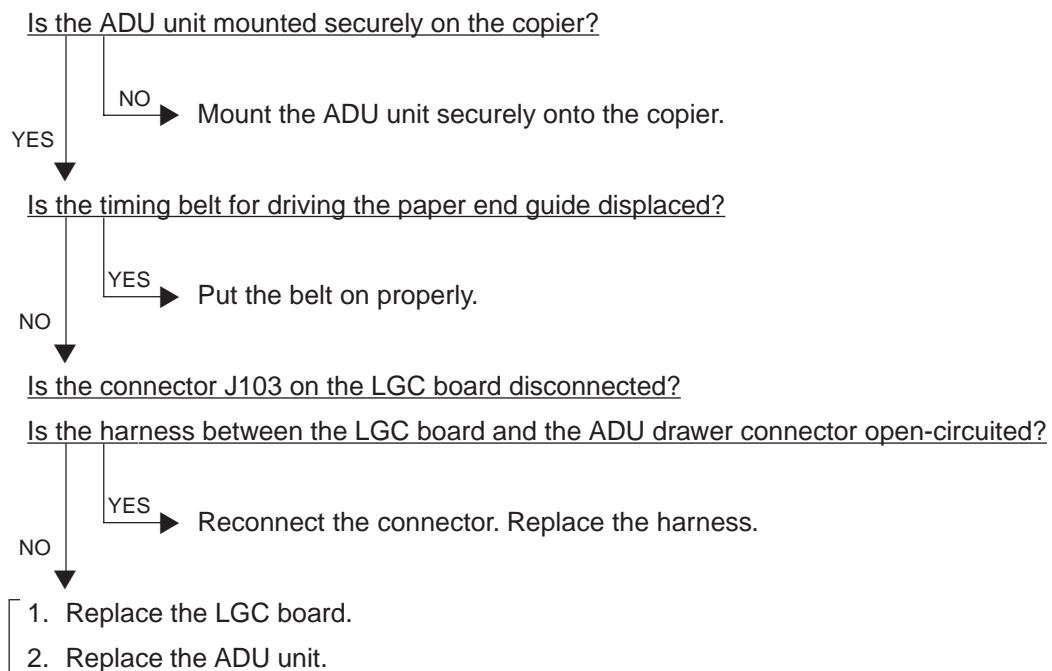

**C13** 1st cassette tray function abnormal

**C14** 2nd cassette tray function abnormal

**C15** 3rd cassette tray function abnormal

**C16** 4th cassette tray function abnormal

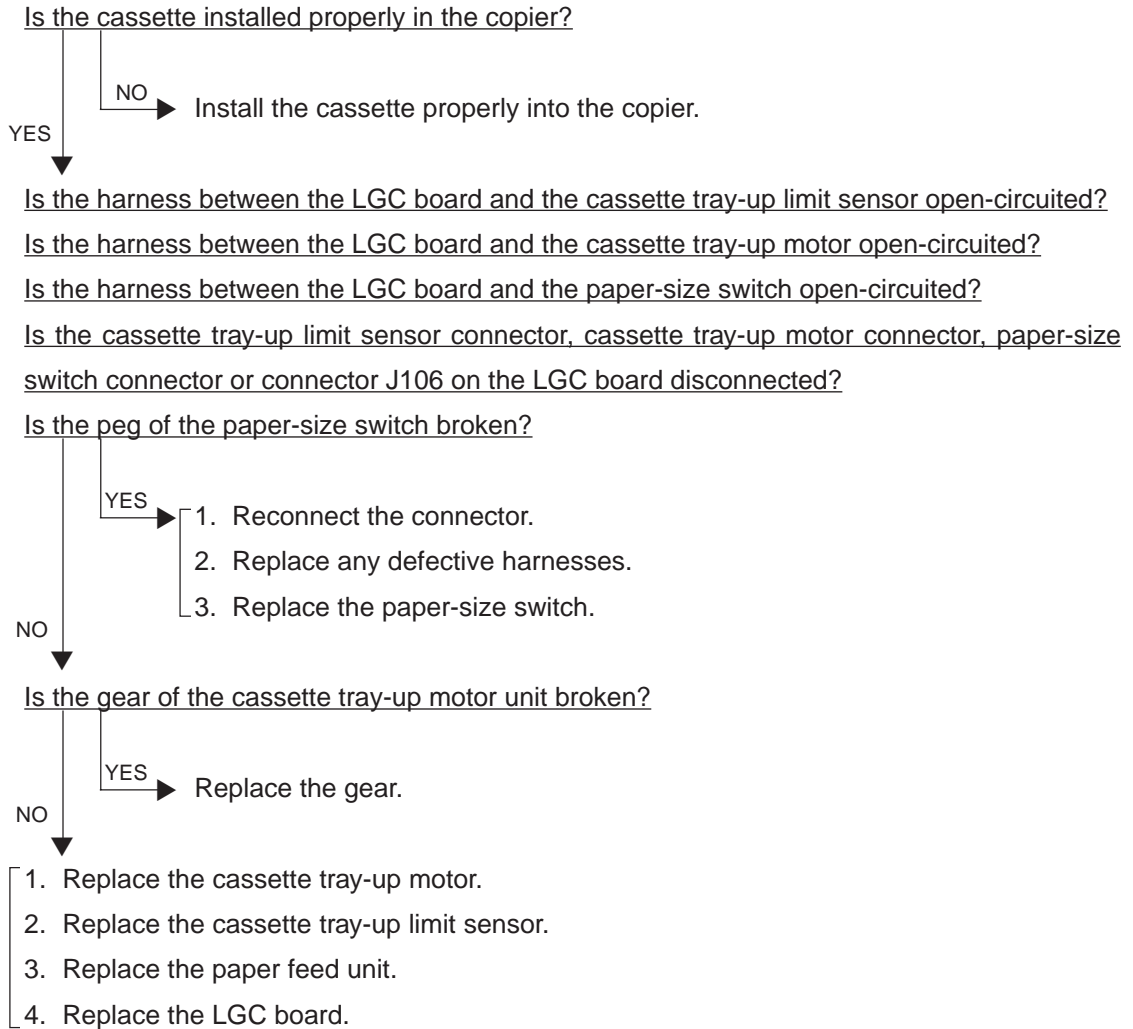

**C18** LCF tray function abnormal

Is the harness between the LGC board and the LCF unit open-circuited?

Is the relay connector of the harness between the LGC board and the LCF unit or the connector J105 on the LGC board disconnected?

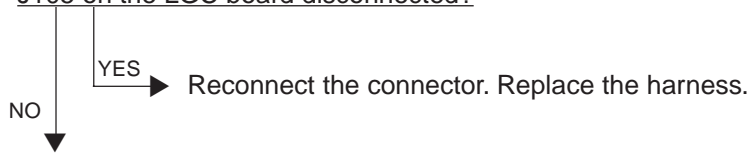

Do the switches and sensors in the LCF unit function?

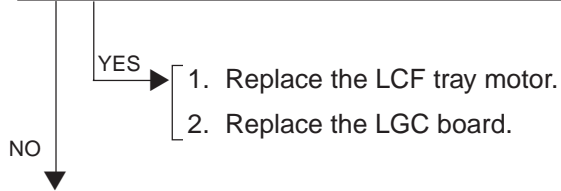

- 1. Replace any faulty sensor or switch in the LCF unit.
- 2. Replace the LCF drive PC board or the LCF tray-down switch PC board.
- 3. Replace the LGC board.



#### 4.1.11 Scanner related service call

**C27** Carriage home position sensor not turning OFF within a fixed time

**C28** Carriage home position sensor not turning ON within a fixed time

Remove the original glass, move the carriage to the paper feed side, turn ON the power switch, and then proceed to check the following items.

**C27** Is the carriage stuck at a point other than the home position?

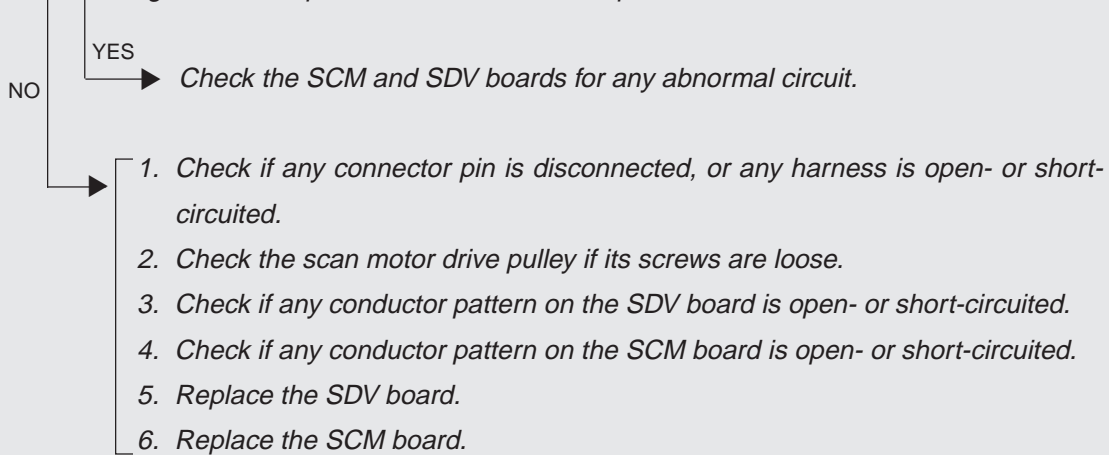

**C28** Does the carriage, after arriving at its home position, make a big noise?

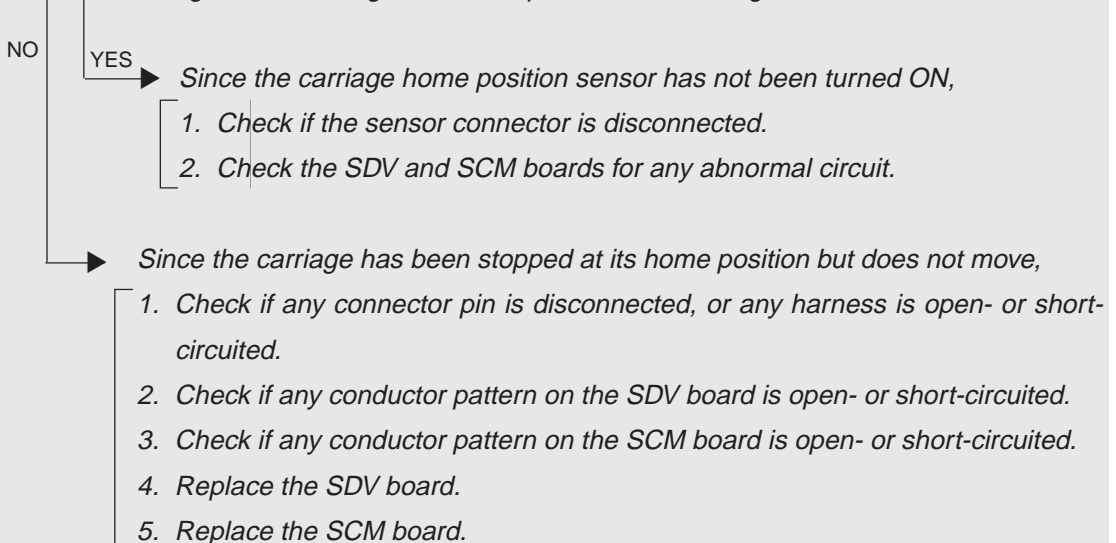



**C29** *Exposure lamp disconnection detected*

*Does the exposure lamp light?*

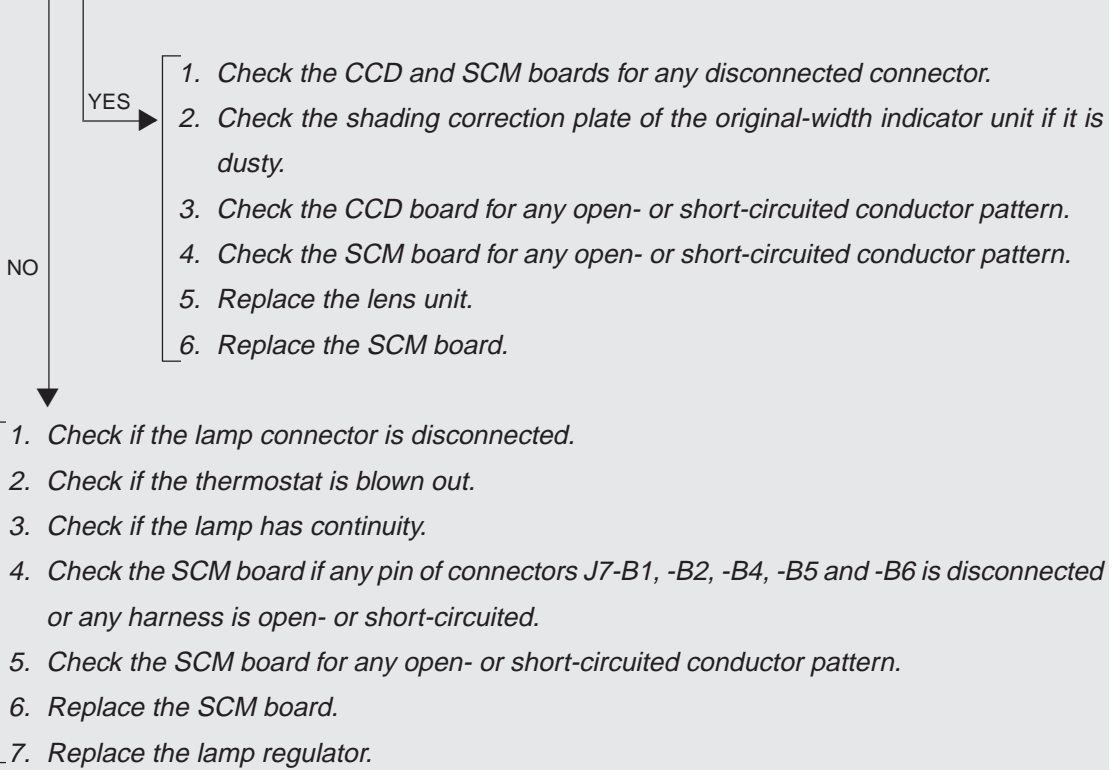

#### 4.1.12 Copy process related service call

##### **C31** Used toner transport motor rotation abnormal

Is the harness between the LGC board and the used toner transport motor open-circuited?  
Is the connector J122 or J102 on the LGC board, the relay connector or the used toner transport motor connector disconnected?

NO  
YES → Replace the harness. Reconnect the connectors.

Is used toner jammed? Is any abnormal mechanical load found?

NO  
YES →  
1. Remove the jammed used toner.  
2. Check for any foreign matter in the drive system.  
3. Check the bearing of the used toner transport auger for any abnormality.  
4. Check if the toner bag is covered with used toner.

- 1. Replace the used toner transport motor.
- 2. Replace the LGC board.

\* Since the used toner jamming can cause a serious damage to EPU, be sure to check that the EPU functions normally.

**C33 Developer removal shutter function abnormal**

Reduce the mechanical load by adjusting the drive system. Remove any foreign matter.



Is the harness between the LGC board and the developer removal shutter open/close motor open-circuited?

Is any of the connectors J115 and J102 on the LGC board and the developer removal shutter open/close motor connector disconnected?

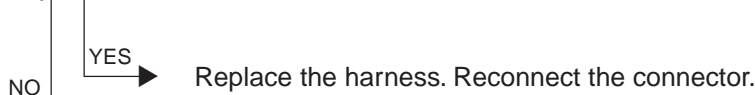

- 1. Replace the developer removal shutter open/close motor.
- 2. Replace the LGC board.

**C35 Transfer belt unit contact/release function abnormal**

Reduce the mechanical load by adjusting the drive system. Remove any foreign matter.



Is the harness between the LGC board and the transfer/transport unit drawer connector, or the harness inside the transfer/transport unit open-circuited?

Is the transfer belt contact/release drive motor connector, LGC board connectors J115 or J102, transfer belt home position switch connector, or transfer belt limit switch connector disconnected?

Is the transfer belt home position switch or the transfer belt limit switch defectively installed?

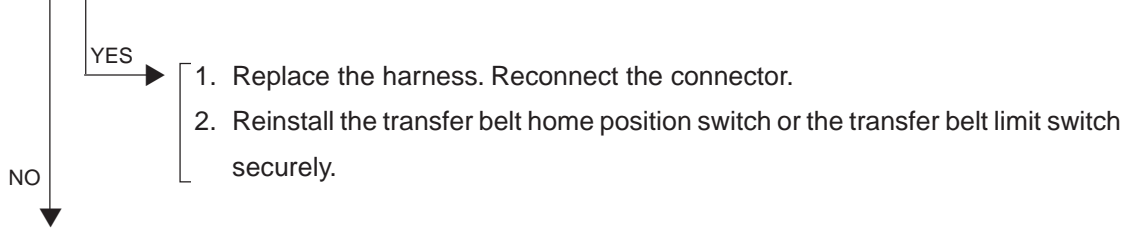

- 1. Replace the transfer belt home position switch and the transfer belt limit switch.
- 2. Replace the transfer belt contact/release drive motor.
- 3. Replace the LGC board.



### C37 Transfer belt motor rotation abnormal

- \* Before performing the following checks, be sure to place the transfer belt unit in a lowered position; otherwise, the drums and the transfer belt would be damaged when you rotate the drum motor.

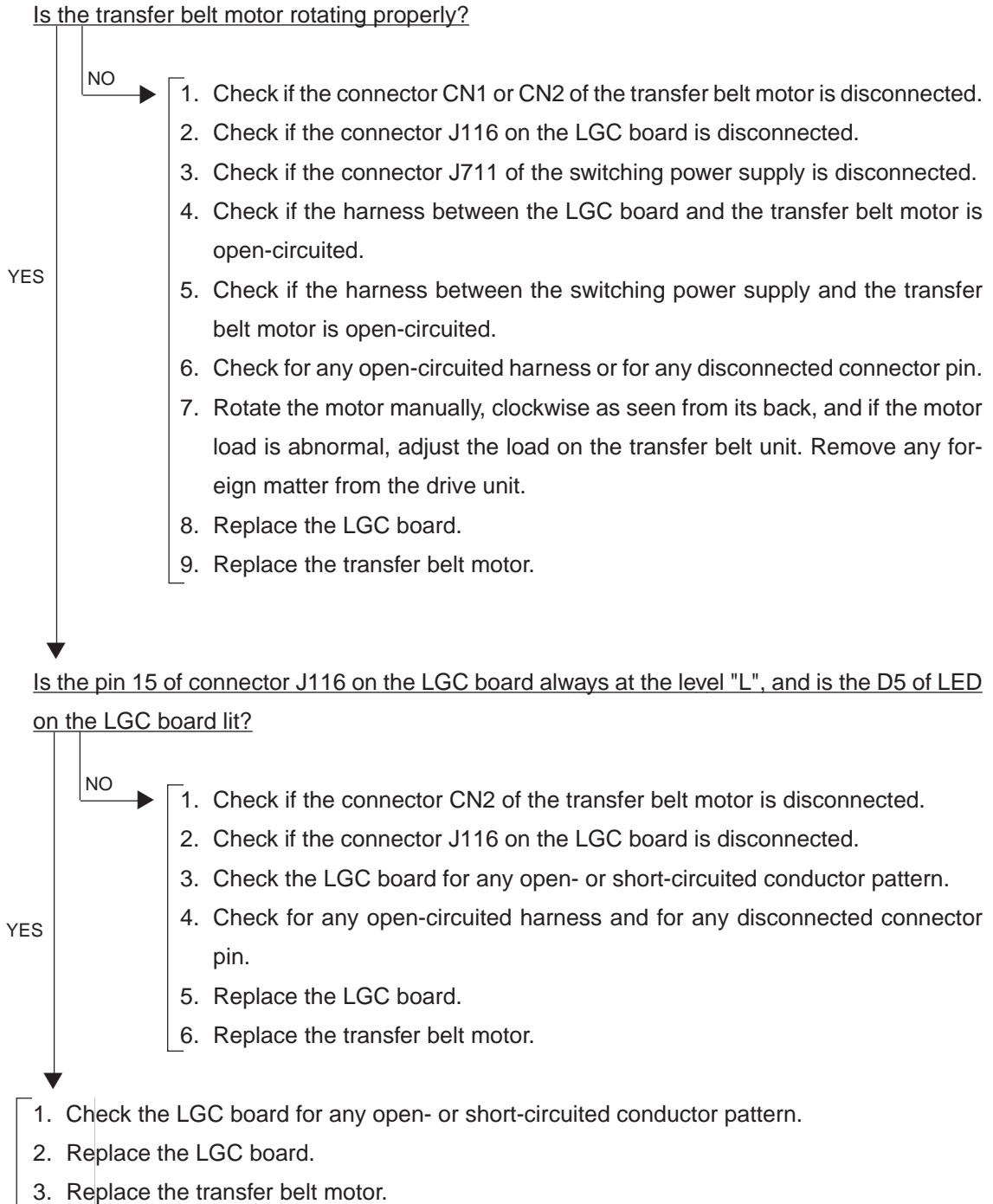

**C38** Auto toner initializing error (K)

**C39** Auto toner initializing error (C)

**C3A** Auto toner initializing error (M)

**C3B** Auto toner initializing error (Y)

Is the harness between the LGC board and the EPU drawer connector open-circuited?

Is any harness inside the EPU or the auto toner sensor harness open-circuited?

Is the auto toner sensor connector or the connector J119 on the LGC board disconnected?

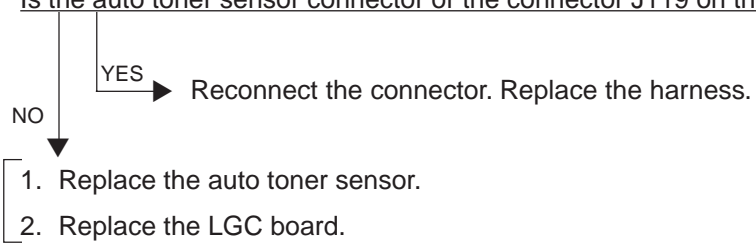

- C3C** Main charger wire abnormal (K)
- C3D** Main charger wire abnormal (C)
- C3E** Main charger wire abnormal (M)
- C3F** Main charger wire abnormal (Y)

Is the harness between the LGC board and the EPU drawer connector or any harness inside the EPU open-circuited?

Is the wire cleaner drive motor connector, the connector J119 on the LGC board, the connector of the wire cleaner home position switch, or the connector of the wire cleaner limit switch disconnected?

Is the wire cleaner home position switch or the wire cleaner limit switch defectively installed?

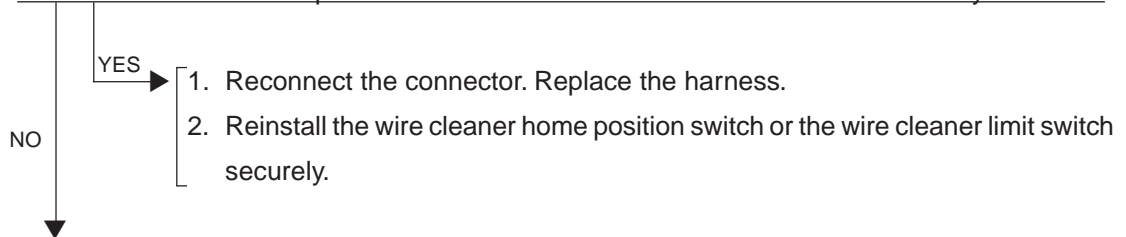

Is the main charger dislocated?

Is the wire cleaner home position switch or the wire cleaner limit switch disconnected?

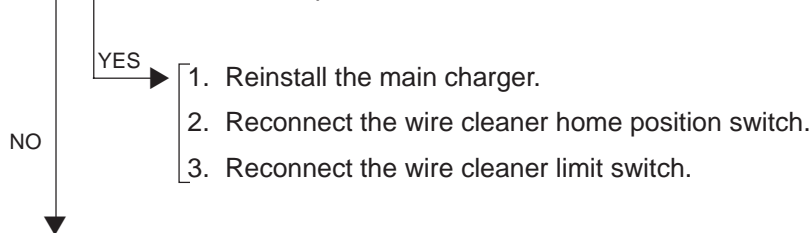

Is the mechanical load too heavy?

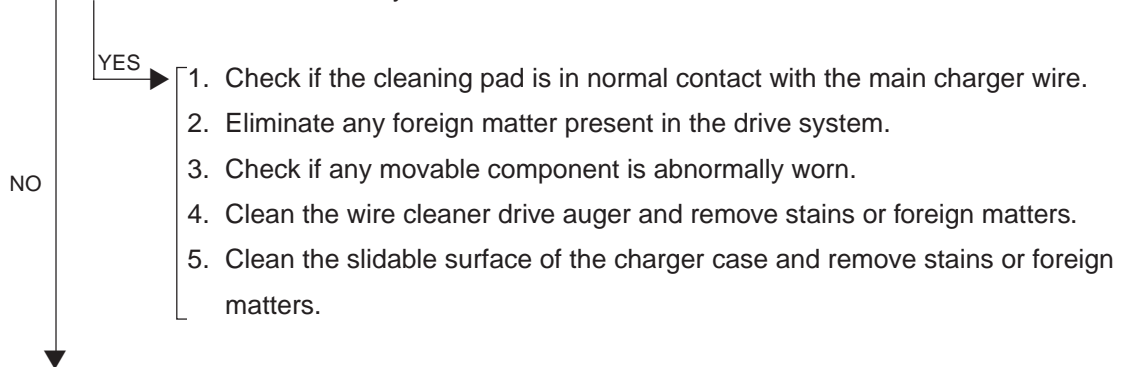

1. Replace the wire cleaner home position switch or the wire cleaner limit switch.
2. Replace the wire cleaner drive motor.
3. Replace the LGC board.

#### 4.1.13 Fuser unit related service call

##### **C41** Thermistor or heater abnormal when warming-up is started

- \* To avoid any safety hazards, be sure to unplug the power cable before proceeding to check items in 1. and 2. below.
- \* Be sure that the fuser unit is set in place securely.

##### 1. Checking the thermistors

- (1) Is any thermistor connector disconnected?
- (2) Are the thermistors (upper and lower, center and rear) in proper contact with the upper and lower fuser rollers?
- (3) Is the harness for the thermistors (upper and lower, center and rear) open-circuited?

##### 2. Checking the fuser lamps and SSR

- (1) Check if the upper or lower fuser lamp is open-circuited.
- (2) Check if the upper or lower fuser lamp connector is disconnected.
- (3) Check if the thermostat is blown out.
- (4) Check if the upper fuser roller or lower fuser roller SSR connector is disconnected.
- (5) Check if the AC harness is open-circuited.
- (6) Check if SSR or the switching power supply is broken.

##### 3. Checking the LGC board

- (1) Check the LGC board if the connector J122 is disconnected.
- (2) Check the LGC board for any abnormal condition, such as an open- or short-circuited conductor pattern.
- (3) Replace the LGC board.

##### 4. Clearing the status counter

After completing the repair of what caused the problem **C41**, proceed to do the following:

- (1) While pressing [0] and [8] simultaneously, turn ON the power.
- (2) Enter [700] with digital keys, then press the START key.
- (3) Rewrite [1] or [2] displayed on the status counter to [0], then press the INTERRUPT key (**C41** cleared).
- (4) Turn OFF the power and then back it ON again, and make sure that the copier gets ready normally.

##### **C42** Thermistor abnormal after the copier becomes ready

##### 1. Checking the thermistors, fuser lamps, SSR and LGC board.

Check the thermistors, fuser lamps, SSR and LGC board, using the same procedure as in 1, 2 and 3 of **C41**.

##### 2. Clearing the status counter

Since [6] is shown on the status counter, rewrite it to [0] using the same procedure as in 4 of **C41**.

### **C43 Thermistor abnormal during warming-up after abnormality judgment**

#### 1. Checking the thermistors, fuser lamps, SSR and LGC board

Check the thermistors, fuser lamps, SSR and LGC board, following the same procedure as in 1, 2 and 3 of **C41**.

#### 2. Clearing the status counter

Since [4] is shown on the status counter, rewrite it to [0], following the same procedure as in 4 of **C41**.

### **C44 Heater abnormal during warming-up after abnormality judgment**

#### 1. Checking the thermistors, fuser lamps, SSR and LGC board

Check the thermistors, fuser lamps, SSR and LGC board, following the same procedure as in 1, 2 and 3 of **C41**.

#### 2. Clearing the status counter

Since [5] is shown on the status counter, rewrite it to [0], following the same procedure as in 4 of **C41**.

### **C46 Heater abnormal (low temperature) after the copier has become ready**

#### 1. Checking the thermistors, fuser lamps, SSR and LGC board

Check the thermistors, fuser lamps, SSR and LGC board, following the same procedure as in 1, 2 and 3 of **C41**.

#### 2. Clearing the status counter

Since [7] is shown on the status counter, rewrite it to [0], following the same procedure as in 4 of **C41**.

### **C47 Rear thermistor abnormal after the copier has become ready**

#### 1. Checking the thermistors, fuser lamps, SSR and LGC board

Check the thermistors, fuser lamps, SSR and LGC board, following the same procedure as in 1, 2 and 3 of **C41**.

#### 2. Clearing the status counter

Since [8] is shown on the status counter, rewrite it to [0], following the same procedure as in 4 of **C41**.

## **C48** Heater abnormal (high temperature)

### 1. Checking the thermistors, fuser lamps, SSR and LGC board

Check the thermistors, fuser lamps, SSR and LGC board, following the same procedure as in 1, 2 and 3 of **C41**.

### 2. Clearing the status counter

Since [9] is shown on the status counter, rewrite it to [0], following the same procedure as in 4 of **C41**.

## **C7** Error C7

- \* To avoid any safety hazards, be sure to unplug the power cord before proceeding to check the items in 1. and 2. below.
- \* Be sure that the fuser unit is set in place securely.

1. Check if any thermistor connector is disconnected.
2. Check if any harness for the thermistors (center and rear, upper and lower) is open-circuited.
3. Check the LGC board if the connector J122 is disconnected.
4. After completing the repair of what caused the **C7** problem, proceed to rewrite the status counter to [0], following the same procedure as for **C41**.

#### 4.1.14 Communications related service call

##### **C57** Communications error between Main-CPU and Sorter-CPU

1. Check if a sorter other than specified is attached.
2. Check the LGC board if any conductor pattern around IC88, IC89, IC96 or J123 is open- or short-circuited.
3. Check the IPC board for any open- or short-circuited conductor pattern.
4. Check the harness connected to the connector J2 on the IPC board for any disconnected pin or any open-circuit.
5. Check if the switching power supply fuse F9 is blown out.
6. Check the controller PC board inside the sorter for any open- or short-circuited conductor pattern.
7. Check the connection between the sorter and the copier for any disconnected connector pin or for any open-circuited harness.
8. Replace the IPC board.
9. Replace the LGC board.

## **C5A** Communications error between Main-CPU and printer controller

<<For a built-in type printer controller>>

1. Check if the printer controller unit is securely mounted on the copier.
2. Check if the harness between the LGC and IMC boards is open-circuited, and if the connector J113 on the LGC board and the connector J168 on the IMC board are disconnected.
3. Check if the harness between the switching power supply and the printer controller is open-circuited.
4. Check if the connector J710 of the switching power supply is disconnected.
5. Check the IMC and LGC boards for any open- or short-circuited conductor pattern.
6. Replace the LGC board.
7. Replace the IMC board.



<<For an external type printer controller>>

1. *Check if the printer controller power is turned ON.*
2. *Check if the harness between the PIF board and the printer controller is open-circuited.*
3. *Check if the PIF board is firmly connected to the IMC board.*
4. *Check if the harness between the LGC and IMC boards is open-circuited, and if the connector J113 on the LGC board and the connector J168 on the IMC board are disconnected.*
5. *Check the PIF, IMC and LGC boards for any open- or short-circuited conductor pattern.*
6. *Replace the PIF board.*
7. *Replace the LGC board.*
8. *Replace the IMC board.*



**C5B** Main-CPU signal transmission error to IMC-CPU

**C5C** Main-CPU signal reception error from IMC-CPU

1. Check if the harness between the LGC and IMC boards is open-circuited, and if the connector J113 on the LGC board and the connector J168 on the IMC board are disconnected.
2. Replace the LGC board.
3. Replace the IMC board.



#### 4.1.15 ADF related service call

##### **C72** Error of aligning sensor automatic adjustment

1. Check if any foreign matter is present between the aligning sensor and the reflecting mirror, and if the reflecting mirror is stained.
2. Check if the harness between the aligning sensor and PWA-F-LGC-770 is open-circuited.
3. Check PWA-F-LGC-770 for any open- or short-circuit around IC1, IC14 and CN14.
4. Replace the aligning sensor.
5. Replace PWA-F-LGC-770.
6. Initialize the RADF's EEPROM and perform the sensor automatic adjustment.

##### **C73** EEPROM initializing error

1. Check PWA-F-LGC-770 if any open- or short circuit is present around IC7.
2. Replace PWA-F-LGC-770.
3. Initialize the RADF's EEPROM and perform the sensor automatic adjustment.

##### **C74** Error of exit sensor automatic adjustment

1. Check if any foreign matter is present between the exit sensor and the reflecting mirror, and if the reflecting mirror is stained.
2. Check if the harness between the exit sensor and PWA-F-LGC-770 is open-circuited.
3. Check PWA-F-LGC-770 for any open- or short-circuit around IC1, IC14 and CN14.
4. Replace the exit sensor.
5. Replace PWA-F-LGC-770.
6. Initialize the RADF's EEPROM and perform the sensor automatic adjustment.

#### 4.1.16 Other service calls

##### **C94** Main-CPU abnormal

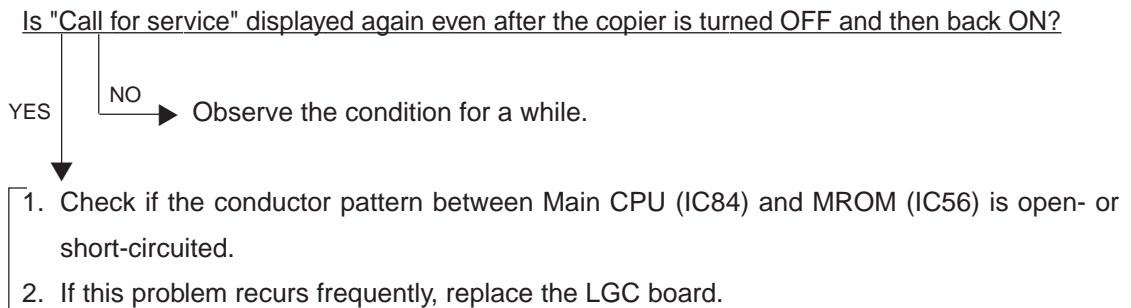

##### **C9A** Main memory abnormal

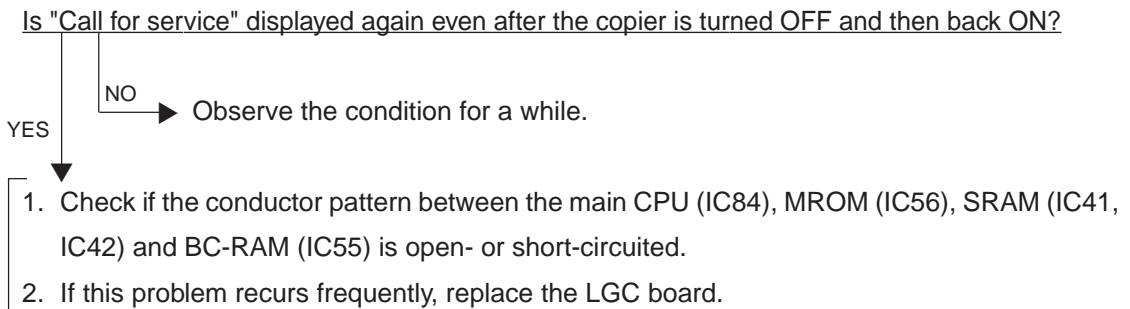

##### **C9E** IMC board connection abnormal

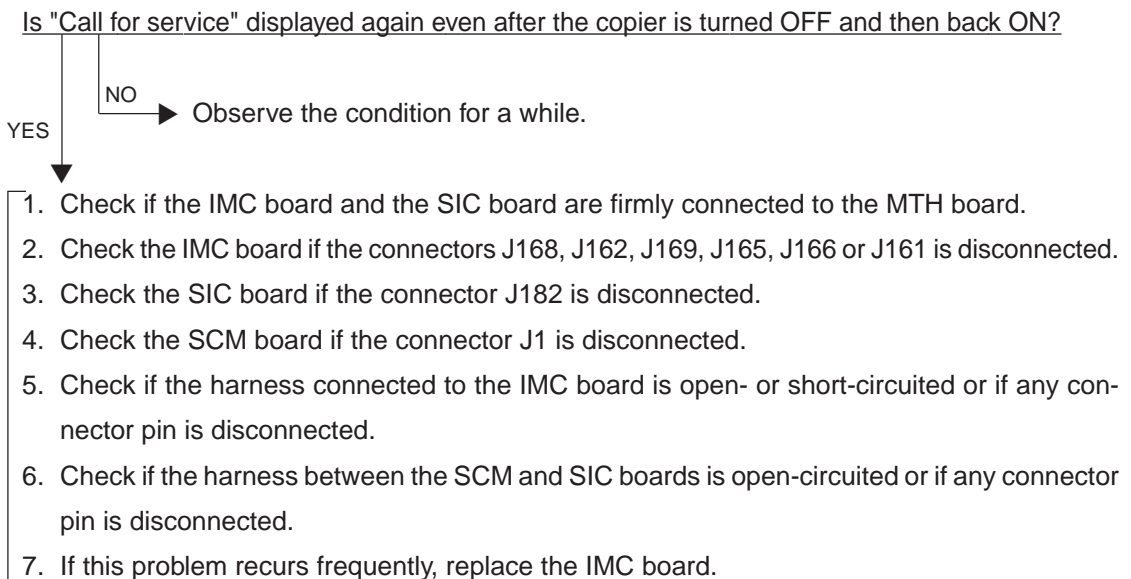

#### 4.1.17 Laser optical unit related service call

##### CA1 Polygonal motor rotation abnormal

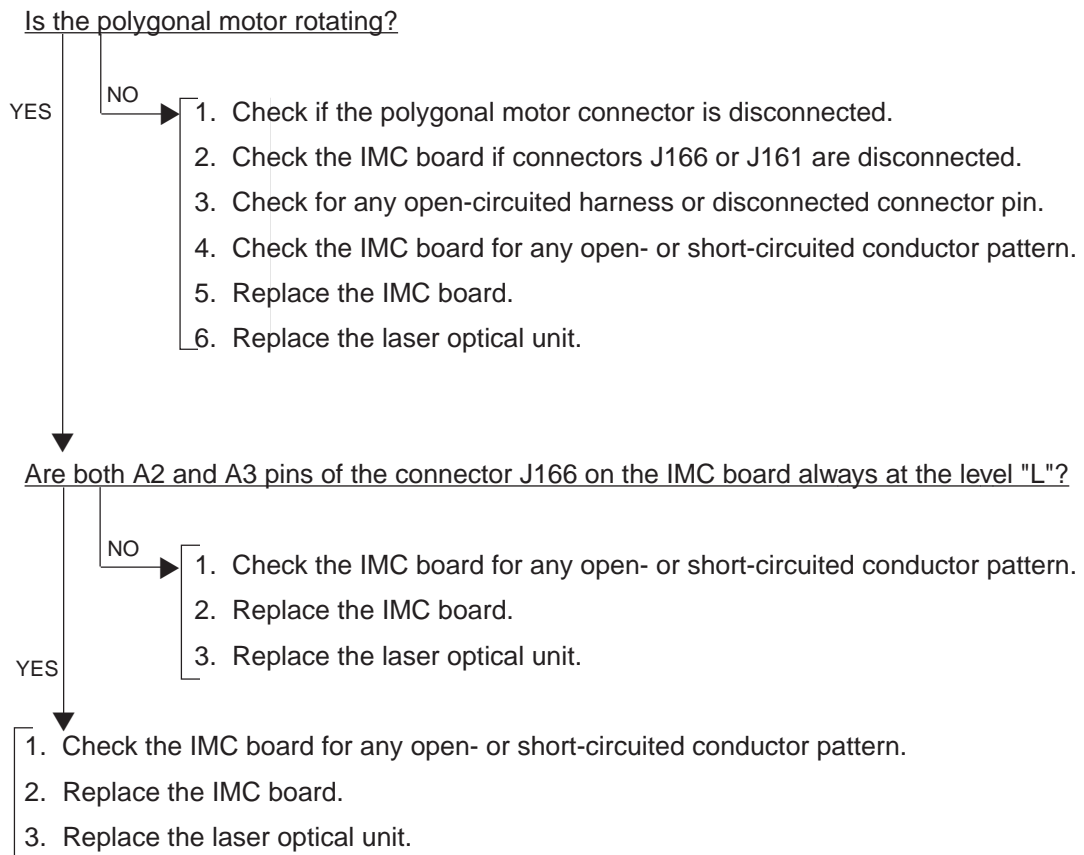

## CA2 H-SYNC abnormal

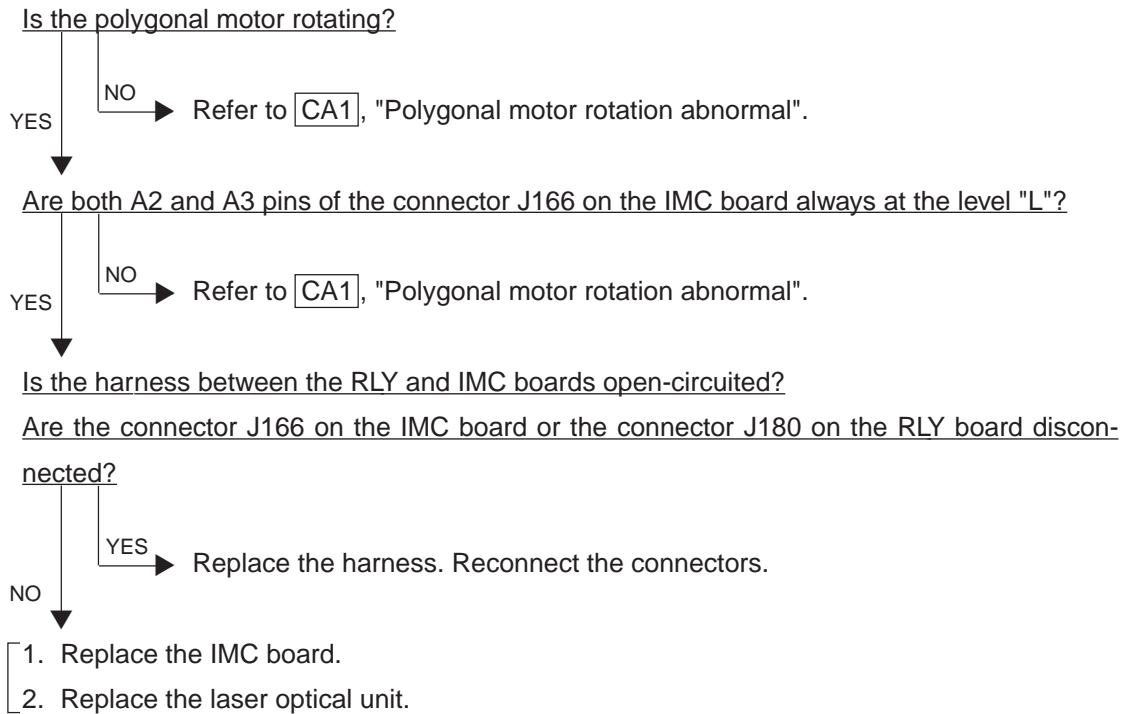

### CD1 Laser calibration error (K)

### CD2 Laser calibration error (C)

### CD3 Laser calibration error (M)

### CD4 Laser calibration error (Y)

1. Check if the harness between the IMC and RLY boards is open-circuited.
2. Check if the connector J162 on the IMC board is disconnected.
3. Check if the connector J178 on the RLY board is disconnected.
4. Check if the harness between the RLY board and the switching power supply is open-circuited.
5. Check if the connector J179 on the RLY board is disconnected.
6. Check if the connector J161 on the IMC board is disconnected.
7. Check the switching power supply if the connector J705 or J707 is disconnected.
8. Check the RLY board if the harness of the connector J174 (Y), J175 (M), J176 (C) or J177 (K) is open-circuited.
9. Replace the IMC board.
10. Replace the laser optical unit.



#### 4.1.18 Sorter related service call

##### CC1 Transport motor rotation abnormal

After setting the DIP switch (SW1) on the sorter controller board, as shown on the right, when you press the push switch SW2 or SW3, will the transport motor (M1) start rotating? (To stop the motor, press the switch again.)

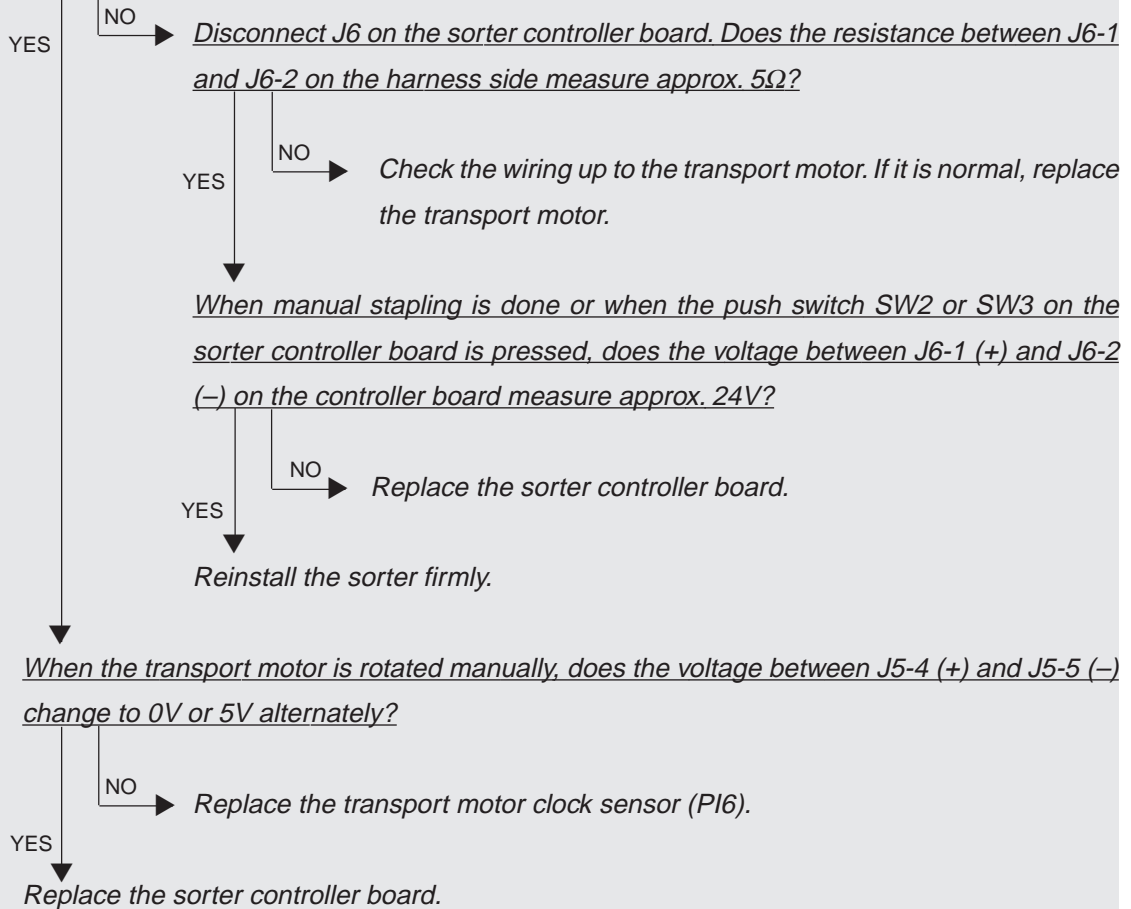



**CC3** *Bin-shift motor rotation abnormal*

When the push switch SW2 or SW3 on the sorter controller board is pressed, does the bin unit move upward (or downward)?

NO  
YES → *Replace the lead-cam home position sensor (PI2).*

While the above procedure is proceeding, does the bin-shift motor rotate?

NO → *Check if the lead-cam drive belt is properly fitted on the sprocket.*  
YES

Disconnect J15 on the sorter controller board. Does the resistance between J15-5 and J15-6 on the harness side measure approx. 3Ω?

NO → *Check the wiring up to the bin-shift motor (M2). If it is normal, replace the bin-shift motor (M2).*  
YES

Connect J15 on the sorter controller board. Having tester probes touch J15-5 (+) and J15-6 (-), press SW2; does the tester's pointer swing?

NO → *Replace the sorter controller board.*  
YES

*Replace the bin-shift motor (M2).*



**CC4** *Guide bar swing motor rotation abnormal*

At the time the guide bar swings, does pulse output occur on J13-3 to J13-6 on the sorter controller board? In addition, does the voltage between J13-1 and J13-2 show 24V?

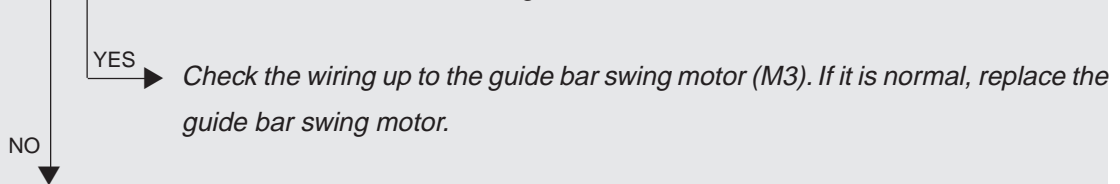

Is a voltage of 24V being supplied from the copier?

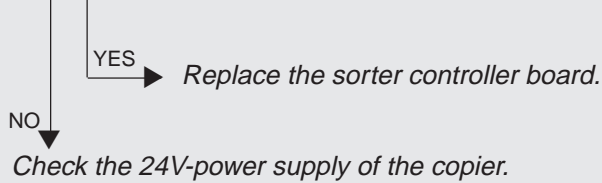

**CC5** *Stapler-unit swing motor rotation abnormal*

At the time the stapler unit swings, does the voltage between J9-1 (+) and J9-2 (-) on the sorter controller board show 24V?

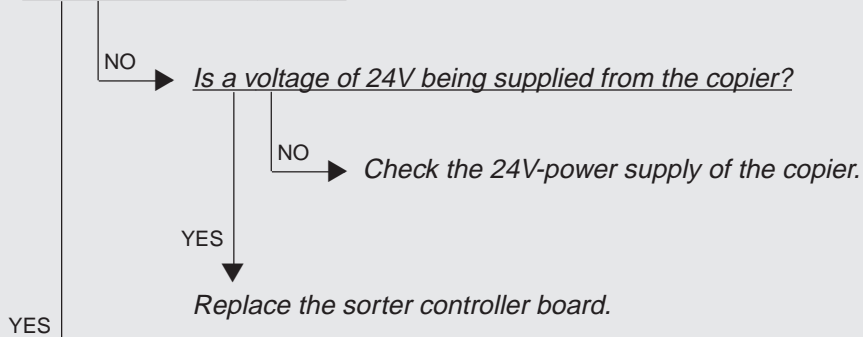

Is stapler-unit swing switch (MS9) working normally?

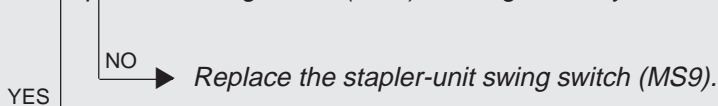

Does the resistance between J9-1 and J9-2 on the harness side measure approx. 25Ω?

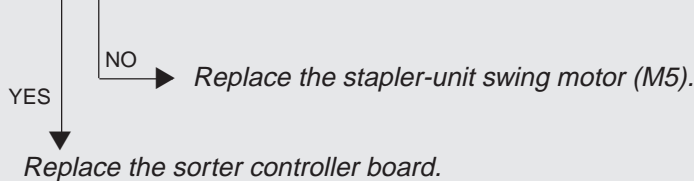





**CCA** *Automatic adjustment error of bin inside paper sensor*

*After having retried automatic adjustment of the bin inside paper sensor, is there any abnormality found?*

NO → *Complete.*  
YES ↓

*Is the connector J12 on the sorter controller board connected normally?*

NO → *Insert the connector J12 properly.*  
YES ↓

*After having tried automatic adjustment of the bin inside paper sensor, is there any abnormality found?*

NO → *Complete.*  
YES ↓

*Replace the sorter controller board.*

*After having tried automatic adjustment of the bin inside paper sensor, is there any abnormality found?*

NO → *Complete.*  
YES ↓

*Check if the bin inside paper sensor is installed securely.*

*After having tried automatic adjustment of the bin inside paper sensor, is there any abnormality found?*

NO → *Complete.*  
YES ↓

*Replace the bin inside paper sensor.*

*After having tried automatic adjustment of the bin inside paper sensor, is there any abnormality found?*

NO → *Complete.*  
YES → *Replace the sorter controller board.*

**CCC** No power being supplied

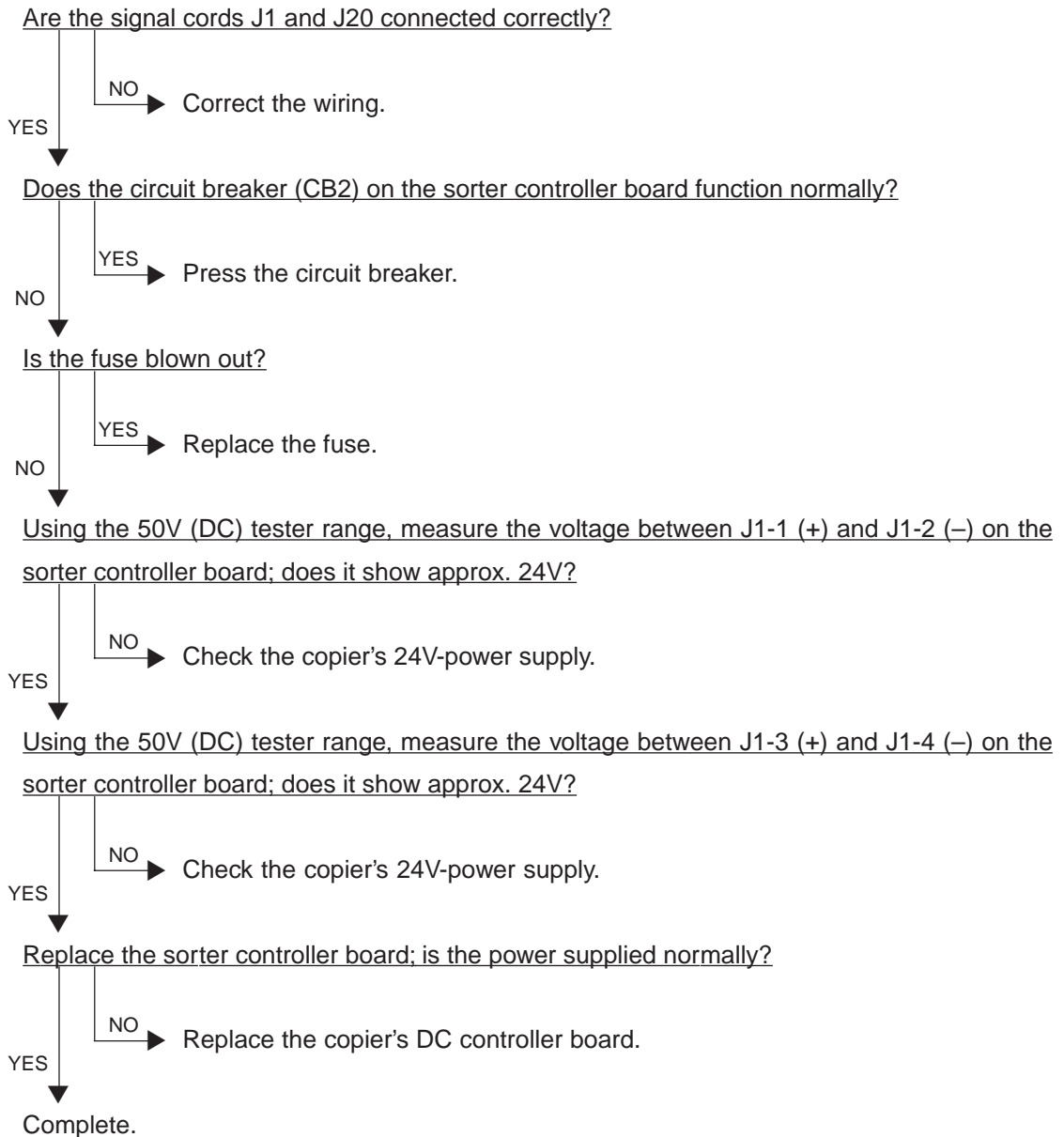

#### 4.1.19 Image quality related service call

- (1) After checking **CE1**, **CE2** and **CE4**, and taking appropriate action, perform the following steps.
  1. While pressing [0] and [5] simultaneously, turn ON the power.
  2. Enter [878] with digital keys, and then press the [START] key.
  3. Turn OFF and then back ON the power, and check that the copier will become ready normally.
  
- (2) After confirming the items in (1), perform the following steps.
  1. While pressing [0] and [8] simultaneously, turn ON the power.
  2. Enter [415] with digital keys, and then press the [START] key.
  3. Rewrite the displayed status counter from [1], [2] or [3] to [0], and then press the [INTER-RUPT] key.
  4. Enter [416] with digital keys, and then press the [START] key.
  5. Rewrite the displayed status counter from [1], [2] or [3] to [0], and then press the [INTER-RUPT] key.
  6. Enter [417] with digital keys, and then press the [START] key.
  7. Rewrite the displayed status counter from [1], [2] or [3] to [0], and then press the [INTER-RUPT] key.
  8. Enter [418] with digital keys, and then press the [START] key.
  9. Rewrite the displayed status counter from [1], [2] or [3] to [0], and then press the [INTER-RUPT] key.
  10. Turn OFF and then back ON the power, and check that the copier will become ready normally.

#### **CE1** Image quality sensor abnormal (OFF level)

Is the connector of the image quality sensor, or the connector J113, J114, J115 or J118 on the LGC board, or the connector J168 on the IMC board disconnected?

Is the harness between the LGC board and the image quality sensor, or the harness between the LGC board and the IMC board, or the harness between the LGC board and the switching power supply open-circuited?

NO ↓  
YES → Reconnect the connector. Replace the harness.

Is LED (D21) on the LGC lit? Is the output voltage from the 12V-power supply normal?

NO ↓  
YES → Check the power supply system and replace the switching power supply.

1. Replace the image quality sensor.
2. Replace the LGC board.
3. Replace the IMC board.

**CE2** Image quality sensor (no pattern level)

1. Check that the transfer belt unit is fully raised.
2. Check that the transfer belt unit is fully mounted inward.
3. Check for any abnormal stain, large scar or fray on the transfer belt surface.
4. Check that the drum and transfer belt are rotating. If abnormal, repair any mechanical problem.

Is any of the connectors J113, J114, J115, J118 or J122 on the LGC board disconnected?

Is the connector J168 on the IMC board disconnected?

Is the harness between the LGC board and the IMC board open-circuited?

Is the connector of the image quality sensor disconnected or stained?

Is the harness between the LGC board and the image quality sensor open-circuited?

Is the main high-voltage transformer connector disconnected?

Is the harness between the LGC board and the main high-voltage transformer open-circuited?

Is the transfer transformer connector disconnected?

Is the harness between the LGC board and the transfer transformer open-circuited?

Is any of the high-voltage contact points of the transfer belt unit in faulty contact? Is any contact points stained?

Is the harness of the main high-voltage transformer or the transfer transformer disconnected or open-circuited?

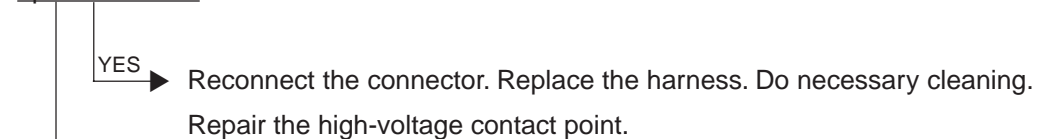

Is LED (D21) on the LGC board lit? Is the output voltage from the 12V-power supply normal?

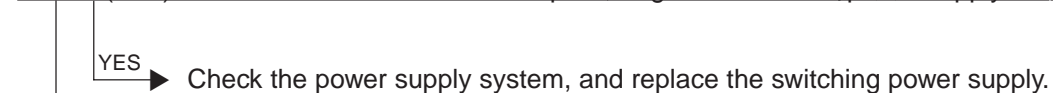

1. Replace the image quality sensor.
2. Replace the LGC board.
3. Replace the IMC board.

## **CE4** Image quality control test pattern abnormal

(1) Check 08-415 to 418 [Abnormal detection counter Y to K (display/0 clearing)] and check which color is in error (the value of the color in error is other than 0).

(2) Check 05-819 [Output value indication of image quality sensor/Low density pattern] and check whether the value of the color in error (the color checked in (1)) is under 300.

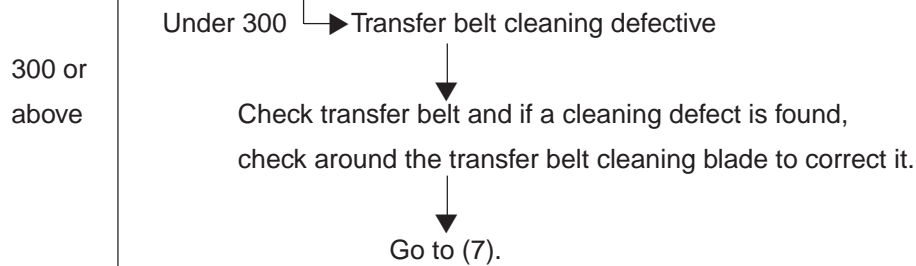

(3) Set 08-401 [Image quality control 2] to [0](disabled).

(4) Specify the color in error (the color checked in (1)) on 04-231 [Gradation check pattern] and check the output image if there is any error (image lacking, white paper, solid over the whole page, etc.).

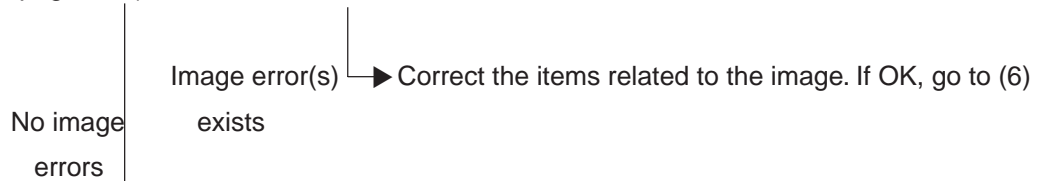

(5) Sensor fault: Replace image quality sensor.

(6) Change 08-401 [Image quality control 2] back to [1](enabled) if it is [0].

(7) Perform 05-878 [Forced performing of image quality control] to check that it completes normally (that it does not generate the error [CE4]).

(8) Clear all of 08-415 to 418 [Abnormal detection counter Y to K (display/0 clearing)].

(9) Perform 05-879 [Automatic initialization of image quality control] (only when replacing specified parts; see Chapter 1.5).

### **CE5** Temperature/humidity sensor upper-limit abnormal

Is the harness between the LGC board and the temperature/humidity sensor disconnected ?

Is the LGC board connector J112 or the temperature/humidity sensor connector disconnected ?

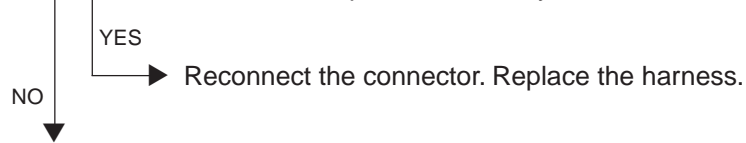

1. Replace the temperature/humidity sensor.
2. Replace the LGC board.

### **CF1** Color registration control abnormal

<Check of the status of color registration sensor error>

1. While pressing [0] and [5] simultaneously, turn the power ON.
2. Input [461] with digital keys and press [START].
3. The four values of the color registration control result are displayed (Y(0), M(1), C(2), K(3)).
4. Check the value for Y(0) displayed in 3.

When [CF1] is generated, a value from 1 to 15 is displayed (normal if 0 or 16 or above).

- 1-14: Data error (color registration sensor is normal)
- 15: Reading error of color registration test pattern

<Disabling the color registration control>

5. While pressing [0] and [8] simultaneously, turn the power ON.
6. Input [742] with digital keys and press [START].
7. Set the color registration control setting to [1](manual).
8. Input [743] with digital keys and press [START].
9. Set the color registration control for warming-up to [0](disabled).
10. Turn the power OFF.

<Check by color registration control forced performing>

11. While pressing [0] and [5] simultaneously, turn the power ON.
12. Input [407] with digital keys and press [START]. This will result in forced performing of color registration control.

\* At this time, use a digital tester to monitor the test point TP91 (front color registration sensor output) and TP93 (rear color registration sensor output) on the LGC board.

– If they are normal –

Before starting the color registration control forced performing, a voltage of approximately 0.7V DC is displayed.

After starting it, the voltage changes to approximately 4.4V DC, and this may drop instantaneously down to 0.7V DC. (There may be no fluctuations in voltage, depending on the reaction speed of the digital tester.)

When the color registration control forced performing ends, it returns to a voltage of approximately 0.7V DC.

#### Voltage before color registration control forced performing

DC 0.7V	Normal
DC 0V	Check if there is any disconnection or short-circuit of harness between LGC board and color registration sensor, or harness between LGC board and IMC board. Inspect connector section (J168 on IMC board, J113 and J114 on LGC board, connector on color registration sensor). If there is no abnormality, check color registration sensor.
DC 5V	Check if there is any disconnection or short-circuit of harness between LGC board and color registration sensor. Inspect connector section (J113 and J114 on LGC board, connector on color registration sensor).
DC 4.4V	Check if there is any disconnection or short-circuit of harness between LGC board and color registration sensor or harness between LGC board and IMC board. Inspect connector section (J168 on IMC board, J113 and J114 on LGC board, connector on color registration sensor) If there is no abnormality, check color registration sensor.

#### Voltage during color registration control forced performing

Normally DC 4.4V. Instantaneously may drop down to 0.7V DC	
Normally DC 0.7V	Check if there is any charge defects or exposure errors onto the photoconductive drum (errors in the laser optical unit). Follow the next check item 13. and after.
Normally DC 4.4V	Reading defect of color registration test pattern. Follow the next check item 13. and after.

<Check by grid pattern>

13. While pressing [0] and [5] simultaneously, turn the power ON.

14. Input [1] with digital key and press [SETTINGS].

15. Check that there is no image density difference among the front/center/rear areas of the output grid pattern for each of yellow, magenta, cyan and black. Check that there is no abnormality in the overall image.

\* At this point, there is no problem if the Y, M, C and K grid patterns are out of alignment.

– If there is difference in tonal balance between front and rear area –

- Check the state of contact of the photoconductive drum and the transfer belt.
- Check the quantity of developer (check whether developer material is properly supplied onto the surface of the developer sleeve).

– If there is any yellow, magenta, cyan or black streak in the secondary scanning direction –

- Check if there is any stain or dust on the main charger wire that corresponds to the color of the streak.

– If there is any white streak in the secondary scanning direction –

- Check if there is any stain or dust on the slit glass of the laser optical unit.

– If the entire page is solid in a specific color –

- Defect in main high-voltage transformer corresponding to that color or defect in the laser optical unit.

Of the four main high-voltage transformers, replace the main high-voltage transformer considered to be defective with other main high-voltage transformer considered to be normal, and then output the chart again.

If the solid color over the entire page changes as the result of replacing the main high-voltage transformer, that main high-voltage transformer replaced is defective.

If the solid color over the entire page does not change, check whether there is any disconnection of the harness between the LGC board and the main high-voltage transformer or any defects in the power supply to the main charger (disconnection of high-voltage harness or contact defects). If there is no problem, check the laser optical unit.

If the density is low on both front and rear sides and any of the above abnormalities are not found, make the following check.



<Check by the gradation pattern>

16. While pressing [0] and [5] simultaneously, turn the power ON.

17. Input [4] with digital key and press [SETTINGS].

18. Check the output gradation images for gamma adjustment if there is any abnormality in yellow, magenta, cyan and black.

– If there are any abnormalities –

- ① Check if the drum and transfer belt are rotating. If not, correct any mechanical problems.
- ② Check if the transfer belt unit is set fully upward.
- ③ Check if the transfer belt unit is set fully inside.
- ④ Check the surface of the transfer belt for any abnormal stain, large scar or tear.
- ⑤ Check if the connector of the transfer transformer is disconnected.
- ⑥ Check if the high-voltage harness of the main high-voltage transformer/transfer is disconnected.
- ⑦ Check the harness between the LGC board and the transfer transformer if it is open-circuited.
- ⑧ Check the high-voltage contact of the transfer belt unit if it is contacting properly or if it is not dirty.
- ⑨ Check if the high-voltage harness is disconnected.
- ⑩ Check if the connector J113, J114 or J118 on the LGC board is disconnected.
- ⑪ Check if the connector J166 or J168 on the IMC board is disconnected.
- ⑫ Check if the harness between the LGC board and the color registration sensor is open-circuited.
- ⑬ Check if the color registration sensor connector is disconnected.
- ⑭ Check if the main high-voltage transformer connector is disconnected.
- ⑮ Check if the harness between the LGC board and the main high-voltage transformer is open-circuited.
- ⑯ Replace the transfer transformer.
- ⑰ Replace the main high-voltage transformer.

19. Check the sensor detection area of the transfer belt for any damage, and if damaged, replace the transfer belt.

20. Check the light receiving area of the color registration sensor if it is not dirty.

\* Be sure to do the following after having made checks and corrections:

1. While pressing [0] and [8] simultaneously, turn ON the power.
2. Enter [742] with digital keys and press the [START] key.
3. Set the color registration control setting to [0] (automatic).
4. Enter [743] with digital keys and press the [START] key.
5. Set the color registration control for warming-up setting to [1] (enabled).
6. Turn OFF the power.

#### 4.1.20 Options related service call

##### **F07** Communications error between System-CPU and Main-CPU

1. Check if the SIC board is firmly connected to the MTH board.
2. Check if the IMC board is firmly connected to the MTH board.
3. Check if the IMC board connector J168 is disconnected.
4. Check if the LGC board connector J113 is disconnected.
5. Check if the harness between the IMC and LGC boards is open-circuited.
6. Check the version of FROM on the SIC board.
7. Check the version of MROM on the LGC board.
8. Check the version of IMC-ROM on the IMC board.
9. Replace the SIC board.
10. Replace the IMC board.
11. Replace the LGC board.



##### **F11** Communications error between System-CPU and Scanner-CPU

1. *Check if the SIC board connector J182 is disconnected.*
2. *Check if the SCM board connector J1 is disconnected.*
3. *Check if the harness between the SIC and SCM boards is open-circuited.*
4. *Check the version of FROM on the SIC board.*
5. *Check the version of SROM on the SCM board.*
6. *Replace the SIC board.*
7. *Replace the SCM board.*



#### 4.1.21 *Image processing options related service call*

##### **F51** *Communications error between System-CPU and AI board during pre-scanning*

1. *Check if the AI board is securely connected to the connector on the SIC board.*
2. *Check if FROM is mounted on the IC8 on the AI board.*
3. *Check if FROM is mounted in the proper direction on the AI board.*
4. *Replace the AI board.*
5. *Replace the SIC board.*

\* Service call **F51** occurs only when copying with the copy mode "AI" selected. The other copy modes are operable.

## 4.2 Troubleshooting of Image

### (1) Color deviation

<Symptoms>

Condition	Location	Phenomena
All modes	White void areas, color blur	Color deviation
Text mode Text/Photo mode	Black text outlines in color background	White void
Photo mode Map mode	Color blur in outline of line or text	Color deviation

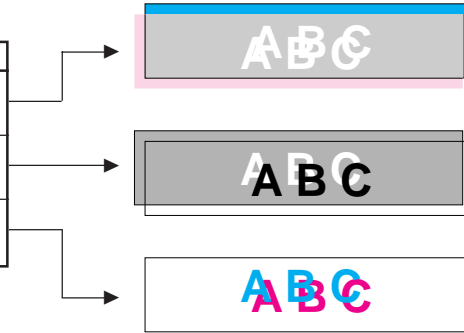

Defect area	Step	Cause			Check Item
		Main-Classification	Sub-Classification	Specific-Classification	
	1				Output build-in grid pattern on A3/LD.
Color registration Control	2	Control error or poor optimization			Check grid pattern.
Abnormal paper transport speed	3	Paper transport speed in registration section	Low speed	Adjustment defect	Check grid pattern.
			Low speed	Registration roller aging change	
			Low speed	Registration roller life worn out	Check condition of registration rubber roller surface.
			High speed	Adjustment defect	Check grid pattern
	4	Paper transport speed in fuser unit	High speed	Adjustment defect	Check grid pattern.
					Feed the paper with the front door open and check the paper transport between transfer belt and fuser unit. No defect in normal paper mode, but in thick paper 3 mode, deviation occurs in order (Y) MCK, at trailing edge of A3/LD sheet.
Drum drive system	5	Drum rotation	Unstable	Motor abnormal	Run operation check in test mode.
				Control circuit abnormal	Run operation check in test mode.
		Drum motor rotation speed	Inadequate	Adjustment defect	Re-check values set for drum motor rotation speed.
				Drum coupling	Loose coupling
			Damage		
			Deformation		
Transfer belt system	6	Transfer belt	Deformation or damage		Check grid pattern.
					Check condition of transfer belt edge
		Drive roller	Slipping	Stain	Check grid pattern.
					Check condition of roller surface.
Large driving load	Used toner	Over capacity	Check grid pattern.		
		Cleaning blade	Peeling		
Laser optical unit	7	Tilt adjustment mechanism	Adjustment mechanism defect		Check grid pattern.
		Reflection mirror warp			Check grid pattern.
		f $\theta$ lens characteristic defect			Check grid pattern.

	Criteria	Measures
	Perform following procedures from 2 and after.	
	Grid line deviation?	Color registraion control forced performing.
	Parallel deviation in secondary-scanning, occurring all over the face, almost in order Y-M-C-K from paper exit side?	Re-adjust paper feed motor speed. * See P. 4-58.
		Re-adjust paper feed motor speed. * See P. 4-58.
	Does the roller surface lack in friction and is it slippery?	Replace registration roller.
	Parallel deviation in secondary-scanning, occurring all over the face, almost in order Y-M-C-K from paper exit side?	By fine adjustment (a few steps at a time), slacken paper slightly, not tighten it (to a straight line in side view) between transfer belt and fuser unit.
	Is paper tightened?	
	Is paper tightened?	Increase the value of 05-408 (correction of fuser motor rotation speed in the thick paper 3 mode), by finely adjusting a few steps at a time.
		Troubleshoot drum driving.
		Troubleshoot drum driving.
	Is the value significantly different from the default value 1700? (The value shifts one step each in connection with transfer belt speed.)	Reset drum motor speed to 1700.
		Tighten screws.
		Replace couplings.
		Replace couplings.
	Fluctuating primary-scanning deviation? Damaged or broken edge?	Replace belt (troubleshoot transfer belt).
	Fluctuating secondary-scanning deviation? Is there any stain?	Clean it.
	Fluctuating secondary-scanning deviation?	Troubleshoot used toner system.
		Replace cleaning blade(troubleshoot transfer belt).
	Deviation at front or rear of primary-scanning line?	Replace unit.
	Primary-scanning line warp?	Replace unit. (Reflection mirror)
	Primary-scanning line warp?	Replace unit.

(2) Uneven pitch and blur

<Symptoms>

Condition	Location	Phenomenon
All modes	Occurs cyclically at right angles to paper feeding direction	Uneven pitch

Feeding direction

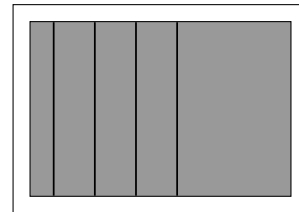

Defect area	Step	Cause			Check item	
		Main-Classification	Sub-Classification	Specific-Classification		
	1				Output built-in halftone pattern on A3/LD.	
Abnormal paper transport speed	2	Paper transport speed in registration section	Low speed	Adjustment defect	Check grid pattern.	
			Low speed	Registration roller aging change		
			Low speed	Registration roller life worn out	Check condition of registration rubber roller surface.	
			High speed	Adjustment defect	Check grid pattern.	
	3	Paper transport speed in fuser unit	High speed	Adjustment defect	Check pattern. Feed the paper with the front door open and check the paper transport between transfer belt and fuser unit.	
Drum drive system	4	Drum	Surface condition		Check pattern.	
			Damage		Check drum surface.	
			Attached foreign matter		Check drum surface.	
	5	Drum rotation	Unstable	Motor abnormal		Run operation check in test mode.
				Control circuit abnormal		Run operation check in test mode.
		Drum motor rotation speed	Inadequate	Adjustment defect	Re-check values set for drum motor rotation speed.	
6	Drum coupling	Loose coupling			Check pattern.	
			Damaged			
			Deformation			
Transfer belt system	6	Drive unit	Timing belt	Tension looseness	Check pattern.	
					Check pattern.	
	7	Transfer belt	Deformation or damage			Condition of transfer belt edge.
						Check pattern.
Drive roller	Slipping	Stain			Check condition of roller surface.	
					Check pattern.	
Large driving load	Used toner	Over capacity			Check pattern.	
					Cleaning blade	Peeling
Laser optical unit	8	Polygonal mirror	Surface inclined	Deformation	Check pattern.	

	Criteria	Measures
	Perform following procedures from 2 and after.	
	Uneven pitch extending 2.5mm to 3mm within an area about 130mm wide from leading edge of the image?	Re-adjust paper feed motor rotation speed. * See P. 4-58.
		Re-adjust paper feed motor rotation speed. * See P. 4-58.
	Does the roller surface lack in friction and is it slippery?	Replace registration roller.
	Uneven pitch extending approx. 2.9mm within an area about 150mm wide from trailing edge of the image?	By fine adjustment (a few steps at a time), slacken paper slightly, not tighten it (to a straight line in side view) between transfer belt and fuser unit.
	Is paper tightened?	
	Uneven pitch approx. 94mm overall?	
	Is there damage?	Replace drum.
	Is there any attached foreign matter?	Clean or replace drum.
		Troubleshoot drum driving.
		Troubleshoot drum driving.
	Is the value significantly different from the default value 1700? (The value shifts one step each in connection with transfer belt speed)	Reset drum motor rotation speed to 1700.
		Re-fasten screws.
		Replace couplings.
		Replace couplings.
	Uneven pitch approx. 2.5 mm overall?	
	Uneven pitch approx. 75 mm overall?	Re-fasten screws to fix tension arm.
	Damaged or broken edge?	Replace transfer belt (troubleshoot transfer belt).
	Uneven pitch approx. 75 mm overall?	Clean it.
	Is there any stain?	
	Uneven pitch approx. 75 mm overall?	Troubleshoot used toner system.
		Replace cleaning blade (troubleshoot transfer belt).
	Uneven pitch approx. 0.3 mm overall?	Replace unit.

\* Fine adjustment of registration roller paper transport speed

The optimized value is not always obtained for jitter and color deviation because fine error is generated in automatic adjustment.

If uneven color is generated in the secondary-scanning direction of the image and the further adjustment is necessary, perform the following procedure from 1 to 7.

1. Start up with the test print mode [04].
2. Select the A3/LD cassette.
3. Input the code [234] (output the half tone pattern).
4. Select [M] on the control panel and press [START] key. Since the halftone image is to be continuously printed out, press [STOP] key when the first paper starts being fed, to make only one print.
5. According to the steps 3 and 4, print out the halftone image of cyan (C) and black (K).
6. Criteria for judging paper transport speed by image  
Uneven color of 2.5mm pitch in halftone image is generated.  
→Paper transport speed is low.  
Uneven color is partially generated at 120mm with magenta, 195mm with cyan and 270mm with black from the trailing edge.  
→Paper transport speed is high.
7. Adjust "Fine adjustment of feed motor rotation speed" of code 05-404 by two steps, assuming the speed status from the grid pattern image and from the above image criteria 6. After adjusting, repeat the procedure from 1 to 6. When the step value decreases, the paper transport speed becomes higher.  
When the step value increases, the paper transport speed becomes lower. The speed should not be too low or too high because either case has harmful effect. (The step value should be approx. within  $4289 \pm 30$ .)

**Note:** First perform the adjustments 05-401 to 403, before proceeding to 05-404, "Fine adjustment of feed motor rotation speed".

If the adjustment 05-406 is performed, the value of 05-404 is changed. Therefore, perform the settings of 05-404 again.



(3) Defect of image density, color reproduction and gray balance

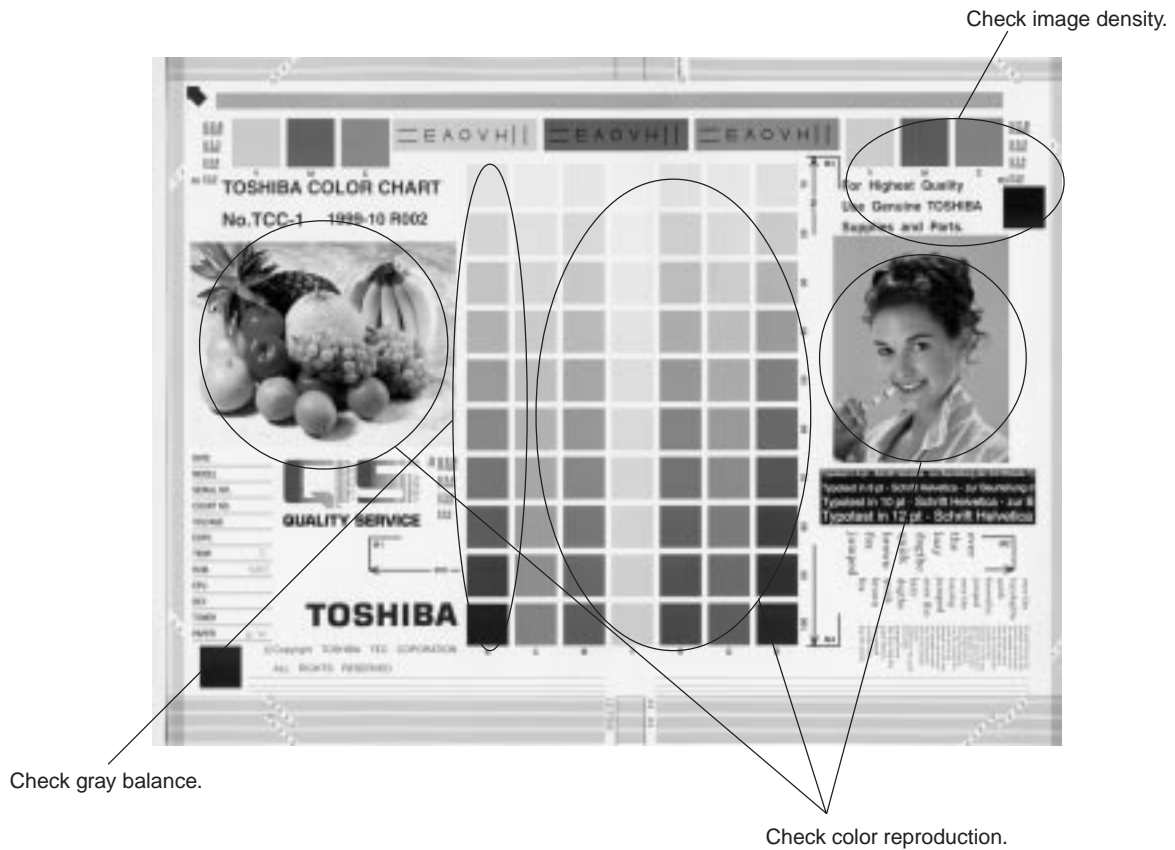

Cause/Defect area	Step	Check items	Measures	Remarks
Density/Color reproduction /Gray balance	1	Check density/color reproduction/ gray balance.	Perform automatic adjustment of gamma correction.	
Printer section (Note 1)	2	Check printer image.	Output test print image for each color (04-231).	See step 6 if defect occurs.
Parameter adjustment value (Note 2)	3	Check image parameters.	Adjust color balance. Adjust image density.	
Scanner	4	Is the original glass or mirrors or lens filter dirty?	Clean them.	
Printer density error (Note 1)	5	Check density of printer image.	Perform image quality control forced performing (05-878). Output test print image in each color (04-231).	
Printer image error (Note 2)	6	Is there any faded image (low density)?	Perform troubleshooting procedures against faded image.	
		Is there any fog in the background?	Perform troubleshooting procedures against background fogging.	
		Is there any blotch image?	Perform troubleshooting procedure against blotch image.	
		Is there any transfer defect?	Perform troubleshooting procedure against transfer defect.	
		Is there any cleaning defect in the transfer belt? (Check inside the machine.)	Modify transfer belt (refer to Service Manual).	

**Note:** 1) When adjusting printer section, perform "image quality control forced performing" and then "automatic adjustment of gamma correction".  
2) When adjusting parameters, perform "automatic adjustment of gamma correction".

#### (4) Background Fogging

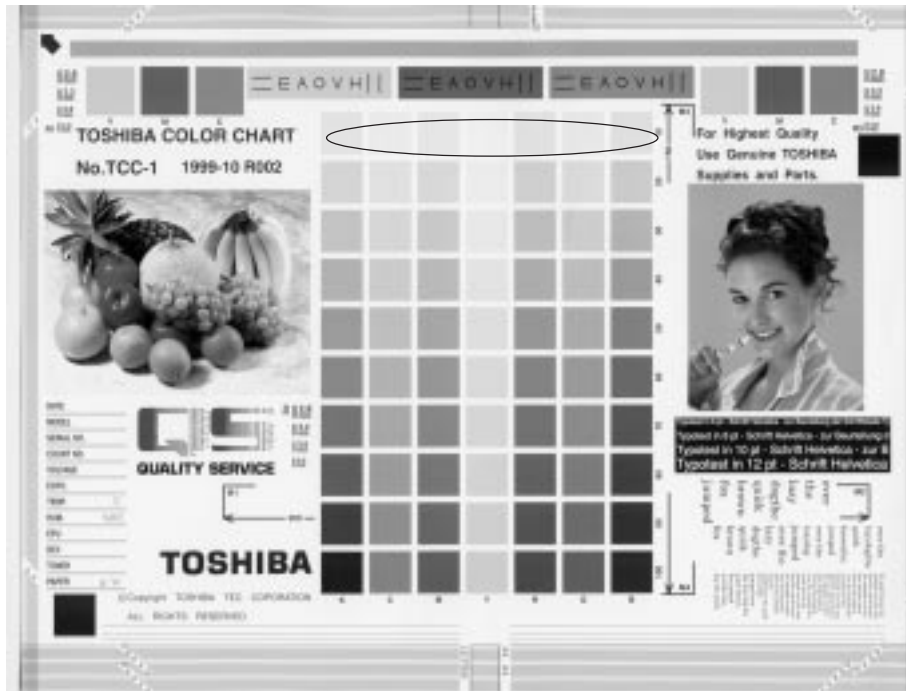

Cause/Defect area	Step	Check items	Measures	Remarks
Density reproduction	1	Image density reproduction defect	Perform automatic adjustment of gamma correction.	Go to step 5 If defects occur.
Printer	2	Check printer image.	Output test print image (04-231) for each color and check it.	
Parameter adjustment value	3	Check image processing parameters.	Check the value of offset amount of processing background.	
	4	Adjust image processing parameters.	While checking the above encircled image, remove background fog by adjusting offset amount of processing background.	
Scanner stain	5	Is the original glass or mirrors or lens filter dirty?	Clean them.	
Auto-toner	6	Is the auto-toner sensor normal?	Check operation of auto-toner sensor and re-adjust.	
	7	Is the toner supply operating constantly?	Inspect motor and circuits.	
Main charger output	8	Is the main charger output normal?	Check circuits. (Note)	
Developer bias	9	Is the developer bias proper?	Check circuits. (Note)	
Developer unit	10	Is the contact between the drum and developer material right?	Adjust doctor-to-sleeve gap and pole position.	
Developer material	11	Is the developer's life finished?	Replace developer material.	
Drum cleaning blade	12	Is it cleaned properly?	Inspect drum cleaning blade pressure.	
Toner dusting	13	Is toner accumulated on the seals of the developer unit?	Remove toner and clean.	

**Note:**

If the main charger and developer bias outputs seem to be abnormal, replace the main high-voltage transformer of the color likely to be abnormal with another transformer of another color likely to be normal, and then, output the chart again.  
 If the same color remains abnormal, check if there is any disconnection of harness between the LGC board and the main high-voltage transformer, disconnection of high-voltage harness, the power supply defect, or stain on the main charger wire.  
 If the color changes as the result of replacing the main high-voltage transformer, this fogging trouble is caused by the main high-voltage transformer defect. Therefore, replace the main high-voltage transformer of the abnormal color with new one.  
 After this checking, return the other main high-voltage transformer back to the original color position.

(5) Moire/lack of sharpness

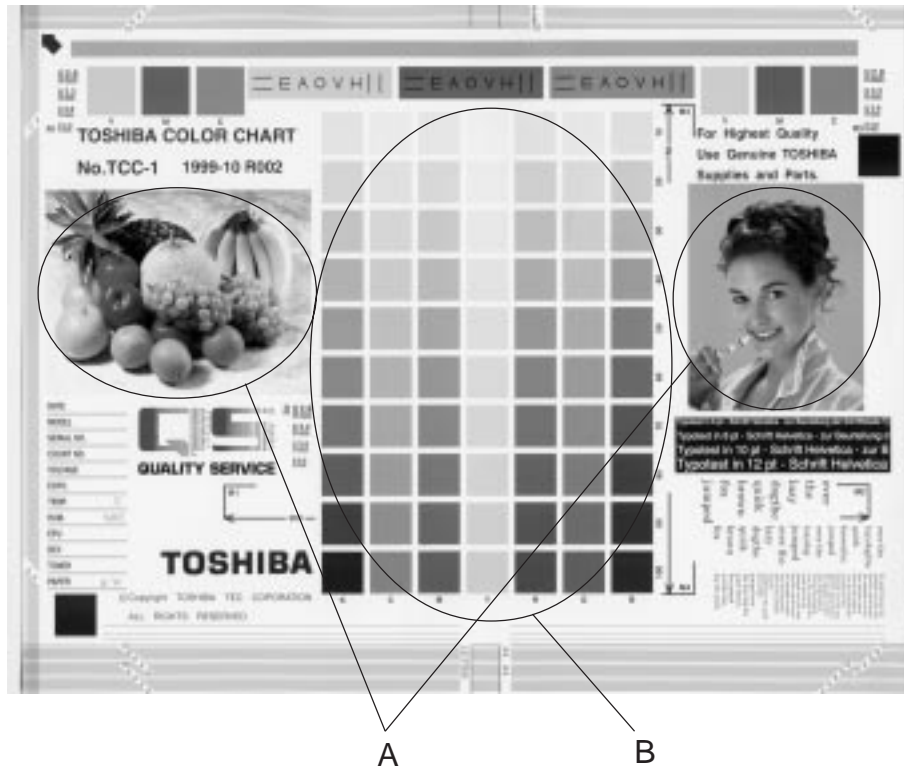

Moire

Cause/Defect area	Step	Check items	Measures	Remarks
Density reproduction	1	Image density reproduction defect	Perform automatic adjustment of gamma correction.	
Parameter adjustment value	2	Check image processing parameters.	Check sharpness adjustment value.	
Printer section	3	Check printer image.	Output test print image (04-231) for each color and check.	When defects occur, perform the corresponding troubleshooting procedures.
	4	Adjust image processing parameters.	While checking the above encircled images A and B, control moire by sharpness adjustment.	

Lack of sharpness

Cause/Defect area	Step	Check items	Measures	Remarks
Density reproduction	1	Image density reproduction defect	Perform automatic adjustment of gamma correction.	
Parameter adjustment value	2	Check image processing parameters.	Check sharpness adjustment value.	
Printer section	3	Check printer image.	Output test print image (04-231) for each color and check.	When defects occur, perform the corresponding troubleshooting procedures.
	4	Adjust image processing parameters.	While checking the above encircled image A, modify sharpness by sharpness adjustment.	

(6) Toner offset



Toner offset (Shadow image appears approx. 195 mm behind the high density image.)

Cause/Defect area	Step	Check items	Measures	Remarks
Density	1	Is density too high?	Perform automatic adjustment of gamma correction.	
Fuser unit	2	Is fuser roller pressure proper?	Check pressure removal parts and pressure mechanism.	
	3	Is thermostat contact good?	Establish contact.	
	4	Is there scratch on the fuser roller surface?	Replace fuser roller.	
	5	Did fuser roller life end?	Replace fuser roller.	
	6	Is fuser roller temperature proper?	Check control circuit.	
Paper	7	Check paper thickness and its mode.	Select proper mode.	
	8	Is non-recommended paper used?	Advise to use recommended paper.	
Developer material	9	Is specified developer used?	Use specified developer and toner.	
Scanner	10	Are mirrors or original glass or lens filter dirty?	Clean them.	
Printer section	11	Check printer image.	Check test print image (04-231).	See next steps 12 and 13 if defect occurs.
Printer density error *	12	Is printer density too high?	Perform image quality control forced performing (05-878). Check test print image (04-231).	Repeat a few times if necessary.
Image quality control	13	Is the control activated?	Check image quality control related codes.	

\* When adjusting printer section, perform "image quality control forced performing" and then "automatic adjustment of gamma correction".

(7) Blurred image

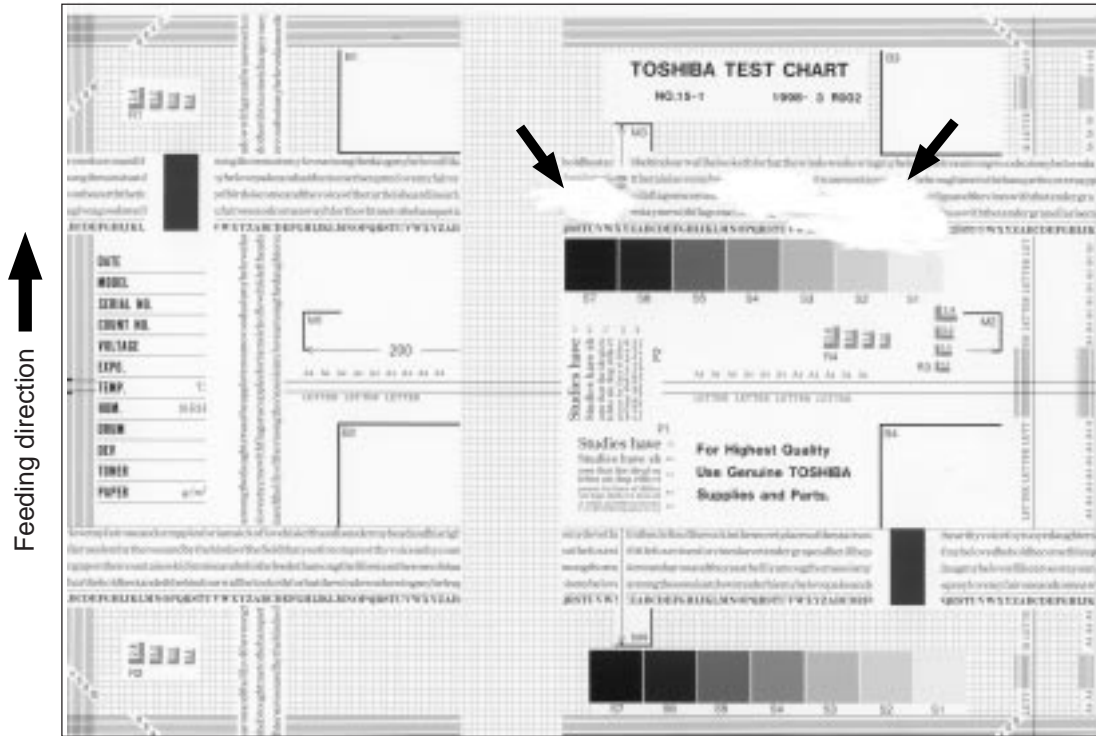

Cause/Defect area	Step	Check items	Measures
Scanner bedewing	1	Scanner bedewed?	Clean it.
Drum	2	Drum bedewed or dirty?	Wipe drum with dry cloth. * Be sure never to use alcohol or other organic solvents because they have bad effect on drum.

(8) Poor fusing

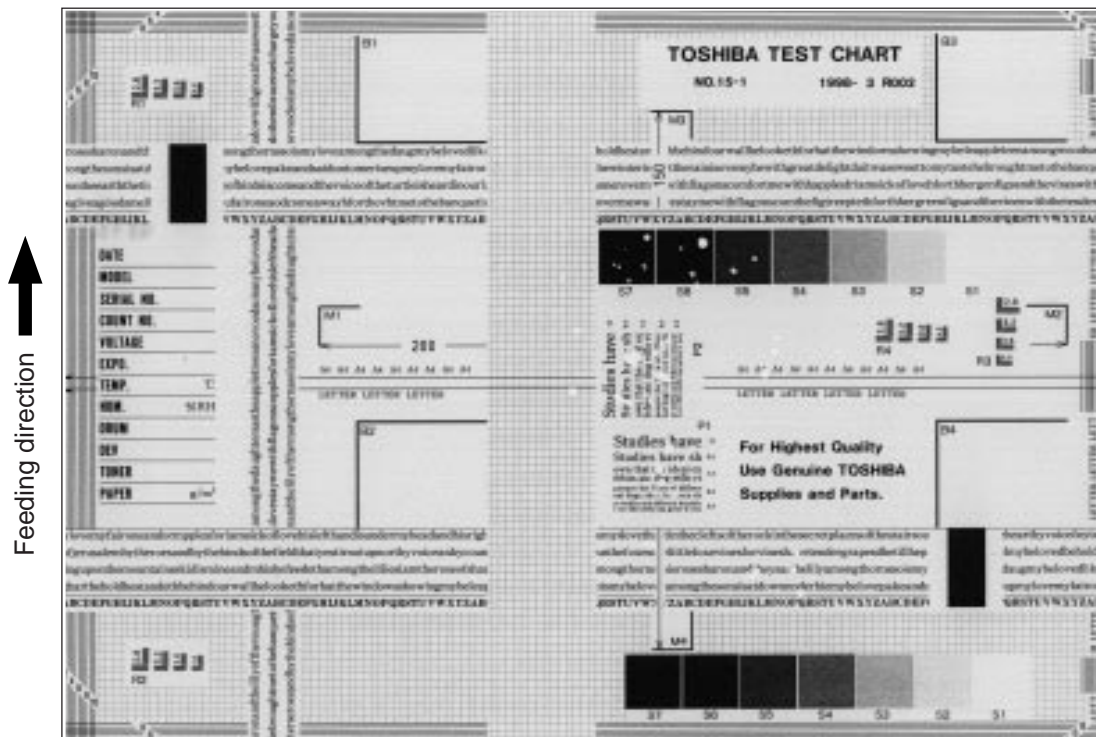

Cause/Defect area	Step	Check items	Measures
Fuser lamp unlighted	1	Contact defect at terminal point?	Correct it.
	2	Fuser lamp open-circuited?	Replace it.
Fuser roller pressure defect	3	Pressure springs working properly?	Check/adjust pressure springs.
Thermistor, LGC board	4	Fuser roller temperature too low?	Check/correct related circuit.
Paper	5	Paper dump?	Change paper.

(9) Blank copy



Feeding direction



Cause/Defect area	Step	Check items	Measures
High-voltage transformer (transfer roller/ developer bias)	1	High-voltage transformer output defective?	Adjust output and correct circuit, or replace defective transformer.
Process unit (EPU)/ developer unit set position	2	Process unit (EPU) or developer unit installation defective?	Check/correct developer sleeve coupling engaging. Check EPU sliding mechanism.
Developer drive system	3	Developer sleeve and mixer rotate?	Check/correct developer drive system.
Developer material	4	Developer material properly transported?	Remove foreign matter from developer material, if any.
Developer pole position	5	Magnetic brush phase error?	Adjust developer pole position.
Doctor blade position	6	Doctor sleeve gap incorrect?	Adjust gap with doctor-sleeve jig.
Drum	7	Drum rotating?	Check that drum shaft is inserted. Check drum drive system.
Harness for SCM, SIC, IMC and LGC boards	8	Connectors securely connected? Any open-circuited harness between boards?	Re-connect connectors securely. Replace harness.

(10) Solid copy

↑  
Feeding direction



Cause/Defect area	Step	Check items	Measures
Exposure lamp Lamp regulator	1	Does exposure lamp light?	Check lamp terminal contact. Check circuit and replace thermostat if it is not alive. Replace defective lamp regulator if any.
Scanner	2	Foreign matter in optical path?	Remove it.
Bedewing of scanner and drum	3	Scanner or drum bedewed?	Clean mirrors, lens and drum. Keep power cord plugged so that damp heater can work.
Main charger	4	Main charger securely installed?	Re-install it securely.
	5	Main charger wire open-circuited?	Replace it.
High-voltage transformer (Main charger)	6	High-voltage transformer output defective?	Adjust output and correct circuit, or replace high-voltage transformer.
Harness for SCM, SIC, IMC and LGC boards	7	Connectors securely connected?	Re-connect connectors securely.
		Any open-circuited harness between boards?	Replace harness.



(11) White banding (in feeding direction)

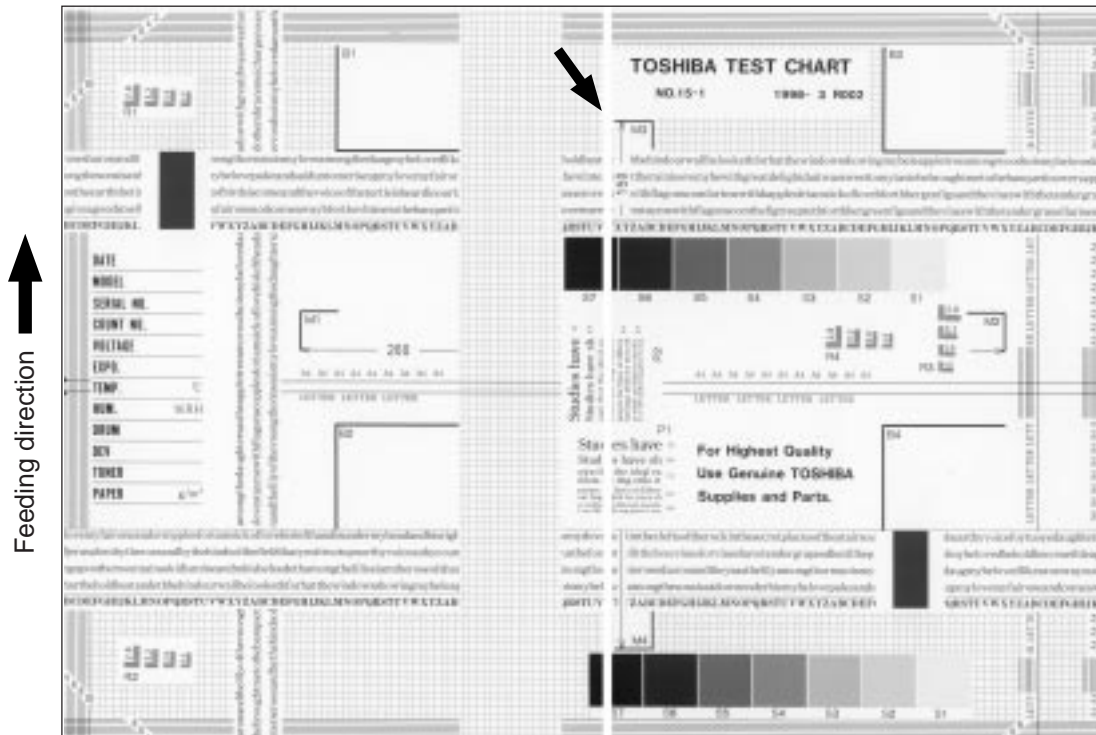

Cause/Defect area	Step	Check items	Measures
Laser optical unit	1	Foreign matter or dust on slit glass?	Clean slit glass.
Main charger grid	2	Foreign matter on charger grid?	Remove foreign matter.
Developer unit	3	Foreign matter in developer unit?	Remove foreign matter.
	4	Foreign matter on drum seal?	Remove foreign matter.
	5	Drum seal of developer unit in proper contact with drum?	Modify position of drum seal or replace it.
Drum	6	Any abnormalities on drum surface?	Replace drum.
Transport path	7	Does toner image touch foreign matter after transfer, before entering fuser unit?	Remove foreign matter.
Discharge LED array	8	Any lamp of discharge LED array gone out?	Replace discharge LED array.
Scanner	9	Foreign matter or dust in optical path?	Clean lens and mirrors.

(12) White banding (at right angles to feeding direction)

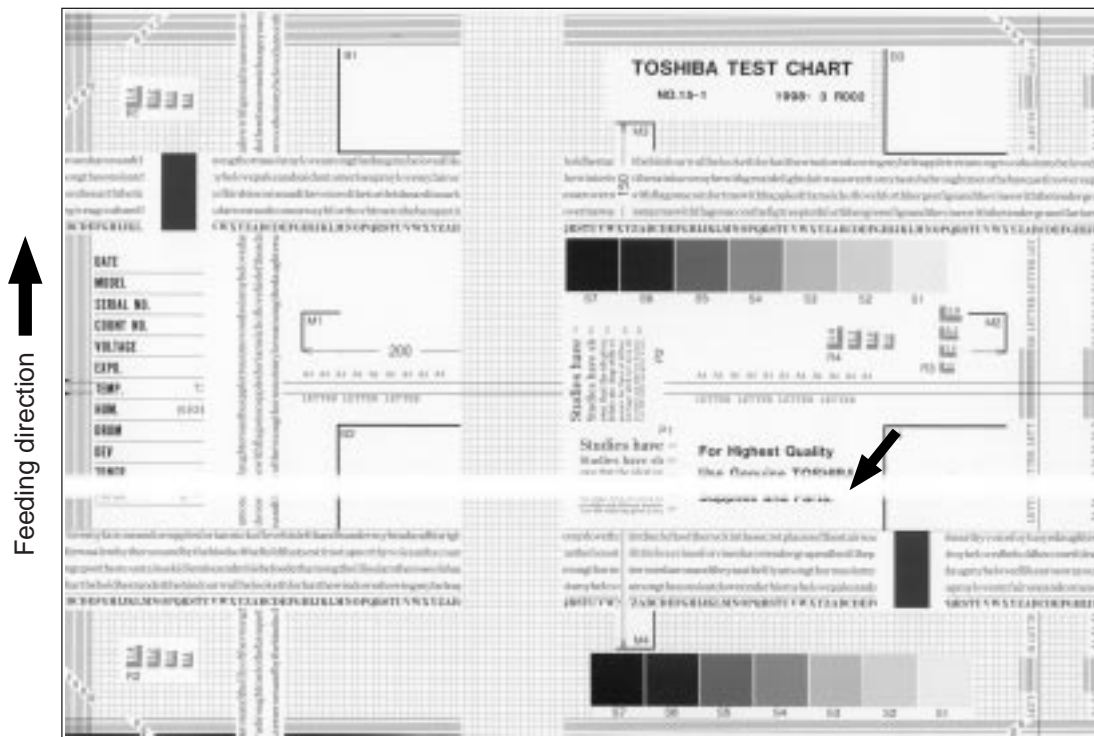

Cause/Defect area	Step	Check items	Measures
Main charger	1	Foreign matter on charger?	Remove foreign matter.
	2	Terminal contact defective?	Clean or adjust terminals.
Drum	3	Any abnormalities on drum surface?	Replace drum.
Discharge LED array	4	Discharge LED array lighting properly?	Replace discharge LED array or clean terminals.
Developer unit	5	Developer sleeve rotation defective? Any abnormalities on sleeve surface?	Check developer drive system, or clean sleeve surface.
Drive system	6	Drum or scanner jittery?	Check each drive system.
High-voltage transformer (main charger and transfer roller)	7	High-voltage transformer output defective?	Check/correct related circuits. If high-voltage transformer is defective, replace it.

(13) Skew (slantwise copying)

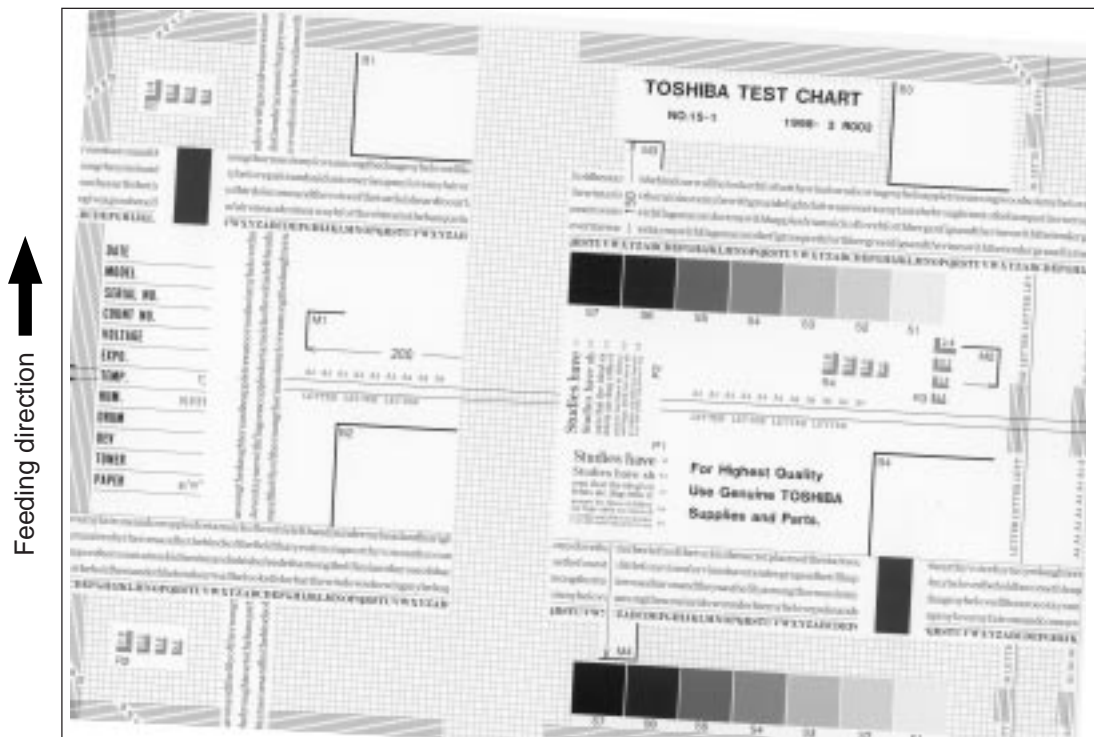

Cause/Defect area	Step	Check items	Measures
Cassette LCF	1	Is cassette or LCF properly installed?	Re-install cassette or LCF properly.
	2	Too much paper loaded in cassette or LCF?	Reduce paper to 600 sheets or less. (1500 sheets or less for LCF)
	3	Paper corner folded?	Change paper direction and reinsert.
	4	Cassette or LCF side guides properly set?	Adjust side guides.
Paper feed roller	5	Is surface of paper feed roller dirty?	Clean roller surface with alcohol, or replace roller.
Rollers	6	Defective mounting of roller to shaft?	Check and fasten E-rings, pins, clips and setscrews.
Registration roller	7	Registration roller spring out of place?	Mount spring correctly. Clean roller if it is dirty.
Pre-registration guide	8	Pre-registration guide improperly mounted?	Correct it.
Original scale	9	Original scale slanted?	Adjust it.

(14) Color banding (in feeding direction)

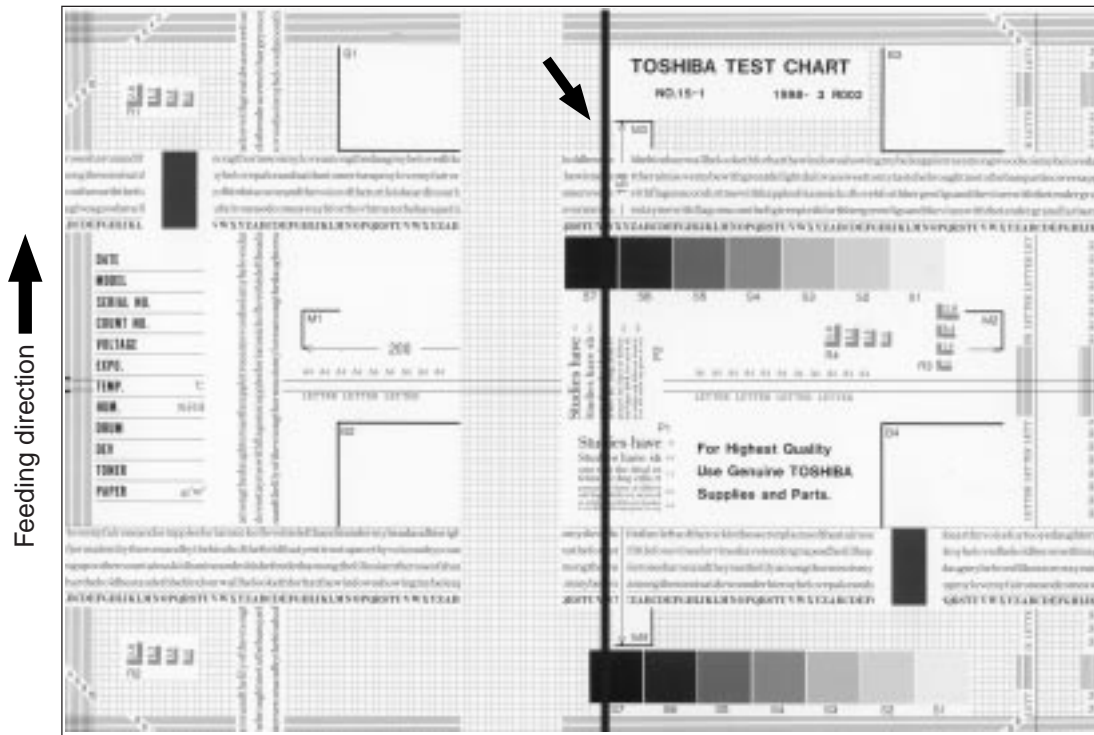

Cause/Defect area	Step	Check items	Measures
Scanner	1	Foreign matter in optical path?	Clean slit, lens and mirrors.
Main charger grid	2	Foreign matter on grid?	Remove foreign matter.
	3	Grid dirty or deformed?	Clean or replace grid.
Main charger	4	Foreign matter on main charger?	Remove foreign matter.
	5	Charger wire dirty or deformed?	Clean or replace charger wire.
	6	Foreign matter inside charger case?	Remove foreign matter.
	7	Inner surface of charger case dirty?	Clean inside.
Cleaner	8	Paper dust on cleaning blade edge?	Clean or replace paper dust removal brush for registration roller. Clean or replace cleaning blade.
	9	Cleaning blade contact improper?	Readjust cleaning blade contact.
	10	Toner recovery defective?	Clean toner recovery auger section.
Fuser unit	11	1. Dirt or scratches on fuser roller surface? 2. Thermistor cleaned at PM?	1. Clean or replace fuser roller. 2. Clean thermistor.
Drum	12	Scratches on drum surface?	Replace drum.
Laser optical unit	13	Foreign matter or dust on slit glass?	Remove foreign matter or dust.
Shading correction plate	14	Dust or stain on shading correction plate?	Clean plate.

(15) Color banding (at right angles to feeding direction)

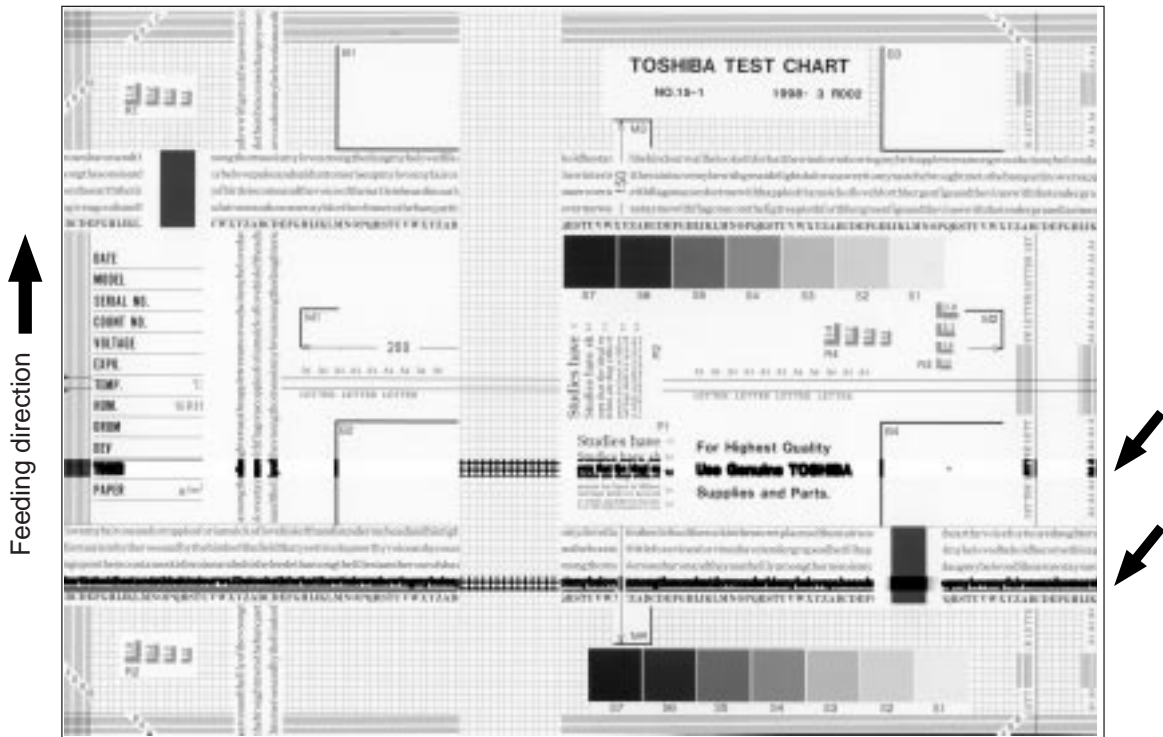

Cause/Defect area	Step	Check items	Measures
Main charger wire	1	Charger wire dirty or deformed?	Clean or replace charger wire.
Fuser roller	2	Fuser roller or oil roller dirty?	Clean them.
High-voltage transformer (main charger/transfer roller)	3	High-voltage transformer output defective?	Check circuit and replace high-voltage transformer if defective.
Drum	4	Deep scratch on drum surface?	Replace drum if scratch has reached aluminum base.
	5	Fine scratches on drum surface (drum pitting)?	Check and adjust contact of cleaning blade and recovery blade.
Scattered toner recovery roller of developer unit	6	Electrical continuity secured between developer bias supply spring and recovery roller?	If not, replace developer bias supply spring.
Scanner carriage section	7	Foreign matter on carriage rail?	Remove foreign matter.

(16) White spots



Cause/Defect area	Step	Check items	Measures
Developer unit/ Toner cartridge	1	Toner density of developer material proper?	Check and correct auto-toner sensor and toner supply operation. Check whether amount of toner is sufficient in toner cartridge.
Doctor-sleeve gap	2	Doctor-sleeve gap proper?	Adjust gap.
Main charger	3	Foreign matter on charger?	Remove it.
	4	Charger wire dirty or deformed?	Clean or replace charger wire.
High-voltage transformer (main charger/ developer bias/transfer roller)	5	High-voltage transformer output defective?	Adjust output.
Developer material	6	Accumulated copy volume for replacement attained?	Replace developer material.

(17) Poor image transfer

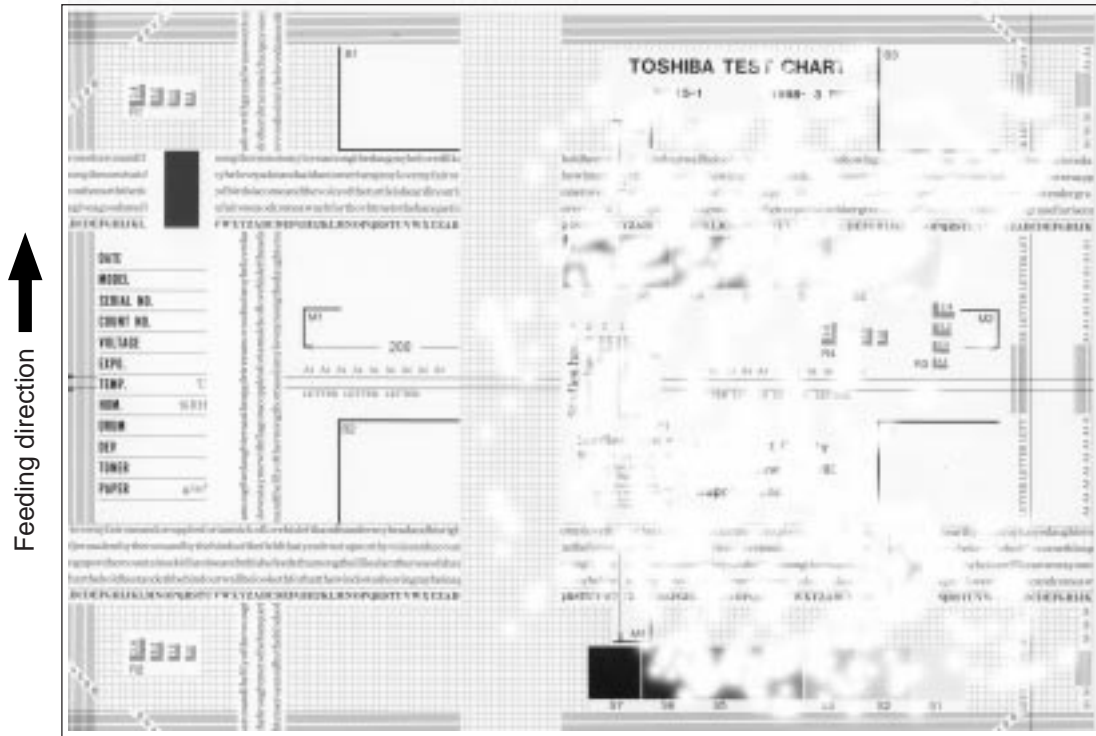

Cause/Defect area	Step	Check items	Measures
Transfer belt	1	Transfer belt dirty?	Clean it.
	2	Transfer belt in defective contact with drum?	Adjust contact.
	3	Any deformation or abnormalities on transfer belt?	Replace belt.
Paper	4	Paper in cassette or LCF curled?	Reinsert paper with reverse side up or change paper.
	5	Paper in cassette or LCF damp?	Change paper. * Avoid storing paper in damp place.
Registration roller	6	Registration roller malfunctioning?	Clean roller, re-mount spring, or replace defective clutch-related parts. Readjust roller speed.
High-voltage transformer (transfer roller)	7	High-voltage transformer output defective?	Check circuit and adjust transformer output.

(18) Uneven image density

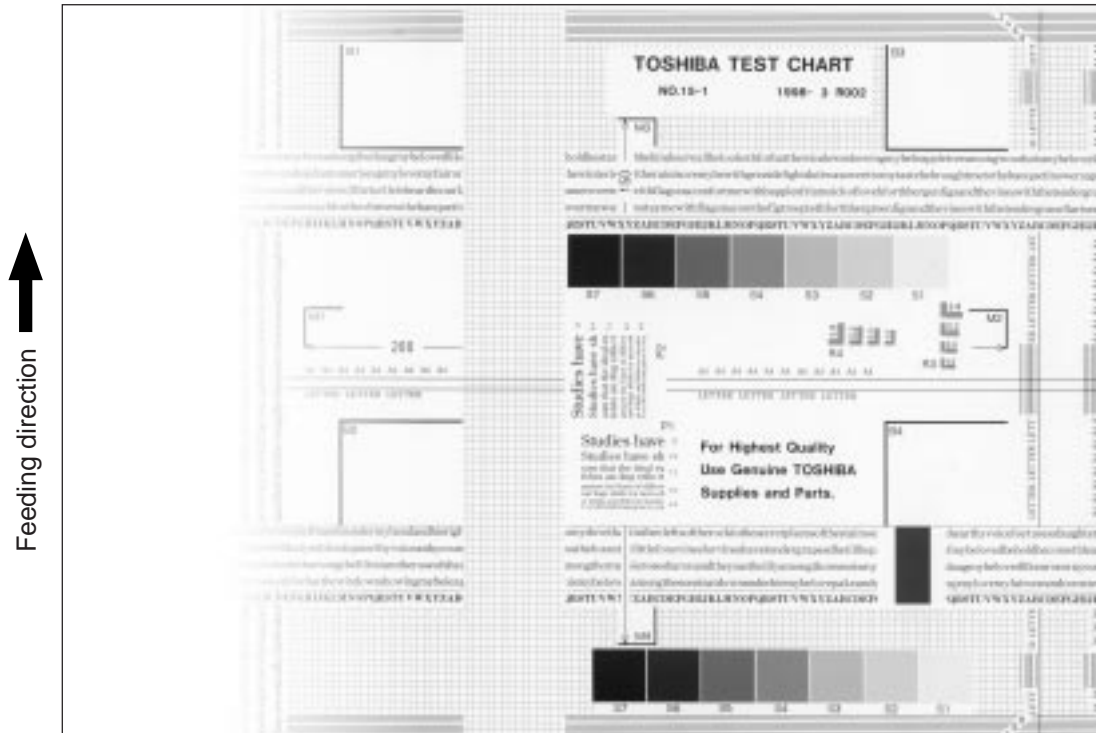

Cause/Defect area	Step	Check items	Measures
Main charger	1	Main charger dirty?	Clean it or replace charger wire.
Transfer belt	2	Transfer belt dirty?	Clean belt.
	3	Transfer belt in defective contact with drum?	Adjust belt.
	4	Any abnormalities or deformation on belt?	Replace belt.
	5	Foreign matter or dust on slit glass?	Clean slit glass.
Discharge LED array	6	Discharge LED array dirty?	Clean it.
	7	Any lamp of discharge LED array gone out?	Replace it.
Developer unit	8	Magnetic brush in defective contact with drum?	Adjust doctor-sleeve gap.
	9	Developer unit pressure mechanism malfunctioning?	Check mechanism.
	10	Defective transport of developer material?	Remove foreign matter if any.
Scanner section	11	1. Platen cover open?	1. Close platen cover.
		2. Glass, mirrors, or lens filter dirty?	2. Clean them.



(19) Faded image (low density, color reproduction defect, gray balance defect)

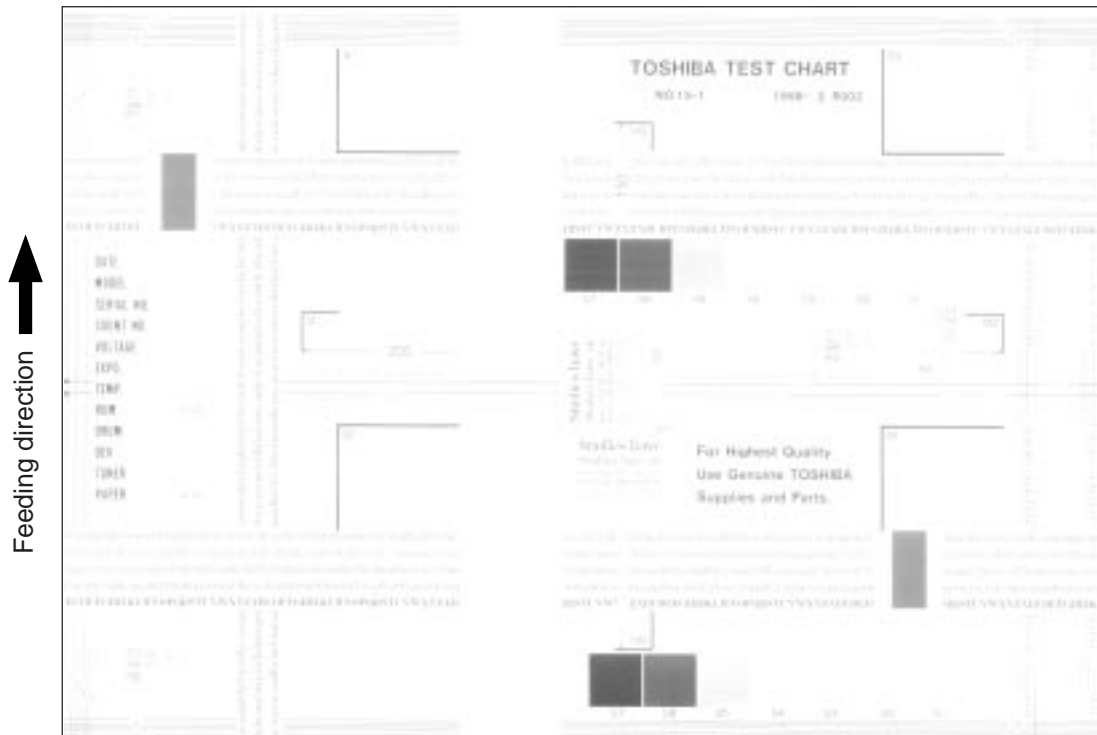

Cause/Defect area	Step	Check items	Measures
Toner empty	1	"ADD TONER" symbol flashing?	Replace toner cartridge.
Auto-toner circuit	2	Enough toner in cartridge?	Check auto-toner circuit function.
	3	Toner density in developer material too low?	
Toner motor	4	Toner motor malfunctioning?	Check motor drive circuit.
Toner cartridge	5	Any abnormalities in toner cartridge?	Replace toner cartridge.
Developer material	6	Developer material life ended?	Replace developer material.
Developer unit	7	Magnetic brush in proper contact with drum?	Check developer unit installation. Adjust doctor-sleeve gap and pole position.
Main charger	8	Main charger dirty?	Clean it or replace charger wire.
Drum	9	Film formed on drum surface?	Clean or replace drum.
High-voltage transformer	10	High-voltage transformer settings improper?	Adjust high-voltage transformer output.

(20) Image dislocation in feeding direction

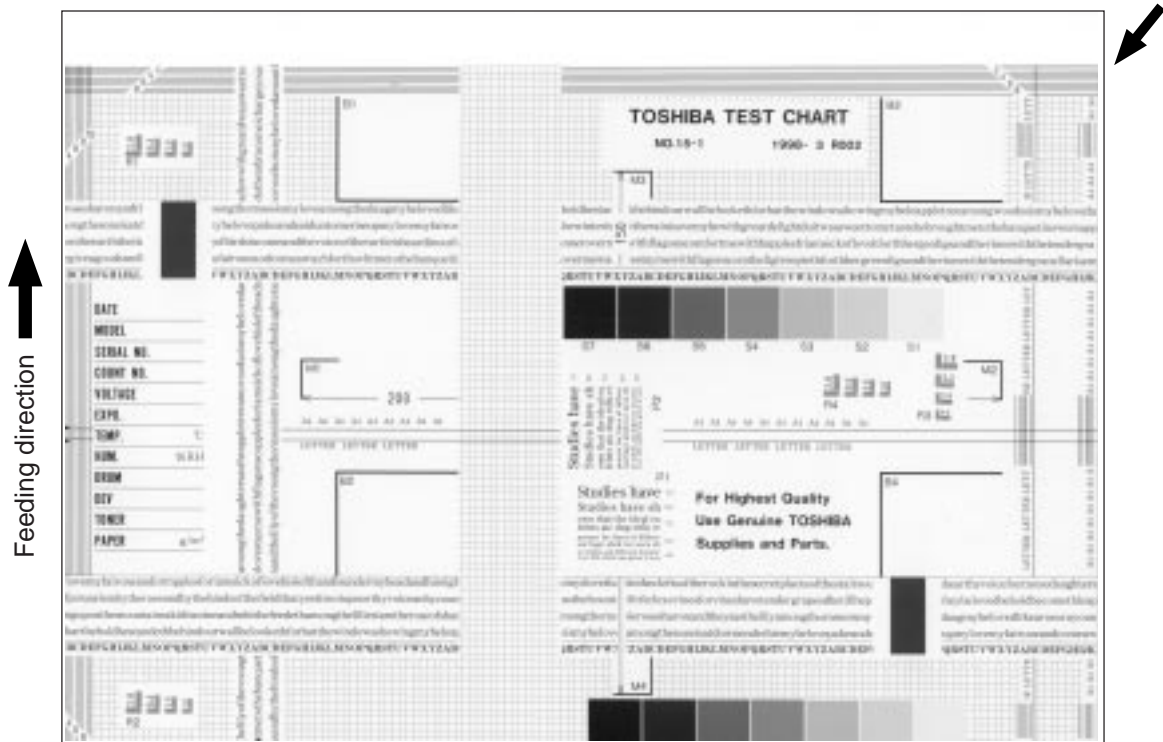

Cause/Defect area	Step	Check items	Measures
Scanner/printer adjustment defect	1	Same dislocation on every copy?	Adjust scanner/printer using adjustment mode.
Registration roller	2	Registration roller dirty, or spring out of place?	Clean roller with alcohol. Re-install spring.
	3	Registration motor malfunctioning?	Adjust or replace gears, etc. if they are not engaged properly.
Paper feed motor	4	Paper feed motor malfunctioning?	Check circuit or motor and replace them if necessary.
Pre-registration guide	5	Pre-registration guide mounted defectively?	Re-install guide.

(21) Image jittering

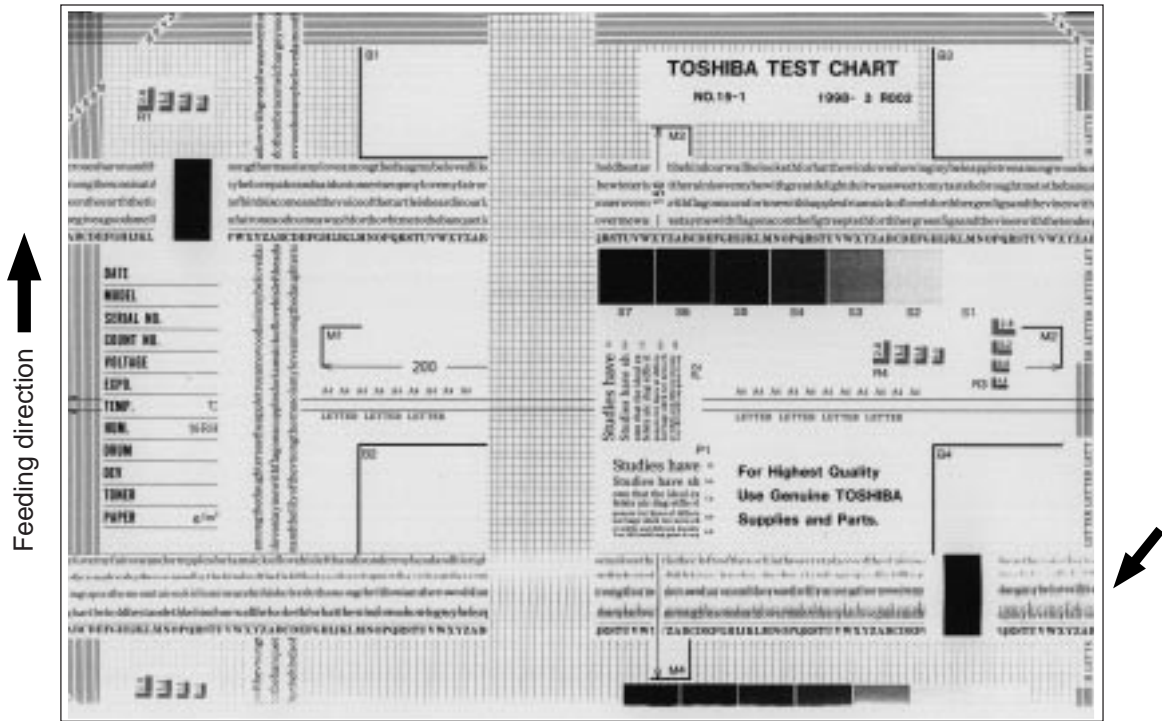

Cause/Defect area	Step	Check items	Measures
—	0	Toner image proper on drum?	If proper, perform step 1 to 3; otherwise perform step 4 and after.
Registration roller	1	Registration roller rotation defective?	Check registration roller section and its springs.
Transfer belt	2	Transfer belt malfunctioning?	Check drive system and replace transfer belt if necessary.
Fuser roller	3	Fuser roller rotation defective?	Check fuser roller drive system. Replace rollers if necessary.
Drum	4	Large scratch on drum?	Replace drum.
Carriage operation	5	Slider sheet defective?	Replace it.
	6	Any abnormalities on carriage feet?	Replace feet.
	7	Tension of timing belt inappropriate?	Adjust tension.
	8	Carriage drive system malfunctioning?	Check carriage drive system.
Scanner	9	Mirror loosely mounted?	Fix it properly.
Drum drive system	10	Drum drive system malfunctioning?	Check drum drive system. Clean or replace belt, pulley, bushing if they have dirt or scratches.
EPU load	11	EPU load too high?	Check EPU.

(22) Poor cleaning

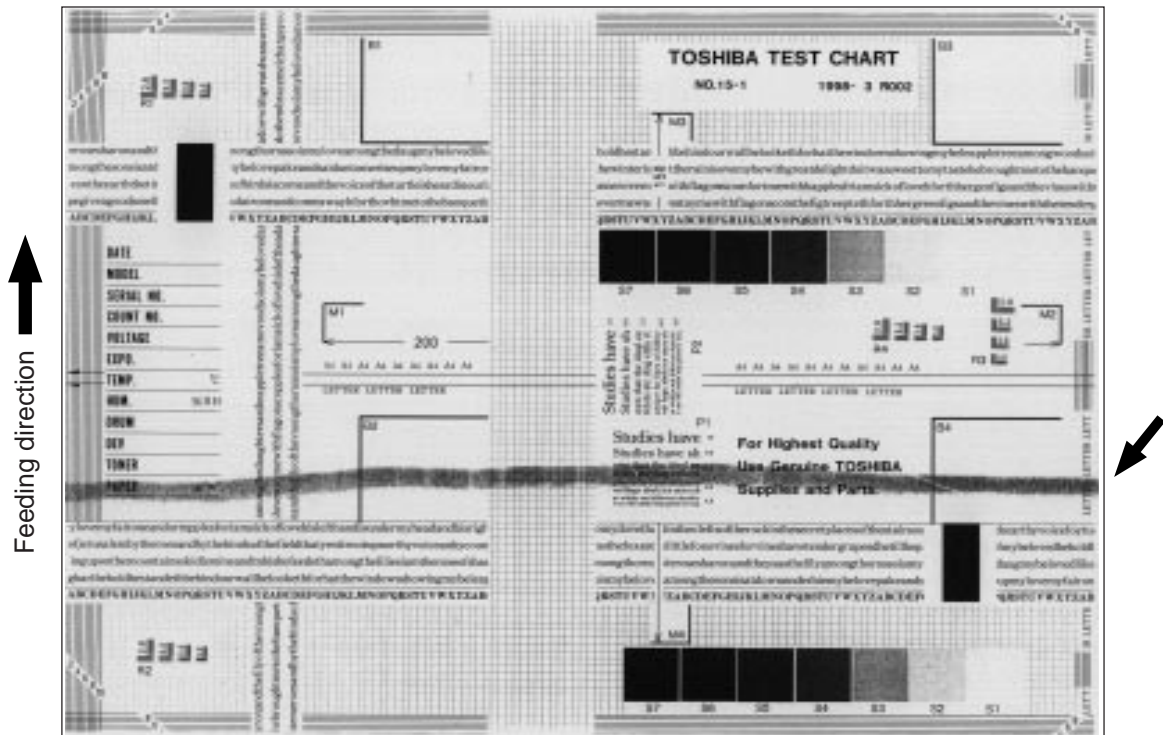

Cause/Defect area	Step	Check items	Measures
Developer material	1	Specified developer material not used?	Use specified developer material and toner.
Cleaning roller/ Oil roller	2	Cleaning roller or oil roller damaged or their life ended?	Replace defective rollers.
Fuser roller	3	Bubbles on fuser roller (188.5 mm pitch on copy)?	Replace fuser roller. Check and modify heater control circuit.
	4	Fuser roller life ended?	Replace it.
	5	Fuser roller pressure improper?	Check and adjust pressure mechanism.
	6	Fuser roller temperature abnormal?	Check and correct circuit.
Cleaning blade	7	Paper dust on cleaning blade edge?	Clean it.
	8	Cleaning blade peeled?	Replace blade. Check and replace drum.
Toner recovery auger	9	Toner recovery defective?	Clean toner recovery auger. Check cleaning blade pressure.

(23) Uneven light distribution



Cause/Defect area	Step	Check items	Measures
Original glass	1	Original glass dirty?	Clean glass.
Main charger wire	2	Main charger wire dirty?	Clean or replace wire.
Discharge LED array	3	Discharge LED array dirty?	Clean it.
Scanner	4	Reflector, exposure lamp, mirrors, lens, etc. dirty?	Clean them.
Exposure lamp	5	Exposure lamp tilted?	Adjust lamp mounting.
	6	Lamp discolored or degraded?	Replace it.

(24) Blotched image

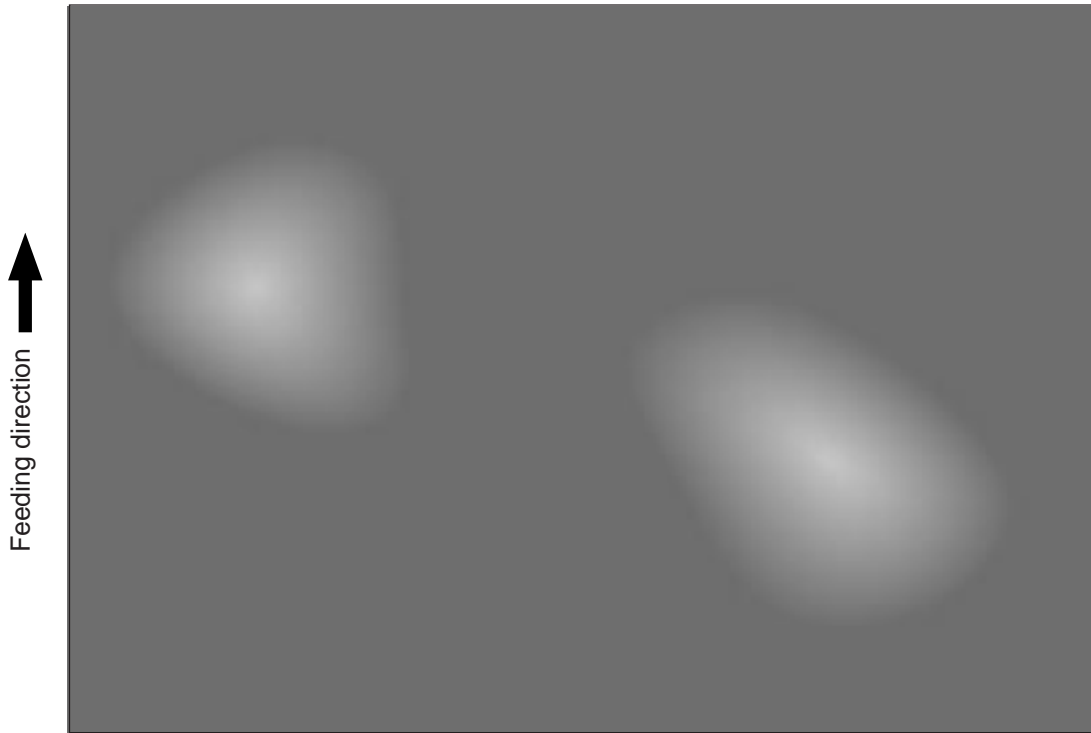

Cause/Defect area	Step	Check items	Measures
Paper	1	Too thin paper used?	Change paper.
	2	Paper too dry?	Change paper.
Transfer belt	3	Transfer belt in proper contact with drum?	Correct/adjust belt.
	4	Any abnormalities on belt?	Clean or replace belt.
High-voltage transformer (transfer roller)	5	High-voltage transformer output abnormal?	Adjust output. Replace transformer, if necessary.

## 5. FIRMWARE UPDATING

### 5.1 [ 3 ][ 9 ] Mode Operation

#### 5.1.1 Outline

Connect copier and PC with serial cable and turn the power on pressing 3 and 9 keys, the copier goes into "Firmware Version Up Mode". Then you can update system software data and/or UI data through the PC.

#### 5.1.2 Preparation of PC

To update the firmware of copier, the following preparations are necessary.

(1) Software Installation

"Virtual modem" and "War FTP Daemon" have to be installed in your PC.

Please refer to "5.2 Installation Instructions for Firmware Update through PC"

And also, War FTP Daemon has to be "ONLINE" mode.

(2) Preparation of updated files.

New files for update are stored in the following folder of the PC.

And also, the files must be named as follows

C:\WEBSHARE\FTPROOT



New files for update :

Kind of data	File name
- Program data	sysfirm.tz
- Fixed UI data	uidataF.tz
- Common UI data	uidata0.tz
- 1st language UI data	uidata1.tz
- 2nd language UI data	uidata2.tz
- 3rd language UI data	uidata3.tz



(3) Connection between copier and PC

Connect MMF(FSMS) port of the copier and serial communication port of PC specified by the setup of virtual modem using a crossing cable.

### 5.1.3 Firmware update operation

1. Turn ON the power of copier on pressing 3 and 9 keys.
2. The following messages are displayed on copier control panel.

```
Firmware Version Up Mode  
  
> Make a connection from PC.
```

3. Serial connection is made by dial-up from PC.

Refer to "5.2 Installation Instructions for Firmware Update through PC" about procedures for dial-up network connection.

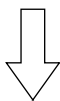
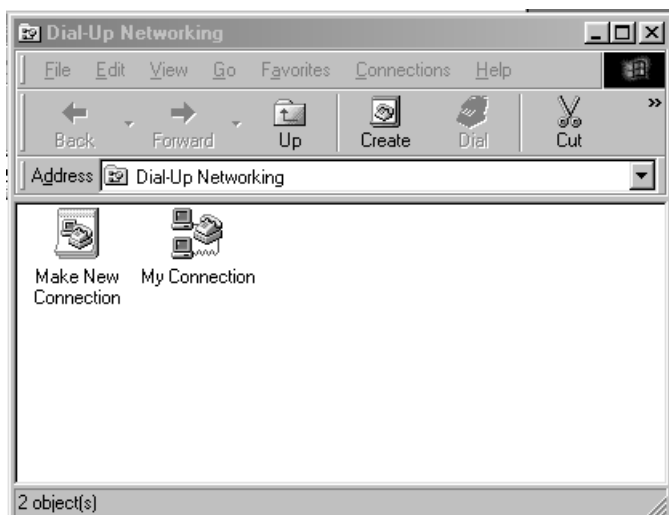

Key in "#39" for "Phone number".

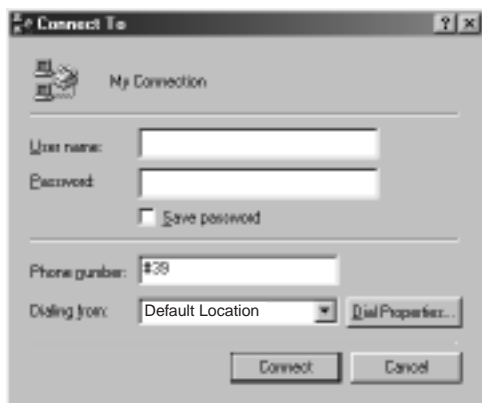

4. The following screens will be displayed if it succeeds in serial connection.

```
Firmware Version Up Mode
                                     Target: 1
Established serial connection with PC.
> Press START key to install new
firmwares.

> Please select a target with DIGI-
TAL keys.
```

Target area number

Press [HELP], and you can confirm the version number of firmware and UI data, before updating to new one. (To return to previous screen, press [HELP] again.)

```
Firmware Version Up Mode
                                     Target: 1
Established serial connection with PC.
target  version  code
  1      005.101  SEU
  2      004.001   0
  3      005.002   0
  4      006.001   3
  5      006.001   7
  6      006.003  11
```

One of the followings:  
SJP, SEU, SUC, SX

The number of "target" provides with following information.

- 1 : Program data
- 2 : Fixed UI data
- 3 : Common UI data
- 4 : 1st language UI data
- 5 : 2nd language UI data
- 6 : 3rd language UI data

"version" is displayed like "XXX.YYY".

"XXX" is major version and "YYY" is minor version.

"Code" provides with following information.

A. In the case of Program data("target" is 1), "code" means the destination.

SUC: for USA and Canada

SEU: for European countries

SX: for Australia and Asian countries

SJP: for Japan

B. In the case of UI data("target" is 2-6), "code" means Language.

Code	Language	Code	Language
2	Japanese	13	Finnish
3	American English	14	Norwegian
4	English	15	Australian English
5	reserved	16	Polish
6	French	17	Czech
7	German	18	Greek
8	Swedish	19	Romanian
9	Dutch	20	Bulgarian
10	Italian	21	Portuguese
11	Spanish	22	Hungarian
12	Danish	23	reserved

5. Select the area for update using ten keys.

Using [1] to [6] keys and [INTERRUPT] key, you can select a target area.

A selected number is displayed at target area. Press [INTERRUPT] to input "#".

The relation between target area number and firmware data is as follows.

1 : Program data

2 : Fixed UI data

3 : Common UI data

4 : 1st language UI data

5 : 2nd language UI data

6 : 3rd language UI data

#1 : All data (1, 2, 3, 4, 5 and 6)

#2 : All UI data (2, 3, 4, 5 and 6)

#3 : All language UI data (4, 5 and 6)

6. Press [START] key and copier starts to update the data.

**Do not turn OFF the power of the copier or the computer, or disconnect the connection between the copier and computer after pressing the START key.**

**Interrupting the transmission of a file to the copier will result in corrupting the file in F-ROM of the copier. If this file is corrupted, you have to re-install the data again.**

In the case of 1 - 6 :

```
Firmware Version Up Mode
                                Target: 1

Installing a new firmware.
- reading a file
```

Displaying current status as follows.  
- reading a file.  
- erasing the device.  
- writing to the device.

In the case of #1 - #3

```
Firmware Version Up Mode
                                Target:#1

Installing a new firmware.
- reading a file.

Target Version
  1 installing
```

Displaying current data area being loaded

7. The following screen will be displayed after firmware data is updated.

In the case of 1 - 6:

If you want to update other area continuously, press [START] key and repeat the operation from step 5.

After finished, turn OFF the power or press [CLEAR] key.

```
Firmware Version Up Mode
                                Target: 1

Firmware version up completed.
Version: 001.003 code:SEU

> Press START key to continue.
```

Updated data version number

In the case of #1 - #3:

The following screen is displayed after finished.

```
Firmware Version Up Mode
                                Target: #1
Firmware version up completed.
  Target  version
    1     001.002
    2     002.001
    3     002.031
    4     003.022
    5     003.022
    6     003.033
```

Updated data version numbers

8. Press [CLEAR] key to cancel downloading on the way.

However, it becomes unable to cancel after start of elimination process of flash ROM.

```
Firmware Version Up Mode
                                Target: 1
Program canceled.
```

9. When failing in update, the following error message is displayed.

(If an error occurs, "Recovery Mode" starts automatically when you turn ON the power next time. See 10:Recovery mode)

```
Firmware Version Up Mode
                                Target: 1
Failed to install a new firmware.
- file read error.
```

ERROR MESSAGE

- file read error.
- file information error.
- unfit device.
- device erase error.
- device write error.
- verify error.
- cannot set NvRAM flags.

## 10. Recovery mode

When you turn ON the power after an error occurs, you'll see following display.

```
Firmware Version Up Mode

Recovery mode : target 4-6 failed.
> make a connection from PC
```

Connect with dial-up network (see procedure 3), and the display changes as follows.

```
Firmware Version Up Mode
                                Target: #3

Recovery mode : target 4-6 failed.
Established serial connection with PC.
> Press START key to install new
firmwares.
```

Further procedure is the same as normal sequence.

### 5.1.4 Screen details

The following screen will be displayed in [ 3 ][ 9 ] mode.

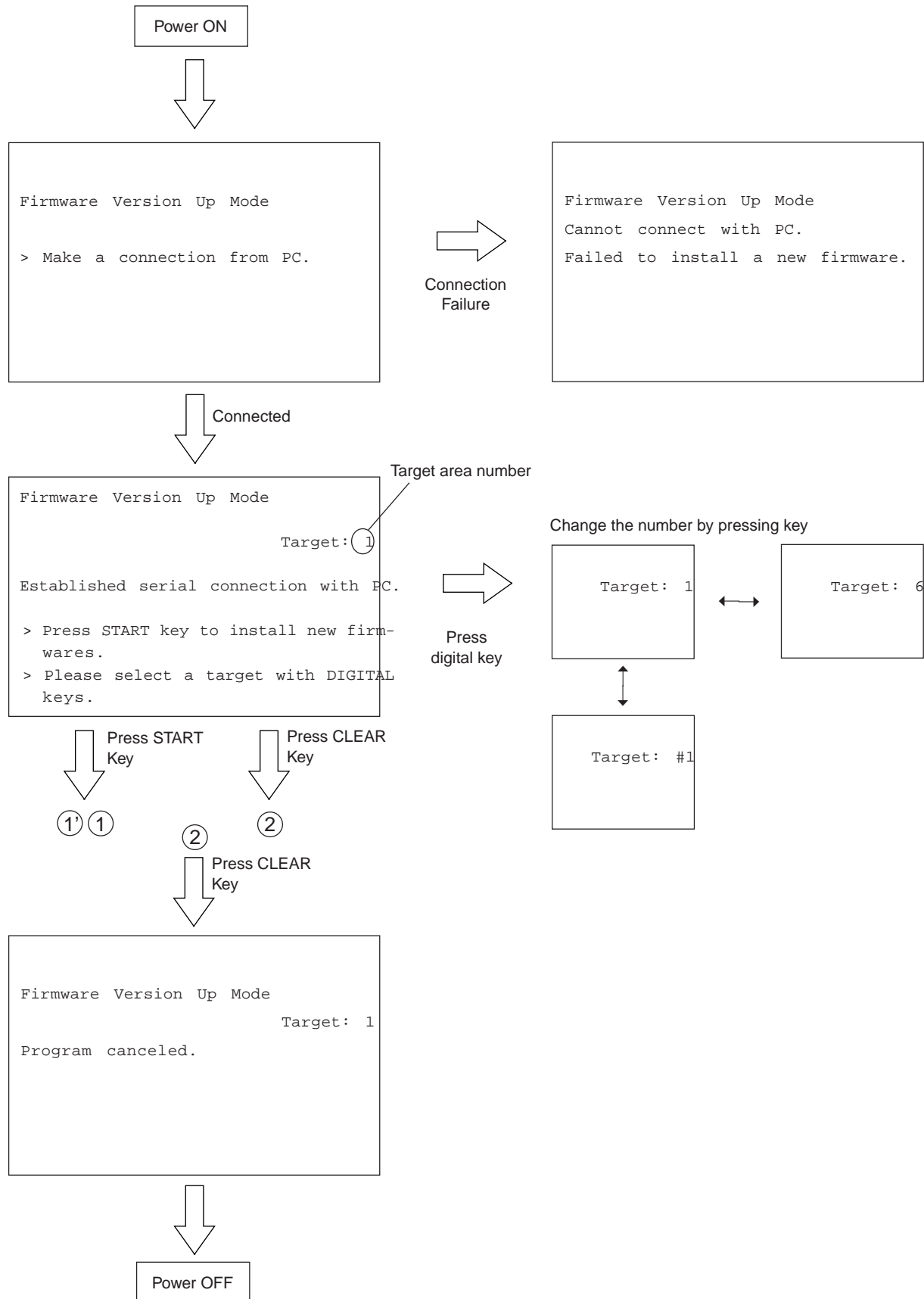



In the case of 1 - 6:

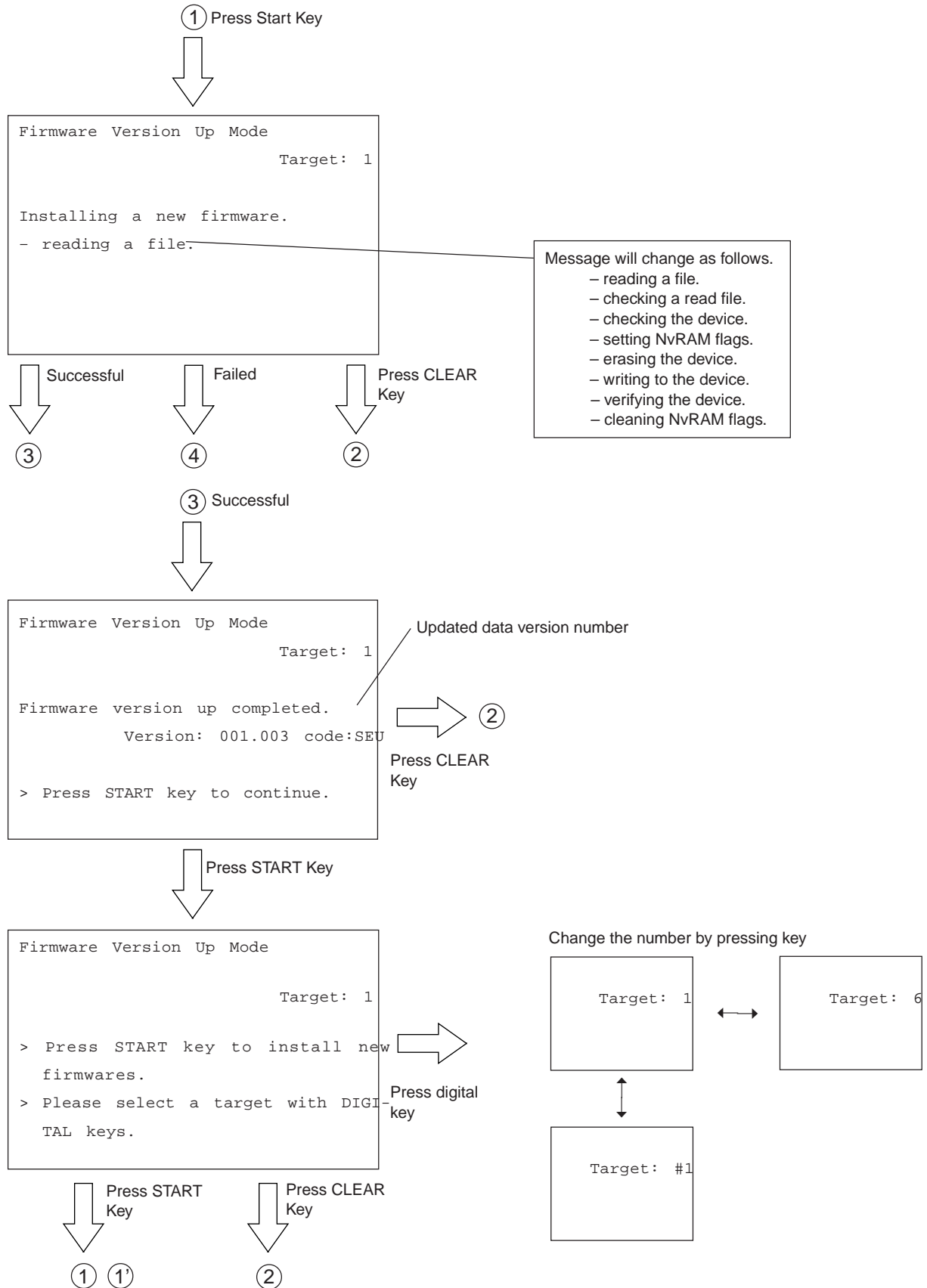

In the case of #1- #3:

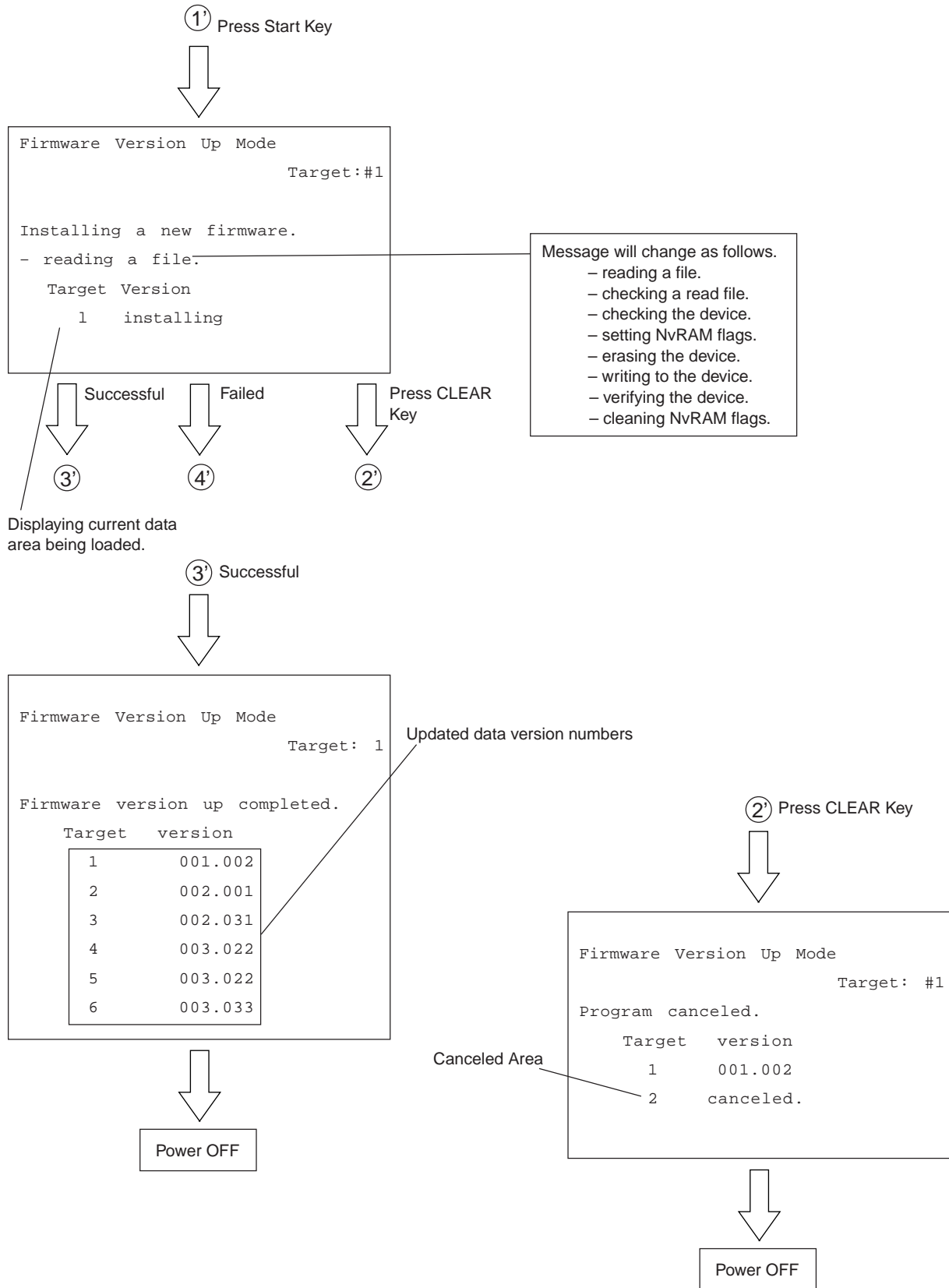

In the case of 1 - 6:

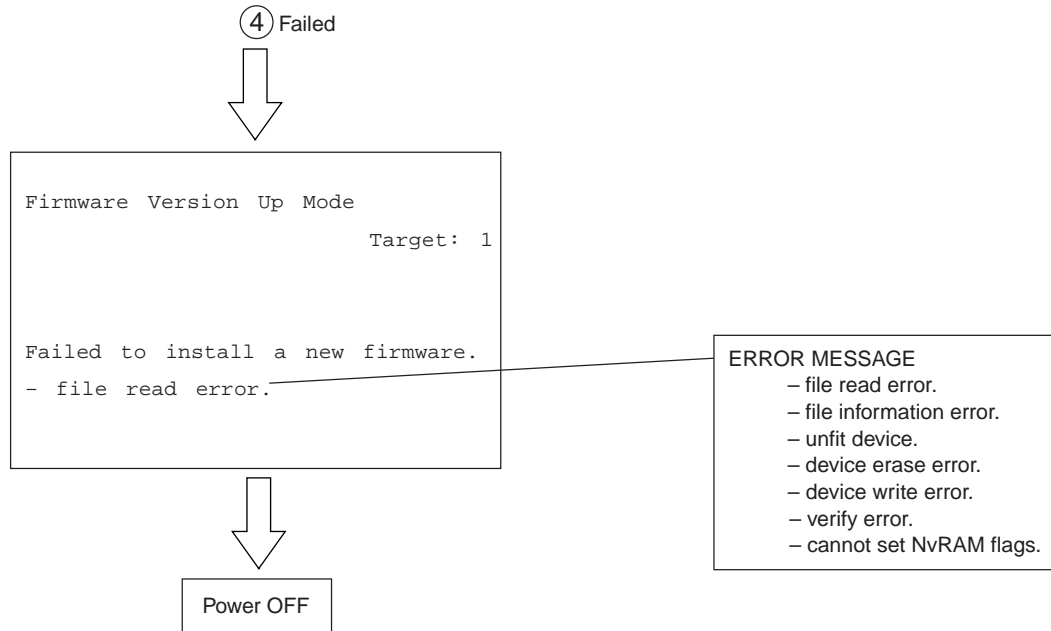

In the case of #1 - #3:

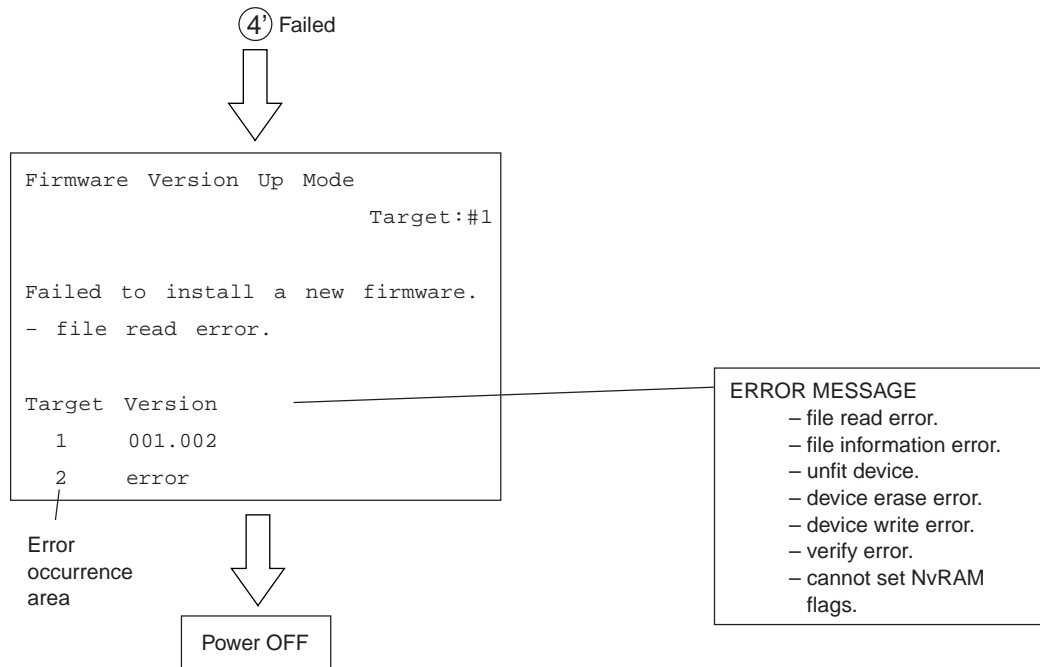

## 5.2 Installation Instructions for Firmware Update through PC

### 5.2.1 Outline

The following instructions show how to update system firmwares using your PC and FTP(File Transfer Protocol).

### 5.2.2 System configuration

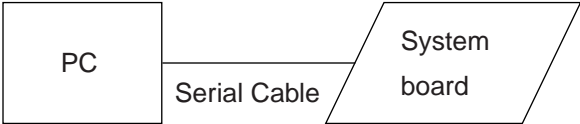

Software Requirements for PC.

- Microsoft Windows95.      - The official name is Microsoft Windows 95 Operating System. -
- Virtual Modem.
- FTP Server tools. (Ex. War FTP Daemon)

Serial Cable.

- PC and System board are connected with the following cross line cable.

DTE-DTE connections (D-SUB 9 PIN/RS-232C)

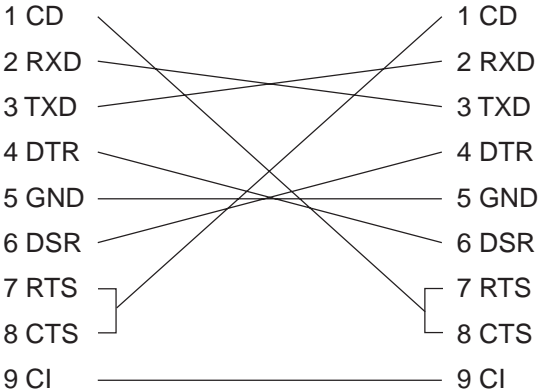

Protocol specifications between PC and system board.

SPEED	115200bps
DATA BITS	8 BITS
PARITY	NONE
STOP BITS	1 BIT
FLOW CONTROL	NONE
ECHO	OFF

### 5.2.3 Preparation of PC to use a network

#### (1) Setting Virtual Modem.

The connection between PC and copier is made using PPP(Point-to-Point Protocol). It is necessary to use a dial-up networking, and use a virtual modem.

First, install the virtual modem. The virtual modem can be downloaded from the following web site.

**URL: <http://www.mindspring.com/~kewells/net/scripts.html>**

After download, set up the modem as follows.

Click "Start" button, point at "Settings", and then click "Control Panel".

Click on Modems.



Click "Add" Button, and open "Install New Modem" wizard.

And then, check "Don't detect my modem; I will select it from a list", and click "Next" button.

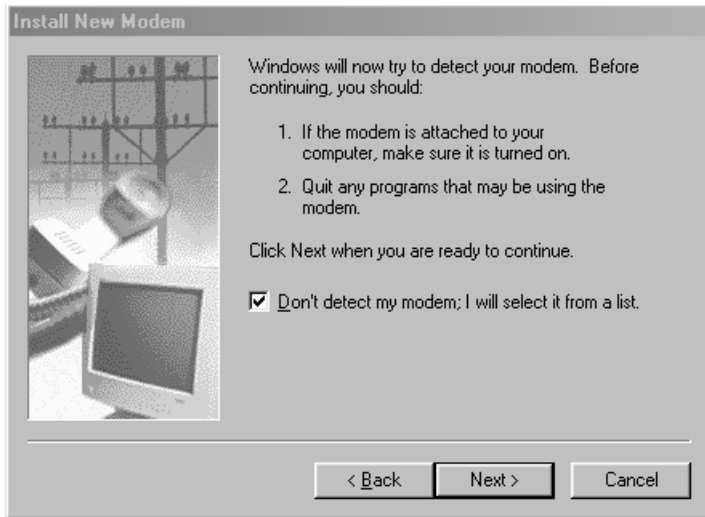

Click "Have Disk" button, and then select a folder download file is stored in.

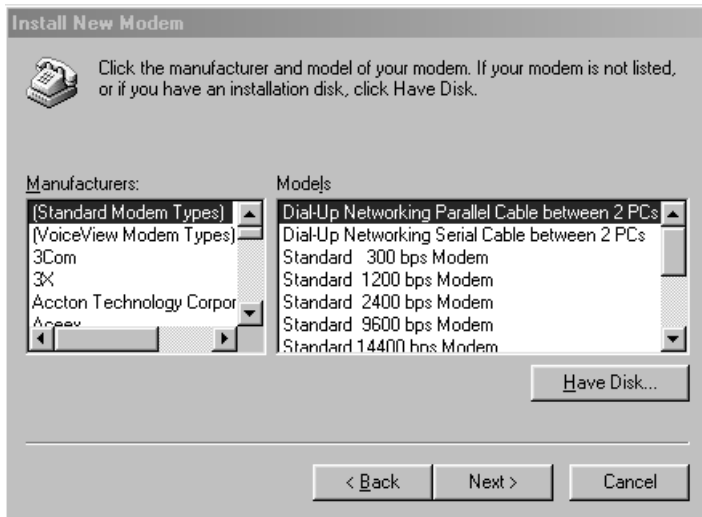

Select "Direct Connection", and then click "Next" button.

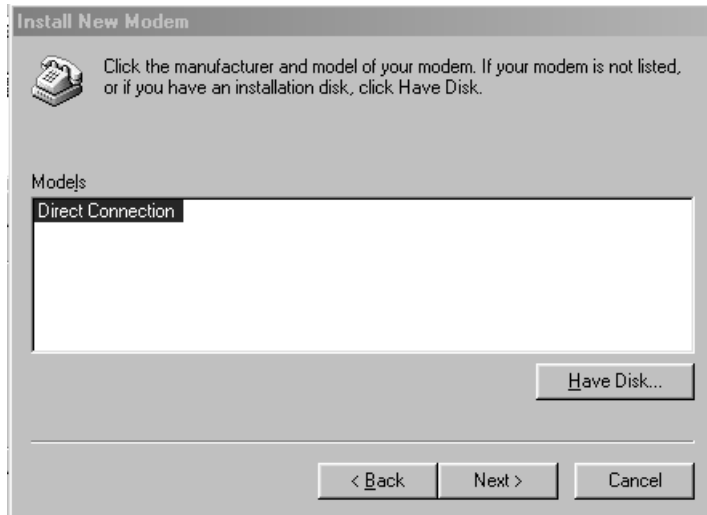

Select "Communications Port(COM1)", and then click "Next" button.

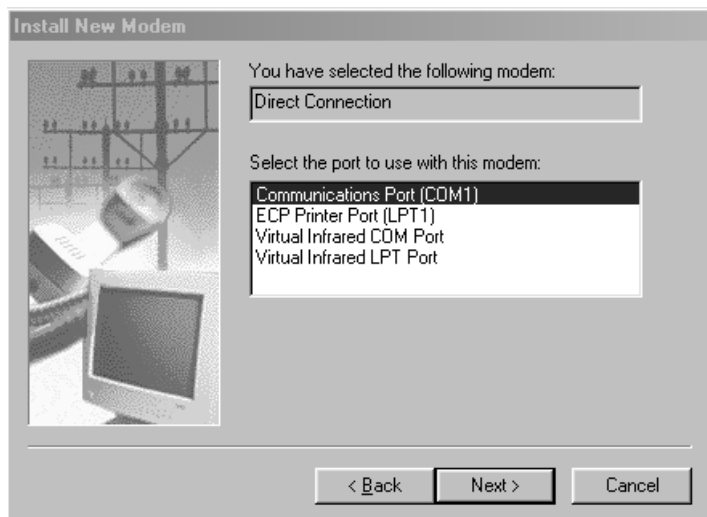

Click "Finish" button, then Virtual Modem installation is completed.

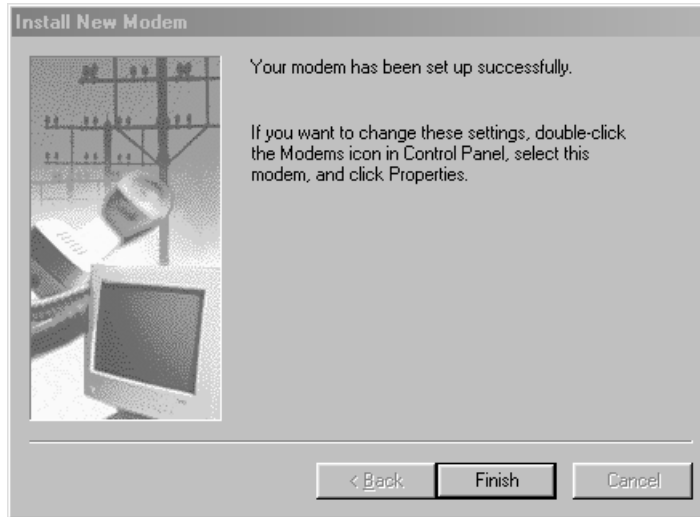



(2) Using Dial-Up Networking.

**Note:** Your computer may be already set up to use a network. If Windows prompts you for a network password at startup and if Network Neighborhood icon appears on Windows desktop, your network is already set up. In this case, you can skip this section.

In Network dialog box, click "Configuration" tab.

Confirm that "Dial-Up Adapter" and "TCP/IP" are displayed.

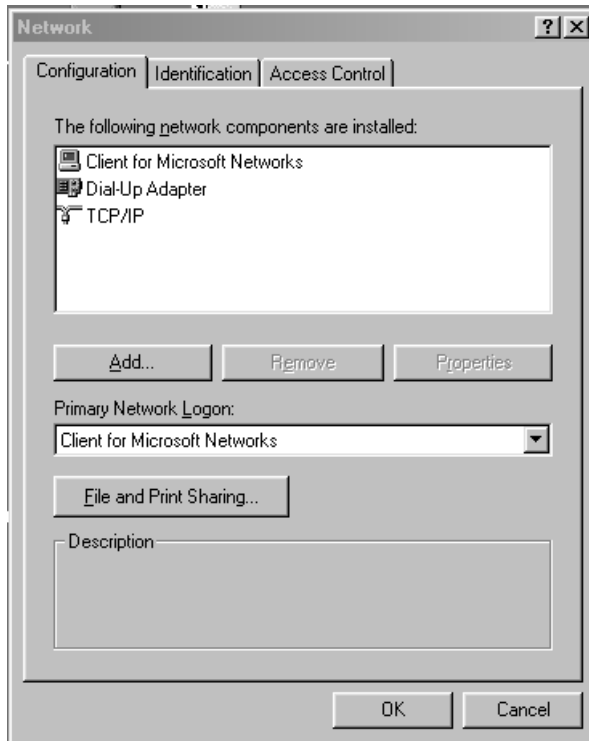

If your PC does not have "Dial-Up Adapter", then click "Add" button.

Select "Microsoft" in Manufactures list box, and select "Dial-Up Adapter" in Network Adapters list box, and then click "OK" button.

When you click "OK" button, Windows automatically set up the TCP/IP Protocol components with Dial-Up Adapter.

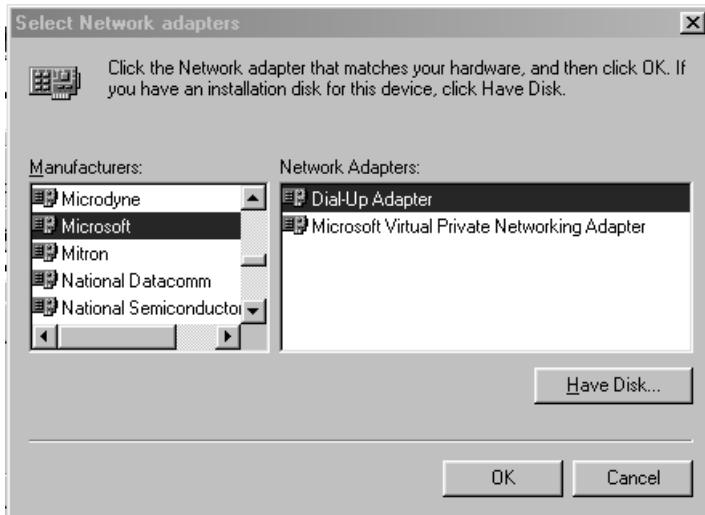

(3) Using New Connection.

Double-click "My Computer". If "Dial-Up Networking" icon is not in the window, click "Add/Remove Programs" in Control Panel.

Otherwise, skip to the next step to create a connection.

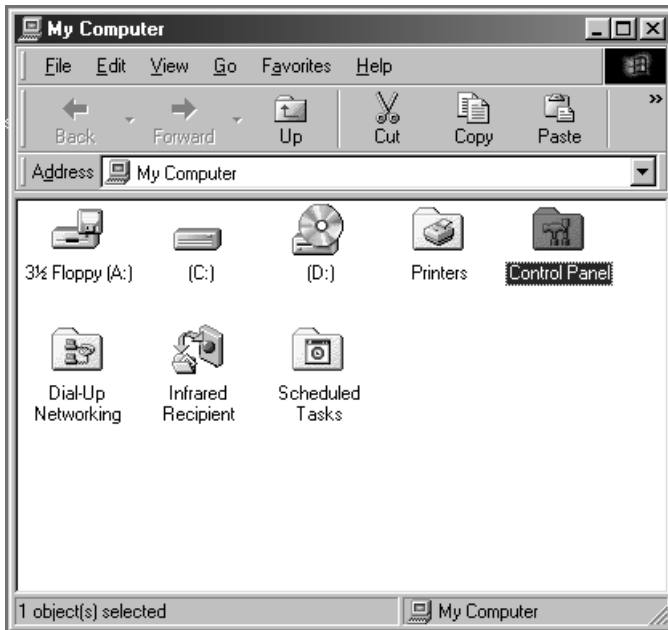

Double-click "Dial-Up Networking".

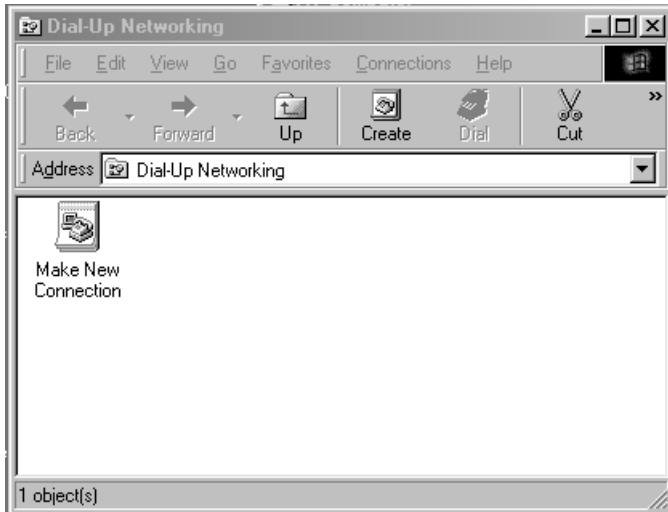

Type something in "Type a name for the computer you are dialing".

Select "Direct Connection" for "Select a device", and click "Configure" button.

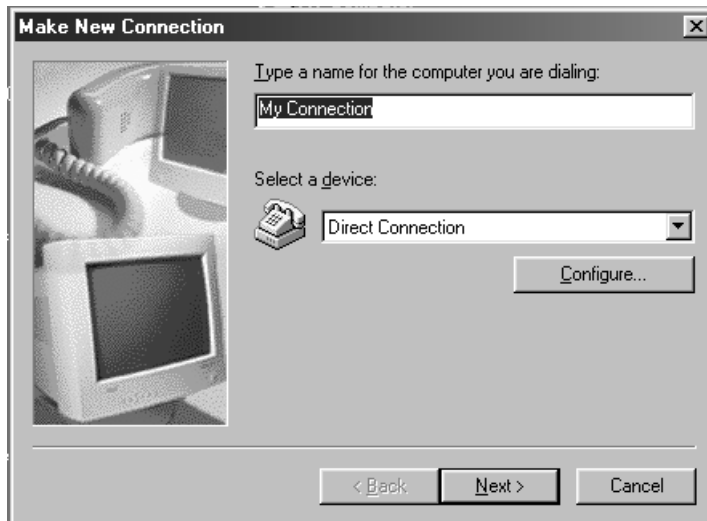

Click "General" tab in "Direct Connection Properties" box, select 115200 for "Maximum speed", check "Only connect at this speed".

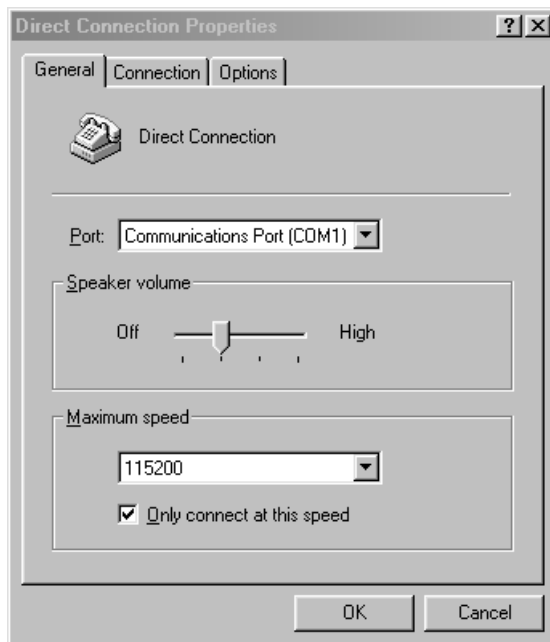

Click "Connection" tab, confirm that all check boxes in "Call preferences" are not selected, and click "Advanced" button.

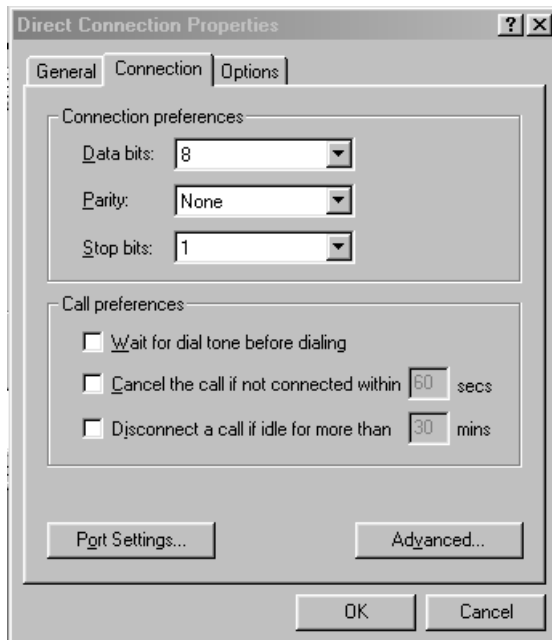

Confirm that all check boxes in "Advanced Connection Settings" dialog box is not selected, click "OK" button, and then return to "Make New Connection" dialog box.

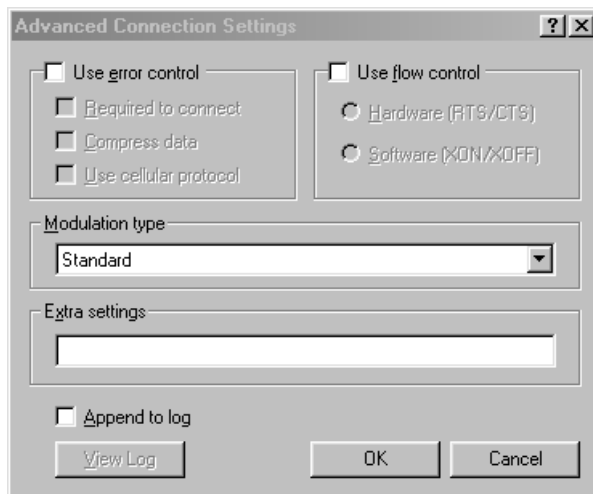

After returning to "Make New Connection" dialog box, click "Next" button.

Type #39 for "Telephone number".

To change "Country code", click the arrow next to the country, and select a country you want. After that, click "Next" button.

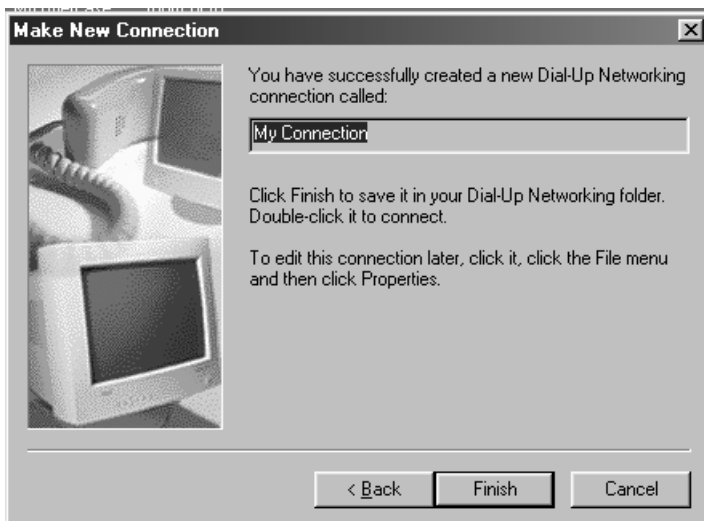
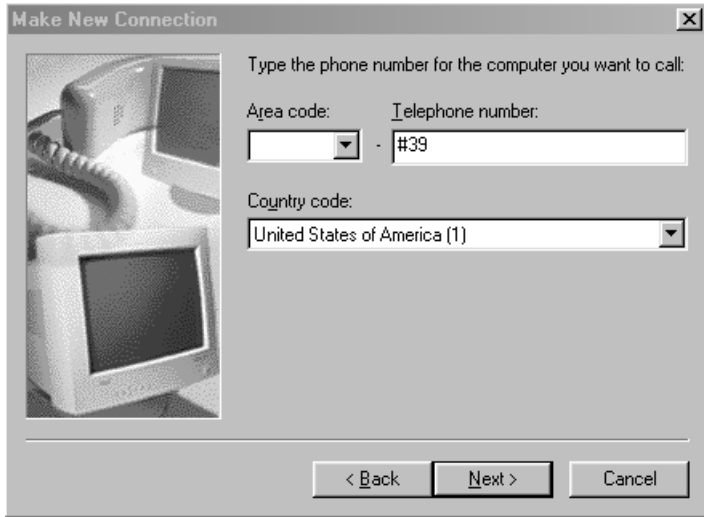

Click "Finish" button, then "Make New Connection" is completed.

## 5.2.4 Installation of FTP server

First, it is necessary to install Free Software "War FTP Daemon Version 1.65" as an FTP server. War FTP Daemon can be downloaded from the following web site.

**URL:** <http://www.jgaa.com/downloadpage.htm>

Download the file "ward165.exe" from the above site, and execute it. Some files are created, and then execute "Setup.exe".

Create the C:\WEBSHARE\FTPROOT folder.

After that, execute "war-ftpd.exe" in "war-ftpd" folder.

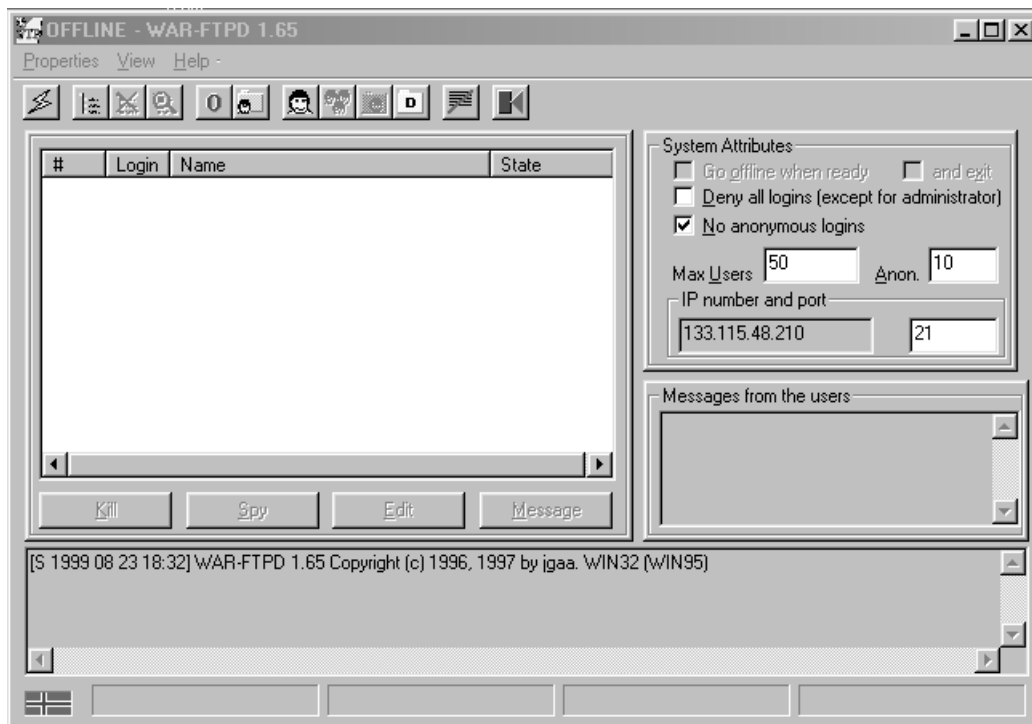

Select [Properties]-[Security]-[Edit User]

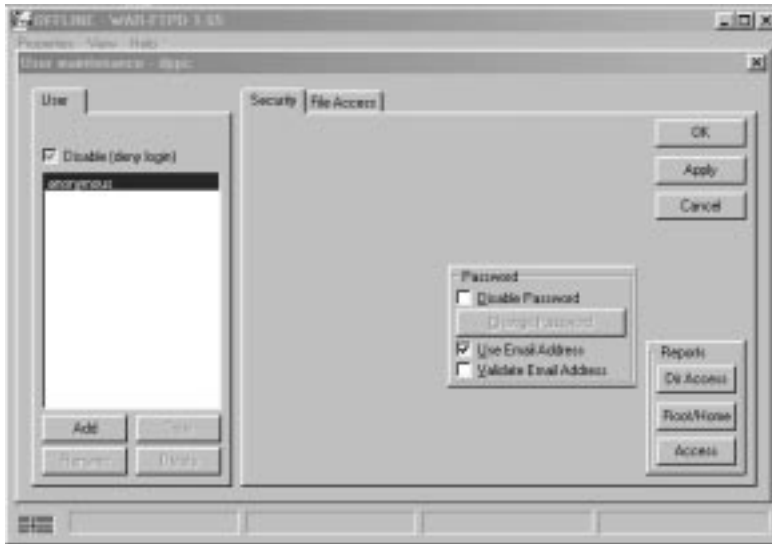

Click "Add" button, and key in dppc for "New name".



Key in dppc for "New Password" and "Verify Password", and click "OK" button.

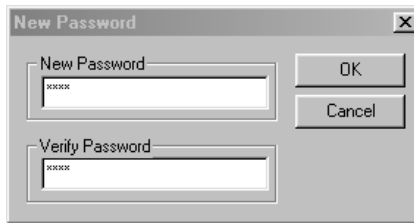
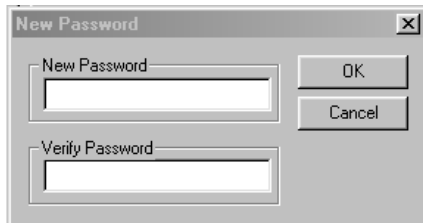

Select "dppc" and click "File Access". Click "Add" button.

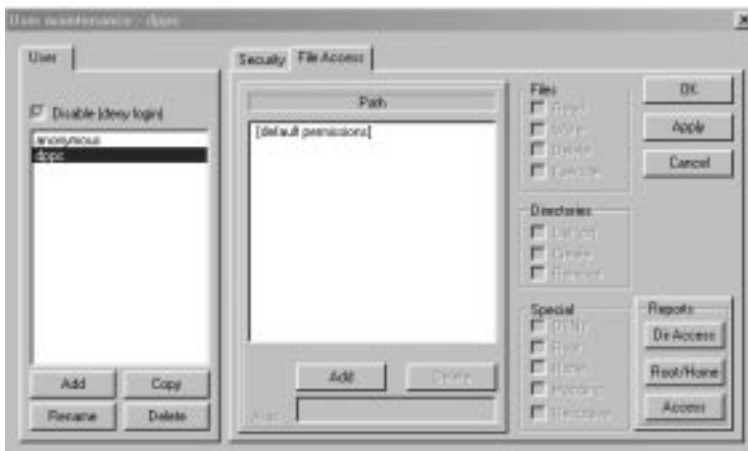



Double-click "Webshare".

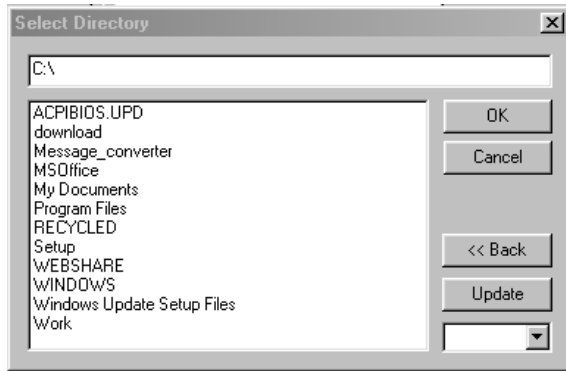

Double-click "Ftproot" and click "OK" button.

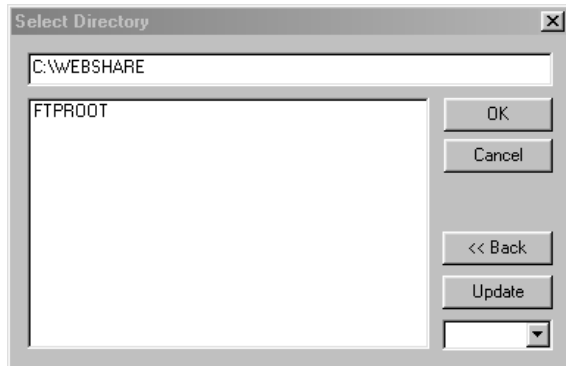

Change "Read", "Write", "Delete", "Execute", "List", "Create" and "Remove" from Gray Check to Black Check.

Check "Root", "Home" and "Recursive" in "Special" box as follows.

And then, click "Apply" and "OK".

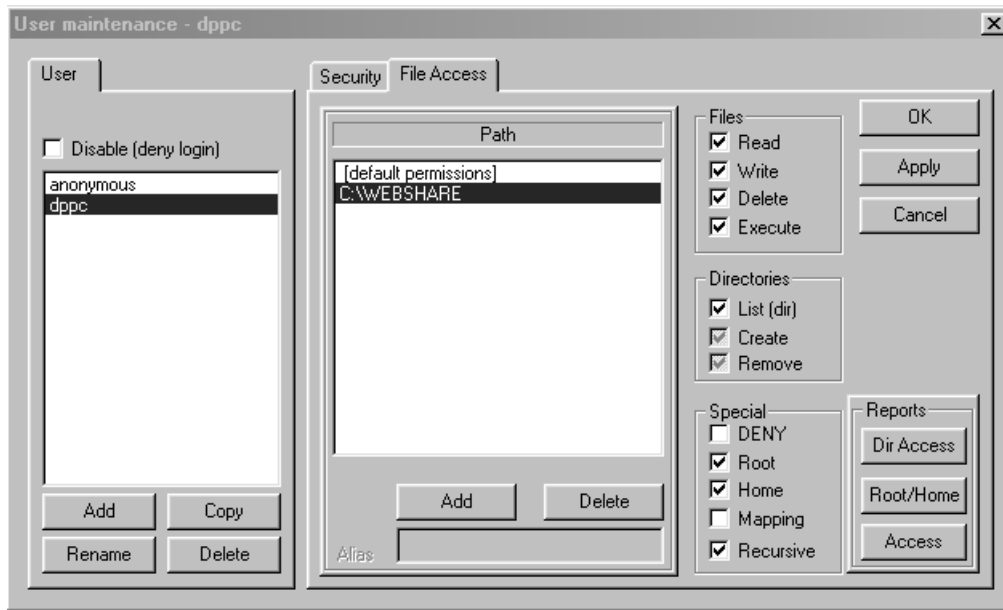

To make the connection "ONLINE" mode, click the button  before firmware updating.

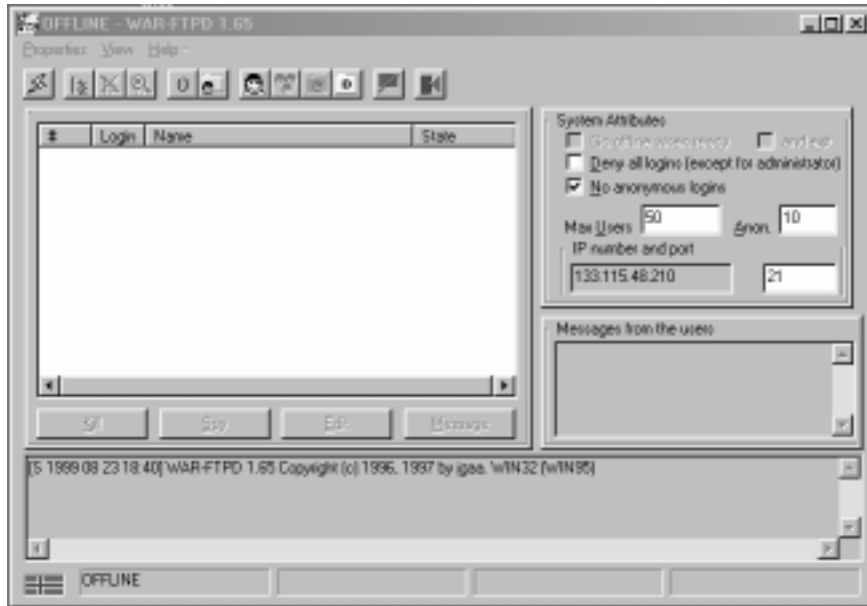



## 6. WIRE HARNESS CONNECTION DIAGRAMS

### 6.1 AC Wire Harness

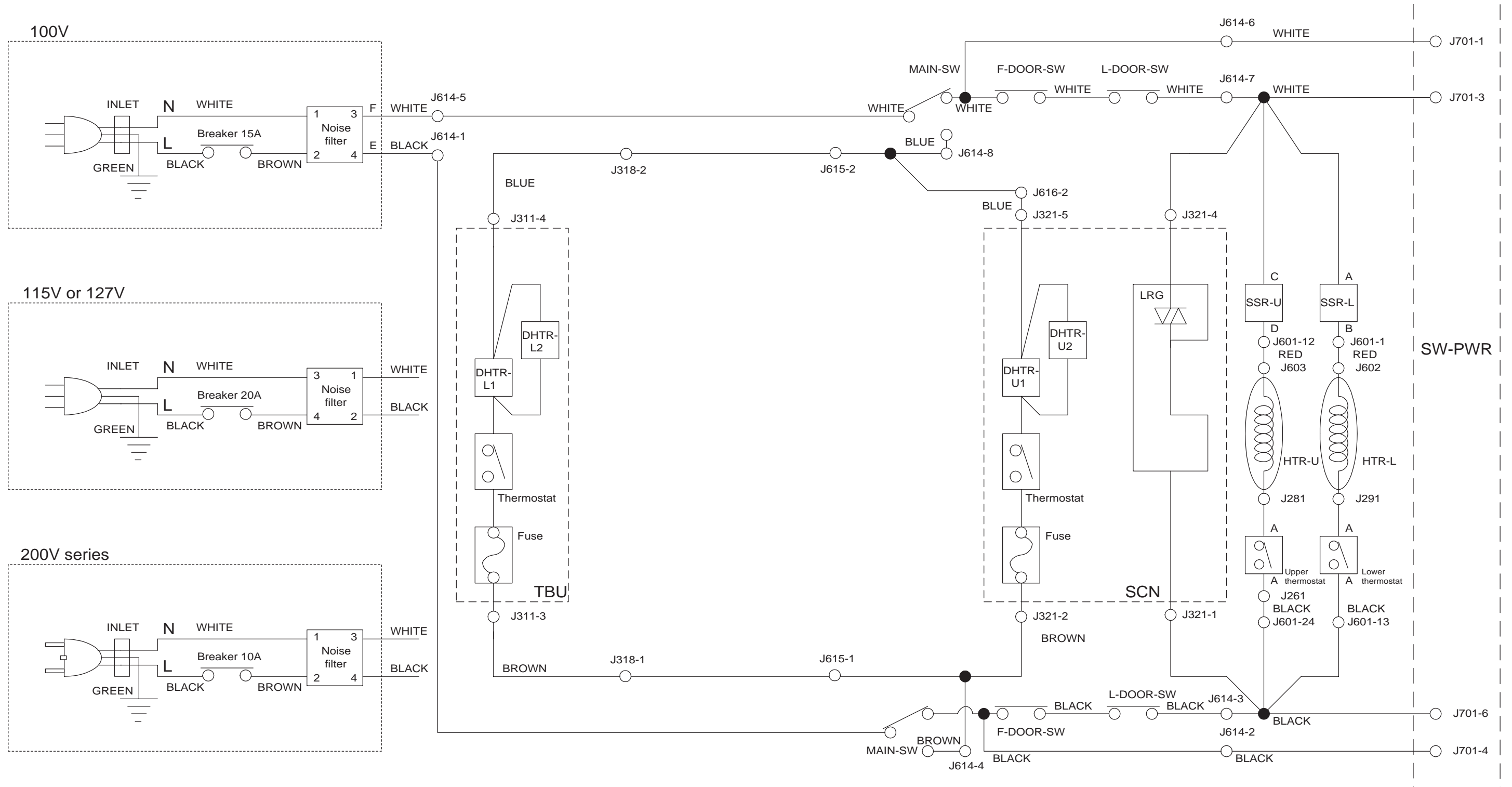

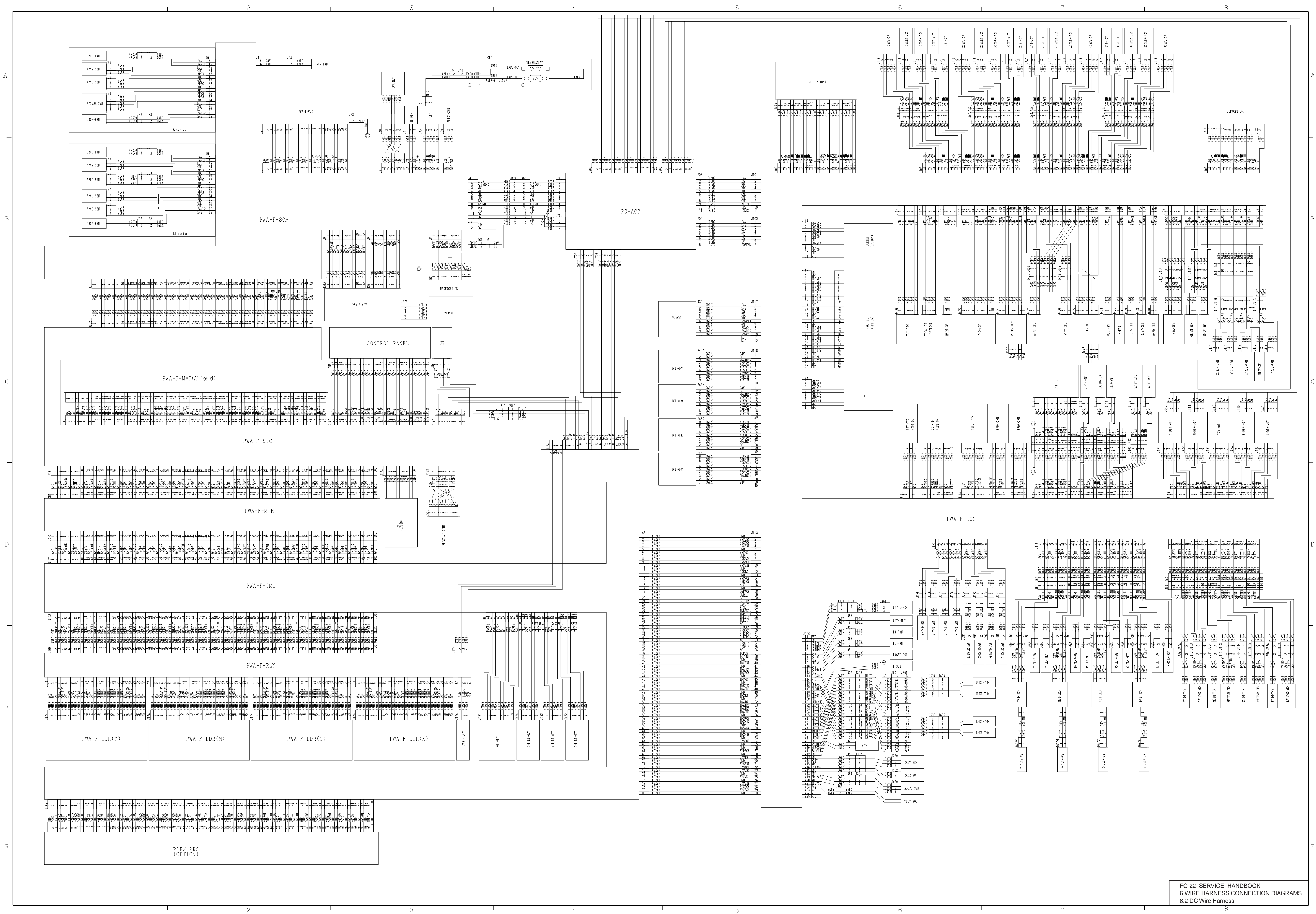



## Free Manuals Download Website

<http://myh66.com>

<http://usermanuals.us>

<http://www.somanuals.com>

<http://www.4manuals.cc>

<http://www.manual-lib.com>

<http://www.404manual.com>

<http://www.luxmanual.com>

<http://aubethermostatmanual.com>

Golf course search by state

<http://golfingnear.com>

Email search by domain

<http://emailbydomain.com>

Auto manuals search

<http://auto.somanuals.com>

TV manuals search

<http://tv.somanuals.com>