

TOSHIBA

MULTIFUNCTIONAL DIGITAL SYSTEMS

Operator's Manual for Basic Function

e-STUDIO520/600/720/850

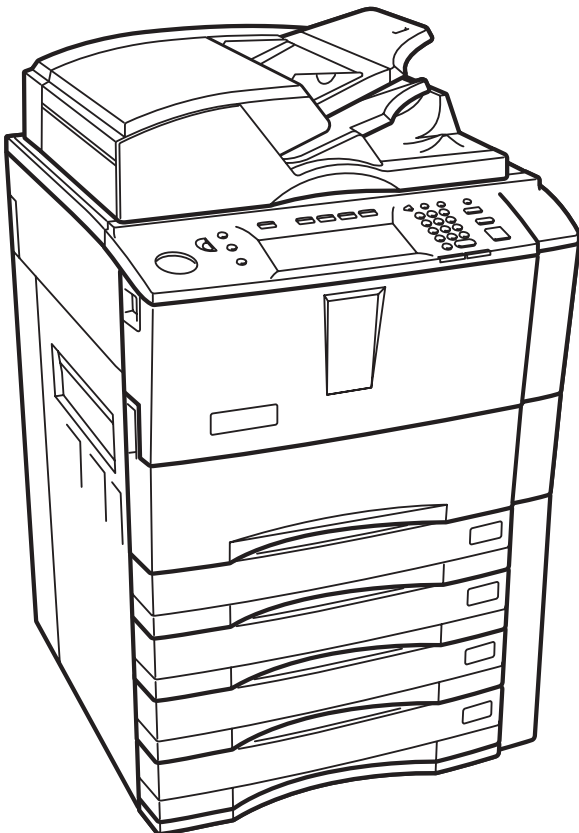



EPA ENERGY STAR® (MFD)

The United States Environmental Protection Agency (EPA) has introduced a voluntary program, the ENERGY STAR program, to encourage the widespread and voluntary use of energy-efficient technologies that enhance the workplace, improve product performance and prevent pollution. As an ENERGY STAR Partner, the TOSHIBA TEC CORPORATION has determined that this copier model meets the ENERGY STAR guidelines for energy efficiency.

ENERGY STAR guidelines for this class of copier require ENERGY STAR copiers to have a 'Sleep Mode' feature that automatically makes the copier enter the sleep mode after a period of inactivity. The copier must also automatically change to a 'Low Power Mode' (Automatic Energy Save) after a period of time since the last usage. Specifically, this copier complies with the following requirements.

◇ e-STUDIO520/600/720/850 Copier model (Base model)

'Automatic Energy Save'-

The copier consumes less than 205 W (e-STUDIO520)/236 W (e-STUDIO600)/282 W (e-STUDIO720)/332 W (e-STUDIO850) during Energy Save.

'Automatic Energy Save' Default Time-

The default time for the 'Automatic Energy Save' is 15 minutes.

'Off Mode'

The copier consumes less than 20 W (e-STUDIO520/600/720/850).

'Off Mode' Default Time-

The default time for the 'Off Mode' is 90 minutes.

◇ e-STUDIO520/600/720/850 Copier/Printer + Fax model (Multifunction model)

'Automatic Energy Save'-

The copier consumes less than 250 W (e-STUDIO520)/281 W (e-STUDIO600)/327 W (e-STUDIO720)/377 W (e-STUDIO850) during Energy Save.

'Automatic Energy Save' Default Time-

The default time for the 'Automatic Energy Save' is 15 minutes.

'Sleep Mode'

The copier consumes less than 95 W (e-STUDIO520/600/720/850) in the 'Sleep Mode'.

'Sleep Mode' Default Time-

The default time for the 'Sleep Mode' is 90 minutes.

Note1- The default setting for the 'Sleep Mode' and 'Automatic Energy Save' can be changed.

Note2- For Multifunction model, if the Fax or printer data is received in the sleep mode, the copier starts warming itself up and prints out the data when it becomes ready. Also, when the start button or the energy saver button on the control panel is pressed, the copier starts warming itself up.

Note3- If 'Automatic Energy Save' and 'Sleep Mode' have the same setting time, 'Sleep Mode' takes priority.

In accordance with EPA ENERGY STAR program guidelines, Toshiba recommends the following recycled paper.

Great White MultiUse 20 paper

Great White MultiUse 24 paper

If you have any questions regarding the use of recycled paper or some recommended types of recycled paper, please contact your authorized Toshiba dealer.

ENERGY STAR is a U.S. registered mark.

CONTENTS

Notice to Users	5
TOSHIBA Quality is Second to None	6
Preface	8
Features of the e-STUDIO520/600/720/850.....	9
General Precautions	10
• When installing or moving	10
• When using the multifunctional digital systems.....	13
• During maintenance or inspection.....	16
• When handling supplies	17
Disclaimer Notice.....	18
1. BEFORE USING EQUIPMENT	19
1. Description of Each Component	20
• Main components	20
• Configuration of options	21
• Control panel	23
• Touch panel.....	25
2. Turning Power On / Shutdown.....	29
• Turning power on.....	29
• Shutdown.....	30
3. Energy Saving Mode.....	33
4. Setting Copy Paper.....	34
• About the “width” and the “length” of the original and the copy paper	34
• Copy paper types and sizes	35
• Toshiba-recommended paper / Handling and storing paper	36
• Setting copy paper (size change) / Setting the drawer for special uses	37
• Changing the setting of paper size	40
2. HOW TO MAKE COPIES.....	47
1. General Copying Procedures.....	48
2. Setting Originals.....	51
• Originals sizes and types / Maximum number of sheets	51
• Placing originals on the glass	54
• Using the Reversing Automatic Document Feeder.....	56
3. Auto Job Start (Job Preset).....	59
4. Interrupt Copying	61
5. Stopping Copy Operation.....	62
6. Bypass Copying	63
• Bypass copying.....	63
• Bypass copying on standard size paper.....	64
• Bypass copying on non-standard size paper.....	68
• Registering non-standard size in the memory	70
3. SETTING OF BASIC COPY MODES.....	71
1. Paper Selection.....	72
• Automatic Paper Selection (APS).....	72
• Manual paper selection.....	74
• When copying mixed-size originals in one go	75
2. Enlargement and Reduction Copying	77
3. Selecting Finishing Modes	83
• Finishing modes and finishers (optional)	83
• Sort/Group copying	85
• Rotate sort mode	87
• Staple sort mode.....	88
• Magazine sort & saddle stitch mode (booklet mode).....	90
• Hole punch mode (optional).....	93
• Inserter mode (optional).....	95

4. Duplex Copying.....	97
5. Original Mode.....	106
6. Copy Density Adjustment.....	107
4. IMAGE ADJUSTMENT	109
1. Background Adjustment.....	110
2. Sharpness.....	111
5. USING THE EDITING FUNCTIONS.....	113
1. IMAGE SHIFT.....	114
2. EDGE ERASE.....	120
3. BOOK CENTER ERASE.....	121
4. DUAL PAGE	123
5. 2IN1 / 4IN1.....	126
6. MAGAZINE SORT	129
7. EDITING	131
• Trimming / Masking	131
• Mirror image.....	134
• Negative/Positive reversal	135
8. XY ZOOM	136
9. COVER SHEET	138
10. SHEET INSERTION	141
11. TIME STAMP	143
12. PAGE NUMBER	144
13. JOB BUILD	146
14. IMAGE DIRECTION.....	150
15. BOOK - TABLET	152
16. ADF / SADF	154
17. TAB PAPER.....	157
18. INSERTER.....	167
6. e-FILING.....	171
1. e-Filing	172
2. Creating User Boxes.....	174
3. Changing Data of User Boxes	176
4. Deleting User Boxes	179
5. Storing Documents in e-Filing.....	181
6. Printing Stored Documents.....	185
7. Deleting Folders or Documents	190
7. TEMPLATE	193
1. Template	194
2. Registering User Groups and Templates.....	195
3. Changing Data of User Groups and Templates.....	206
4. Recalling Templates	213
5. Deleting User Groups or Templates	218
8. JOB STATUS.....	223
1. Job Status.....	224
2. Confirming Print Job Status	225
• Print jobs.....	226
• Proof print jobs.....	229
• Private print jobs.....	232
• When using department codes	235
3. Confirming Scan Job Status	238
4. Log List	239
• Confirming job history in log list.....	240
• Registering into address book from log lists	244
• Printing journals (send/receive log list).....	246

5. Print Status Display.....	247
6. Error Code	250
9. BLINKING GRAPHIC SYMBOLS	261
1. Blinking Graphic Symbols	262
2. Drawer Display on the Touch Panel	263
3. Toner-Related Symbols	264
4. Jam Symbols	267
5. Call Service Symbol.....	288
10.WHEN THIS MESSAGE APPEARS.....	289
1. "Toner low"	290
2. "Check staple cartridge"	292
3. "Check staple cartridge in the saddle stitch unit"	294
4. "Examine stapler"	296
5. "READY (CHECK STAPLER)"	298
6. "Examine stapler in the saddle stitch unit"	299
7. "READY (CHECK SADDLE STITCH STAPLER)"	302
8. "READY (HOLE PUNCH DUST BIN IS FULL)"	303
9. "POWER FAILURE"	304
10. "Time for periodic maintenance"	305
11. "Check paper size setting on control panel for drawer N"	306
12. "Reboot the machine"	314
11.MAINTENANCE.....	315
1. Daily Inspection	316
2. Simple Troubleshooting	317
12.SPECIFICATIONS & OPTIONS	321
1. e-STUDIO520/600/720/850 Specifications	322
2. Specificatons of Options	326
3. Packing List.....	328
4. Copying Function Combination Matrix	329
• Combination Matrix 1/2.....	329
• Combination Matrix 2/2.....	330

Notice to Users

USE OF RECYCLED PAPER IN THE COPIER

As with all copiers and reproduction devices, the use of the appropriate paper ensures the best image quality of the copies and the machine's performance and reliability.

Because of the extreme variances in composition and quality of paper from various manufacturers, consumers should ensure the recycled paper they use is suitable for the copier. In accordance with the EPA Energy Star Program guidelines, Toshiba recommends the following recycled paper for use in the copier-

Great White MultiUse 20 paper
Great White MultiUse 24 paper

If you have any questions regarding the use of recycled paper in your copier, contact your authorized service technician.

FCC NOTICE

This equipment has been tested and found to comply with limits for a Class A digital device, pursuant to Part 15 and Part 18 of the FCC Rules. These limits are designed to provide reasonable protection against harmful interference when the equipment is operated in a commercial environment. This equipment generates, uses and can radiate radio frequency energy and, if not installed and used in accordance with the instruction manual, may cause harmful interference to radio communications. Operation of this equipment in a residential area is likely to cause harmful interference in which case the user will be required to correct the interference at his own expense.

WARNING:

Changes or modification made to this equipment, not expressly approved by Toshiba TEC or parties authorized by Toshiba TEC, could void the user's authority to operate the equipment.

This Class A digital apparatus complies with Canadian ICES-003.

Cet appareil numérique de la classe A est conforme à la norme NMB-003 du Canada.

User Safety

This Toshiba multifunctional digital systems does not produce laser radiation hazardous to the user. It is certified as a Class 1 laser product under the U.S Department of Health and Human Services (DHHS) Radiation Performance Standard according to the Radiation Control Health and Safety Act of 1968.

Protective housing and external covers completely confine the laser beam light emitted inside the multifunctional digital systems. The laser beam cannot escape from the machine during any phase of user operation.

Regulations implemented on August 2, 1976 by the Bureau of Radiological Health (BRH) of the U.S Food and Drug Administration apply to laser products manufactured from August 1, 1976. Laser products marketed in the United States must comply with these regulations.

Caution

Using controls or adjustments or performing procedures, other than those specified herein may result in hazardous radiation exposure.

TOSHIBA Quality is Second to None

e-STUDIO520/600/720/850 Toner Cartridges.

It is recommended that genuine TOSHIBA supplies and parts be used to obtain optimum results.

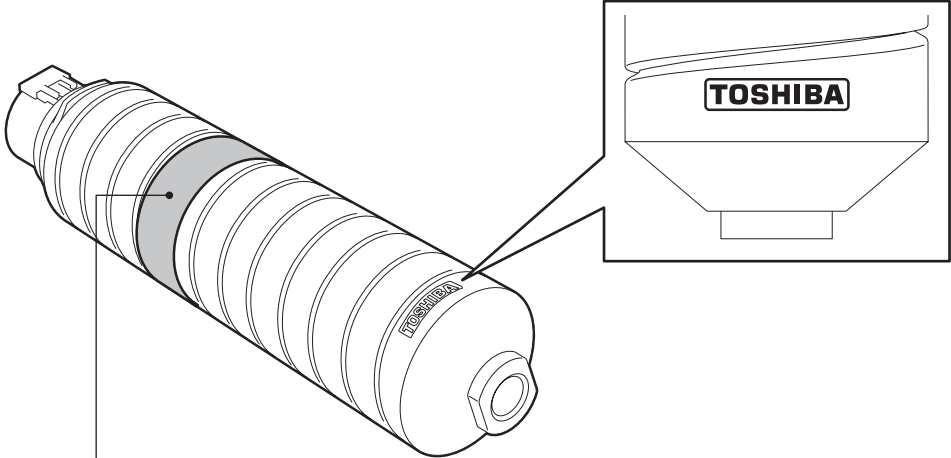

TOSHIBA

T-6000

NET 1350g

FOR e-STUDIO520/600/720/850

COMPONENTS: Polyester resin, Carbon black(1333-B6-4), Wax, Silica

ORIGINAL & GENUINE TOSHIBA TONER

- HANDLE WITH CARE.
- STORE IN A DRY PLACE BELOW 35°C(95° F).
- READ THE OPERATING INSTRUCTIONS OF THE MACHINE BEFORE USING.
- MANIPULER AVEC PRECAUTION.
- GARDER DANS UN ENDROIT SANS HUMIDITE OU LA TEMPERATURE AMBIANTE EST MOINS DE 35°C.
- LIRE LE MANUEL D'EMPLOI DE L'APPAREIL AVANT D'EN FAIRE USAGE.

TOSHIBA AMERICA BUSINESS SOLUTIONS, INC.
2 Music, Irvine, CA 92618-1631
(408) 462-9000

MADE IN U.S.A. / FABRIQUÉ AUX ÉTATS-UNIS

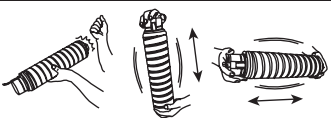

- SHAKE WELL BEFORE USING.
- TAP THE BOTTLE REPEATEDLY.
- AGITER AVANT EMPLOI.
- TAPER DE FACON REPETER SUR LA BOUTEILLE.

PAT.P.

Supplies / Parts

- **Dependability**
Genuine Toshiba supplies are subjected to the strictest of inspections so that every supply you receive will perform at optimal levels.
- **High Productivity**
Genuine Toshiba supplies are created to meet the demands of our competitive world and provide high-speed reliable trouble-free copies when you need them.
- **Stable Image Quality**
Genuine Toshiba supplies are designed to provide consistently stable image output.
- **Copier Kind**
Genuine Toshiba supplies are designed to keep the copier and all its parts in trouble-free working order.
Reduction of machine wear is due to Toshiba's intimate knowledge of the copier's characteristics ensuring the highest standard of care.
- **Machine Balance**
From the beginning Toshiba supplies and machines were made for each other. Whenever Toshiba designs a new machine, it also designs a new toner that is made just for that machine. By using Genuine Toshiba supplies with Toshiba copiers, you are guaranteed optimum performance.

Toner

- **Optimum image Quality**
Toshiba toner is manufactured using ultra-fine quality materials under precisely controlled conditions to ensure that your Toshiba copiers will continually generate sharp high-quality images.
- **Cost Advantage**
Genuine Toshiba toner provides value. Only the proper amount of toner is used during the reproduction process thereby enabling the machine to continue to operate until all the toner has been used. In this way you get the full value from each cartridge used.
- **Environmental Harmony**
Genuine Toshiba toner is manufactured with the environment in mind. To care for Mother Earth, we use embossed or plastic labels making our toner fully recyclable. In addition, harmful dust and ozone levels have been reduced to improve the working environment.
- **User Friendly**
Genuine Toshiba toner is people-friendly. Before approving our toners for sale, we test them to be sure that they pass the strictest of health standards. This takes the worry out of handling the toner.

General

- **ISO 9000 and ISO 14000**
Toshiba TEC toner plants are ISO 9001 and ISO 14001 certified. Our toners are of the highest quality and are environmental friendly.
- **Service and Support Benefits**
Toshiba's Service engineers are certified to keep your copier performing at optimum levels. To ensure continuous image quality, utilize an authorized Toshiba Service provider to care for and perform periodical maintenance on your copier.

Preface

Thank you for purchasing the Toshiba Multifunctional Digital Systems e-STUDIO520/600/720/850. This Operator's Manual describes the following:

- How to use the Multifunctional Digital Systems.
- How to inspect and carry out maintenance on the Multifunctional Digital Systems.
- How to remedy mechanical and copying problems.

Before using the Multifunctional Digital Systems, thoroughly read and understand this Operator's Manual. To ensure that clean copies are made at all times and to keep your Multifunctional Digital Systems in optimum working order, this Operator's Manual should be readily available for future reference.

To ensure correct and safe use of the Toshiba Multifunctional Digital Systems e-STUDIO520/600/720/850, this Operator's Manual describes safety precautions according to the following three levels of warning:

Before reading this Operator's Manual, you should fully understand the meaning and importance of these signal words.

- **Warning**
Indicates a potentially hazardous situation which, if not avoided, could result in death, serious injury, or serious damage, or fire in the equipment or surrounding assets.
- **Caution**
Indicates a potentially hazardous situation which, if not avoided, may result in minor or moderate injury, partial damage of the equipment or surrounding assets, or loss of data.
- **Note**
Indicates a procedure you should follow to ensure the optimal performance of the Multifunctional Digital Systems and problem-free copying.
- **Tip**
Describes handy information that is useful to know when operating the Multifunctional Digital Systems.

Features of the e-STUDIO520/600/720/850

The e-STUDIO600/720/850 is a multifunctional digital system which realizes a high-speed, high-image quality and higher performance. Its great variety of options, as well as the standard networking function, strongly supports your office work.

- The copy speed of the e-STUDIO520 is as fast as 52 copies per minute. The e-STUDIO600 has reached a copy speed of 60 copies per minute, the e-STUDIO720 has reached a copy speed of 72 copies per minute, and the e-STUDIO850 has reached 85 copies per minute. (When 1-sided LT landscape continuous copy is made in the non-sort mode without the Reversing Automatic Document Feeder being used.)
- The high-speed scanning of 71 sheets per minute (LT Landscape: 600 dpi) remarkably reduces working time.
- Availability of toner cartridge replacement during copying enhances its usability.
- Improved security-related features ensure users of the safe and pleasant working environment.
- The advanced e-BRIDGE features simplify the operation of multiple copy settings.
- The built-in wireless LAN unit and Bluetooth-compliant options are introduced to respond to user's wide-ranging needs.
- Toner remaining on the photoconductive drum can be recycled to reduce waste toner.
- The finisher for this high-speed equipment quickly finishes complex sorting or mass-copying.

General Precautions

When installing or moving

Warning

- This multifunctional digital systems requires 115 V, 20 A, 50/60 Hz electric power. Do not use a power supply with a voltage other than that specified. Avoid multiple connections in the same outlet. This could cause a fire or give you an electric shock. If you are considering increasing the number of outlets, contact an electrician.
- Always connect this multifunctional digital systems to an outlet with a ground connection to avoid the danger of fire or electric shock in case of short-circuiting. Contact your service representative for the details. Be sure to use a 3-conductor, grounded wall outlet. In areas, except U.S. and Canada, where a 2-pin plug is used, the multifunctional digital systems must be grounded for safety. Never ground it to a gas pipe, a water pipe, or any other object not suitable for grounding.
- Plug the power cord securely into the outlet. If it is not plugged in properly, it could heat up and cause a fire or give you an electric shock.
- Do not damage, break or attempt to repair the power cord. The following things should not be done to the power cord.
 - Twisting it
 - Bending it
 - Pulling it
 - Placing anything on it
 - Making it hot
 - Situating it near radiators or other heat sourcesThis could cause a fire or give you an electric shock. If the power cord is damaged, contact your service representative.
- When removing the plug from the outlet, do not pull the power cord. Always hold the plug when removing it from the outlet. If the power cord is pulled, the wires may become broken and this could cause a fire or give you an electric shock.
- Make sure that the ventilation holes are not blocked up. If the temperature within the multifunctional digital systems becomes too high, a fire could result.
- Do not move the multifunctional digital systems to another building, up and down the stairs or for any great distance. This could cause an injury or give you and electric shock. When lifting or moving the multifunctional digital systems, contact your service representative.
- Do not move the multifunctional digital systems with optional equipment, such as the finisher, attached. This could cause a fire or give you an electric shock. When lifting or moving the multifunctional digital systems, contact your service representative.
- When moving the multifunctional digital systems, be sure to shut down the power prior to pulling out the plug from the outlet. If the power cord is damaged, this could cause a fire or give you an electric shock.
- The socket outlet should be near the equipment and be easily accessible.
- Pull out the plug from the outlet more than once a year to clean around the prongs. Accumulating dust and dirt could cause a fire due to the heat released by electric leakage.

Caution

- Do not tilt the multifunctional digital systems more than 10 degrees when moving it. If it falls, this could result in personal injury.
- Avoid placing the multifunctional digital systems in a place unsuitable for its weight and also make sure the surface is level.
Remember that if the multifunctional digital systems falls over, serious injuries could result.
Weight of the multifunctional digital systems: approx. 463 lb.
- There are 4 adjusters (stoppers) at the bottom of the equipment (2 in the rear, 2 in the front). After moving/installing the equipment, be sure to turn and lower the adjusters, and then fix them firmly on the floor.

Before moving the equipment, turn and raise the adjusters.

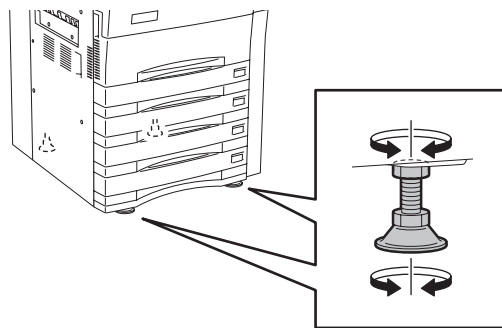

- When connecting the optional equipment and interface cable to the multifunctional digital systems, be sure to turn the power OFF. If the power is not turned off, you could get an electric shock. To turn the power OFF, see  P.30 "Shutdown".

Other points

- Make sure that there is enough space around the system to facilitate changing of parts, maintenance and clearing paper jam.
If there is insufficient space, some operations, such as bypass feeding, will become difficult and the multifunctional digital systems could even break down.

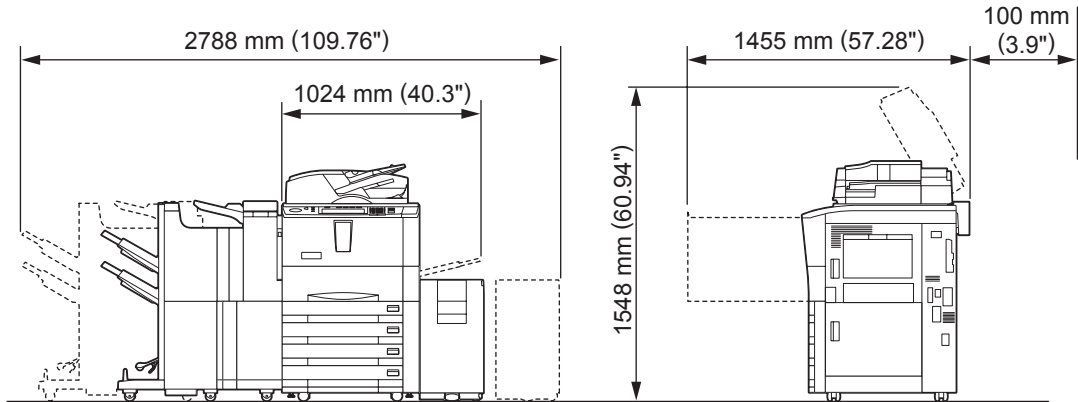

- Be sure to fix the power cable securely so that no one trips over it.
- Adverse environmental conditions may affect the safe operation and performance of the multifunctional digital systems, and the multifunctional digital systems could break down.
 - Avoid locations near windows or with exposure to direct sunlight.
 - Avoid locations with drastic temperature fluctuations.
 - Avoid too much dust.
 - Avoid location that suffer from vibration.
- Allow the air to flow freely and make sure there is a ventilator.
With inadequate ventilation, the unpleasant odor released by ozone will begin to dominate the atmosphere.

When using the multifunctional digital systems

Warning

- Do not place metallic objects or containers with water (flower vases, coffee cups, etc.) on or near the multifunctional digital systems. And keep paper clips and staples away from the air vent. This could cause a fire or give you an electric shock.
- If the multifunctional digital systems becomes excessively hot, smoke comes out of it or there is an odd smell or noise, proceed as follows.
Turn the main switch OFF and remove the plug from the outlet, then contact your service representative.
- If the multifunctional digital systems will not be used for more than one month, remove the plug from the outlet for safety purposes during that time.
This could cause a fire or give you an electric shock if an insulation failure occurs.

Caution

- Do not place heavy objects (9 lb. or more) on the original glass and do not press on it with force.
Breaking the glass could cause personal injury.
- Do not place heavy objects (9 lb. or more) on the multifunctional digital systems. If the objects fall off, this could cause injury.
- Do not remove or connect the plug with wet hands, as this could give you an electric shock.
- Do not touch the fuser unit and the metal area around it. Since they are very hot, you could be burned or the shock could cause you to get your hand injured in the machine.
- Be careful not to let your fingers be caught when closing the drawer.
This could injure you.
- Be careful not to let your fingers be caught between the equipment and the finisher (optional).
This could injure you.
- Do not touch the metal portion of the guide board in the automatic duplexer as it could burn you.

Position of Certification label, etc.

Explanatory label



Identification label

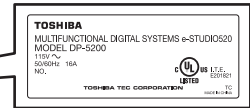

Certification label

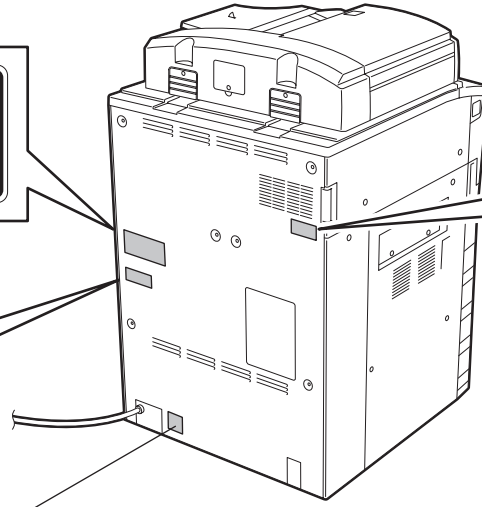

Warning for grounding wire

Warning label

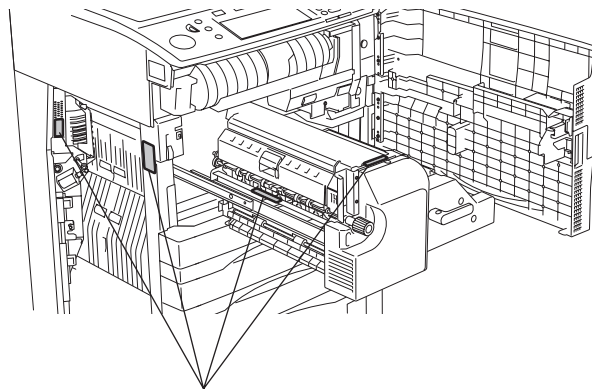
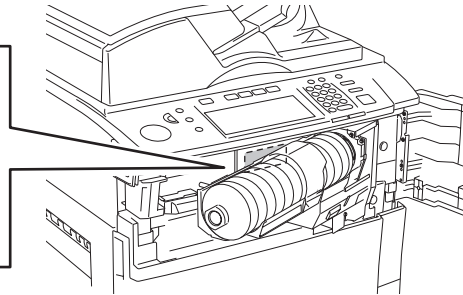

Warning for high temperature areas

Other points

- Be very careful to treat the touch panel gently and never hit it. Breaking the surface could cause malfunctions.
- Do not turn the power OFF with jammed paper left inside the multifunctional digital systems. This could cause malfunctions when the main switch is turned ON next time. To turn the power OFF, see  P.30 "Shutdown".

During maintenance or inspection

Warning

- Never attempt to repair, disassemble or modify the multifunctional digital systems by yourself. You could cause a fire or get an electric shock.
Always contact your Service representative for maintenance or repair of the internal parts of the multifunctional digital systems.
- Always keep the plug and outlet clean. Prevent them from accumulating dust and dirt. This could cause a fire and give you an electric shock due to the heat released by electric leakage.
- Do not let liquids such as water and oil get into the system when cleaning the floor. This could cause a fire and give you an electric shock.

Caution

- Do not touch the stapling area. The actual needle point could cause you personal injury.
Saddle Stitch Finisher (optional) 📖 P.299
Finisher (optional) 📖 P.296

Other points

- Do not use such solvents as thinner or alcohol when cleaning the surface of the multifunctional digital systems.
 - This could warp the shape of the surface or leave it discolored.
 - When using a chemical cleaning pad to clean it, pay attention to any cautionary points.

When handling supplies

Caution

- Never attempt to incinerate toner cartridges. This could cause an explosion. Do not dispose of used toner cartridges. Your service technician will collect them. (📖 P.264 “3.Toner-Related Symbols”)

Disclaimer Notice

The following notice sets out the exclusions and limitations of liability of TOSHIBA TEC CORPORATION (including its employees, agents and sub-contractors) to any purchaser or user ('User') of the e-STUDIO520/600/720/850, including its accessories, options and bundled software ('Product').

1. The exclusion and limitations of liability referred to in this notice shall be effective to the fullest extent permissible at law. For the avoidance of doubt, nothing in this notice shall be taken to exclude or limit TOSHIBA TEC CORPORATION's liability for death or personal injury caused by TOSHIBA TEC CORPORATION's negligence or TOSHIBA TEC CORPORATION's fraudulent misrepresentation.
2. All warranties, conditions and other terms implied by law are, to the fullest extent permitted by law, excluded and no such implied warranties are given or apply in relation to the Products.
3. TOSHIBA TEC CORPORATION shall not be liable for any loss, cost, expense, claim or damage whatsoever caused by any of the following:
 - use or handling of the Product otherwise than in accordance with the manuals, including but not limited to Operator's Manual, User's Guide, and/or incorrect or careless handling or use of the Product;
 - any cause which prevents the Product from operating or functioning correctly which arises from or is attributable to either acts, omissions, events or accidents beyond the reasonable control of TOSHIBA TEC CORPORATION including without limitation acts of God, war, riot, civil commotion, malicious or deliberate damage, fire, flood, or storm, natural calamity, earthquakes, abnormal voltage or other disasters;
 - additions, modifications, disassembly, transportation, or repairs by any person other than service technicians authorized by TOSHIBA TEC CORPORATION; or
 - use of paper, supplies or parts other than those recommended by TOSHIBA TEC CORPORATION.
4. Subject to paragraph 1, TOSHIBA TEC CORPORATION shall not be liable to Customer for:
 - loss of profits; loss of sales or turnover; loss of or damage to reputation; loss of production; loss of anticipated savings; loss of goodwill or business opportunities; loss of customers; loss of, or loss of use of, any software or data; loss under or in relation to any contract; or
 - any special, incidental, consequential or indirect loss or damage, costs, expenses, financial loss or claims for consequential compensation;

whatsoever and howsoever caused which arise out of or in connection with the Product or the use or handling of the Product even if TOSHIBA TEC CORPORATION is advised of the possibility of such damages.

TOSHIBA TEC CORPORATION shall not be liable for any loss, cost, expense, claim or damage caused by any inability to use (including, but not limited to failure, malfunction, hang-up, virus infection or other problems) which arises from use of the Product with hardware, goods or software which TOSHIBA TEC CORPORATION has not directly or indirectly supplied

1. BEFORE USING EQUIPMENT

1. Description of Each Component	20
• Main components	20
• Configuration of options	21
• Control panel	23
• Touch panel	25
2. Turning Power On / Shutdown	29
• Turning power on	29
• Shutdown	30
3. Energy Saving Mode	33
4. Setting Copy Paper	34
• About the “width” and the “length” of the original and the copy paper	34
• Copy paper types and sizes	35
• Toshiba-recommended paper / Handling and storing paper	36
• Setting copy paper (size change) / Setting the drawer for special uses	37
• Changing the setting of paper size	40

1. Description of Each Component

Main components

1

1. Touch panel contrast adjustment volume
2. Toner cover
3. Front cover
4. Drawers
5. Reversing Automatic Document Feeder (RADF)
6. Operator's Manual pocket (Back side)
7. Bypass cover
8. Bypass tray
9. Paper feed cover
10. Paper size indicator
11. Original cover
12. Original scale
13. Scanning area
14. Power switch
15. Toner cartridge
16. Exit cover
17. Original glass
18. Touch panel
19. Control panel
20. Toner cartridge holder
21. Transfer/Transport unit

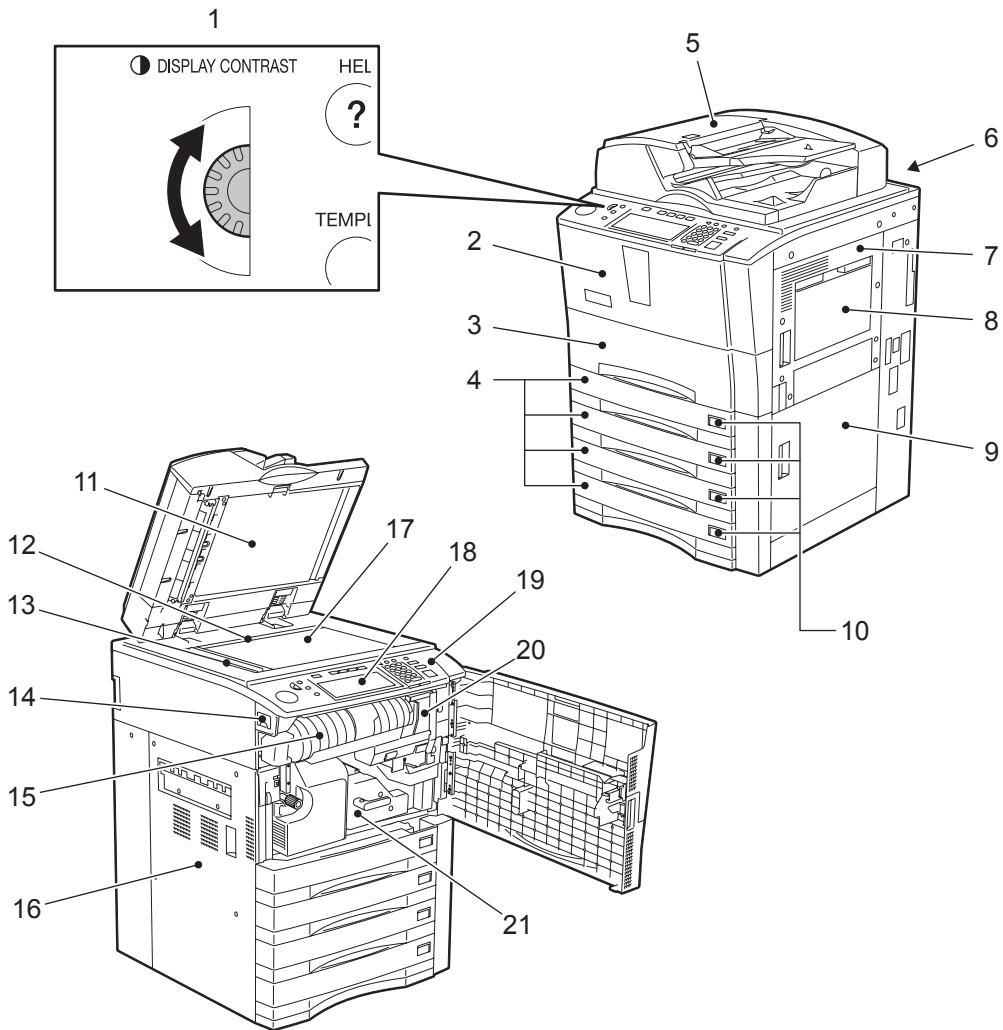

Configuration of options

1

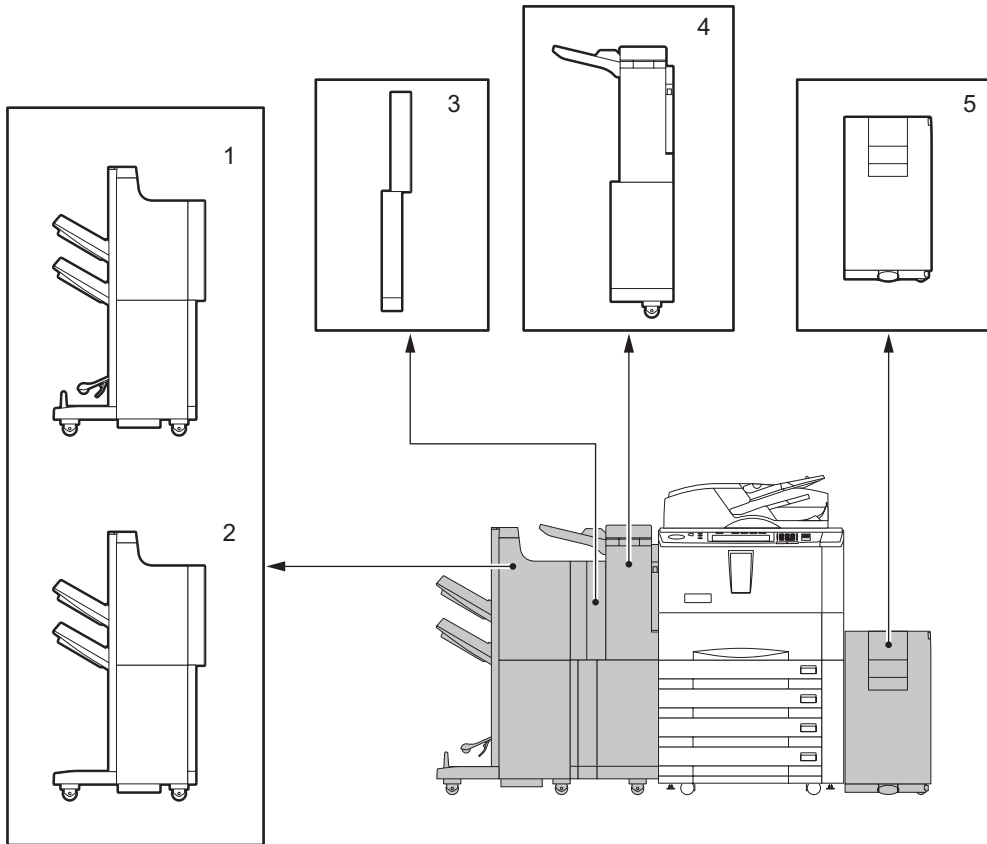

1. **Saddle Stitch Finisher**

This finisher enables saddle stitching, in addition to sort/group finishing and stapling. (The Hole Punch Unit and the Inserter sold separately are installable to this finisher.)

2. **Finisher**

This finisher enables sort/group finishing and stapling. (The Hole Punch Unit and the Inserter sold separately are installable to this finisher.)

3. **Hole Punch Unit**

This unit enables you to punch holes on printouts.

4. **Inserter Unit**

This unit enables you to insert a sheet of paper which does not need to be copied. An already copied sheet, as well as a blank sheet, can be inserted. This inserter is also usable for single finishing operation without copying, such as stapling or hole-punching.

5. **External Large Capacity Feeder**

This feeder enables you to feed LT paper up to 4000 sheets (20 lb. Bond). Thick paper (- 110 lb. Index) can also be set in this feeder.

1

Other options available are as follows. Contact your service technician or Toshiba product distributors for details.

FAX Unit

Printer Kit

Printer/Scanner Kit

Scanner Kit

Data Overwrite Kit

Scrambler Board

Parallel Board

PCI Slot

Wireless LAN Module

Bluetooth Module

Antenna

Finisher Guide Rail

Control panel

Use the buttons on the control panel for various operations and settings through the equipment.

1

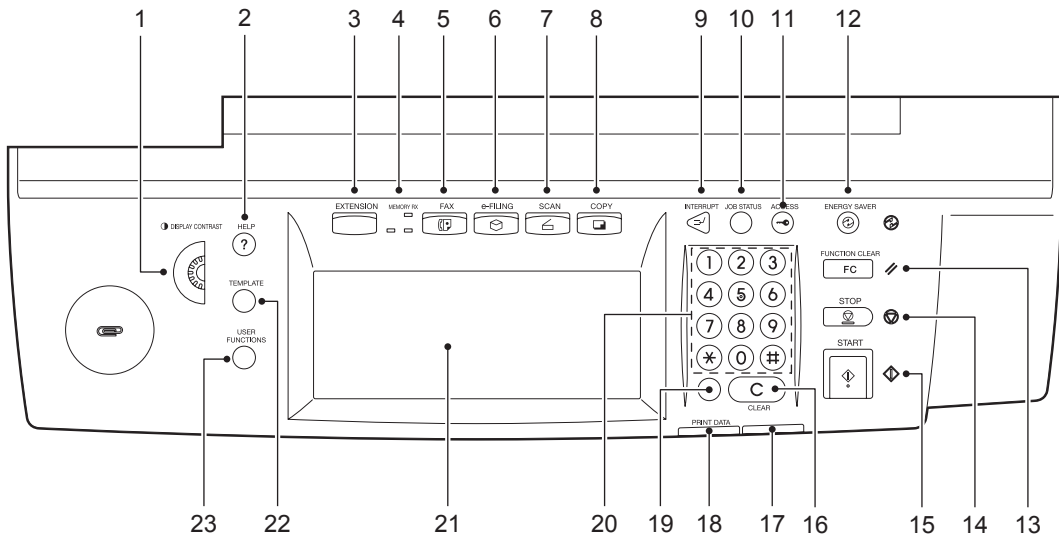

1. **Touch panel contrast adjustment volume**

Adjust the contrast of the touch panel with this volume.

2. **[HELP] button**

Use this button to display a desired operation procedure.

3. **[EXTENSION] button**

Any operation with this button is invalid at present. This button is to extend functions in the future.

4. **MEMORY RX / FAX communication lamps**

These lamps show the status of FAX data reception and FAX communication.

5. **[FAX] button**

Use this button to use the FAX / Internet FAX function.

6. **[e-FILING] button**

Use this button to access saved image data.

7. **[SCAN] button**

Use this button to use the scanning function.

8. **[COPY] button**

Use this button to use the copier function.

9. **[INTERRUPT] button**

Use this button to interrupt the copy job in process and perform another one. The interrupted job is resumed by your pressing this button again.

10. **[JOB STATUS] button**

Use this button to confirm each job status, printing status, and FAX transmission/reception status of a print job, scan job and FAX job. (P.224 "1.Job Status")

11. **[ACCESS] button**

Use this button when the department code has been set. If this button is pressed after copying, the next user cannot use the copier function without keying in the registered department code. See the User Functions Guide for the department management.

12. **[ENERGY SAVER] button**

Use this button when you want to shut down the equipment or when you want the equipment enter into the energy saving mode. When you press this button, the menu for the energy saving mode appears. Press the [SLEEP] button on this menu to enter into the energy saving mode and press the [SHUT-DOWN] button to shut down the equipment.

13. **[FUNCTION CLEAR] button**

When this button is pressed, all selected functions are cleared and returned to the default settings.

14. **[STOP] button**

Use this button to stop any scanning and copying operations in progress.

15. **[START] button**

Use this button to start copying, scanning and FAX operations.

16. **[CLEAR] button**

Use this button to correct numbers keyed in, such as the copy quantity.

17. **ERROR lamp**

This lamp lights when an error occurs and the equipment needs some actions to be taken.

18. **PRINT DATA lamp**

This lamp lights when print data are being received.

19. **[MONITOR/PAUSE] button**

Use this button only when a FAX Unit (optional) is installed. (See the [Operator's Manual for Facsimile Function] for details.)

20. **Digital keys**

Use these keys to enter any numbers such as the copy quantity.

21. **Touch panel**

Use this panel for the various settings of each function of the copier, scanner and FAX. This panel also indicates the status of the equipment, such as when you run out of paper or there is a paper jam.

22. **[TEMPLATE] button**

Use this button to store and recall frequently used copy, scan, and FAX settings.

23. **[USER FUNCTIONS] button**

Use this button for paper size or media type setting of drawers, and registration of the copy, scan and FAX settings (including a default setting change.) See the User Functions Guide for the functions enabled by this button.

Touch panel

When the power is turned on, the basic menu for the copier function appears on this touch panel. The status of the equipment is also displayed on the touch panel with messages and illustrations.

1

1. Message
2. Reproduction ratio
3. Total copy quantity
4. Currently selected drawer size
5. Remaining paper level
6. Date and time
7. Set functions confirmation ([SETTINGS]) button
8. Finisher button
9. Enlargement/Reduction ([Zoom...]) button
10. Original mode button
11. Density adjustment buttons
12. Simplex / duplex button
13. Paper source selection buttons
14. Equipment status indication area
15. Function setting area
16. Index buttons

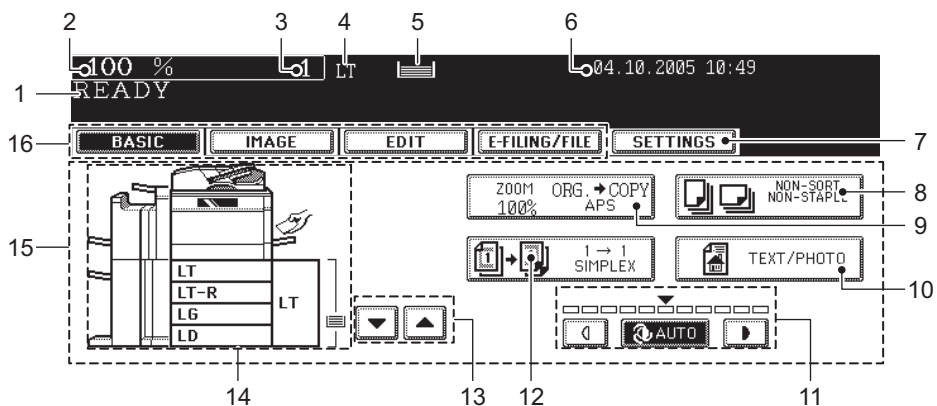

Message display

The following information appears at the top of the touch panel:

Equipment status, operational instructions, cautionary messages, reproduction ratios, total copy quantity, paper size of a selected drawer, amount of paper in a selected drawer and date and time.

Touch-buttons

Press these buttons on the touch panel lightly to set various functions.

Index buttons

Press these buttons to switch menus. The type and number of the index buttons vary depending on the function of the copier, scanner and e-Filing.

Function setting area

This area includes buttons for selecting and setting each function.

Setting functions confirmation ([SETTINGS] button)

Press this button to confirm currently set functions.
(An example is shown below.)



Buttons appearing on the various menus are as follows (some buttons may not appear on the menu):

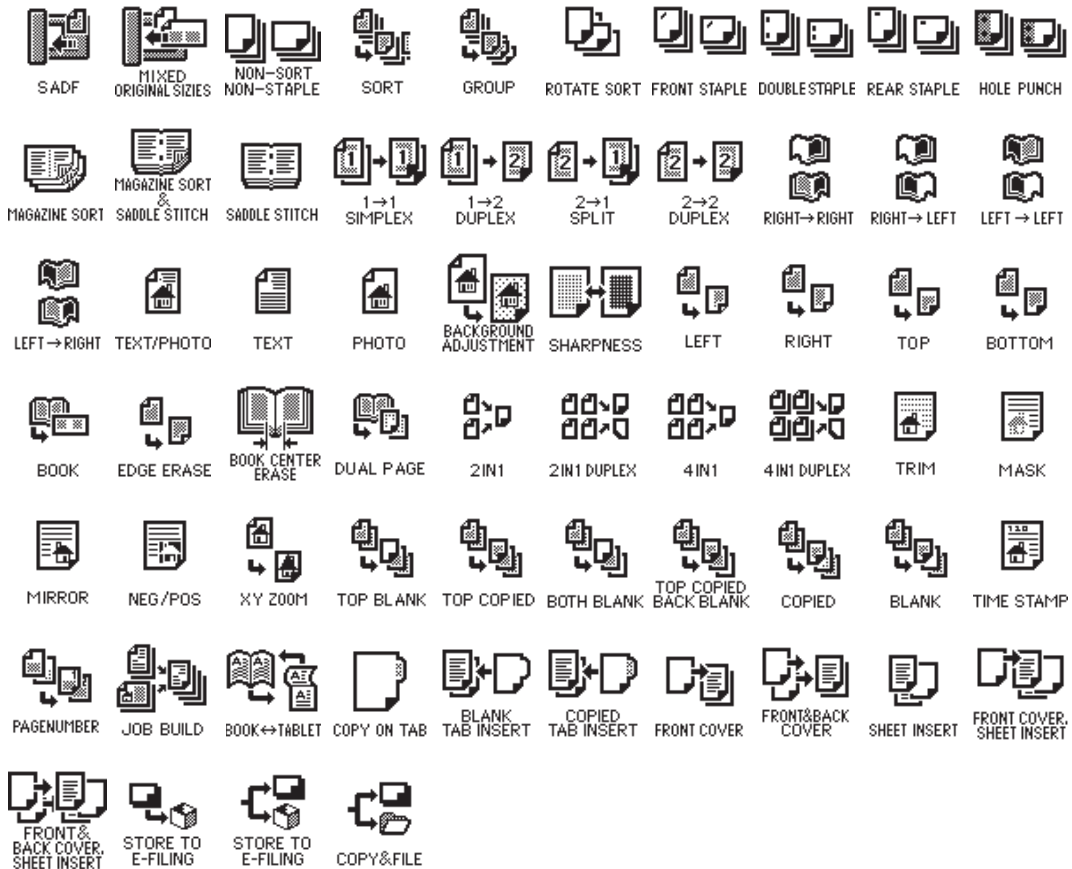

Clearing functions selected

When you press the selected button, the function which has been selected is cleared. Or the selected setting is cleared automatically by the automatic function clear* when the equipment has been left inactive for a specified period of time.

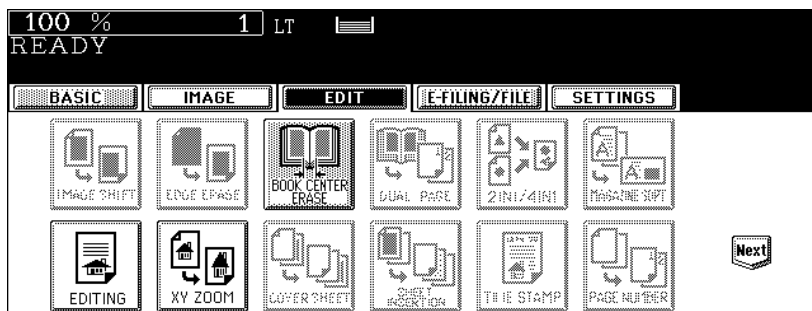

* Automatic function clear:

This function works when a specified period of time has passed since the last paper exit or the last entry of any button. This function returns all the function settings to default without the need to press the [FUNCTION CLEAR] button. When the department management function is being used, the display returns to the department code input menu. When this function is not being used, the display returns to the basic menu of the copier function.

The period for the automatic function clear is set at 45 seconds by default at the time of installation of the equipment. See the User Functions Guide for change of this setting.

Adjusting the contrast of the touch panel

Turn this adjustment volume on the left side of the control panel to adjust the contrast of the touch panel.

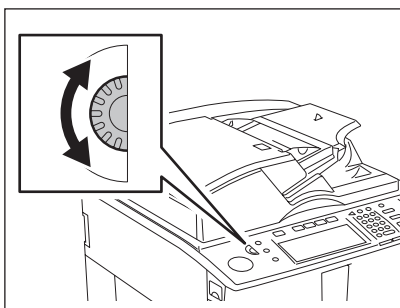

1

Setting letters

The following menu appears when any letter entry is required for the operations of scanning, e-Filing, template and Internet FAX.

Use the buttons on the touch panel for letter entry and use the digital keys on the control panel for number entry.

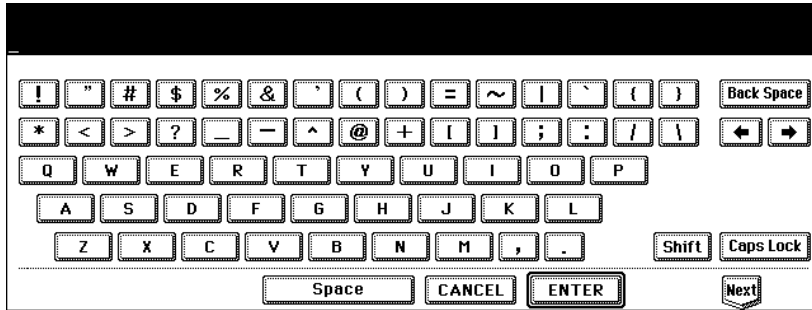

The following buttons are used for letter entry.

- [Space]: Press this to enter a space.
- [Cancel]: Press this to cancel the entry of letters.
- [ENTER]: Press this to fix all entered letters.
- [Back Space]: Press this to delete the letter before the cursor.
- [←][→]: Press them to move the cursor.
- [Shift]: Press this to enter capital letters.
- [Caps Lock]: Press this to switch capital letters and small letters.
- [Next]: Press this to access the special keys.

2. Turning Power On / Shutdown

Turning power on

Open the switch cover, and then turn the power switch on.

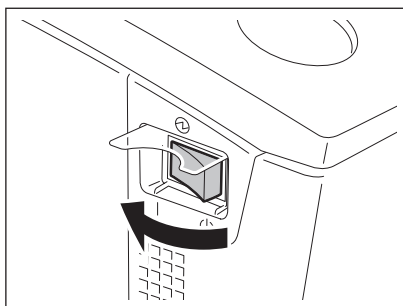

1

- The equipment starts warming-up. “Wait Warming Up” appears during warming-up.
- While the equipment is warming up, you can use the auto job start function. (P.59 “3.Auto Job Start (Job Preset)”)

The equipment will be ready for copying after about 130 seconds and “READY” appears.

When controlling use of equipment with department codes

You can restrict users or manage copy volumes made by an individual group or department in your company using the department codes. When the copy volume is controlled under the department code, enter the code after turning the power on. See the User Functions Guide for setting and registration of the department codes.

When the power is turned on, the following menu appears.

- This menu also appears when the [ACCESS] button is pressed or the automatic function clear has worked.

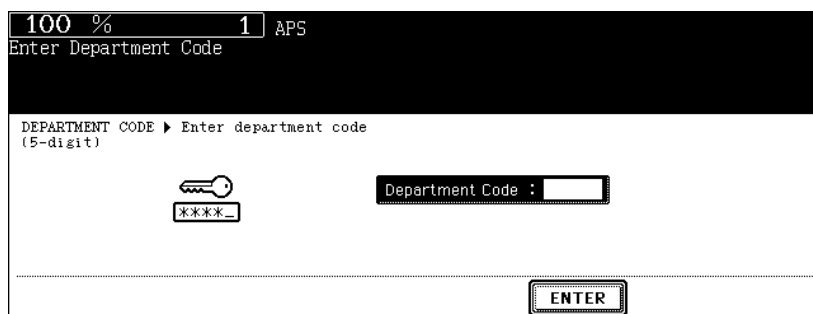

Key in a registered department code (5 digits). The equipment will be ready for copying.

- If the department code keyed in is incorrect, the menu does not change. In this case, press the [FUNCTION CLEAR] button and then key in the correct code.

When copying is finished

When you finish all operations, press the [ACCESS] button to prevent unauthorized use of the equipment. The display returns to the department code input menu.

Shutdown

1

Be sure to shut down the equipment following the procedure below. Do not turn the power off by pressing the power switch, otherwise the hard disk may be damaged. Be sure to confirm the following three points before shutdown.

- No jobs should be left in the print job list. (P.224 “1.Job Status”)
- None of the PRINT DATA, MEMORY RX and FAX communication lamps should be blinking. (If the equipment is shut down while any of the above lamps is blinking, jobs in progress such as FAX reception will be aborted.)
- No PC should access the equipment via the network.

1 Press the [USER FUNCTIONS] button on the control panel.

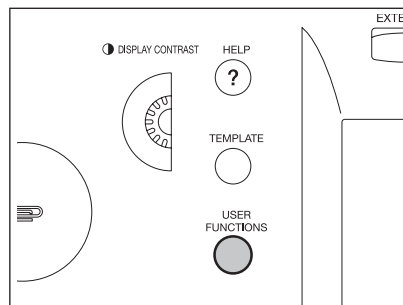

2 Press the [USER] button on the touch panel to enter the user setting menu, and then press the [SHUTDOWN] button.

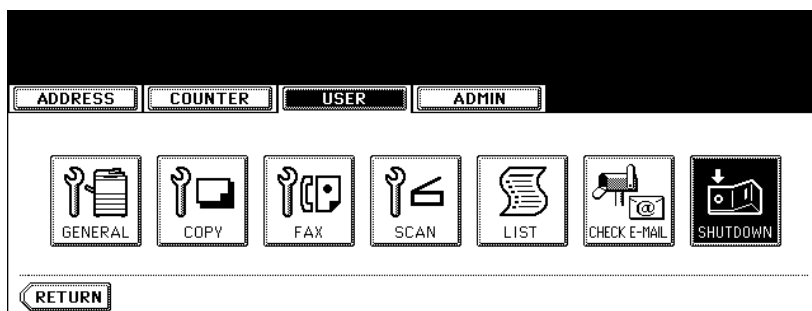

3 “Processing job will be deleted. Are you sure you want to shutdown?” appears on the menu. Press the [YES] button.

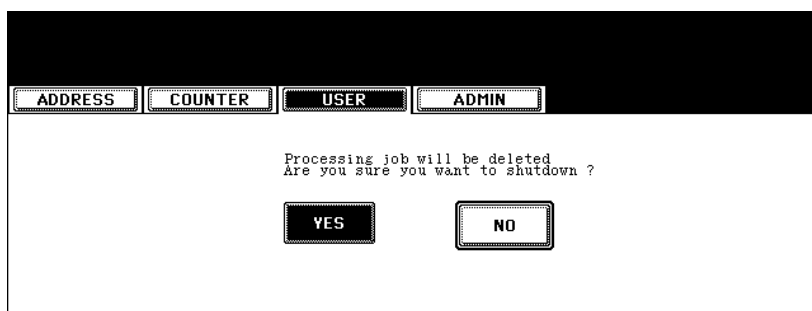

- To cancel the shutdown operation, press the [NO] button.

- 4** “Shutdown in progress” appears on the menu. After a while, the equipment is shut down.

1

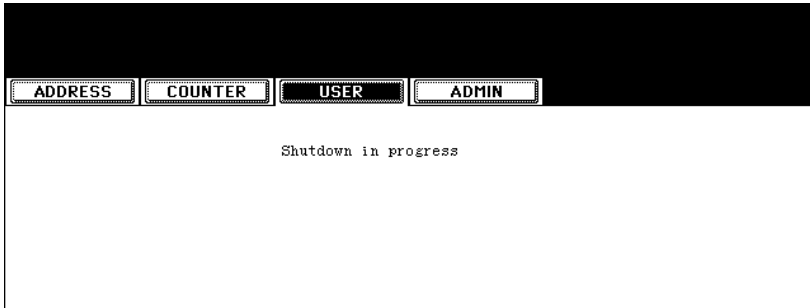

- The power switch automatically returns to the OFF position.

Shutting down with the [ENERGY SAVER] button

The equipment can also be shut down by following the procedure below.

- 1** Press the [ENERGY SAVER] button on the control panel.

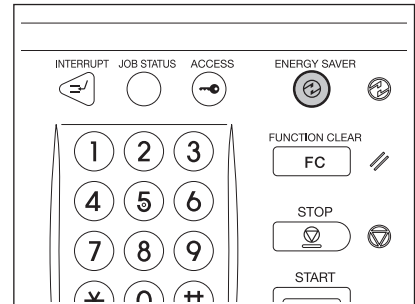

- 2** Press the [SHUTDOWN] button on the touch panel.

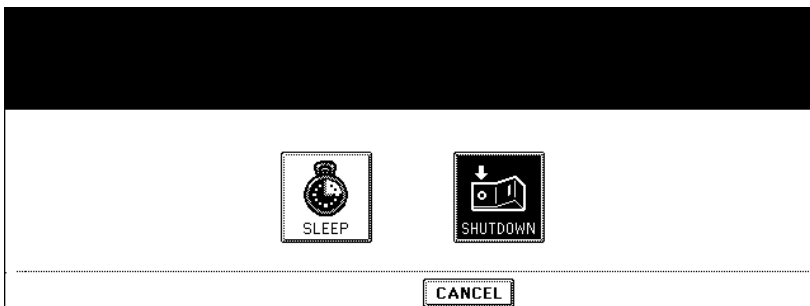

- To cancel the shutdown operation, press the [CANCEL] button.

1

3 “Shutdown in progress” appears on the menu. After a while, the equipment is shut down.

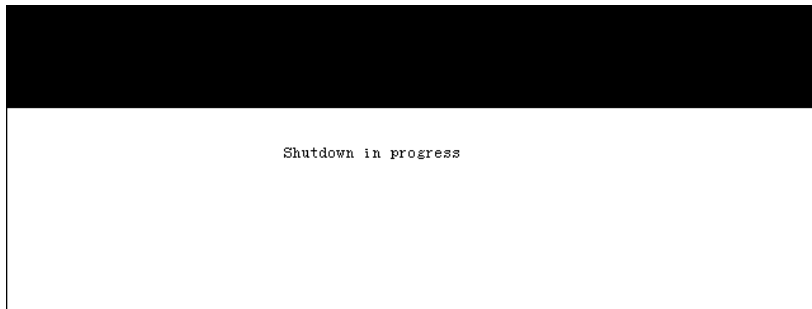

- The power switch automatically returns to the OFF position.

3. Energy Saving Mode

This equipment is designed to enter into the energy saving mode automatically to lower its power consumption when a specified period of time has passed since the last use of the equipment (=automatic energy saving mode). In this mode, "Saving energy - press START button" appears. Then after a certain period of time, the display on the touch panel disappears and the [ENERGY SAVER] button lights in green. This mode is automatically cleared upon reception of printer data, a FAX, Internet FAX or e-mail. The period to enter into the energy saving mode is set at 15 minutes by default at the time of installation of the equipment. See the User Functions Guide for change of this setting.

The equipment can also be made to enter the energy saving mode manually by means of the following procedure.

1 Press the [ENERGY SAVER] button on the control panel.

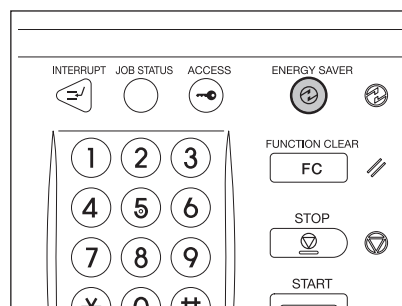

2 Press the [SLEEP] button on the touch panel.

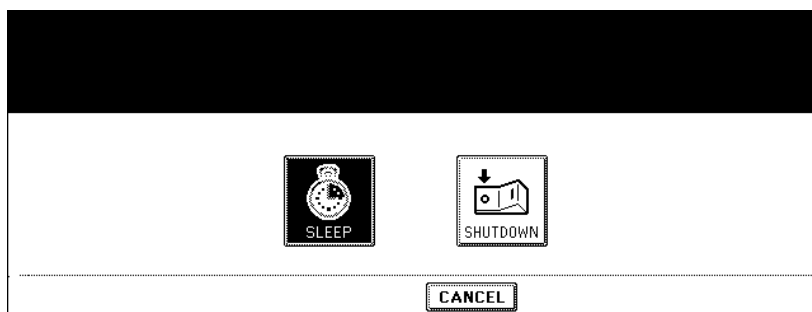

- The equipment enters into the energy saving mode. During this mode, the display on the touch panel disappears and the [ENERGY SAVER] button lights in green.

To canceling the energy saving mode

Press the [ENERGY SAVER] button on the control panel again. The energy saving mode is cleared and the equipment will be ready for copying.

The energy saving mode is also cleared by pressing any button of [COPY], [SCAN], [FAX], [e-FILING] and [START].

- The [SCAN] button is enabled only when the Printer/Scanner Kit or the Scanner Kit (both optional) is installed.
- The [FAX] button is enabled only when any of the FAX Unit, Printer/Scanner Kit and Scanner Kit (all optional) is installed.

4. Setting Copy Paper

About the “width” and the “length” of the original and the copy paper

1

Originals and copy paper whose size is LT can be set in both portrait and landscape directions. In the size descriptions of original and copy paper throughout this manual, “A” in the figure below is called “length” and “B” is called “width”. (In the figure below, the operator is standing in front of the equipment.)

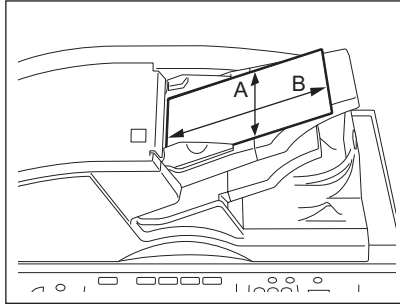

When “B” is shorter than “A”, it is called “placing the original in a portrait direction.”

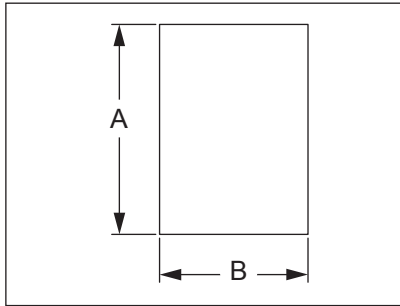

When “B” is longer than “A”, it is called “placing the original in a landscape direction.”

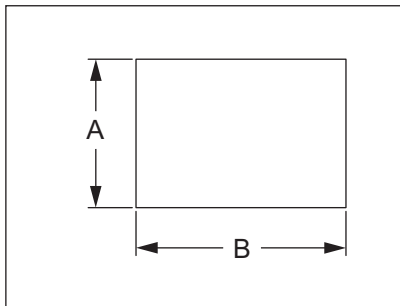

In this manual, when an original or copy paper which can be set in both in portrait and landscape directions is placed horizontally, its paper size is identified by adding “-R” at the end. (e.g. “LT-R”)

Copy paper types and sizes

Feeder	Paper type	Paper size	Maximum sheet capacity
Drawers	Plain paper (16 - 20 lb. Bond)	(Standard size) LT format: LD, LG, LT, LT-R, ST-R, COMP, 13"LG, 8.5"SQ	550 sheets (17 lb. Bond) 500 sheets (20 lb. Bond)
	Thick 1 (- 28 lb. Bond)	A/B format: A3, A4, A4-R, A5-R, B4, B5, B5-R, FOLIO	400 sheets
	Thick 2 (- 90 lb. Index)	K format: 8K, 16K, 16K-R	200 sheets
	Thick 3 (- 110 lb. Index)	(Standard size) LT, A4	150 sheets
	Tab paper		The tab paper can be set in any one drawer and the bypass tray except Large Capacity Feeder. (The recommendation is to set in the 2nd drawer.) ^{*1}
External Large Capacity Feeder (optional)	Plain paper (16 - 20 lb. Bond)	(Standard size) LT, A4	4500 sheets (17 lb. Bond) 4000 sheets (20 lb. Bond)
	Thick 1 (- 28 lb. Bond)		3500 sheets
	Thick 2 (- 90 lb. Index)		2000 sheets
	Thick 3 (- 110 lb. Index)		1500 sheets
Bypass tray	Plain paper (16 - 20 lb. Bond)	(Standard size) LT format: LD, LG, LT, LT-R, ST-R, COMP, 13"LG, 8.5"SQ	100 sheets (17 lb. Bond) 100 sheets (20 lb. Bond)
	Thick 1 (- 28 lb. Bond)	A/B format: A3, A4, A4-R, A5-R, B4, B5, B5-R, FOLIO	80 sheets (- 28 lb. Bond)
	Thick 2 (- 90 lb. Index)	K format: 8K, 16K, 16K-R	40 sheets (- 90 lb. Index)
	Thick 3 (- 110 lb. Index)	(Non-Standard size) Length: 3.9-11.7", Width: 5.8-17"	30 sheets (- 110 lb. Index)
	Tracing paper (20 lb. Bond only)		^{*1}
	Sticker labels		^{*2}
	Tab paper	(Standard size) LT, A4	^{*1}
	OHP film	(Standard size) LT only	30 sheets ^{*1}

^{*1} Automatic duplex copying is not available.

^{*2} Use Thick 2 mode for sticker labels.

- Multiple paper sizes cannot be set in one drawer.
- "Maximum Sheet Capacity" refers to the maximum number of sheets when Toshiba-recommended paper is set.
- "K format" is a Chinese standard size.

Abbreviations for paper sizes:

LT: Letter, LD: Ledger, LG: Legal, ST: Statement, COMP: Computer, SQ: Square

Toshiba-recommended paper / Handling and storing paper

1

Recommended paper

To make copies with a fine image, the following types of paper are recommended.
If you wish to use copy paper other than the recommended types, consult your service technician.

Paper type	Toshiba recommendations/Manufacturer	Mode	
Plain paper	TIDAL/Hammermill (20 lb. Bond)	PLAIN	
Thick	Laser/Hammermill	(24 lb. Bond)	THICK1
		(32 lb. Bond)	THICK2
	Exact Index/WAUSAU	(90 lb. Index)	THICK2
		(110 lb. Index)	THICK3
Tab paper	CopyTabs/Blanks USA	TAB	
Tracing paper	Tracing Paper/Ostrich International (20 lb. Bond only)	PLAIN	
Sticker labels	5165/Avery	THICK3	
OHP film *	PP2500L/3M	OHP FILM	
	X-10.0/Folex	OHP FILM	

* Only Toshiba-recommended OHP film should be used. Using any other film may cause a malfunction.

Handling and storing paper

Pay attention to the following points:

- Avoid using paper that is specially treated or previously printed on another machine, and also avoid performing double copying on the same side of the paper, since this may cause a malfunction.
- Do not use paper with creases, wrinkles or curls, paper prone to curling, smooth or tough paper; this may cause paper misfeeds.
- Paper should be wrapped in its wrapping and stored in a damp-free place.
- To prevent paper from being folded or bent, store it evenly on a flat surface.

Setting copy paper (size change) / Setting the drawer for special uses

When you set or add copy paper in the drawer, follow the procedure below.

1

Placing paper in the drawer

- 1 Turn the power on.
- 2 Pull out the drawer carefully until it comes to a stop.

A: Slide rail

- Be careful not to touch the slide rail of the drawer.

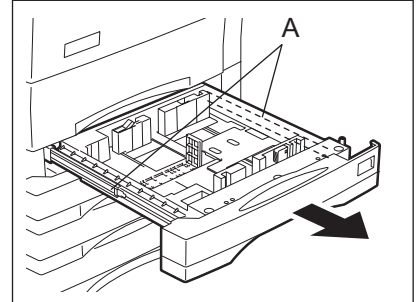

- 3 Push the lower part of the end guide in the direction of the arrow to remove it, then reinstall it at the desired paper size (indicated on the bottom inner surface on the drawer).

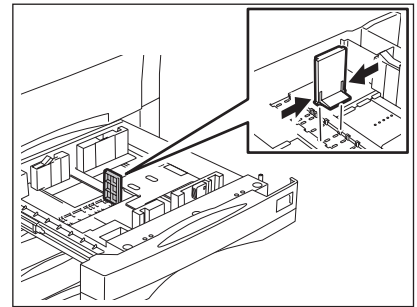

- 4 Push the arrow part (right side) of the side guide to unlock it.

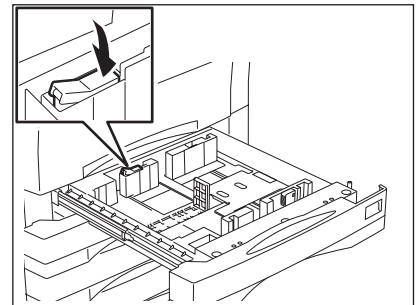

1

5 While pushing the green lever of the side guide in the direction of the arrow, set the side guide to the desired paper size.

- Adjust the side guides with both hands.

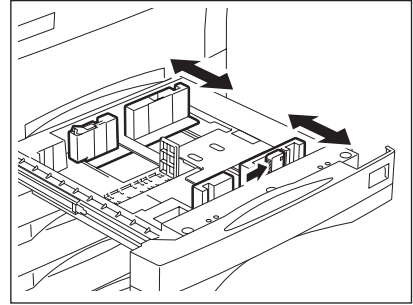

6 Push the arrow part (left side) to lock the side guide.

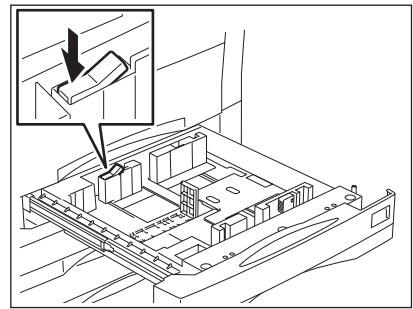

7 Place paper in the drawer(s).

- Place paper with its copy side down. (The copy side may be described on the wrapping paper.)
- For the maximum number of sheets that can be set, see P.35 "Copy paper types and sizes".
- Fan the paper well before placing it in the drawer.
- Be sure that the paper height does not exceed the line indicated inside of the guide.
- Do not use creased, folded, wrinkled or damp sheets of paper.

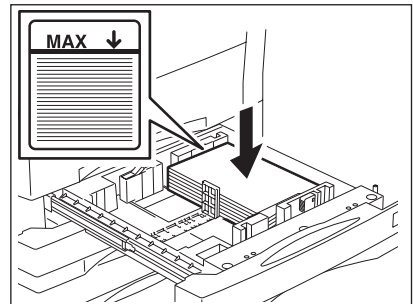

Note

Make sure that a gap of 0.02" (0.04" or less in total) is left between the paper and the side guide for plain paper, and approx. 0.02" to 0.04" (approx. 0.04" to 0.08" in total) for thick paper. If the gap is insufficient, it could cause paper misfeeding.

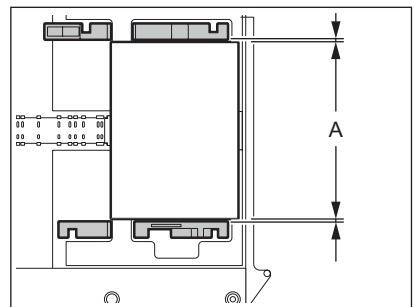

- 8** When the paper size is different from the one in the drawer, change the paper size indicator to match with the size of paper which has been set.

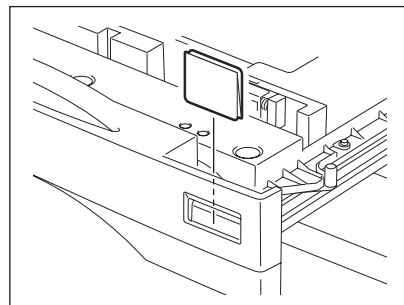

- 9** Push the drawer straight into the equipment until it comes to a stop.
- Be sure to close the drawer securely and carefully.

Caution

Be careful not to let your fingers be caught when closing the drawer. This could injure you.

- 10** When the paper size is different from the one in the drawer, press the [YES] button. When the paper is the same size as the one in the drawer, press the [NO] button.

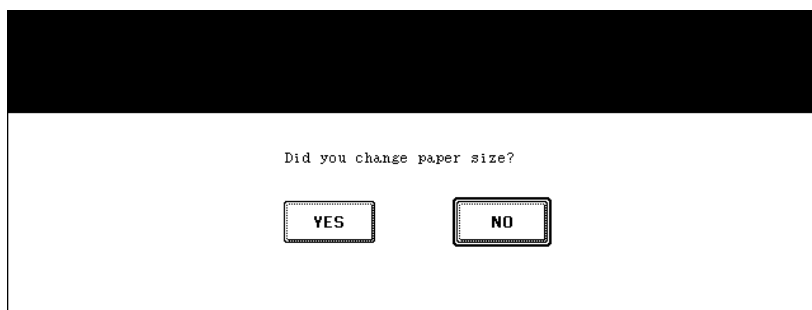

- When setting the same size of paper, step 11 is not necessary.

- 11** Press the paper size button corresponding to the paper that has been set, and then press the [ENTER] button.

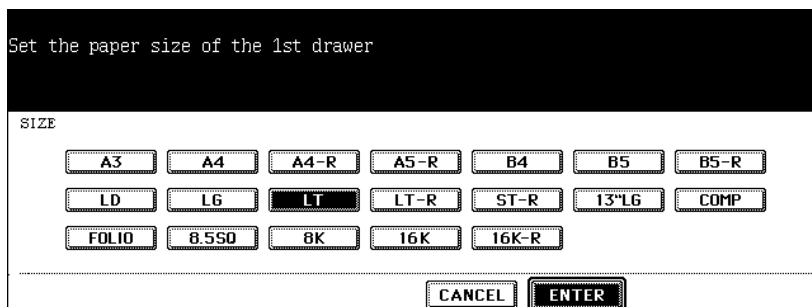

Changing the setting of paper size

1

If the setting of the paper size registered in the equipment does not correspond to the one in the drawer, it could cause a paper jam. In this case, replace the paper corresponding to the setting of the paper size (P.37 “Placing paper in the drawer”), or change the setting of the paper size according to the following procedure.

- 1 Press the [USER FUNCTIONS] button on the control panel.

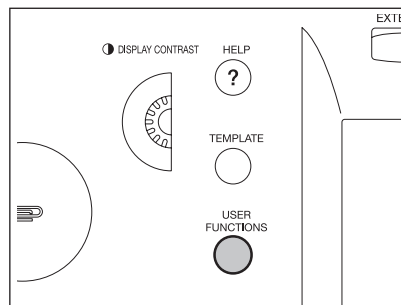

- 2 Press the [USER] button on the touch panel to enter the user setting menu, then press the [GENERAL] button.

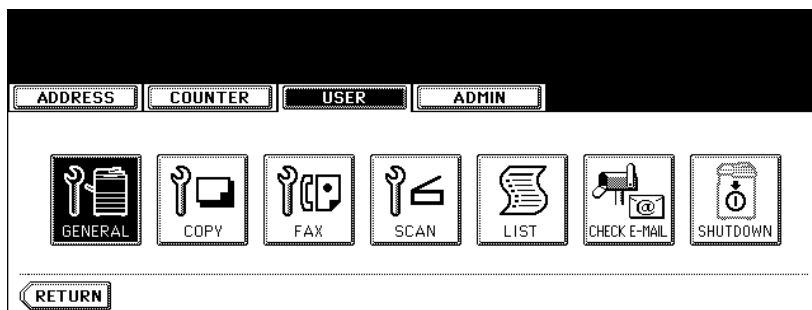

- 3 Press the [DRAWER] button on the touch panel.

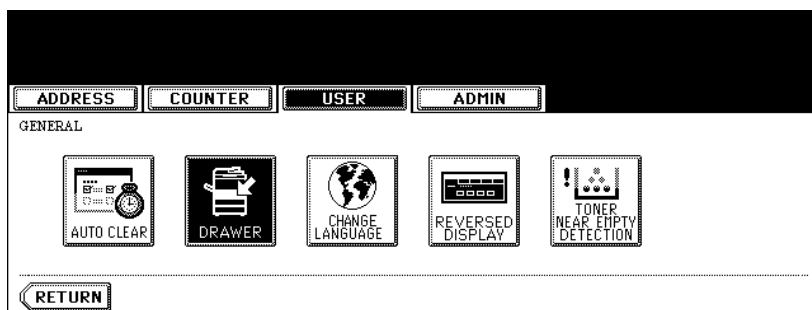

- 4** Press the drawer on the touch panel corresponding to the one in which the paper size has been set, and then press the button indicating the new one.

1

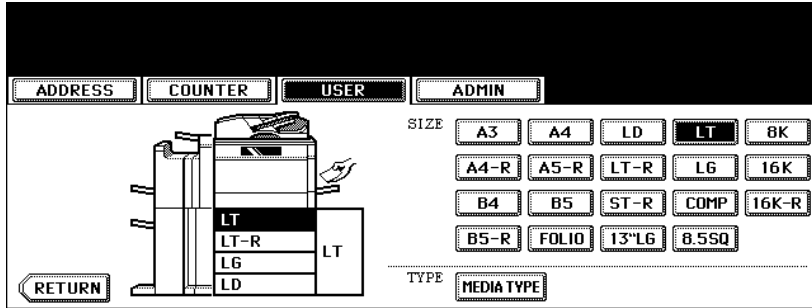



1





Drawer for special uses

When you set paper for special uses other than normal copying (e.g. sheets for cover copying) in the drawer, you need to set this drawer for the special use in advance. If the drawer has been set for a special use, its indication will change on the touch panel. A drawer with this setting will not be used for normal copying.

The following paper types are selectable according to each purpose.

Paper type	Purpose	Indication	Reference
Cover sheet	Sheet used in the cover copying mode	"COVER"	 P.138 "9.COVER SHEET"
Insertion sheet	Sheet used in the sheet insertion mode (Up to 2 drawers can be set for this mode. First, set Insert source 1, then press the drawer for the paper type of Insert source 2, and then press the [INSERT] button.)	"INSERT 1" (or "INSERT 2")	 P.141 "10.SHEET INSERTION"
Tab paper	Paper used for the tab paper mode	"TAB PAPER"	 P.157 "17.TAB PAPER"
FAX paper	Paper to print data from the FAX Unit, Printer Kit, Scanner Kit, Printer/Scanner Kit when any of them is installed.	F	(See the manual of each option.)
Special paper	Special types of paper (e.g. Paper with a watermark)	*	-

Select the suitable paper type from the following according to its paper weight.

Paper type	Paper wight	Indication	Reference
Thick 1	- 28 lb. Bond	 ₁	 P.35 "Copy paper types and sizes"
Thick 2	- 90 lb. Index	 ₂	
Thick 3	- 110 lb. Index	 ₃	

Setting the drawer for special uses

1 Place paper in the drawer(s).

- Set the paper with its copy side down.
- Set the paper size as required. (☞ P.40 “Changing the setting of paper size”)
- To set tab paper, see ☞ P.157 “17.TAB PAPER”.

2 Press the [USER FUNCTIONS] button on the control panel.

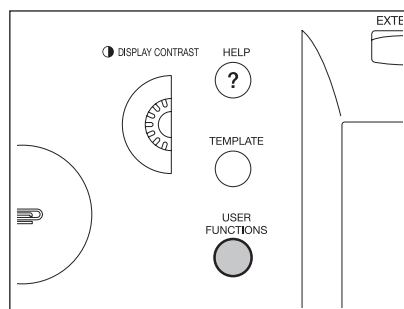

3 Press the [USER] button on the touch panel to enter the user setting menu, then press the [GENERAL] button.

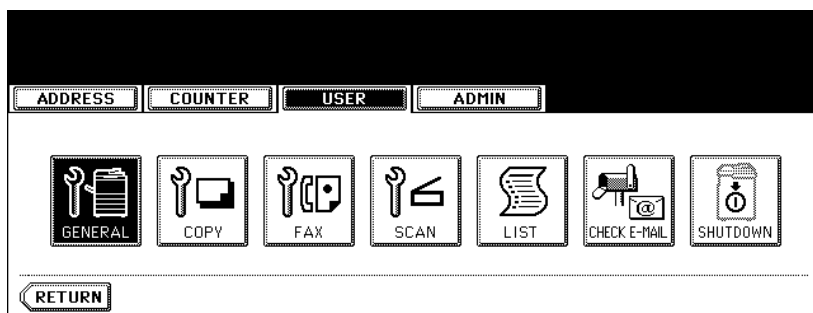

4 Press the [DRAWER] button on the touch panel.

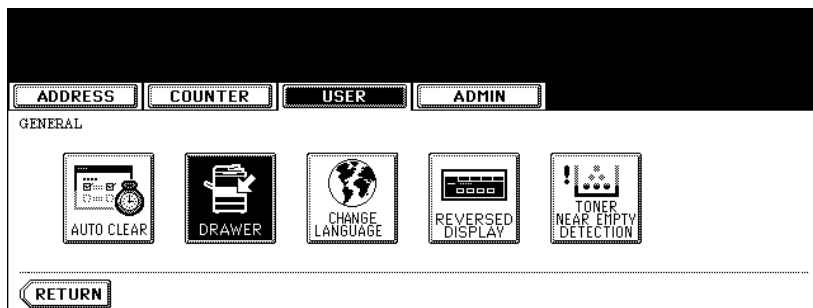

1

5 Press the [MEDIA TYPE] button.

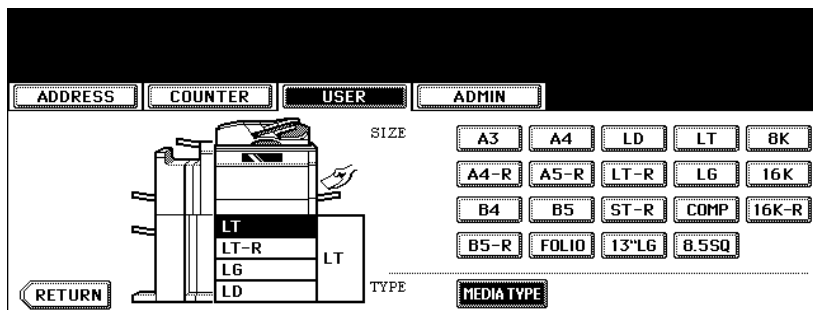

6 Press the drawer on the touch panel corresponding to the one in which the paper type has been set, and then press the button indicating the new one.

(e.g. when paper with a paper weight of "Thick 1" is set as a cover sheet in the 1st drawer)

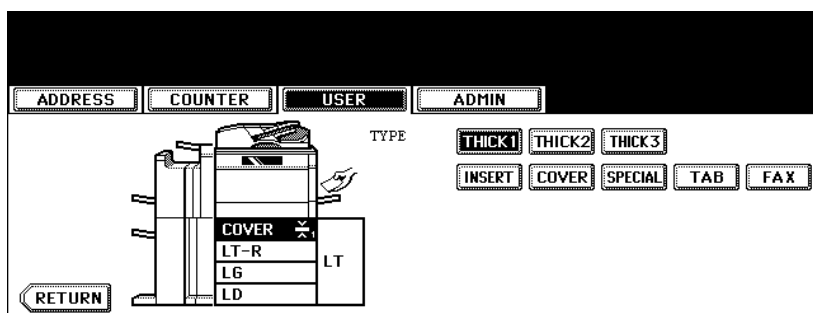

Clearing the drawer for special uses

- 1 Follow steps 1 to 4 of “Setting the drawer for special uses” (📖 P.43).
- 2 Press the drawer on the touch panel corresponding to the one whose setting you want to clear, and then press the button indicating the paper type in this drawer.

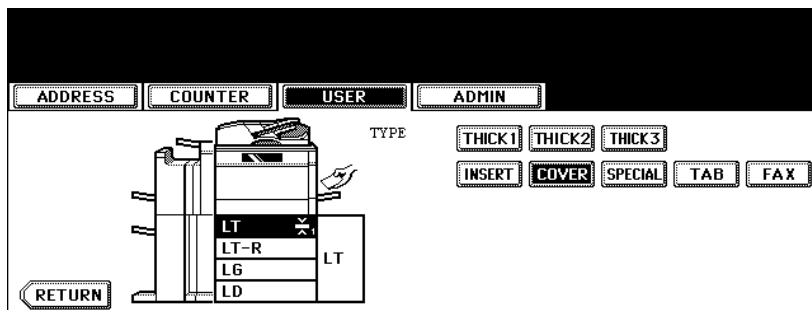

- The paper type setting is cleared and the indication of drawer returns to the original state.

Tip

When both [INSERT SOURCE 1] and [INSERT SOURCE 2] have been set and only the setting of [INSERT SOURCE 1] is cleared, the drawer for [INSERT SOURCE 2] changes to the one for [INSERT SOURCE 1].

Setting paper in the External Large Capacity Feeder (optional)

- 1 Pull out the External Large Capacity Feeder carefully until it comes to a stop.

A: Slide rail

B: Elevator tray

- Be careful not to touch the slide rail.

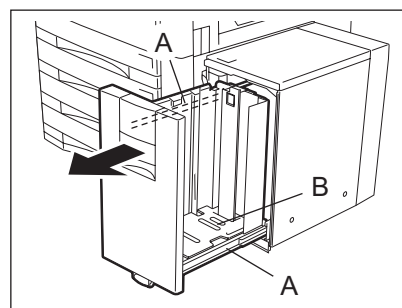

1

2 Place the paper on the elevator tray.

- Set the paper with its copy side up.
- For the maximum number of sheets that can be set, see  P.35 "Copy paper types and sizes".
- Fan and jog the paper well before placing it on the elevator tray. Set the paper aligned with the rear guide.
- If there is a gap between the set paper and the rear guide, the copied image may tilt.
- Be sure that the paper height does not exceed the line indicated on the rear guide.
- Do not use creased, folded, wrinkled or damp sheets of paper.

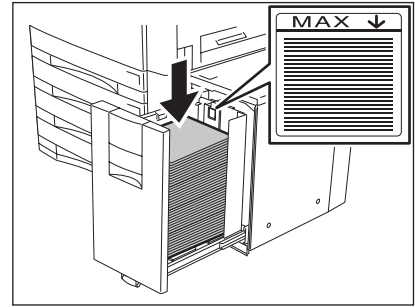

3 Push the drawer of the External Large Capacity Feeder straight into the equipment until it comes to a stop.

- Close the drawer completely. The elevator tray automatically moves up to the paper feeding position.

Caution

Be careful not to let your fingers be caught when closing the drawer. This could injure you.

2. HOW TO MAKE COPIES

1. General Copying Procedures.....	48
2. Setting Originals.....	51
• Originals sizes and types / Maximum number of sheets.....	51
• Placing originals on the glass.....	54
• Using the Reversing Automatic Document Feeder.....	56
3. Auto Job Start (Job Preset).....	59
4. Interrupt Copying	61
5. Stopping Copy Operation.....	62
6. Bypass Copying	63
• Bypass copying.....	63
• Bypass copying on standard size paper.....	64
• Bypass copying on non-standard size paper	68
• Registering non-standard size in the memory.....	70

1. General Copying Procedures

Set originals after placing paper or confirming that there is paper in the drawers. When the [START] button on the control panel is pressed with any of the settings unchanged, copies are made in the initial (default) settings. You can make copies as desired by setting various copy modes.

2

Initial (Default) settings

When the power is turned on, when the energy saving mode is cleared, and when the [FUNCTION CLEAR] button on the control panel is pressed, various setting items are automatically set. These items are called the initial (default) settings. These initial settings can be changed as desired. See the User Functions Guide for details.

The table below lists the various items of the initial settings at the time of installation of this equipment.

Item	Initial (Default) setting
Reproduction ratio	100%
Copy quantity	1
Paper selection	Automatic Paper Selection (APS)
Original -> Copy	1-Sided -> 1-Sided
Density adjustment	Automatic copy density adjustment
Image quality	TEXT/PHOTO MODE
Finishing mode	Placing originals on the original glass: Non-sort/ Non-staple mode Placing originals on the Reversing Automatic Document Feeder: Sort mode
Using Reversing Automatic Document Feeder	Continuous feed mode

Copying procedure

1 Place paper in the drawer(s).

- For the types and sizes of paper selectable, see [P.35](#) "Copy paper types and sizes".

Tip

When the desired size or type of paper is not in any of the drawers or the External Large Capacity Feeder, see the following pages.

- [P.37](#) "Setting copy paper (size change) / Setting the drawer for special uses"
- [P.45](#) "Setting paper in the External Large Capacity Feeder (optional)"
- [P.63](#) "6.Bypass Copying"

2 Place the original(s). See the following pages to set the originals.

- P.51 “Originals sizes and types”
- P.54 “Placing originals on the glass”
- P.56 “Using the Reversing Automatic Document Feeder”

The originals are copied in the order of being scanned.

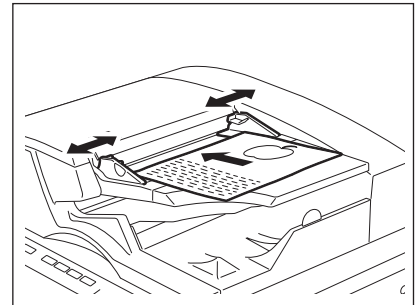

2

3 Select the copy modes as required. When you want to copy more than one set, key in the desired number of copies.

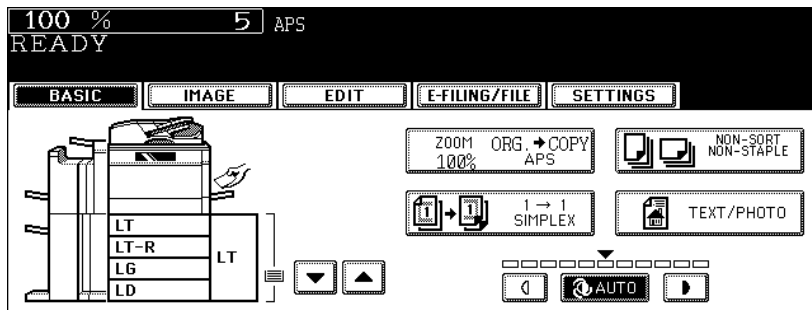

- Press the [CLEAR] button on the control panel to correct the number keyed in.
- Note that some combinations of copy modes are restricted. (P.329 “4. Copying Function Combination Matrix”)
- Once the [START] button on the control panel has started, any change in copy modes (including setting of the previously divided sets of originals) cannot be applied afterward.

4 Press the [START] button.

- Copying starts.

Tip

When you copy by placing originals on the original glass (e.g. using the sort mode, or making 1-sided original 2-sided copies), the data of these originals are scanned into the memory. In this case, proceed to steps 5 and 6.

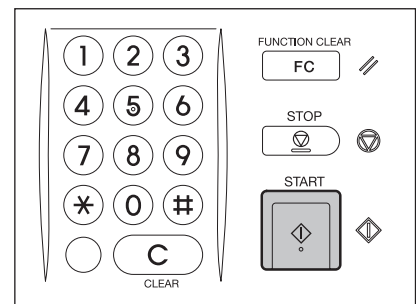

5 Place the next original, and press the [START] button.

- Data scanning of this original starts.
- The next original will also be scanned in the same manner when you press the [YES] button on the touch panel, and then press the [START] button on the control panel.
- Repeat the above procedure until the scanning of the last page of the original finishes.

6 When scanning of all pages has finished, press the [FINISHED] button on the touch panel.

2



- Copying starts. The paper exits with its copied side down.
- When the drawer runs out of paper during copying, the corresponding drawer on the touch panel and the [JOB STATUS] button on the control panel blink. Add paper to this drawer or select another one with the same paper size.

2. Setting Originals

Originals sizes and types / Maximum number of sheets

Originals sizes and types

Setting position	Type of original	Maximum size	Acceptable sizes for automatic size detection
Original glass *1	Sheets 3-dimensional object Books	Length: 11.69" Width: 17.01"	(Standard size) LD, LG, LT, LT-R, ST-R
Reversing Auto- matic Document Feeder *2 *3	Plain paper Recycled paper 1-sided originals: 13.3 - 33.8 lb. 2-sided originals: 13.3 - 27.7 lb.	Length: 11.69" Width: 17.01"	(Standard size) LD, LG, LT, LT-R, ST-R, COMP

*1 Do not place any heavy objects (9 lb. or over) on the glass.

*2 Even if listed under "Type of original", some originals may not be possible depending on their paper quality.

*3 Be sure to place ST-size originals in the landscape direction.

Automatic size detection does not work properly when A/B or K format paper is used for printing. (K format is a standard paper size for China.)

Tips

- Regardless of their sizes, originals are acceptable up to 100 sheets (13.3 to 20 lb.) or 0.62" in height.
- Scanned originals automatically exit on A or B depending upon the size of originals.

A: LT, ST-R

B: LD, LG, LT-R, COMP

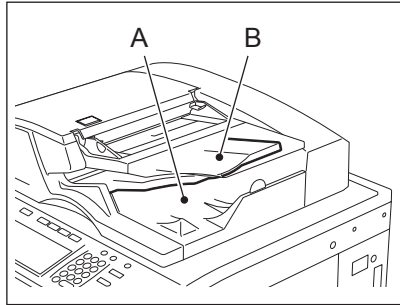

- When you copy a large number of landscape originals using the Reversing Automatic Document Feeder, use the original stopper to prevent them from being scattered.

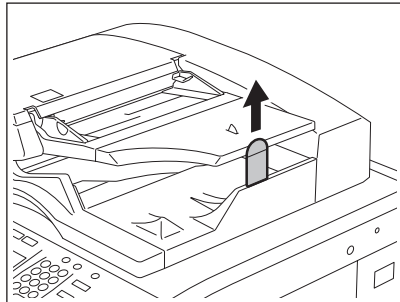

Maximum number of sheets

A maximum of 2000 LT sheets, or up until the memory becomes full can be accepted per 1 copy job. When the number of scanned sheets has exceeded the above limit, a message "The number of originals exceeds the limits. Will you copy stored originals?" appears. If you want to print out the data of originals stored (scanned) up till then, press the [YES] button on the touch panel. If you want to delete the stored data, press the [NO] button.

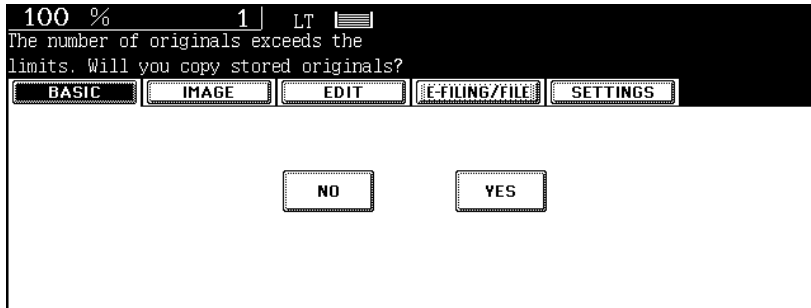

Placing originals on the glass

Sheet originals

Caution

2

Do not place heavy objects (9 lb. or more) on the original glass and do not press on it with force. Breaking the glass could injure you.

1 Raise the Reversing Automatic Document Feeder.

- Raise it 60 degrees or more for detecting the original.

2 Place the original face down on the original glass and align it against the left rear corner of the glass.

A: Original

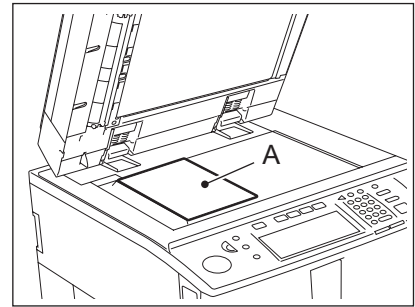

3 Lower the Reversing Automatic Document Feeder slowly.

- When you want to copy originals with high transparency such as OHP films or tracing paper, place a blank sheet of paper, the same size as the original or larger, over the original.

A: Original

B: Blank sheet

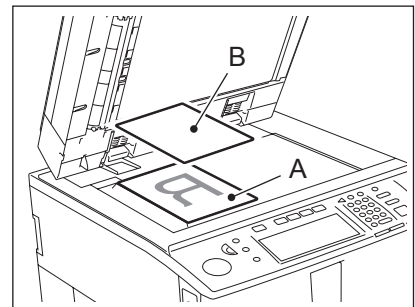

Book-type originals

Caution

Do not place heavy objects (9 lb. or more) on the original glass and do not press on it with force. Breaking the glass could injure you.

2

1 Raise the Reversing Automatic Document Feeder.

2 Open the desired page of the original and place it face down. Align it against the left rear corner of the glass.

- When you want to use the 2-sided copying function or the dual-page function on the book-type originals, align the center of the original on the yellow indicator line of the glass.
(📖 P.102 "Book-type original -> 2-sided copy")
(📖 P.123 "4.DUAL PAGE")

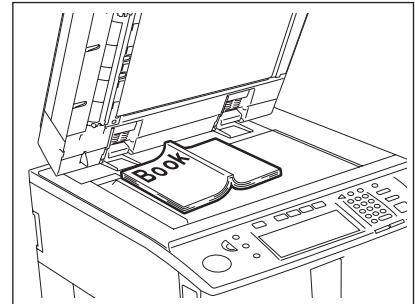

3 Lower the Reversing Automatic Document Feeder slowly.

- Do not lower the Reversing Automatic Document Feeder forcibly when the original is very thick. There will be no problem in copying even if the Reversing Automatic Document Feeder is not fully lowered.
- Do not look fully at the original glass because intensive light may leak out during copying.

Using the Reversing Automatic Document Feeder

Precautions

Do not use the types of original 1 to 8 shown below because such types may cause misfeeding or damage to the equipment.

1. Badly wrinkled, folded or curled originals
2. Original with carbon paper
3. Taped, pasted or cut-out originals
4. Clipped or stapled originals
5. Originals with holes or tears
6. Damp originals
7. OHP films or tracing paper
8. Coating paper (coated with wax, etc.)

Use types of original 9 and 10 shown below with extra care.

9. Originals which cannot be moved with the fingers, or surface-treated originals
(The sheets of such originals may not be able to be separated.)
10. Folded or curled originals should be smoothed out before being used.

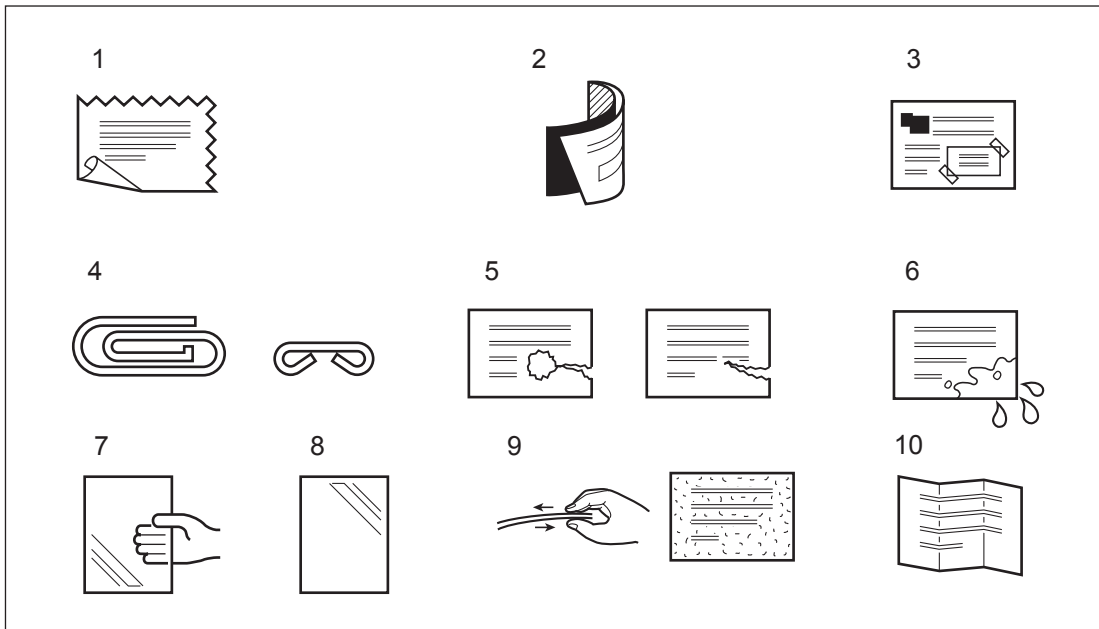

Tip

If the scanning area or the guide area is dirty, image trouble such as black streaks may occur in the print-out. Weekly cleaning of these areas is recommended. (📖 P.316 “1.Daily Inspection”)

Continuous feed mode

1 Align all the originals. Then place them face up and align the side guides to the original length.

- Place the originals straight along the side guides.
- Collate the originals in the order that you want them to be copied. The top sheet of the originals will be fed first.
- This mode is also available for one-sheet originals.
- Regardless of their sizes, originals are acceptable up to 100 sheets (13.3 to 20 lb.) or 0.62" in height.
- For mixed-size originals, see  P.75 "When copying mixed-size originals in one go".

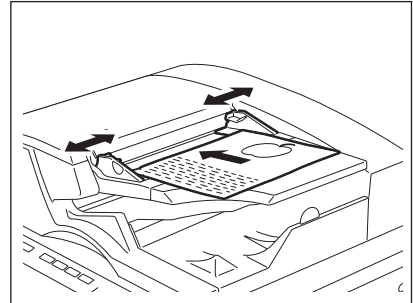

- Use the original stopper as required.

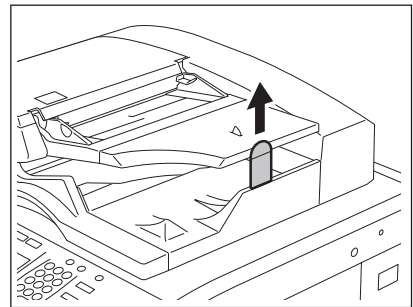

Tip

When the number of originals is too large to be set at one time, you can previously divide the originals into several sets to copy them continuously. To do so, place the first set of the originals and press the [CONTINUE] button on the touch panel while the data of this set are being scanned. When this scanning has finished, set the next set of the originals and press the [START] button on the control panel.

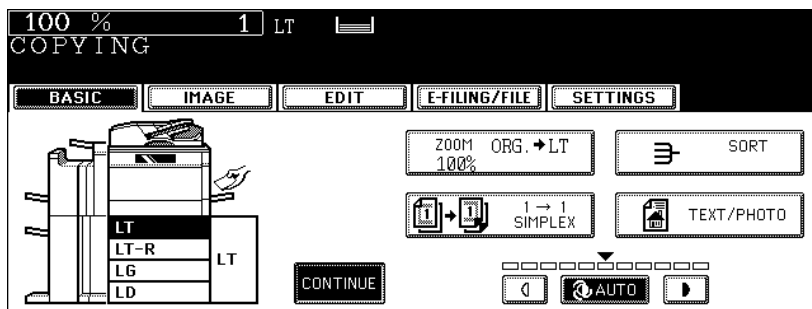

Single feed mode

To switch over between the continuous feed mode and the single feed mode, see  P.154 "16.ADF / SADF".

2

1 Align the side guides to the original width.

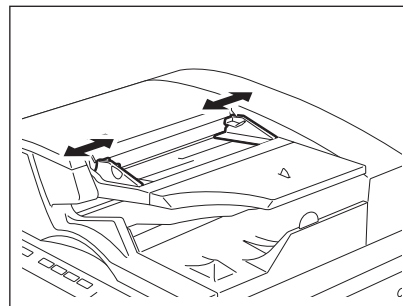

2 Insert the original with its face up and straight along the side guides.

- The original will be pulled in automatically. Be sure to let go of it when it starts being pulled.
- The menu of step 3 will be displayed.

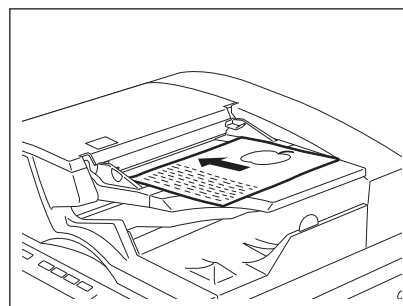

3 If there are more originals, set them in the same way.

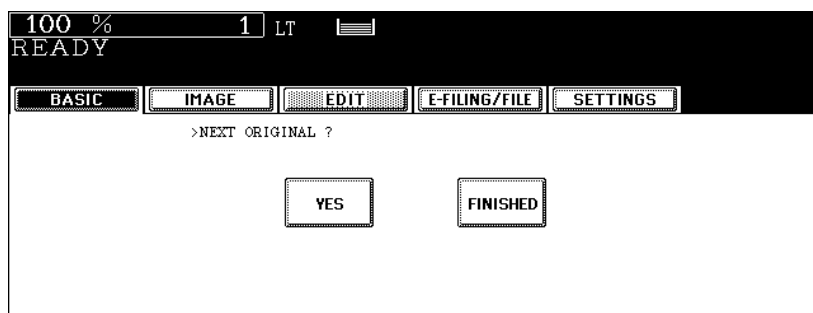

- The same operation is performed whether or not you press the [YES] button.

4 After all originals have finished being fed, press the [FINISHED] button.

3. Auto Job Start (Job Preset)

You can reserve a copy job during warming-up or continuous copying of another job by scanning the data of the job.

Setting auto job start

- 1 Place the original(s).
- 2 Select the copy mode and set the number of copies.

Tip

Note that the job starts in the copy modes of the previous job unless you set new ones particularly for this job.

- 3 Press the [START] button on the control panel.

- Up to 10 jobs can be stored in the memory. When an 11th job is placed on the original glass or the Reversing Automatic Document Feeder and the [START] button is pressed, "Auto Start" appears on the touch panel.
- A maximum of 2000 LT sheets, or up until the memory becomes full can be accepted per 1 copy job. (P.53 "Maximum number of sheets")

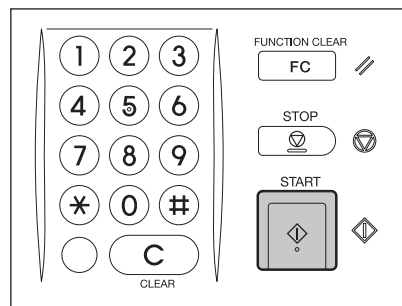

Confirming and canceling auto job

Confirming auto job and canceling job in waiting

Press the [JOB STATUS] button on the control panel to display the job list for confirming the set auto job and canceling a job waiting to be copied. To cancel auto jobs, see P.226 “Deleting print jobs”.

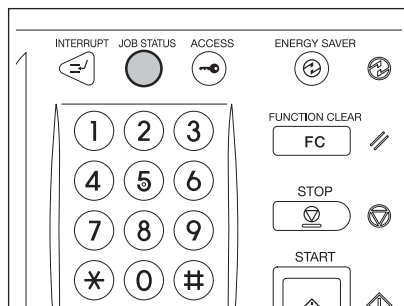

Canceling auto job

Press the [STOP] button on the control panel to stop a job while originals are being scanned. To restart the job, press the [START] button. To clear the job, press the [FUNCTION CLEAR] button. (However, the originals which have been scanned before the job is stopped are copied even though the [FUNCTION CLEAR] button is pressed.)

To cancel the 11th auto job, press the [STOP] button.

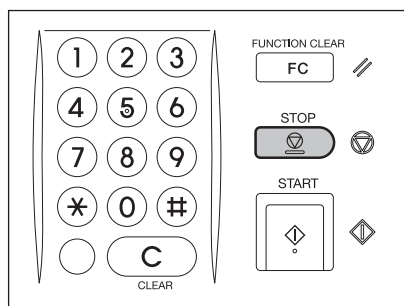

4. Interrupt Copying

While continuous copying is in progress, you can interrupt this job with another copy job. The following features cannot be used together with interrupt copying:

- Cover sheet copying
- Sheet insertion copying
- Scan to e-Filing / Save as file

Tip

To enable "Save as file", the Scanner Kit or the Printer/Scanner Kit (both optional) is required.

1 Press the [INTERRUPT] button on the control panel.

- The [INTERRUPT] button blinks first, then lights after "Job interrupted job 1 saved" appears.

Tip

When the [INTERRUPT] button is pressed while originals are being scanned, the [INTERRUPT] button blinks first. Then the button lights after "Job interrupted job 1 saved" appears when the scanning is finished.

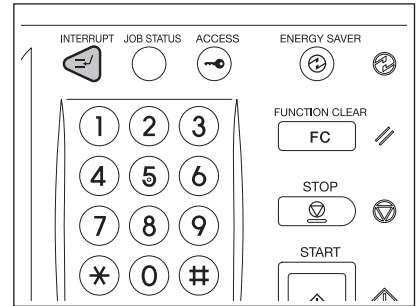

2 Replace the original with a new one.

- Set other copy modes as required.

3 Press the [START] button on the control panel.

4 After you have finished the interrupt copying, press the [INTERRUPT] button again.

- The message "READY to resume job 1" appears and the interrupted job resumes.

Tip

Interrupt copying is automatically canceled after a certain period by automatic function clearing without the need to press the [INTERRUPT] button again. The interrupted job (= Job 1) resumes after this automatic function clearing.

5. Stopping Copy Operation

Press the [STOP] button on the control panel to stop scanning or continuous copying.

- 1 Press the [STOP] button on the control panel during scanning (or continuous copying).

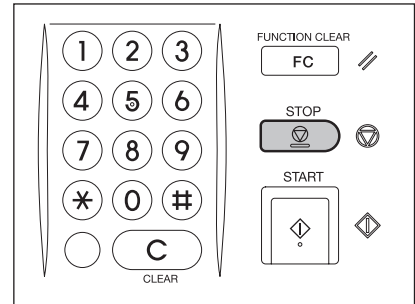

- 2 When the following menu is displayed, press the [MEMORY CLEAR] button on the touch panel.

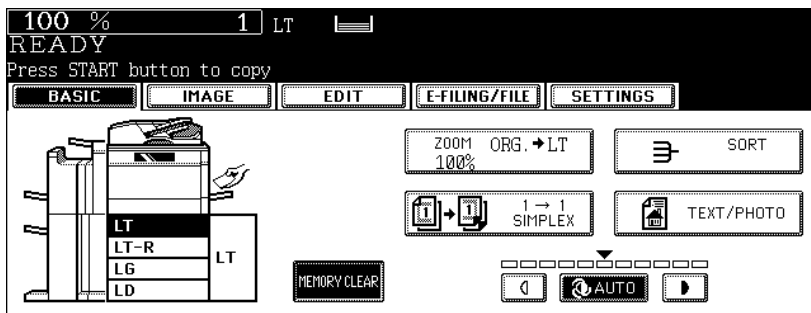

- During scanning: The data scanned up to then are deleted.
- During continuous copying: Copying stops and the data scanned up to then are deleted.

Tip

If there is any copy job waiting, this job will start.

6. Bypass Copying

Bypass copying

When you want to make copies on OHP film, sticker labels, or non-standard size paper, place the sheets of paper on the bypass tray.

Bypass copying is also recommended for copying on tab paper or standard size paper which is not in any of the drawers.

The following features can be used by specifying the paper size even in the bypass copy mode.

- 2-sided copying
- Image shift
- Edge erase
- Dual-page

To carry out bypass copying, open the bypass tray.

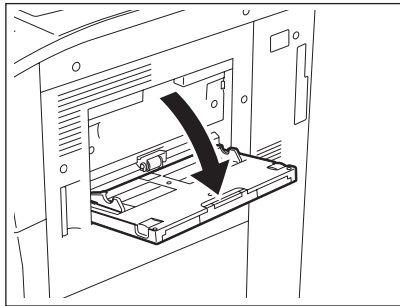

The operating procedure of bypass copying differs depending on the paper size used. See the corresponding page for the operating procedure of each size. The table below shows these pages.

Paper size		Procedure
Standard size	LD, LT, LG, ST-R	📖 P.64
	Other than the above	📖 P.66
Others (Non-standard size)		📖 P.68

To set tab paper on the bypass tray, see 📖 P.159 “Setting tab paper on the bypass tray”.

Tips

- Bypass copying stops when the paper placed on the bypass tray runs out during copying, even if the same size paper is in any of the drawers. Copying is resumed when paper is supplied to the bypass tray.
- When bypass copying has completed, the [FUNCTION CLEAR] button on the control panel blinks. Press this button to switch it to default copying using the drawers. (Bypass copying is automatically canceled after a certain period by automatic function clearing without the need to press the [FUNCTION CLEAR] button. The bypass copying returns to default copying using the drawers after this automatic function clearing.)

Bypass copying on standard size paper

Making bypass copies on LD, LT, LG and ST-R

2

1 Place some sheets of paper with their copy side up on the bypass tray, and align the side guides to the paper length.

- The message "Ready for bypass feeding" appears.
- Rear side of the side guides of the bypass tray has an indicator for paper height. The height of the sheets must not exceed this indicator.
- When you use more than one sheet, fan the sheets well before setting them on the tray.
- Do not push the sheets into the entrance of the bypass feeder; this may cause a paper jam.

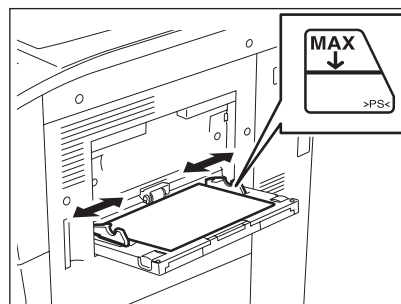

Tip

When the paper size is larger, draw out the three-stage paper holder.

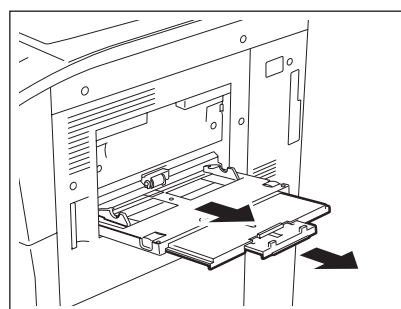

2 Place the original(s).

3 Press the button of the same size as the one of the paper you have set on the tray.

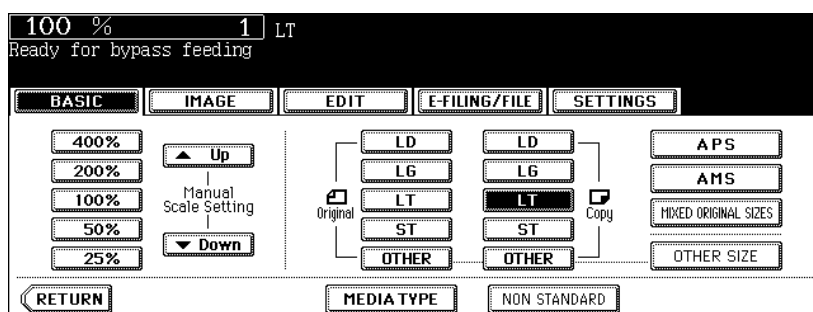

- If the paper size is not specified here, some operations such as cleaning may slow down the copying.

- 4** Press the [MEDIA TYPE] button on the touch panel if the media type of the paper you have set on the tray is other than plain paper.

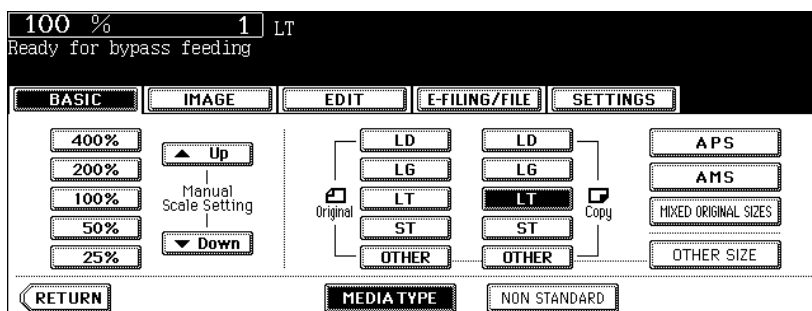

- 5** Press the button of the same media type as the one of the paper you have set on the tray, and then press the [ENTER] button on the touch panel.

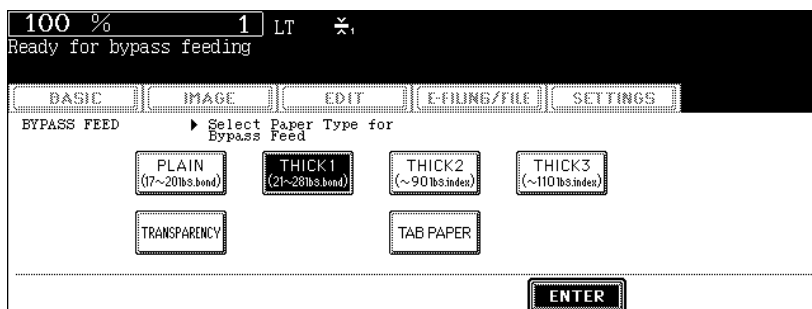

- Set other copy modes as required.
- If a media type which is not same as the one you have set is selected here, this may cause a paper jam or significant image trouble.

- 6** Press the [START] button on the control panel.

Tip

When you copy on OHP films, remove the copied OHP films, which have exited on to the receiving tray one by one. When the films pile up, they may become curled and may not be projected properly.

Making bypass copies on standard size paper other than LD, LT, LG and ST-R

- 1 Follow steps 1 to 2 of  P.64 “Making bypass copies on LD, LT, LG and ST-R”
- 2 Press the [OTHER SIZE] button on the touch panel.

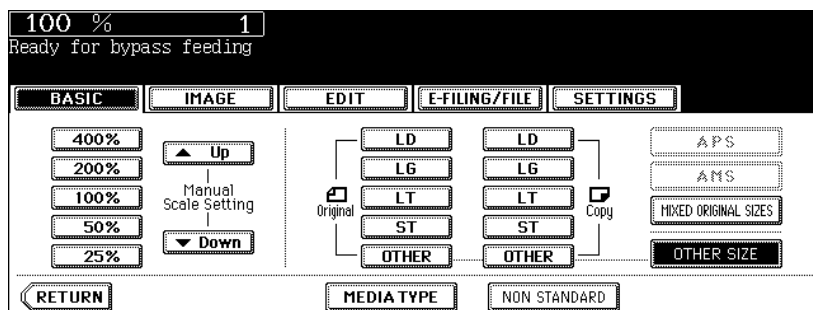

- 3 Press the button of the same size as the one of the paper you have set on the tray.

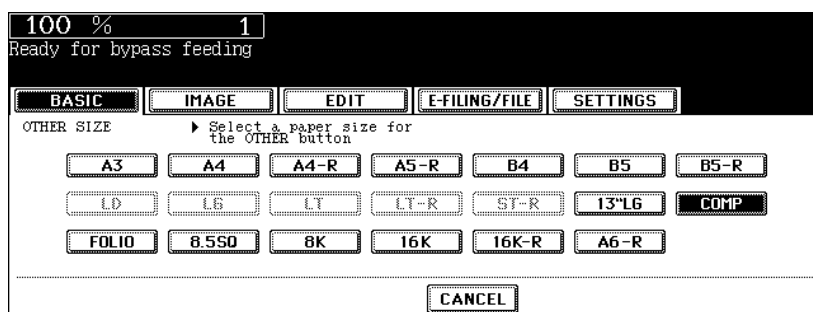

- 4 Press the [OTHER] button for the media type.

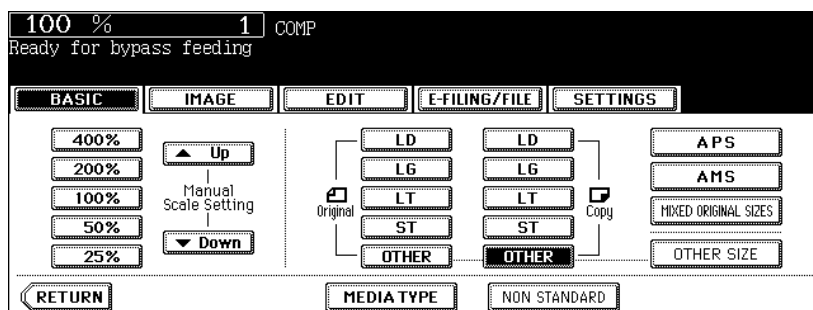

- If the paper size is not specified here, some operations such as cleaning may slow down the copying.

- 5** Press the [MEDIA TYPE] button on the touch panel if the media type of the paper you have set on the tray is other than plain paper.

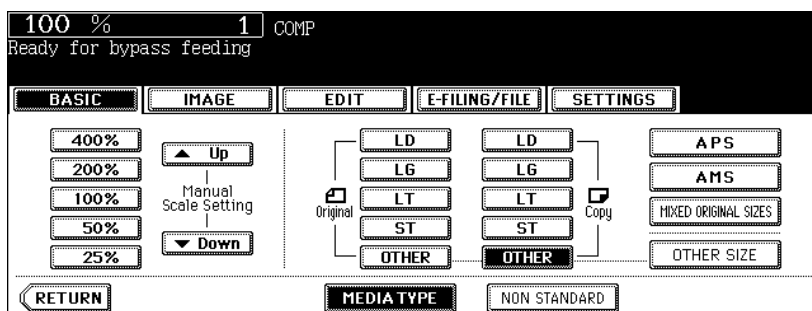

- 6** Press the button of the same media type as the one of the paper you have set on the tray, and then press the [ENTER] button on the touch panel.

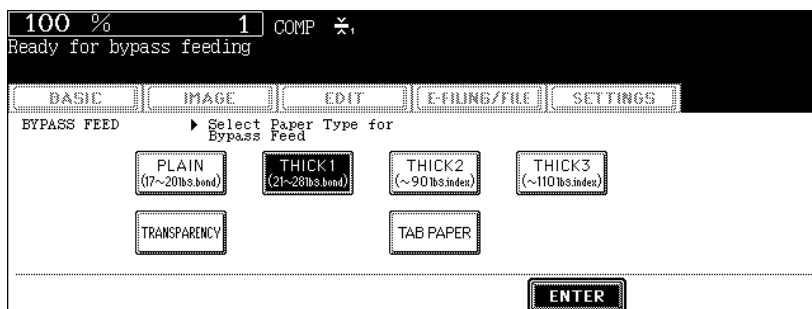

- Set other copy modes as required.
- If a media type which is not same as the one you have set is selected here, this may cause a paper jam or significant image trouble.

- 7** Press the [START] button on the control panel.

Tip

When you copy on OHP films, remove the copied OHP films, which have exited on to the receiving tray one by one. When the films pile up, they may become curled and may not be projected properly.

Bypass copying on non-standard size paper

Non-standard size paper should be within the following ranges:
A (Length): 3.9" to 11.7", B (Width): 5.8" to 17"

2

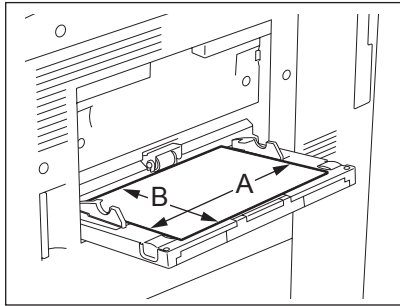

1 Place some sheets of paper with their copy side up on the bypass tray, and align the side guides to the paper length.

- The message "Ready for bypass feeding" appears.
- Rear side of the side guides of the bypass tray has an indicator for paper height. The height of the sheets must not exceed this indicator.
- When you use more than one sheet, fan the sheets well before setting them on the tray.
- Do not push the sheets into the entrance of the bypass feeder; it may cause a paper jam.

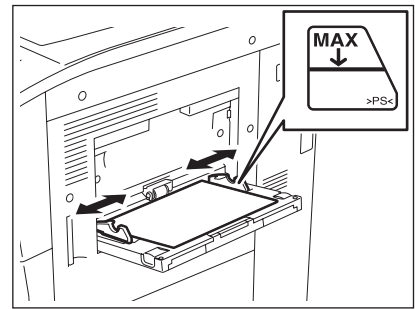

Tip

When the paper size is larger, draw out the three-stage paper holder.

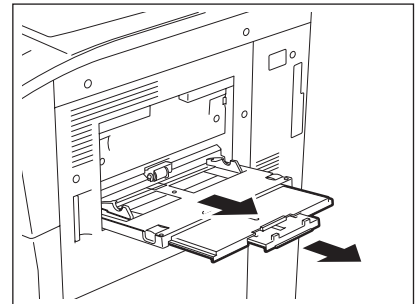

2 Place the original(s).

3 Press the [NON STANDARD] button on the touch panel.

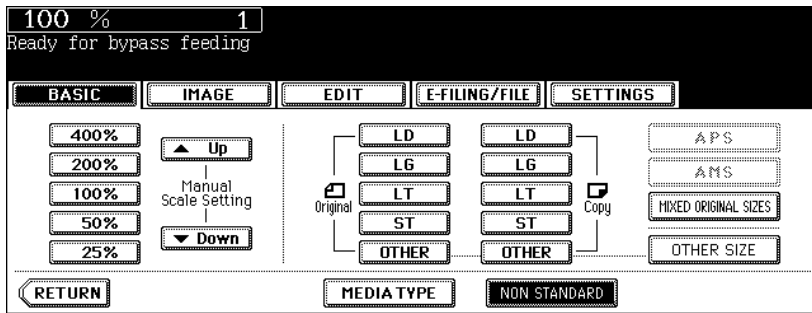

2

4 Set each dimension following the procedure below.

Using the digital keys

Key in the value in [Length] and press the [SET] button on the touch panel. Set the width in the same way and press the [ENTER] button.

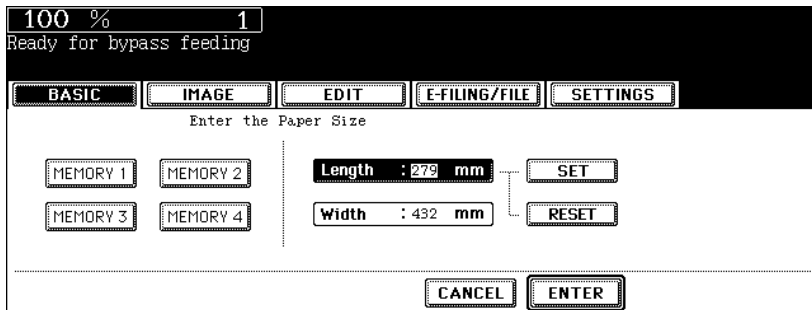

Recalling dimensions registered in the memory

Press the desired memory number button from [MEMORY 1] to [MEMORY 4] to recall the dimension data registered previously, and then press the [ENTER] button.

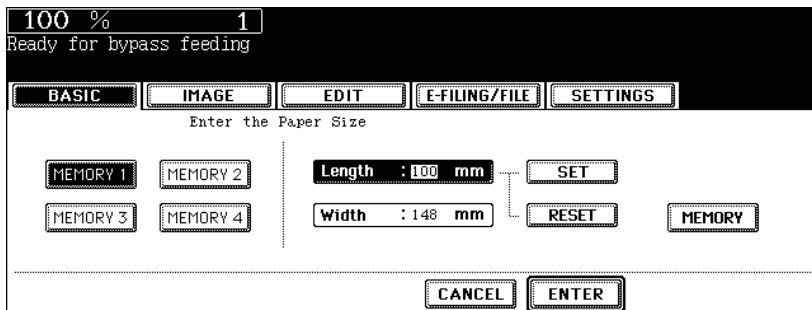

- Maximum paper size to be set: 297 mm (11.69") (length) x 432 mm (17.01") (width)
- To register the dimension data in the memory, see P.70 "Registering non-standard size in the memory".
- Set other copy modes as required.

5 Press the [START] button on the control panel.

Registering non-standard size in the memory

- 1 Follow steps 1 to 3 on  P.68 “Bypass copying on non-standard size paper”.
- 2 Press the memory number button (from [MEMORY 1] to [MEMORY 4]) you want to register the dimension.

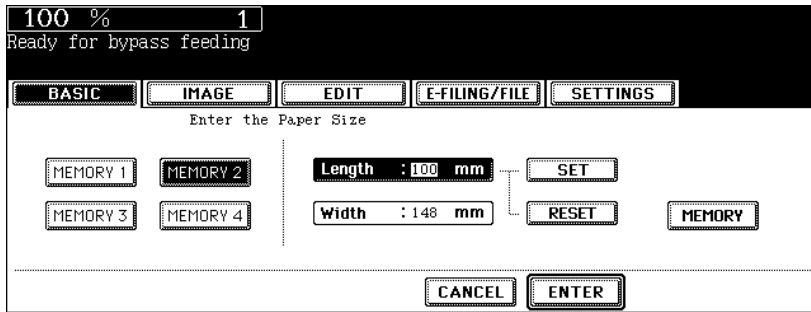

- 3 Key in each dimension, and press the [MEMORY] button on the touch panel.

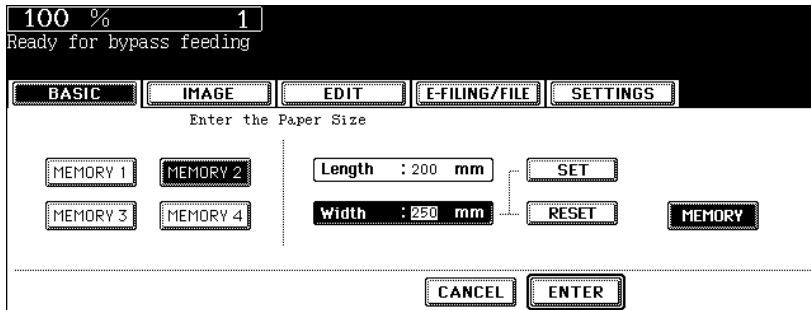

- Key in its length in [Length] and press the [SET] button on the touch panel. Set its width in the same manner.
- Maximum paper size to be set: 297 mm (11.69") (length) x 432 mm (17.01") (width)

3. SETTING OF BASIC COPY MODES

1. Paper Selection.....	72
• Automatic Paper Selection (APS).....	72
• Manual paper selection.....	74
• When copying mixed-size originals in one go.....	75
2. Enlargement and Reduction Copying.....	77
3. Selecting Finishing Modes.....	83
• Finishing modes and finishers (optional).....	83
• Sort/Group copying.....	85
• Rotate sort mode.....	87
• Staple sort mode.....	88
• Magazine sort & saddle stitch mode (booklet mode).....	90
• Hole punch mode (optional).....	93
• Inserter mode (optional).....	95
4. Duplex Copying.....	97
5. Original Mode.....	106
6. Copy Density Adjustment.....	107

1. Paper Selection

Automatic Paper Selection (APS)

When you place standard size originals on the original glass or the Reversing Automatic Document Feeder, the size of the originals is automatically detected, which helps the equipment select paper that is the same size as the originals.

- The automatic paper selection may not work correctly depending on the type of the originals. In that case, select the paper size manually. (P.74 “Manual paper selection”)
- For original sizes available for automatic paper selection, see P.51 “Originals sizes and types”.

3 1 Place paper in the drawer(s).

2 Place the original(s).

3 Confirm that automatic paper selection has been selected on the basic menu.

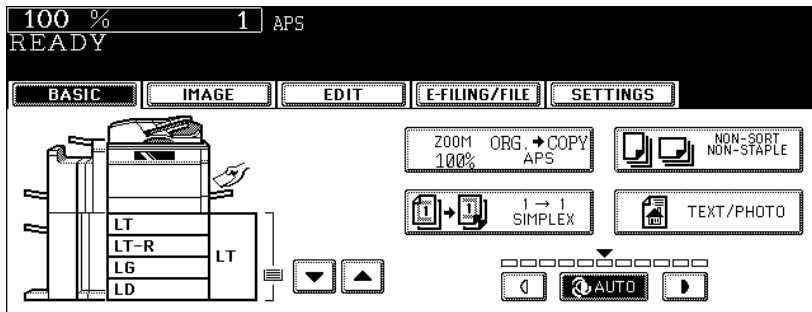

- Automatic paper selection is selected by default at the installation of the equipment.
- If “Change direction of original” or “CHANGE DRAWER TO CORRECT PAPER SIZE” appears, perform the action accordingly.
- Set other copy modes as required.

Tip

Even if the direction of the paper set in the selected drawer differs from that of the original, the equipment rotates the data of the original by 90 degrees to make copies as long as their sizes are the same. (This works on LT paper only.) For example, when an LT original is set vertically and LT-R paper is placed in the drawer, the data of LT original will be rotated and copied correctly on LT-R paper.

When automatic paper selection is not selected

(1) Press the Enlargement/Reduction ([ZOOM...]) button.

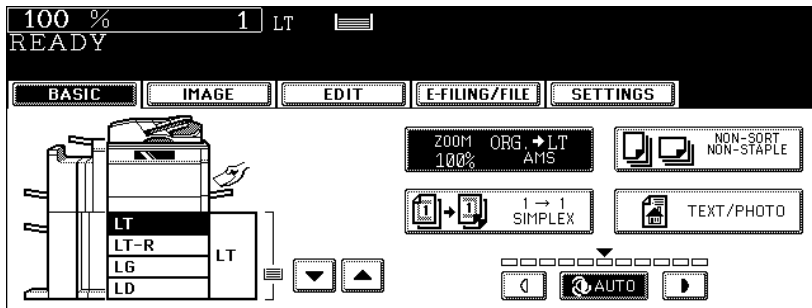

(2) Press the [APS] button.

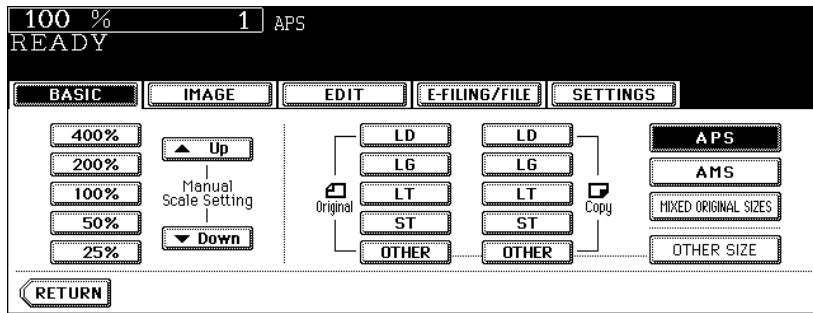

3

4 Press the [START] button.

Manual paper selection

Automatic paper selection cannot be selected for the following originals because their sizes are not detected correctly. Select the paper size manually for these originals.

- Highly transparent originals (e.g. OHP film, tracing paper)
- Wholly dark originals or originals with dark borders
- Non-standard size originals (e.g. newspapers, magazines)

Tip

3

When the desired size of paper is not set in any of the drawers, place this size of paper in the selected drawer or place the paper on the bypass tray manually.

(P.37 "Placing paper in the drawer", P.63 "Bypass copying")

1 Place paper in the drawer(s).

- When using the bypass tray, be sure to specify the paper size.

2 Place the original(s).

3 Press the drawer button representing the desired paper size on the touch panel.

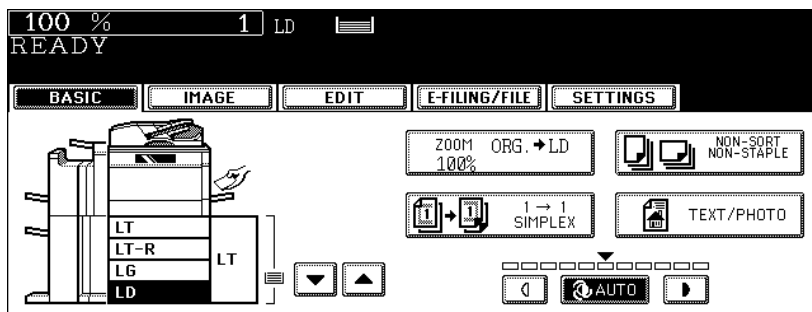

- You can use the paper source selection (/) buttons to select the desired drawer.
- Set other copy modes as required.

4 Press the [START] button.

When copying mixed-size originals in one go

You can copy a set of originals whose sizes are individually different, using the Reversing Automatic Document Feeder, by pressing the [MIXED ORIGINAL SIZE] button.

- This mixed original size setting is available only in the following combinations.
LD, LG, LT, LT-R, 8.5", SQ, COMP
- Note that the copied image may be dislocated depending on the combination.

1 Place paper in the drawer(s).

- Bypass copying is not available.

2 Adjust the side guides to the widest original, and then align the original against the guide at the front side.

- Place the originals face up.

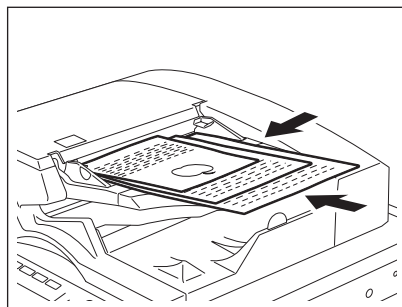

3 Press the Enlargement/Reduction ([ZOOM...]) button to enter the setting menu of the original or paper size.

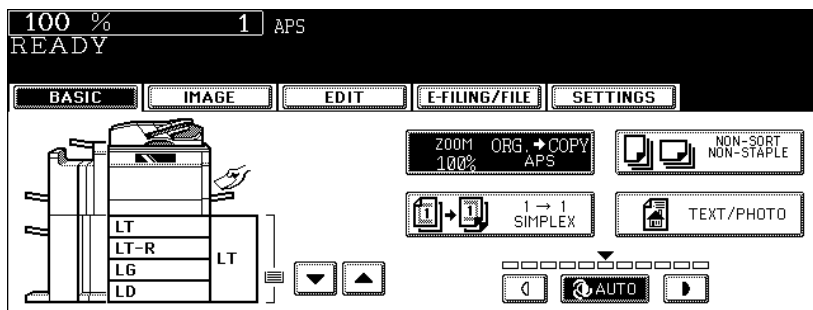

4 Press the [MIXED ORIGINAL SIZES] button.

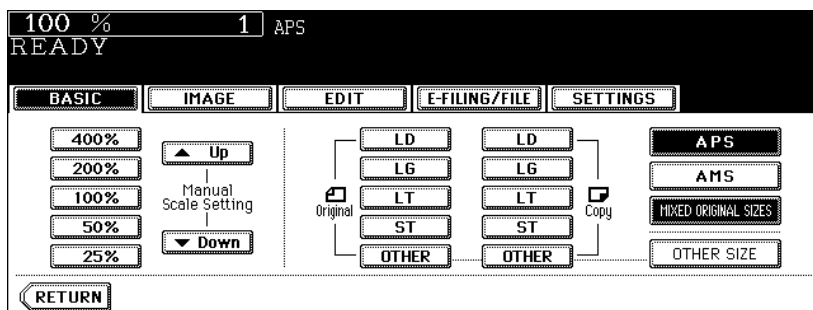

5 Select either automatic paper selection (APS) or automatic magnification selection (AMS).

Automatic paper selection: Copies on the same size of paper as that of originals (P.72).

Automatic magnification selection: Copies all in one size (P.77).

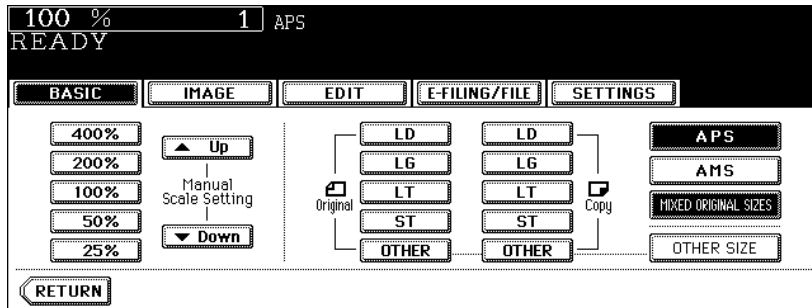

- Before you use automatic paper selection, be sure that all paper sizes corresponding to the original sizes have been set in the drawers.
- In automatic magnification selection, the copies cannot be enlarged from LT (portrait) to LD (landscape)/LG (landscape).
- Set other copy modes as required.

6 Press the [START] button.

2. Enlargement and Reduction Copying

You can enlarge or reduce the size of copies by means of the following procedures.

- Specifying the copy paper size in advance so that the equipment will detect the original size and automatically select the most appropriate reproduction ratio for the copy paper size (= automatic magnification selection)
- Specifying both original size and copy paper size separately
- Using the zoom buttons or the one-touch zoom buttons

Tip

The enlargement/reduction ratio available differs depending on whether the originals have been set on the original glass or on the Reversing Automatic Document Feeder.

On the original glass: 25 to 400%

On the Reversing Automatic Document Feeder: 25 to 200%

3

Automatic Magnification Selection (AMS)

- The automatic magnification selection cannot be selected for the following originals. Set their reproduction ratios in other ways.
 - Highly transparent originals (e.g. OHP film, tracing paper)
 - Wholly dark originals or originals with dark borders
 - Non-standard size originals (e.g. newspapers, magazines)
- For the original sizes available for this automatic magnification selection, see  P.51 “Originals sizes and types / Maximum number of sheets”.

1 Place paper in the drawer(s).

2 Press the Enlargement/Reduction ([ZOOM...]) button.

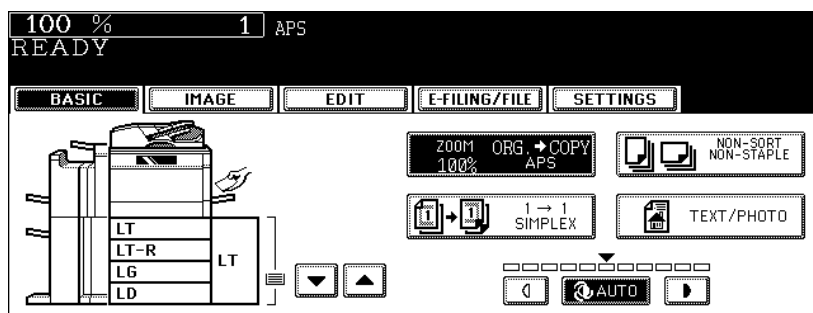

3 Press the button representing the desired copy paper size.

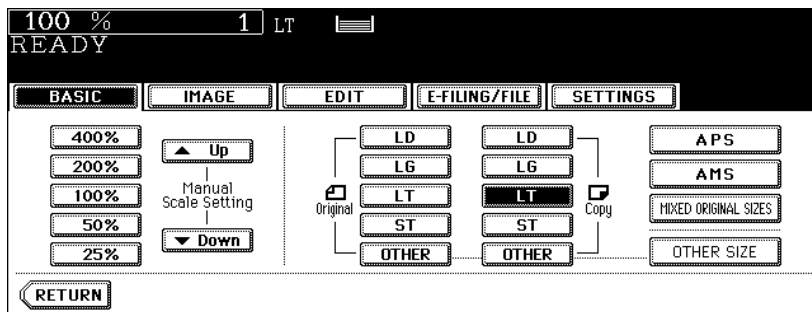

- The copy paper size can also be set by pressing the drawer button on the touch panel.

4 Press the [AMS] button.

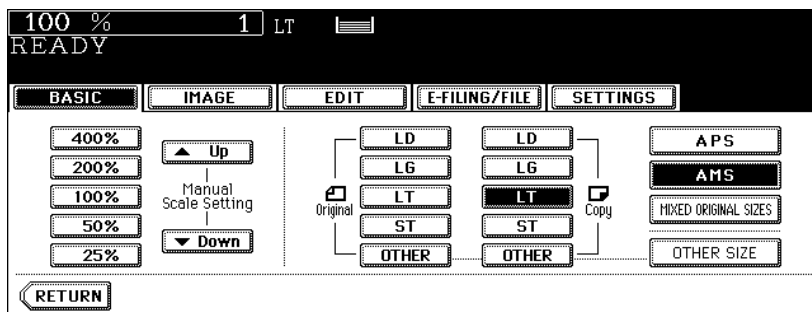

5 Place the original(s).

- When the original is placed, the equipment detects the original size, then computes and displays the most appropriate reproduction ratio for the specified copy paper size.
- If "Change direction of original" appears, make the change accordingly.
- Set other copy modes as required.

6 Press the [START] button.

Specifying both original size and copy size separately

1 Place paper in the drawer(s).

2 Place the original(s).

3 Press the Enlargement/Reduction ([ZOOM...]) button.

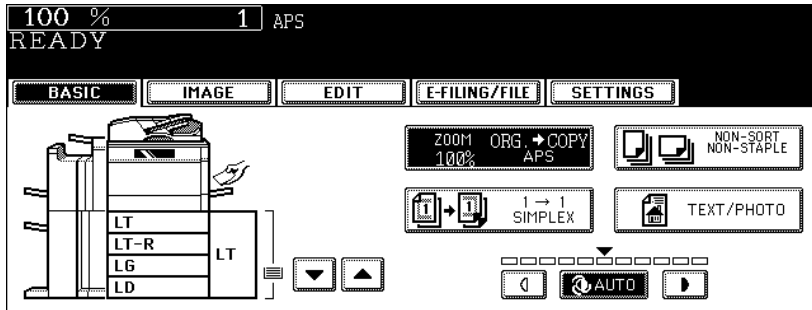

4 Specify the original size and copy paper size.

Original size: Press the size button representing the same size as that of the set original.

Copy paper size: Press the size button representing the desired copy paper size.

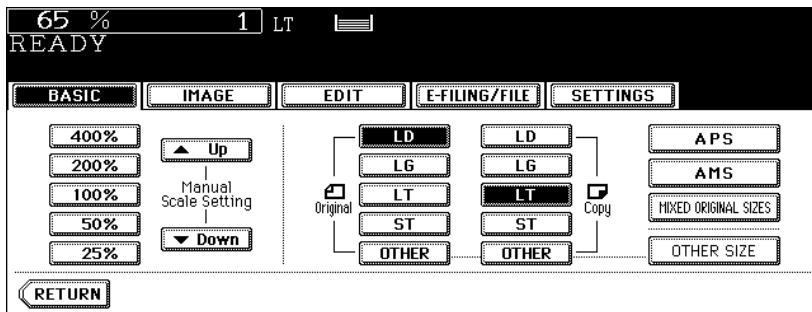

- The copy paper size can also be set by pressing the drawer button on the touch panel.
- When the original size and copy paper size have been specified, the enlargement/reduction ratio is computed and displayed on the touch panel.
- Set other copy modes as required.

Tip

When the original or copy paper is a standard size other than LD, LG, LT or ST, you need to register this paper size in the selections of the [OTHER] button in advance. See "When a standard size paper other than LD, LG, LT and ST-R is set" below for the registration.

5 Press the [START] button.

When a standard size paper other than LD, LG, LT and ST-R is set

Register the size of the placed paper to the [OTHER] button with the following procedure. The registered paper size is automatically selected when the [OTHER] button is pressed.

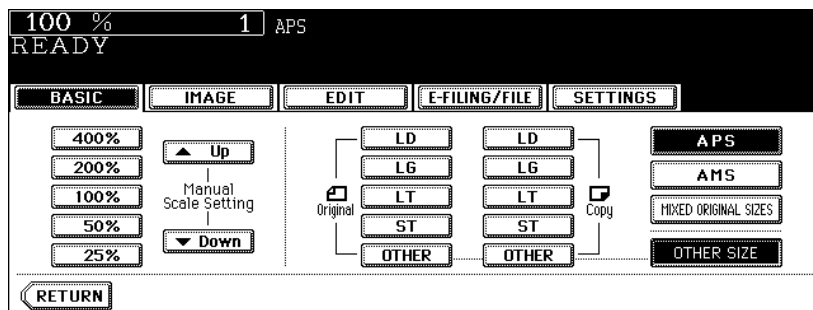
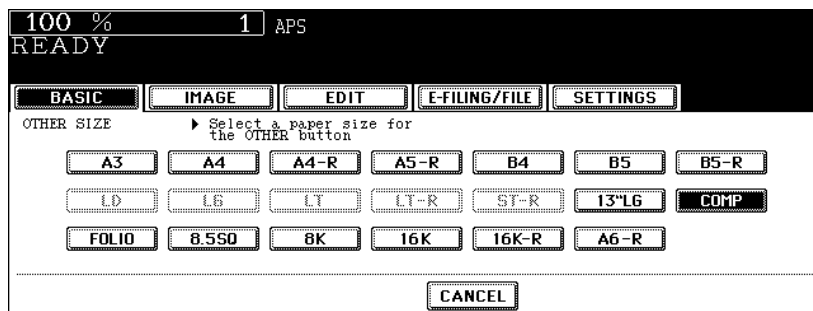
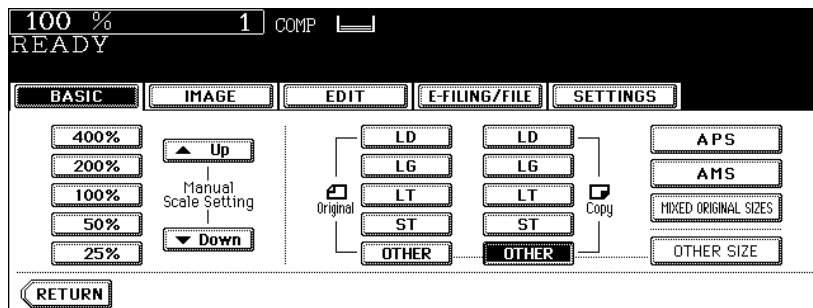
1 Press the [OTHER SIZE] button.**2 Press the paper size button corresponding to the paper that has been set.****3 Press the [OTHER] button.**

Using the zoom buttons or the one-touch zoom buttons

- 1 Place paper in the drawer(s).
- 2 Place the original(s).
- 3 Press the Enlargement/Reduction ([ZOOM...]) button.

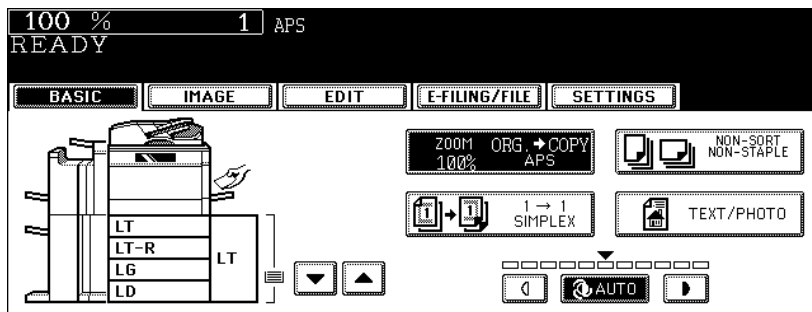

4 Press the following buttons to set the desired reproduction ratio.

A: Zoom ([▲ Up] and [▼ Down]) buttons

The reproduction ratio changes by 1% every time it is pressed. When you hold down either of them, the ratio goes up or down automatically.

B: One-touch zoom buttons

You can select the ratio from [400%], [200%], [100%], [50%] and [25%].

- The maximum ratio when the Reversing Automatic Document Feeder is used is 200%.

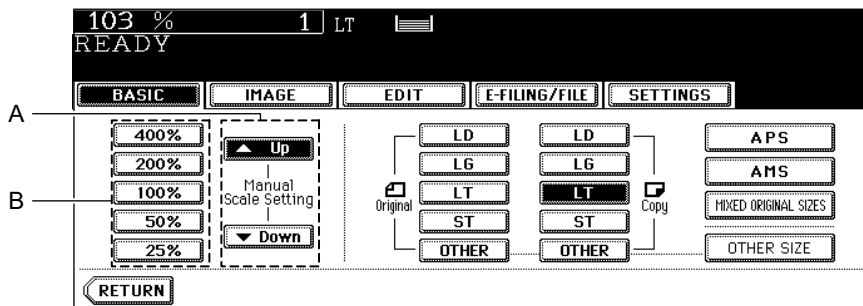

5 Press the button representing the desired copy paper size.

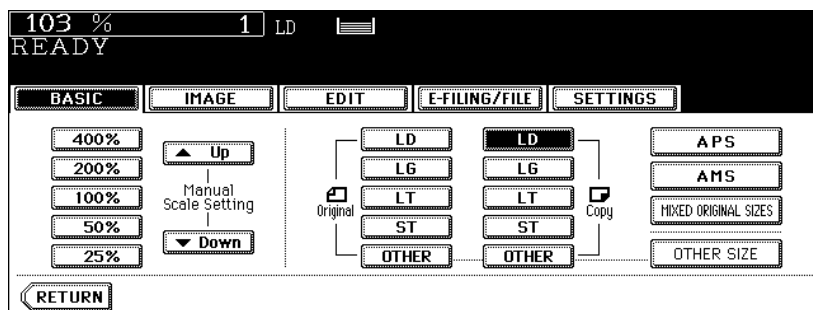

- The copy paper size can also be set by pressing the drawer button on the touch panel.
- Set other copy modes as required.

6 Press the [START] button.

3. Selecting Finishing Modes

Finishing modes and finishers (optional)

The available finishing modes differ depending on the type of finishing device installed (MJ-1027, MJ-1028, MJ-6003 or MJ-7001).

Type of finishing mode

Check the available finishing modes with the table below.

Yes: Available
No: Not available

Finishing device		Type of finishing mode						
		Sort/ Group	Rotate sort	Staple sort	Maga- zine sort	Maga- zine sort & Saddle stitch	Saddle stitch	Hole punch
MJ-1027	MJ-1027 only	Yes	No	Yes	Yes	No	No	No
	MJ-1027 + MJ-6003	Yes	No	Yes	Yes	No	No	Yes
	MJ-1027 + MJ-7001	Yes	No	Yes	Yes	No	No	No
	MJ-1027 + MJ-6003 + MJ-7001	Yes	No	Yes	Yes	No	No	Yes
MJ-1028	MJ-1028 only	Yes	No	Yes	Yes	Yes	Yes	No
	MJ-1028 + MJ-6003	Yes	No	Yes	Yes	Yes	Yes	Yes
	MJ-1028 + MJ-7001	Yes	No	Yes	Yes	Yes	Yes	No
	MJ-1028 + MJ-6003 + MJ-7001	Yes	No	Yes	Yes	Yes	Yes	Yes
No finishing device		Yes	Yes	No	Yes	No	No	No

MJ-1027: Finisher

MJ-1028: Saddle Stitch Finisher

MJ-6003: Hole Punch Unit

MJ-7001: Inserter Unit

Name of each part in the Finisher (optional)

1. Tray
2. Sub-tray
3. Upper cover
4. Inserter Unit (MJ-7001)
5. Hole Punch Unit (MJ-6003)
6. Saddle stitch unit
7. Saddle stitch tray

3

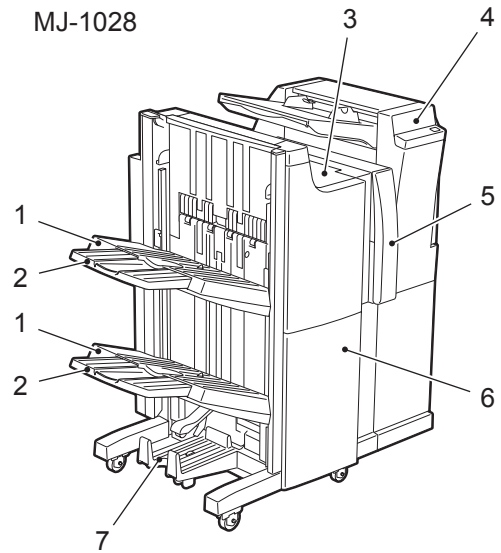
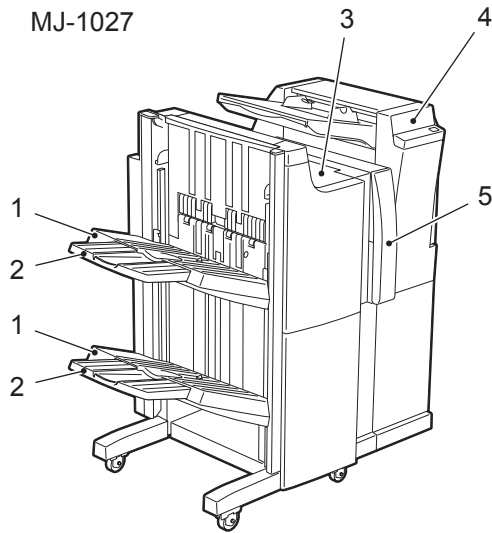

Sort/Group copying

To make multiple copies, select the sort mode or the group mode as required.

(Example of making 5 sets of copies from 5 original sheets)

1. Sort copying
2. Group copying

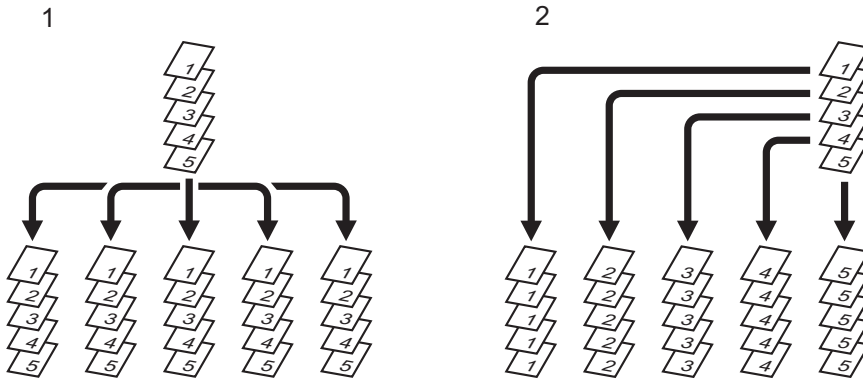

Tip

When you use the LD or LG size copy paper, pull out the sub-tray in advance. The copied paper may fall or may not be sorted properly without the sub-tray.

1 Place paper in the drawer(s).

2 Place the original(s).

3 Press the finisher button on the basic menu.

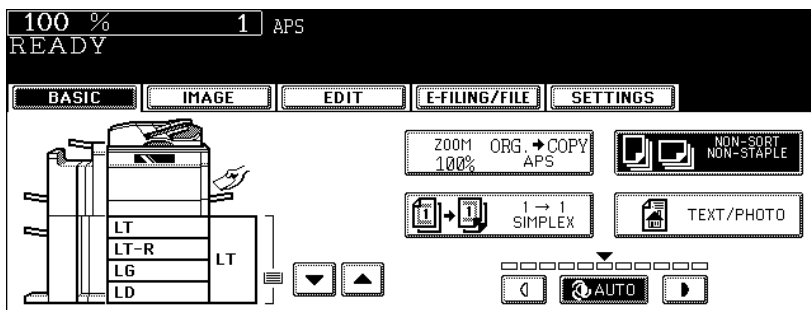

Tip

When the original is placed in the Reversing Automatic Document Feeder, the sort mode is automatically selected.

4 Press the [SORT] (or [GROUP]) button.

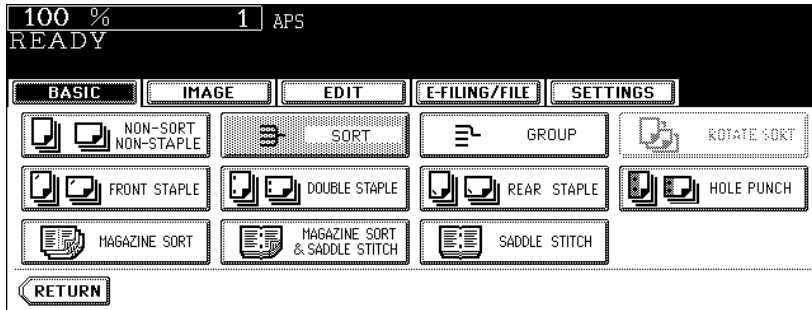

- Set other copy modes as required.

5 Press the [START] button.

3

Rotate sort mode

In the rotate sort mode, one set of copies is made to exit on another set of copies, being alternated lengthwise or crosswise.

The available paper sizes for this mode is LT/LT-R. Set the LT/LT-R size paper in the drawers in advance.

- This mode cannot be used with automatic paper selection.
- When the Finisher or Saddle Stitch Finisher is installed, this mode cannot be used.

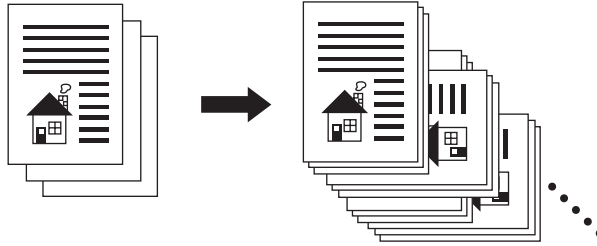

3

1 Place paper in the drawer(s).

2 Place the original(s).

3 Press the finisher button on the basic menu.

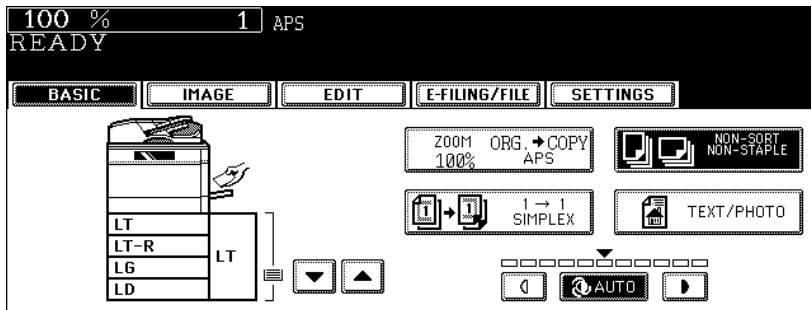

4 Press the [ROTATE SORT] button.

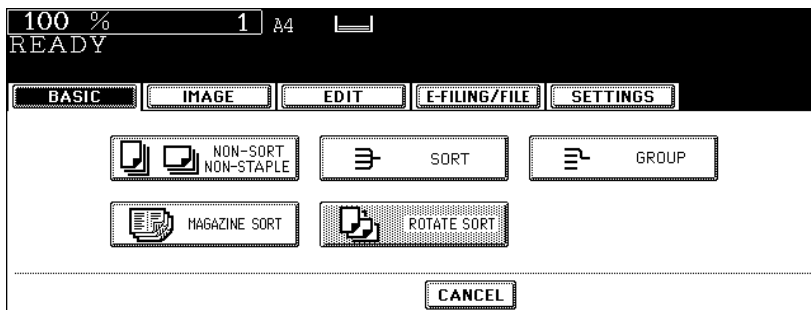

- Set other copy modes as required.

5 Press the [START] button.

Staple sort mode

When the Finisher or the Saddle Stitch Finisher (both optional) is installed, automatic stapling is enabled. You can select the stapling position from three types.

- The paper weight applicable for this mode is 17 to 28 lb. Bond.
- Special paper such as OHP films or sticker label cannot be used for stapling.
- Copies in different size cannot be stapled.

When the lengths of the copies are the same, they can be stapled even if their sizes are different.

(Example of selecting the [FRONT STAPLE] button)

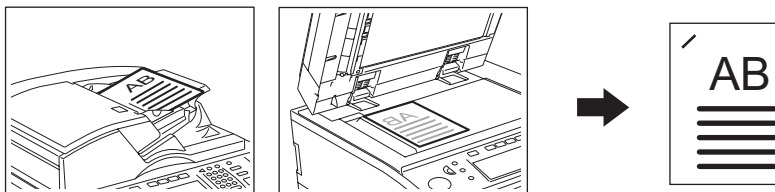

Setting the staple sort mode

1 Place paper in the drawer(s).

- When using this mode in bypass copying, specify the paper size in advance. (P.63 "6.Bypass Copying")

2 Place the original(s).

3 Press the finisher button on the basic menu.

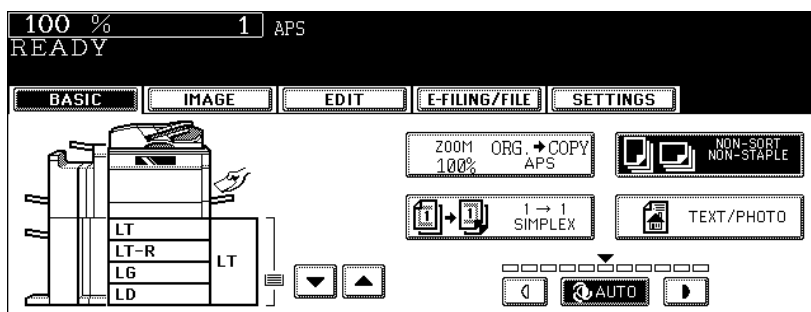

4 Press the [FRONT STAPLE] (or [DOUBLE STAPLE] or [REAR STAPLE]) button.

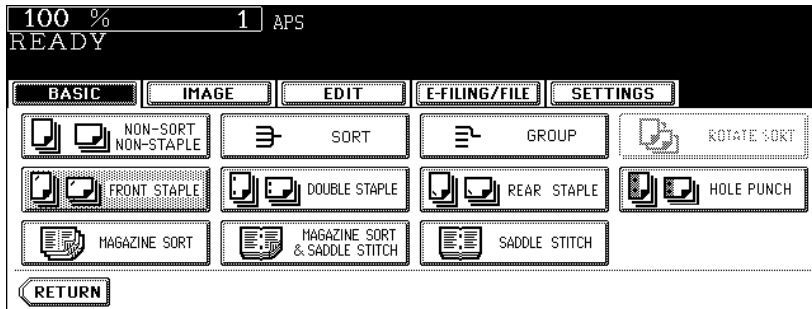

- Set other copy modes as required.

5 Press the [START] button.

Tip

If the paper quantity exceeds the maximum number of sheets that can be stapled, the Finisher automatically enters the sort mode.

Maximum number of sheets for stapling

The maximum number of sheets can be stapled at a time (in case of 17 to 20 lb. Bond plain paper) is shown below.

Finisher (MJ-1027)

Paper size	Number of sheets
LT, A4, B5	50
LD, LG, LT-R, COMP, A3, B4, A4-R, FOLIO	30

Saddle Stitch Finisher (MJ-1028)

Paper size	Number of sheets
LT, A4, B5	50
LD, LG, LT-R, COMP, A3, B4, A4-R, FOLIO	30

- For the tray loading capacity, see P.326 “2.Specifications of Options”
- Two covers of 17 lb. Bond to 110 lb. Index can be added. In this case, the covers are included in the maximum number of sheets that can be stapled.

Magazine sort & saddle stitch mode (booklet mode)

In the magazine sort mode, more than one original can be copied and bound like magazines or booklets. Also, a set of copied sheets can be automatically folded and stapled at its center when the Saddle Stitch Finisher (optional) is installed. The available copy paper sizes for these modes are LD, LT-R and LG.

- Special paper such as OHP films or sticker label cannot be used for saddle stitching.
- The paper weight applicable for this mode is 17 to 28 lb. Bond.

Tip

3

When placing portrait originals horizontal to you in the magazine sort mode, set the Image Direction in the edit menu. Otherwise the originals will not be copied in the proper page order. (📖 P.150 "14.IMAGE DIRECTION")

1. When [MAGAZINE SORT] is selected

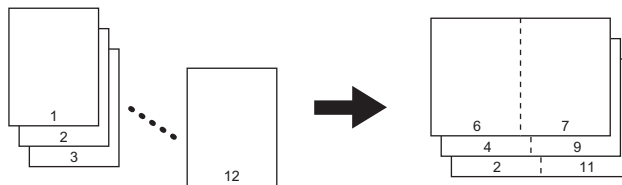

2. When [MAGAZINE SORT & SADDLE STITCH] is selected

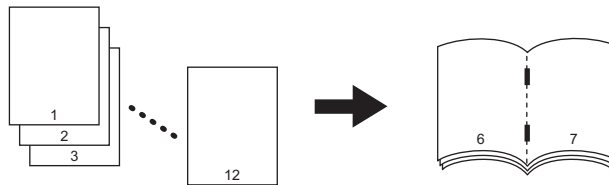

3. When [SADDLE STITCH] is selected

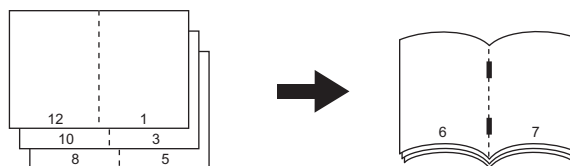

You can select the magazine sort mode from the edit menu, as well as from the basic menu. When this mode is selected from the edit menu, you can adjust the binding margin of the copy. To select this mode from the edit menu, see 📖 P.129 "6.MAGAZINE SORT".

Setting magazine sort & saddle stitch mode

1 Place paper in the drawer(s).

2 Select the paper size.

- Available copy paper sizes are LD, LT-R and LG.
- For bypass copying, see  P.63 “6.Bypass Copying”.

3 Place the original(s).

- When placing originals on the Reversing Automatic Document Feeder, see the illustrations ( P.90) for the proper page order of the copies.
- When placing originals on the original glass, follow the procedure below.
 - When [MAGAZINE SORT] or [MAGAZINE SORT & SADDLE STITCH] is selected: Place the first page of the originals first.
 - When [SADDLE STITCH] is selected: In case of 12-page originals, set them in the order of pages 12-1, 2-11, 10-3, 4-9, 8-5, then 6-7.

4 Press the finisher button on the basic menu.

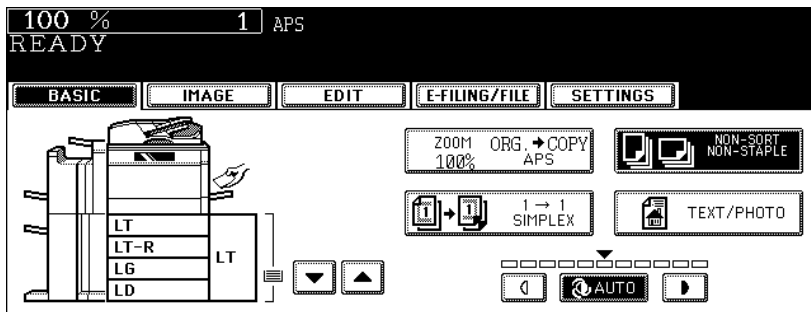

5 Press the [MAGAZINE SORT] (or [MAGAZINE SORT & SADDLE STITCH] or [SADDLE STITCH]) button.

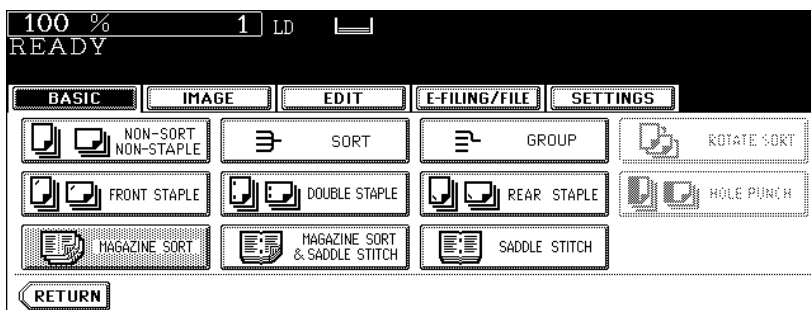

- The [MAGAZINE SORT & SADDLE STITCH] button and the [SADDLE STITCH] button are selectable only when the Saddle Stitch Finisher is installed.
- Set other copy modes as required.

6 Press the [START] button.

- When placing the originals on the original glass, follow the procedure in  P.54 “Placing originals on the glass”.

Available conditions for saddle stitching

Paper size	Paper weight	Maximum number of sheets for saddle stitching	Tray loading capacity
LD, LT-R	17 - 20 lb. Bond	15	Set of 11 - 15 sheets: 10 sets, Set of 6 - 10 sheets: 20 sets, Set of 2 - 5 sheets: 25 sets
	21 - 28 lb. Bond	10	Set of 6 - 10 sheets: 15 sets, Set of 2 - 5 sheets: 25 sets
LG	17 - 20 lb. Bond	15	Set of 11 - 15 sheets: 10 sets, Set of 6 - 10 sheets: 10 sets, Set of 2 - 5 sheets: 20 sets
	21 - 28 lb. Bond	10	Set of 6 - 10 sheets: 10 sets, Set of 2 - 5 sheets: 20 sets

- One cover of 17 lb. Bond to 110 lb. Index can be added. In this case, this cover is included in the maximum number of sheets that can have saddle stitching.
- When paper of different weights is loaded, the maximum number of sheets for saddle stitching should refer to that of the paper with the highest weight.
- To add one cover of 110 lb. Index or more to the paper of 21 to 28 lb. Bond, the tray loading capacity is always 5 sets.

Hole punch mode (optional)

When the Hole Punch Unit (optional) is installed to the Finisher or the Saddle Stitch Finisher (both optional), you can punch holes in the copies.

- The available copy paper sizes for this mode are LD, LG, LT, LT-R and COMP.
- The paper weight applicable for this mode is 17 lb. Bond to 140 lb. Index.
- Special paper such as OHP films or sticker label cannot be used for hole punching.

1 Place paper in the drawer(s).

- When using this mode in bypass copying, specify the paper size in advance. (P.63 "6.Bypass Copying")

2 Place the original(s).

3 Press the finisher button on the basic menu.

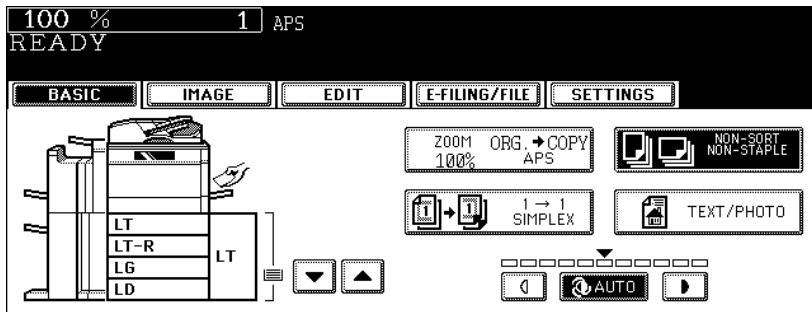

4 Press the [HOLE PUNCH] button.

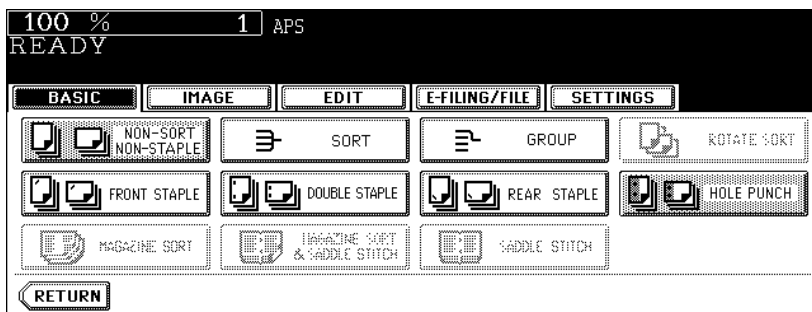

- Set other copy modes as required.

5 Press the [START] button.

Tip

When the Inserter Unit (optional) is installed, you can punch holes without the need to go through any copying operation by setting paper on the unit.

Number of punch holes and available paper sizes

Since the number of punch holes and the distance between the holes vary depending on the country/region, purchase a hole punch unit that meets your requirements. (For details, consult your service technician.)

	Number of punch holes and hole diameter	Available paper sizes
MJ-6003E (Japan and most of Europe)	2 holes (0.26" dia.)	LD, LG, LT, LT-R, COMP, A3, A4, A4-R, B4, B5, B5-R, FOLIO
MJ-6003N (North America)	2/3 holes switchable (0.32" dia.)	2 holes: LG, LT-R 3 holes: LD, LT, A3, A4
MJ-6003F (France)	4 holes (0.26" dia.; 3.15" pitch)	LD, LT, A3, A4
MJ-6003S (Sweden)	4 holes (0.26" dia.; 2.76", 0.83" pitch)	LD, LG, LT-R, COMP, A3, A4, A4-R, B4, B5, B5-R, FOLIO

Inserter mode (optional)

When you want to staple or punch holes on the paper without going through any copying operation, place sheets on the Inserter Unit (optional).

Also, when you want to insert blank sheets of paper at specified pages, place sheets on the Inserter Unit. (☞ P.167 "18.INSERTER")

- Be sure to place the same size of sheets of paper on the Inserter Unit and align them.
- If the paper is fed from more than one paper source, such as the drawer, External Large Capacity Feeder, bypass tray or Inserter Unit, set all sheets of paper in one size in the same direction.

Available paper size and type for the Inserter Unit

Paper size	LD, LG, LT, LT-R, COMP
Media type	Plain paper (17 - 20 lb. Bond) Thick paper (21 lb. Bond - 140 lb. Index) Recycled paper Special paper (e.g. OHP film, color paper) (Contact a Toshiba-product distributor for details of the special paper available.)
Maximum number of sheets can be set	17 - 20 lb. Bond: 100 sheets 21 lb. Bond - 140 lb. Index: Less than 0.47" in paper height (less than 0.28" in case of special paper)

- Note that some types of paper may not be applicable for the Inserter Unit due to their paper qualities, even if you are using the paper listed above.
- The use of the Inserter Unit has some restrictions on stapling and saddle stitching respectively. (☞ P.89 "Maximum number of sheets for stapling", ☞ P.92 "Available conditions for saddle stitching")

Setting paper on the Inserter Unit

1 Place paper on the Inserter Unit and adjust the side guides to the width of the paper.

- Place the paper with its face up.
- Be sure that the top and bottom of the paper to be inserted are the same as those of originals.
- Be sure that the height of the paper placed on the Inserter Unit does not exceed the indicator on the side guide.

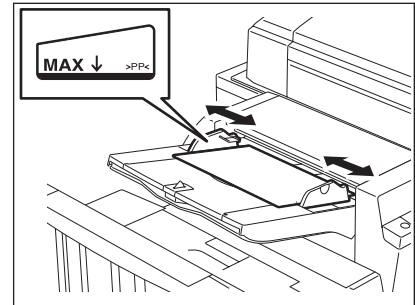

- When you place large-sized paper on the Inserter Unit, widen the tray as shown in the illustration on the right.

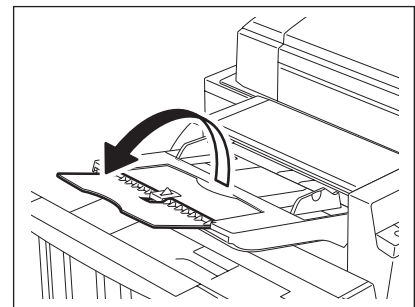

Using only staple mode or hole punch mode

When the Inserter Unit is installed, the individual operations of stapling, saddle stitching and hole punching without the need for any copying operation are enabled. In this case, use the control panel of the Inserter Unit.

1 Place paper on the Inserter Unit.

 P.95 "Setting paper on the Inserter Unit"

- When paper is placed on the unit, the [START] button of the unit is lit green.

Tip

When you use the saddle stitch mode, place the sheets to be the top and back covers of the document at the bottom of the paper. (If paper is placed in the Inserter Unit as shown in the figure, it will be stapled in the position indicated by the arrows.)

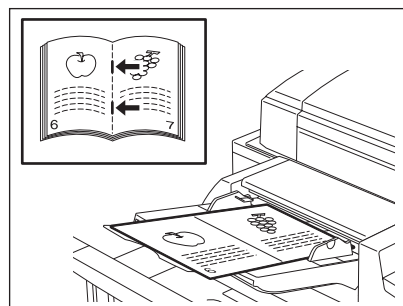

2 Set each mode with the control panel of the Inserter Unit.

- When you use the hole punch mode, press the button 1 on the control panel of the unit. The hole punch mode lamp is lit.
- When you use the staple mode or the saddle stitch mode, press the button 2 on the control panel of the unit. The lamp for the mode you have selected is lit. Each time you press the button 2, these two modes switch over.

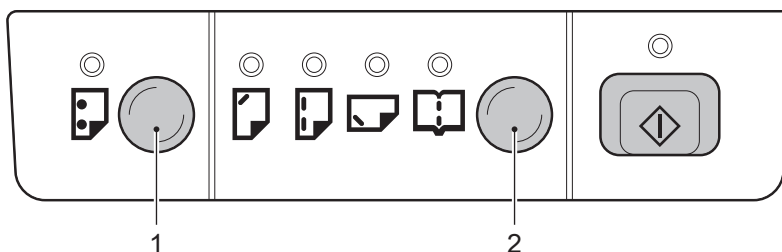

Tips

- The saddle stitch mode is available only when the Saddle Stitch Finisher (optional) is installed.
- The hole punch mode and the staple mode can be used together. The hole punch mode and the saddle stitch mode cannot be used together.

3 Press the [START] button on the control panel of the unit.

- The operation starts and the [START] button on the control panel of the unit blinks in green. When the operation has finished, all the lamps on the control panel of the unit go out.

4. Duplex Copying

The following 5 combinations are available for duplex copying.

1. 1-sided original -> 1-sided copy (default setting at installation)
2. 1-sided original -> 2-sided copy
3. 2-sided original -> 2-sided copy
4. 2-sided original -> 1-sided copy
5. Book-type original -> 2-sided copy

- Duplex copying is available for plain paper (17 to 20 lb. Bond), thick 1 paper (- 28 lb. Bond), thick 2 paper (- 90 lb. Index) and thick 3 paper (- 110 lb. Index).

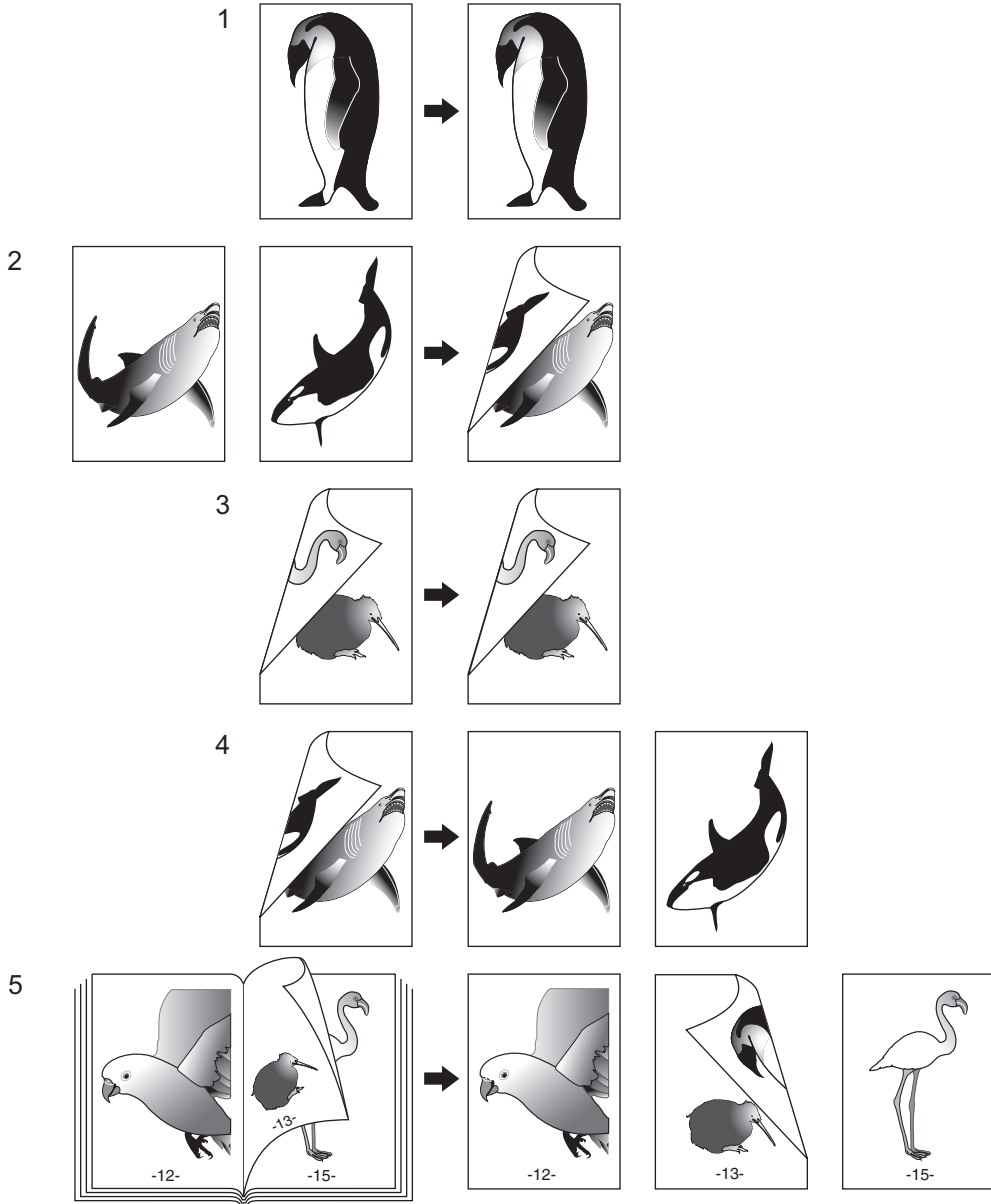

1-sided original -> 1-sided copy (default setting at installation)

1 Place paper in the drawer(s).

2 Place the original(s).

3 Confirm that the simplex/duplex button on the basic menu is [1 -> 1 SIMPLEX].

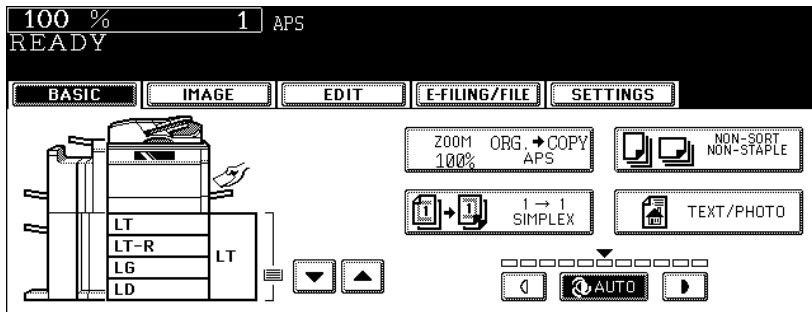

- If [1 -> 1 SIMPLEX] is not shown, press the simplex/duplex button to display the next menu, and then press the [1 -> 1 SIMPLEX] button on that menu.

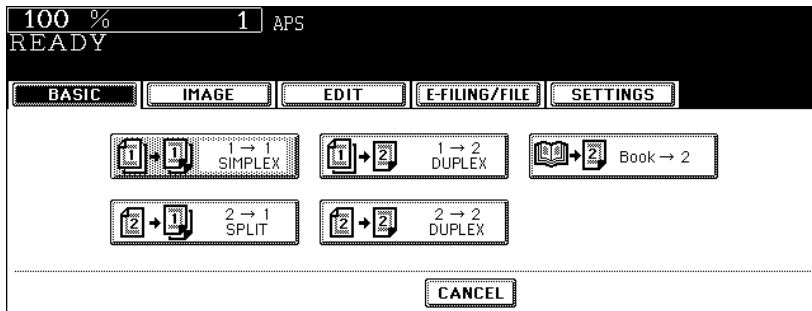

- Set other copy modes as required.

4 Press the [START] button.

1-sided original -> 2-sided copy

When you copy 1-sided portrait originals to 2-sided copies, you can make a booklet-type copy in the direction of “open to left” opening, using the image direction mode in the edit menu. (P.150 “14.IMAGE DIRECTION”)

1 Place paper in the drawer(s).

- When using this mode in bypass copying, specify the paper size in advance. (P.63 “6.Bypass Copying”)

2 Place the original(s).

3 Press the simplex/duplex button on the basic menu.

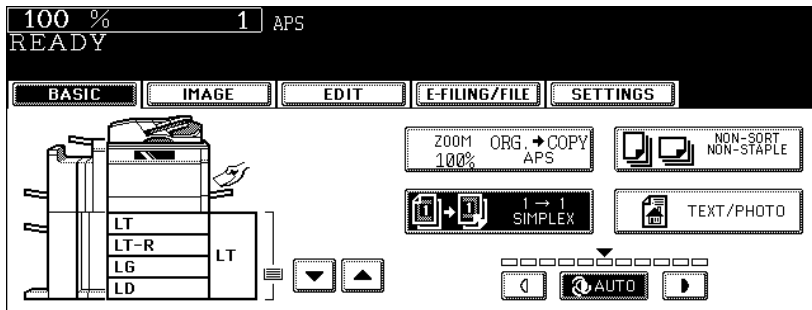

4 Press the [1 -> 2 DUPLEX] button.

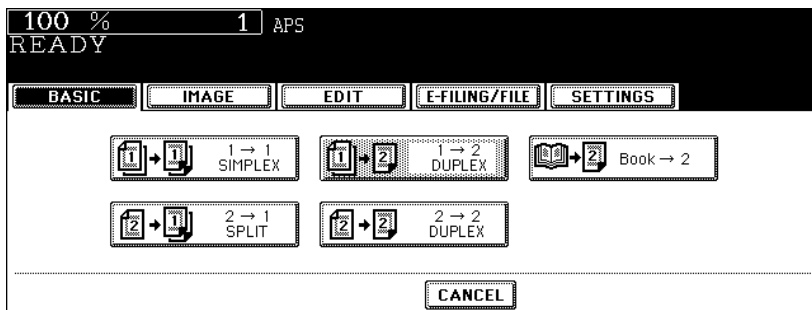

- Set other copy modes as required.

5 Press the [START] button.

- When placing an original on the original glass, follow steps 5 to 6 of P.48 “Copying procedure” continuously.

2-sided original -> 2-sided copy

1 Place paper in the drawer(s).

- When using this mode in bypass copying, specify the paper size in advance. (☞ P.63 "6.Bypass Copying")

2 Place the original(s).

3 Press the simplex/duplex button on the basic menu.

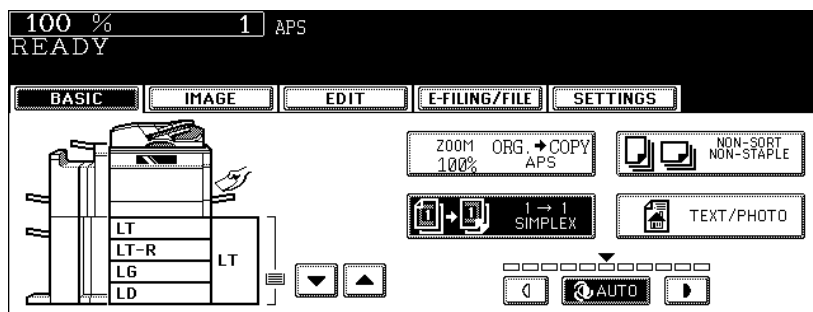

4 Press the [2 -> 2 DUPLEX] button.

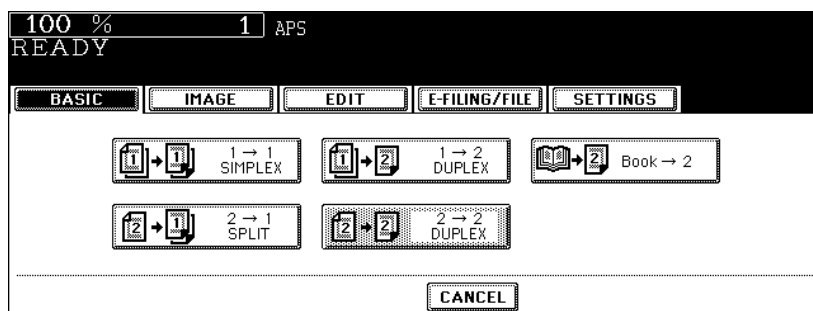

- Set other copy modes as required.

5 Press the [START] button.

- When placing an original on the original glass, follow steps 5 to 6 of ☞ P.48 "Copying procedure" continuously.

2-sided original -> 1-sided copy

When a 2-sided 'open to left' (Book) portrait original is copied using the image direction mode in the edit menu with [2-Sided Originals to 1-Sided Copies], copies can be adjusted to the same direction. (P.150 "14.IMAGE DIRECTION")

- 1 Place paper in the drawer(s).
- 2 Place the original(s).
- 3 Press the simplex/duplex button on the basic menu.

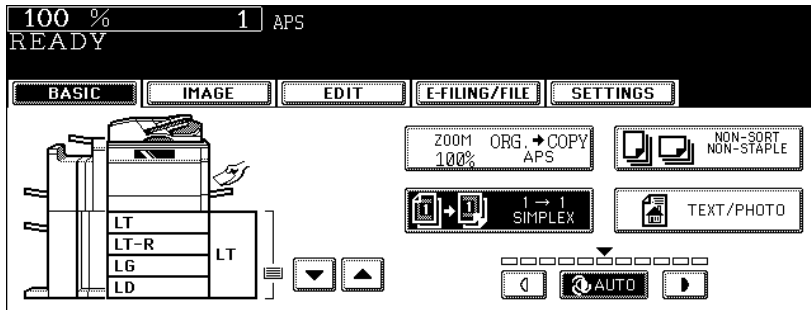

- 4 Press the [2 -> 1 SPLIT] button.

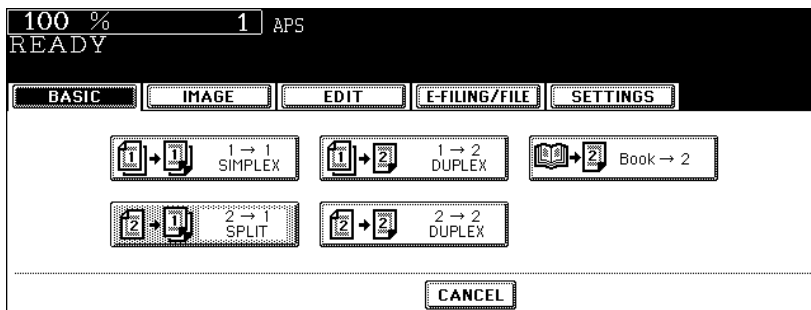

- Set other copy modes as required.

- 5 Press the [START] button.

Book-type original -> 2-sided copy

You can make a booklet-type copy in the same page configuration in which the original is.

- The acceptable paper size for this function is LT only.

1 Place paper in the drawer(s).

- When using this mode in bypass copying, specify the paper size in advance. (P.63 "6.Bypass Copying")

2 Press the simplex/duplex button on the basic menu.

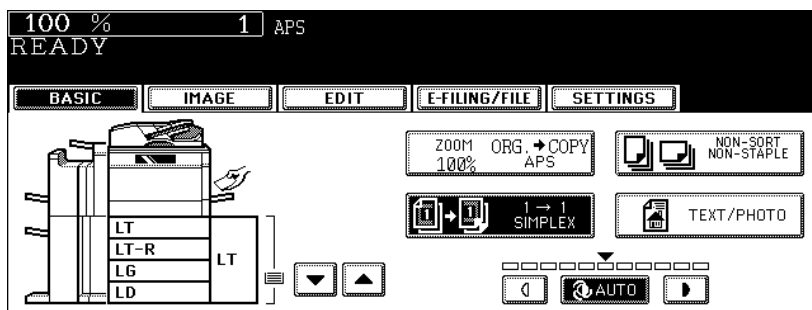

3 Press the [BOOK -> 2] button.

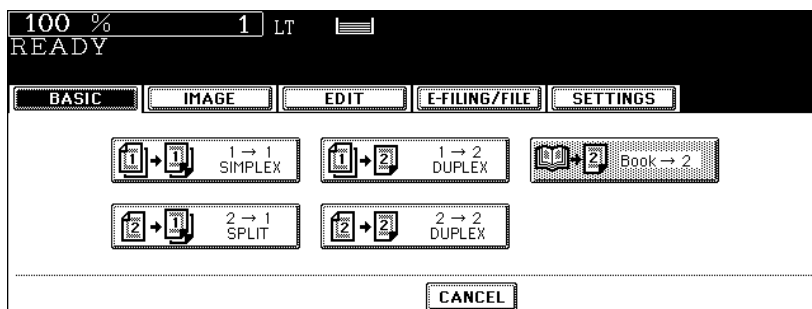

4 Select the book copying type.

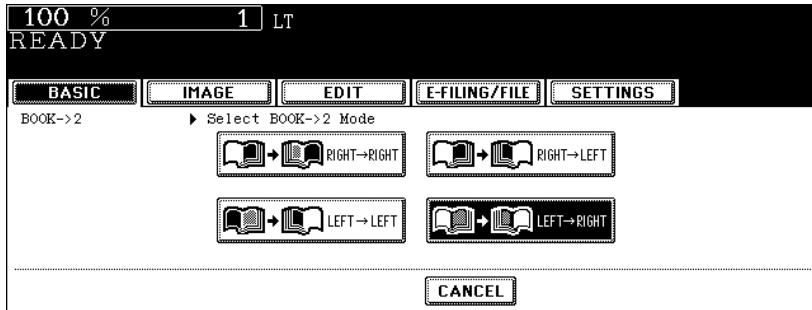

- Press the [RIGHT -> RIGHT] button (= default setting at the installation) if copying should start at a right-hand page and end at a right-hand page. Other copying types are selectable by pressing any of the [RIGHT -> LEFT], [LEFT -> LEFT] and [LEFT -> RIGHT] buttons.

e.g.: If pages 2 to 6 of a book which opens to the left are to be copied, select [LEFT -> RIGHT].

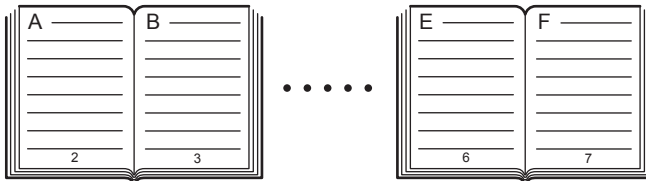

- The yellow indicator line for booklet copying moves to the center of the original glass.

5 Select LT copy size.

- Only LT size is available. Press the drawer button on the touch panel, or use the paper source selection (▼/▲) buttons to select LT size.

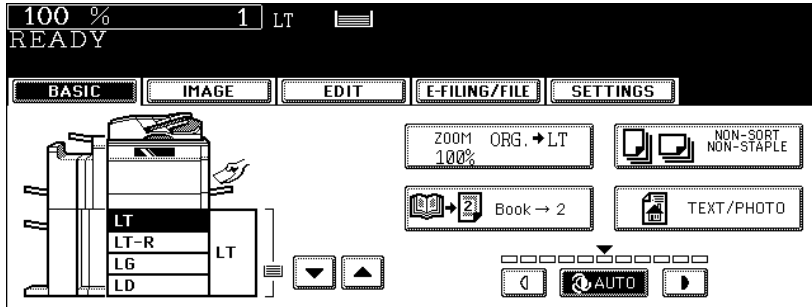

- If you need a binding space, select the book margin mode. (P.114 "1.IMAGE SHIFT")
 - Set other copy modes as required.

6 Open and place the first page(s) on the original glass.

Caution

Do not place heavy objects (9 lb. or more) on the original glass and do not press on it with force. Breaking the glass could injure you.

- Center the booklet on the yellow indicator line with its bottom toward you.

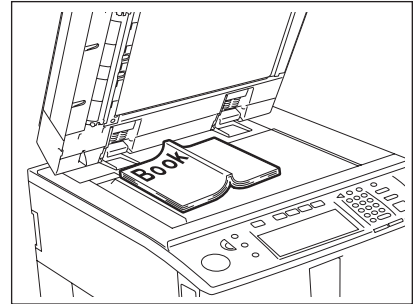

7 Press the [START] button. When the data of the opened pages have been scanned, open the next page and set the booklet on the original glass again.

- Repeat the procedures above until all the desired pages have been scanned. If the last copy is only a single page, press the [COPY FINAL PAGE] button on the touch panel before the scanning of this page is started.



-
- 8** When all the pages have been scanned, press the [FINISHED] button on the touch panel.

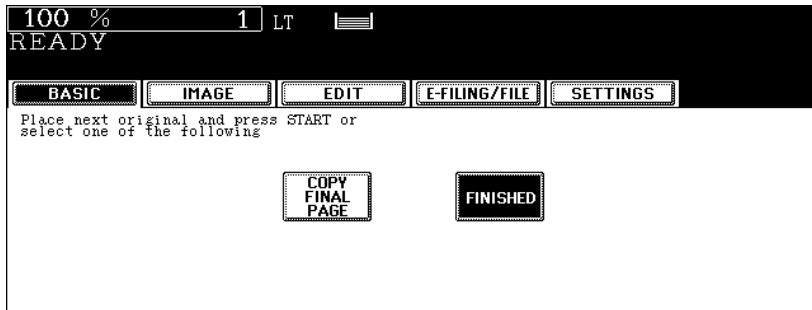

- The scanned pages will be copied.

5. Original Mode

You can select the most appropriate image processing mode (= original mode) for your original from the following 3 modes.

[TEXT/PHOTO]: Original with text and photographs (default setting at installation)

[TEXT]: Original with text only (or text and line art only)

[PHOTO]: Original with photographs only

1 Place paper in the drawer(s).

2 Place the original(s).

3 Press the original mode button on the basic menu.

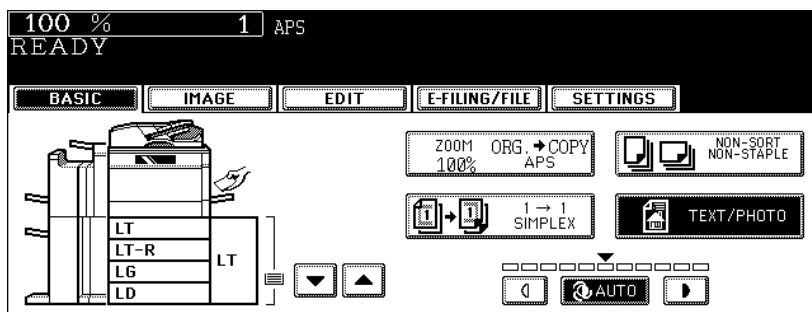

4 Select and press the button for the most appropriate original mode for your original.

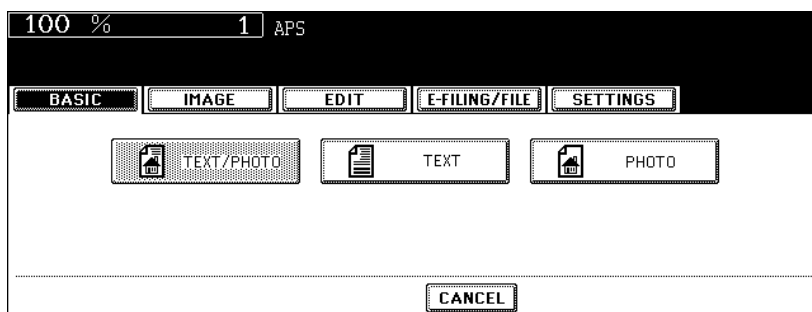

- Set other copy modes as required.

5 Press the [START] button.

6. Copy Density Adjustment

There are 2 types of copy density adjustment: the automatic copy density mode and the manual copy density mode. In the automatic copy density mode, the equipment automatically selects the most appropriate copy density by detecting the density of the original. In the manual copy density mode, you can adjust the copy density manually according to the conditions of the original.

- The automatic copy density mode is selected by default when the equipment is installed.

Automatic copy density mode

- 1 Place paper in the drawer(s).
- 2 Place the original(s).
- 3 Confirm that the [AUTO] button on the basic menu is selected. If it is not, press the button.

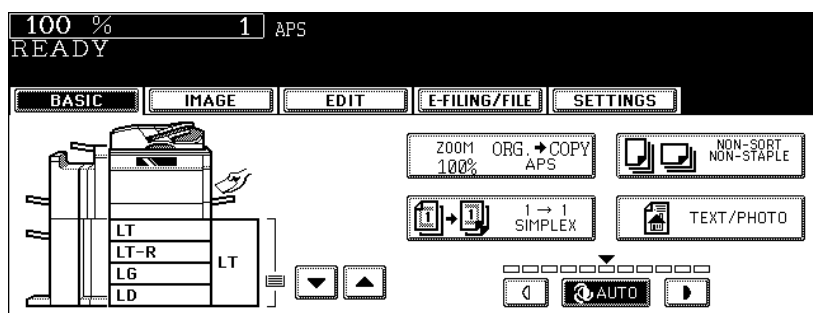

- Set other copy modes as required.

- 4 Press the [START] button.

Manual copy density mode

- 1 Place paper in the drawer(s).
- 2 Place the original(s).
- 3 Press either the ◀ or ▶ button to adjust the copy density to the desired level.

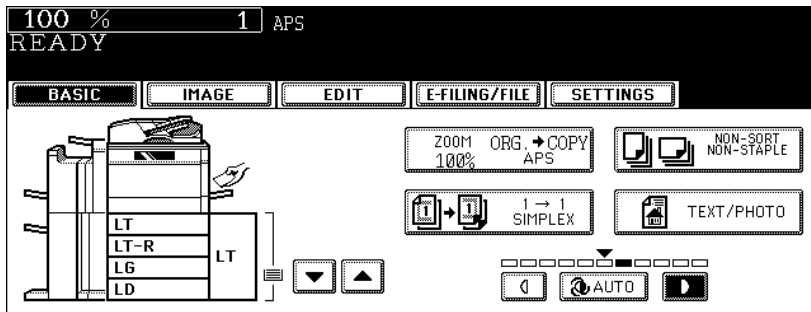

- The copied image becomes lighter as you press the ◀ button and darker as you press the ▶ button.
- Set other copy modes as required.

- 4 Press the [START] button.

4. IMAGE ADJUSTMENT

1. Background Adjustment.....	110
2. Sharpness.....	111

1. Background Adjustment

This function allows you to adjust the density of the original's background. It avoids the back side of 2-sided originals becoming visible on the front side of the original through the copy.

1 Place paper in the drawer(s).

2 Place the original(s).

3 Press the [IMAGE] button to enter the image menu, and then press the [BACKGROUND ADJUSTMENT] button.

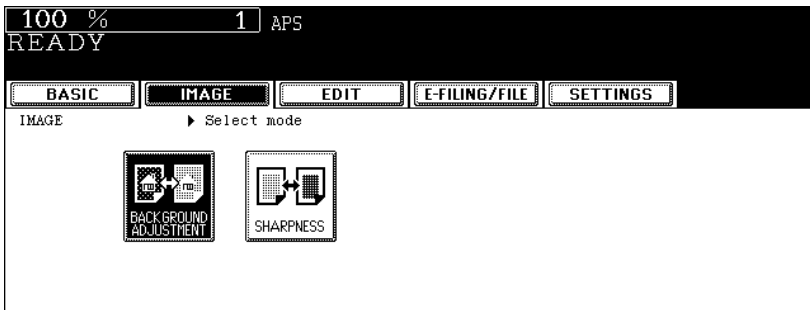

4 Press the [LIGHT] (or [DARK]) button to adjust the density, and then press the [ENTER] button.

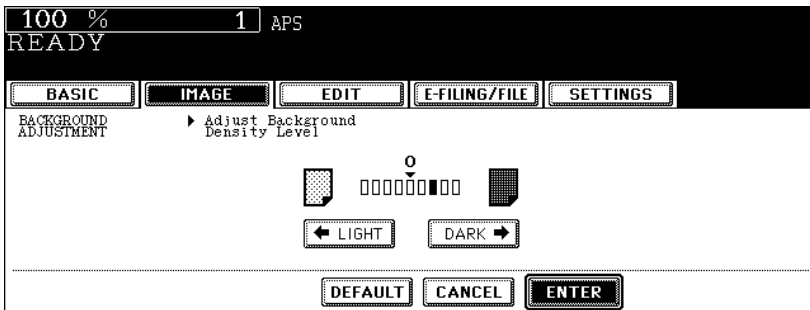

- Select other copy modes as required.

5 Press the [START] button.

Canceling the background adjustment

There are 2 ways to clear the setting.

- Press the [DEFAULT] button and then the [ENTER] button.
- Adjust the background level to "0", and then press the [ENTER] button.

2. Sharpness

This function allows you to emphasize or blur the outline of the image. When the sharpness level is adjusted to the [SOFT] side, the moire fringes are suppressed. If it is adjusted to the [SHARP] side, the letters and fine lines become sharper.

1 Place paper in the drawer(s).

2 Place the original(s).

3 Press the [IMAGE] button to enter the image menu, and then press the [SHARPNESS] button.

4

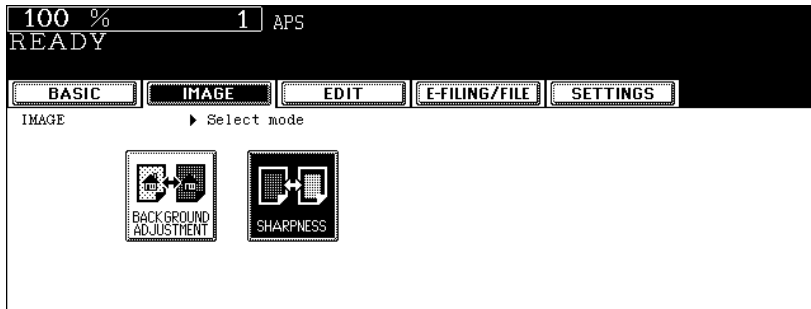

4 Press the [SOFT] (or [SHARP]) button to adjust the sharpness, and then press the [ENTER] button.

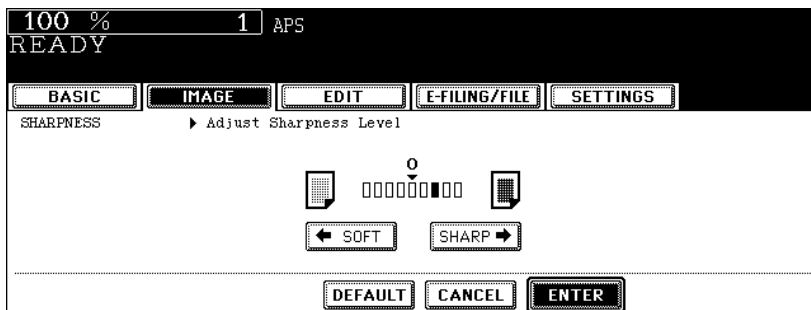

- When the sharpness level is adjusted to the [SOFT] side, the moire fringes are suppressed. If it is adjusted to the [SHARP] side, the letters and fine lines become sharper.
- Select other copy modes as required.

5 Press the [START] button.

Canceling the sharpness adjustment

There are 2 ways to clear the setting.

- Press the [DEFAULT] button and then the [ENTER] button.
- Adjust the sharpness level to "0", and then press the [ENTER] button.



4

5. USING THE EDITING FUNCTIONS

1. IMAGE SHIFT	114
2. EDGE ERASE.....	120
3. BOOK CENTER ERASE.....	121
4. DUAL PAGE.....	123
5. 2IN1 / 4IN1.....	126
6. MAGAZINE SORT	129
7. EDITING	131
• Trimming / Masking.....	131
• Mirror image.....	134
• Negative/Positive reversal.....	135
8. XY ZOOM	136
9. COVER SHEET	138
10.SHEET INSERTION.....	141
11. TIME STAMP	143
12.PAGE NUMBER.....	144
13.JOB BUILD	146
14.IMAGE DIRECTION.....	150
15.BOOK - TABLET	152
16.ADF / SADF	154
17.TAB PAPER	157
18.INSERTER.....	167

1. IMAGE SHIFT

A margin for binding can be created. The following types are available.

1. Created by shifting the original image to either the right or left side (Right or Left margin)
2. Created by shifting the original image to either the upper or lower side (Top or Bottom margin)
3. Created binding margins in the center (inner margin) (Bookbinding margin)
Select this setting when using "Book-type original -> 2-sided copy" (📖 P.102).

Tip

The 'Top or Bottom margin' can be used in combination with the 'Right or Left margin' or the 'Bookbinding margin'.

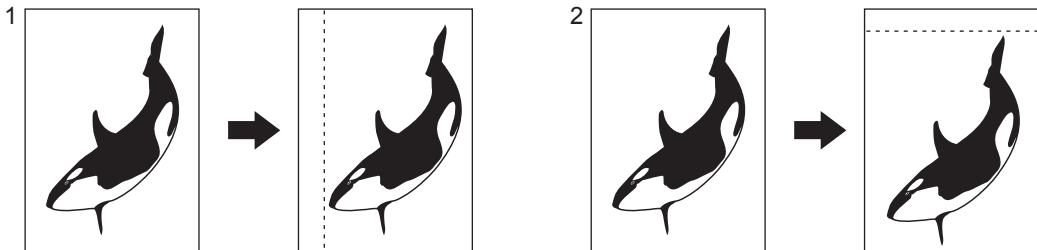

5

Creating a right or left margin

1 Place paper in the drawer(s).

- When using this mode in bypass copying (📖 P.63), be sure to specify the paper size.

2 Place the original(s).

3 Press the [EDIT] button to enter the edit menu, and then press the [IMAGE SHIFT] button.

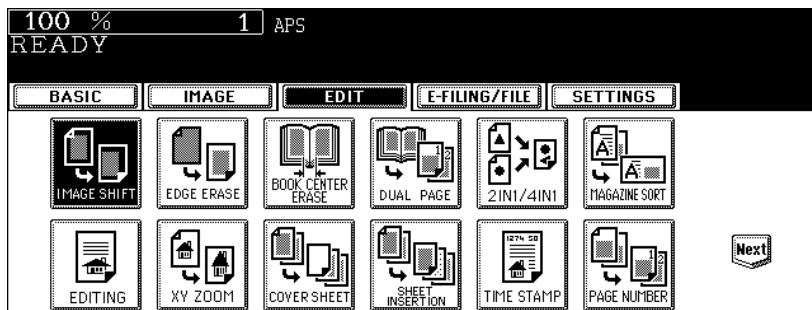

4 Press the [LEFT] (or [RIGHT]) button.

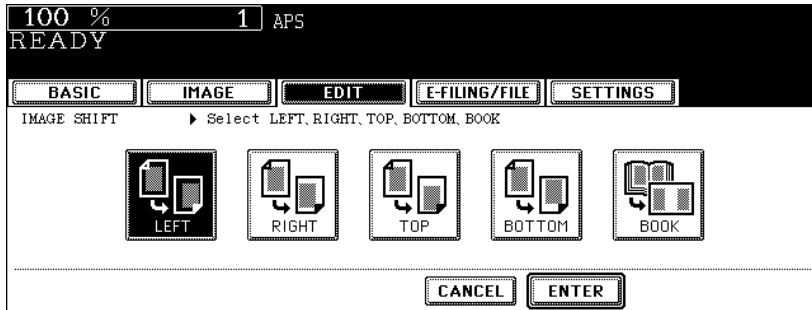

5 Adjust the margin width by pressing the [2 mm] or [100 mm] button, and then press the [ENTER] button.

5

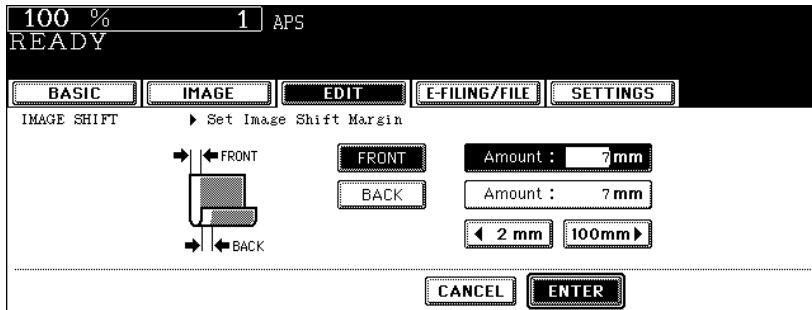

- The default width of the margin is 7 mm (0.276").
- In duplex copying, margins on the back are created on the other side of those in the front. (P.97 "4. Duplex Copying")

6 Press the [ENTER] button.

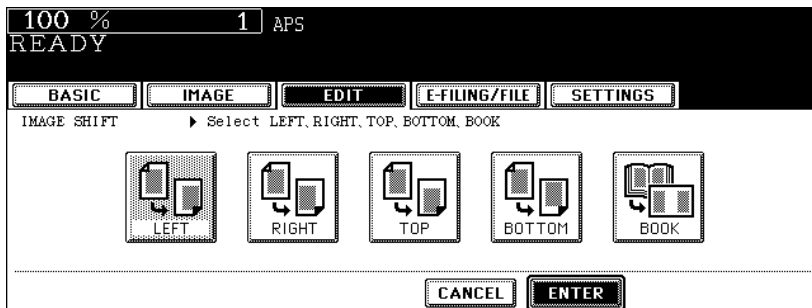

- Select other copy modes as required.

7 Press the [START] button.

Creating a top or bottom margin

1 Place paper in the drawer(s).

- When using this mode in bypass copying (P.63), be sure to specify the paper size.

2 Place the original(s).

3 Press the [EDIT] button to enter the edit menu, and then press the [IMAGE SHIFT] button.

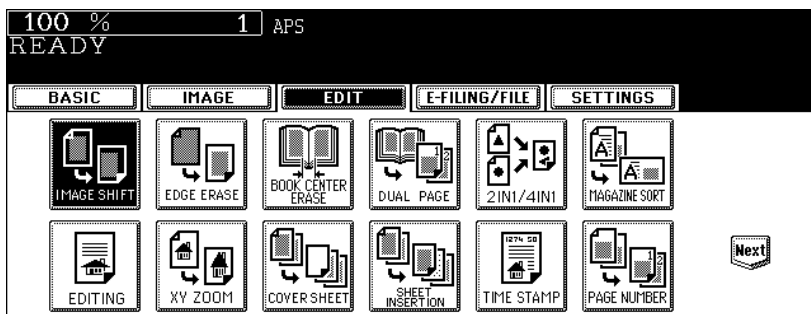

4 Press the [TOP] (or [BOTTOM]) button.

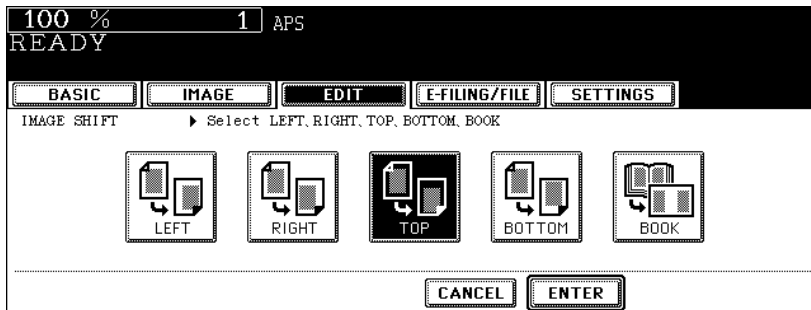

- 5** Adjust the margin width by pressing the [2 mm] or [100 mm] button, and then press the [ENTER] button.

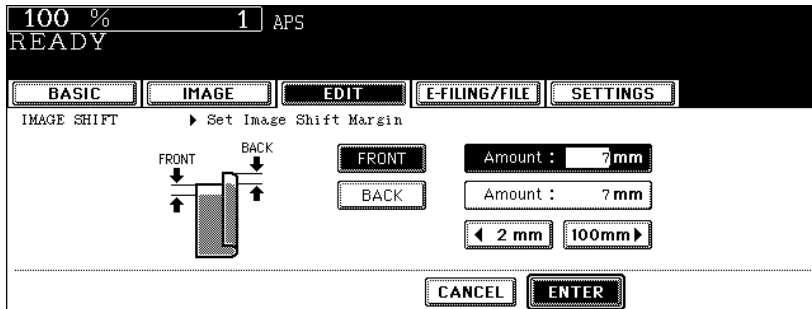

- The default width of the margin is 7 mm (0.276").
- In duplex copying, margins on the back are created on the other side of those in the front. (P.97 "4.Duplex Copying")

5

- 6** Press the [ENTER] button.

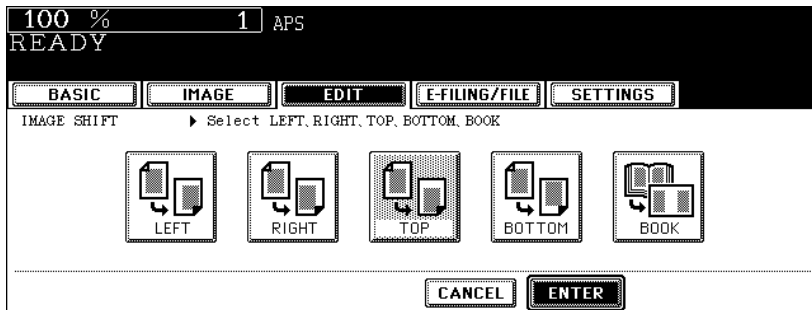

- Select other copy modes as required.

- 7** Press the [START] button.

Creating a bookbinding margin

This is used when setting "Book-type original -> 2-sided copy" (P.102) in duplex copying. The margin is created in the center (inner margin).

- Acceptable paper sizes for this function is LT only.

- 1 Press the [EDIT] button to enter the edit menu, and then press the [IMAGE SHIFT] button.

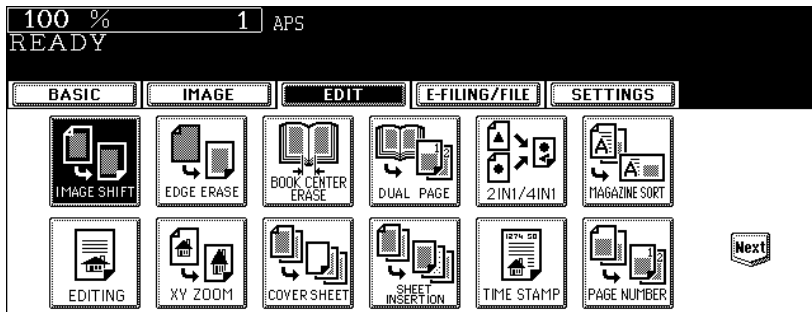

- 2 Press the [BOOK] button.

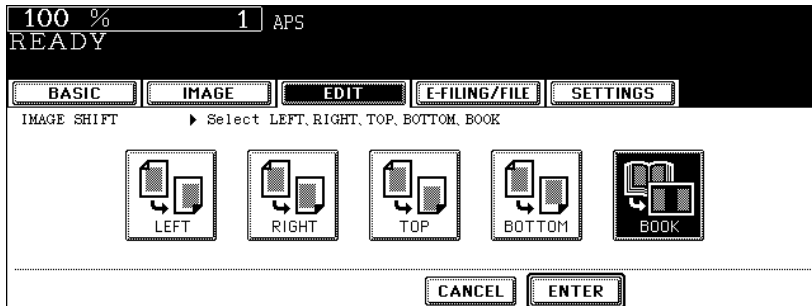

- 3 Adjust the margin width by pressing the [2 mm] or [30 mm] button, and then press the [ENTER] button.

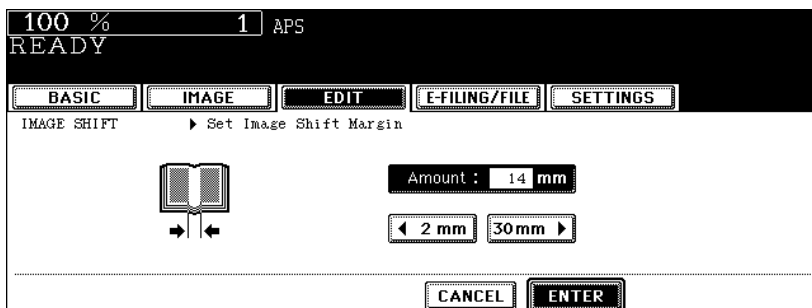

- The default width of the margin is 14 mm (0.551").

4 Press the [ENTER] button.

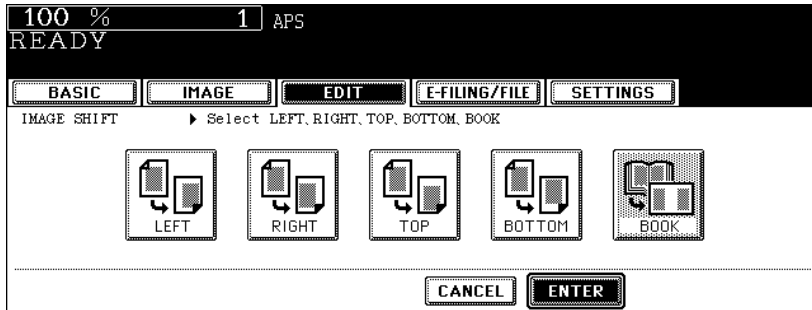

- Set "Book-type original -> 2-sided copy" (📖 P.102) in duplex copying as well.

2. EDGE ERASE

If the original has a dirty or torn edge, it may be reproduced as a black stain on the copy. In that case, set the edge erase. A white border is created along the edges of the copy, eliminating those black stains.

- This function is available only in the case of standard-size originals.

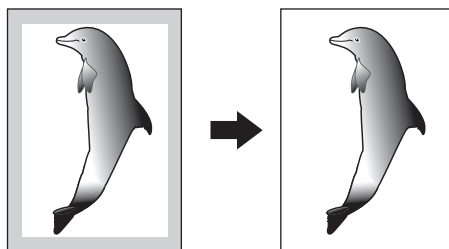

5

1 Place paper in the drawer(s).

- When using this mode in bypass copying (P.63), be sure to specify the paper size.

2 Place the original(s).

3 Press the [EDIT] button to enter the edit menu, and then press the [EDGE ERASE] button.

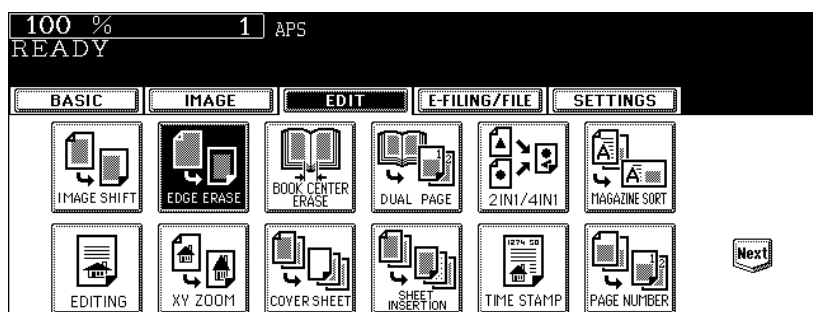

4 Adjust the width by pressing the [2 mm] or [50 mm] button, and then press the [ENTER] button.

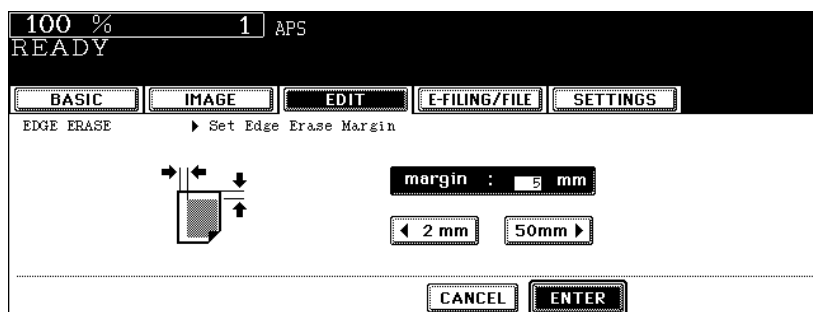

- The default width of the white border is 5 mm (0.197").
- Select other copy modes as required.

5 Press the [START] button.

3. BOOK CENTER ERASE

This function allows you to erase the shadow in the center of a book original.

1. Before book center erase is set
2. After book center erase is set

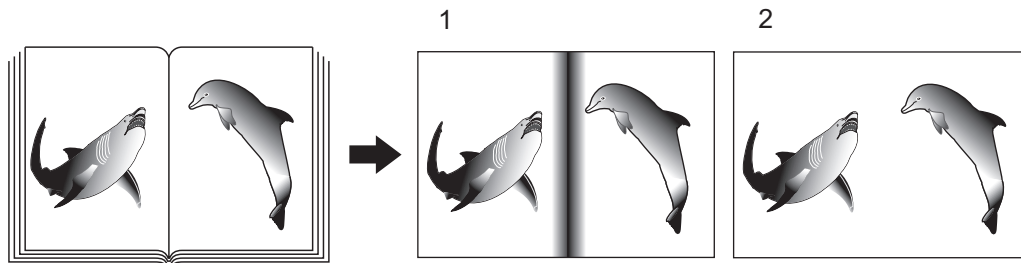

1 Place paper in the drawer(s).

- When using this mode in bypass copying (P.63), be sure to specify the paper size.

2 Place the original(s).

Caution

Do not place heavy objects (9 lb. or more) on the original glass and do not press on it with force. Breaking the glass could injure you.

3 Press the [EDIT] button to enter the edit menu, and then press the [BOOK CENTER ERASE] button.

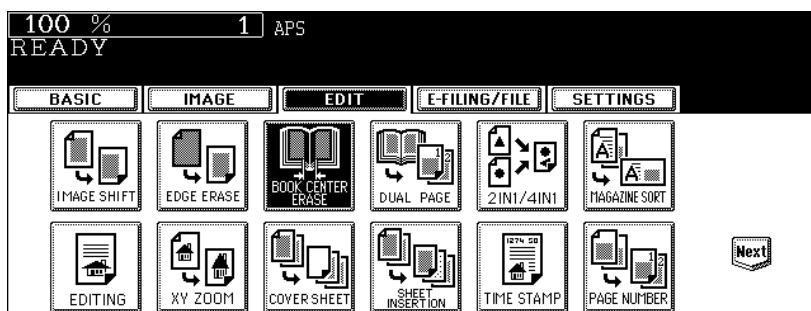

4 Adjust the width by pressing the [2 mm] or [50 mm] button, and then press the [ENTER] button.

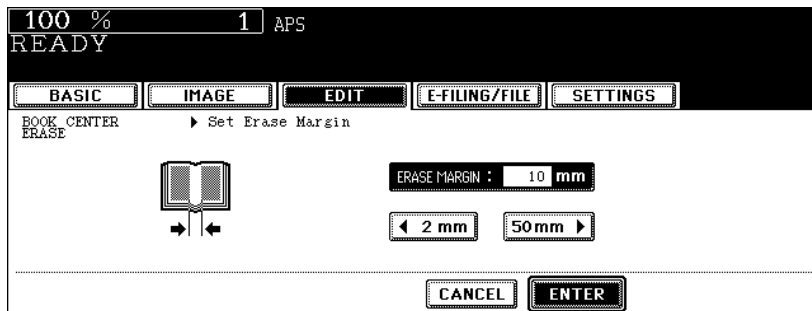

5

- The default width of the erase margin is 10 mm (0.393").
- Select other copy modes as required.

5 Press the [START] button.

4. DUAL PAGE

This function allows the facing pages of a book or magazine to be copied page by page onto 2 separate sheets of paper or duplex-copied on one sheet. It is not necessary to move the original on the glass. You can also place a pair of LT sized originals side by side and copy them on separate sheets of paper.

- Acceptable paper sizes for this function is LT only.

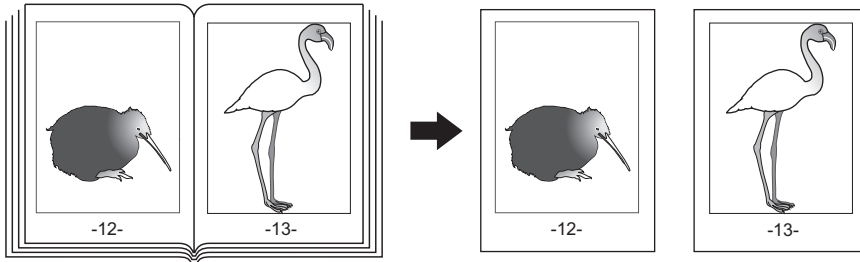

5

1 Place paper in the drawer(s).

2 Press the [EDIT] button to enter the edit menu, and then the [DUAL PAGE] button.

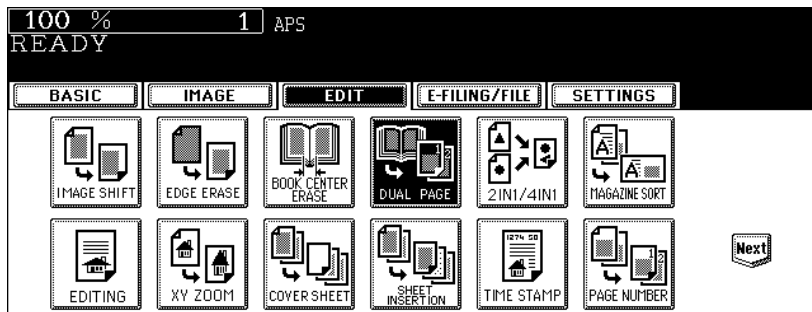

3 Press the [1 SIDE] (or [2 SIDE]) button.

- 1 SIDE:** Making copies of the facing pages on 2 separate sheets of paper page by page
- 2 SIDE:** Making duplex copies of them on one sheet

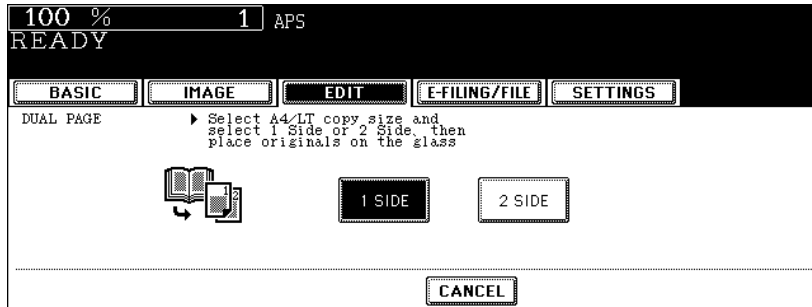

- The yellow indicator line for placing a book moves near the center of the original glass.
- If you need a binding margin, set the right or left margin. (P.114 "Creating a right or left margin")

4 Press the [BASIC] button to enter the basic menu, and then select the copy size (LT).

- When using this mode in bypass copying (P.63), be sure to specify the paper size.
- Select other copy modes as required.

5 Place the first page(s) to be copied on the glass, and then press the [START] button.

- Center the book on the yellow indicator line with the bottom toward you. (P.55 "Book-type originals")

Caution

Do not place heavy objects (9 lb. or more) on the original glass and do not press on it with force. Breaking the glass could injure you.

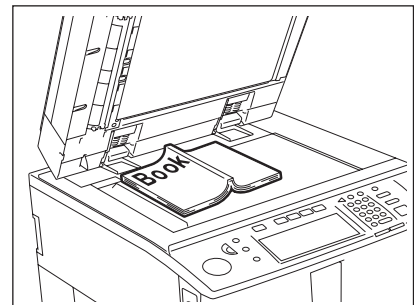

6 Turn to the next page, set the book again, and then press the [START] button.

- Repeat this step until all the originals have finished being scanned.

7 After all the originals have finished being scanned, press the [FINISHED] button.



- Press the [COPY FINAL PAGE] button if the last original is a 1-sided page.

5. 2IN1 / 4IN1

This feature allows multiple originals to be reduced and copied onto a single sheet of paper. There are 2 modes: 2IN1 copying, where 2 originals are copied onto a single sheet, and 4IN1 copying, where 4 originals are copied onto a single sheet. In addition, duplex 2IN1 / 4IN1 modes are available, where four/eight originals can be copied to 2 sides of a single sheet of paper.

2IN1

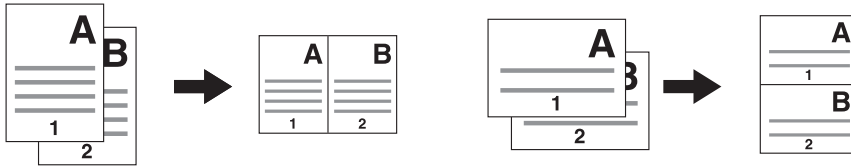

4IN1

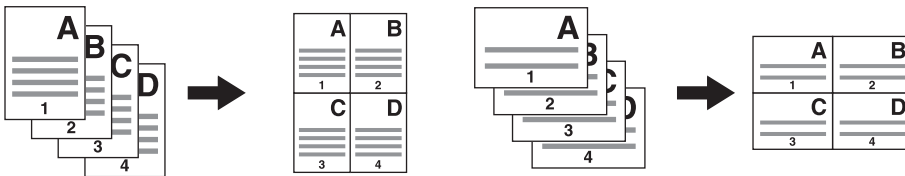

2IN1 DUPLEX (a: Side 1, b: Side 2)

- When a copy is turned with the line as a pivot, originals are printed on Side 2 (back face) as shown.

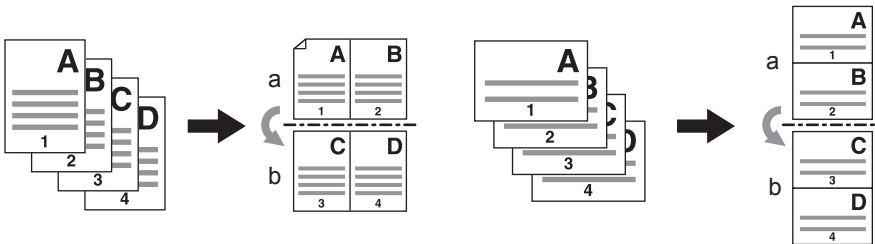

4IN1 DUPLEX (a: Side 1, b: Side 2)

- When a copy is turned with the line as a pivot, originals are printed on Side 2 (back face) as shown.

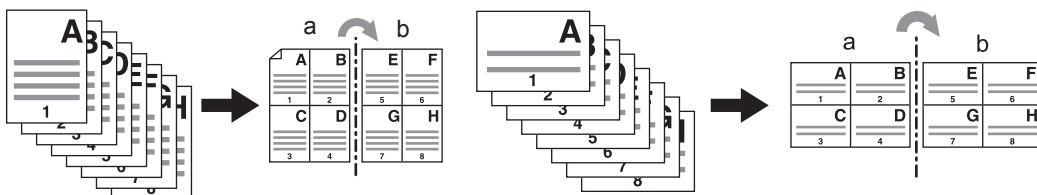

1 Place paper in the drawer(s).

- When using this mode in bypass copying (P.63), be sure to specify the paper size.

Tip

To make copies on paper which is not the same size as the original, press the [ZOOM] button on the basic menu to enter the following menu, select the desired paper size and press the [AMS] button.

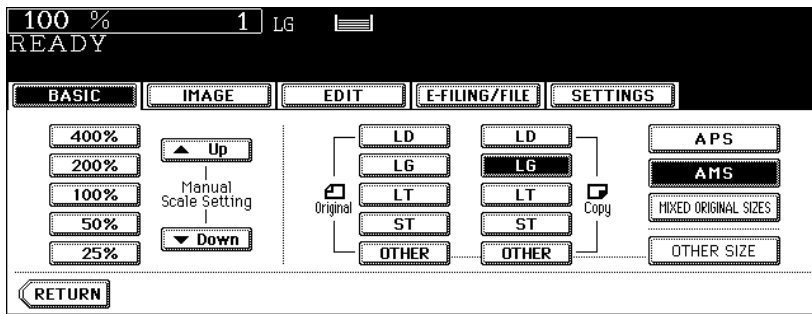

- If the paper size is not changed, paper of the same size as the original is selected.

2 Place the original(s).

3 Press the [EDIT] button to enter the edit menu, and then press the [2 IN1 / 4IN1] button.

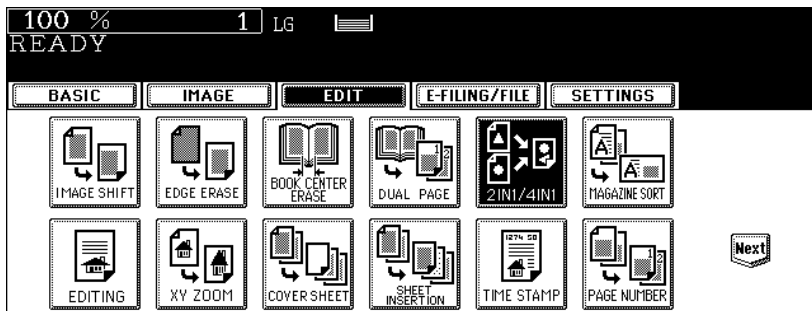

4 Select the type of image combination.

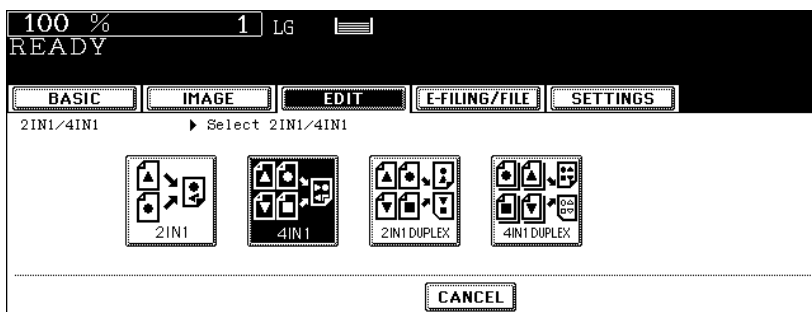

5 Press the [1 SIDE] (or [2 SIDE]) button.

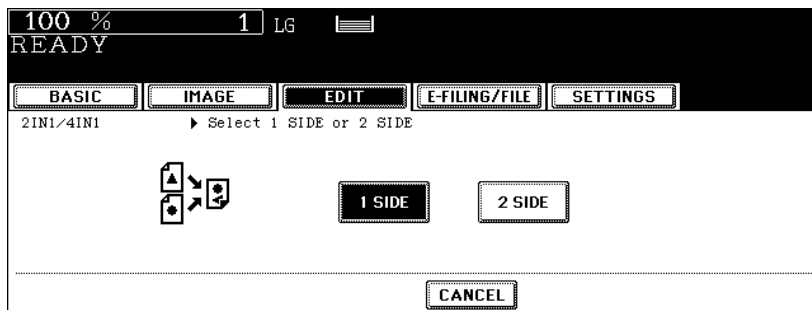

- Select other copy modes as required.

5 6 Press the [START] button.

6. MAGAZINE SORT

This function allows 1-sided originals to be copied and sorted so that they can be folded and bound along a center line like typical magazines or booklets.

Example of copying a 12-page document

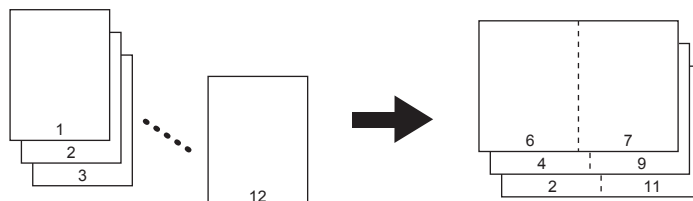

Tip

When placing a portrait originals horizontal to you in the magazine sort mode, be sure to set the correct direction of the originals. (📖 P.150 "14.IMAGE DIRECTION")

5

Using this function in combination with the Saddle Stitch Finisher (optional) makes copies automatically folded in half and stapled along their center line.

Example of copying with the Saddle Stitch Finisher (optional)

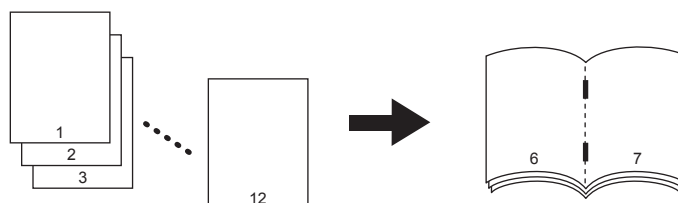

The Magazine sort function has 2 procedures; operating from the basic menu and operating from the edit menu. When operating from the edit menu, the margin width can be adjusted.

To operate from the basic menu, see 📖 P.90 "Magazine sort & saddle stitch mode (booklet mode)".

1 Place paper in the drawer(s).

- When using the Saddle Stitch Finisher, LD, LG, LT-R, A3, A4-R and B4 are available.

2 Select the paper type.

- For drawer feeding, see 📖 P.74 "Manual paper selection".
- For bypass feeding, see 📖 P.63 "6.Bypass Copying".

3 Place the original(s).

4 Press the [EDIT] button to enter the edit menu, and then press the [MAGAZINE SORT] button.

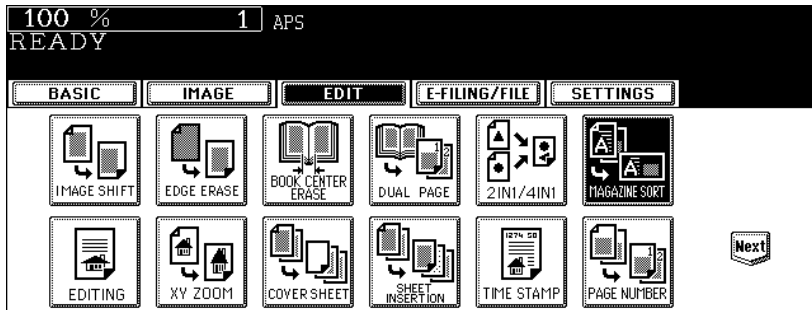

5

5 Set the saddle-stitch and the binding margin.

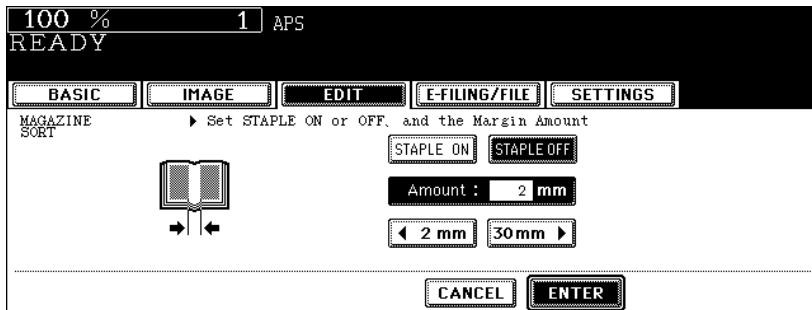

- To staple the center line using the Saddle Stitch Finisher (optional), press the [STAPLE ON] button. For the maximum number of sheets that can be stapled, see [P.92](#) "Available conditions for saddle stitching".
- To adjust the width, press the [2 mm] or [30 mm] button.
- The default width of the margin is 2 mm (0.08").
- Select other copy modes as required.

6 Press the [START] button.

7. EDITING

Trimming / Masking

This function allows you to copy only the inside of the specified area on an original (trimming) or copy with the specified area masked (masking). Up to 4 rectangular areas can be specified on an original.

- Image editing is only available with standard-size originals.
- If the original and copy paper sizes are set incorrectly, the image in the specified range may not be copied correctly.
 1. An example of trimming
 2. An example of masking

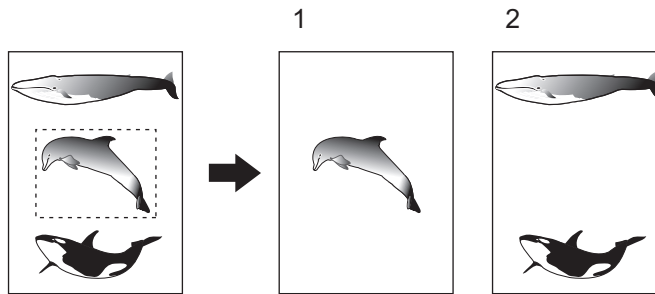

5

1 Place paper in the drawer(s).

- When using this mode in bypass copying, be sure to specify the paper size (☞ P.72 "1.Paper Selection").

2 Press the [EDIT] button to enter the edit menu, and then press the [EDITING] button.

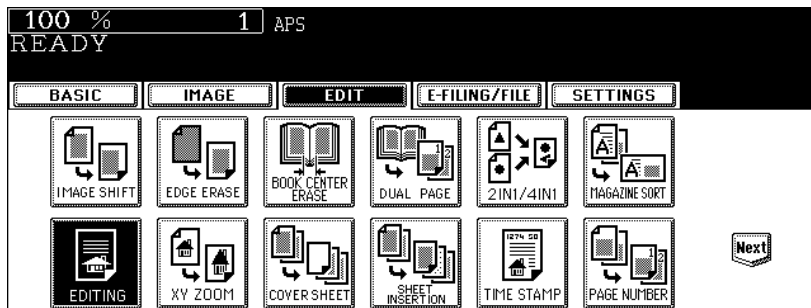

3 Press the [TRIM] (or [MASK]) button.

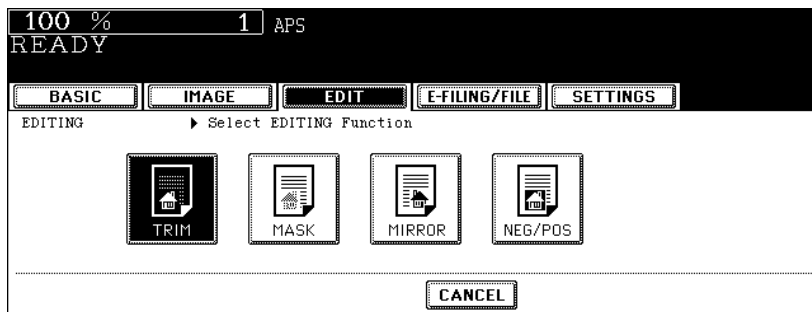

4 Place the original with its face up on the original glass.

- Set the original face up with its bottom toward you and fit its top left corner against the top left corner of the original glass, and align it with the original scales.

Caution

Do not place heavy objects (9 lb. or more) on the original glass and do not press on it with force. Breaking the glass could injure you.

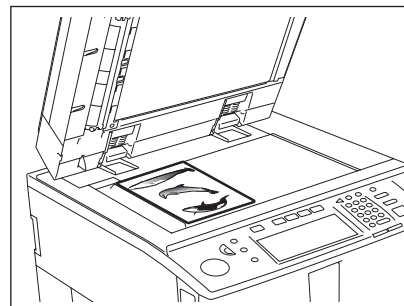

5 Specify the area. Using the original scale on the left and the inner (top) scale, read the following 4 values:

- X1:** Distance from the top left to the left edge of the specified area
 - X2:** Distance from the top left to the right edge of the specified area
 - Y1:** Distance from the top left to the upper edge of the specified area
 - Y2:** Distance from the top left to the lower edge of the specified area
- The marks of the original scale have a 2 mm (0.08") pitch.

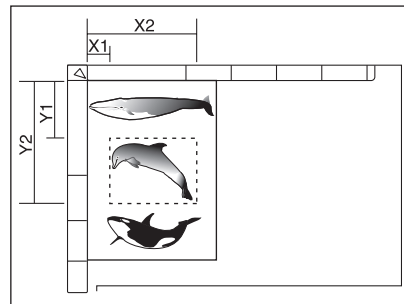

6 Enter the values read in step 5 for the specified area, and then press the [SET] button. Set 4 values in order.

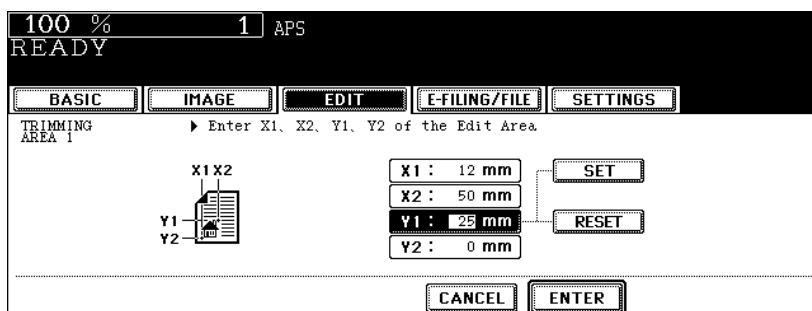

- After the setting of 4 values is finished, the next edit area menu is displayed. Repeat steps 5 and 6 when you specify other areas. Up to 4 areas can be specified on an original.
- To correct the value which has been set, press the [RESET] button. Pressing it once makes the highlighted field move one position upward. Highlight the field in which you want to rectify the value, and then key in the correct one.
- If the [RESET] button is pressed while the X1 field is highlighted, all values in the fields will become "0".

5

7 Press the [ENTER] button after specifying the area.

8 Place the original(s) with its face down.

- Set the original face down with its bottom toward you and fit its top left corner against the top left corner of the original glass.
- Select other copy modes as required.

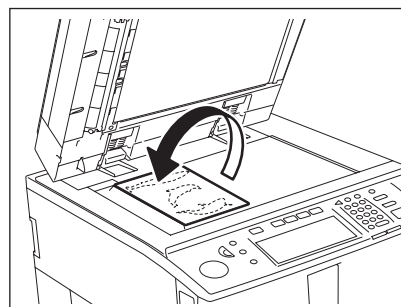

9 Press the [START] button.

Mirror image

This function allows you to make copies with images completely reversed (right and left).

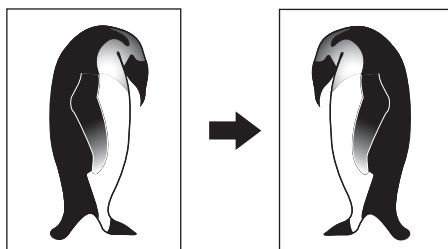

1 Place paper in the drawer(s).

- When using this mode in bypass copying, be sure to specify the paper size (☞ P.72 “1.Paper Selection”).

2 Place the original(s).

3 Press the [EDIT] button to enter the edit menu, and then press the [EDITING] button.

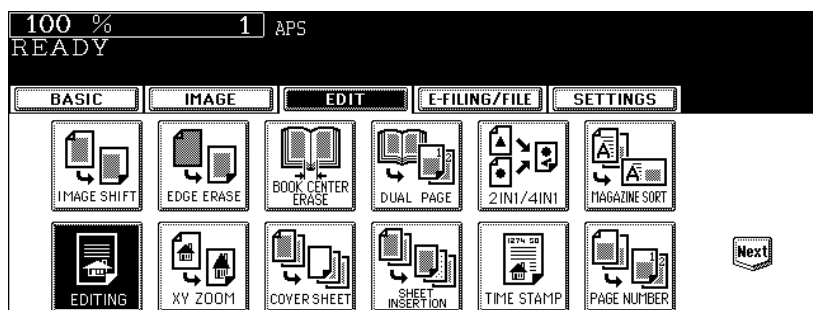

4 Press the [MIRROR] button.

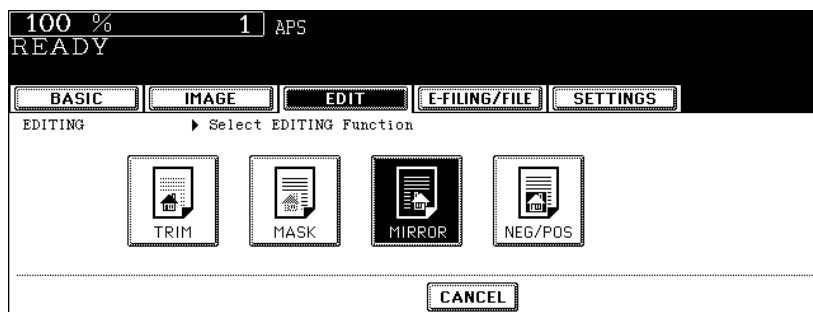

- Select other copy modes as required.

5 Press the [START] button.

Negative/Positive reversal

This function allows you to make copies reversing the black areas on the original to white ones, or vice versa.

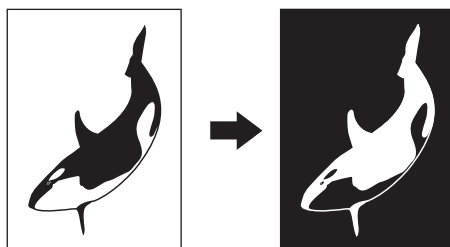

1 Place paper in the drawer(s).

- When using this mode in bypass copying, be sure to specify the paper size (☞ P.72 “1.Paper Selection”).

2 Place the original(s).

3 Press the [EDIT] button to enter the edit menu, and then press the [EDITING] button.

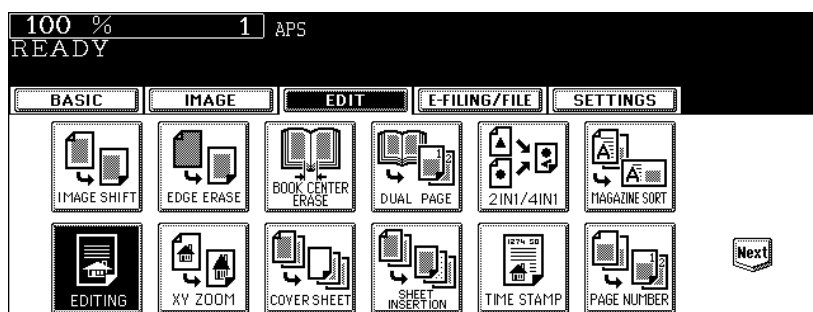

4 Press the [NEG/POS] button.

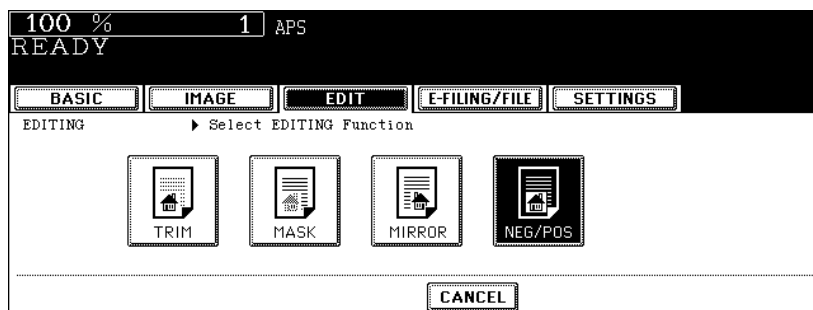

- Select other copy modes as required.

5 Press the [START] button.

8. XY ZOOM

This function allows you to make copies with different reproduction ratios set for the X (horizontal) and Y (vertical) direction in the range of 25 to 400%.

- When an original is placed on the Reversing Automatic Document Feeder, the reproduction ratio is in the range of 25 to 200%.



5

1 Place paper in the drawer(s).

- When using this mode in bypass copying (P.63), be sure to specify the paper size.

2 Place the original(s).

3 Press the [EDIT] button to enter the edit menu, and then press the [XY ZOOM] button.

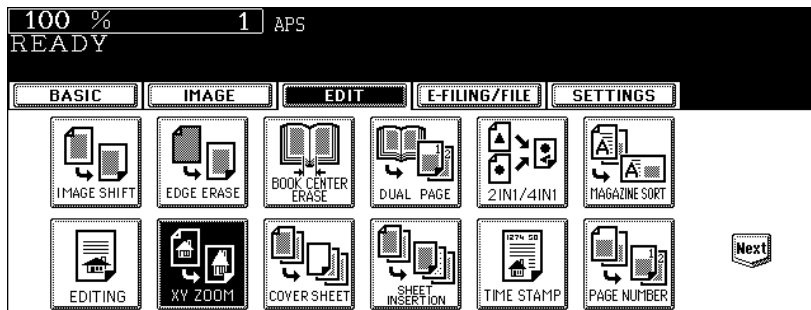

4 Set the reproduction ratios for the X (horizontal) and Y (vertical) directions.

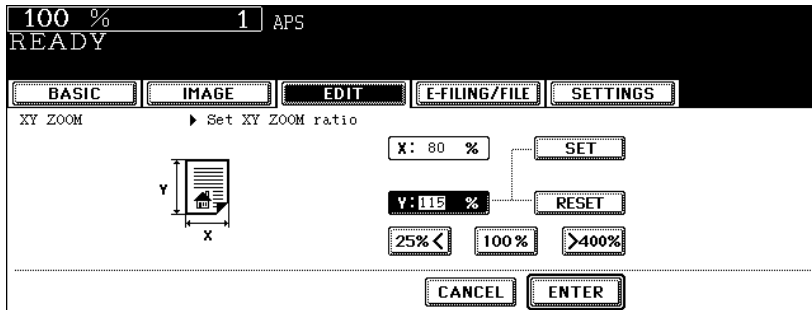

- Using the [25%] and [400%] buttons, set the reproduction ratio for X and press the [SET] button. Then set the reproduction ratio for Y.

5 Press the [ENTER] button.

- Select other copy modes as required.

6 Press the [START] button.

5

9. COVER SHEET

This function allows you to insert special sheets of paper (such as color paper) into a set of copies as cover sheets. A copied front cover sheet can be inserted. The back cover sheet is inserted blank. There are 4 types of sheet insertion modes:

1. Adding a blank front cover sheet ([TOP BLANK])
2. Adding a copied front cover sheet ([TOP COPIED])
3. Adding a blank front and blank back cover sheets ([BOTH BLANK])
4. Adding a copied front and blank back cover sheets ([TOP COPIED BACK BLANK])

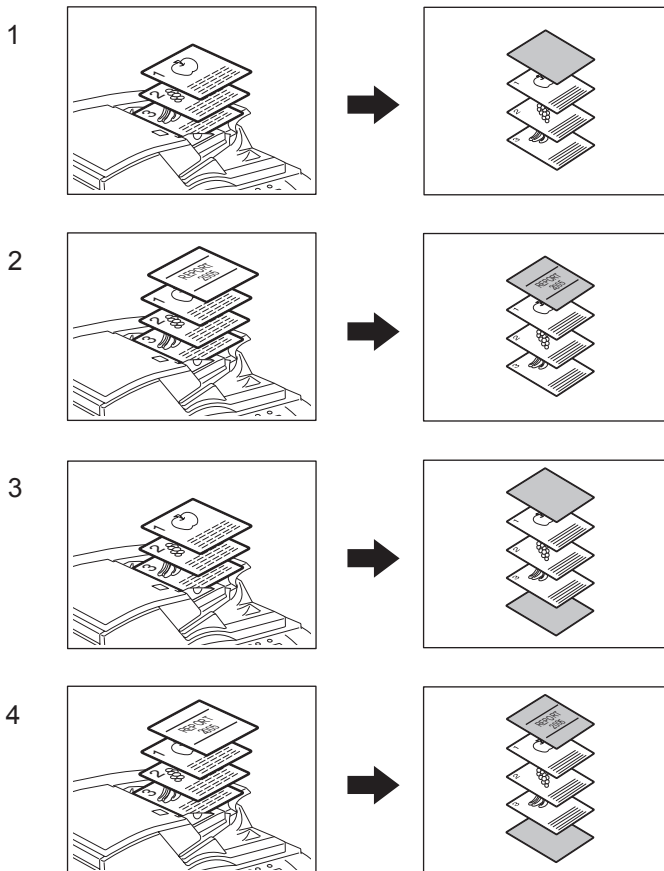

5

1 Place the cover sheet.

- Place the cover sheet in the drawer selected for cover sheets, on the bypass tray or the Inserter Unit. (However, the Inserter Unit cannot be used with [TOP COPIED] or [TOP COPIED BACK BLANK].)
- When it is placed in the drawer for the cover sheets, you must set the paper type (cover sheet), size and thickness. (☞ P.42 "Drawer for special uses")
- When it is placed on the bypass tray, you must set the paper size and thickness. (☞ P.63 "6.Bypass Copying")
- When you use the Inserter Unit with [TOP BLANK] or [BOTH BLANK], see ☞ P.167 "18.INSERTER".
- Make sure the cover sheet and the sheets other than the cover sheet are placed in the same direction and of the same size.

2 Place paper (other than cover paper) in the drawer(s).

- Make sure the cover sheet and the copy paper have the same orientation and size.

3 Place the original(s).

- Originals should be placed from the first page on the original glass.

4 Press the [EDIT] button to enter the edit menu and then the [COVER SHEET] button.

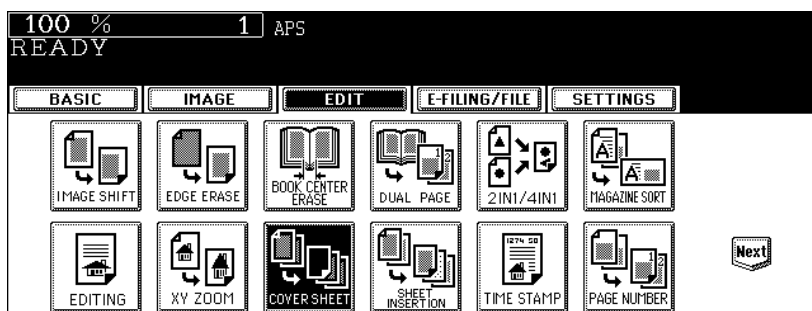

5

5 Press the desired cover sheet button.

TOP BLANK: To add a blank front cover sheet

TOP COPIED: To add a copied front cover sheet

BOTH BLANK: To add blank front and back cover sheets

TOP COPIED BACK BLANK: To add copied front and blank back cover sheets

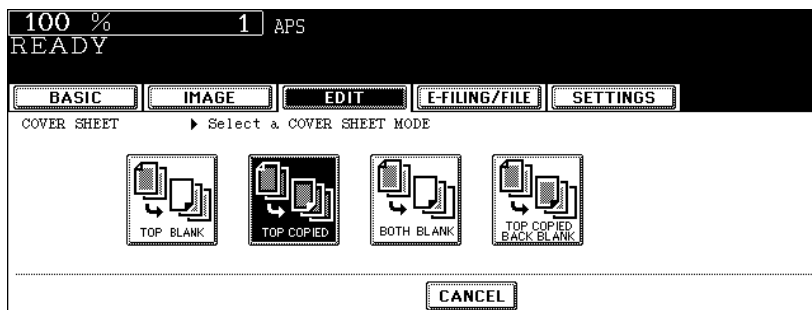

Tip

When "1-Sided Original to 2-Sided Copy" with the [TOP COPIED] or [TOP COPIED BACK BLANK] button pressed is performed, a 1-sided copy is made for a cover sheet.

- 6** Press the [BASIC] button to enter the basic menu, and then select a paper source of the same size and direction as the cover sheet.

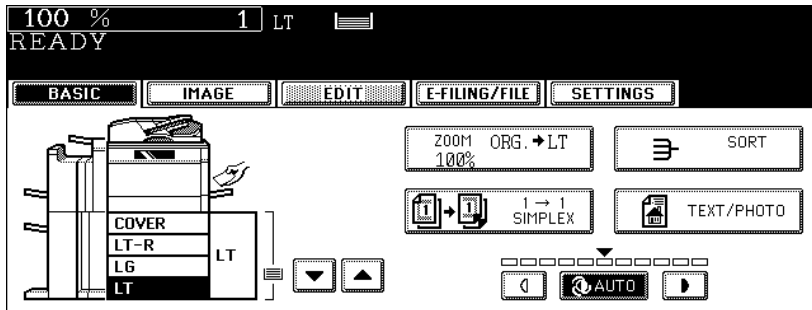

- Select other copy modes as required.

- 7** Press the [START] button.

- When the Reversing Automatic Document Feeder is used, the original is scanned and copying starts.
- When the original is placed on the original glass, perform steps 8 and 9.

- 8** Press the [YES] button and place the next original. Then press the [START] button.

- Repeat this step until all the originals have finished being scanned.

- 9** After all the originals have finished being scanned, press the [FINISHED] button.

- Copying starts.

10. SHEET INSERTION

This function allows you to insert special sheets of paper (such as color paper) into the specified pages. 2 kinds of sheets for insertion are available. Up to 50 pages can be specified for [INSERT SOURCE 1] and [INSERT SOURCE 2], respectively. There are 2 types of sheet insertion modes:

1. Inserting a copied sheet into the specified page ([COPIED])
2. Inserting a blank sheet into the page previous to the specified one ([BLANK])

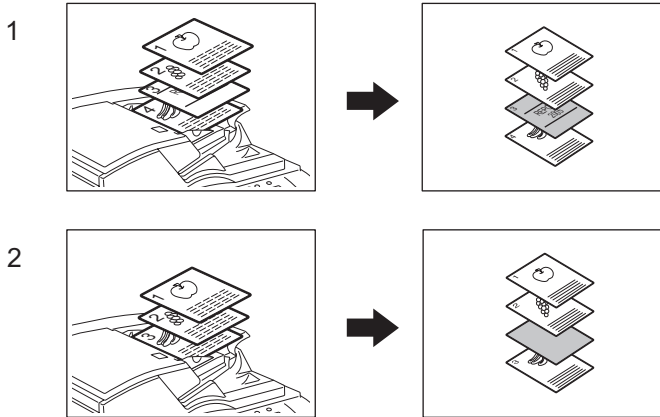

5

1 Place the special sheets of paper.

📖 P.42 “Drawer for special uses”

- Place the special sheets of paper in the drawer selected for sheet insertion, on the bypass tray or the Inserter Unit. (However, the Inserter Unit cannot be used with [COPIED].)
- When you use the Inserter Unit with [BLANK], see 📖 P.167 “18.INSERTER”.
- Both special sheets of paper and plain paper should be placed in the same direction and be of the same size.

2 Place plain paper in the drawer(s).

3 Place the original(s).

4 Press the [EDIT] button to enter the edit menu, and then press the [SHEET INSERTION] button.

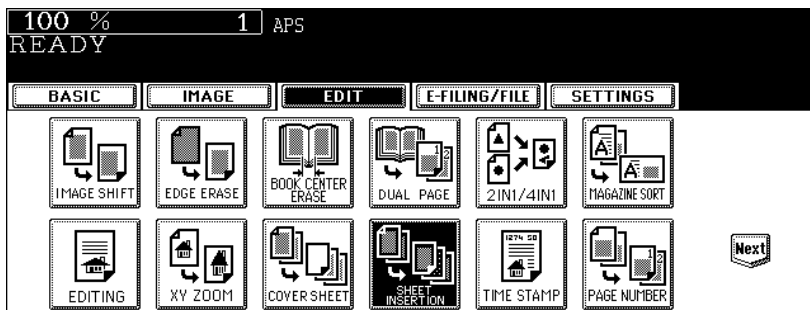

5 Press the [COPIED] (or [BLANK]) button.

COPIED: To insert a copied sheet into the specified page

BLANK: To insert a blank sheet into the page previous to the specified one

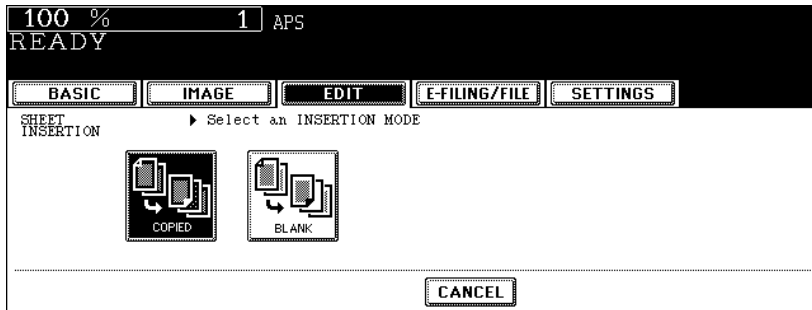

6 Press the [INSERT SOURCE 1] (or [INSERT SOURCE 2]) button.

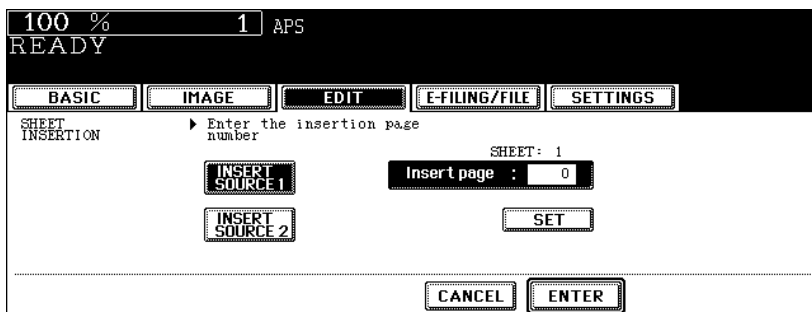

7 Key in the desired page number (3 digits or less) for insertion and press the [SET] button.

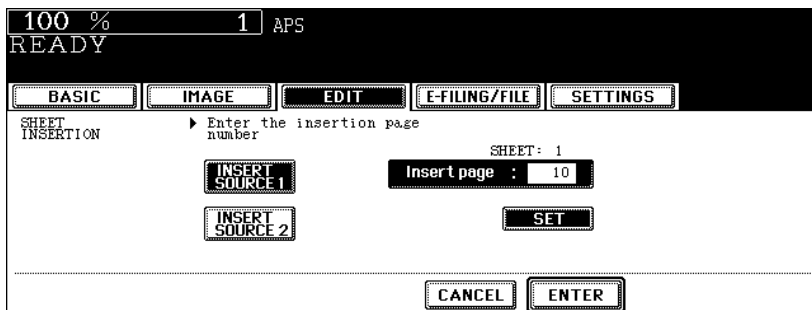

- When [COPIED] is selected on step 5, a copied sheet is inserted into the specified page. When [BLANK] is selected, a blank sheet is inserted into the page previous to the specified one.
- Up to 50 pages can be specified for [INSERT SOURCE 1] and [INSERT SOURCE 2]. When inserting multiple sheets one by one at specified pages, repeat steps 6 and 7. (Up to 15 pages are registered in the template. (P.195))

8 After the specifying of all insertion pages is finished, press the [ENTER] button.

- Select other copy modes as required.

9 Press the [START] button.

11. TIME STAMP

This function allows you to add the time and date of the scanning to the copies.

1. Printed at the bottom of a portrait copy
2. Printed at the top of a landscape copy

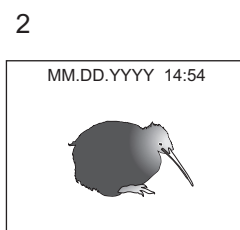
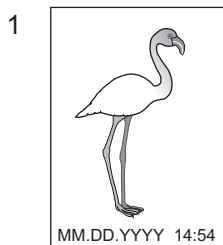

1 Place paper in the drawer(s).

2 Place the original(s).

3 Press the [EDIT] button to enter the edit menu, and then press the [TIME STAMP] button.

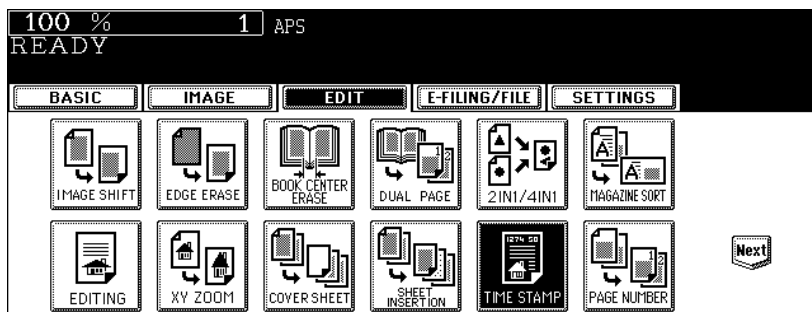

4 Select the orientation ([Short edge] or [Long edge]) and position ([UPPER] or [LOWER]) of the date and time to be printed, and then press the [ENTER] button.

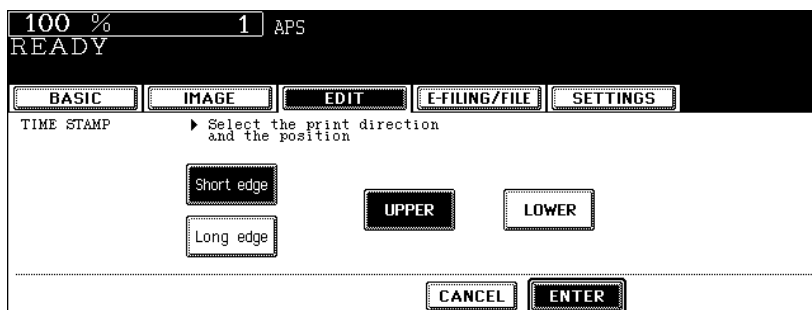

- Select other copy modes as required.

5 Press the [START] button.

12. PAGE NUMBER

This function allows you to add page numbers to the copies.

1. Printed at the bottom center of a portrait copy
2. Printed at the top right of a landscape copy

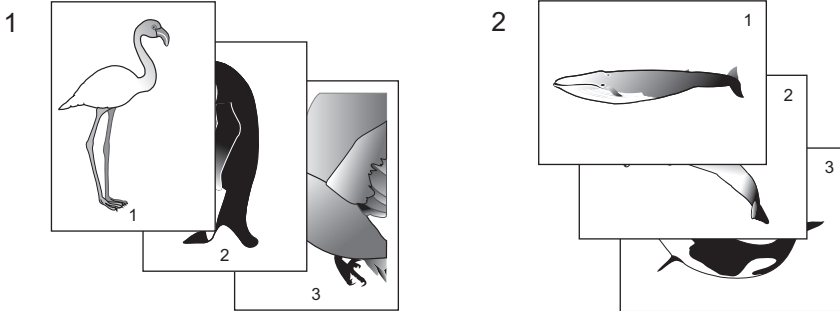

5

1 Place paper in the drawer(s).

2 Place the original(s).

3 Press the [EDIT] button to enter the edit menu, and then press the [PAGE NUMBER] button.

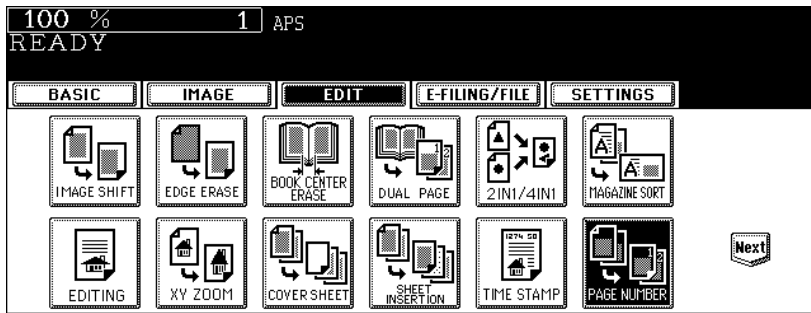

- 4** Select the orientation ([Short edge] or [Long edge]) and position ([TOP LEFT], [TOP CENTER], [TOP RIGHT], [BOTTOM LEFT], [BOTTOM CENTER] or [BOTTOM RIGHT]) of the page number to be printed, and then press the [ENTER] button.

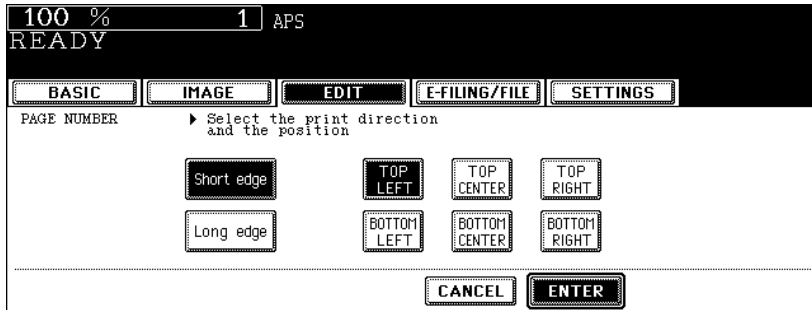

5

- 5** Key in the starting page number and then press the [ENTER] button.

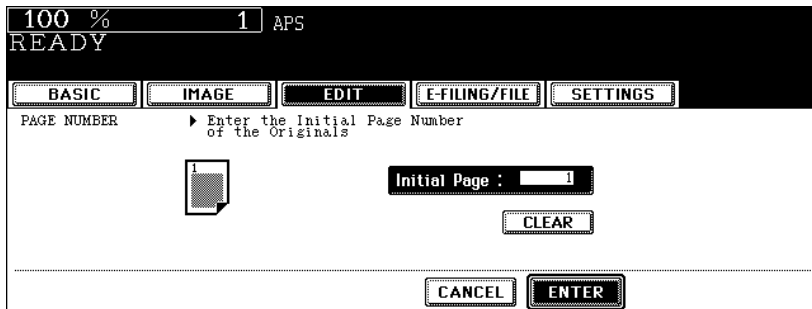

- Select other copy modes as required.

- 6** Press the [START] button.

13. JOB BUILD

This function allows you to copy different kinds of originals at one time.

Scanning is performed by setting the optimal original mode and image adjustment for each original (it is called a job). After all the originals have finished being scanned, they can be copied at one time.

For example, after originals such as multiple LD texts, news clips, photographs in magazines and multiple LT photographs with the appropriate settings have finished being scanned, they can be copied in the scanned order in one go. Also, the scanned data can be stored in e-Filing.

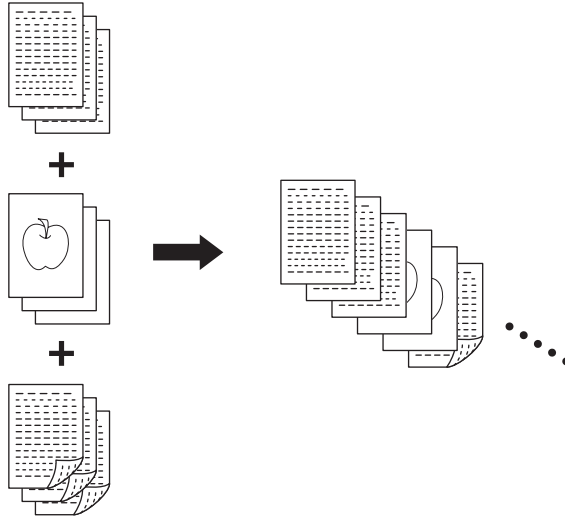

5

- Up to 2000 pages of originals are possible.
- Any number of jobs can be set until the total number of scanned original pages reaches 2000.

There are restrictions on the settings for JOB BUILD: Settings not available for JOB BUILD, common settings for all jobs and changeable settings for each job. See the following table to perform the setting.

Settings not available for JOB BUILD	Common settings for all jobs	Changeable settings per each job
Automatic Paper Selection (APS) Book to 2 Image editing XY zoom Cover copying Sheet insertion mode Magazine sort Magazine sort & Saddle stitch 2IN1 / 4IN1 Tab paper Inserter	e-Filing/file Mixed-size original Paper size to be copied Sort mode Image shift Book center erase Time stamp Page number Image direction in 2-sided copying Book <-> tablet	Reproduction ratio Automatic magnification selection Original size Original mode 2-sided (or 1-sided) copying Background adjustment Sharpness Edge erase Dual-page ADF / SADP

1 Place the originals of the 1st job.

Tips

- When an original is placed on the original glass, one page is regarded as one job.
- To copy mixed-size originals using the Reversing Automatic Document Feeder, see P.75 “When copying mixed-size originals in one go”.
- Select the drawer if you want to specify it.

2 Press the [EDIT] button to enter the edit menu, and then press the [JOB BUILD] button.

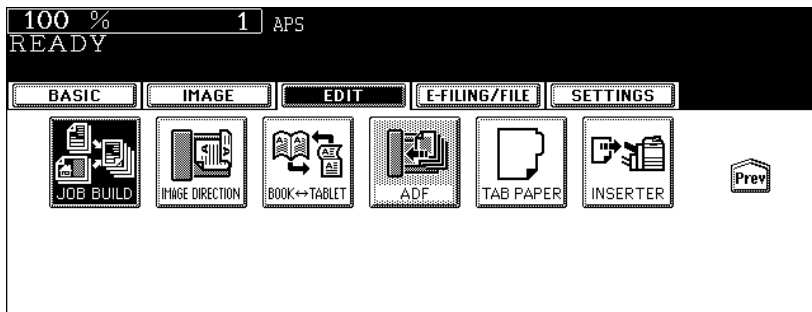

- If the desired function button is not displayed, press the [Prev] or [Next] button to switch the menu.

3 Press the [ENTER] button.

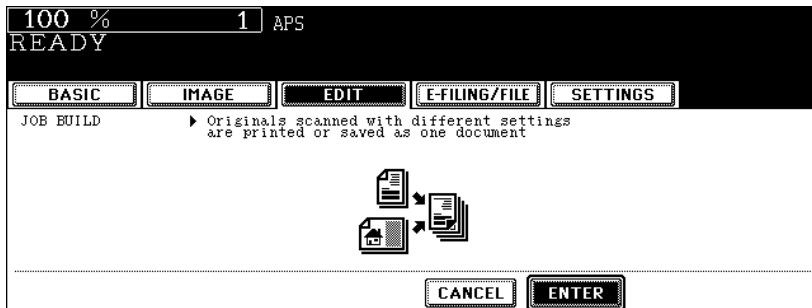

- Read the brief description of JOB BUILD on the touch panel.
- JOB BUILD is set and the basic menu is displayed.

- 4** After “Press START button to copy after changing settings.” appears, perform the settings for the 1st job and the common settings for all jobs.

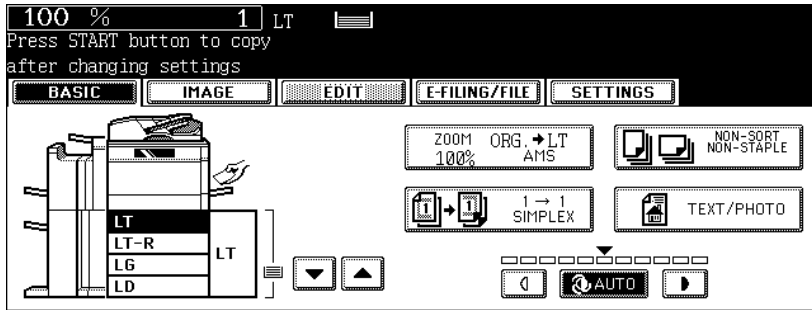

- Press the [SETTINGS] button to confirm the settings.
- To change the settings, press the [FUNCTION CLEAR] button, and then start the procedure again from step 1.

- 5** Press the [START] button.

- The scanning of the originals for the 1st job starts.

- 6** After “Press START button to copy after changing settings.” appears, place the originals of the 2nd job. Perform the settings for the 2nd job.

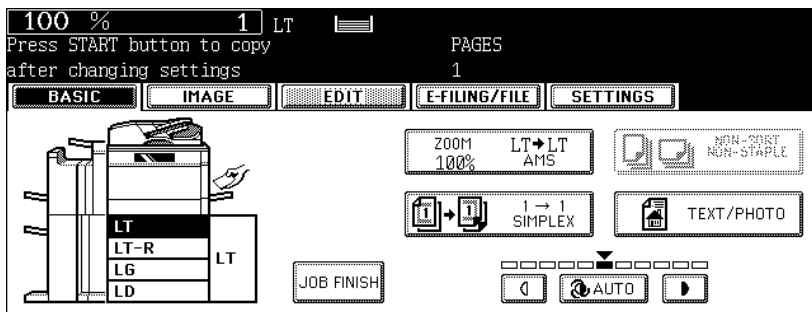

- Note that copying will be performed in the same modes as those of the 1st job if the settings are not changed.
- Press the [SETTINGS] button to confirm the settings.

- 7** Press the [START] button.

- The scanning of the originals for the 2nd job starts.
- Repeat steps 6 to 7 until all the originals have finished being scanned.

- 8** After all the originals have finished being scanned, confirm the number of copies on the menu and change if needed.

9 Press the [JOB FINISH] button on the basic menu.

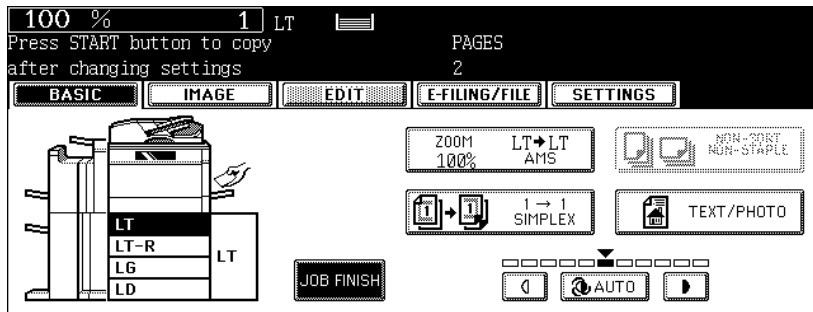

- The copying of the originals starts.
- When copy and e-Filing/file functions are set, storing starts.

14. IMAGE DIRECTION

This function allows you to adjust the direction to 'open to left' when a lengthwise LD, LG original, etc. is copied under the mode of 1-Sided Originals to 2-Sided Copies (or 2-Sided Originals to 1-Sided Copies).

- This function is not necessary for copying in the direction of 'open to top'.

When a 2-sided 'open to left' (Book) portrait LD, LG original, etc. is copied using this function with [2-Sided Originals to 1-Sided Copies], copies can be adjusted to the same direction.

[IMAGE DIRECTION]:

1. Set
2. No setting

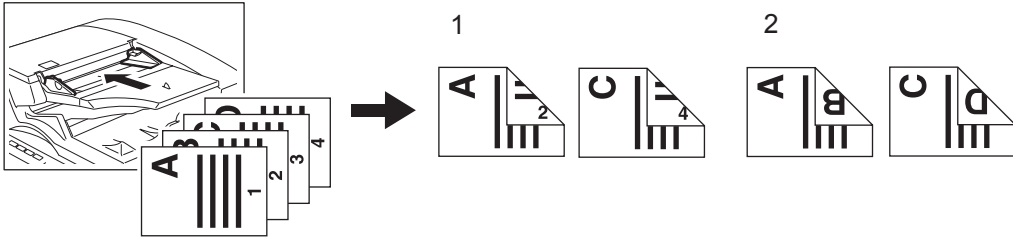

5

- 1 Place paper in the drawer(s).
- 2 Place the original(s).
- 3 Perform the setting of [1 -> 2 DUPLEX] (or [2 -> 1 SIMPLEX]).
📖 P.97 "4.Duplex Copying"
- 4 Press the [EDIT] button to enter the edit menu, and then press the [IMAGE DIRECTION] button.

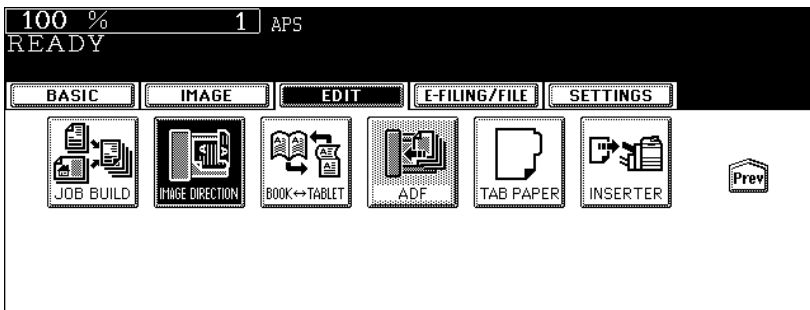

- The direction of the copy is adjusted by this operation.
- If the desired function button is not displayed, press the [Prev] or [Next] button to switch the menu.

5 Press the [ENTER] button.

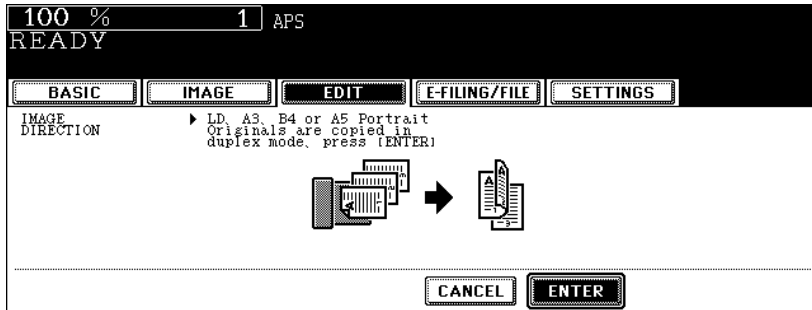

- Select other copy modes as required.

6 Press the [START] button.

5

15. BOOK - TABLET

When copying under the mode of 2-Sided Originals to 2-Sided-Copies, this function allows you to rotate the back side of the original to be copied by 180°. It is useful when 'open to left' (Book) originals need to be copied in 'open to top' (Tablet), and the opposite condition is available.

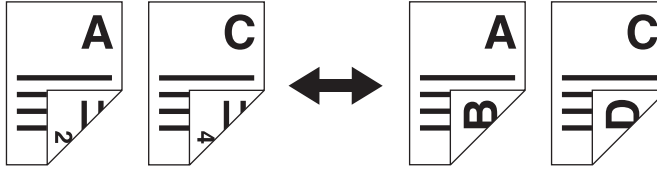

1 Place paper in the drawer(s).

5

2 Place the original(s).

3 Perform the setting of [2 -> 2 DUPLEX].

P.97 "4.Duplex Copying"

4 Press the [EDIT] button to enter the edit menu, and then press the [BOOK <-> TABLET] button.

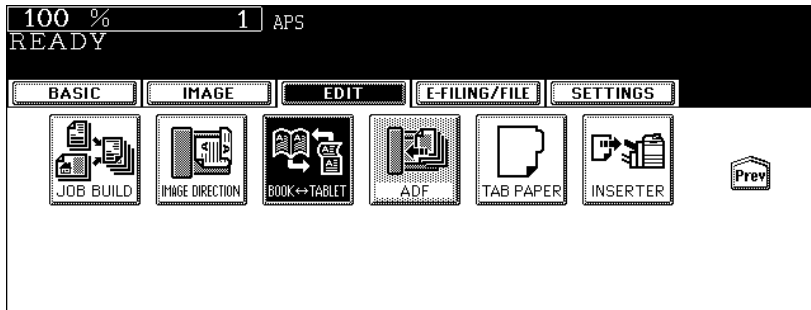

- 'Open to left' originals are copied in 'open to top' and 'open to top' originals are copied in 'open to left' by this operation.
- If the desired function button is not displayed, press the [Prev] or [Next] button to switch the menu.

5 Press the [ENTER] button.

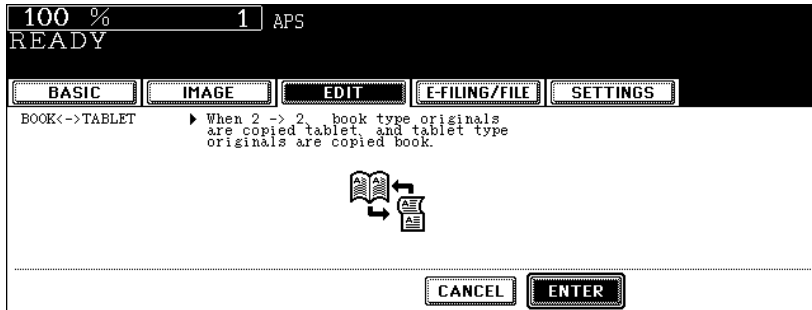

- Select other copy modes as required.

6 Press the [START] button.

5

16. ADF / SADF

When using the Reversing Automatic Document Feeder, you can select either; the continuous feed mode (default setting), in which originals are automatically fed in one by one after the [START] button is pressed, or the single feed mode, in which an original is automatically pulled in after insertion and copying is started.

It is useful to select the continuous feed mode for copying multiple originals at one time, and the single feed mode for copying one original individually.

- To set different size originals, see  P.75 “When copying mixed-size originals in one go”.

Continuous feed mode

1 Place paper in the drawer(s).

5

2 Press the [EDIT] button to enter the edit menu, and then press the [SADF] button.

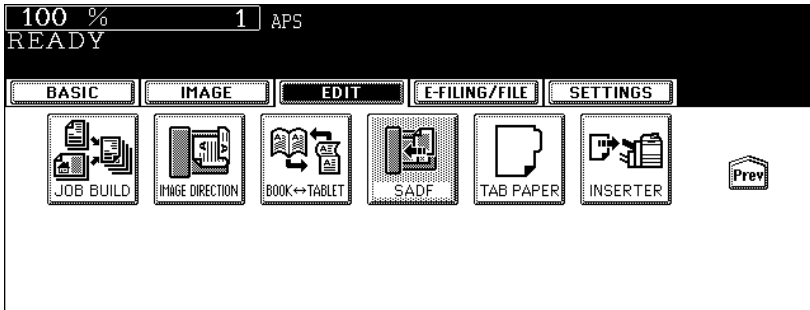

- If the [ADF] button is already displayed, the continuous feed mode is set. In this case, skip to step 5.
- If the desired function button is not displayed, press the [Prev] or [Next] button to switch the menu.

3 Place the original(s) on the Reversing Automatic Document Feeder.

 P.56 “Using the Reversing Automatic Document Feeder”

4 Press the [ADF] button.

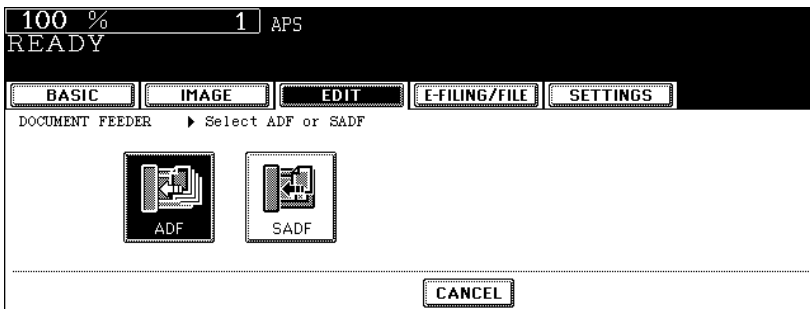

- Select other copy modes as required.

5 Press the [START] button.

Single feed mode

- 1 Place paper in the drawer(s).
- 2 Press the [EDIT] button to enter the edit menu, and then press the [ADF] button.

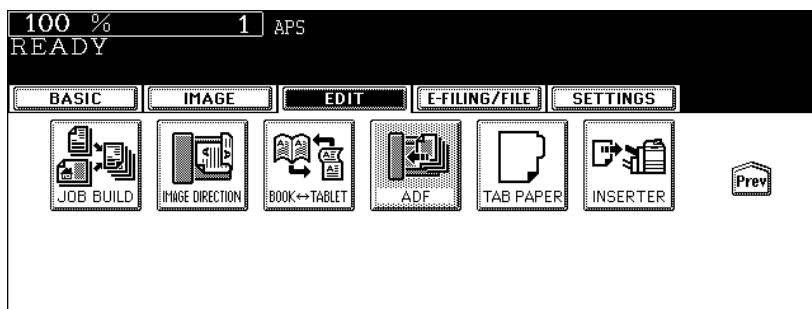

- If the [SADF] button is already displayed, the single feed mode is set. In this case, skip to step 4.
- If the desired function button is not displayed, press the [Prev] or [Next] button to switch the menu.

- 3 Press the [SADF] button.

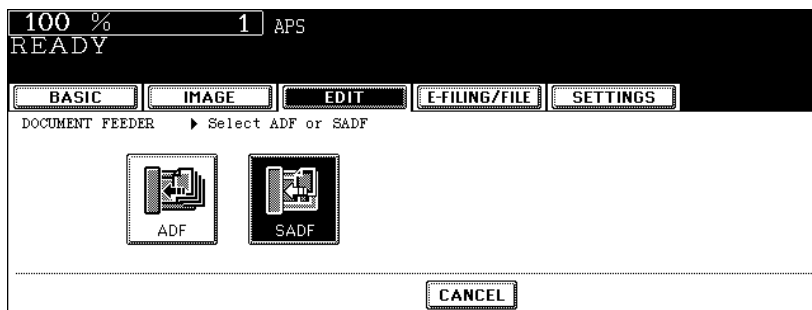

- Select other copy modes as required.

4 Place the original on the Reversing Automatic Document Feeder.

- The original is automatically pulled in and the following menu is displayed.

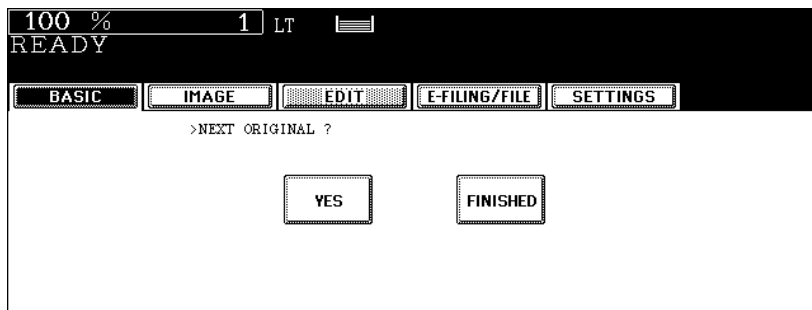

- If there are more originals, set them in the same way. (The same operation is performed whether or not you press the [YES] button.)

5 After all originals have finished being fed, press the [FINISHED] button.

5

17. TAB PAPER

Tab paper copying and insertion are available. There are the following 3 modes.

1. Copying on the tab of tab paper ([COPY ON TAB])
2. Inserting blank tab paper prior to a selected page ([BLANK TAB INSERT])
3. Combination of copying on tab paper and inserting tab paper ([COPIED TAB INSERT])

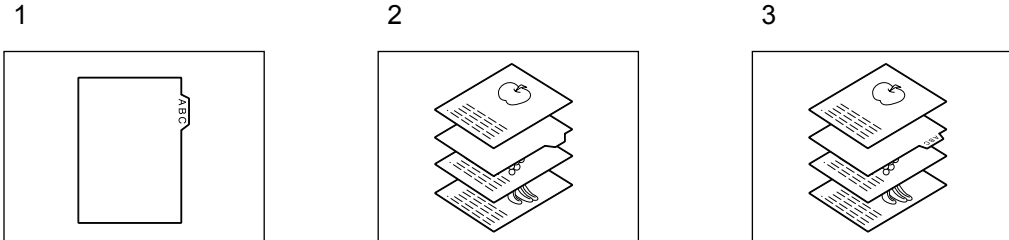

- Before copying on tab paper, adjust the tab width. (📖 P.160)
- The tab paper can be set in any one drawer and the bypass tray except Large Capacity Feeder. (The recommendation is to set in the 2nd drawer.)
- Be sure to set "TAB PAPER" for the drawer for special uses. (📖 P.42 "Drawer for special uses")
- Only LT/A4 can be used in this mode.

5

Preparing an original to copy on the tab of the tab paper

LT/A4 originals are used. In copying on tab or copied tab insert, the image is shifted to copy the index of the original on the tab position.

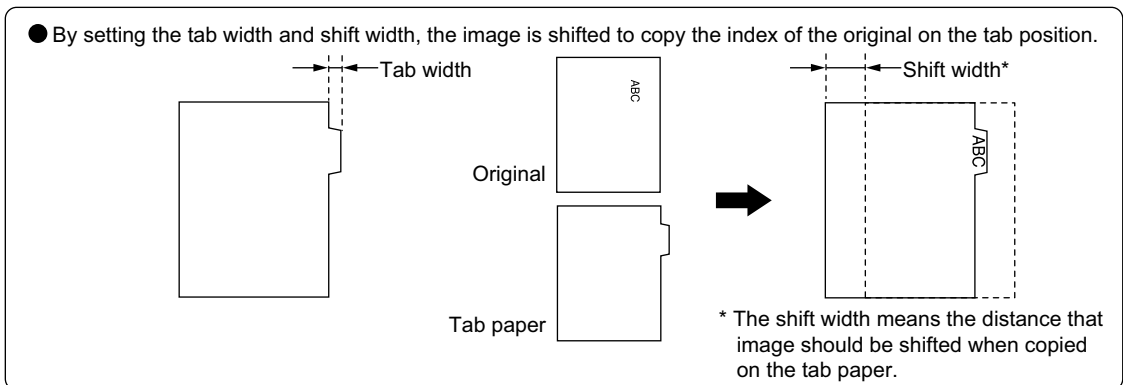

Setting tab paper in the drawer

The setting order is different between when the tab paper is set in the drawer and when it is set on the bypass tray.

1 Pull out the drawer.

- Placing paper in the second drawer is recommended.

2 Insert the tab paper back guide into the slit of LT-TAB (or A4-TAB).

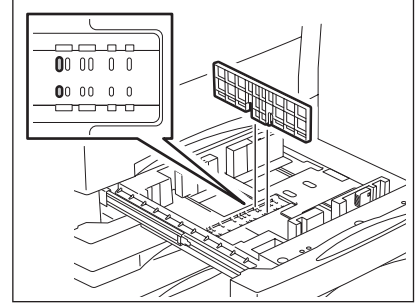

3 Align the tab paper with the original.

● Originals

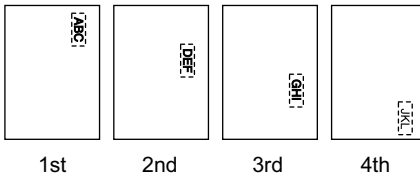

● Sheets of tab paper

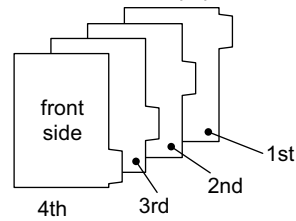

4 Place the tab paper with its face down in the drawer.

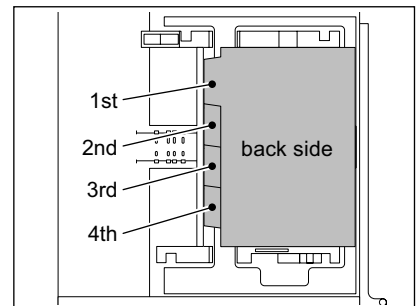

5 Close the drawer.

- Check if the drawer for special uses is "TAB PAPER".

Setting tab paper on the bypass tray

The setting order is different between when the tab paper is set in the drawer and when it is set on the bypass tray.

1 Align the tab paper with the original.

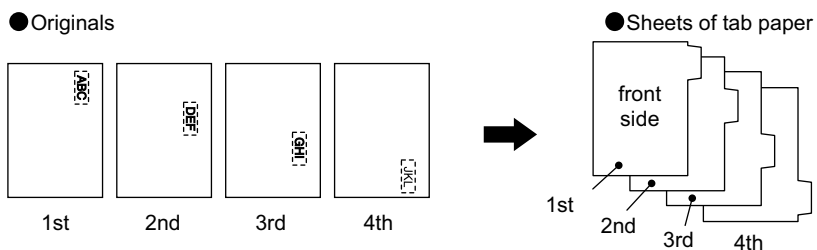

2 Place the tab paper with its face up on the bypass tray.

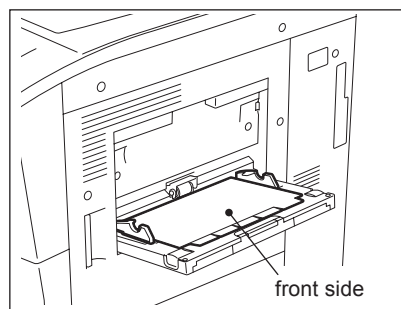

3 Set the size and thickness.

- Be sure to select "TAB PAPER" for the paper type. (📖 P.63 "6.Bypass Copying")

Setting the tab width

To copy on tab paper, adjust both the tab width and the shift width for the drawer and the bypass tray respectively. This setting is different between when the tab paper is set in the drawer and when it is set on the bypass tray.

- 1 Press the [EDIT] button to enter the edit menu, and then press the [TAB PAPER] button.

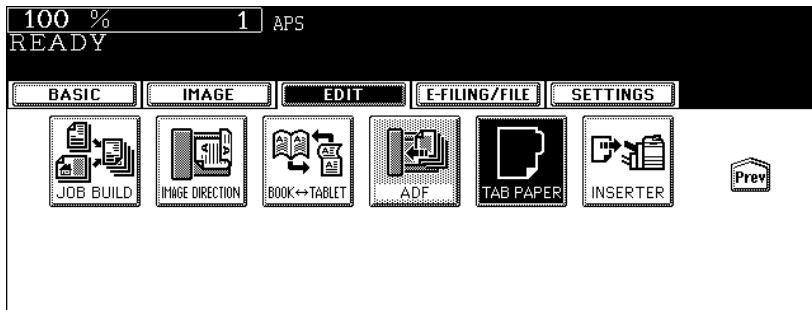

- 2 Press the [TAB EXTENSION] button.

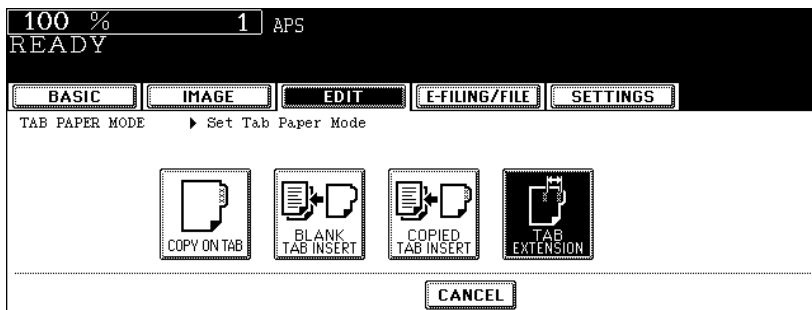

- 3 Press the [CASSETTE] button for setting tab paper in the drawer or the [BYPASS FEED] button for setting it on the bypass tray.

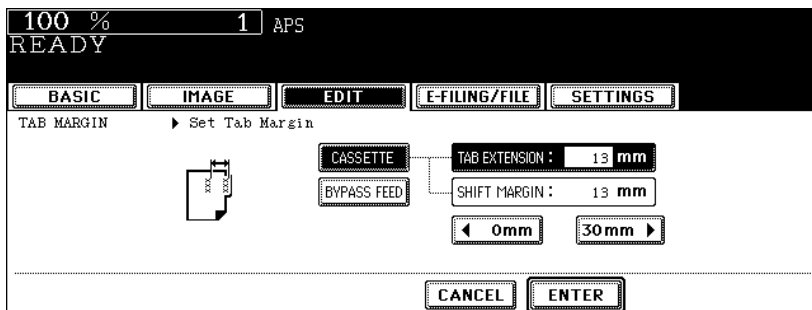

4 Adjust the tab width and the shift width using the [0 mm] or [30 mm] button, and then press the [ENTER] button.

- Press [TAB EXTENSION] or [SHIFT MARGIN] to switch the item to be set.
- The initial value is set to 13 mm (0.5") for both the tab width and the shift width.
- The default setting value can be changed for both the tab width and the shift width. For details, refer to the User Functions Guide.

Range of the tab width and shift width

The range of the tab width and the shift width is different between when the tab paper is set in the drawer and when it is set on the bypass tray.

	Tab width	Shift width
Drawer	12 to 17 mm (0.4" to 0.6")	0 to 30 mm (0 to 1.1")
Bypass tray	10 to 20 mm (0.4" to 0.7")	0 to 30mm (0 to 1.1")

5

Measuring the tab width and shift width

The tab width and the shift width can be measured by the scale on the left side and rear side of the original glass. The marks of the original scale have a 2 mm (0.08") pitch.

• Measuring the tab width

Place tab paper on the original glass to measure the tab width.

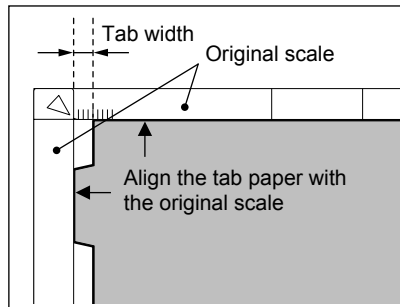

• Measuring the shift width

Place the original on the original glass to measure the shift width.

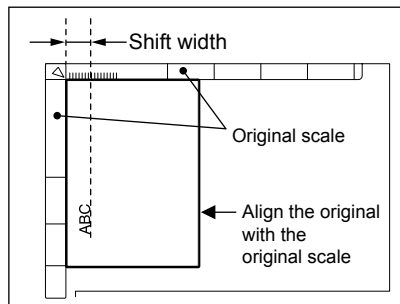

Tab paper copying

The original is copied on the tab of the tab paper.

1 Prepare the original to copy on the tab of the tab paper.

📖 P.157 “Preparing an original to copy on the tab of the tab paper”

2 Place tab paper in the drawer or on the bypass tray.

- For placing tab paper in the drawer, see 📖 P.158 “Setting tab paper in the drawer”.
- For placing tab paper on the bypass tray, see 📖 P.159 “Setting tab paper on the bypass tray”.

3 Place the original(s).

4 Press the [EDIT] button to enter the edit menu, and then press the [TAB PAPER] button.

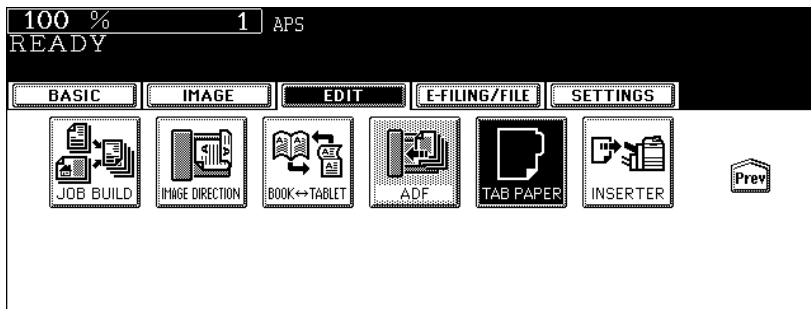

- If the desired function button is not displayed, press the [Prev] or [Next] button to switch the menu.

5 Press the [COPY ON TAB] button.

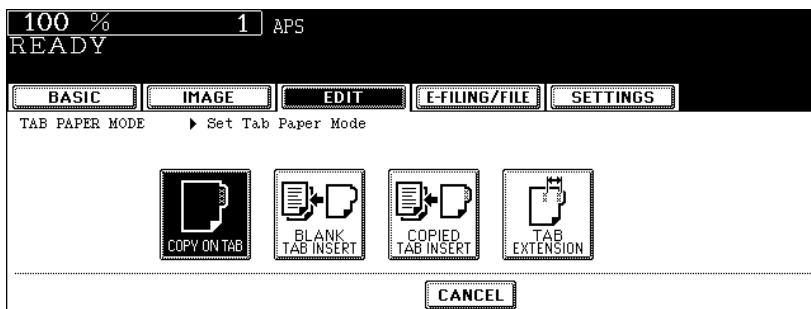

6 Press the [ENTER] button.

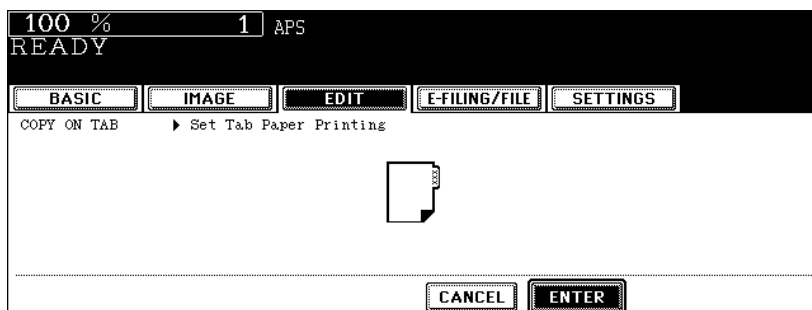

- Select other copy modes as required.

7 Press the [START] button.

- Copying on the tab of tab paper is started.

5

Tab paper insertion

The blank tab paper is inserted prior to a selected page. Up to 50 sheets of tab paper can be inserted.

- Copying on the tab of the tab paper is not performed.
- Up to 15 pages are registered in the template. (📖 P.195)

1 Place tab paper in the drawer or on the bypass tray.

- For placing tab paper in the drawer, see 📖 P.158 "Setting tab paper in the drawer".
- For placing tab paper on the bypass tray, see 📖 P.159 "Setting tab paper on the bypass tray".

2 Place the original(s).

3 Press the [EDIT] button to enter the edit menu, and then press the [TAB PAPER] button.

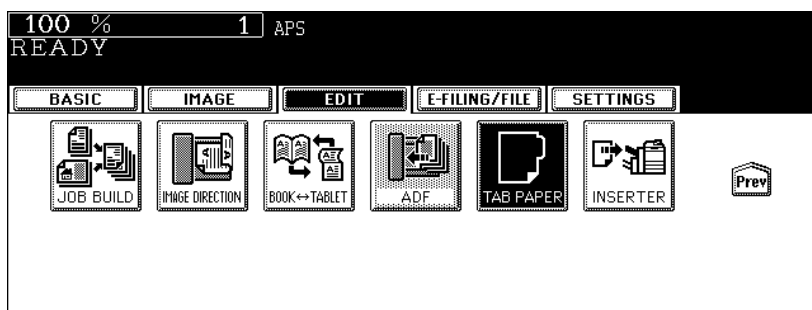

- If the desired function button is not displayed, press the [Prev] or [Next] button to switch the menu.

4 Press the [BLANK TAB INSERT] button.

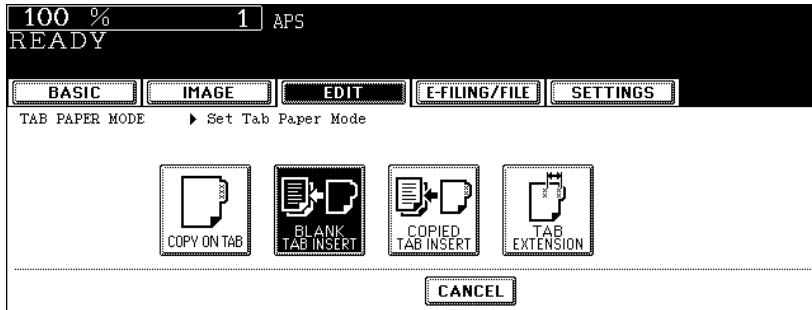

5

5 Key in the page number (3 digits or less) for inserting the tab paper, and then press the [SET] button.

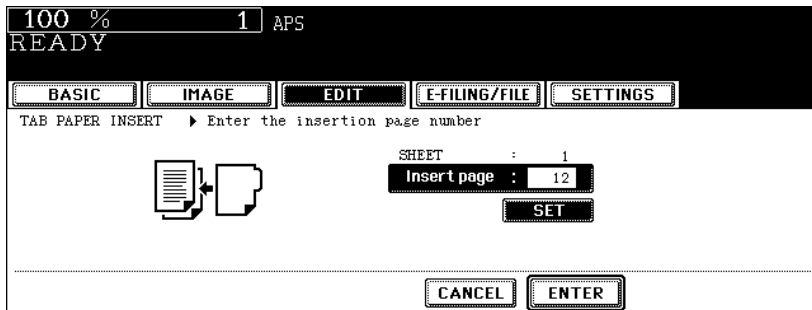

- When 2 sheets of tab paper or more are inserted, repeat step 5. The tab paper is inserted prior to a selected page. Up to 50 sheets of tab paper can be inserted. (Up to 15 pages are registered in the template. (P.195))

6 Press the [ENTER] button.

- Select other copy modes as required.

7 Press the [START] button.

Tab paper insertion and copying

Copied tab paper is inserted prior to the selected pages. Up to 50 sheets of tab paper can be inserted.

- Up to 15 pages are registered in the template. (📖 P.195)

1 Prepare an original to copy on the tab of the tab paper.

2 Place tab paper.

- For placing tab paper in the drawer, see 📖 P.158 “Setting tab paper in the drawer”.
- For placing tab paper on the bypass tray, see 📖 P.159 “Setting tab paper on the bypass tray”.

3 Place the originals.

- Before placing them, insert an original for tab paper prepared in step 1 prior to the desired page.

4 Press the [EDIT] button to enter the edit menu, and then press the [TAB PAPER] button.

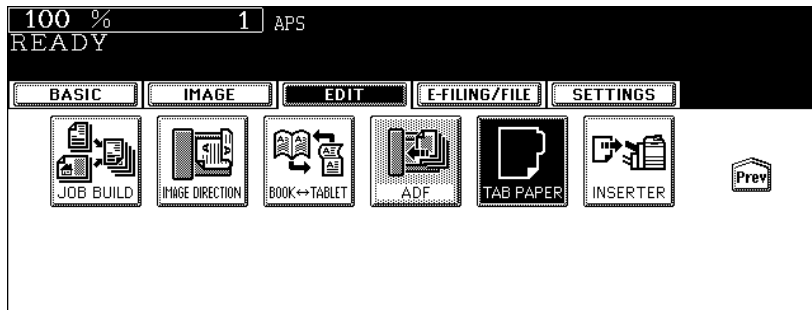

- If the desired function button is not displayed, press the [Prev] or [Next] button to switch the menu.

5 Press the [COPIED TAB INSERT] button.

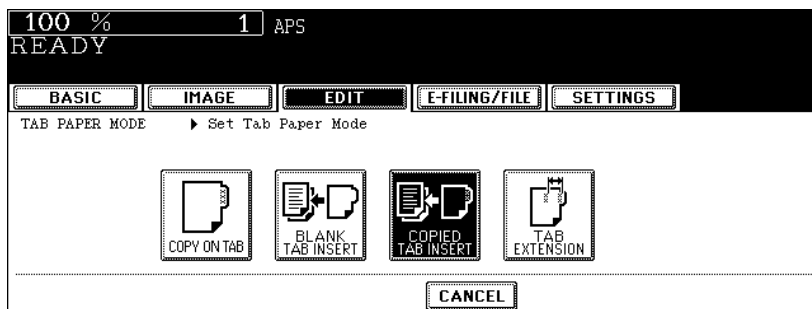

6 Key in the page number (3 digits or less) for inserting the tab paper, and then press the [SET] button.

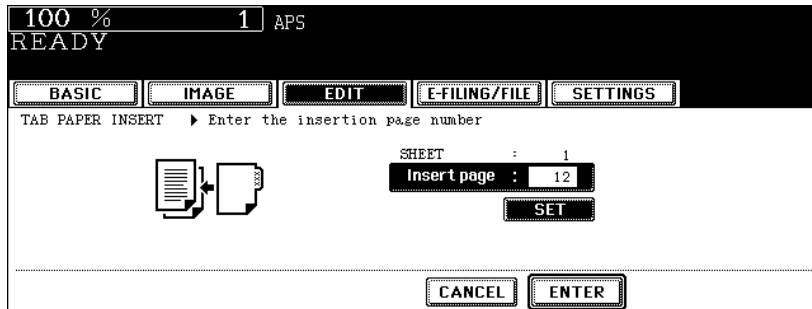

5

- When 2 sheets of tab paper or more are inserted, repeat step 6. Up to 50 sheets of tab paper can be inserted. (Up to 15 pages are registered in the template. (P.195))
- Check that the page number corresponds to the inserted page for tab paper in step 3.

7 Press the [ENTER] button.

- Select other copy modes as required.

8 Press the [START] button.

18. INSERTER

You can insert a blank sheet set in the Inserter Unit (optional) at the specified page (including a top cover and a back cover) of the document.

1. Adding a blank front cover sheet ([FRONT COVER])
 2. Adding a blank front and blank back cover sheets ([FRONT & BACK COVER])
 3. Inserting a blank sheet into the page previous to the specified one ([SHEET INSERT])
- [SHEET INSERT] can be used in combination with [FRONT COVER] or [FRONT & BACK COVER].
 - A back cover sheet can be inserted with its backside up. See the User Functions Guide for details.
 - When you want to insert a sheet and make a copy on it, use the drawer or the bypass tray of the equipment, not the Inserter Unit. Use the cover copying mode or the sheet insertion mode from the edit menu. (📖 P.138 “9.COVER SHEET”, 📖 P.141 “10.SHEET INSERTION”)

1 Place paper on the Inserter Unit.

📖 P.95 “Setting paper on the Inserter Unit”

2 Place the original(s).

3 Press the [EDIT] button to enter the edit menu, and then press the [INSERTER] button.

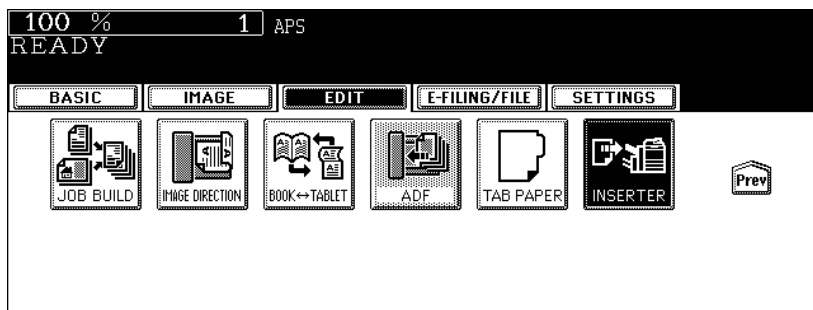

- If the desired function button is not displayed, press the [Prev] or [Next] button to switch the menu.

4 Press the [PAPER SIZE] button.

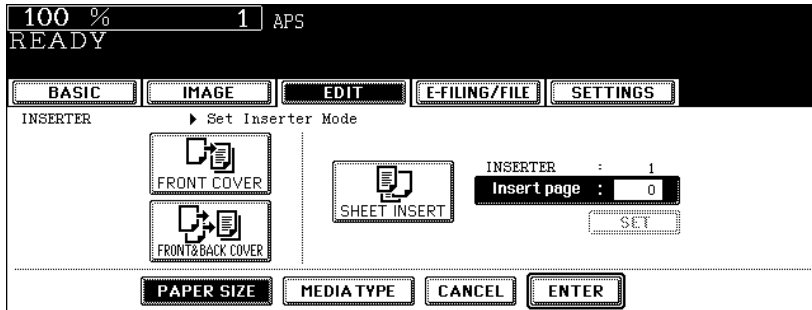

5

Tip

If no paper is set on the Inserter Unit, the [PAPER SIZE] button and the [MEDIA TYPE] button are not selectable.

5 Press the button representing the paper size set on the Inserter Unit.

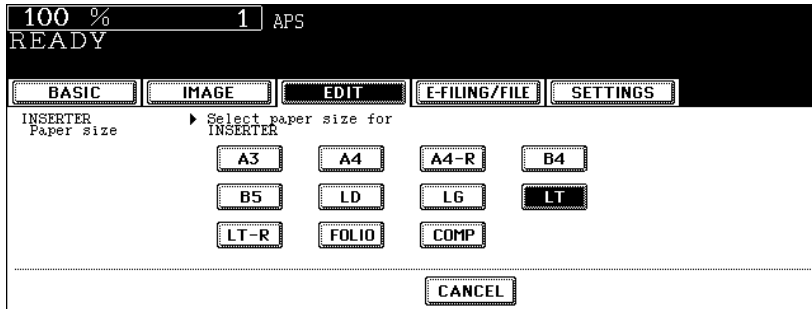

6 Press the [MEDIA TYPE] button.

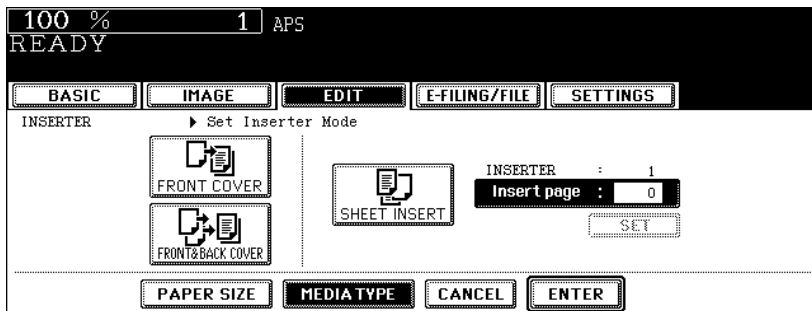

7 Press the button representing the media type set on the Inserter Unit.

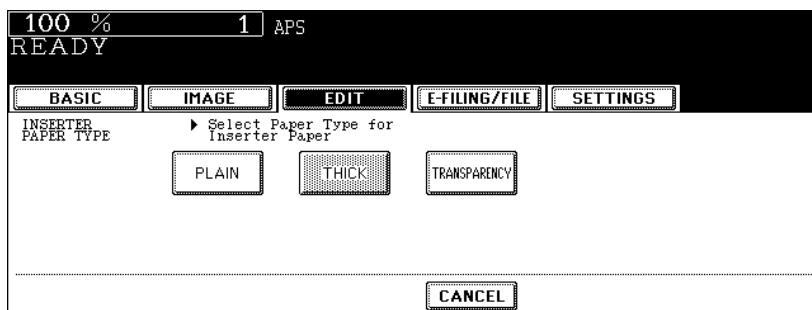

Selecting [FRONT COVER] / [FRONT & BACK COVER]

8 Press the [FRONT COVER] (or [FRONT & BACK COVER]) button, then press the [ENTER] button.

5

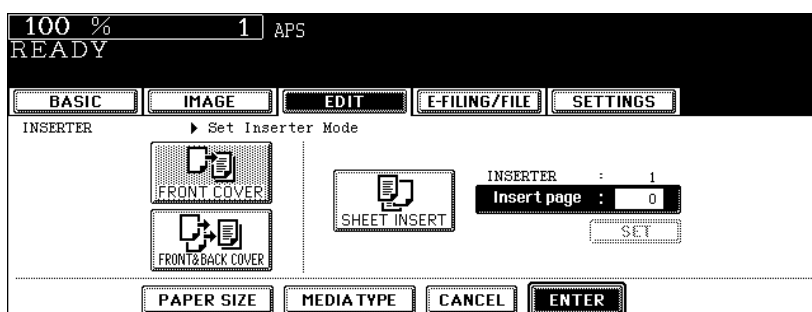

- When using these modes with the sheet insertion mode, press the [SHEET INSERT] button before pressing the [ENTER] button.
- Set other copy modes as required.

9 Press the [START] button.

Selecting [SHEET INSERT]

A blank sheet is inserted before the page specified.

8 Press the [SHEET INSERT] button.

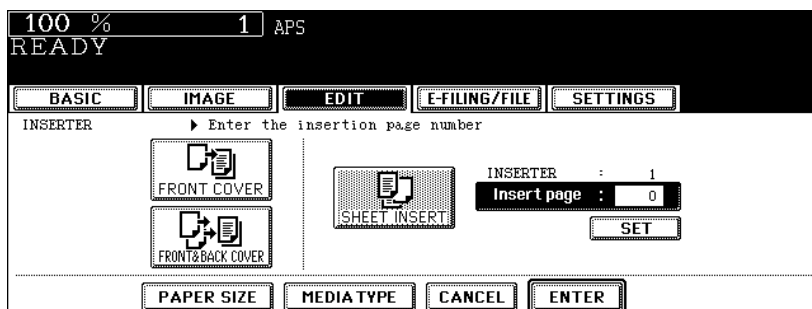

- 9** Key in the desired page number (no more than 3 digits) for insertion and press the [SET] button.

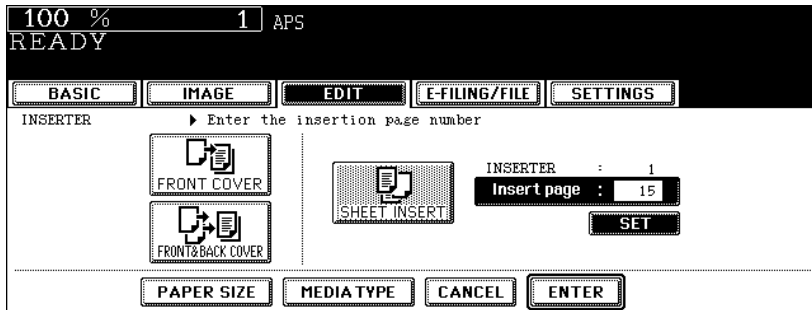

5

- A blank sheet is inserted before the page specified.
- Up to 50 pages can be specified. To specify more than one page, repeat this procedure. (Up to 15 pages are registered in the template. (P.195))

- 10** After you have finished specifying the pages, press the [ENTER] button.

- When using the sheet insertion mode with [FRONT COVER] or [FRONT & BACK COVER], press the [FRONT COVER] or [FRONT & BACK COVER] button before pressing the [ENTER] button.
- Set other copy modes as required.

- 11** Press the [START] button.

6. e-FILING

1. e-Filing	172
2. Creating User Boxes	174
3. Changing Data of User Boxes.....	176
4. Deleting User Boxes	179
5. Storing Documents in e-Filing	181
6. Printing Stored Documents	185
7. Deleting Folders or Documents.....	190

1. e-Filing

This feature allows you to store, print and manage documents obtained by copying, printing from a PC, scanning, receiving Fax and receiving Internet Fax. The document is stored into the hard disk embedded in this equipment.

- To use documents printed from a PC in e-Filing, a Printer Kit or Printer/Scanner Kit (both optional) is required.
- To use scanned documents or documents received by Internet Fax in e-Filing, a Scanner Kit or Printer/Scanner Kit (both optional) is required.
- To use documents received by Fax in e-Filing, a Fax Unit is required.

There are two kinds of e-Filing as follows.

Public box:

This is prepared as a default setting. This is used to store a shared document that can be accessed by any users without restrictions.

User box:

Up to 200 boxes can be created. Passwords can be set for each user box.

- Up to 100 folders per one box can be created. A maximum of 400 documents can be stored in one folder. The maximum number of original pages is 1000. (However, it may be restricted depending on the amount of free space on the hard disk embedded in this equipment.)

6

An outline of e-Filing is as follows.

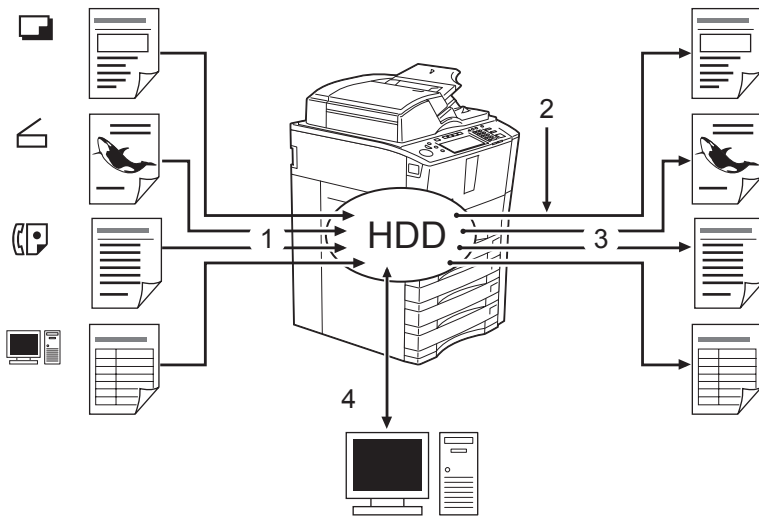

1. Store a document into e-Filing.
2. Add a printing setting to the stored document as required.
3. Print the document.
4. Use the document on the PC. (See the e-Filing Guide for details.)
 - The stored document in e-Filing can be downloaded to a client PC by using the “File Downloader”.
 - The stored document in e-Filing can be imported as an image into the TWAIN-compatible application by the TWAIN driver.
 - You can edit and back up the document, create a folder, etc. in the e-Filing using “TopAccess”.

Tips

- The available settings differ between when the operation is performed from the touch panel of this equipment or using “TopAccess” from a client PC. See the e-Filing Guide for details.
- When the preservation period for documents in e-Filing is specified, the stored documents will be deleted after this period has passed. You need to print the documents or download them into a client PC using the “File Downloader”. See the e-Filing Guide for details. (For setting the storing period of the documents in e-Filing, ask the network administrator.)
- Be sure to back up the data stored in e-Filing regularly in case of a hard disk failure. See the e-Filing Guide for details.

This chapter explains about when copied original data are stored to e-Filing. See the e-Filing Guide for storing, printing and managing the document obtained by printing from a PC, scanning, receiving fax and receiving Internet Fax (except for copying) and operating e-Filing via network.

2. Creating User Boxes

Up to 200 user boxes can be created. To prepare user boxes for different purposes enables you to have efficient document management.

Folders can be created in each user box. Also, password can be set to each user box.

- You can create folders using “TopAccess” from a client PC. See the e-Filing Guide for details.

Set up a user box following the procedure below.

- 1 Press the [e-FILING] button on the control panel.

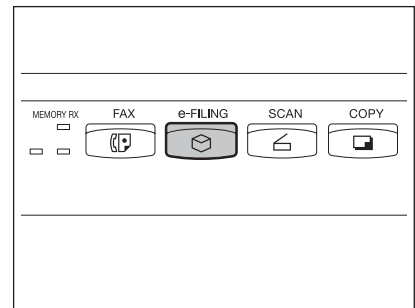

- 2 Select a blank box number between “001” and “200”, and then press the [SETUP] button.

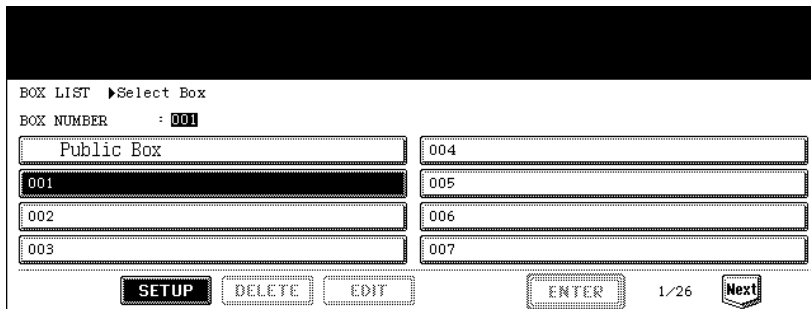

- 3 Enter the box name.

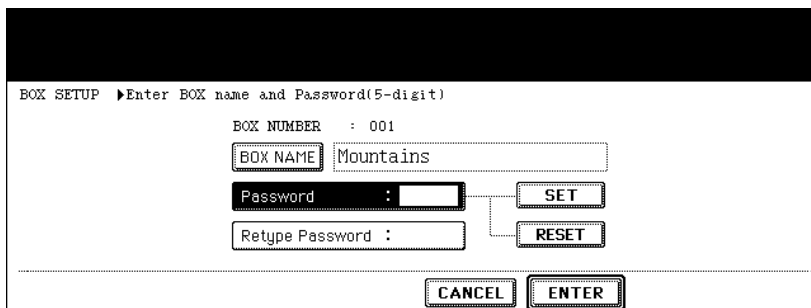

- When the [BOX NAME] button is pressed, the letter entry menu (P.28) is displayed. Up to 32 letters can be entered.

4 Key in the password in “Password” as required, and then press the [SET] button to fix it.

BOX SETUP ▶Enter BOX name and Password(5-digit)

BOX NUMBER : 001

BOX NAME Mountains

Password : *****

Retype Password :

SET

RESET

CANCEL ENTER

Detailed description: This is a screenshot of a terminal-style interface for setting up a box. The title is 'BOX SETUP ▶Enter BOX name and Password(5-digit)'. Below the title, it shows 'BOX NUMBER : 001'. There are two input fields: 'BOX NAME' containing 'Mountains' and 'Password' containing five asterisks. To the right of the 'Password' field is a 'SET' button. Below the 'Password' field is a 'Retype Password' field, which is currently empty. To the right of the 'Retype Password' field is a 'RESET' button. At the bottom of the screen are two buttons: 'CANCEL' and 'ENTER'. The 'Password' field and its associated 'SET' button are highlighted with a thick black border.

- Be sure to key in the 5-digit password.
- * (asterisk) is displayed in “Password” when the password is entered.
- To correct the entered password, press the [CLEAR] button on the control panel.
- When the [SET] button is pressed, “Retype Password” becomes highlighted.

5 Key in the password in “Retype Password”.

BOX SETUP ▶Enter BOX name and Password(5-digit)

BOX NUMBER : 001

BOX NAME Mountains

Password : *****

Retype Password : *****

SET

RESET

CANCEL ENTER

Detailed description: This is a screenshot of the same terminal-style interface as in step 4. The title and 'BOX NUMBER' are the same. The 'BOX NAME' field still contains 'Mountains'. The 'Password' field now contains five asterisks. The 'Retype Password' field also contains five asterisks. The 'SET' button is now disabled and faded. The 'RESET' button is now highlighted with a thick black border. The 'CANCEL' and 'ENTER' buttons remain at the bottom.

- * (asterisk) is displayed in “Retype Password” when the password is entered.
- To correct the entered password, press the [CLEAR] button on the control panel.

6 Press the [ENTER] button.

BOX SETUP ▶Enter BOX name and Password(5-digit)

BOX NUMBER : 001

BOX NAME Mountains

Password : *****

Retype Password : *****

SET

RESET

CANCEL ENTER

Detailed description: This is a screenshot of the same terminal-style interface. The 'Password' and 'Retype Password' fields both contain five asterisks. The 'SET' button is now highlighted with a thick black border. The 'RESET' button is faded. The 'CANCEL' and 'ENTER' buttons remain at the bottom.

- The user box is created.

3. Changing Data of User Boxes

Created user boxes and passwords can be changed.

- You cannot change the folder name using the control panel of this equipment. It can be changed using “TopAccess” from a client PC. See the e-Filing Guide for details.

1 Press the [e-FILING] button on the control panel.

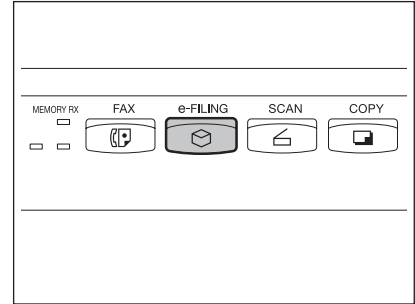

2 Select the desired box, and then press the [EDIT] button.

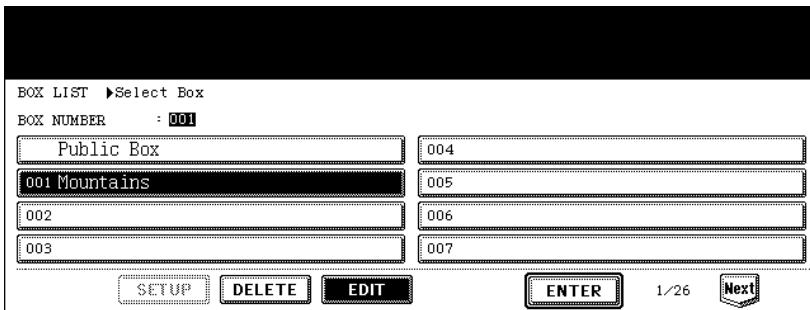

- If the desired box is not displayed, press the [Prev] or [Next] button to switch the menu.
- To display the applicable menu immediately, key in the box number.

3 Key in the password (5 digits) for the selected box, and then press the [ENTER] button.

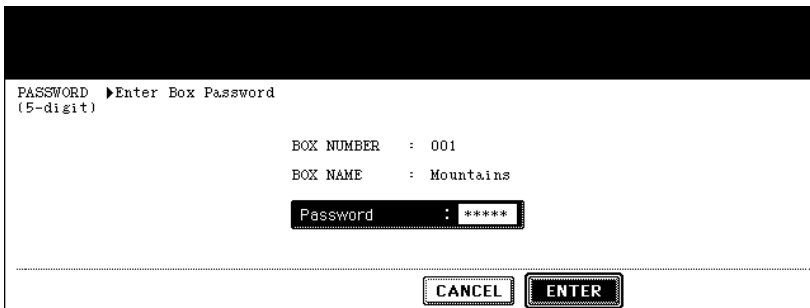

- If no password was set when the box was created, skip to step 4.

4 Enter the new box name.

BOX MODIFY ▶Enter BOX Name and Password(5-digit)

BOX NUMBER : 001

BOX NAME River

Password :

Retype Password :

SET

RESET

CANCEL ENTER

- When [BOX NAME] is pressed, the letter entry menu (P.28) is displayed. A box name can contain up to 32 letters.

5 Key in the new password in “Password”, and then press the [SET] button to fix it.

BOX MODIFY ▶Enter BOX Name and Password(5-digit)

BOX NUMBER : 001

BOX NAME River

Password : *****

Retype Password :

SET

RESET

CANCEL ENTER

- Be sure to key in the 5-digit password.
- * (asterisk) is displayed in “Password” when the password is entered.
- To correct the entered password, press the [CLEAR] button on the control panel.
- When the [SET] button is pressed, “Retype Password” becomes highlighted.

6 Key in the password in “Retype Password”.

BOX MODIFY ▶Enter BOX Name and Password(5-digit)

BOX NUMBER : 001

BOX NAME River

Password : *****

Retype Password : *****

SET

RESET

CANCEL ENTER

- * (asterisk) is displayed in “Retype Password” when the password is entered.
- To correct the entered password, press the [CLEAR] button on the control panel.

7 Press the [ENTER] button.

BOX MODIFY ▶Enter BOX Name and Password(5-digit)

BOX NUMBER : 001

BOX NAME : River

Password : *****

Retype Password : *****

SET

RESET

CANCEL ENTER

- The box settings are updated.

4. Deleting User Boxes

Unnecessary user boxes can be deleted. All folders and documents in the user boxes are also deleted.

- Public box cannot be deleted.

- 1 Press the [e-FILING] button on the control panel.

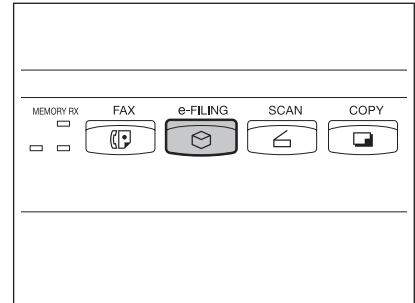

- 2 Select the box you want to delete, and then press the [DELETE] button.

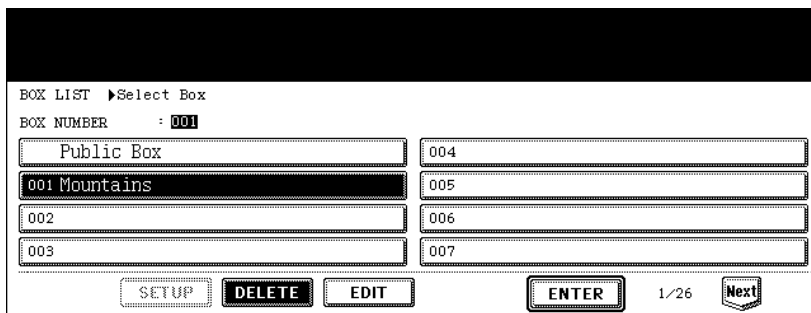

- If the desired box is not displayed on the menu, press the [Prev] or [Next] button to switch the menu.
- To display the applicable menu immediately, key in the box number.

- 3 Key in the password (5 digits) for the selected box, and then press the [ENTER] button.

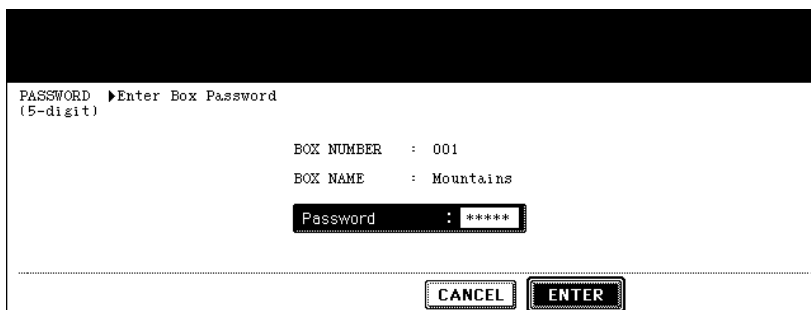

- If no password was set when the box was created, skip to step 4.

4 “Are you sure you want to delete this box?” appears. Press the [Yes] button to delete the box.

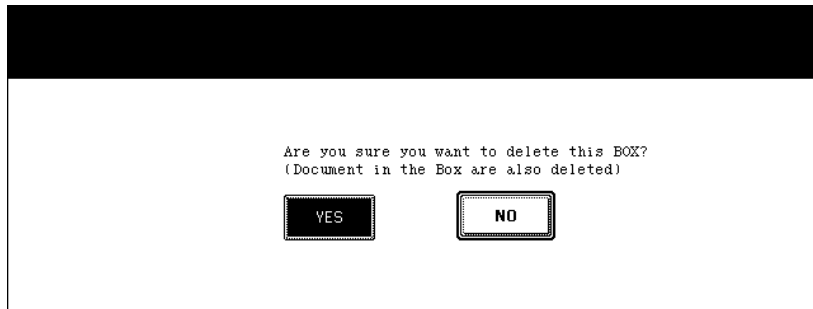

- The box is deleted.

5. Storing Documents in e-Filing

Scanned original data can be stored in e-Filing. The copy mode settings will be saved with the e-Filing document. You can copy originals and store the data at one time. After storing the original data, you can print them out at any time.

- There are two types of e-Filing, public box and user boxes. To store the data in a user box, you need to set it up in advance. (P.174 “2.Creating User Boxes”)
- The data scanned with the scanning function can be also stored in e-Filing by installing the Scanner Kit (optional). The stored data can be downloaded to the client PC as a JPEG, PDF or TIFF file. For details, refer to the Scanning Guide.

1 Place the original(s).

- Up to 100 folders can be created in one e-Filing, and a maximum of 400 documents can be stored in one folder. The maximum number of original pages is 1000. (However this may be restricted depending on the amount of free space of the hard disk in this equipment.)
- Set the copy mode as required.

2 Press the [E-FILING/FILE] button to enter the e-Filing/file menu.

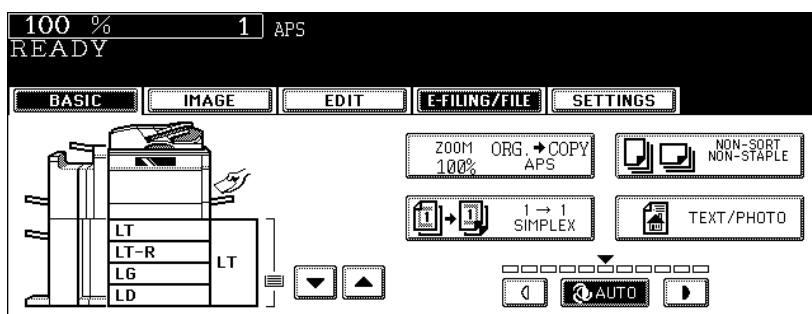

3 Press the [STORE TO E-FILING] button.

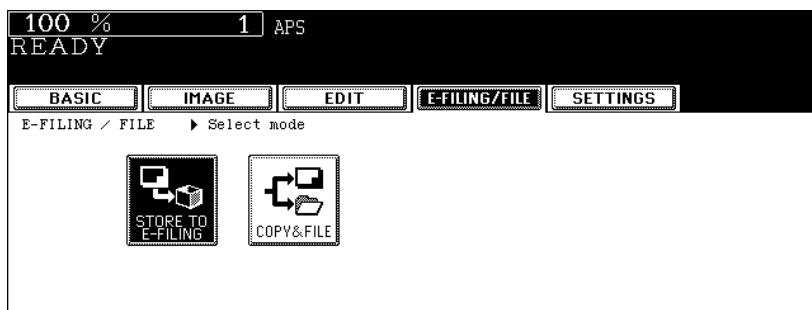

4 Press the [BOX/FOLDER] button.

100 % 1 APS
READY

BASIC IMAGE EDIT **E-FILING/FILE** SETTINGS

STORE TO E-FILING ▶ Select box and folder

BOX/FOLDER BOX NUMBER :
BOX NAME :
FOLDER NAME :

DOCUMENT NAME DOC031002

CANCEL ENTER

5 Select the box in which you want to store the document, and then press the [ENTER] button.

6

BOX LIST ▶ Select Box

BOX NUMBER : 001

Public Box	004
001 Mountains	005
002	006
003	007

CANCEL ENTER 1/26 Next

- If the desired box is not displayed on the menu, press the [Prev] or [Next] button to switch the menu.

When the password entry menu is displayed

When the password entry menu is displayed, the password is set in the selected user box. Key in the password.

PASSWORD ▶ Enter Box Password
(5-digit)

BOX NUMBER : 001
BOX NAME : Mountains

Password : *****

CANCEL ENTER

6 The document list in the selected box is displayed. Press the [ENTER] button to store in this box.

STORE TO E-FILING ▶ Select Storage Location

Document/Folder Name	Date,Time	Paper	Pages
HAKKODA	02,19:55	LT	1
HAKKODA-001	02,19:57	LT	1
New	01,08:27		

[OPEN FOLDER] [CANCEL] [ENTER] 1/1

To store the document in the folder

To store the document in the folder, select the folder to be stored, press the [OPEN FOLDER] button. The document list in the selected folder is displayed. Press the [ENTER] button to store in this folder.

STORE TO E-FILING ▶ Select Storage Location

Document Name	Date,Time	Paper	Pages
HAKKODA-002	02,19:59	LT	1

[CLOSE FOLDER] [CANCEL] [ENTER] 1/1

- If you want to close the folder and go back to the box above, press the [CLOSE FOLDER] button.
- Creating the folder can be performed from the client PC using "TopAccess". For details, see e-Filing Guide.

7 Enter the document name.

100 % 1 APS
READY

BASIC IMAGE EDIT E-FILING/FILE SETTINGS

STORE TO E-FILING ▶ Select box and folder

[BOX/FOLDER] BOX NUMBER : 001
BOX NAME : Mountains
FOLDER NAME :

[DOCUMENT NAME] TANIGAWA

[CANCEL] [ENTER]

- When the [DOCUMENT NAME] button is pressed, the letter entry menu (P.28) is displayed. Up to 64 letters can be entered.

8 Press the [ENTER] button.

100 % 1 APS
READY

BASIC IMAGE EDIT **E-FILING/FILE** SETTINGS

STORE TO E-FILING ▶ Select box and folder

BOX/FOLDER BOX NUMBER : 001
BOX NAME : Mountains
FOLDER NAME :
DOCUMENT NAME : TANIGAWA

CANCEL ENTER

9 “PRINT THIS DOCUMENT?” appears. Press the [YES] button to store and print it out at one time.

100 % 1 APS
READY

BASIC IMAGE EDIT **E-FILING/FILE** SETTINGS

>PRINT THIS DOCUMENT ?

YES NO

CANCEL

- If you want to store the document without printing it, press the [NO] button.

10 Press the [START] button.

- Storing the document starts.

Tip

When the original is placed on the original glass or on the Reversing Automatic Document Feeder in the Single original feeding mode, the following menu is displayed. If you have another original to be stored, press the [YES] button. After the last page has finished being scanned, press the [FINISHED] button.

100 % 1 LT

READY

BASIC IMAGE EDIT **E-FILING/FILE** SETTINGS

>NEXT ORIGINAL ?

YES FINISHED

11 After all originals have finished being stored, press the [FUNCTION CLEAR] button.

- The basic menu is displayed.

6. Printing Stored Documents

Stored documents can be printed out. You can also print out a part of a document and change the setting in the finishing mode or the like before printing the documents.

Printing the whole document

All pages of the document are printed. If printing multiple copies is desired, see  P.188 "Printing the stored document after changing the settings".

- 1 Press the [e-FILING] button on the control panel.

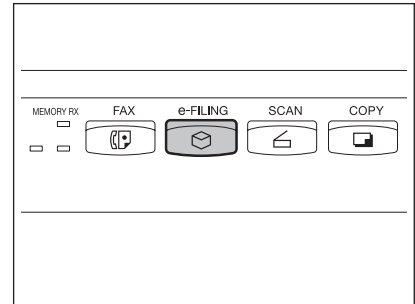

- 2 Select the box in which the desired printing document is stored, and then press the [ENTER] button.

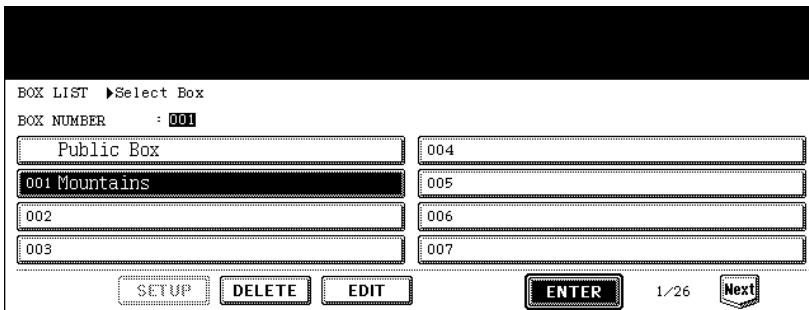

- If the desired box is not displayed on the menu, press the [Prev] or [Next] button to switch the menu.
- To display the applicable menu immediately, key in the box number.

- 3 Key in the password (5 digits) for the selected box, and then press the [ENTER] button.

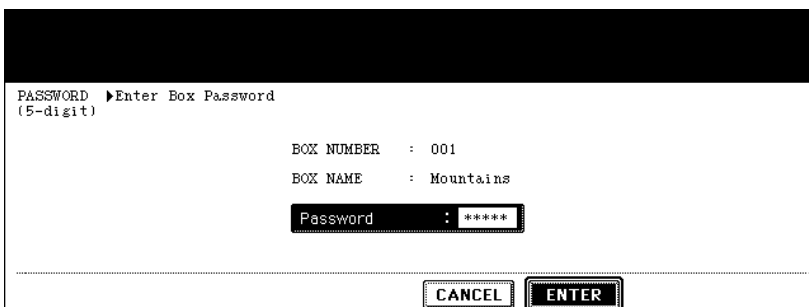

- If no password was set when the box was registered, skip to step 4.

4 Select the document to be printed.

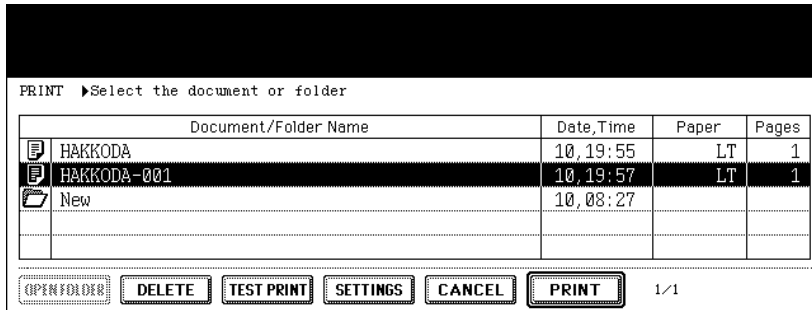

- To print a document in the folder, select the folder in which you want to print the document out and press the [OPEN FOLDER] button. Select the desired document on the menu.

5 Press the [PRINT] button.

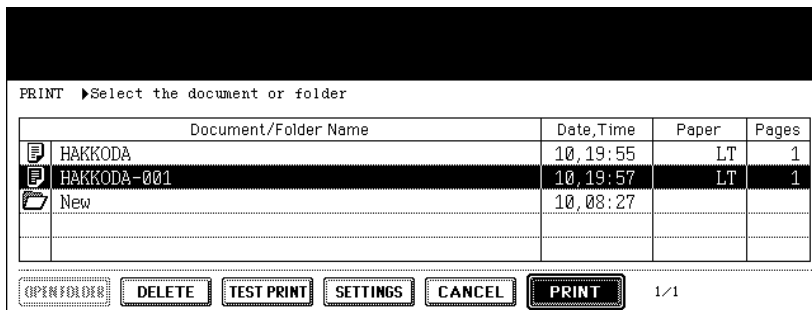

- Printing starts.

To stop printing a stored document during the operation

Select the job you want to stop from the print job menu or scan job menu, and then press the [DELETE] button. For details, see P.223 "8.JOB STATUS".

Test printing

A part of a document of several pages can be printed out.

1 Follow steps 1 to 4 of P.185 "Printing the whole document".

2 Press the [TEST PRINT] button.

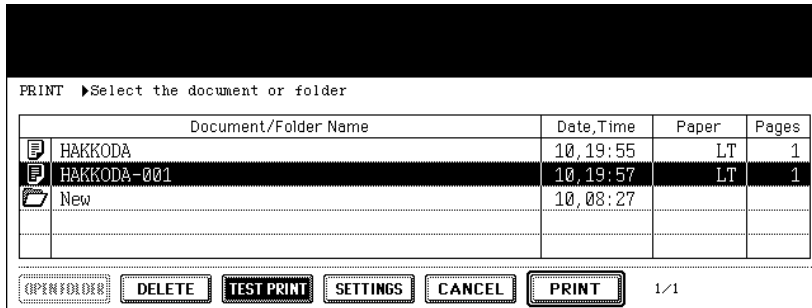

3 Key in the number of the last page and change the first page to be printed if necessary.

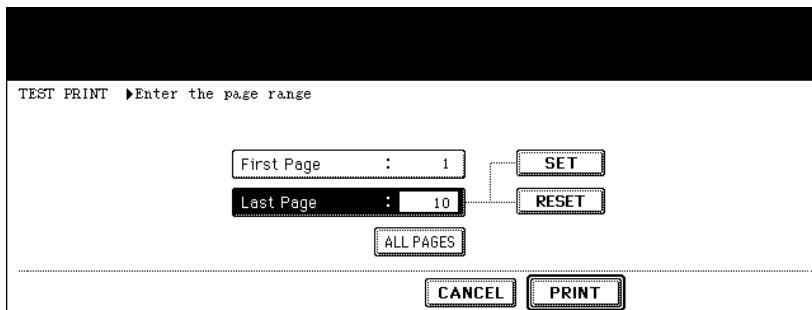

- Key in the number of the last page, press the [SET] button, and then key in the number of the first page.
- To correct the pages, press the [CLEAR] button on the control panel.
- To print all pages, press the [ALL PAGES] button.

4 Press the [PRINT] button.

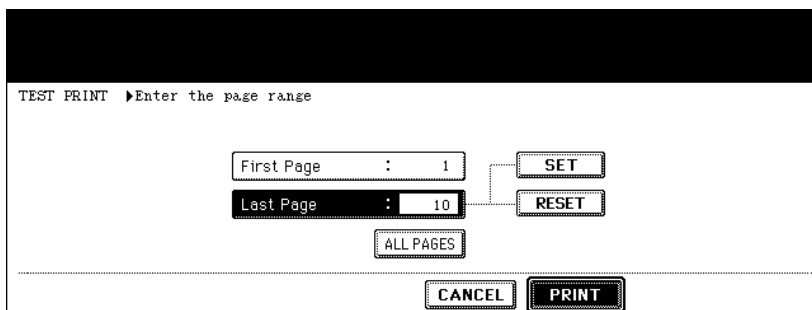

- Printing of the set pages starts.

To stop printing a stored document during this operation

Select the job you want to stop from the print job menu or scan job menu, and then press the [DELETE] button. For details, see P.223 "8.JOB STATUS".

Printing the stored document after changing the settings

The following settings are available before the stored document is printed.

1. Feeding source (Press the drawer area of the feeding source. Paper in the drawer selected for the feeding source is used only when its size and type correspond to those of the original.)
2. Number of printings (Key them in.)
3. Simplex printing / duplex printing
4. Finishing mode (Selecting the mode is limited depending on the installed optional equipment.)
5. Paper exit (Available when the Finisher or Saddle Stitch Finisher (both are optional) is installed)
6. Image shift position
7. Added date and time position
8. Page number position

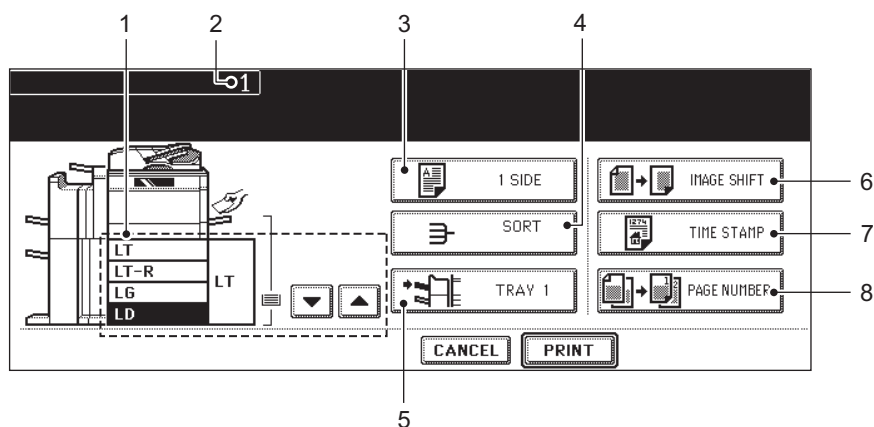

1 Follow steps 1 to 4 of P.185 “Printing the whole document”.

2 Press the [SETTINGS] button.

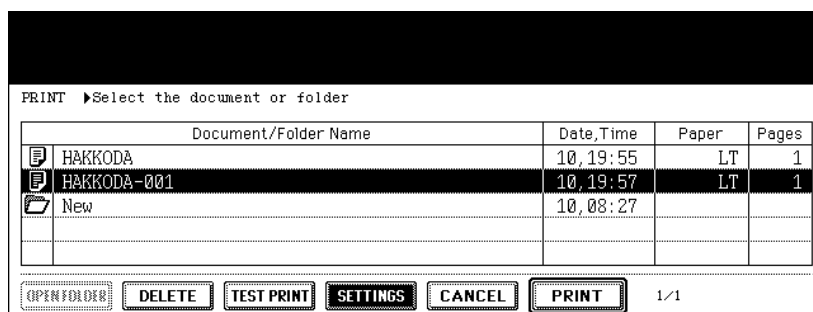

3 Set the printing modes as required.

- See the eight items mentioned above for the setting mode. To set items 3 to 8, press the button and set the required setting on the menu.

4 Press the [PRINT] button.

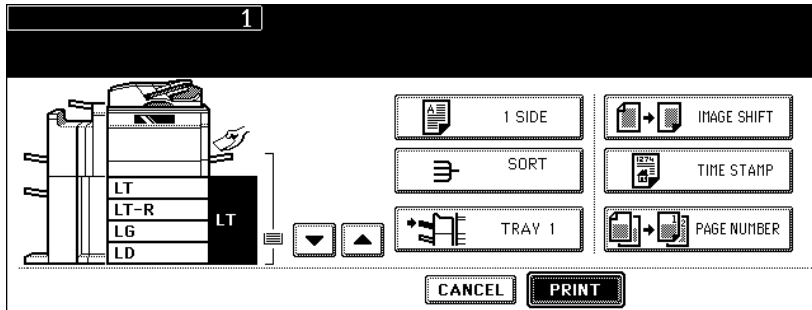

- Printing starts.

To stop printing a stored document during this operation

Select the job you want to stop from the print job menu or scan job menu, and then press the [DELETE] button. For details, see [P.223](#) "8.JOB STATUS".

7. Deleting Folders or Documents

Unnecessary folders or documents can be deleted. If a folder is deleted, all documents in the folder are also deleted.

1 Press the [e-FILING] button on the control panel.

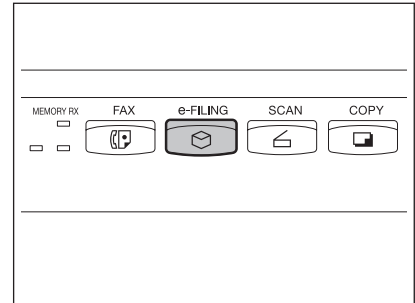

2 Select the box in which you want to delete the folder or document, and then press the [ENTER] button.

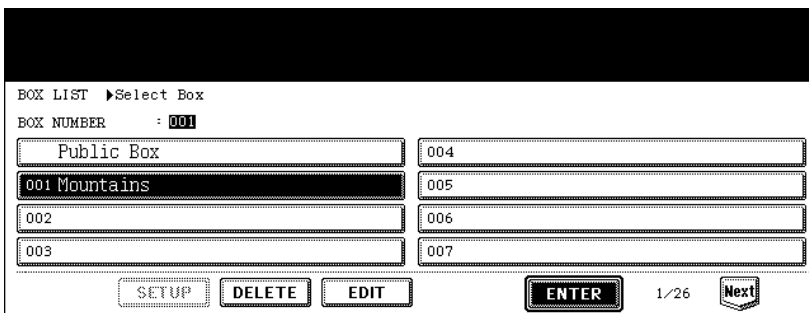

- If the desired box is not displayed on the menu, press the [Prev] or [Next] button to switch the menu.
- To display the applicable menu immediately, key in the box number.

3 Key in the password (5 digits) for the selected box, and then press the [ENTER] button.

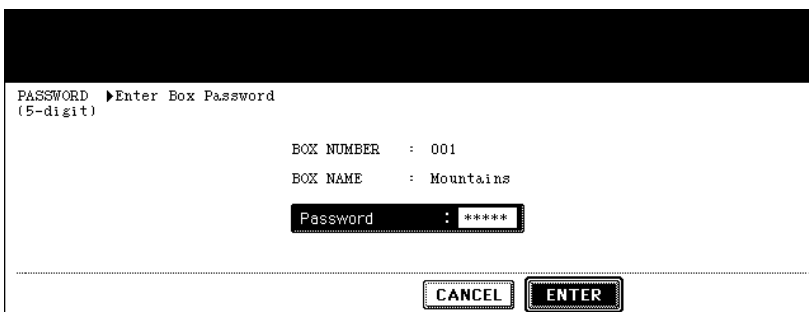

- If no password was set when the box was created, skip to step 4.

4 Select the folder or document to be deleted, and then press the [DELETE] button.

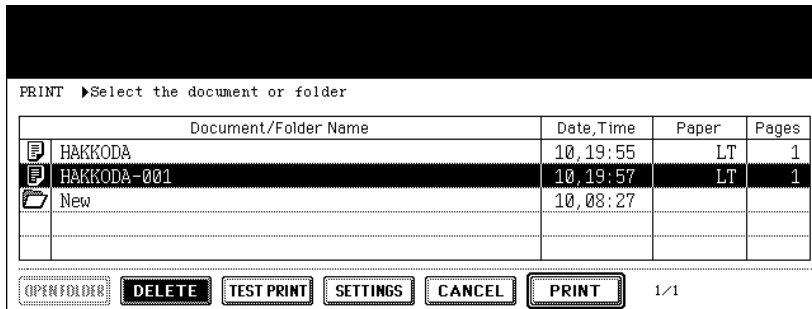

To delete a document in the folder

To delete a document in the folder, select the folder in which you want to delete the document and press the [OPEN FOLDER] button. Select the desired document and press the [DELETE] button.

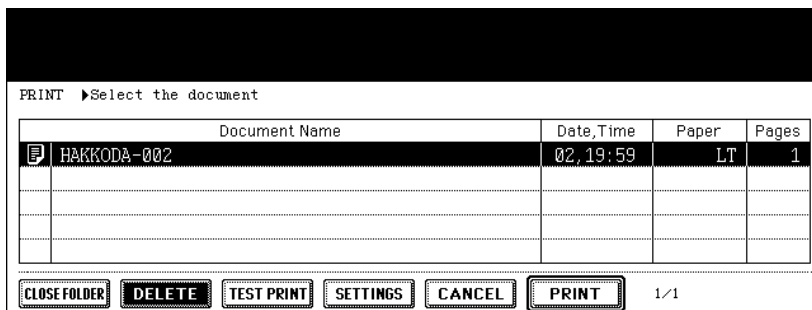

5 “Are you sure you want to delete this folder?” or “Are you sure you want to delete this document?” appears. Press the [Yes] button to delete the folder or document.

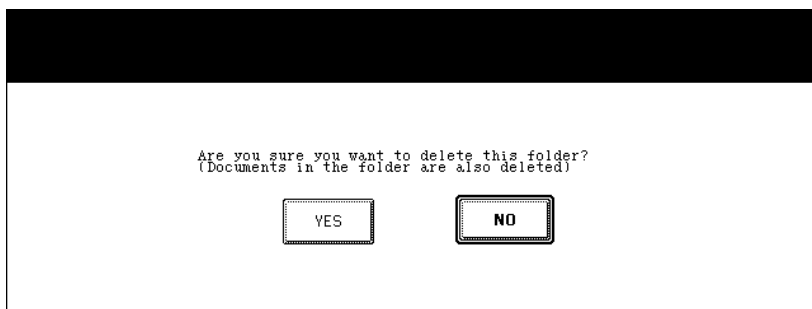

- The folder or document is deleted.



6

7. TEMPLATE

1. Template	194
2. Registering User Groups and Templates	195
3. Changing Data of User Groups and Templates	206
4. Recalling Templates	213
5. Deleting User Groups or Templates	218

1. Template

A combination of functions frequently used can be registered as a template and recalled as required. Templates can be used with the copy, scanning and Fax functions.

- To use scanning functions, the Scanner Kit or the Printer/Scanner Kit (both optional) is required.
- To use Fax functions, the optional Fax Unit is required.

1. Register the combination of the functions to the template.
2. Place the original.
3. Recall and copy the desired template.

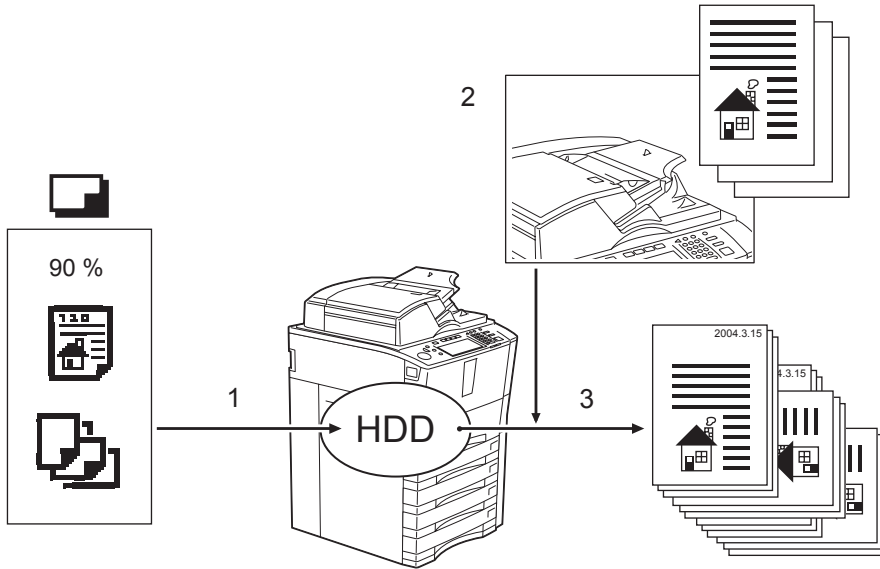

2. Registering User Groups and Templates

A template can be registered either in “PUBLIC TEMPLATE GROUP” or “USER GROUP” depending on your purpose. Passwords can be set to restrict the unauthorized use of a template.

PUBLIC TEMPLATE GROUP:

This is prepared as a default setting. Anyone can use a template registered in this group.

It is useful if the setting combinations of functions frequently used throughout the company or organization are registered in this group. Up to 60 templates can be registered.

- When registering a template in the public template group, keying in the Admin Password is required.

USER GROUP:

Up to 200 groups can be registered. It is useful if you register each department, section or person as a user group. Up to 60 templates can be registered in each group. Passwords can be set for the user groups.

Registering a template in the public template group

1 Set every function you want to include in the combination.

- e.g.: Setting “Image shift”, “90% reduction” and “10 sets of copies” of the copy function.
- Up to 15 pages are registered in the template for each setting of “SHEET INSERTION”, [BLANK TAB INSERT] and [COPIED TAB INSERT] for “TAB PAPER”, and [SHEET INSERT] for “INSERTER”.

2 Press the [TEMPLATE] button on the control panel.

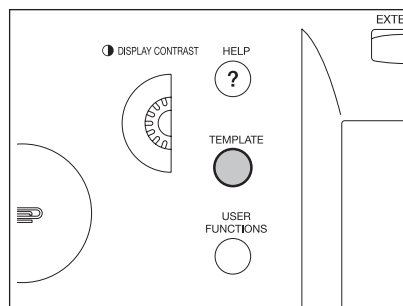

7

3 Press the [REGISTRATION] button on the touch panel.

A screenshot of a touch panel interface. At the top, it says "Select a GROUP". Below that are two buttons: "RECALL" and "REGISTRATION". Underneath is a "GROUP Number" field with a small black box. Below that is a grid of buttons for selecting a group. The first row has "PUBLIC TEMPLATE GROUP" and "004". The second row has "001" and "005". The third row has "002" and "006". The fourth row has "003" and "007". At the bottom are buttons for "DELETE", "EDIT", "CANCEL", and "ENTER". In the bottom right corner, it says "1/26" and a "Next" button.

- 4** Press the [PUBLIC TEMPLATE GROUP], and then press the [ENTER] button.

Select a GROUP

RECALL REGISTRATION

GROUP Number

PUBLIC TEMPLATE GROUP	004
001	005
002	006
003	007

DELETE EDIT CANCEL ENTER 1/26 Next

- 5** Press the [PASSWORD] button, key in the Admin Password (6 to 10 digits), and then press the [ENTER] button.

ADMINISTRATOR PASSWORD

KEY PASSWORD

CANCEL

- 6** The corresponding buttons of the template registered in the public template group are displayed. Press the blank key, and then press the [SAVE] button.

Select a TEMPLATE

RECALL REGISTRATION

COPY MODE			
001			

DELETE EDIT CANCEL SAVE 1/5 Next

7 Enter the template name.

RECALL REGISTRATION

PUBLIC TEMPLATE GROUP

NAME 1 COPY MODE

NAME 2 002

USER NAME

PASSWORD

AUTOMATIC START

ENABLE DISABLE

This icon is indicated when an automatic start is enabled.

CANCEL SAVE

- [NAME 1] is displayed on the upper side and [NAME 2] is displayed on the lower side of the template button. Enter [NAME 1] and/or [NAME 2]. When both are entered, [NAME 1] is displayed on the upper side and [NAME 2] on the lower side of the button.
- When the [NAME 1] or [NAME 2] button is pressed, the letter entry menu (P.28) is displayed. Up to 11 letters can be entered.

8 Enter the user name of the template as required.

RECALL REGISTRATION

PUBLIC TEMPLATE GROUP

NAME 1 COPY MODE

NAME 2 002

USER NAME GUEST

PASSWORD

AUTOMATIC START

ENABLE DISABLE

This icon is indicated when an automatic start is enabled.

CANCEL SAVE

- When the [USER NAME] button is pressed, the letter entry menu (P.28) is displayed. Up to 30 letters can be entered.

9 Key in the password in “Password” as required, and then press the [SET] button to fix it.

RECALL REGISTRATION

PUBLIC TEMPLATE GROUP
(PASSWORD:5-digit)

Password : *****

Retype Password :

SET

RESET

CANCEL ENTER

- Be sure to key in the 5-digit password.
- * (asterisk) is displayed in “Password” when the password is entered.
- To correct the entered password, press the [CLEAR] button on the control panel.
- When the [SET] button is pressed, “Retype Password” becomes highlighted.

10 Key in the password in “Retype Password”, and then press the [ENTER] button to fix it.

RECALL REGISTRATION

PUBLIC TEMPLATE GROUP
(PASSWORD:5-digit)

Password : ***** SET

Retype Password : ***** RESET

CANCEL ENTER

- * (asterisk) is displayed in “Retype Password” when the password is entered.
- To correct the entered password, press the [CLEAR] button on the control panel.

11 Select whether to enable “AUTOMATIC START” or not when the template is recalled.

RECALL REGISTRATION

PUBLIC TEMPLATE GROUP

NAME 1 COPY MODE

NAME 2 002

USER NAME GUEST



PASSWORD *****

AUTOMATIC START

ENABLE DISABLE

This icon is indicated when an automatic start is enabled.

CANCEL SAVE

- Press the [ENABLE] or [DISABLE] button.
- When [ENABLE] is selected, the  icon is added to the template button. (The operation of the setting functions is automatically started by pressing the template button with the  icon when the template is recalled. However, if a password is set for the template, you need to key it in when an operation with the function set to the template is performed, though automatic start is enabled.)

12 Press the [SAVE] button.

RECALL REGISTRATION

PUBLIC TEMPLATE GROUP

NAME 1 COPY MODE

NAME 2 002

USER NAME GUEST

PASSWORD *****

AUTOMATIC START

ENABLE DISABLE

This icon is indicated when an automatic start is enabled.

CANCEL SAVE

- The screen returns to the one of step 1, which is the menu before the [TEMPLATE] button on the control panel is pressed.

Registering the new user group

- 1 Press the [TEMPLATE] button on the control panel.

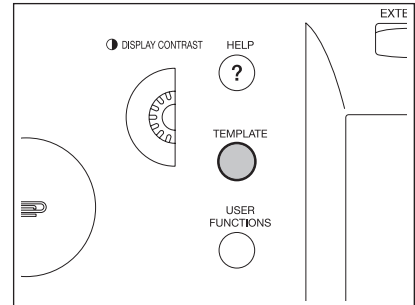

- 2 Press the [REGISTRATION] button on the touch panel.

The screenshot shows a screen titled "Select a GROUP". At the top, there are two buttons: "RECALL" and "REGISTRATION", with "REGISTRATION" being highlighted. Below this is a "GROUP Number" field with a small black box. A table of group names and numbers is displayed:

PUBLIC TEMPLATE GROUP	004
001	005
002	006
003	007

At the bottom, there are buttons for "DELETE", "EDIT", "CANCEL", and "ENTER". The "ENTER" button is highlighted. A "Next" button is also present. The page number "1/26" is shown in the bottom right.

- 3 Select an unregistered user group between "001" and "200", and then press the [ENTER] button.

The screenshot shows the same "Select a GROUP" screen. The "REGISTRATION" button remains selected. In the "GROUP Number" field, the number "001" is now entered. In the table, the row for "001" is highlighted with a dark background. The "ENTER" button at the bottom is also highlighted. The "Next" button and page number "1/26" are still visible.

4 Enter the user group name.

The screenshot shows a control panel with two buttons at the top: "RECALL" and "REGISTRATION". Below them, the text "TEMPLATE GROUP :" is displayed. There are three input fields, each with a corresponding button to its left: "NAME" with "COMMON" entered, "USER NAME" (empty), and "PASSWORD" (empty). At the bottom of the screen are "CANCEL" and "ENTER" buttons.

- When the [NAME] button is pressed, the letter entry menu (P.28) is displayed. Up to 20 letters can be entered.

5 Enter the user name of the user group as required.

The screenshot shows the same control panel as in step 4. The "NAME" field still contains "COMMON". The "USER NAME" field now contains "USER01". The "PASSWORD" field remains empty. The "CANCEL" and "ENTER" buttons are at the bottom.

- When the [USER NAME] button is pressed, the letter entry menu (P.28) is displayed. Up to 30 letters can be entered.

6 Key in the password in “Password” as required, and then press the [SET] button to fix it.

The screenshot shows the control panel with the "REGISTRATION" button highlighted. The text "TEMPLATE GROUP :" is followed by "(PASSWORD:5-digit)". There are two input fields: "Password" containing "*****" and "Retype Password" (empty). To the right of the "Password" field are "SET" and "RESET" buttons. At the bottom are "CANCEL" and "ENTER" buttons.

- Be sure to key in the 5-digit password.
- * (asterisk) is displayed in “Password” when the password is entered.
- To correct the entered password, press the [CLEAR] button on the control panel.
- When the [SET] button is pressed, “Retype Password” becomes highlighted.

7 Key in the password in “Retype Password”, and then press the [ENTER] button to fix it.

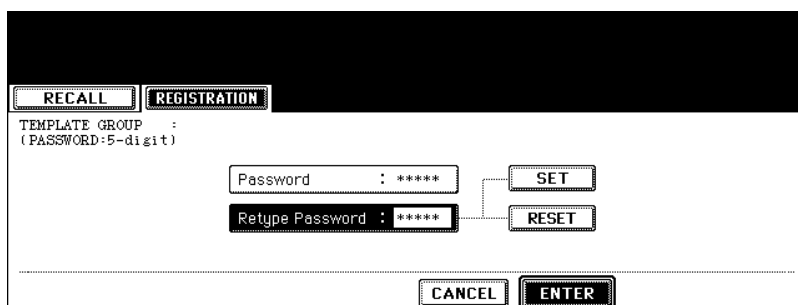

The screenshot shows a control panel menu with two tabs: 'RECALL' and 'REGISTRATION'. Under 'REGISTRATION', the text 'TEMPLATE GROUP : (PASSWORD:5-digit)' is displayed. There are two input fields: 'Password : *****' and 'Retype Password : *****'. To the right of the 'Password' field is a 'SET' button, and to the right of the 'Retype Password' field is a 'RESET' button. At the bottom of the screen are 'CANCEL' and 'ENTER' buttons.

- * (asterisk) is displayed in “Retype Password” when the password is entered.
- To correct the entered password, press the [CLEAR] button on the control panel.

8 Press the [ENTER] button.

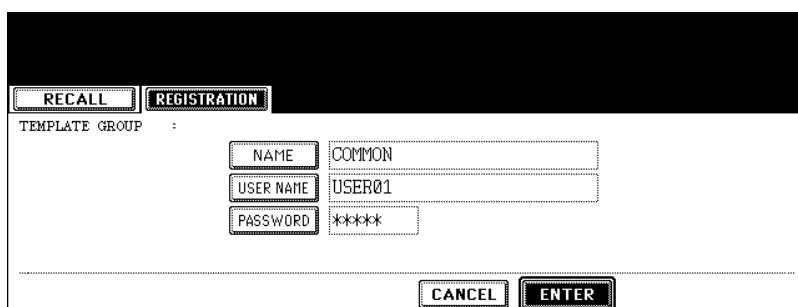

The screenshot shows the 'REGISTRATION' menu with the following fields: 'NAME' (COMMON), 'USER NAME' (USER01), and 'PASSWORD' (*****). 'CANCEL' and 'ENTER' buttons are at the bottom.

- The user group is registered.

7

Registering a template in the user group

1 Set every function you want to include in the combination.

- e.g.: Setting “Image shift”, “90% reduction” and “10 sets of copies” of the copy function.
- Up to 15 pages are registered in the template for each setting of “SHEET INSERTION”, [BLANK TAB INSERT] and [COPIED TAB INSERT] for “TAB PAPER”, and [SHEET INSERT] for “INSERTER”.

2 Press the [TEMPLATE] button on the control panel.

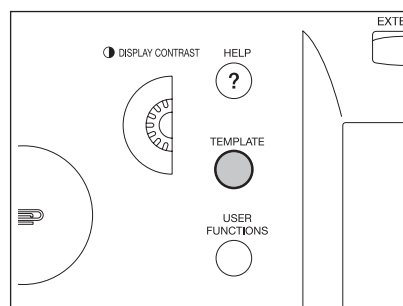

3 Press the [REGISTRATION] button on the touch panel.

Select a GROUP

RECALL REGISTRATION

GROUP Number

PUBLIC TEMPLATE GROUP	004
001 COMMON	005
002	006
003	007

DELETE EDIT CANCEL ENTER 1/26 Next

4 Select the desired user group, and then press the [ENTER] button.

Select a GROUP

RECALL REGISTRATION

GROUP Number 001

PUBLIC TEMPLATE GROUP	004
001 COMMON	005
002	006
003	007

DELETE EDIT CANCEL ENTER 1/26 Next

- If the desired user group is not displayed, press the [Prev] or [Next] button to switch the menu.

5 Key in the password (5 digits) for the selected user group, and then press the [ENTER] button.

PASSWORD
(5-digit)

NAME : COMMON

USER NAME : USER01

Password : *****

CANCEL ENTER

- If no password was set when the user group was registered, skip to step 6.

- 6** The corresponding buttons of the template registered in the user group are displayed. Press the blank key, and then press the [SAVE] button.

Select a TEMPLATE

RECALL REGISTRATION

<input type="checkbox"/> COPY MODE 001			

DELETE EDIT CANCEL SAVE 1/5 Next

- 7** Enter the template name.

RECALL REGISTRATION

TEMPLATE GROUP : COMMON

NAME 1 COPY MODE

NAME 2 002

USER NAME

PASSWORD

AUTOMATIC START

ENABLE DISABLE

This icon is indicated when an automatic start is enabled.

CANCEL SAVE

7

- [NAME 1] is displayed in the upper side and [NAME 2] is displayed in the lower side of the template button. Enter [NAME 1] and/or [NAME 2]. When both are entered, [NAME 1] is displayed in the upper side and [NAME 2] is displayed in the lower side of the button.
- When the [NAME 1] or [NAME 2] button is pressed, the letter entry menu (P.28) is displayed. Up to 11 letters can be entered.

- 8** Enter the user name of the template as required.

RECALL REGISTRATION

TEMPLATE GROUP : COMMON

NAME 1 COPY MODE

NAME 2 002

USER NAME GUEST01

PASSWORD

AUTOMATIC START

ENABLE DISABLE

This icon is indicated when an automatic start is enabled.

CANCEL SAVE

- When the [USER NAME] button is pressed, the letter entry menu (P.28) is displayed. Up to 30 letters can be entered.

9 Key in the password in “Password” as required, and then press the [SET] button to fix it.

The screenshot shows a control panel with two tabs: **RECALL** and **REGISTRATION**. Below the tabs, the text reads: **TEMPLATE GROUP : COMMON** and **(PASSWORD:5-digit)**. There are two input fields: **Password : ******* and **Retype Password :**. The **Password** field is highlighted with a thick border. To the right of the **Password** field is a **SET** button, and to the right of the **Retype Password** field is a **RESET** button. At the bottom of the panel are **CANCEL** and **ENTER** buttons.

- Be sure to key in the 5-digit password.
- * (asterisk) is displayed in “Password” when the password is entered.
- To correct the entered password, press the [CLEAR] button on the control panel.
- When the [SET] button is pressed, “Retype Password” becomes highlighted.



10 Key in the password in “Retype Password”, and then press the [ENTER] button to fix it.

The screenshot shows the same control panel as in step 9. The **REGISTRATION** tab is active. The text **TEMPLATE GROUP : COMMON** and **(PASSWORD:5-digit)** is present. The **Retype Password : ******* field is now highlighted with a thick border. The **SET** button is now disabled and dimmed, while the **RESET** button is active. The **ENTER** button at the bottom is also highlighted.

- * (asterisk) is displayed in “Retype Password” when the password is entered.
- To correct the entered password, press the [CLEAR] button on the control panel.

11 Select whether to enable “AUTOMATIC START” or not when the template is recalled.

The screenshot shows a menu with two tabs: 'RECALL' and 'REGISTRATION'. The 'REGISTRATION' tab is active. Below the tabs, it says 'TEMPLATE GROUP : COMMON'. There are four input fields: 'NAME 1' with 'COPY MODE', 'NAME 2' with '002', 'USER NAME' with 'GUEST01', and 'PASSWORD' with '****'. To the right, under 'AUTOMATIC START', there are two buttons: 'ENABLE' (which is highlighted) and 'DISABLE'. Below these buttons is a small icon of a document with a checkmark and the text 'This icon is indicated when an automatic start is enabled.' At the bottom, there are 'CANCEL' and 'SAVE' buttons.

- Press the [ENABLE] or [DISABLE] button.
- When [ENABLE] is selected, the  icon is added to the template button. (The operation of the setting functions is automatically started by pressing the template button with the  icon when the template is recalled. However, if a password is set for the template, you need to key it in when an operation with the function set to the template is performed, though automatic start is enabled.)

12 Press the [SAVE] button.

This screenshot is identical to the one above, but the 'SAVE' button at the bottom right is now highlighted, indicating it is the next step in the process.

- The screen returns to the one of step 1, which is the menu before the [TEMPLATE] button on the control panel is pressed.

3. Changing Data of User Groups and Templates

Registered names, user names and passwords of user groups or templates, and the automatic start setting of a template can be changed.

- The data of a public group cannot be changed.

Changing the data of a user group

1 Press the [TEMPLATE] button on the control panel.

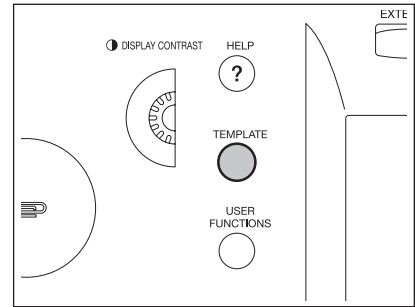

2 Press the [REGISTRATION] button on the touch panel.

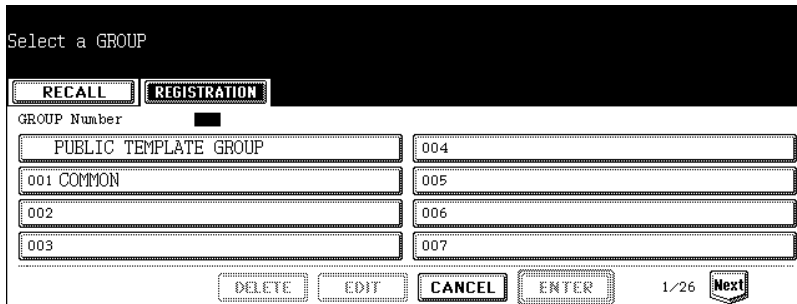

3 Select the user group you want to change, and then press the [EDIT] button.

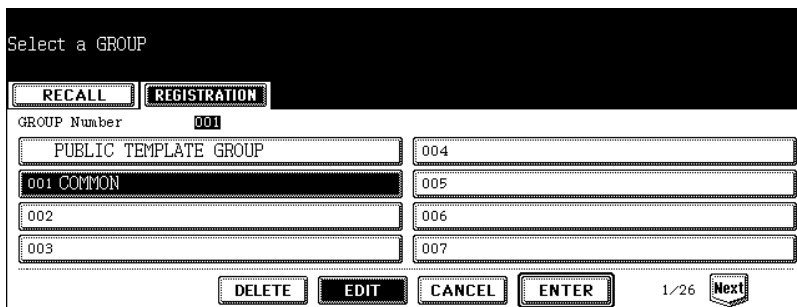

- If the desired user group is not displayed on the menu, press the [Prev] or [Next] button to switch the menu.
- To display the applicable menu immediately, key in the user group number.

4 Key in the password (5 digits) for the selected user group, and then press the [ENTER] button.

PASSWORD
(5-digit)

NAME : COMMON
USER NAME : USER01

Password : *****

CANCEL ENTER

- If no password was set when the user group was registered, skip to step 5.

5 Enter the new name of the user group.

RECALL REGISTRATION

TEMPLATE GROUP : COMMON

NAME LOCAL

USER NAME

PASSWORD

CANCEL ENTER

- When the [NAME] button is pressed, the letter entry menu (P.28) is displayed. Up to 20 letters can be entered.

6 Enter the new user name of the user group.

RECALL REGISTRATION

TEMPLATE GROUP : COMMON

NAME LOCAL

USER NAME USER02

PASSWORD

CANCEL ENTER

- When the [USER NAME] button is pressed, the letter entry menu (P.28) is displayed. Up to 30 letters can be entered.

7 Key in the new password in “Password”, and then press the [SET] button to fix it.

RECALL REGISTRATION

TEMPLATE GROUP : COMMON
(PASSWORD:5-digit)

Password : *****

Retype Password :

SET

RESET

CANCEL ENTER

- Be sure to key in the 5-digit password.
- * (asterisk) is displayed in “Password” when the password is entered.
- To correct the entered password, press the [CLEAR] button on the control panel.
- When the [SET] button is pressed, “Retype Password” becomes highlighted.

8 Key in the password in “Retype Password”, and then press the [ENTER] button to fix it.

RECALL REGISTRATION

TEMPLATE GROUP : COMMON
(PASSWORD:5-digit)

Password : *****

Retype Password : *****

SET

RESET

CANCEL ENTER

- * (asterisk) is displayed in “Retype Password” when the password is entered.
- To correct the entered password, press the [CLEAR] button on the control panel.

9 Press the [ENTER] button.

RECALL REGISTRATION

TEMPLATE GROUP : COMMON

NAME LOCAL

USER NAME USER02

PASSWORD ****

CANCEL ENTER

- The data of the user group are changed.

Changing the data of a template

- 1 Press the [TEMPLATE] button on the control panel.

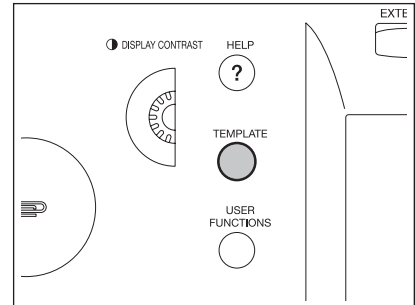

- 2 Press the [REGISTRATION] button on the touch panel.

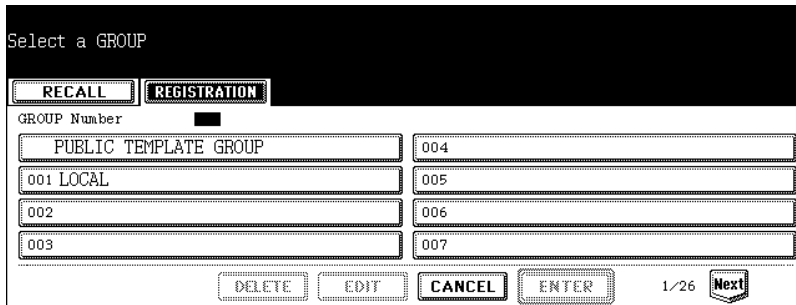

- 3 Select the user group in which the template to be changed was registered, and then press the [ENTER] button.

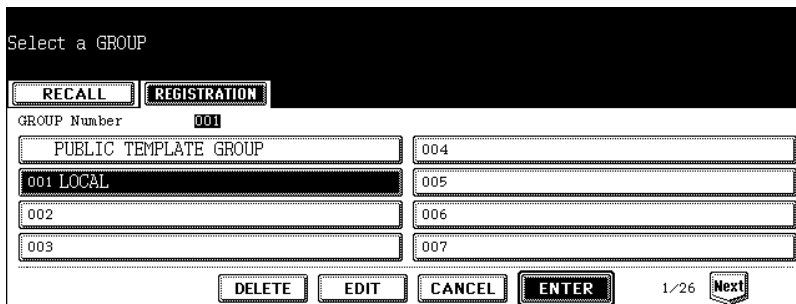

- If the desired user group is not displayed on the menu, press the [Prev] or [Next] button to switch the menu.
- To display the applicable menu immediately, key in the user group number.

4 Enter the following password, and then press the [ENTER] button.

When the public group is selected:

Key in the Admin Password (6 to 10 digits).

When the user group is selected:

Key in the password (5 digits) for the selected user group. (If no password was set when the user group was registered, skip to step 5.)

SCREENSHOT: A terminal window showing a password entry screen. The text reads: "PASSWORD (5-digit)", "NAME : LOCAL", "USER NAME : USER02", and a "Password : *****" input field. At the bottom are "CANCEL" and "ENTER" buttons.

5 Select the template to be changed, and then press the [EDIT] button.

SCREENSHOT: A terminal window titled "Select a TEMPLATE". It shows two tabs: "RECALL" and "REGISTRATION". Under "REGISTRATION", there are two template options: "COPY MODE 001" and "COPY MODE 002". The "COPY MODE 002" option is highlighted with a cursor. Below the templates are "DELETE", "EDIT", "CANCEL", and "SAVE" buttons. At the bottom right, it shows "1/5" and a "Next" button.

- If the desired template is not displayed on the menu, press the [Prev] or [Next] button to switch the menu.

6 Key in the password (5 digits) for the selected template, and then press the [ENTER] button.

SCREENSHOT: A terminal window showing a password entry screen for a template. The text reads: "PASSWORD (5-digit)", "NAME : COPY MODE 002", "USER NAME : GUEST01", and a "Password : *****" input field. At the bottom are "CANCEL" and "ENTER" buttons.

- If no password was set when the template was registered, skip to step 7.

7 Enter the new name of the template.

RECALL REGISTRATION

TEMPLATE GROUP : LOCAL

NAME 1 COPY MODE

NAME 2 005

USER NAME

PASSWORD

AUTOMATIC START

ENABLE DISABLE

This icon is indicated when an automatic start is enabled.

CANCEL ENTER

- When the [NAME 1] or [NAME 2] button is pressed, the letter entry menu (P.28) is displayed. Up to 11 letters can be entered.

8 Enter the new user name of the template.

RECALL REGISTRATION

TEMPLATE GROUP : LOCAL

NAME 1 COPY MODE

NAME 2 005

USER NAME USER05

PASSWORD

AUTOMATIC START

ENABLE DISABLE

This icon is indicated when an automatic start is enabled.

CANCEL ENTER

- When the [USER NAME] button is pressed, the letter entry menu (P.28) is displayed. Up to 30 letters can be entered.

9 Key in the new password in “Password”, and then press the [SET] button to fix it.

RECALL REGISTRATION

TEMPLATE GROUP : LOCAL
(PASSWORD:5-digit)

Password : *****

Retype Password :

SET

RESET

CANCEL ENTER

- Be sure to key in the 5-digit password.
- * (asterisk) is displayed in “Password” when the password is entered.
- To correct the entered password, press the [CLEAR] button on the control panel.
- When the [SET] button is pressed, “Retype Password” becomes highlighted.

10 Key in the password in “Retype Password”, and then press the [ENTER] button to fix it.

The screenshot shows the 'REGISTRATION' screen with the following elements:



- Buttons: **RECALL** and **REGISTRATION** (selected).
- Text: **TEMPLATE GROUP : LOCAL (PASSWORD:5-digit)**
- Fields: **Password : ******* and **Retype Password : *******
- Buttons: **SET** (next to Password), **RESET** (next to Retype Password), **CANCEL**, and **ENTER** (at the bottom).

- * (asterisk) is displayed in “Retype Password” when the password is entered.
- To correct the entered password, press the [CLEAR] button on the control panel.

11 Change the setting of “AUTOMATIC START” for recalling the template.

The screenshot shows the 'REGISTRATION' screen with the following elements:

- Buttons: **RECALL** and **REGISTRATION** (selected).
- Text: **TEMPLATE GROUP : LOCAL**
- Fields: **NAME 1 : COPY MODE**, **NAME 2 : 005**, **USER NAME : USER05**, **PASSWORD : *******
- Buttons: **ENABLE** and **DISABLE** (under **AUTOMATIC START**)
- Text: **This icon is indicated when an automatic start is enabled.**
- Icon: A small icon of a device with a square symbol inside.
- Buttons: **CANCEL** and **ENTER** (at the bottom).

- Press the [ENABLE] or [DISABLE] button.
- When [ENABLE] is selected, the  icon is added to the template button. (The operation of the setting functions is automatically started by pressing the template button with the  icon when the template is recalled. However, if a password is set for the template, you need to key it in when an operation with the function set to the template is performed, though automatic start is enabled.)

12 Press the [ENTER] button.

The screenshot shows the 'REGISTRATION' screen with the following elements:

- Buttons: **RECALL** and **REGISTRATION** (selected).
- Text: **TEMPLATE GROUP : LOCAL**
- Fields: **NAME 1 : COPY MODE**, **NAME 2 : 005**, **USER NAME : USER05**, **PASSWORD : *******
- Buttons: **ENABLE** and **DISABLE** (under **AUTOMATIC START**)
- Text: **This icon is indicated when an automatic start is enabled.**
- Icon: A small icon of a device with a square symbol inside.
- Buttons: **CANCEL** and **ENTER** (at the bottom).

- The data of the template are changed.

4. Recalling Templates

When a template is recalled, the registered setting functions of the template are reflected in the equipment.

If [ENABLE] is selected for "AUTOMATIC START" when the template is registered, operation of the setting functions is automatically started by pressing the template button.

When recalling a template in a public group

- 1 Place paper in the drawer(s).
- 2 Place the original(s).
- 3 Press the [TEMPLATE] button on the control panel.

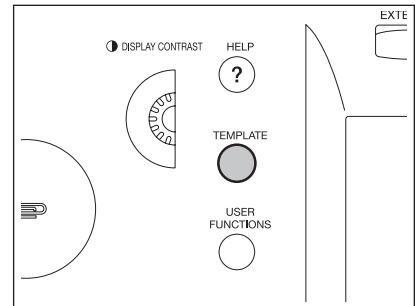

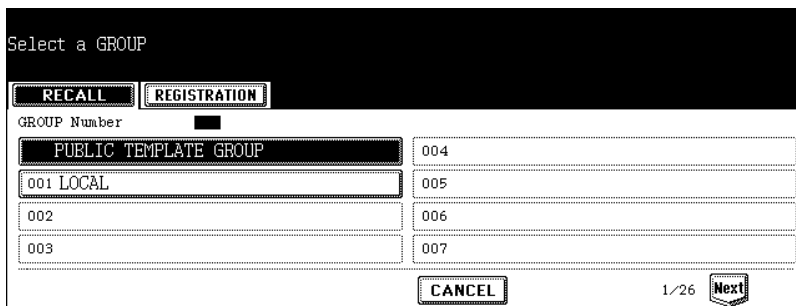

7

- 4 Press the [PUBLIC TEMPLATE GROUP].

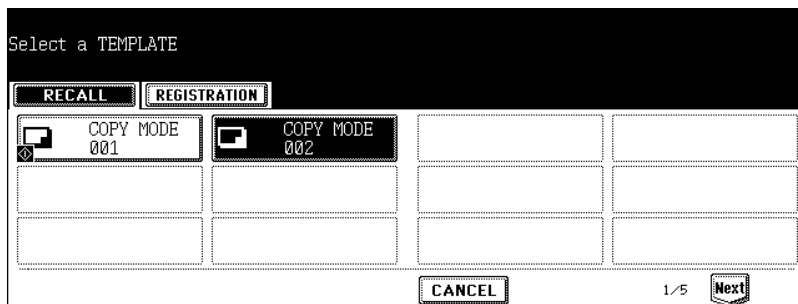

5 Press the desired template button.



- If the desired template is not displayed on the menu, press the [Prev] or [Next] button to switch the menu.
- If you press the template button with the  icon, the operation of the registered setting functions is automatically started.

6 Key in the password (5 digits) for the selected template, and then press the [ENTER] button.

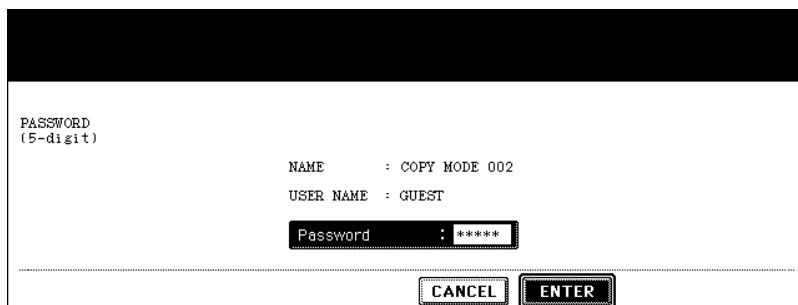

- If no password was set when the template was registered, skip to step 7.

7 Confirm that “Updated the template setting” appears on the menu.

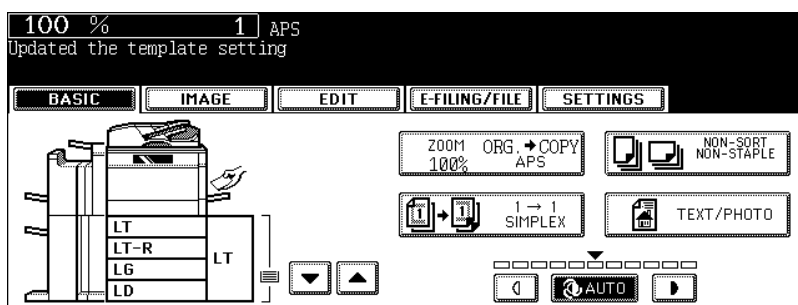

- Select other copy modes as required.

8 Press the [START] button.

When recalling a template in a user group

- 1 Place paper in the drawer(s).
- 2 Place the original(s).
- 3 Press the [TEMPLATE] button on the control panel.

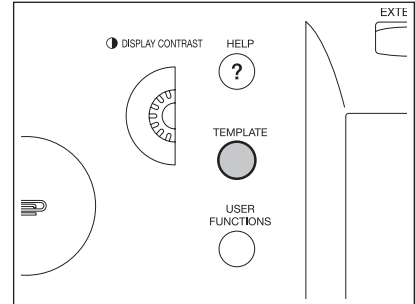

- 4 Select the user group in which the template to be recalled is registered.

7

A screenshot of a menu titled "Select a GROUP". At the top are two tabs: "RECALL" and "REGISTRATION". Below the tabs, "GROUP Number" is followed by "001". A list of options is shown in a grid:

PUBLIC TEMPLATE GROUP	004
001 LOCAL	005
002	006
003	007

At the bottom, there is a "CANCEL" button, a page indicator "1/26", and a "Next" button.

- If the desired user group is not displayed on the menu, press the [Prev] or [Next] button to switch the menu.
- To display the applicable menu immediately, key in the user group number.

5 Key in the password (5 digits) for the selected user group, and then press the [ENTER] button.

PASSWORD
(5-digit)

NAME : LOCAL
USER NAME : USER02

Password : *****

CANCEL ENTER

- If no password was set when the user group was registered, skip to step 6.

6 Press the desired template button.

Select a TEMPLATE

RECALL REGISTRATION

COPY MODE 001 COPY MODE 005

CANCEL 1/5 Next

- If the desired template is not displayed on the menu, press the [Prev] or [Next] button to switch the menu.
- If you press the template button with the  icon, the operation of the registered setting functions is automatically started.

7 Key in the password (5 digits) for the selected template, and then press the [ENTER] button.

PASSWORD
(5-digit)

NAME : COPY MODE 005
USER NAME : USER05

Password : *****

CANCEL ENTER

- If no password was set when the template was registered, skip to step 8.

8 Confirm that “Updated the template setting” appears on the menu.

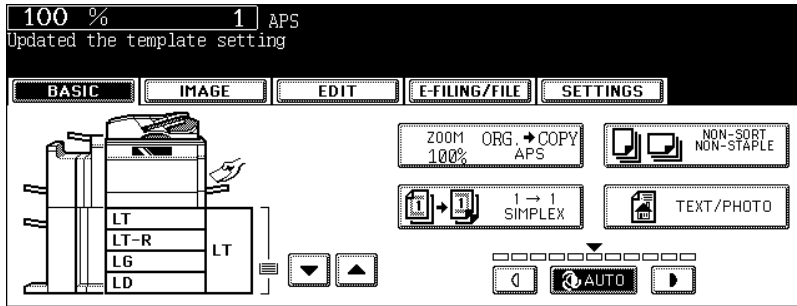

- Select other copy modes as required.

9 Press the [START] button.

5. Deleting User Groups or Templates

Unnecessary user groups and templates can be deleted. If a user group is deleted, all templates in the user group are also deleted.

Deleting a user group

1 Press the [TEMPLATE] button on the control panel.

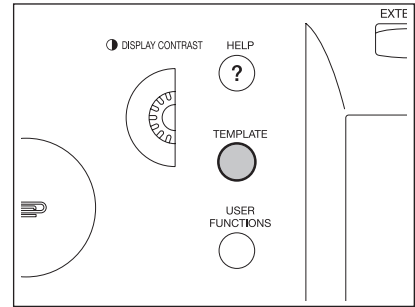

2 Press the [REGISTRATION] button on the touch panel.

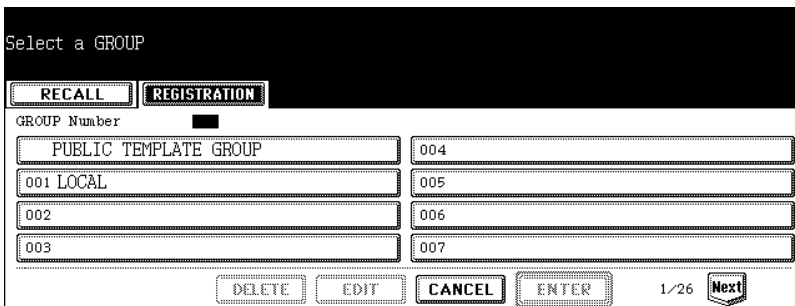

3 Select the user group GROUP you want to delete, and then press the [DELETE] button.

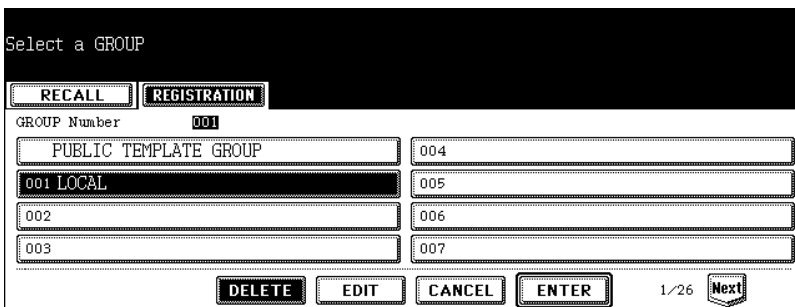

- If the desired user group is not displayed on the menu, press the [Prev] or [Next] button to switch the menu.
- To display the applicable menu immediately, key in the user group number.

-
- Key in the password (5 digits) for the selected user group, and then press the [ENTER] button.

PASSWORD
(5-digit)

NAME : LOCAL
USER NAME : USER02

Password : *****

CANCEL ENTER

- If no password was set when the user group was registered, skip to step 5.

- Press the [DELETE] button.

- The selected user group is deleted.

Deleting a template

- Press the [TEMPLATE] button on the control panel.

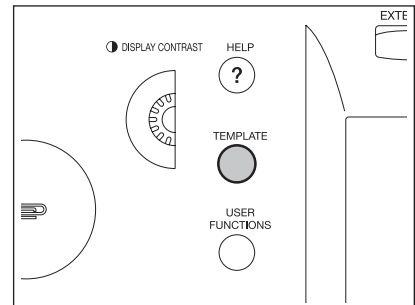

- Press the [REGISTRATION] button on the touch panel.

Select a GROUP

RECALL REGISTRATION

GROUP Number

PUBLIC TEMPLATE GROUP	004
001 LOCAL	005
002	006
003	007

DELETE EDIT CANCEL ENTER 1/26 Next

3 Select the user group in which the template to be deleted is registered, and then press the [ENTER] button.

Select a GROUP

RECALL REGISTRATION

GROUP Number 001

PUBLIC TEMPLATE GROUP	004
001 LOCAL	005
002	006
003	007

DELETE EDIT CANCEL ENTER 1/26 Next

- If the desired user group is not displayed on the menu, press the [Prev] or [Next] button to switch the menu.
- To display the applicable menu immediately, key in the user group number.

4 Enter the following password, and then press the [ENTER] button.

When the public group is selected:

Press the [PASSWORD] button and key in the Admin Password (6 to 10 digits).

When the user group is selected:

Key in the password (5 digits) for the selected user group. (If no password was set when the user group was registered, skip to step 5.)

PASSWORD
(5-digit)

NAME : LOCAL
USER NAME : USER02

Password : *****

CANCEL ENTER

5 Select the template you want to delete, and then press the [DELETE] button.

Select a TEMPLATE

RECALL REGISTRATION

COPY MODE 001	COPY MODE 005		

DELETE EDIT CANCEL SAVE 1/5 Next

- If the desired template is not displayed on the menu, press the [Prev] or [Next] button to switch the menu.

6 Key in the password (5 digits) for the selected template, and then press the [ENTER] button.

```

PASSWORD
(5-digit)

NAME      : COPY MODE 005
USER NAME : USER

Password  : *****

-----
          CANCEL  ENTER

```

- If no password was set when the template was registered, skip to step 7.

7 Press the [DELETE] button.

- The selected template is deleted.



8. JOB STATUS

1. Job Status	224
2. Confirming Print Job Status	225
• Print jobs	226
• Proof print jobs	229
• Private print jobs	232
• When using department codes	235
3. Confirming Scan Job Status.....	238
4. Log List	239
• Confirming job history in log list	240
• Registering into address book from log lists	244
• Printing journals (send/receive log list)	246
5. Print Status Display	247
6. Error Code	250

1. Job Status

When you press the [JOB STATUS] button on the control panel, the job status menu is displayed. The following information can be confirmed on this menu.

- Status of jobs (print, Internet Fax and scan) in waiting
- Log list of jobs (print, sending/receiving, scan) performed
- Print status

You can also start, pause, release, delete and move the job in waiting.

- For the status confirmation of the Fax job, see the Operator's Manual for Facsimile Function.

Tips

- The Scanner Kit or the Printer/Scanner Kit (both optional) is necessary for the scanning function.
 - The FAX Unit (optional) is necessary for the Fax function.
 - The Scanner Kit or the Printer/Scanner Kit (both optional) is necessary for the Internet Fax and E-mail functions.
 - The Printer Kit or the Printer/Scanner Kit (both optional) is necessary for printing from a client PC through the network.
-

2. Confirming Print Job Status

You can confirm the status of the print job. The following information is displayed in a list.

Printing LT PRINTING
Press JOB STATUS to return

PRINT FAX SCAN LOG STATUS

PRINT JOB

User Name	Date, Time	Paper	Pages	Sets	Status
User 01	10, 10:12	LT	1	1	Printing
User 02	10, 10:13	LT	2	2	Wait
User 03	10, 10:13	LT	1	2	Wait

PRINT PROOF PRIVATE INVALID

RETURN DELETE PAUSE MOVE EDIT RELEASE 1/1

- User Name: Name of user for whom the job was registered
Date, Time: Date and time the job was registered
Paper: Paper size to be printed
Pages: Number of pages to be printed
Sets: Number of sets to be printed
Status: Status of jobs or specified time for “Delayed TX Reservation” setting

Tip

4 jobs are displayed in 1 page. Up to 250 pages (1000 jobs) can be displayed. When you want to confirm the 5th and following jobs, press the [Next] button, and when you want to return to the previous page, press the [Prev] button.

Print jobs

Copying and printing of the document, and printing of an E-mail, etc. are called print jobs. Print jobs can be deleted, paused and released, moved, and printed on the print job list.

Displaying print job list

1 Press the [JOB STATUS] button on the control panel.

- The print job list is displayed.

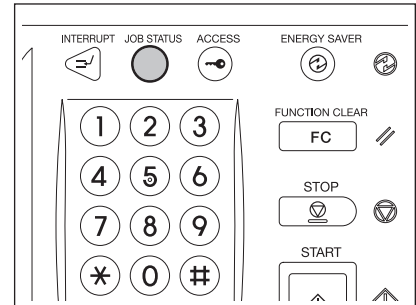

Deleting print jobs

1 Select the job you want to delete on the print job list, then press the [DELETE] button.

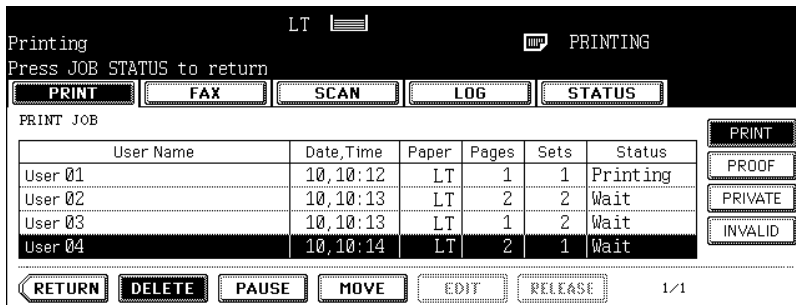

- If the subject job is not displayed on the page, press the [Prev] or [Next] button to switch the page.

2 "Delete OK?" appears. Press the [DELETE] button.

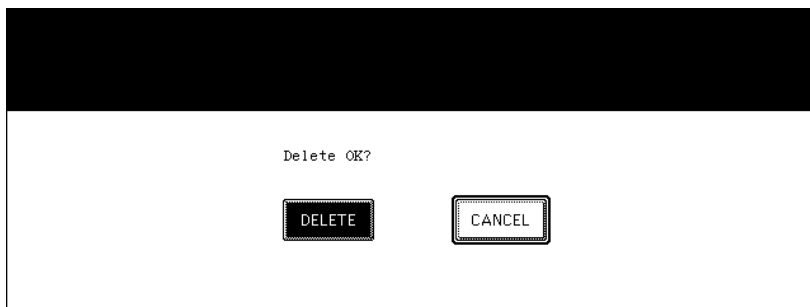

- The job is deleted.

Pausing print jobs

The 11th job or later counting from the one in progress can be paused.

- 1 Select the job you want to pause on the print job list, then press the [PAUSE] button.

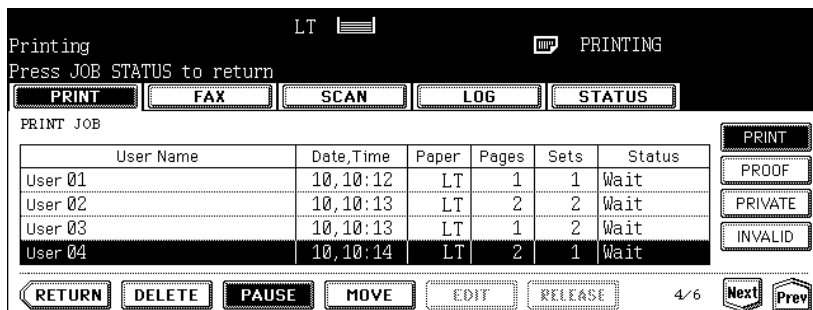

- When the [PAUSE] button is pressed, the display of this button changes to [RELEASE].
- When the job is paused, the next job is started.

Releasing print job

Press the [RELEASE] button. A job once paused will not be printed out unless the [RELEASE] button is pressed.

Moving print jobs

The 11th job or later counting from the one in progress can be moved.

- 1 Select the job you want to move on the print job list, then press the [MOVE] button.

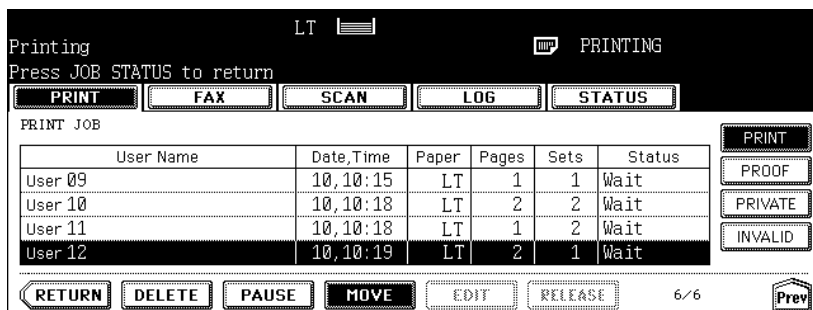

- If the corresponding job is not displayed on the page, press the [Prev] or [Next] button to switch the page.

2 Select the position where you want to move the job. (The job comes right under the job you selected on the list.)

Printing LT PRINTING
Press JOB STATUS to return

PRINT FAX SCAN LOG STATUS

PRINT JOB

User Name	Date,Time	Paper	Pages	Sets	Status
User 01	10,10:12	LT	1	1	Wait
User 02	10,10:13	LT	2	2	Wait
User 03	10,10:13	LT	1	2	Wait
User 04	10,10:14	LT	2	1	Wait

PRINT PROOF PRIVATE INVALID

RETURN DELETE PAUSE MOVE EDIT RELEASE 4/6 Next Prev



Printing LT PRINTING
Press JOB STATUS to return

PRINT FAX SCAN LOG STATUS

PRINT JOB

User Name	Date,Time	Paper	Pages	Sets	Status
User 01	10,10:12	LT	1	1	Wait
User 12	10,10:19	LT	2	1	Wait
User 02	10,10:13	LT	2	2	Wait
User 03	10,10:13	LT	1	2	Wait

PRINT PROOF PRIVATE INVALID

RETURN DELETE PAUSE MOVE EDIT RELEASE 4/6 Next Prev

Proof print jobs

“Proof print” is a function to print only 1 set as a proof print when you print more than one set of documents from a client PC on the network before you print out all the sets of the documents.

You can check this proof print and then select whether you print the rest of the documents or quit printing to change the setting on the proof print job list. If you want to print the rest, you can change the number of printouts.

- For details of proof print, see the Printing Guide.

Displaying proof print job list

1 Press the [JOB STATUS] button on the control panel.

- The print job list is displayed.

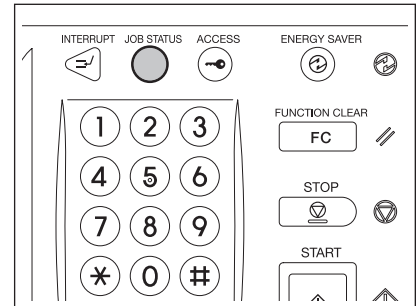

2 Press the [PROOF] button.

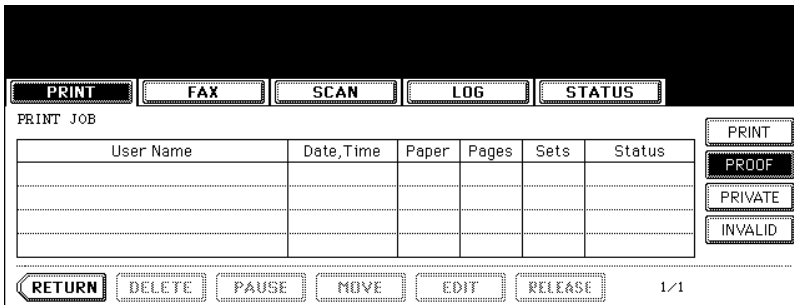

- The proof print job list is displayed.

Continuing printing after proof printing

1 Select the job you want to print on the proof print job list.

User Name	Date,Time	Paper	Pages	Sets
User 01	10,10:12	LT	1	1

- If the corresponding job is not displayed on the page, press the [Prev] or [Next] button to switch the page.

2 Press the [RELEASE] button.

- Printing starts.
- The printing status can be confirmed on the print job list.

When you want to change the number of sets

When you want to change the number of sets, press the [EDIT] button and key in the desired number. Then press the [RELEASE] button to start printing.

FileName : Project-01.txt
 Owner : User01
 Pages : 1
 Sets : 5

Deleting proof print jobs

- 1 Select the job you want to delete on the proof print job list, and then press the [DELETE] button.

User Name	Date,Time	Paper	Pages	Sets
User 01	10,10:12	LT	1	1

Buttons: PRINT, FAX, SCAN, LOG, STATUS, PRINT, PROOF, PRIVATE, INVALID, RETURN, DELETE, PAUSE, MOVE, EDIT, RELEASE, 1/1

- If the corresponding job is not displayed on the page, press the [Prev] or [Next] button to switch the page.

- 2 “Delete OK?” appears. Press the [DELETE] button.

Delete OK?

Buttons: DELETE, CANCEL

- The job is deleted.

Private print jobs

“Private print” is a function to print a document from a client PC on the network only when a previously set password is keyed in from the control panel of this equipment. This function is useful when you want to print confidential documents.

- For details of private print jobs, see the Printing Guide.

Displaying private print job list

1 Press the [JOB STATUS] button on the control panel.

- The print job list is displayed.

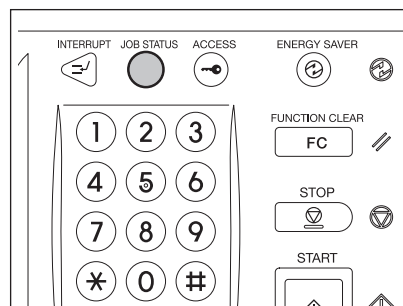

2 Press the [PRIVATE] button.

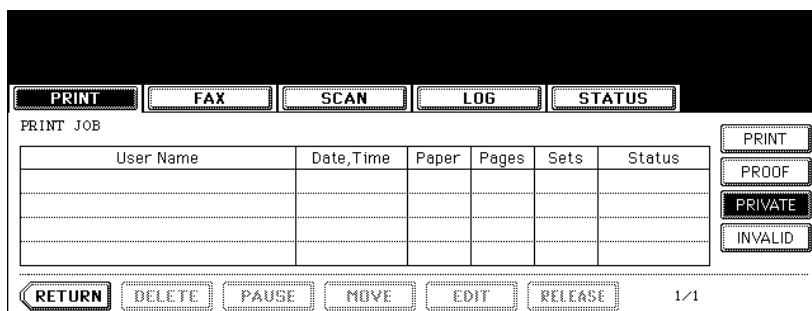

3 Select the appropriate user name.

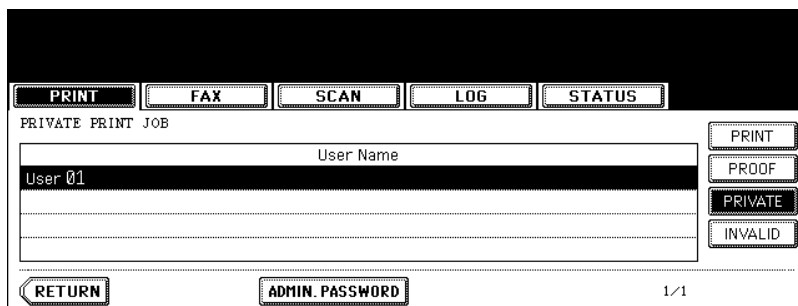

- The letter entry menu (P.28) is displayed. Key in the password, which has previously been set from the client PC, and then press the [ENTER] button.
- You can key in the Admin Password (6 to 10 digits) by pressing the [ADMIN. PASSWORD] button instead of keying in the password, previously set from the client PC. In this case, jobs can be deleted but not printed.
- The private print job list is displayed.

Printing private print jobs

1 Select the job you want to print on the private print job list.

Document Name	Date,Time	Paper	Pages	Sets
Project-01.txt	10,10:12	LT	1	1

- If the corresponding job is not displayed on the page, press the [Prev] or [Next] button to switch the page.
- To select all jobs on the private print job list, press the [SELECT ALL] button. To clear the selection, press the [ALL CLEAR] button.

2 Press the [RELEASE] button.

Document Name	Date,Time	Paper	Pages	Sets
Project-01.txt	10,10:12	LT	1	1

- Printing starts.
- The printing status can be confirmed on the print job list.

Deleting private print jobs

- 1 Select the job you want to delete on the private print job list, and then press the [DELETE] button.

Document Name	Date,Time	Paper	Pages	Sets
Project-01.txt	10,10:12	LT	1	1

- If the corresponding job is not displayed on the page, press the [Prev] or [Next] button to switch the page.
- To select all jobs on the private print job list, press the [SELECT ALL] button. To clear the selection, press the [ALL CLEAR] button.

- 2 “Delete OK?” appears. Press the [DELETE] button.

Delete OK?

- The job is deleted.

When using department codes

If the department code keyed in at printing is not correct, this job will be stored in the invalid queue (= the list of jobs with an incorrect department code or with no department code), and will not be printed out. However, the jobs stored in the invalid queue can be printed when the correct department code is newly keyed in.

A print job, whose number of pages exceeds that specified for a particular department code, will not be printed out either. In this case, contact the administrator in your office.

Displaying invalid queues

1 Press the [JOB STATUS] button on the control panel.

- The print job list is displayed.

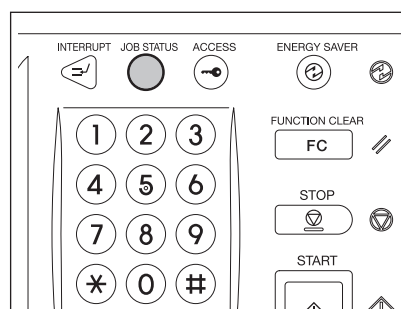

2 Press the [INVALID] button.

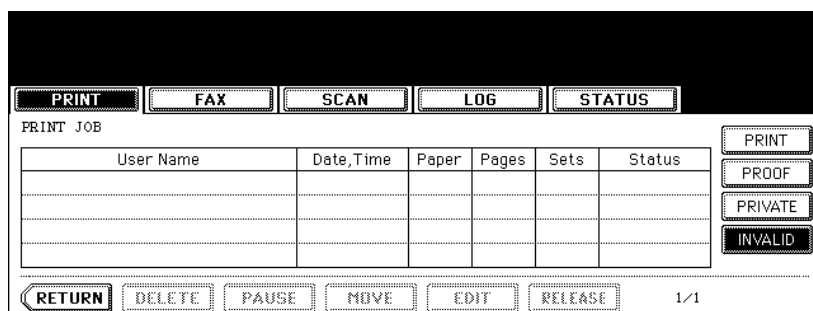

- The menu for the invalid queue is displayed.

Keying in correct department code to print

When an incorrect department code has been keyed in at printing, you can key in the correct department code again to print the subject job.

1 Select the job you want to print on the menu for the invalid queue.

INVALID DEPARTMENT CODE PRINT JOB

User Name	Date,Time	Paper	Pages	Sets
User 01	10,10:12	LT	1	1

Buttons: PRINT, PROOF, PRIVATE, INVALID, RETURN, DELETE, PAUSE, MOVE, EDIT, RELEASE 1/1

- If the corresponding is not displayed on the page, press the [Prev] or [Next] button to switch the page.

2 Press the [RELEASE] button.

INVALID DEPARTMENT CODE PRINT JOB

User Name	Date,Time	Paper	Pages	Sets
User 01	10,10:12	LT	1	1

Buttons: PRINT, PROOF, PRIVATE, INVALID, RETURN, DELETE, PAUSE, MOVE, EDIT, RELEASE 1/1

3 Key in the correct department code, and then press the [ENTER] button.

DEPARTMENT CODE ▶ Enter department code (5-digit)

Department Code : *****

Buttons: CANCEL, ENTER

- Printing starts.
- The printing status can be confirmed on the print job list.

Deleting invalid print jobs

- 1 Select the job you want to delete on the menu for the invalid queue, then press the [DELETE] button.

The screenshot shows a printer control panel menu for an "INVALID DEPARTMENT CODE PRINT JOB". At the top, there are buttons for PRINT, FAX, SCAN, LOG, and STATUS. Below these is a table with the following data:

User Name	Date,Time	Paper	Pages	Sets
User 01	10,10:12	LT	1	1

To the right of the table are buttons for PRINT, PROOF, PRIVATE, and INVALID. At the bottom of the menu are buttons for RETURN, DELETE, PAUSE, MOVE, EDIT, and RELEASE. The page number 1/1 is displayed in the bottom right corner.

- If the corresponding job is not displayed on the page, press the [Prev] or [Next] button to switch the page.

- 2 "Delete OK?" appears. Press the [DELETE] button.

The screenshot shows a confirmation dialog box with the text "Delete OK?". Below the text are two buttons: DELETE and CANCEL.

- The job is deleted.

3. Confirming Scan Job Status

You can confirm the scan job status and delete a scan job. For details, refer to the Scanning Guide.

- The Scanner Kit or the Printer/Scanner Kit (both optional) is necessary for the scanning function.

Press the [JOB STATUS] button on the control panel. Then press the [SCAN] button on the touch panel to display the scan job list.

To	Agent	Date,Time	Pages	Status
Project-2	Store to e-Filing	17,18:19	7	Process

The following information is displayed.

To: Where the scanned data are to be filed or to be sent
Agent: Agent by which performed
Date, Time: Date and time the job was registered
Pages: Number of originals
Status: Status of jobs

8

Tip

4 jobs are displayed in 1 page. Up to 250 pages (1000 jobs) can be displayed. When you want to confirm the 5th and the following jobs, press the [Next] button, and when you want to return to the previous page, press the [Prev] button.

Deleting scan job

Select the job you want to delete on the scan job list, and then press the [DELETE] button.

4. Log List

You can confirm the history of each copy, print, scan, and, sending and receiving of Fax, Internet Fax and E-mail job on the log list.

You can also register unregistered Fax numbers or E-mail addresses into the address book from the log list of the Fax and Internet Fax, or the log list of scan jobs.

- The Scanner Kit or the Printer/Scanner Kit (both optional) is necessary for the scanning function.
- The FAX Unit (optional) is necessary for the Fax function.
- The Scanner Kit or the Printer/Scanner Kit (both optional) is necessary for the Internet Fax and E-mail functions.
- The Printer Kit (optional) is necessary for printing from a client PC through the network.

When you press the [JOB STATUS] button on the control panel and the [LOG] button on the touch panel, the log menu is displayed.

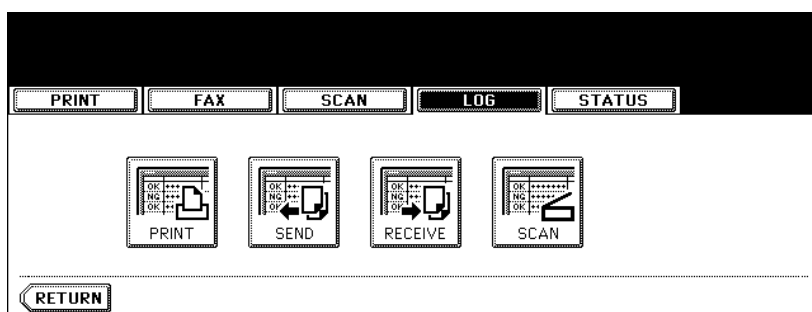

Confirming job history in log list

Print log

When you press the [PRINT] button on the log menu, the history of copy jobs and print jobs is displayed.

PRINT LOG					
User Name	Date, Time	Paper	Pages	Sets	
COPY	02, 19:53	LT	2	1	
COPY	02, 19:52	LT	1	1	
COPY	02, 19:50	LT	2	1	
COPY	02, 18:23	LT	1	1	

1/3

The following information is displayed.

User Name: Name of the senders of the copy/print job
 Date, Time: Date and time the job was printed
 Paper: Paper size printed
 Pages: Number of pages of the copy/print job
 Sets: Number of sets printed

Tip

8

4 jobs are displayed in 1 page. Up to 30 pages (120 jobs) can be displayed. When you want to confirm the 5th and the following jobs, press the [Next] button, and when you want to return to the previous page, press the [Prev] button.

The following button is displayed.

[RETURN]: Press this button to return to the log menu.

Send log

When you press the [SEND] button on the log menu, the sending history of Fax jobs and Internet Fax jobs is displayed. (The Fax function and the Internet Fax function are both optional.)

File No.	To	Date, Time	Pages	Status
012	User 04	14, 14:32	1	OK
006	User 02	14, 11:20	1	OK
005	User 01	07, 10:23	1	OK
003	User 04	04, 18:11	1	OK

The following information is displayed.

File No.: Order of job registered
To: Recipient's Fax number or E-mail address of Internet Fax
Date, Time: Date and time the Fax or Internet Fax was sent
Pages: Number of pages of the Fax or Internet Fax sent
Status: Result is displayed as "OK" or in error codes.
(For the error codes, see [P.250 "6.Error Code"](#).)

Tip

4 jobs are displayed in 1 page. Up to 30 pages (120 jobs) can be displayed. When you want to confirm the 5th and the following jobs, press the [Next] button, and when you want to return to the previous page, press the [Prev] button.

The following buttons are displayed.

[JOURNAL]: Press this button to print the history of sent jobs (= journal). (For details, see [P.246 "Printing journals \(send/receive log list\)"](#).)
[ENTRY]: Press this button to register unregistered Fax numbers or E-mail addresses on the send log list into the address book. (For details, see [P.244 "Registering into address book from log lists"](#).)
[RETURN]: Press this button to return to the log menu.

Receive log

When you press the [RECEIVE] button on the log menu, the receiving history of Fax jobs, Internet Fax jobs and E-mail jobs is displayed. (The Fax function and the Internet Fax function are both optional.)

PRINT FAX SCAN LOG STATUS				
RECEIVE LOG				
File No.	From	Date,Time	Pages	Status
014	User 01	17,09:52	1	OK
013	User 02	15,12:27	0	3C12
011	User 04	11,18:10	0	3C12
009	User 02	10,18:07	0	3C12

RETURN JOURNAL ENTRY
1/1

The following information is displayed.



File No.: Order of job registered
From: Sender's Fax number or E-mail address of Internet Fax
Date, Time: Date and time the Fax, Internet Fax or E-mail was received
Pages: Number of pages of the Fax, Internet Fax or E-mail received
Status: Result is displayed as "OK" or in error codes.
 (For the error codes, see  P.250 "6.Error Code".)

8

Tip

4 jobs are displayed in 1 page. Up to 30 pages (120 jobs) can be displayed. When you want to confirm the 5th and the following jobs, press the [Next] button, and when you want to return to the previous page, press the [Prev] button.

The following buttons are displayed.

[JOURNAL]: Press this button to print the history of received jobs (= journal). (For details, see  P.246 "Printing journals (send/receive log list)".)
[ENTRY]: Press this button to register unregistered Fax numbers or E-mail addresses on the receive log list into the address book. (For details, see  P.244 "Registering into address book from log lists".)
[RETURN]: Press this button to return to the log menu.

Scan log

When you press the [SCAN] button on the log menu, the histories of the following items are displayed.

- Job filed in e-Filing by copying
- Job filed in a shared folder by copying (= SAVE AS FILE) (The Scanner Kit or the Printer/Scanner Kit (both optional) is necessary.)
- Job filed in e-Filing or a shared folder by scanning (= SCAN TO FILE) (The Scanner Kit or the Printer/Scanner Kit (both optional) is necessary.)
- E-mail sent by scanning (= SCAN TO E-MAIL) (The Scanner Kit or the Printer/Scanner Kit (both optional) is necessary.)

To	Agent	Date,Time	Pages	Status
HAKKODA-001	Store to e-Filing	10,10:13	1	OK
HAKKODA	Store to e-Filing	10,10:12	1	OK

The following information is displayed.

- To: Where the scanned data are to be filed or sent
Agent: Agent by which performed
Date, Time: Date and time the scan job was performed
Pages: Number of pages of job scanned or E-mailed
Status: Result is displayed as "OK" or in error codes.
(For the error codes, see [P.250](#) "6.Error Code".)

Tip

4 jobs are displayed in 1 page. Up to 30 pages (120 jobs) can be displayed. When you want to confirm the 5th and the following jobs, press the [Next] button, and when you want to return to the previous page, press the [Prev] button.

The following buttons are displayed.

- [ENTRY]: Press this button to register unregistered E-mail addresses on the scan log list into the address book. (For details, see [P.244](#) "Registering into address book from log lists".)
[RETURN]: Press this button to return to the log menu.

Registering into address book from log lists

You can register Fax numbers and E-mail addresses, which have not yet been registered, into the address book from the send, receive or scan log list.

- 1 Press the [SEND] (or [RECEIVE] or [SCAN]) button on the log menu.

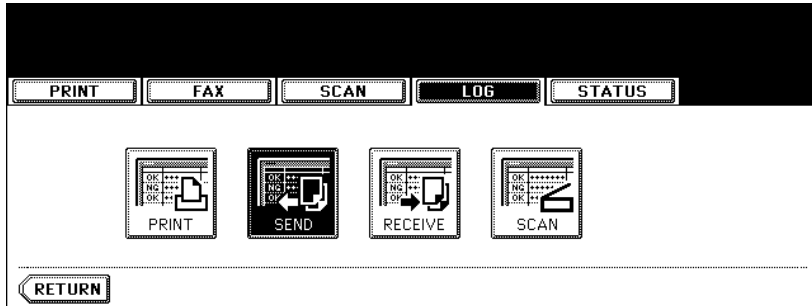

- The send (or receive or scan) log list is displayed.

- 2 Select the job which includes the Fax number or E-mail address you want to register into the address book.

The screenshot shows the 'SEND LOG' menu. At the top are buttons for PRINT, FAX, SCAN, LOG, and STATUS. Below is a table with the following data:

File No.	To	Date,Time	Pages	Status
005	055-000-0000	10,10:14	1	OK
002	045-000-0000	10,10:13	1	OK
001	044-000-0000	10,10:11	1	OK

Below the table are buttons for RETURN, JOURNAL, and ENTRY, and a page indicator '1/1'.

- 3 Press the [ENTRY] button.

The screenshot shows the 'SEND LOG' menu, identical to the previous one, but with the 'ENTRY' button highlighted.

4 Enter the following information. (You need to enter at least either of [FIRST NAME] or [LAST NAME], and either of [FAX NO.] or [E-MAIL].)

The screenshot shows a control panel interface for 'ADDRESS BOOK REGISTRATION'. At the top, there are five buttons: PRINT, FAX, SCAN, LOG, and STATUS. Below these, the screen displays 'ADDRESS BOOK REGISTRATION' on the left and 'ID NO. : 0041' on the right. The main area contains several input fields with labels: FIRST NAME (containing 'User 01'), LAST NAME (containing 'User'), FAX NO. (containing '045-000-0000'), 2ND FAX (empty), E-MAIL (empty), CORP. (empty), DEPT. (empty), and KEYWORD (empty). At the bottom, there are three buttons: OPTION, CANCEL, and ENTER.

- **[FIRST NAME]:** Enter the first name. The entered first name is displayed in the address book list on the touch panel.
- **[LAST NAME]:** Enter the last name. The entered last name is displayed in the address book list on the touch panel.
- **[FAX NO.]:** Enter the Fax number.
- **[2ND FAX]:** Enter the second Fax number.
- **[E-MAIL]:** Enter the E-mail address.
- **[CORP.]:** Enter the company name.
- **[DEPT.]:** Enter the department name.
- **[KEYWORD]:** Enter a keyword with which you can search for the desired contact.

Tip

When you press any of the above, the letter entry menu (P.28) is displayed. Enter the information with the buttons on this menu and the digital keys on the control panel.

5 Press the [ENTER] button.

- The information has been registered in the address book.
- For details of the address book, see the User Functions Guide.

Printing journals (send/receive log list)

You can print the send and receive log lists of the Fax job. The 40 latest send-and-receive logs (1 page), or the 120 latest send-and-receive logs (3 pages) can be printed out. You can also select and print only 1 log.

- For details, see the Operator's Manual for Facsimile Function.

1 Press the [SEND] (or [RECEIVE]) button on the log menu.

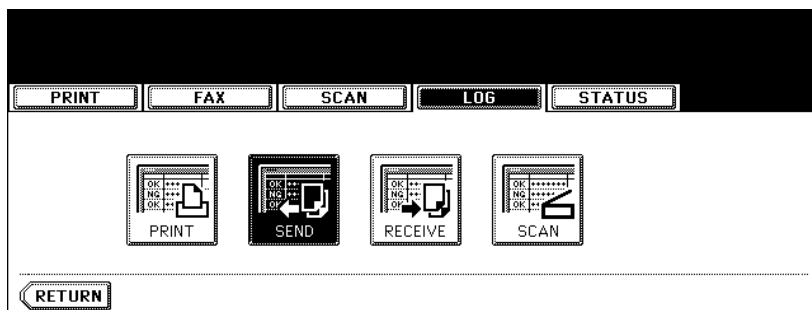

- The send (receive) log list is displayed.

2 Press the [JOURNAL] button.

File No.	To	Date,Time	Pages	Status
005	055-000-0000	10,10:14	1	OK
002	045-000-0000	10,10:13	1	OK
001	044-000-0000	10,10:11	1	OK

- The send (receive) log list is printed.

5. Print Status Display

When you press the [STATUS] button on the touch panel while no operation is in progress, the size of the paper set in the drawer is displayed. When you press the [STATUS] button during printing, the drawer button being used for the feeding of this printing is highlighted.

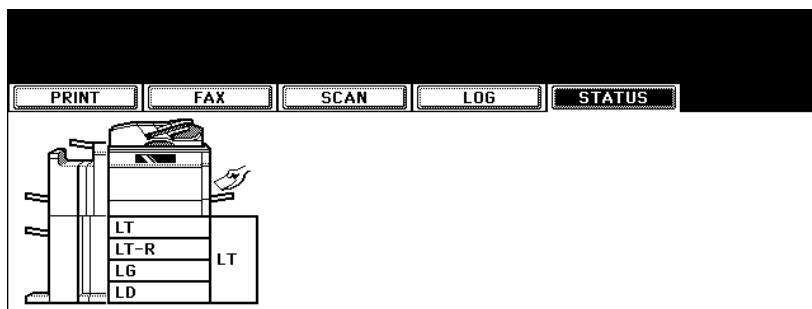

Releasing print job errors

If the specified size of paper is not in the drawer when printing is to be performed from a client PC, a print job error occurs. The [JOB STATUS] button blinks and the following menu is displayed.

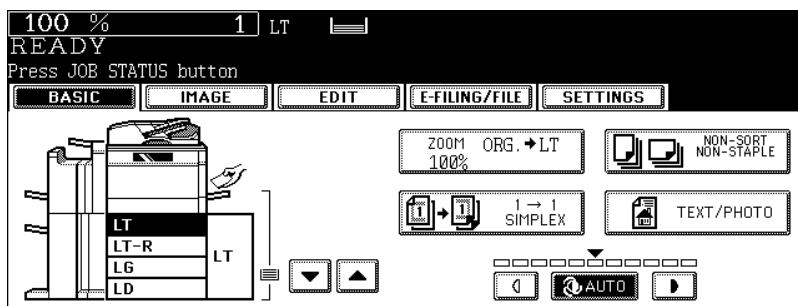

Follow the procedure below to release the error.

Printing by placing sheets of paper on the bypass tray

- 1 Press the blinking [JOB STATUS] button.

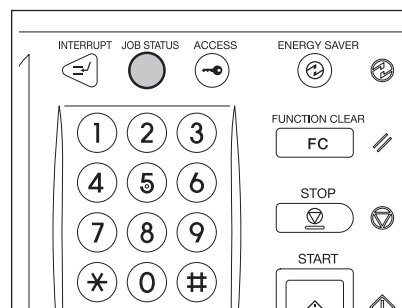

2 Place the specified size of paper on the bypass tray, and then press the [START] button.

- Printing is performed. Press the [JOB STATUS] button.

Printing by placing appropriate size of sheets in the drawer

1 Press the blinking [JOB STATUS] button.

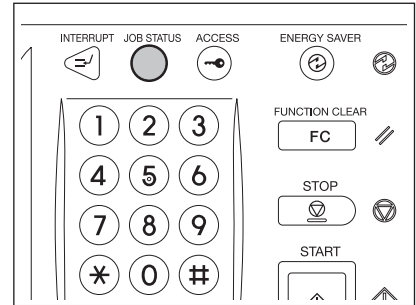

2 Press the drawer button whose size you want to change on the touch panel.

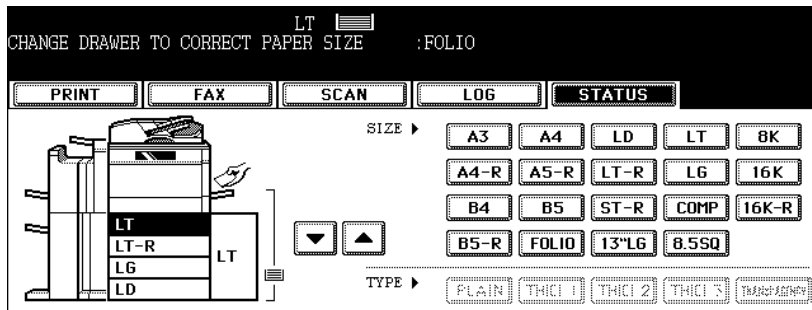

- You can select the desired drawer with the paper source selection (▼/▲) buttons.

3 Place paper in the corresponding drawer.

4 Press the paper size button corresponding to the one you have placed.

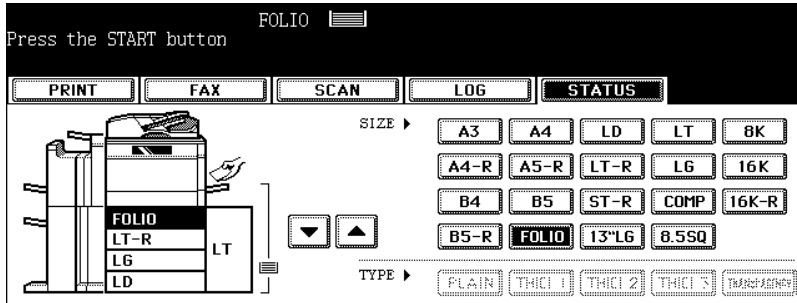

5 Press the [START] button.

- Printing is performed. Press the [JOB STATUS] button.

Printing by selecting a paper size already placed in another drawer

When the specified size of paper is not in the drawer, you can release the error by selecting another size of paper already placed in another drawer, instead of placing the specified size of paper in the drawer. However, a part of the image may not be printed if the size of the paper placed in the drawer is smaller than the specified one.

Press the drawer button whose size you want to use on the touch panel. Then press the [START] button.

6. Error Code

If an error occurs while using the optional Fax, optional Internet Fax or optional scan, the error code is displayed in the status of each log. Take an appropriate action with reference to the following.

Fax / Internet Fax

Error code	Problem	What to do
Fax		
0012	Original jam	Clear the jammed original.
0013	Door open	Firmly close the open door.
0020	Power interruption	Check the power interruption report.
0030	Reset	Transmission is cancelled. (The transmission is terminated by the jammed printing paper during the Direct Transmission.)
0033	Polling Error	Check polling options setup (Security Code, etc.), and check if the polling document exists.
0042	Memory full	Make sure that there is sufficient memory before making the call again.
0050	Line busy	Retry communications.
0053	Security Mismatch in Relay or Mail Box transmission	Confirm the remote party's Security Code, system password, and your setup.
00B0 - 00B5 00C0 - 00C4 00D0 - 00D2 00F0, 00F1	Signal Error or Line Condition Error	Retry communications. Frequent failures may indicate a phone line problem. If possible, move the unit to another line and try your communications again.
00E8	HDD Error	Retry communications.
Internet Fax		
1C10	System access abnormality	Turn the power OFF and then back ON. Perform the job in error again. If the error still occurs, contact your service representative.
1C11	Insufficient memory	When there are running jobs, perform the job in error again after the completion of the running jobs. If the error still occurs, turn the power OFF and then back ON, and perform the job again.
1C12	Message reception error	Turn the power OFF and then back ON. Perform the job in error again.
1C13	Message transmission error	Turn the power OFF and then back ON. Perform the job in error again.
1C14	Invalid parameter	When a template is used, form the template again. If the error still occurs, turn the power OFF and then back ON, and perform the job again.
1C15	Exceeding file capacity	Ask your administrator to change the "Fragment Page Size" setting for the Internet Fax setting, or reduce the number of pages and perform the job again.
1C20	System management module access abnormality	Turn the power OFF and then back ON. Perform the job in error again. If the recovery is still not completed, contact your service representative.
1C21-1C22	Job control module access abnormality	Turn the power OFF and then back ON. Perform the job in error again. If the recovery is still not completed, contact your service representative.

Error code	Problem	What to do
1C30	Directory creation failure	Check if the access privilege to the storage directory is writable. Check if the server or local disc has a sufficient space in disc capacity.
1C31	File creation failure	Check if the access privilege to the storage directory is writable. Check if the server or local disc has a sufficient space in disc capacity.
1C32	File deletion failure	Check if the access privilege to the storage directory is writable. Check if the server or local disc has a sufficient space in disc capacity.
1C33	File access failure	Check if the access privilege to the storage directory is writable. Check if the server or local disc has a sufficient space in disc capacity.
1C40	Image conversion abnormality	Turn the power OFF and then back ON. Perform the job in error again. If the error still occurs, contact your service representative.
1C60	HDD full failure during processing	Reduce the number of pages of the job in error and perform the job again. Check if the server or local disc has a sufficient space in disc capacity.
1C61	Address Book reading failure	Turn the power OFF and then back ON. Perform the job in error again. Reset the data in the Address Book and perform the job again. If the error still occurs, contact your service representative.
1C62	Memory acquiring failure	Turn the power OFF and then back ON. Perform the job in error again. If the error still occurs, contact your service representative.
1C63	Terminal IP address unset	Ask your administrator to set the IP address of the equipment.
1C64	Terminal mail address unset	Ask your administrator to set the E-mail address of the equipment.
1C65	SMTP address unset	Ask your administrator to set the SMTP server address.
1C66	Server time time-out error	Check if the SMTP server is operating properly.
1C69	SMTP server connection error	Ask your administrator to set the login name or password of SMTP server and perform the job again. Check if the SMTP server is operating properly.
1C6A	HOST NAME error	Ask your administrator to check if there is an illegal character in the device name. Delete the illegal character and reset the appropriate device name.
1C6B	Terminal mail address error	Ask your administrator to check if there is an illegal character in the E-mail address of the equipment. Delete the illegal character and reset the appropriate E-mail address, then perform the job again.
1C6C	Destination mail address error	Check if there is an illegal character in the Destination E-mail address. Delete the illegal character and reset the appropriate Destination E-mail address, then perform the job again.
1C6D	System error	Turn the power OFF and then back ON. Perform the job in error again. If the error still occurs, contact your service representative.

Error code	Problem	What to do
1C70	SMTP client OFF	Ask your administrator to enable the SMTP Client and perform the job again.
1C71	SMTP authentication error	Check if the SMTP authentication method, login name and password are correct.
1C72	POP Before SMTP error	Check if the settings of POP Before SMTP and POP3 are correct.
1C80	Internet Fax transmission failure when processing E-mail job received	Confirm the "Received Internet Fax Forward" settings.
1C81	Onramp Gateway transmission failure	Confirm the mail box settings.
1C82	Internet Fax transmission failure when processing Fax job received	Confirm the "Received Fax Forward" setting.
1CC0	Job canceling	Job was canceled
1CC1	Power failure	Check if the power cable is connected properly and it is inserted securely. Check if the power voltage is unstable.
3A10-3A12	MIME format error	Ask the sender to resend the E-mail in the MIME1.0 format.
3A20-3A22	E-mail process error	Ask the sender to resend the E-mail.
3A30	Partial E-mail timeout error	Ask the sender to resend the E-mail, or change the Partial Wait time setting.
3A40	Invalid partial E-mail received	Ask the sender to resend the partial E-mail in the RFC2046 format.
3A50-3A52	HDD full error	Ask the sender to resend the E-mail by separating it to several E-mails. If this error occurs because the paper empty occurs and too much waiting jobs are stored in the hard disc, add the paper to activate other jobs.
3A60-3A62	HDD full alert	Ask the sender to resend the E-mail by separating it to several E-mails. If this error occurs because the paper empty occurs and too much waiting jobs are stored in the hard disc, add the paper to activate other jobs.
3A70	Interrupt partial E-mail reception	Ask your administrator to enable the Enable Partial E-mail setting and ask the sender to resend the E-mail.
3A80-3A82	Partial E-mail disabled	Ask your administrator to enable the Enable Partial E-mail setting and ask the sender to resend the E-mail.
3B10-3B12	E-mail format error	Ask your administrator to enable the Enable Partial E-mail setting and ask the sender to resend the E-mail.
3B20-3B22	Context-Type error	Ask the sender to resend the E-mail with attached files that are the TIFF format.
3B30-3B32	Invalid character set	Ask the sender to resend the E-mail in the ISO-8559-1/2 format.
3B40-3B42	E-mail decode error	Ask the sender to resend the E-mail.
3C10-3C13	TIFF analysis error	Ask the sender to resend the E-mail with attached files that are the TIFF format.

Error code	Problem	What to do
3C20-3C22	TIFF compression error	Ask the sender to resend the E-mail with attached TIFF files in the MH, MR, MMR, or JPEG compression.
3C30-3C32	TIFF resolution error	Ask the sender to resend the E-mail with attached TIFF files whose resolution is either 200 x 100, 200 x 200, 200 x 400, 300 x 300, or 400 x 400 dpi.
3C40-3C42	TIFF paper size error	Ask the sender to resend the E-mail with attached TIFF files that can be printed on the paper available for this equipment.
3C50-3C52	Offramp transmission error	Ask the sender to specify the correct fax numbers and resend the E-mail.
3C60-3C62	Offramp security error	Confirm the fax numbers that are specified in the received offramp gateway job and ask the sender to resend the E-mail with correct fax numbers.
3C70	Power failure	Confirm the job is recovered or not. If not, ask the sender to resend the E-mail.
3D10	Destination address error	Ask your administrator whether the DNS and mail server settings are correctly set. If they are correctly set, ask the sender to confirm the destination address is correct.
3D20	Exceeding maximum offramp destinations	Ask the sender to specify up to 40 destinations for one offramp gateway job. The equipment cannot perform the offramp gateway transmission for more than 40 destinations.
3D30	Fax unit is not installed	Make sure the Fax unit is installed, or connected correctly.
3E10	POP3 server communication error	Ask your administrator that the POP3 server address is correctly set, or the POP3 server works properly.
3E20	POP3 server communication timeout	Ask your administrator that the POP3 server works properly and the LAN cable is connected to the server.
3E30	POP3 login error	Ask your administrator that the POP3 user name and password is set correctly.
3E40	POP3 login type error	Ask your administrator if the login types (Auto, POP3, APOP) to the POP3 server are correct.
3F00, 3F10, 3F20, 3F30, 3F40	File I/O error	Ask the sender to resend the E-mail. If the error still occurs, contact your service representative.

Scan Job

Error code	Problem	What to do
Scan to E-mail		
2C10, 2C12, 2C13, 2C20-2C22	Illegal Job status	A system error has occurred during sending an E-mail. Retry it. If the error still occurs, contact your service representative.
2C11, 2C62	Not enough memory	Scan job exceeded the limit or maximum size. Send your documents separately.
2C14	Invalid parameter specified	Make sure you specify the settings correctly and try again.
2C15	Message size exceeded limit or maximum size	You are sending too many documents at a time. Send your documents separately.
2C30	Failed to create directory	Make sure that the access privilege to the storage directory is writable and the server or local disc has a sufficient space. Then retry the scan.
2C31, 2C33	Failed to create file	Make sure that the access privilege to the storage directory is writable and the server or local disc has a sufficient space. Then retry the scan.
2C32	Failed to delete file	Make sure that the access privilege to the storage directory is writable and the server or local disc has a sufficient space. Then retry the scan.
2C40	Failed to convert image file format	Turn the power OFF and then back ON. Retry the scan. If the error still occurs, contact your service representative.
2C61	Failed to read AddressBook	Turn the power OFF and then back ON. Retry the job in error. Reset the data in the Address Book and retry it. If the error still occurs, contact your service representative.
2C63, 2C64	Invalid Domain Address	Ask your administrator to set the IP address.
2C65, 2C66, 2C69	Failed to connect to SMTP server	Make sure the SMTP server is correctly working, or the SMTP server address has been set correctly. Then retry the scan.
2C6A	Failed to send E-Mail message	Turn the power OFF and then back ON. Retry the scan. If the error still occurs, contact your service representative.
2C6B	Invalid address specified in From: field	Ask your administrator to check if there is an illegal character in the E-mail address of the equipment. Delete the illegal character and reset the appropriate E-mail address, then perform the job again.
2C6C	Invalid address specified in To: field	Check if there is an illegal character in the Destination E-mail address. Delete the illegal character and reset the appropriate Destination E-mail address, then perform the job again.
2C6D	NIC system error	Turn the power OFF and then back ON. Retry the job in error. If the error still occurs, contact your service representative.
2C70	SMTP service is not available	Ask your administrator to enable the SMTP setting.
2C71	SMTP authentication error	Check if the SMTP authentication method, login name and password are correct.

Error code	Problem	What to do
2C72	POP Before SMTP error	Check if the settings of POP Before SMTP and POP3 are correct.
2C80	Failed to process received E-mail job	Ask your administrator to confirm whether the Received Internet Fax Forward is set.
2C81	Failed to process received Fax job	Ask your administrator to confirm whether the Received Fax Forward is set.
2CC0	Job canceled	Job was canceled.
2CC1	Power failure occurred	Make sure that the power cable is connected properly and it is inserted securely. Resend the job.
Save as File		
2D10, 2D12, 2D13, 2D20-2D22	Illegal Job status	Turn the power OFF and then back ON. Retry sending. If the error still occurs, contact your service representative.
2D11	Not enough memory	Make sure there are enough memory to save the scan job.
2D14	Invalid parameter specified	Make sure you specify the settings correctly and try again.
2D15, 2D65	There are too many documents in the folder. Failed in creating new document.	Delete the data in the local shared folder in the equipment and retry the scan.
2D30	Failed to create directory	Make sure that the access privilege to the storage directory is writable and the server or local disc has a sufficient space. Then retry the scan.
2D31, 2D33	Failed to create file	Make sure that the access privilege to the storage directory is writable and the server or local disc has a sufficient space. Then retry the scan.
2D32	Failed to delete file	Make sure that the access privilege to the storage directory is writable and the server or local disc has a sufficient space. Then retry the scan.
2D40	Failed to convert image file format	Turn the power OFF and then back ON. Retry the scan. If the error still occurs, contact your service representative.
2D60	Failed to copy file	Turn the power OFF and then back ON. Retry the scan. If the error still occurs, contact your service representative.
2D62	Failed to connect to network destination. Check destination path.	Check destination path. Make sure that the network path is correct, and retry the scan. If the error still occurs, ask your administrator to confirm whether the IP address or path of the server is correct. Also make sure that the server is operating properly.?
2D63	Specified network path is invalid. Check destination path.	Make sure you specify correct network folder and retry the scan.
2D64	Logon to file server failed. Check username and password.	Make sure you specify correct user name and password to logon the file server and retry the scan.
2D66	Failed to process your job. Insufficient disk space.	Delete the data in the local shared folder in the equipment and retry the scan.

Error code	Problem	What to do
2D67	FTP service is not available.	Ask your administrator whether the FTP service is configured correctly.
2D68	File Sharing service is not available.	Ask your administrator whether the SMB protocol is enabled.
2DC0	Job canceled	Job was canceled.
2DC1	Power failure occurred	Make sure that the power cable is connected properly and it is inserted securely. Resend the job.
Store to e-Filing		
2B10	There was no applicable job.	Turn the power OFF and then back ON. Retry the scan. If the error still occurs, contact your service representative.
2B11	Job status failed.	Turn the power OFF and then back ON. Retry the scan. If the error still occurs, contact your service representative.
2B20	Failed to access file.	Turn the power OFF and then back ON. Retry the scan. If the error still occurs, contact your service representative.
2B30	Insufficient disk space.	Delete unnecessary documents in e-Filing and try again.
2B31	Failed to access Electronic Filing.	Make sure that the specified e-Filing or folder exists. (If not, this error would not occur.). Turn the power OFF and then back ON. Delete the specified e-Filing or folder and reset them. Retry the job in error. If the specified e-Filing or folder cannot be deleted, contact your service representative.
2B32	Failed to print Electronic Filing document.	Make sure that the specified document exists. (If not, this error would not occur.). Turn the power OFF and then back ON. Delete the specified document. If the specified document cannot be deleted, contact your service representative.
2B50	Failed to process image.	Turn the power OFF and then back ON. Retry the scan. If the error still occurs, contact your service representative.
2B51	Failed to process print image.	Make sure that the Function List can be printed out. Retry the print. If the error still occurs, contact your service representative.
2B90	Insufficient Memory.	Turn the power OFF and then back ON. Retry the scan. If the error still occurs, contact your service representative.
2BA0	Invalid Box password specified.	Make sure that the password is correct and retry the scan, or reset the password and retry the scan. When this error occurs for the print of the data in the e-Filing, perform the print with the administrator's password. If the recovery is still not completed or in case of invalid password for the operation other than printing (opening the file, etc.), contact your service representative.
2BB0	Job canceled	Job was canceled by the user.
2BB1	Power failure occurred	Make sure that the power cable is connected properly and it is inserted securely.
2BC0	System fatal error.	Turn the power OFF and then back ON. Retry the print. If the error still occurs, contact your service representative.
2BC1	Failed to acquire resource.	Turn the power OFF and then back ON. Retry the print. If the error still occurs, contact your service representative.
2B60	The folder was renamed. A folder of the same name already existed.	Check the folder to be made.

Error code	Problem	What to do
2B70	The document was renamed. A document of the same name already existed.	Check the data to be stored.
2B71	The storage period of e-Filing documents will expire.	Check the storage period.
2B80	The HDD for storing e-Filing data is running out of space.	Delete the unnecessary data in HDD.
2BA1	Incorrect paper size	This size is not supported by e-Filing. Check the paper size.
2BD0	Power failure occurred during restoring.	Check the power cable.
2BE0	Failed to obtain the machine parameters.	Turn the power OFF and then back ON to print again.
2BF0	Reached the maximum number of pages.	Reduce the pages to be inserted, and print them.
2BF1	Reached the maximum number of documents.	Delete unnecessary documents in the box or e-Filing.
2BF2	Reached the maximum number of folders.	Delete unnecessary documents in the box or e-Filing.
Printer		
4030	No print enabler/invalid or Proof and Private Printing is Disabled	Check if the Printer Kit is connected properly and inserted securely. Or check if the trial period is expired.
4031	HDD full for printing	Too many jobs of Private print and department code print are stored in HDD.
4032	Private-print-only error	Jobs other than Private print cannot be printed. Perform Private printing.
4033	Printing data storing limitation error	Printing with its data being stored to the HDD temporarily (Proof print, Private print, Scheduled print, etc.) cannot be performed. Perform normal printing.
4034	e-Filing storing limitation error	Printing with its data being stored to the HDD (print and e-Filing, print to e-Filing, etc.) cannot be performed. Perform normal printing.
4035	Local file storing limitation error	Network Fax or Internet Fax cannot be sent when "Local" is selected for the destination of the file to save. Select "Remote" (SMB/FTP) for the destination.
4036	User authentication error	The user performing the printing has not been authenticated or user-registered. Perform user authentication or user registration.
A221	Print job cancel	Print job is canceled. Retry the print.
A222	Print Job power interruption	Power failure occurred. Retry the print.

Error code	Problem	What to do
A290	Limit over error	Number of prints has exceeded the one specified with the department code and user code at the same time. Clear the limit counter.
A291	Limit over error	Number of prints has exceeded the one specified with the user code. Clear the limit counter.
A292	Limit over error	Number of prints has exceeded the one specified with the department code. Clear the limit counter.

RFC related

Error code	Problem	What to do
2500	Syntax error, command unrecognized: HOST NAME error (RFC: 500), Destination mail address error (RFC: 500), Terminal mail address error (RFC: 500)	Check if the Terminal mail address and Destination mail address are correct. Check if the mail server is operating properly. Turn the power OFF and then back ON, and perform the job in error again.
2501	Syntax error in parameters or arguments: HOST NAME error (RFC: 501), Destination mail address error (RFC: 501), Terminal mail address error (RFC: 501)	Check if the Terminal mail address and Destination mail address are correct. Check if the mail server is operating properly. Turn the power OFF and then back ON, and perform the job in error again.
2503	Destination mail address error (RFC: 503)	Check if the mail server is operating properly. Turn the power OFF and then back ON, and perform the job in error again. If the error still occurs, contact your service representative.
2504	HOST NAME error (RFC: 504)	Check if the mail server is operating properly. Turn the power OFF and then back ON, and perform the job in error again. If the error still occurs, contact your service representative.
2550	Destination mail address error (RFC: 550)	Check if the Destination mail address is correct. Check the status of mailbox access restriction, etc. on the mail server.
2551	Destination mail address error (RFC: 551)	Check the Destination mail address. Check if the mail server is operating properly.
2552	Terminal/Destination mail address error (RFC: 552)	Check if the Destination mail address is correct. Check the restriction of the capacity in the mailbox of the mail server.
2553	Terminal/Destination mail address error (RFC: 552)	Check if there is an illegal character in the mailbox in the mail server.



9. BLINKING GRAPHIC SYMBOLS

1. Blinking Graphic Symbols	262
2. Drawer Display on the Touch Panel	263
3. Toner-Related Symbols	264
4. Jam Symbols	267
5. Call Service Symbol	288

1. Blinking Graphic Symbols

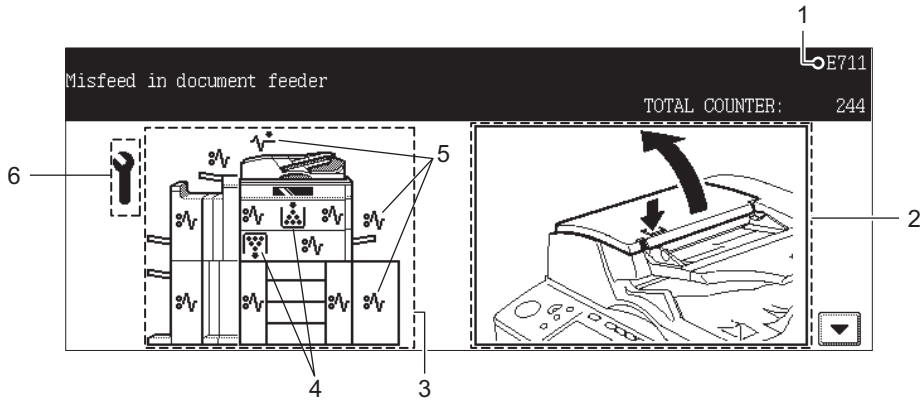

1. Error code
2. Guidance display area
3. Illustration of the equipment
4. Toner-related symbol (📖 P.264 "3.Toner-Related Symbols")
5. Jam symbol (📖 P.267 "4.Jam Symbols")
6. Call service symbol (📖 P.288 "5.Call Service Symbol")

When one of the graphic symbols 4 to 6 blinks, take the appropriate action referring to the indicated pages.

2. Drawer Display on the Touch Panel

When the drawer runs out of paper, the drawer display on the touch panel starts blinking. Add paper to the drawer.

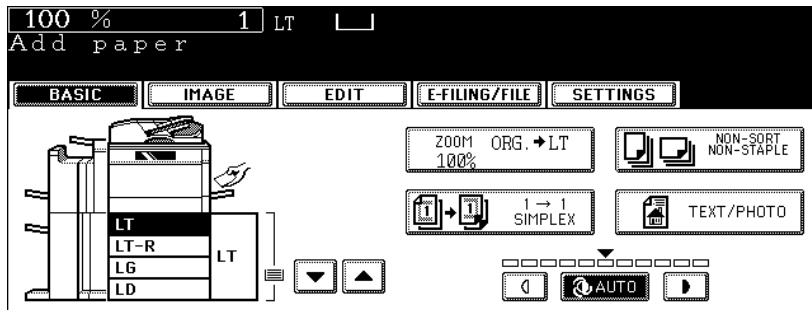

3. Toner-Related Symbols

Toner cover symbol

Caution

Never attempt to incinerate toner cartridges. This could cause an explosion. Do not dispose of used toner cartridges. Your service technician will collect them.

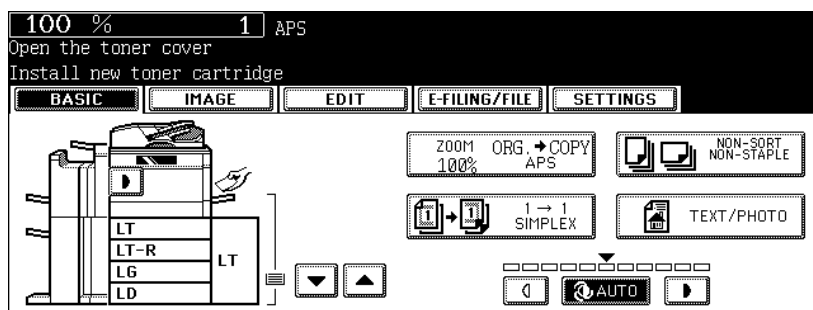

When the toner cartridge runs out of toner, the toner cover symbol blinks, and the above message appears.

Approx. 2000 sheets of copy are available after the toner cover symbol starts blinking. Also the toner cartridge can be replaced during the copy process while the toner cover symbol is blinking.

Replace the toner cartridge according to the following procedure.

- 1 Insert your fingers in the access on the front and open the toner cover.**

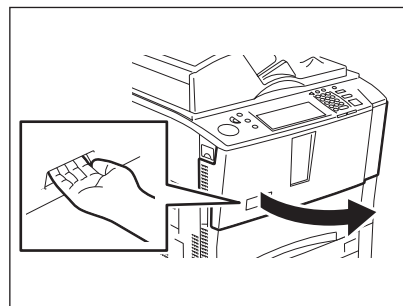

- 2 Pull the toner cartridge holder toward you.**

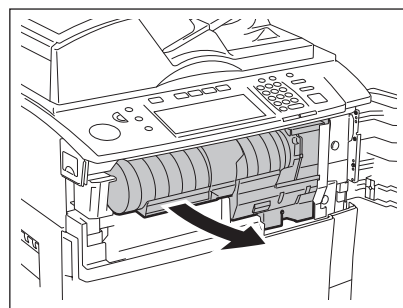

3 Take out the empty toner cartridge.

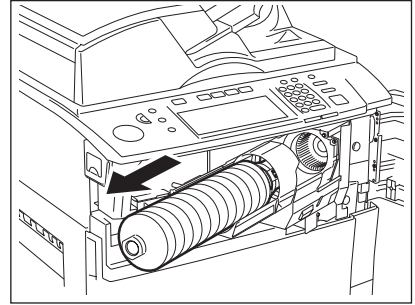

4 Shake the new toner cartridge well to loosen the toner inside.

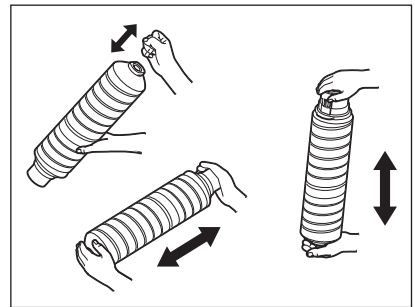

5 Holding the new toner cartridge horizontally, pull out the seal in the direction of the arrow.

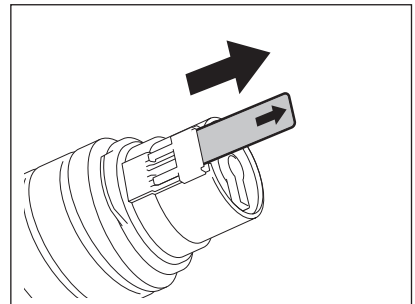

6 Install the toner cartridge to the toner cartridge holder.

- Match the label (orange) on the equipment with the shutter (orange) on the toner cartridge, then insert the toner cartridge to the end.
- If you cannot insert the toner cartridge completely, rotate it slightly to check the position and insert it again.
- If the toner scatters, wipe it off completely.

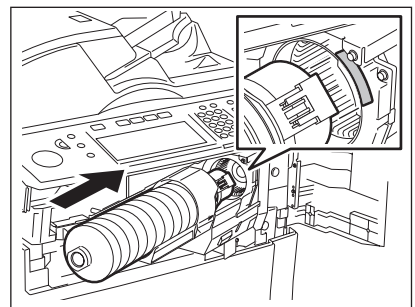

7 Return the toner cartridge holder to its original position.

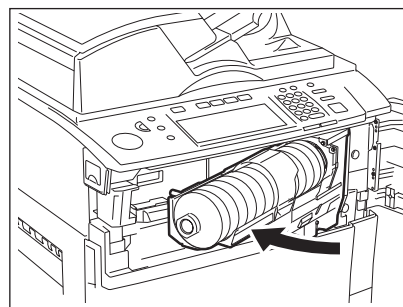

8 Close the toner cover.

- "Wait adding toner" appears and supplying toner starts automatically.

Toner cartridge symbol



When toner completely runs out and copying is disabled, the toner cartridge symbol starts blinking and the above message appears.

Replace the toner cartridge. (P.264 "Toner cover symbol")

Replace toner bag symbol

When the toner bag installed in the equipment becomes full, the replace toner bag symbol starts blinking.

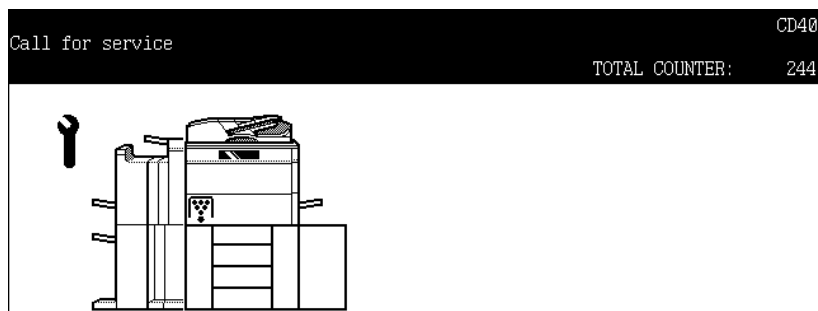

Your service technician will replace the toner bag. When the replace toner bag symbol blinks, please contact your service representative.

4. Jam Symbols

When a paper misfeed occurs in the equipment, the jam symbol blinks in the positions where the paper is misfed. Follow the guidance on the touch panel to remove the misfed paper properly.

- The misfed paper may not be on the correct position as shown in the illustration depending on the timing of the misfeeding.

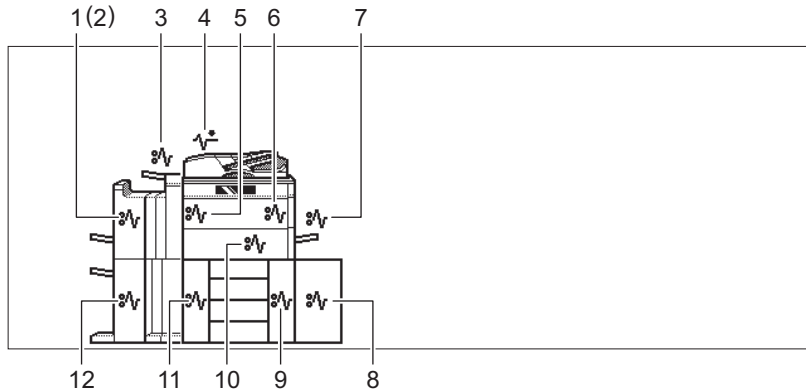

1. Finisher or Saddle Stitch Finisher (optional)
2. Hole Punch Unit (optional)
3. Inserter Unit (optional)
4. Reversing Automatic Document Feeder
5. Inside of the equipment (paper exit area)
6. Inside of the equipment (paper transport area)
7. Bypass tray
8. External Large Capacity Feeder (optional)
9. Inside of the equipment (paper feed area)
10. Inside of the equipment (duplex unit area)
11. Inside of the equipment (reversing area)
12. Saddle Stitch Unit of Saddle Stitch Finisher (optional)

Procedure of clearing a paper jam

When misfeeding occurs, remove the misfed paper by means of the following procedure.

Reversing Automatic Document Feeder (📖 P.269)



Bypass tray (📖 P.272)



External Large Capacity Feeder (optional) (📖 P.272)



Finishing device (optional) (📖 P.274)
(including the Hole Punch Unit and Inserter Unit)



Inside of the equipment (📖 P.282)

Separation/Installation and moving of the options

Perform the following procedure to separate, install and move the finishing device (including the Hole Punch Unit and Inserter Unit) and the External Large Capacity Feeder when clearing the jam.

Caution

When installing the options, be careful not to let your fingers be caught between the equipment and the optional unit.

Separating/Installing and moving the finishing device

When separating the finishing device from the equipment:

While placing your hand (position A) and pressing the button, gently move the finishing device away from the equipment.

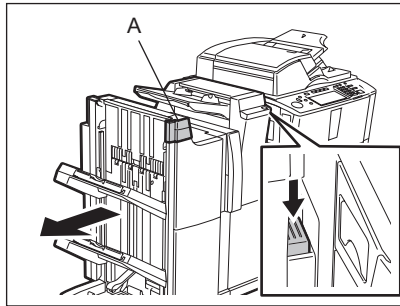

When installing the finishing device to the equipment:

While placing your hand (position A) and pressing the button, gently install the finishing device.

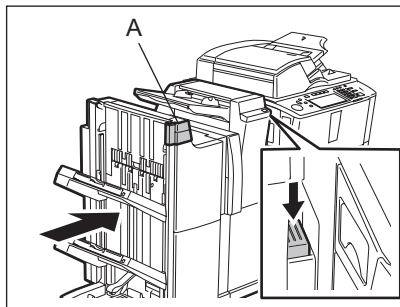

Separating/Installing and moving of the External Large Capacity Feeder

When separating the External Large Capacity Feeder from the equipment:

While pressing the button, gently separate the External Large Capacity Feeder.

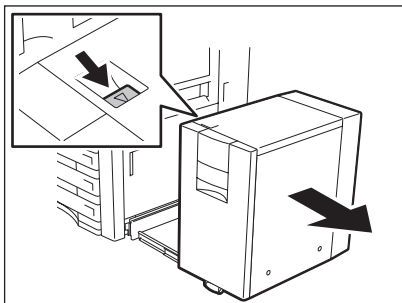

When installing the External Large Capacity Feeder to the equipment:

While placing your hand (position A) and pressing the button, gently install the External Large Capacity Feeder.

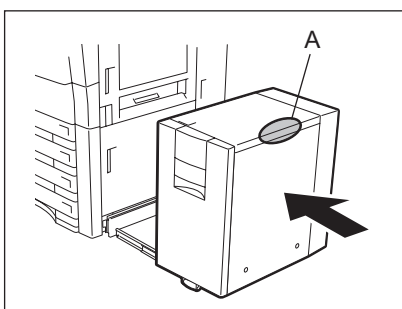

Reversing Automatic Document Feeder

- 1 Press the button on the Reversing Automatic Document Feeder to open the upper cover.

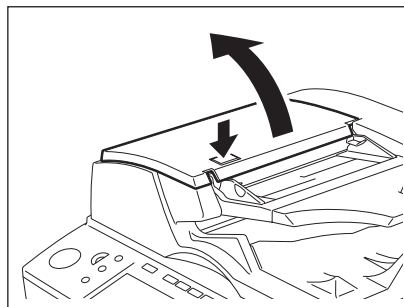

2 Rotate the knob to remove any misfed originals.

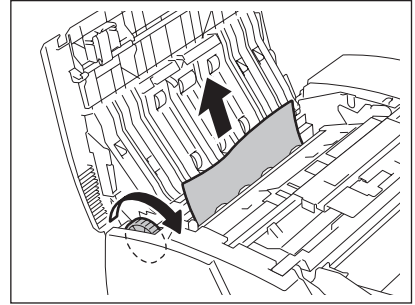

3 Open the guide plate to remove any misfed paper.

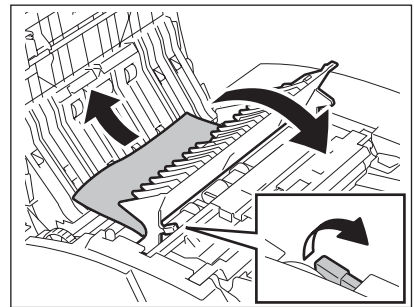

4 Close the guide plate.

5 Open the original feeding tray and remove any misfed originals.

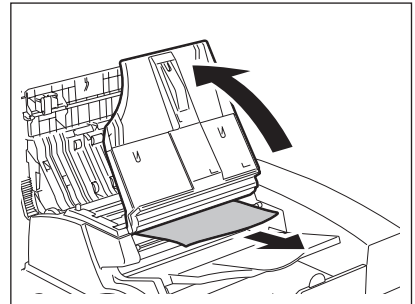

6 Open the large size original exit tray, and remove any misfed originals.

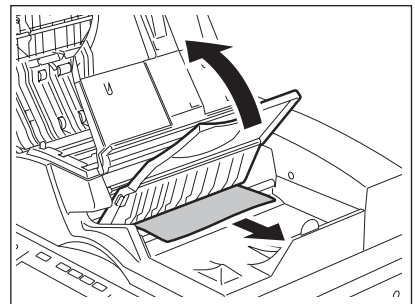

7 Close the large size original exit tray, the original feeding tray and close the upper cover of the Reversing Automatic Document Feeder.

8 Open the Reversing Automatic Document Feeder.

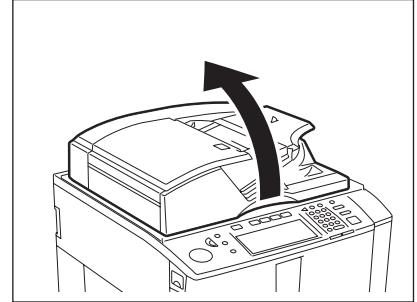

9 Release the lock to open the platen sheet.

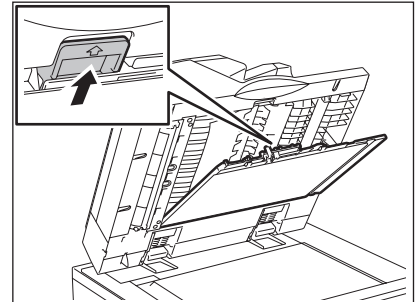

10 Remove any misfed originals in the reversing area.

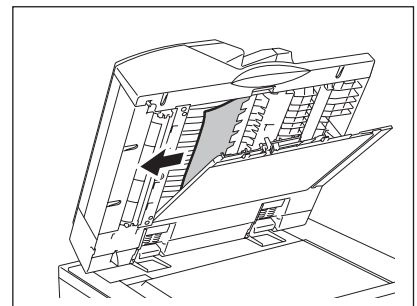

11 Close the platen sheet and the Reversing Automatic Document Feeder.

Bypass tray

- 1 Remove the paper from the bypass tray.

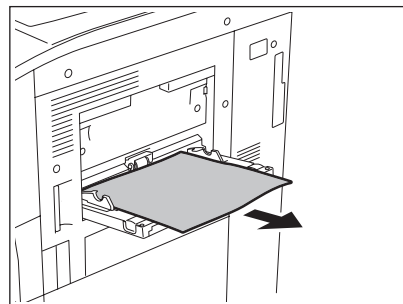

External Large Capacity Feeder

- 1 While pressing the button, gently separate the External Large Capacity Feeder from the equipment.

(See  P.268 for cautionary points regarding separation/ installation and moving of the options.)

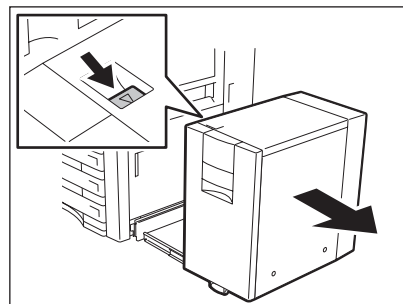

- 2 Turn the knob of the External Large Capacity Feeder to remove the paper.

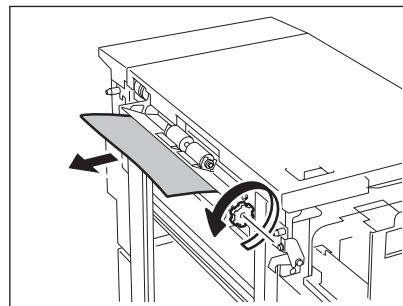

3 Remove the paper from the bypass cover.

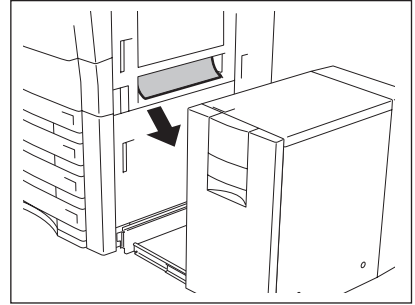

4 Open the drawer to remove the misfed paper.

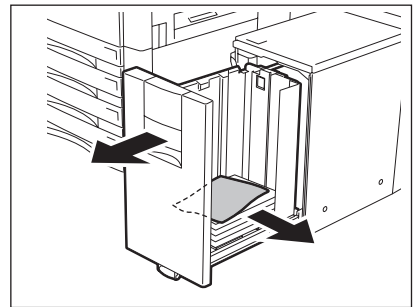

5 Close the drawer and install the External Large Capacity Feeder to the equipment.

(See  P.268 for cautionary points regarding separation/ installation and moving of the options.)

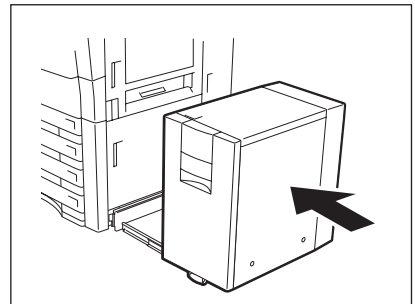

Finisher

<Hole Punch Unit>

Procedure for releasing the paper misfeed in the Hole Punch Unit. If the Hole Punch Unit is not installed, this procedure is not necessary.

<Inserter Unit>

Procedure for releasing the paper misfeed in the Inserter Unit. If the Inserter Unit is not installed, this procedure is not necessary.

<Saddle Stitch Finisher>

Procedure for releasing the paper misfeed in the saddle stitch unit. If the Saddle Stitch Finisher is not installed, this procedure is not necessary.

1 While pressing the button, separate the finishing device from the equipment.

(See  P.268 for cautionary points regarding separation/ installation and moving of the options.)

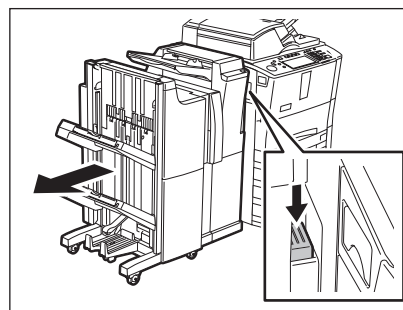

2 <Hole Punch Unit> Open the cover of the Hole Punch Unit.

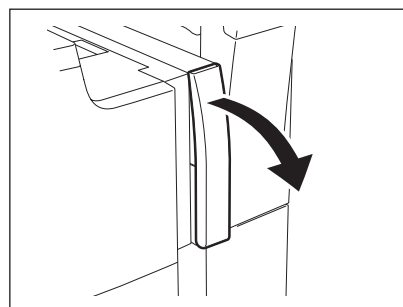

3 <Hole Punch Unit> Rotate the knob to locate the triangle mark within the indicated area on the label.

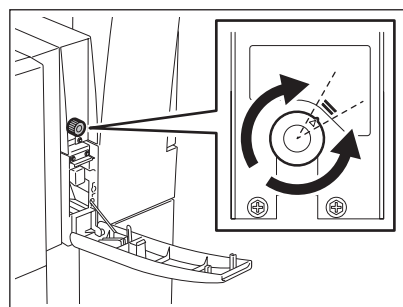

4 <Hole Punch Unit>

Close the cover of the Hole Punch Unit.

5 Remove any misfed paper seen on the feeding area of the finishing device.

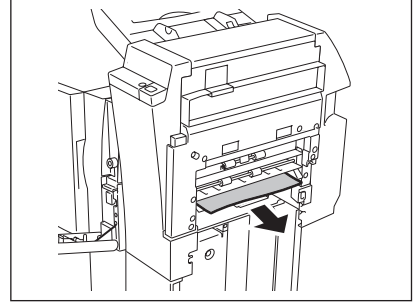

6 <Inserter Unit>

Pull the lever to open the jam access cover.

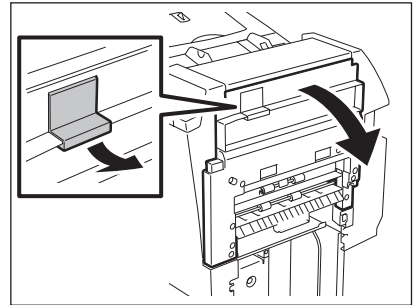

7 <Inserter Unit>

Remove the paper.

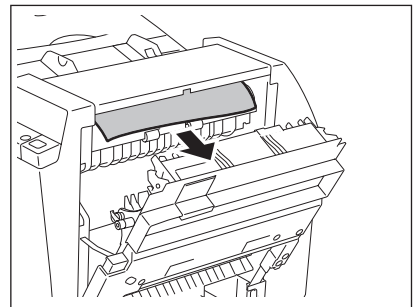

8 Close the jam access cover.

9 <Inserter Unit>
Open the lower cover.

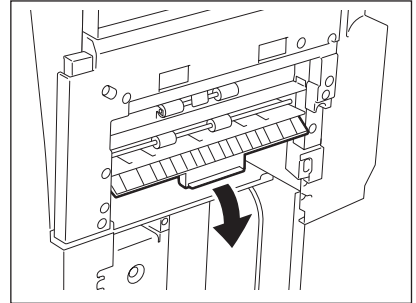

10 <Inserter Unit>
Remove the paper.

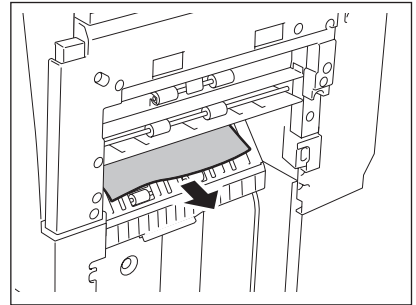

11 <Inserter Unit>
Close the lower cover.

12 <Inserter Unit>
Open the paper feeding tray to remove the paper.

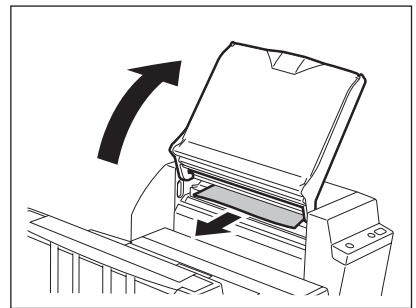

13 Open the upper cover of the Finisher or Saddle Stitch Finisher.

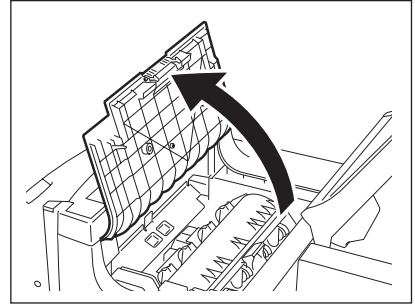

14 Pull the knob 1 to open the buffer roller cover, and then remove the paper.

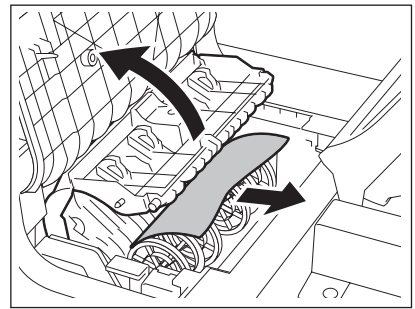

15 Pull the knob up in the rear side of the Finisher to open the guide.

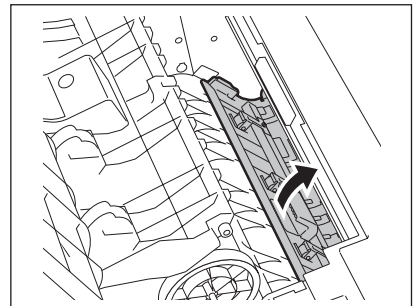

16 Remove the paper, then close the guide.

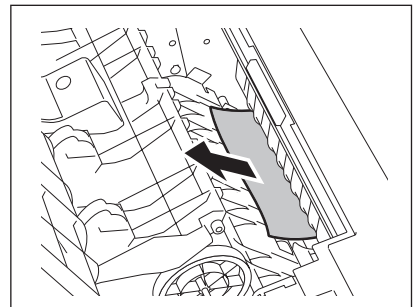

17 Pull the knob 2 up to open the buffer roller.

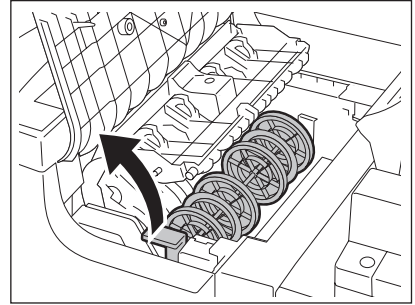

18 Remove the paper from the lower area.

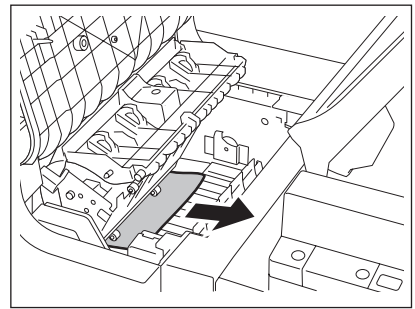

19 Remove the paper from the paper exit side of the Finisher or Saddle Stitch Finisher.

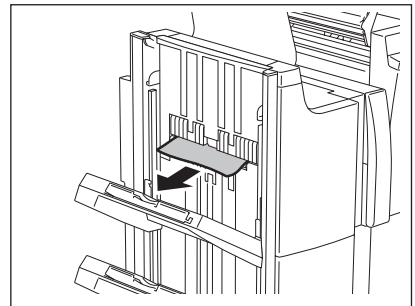

20 Close the buffer roller, buffer roller cover and upper cover of the Finisher or Saddle Stitch Finisher.

21 <Inserter Unit>
Return the paper feed tray of the Inserter Unit to its original position.

- 22** <Saddle Stitch Finisher> <Inserter Unit>
Open the lower cover of the Inserter Unit.

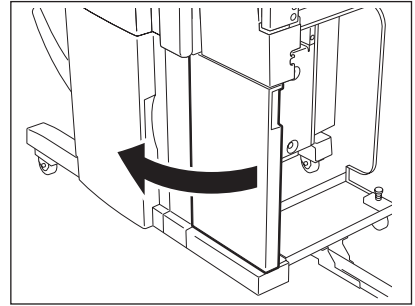

- 23** <Saddle Stitch Finisher>
Open the guide plate.

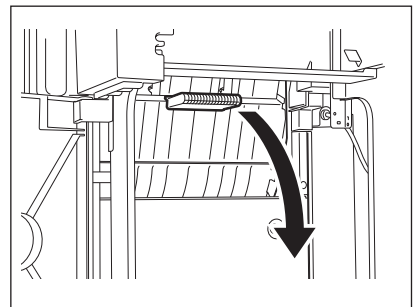

- 24** <Saddle Stitch Finisher>
Remove the paper and close the guide plate.

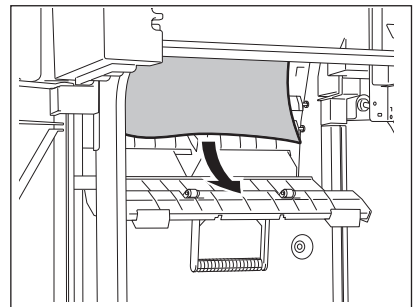

- 25** <Saddle Stitch Finisher> <Inserter Unit>
Close the lower cover of the Inserter Unit.

26 <Saddle Stitch Finisher>

Open the lower cover of the Saddle Stitch Finisher.

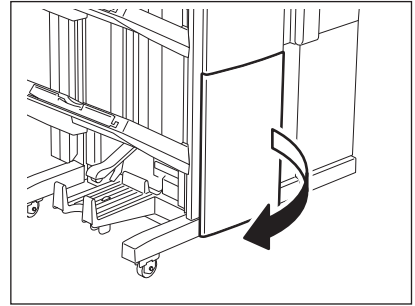

27 <Saddle Stitch Finisher>

Turn the right-hand knob counterclockwise until it stops.



28 <Saddle Stitch Finisher>

While pushing the left-hand knob clockwise, turn it to remove the paper.

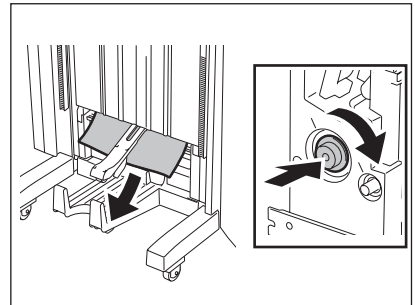

29 <Saddle Stitch Finisher>

Open the paper exit cover.

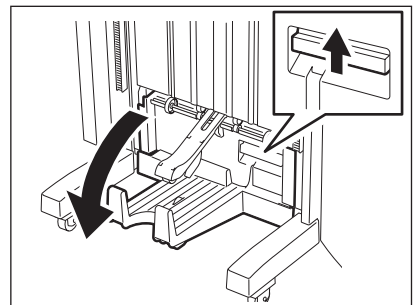

30 <Saddle Stitch Finisher>
Remove the paper.

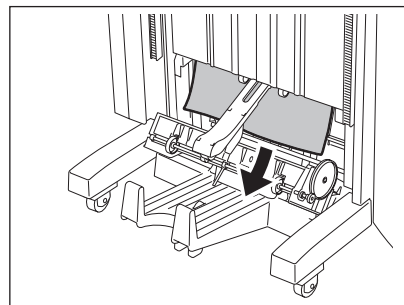

31 <Saddle Stitch Finisher>
Close the paper exit cover and the lower cover of the Saddle Stitch Finisher.

32 While pressing the button, install the finishing device to the equipment.

(See  P.268 for cautionary points regarding separation/ installation and moving of the options.)

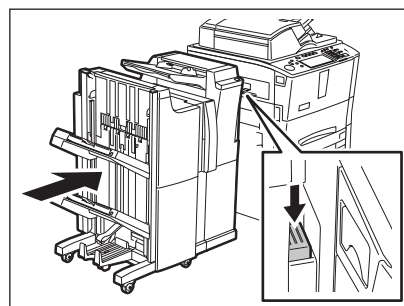

Inside of the equipment

<Finishing device>

If the finishing device is not installed, this procedure is not necessary.

<External Large Capacity Feeder>

If the External Large Capacity Feeder is not installed, this procedure is not necessary.

- 1 <External Large Capacity Feeder>
Press the button to separate the External Large Capacity Feeder from the equipment.**

(See  P.268 for cautionary points regarding separation/ installation and moving of the options.)

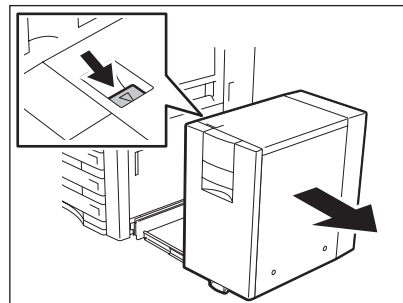

- 2 Open the paper feed cover.**

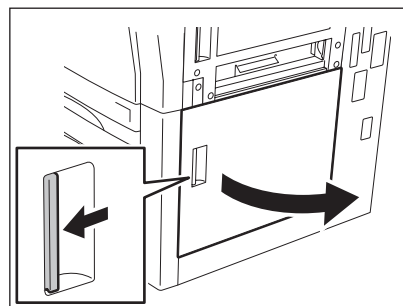

- 3 Remove the paper from the side of the drawer.**

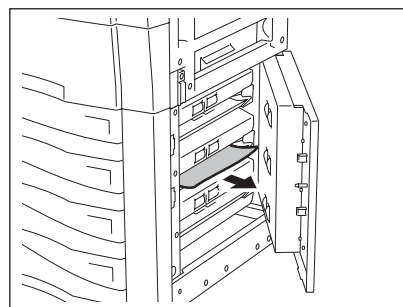

-
- 4** Open the drawer, in which the paper has been set, to remove the paper.

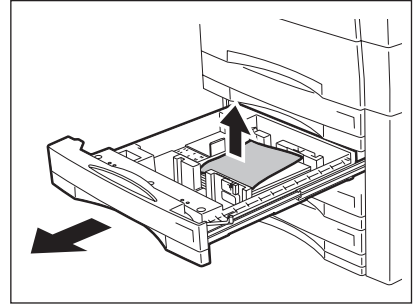

- 5** Close the drawer and the paper feed cover.

- 6** Open the bypass cover.

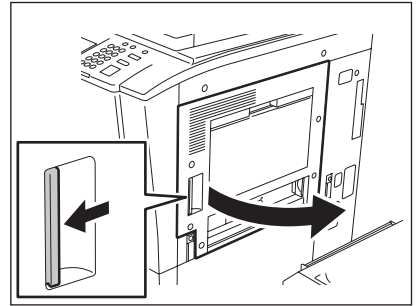

- 7** Remove the paper.

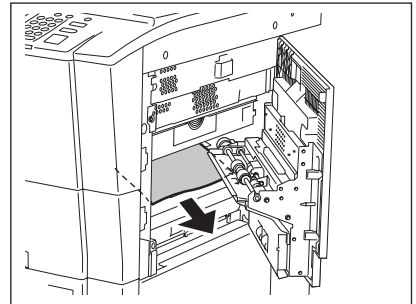

8 Close the bypass cover.

9 <External Large Capacity Feeder>
Install the External Large Capacity Feeder to the equipment.

(See  P.268 for cautionary points regarding separation/ installation and moving of the options.)

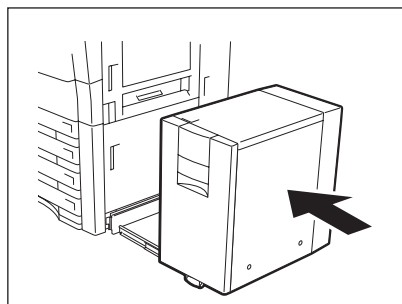

10 <Finishing device>
While pressing the button, separate the finishing device from the equipment.

(See  P.268 for cautionary points regarding separation/ installation and moving of the options.)

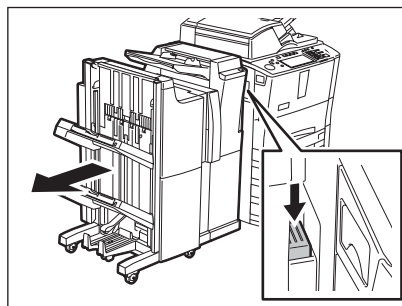

11 Open the exit cover.

9

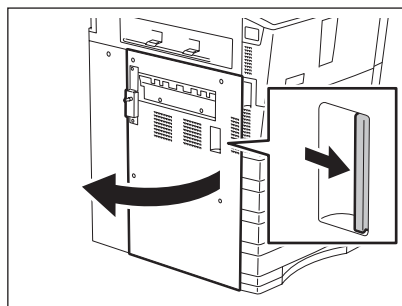

12 Remove the paper from the cover side.

- A: Reverse unit
- B: Guide plate

Caution

Do not touch the metal area of the reverse unit and the guide plate. It could burn you.

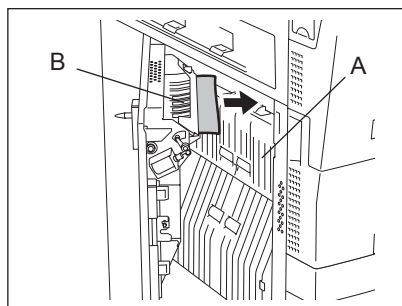

13 Remove the paper from the middle of the reverse unit.

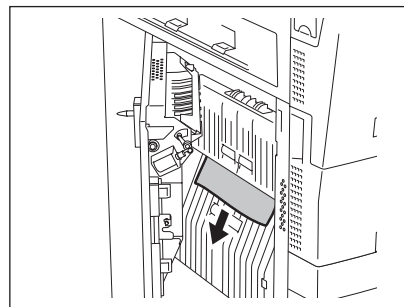

14 Open the front cover.

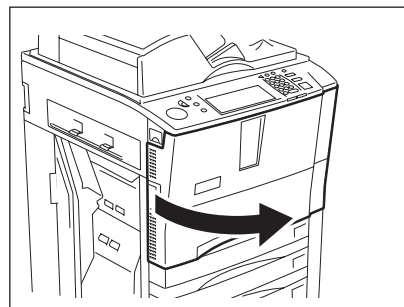

15 Turn the knob of the fuser unit counter-clockwise to remove the paper.

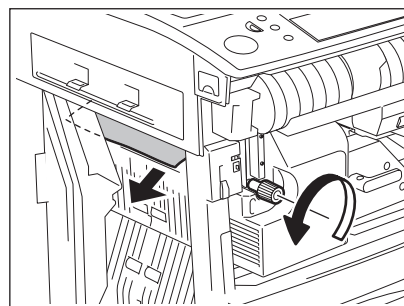

16 Close the exit cover.

17 <Finishing device>

While pressing the button, install the finishing device to the equipment.

(See  P.268 for cautionary points regarding separation/ installation and moving of the options.)

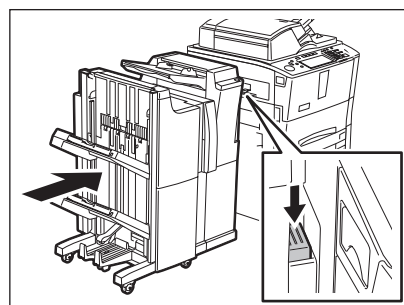

18 Turn the lever 90° clockwise to release the lock and then pull out the transfer/transport unit.

- Pull out the transfer/transport unit it stops.

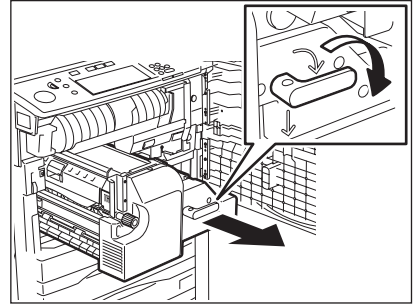

19 Open the fuser unit cover.

Caution

Do not touch the fuser unit and around the metal area around it. It could burn or injure you.

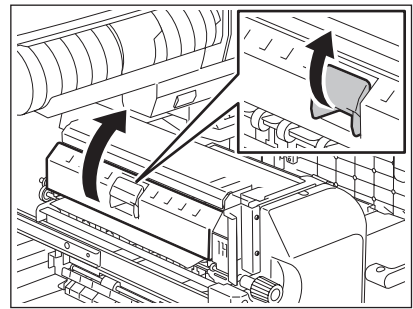

20 Turn the knob to remove the paper.

9

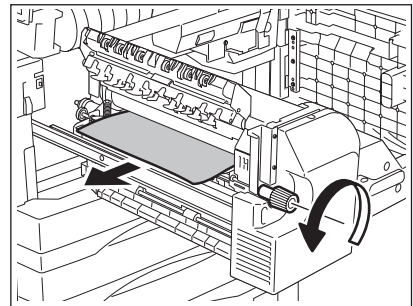

21 Close the fuser unit cover slowly.

22 Open the duplexer guide.

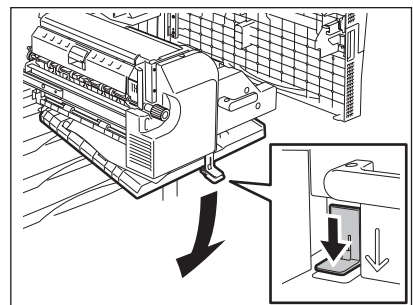

23 Remove the paper.

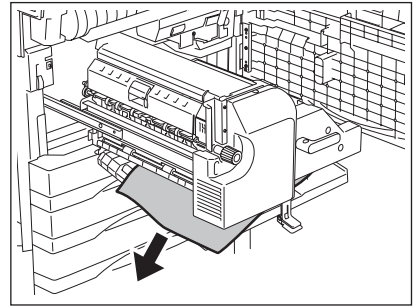

24 Close the duplexer guide.

25 Push the transfer/transport unit into the equipment, and then turn the lever counterclockwise to lock it.

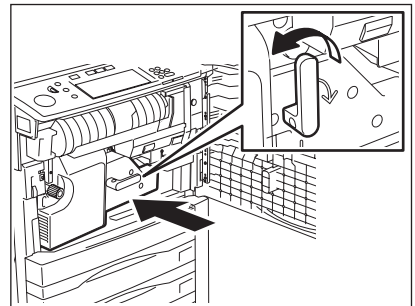

26 Close the front cover.

5. Call Service Symbol



1. Call service symbol
2. Error code

Warning

Never attempt to repair, disassemble or modify the equipment by yourself. You could cause a fire or get an electric shock.

Always contact your service representative for maintenance or repair of the internal parts of the equipment.

When the call service symbol blinks and "Misfeed in copier Press HELP" appears, output is no longer possible. Contact your service representative with the information of the displayed error code.

10. WHEN THIS MESSAGE APPEARS

1. "Toner low"	290
2. "Check staple cartridge"	292
3. "Check staple cartridge in the saddle stitch unit"	294
4. "Examine stapler"	296
5. "READY (CHECK STAPLER)"	298
6. "Examine stapler in the saddle stitch unit"	299
7. "READY (CHECK SADDLE STITCH STAPLER)"	302
8. "READY (HOLE PUNCH DUST BIN IS FULL)"	303
9. "POWER FAILURE"	304
10. "Time for periodic maintenance"	305
11. "Check paper size setting on control panel for drawer N"	306
12. "Reboot the machine"	314

1. "Toner low"

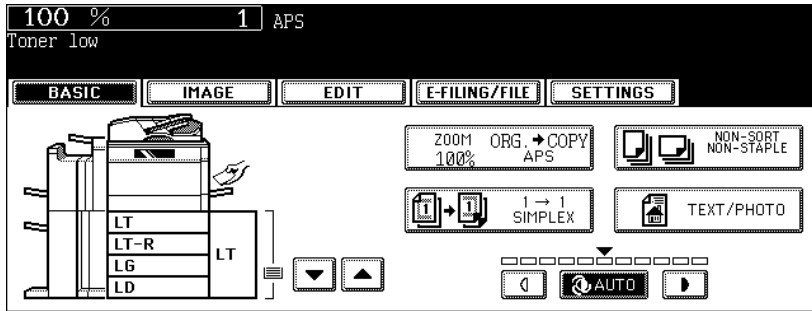

This message appears to notify you that the toner cartridge is running out of toner. Approx. 5000 sheets of paper can be copied until the toner cartridge becomes empty after this message has appeared. Prepare a new toner cartridge before the toner runs out.

- Replace the toner cartridge after "Install new Black toner cartridge" has appeared and the toner cover symbol blinks. (P.264 "Toner cover symbol")

Tip

If this message does not disappear after the new cartridge has been installed, perform the following procedure to delete the message.

1 Press the [USER FUNCTION] button.

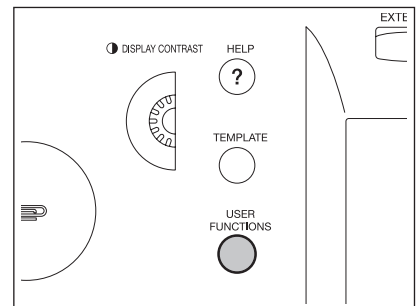

2 Press the [USER] button.

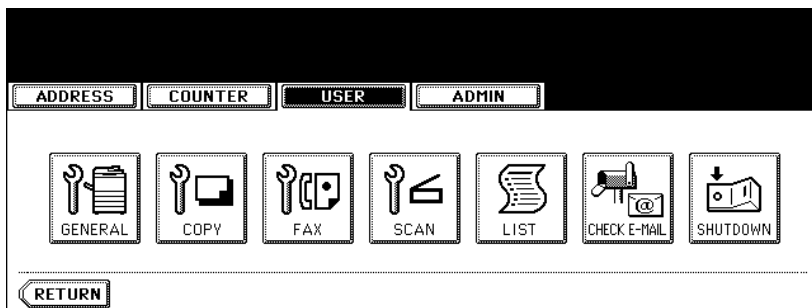

3 Press the [GENERAL] button.

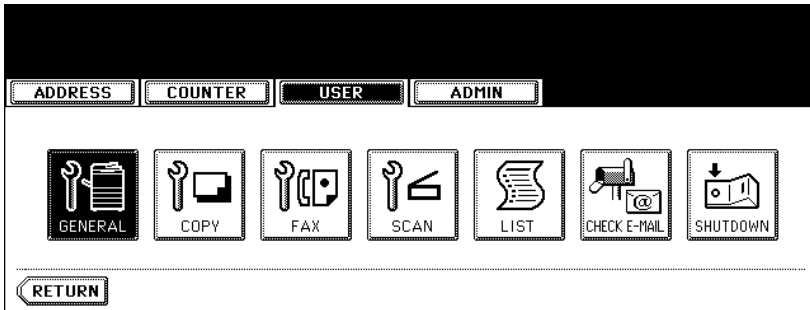

4 Press the [TONER NEAR EMPTY DETECTION] button.

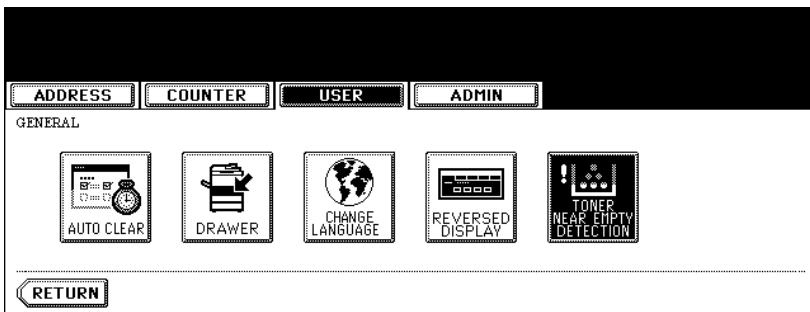

5 Press the [YES] button.

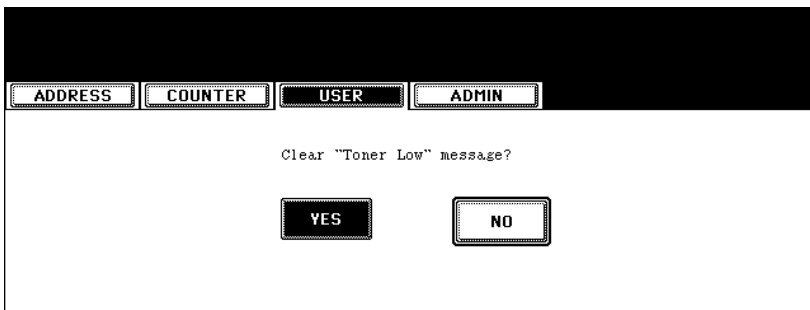

2. "Check staple cartridge"

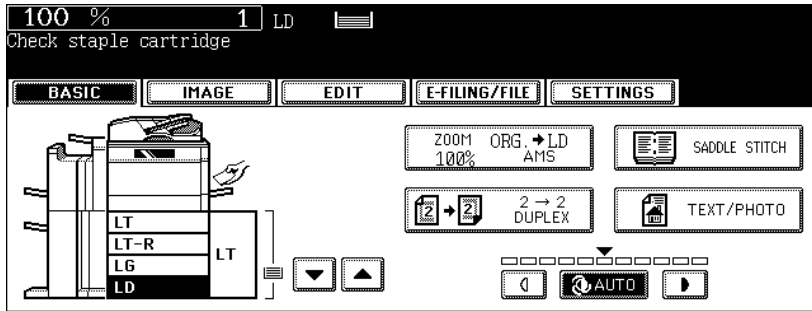

This message will be shown only if the Finisher (optional) is installed. When the staples in the stapler of the Finisher run out, this message appears. Add staples to the cartridge according to the following procedure.

1 Open the front cover of the Finisher.

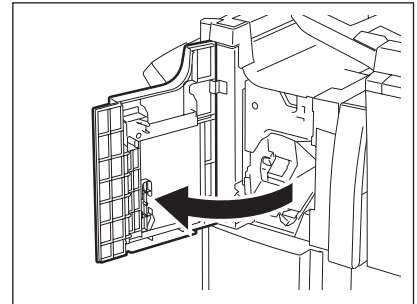

2 Lower the lever of the stapler to release the lock, and then take out the staple cartridge.

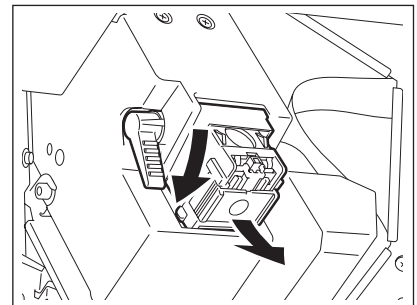

3 Remove the empty staple case from the cartridge.

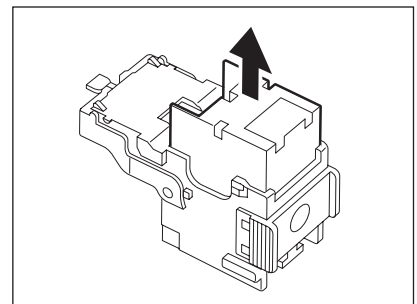

4 Attach a new staple case in the staple cartridge.

- Push a new staple case until it clicks.
- Do not peel the seal keeping the staples together before the staple case is attached in the cartridge.

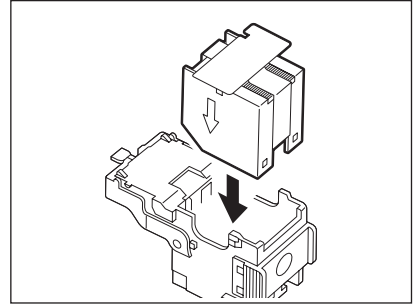

5 Pull out the seal fastening the staples upward.

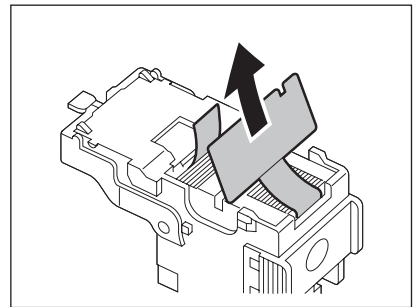

6 Install the staple cartridge to the stapler.

- Insert the cartridge until the lever of the stapler goes up to be fixed securely.

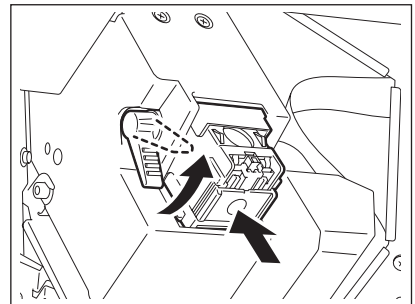

7 Close the front cover of the Finisher.

3. “Check staple cartridge in the saddle stitch unit”

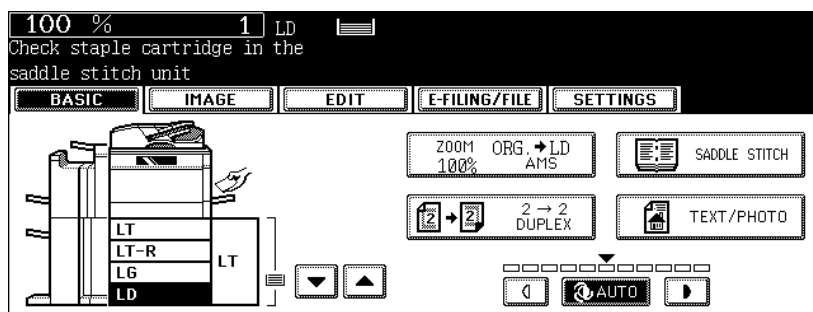

This message will be shown only if the Saddle Stitch Finisher (optional) is installed. When the staples in the stapler of the Saddle Stitch Finisher (optional) run out, this message appears. Replace the staple cartridge according to the following procedure.

1 Open the lower cover of the Saddle Stitch Finisher.

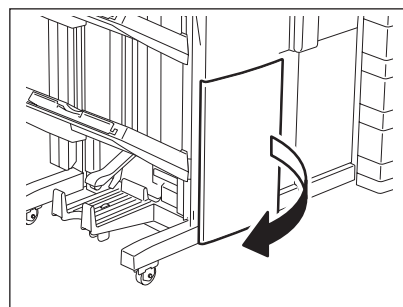

2 Pull out the saddle stitch unit slowly.

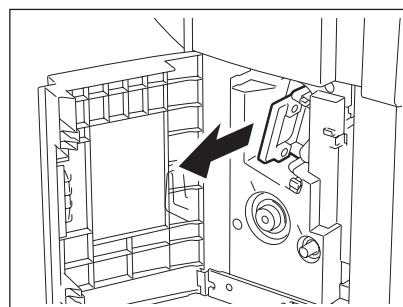

3 Pull the handle of the stapler of the saddle stitch unit to release the lock. Then rotate the stapler approx. 60° clockwise.

- The stapler is locked and fixed when it comes to a near-horizontal position.

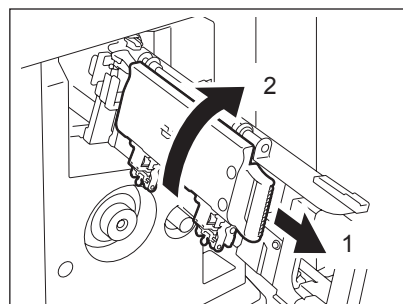

4 Take out the empty cartridge and then install a new cartridge.

- Replace both cartridges in one go.

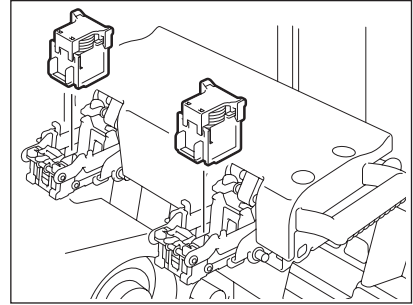

5 Pull out the handle of the stapler to release the lock and return to its original position.

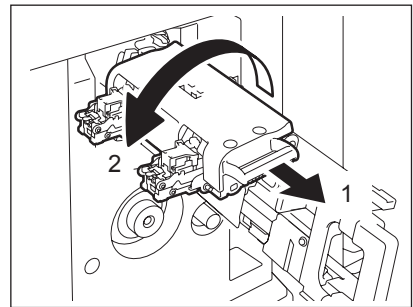

6 Insert the saddle stitch unit into the Saddle Stitch Finisher slowly.

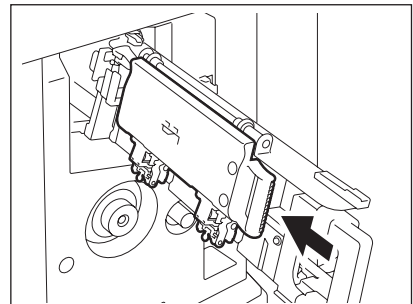

7 Close the lower cover of the Saddle Stitch Finisher.

4. "Examine stapler"

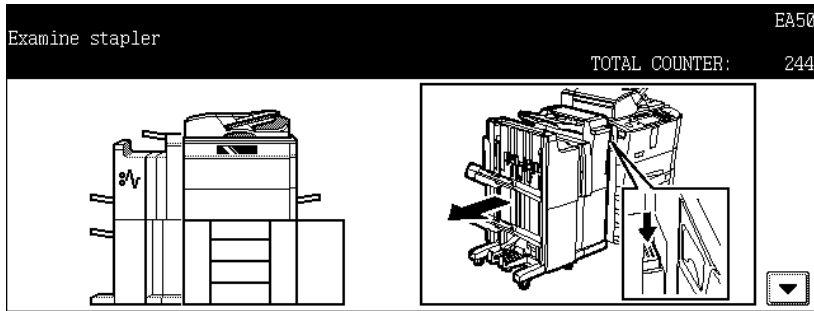

This message appears when the staples in the Finisher (optional) are jammed. To remove them, follow the procedure below.

1 Open the front cover of the Finisher.

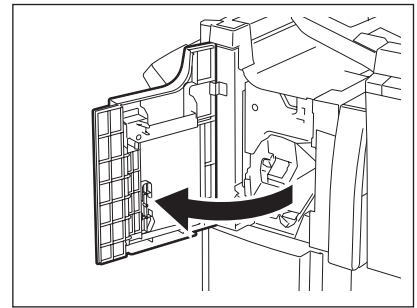

2 Lower the lever of the stapler to release the lock, and then take out the staple cartridge.

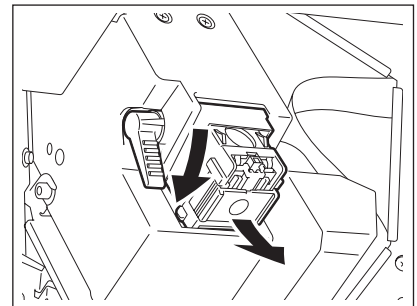

3 Lower the guide holding the knob.

A: Stapling area

Caution

Do not touch the stapling area. The stapler could injure you.

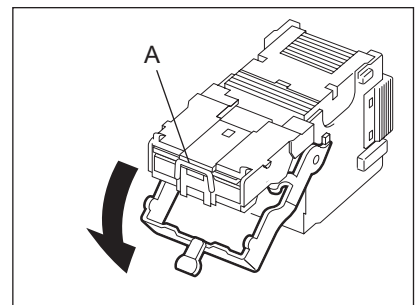

-
- 4** Remove any jammed staples with something sharp.

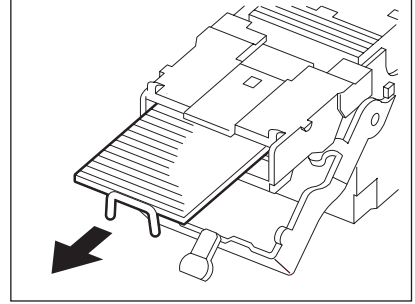

- 5** Lift up the guide holding the knob to return it to its original position.

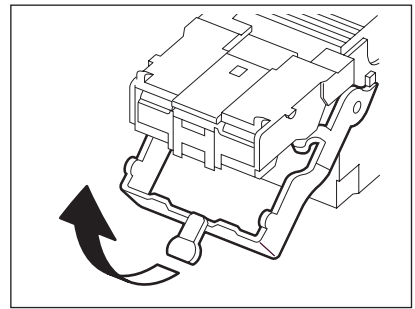

- 6** Install the staple cartridge in the stapler.
- Insert the cartridge until the lever of the stapler goes up to be fixed securely.

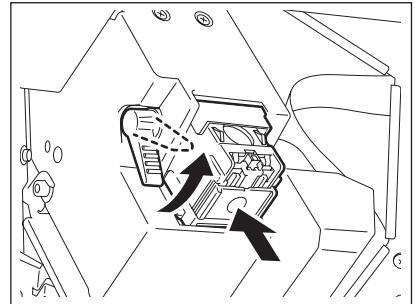

- 7** Close the front cover of the Finisher.

5. “READY (CHECK STAPLER)”

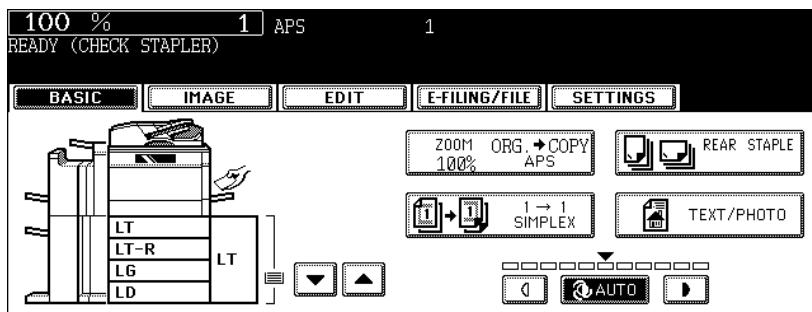

This message will be shown only when the Finisher (optional) is installed. It appears when the staples in the stapler of the Finisher run out or when the staples in the Finisher are jammed. Clear the error according to the procedure in [P.292](#) “2. “Check staple cartridge”” or [P.296](#) “4. “Examine stapler””.

6. "Examine stapler in the saddle stitch unit"

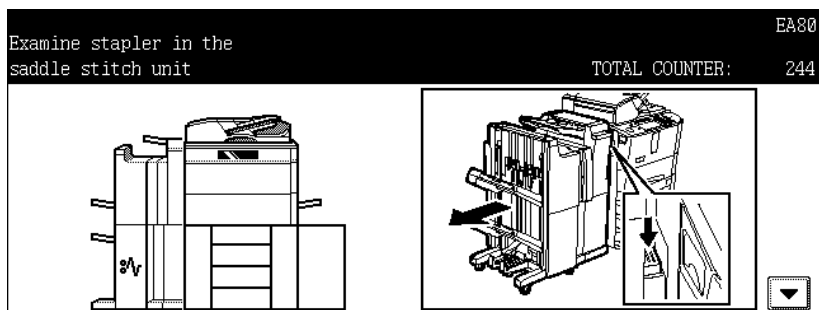

This message appears when the staples in the saddle stitch unit (optional) are jammed. To remove them, follow the procedure below.

1 Open the lower cover of the Saddle Stitch Finisher.

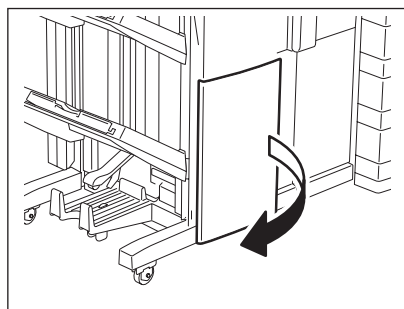

2 Pull out the saddle stitch unit slowly.

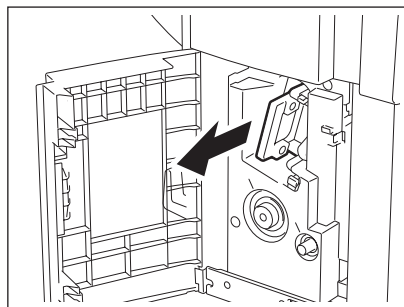

3 Pull the handle of the stapler of the saddle stitch unit to release the lock. And then rotate the stapler approx. 60° clockwise.

- The stapler is locked and fixed when it comes to a near-horizontal position.

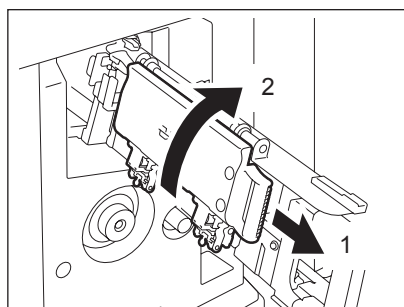

4 Take out the cartridge.

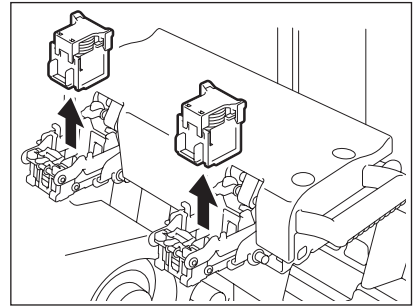

5 Press 1 to release the lock, and then pull up the shutter by holding knob 2.

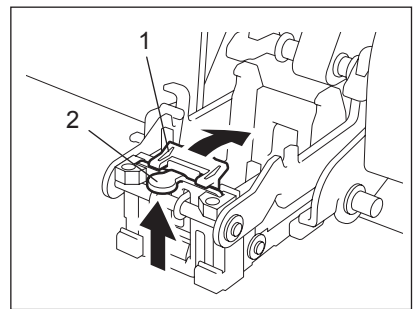

6 Remove any jammed staples.

A: Stapling area

Caution

Do not touch the stapling area. The stapler could injure you.

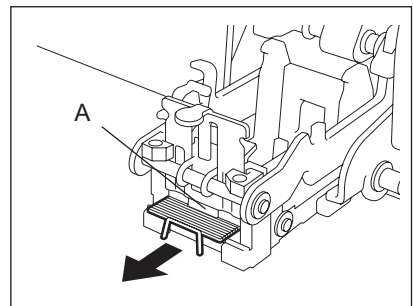

7 Return the shutter to its original position by pressing knob 2.

- Check that the latch of 1 is hung on the shutter.

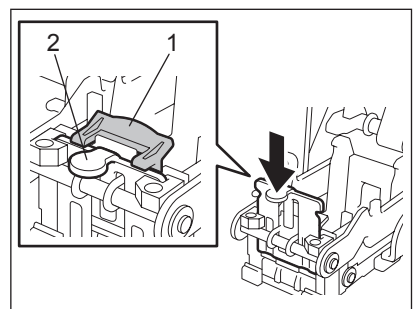

8 Install the cartridge.

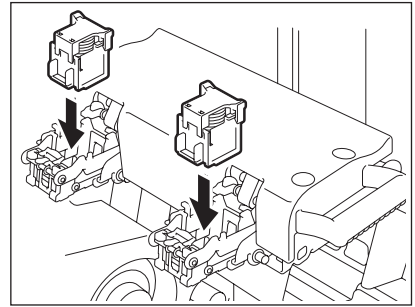

9 Pull the knob on the stapler to release the lock, and then pull the stapler down to its original position.

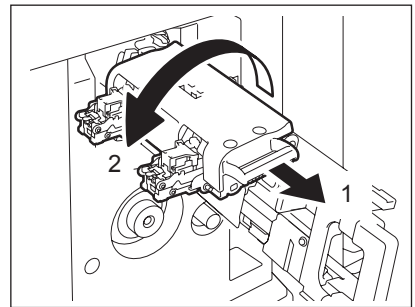

10 Insert the saddle stitch unit into the Saddle Stitch Finisher slowly.

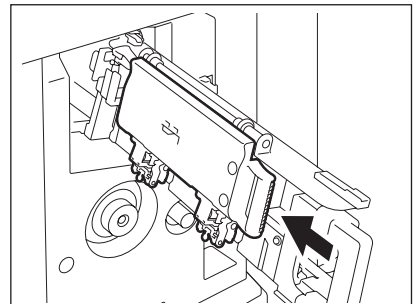

10

11 Close the lower cover of the Saddle Stitch Finisher.

7. “READY (CHECK SADDLE STITCH STAPLER)”

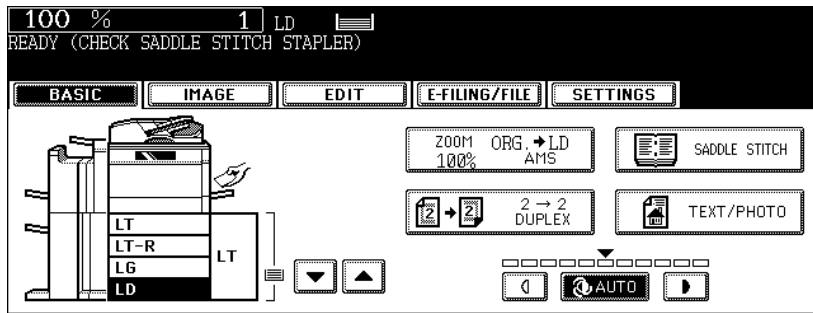

This message will be shown only when the Saddle Stitch Finisher (optional) is installed. It appears when the staples in the stapler of the Saddle Stitch Finisher run out or when the staples in the Saddle Stitch Finisher are jammed.

Remove the jammed staples according to the procedure in [P.299](#) “6. “Examine stapler in the saddle stitch unit””.

If the staples run out, follow the procedure below as well as the procedure in [P.294](#) “3. “Check staple cartridge in the saddle stitch unit””.

1 Follow steps 1 to 6 of [P.294](#) “3. “Check staple cartridge in the saddle stitch unit””.

- Do not close the lower cover of the Saddle Stitch Finisher.

2 Check the following 2 items to perform test stapling.

- Whether the Saddle Stitch Finisher is securely installed in the equipment.
- Whether any LD, LG or LT-R paper is set in the equipment.

3 Close the lower cover of the Saddle Stitch Finisher.

- The test stapling is automatically performed.

Tip

If the lower cover of the Saddle Stitch Finisher is closed without satisfying the condition of step 2, test stapling is not performed. Test stapling is necessary for anti-idling of stapling. After satisfying the condition of step 2 and opening/closing the lower cover of the Saddle Stitch Finisher again, be sure to perform the test stapling.

8. "READY (HOLE PUNCH DUST BIN IS FULL)"

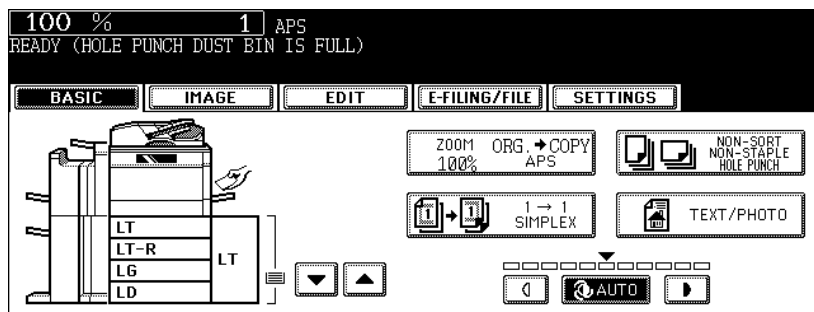

This message appears when the hole punch dustbin in the Hole Punch Unit (optional) becomes full. To dispose of the paper bits, follow the procedure below.

1 Open the cover of the Hole Punch Unit.

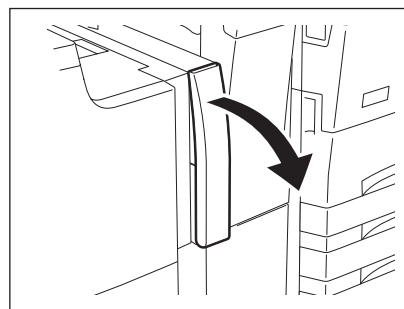

2 Pull out the hole punch dustbin.

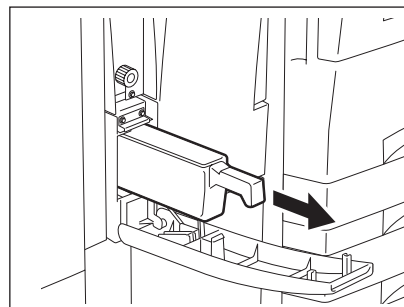

3 Dispose of the paper bits.

4 Attach the hole punch dustbin.

5 Close the cover of the Hole Punch Unit.

9. "POWER FAILURE"

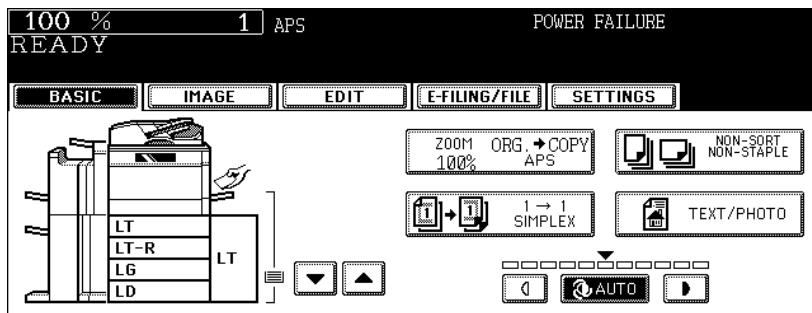

This message appears when a job is interrupted due to a power failure, etc. A job in progress at the time of the power failure may be deleted. Confirm the job status by pressing the [JOB STATUS] button. If this message appears during Fax reception, ask the sender to resend the Fax.

10. “Time for periodic maintenance”

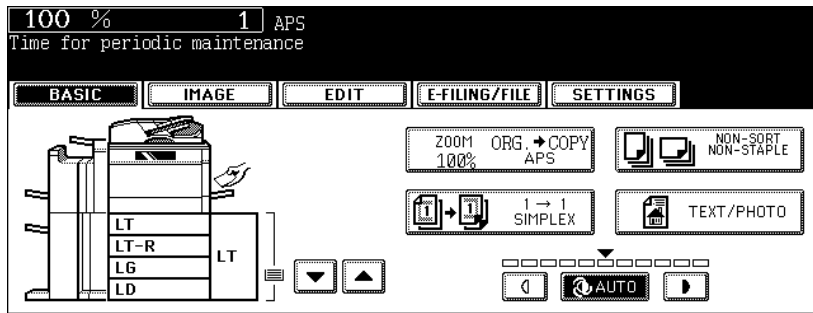

This message appears when assistance from a qualified service technician is required. Contact your service representative.

The following message also appears when such assistance is required. Contact your service representative.

“Time for periodic maintenance (Fuser cleaning web)”.

Tip

Continuous use of the equipment without the fuser cleaning web being changed causes stains on the printed image.

11. “Check paper size setting on control panel for drawer N”

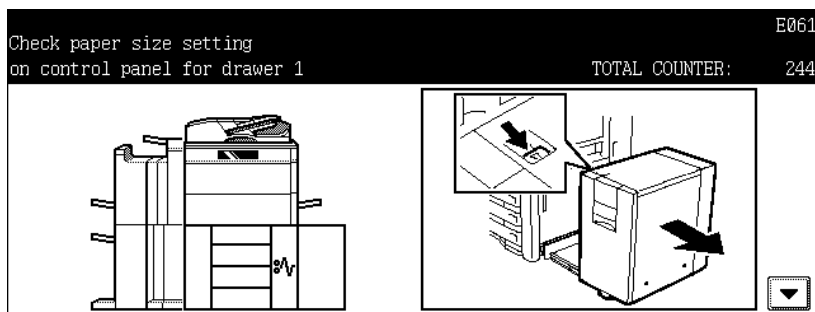

This message appears when the size of the paper actually placed in the drawer or on the bypass tray differs from the one registered in the equipment for the corresponding drawer or the bypass tray. There are 5 messages of this type as shown below.

- “Check paper size setting on control panel for drawer 1”
- “Check paper size setting on control panel for drawer 2”
- “Check paper size setting on control panel for drawer 3”
- “Check paper size setting on control panel for drawer 4”
- “Check paper size setting on control panel for Bypass”

In case that a paper misfeed occurs and one of the above messages consequently appears, another paper misfeed will occur if you just remove the jammed paper. Instead, be sure to follow the procedure below.

- Make a note of the position of the jammed paper and the number of the drawer displayed in the message in advance because guidance for removing the jammed paper is not displayed while you are working on the procedure.

This countermeasure differs depending on when the paper misfeeding has occurred – during copying or during printing from the Fax or the Printer.

During copying (using a drawer)

1 Turn the power of the equipment OFF.

- You cannot shut down the equipment.

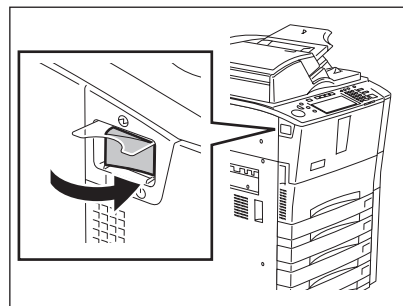

2 Remove the jammed paper.

- P.267 “4.Jam Symbols”

- 3** Pull out the drawer mentioned in the message. Then remove all paper in it.

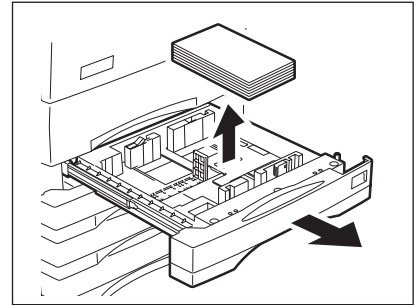

- 4** Close the drawer and then turn the power ON.

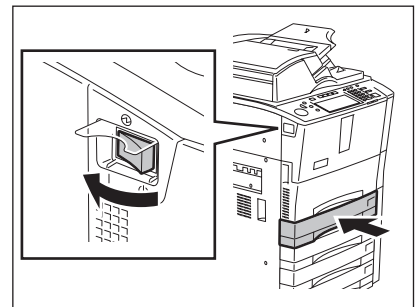

- 5** Press the [USER FUNCTIONS] button on the control panel.

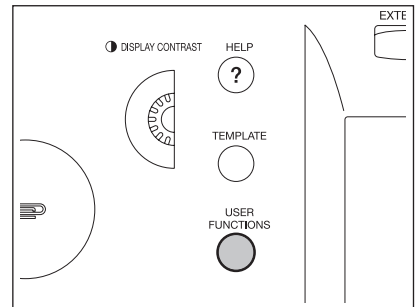

- 6** Press the [USER] button on the touch panel to display the [USER] menu.

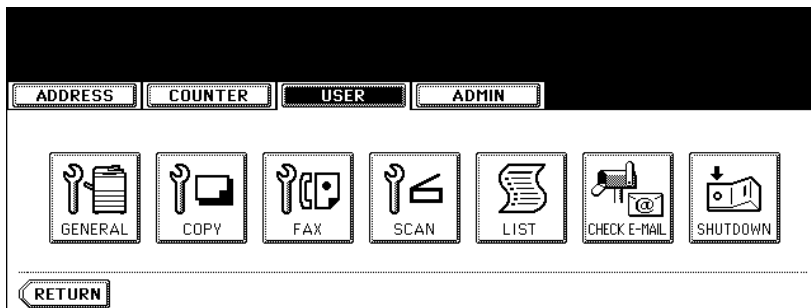

7 Press the [GENERAL] button on the touch panel.

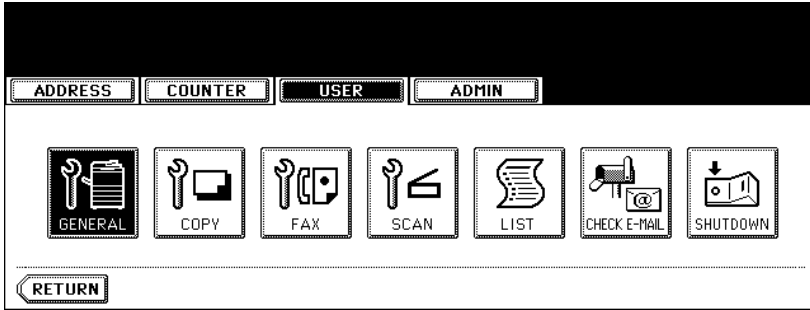

8 Press the [DRAWER] button on the touch panel.

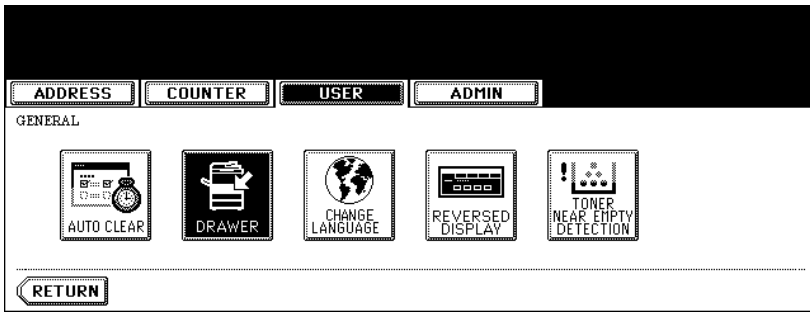

9 Press the drawer button corresponding to the one mentioned in the message on the touch panel.

10

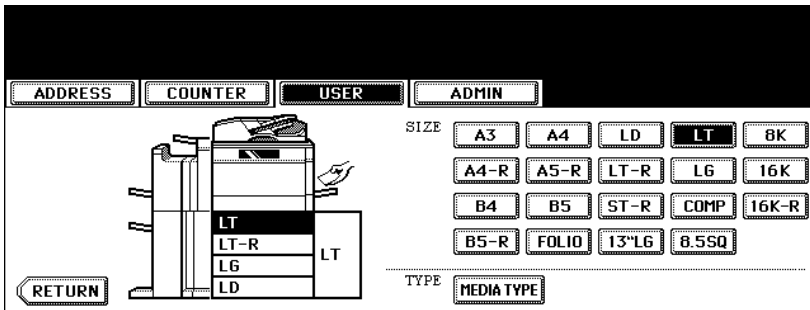

10 Press the paper size button corresponding to the one placed in the drawer.

📖 P.34 "4.Setting Copy Paper"

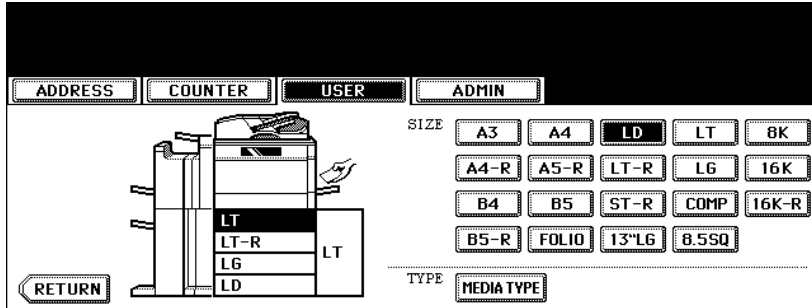

11 Place the removed paper and the original, and then try to copy again.

During copying (using the bypass tray)

1 Turn the power of the equipment OFF.

- You cannot shut down the equipment.

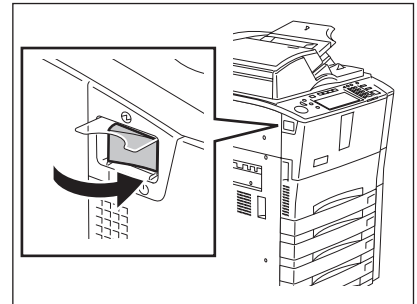

2 Remove the jammed paper.

📖 P.267 "4.Jam Symbols"

3 Remove all paper on the bypass tray.

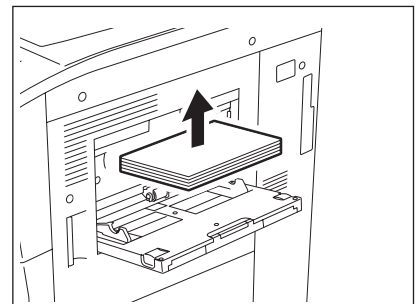

4 Turn the power ON.

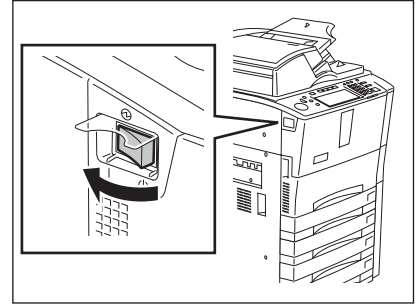

5 Place paper on the bypass tray and select the paper size.

P.63 "6.Bypass Copying"

6 Place the original and try to copy again.

During printing from the FAX or Printer (using a drawer)

1 Turn the power of the equipment OFF.

- You cannot shut down the equipment.

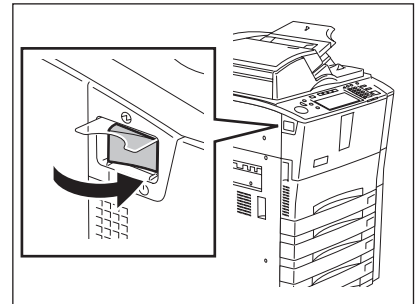

2 Remove the jammed paper.

P.267 "4.Jam Symbols"

3 Pull out the drawer mentioned in the message. Then remove all paper in it.

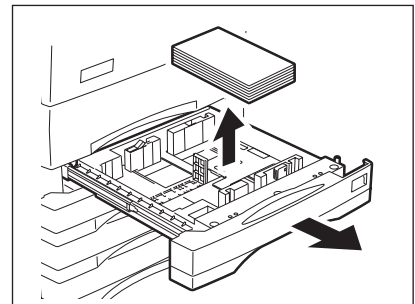

- 4** Close the drawer and then turn the power ON.

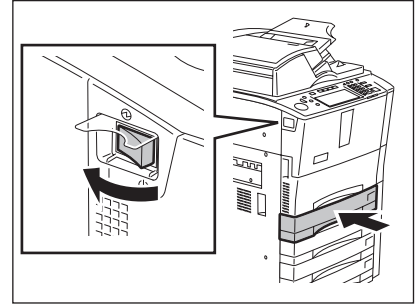

- 5** See the size indication on the touch panel to check the paper size registered for the drawer mentioned in the message.

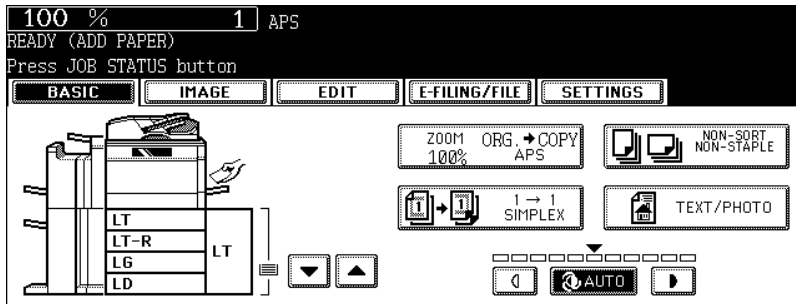

- 6** Place the paper, whose size is same as the one you have checked at step 5, in the drawer mentioned in the message.

📖 P.34 "4.Setting Copy Paper"

- 7** The job is resumed.

- If you change the paper size again after the completion of the job, check that the paper size placed in the drawer is the same as the one registered in the equipment for the corresponding drawer.

During printing from the Printer (using the bypass tray)

- Paper will not be fed out of the bypass tray during a FAX reception.

1 Turn the power of the equipment OFF.

- You cannot shut down the equipment.

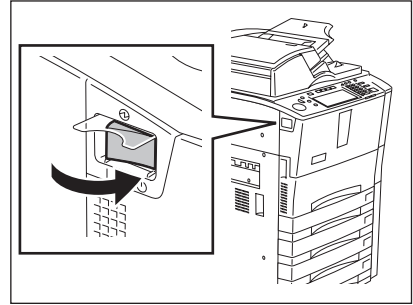

2 Remove the jammed paper.

 P.267 "4. Jam Symbols"

3 Remove all paper on the bypass tray.

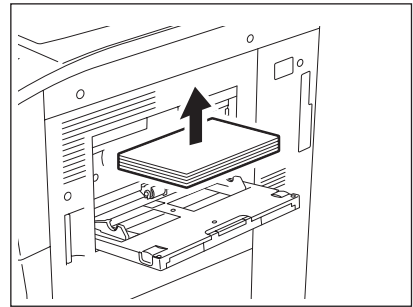

4 Turn the power ON.

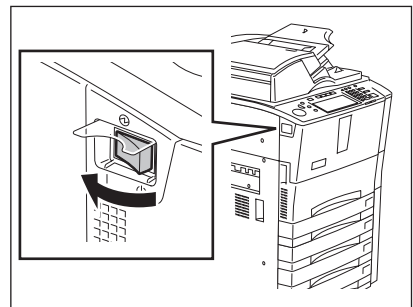

- 5** Press the [JOB STATUS] button on the control panel.

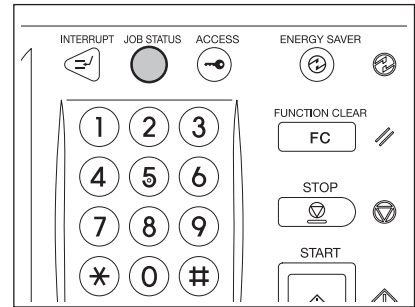

- 6** Place the paper of the size corresponding to the one shown next to the message “Place Paper in the Bypass tray :” on the bypass tray.

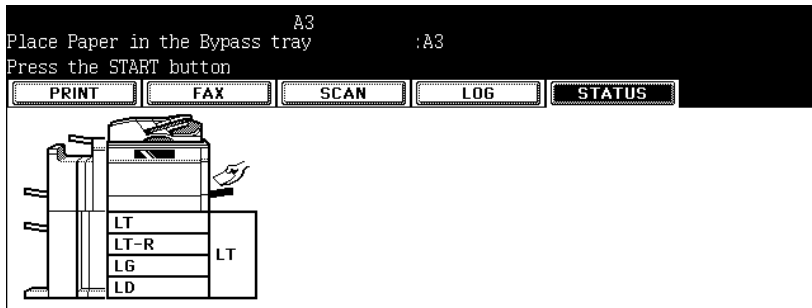

- 7** Press the [START] button.

12. “Reboot the machine”

Reboot the machine	CBF0
TOTAL COUNTER:	244

This message appears when the equipment cannot be operated normally because an error occurs but it may be released by rebooting the equipment. Since the equipment cannot be shut down with the control panel, reboot it with the power switch.

11. MAINTENANCE

1. Daily Inspection.....	316
2. Simple Troubleshooting	317

1. Daily Inspection

We recommend you to clean the following items weekly, so that the originals can be scanned in unsoiled conditions.

Be careful not to scratch the parts that you are cleaning.

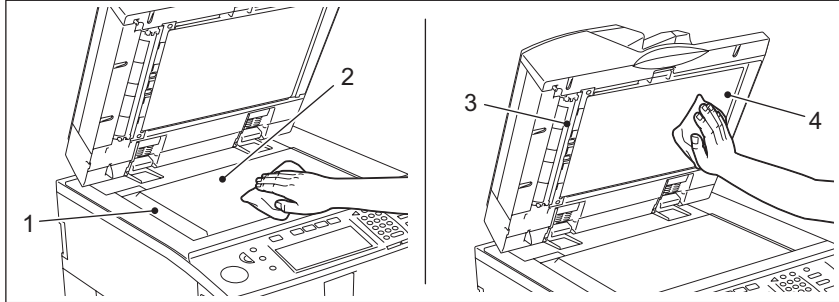

1. Scanning area

Clean the surface with a dried cloth (co-packed) or a cloth lightly moistened with water. Do not use solvents such as alcohol.

2. Original glass

3. Guide

4. Platen sheet

Clean the surface as follows depending on the staining.

- Clean it with a cloth (co-packed).
- Clean it with a soft cloth lightly moistened with water.
- Clean it with a soft cloth lightly moistened with alcohol, and then wipe it with a dry cloth.
- Clean it with a soft cloth lightly moistened with watered-down neutral detergent, and then wipe it with a dry cloth.

Caution

- Do not use solvents such as thinner or benzine when cleaning the surface of the equipment. This could warp the shape of the surface or leave it discolored.
- When using a chemical cleaning pad to clean it, follow the instructions.





2. Simple Troubleshooting

Check the following items and, if the problem still occurs, call your service representative for assistance.

Equipment does not start

Item to be checked	Countermeasure	Reference page
Is the power cord plug securely inserted in the outlet?	Insert the power cord plug until it comes to a stop.	-
Are the front cover and toner cover securely closed?	Close the cover properly.	 P.20 "1.Description of Each Component"

Paper jamming occurs frequently

Item to be checked	Countermeasure	Reference page
Does the message: "Check paper size setting on control panel for drawer N (Bypass)" appear?	Match the size of the paper placed in the drawer or on the bypass tray and the one registered to the equipment.	 P.306 "11."Check paper size setting on control panel for drawer N""
Does the paper placed exceed the line indicated inside of the side guide?	Remove some of the sheets of paper and place them with the paper height not exceeding the line indicated.	 P.37 "Placing paper in the drawer"
Is the space between the side guide of the drawer or the bypass tray and the paper too narrow/wide?	Keep an appropriate space between the side guide and paper, and then place paper straight along the side guide.	 P.37 "Placing paper in the drawer"
Has all of the jammed paper removed?	Since the jammed paper may not be easily found, follow the guidance shown on the touch panel.	 P.267 "4.Jam Symbols"

Display does not change when buttons or icons are pressed

Item to be checked	Countermeasure	Reference page
Is the equipment in the energy saving mode (Automatic energy saving mode)?	Press the [ENERGY SAVER] or [START] button on the control panel to clear the mode. (It takes a while for the equipment to become ready.)	📖 P.33 “3.Energy Saving Mode”
Is the power OFF because the weekly timer functions?	Press the [START] button to return the power ON.	See the [User Function Guide]
Is the department code keyed in?	Key in the correct department code.	📖 P.29 “When controlling use of equipment with department codes”
Is the “Warming up” message displayed?	Wait until the equipment becomes ready.	📖 P.29 “Turning power on”

Functions cannot be set

Item to be checked	Countermeasure	Reference page
Are there functions that cannot be combined set together?	See the copying function combination and image quality adjustment combination matrices and set again.	📖 P.329 “4.Copying Function Combination Matrix”

Image density is too low

Item to be checked	Countermeasure	Reference page
Has the message “Install new toner cartridge” appeared on the screen?	Replace the toner cartridge.	📖 P.264 “Toner cover symbol”
Is the image density or background adjustment set lighter than standard?	Use the manual density buttons or the background adjustment function to adjust the image density properly.	📖 P.107 “6.Copy Density Adjustment”, 📖 P.110 “1.Background Adjustment”

Image density is too high

Item to be checked	Countermeasure	Reference page
Is the image density or background adjustment set darker than standard?	Use the manual density buttons or the background adjustment function to adjust the image density properly.	📖 P.107 “6.Copy Density Adjustment”, 📖 P.110 “1.Background Adjustment”

Images are stained

Item to be checked	Countermeasure	Reference page
Is the Reversing Automatic Document Feeder securely closed?	Close the cover or feeder properly to shut out any outer light.	📖 P.51 "2.Setting Originals"
Are the platen sheet, original cover and scanning area dirty?	Clean them up.	📖 P.316 "1.Daily Inspection"
Is the image density set properly?	Adjust the image density properly with the [AUTO] button or manual density buttons.	📖 P.107 "6.Copy Density Adjustment"
Are 2-sided originals used?	As the other side of the originals can be seen, adjust the image density properly (lighter) with the background adjustment function.	📖 P.110 "1.Background Adjustment"
Are originals with high transparency used?	Place a blank sheet of paper with originals of the same size or larger over the original.	📖 P.54 "Sheet originals"

Images are blurred

Item to be checked	Countermeasure	Reference page
Does the entire original lie properly on the surface of the glass?	Place the original on the glass, and then close the Reversing Automatic Document Feeder firmly.	-
Is the paper moist?	Replace it with new paper.	-

Copy images are partially missing

Item to be checked	Countermeasure	Reference page
Are the original size, direction and the reproduction ratio suitable for the paper size?	Select copy paper of the same size as the original, or set the reproduction ratio suitable for the paper size.	📖 P.72 "Automatic Paper Selection (APS)", 📖 P.77 "2.Enlargement and Reduction Copying"
Is the margin on the copy set properly?	Adjust the image shift value.	📖 P.114 "1.IMAGE SHIFT"



12. SPECIFICATIONS & OPTIONS

1. e-STUDIO520/600/720/850 Specifications	322
2. Specificatons of Options	326
3. Packing List.....	328
4. Copying Function Combination Matrix	329
• Combination Matrix 1/2	329
• Combination Matrix 2/2	330

1. e-STUDIO520/600/720/850 Specifications

Model name		DP-5200/6000/7200/8500
Type		Console type
Original glass		Fixed
Copying system		Indirect electrophotographic method
Developing system		2-component magnetic brush developing
Fixing method		Induction heating
Photoconductor type		OPC
Original scanning system		Flat surface scanning system (When the Reversing Automatic Document Feeder is used: Fixed scanning system by feeding the original)
Original scanning sensor		Linear CCD sensor
Scanning light source		Xenon lamp
Resolution	Scanning	600 dpi x 600 dpi
	Writing	2400 dpi x 600 dpi (smoothing process)
Acceptable originals		Sheets, books and three-dimensional objects
Acceptable original size		Max. LD
Acceptable copy paper size		Drawer: LD, LG, LT, LT-R, ST-R, COMP, 13" LG, 8.5" SQ, A3, A4, A4-R, A5-R, B4, B5, B5-R, FOLIO, 8K, 16K, 16K-R Bypass feeding: Paper size within 3.94" - 11.69" (Length), 5.83" - 17.01" (Width)
Acceptable paper weight		17 lb. Bond - 110 lb. Index (drawer and bypass feeding)
Warm-up time		Approx. 130 sec.
First copy time (LT)		e-STUDIO520/600/720 less than 4.0 sec., e-STUDIO850 less than 3.5 sec.
Continuous copying speed		See  P.324 "Continuous copying speed".
Multiple copying		Up to 9999 copies (digital key entry)
Excluded image width	Copy	Leading edge: 0.12±0.08", Trailing edge: 0.08±0.08", Both edges: 0.08±0.08"
	Printer	Leading edge: 0.20±0.08", Trailing edge: 0.20±0.08", Both edges: 0.20±0.08"
Reproduction ratio		Actual size: 100±0.5%
		Zoom: 25 - 400% (in 1% increments)
		For the reversing document feeder 25 - 200% (in 1% increments)
Paper supply		Drawer: 500 sheets (20 lb. Bond)
		Sheets bypass: 100 sheets (20 lb. Bond)
Toner Density adjustment		Magnetic auto-toner system
Environment (for normal use)		Temperature: 10 - 30°C, Humidity: 20 - 85% (No condensation)
Power requirements		115 V, 50/60 Hz, 16 A
Power consumption		2.0 kW
Dimensions (equipment only)		27.48" (W) x 31.06" (D) x 47.76" (H)

Weight (equipment only)	Approx. 463 lb.
Space occupied	55.16" (W) x 31.06" (D) (paper exit tray + bypass tray)
Storage capacity	Max. 2000 images (1 job) (Toshiba's own chart)

- This specification varies depending on the copying conditions and the environment.
- The paper mentioned above is Toshiba-recommended paper. Specifications and appearance are subject to change without notice in the interest of product improvement.

Continuous copying speed

sheets/min.

Paper type	Paper size	Feeder	e-STUDIO520		e-STUDIO600		e-STUDIO720		e-STUDIO850		
			Face up	Face down	Face up	Face down	Face up	Face down	Face up	Face down	
Plain paper (17 - 20 lb. Bond)	LT, ST-R, 8.5" SQ, A4, A5-R, B5	Drawer	52	52	60	60	72	72	85	85	
		Bypass	45	45	46	46	46	46	50	50	
	LT-R, A4-R, B5-R	Drawer	42	42	46	46	52	50	61	56	
		Bypass	37	37	38	38	38	38	42	42	
	LG, COMP, 13" LG, B4, FOLIO	Drawer	37	37	41	38	44	41	52	45	
		Bypass	32	32	34	34	34	34	38	38	
	LD, A3	Drawer	33	31	36	32	37	34	43	37	
		Bypass *1	28	28	30	30	30	30	34	34	
	Thick 1 (- 28 lb. Bond)	LT, ST-R, 8.5" SQ, A4, A5-R, B5	Drawer	52	52	60	60	72	72	85	85
			Bypass	45	45	46	46	46	46	50	50
LT-R, A4-R, B5-R		Drawer	42	42	46	46	52	50	61	56	
		Bypass	37	37	38	38	38	38	42	42	
LG, COMP, 13" LG, B4, FOLIO		Drawer	37	37	41	38	44	41	52	45	
		Bypass	32	32	34	34	34	34	38	38	
LD, A3		Drawer	33	31	36	32	37	34	43	37	
		Bypass *1	28	28	30	30	30	30	34	34	
Thick 2 (- 90 lb. Index)		LT, ST-R, 8.5" SQ, A4, A5-R, B5	Drawer	52	52	60	60	72	72	85	85
			Bypass	45	45	46	46	46	46	50	50
	LT-R, A4-R, B5-R	Drawer	42	42	46	46	52	50	61	56	
		Bypass	37	37	38	38	38	38	42	42	
	LG, COMP, 13" LG, B4, FOLIO	Drawer	37	37	41	38	44	41	52	45	
		Bypass	32	32	34	34	34	34	38	38	
	LD, A3	Drawer	33	31	36	32	37	34	43	37	
		Bypass *1	28	28	30	30	30	30	34	34	
	Thick 3 (- 110 lb. Index)	LT, ST-R, 8.5" SQ, A4, A5-R, B5	Drawer	52	52	60	60	65	65	72	72
			Bypass	45	45	46	46	46	46	46	46
LT-R, A4-R, B5-R		Drawer	42	42	46	46	50	48	52	50	
		Bypass	37	37	38	38	38	38	38	38	
LG, COMP, 13" LG, B4, FOLIO		Drawer	37	37	41	38	43	40	44	41	
		Bypass	32	32	34	34	34	34	34	34	
LD, A3		Drawer	33	31	36	32	37	34	37	34	
		Bypass *1	28	28	30	30	30	30	30	30	

- The bypass copying speed is as listed above when specifying the paper size; however when the paper size is not specified, the copy speed of all sizes is on '*1'.
- The values above are measured when originals are set on the original glass, 1-sided, 100% and non-sort multiple copies are made.
- "Face up" and "Face down" in the table mean the paper exit faces.
- This specification varies depending on the copying conditions and the environment.

Reversing Automatic Document Feeder

Copy sides	1-side, Duplex
Number of originals (LT)	100 originals or less than 0.63" in height (13 - 20 lb.)
Feeding speed	600 dpi: 71 sheets/min. 300/150 dpi: 83 sheets/min. 400/200 dpi: 79 sheets/min.
Acceptable originals	LD - ST-R, A3 - A5-R (ST and A5 are not acceptable)
Paper weight	13 - 34 lb. (1-sided original), 13 - 28 lb. (2-sided original)
Power source	Power supplied from the equipment

2. Specifications of Options

Finishers

Model name	MJ-1027		MJ-1028		
Type	Floor type				
Acceptable paper size	LD, LG, LT, LT-R, COMP, A3, A4, A4-R, B4, B5, FOLIO				
Acceptable paper weight	17 lb. Bond - 140 lb. Index				
Number of copies stapled at a time (MJ-1027, MJ-1028)			20 lb. Bond	24 lb. Bond	28 lb. Bond
	LT, A4, B5		50 sheets	30 sheets	30 sheets
	LD, LG, LT-R, COMP, A3, A4-R, B4, FOLIO		30 sheets	15 sheets	15 sheets
Stapling position	Rear, Front, Front diagonal, Double				
Saddle stitch unit	No		Yes		
Stitch capacity	LD, LT-R, A3, A4-R, B4				
			20 lb. Bond	24 lb. Bond	28 lb. Bond
			15 sheets	10 sheets	10 sheets
Hole Punch Unit	Optional				
Power source	Supplied from the copier				
Dimensions	24.25 (29.13")* (W) x 24.8" (D) x 40.28" (H)				
Weight	Approx. 94.8 lb.		Approx. 138.9 lb.		
Power consumption	170 W max.		170 W max.		

* The dimension values in parentheses are measured when the sub-tray is pulled out.

Tray loading capacity

Units of inches $\pm 0.28''$

Values in parentheses = the number of 20 lb. Bond sheets

Mode	Non-Sort		Sort/Group		Staples loaded	
					Mixed paper not loaded	Mixed paper loaded
Tray No.	1	2	1	2	1, 2	1, 2
ST-R, A5-R	5.5 (1000)	5.5 (1000)	-	-	-	-
B5-R	5.5 (1000)	5.5 (1000)	-	-	-	-
LT, A4, B5	9.8 (2000)	9.8 (2000)	9.8 (2000)	9.8 (2000)	Whichever of 4.3", 750 sheets or 100 copies is reached first	Whichever of 2.9", 500 sheets or 50 cop- ies is reached first
LD, LG, LT-R, COMP, A3, A4-R, B4, FOLIO	5.5 (1000)	5.5 (1000)	5.5 (1000)	5.5 (1000)	Whichever of 2.9", 500 sheets or 50 cop- ies is reached first	Whichever of 2.9", 500 sheets or 50 cop- ies is reached first

Hole Punch Unit

Paper weight: 17 lb. Bond - 140 lb. Index

	Number of punching holes and hole diameter	Available paper size
Japan and most of Europe (MJ-6003E)	2 holes (0.26" dia.)	LD, LG, LT, LT-R, COMP, A3, A4, A4-R, B4, B5, B5-R, FOLIO
North America (MJ-6003N)	2/3 holes switchable (0.32" dia.)	2 holes: LG, LT-R 3 holes: LD, LT, A3, A4
France (MJ-6003F)	4 holes (0.26" dia.; 3.15" pitch)	LD, LT, A3, A4
Sweden (MJ-6003S)	4 holes (0.26" dia.; 2.76" and 0.83" pitch)	LD, LG, LT-R, COMP, A3, A4, A4-R, B4, B5, B5-R, FOLIO

Inserter Unit

Model name	MJ-7001	
Type	Floor type	
Acceptable paper size	LD, LG, LT, LT-R, COMP, A3, A4, A4-R, B4, B5, FOLIO	
Acceptable paper weight	17 lb. Bond - 140 lb. Index	
Maximum capacity	17 - 20 lb. Bond	140 lb. Index
	100 sheets	Height: approx. 0.47"
	* Special paper: 60% less than above	
Power source	Supplied from the equipment	
Dimensions	21.0" (W) x 24.1" (D) x 42.2" (H)	
Weight	Approx. 6.2 lb.	
Power consumption	99 W max.	

External Large Capacity Feeder

Model name	MP-4004L
Type	Floor type
Acceptable paper size	LT
Acceptable paper weight	17 lb. Bond - 110 lb. Index
Maximum capacity	4000 sheets (20 lb. Bond)
Power source	Supplied from the copier
Dimensions	12.8" (W) x 23.6" (D) x 24.3" (H)
Weight	Approx. 88.2 lb.
Power consumption	27 W max.

- The paper mentioned above is Toshiba-recommended paper. Specifications and appearance are subject to change without notice in the interest of product improvement.

3. Packing List

Packing list	Set-up instructions
	Set-up report
	Photoconductive drum
	Operator's Manual pocket
	Tray spacer of Reversing Automatic Document Feeder
	Tab paper back guide
	Warranty Sheet
	Cleaning cloth
	Cleaning cloth pocket

Combination Matrix 2/2

	2N1/4N1 (2-1 Split)		2N1/4N1 (1-1 Simplex)		Image shift	Edge erase	Book - Robot	Image direction	SADF	Mixed original sizes	Rotate 90° ¹	Saddle stitch	Hole punch	Magazine saddle stitch	Magazine sort	Staple sort	Group	Sort	Non-sort/Non-staple	Book-2 Duplex	5-2 Split	1-2 Duplex	1-1 Simplex
	2N1 (2-1 Split)	4N1 (1-1 Simplex)	2N1 (2-1 Split)	4N1 (1-1 Simplex)																			
1-1 Simplex	3	YES	3	YES	YES	YES	3	YES	YES	YES	3	3	YES	3	YES	YES	YES	YES	YES	--	--	--	
1-2 Duplex	3	3	3	3	YES	YES	3	YES	YES	YES	3	3	YES	3	YES	YES	YES	YES	YES	--	--	--	
2-1 Split	YES	3	YES	3	YES	YES	3	YES	YES	YES	3	3	YES	3	YES	YES	YES	YES	YES	--	--	--	
2-2 Duplex	NO	NO	NO	NO	YES	YES	NO	YES	NO	NO	3	3	YES	3	YES	YES	YES	YES	YES	--	--	--	
Book-2	YES	YES	YES	YES	YES	YES	YES	YES	YES	YES	--	--	YES	--	--	--	--	--	YES	--	--	--	
Non-sort/Non-staple	YES	YES	YES	YES	YES	YES	YES	YES	YES	YES	--	--	YES	--	--	--	--	--	YES	--	--	--	
Sort	YES	YES	YES	YES	YES	YES	YES	YES	YES	YES	--	--	YES	--	--	--	--	--	YES	--	--	--	
Group	YES	YES	YES	YES	YES	YES	YES	YES	YES	YES	--	--	YES	--	--	--	--	--	YES	--	--	--	
Magazine sort	NO	NO	NO	NO	NO	NO	NO	YES	NO	YES	NO	NO	NO	NO	NO	NO	NO	NO	NO	NO	NO	NO	
Magazine sort & Saddle stitch	YES	YES	YES	YES	YES	YES	YES	YES	YES	YES	NO	NO	NO	NO	NO	NO	NO	NO	NO	NO	NO	NO	
Hole punch	NO	NO	NO	NO	NO	NO	NO	NO	NO	NO	NO	NO	NO	NO	NO	NO	NO	NO	NO	NO	NO	NO	
Saddle stitch	NO	NO	NO	NO	NO	NO	NO	YES	YES	YES	NO	NO	NO	NO	NO	NO	NO	NO	NO	NO	NO	NO	
Route sort ¹	YES	YES	YES	YES	YES	YES	YES	YES	YES	YES	YES	YES	YES	YES	YES	YES	YES	YES	YES	YES	YES	YES	
Mixed original sizes	NO	NO	NO	NO	NO	NO	NO	NO	NO	NO	NO	NO	NO	NO	NO	NO	NO	NO	NO	NO	NO	NO	
SADF	YES	YES	YES	YES	YES	YES	YES	YES	YES	YES	YES	YES	YES	YES	YES	YES	YES	YES	YES	YES	YES	YES	
Image direction	3	3	3	3	YES	YES	YES	YES	YES	YES	YES	YES	YES	YES	YES	YES	YES	YES	YES	YES	YES	YES	
Book - Tablet	NO	NO	NO	NO	NO	NO	NO	NO	NO	NO	NO	NO	NO	NO	NO	NO	NO	NO	NO	NO	NO	NO	
Edge erase	YES	YES	YES	YES	YES	YES	YES	YES	YES	YES	YES	YES	YES	YES	YES	YES	YES	YES	YES	YES	YES	YES	
Image shift	YES	YES	YES	YES	YES	YES	YES	YES	YES	YES	YES	YES	YES	YES	YES	YES	YES	YES	YES	YES	YES	YES	
2N1 (1-1 Simplex)	--	--	--	--	--	--	--	--	--	--	--	--	--	--	--	--	--	--	--	--	--	--	
2N1 (2-1 Split)	--	--	--	--	--	--	--	--	--	--	--	--	--	--	--	--	--	--	--	--	--	--	
4N1 (1-1 Simplex)	--	--	--	--	--	--	--	--	--	--	--	--	--	--	--	--	--	--	--	--	--	--	
4N1 (2-1 Split)	--	--	--	--	--	--	--	--	--	--	--	--	--	--	--	--	--	--	--	--	--	--	
2N1 (1-2 Duplex)	--	--	--	--	--	--	--	--	--	--	--	--	--	--	--	--	--	--	--	--	--	--	
2N1 (2-2 Duplex)	--	--	--	--	--	--	--	--	--	--	--	--	--	--	--	--	--	--	--	--	--	--	
4N1 (1-2 Duplex)	--	--	--	--	--	--	--	--	--	--	--	--	--	--	--	--	--	--	--	--	--	--	
4N1 (2-2 Duplex)	--	--	--	--	--	--	--	--	--	--	--	--	--	--	--	--	--	--	--	--	--	--	
Book center erase																							
Xy zoom																							
Dual page																							
Mirror																							
Trim																							
Mark																							
Negative																							
Top blank																							
Top copied																							
Both blank																							
Top copied back blank																							
Blank																							
Copied																							
Copy on tab																							
Blank tab insert																							
Copied tab insert																							
Front cover																							
Front & Back cover																							
Sheet insert																							
Job build																							
Copy & File																							
Store to e-File																							

¹ Valid only for the equipment without the Finisher (optional).
² The data stored into the file are the same as the ones for simplex copying.
³ The function set later will be valid.
⁴ The setting cannot be changed from 2nd job or later.

INDEX

Numerics

1-sided original -> 1-sided copy	97, 98
1-sided original -> 2-sided copy	97, 99
2IN1 / 4IN1	126
2-sided original -> 1-sided copy	97, 101
2-sided original -> 2-sided copy	97, 100

A

ACCESS button	24
address book	244
ADF	154
Adjusting the contrast of the touch panel	27
AMS	77
APS	72
Auto job start	59
Automatic copy density mode	107
Automatic function clear	27
Automatic Magnification Selection (AMS)	77
Automatic Paper Selection (APS)	72
AUTOMATIC START	198, 205

B

Background adjustment	110
BLANK	141
BLANK TAB INSERT	157
Blinking graphic symbols	262
BOOK - TABLET	152
BOOK CENTER ERASE	121
Book-type original -> 2-sided copy	97, 102
Book-type originals	55
BOTH BLANK	138
Bottom margin	114
Bypass copying	
Bypass copying	63
Non-standard size paper	68
Standard size paper	64
Bypass cover	20
Bypass tray	20, 63, 272

C

Call service symbol	288
Canceling the energy saving mode	33
Caution	11
Changing data of user boxes	176
Changing the data of a template	209
Changing the data of a user group	206
Changing the setting of paper size	40
Cleaning	316
CLEAR button	24
Clearing functions selected	27
Clearing the drawer for special uses	45
Configuration of options	21
Confirming and canceling auto job	60
Confirming job history in log list	240
Confirming print job status	225
Confirming scan job status	238
Continuing printing after proof printing	230

Continuous feed mode	57, 154
Control panel	20, 23
COPIED	141
COPIED TAB INSERT	157
COPY button	23
Copy density adjustment	107
COPY ON TAB	157
Copy paper types and sizes	35
Copying Function Combination Matrix	329
Copying mixed-size originals in one go	75
Copying procedure	48
COVER SHEET	138
Creating user boxes	174
Currently selected drawer size	25

D

Daily inspection	316
Date and time	25
Deleting a template	219
Deleting a user group	218
Deleting folders or documents	190
Deleting invalid print jobs	237
Deleting print jobs	226
Deleting private print jobs	234
Deleting proof print jobs	231
Deleting user boxes	179
Density adjustment buttons	25
Department codes	29, 235
Description of each component	20
Digital keys	24
Disclaimer notice	18
Displaying invalid queues	235
Displaying private print job list	232
Displaying proof print job list	229
Drawer display on the touch panel	263
Drawer for special uses	42
Drawers	20
DUAL PAGE	123
Duplex copying	97

E

EDGE ERASE	120
EDITING	131
e-Filing	172
e-FILING button	23
ENERGY SAVER button	24, 31, 33
Energy saving mode	33
Enlargement and reduction copying	77
Enlargement/Reduction (Zoom...) button	25
Equipment status indication area	25
Error code	250, 262
ERROR lamp	24
Exit cover	20
EXTENSION button	23
External Large Capacity Feeder	21, 272, 327

F	
FAX button	23
Features	9
File Downloader	172
Finisher	21, 83, 274, 326
Finisher button	25
Finishing modes and finishers	83
Folder	190
FRONT & BACK COVER	167
FRONT COVER	167
Front cover	20
FUNCTION CLEAR button	24
Function setting area	25
G	
General copying procedures	48
General precautions	
During maintenance or inspection	16
General precautions	10
When handling supplies	17
When installing or moving	10
When using the multifunctional digital systems	13
Group copying	83, 85
H	
Handling and storing paper	36
HELP button	23
Hole punch	83, 93
Hole Punch Unit	21, 83, 84, 327
I	
IMAGE DIRECTION	150
IMAGE SHIFT	114
Index buttons	25
Initial (default) settings	48
INSERTER	167
Inserter mode	95
Inserter Unit	21, 83, 84, 95, 138, 141, 167, 327
INTERRUPT button	23
Interrupt copying	61
J	
Jam symbols	267
JOB BUILD	146
Job preset	59
Job status	224
JOB STATUS button	23
K	
K format	51
Keying in correct department code to print	236
L	
Left margin	114
Log list	239
M	
MAGAZINE SORT	129
Magazine sort	83
Magazine sort & Saddle stitch	83, 90
Manual copy density mode	108
Manual paper selection	74
Margin	114, 116, 118
Masking	131
Maximum number of sheets	53
Maximum number of sheets for stapling	89
MEMORY RX / FAX communication lamps	23
Message	25
Message display	25
Mirror image	134
MONITOR/PAUSE button	24
Moving print jobs	227
N	
Negative/Positive reversal	135
Notice to users	5
O	
One-touch zoom buttons	81
Operator's Manual pocket	20
Original cover	20
Original glass	20
Original mode	106
Original mode button	25
Original scale	20
Original stopper	52
Originals sizes and types	51
P	
Packing list	328
PAGE NUMBER	144
Paper feed cover	20
Paper misfeed	274
Paper selection	72
Paper size indicator	20
Paper source selection buttons	25
Paper type	42
Pausing print jobs	227
Placing originals on the glass	54
Placing paper in the drawer	37
Power switch	20
Preface	8
PRINT DATA lamp	24
Print jobs	226
Print log	240
Print status display	247
Printing journals	246
Printing private print jobs	233
Printing stored documents	185
Private print jobs	232
Procedure of clearing a paper jam	267
Proof print jobs	229
Public box	172

Public group	213
Public template group	195

R

Recalling templates	213
Receive log	242
Recommended paper	36
Registering a template in the public template group	195
Registering a template in the user group	201
Registering into address book from log lists ...	244
Registering non-standard size in the memory ..	70
Registering the new user group	199
Releasing print job errors	247
Remaining paper level	25
Replace toner bag symbol	266
Reproduction ratio	25
Reversing Automatic Document Feeder	20, 56, 269
Right margin	114
Rotate sort	83, 87

S

Saddle stitch	
Available conditions	92
Saddle stitch	83
Saddle Stitch Finisher	21, 83
Saddle stitch tray	84
Saddle stitch unit	84
SADF	154
SCAN button	23
Scan log	243
Scanning area	20
Send log	241
Separating/Installing and moving of the External Large Capacity Feeder	269
Separating/Installing and moving the finishing device	268
Set functions confirmation (SETTINGS) button	25
Setting copy paper	34
Setting letters	28
Setting originals	51
Setting paper in the External Large Capacity Feeder	45
Setting tab paper in the drawer	158
Setting the staple sort mode	88
Setting the tab width	160
Sharpness	111
SHEET INSERT	167
SHEET INSERTION	141
Sheet originals	54
Shutdown	30
Simplex / duplex button	25
Single feed mode	58, 155
Sort copying	83, 85

Specifications

e-STUDIO520/600/720/850	322
Options	326
Specifying both original size and copy size separately	78
Staple sort	83, 88
START button	24
STOP button	24
Stopping copy operation	62
Storing documents in e-Filing	181
Sub-tray	84

T

TAB PAPER	157
Tab paper back guide	158
Tab paper copying	162
Tab paper insertion	163
Tab paper insertion and copying	165
Template	194
TEMPLATE button	24
Test printing	186
TIME STAMP	143
Toner cartridge	20
Toner cartridge holder	20
Toner cartridge symbol	266
Toner cover	20
Toner cover symbol	264
TOP BLANK	138
TOP COPIED	138
TOP COPIED BACK BLANK	138
Top margin	114
TopAccess	172
Total copy quantity	25
Touch panel	20, 24, 25
Touch panel contrast adjustment volume ...	20, 23
Touch-buttons	25
Transfer/Transport unit	20
Tray	84
Trimming	131
Troubleshooting	
Copy images are partially missing	319
Display does not change when buttons or icons are pressed	318
Equipment does not start	317
Functions cannot be set	318
Image density is too high	318
Image density is too low	318
Images are blurred	319
Images are stained	319
Paper jamming occurs frequently	317
Turning power on	29
TWAIN driver	172
Type of finishing mode	83

U

Upper cover	84
User box	172, 174
USER FUNCTIONS button	24
User group	201, 215

W

Warning	10
---------------	----

X

XY ZOOM	136
---------------	-----

Z

Zoom buttons	81
--------------------	----

MULTIFUNCTIONAL DIGITAL SYSTEMS
Operator's Manual for Basic Function

e-STUDIO520/600/720/850



TOSHIBA TEC CORPORATION

2-17-2, HIGASHIGOTANDA, SHINAGAWA-KU, TOKYO, 141-8664, JAPAN



Printed on 100% Recycled Paper

Free Manuals Download Website

<http://myh66.com>

<http://usermanuals.us>

<http://www.somanuals.com>

<http://www.4manuals.cc>

<http://www.manual-lib.com>

<http://www.404manual.com>

<http://www.luxmanual.com>

<http://aubethermostatmanual.com>

Golf course search by state

<http://golfingnear.com>

Email search by domain

<http://emailbydomain.com>

Auto manuals search

<http://auto.somanuals.com>

TV manuals search

<http://tv.somanuals.com>