

**Toshiba Personal Computer  
Satellite R20 / TECRA M7  
Maintenance Manual**

**TOSHIBA CORPORATION**

**File Number 960-572**

*[CONFIDENTIAL]*

## **Copyright**

© 2006 by Toshiba Corporation. All rights reserved. Under the copyright laws, this manual cannot be reproduced in any form without the prior written permission of Toshiba. No patent liability is assumed, with respect to the use of the information contained herein.

Toshiba Satellite R20/TECRA M7 Maintenance Manual

First edition June 2006

## **Disclaimer**

This manual has been validated and reviewed for accuracy. The instructions and descriptions it contains are accurate for the Toshiba Satellite R20/TECRA M7 at the time of this manual's production. However, succeeding computers and manuals are subject to change without notice. Toshiba assumes no liability for damages incurred directly or indirectly from errors, omissions or discrepancies between the computer and the manual.

## **Trademarks**

IBM is a registered trademark and IBM PC is a trademark of International Business Machines Corporation.

Intel, Intel SpeedStep, Intel Core, Celeron and Centrino are trademarks or registered trademarks of Intel Corporation.

Windows and Microsoft are registered trademarks of Microsoft Corporation.

Photo CD is a trademark of Eastman Kodak.

Bluetooth is a trademark owned by its proprietor and used by TOSHIBA under license.

Memory Stick and i.LINK are trademark and registered trademark of Sony Corporation.

Other trademarks and registered trademarks not listed above may be used in this manual.

---

## Preface

---

This maintenance manual describes how to perform hardware service maintenance for the Toshiba Personal Computer Satellite R20/TECRA M7, referred to as Satellite R20/TECRA M7 in this manual.

The procedures described in this manual are intended to help service technicians isolate faulty Field Replaceable Units (FRUs) and replace them in the field.

### SAFETY PRECAUTIONS

Four types of messages are used in this manual to bring important information to your attention. Each of these messages will be italicized and identified as shown below.

***DANGER:*** “Danger” indicates the existence of a hazard that could result in death or serious bodily injury, if the safety instruction is not observed.

***WARNING:*** “Warning” indicates the existence of a hazard that could result in bodily injury, if the safety instruction is not observed.

***CAUTION:*** “Caution” indicates the existence of a hazard that could result in property damage, if the safety instruction is not observed.

***NOTE:*** “Note” contains general information that relates to your safe maintenance service.

Improper repair of the computer may result in safety hazards. Toshiba requires service technicians and authorized dealers or service providers to ensure the following safety precautions are adhered to strictly.

- ❑ Be sure to fasten screws securely with the right screwdriver. Be sure to use the PH Point size “0” and “1” screwdrivers complying with the ISO/DIS 8764-1:1996. If a screw is not fully fastened, it could come loose, creating a danger of a short circuit, which could cause overheating, smoke or fire.
- ❑ If you replace the battery pack or RTC battery, be sure to use only the same model battery or an equivalent battery recommended by Toshiba. Installation of the wrong battery can cause the battery to explode.

The manual is divided into the following parts:

- Chapter 1      Hardware Overview describes the Satellite R20/TECRA M7 system unit and each FRU.
- Chapter 2      Troubleshooting Procedures explains how to diagnose and resolve FRU problems.
- Chapter 3      Test and Diagnostics describes how to perform test and diagnostic operations for maintenance service.
- Chapter 4      Replacement Procedures describes the removal and replacement of the FRUs.
- Appendices    The appendices describe the following:
  - Handling the LCD module
  - Board layout
  - Pin assignment
  - Keyboard scan/character codes
  - Key layout
  - Wiring Diagrams
  - BIOS Rewrite Procedures
  - EC/KBC Rewrite Procedures
  - Reliability

## Conventions

This manual uses the following formats to describe, identify, and highlight terms and operating procedures.

### *Acronyms*

On the first appearance and whenever necessary for clarification acronyms are enclosed in parentheses following their definition. For example:

Read Only Memory (ROM)

### *Keys*

Keys are used in the text to describe many operations. The key top symbol as it appears on the keyboard is printed in **boldface** type.

### *Key operation*

Some operations require you to simultaneously use two or more keys. We identify such operations by the key top symbols separated by a plus (+) sign. For example, **Ctrl + Pause (Break)** means you must hold down **Ctrl** and at the same time press **Pause (Break)**. If three keys are used, hold down the first two and at the same time press the third.

### *User input*

Text that you are instructed to type in is shown in the boldface type below:

**DISKCOPY A: B:**

### *The display*

Text generated by the TECRA M7/Sattellite R20 that appears on its display is presented in the type face below:

```
Format complete
System transferred
```

---

# Table of Contents

---

## Chapter 1 Hardware Overview

1.1	Features .....	1-1
1.2	System block diagram.....	1-8
1.3	2.5-inch Hard Disk Drive.....	1-14
1.4	Optical Drive.....	1-17
1.5	Keyboard.....	1-25
1.6	TFT Color Display .....	1-26
1.7	Power Supply .....	1-28
1.8	Batteries .....	1-31
1.9	AC Adapter .....	1-34

## Chapter 2 Troubleshooting Procedures

2.1	Troubleshooting .....	2-1
2.2	Troubleshooting Flowchart.....	2-2
2.3	Power Supply Troubleshooting.....	2-6
2.4	System Board Troubleshooting.....	2-16
2.5	USB 3.5" FDD Troubleshooting.....	2-32
2.6	2.5" HDD Troubleshooting.....	2-35
2.7	Keyboard Troubleshooting .....	2-40
2.8	Display Troubleshooting.....	2-41
2.9	Touch Pad Troubleshooting.....	2-43
2.10	Optical Drive Troubleshooting .....	2-44
2.11	Modem Troubleshooting.....	2-45
2.12	Bluetooth Troubleshooting .....	2-47
2.13	LAN Troubleshooting .....	2-49
2.14	Sound Troubleshooting.....	2-50
2.15	Bridge media Slot Troubleshooting .....	2-51
2.16	Tablet Pen Troubleshooting.....	2-52
2.17	Wireless LAN Troubleshooting.....	2-54
2.18	Fingerprint sensor Troubleshooting.....	2-56

## Chapter 3 Tests and Diagnostics

3.1	The Diagnostic Test .....	3-1
3.2	Executing the Diagnostic Test .....	3-4
3.3	Setting of the hardware configuration.....	3-8
3.4	Heatrun Test.....	3-11
3.5	Subtest Names.....	3-12
3.6	System Test.....	3-14
3.7	Memory Test.....	3-16
3.8	Keyboard Test.....	3-17
3.9	Display Test .....	3-18
3.10	Floppy Disk Test.....	3-21
3.11	Printer Test.....	3-23
3.12	Async Test .....	3-25
3.13	Hard Disk Test .....	3-26
3.14	Real Timer Test.....	3-29
3.15	NDP Test.....	3-31
3.16	Expansion Test.....	3-32
3.17	CD-ROM/DVD-ROM Test .....	3-34
3.18	Error Code and Error Status Names.....	3-35
3.19	Hard Disk Test Detail Status.....	3-38
3.20	Only One Test .....	3-40
3.21	Head Cleaning.....	3-49
3.22	Log Utilities .....	3-50
3.23	Running Test.....	3-52
3.24	Floppy Disk Drive Utilities.....	3-53
3.25	System Configuration .....	3-58
3.26	Wireless LAN Test Program (Intel-made b/g).....	3-60
3.27	Wireless LAN Test Program (Intel-made a/b/g).....	3-64
3.28	Wireless LAN Test Program (Atheros) .....	3-69
3.29	LAN/Modem/Bluetooth/IEEE1394 Test Program .....	3-76
3.30	Sound Test Program.....	3-90
3.31	SETUP .....	3-96

## Chapter 4 Replacement Procedures

4.1	Overview.....	4-1
4.2	Battery pack .....	4-8
4.3	Reserve pen.....	4-10
4.4	Tablet PC pen.....	4-11
4.5	PC card/Bridge media.....	4-12
4.6	MDC/USIM card .....	4-14
4.7	HDD .....	4-16
4.8	Keyboard.....	4-20
4.9	Memory module.....	4-23
4.10	SW membrane.....	4-26
4.11	Optical disk drive.....	4-28
4.12	Cover assembly and Base assembly .....	4-31
4.13	Base latch.....	4-35
4.14	Touch pen case/Battery lock.....	4-36
4.15	Bluetooth module.....	4-37
4.16	Wireless LAN card .....	4-39
4.17	Microphone/Front panel.....	4-41
4.18	Modem jack/USB board/DC-IN jack.....	4-43
4.19	RTC battery.....	4-46
4.20	System board.....	4-48
4.21	GPU heat sink .....	4-50
4.22	Fan/Heat sink/CPU .....	4-52
4.23	Sensor board.....	4-56
4.24	Speaker.....	4-57
4.25	Touch pad.....	4-59
4.26	LCD mask .....	4-61
4.27	Fingerprint sensor board .....	4-65
4.28	Switch board .....	4-66
4.29	LCD unit/FL inverter .....	4-67
4.30	Digitizer .....	4-71
4.31	LCD latch assembly .....	4-78



4.32	Hinge assembly .....	4-79
4.33	Fluorescent Lamp.....	4-82

## Appendices

Appendix A	Handling the LCD Module .....	A-1
Appendix B	Board Layout .....	B-1
Appendix C	Pin Assignment .....	C-1
Appendix D	Keyboard Scan/Character Codes .....	D-1
Appendix E	Key Layout.....	E-1
Appendix F	Wiring Diagrams.....	F-1
Appendix G	BIOS Rewrite Procedures .....	G-1
Appendix H	EC/KBC Rewrite Procedures.....	H-1
Appendix I	Reliability.....	I-1



---

# Chapter 1

## Hardware Overview

---



---

## Chapter 1 Contents

---

1.1	Features.....	1-1
1.2	System block diagram.....	1-8
1.3	2.5-inch Hard Disk Drive.....	1-14
1.4	Optical Drive.....	1-17
	1.4.1 DVD-ROM Drive.....	1-17
	1.4.2 DVD-ROM & CD-R/RW Drive .....	1-19
	1.4.3 DVD Super Multi Drive .....	1-22
1.5	Keyboard.....	1-25
1.6	TFT Color Display .....	1-26
	1.6.1 LCD Module .....	1-26
	1.6.2 FL Inverter Board.....	1-27
1.7	Power Supply .....	1-28
1.8	Batteries .....	1-31
	1.8.1 Main Battery.....	1-31
	1.8.2 Battery Charging Control.....	1-32
	1.8.3 RTC Battery .....	1-33
1.9	AC Adapter .....	1-34

**Figures**

Figure 1-1 Front of the computer..... 1-6  
Figure 1-2 System units configuration ..... 1-7  
Figure 1-3 System block diagram..... 1-8  
Figure 1-4 2.5-inch HDD..... 1-14  
Figure 1-5 DVD-ROM drive ..... 1-17  
Figure 1-6 DVD-ROM & CD-R/RW drive ..... 1-19  
Figure 1-7 DVD Super Multi drive ..... 1-22  
Figure 1-8 Keyboard..... 1-25  
Figure 1-9 LCD module..... 1-26

**Tables**

Table 1-1 2.5-inch HDD Specifications ..... 1-14  
Table 1-2 DVD-ROM drive outline dimensions ..... 1-17  
Table 1-3 DVD-ROM drive specifications ..... 1-18  
Table 1-4 DVD-ROM & CD-R/RW drive outline dimensions..... 1-19  
Table 1-5 DVD-ROM & CD-R/RW drive specifications ..... 1-20  
Table 1-6 DVD Super Multi drive outline dimensions ..... 1-22  
Table 1-7 DVD Super Multi drive specifications ..... 1-23  
Table 1-8 LCD module specifications (14.1 TFT)..... 1-26  
Table 1-9 FL inverter board specifications ..... 1-27  
Table 1-10 Power supply output specifications ..... 1-29  
Table 1-11 Battery specifications..... 1-31  
Table 1-12 Time required for charges of main battery ..... 1-32  
Table 1-13 Data preservation time ..... 1-32  
Table 1-14 RTC battery charging/data preservation time ..... 1-33  
Table 1-15 AC adapter specifications ..... 1-34

## 1.1 Features

The Satellite R20/TECRA M7 is an ultra thin and lightweight tablet PC realizing cable-less environment on a table by wireless function with an Intel® Core™ Duo/Solo or Intel® Celeron® M processor realizing high performance.

There some models and options. Refer to the Parts List for the configuration of each model and option.

### ❑ Microprocessor

Microprocessor that is used will be different of the model.

The PC comes in with one of the following speeds:

#### • Intel® Core™ Duo

- Core™ Duo 1.60GHz (Processor Number : T2050)
- 1.66GHz (Processor Number : T2300E)
- 1.66GHz (Processor Number : T2300)
- 1.73GHz (Processor Number : T2250)
- 1.83GHz (Processor Number : T2400)
- 2.00GHz (Processor Number : T2500)
- 2.16GHz (Processor Number : T2600)
- 2.33GHz (Processor Number : T2700)

#### • Intel® Core™ Solo

- Core™ Solo 1.66GHz (Processor Number : T1300)
- 1.83GHz (Processor Number : T1400)
- 1.86GHz (Processor Number : T1350)

#### • Intel® Celeron® M

- Celeron® M 1.60GHz (Processor Number : 420)
- 1.73GHz (Processor Number : 430)

### ❑ Chipset

Equipped with Intel 945GM or 945PM as North Bridge, Intel ICH7-M as South Bridge and Texas Instrument PCI7412ZHK as Card Controller.

### ❑ VGA Controller

An internal Graphics Controller in North Bridge or an nVIDIA Quadro NVS 110M is used.

Memory

Two DDR2 SO-DIMM slots support DDR2 533 or DDR2 667. Memory modules can be installed to a maximum of 4GB (4,096MB). Memory modules of 256MB, 512MB, 1GB and 2GB sizes are available.

 HDD

The computer has a 2.5-inch SATA HDD. The following capacities are available.

- 40/60/80/100/120GB

 Optical disk drive

DVD-ROM drive, DVD-ROM&CD-R/RW drive or DVD Super Multi drive (double layer) can be installed.

 USB FDD

A 3.5 inch USB FDD supports 720KB/1.44MB formats.

 Display

The display swivels automatically 0/90/180/270 degrees by display driver. LCD and External monitor can be displayed at the same time.

LCD : Built-in 14.1 inch, 16M colors, WXGA+ (1,440×900 dots), thin type low temperature poly-silicon TFT color display.

External monitor : Supported via an RGB connector.

DVI : Supported by a TOSHIBA Express Port Replicator. (Only in TECRA M7)

 Digitizer

A digitizer is installed at the rear of LCD unit. The supplied tablet pen enables pen computing.

 Tablet pen / Reserve pen

The Tablet pen / Reserve pen can be used as a mouse by touching the display softly with the pen tip. Tablet button on the side of the pen corresponds to the right click of the mouse. Erase button on the pen tail can be used as an eraser depending on the application.

 Keyboard

The keyboard has 85(US)/87(UK) keys and supports Windows key and Hot key.



Touch pad

A touch pad is installed as a pointing device.

 Batteries

The computer has three batteries: a rechargeable Lithium-Ion main battery pack, a rechargeable Lithium-Ion secondary battery pack (Provided with some models or option) and an RTC battery (that backs up the Real Time Clock and CMOS memory).

 USB (Universal Serial Bus)

Four USB ports are usable. The ports comply with the USB2.0 standard, which enables data transfer speeds 40 times faster than USB1.1 standard. USB1.1 is also supported.

 PC card slot

The PC card slot (PCMCIA) accommodates one 5mm Type II card. (Based on PC Card Standard, supporting CardBus)

 Bridge media slot

The Bridge media slot supports one SD memory card/SDIO card/Memory stick/Memory stick PRO/xD picture card/MultiMediaCard slot. Data can be read and written by inserting each media to the slot.

 Sound system

The sound system is equipped with the following features:

- Built-in stereo speakers
- Built-in monaural microphone
- Stereo Headphone jack
- External microphone jack
- Digital volume
- VoIP (Receiving)

Switch/Button

The following switches and buttons are equipped.

## Satellite R20/TECRA M7

- Windows-Security button
- Escape/Rotation button
- Cross Function button
- Wireless communication switch
- Power on switch

## Satellite R20

- Internet button
- Mail button
- CD/DVD button
- Play button
- Stop button
- Rewind button
- Fast forward button

## TECRA M7

- Presentation button
- Toshiba Assist button
- General 1 button
- General 2 button

 Internal Modem

The internal modem is equipped as a modem daughter card (MDC).

The internal modem provides capability for data and fax communication and supports ITU-T V.90 standard. For data reception it operates at 56Kbps and for data transmission it operates at 33.6Kbps. For fax transmission, it operates at 14,4Kbps. The speed of data transfer and fax depends on analog telephone line condition. It has an RJ11 modem jack for connecting to a telephone line.

 LAN

The computer has built-in support for Ethernet LAN (10 megabits per second, 10BASE-T), Fast Ethernet LAN (100 megabits per second, 100BASE-TX) and Gigabit Ethernet LAN (1000 megabits per second, 1000BASE-T). Some models are not equipped with a Gigabit Ethernet LAN.

Wireless LAN

The computer is equipped with PCI Express Mini Card type wireless LAN card that supports 802.11 b/g or 802.11 a/b/g in the PCI Express MiniCard slot. This function can be switched on and off by a switch on the computer.

i.LINK (IEEE1394)

This port enables high-speed data transfer directly from external devices such as digital video cameras.

Docking port

TOSHIBA Express Port Replicator can be connected through docking port on the bottom.

Bluetooth

The computer is equipped with Bluetooth (V2.0) communications standard that enables wireless connection between electronic devices such as computers and printers. It supports wireless communication switch.

Fingerprint sensor

The computer is equipped with a fingerprint sensor and fingerprint authentication utility. They enable only person who has registered his/her fingerprint to use the computer.

Figure 1-1 shows the front of the computer and Figure 1-2 shows the system units configuration.

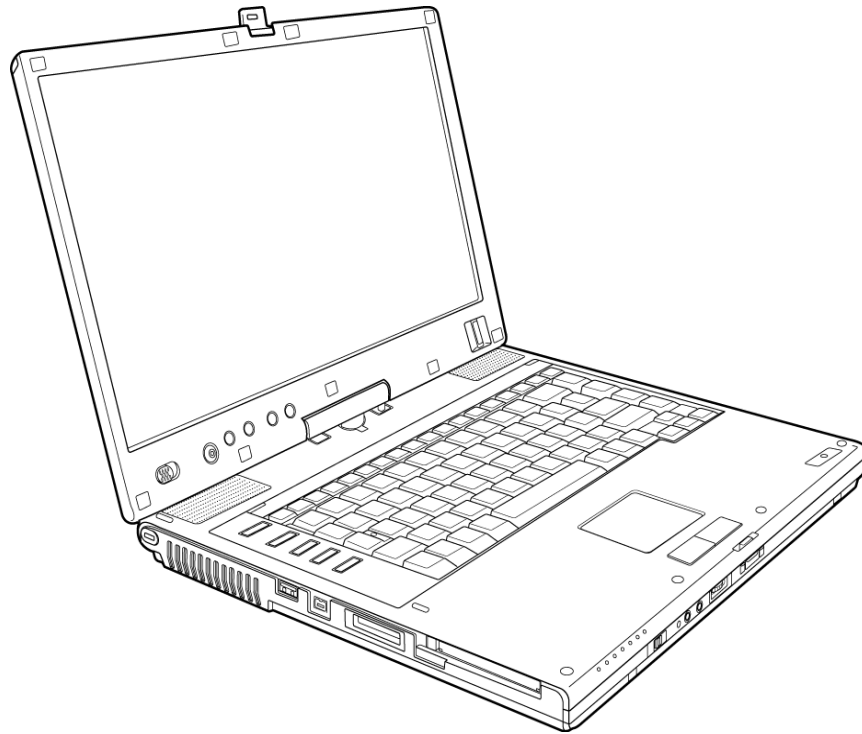

*Figure 1-1 Front of the computer*

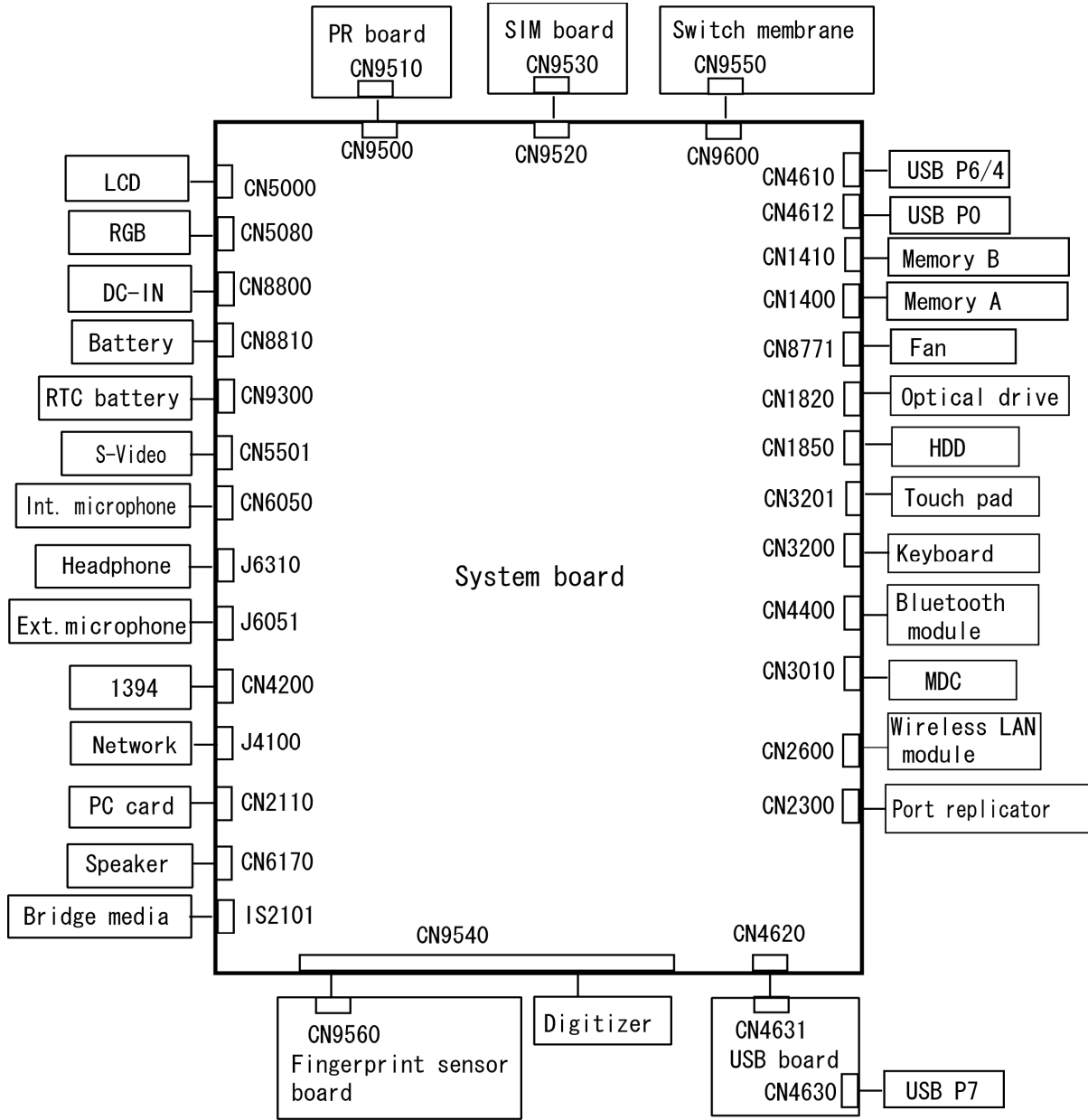

Figure 1-2 System units configuration

## 1.2 System block diagram

Figure 1-3 shows the system block diagram.

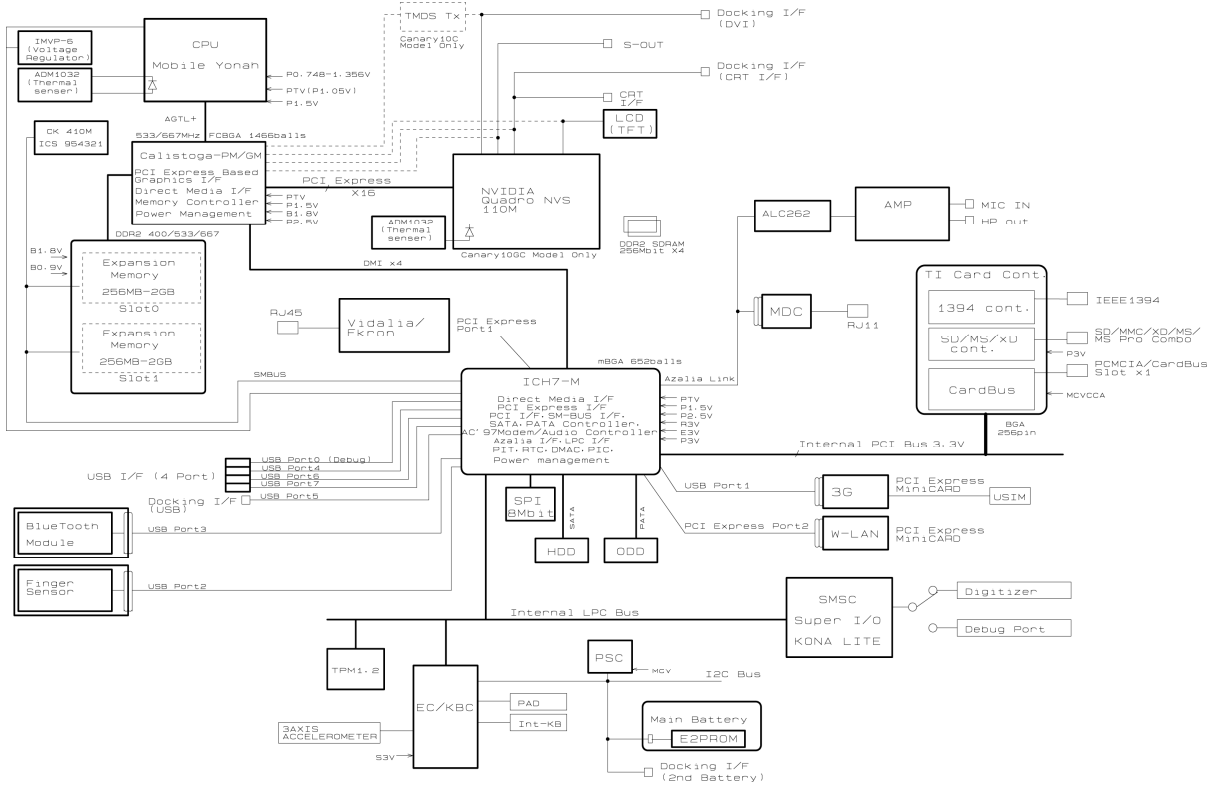

Figure 1-3 System block diagram

The PC contains the following components.

❑ Processor

Intel® Core™ Duo Processor (dual core) or Intel® Core™ Solo Processor (single core)

• Core speed:

Dual core: 1.60GHz (T2050)/1.66GHz (T2300E)/1.66GHz (T2300)/  
1.73GHz(T2250)/1.83GHz (T2400)/2.00GHz (T2500)/  
2.16GHz(T2600)/ 2.33GHz (T2700)

Single core: 1.66GHz (T1300)/1.83GHz (T1400)/1.86GHz (T1350)

( ): Processor Number

- Processor bus speed: 533MHz/667MHz
- Core voltage: 0.50 to 1.30V
- Integrated L1 cache memory of 64KB (32KB +32KB)
- Integrated L2 cache memory of 2MB
- Integrated NDP
- 478-pin Micro FC-PGA package

Intel® Celeron® M Processor

• Core speed:

1.60GHz (420)/1.72GHz (430)

( ): Processor Number

- Processor bus speed: 533MHz
- Core voltage: 1.00 to 1.30V
- Integrated L1 cache memory of 64KB (32KB +32KB)
- Integrated L2 cache memory of 1MB
- Integrated NDP
- 478-pin Micro FC-PGA package

❑ Memory

Two memory slots capable of accepting DDR2-SDRAM 256MB, 512MB, 1024MB or 2048MB memory modules for a maximum of 4GB.

- 200-pin Small Outline DIMM
- 1.8V operation
- PC2-4200(DDR2-533)/PC2-5300(DDR2-667) support

❑ BIOS ROM (Serial Peripheral Interface (SPI))

- One STMicro M25PE80 is used.
- 8Mbits of flash memory are used.
  - 288KB for System BIOS
  - 64KB for VGA BIOS
  - 64KB for Finger Print PBA
  - 128KB for LAN BIOS
  - 24KB for Boot
  - 16KB for Parameter Block
  - 32KB for Option Log
  - Others



## ❑ PCI chipset

This gate array incorporates the following elements and functions.

### North Bridge (Intel 945GM (Satellite R20/TECRA M7)/945PM (TECRA M7))

- Yonah Processor System Bus Support
- System Memory Interface : supports DDR2-400/DDR2-533/DDR2-667 4GBmax.
- Internal Graphics Controller : Inter Generation 3.5 Integrated GFX Core (250MHz)
- DMI (Direct Media Interface)
- ICH Support
- 1,466-ball, 37.5×37.5×2.56mm, FC-BGA package

### South Bridge (Intel ICH7-M)

- DMI (Direct Media Interface)
- PCI Express I/F (4 ports)
- PCI Bus I/F Rev2.3 (6 PCI REQ/GNT Pairs)
- Integrated Serial ATA Host Controller (2 Prots,150MB/S)
- Integrated IDE Controller (Ultra ATA 100/66/33)
- AC'97 2.3 Controller
- Inter High Definition Controller (Azalia)
- USB 1.1/2.0 Controller 8 ports (EHCI: Enhanced Host Controller Interface)
- Built-in LAN Controller (WfM 2.0 & IEEE 802.3 compliance)
- Power Management (ACPI 2.0 compliance)
- SMBus2.0 Controller
- Serial Peripheral Interface (SPI) (BIOS)
- Low Pin Count (LPC) interface (EC/KBC, Super I/O)
- IRQ Controller
- Serial Interrupt Function
- Controlling Suspend/Resume
- Built –in RTC
- GPIO
- 652-ball, 31mm×31mm×2.51mm, BGA Package

### PC Card Controller (Texas Instruments PCI7412ZHK)

- PCI interface
- CardBus/Ultra Media Controller (1socket)
- SD/MMC, Memory Stick, XD card Controller
- IEEE1394 controller
- 288-ball, 16mm×16mm×1.4mm BGA package

GPU controller

(Internal graphic controller)

- Graphics interface in North Bridge (Intel 945GM) is used.
- VRAM : External DDR SDRAM MAX=128MB, Default=8MB
- LCD Interface LVDS 2ch, Supports 1440×900
- Analog CRT : 360MHz RAMDAC, QXGA (2048×1536) monitor
- DVI : Supported on the dock side  
External DVI transmitter (Chrontel-made CH7313) is need

(nVIDIA Quadro NVS 110M)

- VRAM : 128MB
- PCI Express interface
- LCD Interface LVDS 2ch, Supports 1440×900
- Analog CRT : 400MHz RAMDAC, QXGA (2048×1536) monitor
- DVI : Supported on the dock side

 Batteries

The main battery is a detachable lithium-ion battery (10.8V, 4700mAh, 6cell), the secondary battery (Provided with some models or option) is a detachable lithium-ion battery (10.8V, 4000mAh, 6cell) and the RTC battery is a nickel hydrogen battery (2.4V-16mAh).

 Modem controller

- Askey-made one MDC (Azalia) is used.
- This controller has the following functions:
  - One RJ11 port
  - V.92 (V.90) 56K Modem/FAX
  - Supports Ring Wakeup

 LAN controller (Intel-made Vidalia (Gigabit)/Ekron (10/100Mbit))

- This controller has the following functions:
  - PCI-Ex connection
  - Supports Gigabit Ethernet
  - Supports 10/100Mbit Ethernet
  - One RJ45 port
  - Supports WOL

- Supports Magic Packet
  - Supports LED
  - Makes LAN to “Disable” in BIOS
- ❑ Wireless LAN
- One Mini PCI Express Card slot
    - Supports 802.11b/g or 802.11a/b/g
    - Supports Communication SW
    - Supports W-LAN via PCMCIA (Euro : GSM/GPRS)
- ❑ Sound Controller
- Azalia Link (Intel High Definition Audio I/F) built in the South Bridge (ICH7-M) + ADI AD1981HD
    - Stereo speakers
    - Built-in microphone
    - Digital volume
    - Stereo headphone jack
    - External microphone jack
    - VOIP
- ❑ Other main system chips
- EC/KBC (Renesas-made LPC microcontroller M306KAFCLRP U0)
  - PSC (Toshiba-made TMP86FS49UG)
  - Temperature sensor (ADM-made 1032ARMZ)
  - Acceleration sensor (ST Micro-made LIS3L02AQ3)
  - Super I/O (SMSC-made LPC47N217-JV)
  - Sound Codec (ADI-made AD1981HD)
  - SP AMP (Matsushita-made AN12941A) + HP AMP (MAX9722)
  - Clock Generator (ICS-made 954321AGLFT)

### 1.3 2.5-inch Hard Disk Drive

A compact, high-capacity SATA HDD with a height of 9.5mm contains a 2.5-inch magnetic disk and magnetic heads.

Figure 1-4 shows a view of the 2.5-inch HDD and Tables 1-1 list the specifications.

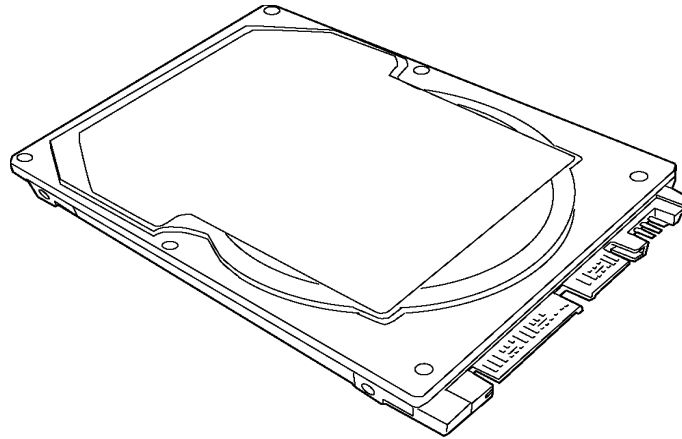

Figure 1-4 2.5-inch HDD

Table 1-1 2.5-inch HDD Specifications (1/3)

Items		Specifications			
		FUJITSU G8BC0002W410	FUJITSU G8BC0002W610	FUJITSU G8BC0002W810	FUJITSU G8BC0002WA10
Outline dimensions	Width (mm)	70			
	Height (mm)	9.5			
	Depth (mm)	100			
	Weight (g)	96 max.		101 max.	
Storage size (formatted)		40GB	60GB	80GB	100GB
Speed (RPM)		5,400			
Data transfer rate To/From media (MB/s) To/From host (Gbps)		61.3 max. 1.5 max.			
Data buffer size (MB)		8			
Average seek time Read (ms)		12 typ.			
Motor startup time (s)		4 typ.			

Table 1-1 2.5-inch HDD Specifications (2/3)

Items		Specifications			
		TOSHIBA HDD2D34BZK01	TOSHIBA HDD2D35BZK01	TOSHIBA HDD2D32BZK01	TOSHIBA HDD2D30BZK01
Outline dimensions	Width (mm)	69.85±0.25			
	Height (mm)	9.5±0.2			
	Depth (mm)	100±0.41			
	Weight (g)	98 max.		102 max.	
Storage size (formatted)		40GB	60GB	80GB	100GB
Speed (RPM)		5,400			
Data transfer rate (Mb/s)		218-429	244.7-474.7	218-429	236.1-456.0
Data buffer size (KB)		8,192			16,384
Average seek time Read (ms)		12			
Motor startup time (s)		4 typ.	3.5 typ.	4 typ.	

Items		Specifications			
		HITACHI GST G8BC00029411	HITACHI GST G8BC00029611	HITACHI GST G8BC00029811	HITACHI GST G8BC00029A11
Outline dimensions	Width (mm)	69.85±0.25			
	Height (mm)	9.5±0.2			
	Depth (mm)	100.2±0.25			
	Weight (g)	95 max.	102 max.		
Storage size (formatted)		40GB	60GB	80GB	100GB
Speed (RPM)		5,400			
Data transfer rate To/From media (Mb/s) To/From host (Gbps)		493 max. 1.5			
Data buffer size (MB)		8			
Average seek time Read (ms)		12 typ.			
Motor startup time (s)		3.5 typ.			

Table 1-1 2.5-inch HDD Specifications (3/3)

Items		Specifications	
		TOSHIBA HDD2D31BZK01	FUJITSU G8BC0002WC10
Outline dimensions	Width (mm)	69.85±0.25	70
	Height (mm)	9.5±0.2	9.5
	Depth (mm)	100±0.41	100
	Weight (g)	102 max.	101 max.
Storage size (formatted)		120GB	
Speed (RPM)		5,400	
Data transfer rate To/From media To/From host (Gbps)		244.7-474.7 (Mb/s) -	61.3 (MB/s) max. 1.5 (150 Mb/s)
Data buffer size (MB)		8	
Average seek time Read (ms)		12 typ.	
Motor startup time (s)		3.5 typ.	4 typ.

Items		Specifications	
		HITACH GST G8BC0002N810	HITACH GST G8BC0002NA10
Outline dimensions	Width (mm)	69.85±0.25	
	Height (mm)	9.5±0.2	
	Depth (mm)	100.2±0.25	
	Weight (g)	115 max.	
Storage size (formatted)		80GB	100GB
Speed (RPM)		7,200	
Data transfer rate To/From media (Mb/s) To/From host (Gbps)		629 max. 1.5	
Data buffer size (KB)		8,192	
Average seek time Read (ms)		10 typ.	
Motor startup time (s)		4 typ.	

## 1.4 Optical Drive

### 1.4.1 DVD-ROM Drive

The DVD-ROM drive accommodates either 12 cm (4.72-inch) or 8 cm (3.15-inch) CD-ROM and DVD-ROM.

The DVD-ROM drive is shown in Figure 1-5. The dimensions and specifications of the DVD-ROM drive are described in Table 1-2, Table 1-3.

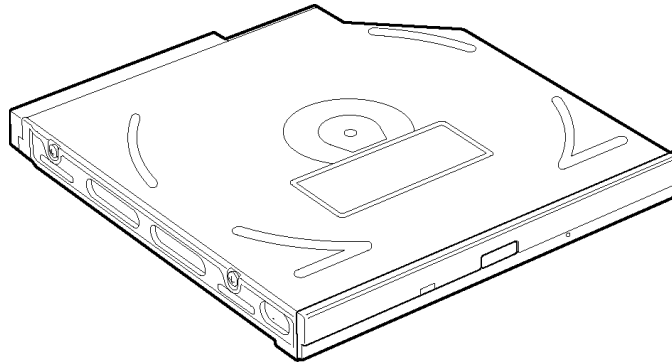

Figure 1-5 DVD-ROM drive

Table 1-2 DVD-ROM drive outline dimensions

Parameter		Standard value
Outline dimensions	Maker (code)	TEAC (G8CC0002E520)
	Width (mm)	128 (excluding the front bezel)
	Height (mm)	12.7 (excluding the front bezel)
	Depth (mm)	129.4 (excluding the eject button)
	Mass (g)	180 or less

Table 1-3 DVD-ROM drive specifications

Item	Specifications
	TEAC G8CC0002E520
Data transfer speed (Read) DVD-ROM CD-ROM	Max. 8x CAV Max. 24x CAV
ATAPI Burst (MB/s) PIO Mode DMA Mode Ultra DMA Mode	16.7 (PIO Mode 0 to 4) 16.7 (Multi Word Mode 0 to 2) 33.3
Access time (ms) CD-ROM DVD-ROM	120 typ. (Random) 130 typ. (Random)
Data Buffer Capacity	256KB
Readable Discs	CD/CD-ROM (12cm, 8cm), CD-R (Recorded), CD-RW (Recorded), DVD-ROM, DVD-R (Recorded), DVD-RW (Recorded), DVD-RAM (Recorded) DVD+R (Recorded), DVD+RW (Recorded)
Applicable Format	CD CD-DA, CD-ROM Mode1, Mode2 CD-ROM XA, Mode 2 (Form1, Form2) Photo-CD, Enhanced CD, CD-TEXT, Multisession CD, Addressing method 2 DVD DVD-ROM, DVD-R (General, Authoring, Single/Multi- border), DVD-RW (Single/Multi-border, Packet), DVD-Video, DVD-RAM (4.7GB, 2.6GB), DVD-R/RW (Single/Multi-border, Packet)



### 1.4.2 DVD-ROM & CD-R/RW Drive

The DVD-ROM & CD-R/RW drive accommodates either 12 cm (4.72-inch) or 8 cm (3.15-inch) CD-ROM, DVD-ROM and CD-R/RW.

The DVD-ROM & CD-R/RW drive is shown in Figure 1-6. The dimensions and specifications of the DVD-ROM & CD-R/RW drive are described in Table 1-4 and Table 1-5.

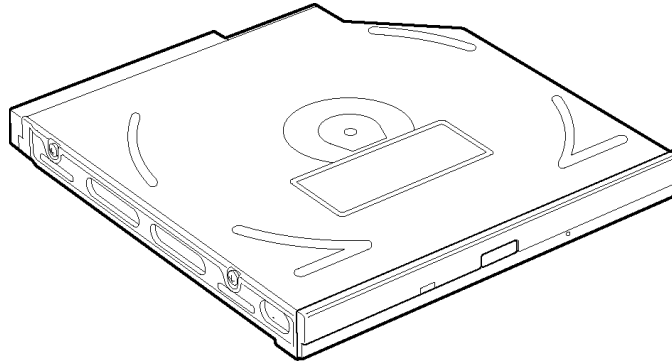

Figure 1-6 DVD-ROM & CD-R/RW drive

Table 1-4 DVD-ROM & CD-R/RW drive outline dimensions

Parameter		Standard value
Outline dimensions	Maker (code)	MATSUSHITA (G8CC0002J520)
	Width (mm)	128 (excluding projections)
	Height (mm)	12.7 (excluding projections)
	Depth (mm)	129 (excluding projections)
	Mass (g)	180±10

Parameter		Standard value
Outline dimensions	Maker (code)	TEAC (G8CC00032520)
	Width (mm)	128 (excluding projections)
	Height (mm)	12.7 (excluding projections)
	Depth (mm)	129.4 (excluding projections)
	Mass (g)	190 or less (including the front bezel)

Table 1-5 DVD-ROM &amp; CD-R/RW drive specifications (1/2)

Item	Specifications
	MATSUSHITA G8CC0002J520
Data transfer speed (Read) DVD-ROM CD-ROM	Max. 8x CAV Max. 24x CAV
Data transfer speed (Write) CD-R CD-RW High Speed CD-RW Ultra Speed CD-RW	Max. 24x CAV Max. 4x CLV Max. 10x CLV Max. 24x CAV
ATAPI Burst (MB/s) PIO Mode DMA Mode Ultra DMA Mode	16.6 (PIO MODE4) 16.6 (Multi Word Mode2) 33.3 (Ultra DMA Mode2)
Access time (ms) CD-ROM DVD-ROM	150 typ. (Random) 180 typ. (Random)
Data Buffer Capacity	2MB
Supported Disks	CD: CD/CD-ROM (12cm, 8cm), CD-R, CD-RW DVD: DVD-ROM, DVD-R, DVD-RW, DVD+R, DVD+RW, DVD+RAM, DVD+R DL
Supported Formats	CD: CD-DA, CD-ROM, CD-ROM XA, Photo CD, CD-Extra(CD+), CD-text DVD: DVD-R, DVD-RW (Ver.1.1, 1.2), DVD-Video, DVD+R, DVD+RW, DVD-RAM (2.6GB/4.7GB)

Table 1-5 DVD-ROM &amp; CD-R/RW drive specifications (2/2)

Item	Specifications
	TEAC G8CC00032520
Data transfer speed (Read) DVD-ROM CD-ROM	Max. 8x CAV Max. 24x CAV
Data transfer speed (Write) CD-R CD-RW High Speed CD-RW Ultra Speed CD-RW	Max. 24x CAV Max. 4x CLV Max. 10x CLV Max. 24x CAV
ATAPI Burst (MB/s) PIO Mode DMA Mode Ultra DMA Mode	16.7 (Mode 0 to 4) 16.7 (Mode 0 to 2) 33.3
Access time (ms) CD-ROM DVD-ROM	90 (Average) 110 (Average)
Data Buffer Capacity	2MB
Readable Disks	CD: CD/CD-ROM (12cm, 8cm), CD-R (Recorded), CD-RW (Recorded)  DVD: DVD-ROM, DVD-R (Recorded), DVD-RW (Recorded), DVD+R (Recorded), DVD+RW (Recorded), DVD-RAM (Recorded), DVD+R DL, DVD-R DL
Applicable Formats	CD: CD-DA, CD-ROM Mode1, Mode2, CD-ROM XA Mode2 (Form1, Form2 ), Photo CD (Single/Multi-session), Enhanced CD, CD-TEXT  DVD: DVD-ROM, DVD-R (General, Authoring), DVD-Video, DVD-RAM (4.7GB, 2.6GB), DVD+R/RW (Single/Multi-session, Packet), DVD-RW, DVD-R/RW (Multi-border), DVD-R DL (format1), DVD+R DL

### 1.4.3 DVD Super Multi Drive (Double-layer)

The DVD Super Multi drive accommodates either 12 cm (4.72-inch) or 8 cm (3.15-inch) CD/DVD-ROM, CD-R/RW, DVD±R/±RW (DL) and DVD-RAM.

The DVD Super Multi drive is shown in Figure 1-7. The dimensions and specifications of the DVD Super Multi drive are described in Table 1-6 and Table 1-7.

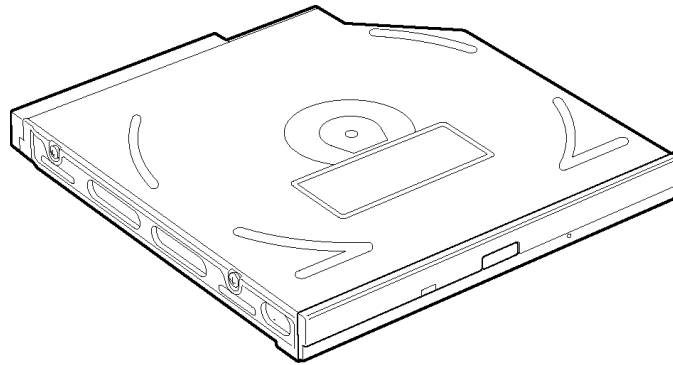

Figure 1-7 DVD Super Multi drive

Table 1-6 DVD Super Multi drive outline dimensions

Parameter		Standard value
Outline dimensions	Maker (code)	MATSUSHITA (G8CC0002T520)
	Width (mm)	128 (excluding projections)
	Height (mm)	12.7 (excluding projections)
	Depth (mm)	129 (excluding projections)
	Mass (g)	190±10

Parameter		Standard value
Outline dimensions	Maker (code)	Pioneer (G8CC0002U530)
	Width (mm)	128 (excluding projections)
	Height (mm)	12.7 (excluding projections)
	Depth (mm)	129 (excluding projections)
	Mass (g)	190 max

Table 1-7 DVD Super Multi drive specifications (1/2)

Item	Specifications
	MATSUSHITA G8CC0002T520
Data transfer speed (Read) DVD-ROM CD-ROM	Max. 8x CAV Max. 24x CAV
Data transfer speed (Write) CD-R CD-RW High Speed CD-RW Ultra Speed CD-RW DVD-R DVD-R DL DVD-RW DVD+R DVD+R DL DVD+RW DVD-RAM	Max. 24x ZCLV Max. 4x CLV Max. 10x CLV Max. 10x CLV Max. 8x ZCLV Max. 2x CLV Max. 4x ZCLV Max. 8x ZCLV Max. 2.4x CLV Max. 4x ZCLV Max. 3-5x ZCLV (4.7GB)
ATAPI Burst (MB/s) PIO Mode DMA Mode Ultra DMA Mode	16.6 (PIO MODE4) 16.6 (Multi Word Mode2) 33.3 (Ultra DMA Mode2)
Access time (ms) CD-ROM DVD-ROM	150 typ. (Random) 180 typ. (Random)
Data Buffer Capacity	2MB
Supported Disks	CD: CD-ROM (12cm, 8cm), CD-R, CD-RW DVD: DVD-ROM, DVD-R, DVD-RAM, DVD-RW, DVD+R, DVD+R DL, DVD+RW,
Supported Formats	CD: CD-DA, CD-ROM, CD-ROM XA, Photo CD, CD-Extra (CD+), CD-text DVD: DVD-R, DVD-RW (Ver. 1.1, Ver. 1.2), DVD-Video, DVD+R, DVD+RW, DVD-RAM (2.6GB/4.7GB)

Table 1-7 DVD Super Multi drive specifications (2/2)

Item	Specifications
	Pioneer G8CC0002U530
Data transfer speed (Read) DVD-ROM CD-ROM	Max. 8x CAV Max. 24x CAV
Data transfer speed (Write) CD-R CD-RW DVD-R DVD-R DL DVD-RW DVD+R DVD+R DL DVD+RW DVD-RAM	Max. 24x ZCLV Max. 10x ZCLV Max. 8x ZCLV Max. 2x CLV Max. 4x ZCLV Max. 8x ZCLV Max. 2.4x CLV Max. 4x ZCLV Max. 5x ZCLV
ATAPI Burst (MB/s) PIO Mode DMA Mode Ultra DMA Mode	16.6 (PIO MODE4) 16.6 (Multi Word Mode2) 33.3 (Ultra DMA Mode2)
Access time (ms) CD-ROM DVD-ROM	150 (Random Average) 160 (Random Average)
Data Buffer Capacity	2MB
Disk Format Supported	CD: KODAK Photo CD single and Multi-session, CD Extra (CD PLUS), Video CD, CD text data (Read/Write), CD-R discs (Read/Write), CD-RW discs (Read/Write)  DVD: DVD-ROM, DVD-R Ver.2.00 for General (Read/Write), DVD-R DL Ver.3.0 (Read/Write), DVD-RW Ver.1.0, 1.1, 1.2 (Read/Write), DVD+R Ver.1.0, 1.1, 1.2 (Read/Write), DVD+R DL Ver.1.0 (Read/Write), DVD+RW Ver.1.1, 1.2 (Read/Write), DVD+RW high speed Ver.1.0 (Read/Write), DVD-RAM Ver.2.0, 2.1, 2.2 (Read/Write)

## **1.5 Keyboard**

The keyboard is mounted 85(US)/87(UK) keys that consist of character key and control key. The keyboard is connected to membrane connector on the system board and controlled by the keyboard controller.

Figure1-8 is a view of the keyboard.

See Appendix E about a layout of the keyboard.



*Figure 1-8 Keyboard*

## 1.6 TFT Color Display

The TFT color display consists of a LCD module and FL inverter board.

### 1.6.1 LCD Module

The LCD module used for the TFT color display uses a backlight as the light source and can display images and characters of 16M colors with 1,440×900 (WXGA+) resolution.

Figure 1-9 shows a view of the LCD module and Table 1-8 lists the specifications.

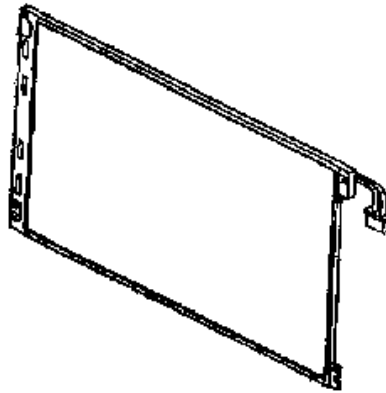

Figure 1-9 LCD module

Table 1-8 LCD module specifications (14.1 TFT)

Item	Specifications
	CHIMEI G33C0003B110 (WXGA+)
Number of Dots	1,440 (W) x 900 (H)
Dot spacing (mm)	0.21075(H) x 0.21075(V)
Display range (mm)	303.48(H) x 189.675(V)
Outline dimensions	319.5(W) x 205.5(H) x 7.5Max(D)



### 1.6.2 FL Inverter Board

The FL inverter board supplies a high frequency current to illuminate the LCD module FL.

Table 1-9 lists the FL inverter board specifications.

*Table 1-9 FL inverter board specifications*

Item		Specifications
		G71C00011111
Input	Voltage (V)	5 (DC)
	Power (W)	7
Output	Voltage (V)	750 (r.m.s)
	Power (W/VA)	5/7
	Current (mA)	6.00 (r.m.s)

## **1.7 Power Supply**

The power supply supplies different voltages to the system board.

The power supply microcontroller has the following functions.

1. Judges that the DC power supply (AC adapter) is connected to the computer.
2. Detects DC output and circuit malfunctions.
3. Controls the battery icon, and DC IN icon.
4. Turns the battery charging system on and off and detects a fully charged battery.
5. Turns the power supply on and off.
6. Provides more accurate detection of a low battery.
7. Calculates the remaining battery capacity.
8. Controls the transmission of the status signal of the main battery.

Table 1-10 lists the power supply output specifications.

Table 1-10 Power supply output specifications (1/2)

Name	Power supply (Yes/No)				
	Voltage [V]	Power OFF (Suspend mode)	Power OFF (Boot mode)	No battery	Object
PPV	1.500 - 0.300	No	No	No	CPU
PTV	1.05	No	No	No	CPU, MCH, GMCH, ICH7-M
1R5-P1V	1.5	No	No	No	CPU, MCH, GMCH, ICH7-M, PCI-e Mini Card
1R8-B1V	1.8	Yes	No	No	MCH, GMCH, DDR2-SDRAM
1R8-P1V	1.8	No	No	No	GPU, VRAM
2R5-P2V	2.5	No	No	No	MCH, GMCH, ICH7-M
LAN2R5-E2V	2.5	Yes	Yes/No	No	LAN
MR0R9-B0V	0.9	Yes	No	No	MCH, GMCH, DDR2-SDRAM
0R9-P0V	0.9	No	No	No	DDR2-SDRAM
P3V	3.3	No	No	No	Clock Generator, Thermal Sensor, MCH, GMCH, SDRAM (SPD), ICH7-M, HDD, PC-Card Cont., PC-Card Power, PCI-e Mini Card (WLAN, 3G), TPM, Super I/O, LCD, ALC262, SPI
E3V	3.3	Yes	Yes/No	No	ICH7-M, PCI-e Mini Card (WLAN, 3G), MDC
S3V	3.3	Yes	Yes	No	EC/KBC
FM-P3V	3.3	No	No	No	Flash Media
BT-P3V	3.3	No	No	No	Bluetooth
LAN-E3V	3.3	Yes	Yes/No	No	LAN
PGV	1.2	No	No	No	GPU
1R2-P1V	1.2	No	No	No	GPU
LAN1R2-E1V	1.2	Yes	Yes/No	No	LAN
P5V	5	No	No	No	ICH7-M, ODD, HDD, PC-Card Power, LED, KB, PAD, CRT, FAN, FL-Inv, LED
E5V	5	Yes	Yes/No	No	ICH7-M, USB Power
M5V	5	Yes	Yes	No	LED
MCV	5	Yes	Yes	No	PSC

Table 1-10 Power supply output specifications (2/2)

Name	Power supply (Yes/No)				
	Voltage [V]	Power OFF (Suspend mode)	Power OFF (Boot mode)	No battery	Object
SND-P5V	5	No	No	No	AN12941A
A4R7-P4V	4.7	No	No	No	ALC262, AN12941A
R3V	2.0-3.5	<b>Yes</b>	<b>Yes</b>	<b>Yes</b>	ICH7-M (RTC)

## 1.8 Batteries

The PC has the following three batteries.

- Main battery
- Secondary battery (Provided with some models or option)
- Real time clock (RTC) battery

Table 1-11 lists the specifications for these two batteries.

*Table 1-11 Battery specifications*

Battery Name		Battery Element	Output Voltage	Capacity
Main battery	G71C0004S510	Lithium ion (6 cell)	10.8 V	4,700mAh
	G71C0004S610			
Secondary battery	G71C0006K110	Lithium ion (6 cell)	10.8 V	4,000mAh
	G71C0006K210			
Real time clock (RTC) battery	GDM710000041	Nickel hydrogen	2.4V	16mAh

### 1.8.1 Main Battery

The main battery is the primary power supply for the computer when the AC adapter is not connected. In standby (instant recovery) mode, the main battery maintains the current status of the computer.

## 1.8.2 Battery Charging Control

Battery charging is controlled by a power supply microprocessor. The power supply microprocessor controls power supply and detects a full charge when the AC adapter and battery are connected to the computer.

### Quick Battery Charge

When the AC adapter is connected, normal charging is used while the system is turned on and quick charge is used while the system is turned off or in standby mode. Table 1-12 lists the main battery charging time.

*Table 1-12 Time required for charges of main battery*

Battery Capacity	Charging Time	
	Normal charge	Quick charge
Main (4700mAh)	about 3.0 to 13.0	about 3.0
Second (4000mAh)	about 3.0 to 9.5	about 3.0

Quick battery charge is stopped in the following cases.

1. The main battery is fully charged.
2. The main battery is removed.
3. Main battery or AC adapter voltage is abnormal.
4. Charging current is abnormal.

### Data preservation time

When turning off the power in being charged fully, the preservation time is as following Table 1-13.

*Table 1-13 Data preservation time*

Condition		preservation time
Main (4700mAh)	Standby mode	About 5 days
	Boot mode	About 60 days
Second (4000mAh)	Standby mode	About 5 days
	Boot mode	About 50 days

### 1.8.3 RTC Battery

The RTC battery provides the power supply to maintain the date, time, and other system information in memory. Table 1-14 lists the battery charging time and data preservation times.

*Table 1-14 RTC battery charging/data preservation time*

		<b>Time</b>
Charging time	AC adapter or main battery in use (Power ON)	8 hours
Data preservation time (when fully charged)		30 days

## 1.9 AC Adapter

The AC adapter is also used to charge the battery.

Table 1-15 lists the AC adapter specifications.

*Table 1-15 AC adapter specifications*

Parameter	Specification	
	G71C00043310 (2-pin)	G71C00049510 (3-pin)
Power	75W (Peak 90W)	
Input voltage	100V/240V	
Input frequency	50Hz to 60Hz	
Input current	1.5A or less (100V-240V)	
Output voltage	15V	
Output current	0A to 5A (At constant voltage mode) 5A to 6A (At surge load mode)	

Parameter	Specification	
	G71C0006Q210 (2-pin)	G71C0006R210 (3-pin)
Power	75W (Peak 90W)	
Input voltage	100V/240V	
Input frequency	47Hz to 63Hz	
Input current	1.5A or less (100Vac / 5.0A load) 1.125A or less (240Vac / 5.0A load)	
Output voltage	15V	
Output current	0A to 5A (At constant voltage mode) 5A to 6A (At surge load mode)	



---

# **Chapter 2**

# **Troubleshooting**

---



---

## Chapter 2 Contents

---

2.1	Troubleshooting .....	2-1
2.2	Troubleshooting Flowchart.....	2-2
2.3	Power Supply Troubleshooting.....	2-6
	Procedure 1    Power Supply Icon Check.....	2-7
	Procedure 2    Error Code Check .....	2-9
	Procedure 3    Connection Check.....	2-14
	Procedure 4    Quick Charge Check.....	2-15
	Procedure 5    Replacement Check .....	2-15
2.4	System Board Troubleshooting.....	2-16
	Procedure 1    Message Check .....	2-17
	Procedure 2    Debug Port (D port) Check on Boot Mode.....	2-19
	Procedure 3    Diagnostic Test Program Execution Check .....	2-31
	Procedure 4    Replacement Check .....	2-31
2.5	USB 3.5" FDD Troubleshooting.....	2-32
	Procedure 1    FDD Head Cleaning Check .....	2-32
	Procedure 2    Diagnostic Test Program Execution Check .....	2-33
	Procedure 3    Connector Check.....	2-34
	Procedure 4    Replacement Check .....	2-34
2.6	2.5" HDD Troubleshooting.....	2-35
	Procedure 1    Partition Check.....	2-35
	Procedure 2    Message Check .....	2-36
	Procedure 3    Format Check.....	2-37
	Procedure 4    Diagnostic Test Program Execution Check .....	2-38
	Procedure 5    Connector Check and Replacement Check.....	2-39
2.7	Keyboard Troubleshooting .....	2-40
	Procedure 1    Diagnostic Test Program Execution Check .....	2-40
	Procedure 2    Connector Check and Replacement Check.....	2-40

2.8	Display Troubleshooting.....	2-41
	Procedure 1    External Monitor Check.....	2-41
	Procedure 2    Diagnostic Test Program Execution Check .....	2-41
	Procedure 3    Connector and Cable Check.....	2-42
	Procedure 4    Replacement Check .....	2-42
2.9	Touch Pad Troubleshooting.....	2-43
	Procedure 1    Diagnostic Test Program Execution Check .....	2-43
	Procedure 2    Connector and Cable Check.....	2-43
	Procedure 3    Replacement Check .....	2-43
2.10	Optical Drive Troubleshooting .....	2-44
	Procedure 1    Diagnostic Test Program Execution Check .....	2-44
	Procedure 2    Connector Check and Replacement Check.....	2-44
2.11	Modem Troubleshooting.....	2-45
	Procedure 1    Diagnostic Test Program Execution Check .....	2-45
	Procedure 2    Connector Check and Replacement Check.....	2-46
2.12	Bluetooth Troubleshooting .....	2-47
	Procedure 1    Diagnostic Test Program Execution Check .....	2-47
	Procedure 2    Connection Check.....	2-48
	Procedure 3    Replacement Check .....	2-48
2.13	LAN Troubleshooting.....	2-49
	Procedure 1    Diagnostic Test Program Execution Check .....	2-49
	Procedure 2    Connector Check and Replacement Check.....	2-49
2.14	Sound Troubleshooting.....	2-50
	Procedure 1    Diagnostic Test Program Execution Check .....	2-50
	Procedure 2    Connector Check.....	2-50
	Procedure 3    Replacement Check .....	2-50
2.15	Bridge media Slot Troubleshooting .....	2-51
	Procedure 1    Check on Windows XP Tablet PC Edition .....	2-51
	Procedure 2    Connector check and Replacement Check.....	2-51

2.16	Tablet Pen Troubleshooting.....	2-52
	Procedure 1    Check on Windows XP Tablet PC Edition.....	2-52
	Procedure 2    Tablet pen replacement Check.....	2-52
	Procedure 3    Connector Check and Replacement Check.....	2-53
2.17	Wireless LAN Troubleshooting.....	2-54
	Procedure 1    Transmitting/Receiving Check .....	2-54
	Procedure 2    Check of Antennas connection .....	2-55
	Procedure 3    Replacement Check .....	2-55
2.18	Fingerprint sensor Troubleshooting.....	2-56
	Procedure 1    Setting Windows Log-ON password .....	2-57
	Procedure 2    Registration of fingerprint.....	2-57
	Procedure 3    Authentication of fingerprint .....	2-64
	Procedure 4    Connector Check and Replacement Check.....	2-65

## Figures

Figure 2-1	Troubleshooting flowchart.....	2-3
Figure 2-2	A set of tool for debug port test .....	2-19

## Tables

Table 2-1	Battery icon.....	2-7
Table 2-2	DC IN icon.....	2-7
Table 2-3	Error cord.....	2-9
Table 2-4	Debug port (Boot mode) error status .....	2-21
Table 2-5	FDD error code and status .....	2-33
Table 2-6	2.5" HDD error code and status.....	2-38



## 2.1 Troubleshooting

Chapter 2 describes how to determine which Field Replaceable Unit (FRU) in the computer is causing the computer to malfunction. (The “FRU” means the replaceable unit in the field.)

The FRUs covered are:

- |                  |                        |
|------------------|------------------------|
| 1. Power supply  | 9. Modem               |
| 2. System board  | 10. Bluetooth          |
| 3. 3.5” USB FDD  | 11. LAN                |
| 4. 2.5” HDD      | 12. Sound              |
| 5. Keyboard      | 13. Bridge media slot  |
| 6. Display       | 14. Tablet pen         |
| 7. Touch pad     | 15. Wireless LAN       |
| 8. Optical drive | 16. Fingerprint sensor |

The Detailed replacement procedures are given in Chapter 4. Test Program operations are described in Chapter 3.

**NOTE:** After replacing the System board or CPU, it is necessary to execute the subtest 01 Initial configuration of 3.3 Setting of the hardware configuration in Chapter 3.

The following tools are necessary in addition to tools described in Chapter 3 for implementing the Diagnostics procedures:

1. Phillips screwdrivers
2. Toshiba DOS system FD
3. Debug test cable (for debug port test)
4. RS-232C cross-cable (for debug port test)
5. Test board (for debug port test)
6. External monitor (for display check)

There are following two types of connections in the figures of board and module connection in and after 2.3 Power Supply Troubleshooting.

(1) Cable connection is described as a line in the figures.

(2) Pin connection is described as an arrow in the figure.

<e.g> Connection of modem

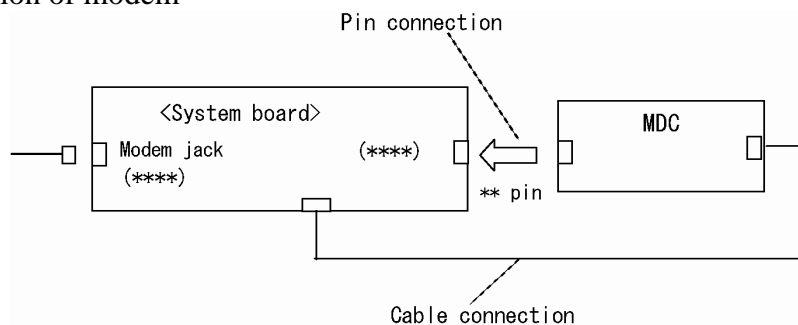

## 2.2 Troubleshooting Flowchart

Use the flowchart in Figure 2-1 as a guide for determining which FRU malfunctions. Before going through the flowchart steps, check the following:

- Make sure that Toshiba Windows® XP Tablet PC Edition is installed on the hard disk. Other operating systems can cause the computer malfunction.
- Make sure all optional equipment is removed from the computer.



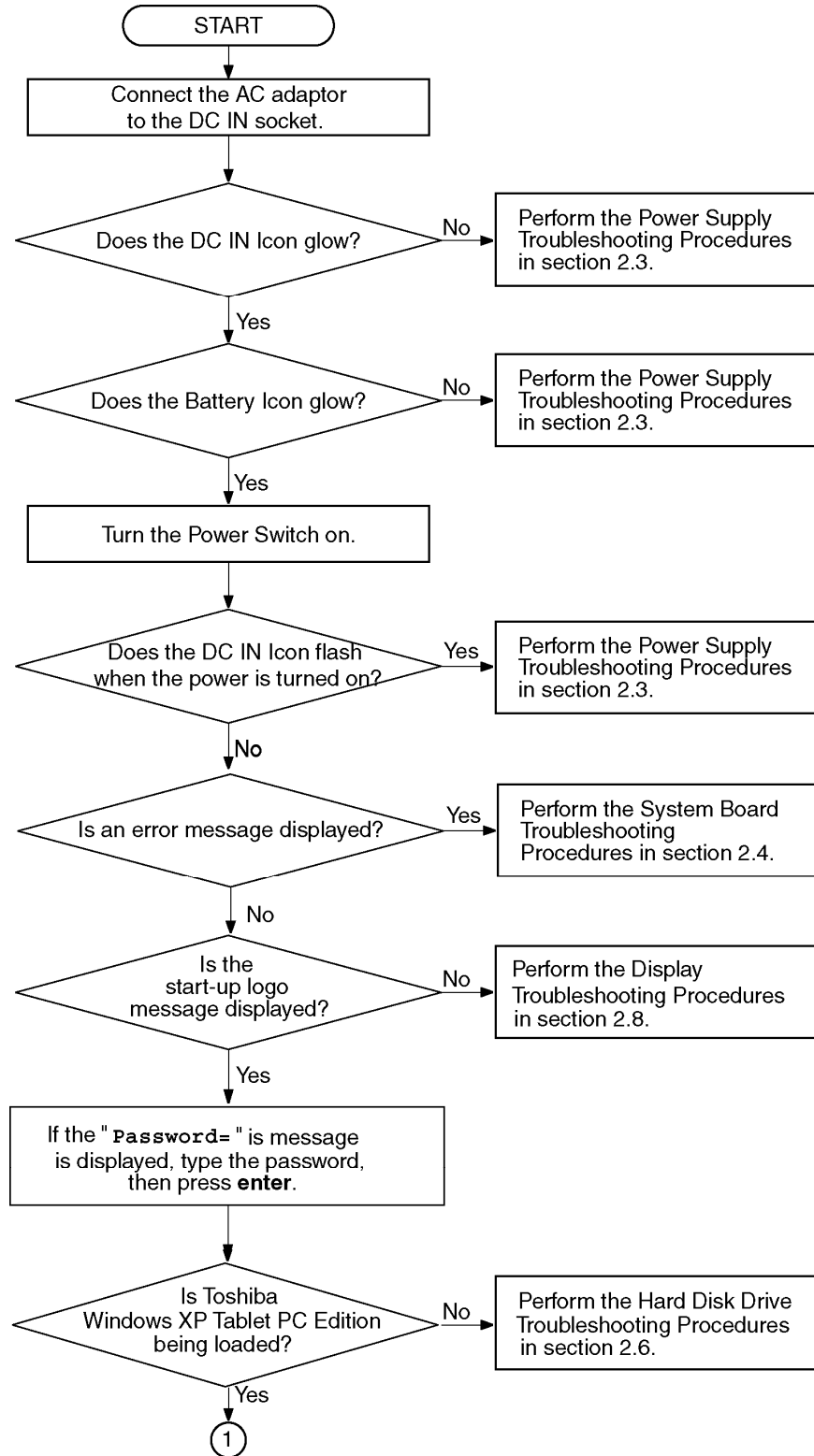

Figure 2-1 Troubleshooting flowchart (1/2)

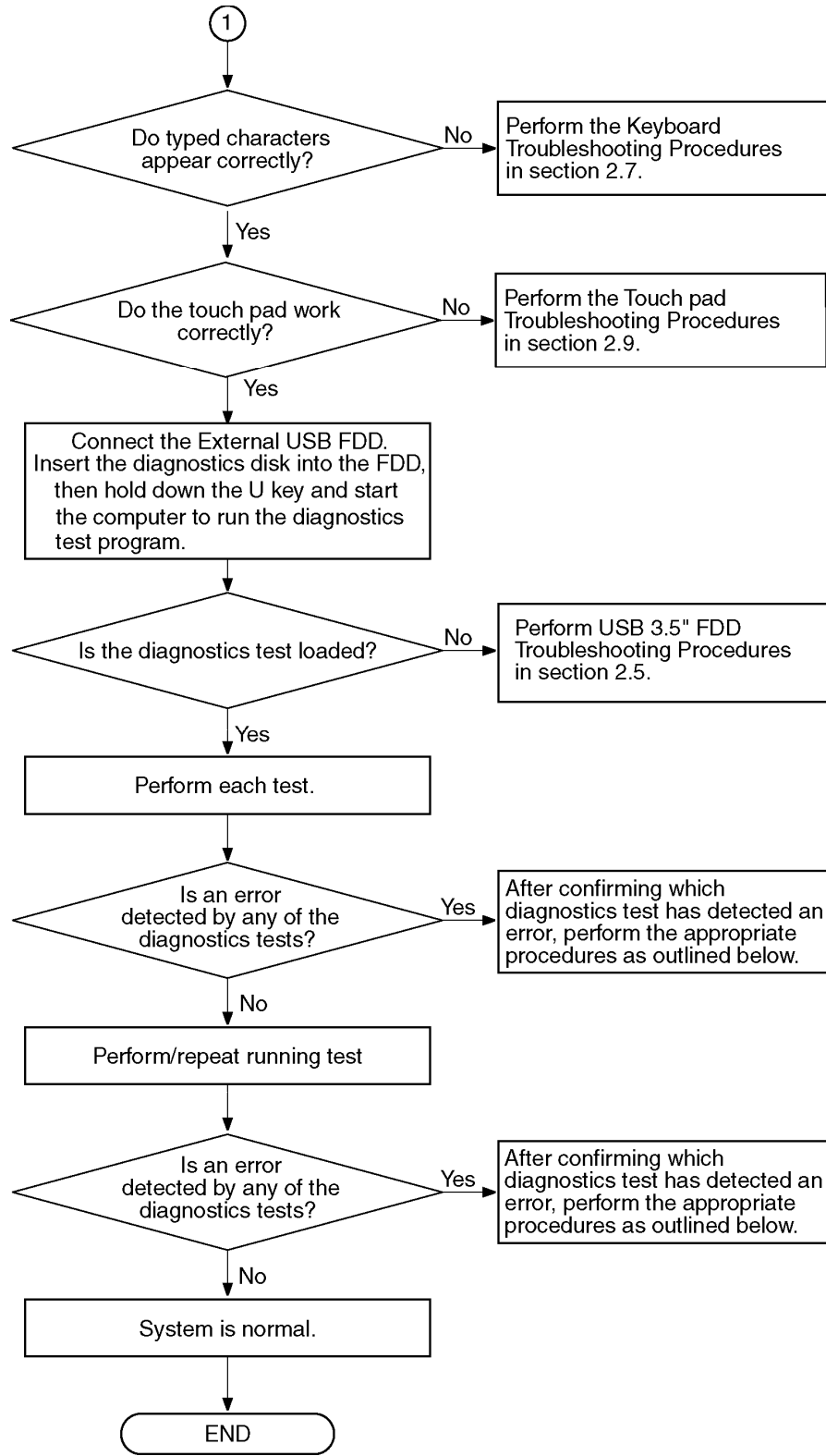

Figure 2-1 Troubleshooting flowchart (2/2)

If the diagnostics program cannot detect an error, the problem may occur intermittently. The Test program should be executed several times to isolate the problem. Check the Log Utilities function to confirm which diagnostic test detected an error(s), and perform the appropriate troubleshooting procedures as follows:

1. If any trouble is detected on the System test, Memory test, ASYNC test, Real timer test, NDP test or expansion test, perform the System board Troubleshooting Procedures in Section 2.4.
2. If any trouble is detected on the keyboard, perform the Keyboard Troubleshooting Procedures in Section 2.7.
3. If any trouble is detected on the display, perform the Display Troubleshooting Procedures in Section 2.8.
4. If any trouble is detected on the floppy disk, perform the USB FDD Troubleshooting Procedures in Section 2.5.
5. If any trouble is detected on the hard disk, perform the HDD Troubleshooting Procedures in Section 2.6.
6. If any trouble is detected on the touch pad, perform the Touch Pad Troubleshooting Procedures in Section 2.9.
7. If any trouble is detected on the optical drive, perform the Optical Drive Troubleshooting Procedures in Section 2.10.
8. If any trouble is detected on the modem, perform the Modem Troubleshooting Procedures in Section 2.11.
9. If any trouble is detected on the Bluetooth, perform the Bluetooth Troubleshooting Procedures in Section 2.12.
10. If any trouble is detected on the LAN, perform the LAN Troubleshooting Procedures in Section 2.13.
11. If any trouble is detected on the sound, perform the Sound Troubleshooting Procedures in Section 2.14.
12. If any trouble is detected on the Bridge media, perform the Bridge media Slot Troubleshooting Procedures in Section 2.15.
13. If any trouble is detected on the Tablet pen, perform the Tablet Pen Troubleshooting Procedures in Section 2.16.
14. If any trouble is detected on the Wireless LAN, perform the Wireless LAN Troubleshooting Procedures in Section 2.17.
15. If any trouble is detected on the Fingerprint sensor, perform the Fingerprint sensor Troubleshooting Procedures in Section 2.18.

## 2.3 Power Supply Troubleshooting

The power supply controller controls many functions and components. To determine if the power supply is functioning properly, start with Procedure 1 and continue with the other Procedures as instructed. The procedures described in this section are:

Procedure 1: Power Supply Icon Check

Procedure 2: Error Code Check

Procedure 3: Connection Check

Procedure 4: Quick Charge Check

Procedure 5: Replacement Check

### Procedure 1 Power Supply Icon Check

The following two icons indicate the power supply status:

- Battery icon
- DC IN icon

The power supply controller uses the power supply status with the Battery icon and the DC IN icon as listed in the tables below.

*Table 2-1 Battery icon*

Battery icon	Power supply status
Lights orange	Battery is charged and the external DC is input. It has no relation with ON/OFF of the system power.
Lights green (Satellite R20) / blue (TECRA M7)	Battery is fully charged and the external DC is input. It has no relation with ON/OFF of the system power.
Blinks orange (even intervals)	The battery level is low while the system power is ON.
Flashes orange (at being switched on)	The battery level is low and the power is turned on only with the battery.
Doesn't light	Any condition other than those above.

*Table 2-2 DC IN icon*

DC IN icon	Power supply status
Lights green (Satellite R20) / blue (TECRA M7)	DC power is being supplied from the AC adapter.
Blinks orange	Power supply malfunction <sup>*1</sup>
Doesn't light	Any condition other than those above.

\*1 When the power supply controller detects a malfunction, the DC IN icon blinks orange. It shows an error code.

When icons are blinking, perform the following procedure.

1. Remove the battery pack and the AC adapter and cut off the power supply to the computer by force.
2. Re-attach the battery pack and the AC adapter.

If icons are still blinking after the operation above, check the followings:

- Check 1 If the DC IN icon blinks orange, go to Procedure 2.
- Check 2 If the DC IN icon does not light, go to Procedure 3.
- Check 3 If the battery icon does not light orange or green (Satellite R20) / blue (TECRA M7), go to Procedure 4.

**NOTE:** Use a recommended AC adapter (G71C00043310 (2-pin), G71C0006Q210 (2-pin), G71C00049510 (3-pin) or G71C0006R210 (3-pin)).

## Procedure 2 Error Code Check

If the power supply microprocessor detects a malfunction, the DC IN icon blinks orange. The blink pattern indicates an error as shown below.

- |   |                    |
|---|--------------------|
| <input type="checkbox"/> Start              | Off for 2 seconds  |
| <input type="checkbox"/> Error code (8 bit) |                    |
| "1"   | On for one second  |
| "0"   | On for half second |
| Interval between data bits                  | On for half second |

The error code begins with LSB (Least Significant bit)

Example: Error code 11h (Error codes are given in hexadecimal format.)

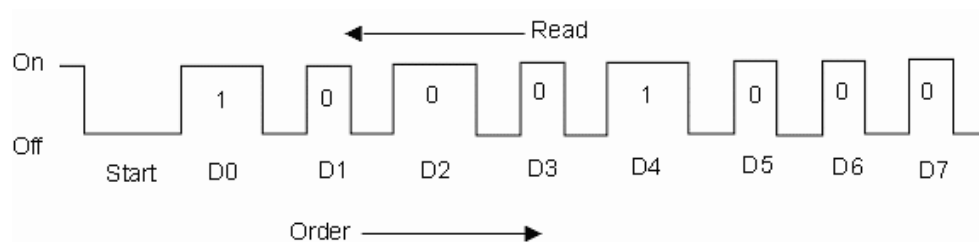

- Check 1 Convert the DC IN icon blink pattern into the hexadecimal error code and compare it to the tables below. Then go to Check 2.

Table 2-3 Error cord

Error code	Power supply of error detected
1*h	DC power supply (AC Adapter)
2*h	Main battery
3*h	Second battery
4*h	S3V output
5*h	E5V output
6*h	E3V output
7*h	1R5-E1V output
8*h	1R8-B1V output
9*h	PPV output
A*h	PTV output
B*h	1R5-E1V output
C*h	1R8-B1V output
D*h	PPV output
E*h	PTV output (Intel 945GM model) or PGV output (Intel 945PM model)
F*h	-

DC power supply (AC adapter)

Error code	Meaning
10h	AC Adapter output voltage is over 16.5V.
11h	TOSHIBA Express Port Replicator output voltage is over 16.5V.
12h	Current from the DC power supply is over 7.0A.
13h	Current from the DC power supply is over 0.5A in no load.
14h	Abnormal current of 0[A] correction has been sensed.

Main Battery

Error code	Meaning
22h	Main battery discharge current is over 0.5A in no load.
23h	Main battery charge current is over 4.3A in charging.
24h	Abnormal current of 0[A] correction has been sensed.
25h	Main battery charge current is over 0.3A in not charging.

Second Battery

Error code	Meaning
32h	Second battery discharge current is over 0.5A in no load.
33h	Second battery charge current is over 3.5A in charging.
34h	Abnormal current of 0[A] correction has been sensed.
35h	Second battery charge current is over 0.3A in not charging.

S3V output

Error code	Meaning
40h	S3V voltage is over 3.47V.
45h	S3V voltage is under 3.14V in normal conditions.
46h	S3V voltage is under 3.14V at booting up.



❑ E5V output

Error code	Meaning
50h	E5V voltage is over 6.00V.
51h	E5V voltage is under 4.50V when the computer is powered on.
52h	E5V voltage is under 4.50V at booting up.
54h	E5V voltage is under 4.50V when EV power is maintained and "OUTV1 power = EV power" is specified.

❑ E3V output

Error code	Meaning
60h	E3V voltage is over 3.96V.
61h	E3V voltage is under 2.81V when the computer is powered on.
62h	E3V voltage is under 2.81V at booting up.
64h	E3V voltage is under 2.81V when EV power is maintained and "OUTV2 power = EV power" is specified.

❑ 1R5-E1V output

Error code	Meaning
70h	1R5-E1V voltage is over 1.80V.
71h	1R5-E1V voltage is under 1.275V when the computer is powered on.
72h	1R5-E1V voltage is under 1.275V at booting up.

❑ 1R8-B1V output

Error code	Meaning
80h	1R8-B1V voltage is over 2.16V.
81h	1R8-B1V voltage is under 1.53V when the computer is powered on.
82h	1R8-B1V voltage is under 1.53V at booting up.
84h	1R8-B1V voltage is under 1.53V when BV power is maintained and "OUTV4 power = BV power" is specified.

PPV output

Error code	Meaning
90h	PPV voltage is over 1.80V.
91h	PPV voltage is under 0.32V when the computer is powered on.
92h	PPV voltage is under 0.32V at booting up.

PTV output

Error code	Meaning
A0h	PTV voltage is over 1.32V.
A1h	PTV voltage is under 0.85V when the computer is powered on.
A2h	PTV voltage is under 0.85V at booting up.

1R5-E1V output

Error code	Meaning
B0h	1R5-E1V voltage is over 1.80V.
B1h	1R5-E1V voltage is under 1.275V when the computer is powered on.
B2h	1R5-E1V voltage is under 1.275V at booting up.
B4h	1R5-E1V voltage is under 1.275V when EV power is maintained and "OUTV7 power = EV power" is specified.

1R8-B1V output

Error code	Meaning
C0h	1R8-B1V voltage is over 2.16V.
C1h	1R8-B1V voltage is under 1.53V when the computer is powered on.
C2h	1R8-B1V voltage is under 1.53V at booting up.
C4h	1R8-B1V voltage is under 1.53V when BV power is maintained and "OUTV8 power = BV power" is specified.

PPV output

Error code	Meaning
D0h	PPV voltage is over 1.80V.
D1h	PPV voltage is under 0.32V when the computer is powered on.
D2h	PPV voltage is under 0.32V at booting up.

 PTV (Intel 945GM model) or PGV (Intel 945PM model)

Error code	Meaning
E0h	PTV or PGV voltage is over 1.32V.
E1h	PTV or PGV voltage is under 0.85V when the computer is powered on.
E2h	PTV or PGV voltage is under 0.85V at booting up.

Check 3 In the case of error code 10h or 12h, go to Procedure 3.

Check 4 In the case of error code 2\*h, go to Check 3 of Procedure 3.

Check 5 For any other errors, go to Procedure 5.

**Procedure 3 Connection Check**

The wiring diagram related to the power supply is shown below:

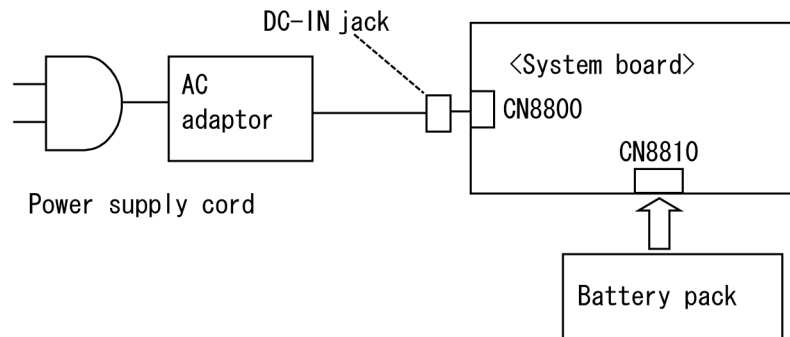

Any of the connectors may be disconnected. Perform starting from Check 1.

- Check 1 Make sure the AC adaptor and the AC power cord are firmly plugged into the DC IN jack and wall outlet. If these cables are connected correctly, go to Check 2.
- Check 2 Replace the AC adaptor and the AC power cord with new ones.
- If the DC IN icon does not light, go to Procedure 5.
  - If the battery icon does not light, go to Check 3.
- Check 3 Make sure the battery pack is installed in the computer correctly. If the battery is properly installed and the battery icon still does not light, go to Procedure 4.

**Procedure 4 Quick Charge Check**

Check if the power supply controller charges the battery pack properly. Perform the following procedures:

- Check 1 Make sure the AC adapter is firmly plugged into the DC IN socket.
- Check 2 Make sure the battery pack is properly installed to the PC. If the battery is properly installed, go to Check 3.
- Check 3 The battery pack may be completely discharged. Wait a few minutes to charge the battery pack while connecting the battery pack and the AC adapter to the PC. If the battery pack is still not charged, go to Check 4.
- Check 4 The battery's temperature is too high or low. Return the temperature to normal operating condition. If the battery pack is still not charged, go to Check 5.
- Check 5 Replace the battery pack with a new one. If the battery pack is still not charged, go to Procedure 5.

**Procedure 5 Replacement Check**

The system board processor module may be disconnected or damaged. Disassemble the computer following the steps described in Chapter 4. Check the connection between the AC adapter and system board. After checking the connections, perform the following Check 1:

When AC adapter is connected:

- Check 1 The AC adapter may be faulty. Replace the AC adapter with a new one. If the problem still occurs, perform Check 2.
- Check 2 The system board may be faulty. Replace the system board with a new one.

When AC adapter is not connected:  
(When driving with battery pack)

- Check 1 The Battery pack may be faulty. Replace it with a new one. If the problem still occurs, perform Check 2.
- Check 2 The system board may be faulty. Replace it with a new one.

## 2.4 System board Troubleshooting

This section describes how to determine if the System board is defective. Start with Procedure 1 and continue with the other procedures as instructed. The procedures described in this section are:

Procedure 1: Message Check

Procedure 2: Debug port (D port) Check on Boot Mode

Procedure 3: Diagnostic Test Program Execution Check

Procedure 4: Replacement Check

### Procedure 1 Message Check

When the power is turned on, the system performs the Initial Reliability Test (IRT) installed in the BIOS ROM. The IRT tests each IC on the System board and initializes it.

- If an error message is shown on the display, perform Check 1.
- If there is no error message, go to Procedure 2.
- If DOS or Windows XP Tablet PC Edition is properly loaded, go to Procedure 4.

**Check 1** If one of the following error messages is displayed on the screen, press the **F1** key as the message instructs. These errors occur when the system configuration preserved in the RTC memory (CMOS type memory) is not the same as the actual configuration or when the data is lost.

If you press the **F1** key as the message instructs, the SETUP screen appears to set the system configuration. If any other error message is displayed, perform Check 2.

- (a)\*\*\* Bad HDD type \*\*\*  
Check system. Then press [F1] key .....
- (b)\*\*\* Bad configuration \*\*\*  
Check system. Then press [F1] key .....
- (c)\*\*\* Bad memory size \*\*\*  
Check system. Then press [F1] key .....
- (d)\*\*\* Bad time function \*\*\*  
Check system. Then press [F1] key .....
- (e)\*\*\* Bad check sum (ROM) \*\*\*  
Check system. Then press [F1] key .....
- (f)RTC battery is low or CMOS checksum is inconsistent  
Press [F1] key to set Date/Time

**Check 2** If the following error message is displayed on the screen press any key as the message instructs.  
The following error message appears when data stored in RAM under the resume function is lost because the battery has become discharged or the System board is damaged. Go to Procedure 3.

```
WARNING: RESUME FAILURE.  
PRESS ANY KEY TO CONTINUE.
```

If any other error message is displayed, perform Check 3.

Check 3 The IRT checks the System board. When the IRT detects an error, the system stops or an error message appears.

If one of the following error messages (1) through (15), (20) or (21) appears, go to Procedure 4.

If the error message (16) appears, go to the Keyboard Troubleshooting Procedures in Section 2.7.

If the error message (17) or (18) appears, go to the HDD Troubleshooting Procedures in Section 2.6.

If the error message (19) appears, go to the Optical Drive Troubleshooting Procedures in Section 2.10.

- (1) PIT ERROR
- (2) MEMORY REFRESH ERROR
- (3) TIMER CH.2 OUT ERROR
- (4) FIRST 64KB MEMORY ERROR
- (5) FIRST 64KB MEMORY PARITY ERROR
- (6) VRAM ERROR
- (7) SYSTEM MEMORY ERROR
- (8) SYSTEM MEMORY PARITY ERROR
- (9) MEMORY ERROR
- (10) EXTENDED MEMORY PARITY ERROR
- (11) DMA PAGE REGISTER ERROR
- (12) DMAC #1 ERROR
- (13) DMAC #2 ERROR
- (14) PIC #1 ERROR
- (15) PIC #2 ERROR
- (16) KBC ERROR
- (17) HDC ERROR
- (18) Built-in HDD ERROR
- (19) CD-ROM ERROR
- (20) TIMER INTERRUPT ERROR
- (21) RTC UPDATE ERROR



## Procedure 2 Debug Port (D port) Check on Boot Mode

Check the D port status by a debug port test. The tool for debug port test is shown below.

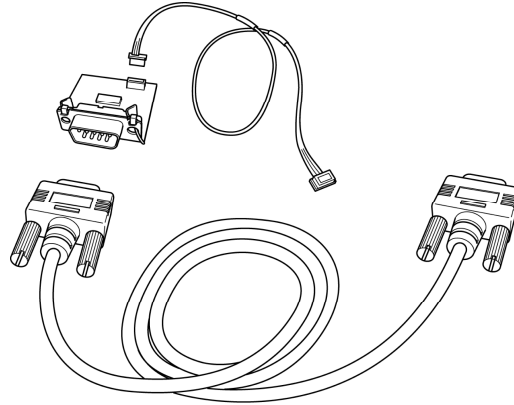
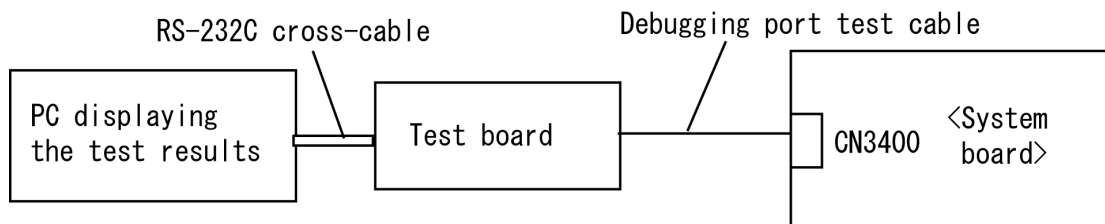

Figure 2-2 A set of tool for debug port test

The test procedures are follows;

1. Connect the debug port test cable to the connector CN3400 of the system board. For disassembling the PC to connect the test cable, refer to Chapter 4.
2. Connect the debug port test cable and RS-232C cross-cable to the test board.
3. Connect the RS-232C cross-cable to the PC displaying the test results.



4. Boot the computer in DOS mode.

- Execute GETDPORT.COM in the text menu in CPU REAL mode. (Insert the FD for starting D port into FDD and input “FD starting drive:>dport”.)  
The D port status is displayed in the following form;

F100 : 000.000382	IRT_CHK_INI\SYSI_START
D port status	Time (second) to process
	Contents of process

- When the D port status is FFFFh (normal status), go to Procedure 3.
- When the D port status falls into any status in Table 2-4, execute Check 1.

Table 2-4 Debug port (Boot mode) error status (1/10)

D port status	Inspection items	Details
	Permission of A20 and Clear of software reset bit	
	Prohibition of APIC	
	Initialization of MCH, ICH	
	Initialization of Super I/O	
	Initialization of debug port	
	Dummy read of 3 <sup>rd</sup> Bus data	
F000h	PIT CH0 initialization (for HOLD_ON)	
	BIOS rewrite factor flag initialization	
	CHECK SUM CHECK	Transition to protected mode
		Boot block checksum (skipped when returned to S3) Halts when error occurs
	Checksum other than boot block (skip when returned to S3)	
F001h	EC/KBC rewrite check	If "rewrite" is requested, go to "BIOS rewrite process"
	Transition of process to system BIOS IRT when returned to S3	
	Key input	When a key is pressed, check if it is Tilde key or Tab key
F002h	Initialization of SC	Halts when error occurs D port=F003h or F004h
F006h	BIOS rewrite request check	If Checksum check error occurred on other than Boot Block or rewrite is required by user, go to "BIOS rewrite process"
F007h	Transits to system BIOS IRT	
	BIOS rewrite process	Initialization of ICH. D31
		DRAM configuration
		Permission of cache (L1 cache only)
		Memory clear
	Transits to real mode and copies BIOS to RAM	

Table 2-4 Debug port (Boot mode) error status (2/10)

D port status	Inspection items	Details	
F009h	Saving key scan code		
	Setting TASK_1ms_TSC		
	Controlling fan		
	Initializing sound items (for BEEP)		Enabling system speaker
			Releasing mute
			Making the volume max (for models that can control volume)
	When BIOS, EC/KBC rewriting is requested		Blinks green (cycle:2s, on:1s, off:1s)
	When BIOS ROM is abnormal		Blinks orange (cycle:2s, on:1s, off:1s)
	When BIOS renewal is prohibited		Blinks orange (cycle:8s, on:4s, off:4s) Beeps 30 second and halts D port=F00Bh (Class 2 security model only)
	Key input		Temporary prohibition of USB
			Beeps
			Waiting for key input
	Reading CHGBIOSA.EXE / CHGFIRMA.EXE		FDC reset
			Setting parameters for 2HD(1.44MB)
			Reading of first sector, If it is the data of 1.44MB (2HD), the media type is definite
			Setting of parameters for 2DD (720KB)
			Retrieval of "CHGBIOSA.EXE" from the root directory
		Calculation of directory start head and sector	
		Read one sector of the root directory	
		Retrieval of entry of "CHGBIOSA.EXE" / "CHGFIRMA.EXE" from the sector read	
	Reading of EXE header of "CHGBIOSA.EXE" and "CHGFIRMA.EXE"		
	Key input when error occurred		
	Execution of "CHGBIOSA.EXE" and "CHGFIRMA.EXE"		
F100h	Renewal of micro code (for models supporting HTT)		
	Prohibition of cache		
	Permission of L1/L2 cache in Flash ROM area		

Table 2-4 Debug port (Boot mode) error status (3/10)

D port status	Inspection items	Details
(F100h)	Initialization of H/W (before DRAM recognition)	Initialization of MCHM
		Initialization of ICH7M.D30.Func0
		Initialization of ICH7M.D31.Func0
		Initialization of ICH7M.D31.Func1/2
		Initialization of USB controller
		Initialization of ICH7M.D31.Func3
	Initialization of TI controller	
	Initialization of PIT channel 1	(Setting the refresh interval to "30 $\mu$ s")
F101h	Checking DRAM type and size (at cold boot)	When unsupported memory is connected, the system beeps and halts When DRAM size = 0, halts
	Testing the stack area of SM-RAM	When it can not be used as stack area, halts
F102h	Configuring cache memory	
	Permission of L1/L2 cache memory	
	Checking the access of a CMOS (Only in Cold Boot)	When error is detected, halts
	Examining the battery level of CMOS	
	Checksum check of CMOS	
	Initializing data in CMOS (1)	
	Setting up of IRT status	(Setting of boot status and IRT busy flag, The rest bits are set to 0)
	Storing the size of DRAM	
F103h	Branch of resuming (only in Cold Boot)	When a CMOS error is detected, it does not resume
		If "resume status code" is not set, no resume occurs

Table 2-4 Debug port (Boot mode) error status (4/10)

D port status	Inspection items	Details
(F103h)		Resume error check S3 recovery error (ICH) Resume error F17Ah SM-RAM checksum check Resume error F173h Memory configuration change check Resume error F173h Checksum check of system BIOS RAM area Resume error F179h Checksum check of expansion memory (Montara) Resume error F176h Checksum check of PnP RAM Resume error F177h To resume process (RESUME_MAIN)
	To resume error process	Returns the CPU clock to "Low"
		Prohibition of all SMIs
		Clears resume status
		Returns to ROM
		Forwards the area of C0000h to EFFFFh to PCI (prohibition of DRAM)
		Sets resume error request
Copying ROM/RAM of system BIOS	Halts, when error occurred	
F105h	SMRAM initialization	
	Check if CPU corresponds to Hyper Threading (for models supporting HTT)	
	Initialization of APIC	
	WakeUp factor check	
	SMRAM base rewriting and CPU state map saving for BIOS	
	Permission of SMI based on ASMI	

Table 2-4 Debug port (Boot mode) error status (5/10)

D port status	Inspection items	Details		
F106h	Initialization of devices which need initialization before PCI bus initialization	PIT test (at Cold boot only) and initialization Setting of test pattern to channel 0 of PIT#0 Check whether the set test pattern can be read. Initialization of PIT channel 0 (Setting of timer interruption interval to 55ms) Initialization of PIT channel 2 (Setting of the sound generator frequency to 664Hz) Test of PIT channel 1 (Check whether the refresh signal works properly in 30 micro-s refresh interval.) The system halts when the time is out. Test of PIT channel 2 (Check whether the speaker gate works properly)		
		CPU clock measurement		
		Check of parameter block A		
		Permission of SMI except auto-off function		
		Over control of rated input power		
		Battery discharge current control (1CmA)		
		Over control of AC adapter rated current		
		Dividing procedures for time measuring by IRT		
		Setting for clock generator		
		Checking parameter tab lock A		
		CPU Initialization Updating micro-code Judging of CPU type Geyserville support check Setting of CPU clock to "High"		
		F107h	Saving memory configuration to buffer	
			Reading of EC version	
Update of flash ROM type				
Judging of destination (Japan or other than Japan) based on DMI data				
CMOS default setting check	Sets default setting if bad battery or bad checksum (ROM, CMOS) is detected.			
ACPI table initialization (for execution of option ROM)				

Table 2-4 Debug port (Boot mode) error status (6/10)

D port status	Inspection items	Details
F107h	Initialization of devices which need initialization before PCI bus initialization	Setting operation mode of IDE device
		Setting operation mode of AC'97/Azalia
		Initialization of temperature control information
		KBC initialization
		VGA display off, Reset control
		PCI Express initialization
		Sound initialization
		PC multi-box status acquisition
		HC initialization, USB device connection recognition and initialization
		Recognizing an initializing of SD memory card
		Control of built-in LAN permission/prohibition
	PIC initialization	
	PIC test	
Password Initialization		
F108h	PCI bus initialization (connection of DS Bus)	
	Initialization of LAN information	
	Check of WakeUp factor	
F109h	Task generation for waiting INIT_PCI completion	
	CMOS data initialization (2)	
	PnP initialization	
	Setting of setup items	
	Waiting for the completion of Multi-box status check	
	H/W setting based on resource	
F10AH	Task generation for waiting PnP resource making completion	
	PnP H/W initialization	PC card slot initialization
		SIO initialization (for models supporting SIO)
		FIR initialization (for models supporting FIR)



Table 2-4 Debug port (Boot mode) error status (7/10)

D port status	Inspection items	Details
F10Ah	PCI automatic configuration	Making of work for automatic configuration
		Acquisition of PCI IRQ
		Configuration
		Saving of VGA configuration result
F10Bh	Task generation for waiting PCI_CONFIGURATION completion	
	Initialization of H/W needed after PCI configuration	Printer port setting (for models supporting printer) HDD initialization sequence start
	Enabling power off	
	Output code generation	
F10Ch	FIRST_64KB_CHECK	(Check of first 64KB memory)
F10Dh	INIT_INT_VECTOR	(Initialization of vectors)
F10Eh	INIT_NDP	(Initialization of NDP)
F10Fh	INIT_SYSTEM (Initialization of system)	Storing of CMOS error status to IRT_ERR_STS_BUF
		Timer initialization start
		EC initialization & Reading of battery information
		Update of system BIOS (Update of EDID information for LCD)
F110h	INIT_DISPLAY (Waiting for VGA chip initialization completion, VGA BIOS initialization)	
F111h	VGA POST	
F113h	DISP_LOGO	Displaying logo
F114h	SYS_MEM_CHECK (boot mode)	Check of convention memory
F115h	EXT_MEM_CHECK (boot mode)	Check of exception in the protected mode
F116h	Exception check in the protected mode	Dport=F117h when error occurs
	INIT_SYS_MEM (reboot mode)	Initialization of conventional memory
F118h	CHK_DMA_PAGE (boot mode)	Check of DMA Page Register
F119h	CHECK_DMAC (boot mode)	Check of DMAC

Table 2-4 Debug port (Boot mode) error status (8/10)

D port status	Inspection items	Details
F11Ah	INIT_DMAC (boot mode)	Initialization of DMAC
F11Bh	CHECK_SIO (for models supporting SIO)	Check of SIO
F11Dh	Diagnostic Test	In Models supporting Diagnostic Mode, it is enabled.
F11Eh	BOOT_PASSWORD (password check)	Waiting for FDD initialization completion (for models supporting built-in FDD)
		(In Reboot Mode) Waiting for HDD initialization completion Check of key input during IRT (waiting for KBC initialization completion) ATA priority initialization
		(In Boot Mode) BM loading process (for models supporting fingerprint authentication) Initialization of BM (for models supporting fingerprint authentication) Check of key input during IRT (waiting for KBC initialization completion) Input of password I/O LOCK process (for models supporting I/O lock) TPM initialization (models supporting TPM)
F11Fh	EX_IO_ROM_CHECK	Check of option I/O ROM
F120h	PRE_BOOT_SETUP	Saving of value in 40:00h (for SIO saving/restoring)
		Setting of font address for resume password
		Setting of repeat parameter for USB KB
		Final check of key input during IRT
		Storing of T_SHADOW_RAM_SIZE
		Update of system resource just before booting
		Rewriting of memory map data of INT15h E820h function
		Waiting for AC-Link initialization completion
		Renewal of table for DMI
		Copying ACPI table to uppermost of extension memory
		Waiting for completion of BIOS rewriting of PSC version

Table 2-4 Debug port (Boot mode) error status (9/10)

D port status	Inspection items	Details
(F120h)		Waiting for completion of initialization of Serial Port (for models supporting SIO)
		Waiting for completion of setting clock generator When error occurred, halts at D port=F121h
		Cancel of NMI Mask
		TIT check sum
		Clear of the IRT flag of Runtime side
		Update of check sum of Runtime side
		Hibernation branch (for models supporting BIOS Hibernation)
		Initialization of Bluetooth (for models supporting Bluetooth)
		Check for existence of target maintenance card
		Prohibition of unused PC card
		Setting Wakeup status data for ACPI
		HW initialization just before booting, Waiting for initialization completion
		Notifies the DVI connection status to VGA BIOS (for models supporting DVI)
		Setting of battery save mode
Setting of date		
Waiting for Bluetooth initialization completion (for models supporting Bluetooth)		
Update of DMI Wakeup factor, Update of SM-BIOS structure table		
PCI device configuration space close		
Cache control		
Process for CPU Make the CPU clock to be set by SETUP		
Waiting of motor-off completion of disabled HDD		
Final decision of USB FDD information		
Post processing of PRE_BOOT_SETUP Clear of PWRBTN_STS		
Enabling POWER Button		

Table 2-4 Debug port (Boot mode) error status (10/10)

D port status	Inspection items	Details
F122h	Start of BIOS security check	When error occurred, halts at D port=F166h
F123h	End of BIOS security check	
F124h	Clear of IRT status, renewal of check sum of Runtime side	
FFFFh	End	

Check 1 If the D port is status F11Eh or F120h is displayed, go to HDD Troubleshooting Procedure in Section 2.6.

Check 2 If any other D port status error code is displayed, perform Procedure 3.

D port error code is as follows:

Error code	Contents
F003h or F004h	SC initialization error
F00Bh	BIOS update error
F117h	Exception check error
F121h	Clock generator error
F166h	BIOS security error

**Procedure 3 Diagnostic Test Program Execution Check**

Execute the following tests from the Diagnostic Test Menu. These tests check the System board. Refer to Chapter 3, *Tests and Diagnostic*, for more information on how to perform these tests.

1. System test
2. Memory test
3. Keyboard test
4. Display test
5. Floppy Disk test
6. Printer test
7. ASYNC test
8. Hard Disk test
9. Real Timer test
10. NDP test
11. Expansion test
12. CD-ROM/DVD-ROM test
13. Only One test
14. Wireless LAN test
15. LAN/Modem/Bluetooth/IEEE1394 test
16. Sound test

If an error is detected during these tests, go to Procedure 4.

**Procedure 4 Replacement Check**

The system board connectors may be disconnected. Disassemble the computer following the steps described in Chapter 4, *Replacement Procedures* and perform Check 1.

Check 1 Visually check for the following:

- a) Cracked or broken connector housing
- b) Damaged connector pins

If connectors are in good condition, but there is still a problem, go to Check 2.

Check 2 The system board may be damaged. Replace the system board with a new one following the steps described in Chapter 4, *Replacement Procedures*.

---

# **Chapter 3**

## **Tests and Diagnostics**

---



---

## Chapter 3 Contents

---

3.1	The Diagnostic Test .....	3-1
3.1.1	Diagnostics menu .....	3-1
3.1.2	H/W (Hardware) initial information setting tool.....	3-3
3.1.3	Heatrun test program.....	3-3
3.2	Executing the Diagnostic Test .....	3-4
3.2.1	Diagnostics menu (T&D).....	3-5
3.2.2	H/W initial information setting tool .....	3-7
3.2.3	Heatrun test program .....	3-7
3.3	Setting of the hardware configuration .....	3-8
3.4	Heatrun Test.....	3-11
3.5	Subtest Names.....	3-12
3.6	System Test.....	3-14
3.7	Memory Test.....	3-16
3.8	Keyboard Test.....	3-17
3.9	Display Test .....	3-18
3.10	Floppy Disk Test.....	3-21
3.11	Printer Test.....	3-23
3.12	Async Test .....	3-25
3.13	Hard Disk Test .....	3-26
3.14	Real Timer Test.....	3-29
3.15	NDP Test.....	3-31
3.16	Expansion Test.....	3-32
3.17	CD-ROM/DVD-ROM Test .....	3-34
3.18	Error Code and Error Status Names .....	3-35
3.19	Hard Disk Test Detail Status .....	3-38
3.20	Only One Test.....	3-40
3.20.1	Program Description .....	3-40
3.20.2	Operations .....	3-40
3.21	Head Cleaning.....	3-49



3.21.1	Function Description .....	3-49
3.21.2	Operations .....	3-49
3.22	Log Utilities .....	3-50
3.22.1	Function Description .....	3-50
3.22.2	Operations .....	3-51
3.23	Running Test.....	3-52
3.23.1	Function Description .....	3-52
3.23.2	Operations .....	3-52
3.24	Floppy Disk Drive Utilities.....	3-53
3.24.1	Function Description .....	3-53
3.24.2	Operations .....	3-54
3.25	System Configuration .....	3-58
3.25.1	Function Description .....	3-58
3.25.2	Operations .....	3-59
3.26	Wireless LAN Test Program (Intel-made b/g).....	3-60
3.27	Wireless LAN Test Program (Intel-made a/b/g).....	3-64
3.28	Wireless LAN Test Program (Atheros) .....	3-69
3.28.1	Setting the responder machine .....	3-70
3.28.2	Test procedure .....	3-71
3.28.3	Contents of the test and errors.....	3-72
3.29	LAN/Modem/Bluetooth/IEEE1394 Test Program .....	3-76
3.29.1	LAN test .....	3-76
3.29.2	Modem test .....	3-79
3.29.3	Bluetooth test.....	3-80
3.29.4	IEEE1394 test.....	3-89
3.30	Sound Test Program.....	3-90
3.30.1	Sound (Standard) .....	3-90
3.30.2	Sound (Legacy) .....	3-92
3.30.3	CD Sound (Standard) .....	3-93
3.30.4	CD Sound (Legacy) .....	3-95
3.31	SETUP .....	3-96

3.31.1	Function Description .....	3-96
3.31.2	Accessing the SETUP Program.....	3-98

## Figures

Figure 3-1	Name and positions of each side.....	3-46
------------	--------------------------------------	------

## Tables

Table 3-1	Subtest names.....	3-12
Table 3-2	Error codes and error status names .....	3-35
Table 3-3	HDC status register contents.....	3-38
Table 3-4	Error register contents.....	3-39
Table 3-5	Error message.....	3-82
Table 3-6	Error code for Bluetooth test (BD_ADDR).....	3-83
Table 3-7	Error code for Bluetooth test (BD_ADDR of the DUT).....	3-87



## 2.5 USB 3.5" FDD Troubleshooting

This section describes how to determine if the USB 3.5" FDD is functioning properly. Perform the steps below starting with Procedure 1 and continuing with the other procedures as required.

Procedure 1: FDD Head Cleaning Check

Procedure 2: Diagnostic Test Program Execution Check

Procedure 3: Connector Check

Procedure 4: Replacement Check

### Procedure 1 FDD Head Cleaning Check

FDD head cleaning is one option available in the Diagnostic Program.

Insert the Diagnostics Disk in the USB floppy disk drive, turn on the computer and run the test. And then clean the FDD heads using the cleaning kit. If the FDD still does not function properly after cleaning, go to Procedure 2.

Detailed operation is given in Chapter 3, *Tests and Diagnostics*.

If the test program cannot be executed on the computer, go to Procedure 3.

## Procedure 2 Diagnostic Test Program Execution Check

Insert the Diagnostics Disk in the USB FDD, turn on the computer and run the test. Refer to Chapter 3, *Tests and Diagnostics*, for more information about the diagnostics test procedures.

Make sure the floppy disk is formatted correctly and that the write protect tab is disabled. Floppy disk drive test error codes and their status names are listed in Table 2-5. If any other errors occur while executing the FDD diagnostics test, go to Check 1.

Table 2-5 FDD error code and status

Code	Status
01h	Bad command
02h	Address mark not found
03h	Write protected
04h	Record not found
06h	Media replaced
08h	DMA overrun error
09h	DMA boundary error
10h	CRC error
20h	FDC error
40h	Seek error
60h	FDD not drive
80h	Time out error (Not ready)
EEh	Write buffer error
FFh	Data compare error

Check 1 If the following message is displayed, disable the write protect tab on the floppy disk by sliding the write protect tab to “write enable”. If any other message appears, perform Check 2.

Write protected

Check 2 Make sure the floppy disk is formatted correctly. If it is, go to Procedure 3.

### Procedure 3 Connector Check

The USB FDD connector may be disconnected from the connector on the system board or USB board. Check visually that the connector is connected firmly.

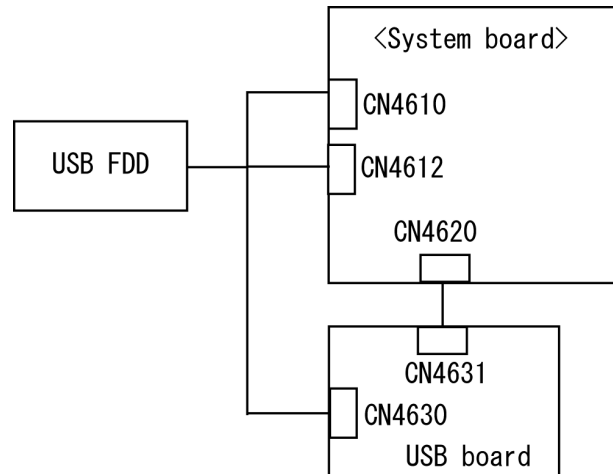

Check 1 Make sure the USB FDD cable is firmly connected to the CN4610 (port 4/6), CN4612 (port 0) on the system board or CN4630 (port 7) on the USB board.

If the connection is loose, reconnect firmly and repeat Procedure 2. If there is still an error, go to Check 2.

Check 2 Make sure the USB board cable is firmly connected to the CN4620 on the system board and CN4631 on the USB board.

If the connection is loose, reconnect firmly and repeat Procedure 2. If there is still an error, go to procedure 4.

### Procedure 4 Replacement Check

Prepare a USB FDD works properly. Connect the USB FDD to the CN4610, CN4612 on the system board and CN4630 on the USB board and check if the USB FDD works properly. If the USB FDD is not functioning properly, go to Check 1 (when connecting to the CN4630) or check 2 (when connecting to the CN4612 or CN4612).

Check 1 The USB board or USB board cable may be defective or damaged. Replace it (them) with a new one. If the USB FDD is still not functioning properly, perform Check 2.

Check 2 Replace the system board with a new one following the steps in Chapter 4, *Replacement Procedures*.

## 2.6 2.5" HDD Troubleshooting

This section describes how to determine if the 2.5" HDD is functioning properly. Perform the steps below starting with Procedure 1 and continuing with the other procedures as required.

Procedure 1: Partition Check

Procedure 2: Message Check

Procedure 3: Format Check

Procedure 4: Diagnostic Test Program Execution Check

Procedure 5: Connector Check and Replacement Check

**CAUTION:** *The contents of the 2.5" hard disk will be erased when the 2.5" HDD troubleshooting procedures are executed. Transfer the contents of the hard disk to floppy disks or other storage drive(s). For the backup, refer to the User's Manual.*

### Procedure 1 Partition Check

Insert the Toshiba DOS system disk and start the computer. Perform the following checks:

- Check 1 Type **C:** and press **Enter**. If you cannot change to drive C, go to Check 2. If you can change to drive C, go to Procedure 2.
- Check 2 Type **FDISK** and press **Enter**. Choose Display Partition Information from the FDISK menu. If drive C is listed in the Display Partition Information, go to Check 3. If drive C is not listed, return to the FDISK menu and choose the option to create a DOS partition or a logical DOS drive on drive C. If the problem still exists, go to Procedure 2.
- Check 3 If drive C is listed as active in the FDISK menu, go to Check 4. If drive C is not listed as active, return to the FDISK menu and choose the option to set the active partition for drive C. Then go to Procedure 2.
- Check 4 Remove the system disk from the FDD and reboot the computer. If the problem still exists, go to Procedure 2. Otherwise, the HDD is operating normally.

## Procedure 2 Message Check

When the power is turned on, the system performs the Initial Reliability Test (IRT) installed in the BIOS ROM. When the test detects an error, an error message is displayed on the screen.

Make sure of no floppy disk in the FDD. Turn on the computer and check the message on the screen. When an OS starts from the 2.5" HDD, go to Procedure 3. Otherwise, start with Check 1 below and perform the other checks as instructed.

Check 1 If any of the following messages appear, go to Procedure 3. If the following messages do not appear, perform Check 2.

Built-in HDD ERROR (After 5 seconds this message will disappear.)

or

CD-ROM ERROR (After 5 seconds this message will disappear.)

Check 2 If either of the following messages appears, go to Check 3. If the following messages do not appear, perform Check 4.

Insert system disk in drive  
Press any key when ready .....

or

Non-System disk or disk error  
Replace and press any key when ready

Check 3 Using the SYS command of the DOS, transfer the system to the 2.5" HDD. If the system is not transferred, go to Procedure 3. Refer to the DOS Manual for detailed operation.

If the following message appears on the display, the system program has been transferred to the HDD.

System Transferred

If an error message appears on the display, perform Check 4.

Check 4 The 2.5" HDD and the connector on the system board may be disconnected (Refer to the steps described in Chapter 4, *Replacement Procedures* for disassembling the PC.). Reconnect them firmly. If they are firmly connected, go to Procedure 3.



**Procedure 3    Format Check**

The computer's 2.5" HDD is formatted using the DOS FORMAT program or the physical format program of the test program. To format the 2.5" HDD, start with Check 1 below and perform the other steps as required.

Refer to the DOS Manual for the operation of DOS. For the format by the test program, refer to the Chapter 3.

Check 1    Format the 2.5" HDD using DOS FORMAT command. Type as **FORMAT C:/S/U**.

If the 2.5" HDD can not be formatted, perform Check 2.

Check 2    Using the DOS FDISK command, set the 2.5" HDD partition. If the partition is not set, go to Check 3. If it is set, format the 2.5" HDD using DOS FORMAT command.

Check 3    Using the Diagnostic Disk, format the 2.5" HDD with a format option (physical format). If the 2.5" HDD is formatted, set the 2.5" HDD partition using DOS FDISK command.

If you cannot format the 2.5" HDD using the Tests and Diagnostic program, go to Procedure 4.

#### Procedure 4 Diagnostic Test Program Execution Check

The HDD test program is stored in the Diagnostics Disk. Perform all of the HDD tests in the Hard Disk Drive Test. Refer to Chapter 3, *Tests and Diagnostics*, for more information about the HDD test program.

If an error is detected during the HDD test, an error code and status will be displayed. The error codes and statuses are described in Table 2-6. If an error code is not displayed but the problem still exists, go to Procedure 5.

Table 2-6 2.5" HDD error code and status

Code	Status
01h	Bad command
02h	Address mark not found
04h	Record not found
05h	HDC not reset
07h	Drive not initialized
08h	HDC overrun error (DRQ)
09h	DMA boundary error
0Ah	Bad sector error
0Bh	Bad track error
10h	ECC error
11h	ECC recover enable
20h	HDC error
40h	Seek error
80h	Time out error
AAh	Drive not ready
BBh	Undefined error
CCh	Write fault
E0h	Status error
EEh	Access time out error
DAh	No HDD

**Procedure 5 Connector Check and Replacement Check**

The HDD is connected to the system board with a HDD cable. The connecting portions may be loose. Disassemble the computer following the steps described in Chapter 4, *Replacement Procedures* and perform the following checks to check the connecting portions:

- Check 1 Make sure the HDD cable is firmly connected to the connector CN1850 on the system board and HDD.

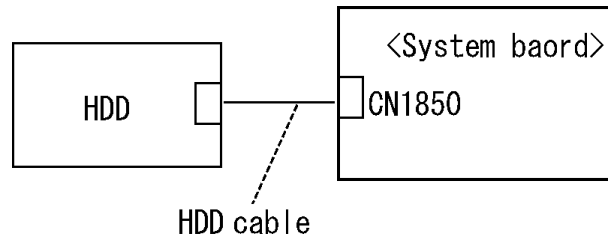

If connection is loose, reconnect firmly and repeat Procedure 4. If there is still an error, go to Check 2.

- Check 2 The 2.5" HDD may be damaged. Replace it with a new one and check the operation. If the problem still exists, perform Check 3.
- Check 3 The system board may be damaged. Replace it with a new one following the instructions in Chapter 4, *Replacement Procedures*.

## 2.7 Keyboard Troubleshooting

To determine if the computer's keyboard is functioning properly, perform the following procedures. Start with Procedure 1 and continue with the other procedures as instructed.

Procedure 1: Diagnostic Test Program Execution Check

Procedure 2: Connector Check and Replacement Check

### Procedure 1 Diagnostic Test Program Execution Check

Execute the Keyboard Test in the Diagnostic Program. Refer to Chapter 3, *Tests and Diagnostics* for more information on how to perform the test program.

If an error occurs, go to Procedure 2. If an error does not occur, the keyboard is functioning properly.

### Procedure 2 Connector Check and Replacement Check

The keyboard or system board may be disconnected or damaged. Disassemble the computer following the steps described in Chapter 4, *Replacement Procedures* and perform the following checks:

Check 1 Make sure the keyboard cable is firmly connected to the connector CN3200 on the system board.

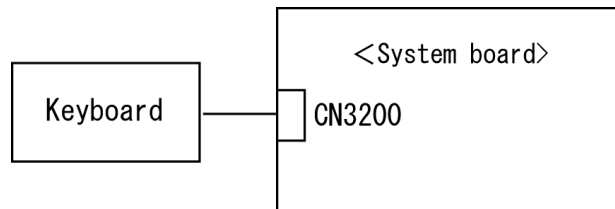

If the connection is loose, reconnect the cable firmly and repeat Procedure 1. If there is still an error, go to Check 2.

Check 2 The keyboard may be damaged. Replace it with a new one following the instructions in Chapter 4, *Replacement Procedures*. If the problem still exists, perform Check 3.

Check 3 The system board may be damaged. Replace it with a new one following the instructions in Chapter 4, *Replacement Procedures*.

## 2.8 Display Troubleshooting

This section describes how to determine if the computer's display is functioning properly. Start with Procedure 1 and continue with the other procedures as instructed.

Procedure 1: External Monitor Check

Procedure 2: Diagnostic Test Program Execution Check

Procedure 3: Connector and Cable Check

Procedure 4: Replacement Check

### Procedure 1 External Monitor Check

Connect an external monitor to the computer's external monitor port, and then boot the computer. The computer automatically detects the external monitor.

If the external monitor works correctly, the internal LCD may be damaged. Go to Procedure 3.

If the same problem as the internal monitor appears on the external monitor, the System board may be damaged. Go to Procedure 2.

### Procedure 2 Diagnostic Test Program Execution Check

The Display Test program is stored on the Diagnostics disk. Insert the Diagnostics disk in the USB floppy disk drive, turn on the computer and run the test. Refer to Chapter 3, *Tests and Diagnostics* for details.

This program checks the display controller on the system board. If an error is detected, go to Procedure 3.

### Procedure 3 Connector and Cable Check

The LCD module is connected to the System board through the LCD/FL cable. Also, the FL inverter is connected the system board through the LCD/FL cable. The cable may be firmly disconnected the board or damaged. Disassemble the computer following the steps described in Chapter 4, *Replacement Procedures*. If the connection is loose, reconnect the cable firmly and repeat Procedure 2. If there is still an error, go to Procedure 4.

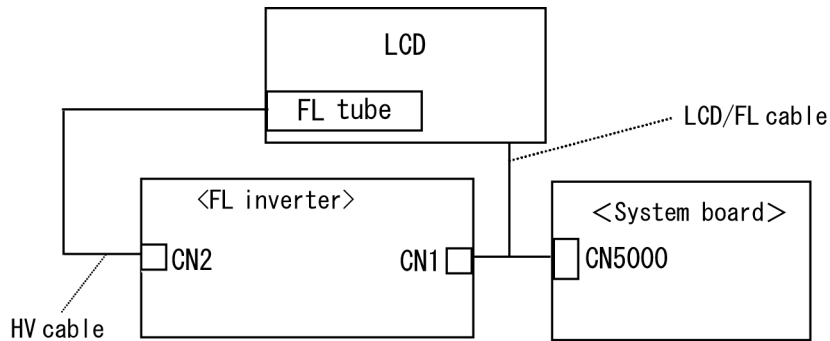

### Procedure 4 Replacement Check

- (1) If characters or graphics are not displayed on the internal display, perform Check 1.
- (2) If characters or images are displayed on the internal display but the display is not normal, perform Check 2.
- (3) If characters or images are displayed on the internal display but the display is dark (the back-light does not light), perform Check 5.

- Check 1 The display ON/OFF switch may be damaged. Replace it with a new one following the instructions in Chapter 4, *Replacement Procedures* and test the display again. If there is still an error, go to Check 2.
- Check 2 The LCD/FL cable may be damaged. Replace it with a new one following the instructions in Chapter 4, *Replacement Procedures* and test the display again. If there is still an error, go to Check 3.
- Check 3 The LCD may be damaged. Replace it with a new one following the instructions in Chapter 4, *Replacement Procedures* and test the display again. If there is still an error, go to Check 4.
- Check 4 The FL inverter may be damaged. Replace it with a new one following the instructions in Chapter 4, *Replacement Procedures* and test the display again. If there is still an error, go to Check 5.
- Check 5 The FL tube may be damaged. Replace it with a new one following the instructions in Chapter 4, *Replacement Procedures* and test the display again. If there is still an error, go to Check 6.
- Check 6 The system board may be damaged. Replace it with a new one following the instructions in Chapter 4, *Replacement Procedures*.

## 2.9 Touch pad Troubleshooting

To determine whether the Touch pad is faulty or not, perform the following procedures:

Procedure 1: Diagnostic Test Program Execution Check

Procedure 2: Connector and Cable Check

Procedure 3: Replacement Check

### Procedure 1 Diagnostic Test Program Execution Check

Execute the test for Touch pad in ONLY ONE test in the Diagnostic Program. Refer to Chapter 3, *Tests and Diagnostics*, for more information on how to perform the test program.

If an error occurs, go to Procedure 2. If an error does not occur, the Touch pad keyboard is functioning properly.

### Procedure 2 Connector and Cable Check

The Touch pad is connected to the connector CN3201 on the system board with a cable. This cable may have come off the connector of the touch pad or of the System board. Disassemble the computer and check the cable connections. See Chapter 4 for the disassembly procedure. If the cable has come off, connect firmly and make sure the operation. If there is still an error, go to Procedure 3.

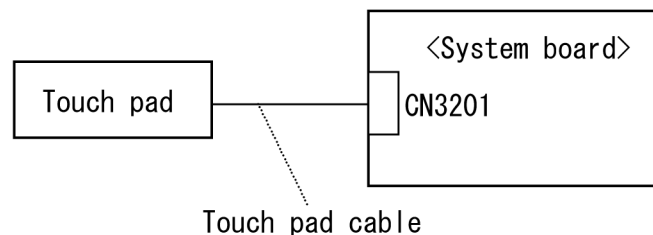

### Procedure 3 Replacement Check

Check 1 The touch pad may be damaged. Replace it with a new one and repeat Procedure 1. If there is still an error, go to Check 2.

Check 2 The touch pad cable may be damaged. Replace it with a new one and repeat Procedure 1. If there is still an error, go to Check 3.

Check 3 The system board may be damaged. Replace the system board with a new one according to the procedure in Chapter 4.

## 2.10 Optical drive Troubleshooting

To check if the optical drive is defective or not, follow the troubleshooting procedures below as instructed.

Procedure 1: Diagnostic Test Program Execution Check

Procedure 2: Connector Check and Replacement Check

### Procedure 1 Diagnostic Test Program Execution Check

Prepare the tools before the test. (Refer to tools for implementing the Diagnostics procedures on Chapter 3.)

Execute the CD-ROM/DVD-ROM Test in the Diagnostic Program. Refer to Chapter 3, *Tests and Diagnostics* for more information on how to perform the test program.

If any error is detected by the test, go to Procedure 2.

### Procedure 2 Connector Check and Replacement Check

The optical drive may be disconnected from the system board or faulty. Disassemble the computer following the steps described in Chapter 4 and perform the following checks:

Check 1 Make sure the optical drive is firmly connected to the connector CN1820 on the System board.

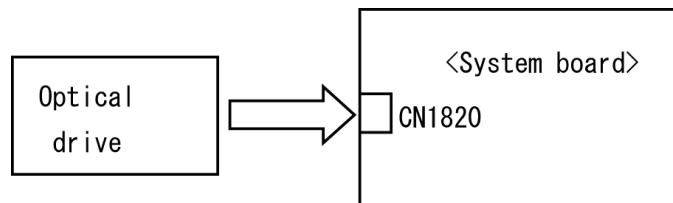

If the connection is loose, reconnect it firmly and return to Procedure 1. If there is still an error, perform Check 2.

Check 2 The optical drive may be faulty. Replace the optical drive with a new one following the steps in Chapter 4. If the problem still occurs, perform Check 3.

Check 3 The system board may be faulty. Replace it with new one following the instructions in Chapter 4.



## **2.11 Modem Troubleshooting**

To check if the modem is defective or malfunctioning, follow the troubleshooting procedures below as instructed.

Procedure 1: Diagnostic Test Program Execution Check

Procedure 2: Connector Check and Replacement Check

### **Procedure 1 Diagnostic Test Program Execution Check**

Insert the LAN/Modem/Bluetooth/IEEE1394 test program in the USB floppy disk drive, turn on the computer and run the test. Refer to Chapter 3, *Tests and Diagnostics*, for more information about the diagnostics test procedures.

If any errors occur while executing the Sound/Modem/LAN test, go to Procedure 2.

## Procedure 2 Connector Check and Replacement Check

The Modem jack (RJ11) is mounted on the system board and MDC is connected to the system board. If the modem malfunctions, the connections may be bad or the MDC or system board might be faulty.

Disassemble the computer following the steps described in Chapter 4 and perform the following checks:

Check 1 Make sure the MDC is firmly connected to the CN3010 on the system board.

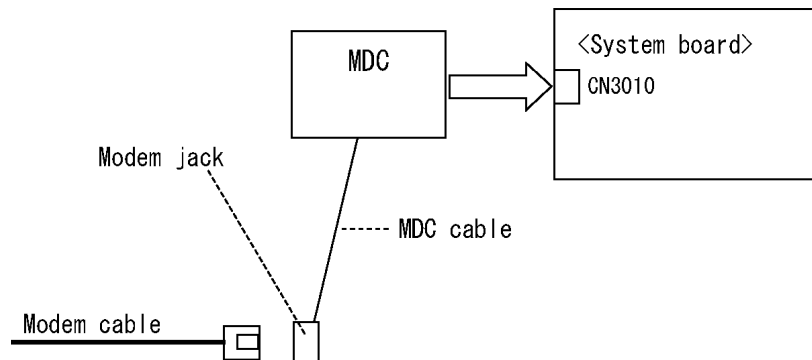

If any connector is disconnected, connect it firmly and return to Procedure 1. If there is still an error, perform Check 2.

- Check 2 The Modem cable may be faulty. Replace it with a new one. If the modem is not still working properly, perform Check 3.
- Check 3 The Modem jack may be faulty. Replace it with a new one following the steps in Chapter 4. If the modem is not still working properly, perform Check 4.
- Check 4 The MDC may be faulty. Replace it with a new one following the steps in Chapter 4. If the modem is not still working properly, perform Check 5.
- Check 5 The MDC cable may be faulty. Replace it with a new one following the steps in Chapter 4. If the modem is not still working properly, perform Check 6.
- Check 6 The system board may be faulty. Replace it with a new one following the instructions in Chapter 4.

## **2.12 Bluetooth Troubleshooting**

This section describes how to determine if the Bluetooth in the computer is functioning properly. Perform the steps below starting with Procedure 1 and continuing with the other procedures as required.

Procedure 1: Diagnostic Test Program Execution Check

Procedure 2: Connection Check

Procedure 3: Replacement Check

### **Procedure 1 Diagnostic Test Program Execution Check**

Make sure the wireless communication switch of the computer is turned “On”. If it is not, turn it “On”.

Check 1 Execute Bluetooth test program. Perform the test following the instructions described in Chapter 3, Bluetooth Test Program. You will need a second computer that can communicate by the Bluetooth.

If the computer passes the test, the function is correctly working. If the computer does not pass the test, go to check 2.

Check 2 The Bluetooth module may be defective or damaged. Replace it with a new one. Then perform the test program again.

If the computer still does not pass the test, go to Procedure 2.

### Procedure 2 Connection Check

The Bluetooth functional wiring diagram is shown below:

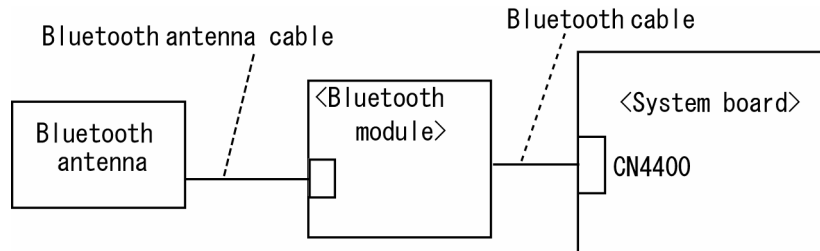

Any of the connections may be disconnected. Disassemble the computer following the steps described in Chapter 4, *Replacement Procedures*, and perform the following checks:

- Check 1 Make sure the Bluetooth cable is firmly connected to connector on the Bluetooth module CN4400 on the System board. If the connector is disconnected, connect it firmly and perform Procedure 1. If the Bluetooth module is still not functioning properly, perform Check 2.
- Check 2 Make sure the Bluetooth antenna cable (brown) is firmly connected to the Bluetooth module. If the Bluetooth antenna cable is disconnected, connect it firmly and perform Procedure 1. If the Bluetooth function is still not functioning properly,

### Procedure 3 Replacement Check

The Bluetooth antenna, Bluetooth module, CN board and System board are connected to the circuits. Any of these components may be damaged. Refer to Chapter 4, *Replacement Procedures*, for instructions on how to disassemble the computer and then perform the following checks:

- Check 1 The Bluetooth cables may be defective or damaged. Replace the cable with a new one following the steps in Chapter 4, *Replacement Procedures*. If the Bluetooth is still not functioning properly, perform Check 2.
- Check 2 The Bluetooth module may be defective or damaged. Replace the Bluetooth module with a new one following the steps in Chapter 4, *Replacement Procedures*. If the Bluetooth is still not functioning properly, perform Check 3.
- Check 3 The Bluetooth antenna may be defective or damaged. Replace the Bluetooth antenna with a new one following the steps in Chapter 4, *Replacement Procedures*. If the Bluetooth is still not functioning properly, perform Check 4.
- Check 4 The System board may be defective or damaged. Replace the System board with a new one following the steps in Chapter 4, *Replacement Procedures*.

## 2.13 LAN Troubleshooting

To check if the computer's LAN is defective or malfunctioning, follow the troubleshooting procedures below as instructed.

Procedure 1: Diagnostic Test Program Execution Check

Procedure 2: Connector Check and Replacement Check

### Procedure 1 Diagnostic Test Program Execution Check

To check the LAN function, execute the LAN/Modem/Bluetooth/IEEE1394 test program. See Chapter 3 for information on how to perform the test.

If any error is detected by the test, go to Procedure 2.

### Procedure 2 Connector Check and Replacement Check

The LAN function is installed on the system board and the RJ45 jack and the controller is mounted on the system board. If the LAN malfunctions, the system board might be faulty.

Disassemble the computer following the steps described in Chapter 4 and replace the System board.

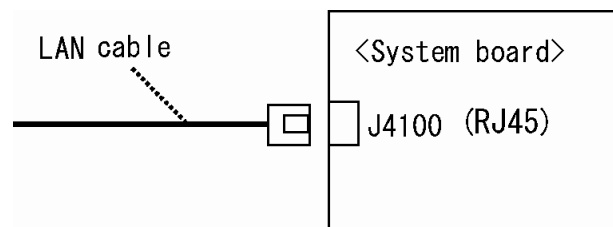

## 2.14 Sound Troubleshooting

To check if the sound function is defective or malfunctioning, follow the troubleshooting procedures below as instructed.

Procedure 1: Diagnostic Test Program Execution Check

Procedure 2: Connector Check

Procedure 3: Replacement Check

### Procedure 1 Diagnostic Test Program Execution Check

Insert the Sound test program in the USB floppy disk drive, turn on the computer and run the test. Refer to Chapter 3, Tests and Diagnostics, for details.

If any error is detected by the test, go to Procedure 2

### Procedure 2 Connector Check

The speaker, internal microphone, external microphone and headphone are connected to the system board shown in the following figure. These connections may be loose or cables may come off. Disassemble the computer referring to the steps described in Chapter 4 and make sure each connection. If there is still an error, perform Procedure 3.

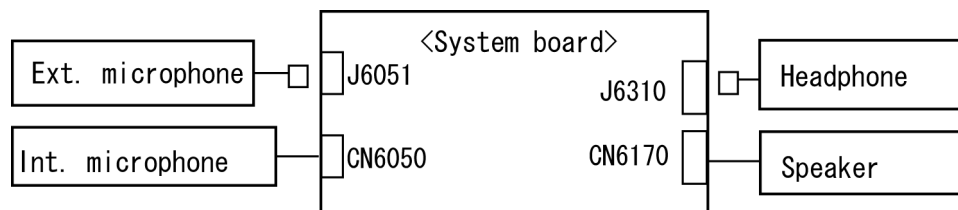

### Procedure 3 Replacement Check

- Check 1 If the speaker or headphone is not working properly, it may be faulty. Replace it with a new one. If there is still an error, go to Check 3.
- Check 2 If the external microphone or internal microphone is not working properly, it may be faulty. Replace it with a new one following the step in Chapter 4. If there is still an error, go to Check 3.
- Check 3 The system board may be faulty. Replace it with a new one following the step in Chapter 4.

## 2.15 Bridge media Slot Troubleshooting

To check if the Bridge media slot is good or no good, follow the troubleshooting procedures below as instructed.

Procedure 1: Check on Windows XP Tablet PC Edition

Procedure 2: Connector Check and Replacement Check

### Procedure 1 Check on Windows XP Tablet PC Edition

Insert a Bridge media (SD memory card/SDIO card/Memory stick/Memory stick Pro/xD Picture card/Multimedia card) into the slot. Check if the installed Windows XP Tablet PC Edition recognizes automatically the Bridge media and the data in the Bridge media can be read.

If the card is not recognized or data are not read, go to Procedure 2.

### Procedure 2 Connector Check and Replacement Check

The Bridge media is connected to the connector IS2101 of the system board.

Bridge media supports SD memory card/SDIO card/Memory stick/Memory stick Pro/xD Picture card/Multimedia card.

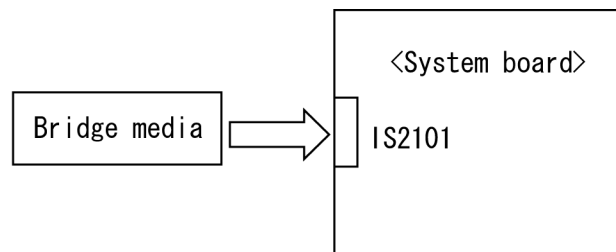

Check 1 Bridge media and system board may be disconnected. Make sure the Bridge media is firmly inserted to IS2101 on the system board. If not, insert it firmly. If the Bridge media is still not functioning properly, perform Check 2.

Check 2 Bridge media may be faulty. Replace it with a new one following the step in Chapter 4. If the problem continues, perform Check 3.

Check 3 System Board may be faulty. Replace it with a new one following the step in Chapter 4.

## 2.16 Tablet Pen Troubleshooting

To check if the Tablet Pen is defective or not, follow the troubleshooting procedures below as instructed.

**CAUTION:** Use the Tablet Pen supplied to this model.

Procedure 1: Check on Windows XP Tablet PC Edition

Procedure 2: Tablet pen replacement Check

Procedure 3: Connector Check and Replacement Check

### Procedure 1 Check on Windows XP Tablet PC Edition

This procedure checks if the tablet pen is working properly by using the function of Windows XP Tablet Edition.

Check 1 Make sure the mouse cursor is following the tablet pen when you move the pen on the display. If it does not work properly, go to Procedure 2.

Check 2 Make sure the “click” function works properly when you tap (touch) the display with the tablet pen. If it does not work properly, go to Procedure 2.

When both the functions work correctly, the tablet pen is not defective.

### Procedure 2 Tablet pen replacement Check

Check 1 The core of the tablet pen might be worn out. Replace the core with a new one following the steps in the User’s manual, and check the tablet pen is working properly. If there is still an error, go to Check 2.

Check 2 The tablet pen might be defective. Replace the tablet pen with a new one and check if the tablet pen is working properly. If there is still an error, execute Procedure 3.



**Procedure 3 Connector Check and Replacement Check**

The Digitizer and LCD are connected to the system board as below.

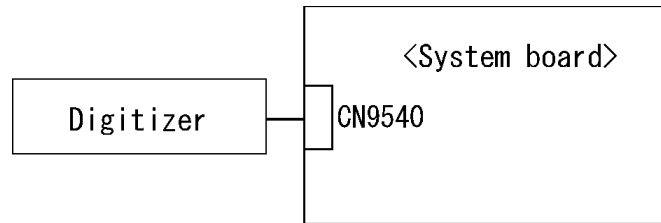

- Check 1 The Digitizer may be disconnected. Make sure the Digitizer is connected to the CN9540 on the system board. If there is still an error, go to Check 2.
- Check 2 The Digitizer or the system board may be defective. Replace it with a new one following the steps in Chapter 4. Then check the tablet pen is working properly.

## 2.17 Wireless LAN Troubleshooting

To check if the Wireless LAN is defective or not, follow the troubleshooting procedures below as instructed.

Procedure 1: Transmitting/Receiving Check

Procedure 2: Check of Antenna connection

Procedure 3: Replacement Check

### Procedure 1 Transmitting/Receiving Check

Make sure the wireless communication switch on the computer is turned ON. If it is not, turn ON.

Check 1 Execute test program for the wireless LAN function to check the transmitting/receiving function of the wireless LAN. You will need another computer that can communicate by the wireless LAN.

If the computer passes the test, the function is correctly working.

If the computer does not pass the test, perform Procedure 2.

### Procedure 2 Check of Antenna connection

The wireless LAN functional wiring diagram is shown below:

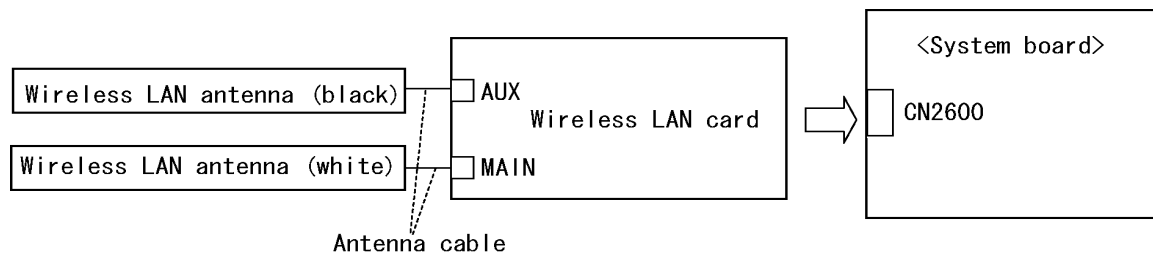

Any of the connections may be disconnected. Disassemble the computer following the steps described in Chapter 4, and perform the following checks:

**Check 1** The wireless LAN card and the system board may be disconnected. Make sure the wireless LAN card is firmly connected to the CN2600 of the system board.

If the board connector is disconnected, connect it firmly and return to Procedure 1. If there is still an error, go to Check 2.

**Check 2** Make sure the wireless LAN antennas (black and white) are firmly connected to the wireless LAN card. If the antennas are disconnected, connect firmly then return to Procedure 1. If there is still an error, perform Procedure 3.

### Procedure 3 Replacement Check

Check if the wireless LAN card and the system board are connected properly. If they are properly connected but there is still an error, any of these components may be damaged. Disassemble the computer following the steps described in Chapter 4 and replace the board with a new one.

**Check 1** The wireless LAN card may be defective or damaged. Disassemble the computer following the steps described in Chapter 4 and replace the board with a new one. If there is still an error go to Check 2.

**Check 2** The wireless LAN antennas may be defective or damaged. Disassemble the computer following the steps described in Chapter 4 and replace the board with a new one. If there is still an error go to Check 3.

**Check 3** The system board may be defective or damaged. Disassemble the computer following the steps described in Chapter 4 and replace the board with a new one.

## 2.18 Fingerprint sensor Troubleshooting

**CAUTION:** To delete the account for confirming the fingerprint operation, it is necessary to log on by the account with the management authority. If the password has been set to log on, ask the Log-ON password to the user.

To check if the Fingerprint sensor works correctly or not, follow the troubleshooting procedures below as instructed.

When failed in Procedure 1 to Procedure 3, execute Procedure 4.

Procedure 1: Setting Windows Log-ON password

Procedure 2: Registration of fingerprint

Procedure 3: Authentication of fingerprint

Procedure 4: Connector Check and Replacement Check

**CAUTION:** Scan your finger shown below.

1. Lay your finger straight to the sensor and put lightly the first joint of your finger at the centerline of the fingerprint sensor.
2. Slide slowly your finger from the first joint to fingertip at constant speed.  
When not recognized, adjust the speed.

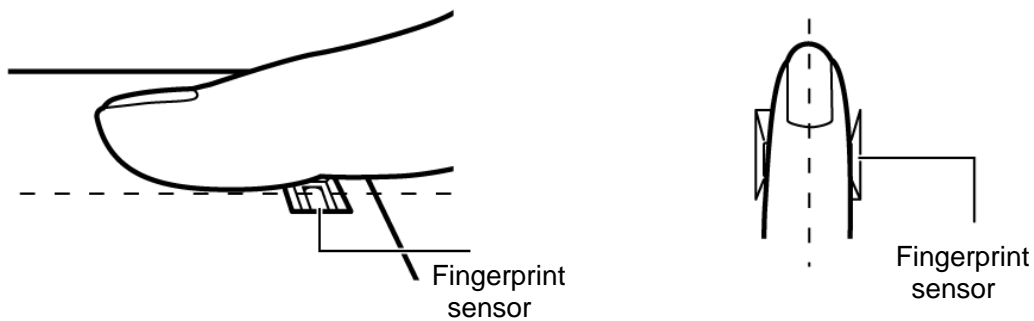

**Procedure 1 Setting Windows Log-ON password**

1. Open [User Account] from [Control Panel].
2. Click [User Account].
3. Click the icon of the account (user's name) that you want to set the password.
4. Click "Create Account".
5. Type a password in "Type a new password".
6. Press **Tab** key.
7. Type the password again.
8. Click "Create Password" button.
9. When "Do you want to make your files and folders private" appears in [Computer administrator], click [Yes, Make Private].

**Procedure 2 Registration of fingerprint**

1. Logon by user's account to register the fingerprint.
2. Open [Start] → [All Programs] → [Protector Suite QL] → [User Enrollment].
3. After displaying [User Enrollment], click [Next].

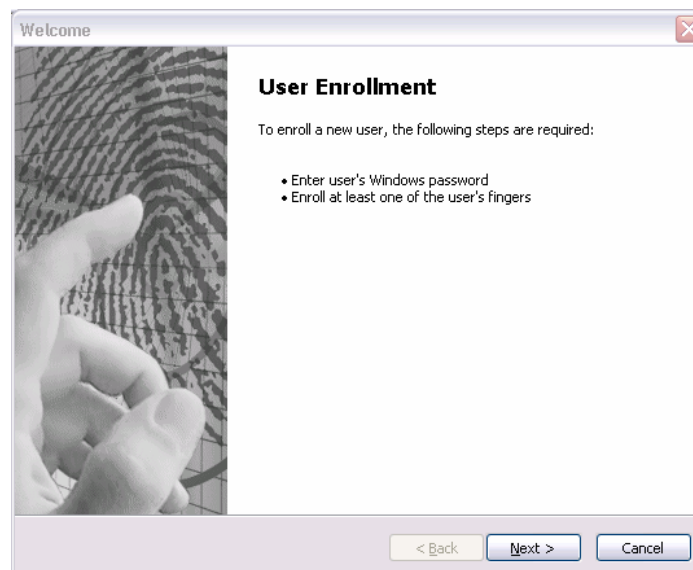

[User's Passport] appears in “Enter your password”. Click [Next].

When the finger print has been enrolled, [User's Password] appears. Slide your finger enrolled or type the password. Click [Next].

4. Type the Windows logon password in “Enter your password” and click [Next].  
[User's Password] appears.

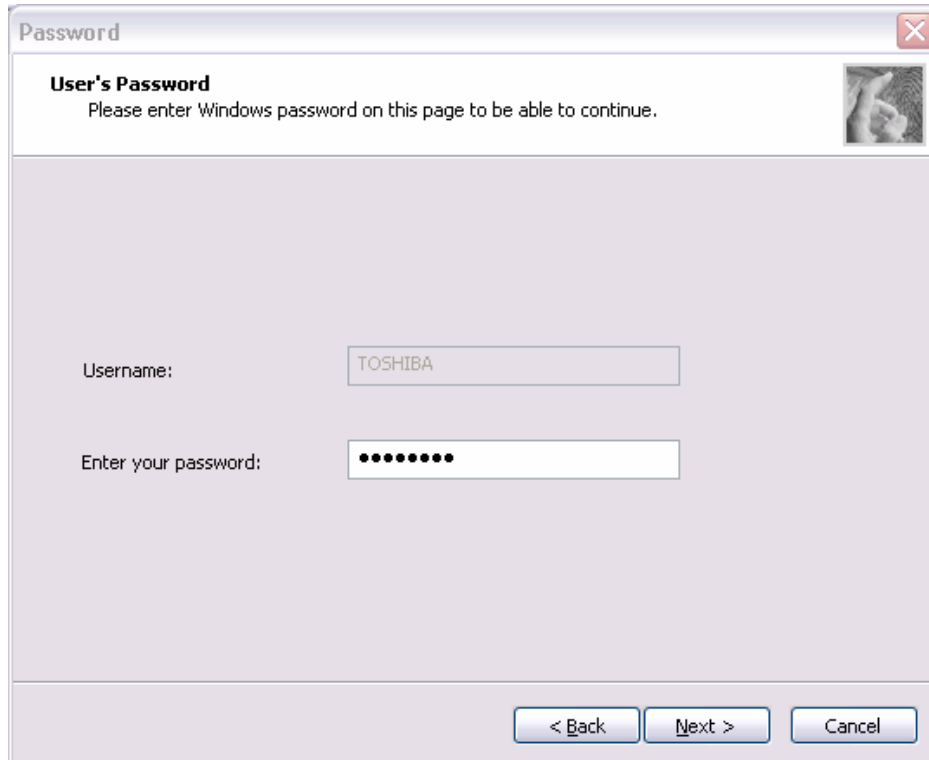

**Password**

**User's Password**  
Please enter Windows password on this page to be able to continue.

Username: TOSHIBA

Enter your password: ●●●●●●●●●●

< Back    Next >    Cancel

5. Confirm that the box of [Run interactive tutorial] is checked (when proceeding with seeing Tutorial) and click [Next].

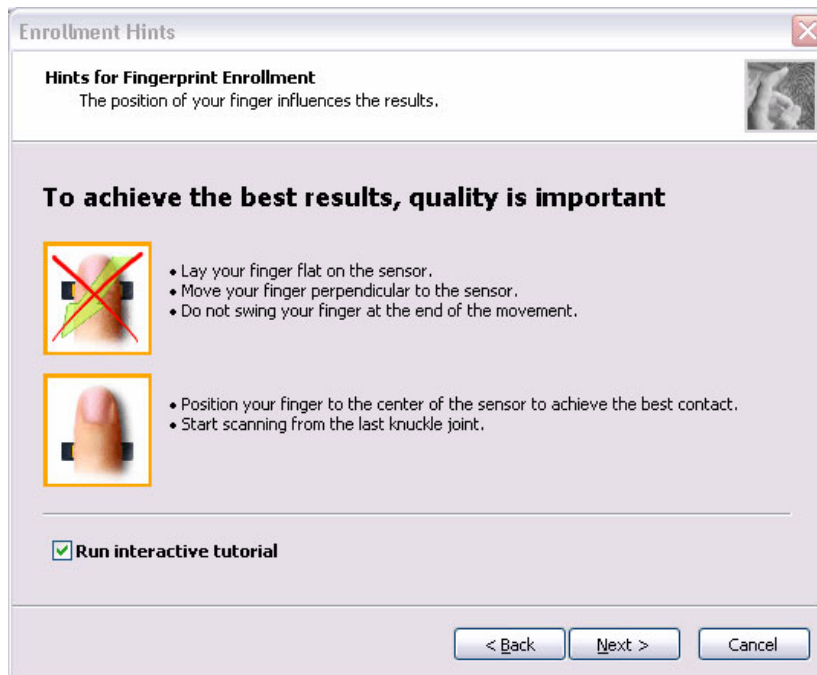

6. Watch the Video carefully, click [Next].

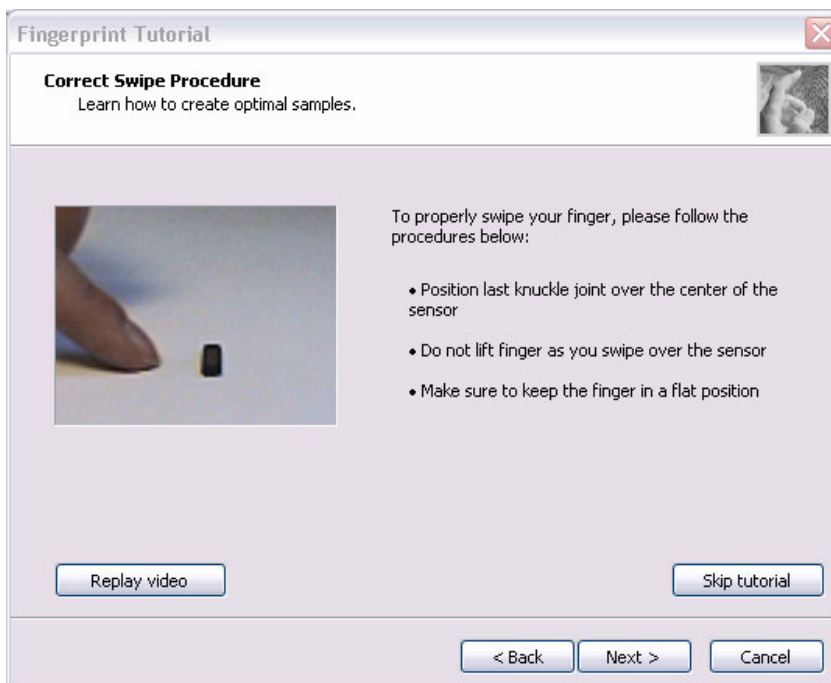

- Put lightly your finger on the fingerprint sensor at the bottom right side of the display and slide your finger toward the right.

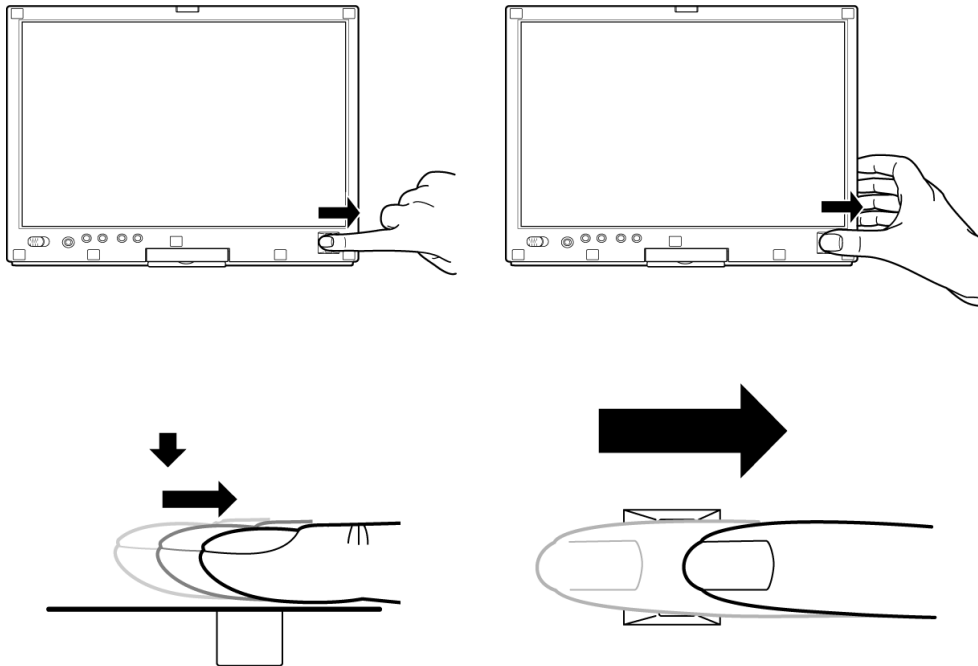

Slide your finger four times. Four boxes are filled with fingerprints. At this time, when you click the [Replay video], you can watch the video that you have watched in Procedure 6.

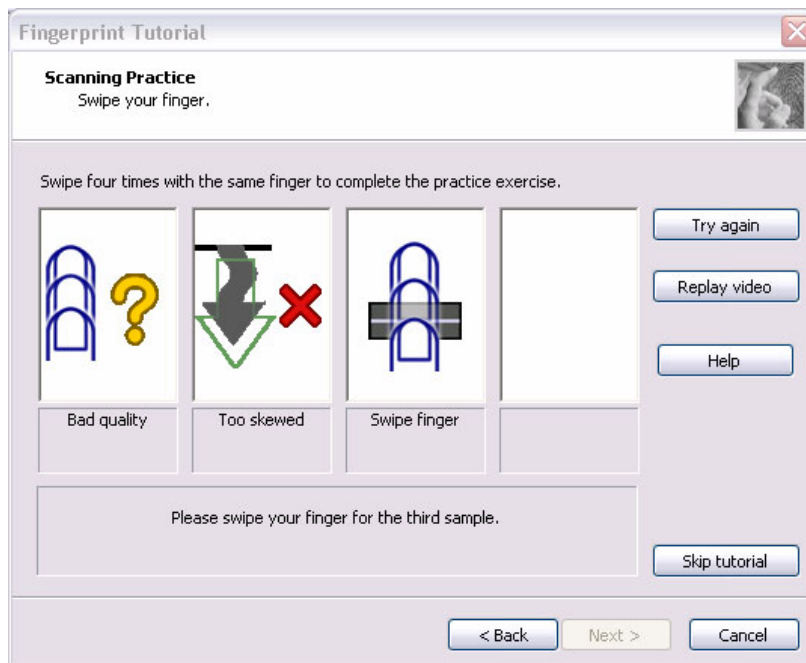



When you have failed in any time of four times reading and want to practice again, click [Try again]. When you have fully succeeded in four times of reading, the message of “Fully succeeded” appears.



8. Click [Next]. The display of [User's Fingers]
9. Click the box you want to enroll.

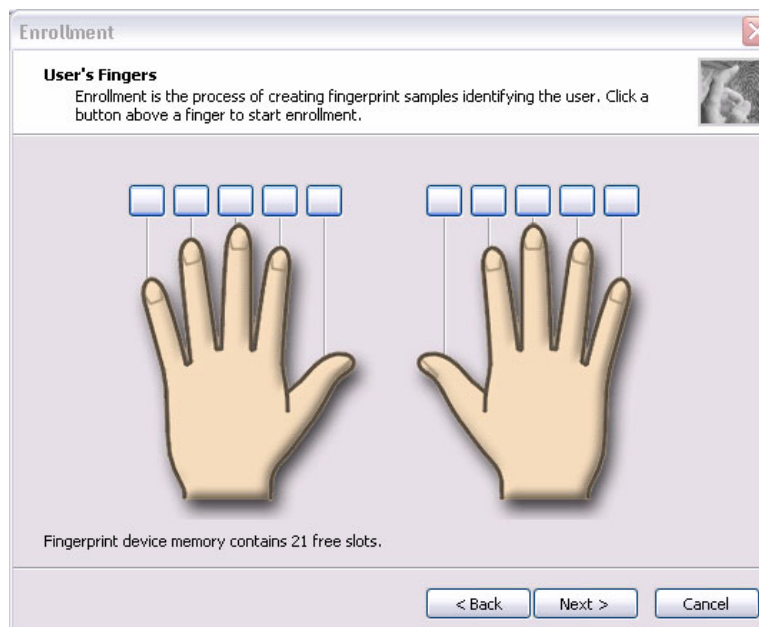

Put lightly the first joint of your finger you want to enroll on the fingerprint sensor and slide your finger toward you. Enroll your finger three times. Every time your finger has been successfully enrolled, one box is checked. When your finger has been successfully enrolled three times, the message of “Succeeded” appears.

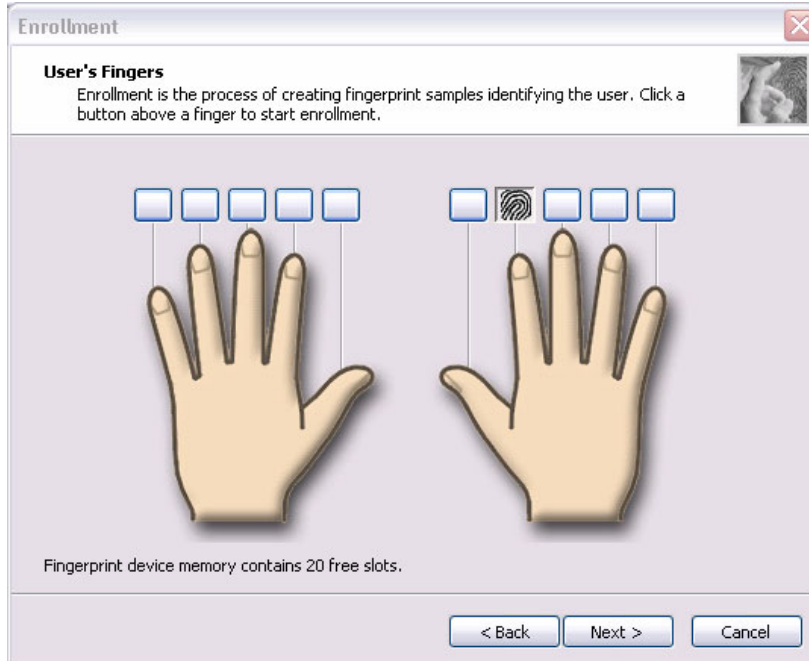

When you do not enroll your finger within two minutes after [User's Fingerprint] has been displayed, an error message appears. At the time, click [OK] and enroll your fingerprint.

When you attempt to enroll your finger that has been enrolled, you can not enroll. Enroll your other finger again.

10. Enroll another finger in Procedure 9. Enroll two fingers at least.
11. The display that recommend you to register a password.
12. Click [OK] in the following display.

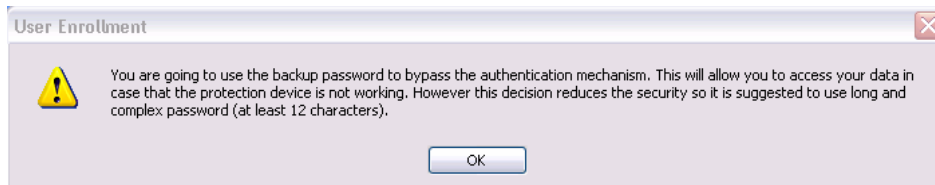

13. Type a backup password two times in the following display. (This password is different from the password of Windows logon.)



14. Click [Next]. The [Finish] display appears.
15. Click [Finish], “Welcome” display appears.

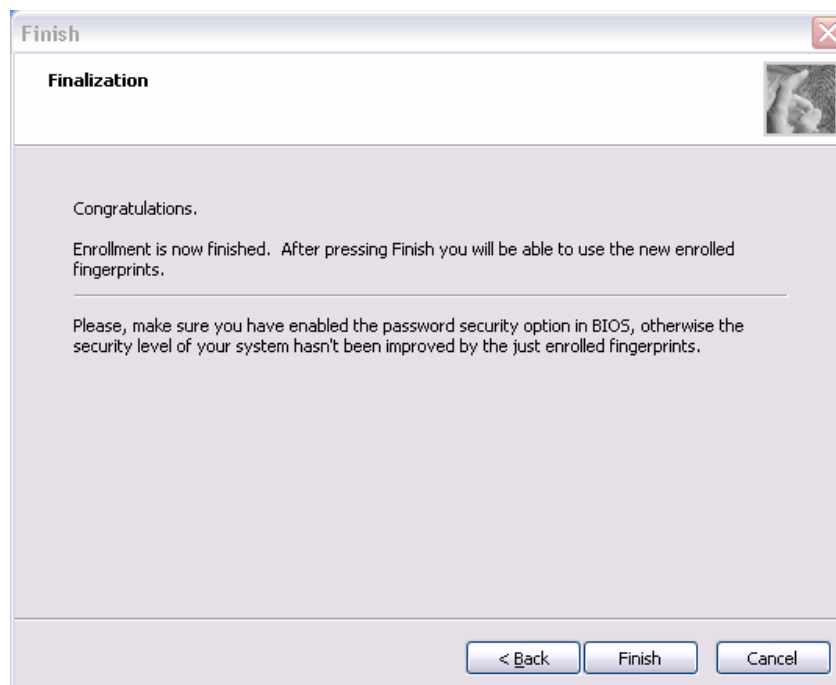

**Procedure 3 Authentication of fingerprint**

1. Turn on the computer to start up Windows.
2. In the Windows logon window, put lightly the first joint of your finger registered and slide your finger toward the right.

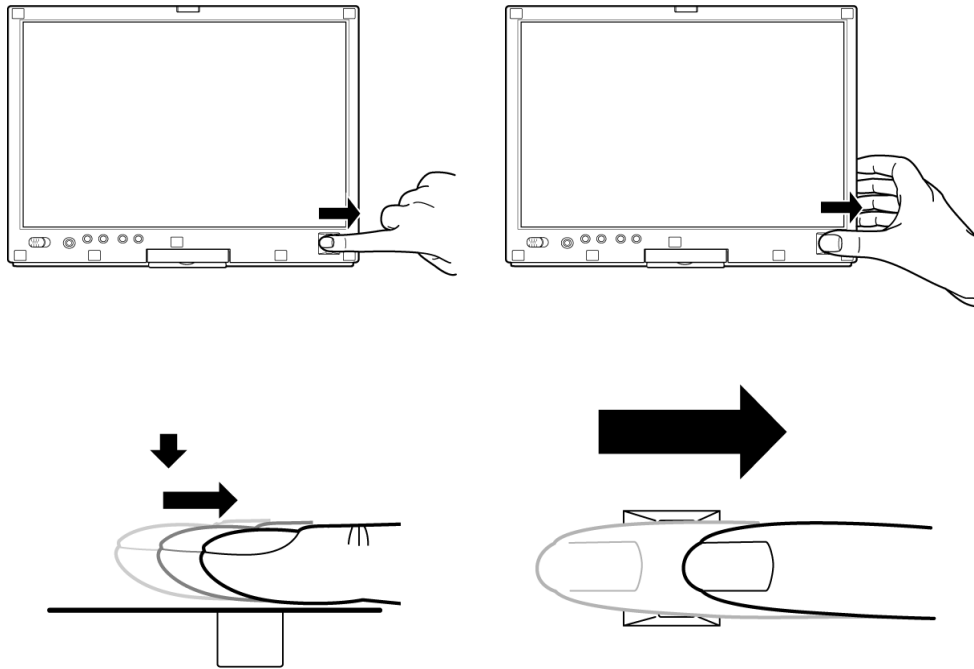

When authenticated, [Success] is displayed in the fingerprint authentication display.

When not authenticated well, warning message appears. If you fail continually ten times or more, you can not use the fingerprint authentication about one minute.

When not authenticated, type the password to logon to Windows.

**Procedure 4 Connector Check and Replacement Check**

The Fingerprint sensor cable is connected to the connector CN9560 on the Fingerprint sensor board and connector CN9540 on the system board.

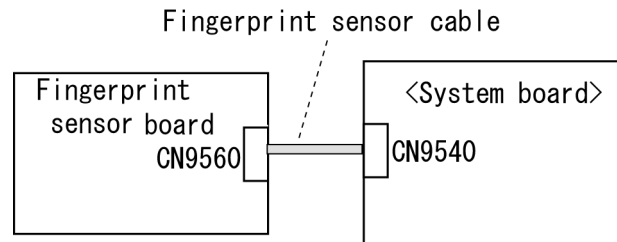

- Check 1 Check the Fingerprint sensor cable is firmly connected to the connector CN9560 on the Fingerprint sensor board and connector CN9540 on the system board. If not, connect it firmly. If the Fingerprint sensor is still not functioning properly, perform Check 2.
- Check 2 The Fingerprint sensor cable may be faulty. Replace it with a new one. If the problem persists, perform Check 3.
- Check 3 The Fingerprint sensor board may be faulty. Replace it with a new one. If the problem persists, perform Check 4.
- Check 4 The system board may be faulty. Replace it with a new one following the steps in Chapter 4.



## 3.1 The Diagnostic Test

This chapter explains how to use the Diagnostic Test programs to test the functions of the computer's hardware modules. The Diagnostics Programs are stored on some Diagnostic Disks. There are Service Program Modules (DIAGNOSTIC MENU) and the Test Program Modules (DIAGNOSTIC TEST MENU) on the Diagnostic Disk.

The Hardware Initial information Setting Tool consists of some programs that write the hardware information or displays the current information of the computer. It is also included in one of Diagnostic Disks.

The heatrun test is automatic test program that executes the some tests successively.

**NOTE:** Before starting the diagnostics, be sure to follow these steps:

1. Check all cables are connected firmly.
2. Exit any application and close Windows.
3. Check if "ALL Device" is selected in the item [Device Config.] in SETUP menu. After checking the diagnostics, be sure to select "Setup by OS".

### 3.1.1 Diagnostics menu

The DIAGNOSTIC MENU consists of the following functions.

- DIAGNOSTIC TEST
- ONLY ONE TEST
- HEAD CLEANING
- LOG UTILITIES
- RUNNING TEST
- FDD UTILITIES
- SYSTEM CONFIGURATION
- POWER OFF

The DIAGNOSTIC TEST MENU contains the following functional tests.

- SYSTEM TEST
- MEMORY TEST
- KEYBOARD TEST
- DISPLAY TEST
- FLOPPY DISK TEST
- PRINTER TEST
- ASYNC TEST
- HARD DISK TEST

- REAL TIMER TEST
- NDP TEST
- EXPANSION TEST
- CD-ROM/DVD-ROM TEST

Other tests are:

- Wireless LAN TEST (Wireless LAN test disk)
- LAN/Modem/Bluetooth/IEEE1394 TEST (LAN/Modem/Bluetooth/IEEE1394 test disk)
- Sound TEST (Sound test disk)

You will need the following equipment to perform some of the Diagnostic test programs.

- USB FDD
- The Diagnostic Disks  
(T&D for maintenance, LAN/Modem/Bluetooth/IEEE1394 test disk for maintenance, Wireless LAN test disk for maintenance and Sound test disk for maintenance)
- A formatted working disk (Floppy disk test)
- A cleaning kit to clean the floppy disk drive heads (Head Cleaning)
- An external CRT monitor supporting monitor ID (Expansion test)
- A CD test media TOSHIBA CD-ROM TEST DISK or ABEX TEST CD-ROM (Sound test)
- A DVD test media (DVD-ROM TEST DISK TSD-1) (Sound test)
- A music CD (Sound test)
- A CD-RW test media (CD-ROM/DVD-ROM test)
- A USB test module (USB test )
- A USB cable (USB test)
- LAN wraparound connector (LAN test)
- Module cable and RJ11 connector checker (Modem test)
- Headphones (Sound test)
- A microphone (Sound test)
- A PC for wraparound test (Wireless LAN test/Bluetooth test/IEEE1394 test)
- PC card wraparound connector (Expansion test)
- RS-232C wraparound connector (Async test)



### **3.1.2 H/W (Hardware) initial information setting tool**

The H/W initial information setting tool consists of the following programs.

- Initial configuration
- DMI information save
- DMI information recovery
- System configuration display
- E2PROM test (MAC/GUID/DMI)

You will need the following equipment to perform some of the programs.

- The Diagnostics Disk (Main T&D)

### **3.1.3 Heatrun test program**

The heatrun test starts automatically after the selection.

You will need the following equipment to perform this program.

- The Diagnostics Disk (Main T&D)

## 3.2 Executing the Diagnostic Test

To start the DIAGNOSTIC PROGRAM, follow these steps:

1. Insert the Diagnostics disk in the USB floppy disk drive.
2. Turn on the computer with pressing the **U**. Then, the following menu appears.

```
Repair test program (XXXXXXX/XXXXXXX)
-----
1. Repair Main (T&D)
2. Repair initial config set
3. Repair Heatrun (T&D)

Select from Menu [1 2 3], or press [Enter] (Selection=1)

Singlestepping (F8) is: OFF
```

Select the program you want to execute.

To start the Diagnostics menu (T&D), press **1**, or select (1) Repair Main and press **Enter**.

To start the H/W initial information setting tool, press **2**, or select (2) Repair Initial config set and press **Enter**.

To start the Heatrun test, press **3**, or select (3) Repair Heatrun and press **Enter**.

**NOTE:** After replacing the system board or CPU, it is necessary to execute the subtest 01 Initial configuration in 3.3 Setting of the hardware configuration.

### 3.2.1 Diagnostics menu (T&D)

To execute this program, press **1**, or select 1-Repair Main (T&D) in the startup menu and press **Enter**. The following menu appears.

```
TOSHIBA personal computer Common DIAGNOSTICS
Version X.XX (c) copyright TOSHIBA Corp. 20XX
```

```
DIAGNOSTICS MENU :

1 - DIAGNOSTIC TEST
2 - ONLY ONE TEST
3 -
4 - HEAD CLEANING
5 - LOG UTILITIES
6 - RUNNING TEST
7 - FDD UTILITIES
8 - SYSTEM CONFIGURATION
9 - POWER OFF
```

```
↑↓→← : Select items
Enter  : Specify
Esc    : Exit
```

**NOTE:** To exit the DIAGNOSTIC TEST MENU, press the **Esc** key. If a test program is in progress, press **Ctrl + Break** to exit the test program. If a test program is in progress, press **Ctrl + C** to stop the test program.

Set the highlight bar to **1**, and press **Enter**. The following DIAGNOSTIC TEST MENU will appear:

```
TOSHIBA personal computer Common DIAGNOSTICS
version X.XX (c) copyright TOSHIBA Corp. 20XX
```

```
DIAGNOSTIC TEST MENU :

1 - SYSTEM TEST
2 - MEMORY TEST
3 - KEYBOARD TEST
4 - DISPLAY TEST
5 - FLOPPY DISK TEST
6 - PRINTER TEST           [ It is not supported ]
7 - ASYNC TEST             [ It is not supported ]
8 - HARD DISK TEST
9 - REAL TIMER TEST
10 - NDP TEST
11 - EXPANSION TEST
12 - CD-ROM/DVD-ROM TEST
88 - ERROR RETRY COUNT SET [FDD & HDD]
99 - EXIT TO DIAGNOSTICS MENU
```

```
↑↓→← : Select items
Enter  : Specify
Esc    : Exit
```

Functions 1 through 12 are the Diagnostic Tests. Function 88 sets the floppy disk drive and hard disk drive error retry count (0-255).

To exit the submenu of the Diagnostic Test and returns to the Diagnostics Menu, set the highlight bar to function 99 and press **Enter**.

Select the option you want to execute and press **Enter**. When you select 1- SYSTEM TEST, the following message will appear:

```

SYSTEM TEST NAME      XXXXXXXX
                      xxxxxxxx DIAGNOSTIC TEST VX.XX
                      [Ctrl]+[Break] : test end
                      [Ctrl]+[C]   : key stop

SUB-TEST      : XX
PASS COUNT   : XXXXX      ERROR COUNT : XXXXX
WRITE DATA  : XX         READ DATA  : XX
ADDRESS     : XXXXXXXX   STATUS      : XXX

SUB-TEST MENU :
01 - ROM checksum
02 - Fan ON/OFF
03 - Geyserville
04 - Quick charge
05 - DMI read
99 - Exit to DIAGNOSTIC TEST MENU

                               ↑↓→← : Select items
                               Enter  : Specify
                               Esc    : Exit

```

**NOTE:** The menu displayed by your computer may be slightly different from the one shown above.

Select the desired subtest number from the subtest menu and press **Enter**. The following message will appear:

```

TEST LOOP   : YES (or NO)
ERROR STOP  : YES (or NO)

```

Use the right and left arrow keys to move the cursor to the desired option.

Selecting **YES** of TEST LOOP increases the pass counter by one, each time the test cycle ends and restarts the test cycle.

Selecting **NO** returns the process to the subtest menu after the test is complete.

Use the up and down arrow keys to move the cursor to “ERROR STOP”.

Use the right and left arrow keys to move the cursor to the desired option and press **Enter**.

Selecting **YES** of ERROR STOP stops the test program when an error is found and displays the operation guide on the right side of the display screen as shown below:

```

ERROR STATUS NAME    [[ HALT OPERATION ]]

                                1: Test end
                                2: Continue
                                3: Retry

```

These three selections have the following functions respectively:

1. Terminates the test program and exits to the subtest menu.
2. Continues the test.
3. Restarts the test from the error.

Selecting **NO** keeps the test running even if an error is found. When an error occurred, the error status is displayed and one error is added to the error counter.

Table 3-1 in section 3.5 describes the function of each test on the subtest menu. Table 3-2 in section 3.18 describes the error codes and error status for each error.

### 3.2.2 H/W initial information setting tool

After selecting this test, the following menu appears in the display.

```

#####
#####   H/W initial information setting tool   VX.XX   #####
#####
*      1      Initial configuration                *
*      2      DMI information save                 *
*      3      DMI information recovery             *
*      4      System configuration display         *
*      5      E2PROM test (MAC/GUID/DMI)          *
*****
... Press test number [1-5] ?

```

For more details on this test, refer to the section 3.3.

### 3.2.3 Heatrun test program

Heatrun test starts executing the same subtest as 3.23 Running Test.

For more details on this test, refer to the section 3.4.

### 3.3 Setting of the hardware configuration

To execute this program, press **2** or select `2-Repair initial config set` in the startup menu and press **Enter** and follow the directions on the screen. The H/W initial information setting tool consists of four subtests. Move the highlight bar to the subtest you want to execute and press **Enter**.

#### Subtest 01 Initial configuration

This subtest executes the following items and shows their contents in the display. When an item ends normally, the program proceeds automatically to the next one. When an error is found, the program stops and waits for key input. (After solving the problem, the program executes the item again.)

Setting of the CPU set table  
Setting of the microcode  
Setting of the EHSS  
Inputting and writing of DMI information

When the DMI information is displayed, the following messages appear in order. Input each information. (If you do not replace the PCB, the DMI information should not be changed.)

1. "Enter Model Name ?" is displayed. Input the computer's model name and press **Enter**. (e.g. PORTEGE)
2. "Enter Version Number ?" is displayed. Input the computer's version number and press **Enter**. (e.g. PC18070C313S)
3. "Enter Serial Number ?" is displayed. Input the computer's serial number and press **Enter**. (e.g. 12345678)
4. "Enter Model Number ?" is displayed. Input the computer's sales model number and press **Enter**. (e.g. PP200-AAAAA)
5. "Enter Bundle Number ?" is displayed. Input the computer's PCN/Bundle number and press **Enter**. (e.g. PMSREQ3Q34H/S0123456789)
6. "Write data OK (Y/N) ?" is displayed. To write the DMI information to the Flash ROM, press **Y**, and then **Enter**.
7. "Create DMIINFO TXT (Y/N) ?" is displayed. Press **Y**, then the DMI information (text data) is written to the Floppy disk, etc.

Setting of the HWSC  
 Setting of the UUID  
 Display of the DMI information (including UUID)  
 Setting of DVD region code (Yes/No)

After completion of the above settings, H/W configuration & DMI information are appeared in order. Check the contents and press **Enter**.

Following message appears in the display. Press any key, then return to the H/W initial information setting tool menu.

```
+-----+
+  It switches off the power on automatically.  +
+-----+
Press any key to continue...
```

#### Subtest 02     DMI information save

**NOTE:** *Before replacing the system board, be sure to execute this subtest and save the DMI information to the floppy disk.*

This is one of tools to copy the DMI information to a new system board after replacing.

This subtest saves all the DMI data in a floppy disk.

#### Subtest 03     DMI information recovery

**NOTE:** *1. After replacing the system board, be sure to execute this subtest and copy the DMI information to a new system board.*

*2. Since the data of UUID is updated every time when this subtest, DMI information recovery, is done, the saved UUID data is not written.*

This is one of tools to copy the DMI information to a new system board after replacing.

This subtest writes all the DMI data in the floppy disk into the new system board.

Subtest 04 System configuration display

This subtest displays the information of the system configuration.

Confirm the contents and press **Enter**.

For more details on the system configuration information, refer to 3.25 “System configuration”.

Subtest 05 E2PROM test (MAC/GUID/DMI)

It checks whether the MAC address, GUID of IEEE1394 and DMI information are written.



### 3.4 Heatrun Test

To execute this program, press **3** or select 3-Repair heatrun (T&D) in the startup menu and press **Enter**.

After selecting the test, the same subtests as 3.23 RUNNING TEST are executed successively.

For more details on the procedure and test content, refer to RUNNING TEST.

When the heatrun test ends, following message appears in the display.

```
*****  
HEATRAN TEST END  
*****  
Press any key to continue...
```

Press any key and return to the startup menu.

**NOTE:** The test result (*Errorlog.txt*) is stored in the floppy disk. The result is displayed in the same way as 3.22 LOG UTILITIES. For more detail in the display, refer to LOG UTILITIES.

### 3.5 Subtest Names

Table 3-1 lists the subtest names for each test program in the DIAGNOSTIC TEST MENU.

*Table 3-1 Subtest names (1/2)*

No.	Test Name	Subtest No.	Subtest Name
1	SYSTEM	01	ROM checksum
		02	Fan ON/OFF
		03	Geyserville
		04	Quick charge
		05	DMI read
2	MEMORY	01	Conventional memory
		02	Protected mode
		03	Protected mode (cache off)
		04	Cache memory (on/off)
		05	Stress
3	KEYBOARD	01	Pressed key code display
4	DISPLAY	01	VRAM read/write for VGA
		02	Gradation for VGA
		03	Gradation for LCD
		04	Gradation & Mode test for VGA
		05	All dot on/off for LCD
		06	"H" pattern display
		07	LCD brightness
5	FLOPPY DISK	01	Sequential read
		02	Sequential read/write
		03	Random address/data
		04	Write specified address
		05	Read specified address

Table 3-1 Subtest names (2/2)

No.	Test Name	Subtest No.	Subtest Name
6	PRINTER [It is not supported]	01	Ripple pattern
		02	Function
		03	Wraparound
7	ASYNC [It is not supported]	01	FIR/SIR point to point (send)
		02	FIR/SIR point to point (receive)
		03	Wraparound (board)
8	HARD DISK	01	Sequential read
		02	Address uniqueness
		03	Random address/data
		04	Cross talk & peak shift
		05	Partial read
		06	Write specified address
		07	Read specified address
		08	Sequential write
		09	W-R-C specified address
9	REAL TIMER	01	Real time
		02	Backup memory
		03	Real time carry
10	NDP	01	NDP test
11	EXPANSION	01	PCMCIA wraparound [It is not supported]
		02	RGB monitor ID
12	CD-ROM/DVD-ROM	01	Sequential read
		02	Read specified address
		03	Random address/data
		04	RW 1point W/R/C

## 3.6 System Test

To execute the System Test select **1** from the DIAGNOSTIC TEST MENU, press **Enter** and follow the directions on the screen. Move the highlight bar to the subtest you want to execute and press **Enter**.

### Subtest 01 ROM checksum

This subtest executes a checksum test of the BIOS ROM (range: F0000h to FFFFFh, 64KB) on the System board.

### Subtest 02 Fan ON/OFF

This subtest turns on/off the fan motor by force with Fan ON/OFF commands.

The following message will appear.

```
Fan number select (1;FAN#1(CPU), 2;FAN#2(GPU), 0; FAN#1&#2)?
```

To check the CPU fan, press **1** and **Enter**.

To check the GPU fan, press **2** and **Enter**.

To check both CPU fan and GPU fan, press **0** and **Enter**.

The following message will appear.

```
*** Test Fan Revolution 0000RPM start
```

Make sure the fan does not rotate, then press **Enter**.

The following message will appear.

```
*** Test Fan Revolution Low speed Start
```

Make sure the fan rotates at low speed, then press **Enter**.

The following message will appear.

```
*** Test Fan Revolution High speed Start
```

Make sure the fan rotates at high speed, then press **Enter**.

After a while, the fan rotating will stop.

### Subtest 03 Geyserville

If the CPU supports Geyserville (SpeedStep), this Subtest checks that the CPU operating clock speed can be changed.

### Subtest 04 Quick charge

This subtest checks the status for the quick charge.

Subtest 05 DMI read

This subtest displays the information in the Flash-ROM in the following format.

```
*** DMI Data Display Ver X.XX ***  
Model Name       : XXXXXXXXXXXX  
Version Number  : XXXXXXXXXXXX  
Serial Number   : XXXXXXXX  
Model Number    : XXXXXX-XXXXX  
PCN/BND Number : XXXXXXXXXXXX/XXX  
UUID Number     : XXXXXXXXXXXXXXXXXXXXXXXXXXXXXXXX  
Press [Enter] to EXIT
```

To exit this subtest and return to the SYSTEM test menu, press **Enter**.

## 3.7 Memory Test

To execute the Memory Test, select **2** from the DIAGNOSTIC TEST MENU, press **Enter** and follow the directions on the screen. Move the highlight bar to the subtest you want to execute and press **Enter**.

Subtest 01 Conventional memory

This subtest writes a constant data to conventional memory (0 to 640 KB), then reads the new data and compares the result with the original data.

Subtest 02 Protected mode

**NOTE:** The CONFIG.SYS file must be configured without expanded memory manager programs such as EMM386.EXE, EMM386.SYS or QEMM386.SYS. Also, the HIMEM.SYS must be deleted from the CONFIG.SYS file.

This subtest writes constant data and address data (from 1MB to maximum MB), and reads the new data and compares the result with the original data.

Subtest 03 Protected mode (cache off)

This subtest executes the same way as the subtest02 with the cache off.

Subtest 04 Cache memory (on/off)

To test the cache memory, a pass-through write-read comparison of '5Ah' data is run repeatedly to the test area ('7000': 'Program size' to '7000': '7FFF' (32 KB)) to check the hit-miss ratio (on/off status) for CPU cache memory. One test takes 3 seconds.

Number of misses < Number of hits → OK

Number of misses ≥ Number of hits → Fail

Subtest 05 Stress

Data (from 1MB to the maximum MB) is written from the 16KB write buffer to the 16KB read buffer and compared the data in the buffers. The read buffer starts from 0001 and the comparison is continued with the following read buffer addresses: 0001, 0003, 0005, 0007, 0009, 000b, 000d and 000f.

## 3.8 Keyboard Test

To execute the Keyboard Test, select **3** from the DIAGNOSTIC TEST MENU, press **Enter** and follow the directions on the screen. Move the highlight bar to the subtest you want to execute and press **Enter**.

### Subtest 01 Pressed key code display

When a key is pressed, the scan code, character code, and key top name are displayed on the screen in the format shown below. The **Ins Lock**, **Caps Lock**, **Num Lock**, **Scroll Lock**, **Alt**, **Ctrl**, **Left Shift**, and **Right Shift** keys are displayed in reverse screen mode when pressed. The scan codes, character codes, and key top names are shown in Appendix D.

```
KEYBOARD TEST  IN PROGRESS  302000
      Scan code      =
      Character code  =
      Keytop         =
Ins Lock  Caps Lock  Num Lock   Scroll Lock
Alt       Ctrl       Left Shift  Right Shift
PRESS [Enter] KEY
```

### 3.9 Display Test

To execute the Display Test, select **4** from the DIAGNOSTIC TEST MENU, press **Enter** and follow the directions on the screen. Move the highlight bar to the subtest you want to execute and press **Enter**.

Subtest 01 VRAM read/write for VGA

This subtest writes the constant data (AAh and 55h) to the video RAM. The data is read and compared to the original data.

Subtest 02 Gradation for VGA

This subtest displays four colors: red, green, blue and white from left to right across the screen from black to maximum brightness. The display below appears on the screen, when this subtest is executed.

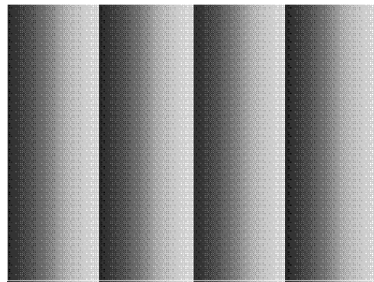

To exit this subtest and return to the DISPLAY TEST menu, press **Enter**.

Subtest 03 Gradation for LCD

This subtest displays bands of gradations for mixed colors, then for red, green, and blue. Next, it displays eight solid colors full screen: red, semi-red, green, semi-green, blue, semi-blue, white, and semi-white. Each color displays for three seconds.



**Subtest 04 Gradation & Mode test for VGA**

This subtest displays gradations for following modes. To change the mode, press **Enter**.

```
[Mode 12]
[Mode 13]
[Mode 3]
[Mode 111  640*480  64K]
[Mode 112  640*480  16M]
[Mode 114  800*600  64K]
[Mode 115  800*600  16M]
[Mode 117 1024*768  64K]
[Mode 118 1024*768  16M]
```

The display below appears on the screen when this subtest is executed.

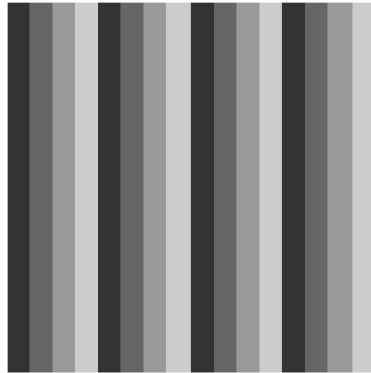

[ Mode 12 ]

(Display example: Mode 12)

To exit this subtest and return to the DISPLAY TEST menu, press **Enter** after displaying the Mode 118.

**Subtest 05 All dot on/off for LCD**

This subtest displays an all-white screen then an all-black screen. The display changes automatically every three seconds, then returns to the DISPLAY TEST menu.



## 3.10 Floppy Disk Test

**CAUTION:** Before running the floppy disk test, prepare a formatted work disk. Remove the Diagnostics Disk and insert the work disk into the FDD. The contents of the floppy disk will be erased.

To execute the Floppy Disk Test, select **5** from the DIAGNOSTIC TEST MENU, press **Enter** and follow the directions displayed on the screen.

1. The following message will appear. Select the media mode and start track to be tested, then press **Enter**.

```
Test start track      (Enter:0/dd:00-79) ?
```

2. The Floppy Disk test contains five subtests that test the FDD. The floppy disk test menu will appear after you select FDD test parameters.

```
FLOPPY DISK          XXXXXXXX
```

```
XXX DIAGNOSTIC TEST VX.XX
[Ctrl]+[Break]:test end
[Ctrl]+[C]   :key stop
```

```
SUB-TEST      : XX
PASS COUNT    : XXXXX   ERROR COUNT   : XXXXX
WRITE DATA   : XX      READ DATA   : XX
ADDRESS       : XXXXXXX  STATUS       : XXX
```

```
SUB-TEST MENU :
```

```
01 - Sequential read
02 - Sequential read/write
03 - Random address/data
04 - Write specified address
05 - Read specified address
99 - Exit to DIAGNOSTIC TEST MENU
```

```
↑↓→← : Select items
Enter : Specify
Esc   : Exit
```

Select the number of the subtest you want to execute and press **Enter**. The following message will appear during the floppy disk test.

```
FLOPPY DISK IN PROGRESS  XXXXXXXX  XXX DIAGNOSTIC TEST VX.XX
                               [Ctrl]+[Break] : test end
                               [Ctrl]+[C]   : key stop
```

```
SUB-TEST      : XX
PASS COUNT    : XXXXX  ERROR COUNT   : XXXXX
WRITE DATA   : XX     READ DATA    : XX
ADDRESS       : XXXXXX  STATUS        : XXX
```

When the subtest 04 or 05 is selected, the following messages will appear on the screen. Select the test data (subtest 04 only), track number and head number you want to test.

```
Test data ?? (subtest 04 only)
Track No. ??
Head No.  ?
```

#### Subtest 01 Sequential read

This subtest performs a Cyclic Redundancy Check (CRC) that continuously reads all the tracks (track: 0 to 39/0 to 79) on a floppy disk.

#### Subtest 02 Sequential read/write

This subtest continuously writes data pattern B5ADADh to all the tracks (track: 0 to 39/0 to 79) on a floppy disk. The data is then read and compared to the original data.

#### Subtest 03 Random address/data

This subtest writes random data to random addresses on a floppy disk. The data is then read and compared to the original data.

#### Subtest 04 Write specified address

This subtest writes the data specified by an operator to a specified track, head, and address.

#### Subtest 05 Read specified address

This subtest reads data from a track, head, and address specified by an operator.

## 3.11 Printer Test

**CAUTION:** *Printer Test is not supported for this model.*

To execute the Printer Test, select **6** from the DIAGNOSTIC TEST MENU, press **Enter** and follow the directions on the screen.

**NOTE:** *An IBM compatible printer must be connected to the system to execute this test. Also, printer port wraparound connector must be connected.*

The following message will appear, after selecting the subtest 01 to 03 of the printer test:

```
channel#1 = XXXXh
channel#2 = XXXXh
channel#3 = XXXXh
```

Select the channel number (1-3) ?

The printer I/O port address is specified by the XXXXh number. The computer supports three printer channels. Select the printer channel number, and press **Enter** to execute the selected subtest.

### Subtest 01     Ripple Pattern

This subtest prints characters for codes 20h through 7Eh line-by-line while shifting one character to the left at the beginning of each new line.

```
!"#$%&'()*+,-./0123456789:;<=>?@ABCDEFGHIJKLMNOpqrstuvwxyz[\]^_`abcdefghijklmnop
!"#$%&'()*+,-./0123456789:;<=>?@ABCDEFGHIJKLMNOpqrstuvwxyz[\]^_`abcdefghijklmnop
!"#$%&'()*+,-./0123456789:;<=>?@ABCDEFGHIJKLMNOpqrstuvwxyz[\]^_`abcdefghijklmnopqr
!"#$%&'()*+,-./0123456789:;<=>?@ABCDEFGHIJKLMNOpqrstuvwxyz[\]^_`abcdefghijklmnopqrs
!"#$%&'()*+,-./0123456789:;<=>?@ABCDEFGHIJKLMNOpqrstuvwxyz[\]^_`abcdefghijklmnopqrst
!"#$%&'()*+,-./0123456789:;<=>?@ABCDEFGHIJKLMNOpqrstuvwxyz[\]^_`abcdefghijklmnopqrstu
!"#$%&'()*+,-./0123456789:;<=>?@ABCDEFGHIJKLMNOpqrstuvwxyz[\]^_`abcdefghijklmnopqrstuv
!"#$%&'()*+,-./0123456789:;<=>?@ABCDEFGHIJKLMNOpqrstuvwxyz[\]^_`abcdefghijklmnopqrstuvw
!"#$%&'()*+,-./0123456789:;<=>?@ABCDEFGHIJKLMNOpqrstuvwxyz[\]^_`abcdefghijklmnopqrstuvwx
!"#$%&'()*+,-./0123456789:;<=>?@ABCDEFGHIJKLMNOpqrstuvwxyz[\]^_`abcdefghijklmnopqrstuvwxy
```

## Subtest 02      Function

This subtest is for IBM compatible printers, and tests the following functions:

Normal print  
 Double-width print  
 Compressed print  
 Emphasized print  
 Double-strike print  
 All characters print

This subtest prints the various print types shown below:

```

PRINTER TEST
1. THIS LINE SHOWS NORMAL PRINT.
2. THIS LINE SHOWS DOUBLE-WIDTH PRINT.
3. THIS LINE SHOWS COMPRESSED PRINT.
4. THIS LINE SHOWS EMPHASIZED PRINT.
5. THIS LINE SHOWS DOUBLE-STRIKE PRINT.
6. ALL CHARACTERS PRINT
!"#$%&'()*+,-./0123456789:;<=>?@ABCDEFGHIJKLMN
OPQRSTUVWXYZ[\]^_`abcdefghijklmnopqrstuvwxyz{|}~

```

## Subtest 03      Wraparound

**NOTE:** To execute this subtest, a printer wraparound connector must be connected to the computer's printer port.

This subtest checks the output and bi-directional modes of the data control and status lines through the parallel port wraparound connector (34M741986G01). (Both output and bi-directional modes are tested.)

## 3.12 Async Test

**CAUTION:** Async Test is not supported for this model.

To execute the Async Test, select **7** from the DIAGNOSTIC TEST MENU, press **Enter** and follow the directions displayed on the screen. Move the highlight bar to the subtest you want to execute and press **Enter**.

Subtest 01 and 02 require the following data format:

Method: Asynchronous  
Speed: 38400BPS  
Data: 8 bits and one parity bit (EVEN)  
Data pattern: 20h to 7Eh

Subtest 01    FIR/SIR point to point (send)

**NOTE:** To execute subtests 01 and 02, each computer must have access to the other computer's infrared port.

This subtest sends 20h through 7Eh data to the receive side, then receives the sent data and compares it to the original data through the FIR/SIR port.

Subtest 02    FIR/SIR point to point (receive)

This subtest is used with subtest 01 described above. This subtest receives the data from the send side, then sends the received data through the FIR/SIR port.

Subtest 03    Wraparound (board)

**NOTE:** To execute this subtest, an RS-232C wraparound connector must be connected to the RS-232C port.

This subtest checks the data send/receive function through the wraparound connector.

### 3.13 Hard Disk Test

To execute the Hard Disk Test, select **8** from the DIAGNOSTIC TEST MENU, press **Enter**, and follow the directions on the screen.

**CAUTION:** 1. When executing *subtest02, 03, 04, 06, 08 and 09*, the message *[The hard disk will be destroyed.]* will be displayed. The contents of the hard disk will be erased when these tests are executed. Before running the test, the customer should transfer the contents of the hard disk to floppy disk or another hard disk. If the customer has not or cannot perform the back-up, create back-up disks as described below.

2. Check to see if the Microsoft Create System Disks Tools (*MSCSD.EXE*) still exists in the System Tools Folder. (This tool can be used only once.) If it exists, use it to back up the pre-installed software, then use the Backup utility in the System Tools folder to back up the entire disk, including the user's files.

3. Refer to the operating system instructions.

1. The following message appears for the error dump operation when a data compare error is detected. Select **1** or **2**.

Data compare error dump (1:no, 2:yes)

2. The following message appears for whether or not the HDC status is displayed on the screen. The HDC status is described in section 3.19. Select **1** or **2**.

Detail status display (1:no, 2:yes)



3. The Hard Disk Test message will appear after you respond to the Detail Status prompt. Select the number of the subtest you want to execute and press Enter. The following message will appear during each subtest.

```

Hard DISK TEST          XXXXXXXX
                        XXX DIAGNOSTIC TEST VX.XX
                        [Ctrl]+[Break]:test end
                        [Ctrl]+[C]   :key stop

SUB TEST                : XX
PASS COUNT              : XXXXX      ERROR COUNT      : XXXXX
WRITE DATA             : XX         READ DATA       : XX
ADDRESS                 : XXXXXXXX   STATUS           : XXX

```

The first three digits of the ADDRESS indicate which cylinder is being tested, the fourth digit indicates the head and the last two digits indicate the sector.

The first digit of the STATUS number indicates the drive being tested and the last two digits indicate the error status code as explained in table 3-3 of the section 3.19.

#### Subtest 01 Sequential read

This subtest is a sequential reading of all the tracks on the HDD starting at track 0.

#### Subtest 02 Address uniqueness

This subtest writes unique address data to each sector of the HDD track-by-track. The data written to each sector is then read and compared with the original data. There are three ways the HDD can be read:

1. Forward sequential
2. Reverse sequential
3. Random

#### Subtest 03 Random address/data

This subtest writes random data in a random length to random addresses. This data is then read and compared to the original data.

**Subtest 04** Cross talk & peak shift

This subtest writes eight types of worst pattern data (listed below) to a cylinder, then reads the data while moving from cylinder to cylinder. (Test the data interference in the neighbor track)

<b>Worst pattern data</b>	<b>Cylinder</b>
'B5ADAD'	0 cylinder
'4A5252'	1 cylinder
'EB6DB6'	2 cylinder
'149749'	3 cylinder
'63B63B'	4 cylinder
'9C49C4'	5 cylinder
'2DB6DB'	6 cylinder
'D24974'	7 cylinder

**Subtest 05** Partial read

This subtest reads 1GB data that is in minimum, middle and maximum address of the HDD area.

**Subtest 06** Write specified address

This subtest writes specified data to a specified cylinder and head on the HDD.

**Subtest 07** Read specified address

This subtest reads data, which has been written to a specified cylinder and head on the HDD.

**Subtest 08** Sequential write

This subtest writes specified 2-byte data to all of the cylinders on the HDD.

**Subtest 09** W-R-C specified address

This subtest writes data to a specified cylinder and head on the HDD, then reads the data and compares it to the original data.

### 3.14 Real Timer Test

To execute the Real Timer Test, select **9** from the DIAGNOSTIC TEST MENU, press **Enter** and follow the directions on the screen. Move the highlight bar to the subtest you want to execute and press **Enter**.

#### Subtest 01 Real time

A new date and time can be input during this subtest. To execute the real time subtest, follow these steps:

1. Select subtest 01 and the following messages will appear:

```
Current date : XX-XX-XXXX
Current time : XX:XX:XX
```

```
Enter new date:
```

```
PRESS [ENTER] KEY TO EXIT TEST
```

2. If the current date is not correct, input the correct date at the “Enter new date” prompt and press **Enter**.

3. The date is updated and the following messages will appear:

```
Current date : XX-XX-XXXX
Current time : XX:XX:XX
```

```
Enter new time:
```

```
PRESS [ENTER] KEY TO EXIT TEST
```

4. If the current time is not correct, input the correct time in 24-hour format. To enter “:”, press **Shift + ;**. The time is updated.

To exit the test, press **Enter**.

#### Subtest 02 Backup memory

This subtest checks the following backup memories:

Writes 1-bit of “on” data (01h through 80h) to address 0Eh through 7Fh

Writes 1-bit of “off” data (FEh through 7Fh) to address 0Eh through 7Fh

Writes the data pattern AAh and 55h to the address 0Eh to 7Fh

Then the subtest reads and compares this data with the original data.

## Subtest 03 Real time carry

**CAUTION:** *When this subtest is executed, the current date and time are erased.*

This subtest checks the real time clock increments. Make sure the date and time are displayed in the following format:

```
Current date : 12-31-1999  
Current time : 23:59:58
```

The real time increments are automatically executed and the following is displayed:

```
Current date : 01-01-2000  
Current time : 00:00:00
```

```
PRESS [Enter] KEY TO EXIT TEST
```

To exit the test, press **Enter**.

### 3.15 NDP Test

To execute the NDP test, select **10** from the DIAGNOSTICS TEST MENU, press **Enter** and follow the directions on the screen.

Subtest 01    NDP test

This test checks the following functions of NDP:

- Control word
- Status word
- Bus
- Addition
- Multiplication

### 3.16 Expansion Test

To execute the expansion test, select **11** from the DIAGNOSTICS TEST MENU, press **Enter** and follow the directions on the screen.

Subtest 01 PCMCIA wraparound

**CAUTION:** PCMCIA wraparound test is not supported for this model.

**NOTE:** To execute this subtest, the PC card wraparound connector is required.

This subtest checks the following signal line of the PC card slot:

- Address line
- REG#, CE#1, CE#2 line
- Data line
- Speaker line
- Wait line
- BSY#, BVD1 line

This subtest is executed in the following order:

Sub#	Address	Good	Bad	Contents
01	00001 00001	nn nn	xx xx	Address line REG#, CE#1, CE#2 nn=A0, 90, 80, 00
02	00002	ww	rr	Data line ww=write data, rr=read data
03	00003	—	—	Speaker line
04	00004	40,80	xx	Wait line (40<xx<80)
05	00005	nn	xx	Other lines (BSY#, BVD1) NN=21, 00

**NOTE:** When selecting the subtest number 01, the following message will appear:  
Test slot number select (1:slot0, 2:slot1, 0:slot0&1)?

## Subtest 02 RGB monitor ID

**NOTE:** *To execute this subtest, an external monitor with monitor ID function is required.*

Connect the external monitor to the PC for the test of ID acquisition.

The judgment of acquisition is based on the panel data. In simultaneous display mode or internal display mode, in which the panel data is acquired, this subtest will fail. Therefore, make sure only the external display is selected when executing this subtest.

### 3.17 CD-ROM/DVD-ROM Test

To execute the CD-ROM/DVD-ROM test, select **12** from the DIAGNOSTICS TEST MENU, press **Enter** and follow the directions on the screen.

**NOTE:** For the subtest 01, 02 and 03, use the TOSHIBA CD-ROM TEST DISK TDY-01 or ABEX TEST CD-ROM TCDR-702 and DVD-ROM TEST DISK TSD-1. For the subtest 04, use a CD-RW media on the market.

Subtest 01      Sequential read

This subtest is a sequential reading of one-block units (2K bytes) of all the logical addresses.

Subtest 02      Read specified address

This subtest reads one-block data from a specified address.

Subtest 03      Random address/data

This subtest reads one-block data and multi-block data from random addresses 200 times.

Subtest 04      RW 1point W/R/C

This subtest writes, reads and compares data at one point on a CD-RW media.



### 3.18 Error Code and Error Status Names

Table 3-2 lists the error codes and error status names for the Diagnostic Test.

*Table 3-2 Error codes and error status names (1/3)*

Device name	Error code	Error status name
Common	FF	Data Compare Error
System	01 03 04 05 06 07 08 09 10	ROM - CHECKSUM ERROR ROM - SERIAL ID WRITE ERROR ROM - NOT SUPPORTED PS-SYSTEM ROM - SENSING ERROR(AC-ADAPT) ROM - SENSING ERROR(1st Batt) ROM - SENSING ERROR(2nd Batt) ROM - THORMISTOR ERROR(1) ROM - THORMISTOR ERROR(2) ROM - THORMISTOR ERROR(3)
Memory	01 02 DD	RAM - PARITY ERROR RAM - PROTECTED MODE NO CHANGE RAM - CACHE MEMORY ERROR
Keyboard	FE FD F0 F1 F2 F3 F4 F5 F6 F7 F8 F9 FA EF ED	USB - GET DESCR.ERROR (FIRST) USB - SET ADDRESS ERROR HUB - GET DESCR.ERROR(Top 8B) HUB - GET DESCR.ERROR (Whole) HUB - SET CONFIGURATION ERROR HUB - GET DESCR.ERROR(DESCR.) HUB - SET FEATURE ERROR(P ON) HUB - GET STATUS ERROR HUB - SET FEATURE ERROR(RESET) HUB - CLEAR FEATURE ERROR HUB - CLEAR FEATURE1 ERROR HUB - SET FEATURE ERROR(Enab.) HUB - CLEAR FEATURE2 ERROR USB - OVER CURRENT ERROR USB - GET DESCR.ERROR(SECOND)
Display	EE	VRAM SIZE NOT SUPPORT

Table 3-2 Error codes and error status names (2/3)

Device name	Error code	Error status name
FDD	01 02 03 04 08 09 10 20 40 80 60 06 EE	FDD - BAD COMMAND ERROR FDD - ADDRESS MARK NOT FOUND FDD - WRITE PROTECTED FDD - RECORD NOT FOUND FDD - DMA OVERRUN ERROR FDD - DMA BOUNDARY ERROR FDD - CRC ERROR FDD - FDC ERROR FDD - SEEK ERROR FDD - TIME OUT ERROR FDD - NOT DRIVE ERROR FDD - MEDIA REMOVED FDD - WRITE BUFFER ERROR
Printer	01 08 10 20 40 80	PRT - TIME OUT PRT - FAULT PRT - SELECT LINE PRT - OUT OF PAPER PRT - POWER OFF PRT - BUSY LINE
ASYNC	01 02 04 08 10 20 40 80 88 05 06	RS232C - [DTR ON] TIME OUT RS232C - [CTS ON] TIME OUT RS232C - [RX READY] TIME OUT RS232C - [TX FULL] TIME OUT RS232C - PARITY ERROR RS232C - FRAMING ERROR RS232C - OVERRUN ERROR RS232C - LINE STATUS ERROR RS232C - MODEM STATUS ERROR SIR - TIME OUT ERROR FIR - TIME OUT ERROR
HDD	05 07 09 0B BB 08 01 02 04 10 20 40 80 11 AA	HDD - HDC NOT RESET ERROR HDD - DRIVE NOT INITIALIZE HDD - DMA BOUNDARY ERROR HDD - BAD TRACK ERROR HDD - UNDEFINED ERROR HDD - OVERRUN ERROR (DRQ ON) HDD - BAD COMMAND ERROR HDD - ADDRESS MARK NOT FOUND HDD - RECORD NOT FOUND ERROR HDD - ECC ERROR HDD - HDC ERROR HDD - SEEK ERROR HDD - TIME OUT ERROR HDD - ECC RECOVER ENABLE HDD - DRIVE NOT READY

Table 3-2 Error codes and error status names (3/3)

Device name	Error code	Error status name
(HDD)	CC E0 0A EE DA 12	HDD - WRITE FAULT HDD - STATUS ERROR HDD - BAD SECTOR HDD - ACCESS TIME ERROR HDD - NO HDD HDD - DMA CRC ERROR
NDP	01 02 03 04 05 06	NDP - NO CO-PROCESSOR NDP - CONTROL WORD ERROR NDP - STATUS WORD ERROR NDP - BUS ERROR NDP - ADDITION ERROR NDP - MULTIPLAY ERROR
EXPANSION	C1 C3 C4 C5 C6 C7 C8 CB CC CE CF	ADDRESS LINE ERROR CE#1 LINE ERROR CE#2 LINE ERROR DATA LINE ERROR WAIT LINE ERROR BSY# LINE ERROR BVD1 LINE ERROR ZV-Port ERROR NO PCMCIA CARD TYPE ERROR ZV-CONT# ERROR
CD-ROM /DVD-ROM	01 02 03 04 05 06 09 11 20 40 80 90 B0	BAD COMMAND ILLEGAL LENGTH UNIT ATTENTION MEDIA CHANGE REQUEST MEDIA DETECTED ADDITIMAL SENSE BOUNDARY ERROR CORRECTED DATA ERROR DRIVE NOT READY SEEK ERROR TIME OUT RESET ERROR ADDRESS ERROR

### 3.19 Hard Disk Test Detail Status

When an error occurs in the hard disk test, the following message is displayed:

```
HDC status = XXXXXXXX
```

Detailed information about the hard disk test error is displayed on the screen by an eight-digit number. The first four digits represent the hard disk controller (HDC) error status number and the last four digits are not used.

The hard disk controller error status is composed of two bytes; the first byte displays the contents of the HDC status register in hexadecimal form and the second byte displays the HDC error register.

The contents of the HDC status register and error register are listed in Tables 3-3 and 3-4.

*Table 3-3 HDC status register contents*

Bit	Name	Description
7	BSY (Busy)	"0" ... HDC is ready. "1" ... HDC is busy.
6	DRY (Drive ready)	"0" ... Hard disk drive is not ready to accept any command. "1" ... Hard disk drive is ready.
5	DWF (Drive write fault)	"0" ... DWF error is not detected. "1" ... Write fault condition occurred.
4	DSC (Drive seek complete)	"0" ... The hard disk drive heads are not settled over a track. "1" ... The hard disk drive heads are settled over a track.
3	DRQ (Data request)	"0" ... Drive is not ready for data transfer. "1" ... Drive is ready for data transfer.
2	COR (Corrected data)	"0" ... Not used "1" ... Correctable data error is corrected.
1	IDX (Index)	"0" ... Not used "1" ... Index is sensed.
0	ERR (Error)	"0" ... Normal "1" ... The previous command was terminated with an error.

Table 3-4 Error register contents

Bit	Name	Description
7	BBK (Bad block mark)	"0" ... Not used "1" ... A bad block mark is detected.
6	UNC (Uncorrectable)	"0" ... There is no uncorrectable data error. "1" ... Uncorrectable data error has been detected.
5	—	Not used
4	IDN (Identification)	"0" ... Not used "1" ... There is no ID field in the requested sector.
3	—	Not used
2	ABT (Abort)	"0" ... Not used "1" ... Illegal command error or command abort.
1	TK0 (Track 0)	"0" ... The hard disk found track 0 during a recalibrate command. "1" ... The hard disk could not find track 0 during a recalibrate command.
0	—	Not used

## 3.20 Only One Test

### 3.20.1 Program Description

This program tests the unique functions of this model.

### 3.20.2 Operations

Select test **2** from the DIAGNOSTIC MENU and press **Enter**. The following menu appears in the display.

```
#####
#####          Only One Test Menu (XXXXXXXX)          #####
#####
*
*      1          Pressed Key Display          *
*      2          Touch Pad          *
*      3          Wireless Communication Switch    *
*      4          USB          *
*      5          LED          *
*      6          Button          *
*      7          Acceleration sensor          *
*
*      9          Exit to Common Test          *
*
*****
.... Press test number[1-7, 9] ?
```

Input the subtest number you want to test and press **Enter**.

To return to the DIAGNOSTIC TEST menu, select **9** and press **Enter**.

## Subtest 01 Pressed Key Display

When you execute this subtest, the keyboard layout is drawn on the display as shown below. When any key is pressed, the corresponding key on the screen changes to the key character that was pressed. Holding a key down enables the auto-repeat function which causes the key's display character to blink.

Press **Del + Enter** to end the test.

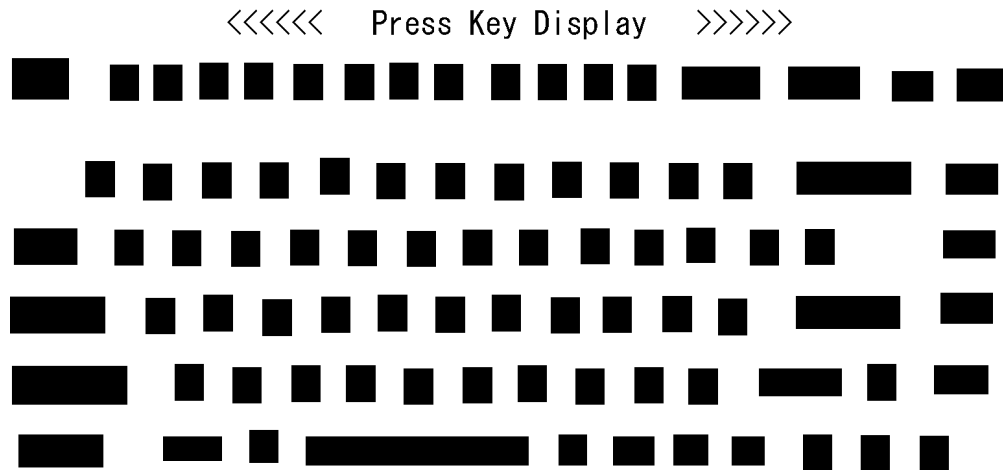

IF TEST OK, Press [Dell][Enter]key

## Subtest 02 Touch Pad

This subtest checks the functions of the touch pad as shown below.

A) Touch Pad direction and parameter.

B) Touch Pad switch function check.

This test displays the response from the touch pad and touch pad switch. When moving your finger on the touch pad towards the upper left, the <POINTING> display changes according to the following illustration. If a touch pad switch is pressed, the <BUTTONS> displays appear on the right side one by one. The parameters appear above the <BUTTONS> (1) or (2) corresponding to the pressed touch pad switch highlights. To end this subtest, press two touch pad switches at the same time.

```

*** IPS (PAD) TEST PROGRAM (Vx.xx) ***

<POINTING>
<PARAMETER>
STATUS:0000h
X-RATE:0000h
Y-RATE:0000H

<BUTTON>
(1) (2)

<< PRESS BUTTON1+BUTTON2 THEN END >>

*** IPS (PAD) TEST PROGRAM (Vx.xx) ***

< POINTING >
<PARAMETER>
STATUS: 0018h
X-RATE: OK
Y-RATE: OK

<BUTTON>
(1) (2)

<< PRESS BUTTON1+BUTTON2 THEN END >>

```

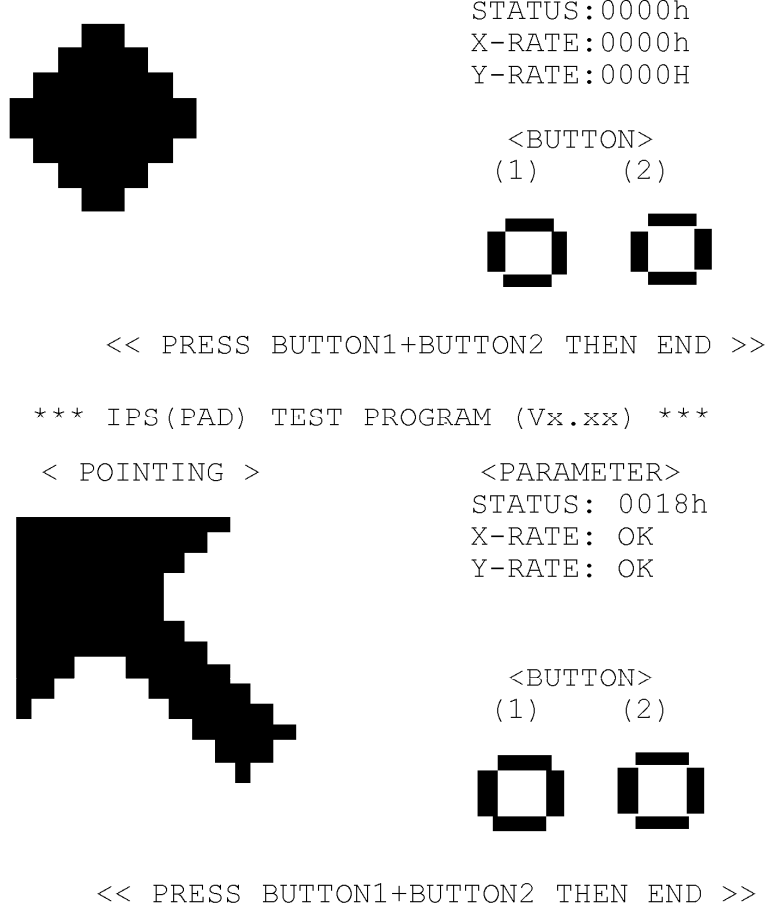



## Subtest 03 Wireless Communication Switch

This subtest checks if the Wireless communication switch works properly.

If the test is started with the switch ON, the following message appears in the display.

```
Wireless communication switch is set to a start
position (OFF)
```

Slide the switch to OFF position. Then, the following message appears in the display.

```
Wireless communication SWITCH ON !!
```

Slide the switch to ON position. Then, the following message appears in the display.

```
Wireless communication SWITCH OFF !!
```

After Sliding the switch to OFF position, the screen returns to the Only One Test menu automatically.

## Subtest 04 USB

**NOTE:** When executing this subtest, USB test module and USB cable must be connected.

This subtest checks if USB ports work properly.

The following menu appears in the display.

```
#####
#####          USB Port Select (XXXXXXXXXX)          #####
#####
*
* 0             Port 0 (Left side)                       *
* 1             Port 1 (Upper part of the back)          *
* 2             Port 2 (Lower part of the back)          *
*
* 9             EXIT                                     *
*
*****
.... Press test number[0-2, 9] ?
```

Connect the USB test module and USB cable to the computer.

Input the test port number and press **Enter**.

**OK** message appears in the display if the test ends without an error.

**NG** message appears in the display if an error is found during the test. Confirm the connection of cable, and then execute the test again.

Press **9** and **Enter** to return to Only One Test menu.

Subtest 05 LED

This subtest checks if each LED lights properly.

The following message appears in the display in order. Follow the instructions in the display to execute the test.

```
[HDD Access LED test]
```

Confirm the LED of HDD status blinks properly.

Press any key and following message appears in the display.

```
[Caps/Num/Overlay BT/W-LAN LED test]
```

```
(1) Press [Caps Lock ] key ! ...Caps      (on/off)
```

```
(2) Press [Fn + F10 ] key ! ...Arrow     (on/off)
```

```
(3) Press [Fn + F11 ] key ! ...Num      (on/off)
```

```
(4) Slide [BT/W-LAN switch L&R]!      (on/off)
```

Confirm corresponding LED lights properly.

Press **Enter** and following message appears in the display.

```
TECRA M7
```

```
Check [DC-IN]&[Power]&[Main Battery] LED= Green/Orange
```

```
Satellite R20
```

```
Check [DC-IN]&[Power]&[Main Battery] LED= Blue/Orange
```

Check if the each LED lights in the same color shown in the display (Message switches Green <-> Orange).

Press **Enter** to return to the Only One Test menu.

## Subtest 06 Button

This subtest checks if the buttons in the following figure work properly.

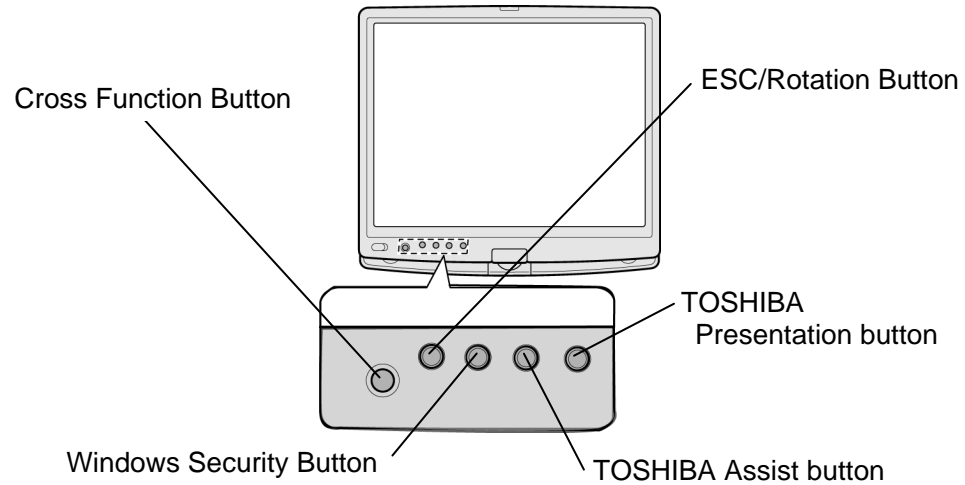

The following message appears in the display.

"Press Function Button key"

Press Cross Function button. Then the following message appears in the display.

"Press Function Button key"

Press Escape/Rotation button. Then the following message appears in the display.

"Press Function Button key"

Press Windows security button. Then the following message appears in the display.

"Press Function Button key"

Press TOSHIBA Assist button. Then the following message appears in the display.

"Press Function Button key"

Press TOSHIBA Presentation button. If the test ends successfully, the screen returns to the ONLY ONE TEST menu automatically.

## Subtest 07 Acceleration sensor

This subtest detects and corrects the each axis (X, Y, Z).

**NOTE:** Make sure that this subtest is executed on the following condition:

1. Flat desk with vertical plane to get the stability of machine.
2. Prevent the machine from shake or shock.

<Example>

Set the machine  
against the vertical plane  
with the Front upward

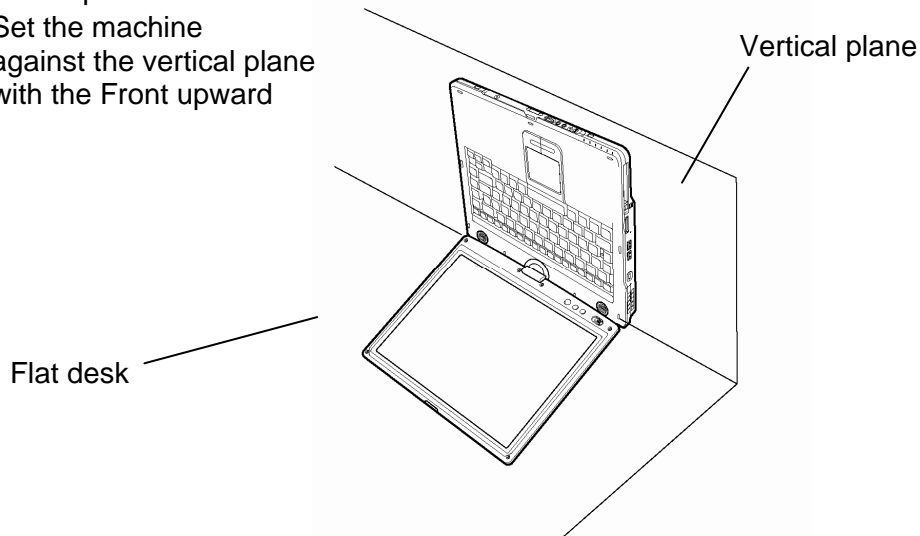

The figure below shows the name and position of each side.

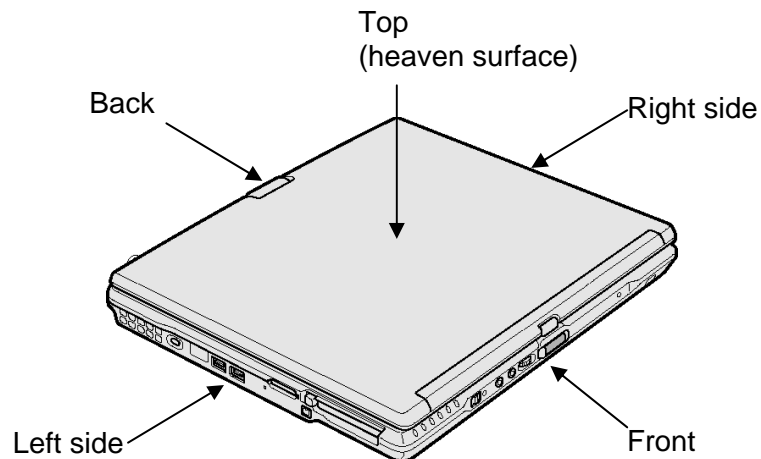

Figure 3-1 Name and positions of each side

When this subtest is selected, the following message appears in the display.

The revision data has written in

Exit to [Enter] / Continue to [Space] key

Then press **Space** to continue the test. The following message appears in the display.

The heaven surface establishes in the upper direction  
Press [Enter] key

**NOTE:** Be sure to execute the test with the display panel opened.

Set the machine on the flat desk. Then press **Enter** to detect the data on this setting of machine. The following message appears in the display.

The back establishes in the upper direction  
Press [Enter] key

Set the machine against the vertical plane on the flat desk with the back of machine upward. Then press **Enter** to detect the data on this setting of machine. The following message appears in the display.

The right establishes in the upper direction  
Press [Enter] key

Set the machine against the vertical plane on the flat desk with the right side of machine upward. Then press **Enter** to detect the data on this setting of machine. The following message appears in the display.

The front establishes in the upper direction  
Press [Enter] key

Set the machine against the vertical plane on the flat desk with the front of machine upward. Then press **Enter** to detect the data on this setting of machine. The following message appears in the display.

The left establishes in the upper direction  
Press [Enter] key

Set the machine against the vertical plane on the flat desk with the left side of machine upward. Then press **Enter** to detect the data on this setting of machine.

When there is no defective during the all checks above, the following message appears in the display. Then press **Enter** and return to the Only One Test menu.

\*\* Setting OK! \*\*  
Press [Enter] key

When a defective is found during the each check above, the following message appears in the display. The test is halted at the point when the defective is found.

\*\* Setting ERROR! \*\*  
Press [Enter] key

Press **Enter** and return to the Only One Test menu. Then execute the test again.

## 3.21 Head Cleaning

### 3.21.1 Function Description

This function cleans the heads in the FDD by executing a series of head load/seek and read operations. A cleaning kit is necessary to perform this program.

### 3.21.2 Operations

1. Selecting test **4** from the DIAGNOSTIC MENU and pressing **Enter** displays the following messages:

```
DIAGNOSTICS - FLOPPY DISK HEAD CLEANING : VX.XX  
Mount cleaning disk(s) on drive(s).  
Press any key when ready.
```

2. Remove the Diagnostics Disk from the FDD, then insert the cleaning disk and press **Enter**.
3. When the “cleaning start” message appears, the FDD head cleaning has begun.
4. The display automatically returns to the DIAGNOSTIC MENU when the program is completed.

## 3.22 Log Utilities

### 3.22.1 Function Description

This function logs error information generated while a test is in progress and stores the results in RAM. This function can store data on a floppy disk, or output the data to a printer or the display.

The error information is displayed in the following order:

1. Error count (CNT)
2. Test name, Subtest number (TS-No)
3. Pass count (PASS)
4. Error status (STS)
5. FDD/HDD or memory address (ADDR)
6. Write data (WD)
7. Read data (RD)
8. HDC status (HSTS)
9. Error status name (ERROR STATUS NAME)

If the power switch is turned off, the error information will be lost.





## 3.23 Running Test

### 3.23.1 Function Description

This function automatically executes the following tests in sequence:

1. System test (subtest 01)
2. Memory test (subtests 01, 02, 06)
3. Display test (subtest 01)
4. Real timer test (subtest 02)
5. HDD test (subtests 01)

The system automatically detects the number of floppy disk drives connected to the computer for the FDD test.

### 3.23.2 Operations

1. Select **6** from the DIAGNOSTIC MENU and press **Enter**, the following messages for selectable tests will appear in the display in order.

```
FDD write/read test (Y/N)?  
Printer wrap around test (Y/N)?  
Serial wrap around test (Y/N)?  
CD-ROM/DVD-ROM test (Y/N)?
```

2. To execute the test, press **Y** and **Enter**. To cancel the test, press **N** and **Enter**. If you select the selectable tests, follow the instruction message in the display.
3. After selecting the selectable tests, the running test starts automatically. To terminate the program, press **Ctrl + Break**.

## 3.24 Floppy Disk Drive Utilities

### 3.24.1 Function Description

This function formats the FDD, copies the floppy disk and displays the dump list for both the FDD and HDD.

#### 1. FORMAT

**NOTE:** *This program is only for testing a floppy disk drive. It is different from the Toshiba MS-DOS FORMAT command.*

This program can format a floppy disk in the following formats:

- (a) 2DD: Double-sided, double-density, double-track, 96/135 TPI, MFM mode, 512 bytes, 9 sectors/track.
- (b) 2HD: Double-sided, high-density, double-track, 96/135 TPI, MFM mode, 512 bytes, 18 sectors/track.

#### 2. COPY

This program copies data from a source floppy disk to a target floppy disk.

#### 3. DUMP

This program displays the contents of the floppy disk and the designated sectors of the hard disk on the display.

#### 4. HDD ID READ

This program reads the hard disk ID and displays hard disk model number.

### 3.24.2 Operations

1. Selecting **7** from the DIAGNOSTIC MENU and pressing **Enter** displays the following message:

```
[ FDD UTILITIES ]

1 - FORMAT
2 - COPY
3 - DUMP
4 - HDD-ID READ
9 - EXIT TO DIAGNOSTICS MENU
```

2. FORMAT program

- (a) Selecting FORMAT displays the following message:

```
DIAGNOSTICS - FLOPPY DISK FORMAT : VX.XX
Drive number select (1:A, 2:B) ?
```

- (b) Select a drive number to display the following message:

```
Type select (0:2DD, 3:2HD) ?
```

- (c) Select a media/drive type number and press **Enter**. A message similar to the one below will be displayed:

```
Warning : Disk data will be destroyed.
Insert work disk into drive A:
Press any key when ready.
```

- (d) Remove the Diagnostics Disk from the FDD, insert the work disk and press any key.

The following message will be displayed when the FDD format is executed:

```
[ FDD TYPE ] : TRACK   = XXX
[ FDD TYPE ] : HEAD    = X
[ FDD TYPE ] : SECTOR  = XX

Format start

[[track, head = XXX X]]
```

After the floppy disk is formatted, the following message will appear:

```
Format complete
Another format (1:Yes/2:No) ?
```

- (e) Typing **1** displays the message from step (c) above. Typing **2** returns the test to the DIAGNOSTIC MENU.

## 3. COPY program

- (a) When COPY is selected, the following message appears:

```
FLOPPY DISK FORMAT & COPY : VX.XX
Type select (0:2DD,3:2HD) ?
```

- (b) Selecting a media/drive type number will display a message similar to the one below:

```
Insert source disk into drive A:
Press any key when ready.
```

- (c) Remove the Diagnostics Disk from the FDD, insert the source disk and press any key. The following message will appear, indicating the program has started.

```
[ FDD TYPE ] : TRACK      = XXX
[ FDD TYPE ] : HEAD       = X
[ FDD TYPE ] : SECTOR    = XX

Copy start
                [[ track,head = XXX X ]]
```

- (d) The following message will appear.

```
Insert target disk into drive A:
Press any key when ready.
```

- (e) Remove the source disk from the FDD, then insert a formatted work disk and press any key. The following message will appear and start copying to the target disk.

```
                [[ track,head = XXX X ]]
```

- (f) When the amount of data is too large to be copied in one operation, the message from step (b) is displayed again. After the floppy disk has been copied, the following message will appear:

```
Copy complete
Another copy (1:Yes/2:No) ?
```

- (g) To copy another disk, type
- 1**
- and the message from step (a) is displayed again. Entering
- 2**
- returns the test program to the DIAGNOSTIC MENU.

## 4. DUMP program

- (a) When DUMP is selected, the following message appears:

```
DIAGNOSTICS-HARD DISK & FLOPPY DISK DUMP : VX.XX
Drive type select (1:FDD, 2:HDD) ?
```

- (b) Select a drive type. If 2:HDD is selected, the display will go to step (h). If 1:FDD is selected, the following message will appear:

```
Select drive number (1:A, 2:B) ?
```

- (c) Select a drive number and the following message will be displayed.

```
Format type select (1:2DD, 3:2HD) ?
```

- (d) If 3:2HD is selected, the following message will appear. Select a media mode.

```
2HD media mode (1:1.20MB, 2:1.44MB, 3:1.23MB)?
```

- (e) The following message will appear:

```
Insert source disk into drive A:
Press any key when ready.
```

- (f) Insert a source disk and press any key and the following message will appear:

```
— Max. address —
[Track ] = XXXX
[Head  ] = XX
[Sector] = XX
Track number ?????
```

- (g) Set the track number, head number and sector number you want to dump. The system will access the disk and dump a list. Then the message shown in (k) will appear.

- (h) The following message will appear when selecting 2:HDD in (a).

```
Select drive number (1:C, 2:D) ?
```

- (i) Select a drive number and the following message will be displayed.

```
---Max. address ---
[LBA ] = XXXXXXXXXXXX
LBA number ??????????
```

- (j) Set the LBA number you want to dump. The system will access the disk and dump a list.

- (k) The following message will appear. To finish the dump, select **3**.

Press number key (1:up,2:down,3:end) ?

- (l) The following message will appear. Selecting **2** returns to the FDD UTILITIES MENU.

Another dump (1:Yes,2:No) ?

#### 5. HDD ID READ program

Selecting HDD ID displays the following HDD ID configuration:

```
[HDD ID Read (VX.XX)] [Drive #1]    [Drive #2]
Model No.                = XXXXXXXX    = YYYYYYYY
```

Press **Enter** to return to the FDD UTILITIES MENU.

## 3.25 System Configuration

### 3.25.1 Function Description

The System Configuration program contains the following configuration information for the computer:

1. Processor Type [Code/L2 cache]
2. Chip set [VRAM]
3. BIOS ROM version [1st ID, 2nd ID]
4. Boot ROM version
5. EC Total version
6. PS Microprocessor version
7. SVP parameter version [Panel/Manufacture code/Product code]
8. Microcode revision [Processor number]
9. Total memory size [Conventional memory]
10. Battery code
11. HWSC
12. FSB [Voltage]
13. The number of printer ports
14. The number of ASYNC ports
15. Math co-processors
16. Floppy Disk Drive [Track/Head/Sector]
17. Hard Disk Drive [Sector/Drive size/Manufacture code]
18. ODD Drive
19. T&D total version
20. Date/Time



### 3.25.2 Operations

Select **8** from the DIAGNOSTIC MENU and press **Enter**. Then, the following system configuration appears in the display.

```
System Configuration Display : Ver X.XX [Machine Name ???]

* - Processor Type      = XXXXXX-XXXXXXMHz      Code = XX      L2 Cache = XXXXXXKB
* - Chip set           = XXXXXX                      VRAM = XXXXXXMB
* - BIOS-ROM Version   = VX.XX      1st ID = XXH, 2nd ID = XXH
* - BOOT-ROM Version   = VX.XX
* - EC Total Version   = VX.XX
* - PS Microm Version   = VX.XX
* - SVP Par. Version   = VX.XX      (Panel=XXXXXXXX, Manu=XXXX, Prod=XXXX)
* - Microcode Revision = VX.XX      (Processor=XXXh)
* - Total Memory Size  = XXXXXXMB (Conventional Memory = XXXXKB)
* - Battery Code       = XXXXXXXXXXXX
* - HWSC               = XXXXXXXX
* - FSB               = XXXXXXMHz (Voltage = XEh)
* - X Printer Adapter  LPT1 = XXXX LPT2 = XXXX LPT3 = XXXX
* - X ASYNC Adapter    COM1 = XXXX COM2 = XXXX COM3 = XXXX
* - X Math CO-Processor
* - X Floppy Disk Drive(s) Track = XX Head = XX, Sector = XX
* - X Hard Disk Drive(s) #1 Sectors = XXXXXXXXXXX (XXXGB) [XXXXXXXXXXXXXXXXXXXX]
*                       #2 Sectors = XXXXXXXXXXX (XXXGB) [XXXXXXXXXXXXXXXXXXXX]
* - ODD Drive          = XXXXXXXXXXX

* - T&D Total Version  = VX.XX

Press [Enter] Key      [Date = XXXX-YY-ZZ, XX:YY:ZZ]
```

Press **Enter** to return to the DIAGNOSTIC MENU.

### 3.26 Wireless LAN Test Program (Intel-made b/g)

This section describes how to perform the wireless LAN transmitting-receiving test (Intel-made Calexico 802.11b/g). To execute the wireless LAN test, use the Diagnostics disk for wireless LAN test. Finish the tests of the Main test program by selecting 99 - EXIT TO DIAGNOSTICS MENU in the DIAGNOSTIC TEST MENU. Then in the DIAGNOSTICS MENU, select 9 - EXIT TO MS-DOS.

Insert the Diagnostics disk for wireless LAN test into the Floppy Disk Drive. Turn on the power while pressing **U**.

The following menu appears in the display.

```
*****Intel Calexico 11b/g Card Maintenance test Menu*****
*
*   1 : SKU check of Module
*
*   2 : MAC Address Check
*
*   3 : Antenna Check & communication test of 11b mode
*
*   4 : Communication test of 11g mode
*
*   5 : All the tests of Calexico 11g Card
*       (SKU & MAC Check, 11b/g communication test)
*
*****
```

SELECT TEST No, (1-5) :

To execute the subtest, input the subtest number and press **Enter**.

Subtest01      SKU check of Module

This subtest displays SKU information on the wireless LAN card installed. Selecting this subtest, following message will appear in the display. Confirm if the right information on the wireless LAN card is described.

```
*****
*
*   Module: Intel Calexico 802.11b/g (MoW)
*   G-code  : G36C0000X310
*   PBA No.  : C55369
*
*****
```

If a defective is found during the test, **NG** message will appear in the display.

Press any key and return to the test menu.

When a defective is detected in the test, following typical cause is considered.

- Connection of wireless LAN card
- Using a wrong wireless LAN card (Using unspecified card)
- Defective wireless LAN card

Checking the connection, execute the subtest again.

#### Subtest02 MAC Address Check

This subtest displays the MAC address. Selecting this subtest, following message will appear in the display.

```
*****
MAC = XXXXXXXXXXXX
*****
*****
*
*   MAC Address Check : OK !!
*
*****
```

Press any key and return to the test menu.

If a defective is found during the test, following message will appear in the display.

```
*****
ERROR: MAC all 0
MAC = XXXXXXXXXXXX
*****
*****
*
*   MAC Address Check : NG !!
*
*****
```

Press any key and return to the test menu.

When a defective is detected in the test, following typical cause is considered.

- Connection of wireless LAN card
- Defective wireless LAN card
- Disappearance of MAC address data

Checking the connection, execute the subtest again.

## Subtest03      Antenna check &amp; communication test of 11b mode

**CAUTION:** 1. To execute subtest 03-05, use another computer (with Callexico wireless LAN card) that can communicate by the wireless LAN as a responder machine to perform those tests. Access points are also required. (Access point for 802.11b and 802.11g)

2. Be sure to turn the wireless communication switch ON before executing wireless LAN communication test. (The wireless communication LED lights orange.)

3. Release the write-protection of floppy disk for the test.

**Setting the responder machine**

Connect the responder machine to the access points (for 802.11b and 802.11g) with a cross cable and turn on the access points.

Insert the floppy disk containing the wireless LAN test program into the FDD of the responder machine and turn on the responder machine.

This subtest checks the connection and communication of wireless LAN antenna of Callexico 802.11b mode.

After finishing the test, **OK** message will appear in the display. Press any key and return to the test menu.

When a defective is found during the test, **NG** message will appear in the display. Press any key and following message will appear in the display. Check which antenna (Main/Aux) is defective.

```
*****
*
*           Main Antenna Test : NG !!
*
*****
```

Press any key and return to the test menu.

When a defective is detected in the test, following typical cause is considered.

- Connection of wireless LAN card
- Connection of wireless LAN antenna cable (Main/Aux)
- Condition of wireless LAN communication (Interference/obstruction)
- Defective wireless LAN card

Checking the connection and condition, execute the subtest again.

**Subtest04**      Communication test of 11g mode

This subtest checks the communication of wireless LAN antenna of Calexico 802.11g mode.

After finishing the test, **OK** message will appear in the display. Press any key and return to the test menu.

When a defective is found during the test, **NG** message will appear in the display. Press any key and following message will appear in the display.

```
*****
*
*           11g Communication Test : NG !!
*
*****
```

Press any key and return to the test menu.

When a defective is detected in the test, following typical cause is considered.

- Connection of wireless LAN card
- Connection of wireless LAN antenna cable (Main)
- Condition of wireless LAN communication (Interference/obstruction)
- Defective wireless LAN card

Checking the connection and condition, execute the subtest again.

**Subtest05**      All the tests of Calexico 11g Card

This subtest checks SKU information, MAC address, connection and communication of wireless LAN antenna of Calexico 802.11b/g card. The test stops at when a defective is found. For more details, refer to each subtest.

### 3.27 Wireless LAN Test Program (Intel-made a/b/g)

This section describes how to perform the wireless LAN transmitting-receiving test (Intel-made Calexico 802.11a/b/g). To execute the wireless LAN test, use the Diagnostics disk for wireless LAN test. Finish the tests of the Main test program by selecting 99 - EXIT TO DIAGNOSTICS MENU in the DIAGNOSTIC TEST MENU. Then in the DIAGNOSTICS MENU, select 9 - EXIT TO MS-DOS.

Insert the Diagnostics disk for wireless LAN test into the Floppy Disk Drive. Turn on the power while pressing **U**.

The following menu appears in the display.

```
*****
*      Intel Calexico2 11a/g Maintenance T&D Menu      *
*
*      1 : SKU check of Module                          *
*
*      2 : MAC Address Check                            *
*
*      3 : Antenna Check & communication test of 11b mode *
*
*      4 : Communication test of 11a mode                *
*
*      5 : Communication test of 11g mode                *
*
*      6 : All the tests of Calexico 11a/g Card          *
*      (SKU & MAC Check, 11a/b/g communication test)   *
*
*****
```

SELECT TEST No, (1-6) :

To execute the subtest, input the subtest number and press **Enter**.

Subtest01      SKU check of Module

This subtest displays SKU information on the wireless LAN card installed. Selecting this subtest, following message will appear in the display. Confirm if the right information on the wireless LAN card is described.

```
*****
*
*      Module   : Intel Calexico 802.11a/g (MoW)      *
*      G-code   : G36C00018510                       *
*      PBA No.  : C67287                               *
*
*****
```

Press any key and return to the test menu.

If a defective is found during the test, **NG** message will appear in the display.

Press any key and following message will appear in the display.

```

*****
*
*                SKU NG !!
*
*      Other Card or Module not found
*
*****

```

Press any key and return to the test menu.

When a defective is detected in the test, following typical cause is considered.

- Connection of wireless LAN card
- Using a wrong wireless LAN card (Using unspecified card)
- Defective wireless LAN card

Checking the connection, execute the subtest again.

Subtest02 MAC Address Check

This subtest displays the MAC address. Selecting this subtest, following message will appear in the display.

```

*****
*
*      MAC = XXXXXXXXXXXX
*
*****
*
*      MAC Address Check : OK !!
*
*****

```

Press any key and return to the test menu.

If a defective is found during the test, following message will appear in the display.

```

*****
*
*      ERROR: MAC all F
*      MAC = XXXXXXXXXXXX
*
*****
*
*      MAC Address Check : NG !!
*
*****

```

Press any key and return to the test menu.

When a defective is detected in the test, following typical cause is considered.

- Connection of wireless LAN card
- Defective wireless LAN card
- Disappearance of MAC address data

Checking the connection, execute the subtest again.

Subtest03     Antenna check & communication test of 11b mode

**CAUTION:** 1. To execute subtest 03-06, use another computer (with Callexico wireless LAN card) that can communicate by the wireless LAN as a responder machine to perform those tests. Access points are also required. (Access point for 802.11a, 802.11b and 802.11g)

2. Be sure to turn the wireless communication switch ON before executing wireless LAN communication test. (The wireless communication LED lights orange.)

3. Release the write-protection of floppy disk for the test.

### Setting the responder machine

Connect the responder machine to the access points (for 802.11a, 802.11b and 802.11g) with a cross cable and turn on the access points.

Insert the floppy disk containing the wireless LAN test program into the FDD of the responder machine and turn on the responder machine.

This subtest checks the connection and communication of wireless LAN antenna of Callexico 802.11b mode.

After finishing the test, **OK** message will appear in the display. Press any key and return to the test menu.

When a defective is found during the test, **NG** message will appear in the display. Press any key and following message will appear in the display. Check which antenna (Main/Aux) is defective.

```
*****
*
*           Aux Antenna Test : NG !!
*
*****
```

Press any key and return to the test menu.



When a defective is detected in the test, following typical cause is considered.

- Connection of wireless LAN card
- Connection of wireless LAN antenna cable (Main/Aux)
- Condition of wireless LAN communication (Interference/obstruction)
- Defective wireless LAN card

Checking the connection and condition, execute the subtest again.

#### Subtest04 Communication test of 11a mode

This subtest checks the communication of wireless LAN antenna of Calxico 802.11a mode.

After finishing the test, **OK** message will appear in the display. Press any key and return to the test menu.

When a defective is found during the test, **NG** message will appear in the display. Press any key and following message will appear in the display.

```
*****
*
*           11a Communication Test : NG !!
*
*
*****
```

Press any key and return to the test menu.

When a defective is detected in the test, following typical cause is considered.

- Connection of wireless LAN card
- Connection of wireless LAN antenna cable (Main)
- Condition of wireless LAN communication (Interference/obstruction)
- Defective wireless LAN card

Checking the connection and condition, execute the subtest again.

Subtest05      Communication test of 11g mode

This subtest checks the communication of wireless LAN antenna of Callexico 802.11g mode.

For more details on procedure and contents of this subtest, refer to Subtest04 Communication test of 11a mode.

Subtest06      All the tests of Callexico 11a/ g Card

This subtest checks SKU information, MAC address of Callexico 802.11a/b/g card, antenna connection and communication test of Callexico 802.11b card and communication test of Callexico 802.11a and Callexico 802.11g. The test stops at when a defective is found. For more details, refer to each subtest.

### 3.28 Wireless LAN Test Program (Atheros)

This section describes how to perform the wireless LAN transmitting-receiving test with the test program.

**NOTE:** Use another computer (with Atheros 11a/g(MB44ag)/Atheros 11a/g(MB62HL)) that can communicate by the wireless LAN as a responder machine to perform this test.

*The computer must be booted by the Responder T&D.*

In this test, the following items are tested:

- (1) SKU check of Module
- (2) MAC Address Check
- (3) Communication test of 11a mode
- (4) Communication test of 11b mode
- (5) Communication test of 11g mode
- (6) SKU & MAC Check, 11a/b/g communication test

**NOTE:** This test takes time until it completes.

To start the Wireless LAN test program, follow the steps below:

**NOTE:** Before starting the wireless LAN test, make sure the Wireless Communication Switch of the computer is turned on. (The Wireless Communication LED lights orange.)

### 3.28.1 Setting the responder machine

#### 1. MB44ag is installed

- 1) Boot the computer by MB4x Responder media.
- 2) The Responder T&D is automatically started.

#### 2. MB6x is installed

As the capacity of MB6x T&D is over the one of a FD, a RAM drive is used.

- 1) Boot the computer by MB6x Responder media.
- 2) After starting the OS, following message is displayed. Input **m** and press **Enter**.

```
*****
*
*      Atheros MB4x/MB5x/MB6x Maintenance T&D Menu      *
*
*      s : Atheros MB4x DUT mode                          *
*
*      Please exchange FD for MB4x DUT media             *
*
*      h : Atheros MB5x DUT mode                          *
*
*      Please exchange FD for MB5x DUT media             *
*
*      r : Atheros MB5x Responder mode                    *
*
*      Please exchange FD for MB5x Responder media       *
*
*      m : Atheros MB6x setup mode                        *
*
*****
```

Please input the ( s / h / r / m ) key and push the "Enter" key :

- 3) The RAM drive name which has been set at booting is displayed and command input is requested. Input **mb6x X** and press **Enter**. The part of **X** is the RAM drive name. In the following display, it is "C".

```
1,440 (1K) C:      Installed Device=RAMDRIVE
Please input the following command. "mb6x X" > mb6x c [Enter]
```

- 4) The following message is displayed. Change the FD with "MB6x setup media 1" and press **Enter**. The file copy from the FD to the RAM drive is started.

```
Please exchange FD for "MB6x setup media 1"
Press any Key to continue . . .
```

- 5) The following message is displayed. Change the FD with "MB6x setup media 2" and press **Enter**. The file copy from the FD to the RAM drive is started.

```
Please exchange FD for "MB6x setup media 2"
Press any Key to continue . . .
```

- 6) When the file copy is completed, the following test menu is displayed. Press **r**. The Responder T&D is started.

```
*****
*
*   Atheros MB6x DUT mode Maintenance T&D Menu   *
*
*   d : DUT mode                                 *
*
*   r : Responder mode                           *
*
*****

SELECT MODE No. (d or r) :
```

### 3.28.2 Test procedure

The following procedures show how to start the computer of DUT side.

- 1) Boot the computer by Atheros T&D boot media.
- 2) After displaying the following menu, input **m** and press **Enter**.

```
*****
*
*   Atheros MB4x/MB5x/MB6x Maintenance T&D Menu   *
*
*   s : Atheros MB4x DUT mode                       *
*
*   Please exchange FD for MB4x DUT media           *
*
*   h : Atheros MB5x DUT mode                       *
*
*   Please exchange FD for MB5x DUT media           *
*
*   r : Atheros MB5x Responder mode                 *
*
*   Please exchange FD for MB5x Responder media     *
*
*   m : Atheros MB6x setup mode                     *
*
*****
```

Please input the ( s / h / r / m ) key and push the "Enter" key :

- 3) The following message is displayed. Change the FD with "MB6x setup media 1" and press **Enter**. The file copy from the FD to the RAM drive is started.

```
Please exchange FD for "MB6x setup media 1"
Press any Key to continue . . .
```

- 4) The following message is displayed. Change the FD with "MB6x setup media 2" and press **Enter**. The file copy from the FD to the RAM drive is started.

```
Please exchange FD for "MB6x setup media 2"
Press any Key to continue . . .
```

- 5) When the file copy is completed, the following test menu is displayed. Press **d**. The Responder T&D is started.

```
*****
*
*   Atheros MB6x DUT mode Maintenance T&D Menu
*
*   d : DUT mode
*
*   r : Responder mode
*
*****

SELECT MODE No. (d or r) :
```

- 6) The following test menu is displayed. Select the test number.

```
*****
*   Atheros MB6x DUT mode Maintenance T&D Menu
*
*   1 : SKU check of Module
*   2 : MAC Address Check
*   3 : Communication test of 11a mode
*   4 : Communication test of 11a mode(Main Antenna Only)
*   5 : Communication test of 11b mode
*   6 : Communication test of 11b mode(Main Antenna Only)
*   7 : Communication test of 11g mode
*   8 : Communication test of 11g mode(Main Antenna Only)
*   9 : All the tests of module
*       (SKU & MAC Check,11a/b/g communication test)
*   A : All the tests of module(Main Antenna Only)
*       (SKU & MAC Check,11a/b/g communication test)
*
*****

SELECT TEST No. (1-A) :
```

### 3.28.3 Contents of the test and errors

#### 1. SKU check of Module

The SKU (destination) of the Wireless LAN card installed is displayed. Visually check it.

```
*****
*
*   Module   : Atheros MB62HL (MoW)
*   G-code   : G360001Q210
*
*****
```

When an error (read error of EEPROM date) has detected, the following is displayed.

```
-----ERROR-----
file bac.txt cannot be opened
```

## 2. MAC Address Check

The MAC address of the installed Wireless LAN card is checked. If it is not incorrect MAC address, the following is displayed.

```
*****
*                               *
*   MAC Address Check : OK !!   *
*                               *
*****
```

### a. Case of All FF error

```
*****
*                               *
*   Mac Address Check NG       *
*                               *
*   FFFFFFF-FFFFFFh           *
*                               *
*****
```

### b. Case of All 00 error

```
*****
*                               *
*   Mac Address Check NG       *
*                               *
*   000000-000000h            *
*                               *
*****
```

## 3. Communication test of 11a mode

The check of connection of 11a mode antenna and transmitting/receiving test are executed.

When the test has been finished normally, the following is displayed.

```
*****
*                               *
*   11a Communication Test : OK !!   *
*                               *
*****
```

When an error has detected, the following is displayed.

```

*****
*
* 11a Communication Test : NG !! *
*
* Please refer to log.txt *
*
*****

```

4. Communication test of 11b mode

The check of connection of 11b mode antenna and transmitting/receiving test are executed.

When the test has been finished normally, the following is displayed.

```

*****
*
* 11b Communication Test : OK !! *
*
*****

```

When an error has detected, the following is displayed.

```

*****
*
* 11b Communication Test : NG !! *
*
* Please refer to log.txt *
*
*****

```

5. Communication test of 11g mode

The check of connection of 11g mode antenna and transmitting/receiving test are executed.

When the test has been finished normally, the following is displayed.

```

*****
*
* 11g Communication Test : OK !! *
*
*****

```

When an error has detected, the following is displayed.

```

*****
*
* 11g Communication Test : NG !! *
*
* Please refer to log.txt *
*
*****

```



6. SKU & MAC Check 11a/b/g communication test

All the test is executed in the order of SKU check of Module, MAC Address Check, Communication test of 11a mode, Communication test of 11b mode and Communication test of 11g mode.

The check of connection of 11g mode antenna and transmitting/receiving test are executed.

## 3.29 LAN/Modem/Bluetooth/IEEE1394 Test Program

This section describes how to perform the LAN/Modem/Bluetooth/IEEE1394 test with the test program.

Insert the test program disk for LAN/Modem/Bluetooth/IEEE1394 test in FDD and turn on the power. The following message will appear:

```
Microsoft Windows XX Startup Menu
-----
```

1. LAN
2. Modem
3. Bluetooth
4. IEEE1394

Enter a choice:

Press the number you want to test and press **Enter**.

**NOTE:** It is impossible to go back to startup menu once you choose the test. Therefore, LAN/Modem/Bluetooth/IEEE1394 test can not be executed successively.

### 3.29.1 LAN test

To execute LAN test, press **1** and **Enter**. The following message will appear:

```
#####
##### i82562 ICHx GbE (i82540) Diagnostics program #####
#####
*
* 1 ..... (i82562 + ICHx) *
* *
* 2 ..... (GbE) *
* *
*****
.... Press test number[1-2] ?
```

Press the number you want to test and press **Enter**.

## Subtest01 (i82562 + ICHx)

This subtest checks the operation of mini-PCI I/F by the loopback test in the chip.

The following message will appear:

```
[LAN transmit & receive test !]
                                COMPLETED Repeat count = 00000
                                Error count   = 00000

LOOPBACK TEST

100Mbps Auto-negotiation TxRx Test
Destination Address = xxxxxxxxxxxxxx
Source Address      = xxxxxxxxxxxxxx

** 100Base-TX Full-Duplex **
< TRANSMIT >
< RECEIVE >
```

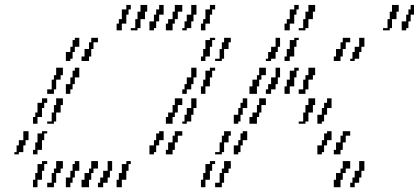

**NOTE:** *The menu displayed by your computer may be slightly different from the one shown above.*

If a defective is found, **NG** message will appear in the display.

## Subtest02 (GbE)

This subtest checks the operation of mini-PCI I/F by the loopback test in the chip. Select **2** to execute and press **Enter**.

The following message will appear:

```
Testing adapter...hit <ESC> to abort.
*
External Loopback Test...PASSED
Testing completed.
*
*
Loopback Test Complete
*
*
* 1000Base Auto-negotiation TxRx Test
*
* CE Test Complete
```

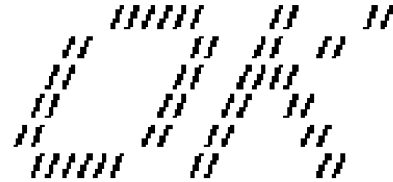

**NOTE:** The menu displayed by your computer may be slightly different from the one shown above.

If a defective is found, **NG** message will appear in the display.

### 3.29.2 Modem test

For this subtest, connect the modem PCB and RJ11 connector with a harness. Use the dedicated “FAT-MODE inspection device (product code: QE2000P01 made by Nitto Denki Seisakusyo)” for the tests.

To execute Modem test, press **2** and **Enter**. Following message will appear:

```
[Modem loopback test !]
ICHx MDC Test Program with Modem Sound (Line Test)
Version X.X
* Scorpio Modem Initialize      :OK
* Digital Loopback Test        :OK
* RJ11 Connector Check (LED)   :(Operator's Check!!)
```

**NOTE:** *The menu displayed by your computer may be slightly different from the one shown above.*

RJ11 Connection Check (LED) (Operator's Check LED) test will be executed, and the following message will appear:

```
...Press Key (Y = OK , N =NG)
```

If the color in the LED of the connection checker is orange, press **Y**, otherwise, press **N**.

### 3.29.3 Bluetooth test

To execute this test, input **3** and press **Enter**.

**NOTE:** Use another computer that can communicate by the Bluetooth as a reference machine to perform this test.

Insert a floppy disk containing the test program into the target machine and turn on the target machine. The following Bluetooth test menu will appear:

```
#####
##### Bluetooth sub system test program VX.XX #####
#####
*
*          1....BD_ADDR check                               *
*
*          3... Communications test (DUT mode)              *
*
*          T....communications test (TEST mode)            *
*
*****
....Press test number [1, 3, T] ?
```

Press **1** or **3** key to perform the corresponding subtest. To quit the Bluetooth test program, eject the floppy disk and turn the computer off while the menu above is displayed.

## Subtest01 BD\_ADDR check

This subtest checks the BD\_ADDR functions. When the Bluetooth test menu is displayed, press **1** to select the test and press **Enter**. The following message will appear:

```

-----
Bluetooth Subsystem T&D for PCSE(BD_ADDR) VerX.XX Copyright (C) by TOSHIBA Co.
-----

Initializing ...

```

When the machine has passed the test, it displays BD\_ADDR. If BD\_ADDR has no problem, the following message is displayed.

```

-----
Bluetooth Subsystem T&D for PCSE(BD_ADDR) VerX.XX Copyright (C) by TOSHIBA Co.
-----

My BD_ADDR = XXXXXXXXXXXX [h]

PPPPPP  A  SSSS  SSSS
P  P  A A  S  S  S  S
P  P  A  A  S  S
PPPPPP  A  A  SSSS  SSSS
P  AAAAAA  S  S
P  A  A  S  S  S  S
P  A  A  SSSS  SSSS

```

If the target machine has any problem, it displays Error CODE. The following message is displayed.

```

-----
Bluetooth Subsystem T&D for PCSE(BD_ADDR) VerX.XX Copyright (C) by TOSHIBA Co.
-----

My BD_ADDR = XXXXXXXXXXXX [h]

FFFFFF      A      III  L
F           A A     I   L
F           A  A    I   L
FFFFFFF A      A    I   L
F           AAAAAA  I   L
F           A      A  I   L
F           A      A  III  LLLLLL
    
```

Table 3-5 Error message

Message	Contents
Invalid BD_ADDR (all 00)	0x000000000000
Invalid BD_ADDR (all FF)	0xFFFFFFFFFFFF
Invalid BD_ADDR (bit0=1)	bit40=1b
Invalid BD_ADDR (bit1=1)	bit41=1b
Invalid BD_ADDR (define in the file)	Defined BD_ADDR



If the machine detects a malfunction, it indicates the error code as shown below.

The error code begins with the least significant digit.

Error code

Table 3-6 Error code for Bluetooth test (BD\_ADDR) (1/2)

Error code	Meaning
0x01	Unknown HCI Command.
0x02	No Connection.
0x03	Hardware Failure.
0x04	Page Timeout.
0x05	Authentication Failure.
0x06	Key Missing.
0x07	Memory Full.
0x08	Connection Timeout.
0x09	Max Number Of Connections.
0x0a	Max Number Of SCO Connections To A Device.
0x0b	ACL Connection already exists.
0x0c	Command Disallowed.
0x0d	Host Rejected due to limited resources.
0x0e	Host Rejected due to security reasons.
0x0f	Host Rejected due to remote device is only a personal device.
0x10	Host Timeout.
0x11	Unsupported Feature or Parameter Value.
0x12	Invalid HCI Command Parameters.
0x13	Other End Terminated Connection: Used Ended Connection.
0x14	Other End Terminated Connection: Low Resources.
0x15	Other End Terminated Connection: About to Power Off.
0x16	Connection Terminated by Local Host.
0x17	Repeated Attempts.
0x18	Paring Not Allowed.
0x19	Unknown LMP PDU.
0x1a	Unsupported Remote Feature.
0x1b	SCO Offset Rejected.
0x1c	SCO Interval Rejected.
0x1d	SCO Air Mode Rejected.
0x1e	Invalid LMP Parameters.
0x1f	Unspecified Error.

\*\* See the Specification of the Bluetooth System for details.



When the Bluetooth test menu is displayed, press **T** to select the test and press **Enter** in the test machine. The following message will appear:

```

-----
Bluetooth Subsystem T&D for PCSE(CS-Air) VerX.XX Copyright (C) by TOSHIBA Co.
-----
+-----+
|           |
|   Tester   |
|           |
+-----+

[ESC]:Finish Tester  [SPACE]:Start
Is DUT ready?
    
```

Then press **Space** to start the Bluetooth communication test.

When the machine has passed the test, it displays BD\_ADDR of the DUT. If the connection with the tester is completed, the progress bar stops. The following message is shown.

```

-----
Bluetooth Subsystem T&D for PCSE(CS-Air) VerX.XX Copyright (C) by TOSHIBA Co.
-----
+-----+
|           | BD_ADDR of the DUT = XXXXXXXXXXXXX [h]
+-----+

  CCCC   OOO   M   M PPPPPP L   EEEEEE TTTTTT EEEEEEE DDDDD
C   C O   O MM   MM P   P L   E       T   E       D   D
C     O   O M M M M P   P L   E       T   E       D   D
C     O   O M M M PPPPPP L   EEEEEE T   EEEEEEE D   D
C     O   O M   M P   L   E       T   E       D   D
C   C O   O M   M P   L   E       T   E       D   D
  CCCC   OOO   M   M P   LLLLLL EEEEEE T   EEEEEEE DDDDD

Testing is finished

A>_
    
```

If the target machine has any problem, the following message “INCOMPLETE” is displayed with the Error Code.

```

-----
Bluetooth Subsystem T&D for PCSE(CS-Air) VerX.XX Copyright (C) by TOSHIBA Co.
-----

+-----+
|          DUT          |   BD_ADDR of the DUT = XXXXXXXXXXXXX [h]
+-----+

III N   N   CCCC   OOO   M   M P P P P P P L   EEEEE TTTTTT EEEEE
I  NN  N C   C O   O MM  MM P   P L   E       T   E
I  NN  N C   O   O M M M M P   P L   E       T   E
I  NN  N C   O   O M M M P P P P P L   EEEEE T   EEEEE
I  NN  N C   O   O M   M P   L   E       T   E
I  NN  N C   C O   O M   M P   L   E       T   E
III N   N   CCCC   OOO   M   M P           LLLLLL EEEEE T   EEEEE

                                Testing is finished

_Press any key to continue. . .

```

If the machine detects a malfunction, it indicates the error code as shown below.

The error code begins with the least significant digit.

Error code

Table 3-7 Error code for Bluetooth test (BD\_ADDR of the DUT) (1/2)

Error code	Meaning
0x01	Unknown HCI Command.
0x02	No Connection.
0x03	Hardware Failure.
0x04	Page Timeout.
0x05	Authentication Failure.
0x06	Key Missing.
0x07	Memory Full.
0x08	Connection Timeout.
0x09	Max Number Of Connections.
0x0a	Max Number Of SCO Connections To A Device.
0x0b	ACL Connection already exists.
0x0c	Command Disallowed.
0x0d	Host Rejected due to limited resources.
0x0e	Host Rejected due to security reasons.
0x0f	Host Rejected due to remote device is only a personal device.
0x10	Host Timeout.
0x11	Unsupported Feature or Parameter Value.
0x12	Invalid HCI Command Parameters.
0x13	Other End Terminated Connection: Used Ended Connection.
0x14	Other End Terminated Connection: Low Resources.
0x15	Other End Terminated Connection: About to Power Off.
0x16	Connection Terminated by Local Host.
0x17	Repeated Attempts.
0x18	Paring Not Allowed.
0x19	Unknown LMP PDU.
0x1a	Unsupported Remote Feature.
0x1b	SCO Offset Rejected.
0x1c	SCO Interval Rejected.
0x1d	SCO Air Mode Rejected.
0x1e	Invalid LMP Parameters.
0x1f	Unspecified Error.

\*\* See the Specification of the Bluetooth System in detail.

Table 3-7 Error code for Bluetooth test (BD\_ADDR of the DUT) (2/2)

Error code	Meaning
0x20	Unsupported LMP Parameter Value.
0x21	Role Change Not Allowed.
0x22	LMP Response Timeout.
0x23	LMP Error Transaction Collision.
0x24	LMP PDU Not Allowed.
0x25	Not Exist
0x26	Not Exist
0x27	Not Exist
0x28	Not Exist
0x29	Not Exist
0x2a	Not Exist
0x2b	Not Exist
0x2c	Not Exist
0x2d	Not Exist
0x2e	Not Exist
0x2f	Not Exist

\*\* See the Specification of the Bluetooth System in detail.

**3.29.4 IEEE1394 test**

To execute this test, input **4** and press **Enter**.

**NOTE:** Use another computer that can communicate by IEEE1394 (i. Link) cable as a reference machine to perform this test.

The following menu will appear:

```

*****
*****      IEEE1394[XXXXX] Diagnostics program      *****
*****
*                                                     *
*      1 .... Transmit & Receive test                  *
*                                                     *
*      2 .... Responder set                            *
*                                                     *
*      3 .... 1394 GUID Display                        *
*                                                     *
*****
.... Press test number[1-3] ?

```

To execute the TEST, select the test number you want to execute and press **Enter**.

Subtest01      Transmit & Receive test

**NOTE:** Before executing subtest 01, be sure to execute subtest 02 in the responder machine.

This program checks the data transporting between responder machine and target machine and compare them with the original data through the IEEE1394 cable.

Subtest02      Responder set

This program is executed in the responder machine to initialize the responder machine with the IEEE1394 cable connected to the target machine before executing subtest 01.

Subtest03      1394 GUID Display

This program checks the GUID of IEEE1394.

### 3.30 Sound Test program

This section describes how to perform the Sound test. To execute the sound test, refer to the following description.

Insert the test program disk for Sound test in the floppy disk drive and turn on the power. The following message will appear:

```
#####
#####      WSS, Sound blaster pro Diagnostics program      #####
#####
*
*      1 .....      Sound (Standard)      *
*
*      2 .....      Sound (Legacy)      *
*
*      3 .....      CD Sound (Standard)  *
*
*      4 .....      CD Sound (Legacy)    *
*
*      ---It outputs at the speaker and lineout---
*
*****
.... Press test number[1-4] ?
```

Input the test number and press **Enter**.

#### 3.30.1 Sound (Standard)

To execute the Sound (Standard) test, press **1** and **Enter**. The following menu will appear in the display.

```
#####
#####      ICH4-M + AD1981A Diagnostics program      #####
#####
*
*      1 .....      ( Microphone recording & play )      *
*      2 .....      ( Sine wave )      *
*      3 .....      ( Line IN recording & play )      *
*
*      9 .....      Exit to Main      *
*
*****
.. Press test number[1-3, 9] ?
```



To return to the Sound test menu, Press **9** and **Enter**. Then following message will appear in the display.

```
*****
*****  May I Restart ?  *****
*****
Press any key to continue..
```

After pressing any key, the machine starts rebooting and sound test menu will appear in the display.

#### Subtest01 Microphone recording & play

This subtest checks the function of the CODEC A/D, D/A converter.

When this subtest is selected, the following message will appear.

```
[Recording & play test !]
```

And the following message will appear.

```
DOS/4GW Protected Mode Run-time Version X.XX
Copyright (c) Tenberry Software, Inc. XXXX
```

After this message appears, display stops briefly. In this timing, sound is recorded from internal microphone.

After the recording is completed, the computer plays back the sound recorded after the following message.

```
STACWAVE Version X.XX
Build data: XXX XX XXXX at XX:XX:XX
Loading "mic.wav".
```

<p><b>NOTE:</b> <i>The message in the display might have slight difference from those above.</i></p>
--

The display returns to the Sound (Standard) test menu after the test ends.

**Subtest02 Sine Wave**

This subtest is executed by loading the COM file (ADSIN.COM). The program expands sine wave data table from 16KB to 64KB, and creates the play data. Then it transfers the data between the DMA and the CODEC to play the sine wave. (It sounds like a continuous beep). By using wave measurable devices such as an oscilloscope, the data can be measured as a sine wave.

When the subtest is executed, the sine wave is played while expanding sine wave from 16KB to 64KB.

The display returns to the Sound (Standard) test menu after the test ends.

**Subtest03 Line IN recording & play**

This subtest executes the same test as the subtest01 by recorded sound from the different port (Line-in port).

For more details on the subtest, refer to the subtest01 Microphone recording & play.

The display returns to the Sound (Standard) test menu after the test ends.

**3.30.2 Sound (Legacy)**

To execute the Sound (Legacy) test, select **2** and press **Enter**.

**CAUTION:** *Sound (Legacy) test is not supported in this model.*

### 3.30.3 CD Sound (Standard)

To execute the CD Sound (Standard) test, press **3** and **Enter**. Insert the test media (TOSHIBA TEST CD-ROM or ABEX TEST CD-ROM) or music CD on the market (if the test media can not be prepared). Following menu appears in the display.

For details on use of test media, refer to (1) Test media (Toshiba-made test media).  
For details on use of audio CD on the market, refer to (2) Audio CD.

#### (1) Test media (Toshiba-made test media)

```
CD/DVD TEST  IN PROGRESS  XXXXXXXX
```

```
xxxxxxx DIAGNOSTIC TEST VX.XX
[Ctrl]+[Break] : test end
[Ctrl]+[C]     : key stop
```

```
SUB-TEST      : XX
PASS COUNT    : XXXXX      ERROR COUNT: XXXXX
WRITE DATA   : XX         READ DATA  : XX
ADDRESS       : XXXXXXX    STATUS      : XXX
```

```
01 - Japanese Narration
02 - English Narration
03 - Test Tone A (100Hz - 20Hz)
04 - Test Tone B (400Hz - 3KHz L-R)
```

```
Drive # = 0, ATAPI status =00
Command = XX
[[Block address = XXXXXXXXX]]
[[Block length  = XXXXXXXXX]]
Final : Block address = XXXXXXXXX
```

#### Subtest01 Japanese Narration

Selected this subtest, narration in Japanese starts and following message appears in the display.

```
Play start CD sound !
Press any key <Play stop>.
```

Press any key and stop the narration. Then return to the CD Sound (Standard) test menu.

Subtest02 English Narration

Selected this subtest, narration in English starts.

For more details on the procedure, refer to the subtest01.

Subtest03 Test Tone A

**CAUTION:** Before starting subtest03, be sure to set the sound at proper volume.

This subtest plays sine wave while changing its table from 100Hz to 20Hz.

Return to the CD Sound (Standard) menu after the test ends.

Subtest 04 Test Tone B

This subtest plays sine wave while changing its table from 400Hz to 3KHz and also changing the channel from left speaker to right speaker.

Return to the CD Sound (Standard) menu after the test ends.

## (2) Audio CD

Insert an audio CD and the following menu appears in the display.

```

CD/DVD TEST  IN PROGRESS XXXXXXXX

```

```

xxxxxxx DIAGNOSTIC TEST VX.XX
[Ctrl]+[Break] : test end
[Ctrl]+[C]      : key stop

```

```

SUB-TEST      : XX
PASS COUNT    : XXXXX      ERROR COUNT: XXXXX
WRITE DATA   : XX         READ DATA  : XX
ADDRESS       : XXXXXXXX   STATUS      : XXX

```

CD Sound track number (01-98 : Track) ?

```

Drive # = 0, ATAPI status =00
Command = XX
[[Block address = XXXXXXXXX]]
[[Block length  = XXXXXXXXX]]
Final : Block address = XXXXXXXXX

```

Select the track number you want to test and press **Enter** twice.

The following message appears in the display and selected track is played.

```

Play start CD sound !
Press any key <play stop>

```

After pressing any key, the music stops and the display returns to the selection menu of the track number.

**NOTE:** When the CD-ROM test is executed, "ALL DEVICE" must be selected in the [Device Config.] of the BIOS SETUP. If the "ALL DEVICE" is not selected, music can not be played.

### 3.30.4 CD Sound (Legacy)

To execute the CD Sound (Legacy) test, select **4** and press **Enter**.

**CAUTION:** Sound (Legacy) test is not supported in this model.

## 3.31 SETUP

### 3.31.1 Function Description

This program displays the current system setup information as listed below:

1. Memory
2. System Date/Time
3. Battery
  - (a) Battery Save Mode
  - (b) PCI Express Link ASPM
  - (c) Enhanced C-States
4. Password
5. HDD Password
  - (a) HDD
  - (b) HDD Password Mode
  - (c) User Password
  - (d) Master Password
6. Boot Priority
  - (a) Boot Priority
  - (b) HDD Priority
  - (c) Network Boot Protocol
7. Others
  - (a) Core-Multi Processing
  - (b) Dynamic CPU Frequency Mode
  - (c) Execute-Disable Bit Capability
  - (d) Virtualization Technology
  - (e) Auto Power On
  - (f) Beep Volume
  - (g) Diagnostic Mode
  - (h) Language During Bootup
8. Configuration
9. Drives I/O
10. PCI Bus

## 11. Security Controller

- (a) TPM
- (b) Clear TPM Owner

## 12. Display

- (a) Power On Display
- (b) LCD Display Stretch
- (c) TV Type

## 13. Peripheral

## 14. LEGACY EMULATION

- (a) USB KB/Mouse Legacy Emulation
- (b) USB-FDD Legacy Emulation
- (c) USB Memory BIOS Support Type

## 15. PCI LAN

### 3.31.2 Accessing the SETUP Program

Turn on the power while pressing **ESC**, the following menu appears.

Check system. Then press [F1] key.

Then press **F1**. The following display appears.

SYSTEM SETUP (1/2) ACPI BIOS version = X.XX

<p style="text-align: center;"><b>MEMORY</b></p> <p>Total = XXXXX MB</p> <hr/> <p style="text-align: center;"><b>SYSTEM DATE/TIME</b></p> <p>Date (MM-DD-YY) = XX-XX-XXXX Time (HH:MM:SS) = XX:XX:XX</p> <hr/> <p style="text-align: center;"><b>BATTERY</b></p> <p>Battery Save Mode = Full Power PCI Express Link ASPM = Enabled Enhanced C-Status = Enabled *4</p> <hr/> <p style="text-align: center;"><b>PASSWORD</b></p> <p>Not Registered</p> <hr/> <p style="text-align: center;"><b>HDD PASSWORD*1</b></p> <p>HDD = Built-in HDD HDD Pasword = User Only User Password = Not Registered Master Password = Not Registered</p>	<p style="text-align: center;"><b>BOOT PRIORITY</b></p> <p>Boot Priority = HDD→FDD→CD-ROM→LAN HDD Priority = Built-in HDD→USB Network Boot Protocol = PXE *3</p> <hr/> <p style="text-align: center;"><b>OTHERS</b></p> <p>Core-Multi Processing = Enabled *4 Dynamic CPU Frequency Mode = Dynamically Switchable Execute-Disable Bit Capability *4 = Not Available Virtualization Technology = Disabled *4 Auto Power On = Disabled Beep Volume = Medium Diagnostic Mode = Disabled Language During Bootup = English *2</p>
---	--

↓↑←→: Select items    Space, BkSp: Change values    PgDn, PgUp: Change pages  
Esc: Exit without saving    Home: Set default values    End: Save changes and Exit

SYSTEM SETUP (2/2) ACPI BIOS version = X.XX

<p style="text-align: center;"><b>CONFIGURATION</b></p> <p>Device Config. = Setup by OS</p> <hr/> <p style="text-align: center;"><b>DRIVERS I/O</b></p> <p>Built-in HDD = Primary IDE (1F0H/IRQ14) CD-ROM = Secondary IDE (170H/IRQ15)</p> <hr/> <p style="text-align: center;"><b>PCI BUS</b></p> <p>PCI BUS = IRQ10, IRQ11</p> <hr/> <p style="text-align: center;"><b>SECURITY CONTROLLER *5</b></p> <p>TPM = Disabled Clear TPM Owner</p>	<p style="text-align: center;"><b>DISPLAY</b></p> <p>Power On Display = Auto-Selected LCD Display Stretch = Enabled TV Type = PAL</p> <hr/> <p style="text-align: center;"><b>PERIPHERAL</b></p> <p>Internal Pointing Device = Enabled</p> <hr/> <p style="text-align: center;"><b>LEGACY EMULATION</b></p> <p>USB KB/Mouse Legacy Emulation = Enabled USB-FDD Legacy Emulation = Enabled USB Memory BIOS Supportr Type =HDD</p> <hr/> <p style="text-align: center;"><b>PCI LAN</b></p> <p>Built-in LAN = Enabled</p>
---	--

↓↑←→: Select items    Space, BkSp: Change values    PgDn, PgUp: Change pages  
Esc: Exit without saving    Home : Set default values    End: Save changes and Exit

**NOTE:** \*1: Follow the HWSC about display / non-display of HDD Password window.  
\*2: This appears in models for TCL (Canada).  
\*3: This appears in models that have 10/100M Ether Net LAN.  
\*4: This appears in models that have a CPU supporting this function.  
\*5: This appears in models that have a CPU supporting TPM.



### Moving Within the SETUP Menu and Changing Values

1. Press **←** and **→** to move between the two columns. Press **↑** and **↓** to move between items in a column. Press **Fn+↑ (PgUp)** and **Fn + ↓ (PgDn)** to move between the two pages.
2. Press either the **Space bar** or **Back Space** to change the value.

### Accepting Changes and Exiting the SETUP Window

1. Press **End** to accept the changes you made.

If the changed item does not require the system to reboot, the following message is displayed:

Are you sure? (Y/N)

If the changed item requires the system to reboot, the following message is displayed:

Are you sure? (Y/N)  
The changes you made will cause the system to reboot.

2. To make other changes, press **N**. Repeat the steps above.
3. To accept the changes, press **Y**.

**NOTE:** You can press **Esc** to quit at any time without saving changes. *SETUP* asks you to confirm that you do not want to save your changes. When *SETUP* is displayed at the next time, the current configuration appears.

### The Factory Preset Configuration

When you access *SETUP*, the current configuration is displayed.

1. To show the factory preset configuration, press **Home**.
2. To accept the default settings, press **End** and then press **Y**.

**NOTE:** When you execute the default setting, the following settings are not changed: Password, HDD Password, Core-Multi Processing and Security Controller.

## SETUP Options

The SETUP screen is divided into 15 functionally related groups. This section describes each group and its options.

### 1. Memory

This group of options displays the computer's memory.

This field displays the total amount of memory installed and is automatically calculated by the computer. You cannot change this value.

### 2. System Date/Time

Sets the date and time.

**System Date**            Sets date.

**System Time**           Sets time.

### 3. Battery

#### (a) Battery Save Mode

This option is used to select **Full Power**, **Low Power** or **User Setting** of the battery save mode. When you select the battery save mode, the followings will appear.

**Full Power**    The following shows full power settings.

```

— BATTERY SAVE OPTIONS —
Processing Speed = High
CPU Sleep Mode  = Enabled
LCD Brightness  = Bright (*1)
                  = Super-Bright (*2)
Cooling Method  = Maximum Performance
  
```

**Low Power**    The following shows low power settings.

```

— BATTERY SAVE OPTIONS —
Processing Speed = Low
CPU Sleep Mode  = Enabled
LCD Brightness  = Semi-Bright (*1)
                  = Bright (*2)
Cooling Method  = Battery Optimized
  
```

**NOTE:** *Display of the LCD Brightness will be changed in the condition below:*

(\*1) *Operating the battery*

(\*2) *Using the AC adapter*

**User Setting** Use this option to set the battery save parameters on the sub-window, **BATTERY SAVE OPTIONS**.

#### Battery Save Options

##### Processing Speed

This feature changes the CPU processing speed.

**High** CPU operates at 1 high speed.  
(Default in Full Power Mode)

**Low** CPU operates at low speed.  
(Default in Low Power Mode)

##### CPU Sleep Mode

Use this option to enable or disable the CPU sleep function.

**Enabled** Enables sleep mode. (Default)

**Disabled** Disables sleep mode.

##### LCD Brightness

Use this option to set the level of LCD brightness.

**Super-Bright** Full brightness for maximum visibility.

**Bright** Full brightness for high visibility.

**Semi-Bright** Less than full brightness for saving power.

Cooling Method

<b>Maximum Performance</b>	If the CPU becomes too hot, the fan turns on automatically in a high speed to cool down the CPU.
<b>Performance</b>	If the CPU becomes too hot, the fan turns on automatically. When the CPU temperature falls to a normal range, the fan turns off.
<b>Battery optimized</b>	If the CPU becomes too hot, the processing speed is lowered. If the temperature is still too high, the fan turns on. When the CPU temperature falls to a normal range, the fan is turned off and the processing speed is increased.
<b>Cooling optimized</b>	If the CPU becomes too hot, the fan turns on automatically in a high speed to cool down the CPU. Gives priority to the decrease of temperature at the bottom of the PC.

**NOTE:** Too hot condition may cause defect on the CPU. When the hot condition continues, the power is automatically turned off in resume mode.

## (b) PCI Express Link ASPM

This option sets the power saving function of the PCI Express.

<b>Auto</b>	Saves power consumption, when the PCI Express device is not used while the battery is working.
<b>Disabled</b>	Disables the power saving function and gives priority to the performance.
<b>Enabled</b>	Saves power consumption, when the PCI Express device is not used. (Default)

## (C) Enhanced C-States

This option enables or disables the Enhanced C-States.

<b>Enabled</b>	Lowers the power consumption. (Default)
<b>Disabled</b>	Does not lower power consumption.

## 4. Password

This option sets or resets the user password for power on.

**Registered**            The user password has been registered.

**Not registered**        The user password has not been registered.

For details on setting the user password, refer to the User's Manual.

## 5. HDD Password

This option registers, resets or changes the HDD password.

## (a) HDD

Hard disk for setting the password.

**Built-in HDD**        The password is set to Built-in HDD. (This can be changed when HDD is installed in Select Bay. "Second HDD" is displayed.)

## (b) HDD Password Mode

This item registers HDD Password and can be selected only for registering HDD password. To change HDD Password Mode when HDD Password is registered, delete the registered HDD Password first, and then register new password.

**User Only**            Sets only User HDD Password (Default)

**Master+User**        Sets Master HDD Password and User HDD Password

## (c) User Password

This item sets User password.

For details on setting user password, refer to the User's Manual.

## (d) Master Password

This item sets the Master HDD password.

This can be set, only when **Master+User** is set in the HDD password Mode.

For details, refer to the User's Manual.

## 6. Boot Priority

## (a) Boot Priority

This option sets the priority for booting the computer. Select from the following settings.

**FDD→HDD→CD-ROM→LAN:** The computer looks for bootable files in the following order: FDD, HDD, CD-ROM and LAN

**HDD→CD-ROM→LAN→FDD:** The computer looks for bootable files in the following order: HDD, CD-ROM, LAN and FDD.

**FDD→CD-ROM→LAN→HDD:** The computer looks for bootable files in the following order: FDD, CD-ROM, LAN and HDD.

**CD-ROM→LAN→HDD→FDD:** The computer looks for bootable files in the following order: CD-ROM, LAN, HDD and FDD.

**CD-ROM→LAN→FDD→HDD:** The computer looks for bootable files in the following order: CD-ROM, LAN, FDD and HDD.

**HDD→FDD→CD-ROM→LAN:** The computer looks for bootable files in the following order: HDD, FDD, CD-ROM and LAN. (Default)

**NOTE:** 1. CD-ROM refers to an Optical drive.

2. When a floppy disc drive is not connected, it boots up from SD memory card in spite of selecting FDD.

## (b) HDD Priority

Use this option to set the starting method from hard disk drive.

**Built-in HDD → USB** (Default)

: The priority is set as Built-in HDD → USB. (Default)

**USB → Built-in HDD**

: The priority is set as USB → Built-in HDD.

## (c) Network Boot Protocol

Use this option to set the starting method via a network.

**PXE** Sets to PXE protocol. (Default)

**RPL** Sets to RPL protocol.

## 7. Others

Whether or not you need to configure the computer with these options depends primarily on the kind of software or peripherals you use.

## (a) Core-Multi Processing

**NOTE:** This is not displayed in PCs with a single core CPU.

The Core Multi-Processing sets the CPU operating mode.

**Enabled** Enables Core Multi-Processing functions. (Default)

**Disabled** Disables Core Multi - Processing functions.

## (b) Dynamic CPU Frequency Mode

Use this option to choose a setting from the followings. When the CPU of the computer is Celeron-M, this option is not displayed.

**Dynamically Switchable**

Enables Intel SpeedStep technology. When the computer is in use, the CPU power consumption and clock speed are automatically switched when necessary. (Default)

**Always High** Disables Intel SpeedStep technology and always runs the processor at its fastest speed.

**Always Low** Disables Intel SpeedStep technology and always runs the processor at low power consumption and low speed.

## (c) Execute-Disable Bit Capability

Selects the function to reports whether the CPU Execute-Disable Bit is available or not to OS. The Execute-Disable Bit Capability is a function that strengthens the security to protect PC from the buffer overflow attack by a computer virus and an illegal access.

**Available** Make the Execute-Disable Bit Capability usable.

**Not Available** Disables the Execute-Disable Bit Capability. (Default)

## (d) Virtualization Technology

Virtualization Technology sets enable or disable of the Intel Virtualization Technology installed in the CPU.

Intel Virtualization Technology is the technique that allows one machine to operate as multiple virtual machines.

**Enabled** Enables Virtualization Technology.

**Disabled** Disables Virtualization Technology. (Default)

## (e) Auto Power On

This option displays setting for Auto Power On.

**Disabled** Indicates auto power on is not set.

**Enabled** Indicates auto power on is set.

When “Enabled” is selected, the following sub-window appears.

OPTIONS	
Alarm Time	= 00:00:00
Alarm Date Option	= Disabled
Wake-up on LAN	= Disabled

Set the parameters for the Auto Power On (automatic power on) function in the “OPTIONS” window. To set the time, use **Space** or **BackSpace**. Press ↓ to move the cursor to the right and ↑ to move the cursor to the left when you set the date and time.

For the **Alarm Time**, set the time to turn on the power automatically. The “second” cannot be set. When it is set to “Disabled”, the time to turn on automatically is not set.

For the **Alarm Date Option**, set the date to turn on the power automatically. When it is set to “Disabled”, the time to turn on automatically is not set.

The **Wake-up on LAN** is a function to turn on the power automatically by the call from the administrator. It can be set to “Enabled” only when “Built-in LAN” is set to “Enabled”. To activate this function, use the AC adapter.



- NOTE:**
1. Do not remove the AC adapter and battery pack at the same time when you use this feature. If you do so, data saved by the resume function will be lost. You must also reset this option.
  2. If you have set a password and the computer boots by the Auto Power On function and Standby is on, the computer will start with the instant security function enabled. The **password =** message is not displayed; however, you must enter the password to use the computer.
  3. This option is enabled only once, the setting is reset, after booting up.

## (f) Beep Volume

This option selects the volume of beep (Warning). “OFF”, “Low”, “Medium” (Default) or “High” can be selected. If a memory module that does not comply with the standards, the computer beeps at maximum volume.

## (g) Diagnostic Mode

This option sets whether the BIOS Setup Diagnostic test is enabled.

**Disabled**            The Diagnostic test is disabled. (Default)

**Enabled**            The Diagnostic test is enabled.

## (h) Language During Bootup

This option selects the language during bootup. This message appears only on the model for TCL (Canada).

**English**            The message is displayed in English. (Default)

**French**             The message is displayed in French.

## 8. Configuration

This option lets you set the device configuration.

**All Devices**            BIOS sets all devices.

**Setup by OS**            Initializes devices, which is needed to load an operating system. Operating system initializes other devices. (Default)

- NOTE:**
1. When using installed OS, selecting “Setup by OS” is recommended.
  2. When executing test programs, be sure to select “ALL Devices”.

## 9. Drives I/O

This option displays the address and interrupt level for hard disk drive and optical disk drive. It is for information only and cannot be changed.

**Built-in HDD**            This item cannot be changed.

**CD-ROM**                This item cannot be changed.

#### 10. PCI Bus

This option displays the interrupt level for the Card Bus in the computer. It is for information only and cannot be changed.

PCI BUS            = IRQ10, IRQ11

#### 11. Security Controller

##### (a) TPM

Disables the security controller called TPM (Trusted Platform Module). When the cursor is on the **Enable (Disable)** and the **Space** is pressed, message is displayed and the PC waits **Y** or **N** key input by the user. When **Y** is pressed, it is sets to **Enable (Disable)**. After changing, the cursor could not be moved on the **TPM** tem. This option can be changed after rebooting.

**Disabled**                Disables the TPM. (Default)

**Enabled**                Enables the TPM.

##### (b) Clear TPM Owner

This is not displayed when the **TPM** is set to **Disabled**. This is executed, when the PC is disposed or the owner of the PC changes. When the cursor is on this item and the **Space** is pressed, message is displayed and the PC waits **Y, E, S** and **Enter** key inputs by the user. When **Y, E, S** and **Enter** keys are pressed, the data is disposed. After changing, the display of **TPM** item is changed to **Disabled** and this item becomes not displayed and the cursor could not be moved on the **TPM** item.

## 12. Display

This group of options configures the computer's display.

## (a) Power On Display

This option is used to select the display when booting up.

**Auto-Selected** Selects an external monitor if one is connected. Otherwise it selects the internal LCD. (Default)

**LCD +Analog RGB** Selects both the internal LCD and the external CRT for simultaneous display.

**System LCD only** Selects only internal LCD display even if the external monitor is connected.

**NOTE:** 1. When starting the computer in Standby or Hibernation, the last configuration is saved. If data does not appear on the display you are using after starting in Standby or Hibernation, press **Fn+F5** to change the active display device.

2. When an external CRT display, which does not support SVGA mode is connected and "LCD+AnalogRGB" is selected, the external display is not displayed.

## (b) LCD Display Stretch

LCD Display Stretch enables or disables a larger display area of the screen.

**NOTE:** This is not displayed in PCs with a SXGA+ LCD.

**Enabled** Enables the LCD display stretch feature. (Default)

**Disabled** Disables the LCD display stretch feature.

## (c) TV Type

This option allows you to select the type of TV. The default depends on the destination.

**NTSC (Japan)** TV in Japanese system

**NTSC (US)** TV in the U.S. system

**PAL (S-Video)** TV in Europe system

## 13. Peripheral

Use this option to select the peripheral's mode.

## (a) Internal Pointing Device

This option enables or disables the touch pad

**Enabled** Enables the touch pad. (Default)

**Disabled** Disables the touch pad.

## 14. LEGACY EMULATION

## (a) USB KB/Mouse Legacy Emulation

This option sets the Legacy support condition of the USB keyboard and the USB mouse.

**Enabled** Enables LEGACY support. (Default)  
USB keyboard/USB mouse are available without the driver.

**Disabled** Disables LEGACY support

## (b) USB-FDD Legacy Emulation

This option sets the Legacy support condition of the USB floppy disk drive. When a computer is FDD built-in model, this option is not displayed.

**Enabled** Enables LEGACY support. (Default)  
USB floppy disk is available without the driver.

**Disabled** Disables LEGACY support

## (c) USB Memory BIOS Support Type

This option sets the type of the USB memory as a startup device.

**HDD** Sets the type of the USB memory to be equivalent to the HDD (Default).  
(Based on the [HDD] order in the [Boot Priority Options] item. The order with respect to the other HDD can be set in the [HDD Priority Options] item.)

**FDD** Sets the type of the USB memory to be equivalent to the FDD.  
(Based on the [HDD] order in the [Boot Priority Options] item.)

## 15. PCI LAN

This option sets the Enable / Disable of the built-in LAN functions.

**Enabled** Enables built-in LAN functions. (Default)

**Disabled** Disables built-in LAN functions.

---

## **Chapter 4**

# **Replacement Procedures**

---



---

## Chapter 4 Contents

---

4.1	Overview.....	4-1
	Safety Precautions.....	4-2
	Before You Begin.....	4-3
	Disassembly Procedure.....	4-4
	Assembly Procedure.....	4-5
	Tools and Equipment.....	4-5
	Screw Tightening Torque.....	4-6
	Grip Color.....	4-7
	Screw Notation.....	4-7
4.2	Battery pack.....	4-8
4.3	Reserve pen.....	4-10
4.4	Tablet PC pen.....	4-11
4.5	PC card/Bridge media.....	4-12
	4.5.1 PC card.....	4-12
	4.5.2 Bridge media.....	4-13
4.6	MDC/USIM card.....	4-14
4.7	HDD.....	4-16
4.8	Keyboard.....	4-20
4.9	Memory module.....	4-23
4.10	SW membrane.....	4-26
4.11	Optical disk drive.....	4-28
4.12	Cover assembly and Base assembly.....	4-31
4.13	Base latch.....	4-35
4.14	Touch pen case/Battery lock.....	4-36
4.15	Bluetooth module.....	4-37
4.16	Wireless LAN card.....	4-39
4.17	Microphone/Front panel.....	4-41
4.18	Modem jack/USB board/DC-IN jack.....	4-43
4.19	RTC battery.....	4-46
4.20	System board.....	4-48

## 4 Replacement Procedures

---

4.21	GPU heat sink .....	4-50
4.22	Fan/Heat sink/CPU .....	4-52
4.23	Sensor board.....	4-56
4.24	Speaker .....	4-57
4.25	Touch pad.....	4-59
4.26	LCD mask .....	4-61
4.27	Fingerprint sensor board .....	4-65
4.28	Switch board .....	4-66
4.29	LCD unit/FL inverter .....	4-67
4.30	Digitizer .....	4-71
4.31	LCD latch assembly .....	4-78
4.32	Hinge assembly .....	4-79
4.33	Fluorescent Lamp.....	4-82
	4.33.1 Replacing the 14.1 Inch CHIMEI fluorescent Lamp .....	4-83



## Figures

Figure 4-1 Removing the battery pack.....	4-8
Figure 4-2 Removing the reserve pen.....	4-10
Figure 4-3 Removing the tablet PC pen.....	4-11
Figure 4-4 Removing the PC card .....	4-12
Figure 4-5 Removing the Bridge media.....	4-13
Figure 4-6 Removing the USIM card .....	4-14
Figure 4-7 Removing the MDC .....	4-15
Figure 4-8 Removing the HDD slot cover.....	4-16
Figure 4-9 Removing the HDD assembly.....	4-17
Figure 4-10 Removing the HDD.....	4-18
Figure 4-11 Removing the keyboard holder .....	4-20
Figure 4-12 Removing the keyboard .....	4-21
Figure 4-13 Removing the memory slot cover .....	4-23
Figure 4-14 Removing the memory module.....	4-24
Figure 4-15 Removing the SW membrane .....	4-26
Figure 4-16 Removing the optical disk drive .....	4-28
Figure 4-17 Detaching the optical disk drive assembly.....	4-29
Figure 4-18 Removing the cover assembly and base assembly (1).....	4-31
Figure 4-19 Removing the cover assembly and base assembly (2).....	4-32
Figure 4-20 Removing the cover assembly and base assembly (3).....	4-33
Figure 4-21 Removing the base latch .....	4-35
Figure 4-22 Removing the touch pen case/battery lock.....	4-36
Figure 4-23 Removing the Bluetooth module .....	4-37
Figure 4-24 Removing the Wireless LAN card .....	4-39
Figure 4-25 Removing the front panel.....	4-41
Figure 4-26 Removing the microphone .....	4-42
Figure 4-27 Removing the modem jack.....	4-43
Figure 4-28 Removing the USB board .....	4-44
Figure 4-29 Removing the DC-IN jack .....	4-45
Figure 4-30 Removing the RTC battery holder.....	4-46
Figure 4-31 Removing the RTC battery .....	4-47

Figure 4-32 Removing the system board..... 4-48

Figure 4-33 Removing the GPU heat sink..... 4-50

Figure 4-34 Removing the fan/heat sink..... 4-52

Figure 4-35 separating the fan and heat sink ..... 4-53

Figure 4-36 Removing the CPU ..... 4-53

Figure 4-37 Installing the CPU ..... 4-54

Figure 4-38 Applying new grease..... 4-55

Figure 4-39 Removing the sensor board..... 4-56

Figure 4-40 Removing the speaker ..... 4-57

Figure 4-41 Removing the touch pad cover..... 4-59

Figure 4-42 Removing the touch pad..... 4-60

Figure 4-43 Removing the LCD mask..... 4-61

Figure 4-44 Removing the fingerprint sensor board..... 4-65

Figure 4-45 Removing the switch board..... 4-66

Figure 4-46 Removing the FL inverter ..... 4-67

Figure 4-47 Removing the LCD unit ..... 4-68

Figure 4-48 Removing the LCD support ..... 4-69

Figure 4-49 Removing the digitizer..... 4-76

Figure 4-50 Removing the LCD latch assembly..... 4-78

Figure 4-51 Removing the hinge assembly (1)..... 4-79

Figure 4-52 Removing the hinge assembly (2)..... 4-80

Figure 4-53 Removing the hinge assembly (3)..... 4-81

Figure 4-54 to 4-59

Replacing the 14.1 Inch CHIMEI fluorescent Lamp (1) to (6).....4-83 to 4-88

## 4.1 Overview

This chapter describes the procedure for removing and replacing the field replaceable units (FRUs) in the PC. It may not be necessary to remove all the FRUs in order to replace one. The chart below provides a guide as to which other FRUs must be removed before a particular FRU can be removed. The numbers in the chart indicate the relevant section numbers in this manual.

In all cases when removing an FRU, the battery pack must also be removed. When repairing an FRU that is the potential cause of a computer fault, use the chart to determine the order in which FRUs need to be removed.

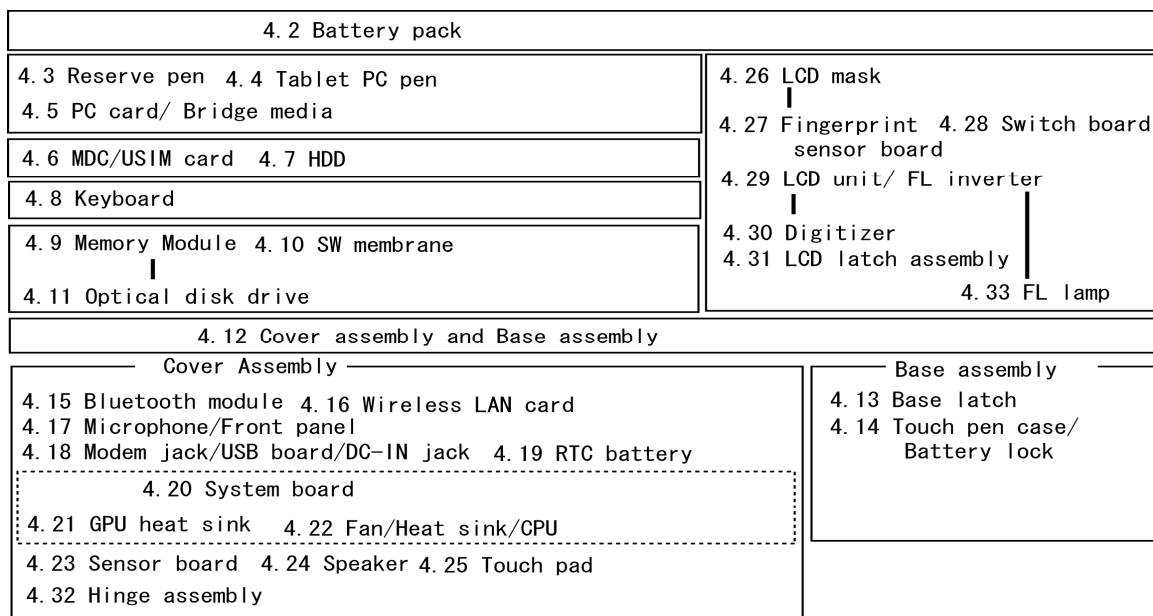

### Chart Notation

The chart shows the case for the following example:

- Removing the Base assembly and Cover assembly

All FRUs down to the “4.2 Battery pack” to “4.11 Optical drive” above a 4.12 Cover assembly must be

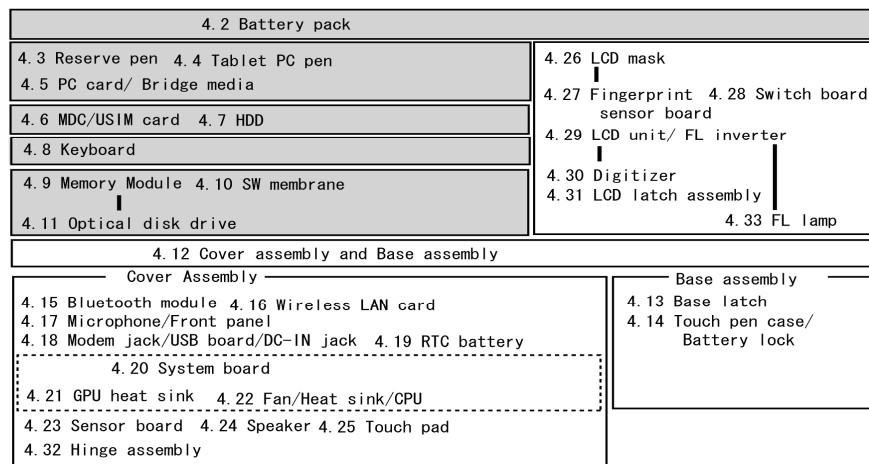

## Safety Precautions

Please read the following safety instructions before disassembling the computer and always follow the instructions while working on the computer.

**DANGER:** 1) *Always use the genuine battery that is authorized by Toshiba or compatible with the unit. Since other battery packs have different specifications, they may be incompatible with the unit, and may burst or explode.*  
*Never heat or disassemble the battery pack, as that could cause leakage of alkaline solution. Never throw the battery pack into a fire, as that could cause the battery pack to explode.*

2) *The power supply, FL inverter and other components carry high voltages. If you need to turn on the power of a partially disassembled computer to check its operation, be very careful not to touch connectors or components, in order to avoid the risk of electric shock. Also, do not disassemble individual components in first-level maintenance.*

**WARNING:** 1) *Turn off the power and disconnect the AC adaptor from the power source, to avoid exposure to electric shock.*

2) *Batteries in the computer retain an electrical charge, so there is danger of electrical shock even when the computer is disconnected from an AC power source. Remove any metal jewelry or accessories such as necklaces, bracelets or rings, in order to reduce the risk of electric shock. Never work with wet or damp hands.*

3) *Be careful of edges and corners as these may cut.*

**CAUTION:** 1) *When you change a component, be sure the replacement component meets the required specifications. Never use foreign parts, to avoid any risk of damage to the computer.*

2) *To avoid any risk of short-circuit, fire or other internal damage, never allow any metal objects such as screws or paper clips to fall into the unit. Be sure to replace screws with the same size as those removed. Make sure all screws are securely fastened. Loose screws can cause short circuits, resulting in heat, smoke or fire.*

3) *Before lifting out an FRU or other component, make sure all cables to the component have been disconnected, in order to reduce the risk of accidental electric shock.*

4) *If you use AC power, be sure to use the cable that came with the computer or one recommended by Toshiba.*

5) *Make sure that all replacement components meet the specifications for the computer and that all cables and connectors are securely fastened, in order to avoid the risk of electric shock.*

6) *Some parts inside the computer, such as the CPU and cooling module, become very hot during operation. Conduct repair work after they have cooled. Be careful around the CPU and cooling module to avoid burns.*

**Before You Begin**

Take note of the following points before starting work. Always remove the AC adapter and battery pack before commencing any of the procedures. The procedure for removing the battery pack is described in section “4.2. Battery Pack”.

Do not disassemble the computer unless it is operating abnormally.

Use the designated tools.

Ensure that the environment for working on and storing parts does not contain any of the following.

- Dust or dirt
- Static electricity
- Extremely hot, cold, or humid conditions

Perform the diagnostic tests described in Chapter 2 to determine which FRU is the cause of the fault.

Do not perform any unnecessary work. Always work in accordance with the disassembly and re-assembly procedures in this manual.

Keep parts removed from the computer in a safe place away from the computer where they will not be damaged or interfere with your work.

Disassembling requires the removal of a large number of screws. Keep removed screws in a safe place such that you can determine which screws belong to which part.

When re-assembling, ensure that you use the correct screws and fit parts in the correct position. Screw sizes are noted in the text and figures.

As all parts have sharp edges and corners, take care not to cut yourself.

After replacing an FRU, check that the computer and replaced part operate correctly.

## Disassembly Procedure

Four main types of cable connector are used.

- Pressure plate connector
- Spring connector
- Back flip connector
- Normal pin connector

When disconnecting a pressure plate connector, lift up the tag on one side of the plastic pressure plate on the connector and pull the cable out from the connector. When reconnecting a cable to a pressure plate connector, lift up the pressure plate to a suitable height and insert the cable into the connector. Press down on both sides of the pressure plate such that both sides of the plate and connector are at the same height and that the cable is fixed in the correct position. Pull the cable to ensure that it is securely connected. If the cable is disconnected from the connector, reconnect it making sure that you lift the pressure plate high enough to insert fully the cable.

For spring connectors, lifting up the stopper frees the cable and allows it to be pulled out. To reconnect, hold the stopper in the up position and insert the cable, then lower the stopper to secure the cable.

For back flip connectors, lifting up the flip plate frees the cable and allows it to be pulled out. To reconnect, hold the flip plate in the up position and insert the cable, then lower the flip plate to secure the cable.

Normal pin connectors are used for all other cables. Simply pull out or push in these connectors to disconnect or reconnect.

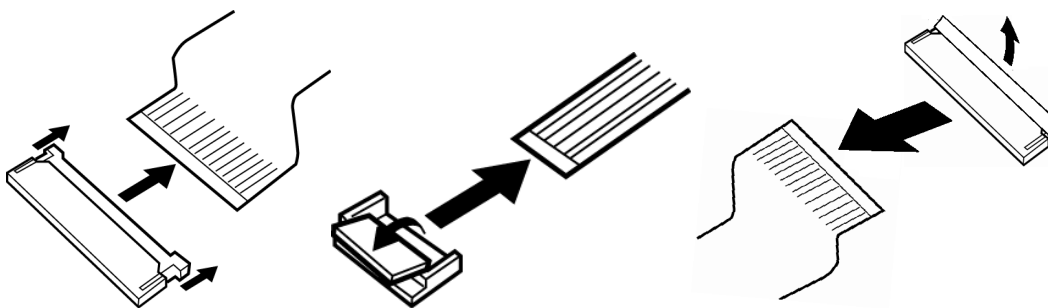

Pressure plate connector

Spring connector

Back flip connector

## Assembly Procedure

After the computer has been disassembled and the part that caused the fault has been repaired or replaced, the computer must be reassembled.

Take note of the following general points when assembling the computer.

- Take your time and follow the instructions carefully. Hurrying the assembly work will only introduce new problems.
- Check that all cables and connectors are securely connected.
- Before fastening FRUs or other parts in place, ensure that no cables are caught on screws or the FRU.
- Check that all latches are securely closed.
- Ensure that you have installed all FRUs correctly and do not have any screws left over. Using an incorrect screw may damage the thread or screw head and result in the FRU not being securely fastened in place.

After installing FRUs, check that the computer operates correctly.

## Tools and Equipment

For your safety and the safety of the people around you, it is important that you use Electrostatic Discharge (ESD) equipment. Correctly utilizing of the equipment increases the percentage of successful repairs and saves on the cost of damaged or destroyed parts. The following equipment is required for disassembly and assembly.

- One Philips screwdriver with type 0 bit (for THIN HEAD screws)
- One Philips screwdriver with type 1 bit (for screws other than above)
- One screwdriver for TORX screw
- Tweezers (for lifting screws)
- ESD mats (lay on work table or floor)
- An ESD wrist strap and heel grounder
- Anti-static carpet or flooring
- A pair of needle-nose pliers
- Air-ionizers in highly static sensitive areas
- Antenna coaxial cable disconnecter

## Screw Tightening Torque

Use the following torque when tightening screws.

**CAUTION:** Overtightening may damage screws or parts. Undertightening may allow screws to loosen (and possibly fall out) causing a short circuit or other damage.

**NOTE:** To tighten screws quickly and accurately, an electric screwdriver is recommended.

- M2 (2mm) 0.167 N•m (1.7 kgf•cm)
- M2.5 (2.5mm) 0.294 N•m(3.0 kgf•cm)
- M3 (3mm) 0.549 N•m(5.6 kgf•cm)

**NOTE:** To prevent damage to **THIN HEAD** screws, use type 0 pit philips screwdriver. Use, however, the PH point size "1" screwdriver for screws fixing the expansion memory slot cover and the keyboard. Press along the axis of the screwdriver while turning the screw. This is because the contact area between the screw and driver is less than for a pan head screw (standard pan-shaped screw head).

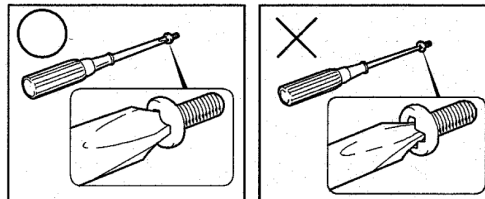



## Grip Color

Some screws have a colored grip area to help you determine the length of the screw.

- Even numbered length screws: Brown
- Odd numbered length screws: White
- Special length screw: Blue

“Special length screw” means screws whose length is indicated in an integral number to the first decimal places such as 2.5 mm, 2.6 mm and so on.



## Screw Notation

To make maintenance of the computer easier, markings of the kinds of the screws including the types and lengths of the screws are indicated on the computer body.

Format:

Screw shape + Screw length (mm)

Screw shape

- B: Bind screw
- F: Flat head screw
- S: Super thin head screw
- T: Tapping screw
- U: Other screws (Unique screws: pan head, stud, etc.)

Example: B6 ... 6mm BIND screw

## 4.2 Battery pack

### Removing the battery pack

The following describes the procedure for removing the battery pack. (See Figure 4-1.)

**CAUTION:** Take care not to short circuit the terminals when removing the battery pack. Similarly, do not drop, knock, scratch, disassemble, twist, or bend the battery pack.

1. Turn off the power of the computer.
2. Disconnect the AC adapter and all other external devices from the computer.
3. Turn the computer upside down.
4. Release the **battery lock**.
5. Pull out the **battery pack** while sliding the **battery latch** toward the arrow pointing.

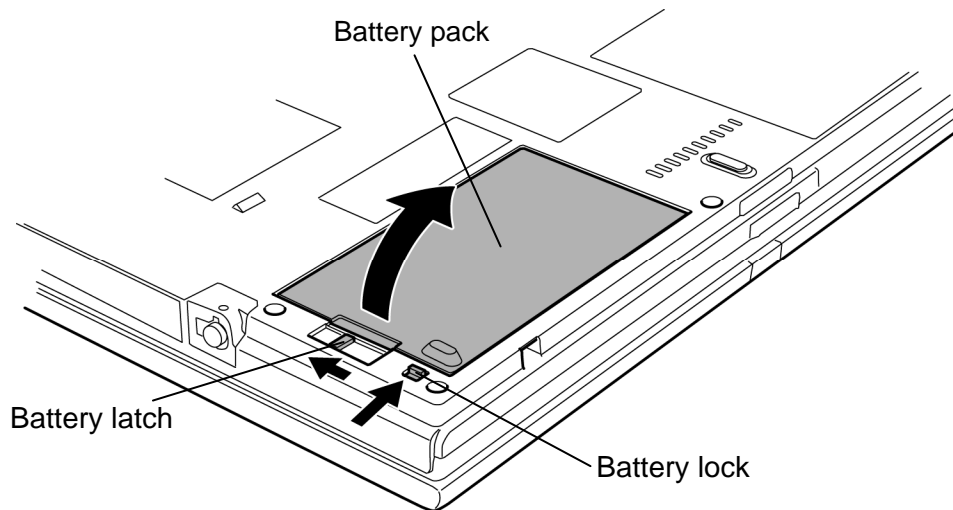

Figure 4-1 Removing the battery pack

**NOTE:** Dispose of the used battery pack in accordance with the laws and ordinances of your local authority.

## Installing the battery pack

The following describes the procedure for installing the battery pack. (See Figure 4-1.)

**CAUTION:** *There is a danger that the lithium ion battery pack may explode if not fitted, operated, handled, or disposed correctly. Dispose always the used batteries pack in accordance with the laws and ordinances of your local authority. Use only the batteries approved by Toshiba.*

**NOTE:** *Check visually the battery terminals and clean off any dirt with a dry cloth.*

1. Turn off the power of the computer.
2. Disconnect the AC adapter and all other external devices from the computer.
3. Install the **battery pack** into the battery slot. Make sure the battery pack is installed securely.
4. Slide the **battery lock** into the lock position.

### 4.3 Reserve pen

#### Removing the reserve pen

The following describes the procedure for removing the reserve pen. (See Figure 4-2.)

1. Remove the **reserve pen** from the pen holder.

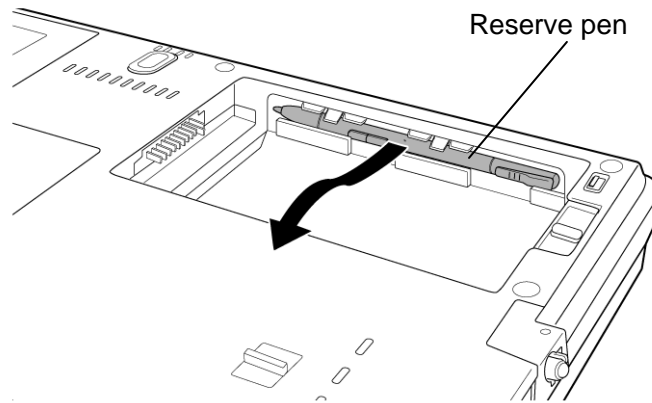

*Figure 4-2 Removing the reserve pen*

#### Installing the reserve pen

The following describes the procedure for installing the reserve pen. (See Figure 4-2.)

1. Install the **reserve pen** to the pen holder.

## 4.4 Tablet PC pen

### Removing the tablet PC pen

The following describes the procedure for removing the tablet PC pen. (See Figure 4-3.)

1. Gently push the **tablet PC pen**. The pen will then protrude slightly from the side.
2. Remove the **tablet PC pen** from the tablet PC pen slot.

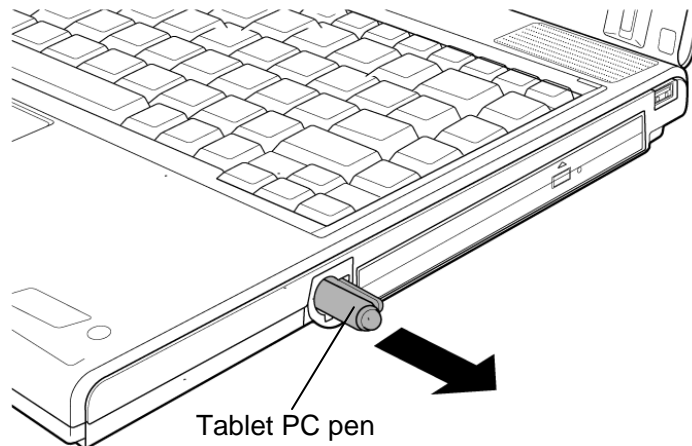

Figure 4-3 Removing the tablet PC pen

### Installing the tablet PC pen

The following describes the procedure for installing the tablet PC pen. (See Figure 4-3.)

1. Insert the **tablet PC pen** into the tablet PC pen slot.

**CAUTION:** The tablet PC pen and the reserve pen are different in shape. Do not insert the reserve pen into the tablet PC pen slot.

## 4.5 PC card/Bridge media

### 4.5.1 PC card

#### Removing the PC card

The following describes the procedure for removing the PC card. (See Figure 4-4.)

**CAUTION:** Insert or remove the PC card in accordance with any instructions in the PC card manual or the manuals of this computer.

1. Turn the computer upside down.
2. Push the **ejection button**. It will pop out. Then press the eject button again to eject the PC card.
3. Grasp the **PC card** and remove it.

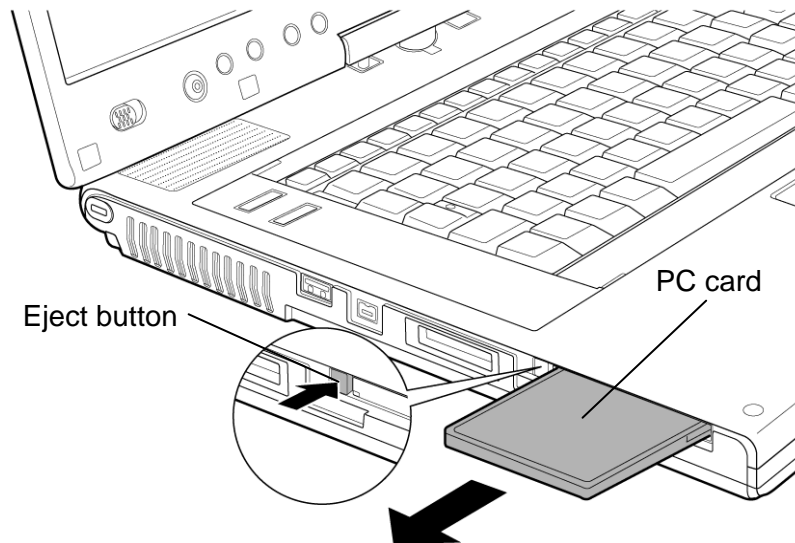

Figure 4-4 Removing the PC card

#### Installing the PC card

The following describes the procedure for installing the PC card. (See Figure 4-4.)

1. Make sure the eject button does not stick out.
2. Insert the **PC card** carefully and make sure a firm connection.

## 4.5.2 Bridge media

### Removing the Bridge media

The following describes the procedure for removing the Bridge media. (See Figure 4-5.)

**CAUTION:** Insert or remove the Bridge media in accordance with any instructions in the Bridge media manual or the manuals of this computer.

1. Push the **Bridge media**. It will pop out partly, so pull out the card. (For an instance, SD card is described in the figure 4-5.)

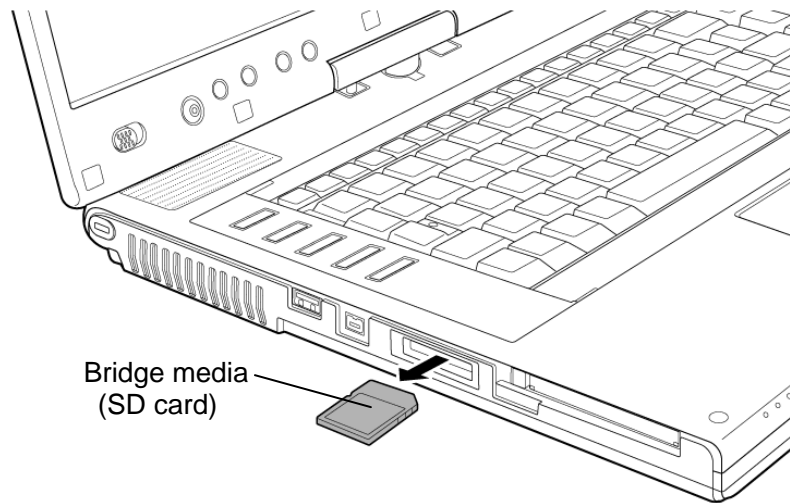

*Figure 4-5 Removing the Bridge media*

### Installing the Bridge media

The following describes the procedure for installing the Bridge media. (See Figure 4-5.)

1. Insert the **Bridge media** and press it until it securely connected.

## 4.6 MDC/USIM card

### Removing the MDC/USIM card

The following describes the procedure for removing the MDC/USIM card. (See Figure 4-6 and 4-7.)

1. Loosen the **screw** (with e-ring) and remove the **MDC/USIM card cover**.
2. Remove the following **screws** securing the USIM card and MDC.
  - M2×8B BIND screw ×2 (For models with USIM card)  
or
  - M2×4B BIND screw ×2 (For models without USIM card)
3. Disconnect the **USIM card cable** from the connector **CN9520** on the system board and remove the **USIM card**.
4. Disconnect the **USIM card cable** from the connector on the USIM card.

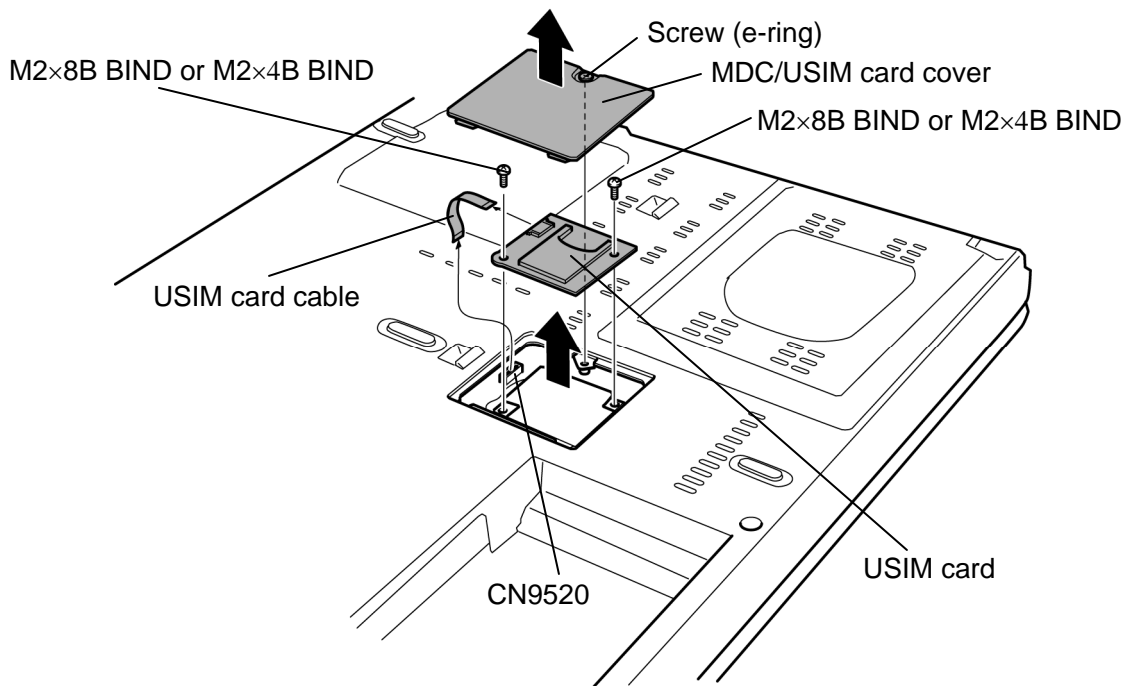

Figure 4-6 Removing the USIM card



5. Remove the **MDC** from the connector **CN3010** on the system board.
6. Disconnect the **MDC cable** from the connector on the MDC.

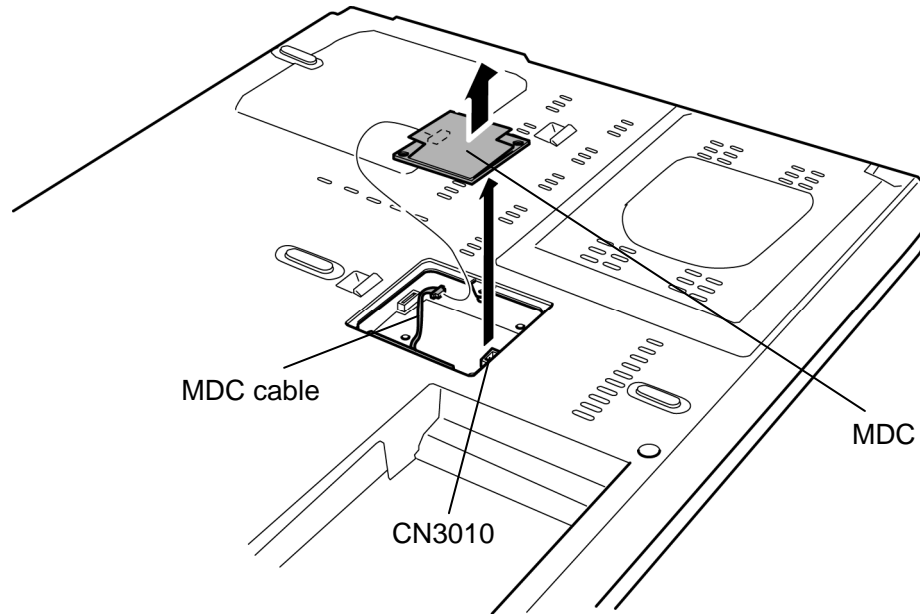

Figure 4-7 Removing the MDC

### Installing the MDC/USIM card

The following describes the procedure for installing the MDC/USIM card. (See Figure 4-6 and 4-7.)

1. Connect the **MDC cable** to the connector on the MDC.
2. Set the **MDC** and press it carefully to connect it to the connector **CN3010** on the system board. Be careful not to damage the MDC and connector.
3. Connect the **USIM card cable** to the connector on the USIM card.
4. Connect the **USIM card cable** to the connector **CN9520** on the system board.
5. Install the **USIM card** to the slot and secure it with the following **screws**.
  - M2×8B      BIND screw      ×2 (For models with USIM card)
  - or
  - M2×4B      BIND screw      ×2 (For models without USIM card)
6. Install the **MDC/USIM card cover** and secure it with **screw** (with e-ring).

## 4.7 HDD

### Removing the HDD

The following describes the procedure for removing the HDD. (See Figure 4-8 to 4-10.)

**CAUTION:** Take care not to press on the top or bottom of the HDD. Pressure may cause data loss or damage to the device.

1. Turn the computer upside down.
2. Remove the following screws and **HDD slot cover**.

- M2.5×16B FLAT HEAD screw ×2

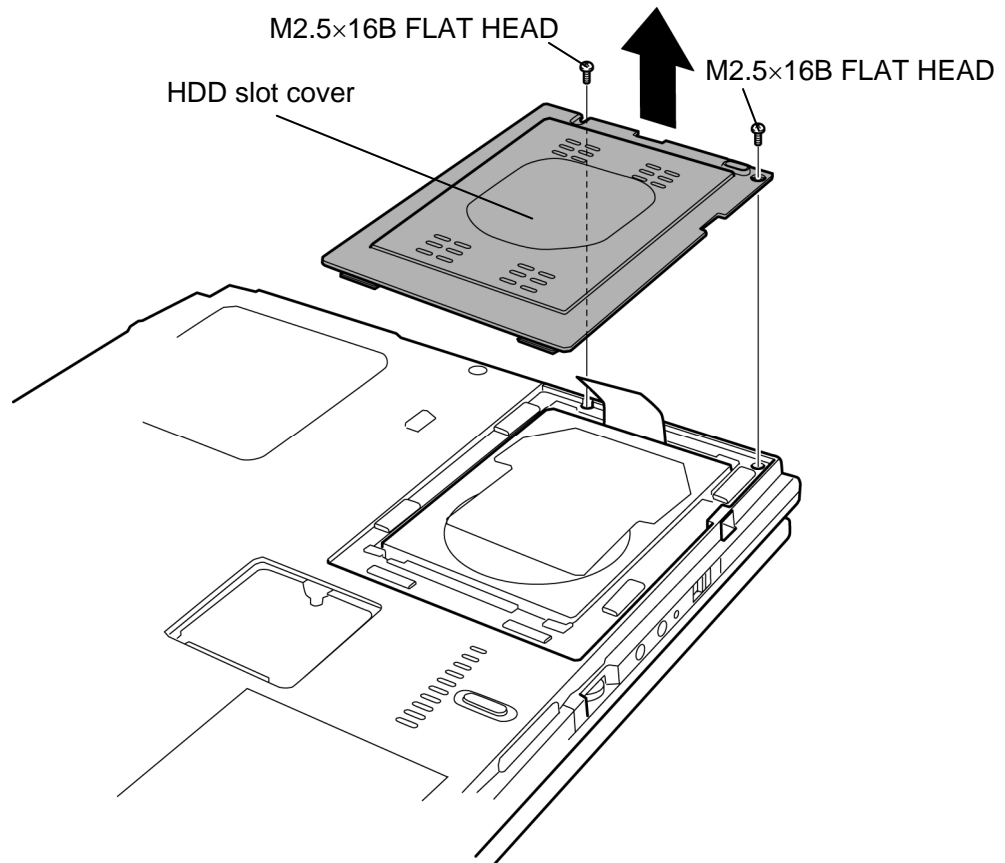

Figure 4-8 Removing the HDD slot cover

3. Hold the **tab** to raise the HDD assembly and pull out the **HDD assembly** from the connector of the **HDD cable**.

**NOTE:** When removing the HDD assembly, be careful not to tear the tab. If the tab is torn, replace the HDD holder with a new one.

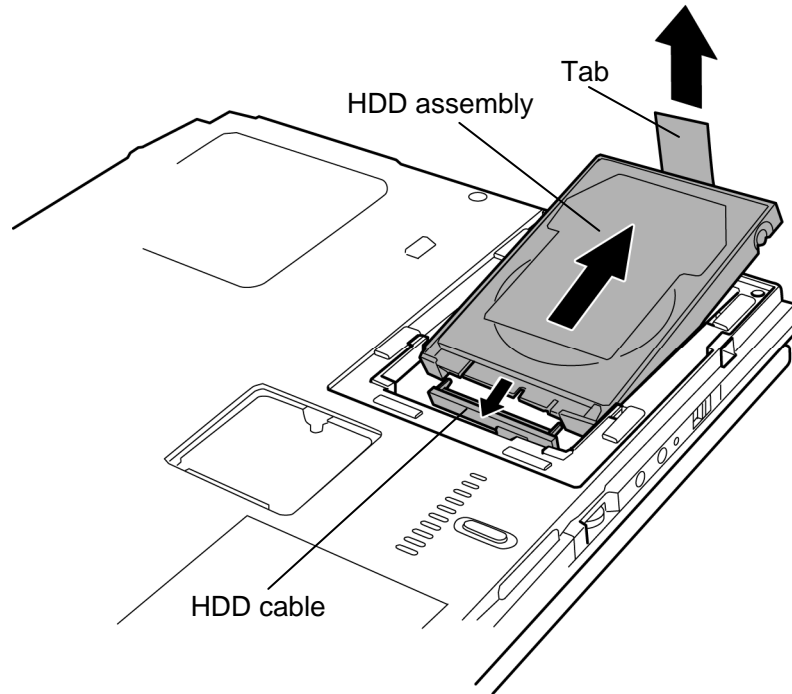

Figure 4-9 Removing the HDD assembly

- Place the HDD assembly on a flat surface and remove the following **screws** fixing the HDD holder.

- M3x4S FLAT HEAD screw ×4

- Separate the **HDD holder** and **HDD**.

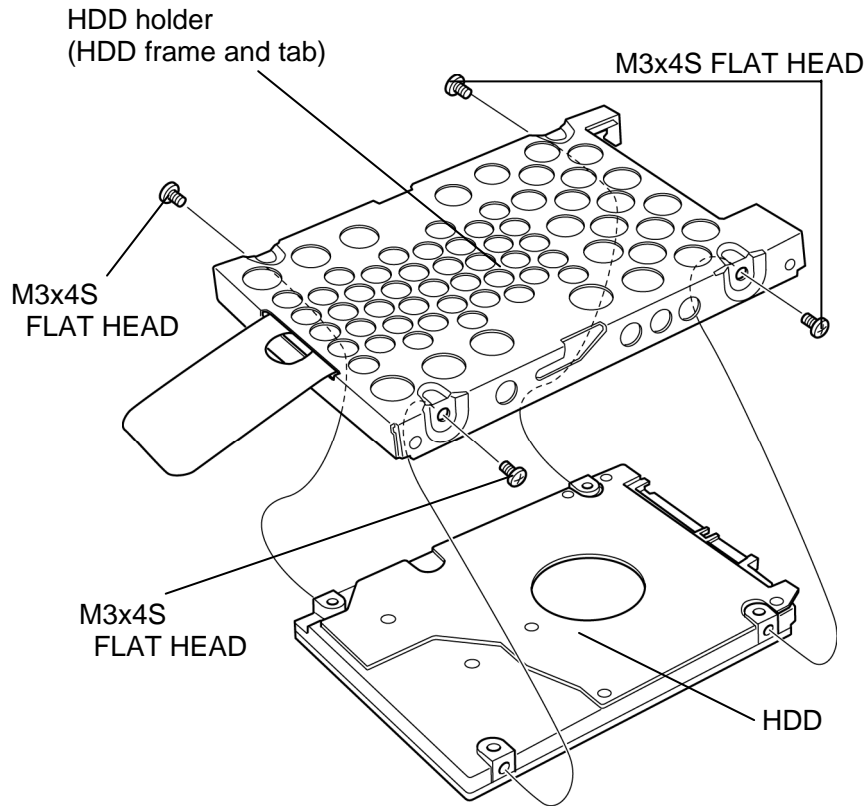

Figure 4-10 Removing the HDD

### Installing the HDD

The following describes the procedure for installing the HDD. (See Figure 4-8 to 4-10.)

**CAUTION:** Do not hold the HDD by its top and bottom face. It may damage the HDD.

1. Seat the **HDD** in the **HDD holder** and secure them with the following **screws**.

- M3×4S      FLAT HEAD screw      ×4

**CAUTION:** Do not apply pressure to the middle of the HDD assembly. It may damage the HDD assembly. Hold the HDD assembly by its corners.

2. Set the connector of the **HDD cable** upward and connect the **HDD assembly** to the connector. Press the HDD assembly to ensure a firm connection.

3. Set the **HDD assembly** into the slot.

4. Seat the **HDD cover** and secure it with following **screws**.

- M2.5×16B      FLAT HEAD screw      ×2

## 4.8 Keyboard

### Removing the keyboard

The following describes the procedure for removing the keyboard. (See Figure 4-11 to 4-12.)

1. Turn the computer face up and open the display.
2. Insert your fingers into the slots on both sides and remove the **keyboard holder A**.
3. Remove the following screws securing the keyboard.
  - M2.5×3S S-THIN HEAD screw ×2
4. Remove the **keyboard holder B** while releasing latches.
5. Lift the top edge of the **keyboard** while releasing the **latch** and turn the keyboard face down on the palm rest.

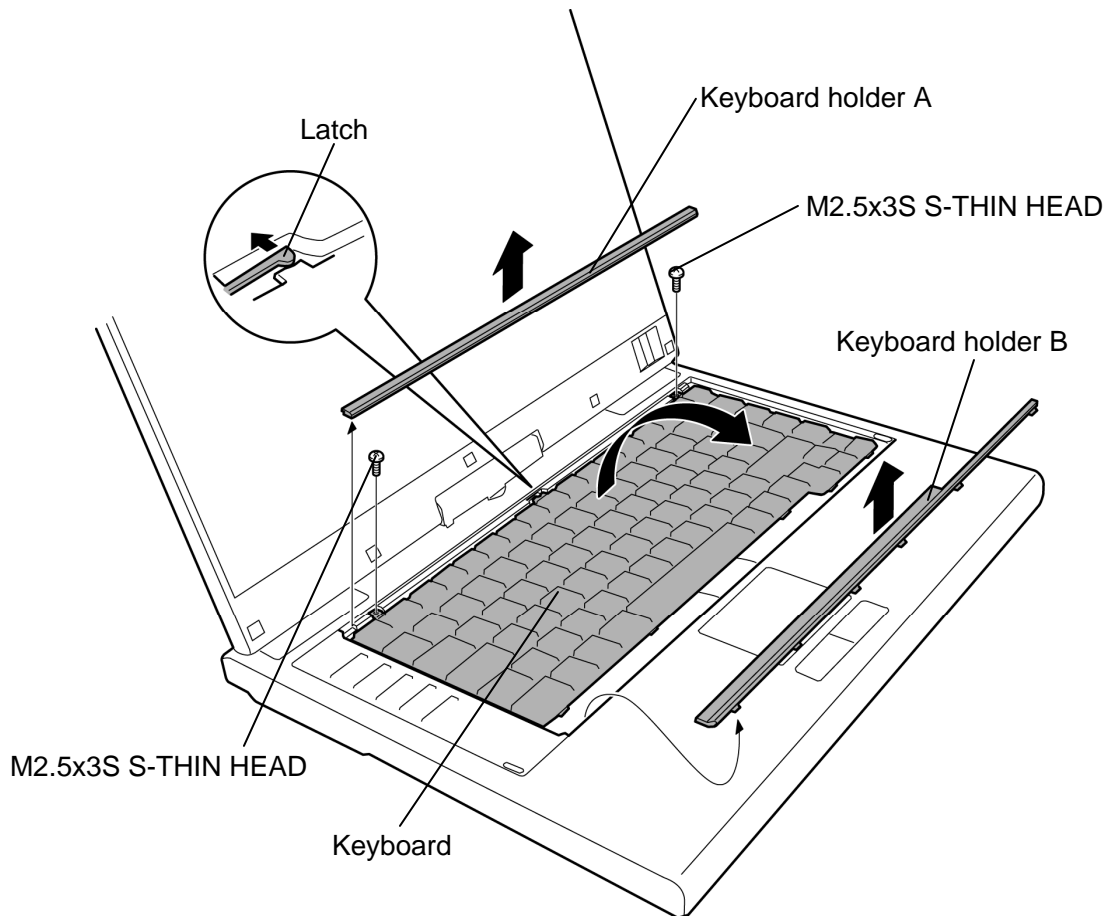

Figure 4-11 Removing the keyboard holder

6. Remove the following **screw** and **keyboard support plate**.
  - M2.5×8B FLAT HEAD screw ×1
7. Disconnect the **keyboard cable** from the connector **CN3200** on the system board and remove the **keyboard**.

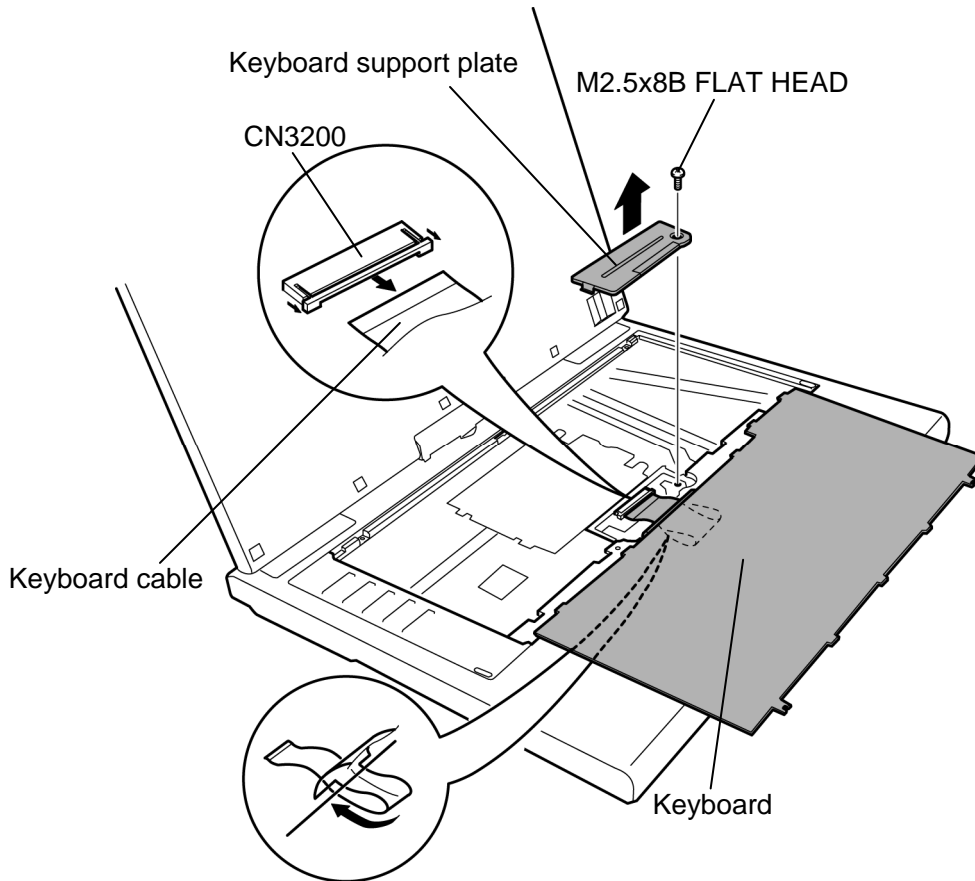

Figure 4-12 Removing the keyboard

## Installing the keyboard

The following describes the procedure for installing the keyboard. (See Figure 4-11 to 4-12.)

1. Place the keyboard face down on the palm rest.
2. Connect the **keyboard cable** to the connector **CN3200** on the system board.
3. Install the **keyboard support plate** and secure it with the following **screw**. (Insert the guide of the keyboard support plate first)

- M2.5×8B      FLAT HEAD screw      ×1

**CAUTION:** *Extra portion of the keyboard cable must be put under the keyboard support plate.*

4. Turn the **keyboard** face up and set it in place. Make sure that there is no gap between the keyboard and edge of the palm rest.
5. Secure the **keyboard** with the following **screws**.
  - M2.5×3S      S-THIN HEAD screw      ×2
6. Install the **keyboard holder A** and **B** while engaging the latches.



## 4.9 Memory module

**CAUTION:** *The power must be turned off when you remove the memory module. Removing the memory module with the power on risks damaging the module or the computer itself.*

*Do not touch the memory module terminals. Any dirt on the terminals may cause memory access problems.*

*Never press hard or bend the memory module.*

### Removing the memory module

To remove the memory module(s), make sure the computer is in boot mode and powered off. Then perform the following procedure. (See Figure 4-13 and 4-14.)

1. Remove the following screws and **memory slot cover**.

- M2.5×3S S-THIN HEAD screw ×2

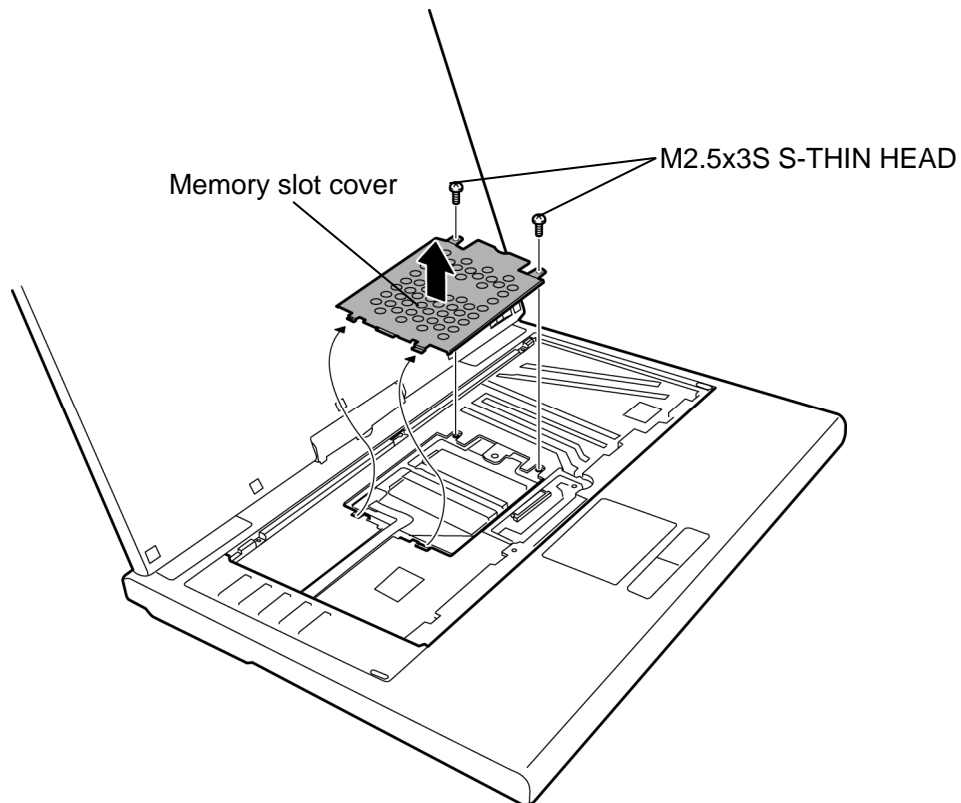

Figure 4-13 Removing the memory slot cover

2. Open the left and right **latches** outside and remove the **memory module(s)**.

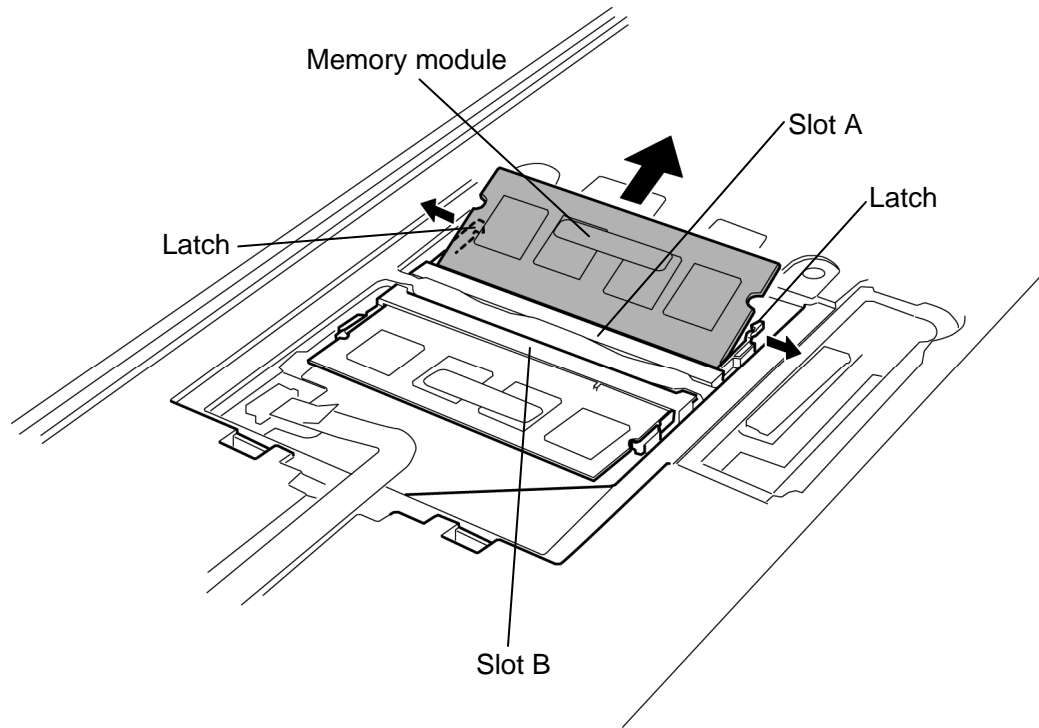

Figure 4-14 Removing the memory module

## Installing the memory module

To install the memory module(s), make sure the computer is in boot mode and powered off. Then perform the following procedure. (See Figure 4-13 and 4-14.)

1. Insert the **memory module(s)** into the connector slantwise (the terminal side first) and press it to connect firmly.

**CAUTION:** *The power must be turned off when you insert the memory module. Inserting the memory module with the power on risks damaging the module or the computer itself.*

*Use the **slot A** prior to the **slot B**. Do not install a memory module only in the **slot B**. Otherwise, the computer or the memory may be damaged.*

*Never press hard or bend the memory module.*

*After installing the memory module, confirm that the memory module is fixed with the left and right latches.*

2. Install the **memory slot cover** and secure it with the following **screws**.

- M2.5×3S                      S-THIN HEAD screw                      ×2

## 4.10 SW membrane

### Removing the SW membrane

To remove the SW membrane, perform the following procedure. (See Figure 4-15.)

1. Remove the **SW membrane cover** while releasing latches.
2. Disconnect the **SW membrane cable** from the connector **CN9600** on the system board.
3. Slide the **SW membrane** in the direction of the arrow in the figure to remove it.

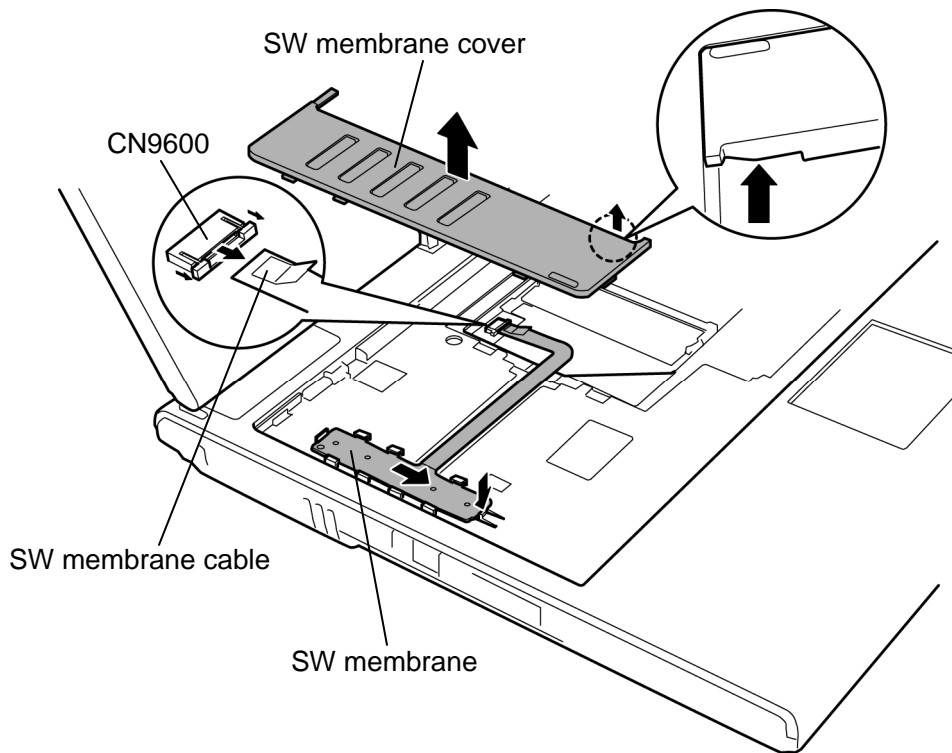

Figure 4-15 Removing the SW membrane

**Installing the SW membrane**

To install the SW membrane, perform the following procedure. (See Figure 4-15.)

1. Install the **SW membrane** to the slot while sliding it in the opposite direction at removing.
2. Connect the **SW membrane cable** to the connector **CN9600** on the system board.
3. Install the **SW membrane cover** while engaging latches.

## 4.11 Optical disk drive

### Removing the optical disk drive

The following describes the procedure for removing the optical disk drive. (See Figure 4-16 and 4-17.)

1. Remove the following **screw**.
  - M2.5×8B FLAT HEAD screw ×1
2. Turn over the computer and remove the following **screw**.
  - M2.5×6B FLAT HEAD screw ×1
3. Turn the computer face up. While pushing the **latch** toward the arrow in the Figure 4-16, pull out the **optical disk drive** from the slot.

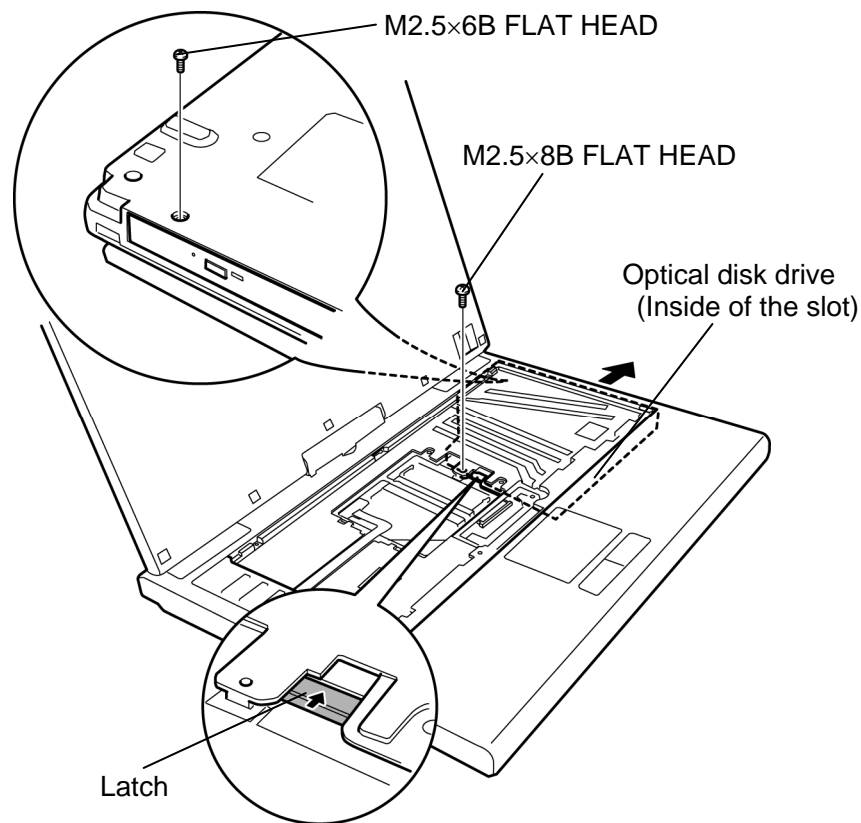

Figure 4-16 Removing the optical disk drive

4. Remove the following **screws** and **pushing plate** from the optical drive assembly.

- Stud screw ×2

5. Remove the following **screw** and **mounting plate** from the optical drive assembly.

- M2×3S S-THIN HEAD screw ×1

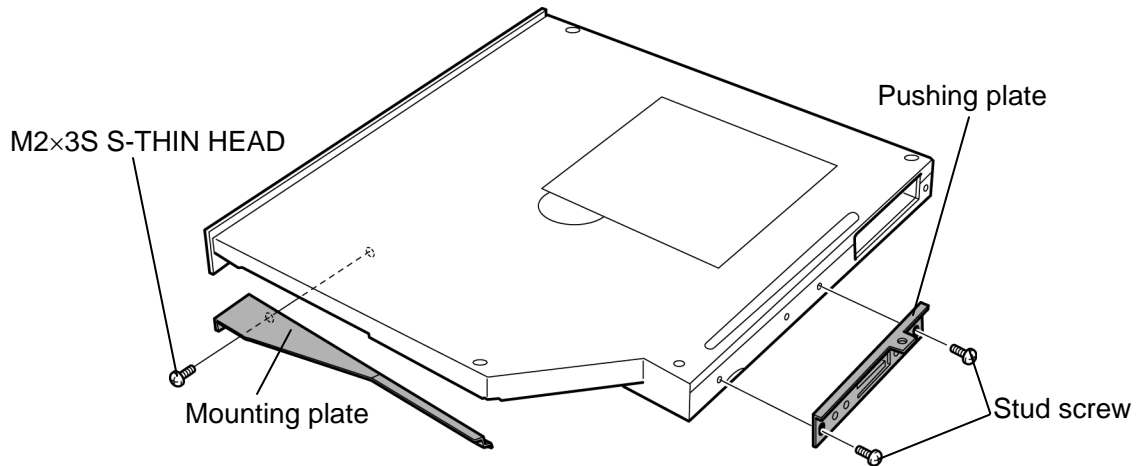

Figure 4-17 Detaching the optical disk drive assembly

### Installing the optical disk drive

The following describes the procedure for installing the optical drive. (See Figure 4-16 and 4-17.)

1. Install the **mounting plate** to the optical disk drive assembly and secure it with the following **screw**.
  - M2×3S            S-THIN HEAD screw            ×1
2. Install the **pushing plate** and **connector** to the optical disk drive assembly and secure it with the following **screws**.
  - Stud screw                            ×2
3. Insert the **optical disk drive** into slot to connect it to the connector on the system board. Press to ensure a firm connection.
4. Secure the optical disk drive with the following **screw**.
  - M2.5×8B        FLAT HEAD screw            ×1
5. Turn over the computer and secure the optical disk drive with the following **screw**.
  - M2.5×6B        FLAT HEAD screw            ×1



## 4.12 Cover assembly and Base assembly

### Removing the cover assembly and base assembly

The following describes the procedure for removing the cover assembly and base assembly. (See Figure 4-18 to 4-20.)

1. Turn the display 90 degrees clockwise and remove the **hinge rear cover**.
2. Remove the following **screws**. Be careful not to forget removing these screws.
  - M2.5×6B FLAT HEAD screw ×2
3. Remove the following **screw**.
  - M2.5×8B FLAT HEAD screw ×1

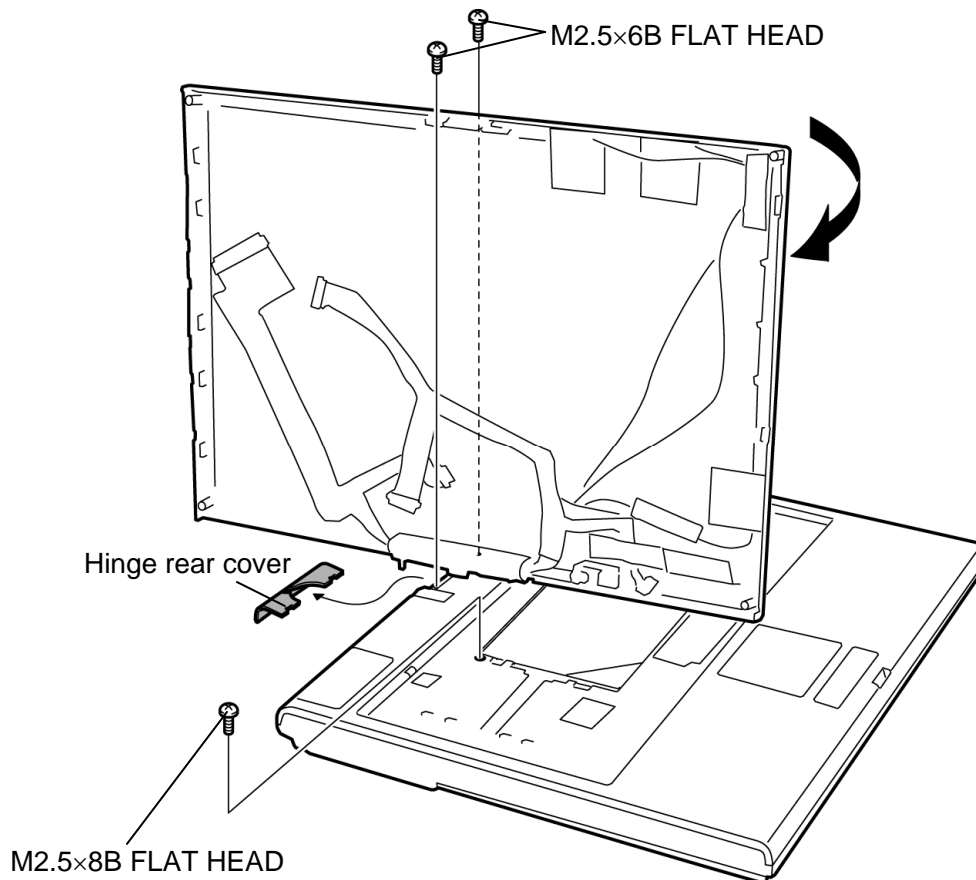

Figure 4-18 Removing the cover assembly and base assembly (1)

4. Turn the display 90 degrees counter clockwise.
5. Close the display and turn over the computer.
6. Remove the following screws.
  - M2.5×16B FLAT HEAD screw ×3 (“16” in the figure below)
  - M2.5×6B FLAT HEAD screw ×9 (“6” in the figure below)

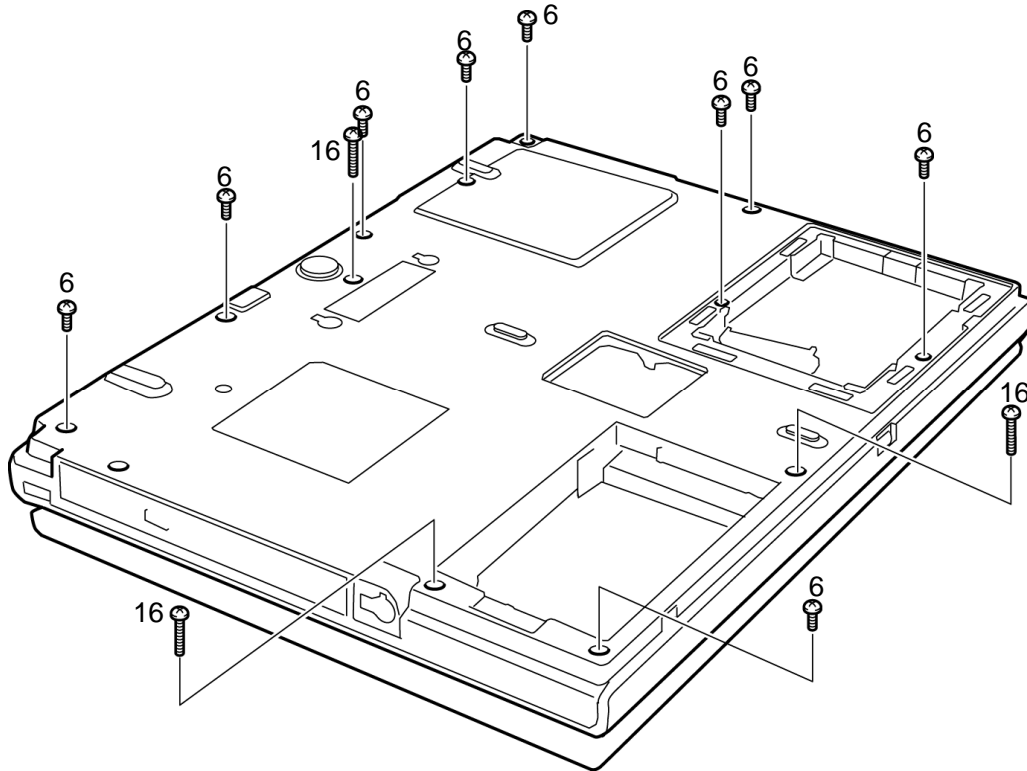

Figure 4-19 Removing the cover assembly and base assembly (2)

7. Separate the **base assembly** and **cover assembly**.

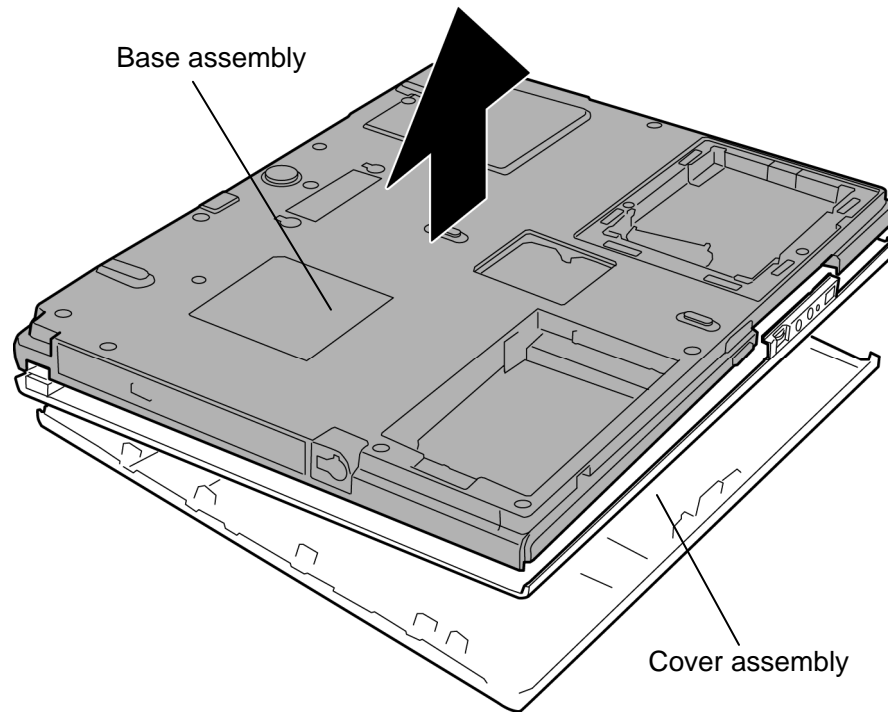

Figure 4-20 Removing the cover assembly and base assembly (3)

### Installing the Cover assembly and Base assembly

The following describes the procedure for installing the cover assembly and base assembly. (See Figure 4-18 to 4-20.)

1. Install the **base assembly** to the **cover assembly**.
2. Secure the cover assembly with the following **screws**.
  - M2.5×16B FLAT HEAD screw ×3
  - M2.5×6B FLAT HEAD screw ×9

**CAUTION:** Securing the screws in the order shown in the following figure.

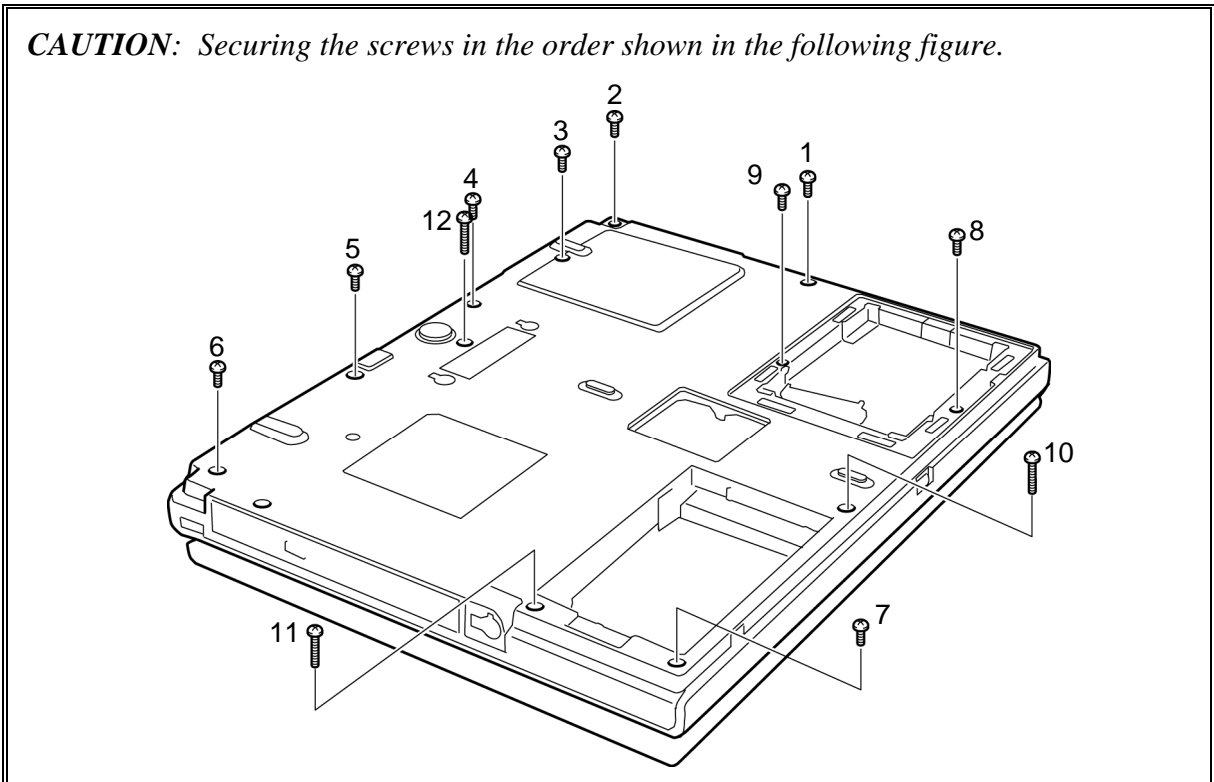

3. Turn over the computer and open the display.
4. Secure the cover assembly with the following **screw**.
  - M2.5×8B FLAT HEAD screw ×1
5. Turn the display 90 degrees counter clockwise.
6. Secure the cover assembly with the following **screws**.
  - M2.5×6B FLAT HEAD screw ×2
7. Install the **hinge rear cover**.

## 4.13 Base latch

### Removing the base latch

The following describes the procedure for removing the base latch. (See Figure 4-21.)

1. Remove the **base latch** while releasing the **latches** of the back.

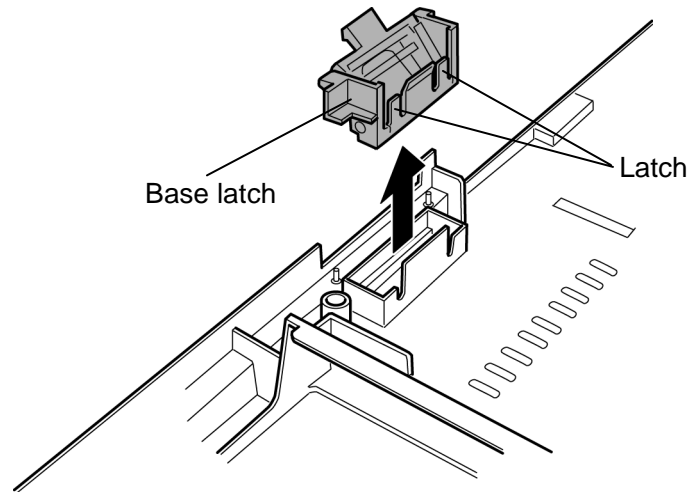

Figure 4-21 Removing the base latch

### Installing the base latch

The following describes the procedure for installing the base latch (See Figure 4-21).

1. Install the **base latch** to the slot of the base assembly.

## 4.14 Touch pen case/Battery lock

### Removing the Touch pen case/Battery lock

The following describes the procedure for removing the touch pen case/battery lock. (See Figure 4-22.)

1. Remove the **touch pen case** while releasing the **latches**.
2. Remove the **battery lock**.

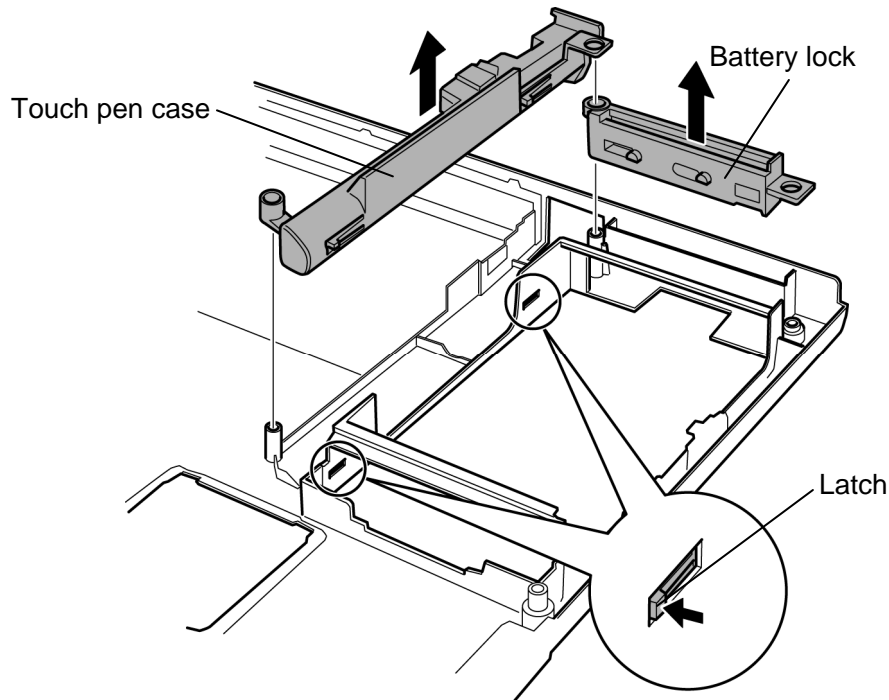

Figure 4-22 Removing the touch pen case/battery lock

### Installing the Touch pen case/Battery lock

The following describes the procedure for installing the touch pen case/battery lock. (See Figure 4-22.)

1. Install the **battery lock** to the slot.
2. Install the **touch pen case** while engaging the **latches**.

## 4.15 Bluetooth module

### Removing the Bluetooth module

To remove the Bluetooth module, follow the steps below. (See Figure 4-23.)

**CAUTION:** Do not try to remove the Bluetooth module with the computer turned on. You can damage the computer or Bluetooth module. Do not touch the connectors on the Bluetooth module on the computer. Debris on the connectors may cause Bluetooth access problems.

1. Peel off the **glass tape**.
2. Disconnect the **Bluetooth antenna cable** from the Bluetooth module using an antenna coaxial cable disconnecter.
3. Disconnect the **Bluetooth cable** from the connector **CN4400** on the system board.
4. Remove the **Bluetooth module** from the slot and disconnect the **Bluetooth cable** from the connector on the Bluetooth module.

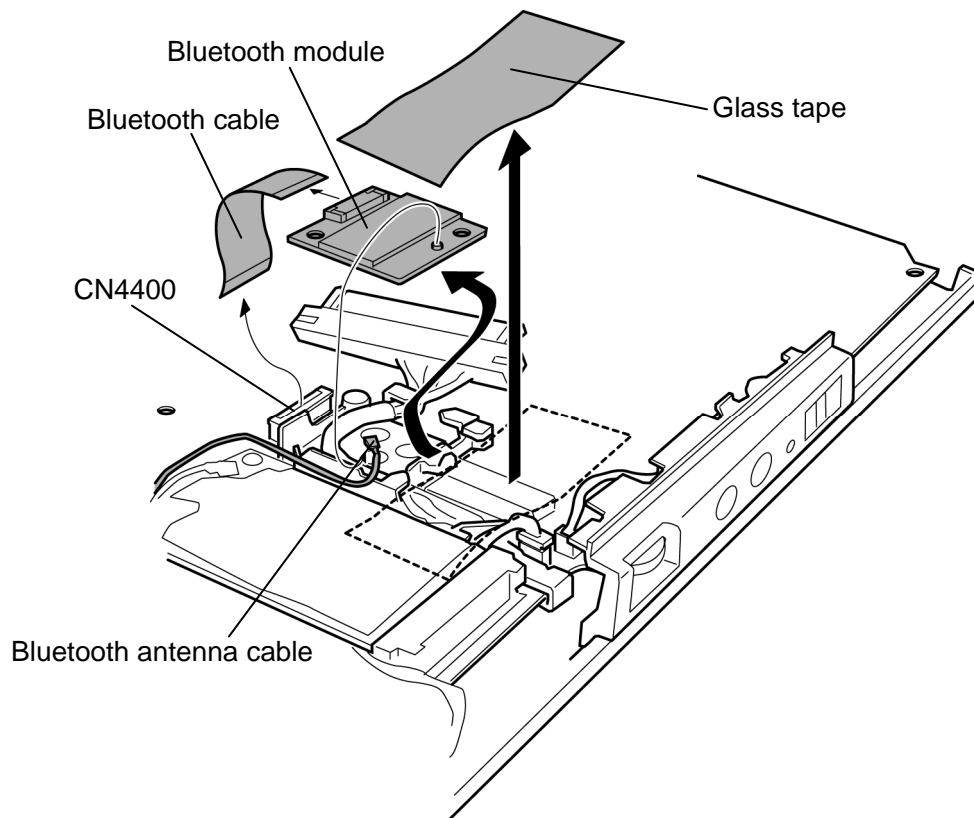

Figure4-23 Removing the Bluetooth module

**Installing the Bluetooth module**

To install the Bluetooth module, follow the steps below. (See Figure 4-23.)

1. Connect the **Bluetooth cable** to the connector on the Bluetooth module.
2. Connect the **Bluetooth cable** to the connector **CN4400** on the system board and set the **Bluetooth module** to the slot in place.
3. Connect the **Bluetooth antenna cable** to the connector on the Bluetooth module.
4. Stick the **glass tape** in place.



## 4.16 Wireless LAN card

### Removing the Wireless LAN card

To remove the Wireless LAN card, follow the steps below. (See Figure 4-24.)

**CAUTION:** Do not try to remove the wireless LAN card with the computer turned on. The computer or the wireless LAN card can be damaged. Do not touch the connectors on the wireless LAN card on the computer. Debris on the connectors may cause the wireless LAN card access problems.

1. Remove the following **screw** and **wireless LAN card cover**. (Some models are not equipped with the wireless LAN card cover.)
  - M2×4B BIND screw      ×1 (For models without wireless LAN card cover)
  - or
  - M2×4B Security torx screw      ×1 (For models with wireless LAN card cover)
2. Disconnect the **wireless LAN antenna cables** (black and white) from the wireless LAN card using an antenna coaxial cable disconnecter.
3. Remove the following **screw** and disconnect the **wireless LAN card** from the connector on the system board.

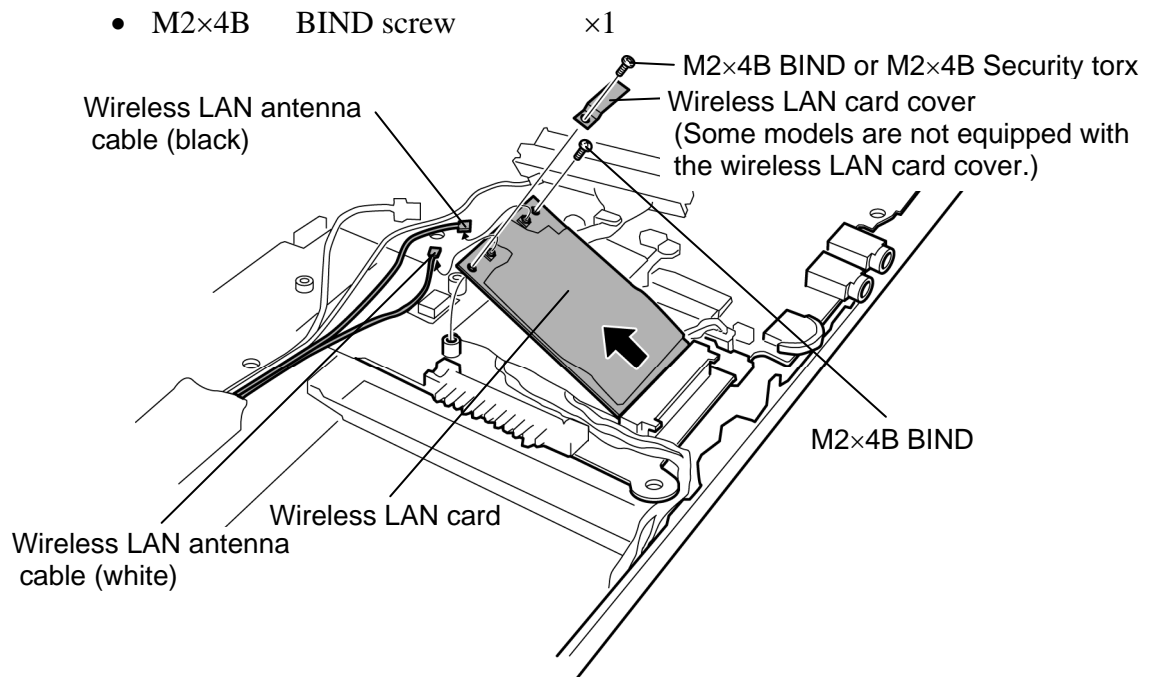

Figure 4-24 Removing the Wireless LAN card  
(For an instance, Wireless LAN card cover and Security torx model is described.)

### Installing the Wireless LAN card

To install the Wireless LAN card, follow the steps below. (See Figure 4-24.)

**CAUTION:** *Be sure to switch the computer off before installing the wireless LAN card. Otherwise, the computer or the wireless LAN card may be damaged.*

1. Insert the **wireless LAN card** to the connector on the system board slantwise and press it to connect firmly.
2. Connect the **wireless LAN antenna cables** to the connectors on the wireless LAN card and secure it with the following **screw**.
  - M2×4B BIND screw                    ×1
3. Install the **wireless LAN card cover** in place and secure it with the following **screw**. (Some models are not equipped with the wireless LAN card cover.)
  - M2×4B BIND screw    ×1 (For models without wireless LAN card cover)  
or
  - M2×4B Security torx screw    ×1 (For models with wireless LAN card cover)

## 4.17 Microphone/Front panel

### Removing the Microphone/Front panel

The following describes the procedure for removing the microphone/front panel. (See Figure 4-25 and 4-26.)

1. Disconnect the **microphone cable** from the connector **CN6050** on the system board.
2. Lift the system board a little and remove the **front panel** (with the microphone) from the cover assembly.

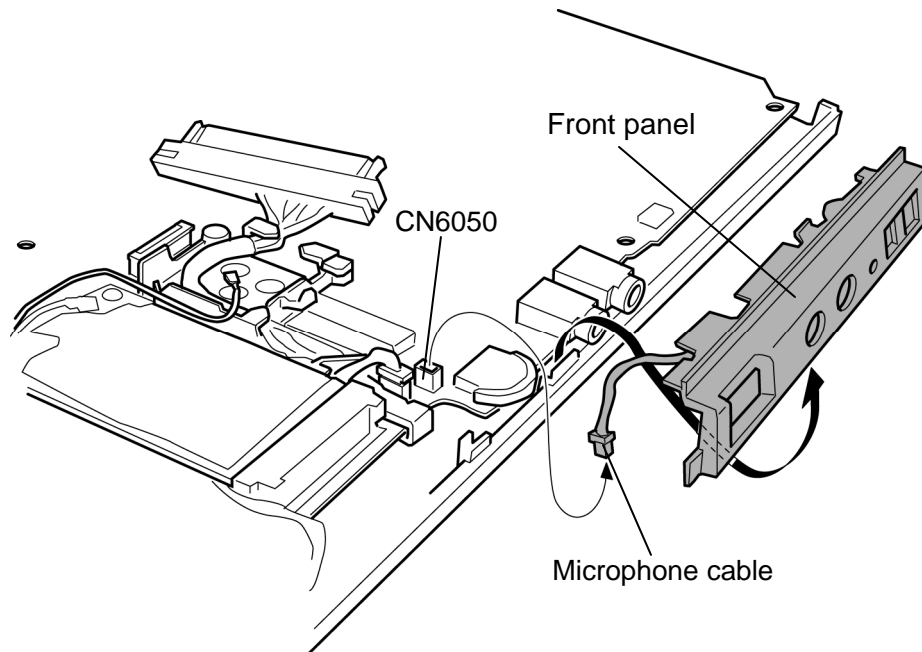

Figure 4-25 Removing the front panel

3. Remove the **microphone cable** from the **guides** of the front panel.
4. Remove the **microphone hold plate** and **microphone** from the front panel.

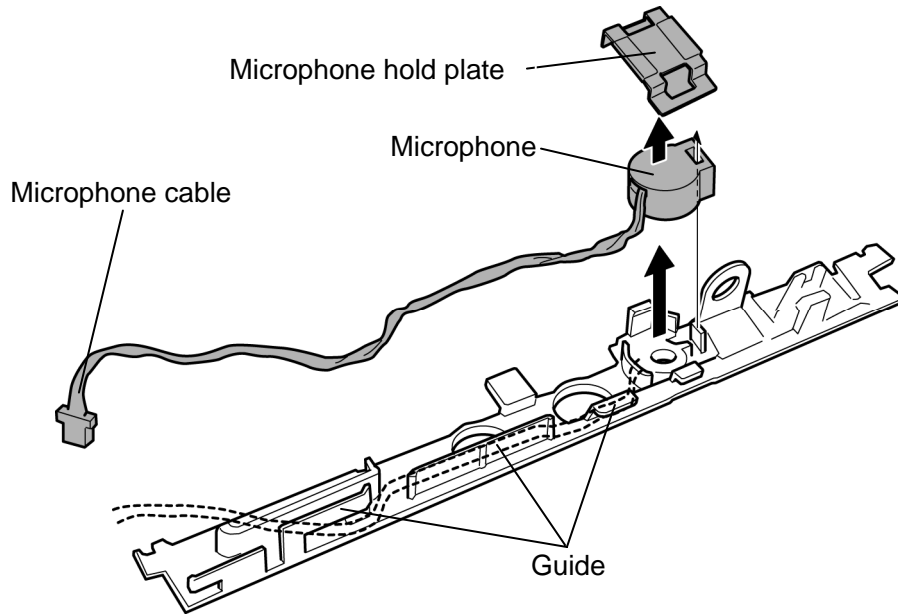

Figure 4-26 Removing the microphone

### Installing the Microphone/Front panel

The following describes the procedure for installing the microphone/front panel. (See Figure 4-25 and 4-26.)

1. Install the **microphone** to the front panel.
2. Install the **microphone hold plate** to the front panel.
3. Arrange the **microphone cable** along the **guides** of the front panel.
4. Install the **front panel** to the cover assembly in place while lifting up the system board a little.
5. Connect the **microphone cable** to the connector **CN6050** on the system board.

## 4.18 Modem jack/USB board/DC-IN jack

### Removing the Modem jack/USB board/DC-IN jack

The following describes the procedure for removing the modem jack/USB board/DC-IN jack. (See Figure 4-27 to 4-29.)

1. Peel off the **glass tape** and insulator and remove the **modem jack** from the slot.

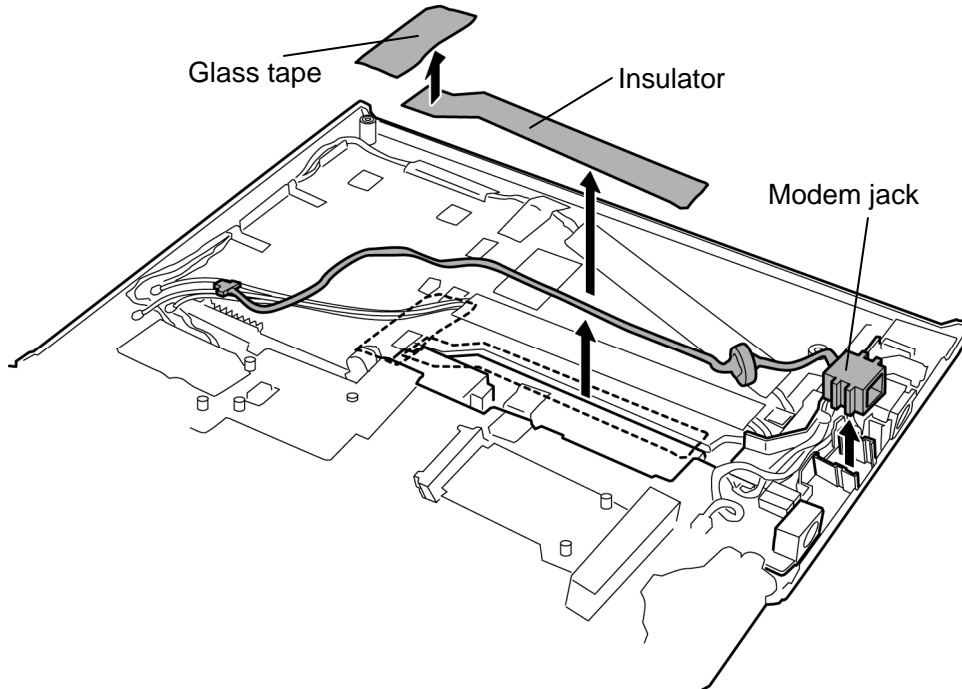

Figure 4-27 Removing the modem jack

2. Disconnect the **USB board cable** from the connector **CN4620** on the system board.
3. Remove the **USB board** from the slot.
4. Disconnect the **USB board cable** from the connector **CN4631** on the USB board.

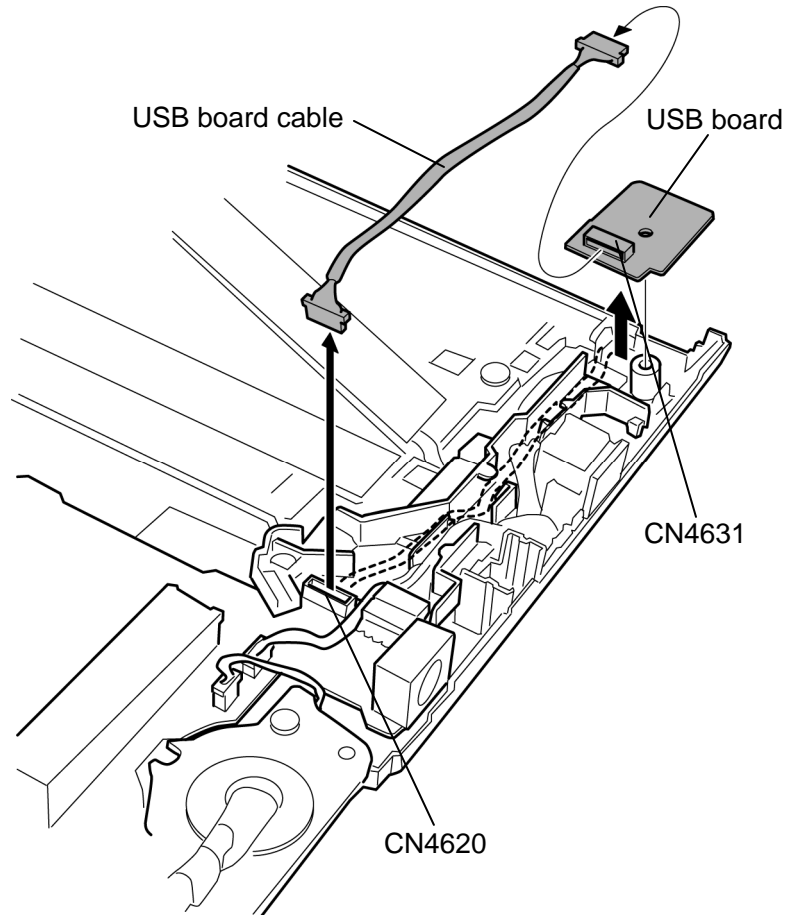

Figure 4-28 Removing the USB board

5. Disconnect the **DC-IN jack cable** from the connector **CN8800** on the system board.
6. Remove the **DC-IN jack** from the slot

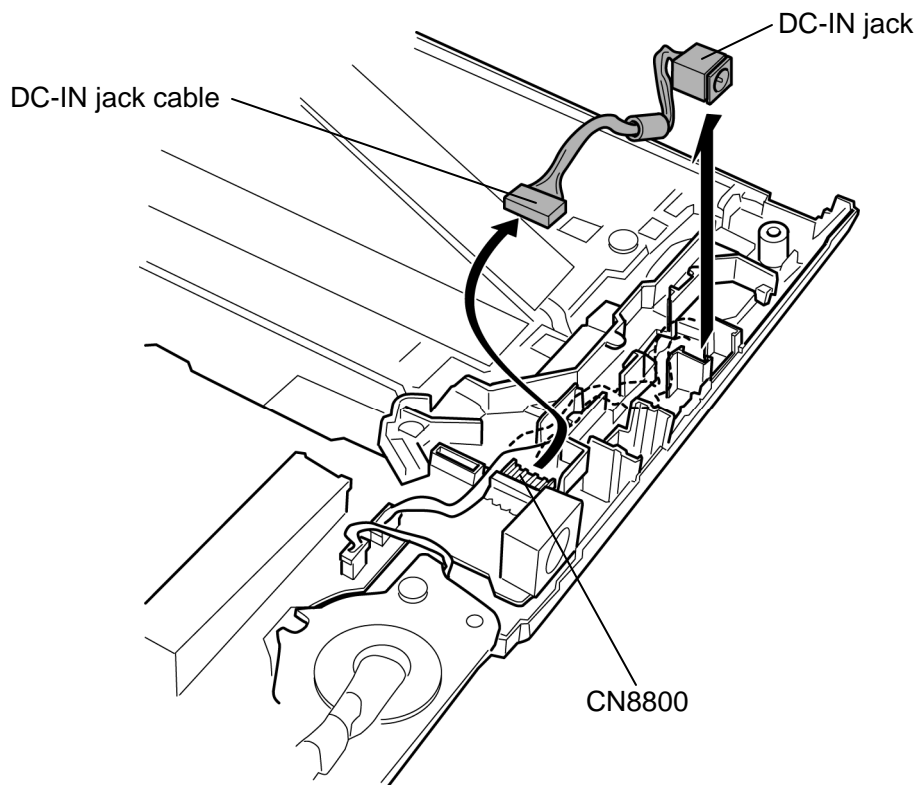

Figure 4-29 Removing the DC-IN jack

### Installing the Modem jack/USB board/DC-IN jack

The following describes the procedure for installing the modem jack/USB board/DC-IN jack. (See Figure 4-27 to 4-29.)

1. Connect the **DC-IN jack cable** to the connector **CN8800** on the system board and install the **DC-IN jack** to the slot.
2. Connect the **USB board cable** to the connector **CN4631** on the USB board and install the **USB board** to the slot.
3. Connect the **USB board cable** to the connector **CN4620** on the system board.
4. Install the **modem jack** to the slot and arrange the **modem jack cable** in place.
5. Stick the **insulator** and **glass tape** in place.

## 4.19 RTC battery

### Removing the RTC battery

The following describes the procedure for removing the RTC battery. (See Figure 4-30 and 4-31.)

1. Disconnect the **RTC battery cable** from the connector **CN9300** on the system board.
2. Remove the following **screw and RTC battery holder**.

- M2.5×6B FLAT HEAD screw ×1

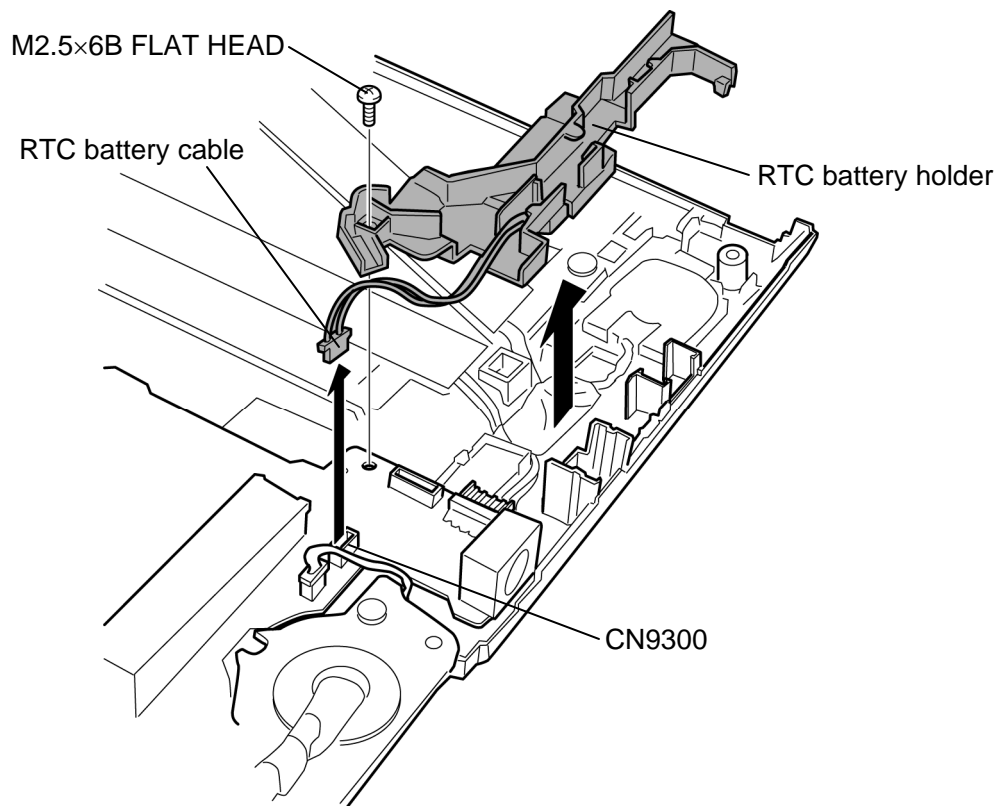

Figure 4-30 Removing the RTC battery holder



3. Open the **insulator** and remove the **RTC battery** from the RTC battery holder.

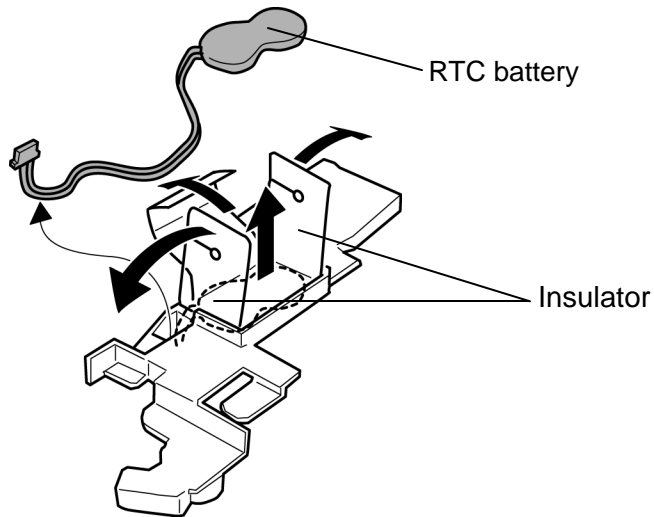

Figure 4-31 Removing the RTC battery

### Installing the system board/RTC battery

The following describes the procedure for installing the RTC battery. (See Figure 4-30 and 4-31.)

1. Install the **RTC battery** to the RTC battery holder and wrap it with the **insulator**.
2. Install the **RTC battery holder** and secure it with the following **screw**.
  - M2.5×6B FLAT HEAD screw ×1
3. Connect the **RTC battery cable** to the connector **CN9300** on the system board.

## 4.20 System board

### Removing the System board

The following describes the procedure for removing the system board. (See Figure 4-32.)

1. Disconnect the **sensor cable**, **digitizer cable**, **LCD cable** and **touch pad cable** from the connector **CN9500**, **CN9540**, **CN5000** and **CN3201** on the system board.
2. Peel off the **glass tape** and disconnect the **speaker cable** from the connector **CN6170** on the system board.
3. Remove the following **screw** and **system board**.

- M2.5×6B FLAT HEAD screw ×1

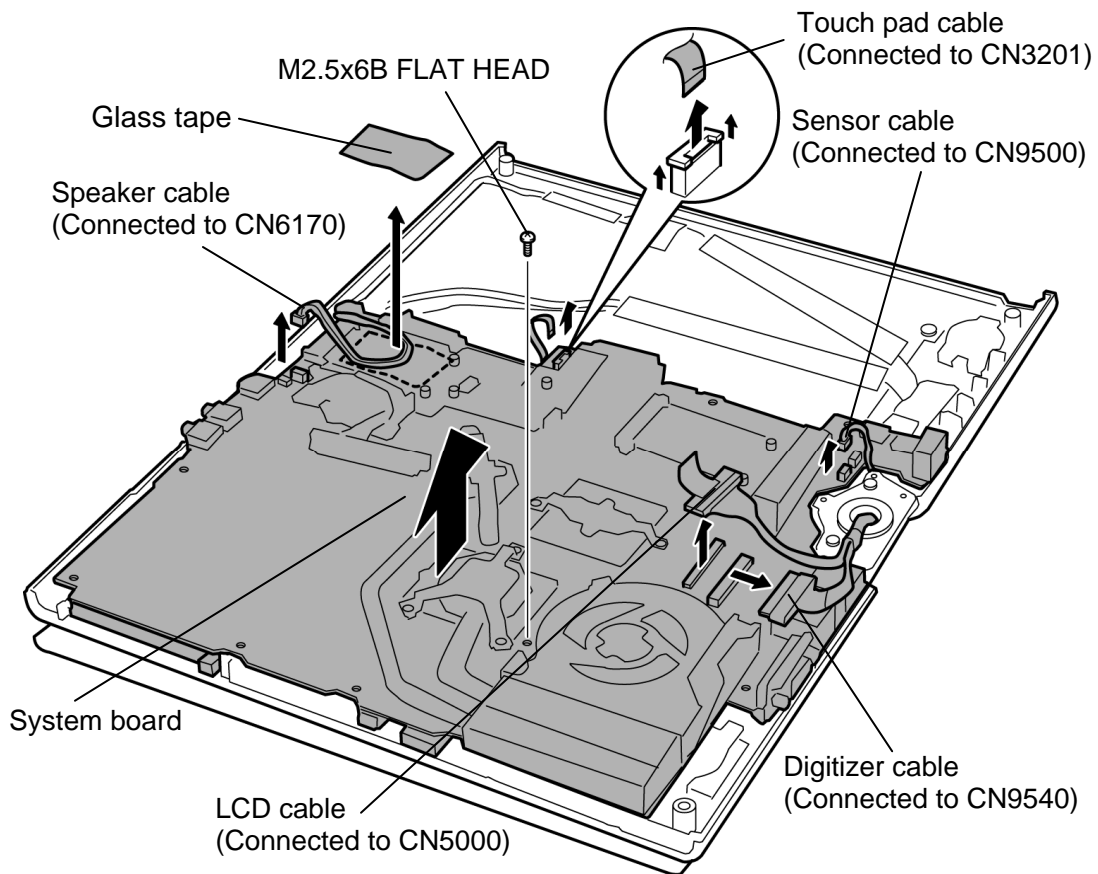

Figure 4-32 Removing the system board

### Installing the system board

The following describes the procedure for installing the system board. (See Figure 4-32.)

1. Install the **system board** to the cover assembly and secure it with the following **screw**.
  - M2.5×6B      FLAT HEAD screw      ×1
2. Connect the **speaker cable** to the connector **CN6170** on the system board and stick the **glass tape** in place.
3. Connect the **sensor cable**, **digitizer cable**, **LCD cable** and **touch pad cable** to the connector **CN9500**, **CN9540**, **CN5000** and **CN3201** on the system board.

## 4.21 GPU heat sink

### Removing the GPU heat sink

The following describes the procedure for removing the GPU heat sink. (See Figure 4-33.)

1. Peel of the **insulator**.
2. Remove the following **screws and GPU heat sink**.

- M2×4B BIND screw ×2

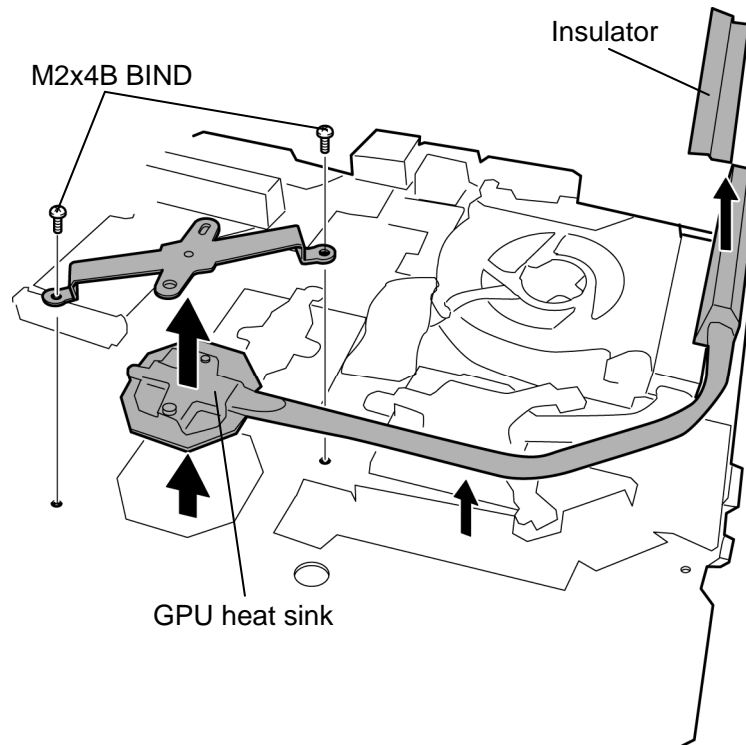

Figure 4-33 Removing the GPU heat sink

### Installing the GPU heat sink

The following describes the procedure for installing the GPU heat sink. (See Figure 4-33.)

1. If there is already silicon grease on the GPU and GPU heat sink, clean it with a cloth. Using a special applicator, apply silicon grease so that the GPU chip on the GPU is completely covered.

<p><b>NOTE:</b> For details on applying the silicon grease, refer to <i>Installing the CPU</i>.</p>
---

2. Install the **GPU heat sink** and secure it with the following **screws**.
  - M2×4B BIND screw ×2
3. Stick the **insulator** in place.

## 4.22 Fan/Heat sink/CPU

### Removing the Fan/Heat sink/CPU

The following describes the procedure for removing the fan/heat sink/CPU. (See Figure 4-34 to 4-36.)

1. Peel off the **glass tape** and disconnect the **fan cable** from the connector **CN8771** on the system board.
2. Remove the following **screws** securing the CPU hold plate in the reverse order of the number marked (3 to 1) on the CPU hold plate and remove the **CPU hold plate**.
  - M2×4B BIND screw ×3
3. Remove the **fan** and **heat sink**.

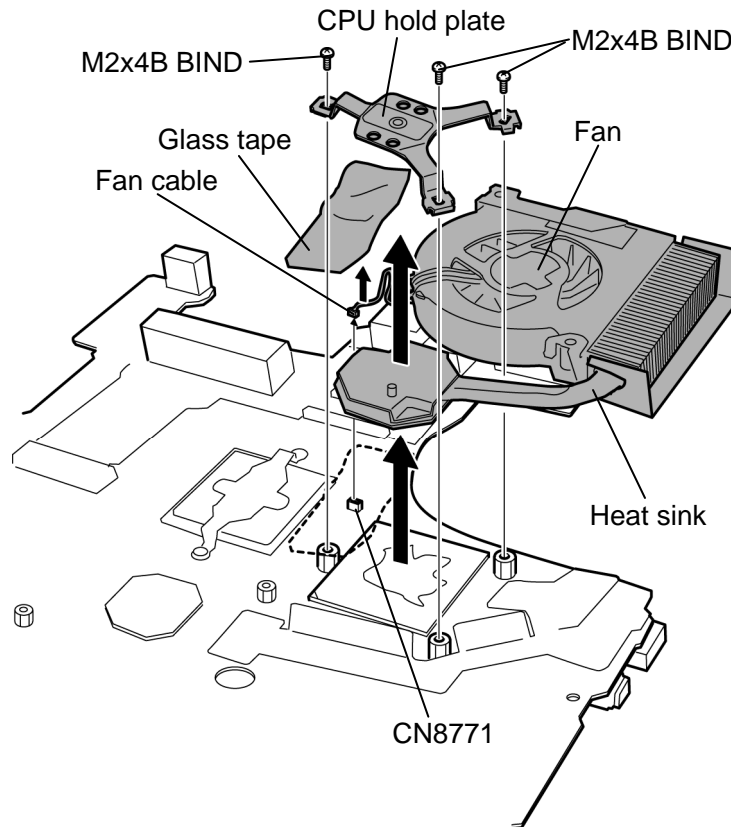

Figure 4-34 Removing the fan/heat sink

4. Remove the following **screws** and separate the **fan** and **heat sink**.

- M2.5×4B FLAT HEAD screw ×2

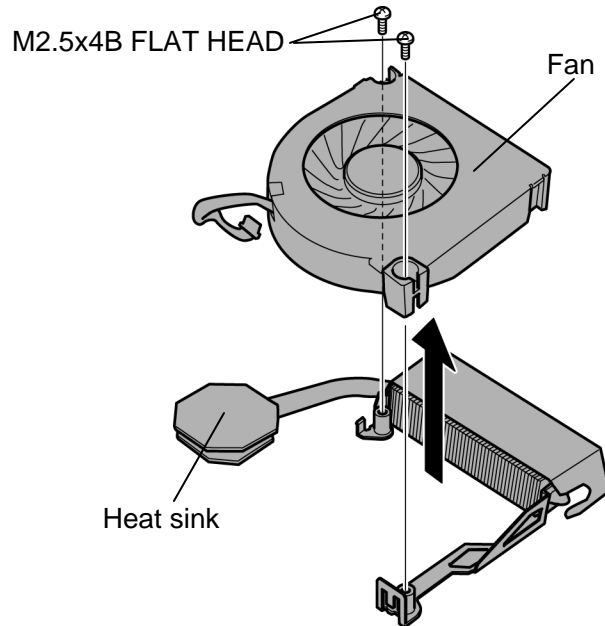

Figure 4-35 separating the fan and heat sink

5. Unlock the **CPU** by turning the **cam** counterclockwise on the CPU socket by 90 degrees with a flat-blade screwdriver.

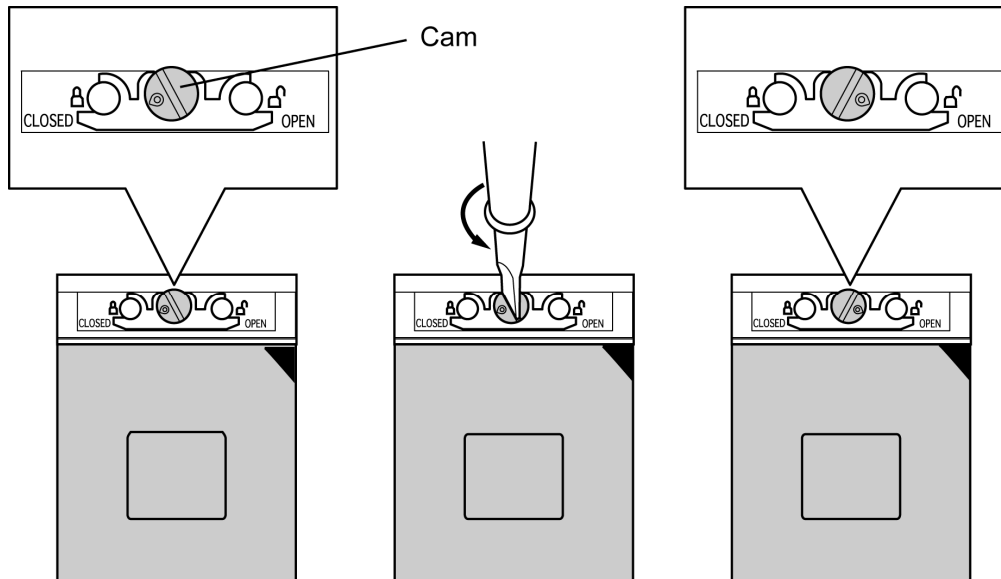

Figure 4-36 Removing the CPU

- Remove the **CPU** from the CPU socket.

**CAUTION:** When removing the CPU, lift it up right above. Otherwise, pins of CPU may be damaged.

### Installing the Fan/Heat sink/CPU

The following describes the procedure for installing the fan/heat sink/CPU. (See Figure 4-34 to 4-38.)

- Make sure the **cam** is in the open position.
- Seat the **CPU** in the CPU socket. Make sure the direction and position of CPU is correct to avoid damaging pins on the CPU.

**CAUTION:** Place the CPU in such direction as shown below. (Pay attention to the position of the triangle mark on the CPU.)

- Fix the **CPU** by turning the **cam** on the CPU socket by 90 degrees clockwise with a flat-blade screwdriver (as shown in the figure below).

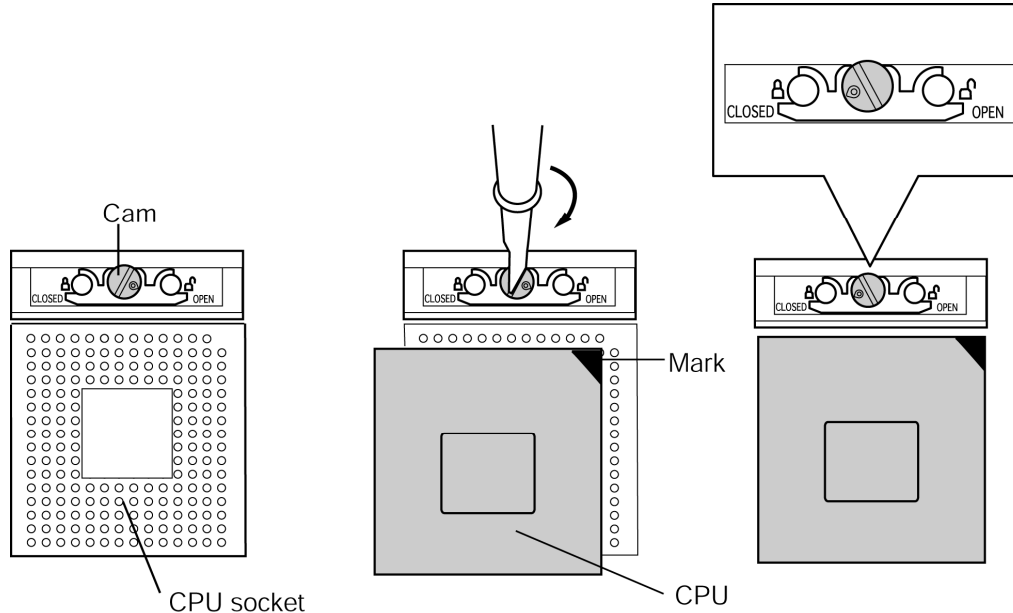

Figure 4-37 Installing the CPU



4. Apply new **grease** on the CPU using a special syringe as shown in the following figure. Apply quarter of scale (0.25ml) of grease evenly on the CPU chip. When silicon grease is already applied to the CPU, wipe them off with a cloth in advance.

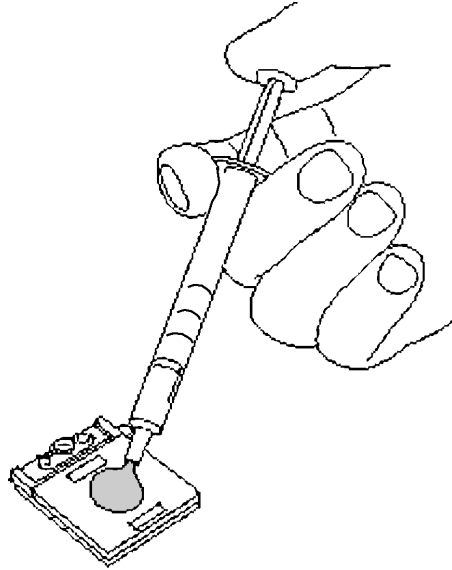

Figure 4-38 Applying new grease

5. Install the **fan** to the **heat sink** and secure them with the following **screws**.
  - M2.5×4B      FLAT HEAD screw      ×2
6. Install the **fan** and **heat sink**.
7. Place the **CPU holder** and secure it with the following **screws** in the order of the number marked on the holder.
  - M2×4B      BIND screw      ×3
8. Connect the **fan cable** to the connector **CN8771** on the system board and stick the **glass tape**.

## 4.23 Sensor board

### Removing the Sensor board

The following describes the procedure for removing the sensor board. (See Figure 4-39.)

1. Remove the **sensor board** from the slot.
2. Disconnect the **sensor cable** from the connector **CN9510** on the sensor board.

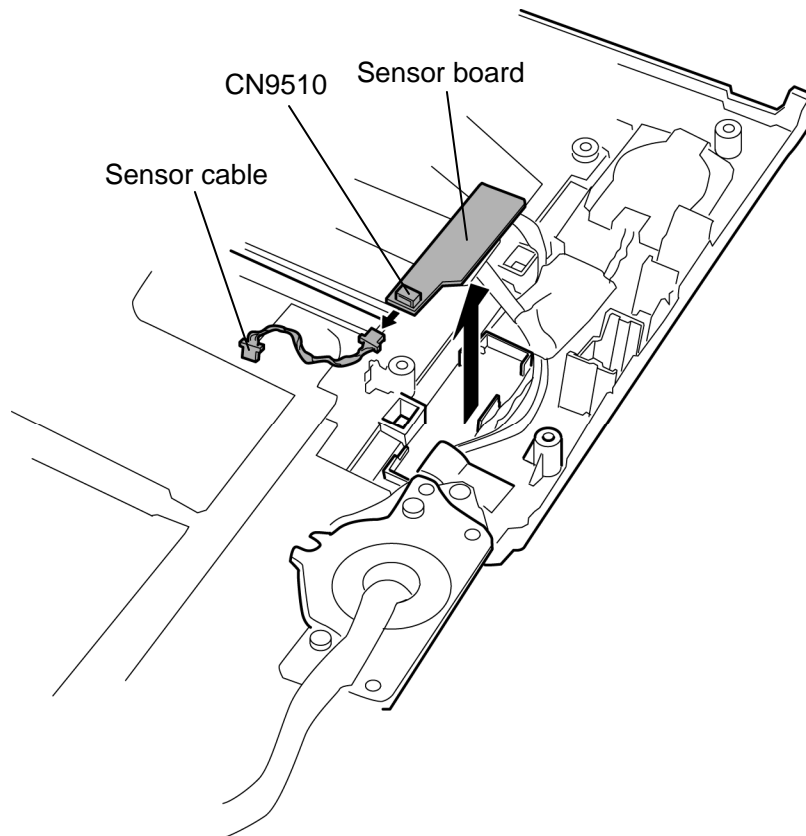

Figure 4-39 Removing the sensor board

### Installing the Sensor board

The following describes the procedure for installing the sensor board. (See Figure 4-39.)

1. Connect the **sensor cable** to the connector **CN9510** on the sensor board.
2. Install the **sensor board** to the slot.

## 4.24 Speaker

### Removing the speaker

The following describes the procedure for removing the speaker. (See Figure 4-40.)

1. Peel off the **insulators** and **acetate tapes**.
2. Remove the **speaker covers** while releasing latches.
3. Remove the **speakers** from the slots.

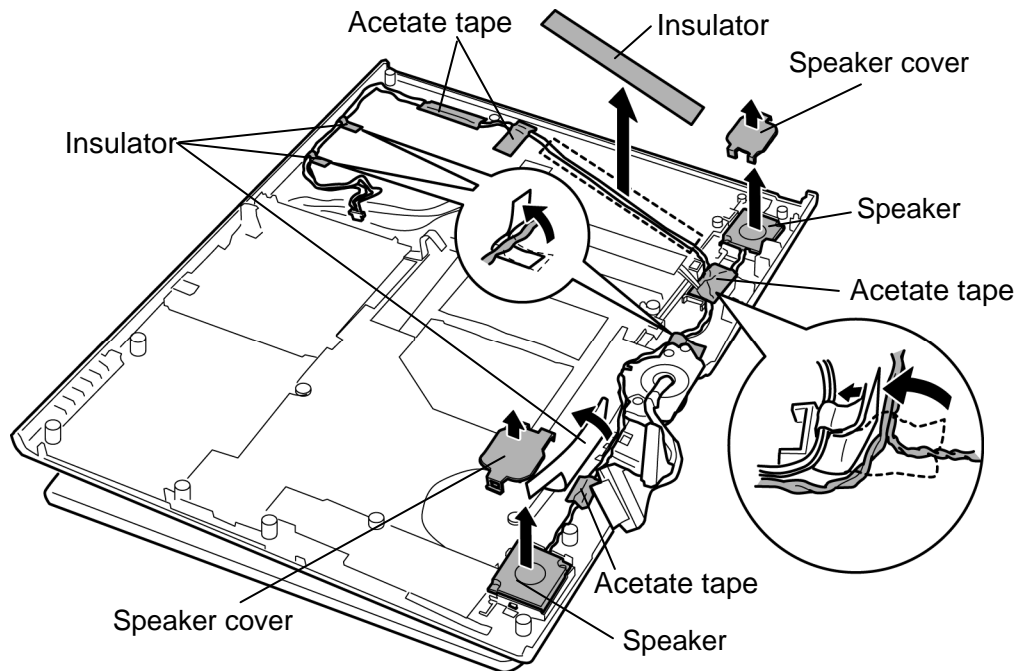

Figure 4-40 Removing the speaker

**Installing the speaker**

The following describes the procedure for installing the speaker. (See Figure 4-40.)

1. Install the **speakers** to the slots on both sides.
2. Install the **speaker covers** to the slots on both sides while hooking the latches.
3. Arrange the **speaker cables** in place.
4. Stick **insulators** and **acetate tapes** in place.

## 4.25 Touch pad

### Removing the Touch pad

The following describes the procedure for removing the touch pad. (See Figure 4-41 and 4-42.)

1. Remove the following screw.
  - M2.5×6B FLAT HEAD screw ×1
2. Remove the **touch pad cover** while releasing four **latches**.

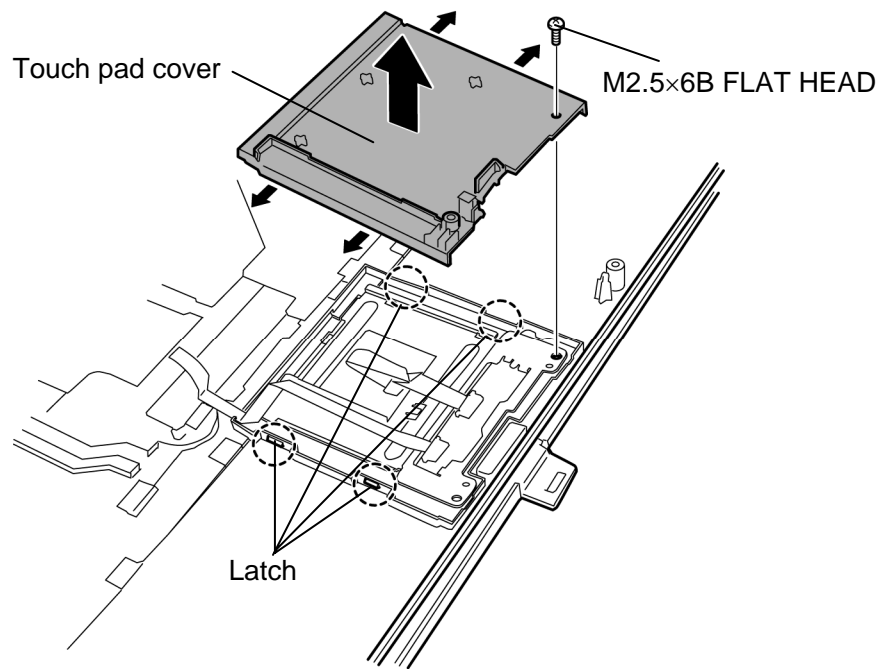

Figure 4-41 Removing the touch pad cover

3. Remove the **touch pad** from the slot.
4. Disconnect the **touch pad cable** from the connector on the touch pad.

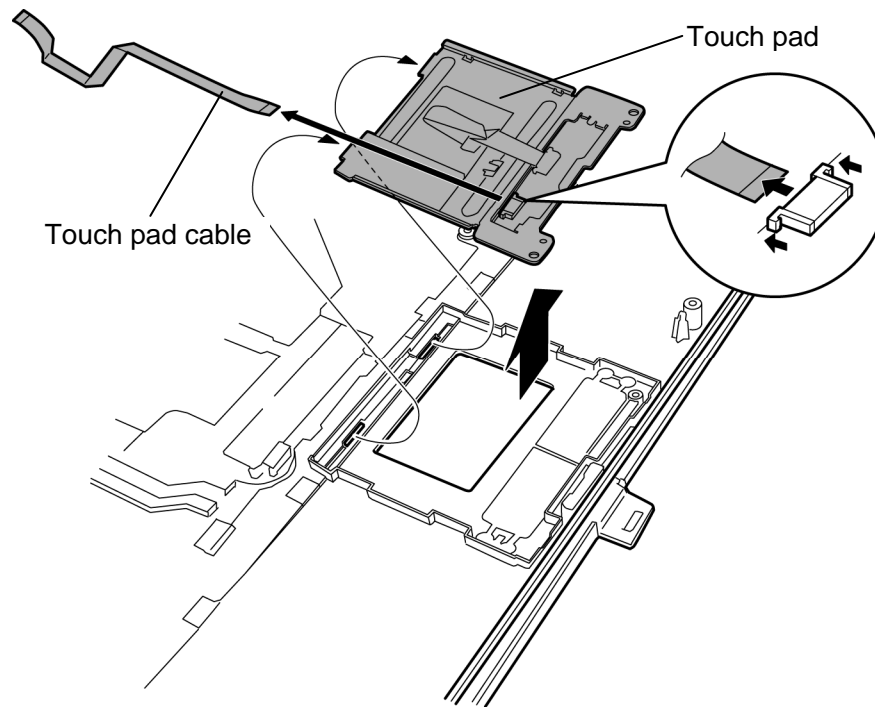

Figure 4-42 Removing the touch pad

### Installing the Touch pad

The following describes the procedure for installing the touch pad. (See Figure 4-41 to 4-42.)

1. Connect the **touch pad cable** to the connector on the touch pad.
2. Install the **touch pad** to the slot.
3. Install the **touch pad cover** while engaging latches and secure it with following screw.
  - M2.5×6B FLAT HEAD screw ×1

## 4.26 LCD mask

### Removing the LCD mask

The following describes the procedure for removing the LCD mask. (See Figure 4-43.)

1. Peel off the **mask seals** (9 points) from the LCD mask and remove the following **screws** securing the LCD mask.

- M2.5×6B FLAT HEAD screw ×9

2. Remove the **LCD mask** while releasing latches.

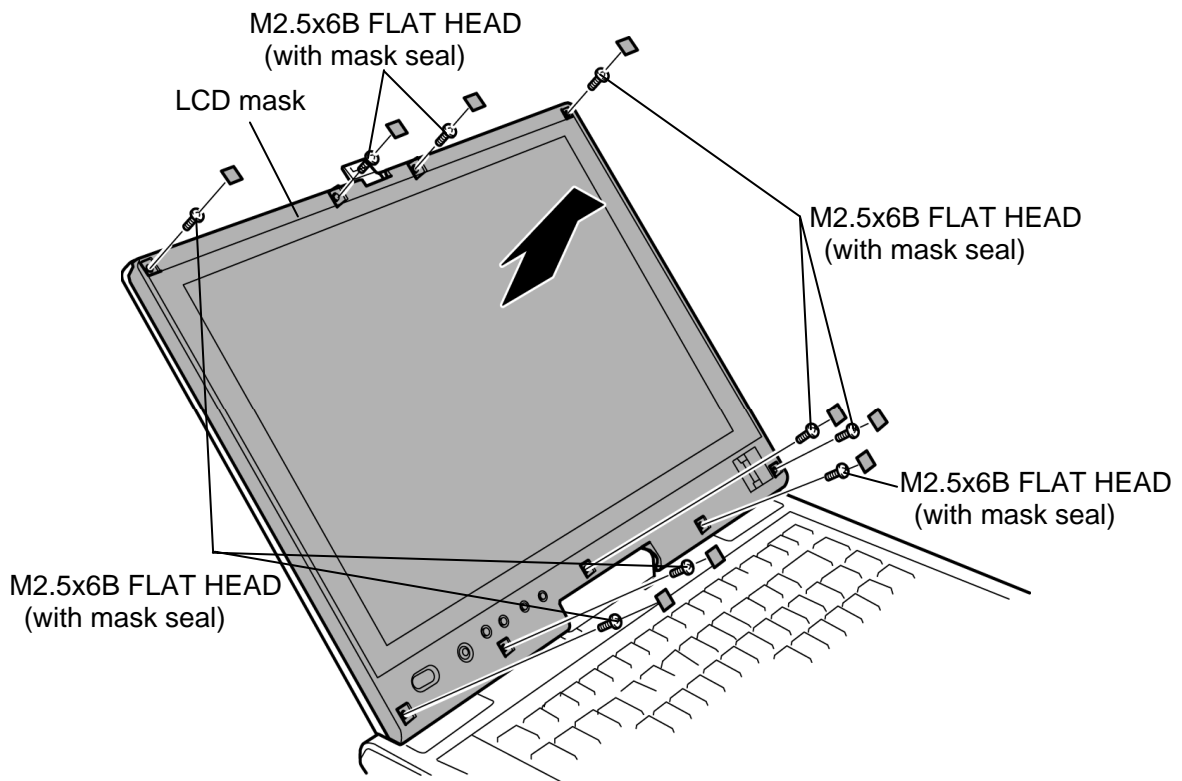
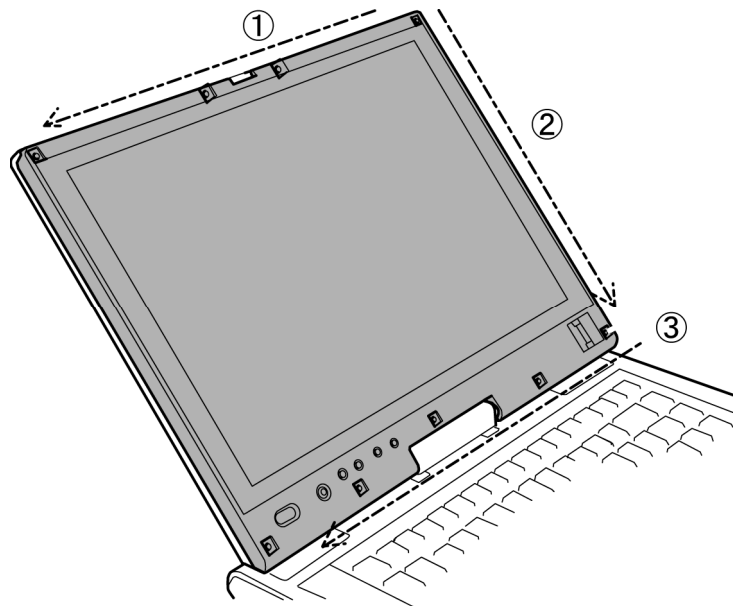

Figure 4-43 Removing the LCD mask

**CAUTION:** When removing the LCD mask, be sure to keep the following steps (order) referring to the figure below.

1. Release the latches on the top from the right to the left.
2. Release the latches on the right side from the top to the bottom.
3. Release the latches on the bottom from the right toward the left.



4. Release the latches of the left side.

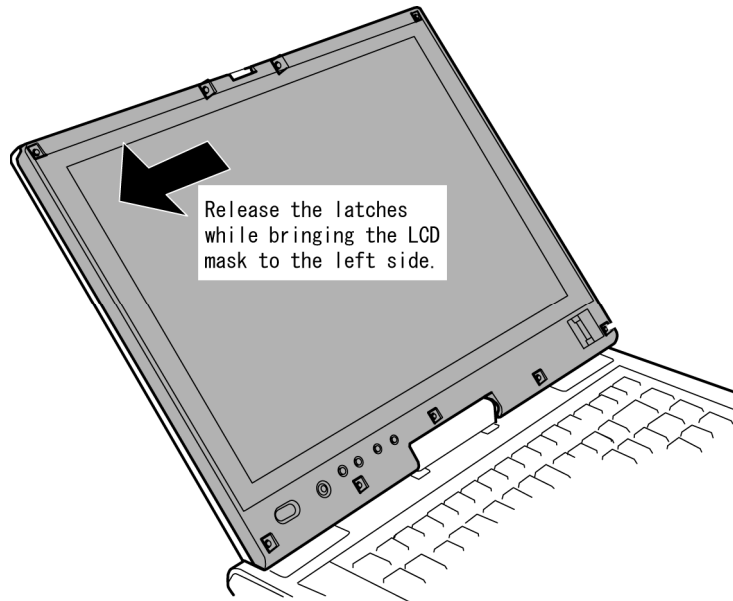



### Installing the LCD mask

The following describes the procedure for installing the LCD mask. (See Figure 4-43.)

1. Install the **LCD mask** to the display cover while securing the latches.

**NOTE:** When installing the LCD mask, wipe the LCD with a soft cloth and make the back of the LCD mask clean with an ionizer.

2. Secure the LCD mask with the following **screws** and stick the **mask seals** (9 points).

- M2.5×6B            FLAT HEAD screw            ×9

**CAUTION:** When installing the LCD mask, be sure to keep the following steps (order) referring to the figure below.

1. Engage the latches on the left side while fitting the LCD mask to the correct position.

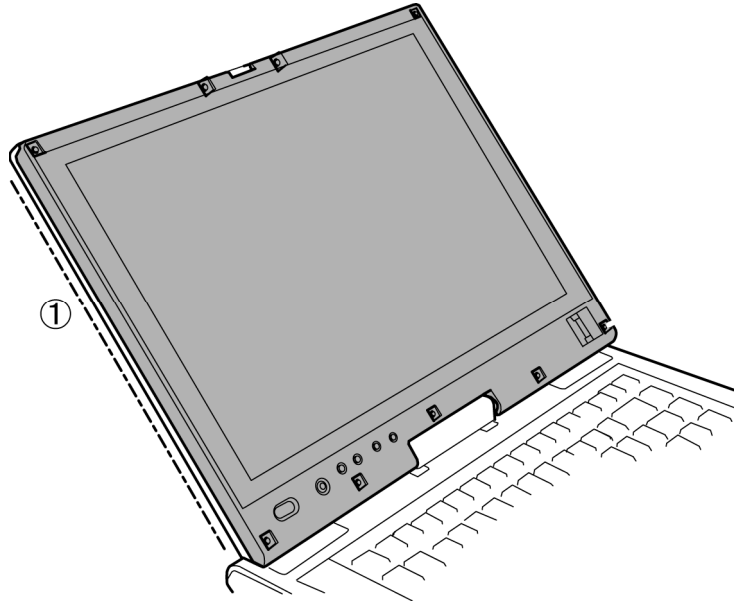

2. Engage the latches on the top from the left to the right.
3. Engage the latches on the right side from the top to the bottom.
4. Engage the latches on the bottom from the right to the left.

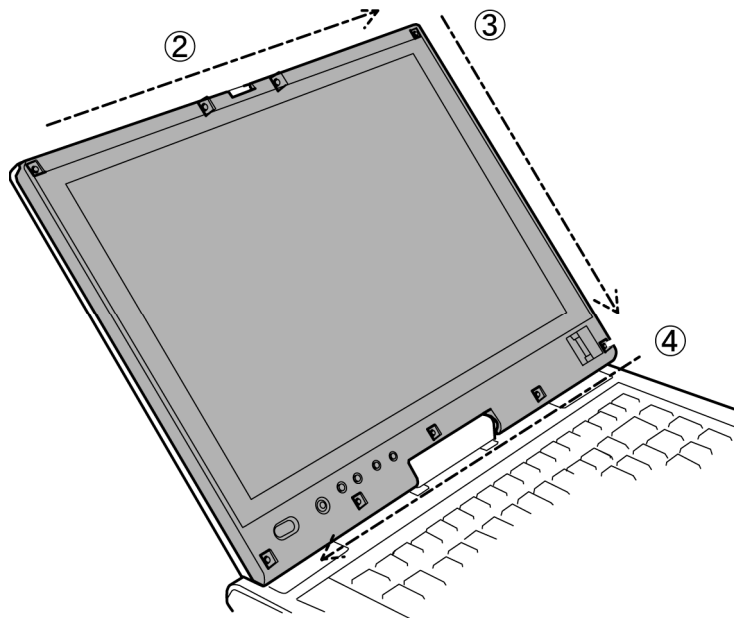

## 4.27 Fingerprint sensor board

### Removing the Fingerprint sensor board

The following describes the procedure for removing the fingerprint sensor board.  
(See Figure 4-44.)

1. Remove the following **screw** and **fingerprint sensor board**.
  - M2.5×6B FLAT HEAD screw ×1
2. Disconnect the **fingerprint sensor cable** from the connector **CN9560** on the fingerprint sensor board.

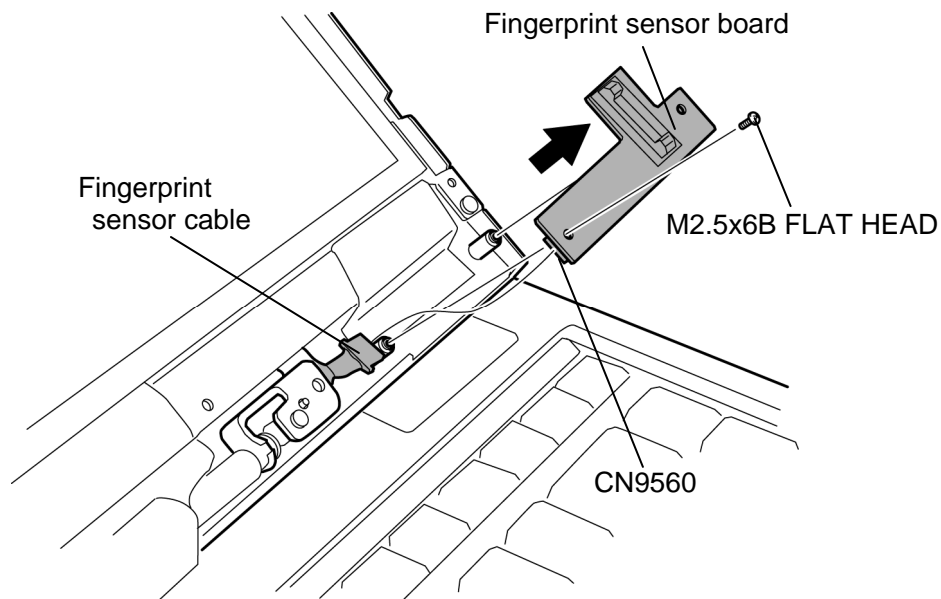

Figure 4-44 Removing the fingerprint sensor board

### Installing the Fingerprint sensor board

The following describes the procedure for installing the fingerprint sensor board.  
(See Figure 4-44.)

1. Connect the **fingerprint sensor cable** to the connector **CN9560** on the fingerprint sensor board.
2. Install the **fingerprint sensor board** and secure it with the following **screw**.
  - M2.5×6B FLAT HEAD screw ×1

## 4.28 Switch board

### Removing the Switch board

The following describes the procedure for removing the switch board. (See Figure 4-45.)

1. Remove the following **screw** securing the switch board and pull up the **switch board**.
  - M2.5×6B FLAT HEAD screw ×1
2. Disconnect the **switch cable** from the connector **CN9550** on the back of the switch board.

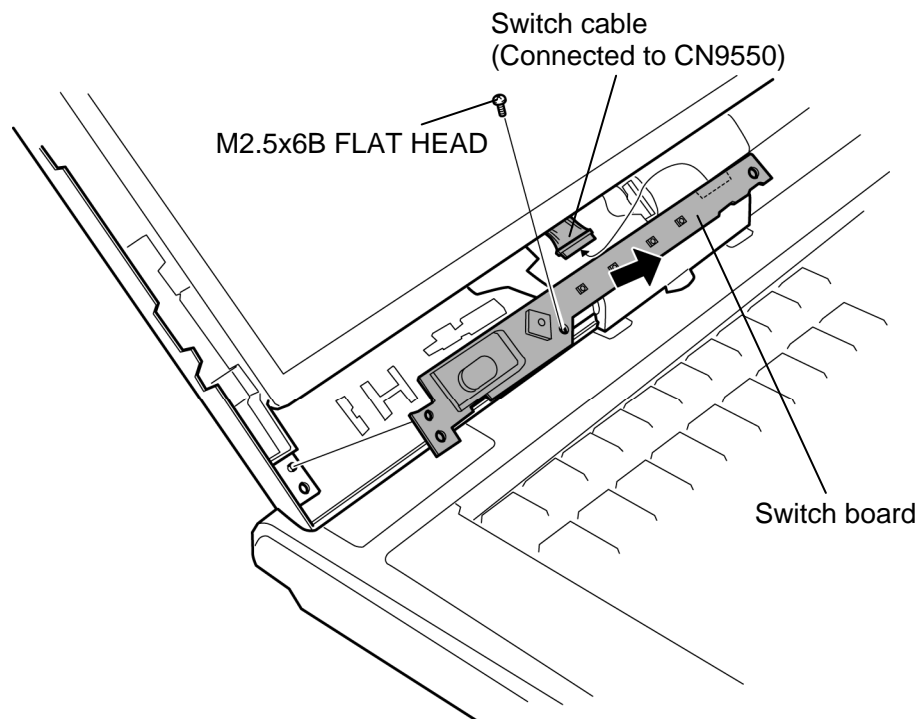

Figure 4-45 Removing the switch board

### Installing the Switch board

The following describes the procedure for installing the switch board. (See Figure 4-45.)

1. Connect the **switch cable** to the connector **CN9550** on the switch board.
2. Install the **switch board** and secure it with the following **screw**.

- M2.5×6B FLAT HEAD screw ×1

## 4.29 LCD unit/FL inverter

### Removing the LCD unit/FL inverter

The following describes the procedure for removing the LCD unit/FL inverter. (See Figure 4-46 to 4-48.)

**NOTE:** When replacing the LCD unit, do not give the hinge portion a strong press. It may cause the breakage of the hinge assembly.  
Also, Use a stand or something under the LCD part to keep the LCD part level while replacing it.

1. Peel off one **insulator** from the FL inverter.
2. Disconnect two **cables** from the connector on the FL inverter and remove the **FL inverter** from the slot while peeling the adhered portion.

**CAUTION:** Do not reuse the removed FL inverter.

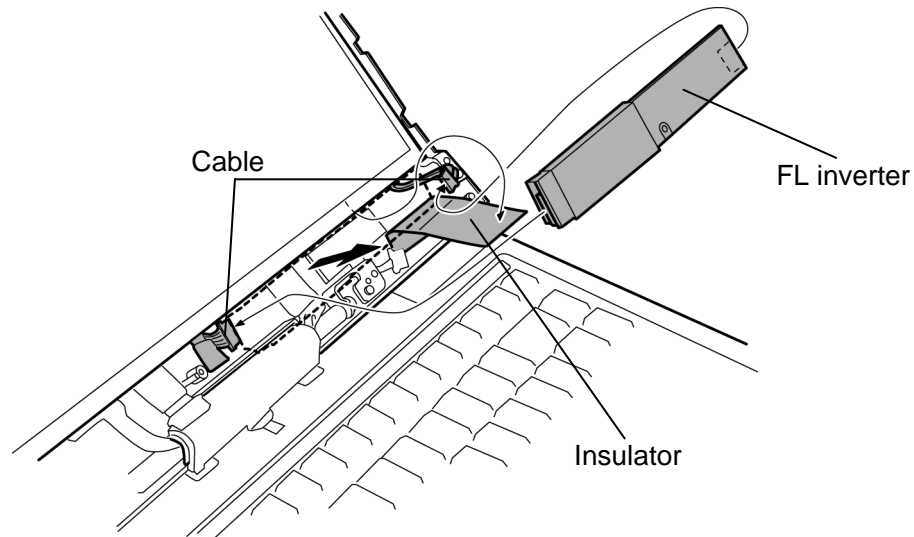

Figure 4-46 Removing the FL inverter

3. Remove the following **screw** securing the LCD unit.
  - M2.5×6B FLAT HEAD screw ×1
4. Carefully lift up the top of the **LCD unit**.

**NOTE:** When lifting up the top of the LCD unit, hold the corners of the LCD unit. The top edge of LCD unit is sensitive area.

5. Peeling off two **glass tapes** and disconnect the **LCD cable** and **digitizer cable** from the connectors on the back of the LCD unit.

**CAUTION:** When removing the cables, be careful not to damage the connectors.

6. Remove the **LCD unit** from the display cover.

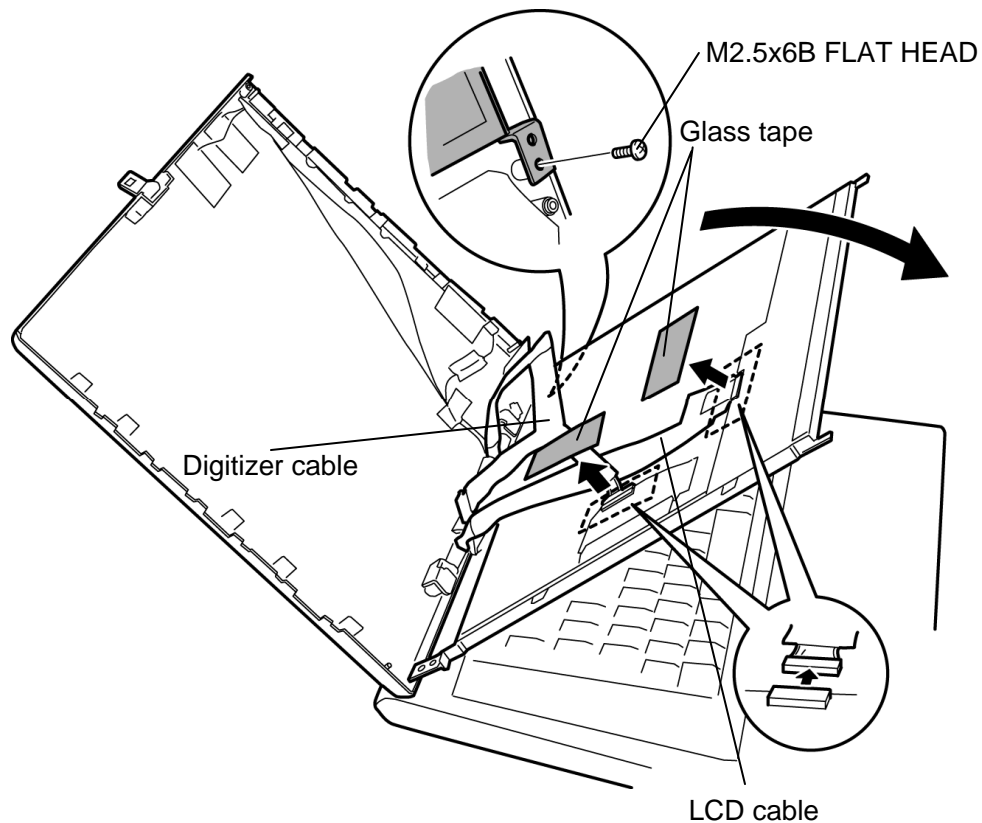

Figure 4-47 Removing the LCD unit

7. Remove the following screws and two LCD supports from the LCD.

- M2×3S S-THIN HEAD screw ×4

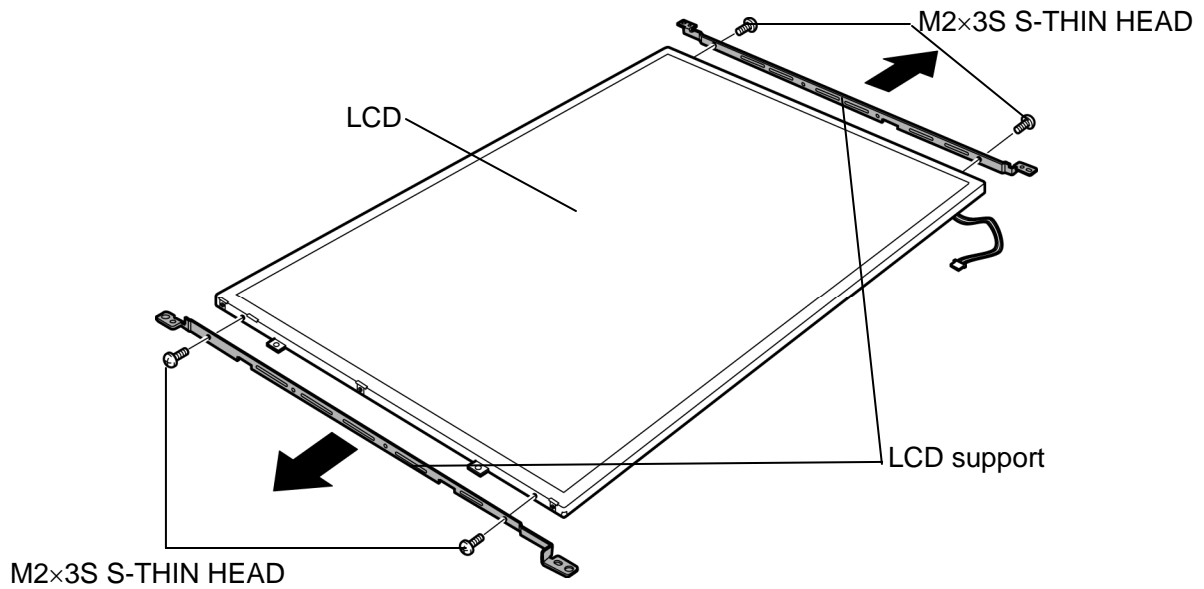

Figure 4-48 Removing the LCD support

- NOTE:** 1) Be careful not to apply pressure to the ICs along the edge of LCD unit. The ICs are easily damaged.
- 2) For environmental reasons, do not throw away a malfunctioning LCD unit (or FL). Please follow local ordinances or regulations for its disposal.

### Installing the LCD unit/FL inverter

The following describes the procedure for installing the LCD unit/FL inverter. (See Figure 4-46 to 4-48.)

1. Set two **LCD supports** to the LCD and secure them with the following **screws**.
  - M2×3S      S-THIN HEAD screw      ×4
2. Stand the LCD unit on the display cover and connect the **digitizer cable** and **LCD cable** on the back of the LCD unit.
3. Stick two **glass tapes** on each connector.
4. Install the **LCD unit** to the display cover and secure it with the following **screw**.
  - M2.5×6B      FLAT HEAD screw      ×1
5. Stick the **FL inverter** to the slot with the double-sided tape.

**CAUTION:** *The FL inverter is stuck to the cover with a double-sided tape. Once removing a FL inverter, be sure not to reuse it. Use new one.*

6. Stick the **insulator** on the FL inverter.
7. Connect two **cables** to the connectors on the FL inverter.



## 4.30 Digitizer

**CAUTION:** Read following instructions before handling the Digitizer.

Do not carry the LCD module by holding the FL cable in one's hand because it may result to cut the FL cable, and cause display function failure or lighting failure.

**NO**

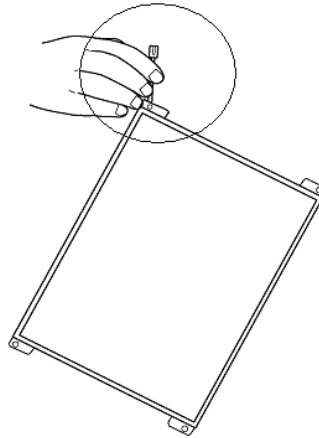

Do not carry the LCD module by holding the FL cable in one's hand.

Be careful to handle the bezel guide.

There is a portion where the bezel is sticking out because of the digitizer guide. Do not press and rub the portion with bare hands or it may cut your finger.

**NO**

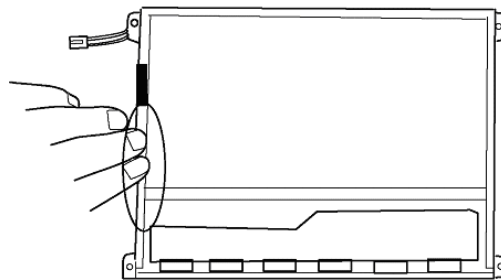

Be careful to handle the bezel guide.

*Do not make any scratches on the B/L and TAB by the edge of the digitizer when installing the digitizer because it may result to break the TAB or make scratches on the B/L and cause display function failure.*

**NO**

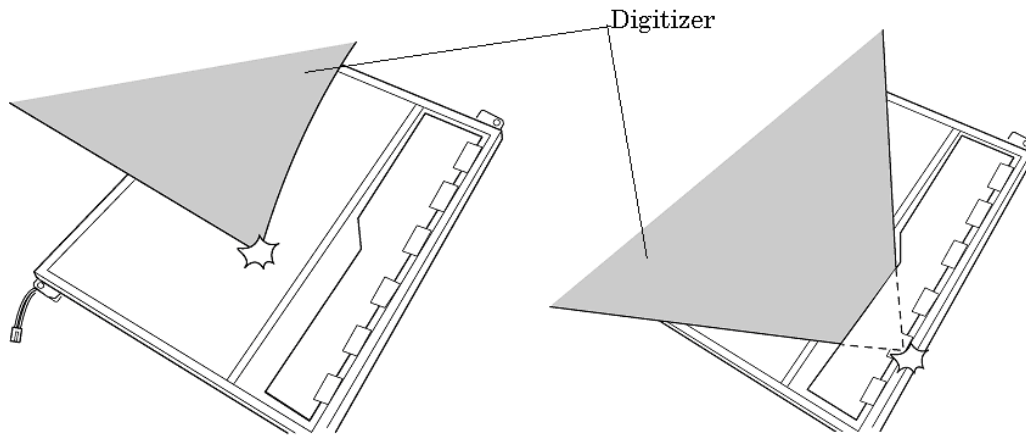

Do not hit the corner of the digitizer

*Do not pull up the PCB hardly when installing the digitizer because it may result to give stress on the TAB or PCB and cause the display function failure.*

**NO**

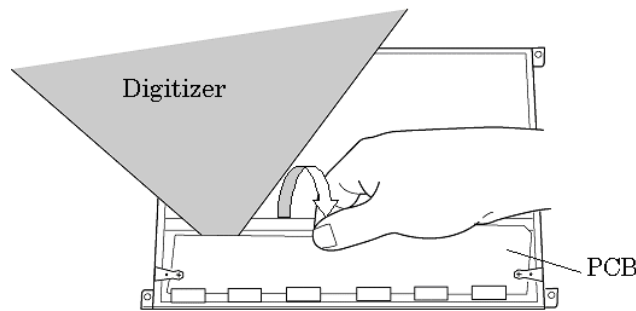

Do not pull up the PCB.

*Make sure that three latches fit the digitizer securely.*

*If the latches are not locked securely, it may result to move the digitizer and give stress on the TAB or PCB and cause the display function failure.*

*Do not turn up the digitizer because it may result to give stress on the TAB or PCB and cause the display function failure.*

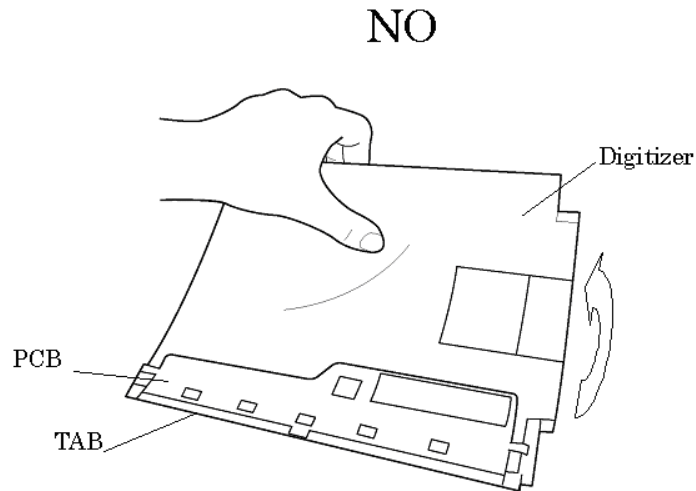

Do not turn up the digitizer to avoid wrap of the PCB.

*Do not put any instrument on the LCD module because it may result to make scratch on the cell, polarization sheet or B/L and break the TAB and may cause the display function failure.*

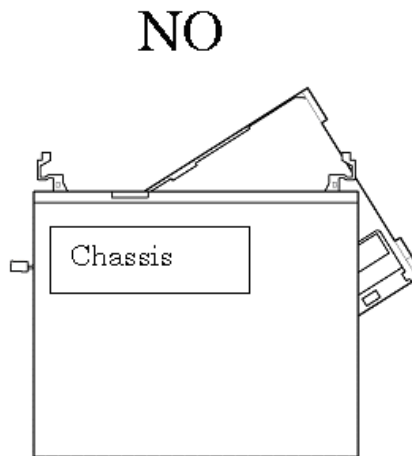

Do not put the chassis on the LCD.

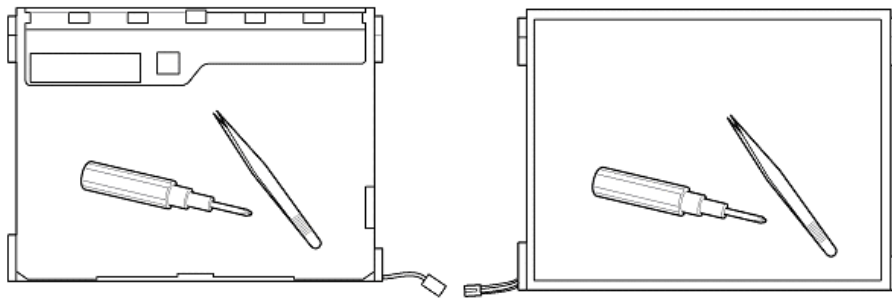

Do not put the instrument on the LCD.

*Do not hold, press and rub the TAB because it may result to break the TAB and cause the display function failure.*

**NO**

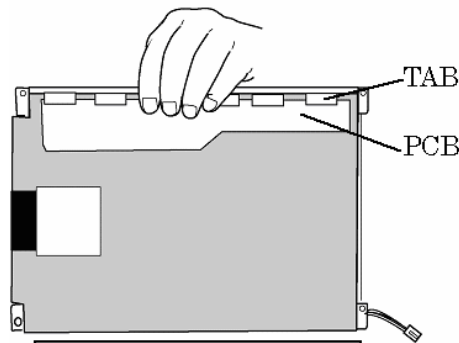

Do not hold the TAB.

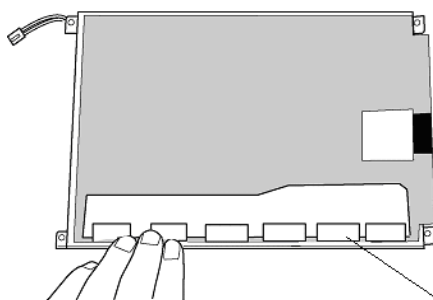

Do not press the TAB.

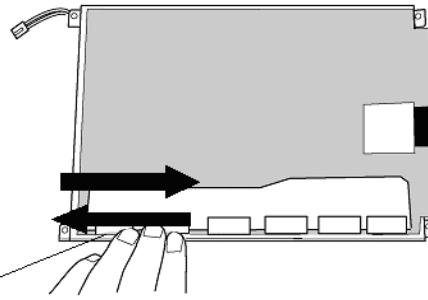

Do not rub the TAB.

*Make sure to put the LCD module on the flat place. If the LCD module is put on the uneven place, it may result to break the TAB, make scratch on the B/L or polarization sheet and cause the display function failure.*

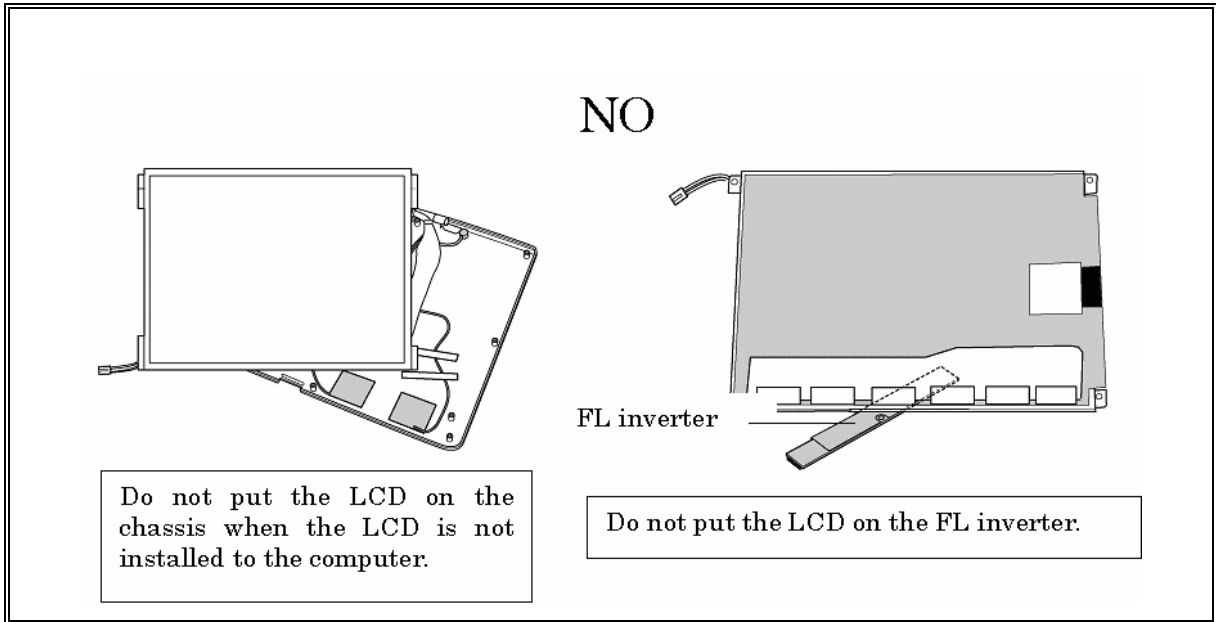

## Removing the Digitizer

The following describes the procedure for removing the digitizer. (See Figure 4-49.)

1. Remove the following **screws** securing the digitizer.

- M2×3S S-THIN HEAD screw ×3

2. Remove the **digitizer** from the LCD unit.

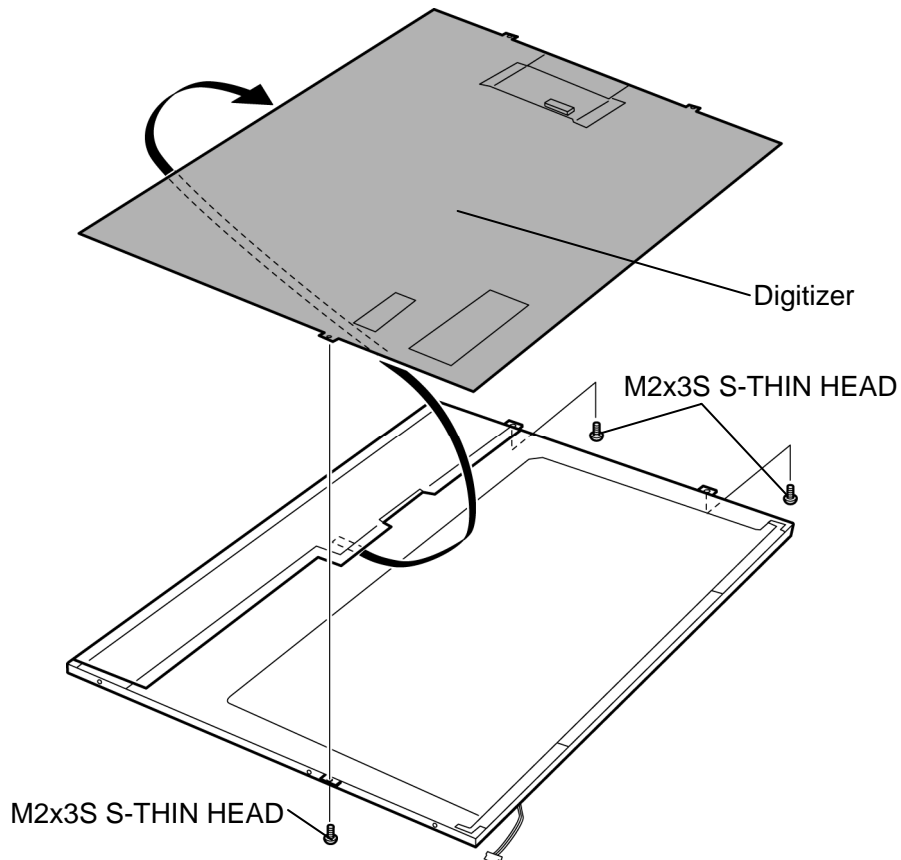

Figure 4-49 Removing the digitizer

### Installing the digitizer

The following describes the procedure for installing the digitizer. (See Figure 4-49.)

1. Slide the **digitizer** into the back pocket of the LCD.

**CAUTION:** When replacing the digitizer, fit the digitizer into the back of the LCD toward the arrow pointing.

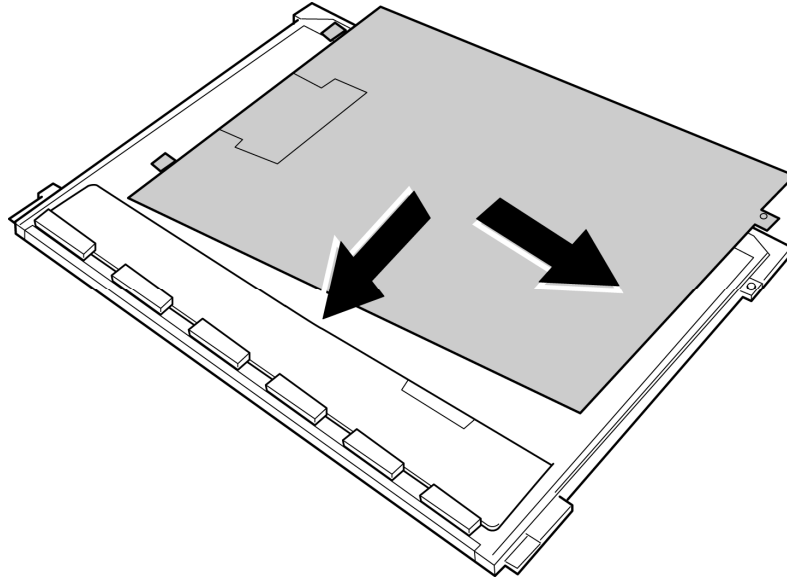

2. Secure the digitizer with the following **screws**.

- M2×3S S-THIN HEAD screw ×3

## 4.31 LCD latch assembly

### Removing the LCD latch assembly

The following describes the procedure for removing the LCD latch assembly. (See Figure 4-50.)

1. Remove the **LCD latch assembly** from the slot as shown in the following figure.

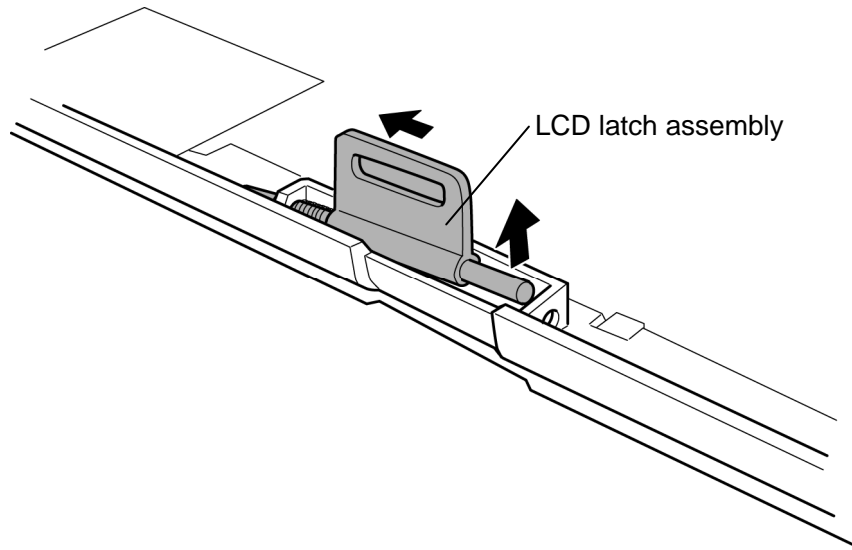

*Figure 4-50 Removing the LCD latch assembly*

### Installing the LCD latch assembly

The following describes the procedure for installing the LCD latch assembly. (See Figure 4-50.)

1. Install the **LCD latch assembly** to the slot.



## 4.32 Hinge assembly

### Removing the Hinge assembly

The following describes the procedure for removing the hinge assembly. (See Figure 4-51 to 4-53.)

1. Peel off the **insulator** and **acetate tape** to release the wireless LAN antenna cable and Bluetooth antenna cable.

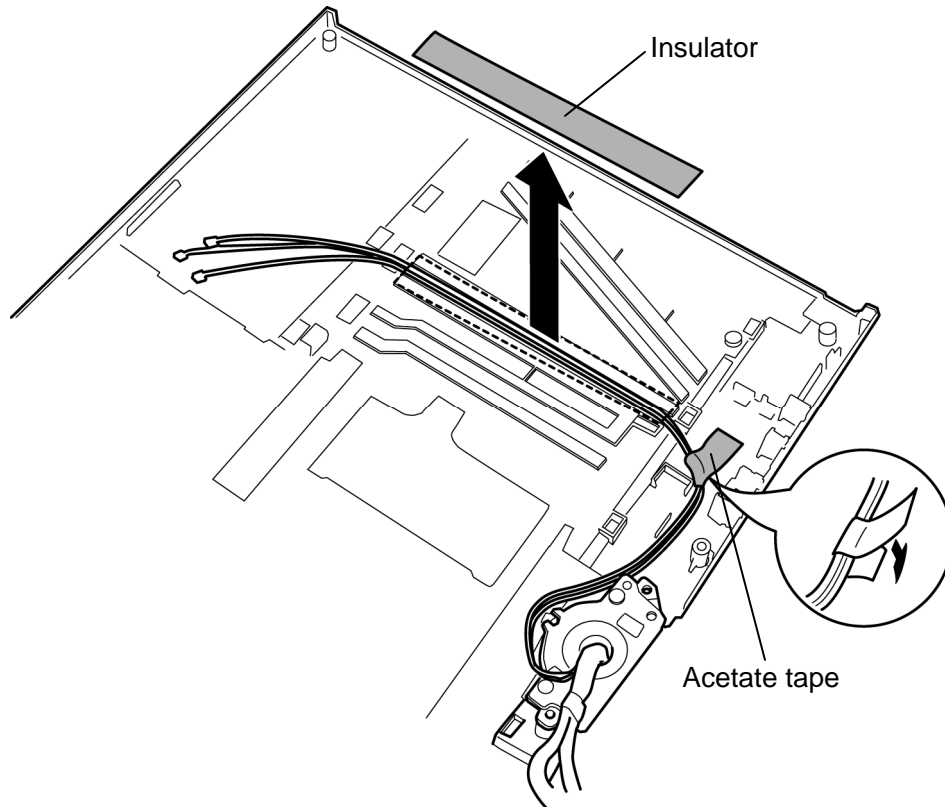

Figure 4-51 Removing the hinge assembly (1)

2. Remove the following **screws**.

- M3×4S FLAT HEAD screw ×2

3. Turn the display rear cover 90 degrees clockwise and remove the **display rear cover** from the cover assembly.

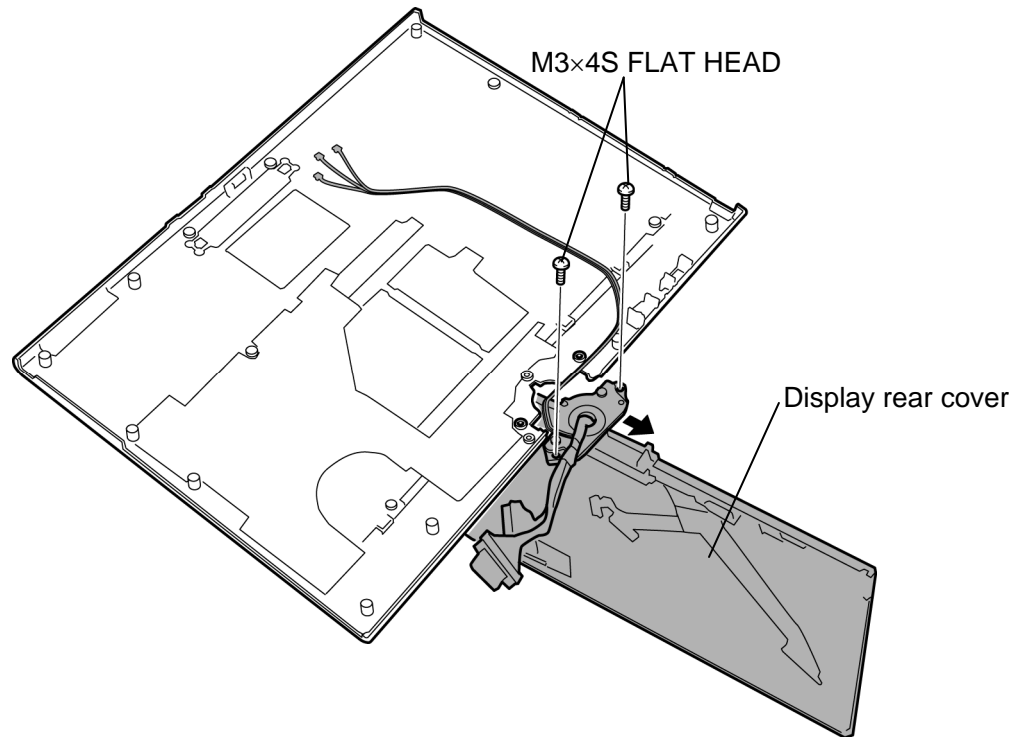

Figure 4-52 Removing the hinge assembly (2)

4. Remove the following **screws** and **hinge assembly** by lifting it up.

- M2.5×6S S-THIN HEAD screw ×2

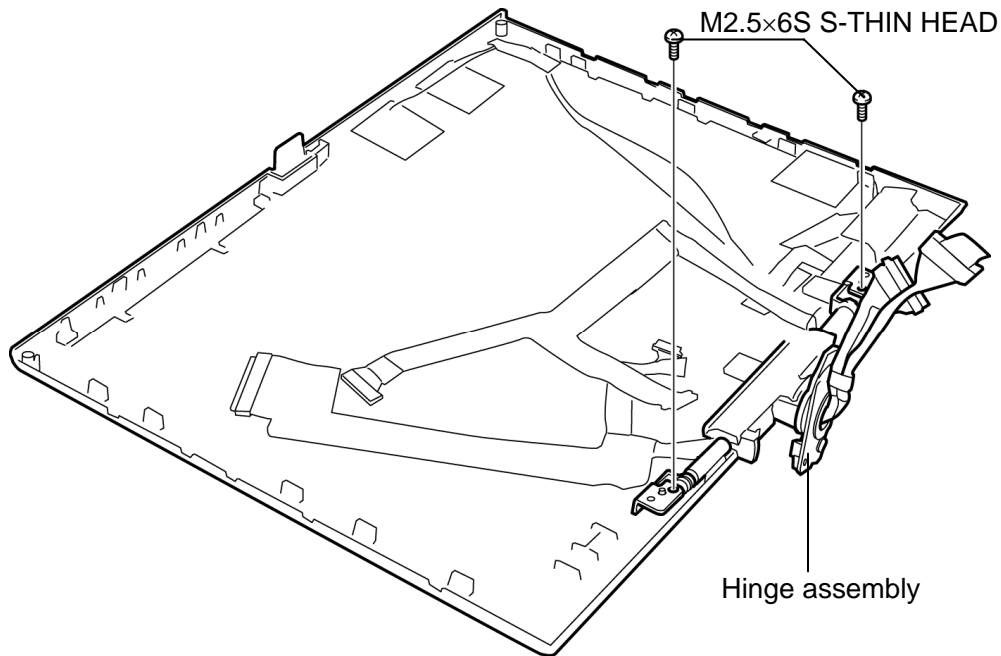

Figure 4-53 Removing the hinge assembly (3)

### Installing the Hinge assembly

The following describes the procedure for installing the hinge assembly. (See Figure 4-51 to 4-53.)

1. Seat the **hinge assembly** in place and secure it with the following **screws**.

- M2.5×6S S-THIN HEAD screw ×2

2. Turn the display rear cover 90 degrees clockwise.

3. Install the **display rear cover** to the cover assembly and secure it with the following **screws**.

- M3×4S FLAT HEAD screw ×2

4. Turn the display rear cover 90 degrees counter clockwise.

5. Arrange the wireless LAN antenna cable and Bluetooth antenna cable in place and stick the **insulator** and **acetate tape**.

### 4.33 Fluorescent lamp

This system uses LCD modules from the following suppliers. The procedure for replacing the fluorescent lamp is different for each LCD module. Refer to the appropriate procedure.

Type	Part No.	Supplier	Section
14.1-inch (WXGA+)	G33C0003B110	CHIMEI	4.33.1

- NOTE:**
- *When working with a LCD module, always use a flat, grounded table.*
  - *Handle the backlight unit in the environment without dust, such as on the clean bench. Keep the worktable free from any screws or other material that may scratch the LCD surface.*
  - *Use an anti-static or protective sheet.*
  - *When replacing the FL unit, cover with a finger protector or similar to prevent soiling or scratching the LCD panel.*
  - *Be careful when handling the lamp. Excessive force may break the lamp.*
  - *Be careful not to soil or deform the lamp reflector.*
  - *Make sure that the power of the LCD module is turned off before connecting or disconnecting cables and connectors.*

### 4.33.1 Replacing the 14.1 Inch CHIMEI Fluorescent lamp

The following describes the procedure for replacing the fluorescent lamp (See Figure 4-54 to 4-59).

#### Disassembling Fluorescent lamp

1. Tear off the AL tape (1) and PCBA protector film (2).

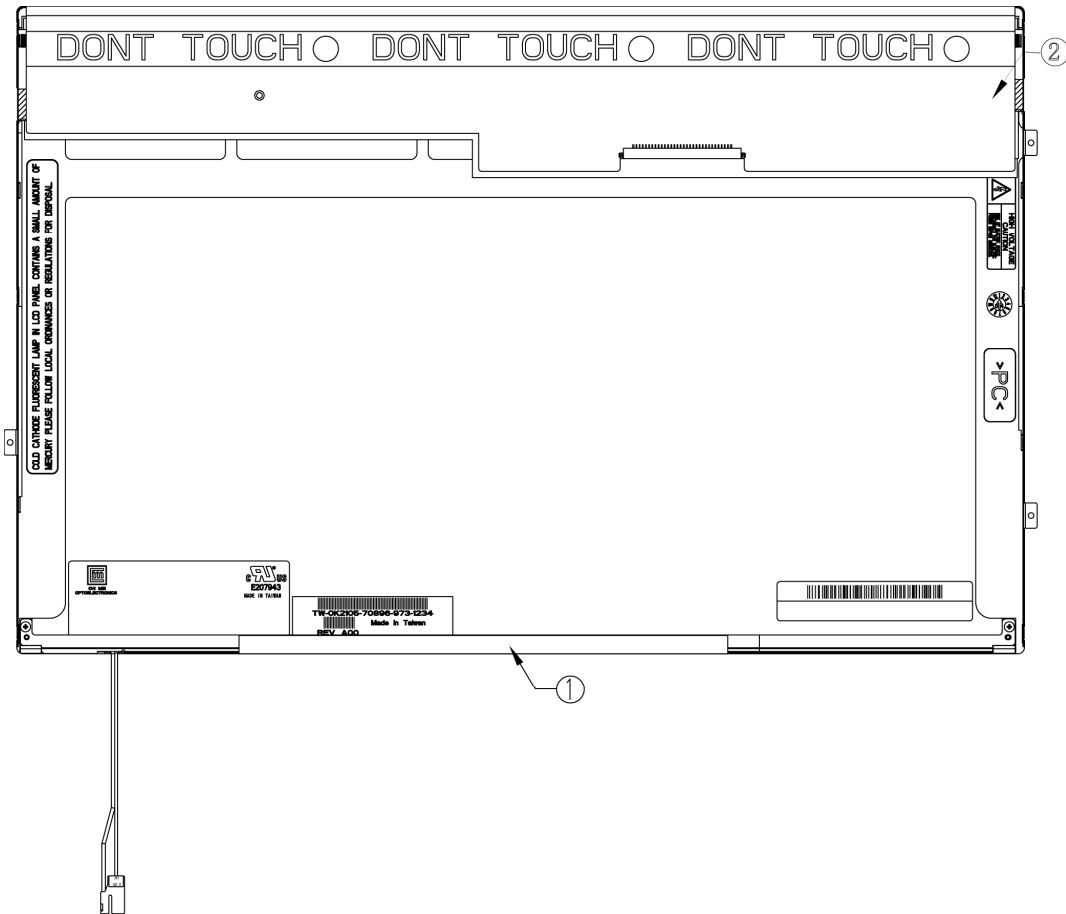

Figure 4-54 Replacing 14.1 Inch CHIMEI fluorescent lamp (1)

2. Tear off the CU tape (1) and unscrew the metal frame fixed screws (2).

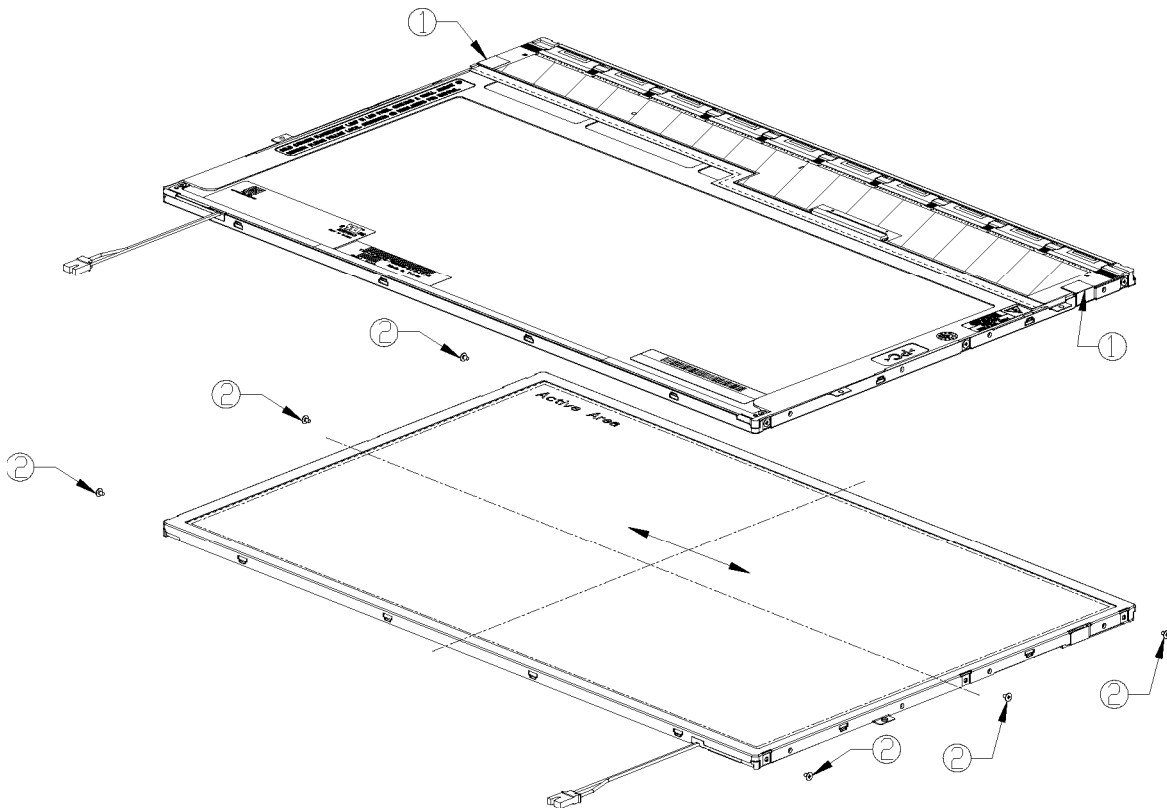

Figure 4-55 Replacing 14.1 Inch CHIMEI fluorescent lamp (2)

3. To remove the metal frame hooks out of the backlight unit (1), first remove the hooks of the bottom side, left side and right side and then remove the metal frame (2).

**CAUTION:** Be sure to take the frame off parallelly in case of any deformation.

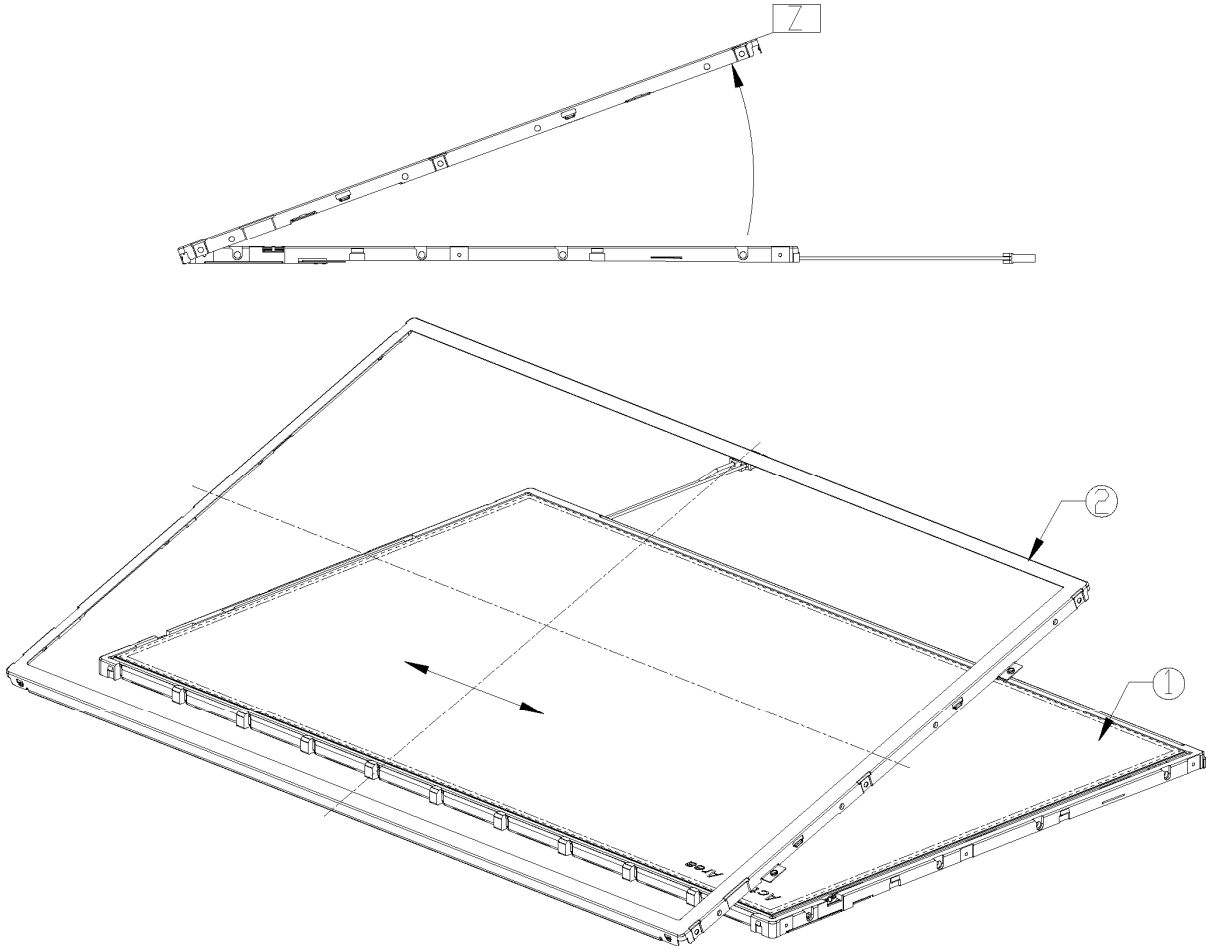

Figure 4-56 Replacing 14.1 Inch CHIMEI fluorescent lamp (3)

4. Take of the X-PCB oppositely.

**CAUTION:** Be careful upon taking off the PCB in case of any twisting deformation to TCP.

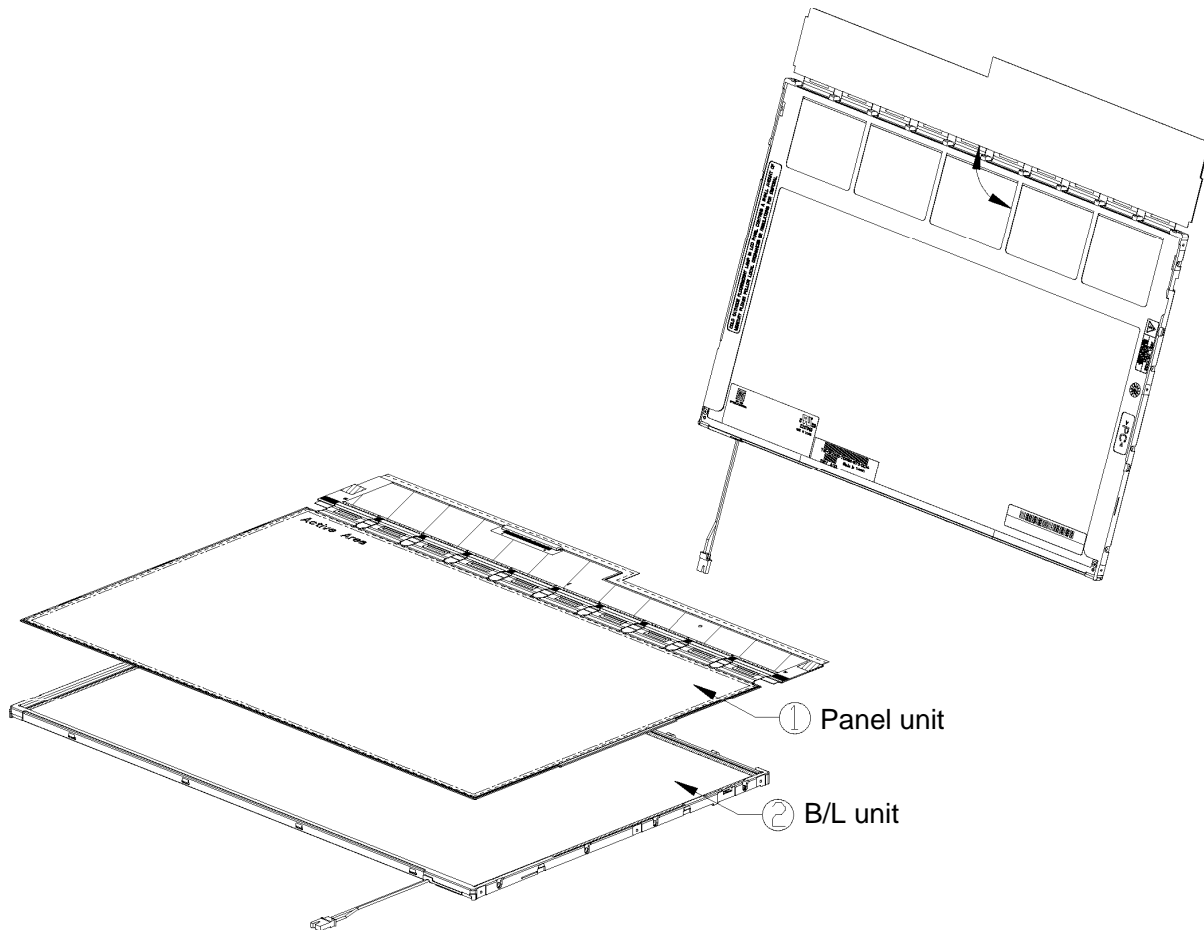

Figure 4-57 Replacing 14.1 Inch CHIMEI fluorescent lamp (4)



5. Tear off the film tape (1) from the protector sheet.
6. Tear off the protector sheet (2), prism (3), LGP (4), LGP tape (5) and reflector (6) from the backlight unit in turn.

**CAUTION:** Be careful upon taking off each sheet in case any damage.

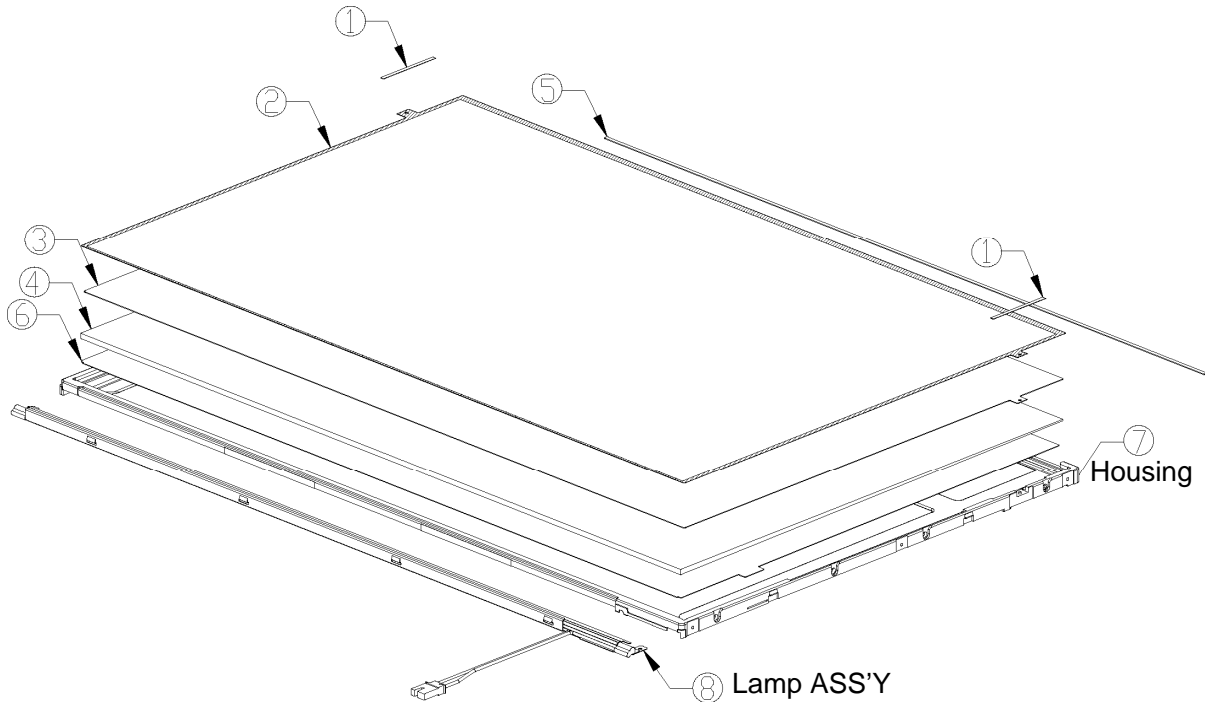

Figure 4-58 Replacing 14.1 Inch CHIMEI fluorescent lamp (5)

7. Unscrew the lamp ASS'Y fixed screws (1).

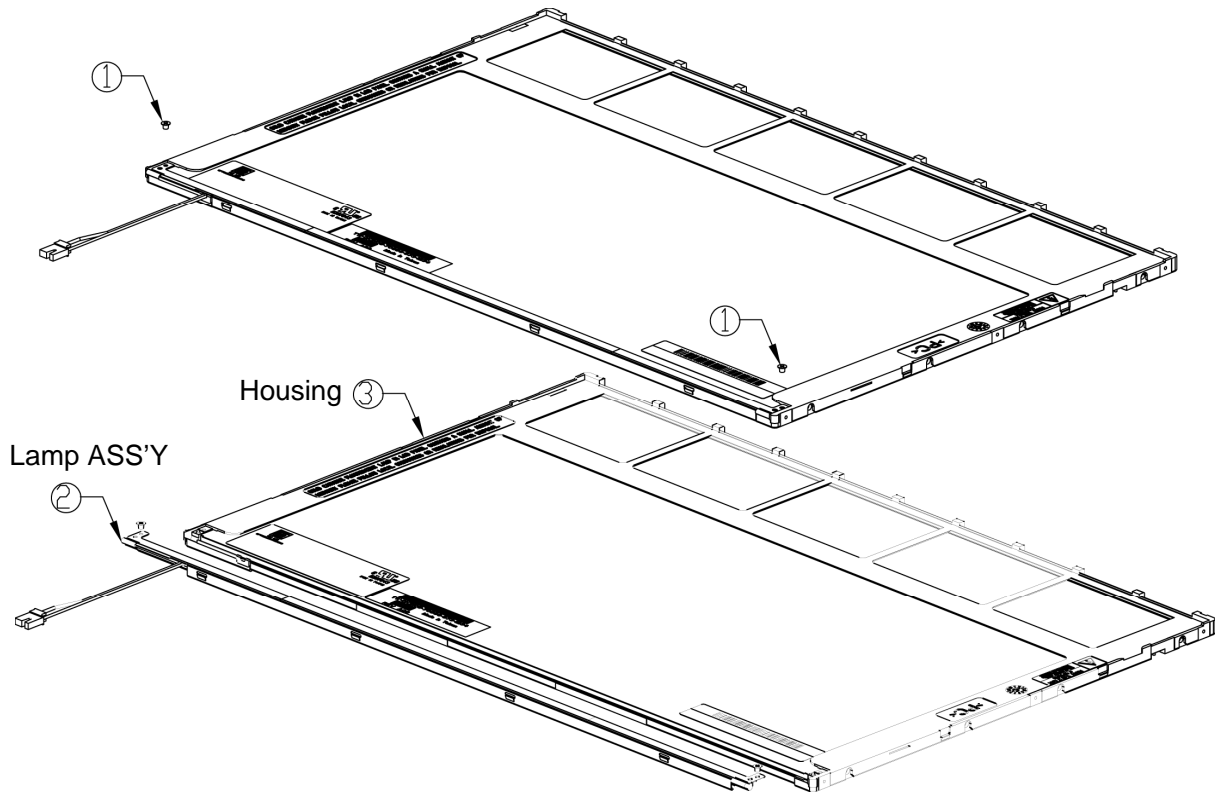

Figure 4-59 Replacing 14.1 Inch CHIMEI fluorescent lamp (6)

### **Assembling Fluorescent lamp**

Assembling is the opposite order of the disassembling.



---

# Appendices

---



---

## Appendix Contents

---

**Appendix A Handling the LCD Module..... A-1**

**Appendix B Board Layout.....B-1**

B.1	System Board Front View.....	B-1
B.2	System Board Back View .....	B-3
B.3	Fingerprint Sensor Board Front and Back View.....	B-5
B.4	Panel Switch Board Front and Back View .....	B-6
B.5	SIM Board Front and Back View .....	B-7
B.6	Switch Board Front and Back View .....	B-8
B.7	Touch Pad Board Front and Back View .....	B-9
B.8	USB Board Front and Back View.....	B-10

**Appendix C Pin Assignment..... C-1**

System board (FCYSY\*)

C.1	CN1410 Memory B connector (200-pin).....	C-1
C.2	CN1400 Memory A connector (200-pin) .....	C-4
C.3	CN1820 ODD I/F connector (50-pin).....	C-7
C.4	CN1850 SATA I/F connector (10-pin) .....	C-8
C.5	CN2110 PC card I/F connector (70-pin).....	C-8
C.6	IS2101 Bridge Media I/F connector (42-pin) .....	C-10
C.7	CN2300 Docking I/F connector (140-pin).....	C-11
C.8	CN2600 PCI-Express mini card (WLAN) I/F connector (52-pin) .....	C-13
C.9	CN2610 PCI-Express mini card (3G) I/F connector (52-pin) .....	C-14
C.10	CN3010 MDC I/F connector (12-pin) .....	C-15
C.11	CN3200 Keyboard connector (34-pin) .....	C-15
C.12	CN3201 PAD connector (8-pin) .....	C-16
C.13	CN3400 Debugging connector (4-pin) .....	C-16
C.14	J4100 Network I/F connector (14-pin) .....	C-16
C.15	CN4200 IEEE1394 connector (4-pin) .....	C-17

C.16	CN4400 Bluetooth connector (20-pin) .....	C-17
C.17	CN4610 USB connector (Port 6/ 4) (8-pin).....	C-18
C.18	CN4612 USB connector (Port 0) (6-pin).....	C-18
C.19	CN4620 USB connector (Port 7) (8-pin).....	C-18
C.20	CN5000 LCD connector (40-pin) .....	C-19
C.21	CN5080 RGB connector (15-pin).....	C-19
C.22	CN5501 S-Video connector (4-pin).....	C-20
C.23	CN6050 Internal microphone connector (2-pin).....	C-20
C.24	J6051 External microphone connector (6-pin) .....	C-20
C.25	CN6170 Speaker connector (4-pin) .....	C-20
C.26	J6310 Headphone connector (6-pin).....	C-21
C.27	CN8800 DC-IN connector (4-pin).....	C-21
C.28	CN8810 Main battery connector (10-pin).....	C-21
C.29	CN9300 RTC battery connector (3-pin) .....	C-21
C.30	CN8771 Fan connector (4-pin) .....	C-22
C.31	CN9500 PR board I/F connector (3-pin) .....	C-22
C.32	CN9520 SIM board I/F connector (10-pin) .....	C-22
C.33	CN9540 Digitizer switch I/F connector (41-pin).....	C-23
C.34	CN9600 SW board I/F connector (13-pin) .....	C-24
Fingerprint sensor board (FCYFS*)		
C.35	CN9560 System board I/F connector (6-pin).....	C-25
Panel switch board (FCYPR*)		
C.36	CN9510 System board I/F connector (3-pin).....	C-26
SIM board (FCYSM*)		
C.37	CN9530 System board I/F connector (10-pin).....	C-27
USB board (FCYUS*)		
C.38	CN4631 System board I/F connector (8-pin).....	C-28
C.39	CN4630 USB connector (Port 5) (6-pin).....	C-28



SW board (FCYSW\*)

C.40	CN9550 System board I/F connector (15-pin).....	C-29
<b>Appendix D</b>	<b>Keyboard Scan/Character Codes .....</b>	<b>D-1</b>
<b>Appendix E</b>	<b>Key Layout .....</b>	<b>E-1</b>
<b>Appendix F</b>	<b>Wiring Diagrams.....</b>	<b>F-1</b>
<b>Appendix G</b>	<b>BIOS Rewrite Procedures .....</b>	<b>G-1</b>
<b>Appendix H</b>	<b>EC/KBC Rewrite Procedures .....</b>	<b>H-1</b>
<b>Appendix I</b>	<b>Reliability.....</b>	<b>I-1</b>

**Figures**

Figure B-1	System board layout (front) .....	B-1
Figure B-2	System board layout (back) .....	B-3
Figure B-3	Fingerprint sensor board layout .....	B-5
Figure B-4	Panel switch board layout .....	B-6
Figure B-5	SIM board layout .....	B-7
Figure B-6	Switch board layout .....	B-8
Figure B-7	Touch pad board layout .....	B-9
Figure B-8	USB board layout.....	B-10
Figure E-1	Key layout (UK) .....	E-1
Figure E-2	Key layout (US) .....	E-1
Figure F-1	RGB Monitor Wraparound connector .....	F-1
Figure F-2	LAN Loopback Connector.....	F-1

**Tables**

Table B-1	System board ICs and connectors (front).....	B-2
Table B-2	System board ICs and connectors (back).....	B-4
Table B-3	Fingerprint sensor board connector .....	B-5
Table B-4	Panel switch board connector .....	B-6
Table B-5	SIM board connector .....	B-7
Table B-6	Switch board connector .....	B-8
Table B-7	Touch pad board connectors.....	B-9
Table B-8	USB board connectors .....	B-10

System board (FCYSY\*)

Table C-1	Memory B connector (200-pin) .....	C-1
Table C-2	Memory A connector (200-pin).....	C-4
Table C-3	ODD I/F connector (50-pin) .....	C-7
Table C-4	SATA I/F connector (10-pin).....	C-8

Table C-5	PC card I/F connector (70-pin).....	C-8
Table C-6	Bridge Media I/F connector (42-pin).....	C-10
Table C-7	Docking I/F connector (140-pin).....	C-11
Table C-8	PCI-Express mini card (WLAN) I/F connector (52-pin).....	C-13
Table C-9	PCI-Express mini card (3G) I/F connector (52-pin).....	C-14
Table C-10	MDC I/F connector (12-pin).....	C-15
Table C-11	Keyboard connector (34-pin).....	C-15
Table C-12	PAD connector (8-pin).....	C-16
Table C-13	Debugging connector (4-pin).....	C-16
Table C-14	Network I/F connector (14-pin).....	C-16
Table C-15	IEEE1394 connector (4-pin).....	C-17
Table C-16	Bluetooth connector (20-pin).....	C-17
Table C-17	USB connector (Port 6) (8-pin).....	C-18
Table C-18	USB connector (Port 0) (6-pin).....	C-18
Table C-19	USB connector (Port 7) (8-pin).....	C-18
Table C-20	LCD connector (40-pin).....	C-19
Table C-21	RGB connector (15-pin).....	C-19
Table C-22	S-Video connector (4-pin).....	C-20
Table C-23	Internal microphone connector (2-pin).....	C-20
Table C-24	External microphone connector (6-pin).....	C-20
Table C-25	Speaker connector (4-pin).....	C-20
Table C-26	Headphone connector (6-pin).....	C-21
Table C-27	DC-IN connector (4-pin).....	C-21
Table C-28	Main battery connector (10-pin).....	C-21
Table C-29	RTC battery connector (3-pin).....	C-21
Table C-30	Fan connector (4-pin).....	C-22
Table C-31	PR board I/F connector (3-pin).....	C-22
Table C-32	SIM board I/F connector (10-pin).....	C-22
Table C-33	Digitizer switch I/F connector (41-pin).....	C-23
Table C-34	SW board I/F connector (13-pin).....	C-24
Fingerprint sensor board (FCYFS*)		
Table C-35	System board I/F connector (6-pin).....	C-25

Panel switch board (FCYPR\*)

Table C-36 System board I/F connector (3-pin) ..... C-26

SIM board (FCYSM\*)

Table C-37 System board I/F connector (10-pin) ..... C-27

USB board (FCYUS\*)

Table C-38 System board I/F connector (8-pin) ..... C-28

Table C-39 USB connector (Port 5) (6-pin)..... C-28

SW board (FCYSW\*)

Table C-40 System board I/F connector (15-pin) ..... C-29

Table D-1 Scan codes (set 1 and set 2) ..... D-1

Table D-2 Scan codes with left Shift key..... D-5

Table D-3 Scan codes in Numlock mode..... D-6

Table D-4 Scan codes with Fn key..... D-6

Table D-5 Scan codes in overlay mode..... D-7

Table D-6 No.124 Key scan code ..... D-7

Table D-7 No.126 key scan code ..... D-8

Table I-1 MTBF..... I-1

---

## Appendix A Handling the LCD Module

---

### Precautions for handling the LCD module

The LCD module can be easily damaged during assembly or disassembly. Observe the following precautions when handling the LCD module:

1. When installing the LCD module in the LCD cover, be sure to seat it so that it is properly aligned and maximum visibility of the display is maintained.

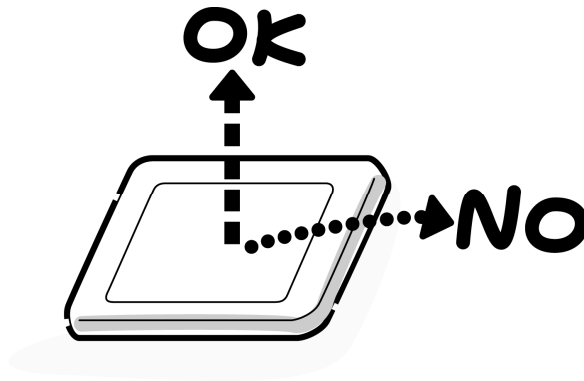

2. Be careful to align the holes at the four corners of the LCD module with the corresponding holes in the LCD cover before securing the module with screws. Do not force the module into place, because stress can affect its performance.

Also, the panel's polarized surface is easily scarred, so be careful when handling it.



3. If the panel's surface gets dirty, wipe it with cotton or a soft cloth. If it is still dirty, try breathing on the surface to create a light condensate and wipe it again.

If the surface is very dirty, we recommend a LCD cleaning agent. Apply the agent to a cloth and then wipe the panel's surface. Do not apply cleanser directly to the panel.

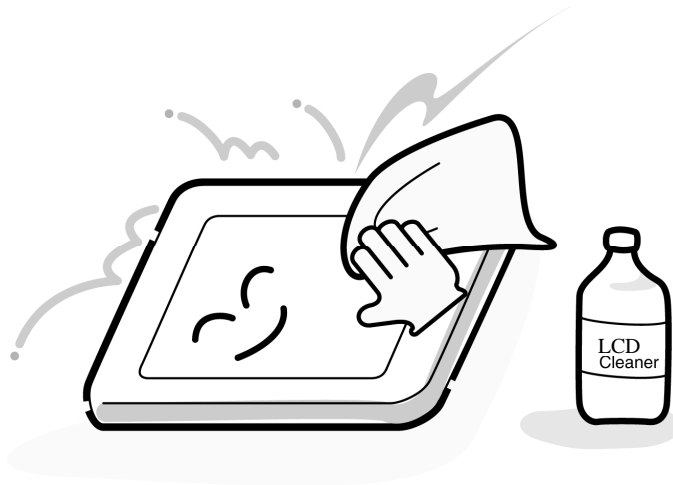

4. If water or other liquid is left on the panel's surface for a long period, it can change the screen's tint or stain it. Be sure to quickly wipe off any liquid.



5. Glass is used in the panel, so be careful not to drop it or let it strike a hard object, which could cause breakage or cracks.

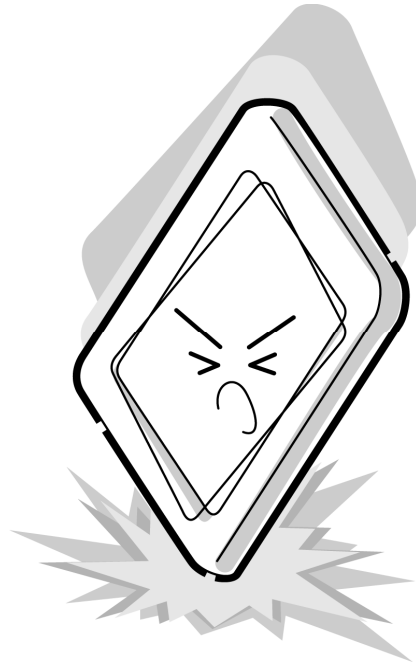

6. CMOS-LSI circuits are used in the module, so guard against damage from electrostatic discharge. Be sure to wear a wrist or ankle ground when handling the module.

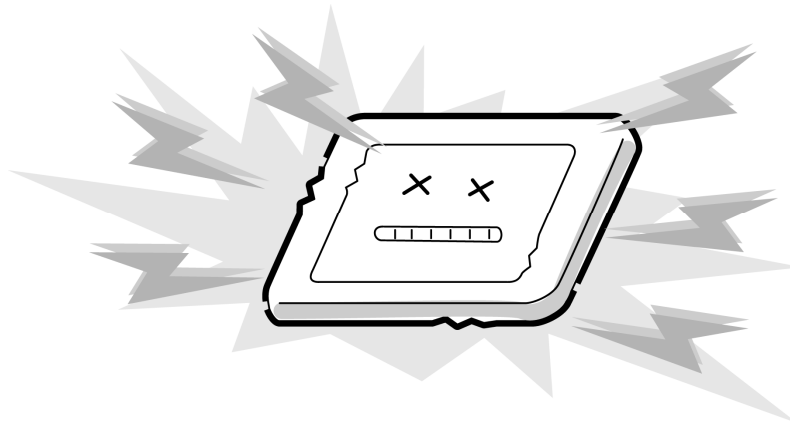

7. Do not expose the module to direct sunlight or strong ultraviolet rays for long periods.



8. Do not store the module at temperatures below specifications. Cold can cause the liquid crystals to freeze, lose their elasticity or otherwise suffer damage.

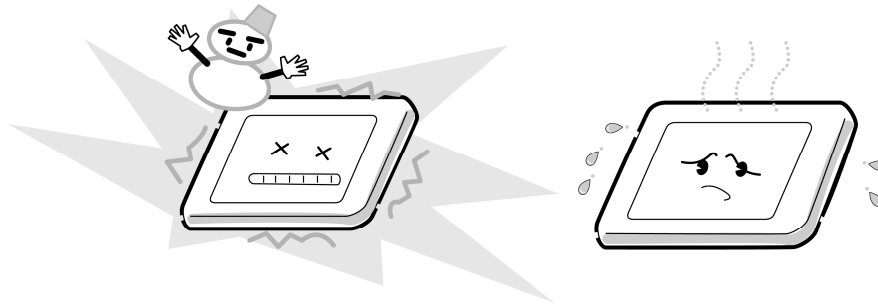

9. Do not disassemble the LCD module. Disassembly can cause malfunctions.

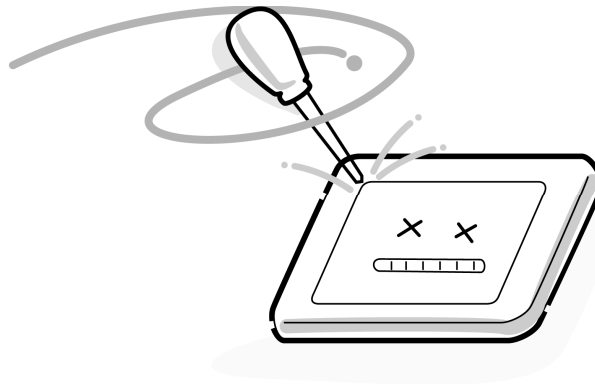



10. If you transport the module, do not use packing material that contains epoxy resin (amine) or silicon glue (alcohol or oxime). These materials can release gas that can damage the panel's polarization.

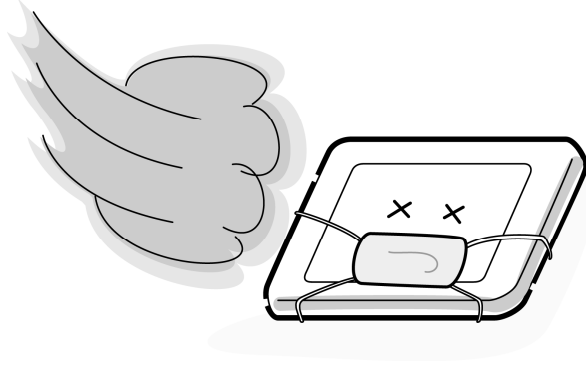



---

## Appendix B Board Layout

---

### B.1 System Board Front View

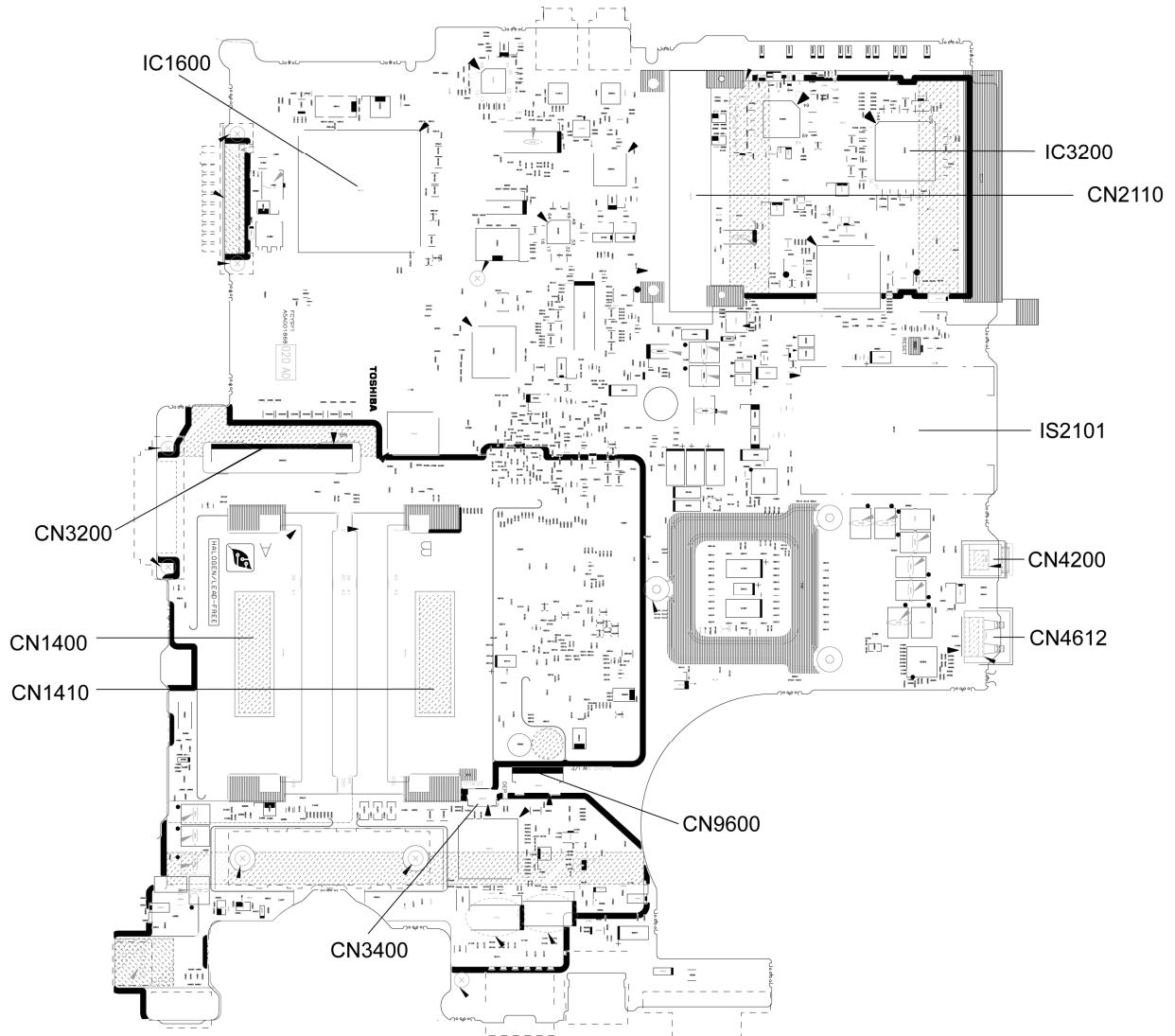

Figure B-1 System board layout (front)

*Table B-1 System board ICs and connectors (front)*

<b>Number</b>	<b>Part's name</b>
IS2101	Bridge media connector
CN1400	Memory connector (A)
CN1410	Memory connector (B)
CN9600	Switch board I/F connector
CN3200	Keyboard connector
CN3400	Debug port I/F connector
CN2110	PC card I/F connector
IC1600	ICH7-M
IC3200	EC/KBC
CN4200	IEEE 1394 port
CN4612	USB port 0

## B.2 System Board Back View

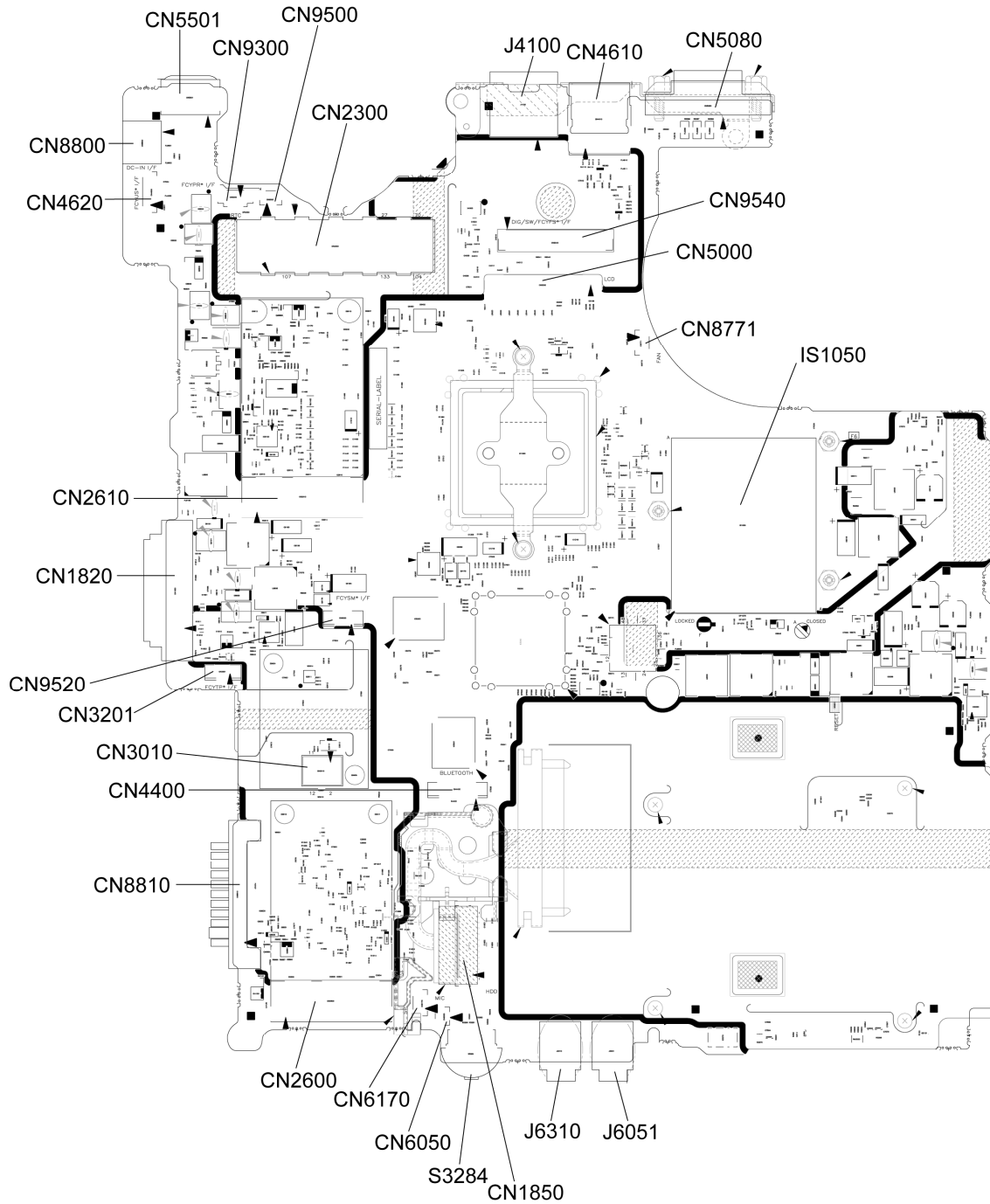

Figure B-2 System board layout (back)

Table B-2 System board ICs and connectors (back)

Number	Name
CN5501	S-Video connector
CN8800	DC-IN jack
CN4620	USB board I/F connector
CN2610	3G connector
CN1820	Optical drive connector
CN9520	SIM board I/F connector
CN3201	Touch pad board I/F connector
CN3010	MDC connector
CN4400	Bluetooth I/F connector
CN8810	Battery connector
CN2600	Wireless LAN connector
CN6170	Speaker connector
CN6050	Internal microphone connector
S3284	Sound volume
CN1850	HDD I/F connector
J6310	Headphone jack
J6051	External microphone jack
IS1050	CPU
CN8771	Fan connector
CN5000	LCD I/F connector
CN9540	Fingerprint sensor board I/F and Digitizer connector
CN5080	RGB connector
CN4610	USB port 6/4
J4100	Network jack
CN2300	Port replicator I/F connector
CN9500	Panel switch board I/F connector
CN9300	RTC battery connector

### B.3 Fingerprint Sensor Board Front and Back View

<Front layout>

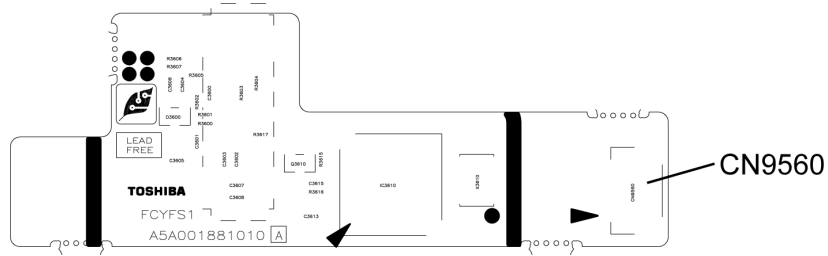

<Back layout>

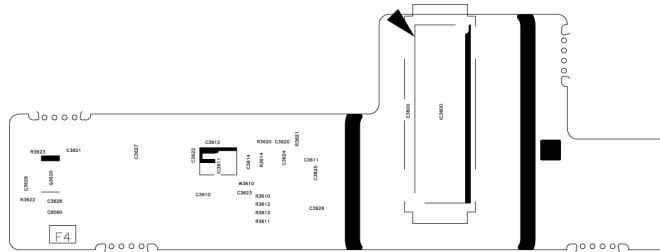

Figure B-3 Fingerprint sensor board layout

Table B-3 Fingerprint sensor board connector

Number	Name
CN9560	System board I/F connector

### B.4 Panel Switch Board Front and Back View

<Front layout>

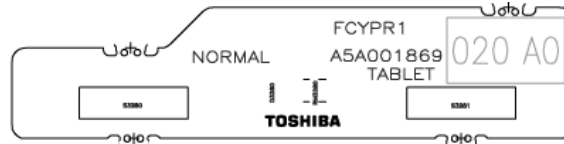

<Back layout>

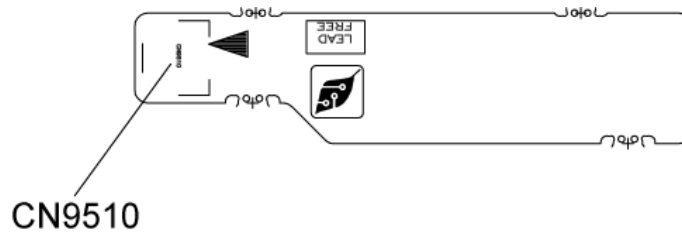

Figure B-4 Panel switch board layout

Table B-4 Panel switch board connector

Number	Name
CN9510	System board I/F connector



## B.5 SIM Board Front and Back View

<Front layout>

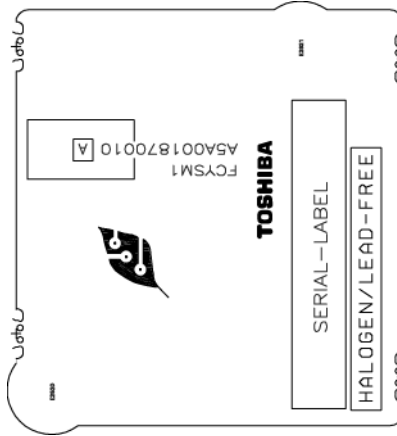

<Back layout>

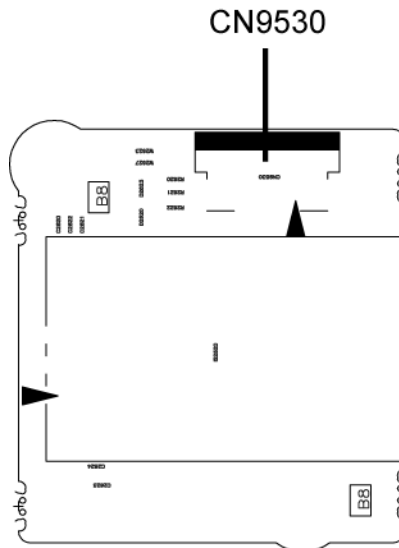

Figure B-5 SIM board layout

Table B-5 SIM board connector

Number	Name
CN9530	System board I/F connector

## B.6 Switch Board Front and Back View

<Front layout>

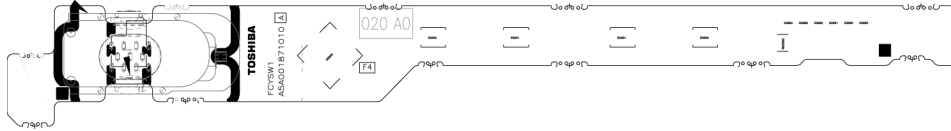

<Back layout>

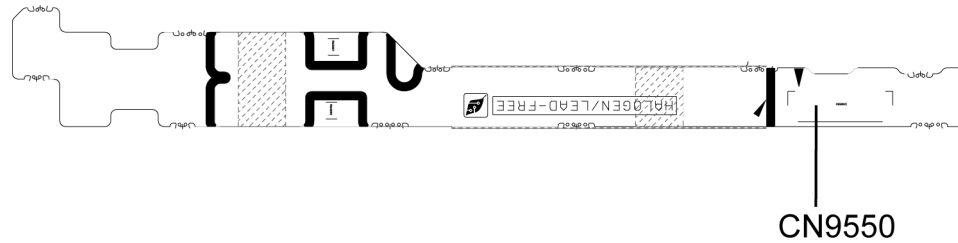

Figure B-6 Switch board layout

Table B-6 Switch board connector

Number	Name
CN9550	System board I/F connector

## B.7 Touch Pad Board Front and Back View

<Front layout>

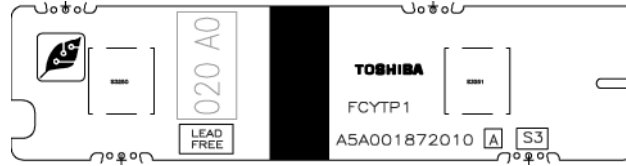

<Back layout>

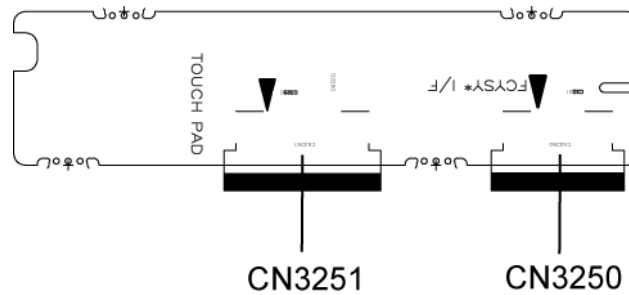

Figure B-7 Touch pad board layout

Table B-7 Touch pad board connectors

Number	Name
CN3250	System board I/F connector
CN3251	Touch pad I/F connector

## B.8 USB Board Front and Back View

<Front layout>

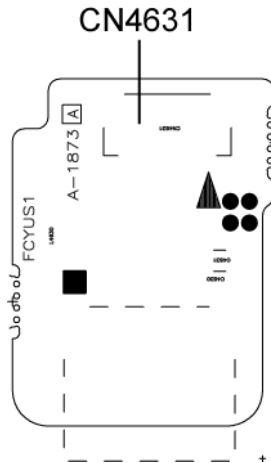

<Back layout>

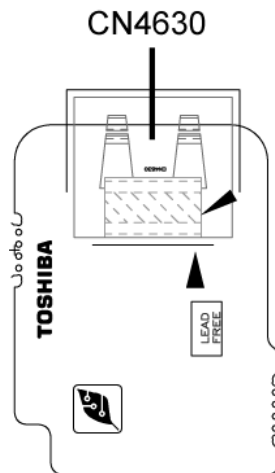

Figure B-8 USB board layout

Table B-8 USB board connectors

Number	Name
CN4631	System board I/F connector
CN4630	USB port 7

## Appendix C Pin Assignment

### System board (FAPNS\*)

#### C.1 CN1410 Memory B connector (200-pin)

Table C-1 Memory B connector (200-pin) (1/3)

Pin No.	Signal Name	I/O	Pin No.	Signal Name	I/O
1	MRVREF-B0V	I	2	GND	-
3	GND	-	4	BDQ01-B1P	I/O
5	BDQ02-B1P	I/O	6	BDQ04-B1P	I/O
7	BDQ06-B1P	I/O	8	GND	-
9	GND	-	10	BDM0-B1P	I
11	BDQS0-B1N	I/O	12	GND	-
13	BDQS0-B1P	I/O	14	BDQ05-B1P	I/O
15	GND	-	16	BDQ00-B1P	I/O
17	BDQ03-B1P	I/O	18	GND	-
19	BDQ07-B1P	I/O	20	BDQ12-B1P	I/O
21	GND	-	22	BDQ13-B1P	I/O
23	BDQ08-B1P	I/O	24	GND	-
25	BDQ09-B1P	I/O	26	BDM1-B1P	I
27	GND	-	28	GND	-
29	BDQS1-B1N	I/O	30	MCK3-B1P	I
31	BDQS1-B1P	I/O	32	MCK3-B1N	I
33	GND	-	34	GND	-
35	BDQ10-B1P	I/O	36	BDQ14-B1P	I/O
37	BDQ11-B1P	I/O	38	BDQ15-B1P	I/O
39	GND	-	40	GND	-
41	GND	-	42	GND	-
43	BDQ16-B1P	I/O	44	BDQ17-B1P	I/O
45	BDQ21-B1P	I/O	46	BDQ20-B1P	I/O
47	GND	-	48	GND	-
49	BDQS2-B1N	I/O	50	N.C.	-
51	BDQS2-B1P	I/O	52	BDM2-B1P	I
53	GND	-	54	GND	-
55	BDQ23-B1P	I/O	56	BDQ18-B1P	I/O

Table C-1 Memory B connector (200-pin)(2/3)

Pin No.	Signal Name	I/O	Pin No.	Signal Name	I/O
57	BDQ22-B1P	I/O	58	BDQ19-B1P	I/O
59	GND	-	60	GND	-
61	BDQ29-B1P	I/O	62	BDQ25-B1P	I/O
63	BDQ28-B1P	I/O	64	BDQ24-B1P	I/O
65	GND	-	66	GND	-
67	BDM3-B1P	I	68	BDQS3-B1N	I/O
69	N.C.	-	70	BDQS3-B1P	I/O
71	GND	-	72	GND	-
73	BDQ26-B1P	I/O	74	BDQ30-B1P	I/O
75	BDQ27-B1P	I/O	76	BDQ31-B1P	I/O
77	GND	-	78	GND	-
79	MCKE2-B1P	I	80	MCKE3-B1P	I
81	1R8-B1V	I	82	1R8-B1V	I
83	N.C.	-	84	N.C	-
85	BBS2-B1P	I	86	N.C	-
87	1R8-B1V	I	88	1R8-B1V	I
89	BMA12-B1P	I	90	BMA11-B1P	I
91	BMA09-B1P	I	92	BMA07-B1P	I
93	BMA08-B1P	I	94	BMA06-B1P	I
95	1R8-B1V	I	96	1R8-B1V	I
97	BMA05-B1P	I	98	BMA04-B1P	I
99	BMA03-B1P	I	100	BMA02-B1P	I
101	BMA01-B1P	I	102	BMA00-B1P	I
103	1R8-B1V	I	104	1R8-B1V	I
105	BMA10-B1P	I	106	BBS1-B1P	I
107	BBS0-B1P	I	108	BRAS-B1N	I
109	BWE-B1N	I	110	MCS2-B1N	I
111	1R8-B1V	I	112	1R8-B1V	I
113	BCAS-B1N	I	114	MODT2-B1P	I
115	MCS3-B1N	I	116	BMA13-B1P	I
117	1R8-B1V	I	118	1R8-B1V	I
119	MODT3-B1P	I	120	N.C	-
121	GND	-	122	GND	-
123	BDQ32-B1P	I/O	124	BDQ36-B1P	I/O
125	BDQ33-B1P	I/O	126	BDQ37-B1P	I/O
127	GND	-	128	GND	-

Table C-1 Memory B connector (200-pin) (3/3)

Pin No.	Signal Name	I/O	Pin No.	Signal Name	I/O
129	BDQS4-B1N	I/O	130	BDM4-B1P	I
131	BDQS4-B1P	I/O	132	GND	-
133	GND	-	134	BDQ38-B1P	I/O
135	BDQ34-B1P	I/O	136	BDQ39-B1P	I/O
137	BDQ35-B1P	I/O	138	GND	-
139	GND	-	140	BDQ44-B1P	I/O
141	BDQ40-B1P	I/O	142	BDQ45-B1P	I/O
143	BDQ41-B1P	I/O	144	GND	-
145	GND	-	146	BDQS5-B1N	I/O
147	BMD5-B1P	I	148	BDQS5-B1P	I/O
149	GND	-	150	GND	-
151	BDQ47-B1P	I/O	152	BDQ46-B1P	I/O
153	BDQ42-B1P	I/O	154	BDQ43-B1P	I/O
155	GND	-	156	GND	-
157	BDQ48-B1P	I/O	158	BDQ53-B1N	I/O
159	BDQ52-B1P	I/O	160	BDQ49-B1N	I/O
161	GND	-	162	GND	-
163	N.C.	-	164	MCK2-B1P	I
165	GND	-	166	MCK2-B1N	I
167	BDQS6-B1N	I/O	168	GND	-
169	BDQS6-B1P	I/O	170	BDM6-B1P	I
171	GND	-	172	GND	-
173	BDQ51-B1P	I/O	174	BDQ50-B1P	I/O
175	BDQ54-B1P	I/O	176	BDQ55-B1P	I/O
177	GND	-	178	GND	-
179	BDQ57-B1P	I/O	180	BDQ56-B1P	I/O
181	BDQ61-B1P	I/O	182	BDQ60-B1P	I/O
183	GND	-	184	GND	-
185	BDM7-B1P	I	186	BDQS7-B1N	I/O
187	GND	-	188	BDQS7-B1P	I/O
189	BDQ58-B1P	I/O	190	GND	-
191	BDQ59-B1P	I/O	192	BDQ62-B1P	I/O
193	GND	-	194	BDQ63-B1P	I/O
195	SMBDAT-P3P	I/O	196	GND	-
197	SMBCLK-P3P	I/O	198	GND	-
199	P3V	I	200	P3V	I
1T	GND	-	2T	GND	-

## C.2 CN1400 Memory A connector (200-pin)

Table C-2 Memory A connector (200-pin) (1/3)

Pin No.	Signal Name	I/O	Pin No.	Signal Name	I/O
1	MRVREF-BOV	I	2	GND	-
3	GND	-	4	ADQ04-B1P	I/O
5	ADQ07-B1P	I/O	6	ADQ06-B1P	I/O
7	ADQ00-B1P	I/O	8	GND	-
9	GND	-	10	ADM0-B1P	I
11	ADQS0-B1N	I/O	12	GND	-
13	ADQS0-B1P	I/O	14	ADQ05-B1P	I/O
15	GND	-	16	ADQ01-B1P	I/O
17	ADQ03-B1P	I/O	18	GND	-
19	ADQ02-B1P	I/O	20	ADQ12-B1P	I/O
21	GND	-	22	ADQ13-B1P	I/O
23	ADQ14-B1P	I/O	24	GND	-
25	ADQ08-B1P	I/O	26	ADM1-B1P	I
27	GND	-	28	GND	-
29	ADQS1-B1N	I/O	30	XMCK0-B1P	I
31	ADQS1-B1P	I/O	32	XMCK0-B1N	I
33	GND	-	34	GND	-
35	ADQ15-B1P	I/O	36	ADQ10-B1P	I/O
37	ADQ09-B1P	I/O	38	ADQ11-B1P	I/O
39	GND	-	40	GND	-
41	GND	-	42	GND	-
43	ADQ21-B1P	I/O	44	ADQ17-B1P	I/O
45	ADQ20-B1P	I/O	46	ADQ16-B1P	I/O
47	GND	-	48	GND	-
49	ADQS2-B1N	I/O	50	N.C.	-
51	ADQS2-B1P	I/O	52	ADM2-B1P	I
53	GND	-	54	GND	-
55	ADQ23-B1P	I/O	56	ADQ18-B1P	I/O
57	ADQ19-B1P	I/O	58	ADQ22-B1P	I/O
59	GND	-	60	GND	-
61	ADQ25-B1P	I/O	62	ADQ29-B1P	I/O
63	ADQ28-B1P	I/O	64	ADQ24-B1P	I/O
65	GND	-	66	GND	-
67	ADM3-B1P	I	68	ADQS3-B1N	I/O



Table C-2 Memory A connector (200-pin)(2/3)

Pin No.	Signal Name	I/O	Pin No.	Signal Name	I/O
69	N.C.	-	70	ADQS3-B1P	I/O
71	GND	-	72	GND	-
73	ADQ30-B1P	I/O	74	ADQ27-B1P	I/O
75	ADQ26-B1P	I/O	76	ADQ31-B1P	I/O
77	GND	-	78	GND	-
79	MCKE0-B1P	I	80	MCKE1-B1P	I
81	1R8-B1V	I	82	1R8-B1V	I
83	N.C.	-	84	N.C	-
85	ABS2-B1P	I	86	N.C	-
87	1R8-B1V	I	88	1R8-B1V	I
89	AMA12-B1P	I	90	AMA11-B1P	I
91	AMA09-B1P	I	92	AMA07-B1P	I
93	AMA08-B1P	I	94	AMA06-B1P	I
95	1R8-B1V	I	96	1R8-B1V	I
97	AMA05-B1P	I	98	AMA04-B1P	I
99	AMA03-B1P	I	100	AMA02-B1P	I
101	AMA01-B1P	I	102	AMA00-B1P	I
103	1R8-B1V	I	104	1R8-B1V	I
105	AMA10-B1P	I	106	ABS1-B1P	I
107	ABS0-B1P	I	108	ARAS-B1N	I
109	AWE-B1N	I	110	MCS0-B1N	I
111	1R8-B1V	I	112	1R8-B1V	I
113	ACAS-B1N	I	114	MODT0-B1P	I
115	MCS1-B1N	I	116	AMA13-B1P	I
117	1R8-B1V	I	118	1R8-B1V	I
119	MODT1-B1P	I	120	NC	-
121	GND	-	122	GND	-
123	ADQ34-B1P	I/O	124	ADQ36-B1P	I/O
125	ADQ33-B1P	I/O	126	ADQ37-B1P	I/O
127	GND	-	128	GND	-
129	ADQS4-B1N	I/O	130	ADM4-B1P	I
131	ADQS4-B1P	I/O	132	GND	-
133	GND	-	134	ADQ38-B1P	I/O
135	ADQ39-B1P	I/O	136	ADQ35-B1P	I/O
137	ADQ38-B1P	I/O	138	GND	-
139	GND	-	140	ADQ40-B1P	I/O

Table C-2 Memory A connector (200-pin )(3/3)

Pin No.	Signal Name	I/O	Pin No.	Signal Name	I/O
141	ADQ40-B1P	I/O	142	ADQ41-B1P	I/O
143	ADQ45-B1P	I/O	144	GND	-
145	GND	-	146	ADQS5-B1N	I/O
147	AMD5-B1P	I	148	ADQS5-B1P	I/O
149	GND	-	150	GND	-
151	ADQ42-B1P	I/O	152	ADQ46-B1P	I/O
153	ADQ43-B1P	I/O	154	ADQ47-B1P	I/O
155	GND	-	156	GND	-
157	ADQ48-B1P	I/O	158	ADQ52-B1N	I/O
159	ADQ49-B1P	I/O	160	ADQ53-B1N	I/O
161	GND	-	162	GND	-
163	N.C.	-	164	XMCK1-B1P	I
165	GND	-	166	XMCK1-B1N	I
167	ADQS6-B1N	I/O	168	GND	-
169	ADQS6-B1P	I/O	170	ADM6-B1P	I
171	GND	-	172	GND	-
173	ADQ55-B1P	I/O	174	ADQ54-B1P	I/O
175	ADQ51-B1P	I/O	176	ADQ50-B1P	I/O
177	GND	-	178	GND	-
179	ADQ56-B1P	I/O	180	ADQ60-B1P	I/O
181	ADQ57-B1P	I/O	182	ADQ61-B1P	I/O
183	GND	-	184	GND	-
185	ADM7-B1P	I	186	ADQS7-B1N	I/O
187	GND	-	188	ADQS7-B1P	I/O
189	ADQ58-B1P	I/O	190	GND	-
191	ADQ62-B1P	I/O	192	ADQ59-B1P	I/O
193	GND	-	194	ADQ63-B1P	I/O
195	SMBDAT-P3P	I/O	196	GND	-
197	SMBCLK-P3P	I/O	198	GND	-
199	P3V	I	200	GND	-
1T	GND	-	2T	GND	-

**C.3 CN1820 ODD I/F connector (50-pin)***Table C-3 ODD I/F connector (50-pin)*

Pin No.	Signal Name	I/O	Pin No.	Signal Name	I/O
1	NC	-	2	NC	-
3	NC	-	4	NC	-
5	(IDRSTB-P3N)	O	6	PDD08-P3P	I/O
7	CDD07-P3P	I/O	8	PDD09-P3P	I/O
9	PD06-P3P	I/O	10	PDD10-P3P	I/O
11	PDD05-P3P	I/O	12	PDD11-P3P	I/O
13	PDD04-P3P	I/O	14	PDD12-P3P	I/O
15	PDD03-P3P	I/O	16	PDD13-P3P	I/O
17	PDD02-P3P	I/O	18	PDD14-P3P	I/O
19	PDD01-P3P	I/O	20	PDD15-P3P	I/O
21	PDD00-P3P	I/O	22	PDDREQ-P3P	I
23	GND	-	24	PDIOR-P3N	O
25	PDIOW-P3N	O	26	GND	-
27	PIORDY-P3P	I	28	PDDACK-P3N	O
29	IDERQ-P3P	I	30	N.C	-
31	PDA1-P3P	O	32	N.C	O
33	PDA0-P3P	O	34	PDA2-P3P	O
35	PDCS1-P3N	O	36	PDCS3-P3N	O
37	NC	I/O	38	SB-P5V	I
39	SB-P5V	I	40	SB-P5V	I
41	SB-P5V	I	42	SB-P5V	I
43	GND	-	44	GND	-
45	GND	-	46	N.C	-
47	N.C	-	48	GND	-
49	N.C	-	50	NC	-

**C.4 CN1850 SATA I/F connector (10-pin)***Table C-4 SATA I/F connector (10-pin)*

Pin No.	Signal Name	I/O	Pin No.	Signal Name	I/O
1	ZSATT0-P1P	O	2	ZSATT0-P1N	O
3	GND	-	4	ZSATR0-P1N	I
5	ZSATR0-P1P	I	6	GND	-
7	P3V	-	8	GND	-
9	P5V	-	10	GND	-
1T	GND	-	2T	GND	-
3T	GND	-	4T	GND	-

**C.5 CN2110 PC card I/F connector (70-pin)***Table C-5 PC card I/F connector (70-pin)) (1/2)*

Pin No.	Signal Name	I/O	Pin No.	Signal Name	I/O
1	GND	-	2	ACAD00-EYP	I/O
3	ACAD01-PYP	I/O	4	ACAD03-PYP	I/O
5	ACAD05-PYP	I/O	6	ACAD07-PYP	I/O
7	ACCBEO-PYN	I/O	8	ACAD09-PYP	I/O
9	ACAD11-PYP	I/O	10	ACAD12-PYP	I/O
11	ACAD14-PYP	I/O	12	ACCBE1-PYN	I/O
13	ACPAR-PYP	I/O	14	ACPERR-PYN	I/O
15	ACGNT-PYN	I/O	16	ACINT-PYN	I/O
17	MCVCCA-PYV	I/O	18	MCVPPA-PYV	I/O
19	ACCLK-PYP	I/O	20	ACIRDY-PYN	I/O
21	ACCBE2-PYN	I/O	22	ACAD18-PYP	I/O
23	ACAD20-PYP	I/O	24	ACAD21-PYP	I/O
25	ACAD22-PYP	I/O	26	ACAD23-PYP	I/O
27	ACAD24-PYP	I/O	28	ACAD25-PYP	I/O
29	ACAD26-PYP	I/O	30	ACAD27-PYP	I/O
31	ACAD29-PYP	I/O	32	ACD02-PYP	I/O
33	ACCLKR-PYN	I/O	34	GND	-

Table C-5 PC card I/F connector (70-pin) (2/2)

Pin No.	Signal Name	I/O	Pin No.	Signal Name	I/O
35	GND	-	36	ACCD1-P3N	I/O
37	ACAD02-PYP	I/O	38	ACAD04-PYP	I/O
39	ACAD06-PYP	I/O	40	ACD14-PYP	I/O
41	ACAD08-PYP	I/O	42	ACAD10-PYP	I/O
43	ACVS1-P3P	I/O	44	ACAD13-PYP	I/O
45	ACAD15-PYP	I/O	46	ACAD16-PYP	I/O
47	ACA18-PYP	I/O	48	ACLOCK-PYN	I/O
49	ACSTOP-PYN	I/O	50	ACDEVS-PYN	I/O
51	MCVCCA-PYV	I	52	MCVPPA-PYV	I/O
53	ACTRDY-PYN	I/O	54	ACFRAM-PYN	I/O
55	ACAD17-PYP	I/O	56	ACAD19-PYP	I/O
57	ACVS2-P3P	I/O	58	ACRST-PYN	I/O
59	ACSERR-PYN	I/O	60	ACREQ-PYN	I/O
61	ACCBE3-PYN	I/O	62	ACAUDI-PYP	O
63	ACSTSC-PYP	O	64	ACAD28-PYP	I/O
65	ACAD30-PYP	I/O	66	ACAD31-PYP	I/O
67	ACCD2-P3N	O	68	GND	-
69	GND	-	70	GND	-

## C.6 IS2101 Bridge Media I/F connector (42-pin)

Table C-6 Bridge Media I/F connector (42-pin)

Pin No.	Signal Name	I/O	Pin No.	Signal Name	I/O
1	MSDAT2-P3P	I/O	2	MSDAT3-P3P	I/O
3	MSBS-P3P	I/O	4	GND	-
5	GND	-	6	FM-P3V	I
7	MSCLK-P3P	I/O	8	MSDAT3-P3P	I/O
9	MSCD-P3N	O	10	MSDAT2-P3P	I/O
11	MSSDIO-P3P	I/O	12	MSDAT1-P3P	I/O
13	MSBS-P3P	I/O	14	GND	-
15	FM-P3V	I	16	MSCLK-P3P	I/O
17	GND	-	18	MSSDIO-P3P	I/O
19	MSSDAT1-P3P	I/O	20	FM-P3V	I
21	SDAT3-P3P	I/O	22	SDAT2-P3P	I/O
23	SDAT1-P3P	I/O	24	SDAT0-P3P	I/O
25	MSDAT3-P3P	I/O	26	MSDAT2-P3P	I/O
27	MSDAT1-P3P	I/O	28	MSSDIO-P3P	I/O
29	GND	-	30	MSCLK-P3P	I/O
31	XDWE-P3N	I	32	SDCMD-P3P	I/O
33	SMCLE-P3P	I/O	34	XDCE-P3N	I
35	XDRE-P3N	I	36	SMRDY-P3P	I
37	MXDCD-P3N	I	38	GND	-
39	GND	-	40	SDCD-P3N	O
41	GND	-	42	SDWP-P3P	O

**C.7 CN2300 Docking I/F connector (140-pin)***Table C-7 Docking I/F connector (140-pin) (1/2)*

Pin No.	Signal Name	I/O	Pin No.	Signal Name	I/O
A1	GND	-	A2	GND	-
A3	DSKDC	-	A4	PVBAT2	-
1	DCOUT	-	2	DCOUT	-
3	DOCDT1-S3N	I	4	GND	-
5	BT2VD	-	6	BT2VD	-
7	PSCL-S5P	I/O	8	PSDA-S5P	I/O
9	GND	-	10	ZUSBDC-E3P	I/O
11	ZUSBDC-E3N	I/O	12	GND	-
13	GND	-	14	NC	-
15	NC	-	16	GND	-
17	NC	-	18	NC	-
19	GND	-	20	GND	-
21	GND	-	22	ZDVTX2-P3P	O
23	ZDVTX2-P3N	O	24	GND	-
25	ZDVTX1-P3N	O	26	ZDVTX1-P3P	O
27	GND	-	28	DVIDET-S3N	I
29	VOID	-	30	VOID	-
31	VOID	-	32	VOID	-
33	VOID	-	34	VOID	-
35	VOID	-	36	DCOUT	-
37	DCOUT	-	38	NC	-
39	NC	-	40	DBT20V-S5N	O
41	BTMP2	-	42	GND	-
43	CDCHG2-S5P	I	44	GND	-
45	DPCONF-S5P	I	46	GND	-
47	GND	-	48	XDVCLK-P3N	O
49	GND	-	50	GND	-
51	NC	-	52	NC	-
53	GND	-	54	ZDVTX0-P3P	-
55	ZDVTX0-P3N	O	56	GND	-
57	GND	-	58	GND	-
59	GND	-	60	DVISCL-P5P	I/O
61	DVISDA-P5P	I/O	62	LAN-E3V	-
63	LINK-E3N	O	64	VOID	-

Table C-7 Docking I/F connector (140-pin) (2/2)

Pin No.	Signal Name	I/O	Pin No.	Signal Name	I/O
65	VOID	-	66	VOID	-
67	ZBIDDP-EXP	I/O	68	ZBIDON-EXN	I/O
69	ZBIDCN-EXP	I/O	70	ZBIDCP-EXP	
71	DCOUT	-	72	DCOUT	-
73	PWRSW-S3N	I	74	DDCON-P5P	O
75	NC	-	76	NC	-
77	GND	-	78	GND	-
79	GND	-	80	NC	-
81	GND	-	82	GND	-
83	GND	-	84	GND	-
85	NC	-	86	GND	-
87	NC	-	88	GND	-
89	GND	-	90	DBLUE-PXP	O
91	GND	-	92	DRED-PXP	O
93	GND	-	94	GND	-
95	SCRTSD-P3P	I/O	96	SCRTSC-P3P	I/O
97	GND	-	98	ACT-E3N	I
99	VOID	-	100	VOID	-
101	VOID	-	102	ZBIDBN-EXN	O
103	ZBIDBP-EXP	O	104	ZBIDAN-EXN	I
105	ZBIDAP-EXP	I	106	DCOUT	-
107	DCOUT	-	108	EJCTRQ-S3N	I
109	M5V	-	110	NC	-
111	NC	-	112	GND	-
113	DHSYNC-P3P	I/O	114	DVSYNC-P3P	I/O
115	GND	-	116	GND	-
117	NC	-	118	NC	-
119	GND	-	120	GND	-
121	GND	-	122	NC	-
123	NC	-	124	GND	-
125	GND	-	126	DGREEN-PXP	O
127	GND	-	128	GND	-
129	GND	-	130	DSSCL-S5P	I/O
131	DSSDA-S5P	I/O	132	GND	-
133	DOCDT2-S3N	I	134	VOID	-
135	VOID	-	136	VOID	-
137	VOID	-	138	VOID	-
139	VOID	-	140	VOID	-



**C.8 CN2600 PCI-Express mini card (WLAN) I/F connector (52-pin)***Table C-8 PCI-Express mini card (WLAN) I/F connector (52-pin)*

Pin No.	Signal Name	I/O	Pin No.	Signal Name	I/O
1	PEWAKE-E3N	O	2	P3V	-
3	WCHDAT-P3P	O	4	GND	-
5	WCHCLK-P3P	O	6	1R5-P1V	-
7	MPEXRQ-P3N	I	8	NC	-
9	GND	-	10	NC	-
11	XPEWL-P3N	O	12	NC	-
13	XPEWL-P3P	O	14	NC	-
15	GND	-	16	NC	-
17	NC	-	18	GND	-
19	NC	-	20	(WLRFON- S3N)	O
21	GND	-	22	PLTRS3-E3N	-
23	ZPERWL-P1N	I	24	(E3V)	-
25	ZPERWL-P1P	I	26	GND	-
27	GND	-	28	1R5-P1V	-
29	GND	-	30	NC	-
31	ZPETWL-P1N	O	32	NC	-
33	ZPETWL-P1P	O	34	GND	-
35	GND	-	36	NC	-
37	NC	-	38	NC	-
39	NC	-	40	GND	-
41	NC	-	42	NC	-
43	NC	-	44	NC	-
45	NC	-	46	NC	-
47	NC	-	48	1R5-P1V	-
49	NC	-	50	GND	-
51	NC	-	52	P3V	-
1T	GND	-	2T	GND	-

**C.9 CN2610 PCI-Express mini card (3G) I/F connector (52-pin)**

Table C-9 PCI-Express mini card (3G) I/F connector (52-pin)

Pin No.	Signal Name	I/O	Pin No.	Signal Name	I/O
1	PEWAKE-E3N	O	2	P3V	-
3	NC	-	4	GND	-
5	NC	-	6	1R5-P1V	-
7	NC	-	8	UIMPWR-P3V	I
9	GND	-	10	UIMDAT-P3P	I/O
11	NC	-	12	UIMCLK-P3P	I
13	NC	-	14	UIMRST-P3P	I
15	UIM-GND	-	16	NC	-
17	NC	-	18	GND	-
19	NC	-	20	(3GRFON-S3N)	O
21	GND	-	22	PLTRS1-E3N	-
23	NC	-	24	E3V	-
25	NC	-	26	GND	-
27	GND	-	28	1R5-P1V	-
29	GND	-	30	NC	-
31	NC	-	32	NC	-
33	NC	-	34	GND	-
35	GND	-	36	ZUSB3G-E3N	I/O
37	NC	-	38	ZUSB3G-E3P	I/O
39	NC	-	40	GND	-
41	NC	-	42	NC	-
43	NC	-	44	NC	-
45	NC	-	46	NC	-
47	NC	-	48	1R5-P1V	-
49	NC	-	50	GND	-
51	NC	-	52	P3V	-
1T	GND	-	2T	GND	-

**C.10 CN3010 MDC I/F connector (12-pin)***Table C-10 MDC I/F connector (12-pin)*

Pin No.	Signal Name	I/O	Pin No.	Signal Name	I/O
1	GND	-	2	NC	-
3	ACZOT1-P3P	I/O	4	NC	-
5	GND	-	6	E3V	-
7	ACZSY1-P3P	O	8	GND	-
9	ACZIN1-E3P	I/O	10	GND	-
11	ACZRS1-E3N	O	12	XAZBC1-P3P	O
1T	GND	-	2T	GND	-
3T	GND	-	4T	GND	-
5T	GND	-	6T	GND	-

**C.11 CN3200 Keyboard connector (34-pin)***Table C-11 Keyboard connector (34-pin)*

Pin No.	Signal Name	I/O	Pin No.	Signal Name	I/O
1	NC	-	2	NC	-
3	NC	-	4	NC	-
5	NC	-	6	NC	-
7	KBSC15-S3N	O	8	KBSC14-S3N	O
9	KBRT07-S3N	O	10	KBRT06-S3N	O
11	KBSC13-S3N	O	12	KBSC12-S3N	O
13	KBRT05-S3N	O	14	KBRT04-S3N	O
15	KBSC11-S3N	O	16	KBSC10-S3N	O
17	KBRT03-S3N	O	18	KBRT02-S3N	O
19	KBRT01-S3N	O	20	KBSC09-S3N	O
21	KBSC08-S3N	O	22	KBSC07-S3N	O
23	KBRT00-S3N	O	24	KBSC06-S3N	O
25	KBSC05-S3N	O	26	KBSC04-S3N	O
27	KBSC03-S3N	O	28	KBSC02-S3N	O
29	KBSC01-S3N	O	30	KBSC00-S3N	O
31	P5V	I	32	CAPLED-P5N	I
33	ARWLED-P5N	I	34	NUMLED-P5N	I
1T	GND	-	2T	GND	-

**C.12 CN3201 PAD connector (8-pin)***Table C-12 PAD connector (8-pin)*

Pin No.	Signal Name	I/O	Pin No.	Signal Name	I/O
1	GND	-	2	GND	-
3	IPDCLK-P5P	I/O	4	IPDCLK-P5P	I/O
5	IPDDAT-P5P	I/O	6	IPDDAT-P5P	I/O
7	P5V	-	8	P5V	-

**C.13 CN3400 Debugging connector (4-pin)***Table C-13 Debugging connector (4-pin)*

Pin No.	Signal Name	I/O	Pin No.	Signal Name	I/O
1	P3V	-	2	DBGTX-P3P	I
3	DBGTX-P3P	O	4	GND	-

**C.14 J4100 Network I/F connector (14-pin)***Table C-14 Network I/F connector (14-pin)*

Pin No.	Signal Name	I/O	Pin No.	Signal Name	I/O
A1	ZBIDAP-EXP	I/O	A2	ZBIDAN-EXN	I/O
A3	ZBIDBP-EXP	I/O	A4	ZBIDCP-EXP	I/O
A5	ZBIDCN-EXP	I/O	A6	ZBIDBN-EXN	I/O
A7	ZBIDDP-EXP	I/O	A8	ZBIDDN-EXN	-
A9	LNK-E3N	I	A10	(LAN-E3V)	-
A11	ACT-E3N	I	A12	(LAN-E3V)	-
B1	MDMTIP-P3P	I/O	B2	MDMRNG-B3P	I/O
1T	GND	-	2T	GND	-

**C.15 CN4200 IEEE1394 connector (4-pin)***Table C-15 IEEE1394 connector (4-pin)*

Pin No.	Signal Name	I/O	Pin No.	Signal Name	I/O
1	ZTPB0-P3N	I/O	2	ZTPB0-P3P	I/O
3	ZTPA0-P3N	I/O	4	ZTPA0-P3P	I/O
1T	GND	-	2T	GND	-
3T	GND	-	4T	GND	-

**C.16 CN4400 Bluetooth connector (20-pin)***Table C-16 Bluetooth connector (20-pin)*

Pin No.	Signal Name	I/O	Pin No.	Signal Name	I/O
1	GND	-	2	NC	-
3	BTMDL-P3N	I	4	NC	-
5	NC	-	6	NC	-
7	NC	-	8	BTRST-S3N	O
9	NC	-	10	NC	-
11	GND	-	12	NC	-
13	(GND)	-	14	WCHCLK-P3P	O
15	NC	-	16	ZUSBBT-E3P	I/O
17	ZUSBBT-E3N	I/O	18	WCHDAT-P3P	O
19	NC	-	20	BT-P3V	-
1T			2T		

**C.17 CN4610 USB connector (Port 6/4) (8-pin)***Table C-17 USB connector (Port 6/4) (8-pin)*

Pin No.	Signal Name	I/O	Pin No.	Signal Name	I/O
1	USB0PS-E3V	-	2	ZUSBP6-E3N	I/O
3	ZUSBP6-E3P	I/O	4	GND	-
5	USB0PS-E3V	-	6	ZUSBP4-E3N	I/O
7	ZUSBP4-E3P	I/O	8	GND	-
1T	GND	-	2T	GND	-

**C.18 CN4612 USB connector (Port 0) (6-pin)***Table C-18 USB connector (Port 0) (6-pin)*

Pin No.	Signal Name	I/O	Pin No.	Signal Name	I/O
1	USB1PS-E5V	-	2	ZUSBP0-E3N	I/O
3	ZUSBP0-E3P	I/O	4	GND	-
5	GND	-	6	GND	-

**C.19 CN4620 USB connector (Port 7) (8-pin)***Table C-19 USB connector (Port 7) (8-pin)*

Pin No.	Signal Name	I/O	Pin No.	Signal Name	I/O
1	USB2PS-E5V	-	2	ZUSBP7-E3N	I/O
3	ZUSBP7-E3P	I/O	4	GND	-
5	GND	-	6	GND	-
7	GND	-	8	GND	-

**C.20 CN5000 LCD connector (40-pin)***Table C-20 LCD connector (40-pin)*

Pin No.	Signal Name	I/O	Pin No.	Signal Name	I/O
1	BRT2DA-S3P	O	2	BRT1-P5P	O
3	BRT0-P5P	O	4	FL-P5V	-
5	FL-P5V	-	6	FL-P5V	-
7	NC	-	8	GND	-
9	GND	-	10	GND	-
11	P3V	-	12	PNL-P3V	-
13	PNL-P3V	-	14	LCDSDA-P3P	I/O
15	LCDSCL-P3P	I/O	16	GND	-
17	ZTXDA2-PYP	O	18	ZTXDA2-PYN	O
19	GND	-	20	ZTXDA1-PYP	O
21	ZTXDA1-PYN	O	22	GND	-
23	ZTXDA0-PYP	O	24	ZTXDA0-PYN	O
25	GND	-	26	XTXCKA-PYN	O
27	XTXCKA -PYP	O	28	GND	-
29	ZTXDB2-PYN	O	30	ZTXDB2-PYP	O
31	GND	-	32	ZTXDB1-PYN	O
33	ZTXDB1-PYP	O	34	GND	-
35	ZTXDB0-PYN	O	36	ZTXDB0-PYP	O
37	GND	-	38	XTXCKB-PYN	O
39	XTXCKB-PYP	O	40	GND	-

**C.21 CN5080 RGB connector (15-pin)***Table C-21 RGB connector (15-pin)*

Pin No.	Signal Name	I/O	Pin No.	Signal Name	I/O
1	MRED-PXP	O	2	MGREEN-PXP	O
3	MBLUE-PXP	O	4	NC	-
5	GND	-	6	GND	-
7	GND	-	8	GND	-
9	DDC-P5V	-	10	GND	-
11	NC	-	12	CRTSDA-P5P	I/O
13	MHSYNC-P5P	O	14	MVSYNC-P5P	O
15	CRTSCL-P5P	I/O			
1T	GND	-	2T	GND	-

**C.22 CN5501 S-Video connector (4-pin)***Table C-22 S-Video connector (4-pin)*

Pin No.	Signal Name	I/O	Pin No.	Signal Name	I/O
1	AGND	-	2	AGND	-
3	LUMINA-PYP	O	4	CHROMA-PYP	O
1T	GND	-	2T	GND	-
3T	GND	-	4T	GND	-

**C.23 CN6050 Internal microphone connector (2-pin)***Table C-23 Internal microphone connector (2-pin)*

Pin No.	Signal Name	I/O	Pin No.	Signal Name	I/O
1	(IMICL-PXP)	O	2	A-GND	-

**C.24 J6051 External microphone connector (6-pin)***Table C-24 External microphone connector (6-pin)*

Pin No.	Signal Name	I/O	Pin No.	Signal Name	I/O
1	(A-GND)	-	4	DETECTA-P4N	I
2	(MICIN)	O	5	(A-GND)	-
3	EMICB-P2V	-	6	EMICB-P2V	-

**C.25 CN6170 Speaker connector (4-pin)***Table C-25 Speaker connector (4-pin)*

Pin No.	Signal Name	I/O	Pin No.	Signal Name	I/O
1	SPOTL-PXN	O	2	SPOTL-PXP	O
3	SPOTR-PXP	O	4	SPOTR-PXN	O



**C.26 J6310 Headphone connector (6-pin)***Table C-26 Headphone connector (6-pin)*

Pin No.	Signal Name	I/O	Pin No.	Signal Name	I/O
1	(A-GND)	-	2	HEADL-PXP	O
3	HEADR-PXP	O	4	DETECTA-P4N	I
5	A-GND	-	6	N.C.	-

**C.27 CN8800 DC-IN connector (4-pin)***Table C-27 DC-IN connector (4-pin)*

Pin No.	Signal Name	I/O	Pin No.	Signal Name	I/O
1	ADPDC	I	2	ADPDC	I
3	GND	-	4	GND	-

**C.28 CN8810 Main battery connector (10-pin)***Table C-28 Main battery connector (10-pin)*

Pin No.	Signal Name	I/O	Pin No.	Signal Name	I/O
1	(PVBL1)	O	2	BTMP1	-
3	(DCHG)	I	4	(M5V)	-
5	PSCL-S5P	I/O	6	PSDA-S5P	I/O
7	GND	-	8	DBT1OV-S5N	O
9	GND	-	10	GND	-

**C.29 CN9300 RTC battery connector (3-pin)***Table C-29 RTC battery connector (3-pin)*

Pin No.	Signal Name	I/O	Pin No.	Signal Name	I/O
1	(R3V)	I	2	N.C.	-
3	GND	-			
1T	GND	-	2T	GND	-

**C.30 CN8771 Fan connector (4-pin)***Table C-30 Fan connector (4-pin)*

Pin No.	Signal Name	I/O	Pin No.	Signal Name	I/O
1	P5V	-	2	FANG-P3P	I
3	GND	-	4	(FPWM-S3P)	O

**C.31 CN9500 PR board I/F connector (3-pin)***Table C-31 PR board I/F connector (3-pin)*

Pin No.	Signal Name	I/O	Pin No.	Signal Name	I/O
1	PNLOFF-S3N	I	2	TPLOFF-S3V	I
3	GND	-			

**C.32 CN9520 SIM board I/F connector (10-pin)***Table C-32 SIM board I/F connector (10-pin)*

Pin No.	Signal Name	I/O	Pin No.	Signal Name	I/O
1	UIMPWR-P3V	O	2	NC	-
3	UIMRST-P3V	O	4	UIMCLK-P3P	O
5	UIMDAT-P3P	I/O	6	NC	-
7	NC	-	8	UIM-GND	-
9	GND	-	10	GND	-
1T	GND	-	2T	GND	-

**C.33 CN9540 Digitizer switch I/F connector (41-pin)***Table C-33 Digitizer switch I/F connector (41-pin)*

Pin No.	Signal Name	I/O	Pin No.	Signal Name	I/O
1	GND	-	22	GND	-
2	GND	-	23	GND	-
3	GND	-	24	GND	-
4	E3V	-	25	GPBTNA-S3N	I
5	FGSPON-S3N	O	26	GPBTNB-S3N	I
6	GND	-	27	PWRSW-S3N	I
7	ZUSBFS-E3N	I/O	28	GND	-
8	ZUSBFS-E3P	I/O	29	KBRT00-S3N	I
9	GND	-	30	KBRT01-S3N	I
10	GND	-	31	KBRT02-S3N	I
11	GND	-	32	KBRT03-S3N	I
12	GND	-	33	KBRT04-S3N	I
13	GND	-	34	KBRT05-S3N	I
14	DGDTR-P3N	O	35	KBRT06-S3N	I
15	DGRTS-P3N	O	36	GND	-
16	DGRXD-P3P	I	37	KBSC16-S3N	I
17	DGTXD-P3P	O	38	GND	-
18	(GRD)	I	39	GND	-
19	DBGEN-P3N + PLTRS1-E3N	O	40	GND	-
20	P3V	-	41	GND	-
21	GND	-			
1T	GND	-	2T	GND	-

**C.34 CN9600 SW board I/F connector (13-pin)***Table C-34 SW board I/F connector (13-pin)*

Pin No.	Signal Name	I/O	Pin No.	Signal Name	I/O
1	GND	-	8	CDSTOP-S3N	O
2	NC	-	9	CDNEXT-S3N	O
3	NC	-	10	CDPREV-S3N	O
4	GPBTNC-S3N	I	11	NC	-
5	GPBTND-S3N	I	12	NC	-
6	NC	-	13	GND	-
7	NC	-			
1T	GND	-	2T	GND	-

**Fingerprint sensor board (FCYFS\*)****C.35 CN9560 System board I/F connector (6-pin)***Table C-35 System board I/F connector (6-pin)*

Pin No.	Signal Name	I/O	Pin No.	Signal Name	I/O
1	Power E3V	-	2	FGSPON-S3N	I
3	GND	-	4	ZUSBFS-E3N	I/O
5	ZUSBFS-E3P	I/O	6	GND	-

**Panel switch board (FCYPR\*)****C.36 CN9510 System board I/F connector (3-pin)***Table C-36 System board I/F connector (3-pin)*

Pin No.	Signal Name	I/O	Pin No.	Signal Name	I/O
1	PNLOFF-S3N	O	2	TPLOFF-S3V	O
3	GND	-			

**SIM board (FCYSM\*)****C.37 CN9530 System board I/F connector (10-pin)***Table C-37 System board I/F connector (10-pin)*

Pin No.	Signal Name	I/O	Pin No.	Signal Name	I/O
1	UIMPWR-P3V	O	2	NC	-
3	UIMRST-P3V	O	4	UIMCLK-P3P	O
5	UIMDAT-P3P	I/O	6	NC	-
7	NC	-	8	UIM-GND	-
9	GND	-	10	GND	-
1T	GND	-	2T	GND	-

**USB board (FCYUS\*)****C.38 CN4631 System board I/F connector (8-pin)***Table C-38 System board I/F connector (8-pin)*

Pin No.	Signal Name	I/O	Pin No.	Signal Name	I/O
1	USB2PS-E5V	-	2	USB2PS-E5V	-
3	ZUSBP5-E3N	I/O	4	ZUSBP5-E3P	I/O
5	GND	-	6	GND	-
7	GND	-	8	GND	-

**C.39 CN4630 USB connector (Port 5) (6-pin)***Table C-39 USB connector (Port 5) (6-pin)*

Pin No.	Signal Name	I/O	Pin No.	Signal Name	I/O
1	USB2PS-E5V	-	2	USB2PS-E5V	-
3	ZUSBP5-E3N	I/O	4	ZUSBP5-E3P	I/O
5	GND	-	6	GND	-



**SW board (FCYSW\*)****C.40 CN9550 System board I/F connector (15-pin)***Table C-40 System board I/F connector (15-pin)*

Pin No.	Signal Name	I/O	Pin No.	Signal Name	I/O
1	GND	-	2	GPBTNA-S3N	O
3	GPBTNB-S3N	O	4	PWRSW-S3N	O
5	GND	-	6	KBRT00-S3N	O
7	KBRT01-S3N	O	8	KBRT02-S3N	O
9	KBRT03-S3N	O	10	KBRT04-S3N	O
11	KBRT05-S3N	O	12	KBRT06-S3N	O
13	GND	-	14	KBSC16-S3N	O
15	GND	-			



## Appendix D Keyboard Scan/Character Codes

Table D-1 Scan codes (set 1 and set 2) (1/4)

Cap No.	Keytop	Code set 1		Code set 2			Note
		Make	Break	Make	Break		
01	' ~	29	A9	0E	F0	0E	
02	1 !	02	82	16	F0	16	
03	2 @	03	83	1E	F0	1E	
04	3 #	04	84	26	F0	26	
05	4 \$	05	85	25	F0	25	
06	5 %	06	86	2E	F0	2E	
07	6 ^	07	87	36	F0	36	
08	7 &	08	88	3D	F0	3D	*1
09	8 *	09	89	3E	F0	3E	*1
10	9 (	0A	8A	46	F0	46	*1
11	0 )	0B	8B	45	F0	45	*1
12	- _	0C	8C	4E	F0	4E	
13	= +	0D	8D	55	F0	55	
15	BkSp	0E	8E	66	F0	66	
16	Tab	0F	8F	0D	F0	0D	
17	Q	10	90	15	F0	15	
18	W	11	91	1D	F0	1D	
19	E	12	92	24	F0	24	
20	R	13	93	2D	F0	2D	
21	T	14	94	2C	F0	2C	
22	Y	15	95	35	F0	35	
23	U	16	96	3C	F0	3C	*1
24	I	17	97	43	F0	43	*1
25	O	13	98	44	F0	44	*1
26	P	19	99	4D	F0	4D	*1
27	[ {	1A	9A	54	F0	54	
28	] }	1B	9B	5B	F0	5B	

Table D-1 Scan codes (set 1 and set 2) (2/4)

Cap No.	Keytop	Code set 1		Code set 2		Note
		Make	Break	Make	Break	
29	\	2B	AB	5D	F0 5D	*2
30	Caps Lock	3A	BA	58	F0 58	
31	A	1E	9E	1C	F0 1C	
32	S	1F	9F	1B	F0 1B	
33	D	20	A0	23	F0 23	
34	F	21	A1	2B	F0 2B	
35	G	22	A2	34	F0 34	
36	H	23	A3	33	F0 33	
37	J	24	A4	3B	F0 3B	*1
38	K	25	A5	42	F0 42	*1
39	L	26	A6	4B	F0 4B	*1
40	; :	27	A7	4C	F0 4C	*1
41	' "	28	A8	52	F0 52	
43	Enter	1C	9C	5A	F0 5A	*3
44	Shift (L)	2A	AA	12	F0 12	
45	No.102 key	56	D6	61	F0 61	
46	Z	2C	AC	1A	F0 1A	
47	X	2D	AD	22	F0 22	
48	C	2E	AE	21	F0 21	
49	V	2F	AF	2A	F0 2A	
50	B	30	B0	32	F0 32	
51	N	31	B1	31	F0 31	
52	M	32	B2	3A	F0 3A	*1
53	, <	33	B3	41	F0 41	*1
54	. >	34	B4	49	F0 49	*1
55	/ ?	35	B5	4A	F0 4A	*1
57	Shift (R)	36	B6	59	F0 59	

Table D-1 Scan codes (set 1 and set 2) (3/4)

Cap No.	Keytop	Code set 1		Code set 2		Note	
		Make	Break	Make	Break		
58	Ctrl	1D	9D	14	F0	14	*3
60	Alt (L)	38	B8	11	F0	11	*3
61	Space	39	B9	29	F0	29	
62	ALT (R)	E0 38	E0 B8	E0 11	E0 F0	11	
75	Ins	E0 52	E0 D2	E0 70	E0 F0	70	*4
76	Del	E0 53	E0 D3	E0 71	E0 F0	71	*4
79	←	E0 4B	E0 CB	E0 6B	E0 F0	6B	*4
80	Home	E0 47	E0 C7	E0 6C	E0 F0	6C	*4
81	End	E0 4F	E0 CF	E0 69	E0 F0	69	*4
83	↑	E0 48	E0 C8	E0 75	E0 F0	75	*4
84	↓	E0 50	E0 D0	E0 72	E0 F0	72	*4
85	PgUp	E0 49	E0 C9	E0 7D	E0 F0	7D	*4
86	PgDn	E0 51	E0 D1	E0 7A	E0 F0	7A	*4
89	→	E0 4D	E0 CD	E0 74	E0 F0	74	*4
110	Esc	01	81	76	F0	76	
112	F1	3B	BB	05	F0	05	
113	F2	3C	BC	06	F0	06	
114	F3	3D	BD	04	F0	04	
115	F4	3E	BE	0C	F0	0C	
116	F5	3F	BF	03	F0	03	
117	F6	40	C0	0B	F0	0B	
118	F7	41	C1	83	F0	83	
119	F8	42	C2	0A	F0	0A	
120	F9	43	C3	01	F0	01	
121	F10	44	C4	09	F0	09	*3

Table D-1 Scan codes (set 1 and set 2) (4/4)

Cap No.	Keytop	Code set 1				Code set 2				Note	
		Make		Break		Make		Break			
122	F11	57		D7		78		F0	78	*3	
123	F12	58		D8		07		F0	07	*3	
124	PrintSc	Refer to table 2-25									
126	Pause	Refer to table 2-25									
202	Fn										*5
203	Win	E0	5B	E0	DB	E0	1F	E0	F0	1F	
204	App	E0	5D	E0	DD	E0	2F	E0	F0	2F	

**Notes:**

1. \* Scan codes differ by overlay function.
2. \* This key corresponds to key No. 42 in the 102 key mode.
3. \* Combination with the **Fn** key makes different codes.
4. \* Scan codes differ by mode.
5. \* The Fn key does not generate a code by itself..

Table D-2 Scan codes with left Shift key

Cap No.	Key top	Code set 1		Code set 2	
		Make	Break	Make	Break
55	/	E0 AA E0 35	E0 B5 E0 2A	E0 F0 12 E0 4A	E0 F0 4A E0 12
75	INS	E0 AA E0 52	E0 D2 E0 2A	E0 F0 12 E0 70	E0 F0 70 E0 12
76	DEL	E0 AA E0 53	E0 D3 E0 2A	E0 F0 12 E0 71	E0 F0 71 E0 12
79	←	E0 AA E0 4B	E0 CB E0 2A	E0 F0 12 E0 6B	E0 F0 6B E0 12
80	Home	E0 AA E0 47	E0 C7 E0 2A	E0 F0 12 E0 6C	E0 F0 6C E0 12
81	End	E0 AA E0 4F	E0 CF E0 2A	E0 F0 12 E0 69	E0 F0 69 E0 12
83	↑	E0 AA E0 48	E0 C8 E0 2A	E0 F0 12 E0 75	E0 F0 75 E0 12
84	↓	E0 AA E0 50	E0 D0 E0 2A	E0 F0 12 E0 72	E0 F0 72 E0 12
85	PgUp	E0 AA E0 49	E0 C9 E0 2A	E0 F0 12 E0 7D	E0 F0 7D E0 12
86	PgDn	E0 AA E0 51	E0 D1 E0 2A	E0 F0 12 E0 7A	E0 F0 7A E0 12
89	→	E0 AA E0 4D	E0 CD E0 2A	E0 F0 12 E0 74	E0 F0 74 E0 12
203	Win	E0 AA E0 5B	E0 DB E0 2A	E0 F0 12 E0 1F	E0 F0 1F E0 12
204	App	E0 AA E0 5D	E0 DD E0 2A	E0 F0 12 E0 2F	E0 F0 2F E0 12

**Note :** The table above shows scan codes with the left **Shift** key.  
In the case of Key no. 55 Overlay mode only.

In combination with the right **Shift** key, scan codes are changed as listed below:

	With left <b>Shift</b>	With right <b>Shift</b>
Set 1	E0 AA _____	E0 B6
	E0 2A _____	E0 36
Set 2	E0 F0 12 _____	E0 F0 59
	E0 12 _____	E0 59

Table D-3 Scan codes in Numlock mode

Cap No.	Key top	Code set 1				Code set 2			
		Make		Break		Make		Break	
75	INS	E0 2A E0 52	E0 D2 E0 AA	E0 12 E0 70	E0 F0 70 E0 F0 12				
76	DEL	E0 2A E0 53	E0 D3 E0 AA	E0 12 E0 71	E0 F0 71 E0 F0 12				
79	←	E0 2A E0 4B	E0 CB E0 AA	E0 12 E0 6B	E0 F0 6B E0 F0 12				
80	Home	E0 2A E0 47	E0 C7 E0 AA	E0 12 E0 6C	E0 F0 6C E0 F0 12				
81	End	E0 2A E0 4F	E0 CF E0 AA	E0 12 E0 69	E0 F0 69 E0 F0 12				
83	↑	E0 2A E0 48	E0 C8 E0 AA	E0 12 E0 75	E0 F0 75 E0 F0 12				
84	↓	E0 2A E0 50	E0 D0 E0 AA	E0 12 E0 72	E0 F0 72 E0 F0 12				
85	PgUp	E0 2A E0 49	E0 C9 E0 AA	E0 12 E0 7D	E0 F0 7D E0 F0 12				
86	PgDn	E0 2A E0 51	E0 D1 E0 AA	E0 12 E0 7A	E0 F0 7A E0 F0 12				
89	→	E0 2A E0 4D	E0 CD E0 AA	E0 12 E0 74	E0 F0 74 E0 F0 12				
203	Win	E0 2A E0 5B	E0 DB E0 AA	E0 12 E0 1F	E0 F0 1F E0 F0 12				
204	App	E0 2A E0 5D	E0 DD E0 AA	E0 12 E0 2F	E0 F0 2F E0 F0 12				

Table D-4 Scan codes with Fn key

Cap No.	Key top	Code set 1		Code set 2	
		Make	Break	Make	Break
43	ENT	E0 1C	E0 9C	E0 5A	E0 F0 5A
58	CTRL	E0 1D	E0 9D	E0 14	E0 F0 14
60	LALT	E0 38	E0 B8	E0 11	E0 F0 11
121	ARROW	45	C5	77	F0 77
122	NUMERIC	45	C5	77	F0 77
123	Scrl	46	C5	7E	F0 7E



Table D-5 Scan codes in overlay mode

Cap No.	Keytop		Code set 1		Code set 2		
			Make	Break	Make	Break	
09	8	(8)	48	C8	75	F0	75
10	9	(9)	49	C9	7D	F0	7D
11	0	(*)	37	B7	7C	F0	7C
23	U	(4)	4B	CB	6B	F0	6B
24	I	(5)	4C	CC	73	F0	73
25	O	(6)	4D	CD	74	F0	74
26	P	(-)	4A	CA	7B	F0	7B
37	J	(1)	4F	CF	69	F0	69
38	K	(2)	50	D0	72	F0	72
39	L	(3)	51	D1	7A	F0	7A
40	;	(+)	4E	CE	79	F0	79
52	M	(0)	52	D2	70	F0	70
54	.	(.)	53	D3	71	F0	71
55	/	(/)	E0 35	E0 B5	40 4A	E0 F0	4A

Table D-6 No.124 key scan code

Key top	Shift	Code set 1				Code set 2			
		Make		Break		Make		Break	
Prt Sc	Common	E0 2A	E0 37	E0 B7	E0 AA	E0 12	E0 7C	E0 F0 7C	E0 F0 12
	Ctrl +	E0 37		E0 B7		E0 7C		E0 F0 7C	
	Shift +	E0 37		E0 B7		E0 7C		E0 F0 7C	
	Alt +		54	D4		84		F0 B4	

Table D-7 No.126 key scan code

Key top	Shift	Code set 1						Code set 2							
		Make						Make							
Pause	Common *	E1	1D	45	E1	9D	C5	E1	14	77	E1	F0	14	F0	77
	Ctrl*	E0	46	E0	C6			E0	7E	E0	F0	7E			

\*: This key generates only make codes.

# Appendix E Key Layout

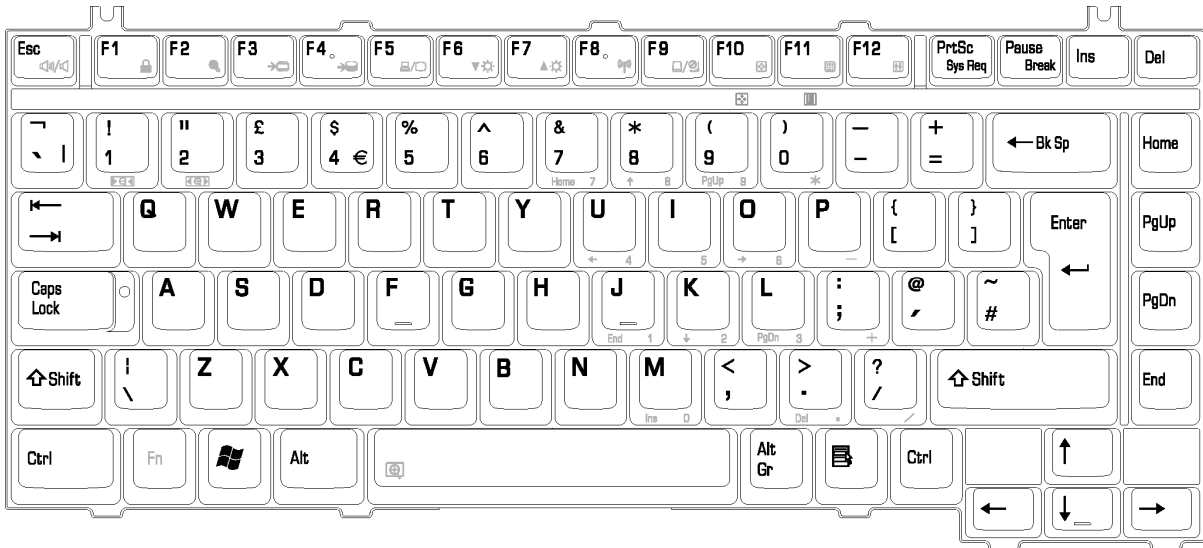

Figure E-1 Key layout (UK)

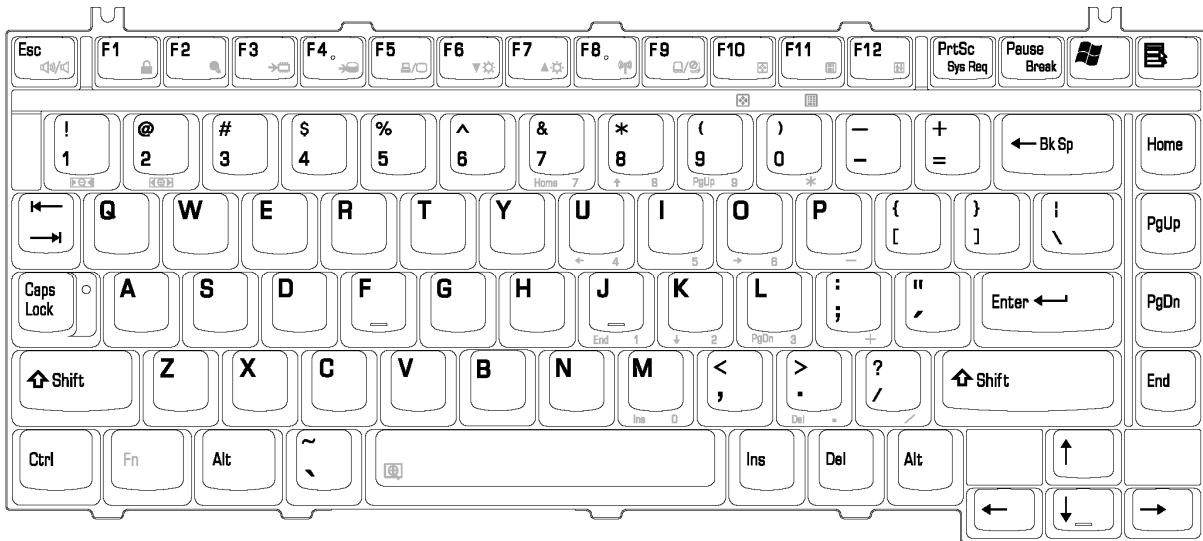

Figure E-2 Key layout (US)



---

## Appendix F Wiring Diagrams

---

### F.1 RGB Monitor Wraparound connector

(1) RED	_____	RED	(1)
(2) GREEN	_____	GREEN	(2)
(3) BLUE	_____	BLUE	(3)
(4) NC	_____	NC	(4)
(5) GND	_____	GND	(5)
(6) GND	_____	GND	(6)
(7) GND	_____	GND	(7)
(8) GND	_____	GND	(8)
(9) 5V	_____	5V	(9)
(10) GND	_____	GND	(10)
(11) NC	_____	NC	(11)
(12) SDA	_____	SDA	(12)
(13) HSYNC	_____	HSYNC	(13)
(14) VSYNC	_____	VSYNC	(14)
(15) SDL	_____	SCL	(15)

*Figure F-1 RGB Monitor Wraparound connector*

### F.2 LAN Loopback Connector

(1) BIBAP (TX+)	_____	(3) BIDBP (RX+)
(2) BIDAN (TX-)	_____	(6) BIDBN (RX-)

*Figure F-2 LAN loopback Connector*



---

## Appendix G BIOS Rewrite Procedures

---

This Appendix explains how to rewrite the system BIOS program when you update the system BIOS.

### Tools



To rewrite the BIOS, you need the following tool:

- BIOS rewriting disk for the computer that has renewed BIOS data.

### Rewriting the BIOS

**Note:**

1. *Connect the AC adaptor to the computer when you rewrite the BIOS.*
2. *Do not turn off the power while you are rewriting the BIOS. If the rewrite fails, it might be impossible to start up the computer.*
3. *If you fail to rewrite BIOS, then when you next turn on the power, a message may be displayed that the contents of the BIOS have been damaged. In this case, insert the BIOS rewriting disk and the BIOS will be rewritten.*

1. Set the system to boot mode.
2. Turn off the power to the computer.
3. Remove the external cable and PC card.
4. Connect a USB FDD and insert the BIOS rewriting disk into either the USB FDD.
5. Turn on the power while holding down the  key (US) or  key (UK) until a beep sounds.  
The BIOS rewriting will start.
6. When the process is completed, eject the BIOS rewriting disk and the system is reset.





---

## Appendix H EC/KBC Rewrite Procedures

---

This Appendix explains how to rewrite the EC/KBC system program when you update the EC/KBC system.

### Tools

To rewrite the EC/KBC, you need the following tool:

- EC/KBC rewriting disk for the computer

### Rewriting the EC/KBC

- NOTE:**
1. Rewrite the EC/KBC only when instructed by a diagnostic disk release notice.
  2. Be sure to connect both battery and AC adapter to the computer when you rewrite the EC/KBC.
  3. Do not turn off the power while you are rewriting the EC/KBC. If the rewrite fails, it might be impossible to start up the computer.
  4. If you fail to rewrite EC/KBC, then when you next turn on the power, a message may be displayed that the content of the EC/KBC has been erased. In this case, insert the EC/KBC rewriting disk, and the EC/KBC will be rewritten.
  5. The time of rewriting EC/KBC depends on the conditions of the computer or ICs. The computer is not hung up. Allow sufficient time. Never reboot or turn off the power to the computer before the rewriting is completed.

1. Set the system to boot mode.
2. Turn off the power to the computer.
3. Remove the external cable and PC Card.
4. Connect a USB FDD and insert the EC/KBC rewriting disk into the USB FDD.
5. Turn on the power while holding down the **Tab** key until a beep sounds. The EC/KBC rewriting will start.
6. When the EC/KBC rewrite is completed, the system is automatically turned off.



---

## Appendix I Reliability

---

The following table shows MTBF (Mean Time between Failures).

*Table I-1 MTBF*

<b>MTBF</b>	<b>Time (hours)</b>
System (Satellite R20)	5943.86
System (TECRA M7 Intel 945GM model)	5931.18
System (TECRA M7 Intel 945PM model)	5864.65



## Free Manuals Download Website

<http://myh66.com>

<http://usermanuals.us>

<http://www.somanuals.com>

<http://www.4manuals.cc>

<http://www.manual-lib.com>

<http://www.404manual.com>

<http://www.luxmanual.com>

<http://aubethermostatmanual.com>

Golf course search by state

<http://golfingnear.com>

Email search by domain

<http://emailbydomain.com>

Auto manuals search

<http://auto.somanuals.com>

TV manuals search

<http://tv.somanuals.com>