

**Toshiba Personal Computer
Satellite A50S/TECRA A3X Series
Maintenance Manual**

TOSHIBA CORPORATION

File Number 960-534

[CONFIDENTIAL]

Copyright

© 2005 by Toshiba Corporation. All rights reserved. Under the copyright laws, this manual cannot be reproduced in any form without the prior written permission of Toshiba. No patent liability is assumed with respect to the use of the information contained herein.

Toshiba Satellite A50S/TECRA A3X Series Maintenance Manual

First edition September 2005

Disclaimer

The information presented in this manual has been reviewed and validated for accuracy. The included set of instructions and descriptions are accurate for the Satellite A50S/TECRA A3X series at the time of this manual's production. However, succeeding computers and manuals are subject to change without notice. Therefore, Toshiba assumes no liability for damages incurred directly or indirectly from errors, omissions, or discrepancies between any succeeding product and this manual.

Trademarks

Intel, Intel SpeedStep, Pentium and Celeron are trademarks or registered trademarks of Intel Corporation or its subsidiaries in the United States and other countries/regions.

Windows and Microsoft are registered trademarks of Microsoft Corporation.

Other trademarks and registered trademarks not listed above may be used in this manual.

Preface

This maintenance manual describes how to perform hardware service maintenance for the Toshiba Personal Computer Satellite A50S/TECRA A3X series.

NOTE: *This Satellite A50S/TECRA A3X series is a BTO-support personal computer. Each model has a different configuration. For each model's configuration, refer to the parts list dedicated to it.*

The procedures described in this manual are intended to help service technicians isolate faulty Field Replaceable Units (FRUs) and replace them in the field.

SAFETY PRECAUTIONS

Four types of messages are used in this manual to bring important information to your attention. Each of these messages will be italicized and identified as shown below.

DANGER: *“Danger” indicates the existence of a hazard that could result in death or serious bodily injury, if the safety instruction is not observed.*

WARNING: *“Warning” indicates the existence of a hazard that could result in bodily injury, if the safety instruction is not observed.*

CAUTION: *“Caution” indicates the existence of a hazard that could result in property damage, if the safety instruction is not observed.*

NOTE: *“Note” contains general information that relates to your safe maintenance service.*

Improper repair of the computer may result in safety hazards. Toshiba requires service technicians and authorized dealers or service providers to ensure the following safety precautions are adhered to strictly.

- ❑ Be sure to fasten screws securely with the right screwdriver. Be sure to use the PH Point size “0” and “1” screwdrivers complying with the ISO/DIS 8764-1:1996. If a screw is not fully fastened, it could come loose, creating a danger of a short circuit, which could cause overheating, smoke or fire.
- ❑ If you replace the battery pack or RTC battery, be sure to use only the same model battery or an equivalent battery recommended by Toshiba. Installation of the wrong battery can cause the battery to explode.

The manual is divided into the following parts:

- Chapter 1 Hardware Overview describes Satellite A50S/TECRA A3X series system unit and each FRU.
- Chapter 2 Troubleshooting Procedures explains how to diagnose and resolve FRU problems.
- Chapter 3 Test and Diagnostics describes how to perform test and diagnostic operations for maintenance service.
- Chapter 4 Replacement Procedures describes the removal and replacement of the FRUs.
- Appendices The appendices describe the following:

- Handling the LCD module
- Board layout
- Pin assignment
- Display codes
- Key layout
- Wiring diagrams
- BIOS/KBC/EC Update
- Reliability

Conventions

This manual uses the following formats to describe, identify, and highlight terms and operating procedures.

Acronyms

On the first appearance and whenever necessary for clarification acronyms are enclosed in parentheses following their definition. For example:

Read Only Memory (ROM)

Keys

Keys are used in the text to describe many operations. The key top symbol as it appears on the keyboard is printed in **boldface** type.

Key operation

Some operations require you to simultaneously use two or more keys. We identify such operations by the key top symbols separated by a plus (+) sign. For example, **Ctrl + Pause (Break)** means you must hold down **Ctrl** and at the same time press **Pause (Break)**. If three keys are used, hold down the first two and at the same time press the third.

User input

Text that you are instructed to type in is shown in the boldface type below:

DISKCOPY A: B:

The display

Text generated by this computer that appears on its display is presented in the type face below:

```
Format complete
System transferred
```

Table of Contents

Chapter 1 Hardware Overview

1.1	Features	1-1
1.2	System Block Diagram	1-6
1.3	3.5-inch USB Floppy Disk Drive.....	1-10
1.4	2.5-inch Hard Disk Drive.....	1-11
1.5	CD-ROM Drive	1-13
1.6	DVD-ROM Drive	1-15
1.7	DVD-ROM & CD-R/RW Drive	1-18
1.8	DVD Super Multi Drive.....	1-21
1.9	Keyboard.....	1-24
1.10	TFT Color Display	1-25
1.11	Power Supply	1-28
1.12	Batteries	1-30
1.13	AC Adapter	1-33

Chapter 2 Troubleshooting Procedures

2.1	Troubleshooting	2-1
2.2	Troubleshooting Flowchart.....	2-2
2.3	Power Supply Troubleshooting.....	2-6
2.4	System Board Troubleshooting.....	2-15
2.5	3.5" FDD Troubleshooting	2-29
2.6	2.5" HDD Troubleshooting.....	2-32
2.7	Keyboard Troubleshooting	2-37
2.8	Display Troubleshooting.....	2-38
2.9	Touch Pad Troubleshooting.....	2-41
2.10	Optical Drive Troubleshooting	2-42
2.11	Modem Troubleshooting.....	2-43
2.12	LAN Troubleshooting.....	2-44

2.13	Sound Troubleshooting.....	2-45
2.14	Wireless LAN Troubleshooting.....	2-47

Chapter 3 Tests and Diagnostics

3.1	The Diagnostic Test	3-1
3.2	Executing the Diagnostic Test	3-4
3.3	Setting of the hardware configuration.....	3-8
3.4	Heatrun Test.....	3-11
3.5	Subtest Names.....	3-12
3.6	System Test.....	3-14
3.7	Memory Test.....	3-16
3.8	Keyboard Test.....	3-17
3.9	Display Test	3-18
3.10	Floppy Disk Test.....	3-21
3.11	Printer Test.....	3-23
3.12	Async Test	3-25
3.13	Hard Disk Test	3-26
3.14	Real Timer Test.....	3-29
3.15	NDP Test.....	3-31
3.16	Expansion Test.....	3-32
3.17	CD-ROM/DVD-ROM Test	3-34
3.18	Error Code and Error Status Names.....	3-35
3.19	Hard Disk Test Detail Status.....	3-38
3.20	ONLY ONE TEST.....	3-40
3.21	Head Cleaning.....	3-46
3.22	Log Utilities	3-47
3.23	Running Test.....	3-49
3.24	Floppy Disk Drive Utilities.....	3-50
3.25	System Configuration	3-55
3.26	Wireless LAN Test Program (Intel-made b/g).....	3-57
3.27	Wireless LAN Test Program (Intel-made a/b/g).....	3-61
3.28	Wireless LAN Test Program (Askey-made).....	3-66

3.29	LAN/Modem/Bluetooth/IEEE1394 Test Program	3-70
3.30	Sound Test program.....	3-84
3.31	SETUP	3-90

Chapter 4 Replacement Procedures

4.1	Overview.....	4-1
4.2	Battery Pack/PC Card.....	4-8
4.3	Memory Module	4-11
4.4	MDC	4-14
4.5	HDD.....	4-16
4.6	Wireless LAN Card.....	4-19
4.7	Cooling Fin/CPU	4-21
4.8	Keyboard.....	4-26
4.9	Switch Membrane Board	4-30
4.10	Optical Drive.....	4-32
4.11	Display Assembly	4-34
4.12	Sound Board.....	4-38
4.13	Parallel port board/Serial port board/S-Video board	4-39
4.14	FAN.....	4-46
4.15	System Board/DC-IN Jack/RTC Battery	4-47
4.16	PC card cover.....	4-50
4.17	Battery Latch.....	4-51
4.18	Battery Lock.....	4-53
4.19	Touch Pad	4-55
4.20	LCD Unit/FL Inverter	4-57
4.21	Latch Assembly	4-61
4.22	Wireless LAN Antenna/Speaker/Hinge.....	4-62
4.23	Fluorescent Lamp.....	4-71

Appendices

Appendix A	Handling the LCD Module	A-1
Appendix B	Board Layout	B-1

Appendix C	Pin Assignment	C-1
Appendix D	Keyboard Scan/Character Codes	D-1
Appendix E	Key Layout.....	E-1
Appendix F	Wiring Diagrams.....	F-1
Appendix G	BIOS/KBC/EC Update	G-1
Appendix H	Reliability.....	H-1

Chapter 1

Hardware Overview

Chapter 1 Contents

1.1	Features	1-1
1.2	System Block Diagram	1-6
1.3	3.5-inch USB Floppy Disk Drive.....	1-10
1.4	2.5-inch Hard Disk Drive.....	1-11
1.5	CD-ROM Drive	1-13
1.6	DVD-ROM Drive	1-15
1.7	DVD-ROM & CD-R/RW Drive	1-18
1.8	DVD Super Multi Drive.....	1-21
1.9	Keyboard.....	1-24
1.10	TFT Color Display	1-25
	1.10.1 LCD Module	1-25
	1.10.2 FL Inverter Board.....	1-27
1.11	Power Supply	1-28
1.12	Batteries	1-30
	1.12.1 Main Battery.....	1-30
	1.12.2 Battery Charging Control.....	1-31
	1.12.3 RTC Battery	1-32
1.13	AC Adapter	1-33

Figures

Figure 1-1	Front of the computer.....	1-4
Figure 1-2	System units configuration	1-5
Figure 1-3	System block diagram.....	1-6
Figure 1-4	3.5-inch USB FDD.....	1-10
Figure 1-5	2.5-inch HDD.....	1-11
Figure 1-6	CD-ROM Drive	1-13
Figure 1-7	DVD-ROM Drive	1-15
Figure 1-8	DVD-ROM & CD-R/RW Drive	1-18
Figure 1-9	DVD Super Multi Drive.....	1-21
Figure 1-10	Keyboard.....	1-24
Figure 1-11	LCD module.....	1-25

Tables

Table 1-1	3.5-inch USB FDD specifications.....	1-10
Table 1-2	2.5-inch HDD dimensions	1-11
Table 1-3	2.5-inch HDD specifications.....	1-12
Table 1-4	CD-ROM Drive dimensions	1-13
Table 1-5	CD-ROM Drive specifications	1-14
Table 1-6	DVD-ROM Drive dimensions	1-15
Table 1-7	DVD-ROM Drive specifications	1-16
Table 1-8	DVD-ROM & CD-R/RW Drive dimensions.....	1-18
Table 1-9	DVD-ROM & CD-R/RW Drive specifications	1-19
Table 1-10	DVD Super Multi Drive dimensions	1-21
Table 1-11	DVD Super Multi Drive speciifcations.....	1-22
Table 1-12	LCD module specifications.....	1-26
Table 1-13	FL inverter board specifications	1-27
Table 1-14	Power supply output rating	1-29
Table 1-15	Battery specifications.....	1-30
Table 1-16	Time required for charges of main battery	1-31
Table 1-17	Battery preservation time.....	1-31

Table 1-18 Time required for charges of RTC battery..... 1-32
Table 1-19 AC adapter specifications 1-33

1.1 Features

The Satellite A50S/TECRA A3X is a high performance all-in-one PC running a Pentium M or Celeron M processor.

Features are listed below.

Microprocessor [CPU Easy Replaceable]

Microprocessor used is different from each model.

Mobile Intel® Pentium® -M model

A 730/740/750/760/770/780 Pentium M processor with 533MHz bus operation.

Mobile Intel® Celeron® -M model

A 360/370/380/390 Celeron M processor with 400MHz bus operation.

Memory

Two SO-DIMM slots for DDR2-533. Memory modules can be installed to provide a maximum of 2GB. Memory modules are available in 256MB, 512MB and 1,024MB sizes. (Celeron M processor model operates with DDR2-400)

Montara-GML model can support 1GB in total as its maximum memory.

Montara-GM+ model can support 2GB in total as its maximum memory.

HDD

Single 20GB, 30GB, 40GB, 60GB or 80GB internal drive. 2.5 inch x 9.5mm height.

USB FDD

The two-mode 3.5-inch USB FDD supports 720KB, and 1.44MB formats.

Display

LCD

Built-in 15.0-inch, XGA (1,024 x 768 dots), or 15-inch, SXGA+ (1,400 x 1,050 dots), 262,144 colors, amorphous silicon TFT color display.

Interface

Image output - an RGB connector

- an S-Video connector (It depends on the model.)

VRAM

The computer has VGA imbedded in North Bridge and VRAM in 128MB(max).

 Keyboard

An easy-to-use 85(US)-/86(UK)-key keyboard. Windows key is supported.
The keyboard also supports touchpad as a pointing device.

 Optical devices

A CD-ROM, DVD-ROM, DVD-ROM & CD-R/RW or DVD Super Multi (supporting Double Layer) Drive is supported.

 Battery

The RTC battery is mounted inside the computer.
The main battery is a detachable lithium ion battery (4,400mAh: Li-Ion, 6cell / 8,800mAh: Li-Ion, 12cell).

 USB (Universal Serial Bus)

Two or three USB ports are provided. The ports comply with the USB2.0 standard, which enables data transfer speeds 40 times faster than USB1.1 standard. USB1.1 is also supported.

 PC card slot

The PC card slot accepts one Type II (5mm thick) card. The slot is equipped with an ejector and supports ToPIC-100 (3.3V/CardBus).

 Parallel port (It depends on the model.)

A parallel port is provided for some models.

 Serial port (It depends on the model.)

A serial port is provided for some models.

 Sound system

The computer has an external monaural microphone connector, stereo headphone connector and internal stereo speakers.

 Wireless LAN (Mini PCI slot)

The wireless LAN card (802.11b/g or 802.11a/b/g) is equipped on the mini PCI slot.

LAN/MODEM

Connectors for LAN and Modem are separately mounted.

RGB

The port enables connection of an external monitor.

Docking interface port

Advanced Port Replicator III can be connected through docking port on the bottom.

Figure 1-1 shows the front of the computer.

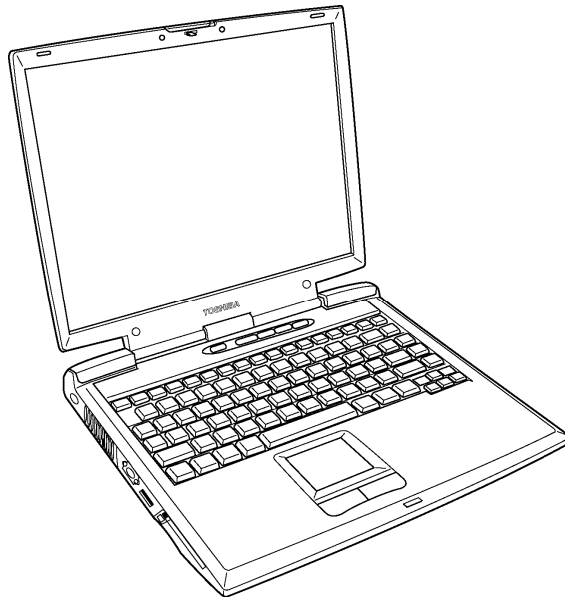

Figure 1-1 Front of the computer

Figure 1-2 shows the system units configuration.

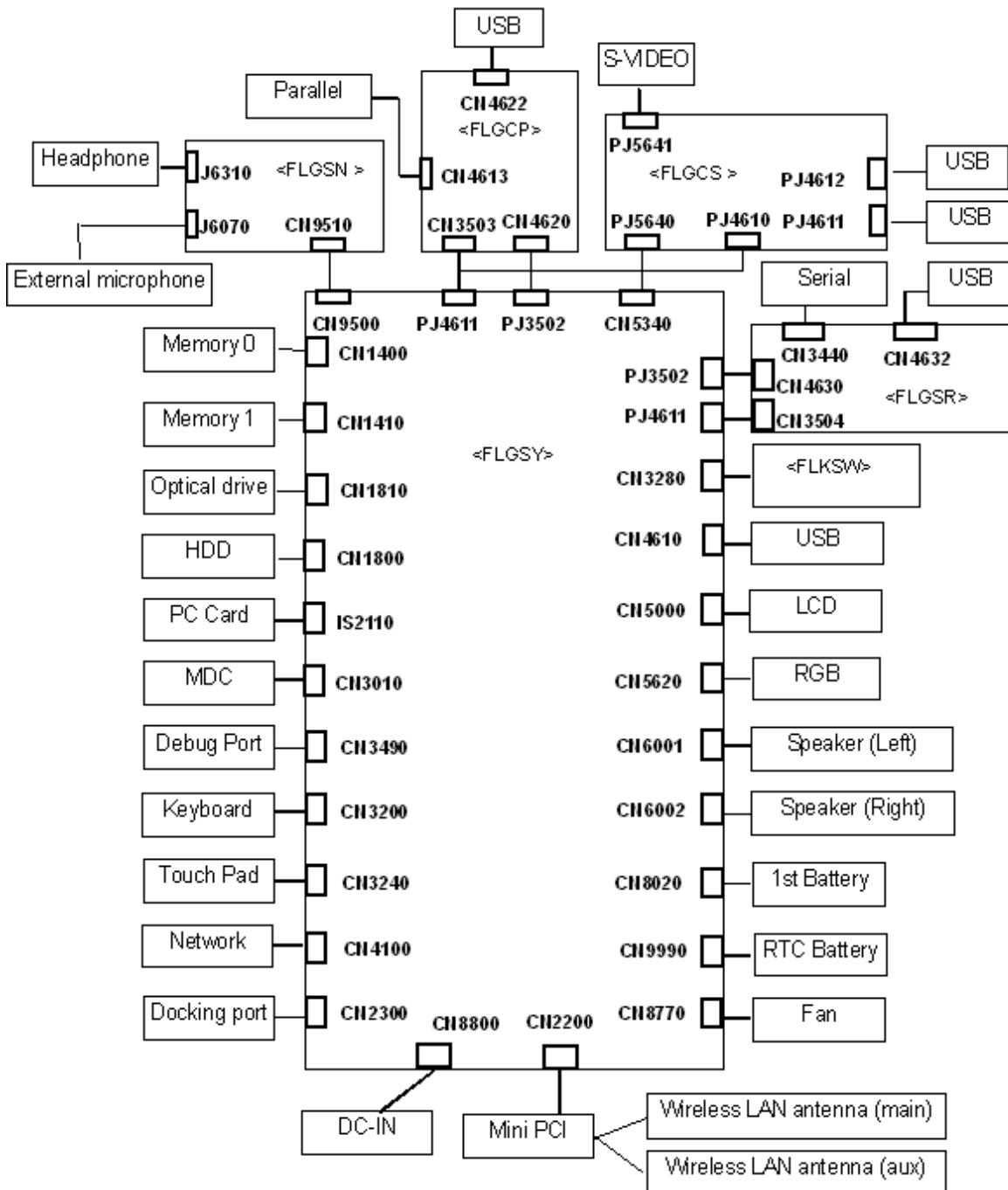

Figure 1-2 System units configuration

1.2 System Block Diagram

Figure 1-3 shows the system block diagram.

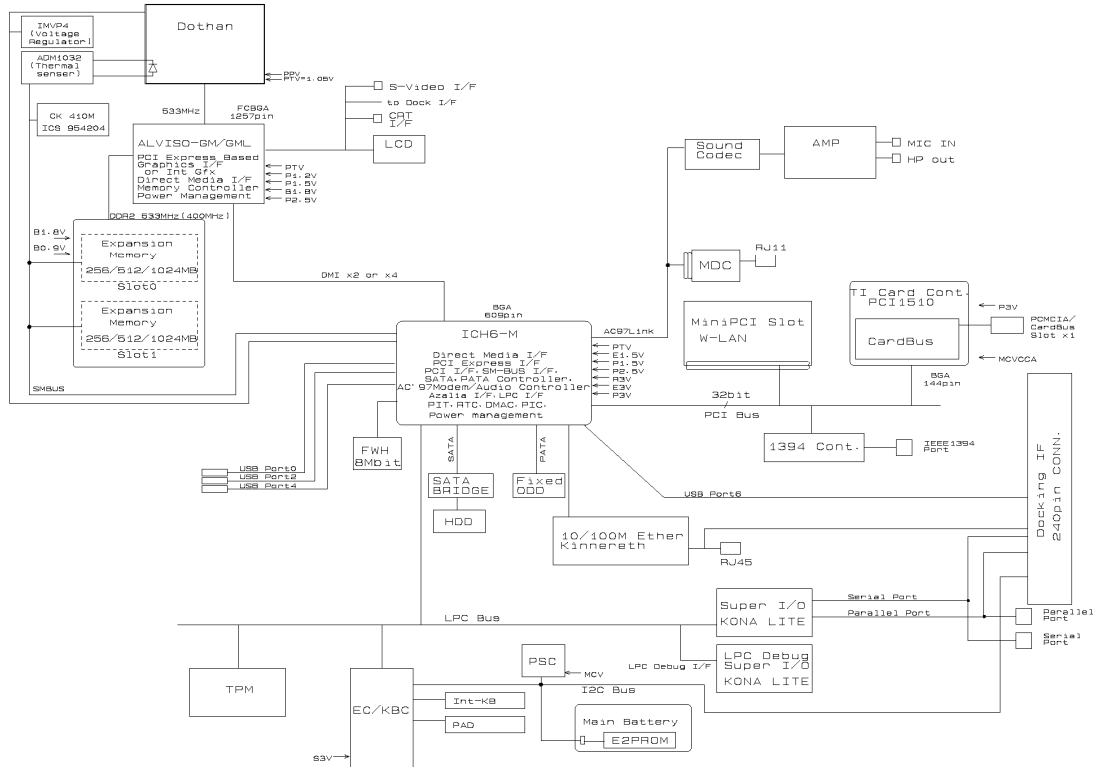

Figure 1-3 System Block Diagram

The PC contains the following components.

❑ CPU

Intel® Mobile Pentium®-M model

Pentium-M 1.60GHz (Processor Number ; 730)
1.73GHz (Processor Number ; 740)
1.86GHz (Processor Number ; 750)
2.00GHz (Processor Number ; 760)
2.13GHz (Processor Number ; 770)
2.26GHz (Processor Number ; 780)

L1 cache : 64KB (32KB + 32KB)
L2 cache : 2MB
FSB : 533MHz Core voltage : 1.280~1.356V

Intel® Mobile Celeron®-M model

Celeron-M 1.40GHz (Processor Number ; 360)
1.50GHz (Processor Number ; 370)
1.60GHz (Processor Number ; 380)
1.70GHz (Processor Number ; 390)

L1 cache : 64KB (32KB + 32KB)
L2 cache : 1MB
FSB : 400MHz Core voltage : 1.004~1.292V

❑ Memory

Two memory slots capable of accepting 256MB, 512MB or 1024MB memory modules for a maximum of 2GB.

- 200-pin DDR-SDRAM (PC4300)
- Pipeline configuration
- 2.5V operation

❑ Firmware Hub

- 8Mbit (Flash memory)
- Vcc : 3.3V±0.3V
- Vpp : 3.3V/12V

❑ Chipset

This gate array has the following elements and functions.

➤ North Bridge (Intel 915GM <Express Chipset>)

- Support Pentium-M(915GM)/Celeron-M(915GM/910GML) Processor System Bus
- System Memory Interface
- Memory Controller : DDR333/DDR2-400/DDR2-533, 2GB(max)
- Graphics I/F : x16 PCI Express Based Graphics I/F
- DMI (Direct Media Interface)
- Integrated Display interface
- 1,257-ball 40.0mmx37.5mmx2.6mm FC-BGA Package

➤ South Bridge (Intel 82801DBM (ICH6-M))

- DMI (Direct Media Interface)
- PCI Express I/F (4 ports)
- PCI Bus I/F Rev 2.3 (PCI REQ/GNT Pairs)
- Integrated Serial ATA Host Controller (2 ports, 150MB/S)
- Integrated IDE Controller (Ultra ATA 100/66/33)
- AC'97 2.3 codes
- USB 1.1/2.0 Controller 8 ports (EHCI: Enhanced Host Controller Interface)
- Built-in LAN Controller (Wfm 2.0& IEEE802.3 compliance)
- Power Management (ACPI 2.0 compliance)
- SMBus2.0 controller
- FWH interface (BIOS)
- LPC interface (EC/KBC, Super I/O)
- IRQ controller
- Serial Interrupt Function
- Suspend/Resume control
- Built-in RTC
- GPIO
- 609-ball 31mmx31mm micro BGA Package

❑ PC card controller (Texas Instruments PCI7411)

- PCI Interface (PCI Rev. 2.3)
- PC Card Controller
- IEEE1394 Controller
- Flash Media Controller
- SD Host Controller

VGA controller

Imbedded in North Bridge

 Other main system chips

- EC/KBC (M306KAFCLRP x 1)
- PSC (Toshiba-made TMP86PM49UG x 1)
- Thermal sensor (AnalogDevice-made ADM1032 x 1)
- Audio AMP (Mitsumi-made MM1517X x1)
- AC97-CODEC (SigmaTel-made STAC9750TG x1)
- Clock generator (ICS954204 x1)

 Mini PCI (Intel/Askey made 802.11b/g or 802.11a/b/g)

2.4 GHz DSSS wireless LAN card is equipped in the mini PCI card slot. Conformity with IEEE 802.11b (WiFi). Supports 128bit WEP.

 LAN (Intel-made Kinnereth (ED82562 x 1)

Controls LAN.

Supports 100Base-TX and 10Base-T.

 MODEM (Askey-made 1456VQL4A (INT) x 1)

Supported by MDC.

Uses secondary AC97 line.

Data and FAX transmission is available.

Supports ITU-TV.90 and V.92.

The transfer speed of data receiving is 56kbps, of data sending is 33.6kbps and of FAX is 14.4Kbps. Actual speed depends on the quality of the line used.

Connected to telephone line through RJ11 modem jack.

1.3 3.5-inch USB Floppy Disk Drive

This compact, lightweight and high-reliability FDD can be used with 720KB and 1.44MB floppy disks.

Figure 1-4 shows the 3.5-inch FDD. Table 1-1 lists the specifications.

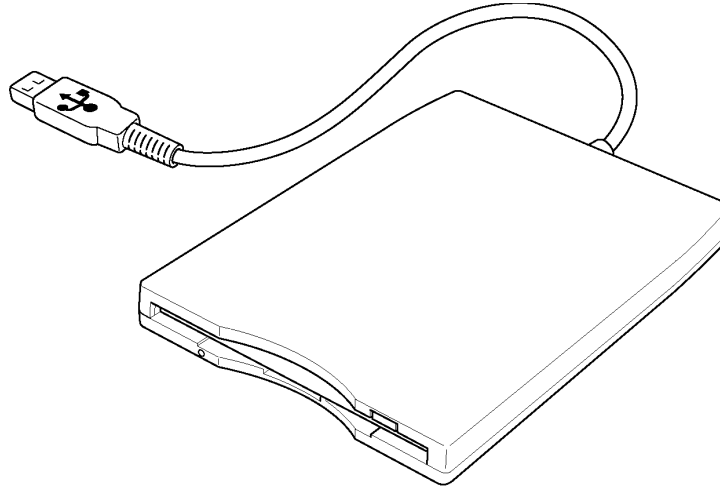

Figure 1-4 3.5-inch USB FDD

Table 1-1 3.5-inch USB FDD specifications

Item	Specifications	
Disk used	2DD	2HD
Unformatted capacity	1.0MB	2.0MB
Formatted capacity	720KB	1.44MB
Data transfer speed (Kb/s)	250	500
Rotation speed (rpm)	300	300

1.4 2.5-inch Hard Disk Drive

The computer has a compact, high-capacity HDD with a height of 9.5 mm. The HDD contains a 2.5-inch magnetic disk and magnetic heads.

Figure 1-5 shows a view of the 2.5-inch HDD and Tables 1-2 and 1-3 list the dimensions and specifications.

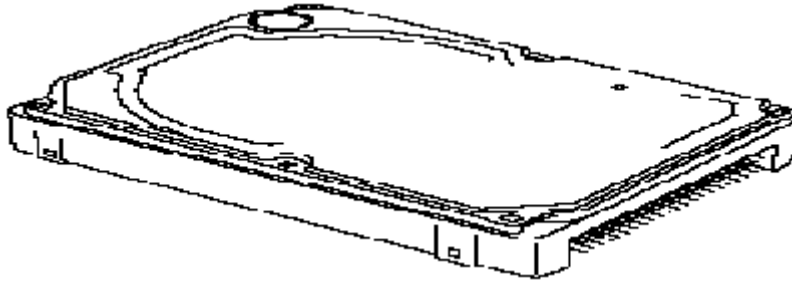

Figure 1-5 2.5-inch HDD

Table 1-2 2.5-inch HDD dimensions (1/2)

Item	Standard		
	TOSHIBA		
	HDD2193VZK01	HDD2194VZK01	HDD2191VZK01
Width (mm)	69.85		
Height (mm)	9.5		
Depth (mm)	100.0		
Weight (g) (MAX)	95		

Table 1-2 2.5-inch HDD dimensions (2/2)

Item	Standard			
	HITACHI-GST			
	G8BC0001N410	G8BC0001N610	G8BC0001N810	G8BC0001NA10
Width (mm)	69.85±0.25			
Height (mm)	9.5±0.2			
Depth (mm)	100.2±0.25			
Weight (g) (MAX)	95	102		

Table 1-3 2.5-inch HDD specifications (1/2)

Item	Specifications		
	TOSHIBA		
	HDD2193VZK01	HDD2194VZK01	HDD2191VZK01
Storage size (formatted)	40GB	60GB	80GB
Rotation speed (RPM)	5,400		
Data transfer rate (MB/s)	154.3-298.0	258.0-394.0	233.0-446.0
Interface transfer rate (MB/s)	100		
Storage density (Kbpi)	728	735	728
Track density (Ktpi)	88.8		
Average random seek time (read) (ms)	12		
Average random seek time (write) (ms)	12		
Motor startup time (ms)	4		

Table 1-3 2.5-inch HDD specifications (2/2)

Item	Specifications			
	HITACHI-GST			
	G8BC0001N410	G8BC0001N610	G8BC0001N810	G8BC0001NA10
Storage size (formatted)	40GB	60GB	80GB	100GB
Rotation speed (RPM)	5,400			
Data transfer rate (MB/s)	493			
Interface transfer rate (MB/s)	100			
Storage density (Kbpi)	717	764		
Track density (Ktpi)	96.6	113.2		
Average random seek time (read) (ms)	14			
Average random seek time (write) (ms)	12			
Motor startup time (ms)	3.5			

1.5 CD-ROM Drive

The CD-ROM drive accommodates either 12 cm (4.72-inch) or 8 cm (3.15-inch) CD. It is a high-performance drive that reads at maximum 24-speed.

The CD-ROM drive is shown in Figure 1-6. The specifications of the CD-ROM drive are described in Table 1-4 and 1-5.

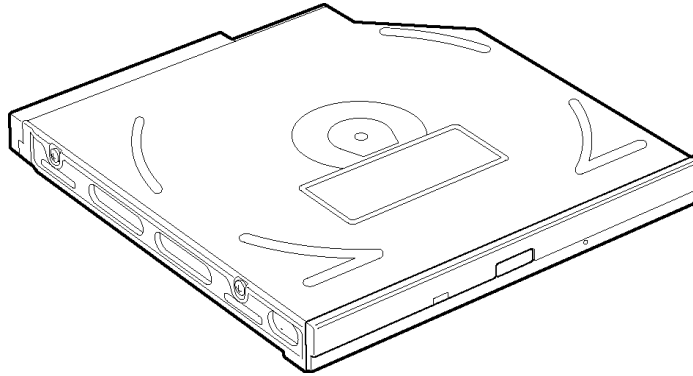

Figure 1-6 CD-ROM drive

Table 1-4 CD-ROM drive dimensions

Item		Standard
Dimensions	Maker	TEAC (G8CC0002R220)
	Width (mm)	128
	Height (mm)	12.7
	Depth (mm)	129.4
	Weight (g)	165 (max)

Table 1-5 CD-ROM drive specifications

Items		Specifications
		TEAC (G8CC0002R220)
Transfer Speed	Data transfer rate (MB/s)	33.3Mbytes/sec (max) 1,545 – 3,600KB/sec
	Burst data transfer rate (MB/s)	PIO mode 16.7 MB/s (PIO MODE4) DMA mode 16.7 MB/s (Multiword MODE2) Ultra DMA mode 33.3 MB/s (Ultra DMA MODE2)
Access Time (ms)	CD-ROM	110 (Random)
		240 (Full stroke)
Buffer memory		256KB
Supported formats	CD	CD-DA, CD-ROM Mode1, Mode2 CD-ROM XA Mode2 (Form1, Form2), Photo CD (single/multi-session), Enhanced CD

1.6 DVD-ROM Drive

The DVD-ROM drive accommodates either 12 cm (4.72-inch) or 8 cm (3.15-inch) CD, CD-R/RW and DVD. It is a high-performance drive that reads DVD at maximum 8-speed, and reads CD at maximum 24-speed (3,600 KB per second).

The DVD-ROM drive is shown in Figure 1-7. The specifications of the DVD-ROM drive are described in Table 1-6 and 1-7.

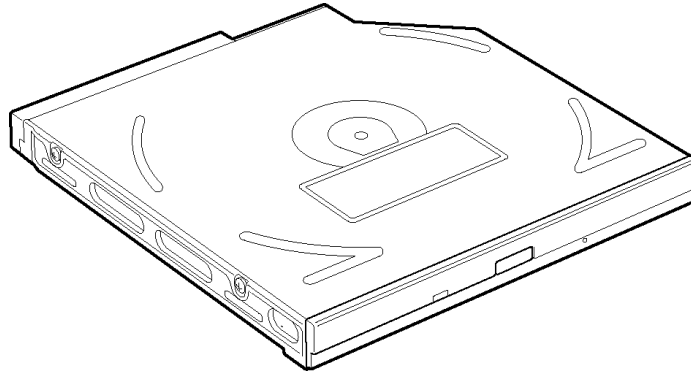

Figure 1-7 DVD-ROM drive

Table 1-6 DVD-ROM drive dimensions

Item		Standard	
Dimensions	Maker	TSST (G8CC0002W220)	TEAC (G8CC0002E220)
	Width (mm)	128	
	Height (mm)	12.7	
	Depth (mm)	129.0	
	Weight (g)	179 ± 15	

Table 1-7 DVD-ROM drive specifications (1/2)

Items		Specifications
		TSST (G8CC0002W220)
Transfer Speed	Data transfer rate (MB/s)	DVD(Single Layer); 4,460-10,816 (CAV) DVD(Dual Layer); 3,380-8,112 (CAV) DVD-R/-RW ; 2,298-5,408 (CAV) DVD+R/+RW ; 2,298-5,408 (CAV) DVD+R Double Layer; 2,298-5,408 (CAV) DVD-RAM; 2,704 (ZoneCLV) CD(Mode1); 1,546-3,600 (CAV) CD(Mode2); 1,761-4,104 (CAV)
	Burst data transfer rate (MB/s)	PIO mode 16.7 MB/s (PIO Mode 4) DMA mode 16.7 MB/s (Multi-word DMA Mode 2) Ultra DMA mode 33.3 MB/s (Ultra DMA Mode 2)
Access Time (ms)	CD-ROM	110 (Random)
	DVD-ROM	110 (Random)
	DVD-RAM	140 (Random)
Buffer Memory		256KB
Supported formats	CD	CD-DA, CD+(E)G, CD-MIDI, CD-text, CD-ROM, CD-ROM XA, CD-I, CD-I Bridge, Multi-session CD, CD-R, CD-RW
	DVD	DVD-ROM (DVD-5, DVD-9, DVD-10, DVD-18), DVD-R (Ver1.0, 2.1), DVD-RW (Ver1.0, 1.1), DVD+R, DVD+R DL, DVD+RW, DVD-RAM (Ver2.1)

Table 1-7 DVD-ROM drive specifications (2/2)

Items		Specifications
		TEAC (G8CC0002E220)
Transfer Speed	Data transfer rate (MB/s)	DVD-ROM; 8x (CAV) DVD-Video; 4x (CAV) CD-ROM (Mode1); 24x (CAV) CD-ROM (Mode2); 20x (CAV) CD-DA; 20x (CAV) CD-RW; 24x (CAV) DVD-R/-RW; 8x (CAV) DVD+R/+RW; 8x (CAV) DVD-RAM (4.7GB); 5x (CAV) DVD-RAM (2.6GB); 2.5x (CAV)
	Burst data transfer rate (MB/s)	PIO mode 16.7 MB/s (PIO Mode 4) DMA mode 16.7 MB/s (Multi-word DMA Mode 2) Ultra DMA mode 33.3 MB/s (Ultra DMA Mode 2)
Access Time (ms)	CD-ROM	120 (Random)
	DVD-ROM	130 (Random)
Buffer Memory		256KB
Supported formats	CD	CD-DA, CD-ROM Mode1, CD-ROM XA Mode2, Multi-session CD, CD-I, Video CD, Enhanced CD, CD-TEXT, Photo CD, Addressing Method2
	DVD	DVD-ROM, DVD-R, DVD Video, DVD-RW DVD+R, DVD+RW, DVD-RAM (2.6GB/4.7GB)

1.7 DVD-ROM & CD-R/RW Drive

The DVD-ROM & CD-R/RW drive accommodates either 12 cm (4.72-inch) or 8 cm (3.15-inch) CD, CD-R/RW and DVD. It is a high-performance drive that reads DVD at maximum 8-speed, and reads CD at maximum 24-speed.

The DVD-ROM & CD-R/RW drive is shown in Figure 1-8. The specifications of the DVD-ROM & CD-R/RW drive are described in Table 1-8 and 1-9.

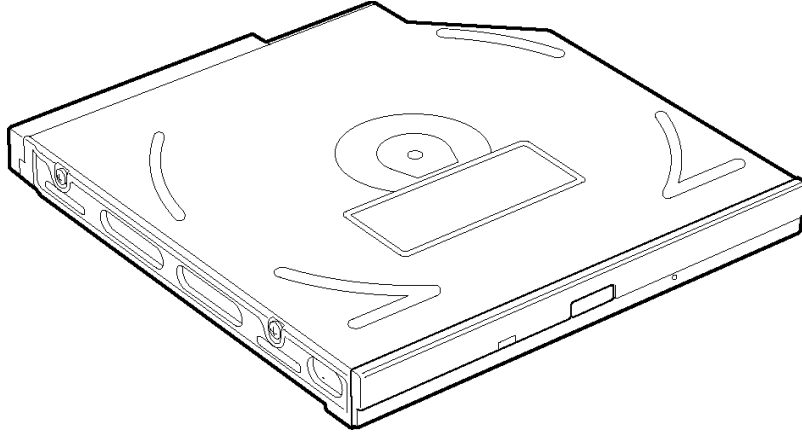

Figure 1-8 DVD-ROM & CD-R/RW drive

Table 1-8 DVD-ROM & CD-R/RW drive dimensions

Items		Standard	
Dimensions	Maker	Panasonic (G8CC0002J220)	TSST (G8CC0002V220)
	Width (mm)	128	
	Height (mm)	12.7	
	Depth (mm)	129.0	
	Weight (g)	180 ± 10	179 ± 15

Table 1-9 DVD-ROM & CD-R/RW drive specifications (1/2)

Items		Specifications
		Panasonic (G8CC0002J220)
Transfer Speed	Read(KB/s)	CD-ROM; 24x (CAV) DVD-ROM MAX 8x CAV
	Write	CD-R 24x (CAV) CD-RW 4x (CLV) High Speed CD-RW 10x (CLV) Ultra Speed CD-RW 24x (CAV)
	Burst data transfer rate (MB/s)	PIO mode 16.6 MB/s (PIO Mode 4) DMA mode 16.6 MB/s (Multi-word DMA Mode 2) Ultra DMA mode 33.3 MB/s (Ultra DMA Mode 2)
Access Time (ms)	CD-ROM	150 (Random)
	DVD-ROM	180 (Random)
Buffer Memory		2MB
Supported formats	CD	CD-DA, CD-ROM, CD-ROM XA, Photo CD, CD-Extra(CD+), CD-Text
	DVD	DVD-R, DVD-RW, DVD Video, DVD+R, DVD+RW, DVD-RAM

Table 1-9 DVD-ROM & CD-R/RW drive specifications (2/2)

Items		Specifications
		TSST (G8CC0002V220)
Transfer Speed	Read(KB/s)	CD-ROM; 24x (CAV) CD-RW; 24x (CAV) DVD-ROM MAX 8x CAV
	Write	CD-R 24x (P-CAV) CD-RW 4x (CLV) High Speed CD-RW 10x (CLV) Ultra Speed CD-RW 24x (P-CAV)
	Burst data transfer rate (MB/s)	PIO mode 16.6 MB/s (PIO Mode 4) DMA mode 16.6 MB/s (Multi-word DMA Mode 2) Ultra DMA mode 33.3 MB/s (Ultra DMA Mode 2)
Access Time (ms)	CD-ROM	130 (Random)
	DVD-ROM	150 (Random)
Buffer Memory		2MB
Supported formats	CD	CD-ROM, CD-R, CD-RW, CD-Audio Disc, CD-DA, Video-CD
	DVD	DVD-R, DVD-RW, DVD Video, DVD+R, DVD+RW, DVD-RAM

1.8 DVD Super Multi drive

The DVD Multi drive accommodates either 12 cm (4.72-inch) or 8 cm (3.15-inch) CD, CD-R/RW and DVD. It is a high-performance drive that reads CD at maximum 24-speed (3,600 KB per second) and writes DVD-RW at 2-speed, DVD-RAM at 2-speed, DVD-R at 4-speed, DVD+R at 2.4-speed and DVD+RW at 2.4-speed.

The DVD Super Multi drive is shown in Figure 1-9. The specifications of the DVD Super Multi drive are described in Table 1-10 and 1-11.

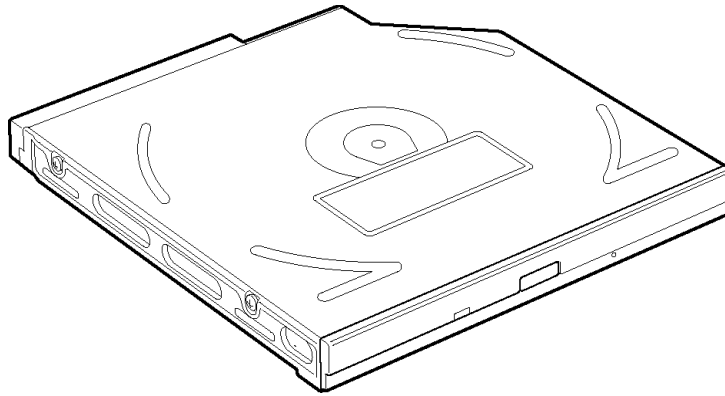

Figure 1-9 DVD Super Multi drive

Table 1-10 DVD Super Multi drive dimensions

Items		Standards	
Dimensions	Maker	Panasonic (G8CC0002T220)	TEAC (G8CC0002S220)
	Width (mm)	128	
	Height (mm)	12.7	
	Depth (mm)	129.0	129.4
	Weight (g)	190 ± 10	190 (max)

Table 1-11 DVD Super Multi drive specifications (1/2)

Items		Specifications
		Panasonic (G8CC0002T220)
Transfer Speed	Read(KB/s)	DVD-ROM MAX 8x CAV CD-ROM MAX 24x CAV
	Write	CD-R 24x (ZoneCLV) CD-RW 4x (CLV) High Speed CD-RW 10x (CLV) Ultra Speed CD-RW 10x (CLV) DVD-R 8x (ZoneCLV) DVD-R Double Layer 2x (CLV) DVD-RW 4x (ZoneCLV) DVD+R 8x (ZoneCLV) DVD+R Double Layer 2.4x (CLV) DVD+RW 4x (ZoneCLV) DVD-RAM 5x (ZoneCLV)
	Burst data transfer rate (MB/s)	PIO mode 16.6 MB/s (PIO Mode 4) DMA mode 16.6 MB/s (Multi-word DMA Mode 2) Ultra DMA mode 33.3 MB/s (Ultra DMA Mode 2)
Access Time (ms)	CD-ROM	150 (Random)
	DVD-ROM	180 (Random)
Buffer memory		2MB
Supported formats	CD	CD-DA, CD-ROM, CD-ROM XA, Photo CD, CD-Extra(CD+), CD-text
	DVD	DVD-R, DVD-RW (Ver1.1) DVD Video, DVD+R, DVD+RW, DVD-RAM (2.6GB/4.7GB)

Table 1-11 DVD Super Multi drive specifications (2/2)

Items		Specifications
		TEAC (G8CC0002S220)
Transfer Speed	Read(KB/s)	DVD-ROM 8x (CAV) CD-ROM 24x (CAV)
	Write	CD-R 24x (ZoneCLV) CD-RW 16x (CLV) DVD-R 8x (ZoneCLV) DVD-RW 4x (ZoneCLV) DVD+R 8x (ZoneCLV) DVD+R Double Layer 2.4x (CLV) DVD+RW 4x (ZoneCLV) DVD-RAM 3x (ZoneCLV)
	Burst data transfer rate (MB/s)	PIO mode 16.7 MB/s (PIO Mode 4) DMA mode 16.7 MB/s (Multi-word DMA Mode 2) Ultra DMA mode 33.3 MB/s (Ultra DMA Mode 2)
Access Time (ms)	CD-ROM	130 (Random)
	DVD-ROM	130 (Random)
Buffer memory		2MB
Supported formats	CD	CD-DA, CD-ROM, CD-ROM XA, CD-I, Video CD, Photo CD, CD-Extra(CD+),CD-text
	DVD	DVD-R, DVD-RW (Ver1.1), DVD Video, DVD+R, DVD+R (Double layer), DVD+RW, DVD-RAM (2.6GB/4.7GB)

1.9 Keyboard

An 85(US)-/86(UK)- key keyboard is mounted on the system unit. The keyboard is connected to membrane connector on the system board and controlled by the keyboard controller.

Figure 1-10 shows a view of the keyboard.

See Appendix E for details of the keyboard layout.



Figure 1-10 Keyboard

1.10 TFT Color Display

The TFT color display has a 15.0-inch (XGA, SXGA+) LCD module and the FL inverter board.

1.10.1 LCD Module

The LCD module used for the TFT color display uses a backlight as the light source and can display a maximum of 262,144 colors with 1,024 x 768 or 1,400 x 1,050 resolution. North Bridge can control both internal and external XGA or SXGA+ support displays simultaneously.

Figure 1-11 shows a view of the LCD module and Table 1-12 lists the specifications.

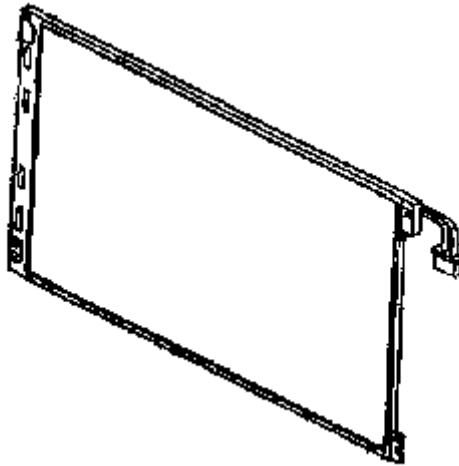

Figure 1-11 LCD module

Table 1-12 LCD module specifications (15.0-inch XGA TFT) (1/2)

Item	Specifications		
	G33C0002W110	G33C0002Y110	G33C00030110
Number of Dots	1,024(W) × 768(H)		
Dot spacing (mm)	0.297(H) × 0.297(V)		
Display range (mm)	304.128(H) × 228.096(V)		

Table 1-12 LCD module specifications (15.0-inch SXGA+ TFT) (2/2)

Item	Specifications
	G33C0001X210
Number of Dots	1,400(W) × 1,050(H)
Dot spacing (mm)	0.2175(H) × 0.2175(V)
Display range (mm)	304.5(H) × 228.375(V)

1.10.2 FL Inverter Board

The FL inverter board supplies a high frequency current to illuminate the LCD module fluorescent lamp.

Table 1-13 lists the FL inverter board specifications.

Table 1-13 FL inverter board specifications

Item		Specifications
Input	Voltage (V)	DC5
	Power (W)	7
Output	Voltage (V)	750
	Current (mA)	6.00
	Power (W)	5W/7VA

1.11 Power Supply

The power supply supplies 26 different voltages to the system board.

The power supply microcontroller has the following functions.

1. Judges if the DC power supply (AC adapter) is connected to the computer.
2. Detects DC output and circuit malfunctions.
3. Controls the battery icon, and DC IN icon.
4. Turns the battery charging system on and off and detects a fully charged battery.
5. Turns the power supply on and off.
6. Provides more accurate detection of a low battery.
7. Calculates the remaining battery capacity.
8. Controls the transmission of the status signal of the main battery.

Table 1-14 lists the power supply output specifications.

Table 1-14 Power supply output rating

Power Supply (Yes / No)					
Name	Voltage [V]	S3	S4/S5	G3	Use
PPV	1.308 – 0.748	No	No	No	CPU
PTV	1.05	No	No	No	CPU, MCH, ICH6-M
PGV	1.056	No	No	No	GPU
1R5-P1V	1.5	No	No	No	CPU, MCH, ICH6-M, ExpressCard
1R8-B1V	1.8	Yes	No	No	MCH, DDR2-SDRAM
VG1R8-P1V	1.8	No	No	No	GPU
2R5-P2V	2.5	No	No	No	MCH, ICH6-M
MR0R9-B0V	0.9	Yes	No	No	MCH, DDR2-SDRAM
0R9-P0V	0.9	No	No	No	DDR2-SDRAM
P3V	3.3	No	No	No	Clock Generator, GPU, Thermal Sensor, TPM, SDRAM(SPD), Mini-PCI, Super I/O, ICH6-M, LCD, Express Card, FWH, FIR, STAC9200, HDD(SATA), Finger Print Sensor
E3V	3.3	Yes	Yes / No	No	ICH6-M, TI CARD Cont., PC Card Power, Mini-PCI, Express Card, MDC, RS-232C
SD-E3V	3.3	No	No	No	SD Card
LAN-E3V	3.3	Yes	Yes / No	No	LAN Power
LAN2R5-E2V	2.5	Yes	Yes / No	No	LAN Power
BT-P3V	3.3	No	No	No	Bluetooth
USB0PS-E5V	5	Yes	Yes / No	No	USB
USB1PS-E5V	5	Yes	Yes / No	No	USB
S3V	3.3	Yes	Yes	No	EC/KBC, PSC, 3AXIS Accerelometer
P5V	5	No	No	No	CRT, ICH6-M, FL inverter, LEDs, ODD, KB, PAD,Bluetooth Power, HDD(SATA), Parallel
1R5-E1V	1.5	Yes	Yes / No	No	ICH6-M
SND-P5V	5	No	No	No	AN12941
A4R7-P4V	4.7	No	No	No	STAC9200, AN12941
E5V	5	Yes	Yes / No	No	ICH6-M, PC Card Power, USB Power
M5V	5	Yes	Yes	No	Docker, MAX6501, LED
MCV	5	Yes	Yes	No	PSC
R3V	2.0 - 3.5	Yes	Yes	Yes	ICH6-M(RTC)

1.12 Batteries

The PC has the following two batteries.

- Main battery
- Real time clock (RTC) battery

Table 1-15 lists the specifications for these two batteries.

Table 1-15 Battery specifications

Battery Name		Capacity	Material	Output Voltage
Main battery	G71C0003V910	4,400mAh	lithium ion (6-cell)	10.8V
	G71C0003VA10			
	G71C0003VD10			
	G71C0003VE10			
	G71C0005H110			
	G71C0005H210			
	G71C0004G510	4,700mAh	lithium ion (12-cell)	
	G71C0004G610			
	G71C0003W210	8,800mAh	Nickel metal hydride	
	G71C0003W110			
Real time clock (RTC) battery	GDM710000041	17mAh		3.0V

1.12.1 Main Battery

The main battery is the primary power supply for the computer when the AC adapter is not connected. In resume (instant recovery) mode, the main battery maintains the current status of the computer.

1.12.2 Battery Charging Control

Battery charging is controlled by a power supply microprocessor. The power supply microprocessor controls power supply and detects a full charge when the AC adaptor and battery are connected to the computer.

Battery Charge

When the AC adapter is connected, normal charging is used while the system is turned on, and quick charge is used while the system is turned off or in suspend mode. Table 1-16 shows the time required for charges of main battery.

Table 1-16 Time required for charges of main battery

Condition		Charging Time
Normal charge	4,400mAh	About 4.5 to 12.0 hours or longer
	8,800mAh	About 7.0 to 21.0 hours or longer
Quick charge	4,400mAh	About 3.0 hours
	8,800mAh	About 4.5 hours

Charge is stopped in the following cases.

1. The main battery is fully charged
2. The main battery is removed
3. Main battery or AC adapter voltage is abnormal
4. Charging current is abnormal

Battery preservation time

When turning off the power in being charged fully, the preservation time is as follows:

Table 1-17 Battery preservation time

Condition		Preservation Time
Power OFF or Hibernation	4,400mAh	About 85 days
	8,800mAh	About 160 days
Stanby	4,400mAh	About 5 days
	8,800mAh	About 8 days

1.12.3 RTC Battery

The RTC battery provides the power supply to maintain the date, time, and other system information in memory.

Table 1-18 lists the Time required for charges of RTC battery.

Table 1-18 Time required for charges of RTC battery

Condition	Time
Power ON (Lights Power LED)	8 hours or longer
Power OFF (Doesn't light Power LED)	Doesn't charge

1.13 AC Adapter

The AC adapter is used to charge the battery.

Table 1-19 lists the AC adapter specifications.

Table 1-19 AC adapter specifications (1/2)

Item	Specifications	
	G71C0002SB10	G71C0004A410
Input voltage	100V/240V	
Input frequency	50Hz/60Hz	
No load input power	0.5W or less	
Output voltage	15.0V	
Output current	4.0A	

Table 1-19 AC adapter specifications (2/2)

Item	Specifications	
	G71C00043310	G71C00049310/ G71C00049410
Input voltage	100V/240V	
Input frequency	47Hz - 63Hz	
No load input power	0.7W or less	1.0W or less
Output voltage	15.0V	
Output current	5.0A	

Chapter 2

Troubleshooting Procedures

Chapter 2 Contents

2.1	Troubleshooting	2-1
2.2	Troubleshooting Flowchart.....	2-2
2.3	Power Supply Troubleshooting.....	2-6
	Procedure 1 Power Status Check	2-6
	Procedure 2 Error Code Check	2-8
	Procedure 3 Connection Check.....	2-13
	Procedure 4 Charging Check	2-13
	Procedure 5 Replacement Check	2-14
2.4	System Board Troubleshooting.....	2-15
	Procedure 1 Message Check	2-16
	Procedure 2 Debug Port Check.....	2-18
	Procedure 3 Diagnostic Test Program Execution Check	2-28
	Procedure 4 Replacement Check	2-28
2.5	3.5" FDD Troubleshooting	2-29
	Procedure 1 FDD Head Cleaning Check	2-29
	Procedure 2 Diagnostic Test Program Execution Check	2-30
	Procedure 3 Connector Check and Replacement Check.....	2-31
2.6	2.5" HDD Troubleshooting.....	2-32
	Procedure 1 Partition Check.....	2-32
	Procedure 2 Message Check	2-33
	Procedure 3 Format Check.....	2-34
	Procedure 4 Diagnostic Test Program Execution Check	2-35
	Procedure 5 Connector Check and Replacement Check.....	2-36
2.7	Keyboard Troubleshooting	2-37
	Procedure 1 Diagnostic Test Program Execution Check	2-37
	Procedure 2 Connector Check and Replacement Check.....	2-37

2.8	Display Troubleshooting.....	2-38
	Procedure 1 External Monitor Check.....	2-38
	Procedure 2 Diagnostic Test Program Execution Check	2-38
	Procedure 3 Connector and Cable Check.....	2-39
	Procedure 4 Replacement Check	2-40
2.9	Touch Pad Troubleshooting.....	2-41
	Procedure 1 Diagnostic Test Program Execution Check	2-41
	Procedure 2 Connector Check and Replacement Check.....	2-41
2.10	Optical Drive Troubleshooting	2-42
	Procedure 1 Diagnostic Test Program Execution Check	2-42
	Procedure 2 Connector Check and Replacement Check.....	2-42
2.11	Modem Troubleshooting.....	2-43
	Procedure 1 Diagnostic Test Program Execution Check	2-43
	Procedure 2 Connector Check and Replacement Check.....	2-43
2.12	LAN Troubleshooting.....	2-44
	Procedure 1 Diagnostic Test Program Execution Check	2-44
	Procedure 2 Connector Check and Replacement Check.....	2-44
2.13	Sound Troubleshooting.....	2-45
	Procedure 1 Diagnostic Test Program Execution Check	2-45
	Procedure 2 Connector Check.....	2-45
	Procedure 3 Replacement Check	2-46
2.14	Wireless LAN Troubleshooting	2-47
	Procedure 1 Transmitting-Receiving Check	2-47
	Procedure 2 Antennas' Connection Check	2-47
	Procedure 3 Replacement Check	2-48

Figures

Figure 2-1 Troubleshooting flowchart..... 2-3
Figure 2-2 A set of tool for debug port test 2-18

Tables

Table 2-1 Battery icon..... 2-6
Table 2-2 DC IN icon..... 2-6
Table 2-3 D port status 2-19
Table 2-4 FDD error code and status 2-30
Table 2-5 2.5” Hard disk drive error code and status..... 2-35

2.1 Troubleshooting

Chapter 2 describes how to determine which Field Replaceable Unit (FRU) in the computer is causing the computer to malfunction. (The “FRU” means the replaceable unit in the field.) The FRUs covered are:

- | | | |
|-----------------|------------------|------------------|
| 1. Power supply | 7. Touch pad | 13. Wireless LAN |
| 2. System Board | 8. Optical Drive | |
| 3. 3.5” USB FDD | 9. Modem | |
| 4. 2.5” HDD | 10. LAN | |
| 5. Keyboard | 11. Sound | |
| 6. Display | 12. Wireless LAN | |

The Test Program operations are described in Chapter 3. Detailed replacement procedures are given in Chapter 4.

The following tools are necessary for implementing the Diagnostics procedures (also tools for Chapter 3 and Chapter 4 are necessary if it is required.):

1. Diagnostics Disk (Test program for maintenance)
2. Phillips screwdrivers

NOTE: Be sure to use the PH point size “0” screwdriver complying with the ISO/DIS 8764-1:1996.

3. Toshiba MS-DOS system FD
4. Tester

There are following two types of connections in the figure of board and module connection in and after 2.3 Power Supply Troubleshooting.

- (1) Cable connection is described in the figure as line.
- (2) Pin connection is described in the figure as arrow.

<Example>

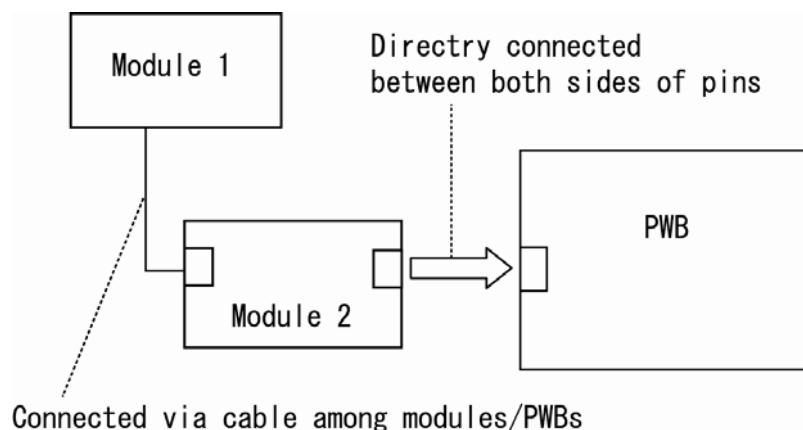

2.2 Troubleshooting Flowchart

Use the flowchart in Figure 2-1 as a guide for determining which troubleshooting procedure is executed. Before going through the flowchart steps, check the following:

- Make sure that Toshiba Windows[®] OS is installed on the hard disk. Non-Toshiba operating systems can cause the computer malfunction.
- Make sure all optional equipment is removed from the computer.

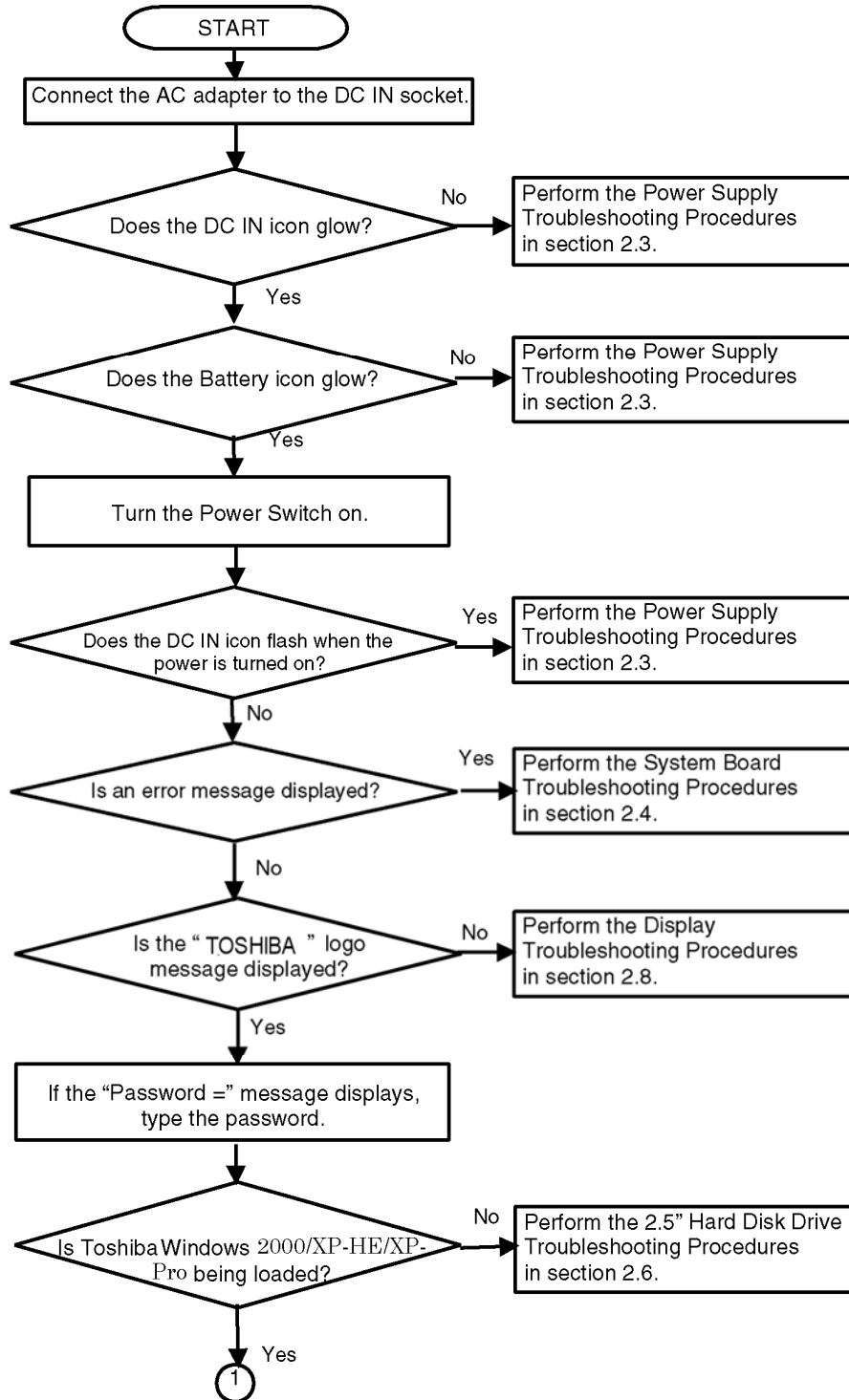

Figure 2-1 Troubleshooting flowchart (1/2)

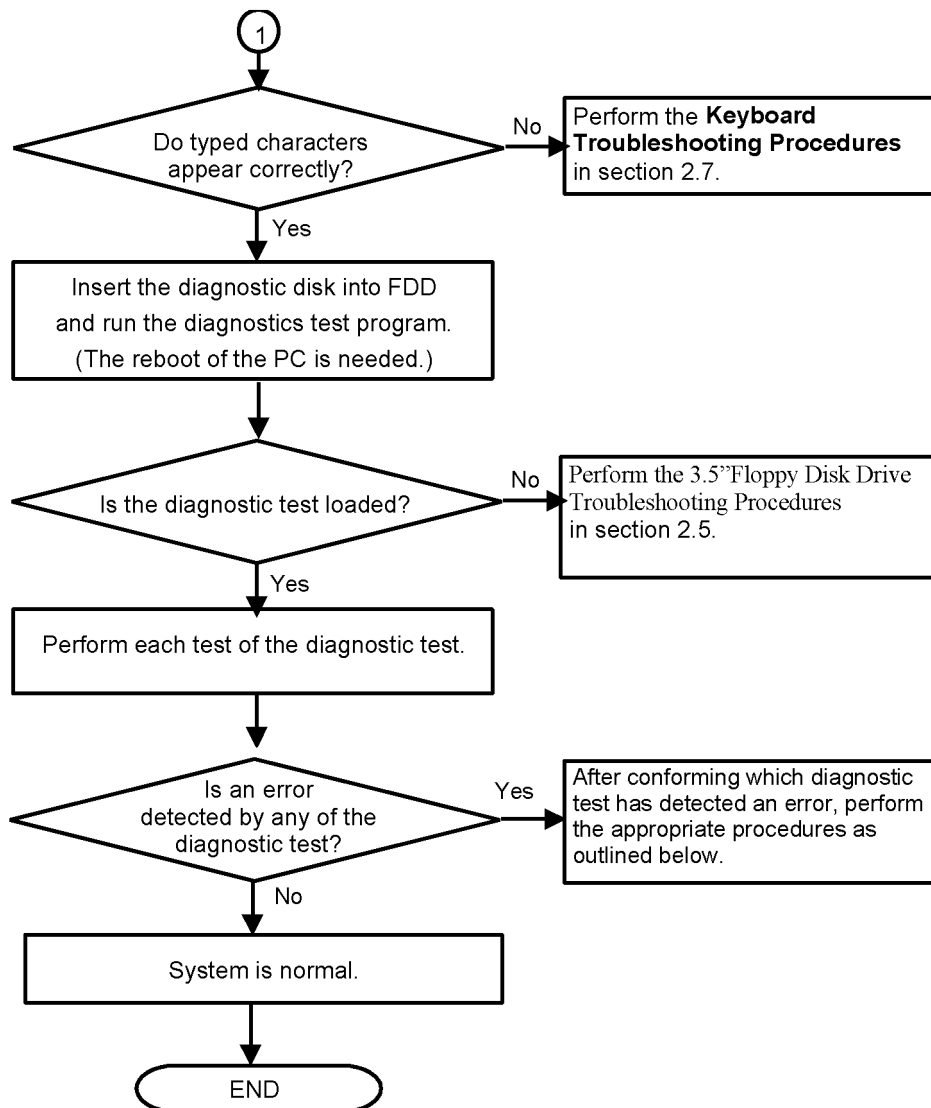

Figure 2-1 Troubleshooting flowchart (2/2)

If the diagnostics program cannot detect an error, the problem may be intermittent. The Test program should be executed several times to isolate the problem. Check the Log Utilities function to confirm which diagnostic test detected an error(s), then perform the appropriate troubleshooting procedures as follows:

1. If an error is detected on the system test, memory test, printer test, Async test, expansion test, real timer test, NDP test or IEEE1394 test, perform the System Board Troubleshooting Procedures in Section 2.4.
2. If an error is detected on the floppy disk test, perform the FDD Troubleshooting Procedures in Section 2.5.
3. If an error is detected on the hard disk test, perform the HDD Troubleshooting Procedures in Section 2.6.
4. If an error is detected on the keyboard test, perform the Keyboard Troubleshooting Procedures in Section 2.7.
5. If an error is detected on the display test, perform the Display Troubleshooting Procedures in Section 2.8.
6. If an error is detected on the test for the touch pad function, perform the Touch Pad Troubleshooting Procedures in Section 2.9.
7. If an error is detected on the CD-ROM/DVD-ROM test, perform the Optical Drive Troubleshooting Procedures in Section 2.10.
8. If an error is detected on the modem test, perform the Modem Troubleshooting Procedures in Section 2.11.
9. If an error is detected on the LAN test, perform the LAN Troubleshooting Procedures in Section 2.12.
10. If an error is detected on the sound test, perform the Sound Troubleshooting Procedures in Section 2.13.
11. If an error is detected on the Wireless LAN test, perform the Wireless LAN Troubleshooting Procedures in Section 2.14.

2.3 Power Supply Troubleshooting

The power supply controller controls many functions and components. To determine if the power supply is functioning properly, start with Procedure 1 and continue with the other Procedures as instructed. The procedures described in this section are:

Procedure 1: Power Status Check

Procedure 2: Error Code Check

Procedure 3: Connection Check

Procedure 4: Charging Check

Procedure 5: Replacement Check

Procedure 1 Power Status Check

The following icons indicate the power supply status:

Battery icon

DC IN icon

The power supply controller displays the power supply status with the Battery icon and the DC IN icon as listed in the tables below.

Table 2-1 Battery icon

Battery icon	Power supply status
Lights orange	Battery is charged and the external DC is input. It has no relation with ON/OFF of the system power.
Lights green	Battery is fully charged and the external DC is input. It has no relation with ON/OFF of the system power.
Blinks orange (even intervals)	The battery level is low while the system power is ON.
Doesn't light	Any condition other than those above.

Table 2-2 DC IN icon

DC IN icon	Power supply status
Lights green	DC power is being supplied from the AC adapter.
Blinks orange	Power supply malfunction*1
Doesn't light	Any condition other than those above.

*1 When the power supply controller detects a malfunction, the DC IN icon blinks orange. It shows an error code.

When the icon is blinking, perform the following procedure.

1. Remove the battery pack and the AC adapter.
2. Re-attach the battery pack and the AC adapter.

If the icon is still blinking after the operation above, check the followings:

- Check 1 If the DC IN icon blinks orange, go to Procedure 2.
- Check 2 If the DC IN icon does not light, go to Procedure 3.
- Check 3 If the battery icon does not light orange or green, go to Procedure 4.

NOTE: Use the following supplied AC adapter (G71C0002SB10, G71C0004A410, G71C00043310, G71C00049310 or G71C00049410).

Procedure 2 Error Code Check

If the power supply microprocessor detects a malfunction, the DC IN icon blinks orange. The blink pattern indicates an error as shown below.

- Start Off for 2 seconds
- Error code (8 bit)
 - “1” ON for one second
 - “0” ON for half second
 - Interval between data bits Off for half second

The error code begins with the least significant digit.

Example: Error code 13h (Error codes are given in hexadecimal format.)

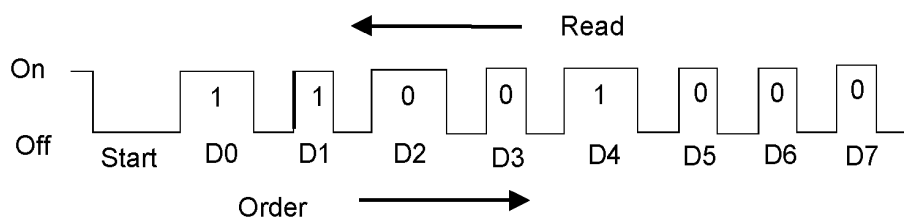

Check 1 Convert the DC IN icon blink pattern into the hexadecimal error code and compare it to the tables below. Then go to Check 2.

Error code	Where Error occurs
1*h	Adapter (AC Adapter, DS)
2*h	1 st battery
3*h	2 nd battery
4*h	S3V output
5*h	E5V output
6*h	E3V output
7*h	PPV output
8*h	1R8-B1V output
9*h	PPV output
A*h	PTV output
B*h	1R5-E1V output
C*h	PGV output
D*h	VG1R8-P1V output
E*h	PTV output
F*h	-

DC power supply (AC adapter)

Error code	Meaning
10h	AC Adapter output voltage is over 16.5V.
11h	Common Dock output voltage is over 16.5V.
12h	Current from the DC power supply is over 7.00A.
13h	Current from the DC power supply is over 0.5A when there is no load.
14h	Abnormal current has been sensed.

Main Battery

Error code	Meaning
22h	Main battery discharge current is over 0.5A when there is no load.
23h	Main battery charge current is over 3.9A when AC adapter is not connected.
24h	Abnormal current has been sensed.
25h	Main battery charge current is over 0.3A.

Second Battery

Error code	Meaning
32h	Second battery discharge current is over 0.5A when there is no load.
33h	Second battery charge current is over 3.9A. when AC adapter is not connected.
34h	Abnormal current has been sensed.
35h	Second battery charge current is over 0.3A.

S3V output (P60)

Error code	Meaning
40h	S3V voltage is 3.47V or less when the computer is powered on/off.
45h	S3V voltage is 3.14V or less when the computer is powered on.
46h	S3V voltage is 3.14V or less when the computer is booting up.(CV support)

❑ E5V output (P61)

Error code	Meaning
50h	E5V voltage is over 6.00V when the computer is powered on/off.
51h	E5V voltage is 4.50V or less when the computer is powered on.
52h	E5V voltage is 4.50V or less when the computer is booting up.
53h	E5V voltage is over 4.50V when the computer is powered off. (EV power is off)
54h	E5V voltage is 4.50V or less when the computer is powered off. (EV power is on)

❑ E3V output (P62)

Error code	Meaning
60h	E3V voltage is over 3.96V when the computer is powered on/off.
61h	E3V voltage is 2.81V or less when the computer is powered on.
62h	E3V voltage is 2.81V or less when the computer is booting up.
63h	E3V voltage is over 2.81V when the computer is powered off. (EV power is off)
64h	E3V voltage is 2.81V or less when the computer is powered off. (EV power is on)

❑ 1R5-E1V output (P63: MUX_CH0)

Error code	Meaning
70h	1R5-E1V voltage is over 1.80V when the computer is powered on/off.
71h	1R5-E1V voltage is 1.275V or less when the computer is powered on.
72h	1R5-E1V voltage is 1.275V or less when the computer is booting up.
73h	1R5-E1V voltage is over 1.275V when the computer is powered off. (EV power is off)

❑ 1R8-B1V output (P64)

Error code	Meaning
80h	1R8-B1V voltage is over 3.00V when the computer is powered on/off.
81h	1R8-B1V voltage is 1.53V or less when the computer is powered on.
82h	1R8-B1V voltage is 1.53V or less when the computer is booting up.
83h	1R8-B1V voltage is over 1.53V when the computer is powered off.
84h	1R8-B1V voltage is 1.53V or less when the computer is powered off. (BV power is on)

PPV output (P65)

Error code	Meaning
90h	PPV voltage is over 1.80V when the computer is powered on/off.
91h	PPV voltage is 0.56V or less when the computer is powered on.
92h	PPV voltage is 0.56V or less when the computer is booting up.
93h	PPV voltage is over 0.56V when the computer is powered off. (PV power is off)

PTV output (P66)

Error code	Meaning
A0h	PTV voltage is over 1.26V when the computer is powered on/off.
A1h	PTV voltage is 0.89V or less when the computer is powered on.
A2h	PTV voltage is 0.89V or less when the computer is booting up.
A3h	PTV voltage is over 0.89V or more when the computer is powered off. (PV power is off)

1R5-E1V output (P63: MUX_CH1)

Error code	Meaning
B0h	1R5-E1V voltage is over 1.80V when the computer is powered on/off.
B1h	1R5-E1V voltage is 1.275V or less when the computer is powered on.
B2h	1R5-E1V voltage is 1.275V or less when the computer is booting up.
B3h	1R5-E1V voltage is over 1.275V when the computer is powered off. (EV power is off)
B4h	1R5-E1V voltage is 1.275V or less when the computer is powered off. (EV power is on)

PTV output (P73)

Error code	Meaning
C0h	PTV voltage is over 1.63V when the computer is powered on/off.
C1h	PTV voltage is 0.68V or less when the computer is powered on.
C2h	PTV voltage is 0.68V or less when the computer is booting up.
C3h	PTV voltage is over 0.68V when the computer is powered off. (BV power is on)
C4h	PTV voltage is 0.68V or less when the computer is powered off. (BV power is on)

PTV output (P75)

Error code	Meaning
D0h	PTV voltage is over 2.16V when the computer is powered on/off.
D1h	PTV voltage is 0.89V or less when the computer is powered on.
D2h	PTV voltage is 0.89V or less when the computer is booting up.
D3h	PTV voltage is 0.89V or more when the computer is powered off. (PV power is off)

PTV output (P77: MUX_CH1)

Error code	Meaning
E0h	PTV voltage is over 1.26V when the computer is powered on/off.
E1h	PTV voltage is 0.89V or less when the computer is powered on.
E2h	PTV voltage is 0.89V or less when the computer is booting up.
E3h	PTV voltage is 0.89V or less when the computer is powered off. (PV power is off)

Check 2 In the case of error code 10h or 12h:

- Make sure the AC adapter and AC power cord are firmly plugged into the DC IN 15 V socket and wall outlet. If the cables are connected correctly, go to the following step:
- Connect a new AC adapter and AC power cord. If the error still exists, go to Procedure 5.

Check 3 In the case of error code 21h:

- Go to Procedure 3.

Check 4 For any other errors, go to Procedure 5.

Procedure 3 Connection Check

The wiring diagram related to the power supply is shown below:

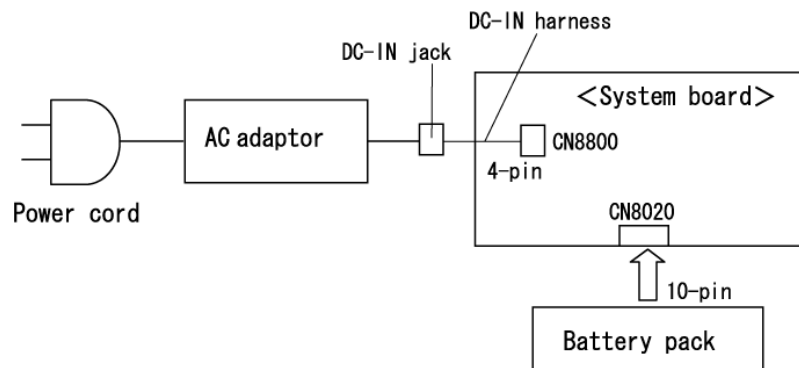

Any of the connectors may be disconnected. Perform Check 1.

- Check 1 Make sure the AC adaptor and the AC power cord are firmly plugged into the DC IN 15 V socket and wall outlet. If these cables are connected correctly, go to Check 2.
- Check 2 Replace the AC adaptor and the AC power cord with new ones.
- If the DC IN icon does not light, go to Procedure 5.
 - If the battery icon does not light, go to Check 3.
- Check 3 Make sure the battery pack is installed in the computer correctly. If the battery is properly installed and the battery icon still does not light, go to Procedure 4.

Procedure 4 Charging Check

Check if the power supply controller charges the battery pack properly. Perform the following procedures:

- Check 1 Make sure the AC adaptor is firmly plugged into the DC IN socket.
- Check 2 Make sure the battery pack is properly installed. If the battery is properly installed, go to Check 3.
- Check 3 The battery pack may be completely discharged. Wait a few minutes to charge the battery pack while connecting the battery pack and the AC adaptor. If the battery pack is still not charged, go to Check 4.
- Check 4 The battery's temperature is too high or low. Return the temperature to normal operating condition. If the battery pack is still not charged, go to Check 5.
- Check 5 Replace the battery pack with a new one. If the battery pack is still not charged, go to Procedure 5.

Procedure 5 Replacement Check

The power is supplied to the system board by the AC adapter. If either the AC adapter or the system board was damaged, perform the following Checks.

To disassemble the computer, follow the steps described in Chapter 4, *Replacement Procedures*.

- Check 1 Replace the AC adapter with a new one. If the AC adapter is still not functioning properly, perform Check 2.
- Check 2 Replace the DC-IN harness with a new one. If the AC adapter is still not functioning properly, perform Check 2.
- Check 3 Replace the system board with a new one.

2.4 System Board Troubleshooting

This section describes how to determine if the system board is defective. Start with Procedure 1 and continue with the other procedures as instructed. The procedures described in this section are:

Procedure 1: Message Check

Procedure 2: Debug Port Check

Procedure 3: Diagnostic Test Program Execution Check

Procedure 4: Replacement Check

Procedure 1 Message Check

When the power is turned on, the system performs the Initial Reliability Test (IRT) installed in the BIOS ROM. The IRT tests each IC on the system board and initializes it.

- If an error message is shown on the display, perform Check 1.
- If there is no error message, go to Procedure 2.
- If MS-DOS or Windows OS is properly loaded, go to Procedure 4.

Check 1 If one of the following error messages is displayed on the screen, press the **F1** key as the message instructs. These errors occur when the system configuration preserved in the RTC memory (CMOS type memory) is not the same as the actual configuration or when the data is lost.

If you press the **F1** key as the message instructs, the SETUP screen appears to set the system configuration. If error message (b) appears often when the power is turned on, replace the RTC battery. If any other error message is displayed, perform Check 2.

- (a) *** Bad HDD type ***
Check system. Then press [F1] key
- (b) *** Bad RTC battery ***
Check system. Then press [F1] key
- (c) *** Bad configuration ***
Check system. Then press [F1] key
- (d) *** Bad memory size ***
Check system. Then press [F1] key
- (e) *** Bad time function ***
Check system. Then press [F1] key
- (f) *** Bad check sum (CMOS) ***
Check system. Then press [F1] key
- (g) *** Bad check sum (ROM) ***
Check system. Then press [F1] key

Check 2 If the following error message is displayed on the screen, press any key as the message instructs. If any other error message displays, perform Check 3. The following error message appears when data stored in RAM under the resume function is lost because the battery has become discharged or the system board is damaged. Go to Procedure 3.

```
WARNING: RESUME FAILURE.  
PRESS ANY KEY TO CONTINUE.
```

Check 3 The IRT checks the system board. When the IRT detects an error, the system stops or an error message appears.

If one of the following error messages (1) through (17), (23) or (24) is displayed, go to Procedure 4.

If error message (18) is displayed, go to the Keyboard Troubleshooting Procedures in Section 2.7.

If error message (19), (20) or (21) is displayed, go to the 2.5" HDD Troubleshooting Procedures in Section 2.6.

- (1) PIT ERROR
- (2) MEMORY REFRESH ERROR
- (3) TIMER CH.2 OUT ERROR
- (4) CMOS CHECKSUM ERROR
- (5) CMOS BAD BATTERY ERROR
- (6) FIRST 64KB MEMORY ERROR
- (7) FIRST 64KB MEMORY PARITY ERROR
- (8) VRAM ERROR
- (9) SYSTEM MEMORY ERROR
- (10) SYSTEM MEMORY PARITY ERROR
- (11) EXTENDED MEMORY ERROR
- (12) EXTENDED MEMORY PARITY ERROR
- (13) DMA PAGE REGISTER ERROR
- (14) DMAC #1 ERROR
- (15) DMAC #2 ERROR
- (16) PIC #1 ERROR
- (17) PIC #2 ERROR
- (18) KBC ERROR
- (19) HDC ERROR
- (20) HDD #0 ERROR
- (21) HDD #1 ERROR
- (22) TIMER INTERRUPT ERROR
- (23) RTC UPDATE ERROR

Procedure 2 Debug Port Check

Check the D port status by a debug port test. The tool for debug port test is shown below.

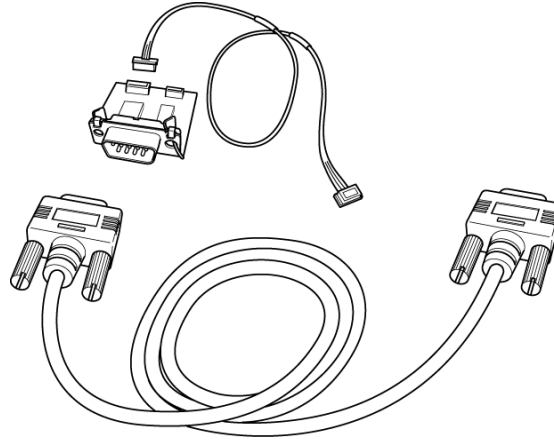
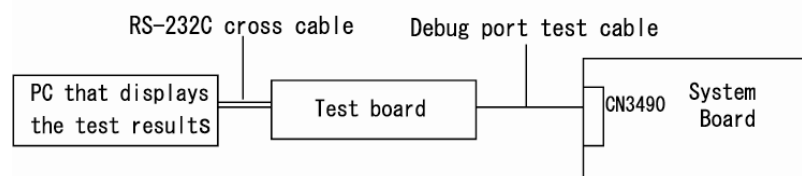

Figure 2-2 A set of tool for debug port test

The test procedures are follows;

1. Connect the debug test cable to the connector CN3490 of the system board. For disassembling to connect the test cable, refer to Chapter 4.
2. Connect the debug port test cable and RS-232C cross cable to the test board.
3. Connect the RS-232C cross cable to the PC that displays the results.



4. Boot the computer in MS-DOS mode.
5. Execute GETDPORT.COM in the text menu in CPU REAL mode. (Insert the FD for starting D port into FDD and input "FD starting drive:>dport".)

The D port status is displayed in the following form;

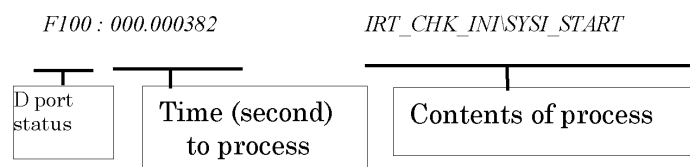

6. When the D port status is FFFFh (normal status), go to Procedure 3
7. When the D port status falls into any status in Table 2-3, execute Check 1.

Table 2-3 D port status (1/9)

D port status	Inspection items	Details
	Enabling address line A20 and Clearing a software reset bit	
	Prohibition of APIC	
	Initializing MCHM	
	Initializing ICHM	
	Initializing Super I/O	
	Initializing debug port	
	Dummy read of 3 rd Bus data	
	Setting of printer port	(Only for the model supporting PRT)
F000H	BTBK_START	
	Initializing the CH0 of a PIT	(For HOLD_ON)
	Initializing flags determining whether BIOS is rewritten	
	CHECK SUM CHECK	Switching to protected mode
		Examining the checksum of Boot Block (Skip when returned to S3) HLT when check sum error
		Examining the checksum other than Boot Block
F001H	BTBK_CALC_CHKSUM_END	
	EC/KBC rewrite check	BIOS rewrite when "rewrite" is requested
		Transition of the process to System BIOS IRT when returned to S3
	Key input	
	When inputting key, [], [半角/全角 (漢字)], [TAB] key check	
F002H	BTBK_INI_SC_START	
	Initializing security controller	
F003H	BTBK_INI_SC_ERR	
F004H	BTBK_SC_HW_FAILURE	
F005H	BTBK_INI_KBC_END	
	Checking whether BIOS rewrite is requested	Checksum error except Boot Block when rewrite is requested by user
		Transition to BIOS rewrite
F006H	BTBK_ENTER_CHK_BIOS_SIGN	
	BIOS signature check	

Table 2-3 D port status (2/9)

D port status	Inspection items	Details
F007H	BTBK_ENTER_SYSTEM_BIOS	
	Transition to System BIOS IRT	
BIOS Rewrite process		
	ICHM.D31 Initialization	
	DRAM Configuration	
	Permission of cache () Only for L1 cache	
	MEMORI CLEAR	
F008H	BTBK_INI_MEM_END	
	Transition to real moded, Copy BIOS in RAM	
F009H	BTBK_CHG_RAM_BIOS	
	Storing key scan code	
	Setting up TASK_1ms_TSC	
F00AH	BTBK_INI_VGA_END	
	Controlling Fan	
	Initializing sound systems (For beep sound)	Enabling system speaker
		Canceling mute
		Maximizing volume
When BIOS,EC/KBC is requested to be rewritten	(Green blinks in 2s cycle (ON:1s, Off: 1s))	
F00BH	BTBK_CANT_UPDATE_BIOS	
	Abnormal BIOS ROM	(Orange blinks in 2s cycle (ON:1s, Off: 1s))
	Key input	Disabling USB first
		Sound beep
		Waiting for key input
	Loading CHGBIOSA.EXE/CHGFIRMA.EXE	FDC RESET
		Setting up the parameter for 2HD (1.44MB)
		Loading first sector and Confirming the media if it is 2HD (1.44MB)
		Setting up the parameter for 2DD (720KB)
		Searching CHGBIOSA.EXE from route directory
Calculate starting directory head, sector		
Loading route directory per sector		

Table 2-3 D port status (3/9)

D port status	Inspection items	Details
		Searching entry of "CHGBIOSA.EXE/CHGFIRMA.EXE" from the loaded sector
		Loading EXE header of "CHGBIOSA.EXE /CHGFIRMA.EXE", Key input when an error occurred
		Executing "CHGBIOSA.EXE"/"CHGFIRMA.EXE"
IRT		
F100H	IRT_START	
	Cache controll for HyperThreading	
	Disabling cache	
	Initializing H/W (before recognizing DRAM)	Initializing MCHM
		Initializing ICH4M.D31.Func0
		Initializing ICH4M.D31.Func1
		Initializing USB.Func0,1,2,7
		Initializing ICH4M.D31.Func3
		Initializing ICH4M.D31.Func5
		Initializing FLUTE
		Initializing the channel 1 of a PIT
F101H	IRT_INI_SPREG_END	
	Checking type and size of DRAM (at Cold boot only)	When no suport memory is connected, HLT after beep
	HLT when DRAM size is 0	
	Testing stack area of SM-RAM	HLT when impossible to use as stack
F102H	IRT_STACK_TEST_END	
	Cache Configuration	
	Enabling L1 and L2 cache	
	Access test of CMOS	(at Cold boot only) (HLT when an error occurred)
	Checking battery level of CMOS	
	Checksum check of CMOS	
	Initializing CMOS data (1)	
	Setting up IRT status	(Setting of Boot status and IRT Busy Flag, The bit left is 0)
	Storing DRAM size	

Table 2-3 D port status (4/9)

D port status	Inspection items	Details
F103H	IRT_RSM_BRANCH	
	Resume branch check (at Cold boot only)	Not resuming when a CMOS error occurred
		Not resuming when status code of resume is not set
		Checking resume error
		S3 Return error (ICH) Resume error 170H RSM_UNKNOWN_ERR
		Checking CheckSum of SM-RAM Resume error 173H RSM_SMRAM_ERR
		Checking the change of memory configuration Resume error 174H RSM_SYSTEM_ERR
		Checking CheckSum of RAM area of system BIOS Resume error 179H RSM_RAMBIOS_ERR
		Checking CheckSum of expanded memory Resume error 176H RSM_EXTMEM_ERR
		Checking CheckSum of PnP RAM Resume error 177H RSM_PNPRAM_ERR
		Processing resume (RESUME_MAIN)
	Processing resume error	Return the CPU clock to Low
		Disabling all SMI
		Clearing resume status
		Return to ROM
		Send the area from C0000h to EFFFFh to PCI (Disabling DRAM)
		Setting up Resume error request
	Copy ROM/RAM of the System BIOS	(HLT when an error occurred)
F104H	IRT_BIOS_SIGN_CHK	
	BIOS signature check	(at Cold boot only)
F105H	IRT_CHG_RAM_BIOS_END	
	SMRAM initialization	
	Checking CPU supporting Hyper-Threading	
	Microcode Update	
	APIC initialization	
	Checking the factor of WakeUp	
	Rewriting the SMRAM base and Storing CPU state map for BIOS	
	Enabling SMI only by ASMI	

Table 2-3 D port status (5/9)

D port status	Inspection items	Details
F106H	IRT_INI_SMBASE_END	
	Initialization of the device Which needs initialization before PCI BUS Initialization	PCI test (at Cold boot only) and Initialization
	Setting test pattern in PIT#0 of Channel 0	
	Checking whether test pattern set can be read	
	Initializing the channel 0 of a PIT (set 55ms for the interval of interrupt timer)	
	Initializing the channel 2 of a PIT	(set 664Hz frequency for sound generator)
	Testing the channel 1 of a PIT	(Checking whether refresh signal works properly with the cycle of refresh interval 30 μ s), HLT when timeout
	Testing the channel 2 of a PIT	(Checking whether speaker gate works properly)
		Measuring the clock speed of a CPU
		Permission of SMI except auto-off function
		Control the excess of the rated input power
		Battery discharge current control (1CmA)
		AC adapter rated over current control
		Dividing procedures for time measuring of IRT
		Setting for clock generator
		Checking the parameter block A
		Initialization of CPU
	Confirming CPU type	
	Check the support of Geyserville	
Set the CPU clock to "High"	Set Graphics Aperture Size	
F107H	IRT_CHK_INI_SYS1_END	
	Storing the configuration of ROM in a buffer	
	Reading EC version	
	Updating the type of flash memory	
	Determining what country the computer is designed to be used in by DMI data	
	Checking the default settings of CMOS (When finding Bad Battery, Bad CheckSum (ROM, CMOS), set default)	
	Initializing ACPI table (For executing option ROM)	

Table 2-3 D port status (6/9)

D port status	Inspection items	Details
	Initialization of the device needed initializing before PCI BUS Initialization	AC'97 control
		Initializing information of thermal control
		Initializing a KBC
		Turning VGA display off and controlling reset
		Initializing sound function
		Acquiring the computer multiple box status
		HC initialization, Recognition of USB device connection and initialization
		Permission/ prohibition of Built-in LAN control
	Initializing a PCI	
	Testing a PIC	
	Initializing password	
F108H	IRT_CHK_INI_SYS2_END	
	Initializing PCI Initializing PCI BUS (connecting DS Bus)	
	Initializing information of LAN	
	Checking the factor of WakeUp	
F109H	IRT_INI_PCI_END	
	Running a task of waiting for the end of INIT_PCI	
	Initializing the data in CMOS (2)	
	Initializing PnP	
	Setting up the setup parameters	
	Waiting for the end of multiple box state check	
	Setting up the hardware parameters based on resources	
F10AH	IRT_MK_SYSRES_END	
	Running a task of waiting for the end of PnP resource creation	
	Serial interrupt control	(performed before interrupt)
	Initializing PnP hardware	Initializing PC Card Slots
		Initializing SIO (for models supporting SIO)
		Initializing FIR (for models supporting FIR)
	PCI automatic configuration	Making of work for automatic configuration
Acquisition of PCI IRQ		
		PCI Configuration

Table 2-3 D port status (7/9)

D port	Inspection items	Details
		Storing of VGA configuration result
F10BH	IRT_PCI_CONF_END	
		Task generation for waiting PCI_CONFIGURATION completion
	Initialization of H/W which is necessary after PCI configuration	Printer port setting (for models supporting printer port)
		HDD initialization sequence start
	FDD initialization sequence start (For models supporting built-in FDD)	
	Enabling power off	
	Output code generation	
F10CH	IRT_CHK_INI_SYS3_END	
	FIRST_64KB_CHECK	Checking the first 64KB of memory
F10DH	IRT_CHK_F64KB_END	
	INIT_INT_VECTOR	Initializing interrupt vectors
F10EH	IRT_INI_VECT_END	
	INIT_NDP	Initializing a NDP
F10FH	IRT_INI_NDP_END	
	INIT_SYSTEM	(Initialization of system)
		Storing CMOS error information in IRT_ERR_STS_BUF
		Timer initialization start
		Initializing an EC, and reading battery
	Updating system BIOS (Updating EDID of the LCD)	
F110H	IRT_INI_SYS_END	
	INIT_DISPLAY	(Waiting for VGA chip initialization completion , Initializing VGA BIOS)
F111H	IRT_VGA_POS_START	
	VGA POST	(Waiting for VGA chip initialization completion , Initializing VGA BIOS)
F112H	IRT_INI_POST_END	
F113H	IRT_INI_DISP_END	
	DISP_LOGO	(Displaying a logo)
F114H	IRT_DISP_LOGO_END	
	SYS_MEM_CHECK	Checking conventional memory (Boot)
F115H	IRT_SYSTEM_CHK_END	
	EXT_MEM_CHECK	Exception check in protect mode (Cold boot only)

Table 2-3 D port status (8/9)

D port status	Inspection items	Details
		Setting up the address of font data for resume password
		Setting up the parameters for character repeat on a USB keyboard
		Final check of key input during IRT
		Storing of T_SHADOW_RAM_SIZE
		Update of system resource before boot
		Rewriting memory map data for INT15h E820h function
		Waiting for AC-Link initialization completion
		Updating of table for DMI
		Waiting for AC-Link initialization completion
		Waiting for the end of writing PSC version on BIOS
		Waiting for clock generator setting completion (Stops in "F121H" when an error is detected)
		Waiting for the end of serial port initialization (for models supporting SIO)
		Canceling NMI mask
		Clearance of the checksum of TIT
		Clearing IRT running flag for runtime
		Update checksum for runtime
		Hibernation branch (for models supporting BIOS Hibernation)
		Initialization of Bluetooth (for models supporting Bluetooth)
		Check of existence of supported maintenance cards
		Prohibition unused PC cards
		Setting of WAKEUP status data for ACPI
		HW initialization before Boot, Waiting for initialization completion
F122H	IRT_SC_INIT_START	
F123H	IRT_SC_INIT_END	
	Notify the DVI connection status to VGA BIOS	(for models supporting DVI)
	Setting up battery safe mode	
	Setting up date	
	Waiting for the end of Bluetooth initialization	(for models supporting Bluetooth)

Table 2-3 D port status (9/9)

D port status	Inspection items	Details	
	Updating DMI Wakeup factor and SM-BIOS structure table		
	Closing configuration space of PCI devices		
	Cache control		
	Update of parameter block A		
	Process for CPU		Make the CPU clock to be set by SETUP
	Waiting for the motor off of a disabled HDD		
	Final decision of USB FDD drive information		
	Post processing of PRE_BOOT_SETUP	Clearing PWRBTN_STS	
		Enabling the power button	
F124H	IRT_PRE_BOOT_SETUP_END		
F125H	IRT_WAIT_DISP_LOGO_START		
	Clearing IRT status		
	Updating of checksum for Runtime		
FFFFH	IRT_POST_END		

Procedure 3 Diagnostic Test Program Execution Check

Execute the following tests from the Diagnostic Test Menu. These tests check the system board. Refer to Chapter 3, *Tests and Diagnostic*, for more information on how to perform these tests.

1. System test
2. Memory test
3. Keyboard test
4. Display test
5. Floppy Disk test
6. Printer test
7. Async test
8. Hard Disk test
9. Real Timer test
10. NDP test
11. Expansion test
12. CD-ROM/DVD-ROM test
13. Only One test
14. Wireless LAN test
15. LAN/Modem/Bluetooth/IEEE1394 test
16. Sound test

If an error is detected during these tests, go to Procedure 4.

Procedure 4 Replacement Check

The system board may be damaged. Disassemble the computer following the steps described in Chapter 4, *Replacement Procedures* and replace the system board with a new one.

2.5 3.5" FDD Troubleshooting

This section describes how to determine if the 3.5" FDD is functioning properly. Perform the steps below starting with Procedure 1 and continuing with the other procedures as required.

Procedure 1: FDD Head Cleaning Check

Procedure 2: Diagnostic Test Program Execution Check

Procedure 3: Connector Check and Replacement Check

Procedure 1 FDD Head Cleaning Check

FDD head cleaning is one option available in the Diagnostic Program.

Insert the Diagnostics Disk in the external floppy disk drive, turn on the computer and run the test. And then clean the FDD heads using the cleaning kit. If the FDD still does not function properly after cleaning, go to Procedure 2.

Detailed operation is given in Chapter 3, *Tests and Diagnostics*.

If the test program cannot be executed on the computer, go to Procedure 3.

Procedure 2 Diagnostic Test Program Execution Check

Insert the Diagnostics Disk in the USB FDD, turn on the computer and run the test. Refer to Chapter 3, *Tests and Diagnostics*, for more information about the diagnostics test procedures.

Make sure the floppy disk is formatted correctly and that the write protect tab is disabled. Floppy disk drive test error codes and their status names are listed in Table 2-4. If any other errors occur while executing the FDD diagnostics test, go to Check 1.

Table 2-4 FDD error code and status

Code	Status
01h	Bad command
02h	Address mark not found
03h	Write protected
04h	Record not found
06h	Media replaced
08h	DMA overrun error
09h	DMA boundary error
10h	CRC error
20h	FDC error
40h	Seek error
60h	FDD not drive
80h	Time out error (Not ready)
EEh	Write buffer error
FFh	Data compare error

Check 1 If the following message is displayed, disable the write protect tab on the floppy disk by sliding the write protect tab to “write enable”. If any other message appears, perform Check 2.

Write protected

Check 2 Make sure the floppy disk is formatted correctly. If it is, go to Procedure 3.

Procedure 3 Connector Check and Replacement Check

The USB connector may be disconnected from the system board. Check visually that the connector is connected firmly.

Check 1 Make sure the following cables and connectors are firmly connected to the each board.

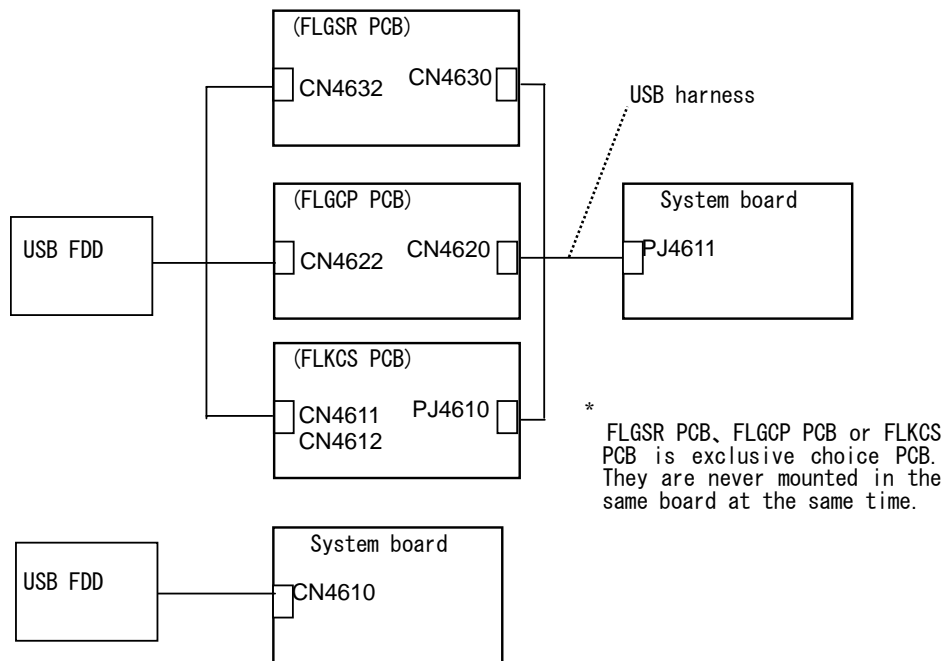

If any of the connections are loose, reconnect firmly and repeat Procedure 2. If there is still an error, go to Check 2.

Check 2 The USB FDD may be defective or damaged. Replace it with a new one. If the FDD is still not functioning properly, perform Check 3.

Check 3 The FLGSR board, FLGCP board or FLKCS board connected to the system board may be defective or damaged. Replace it with a new one. If the FDD is still not functioning properly, perform Check 4.

Check 4 Replace the system board with a new one following the steps in Chapter 4, *Replacement Procedures*.

2.6 2.5" HDD Troubleshooting

This section describes how to determine if the 2.5" HDD is functioning properly. Perform the steps below starting with Procedure 1 and continuing with the other procedures as required.

Procedure 1: Partition Check

Procedure 2: Message Check

Procedure 3: Format Check

Procedure 4: Diagnostic Test Program Execution Check

Procedure 5: Connector Check and Replacement Check

CAUTION: *The contents of the hard disk will be erased when the 2.5" HDD troubleshooting procedures are executed. Transfer the contents of the hard disk to floppy disks or other storage drive(s). For the backup, refer to the User's Manual.*

Procedure 1 Partition Check

Insert the Toshiba MS-DOS system disk and start the computer. Perform the following checks:

- Check 1 Type **C:** and press **Enter**. If you cannot change to drive C, go to Check 2. If you can change to drive C, go to Procedure 2.
- Check 2 Type **FDISK** and press **Enter**. Choose Display Partition Information from the FDISK menu. If drive C is listed in the Display Partition Information, go to Check 3. If drive C is not listed, return to the FDISK menu and choose the option to create a DOS partition or a logical DOS drive on drive C. If the problem still exists, go to Procedure 2.
- Check 3 If drive C is listed as active in the FDISK menu, go to Check 4. If drive C is not listed as active, return to the FDISK menu and choose the option to set the active partition for drive C. Then go to Procedure 2.
- Check 4 Remove the system disk from the FDD and reboot the computer. If the problem still exists, go to Procedure 2. Otherwise, the 2.5" HDD is operating normally.

Procedure 2 Message Check

When the power is turned on, the system performs the Initial Reliability Test (IRT) installed in the BIOS ROM. When the test detects an error, an error message is displayed on the screen.

Make sure of no floppy disk in the FDD. Turn on the computer and check the message on the screen. When an OS starts from the 2.5" HDD, go to Procedure 3. Otherwise, start with Check 1 below and perform the other checks as instructed.

Check 1 If any of the following messages appear, go to Procedure 3. If the following messages do not appear, perform Check 2.

HDC ERROR

or

HDD #X ERROR (After 5 seconds this message will disappear.)

Check 2 If either of the following messages appears, go to Check 3. If the following messages do not appear, perform Check 5.

Insert system disk in drive

Press any key when ready

or

Non-System disk or disk error

Replace and press any key when ready

Check 3 Check SETUP to see whether the Hard Disk option is set to Not used. If it is set to Not used, choose another setting and return to Check 1. If it is not set to Not used, go to Check 4.

Check 4 Using the SYS command of the MS-DOS, transfer the system to the 2.5" HDD. If the system is not transferred, go to Procedure 3. Refer to the MS-DOS Manual for detailed operation.

If the following message appears on the display, the system program has been transferred to the HDD.

System Transferred

If an error message appears on the display, perform Check 5.

Check 5 The 2.5" HDD and the connector of the system board may be disconnected (Refer to the steps described in Chapter 4, *Replacement Procedures* for disassembling.). Insert the connectors firmly. If they are firmly connected, go to Procedure 3.

Procedure 3 Format Check

The computer's HDD is formatted using the MS-DOS FORMAT program or the physical format program of the test program. To format the HDD, start with Check 1 below and perform the other steps as required.

Refer to the MS-DOS Manual for the operation of MS-DOS. For the format by the test program, refer to the Chapter 3.

Check 1 Format an 2.5" HDD using MS-DOS FORMAT command. Type as **FORMAT C:/S/U**.

 If the 2.5" HDD can not be formatted, perform Check 2.

Check 2 Using the MS-DOS FDISK command, set the 2.5" HDD partition. If the partition is not set, go to Check 3. If it is set, format the 2.5" HDD using MS-DOS FORMAT command.

Check 3 Using the Diagnostic Disk, format the 2.5" HDD with a format option (physical format). If the HDD is formatted, set the 2.5" HDD partition using MS-DOS FDISK command.

 If you cannot format the 2.5" HDD using the Tests and Diagnostic program, go to Procedure 4.

Procedure 4 Diagnostic Test Program Execution Check

The HDD test program is stored in the Diagnostics Disk. Perform all of the HDD tests in the Hard Disk Drive Test. Refer to Chapter 3, *Tests and Diagnostics*, for more information about the HDD test program.

If an error is detected during the HDD test, an error code and status will be displayed. The error codes and statuses are described in Table 2-5. If an error code is not displayed but the problem still exists, go to Procedure 5.

Table 2-5 2.5" Hard disk drive error code and status

Code	Status
01h	Bad command
02h	Address mark not found
04h	Record not found
05h	HDC not reset
07h	Drive not initialized
08h	HDC overrun error (DRQ)
09h	DMA boundary error
0Ah	Bad sector error
0Bh	Bad track error
10h	ECC error
11h	ECC recover enable
20h	HDC error
40h	Seek error
80h	Time out error
AAh	Drive not ready
BBh	Undefined error
CCh	Write fault
E0h	Status error
EEh	Access time out error
DAh	No HDD
FFh	Data compare error

Procedure 5 Connector Check and Replacement Check

The HDD is connected to the connector of the system board. The connecting portion may be disconnected. Disassemble the computer following the steps described in Chapter 4, *Replacement Procedures* and perform the following checks to check the connecting portion:

Check 1 Make sure the following connectors are firmly connected to the system board.

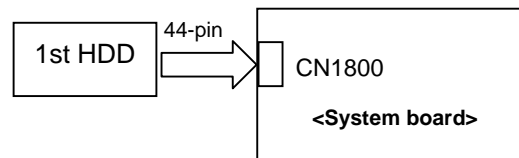

If the connection is loose, reconnect firmly and repeat Procedure 1. If there is still an error, go to Check 2.

Check 2 The 2.5" HDD may be damaged. Replace it with a new one following the instructions in Chapter 4, *Replacement Procedures* and check the operation. If the problem still exists, perform Check 3.

Check 3 The system board may be damaged. Replace it with a new one following the instructions in Chapter 4, *Replacement Procedures*.

2.7 Keyboard Troubleshooting

To determine if the computer's keyboard is functioning properly, perform the following procedures. Start with Procedure 1 and continue with the other procedures as instructed.

Procedure 1: Diagnostic Test Program Execution Check

Procedure 2: Connector Check and Replacement Check

Procedure 1 Diagnostic Test Program Execution Check

Execute the Keyboard Test (DIAGNOSTIC TEST) and Pressed key display test (ONLY ONE TEST) in the Diagnostic Program. Refer to Chapter 3, *Tests and Diagnostics*, for more information on how to perform the test program.

If an error occurs, go to Procedure 2. If an error does not occur, keyboard is functioning properly.

Procedure 2 Connector Check and Replacement Check

The keyboard or system board may be disconnected or damaged. Disassemble the computer following the steps described in Chapter 4, *Replacement Procedures* and perform the following checks:

Check 1 Make sure the keyboard cable is firmly connected to the system board.

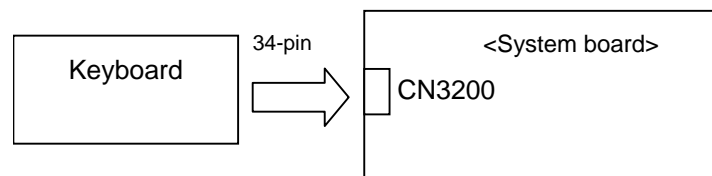

If the connection is loose, reconnect firmly and repeat Procedure 1. If there is still an error, go to Check 2.

Check 2 The keyboard may be damaged. Replace it with a new one following the instructions in Chapter 4, *Replacement Procedures*. If the problem still exists, perform Check 3.

Check 3 The system board may be damaged. Replace it with a new one following the instructions in Chapter 4, *Replacement Procedures*.

2.8 Display Troubleshooting

To check if the computer's display is malfunctioning or not, follow the troubleshooting procedures below as instructed.

Procedure 1: External Monitor Check

Procedure 2: Diagnostic Test Program Execution Check

Procedure 3: Connector and Cable Check

Procedure 4: Replacement Check

Procedure 1 External Monitor Check

Connect an external monitor to the computer's external monitor port, then boot the computer. The computer automatically detects the external monitor.

If the external monitor works correctly, the internal LCD may be faulty. Go to Procedure 3.

If the external monitor appears to have the same problem as the internal monitor, system board may be faulty. Go to Procedure 2.

Procedure 2 Diagnostic Test Program Execution Check

The Display Test program is stored in Diagnostics disk. This program checks the display controller on system board. Insert the Diagnostics disk in the USB FDD, turn on the computer and run the test. Refer to Chapter 3, *Tests and Diagnostics* for details. If an error is detected, go to Procedure 3.

Procedure 3 Connector and Cable Check

LCD Module is connected to system board by an LCD/FL cable. FL inverter board is also connected to system board by an LCD/FL cable. In addition, fluorescent lamp is connected to FL inverter board by HV cable. Their cables may be disconnected from system board or FL inverter board. Disassemble the computer following the steps described in Chapter 4, *Replacement Procedures*.

If the connection is loose, reconnect firmly and restart the computer. If the problem still occurs, go to Procedure 4.

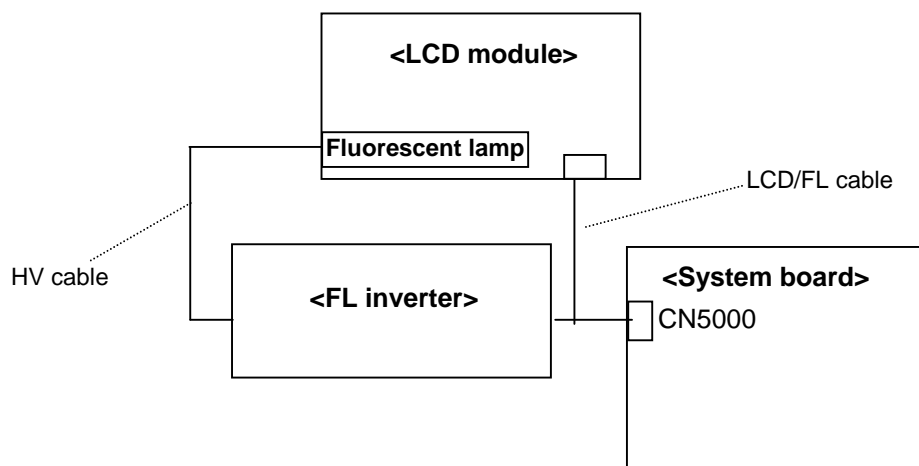

Procedure 4 Replacement Check

Fluorescent lamp, FL inverter, LCD module, HV cable and LCD/FL cable are connected to display circuits. Any of these components may be faulty. Refer to Chapter 4, *Replacement Procedures*, for instructions on how to disassemble the computer and then perform the following checks:

If fluorescent lamp does not light, perform Check 1.

If characters or graphics on the internal display are not displayed clearly, perform Check 4.

If some screen functions do not operate properly, perform Check 4.

If fluorescent lamp remains lit when the display is closed, perform Check 5.

Check 1 Replace fluorescent lamp with a new one following the instructions in Chapter 4, *Replacement Procedures* and test the display again. If the problem still occurs, perform Check 2.

Check 2 LCD/FL cable may be faulty. Replace FL/LCD cable with a new one following the instructions in Chapter 4, *Replacement Procedure* and test the display again. If the problem still occurs, perform Check 3.

Check 3 FL inverter may be faulty. Replace FL inverter with a new one following the instructions in Chapter 4, *Replacement Procedure* and test the display again. If the problem still occurs, perform Check 4.

Check 4 LCD module may be faulty. Replace LCD module with a new one following the instructions in Chapter 4, *Replacement Procedure* and test the display again. If the problem still occurs, perform Check 5.

Check 5 System board may be faulty. Replace it with a new one following the instructions in Chapter 4, *Replacement Procedure*.

2.9 Touch Pad Troubleshooting

To determine whether the Touch Pad is faulty or not, perform the following procedures:

Procedure 1: Diagnostic Test Program Execution Check

Procedure 2: Connector and Cable Check

Procedure 1 Diagnostic Test Program Execution Check

Execute the Touch pad test (ONLY ONE TEST) in the Diagnostic Program. Refer to Chapter 3, *Tests and Diagnostics*, for more information on how to perform the test program.

If an error occurs, go to Procedure 2. If an error does not occur, touch pad is functioning properly.

Procedure 2 Connector Check & Replacement Check

Check 1 Make sure the touch pad cable is firmly connected to the system board.

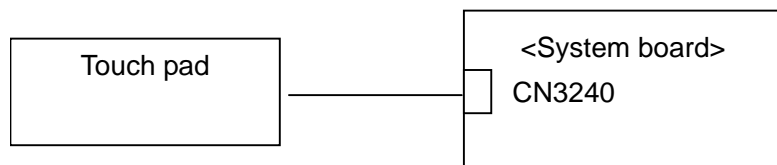

If the connection is loose, reconnect firmly and repeat Procedure 1. If there is still an error, go to Check 2.

Check 2 The touch pad or touch pad cable may be damaged. Replace it with a new one following the instructions in Chapter 4, *Replacement Procedures*. If the problem still exists, perform Check 3.

Check 3 The system board may be damaged. Replace it with a new one following the instructions in Chapter 4, *Replacement Procedures*.

2.10 Optical Drive Troubleshooting

To check if the optical drive is defective or malfunctioning, follow the troubleshooting procedures below as instructed.

Procedure 1 Diagnostic Test Program Execution Check

Procedure 2 Connector Check and Replacement Check

Procedure 1 Diagnostic Test Program Execution Check

Execute the CD-ROM/DVD-ROM Test in the Diagnostic Program. Refer to Chapter 3, *Tests and Diagnostics* for more information on how to perform the test program.

Prepare the tools before the test. (Refer to tools for implementing the Diagnostics procedures on page 2-1.)

If any error is detected by the test, go to Procedure 2.

Procedure 2 Connector Check and Replacement Check

The optical drive is connected to the system board by the connector. The connector may be disconnected from the system board or faulty. Disassemble the computer following the steps described in Chapter 4 and perform the following checks:

Check 1 Make sure the following connector has been firmly connected to the optical drive and the system board.

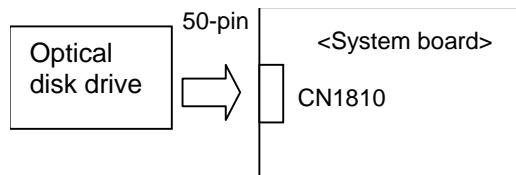

If the connection is loose, reconnect it firmly and return to Procedure 2. If there is still an error, perform Check 2.

Check 2 The optical drive may be faulty. Replace the optical drive with a new one following the steps in Chapter 4. If the optical drive is still not functioning properly, perform Check 3.

Check 3 The system board may be faulty. Replace it with new one following the instructions in Chapter 4.

2.11 Modem Troubleshooting

To check if the modem is defective or malfunctioning, follow the troubleshooting procedures below as instructed.

Procedure 1 Diagnostic Test Program Execution Check

Procedure 2 Connector Check and Replacement Check

Procedure 1 Diagnostic Test Program Execution Check

Execute Modem test in the LAN/Modem/Bluetooth/IEEE1394 test program. Refer to Chapter 3, *Tests and Diagnostics* for more information on how to perform the test program.

If any error is detected, perform Procedure 2.

Procedure 2 Connector Check and Replacement Check

An MDC (Modem Daughter Card) is used as the modem for this computer. The MDC is connected to the system board by connector. If the modem malfunctions, these connections may be bad or the MDC or system board might be faulty.

Disassemble the computer following the steps described in Chapter 4 and perform the following checks:

Check 1 Make sure the MDC has been firmly connected to the CN3010 on the system board and the modem harness has been firmly connected to the both connectors on the system board and on the modem.

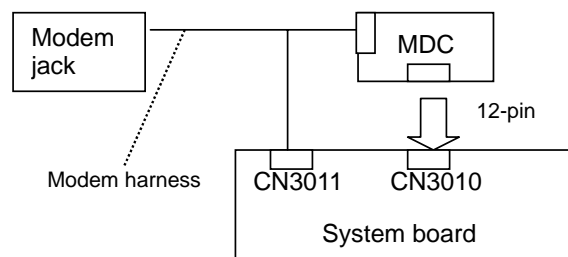

If any connector is disconnected, connect it firmly and return to Procedure 1. If there is still an error, perform Check 2.

Check 2 The Modem jack may be faulty. Replace it with a new one. If the modem function is still not working properly, perform Check 3.

Check 3 The MDC may be faulty. Replace it with a new one following the steps in Chapter 4. If the modem function is still not working properly, perform Check 4.

Check 4 The system board may be faulty. Replace it with a new one following the instructions in Chapter 4

2.12 LAN Troubleshooting

To check if the computer's LAN is defective or malfunctioning, follow the troubleshooting procedures below as instructed.

Procedure 1 Diagnostic Test Program Execution Check

Procedure 2 Connector Check and Replacement Check

Procedure 1 Diagnostic Test Program Execution Check

Execute LAN test in the LAN/Modem/Bluetooth/IEEE1394 test program. Refer to Chapter 3, *Tests and Diagnostics* for more information on how to perform the test program.

If any error is detected by the test, go to Procedure 2.

Procedure 2 Connector Check and Replacement Check

The LAN function is operated by the system board via LAN harness. If the LAN malfunctions, the connection among LAN cable, LAN harness and system board is bad or they might be faulty.

Disassemble the computer following the steps described in Chapter 4 and perform the following checks:

Check 1 Check if the LAN cable and LAN harness are connected firmly to the connectors.

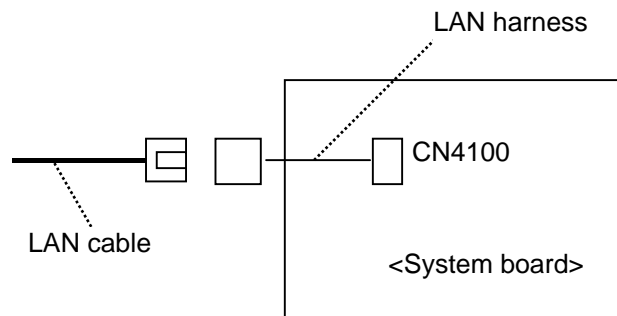

If they are loose or disconnected, connect it firmly and return to Procedure 1. If there is still an error, perform Check 2.

Check 2 The LAN cable may be defective. Replace the LAN cable with a new one. If the problem persists, perform Check 3.

Check 3 The LAN harness may be defective. Replace the LAN harness with a new one. If the problem persists, perform Check 4.

Check 3 The system board may be faulty. Disassemble the computer following the steps described in Chapter 4.

2.13 Sound Troubleshooting

To check if the sound function is defective or malfunctioning, follow the troubleshooting procedures below as instructed.

Procedure 1 Diagnostic Test Program Execution Check

Procedure 2 Connector Check

Procedure 3 Replacement Check

Procedure 1 Diagnostic Test Program Execution Check

Execute the Sound Test in the Diagnostic Program. Refer to Chapter 3, *Tests and Diagnostics* for more information on how to perform the test program.

If any error is detected by the test, go to Procedure 2

Procedure 2 Connector Check

The connection of sound system is shown in the following figure.

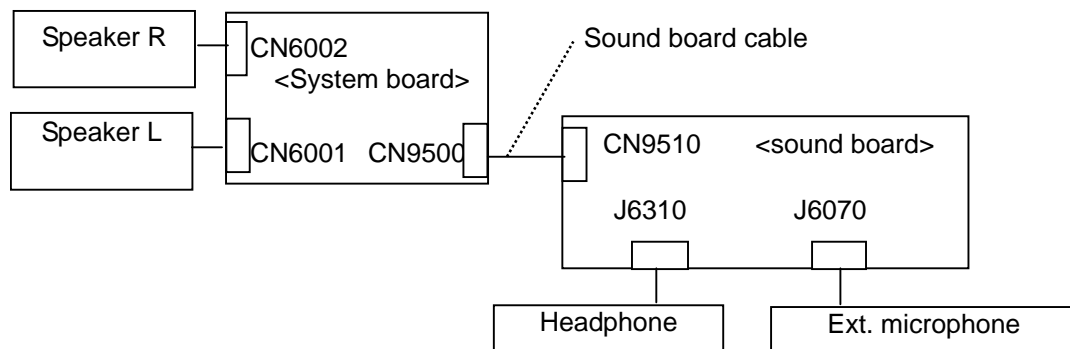

As the connection may be bad, disassemble the PC and check each connection.

If the speakers do not work properly, go to Check 1.

If the headphone or external microphone does not work properly, go to Check 2.

Check 1 Make sure the speaker cables are firmly connected to CN6001 and CN6002 on the system board. If the sound function does not still work properly, perform Procedure 3.

Check 2 Make sure the sound board is firmly connected to the system board via sound board cable. If each function does not still work properly, perform Check 2 of Procedure 3.

Procedure 3 Replacement Check

Check 1 The speaker may be faulty. Replace it with a new one following the steps in Chapter 4. If the problem persists, perform Check 3.

Check 2 The sound board may be faulty. Replace it with a new one following the steps in Chapter 4. If the problem persists, perform Check 3.

Check 3 The system board may be faulty. Replace it with a new one following the instructions in Chapter 4.

2.14 Wireless LAN Troubleshooting

To check if the computer's Wireless LAN is malfunctioning or not, follow the troubleshooting procedures below as instructed.

Procedure 1: Transmitting-Receiving Check

Procedure 2: Antennas' Connection Check

Procedure 3: Replacement Check

Procedure 1 Transmitting-Receiving Check

Before starting the test, make sure the wireless communication switch is set in the ON position.

Check 1 Execute Wireless LAN test program to check the transmitting-receiving function of wireless LAN. You will need a second computer that can communicate by wireless LAN. Perform the test following the instructions described in Chapter 3.

If the computer passes the test, the function is correctly working. If the computer does not pass the test, perform Procedure 2.

Procedure 2 Antennas' Connection Check

The wireless LAN function-wiring diagram is shown below:

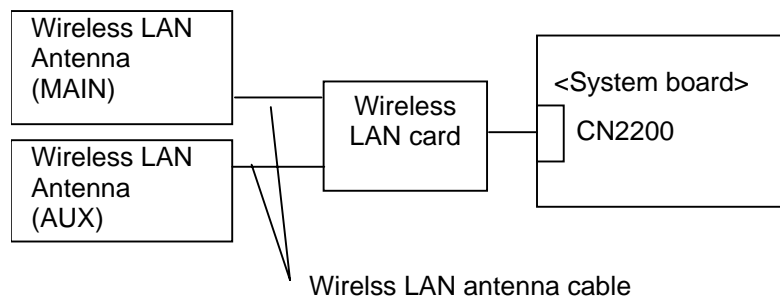

Any of the connections may be disconnected. Disassemble the computer following the steps described in Chapter 4, *Replacement Procedures*, and perform the following checks:

Check 1 Make sure the wireless communication switch is "On".

If the switch is "Off", turn it "On". If there is still an error, perform Check 2.

Check 2 Make sure the Wireless LAN card is firmly connected to the CN2200 on the system board.

If the connector is disconnected, connect it firmly and perform Procedure 1. If the Wireless LAN is still not functioning properly, perform Check 3.

Check 3 Make sure the wireless LAN antenna cables (MAIN and AUX) are firmly connected to the connectors on the wireless LAN card.

If the wireless LAN antenna cables are disconnected, connect them firmly and perform Procedure 1. If the wireless LAN is still not functioning properly, go to Procedure 3.

Procedure 3 Replacement Check

The wireless LAN card, wireless LAN antennas and the system board are may be damaged. Refer to Chapter 4, *Replacement Procedures*, for instructions on how to disassemble the computer and then perform the following checks:

- Check 1 The wireless LAN card may be defective or damaged. Replace the wireless LAN card with a new one following the instructions in Chapter 4, *Replacement Procedures*. If the problem still exists, perform Check 2.
- Check 2 The wireless LAN antennas may be defective or damaged. Replace the wireless LAN antennas with a new one following the instructions in Chapter 4, *Replacement Procedures*. If the problem still exists, perform Check 3.
- Check 3 Replace the system board with a new one following the instructions in Chapter 4, *Replacement Procedures* and test the display again.

Chapter 3

Tests and Diagnostics

Chapter 3 Contents

3.1	The Diagnostic Test	3-1
3.1.1	Diagnostics menu	3-1
3.1.2	H/W (Hardware) initial information setting tool.....	3-3
3.1.3	Heatrun test program.....	3-3
3.2	Executing the Diagnostic Test	3-4
3.2.1	Diagnostics menu (T&D)	3-4
3.2.2	H/W initial information setting tool	3-7
3.2.3	Heatrun test program.....	3-7
3.3	Setting of the hardware configuration.....	3-8
3.4	Heatrun Test.....	3-11
3.5	Subtest Names.....	3-12
3.6	System Test.....	3-14
3.7	Memory Test.....	3-16
3.8	Keyboard Test.....	3-17
3.9	Display Test	3-18
3.10	Floppy Disk Test.....	3-21
3.11	Printer Test.....	3-23
3.12	Async Test	3-25
3.13	Hard Disk Test	3-26
3.14	Real Timer Test.....	3-29
3.15	NDP Test.....	3-31
3.16	Expansion Test.....	3-32
3.17	CD-ROM/DVD-ROM Test	3-34
3.18	Error Code and Error Status Names.....	3-35
3.19	Hard Disk Test Detail Status.....	3-38
3.20	ONLY ONE TEST.....	3-40
3.20.1	Program Description	3-40
3.20.2	Operations	3-40
3.21	Head Cleaning.....	3-46
3.21.1	Function Description	3-46

3.21.2	Operations	3-46
3.22	Log Utilities	3-47
3.22.1	Function Description	3-47
3.22.2	Operations	3-48
3.23	Running Test.....	3-49
3.23.1	Function Description	3-49
3.23.2	Operations	3-49
3.24	Floppy Disk Drive Utilities.....	3-50
3.24.1	Function Description	3-50
3.24.2	Operations	3-51
3.25	System Configuration	3-55
3.25.1	Function Description	3-55
3.25.2	Operations	3-56
3.26	Wireless LAN Test Program (Intel-made b/g).....	3-57
3.27	Wireless LAN Test Program (Intel-made a/b/g).....	3-61
3.28	Wireless LAN Test Program (Askey-made).....	3-66
3.29	LAN/Modem/Bluetooth/IEEE1394 Test Program	3-70
3.29.1	LAN test	3-70
3.29.2	Modem test.....	3-73
3.29.3	Bluetooth test.....	3-74
3.29.4	IEEE1394 test.....	3-83
3.30	Sound Test program.....	3-84
3.30.1	Sound (Standard) test	3-84
3.30.2	Sound (Legacy) test.....	3-86
3.30.3	CD Sound (Standard) test.....	3-87
3.30.4	CD Sound (Legacy) test	3-89
3.31	SETUP	3-90
3.31.1	Function Description	3-90
3.31.2	Accessing the SETUP Program.....	3-92

Tables

Table 3-1 Subtest names 3-12

Table 3-2 Error codes and error status names 3-35

Table 3-3 Hard disk controller status register contents 3-38

Table 3-4 Error register contents 3-39

Table 3-5 Error message 3-76

Table 3-6 Error code for Bluetooth test (BD_ADDR) 3-77

Table 3-7 Error code for Bluetooth test (BD_ADDR of the DUT) 3-81

3.1 The Diagnostic Test

This chapter explains how to use the Diagnostic Test programs to test the functions of the computer's hardware modules. The Diagnostics Programs are stored on some Diagnostic Disks. There are Service Program Modules (DIAGNOSTIC MENU) and the Test Program Modules (DIAGNOSTIC TEST MENU) on the Diagnostic Disk.

The Hardware Initial information Setting Tool consists of some programs that write the hardware information or displays the current information of the computer. It is also included in one of Diagnostic Disks.

The heatrun test is automatic test program that executes the some tests successively.

NOTE: Before starting the diagnostics, be sure to follow these steps:

1. Check all cables are connected firmly.
2. Exit any application and close Windows.
3. Check if [ALL Device] is selected in the "Device Config." in SET UP menu. After checking the diagnostics, be sure to select [Setup by OS] in the "Device Config."

When replacing the system board, be sure to execute the following procedures.

1. Before replacing the system board, execute subtest03 "DMI information save" in 3.3 Setting of the hardware configuration in order to save the DMI information from system board to floppy disk.
2. After replacing the system board, execute the subtest04 "DMI information recovery" and subtest08 "System configuration display" in 3.3 Setting of the hardware configuration in order to copy the DMI information and system information from the floppy disk.

3.1.1 Diagnostics menu

The DIAGNOSTIC MENU consists of the following functions.

- DIAGNOSTIC TEST
- ONLY ONE TEST
- HEAD CLEANING
- LOG UTILITIES
- RUNNING TEST
- FDD UTILITIES
- SYSTEM CONFIGURATION
- EXIT TO MS-DOS

The DIAGNOSTIC TEST MENU contains the following functional tests:

- SYSTEM TEST
- MEMORY TEST
- KEYBOARD TEST
- DISPLAY TEST
- FLOPPY DISK TEST
- PRINTER TEST
- ASYNC TEST
- HARD DISK TEST
- REAL TIMER TEST
- NDP TEST
- EXPANSION TEST
- CD-ROM/DVD-ROM TEST

Other tests are:

- Wireless LAN TEST (Wireless LAN TEST disk)
- LAN/Modem/Bluetooth/IEEE1394 TEST (LAN/Modem/Bluetooth/IEEE1394 TEST disk)
- Sound TEST (Sound TEST disk)

You will need the following equipment to perform some of the Diagnostic test programs.

- USB FDD
- The Diagnostic Disks (T&D for maintenance, LAN/Modem/Bluetooth/IEEE1394 for maintenance, wireless LAN for maintenance and Sound for maintenance)
- A formatted working disk (Floppy disk test)
- A cleaning kit to clean the floppy disk drive heads (Head Cleaning)
- An external display supporting monitor ID (Expansion test)
- A CD test media TOSHIBA CD-ROM TEST DISK or ABEX TEST CD-ROM (Sound test)
- A DVD test media (DVD-ROM TEST DISK TSD-1) (Sound test)
- A music CD (Sound test)
- A CD-RW test media (CD-ROM/DVD-ROM test)
- A USB test module (USB test)
- A USB cable (USB test)
- LAN wraparound connector (LAN test)
- RGB wraparound connector (Expansion test)
- Module cable and RJ11 connector checker (Modem test)
- Headphones (Sound test)
- A microphone (Sound test)
- A PC for wraparound test (Wireless LAN test/Bluetooth test/IEEE1394 test)
- PC card wraparound connector (Expansion test)

3.1.2 H/W (Hardware) initial information setting tool

The H/W initial information setting tool consists of the following programs.

- Initial configuration
- Region write
- System configuration display
- E2PROM test (MAC/GUID/DMI)

You will need the following equipment to perform some of the programs.

- The Diagnostics Disk (Main T&D)
- A LAN wraparound connector (E2PROM test)

3.1.3 Heatrun test program

The heatrun test starts automatically after the selection.

You will need the following equipment to perform this program.

- The Diagnostics Disk (Main T&D)

3.2 Executing the Diagnostic Test

To start the DIAGNOSTIC PROGRAM, follow these steps:

1. Insert the Diagnostics disk in the floppy disk drive.
2. Release the lock of the power switch and turn on the computer with pressing the **F12**. Select the FDD in the display for selecting booting unit. Then, press **Enter** and the following menu appears.

```
Microsoft Windows XX Startup Menu
-----
```

1. Repair Main (T&D)
2. Repair initial config set
3. Repair Heatrun (T&D)

```
Enter a choice: 1
```

To start the Diagnostics menu (T&D), press **1** and **Enter** .

To start the H/W initial information setting tool, press **2** and **Enter** .

To start the Heatrun test, press **3** and **Enter** .

3.2.1 Diagnostics menu (T&D)

After pressing **1** and **Enter** in the startup menu, the following menu appears.

```
TOSHIBA personal computer XXXXXX DIAGNOSTICS
version X.XX (c) copyright TOSHIBA Corp. 20XX
```

```
DIAGNOSTICS MENU :
```

- 1 - DIAGNOSTIC TEST
- 2 - ONLY ONE TEST
- 3 -
- 4 - HEAD CLEANING
- 5 - LOG UTILITIES
- 6 - RUNNING TEST
- 7 - FDD UTILITIES
- 8 - SYSTEM CONFIGURATION
- 9 - EXIT TO MS-DOS

```
↑↓← : Select items
Enter : Specify
Esc : Exit
```

NOTE: To exit the DIAGNOSTIC TEST MENU, press the **Esc** key. If a test program is in progress, press **Ctrl + Break** to exit the test program. If a test program is in progress, press **Ctrl + C** to stop the test program.

Set the highlight bar to **1**, and press **Enter**. The following DIAGNOSTIC TEST MENU will appear:

```
TOSHIBA personal computer XXXXXX DIAGNOSTICS
version X.XX (c) copyright TOSHIBA Corp. 20XX
```

```
DIAGNOSTIC TEST MENU :
```

```
1 - SYSTEM TEST
2 - MEMORY TEST
3 - KEYBOARD TEST
4 - DISPLAY TEST
5 - FLOPPY DISK TEST
6 - PRINTER TEST
7 - ASYNC TEST
8 - HARD DISK TEST
9 - REAL TIMER TEST
10 - NDP TEST
11 - EXPANSION TEST
12 - CD-ROM/DVD-ROM TEST
88 - ERROR RETRY COUNT SET [FDD & HDD]
99 - EXIT TO DIAGNOSTICS MENU
```

```
↑↓←→ : Select items
Enter  : Specify
Esc    : Exit
```

Functions 1 through 12 are the Diagnostic Tests. Function 88 sets the floppy disk drive and hard disk drive error retry count (0-255).

To exit the submenu of the Diagnostic Test and returns to the Diagnostics Menu, set the highlight bar to function 99 and press **Enter**.

Select the option you want to execute and press **Enter**. When you select 1- SYSTEM TEST, the following message will appear:

```

SYSTEM TEST NAME   XXXXXXXX
XXXXXXXXX DIAGNOSTIC TEST VX.XX
[Ctrl]+[Break] ; test end
[Ctrl]+[C]       ; key stop

```

```

SUB-TEST   : XX
PASS COUNT : XXXXX   ERROR COUNT: XXXXX
WRITE DATA : XX     READ DATA  : XX
ADDRESS    : XXXXXXX STATUS      : XXX

```

```

SUB-TEST MENU :
01 - ROM checksum
02 - Fan ON/OFF
03 - Geyserville
04 - Quick charge
05 - DMI read
99 - Exit to DIAGNOSTIC TEST MENU

```

```

↑↓→← : Select items
Enter : Specify
Esc   : Exit

```

NOTE: The menu displayed by your computer may be slightly different from the one shown above.

Select the desired subtest number from the subtest menu and press **Enter**. The following message will appear:

```

TEST LOOP : YES (or NO)
ERROR STOP : YES (or NO)

```

Use the right and left arrow keys to move the cursor to the desired option.

Selecting **YES** of TEST LOOP increases the pass counter by one, each time the test cycle ends and restarts the test cycle.

Selecting **NO** returns the process to the subtest menu after the test is complete.

Use the up and down arrow keys to move the cursor to “ERROR STOP”.

Use the right and left arrow keys to move the cursor to the desired option and press **Enter**.

Selecting **YES** of ERROR STOP stops the test program when an error is found and displays the operation guide on the right side of the display screen as shown below:

```

ERROR STATUS NAME    [[ HALT OPERATION ]]

                                1: Test end
                                2: Continue
                                3: Retry

```

These three selections have the following functions respectively:

1. Terminates the test program and exits to the subtest menu.
2. Continues the test.
3. Restarts the test from the error.

Selecting **NO** keeps the test running even if an error is found. When an error occurred, the error status is displayed and one error is added to the error counter.

Table 3-1 in section 3.5 describes the function of each test on the subtest menu. Table 3-2 in section 3.19 describes the error codes and error status for each error.

3.2.2 H/W initial information setting tool

After selecting this test, the following menu appears in the display.

```

#####
#####      H/W initial information setting tool      VX.XX      #####
#####
*      1 ..... Initial configuration                      *
*      2 ..... Region write                              *
*      3 ..... DMI information save                      *
*      4 ..... DMI information recovery                  *
*      8 ..... System configuration display              *
*      9 ..... E2PROM test (MAC/GUID/DMI)               *
*****
... Press test number[1-4,8,9] ?

```

For more details on this test, refer to the section 3.4.

3.2.3 Heatrun test program

Heatrun test starts executing the same subtest as 3.24 RUNNING TEST.

For more details on this test, refer to the section 3.4.

3.3 Setting of the hardware configuration

To execute this program, select `2-Repair initial config test` in the startup menu, press **Enter** and follow the directions on the screen. The H/W initial information setting tool consists of four subtests. Move the highlight bar to the subtest you want to execute and press **Enter**.

Subtest 01 Initial configuration

This subtest executes the following items and shows their contents in the display. When an item ends normally, the program proceeds automatically to the next one. When an error is found, the program stops and waits for key input. (After solving the problem, the program executes the item again.)

Setting of the CPU set table
Setting of the micro code
Setting of the EHSS
Inputting and writing of DMI information

When the DMI information is displayed, the following messages appear in order. Input each information. (If you do not replace the PCB, the DMI information should not be changed.)

1. “Enter Model Name?” is displayed. Input the computer’s model name and press **Enter**. (e.g. DynaBook)
2. “Enter Version Number?” is displayed. Input the computer’s version number and press **Enter**. (e.g. PC18070C313S)
3. “Enter Serial Number?” is displayed. Input the computer’s serial number and press **Enter**. (e.g. 12345678)
4. “Enter Model Number?” is displayed. Input the computer’s sales model number and press **Enter**. (e.g. PP200-AAAAA)
5. “Enter Bundle Number?” is displayed. Input the computer’s PCN/Bundle number and press **Enter**. (e.g. PMSREQ3Q34H/S0123456789)
6. “Write data OK (Y/N)?” is displayed. To write the DMI information to the Flash ROM, press **Y**, and then **Enter**.
7. “Create DMIINFO TXT (Y/N)?” is displayed. Press **Y**, then the DMI information (text data) is written to the Floppy disk, etc.

Setting of the HWSC
 Setting of the UUID
 Display of the DMI information (including UUID)
 Setting of DVD region code (Yes/No)

After completion of the above settings, H/W configuration & DMI information are appeared in order. Check the contents and press **Enter**.

Subtest 02 Region write

This subtest executes the setting of the region code for DVD drive based on the destination of the machine.

When the region code is already written, test ends without setting.

The following message appears in the display after setting the region code. Press any key to return to the H/W initial information setting tool menu.

```
*****
*****      It completed      *****
*****
*
Press any key to continue...
```

Subtest 03 DMI information save

NOTE: Before replacing the system board, be sure to execute this subtest and save the DMI information to the floppy disk.

This is one of tools to copy the DMI information to a new PCB after replacing.

This subtest saves all the DMI data in a floppy disk.

Subtest 04 DMI information recovery

NOTE: 1. After replacing the system board, be sure to execute this subtest and copy the DMI information to a new system board.

2. Since the data of UUID is updated every time when this subtest, DMI information recovery, is done, the saved UUID data is not written

This is one of tools to copy the DMI information to a new PCB after replacing.

This subtest writes all the DMI data in the floppy disk into the new PCB.

Subtest 08 System configuration display

This subtest displays the information of the system configuration.

Confirm the contents and press **Enter**.

For more details on the system configuration information, refer to 3.26 "System configuration".

Subtest 09 E2PROM test (MAC/GUID/DMI)

It checks whether the MAC address, GUID of IEEE1394 and DMI information are written.

3.4 Heatrun Test

To execute this program, select 3-Repair heatrun in the startup menu, press **Enter**.

After selecting this test, the same subtests as 3.24 RUNNING TEST is executed successively.

For more details on the procedure and test content, refer to RUNNING TEST.

When the heatrun test ends, following message appears in the display.

```
*****  
HEATRUN TEST END  
*****  
Press any key to continue...
```

Press any key and return to the startup menu.

NOTE: The test result (*Errorlog.txt*) is stored in the floppy disk. The result is displayed in the same way as 3.23 LOG UTILITIES. For more detail in the display, refer to LOG UTILITIES.

3.5 Subtest Names

Table 3-1 lists the subtest names for each test program in the DIAGNOSTIC TEST MENU.

Table 3-1 Subtest names (1/2)

No.	Test Name	Subtest No.	Subtest Name
1	SYSTEM	01	ROM checksum
		02	Fan ON/OFF
		03	Geyserville
		04	Quick charge
		05	DMI read
2	MEMORY	01	Conventional memory
		02	Protected Mode
		03	Protected Mode (cache off)
		04	Cache memory (on/off)
		05	Stress
3	KEYBOARD	01	Pressed key code display
4	DISPLAY	01	VRAM read/write for VGA
		02	Gradation for VGA
		03	Gradation for LCD
		04	Gradation & Mode test for VGA
		05	All dot on/off for LCD
		06	"H" pattern display
		07	LCD Brightness
5	FLOPPY DISK	01	Sequential read
		02	Sequential read/write
		03	Random address/data
		04	Write specified address
		05	Read specified address

Table 3-1 Subtest names (2/2)

No.	Test Name	Subtest No.	Subtest Name
6	PRINTER [Not supported]	01	Ripple pattern
		02	Function
		03	Wrap around
7	ASYNC [Not supported]	01	FIR/SIR Point to point (send)
		02	FIR/SIR Point to point (receive)
		03	Wrap around (board)
8	HARD DISK	01	Sequential read
		02	Address uniqueness
		03	Random address/data
		04	Cross talk & peak shift
		05	Partial Read
		06	Write specified address
		07	Read specified address
		08	Sequential write
		09	W-R-C specified address
9	REAL TIMER	01	Real time
		02	Backup memory
		03	Real time carry
10	NDP	01	NDP test
11	EXPANSION	01	PCMCIA wrap around [Not supported]
		03	RGB monitor ID
13	CD-ROM /DVD-ROM	01	Sequential read
		02	Read specified address
		03	Random address/data
		04	RW 1point W/R/C

3.6 System Test

To execute the System Test select **1** from the DIAGNOSTIC TEST MENU, press **Enter** and follow the directions on the screen. Move the highlight bar to the subtest you want to execute and press **Enter**.

Subtest 01 ROM Checksum

This subtest executes a checksum test of the BIOS ROM (range: F0000h to FFFFFh, 64KB) on the System Board.

Subtest 02 Fan ON/OFF

This subtest turns on/off the fan motor by force with Fan ON/OFF commands.

The following message will appear.

```
Fan number select (1;FAN#1, 2;FAN#2, 0; FAN#1&#2) ?
```

To check the CPU fan, press **1** and **Enter**.

To check the VGA fan, press **2** and **Enter**.

To check both CPU fan and VGA fan, press **0** and **Enter**.

The following message will appear.

```
*** Test Fan Revolution 0000RPM start
```

Make sure the fan does not rotate, then press **Enter**.

The following message will appear.

```
*** Test Fan Revolution Low speed Start
```

Make sure the fan rotates at low speed, then press **Enter**.

The following message will appear.

```
*** Test Fan Revolution High speed Start
```

Make sure the fan rotates at high speed, then press **Enter**.

After a while, the fan rotating will stop.

Subtest 03 Geyserville

If the CPU supports Geyserville (SpeedStep), this Subtest checks that the CPU operating clock speed can be changed.

Subtest 04 Quick Charge

This subtest checks the status for the quick charge.

Subtest 05 DMI read

This subtest displays the information in the Flash-ROM in the following format.

```
*** DMI Data Display Ver X.XX ***  
Model Name       : XXXXXXXXXXXX  
Version Number  : XXXXXXXXXXXX  
Serial Number   : XXXXXXXX  
Model Number    : XXXXXX-XXXXX  
UUID Number     : XXXXXXXXXXXXXXXXXXXXXXXXXXXXXXXXXXXX  
Press [Enter] to EXIT
```

To exit this subtest and return to the SYSTEM test menu, press **Enter**.

3.7 Memory Test

To execute the Memory Test, select **2** from the DIAGNOSTIC TEST MENU, press **Enter** and follow the directions on the screen. Move the highlight bar to the subtest you want to execute and press **Enter**.

Subtest 01 Conventional memory

This subtest writes a constant data to conventional memory (0 to 640 KB), then reads the new data and compares the result with the original data.

Subtest 02 Protected Mode

NOTE: The CONFIG.SYS file must be configured without expanded memory manager programs such as EMM386.EXE, EMM386.SYS or QEMM386.SYS. Also, the HIMEM.SYS must be deleted from the CONFIG.SYS file.

This subtest writes constant data and address data (from 1MB to maximum MB), and reads the new data and compares the result with the original data.

Subtest 03 Protected Mode (Cache off)

This subtest executes the same way as the subtest 02 with the cache off.

Subtest 04 Cache Memory

To test the cache memory, a pass-through write-read comparison of '5Ah' data is run repeatedly to the test area ('7000':'Program' size to '7000':'7FFF' (32 KB)) to check the hit-miss ratio (on/off status) for CPU cache memory. One test takes 3 seconds.

Number of misses < Number of hits → OK

Number of misses ≥ Number of hits → Fail

Subtest 05 Stress

Data (from 1MB to the maximum MB) is written from the 16KB write buffer to the 16KB read buffer and compared the data in the buffers. The read buffer starts from 0001 and the comparison is continued with the following read buffer addresses: 0001, 0003, 0005, 0007, 0009, 000b, 000d and 000f.

3.8 Keyboard Test

To execute the Keyboard Test, select **3** from the DIAGNOSTIC TEST MENU, press **Enter** and follow the directions on the screen. Move the highlight bar to the subtest you want to execute and press **Enter**.

Subtest 01 Pressed key code display

When a key is pressed, the scan code, character code, and key top name are displayed on the screen in the format shown below. The **Ins Lock, Caps Lock, Num Lock, Scroll Lock, Alt, Ctrl, Left Shift,** and **Right Shift** keys are displayed in reverse screen mode when pressed. The scan codes, character codes, and key top names are shown in Appendix D.

```
KEYBOARD TEST  IN PROGRESS  302000
      Scan code      =
      Character code  =
      Keytop         =
Ins Lock  Caps Lock  Num Lock   Scroll Lock
Alt       Ctrl       Left Shift  Right Shift
PRESS [Enter] KEY
```

3.9 Display Test

To execute the Display Test, select **4** from the DIAGNOSTIC TEST MENU, press **Enter** and follow the directions on the screen. Move the highlight bar to the subtest you want to execute and press **Enter**.

Subtest 01 VRAM read/write for VGA

This subtest writes the constant data (AAh and 55h) to the video RAM. The data is read and compared to the original data.

Subtest 02 Gradation for VGA

This subtest displays four colors: red, green, blue and white from left to right across the screen from black to maximum brightness. The display below appears on the screen, when this subtest is executed.

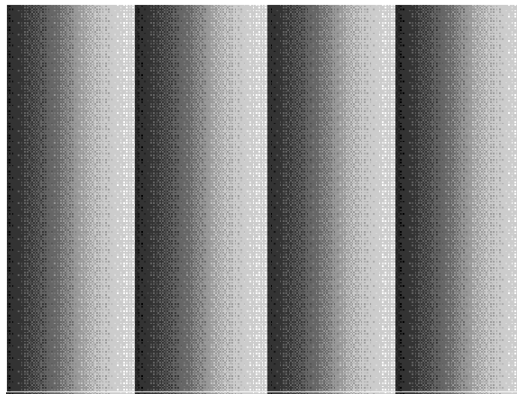

To exit this subtest and return to the DISPLAY TEST menu, press **Enter**.

Subtest 03 Gradation for LCD

This subtest displays bands of gradations for mixed colors, then for red, green, and blue. Next, it displays eight solid colors full screen: red, semi-red, green, semi-green, blue, semi-blue, white, and semi-white. Each color displays for three seconds.

Subtest 04 Gradation & Mode test for VGA

This subtest displays gradations for following modes. To change the mode, press **Enter**.

```
[Mode 12]
[Mode 13]
[Mode 3]
[Mode 111  640*480  64K]
[Mode 112  640*480  16M]
[Mode 114  800*600  64K]
[Mode 115  800*600  16M]
[Mode 117 1024*768  64K]
[Mode 118 1024*768  16M]
```

The display below appears on the screen when this subtest is executed.

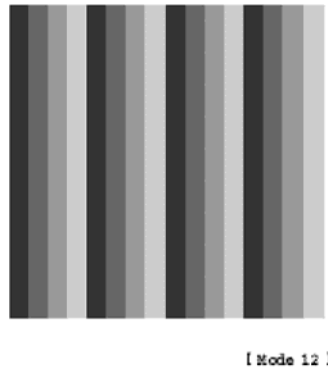

(Display example: Mode 12)

To exit this subtest and return to the DISPLAY TEST menu, press **Enter** after displaying the Mode 118.

Subtest 05 All dot on/off for LCD

This subtest displays an all-white screen then an all-black screen. The display changes automatically every three seconds, then returns to the DISPLAY TEST menu.

Subtest 06 "H" Pattern Display

This subtest displays a full screen of "H" patterns.

```

HHHHHHHHHHHHHHHHHHHHHHHHHHHHHHHHHHHHHHHHHHHHHHHHHHHHHHHHHHHHHH
HHHHHHHHHHHHHHHHHHHHHHHHHHHHHHHHHHHHHHHHHHHHHHHHHHHHHHHHHHHHHH
HHHHHHHHHHHHHHHHHHHHHHHHHHHHHHHHHHHHHHHHHHHHHHHHHHHHHHHHHHHHHH
HHHHHHHHHHHHHHHHHHHHHHHHHHHHHHHHHHHHHHHHHHHHHHHHHHHHHHHHHHHHHH
HHHHHHHHHHHHHHHHHHHHHHHHHHHHHHHHHHHHHHHHHHHHHHHHHHHHHHHHHHHHHH
HHHHHHHHHHHHHHHHHHHHHHHHHHHHHHHHHHHHHHHHHHHHHHHHHHHHHHHHHHHHHH
HHHHHHHHHHHHHHHHHHHHHHHHHHHHHHHHHHHHHHHHHHHHHHHHHHHHHHHHHHHHHH
HHHHHHHHHHHHHHHHHHHHHHHHHHHHHHHHHHHHHHHHHHHHHHHHHHHHHHHHHHHHHH
HHHHHHHHHHHHHHHHHHHHHHHHHHHHHHHHHHHHHHHHHHHHHHHHHHHHHHHHHHHHHH
HHHHHHHHHHHHHHHHHHHHHHHHHHHHHHHHHHHHHHHHHHHHHHHHHHHHHHHHHHHHHH
HHHHHHHHHHHHHHHHHHHHHHHHHHHHHHHHHHHHHHHHHHHHHHHHHHHHHHHHHHHHHH
HHHHHHHHHHHHHHHHHHHHHHHHHHHHHHHHHHHHHHHHHHHHHHHHHHHHHHHHHHHHHH
HHHHHHHHHHHHHHHHHHHHHHHHHHHHHHHHHHHHHHHHHHHHHHHHHHHHHHHHHHHHHH
HHHHHHHHHHHHHHHHHHHHHHHHHHHHHHHHHHHHHHHHHHHHHHHHHHHHHHHHHHHHHH
HHHHHHHHHHHHHHHHHHHHHHHHHHHHHHHHHHHHHHHHHHHHHHHHHHHHHHHHHHHHHH
HHHHHHHHHHHHHHHHHHHHHHHHHHHHHHHHHHHHHHHHHHHHHHHHHHHHHHHHHHHHHH

```

To exit this subtest and return to the DISPLAY TEST menu, press **Enter**.

NOTE: The last row may not be completely filled. This condition does not indicate on error.

Subtest 07 LCD Brightness

The LCD brightness changes in the following order:

Super-Bright → Bright → Semi-Bright → Bright → Super-Bright

After displaying with Super-Bright of LCD brightness, return to the DISPLAY TEST menu.

3.10 Floppy Disk Test

CAUTION: Before running the floppy disk test, prepare a formatted work disk. Remove the Diagnostics Disk and insert the work disk into the FDD. The contents of the floppy disk will be erased.

To execute the Floppy Disk Test, select **5** from the DIAGNOSTIC TEST MENU, press **Enter** and follow the directions displayed on the screen. After selecting the Floppy Disk Test from the DIAGNOSTIC TEST MENU, messages to execute the test drive number, media type and test start truck will be displayed successively. Answer each question with an appropriate response to execute the test.

1. The following message will appear. Select the media mode and start track to be tested, then press **Enter**.

```
Test start track      (Enter:0/dd:00-79) ?
```

2. The Floppy Disk test contains five subtests that test the FDD. The floppy disk test menu will appear after you select FDD test parameters.

```
FLOPPY DISK          XXXXXXXX
```

```
XXX DIAGNOSTIC TEST VX.XX
[Ctrl]+[Break] : test end
[Ctrl]+[C]     : key stop
```

```
SUB-TEST      : XX
PASS COUNT    : XXXXX   ERROR COUNT   : XXXXX
WRITE DATA   : XX      READ DATA    : XX
ADDRESS       : XXXXXXX STATUS        : XXX
```

SUB-TEST MENU :

```
01 - Sequential read
02 - Sequential read/write
03 - Random address/data
04 - Write specified address
05 - Read specified address
99 - Exit to DIAGNOSTIC TEST MENU
```

```
↑↓→← : Select items
Enter : Specify
Esc   : Exit
```

Select the number of the subtest you want to execute and press **Enter**. The following message will appear during the floppy disk test.

```

FLOPPY DISK  IN PROGRESS  XXXXXXXX  xxx DIAGNOSTIC TEST VX.XX
                                         [Ctrl]+[Break] : test end
                                         [Ctrl]+[C]   : key stop

SUB-TEST      : XX
PASS COUNT    : XXXXX   ERROR COUNT   : XXXXX
WRITE DATA   : XX      READ DATA    : XX
ADDRESS       : XXXXXXX  STATUS       : XXX
  
```

When the subtest 04 or 05 is selected, the following messages will appear on the screen. Select the test data (subtest 04 only), track number and head number you want to test.

```

Test data     ?? (subtest 04 only)
Track No.     ??
Head No.      ?
  
```

Subtest 01 Sequential read

This subtest performs a Cyclic Redundancy Check (CRC) that continuously reads all the tracks (track: 0 to 39/0 to 79) on a floppy disk.

Subtest 02 Sequential read/write

This subtest continuously writes data pattern B5ADADh to all the tracks (track: 0 to 39/0 to 79) on a floppy disk. The data is then read and compared to the original data.

Subtest 03 Random address/data

This subtest writes random data to random addresses on all tracks (track: 0 to 39/0 to 79) on a floppy disk. The data is then read and compared to the original data.

Subtest 04 Write specified address

This subtest writes the data specified by an operator to a specified track, head, and address.

Subtest 05 Read specified address

This subtest reads data from a track, head, and address specified by an operator.

3.11 Printer Test

To execute the Printer Test, select **6** from the DIAGNOSTIC TEST MENU, press **Enter** and follow the directions on the screen. The following messages will appear after selecting the Printer Test from the DIAGNOSTIC TEST MENU. Answer each of the questions with an appropriate response to execute the test.

NOTE: An IBM compatible printer must be connected to the system to execute this test. Also, printer port wraparound connector must be connected.

The following message will appear, after selecting the subtest 01 to 03 of the printer test:

```
channel#1 = XXXXh
channel#2 = XXXXh
channel#3 = XXXXh
```

Select the channel number (1-3) ?

The printer I/O port address is specified by the XXXXh number. The computer supports three printer channels. Select the printer channel number, and press **Enter** to execute the selected subtest.

Subtest 01 Ripple Pattern

This subtest prints characters for codes 20h through 7Eh line-by-line while shifting one character to the left at the beginning of each new line.

```
:"#$%&'()*+,-./0123456789:;<=>?@ABCDEFGHIJKLMNopqrstuvwxyz[\]^_`abcdefghijklmnop
:"#$%&'()*+,-./0123456789:;<=>?@ABCDEFGHIJKLMNopqrstuvwxyz[\]^_`abcdefghijklmnop
:"#$%&'()*+,-./0123456789:;<=>?@ABCDEFGHIJKLMNopqrstuvwxyz[\]^_`abcdefghijklmnop
#$%&'()*+,-./0123456789:;<=>?@ABCDEFGHIJKLMNopqrstuvwxyz[\]^_`abcdefghijklmnopqr
#$%&'()*+,-./0123456789:;<=>?@ABCDEFGHIJKLMNopqrstuvwxyz[\]^_`abcdefghijklmnopqrs
%&'()*+,-./0123456789:;<=>?@ABCDEFGHIJKLMNopqrstuvwxyz[\]^_`abcdefghijklmnopqrst
e'()*+,-./0123456789:;<=>?@ABCDEFGHIJKLMNopqrstuvwxyz[\]^_`abcdefghijklmnopqrstu
'()*+,-./0123456789:;<=>?@ABCDEFGHIJKLMNopqrstuvwxyz[\]^_`abcdefghijklmnopqrstuv
()*+,-./0123456789:;<=>?@ABCDEFGHIJKLMNopqrstuvwxyz[\]^_`abcdefghijklmnopqrstuvw
)*+,-./0123456789:;<=>?@ABCDEFGHIJKLMNopqrstuvwxyz[\]^_`abcdefghijklmnopqrstuvwx
*+,-./0123456789:;<=>?@ABCDEFGHIJKLMNopqrstuvwxyz[\]^_`abcdefghijklmnopqrstuvwxy
```

Subtest 02 Function

This subtest is for IBM compatible printers, and tests the following functions:

Normal print
 Double-width print
 Compressed print
 Emphasized print
 Double-strike print
 All characters print

This subtest prints the various print types shown below:

```

PRINTER TEST
1. THIS LINE SHOWS NORMAL PRINT.
2. THIS LINE SHOWS DOUBLE-WIDTH PRINT.
3. THIS LINE SHOWS COMPRESSED PRINT.
4. THIS LINE SHOWS EMPHASIZED PRINT.
5. THIS LINE SHOWS DOUBLE-STRIKE PRINT.
6. ALL CHARACTERS PRINT
!"#$%&'()*+,-./0123456789:;<=>?@ABCDEFGHIJKLMN OPQRSTUVWXYZ[\]^_`abcdefghijklmnop
opqrstuvwxyz{|}~

```

Subtest 03 Wraparound

NOTE: To execute this subtest, a printer wraparound connector must be connected to the computer's printer port.

This subtest checks the output and bi-directional modes of the data control and status lines through the parallel port wraparound connector (34M741986G01). (Both output and bi-directional modes are tested.)

3.12 Async Test

To execute the Async Test, select **7** from the DIAGNOSTIC TEST MENU, press **Enter** and follow the directions displayed on the screen. Move the highlight bar to the subtest you want to execute and press **Enter**.

Subtests 01 and 02 require the following data format:

Method:	Asynchronous
Speed:	38400BPS
Data:	8 bits and one parity bit (EVEN)
Data pattern:	20h to 7Eh

Subtest 01 FIR/SIR Point to point (send)

NOTE: *To execute subtests 01 and 02, each computer must have access to the other computer's infrared port.*

This subtest sends 20h through 7Eh data to the receive side, then receives the sent data and compares it to the original data through the FIR/SIR port.

Subtest 02 FIR/SIR Point to point (receive)

This subtest is used with subtest 01 described above. This subtest receives the data from the send side, then sends the received data through the FIR/SIR port.

Subtest 03 Wraparound (on board)

NOTE: *To execute this subtest, a RS-232C wraparound connector must be connected to the RS-232C port.*

This subtest checks the data send/receive function through the wraparound connector.

3.13 Hard Disk Test

To execute the Hard Disk Test, select **8** from the DIAGNOSTIC TEST MENU, press **Enter**, and follow the directions on the screen.

CAUTION: *The contents of the hard disk will be erased when subtest 02, 03, 04, 06, 08, or 09 is executed. Before running the test, the customer should transfer the contents of the hard disk to floppy disk or another hard disk. If the customer has not or cannot perform the back-up, create back-up disks as described below.*

Check to see if the Microsoft Create System Disks Tools (MSCSD.EXE) still exists in the System Tools Folder. (This tool can be used only once.) If it exists, use it to back up the pre-installed software, then use the Backup utility in the System Tools folder to back up the entire disk, including the user's files.

Refer to the operating system instructions.

When a 2nd HDD is installed, the following messages will appear after selecting the hard disk test from the DIAGNOSTIC TEST MENU.

Test drive number select (1:HDD#1, 2:HDD#2, 0:HDD#1&2) ?

↑↓→← : Select items
Enter : Specify
Esc : Exit

1. Input the number of HDD test and press **Enter**.
2. This message is used to select the error dump operation when a data compare error is detected. Select **1** or **2**.

Data compare error dump (1:no, 2:yes)

3. This message is used to select whether or not the HDD status is displayed on the screen. The HDC status is described in section 3.19. Select **1** or **2**.

Detail status display (1:no, 2:yes)

4. The Hard Disk Test message will appear after you respond to the Detail Status prompt. Select the number of the subtest you want to execute and press Enter. The following message will appear during each subtest.

HARD DISK TEST XXXXXXXX

XXX DIAGNOSTIC TEST VX.XX [Ctrl]+[Break] : test end [Ctrl]+[C] : key stop

SUB TEST	:	XX			
PASS COUNT	:	XXXXX	ERROR COUNT	:	XXXXX
WRITE DATA	:	XX	READ DATA	:	XX
ADDRESS	:	XXXXXX	STATUS	:	XXX

The first three digits of the ADDRESS indicate which cylinder is being tested, the fourth digit indicates the head and the last two digits indicate the sector.

The first digit of the STATUS number indicates the drive being tested and the last two digits indicate the error status code as explained in table 3-2 of the section 3.18.

Subtest 01 Sequential read

This subtest is a sequential reading of all the tracks on the HDD starting at track 0. When all the tracks on the HDD have been read, the test starts at the maximum track and reads the tracks on the HDD sequentially back to track 0.

Subtest 02 Address uniqueness

This subtest writes unique address data to each sector of the HDD track-by-track. The data written to each sector is then read and compared with the original data. There are three ways the HDD can be read:

1. Forward sequential
2. Reverse sequential
3. Random

Subtest 03 Random address/data

This subtest writes random data in a random length to random addresses. This data is then read and compared to the original data.

Subtest 04 Cross talk & peak shift

This subtest writes eight types of worst pattern data (listed below) to a cylinder, then reads the data while moving from cylinder to cylinder. (Test the data interference in the neighbor track)

Worst pattern data	Cylinder
'B5ADAD'	0 cylinder
'4A5252'	1 cylinder
'EB6DB6'	2 cylinder
'153449'	3 cylinder
'63B63B'	4 cylinder
'9C49C4'	5 cylinder
'2DB6DB'	6 cylinder
'D25344'	7 cylinder

Subtest 05 Partial Read

This subtest reads 1GB data that is in minimum, middle and maximum address of the HDD area.

Subtest 06 Write specified address

This subtest writes specified data to a specified cylinder and head on the HDD.

Subtest 07 Read specified address

This subtest reads data, which has been written to a specified cylinder and head on the HDD.

Subtest 08 Sequential write

This subtest writes specified 2-byte data to all of the cylinders on the HDD.

Subtest 09 W-R-C specified address

This subtest writes data to a specified cylinder and head on the HDD, then reads the data and compares it to the original data.

3.14 Real Timer Test

To execute the Real Timer Test, select **9** from the DIAGNOSTIC TEST MENU, press **Enter** and follow the directions on the screen. Move the highlight bar to the subtest you want to execute and press **Enter**.

Subtest 01 Real time

A new date and time can be input during this subtest. To execute the real time subtest, follow these steps:

1. Select subtest 01 and the following messages will appear:

```
Current date : XX-XX-XXXX
Current time : XX:XX:XX
```

```
Enter new date:
```

```
PRESS [ENTER] KEY TO EXIT TEST
```

2. If the current date is not correct, input the correct date at the “Enter new date” prompt and press **Enter**.

3. The following messages will appear:

```
Current date : XX-XX-XXXX
Current time : XX:XX:XX
```

```
Enter new time:
```

```
PRESS [ENTER] KEY TO EXIT TEST
```

4. If the current time is not correct, input the correct time in 24-hour format. To enter ":", press **Shift + ;**. The time is updated.

To exit the test, press **Enter**.

Subtest 02 Backup memory

This subtest checks the following backup memories:

Writes 1-bit of “on” data (01h through 80h) to address 0Eh through 7Fh

Writes 1-bit of “off” data (FEh through 7Fh) to address 0Eh through 7Fh

Writes the data pattern AAh and 55h to the address 0Eh to 7Fh

Then the subtest reads and compares this data with the original data.

Subtest 03 Real time carry

CAUTION: *When this subtest is executed, the current date and time are erased.*

This subtest checks the real time clock increments, making sure the date and time are displayed in the following format:

```
Current date : 12-31-1999
Current time : 23:59:58
```

The real time increments are automatically executed and the following is displayed:

```
Current date : 01-01-2000
Current time : 00:00:00
```

```
PRESS [Enter] KEY TO EXIT TEST
```

To exit the test, press **Enter**.

3.15 NDP Test

To execute the NDP test, select **10** from the DIAGNOSTICS TEST MENU, press **Enter** and follow the directions on the screen.

Subtest 01 NDP

This test checks the following functions of NDP:

- Control word
- Status word
- Bus
- Addition
- Multiplication

3.16 Expansion Test

To execute the expansion test, select **11** from the DIAGNOSTICS TEST MENU, press **Enter** and follow the directions on the screen.

Subtest 01 PCMCIA wraparound

NOTE: To execute this subtest, the PC card wraparound connector is required.

This subtest checks the following signal line of the PC card slot:

- Address line
- REG#, CE#1, CE#2 line
- Data line
- Speaker line
- Wait line
- BSY#, BVD1 line

This subtest is executed in the following order:

Sub#	Address	Good	Bad	Contents
01	00001 00001	nn nn	xx xx	Address line REG#, CE#1, CE#2 nn=A0, 90, 80, 00
02	00002	ww	rr	Data line ww=write data, rr=read data
03	00003	—	—	Speaker line
04	00004	40,80	xx	Wait line (40<xx<80)
05	00005	nn	xx	Other lines (BSY#, BVD1) NN=21, 00

NOTE: Select the subtest number 01, The following message will appear:
Test slot number select (1:slot0, 2:slot1, 0:slot0&1)?

Subtest 02 RGB monitor ID

NOTE: To execute this subtest, RGB monitor ID wraparound connector is required.
The wiring diagram of the connector is described in Appendix F.

Connect a wraparound connector to CRT monitor for the test of ID acquisition.
This subtest is executed by using VESA command.

3.17 CD-ROM/DVD-ROM Test

To execute the CD-ROM/DVD-ROM test, select **13** from the DIAGNOSTICS TEST MENU, press **Enter** and follow the directions on the screen.

NOTE: For the subtest 01, 02 and 03, use the TOSHIBA CD-ROM TEST DISK TDY-01 or ABEX TEST CD-ROM TCDR-702 and DVD-ROM TEST DISK TSD-1. For the subtest 04, use a CD-RW on the market.

Subtest 01 Sequential read

This subtest is a sequential reading of one-block units (2K bytes) of all the logical addresses.

Subtest 02 Read specified address

This subtest reads one-block data from a specified address.

Subtest 03 Random address/data

This subtest reads one-block data and multi-block data from random addresses 200 times.

Subtest 04 RW 1point W/R/C

This subtest writes, reads and compares data at one point on a CD/RW media.

3.18 Error Code and Error Status Names

Table 3-2 lists the error codes and error status names for the Diagnostic Test.

Table 3-2 Error codes and error status names (1/3)

Device name	Error code	Error status name
(Common)	FF	Data Compare Error
System	01 03 04 05 06 07 08 09 10	ROM - CHECKSUM ERROR ROM - SERIAL ID WRITE ERROR ROM - NOT SUPPORTED PS-SYSTEM ROM - SENSING ERROR(AC-ADAPT) ROM - SENSING ERROR(1st Batt) ROM - SENSING ERROR(2nd Batt) ROM - THORMISTOR ERROR(1) ROM - THORMISTOR ERROR(2) ROM - THORMISTOR ERROR(3)
Memory	01 02 DD	RAM - PARITY ERROR RAM - PROTECTED MODE NO CHANGE' RAM - CACHE MEMORY ERROR
Keyboard	FE FD F0 F1 F2 F3 F4 F5 F6 F7 F8 F9 FA EF ED	USB - GET DESCR.ERROR (FIRST) USB - SET ADDRESS ERROR HUB - GET DESCR.ERROR(Top 8B) HUB - GET DESCR.ERROR (Whole) HUB - SET CONFIGURATION ERROR HUB - GET DESCR.ERROR(DESCR.) HUB - SET FEATURE ERROR(P ON) HUB - GET STATUS ERROR HUB - SET FEATURE ERROR(RESET) HUB - CLEAR FEATURE ERROR HUB - CLEAR FEATURE1 ERROR HUB - SET FEATURE ERROR(Enab.) HUB - CLEAR FEATURE2 ERROR USB - OVER CURRENT ERROR USB - GET DESCR.ERROR(SECOND)'
Display	EE	VRAM SIZE NOT SUPPORT

Table 3-2 Error codes and error status names (2/3)

Device name	Error code	Error status name
FDD	01 02 03 04 08 09 10 20 40 80 60 06 EE	FDD - BAD COMMAND ERROR FDD - ADDRESS MARK NOT FOUND FDD - WRITE PROTECTED FDD - RECORD NOT FOUND FDD - DMA OVERRUN ERROR FDD - DMA BOUNDARY ERROR FDD - CRC ERROR FDD - FDC ERROR FDD - SEEK ERROR FDD - TIME OUT ERROR FDD - NOT DRIVE ERROR FDD - MEDIA REMOVED FDD - WRITE BUFFER ERROR
Printer	01 08 10 20 40 80	PRT - TIME OUT PRT - FAULT PRT - SELECT LINE PRT - OUT OF PAPER PRT - POWER OFF PRT - BUSY LINE
ASYNC	01 02 04 08 10 20 40 80 88 05 06	RS232C - [DTR ON] TIME OUT RS232C - [CTS ON] TIME OUT RS232C - [RX READY] TIME OUT RS232C - [TX FULL] TIME OUT RS232C - PARITY ERROR RS232C - FRAMING ERROR RS232C - OVERRUN ERROR RS232C - LINE STATUS ERROR RS232C - MODEM STATUS ERROR SIR - TIME OUT ERROR FIR - TIME OUT ERROR
HDD	05 07 09 0B BB 08 01 02 04 10 20 40 80 11 AA	HDD - HDC NOT RESET ERROR HDD - DRIVE NOT INITIALIZE HDD - DMA BOUNDARY ERROR HDD - BAD TRACK ERROR HDD - UNDEFINED ERROR HDD - OVERRUN ERROR (DRQ ON) HDD - BAD COMMAND ERROR HDD - ADDRESS MARK NOT FOUND HDD - RECORD NOT FOUND ERROR HDD - ECC ERROR HDD - HDC ERROR HDD - SEEK ERROR HDD - TIME OUT ERROR HDD - ECC RECOVER ENABLE HDD - DRIVE NOT READY

Table 3-2 Error codes and error status names (3/3)

Device name	Error code	Error status name
(HDD)	CC E0 0A EE DA 12	HDD - WRITE FAULT HDD - STATUS ERROR HDD - BAD SECTOR HDD - ACCESS TIME ERROR HDD - NO HDD HDD - DMA CRC ERROR
NDP	01 02 03 04 05 06	NDP - NO CO-PROCESSOR NDP - CONTROL WORD ERROR NDP - STATUS WORD ERROR NDP - BUS ERROR NDP - ADDITION ERROR NDP - MULTIPLY ERROR
EXPANSION	C1 C3 C4 C5 C6 C7 C8 CB CC CE CF	ADDRESS LINE ERROR CE#1 LINE ERROR CE#2 LINE ERROR DATA LINE ERROR WAIT LINE ERROR BSY# LINE ERROR BVD1 LINE ERROR ZV-Port ERROR NO PCMCIA CARD TYPE ERROR ZV_CONT# ERROR
CD-ROM /DVD-ROM	01 02 03 04 05 06 09 11 20 40 80 90 B0	BAD COMMAND ILLEGAL LENGTH UNIT ATTENTION MEDIA CHANGE REQUEST MEDIA DETECTED ADDITIMAL SENSE BOUNDARY ERROR CORRECTED DATA ERROR DRIVE NOT READY SEEK ERROR TIME OUT RESET ERROR ADDRESS ERROR

3.19 Hard Disk Test Detail Status

When an error occurs in the hard disk test, the following message is displayed:

```
HDC status = XXXXXXXX
```

Detailed information about the hard disk test error is displayed on the screen by an eight-digit number. The first four digits represent the hard disk controller (HDC) error status number and the last four digits are not used.

The hard disk controller error status is composed of two bytes; the first byte displays the contents of the HDC status register in hexadecimal form and the second byte displays the HDC error register.

The contents of the HDC status register and error register are listed in Tables 3-3 and 3-4.

Table 3-3 Hard disk controller status register contents

Bit	Name	Description
7	BSY (Busy)	"0" ... HDC is ready. "1" ... HDC is busy.
6	DRY (Drive ready)	"0" ... Hard disk drive is not ready to accept any command. "1" ... Hard disk drive is ready.
5	DWF (Drive write fault)	"0" ... DWF error is not detected. "1" ... Write fault condition occurred.
4	DSC (Drive seek complete)	"0" ... The hard disk drive heads are not settled over a track. "1" ... The hard disk drive heads are settled over a track.
3	DRQ (Data request)	"0" ... Drive is not ready for data transfer. "1" ... Drive is ready for data transfer.
2	COR (Corrected data)	"0" ... Not used "1" ... Correctable data error is corrected.
1	IDX (Index)	"0" ... Not used "1" ... Index is sensed.
0	ERR (Error)	"0" ... Normal "1" ... The previous command was terminated with an error.

Tables 3-4 Error register contents

Bit	Name	Description
7	BBK (Bad block mark)	"0" ... Not used "1" ... A bad block mark is detected.
6	UNC (Uncorrectable)	"0" ... There is no uncorrectable data error. "1" ... Uncorrectable data error has been detected.
5	—	Not used
4	IDN (Identification)	"0" ... Not used "1" ... There is no ID field in the requested sector.
3	—	Not used
2	ABT (Abort)	"0" ... Not used "1" ... Illegal command error or command abort.
1	TK0 (Track 0)	"0" ... The hard disk found track 0 during a recalibrate command. "1" ... The hard disk could not find track 0 during a recalibrate command.
0	—	Not used

3.20 ONLY ONE TEST

3.20.1 Program Description

This program tests the unique functions of this model.

3.20.2 Operations

Select test **2** from the DIAGNOSTIC MENU and press **Enter**. The following menu appears in the display.

```
#####
#####          ONLY ONE TEST Menu (XXXXXXXX)          #####
#####
*
*  1 .....      Pressed Key Display                      *
*  2 .....      Touch Pad                                  *
*  3 .....      GP Button                                  *
*  4 .....      Kill Switch                               *
*  5 .....      USB                                        *
*  6 .....      Docker Dock/Undock                        *
*  7 .....      LED                                       *
*
*  9 .....      Exit to Common Test                       *
*
*****
.... Press test number [1-7, 9]?
```

Select the subtest number you want to test and press **Enter**.

To return to the DIAGNOSTIC TEST menu, select **9** and press **Enter**.

Subtest 01 **Pressed key display**

When you execute this subtest, the keyboard layout is drawn on the display as shown below. When any key is pressed, the corresponding key on the screen changes to the key character that was pressed. Holding a key down enables the auto-repeat function that causes the key's display character to blink.

Press **Del + Enter** to end the test.

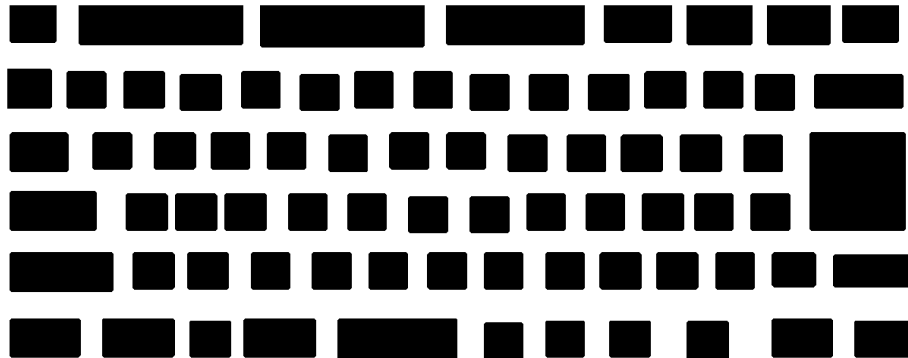

IF TEST OK, Press [Del][Enter]key

Subtest 02 Touch Pad

This subtest checks the functions of the touch pad as shown below.

- A) Direction and parameter
- B) Switching function check.

This test displays the response from the touch pad and touch pad switch. When moving your finger on the touch pad towards the upper left, the <POINTING> display changes according to the following illustration. If a touch pad switch is pressed, the <BUTTONS> displays appear on the right side one by one. The parameters appear above the <BUTTONS> (1) or (2) corresponding to the pressed touch pad switch highlights. To end this subtest, press two touch pad switches at the same time.

```

*** IPS (PAD) TEST PROGRAM (Vx.xx) ***

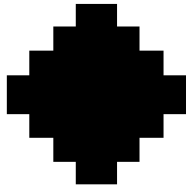
<POINTING>
  
  <PARAMETER>
  STATUS:0000h
  X-RATE:0000h
  Y-RATE:0000H

  <BUTTON>
  (1)    (2)
  

  << PRESS BUTTON1+BUTTON2 THEN END >>

*** IPS (PAD) TEST PROGRAM (Vx.xx) ***

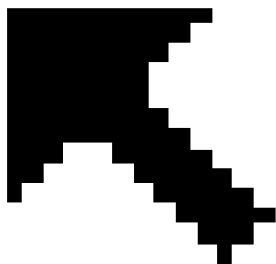
< POINTING >
  
  <PARAMETER>
  STATUS: 0018h
  X-RATE: OK
  Y-RATE: OK

  <BUTTON>
  (1)    (2)
  

  << PRESS BUTTON1+BUTTON2 THEN END >>

```

Subtest 03 GP Button

This subtest checks if the GP buttons work properly.

The following message appears in the display.

```
Press [Console] Button!
```

Press the indicated button, then following message will appear in the display.

```
Press [Console] Button! OK
```

As the same way, press the indicated buttons and run the button test.

If wrong key is pressed, following message will appear in the display.

```
Press [Console] Button! NG
```

```
Functionkeys = XXXX
```

```
Press any key!
```

Pressing any key, indication of pressing button will appear in the display again. Unless the right button is pressed, this operation is repeated.

After checking all the button (Console Button, Presentation Button, Internet Button), return to the ONLY ONE TEST menu automatically.

Subtest 04 Kill Switch

This subtest checks if the Wireless communication switch works properly.

If the test is started with the switch ON, following message appears in the display.

```
Kill switch is set to a start position (OFF)
```

Slide the switch to OFF position. Then, following message appears in the display.

```
KILL SWITCH ON !!
```

Slide the switch to ON position. Then, following message appears in the display.

```
KILL SWITCH OFF !!
```

After Sliding the switch to OFF position, return to the ONLY ONE TEST menu automatically.

Subtest 05 USB

NOTE: When executing this subtest, USB test module and USB cable must be connected.

This subtest checks if USB port works properly.

The following menu appears in the display.

```
#####
#####          ONLY ONE TEST Menu (XXXXXXXX)          #####
#####
*
* 0 ..... Port 0 (Right side)                          *
* 1 ..... Port 1 (Left side)                            *
* 2 ..... Port 2 (Back side)                            *
* 9 ..... Exit to Only One Menu                          *
*
*****
.... Press test number[0-2, 9] ?
```

Connect the USB test module and USB cable to the computer.

Input the port test number and press **Enter**.

OK message appears in the display if the test ends without a defective.

NG message appears in the display if a defective is found during the test.
Confirm the connection of cable, then execute the test again.

Press **9** and return to ONLY ONE TEST menu.

Subtest 06 Docker Dock/Undock

This subtest is executed with Advanced Port Replicator 3 installed.

Press **Enter** while pushing the eject button of the Advanced Port Replicator 3 after the following message appears.

Slide Eject-SW, and press [Enter] Key

Press **Enter** without pushing the eject button of the Advanced Port Replicator 3 after the following message appears.

Release Eject-SW, and press [Enter] Key

If the test ends successfully, the display returns to the ONLY ONE TEST menu.

When the display returns to the ONLY ONE TEST menu, remove the Advanced Port Replicator 3 from the computer.

Subtest 07 LED

This subtest checks if each LED lights properly.

The following message appears in the display in order. Follow the instructions in the display to execute the test.

```
[HDD Access LED test]
```

Confirm the LED of HDD status blinks properly.

Press any key and following message appears in the display.

```
[Caps/Num/Overlay BT/W-LAN LED test]
```

Confirm each LED lights properly.

- (1) Press [Caps Lock] key ! ...Caps (on/off)
- (2) Press [Fn + F10] key ! ...Arrow (on/off)
- (3) Press [Fn + F11] key ! ...Num (on/off)
- (4) Slide [BT/W-LAN switch L&R]! (on/off)

Press **Enter** and following message appears in the display.

```
Check [DC-IN]&[Power]&[Main Battery]LED= Green
```

Check if the each LED lights in the same color as the message in the display (Message switches Green <-> Orange).

Press **Enter** and return to the ONLY ONE TEST menu.

3.21 Head Cleaning

3.21.1 Function Description

This function cleans the heads in the FDD by executing a series of head load/seek and read operations. A cleaning kit is necessary to perform this program.

3.21.2 Operations

1. Selecting test **4** from the DIAGNOSTIC MENU and pressing **Enter** displays the following messages:

```
DIAGNOSTICS - FLOPPY DISK HEAD CLEANING : VX.XX  
Mount cleaning disk(s) on drive(s).  
Press any key when ready.
```

2. Remove the Diagnostics Disk from the FDD, then insert the cleaning disk and press **Enter**.
3. When the "cleaning start" message appears, the FDD head cleaning has begun.
4. The display automatically returns to the DIAGNOSTIC MENU when the program is completed.

3.22 Log Utilities

3.22.1 Function Description

This function logs error information generated while a test is in progress and stores the results in RAM. This function can store data on a floppy disk or output the data to a printer.

The error information is displayed in the following order:

1. Error count (CNT)
2. Test name, Subtest number (TS-No)
3. Pass count (PASS)
4. Error status (STS)
5. FDD/HDD or memory address (ADDR)
6. Write data (WD)
7. Read data (RD)
8. HDC status (HSTS)
9. Error status name (ERROR STATUS NAME)

If the power switch is turned off, the error information will be lost.

3.22.2 Operations

- Select **5** and press **Enter** in the DIAGNOSTIC MENU, logs error information into RAM or onto a floppy disk. The error information is displayed in the following format:

```

XXXXX ERRORS
CNT  TS-NO  PASS STS  ADDR  WD RD HSTS [ERROR STATUS NAME]

001  FDD 02  0000 103  00001  00 00 0000  FDD-WRITE PROTECTED
001  FDD 01  0000 180  00001  00 00 0000  FDD-TIME OUT ERROR

```

| Address
| Error status
| HDC status
| Read data
| Write data
| Error status name
| Error count

[[1:Next,2:Prev,3:Exit,4:Clear,5:Print,6:FD Log Read,7:FD Log Write]]

- The error information displayed on the screen can be manipulated by the following number keys:
 - The **1** key scrolls the display to the next page.
 - The **2** key scrolls the display to the previous page.
 - The **3** key returns to the Diagnostic Menu.
 - The **4** key erases all error log information in RAM.
 - The **5** key outputs the error log information to a printer.
 - The **6** key reads the log information from a floppy disk.
 - The **7** key writes the log information to a floppy disk.
- In the case of “error retry OK,” a capital “R” will be placed at the beginning of the error status. However, it is not added to the error count.

3.23 Running Test

3.23.1 Function Description

This function automatically executes the following tests in sequence:

1. System test (subtest 01)
2. Memory test (subtests 01, 02, 06)
3. Display test (subtest 01)
4. Real timer test (subtest 02)
5. HDD test (subtests 01)

The system automatically detects the number of floppy disk drives connected to the computer for the FDD test.

3.23.2 Operations

1. Select **6** from the Diagnostic Menu and press **Enter**, the following messages will appear in the display in order.

FDD write/read test (Y/N) ?

Printer wrap around test (Y/N) ?

Serial wrap around test (Y/N) ?

CD-ROM/DVD-ROM test (Y/N) ?

2. To execute the test, press **Y (yes)** and **Enter**. To cancel the test, press **N (no)** and **Enter**. If you execute the selectable test, follow the indication message in the display.
3. After setting the selectable test, the test starts automatically. To terminate the program, press **Ctrl + Break**.

3.24 Floppy Disk Drive Utilities

3.24.1 Function Description

This function formats the FDD, copies the floppy disk and displays the dump list for both the FDD and HDD.

1. FORMAT

NOTE: *This program is only for testing a floppy disk drive. The option is different from the Toshiba MS-DOS FORMAT command.*

This program can format a floppy disk in the following formats:

- (a) 2DD: Double-sided, double-density, double-track, 96/135 TPI, MFM mode, 512 bytes, 9 sectors/track.
- (b) 2HD: Double-sided, high-density, double-track, 96/135 TPI, MFM mode, 512 bytes, 18 sectors/track.

2. COPY

This program copies data from a source floppy disk to a target floppy disk.

3. DUMP

This program displays the contents of the floppy disk and the designated sectors of the hard disk on the display.

4. HDD ID READ

This program reads the hard disk ID and displays hard disk information.

3.24.2 Operations

1. Selecting **7** from the DIAGNOSTIC MENU and pressing **Enter** displays the following message:

```
[ FDD UTILITIES ]

1 - FORMAT
2 - COPY
3 - DUMP
4 - HDD-ID READ
9 - EXIT TO DIAGNOSTICS MENU
```

2. FORMAT program

- (a) Selecting FORMAT displays the following message:

```
DIAGNOSTICS - FLOPPY DISK FORMAT : VX.XX
Drive number select (1:A, 2:B) ?
```

- (b) Select a drive number to display the following message:

```
Type select (0:2DD, 3:2HD) ?
```

- (c) Select a media/drive type number and press **Enter**. A message similar to the one below will be displayed:

```
Warning : Disk data will be destroyed.
Insert work disk into drive A:
Press any key when ready.
```

- (d) Remove the Diagnostics Disk from the FDD, insert the work disk and press any key.

The following message will be displayed when the FDD format is executed:

```
[ FDD TYPE ] : TRACK   = XXX
[ FDD TYPE ] : HEAD    = X
[ FDD TYPE ] : SECTOR  = XX

Format start

[[track, head = XXX X]]
```

After the floppy disk is formatted, the following message will appear:

```
Format complete
Another format (1:Yes/2:No) ?
```

- (e) Typing **1** displays the message from step (c) above. Typing **2** returns the test to the DIAGNOSTIC MENU.

3. COPY program

- (a) When COPY is selected, the following message appears:

```
FLOPPY DISK FORMAT & COPY : VX.XX
Type select (0:2DD,3:2HD) ?
```

- (b) Selecting a media/drive type number will display a message similar to the one below:

```
Insert source disk into drive A:
Press any key when ready.
```

- (c) Remove the Diagnostics Disk from the FDD, insert the source disk and press any key. The following message will appear, indicating the program has started.

```
[ FDD TYPE ] : TRACK    = XXX
[ FDD TYPE ] : HEAD     = X
[ FDD TYPE ] : SECTOR   = XX

Copy start
                [[ track,head = XXX X ]]
```

- (d) The following message will appear.

```
Insert target disk into drive A:
Press any key when ready.
```

- (e) Remove the source disk from the FDD, then insert a formatted work disk and press any key. The following message will appear and start copying to the target disk.

```
                [[ track,head = XXX X ]]
```

- (f) When the amount of data is too large to be copied in one operation, the message from step (b) is displayed again. After the floppy disk has been copied, the following message will appear:

```
Copy complete
Another copy (1:Yes/2:No) ?
```

- (g) To copy another disk, type **1** and the message from step (a) is displayed again. Entering **2** returns the test program to the DIAGNOSTIC MENU.

4. DUMP program

- (a) When DUMP is selected, the following message appears:

```
DIAGNOSTICS-HARD DISK & FLOPPY DISK DUMP : VX.XX
Drive type select (1:FDD, 2:HDD) ?
```

- (b) Select a drive type. If 2:HDD is selected, the display will go to step (h). If 1:FDD is selected, the following message will appear:

```
Select drive number (1:A, 2:B) ?
```

- (c) Select a drive number and the following message will be displayed.

```
Format type select (1:2DD, 3:2HD) ?
```

- (d) If 3:2HD is selected, the following message will appear. Select a media mode.

```
2HD media mode (1:1.20MB, 2:1.44MB, 3:1.23MB)?
```

- (e) The following message will appear:

```
Insert source disk into drive A:
Press any key when ready.
```

- (f) Insert a source disk and press any key and the following message will appear:

```
— Max. address —
[Track ] = XXXX
[Head  ] = XX
[Sector] = XX
Track number ????
```

- (g) Set the track number, head number and sector number you want to dump. The system will access the disk and dump a list. Then the message shown in (k) will appear.

- (h) The following message will appear when selecting 2:HDD in (a).

```
Select drive number (1:C, 2:D) ?
```

- (i) Select a drive number and the following message will be displayed.

```
---Max. address ---
[LBA ] = XXXXXXXXXXXX
LBA number ??????????
```

- (j) Set the LBA number you want to dump. The system will access the disk and dump a list.

- (k) The following message will appear. To finish the dump, select **3**.

Press number key (1:up,2:down,3:end) ?

- (l) The following message will appear. Selecting **2** returns to the FDD UTILITIES MENU.

Another dump (1:Yes,2:No) ?

5. HDD ID READ program

Selecting HDD ID displays the following HDD ID configuration:

[HDD ID Read (VX.XX)]	[Drive #1]	[Drive #2]
Model No.	= XXXXXXXX	= XXXXXXXX

NOTE: Only when a 2nd HDD is installed, [Drive #2] message appears in the display.

Press **Enter** to return to the FDD UTILITIES MENU.

3.25 System Configuration

3.25.1 Function Description

The System Configuration program contains the following configuration information for the computer:

1. Processor Type [Code/L2 cache]
2. Chip set [VRAM]
3. BIOS ROM version [1st ID, 2nd ID]
4. Boot ROM version
5. EC total version
6. PS Microprocessor version
7. SVP parameter version [Panel/Manufacture code/Product code]
8. Micro code revision [Processor number]
9. Total Memory Size [Conventional memory]
10. Battery code
11. HWSC
12. FSB [Voltage]
13. The number of printer ports
14. The number of ASYNC ports
15. Math co-processors
16. Floppy Disk Drive [Track/Head/Sector]
17. Hard Disk Drive [Sector/Drive size/Manufacture code]
18. Optical Disk Drive [Maker/Drive type/Manufacture code/Product code]
19. T&D total version
20. Date/Time

3.25.2 Operations

Select **8** from the DIAGNOSTIC MENU and press **Enter**. Then, the following system configuration appears in the display.

```
System Configuration Display: Ver X.XX [Machine Name???]

* - Processor Type      = XXXXXX-XXXXXXMHz      Code = XX      L2 Cache = XXXXXXKB
* - Chip set           = XXXXXX                      VRAM = XXXXMB
* - BIOS ROM Version   = VX.XX      1st ID = XXH, 2nd ID = XXH
* - BOOT ROM Version   = VX.XX
* - EC Total Version   = VX.XX
* - PS Micon Version   = VX.XX
* - SVP Par. Version   = VX.XX      (Panel=XXXXXXXXXX, Manu=XXXX, Prod=XXXX)
* - Micro code Revision = VX.XX      (Processor=XXXh)
* - Total Memory Size   = XXXXXXMB (Conventional Memory = XXXKB)
* - Battery Code       = XXXXXXXXXXXXX
* - HWSC               = XXXXXXXX
* - FSB                = XXXXXXMHz (Voltage = XEh)
* - X Printer Adapter   LPT1 = XXXX   LPT2 = XXXX   LPT3 = XXXX
* - X ASYNC Adapter     COM1 = XXXX   COM2 = XXXX   COM3 = XXXX
* - X Math CO-Processor

* - X Floppy Disk Drive(s)  Track = XX   Head = XX, Sector = XX
* - X Hard Disk Drive(s)   #1 Sectors = XXXXX, (XXXXX GB) [XXXXXXXXXXXXXXXXXXXX]
                          #2 Sectors = XXXXX, (XXXXX GB) [XXXXXXXXXXXXXXXXXXXX]
* - ODD                   = XXXX XXXXXXXX XXXXXXXX [XXXXXXXXXXXXXXXX]
* - T&D Total Version      = VX.XX

Press [Enter] Key      [Date = XXXX-YY-ZZ, XX:YY:ZZ]
```

Press **Enter** to return to the DIAGNOSTIC MENU.

3.26 Wireless LAN Test Program (Intel-made b/g)

This section describes how to perform the wireless LAN transmitting-receiving test (Intel-made Calexico 802.11b/g). To execute the wireless LAN test, use the Diagnostics disk for wireless LAN test. Finish the tests of the Main test program by selecting 99 - EXIT TO DIAGNOSTICS MENU in the DIAGNOSTIC TEST MENU. Then in the DIAGNOSTICS MENU, select 9 - EXIT TO MS-DOS.

Insert the Diagnostics disk for wireless LAN test into the Floppy Disk Drive. Turn on the power while pressing **U**.

The following menu appears in the display.

```
*****Intel Calexico 11b/g Card Maintenance test Menu*****
*
*   1  : SKU check of Module                               *
*
*   2  : MAC Address Check                                 *
*
*   3  : Antenna Check & communication test of 11b mode  *
*
*   4  : Communication test of 11g mode                   *
*
*   5  : All the tests of Calexico 11g Card               *
*         (SKU & MAC Check, 11b/g communication test)    *
*
*
*****
```

SELECT TEST No, (1-5):

To execute the subtest, input the subtest number and press **Enter**.

Subtest01 SKU check of module

This subtest displays SKU information on the wireless LAN card installed. Selecting this subtest, following message will appear in the display. Confirm if the right information on the wireless LAN card is described.

```
*****
*
*   Module      : Intel Calexico 802.11b/g (MoW)          *
*   G-code     : xxxxxxxxxxxxxx                          *
*   PBA No.    : xxxxxxxx                               *
*
*****
```

If a defective is found during the test, **NG** message will appear in the display.

Press any key and return to the test menu.

When a defective is detected in the test, following typical cause is considered.

- Connection of wireless LAN card
- Using a wrong wireless LAN card (Using unspecified card)
- Defective wireless LAN card

Checking the connection, execute the subtest again.

Subtest02 MAC Address Check

This subtest displays the MAC address. Selecting this subtest, following message will appear in the display.

```
*****
MAC = XXXXXXXXXXXX
*****
*****
*
*   MAC Address Check: OK !!
*
*****
```

Press any key and return to the test menu.

If a defective is found during the test, following message will appear in the display.

```
*****
ERROR: MAC all 0
MAC = XXXXXXXXXXXX
*****
*****
*
*   MAC Address Check: NG !!
*
*****
```

Press any key and return to the test menu.

When a defective is detected in the test, following typical cause is considered.

- Connection of wireless LAN card
- Defective wireless LAN card
- Disappearance of MAC address data

Checking the connection, execute the subtest again.

Subtest03 Antenna check & communication test of 11b mode

Caution: To execute subtest 03-05, use another computer (with Callexico wireless LAN card) that can communicate by the wireless LAN as a responder machine to perform those tests. Access points are also required. (Access point for 802.11b and 802.11g)

Be sure to turn the wireless communication switch ON before executing wireless LAN communication test. (The wireless communication LED lights orange.)

Release the write-protection of floppy disk for the test.

Setting the responder machine

Connect the responder machine to the access points (for 802.11b and 802.11g) with a cross cable and turn on the access points.

Insert the floppy disk containing the wireless LAN test program into the FDD of the responder machine and turn on the responder machine.

This subtest checks the connection and communication of wireless LAN antenna of Callexico 802.11b mode.

After finishing the test, **OK** message will appear in the display. Press any key and return to the test menu.

When a defective is found during the test, **NG** message will appear in the display. Press any key and following message will appear in the display. Check which antenna (Main/Aux) is defective.

```
*****
*
*           Main Antenna Test: NG !!
*
*****
```

Press any key and return to the test menu.

When a defective is detected in the test, following typical cause is considered.

- Connection of wireless LAN card
- Connection of wireless LAN antenna cable (Main/Aux)
- Condition of wireless LAN communication (Interference/obstruction)
- Defective wireless LAN card

Checking the connection and condition, execute the subtest again.

Subtest04 Communication test of 11g mode

This subtest checks the communication of wireless LAN antenna of Callexico 802.11g mode.

After finishing the test, **OK** message will appear in the display. Press any key and return to the test menu.

When a defective is found during the test, **NG** message will appear in the display. Press any key and following message will appear in the display.

```
*****
*
*           11g Communication Test: NG !!
*
*****
```

Press any key and return to the test menu.

When a defective is detected in the test, following typical cause is considered.

- Connection of wireless LAN card
- Connection of wireless LAN antenna cable (Main)
- Condition of wireless LAN communication (Interference/obstruction)
- Defective wireless LAN card

Checking the connection and condition, execute the subtest again.

Subtest05 All the tests of Callexico 11b/g Card

This subtest checks SKU information, MAC address, connection and communication of wireless LAN antenna of Callexico 802.11b/g card. The test stops at when a defective is found. For more details, refer to each subtest.

3.27 Wireless LAN Test Program (Intel-made a/b/g)

This section describes how to perform the wireless LAN transmitting-receiving test (Intel-made Calexico 802.11a/b/g). To execute the wireless LAN test, use the Diagnostics disk for wireless LAN test. Finish the tests of the Main test program by selecting 99 - EXIT TO DIAGNOSTICS MENU in the DIAGNOSTIC TEST MENU. Then in the DIAGNOSTICS MENU, select 9 - EXIT TO MS-DOS.

Insert the Diagnostics disk for wireless LAN test into the Floppy Disk Drive. Turn on the power while pressing **U**.

The following menu appears in the display.

```
*****
*      Intel Calexico2 11a/g Maintenance T&D Menu      *
*
*      1  : SKU check of Module                        *
*
*      2  : MAC Address Check                          *
*
*      3  : Antenna Check & communication test of 11b mode *
*
*      4  : Communication test of 11a mode             *
*
*      5  : Communication test of 11g mode            *
*
*      6  : All the tests of Calexico2 11a/g Card      *
*             (SKU & MAC Check, 11a/b/g communication test) *
*
*****
```

SELECT TEST No, (1-6):

To execute the subtest, input the subtest number and press **Enter**.

Subtest01 SKU check of module

This subtest displays SKU information on the wireless LAN card installed. Selecting this subtest, following message will appear in the display. Confirm if the right information on the wireless LAN card is described.

```
*****
*
*      Module   : Intel Calexico 802.11a/g (MoW)      *
*      G-code   : xxxxxxxxxxxx                       *
*      PBA No.  : xxxxxxxx                           *
*
*****
```

Press any key and return to the test menu.

If a defective is found during the test, **NG** message will appear in the display.

Press any key and following message will appear in the display.

```
*****
*
*                SKU NG !!
*
*          Other Card or Module not found
*
*****
```

Press any key and return to the test menu.

When a defective is detected in the test, following typical cause is considered.

- Connection of wireless LAN card
- Using a wrong wireless LAN card (Using unspecified card)
- Defective wireless LAN card

Checking the connection, execute the subtest again.

Subtest02 MAC Address Check

This subtest displays the MAC address. Selecting this subtest, following message will appear in the display.

```
*****
*
*          MAC = XXXXXXXXXXXXX
*
*****
*
*          MAC Address Check : OK !!
*
*****
```

Press any key and return to the test menu.

If a defective is found during the test, following message will appear in the display.

```
*****
*
*          ERROR: MAC all F
*          MAC = XXXXXXXXXXXXX
*
*****
*
*          MAC Address Check : NG !!
*
*****
```

Press any key and return to the test menu.

When a defective is detected in the test, following typical cause is considered.

- Connection of wireless LAN card
- Defective wireless LAN card
- Disappearance of MAC address data

Checking the connection, execute the subtest again.

Subtest03 Antenna check & communication test of 11b mode

Caution: To execute subtest 03-06, use another computer (with Callexico wireless LAN card) that can communicate by the wireless LAN as a responder machine to perform those tests. Access points are also required. (Access point for 802.11a, 802.11b and 802.11g)

Be sure to turn the wireless communication switch ON before executing wireless LAN communication test. (The wireless communication LED lights orange.)

Release the write-protection of floppy disk for the test.

Setting the responder machine

Connect the responder machine to the access points (for 802.11a, 802.11b and 802.11g) with a cross cable and turn on the access points.

Insert the floppy disk containing the wireless LAN test program into the FDD of the responder machine and turn on the responder machine.

This subtest checks the connection and communication of wireless LAN antenna of Callexico 802.11b mode.

After finishing the test, **OK** message will appear in the display. Press any key and return to the test menu.

When a defective is found during the test, **NG** message will appear in the display. Press any key and following message will appear in the display. Check which antenna (Main/Aux) is defective.

```
*****
*
*           Aux Antenna Test : NG !!
*
*****
```

Press any key and return to the test menu.

When a defective is detected in the test, following typical cause is considered.

- Connection of wireless LAN card
- Connection of wireless LAN antenna cable (Main/Aux)
- Condition of wireless LAN communication (Interference/obstruction)
- Defective wireless LAN card

Checking the connection and condition, execute the subtest again.

Subtest04 Communication test of 11a mode

This subtest checks the communication of wireless LAN antenna of Calxico 802.11a mode.

After finishing the test, **OK** message will appear in the display. Press any key and return to the test menu.

When a defective is found during the test, **NG** message will appear in the display. Press any key and following message will appear in the display.

```
*****
*
*           11a Communication Test : NG !!
*
*****
```

Press any key and return to the test menu.

When a defective is detected in the test, following typical cause is considered.

- Connection of wireless LAN card
- Connection of wireless LAN antenna cable (Main)
- Condition of wireless LAN communication (Interference/obstruction)
- Defective wireless LAN card

Checking the connection and condition, execute the subtest again.

Subtest05 Communication test of 11g mode

This subtest checks the communication of wireless LAN antenna of Callexico 802.11g mode.

For more details on procedure and contents of this subtest, refer to Subtest04 Communication test of 11a mode.

Subtest06 All the tests of Callexico 11a/b/g Card

This subtest checks SKU information, MAC address of Callexico 802.11a/b/g card, antenna connection and communication test of Callexico 802.11b card and communication test of Callexico 802.11a and Callexico 802.11g. The test stops at when a defective is found. For more details, refer to each subtest.

3.28 Wireless LAN Test Program (Askey-made)

This section describes how to perform the wireless LAN transmitting-receiving test (Askey-made Atheros b/g, a/b/g).

Caution: To execute subtest 03-07, use another computer (with Atheros wireless LAN card) that can communicate by the wireless LAN as a responder machine to perform those tests.

Another wireless communication tool with 2.4GHz like Bluetooth is interfering with the test. Execute this test in the condition where no interference around the computer.

Be sure to turn the wireless communication switch ON before executing wireless LAN communication test. (The wireless communication LED lights orange.)

Release the write-protection of floppy disk for the test.

Setting the responder machine

To execute subtest 03-07, responder machine with wireless LAN communication function (Atheros-made) is required. To set the responder machine, follow the procedures below.

1. Insert the test program disk to the FDD of responder machine and turn on the power.
2. Start the program for responder machine automatically.
3. The program for responder machine is set.

Setting the tester (DUT) machine

1. Insert the test program disk 1 to the FDD of tester machine and turn on the power.
2. The program disk 1 is executed and following message will appear in the display.

```
*****
*
*           Atheros MBxx Maintenance T&D (DUT)           *
*
*           Please exchange for DUT media 2                *
*****
```

Please input the "S" key and push the "Enter" key:

3. Take out the program disk 1 and insert program disk 2. Then, press **S** and **Enter**.
4. Executing program disk 2, following menu will appear in the display. To execute the subtest, press test number and **Enter**.

```

*****
*   Atheros MBxx(MBxxag/xxg) Maintenance T&D Menu   *
*                                                     *
*   1 : SKU check of Module                         *
*                                                     *
*   2 : MAC Address Check                           *
*                                                     *
*   3 : Communication test of 11a mode(MBxxag)      *
*                                                     *
*   4 : Communication test of 11b mode(MBxxag/MBxxg) *
*                                                     *
*   5 : Communication test of 11g mode(MBxxag/MBxxg) *
*                                                     *
*   6 : All the tests of MBxxg Module               *
*   (SKU & MAC Check, 11b/g communication test)    *
*                                                     *
*   7 : All the tests of MBxxag Module              *
*   (SKU & MAC Check, 11a/b/g communication test)  *
*                                                     *
*****

```

SELECT TEST No, (1-7):

Subtest01 SKU check of module

This subtest displays SKU information on the wireless LAN card installed. Selecting this subtest, following message will appear in the display. Confirm if the right information on the wireless LAN card is described.

```

*****
*                                                     *
*   Module   : Atheros MBxxag (RoW)                 *
*   G code   : xxxxxxxxxxxx                         *
*                                                     *
*****

```

Press any key and return to the test menu.

When a defective is detected in the test, following typical cause is considered.

- Connection of wireless LAN card
- Using a wrong wireless LAN card (Using unspecified card)
- Defective wireless LAN card

Checking the connection, execute the subtest again.

Subtest02 MAC Address Check

This subtest displays the MAC address. Selecting this subtest, following message will appear in the display.

```
*****
*
*           MAC Address Check : OK !!
*
*****
```

Press any key and return to the test menu.

When a defective is detected in the test, following typical cause is considered.

- Connection of wireless LAN card
- Defective wireless LAN card
- Disappearance of MAC address data

Checking the connection, execute the subtest again.

Subtest03 Communication test of 11a mode (MBxxag)

This subtest checks the connection and communication of wireless LAN antenna of Atheros 802.11a mode. Check the packet, throughput and RSSI and compare them with the standard.

After finishing the test, **OK** message will appear in the display. Press any key and return to the test menu.

When a defective is found during the test, **NG** message will appear in the display. Press any key and following message will appear in the display.

```
*****
*
*           11a Communication Test : NG !!
*
*           Please refer to log. txt
*
*****
```

Press any key and return to the test menu.

Open the log file (log.txt) and check the result.

When a defective is detected in the test, following typical cause is considered.

- Connection of wireless LAN card
- Connection of wireless LAN antenna cable (Main/Aux)
- Condition of wireless LAN communication (Interference/obstruction)
- Defective wireless LAN card

Checking the connection and condition, execute the subtest again.

Subtest04 Communication test of 11b mode (MBxxag/MBxxg)

This subtest checks the connection and communication of wireless LAN antenna of Atheros 802.11b mode.

For more details on the contents, refer to subtest 03.

Subtest05 Communication test of 11g mode (MBxxag/MBxxg)

This subtest checks the connection and communication of wireless LAN antenna of Atheros 802.11g mode.

For more details on the contents, refer to subtest 03.

Subtest06 All the tests of MBxxg Module

This subtest checks SKU information, MAC address, connection and communication of wireless LAN antenna of Atheros 802.11b mode and Atheros 802.11g mode. The test stops at when a defective is found. For more details, refer to each subtest.

Subtest07 All the tests of MBxxag Module

This subtest checks SKU information, MAC address, connection and communication of wireless LAN antenna of Atheros 802.11a mode, Atheros 802.11b mode and Atheros 802.11g mode. The test stops at when a defective is found. For more details, refer to each subtest.

3.29 LAN/Modem/Bluetooth/IEEE1394 Test Program

This section describes how to perform the LAN/Modem/Bluetooth/IEEE1394 test with the test program.

Insert the test program disk for LAN/Modem/Bluetooth/IEEE1394 test in FDD and turn on the power. The following message will appear:

```
Microsoft Windows XX Startup Menu
-----
```

1. LAN
2. Modem
3. Bluetooth
4. IEEE1394

Enter a choice:

Press the number you want to test and press **Enter**.

NOTE: It is impossible to go back to startup menu once you choose the test. Therefore, LAN/Modem/Bluetooth/IEEE1394 test can not be executed successively.

3.29.1 LAN test

To execute LAN test, press **1** and **Enter**. The following message will appear:

```
#####
##### i82562 ICHx GbE (i82540) Diagnostics program #####
#####
*
* 1 ..... (i82562 + ICHx) *
* *
* 2 ..... (GbE) *
* *
*****
.... Press test number[1-2] ?
```

Press the number you want to test and press **Enter**.

Subtest01 (i82562 + ICHx)

This subtest checks the operation of mini-PCI I/F by the loopback test in the chip.

The following message will appear:

```
[LAN transmit & receive test !]
                                COMPLETED Repeat count = 00000
                                Error count   = 00000

LOOPBACK TEST

100Mbps Auto-negotiation TxRx Test
Destination Address      = xxxxxxxxxxxxxx
Source Address          = xxxxxxxxxxxxxx

** 100Base-TX Full-Duplex **
< TRANSMIT >
< RECEIVE >
```

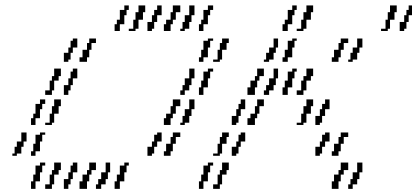

NOTE: The menu displayed by your computer may be slightly different from the one shown above.

If a defective is found, **NG** message will appear in the display.

Subtest02 (GbE)

CAUTION: Gigabit Ethernet test is not supported for this model.

This subtest checks the operation of mini-PCI I/F by the loopback test in the chip. Select **2** to execute and press **Enter**.

The following message will appear:

```
Testing adaptor...hit <ESC> to abort.  
*  
External Loopback Test...PASSED  
Testing completed.  
*  
*  
Loopback Test Complete  
*  
*  
* 1000Base Auto-negotiation TxRx Test  
*  
* CE Test Complete
```

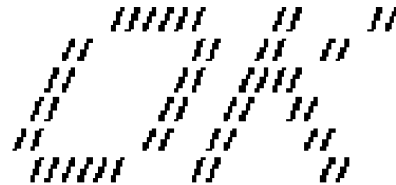

NOTE: The menu displayed by your computer may be slightly different from the one shown above.

If a defective is found, **NG** message will appear in the display.

3.29.2 Modem test

For this subtest, connect the modem PCB and RJ11 connector with a harness. Use the dedicated “FAT-MODE inspection device (product code: QE2000P01 made by Nitto Denki Seisakusyo)” for the tests.

To execute Modem test, press **2** and **Enter**. Following message will appear:

```
[Modem loopback test !]
ICHx MDC Test Program with Modem Sound (Line Test)
Version X.X
* Scorpio Modem Initialize           :OK
* Digital Loopback Test              :OK
* RJ11 Connector Check (LED)         :(Operator's Check!!)
```

NOTE: *The menu displayed by your computer may be slightly different from the one shown above.*

RJ11 Connection Check (LED) (Operator's Check LED) test will be executed, and the following message will appear:

```
...Press Key (Y = OK , N =NG)
```

If the color in the LED of the connection checker is orange, press **Y**, otherwise, press **N**.

3.29.3 Bluetooth test

CAUTION: Bluetooth test is not supported for this model.

To execute this test, input **3** and press **Enter**.

Note: Use another computer that can communicate by the Bluetooth as a reference machine to perform this test.

Insert a floppy disk containing the test program into the target machine and turn on the target machine. The following Bluetooth test menu will appear:

```
#####
##### Bluetooth sub system test program VX.XX #####
#####
*
*          1...BD_ADDR check                               *
*
*          3... Communications test (DUT mode)             *
*
*          T...communications test (TEST mode)            *
*
*****
....Press test number [1, 3, T] ? _
```

Press **1** or **3** key to perform the corresponding subtest. To quit the Bluetooth test program, eject the floppy disk and turn the computer off while the menu above is displayed.

Subtest01 BD_ADDR check

This subtest checks the BD_ADDR functions. When the Bluetooth test menu is displayed, press **1** to select the test and press **Enter**. The following message will appear:

```

-----
Bluetooth Subsystem T&D for PCSE(BD_ADDR) VerX.XX Copyright (C) by TOSHIBA Co.
-----

Initializing ...

```

When the machine has passed the test, it displays BD_ADDR. If BD_ADDR has no problem, the following message is displayed.

```

-----
Bluetooth Subsystem T&D for PCSE(BD_ADDR) VerX.XX Copyright (C) by TOSHIBA Co.
-----

My BD_ADDR = XXXXXXXXXXXX [h]

PPPPPP  A  SSSSS  SSSSS
P  P  A A  S  S  S  S
P  P  A  A  S  S
PPPPPP  A  A  SSSSS  SSSSS
P  AAAAAA  S  S
P  A  A  S  S  S  S
P  A  A  SSSSS  SSSSS

```

If the target machine has any problem, it displays Error CODE. The following message is displayed.

```

-----
Bluetooth Subsystem T&D for PCSE(BD_ADDR) VerX.XX Copyright (C) by TOSHIBA Co.
-----

My BD_ADDR = XXXXXXXXXXXX [h]

FFFFFF      A      III  L
F           A A      I  L
F           A  A      I  L
FFFFFFF A      A      I  L
F           AAAAAA  I  L
F           A  A      I  L
F           A  A      III LLLLLLL

```

Table 3-5 Error message

Message	Contents
Invalid BD_ADDR (all 00)	0x000000000000
Invalid BD_ADDR (all FF)	0xFFFFFFFFFFFF
Invalid BD_ADDR (bit0=1)	bit40=1b
Invalid BD_ADDR (bit1=1)	bit41=1b
Invalid BD_ADDR (define in the file)	Defined BD_ADDR

If the machine detects a malfunction, it indicates the error code as shown below.

The error code begins with the least significant digit.

Error code

Table 3-6 Error code for Bluetooth test (BD_ADDR) (1/2)

Error code	Meaning
0x01	Unknown HCI Command.
0x02	No Connection.
0x03	Hardware Failure.
0x04	Page Timeout.
0x05	Authentication Failure.
0x06	Key Missing.
0x07	Memory Full.
0x08	Connection Timeout.
0x09	Max Number Of Connections.
0x0a	Max Number Of SCO Connections To A Device.
0x0b	ACL Connection already exists.
0x0c	Command Disallowed.
0x0d	Host Rejected due to limited resources.
0x0e	Host Rejected due to security reasons.
0x0f	Host Rejected due to remote device is only a personal device.
0x10	Host Timeout.
0x11	Unsupported Feature or Parameter Value.
0x12	Invalid HCI Command Parameters.
0x13	Other End Terminated Connection: Used Ended Connection.
0x14	Other End Terminated Connection: Low Resources.
0x15	Other End Terminated Connection: About to Power Off.
0x16	Connection Terminated by Local Host.
0x17	Repeated Attempts.
0x18	Paring Not Allowed.
0x19	Unknown LMP PDU.
0x1a	Unsupported Remote Feature.
0x1b	SCO Offset Rejected.
0x1c	SCO Interval Rejected.
0x1d	SCO Air Mode Rejected.
0x1e	Invalid LMP Parameters.
0x1f	Unspecified Error.

** See the Specification of the Bluetooth System for details.

When the Bluetooth test menu is displayed, press **T** to select the test and press **Enter** in the test machine. The following message will appear:

```

-----
Bluetooth Subsystem T&D for PCSE(CS-Air) VerX.XX Copyright (C) by TOSHIBA Co.
-----
+-----+
|           |
|   Tester   |
|           |
+-----+

[ESC]:Finish Tester  [SPACE]:Start
Is DUT ready?

```

Then press **Space** to start the Bluetooth communication test.

When the machine has passed the test, it displays BD_ADDR of the DUT. If the connection with the tester is completed, the progress bar stops. The following message is shown.

```

-----
Bluetooth Subsystem T&D for PCSE(CS-Air) VerX.XX Copyright (C) by TOSHIBA Co.
-----
+-----+
|           | BD_ADDR of the DUT = XXXXXXXXXXXXX [h]
+-----+

  CCCC   OOO   M   M PPPPPP L   EEEEEE TTTTTTT EEEEEEE DDDDD
C   C O   O MM   MM P   P L   E       T   E       D   D
C       O   O M M M M P   P L   E       T   E       D   D
C       O   O M M M PPPPPP L   EEEEEE T   EEEEEEE D   D
C       O   O M   M P   L   E       T   E       D   D
C   C O   O M   M P   L   E       T   E       D   D
  CCCC   OOO   M   M P   LLLLLL EEEEEE T   EEEEEEE DDDDD

Testing is finished

A>_

```

If the target machine has any problem, the following message “INCOMPLETE” is displayed with the Error Code.

```

-----
Bluetooth Subsystem T&D for PCSE(CS-Air) VerX.XX Copyright (C) by TOSHIBA Co.
-----

+-----+
|          DUT          |   BD_ADDR of the DUT = XXXXXXXXXXXXX [h]
+-----+

III  N      N  CCCC   OOO  M      M  P P P P P P  L      EEEEE  TTTTTTT  EEEEEEE
I   NN     N  C      C  O    O  MM   MM  P      P  L      E          T      E
I   N N    N  C      O    O  M M  M  M  P      P  L      E          T      E
I   N N    N  C      O    O  M  M  M  P P P P P P  L      EEEEE  T      EEEEEEE
I   N      N  N  C      O    O  M      M  P      L      E          T      E
I   N      NN  C      C  O    O  M      M  P      L      E          T      E
III  N      N  CCCC   OOO  M      M  P          LLLLLL  EEEEE  T      EEEEEEE

                                Testing is finished

_Press any key to continue. . .

```

If the machine detects a malfunction, it indicates the error code as shown below.

The error code begins with the least significant digit.

Error code

Table 3-7 Error code for Bluetooth test (BD_ADDR of the DUT) (1/2)

Error code	Meaning
0x01	Unknown HCI Command.
0x02	No Connection.
0x03	Hardware Failure.
0x04	Page Timeout.
0x05	Authentication Failure.
0x06	Key Missing.
0x07	Memory Full.
0x08	Connection Timeout.
0x09	Max Number Of Connections.
0x0a	Max Number Of SCO Connections To A Device.
0x0b	ACL Connection already exists.
0x0c	Command Disallowed.
0x0d	Host Rejected due to limited resources.
0x0e	Host Rejected due to security reasons.
0x0f	Host Rejected due to remote device is only a personal device.
0x10	Host Timeout.
0x11	Unsupported Feature or Parameter Value.
0x12	Invalid HCI Command Parameters.
0x13	Other End Terminated Connection: Used Ended Connection.
0x14	Other End Terminated Connection: Low Resources.
0x15	Other End Terminated Connection: About to Power Off.
0x16	Connection Terminated by Local Host.
0x17	Repeated Attempts.
0x18	Paring Not Allowed.
0x19	Unknown LMP PDU.
0x1a	Unsupported Remote Feature.
0x1b	SCO Offset Rejected.
0x1c	SCO Interval Rejected.
0x1d	SCO Air Mode Rejected.
0x1e	Invalid LMP Parameters.
0x1f	Unspecified Error.

** See the Specification of the Bluetooth System in detail.

Table 3-7 Error code for Bluetooth test (BD_ADDR of the DUT) (2/2)

Error code	Meaning
0x20	Unsupported LMP Parameter Value.
0x21	Role Change Not Allowed.
0x22	LMP Response Timeout.
0x23	LMP Error Transaction Collision.
0x24	LMP PDU Not Allowed.
0x25	Not Exist
0x26	Not Exist
0x27	Not Exist
0x28	Not Exist
0x29	Not Exist
0x2a	Not Exist
0x2b	Not Exist
0x2c	Not Exist
0x2d	Not Exist
0x2e	Not Exist
0x2f	Not Exist

** See the Specification of the Bluetooth System in detail.

3.29.4 IEEE1394 test

To execute this test, input **4** and press **Enter**.

NOTE: Use another computer that can communicate by IEEE1394 (i. Link) cable as a reference machine to perform this test.

The following menu will appear:

```

*****
*****      IEEE1394[XXXXX] Diagnostics program      *****
*****
*                                                     *
*      1 ....(Transmit & Receive test)                *
*                                                     *
*      2 ....(Responder set)                          *
*                                                     *
*      3 ....(1394 GUID Display)                      *
*                                                     *
*****
.... Press test number[1-3] ?

```

To execute the TEST, select the test number you want to execute and press **Enter**.

Subtest01 Transmit & Receive test

NOTE: Before executing subtest 01, be sure to execute subtest 02 in the responder machine.

This program checks the data transporting between responder machine and target machine and compare them with the original data through the IEEE1394 cable.

Subtest02 Responder set

This program is executed in the responder machine to initialize the responder machine with the IEEE1394 cable connected to the target machine before executing subtest 01.

Subtest03 IEEE1394 GUID Display

This program checks the GUID of IEEE1394.

3.30 Sound Test program

This section describes how to perform the Sound test. To execute the sound test, refer to the following description.

Insert the test program disk for Sound test in the floppy disk drive and turn on the power. The following message will appear:

```
#####
#####      WSS, Sound blaster pro Diagnostics program      #####
#####
*
*      1 .....      Sound (Standard)      *
*
*      2 .....      Sound (Legacy)      *
*
*      3 .....      CD Sound (Standard)  *
*
*      4 .....      CD Sound (Legacy)    *
*
*      ---It outputs at the speaker and lineout---      *
*
*****
.... Press test number[1-4] ?
```

Input the test number and press **Enter**.

3.30.1 Sound (Standard) test

To execute the Sound (Standard) test, press **1** and **Enter**. The following menu will appear in the display.

```
#####
#####      ICH4-M + AD1981A Diagnostics program      #####
#####
*
*      1 .....      (Microphone recording & play)      *
*
*      2 .....      (Sine wave)      *
*
*      3 .....      (Line IN recording & play)      *
*
*      9 .....      Exit to Main      *
*
*****
.... Press test number[1-3, 9] ?
```

To return to the Sound test menu, Press **9** and **Enter**. Then following message will appear in the display.

```
*****  
*****  May I Restart ?  *****  
*****  
Press any key to continue..
```

After pressing any key, the machine starts rebooting and sound test menu will appear in the display.

Subtest01 Microphone recording & play

This subtest checks the function of the CODEC A/D, D/A converter.

When this subtest is selected, the following message will appear.

```
[Recording & play test !]
```

And the following message will appear.

```
DOS/4GW Protected Mode Run-time Version X.XX  
Copyright (c) Tenberry Software, Inc. XXXX
```

After this message appears, display stops briefly. In this timing, sound is recorded from internal microphone.

After the recording is completed, the computer plays back the sound recorded after the following message.

```
STACWAVE Version X.XX  
Build data: XXX XX XXXX at XX:XX:XX  
Loading "mic.wav".
```

NOTE: *The message in the display might have slight difference from those above.*

The display returns to the Sound (Standard) test menu after the test ends.

Subtest02 Sine Wave

This subtest is executed by loading the COM file (ADSIN.COM). The program expands sine wave data table from 16KB to 64KB, and creates the play data. Then it transfers the data between the DMA and the CODEC to play the sine wave. (It sounds like a continuous beep). By using wave measurable devices such as an oscilloscope, the data can be measured as a sine wave.

When the subtest is executed, the sine wave is played while expanding sine wave from 16KB to 64KB.

The display returns to the Sound (Standard) test menu after the test ends.

Subtest03 Line IN recording & play

This subtest executes the same test as the subtest01 by recorded sound from the different port (Line-in port).

For more details on the subtest, refer to the subtest01 Microphone recording & play.

The display returns to the Sound (Standard) test menu after the test ends.

3.30.2 Sound (Legacy) test

To execute the Sound (Legacy) test, select **2** and press **Enter**.

CAUTION: *Sound (Legacy) test is not supported in this model.*

3.30.3 CD Sound (Standard) test

To execute the CD Sound (Standard) test, press **3** and **Enter**. Insert the test media (TOSHIBA TEST CD-ROM or ABEX TEST CD-ROM) or music CD on the market (if the test media can not be prepared). Following menu appears in the display.

For details on use of test media, refer to (1) Test media (Toshiba-made test media).
For details on use of audio CD on the market, refer to (2) Audio CD.

(1) Test media (Toshiba-made test media)

```
CD/DVD TEST  IN PROGRESS XXXXXXXX
```

```
xxxxxxx DIAGNOSTIC TEST VX.XX
[Ctrl]+[Break] ; test end
[Ctrl]+[C]      ; key stop
```

```
SUB-TEST      : XX
PASS COUNT    : XXXXX      ERROR COUNT: XXXXX
WRITE DATA   : XX         READ DATA  : XX
ADDRESS       : XXXXXXXX   STATUS       : XXX
```

```
01 - Japanese Narration
02 - English Narration
03 - Test Tone A (100Hz - 20Hz)
04 - Test Tone B (400Hz - 3KHz L-R)
```

```
Drive # = 0, ATAPI status =00
Command = XX
[[Block address = XXXXXXXXX]]
[[Block length  = XXXXXXXXX]]
Final : Block address = XXXXXXXXX
```

Subtest01 Japanese Narration

Selected this subtest, narration in Japanese starts and following message appears in the display.

```
Play start CD sound !
Press any key <Play stop>.
```

Press any key and stop the narration. Then return to the CD Sound (Standard) test menu.

Subtest02 English Narration

Selected this subtest, narration in English starts.

For more details on the procedure, refer to the subtest01.

Subtest03 Test Tone A

Caution: Before starting subtest03, be sure to set the sound at proper volume.

This subtest plays sine wave while changing its table from 100Hz to 20Hz.

Return to the CD Sound (Standard) menu after the test ends.

Subtest 04 Test Tone B

This subtest plays sine wave while changing its table from 400Hz to 3KHz and also changing the channel from left speaker to right speaker.

Return to the CD Sound (Standard) menu after the test ends.

(2) Audio CD

Insert an audio CD and the following menu appears in the display.

```

CD/DVD TEST  IN PROGRESS XXXXXXXX

```

```

xxxxxxx DIAGNOSTIC TEST VX.XX
[Ctrl]+[Break] ; test end
[Ctrl]+[C]      ; key stop

```

```

SUB-TEST      : XX
PASS COUNT    : XXXXX      ERROR COUNT: XXXXX
WRITE DATA   : XX         READ DATA  : XX
ADDRESS       : XXXXXXX    STATUS      : XXX

```

```

CD Sound track number (01-98 : Track) ?

Drive # = 0, ATAPI status =00
Command = XX
[[Block address = XXXXXXXXX]]
[[Block length  = XXXXXXXXX]]
Final : Block address = XXXXXXXXX

```

Select the track number you want to test and press **Enter** twice.

The following message appears in the display and selected track is played.

```

Play start CD sound !
Press any key <play stop>

```

After pressing any key, the music stops and the display returns to the selection menu of the track number.

NOTE: When the CD-ROM test is executed, [ALL DEVICE] must be selected in the “Device Config.=” of the BIOS SETUP. If the “ALL DEVICE” is not selected, music can not be played.

3.30.4 CD Sound (Legacy) test

To execute the CD Sound (Legacy) test, select **4** and press **Enter**.

CAUTION: Sound (Legacy) test is not supported in this model.

3.31 SETUP

3.31.1 Function Description

This program displays the current system setup information as listed below:

1. Memory
2. System Date/Time
3. Battery
 - (a) Battery Save Mode
 - (b) PCI Express Link ASPM
4. Password
5. HDD Password
 - (a) HDD
 - (b) HDD Password Mode
 - (c) User Password
 - (d) Master Password
6. Boot Priority
 - (a) Boot Priority
 - (b) HDD Priority
 - (c) Network Boot Protocol
7. Display
 - (a) Power On Display
 - (b) LCD Display Stretch
 - (c) TV Type
8. Others
 - (a) Dynamic CPU Frequency Mode
 - (b) Execute-Disable Bit Capability
 - (c) Auto Power On
 - (d) Diagnostic Mode
 - (e) Language During Bootup
9. Configuration
10. I/O Ports
 - (a) Serial
 - (b) Parallel

11. Drives I/O

- (a) Built-in HDD
- (b) CD-ROM

12. PCI Bus

13. Security Controller

- (a) TPM
- (b) Clear TPM Owner

14. Peripheral

- (a) Internal Pointing Device
- (b) Ext Keyboard “Fn”
- (c) Parallel Port Mode

15. Legacy Emulation

- (a) USB KB/Mouse Legacy Emulation
- (b) USB-FDD Legacy Emulation
- (c) USB Memory BIOS Support Type

16. PCI LAN

3.31.2 Accessing the SETUP Program

Selecting **0** from the DIAGNOSTICS MENU and pressing **Enter** displays the followings:

SYSTEM SETUP (1/2) ACPI BIOS version = X.XX

<p style="text-align: center;">MEMORY</p> <p>Total = XXXX MB</p>	<p style="text-align: center;">BOOT PRIORITY</p> <p>Boot Priority = HDD→FDD→CD-ROM→LAN HDD Priority = Built-in HDD → USB Network Boot Protocol = PXE</p>
<p style="text-align: center;">SYSTEM DATE/TIME</p> <p>Date (MM-DD-YY) = XX-XX-XXXX Time (HH:MM:SS) = XX:XX:XX</p>	<p style="text-align: center;">Display</p> <p>Power On Display = Auto-Selected LCD Display Stretch = Enabled *2 TV Type = NTSC(US)</p>
<p style="text-align: center;">BATTERY</p> <p>Battery Save Mode = Full Power PCI Express Link ASPM = Auto</p>	<p style="text-align: center;">OTHERS</p> <p>Dynamic CPU Frequency Mode *3 = Dynamically Switchable Execute-Disable Bit Capability = Not Available Auto Power On = Disabled Diagnostic Mode = Disabled Language During Bootup = English *4</p>
<p style="text-align: center;">PASSWORD</p> <p>Not Registered</p>	
<p style="text-align: center;">HDD PASSWORD *1</p> <p>HDD = Built-in HDD HDD Password Mode = Master + User User Password = Not Registered Master Password = Not Registered</p>	

↓↑←→: Select items Space, BkSp: Change values PgDn, PgUp: Change pages
Esc: Exit without saving Home: Set default values End: Save changes and Exit

SYSTEM SETUP (2/2) ACPI BIOS version = X.XX

<p style="text-align: center;">CONFIGURATION</p> <p>Device Config. = Setup by OS</p>	<p style="text-align: center;">PERIPHERAL</p> <p>Internal Pointing Device = Enabled Ext Keyboard "Fn" = Disabled *7 Parallel Port Mode = ECP</p>
<p style="text-align: center;">I/O PORTS *5</p> <p>Serial = COM1 (3F8H/IRQ4) Parallel = LPT1 (378H/IRQ7/CH3)</p>	<p style="text-align: center;">LEGACY EMULATION</p> <p>USB KB/Mouse Legacy Emulation = Enabled USB-FDD Legacy Emulation = Enabled USB Memory BIOS Support Type = HDD</p>
<p style="text-align: center;">DRIVERS I/O</p> <p>Built-in HDD = Primary IDE (1F0H/IRQ14) CD-ROM = Secondary IDE (170H/IRQ15)</p>	<p style="text-align: center;">PCI LAN</p> <p>Built-in LAN = Enabled</p>
<p style="text-align: center;">PCI BUS</p> <p>PCI BUS = IRQ10, IRQ11</p>	
<p style="text-align: center;">SECURITY CONTROLLER *6</p> <p>TPM = Disabled Clear TPM Owner</p>	

↓↑←→: Select items Space, BkSp: Change values PgDn, PgUp: Change pages
Esc: Exit without saving Home : Set default values End: Save changes and Exit

- NOTE:**
- *1. *HDD PASSWORD* window shows slightly different display for each model.
 - *2. *LCD Display Stretch* is displayed only for the model with XGA panel.
 - *3. *Dynamic CPU Frequency Mode* is displayed only for the model with Pentium-M processor.
 - *4. *Language During Bootup* is displayed only for the model for TCL (Canada).
 - *5. *I/O PORTS* window shows slightly different display for each model.
 - *6. *SECURITY CONTROLLER* window is displayed only for the model with TPM function when the *SETUP* is operated during IRT.
 - *7. *Ext Keyboard “Fn”* is displayed only for the model supporting its function.

Moving Within the SETUP Menu and Changing Values

1. Press **←** and **→** to move between the two columns. Press **↑** and **↓** to move between items in a column. Press **Fn+↑ (PgUp)** and **Fn + ↓ (PgDn)** to move between the two pages.
2. Press either the **Space bar** or **Back Space** to change the value.

Accepting Changes and Exiting the SETUP Window

1. Press **End** to accept the changes you made.

If the changed item does not require the system to reboot, the following message is displayed:

Are you sure? (Y/N)

If the changed item requires the system to reboot, the following message is displayed:

Are you sure? (Y/N)
The changes you made will cause the system to reboot.

2. To make other changes, press **N**. Repeat the steps above.
3. To accept the changes, press **Y**.

NOTE: You can press **Esc** to quit at any time without saving changes. SETUP asks you to confirm that you do not want to save your changes. When SETUP is displayed at the next time, the current configuration appears.

The Factory Preset Configuration

When you access SETUP, the current configuration is displayed.

1. To show the factory preset configuration, press **Home**.
2. To accept the default settings, press **End** and then press **Y**.

NOTE: When you execute the default setting, the following settings are not changed:

- (1) HDD Mode
- (2) Password
- (3) Write Policy

SETUP Options

The SETUP screen is divided into 14 functionally related groups. This section describes each group and its options.

1. Memory

This group of options displays the computer's memory.

This field displays the total amount of memory installed and is automatically calculated by the computer. You cannot change this value.

2. System Date/Time

Sets the date and time.

System Date Sets date.

System Time Sets time.

3. Battery

(a) Battery Save Mode

This option is used to select **Full Power**, **Low Power** or **User Setting** of the battery save mode. When you select the battery save mode, the followings will appear.

Full Power The following shows full power settings.

```

----- BATTERY SAVE OPTIONS -----
Processing Speed   = High
CPU Sleep Mode    = Enabled
LCD Brightness    = Bright (*1)
                  = Super-Bright (*2)
Cooling Method    = Maximum Performance
  
```

Low Power The following shows low power settings.

```

----- BATTERY SAVE OPTIONS -----
Processing Speed   = Low
CPU Sleep Mode    = Enabled
LCD Brightness    = Semi-Bright (*1)
                  = Bright (*2)
Cooling Method    = Battery Optimized
  
```

NOTE: Display of the LCD Brightness will be changed in the condition below:
 (*1) Operating the battery
 (*2) Using the AC adapter

User Setting Use this option to set the battery save parameters on the sub-window, **BATTERY SAVE OPTIONS**.

Battery Save Options

Processing Speed

This feature changes the CPU processing speed.

High CPU operates at 1.60/1.73/1.87/2.00/2.13GHz(Pentium-M),
 (Default in Full Power Mode)

Low CPU operates at half processing speed.
 (Default in Low Power Mode)

CPU Sleep Mode

Use this option to enable or disable the CPU sleep function.

Enabled Enables sleep mode. (Default)

Disabled Disables sleep mode.

LCD Brightness

Use this option to set the level of LCD brightness.

Super-Bright Full brightness for maximum visibility.

Bright Full brightness for high visibility.

Semi-Bright Less than full brightness for saving power.

Cooling Method

Maximum Performance If the CPU becomes too hot, the fan turns on automatically in a high speed to cool down the CPU.

Performance If the CPU becomes too hot, the fan turns on automatically. When the CPU temperature falls to a normal range, the fan turns off.

Battery optimized

If the CPU becomes too hot, the processing speed is lowered. If the temperature is still too high, the fan turns on. When the CPU temperature falls to a normal range, the fan is turned off and the processing speed is increased.

NOTE: Too hot condition may cause defect on the CPU. When the hot condition continues, the power is automatically turned off in resume mode.

(b) PCI Express Link ASPM

This option set the power-saving function of PCI Express on the following conditions.

Auto

PCI Express devices are not used while battery operation. (Default)

Disabled

Disable the Power-saving function and drive with maximum performance.

Enabled

PCI Express devices are not used.

4. Password

This option sets or resets the user password for power on and instant security (**Fn+F1**).

Registered

The user password has been registered.

Not registered

The user password has not been registered.

For details on setting the user password, refer to the User's Manual.

(a) User Password

Sets the User HDD Password.

For details, refer to the User's Manual.

(b) Master Password

Sets the Master HDD Password. This can be set when **Master+User** is set in the HDD password Mode. For details, refer to the User's Manual.

5. HDD Password

This option registers, resets or changes the HDD password.

(a) HDD

Hard disk for setting the password.

Built-in HDD The password is set to Built-in HDD. (This cannot be changed.)

(b) HDD Password Mode

This item registers HDD password and can be selected only for registering HDD password. To change HDD Password Mode when HDD password is registered, delete the registered HDD password first, and then register new password.

User Only Sets only User HDD Password (Default)

Master+User Sets Master HDD Password and User HDD Password

(c) User Password

This item sets User password.

For details on setting user password, refer to the User's Manual.

(d) Master Password

This item sets the Master HDD password.

This can be set, only when **Master+User** is set in the HDD password Mode.

For details, refer to the User's Manual.

6. Boot Priority

(a) Boot Priority

Use this option to set the priority for booting of the computer and the priority for the HDD for booting.

FDD→HDD→CD-ROM→LAN: The computer looks for bootable files in the following order: FDD, HDD, CD-ROM (*1) and LAN

HDD→CD-ROM→LAN→FDD: The computer looks for bootable files in the following order: HDD, CD-ROM, LAN and FDD.

FDD→CD-ROM→LAN→HDD: The computer looks for bootable files in the following order: FDD, CD-ROM, LAN and HDD.

CD-ROM→LAN→HDD→FDD: The computer looks for bootable files in the following order: CD-ROM, LAN, HDD and FDD.

CD-ROM→LAN→FDD→HDD: The computer looks for bootable files in the following order: CD-ROM, LAN, FDD and HDD.

HDD→FDD→CD-ROM→LAN: The computer looks for bootable files in the following order: HDD, FDD, CD-ROM and LAN. (Default)

(*1) CD-ROM refers to a Optical Disk Drive.

(b) HDD Priority

Use this option to set the booting priority from HDD.

Built in HDD→USB (Default)

: detecting boot-command from Built in HDD

USB →Built in HDD

: detecting boot-command from USB memory

(c) Network Boot Protocol

Use this option to set the starting method via a network.

PXE Sets to PXE protocol. (Default)

RPL Sets to RPL protocol.

7. Display

This group of options configures the computer's display.

(a) Power On Display

This option is used to select the display when booting up.

Auto-Selected Selects an external monitor if one is connected. Otherwise it selects the internal LCD. (Default)

LCD+AnalogRGB Selects both the internal LCD and the external CRT for simultaneous display.

NOTE: When starting the computer in Standby or Hibernation, the last configuration is remembered. If data does not appear on the display you are using after starting in Standby or Hibernation, pressing **Fn+F5**.

Pressing **Fn+F5** changes the display setting as follows in order: the internal LCD, the external display, both the internal LCD and the external display.

When an external display, which does not support SVGA mode is connected and "LCD+AnalogRGB" is selected, the external display is not displayed.

(b) LCD Display Stretch

LCD Display Stretch enables or disables a larger display area of the screen.

Enabled Enables the LCD display stretch feature. (Default)

Disabled Disables the LCD display stretch feature.

(c) TV Type

This option allows you to select the type of TV.

NTSC (Japan) TV in Japanese system

NTSC (US) TV in the U.S. system

PAL (S-Video) TV in Europe and China system

525p (480p,D2) High Definition Television with 480 progressive scan

750p (720p,D4) High Definition Television with 720 progressive scan

1125i (1080i,D3) High Definition Television with 1080 interlace

525i (480i,D1) High Definition Television with 480 interlace

PAL (SCART) TV in Europe system

8. Others

Whether or not you need to configure the computer with these options depends primarily on the kind of software or peripherals you use.

(a) Dynamic CPU Frequency mode

Use this option to choose a setting from the followings.

Dynamically Switchable

Enables Pentium-M processor featuring Intel SpeedStep technology. (Default)

Always High Disables Pentium-M processor featuring Intel SpeedStep technology and always runs the processor at its maximum speed.

Always Low Disables Pentium-M processor featuring Intel SpeedStep technology and always runs the processor at its default speed.

(b) Execute-Disable Bit Capability

This option set the Execute-Disable Bit function of CPU to the operation system. Execute-Disable Bit gives higher security function preventing the PC from the computer viruses and buffer overflow problem on unauthorized access.

Available	Enable the Execute-Disable Bit function.
Not Available	Disable the Execute-Disable Bit function.

(c) Auto Power On

This option displays setting for Auto Power On.

Disabled Indicates auto power on is not set.

Enabled Indicates auto power on is set.

When “Enabled” is selected, the following sub-window appears.

OPTIONS	
Alarm Time	= 00:00:00
Alarm Date Option	= Disabled

Set the parameters for the Auto Power On (automatic power on) function in the “OPTIONS” window. To set the time, use **Space** or **BackSpace**. Press ↓ to move the cursor to the right and ↑ to move the cursor to the left when you set the date and time.

For the **Alarm Time**, set the time to turn on the power automatically. The “second” cannot be set. When it is set to “Disabled”, the time to turn on automatically is not set.

For the **Alarm Date Option**, set the date to turn on the power automatically. When it is set to “Disabled”, the time to turn on automatically is not set.

- NOTE:**
1. Do not remove the AC adaptor and battery pack at the same time when you use this feature. If you do so, data saved by the resume function will be lost. You must also reset this option.
 2. If you have set a password and the computer boots by the Auto Power On function and Standby is on, the computer will start with the instant security function enabled. The **password = message** is not displayed; however, you must enter the password to use the computer.
 3. This option is enabled only once, the setting is reset, after booting up.

(d) Diagnostic Mode

This option enables/disables the HW Diagnostic test function.

Disabled Disables the HW Diagnostic test function. (Default)

Enabled Enables the HW Diagnostic test function.

(e) Language During Bootup

This option selects the language during bootup. This message appears only on the model for TCL (Canada).

English Message is displayed in English. (Default)

French Message is displayed in French.

9. Configuration

This option lets you set the device configuration.

All Devices BIOS sets all devices.

Setup by OS Initializes devices, which is needed to load an operating system. Operating system initializes other devices.

NOTE: (1) *When using installed OS, selecting “Setup by OS” is recommended.*
(2) *When executing test programs, be sure to select “ALL Device”. And after the test end, select “Setup by OS”.*

10. I/O ports

This option controls settings for the serial and parallel ports.

(a) Serial

Use this option to set the COM level for the serial port. The serial port interrupt request level (IRQ) and I/O port base address for each COM level is shown below:

COM level	Interrupt level	I/O address	
COM1	4	3F8H	(Default)
COM2	3	2F8H	
COM3	4	3E8H	
COM3	5	3E8H	
COM3	7	3E8H	
COM4	3	2E8H	
COM4	5	2E8H	
COM4	7	2E8H	
Not Used			Disables port

(b) Parallel

This option sets the interrupt request level and I/O port base address for the parallel port. When the parallel port mode is set to **Std. Bi-direct**, the options are as follows:

LPT setting	Interrupt level	I/O address	
LPT 1	7	378H	
LPT 2	5	278H	
LPT 3	7	3BCH	
Not Used			Disables port

When the parallel port mode (see settings below) is set to **ECP**, the DMA channel can also be set to **1** or **3**. The default is 3.

LPT setting	Interrupt level	I/O address	DMA channel
LPT 1	7	378H	3 (Default)
LPT 2	5	278H	3
LPT 3	7	3BCH	3
Not Used			Disables port

When you select one of the above options, except for **Not Used**, a subwindow similar to the one below appears to let you set the DMA. The options for this setting are Channel 1 and Channel 3 (Default).

OPTIONS	
DMA	= Channel 3 (Default)

For most printers, the port should be set to **ECP**. With some other parallel devices, the setting should be **Std. Bi-Direct**.

11. Drives I/O

This option displays the address and interrupts level for hard disk drive and optical disk drive. It is for information only and cannot be changed.

Built-in HDD	This cannot be changed.
CD-ROM	This cannot be changed.

12. PCI Bus

This option displays the interrupt level for the Card Bus in the computer. It is for information only and cannot be changed.

PCI BUS = IRQ10, IRQ11

13. Security controller

(a) TPM

Disables the security controller called TPM (Trusted Platform Module). When the cursor is on the **Enable (Disable)** and the **Space** is pressed, message is displayed and the PC waits **Y** or **N** key input by the user. When **Y** is pressed, it is sets to **Enable (Disable)**. After changing, the cursor could not be moved on the **TPM** tem. This option can be changed after rebooting.

Disabled	Disables the TPM. (Default)
Enabled	Enables the TPM.

(b) Clear TPM Owner

This is not displayed when the **TPM** is set to **Disabled**. This is executed, when the PC is disposed or the owner of the PC changes. When the cursor is on this item and the **Space** is pressed, message is displayed and the PC waits **Y, E, S** and **Enter** key inputs by the user. When **Y, E, S** and **Enter** keys are pressed, the data is disposed. After changing, the display of **TPM** item is changed to **Disabled** and this item becomes not displayed and the cursor could not be moved on the **TPM** item.

14. Peripheral

Use this option to select the peripheral's mode.

(a) Internal Pointing Device

This option enables or disables the touch pad

Enabled Enables the touch pad. (Default)

Disabled Disables the touch pad.

(b) Ext Keyboard "Fn"

This option enables or disables Fn key function on the external keyboard.

Enabled Enables the feature.

Disabled Disables the feature. (Default)

When "Enabled" is selected, the following sub-window appears.

KEYBOARD
Ext Keyboard "Fn" key equivalent = Left Ctrl + Left Alt

Use this option to set a key combination on an external keyboard to emulate the **Fn** key on the computer's internal keyboard. Setting a **Fn** key equivalent will enable you to use "Hotkeys" by pressing the set combination in place of the **Fn** key. The following items can be selected for this option:

= **Left Ctrl + Left Alt** (*1)

= **Right Ctrl + Right Alt** (*2)

= **Left Alt + Left Shift**

= **Right Alt + Right Shift**

= **Left Alt + Caps Lock**

NOTE: If these selections ((*1) or (*2)) are made, you cannot warm boot the system by pressing **Ctrl + Alt + Del**.

(c) Parallel Port Mode

Use this option to set information of Parallel Port Mode.

ECP Sets the port mode to Extended Capabilities Port (ECP). For most printers, the port should be set to ECP. (Default)

Std. Bi-Direct. Sets the bi-directional setting. This setting should be used with some other parallel devices.

NOTE: When using Windows, the setting of “Toshiba HW setup” is enabled and the setting of “Parallel Port Mode” is disabled.

15. LEGACY EMULATION

(a) USB KB/Mouse Legacy Emulation

This option sets the Legacy support condition of the USB keyboard and the USB mouse.

Enabled Enables LEGACY support. (Default)
USB keyboard/USB mouse are available without the driver.

Disabled Disables LEGACY support

(b) USB-FDD Legacy Emulation

This option sets the Legacy support condition of the USB floppy disk drive. When a computer is FDD built-in model, this option is not displayed.

Enabled Enables LEGACY support. (Default)
USB floppy disk is available without the driver.

Disabled Disables LEGACY support

(c) USB Memory BIOS support Type

This option sets the priority of the USB memory as a startup device.

HDD Sets the priority of the USB memory to be equivalent to the HDD. (Default)

FDD Sets the priority of the USB memory to be equivalent to the FDD.

16. PCI LAN

This option sets the Enable / Disable of the built-in LAN functions.

Enabled Enables built-in LAN functions. (Default)

Disabled Disables built-in LAN functions.

Chapter 4

Replacement Procedures

Chapter 4 Contents

4.1	Overview.....	4-1
	Safety Precautions.....	4-2
	Before You Begin.....	4-3
	Disassembly Procedures.....	4-4
	Assembly Procedures.....	4-5
	Tools and Equipment.....	4-5
	Screw Tightening Torque.....	4-6
	Grip Color.....	4-6
	Screw Notation.....	4-7
4.2	Battery Pack/PC Card.....	4-8
	4.2.1 Battery Pack.....	4-8
	4.2.2 PC Card.....	4-10
4.3	Memory Module.....	4-11
4.4	MDC.....	4-14
4.5	HDD.....	4-16
4.6	Wireless LAN Card.....	4-19
4.7	Cooling Fin/CPU.....	4-21
4.8	Keyboard.....	4-26
4.9	Switch Membrane Board.....	4-30
4.10	Optical Drive.....	4-32
4.11	Display Assembly.....	4-34
4.12	Sound Board.....	4-38
4.13	Parallel port board/Serial port board/S-Video board.....	4-39
4.14	FAN.....	4-46
4.15	System Board/DC-IN Jack/RTC Battery.....	4-47
4.16	PC card cover.....	4-50
4.17	Battery Latch.....	4-51
4.18	Battery Lock.....	4-53
4.19	Touch Pad.....	4-55
4.20	LCD Unit/FL Inverter.....	4-57

4 Replacement Procedures

4.21	Latch Assembly	4-61
4.22	Wireless LAN Antenna/Speaker/Hinge	4-62
4.23	Fluorescent Lamp.....	4-71
4.23.1	Replacing the 15.0 Inch XGA Samsung Fluorescent Lamp	4-72
4.23.2	Replacing the 15.0 Inch XGA Sharp Fluorescent Lamp	4-81
4.23.3	Replacing the 15.0 Inch XGA LG.Philips Fluorescent Lamp	4-98
4.23.4	Replacing the 15.0 Inch SXGA+ LG.Philips Fluorescent Lamp.....	4-105

Figures

Figure 4-1 Removing Battery Pack.....	4-8
Figure 4-2 Removing PC Card	4-10
Figure 4-3 Removing Memory Slot Cover	4-11
Figure 4-4 Removing Memory Module.....	4-12
Figure 4-5 Removing MDC	4-14
Figure 4-6 Removing HDD Slot Cover	4-16
Figure 4-7 Removing HDD ASSY	4-17
Figure 4-8 Removing HDD	4-17
Figure 4-9 Removing Mini PCI Slot Cover.....	4-18
Figure 4-10 Removing wireless LAN Card.....	4-20
Figure 4-11 Removing CPU Cover.....	4-21
Figure 4-12 Removing CPU Holder	4-22
Figure 4-13 Removing Cooling Fin.....	4-23
Figure 4-14 Removing CPU	4-23
Figure 4-15 Installing CPU	4-24
Figure 4-16 Applying Silicon Grease	4-25
Figure 4-17 Removing Keyboard Holder	4-26
Figure 4-18 Removing Keyboard	4-27
Figure 4-19 Removing Keyboard Support Plate.....	4-28
Figure 4-20 Removing Switch membrane Board	4-30
Figure 4-21 Removing optical	4-32
Figure 4-22 Removing bracket	4-33
Figure 4-23 Removing screws on the bottom.....	4-34
Figure 4-24 Removing screws and cables	4-35
Figure 4-25 Removing Display Assembly.....	4-36
Figure 4-26 Removing Sound Board	4-38
Figure 4-27 Removing Harness Holder	4-39
Figure 4-28 Removing parallel port board.....	4-40
Figure 4-29 Removing serial port board.....	4-42

Figure 4-30 Removing S-Video board.....	4-44
Figure 4-31 Removing Fan	4-40
Figure 4-32 Opening Insulators	4-46
Figure 4-33 Removing System Board.....	4-47
Figure 4-34 Removing PC card cover	4-50
Figure 4-35 Removing SB Latch Button	4-51
Figure 4-36 Removing Battery Lock L.....	4-51
Figure 4-37 Removing Battery Lock Button	4-53
Figure 4-38 Removing Battery Lock R	4-53
Figure 4-39 Removing Touch Pad	4-55
Figure 4-40 Removing Display Mask.....	4-57
Figure 4-41 Removing FL Inverter and LCD Unit.....	4-58
Figure 4-42 Removing LCD Bracket.....	4-59
Figure 4-43 Removing Latch Assembly	4-61
Figure 4-44 Removing Wireless LAN Antennas.....	4-63
Figure 4-45 Removing LCD harness Holder	4-64
Figure 4-46 Removing Display Cover.....	4-64
Figure 4-47 Removing Hinge Cap.....	4-64
Figure 4-48 Removing Optical Drive Cover	4-66
Figure 4-49 Removing Speaker Cables	4-67
Figure 4-50 Removing Speakers.....	4-68
Figure 4-51 Removing Hinges.....	4-68
Figure 4-52 Attaching sponges	4-69
Figure 4-53 to 4-100 Replacing Fluorescent Lamp	4-72 to 4-113

4.1 Overview

This chapter describes the procedure for removing and replacing the field replaceable units (FRUs) in the PC. It may not be necessary to remove all the FRUs in order to replace one. The chart below provides a guide as to which other FRUs must be removed before a particular FRU can be removed. The numbers in the chart indicate the relevant section numbers in this manual.

In all cases when removing an FRU, the battery pack must also be removed. When repairing an FRU that is the potential cause of a computer fault, use the chart to determine the order in which FRUs need to be removed.

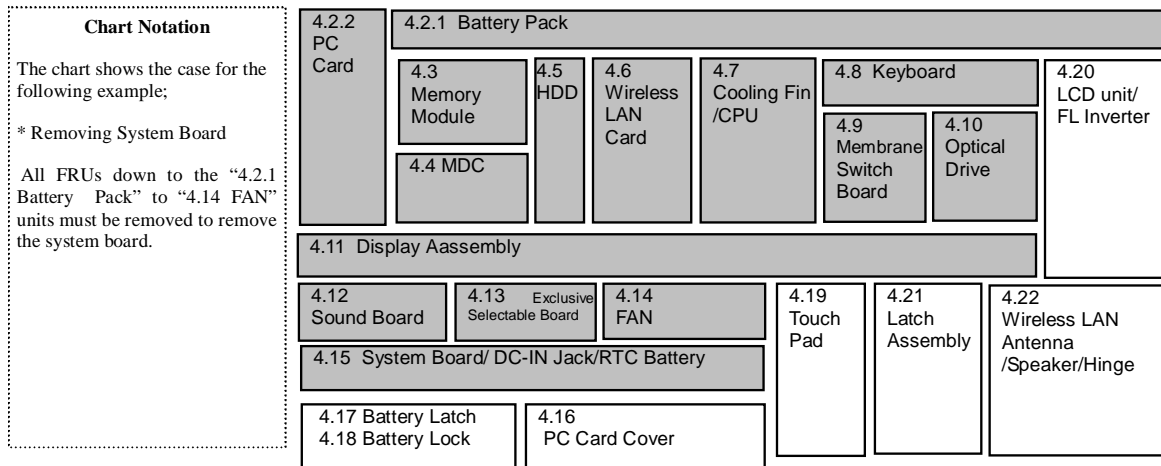
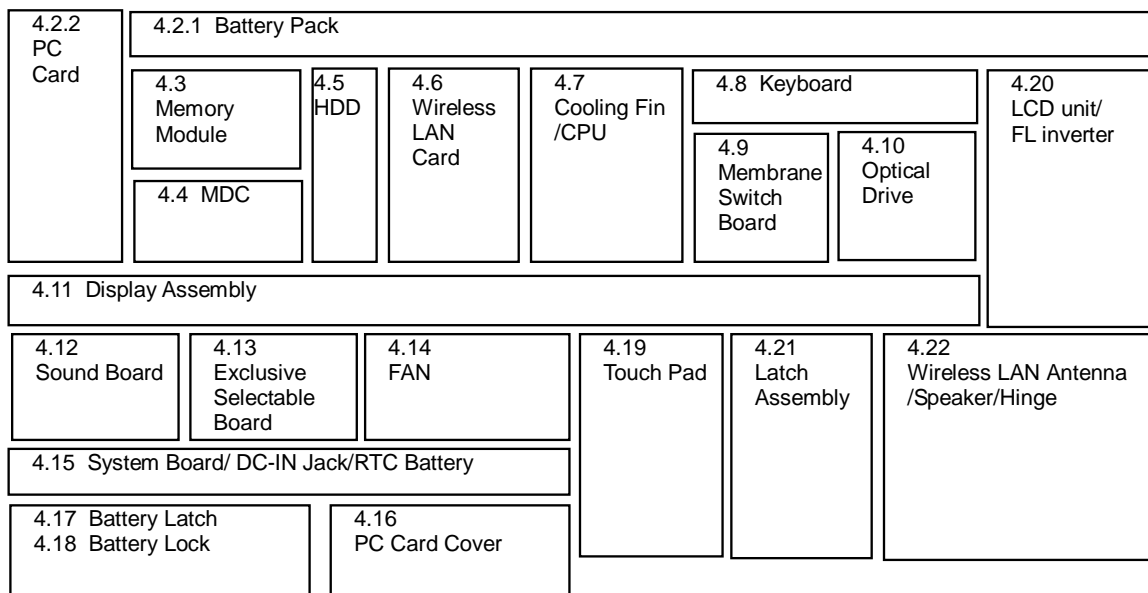

Safety Precautions

Please read the following safety instructions before disassembling the computer and always follow the instructions while working on the computer.

- Danger:**
- 1. In the case of the battery, always use authentic parts or equivalent parts approved by Toshiba. Other batteries may have different specifications that are incompatible with the computer and may result in fire or explosion. Due to the risk of alkali fluid leaks, never attempt to heat or disassemble the battery. Similarly, due to the risk of explosion, never expose the battery to flame.*
 - 2. Some parts including the power supply and FL inverter generate high voltages. If you need to turn on the power while disassembling the computer, do not touch any connectors or other components due to the risk of electric shock. Also, do not disassemble individual parts when performing routine maintenance.*

- Warning:**
- 1. To prevent electric shock, turn off the power unplug the AC adapter from the power source.*
 - 2. As the battery installed to the computer is typically already charged, the risk of electric shock remains even when the AC adapter is unplugged from the socket. To prevent electric shock, always take off any metal jewelry or accessories such as necklaces, bracelets or rings before working on the computer. Never work with wet or moist hands.*
 - 3. Take care not to injury yourself on any edges or corners.*

- Caution:**
- 1. Confirm that replacement parts have compatible specifications before replacing on the computer. Never use incorrect parts as these may cause faults on the computer.*
 - 2. To prevent internal damage such as short circuits or burning, do not allow any screws, paper clips, or other metal objects to fall into the computer. When removing screws, always replace with the same size screw. Ensure that all screws are fully tightened. Loose screws may result in short circuits leading to overheating, smoke or flame.*
 - 3. To prevent electric shock, check that you have disconnected all cables from a part before removing the part.*
 - 4. When connecting to the AC power supply, use only an AC adapter and cable approved by Toshiba.*
 - 5. To prevent electric shock, ensure that all replacement parts are compatible with the computer and that all cables and connectors are securely connected.*

Before You Begin

Take note of the following points before starting work. Always remove the AC adapter and battery pack before commencing any of the procedures. The procedure for removing the battery pack is described in section “4.2.1 Battery Pack”.

1. Do not disassemble the computer unless it is operating abnormally.
2. Use the designated tools.
3. Ensure that the environment for working on and storing parts does not contain any of the following.
 - Dust or dirt
 - Static electricity
 - Extremely hot, cold, or humid conditions
4. Perform the diagnostic tests described in Chapter 2 to determine which FRU is the cause of the fault.
5. Do not perform any unnecessary work. Always work in accordance with the disassembly and reassembly procedures in this manual.
6. Keep parts removed from the computer in a safe place away from the computer where they will not be damaged or interfere with your work.
7. Disassembling requires the removal of a large number of screws. Keep removed screws in a safe place such that you can determine which screws belong to which part.
8. When reassembling, ensure that you use the correct screws and fit parts in the correct position. Screw sizes are noted in the text and figures.
9. As all parts have sharp edges and corners, take care not to cut yourself.
10. After replacing an FRU, check that the computer and replaced part operate correctly.

Disassembly Procedures

Three main types of cable connector are used.

- Pressure plate connector
- Spring connector
- Normal pin connector

When disconnecting a pressure plate connector, lift up the tag on one side of the plastic pressure plate on the connector and pull the cable out from the connector. When reconnecting a cable to a pressure plate connector, lift up the pressure plate to a suitable height and insert the cable into the connector. Press down on both sides of the pressure plate such that both sides of the plate and connector are at the same height and that the cable is fixed in the correct position. Pull the cable to ensure that it is securely connected. If the cable is disconnected from the connector, reconnect it making sure that you lift the pressure plate high enough to insert fully the cable.

For spring connectors, lifting up the stopper frees the cable and allows it to be pulled out. To reconnect, hold the stopper in the up position and insert the cable, then lower the stopper to secure the cable.

Normal pin connectors are used for all other cables. Simply pull out or push in these connectors to disconnect or reconnect.

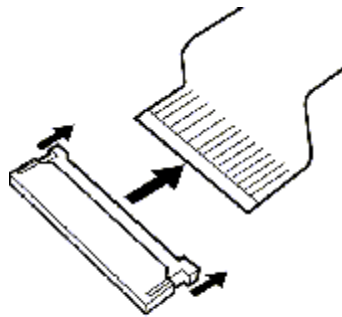

Pressure plate connector

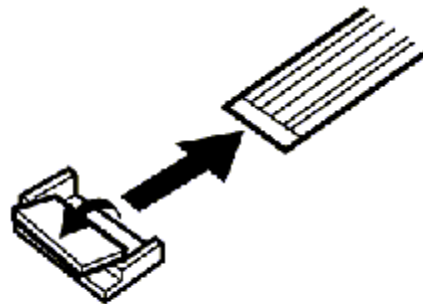

Spring connector

Assembly Procedure

After the computer has been disassembled and the part that caused the fault has been repaired or replaced, the computer must be reassembled.

Take note of the following general points when assembling the computer.

- Take your time and follow the instructions carefully. Hurrying the assembly work will only introduce new problems.
- Check that all cables and connectors are securely connected.
- Before fastening FRUs or other parts in place, ensure that no cables are caught on screws or the FRU.
- Check that all latches are securely closed.
- Ensure that you have installed all FRUs correctly and do not have any screws left over. Using an incorrect screw may damage the thread or screw head and result in the FRU not being securely fastened in place.

After installing FRUs, check that the computer operates correctly.

Tools and Equipment

For your safety and the safety of the people around you, it is important that you use Electrostatic Discharge (ESD) equipment. Correctly utilizing of the equipment increases the percentage of successful repairs and saves on the cost of damaged or destroyed parts. The following equipment is required for disassembly and assembly.

- One Philips screwdriver with type 0 bit (for THIN HEAD screws)
- One Philips screwdriver with type 1 bit (for screws other than above)
- Tweezers (for lifting screws)
- ESD mats (lay on work table or floor)
- An ESD wrist strap and heel grounder
- Anti-static carpet or flooring
- A pair of needle-nose pliers

Screw Tightening Torque

Use the following torque when tightening screws.

CAUTION: *Overtightening may damage screws or parts. Undertightening may allow screws to loosen (and possibly fall out) causing a short circuit or other damage.*

NOTE: *To tighten screws quickly and accurately, an electric screwdriver is recommended.*

- M2 (2mm) 0.167 N·m (1.7 kgf·cm)
- M2.5 (2.5mm) 0.294 N·m (3.0 kgf·cm)
- M3 (3mm) 0.549 N·m (5.6 kgf·cm)

NOTE: *To prevent damage to THIN HEAD screws, press along the axis of the screwdriver while turning the screw. This is because the contact area between the screw and driver is less than for a pan head screw (standard pan-shaped screw head).*

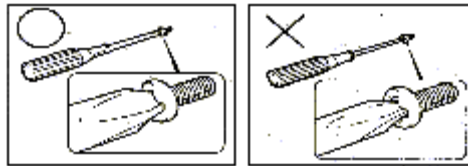

Grip Color

Some screws have a colored grip area to help you determine the length of the screw.

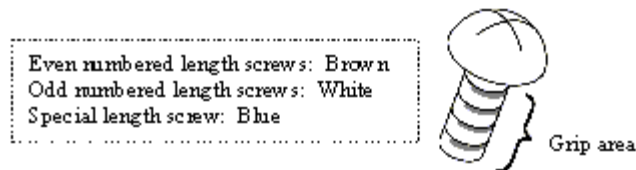

“Special length screw” means screws whose length is indicated in an integral number to the first decimal places such as 2.5 mm, 2.8 mm and so on.

Screw Notation

To make maintenance of the computer easier, markings of the kinds of the screws including the types and lengths of the screws are indicated on the computer body.

Format:

Screw shape + Screw length (mm)

Screw shape

B: Bind screw

F: Thin head screw

S: Super thin head screw

T: Tapping screw

U: Other screws (Unique screws: pan head, stud, etc.)

Example: B6 ... 6mm bind screw

4.2 Battery Pack/PC Card

4.2.1 Battery Pack

Removing the battery pack

The following describes the procedure for removing the battery pack (See Figure 4-1).

CAUTION: Take care not to short circuit the terminals when removing the battery pack. Similarly, do not drop, knock, scratch, disassemble, twist, or bend the battery pack.

1. Turn off the power of the computer.
2. Disconnect the AC adapter and all other external devices from the computer.
3. Turn the computer upside down.
4. Slide the **battery lock** in the direction indicated by the arrow to unlock.
5. While sliding the **battery latch** towards the direction indicated by the arrow, pull out the **battery pack** towards the direction indicated by corresponding arrow.

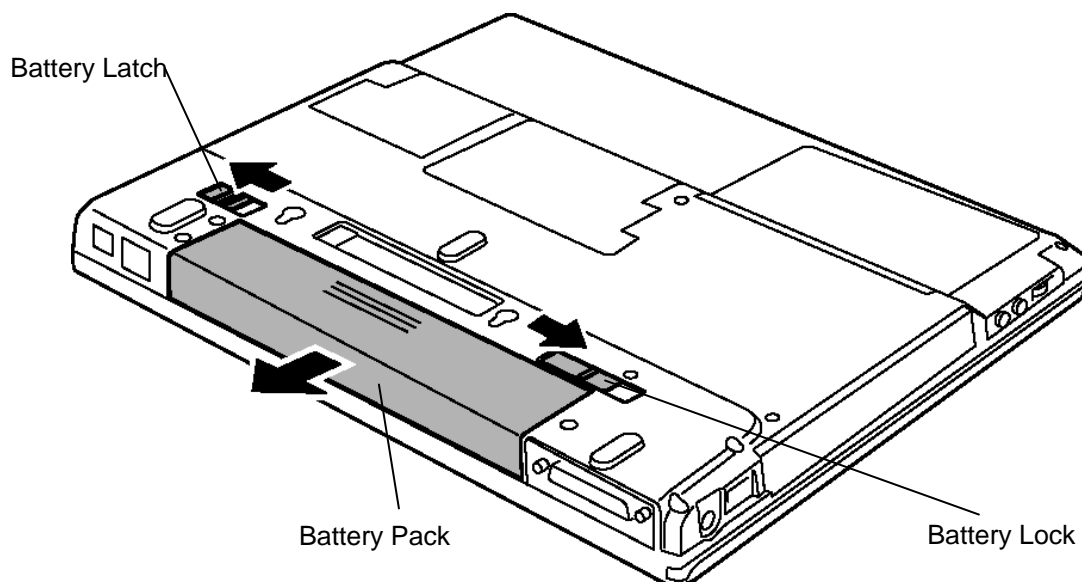

Figure 4-1 Removing Battery Pack

NOTE: For environmental reasons, do not throw away a spent battery pack. Collect the spent battery packs.

Installing the battery pack

The following describes the procedure for reinstalling the battery pack (See Figure 4-1).

CAUTION: *There is a danger that the lithium ion battery pack may explode if not fitted, operated, handled, or disposed correctly. Collect the spent battery packs. Use only the batteries approved by Toshiba.*

NOTE: *Check visually the battery terminals and clean off any dirt with a dry cloth.*

1. Turn off the power of the computer.
2. Disconnect the AC adapter and all other external devices from the computer.
3. Fit the connector of the **battery pack** to the computer's connector and push it until click sounds.

4.2.2 PC Card

Removing the PC card

The following describes the procedure for removing a PC card (See Figure 4-2).

CAUTION: Insert or remove the PC card in accordance with any instructions in the PC card manual or the manuals of the computer system you are using.

1. Push the eject button. It will pop out when you release it. Then press the eject button once more to eject the **PC card**.
2. Grasp the PC card and remove it.

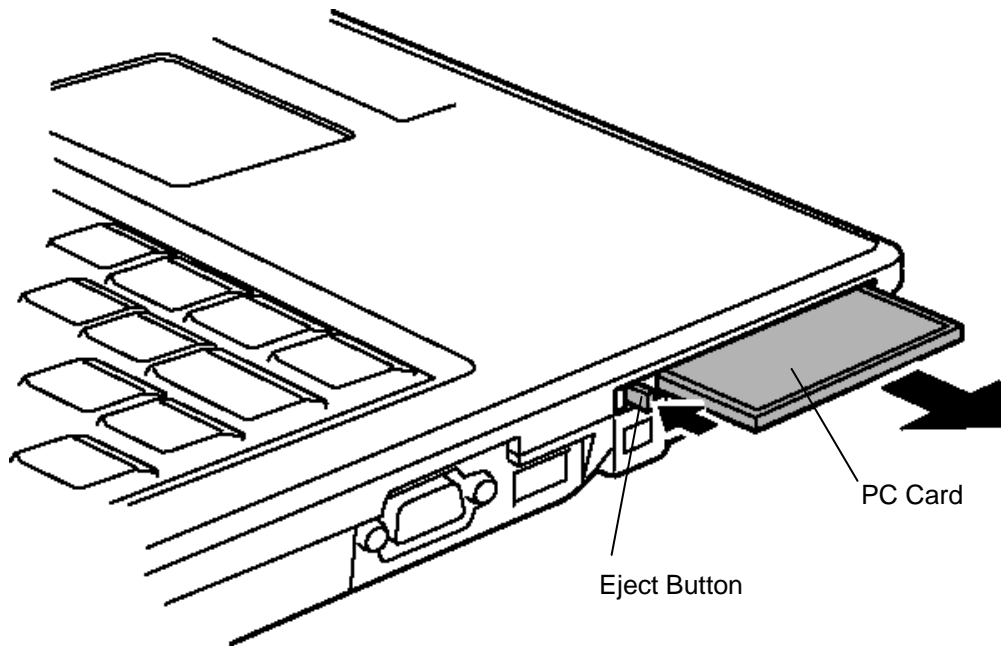

Figure 4-2 Removing PC Card

Installing the PC card

The following describes the procedure for inserting a PC card (See Figure 4-2).

1. Make sure the eject button does not stick out.
2. Insert the **PC card** and press it until it is securely connected.

4.3 Memory Module

CAUTION: The power of the computer must be turned off when you remove the memory module. Removing a memory module with the power on risks damaging the module or the computer itself.

Do not touch the memory module terminals. Any dirt on the terminals may cause memory access problems.

Never press hard or bend the memory module.

Removing the memory module

To remove a memory module, confirm that the computer is not in standby mode or hibernation mode. Then perform the following procedure (See Figure 4-3, 4-4).

1. Turn the computer upside down.
2. Loosen the **screw (with e-ring)** securing the **memory slot cover**.
3. Remove the memory slot cover from the edge near the screw.

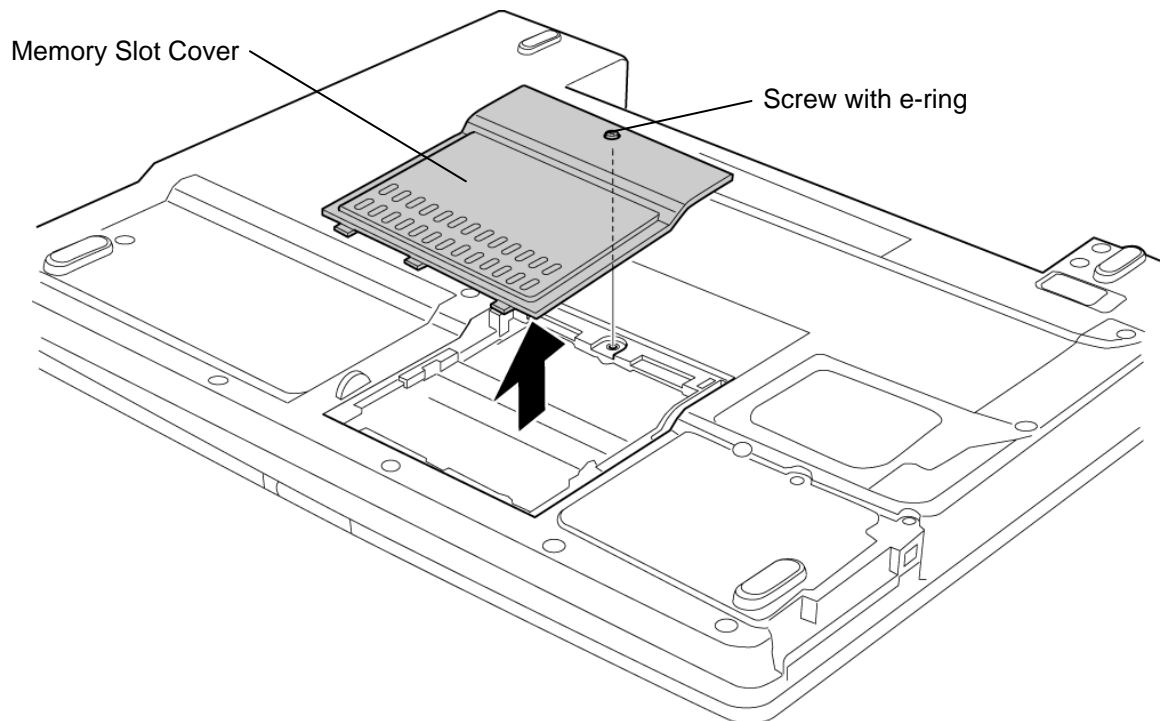

Figure 4-3 Removing Memory Slot Cover

4. Open the left and right **latches** and remove the **memory module**.

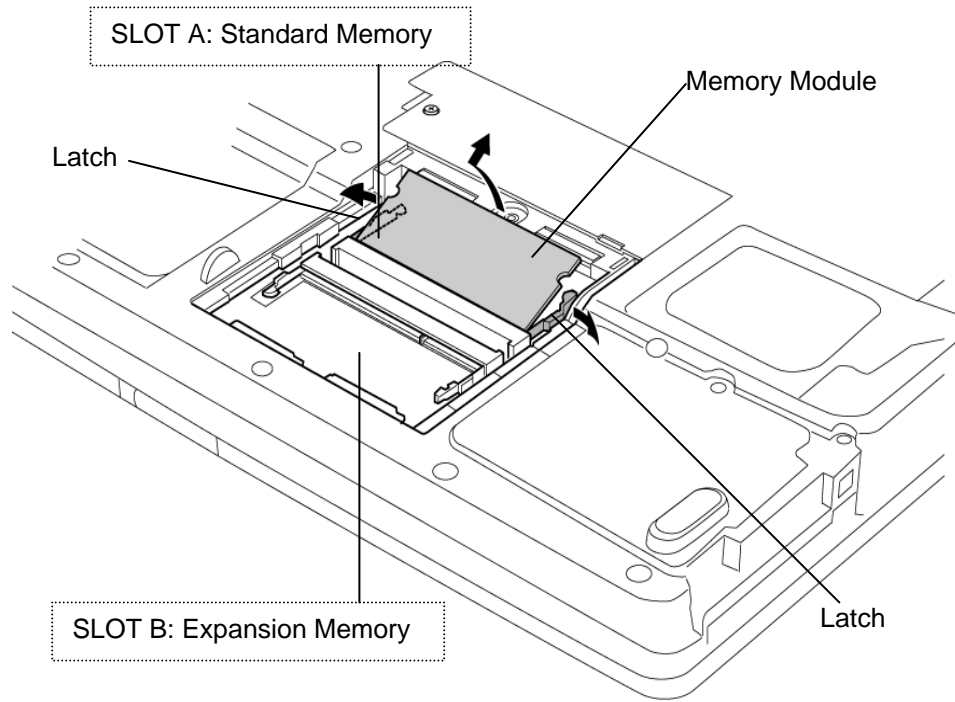

Figure 4-4 Removing Memory Module

Installing the memory module

Before installing the memory module, confirm that the computer is not in standby mode or hibernation mode. Then perform the following procedure (See Figure 4-3, 4-4).

1. Insert the **memory module** into the connector of the computer slantwise (terminal side first) and press it to connect firmly.

CAUTION: *The power must be turned off when you insert a memory module. Inserting a memory module with the power on might damage the module or the computer itself.*

When installing only one memory module, install it SLOT A. Otherwise, it might damage the module or the computer itself

When installing a memory module, confirm that left and right latches are firmly locked a memor module.

2. Install the **memory slot cover** from the front side edge and secure it with the supplied **screw**.
3. When the power of the computer is turned on, the computer checks automatically the memory size. Confirm that the new memory is detected correctly.
4. If the memory is not detected, make sure it is connected surely.

4.4 MDC

Removing the MDC

The following describes the procedure for removing an MDC (See Figure 4-5).

CAUTION: Since the MDC slot cover is easily broken, remove the memory cover first before removing the MDC slot cover.

When replacing the MDC, The power must be turned off when you remove the MDC. Removing an MDC with the power on risks damaging the modem or the computer itself.

1. Turn the computer upside down.
2. Loosen the screw (with e-ring) securing the MDC slot cover and remove the cover.
3. Remove the following screws fixing the MDC.
 - M2x4Z BIND screw x2
4. Lift up the MDC to remove it from the connector on the system board.
5. Remove the MDC cable from the connector on the MDC.

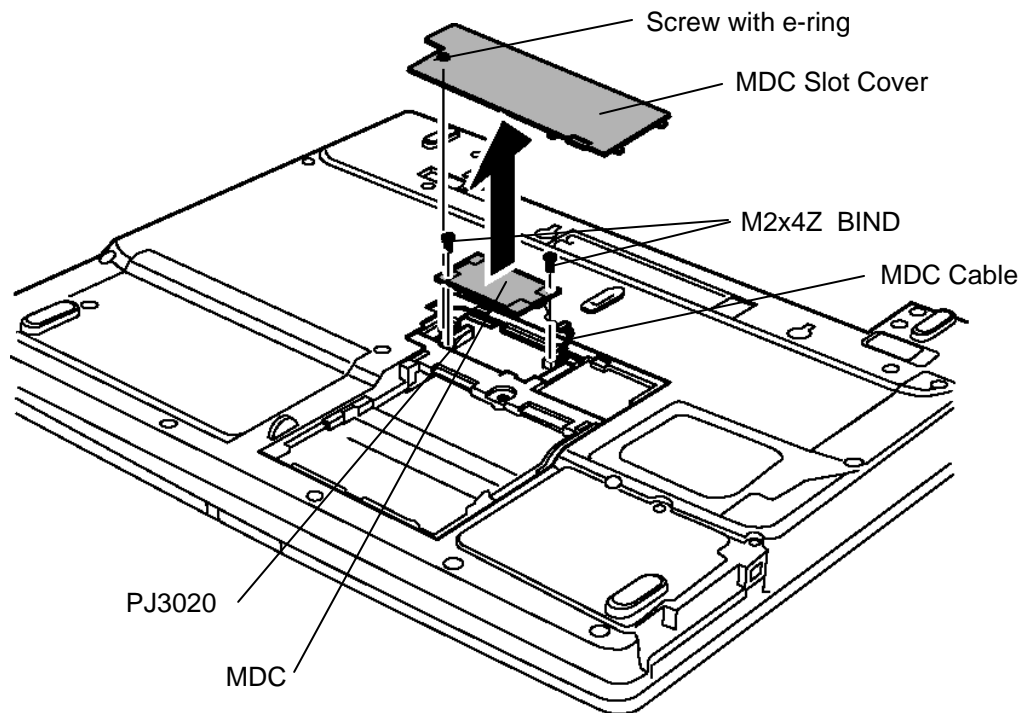

Figure 4-5 Removing MDC

Installing the MDC

The following describes the procedure for installing an MDC(See Figure 4-5).

1. Connect the **MDC cable** to the connector **JP1** on the **MDC**.
2. Set the MDC on the slot and connect the MDC to the connector **CN3020** on the system board by pressing it from the top.
3. Fix the MDC using the following **screws**.
 - M2x4Z BIND screw x2
4. Install the MDC slot cover and secure it with the supplied screw.

4.5 HDD

Removing the HDD

The following describes the procedure for removing an HDD (See Figure 4-6 to 4-8).

CAUTION: Take care not to press on the top or bottom of the HDD. Pressure may cause data loss or damage to the device.

1. Turn the computer upside down.
2. Remove the following screw fixing the **HDD slot cover** and raise the cover to remove.

- M2.5x6B THIN BIND screw x1

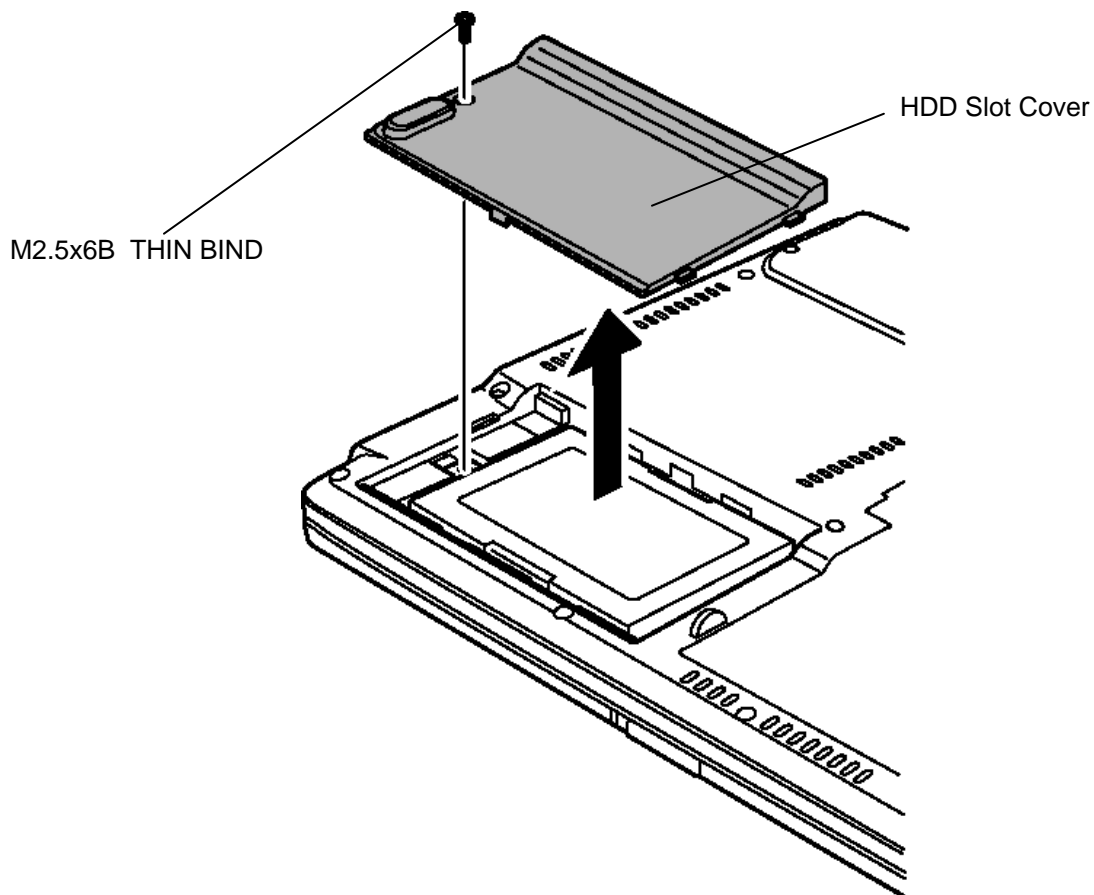

Figure 4-6 Removing HDD Slot Cover

3. Holding the **tab**, pull horizontally the **HDD ASSY** to disconnect it from the connector and remove it.

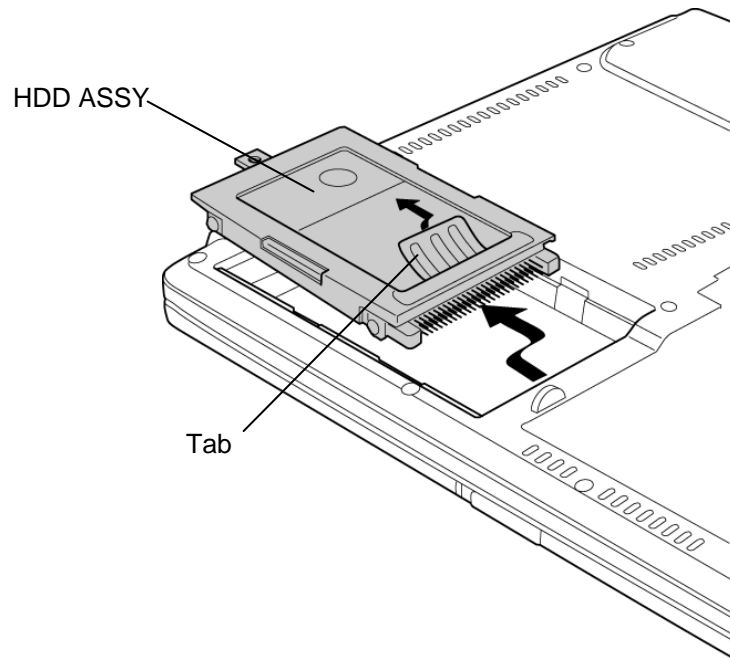

Figure 4-7 Removing HDD ASSY

4. Remove the following **screws** fixing the **HDD**.

- M3x4S THIN BIND screw x4

5. Remove the **HDD holder** from the HDD.

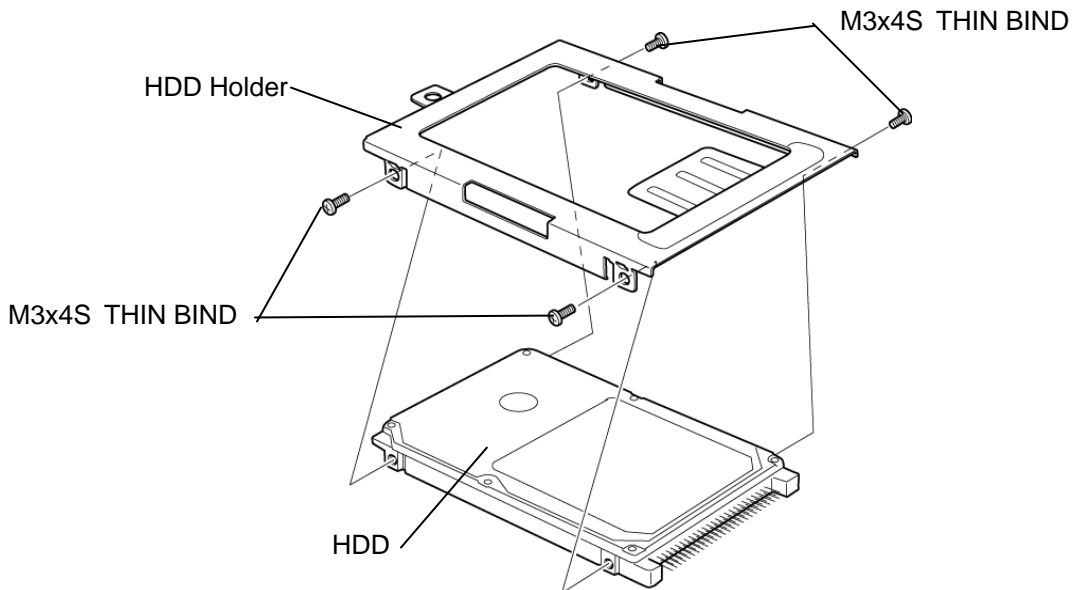

Figure 4-8 Removing HDD

Installing the HDD

The following describes the procedure for installing an HDD (See Figure 4-6 to 4-8).

1. Install the **HDD holder** to the **HDD** with the following **screws**.
 - M3x4S THIN BIND screw x4
2. Put the **HDD ASSY** into the **HDD slot** and connect it to the connector CN1800 on the system board.
3. Install the **HDD slot cover** and secure it by using the following **screws**.
 - M2.5x6B THIN BIND screw x1

4.6 Wireless LAN card

CAUTION: The power must be turned off when you remove a wireless LAN card.
Removing a wireless LAN card with the power on risks damaging the card or the computer itself.
Never press hard or bend the wireless LAN card.

Removing the Wireless LAN card

The following describes the procedure for removing the wireless LAN card (See Figure 4-9, 4-10).

1. Turn the computer upside down.
2. Remove the following screw fixing the **mini PCI slot cover** and remove the cover.

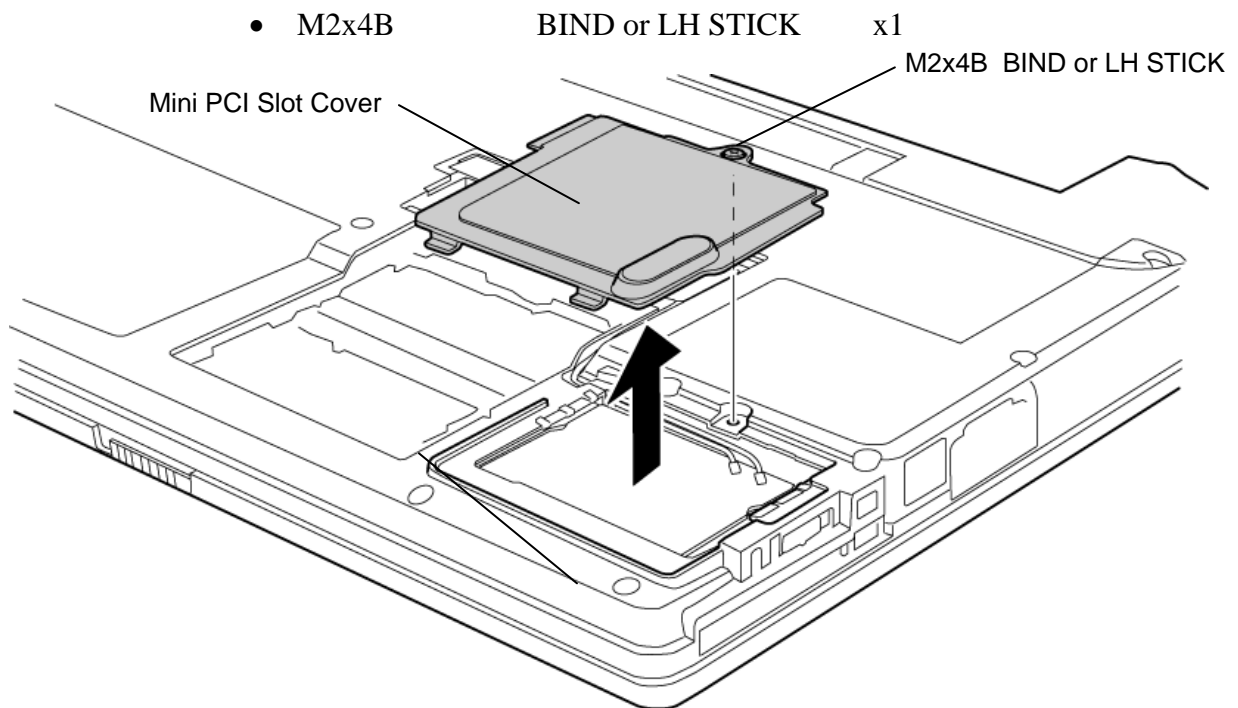

Figure 4-9 Removing Mini PCI Slot Cover

3. Disconnect two **wireless LAN cables** from connectors on the **wireless LAN card**.
4. Peel off one **glass tape** and two **insulators** remove the cables from the guide.
5. Open the left and right latches holding the wireless LAN card and remove the wireless LAN card.

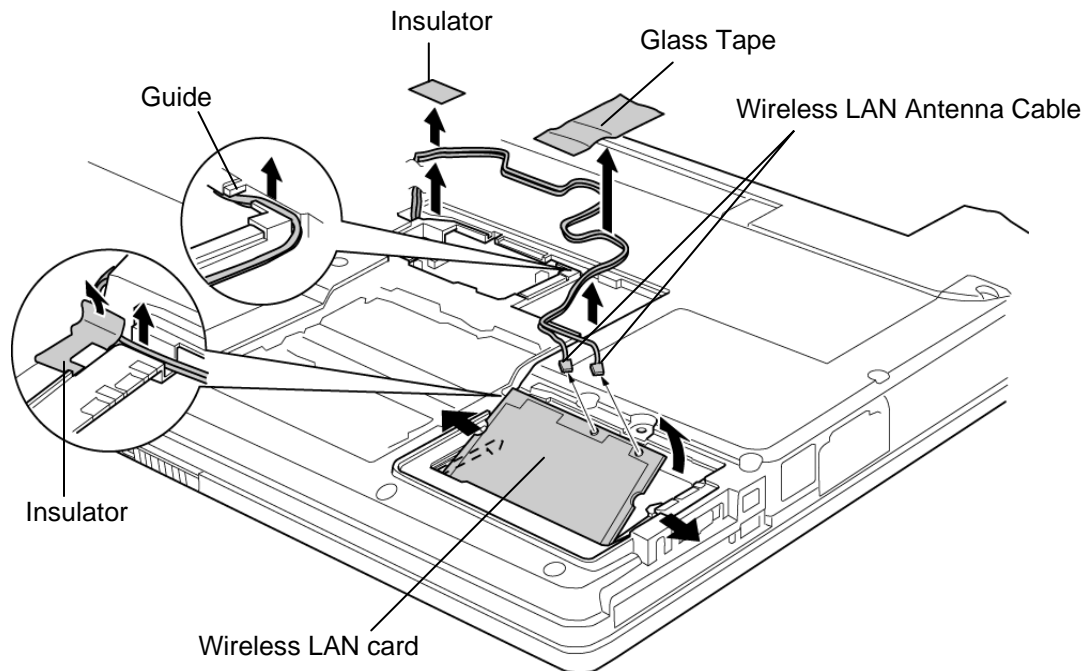

Figure 4-10 Removing Wireless LAN card

Installing the Wireless LAN card

The following describes the procedure for installing a wireless LAN card (See Figure 4-9, 4-10).

1. Insert the wireless LAN card terminals at 45-degree slant into the connector on the computer and press the **wireless LAN card** from the top to secure.
2. Pass the black and white **wireless LAN cables** along the guide and secure them with one **glass tape** and two **insulators**.
3. Connect the wireless LAN cables to the connectors on the wireless LAN card. (White cable = MAIN, Black cable = AUX)
4. Attach the **mini PCI slot cover** and secure it with the following **screw**.

- M2x4B BIND or LH STICK x1

4.7 Cooling Fin/CPU

Removing the Cooling fin/CPU

The following describes the procedure for removing the cooling fin/CPU (See Figure 4-11 to 4-14).

1. Remove the following screws fixing the **CPU cover** and remove the CPU cover.

- M2.5x14B THIN BIND screw x1
- M2.5x18B THIN BIND screw x1

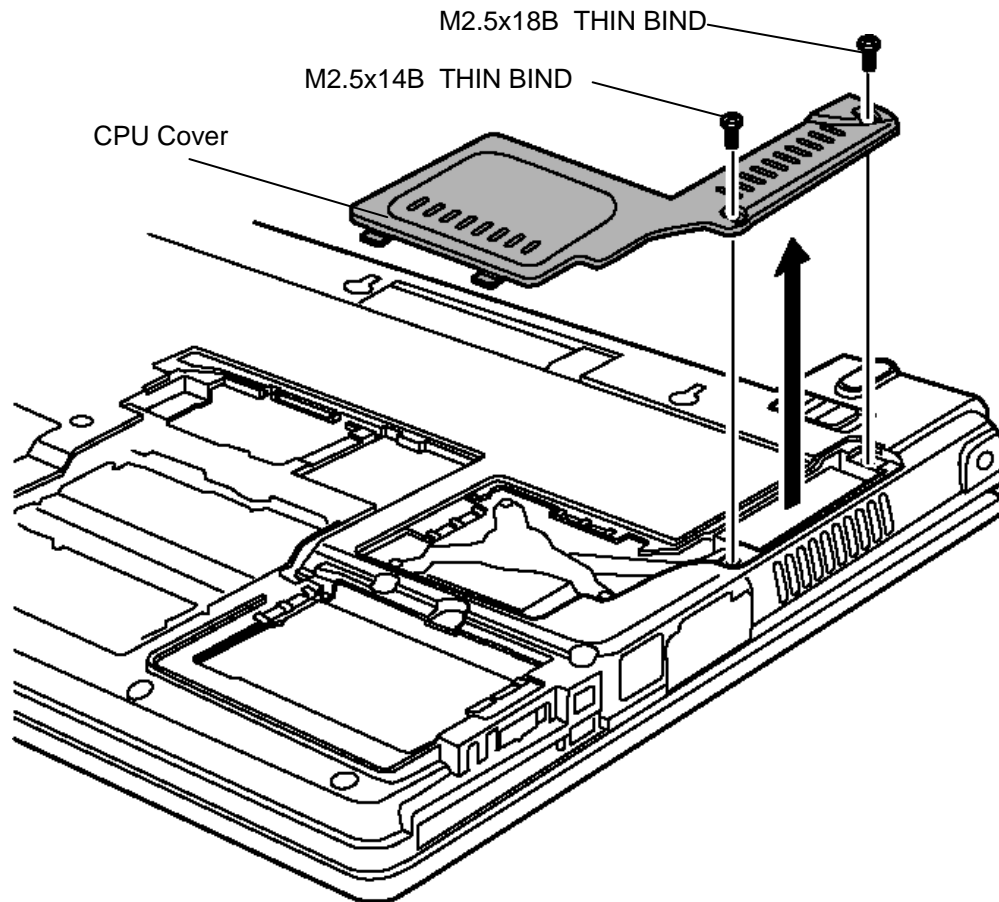

Figure 4-11 Removing CPU Cover

2. Remove the following screws securing the **CPU holder** on the CPU.

- M2x4B BIND screw x3

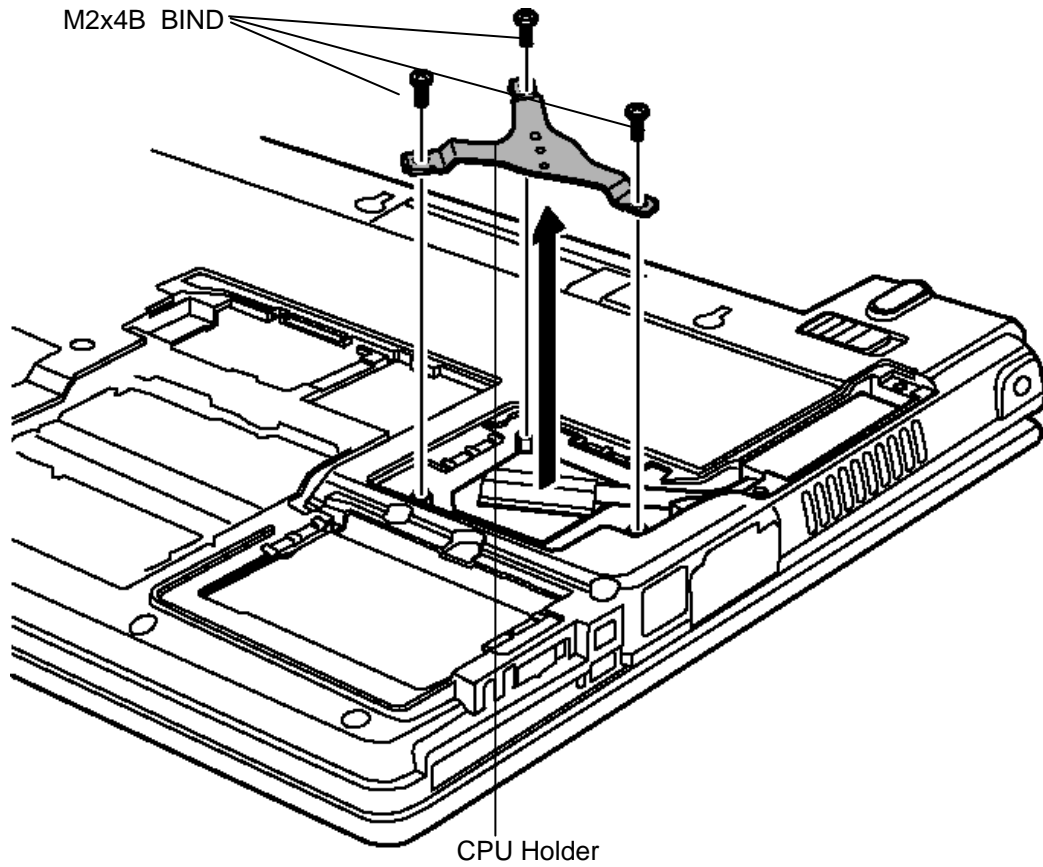

Figure 4-12 Removing CPU Holder

3. Lift up the **cooling fin** and remove it.

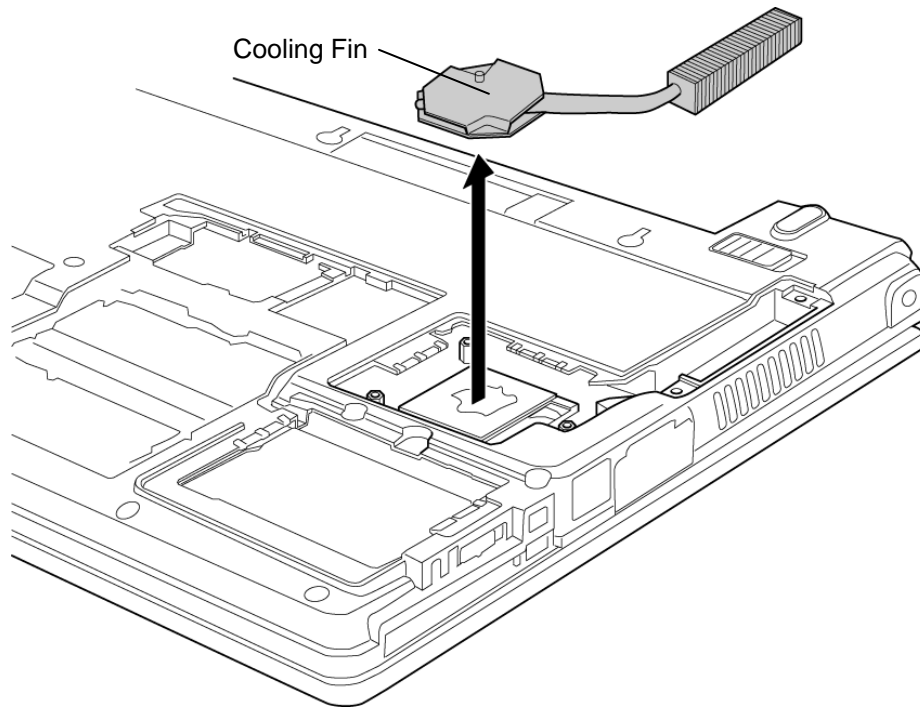

Figure 4-13 Removing Cooling Fin

4. Unlock the CPU by rotating counterclockwise the **cam** on the CPU socket by 90 degrees with a flat-blade screwdriver (in the order shown in the figure below).
5. Remove the **CPU**.

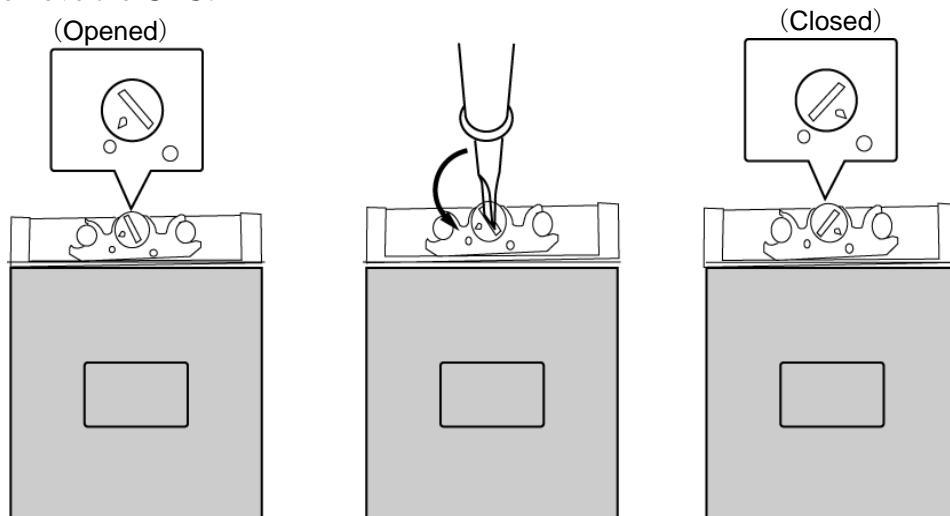

Figure 4-14 Removing CPU

Installing the Cooling fin/CPU

The following describes the procedure for installing the cooling fin/CPU (See Figure 4-11 to 4-16).

1. Check that the **mark** on the cam is in the unlocking position.
2. Attach the **CPU** to the correct position in the **CPU socket**.

CAUTION: Place the CPU in such direction as shown below. (Pay attention to the position of the triangle mark on the CPU.)

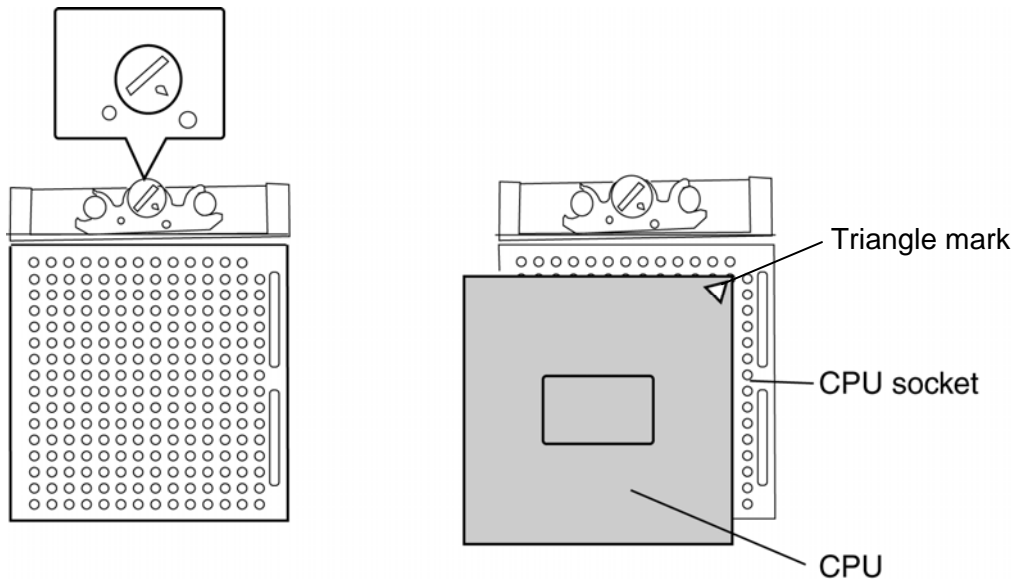

Figure 4-15 Installing CPU

3. Fix the CPU by rotating clockwise the cam by 90 degrees with a flat-blade screwdriver.
4. If there is already **silicon grease** on the CPU and cooling fin, clean it with a cloth. Using a special applicator, apply quarter of scale (0.25ml) of silicon grease evenly on the CPU chip.

NOTE: If silicon grease has already been applied to the CPU or cooling fin, wipe clean with a cloth and apply new silicon grease. The computer will not operate correctly if the CPU is not firmly in contact with the cooling fin.

NOTE: Apply the silicon grease enough to cover the chip surface using the special applicator. When installing the cooling fin, make sure the bottom of the fin covers the top of CPU.

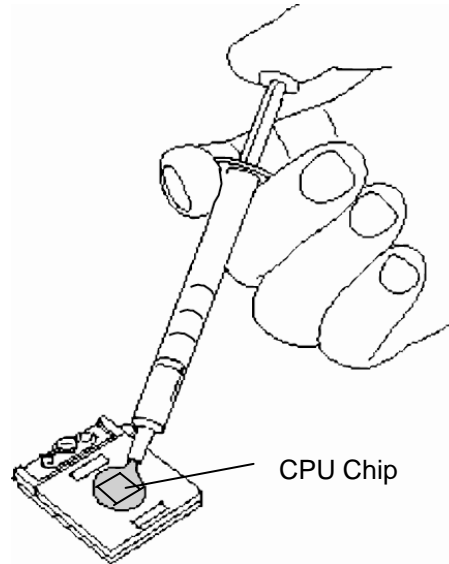

Figure 4-16 Applying Silicon Grease

5. Install the **cooling fin**.
6. Place the **CPU holder** on the cooling fin with its hole fitted to the boss of the cooling fin. Fix the CPU holder with following **screws** in the order of the marks (1 to 3) on the CPU holder.
 - M2x4B BIND screw x3
7. Install the **CPU cover** from the front side and secure it with the following screws.
 - M2.5x18B THIN BIND screw x1
 - M2.5x14B THIN BIND screw x1

4.8 Keyboard

Removing the Keyboard

The following describes the procedure for removing the keyboard (See Figure 4-17 to 4-19).

CAUTION: As the keytop may fall out, when handling the keyboard always hold it by the frame and do not touch the keytop.

1. Open the display.
2. Hold the both ends of the **keyboard holder** and lift it up to remove.

CAUTION: When removing the keyboard holder, be careful not to touch the metal parts of the speakers under it.

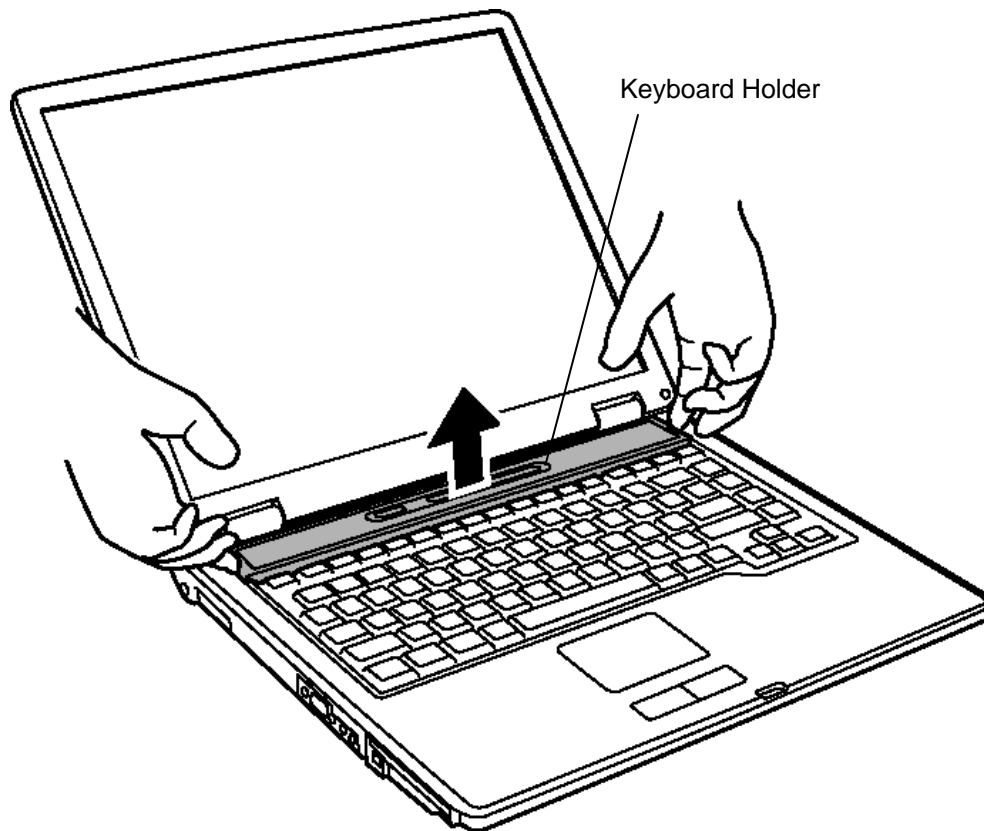

Figure 4-17 Removing Keyboard Holder

3. Remove the following **screws** holding the keyboard.
 - M2.5×2.8B THIN BIND screw x2
4. Remove the following **screw** fixing the **keyboard hold plate** and remove the keyboard hold plate by pulling it to the right side.
 - M2.5×2.8B THIN BIND screw x1
5. Lift the upper side of the **keyboard** out and bring it a little to the display. Then turn it face down on the palm rest.

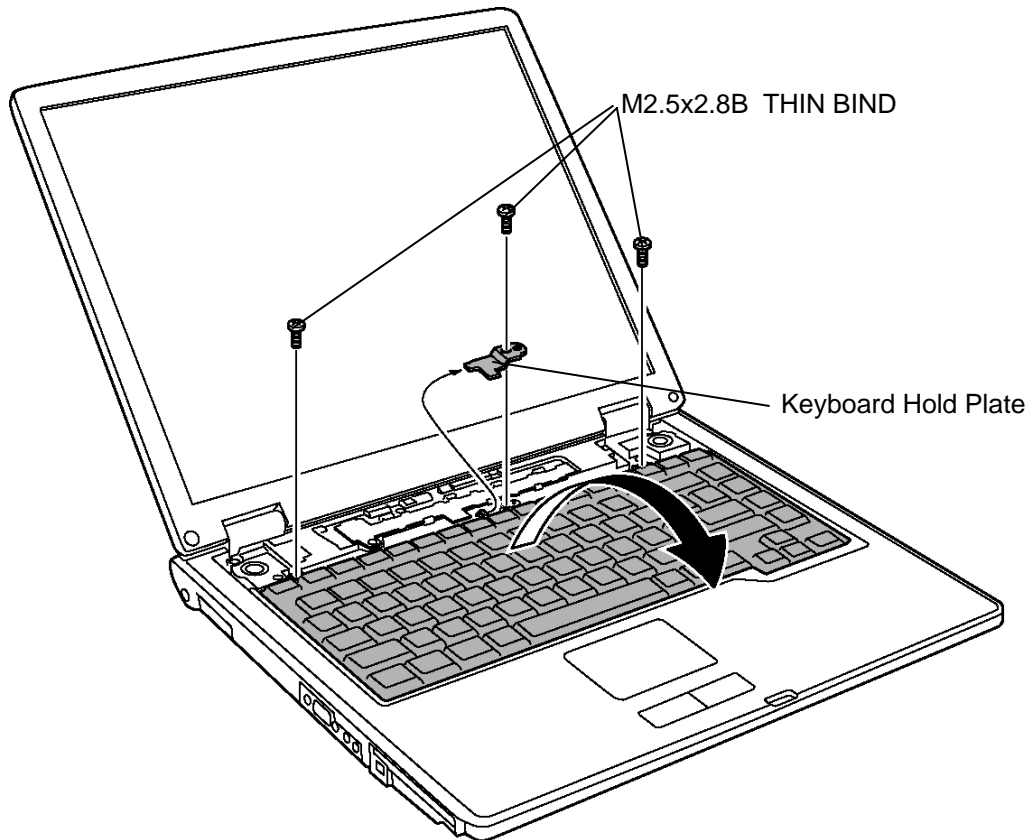

Figure 4-18 Removing Keyboard

6. Remove the following **screw** fixing the **keyboard support plate** underneath the keyboard.

- M2.5x8B THIN BIND screw x2

7. Remove the keyboard support plate.

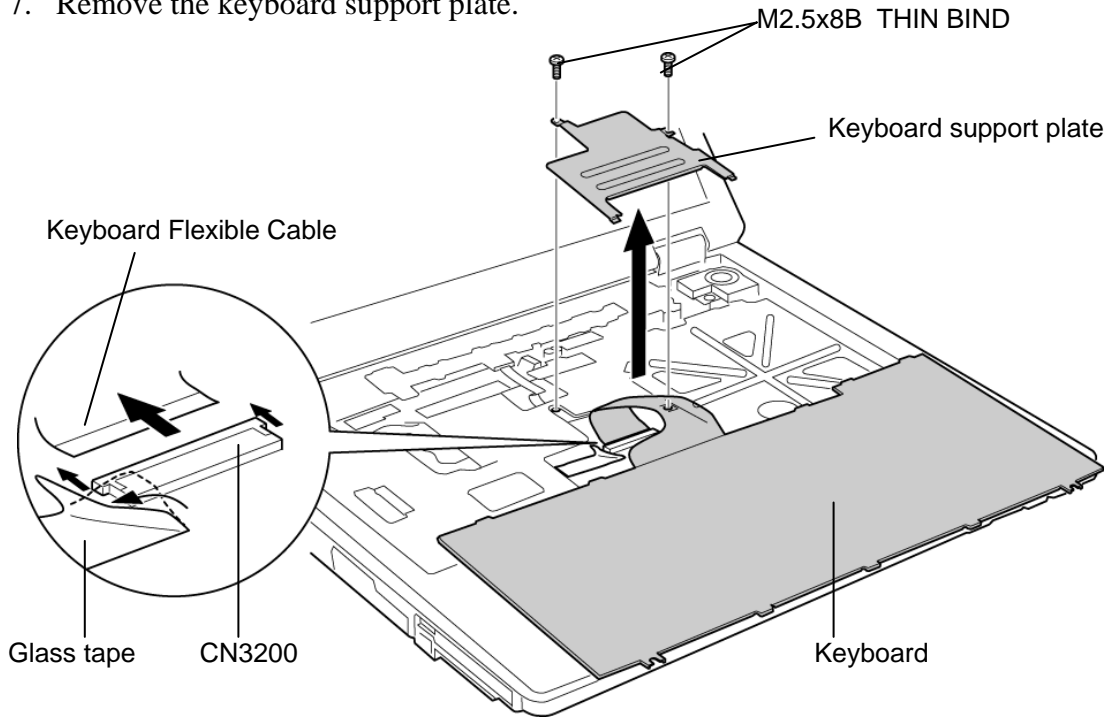

Figure 4-19 Removing Keyboard support plate

8. Peeling off the **glass tape**, unlock the connector and remove the **keyboard flexible cable** from the connector CN3200 of the system board.

Installing the Keyboard

The following describes the procedure for installing the keyboard (See Figure 4-17 to 4-19).

1. Place the keyboard on the palm rest as its face is down. Connect the keyboard flexible cable to the connector CN3200 on the system board.
2. Stick the **glass tape** on the connector CN3200.
3. Install the keyboard support plate on the keyboard flexible cable from the front side part and secure it with the following screws.
 - M2.5x8B THIN BIND screw x2
4. Turn the keyboard face up while inserting the bottom edge of the keyboard under the chassis. Then put it on the computer. Make sure that there is no gap between the keyboard and the computer chassis.
5. Insert the left side of the keyboard hold plate into the slot of the chassis. Set the plate with its hole fitted to the guide pin on the chassis. Secure the keyboard hold plate with the following screw. When installing, make sure the keyboard hold plate holds the center tab of the keyboard.
 - M2.5x2.8B THIN BIND screw x1
6. Secure the keyboard with the following screws.
 - M2.5x2.8B THIN BIND screw x2
7. Install the keyboard holder by pressing it from the top side.

4.9 Switch membrane board

Removing the Switch membrane board

The following describes the procedure for removing the switch membrane board (See Figure 4-20).

1. Open the display and unlock the connector. Disconnect the **switch membrane board cable** from the connector CN3280 on the system board.
2. Remove the following **screw** securing the **switch membrane board**.
 - M2.5x2.8B THIN BIND screw x1
3. Slide the switch membrane board to the left and remove it.

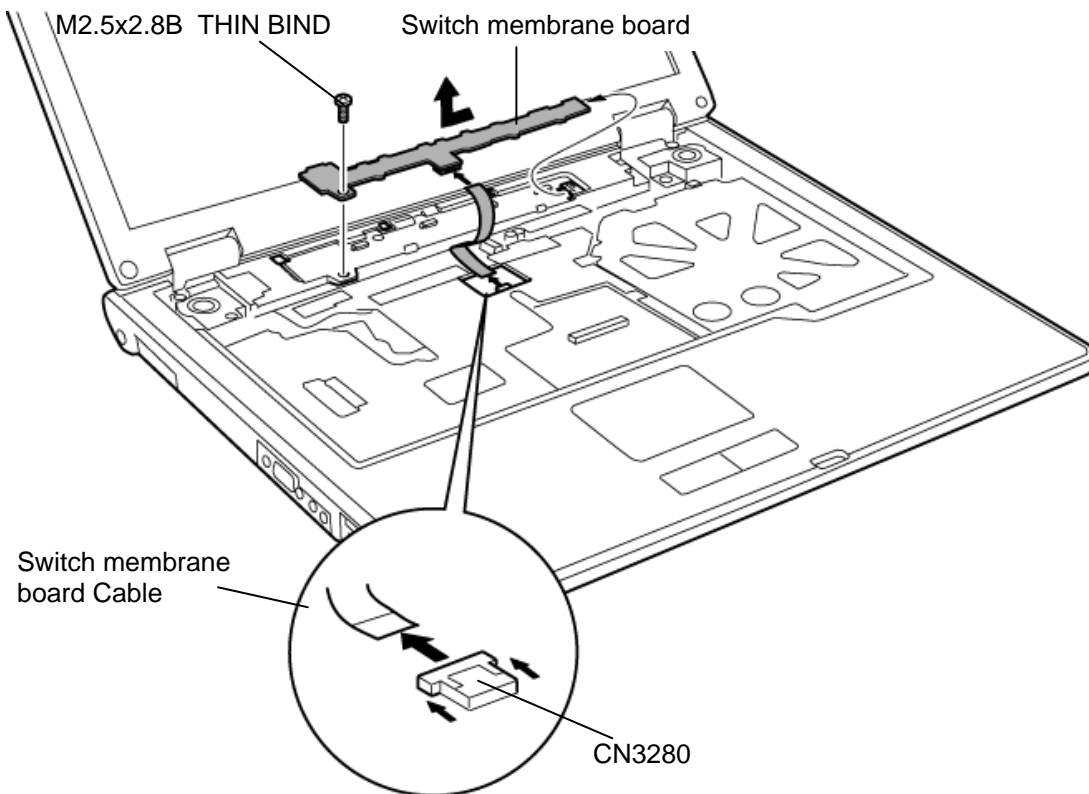

Figure 4-20 Removing Switch membrane board

Installing the Switch membrane board

The following describes the procedure for installing the switch membrane board (See Figure 4-20).

1. Place the **switch membrane board** to the left side of the installation position and slide it to the right to install. Then fix it with the following **screw**.
 - M2.5x2.8B THIN BIND screwx1
2. Connect the switch membrane board cable to the connector **CN3280** on the system board.

4.10 Optical Drive

NOTE: Do not apply excessive force to the top of an optical drive.

Removing the Optical drive

The following describes the procedure for removing the optical drive (See Figure 4-21, 4-22).

1. Turn the computer face down and remove the following **screw** securing the **optical drive assembly**.
 - M2.5x6B THIN BIND screw x1
2. Pull out the optical drive assembly in the direction indicated by arrow to remove.

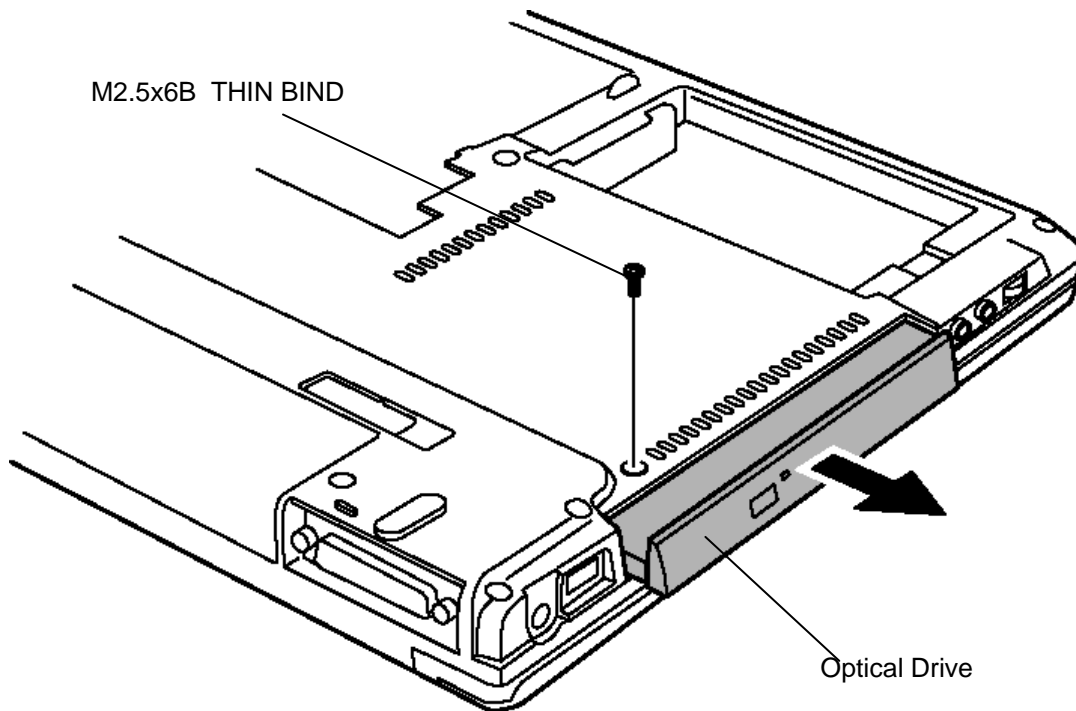

Figure 4-21 Removing optical drive

3. Remove the following **screws** fixing the rear bracket from the optical drive assembly.

- M2x2.7 STEP screw x2

4. Remove the following **screw** fixing the side bracket and remove the side bracket.

- M2x3S SUPER THIN BIND screw x1

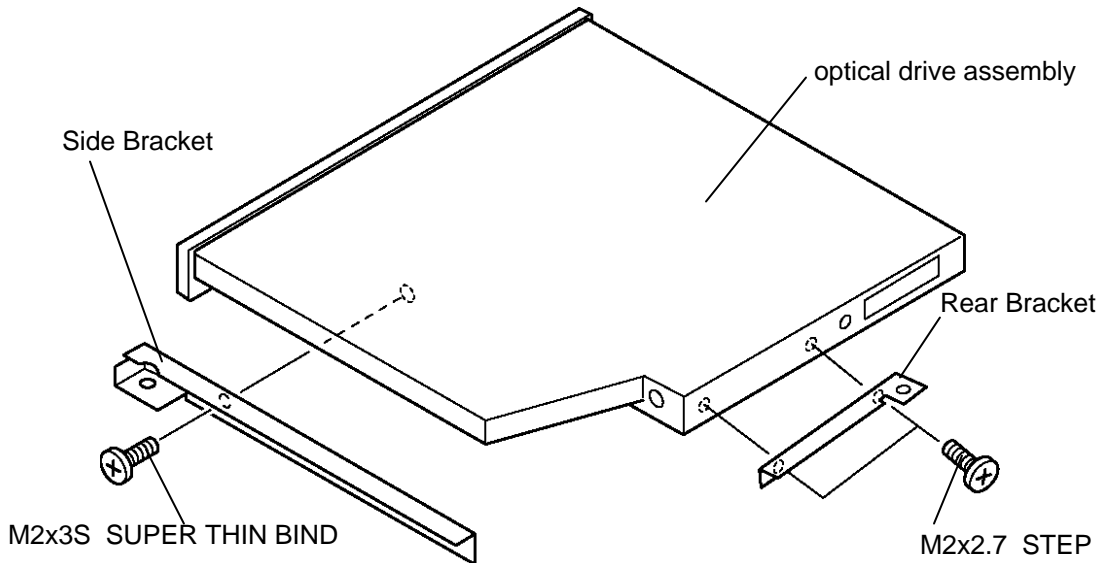

Figure 4-22 Removing the bracket

Installing the Optical drive

The following describes the procedure for installing the optical drive (See Figure 4-21, 4-22).

1. Install the **side bracket** on the optical drive and fix it with the following **screw**.

- M2x3S SUPER THIN BIND screw x1

2. Place the **rear bracket** on the optical drive and fix it with the following **screws**.

- M2x2.7 STEP screw x2

3. Insert the **optical drive assembly** into the slot to connect it to the connector **CN1810** on the system board.

4. Secure the optical drive assembly with the following **screw** from the bottom of the computer.

- M2.5x6B THIN BIND screw x1

4.11 Display Assembly

Removing the Display assembly

The following describes the procedure for removing the display assembly (See Figure 4-23 to 4-25).

1. Close the display and turn the computer face down.
2. Remove the following screws from the bottom of the computer.
 - M2.5x6B THIN BIND screw x9 (“6” in the figure)
 - M2.5x14B THIN BIND screw x5 (“14” in the figure)
 - M2.5x18B THIN BIND screw x1 (“18” in the figure)

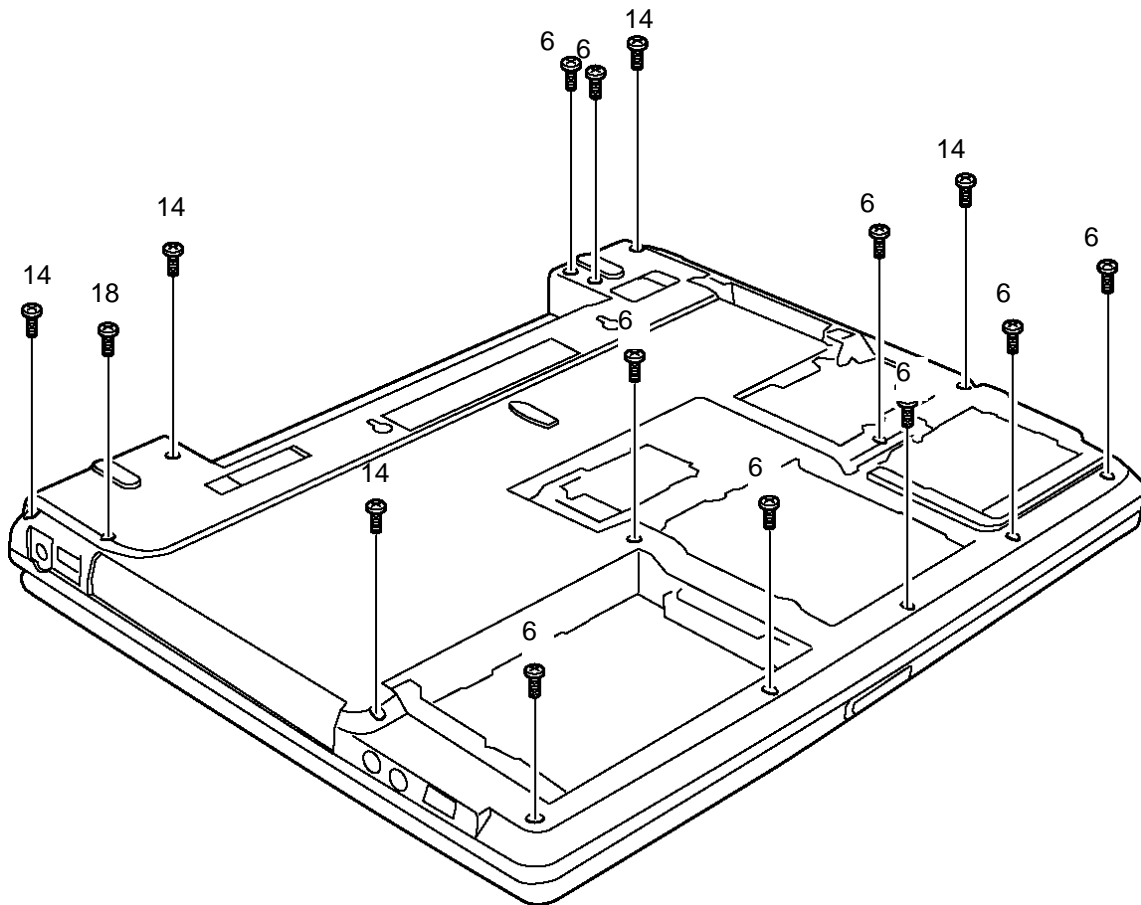

Figure 4-23 Removing the screws on the bottom

3. Turn the computer face up. Open the display and disconnect the **speaker cables (Blue, Red)** from the connectors on the system board. Unlock the connector and disconnect the **touch pad cable** from the system board.
4. Remove the following **screw** securing the LCD harness hold plate and remove the **LCD harness hold plate**. Disconnect the **LCD harness** from the connector CN5000 on the system board.

- M2.5x8B THIN BIND screw x1

5. Remove the following **screws** securing the display assembly.

- M2x8B BIND screw x1
- M2.5x8B THIN BIND screw x1

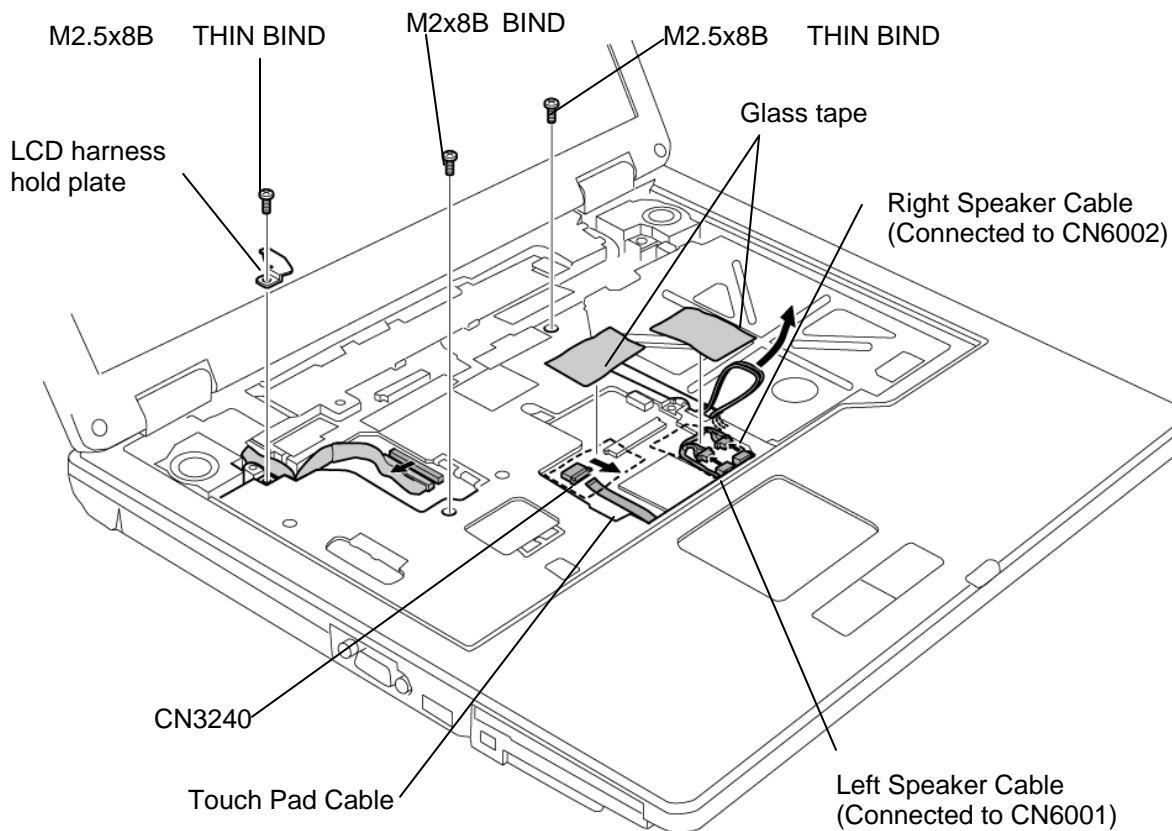

Figure 4-24 Removing screws and cables (under keyboard)

6. Pull out the wireless LAN antenna cables from the slot near the center of the base assembly.

NOTE: When removing the display assembly, be careful not to cut or scratch the wireless LAN antenna cables.

7. Unhook the latches between the **display assembly** and the **base assembly**. Lift the display assembly up and remove it from the base assembly.

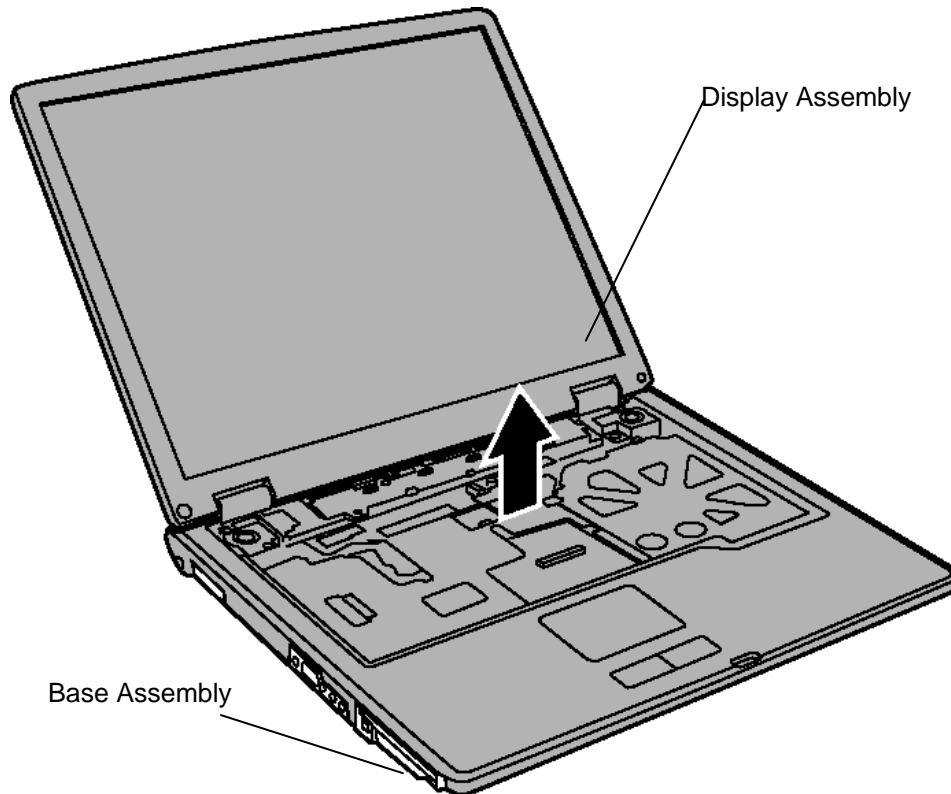

Figure 4-25 Removing Display Assembly

Installing the Display assembly

The following describes the procedure for installing the display assembly (See Figure 4-23 to 4-25).

1. Pass the wireless LAN antenna cables through the slot near the center of the base assembly.
2. Install the **display assembly** on the base assembly from the rear of the computer and secure them with the following **screws**.
 - M2x8B BIND screw x1
 - M2.5x8B THIN BIND screw x1
3. Connect the LCD harness to the connector CN5000 on the system board and install the LCD harness hold plate with the following screw.
 - M2.5x8B THIN BIND screw x1
4. Connect the **speaker cables (blue, red)** to the connectors **CN6001, CN6002** on the system board.
5. Connect the **touch pad cable** to the connector **CN3240** on the system board.
6. Close the display and turn the computer face down. Secure the **base assembly** with the following **screws** from the bottom.
 - M2.5x6B THIN BIND screw x9 (“6” in the figure)
 - M2.5x14B THIN BIND screw x5 (“14” in the figure)
 - M2.5x18B THIN BIND screw x1 (“18” in the figure)

4.12 Sound Board

Removing the Sound Board

The following describes the procedure for removing the sound board (See Figure 4-26).

1. Unlock the connector and disconnect the **sound board cable** from the connector of CN9510 on the sound board.
2. Remove the following **screw** to remove the **sound board**.
3. Unlock the connector and disconnect the sound board cable from the connector CN9500 on the system board

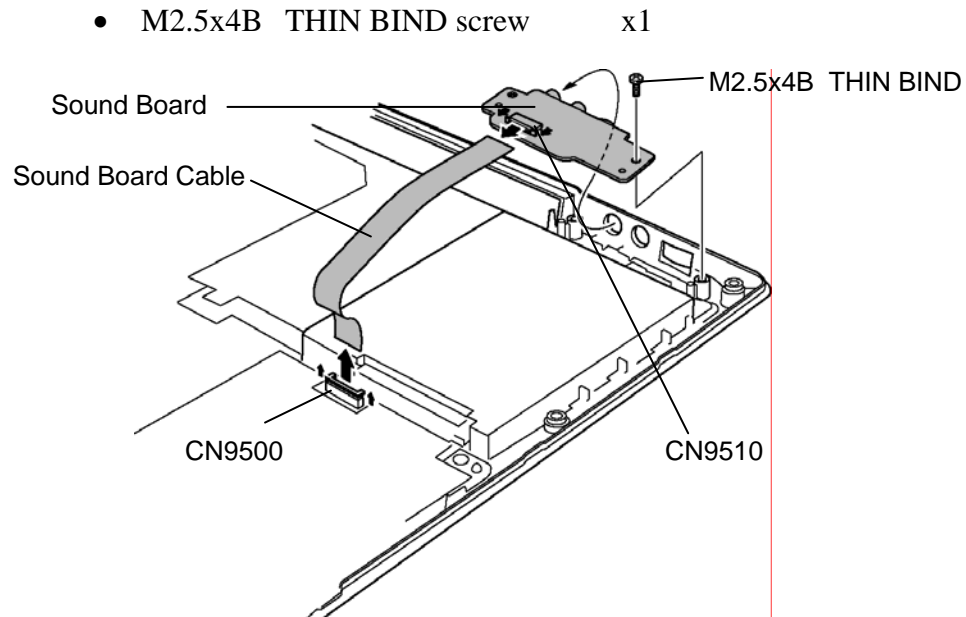

Figure 4-26 Removing Sound Board

Installing the Sound Board

The following describes the procedure for installing the sound board (See Figure 4-26).

1. Connect the **sound board cable** to the connector **CN9510** on the **sound board**.
2. Install the sound board on the base assembly and secure it with the following **screw**.
 - M2.5x4B THIN BIND screw x1
3. Connect the sound board cable to the connector **CN9500** on the system board.

4.13 Parallel port board / Serial port board / S-Video board

Depending on the model, the machine has a different type board (Parallel port board / Serial port board / S-Video board). Refer to the proper procedures below.

4.13.1 Parallel port board

Removing the Parallel port board

The following describes the procedure for removing the Parallel port board (See Figure 4-27, 4-28).

1. Remove the **DC-IN jack** and **core** from the slot of the base assembly.
2. Remove the following **screws** to remove the **harness holder**.

- M2.5x4B THIN BIND screw x2

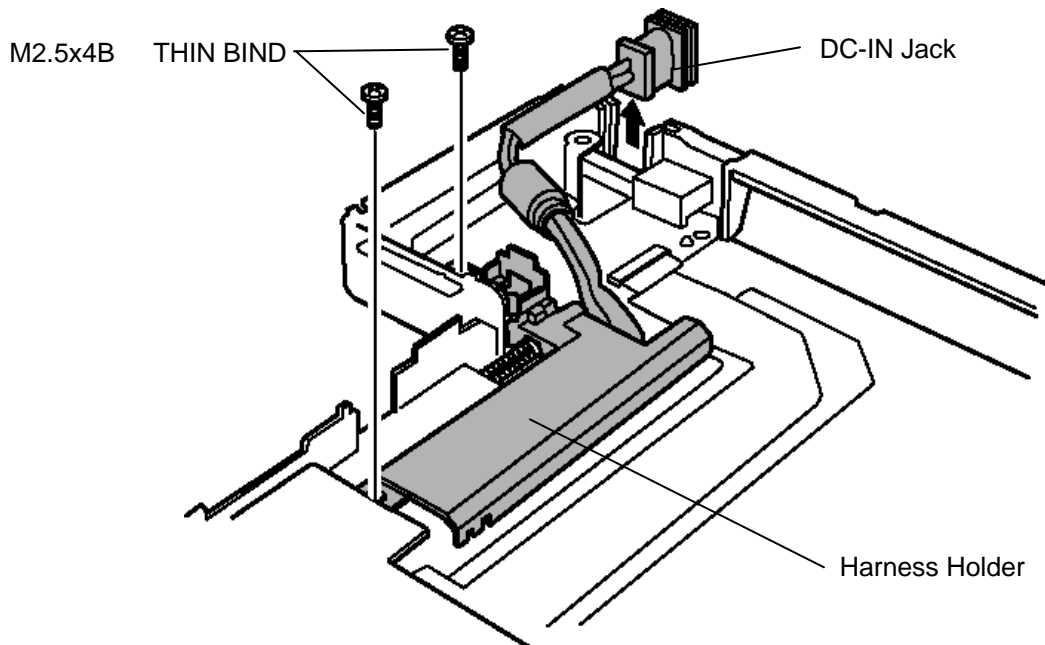

Figure 4-27 Removing Harness Holder

3. Disconnect the **USB harness** from the connector CN4620 and the parallel port cable from the connector CN3503 on the parallel port board.
4. Remove the parallel port board by lifting it.

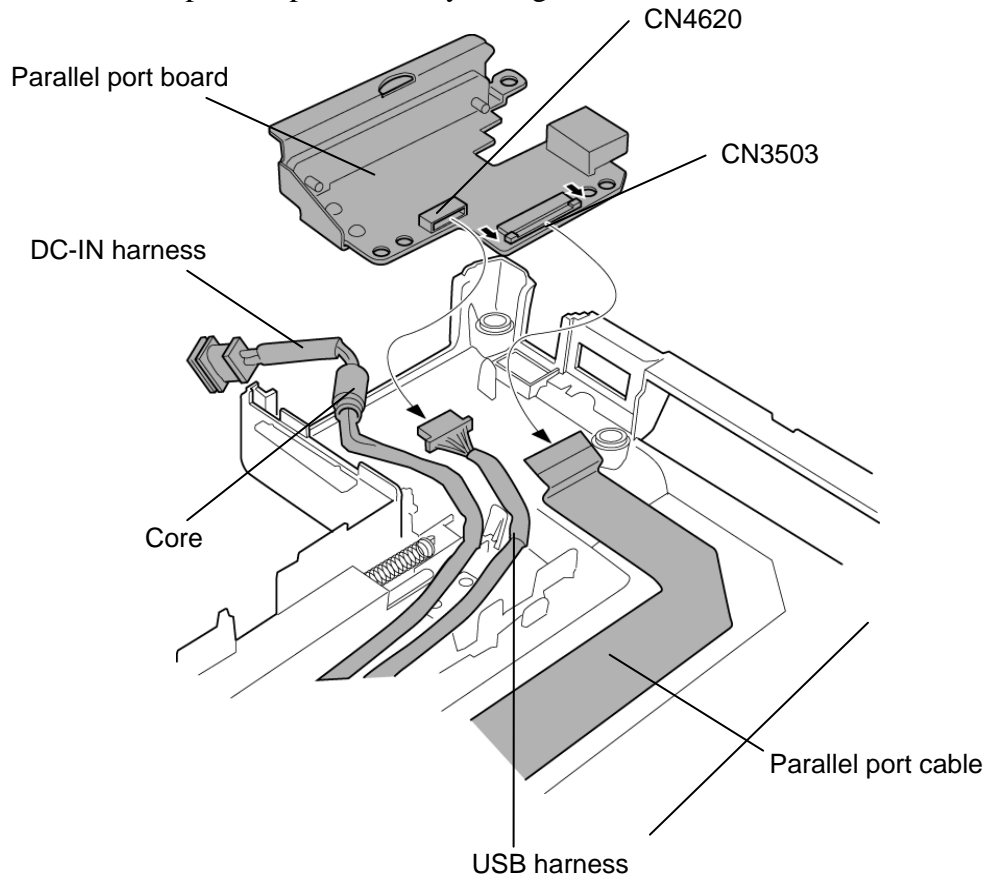

Figure 4-28 Removing parallel port board

Installing the Parallel port board

The following describes the procedure for installing the Parallel port board (See Figure 4-27, 4-28).

1. Install the **parallel port board** on the base assembly.
2. Connect the **USB harness** to the connector CN4620 and the **parallel port cable** to the connector CN3503 on the parallel port board.
3. Pass the **DC-IN harness, USB harness and parallel port cable** along the guide of base assembly.

CAUTION: Pass the cables under harness holder as the following figure.

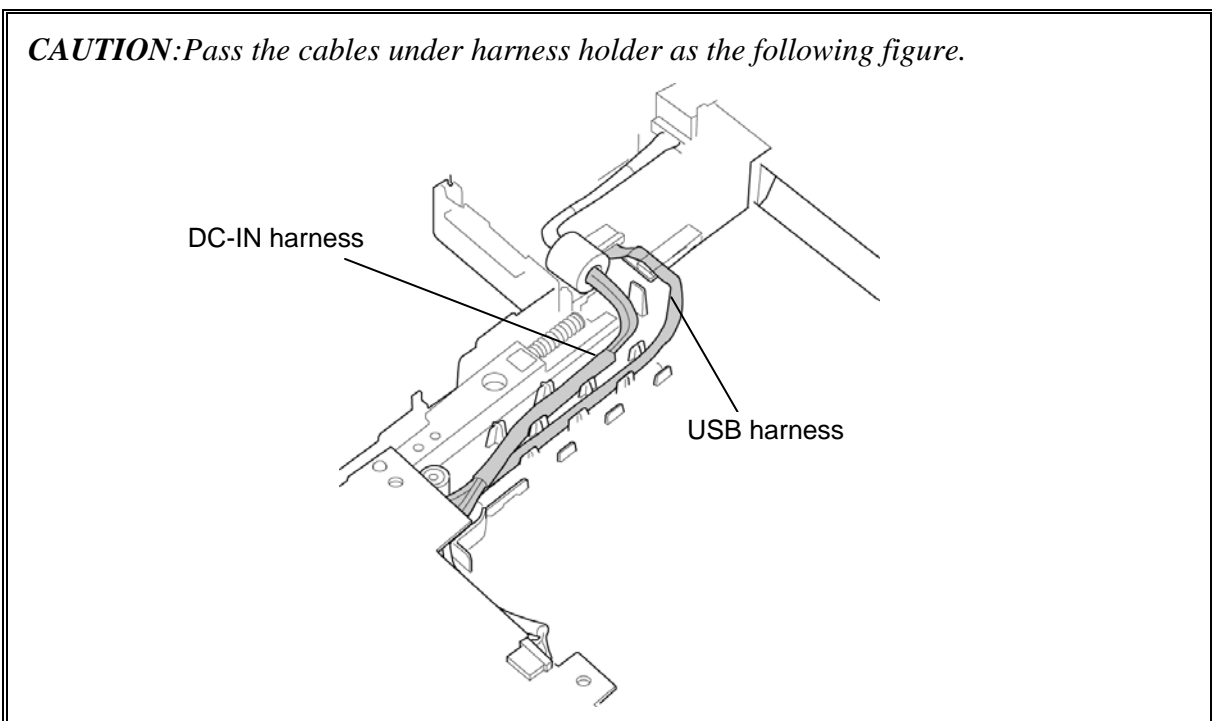

4. Install the **harness holder** and secure it with the following **screws**.
 - M2.5x4B THIN BIND screw x2
5. Set the **core** of the DC-IN harness on the harness holder and install the **DC-IN jack** in the slot of the base assembly.

4.13.2 Serial port board

Removing the serial port board

The following describes the procedure for removing the serial port board (See Figure 4-27, 4-29).

NOTE: The procedure 1 and 2 are the same items as parallel port board. Refer to the figure 4-27 in the parallel port board.

1. Remove the **DC-IN jack** and **core** from the slot of the base assembly.
2. Remove the following **screws** to remove the **harness holder**.
 - M2.5x4B THIN BIND screw x2
3. Disconnect the **USB harness** from the connector CN4630 and the serial port cable from the connector CN3504 on the serial port board.
4. Remove the **serial port board** by lifting it

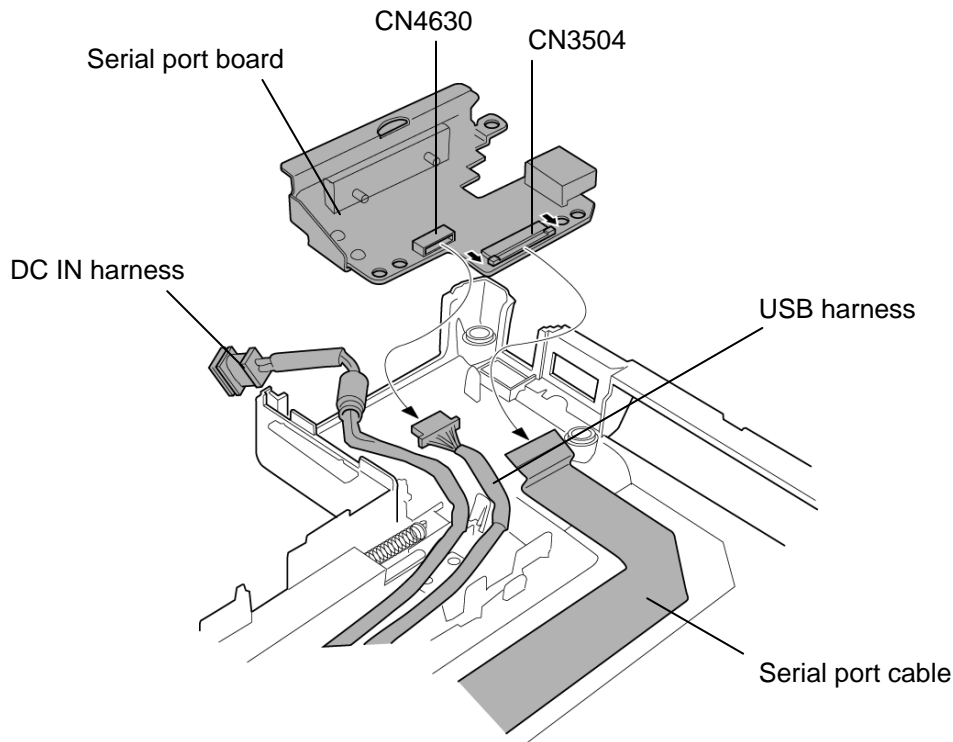

Figure 4-29 Removing serial port board

Installing the Serial port board

The following describes the procedure for installing the Serial port board (See Figure 4-27, 4-29).

1. Install the **serial port board** on the base assembly.
2. Connect the **USB harness** to the connector CN4630 and the **serial port cable** to the connector CN3504 on the parallel port board.
3. Pass the **DC-IN harness**, **USB harness** and **serial port cable** along the guide of base assembly.

CAUTION: Pass the cables under harness holder as the following figure.

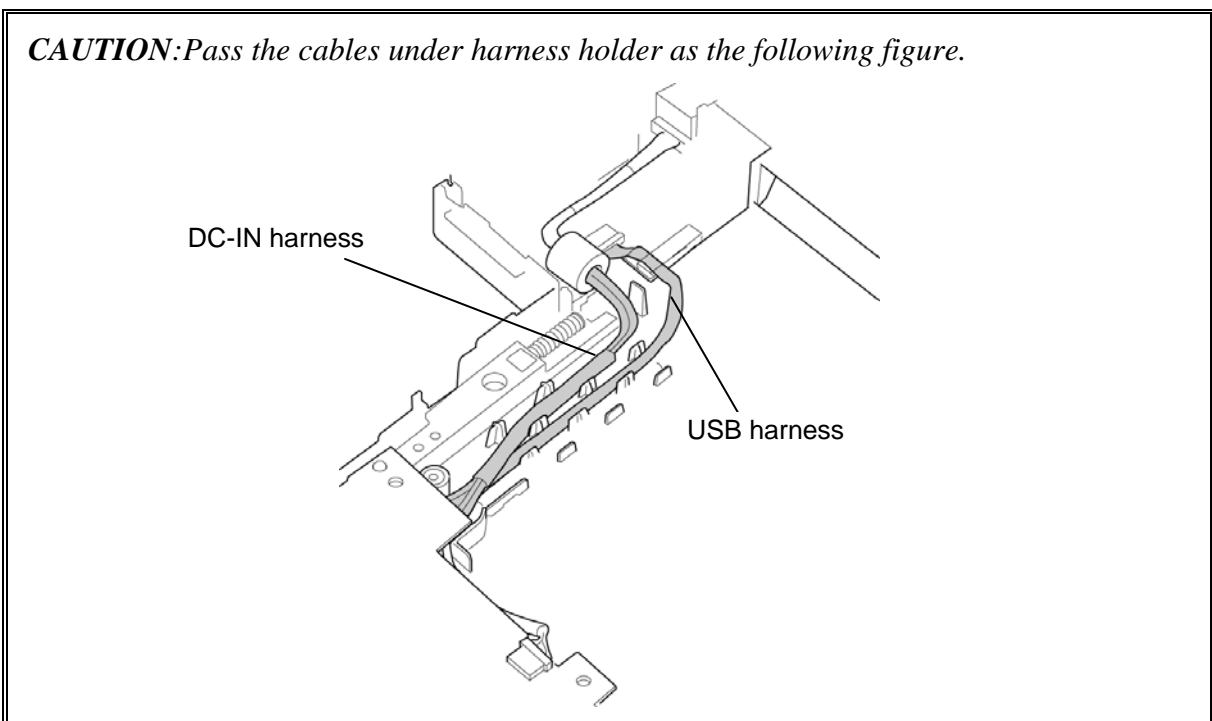

4. Install the **harness holder** and secure it with the following **screws**.
 - M2.5x4B THIN BIND screw x2
5. Set the **core** of the DC-IN harness on the harness holder and install the **DC-IN jack** in the slot of the base assembly.

4.13.3 S-Video board

Removing the S-Video board

The following describes the procedure for removing the S-Video board (See Figure 4-27, 4-30).

NOTE: The procedure 1 and 2 are the same items as parallel port board. Refer to the figure 4-27 in the parallel port board.

1. Remove the **DC-IN jack** and **core** from the slot of the base assembly.
2. Remove the following **screws** to remove the **harness holder**.
 - M2.5x4B THIN BIND screw x2
3. Disconnect the **USB harness** from the connector PJ4610 and the S-Video harness from the connector PJ5640 on the S-Video board.
4. Remove the **S-Video board** by lifting it

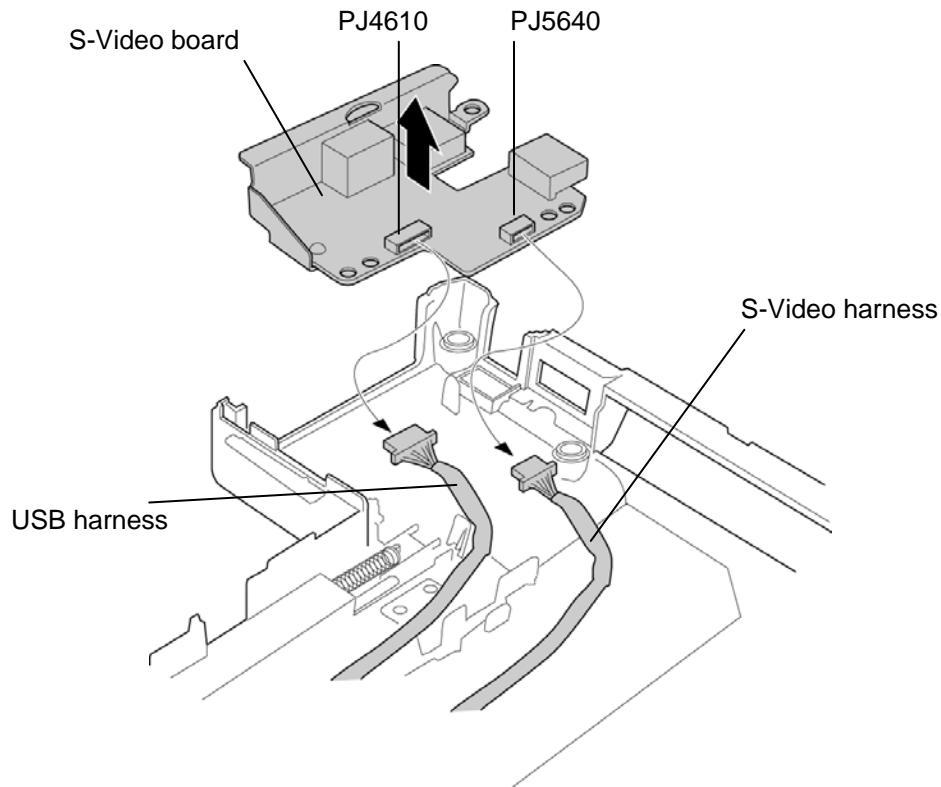

Figure 4-30 Removing S-Video board

Installing the S-Video board

The following describes the procedure for installing the S-Video board (See Figure 4-27, 4-30).

1. Install the **serial port board** on the base assembly.
2. Connect the **USB harness** to the connector PJ4610 and the **S-Video harness** to the connector PJ5640 on the S-Video board.
3. Pass the **DC-IN harness**, **USB harness** and **S-Video harness** along the guide of base assembly.

CAUTION: Pass the cables under harness holder as the following figure.

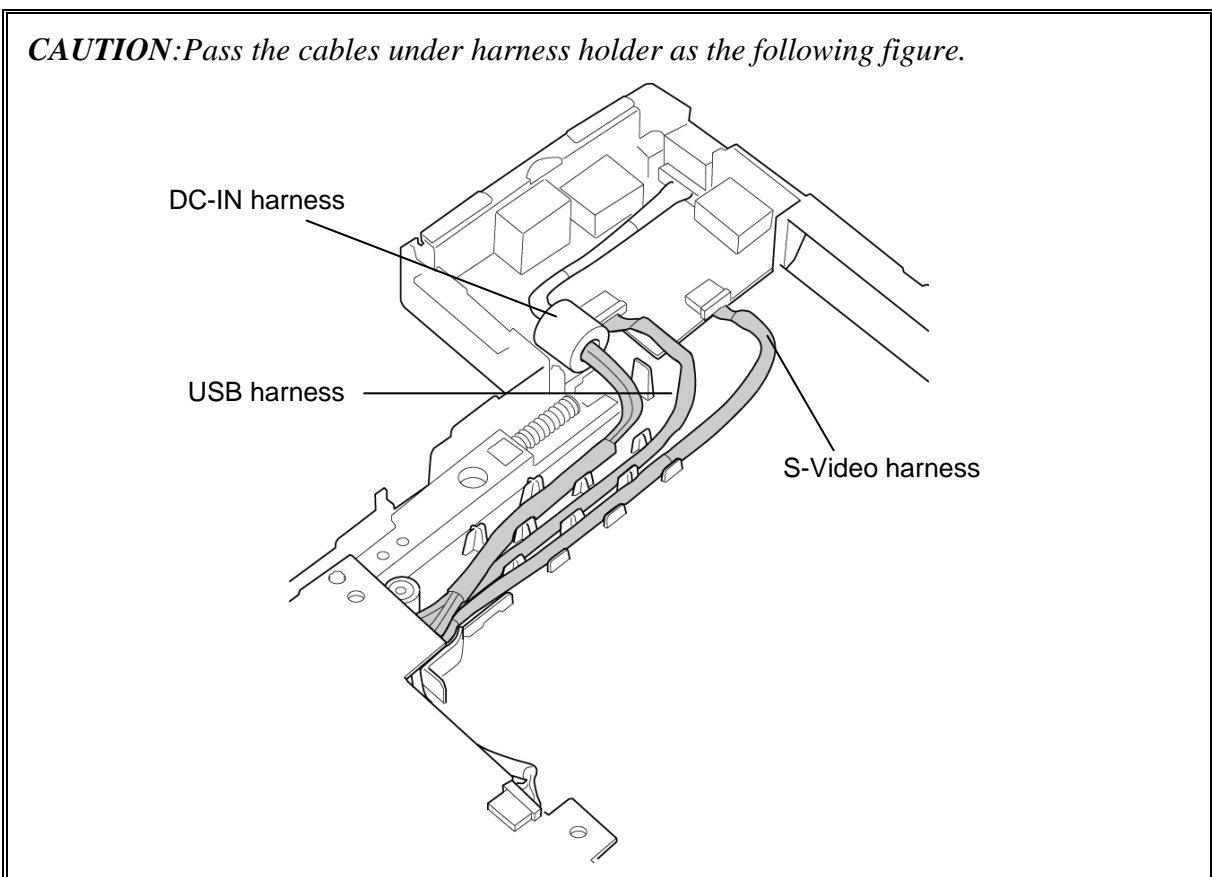

4. Install the **harness holder** and secure it with the following **screws**.
 - M2.5x4B THIN BIND screw x2
5. Set the **core** of the DC-IN harness on the harness holder and install the **DC-IN jack** in the slot of the base assembly.

4.14 Fan

Removing the Fan

The following describes the procedure for removing the fan (See Figure 4-31).

1. Disconnect the **fan cable** from the connector CN8770 on the system board.
2. Remove the following **screws** and remove the **fan** by raising it up.

- M2.5x4B THIN BIND screw x2

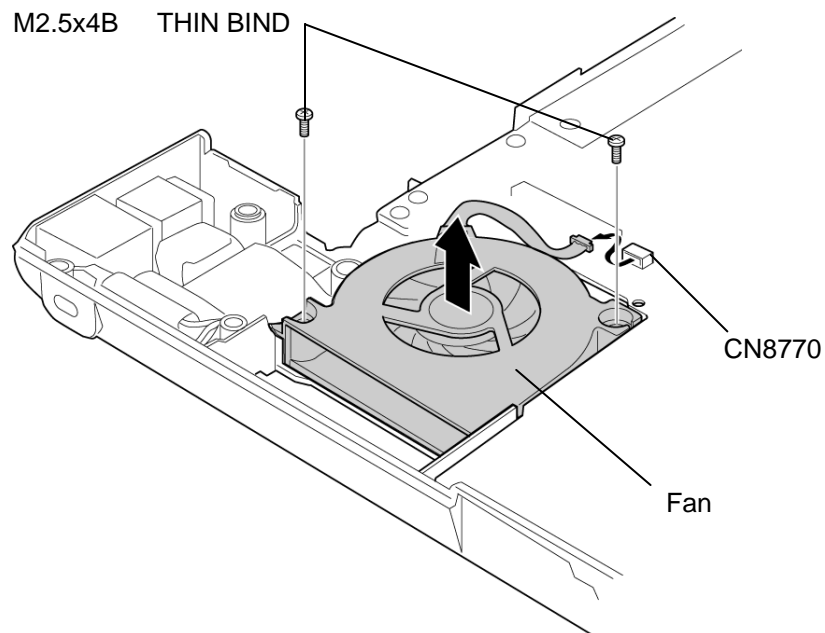

Figure 4-31 Removing Fan

Installing the Fan

The following describes the procedure for installing the fan (See Figure 4-31).

1. Connect the **fan cable** to the connector **CN8770** on the system board.
2. Install the **fan** on the base assembly and secure it with the following **screws**.

- M2.5x4B THIN BIND screw x2

4.15 System Board/DC-IN Jack/RTC Battery

CAUTION: When handling the system board, always hold by the edges. Do not touch the printed circuit face.

After replacing the system board with a new one, update the DMI information as described Chapter 3. Also update with the latest BIOS as described in Appendix G “BIOS/KBC/EC Update”.

Removing the system board/DC-IN jack/RTC battery

The following describes the procedure for removing the system board/DC-IN jack/RTC battery (See Figure 4-32, 4-33).

1. Open **insulators** bundle the **LAN harness**, **Modem harness** and **RTC battery**.
2. Pull out the **RTC battery** from the **RTC battery case**.

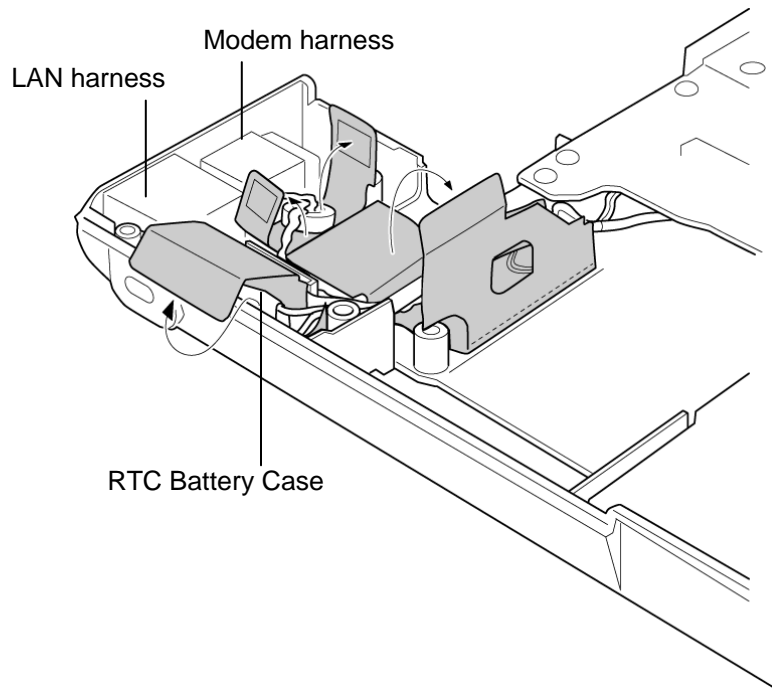

Figure 4-32 Opening the insulators

3. Remove the **LAN harness** and **Modem harness** from the base assembly.
4. Remove the following **screws** securing the **system board**.
 - M2.5x4B THIN BIND screw x2
5. [Parallel port board model or Serial port board model] Disconnect the **parallel port cable** or **serial port cable** from the connector CN3502 on the system board.
6. [S-Video board model] Disconnect the **S-Video harness** from the connector CN5340 on the system board.
7. Remove the system board from the base assembly.
8. Turning over the system board, disconnect the **DC-IN harness** from the connector CN8800 and **USB harness** from the connector PJ4611 on the system board.
9. Disconnect the RTC battery cable from the connector CN9990 on the system board.
10. Peel off glass tapes and disconnect the modem harness and LAN harness.

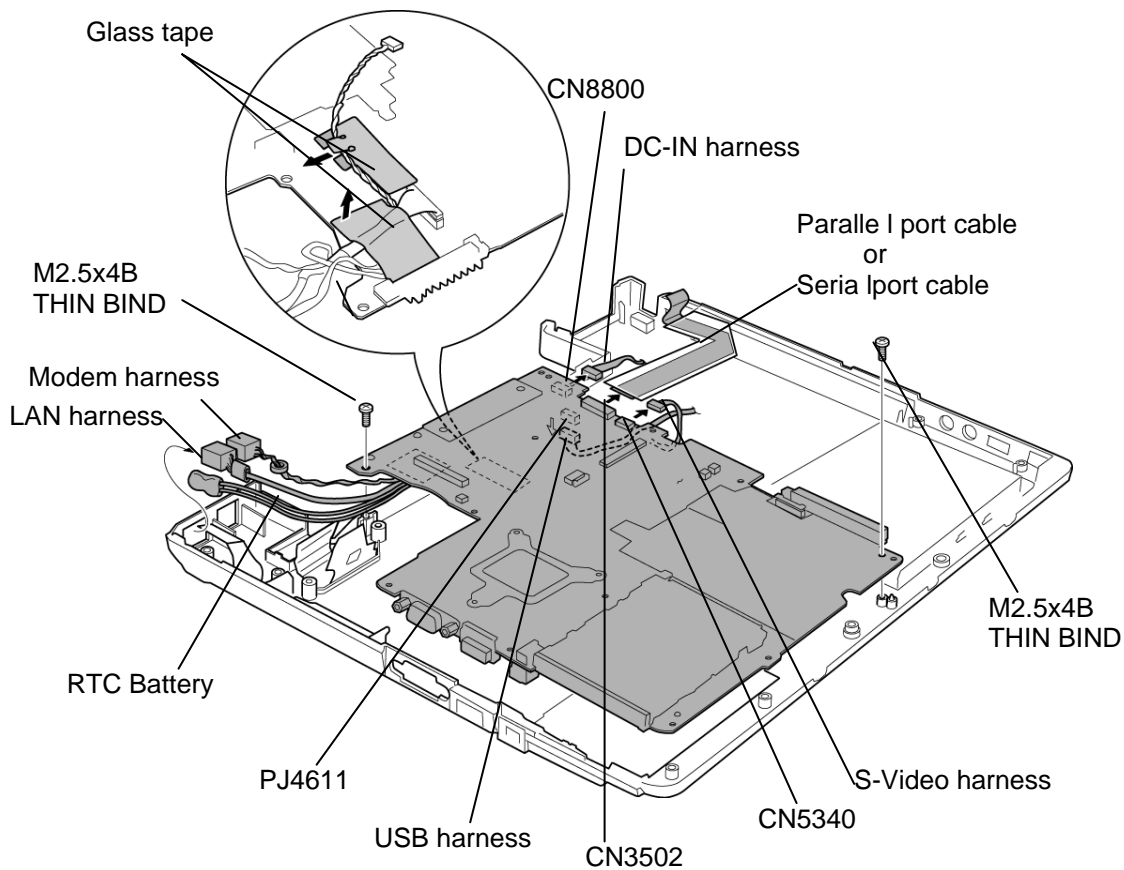

Figure 4-33 Removing System board

Installing the System board/DC-IN jack/RTC battery

The following describes the procedure for installing the system board/DC-IN jack/RTC battery (See Figure 4-32, 4-33).

1. Connect the **Modem harness** to the connector **CN3011** and the **LAN harness** to **CN4100** on the back of the **system board** and secure them with **glass tapes**.
2. Connect the **RTC battery cable** to the connector **CN9990** on the system board.
3. Connect the **DC-IN harness** to the connector **CN8800** and **USB harness** to the connector **PJ4611** on the system board.
4. Secure the system board with the following **screws**.
 - M2.5x4B THIN BIND screw x2
5. [S-Video board model] Connect the **S-Video harness** to the connector **CN5340** on the system board.
6. [Parallel port board model or Serial port board model] Connect the **parallel port cable** or **serial port cable** to the connector **CN3502** on the system board.
7. Arrange LAN harness, Modem harness and RTC battery cable along the guide.

CAUTION: Pass the cables around the guide as the following order.

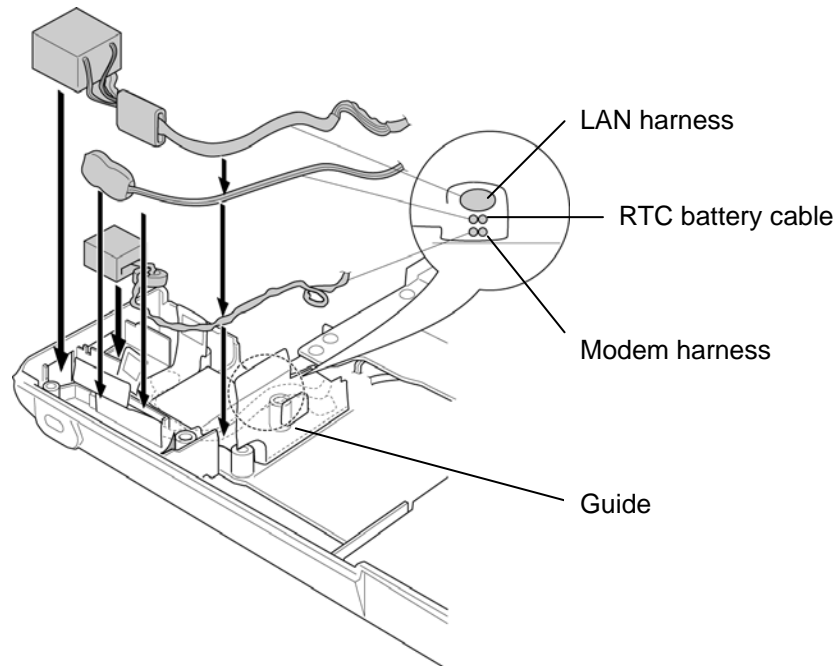

4.16 PC card cover

Removing the PC card cover

The following describes the procedure for removing the PC card cover (See Figure 4-34).

1. Remove the following **screws** securing the PC card cover.
 - M2x4C SUPER THIN BIND screw x2
2. Release the **hooks** securing the PC card cover and remove the **PC card cover**.

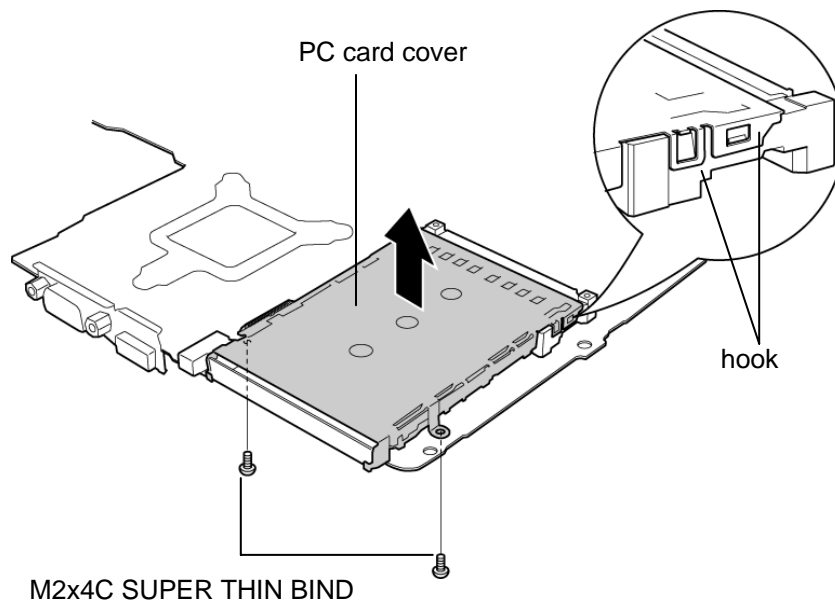

Figure 4-34 Removing the PC card cover

Installing the PC card cover

The following describes the procedure for installing the PC card cover (See Figure 4-34).

1. Secure the **hooks** and install the **PC card cover**.
2. Secure the PC card cover with the following **screws**.
 - M2x4C SUPER THIN BIND screw x2

4.17 Battery Latch

Removing the Battery latch

The following describes the procedure for removing the battery latch (See Figure 4-35, 4-36).

1. While pressing **projections** of the **SB latch button** inside each other, push the SB latch button to the bottom of the base assembly to remove.

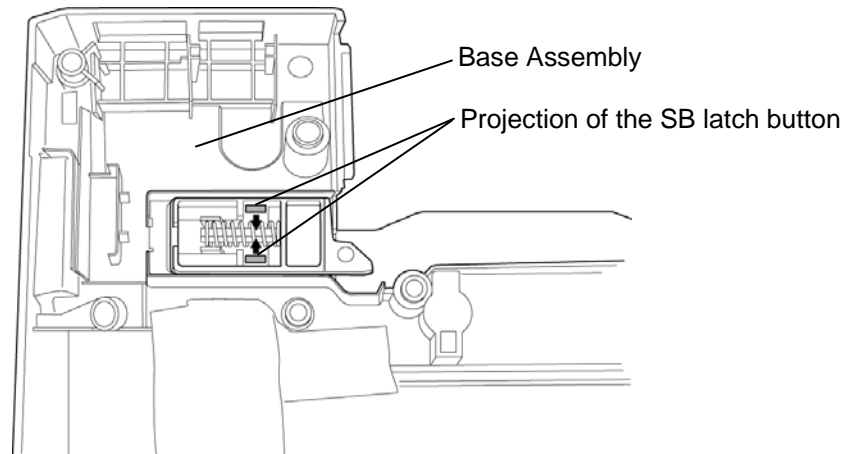

Figure 4-35 Removing SB Latch Button

2. Remove the **battery lock L** from the base assembly and remove the **spring** from the battery lock L.

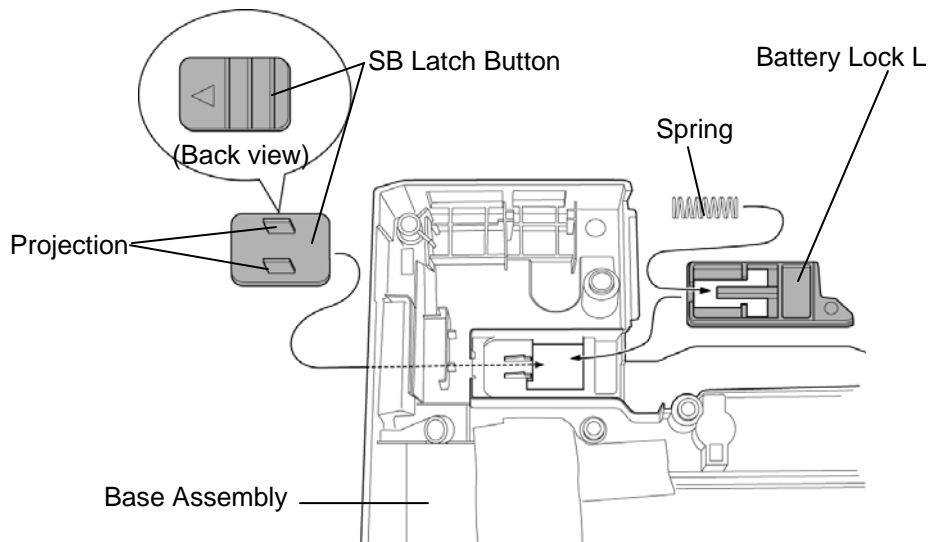

Figure 4-36 Removing Battery Lock L

Installing the Battery latch

The following describes the procedure for installing the battery latch (See Figure 4-35, 4-36).

1. Set the **spring** to the **battery lock L** and install it on the base assembly.
2. Install the **SB latch button** from the bottom of the base assembly and snap their **projections** to the **battery lock L**. When installing the button, make sure the triangle mark on the back side is located in the indicated position. After installation, slide the latch on the bottom of the base assembly to make sure it works properly.

4.18 Battery Lock

Removing the Battery lock

The following describes the procedure for removing the battery lock (See Figure 4-34, 4-35).

1. While pressing **projections** of the **battery lock button** inside each other, push the button to the bottom of the base assembly to remove.

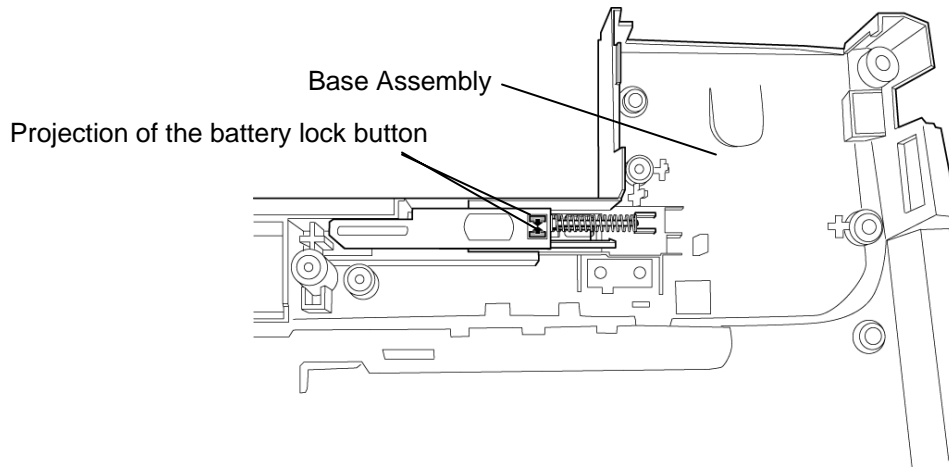

Figure 4-37 Removing Battery Lock Button

2. Remove the **battery lock R** from the base assembly and remove the **spring** from the battery lock R.

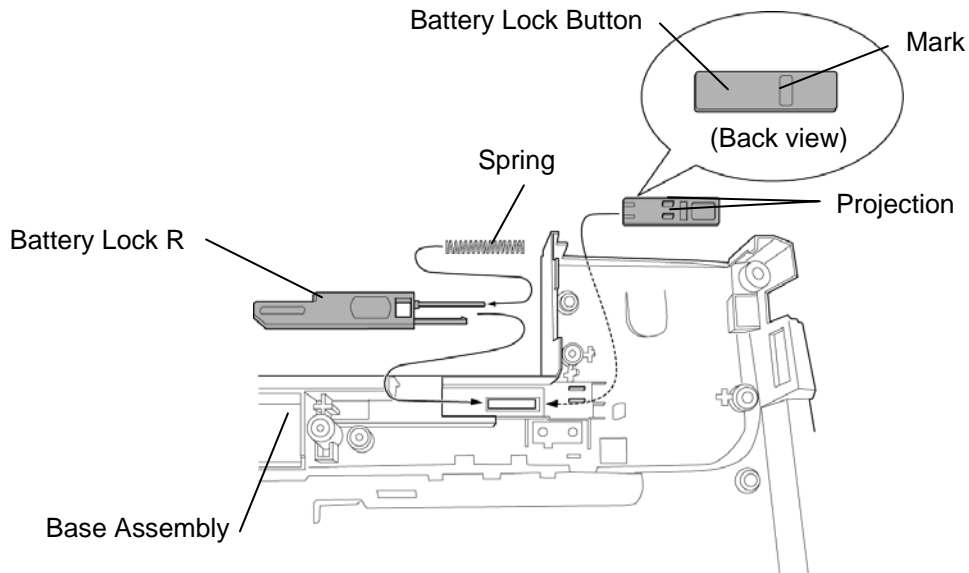

Figure 4-38 Removing Battery Lock R

Installing the Battery lock

The following describes the procedure for installing the battery latch (See Figure 4-37, 4-38).

1. Set the **spring** to the **battery lock R** and install it on the base assembly.
2. Install the **battery lock button** from the bottom of the base assembly and snap their **projections** to the **battery lock R**. When installing the button, make sure the **mark** on the back side is located in the indicated position. After installation, slide the latch on the bottom of the base assembly to make sure it works properly.

4.19 Touch Pad

Removing the Touch pad

The following describes the procedure for removing the touch pad (See Figure 4-36).

1. Remove the following **screws** securing the **touch pad**.
 - M2.5x4B THIN BIND screw x6
2. Remove the touch pad and **touch pad switch** by raising.

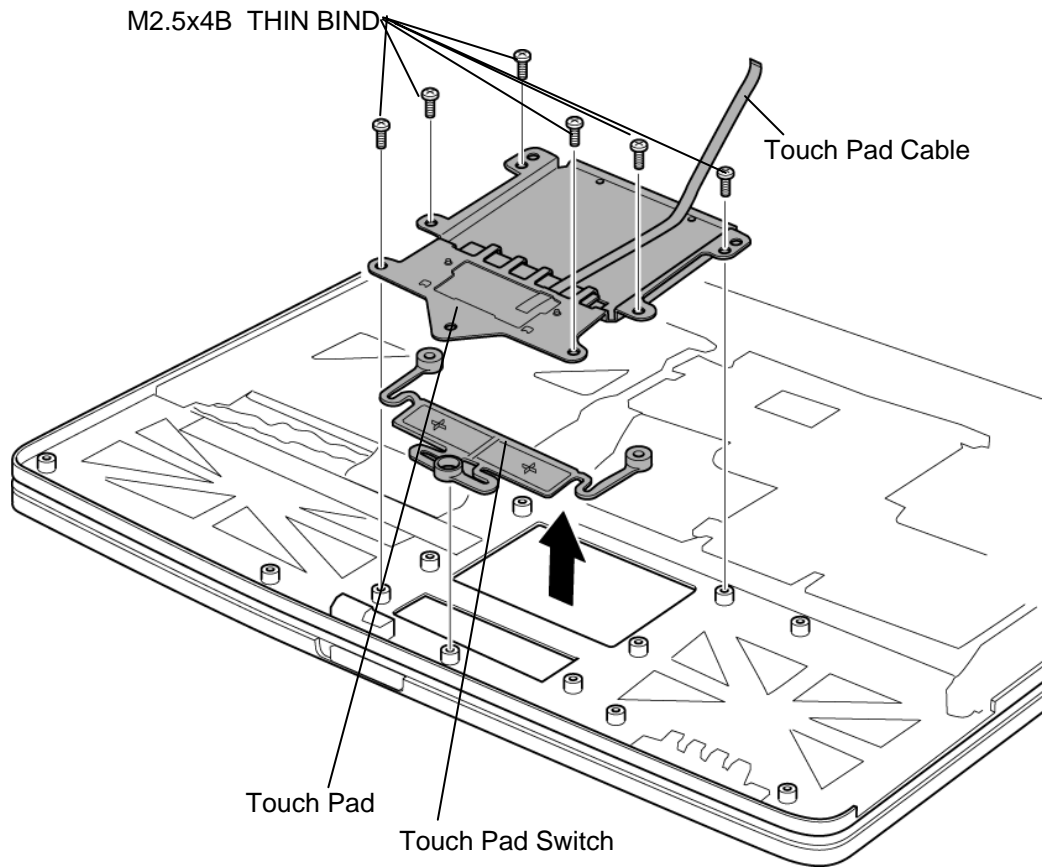

Figure 4-39 Removing Touch Pad

Installing the Touch pad

The following describes the procedure for installing the touch pad (See Figure 4-39).

1. Place the **touch pad switch** fitting to bosses.
2. Place the **touch pad** according to the guide pins.
3. Secure the touch pad with the following **screws**.
 - M2.5x4B THIN BIND screw x6

4.20 LCD Unit/FL Inverter

Removing the LCD unit/FL inverter

The following describes the procedure for removing the LCD unit and FL inverter (See Figure 4-40 to 4-42).

1. Peel off two **mask seals** from the front of the **display mask** and remove the following screws.
 - M2.5x6B THIN BIND screw x2
2. Insert your fingers between the display mask and the **LCD** and remove the display mask after unlatching the display mask.

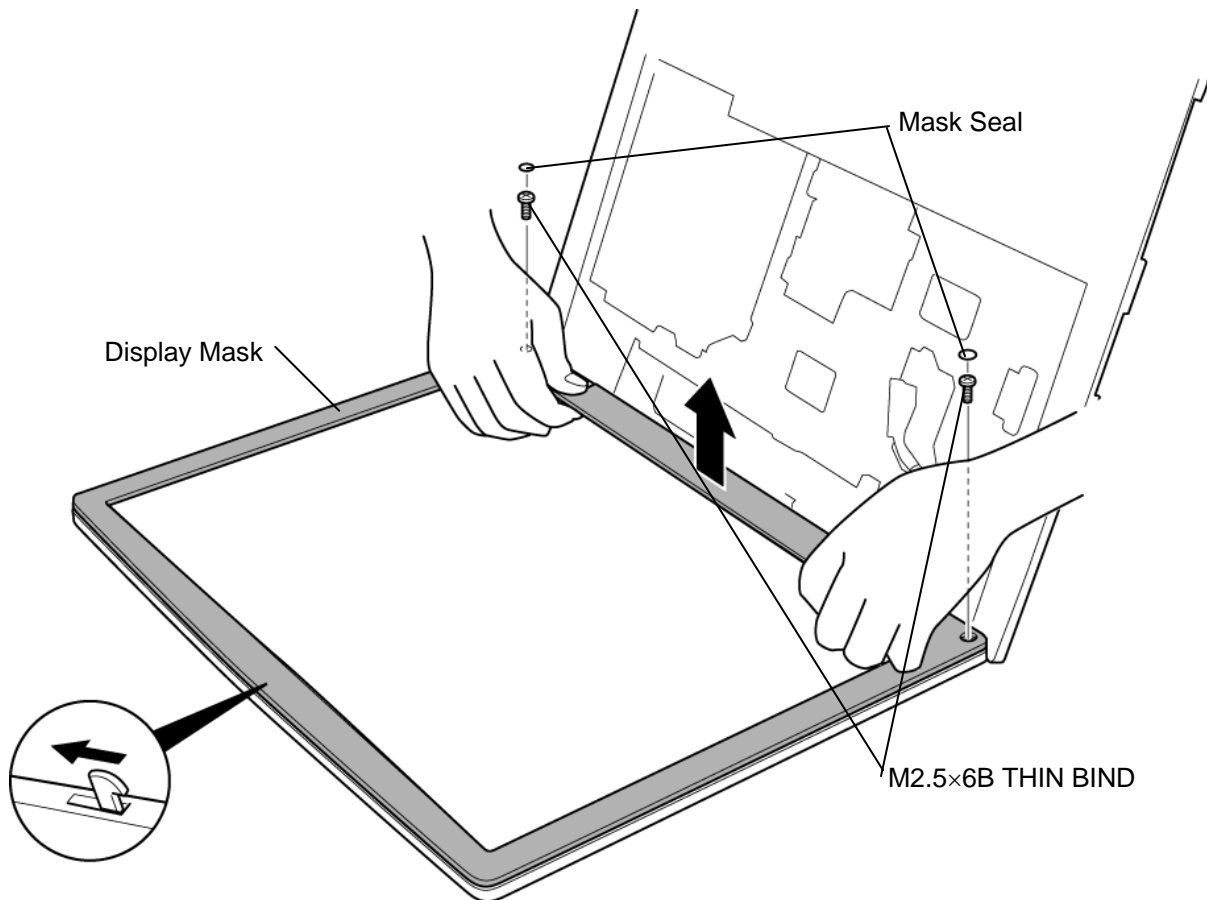

Figure 4-40 Removing Display Mask

3. Remove the following **screw** fixing the **FL inverter**.
 - M2x4Z SUPER THIN BIND screw x1
4. Peel off the **insulators** in the HV cable side and disconnect two **cables** from the FL inverter. Remove the **FL inverter**.
5. Remove the following **screws** fixing the **LCD unit**.
 - M2x4Z SUPER THIN BIND screw x4
6. With the bottom edge of the LCD unit resting on the display cover, raise the top edge of the LCD unit. Peel off the **copper tape** and disconnect the **LCD harness** from the connector on the back of the LCD.
7. Remove the LCD unit from the display cover.

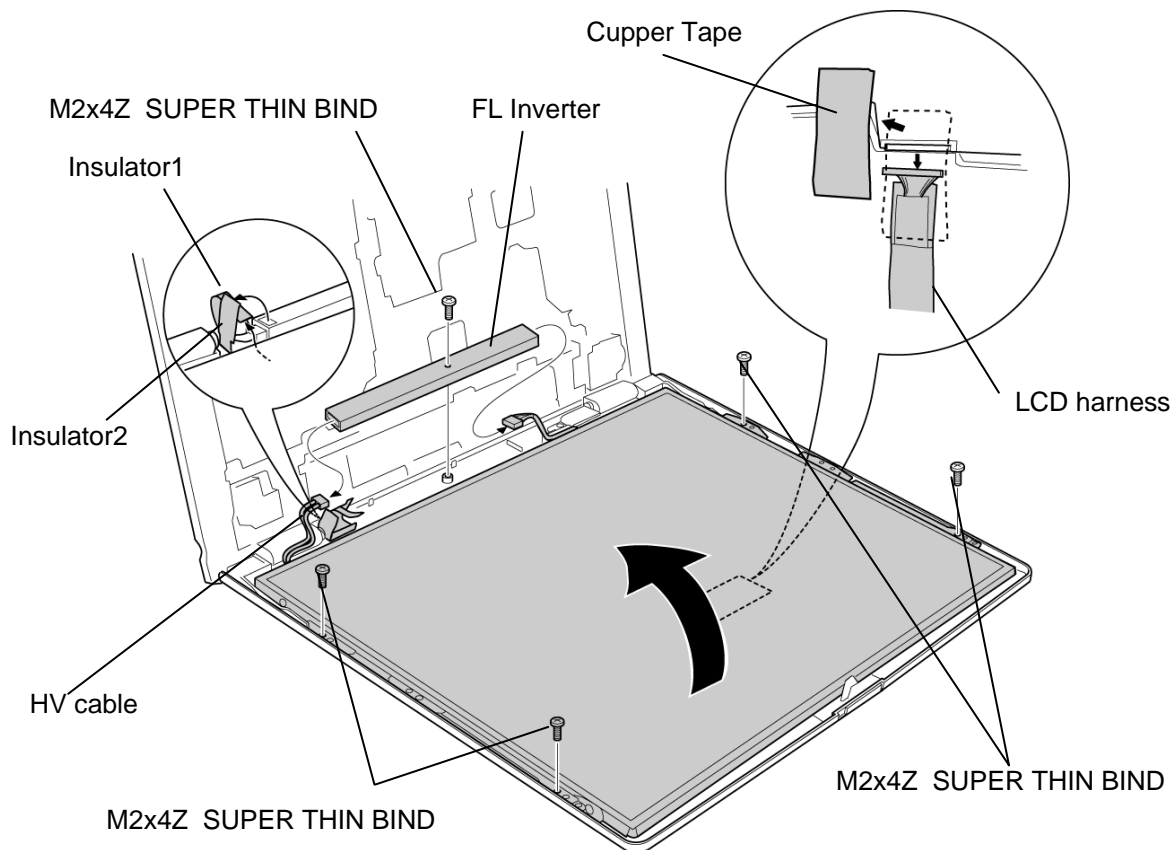

Figure 4-41 Removing FL Inverter and LCD Unit

8. Remove the following **screws** securing the **LCD brackets**. Remove the LCD brackets from the **LCD module**.

- M2x3 SUPER THIN BIND screw x4

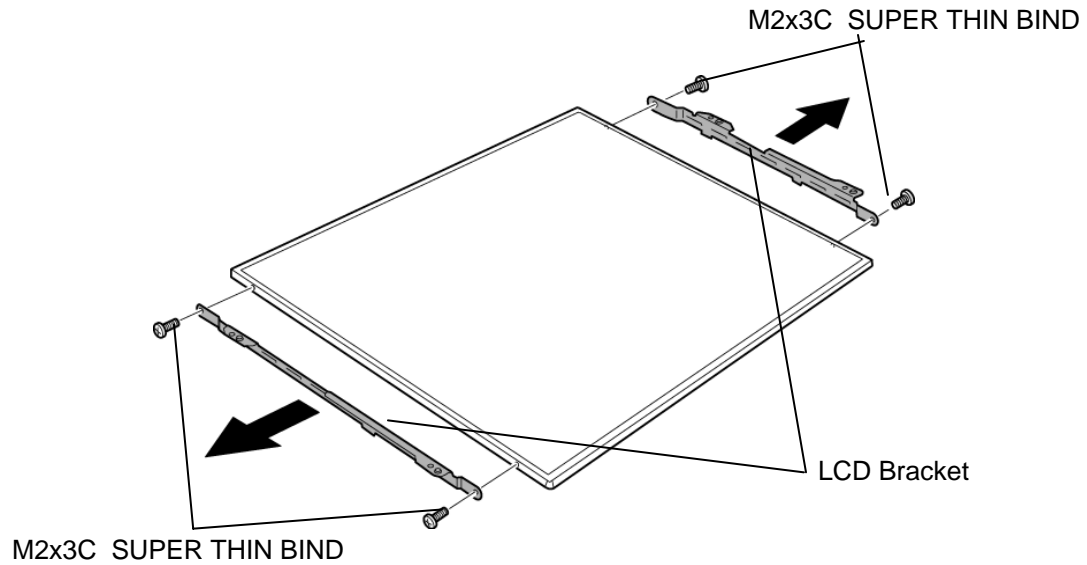

Figure 4-42 Removing LCD Bracket

Installing the FL inverter/LCD unit

The following describes the procedure for installing the LCD unit/FL inverter (See Figure 4-40 to 4-42).

1. Secure the **LCD brackets** to the LCD module with the following **screws**.
 - M2x3C SUPER THIN BIND screw x4
2. Stand the LCD unit on the **display cover** and connect the LCD harness to the back of the LCD. Fix it with the **copper tape**.
3. Put the LCD unit on the display cover and secure the LCD with the following **screws**.
 - M2x4Z SUPER THIN BIND screw x4
4. Connect LCD harness and HV cable to the connectors on the **FL inverter**.
5. Secure the FL inverter with the following **screw**.
 - M2x4Z SUPER THIN BIND screw x1
6. Stick the insulators on the HV cable side and tuck the insulator1 under LCD unit.
7. Install the **display mask** and engage the latches.

NOTE: When installing the display mask, make sure there is no gap between the display mask and the display cover.

8. Secure the display mask with the following **screws** and stick two **mask seals** on the front of the display mask.
 - M2.5x6B THIN BIND screw x2

4.21 Latch Assembly

Removing the Latch assembly

The following describes the procedure for removing latch assembly (See Figure 4-43).

1. Press the **latch assembly** in the direction indicated by arrow to remove it from the display cover.

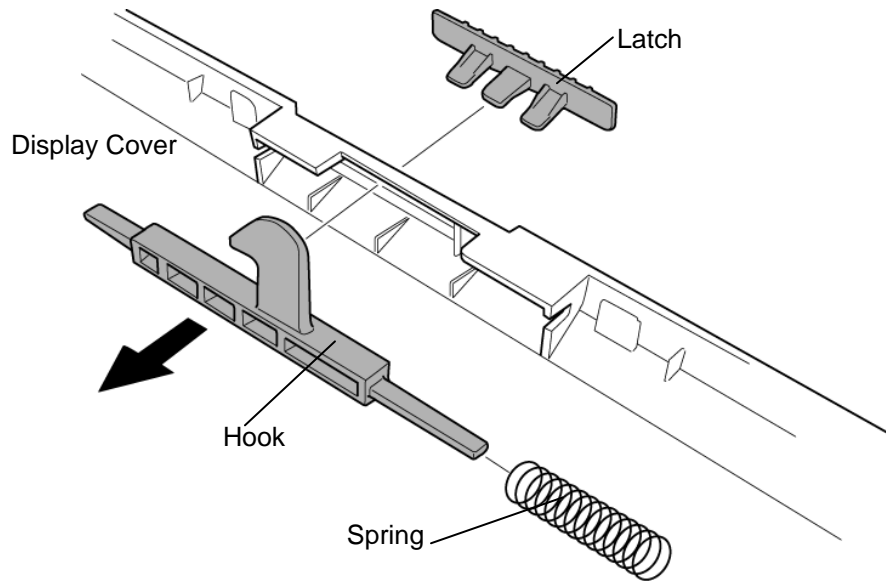

Figure 4-43 Removing Latch Assembly

Installing the Latch Assembly

The following describes the procedure for installing the Latch Assembly (See Figure 4-43).

1. Set the **spring** on the **hook** and fit the hook on the slot of display cover.
2. Install the hook and **latch** by fitting projections on the latch to the holes of the hook.

4.22 Wireless LAN Antenna/Speaker/Hinge

Removing the Wireless LAN antenna/Speaker/Hinge

The following describes the procedure for removing the wireless LAN antenna, speaker and hinge (See Figure 4-44 to 4-52).

1. Peel off eight **glass tapes** securing the **wireless LAN antenna cables** (white and black). Remove the **wireless LAN antennas**. Turn the display assembly face down and unhook the wireless LAN antenna cable from the guides.
[If Sharp-made LCD is installed] Remove two **sponges** from the display assembly.
[If LG Philips-made LCD is installed] Remove one **gasket** and two **aluminum tapes** from the display assembly.

[Samsung-made LCD]

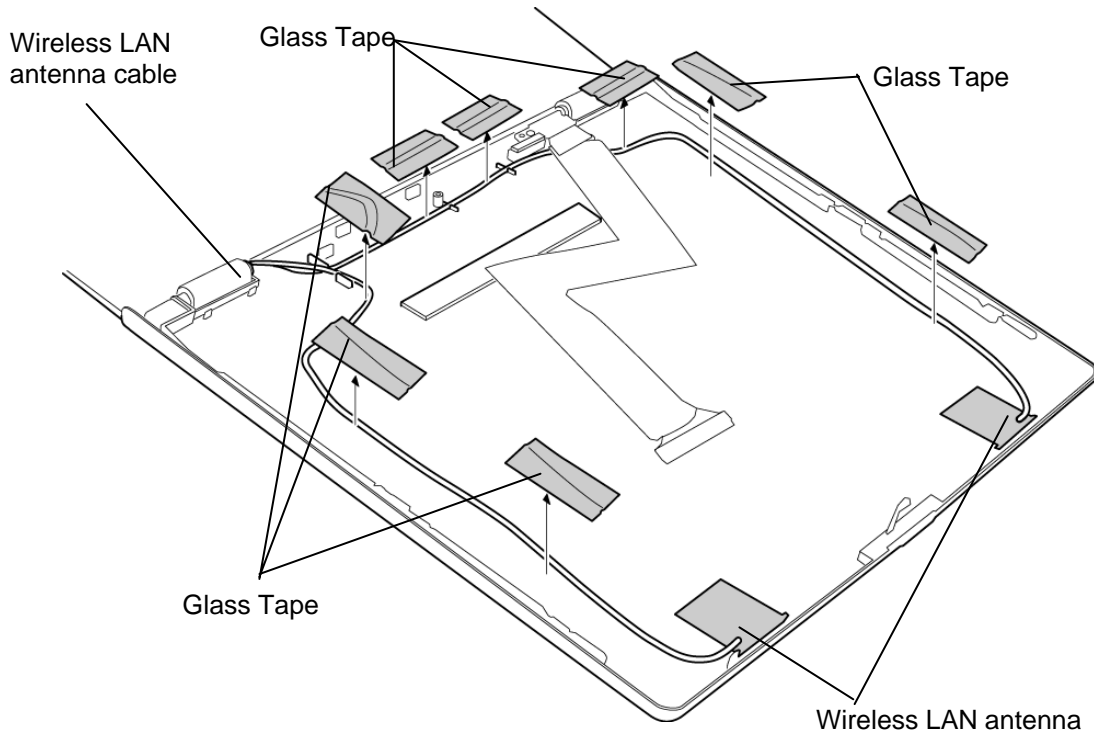

[Sharp-made LCD]

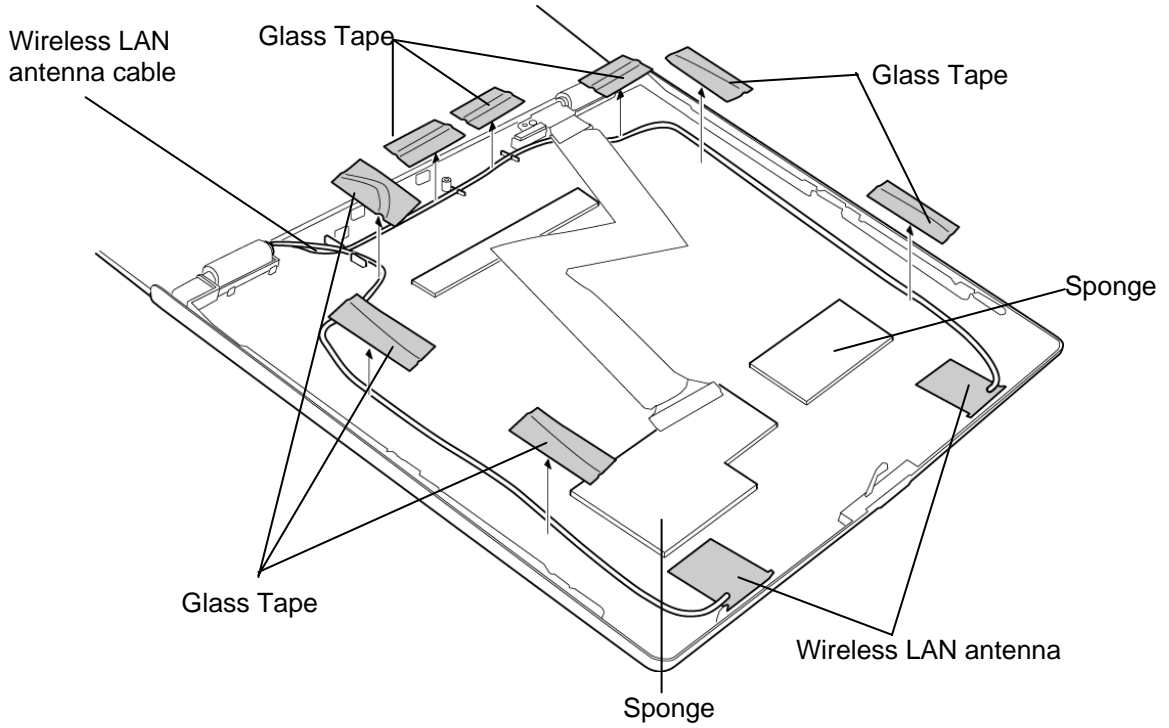

[LG Philips-made LCD]

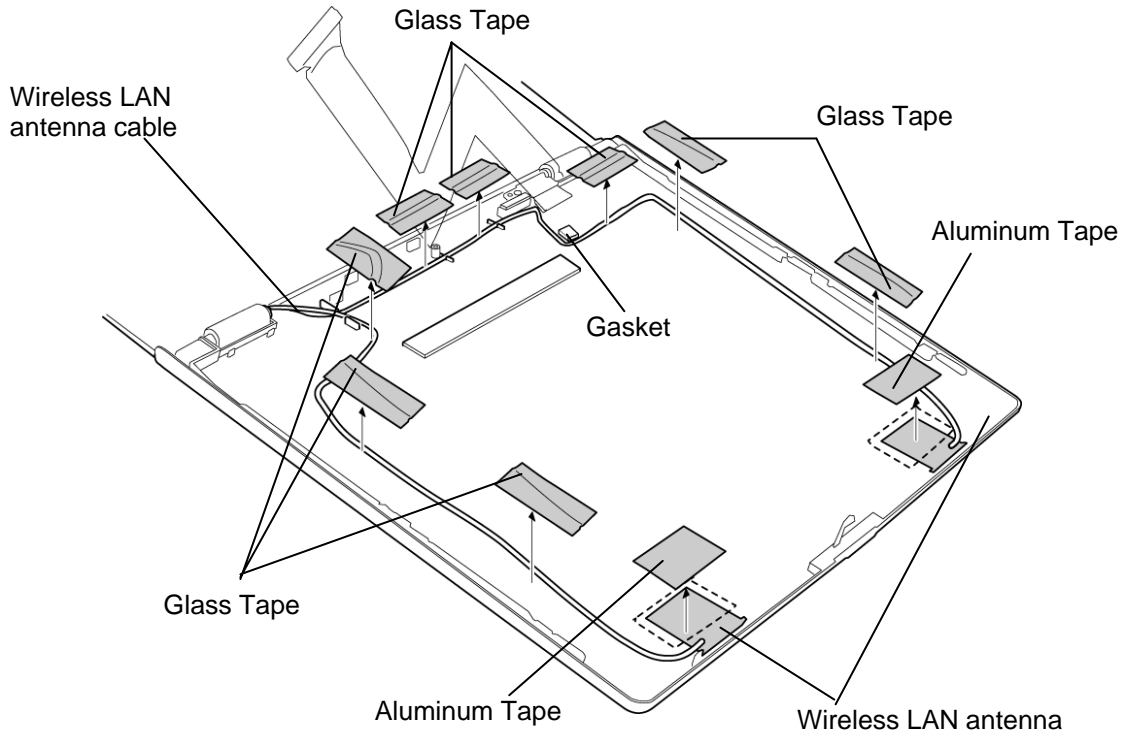

Figure 4-44 Removing wireless LAN antennas

2. Remove the following **screw** securing the **LCD harness holder** to remove it.

- M2x4Z SUPER THIN screw x1

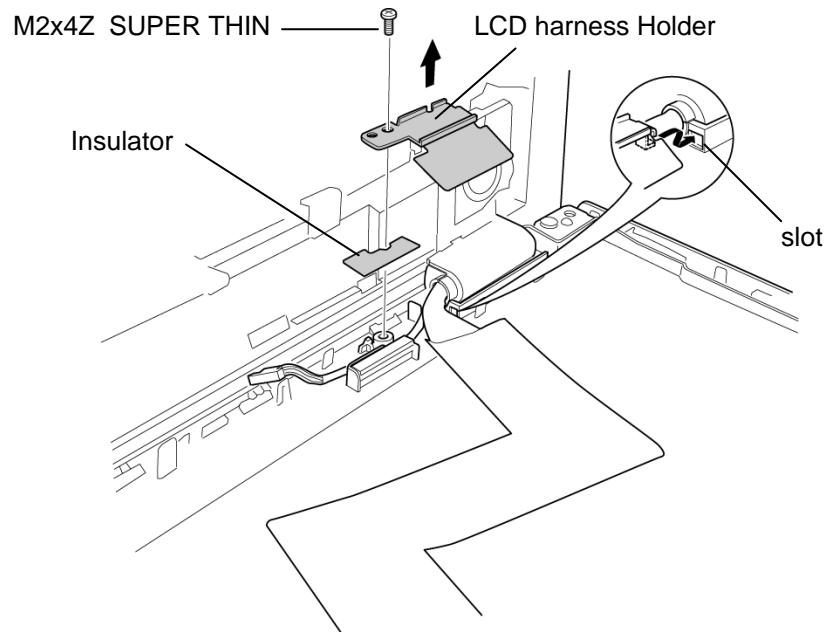

Figure 4-45 Removing LCD harness Holder

3. Remove the following **screws** securing the **display cover** to the hinges.

- M2.5x6C PSP TIGHT screw x4
- M2x5C SUPER THIN screw x2

4. Remove the **display cover** from the hinges.

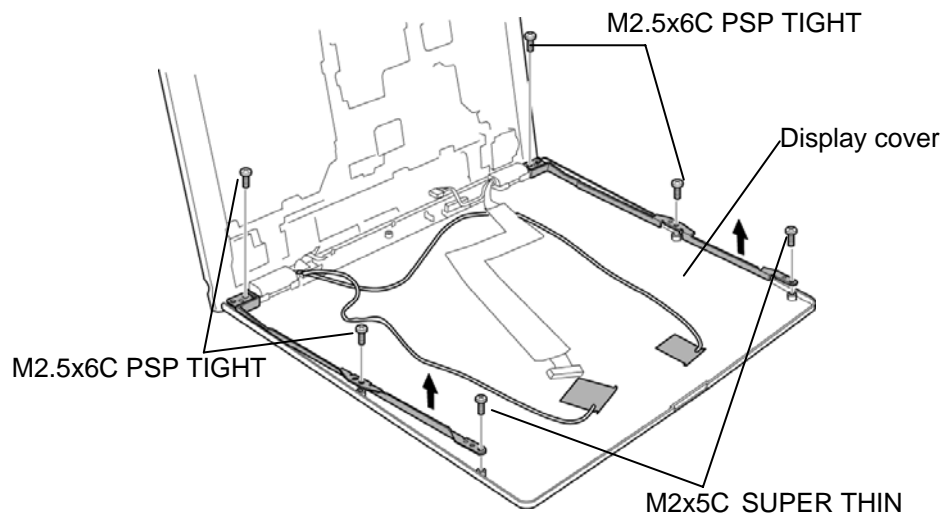

Figure 4-46 Removing display cover

5. Remove the following **screws** securing the hinge caps and remove the **hinge caps**.
 - M2.5x6B THIN BIND screw x2
6. Remove the **LCD harness**.
7. Remove the **wireless LAN antenna cables**.

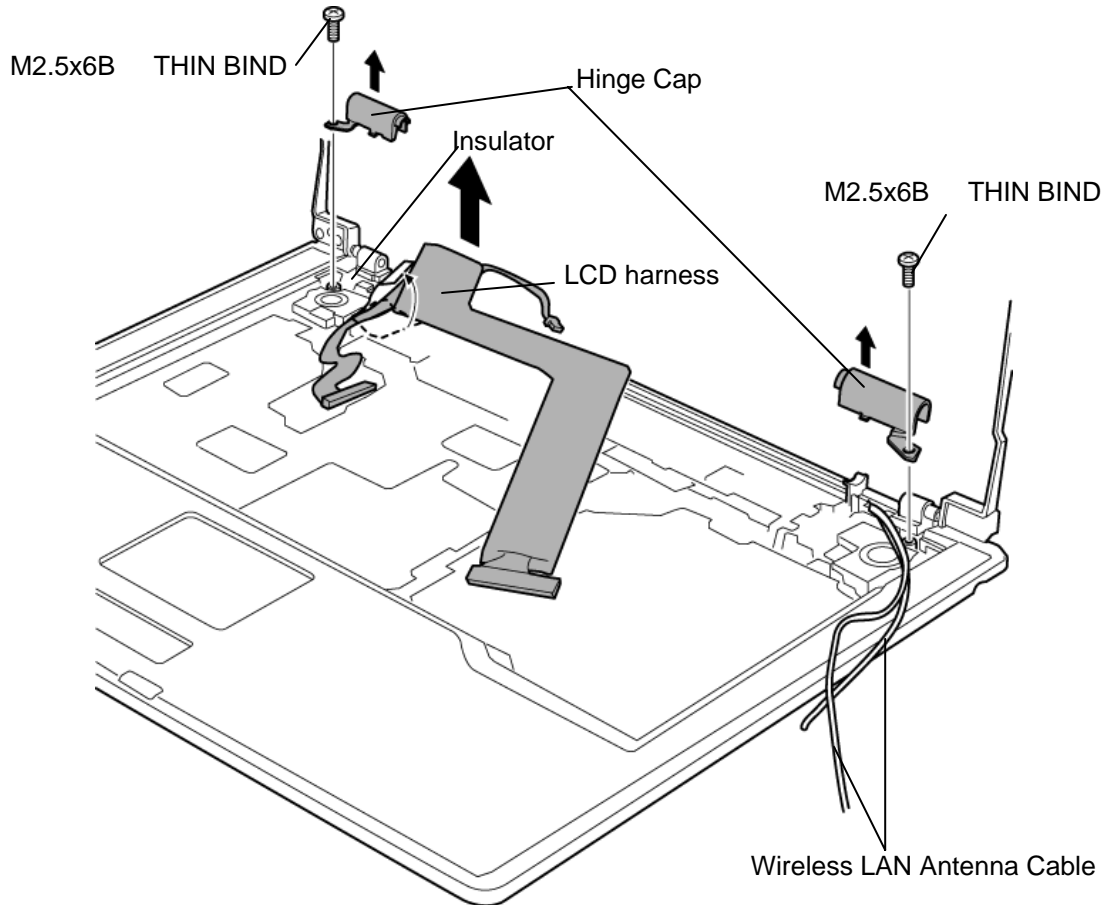

Figure 4-47 Removing Hinge Cap

8. Remove the following **screws** securing the **optical drive cover** from the back of the display assembly. To remove the optical drive cover, pull it out to the right hinge first.

- M2.5x2.8B U-THIN BIND screw x3
- M2.5x4B THIN BIND screw x2

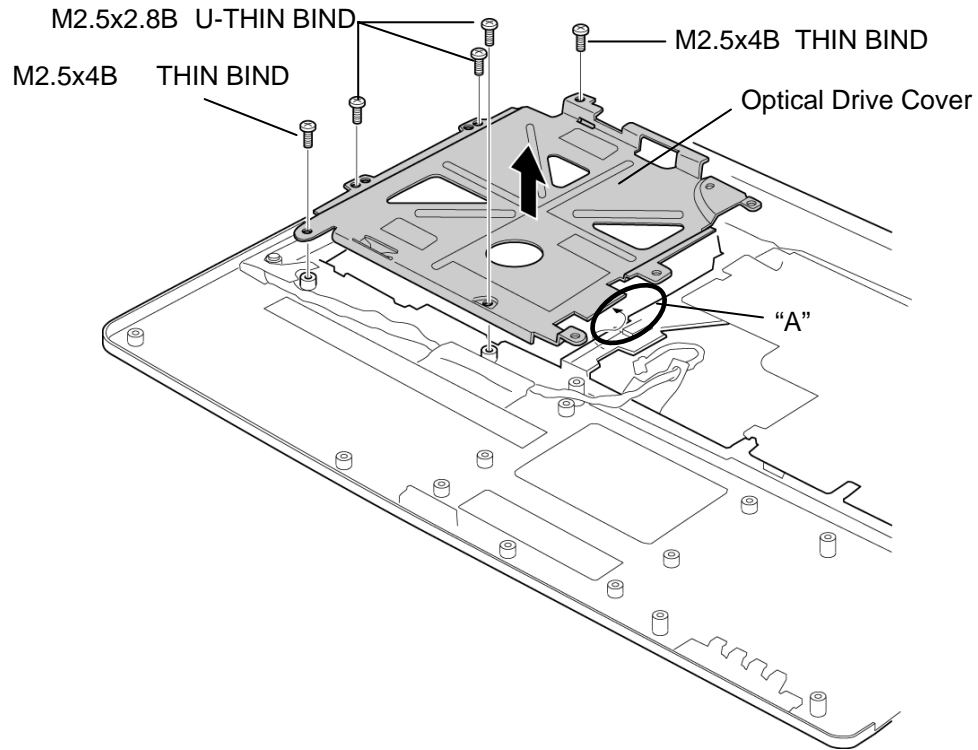

Figure 4-48 Removing Optical drive cover

9. Remove the following **screws** securing the **hinges** to the **display assembly**.

- M2.5x4B THIN BIND screw x3 (Right:1, Left: 2)

10. Peel off the **acetate tapes** securing the **speaker cables** and take out the cable under the **insulator**.

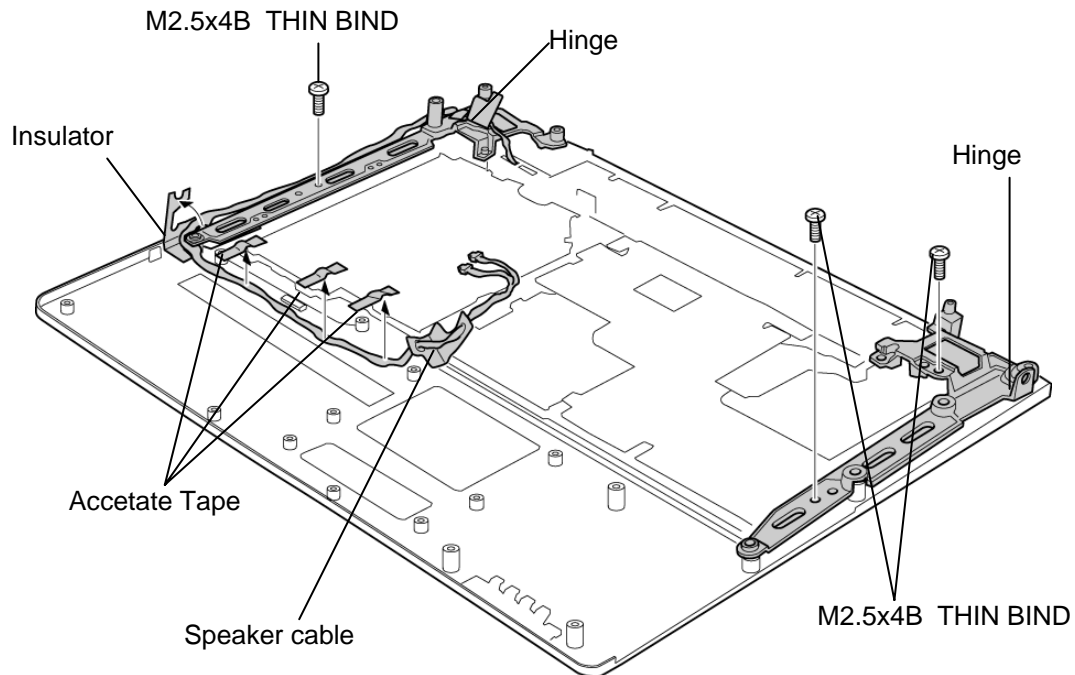

Figure 4-49 Removing speaker cables

11. Remove the following **screws** securing the speakers.

- M2. 5x4B THIN BIND screw x2

CAUTION: When removing the speakers, be careful not to touch the metal part of the speakers. It might damage the speakers.

12. Peel off **insulators** and pull out the **speaker cable (blue)** to the front. Pull out the cable from the guide and remove the **left speaker**. Pull out **right speaker** to remove.

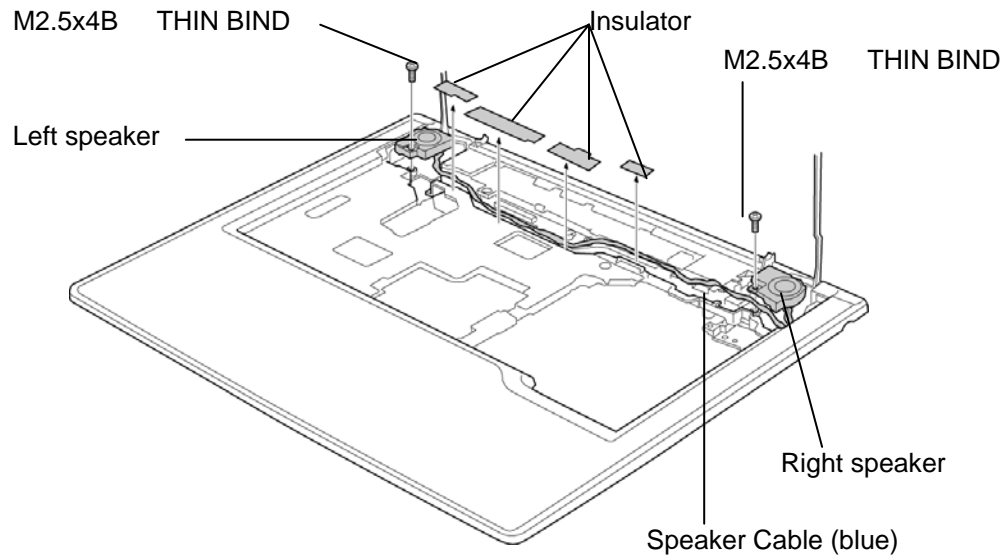

Figure 4-50 Removing Speakers

13. Shift the hinges inside and pull out them to remove.

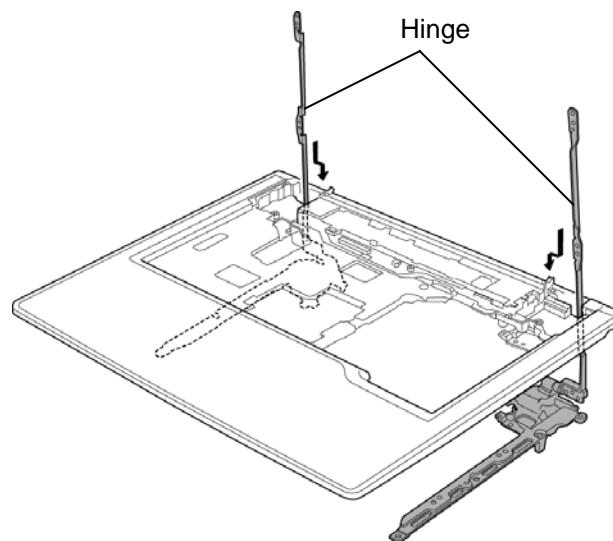

Figure 4-51 Removing Hinges

Installing the Wireless LAN antenna/Speaker/Hinge

The following describes the procedure for installing the wireless LAN antenna, speaker and hinge (See Figure 4-44 to 4-52).

CAUTION: When installing the speakers, be careful not to touch the metal part of the speakers. It might damage the speakers.

1. Install the **hinges** to the **display assembly** and secure them with the following **screws**.

- M2.5x4B THIN BIND screw x3 (Right:1, Left: 2)

2. Attach sponges on both the side of each speaker.

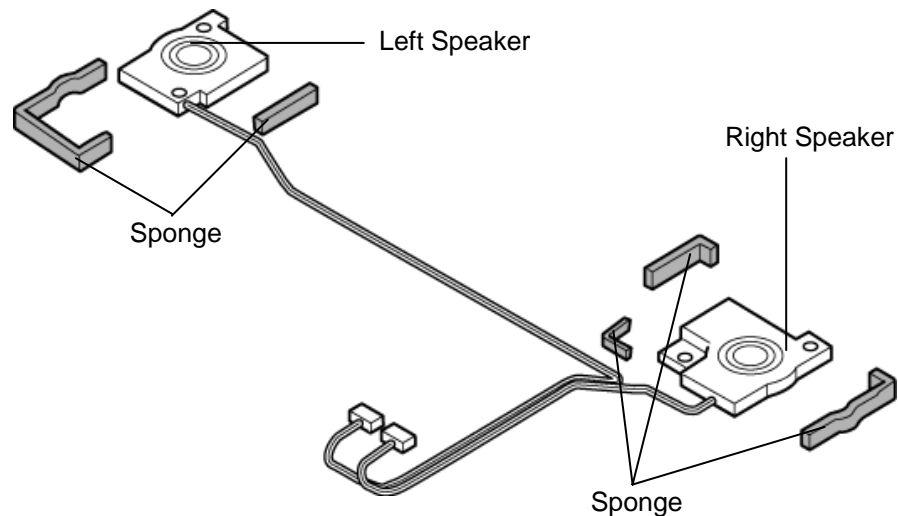

Figure 4-52 Attaching sponges

3. Set the **left speaker** on the base assembly. Pass the **left speaker cable (blue)** along the guide on the front of the display assembly and run toward the back side. Secure the cable with four insulators.
4. Set the **right speaker** on the base assembly and pass the **right speaker cable (red)** toward the back side of the base assembly.
5. Arrange the speaker cables (blue and red) along the guides. Pass the cables under the **insulator** and secure them with **acetate tapes**. Insert the insulator end under the **hinge**.

6. Install the **optical drive cover** and secure it with the following **screws**. When installing, insert the “A” portion (in the figure) first.
 - M2.5x2.8B U-THIN BIND screw x3
 - M2.5x4B THIN BIND screw x2

7. Install the **display cover** on the display assembly. Secure the **hinges** and the display cover with the following **screws**.
 - M2.5x6C PSP TIGHT screw x4
 - M2x5C SUPER THIN screw x2

8. Fit the **wireless LAN antennas** to the lines on the back side of the display cover. Pass the **wireless LAN antenna cables** and secure them with eight **glass tapes**.
[If Sharp-made LCD is installed] Stick two **sponges** along the guide of the display assembly.
[If LG Philips-made LCD is installed] Stick one **gasket** and two **aluminum tapes** along the guide of the display assembly.

9. Pass the wireless LAN antenna cables to the back side of the display assembly.

10. Install the **LCD harness** and **LCD harness holder** on it. Secure the plate with the following **screw**. When installing the LCD harness holder, hook the right projection to the edge of the chassis and secure the cable with the insulator.
 - M2x4Z SUPER THIN screw x1

11. Install the right and left **hinge caps** and secure them with the following **screws**.
 - M2.5x6B THIN BIND screw x2

12. Pass the wireless LAN antenna cable to the back side of the base assembly and arrange them along the guides. Pass the cables to the center of the base assembly.

4.23 Fluorescent Lamp

This system uses LCD modules from the following suppliers. The procedure for replacing the fluorescent lamp is different for each LCD module. Refer to the appropriate procedure.

Type	Part No.	Supplier	Section
15.0 inch (XGA)	G33C0002W110	Samsung	4.23.1
	G33C0002Y110	Sharp	4.23.2
	G33C00030110	LG.Philips	4.23.3
15.0 inch (SXGA+)	G33C0001X210	LG.Philips	4.23.4

NOTE: - When working with a LCD module, always use a flat, grounded table.

- (1) Handle the backlight unit in the environment without dust, such as on the clean bench. Keep the worktable free from any screws or other material that may scratch the LCD surface.
- (2) Use an anti-static or protective sheet.
- (3) When replacing the FL unit, cover with a finger protector or similar to prevent dirtying or scratching the LCD panel.
- (4) Take care when handling the lamp. Excessive force may break the lamp.
- (5) Take care not to dirty or deform the lamp reflector.
- (6) Ensure always that the power of the LCD module is turned off before connecting or disconnecting cables and connectors.

4.23.1 Replacing the 15.0 Inch XGA Samsung Fluorescent Lamp

Disassembling the 15.0 Inch XGA Samsung Fluorescent Lamp

To disassemble the 15.0 inch XGA Samsung fluorescent lamp, follow the steps below and refer to figures 4-53 to 4-61.

1. Remove the PCB cover.

NOTE: When removing the PCB cover, be careful not to damage the COF.

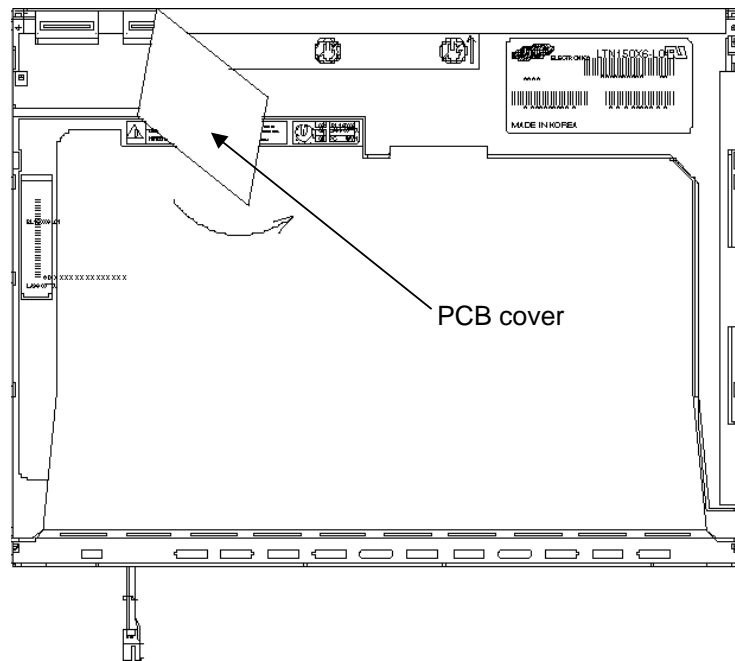

Figure 4-53 Replacing 15.0 Inch Samsung fluorescent lamp (XGA) (1)

2. Remove the two screws.

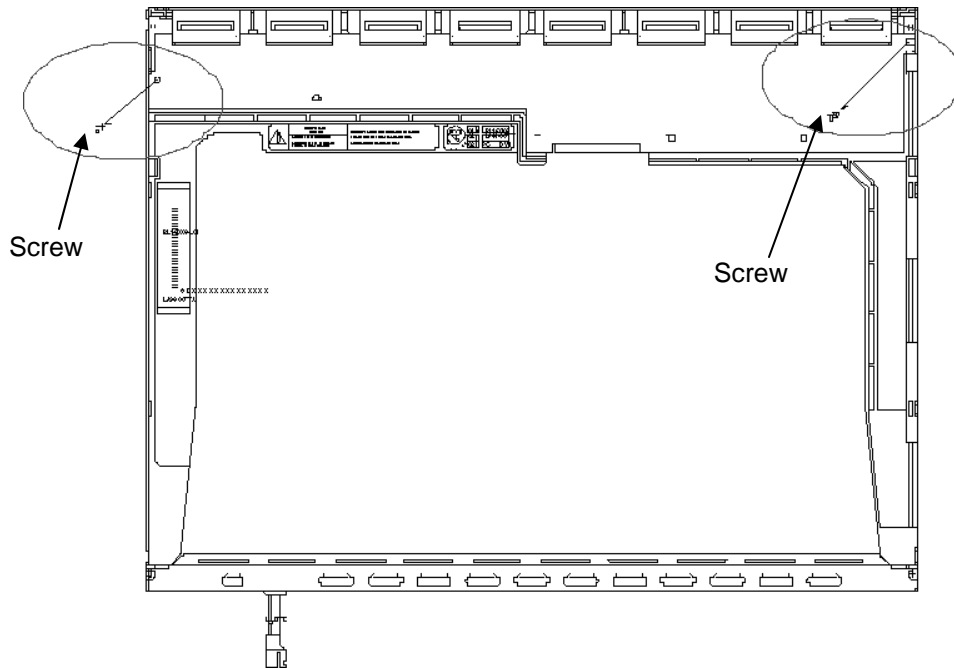

Figure 4-54 Replacing 15.0 Inch Samsung fluorescent lamp (XGA) (2)

3. Remove the four screws from the top chassis.

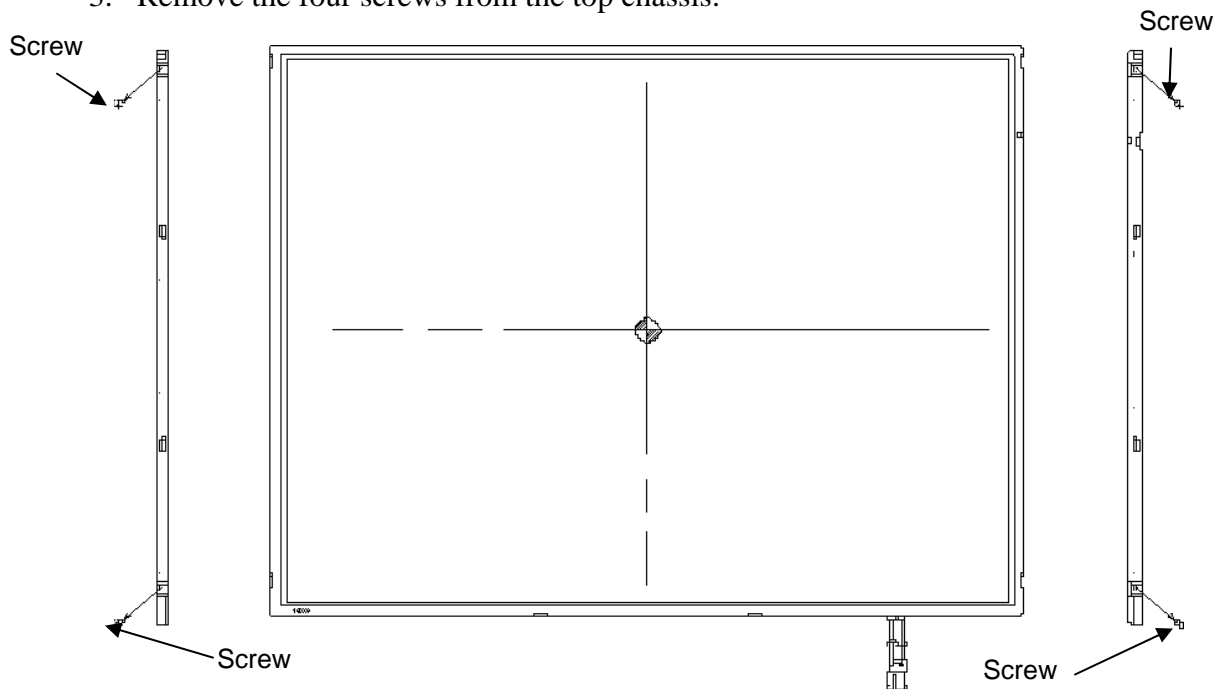

Figure 4-55 Replacing 15.0 Inch Samsung fluorescent lamp (XGA) (3)

4. Remove the four bottom hooks and four side hooks (left and right). Then remove the top chassis from the mold frame.

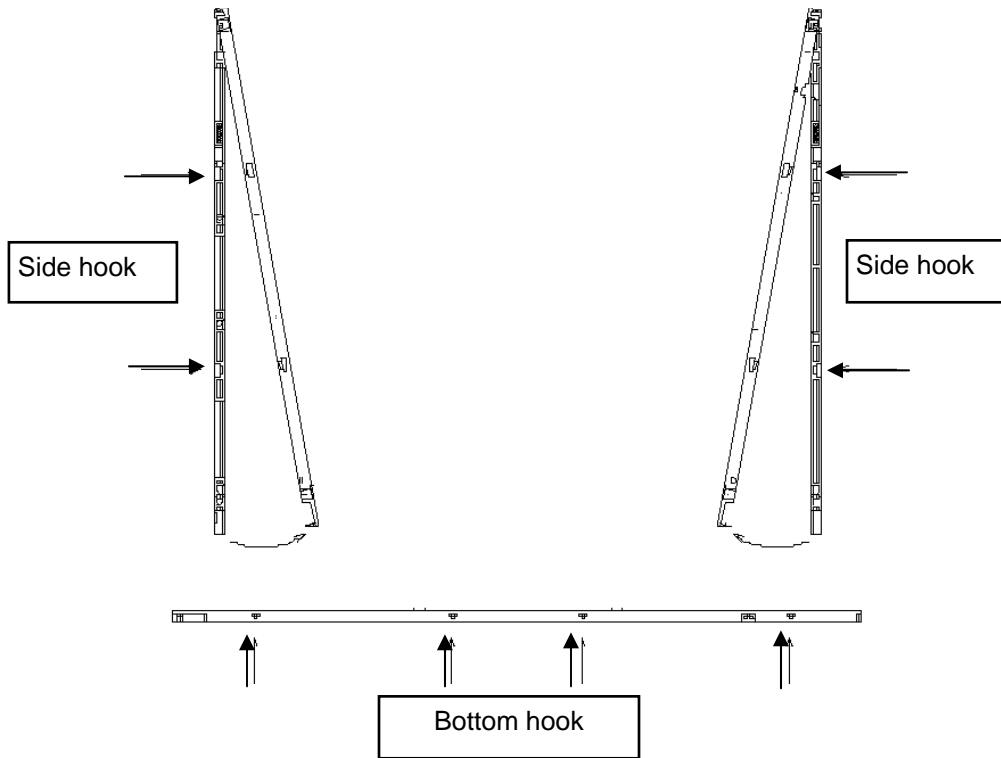

Figure 4-56 Replacing 15.0 Inch Samsung fluorescent lamp (XGA) (4)

5. Remove the panel assembly from the mold frame.

NOTE: When removing the panel assembly, be careful not to damage the COF.

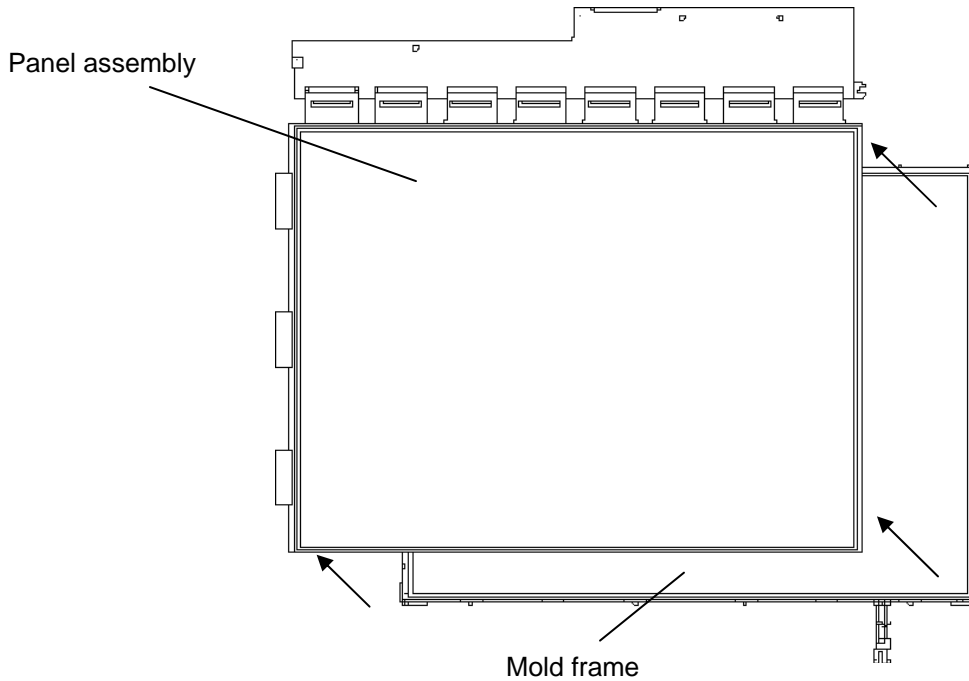

Figure 4-57 Replacing 15.0 Inch Samsung fluorescent lamp (XGA) (5)

6. Remove the sheets and clips.
 - 1) Remove the two clips fixing the sheets.
 - 2) Remove the sheets (protection sheet, prism sheet (L, U), diffusion sheet, LGP and reflection sheet).

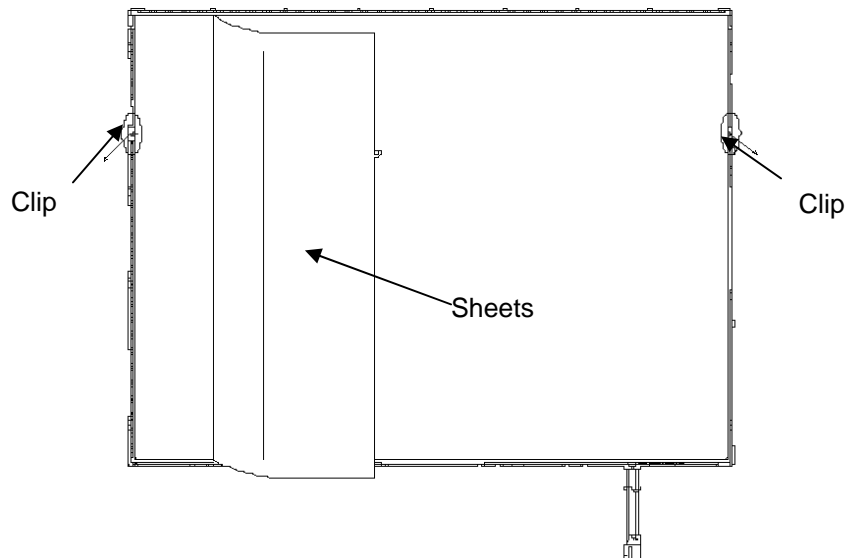

Figure 4-58 Replacing 15.0 Inch Samsung fluorescent lamp (XGA) (6)

7. Remove the lamp back cover.
 - 1) Remove the two screws from the lamp back cover.
 - 2) Remove the lamp back cover.

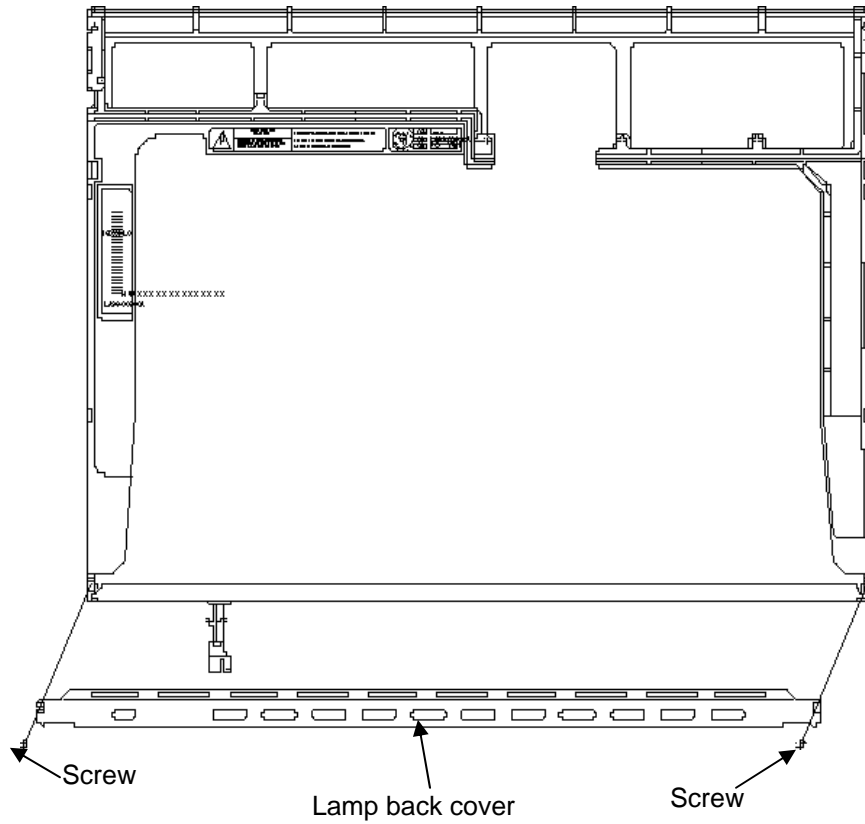

Figure 4-59 Replacing 15.0 Inch Samsung fluorescent lamp (XGA) (7)

8. Remove the lamp wire from the wire guide of the mold frame.

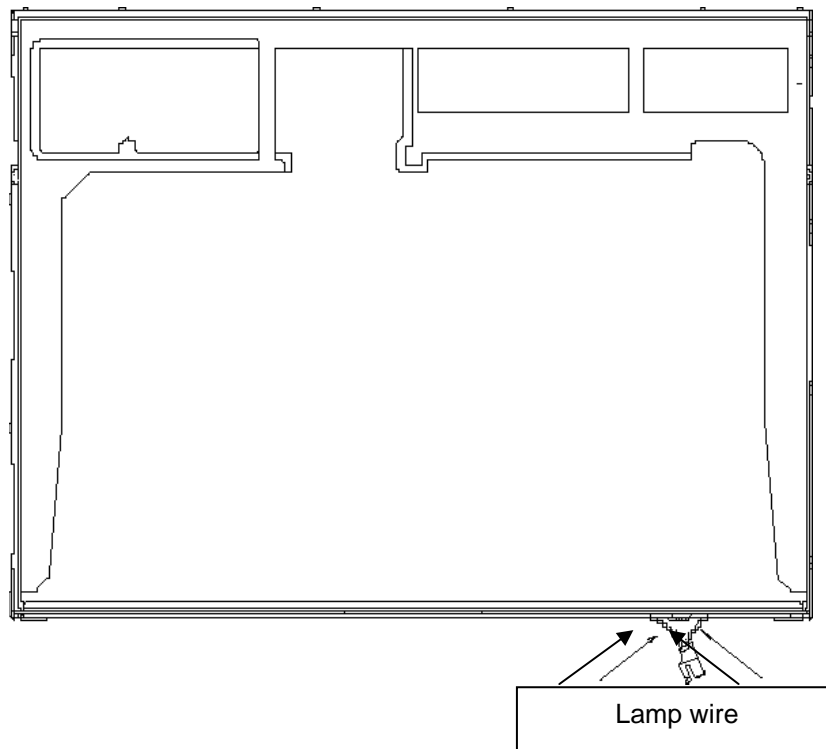

Figure 4-60 Replacing 15.0 Inch Samsung fluorescent lamp (XGA) (8)

9. Remove the lamp assembly from the mold frame.

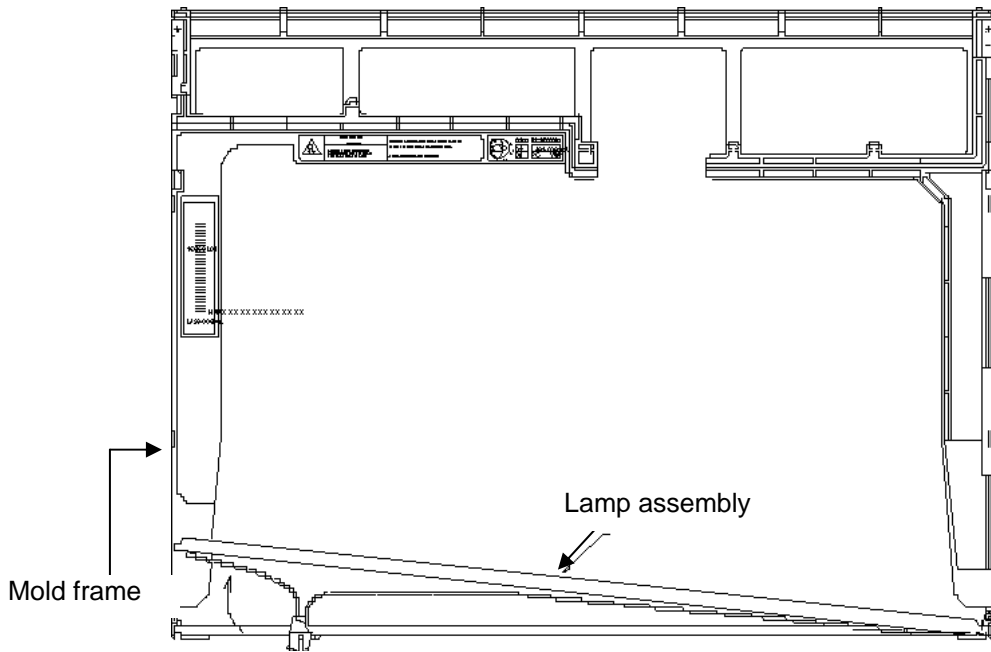

Figure 4-61 Replacing 15.0 Inch Samsung fluorescent lamp (XGA) (9)

Assembling the 15.0-inch XGA Samsung Fluorescent Lamp

The assembly procedure of the 15.0-inch XGA Samsung fluorescent lamp is the reverse of the above disassembly procedure.

4.23.2 Replacing the 15.0 Inch XGA Sharp Fluorescent lamp

Disassembling the 15.0 Inch XGA Sharp Fluorescent lamp

To disassemble the 15.0-inch XGA Sharp fluorescent lamp, follow the steps below and refer to Figures 4-62 to 4-71.

1. Turn the LCD module face down, and remove the protection cover S (A), protection cover G (B), fixing tape (C) and fixing tape for lead wire (D).

NOTE: 1) Be careful not to damage the TCP or chips.
2) The protection cover G is reused. Discard the other tapes removed.

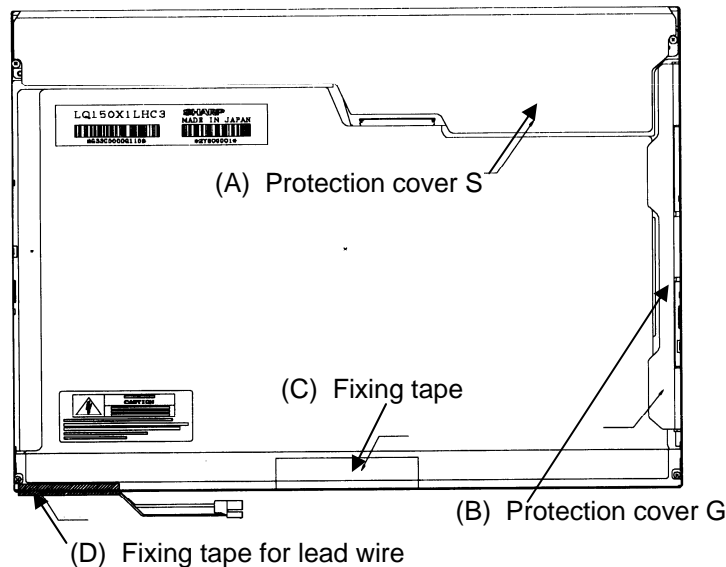

Figure 4-62 Replacing 15.0 Inch Sharp fluorescent lamp (XGA) (1)

- Remove the four screws on the sides.

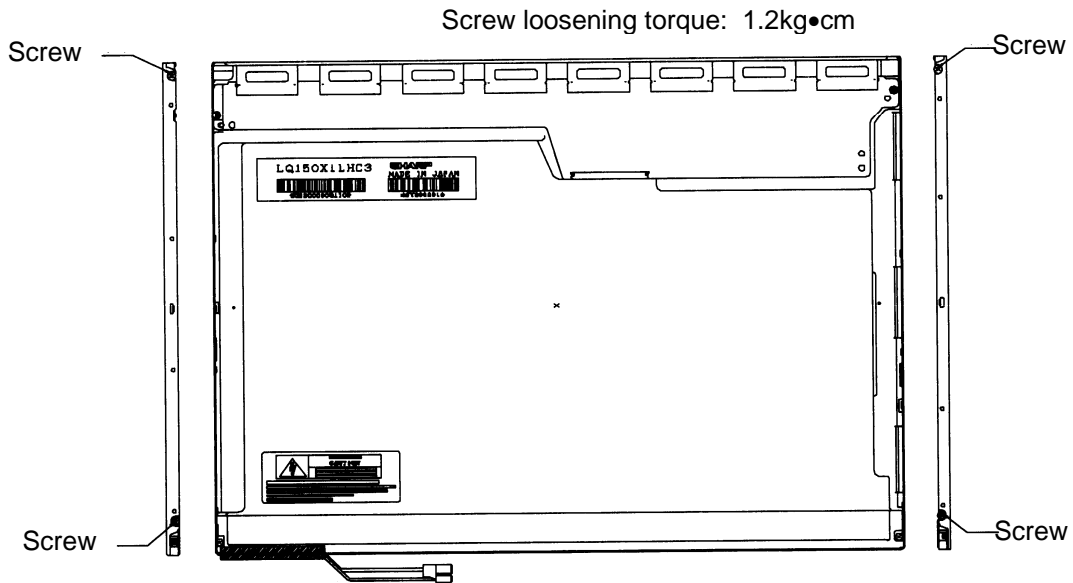

Figure 4-63 Replacing 15.0 Inch Sharp fluorescent lamp (XGA) (2)

- Turn the LCD module face up and remove the bezel (E).

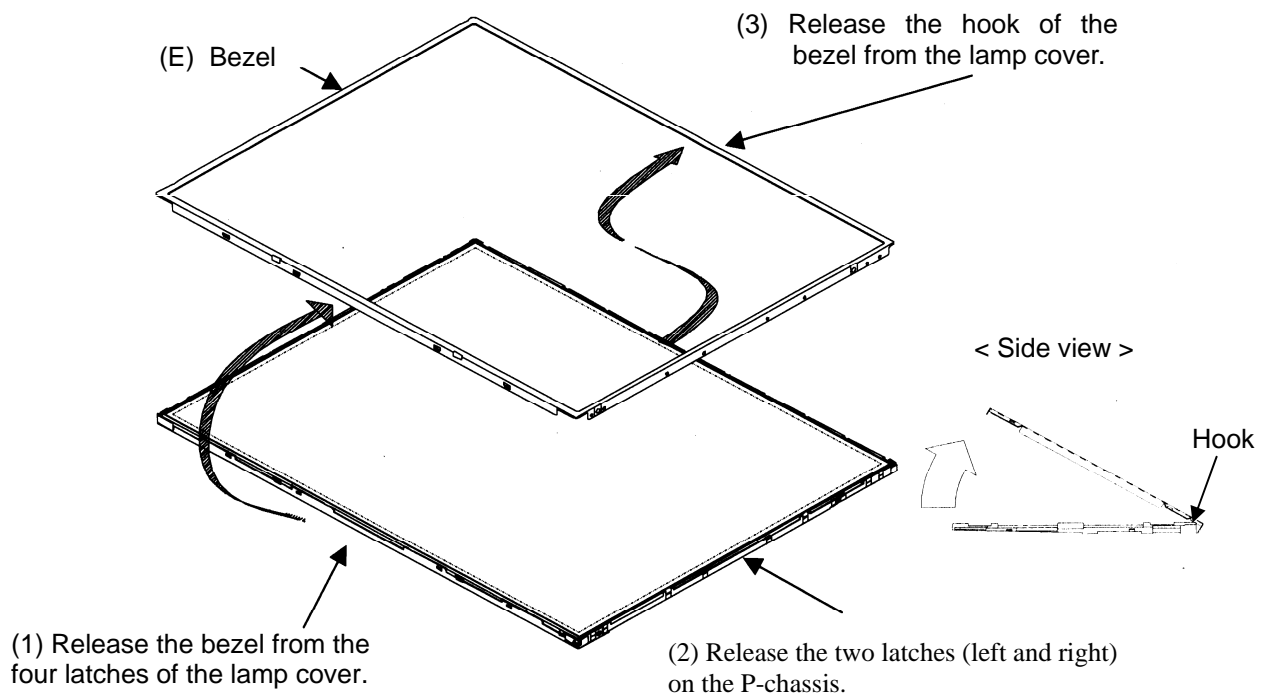

Figure 4-64 Replacing 15.0 Inch Sharp fluorescent lamp (XGA) (3)

4. Turn the LCD module face down and remove the two screws fixing the board. Then open the bent portion of the TCP of the board and remove the backlight.

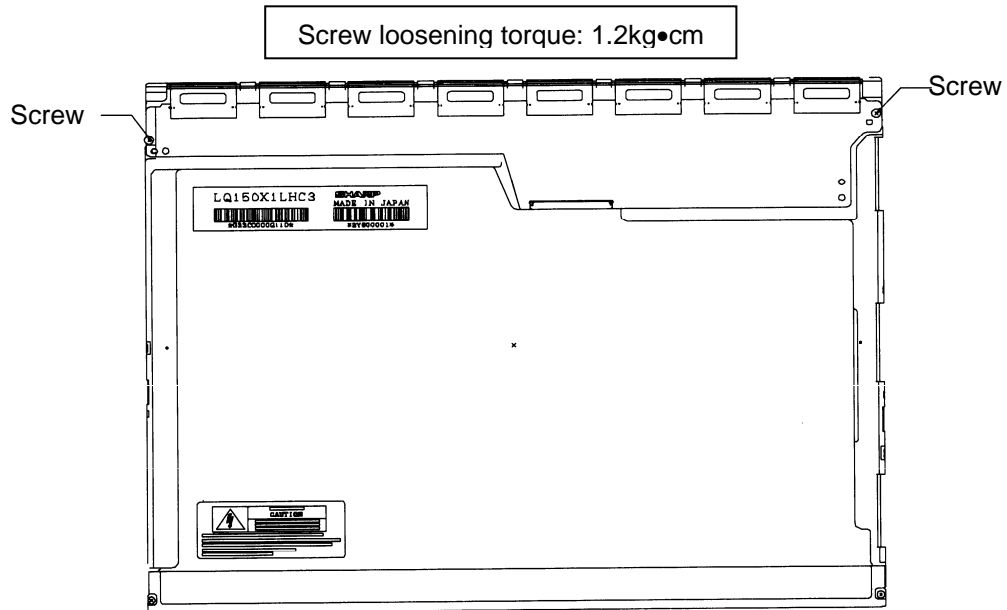

Figure 4-65 Replacing 15.0 Inch Sharp fluorescent lamp (XGA) (4)

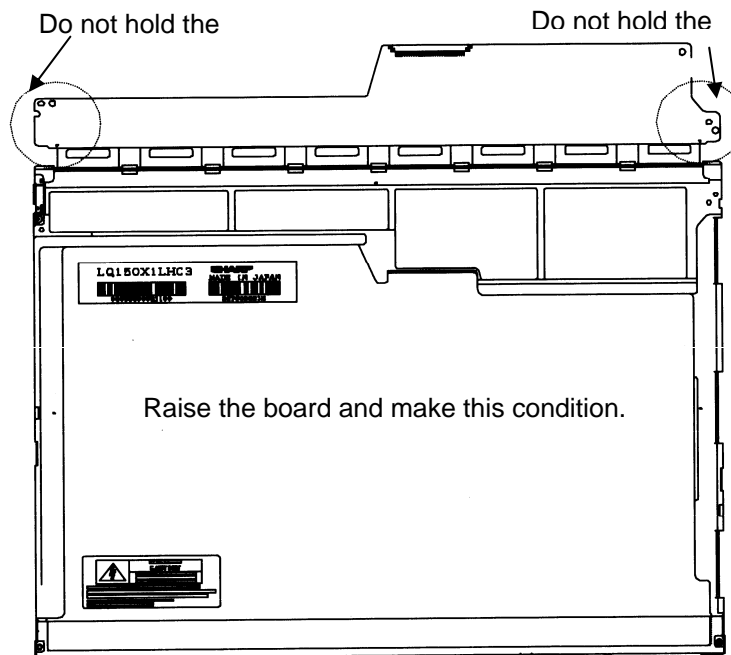

Figure 4-66 Replacing 15.0 Inch Sharp fluorescent lamp (XGA) (5)

5. Turn the LCD module face up and remove the LCD panel (I) from the backlight unit (H).

CAUTION: Wear finger sacks or gloves during the work not to soil or scratch the LCD panel or backlight unit.

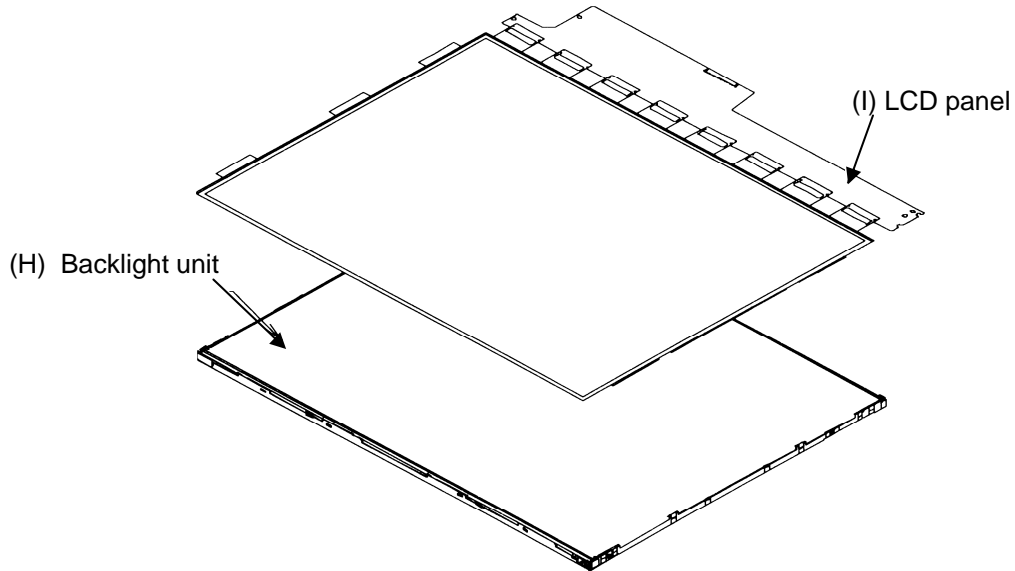

Figure 4-67 Replacing 15.0 Inch Sharp fluorescent lamp (XGA) (6)

- Turn the backlight unit (H) removed face down and remove the two screws (D) and lamp cover (J).

NOTE: Be careful not to scratch or soil the sheets.

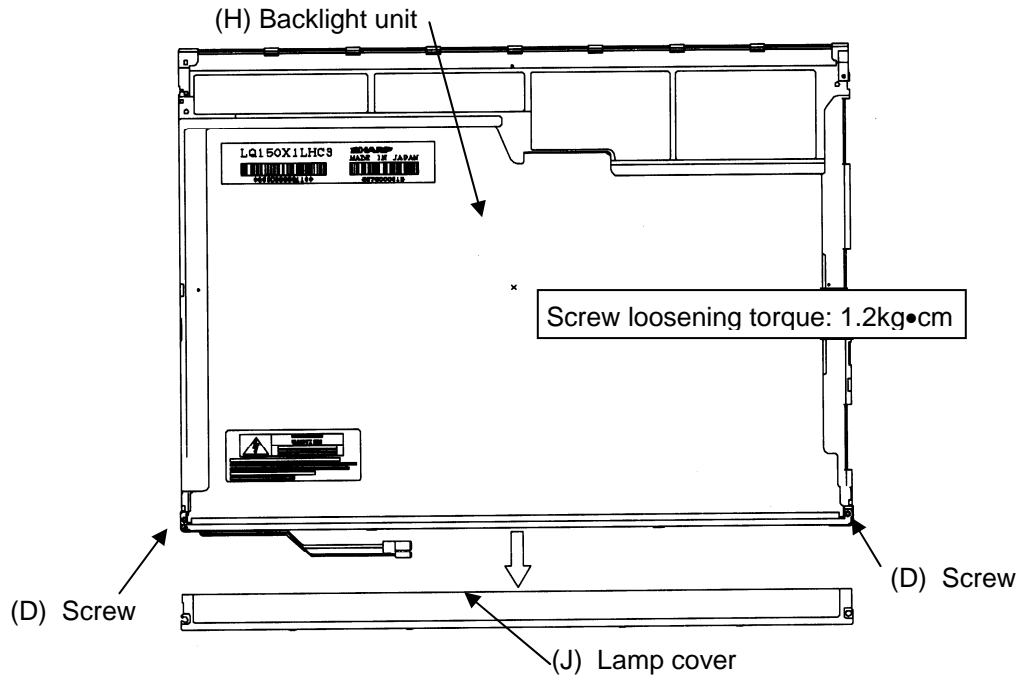

Figure 4-68 Replacing 15.0 Inch Sharp fluorescent lamp (XGA) (7)

7. Turn the backlight unit face up and remove the upper diffusion sheet (K), lens sheet (L) and light guide (M).

NOTE: Be careful not to scratch or soil the removed sheets or light guide to reuse them.

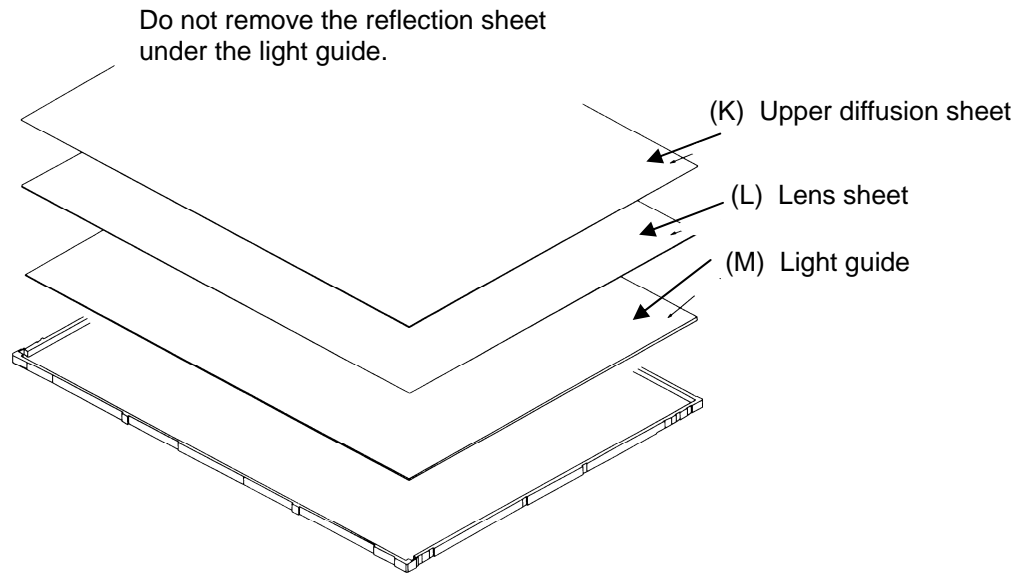

Figure 4-69 Replacing 15.0 Inch Sharp fluorescent lamp (XGA) (8)

8. Remove the four double-sided tapes (N, O, P, Q).

NOTE: Discard the removed tapes. Do not reuse them.

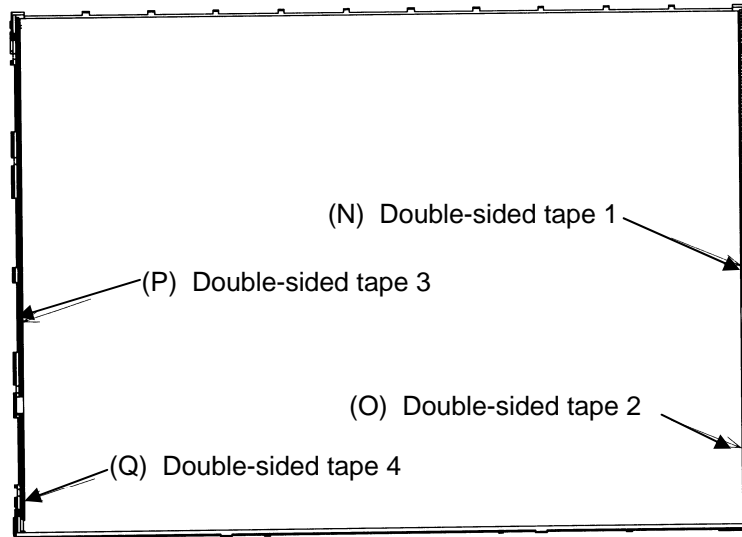

Figure 4-70 Replacing 15.0 Inch Sharp fluorescent lamp (XGA) (9)

9. Turn the backlight unit face down and remove the lamp unit (R) from the P-chassis.

CAUTION: When removing the lamp unit, be careful not to break the lamp, or bend the reflection sheet.

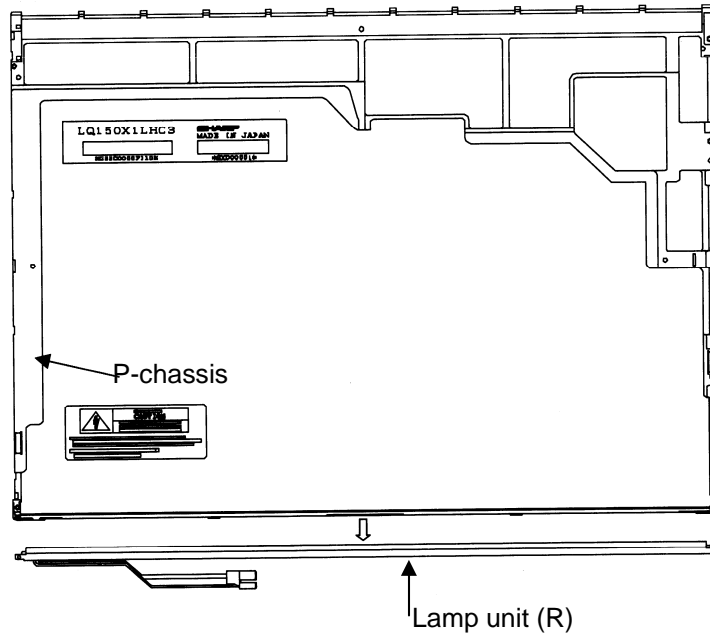

Figure 4-71 Replacing 15.0 Inch Sharp fluorescent lamp (XGA) (10)

Assembling the 15.0 Inch XGA Sharp Fluorescent Lamp

To assemble the 15.0-inch Sharp XGA fluorescent lamp, follow the steps below and refer to Figures 4-72 to 4-84.

1. Stick the four double-sided tapes (N, O, P, Q) on the P-chassis.

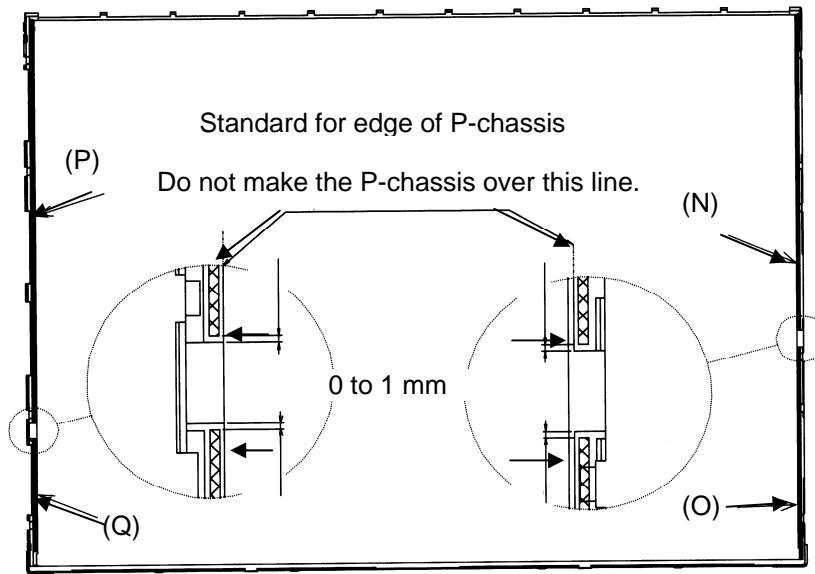

Figure 4-72 Replacing 15.0 Inch Sharp fluorescent lamp (XGA) (11)

2. Turn the backlight unit face down and install a new lamp unit (R) on the P-chassis.

NOTE: When install the lamp unit (R), be careful not to bend or damage the reflection sheet.

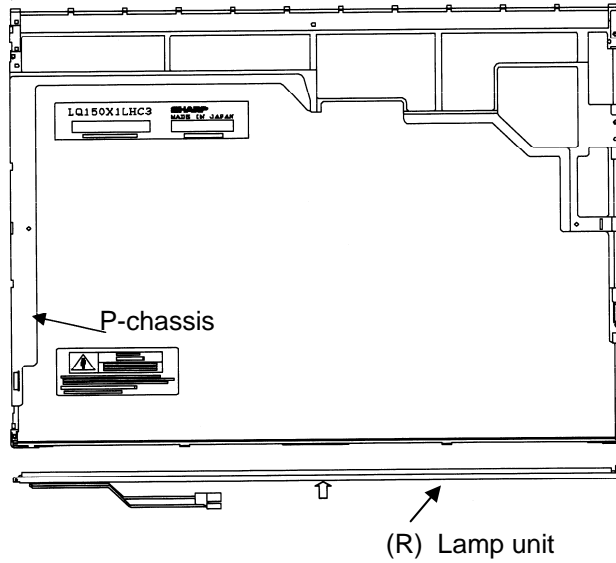
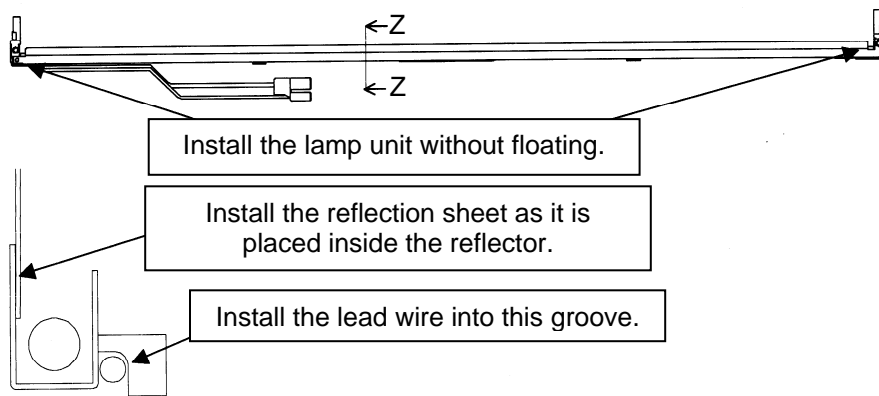

Figure 4-73 Replacing 15.0 Inch Sharp fluorescent lamp (XGA) (12)



Cross-section drawing of Z-Z

Figure 4-74 Replacing 15.0 Inch Sharp fluorescent lamp (XGA) (13)

3. Install the lamp cover (J) on the backlight unit and secure it with the two screws (D).

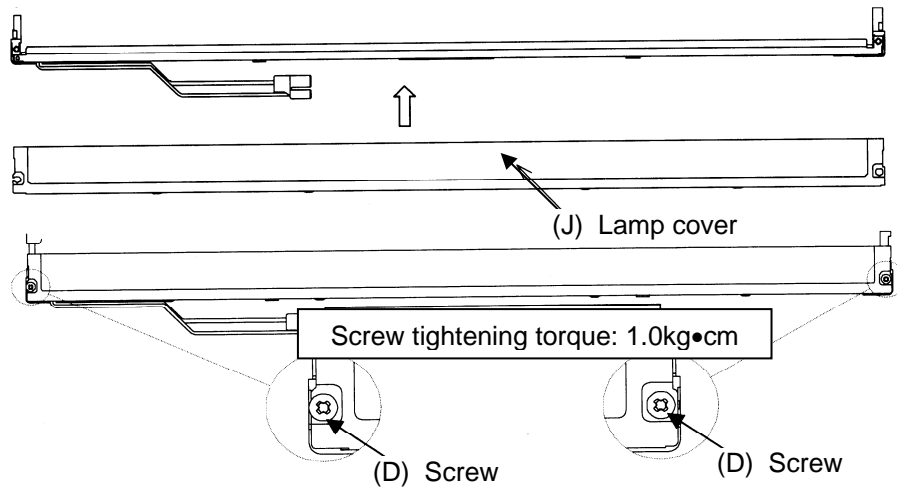

Figure 4-75 Replacing 15.0 Inch Sharp fluorescent lamp (XGA) (14)

4. Install the light guide (M) on the backlight unit.

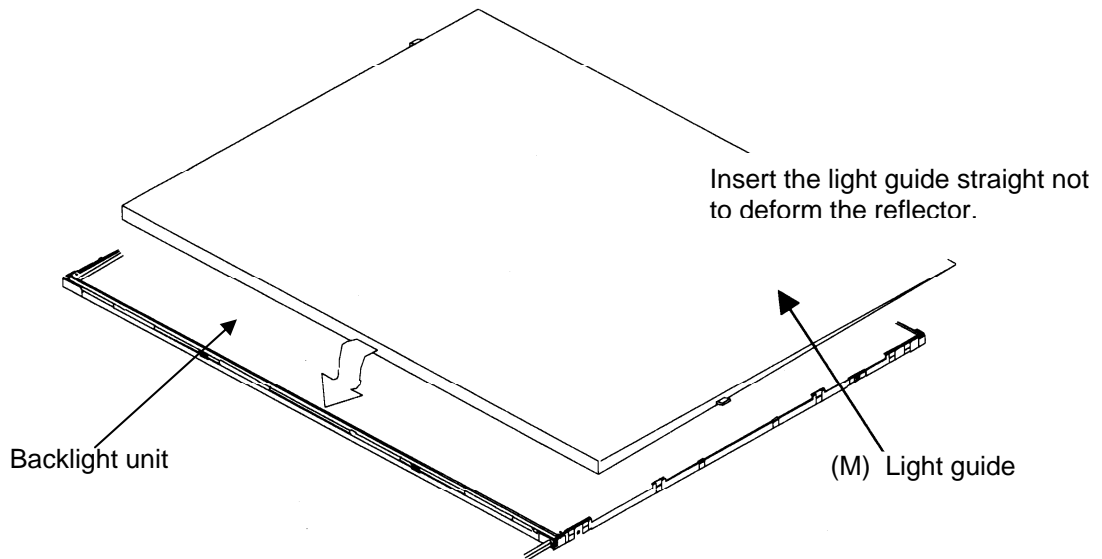

Figure 4-76 Replacing 15.0 Inch Sharp fluorescent lamp (XGA) (15)

5. Place the lens sheet (L) and upper diffusion sheet (K) on the backlight unit with light guide(M).

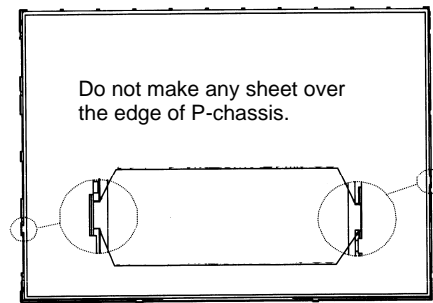
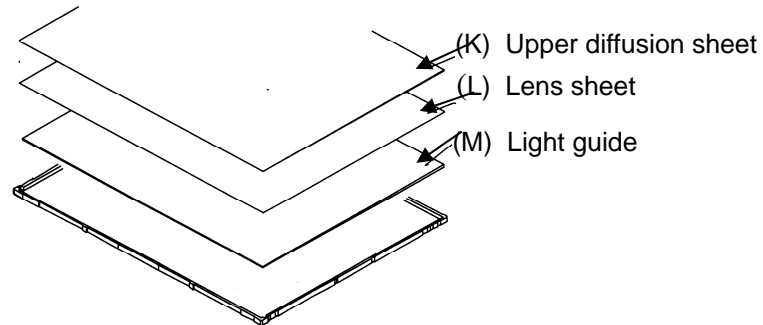

Figure 4-77 Replacing 15.0 Inch Sharp fluorescent lamp (XGA) (16)

6. Place the LCD panel (I) on the backlight unit (H).

NOTE: Make sure there is no dust between the LCD panel and backlight unit. If any dust is found, remove it with crepe tape or others which has no remaining of paste.

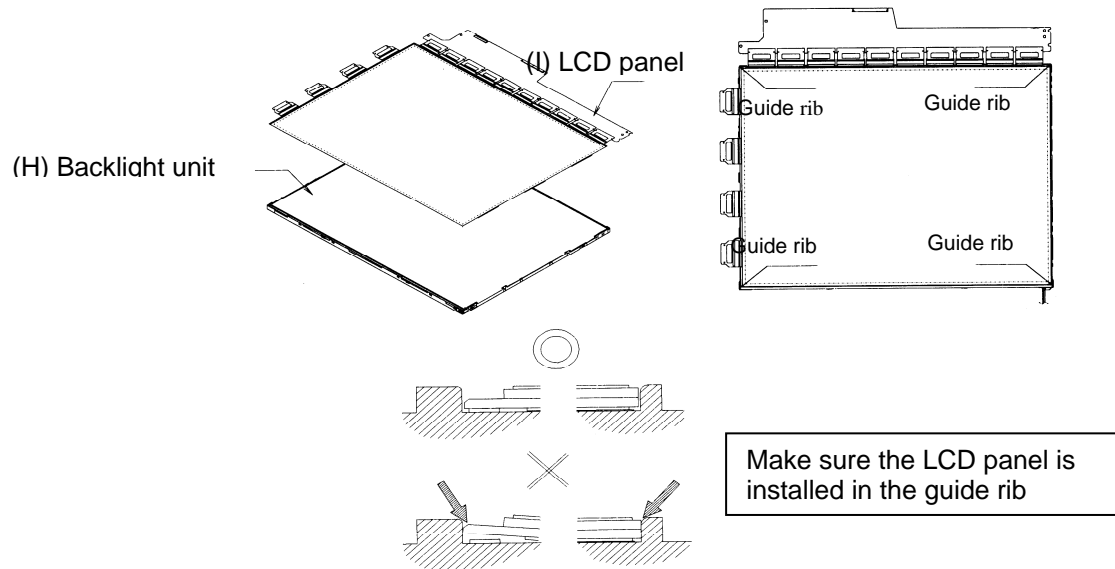

Figure 4-78 Replacing 15.0 Inch Sharp fluorescent lamp (XGA) (17)

7. Bend the TCP attaching to the source board and secure it with the two screws.

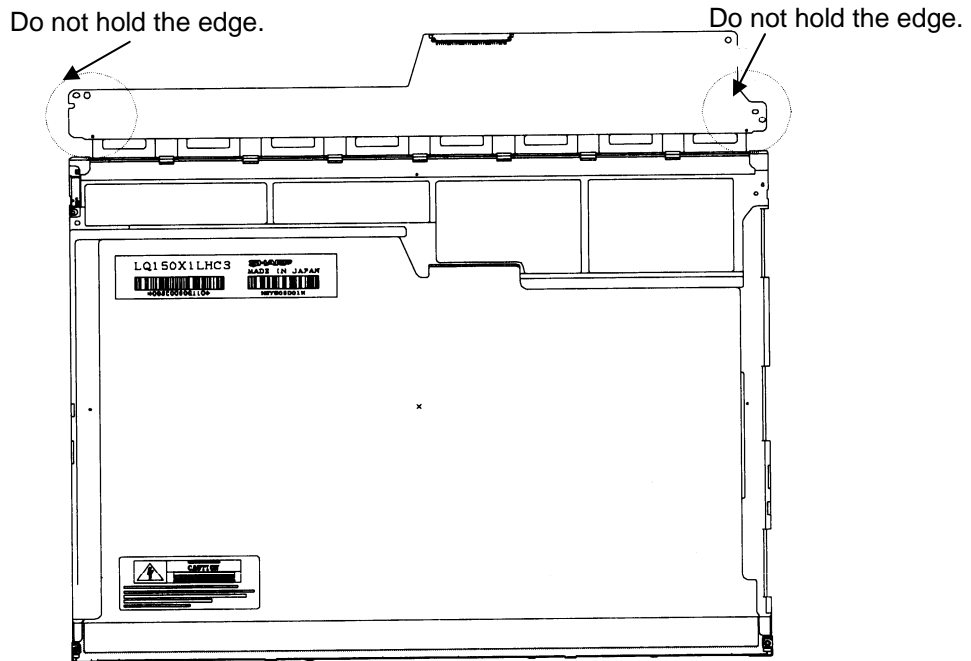

Figure 4-79 Replacing 15.0 Inch Sharp fluorescent lamp (XGA) (18)

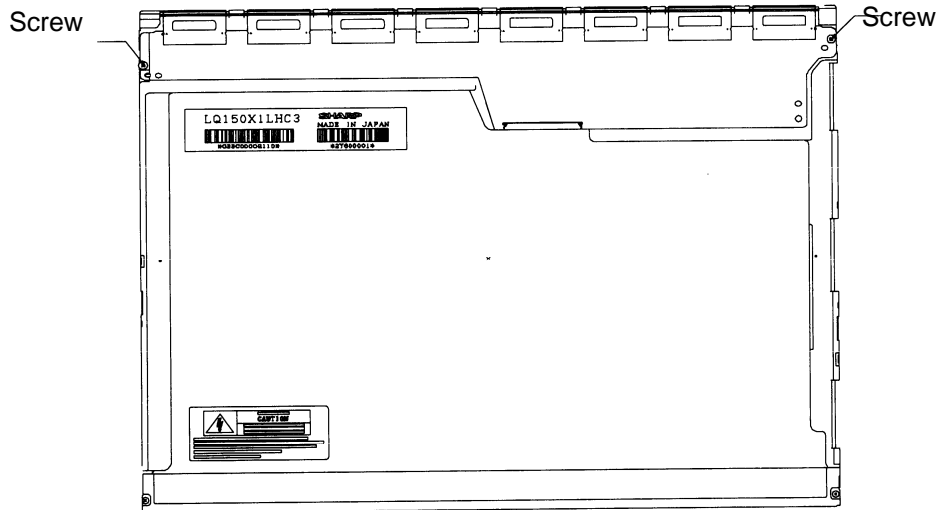
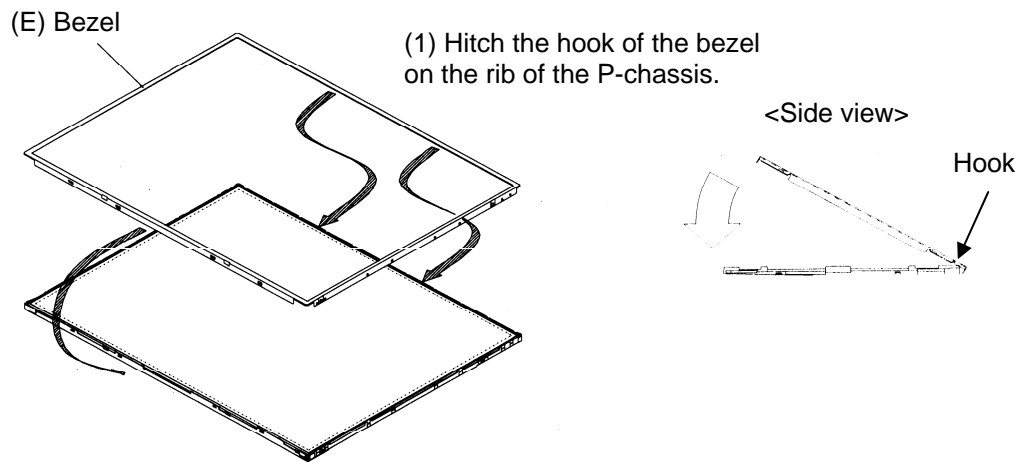

Figure 4-80 Replacing 15.0 Inch Sharp fluorescent lamp (XGA) (19)

8. Install the bezel (E) on the lamp cover and hook the four latches on the lamp cover and two latches on the P-chassis.



- (2) Lean the bezel on the lamp cover without interference with the TCP.

Figure 4-81 Replacing 15.0 Inch Sharp fluorescent lamp (XGA) (20)

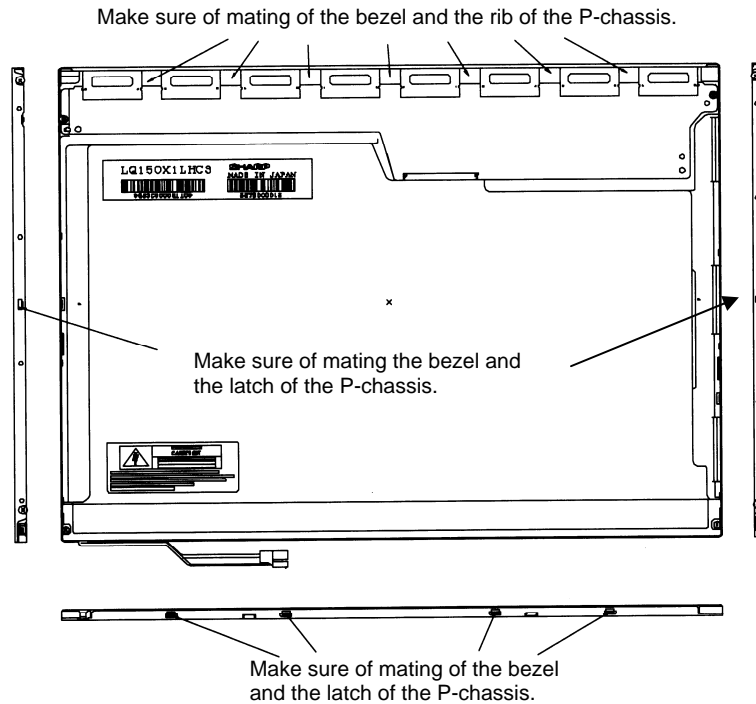

Figure 4-82 Replacing 15.0 Inch Sharp fluorescent lamp (XGA) (21)

9. Secure the sides of the unit with the four screws.

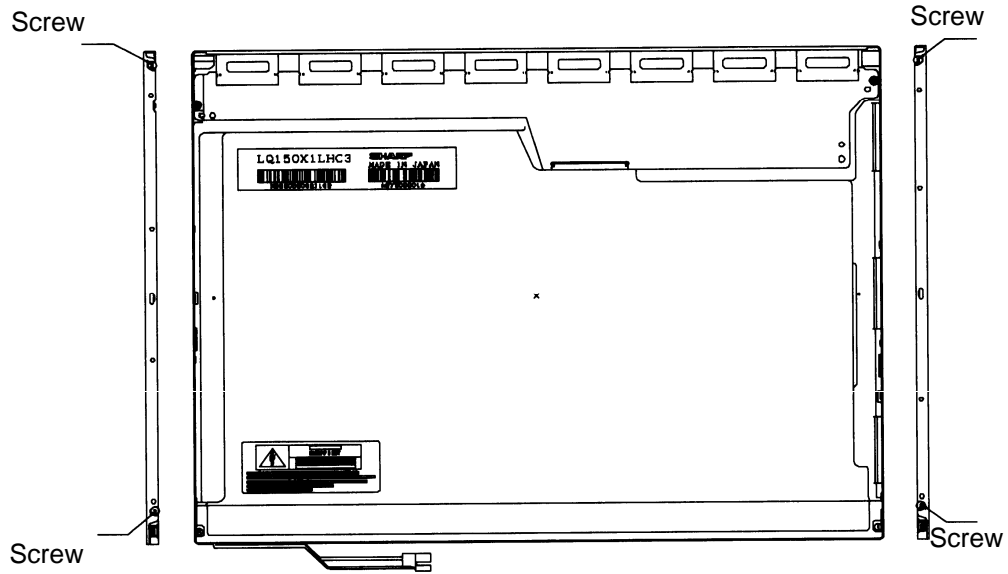

Figure 4-83 Replacing 15.0 Inch Sharp fluorescent lamp (XGA) (22)

10. Stick the protection cover G (B), protection cover S (A), fixing tape (C) and fixing tape for lead wire (D).

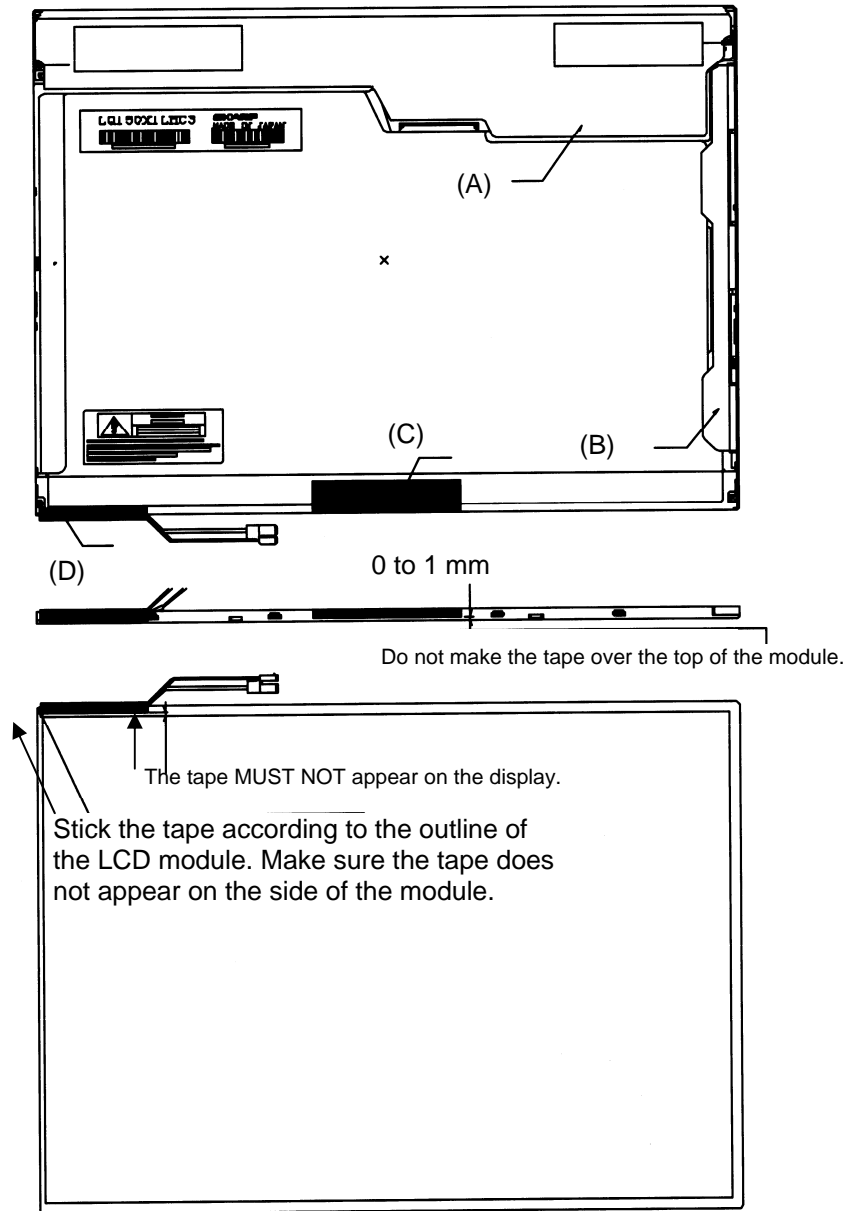

Figure 4-84 Replacing 15.0 Inch Sharp fluorescent lamp (XGA) (23)

4.23.3 Replacing the 15.0 Inch XGA LG.Philips Fluorescent lamp

CAUTION: When replacing the fluorescent lamp, wear finger covers or gloves to avoid contaminating or damaging the LCD panel. Be careful not to let dust or other foreign substance into the module.

Disassembling the 15.0 Inch XGA LG.Philips Fluorescent lamp

To disassemble the 15.0-inch XGA LG.Philips fluorescent lamp, follow the steps below and refer to Figures 4-85 to 4-88.

1. Remove the outside tape and cover shield.
 - 1) Remove the adhesive tape fixing the B/L wire and Top case. Be careful not to apply to the B/L wire.
 - 2) Remove the cover shield (G). Be careful not to apply excessive force to the gate COF and source PCB.

CUATION: Wear anti-static gloves to prevent circuit damage caused by ESC.

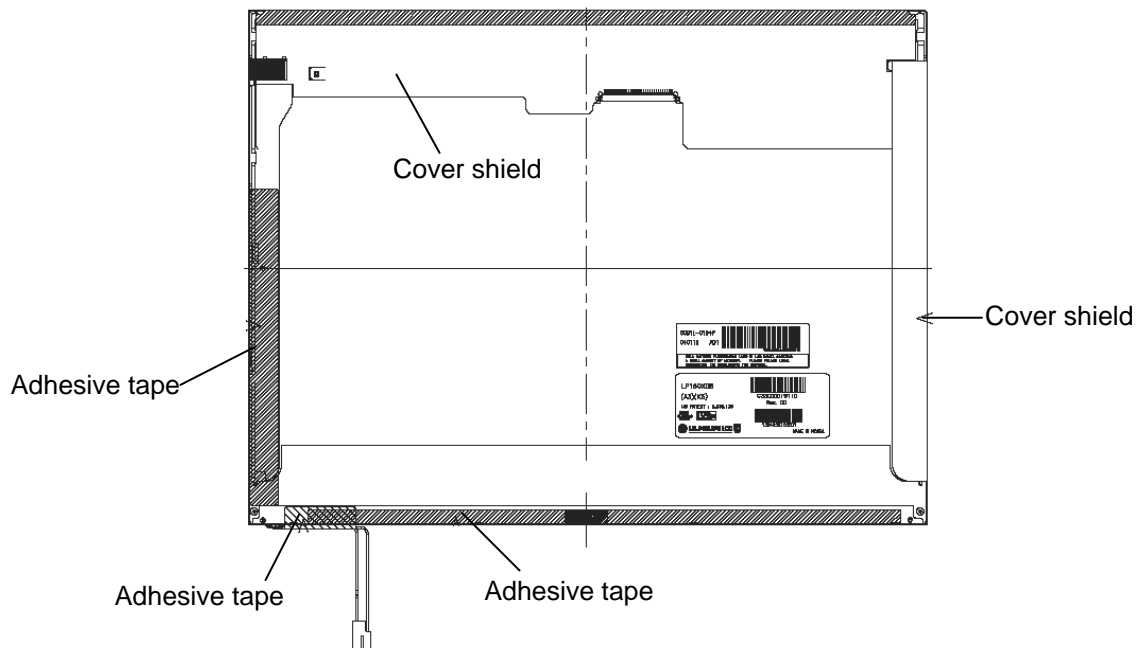

Figure 4-85 Replacing 15.0 Inch LG.Philips fluorescent lamp (XGA) (1)

2. Remove the top case. Be careful not to apply excessive force to the source TCP and gate COF.

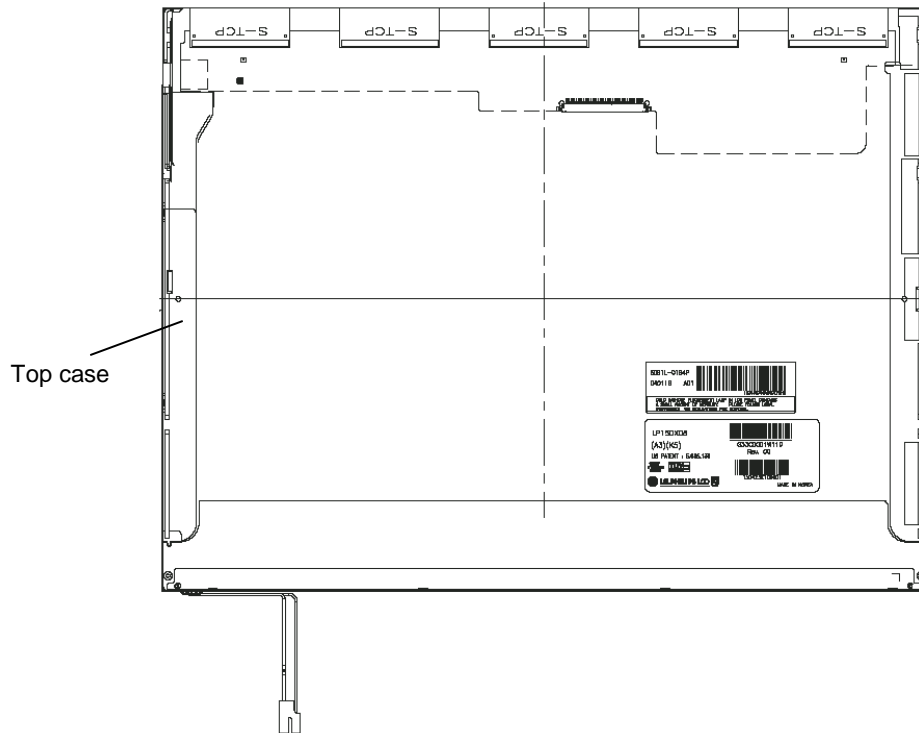

Figure 4-86 Replacing 15.0 Inch LG.Philips fluorescent lamp (XGA) (2)

3. Remove the source PCB.
 - 1) Remove the source PCB. Be careful not to apply excessive force to the PCB and TCP.

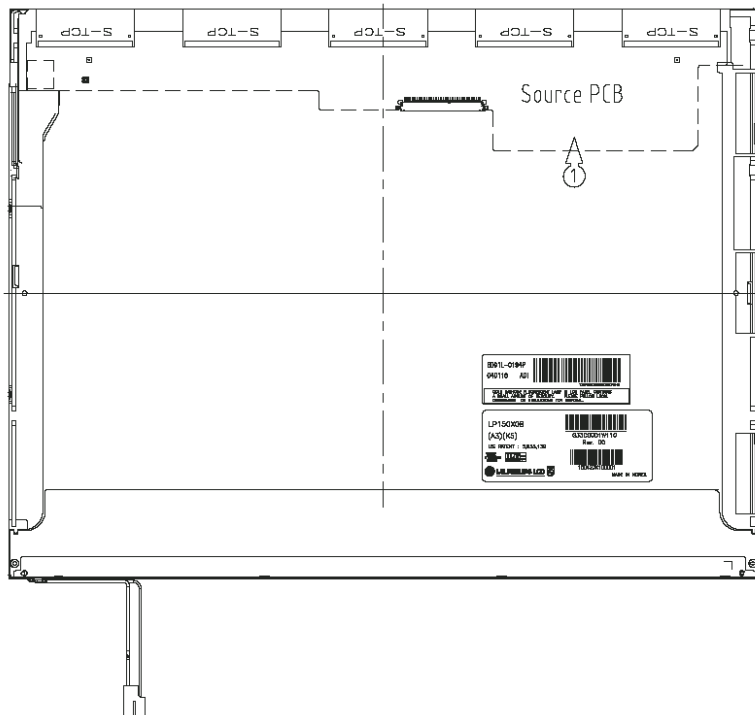

Figure 4-87 Replacing 15.0 Inch LG.Philips fluorescent lamp (XGA) (3)

4. Remove the board assembly, adhesive tape, light guide and cover assembly bottom.

- 1) Remove the board assembly.
- 2) Remove the adhesive tape securing the sheets (four points).
- 3) Remove the sheets and light guide.

NOTE: No penetration of foreign object is indispensable not to scratch the sheets.

- 4) Remove the screw and cover assembly bottom.

NOTE: Maximum value of torque is 1.5kg•cm.

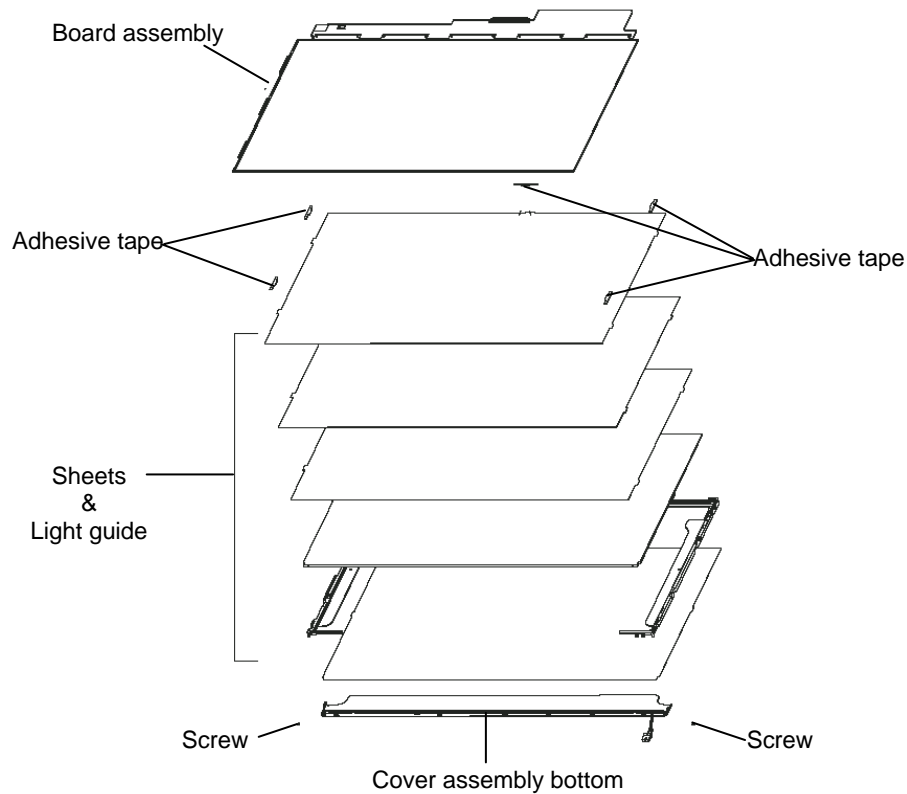

Figure 4-88 Replacing 15.0 Inch LG.Philips fluorescent lamp (XGA) (4)

Assembling the 15.0-inch XGA LG.Philips Fluorescent lamp

To assemble the 15.0-inch XGA LG.Philips fluorescent lamp, follow the steps below and refer to Figures 4-89 to 4-92.

1. Install the cover assembly bottom, sheets, light guide, adhesive tape and board assembly.
 - 1) Secure the cover assembly bottom with the two screws.
 - 2) Install the light guide and sheets. (Secure the reflection sheets with double-sided tape.)

NOTE: No penetration of foreign object is indispensable not to scratch the surface of the sheets.

- 3) Stick the adhesive tape to fix the sheets.
- 4) Install the board assembly.

NOTE: Do not apply excessive force to the PCB and TCP.

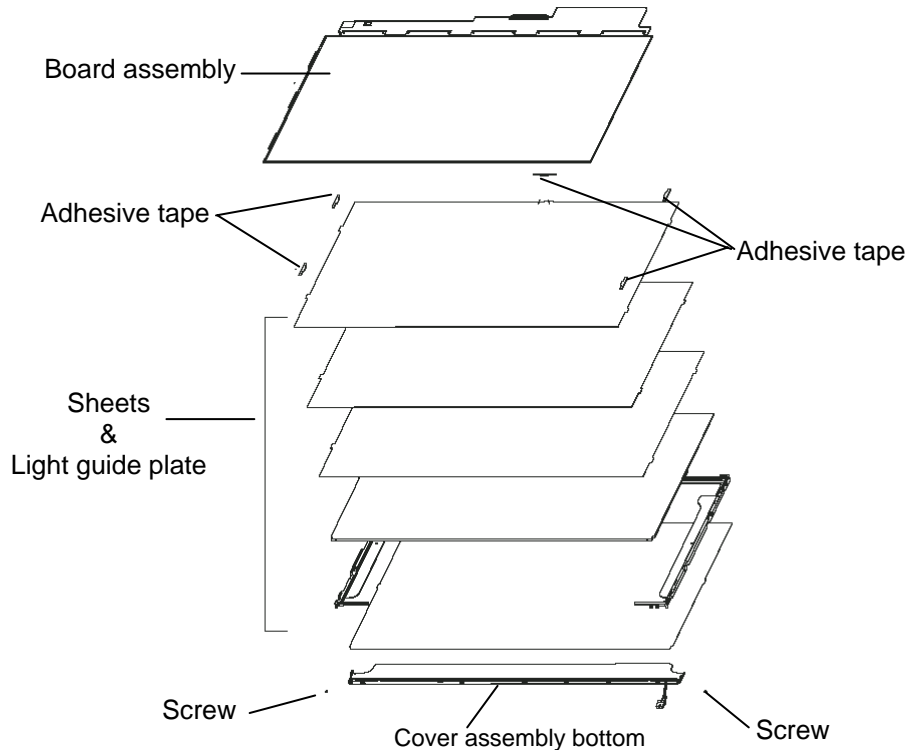

Figure 4-89 Replacing 15.0 Inch LG.Philips fluorescent lamp (XGA) (5)

2. Install the source PCB.

- 1) Install the source PCB. Be careful not to apply excessive force to the TCP.

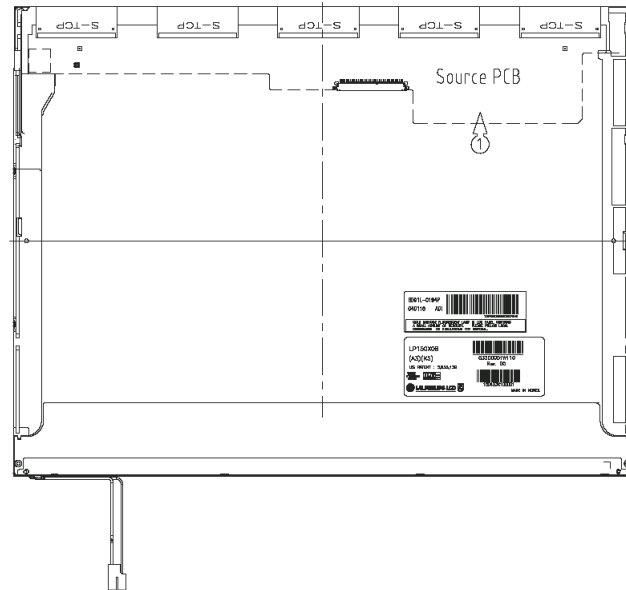

Figure 4-90 Replacing 15.0 Inch LG.Philips fluorescent lamp (XGA) (6)

3. Install the top case.

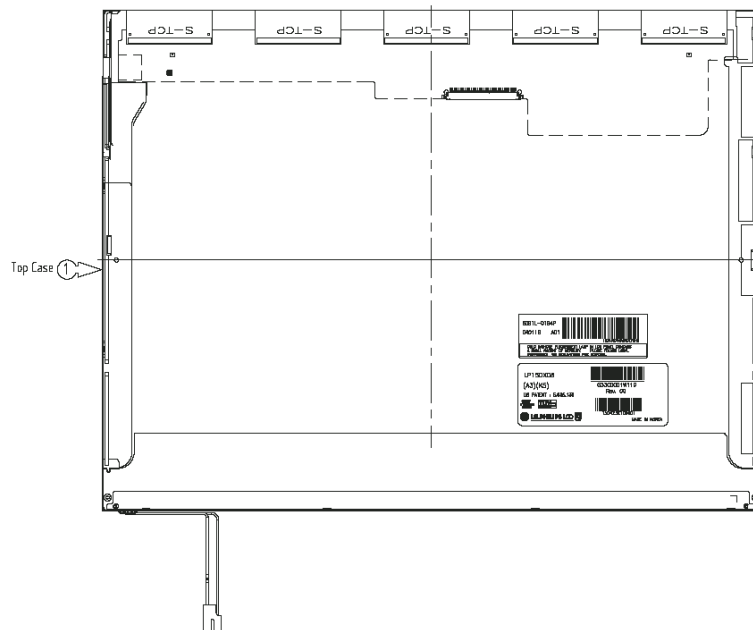

Figure 4-91 Replacing 15.0 Inch LG.Philips fluorescent lamp (XGA) (7)

4. Stick the outside tape and install the cover shield.

1) Install the cover shield.

CAUTION: Wear anti-static gloves to prevent circuit damage to the source PCB.

2) Stick the adhesive tape to fix the top case and B/L wire.

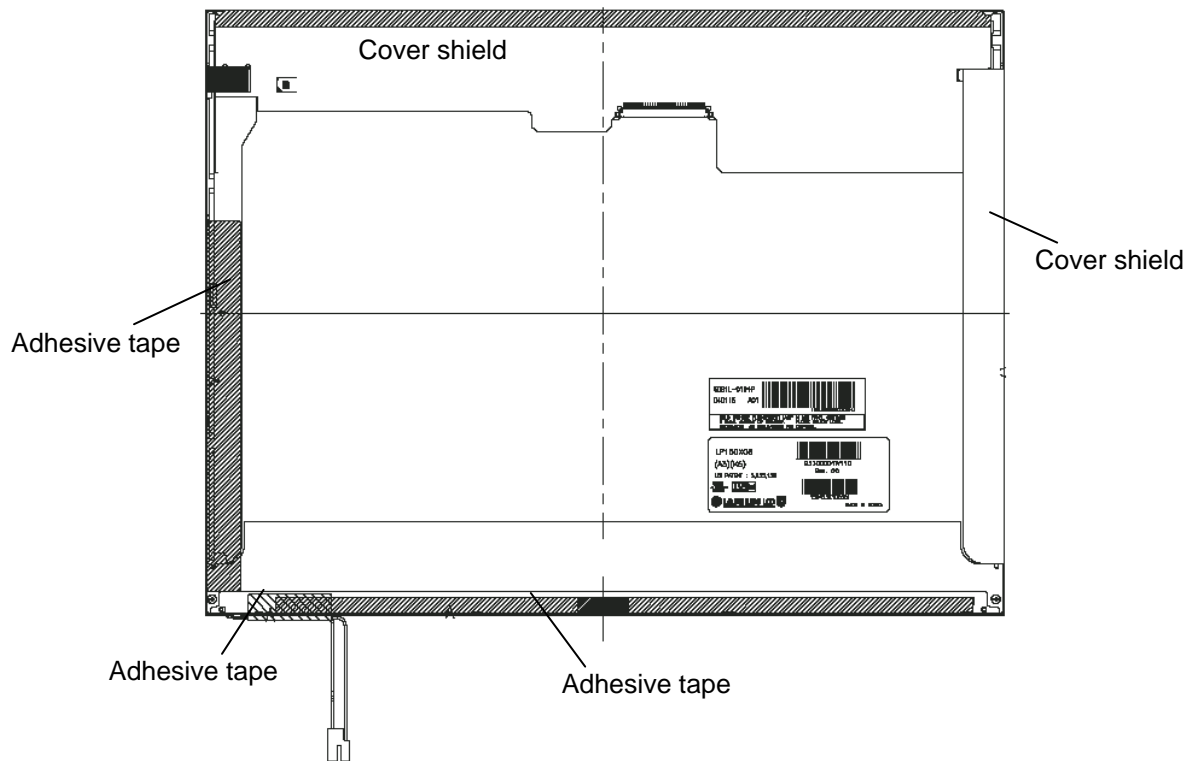

Figure 4-92 Replacing 15.0 Inch LG.Philips fluorescent lamp (XGA) (8)

4.23.4 Replacing the 15.0 Inch SXGA+ LG.Philips Fluorescent lamp

CAUTION: When you replace the fluorescent lamp, wear finger covers or gloves to avoid contaminating or damaging the LCD module. Be careful not to let dust or other foreign substances into the LCD module.

Disassembling the 15.0 Inch SXGA+ LG.Philips Fluorescent lamp

To disassemble the 15.0-inch SXGA+ LG.Philips fluorescent lamp, follow the steps below and refer to Figures 4-93 to 4-96.

5. Remove the outside tape and cover shield.
 - 1) Remove the adhesive tape fixing the B/L wire. Be careful not to apply excessive force to the B/L wire.
 - 2) Remove the cover shield (G). Be careful not to apply excessive force to the gate TCP.
 - 3) Remove the cover shield (C). Be careful not to apply excessive force to the source PCB.

CAUTION: Wear anti-static gloves to prevent circuit damage caused by ESC.

- 4) Remove the tape shield and adhesive tape fixing the top case. Be careful not to apply excessive force to the top case.

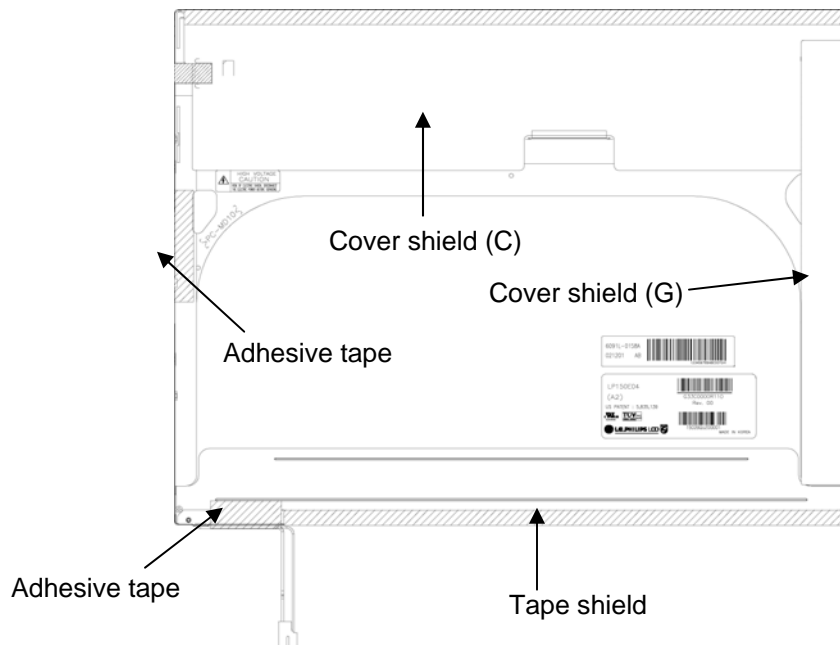

Figure 4-93 Replacing 15.0 Inch LG.Philips fluorescent lamp (SXGA+) (1)

6. Remove the top case. Be careful not to apply excessive force to the top case or gate TCP.

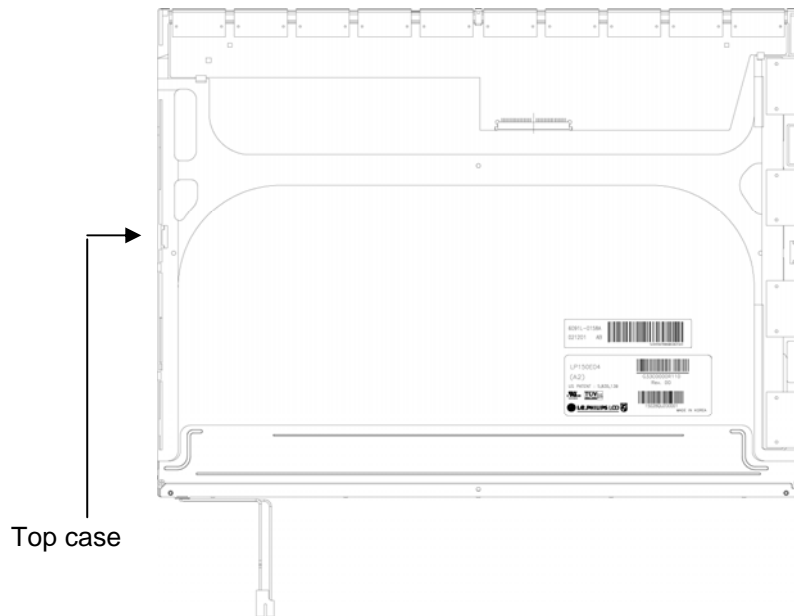

Figure 4-94 Replacing 15.0 Inch LG.Philips fluorescent lamp (SXGA+) (2)

7. Remove the source PCB and gate PCB.
 - 1) Remove the source PCB. Be careful not to apply excessive force to the PCB or TCP when removing double-sided tape.
 - 2) Remove the gate PCB. Be careful not to apply excessive force to the PCB or TCP when removing double-sided tape.

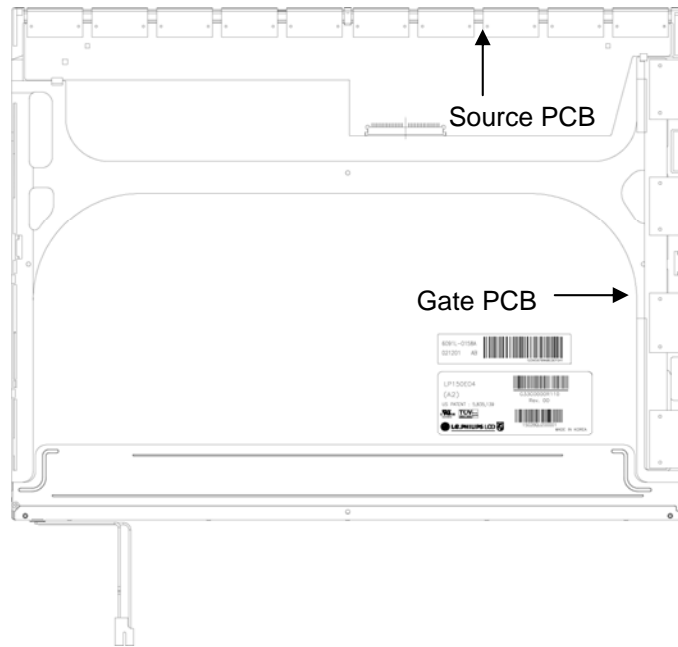

Figure 4-95 Replacing 15.0 Inch LG.Philips fluorescent lamp (SXGA+) (3)

8. Remove the board assembly, adhesive tape, light guide and cover assembly bottom (L).

- 1) Remove the board assembly.

NOTE: This process should be made in a clean room to prevent scratch or particle on polarizer or B/L assembly.

- 2) Remove the adhesive tape fixing the sheets (four points).

- 3) Remove the sheets and light guide.

NOTE: No penetration of foreign object is indispensable not to scratch on the surface of each sheet.

- 4) Remove the two screws fixing the cover assembly bottom (L).

NOTE: Maximum value of torque is 1.5kg•cm.

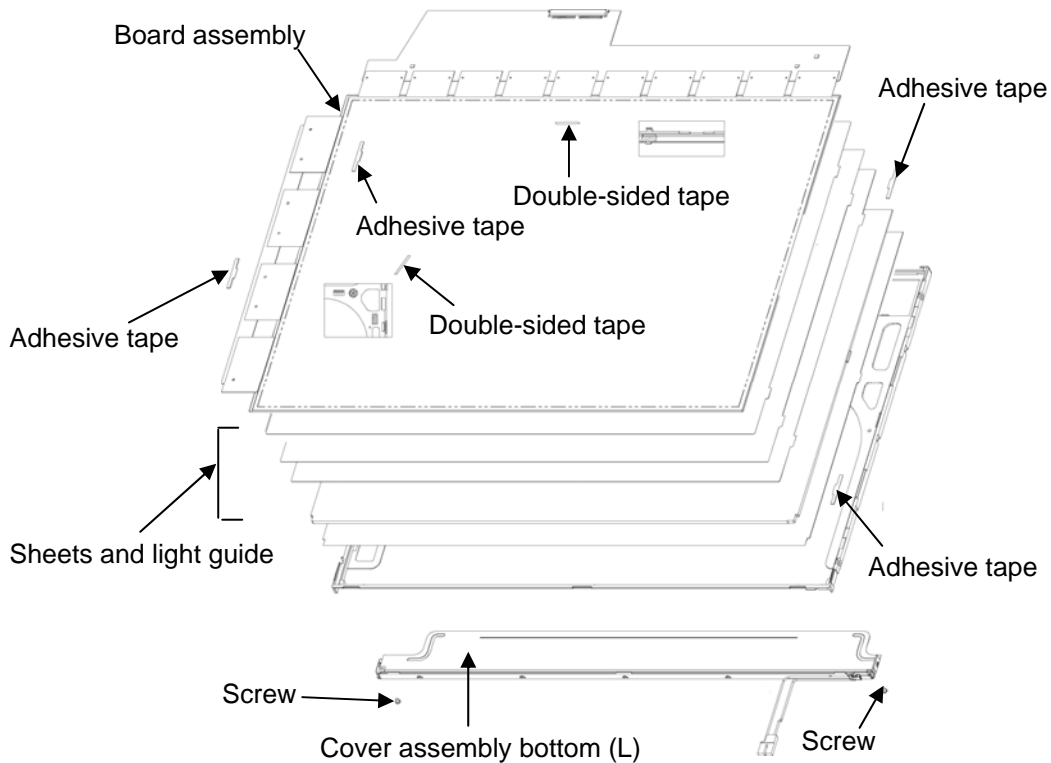

Figure 4-96 Replacing 15.0 Inch LG.Philips fluorescent lamp (SXGA+) (4)

Assembling the 15.0 Inch SXGA+ LG.Philips Fluorescent lamp

To assembling the 15.0-inch SXGA+ LG.Philips fluorescent lamp, follow the steps below and refer to figures 4-97 to 4-100.

1. Install the cover assembly bottom (L), sheets, light guide, adhesive tape and board assembly.
 - 1) Remove the protect sheet from the cover assembly bottom (L).
 - 2) Secure the cover assembly bottom (L) with the two screws.

NOTE: Maximum value of torque is 2.0kg•cm.

- 3) Install the light guide and sheets. (Secure the reflection sheet with double-sided tape.)

NOTE: No penetration of foreign object is indispensable not to scratch on the surface of the sheets and light guide.

- 4) Stick the adhesive tape to fix the sheets.
- 5) Install the board assembly. (Secure the gate PCB with double-sided tape.)

NOTE: Be careful not to apply excessive force to the PCB and TCP.

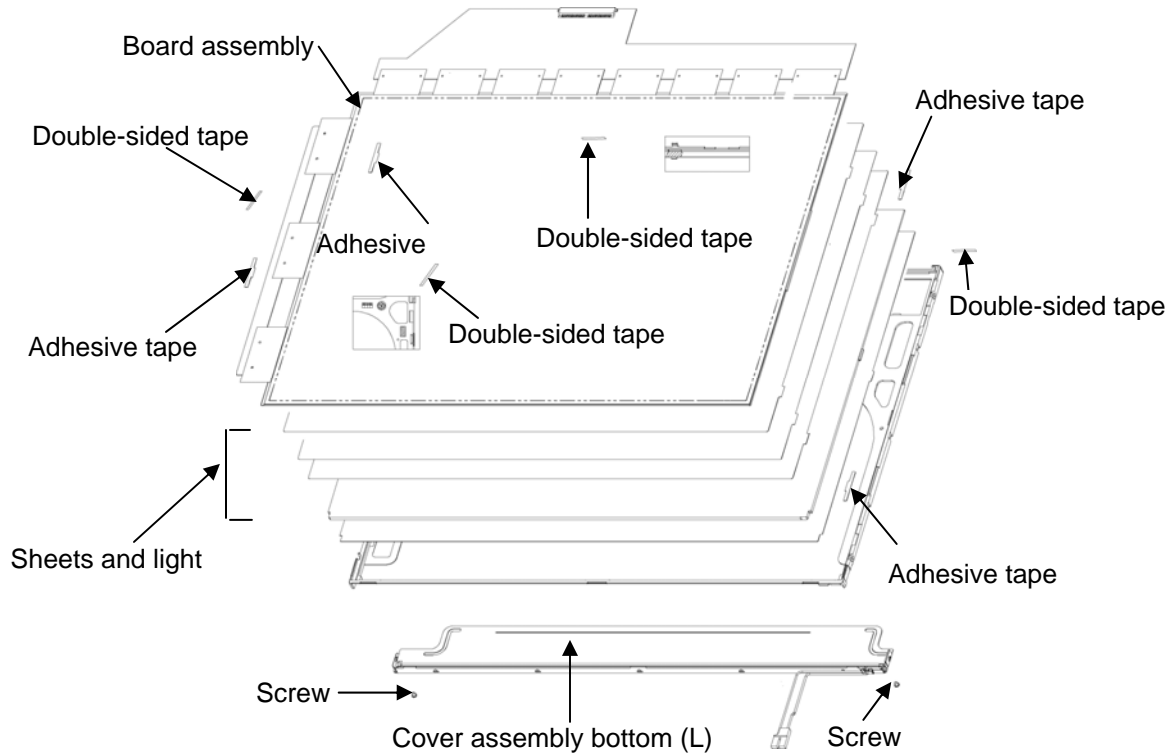

Figure 4-97 Replacing 15.0 Inch LG.Philips fluorescent lamp (SXGA+) (5)

2. Install the source PCB and gate PCB.
 - 1) Install the source PCB. Be careful not to apply excessive force to the TCP.
 - 2) Install the gate PCB. Be careful not to apply excessive force to the TCP.

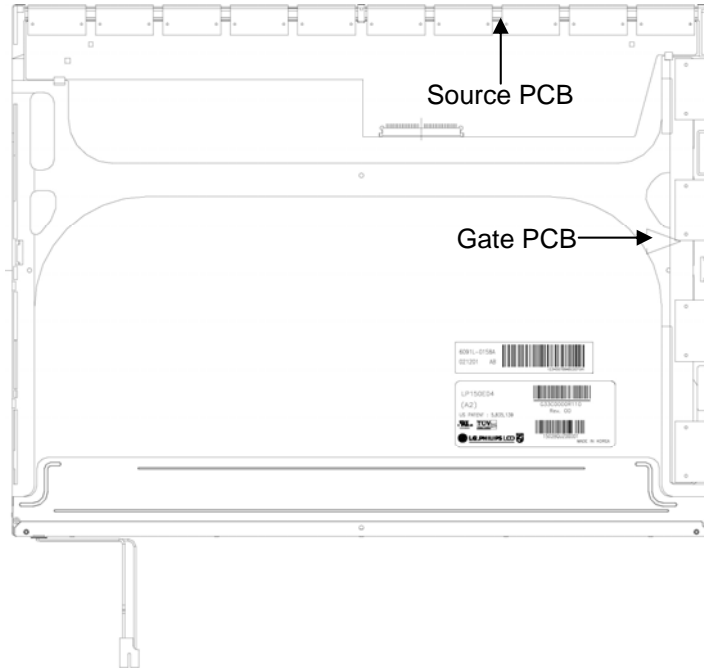

Figure 4-98 Replacing 15.0 Inch LG.Philips fluorescent lamp (SXGA+) (6)

3. Install the top case. Be careful not to apply excessive force to the gate TCP.

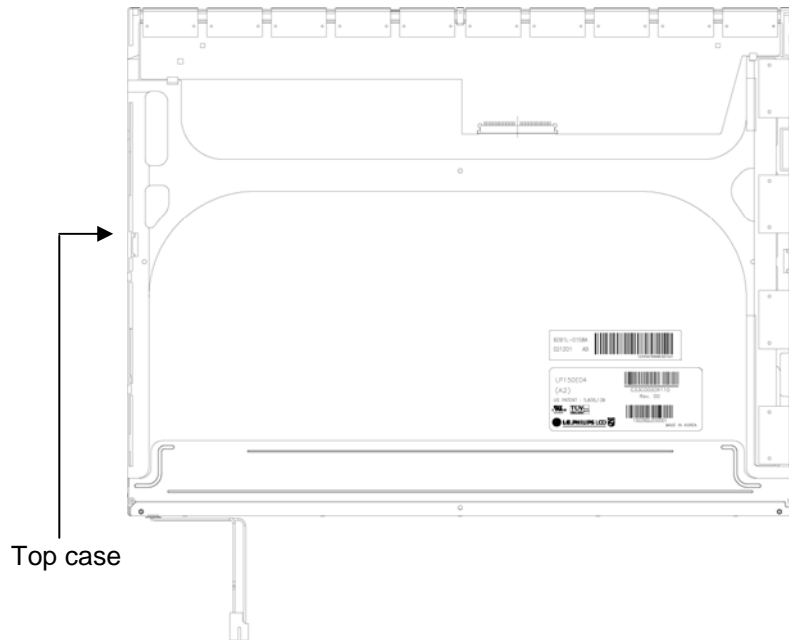

Figure 4-99 Replacing 15.0 Inch LG.Philips fluorescent lamp (SXGA+) (7)

4. Stick the out side tape and cover shield.
 - 1) Install the tape shield and adhesive tape to fix the top case. Be careful not to apply excessive force to the top case.
 - 2) Install the cover shield (C). Be careful not to apply excessive force to the control PCB.

CAUTION: Wear anti-static gloves to prevent circuit damage caused by ESC.

- 3) Install the cover shield (G). Be careful not to apply excessive force to the gate TCP.
- 4) Stick the adhesive tape to fix the B/L wire. Be careful not to apply excessive force to the B/L wire.

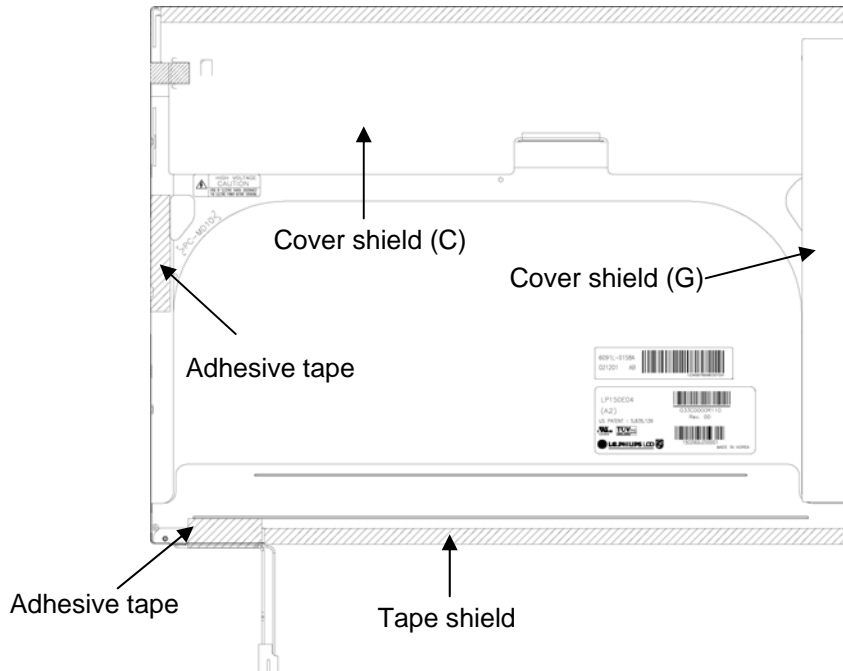

Figure 4-100 Replacing 15.0 Inch LG.Philips fluorescent lamp (SXGA+) (8)

Appendices

Appendix Contents

Appendix A Handling the LCD Module..... A-1

Appendix B Board Layout.....B-1

B.1 System Board Front View.....B-1

B.2 System Board Back ViewB-3

B.3 Sound Board (FLGSN*)B-5

B.4 Parallel port Board (FLGCP*)B-6

B.5 Serial port Board (FLGSR*).....B-7

B.6 S-Video Board (FLKCS*)B-8

Appendix C Pin Assignment..... C-1

System Board

C.1 CN1400 Memory 0 Connector (200-pin) C-1

C.2 CN1410 Memory 1 Connector (200-pin) C-5

C.3 CN1800 HDD I/F Connector (44-pin)..... C-8

C.4 CN1810 Optical Drive I/F Connector (50-pin)..... C-9

C.5 IS2110 PC Card I/F Connector (70-pin)..... C-10

C.6 CN2300 Docking I/F connector (240-pin)..... C-12

C.7 CN2200 Mini PCI I/F Connector (124-pin)..... C-16

C.8 CN3010 MDC I/F Connector (12-pin) C-18

C.9 CN3490 Debug Port Connector (12-pin)..... C-18

C.10 CN3200 Keyboard I/F Connector (34-pin)..... C-19

C.11 CN3240 Touch Pad I/F Connector (4-pin) C-19

C.12 CN3280 Switch Board I/F Connector (10-pin)..... C-20

C.13 CN3502 FLGCP/FLGSR Board I/F Connector (30-pin)..... C-20

C.14 CN4100 Network I/F Connector (14-pin)..... C-21

C.15 CN4611 USB harness I/F Connector (8-pin)..... C-21

C.16 CN4610 USB I/F Connector 0 (4-pin)..... C-21

C.17 CN5000 LCD I/F Connector (41-pin)..... C-21

C.18	CN5620 RGB I/F Connector (15-pin)	C-23
C.19	CN5340 S-Video I/F Connector (5-pin)	C-23
C.20	CN6001 Speaker Connector (Left) (3-pin)	C-23
C.21	CN6002 Speaker Connector (Right) (2-pin).....	C-24
C.22	CN9500 Sound Board I/F Connector (18-pin).....	C-24
C.23	CN8800 DC-IN Connector (4-pin)	C-24
C.24	CN8020 1st Battery Connector (10-pin).....	C-25
C.25	CN9990 RTC Battery Connector (3-pin).....	C-25
C.26	CN8770 FAN I/F Connector (4-pin).....	C-25
Sound Board (FLGSN*)		
C.27	J6070 External Microphone Connector (6-pin)	C-26
C.28	J6310 Headphone Connector (6-pin)	C-26
C.29	CN9510 System Board I/F Connector (18-pin).....	C-26
Switch Board (FLKSW*)		
C.30	PJ3280 System Board I/F Connector (10-pin).....	C-27
Parallel Board (FLGCP*)		
C.31	CN3503 System Board I/F Connector (30-pin)	C-28
C.32	CN4613 Parallel I/F Connector (25-pin)	C-29
C.33	CN4620 USB harness I/F Connector (8-pin).....	C-29
C.34	CN4622 USB I/F Connector 1 (4-pin).....	C-29
S-Video Board (FLGCS*)		
C.35	PJ4610 USB harness I/F Connector (8-pin).....	C-30
C.36	PJ4612 USB I/F Connector 1 (4-pin)	C-30
C.37	PJ4611 USB I/F Connector 2 (4-pin)	C-30
C.38	PJ5640 System Board I/F Connector (5-pin).....	C-31
C.39	PJ5641 Sss-Video Connector (4-pin).....	C-31
Serial Board (FLGSR*)		
C.40	CN3504 System Board I/F Connector (30-pin)	C-32
C.41	CN3440 Serial I/F Connector (9-pin)	C-33
C.42	CN4630 USB harness I/F Connector (8-pin).....	C-33
C.43	CN4632 USB I/F Connector 1 (4-pin).....	C-33

Appendix D Keyboard Scan/Character Codes D-1

 D.1 Keyboard Scan/Character Codes D-1

Appendix E Key LayoutE-1

 E.1 Keyboard LayoutE-1

Appendix F Wiring Diagrams.....F-1

 F.1 RGB monitor ID Wraparound Connector (15-Pin to 15-Pin)..... F-1

 F.2 Parallel Port Wraparound Connector F-1

Appendix G BIOS/KBC/EC Update G-1

Appendix H Reliability..... H-1

Figures

Figure B-1 System board layout (front)B-1
Figure B-2 System board layout (back)B-3
Figure B-3 Sound Board (FLGSN*) layoutB-5
Figure B-4 Parallel port Board (FLGCP*) layoutB-6
Figure B-5 Serial port Board (FLGSR*) layout.....B-7
Figure B-6 S-Video Board (FLKCS*) layoutB-8

Figure E-1 Keyboard layout (for UK).....E-1
Figure E-2 Keyboard layout (for US)E-1

Figure F-1 RGB monitor ID wraparound connector (15-pin to 15-pin)..... F-1
Figure F-2 Parallel port wraparound connector F-1

Tables

Table B-1 System board ICs and connectors (front).....B-2
Table B-2 System board ICs and connectors (back).....B-4
Table B-3 Sound Board (FLGSN*) connectors.....B-5
Table B-4 Parallel port Board (FLGCP*) connectors.....B-6
Table B-5 Serial port Board (FLGSR*) connectors.....B-7
Table B-6 S-Video Board (FLKCS*) connectorsB-8

Table C-1 Memory 0 connector pin assignment (200-pin)C-1
Table C-2 Memory 1 connector pin assignment (200-pin).....C-5
Table C-3 HDD I/F connector pin assignment (44-pin)C-8
Table C-4 Optical drive I/F connector pin assignment (50-pin).....C-9
Table C-5 PC card I/F connector pin assignment (70-pin)C-10
Table C-6 Docking I/F connector (240-pin)C-12
Table C-7 Mini PCI I/F connector pin assignment (124-pin).....C-16
Table C-8 MDC I/F connector pin assignment (12-pin).....C-18

Table C-9	Debug port connector pin assignment (12-pin)	C-18
Table C-10	Keyboard I/F connector pin assignment (34-pin)	C-19
Table C-11	Touch pad I/F connector pin assignment (4-pin)	C-19
Table C-12	Switch board I/F connector pin assignment (10-pin).....	C-20
Table C-13	FLGCP/FLGSR board I/F connector pin assignment (30-pin).....	C-20
Table C-14	Network I/F connector pin assignment (14-pin).....	C-21
Table C-15	USB harness I/F connector pin assignment (8-pin)	C-21
Table C-16	USB I/F connector pin assignment (4-pin)	C-21
Table C-17	LCD I/F connector pin assignment (41-pin).....	C-22
Table C-18	RGB I/F connector pin assignment (15-pin).....	C-23
Table C-19	S-Video I/F connector pin assignment (5-pin).....	C-23
Table C-20	Speaker connector (left) pin assignment (3-pin).....	C-23
Table C-21	Speaker connector (right) pin assignment (2-pin)	C-24
Table C-22	Sound Board I/F connector pin assignment (18-pin).....	C-24
Table C-23	DC-IN connector pin assignment (4-pin)	C-24
Table C-24	1st Battery connector pin assignment (10-pin)	C-25
Table C-25	RTC Battery connector pin assignment (3-pin)	C-25
Table C-26	FAN I/F connector pin assignment (4-pin).....	C-25
Table C-27	External Microphone Connector pin assignment (6-pin).....	C-26
Table C-28	Headphone Connector pin assignment (6-pin)	C-26
Table C-29	System board I/F Connector pin assignment (18-pin)	C-26
Table C-30	System board I/F Connector pin assignment (10-pin)	C-27
Table C-31	System board I/F Connector pin assignment (30-pin)	C-28
Table C-32	Parallel I/F Connector pin assignment (25-pin).....	C-29
Table C-33	USB harness I/F connector pin assignment (8-pin)	C-29
Table C-34	USB I/F Connector 1 pin assignment (4-pin)	C-29
Table C-35	USB harness I/F connector pin assignment (8-pin)	C-30
Table C-36	USB I/F Connector 1 pin assignment (4-pin)	C-30
Table C-37	USB I/F Connector 2 pin assignment (4-pin)	C-30
Table C-38	System board I/F Connector pin assignment (5-pin)	C-31
Table C-39	S-Video Connector pin assignment (4-pin)	C-31
Table C-40	System board I/F Connector pin assignment (30-pin)	C-32

Table C-41	Serial I/F Connector pin assignment (9-pin).....	C-33
Table C-42	USB harness I/F connector pin assignment (8-pin)	C-33
Table C-43	USB I/F Connector 1 pin assignment (4-pin)	C-33
Table D-1	Scan codes (set 1 and set 2)	D-1
Table D-2	Scan codes with left Shift key.....	D-5
Table D-3	Scan codes in Numlock mode.....	D-6
Table D-4	Scan codes with Fn key.....	D-6
Table D-5	Scan codes in overlay mode.....	D-7
Table D-6	No.124 key scan code	D-7
Table D-7	No.126 key scan code	D-8
Table H-1	MTBF.....	H-1

Appendix A Handling the LCD Module

Precautions for handling the LCD module

The LCD module can be easily damaged during assembly or disassembly. Observe the following precautions when handling the LCD module:

1. When installing the LCD module in the LCD cover, be sure to seat it so that it is properly aligned and maximum visibility of the display is maintained.

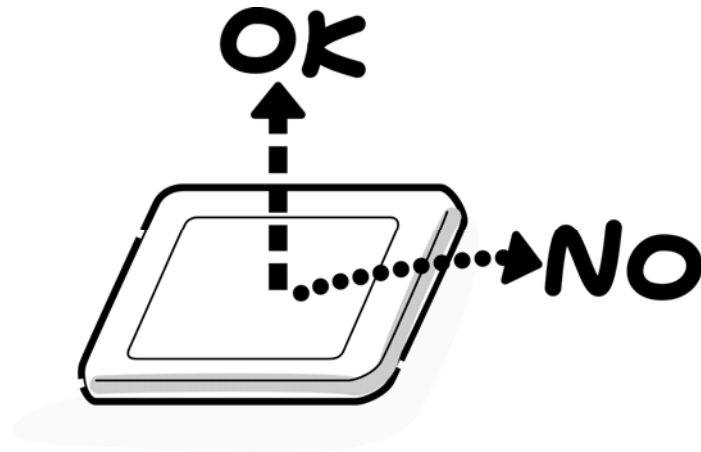

2. Be careful to align the holes at the four corners of the LCD module with the corresponding holes in the LCD cover before securing the module with screws. Do not force the module into place, because stress can affect its performance.

Also, the panel's polarized surface is easily scarred, so be careful when handling it.



3. If the panel's surface gets dirty, wipe it with cotton or a soft cloth. If it is still dirty, try breathing on the surface to create a light condensate and wipe it again.

If the surface is very dirty, we recommend a CRT cleaning agent. Apply the agent to a cloth and then wipe the panel's surface. Do not apply cleanser directly to the panel.



4. If water or other liquid is left on the panel's surface for a long period, it can change the screen's tint or stain it. Be sure to quickly wipe off any liquid.



5. Glass is used in the panel, so be careful not to drop it or let it strike a hard object, which could cause breakage or cracks.

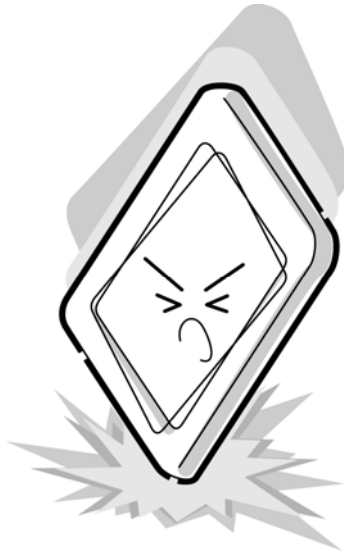

6. CMOS-LSI circuits are used in the module, so guard against damage from electrostatic discharge. Be sure to wear a wrist or ankle ground when handling the module.

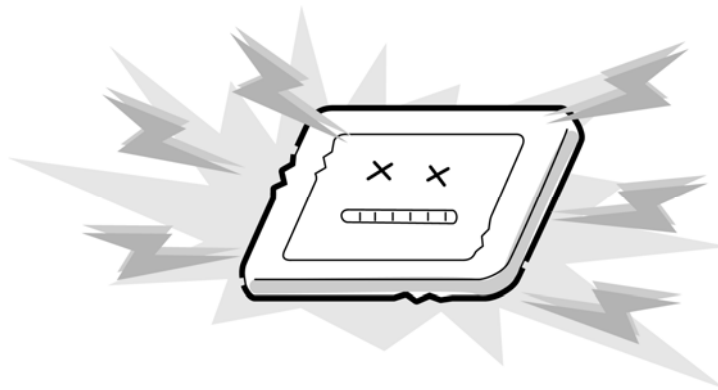

7. Do not expose the module to direct sunlight or strong ultraviolet rays for long periods.

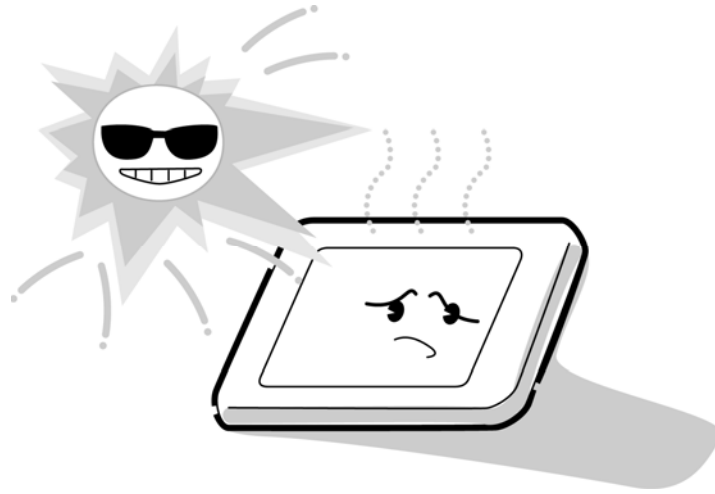

8. Do not store the module at temperatures below specifications. Cold can cause the liquid crystals to freeze, lose their elasticity or otherwise suffer damage.

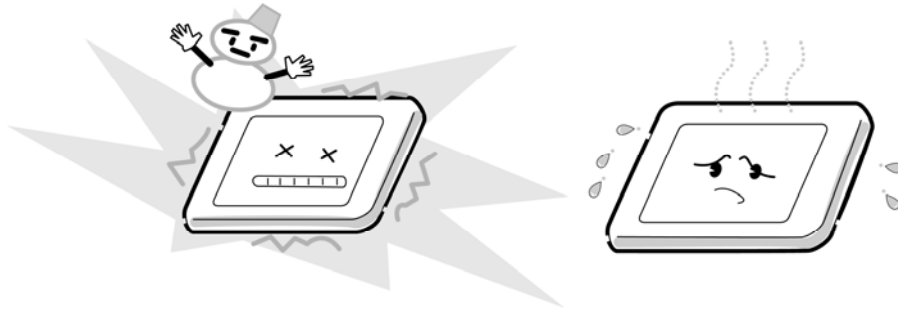

9. Do not disassemble the LCD module. Disassembly can cause malfunctions.

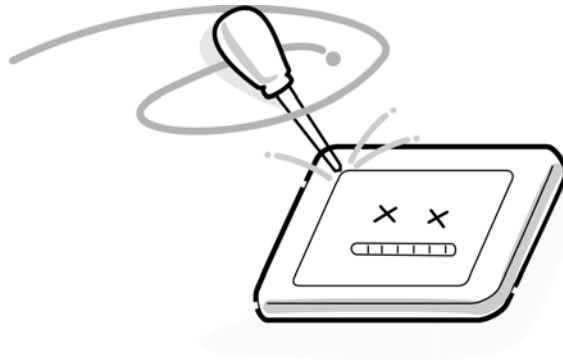

10. If you transport the module, do not use packing material that contains epoxy resin (amine) or silicon glue (alcohol or oxime). These materials can release gas that can damage the panel's polarization.

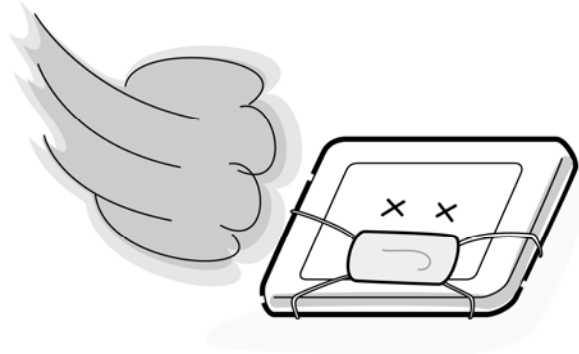

Appendix B Board Layout

B.1 System Board Front View

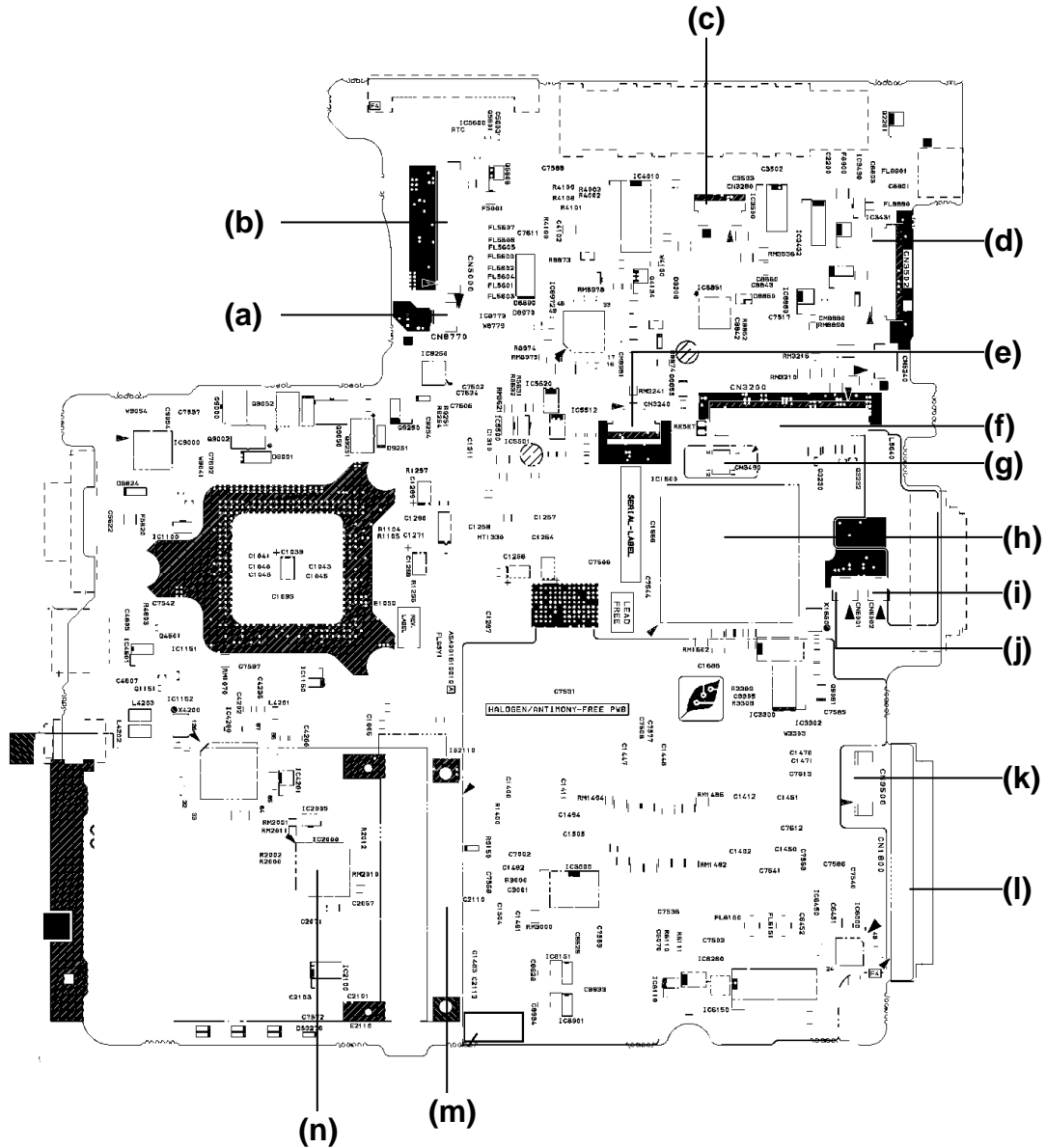

Figure B-1 System board layout (front)

Table B-1 System board ICs and connectors (front)

Mark	Number	Name
(a)	CN8770	Fan cable I/F connector
(b)	CN5000	LCD harness connector
(c)	CN3280	Membrane SW I/F connector
(d)	PJ3502	FLGCP*/FLGSR* I/F connector
(e)	CN3240	Touch pad connector
(f)	CN3200	Keyboard connector
(g)	CN3290	Debuging port connector
(h)	IC1600	ICH6-M
(i)	CN6002	Speaker(R) cable connector
(j)	CN6001	Speaker(L) cable connector
(k)	CN9500	FLGSN* I/F connector
(l)	CN1800	HDD I/F connector
(m)	IS2110	PC card I/F connector
(n)	IC2000	Card Controller

B.2 System Board Back View

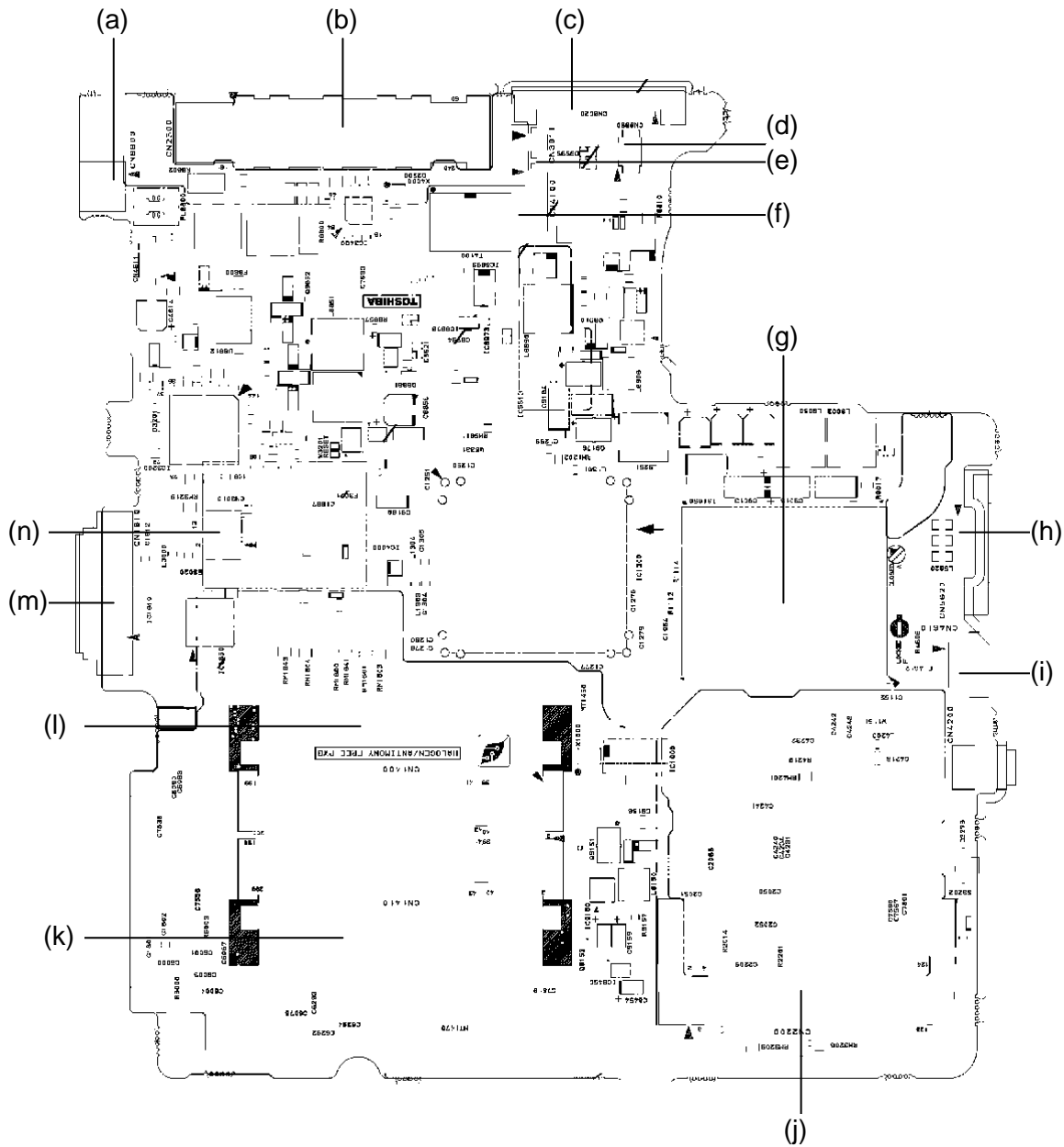

Figure B-2 System board layout (back)

Table B-2 System board ICs and connectors (back)

Mark	Number	Name
(a)	CN8800	DC-IN connector
(b)	CN2300	Docking I/F connector
(c)	CN8020	Battery I/F connector
(d)	CN9990	RTC battery connector
(e)	CN3011	Modem harness I/F connector
(f)	CN4100	Network I/F connector
(g)	IS1050	CPU
(h)	CN5620	RGB I/F connector
(i)	CN4610	USB port
(j)	CN2220	Mini PCI I/F connector
(k)	CN1410	Memory I/F connector (slot B)
(l)	CN1400	Memory I/F connector (slot A)
(m)	CN1810	Optical drive I/F connector
(n)	CN3010	MDC I/F connector

B.3 Sound Board (FLGSN*)

(Front)

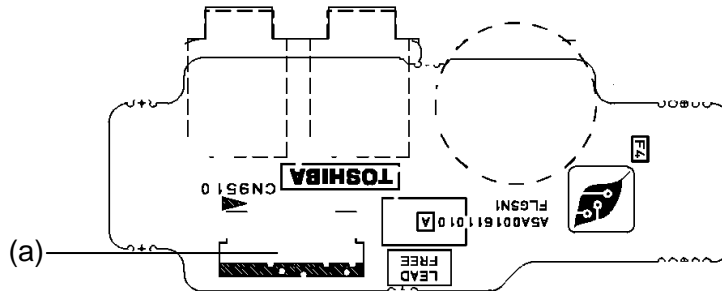

(Back)

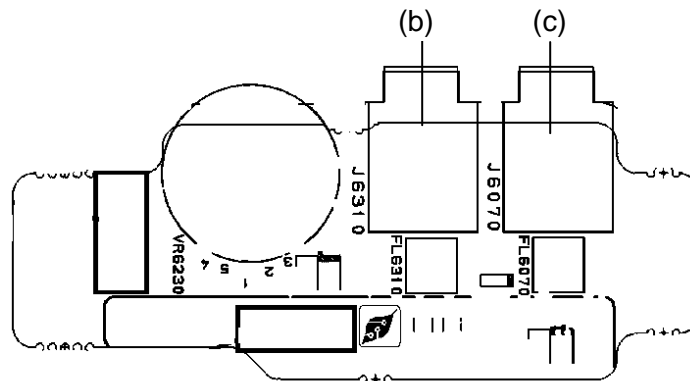

Figure B-3 Sound Board (FLGSN*) layout

Table B-3 Sound Board (FLGSN*) connectors

Mark	Number	Name
(a)	CN9510	System board I/F connector
(b)	J6310	Headphone connector
(c)	J6070	External microphone connector

B.4 Parallel port Board (FLGCP*)

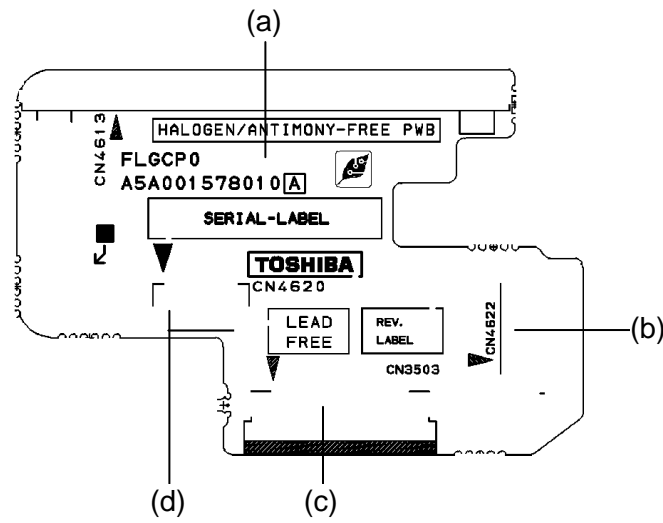

Figure B-4 Parallel port Board (FLGCP*) layout

Table B-4 Parallel port Board (FLGCP*) connectors

Mark	Number	Name
(a)	CN4613	Parallel port
(b)	CN4622	USB connector
(c)	CN3503	System board I/F connector
(d)	CN4620	USB harness connector

B.5 Serial port Board (FLGSR*)

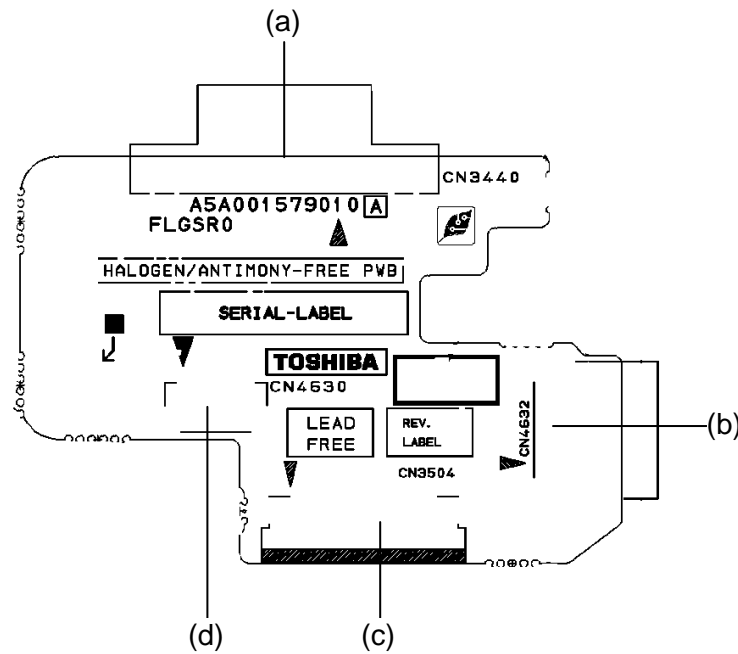

Figure B-5 Serial port Board (FLGSR*) layout

Table B-5 Serial port Board (FLGSR*) connectors

Mark	Number	Name
(a)	CN3440	Serial port
(b)	CN4632	USB connector
(c)	CN3504	System board I/F connector
(d)	CN4630	USB harness connector

B.6 S-Video Board (FLKCS*)

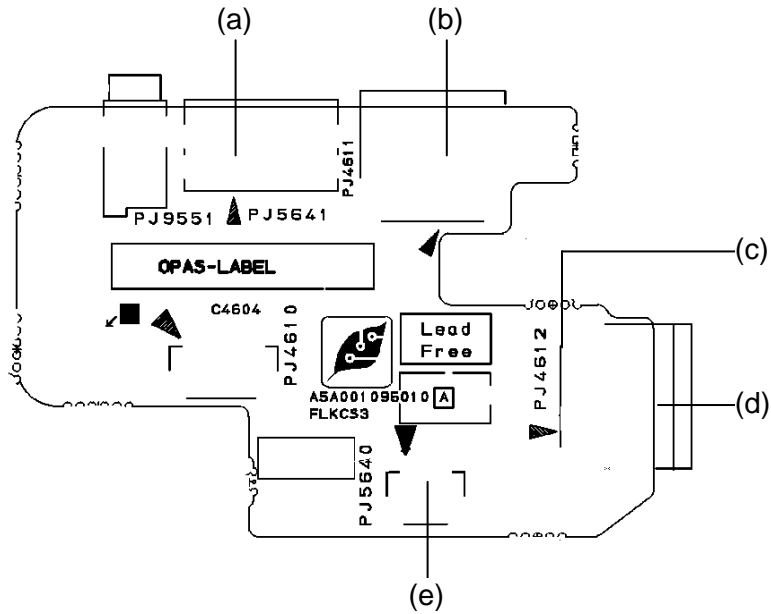

Figure B-6 S-Video Board (FLKCS*) layout

Table B-6 S-Video Board (FLKCS*) connectors

Mark	Number	Name
(a)	PJ5641	S-Video connector
(b)	PJ4611	USB connector
(c)	PJ4610	USB harness connector
(d)	PJ4612	USB connector
(e)	PJ5640	S-Video harness connector

Appendix C Pin Assignment

System Board (FLKSY*)

C.1 CN1400 Memory 0 Connector (200-pin)

Table C-1 Memory 0 connector pin assignment (200-pin) (1/4)

Pin No.	Signal name	I/O	Pin No.	Signal Name	I/O
1	MRVREF-B0V	-	2	GND	-
3	GND	-	4	ADQ04-B1P	I/O
5	ADQ00-B1P	I/O	6	ADQ05-B1P	I/O
7	ADQ01-B1P	I/O	8	GND	-
9	GND	-	10	ADM0-B1P	I/O
11	ADQS0-B1N	I/O	12	GND	-
13	ADQS0-B1P	I/O	14	ADQ02-B1P	I/O
15	GND	-	16	ADQ07-B1P	I/O
17	ADQ03-B1P	I/O	18	GND	-
19	ADQ06-B1P	I/O	20	ADQ12-B1P	I/O
21	GND	-	22	ADQ13-B1P	I/O
23	ADQ08-B1P	I/O	24	GND	-
25	ADQ09-B1P	I/O	26	ADM1-B1P	I/O
27	GND	-	28	GND	-
29	ADQS1-B1N	I/O	30	MCK0-B1P	O
31	ADQS1-B1P	I/O	32	MCK0-B1N	O
33	GND	-	34	GND	-
35	ADQ15-B1P	I/O	36	ADQ10-B1P	I/O
37	ADQ14-B1P	I/O	38	ADQ11-B1P	I/O
39	GND	-	40	GND	-
41	GND	-	42	GND	-
43	ADQ16-B1P	I/O	44	ADQ20-B1P	I/O
45	ADQ17-B1P	-	46	ADQ21-B1P	I/O
47	GND	-	48	GND	-
49	ADQS2-B1N	I/O	50	NC	-
51	ADQS2-B1P	I/O	52	ADM2-B1P	I/O
53	GND	-	54	GND	-

Table C-1 Memory 0 connector pin assignment (200-pin) (2/4)

Pin No.	Signal name	I/O	Pin No.	Signal Name	I/O
55	ADQ23-B1P	I/O	56	ADQ19-B1P	I/O
57	ADQ22-B1P	I/O	58	ADQ18-B1P	I/O
59	GND	-	60	GND	-
61	ADQ24-B1P	I/O	62	ADQ29-B1P	I/O
63	ADQ25-B1P	I/O	64	ADQ28-B1P	I/O
65	GND	-	66	GND	-
67	ADM3-B1P	I/O	68	ADQS3-B1N	I/O
69	NC	-	70	ADQS3-B1P	I/O
71	GND	-	72	GND	-
73	ADQ27-B1P	I/O	74	ADQ30-B1P	I/O
75	ADQ26-B1P	I/O	76	ADQ31-B1P	I/O
77	GND	-	78	GND	-
79	MCKE0-B1P	O	80	MCKE1-B1P	O
81	1R8-B1V	-	82	1R8-B1V	-
83	NC	-	84	NC	-
85	ABS2-B1P	O	86	NC	-
87	1R8-B1V	-	88	1R8-B1V	-
89	AMA12-B1P	O	90	AMA11-B1P	O
91	AMA09-B1P	O	92	AMA07-B1P	O
93	AMA08-B1P	O	94	AMA06-B1P	O
95	1R8-B1V	-	96	1R8-B1V	I
97	AMA05-B1P	O	98	AMA04-B1P	O
99	AMA03-B1P	O	100	AMA02-B1P	O
101	AMA01-B1P	O	102	AMA00-B1P	O
103	1R8-B1V	-	104	1R8-B1V	-
105	AMA10-B1P	O	106	ABS1-B1P	O
107	ABS0-B1P	O	108	ARAS-B1N	I
109	AWE-B1N	I	110	MCS0-B1N	O
111	1R8-B1V	-	112	1R8-B1V	-
113	ACAS-B1N	O	114	MODT2-B1P	O
115	ACS3-B1N	O	116	AMA13-B1P	I/O
117	1R8-B1V	-	118	1R8-B1V	-
119	MODT1-B1P	O	120	NC	-

Table C-1 Memory 0 connector pin assignment (200-pin) (3/4)

Pin No.	Signal name	I/O	Pin No.	Signal Name	I/O
121	GND	-	122	GND	-
123	ADQ32-B1P	I/O	124	ADQ36-B1P	I/O
125	ADQ33-B1P	I/O	126	ADQ37-B1P	I/O
127	GND	-	128	GND	-
129	ADQS4-B1N	I/O	130	ADM4-B1P	O
131	ADQS4-B1P	I/O	132	GND	-
133	GND	-	134	ADQ38-B1P	I/O
135	ADQ34-B1P	I/O	136	ADQ35-B1P	I/O
137	ADQ39-B1P	I/O	138	GND	-
139	GND	-	140	ADQ40-B1P	I/O
141	ADQ45-B1P	I/O	142	ADQ44-B1P	I/O
143	ADQ41-B1P	I/O	144	GND	-
145	GND	-	146	ADQS5-B1N	I/O
147	ADM5-B1P	O	148	ADQS5-B1P	I/O
149	GND	-	150	GND	-
151	ADQ42-B1P	I/O	152	ADQ46-B1P	I/O
153	ADQ43-B1P	I/O	154	ADQ47-B1P	I/O
155	GND	-	156	GND	-
157	ADQ48-B1P	I/O	158	ADQ52-B1P	I/O
159	ADQ49-B1P	I/O	160	ADQ53-B1P	I/O
161	GND	-	162	GND	-
163	NC	-	164	MCK1-B1P	O
165	GND	-	166	MCK1-B1N	O
167	ADQS6-B1N	I/O	168	GND	-
169	ADQS6-B1P	I/O	170	ADM6-B1P	O
171	GND	-	172	GND	-
173	ADQ55-B1P	I/O	174	ADQ54-B1P	I/O
175	ADQ51-B1P	I/O	176	ADQ50-B1P	I/O
177	GND	-	178	GND	-
179	ADQ56-B1P	I/O	180	ADQ60-B1P	I/O
181	ADQ57-B1P	I/O	182	ADQ61-B1P	I/O
183	GND	-	184	GND	-
185	ADM7-B1P	O	186	ADQS7-B1N	I/O

Table C-1 Memory 0 connector pin assignment (200-pin) (4/4)

Pin No.	Signal name	I/O	Pin No.	Signal Name	I/O
187	GND	-	188	ADQS7-B1P	I/O
189	ADQ58-B1P	I/O	190	GND	-
191	ADQ59-B1P	I/O	192	ADQ62-B1P	I/O
193	GND	-	194	ADQ63-B1P	I/O
195	SMBDAT-P3P	I/O	196	GND	-
197	SMBCL2-P3P	I/O	198	GND	-
199	P3V	-	200	GND	-

C.2 CN1410 Memory 1 Connector (200-pin)*Table C-2 Memory 1 connector pin assignment (200-pin) (1/4)*

Pin No.	Signal name	I/O	Pin No.	Signal Name	I/O
1	MR0EF-B0V	-	2	GND	-
3	GND	-	4	BDQ05-B1P	I/O
5	BDQ07-B1P	I/O	6	BDQ04-B1P	I/O
7	BDQ06-B1P	I/O	8	GND	-
9	GND	-	10	BDM0-B1P	I/O
11	BDQS0-B1N	I/O	12	GND	-
13	BDQS0-B1P	I/O	14	BDQ01-B1P	I/O
15	GND	-	16	BDQ00-B1P	I/O
17	BDQ03-B1P	I/O	18	GND	-
19	BDQ02-B1P	I/O	20	BDQ12-B1P	I/O
21	GND	-	22	BDQ13-B1P	I/O
23	BDQ11-B1P	I/O	24	GND	-
25	BDQ08-B1P	I/O	26	BDM1-B1P	I/O
27	GND	-	28	GND	-
29	BDQS1-B1N	I/O	30	MCK3-B1P	O
31	BDQS1-B1P	I/O	32	MCK3-B1N	O
33	GND	-	34	GND	-
35	BDQ09-B1P	I/O	36	BDQ15-B1P	I/O
37	BDQ14-B1P	I/O	38	BDQ10-B1P	I/O
39	GND	-	40	GND	-
41	GND	-	42	GND	-
43	BDQ16-B1P	I/O	44	BDQ21-B1P	I/O
45	BDQ18-B1P	-	46	BDQ17-B1P	I/O
47	GND	-	48	GND	-
49	BDQS2-B1N	I/O	50	NC	-
51	BDQS2-B1P	I/O	52	BDM2-B1P	I/O
53	GND	-	54	GND	-
55	BDQ23-B1P	I/O	56	BDQ19-B1P	I/O
57	BDQ22-B1P	I/O	58	BDQ20-B1P	I/O
59	GND	-	60	GND	-
61	BDQ30-B1P	I/O	62	BDQ24-B1P	I/O

Table C-2 Memory 1 connector pin assignment (200-pin) (2/4)

Pin No.	Signal name	I/O	Pin No.	Signal Name	I/O
63	BDQ28-B1P	I/O	64	BDQ25-B1P	I/O
65	GND	-	66	GND	-
67	BDM3-B1P	I/O	68	BDQS3-B1N	I/O
69	NC	-	70	BDQS3-B1P	I/O
71	GND	-	72	GND	-
73	BDQ26-B1P	I/O	74	BDQ29-B1P	I/O
75	BDQ27-B1P	I/O	76	BDQ31-B1P	I/O
77	GND	-	78	GND	-
79	MCKE2-B1P	O	80	MCKE3-B1P	O
81	1R8-B1V	-	82	1R8-B1V	-
83	NC	-	84	NC	-
85	BBS2-B1P	O	86	NC	-
87	1R8-B1V	-	88	1R8-B1V	-
89	BMA12-B1P	O	90	BMA11-B1P	O
91	BMA09-B1P	O	92	BMA07-B1P	O
93	BMA08-B1P	O	94	BMA06-B1P	O
95	1R8-B1V	-	96	1R8-B1V	I
97	BMA05-B1P	O	98	BMA04-B1P	O
99	BMA03-B1P	O	100	BMA02-B1P	O
101	BMA01-B1P	O	102	BMA00-B1P	O
103	1R8-B1V	-	104	1R8-B1V	-
105	BMA10-B1P	O	106	BBS1-B1P	O
107	BBS0-B1P	O	108	BRAS-B1N	I
109	BWE-B1N	I	110	MCS2-B1N	O
111	1R8-B1V	-	112	1R8-B1V	-
113	BCAS-B1N	O	114	MODT2-B1P	O
115	MCS3-B1N	O	116	BMA13-B1P	I/O
117	1R8-B1V	-	118	1R8-B1V	-
119	MODT3-B1P	O	120	NC	-
121	GND	-	122	GND	-
123	BDQ32-B1P	I/O	124	BDQ36-B1P	I/O
125	BDQ33-B1P	I/O	126	BDQ37-B1P	I/O
127	GND	-	128	GND	-

Table C-2 Memory 1 connector pin assignment (200-pin) (3/4)

Pin No.	Signal name	I/O	Pin No.	Signal Name	I/O
129	BDQS4-B1N	I/O	130	BDM4-B1P	O
131	BDQS4-B1P	I/O	132	GND	-
133	GND	-	134	BDQ38-B1P	I/O
135	BDQ34-B1P	I/O	136	BDQ39-B1P	I/O
137	BDQ35-B1P	I/O	138	GND	-
139	GND	-	140	BDQ44-B1P	I/O
141	BDQ40-B1P	I/O	142	BDQ45-B1P	I/O
143	BDQ41-B1P	I/O	144	GND	-
145	GND	-	146	BDQS5-B1N	I/O
147	BDM5-B1P	O	148	BDQS5-B1P	I/O
149	GND	-	150	GND	-
151	BDQ43-B1P	I/O	152	BDQ46-B1P	I/O
153	BDQ42-B1P	I/O	154	BDQ47-B1P	I/O
155	GND	-	156	GND	-
157	BDQ48-B1P	I/O	158	BDQ52-B1P	I/O
159	BDQ54-B1P	I/O	160	BDQ53-B1P	I/O
161	GND	-	162	GND	-
163	NC	-	164	MCK1-B1P	O
165	GND	-	166	MCK1-B1N	O
167	BDQS6-B1N	I/O	168	GND	-
169	BDQS6-B1P	I/O	170	BDM6-B1P	O
171	GND	-	172	GND	-
173	BDQ51-B1P	I/O	174	BDQ50-B1P	I/O
175	BDQ55-B1P	I/O	176	BDQ49-B1P	I/O
177	GND	-	178	GND	-
179	BDQ57-B1P	I/O	180	BDQ56-B1P	I/O
181	BDQ60-B1P	I/O	182	BDQ61-B1P	I/O
183	GND	-	184	GND	-
185	BDM7-B1P	O	186	BDQS7-B1N	I/O
187	GND	-	188	BDQS7-B1P	I/O
189	BDQ58-B1P	I/O	190	GND	-
191	BDQ59-B1P	I/O	192	BDQ62-B1P	I/O
193	GND	-	194	BDQ63-B1P	I/O

Table C-2 Memory 1 connector pin assignment (200-pin) (4/4)

Pin No.	Signal name	I/O	Pin No.	Signal Name	I/O
195	SMBDAT-P3P	I/O	196	GND	-
197	SMBCL2-P3P	I/O	198	GND	-
199	P3V	-	200	P3V	-

C.3 CN1800 HDD I/F Connector (44-pin)

Table C-3 HDD I/F connector pin assignment (44-pin)

Pin No.	Signal Name	I/O	Pin No.	Signal name	I/O
1	N.C.	-	2	GND	-
3	P5V	I	4	P5V	I
5	GND	-	6	HDDLED-P5N	I/O
7	SODCS3-SO3N	O	8	SODCS1-P3N	O
9	SODA2-SO3SO	O	10	SODA0-P3P	O
11	N.C.	-	12	SODA1-P3P	O
13	N.C.	-	14	IRQ14-P3P	I
15	GND	-	16	SODDACK-P3N	O
17	GND	-	18	SOIORDY-P3P	I
19	GND	-	20	SODIOR-P3N	O
21	GND	-	22	SODIOW-P3N	O
23	GND	-	24	SODDREQ-P3P	I
25	N.C.	-	26	GND	-
27	SODD15-P3P	I/O	28	SODD00-P3P	I/O
29	SODD14-P3P	I/O	30	SODD01-P3P	I/O
31	SODD13-P3P	I/O	32	SODD02-P3P	I/O
33	SODD12-P3P	I/O	34	SODD03-P3P	I/O
35	SODD11-P3P	I/O	36	SODD04-P3P	I/O
37	SODD10-P3P	I/O	38	SODD05-P3P	I/O
39	SODD09-P3P	I/O	40	SODD06-P3P	I/O
41	SODD08-P3P	I/O	42	SODD07-P3P	I/O
43	GND	-	44	SORSTA-P3N	I

C.4 CN1810 Optical Drive I/F Connector (50-pin)*Table C-4 Optical drive I/F connector pin assignment (50-pin)*

Pin No.	Signal name	I/O	Pin No.	Signal Name	I/O
1	N.C.	-	2	N.C.	-
3	GND	-	4	N.C.	-
5	RSTIDB-E3P	O	6	PDD08-P3P	I/O
7	PDD07-P3P	I/O	8	PDD09-P3P	I/O
9	PDD06-P3P	I/O	10	PDD10-P3P	I/O
11	PDD05-P3P	I/O	12	PDD11-P3P	I/O
13	PDD04-P3P	I/O	14	PDD12-P3P	I/O
15	PDD03-P3P	I/O	16	PDD13-P3P	I/O
17	PDD02-P3P	I/O	18	PDD14-P3P	I/O
19	PDD01-P3P	I/O	20	PDD15-P3P	I/O
21	PDD00-P3P	I/O	22	PDDREQ-P3P	I
23	GND	-	24	PDIOR-P3N	O
25	PDIOW-P3N	O	26	GND	-
27	PIORDY-P3P	I	28	PDDACK-P3N	O
29	IDEIRQ-P3P	I	30	N.C.	-
31	PDA1-P3P	O	32	N.C.	-
33	PDA0-P3P	O	34	PDA2-P3P	O
35	PDCS1-P3N	O	36	PDCS3-P3N	O
37	N.C.	-	38	P5V	O
39	P5V	O	40	P5V	O
41	P5V	O	42	P5V	O
43	GND	-	44	GND	-
45	GND	-	46	N.C.	-
47	N.C.	-	48	GND	-
49	N.C.	-	50	N.C.	-

C.5 IS2110 PC Card I/F Connector (70-pin)*Table C-5 PC card I/F connector pin assignment (70-pin) (1/2)*

Pin No.	Signal name	I/O	Pin No.	Signal Name	I/O
1	GND	-	2	ACAD00-PYP	I/O
3	ACAD01-PYP	I/O	4	ACAD03-PYP	I/O
5	ACAD05-PYP	I/O	6	ACAD07-PYP	I/O
7	ACCBEO-PYN	I/O	8	ACAD09-PYP	I/O
9	ACAD11-PYP	I/O	10	ACAD12-PYP	I/O
11	ACAD14-PYP	I/O	12	ACCBE1-PYN	I/O
13	ACPAR-PYP	I/O	14	ACPERR-PYN	I/O
15	ACGNT-PYN	I	16	ACINT-PYN	O
17	MCVCCA-PYV	I	18	MCVPPA-EYV	I
19	ACCLK-PYP	I/O	20	ACIRDY-PYN	I/O
21	ACCBE2-PYN	I/O	22	ACAD18-PYP	I/O
23	ACAD20-PYP	I/O	24	ACAD21-PYP	I/O
25	ACAD22-PYP	I/O	26	ACAD23-PYP	I/O
27	ACAD24-PYP	I/O	28	ACAD25-PYP	I/O
29	ACAD26-PYP	I/O	30	ACAD27-PYP	I/O
31	ACAD29-PYP	I/O	32	ACD02-PYP	I/O
33	ACCLKR-PYN	I/O	34	GND	-
35	GND	-	36	ACCD1-E3N	O
37	ACAD02-PYP	I/O	38	ACAD04-PYP	I/O
39	ACAD06-PYP	I/O	40	ACD14-PYP	I/O
41	ACAD08-PYP	I/O	42	ACAD10-PYP	I/O
43	ACVS1-P3P	I/O	44	ACAD13-PYP	I/O
45	ACAD15-PYP	I/O	46	ACAD16-PYP	I/O
47	ACA18-PYP	I/O	48	ACLOCK-PYN	I/O
49	ACSTOP-PYN	I/O	50	ACDEVS-PYN	I/O
51	MCVCCA-PYV	I	52	MCVPPA-PYV	I
53	ACTRDY-PYN	I/O	54	ACFRAM-PYN	I/O
55	ACAD17-PYP	I/O	56	ACAD19-PYP	I/O
57	ACVS2-P3P	I/O	58	ACRST-PYN	I/O
59	ACSERR-PYN	I/O	60	ACREQ-PYN	O
61	ACCBE3-PYN	I/O	62	ACAUDI-PYP	O

Table C-5 PC Card slot connector pin assignment (70-pin)(2/2)

Pin No.	Signal name	I/O	Pin No.	Signal Name	I/O
63	ACSTSC-PYP	O	64	ACAD28-PYP	I/O
65	ACAD30-PYP	I/O	66	ACAD31-PYP	I/O
67	ACCD2-P3N	O	68	GND	-
69	GND	-	70	GND	-

C.6 CN2300 Docking I/F connector (240-pin)*Table C-6 Docking I/F connector (240-pin)(1/4)*

Pin No.	Signal name	I/O	Pin No.	Signal name	I/O
A1	DSKDC	I	A2	GND	-
1	DCOUT	I	2	DCOUT	I
3	DOCDT1-S3N	O	4	P5V	I
5	EXMSCK-P5P	I/O	6	EXKBCK-P5P	I/O
7	GND	-	8	N.C.	-
9	DPCONF-S5P	O	10	GND	-
11	GND	-	12	DDCACK-P3P	I/O
13	DRED-PXP	I	14	DGREEN-PXP	I
15	DBLUE-PXP	I	16	DVSYNC-P3P	I
17	(DVISC-P3P)	-	18	Reserved	-
19	GND	-	20	(DVI-PRTCT2)	-
21	(DVI-PRTCT1)	-	22	(DVITX2-P3P)	-
23	(DVITX2-P3N)	-	24	(DVITX1-P3P)	-
25	(DVITX1-P3N)	-	26	(DVITX0-P3P)	-
27	(DVITX0-P3N)	-	28	GND	-
29	GND	-	30	(DVITXC-P3P)	-
31	(DVITXC-P3N)	-	32	(DVIDET-S3N)	-
33	(DVIPD1-P3N)	-	34	Reserved	-
35	(QSWON-B3P)	-	36	(DIRQD-S3N)	-
37	GND	-	38	(PCM2SP-B3P)	-
39	(DPMRST-S3N)	-	40	(DAD00-P3P)	-
41	GND	-	42	(DAD00-P3P)	-
43	(DADO2-P3P)	-	44	(DAD06-P3P)	-
45	GND	-	46	(XDPCI-P3P)	-
47	(DAD09-P3P)	-	48	(DAD11-P3P)	-
49	GND	-	50	(DAD11-P3P)	-
51	(DAD15-P3P)	-	52	(DINTA-P3N)	-
53	VOID	-	54	VOID	-
55	BIDDP-EXP	I/O	56	BIDDN-EXN	I/O
57	VOID	-	58	VOID	-

Table C-6 Docking I/F connector (240-pin)(2/4)

Pin No.	Signal name	I/O	Pin No.	Signal name	I/O
59	MDMRNG-E3P	I/O	60	MDMTIP-E3P	I/O
61	DCOUT	I	62	DCOUT	I
63	EJCTRQ-S3N	I/O	64	IF-P5V	I
65	EXMSDT-P5P	I/O	66	EXKBDT-P5P	I/O
67	GND	-	68	(DNVSON-S3P)	-
69	GND	-	70	(NVPCNF-S3P)	-
71	GND	-	72	DDCADA-P3P	I/O
73	GND	-	74	GND	-
75	GND	-	76	DHSYNC-P3P	I
77	(DVISD-P3P)	-	78	(DVI_PRTCT3)	-
79	GND	-	80	(DVITX5-P3P)	-
81	(DVITX5-P3N)	-	82	(DVITX4-P3P)	-
83	(DVITX4-P3N)	-	84	(DVITX3-P3P)	-
85	(DVITX3-P3N)	-	86	(DVI16)	-
87	(DVI17)	-	88	GND	-
89	GND	-	90	(DOC_ON_LED1)	-
91	Reserved	-	92	(DOC_ON_LED2)	-
93	(DVIPD0-P3N)	-	94	(DVI_PRTCT4)	-
95	(DCADIO-S3P)	-	96	(DSMI-B3P)	-
97	GND	-	98	(DCKRUN-P3N)	-
99	(PME-S3P)	-	100	(DAD01-P3P)	-
101	GND	-	102	(DAD03-P3P)	-
103	(DAD05-P3P)	-	104	(DAD07-P3P)	-
105	GND	-	106	(DAD08-P3P)	-
107	(DAD10-P3P)	-	108	(DAD10-P3P)	-
109	GND	-	110	(DAD14-P3P)	-
111	(DCBE1-P3N)	-	112	(DPAR-P3P)	-
113	VOID	-	114	VOID	-
115	BIDCN-EXN	I/O	116	VOID	-
117	BIDCP-EXP	I/O	118	VOID	-
119	VOID	-	120	VOID	-

Table C-6 Docking I/F connector (240-pin)(3/4)

Pin No.	Signal name	I/O	Pin No.	Signal name	I/O
121	DCOUT	I	122	DCOUT	I
123	DSSCL-S5P	I/O	124	IF-P5V	I
125	M5V	I	126	N.C.	-
127	GND	-	128	N.C.	-
129	N.C.	-	130	N.C.	-
131	GND	-	132	N.C.	-
133	N.C.	-	134	SNDMUT-S3N	I
135	(SNDVCC-OFF)	-	136	DOUTL-PXP	I/O
137	DINL-PXP	I/O	138	DINR-PXN	I/O
139	GND	-	140	PWRSW-S3N	O
141	DCD-PYP	O	142	DSR-PYP	O
143	TXD-PYN	I	144	RING-BYP	O
145	PE-P5P	O	146	PDB07-P5P	I/O
147	PDB06-P5P	I/O	148	GND	-
149	GND	-	150	PDB04-P5P	I/O
151	PDB01-P5P	I/O	152	PDB02-P5P	I/O
153	PDB00-P5P	I/O	154	STROB-P5N	I
155	(DPGNT-P3N)	I	156	(DAD30-P3P)	-
157	GND	-	158	(DAD28-P3P)	-
159	(DAD26-P3P)	-	160	(DAD24-P3P)	-
161	GND	-	162	(DIDSL-P3P)	-
163	(DAD22-P3P)	-	164	(DAD20-P3P)	-
165	GND	-	166	(DCBE0-P3N)	-
167	(DAD18-P3P)	-	168	(DAD16-P3P)	-
169	GND	-	170	(DCBE2-P3N)	-
171	(DTRDY-P3N)	-	172	(DSTOP-P3N)	-
173	GND	-	174	VOID	-
175	LAN-E3V	I	176	VOID	-
177	VOID	-	178	N.C.	-
179	BIDAP-EXP	O	180	BIDAN-EXN	O

Table C-6 Docking I/F connector (240-pin)(4/4)

Pin No.	Signal name	I/O	Pin No.	Signal name	I/O
181	DCOUT	I	182	DCOUT	I
183	DSSDA-S5P	I/O	184	IF-P5V	I
185	Reserved	-	186	N.C.	-
187	GND	-	188	N.C.	-
189	USBP2-S3P	I/O	190	USBP2-S3N	I/O
191	GND	-	192	N.C.	-
193	N.C.	-	194	DOUTR-PXP	I/O
195	DOUTR-PXN	I/O	196	DOUTL-PXN	I/O
197	DINL-PXN	I/O	198	DINR-PXP	I/O
199	GND	-	200	RXD-PYN	O
201	RTS-PYP	I	202	CTS-PYP	O
203	DTR-PYP	I	204	SELCT-P5P	O
205	BUSY-P5P	O	206	ACK-P5N	O
207	PDB05-P5P	I/O	208	GND	-
209	GND	-	210	PDB03-P5P	I/O
211	SLIN-P5N	I	212	PINIT-P5N	I
213	ERROR-P5N	O	214	AUTFD-P5N	I
215	(DPREQ-P3N)	-	216	(DAD31-P3P)	-
217	GND	-	218	(DAD29-P3P)	-
219	(DAD27-P3P)	-	220	(DAD25-P3P)	-
221	GND	-	222	(DCBE23-P3N)	-
223	(DAD23-P3P)	-	224	(DAD21-P3P)	-
225	GND	-	226	(DCPCLR-P3P)	-
227	(DAD19-P3P)	-	228	(DAD17-P3P)	-
229	GND	-	230	(DFRAME-P3N)	-
231	(DIRDY-P3N)	-	232	(DDEVSL-P3N)	-
233	GND	-	234	ACT-E3N	O
235	LINK-E3N	O	236	DOCDT2-S3N	O
237	VOID	-	238	VOID	-
239	BIDBP-EXP	I	240	BIDBN-EXN	I

C.7 CN2200 Mini PCI I/F Connector (124-pin)*Table C-7 Mini PCI I/F connector pin assignment (124-pin) (1/2)*

Pin No.	Signal name	I/O	Pin No.	Signal Name	I/O
1	N.C.	-	2	N.C.	-
3	N.C.	-	4	N.C.	-
5	N.C.	-	6	N.C.	-
7	N.C.	-	8	N.C.	-
9	N.C.	-	10	N.C.	-
11	N.C.	-	12	N.C.	-
13	WLON-S3N	I	14	N.C.	-
15	GND	-	16	N.C.	-
17	PIRQD-P3N	I/O	18	P5V	I
19	P3V	I	20	PIRQG-P3N	I/O
21	N.C.	-	22	N.C.	-
23	GND	-	24	E3V	I
25	X33MPC-P3P	O	26	PCIRS0-S3N	O
27	GND	-	28	P3V	I
29	PREQ2-P3N	I	30	PGNT2-P3N	O
31	P3V	I	32	GND	-
33	AD31-P3P	I/O	34	PME-S3N	I
35	AD29-P3P	I/O	36	N.C.	-
37	GND	-	38	AD30-P3P	I/O
39	AD27-P3P	I/O	40	P3V	I
41	AD25-P3P	I/O	42	AD28-P3P	I/O
43	N.C.	-	44	AD26-P3P	I/O
45	CBE3-P3N	I/O	46	AD24-P3P	I/O
47	AD23-P3P	I/O	48	AD26-P3P	I/O
49	GND	-	50	GND	-
51	AD21-P3P	I/O	52	AD22-P3P	I/O
53	AD19-P3P	I/O	54	AD20-P3P	I/O
55	GND	-	56	PAR-P3P	I/O
57	AD17-P3P	I/O	58	AD18-P3P	I/O
59	CBE2-P3N	I	60	AD16-P3P	I/O
61	IRDY-P3N	I/O	62	GND	-

Table C-7 Mini PCI I/F connector pin assignment (124-pin) (2/2)

Pin No.	Signal name	I/O	Pin No.	Signal Name	I/O
63	P3V	I	64	FRAME-P3N	I/O
65	CLKRUN-P3N	O	66	TRDY-P3N	I/O
67	SERR-P3N	I	68	STOP-P3N	I/O
69	GND	-	70	P3V	I
71	PERR-P3N	I/O	72	DEVSEL-P3N	I/O
73	CBE1-P3N	I	74	GND	-
75	AD14-P3P	I/O	76	AD15-P3P	I/O
77	GND	-	78	AD13-P3P	I/O
79	AD12-P3P	I/O	80	AD11-P3P	I/O
81	AD10-P3P	I/O	82	GND	-
83	GND	-	84	AD09-P3P	I/O
85	AD08-P3P	I/O	86	CBE0-P3N	O
87	AD07-P3P	I/O	88	P3V	i
89	P3V	i	90	AD06-P3P	I/O
91	AD05-P3P	I/O	92	AD04-P3P	I/O
93	N.C.	-	94	AD02-P3P	I/O
95	AD03-P3P	I/O	96	AD00-P3P	I/O
97	P5V	-	98	N.C.	-
99	AD01-P3P	I/O	100	N.C.	-
101	GND	-	102	GND	-
103	N.C.	-	104	GND	-
105	N.C.	-	106	N.C.	-
107	N.C.	-	108	N.C.	-
109	N.C.	-	110	N.C.	-
111	N.C.	-	112	N.C.	-
113	GND	-	114	GND	-
115	N.C.	-	116	N.C.	-
117	GND	-	118	N.C.	-
119	GND	-	120	GND	-
121	N.C.	-	122	N.C.	-
123	N.C.	-	124	E3V	I

C.8 CN3010 MDC I/F Connector (12-pin)*Table C-8 MDC I/F connector pin assignment (12-pin)*

Pin No.	Signal name	I/O	Pin No.	Signal Name	I/O
1	GND	-	2	Reserved	-
3	M97OT2-P3P	I/O	4	Reserved	-
5	GND	-	6	E3V	-
7	M97SY2-P3P	I	8	GND	-
9	M97IN2-E3P	I/O	10	GND	-
11	-M97RS2-P3P	I	12	X97BC2-P3P	I

C.9 CN3490 Debug Port Connector (12-pin)*Table C-9 Debug port connector pin assignment (12-pin)*

Pin No.	Signal name	I/O	Pin No.	Signal Name	I/O
1	GND	-	2	P3V	-
3	LPCFRM-P3N		4	DBGDET-P3N	O
5	LAD0-P3P	I/O	6	LAD1-P3P	I/O
7	LAD2-P3P	I/O	8	LAD3-P3P	I/O
9	PLTRS1-E3N	I	10	X33DBG-P3P	I
11	P3V	-	12	GND	-

C.10 CN3200 Keyboard I/F Connector (34-pin)*Table C-10 Keyboard I/F connector pin assignment (34-pin)*

Pin No.	Signal name	I/O	Pin No.	Signal Name	I/O
1	NUMLED-P5N	I	2	ARWLED-P5N	I
3	CAPLED-P5N	I	4	P5V	I
5	KBSC00-S3N	O	6	KBSC01-S3N	O
7	KBSC02-S3N	O	8	KBSC03-S3N	O
9	KBSC04-S3N	O	10	KBSC05-S3N	O
11	KBSC06-S3N	O	12	KBRT00-S3N	O
13	KBSC07-S3N	O	14	KBSC08-S3N	O
15	KBSC09-S3N	O	16	KBRT01-S3N	O
17	KBRT02-S3N	O	18	KBRT03-S3N	O
19	KBSC10-S3N	O	20	KBSC11-S3N	O
21	KBRT04-S3N	O	22	KBRT05-S3N	O
23	KBSC12-S3N	O	24	KBSC13-S3N	O
25	KBRT06-S3N	O	26	KBRT07-S3N	O
27	KBSC14-S3N	O	28	KBSC15-S3N	O
29	P5V	I	30	N.C.	-
31	N.C.	-	32	N.C.	-
33	N.C.	-	34	P5V	I

C.11 CN3240 Touch Pad I/F Connector (4-pin)*Table C-11 Touch pad I/F connector pin assignment (4-pin)*

Pin No.	Signal name	I/O	Pin No.	Signal Name	I/O
1	P5V	I	2	IPDDAT-P5P	I/O
3	IPDCLK-P5P	I/O	4	GND	-

C.12 CN3280 Switch Board I/F Connector (10-pin)*Table C-12 Switch board I/F connector pin assignment (10-pin)*

Pin No.	Signal name	I/O	Pin No.	Signal Name	I/O
1	GND	-	2	GND	-
3	GND	-	4	GPBTND-S3N	O
5	GPBTNC-S3N	O	6	GPBTNB-S3N	O
7	GPBTNA-S3N	O	8	PWRSW-S3N	O
9	GND	-	10	PNLOFF-S3N	O

C.13 CN3502 FLGCP/FLGSR Board I/F Connector (30-pin)*Table C-13 FLGCP/FLGSR board I/F connector pin assignment (30-pin)*

Pin No.	Signal Name	I/O	Pin No.	Signal name	I/O
1	P3V	-	2	P3V	-
3	KRSSDM-P3N	I/O	4	PRTDET-P3N	I/O
5	GND	-	6	STROB-P5N	I
7	BPDB00-P5P	I/O	8	BPDB01-P5P	I/O
9	BPDB02-P5P	I/O	10	BPDB03-P5P	I/O
11	BPDB04-P5P	I/O	12	BPDB05-P5P	I/O
13	BPDB06-P5P	I/O	14	BPDB07-P5P	I/O
15	GND	-	16	GND	-
17	ACK-P5N	I	18	BUSY-P5P	I
19	PE-P5P	I	20	SELCT-P5P	I
21	AUTFD-P5N	O	22	ERROR-P5N	I
23	PINIT-P5N	O	24	SLIN-P5N	O
25	PRTDET-P3N	I/O	26	GND	-
27	GND	-	28	GND	-
29	GND	-	30	GND	-

C.14 CN4100 Network I/F Connector (14-pin)*Table C-14 Network I/F connector pin assignment (14-pin)*

Pin No.	Signal name	I/O	Pin No.	Signal Name	I/O
1	ACT-E3N	I	2	LINK-E3N	I
3	LAN-E3V	I	4	LAN-E3V	I
5	N.C.	-	6	N.C.	-
7	BIDDN-EXN	I/O	8	BIDDP-EXP	I/O
9	BIDCN-EXN	I/O	10	BIDCP-EXP	I/O
11	BIDAP-EXP	I	12	BIDAN-EXN	I
13	BIDBP-EXP	O	14	BIDBN-EXN	O

C.15 CN4611 USB harness I/F Connector (8-pin)*Table C-15 USB harness I/F connector pin assignment (8-pin)*

Pin No.	Signal name	I/O	Pin No.	Signal Name	I/O
1	GND	-	2	USBP0-S3N	I/O
3	USBP0-S3P	I/O	4	USBOPS-E5V	I
5	USBOPS-E5V	I	6	USBP3-S3N	I/O
7	USBP3-S3P	I/O	8	GND	-

C.16 CN4610 USB I/F Connector 0 (4-pin)*Table C-16 USB I/F connector pin assignment (4-pin)*

Pin No.	Signal name	I/O	Pin No.	Signal Name	I/O
1	USB1PS-E5V	I	2	USBP5-S3N	I/O
3	USBP5-S3P	I/O	4	GND	-

C.17 CN5000 LCD I/F Connector (41-pin)*Table C-17 LCD I/F connector pin assignment (41-pin)*

Pin No.	Signal name	I/O	Pin No.	Signal Name	I/O
1	GND	-	2	GND	-
3	TXDTA0-PYP	I	4	TXDTA0-PYN	O
5	TXDTA1-PYP	I	6	TXDTA1-PYN	O
7	GND	-	8	TXDTA2-PYP	I
9	TXDTA2-PYN	O	10	TXCLKA-PYP	I
11	TXCLKA-PYN	O	12	GND	-
13	TXDTB0-PYP	I	14	TXDTB0-PYN	O
15	TXDTB1-PYP	I	16	TXDTB1-PYN	O
17	GND	-	18	TXDTB2-PYP	I
19	TXDTB2-PYN	O	20	TXCLKB-PYP	I
21	TXCLKB-PYN	O	22	GND	-
23	GND	-	24	N.C.	-
25	PNL-P3V	I	26	PNL-P3V	I
27	N.C.	-	28	GND	-
29	GND	-	30	GND	-
31	N.C.	-	32	FL-P5V	I
33	FL-P5V	I	34	FL-P5V	I
35	PNL2-P3P	O	36	PNL1-P3P	O
37	PNL0-P3P	O	38	BRT2DA-S3P	I
39	BRT1-P5P	I	40	BRT0-P5P	I
41	GND	-			

C.18 CN5620 RGB I/F Connector (15-pin)*Table C-18 RGB I/F connector pin assignment (15-pin)*

Pin No.	Signal name	I/O	Pin No.	Signal Name	I/O
1	MRED-PXP	I	2	MGREEN-PXP	I
3	MBLUE-PXP	I	4	N.C.	-
5	GND	-	6	GND	-
7	GND	-	8	GND	-
9	DDC-P5V	I	10	GND	-
11	N.C.	-	12	CRTSDA-P5P	I/O
13	MHSYNC-P3P	I/O	14	MVSYNC-P3P	I/O
15	CRTSCL-P5P	I/O			

C.19 CN5340 S-Video I/F Connector (5-pin)*Table C-19 S-Video I/F connector pin assignment (5-pin)*

Pin No.	Signal name	I/O	Pin No.	Signal Name	I/O
1	GND	-	2	CHROMA-PYP	I
3	GND	-	4	LUMINA-PYP	I
5	GND	-			

C.20 CN6001 Speaker Connector (Left) (3-pin)*Table C-20 Speaker connector (left) pin assignment (3-pin)*

Pin No.	Signal name	I/O	Pin No.	Signal Name	I/O
1	SPOUT (L-)	I	2	N.C.	-
3	SPOUT (L+)	I			

C.21 CN6002 Speaker Connector (Right) (2-pin)*Table C-21 Speaker connector (right) pin assignment (2-pin)*

Pin No.	Signal name	I/O	Pin No.	Signal Name	I/O
1	SPOUT(R+)	I	2	SPOUT (R-)	I

C.22 CN9500 Sound Board I/F Connector (18-pin)*Table C-22 Sound Board I/F connector pin assignment (18-pin)*

Pin No.	Signal name	I/O	Pin No.	Signal Name	I/O
1	A-GND	-	2	A-GND	-
3	A-GND	-	4	LOUTL-PXP	I
5	VROUTL-PXP	O	6	A4R7-P4V	I
7	A4R7-P4V	I	8	VROUTR-PXP	O
9	LOUTR-PXP	I	10	A-GND	-
11	HEADR-PXP	I	12	HEADL-PXP	I
13	SPKEN-P5P	O	14	MMREFV-P2V	O
15	MICIN-PXP	O	16	A-GND	-
17	A-GND	-	18	A-GND	-

C.23 CN8800 DC-IN Connector (4-pin)*Table C-23 DC-IN connector pin assignment (4-pin)*

Pin No.	Signal name	I/O	Pin No.	Signal Name	I/O
1	ADPDC	O	2	PVDC	O
3	PVH	O	4	PVL	O

C.24 CN8020 1st Battery Connector (10-pin)*Table C-24 1st Battery connector pin assignment (10-pin)*

Pin No.	Signal name	I/O	Pin No.	Signal Name	I/O
1	CHGVL	O	2	BTMP1	O
3	DCHG	I	4	M5V	I
5	PSCL-S5P	O	6	PSDA-S5P	O
7	GND	-	8	DBT10V-S5N	O
9	GND	-	10	GND	-

C.25 CN9990 RTC Battery Connector (3-pin)*Table C-25 RTC Battery connector pin assignment (3-pin)*

Pin No.	Signal name	I/O	Pin No.	Signal Name	I/O
1	R3V	O	2	N.C.	-
3	GND	-			

C.26 CN8770 FAN I/F Connector (4-pin)*Table C-26 FAN I/F connector pin assignment (4-pin)*

Pin No.	Signal name	I/O	Pin No.	Signal Name	I/O
1	P5V	I	2	GND	-
3	FANG0-P3P	O	4	FPWM0-S3P	I

Sound Board (FLGSN*)**C.27 J6070 External Microphone Connector (6-pin)***Table C-27 External Microphone Connector pin assignment (6-pin)*

Pin No.	Signal name	I/O	Pin No.	Signal Name	I/O
1	A-GND	-	2	MICIN-PXP	O
3	MMREFV	O	4	A-GND	-
5	N.C.	-	6	MMREFV	O

C.28 J6310 Headphone Connector (6-pin)*Table C-28 Headphone Connector pin assignment (6-pin)*

Pin No.	Signal name	I/O	Pin No.	Signal Name	I/O
1	A-GND	-	2	HEADL-PXP	O
3	HEADR-PXP	O	4	A-GND	-
5	SPKEN-P5N	O	6	N.C.	-

C.29 CN9510 System Board I/F Connector (18-pin)*Table C-29 System board I/F Connector pin assignment (18-pin)*

Pin No.	Signal name	I/O	Pin No.	Signal Name	I/O
1	A-GND	-	2	A-GND	-
3	A-GND	-	4	MICIN-PXP	I
5	MMREFV-P2V	I	6	SPKEN-P5N	I
7	HEADL-PXP	O	8	HEADR-PXP	O
9	A-GND	-	10	LOUTR-PXP	O
11	VROUT-PXP	I	12	A4R7-P4V	O
13	A4R7-P4V	O	14	VROUTL-PXP	I
15	LOUTL-PXP	O	16	A-GND	-
17	A-GND	-	18	A-GND	-

Switch Board (FLKSW*)**C.30 PJ3280 System Board I/F Connector (10-pin)***Table C-30 System board I/F Connector pin assignment (10-pin)*

Pin No.	Signal name	I/O	Pin No.	Signal Name	I/O
1	GND	-	2	GND	-
3	GND	-	4	GPBTND-S3N	I
5	GPBTNC-S3N	I	6	GPBTNB-S3N	I
7	GPBTNA-S3N	I	8	PWRSW-S3N	I
9	GND	-	10	PNLOFF-S3N	I

Parallel Board (FLGCP*)

C.31 CN3503 System Board I/F Connector (30-pin)

Table C-31 System board I/F Connector pin assignment (30-pin)

Pin No.	Signal Name	I/O	Pin No.	Signal name	I/O
1	GND	-	2	GND	-
3	N.C.	-	4	GND	-
5	GND	-	6	STROB-P5N	O
7	BPDB00-P5P	I/O	8	BPDB01-P5P	I/O
9	BPDB02-P5P	I/O	10	BPDB03-P5P	I/O
11	BPDB04-P5P	I/O	12	BPDB05-P5P	I/O
13	BPDB06-P5P	I/O	14	BPDB07-P5P	I/O
15	GND	-	16	GND	-
17	ACK-P5N	I	18	BUSY-P5P	I
19	PE-P5P	I	20	SELCT-P5P	I
21	AUTFD-P5N	O	22	ERROR-P5N	I
23	PINIT-P5N	O	24	SLIN-P5N	O
25	(PRTDET#)	-	26	GND	-
27	GND	-	28	GND	-
29	GND	-	30	GND	-

C.32 CN4613 Parallel I/F Connector (25-pin)*Table C-32 Parallel I/F Connector pin assignment (25-pin)*

Pin No.	Signal name	I/O	Pin No.	Signal Name	I/O
1	STROB-P5N	I	2	BPDB00-P5P	I/O
3	BPDB01-P5P	I/O	4	BPDB02-P5P	I/O
5	BPDB03-P5P	I/O	6	BPDB04-P5P	I/O
7	BPDB05-P5P	I/O	8	BPDB06-P5P	I/O
9	BPDB07-P5P	I/O	10	ACK-P5N	I
11	BUSY-P5P	I	12	PE-P5P	I
13	SELCT-P5P	I	14	AUTFD-P5N	O
15	ERROR-P5N	I	16	PINIT-P5N	O
17	SLIN-P5N	O	18	GND	-
19	GND	-	20	GND	-
21	GND	-	22	GND	-
23	GND	-	24	GND	-
25	GND	-			

C.33 CN4620 USB harness I/F Connector (8-pin)*Table C-33 USB harness I/F connector pin assignment (8-pin)*

Pin No.	Signal name	I/O	Pin No.	Signal Name	I/O
1	USB signal4	-	2	USB signal2	I/O
3	USB signal3	I/O	4	USBPS-E5V	I/O
5	USBPS-E5V	I/O	6	N.C.	-
7	N.C.	-	8	GND	-

C.34 CN4622 USB I/F Connector 1 (4-pin)*Table C-34 USB I/F Connector 1 pin assignment (4-pin)*

Pin No.	Signal name	I/O	Pin No.	Signal Name	I/O
1	USBPS-E5V	I/O	2	USB signal2	I/O
3	USB signal3	I/O	4	USB signal1	I/O

S-Video Board (FLGCS*)**C.35 PJ4610 USB harness I/F Connector (8-pin)***Table C-35 USB harness I/F connector pin assignment (8-pin)*

Pin No.	Signal name	I/O	Pin No.	Signal Name	I/O
1	GND	-	2	USBP0-S3N	I/O
3	USBP0-S3P	I/O	4	USBP0-4	I/O
5	USBP0-5	I/O	6	USBP3-S3N	I/O
7	USBP3-S3P	I/O	8	USBP3-8	I/O

C.36 PJ4612 USB I/F Connector 1 (4-pin)*Table C-36 USB I/F Connector 1 pin assignment (4-pin)*

Pin No.	Signal name	I/O	Pin No.	Signal Name	I/O
1	USBP0-4&5	I/O	2	USBP0-S3N	I/O
3	USBP0-S3P	I/O	4	USBP0-1	I/O

C.37 PJ4611 USB I/F Connector 2 (4-pin)*Table C-37 USB I/F Connector 2 pin assignment (4-pin)*

Pin No.	Signal name	I/O	Pin No.	Signal Name	I/O
1	USBP0-4&5	I/O	2	USBP3-S3N	I/O
3	USBP3-S3P	I/O	4	USBP3-8	I/O

C.38 PJ5640 System Board I/F Connector (5-pin)*Table C-38 System board I/F Connector pin assignment (5-pin)*

Pin No.	Signal name	I/O	Pin No.	Signal Name	I/O
1	GND	-	2	CHROMA	O
3	GND	-	4	LUMINANCE	O
5	GND	-			

C.39 PJ5641 S-Video Connector (4-pin)*Table C-39 S-Video Connector pin assignment (4-pin)*

Pin No.	Signal name	I/O	Pin No.	Signal Name	I/O
1	GND	-	2	GND	-
3	LUMINANCE	I	4	CHROMA	I

Serial Board (FLGSR*)

C.40 CN3504 System Board I/F Connector (30-pin)

Table C-40 System board I/F Connector pin assignment (30-pin)

Pin No.	Signal Name	I/O	Pin No.	Signal name	I/O
1	P3V	-	2	P3V	-
3	KRSSDM-P3N	O	4	N.C.	-
5	GND	-	6	N.C.	-
7	BDSR-P3N	I	8	BCTS-P3N	I
9	BRXD-P3P	I	10	BRING-P3N	I
11	BDGD-P3N	I	12	BDTR-P3N	O
13	BTXD-P3P	O	14	BRTS-P3N	O
15	GND	-	16	GND	-
17	N.C.	-	18	N.C.	-
19	N.C.	-	20	N.C.	-
21	N.C.	-	22	N.C.	-
23	N.C.	-	24	N.C.	-
25	GND	-	26	GND	-
27	GND	-	28	GND	-
29	GND	-	30	GND	-

C.41 CN3440 Serial I/F Connector (9-pin)*Table C-41 Serial I/F Connector pin assignment (9-pin)*

Pin No.	Signal name	I/O	Pin No.	Signal Name	I/O
1	BDCD-P3N	O	2	BRXD-P3P	O
3	BTXD-P3P	I	4	BRTR-P3N	I
5	GND	-	6	BDSR-P3N	O
7	BRTS-P3N	I	8	BCTS-P3N	O
9	BRING-P3N	O			

C.42 CN4630 USB harness I/F Connector (8-pin)*Table C-42 USB harness I/F connector pin assignment (8-pin)*

Pin No.	Signal name	I/O	Pin No.	Signal Name	I/O
1	USB signal4	-	2	USB signal2	I/O
3	USB signal3	I/O	4	USBPS-E5V	I/O
5	USBPS-E5V	I/O	6	N.C.	-
7	N.C.	-	8	GND	-

C.43 CN4632 USB I/F Connector 1 (4-pin)*Table C-43 USB I/F Connector 1 pin assignment (4-pin)*

Pin No.	Signal name	I/O	Pin No.	Signal Name	I/O
1	USBPS-E5V	I/O	2	USB signal2	I/O
3	USB signal3	I/O	4	USB signal1	I/O

Appendix D Keyboard Scan/Character Codes

Table D-1 Scan codes (set 1 and set 2) (1/4)

Cap No.	Keytop	Code set 1		Code set 2			Note
		Make	Break	Make	Break		
01	' ~	29	A9	0E	F0	0E	
02	1 !	02	82	16	F0	16	
03	2 @	03	83	1E	F0	1E	
04	3 #	04	84	26	F0	26	
05	4 \$	05	85	25	F0	25	
06	5 %	06	86	2E	F0	2E	
07	6 ^	07	87	36	F0	36	
08	7 &	08	88	3D	F0	3D	*2
09	8 *	09	89	3E	F0	3E	*2
10	9 (0A	8A	46	F0	46	*2
11	0)	0B	8B	45	F0	45	
12	- _	0C	8C	4E	F0	4E	
13	= +	0D	8D	55	F0	55	
15	BkSp	0E	8E	66	F0	66	
16	Tab	0F	8F	0D	F0	0D	
17	Q	10	90	15	F0	15	
18	W	11	91	1D	F0	1D	
19	E	12	92	24	F0	24	
20	R	13	93	2D	F0	2D	
21	T	14	94	2C	F0	2C	
22	Y	15	95	35	F0	35	
23	U	16	96	3C	F0	3C	*2
24	I	17	97	43	F0	43	*2
25	O	13	98	44	F0	44	*2
26	P	19	99	4D	F0	4D	*2
27	[{	1A	9A	54	F0	54	
28] }	1B	9B	5B	F0	5B	

Table D-1 Scan codes (set 1 and set 2) (2/4)

Cap No.	Keytop	Code set 1		Code set 2		Note	
		Make	Break	Make	Break		
29	\	2B	AB	5D	F0	5D	*5
30	Caps Lock	3A	BA	58	F0	58	
31	A	1E	9E	1C	F0	1C	
32	S	1F	9F	1B	F0	1B	
33	D	20	A0	23	F0	23	
34	F	21	A1	2B	F0	2B	
35	G	22	A2	34	F0	34	
36	H	23	A3	33	F0	33	
37	J	24	A4	3B	F0	3B	*2
38	K	25	A5	42	F0	42	*2
39	L	26	A6	4B	F0	4B	*2
40	; :	27	A7	4C	F0	4C	*2
41	' "	28	A8	52	F0	52	
43	Enter	1C	9C	5A	F0	5A	*3
44	Shift (L)	2A	AA	12	F0	12	
45	No.102 key	56	D6	61	F0	61	
46	Z	2C	AC	1A	F0	1A	
47	X	2D	AD	22	F0	22	
48	C	2E	AE	21	F0	21	
49	V	2F	AF	2A	F0	2A	
50	B	30	B0	32	F0	32	
51	N	31	B1	31	F0	31	
52	M	32	B2	3A	F0	3A	*2
53	, <	33	B3	41	F0	41	*2
54	. >	34	B4	49	F0	49	*2
55	/ ?	35	B5	4A	F0	4A	*2
57	Shift (R)	36	B6	59	F0	59	

Table D-1 Scan codes (set 1 and set 2) (3/4)

Cap No.	Keytop	Code set 1				Code set 2				Note
		Make		Break		Make		Break		
58	Ctrl	1D		9D		14		F0	14	*3
60	Alt (L)	38		B8		11		F0	11	*3
61	Space	39		B9		29		F0	29	
62	ALT (R)	E0 38		E0 B8		E0 11		E0 F0	11	
75	Ins	E0 52		E0 D2		E0 70		E0 F0	70	*1
76	Del	E0 53		E0 D3		E0 71		E0 F0	71	*1
79	←	E0 4B		E0 CB		E0 6B		E0 F0	6B	*1
80	Home	E0 47		E0 C7		E0 6C		E0 F0	6C	*1
81	End	E0 4F		E0 CF		E0 69		E0 F0	69	*1
83	↑	E0 48		E0 C8		E0 75		E0 F0	75	*1
84	↓	E0 50		E0 D0		E0 72		E0 F0	72	*1
85	PgUp	E0 49		E0 C9		E0 7D		E0 F0	7D	*1
86	PgDn	E0 51		E0 D1		E0 7A		E0 F0	7A	*1
89	→	E0 4D		E0 CD		E0 74		E0 F0	74	*1
110	Esc	01		81		76		F0	76	
112	F1	3B		BB		05		F0	05	
113	F2	3C		BC		06		F0	06	
114	F3	3D		BD		04		F0	04	
115	F4	3E		BE		0C		F0	0C	
116	F5	3F		BF		03		F0	03	
117	F6	40		C0		0B		F0	0B	
118	F7	41		C1		83		F0	83	
119	F8	42		C2		0A		F0	0A	
120	F9	43		C3		01		F0	01	
121	F10	44		C4		09		F0	09	*3

Table D-1 Scan codes (set 1 and set 2) (4/4)

Cap No.	Keytop	Code set 1				Code set 2				Note
		Make		Break		Make		Break		
122	F11	57	D7	78	F0	78			*3	
123	F12	58	D8	07	F0	07			*3	
124	PrintSc	*6	*6	*6	*6				*6	
126	Pause	*7	*7	*7	*7				*7	
202	Fn	—	—	—	—				*4	
203	Win	E0	5B	E0	DB	E0	1F	E0	F0	1F
204	App	E0	5D	E0	DD	E0	2F	E0	F0	2F

Notes:

1. * Scan codes differ by mode.
2. * Scan codes differ by overlay function.
3. * Combined with the **Fn** key makes different codes.
4. * **Fn** key does not generate a code by itself.
5. * This key corresponds to key No. 42 in a 102-key model.
6. * Refer to Table D-6, No. 124 key scan code.
7. * Refer to Table D-7, No. 126 key scan code.

Table D-2 Scan codes with left Shift key

Cap No.	Key top	Code set 1		Code set 2			
		Make	Break	Make		Break	
55	/	E0 AA E0 35	E0 B5 E0 2A	E0 F0 12 E0 4A	E0 F0 4A E0 12		
75	INS	E0 AA E0 52	E0 D2 E0 2A	E0 F0 12 E0 70	E0 F0 70 E0 12		
76	DEL	E0 AA E0 53	E0 D3 E0 2A	E0 F0 12 E0 71	E0 F0 71 E0 12		
79	←	E0 AA E0 4B	E0 CB E0 2A	E0 F0 12 E0 6B	E0 F0 6B E0 12		
80	Home	E0 AA E0 47	E0 C7 E0 2A	E0 F0 12 E0 6C	E0 F0 6C E0 12		
81	End	E0 AA E0 4F	E0 CF E0 2A	E0 F0 12 E0 69	E0 F0 69 E0 12		
83	↑	E0 AA E0 48	E0 C8 E0 2A	E0 F0 12 E0 75	E0 F0 75 E0 12		
84	↓	E0 AA E0 50	E0 D0 E0 2A	E0 F0 12 E0 72	E0 F0 72 E0 12		
85	PgUp	E0 AA E0 49	E0 C9 E0 2A	E0 F0 12 E0 7D	E0 F0 7D E0 12		
86	PgDn	E0 AA E0 51	E0 D1 E0 2A	E0 F0 12 E0 7A	E0 F0 7A E0 12		
89	→	E0 AA E0 4D	E0 CD E0 2A	E0 F0 12 E0 74	E0 F0 74 E0 12		
203	Win	E0 AA E0 5B	E0 DB E0 2A	E0 F0 12 E0 1F	E0 F0 1F E0 12		
204	App	E0 AA E0 5D	E0 DD E0 2A	E0 F0 12 E0 2F	E0 F0 2F E0 12		

Note : The table above shows scan codes with the left **Shift** key. In combination with the right **Shift** key, scan codes are changed as listed below:

	With left Shift	With right Shift
Set 1	E0 AA _____	E0 B6
	E0 2A _____	E0 36
Set 2	E0 F0 12 _____	E0 F0 59
	E0 12 _____	E0 59

Table D-3 Scan codes in Numlock mode

Cap No.	Key top	Code set 1				Code set 2			
		Make		Break		Make		Break	
75	INS	E0 2A E0 52	E0 D2 E0 AA	E0 12 E0 70	E0 F0 70 E0 F0 12				
76	DEL	E0 2A E0 53	E0 D3 E0 AA	E0 12 E0 71	E0 F0 71 E0 F0 12				
79	←	E0 2A E0 4B	E0 CB E0 AA	E0 12 E0 6B	E0 F0 6B E0 F0 12				
80	Home	E0 2A E0 47	E0 C7 E0 AA	E0 12 E0 6C	E0 F0 6C E0 F0 12				
81	End	E0 2A E0 4F	E0 CF E0 AA	E0 12 E0 69	E0 F0 69 E0 F0 12				
83	↑	E0 2A E0 48	E0 C8 E0 AA	E0 12 E0 75	E0 F0 75 E0 F0 12				
84	↓	E0 2A E0 50	E0 D0 E0 AA	E0 12 E0 72	E0 F0 72 E0 F0 12				
85	PgUp	E0 2A E0 49	E0 C9 E0 AA	E0 12 E0 7D	E0 F0 7D E0 F0 12				
86	PgDn	E0 2A E0 51	E0 D1 E0 AA	E0 12 E0 7A	E0 F0 7A E0 F0 12				
89	→	E0 2A E0 4D	E0 CD E0 AA	E0 12 E0 74	E0 F0 74 E0 F0 12				
203	Win	E0 2A E0 5B	E0 DB E0 AA	E0 12 E0 1F	E0 F0 1F E0 F0 12				
204	App	E0 2A E0 5D	E0 DD E0 AA	E0 12 E0 2F	E0 F0 2F E0 F0 12				

Table D-4 Scan codes with Fn key

Cap No.	Keytop	Code set 1		Code set 2	
		Make	Break	Make	Break
43	ENT	E0 1C	E0 9C	E0 5A	E0 F0 5A
58	CTRL	E0 1D	E0 9D	E0 14	E0 F0 14
60	LALT	E0 38	E0 B8	E0 11	E0 F0 11
121	ARROW	45	C5	77	F0 77
122	NUMERIC	45	C5	77	F0 77
123	Scrl	46	C5	7E	F0 7E

Table D-5 Scan codes in overlay mode

Cap No.	Keytop		Code set 1				Code set 2			
			Make		Break		Make		Break	
09	8	(8)	48		C8			75	F0	75
10	9	(9)	49		C9			7D	F0	7D
11	0	(*)	37		B7			7C	F0	7C
23	U	(4)	4B		CB			6B	F0	6B
24	I	(5)	4C		CC			73	F0	73
25	O	(6)	4D		CD			74	F0	74
26	P	(-)	4A		CA			7B	F0	7B
37	J	(1)	4F		CF			69	F0	69
38	K	(2)	50		D0			72	F0	72
39	L	(3)	51		D1			7A	F0	7A
40	;	(+)	4E		CE			79	F0	79
52	M	(0)	52		D2			70	F0	70
54	.	(.)	53		D3			71	F0	71
55	/	(/)	E0 35		E0 B5			40 4A	E0 F0	4A

Table D-6 No.124 key scan code

Key top	Shift	Code set 1				Code set 2			
		Make		Break		Make		Break	
Prt Sc	Common	E0 2A	E0 37	E0 B7	E0 AA	E0 12	E0 7C	E0 F0 7C	E0 F0 12
	Ctrl +	E0 37		E0 B7		E0 7C		E0 F0 7C	
	Shift +	E0 37		E0 B7		E0 7C		E0 F0 7C	
	Alt +		54	D4		84		F0 B4	

Table D-7 No.126 key scan code

Key top	Shift	Code set 1						Code set 2							
		Make						Make							
Pause	Common *	E1	1D	45	E1	9D	C5	E1	14	77	E1	F0	14	F0	77
	Ctrl*	E0	46	E0	C6			E0	7E	E0	F0	7E			

*: This key generates only make codes.

Appendix E Key Layout

E.1 Keyboard Layout

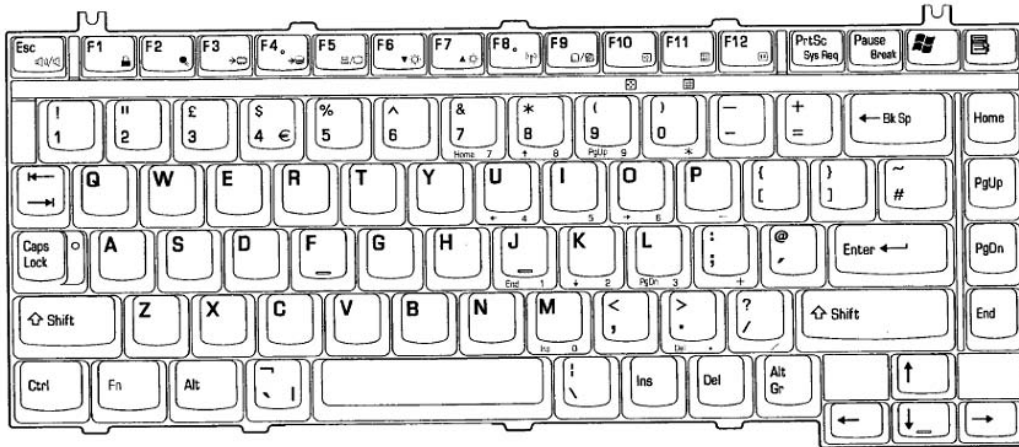

Figure E-1 Keyboard layout (for UK)



Figure E-2 Keyboard layout (for US)

Appendix F Wiring Diagrams

F.1 RGB Monitor ID Wraparound Connector (15-pin to 15-pin)

(1) RED	_____	RED	(1)
(2) GREEN	_____	GREEN	(2)
(3) BLUE	_____	BLUE	(3)
(4) NC	_____	NC	(4)
(5) GND	_____	GND	(5)
(6) GND	_____	GND	(6)
(7) GND	_____	GND	(7)
(8) GND	_____	GND	(8)
(9) 5V	_____	5V	(9)
(10) GND	_____	GND	(10)
(11) NC	_____	NC	(11)
(12) SDA	_____	SDA	(12)
(13) HSYNC	_____	HSYNC	(13)
(14) VSYNC	_____	VSYNC	(14)
(15) SDL	_____	SCL	(15)

Figure F-1 RGB monitor ID wraparound connector

F.2 Parallel Port Wraparound Connector

(9) +PD7	_____	(15) -ERROR
(8) +PD6	_____	(14) -AUTFD
(7) +PD5	_____	(13) -SELECT
(6) +PD4	_____	(16) -PINT
(5) +PD3	_____	(1) -STROBE
		(10) -ACK
(4) +PD2	_____	(12) +PE
(3) +PD1	_____	(17) -SLIN
(2) +PD0	_____	(11) +BUSY

Figure F-2 Parallel port wraparound connector

Appendix G BIOS/KBC/EC Update

To update the BIOS, KBC or EC, insert the FD for update into the FDD. Then turn on the power of the computer while pressing the following key until the power LED blinks.

For BIOS update: ~ (tilde key ; See the following pictures.)



For KBC or EC update: **Tab**

When the update is completed, the message will appear and the beep will sound. Then the power of the computer is turned off.

Make sure of the update using the T&D.

NOTE: *Do not turn off the power of the computer during update. Otherwise the computer may not start again.*

Appendix H Reliability

The following table shows the MTBF (Mean Time Between Failures) of system.

Table H-1 MTBF

Component	Time (hours)
System (maximum configuration)	6,811
System (minimum configuration)	6,822

Free Manuals Download Website

<http://myh66.com>

<http://usermanuals.us>

<http://www.somanuals.com>

<http://www.4manuals.cc>

<http://www.manual-lib.com>

<http://www.404manual.com>

<http://www.luxmanual.com>

<http://aubethermostatmanual.com>

Golf course search by state

<http://golfingnear.com>

Email search by domain

<http://emailbydomain.com>

Auto manuals search

<http://auto.somanuals.com>

TV manuals search

<http://tv.somanuals.com>