

**Toshiba Personal Computer
Satellite
Maintenance Manual**

TOSHIBA CORPORATION

[CONFIDENTIAL]

Copyright

© 2009 by Toshiba Corporation. All rights reserved. Under the copyright laws, this manual cannot be reproduced in any form without the prior written permission of Toshiba. No patent liability is assumed with respect to the use of the information contained herein.

Toshiba Personal Computer Satellite Maintenance Manual

First edition May. 2009

Disclaimer

The information presented in this manual has been reviewed and validated for accuracy. The included set of instructions and descriptions are accurate for the Satellite Series at the time of this manual's production. However, succeeding computers and manuals are subject to change without notice. Therefore, Toshiba assumes no liability for damages incurred directly or indirectly from errors, omissions, or discrepancies between any succeeding product and this manual.

Trademarks

IBM is a registered trademark, and OS/2 and PS/2 are trademarks of IBM Corporation.

Microsoft, MS-DOS, Windows, DirectSound and DirectMusic are registered trademarks of Microsoft Corporation.

Intel and Pentium are registered trademarks, and SpeedStep is a trademark of Intel Corporation.

Sound Blaster is a registered trademark of Creative Technology Ltd.

Centronics is a registered trademark of Centronics Data Computer Corporation.

Photo CD is a trademark of Eastman Kodak.

All other properties are trademarks or registered trademarks of their respective holders.

Preface

This maintenance manual describes how to perform hardware service maintenance for the Toshiba Personal Computer Satellite, referred to as the Satellite Series in this manual.

The procedures described in this manual are intended to help service technicians isolate faulty Field Replaceable Units (FRUs) and replace them in the field.

SAFETY PRECAUTIONS

Four types of messages are used in this manual to bring important information to your attention. Each of these messages will be italicized and identified as shown below.

DANGER: “Danger” indicates the existence of a hazard that could result in death or serious bodily injury if the safety instruction is not observed.

WARNING: “Warning” indicates the existence of a hazard that could result in bodily injury if the safety instruction is not observed.

CAUTION: “Caution” indicates the existence of a hazard that could result in property damage if the safety instruction is not observed.

NOTE: “Note” contains general information that relates to your safe maintenance service.

Improper repair of the computer may result in safety hazards. Toshiba requires service technicians and authorized dealers or service providers to ensure the following safety precautions are adhered to strictly.

Be sure to fasten screws securely with the right screwdriver. If a screw is not fully fastened, it could come loose, creating a danger of a short circuit, which could cause overheating, smoke or fire.

If you replace the battery pack or RTC battery, be sure to use only the same model battery or an equivalent battery recommended by Toshiba. Installation of the wrong battery can cause the battery to explode.

The manual is divided into the following parts:

- Chapter 1 Hardware Overview describes the Satellite Series system unit and each FRU.
- Chapter 2 Troubleshooting Procedures explains how to diagnose and resolve FRU problems.
- Chapter 3 Test and Diagnostics describes how to perform test and diagnostic operations for maintenance service.
- Chapter 4 Replacement Procedures describes the removal and replacement of the FRUs.
- Appendices The appendices describe the following:

- Handling the LCD module
- Board layout
- Pin assignments
- Keyboard scan/character codes
- Key layout
- Screw torque list
- Reliability

Conventions

This manual uses the following formats to describe, identify, and highlight terms and operating procedures.

Acronyms

On the first appearance and whenever necessary for clarification, acronyms are enclosed in parentheses following their definition. For example:

Read Only Memory (ROM)

Keys

Keys are used in the text to describe many operations. The key top symbol as it appears on the keyboard is printed in **boldface** type.

Key operation

Some operations require you to simultaneously use two or more keys. We identify such operations by the key top symbols separated by a plus (+) sign. For example, **Ctrl + Pause (Break)** means you must hold down **Ctrl** and at the same time press **Pause (Break)**. If three keys are used, hold down the first two and at the same time press the third.

User input

Text that you are instructed to type in is shown in the boldface type below:

DISKCOPY A: B:

The display

Text generated by the computer that appears on its display is presented in the typeface below:

```
Format complete  
System transferred
```

Table of Contents

Chapter 1 Hardware Overview

1.1	Features.....	1-1
1.2	2.5-inch HDD	1-11
1.3	DVD Super Multi (+-R Double Layer)	1-13
1.4	Power Supply	1-14
1.5	Batteries	1-16
1.5.1	Main Battery	1-16
1.5.2	Battery Charging Control	1-16
1.5.3	RTC Battery.....	1-17

Chapter 2 Troubleshooting Procedures

2.1	Troubleshooting Introduction	3
2.2	Troubleshooting Flowchart.....	4
2.3	Power Supply Troubleshooting	9
2.4	Display Troubleshooting	14
2.5	Keyboard Troubleshooting	17
2.6	External USB Devices Troubleshooting.....	19
2.7	TV-tuner Troubleshooting.....	21
2.8	TouchPad Troubleshooting.....	25
2.9	Speaker Troubleshooting	27
2.10	Optical drive troubleshooting	29
2.11	MoTroubleshooting	32
2.12	Express card Troubleshooting	34
2.13	Wireless LAN Troubleshooting.....	36
2.12	Camera Troubleshooting	39
2.15	Bluetooth Troubleshooting.....	41

2.16	7 in 1 card Troubleshooting.....	44
2.17	HDD Troubleshooting	46
2.18	CRT failure Troubleshooting.....	48
2.19	HDMI Troubleshooting	50
2.20	Display Port Troubleshooting.....	52
2.21	SPDIF Troubleshooting	54
2.22	MIC Troubleshooting	56
2.23	Finger Troubleshooting.....	58
2.24	FM tuner Troubleshooting	60
2.25	E-SATA Troubleshooting.....	66
2.26	Felica Troubleshooting	69
2.27	UWB Troubleshooting.....	71
2.28	3G Troubleshooting	75

Chapter 3 Tests and Diagnostics

3.1	The Diagnostic Test.....	3
3.2	Executing the Diagnostic Test	4
3.3	Display Configuration	8
3.4	Audio sound Test	9
3.5	Fan ON/OFF Test	9
3.6	Main Battery Charge Test.....	11
3.7	FDD Test.....	11
3.8	Memory Check.....	14
3.9	Keyboard Test.....	14
3.10	Mouse (Pad) Test	16
3.11	LCD Pixels Mode Test	17
3.12	Magnetic switch Test.....	18
3.13	LAN Test	20
3.14	RTC Test.....	23

3.15	BUTTON Test.....	24
3.16	1st HDDTest	26
3.17	RDMI Test.....	27
3.18	WDMI Test	28

Chapter 4 Replacement Procedures

4.1	General.....	4-1
	Safety Precautions.....	4-2
	Before You Begin	4-4
	Disassembly Procedures	4-5
	Assembly Procedures.....	4-5
	Tools and Equipment	4-6
	Screw Tightening Torque	4-6
	Colors of Screw Shanks	4-7
	Symbols of Screws on the Laptop Body.....	4-7
	Symbol examples	4-7
4.2	Battery.....	4-8
	Removing the Battery Pack	4-8
	Installing the Battery Pack.....	4-9
4.3	HDD	4-10
	Removing the HDD	4-10
	Installing the HDD	4-12
4.4	Memory.....	4-13
	Removing the Optional Memory	4-13
	Installing the Optional Memory.....	4-14
4.5	UWB Module.....	4-15
4.6	Modem Card / FM Tuner	4-16
4.7	ODD	4-19
	Removing the ODD Bay Module.....	4-19

	Installing the ODD Bay Module	4-20
	Disassembling the ODD Drive	4-20
	Assembling the ODD Drive	4-21
4.8	Keyboard Cover and Keyboard.....	4-22
	Removing the Keyboard Cover and Keyboard.....	4-22
	Installing the Keyboard Cover and Keyboard.....	4-24
4.9	Logic Upper Assembly	4-25
	Removing the Logic Upper Assembly	4-25
	Installing the Logic Upper Assembly	4-27
4.10	Power Board.....	4-28
	Removing the Power Board	4-28
	Installing the power switch board	4-28
4.11	Speakers	4-29
	Removing the Speakers.....	4-29
	Installing the Speakers	4-29
4.12	Bluetooth Card	4-30
	Removing the Bluetooth card	4-30
	Installing the Bluetooth card.....	4-30
4.13	Touchpad Bracket, Touchpad Boards and Fingerprint Board/ Touchpad Switch Board.....	4-31
	Removing the Touchpad Bracket, Touchpad Boards and Fingerprint Board.....	4-31
	Touchpad Bracket, Touchpad Boards and Fingerprint Board/Touchpad Switch Board .	4-32
4.14	LED board.....	4-33
	Removing the LED Board.....	4-33
	Installing the LED Board	4-33
4.15	Thermal Fan	4-34
	Removing the Thermal Fan.....	4-34
	Installing the Thermal Fan	4-34
4.16	WLAN Card	4-35
	Removing the WLAN Card	4-35
	Installing the WLAN card.....	4-35
4.17	Motherboard.....	4-36

	Removing the Motherboard	4-36
	Installing the Motherboard.....	4-38
4.18	VGA Board and VGA Thermal Module (Optional)	4-40
	Removing the VGA Board and VGA Thermal Module	4-40
	Installing the VGA Board and VGA Thermal Module.....	4-41
4.19	CPU and Thermal Module	4-42
	Removing the CPU and Thermal Module.....	4-42
	Installing CPU and Thermal Module	4-43
4.20	Display Assembly	4-45
	Removing the Display Assembly.....	4-45
	Installing the Display Assembly	4-45
4.21	LCD Bezel Assembly.....	4-46
	Removing the LCD Bezel Assembly	4-46
	For Low-end Model	4-46
	For High-end Model	4-48
	Installing the Display Mask	4-55
4.22	LCD Module and Inverter Board.....	4-57
	Removing the LCD Module and Inverter Board	4-57
	Installing the LCD Module and Inverter Board.....	4-62
4.23	CMOS Board and MIC	4-66
	Removing the CMOS Board and MIC.....	4-66
	Installing the CMOS Board and MIC	4-67
4.24	Left USB Board	4-68
	Removing the USB Board on the Left Side.....	4-68
	Installing the Left USB Board	4-68
4.25	Right USB Board	4-69
	Removing the Right USB Board on the Right Side.....	4-69
	Installing the Right USB Board	4-71

Figures

Figure 4.1	Removing the Battery Pack.....	4-8
Figure 4.2	Removing the HDD door	4-10
Figure 4.3	Removing the HDD from the HDD bay.....	4-11
Figure 4.4	Removing the HDD plate	4-11
Figure 4.5	Removing the RAM door.....	4-13
Figure 4.6	Removing the RAM from the connectors	4-14
Figure 4.7	Removing the UWB module	4-15
Figure 4.8	Removing the modem card.....	4-16
Figure 4.9	Removing the FM Tuner	4-17
Figure 4.10	Removing the ODD Bay module	4-19
Figure 4.11	Removing the bracket from the ODD drive	4-20
Figure 4.12	Removing two screws from the battery lodging	4-22
Figure 4.13	Removing the keyboard cover.....	4-23
Figure 4.14	Removing screws from the keyboard.....	4-23
Figure 4.15	Removing the keyboard	4-24
Figure 4.16	Removing the screws from the bottom of the laptop	4-25
Figure 4.17	Removing eight screws from the laptop.....	4-26
Figure 4.18	Detaching cables from the laptop.....	4-27
Figure 4.19	Removing the power board	4-28
Figure 4.20	Removing the speakers.....	4-29
Figure 4.21	Removing the Bluetooth card.....	4-30
Figure 4.22	Removing the screws from the touchpad bracket	4-31
Figure 4.23	Removing the Touchpad boards and Fingerprint board.....	4-32
Figure 4.24	Removing the LED Board.....	4-33
Figure 4.25	Removing the thermal fan from the logic lower assembly	4-34
Figure 4.26	Removing the WLAN Card.....	4-35
Figure 4.27	Removing motherboard from logic lower assembly	4-36
Figure 4.28	Removing the DC_IN CONN and cable	4-37
Figure 4.29	Picking up the motherboard	4-37

Figure 4.30	Align the DP CONN, S/PDIF CONN, Audio CONN and RJ45 CONN.....	4-38
Figure 4.31	Installing the DC-in jack	4-39
Figure 4.32	Removing the VGA Board.....	4-40
Figure 4.33	Reapply the Shinetsu 7726 grease on the thermal module and remove any release papers.....	4-41
Figure 4.34	Removing the Thermal Module spring screws	4-42
Figure 4.35	Removing the CPU.....	4-43
Figure 4.36	Reapply the Shinetsu 7726 grease on the thermal module and remove any release papers.....	4-44
Figure 4.37	Removing the display assembly.....	4-45
Figure 4.38	Removing the LCD Bezel Assembly from the low-end model	4-46
Figure 4.39	Peel off the bezel.....	4-47
Figure 4.40	Pull out the hinge wall.....	4-47
Figure 4.41	Remove the bezel	4-48
Figure 4.42	Removing the LCD Bezel Assembly from the high-end model	4-48
Figure 4.43	Wrap the flat blade screwdriver with tape	4-49
Figure 4.44	Press the hinge wall.....	4-49
Figure 4.45	Pry up the bezel hinge wall	4-50
Figure 4.46	Release the rest of the hooks.....	4-50
Figure 4.47	Push the right side of the bezel upward	4-51
Figure 4.48	Push the left side of the bezel upward.....	4-52
Figure 4.49	Release hooks from the bottom of the bezel	4-53
Figure 4.50	Release hooks from the right and left side of the bezel	4-53
Figure 4.51	Release the hooks from the upper side of the bezel	4-54
Figure 4.52	Press the bezel hinge wall	4-55
Figure 4.53	Press the bottom hooks on the display assembly	4-55
Figure 4.54	Press the left and right side of the bezel for the low-end model/Press the hooks on the left and right side of the bezel for the high-end model.....	4-56
Figure 4.55	Press the bezel upside hooks	4-56
Figure 4.56	Removing the Inverter Board.....	4-57
Figure 4.57	Removing the LCD Module from the LCD cover assembly (high-end model).....	4-58
Figure 4.58	Removing the LCD Module from the LCD cover assembly	

	(low-end model)	4-59
Figure 4.59	Removing the LCD Hinge Assembly	4-60
Figure 4.60	Removing the LVDS cable from the LCD module	4-61
Figure 4.61	Installing the LCD Hinge Assembly	4-62
Figure 4.62	Installing the LCD Module from the LCD cover assembly (high-end model)	4-63
Figure 4.63	Installing the LCD Module from the LCD cover assembly (low-end model)	4-64
Figure 4.64	Not to pinch codes beside hinges (high-end model)	4-65
Figure 4.65	Not to pinch codes beside hinges (low-end model)	4-65
Figure 4.66	Removing the CMOS board and MIC (high-end model)	4-66
Figure 4.67	Removing the CMOS board and MIC (low-end model)	4-67
Figure 4.68	Removing the left USB Board from the logic lower assembly	4-68
Figure 4.69	Wrap the flat blade screwdriver with tape	4-69
Figure 4.70	Wrap the flat blade screwdriver with tape	4-70
Figure 4.71	Removing the USB Board on the right side	4-70

Appendices

Appendix A	Handling the LCD Module	A-1
Appendix B	Board Layout	B-1
Appendix C	Pin Assignments.....	C-1
Appendix D	Keyboard Scan/Character Codes	D-1
Appendix E	Key Layout.....	E-1
Appendix F	Series Screw Torque List	F-1
Appendix G	Reliability.....	G-1

Chapter 1

Hardware Overview

Chapter 1 Contents

1.1	Features	1-1
1.2	2.5-inch HDD	1-11
1.3	DVD Super Multi (+-R Double Layer).....	1-13
1.4	Power Supply	1-14
1.5	Batteries.....	1-16
1.5.1	Main Battery	1-16
1.5.2	Battery Charging Control	1-16
1.5.3	RTC Battery.....	1-17

Figures

Figure 1-1A ID Parts Description Placement Part A..... 1-7
Figure 1-2 SATA HDD 1-11
Figure 1-3 DVD Super Multi Drive 1-13

Tables

Table 1-1 HDD Specifications 1-12
Table 1-2 DVD Super Multi Drive Specifications 1-13
Table 1-3 Quick/Normal Charging Time 1-16

1.1 Features

The Toshiba Satellite A500/A500D is a full-size PC notebook based on a Dual Core Processor, providing high-speed processing capabilities and advanced features. The computer employs a lithium ion battery that allows it to be battery-operated for a long period of time. The display uses 16.0-inch WXGA LCD panel. The PGA socket supports BTO for the CPU so that the system can be designed to suit your needs.

The computer has the following features:

Processor (BTO)

The computer is equipped with one of the following AMD processors:

- AMD Turion™ 64 X2 Dual-Core Processor
- AMD Athlon™ X2 Dual-Core Processor
- AMD Sable™ X2 Dual-Core Processor

Memory (BTO)

The computer has two SODIMM slots that come standard with 1GB/2GB/4GB, BTO for various memory requirements. It can incorporate up to 8 GB of main memory. It supports DDR2 at 800MHz.

Battery Pack

The computer is powered by one rechargeable and removable lithium ion battery pack. The capacity can be either 3-cell, 6-cell or 12-cell, depending on the model of the computer.

RTC Battery

The internal RTC battery backs up the Real Time Clock and calendar.

Hard Disk Drive (HDD) (BTO)

The computer accommodates 9.5 mm and 12.5 mm HDD sizes with following storage capacities:

- 120/160/250/320 GB (9.5 mm thick) SATA (5,400rpm)
- 160/200/320 GB (9.5 mm thick) SATA (7,200rpm)
- 500 GB (12.5 mm thick) SATA (5,400rpm)
- 64GB/128GB (9.5mm thick) TOSHIBA SSD

❑ ODD (BTO)

- 12.7mm height DVD Super Multi drive supporting $\pm R$ Double Layer
- 12.7mm height DVD Super Multi drive supporting $\pm R$ Double Layer w/ Labelflash

❑ Display (BTO)

The LCD displays available come with one of the following types:

- 16.0" COLOR TFT/HD LCD (Samsung LTN160AT01-A Glare), 1366 X 768 HD Resolution
- 16.0" COLOR TFT/HD LCD (Samsung LTN160HT01-A Glare), 1920 X 1080 FHD Resolution

❑ Graphics (BTO)

- AMD RS780MN/RS780MC integrated graphic
- PM45 with ATI M92-XT//M96/N10M/N10P
(depending on model)

❑ Keyboard (BTO)

The computer is equipped with a Toshiba standard 300mm key board or half gloss black keyboard or half gloss black keyboard with illumination, which has 104keys. It is a Vista compliance keyboard, where you may find Windows key and application keys.

❑ Pointing Device

The integrated Wide Touch Pad and two control buttons in the palm rest allow control of the on-screen pointer and support functions such as the scrolling of windows.

❑ External Monitor Port (BTO)

The analog VGA port provides support for VESA DDC2B compatible functions. A WDDM driver is ready for Vista.

(depending on model)

Universal Serial Bus (USB) Ports

The computer has three USB 2.0 ports. It is supported to daisy-chain a maximum of 127 USB devices. The serial data transfer rate is 480 Mbps or 12 Mbps and 1.5 Mbps. These ports support PnP installation and hot plugging. They also support Sleep and Charge function.

eSATA

The external SATA or eSATA end user can now utilize shielded cable lengths up to 2 meters outside the PC to take advantage of the benefits the SATA interface brings to storage. SATA is now becoming an external standard, with specifically defined cables, connectors, and signal requirements released as new standards in mid-2004. eSATA is hot pluggable.

Express Card Slot

The internal Express Card slot is a universal slot. This slot supports ExpressCard/34/54 and the slot is covered with a dummy card. It also supports USB/PCI Express signals.

Bridge Media Slot

This slot allows you to insert SD, MiniSD/ MicroSD (through adaptor), Memory Stick/Memory Stick Duo (through adaptor), Memory Stick Pro/Memory Stick Duo (through adaptor), xD and MMC memory cards. It supports High-speed SD, SDHC and SD-IO. An I/O port heel cover is needed. This model does not support CF or Smart Media cards.

Sound system

The integrated sound system 'is composed of two Realtek Azalia internal speakers, an internal microphone (equipped with echo cancellation) as well as standard MIC-IN and S/PDIF-OUT ports.

Internal Camera

Camera supports 1.3M pixels with Auto Macro. Comes with a blue LED indicator. (The internal camera is BTO with the internal microphone). The camera is not a rotation type.

HDMI Out Port (BTO)

HDMI 1.3 out port can connect with Type A connector HDMI cable. One HDMI cable can send and receive SD and HD video/audio and control signals.

Headphones/S/PDIF/Line out Jack

This jack connects digital speakers or stereo headphones (16 ohm minimum). When connected to digital speakers or headphones, the internal speaker is automatically disabled. This jack can also be used as a S/PDIF port and can enable connection of optical-digital correspondence devices.

Microphone/ Line-in Jack

A 3.5mm mini microphone jack enables connection of a three-conductor microphone for monaural input and also enables the connection of a stereo device for audio input.

LAN (BTO)

The computer has built-in support for Gigabit Ethernet LAN (1000 megabits per second, 1000BASE-T) and 10M/100M Ethernet LAN (10/100 megabits per second, 10/100BASE-T). It employs a Realtek 8111DL for Gigabit LAN or 8103EL for 10M/100Mbit LAN. It is pre-installed as a standard device in some markets.

Wireless LAN (BTO)

Some computers in this series are equipped with a Wireless LAN card. This WLAN module may come in with the following types (depending on the model):

- Realtek 802.11b/g (8187SE 1x2), b/g/n (8192E 1x2)
- Atheros 802.11b/g (XB63 1x2), b/g/n (XB91 1x2), a/b/g/n (XB92 2x2)

Internal Modem (BTO)

Some models are equipped with an integrated modem. The integrated modem provides capability for data and fax communications that support the V.90 (V.92) standards and includes a modem jack for connection to the telephone line. Please note that both the V.90 and V.92 standards are only supported in the USA, Canada, United Kingdom, France, Germany and Australia - only the V.90 standard is supported in other regions. You should also be aware that the speed of data and fax transfer will depend on the analog telephone line conditions. The integrated model is only installed as a standard device in some markets. This internal modem comes with MDC 1.5 solution (Azalia interface) and is exclusive with FM Turner.

Wireless USB (BTO)

Some computers in this series are equipped with a Wireless USB card that is compatible with other Wireless USB devices based on the IEEE 802.15 Standard. It also includes JET Module with 3x3 WLAN.

Felica (BTO)

Imbedded Felica module writes and reads data to and from contact less Felica IC cards. Having no need for physical contact with the card, the Reader/Writer is immune to performance deterioration caused by wear and contamination, providing easy maintenance and long-term reliability.

FM Tuner (BTO)

- High sensitivity due to integrated low noise Radio Frequency (RF) input amplifier
- FM mixer for conversion of the US/Europe (87.5 MHz to 108 MHz) and Japanese FM band (76 MHz to 90 MHz) to IF
- Preset tuning to receive Japanese TV audio up to 108 MHz and raster 100 kHz
- Autonomous search tuning, 100 kHz grid
- RF Automatic Gain Control (AGC) circuit
- Fully integrated FM IF selectivity
- Fully integrated FM demodulator
- Soft mute, signal level dependent mute function
- Signal level dependent mono/stereo blend, Stereo Noise Cancelling (SNC)
- Soft mute and SNC can be switched off via control interface
- Adjustment free stereo decoder

FM Tuner is bundled exclusively with the modem.

Bluetooth (BTO)

Some computers in this series offer Bluetooth wireless communication functionality which eliminates the need for cables between electronic devices such as computers and printers. When implemented, Bluetooth provides a fast, reliable and secure means to achieve wireless communication in a small space. This module is Version 2.1 + EDR (Antenna on Module type).

Fingerprint Sensor (BTO)

The computer has a fingerprint utility installed for the purpose of enrolling and recognizing fingerprints. By enrolling the ID and password to the fingerprint authentication device, it is no longer necessary to input the password from the keyboard. Just by swiping the finger against the fingerprint sensor. The finger print sensor is located at the center of the Touch Pad panel and is an Authentec AES2550.

DisplayPort (BTO)

A 20-pin DisplayPort is installed on some computers to send and receive HD and SD video and audio signals (similar to HDMI). Support Display port 1.0 and 1.1 protocols for dual mode adapter.

TV Tuner (BTO)

Some models are equipped with ATSC/NSTC for Express card type TV tuner and PCIE mini type for the reception and playback of DVBT.

Sound system (BTO)

The integrated sound system provides support for the computer's internal speakers and microphone, also allowing an external microphone and headphones to be connected via the appropriate jacks. The computer has two Harman or Kardon (Odyssey2) speakers.

❑ Figure 1-1A shows the computer and its system unit configuration.

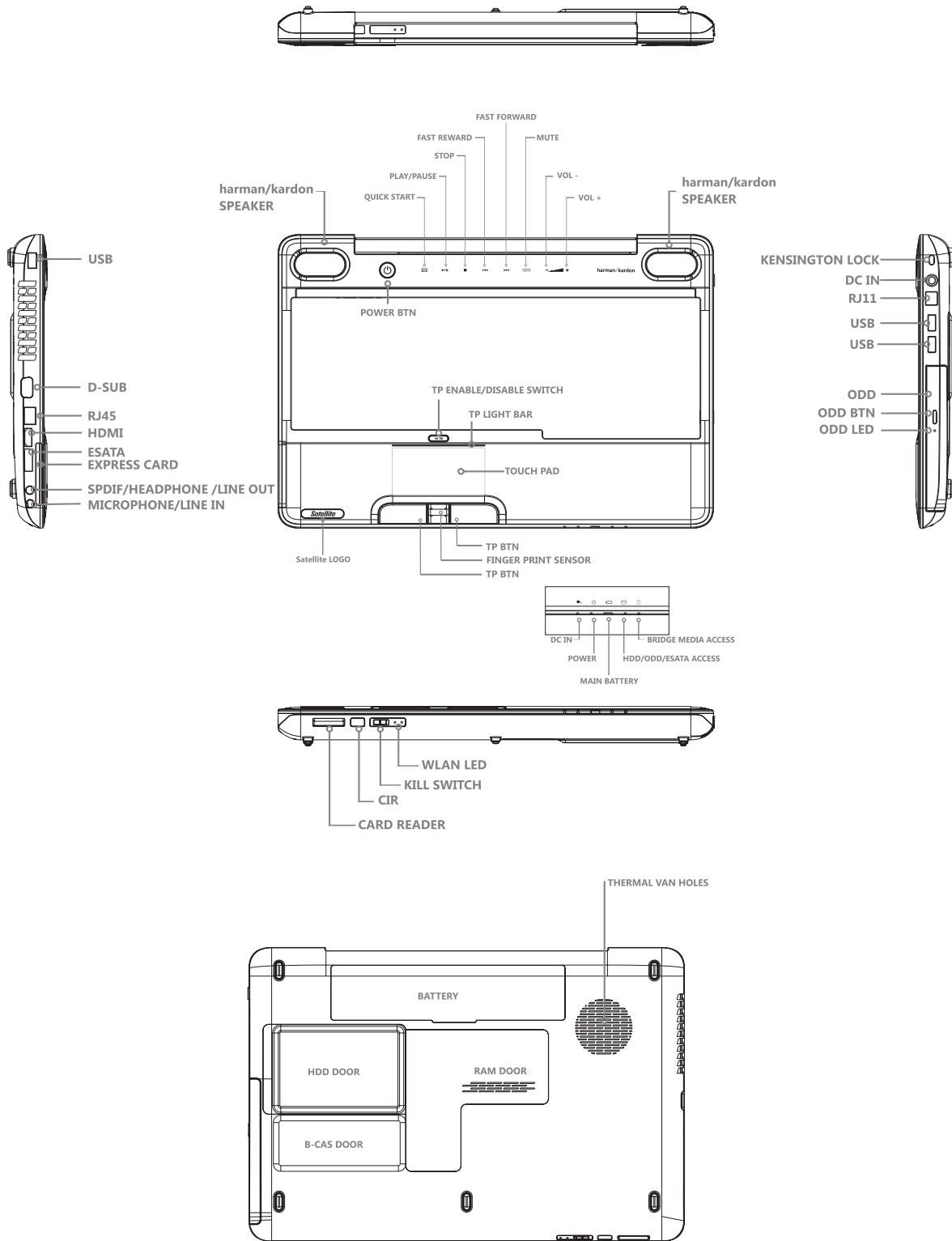
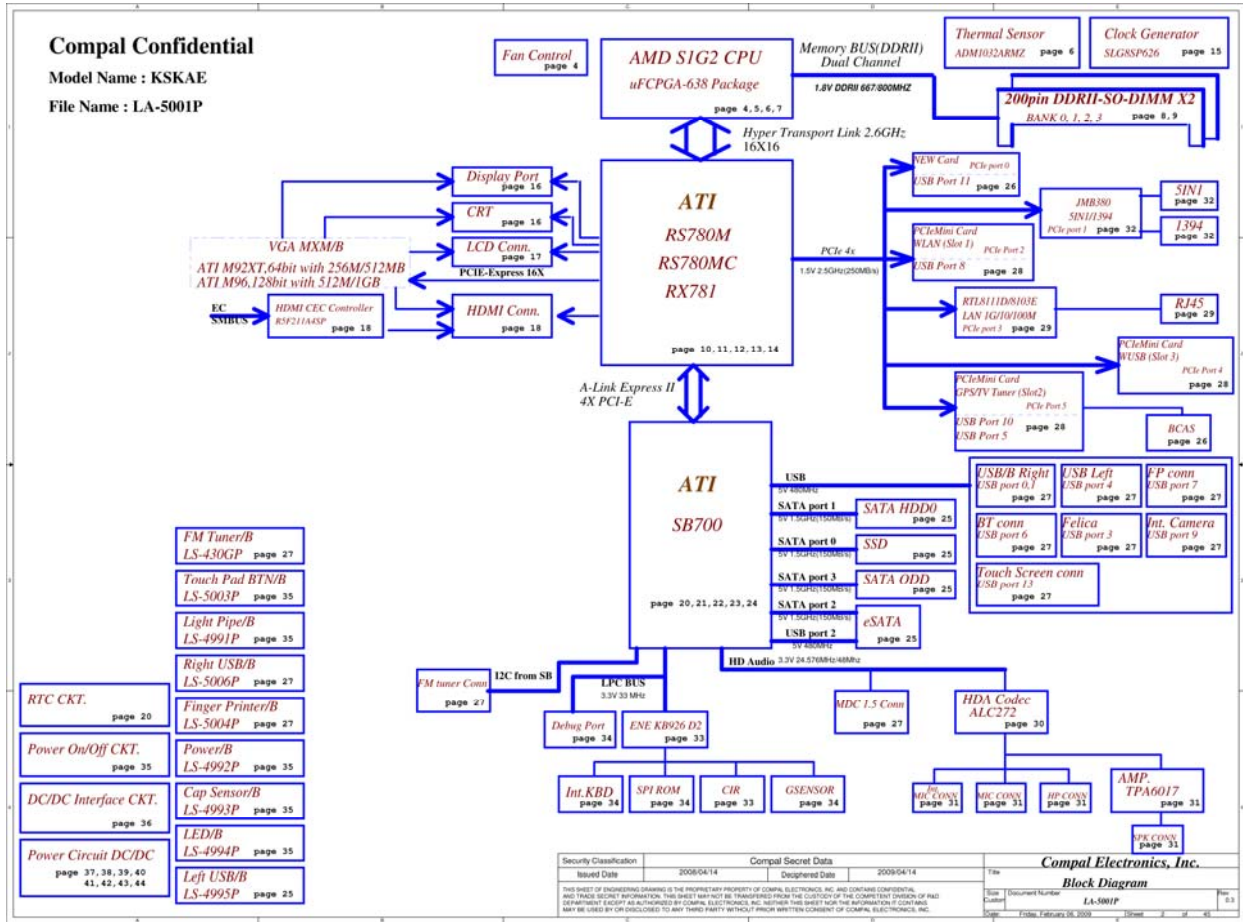

Figure 1-1A ID Parts Description Placement Part A



The system unit of the computer consists of the following components:

Processor (BTO)

The computer is equipped with one of the following AMD[®] processors.

- AMD Turion[™] 64 X2 Dual-Core Processor
- AMD Athlon[™] X2 Dual-Core Processor
- AMD Sable[™] Processor

Memory (BTO)

The computer has two SODIMM slots that come standard with 512MB/1GB/2GB/4GB, BTO for various memory requirements. It can incorporate up to 8 GB of main memory. It supports DDR2 at 667/800MHZ.

BIOS ROM (EEPROM)

The system BIOS and Keyboard BIOS share one single 1024KB flash ROM. The flash utility can be used to program both system and keyboard BIOS at the same time.

System Controllers

- Advanced Power Management 1.2 support
- ACPI2.0 b and PC2001 compliant
- Support SMBus specification V2.0
- Hot keys for system control
- Audio volume output control
- External LED control
- Battery scope report and control
- Sticky key support
- Power switch control
- Two host interface channels support
- Supports three independent devices
- Internal Keyboard country selection
- Wireless LAN on/off button

❑ Graphics Controller

- AMD RS780MN/RS780MC as integrated graphics solution
- Following External Graphic solution with AMD M780G/M770
 - ATI Mobility Radeon™ HD 3470 (512MB)
 - ATI Mobility Radeon™ HD 3650 (1GB)
- HDMI 1.3-CEC Support
- DVI-D supported by conversion cable from HDMI and DP

❑ Express Card Controller

- Support USB/PCI Express signals
- One Express card slot 34/54

❑ Audio Controller

- Realtek Azalia ALC272
- One Audio-in port: Mic.-in/Line-in
- One Audio-out port: Headphone-out / Line-out / S / PDIF-out
- Internal Microphone (with Internal Camera, MIC with echo cancellation)
- Volume control: Digital control, feather touch button, no mute function
- Microsoft inbox audio driver support
- Software EQ support
- Synchronize to change video and audio output to HDMI/DP
- MAXX audio support by SW solution (BTO by image)

❑ Wireless LAN Controller

- Intel 802.11abgn Echo Peak (1x2 or 3x3), Shirley Peak (1x2 or 3x3)
- Atheros 802.11 b/g (XB63L 1x2), a/b/g (XB62L 2x3), b/g/n (XB91 1x2), a/b/g/n (XB92 2x2)
- Realtek 802.11bg (8187SE 1X2), 802.11bgn (8192E 1X2)
- Intel Wireless Application, Cliffside and WPS supported

1.2 2.5-inch HDD

The computer contains an extremely low-profile and lightweight, high-performance HDD. The HDD incorporates 9.5 mm / 12.5 mm height magnetic disk and mini-Winchester type magnetic heads. The HDD interface conforms to Serial ATA. Storage capacities supported are 120, 160, 200, 250, 320 and 500 GB.

The HDD is shown in Figure 1-2 and some of its specifications are listed in Table 1-1.

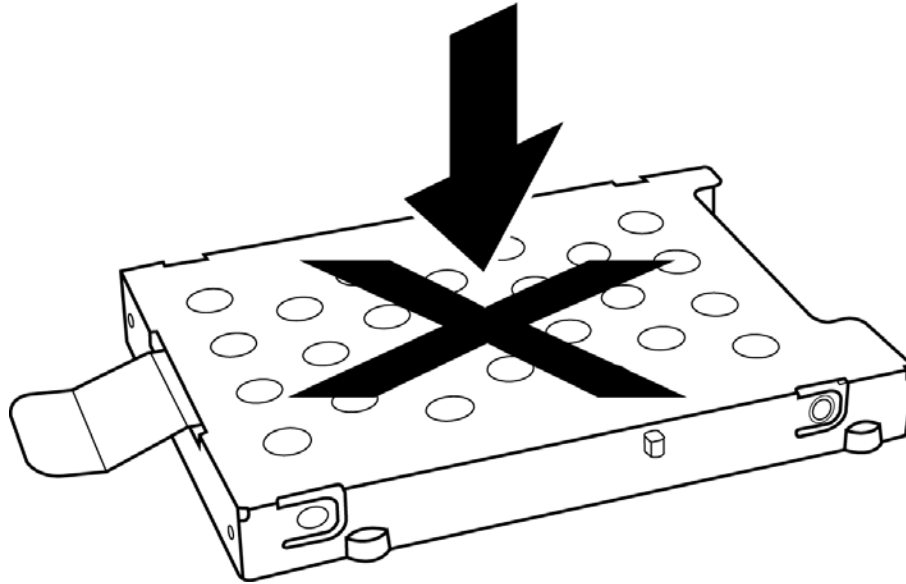

Figure 1-2 SATA HDD

Table 1-1 HDD Specifications

Item	Specifications			
Capacity (GB)	120GB	160 GB	200	250 GB
Rotational Speed (RPM)	5400 or 7200 RPM	5400 or 7200 RPM	7200 RPM	5400 RPM
Height	9.5 mm	9.5 mm	9.5 mm	9.5 mm
User Data Sectors	234,441,648	312,581,808	312,581,808	488,397,168
Bytes / Sector	512	512	512	512

Item	Specifications		
Capacity (GB)	320G	320G	500 GB
Rotational Speed (RPM)	5400 RPM	7200 RPM	5400 RPM
Height	9.5 mm	9.5 mm	12.5 mm
User Data Sectors	625,142,448	625,142,448	976,773,168
Bytes / Sector	512	512	512

1.3 DVD Super Multi (+-R Double Layer)

The DVD Super Multi drive accepts 12-cm (4.72-inch) and 8-cm (3.15-inch) discs. At maximum, the drive can play back a DVD at 8x speed, read CD-ROM at 24x speed, and write CD-R at 24x speed, CD-RW at 6x speed, CD-RW at 16x speed, DVD-R at 8x speed, DVD-RW at 8x speed, DVD+R at 8x speed, DVD+R (Double Layer) at 8x speed, DVD-R (Dual Layer) at 8x speed, DVD+RW at 8x speed and DVD-RAM at 5x speed.

The DVD Super Multi drive is shown in Figure 1-3 and its specifications are listed in Table 1-2.

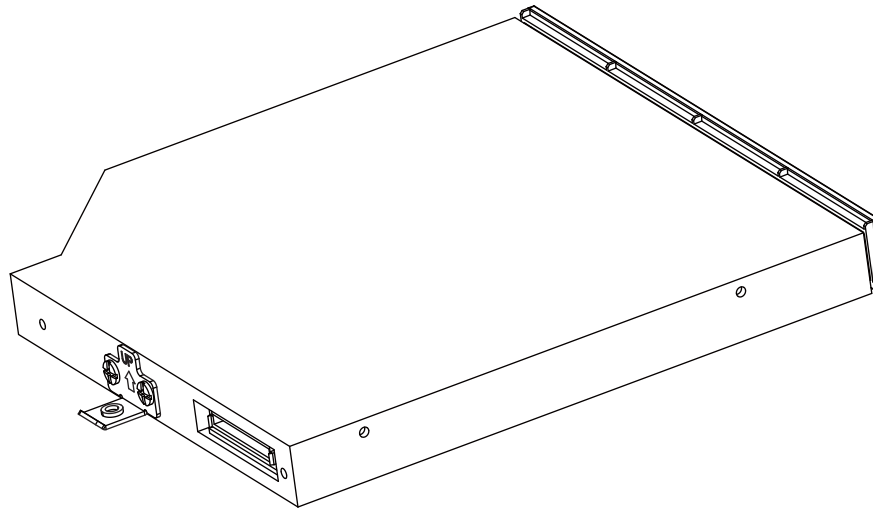

Figure 1-3 DVD Super Multi Drive

Table 1-2 DVD Super Multi Drive Specifications

Item	DVD-ROM Mode	CD-ROM Mode
Data Transfer Rate (Mbytes/s)	33.3 (U-DMA transfer mode 2) 16.6 (PIO mode 4, Multiword DMA mode 2)	
Access Time (ms)		
Average Random Access	130	130
Data Buffer Size (Mbytes)	2MB	
Formats Supported	DVD: DVD-VIDEO, DVD-ROM, DVD-R, DVD-RW, DVD-RAM, DVD+R, DVD+-R (Double Layer), DVD+RW. CD: CD-DA, CD-ROM, CD-R, CD-RW, CD-ROMXA, Photo CD (Multi-Session), Video CD, CD-Extra (CD+), CD-Text.	

1.4 Power Supply

The power supply unit provides constant voltage (19V) for the system board and performs the following functions:

1. Power input monitor
 - Checks whether the AC adapter (DC power supply) is connected to the computer.
 - Checks whether the battery pack is connected to the computer.
 - Monitors the DC power supply input voltage (AC Adapter output voltage).
2. Power supply's internal control
 - Turns on and off the battery pack charging power supply.
 - Issues a charging current instruction to the PWM control IC of the battery pack charging power supply.
 - Controls the supply of DC power supply input (AC Adapter output) to the power supply unit.
 - Controls the supply of power to the system block (load/logic circuit side).
 - Controls forced shutdown if the power supply malfunctions.
3. Logic circuit control
 - Instructs the gate array to enable/disable tuning the power on.
 - Controls power-on/off operation.
4. Status display
 - Turns on the Power LED (in White).
 - Battery indicator (in White or Amber).
 - DC-IN indicator (in White color)
5. External interface
 - Performs communication through the I2C bus (via the internal EC/KBC).
 - Transfers the power supply operation mode.

6. Output monitor

- Monitors the voltage output to the system block (load/logic circuit side).
- Monitors the voltage, over-voltage, input/output current of the battery pack.
- Monitors the internal temperature of the battery pack.
- Monitors the supply voltage from the AC adapter.

1.5 Batteries

The computer has the following two types of batteries:

- Main Battery Pack
- Real Time Clock (RTC) Battery

1.5.1 Main Battery

The main battery pack serves as the computer's main power source when the AC adapter is not attached. The main battery maintains the state of the computer when the AC adapter is detached .

1.5.2 Battery Charging Control

Battery charging is controlled by EC KB926. When the AC adapter and battery pack are attached to the computer, the EC KB926 controls the charge on/off state and detects a full charge.

- Battery Charge

When the AC adapter is attached, the battery is charged by off-state charge when the system is powered off or by on-state charge when it is powered on.

Table 1-3 Quick/Normal Charging Time

State	Charge Time	
Off-State Charge	3/6/12 Cell	About 4 hours max
On-State Charge	3/6/12 Cell	About 12 hours max

NOTE: *The time required for normal charge depends on the power consumption by the system. Using a fluorescent lamp and frequently accessing the disk consumes more power and lengthen the charge time.*

Any of the following can stop battery charge:

1. The battery becomes fully charged.
2. The AC adapter or battery pack is removed.
3. The battery or AC adapter voltage is abnormal.

Detection of full charge

A full charge is detected only when the battery is being charged by quick or normal charge.

A full charge is detected when either of the following conditions is met:

1. The current in the battery charging circuit drops below the predetermined value.
2. The charging time exceeds the fixed limit.

1.5.3 RTC Battery

The RTC battery provides power to maintain the current date, time and other system information in memory while the computer is turned off.

Chapter 2

Troubleshooting Procedures

Chapter 2 Contents

2.1	Troubleshooting Introduction	3
2.2	Troubleshooting Flowchart	4
2.3	Power Supply Troubleshooting.....	9
2.4	Display Troubleshooting.....	14
2.5	Keyboard Troubleshooting	17
2.6	External USB Devices Troubleshooting.....	19
2.7	TV-tuner Troubleshooting	21
2.8	TouchPad Troubleshooting.....	25
2.9	Speaker Troubleshooting	27
2.10	Optical drive troubleshooting.....	29
2.11	Modem Troubleshooting	32
2.12	Express card Troubleshooting.....	34
2.13	Wireless LAN Troubleshooting.....	36
2.14	Camera Troubleshooting.....	38
2.15	Bluetooth Troubleshooting.....	40
2.16	Bridge Media slot Troubleshooting.....	43
2.17	HDD Troubleshooting.....	45
2.18	CRT failure Troubleshooting	47
2.19	HDMI Troubleshooting	49
2.20	Display Port Troubleshooting.....	51
2.21	SPDIF Troubleshooting	53
2.22	MIC Troubleshooting	55
2.23	Finger Troubleshooting	57
2.24	FM tuner Troubleshooting	59
2.25	E-SATA Troubleshooting	62
2.26	Felica Troubleshooting	64
2.27	UWB Troubleshooting	66
2.28	3G Troubleshooting.....	68

Figures

Figure 2-1	Troubleshooting flowchart (1/2)	5
Figure 2-1	Troubleshooting flowchart (2/2)	6
Figure 2-3	Display troubleshooting process	14
Figure 2-4	Keyboard troubleshooting process	17
Figure 2-5	External USB device troubleshooting process	19
Figure 2-6	TV-tuner troubleshooting process	21
Figure 2-7	TouchPad troubleshooting process.....	25
Figure 2-8	Speaker troubleshooting process	27
Figure 2-9	Optical drive troubleshooting process.....	29
Figure 2-10	Modem troubleshooting process.....	32
Figure 2-11	Express card troubleshooting process	34
Figure 2-12	Wireless LAN troubleshooting process.....	36
Figure 2-13	Camera Troubleshooting process.....	38
Figure 2-14	Bluetooth troubleshooting process.....	40
Figure 2-15	7 in 1 card troubleshooting process.....	43
Figure 2-16	HDD troubleshooting process.....	45
Figure 2-17	CRT failure troubleshooting process	47
Figure 2-18	HDMI troubleshooting process	49
Figure 2-19	Display port troubleshooting process	51
Figure 2-20	SPDIF troubleshooting process	53
Figure 2-21	MIC troubleshooting process	55
Figure 2-22	Finger printer troubleshooting process	57
Figure 2-23	FM tuner Troubleshooting	59
Figure 2-24	E-SATA Troubleshooting	62
Figure 2-25	Felica Troubleshooting	64
Figure 2-26	UWB Troubleshooting	66
Figure 2-27	3G Troubleshooting	68

Tables

Table 2-1	Battery LED	10
Table 2-2	DC-IN LED.....	11

2.1 Troubleshooting Introduction

Chapter 2 describes how to determine if a Field Replaceable Unit (FRU) in the computer is causing the computer to malfunction. The FRUs covered are:

1. Display	7. Speaker	13. Bluetooth	19. FM Tuner
2. USB Floppy Drive	8. Optical drive	14 HDMI	20. E-SATA
3. Keyboard	9. Modem	15. Display port	21. Felica
4. USB ports	10. Express card unit	16. SPDIF	22. UWB
5. TV-Tuner	11. Wireless LAN	17. MIC	23. 3G
6. Touch Pad	12. Camera	18. Finger	

The Diagnostics Disk operations are described in Chapter 3. Detailed replacement procedures are given in Chapter 4.

The following tools are necessary for implementing the troubleshooting procedures:

1. Diagnostics Disk (Repair and Sound Repair)
2. Phillips screwdriver (2 mm)
3. 6mm nut driver (for the helix screw nuts on the rear ports for CPU door)
4. 2DD or 2HD formatted work disk for floppy disk drive testing
5. Sycard (EXPRESS CARD test card)
6. Cleaning kit for floppy disk drive troubleshooting
7. Cleaning kit for optical drive troubleshooting
8. Multimeter
9. External monitor
10. USB compatible keyboard
11. Multimedia sound system with line-in and line-out ports

12. Headphones
13. USB test module and USB cable
14. Music CD
15. MIC module and MIC line
16. SPDIF line
17. Finger print module
18. TV tuner signal generator
19. FM tuner signal generator
20. E-SATA HDD
21. Felica card
22. UWB signal generator
23. Remote controller.

2.2 Troubleshooting Flowchart

If you know the location of the malfunction, turn directly to the appropriate section of this chapter. If the problem is unspecified, use the flowchart in Figure 2-1 as a guide for determining which troubleshooting procedures to execute. Before performing any troubleshooting procedures, verify the following:

- Ask the user if a password is registered, if it is, ask him or her to enter the password.
- Verify with the customer that Toshiba Windows Vista is installed on the hard disk. Operating systems that were not preinstalled by Toshiba can cause the computer to malfunction.
- Make sure all optional equipment is removed from the computer.
- Make sure the floppy disk drive, if installed, is empty. If no FDD module is installed, you should use an external FDD to run the diagnostics tests

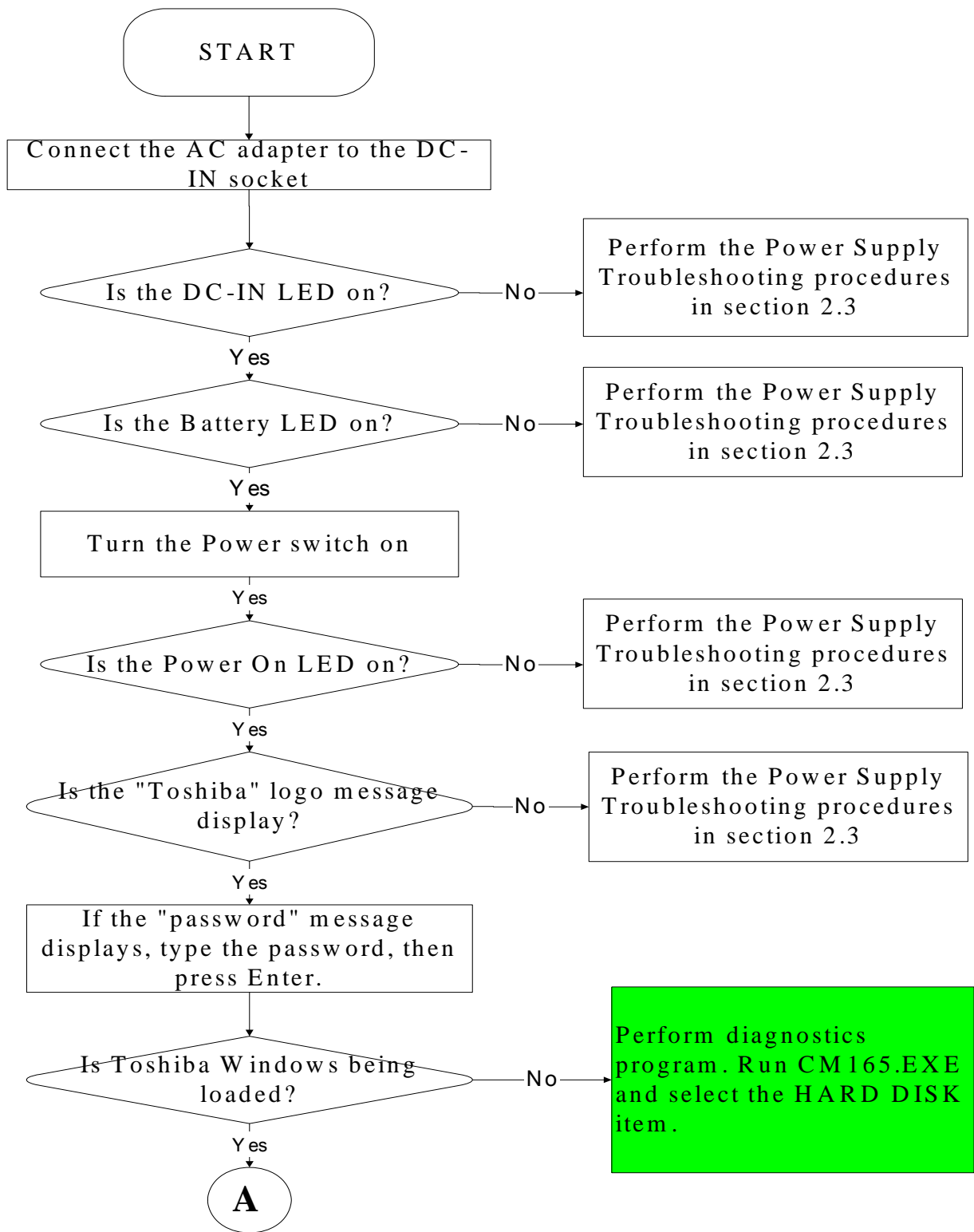

Figure 2-1 Troubleshooting flowchart (1/2)

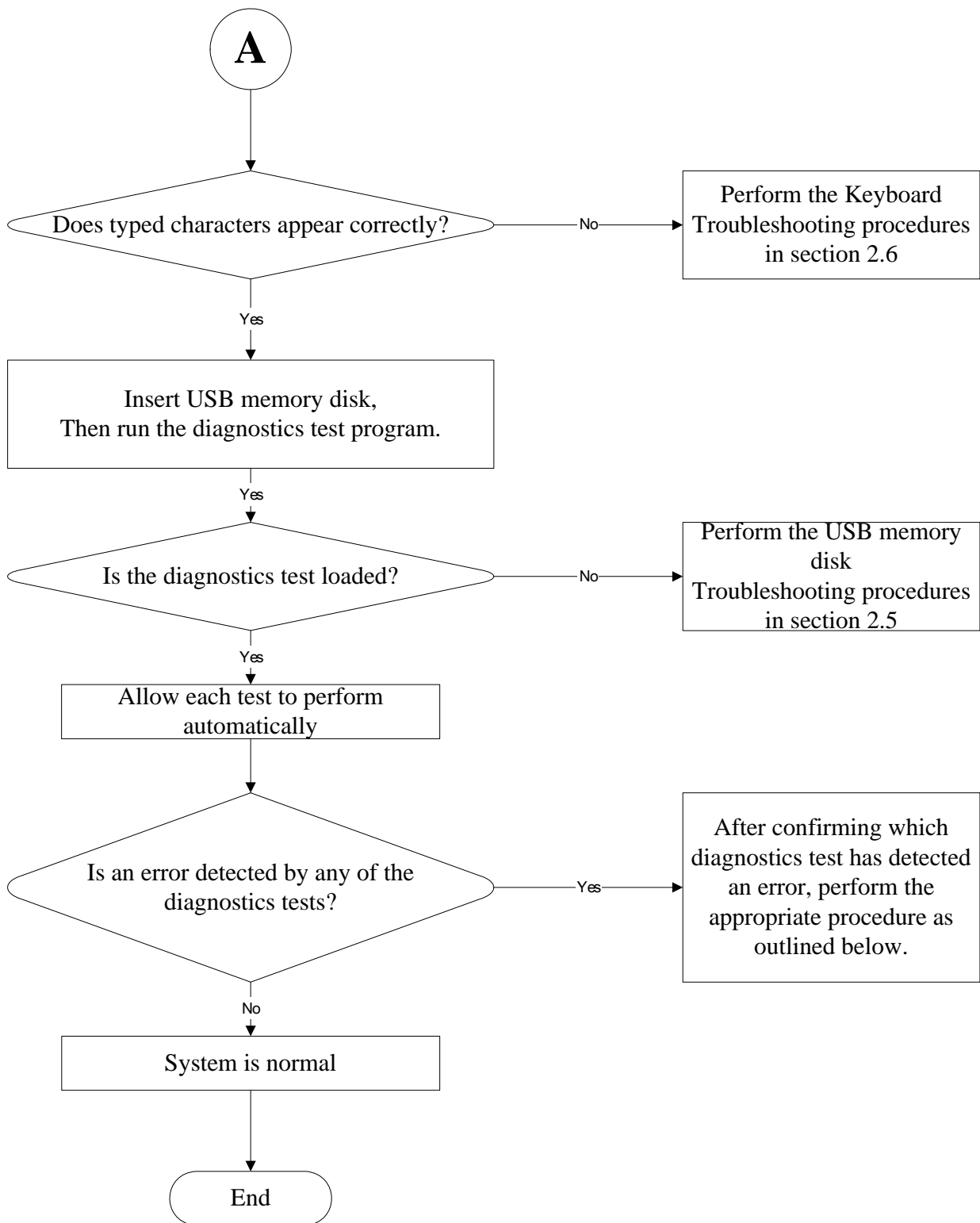

Figure 2-1 Troubleshooting flowchart (2/2)

If the diagnostics program cannot detect an error, the problem may be intermittent. The test program should be executed several times to isolate the problem. When a problem has been located, perform the appropriate troubleshooting procedures as follows:

1. If an error is detected by the battery test, perform the Power Supply Troubleshooting procedures in Section 2.2
2. If an error is detected by the display test, perform the Display Troubleshooting procedures in Section 2.3
3. If an error is detected by the keyboard test, perform the Keyboard Troubleshooting procedures in Section 2.4
4. If an error is detected by the TouchPad test, perform the TouchPad Troubleshooting procedures in Section 2.7
5. If an error is detected by the audio test, perform the Speaker Troubleshooting procedures in Section 2.8 and the Optical Drive Troubleshooting Procedures in Section 2.9
6. If an error is detected by the fingerprint test, perform the fingerprinter troubleshooting Procedures in Section 2.22

Other problems that are not covered by the diagnostics program may be discovered by a user.

1. If an error is detected when using an external USB device, perform the External USB Devices Troubleshooting procedures in Section 2.5
2. If an error is detected when using the TV-out connection, perform the TV-Out Failure Troubleshooting procedures in Section 2.6
3. If an error is detected when using the modem, perform the Modem Troubleshooting procedures in Section 2.10
4. If an error is detected when using the EXPRESS CARD unit, perform the EXPRESS CARD Troubleshooting procedures in Section 2.11
5. If an error is detected when using the Wireless LAN, perform the Wireless LAN Troubleshooting procedures in Section 2.12
6. If an error is detected when using the camera, perform the camera Troubleshooting procedures in Section 2.13
7. If an error is detected when using the Bluetooth, perform the Bluetooth Troubleshooting procedures in Section 2.14
8. If an error is detected when using the HDMI TV, perform the HDMI TV troubleshooting procedures in Section 2.18.
9. If an error is detected when using the MIC, perform the MIC troubleshooting procedures in Section 2.21

2.3 Power Supply Troubleshooting

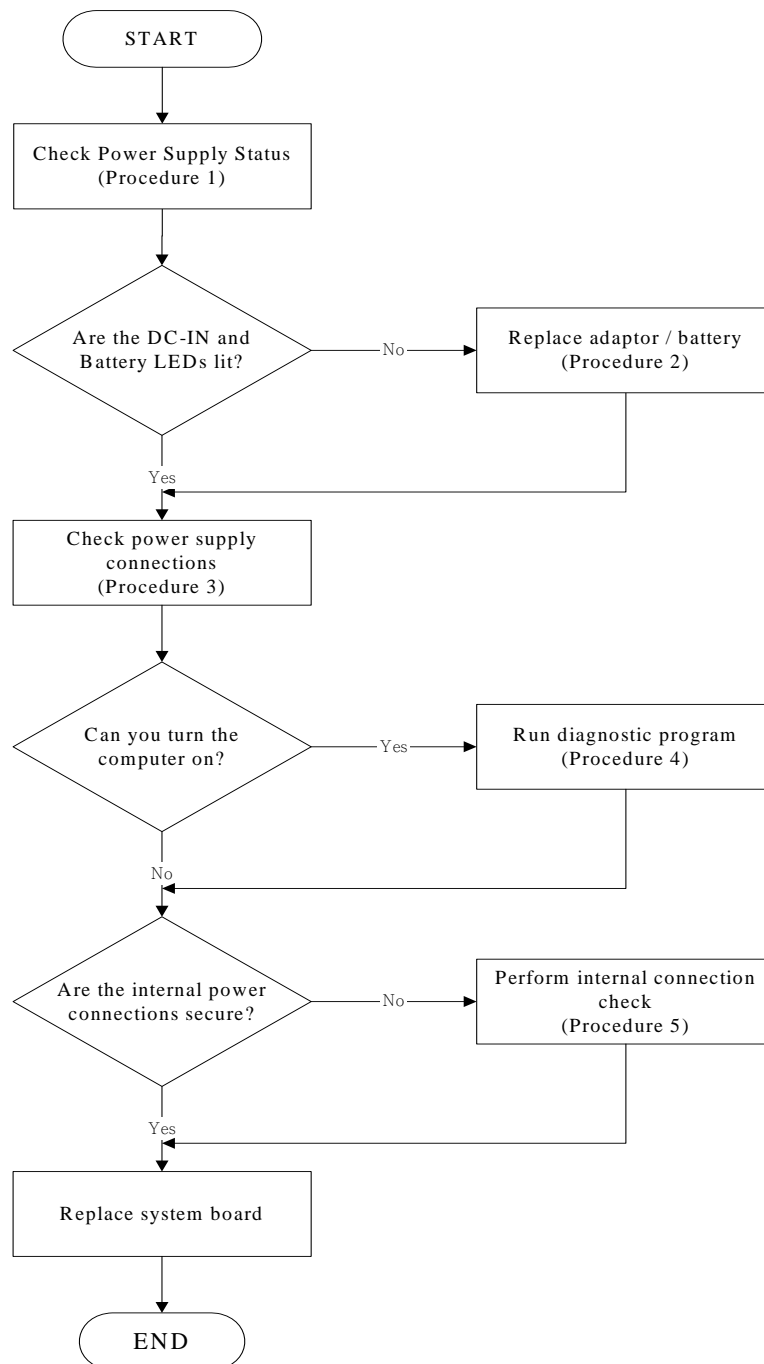

Figure 2-2 Power Supply Troubleshooting Process

The power supply controls many functions and components. To determine if the power supply is functioning properly, start with Procedure 1 and continue with the other Procedures as instructed. The flowchart in Figure 2-2 gives a summary of the process. The procedures described in this section are:

- Procedure 1: Power status check
- Procedure 2: Adaptor / battery replacement
- Procedure 3: Power supply connection check
- Procedure 4: Diagnostic check
- Procedure 5: Internal connection check

Procedure 1 Power Status Check

The following LEDs indicate the power supply status:

 Battery LED

 DC-IN LED

The power supply controller displays the power supply status through the Battery and the DC-IN LEDs as listed in the tables below.

Table 2-1 Battery LED

Battery State	LED colors	Definition
Charging	Amber, solid on	Battery charging with AC.
	White, solid on	Battery fully charged by AC
	Amber color off	Battery abnormal stop charging with AC (Bad cell/ Overheated)
Discharging	Amber, blinking (LED on for 1 second every 4 seconds)	Battery within low state: 12 minutes remaining
	Amber, blinking (LED on for 1 second every 2 seconds)	Battery within critical low state: 3 minutes remaining. The system is protected and cannot be re-powered on without the AC power connected.
	Amber color off	Battery not in low or critical low state; It's in discharging state

Table 2-2 DC-IN LED

AC-IN LED	Power supply status
Solid on	AC power exists (LED is solid White).
Off	No AC power exists.

To check the power supply status, install a battery pack and connect an AC adaptor to the DC-IN port on the computer and to a power supply.

If the DC-IN LED or Battery LED is not lit, go to Procedure 2.

Procedure 2 Adaptor / battery replacement

A faulty adaptor may not supply power or may not charge the battery. Perform Check 1.

Check 1 Connect a new AC adaptor. If the problem is not resolved, go to Check 2.

Check 2 Insert a new battery. If the problem is still not resolved, go to Procedure 3.

Procedure 3 Power supply connection check

The power supply wiring diagram is shown below:

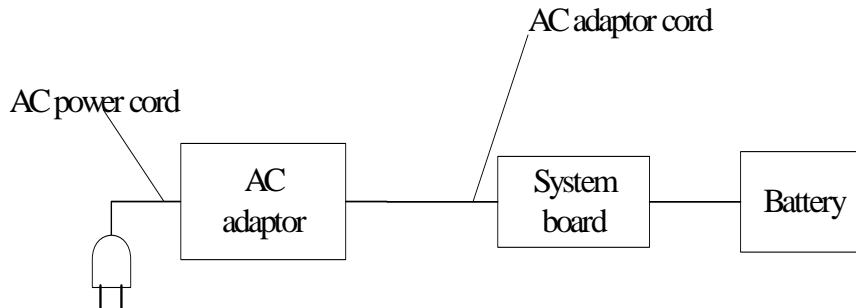

Any of the connectors may be disconnected. Perform Check 1.

- Check 1 Disconnect the AC power cord from wall outlet. Check the power cable for breaks. If the power cord is damaged, connect a new AC power cord. If there is no damage, go to Check 2.
- Check 2 Make sure the AC adaptor cord and AC power cord are firmly plugged into the DC-IN socket, AC adaptor inlet and wall outlet. If these cables are connected correctly, go to Check 3.
- Check 3 Make sure that the DC-IN input port socket is firmly secured to the system board of the computer.
- If the DC-IN input socket is loose, go to Procedure 5.
 - If it is not loose, go to Check 4.
- Check 4 Use a multi-meter to make sure that the AC adaptor output voltage is close to 19 V. If the output is several percent lower than 19 V, go to Check 5. If the output is close to 19 V, go to Check 6.
- Check 5 Connect a new AC adaptor or AC power cord.
- If the DC-IN LED does not light, go to Procedure 4.
 - If the battery LED does not light, go to Check 6.
- Check 6 Make sure the battery pack is installed in the computer correctly. If the battery is properly installed and the battery LED still does not light, go to Procedure 4.

Procedure 4 Diagnostic check

The power supply may not charge the battery pack. Perform the following procedures:

1. Reinstall the battery pack.
2. Attach the AC adaptor and turn on the power. If you cannot turn on the power, go to Procedure 5.
3. Run the Diagnostic test following the procedures described in Chapter 3, Tests and Diagnostics. If no problem is detected, the battery is functioning normally.

Procedure 5 Replacement check

The system board may be disconnected or damaged. Disassemble the computer following the steps described in Chapter 4, *Replacement Procedures*. Check the connection between the AC adaptor and the system board. After checking the connection, perform Check 1:

- Check 1 Use a multi-meter to make sure that the fuses on the system board are not blown. If a fuse is not blown, go to Check 2. If a fuse is blown, go to Check 3.
- Check 2 Make sure that the battery cable is firmly connected to the system board. If it is connected firmly, go to Check 3.
- Check 3 The system board may be damaged. Replace it with a new one following the instructions in Chapter 4.

2.4 Display Troubleshooting

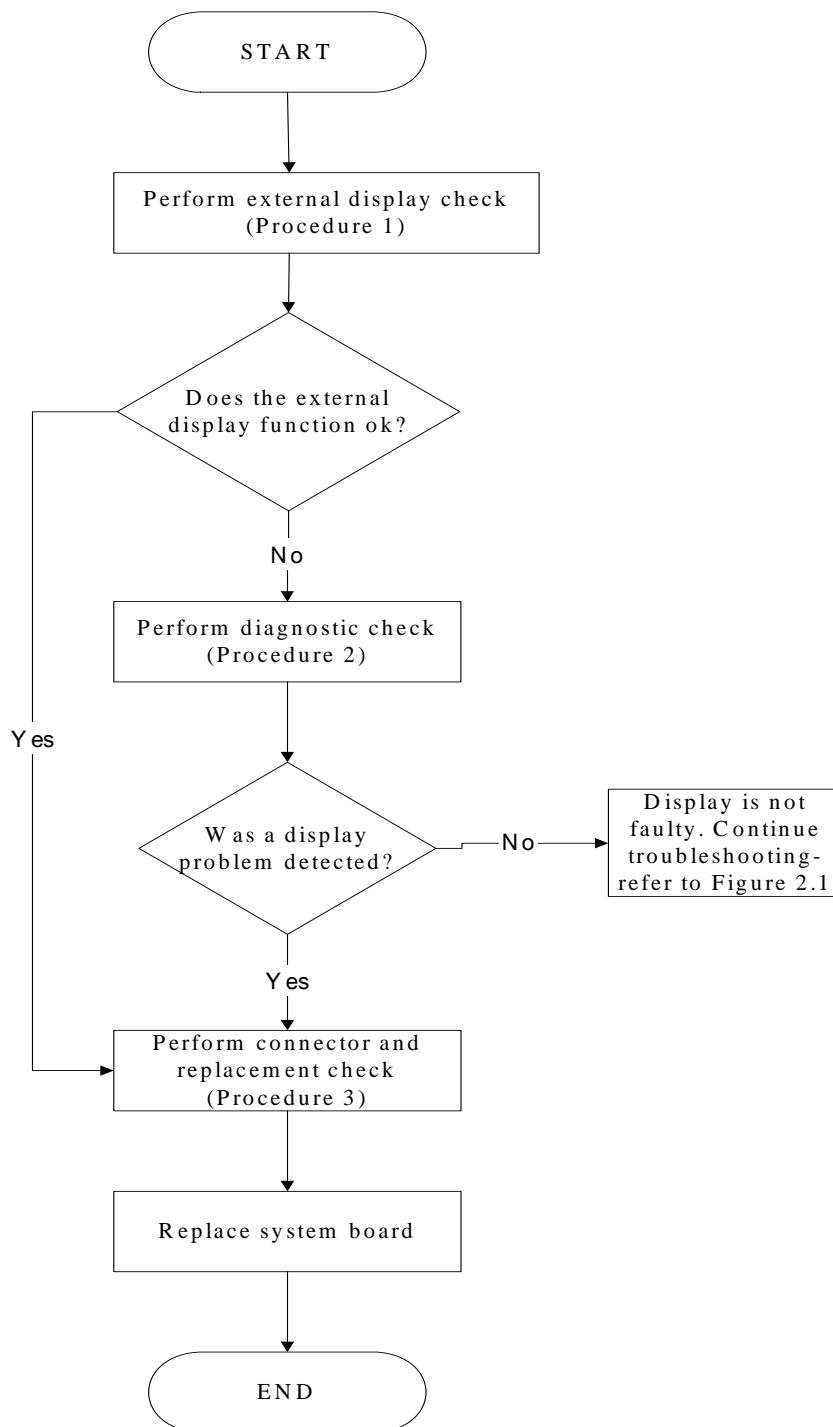

Figure 2-3 Display troubleshooting process

This section describes how to determine if the computer's display is functioning properly. The process is outlined in Figure 2-3. Start with Procedure 1 and continue with the other procedures as instructed.

Procedure 1: External display check

Procedure 2: Diagnostic check

Procedure 3: Connector and replacement check

Procedure 1 External display check

Connect an external display to the computer's external monitor port, and then boot the computer. The computer automatically detects the external display.

If the external display works correctly, the internal LCD may be damaged. Go to Procedure 3.

If the external monitor appears to have the same problem as the internal monitor, the system board may be damaged. Go to Procedure 2.

Procedure 2 Diagnostic check

The Display Test program is stored on the computer's Diagnostics disk. This program checks the display controller on the system board. Insert the Diagnostics disk in the computer's floppy disk drive, turn on the computer and run the test. Refer to Chapter 3, *Tests and Diagnostics* for details.

If an error is detected, go to Procedure 3. If an error is not detected, the display is functioning properly.

Procedure 3 Connector and replacement check

The FL inverter board, LCD module, and system board are connected to the display circuits. Any of these components may be damaged. Refer to Chapter 4, *Replacement Procedures*, for instructions on how to disassemble the computer and then perform the following checks:

- Check 1 Make sure the DDR RAM module is seated properly. Test display again. If the problem still exists, replace the DDR RAM module. If the problem still exists, perform Check 2.
- Check 2 Replace the FL inverter board with a new one and test display again. If the problem still exists, perform Check 3.
- Check 3 Replace the LCD module with a new one and test display again. If the problem still exists, perform Check 4.
- Check 4 Replace the LCD/FL cable with a new one and test display again. If the problem still exists, perform Check 5.
- Check 5 Replace the CPU with another of the same specifications. If the problem still exists, perform Check 6.
- Check 6 The system board may be damaged. Replace it with a new one.

2.5 Keyboard Troubleshooting

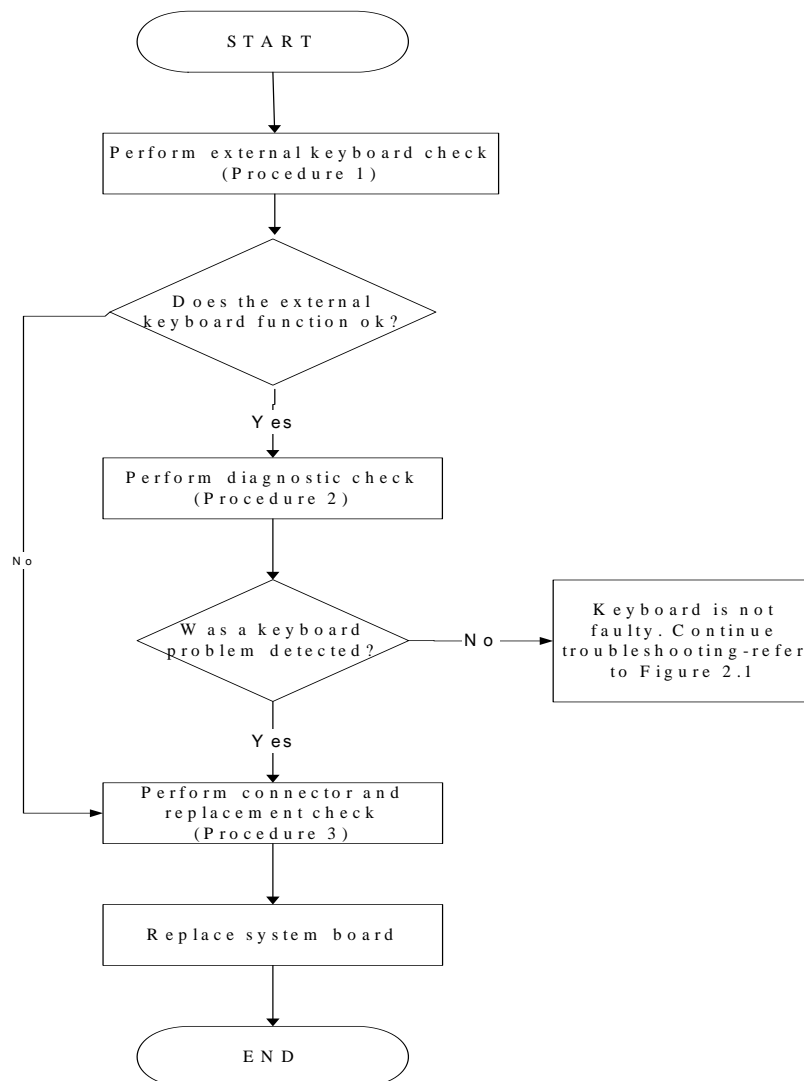

Figure 2-4 Keyboard troubleshooting process

To determine if the computer's keyboard is functioning properly, perform the following procedures. Figure 2-4 outlines the process. Start with Procedure 1 and continue with the other procedures as instructed.

Procedure 1: External keyboard check

Procedure 2: Diagnostic check

Procedure 3: Connector and replacement check

Procedure 1 External keyboard check

Connect a USB keyboard to one of the computer's USB ports, and then boot the computer. The computer automatically detects the external keyboard.

If the external keyboard works correctly, the internal keyboard or its connections may be faulty. Go to Procedure 2.

If the external keyboard appears to have the same problem as the internal keyboard, the system board may be having some problem. Replace it with a new one and following the instructions in Chapter 4.

Procedure 2 Diagnostic check

Run the test and Diagnostics Program, which will automatically execute the Keyboard Test. Refer to Chapter 3, *Tests and Diagnostics* for more information on how to run the program.

If an error is located, go to Procedure 3. If an error does not occur, the keyboard is functioning ok.

Procedure 3 Connector and replacement check

The keyboard and/or system board may be disconnected or damaged. Disassemble the computer following the steps described in Chapter 4, *Replacement Procedures* and perform the following checks.

- Check 1 Make sure the keyboard cable is firmly connected to the system board.
If the connection is loose, reconnect firmly and repeat Procedure 2. If there is still an error, go to Check 2.
- Check 2 The keyboard may be damaged. Replace it with a new one following the instructions in Chapter 4.
If the problem still exists, perform Check 3.
- Check 3 The system board may be damaged. Replace it with a new one following the instructions in Chapter 4.

2.6 External USB Devices Troubleshooting

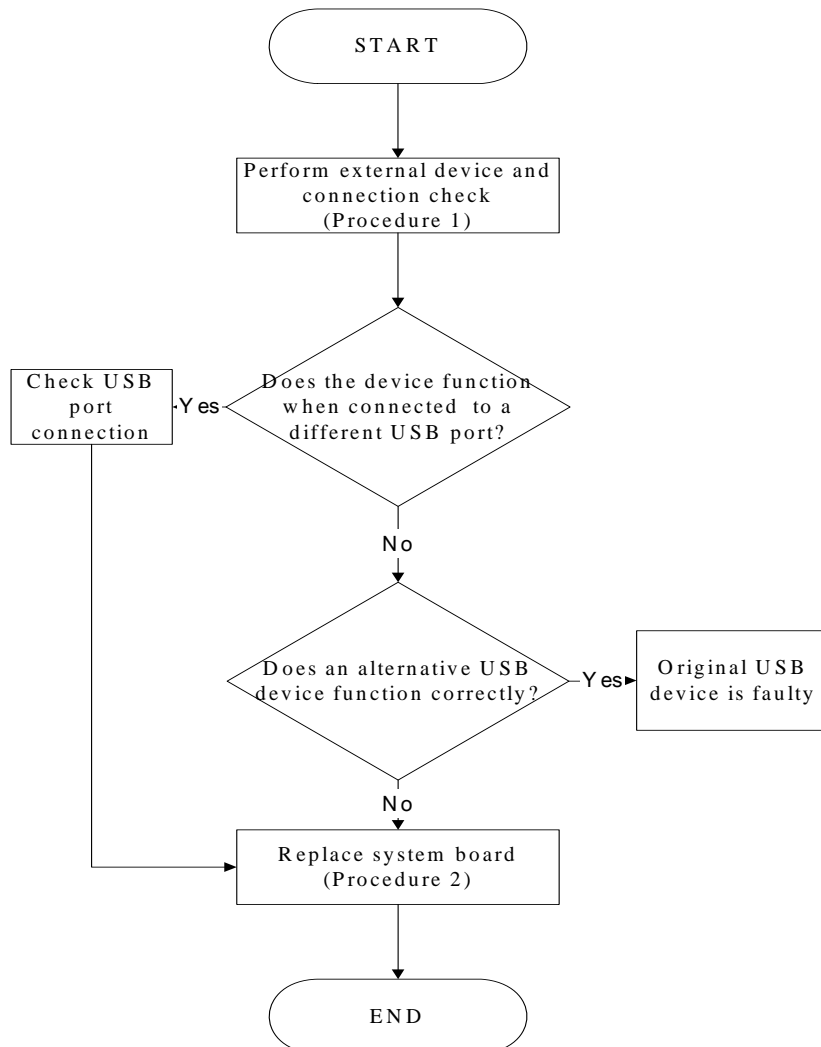

Figure 2-5 External USB device troubleshooting process

To determine if the computer's external USB devices are functioning properly, perform the following procedures. Figure 2-5 outlines the process. Start with Procedure 1 and continue as instructed.

Procedure 1: External device and connection check

Procedure 2: Replace system board

Procedure 1 External device and connection check

The USB device may be damaged or the connection may be faulty. Use windows application to check device can work fine or not, Perform Check 1.

Check 1 Make sure USB device cable is firmly plugged into one of the USB sockets. If the cable is connected correctly, go to Check 2.

Check 2 Plug the USB device into another USB socket (there are three in all). If the USB device still does not work, go to Check 4.

If the device functions correctly when connected to another USB port, go to Check 3.

Check 3 Make sure that the USB socket is firmly secured to the system board of the computer. If the malfunction remains, the system board or USB small board may be damaged. Go to Procedure 2.

Check 4 Connect an alternative USB device to one of the computer's USB ports, and then boot the computer. The computer automatically detects the external device.

If the alternative USB device works correctly, the original device may be damaged and should be replaced.

If the alternative USB device appears to have the same problem as the original device, the system board or USB small board may be damaged. Go to Procedure 2.

Procedure 2 Replace system board

If the error persists, the system board or USB small board may be damaged. Replace it with a new one following the instructions in Chapter 4.

2.7 TV-Tuner Failure Troubleshooting

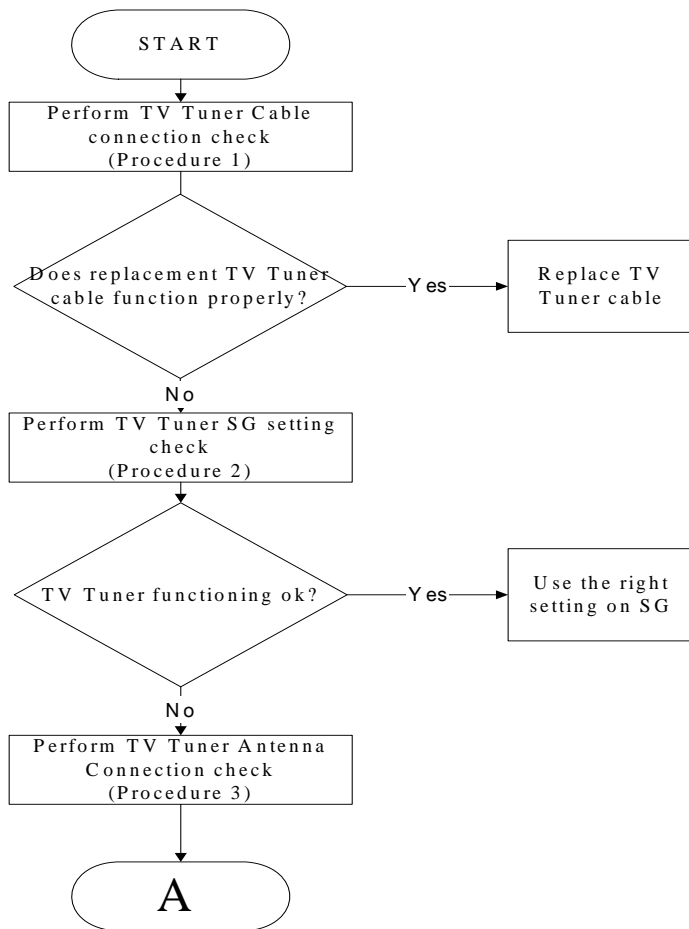
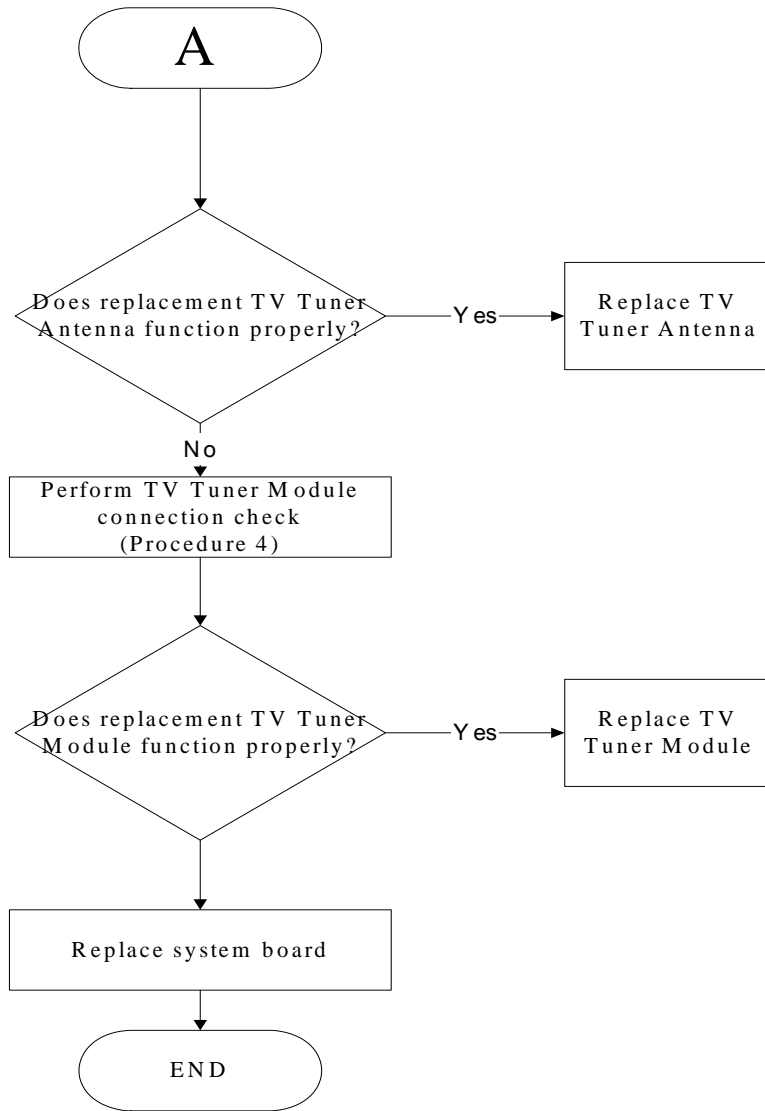

Figure 2-6 TV-out troubleshooting process



To determine if the computer's TV Tuner port is functioning properly, perform the following procedures. Figure 2-6 outlines the process. Start with Procedure 1 and continue as instructed.

- Procedure 1: TV Tuner cable connection check
- Procedure 2: TV Tuner SG setting check
- Procedure 3: TV Tuner Antenna connection check
- Procedure 4: TV Tuner Module connection check

Procedure 1 TV tuner Cable connection check

The TV Tuner cable may be damaged or the connections may be loose. Use windows application to check device can work fine or not. If an error is located, Perform Check 1:

- Check 1 Make sure TV Tuner cable is firmly plugged into both the TV Tuner set and the TV Tuner port of the computer. If the cable is connected correctly, go to Check 2.
- Check 2 Make sure the TV Tuner port is firmly secured to the system board of the computer. If the malfunction remains, go to Check 3.
- Check 3 The TV Tuner cable may be damaged. Replace with a good cable. If the malfunction remains, go to Procedure 2.

Procedure 2 TV Tuner SG setting check

The TV Tuner SG setting may be faulty. Perform Check 1:

- Check 1 Check the TV Tuner Setting was right or wrong, if right; go to check 2, if wrong. Correct it and re-test. If fail symptom still exist, go to Procedure
- Check 2 Try connecting a different TV tuner SG to the computer. If the replacement TV tuner SG works, the original set may be damaged. If the replacement set does not work the TV tuner Antenna may be damaged. Go to Procedure 3.

Procedure 3 TV tuner Antenna connection check

The TV Tuner Antenna may be damaged or the connections may be loose. Perform Check 1:

- Check 1 Make sure TV Tuner Antenna is firmly plugged into both the TV Tuner Module. If the antenna is connected correctly, go to Check 2.
- Check 2 Try connecting a different TV tuner Antenna to the computer. If the replacement TV tuner Antenna works, the original Antenna may be damaged. If the

replacement Antenna does not work the TV tuner Module may be damaged. Go to Procedure 4.

Procedure 4 TV Tuner Module Connection check

The TV Tuner Module connect may be faulty. Perform Check 1:

- Check 1 Check the TV Tuner Module is firmly plugged into system board, if connection was correctly, go to check 2.

- Check 2 Try connecting a different TV tuner Module to the computer. If the replacement TV tuner Module works, the original Module may be damaged. If the replacement Module does not work the system board may be damaged. Replace it with a new one following the instructions in Chapter 4.

2.8 Touch Pad Troubleshooting

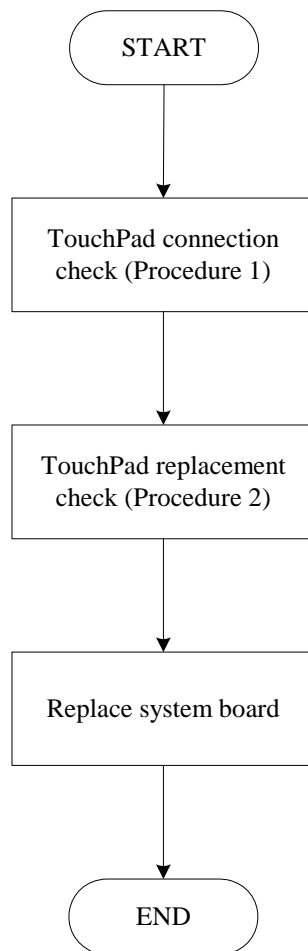

Figure 2-7 Touchpad troubleshooting process

To determine if the computer's built-in TouchPad is functioning properly, perform the following procedures. Figure 2-7 outlines the process. Start with Procedure 1 and continue as instructed.

Procedure 1: TouchPad connection check

Procedure 2: TouchPad replacement check

Procedure 1 TouchPad connection check

The TouchPad is connected via the TouchPad FPC to the system board. Make sure the TouchPad FPC cable is firmly connected to the TouchPad and system board. Refer to Chapter 4, *Replacement Procedures*, for instructions on how to disassemble the computer and then perform the following checks.

If any of the connections are loose, reconnect firmly. If any of the connections is damaged, or there is still an error, go to Procedure 2.

Procedure 2 TouchPad replacement check

The TouchPad unit or FPC may be defective or damaged. Replace each with a new one following the steps in Chapter 4. If the FDD is still not functioning properly, replace the system board with a new one following the steps in Chapter 4.

2.9 Speaker Troubleshooting

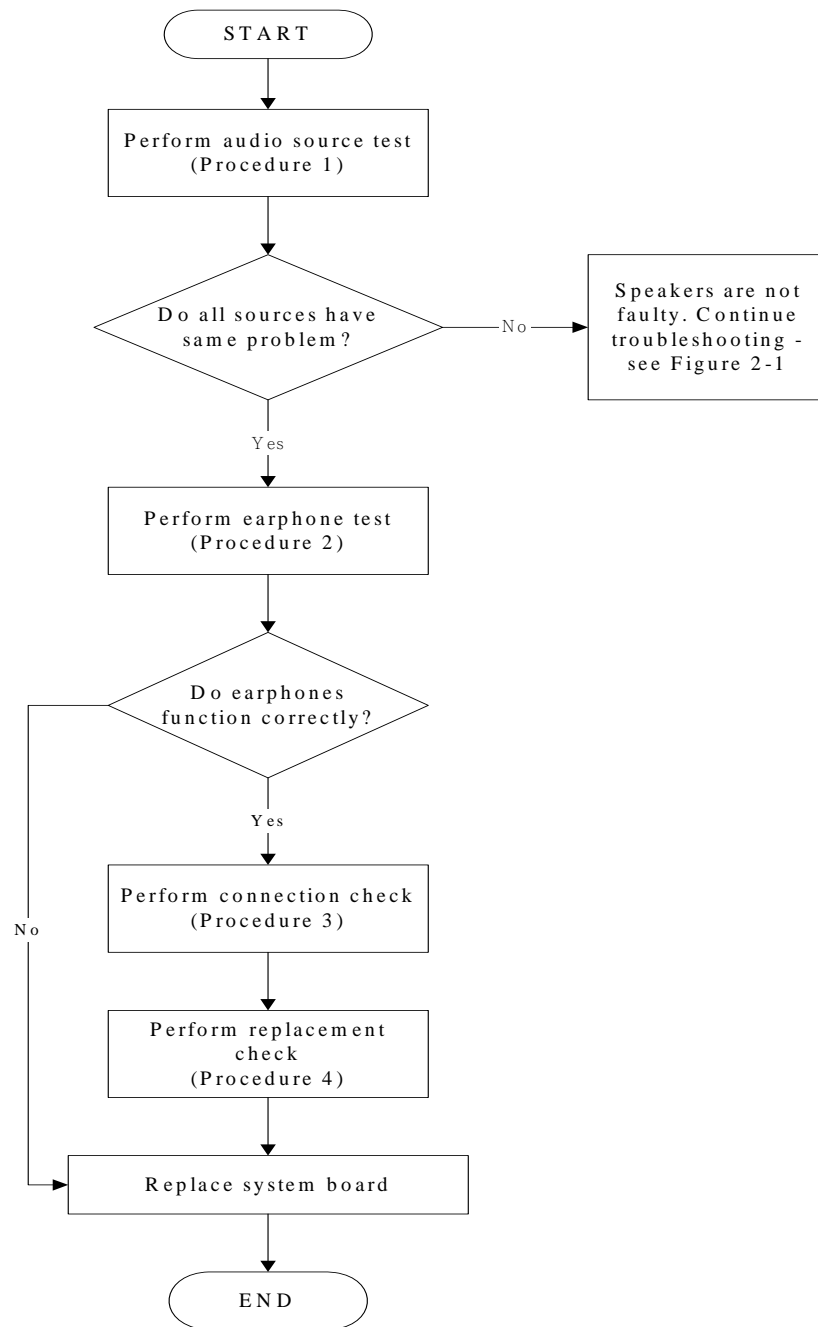

Figure 2-8 Speaker troubleshooting process

To determine if the computer's built-in speakers are functioning properly, perform the following procedures. Figure 2-8 outlines the process. First adjust the speaker volume to an appropriate level. Start with Procedure 1 and continue as instructed.

Procedure 1: Audio source test

Procedure 2: Earphone test

Procedure 3: Connection check

Procedure 4: Replacement check

Procedure 1 Audio source test

Try different audio sources (e.g. an audio CD and digital music file) to determine whether the fault is in the speaker system or not. If not all sources have sound problem, the problem is in the source devices. If all have the same problem, continue with Procedure 2.

Procedure 2 Earphone test

Connect a set of earphones or external speakers. If these function correctly, go to Procedure 3. If they do not function correctly, the system board may be defective or damaged. Replace it with a new one.

Procedure 3 Connection check

Disassemble the computer following the steps described in Chapter 4, *Replacement Procedures* and make sure the speaker cable is firmly connected to the audio board. If the stereo speakers are still not functioning properly, go to Procedure 4.

Procedure 4 Replacement check

If the stereo speakers don't sound properly, the stereo speakers may be defective or damaged. Replace them with new ones. If the stereo speakers still do not work properly, try replacing in turn the audio board and system board.

2.10 Optical Drive Troubleshooting

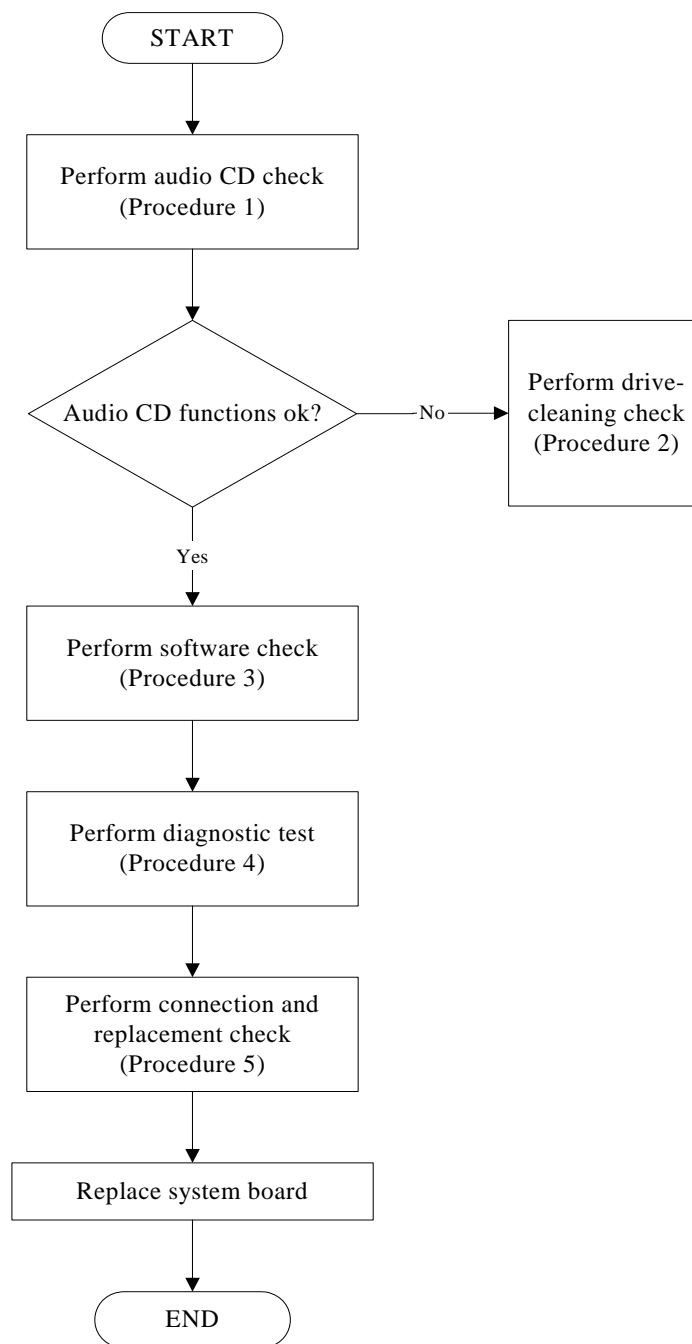

Figure 2-9 Optical drive troubleshooting process

This section describes how to determine if the computer's internal optical drive is functioning properly. The Satellite P200D / P205D Satellite Pro P200D EQUIUM P200D SATEGO

P200D Series Maintenance Manual module bays can accommodate the following optical drives:

DVD SuperMulti supporting +-R Double Rayer

Figure 2-9 outlines the process. Perform the steps below starting with Procedure 1 and continue with the other procedures as required.

Procedure 1: Audio CD test

Procedure 2: Drive cleaning check

Procedure 3: Software check

Procedure 4: Connection and replacement check

Procedure 1 Audio CD check

First, insert an audio CD into the CD/DVD drive. Use windows application to check device can work fine or not. If it works, the problem is not with the drive. Go to Procedure 3. If the audio CD does not work, go to Procedure 2. If the CD/DVD LED on the front panel does not light when the disc is played and the drive gives no response, go straight to Procedure 3.

Procedure 2 Drive cleaning check

Insert a CD/DVD drive-cleaning disk into the drive clean according to the drive-cleaning product instructions. If the problem persists, go to Procedure 3.

Procedure 3 Software check

Ensure that the appropriate driver has been installed on the computer for the CD/DVD drive.

Procedure 4 Connection check and replacement check

The optical drive connects to the system board. The drive may be disconnected, or the drive or system board may be damaged. Disassemble the computer following the steps described in Chapter 4, *Replacement Procedures*, and perform the following checks:

- Check 1 Make sure the drive is firmly connected to the system board. If the connection is good and there is still an error, go to Check 2.
- Check 2 The drive or drive cable may be defective or damaged. Replace each with a new one following the steps in Chapter 4, *Replacement Procedures*. If the drive is still not functioning properly, perform Check 3.
- Check 3 The system board may be damaged. Replace it with new one following the instructions in Chapter 4, *Replacement Procedures*.

2.11 Modem Troubleshooting

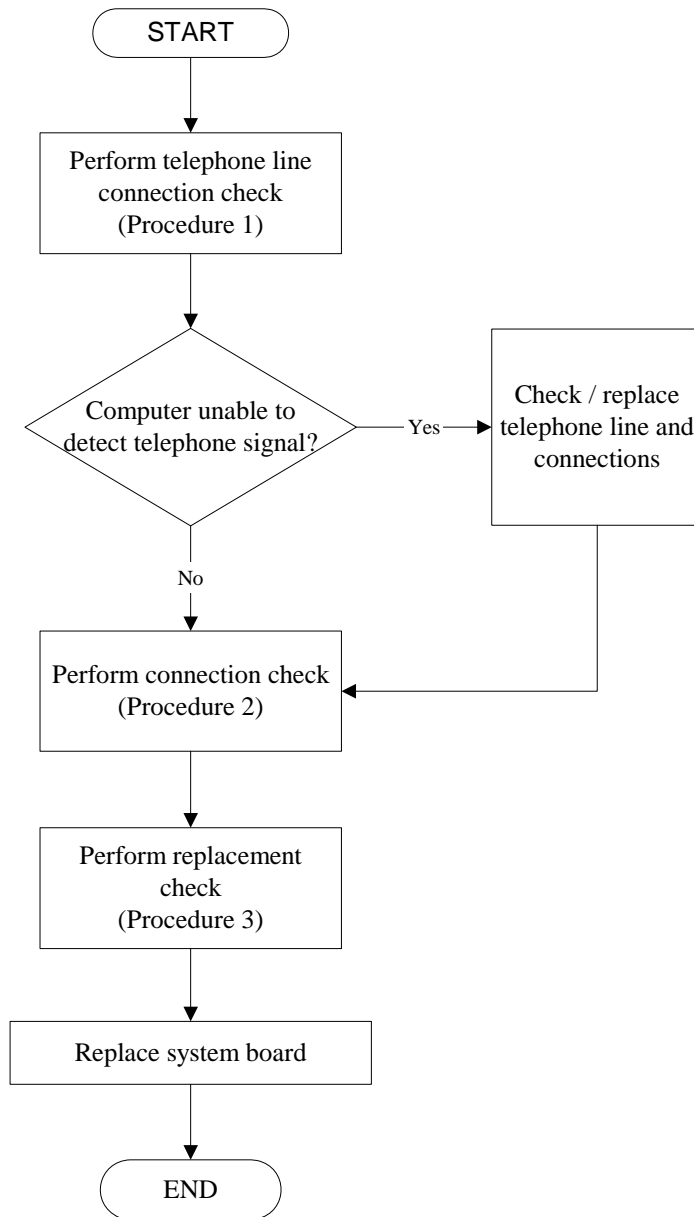

Figure 2-10 Modem troubleshooting process

This section describes how to determine if the computer's modem is functioning properly. Figure 2-10 outlines the process. Perform the steps below starting with Procedure 1 and continuing with the other procedures as required.

Procedure 1: Telephone line connection check

Procedure 2: Modem card connection check

Procedure 3: Modem card replacement check

Procedure 1 Telephone line connection check

The telephone cable may be damaged or the connections may be loose. Use windows application to check device can work fine or not. Attempt to connect the computer to a network through using the modem. If the modem does not function at all, go to Procedure 3. If the attempt fails because the computer detects no telephone signal, the fault may be in the telephone cable, the wall socket or the modem port. Perform Check 1:

- Check 1 Make sure telephone cable is firmly plugged into both the telephone wall socket and the modem port of the computer. If the cable is connected correctly, go to Check 2.
- Check 2 Make sure the modem port is firmly secured to the system board of the computer. If the malfunction remains, go to Check 3.
- Check 3 The telephone cable may be damaged. Replace with a good cable. If the malfunction remains, go to Procedure 2.

Procedure 2 Modem card connection check

Disassemble the computer following the steps described in Chapter 4, *Replacement Procedures* and ensure that the modem card is well connected to the system board. If the problem persists, perform Procedure 3.

Procedure 3 Modem replacement check

The modem card or RJ-11 jack may be faulty. Try replacing them. If the problem persists, the system board may be defective or damaged. Replace the System Board with a new one following the steps in Chapter 4, *Replacement Procedures*.

2.12 Express card Troubleshooting

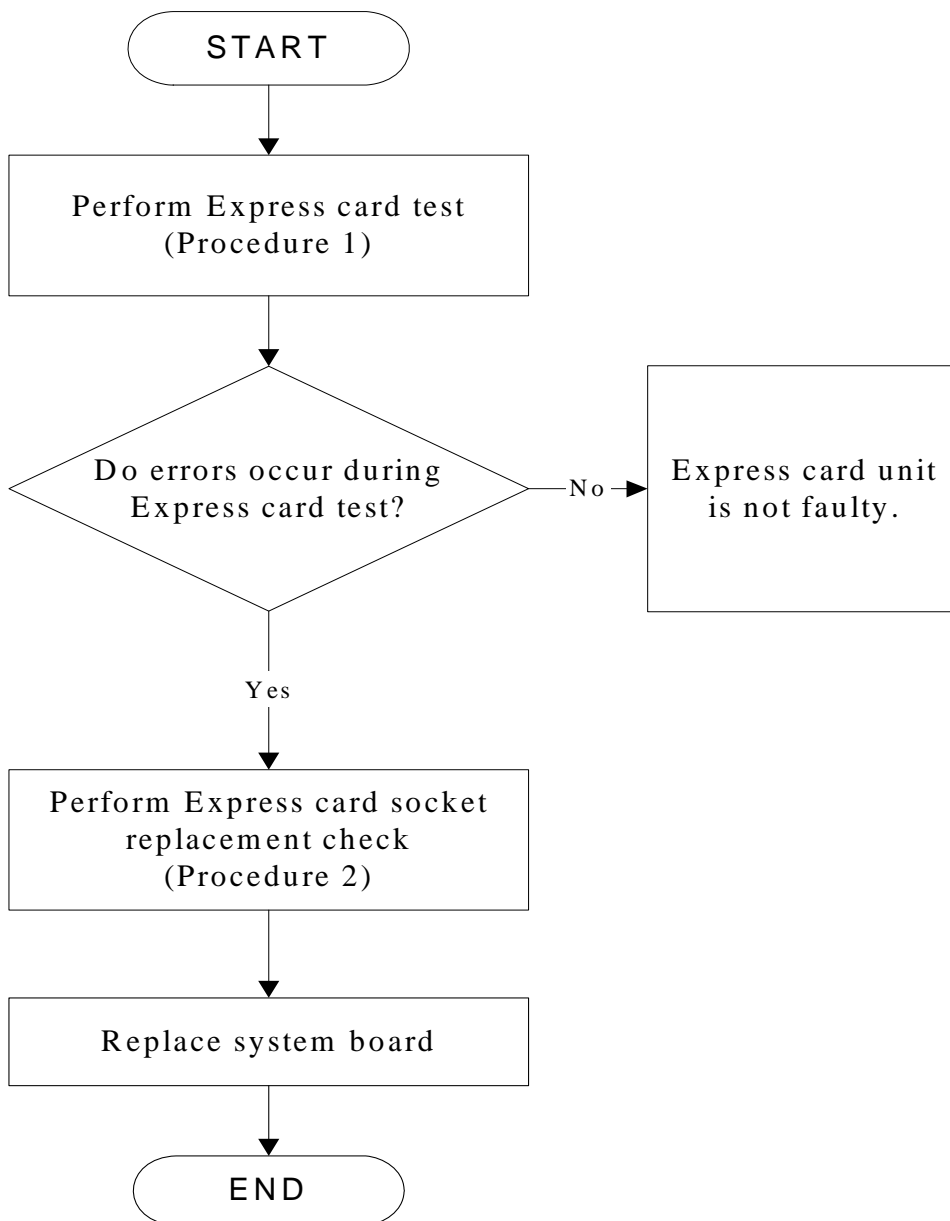

Figure 2-11 Express card troubleshooting process

This section describes how to determine if the Express card player is functioning properly. The process is summarized in Figure 2-11. Perform the steps below starting with Procedure 1 and continuing with the other procedures as required.

Procedure 1: Express card test

Procedure 2: Express card socket replacement check

Procedure 1 Express card test

The Express test card contains a Express test program. Use windows application to check device can work fine or not. If an error occurs. Ensure the card in fully inserted into the socket before running the program.

If an error occurs during the Express card test, perform Procedure 2. If no error occurs, it is likely that the original PC card was faulty.

Procedure 2 Express card socket replacement check

The Express card socket may be damaged or defective, for instance the socket pins can be bent. Disassemble the computer following the steps described in Chapter 4, Replacement Procedures and replace the socket. If the problem persists, the system board may be defective or damaged. Replace the system board with a new one following the steps in Chapter 4.

2.13 Wireless LAN Troubleshooting

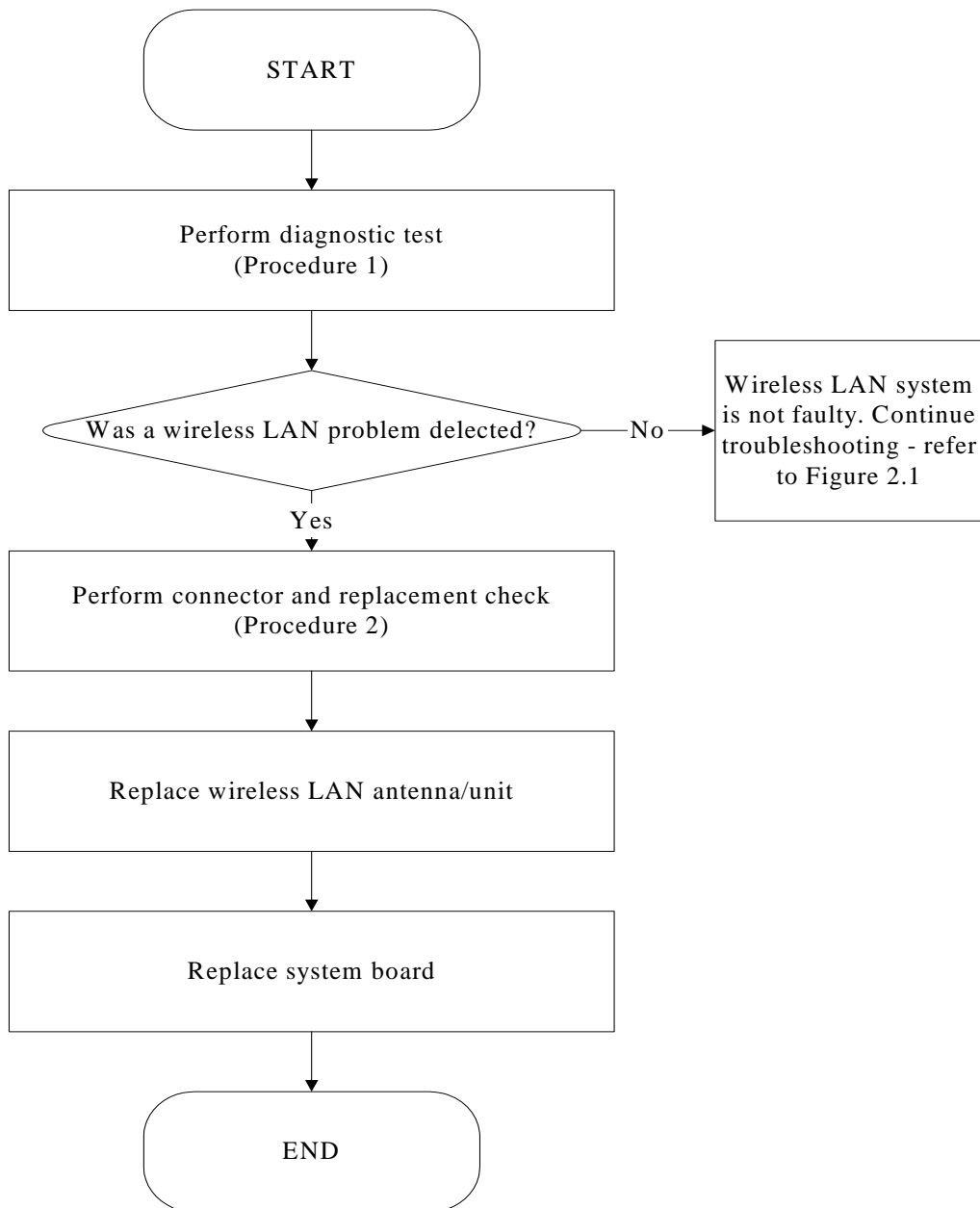

Figure 2-12 Wireless LAN troubleshooting process

The wireless LAN antenna wire, wireless LAN unit or system board may each be the source of a wireless LAN fault. Any of these components may be damaged. To determine if the

computer's wireless LAN system is functioning properly, perform the following procedures.

Figure 2-12 outlines the process. Start with Procedure 1 and continue with the other procedures as instructed.

Procedure 1: Diagnostic test

Procedure 2: Connector and replacement check

Procedure 1 Diagnostic test

Run the Diagnostic Program, which will automatically execute the wireless LAN Device check (refer to chapter 3 system configuration check). Test and Diagnostic for more information PLS use windows application.

If an error is located, go to Procedure 2. If an error is not located, the wireless LAN system is functioning properly.

Procedure 2 Connector and replacement check

The wireless LAN antenna, wireless LAN unit or system board may be disconnected or damaged. Disassemble the computer following the steps described in Chapter 4, *Replacement Procedures*, and perform the following checks.

- Check 1 Make sure that the wireless LAN antenna is firmly connected to the Wireless LAN module (refer to Chapter 4 for instructions) and that the wireless LAN module is securely slotted into the system board. If the problem persists, go to Check 2.
- Check 2 Check that the wireless communication switch is turned to "On", and then make sure that the wireless communication LED on the front panel is light. If the LED is light but the wireless LAN function is still faulty, the antenna may be damaged. Replace with a new antenna following the steps in Chapter 4, *Replacement Procedures*. If the problem persists, or if the wireless LAN LED is not light when the wireless communication switch is turned to "On", go to Check 3.
- Check 3 The wireless LAN unit may be damaged. Replace it with a new one following the instructions in Chapter 4. If the problem still exists, perform Check 4.
- Check 4 The system board may be damaged. Replace it with a new one following the instructions in Chapter 4.

2.14 Camera Troubleshooting

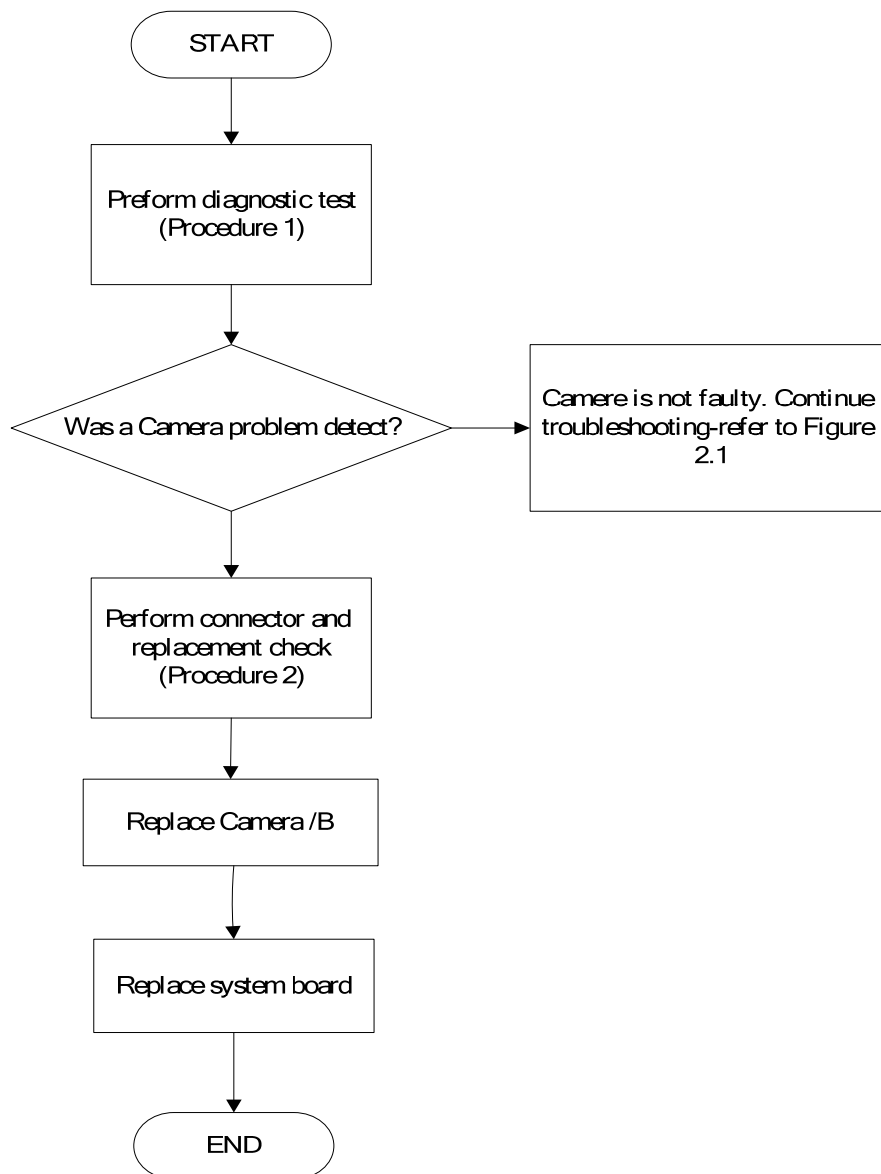

Figure 2-13 Camera troubleshooting process

The Camera board or system board may be the reason of a Camera fault. Either of these two components may be damaged. To determine if the computer's Camera is functioning

properly, perform the following procedures. Figure 2-13 outlines the process. Start with Procedure 1 and continue with the other procedures as instructed.

Procedure 1: Windows Application test

Procedure 2: Connector and replacement check

Procedure 1 Windows Application test

Run the functioning Program in windows, which will display the Camera test result.

If tests and diagnostics result abnormal go to Procedure 2. If an error is not located, the Camera system is functioning properly.

Procedure 2 Connector and replacement check

The Camera board or system board may be disconnected or damaged. Disassemble the computer following the steps described in Chapter 4, *Replacement Procedures*, and perform the following checks.

- Check 1 Make sure that the Camera board FFC is securely slotted into the system board. If the problem persists, go to Check 2.
- Check 2 The Camera board may be damaged. Replace it with a new one following the instructions in Chapter 4. If the problem still exists, perform Check 3.
- Check 3 The system board may be damaged. Replace it with a new one following the instructions in Chapter 4.

2.15 Bluetooth Troubleshooting

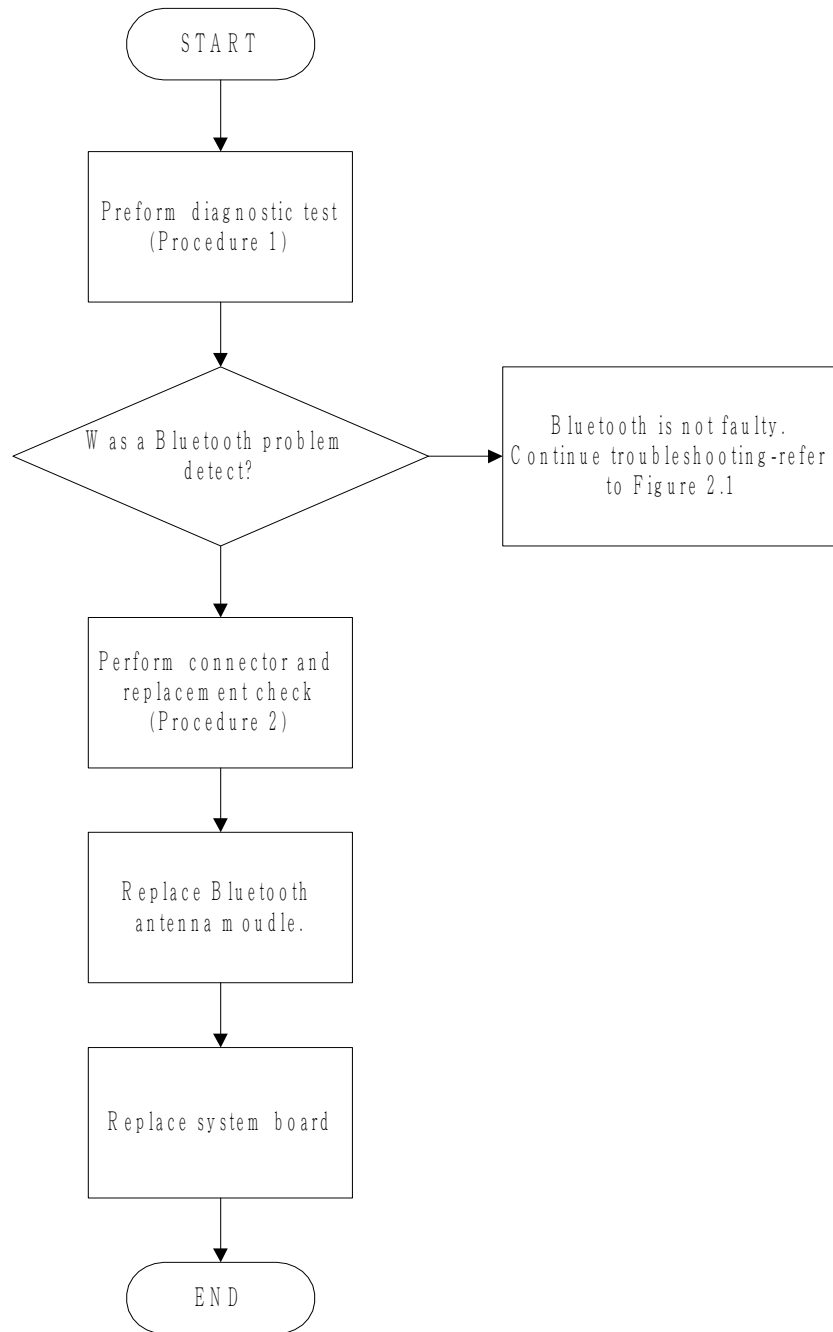

Figure 2-14 Bluetooth troubleshooting process

The Bluetooth antenna wire, Bluetooth module or system board may be the reason of a Bluetooth fault. Any of these components may be damaged. To determine if the computer's Bluetooth is functioning properly, perform the following procedures. Figure 2-14 outlines the process. Start with Procedure 1 and continue with the other procedures as instructed.

Procedure 1: Diagnostic test

Procedure 2: Connector and replacement check

Procedure 1 Diagnostic test

Run the Diagnostic Program, which will automatically execute the Bluetooth device check. (Refer to Chapter 3 system configuration check). Tests and Diagnostics for more information PLS Use windows application to check device can work fine or not.

If an error is located, go to Procedure 2. If an error is not located, the Bluetooth system is functioning properly.

Procedure 2 Connector and replacement check

The Bluetooth, antenna module or system board may be disconnected or damaged. Disassemble the computer following the steps described in Chapter 4, *Replacement Procedures*, and perform the following checks.

- Check 1 Make sure that the Bluetooth antenna is firmly connected to the Bluetooth module (refer to Chapter 4 for instructions) and that the Bluetooth FFC is securely slotted into the system board. If the problem persists, go to Check 2.
- Check 2 Check that the Bluetooth communication switch is turned to "On", then make sure that the communication LED on the left panel is lit. If the LED is lit but the Bluetooth function is still faulty, the antenna module may be damaged. Replace with a new antenna following the steps in Chapter 4, *Replacement Procedures*. If the problem persists, or if the Bluetooth communication LED is not lit when the Bluetooth communication switch is turned to "On", go to Check 3.
- Check 3 The Bluetooth module may be damaged. Replace it with a new one following the instructions in Chapter 4. If the problem still exists, perform Check 4.

Check 4 The system board may be damaged. Replace it with a new one following the instructions in Chapter 4.

2.16 Bridge Media Slot Troubleshooting

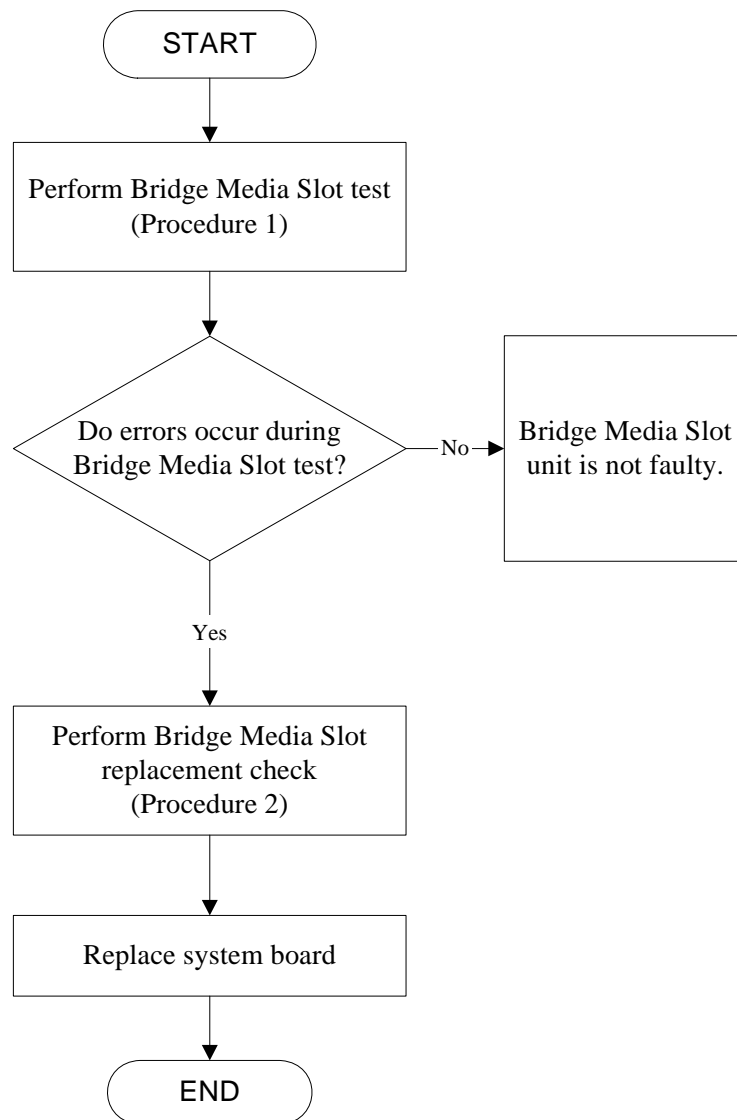

Figure 2-15 Bridge Media Slot troubleshooting process

This section describes how to determine if the Bridge Media Slot player is functioning properly. The process is summarized in Figure 2-15. Perform the steps below starting with Procedure 1 and continuing with the other procedures as required.

Procedure 1: Bridge Media Slot test

Procedure 2: Bridge Media Slot replacement check

Procedure 1 Bridge Media Slot test

The Bridge Media Slot test PLS Use windows application to check device can work fine or not. Ensure the card is fully inserted into the socket before running the program.

If an error occurs during the Bridge Media Slot test, perform Procedure 2. If no error occurs, it is likely that the original Bridge Media Slot was faulty.

Procedure 2 Bridge Media Slot replacement check

The Bridge Media Slot socket may be damaged or defective, for instance the socket pins can be bent. Disassemble the computer following the steps described in Chapter 4, Replacement Procedures and replace the socket. If the problem persists, the system board may be defective or damaged. Replace the system board with a new one following the steps in Chapter 4.

2.17 HDD/SSD Troubleshooting

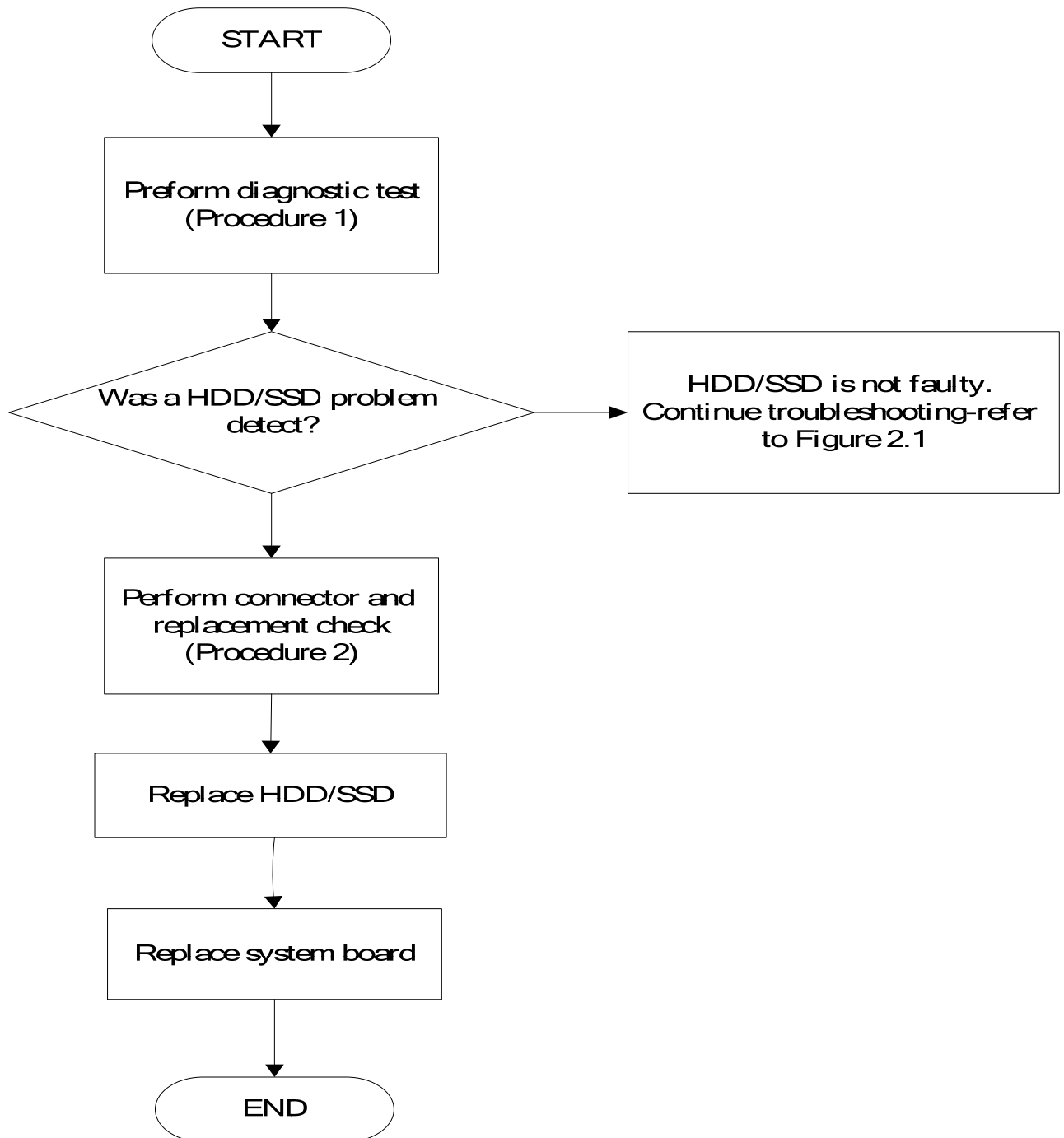

Figure 2-16 HDD/SDD troubleshooting process

The HDD/SSD or system board may be the reason of a HDD/SSD fault. Either of these two components may be damaged. To determine if the computer's HDD/SDD is functioning properly, perform the following procedures. Figure 2-16 outlines the process. Start with Procedure 1 and continue with the other procedures as instructed.

Procedure 1: Diagnostic test

Procedure 2: Connector and replacement check

Procedure 1 Diagnostic test

Run the Diagnostic Program, which will automatically execute the HDD/SSD R/W test. (Refer to Chapter 3 system configuration check), Tests and Diagnostics for more information on the program.

If an error is located, go to Procedure 2. If an error is not located, the HDD/SSD function is functioning properly.

Procedure 2 Connector and replacement check

The HDD module or system board may be disconnected or damaged. Disassemble the computer following the steps described in Chapter 4, *Replacement Procedures*, and perform the following checks.

- Check 1 Make sure that the HDD module is securely slotted into the system board. If the problem persists, go to Check 2.
- Check 2 The HDD module may be damaged. Replace it with a new one following the instructions in Chapter 4. If the problem still exists, perform Check 3.
- Check 3 The system board may be damaged. Replace it with a new one following the instructions in Chapter 4.

2.18 CRT Troubleshooting

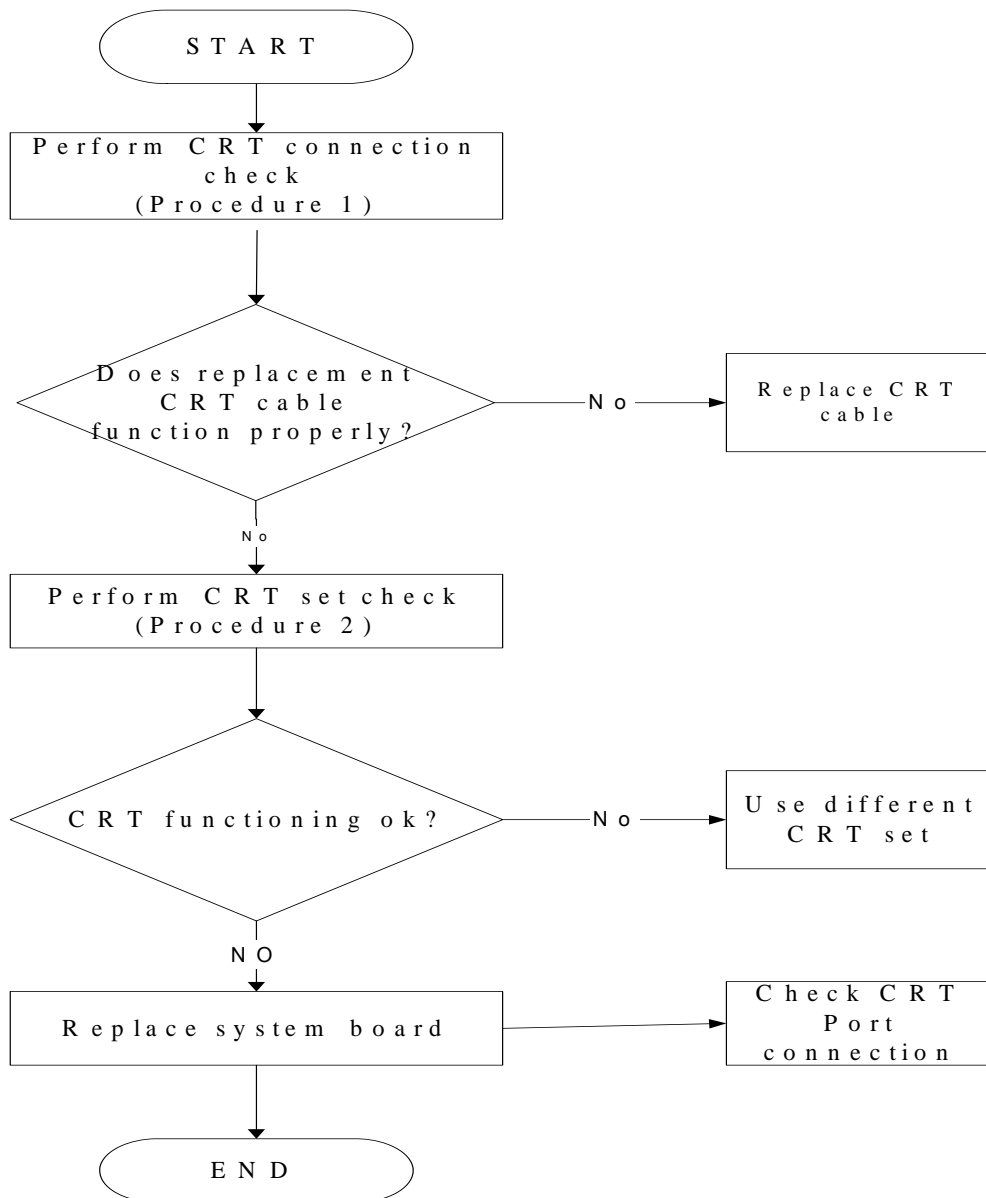

Figure 2-17 CRT troubleshooting process

To determine if the computer's CRT port is functioning properly, perform the following procedures. Figure 2-17 outlines the process. Start with Procedure 1 and continue as instructed.

Procedure 1: CRT connection check

Procedure 2: CRT set check

Procedure 1 CRT connection check

The CRT cable may be damaged or the connections may be loose. Use windows application to check device can work fine or not. Perform Check 1:

- Check 1 Make sure CRT cable is firmly plugged into both the CRT set and the CRT port of the computer. If the cable is connected correctly, go to Check 2.
- Check 2 Make sure the CRT port is firmly secured to the system board of the computer. If the malfunction remains, go to Check 3.
- Check 3 The CRT cable may be damaged. Replace with a good cable. If the malfunction remains, go to Procedure 2.

Procedure 2 CRT set check

The CRT set may be faulty. Perform Check 1:

- Check 1 Try using the set for CRT reception. If it does not work, the set may be damaged. If the set does work, perform Check 2.
- Check 2 Try connecting a different CRT to the computer. If the replacement CRT works, the original set may be damaged. If the replacement set does not work the system board may be damaged. Replace it with a new one following the instructions in Chapter 4.

2.19 HDMI Troubleshooting

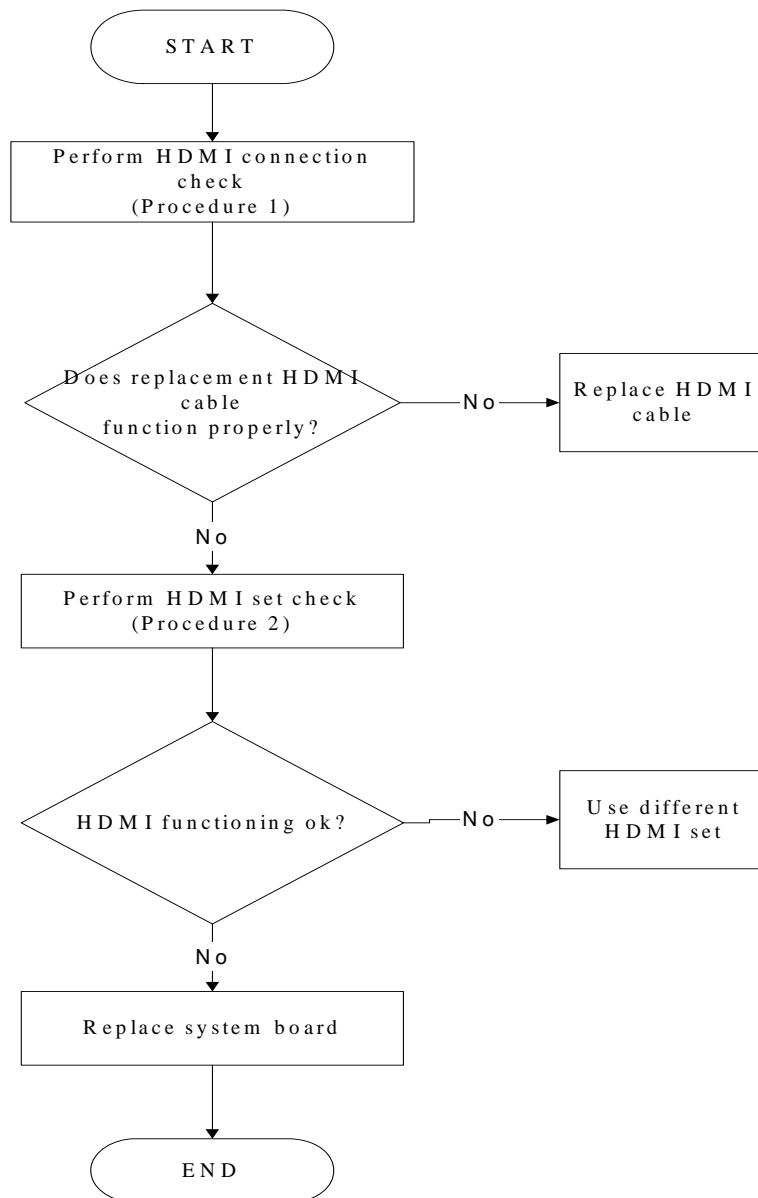

Figure 2-18 HDMI troubleshooting process

To determine if the computer's HDMI port is functioning properly, perform the following procedures. Figure 2-18 outlines the process. Start with Procedure 1 and continue as instructed.

Procedure 1: HDMI connection check

Procedure 2: HDMI set check

Procedure 1 HDMI connection check

The HDMI cable may be damaged or the connections may be loose. Use windows application to check device can work fine or not. Perform Check 1:

- Check 1 Make sure HDMI cable is firmly plugged into both the HDMI set and the HDMI port of the computer. If the cable is connected correctly, go to Check 2.
- Check 2 Make sure the HDMI port is firmly secured to the system board of the computer. If the malfunction remains, go to Check 3.
- Check 3 The HDMI cable may be damaged. Replace with a good cable. If the malfunction remains, go to Procedure 2.

Procedure 2 HDMI set check

The HDMI TV set may be faulty. Perform Check 1:

- Check 1 Try using the set for television reception. If it does not work, the set may be damaged. If the set does work, perform Check 2.
- Check 2 Try connecting a different television to the computer. If the replacement television works, the original set may be damaged. If the replacement set does not work the system board may be damaged. Replace it with a new one following the instructions in Chapter 4.

2.20 Display Port Troubleshooting

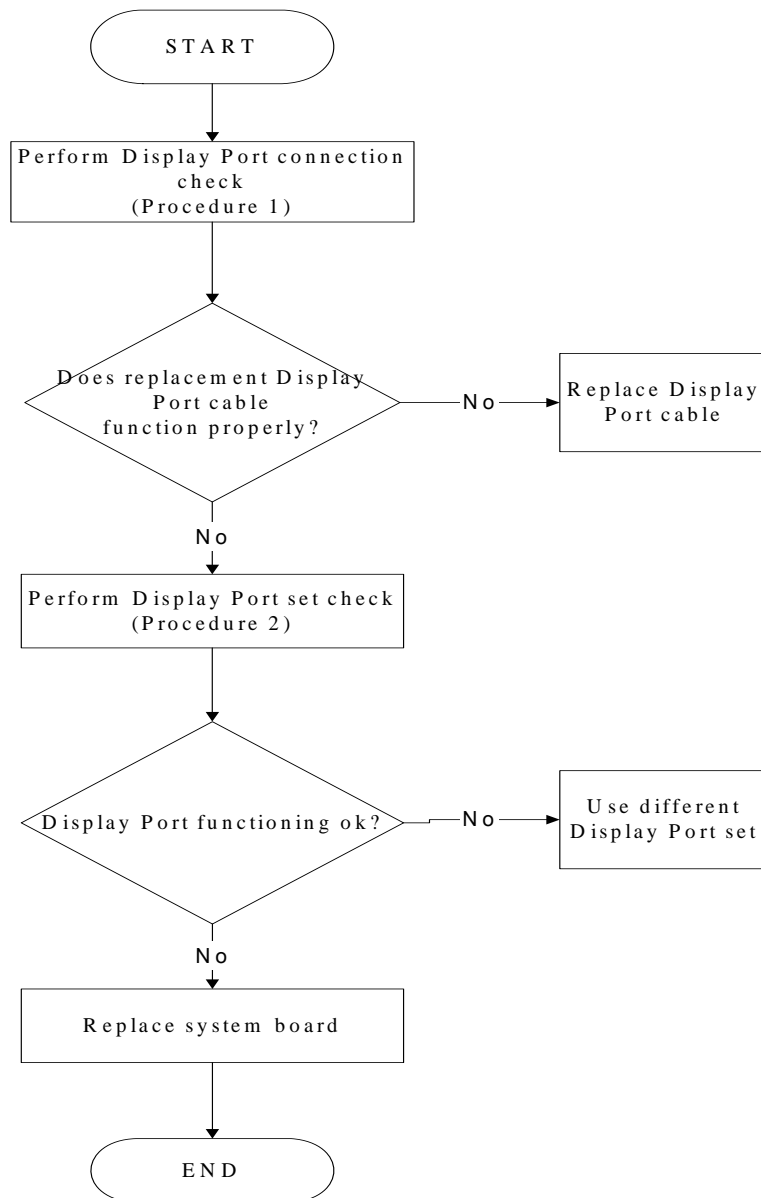

Figure 2-19 Display Port troubleshooting process

To determine if the computer's Display port is functioning properly, perform the following procedures. Figure 2-19 outlines the process. Start with Procedure 1 and continue as instructed.

Procedure 1: Display Port connection check

Procedure 2: Display Port set check

Procedure 1 Display Port connection check

The Display port cable may be damaged or the connections may be loose. Use windows application to check device can work fine or not. Perform Check 1:

- Check 1 Make sure Display Port cable is firmly plugged into both the Display Port set and the Display Port of the computer. If the cable is connected correctly, go to Check 2.
- Check 2 Make sure the Display Port is firmly secured to the system board of the computer. If the malfunction remains, go to Check 3.
- Check 3 The Display Port cable may be damaged. Replace with a good cable. If the malfunction remains, go to Procedure 2.

Procedure 2 Display Port set check

The Display Port TV set may be faulty. Perform Check 1:

- Check 1 Try using the set for television reception. If it does not work, the set may be damaged. If the set does work, perform Check 2.
- Check 2 Try connecting a different television to the computer. If the replacement television works, the original set may be damaged. If the replacement set does not work the system board may be damaged. Replace it with a new one following the instructions in Chapter 4.

2.21 SPDIF troubleshooting

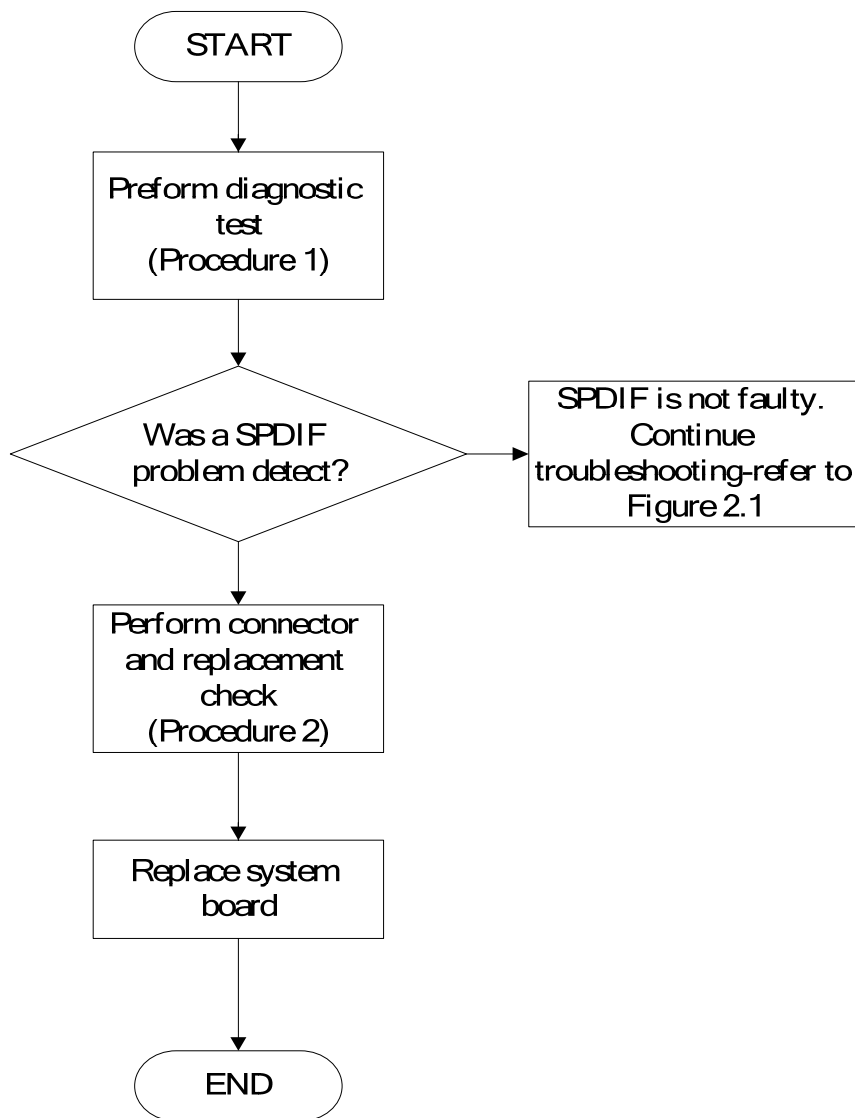

Figure 2-20 SPDIF troubleshooting process

The system board may be the reason of a SPDIF fault. The connector of system board may be damaged. To determine if the computer's SPDIF is functioning properly, perform the

following procedures. Figure 2-20 outlines the process. Start with Procedure 1 and continue with the other procedures as instructed.

Procedure 1: windows application test

Procedure 2: Connector and replacement check

Procedure 1 windows application test

Use windows application to check device can work fine or not.

If tests and diagnostics result abnormal go to Procedure 2. If an error is not located, the SPDIF is functioning properly.

Procedure 2 Connector and replacement check

The system board may be disconnected or damaged. Disassemble the computer following the steps described in Chapter 4, Replacement Procedures, and perform the following checks.

Check 1 the system board may be damaged. Replace it with a new one following the instructions in Chapter 4.

2.22 MIC Troubleshooting

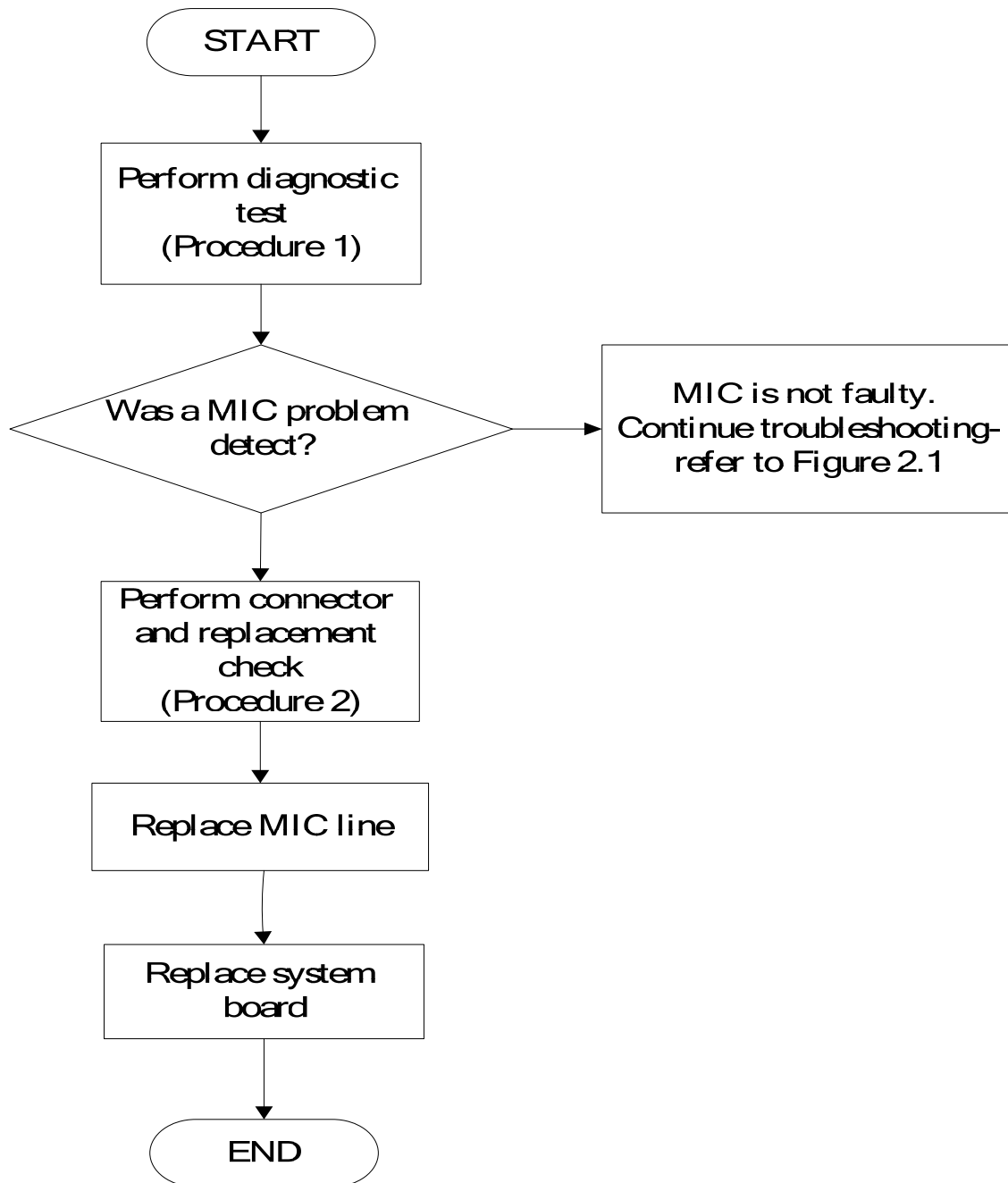

Figure 2.21. MIC troubleshooting process

The MIC line or system board may be the reason of a MIC fault. Either of these two components may be damaged. To determine if the computer's MIC is functioning properly,

perform the following procedures. Figure 2-21 outlines the process. Start with Procedure 1 and continue with the other procedures as instructed.

Procedure 1: Windows Application test

Procedure 2: Connector and replacement check

Procedure 1 Windows Application test

Run the functioning Program (record.exe) on Windows model, which will display the MIC test result.

If tests and diagnostics result abnormal go to Procedure 2. If an error is not located, the MIC module functioning is properly.

Procedure 2 Connector and replacement check

The MIC line or system board may be disconnected or damaged. Disassemble the computer following the steps described in Chapter 4, *Replacement Procedures*, and perform the following checks.

- Check 1 Make sure that the MIC line is securely slotted into the system board. If the problem remains, go to Check 2.
- Check 2 The MIC line may be damaged. Replace it with a new one following the instructions in Chapter 4. If the problem still exists, perform Check 3.
- Check 3 The system board may be damaged. Replace it with a new one following the instructions in Chapter 4.

2.23 Finger printer troubleshooting

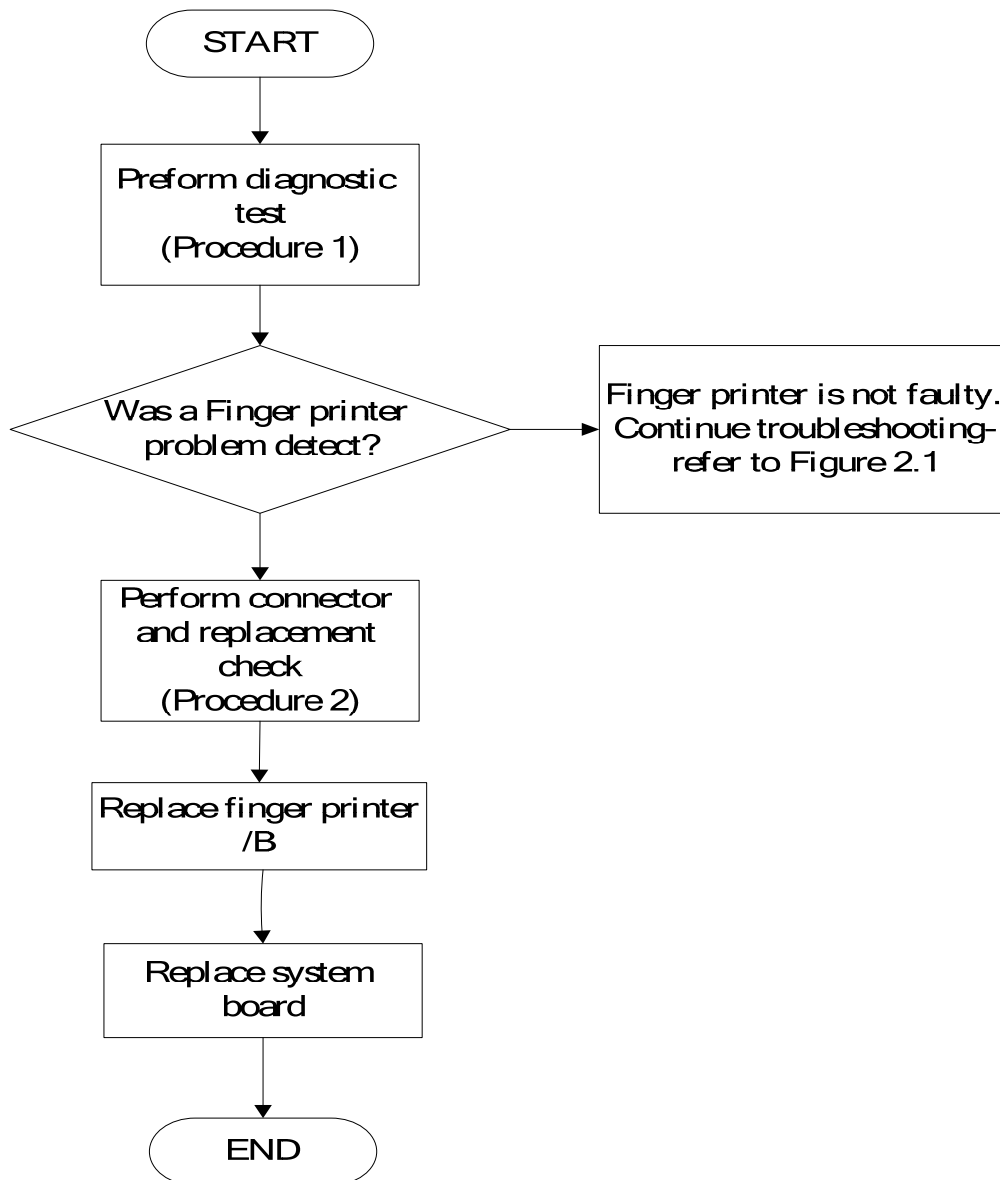

Figure 2-22 Finger printer troubleshooting process

The Finger printer board or system board may be the reason of a finger printer fault. Either of these two components may be damaged. To determine if the computer's Finger printer is

functioning properly, perform the following procedures. Figure 2-22 outlines the process.

Start with Procedure 1 and continue with the other procedures as instructed.

Procedure 1: windows application test

Procedure 2: Connector and replacement check

Procedure 1 windows application test

Use windows application to check device can work fine or not .If an error is located, go to Procedure 2. If an error is not located, the Finger printer system is functioning properly.

Procedure 2 Connector and replacement check

The Finger printer board or system board may be disconnected or damaged. Disassemble the computer following the steps described in Chapter 4, *Replacement Procedures*, and perform the following checks.

- Check 1 Make sure that the Finger printer board FFC is securely slotted into the system board. If the problem persists, go to Check 2.
- Check 2 The Finger printer board may be damaged. Replace it with a new one following the instructions in Chapter 4. If the problem still exists, perform Check 3.
- Check 3 The system board may be damaged. Replace it with a new one following the instructions in Chapter 4.

2.24 FM tuner Failure Troubleshooting

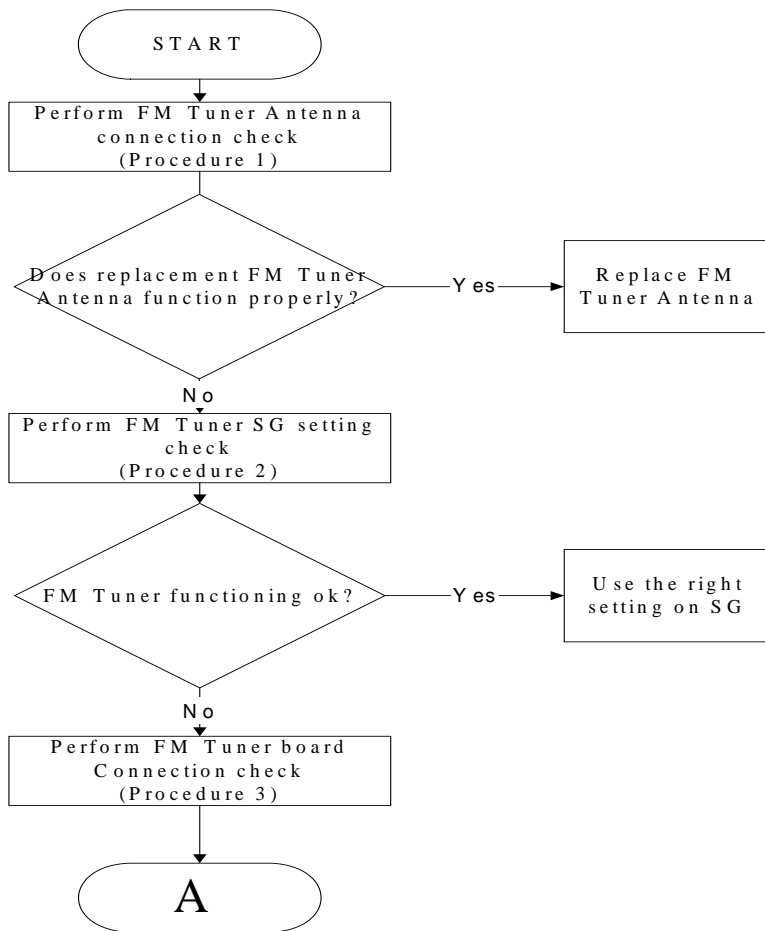
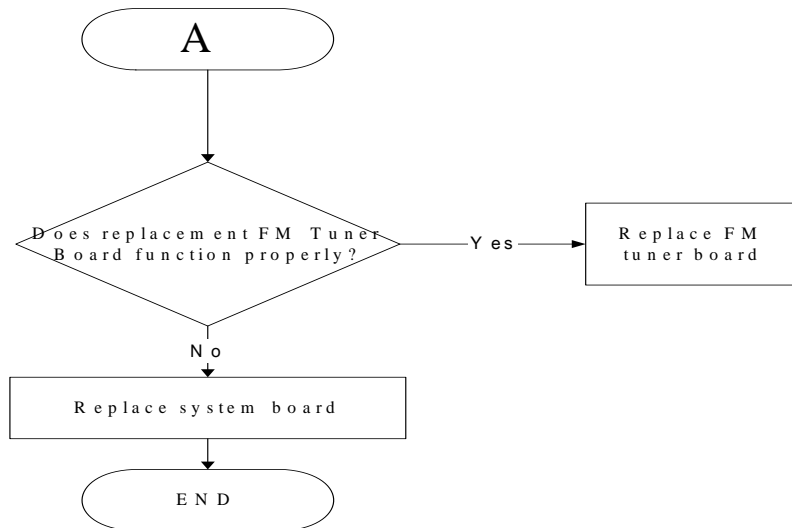

Figure 2-23 FM tuner troubleshooting process



To determine if the computer's FM tuner port is functioning properly, perform the following procedures. Figure 2-23 outlines the process. Start with Procedure 1 and continue as instructed.

Procedure 1: FM Tuner Antenna connection check

Procedure 2: FM Tuner SG setting check

Procedure 3: FM Tuner board connection check

Procedure 1 FM tuner Antenna connection check

Use windows application to check device can work fine or not .If an error is located .The FM Tuner Antenna may be damaged or the connections may be loose. Perform Check 1:

- Check 1 Make sure FM Tuner Antenna is firmly plugged into FM Tuner port of the computer. If the Antenna is connected correctly, go to Check 2.
- Check 2 Try connecting a different FM Tuner Antenna to the computer. If the replacement FM Tuner Antenna works, the original set may be damaged. If the replacement set does not work the FM Tuner SG setting may be incorrect, Go to Procedure 2

Procedure 2 FM Tuner SG setting check

The FM Tuner SG setting may be faulty. Perform Check 1:

- Check 1 Check the FM Tuner SG setting was right or wrong, if right; go to check 2, if wrong. Correct it and re-test. If fail symptom still exist, go to check 2.
- Check 2 Try connecting a different FM tuner SG to the computer. If the replacement FM tuner SG works, the original set may be damaged. If the replacement set does not work the FM Tuner board may be damaged. Go to Procedure 3.

Procedure 3 FM Tuner board connection check

The FM Tuner board may be damaged or the connections may be loose. Perform Check 1:

- Check 1 Make sure FM Tuner board FFC is firmly plugged into the system board. If the FFC is connected correctly, go to Check 2.
- Check 2 Try connecting a different FM Tuner board to the computer. If the replacement FM Tuner board works, the original FM Tuner Board may be damaged. If the replacement FM Tuner board does not work the System board may be damaged. Replace it with a new one following the instructions in Chapter 4.

2.25 E-SATA Troubleshooting

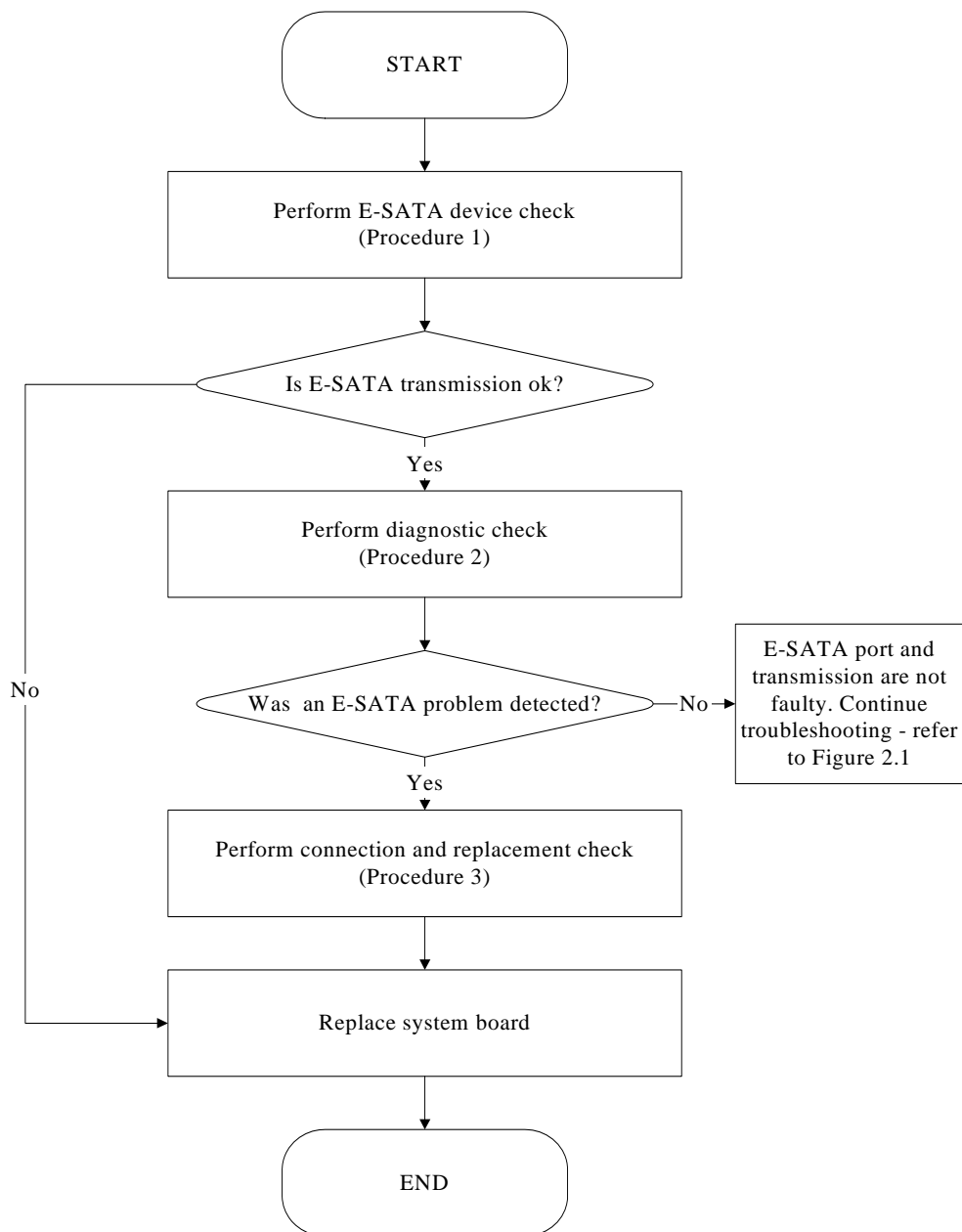

Figure 2-24 E-SATA troubleshooting process

To determine if the computer's E-SATA system is functioning properly, perform the following procedures. Figure 2-24 outlines the process. Start with Procedure 1 and continue with the other procedures as instructed.

Procedure 1: E-SATA device check

Procedure 2: Windows Application check

Procedure 3: Connection and replacement check

Procedure 1 E-SATA device check

Connect an E-SATA device to the computer's E-SATA port, then boot the computer for Windows Vista. The computer should automatically detect the E-SATA device. Check whether the device can transmit data to the computer.

If the device is able to communicate with the computer, the problem may be intermittent or connections may be faulty. Go to Procedure 2.

If communication is impaired, there may be a faulty connection. Go to Procedure 3.

Procedure 2 Windows Application check

Run the Windows Application, which will automatically execute the E-SATA port test for transmission, Tests and Diagnostics for more information on how to run the program.

If an error is located, go to Procedure 3. If an error does not occur, the E-SATA port is functioning properly.

Procedure 3 Connection and replacement check

The transmission cable may be damaged or the connections may be loose. Perform Check 1:

- Check 1 Make sure the transmission cable is firmly plugged into both the E-SATA - compatible device and the E-SATA port of the computer. If the cable is connected correctly, go to Check 2.
- Check 2 Make sure the E-SATA port is firmly secured to the system board of the computer. If the malfunction persists, go to Check 3.
- Check 3 The transmission cable may be damaged. Replace with a good cable. If the malfunction persists, go to Check 4
- Check 4 The system board may be damaged. Replace it with a new one following the instructions in Chapter 4.

2.26 Felica Troubleshooting

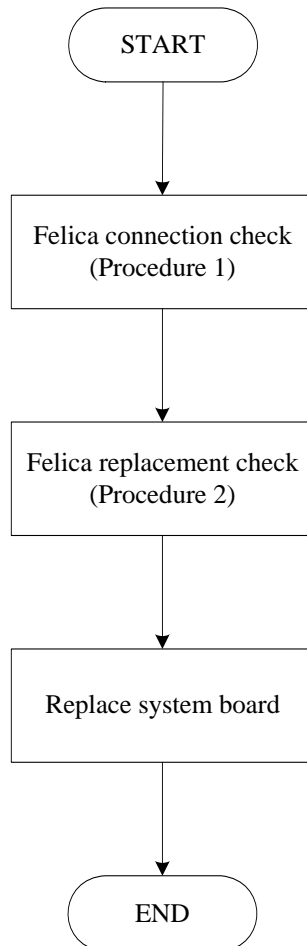

Figure 2-25 Felica troubleshooting process

To determine if the computer's built-in Felica is functioning properly, perform the following procedures. Figure 2-25 outlines the process. Start with Procedure 1 and continue as instructed.

Procedure 1: Felica connection check

Procedure 2: Felica replacement check

Procedure 1 Felica connection check

The Felica is connected via the Felica FPC to the system board. Make sure the Felica FPC cable is firmly connected to the Felica and system board. Refer to Chapter 4, *Replacement Procedures*, for instructions on how to disassemble the computer and then perform the following checks.

Use windows application to check device can work fine or not .If an error is located, make sure the connection was ok. If any of the connections are loose, reconnect firmly. If any of the connections is damaged, or there is still an error, go to Procedure 2.

Procedure 2 Felica replacement check

The Felica unit or FPC may be defective or damaged. Replace each with a new one following the steps in Chapter 4. If the Felica is still not functioning properly, replace the system board with a new one following the steps in Chapter 4.

2.27 UWB Troubleshooting

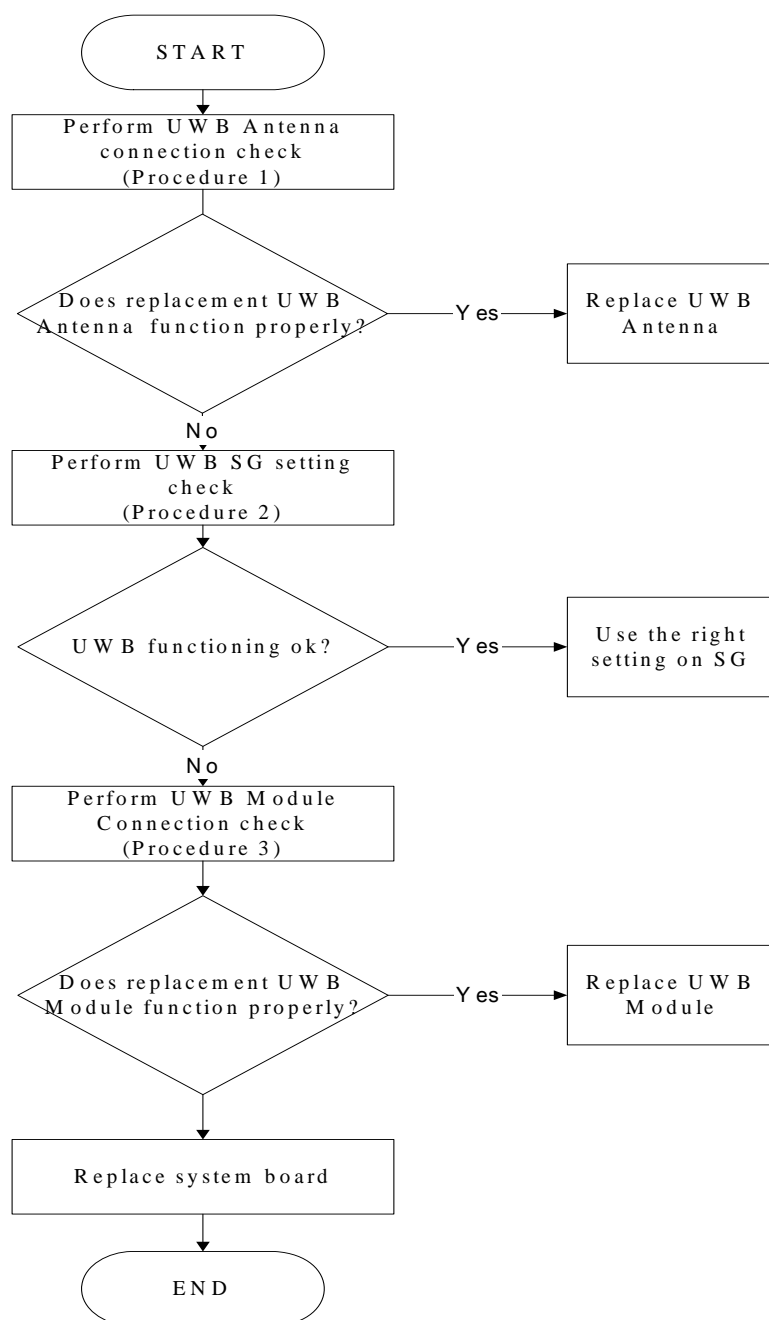

Figure 2-26 UWB troubleshooting process

To determine if the computer's UWB is functioning properly, perform the following procedures. Figure 2-26 outlines the process. Start with Procedure 1 and continue as instructed.

Procedure 1: UWB Antenna connection check

Procedure 2: UWB SG setting check

Procedure 3: UWB Module connection check

Procedure 1 UWB Antenna connection check

Use windows application to check device can work fine or not. If an error is located, make sure The UWB Antenna may be damaged or the connections may be loose. Perform Check 1:

- Check 1 Make sure UWB Antenna is firmly plugged into UWB module of the computer. If the antenna is connected correctly, go to Check 2.
- Check 2 Try connecting a different UWB Antenna to the computer. If the replacement UWB Antenna works, the original Antenna may be damaged. If the replacement Antenna does not work the UWB SG setting may be wrong. Go to Procedure 2.

Procedure 2 UWB SG setting check

The UWB SG setting may be faulty. Perform Check 1:

- Check 1 Check the UWB SG Setting was right or wrong, if right; go to check 2, if wrong. Correct it and re-test. If fail symptom still exist, go to check2
- Check 2 Try connecting a different UWB SG to the computer. If the replacement UWB SG works, the original SG may be damaged. If the replacement set does not work the UWB module may be damaged. Go to Procedure 3.

Procedure 3 UWB Module connection check

The UWB Module connect may be faulty. Perform Check 1:

- Check 1 Check the UWB Module is firmly plugged into system board, if connection was correctly, go to check 2.

Check 2

Try connecting a different UWB Module to the computer. If the replacement UWB Module works, the original Module may be damaged. If the replacement Module does not work the system board may be damaged. Replace it with a new one following the instructions in Chapter 4.

2.28 3G Troubleshooting

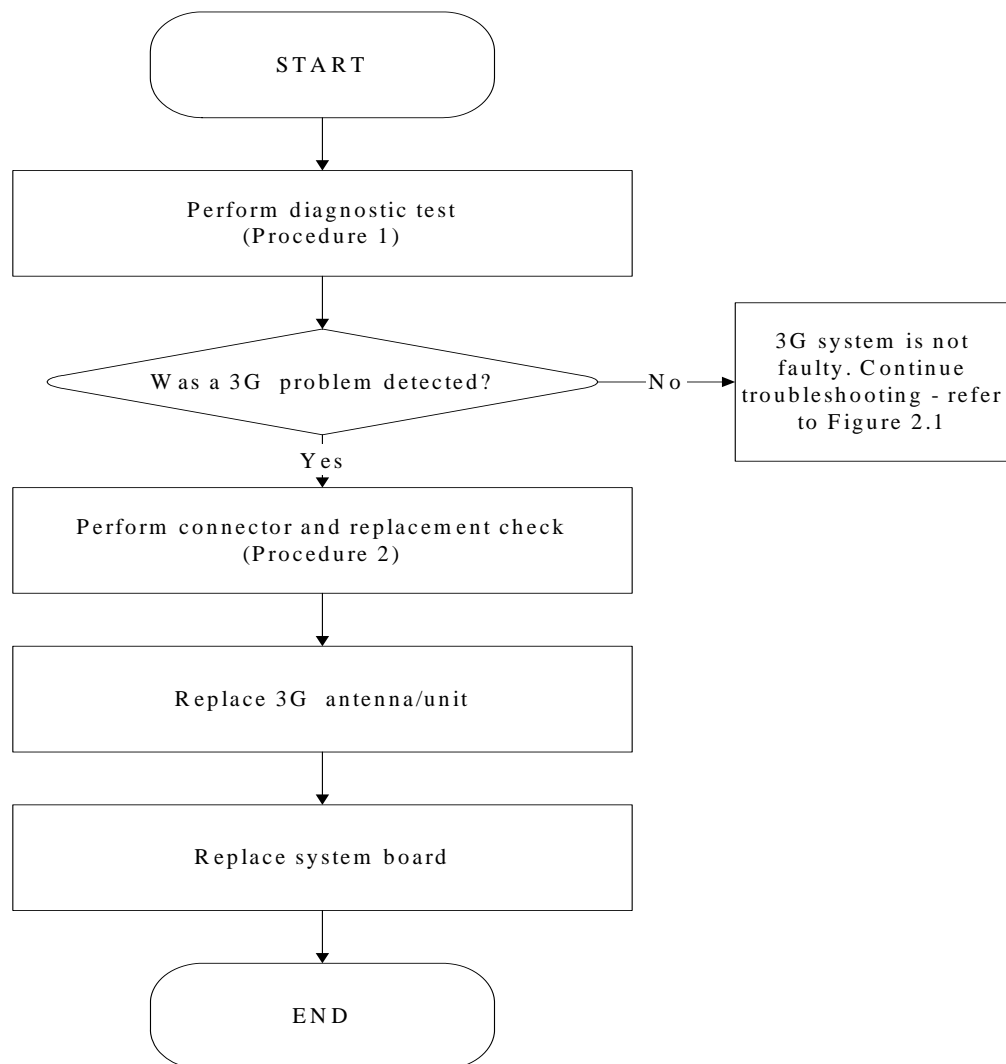

Figure 2-27 3G troubleshooting process

The 3G antenna wire, 3G unit or system board may each be the source of a 3G fault. Any of these components may be damaged. To determine if the computer's wireless LAN system is functioning properly, perform the following procedures. Figure 2-27 outlines the process.

Start with Procedure 1 and continue with the other procedures as instructed.

Procedure 1: Diagnostic test

Procedure 2: Connector and replacement check

Procedure 1 Connector and replacement check

The 3G antenna, 3G unit or system board may be disconnected or damaged. Disassemble the computer following the steps described in Chapter 4, *Replacement Procedures*, and perform the following checks.

- Check 1 Make sure that the 3G antenna is firmly connected to the 3G module (refer to Chapter 4 for instructions) and that the 3G module is securely slotted into the system board. If the problem persists, go to Check 2.
- Check 2 Check the wireless communication function is enabled by BIOS setup and FN+F8, and then make sure that the wireless communication LED on the front panel is light. If the LED is light but the 3G function is still faulty, the antenna may be damaged. Replace with a new antenna following the steps in Chapter 4, *Replacement Procedures*. If the problem persists, or if the wireless LAN LED is not light when the wireless communication function is enabled by BIOS setup and FN+F8, go to Check 3.
- Check 3 3G unit may be damaged. Replace it with a new one following the instructions in Chapter 4. If the problem still exists, perform Check 4.
- Check 4 The system board may be damaged. Replace it with a new one following the instructions in Chapter 4.

Chapter 3

Tests and Diagnostics

3.1	The Diagnostic Test	3
3.2	Executing the Diagnostic Test.....	4
3.3	Display Configuration	8
3.4	Audio sound Test.....	9
3.5	Fan ON/OFF Test.....	10
3.6	Main Battery Charge Test	11
3.7	FDD Test	12
3.8	Memory Check	14
3.9	Keyboard Test	14
3.10	Mouse (Pad) Test	16
3.11	LCD Pixels Mode Test.....	17
3.12	Magnetic switch Test	18
3.13	LAN Test.....	21
3.14	RTC Test	24
3.15	BUTTON Test.....	25
3.16	1st HDDTest	27
3.17	RDMI Test.....	30
3.18	WDMI Test	31
3.19	3D Sensor Test.....	33

3.1 The Diagnostic Test

This chapter explains how to use the Test & Diagnostic program to test the functions of the **(Base on Bradford 10AR/10ARG T&D version 1.0)** hardware modules. The Test & Diagnostic Program is stored on the T&D diskettes. The program consists of a series of tests that run automatically when the Diagnostics Program items are selected and executed.

NOTES: *To start the diagnostics, follow these steps*

1. *Check all cables for loose connections.*
2. *Exit this program when you are at Main Menu.*

The TEST & DIAGNOSTIC PROGRAM contains the following functional tests:

- CONFIG CHECK TEST
- Audio sound TEST
- FAN ON/OFF TEST
- MAIN BATTERY CHARGE TEST
- FDD TEST
- Memory check
- KEYBOARD TEST
- MOUSE(PAD) TEST
- LCD PIXELS MODE TEST
- MAGNETIC SWITCH TEST
- LAN TEST
- RTC TEST
- BUTTON TEST
- 1st HDD Test
- RDMI Test
- WDMI Test
- 3D Sensor Test

You will need the following equipment to perform some of the Diagnostic test programs.

- The diagnostics USB disk
- A formatted working diskette for the floppy disk drive test (Floppy Disk Drive Test)
- A LAN loopback

3.2 Executing the Diagnostic Test

DOS is required to run the DIAGNOSTICS PROGRAM. To start the DIAGNOSTIC PROGRAM, follow these steps:

Insert the diagnostics USB disk drive and turn on the computer. (The diagnostics diskette contains the Free-DOS boot files.) And then follow the instructions for T&D program installed in USB driver)

The T&D Program can run single test by you press responsive English letter of test item, and it also asks you if you like to copy test log file to USB disk as reference at the end of test(s).

The test list is as the following:

- A. CONFIG CHECK TEST
- B. Audio sound TEST
- C. FAN ON/OFF TEST
- D. MAIN BATTERY TEST
- E. FDD TEST
- F. Memory check
- G. KEYBOARD TEST
- H. MOUSE (PAD) TEST
- I. LCD PIXELS MODE TEST
- J. MAGNETIC TEST
- K. LAN TEST
- L. RTC TEST
- M. BUTTON TEST
- N. 1st HDD Test
- O. RDMI Test
- P. WDMI Test
- Q. 3D Sensor Test

The below display will show up at the beginning of T&D program

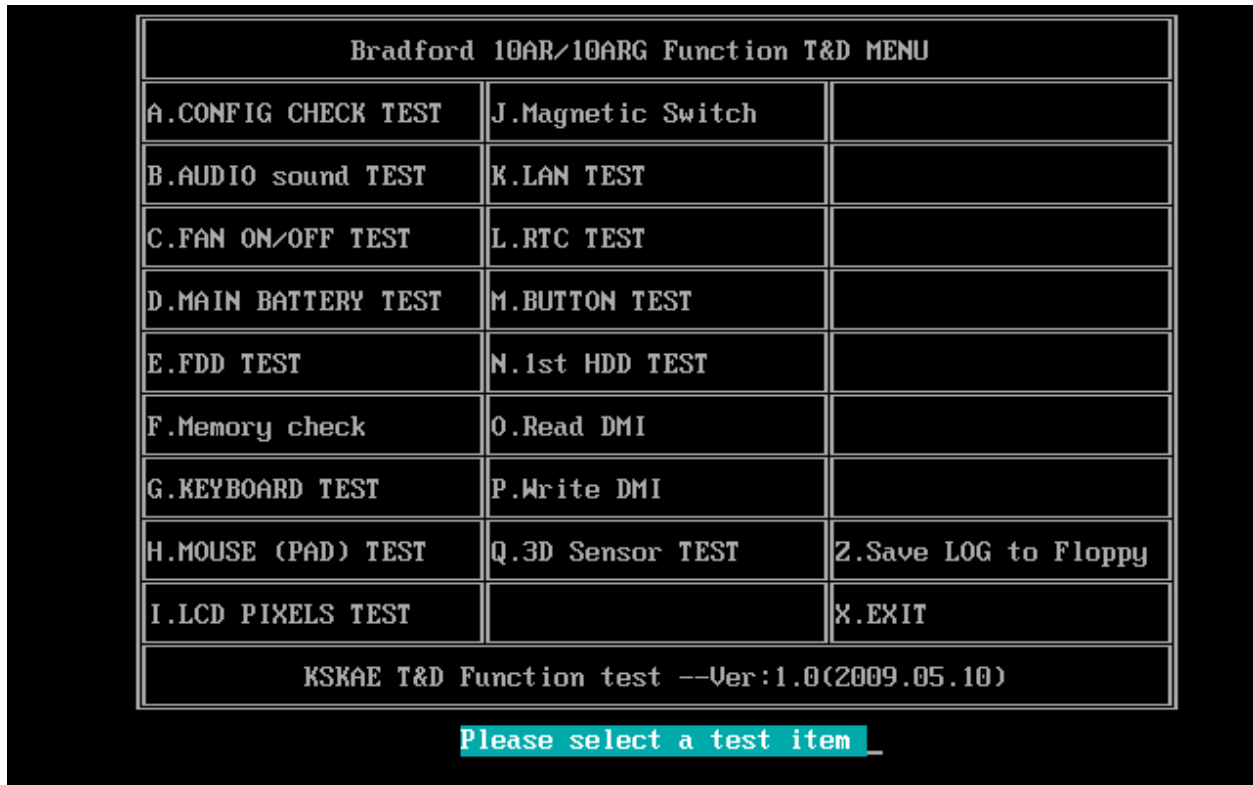

If the test result passes, the following display will show up:



If an error is detected and a test fails, the following message displays:



Then press any key for next actions – the below display presented if copying test log file onto diskette is necessary. This action will be executed when “Y” key pressed.

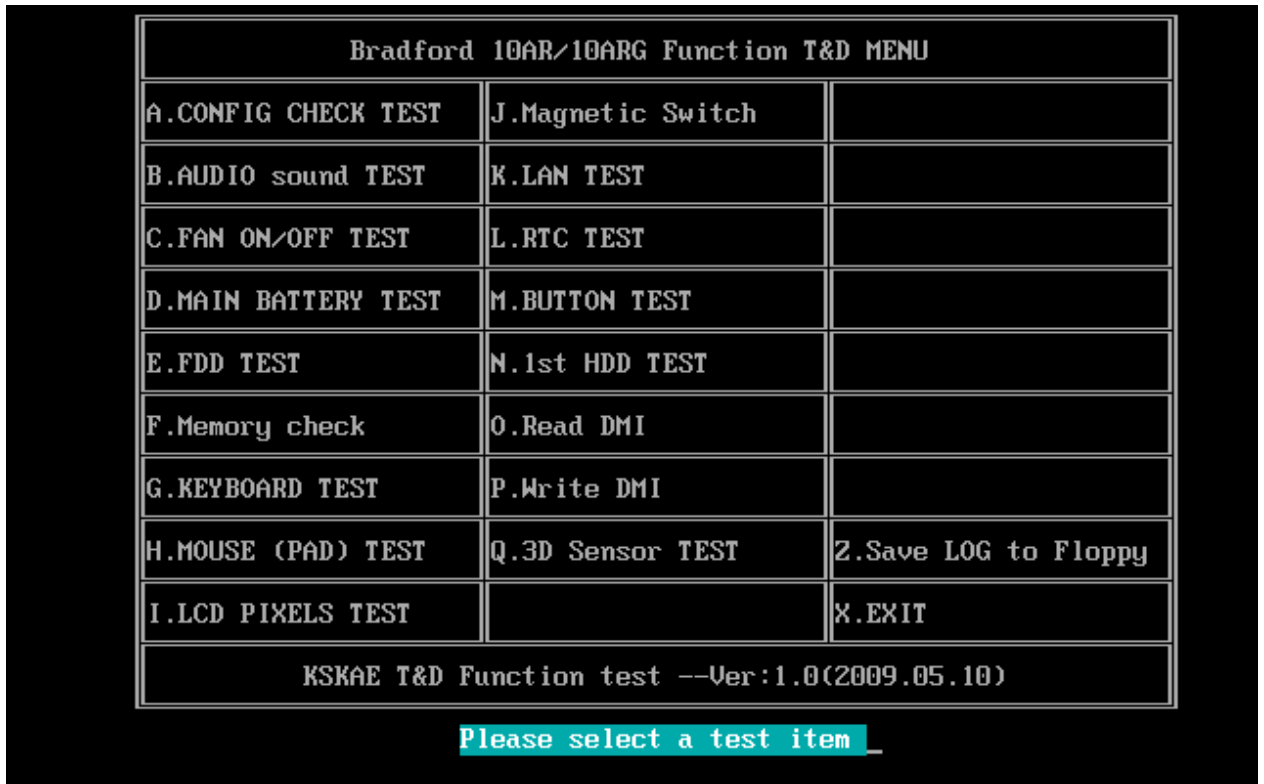

It will skip this process if “N” key pressed.

And then it will check if it’s necessary to leave this program. Program will quit when “Y” key pressed and it will go back main menu for next test if “N” key pressed.

Bradford 10AR/10ARG Function T&D MENU		
A.CONFIG CHECK TEST	J.Magnetic Switch	
B.AUDIO sound TEST	K.LAN TEST	
C.FAN ON/OFF TEST	L.RTC TEST	
D.MAIN BATTERY TEST	M.BUTTON TEST	
E.FDD TEST	N.1st HDD TEST	
F.Memory check	O.Read DMI	
G.KEYBOARD TEST	P.Write DMI	
H.MOUSE (PAD) TEST	Q.3D Sensor TEST	Z.Save LOG to Floppy
I.LCD PIXELS TEST		X.EXIT
KSKAE T&D Function test --Ver:1.0(2009.05.10)		
Please select a test item _		

3.3 Display Configuration

This Item will show the unit configuration. It includes:

- ◆ CPU (CPU type)
- ◆ DDRAM SIZE
- ◆ Panel ID
- ◆ HDD1 type & capacity (Vendor ID. Model .Firmware)
- ◆ VRAM size / VGA CHIP TYPE
- ◆ Battery cell (3cell;6cell;12cell)
- ◆ Wireless type
- ◆ LAN Type
- ◆ Bluetooth

The screen should display as below:

```
=====
===== Configuration as Below =====
=====
cputype=AMDTurion-RM-74
DDRAMS SIZE=4096MBRAM
PanelID=160AT01-T02
HDD1=TOSHIBAMK3255GSX
VRAMS SIZE&VGATYPE=MBRS780MNU
BATT=6cell
WirelessTYPE= Atheros0D200
LANTYPE=8103EL
Bluetooth=NO

ARE YOU TEST OK?[Y,N]?_
```

3.4 Audio sound test

The audio sound test allows the user to aurally confirm the speaker functions. And the speaker will send out music during test.

NOTE: Remember to tune up the volume as “Maximum” before this test starts.

Buffalo only have one speaker, no need test Left/Right Speaker

The screen should display as below, indicating whether the test is passed or failed after the question.

```
=====Speaker audio Test=====
1.Please adjust volume to max level.
2.Please listen to speaker will send out sound

Press any key to continue . . . _
```

3.5 Fan ON/OFF Test

The fan test allows the user to test aurally whether the fan is working. And follow the below procedures for this test:

- ◆ The computer will let the fan be “ON” after any key pressed. Feel the wind or listen the rotating sound to check whether the fan is working or not.

NOTE: Remember to approach fan outlet that is near right side of unit whether fan is “ON”.

- ◆ The computer will stop the fan working after any key pressed. Feel the wind or listen the sound to check if the fan is “OFF”.

The screen should display as below, indicating whether the test is passed or failed after the question.

```
**** Fan ON/OFF Test ,Please Listen To The FAN Sound !! ****
Press Any Key To Fan On Test ..

Fan On Test :rotating.. ( Press Any Key To Fan Off Test )
Fan Off Test :stopping..

Do you feel FAN rotating wind?

[Y,N]?
```

3.6 Main Battery Charge Test

NOTE: The AC adaptor should be connected to successfully run this test

- . 75W with 19V DC for UMA SKU
- . 120W with 19V DC for discrease SKU

This test shows and measures the main battery:

- ◆ Battery type (Lion)
 - ◆ Manufacturer (Sanyo/Panasonic/Sony)
 - ◆ Remain charge capacity (0 ~ 100%)
 - ◆ Charge function (PASS/FAIL)
- “Battery Is Full” showed when “remain charge capacities” is 100%

The screen should display as below, if the charge function is OK, will show:.

```
ONLY FOR 87591 T&D Series Battery Test Program.[591] V1.0 2002/07/23
MAIN Battery

Battery Type: Lion
Manufacturer: Sony
Remain charge capacity : 80.0%

Charge Test-> [ PASS ]

Press any key to continue . . .
```

If the charge function is NG, the screen will display as:

```
ONLY FOR 87591 T&D Series Battery Test Program.[591] V1.0 2002/07/23
MAIN Battery

Battery Type: Lion
Manufacturer: Sony
Remain charge capacity : 86.5%

Charge Test-> [ FAIL ]

Press any key to continue . . .
```

3.7 FDD Test

NOTE: Before running the FDD test, prepare a formatted work diskette (1.44 MB). Need to insert FDD when power on machine. Otherwise the Floppy can not be detected.

The Floppy Disk Test includes three subtests of the:

1. Sequential seek/verify function (Range: Track 0 ~ 79)
2. Funnel code seek/verify function (Range: Track 0 ~ 79)
3. Write/Read/Compare pattern function (Range: Track 75 ~ 79)

NOTE: The write-protected device of this formatted diskette should be "Disable".

The subtests run automatically.

NOTE: Press "Esc" key can skip the current subtest.

The screen should display as below, indicating whether the subtests pass or fail when finished.

```
***** Fdd Test Program V1.3 *****  
Testing Driver A: [1.44 MByte (Cyl:80, Head:2, Sec:18)]...  
Testing Seq. seek/verify... Head: 01, Track: 79... [ PASS ]  
Testing Fun. seek/verify... Head: 01, Track: 06...
```

3.8 Memory check

This test will check if the computer's Memory Frequency and Size is correct in every slot.

```
=====
COMPAL Electronic Inc.                               V1.0.0.1
Author : STD.SID TEAM.
WARNING: THIS PROGRAM IS FOR INTERNAL USE ONLY.
Copyright (c) 2008 COMPAL Electronic Inc. All rights reserved.
=====
DIM: 0
      Size0: 1024 MB
      Speed0: 800
      Manufacturer0: 1GA3700

DIM: 2
      Size2: 2048 MB
      Speed2: 800
      Manufacturer2:

are the RAM type is ok? [Y,N]?_
```

3.9 Keyboard Test

The keyboard test checks the all keys function.

NOTE: The *Num Lock* and the *Overlay* mode must be off to execute the keyboard test.

Before keyboard test starts, the keyboard matrix code should be chosen as below display:

1. **S** (US, for America)
2. **J** (Japan, for Japan)
3. **K**(UK, for Europe)

When you execute this test, the keyboard layout is drawn on the display. When any key is pressed, the corresponding key on the screen changes to black as shown below.

It will indicate whether the sub test is passed or failed after the question.

US Keyboard



Japan keyboard

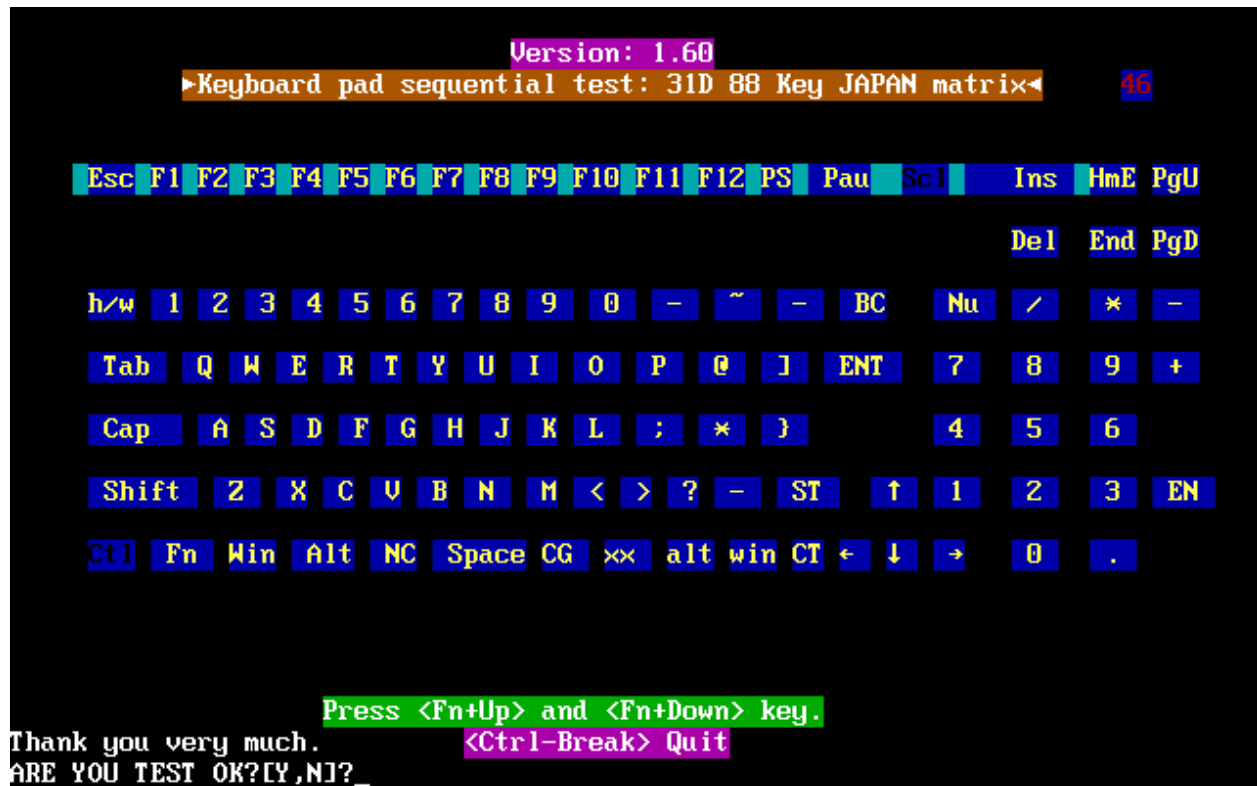

UK keyboard

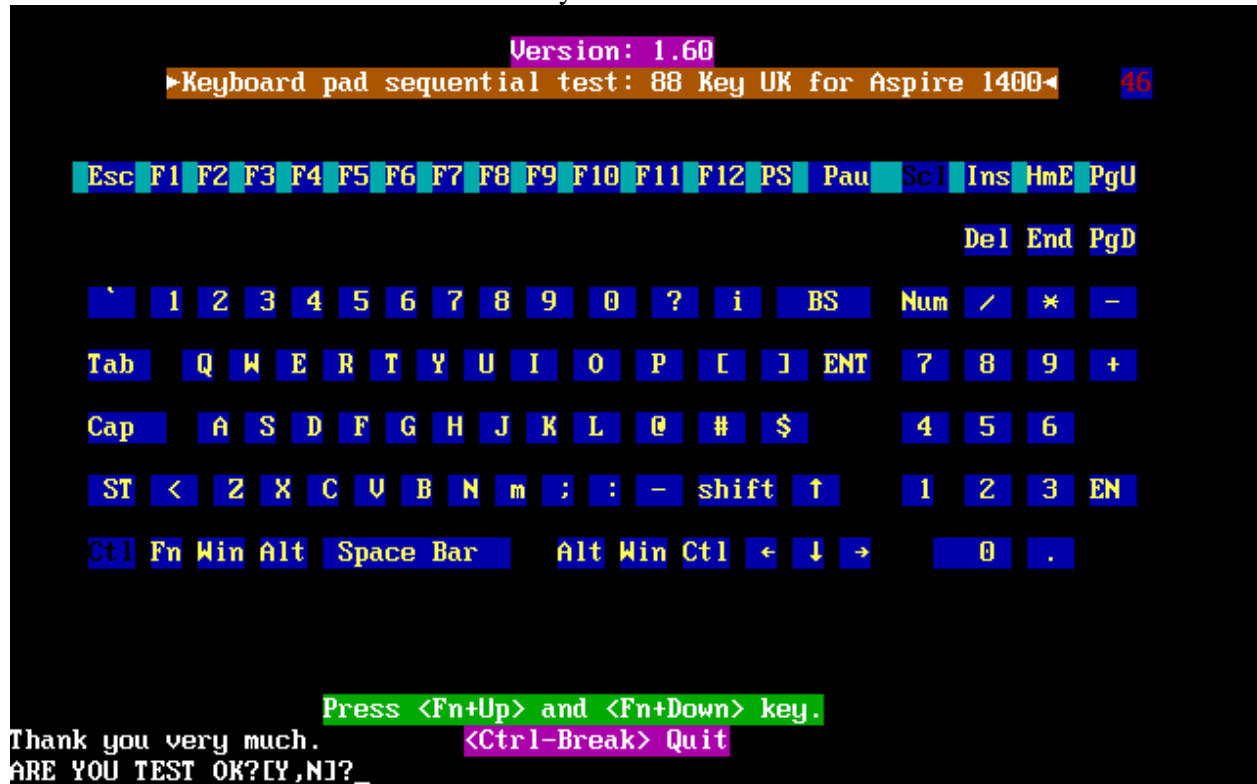

NOTE: The “Fn” key cannot be tested in the keyboard test. To determine whether the “Fn” key is working correctly, press “Fn+F6 ” or “Fn+F7 ” keys to check if LCD display brightness change gradually.

3.10 Mouse (Pad) Test

The Mouse test allows the user to select and assign values to the following, using the Touch Pad or “Tab” key to move between selections:

1. Mouse Speed (on a scale from slow to fast)
2. Acceleration (Off, Low, Medium, High)
3. Button Assignments (Left + Right / Right button, either Unassigned or Drag Lock)
4. Swap Buttons (Left /Right)

NOTE: The Touch Pad test cannot be used to test an external USB mouse.

The Touch Pad button subtest allows users to test their Touch Pad buttons. If the buttons are clicked, the cursors should appear in the corresponding box of the button figure that is displayed on the screen as below.

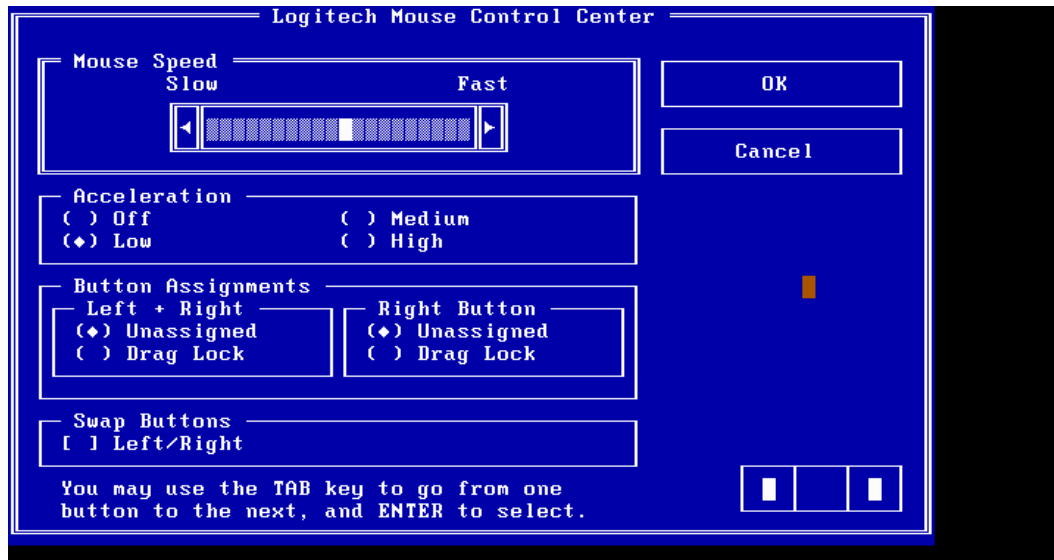

After checking T/Pad buttons and cursor’s function, use “Tab” key or use T/Pad cursor to click the “OK” column will end this test.

It will indicate whether the subtests pass or fail after three questions.

NOTE: *The above figure has three compartments although the Touch Pad installed may only have two buttons. In this case, the central compartment in the figure does not correspond to any button.*

3.11 LCD Pixels Mode Test

This LCD pixels mode test checks whether video display is fine.

This test includes two modes of the test:

1. Text Mode
 - including 40*25 (16 colors) and 80*25 (2/16colors).
2. VGA Mode
 - including 320*200 (4/16/256 colors), 640*200 (2/16 colors), 640*350 (2/16 colors), 640*480 (2/16/256 colors), 800*600 (256 colors) and 1024*768 (256 colors).

The screen should display as below, indicating whether the test is passed or failed after the question.

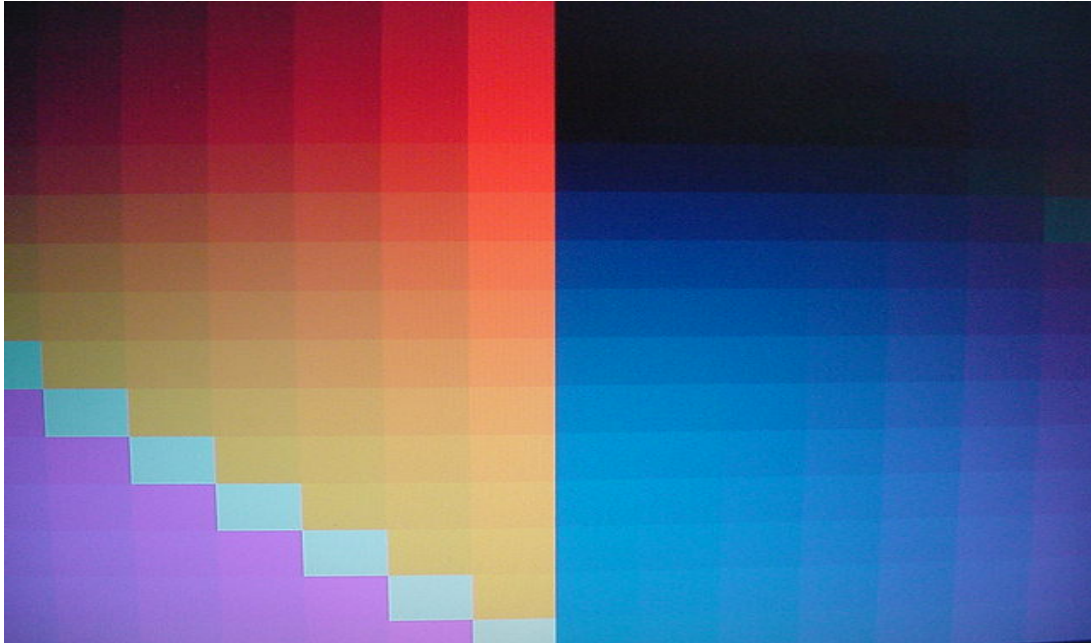

3.12 Magnetic Switch Test

The Magnetic switch test checks the Magnetic function of the unit. When LCD cover closed, the Magnetic should enable to turn off the display.

Follow below steps to run this test:

1. Close the LCD cover.
2. Open the LCD.

Then it will indicate whether the test is passed or failed.

1>. If the Magnetic switch test fail, it will show below display:

```
Magnetic switch test program Ver 1.10 __ PE/SW: Jone  
Please close and open LCD!
```

2>. If the Magnetic switch test pass, it will show below display:

```
Magnetic Switch test is Pass!  
ARE YOU TEST OK?[Y,N]?
```

3.13 LAN Test

The LAN test checks the LAN full-duplex environment.

NOTE: LAN loopback needs to plug in before test begins.

And LAN information will show on the test screen:

- ◆ IO Base – Port: A000H
- ◆ IRQ – BH, it's "IRQ B".
- ◆ Node – it is "MAC Address".
- ◆ Line Speed – 1000Mbps or 100Mbps or 10 Mbps.
- ◆ Bus ID – it's "14".

The LAN test includes three subtests of the:

1. Speed1000
2. Speed100
3. Speed10

The subtests run automatically.

3. Tests and Diagnostics

```
==== LAN TEST ====

1.Please plug-in the Loopback into LAN port.
2.Please see test result in middle of display.
  (Pass: ooo , Fail: xxx )

Press any key to continue . . .
```

The screen should display as below, indicating whether the subtests pass or fail when finished.

```
MP Program for PCI/PCI-E Family LAN Product/Client 1.22 02-01-08 version
IOBASE = A000H IRQ = B H Mode:001EEC3EC8DA 1000M: 10K 100M: 5K 10M: 2K
VID =10ECH DID =8136H SVID =1179H SSID =FF00H Lan Adapters: 1
Now is: 1
Open Your MPLAN.CFG in this machine! 100M Link OK 10M Link OK
Test Item Result(Pass/Fail)
1.PG_LAN=false none
2.Reg_R/W=true Pass
3.Speed1000=true none Rxtimeout 1
4.Speed100=true Pass ROK= 2000 TOK= 2000
5.Speed10=true Pass Error= 0
6.Debug=true Txtimeout = 50
7.AutoRun=true

***** Pass in debugging mode *****
Press 'ESC' key to exit .....

E:\LAN>
```

If an error is detected and a test fails, the following message displays:



3.14 RTC Test

Checks the computer's RTC (Real Time Clock) and calendar functions by comparing the DOS and CMOS values.

The test runs automatically.

The screen should display as below, indicating whether the test is passed or failed when finished.

```
====RTC TEST====

Please Check the result after test.

Press any key to continue . . .

Wait for zero counter...
Testing...
DOS TIME = 22:33:48.04(8122804), CMOS TIME = 22:33:48(8122800)
DOS DATE: 09/19/2002, CMOS DATE: 09/19/2002
DATE & TIME test [ PASS ]

Press any key to continue . . .
```

3.15 BUTTON TEST

NOTE: Only for five buttons SKU.

The tool for five buttons SKU, the Screen would display as below:

```
=====button TEST=====

Please Check the result after test.
===notice: the tool only for eight button SKU===

Press any key to continue . . . _
```

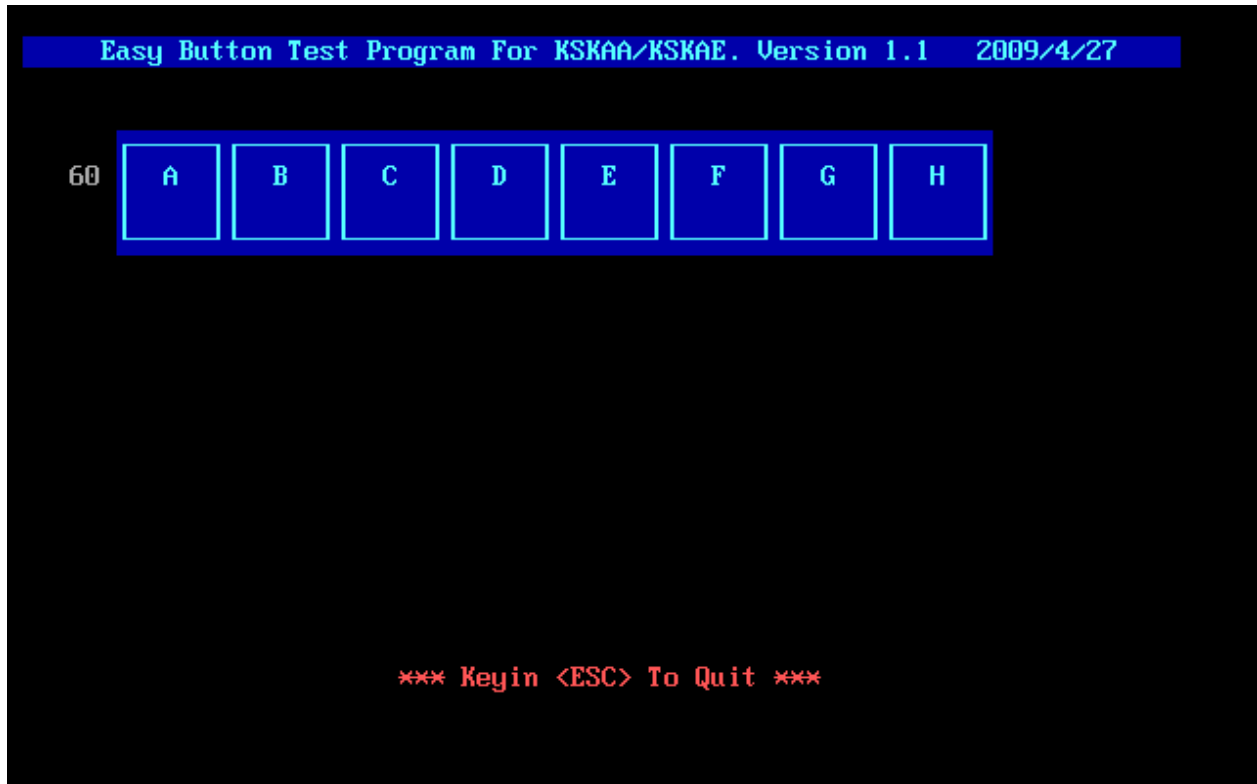

Mechanical type buttons x 8 to relate with above showed.

BUTTON A → ECO

BUTTON B → Quick start

BUTTON C → Play/Pause

BUTTON D → FR

BUTTON D → FF

BUTTON D → Mute

BUTTON D → Volume -

BUTTON D → Volume +

3.16 1st HDD Test

The HDD test allows the user to verify the 1st HDD ok or not. First, please select HDD test method, Screen would display as below:

```
===== HDD TEST =====  
  
1.HDD W/R test(all surface)  
2.Partial W/R + Random W/R  
[1,2]?
```

After you select the method, then input password: “hard disk”, if input password is Right, the screen would display as below:

```
Input password is Right  
Press any key to Test HDD function  
  
Press any key to continue . . .
```

If input password is wrong, the screen would display as below:

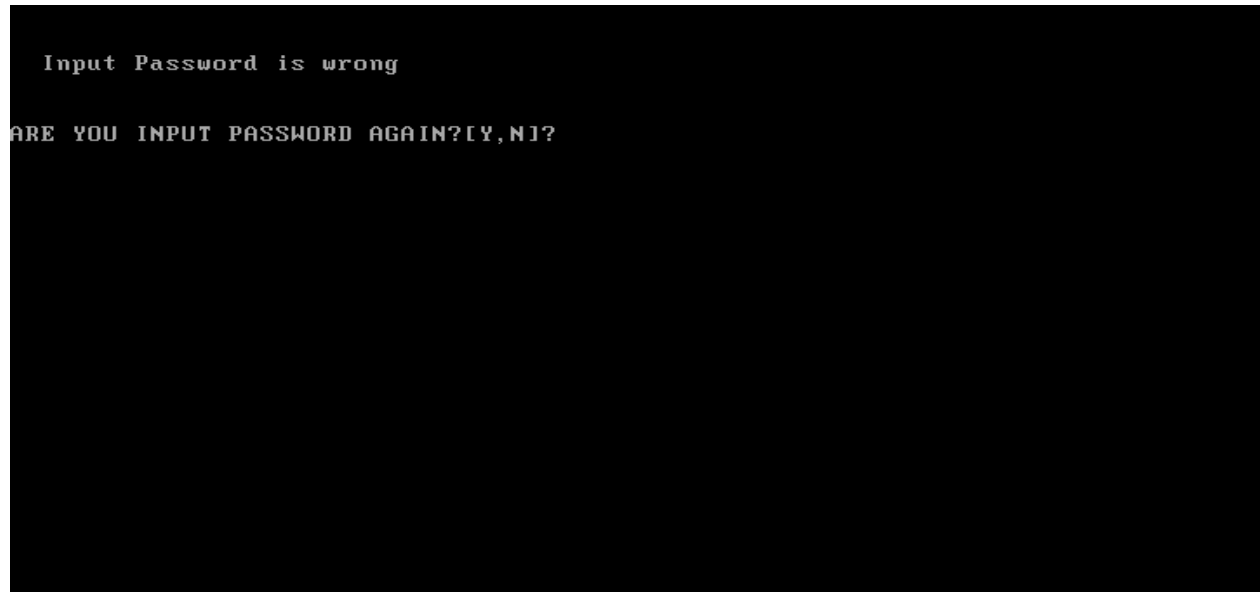

The screen will display as below picture to show the subtest is passed or failed when finished:

If it is show the picture as below, it means HDD function is OK

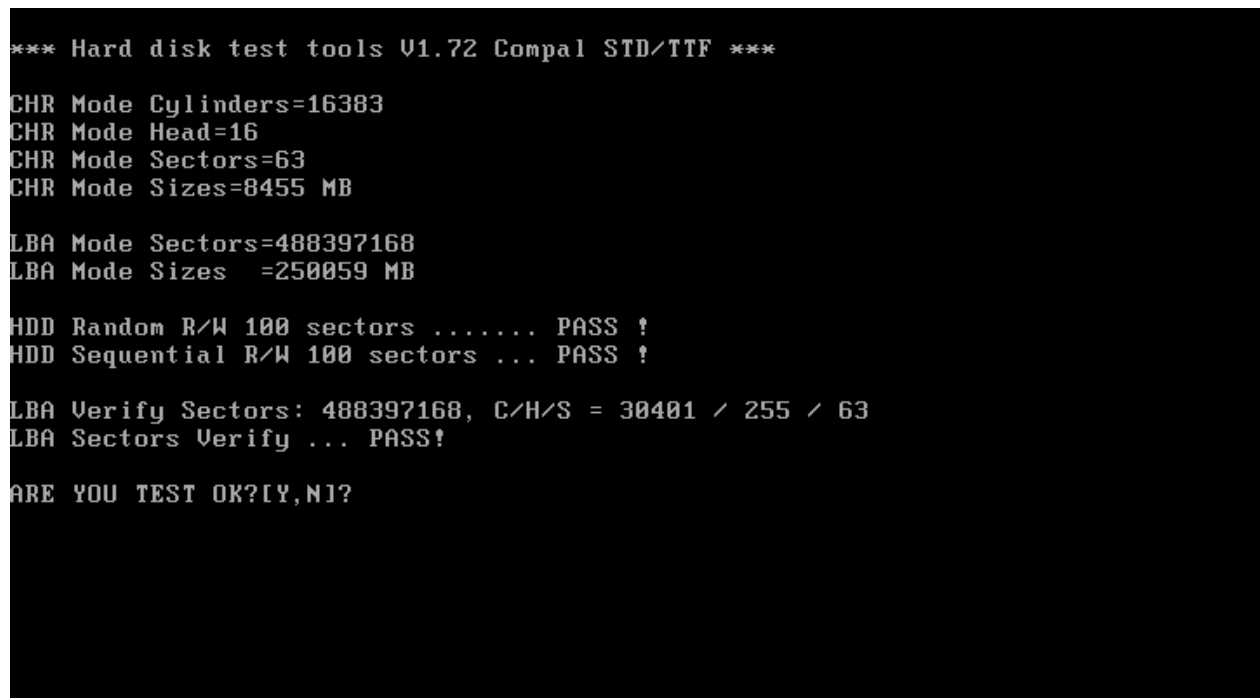

If the picture shows as below, it means he HDD function is NG

```
*** Hard disk test tools V1.60 Compal STD/TTF ***  
Reset DISK1 .....Pass !  
Error ! Can't use Enhanced Disk Drive Support Function  
ARE YOU TEST OK?(Y,N)?
```

3.17 Read DMI

Compal write Toshiba Part No (version), Toshiba Serial No (Serial No), Product Name, OEM string and UUID, If you want to double check the DMI data, please select Read DMI item, the figure below will be displayed:

```
Manufacturer : TOSHIBA
Product_Name : Satellite A355D
Serial_Number : X8116579K
Version      : PSALEU-004005
Asset_Number : *
UUID        : 6C64768B8CE211DD8A58001EEC40A110
OEM_Strings : PSALEU-004005,SQ004806V04,11Q40
Are the DMI data is OK? [Y,N]?
```

3.18 Write DMI

When you want to write DMI data, please select which data you want to write, the figure below will be displayed:

1. Write OME string

2. Write Version
3. Write Serial
4. Write Product

```
please choice the item
1: Write OEM String
2: Write Version
3: Write Serial
4: Write Product
please enter the num you choose:
```

After write OK, you should reboot the system that can make the setting effective, or you can write next data before reboot system, the figure below will displayed:

```
please choice the item
 1: Write OEM String
 2: Write Version
 3: Write Serial
 4: Write Product
please enter the num you choose: 1
please enter the OEM String: psmadk-011002

Modify OEM String to psmadk-011002

Jump to EEPROM Bank : 0

Erase EEPROM Start Offset : a0 End Offset:dd Size:62
.....
Jump to EEPROM Bank : 0

Flash EEPROM Start Offset : a0
.....
Confirm the data ?
.....
Modify EM String success!

*****Please reboot the system.To make the setting effective
*****Do you want to modify other dmi ? *****
Press Y for Yes or N for No:
```

***NOTE:** should input correct DMI data, and should reboot the system that can make the setting effective.*

3. 19 3D Sensor Test

This test will check 3D Sensor function by your computer successful or not.

NOTE: Steps 1 → Keep test unit on platform which must be a flat horizontal surface, then click enter to test

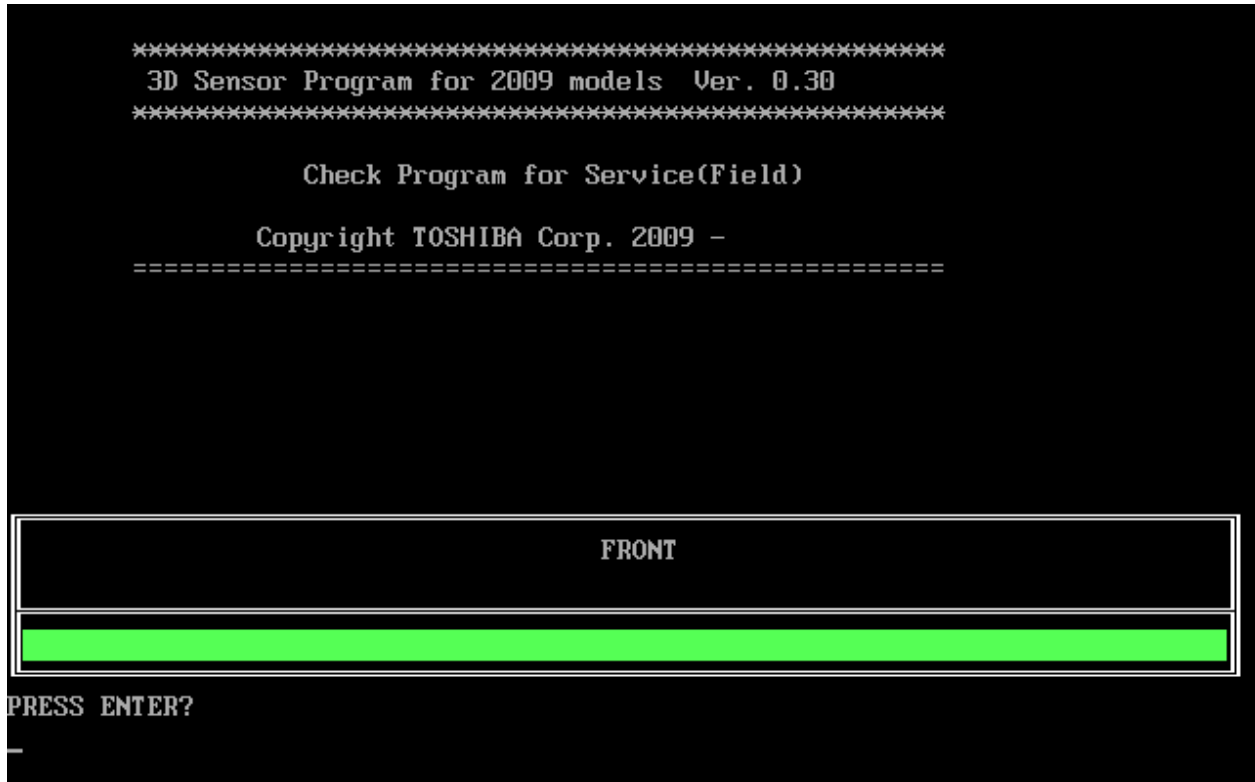

3. Tests and Diagnostics

NOTE: Steps 2 → Keep test unit vertical with platform, then click to test



NOTE: Steps 3 → Turn run 90 degree whirl, then click enter to test



NOTE: Steps 4 → Go on Turn run 90 degree whirl, then click enter to test



NOTE: Step5 → Go on Turn run 90 degree whirl, then click enter to test



Check test result as below picture, PASS will show "OK", FAIL will show "NG".

3. Tests and Diagnostics

```
FRONT

PRESS ENTER?
***** Get The Data form HPC now.** We are going to make the LOG-Data. **
** Please set FDD. Then PRESS ENTER?
=====
=====
      OO          K  K
     O  O       K  K
    O  O  O     K  K
   O  O  O  O   K  K
  O  O  O  O  O K  K
 O  O  O  O  O K  K
O  O  O  O  O K  K
 OO          K  K
=====
=====

ARE YOU TEST OK?[Y,N]?_
```

```
FRONT

PRESS ENTER?
***** Get The Data form HPC now.** We are going to make the LOG-Data. **
** Please set FDD. Then PRESS ENTER?
=====
=====
      NN          GG
     NN  NN      GG  GG
    NN  NN  NN   G  GG
   NN  NN  NN  GG  GG
  NN  NN  NN  GG  GGGGGG
 NN  NN  NN  GG  GGG
NN  NN  NN  G  GGG
NN  NN  NN  GG  GG  G
NN  NN  NN  GG  G
=====
=====

ARE YOU TEST OK?[Y,N]?_
```

Chapter 4

Replacement Procedures

Chapter 4 Contents

4.1	General	4-1
	Safety Precautions	4-2
	Before You Begin.....	4-4
	Disassembly Procedures.....	4-5
	Assembly Procedures	4-5
	Tools and Equipment	4-6
	Screw Tightening Torque.....	4-6
	Colors of Screw Shanks	4-7
	Symbols of Screws on the Laptop Body	4-7
	Symbol examples	4-7
4.2	Battery	4-8
	Removing the Battery Pack.....	4-8
	Installing the Battery Pack	4-9
4.3	HDD	4-10
	Removing the HDD.....	4-10
	Installing the HDD	4-12
4.4	Memory	4-13
	Removing the Optional Memory.....	4-13
	Installing the Optional Memory	4-14
4.5	UWB Module	4-15
4.6	Modem Card / FM Tuner	4-16
4.7	ODD	4-19
	Removing the ODD Bay Module.....	4-19
	Installing the ODD Bay Module	4-20
	Disassembling the ODD Drive.....	4-20
	Assembling the ODD Drive	4-21
4.8	Keyboard Cover and Keyboard.....	4-22
	Removing the Keyboard Cover and Keyboard	4-22

	Installing the Keyboard Cover and Keyboard.....	4-24
4.9	Logic Upper Assembly.....	4-25
	Removing the Logic Upper Assembly	4-25
	Installing the Logic Upper Assembly	4-27
4.10	Power Board.....	4-28
	Removing the Power Board	4-28
	Installing the power switch board	4-28
4.11	Speakers	4-29
	Removing the Speakers.....	4-29
	Installing the Speakers	4-29
4.12	Bluetooth Card	4-30
	Removing the Bluetooth card.....	4-30
	Installing the Bluetooth card	4-30
4.13	Touchpad Bracket, Touchpad Boards and Fingerprint Board/Touchpad Switch Board	4-31
	Removing the Touchpad Bracket, Touchpad Boards and Fingerprint Board	4-31
	Touchpad Bracket, Touchpad Boards and Fingerprint Board/Touchpad Switch Board	4-32
4.14	LED board.....	4-33
	Removing the LED Board.....	4-33
	Installing the LED Board	4-33
4.15	Thermal Fan	4-34
	Removing the Thermal Fan.....	4-34
	Installing the Thermal Fan	4-34
4.16	WLAN Card	4-35
	Removing the WLAN Card.....	4-35
	Installing the WLAN card.....	4-35
4.17	Motherboard.....	4-36
	Removing the Motherboard	4-36
	Installing the Motherboard.....	4-38
4.18	VGA Board and VGA Thermal Module (Optional)	4-40
	Removing the VGA Board and VGA Thermal Module	4-40

4 Replacement Procedures

	Installing the VGA Board and VGA Thermal Module	4-41
4.19	CPU and Thermal Module	4-42
	Removing the CPU and Thermal Module	4-42
	Installing CPU and Thermal Module	4-43
4.20	Display Assembly	4-45
	Removing the Display Assembly	4-45
	Installing the Display Assembly	4-45
4.21	LCD Bezel Assembly	4-46
	Removing the LCD Bezel Assembly	4-46
	For Low-end Model	4-46
	For High-end Model	4-48
	Installing the Display Mask	4-55
4.22	LCD Module and Inverter Board	4-57
	Removing the LCD Module and Inverter Board	4-57
	Installing the LCD Module and Inverter Board	4-62
4.23	CMOS Board and MIC	4-66
	Removing the CMOS Board and MIC	4-66
	Installing the CMOS Board and MIC	4-67
4.24	Left USB Board	4-68
	Removing the USB Board on the Left Side	4-68
	Installing the Left USB Board	4-68
4.25	Right USB Board	4-69
	Removing the Right USB Board on the Right Side	4-69
	Installing the Right USB Board	4-71

Figures

Figure 4.1	Removing the Battery Pack	4-8
Figure 4.2	Removing the HDD door	4-10
Figure 4.3	Removing the HDD from the HDD bay	4-11
Figure 4.4	Removing the HDD plate.....	4-11
Figure 4.5	Removing the RAM door.....	4-13
Figure 4.6	Removing the RAM from the connectors.....	4-14
Figure 4.7	Removing the UWB module.....	4-15
Figure 4.8	Removing the modem card	4-16
Figure 4.9	Removing the FM Tuner.....	4-17
Figure 4.10	Removing the ODD Bay module	4-19
Figure 4.11	Removing the bracket from the ODD drive.....	4-20
Figure 4.12	Removing two screws from the battery lodging.....	4-22
Figure 4.13	Removing the keyboard cover	4-23
Figure 4.14	Removing screws from the keyboard	4-23
Figure 4.15	Removing the keyboard	4-24
Figure 4.16	Removing the screws from the bottom of the laptop.....	4-25
Figure 4.17	Removing eight screws from the laptop.	4-26
Figure 4.18	Detaching cables from the laptop	4-27
Figure 4.19	Removing the power board.....	4-28
Figure 4.20	Removing the speakers	4-29
Figure 4.21	Removing the Bluetooth card	4-30
Figure 4.22	Removing the screws from the touchpad bracket.....	4-31
Figure 4.23	Removing the Touchpad boards and Fingerprint board	4-32
Figure 4.24	Removing the LED Board	4-33
Figure 4.25	Removing the thermal fan from the logic lower assembly.....	4-34
Figure 4.26	Removing the WLAN Card	4-35
Figure 4.27	Removing motherboard from logic lower assembly.....	4-36
Figure 4.28	Removing the DC_IN CONN and cable.....	4-37
Figure 4.29	Picking up the motherboard.....	4-37
Figure 4.30	Align the DP CONN, S/PDIF CONN, Audio CONN and RJ45 CONN	4-38
Figure 4.31	Installing the DC-in jack.....	4-39

4 Replacement Procedures

Figure 4.32	Removing the VGA Board.....	4-40
Figure 4.33	Reapply the Shinetsu 7726 grease on the thermal module and remove any release papers	4-41
Figure 4.34	Removing the Thermal Module spring screws	4-42
Figure 4.35	Removing the CPU	4-43
Figure 4.36	Reapply the Shinetsu 7726 grease on the thermal module and remove any release papers	4-44
Figure 4.37	Removing the display assembly.....	4-45
Figure 4.38	Removing the LCD Bezel Assembly from the low-end model	4-46
Figure 4.39	Peel off the bezel.....	4-47
Figure 4.40	Pull out the hinge wall	4-47
Figure 4.41	Remove the bezel.....	4-48
Figure 4.42	Removing the LCD Bezel Assembly from the high-end model.....	4-48
Figure 4.43	Wrap the flat blade screwdriver with tape	4-49
Figure 4.44	Press the hinge wall	4-49
Figure 4.45	Pry up the bezel hinge wall.....	4-50
Figure 4.46	Release the rest of the hooks.....	4-50
Figure 4.47	Push the right side of the bezel upward	4-51
Figure 4.48	Push the left side of the bezel upward	4-52
Figure 4.49	Release hooks from the bottom of the bezel.....	4-53
Figure 4.50	Release hooks from the right and left side of the bezel	4-53
Figure 4.51	Release the hooks from the upper side of the bezel.....	4-54
Figure 4.52	Press the bezel hinge wall.....	4-55
Figure 4.53	Press the bottom hooks on the display assembly	4-55
Figure 4.54	Press the left and right side of the bezel for the low-end model/Press the hooks on the left and right side of the bezel for the high-end model	4-56
Figure 4.55	Press the bezel upside hooks.....	4-56
Figure 4.56	Removing the Inverter Board	4-57
Figure 4.57	Removing the LCD Module from the LCD cover assembly (high-end model).....	4-58
Figure 4.58	Removing the LCD Module from the LCD cover assembly (low-end model).....	4-59
Figure 4.59	Removing the LCD Hinge Assembly	4-60

Figure 4.60 Removing the LVDS cable from the LCD module 4-61

Figure 4.61 Installing the LCD Hinge Assembly..... 4-62

Figure 4.62 Installing the LCD Module from the LCD cover assembly
(high-end model)..... 4-63

Figure 4.63 Installing the LCD Module from the LCD cover assembly
(low-end model)..... 4-64

Figure 4.64 Not to pinch codes beside hinges (high-end model)..... 4-65

Figure 4.65 Not to pinch codes beside hinges (low-end model)..... 4-65

Figure 4.66 Removing the CMOS board and MIC (high-end model) 4-66

Figure 4.67 Removing the CMOS board and MIC (low-end model) 4-67

Figure 4.68 Removing the left USB Board from the logic lower assembly 4-68

Figure 4.69 Wrap the flat blade screwdriver with tape 4-69

Figure 4.70 Wrap the flat blade screwdriver with tape 4-70

Figure 4.71 Removing the USB Board on the right side 4-70

4.1 General

This chapter explains how to disassemble the laptop and replace Field Replaceable Units (FRUs). Some replacement procedures may not require you to remove all the surrounding FRUs to replace only one FRU. The chart below shows the FRUs in the order in which they should be removed in a top-down manner, irrespective of their physical locations. The FRUs shown in the top area of the chart should normally be removed before removing the FRUs shown in the bottom area. To replace the FRUs, first identify the suspect FRU for the system failure. Next, according to this chart, determine the FRUs that need to be removed before removing the suspect FRU. After you determine those FRUs, go to the appropriate sections according to the section numbers shown in the boxes. Then start removal and replacement.

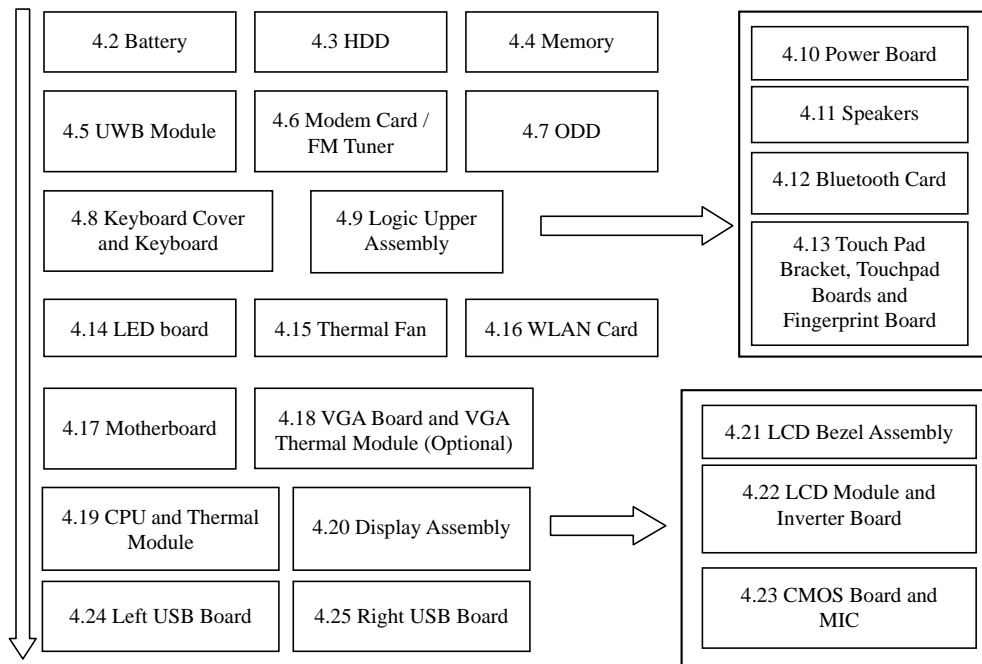

How to use the chart (two examples):

- For removing the Motherboard:
First, remove parts from 4.8 Keyboard Cover & Keyboard, 4.9 Logic Upper Assembly, 4.16 WLAN card, 4.15 Thermal Fan.
- For removing the LCD Module:
First, remove 4.21 LCD Bezel Assembly, then remove 4.22 the LCD module and the Inverter Board.

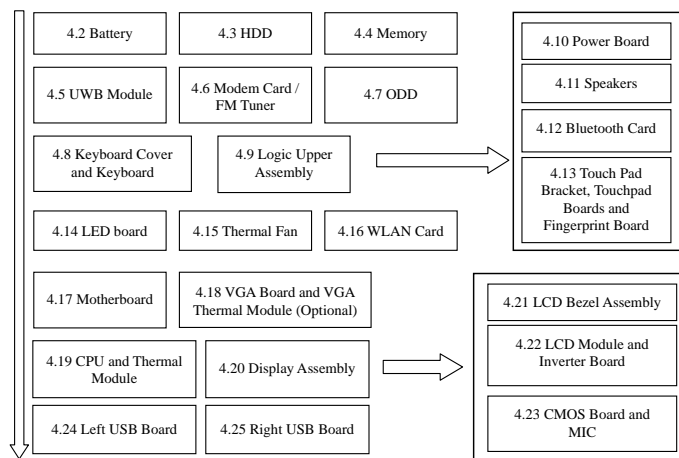

Safety Precautions

Before you begin disassembly read the following safety precautions carefully. Be sure to follow them while you are working.

DANGER:

- 1. Always use the original batteries or replacement batteries authorized by Toshiba. Batteries other than those differ in specifications and are incompatible with the laptop. They may burst or explode. To avoid leakage of alkaline solutions, never heat or disassemble the battery packs. Never throw the battery packs into a fire. If this is violated, they will explode.*
- 2. The components such as the power supply and inverter carry high voltages. When you partially disassemble the laptop and turn on the components, use extreme care not to touch the connectors and components to avoid the risk of electrical shock. Do not disassemble individual components during first-level maintenance.*

WARNING:

- 1. To avoid the risk of electrical shock, turn the laptop off and remove the AC adapter from the electrical outlet.*
- 2. Because the battery in the laptop is left charged, the risk of electrical shock remains even after the AC adapter is removed from the electrical outlet. To avoid the risk of electrical shock, be sure to remove any metal jewelry or accessories such as necklaces, bracelets and rings before starting work. Never work with damp or wet hands.*
- 3. To avoid personal injury, use care to avoid the sharp edges or corners of the components.*

CAUTION:

1. *Before replacing a component, make sure that the replacement component meets the required specifications. To avoid laptop failures, never use components that do not meet the specifications.*
2. *To avoid internal damage such as short circuits and fire, never drop metal objects such as screws, pins, paper clips, etc. into the components. When a screw is removed, be sure to replace a screw that is the same size as the original screw. Make sure that all the screws are fastened securely. Loose screws can cause short circuits, overheating, smoke or fire.*
3. *Before removing a FRU or other component, make sure that all the component cables have been disconnected to avoid the risk of electrical shock caused by accidental contact with the energized components.*
4. *For AC input, be sure to use the AC adapter and AC power cable that come with your laptop or Toshiba-recommended equivalents.*
5. *To avoid the risk of electrical shock, make sure that all the replacement components meet the specifications of the laptop and that all the cables and connectors are fastened securely.*
6. *Inside the PC are components that become hot during operation (such as the CPU and cooling module). To avoid burns, let the hot components cool down before starting inspection or repair task.*

Before You Begin

Before you begin to disassemble the laptop, keep in mind the precautions and advice in this section. Always begin disassembly by removing the AC adapter and battery pack. Remove the optional parts and accessories as well. The procedures for removing the batteries will be explained later.

Disassemble the laptop only when an abnormality has occurred.

Use only the recommended tools.

To run and store the laptop, be sure to prepare a working environment that is free from:

- Dust and contaminants
- Static electricity
- Extremely high or low temperatures and extremely high humidity

Run the diagnostic tests explained in Chapter 2 of this manual to identify the FRU that has probably caused the system failure.

Perform only the required machine operations. Use only the disassembly and reinstallation procedures described in this manual.

Place the removed components in a safe place away from the laptop so that they are not damaged or get in the way of you doing your work.

Normally, a number of screws need to be removed or replaced during disassembling. Place the removed screws in a safe place so that you can easily find the right screws for the right components.

When assembling the laptop, use the specified screws to fasten the parts to the specified locations. See the appropriate explanations and figures for screw sizes.

To avoid personal injury, use care when handling components that have sharp edges or corners.

After you have replaced a FRU, check that the FRU works correctly to ensure normal laptop operation.

Disassembly Procedures

The cable connectors come in these two basic types:

- Pressure plate connectors
- Normal pin connectors

To remove a pressure plate connector, pull up the tabs on either side of the connector's plastic pressure plate and gently pull the cable out of the connector. To reconnect the cable to the pressure plate's connector, raise the pressure plate up to a satisfactory height and slide the cable into the connector. Secure the cable in the correct position by pressing down the sides of the pressure plate so that the plate is flush with the sides of the connector. Grasp and pull the cable gently to check that the cable is connected firmly. If the cable has come off the connector, reinsert the cable by raising the pressure plate up to a satisfactory height.

Normal pin connectors are used for all the other types of cables. These connectors can be installed or removed by simply inserting them or pulling them out.

Assembly Procedures

You have to reassemble the laptop after you have disassembled the laptop and fixed the component that caused the problem.

When reassembling the laptop, keep the following general guidelines in mind:

- Take your time to carry out the suggested instructions completely. Hurried reassembly can often cause problems.
- Check that all the cable and connectors are fastened securely.
- Before securing the FRUs or other parts, check that the cables are not caught by the screws or FRUs.
- Check that all the latches are closed securely.
- Check that all the required screws are used to secure the FRUs. Using wrong screws can damage the threads or heads of the screws or does not ensure that the FRUs are secure.

After installing a FRU, make sure that the FRU and laptop work normally.

Tools and Equipment

For your safety and that of other people in the working environment, it is strongly recommended that you use electrostatic discharge (ESD) equipment. The proper use of this equipment will ensure successful repair work and reduce the costs for repairing damaged components. The equipment and tools required for disassembly and reassembly are:

- One 2 mm Phillips screwdriver
- One 4 mm flat-blade screwdriver
- Torx screwdriver
- Tweezers (for pulling out screws)
- ESD mats (for the floor and work desks)
- An ESD wrist strap or heel grounder
- Anti-static carpets or flooring
- Air ionizers (for highly electrostatic sensitive areas)
- A plastic card (in credit card size)

Screw Tightening Torque

To secure screws, follow the torque values listed below. Over-tightening can damage components and screws. Under-tightening can loosen the screw or cause screws to come off, which may result in short circuits or other damage.

- | | |
|--|------------------------|
| <input type="checkbox"/> M2 (2 mm) | 0.22 N·m (2.2 kgf·cm) |
| <input type="checkbox"/> M2.5 (2.5 mm) | 0.36 N·m (3.5 kgf·cm) |
| <input type="checkbox"/> M3 (3 mm) | 0.51 N·m (5.0 kgf·cm) |
| <input type="checkbox"/> M2.5x4 PSP TITE screws | 0.204 N·m (2.0 kgf·cm) |
| <input type="checkbox"/> M2.5x6 GIZA TITE screws | 0.36 N·m (3.5 kgf·cm) |

Colors of Screw Shanks

For easy identification of the correct screws, the screw shanks are colored according to their lengths, as follows:

- Screws of an odd-numbered length Blue
 - Screws of a special length Black
- Screws of a special length are those of a length having decimal places (i.e. 16mm).

Symbols of Screws on the Laptop Body

For easy maintenance, the screw types are shown on the laptop body as symbols. A symbol consists of a letter representing the screw type and a numeral representing the screw length.

- | <input type="checkbox"/> Screw type | Letter |
|--|--|
| <input type="checkbox"/> Bind screw | B (stands for bind) |
| <input type="checkbox"/> Flat-head screw | F (stands for flat-head) |
| <input type="checkbox"/> Super flat-head screw | S (stands for super flat-head) |
| <input type="checkbox"/> Tapping screw | T (stands for tapping) |
| <input type="checkbox"/> Other screws | U (stands for unique-pan head screws, studs, etc.) |

Symbol examples

- 6 mm bind screw B6
 - 12 mm bind screw B12
 - 5 mm stud U5
- (The numeral represents the rounded length of the threaded portion regardless of the entire stud length.)

4.2 Battery

Removing the Battery Pack

Remove the battery pack according to the following procedures and Figure 4.1.

CAUTION: When handling the battery packs, use care not to short circuit the terminals. Do not drop, hit, twist, or bend the battery packs. Do not scratch or break up their casing.

1. Turn the laptop upside down so that the bottom is facing you.
2. Slide out the battery lock.
3. Slide the battery release latch and remove the battery pack from the laptop.

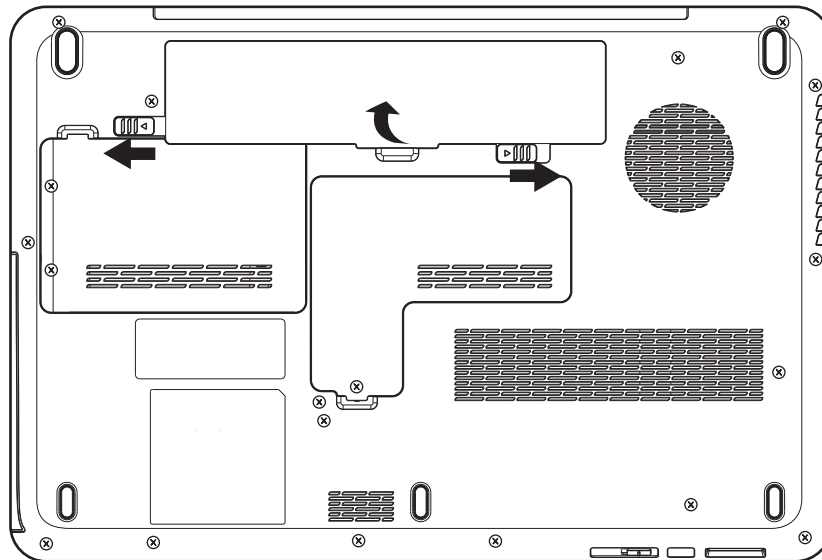

Figure 4.1 Removing the Battery Pack

NOTE: Dispose of the used battery packs as required by local ordinances or regulations.

Installing the Battery Pack

Install the battery pack according to the following procedures.

CAUTION: *The battery packs contain a lithium ion battery, which can explode due to improper replacement, use, handling or disposal. Always dispose of the battery packs as required by local ordinances or regulations. Use only replacement batteries recommended by Toshiba.*

NOTE: *Visually check the battery's terminals. If they are dirty, clean them with a dry cloth.*

1. Gently insert a new or recharged battery pack into place. Check that the battery release latch slides in and stops with a click.
2. Slide the battery lock inwards.

4.3 HDD

Removing the HDD

CAUTION: Do not press on the top or bottom of the drive.
Applying such pressure can either corrupt the data in the drive
or damage the drive.

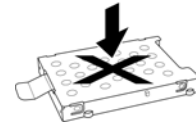

Remove the HDD (hard disk drive) according to the following procedures and Figures 4.2 and 4.3.

1. To remove the HDD, remove two M2.5x5 HDD door screws that secure the HDD and then remove the HDD door.

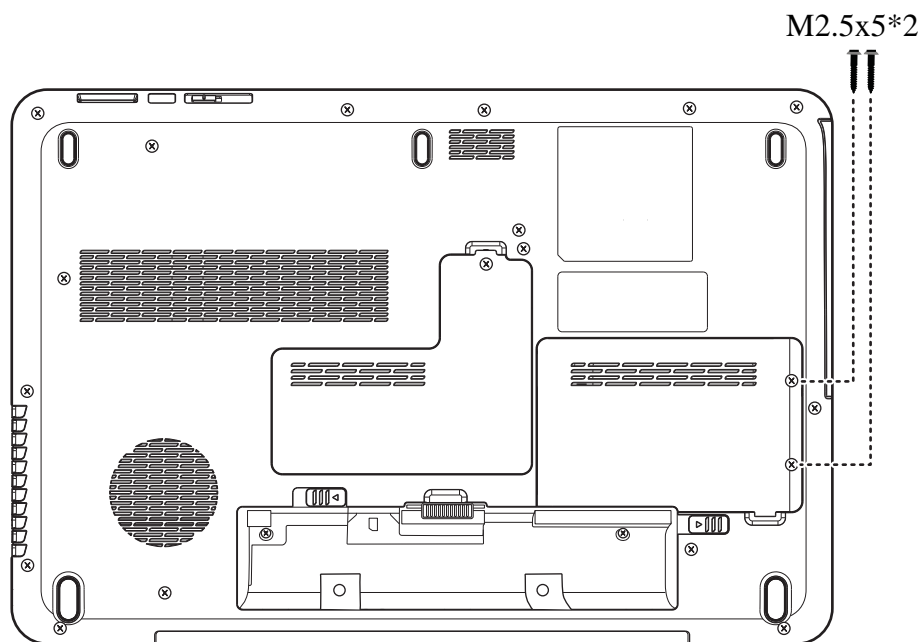

Figure 4.2 Removing the HDD door

2. Pull the tab right to remove the HDD module.

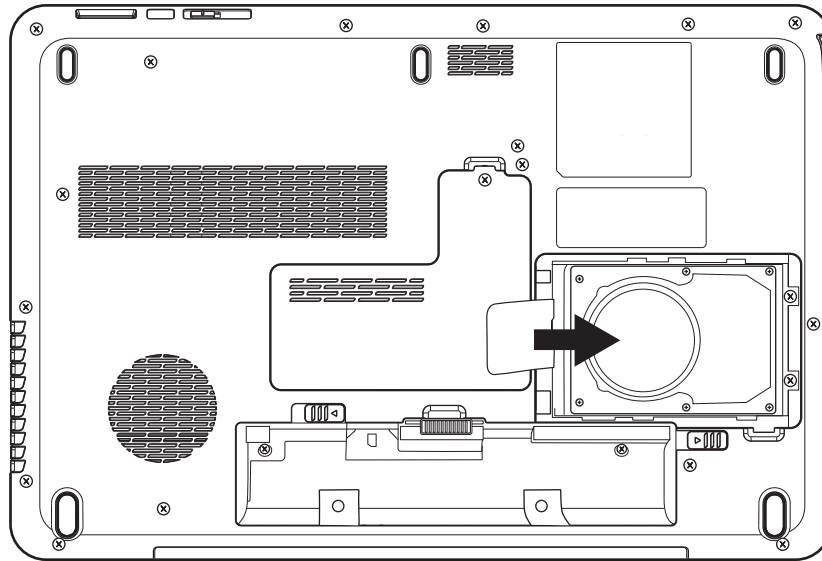

Figure 4.3 Removing the HDD from the HDD bay

NOTE: Do not disassemble the HDD pack when it is working normally. Disassemble or replace the HDD pack only if it fails.

3. Place the HDD pack on a flat surface such as a desk.
4. To separate the plate from the HDD, remove four M2.5x3 screws with torque value 3.5kgf.

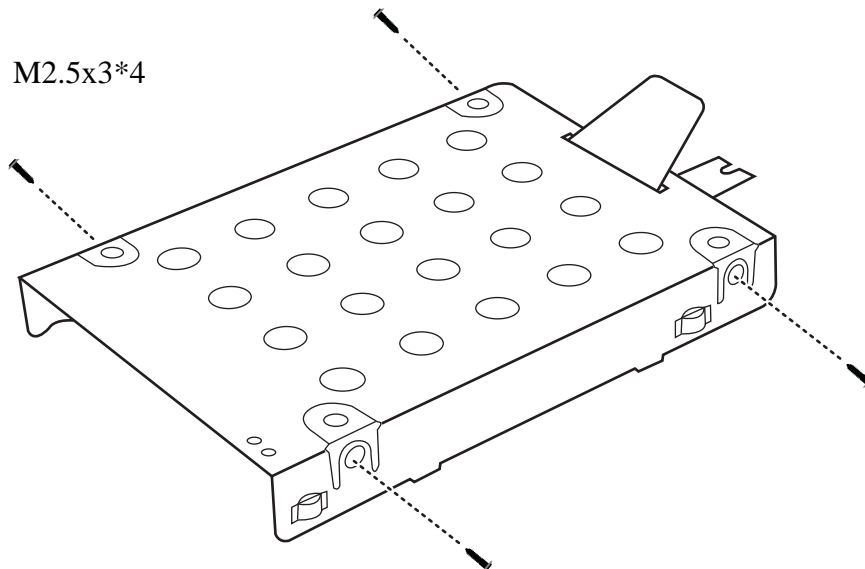

Figure 4.4 Removing the HDD plate

CAUTION: Do not apply pressure to the top or bottom of the drive.

Installing the HDD

Install the HDD according to the following procedures.

CAUTION: To avoid damage, always hold the HDD only by its sides.

1. Place the HDD into the HDD plate.
2. Secure the HDD and its plate with four M2.5x3 screws.

CAUTION: To prevent the HDD plate from being distorted when installing the HDD pack into the laptop, do not press the center of the HDD pack. Always hold the HDD pack by its sides.

3. Install the HDD pack into the correct position in the laptop. Connect the HDD pack to the laptop.
4. Secure the HDD door by tightening two M2.5x5 screws.

4.4 Memory

Removing the Optional Memory

Remove the optional memory according to the following procedures and Figure 4.5 after checking that the laptop is turned off.

CAUTION: Remove the optional memory after turning off the laptop. If this is violated, the laptop or memory can be damaged.

1. Turn the laptop upside down.
2. Remove one M2.5x5 screw that secures the RAM door.
3. Remove the RAM door.

CAUTION: Do not touch the connectors on the memory or in the laptop. Contaminated connectors can cause memory access problems.

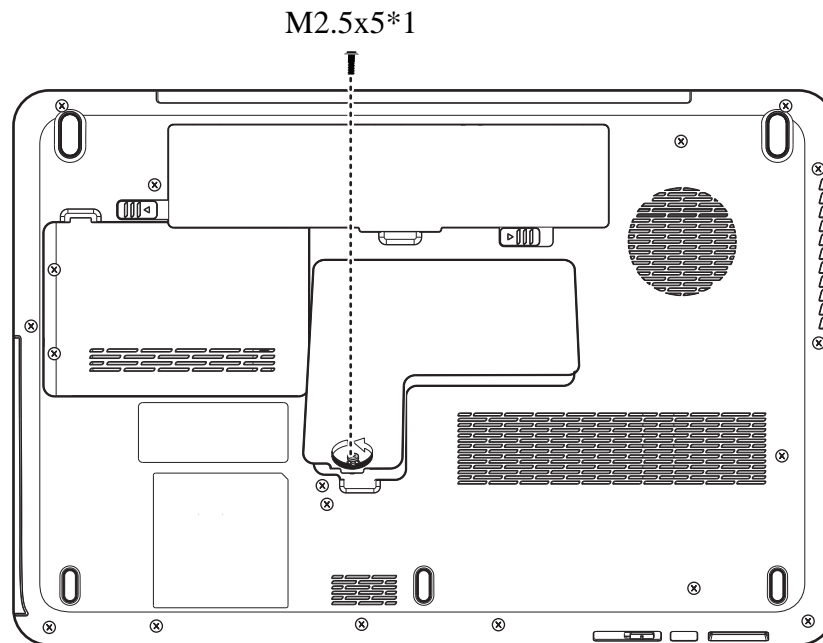

Figure 4.5 Removing the RAM door

4. Spread out the two memory lock latches so that the memory pops up. Please follow the procedure as shown in Figure 4.6.

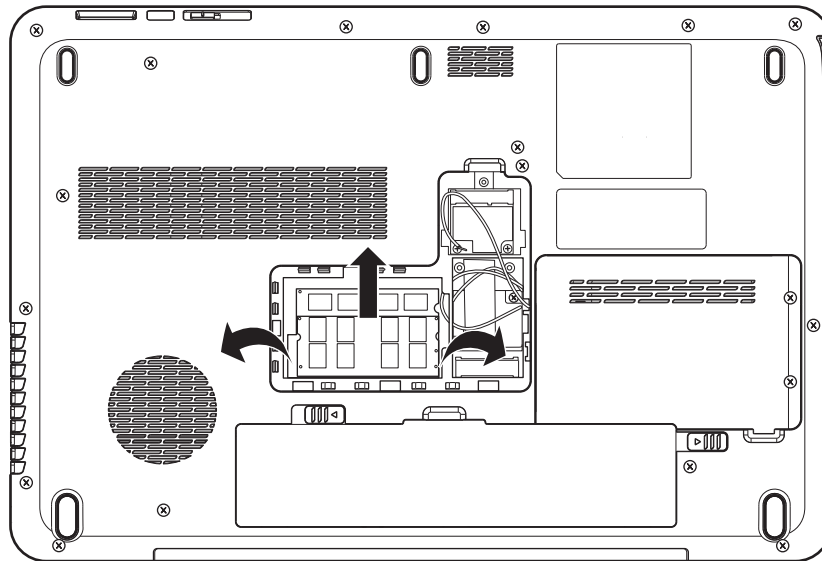

Figure 4.6 Removing the RAM from the connectors

5. Pull the memory up and out at an angle, using care to avoid touching the connectors.

Installing the Optional Memory

Install the optional memory according to the following procedures after checking that the laptop is turned off.

CAUTION: Install the optional memory after turning off the laptop. If this is violated, the laptop or memory can be damaged.

1. Insert the memory into the connector at an angle of 45 degrees.
2. Press down on the memory module so that it is secured with both memory lock latches.
3. Reinstall the optional RAM door.
4. Secure the RAM door with one M2.5x5 screw.

After the laptop is turned on, check the hardware configuration in the Hardware Setup or TESTUP program to make sure that the installed memory has been recognized by the system. If it has not been recognized yet, check the connections.

4.5 UWB Module

Removing the UWB Module

Remove the UWB module according to the following procedures and Figure 4.7.

1. Detach the antenna on the UWB card.
2. Disconnect two antenna cables and remove two M2x4 screws that secure the UWB card.
3. Pull the UWB module out at an angle.

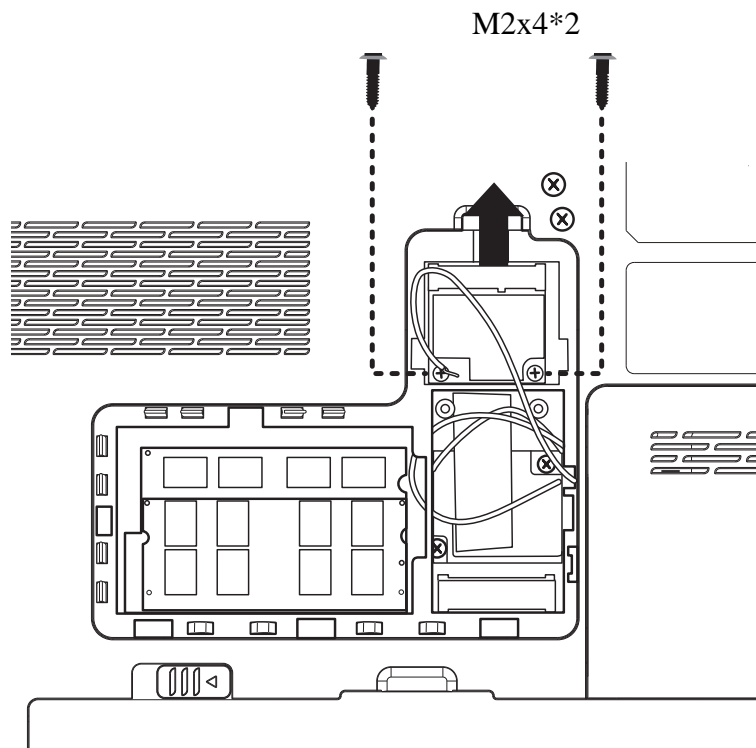

Figure 4.7 Removing the UWB module

Installing the UWB Module

Install the UWB module according to the following procedures.

1. Insert the UWB card into the connector.
2. Press the card down and secure it with two M2x4 screws.
3. Attach the antenna to the UWB module.

4.6 Modem Card / FM Tuner

Removing the Modem Card

Remove the modem card according to the following procedures and Figure 4.8.

1. Remove two M2.5x3 screws that secure the modem card.
2. Flip the modem card over, and detach the cable connected to the card.

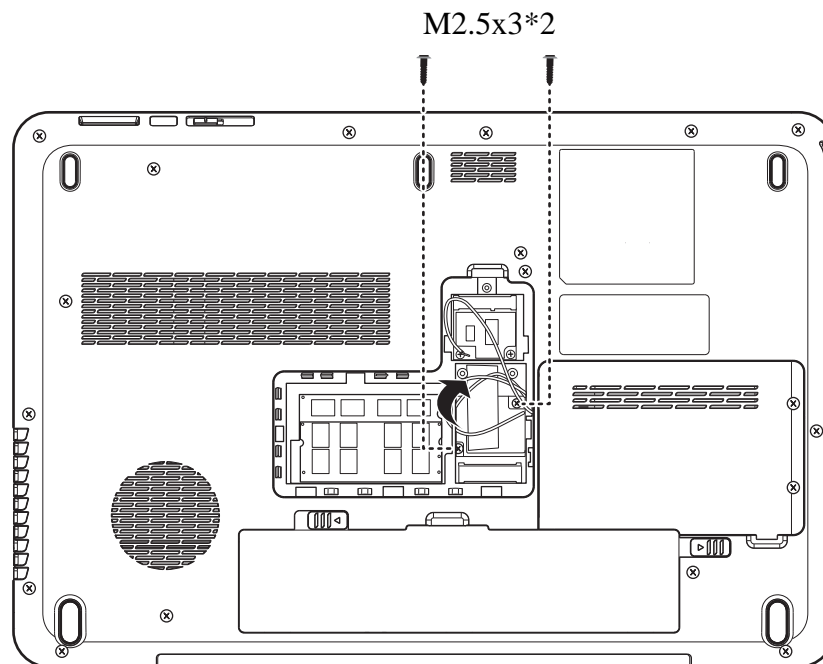

Figure 4.8 Removing the modem card

Removing the FM Tuner

Remove the FM Tuner and FM jack according to the following procedures and Figure 4.9.

1. Remove two M2.5x3 screws from the FM tuner.
2. Detach the two cables from the front and back of the FM tuner.

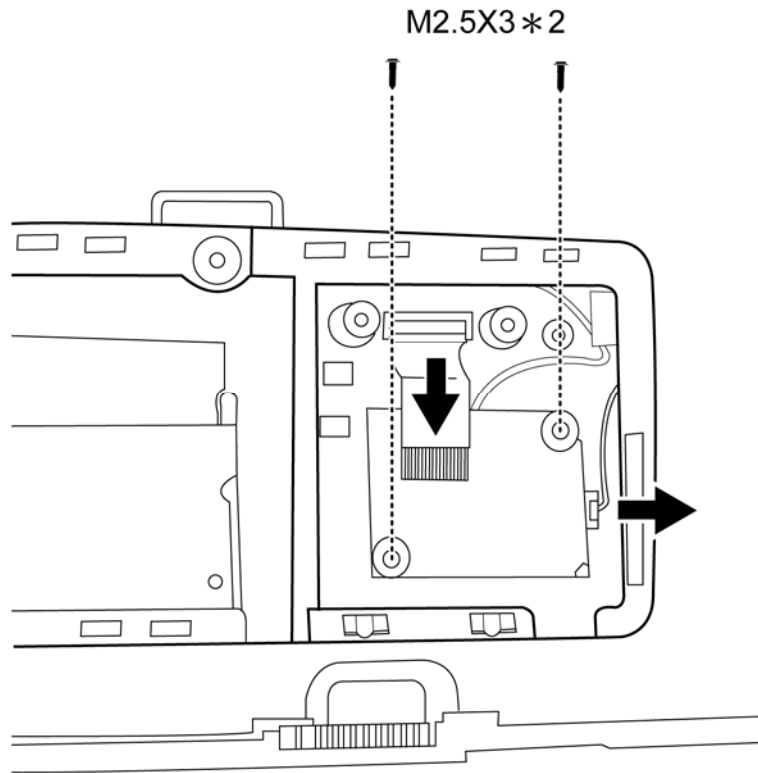

Figure 4.9 Removing the FM Tuner

Installing the Modem Card

Install the modem card according to the following procedures.

1. Attach the cable to the back of the modem card.
2. Install the card in the correct position and secure it with two M2.5x3 screws.

Installing the FM Tuner

1. Attach the cable on the back of the FM Tuner.
2. Seat the FM Tuner in the correct position on the motherboard and attach the cable on the front of the FM Tuner to the motherboard.
3. Secure the FM Tuner to the motherboard with two M2.5x3 screws.

4.7 ODD

Removing the ODD Bay Module

NOTE: The installation and removal procedures are the same for all the modules that can be installed in the ODD bay. See the appropriate sections for the disassembly procedures of specific modules.

Remove the ODD bay module according to the following procedures and Figure 4.10.

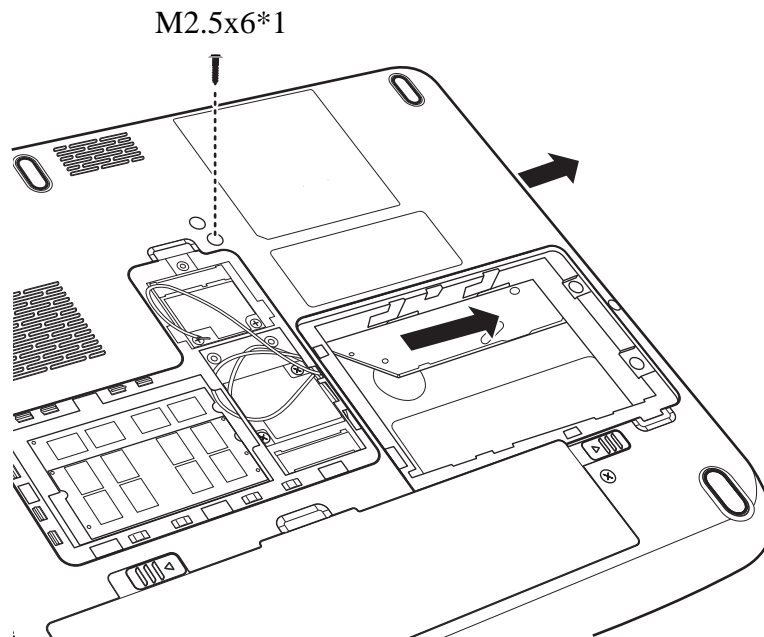

Figure 4.10 Removing the ODD Bay module

1. Turn the laptop upside down.
2. Remove one M2.5x6 screw.
3. Push the ODD bracket in the direction of the arrow.

CAUTION: Handle the ODD bay module carefully. It can become hot during operation.

Installing the ODD Bay Module

Install the ODD bay module according to the following procedures.

1. Place the ODD bay module in the correct position and slide it in.
2. Push it in until it meets the end.
3. Secure the ODD bay module with one M2.5x6 screw.

Disassembling the ODD Drive

NOTE: Do not disassemble the ODD drive when it is working normally. Disassemble or replace the ODD drive only if it fails.

Disassemble the ODD drive according to the following procedures and Figure 4.11.

1. Remove two M2x3 screws.
2. Remove the bracket.

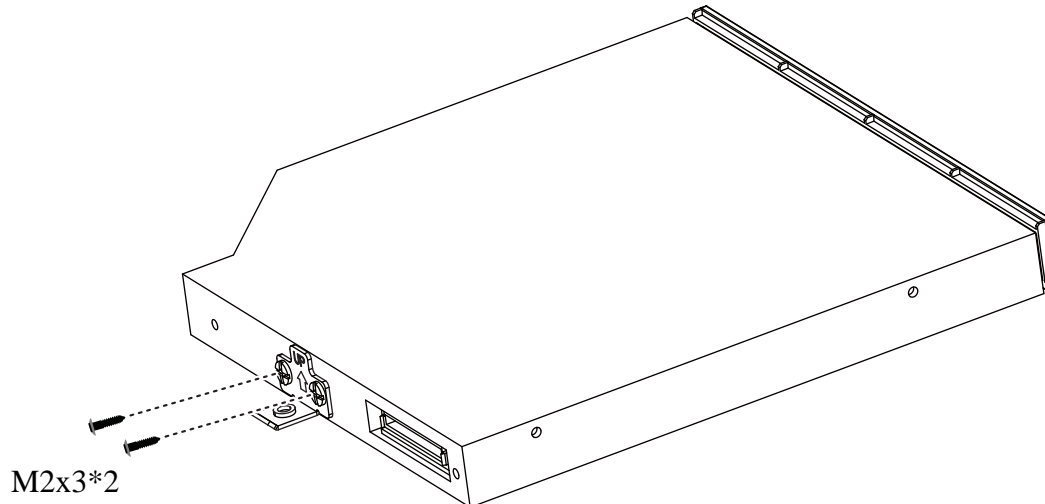

Figure 4.11 Removing the bracket from the ODD drive

Assembling the ODD Drive

Assemble the ODD drive according to the following procedures.

1. Seat the bracket in the correct position.
2. Secure them with two M2×3 screws.

4.8 Keyboard Cover and Keyboard

Removing the Keyboard Cover and Keyboard

Remove the Keyboard Cover and Keyboard according to the following procedures and Figures 4.12, 4.13, 4.14 and 4.15.

1. Close the laptop and turn over. Remove two M2x4 screws from inside the battery lodging.

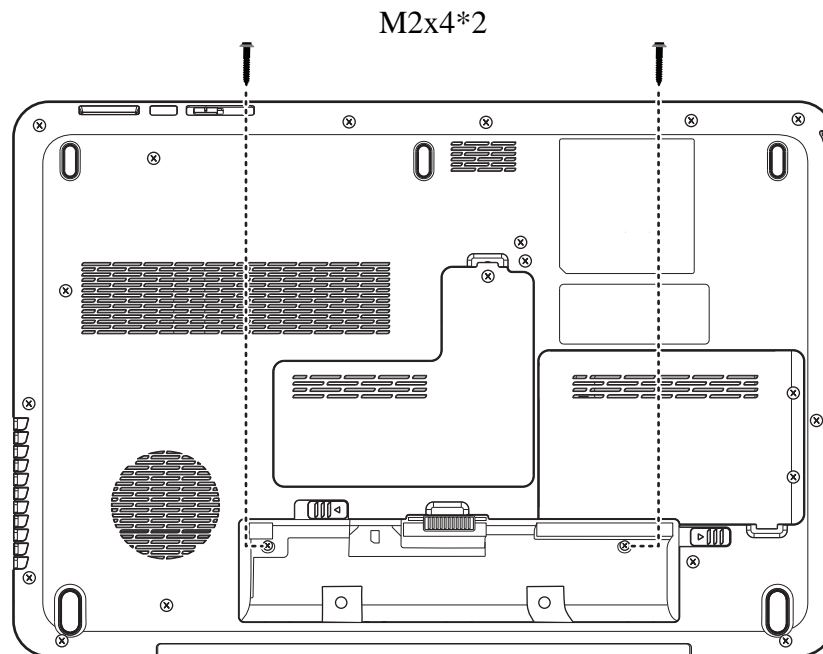

Figure 4.12 Removing two screws from the battery lodging

2. Turn the laptop over and open it. Use a flat head screwdriver to lift the keyboard cover from the laptop.
3. Remove the keyboard cover.

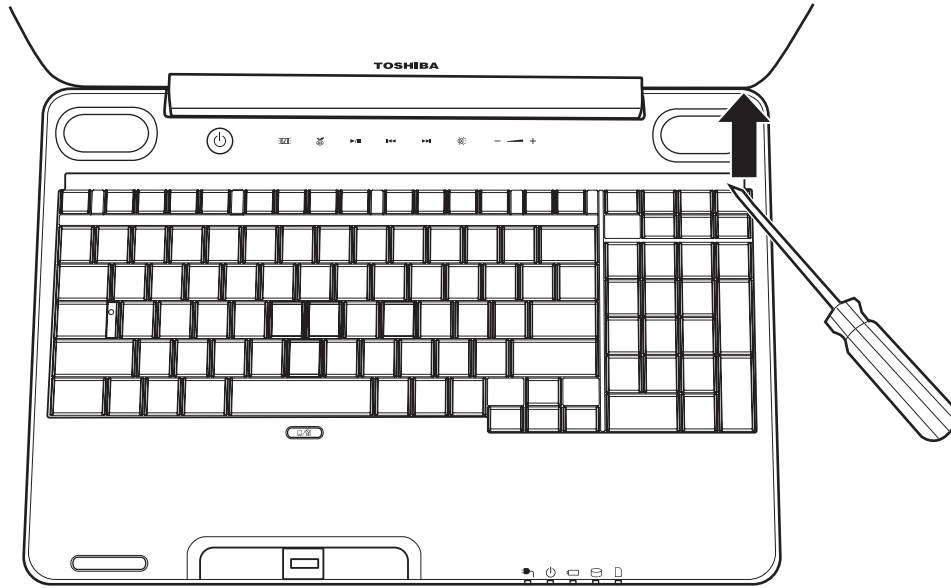

Figure 4.13 Removing the keyboard cover

4. Remove four M2x3 screws.

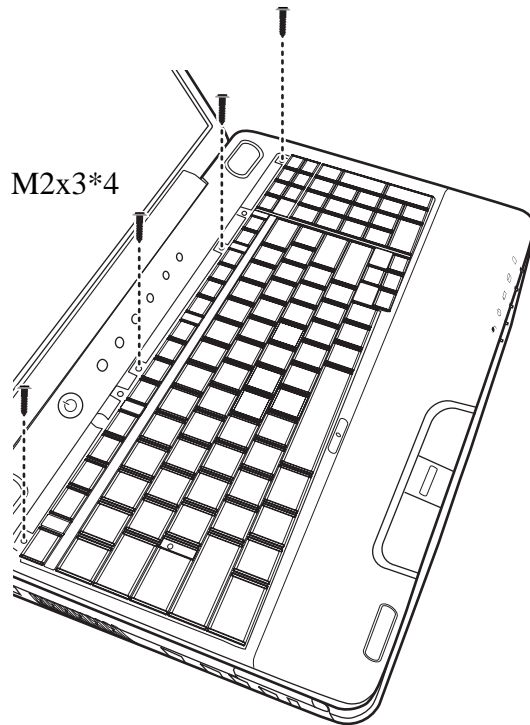

Figure 4.14 Removing screws from the keyboard

5. Lift the keyboard up and detach the cable on the back of the keyboard from the motherboard.

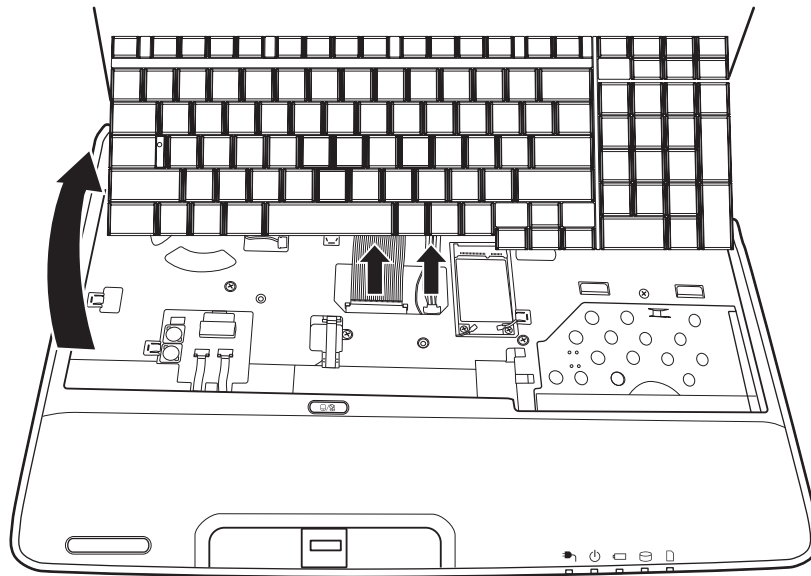

Figure 4.15 Removing the keyboard

Installing the Keyboard Cover and Keyboard

Install the keyboard cover and keyboard according to the following procedures.

1. Attach the cable on the back of the keyboard to the motherboard and place the keyboard in the correct position.
2. Secure the keyboard with four M2x3 screws.
3. Place the keyboard cover in the correct position, then press the cover down from the middle to the left side, making sure the hooks on the back of the cover are inserted correctly.
4. Press down the cover on the right side to make sure the hooks on the back of the cover are securely in the laptop.
5. Press down the cover in the position around the key F9 and slide to the left to make sure the last hook on the back of the cover is secured firmly in the laptop.
6. Close the laptop and turn over. Insert two M2x4 screws in the battery lodging as shown in Figure 4.12.

4.9 Logic Upper Assembly

Removing the Logic Upper Assembly

Remove the logic upper assembly according to the following procedures and Figure 4.16, 4.17 and 4.18.

1. Turn the laptop upside down and remove the following 17 screws:
 - Fifteen M2.5x8 screws
 - Two M2.5x4 screws

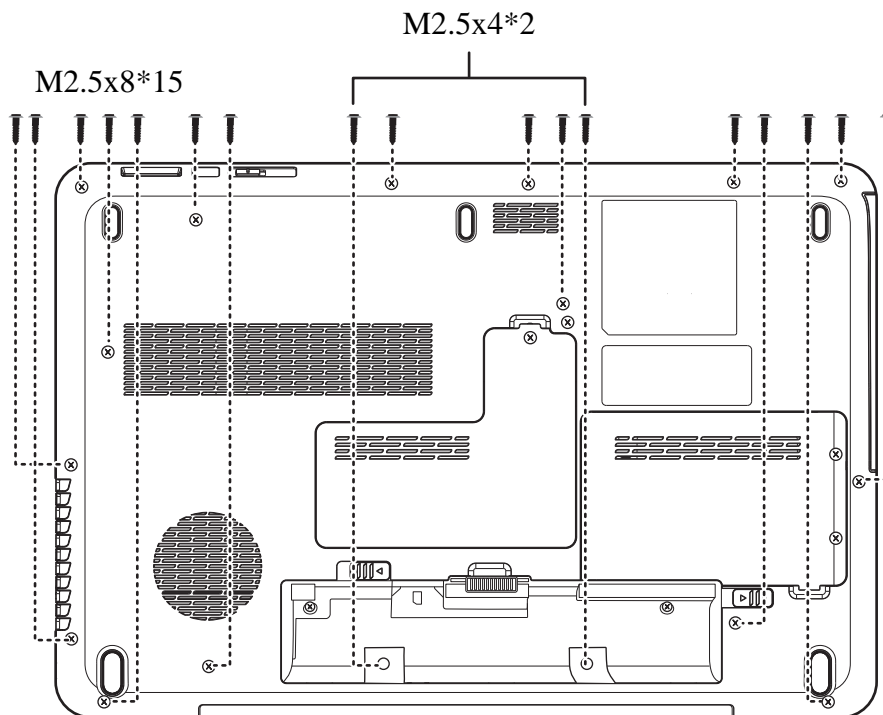

Figure 4.16 Removing the screws from the bottom of the laptop

2. Turn to the front and remove the following screws:
 - Five M2.5x8 screws
 - Three M2.5x5 screws

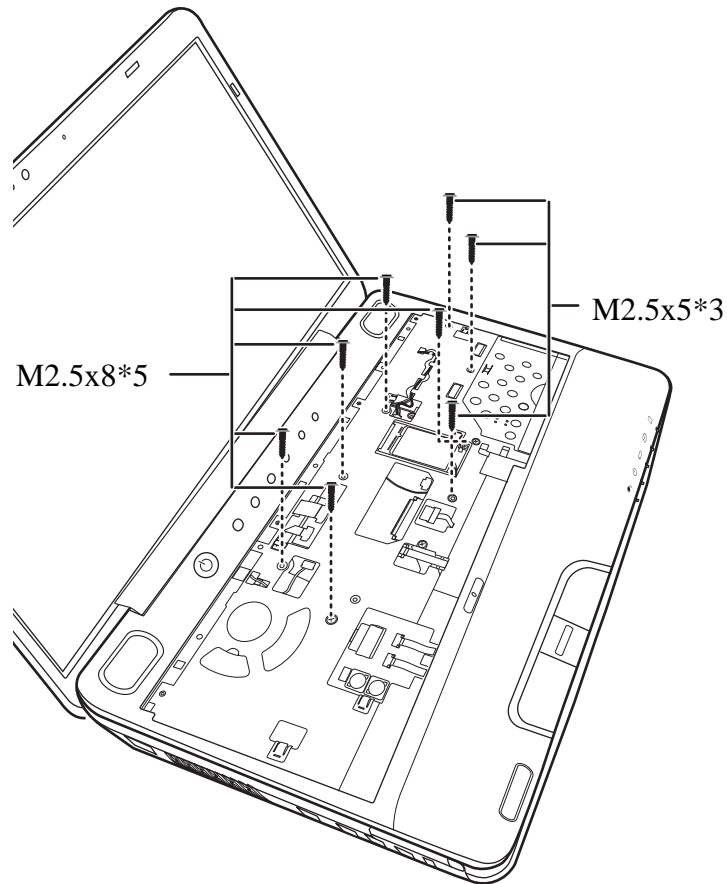

Figure 4.17 Removing eight screws from the laptop.

3. Detach eight connectors: one Power board FFC, one Control Panel FFC, two Speaker cables, one Fingerprinter FFC, one LED Board cable, one Bluetooth cable and one TouchPad cable as shown in Figure 4.18.

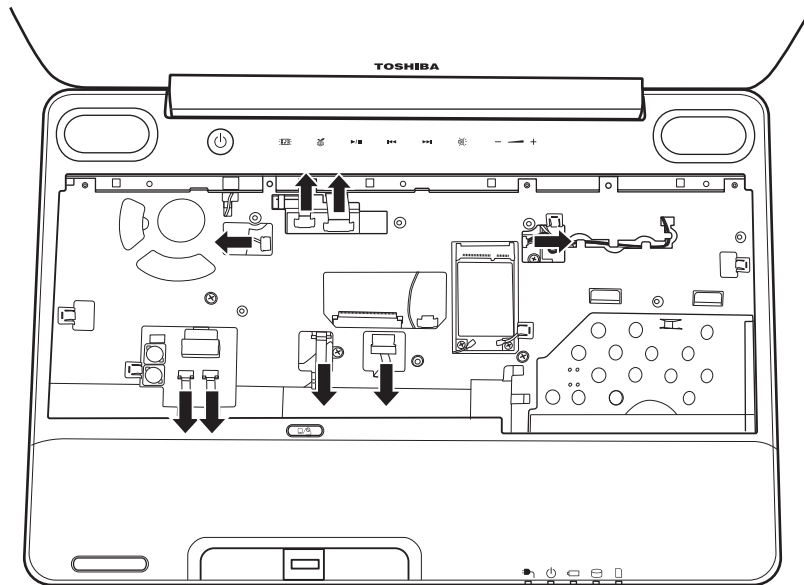

Figure 4.18 Detaching cables from the laptop

4. Lift up the logic upper assembly.

Installing the Logic Upper Assembly

Install the logic upper assembly according to the following procedures.

1. Seat the logic upper assembly to the front of the laptop, and adjust to the correct position.
2. Attach the eight cables and secure the eight screws as indicated in Figure 4.18 and 4.17 respectively.
3. Turn the laptop upside down and secure it with 17 screws as indicated in Figure 4.16:
 - Fifteen M2.5x8 screws
 - Two M2.5x4 screws

4.10 Power Board

Removing the Power Board

Remove the power board according to the following procedures and Figure 4.19.

1. Remove two M2.5x4 screws from the power board.
2. Separate the power board from the logic upper assembly.

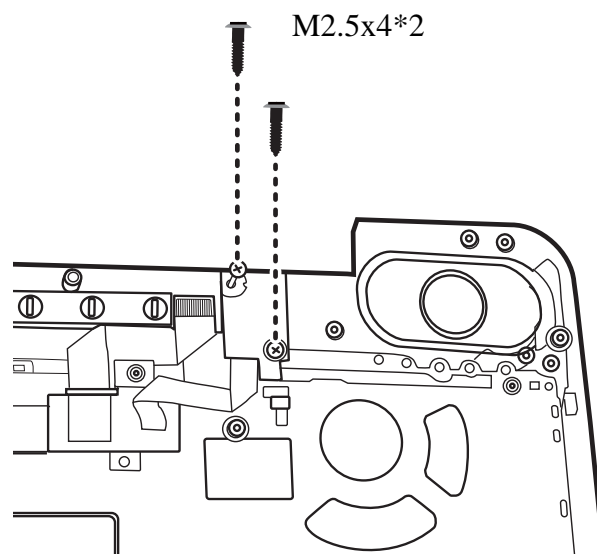

Figure 4.19 Removing the power board

Installing the power switch board

Install the power switch according to the following procedures.

1. Seat the power board in the correct place on the logic upper assembly.
2. Secure the power board with two M2.5x4 screws.

4.11 Speakers

Removing the Speakers

Remove the Speakers according to the following procedures and Figure 4.20.

1. Hold the speaker in place and then remove four special M2.5x6 screws from the left and right speaker.
2. Remove the left and right speakers from the logic upper assembly.

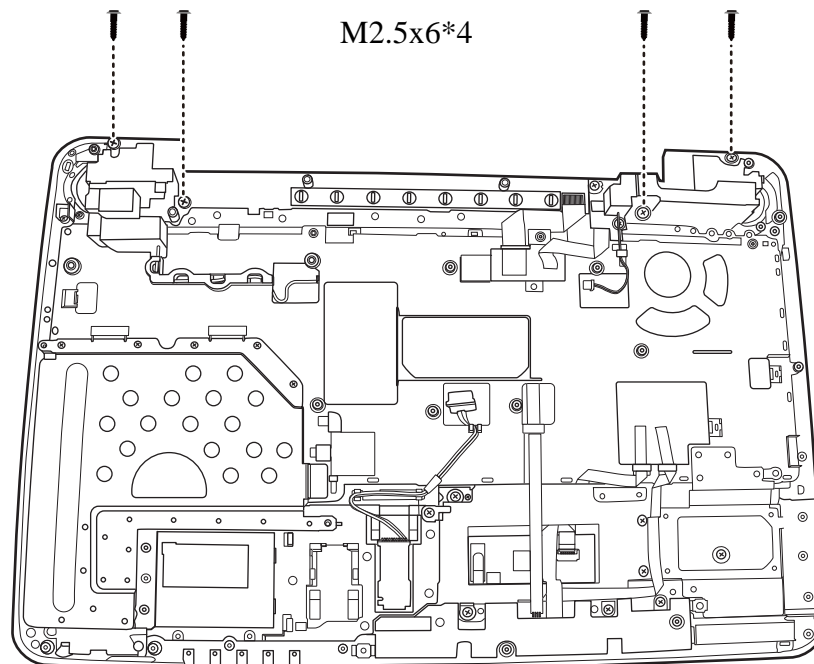

Figure 4.20 Removing the speakers

Installing the Speakers

Install the speakers according to the following procedures.

1. Seat the left and right speaker in the correct position.
2. Press the speakers in place and secure them with four special M2.5x6 screws.

4.12 Bluetooth Card

Removing the Bluetooth card

Remove the Bluetooth card according to the following procedures and Figure 4.21.

1. Remove the Bluetooth cable from the Bluetooth card.
2. Press down the latch and push the Bluetooth card in the direction indicated in the figure 4.21 and slide the Bluetooth card out.
3. Remove the card from the logic upper assembly.

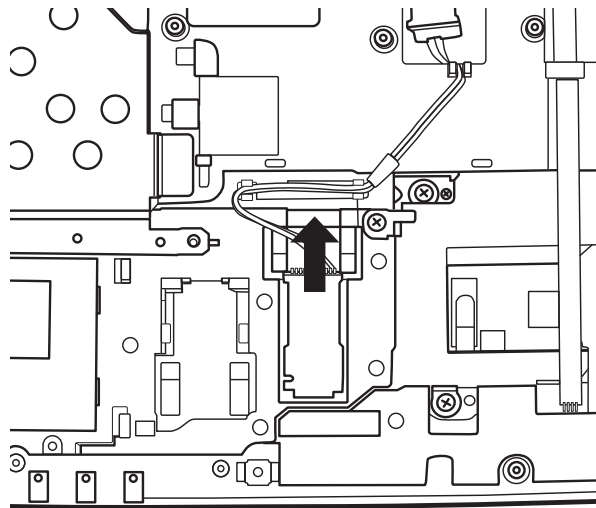

Figure 4.21 Removing the Bluetooth card

Note: Be careful not to damage the Bluetooth Card when connecting it with the cable. Make sure the card is seated in the correct position.

Installing the Bluetooth card

Install the Bluetooth card according to the following procedures.

1. Seat the card in the correct position on the logic upper assembly.
2. Slide the card to the end of the track.
3. Reroute the Bluetooth cable in the cable fixing ribs.

4.13 Touchpad Bracket, Touchpad Boards and Fingerprint Board

Removing the Touchpad Bracket, Touchpad Boards and Fingerprint Board

Remove the Touchpad bracket, Touchpad boards (the button board and switch board) and Fingerprint board according to the following procedures and Figures 4.22, 4.23.

1. Remove four M2.5x4 screws from the Touchpad bracket. Disconnect the Touchpad button cable and pull out the remaining cables from the upper assembly board.

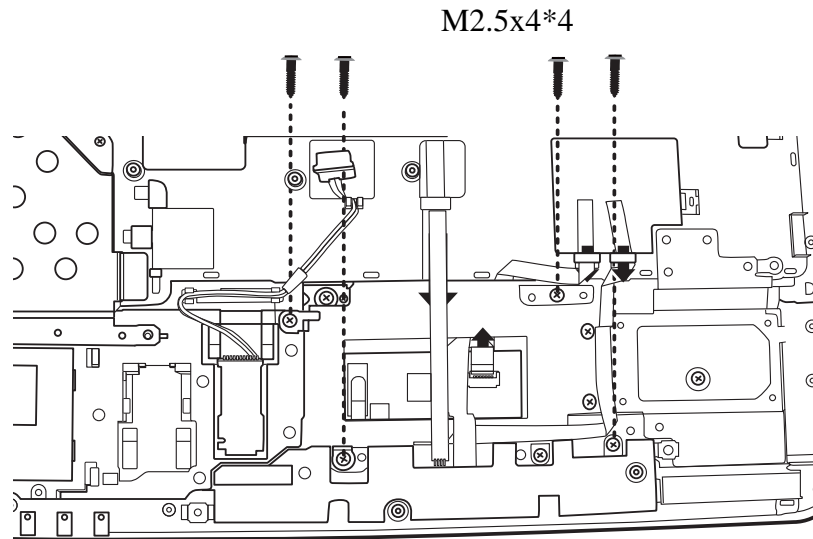

Figure 4.22 Removing the screws from the touchpad bracket

2. Remove the Touchpad bracket.
3. Remove one 2.5x4 screw from the Touchpad button board and the Touchpad switch board.
4. Remove first the Touchpad button board and the Touchpad Switch board from the logic upper assembly.

5. Pull the Fingerprint board up to remove it from the logic upper assembly.

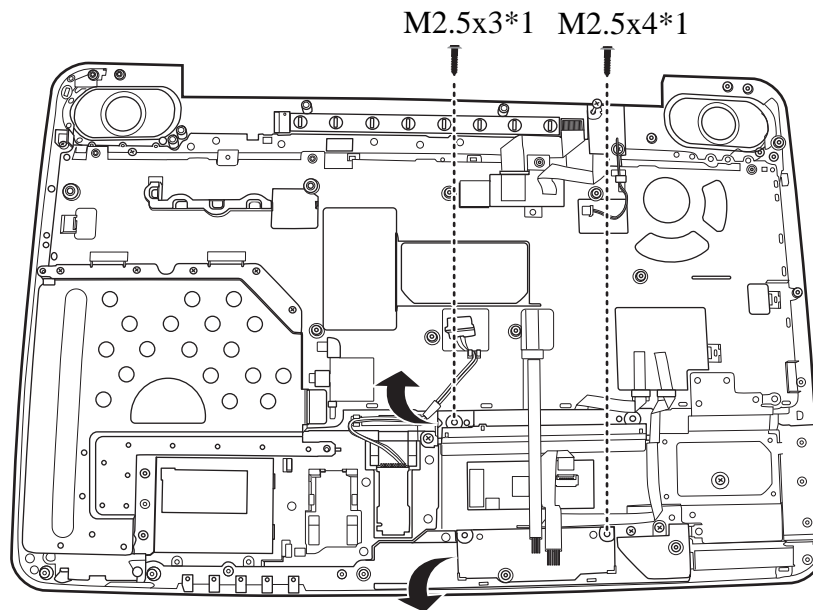

Figure 4.23 Removing the Touchpad boards and Fingerprint board

Installing the Touchpad Bracket, Touchpad Boards and Fingerprint Board/Touchpad Switch Board

Install the Touchpad bracket, the Touchpad boards (the button and switch board) and Fingerprint board according to the following procedures.

1. Seat the Touchpad switch board, the Touchpad button board and Fingerprint board in the correct position.
2. Secure the boards with one M2.5x3 screw and one M2.5x4 screw.
3. Seat the touchpad bracket over the Touchpad boards and Fingerprint board, then secure the bracket with four M2.5x4 screws.
4. Connect the eight cables to the Motherboard.

4.14 LED board

Removing the LED Board

To remove the LED board from the logic lower assembly:

1. Remove one M2.5x4 screw and remove one cable from the motherboard as described in Figure 4.24 below.

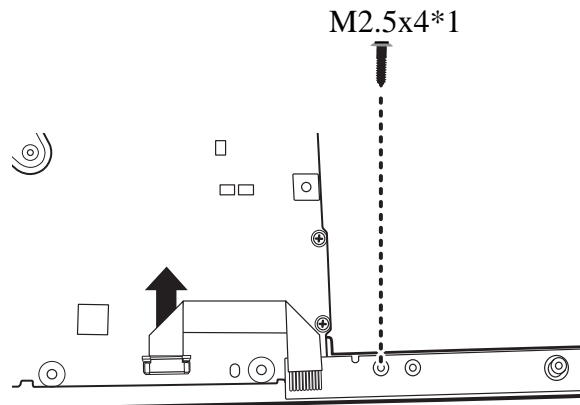

Figure 4.24 Removing the LED Board

Installing the LED Board

Install the LED board according to the following procedure:

1. Seat the LED board on the logic lower assembly. Secure it with one M2.5x4 screw and attach the cable to the motherboard.

4.15 Thermal Fan

Removing the Thermal Fan

Remove the thermal fan according to the following procedures and Figure 4.25.

1. Detach the cable from the motherboard.
2. Remove one M2.5x8 screw from the thermal fan. Remove the thermal fan cable.
3. Remove the thermal fan from the logic lower assembly.

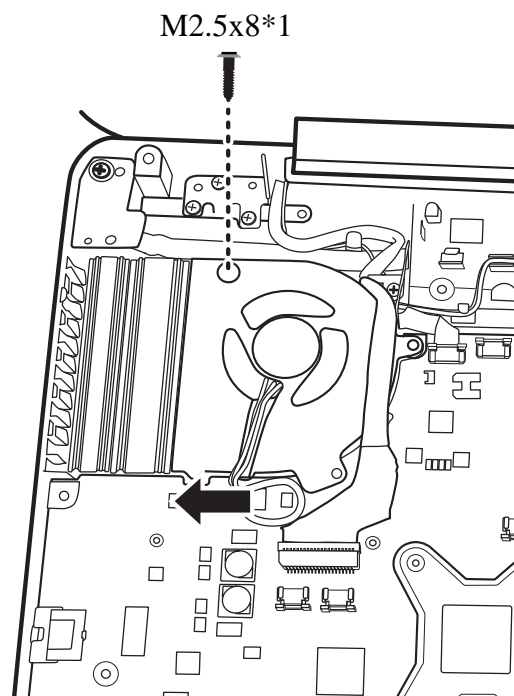

Figure 4.25 Removing the thermal fan from the logic lower assembly

Installing the Thermal Fan

Install the thermal fan according to the following procedures.

1. Seat the thermal fan in the correct position on the logic lower assembly.
2. Secure the thermal fan with one M2.5x8 screw.
3. Attach the cable to the motherboard.

4.16 WLAN Card

Removing the WLAN Card

Remove the WLAN Card according to the following procedures and Figure 4.26.

1. Remove two M2x4 screws from the WLAN Card.
2. Remove the WLAN Card from the motherboard.

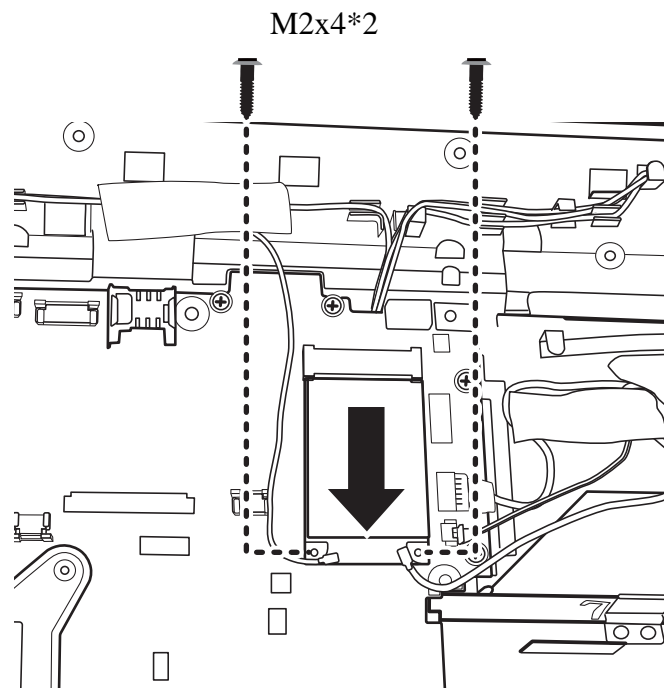

Figure 4.26 Removing the WLAN Card

Installing the WLAN card

Install the WLAN card according to the following procedures.

1. Insert the WLAN card into the connector on the motherboard.
2. Press the WLAN card down and secure it with two M2x4 screws.

4.17 Motherboard

Removing the Motherboard

Remove the motherboard according to the following procedures.

1. Remove one M2.5x4 screw and five cables from the logic lower assembly as indicated by arrows in Figure 4.27.

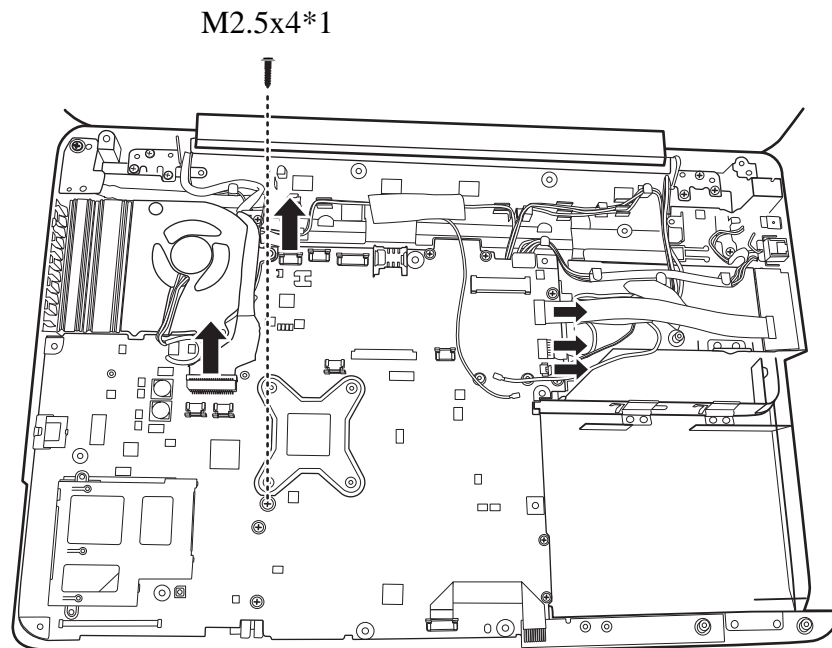

Figure 4.27 Removing motherboard from logic lower assembly

2. Remove the DC_IN CONN and cable out of the logic lower assembly from right to left, as shown in Figure 4.28.

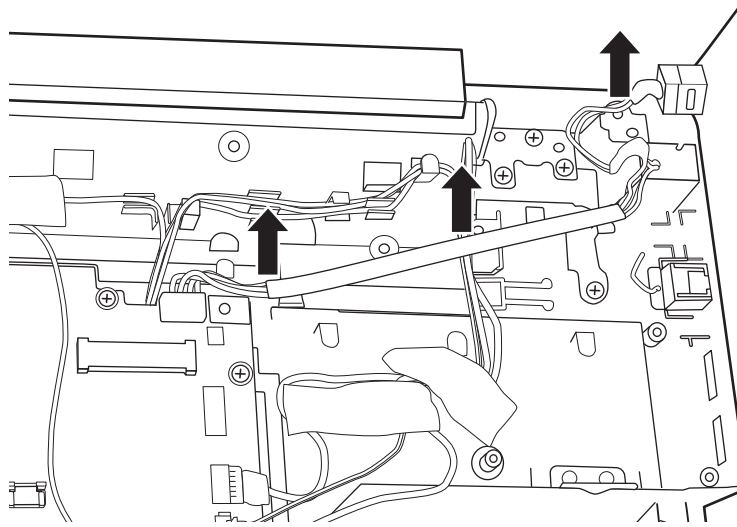

Figure 4.28 Removing the DC_IN CONN and cable

3. Use left hand to hold down the lower part of the motherboard and right hand to pick the motherboard up as shown in figure 4.29.

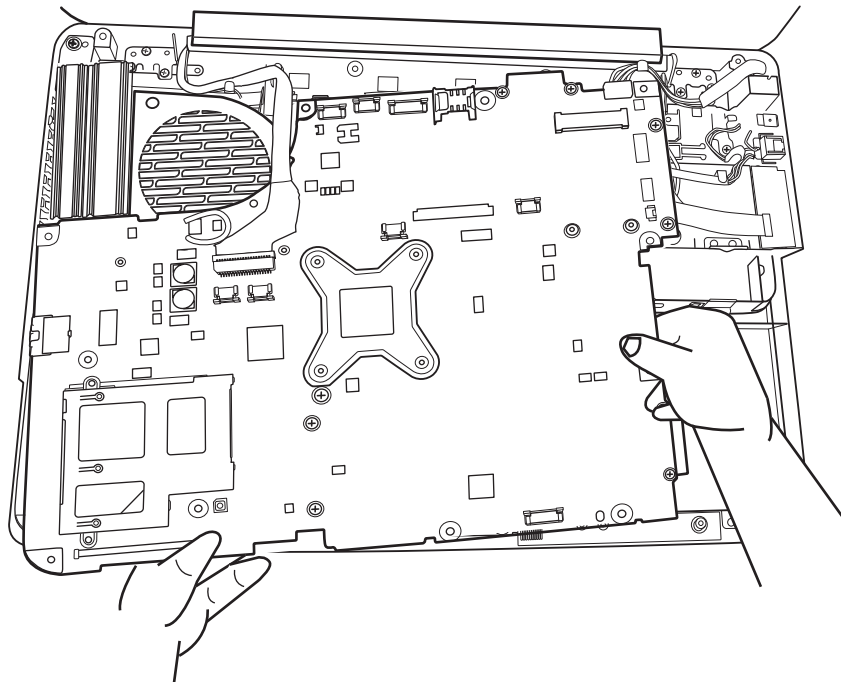

Figure 4.29 Picking up the motherboard

4. Remove the motherboard from the logic lower assembly.

Installing the Motherboard

Install the motherboard according to the following procedures.

1. Before seating the motherboard on the logic lower assembly, pull out the Left USB cable and LDVS cable to avoid being pressed.
2. Align the DP CONN, S/PDIF CONN, Audio CONN and RJ45 CONN to the holes in the logic lower assembly as shown in Figure 4.30.

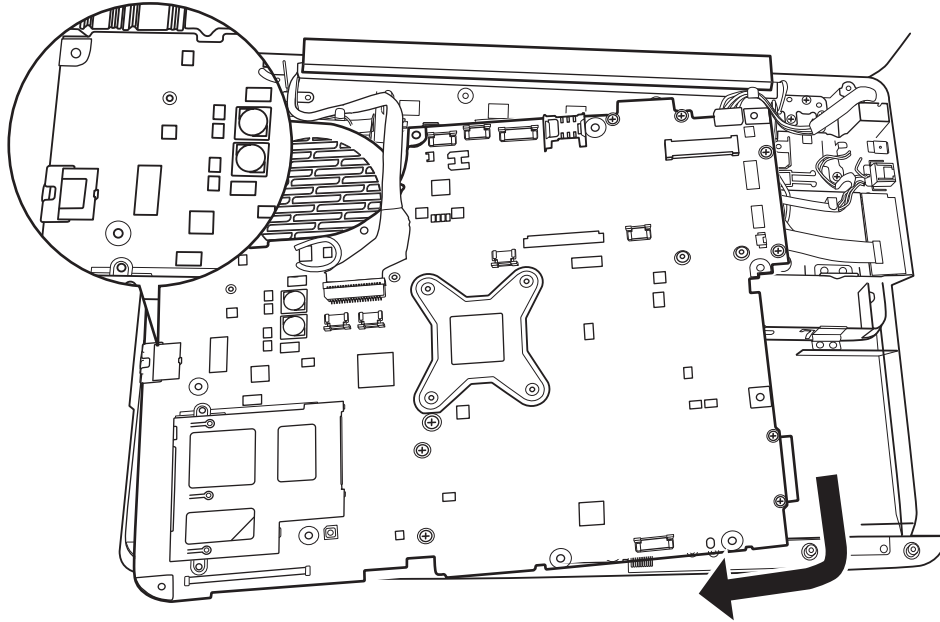

Figure 4.30 Align the DP CONN, S/PDIF CONN, Audio CONN and RJ45 CONN

3. Put the DC_IN CONN in the lower DC_IN trough and route the cable from left to right under the cable-fixed Rib as shown in Figure 4.31.

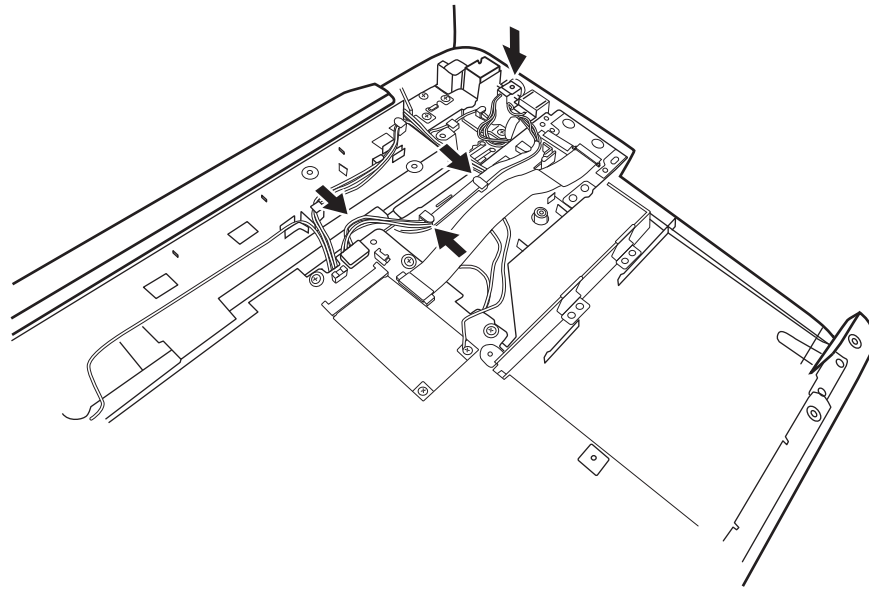

Figure 4.31 Installing the DC-in jack

4. Secure one M2.5x4 screw.
5. Attach five cables to the motherboard as indicated by arrows in Figure 4.27.

4.18 VGA Board and VGA Thermal Module (Optional)

Removing the VGA Board and VGA Thermal Module

Remove the VGA board and thermal module according to the following procedures and Figures 4.32, 4.33.

CAUTION:

When removing the VGA board and VGA thermal module, keep the following in mind:

1. The unit can become very hot during operation. Be sure to let it cool down before starting the repair work.
2. Use care when removing and disassembling the unit in order to avoid damage.
3. If you remove the VGA thermal module, please use soft cloth with alcohol to clean the VGA board and the VGA thermal module. Reapply Shinetsu 7762 grease before installing the VGA thermal module. If you use one new VGA thermal module, please make sure to remove the release paper first.

1. Remove four MM2.0D screws securing the VGA board.
2. Remove the CPU thermal fin from the motherboard.

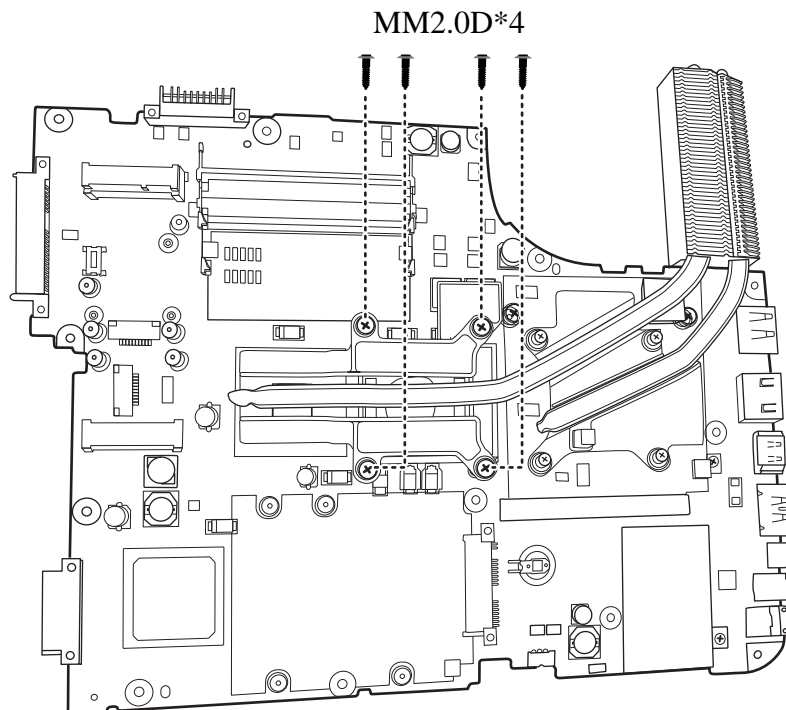

Figure 4.32 Removing the VGA Board

Installing the VGA Board and VGA Thermal Module

Install the VGA board and thermal Module according to the following procedures.

1. Reapply Shinetsu 7762 grease on the VGA thermal module as shown in Figure 4.33. If you use one new VGA thermal module, remove the release papers on the thermal pads first.

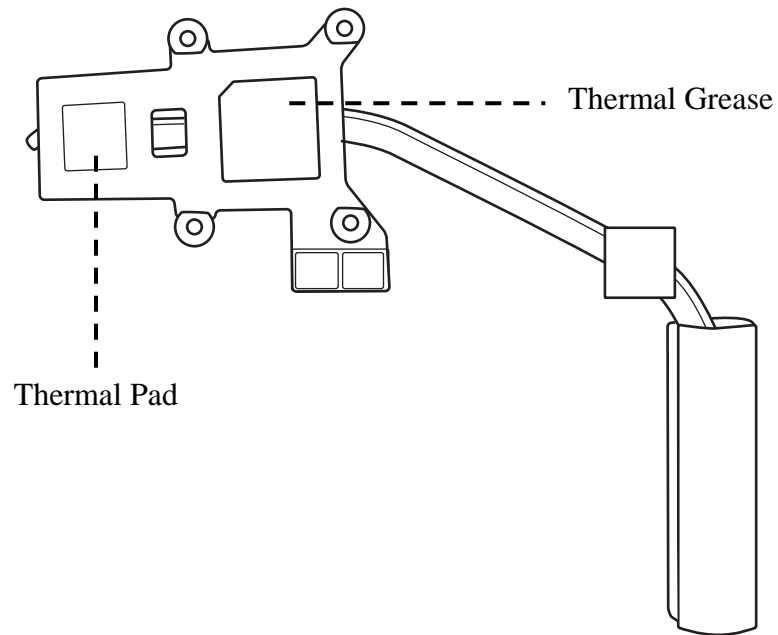

Figure 4.33 Reapply the Shinetsu 7726 grease on the thermal module and remove any release papers

2. Seat the VGA board in the correct position on the motherboard and secure it with four MM2.0D screws according to the number sequence sealed on the thermal module.

4.19 CPU and Thermal Module

Removing the CPU and Thermal Module

Remove the CPU and the CPU thermal module according to the following procedures and Figures 4.34, 4.35.

CAUTION:

When removing the thermal module, keep the following in mind:

- 1. The thermal module can become very hot during operation. Be sure to let it cool down before starting the repair work.*
- 2. If you remove the CPU thermal module, please use soft cloth with alcohol to clean the CPU and CPU thermal module. Reapply Shinetsu 7762 grease before installing the CPU thermal module. If you use one new CPU thermal module, please make sure remove the release paper first.*

1. Remove four spring screws securing the thermal module according to the sequence indicated in the Figure 4.34.
2. Remove the thermal module from the motherboard.

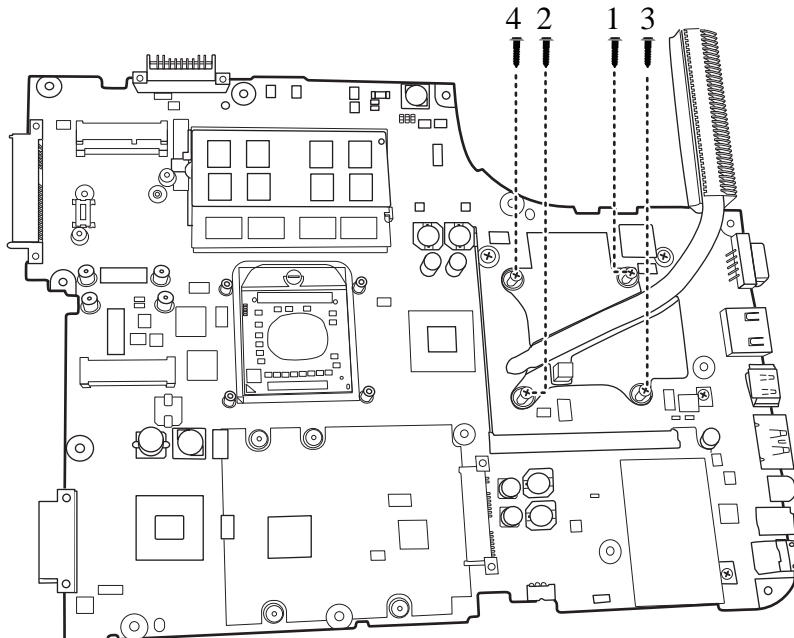

Figure 4.34 Removing the Thermal Module spring screws

CAUTION:

When removing the CPU, keep the following in mind:

The CPU can become very hot during operation. Be sure to let it cool down before starting repair work.

3. Unlock the CPU by rotating the cam on the CPU socket counterclockwise to the unlock position with a flat-blade screwdriver.

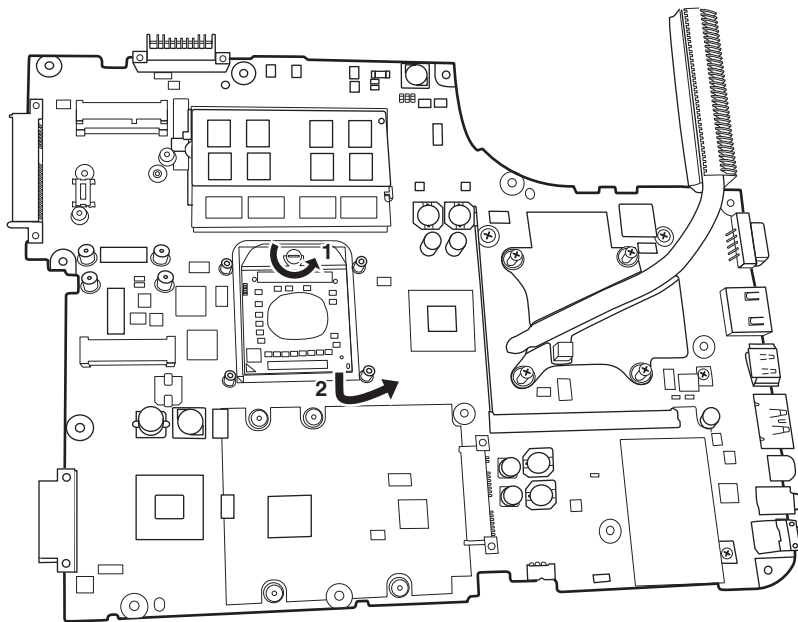

Figure 4.35 Removing the CPU

4. Remove the CPU.

Installing the CPU and Thermal Module

Install the CPU and Thermal Module according to the following procedures.

1. Check the cam is in the unlock position.
2. Seat the CPU on the socket, using care not to damage the pins. Align the CPU with the CPU socket by using the triangle as a guide.
3. Rotate the cam clockwise to the lock position with a flat-blade screwdriver.

CAUTION:

When installing the thermal module, keep the following in mind:

1. Be sure to confirm the correct position for the module.
2. Secure the relevant screws on the motherboard according to the number sequence sealed on the thermal module.

4. Reapply Shinetsu 7762 grease on the CPU thermal module as shown in Figure 4.36. If you use one new CPU thermal module, remove the release papers on the thermal pads first.

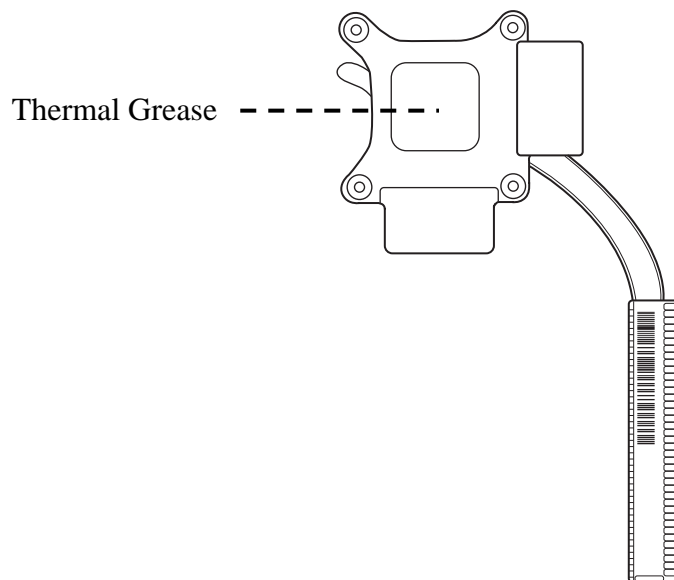

Figure 4.36 Reapply the Shinetsu 7726 grease on the thermal module and remove any release papers

5. Install the thermal module into the correct position in the laptop.
6. Secure it with four spring screws according to the number sequence sealed on the thermal module.

4.20 Display Assembly

Removing the Display Assembly

CAUTION:

Use care to avoid the antenna cable being caught between the display assembly and the laptop.

Remove the display assembly according to the following procedures and Figure 4.37.

1. Remove six M2.5x6 screws securing the display assembly to the laptop.

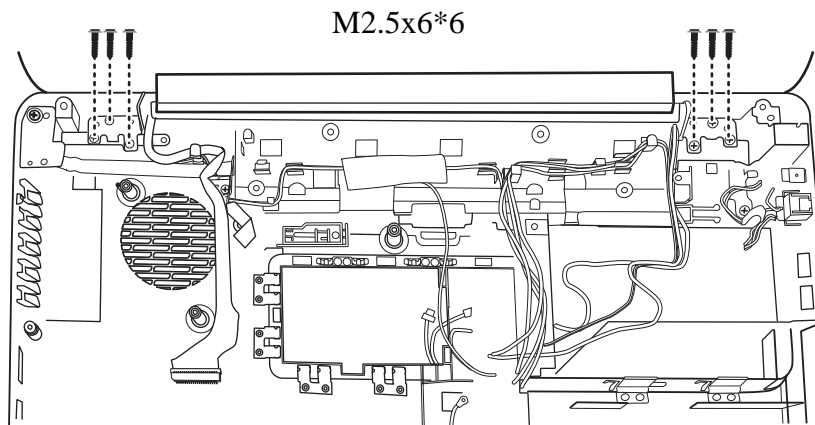

Figure 4.37 Removing the display assembly

2. Remove the display assembly.

Installing the Display Assembly

Install the display assembly according to the following procedures.

1. Place the display assembly in the correct position.
2. Secure the display assembly with six M2.5x6 screws.

4.21 LCD Bezel Assembly

Removing the LCD Bezel Assembly

The LCD comes in two different models: a high-end assembly model and a low-end assembly model. Remove the LCD bezel assembly of each model according to the following procedures.

For Low-end Model

1. Remove four screw rubbers on the LCD bezel. Remove four M2.5x6 screws as shown in Figure 4.38.

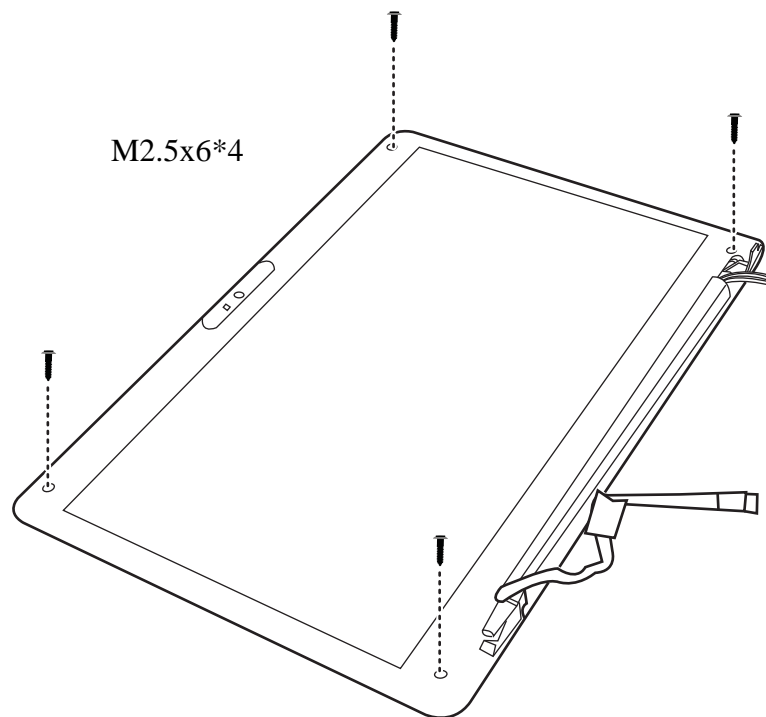

Figure 4.38 Removing the LCD Bezel Assembly from the low-end model

2. Peel off the bezel from left and right side as shown in Figure 4.39.

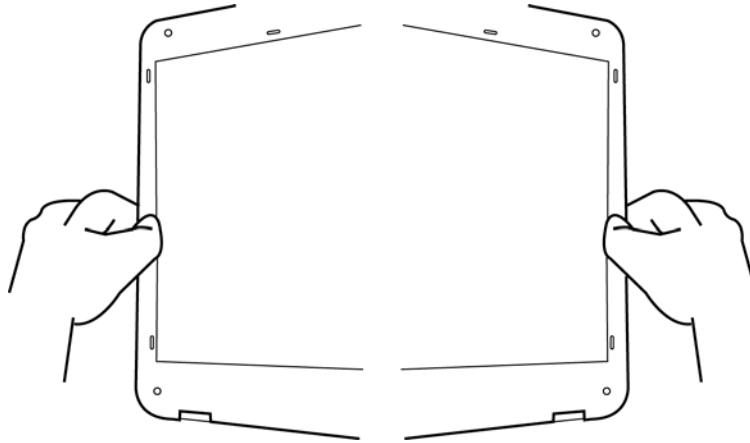

Figure 4.39 Peel off the bezel

3. Pull out the bezel hinge wall from the cover hinge wall as shown in Figure 4.40.

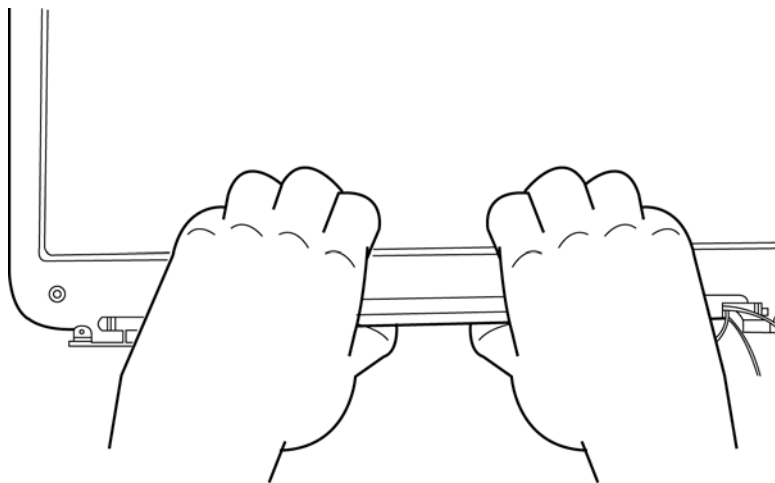

Figure 4.40 Pull out the hinge wall

4. Pull apart the lower half of the bezel; leave this portion above the L/R LCD hinge.

5. Push the bezel from the left and right side as shown in Figure 4.41 and remove the bezel from the display assembly.

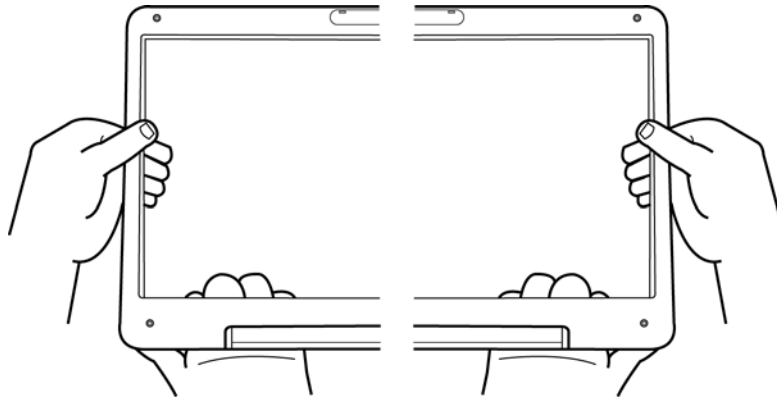

Figure 4.41 Remove the bezel

For High-end Model

1. For the high-end model, remove two screw rubbers on the LCD bezel and remove two M2.5x6 screws as shown in Figure 4.42.

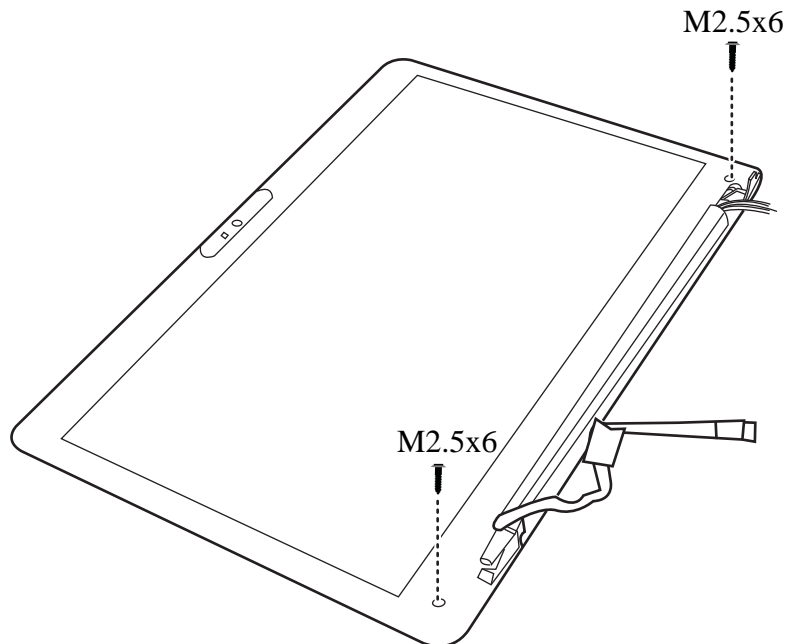

Figure 4.42 Removing the LCD Bezel Assembly from the high-end model

2. Wrap the flat blade screwdriver with three layers of tape.

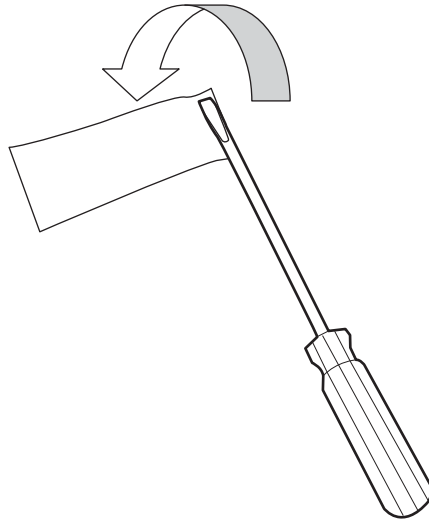

Figure 4.43 Wrap the flat blade screwdriver with tape

3. Press the bezel hinge wall and cover hinge wall as indicated in Figure 4.44.

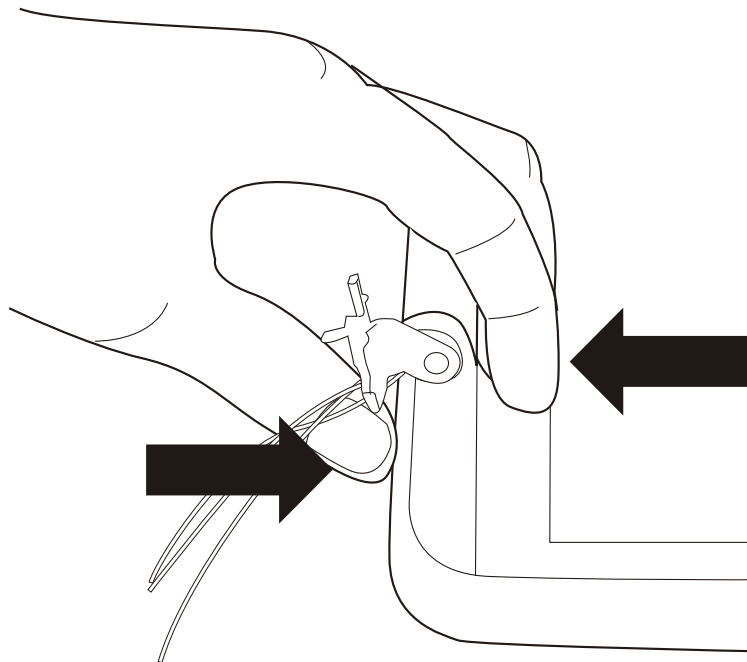

Figure 4.44 Press the hinge wall

4. When pressing the hinge wall, use the flat blade screwdriver to pry up the bezel hinge wall as indicated in Figure 4.45 to release the first hook on the right side.

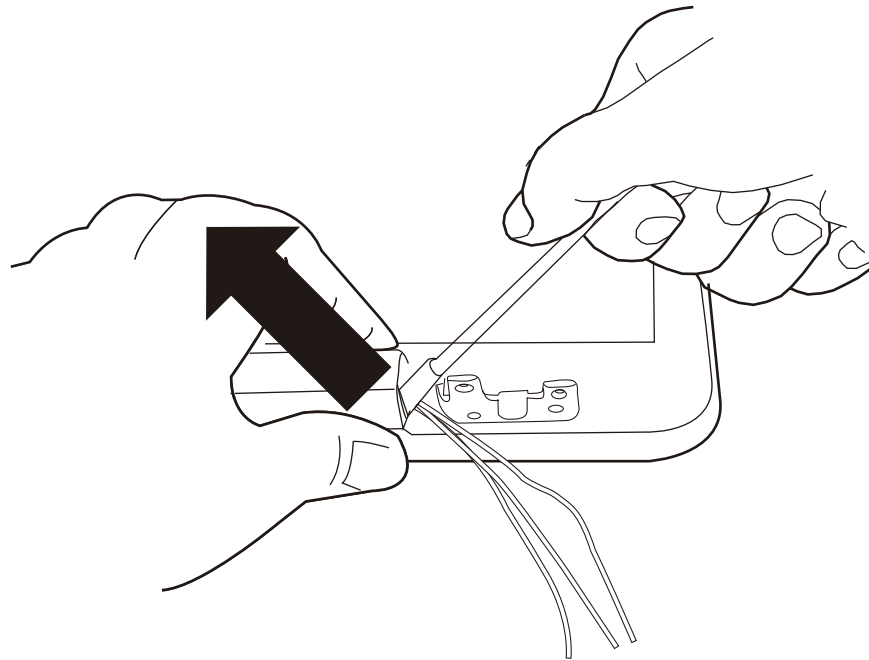

Figure 4.45 Pry up the bezel hinge wall

5. Use both hands to release the rest of the hooks as indicated in Figure 4.46.

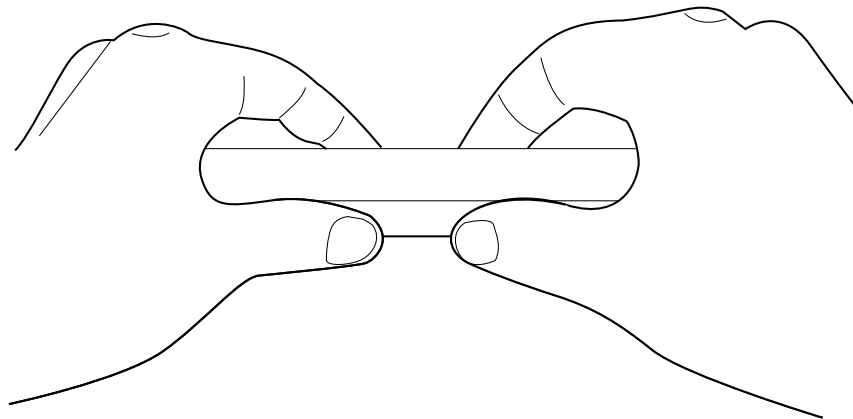

Figure 4.46 Release the rest of the hooks

6. Hold the hinge wall with your left hand, and push the right side of the bezel upward with right hand thumb as indicated in Figure 4.47.

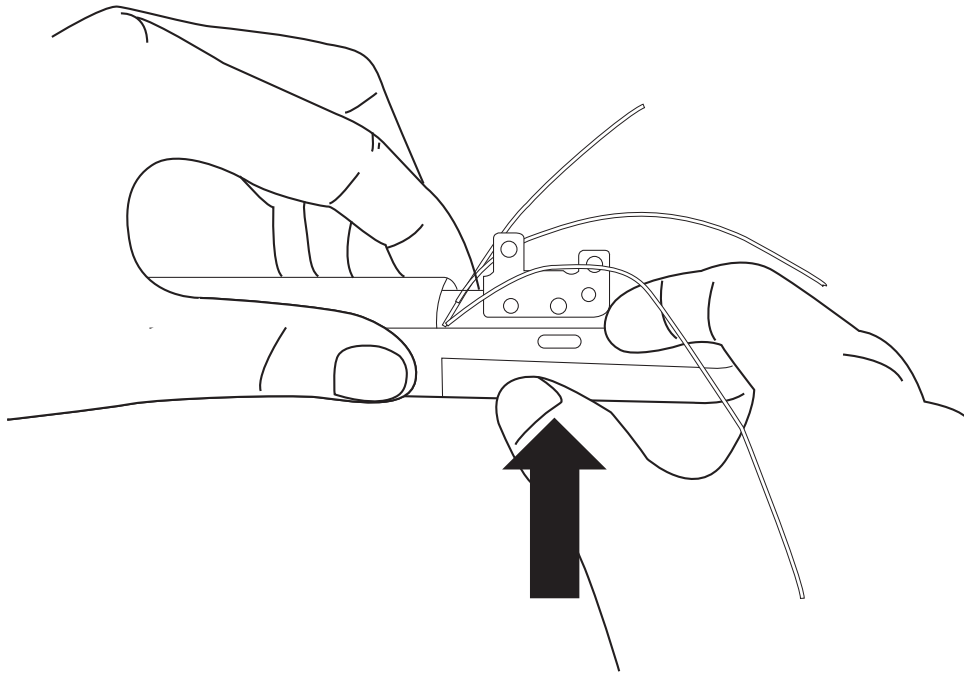

Figure 4.47 Push the right side of the bezel upward

7. Hold the hinge wall with your right hand, and push the left side of the bezel upward with left hand thumb as indicated in Figure 4.48.

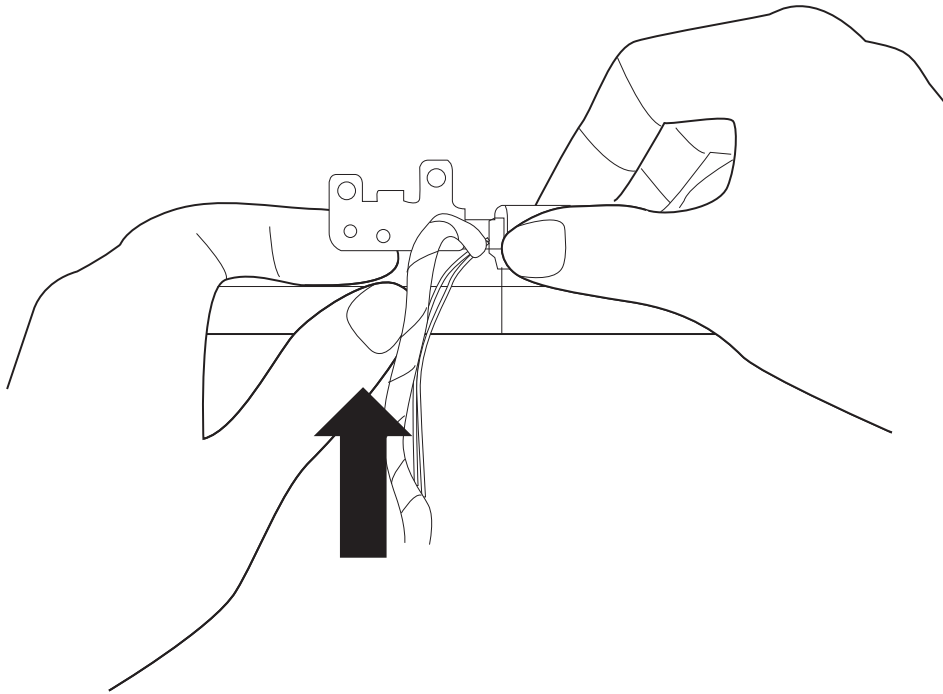

Figure 4.48 Push the left side of the bezel upward

8. Release the hooks from the bottom left and bottom right of the bezel with the wrapped screwdriver as shown in Figure 4.49.

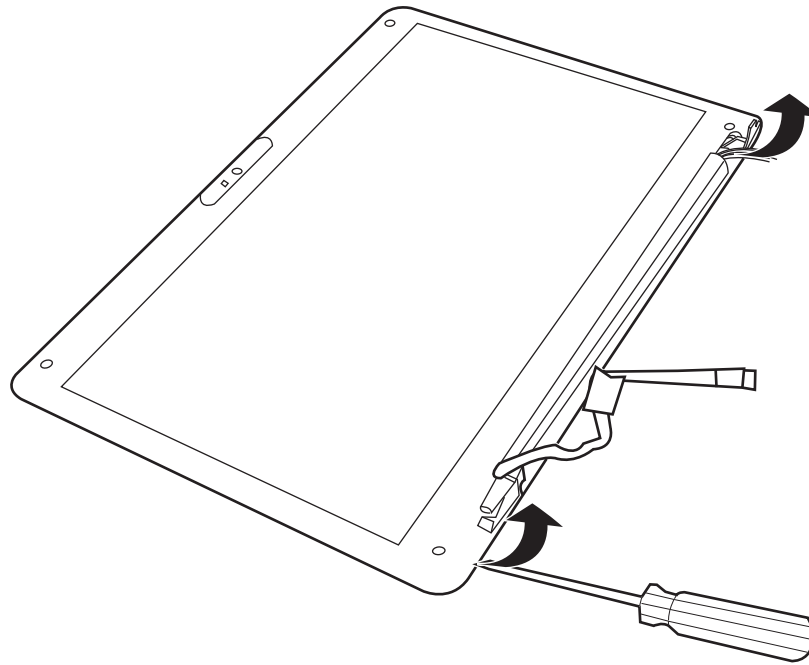

Figure 4.49 Release hooks from the bottom of the bezel

9. Release the hooks on the right side of the bezel with the wrapped screwdriver as indicated in Figure 4.50. Do the same procedure for the left side.

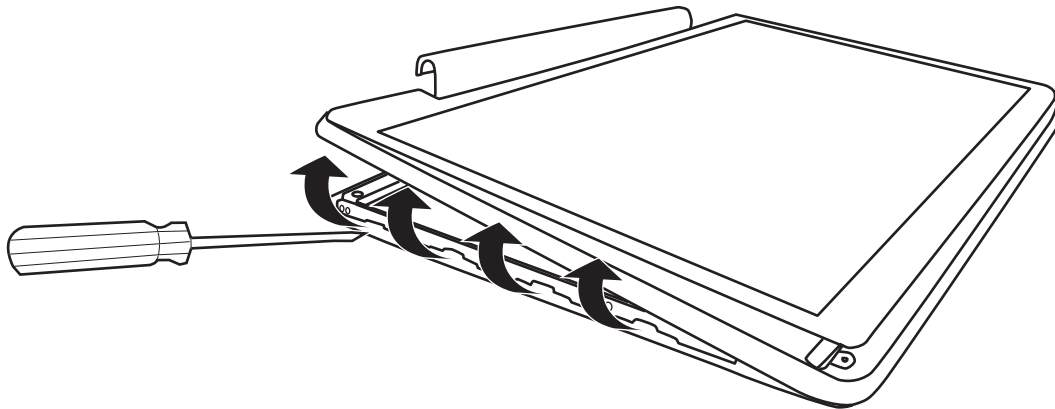

Figure 4.50 Release hooks from the right and left side of the bezel

10. Release the hooks on the upper side of the bezel from left to right with the wrapped screwdriver as indicated in figure 4.51.

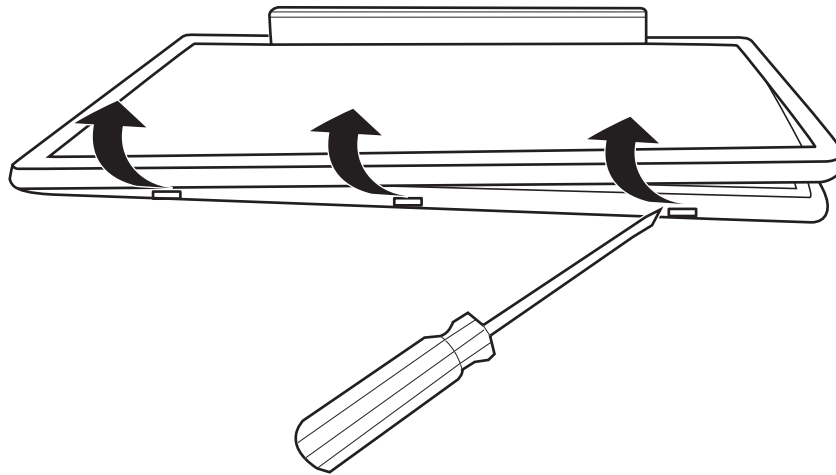

Figure 4.51 Release the hooks from the upper side of the bezel

11. Remove the bezel from the display assembly

Installing the Display Mask

Install the LCD bezel assembly according to the following procedures.

1. Seat the LCD bezel assembly in the correct position.
2. For the low-end model, press the bezel hinge wall against the cover hinge wall as shown in Figure 4.52. For the high-end model, press on the bezel hinge wall to fasten the hooks to the cover hinge wall.

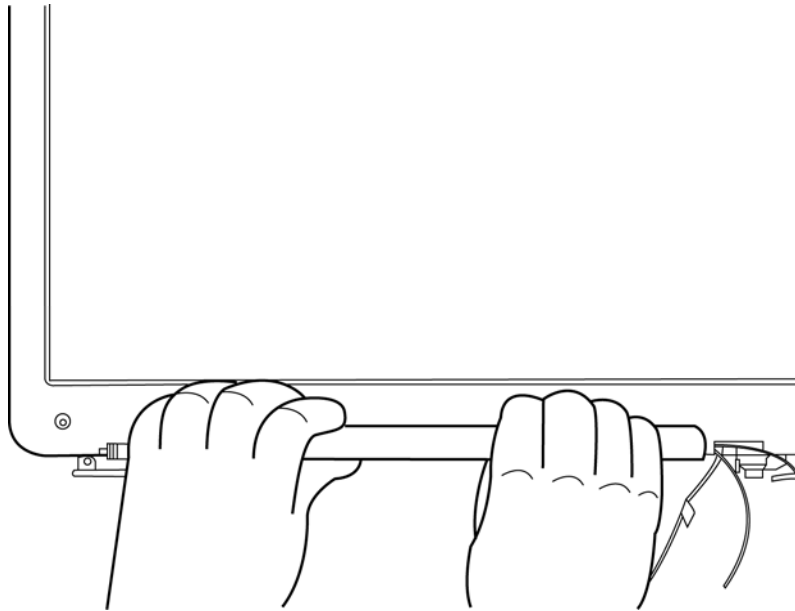

Figure 4.52 Press the bezel hinge wall

3. Press the bezel downside hook near the hinge wall as shown in Figure 4.53.

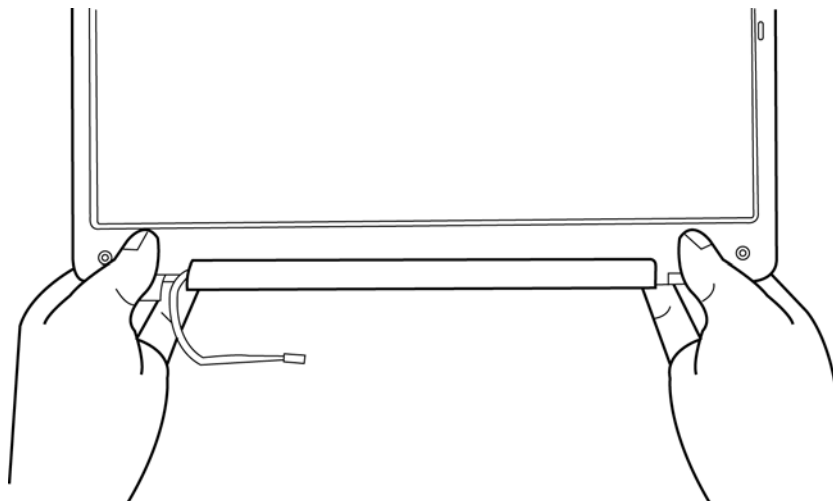
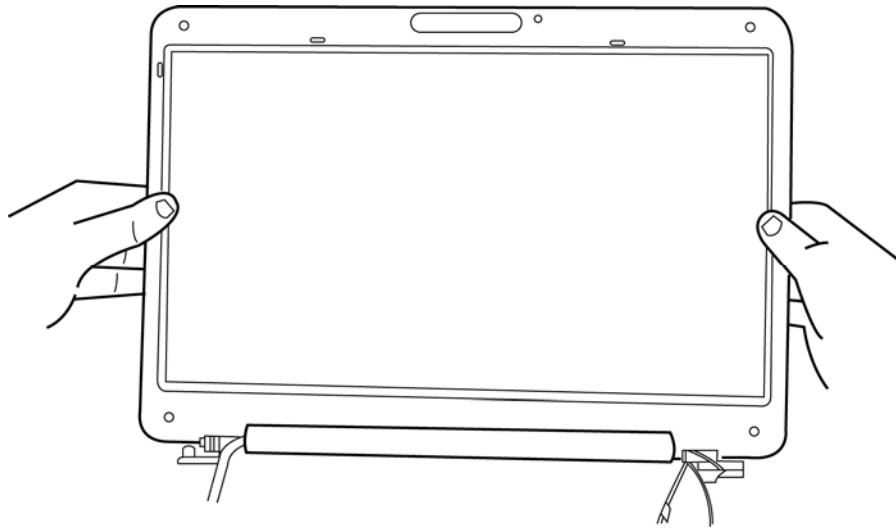

Figure 4.53 Press the bottom hooks on the display assembly

4. For the low-end model, press the left and right side of the bezel as shown in Figure 4.54. For the high-end model, press and secure the hooks on the left and right side of the bezel.



*Figure 4.54 Press the left and right side of the bezel for the low-end model/
Press the hooks on the left and right side of the bezel for the
high-end model*

5. Press the bezel upside hooks as shown in Figure 4.55.

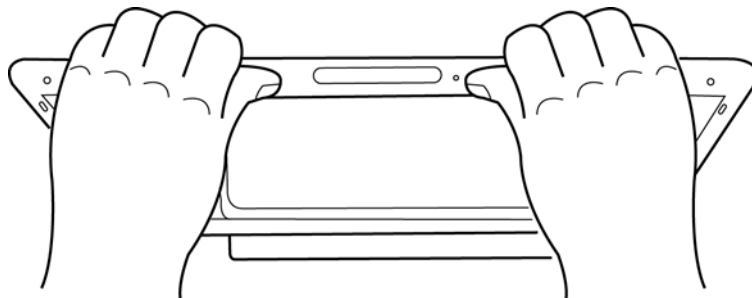

Figure 4.55 Press the bezel upside hooks

6. Secure it to the display assembly with two M2.5x6 screws for the high-end model, or with four M2.5x6 screws for the low-end model.

NOTE: When setting the LCD mask, wipe the LCD with a soft cloth and make the back of the LCD mask clean an ionizer.

4.22 LCD Module and Inverter Board

Removing the LCD Module and Inverter Board

Remove the LCD module and the inverter board according to the following procedures and Figures 4.56, 4.57, 4.58, 4.59 and 4.60.

1. Remove one M2x3 screw securing the inverter board and detach two cables connected to the two ends of the inverter. Then remove the inverter board.

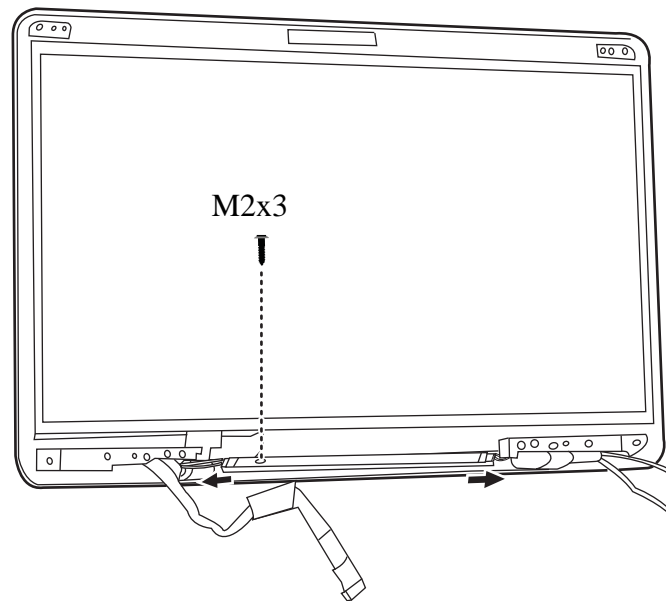

Figure 4.56 Removing the Inverter Board

2. a. For the high-end model, remove eight M2.5x4 screws securing the LCD module according to the sequence indicated in the Figure 4.57.

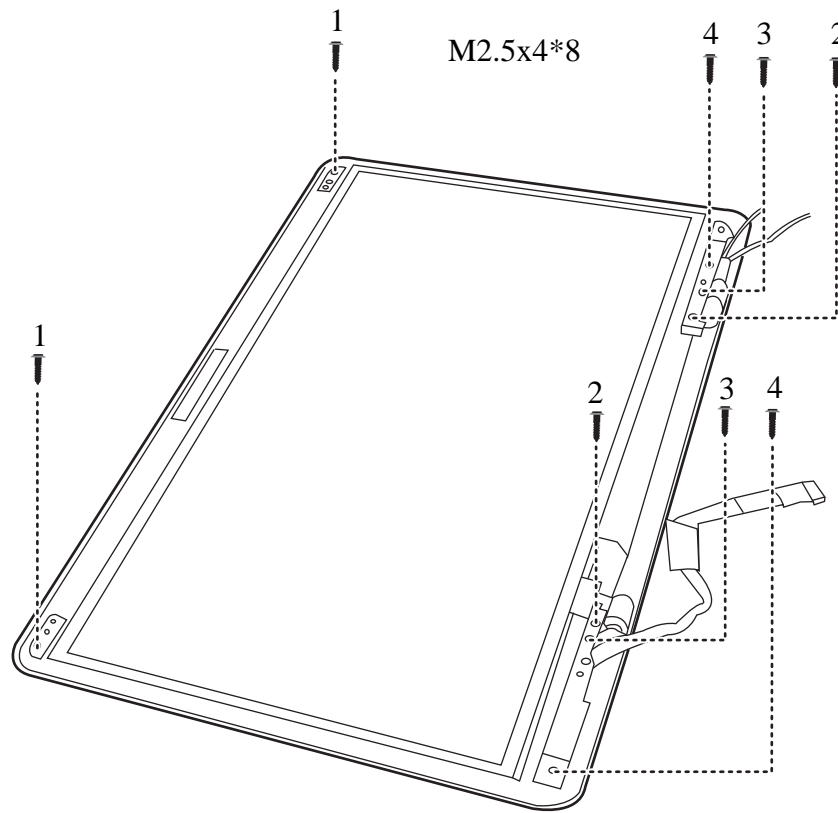

Figure 4.57 Removing the LCD Module from the LCD cover assembly (high-end model)

- b. For the low-end model, remove six M2.5x4 screws securing the LCD module according to the sequence indicated in the Figure 4.58.

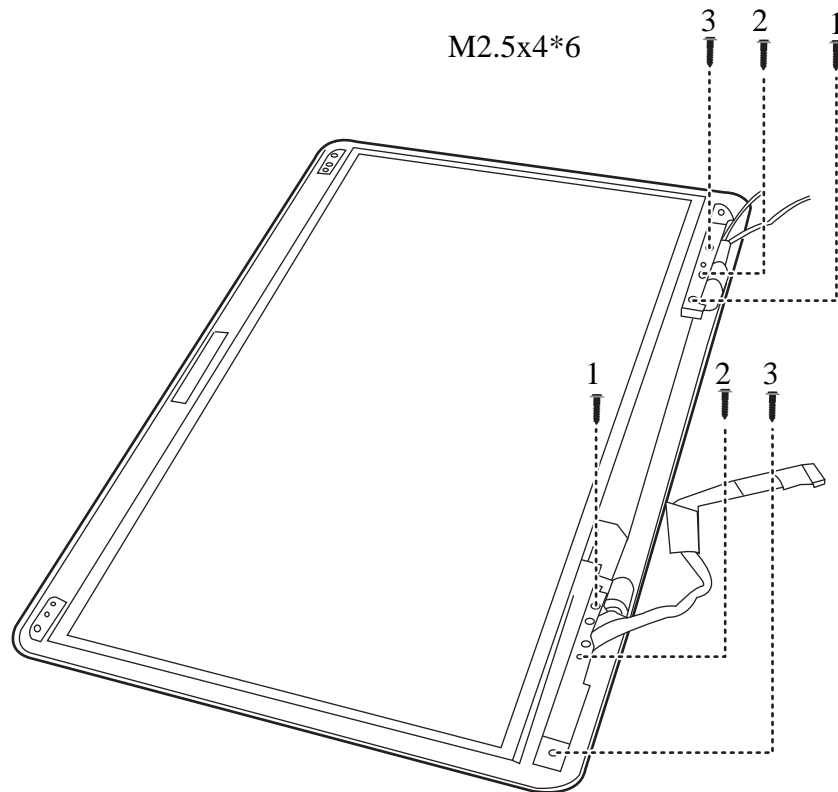

Figure 4.58 Removing the LCD Module from the LCD cover assembly (low-end model)

3. Lift the LCD module out of the LCD cover assembly.

4. Remove six M2x3 screws according to the sequence indicated in the Figure 4.59, and then remove the LCD hinge assembly.

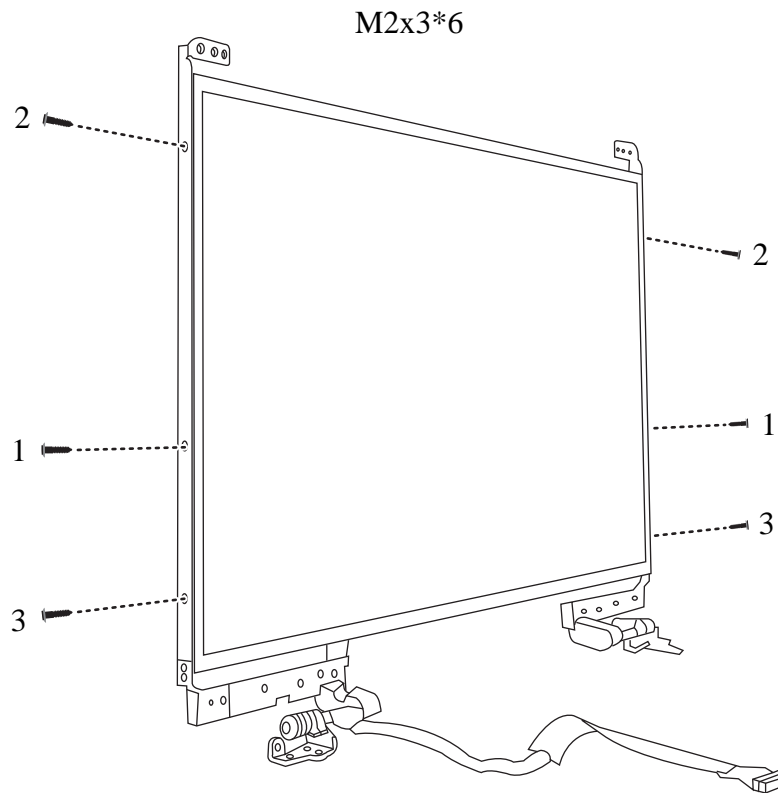

Figure 4.59 Removing the LCD Hinge Assembly

5. Turn the LCD module over and place it face down on a protective surface, such as a foam pad.

6. Remove the tape and LVDS cable connector. Then detach the LVDS cable.

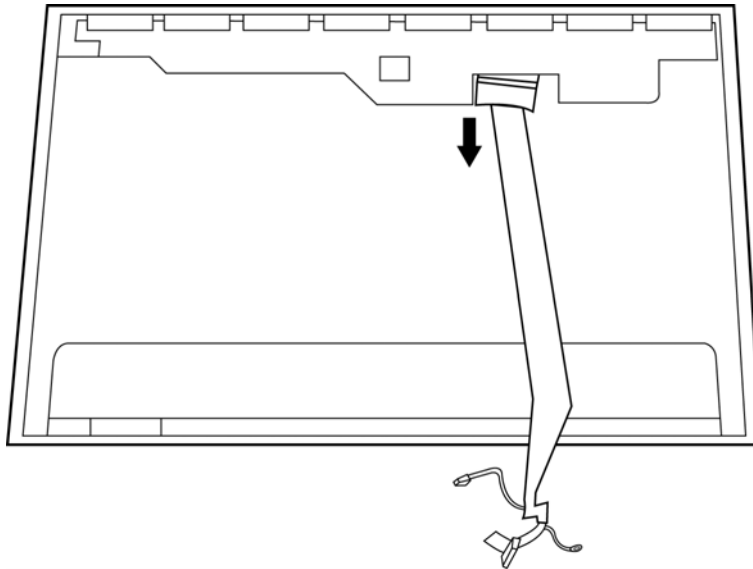

Figure 4.60 Removing the LVDS cable from the LCD module

NOTE:

Integrated Circuits (ICs) are fragile. Use extreme care not to apply pressure to the ICs along the edges of the LCD module.

Dispose of used LCD panels (fluorescent (FL) tubes) as required by local ordinances or regulations.

Tape around the LVDS cable must be carefully peeled away before disconnecting the cable from the LCD panel.

Installing the LCD Module and Inverter Board

Install the inverter board according to the following procedures.

1. Turn the LCD module cover and place it face down on a protective surface such as a foam pad.
2. Connect the LVDS cable to the LCD panel connector.
3. Turn the LCD right side up.
4. Seat the LCD hinge assembly in the correct position beside the LCD panel and secure it with six M2x3 screws according to the sequence indicated in Figure 4.61.

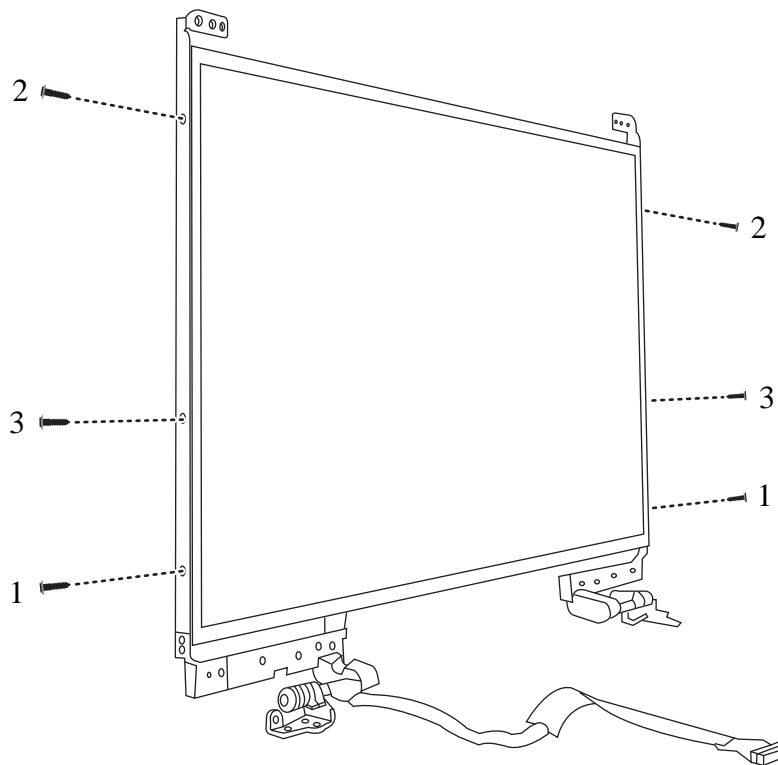

Figure 4.61 Installing the LCD Hinge Assembly

5. Seat the LCD module in the correct position in the LCD cover assembly. Secure it to the LCD cover assembly with eight M2.5x4 screws for the high-end model, or with six M2.5x4 screws for the low-end model, according to the sequence indicated in Figure 4.62 and Figure 4.63. Reroute the CMOS and Antenna cables after securing the LCD panel.

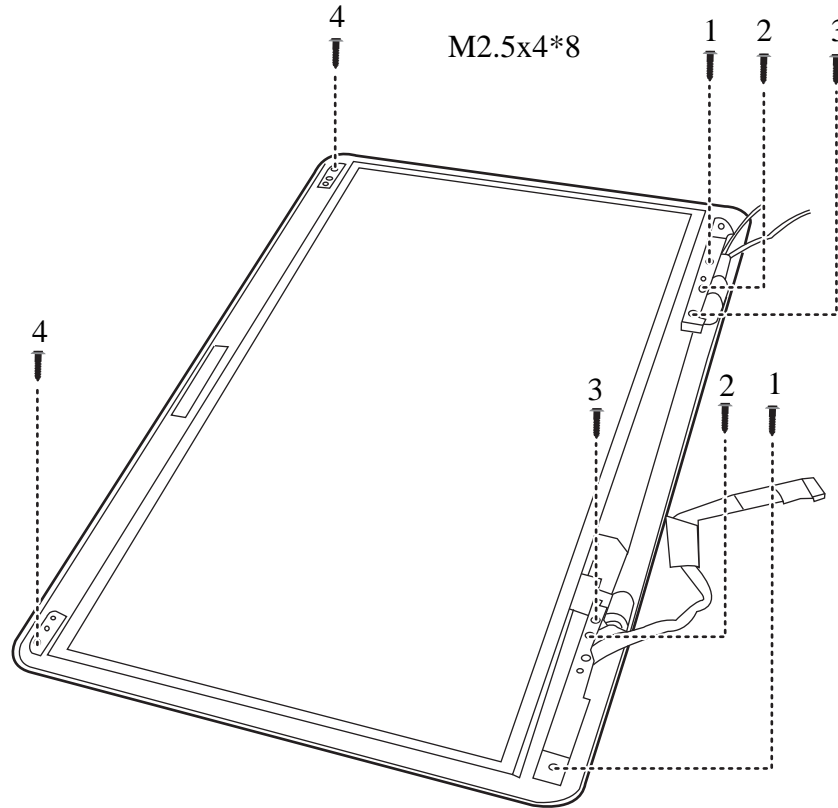

Figure 4.62 Installing the LCD Module from the LCD cover assembly (high-end model)

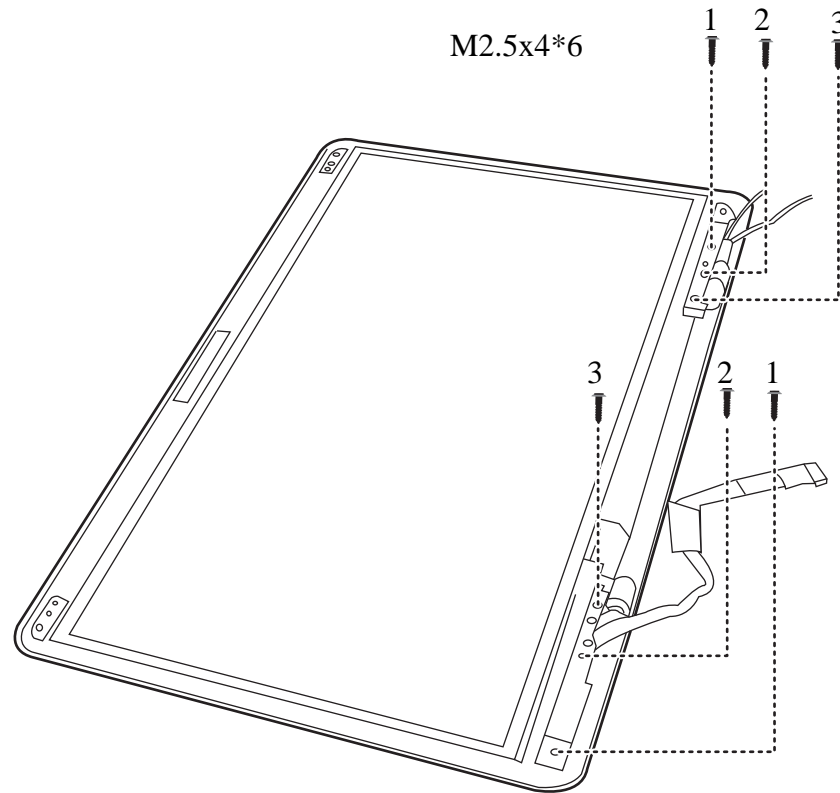

Figure 4.63 Installing the LCD Module from the LCD cover assembly (low-end model)

6. Seat the inverter board in correct position and connect two cables to the two ends of the inverter board. Then secure it with one M2x3 screw.

NOTE: Be careful not to pinch codes beside hinges.

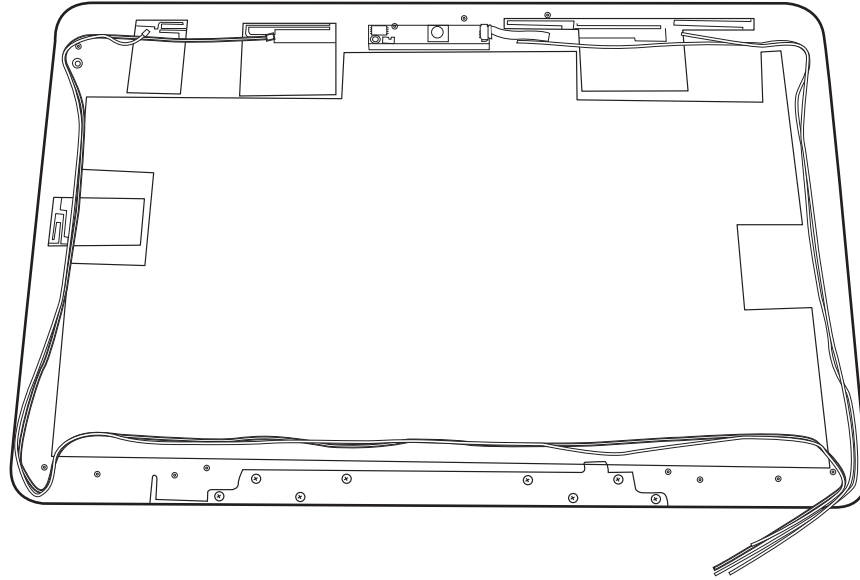

Figure 4.64 Not to pinch codes beside hinges (high-end model)

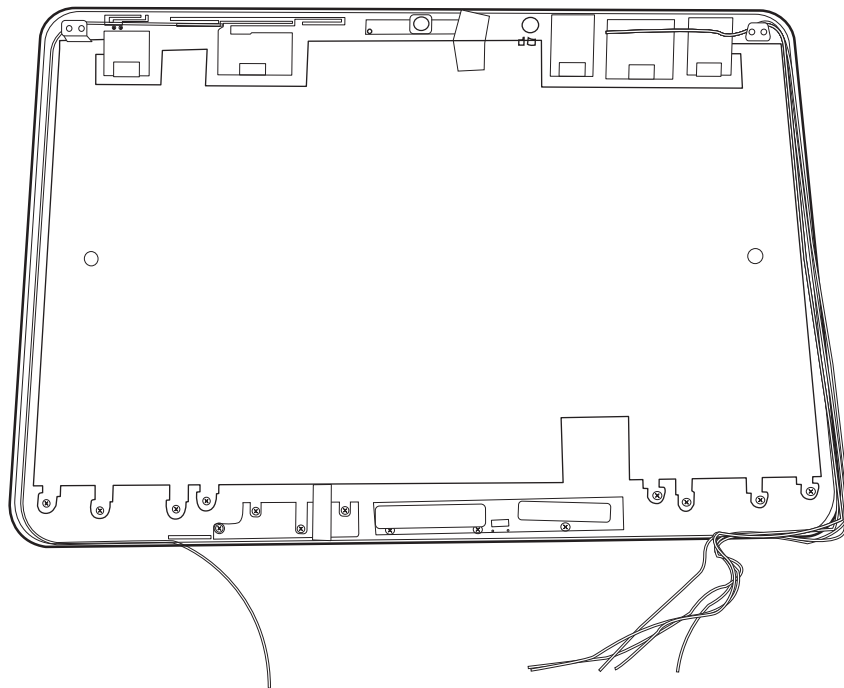

Figure 4.65 Not to pinch codes beside hinges (low-end model)

4.23 CMOS Board and MIC

Removing the CMOS Board and MIC

Remove the CMOS Board and MIC according to the following procedures and Figure 4.66 and 4.67.

1. Disconnect the CMOS cable from the CMOS module connector and remove the CMOS board.

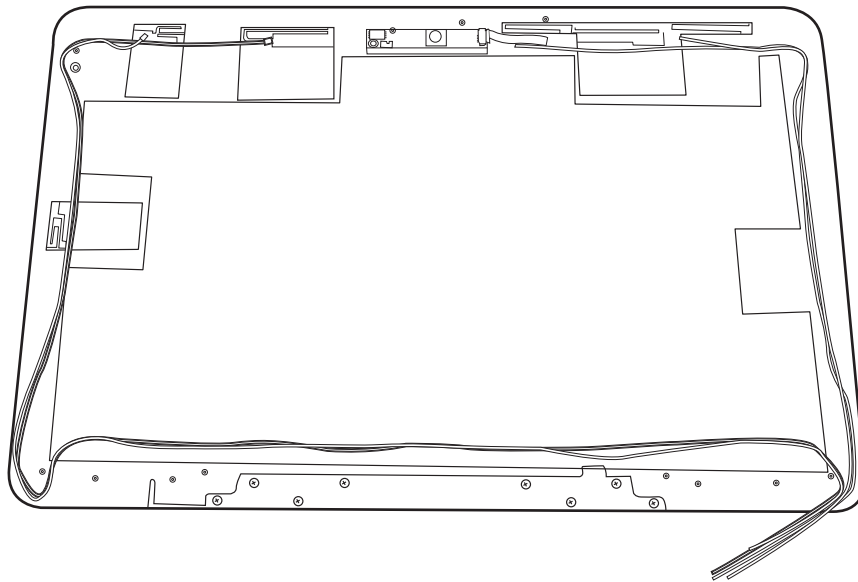

Figure 4.66 Removing the CMOS board and MIC (high-end model)

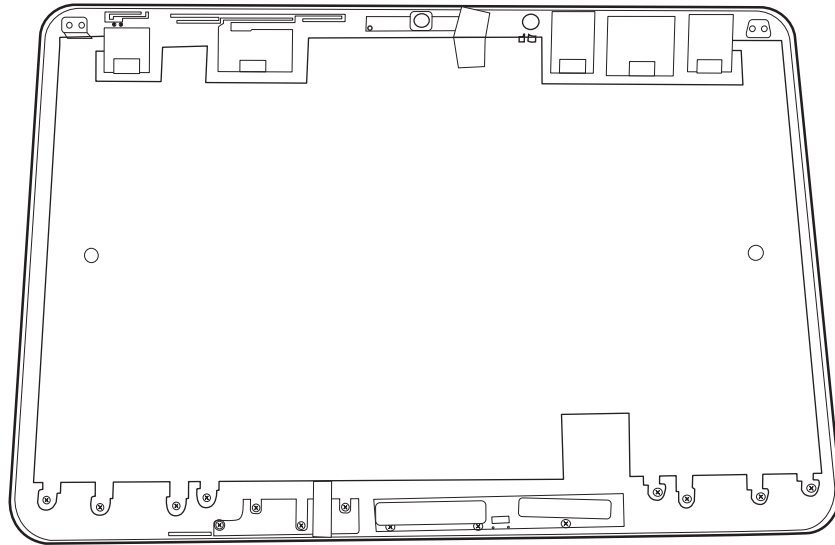

Figure 4.67 Removing the CMOS board and MIC (low-end model)

2. Lift the MIC cable from the LCD cover assembly.

Installing the CMOS Board and MIC

Install the CMOS Board and MIC according to the following procedures.

1. Connect the CMOS module cable to CMOS module connector.
2. Seat the CMOS module and MIC in the correct position on the LCD cover assembly.
3. Fix the CMOS cable and MIC cable with tapes.

4.24 Left USB Board

Removing the USB Board on the Left Side

Remove the left USB board according to the following procedures and Figure 4.68.

1. Remove the USB board from the left side of the logic lower assembly using one M2.5x4 screw.

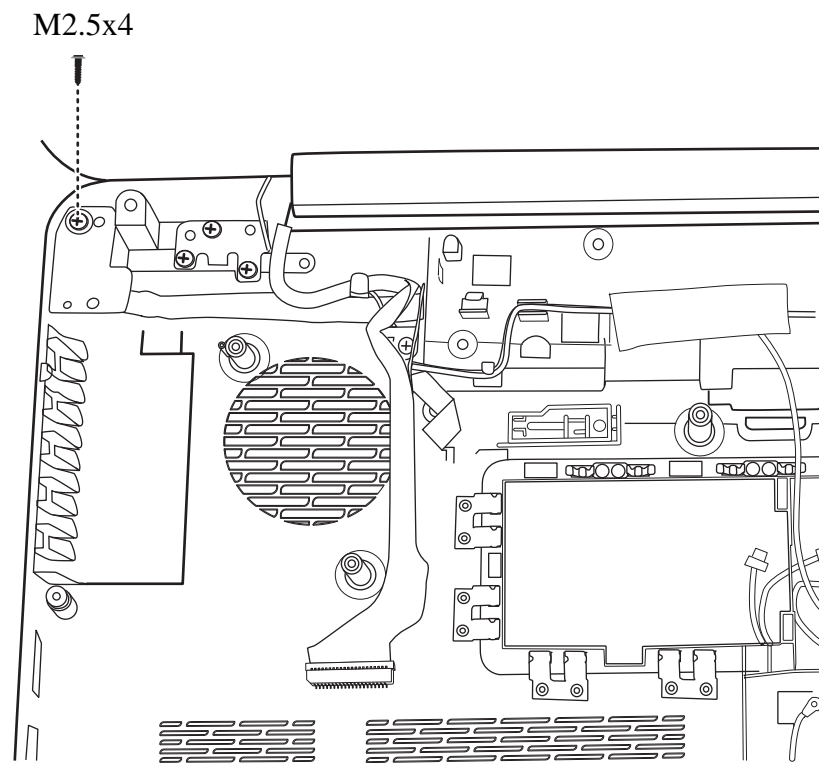

Figure 4.68 Removing the left USB Board from the logic lower assembly

Installing the Left USB Board

Install the left USB board according to the following procedures.

1. Seat the USB board in the correct position on the left side of the logic lower assembly.
2. Secure the USB board to the logic lower assembly with one M2.5x4 screw.

4.25 Right USB Board

Removing the Right USB Board on the Right Side

Remove the Right USB board according to the following procedures and Figure 4.69.

1. Wrap a flat blade screwdriver with three layers of tape.

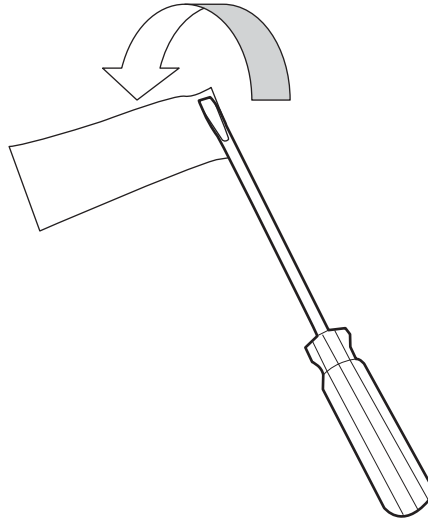

Figure 4.69 Wrap the flat blade screwdriver with tape

2. Disconnect the FFC cable from the motherboard.

3. Tear the FFC cable up from the logic lower assembly.

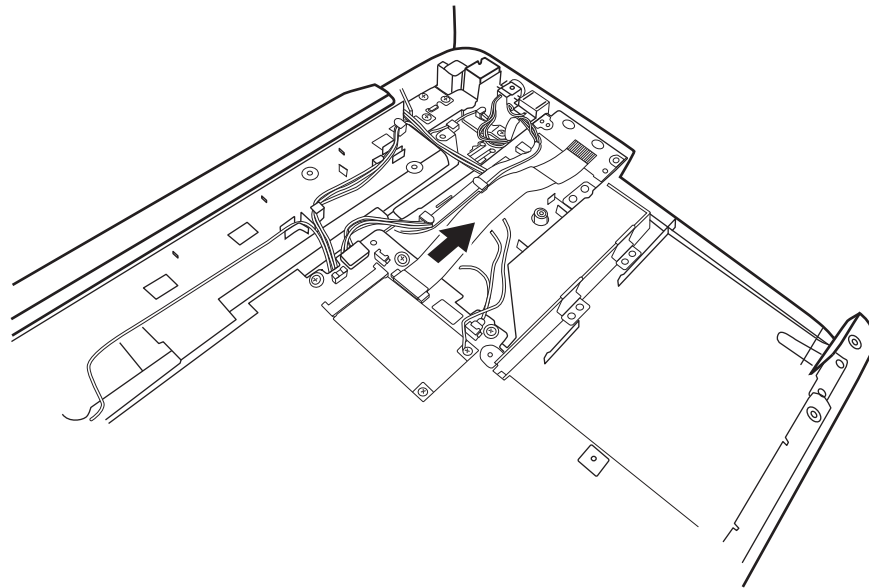

Figure 4.70 Wrap the flat blade screwdriver with tape

4. Pry up the right USB Board from the right side with a flat blade screwdriver wrapped with three layers of tape. Be careful not to scratch the FFC cable.

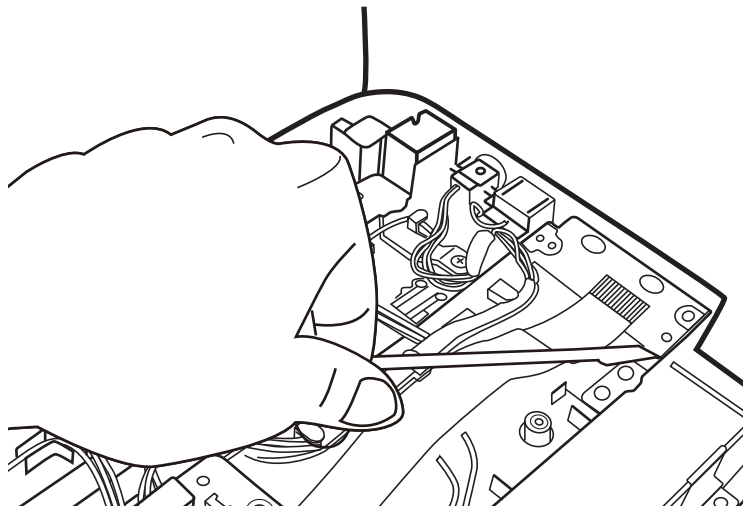

Figure 4.71 Removing the USB Board on the right side

Installing the Right USB Board

Install the Right USB board according to the following procedures.

1. Seat the USB board in the correct position on the right side of the logic lower assembly.
2. Secure the USB board to the logic lower assembly with one M2.5x4 screw.
3. Secure the USB board to the logic lower assembly with one M2.5x4 screw and connect the FFC cable to the Motherboard.

Appendix A Handling the LCD Module

Precautions for handling the LCD module

The LCD module can be easily damaged during assembly or disassembly. Observe the following precautions when handling it to prevent damaging it.

1. When installing the LCD module in the display assembly, make sure that you seat it so that it is properly aligned and maximum visibility of the display is maintained.

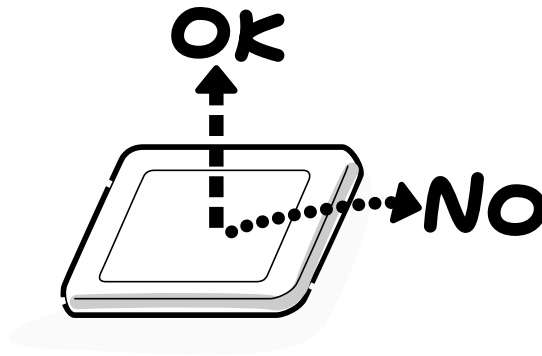

2. Be careful to align the holes at the four corners of the LCD module with the corresponding holes in the LCD cover before securing the module with screws. Do not force the module into place, because stress can affect its performance.

Note: The panel's polarized surface is easily scratched and damaged, so handle it carefully.



3. If the panel's surface gets dirty or moist, wipe it with cotton or a soft cloth. If it is still dirty, try breathing on the surface to create a light condensate and wipe it again.

If the surface is very dirty, we recommend a CRT cleaning agent. Apply the agent to a soft cloth and then wipe the panel's surface. Do not apply cleanser directly to the panel.



4. If water or other liquid is left on the panel's surface for a long period, it can change the screen's tint or stain it. Be sure to quickly wipe off any liquid.



5. Glass is used in the panel, so be careful not to drop it or let it strike a hard object, which could cause breakage or cracks.

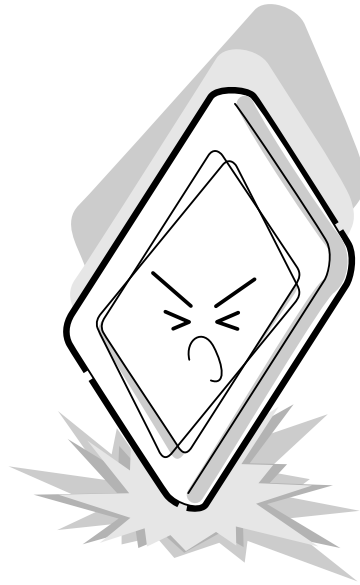

6. CMOS-LSI circuits are used in the module, so guard against damage from electrostatic discharge. Be sure to wear a wrist or ankle grounding device when handling the module.

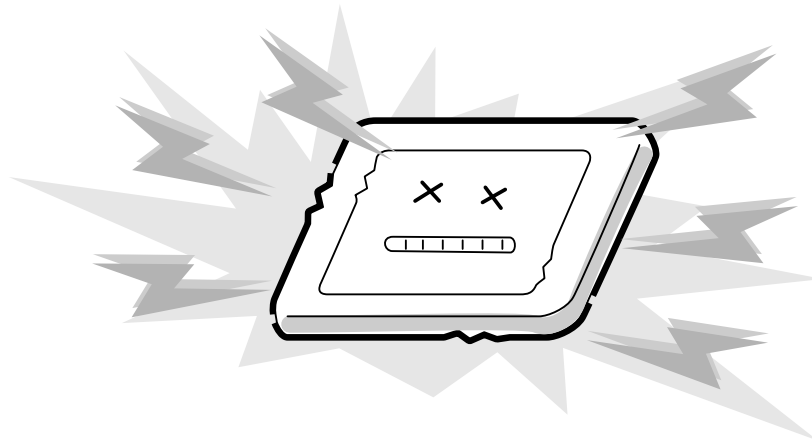

7. Do not expose the module to direct sunlight or strong ultraviolet rays for long periods.

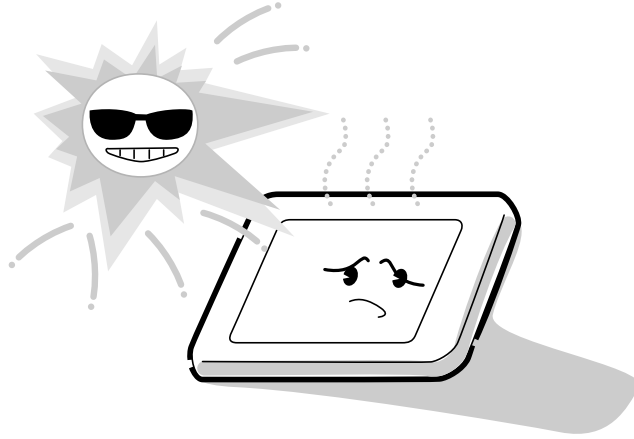

8. Do not store the module at temperatures below its specifications. Cold can cause the liquid crystals to freeze, lose their elasticity or otherwise suffer damage.

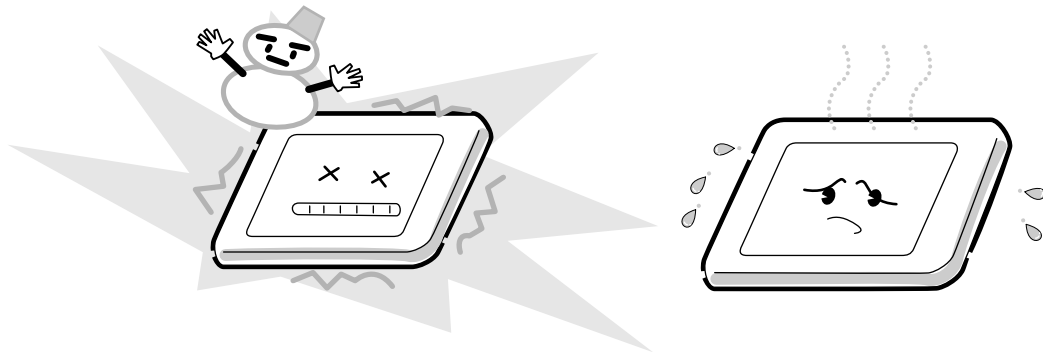

9. Do not disassemble the LCD module. Disassembly can cause malfunctions.

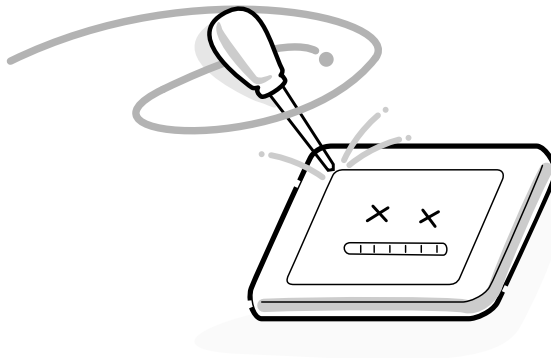

10. If you transport the module, do not use packing material that contains epoxy resin (amine) or silicon glue (alcohol or oxime). These materials can release gas that can damage the panel's polarization.

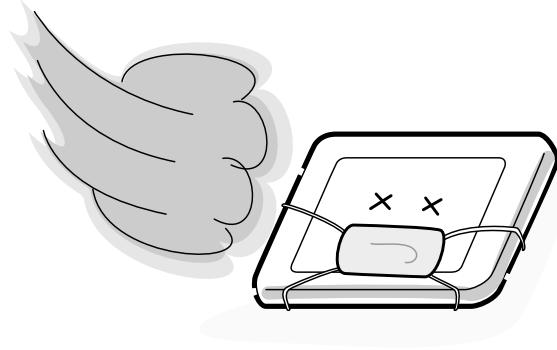

Appendix B Board Layout

B.1 System Board Top View

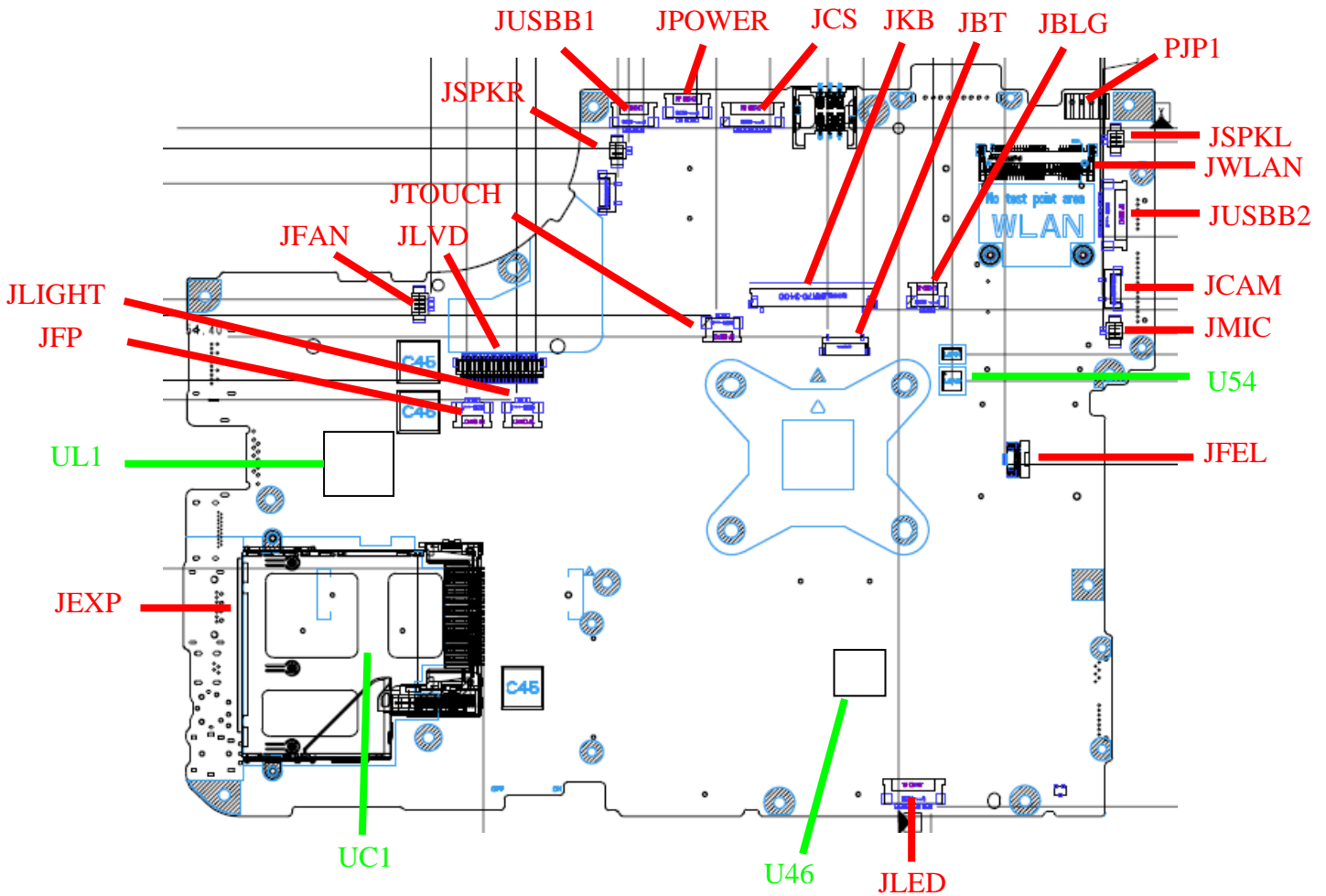

Figure B-1 System Board Layout (Top)

B.2 System Board Bottom View

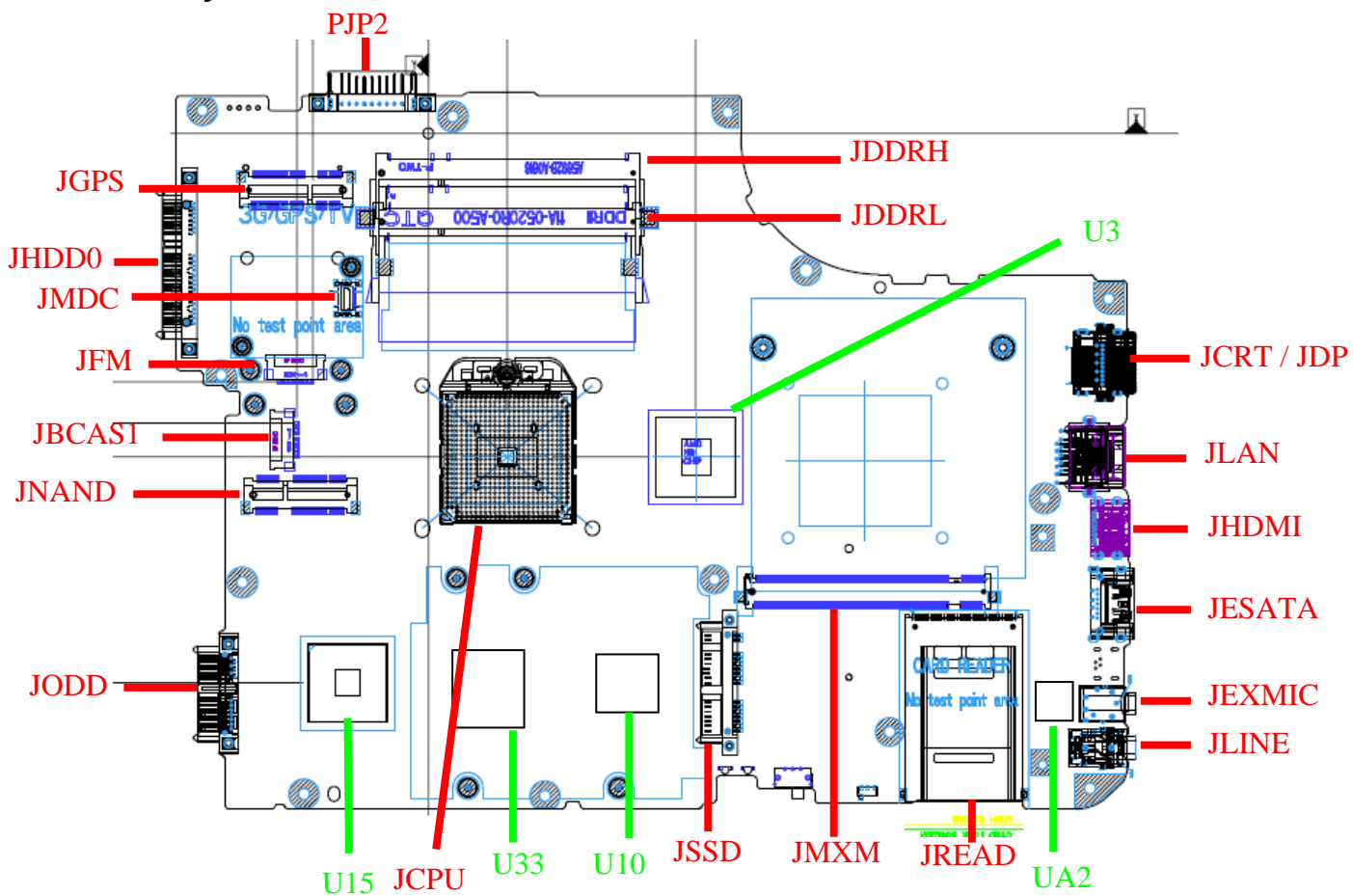

Figure B-2 System Board Layout (Bottom)

Table B-1 System Board ICs (top and bottom)

Number	Name
U3	North bridge AMD RS780/RX781
U10	Clock Generator SLG8SP626VTR
U15	South bridge AMD SB700
U33	KB926QFD3(EC)
U46	BIOS ROM
UA2	ALC272-GR
UC1	JMB385(CARD READ)
UL1	RTL8111DL
U54	G-sensor

Table B-2 System Board Connectors (top and bottom)

Number	Name
JCPU	CPU Socket
JFAN	Fan conn.
JDDRH, JDDRL	DDRII conn.
JCRT	CRT conn.
JBCAS1	B-CAS conn
JBLG	KEYBOARD Back Light conn
JREAD	5 in 1 Card Reader conn.
JMIC	Microphone conn.
JSPKR, JSPKL	Speaker conn.
JEXP	Express Card conn.
JWLAN	WLAN conn.
JDP	Display port conn
JHDD0	1 ST SATA HDD conn.
JODD	ODD conn.
JCAM	Camera conn.
JBT	Bluetooth conn.
JFEL	Felica conn
JFP	Fingerprint/B conn.
JKB	Keyboard conn.
JTOUCH	TP/B conn.
JPOWER	Power/B conn.

JLED	LED/B conn.
JCS	CapSensor/B conn.
JFM	FMTuner/B conn.
JESATA	eSATA conn.
JHDMI	HDMI conn
JLAN	LAN conn.
JLINE	Headphones conn.
JEXMIC	External MIC conn.
JLIGHT	Light Pipe conn
JLVDS	LVDS conn.
JLINE	HeadPhone/LINE Out JACK conn
JGPS	GPS conn.
JMDC	MDC conn
JMXM	MXM conn
JNAND	WUSB or Upconvert conn
JSSD	SSD conn
JUSBB1	LEFT USB
JUSBB2	Right USB
PJP1	AC Adaptor conn.
PJP2	Battery conn.

Appendix C Pin Assignments

System Board

C.1 JFAN

Table C-1 FAN I/F pin assignments (3-pin)

Pin No.	Signal name	I/O	Pin No.	Signal Name	I/O
1	+FAN1		2	FAN_SPEED1	
3	GND				

C.2 JFM

Table C-2 FM I/F pin assignments (10-pin)

Pin No.	Signal name	I/O	Pin No.	Signal Name	I/O
1	+3VS		2	+3VS	
3	FM_I2CCLK		4	FM_I2CDAT	
5	FM_I2C_INT#		6	FM_OUTR	
7	FM_OUTL		8	GND	
9	GND		10	GND	

C.3 JLVDS

Table C-3 LVDS I/F pin assignments (40-pin)

Pin No.	Signal name	I/O	Pin No.	Signal Name	I/O
1	GND		2	+5V_LVDS_CAM	
3	LCD_TXCLK+	O	4	USB20_P9_LVDS	O
5	LCD_TXCLK-	O	6	USB20_N9_LVDS	O
7	GND		8	GND	
9	DAC_BRIG	O	10	INT_MIC	O
11	INVT_PWM	O	12	LCD_TXOUT0+	O
13	GND		14	LCD_TXOUT0-	O
15	LCD_TZCLK+	O	16	LCD_TXOUT1+	O

17	LCD_TZCLK-	O	18	LCD_TXOUT1-	O
19	GND		20	LCD_TXOUT2+	O
21	LCD_EDID_CLK	O	22	LCD_TXOUT2-	O
23	LCD_EDID_DATA	O	24	GND	O
25	+LCDVDD_R		26	LCD_TZOUT0+	O
27	+LCDVDD_R		28	LCD_TZOUT0-	O
29	+3VS		30	LCD_TZOUT1+	O
31	NA		32	LCD_TZOUT1-	O
33	+LCD_INV		34	LCD_TZOUT2+	O
35	+LCD_INV		36	LCD_TZOUT2-	O
37	+LCD_INV		38	GND	
39	+LCD_INV		40	BKOFF#	O

C.4 JCRT

Table C-4 CRT pin assignments (15-pin)

Pin No.	Signal name	I/O	Pin No.	Signal Name	I/O
1	RED_L	O	2	GREEN_L	O
3	BLUE_L	O	4	GND	
5	GND		6	GND	
7	GND		8	GND	
9	+CRT_VCC		10	GND	
11	NC		12	D_DDCCDATA	O
13	HSYNC		14	VSYNC	O
15	D_DDCCCLK	O			

C.5 JHDMI

Table C-5 HDMI I/F pin assignments (19-pin)

Pin No.	Signal name	I/O	Pin No.	Signal Name	I/O
1	HDMI_R_D2+	O	2	GND	
3	HDMI_R_D2-	O	4	HDMI_R_D1+	O
5	GND		6	HDMI_R_D1-	O
7	HDMI_R_D0+	O	8	GND	
9	HDMI_R_D0-	O	10	HDMI_R_CK+	O

11	GND		12	HDMI_R_CK-	O
13	HDMI_CEC	O	14	NC	
15	HDMI_SCLK	O	16	HDMI_SDATA	O
17	GND		18	+HDMI_5V_OUT	O
19	HDMI_HPD	O			

C.6 JHDD0

Table C-6 1st HDD I/F pin assignments (22-pin)

Pin No.	Signal name	I/O	Pin No.	Signal Name	I/O
1	GND		2	SATA_C_TX1+	
3	SATA_C_TX1-		4	GND	
5	SATA_C_RX1-		6	SATA_C_RX1+	
7	GND		8	+3VS	
9	+3VS		10	+3VS	
11	GND		12	GND	
13	GND		14	+5VS	
15	+5VS		16	+5VS	
17	GND		18	NC	
19	GND		20	NC	
21	NC		22	NC	

C.7 JODD

Table C-7 SATA ODD I/F pin assignments (13-pin)

Pin No.	Signal name	I/O	Pin No.	Signal Name	I/O
1	GND		2	SATA_C_TX3+	
3	SATA_C_TX3-		4	GND	
5	SATA_C_RX3-		6	SATA_C_RX3+	
7	GND		8	NC	
9	+5VS		10	+5VS	
11	NC		12	GND	
13	GND				

C.8 JESATA

Table C-8 1st eSATA/USB I/F pin assignments (11-pin)

Pin No.	Signal name	I/O	Pin No.	Signal Name	I/O
1	+USB_VCCB		2	USB20_N2_R_S	
3	USB20_P2_R_S		4	GND	
5	GND		6	SATA_C_TX2+	
7	SATA_C_TX2-		8	GND	
9	SATA_C_RX2-		10	SATA_C_RX2+	
11	GND				

C.9 JBT

Table C-9 Bluetooth Connector pin assignments (10-pin)

Pin No.	Signal name		Pin No.	Signal Name	I/O
1	GND		2	+3VS	
3	+BT_VCC		4	WLAN_BT_DATA	
5	BT_RST#		6	BT_DET#	
7	WLAN_BT_CLK		8	USB20_N6	
9	USB20_P6		10	GND	

C.10 JFP

Table C-10 Finger Printer Connector pin assignments (4-pin)

Pin No.	Signal name	I/O	Pin No.	Signal Name	I/O
1	+3VS_FP	-	2	USB20_N7	I/O
3	USB20_P7	I/O	4	GND	

C.11 JCAM

Table C-11 Internal Camera Connector pin assignments (5-pin)

Pin No.	Signal name	I/O	Pin No.	Signal Name	I/O
1	+CAM_VDD		2	USB20_N9_R	I/O
3	USB20_P9_R	I/O	4	GND	
5	GND				

C.12 JWLAN

Table C-12 Wi-Fi/WiMax Connector pin assignments (52-pin)

Pin No.	Signal name	I/O	Pin No.	Signal Name	I/O
1	NC		2	+3VS	
3	WLAN_BT_DATA		4	GND	
5	WLAN_BT_CLK		6	+1.5VS	
7	CLKREQ_MCARD2#		8	NC	
9	GND		10	NC	
11	CLK_PCIE_MCARD2#		12	NC	
13	CLK_PCIE_MCARD2		14	NC	
15	GND		16	NC	
17	NC		18	GND	
19	NC		20	XMIT_OFF#	
21	GND		22	PLT_RST#	
23	PCIE_PTX_C_IRX_N2		24	+3VS	
25	PCIE_PTX_C_IRX_P2		26	GND	
27	GND		28	+1.5VS	
29	GND		30	SMB_CK_CLK1	
31	PCIE_ITX_C_PRX_N2		32	SMB_CK_DAT1	
33	PCIE_ITX_C_PRX_P2		34	GND	
35	GND		36	USB20_N8	
37	GND		38	USB20_P8	
39	+3VS		40	GND	
41	+3VS		42	LED_WIMAX#	
43	GND		44	NC	
45	NC		46	NC	
47	NC		48	+1.5VS	
49	E51_TXD		50	GND	
51	E51_RXD		52	+3VS	

C.13 JEXP

Table C-13 New Card Connector pin assignments (26-pin)

Pin No.	Signal name	I/O	Pin No.	Signal Name	I/O
1	GND		2	USB20_N5	
3	USB20_P5		4	CP_USB#	
5	NC		6	NC	
7	SMB_CK_CLK0		8	SMB_CK_DAT0	
9	+1.5VS_CARD		10	+1.5VS_CARD	
11	EC_SWI#_R		12	+3VALW_CARD	
13	PERST#		14	+3VS_CARD	
15	+3VS_CARD		16	CLKREQ#	
17	EXP_CPPE#		18	CLK_PCIE_NCARD#	
19	CLK_PCIE_NCARD		20	GND	
21	PCIE_PTX_C_IRX_N0		22	PCIE_PTX_C_IRX_P0	
23	GND		24	PCIE_ITX_C_PRX_N0	
25	PCIE_ITX_C_PRX_P0		26	GND	

C.14 JLAN

Table C-14 LAN Connector pin assignments (14-pin)

Pin No.	Signal name	I/O	Pin No.	Signal Name	I/O
1	RJ45_MIDI0+	I/O	2	RJ45_MIDI0-	I/O
3	RJ45_MIDI1+	I/O	4	RJ45_MIDI2+	I/O
5	RJ45_MIDI2-	I/O	6	RJ45_MIDI1-	I/O
7	RJ45_MIDI3+	I/O	8	RJ45_MIDI3-	I/O
9	+3V_LAN		10	LAN_SK	
11	+3V_LAN		12	LAN_ACTIVITY#	
13	LANGND		14	LANGND	

C.15 JLED

Table C-15 LED/B Connector pin assignments (12-pin)

Pin No.	Signal name	I/O	Pin No.	Signal Name	I/O
---------	-------------	-----	---------	-------------	-----

1	+5VALW		2	+5VS
3	DC_IN		4	POWER_LED
5	SUSPEND_LED		6	HDD_LED
7	CR_LEDCON		8	BATT_FULL_LED#
9	BATT_LOW_LED#		10	GND
11	GND		12	GND

C.16 JGPS

Table C-16 GPS Connector pin assignments (52-pin)

Pin No.	Signal name	I/O	Pin No.	Signal Name	I/O
1	NC		2	+3VS	
3	XBCLKM		4	GND	
5	BCCDET		6	+1.5VS	
7	CLKREQ_MCARD1#		8	+UIM_PWR	
9	GND		10	UIM_DATA	
11	CLK_PCIE_MCARD1#		12	UIM_CLK	
13	CLK_PCIE_MCARD1		14	UIM_RESET	
15	GND		16	COMMON	
17	BCRSTM		18	TV_DET	
19	BCPWON		20	3G_OFF#	
21	GND		22	PLT_RST#	
23	PCIE_PTX_C_IRX_N5		24	+3VS	
25	PCIE_PTX_C_IRX_P5		26	GND	
27	GND		28	+1.5VS	
29	GND		30	USB20_P11	
31	PCIE_ITX_C_PRX_N5		32	USB20_N11	
33	PCIE_ITX_C_PRX_P5		34	GND	
35	GND		36	USB20_N10	
37	GND		38	USB20_P10	
39	+3VS		40	GND	
41	+3VS		42	LED_WIMAX#	
43	GND		44	CPLGP1	
45	NC		46	TV_THER1	
47	TV_THER2		48	+1.5VS	
49	NC		50	GND	

C.17 JDDR1, JPDDRH

Table C-17 SODIMM I/F pin assignments (200-PIN) (1/4)

Pin No.	Signal name	I/O	Pin No.	Signal Name	I/O
1	VREF	O	2	VSS	O
3	VSS	O	4	DQ4	I/O
5	DQ0	I/O	6	DQ5	I/O
7	DQ1	I/O	8	VSS	O
9	VSS	O	10	DM0	I/O
11	DQS0#	I/O	12	VSS	O
13	DQS0	I/O	14	DQ6	I/O
15	VSS	O	16	DQ7	I/O
17	DQ2	I/O	18	VSS	O
19	DQ3	I/O	20	DQ12	I/O
21	VSS	O	22	DQ13	I/O
23	DQ8	I/O	24	VSS	I/O
25	DQ9	I/O	26	DM1	O
27	VSS	O	28	VSS	O
29	DQS1#	I/O	30	CK0	I/O
31	DQS1	I/O	32	CK0#	I/O

Table C-17 SODIMM I/F pin assignments (200-PIN) (2/4)

Pin No.	Signal name	I/O	Pin No.	Signal Name	I/O
33	VSS	O	34	VSS	O
35	DQ10	I/O	36	DQ14	I/O
37	DQ11	I/O	38	DQ15	I/O
39	VSS	O	40	VSS	O
41	VSS	O	42	VSS	O
43	DQ16	I/O	44	DQ20	I/O
45	DQ17	I/O	46	DQ21	I/O
47	VSS	O	48	VSS	O
49	DQS2#	I/O	50v	NC	-
51	DQS2	I/O	52	DM2	I/O

53	VSS	O	54	VSS	O
55	DQ18	I/O	56	DQ22	I/O
57	DQ19	I/O	58	DQ23	I/O
59	VSS	O	60	VSS	O
61	DQ24	I/O	62	DQ28	I/O
63	DQ25	I/O	64	DQ29	I/O
65	VSS	O	66	VSS	O
67	DM3	I/O	68	DQS3#	I/O
69	NC	-	70	DQS3	I/O
71	VSS	O	72	VSS	O
73	DQ26	I/O	74	DQ30	I/O
75	DQ27	I/O	76	DQ31	I/O
77	VSS	O	78	VSS	O
79	CKE0	I/O	80	NC/CKE1	I/O
81	VDD	O	82	VDD	O
83	NC	-	84	NC/A15	-
85	BA2	I/O	86	NC/A14	-
87	VDD	O	88	VDD	O
89	A12	I/O	90	A11	I/O
91	A9	I/O	92	A7	I/O
93	A8	I/O	94	A6	I/O
95	VDD	O	96	VDD	O

Table C-17 SODIMM I/F pin assignments (200-PIN) (3/4)

Pin No.	Signal name	I/O	Pin No.	Signal Name	I/O
97	A5	I/O	98	A4	I/O
99	A3	I/O	100	A2	I/O
101	A1	I/O	102	A0	I/O
103	VDD	O	104	VDD	O
105	A10/AP	I/O	106	BA1	I/O
107	BAD	I/O	108	RAS#	I/O
109	WE#	I/O	110	S0#	I/O
111	VDD	O	112	VDD	O
113	CAS#	I/O	114	ODT0	I/O
115	NC/S1#	I/O	116	NC/A13	I/O

117	VDD	O	118	VDD	O
119	NC/ODT1	I/O	120	NC	-
121	VSS	O	122	VSS	O
123	DQ32	I/O	124	DQ36	I/O
125	DQ33	I/O	126	DQ37	I/O
127	VSS	O	128	VSS	O
129	DQS4#	I/O	130	DM4	I/O
131	DQS4	I/O	132	VSS	O
133	VSS	O	134	DQ38	I/O
135	DQ34	I/O	136	DQ39	I/O
137	DQ35	I/O	138	VSS	O
139	VSS	O	140	DQ44	I/O
141	DQ40	I/O	142	DQ45	I/O
143	DQ41	I/O	144	VSS	O
145	VSS	O	146	DQS5#	I/O
147	DM5	I/O	148	DQS5	I/O
149	VSS	O	150	VSS	O
151	DQ42	I/O	152	DQ46	I/O
153	DQ43	I/O	154	DQ47	I/O
155	VSS	O	156	VSS	O
157	DQ48	I/O	158	DQ52	I/O
159	DQ49	I/O	160	DQ53	I/O

Table C-17 SODIMM I/F pin assignments (200-PIN) (4/4)

Pin No.	Signal name	I/O	Pin No.	Signal Name	I/O
161	VSS	O	162	VSS	O
163	NC,TEST	I/O	164	CK1	I/O
165	VSS	I/O	166	CK1#	I/O
167	DQS6#	O	168	VSS	O
169	DQS6	I/O	170	DM6	I/O
171	VSS	I/O	172	VSS	I/O
173	DQ50	O	174	DQ54	O
175	DQ51	I/O	176	DQ55	I/O
177	VSS	-	178	VSS	I/O
179	DQ56	O	180	DQ60	O

181	DQ57	I/O	182	DQ61	I/O
183	VSS	I/O	184	VSS	I/O
185	DM7	O	186	DQS7#	O
187	VSS	I/O	188	DQS7	I/O
189	DQ58	O	190	VSS	O
191	DQ59	-	192	DQ62	-
193	VSS	I/O	194	DQ63	-
195	SDA	O	196	VSS	O
197	SCL	I/O	198	SA0	I/O
199	VDDSPD	I/O	200	SA1	I/O

C.18 JMIC

Table C-18 Internal Microphone Connector pin assignments (2-pin)

Pin No.	Signal name	I/O	Pin No.	Signal Name	I/O
1	INT_MIC		2	GND	

C.19 JLINE

Table C-19 HEADPHONE Connector pin assignments (10-pin)

Pin No.	Signal name	I/O	Pin No.	Signal Name	I/O
1	NBA_PLUG		2	HP_R	
3	HP_L		4	GND	
5	NBA_PLUG		6	GND	
7	GND		8	SPDIF_R	
9	+5VS		10	GND	

C.20 JKB

Table C-20 Keyboard Connector pin assignments (34-pin)

Pin No.	Signal name	I/O	Pin No.	Signal Name	I/O
1	NUM_LED#		2	NC	

3	CAPS_LED#		4	+3VS	
5	KSI1		6	KSI6	
7	KSI5		8	KSI0	
9	KSI4		10	KSI3	
11	KSI2		12	KSI7	
13	KSO15		14	KSO12	
15	KSO11		16	KSO10	
17	KSO9		18	KSO8	
19	KSO13		20	KSO7	
21	KSO6		22	KSO14	
23	KSO5		24	KSO3	
25	KSO4		26	KSO0	
27	KSO1		28	KSO2	
29	NC		30	NC	
31	KSO17		32	NC	
33	KSO16		34	+3VS	

C.21 JCS

Table C-21 FUN/B connector pin assignments (10P-pin)

Pin No.	Signal name	I/O	Pin No.	Signal Name	I/O
1	+3VL		2	+5VALW	
3	NC		4	NC	
5	NC		6	CAP_INT#	
7	ESB_DAT		8	ESB_CLK	
9	CAP_RST#		10	GND	

C.22 JPOWER

Table C-22 POWER/B connector pin assignments (6P-pin)

Pin No.	Signal name	I/O	Pin No.	Signal Name	I/O
1	POWER_ON_LED		2	+3VS	
3	ON/OFFBTN#		4	GND	
5	EC_SMB_CK2		6	EC_SMB_DA2	

C.23 JREAD

Table C-23 CARD READER connector pin assignments (40P-pin)

Pin No.	Signal name	I/O	Pin No.	Signal Name	I/O
1	XDCD0#_SDCD#		2	XDWP#_SDWP#	
3	+VCC_OUT		4	XD_SD_D7	
5	XD_SD_D6		6	XD_SD_D5	
7	XD_SD_D4		8	XD_SD_MS_D3	
9	XD_SD_MS_D2		10	XD_SD_MS_D1	
11	GND		12	XD_SD_MS_D1	
13	SDCMD_MSBS_X DWE#		14	XD_SD_MS_D0	
15	XD_SD_MS_D1		16	XD_SD_D7	
17	XD_SD_MS_D0		18	XD_SD_D6	
19	XD_SD_MS_D2		20	SDCLK	
21	+VCC_OUT		22	XDCD1#_MSCD#	
23	XD_SD_D5		24	XD_SD_MS_D3	
25	SDCMD_MSBS_X DWE#		26	MSCLK	
27	XD_SD_D4		28	+VCC_OUT	
29	XD_SD_MS_D3		30	XD_SD_MS_D2	
31	GND		32	XD_SD_MS_D0	
33	XDWP#_SDWP#		34	SDCMD_MSBS_X DWE#	
35	XD_ALE		36	XD_CLE	
37	XDCE#		38	XD_RE#	
39	XD_RB#		40	XD_CD#	

C.24 JEXMIC

Table C-24 EXMIC connector pin assignments (5P-pin)

Pin No.	Signal name	I/O	Pin No.	Signal Name	I/O
1	GND		2	MIC1_L	
3	MIC1_R		4	MIC_SENSE	

5	GND				
---	-----	--	--	--	--

C.25 JSPKL

Table C-25 SPKL connector pin assignments (4P-pin)

Pin No.	Signal name	I/O	Pin No.	Signal Name	I/O
1	SPK_L1		2	SPK_L2	
3	NC		4	NC	

C.26 JSPKR

Table C-26 SPKR connector pin assignments (4P-pin)

Pin No.	Signal name	I/O	Pin No.	Signal Name	I/O
1	SPK_R1		2	SPK_R2	
3	NC		4	NC	

C.27 JTOUCH

Table C-27 T/P connector pin assignments (4P-pin)

Pin No.	Signal name	I/O	Pin No.	Signal Name	I/O
1	+5VS		2	TP_CLK	
3	TP_DATA		4	GND	

C.28 JBCAS1

Table C-28 B-CAS connector pin assignments (10P-pin)

Pin No.	Signal name	I/O	Pin No.	Signal Name	I/O
1	NC		2	BCIO	
3	NC		4	GND	
5	GND		6	BCCDET	
7	+5VS_BCAS		8	B_BCRST	
9	B_XBCCLK		10	NC	

C.29 JBLG

Table C-29 KEYBOARD BACKLIGHT connector pin assignments (4P-pin)

Pin No.	Signal name	I/O	Pin No.	Signal Name	I/O
1	+5VS_LED		2	NC	
3	NC		4	GND	

C.30 JDP

Table C-30 Display Port connector pin assignments (20P-pin)

Pin No.	Signal name	I/O	Pin No.	Signal Name	I/O
1	DP_R_TXD0+		2	GND	
3	DP_R_TXD0-		4	DP_R_TXD1+	
5	GND		6	DP_R_TXD1-	
7	DP_R_TXD2+		8	GND	
9	DP_R_TXD2-		10	DP_R_TXD3+	
11	GND		12	DP_R_TXD3-	
13	CAP_DET		14	GND	
15	DP_C_AUXP		16	GND	
17	DP_C_AUXN		18	DP_HPD	
19	GND		20	+3VS_DP	

C.31 JFEL

Table C-31 Felica connector pin assignments (6P-pin)

Pin No.	Signal name	I/O	Pin No.	Signal Name	I/O
1	+FLICA_VCC		2	USB20_N3	
3	USB20_P3		4	GND	
5	NC		6	NC	

C.32 JLIGHT

Table C-32 Light Pipeconnector pin assignments (4P-pin)

Pin No.	Signal name	I/O	Pin No.	Signal Name	I/O
1	+5VS		2	L_LED#	
3	KSI6		4	KSO0	
5	GND		6	GND	

C.33 JMDC

Table C-33 MDC pin assignments (12P-pin)

Pin No.	Signal name	I/O	Pin No.	Signal Name	I/O
1	GND		2	+3VALW	
3	HDA_SDOUT_MDC		4	NC	
5	GND		6	+3VALW	
7	HDA_SYNC_MDC		8	GND	
9	HDA_SDIN1		10	GND	
11	HDA_RST#_MDC		12	HDA_BITCLK_MDC	

C.34 JMXM

Table C-34 MXM pin assignments (230-PIN)

Pin No.	Signal name	I/O	Pin No.	Signal Name	I/O
1	+MXM_B+		2	+1.8VS_MXM	
3	+MXM_B+		4	+1.8VS_MXM	
5	+MXM_B+		6	+1.8VS_MXM	
7	+MXM_B+		8	+1.8VS_MXM	
9	+MXM_B+		10	+1.8VS_MXM	
11	+MXM_B+		12	+1.8VS_MXM	

13	+MXM_B+		14	+1.8VS_MXM	
15	+MXM_B+		16	RUNPWROK	
17	GND		18	+5VALW_MXM	
19	GND		20	GND	
21	GND		22	GND	
23	GND		24	GND	
25	PCIE_GTX_C_MRX_N15		26	GND	
27	PCIE_GTX_C_MRX_P15		28	PCIE_MTX_C_GRX_N15	
29	GND		30	PCIE_MTX_C_GRX_P15	
31	PCIE_GTX_C_MRX_N14		32	GND	
33	PCIE_GTX_C_MRX_P14		34	PCIE_MTX_C_GRX_N14	
35	GND		36	PCIE_MTX_C_GRX_P14	
37	PCIE_GTX_C_MRX_N13		38	GND	
39	PCIE_GTX_C_MRX_P13		40	PCIE_MTX_C_GRX_N13	
41	GND		42	PCIE_MTX_C_GRX_P13	
43	PCIE_GTX_C_MRX_N12		44	GND	
45	PCIE_GTX_C_MRX_P12		46	PCIE_MTX_C_GRX_N12	
47	GND		48	PCIE_MTX_C_GRX_P12	
49	PCIE_GTX_C_MRX_N11		50	GND	
51	PCIE_GTX_C_MRX_P11		52	PCIE_MTX_C_GRX_N11	
53	GND		54	PCIE_MTX_C_GRX_P11	
55	PCIE_GTX_C_MRX_N10		56	GND	
57	PCIE_GTX_C_MRX_P10		58	PCIE_MTX_C_GRX_N10	
59	GND		60	PCIE_MTX_C_GRX_P10	
61	PCIE_GTX_C_MRX_N9		62	GND	
63	PCIE_GTX_C_MRX_P9		64	PCIE_MTX_C_GRX_N9	
65	GND		66	PCIE_MTX_C_GRX_P9	
67	PCIE_GTX_C_MRX_N8		68	GND	
69	PCIE_GTX_C_MRX_P8		70	PCIE_MTX_C_GRX_N8	
71	GND		72	PCIE_MTX_C_GRX_P8	
73	PCIE_GTX_C_MRX_N7		74	GND	
75	PCIE_GTX_C_MRX_P7		76	PCIE_MTX_C_GRX_N7	
77	GND		78	PCIE_MTX_C_GRX_P7	
79	PCIE_GTX_C_MRX_N6		80	GND	
81	PCIE_GTX_C_MRX_P6		82	PCIE_MTX_C_GRX_N6	

83	GND		84	PCIE_MTX_C_GRX_P6	
85	PCIE_GTX_C_MRX_N5		86	GND	
87	PCIE_GTX_C_MRX_P5		88	PCIE_MTX_C_GRX_N5	
89	GND		90	PCIE_MTX_C_GRX_P5	
91	PCIE_GTX_C_MRX_N4		92	GND	
93	PCIE_GTX_C_MRX_P4		94	PCIE_MTX_C_GRX_N4	
95	GND		96	PCIE_MTX_C_GRX_P4	
97	PCIE_GTX_C_MRX_N3		98	GND	
99	PCIE_GTX_C_MRX_P3		100	PCIE_MTX_C_GRX_N3	
101	GND		102	PCIE_MTX_C_GRX_P3	
103	PCIE_GTX_C_MRX_N2		104	GND	
105	PCIE_GTX_C_MRX_P2		106	PCIE_MTX_C_GRX_N2	
107	GND		108	PCIE_MTX_C_GRX_P2	
109	PCIE_GTX_C_MRX_N1		110	GND	
111	PCIE_GTX_C_MRX_P1		112	PCIE_MTX_C_GRX_N1	
113	GND		114	PCIE_MTX_C_GRX_P1	
115	PCIE_GTX_C_MRX_N0		116	GND	
117	PCIE_GTX_C_MRX_P0		118	PCIE_MTX_C_GRX_N0	
119	GND		120	PCIE_MTX_C_GRX_P0	
121	CLK_PCIE_VGA#		122	NC	
123	CLK_PCIE_VGA		124	NC	
125	NC		126	GND	
127	PLT_RST#		128	NC	
129	NC		130	GND	
131	NC		132	NC	
133	EC_SMB_DA2		134	NC	
135	EC_SMB_CK2		136	VGA_CRT_R	
137	NC		138	GND	
139	VGA_CRT_HSYNC		140	VGA_CRT_G	
141	VGA_CRT_VSYNC		142	GND	
143	VGA_CRT_CLK		144	VGA_CRT_B	
145	VGA_CRT_DATA		146	GND	
147	NC		148	VGA_LCD_TZCLK-	
149	NC		150	VGA_LCD_TZCLK+	

151	GND		152	GND	
153	NC		154	NC	
155	NC		156	NC	
157	NC		158	VGA_SPDIF	
159	VGA_AUXN		160	VGA_LCD_TZOUT2-	
161	VGA_AUXP		162	VGA_LCD_TZOUT2+	
163	GND		164	GND	
165	NC		166	VGA_LCD_TZOUT1-	
167	NC		168	VGA_LCD_TZOUT1+	
169	GND		170	GND	
171	NC		172	VGA_LCD_TZOUT0-	
173	NC		174	VGA_LCD_TZOUT0+	
175	GND		176	GND	
177	VGA_DP3-		178	VGA_LCD_TXCLK-	
179	VGA_DP3+		180	VGA_LCD_TXCLK+	
181	DP_HPD		182	GND	
183	NC		184	NC	
185	NC		186	NC	
187	GND		188	GND	
189	VGA_DP0-		190	VGA_LCD_TXOUT2-	
191	VGA_DP0+		192	VGA_LCD_TXOUT2+	
193	GND		194	GND	
195	VGA_DP1-		196	VGA_LCD_TXOUT1-	
197	VGA_DP1+		198	VGA_LCD_TXOUT1+	
199	GND		200	GND	
201	VGA_DP2-		202	VGA_LCD_TXOUT0-	
203	VGA_DP2+		204	VGA_LCD_TXOUT0+	
205	HPD		206	GND	
207	VGA_HDMI_CLK-		208	VGA_LCD_EDID_DATA	
209	VGA_HDMI_CLK+		210	VGA_LCD_EDID_CLK	
211	GND		212	VGA_ENVDD	
213	VGA_HDMI_TXD2-		214	NC	
215	VGA_HDMI_TXD2+		216	VGA_ENBKL	
217	GND		218	VGA_HDMI_DATA	

219	VGA_HDMI_TXD1-		220	VGA_HDMI_CLK	
221	VGA_HDMI_TXD1+		222	NC	
223	GND		224	GND	
225	VGA_HDMI_TXD0-		226	+3VS_MXM	
227	VGA_HDMI_TXD0+		228	+3VS_MXM	
229	GND		230	+3VS_MXM	

C.35 JNAND

Table C-35 NAND pin assignments (52-PIN)

Pin No.	Signal name	I/O	Pin No.	Signal Name	I/O
1	NC		2	+3VS	
3	NC		4	GND	
5	NC		6	+1.5VS	
7	NC		8	NC	
9	GND		10	NC	
11	CLK_PCIE_MCARD3#		12	NC	
13	CLK_PCIE_MCARD3		14	NC	
15	GND		16	NC	
17	NC		18	GND	
19	NC		20	UWB_OFF#	
21	GND		22	PLT_RST#	
23	PCIE_PTX_C_IRX_N4		24	+3VS	
25	PCIE_PTX_C_IRX_P4		26	GND	
27	GND		28	+1.5VS	
29	GND		30	NC	
31	PCIE_ITX_C_PRX_N4		32	NC	
33	PCIE_ITX_C_PRX_P4		34	GND	
35	GND		36	NC	
37	GND		38	NC	
39	+3VS		40	GND	
41	+3VS		42	NC	
43	GND		44	NC	
45	NC		46	NC	
47	NC		48	+1.5VS	

49	NC		50	GND	
51	NC		52	+3VS	

C.36 JSSD

Table C-36 SSD pin assignments (16-PIN)

Pin No.	Signal name	I/O	Pin No.	Signal Name	I/O
1	GND		2	SATA_C_TX0+	
3	SATA_C_TX0-		4	GND	
5	SATA_C_RX0-		6	SATA_C_RX0+	
7	GND		8	+3VS	
9	+3VS		10	GND	
11	GND		12	NC	
13	NC		14	NC	
15	NC		16	NC	

C.37 JUSBB1

Table C-37 USB LEFT pin assignments (6-PIN)

Pin No.	Signal name	I/O	Pin No.	Signal Name	I/O
1	+USB_VCCC		2	+USB_VCCC	
3	USB20_N4_R		4	USB20_P4_R	
5	GND		6	GND	

C.38 JUSBB2

Table C-38 USB RIGHT pin assignments (12-PIN)

Pin No.	Signal name	I/O	Pin No.	Signal Name	I/O
1	+USB_VCCA		2	+USB_VCCA	
3	+USB_VCCA		4	+USB_VCCA	
5	NC		6	GND	
7	USB20_N0_R		8	USB20_P0_R	
9	GND		10	USB20_N1_R	

11	USB20_P1_R	12	GND
----	------------	----	-----

Appendix D Keyboard Scan/Character Codes

Table D-1 Scan codes (set 1 and set 2) (1/4)

Cap No.	Keytop	Code set 1		Code set 2		Note	
		Make	Break	Make	Break		
01	' ~	29	A9	0E	F0	0E	
02	1 !	02	82	16	F0	16	
03	2 @	03	83	1E	F0	1E	
04	3 #	04	84	26	F0	26	
05	4 \$	05	85	25	F0	25	
06	5 %	06	86	2E	F0	2E	
07	6 ^	07	87	36	F0	36	
08	7 &	08	88	3D	F0	3D	*2
09	8 *	09	89	3E	F0	3E	*2
10	9 (0A	8A	46	F0	46	*2
11	0)	0B	8B	45	F0	45	
12	- _	0C	8C	4E	F0	4E	
13	= +	0D	8D	55	F0	55	
15	BkSp	0E	8E	66	F0	66	
16	Tab	0F	8F	0D	F0	0D	
17	Q	10	90	15	F0	15	
18	W	11	91	1D	F0	1D	
19	E	12	92	24	F0	24	
20	R	13	93	2D	F0	2D	
21	T	14	94	2C	F0	2C	
22	Y	15	95	35	F0	35	
23	U	16	96	3C	F0	3C	*2
24	I	17	97	43	F0	43	*2
25	O	18	98	44	F0	44	*2
26	P	19	99	4D	F0	4D	*2
27	[{	1A	9A	54	F0	54	
28] }	1B	9B	5B	F0	5B	

Table D-1 Scan codes (set 1 and set 2) (2/4)

Cap No.	Keypop	Code set 1		Code set 2			Note
		Make	Break	Make	Break		
29	\	2B	AB	5D	F0	5D	*5
30	Caps Lock	3A	BA	58	F0	58	
31	A	1E	9E	1C	F0	1C	
32	S	1F	9F	1B	F0	1B	
33	D	20	A0	23	F0	23	
34	F	21	A1	2B	F0	2B	
35	G	22	A2	34	F0	34	
36	H	23	A3	33	F0	33	
37	J	24	A4	3B	F0	3B	*2
38	K	25	A5	42	F0	42	*2
39	L	26	A6	4B	F0	4B	*2
40	; :	27	A7	4C	F0	4C	*2
41	' "	28	A8	52	F0	52	
43	Enter	1C	9C	5A	F0	5A	*3
44	Shift (L)	2A	AA	12	F0	12	
45	No.102 key	56	D6	61	F0	61	
46	Z	2C	AC	1A	F0	1A	
47	X	2D	AD	22	F0	22	
48	C	2E	AE	21	F0	21	
49	V	2F	AF	2A	F0	2A	
50	B	30	B0	32	F0	32	
51	N	31	B1	31	F0	31	
52	M	32	B2	3A	F0	3A	*2
53	, <	33	B3	41	F0	41	*2
54	. >	34	B4	49	F0	49	*2
55	/ ?	35	B5	4A	F0	4A	*2
57	Shift (R)	36	B6	59	F0	59	

Table D-1 Scan codes (set 1 and set 2) (3/4)

Cap No.	Keytop	Code set 1		Code set 2			Note
		Make	Break	Make	Break		
58	Ctrl(L)	1D	9D	14	F0	14	*3
60	Alt (L)	38	B8	11	F0	11	*3
61	Space	39	B9	29	F0	29	
62	ALT (R)	E0 38	E0 B8	E0 11	E0 F0	11	
64	Ctrl(R)	E0 1D	E0 9D	E0 14	E0 F0	14	
75	Ins	E0 52	E0 D2	E0 70	E0 F0	70	*1
76	Del	E0 53	E0 D3	E0 71	E0 F0	71	*1
79	←	E0 4B	E0 CB	E0 6B	E0 F0	6B	*1
80	Home	E0 47	E0 C7	E0 6C	E0 F0	6C	*1
81	End	E0 4F	E0 CF	E0 69	E0 F0	69	*1
83	↑	E0 48	E0 C8	E0 75	E0 F0	75	*1
84	↓	E0 50	E0 D0	E0 72	E0 F0	72	*1
85	PgUp	E0 49	E0 C9	E0 7D	E0 F0	7D	*1
86	PgDn	E0 51	E0 D1	E0 7A	E0 F0	7A	*1
89	→	E0 4D	E0 CD	E0 74	E0 F0	74	*1
110	Esc	01	81	76	F0	76	
112	F1	3B	BB	05	F0	05	
113	F2	3C	BC	06	F0	06	
114	F3	3D	BD	04	F0	04	
115	F4	3E	BE	0C	F0	0C	
116	F5	3F	BF	03	F0	03	
117	F6	40	C0	0B	F0	0B	
118	F7	41	C1	83	F0	83	
119	F8	42	C2	0A	F0	0A	
120	F9	43	C3	01	F0	01	
121	F10	44	C4	09	F0	09	*3

Table D-1 Scan codes (set 1 and set 2) (4/4)

Cap No.	Keytop	Code set 1				Code set 2				Note
		Make		Break		Make		Break		
122	F11	57		D7		78		F0 78		*3
123	F12	58		D8		07		F0 07		*3
124	PrintSc	*6		*6		*6		*6		*6
126	Pause	*7		*7		*7		*7		*7
X	Fn	—		—		—		—		*4
X	Win	E0	5B	E0	DB	E0	1F	E0	F0 1F	
x	App	E0	5D	E0	DD	E0	2F	E0	F0 2F	

Notes:

1. * Scan codes differ by mode.
2. * Scan codes differ by overlay function.
3. * Combination with the **Fn** key gives different codes.
4. * The **Fn** key does not generate a code by itself.
5. * This key corresponds to key No. 42 in a 102-key model.
6. * Refer to Table D-6, No. 124 key scan code.
7. * Refer to Table D-7, No. 126 key scan code.

Table D-2 Scan codes with left Shift key

Cap No.	Key top	Code set 1		Code set 2	
		Make	Break	Make	Break
55	/	E0 AA E0 35	E0 B5 E0 2A	E0 F0 12 E0 4A	E0 F0 4A E0 12
75	INS	E0 AA E0 52	E0 D2 E0 2A	E0 F0 12 E0 70	E0 F0 70 E0 12
76	DEL	E0 AA E0 53	E0 D3 E0 2A	E0 F0 12 E0 71	E0 F0 71 E0 12
79	←	E0 AA E0 4B	E0 CB E0 2A	E0 F0 12 E0 6B	E0 F0 6B E0 12
80	Home	E0 AA E0 47	E0 C7 E0 2A	E0 F0 12 E0 6C	E0 F0 6C E0 12
81	End	E0 AA E0 4F	E0 CF E0 2A	E0 F0 12 E0 69	E0 F0 69 E0 12
83	↑	E0 AA E0 48	E0 C8 E0 2A	E0 F0 12 E0 75	E0 F0 75 E0 12
84	↓	E0 AA E0 50	E0 D0 E0 2A	E0 F0 12 E0 72	E0 F0 72 E0 12
85	PgUp	E0 AA E0 49	E0 C9 E0 2A	E0 F0 12 E0 7D	E0 F0 7D E0 12
86	PgDn	E0 AA E0 51	E0 D1 E0 2A	E0 F0 12 E0 7A	E0 F0 7A E0 12
89	→	E0 AA E0 4D	E0 CD E0 2A	E0 F0 12 E0 74	E0 F0 74 E0 12
X	Win	E0 AA E0 5B	E0 DB E0 2A	E0 F0 12 E0 1F	E0 F0 1F E0 12
X	App	E0 AA E0 5D	E0 DD E0 2A	E0 F0 12 E0 2F	E0 F0 2F E0 12

Note : The table above shows scan codes with the left **Shift** key. In combination with the right **Shift** key, scan codes are changed as listed below:

	With left Shift	With right Shift
Set 1	E0 AA _____	E0 B6
	E0 2A _____	E0 36
Set 2	E0 F0 12 _____	E0 F0 59
	E0 12 _____	E0 59

Table D-3 Scan codes in Numlock mode

Cap No.	Key top	Code set 1				Code set 2			
		Make		Break		Make		Break	
75	INS	E0 2A	E0 52	E0 D2	E0 AA	E0 12	E0 70	E0 F0	70 E0 F0 12
76	DEL	E0 2A	E0 53	E0 D3	E0 AA	E0 12	E0 71	E0 F0	71 E0 F0 12
79	←	E0 2A	E0 4B	E0 CB	E0 AA	E0 12	E0 6B	E0 F0	6B E0 F0 12
80	Home	E0 2A	E0 47	E0 C7	E0 AA	E0 12	E0 6C	E0 F0	6C E0 F0 12
81	End	E0 2A	E0 4F	E0 CF	E0 AA	E0 12	E0 69	E0 F0	69 E0 F0 12
83	↑	E0 2A	E0 48	E0 C8	E0 AA	E0 12	E0 75	E0 F0	75 E0 F0 12
84	↓	E0 2A	E0 50	E0 D0	E0 AA	E0 12	E0 72	E0 F0	72 E0 F0 12
85	PgUp	E0 2A	E0 49	E0 C9	E0 AA	E0 12	E0 7D	E0 F0	7D E0 F0 12
86	PgDn	E0 2A	E0 51	E0 D1	E0 AA	E0 12	E0 7A	E0 F0	7A E0 F0 12
89	→	E0 2A	E0 4D	E0 CD	E0 AA	E0 12	E0 74	E0 F0	74 E0 F0 12
X	Win	E0 2A	E0 5B	E0 DB	E0 AA	E0 12	E0 1F	E0 F0	1F E0 F0 12
X	App	E0 2A	E0 5D	E0 DD	E0 AA	E0 12	E0 2F	E0 F0	2F E0 F0 12

Table D-4 Scan codes with Fn key

Cap No.	Keytop	Code set 1		Code set 2	
		Make	Break	Make	Break
43	ENT	E0 1C	E0 9C	E0 5A	E0 F0 5A
58	L-CTRL	E0 1D	E0 9D	E0 14	E0 F0 14
60	L-ALT	E0 38	E0 B8	E0 11	E0 F0 11
121	ARROW	45	C5	77	F0 77
122	NUMERIC	45	C5	77	F0 77
123	ScrL	46	C6	7E	F0 7E

Table D-5 Scan codes in overlay mode

Cap No.	Keytop		Code set 1		Code set 2		
			Make	Break	Make	Break	
09	8	(8)	48	C8	75	F0	75
10	9	(9)	49	C9	7D	F0	7D
11	0	(*)	37	B7	7C	F0	7C
23	U	(4)	4B	CB	6B	F0	6B
24	I	(5)	4C	CC	73	F0	73
25	O	(6)	4D	CD	74	F0	74
26	P	(-)	4A	CA	7B	F0	7B
37	J	(1)	4F	CF	69	F0	69
38	K	(2)	50	D0	72	F0	72
39	L	(3)	51	D1	7A	F0	7A
40	;	(+)	4E	CE	79	F0	79
52	M	(0)	52	D2	70	F0	70
54	.	(.)	53	D3	71	F0	71
55	/	(/)	E0 35	E0 B5	E0 4A	E0 F0	4A

Table D-6 No.124 key scan code

Key top	Shift	Code set 1				Code set 2			
		Make		Break		Make		Break	
Prt Sc	Common	E0 2A	E0 37	E0 B7	E0 AA	E0 12	E0 7C	E0 F0 7C	E0 F0 12
	Ctrl +	E0 37		E0 B7		E0 7C		E0 F0 7C	
	Shift +	E0 37		E0 B7		E0 7C		E0 F0 7C	
	Alt +		54	D4		84		F0 84	

Table D-7 No.126 key scan code

Key top	Shift	Code set 1						Code set 2							
		Make						Make							
Pause	Common	E1	1D	45	E1	9D	C5	E1	14	77	E1	F0	14	F0	77
	Ctrl	E0	46	E0	C6			E0	7E	E0	F0	7E			

*: This key generates only make codes.

Appendix E Key Layout

1. United States (US) Keyboard

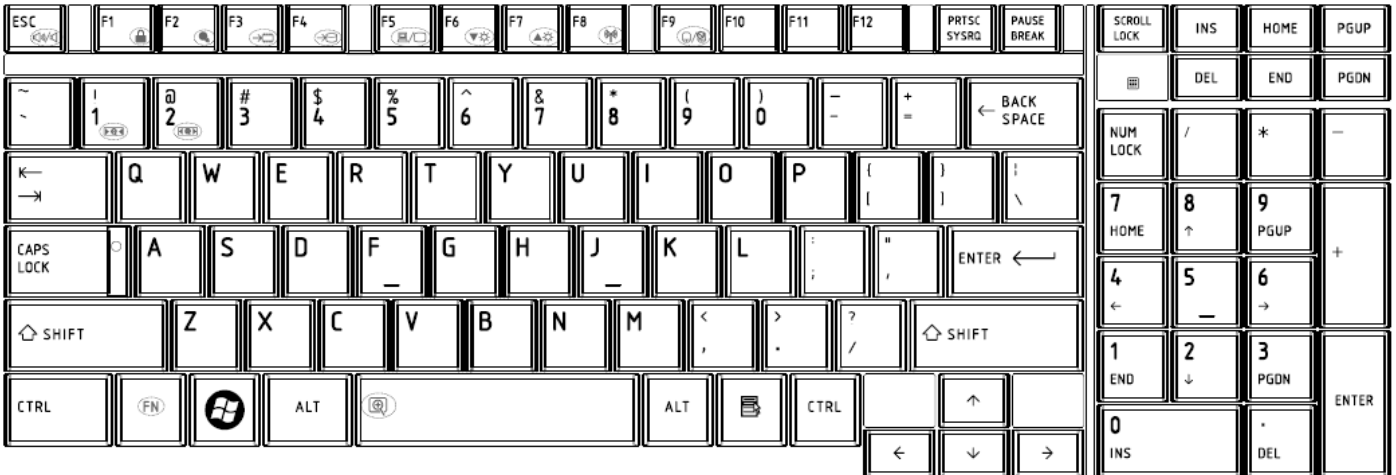

Figure US keyboard

2. Traditional Chinese (CH) Keyboard

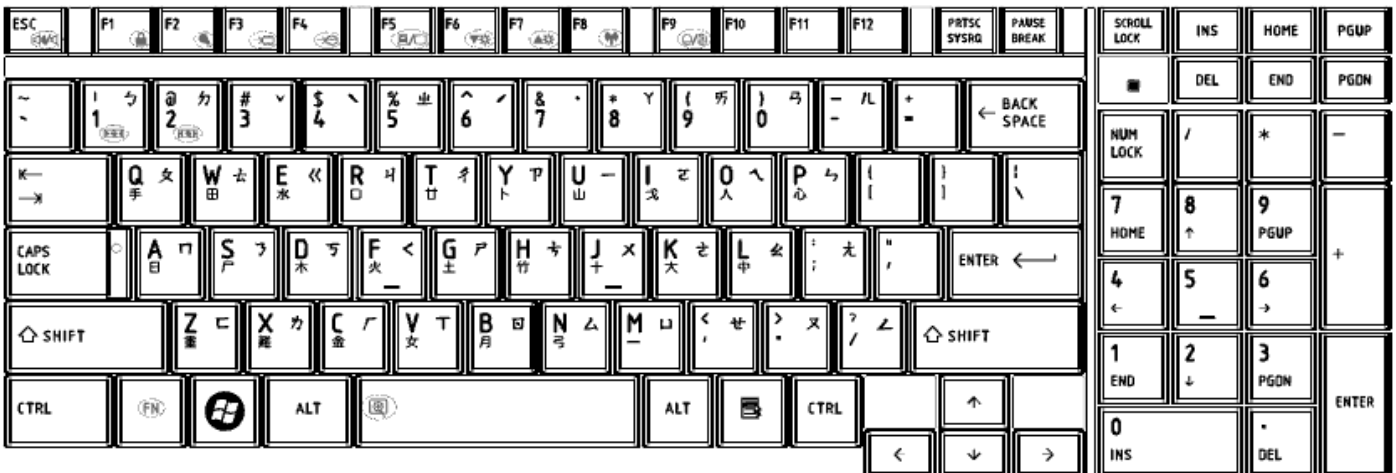

Figure CH keyboard

3. Thai (TI) Keyboard

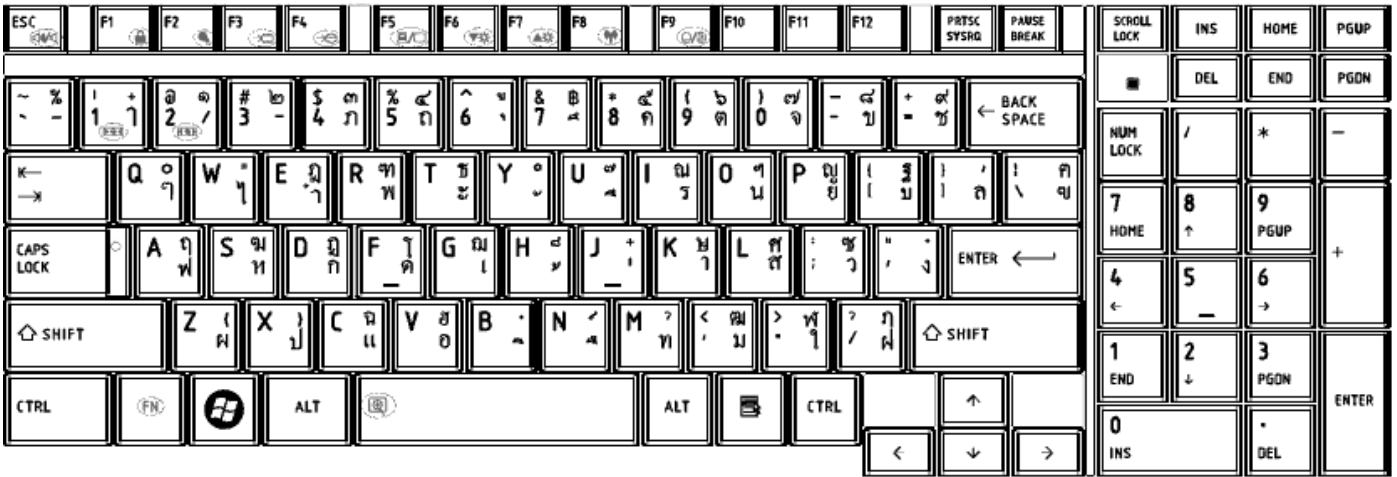

Figure TI keyboard

4. Korean (KO) Keyboard



Figure KO keyboard

5. United Kingdom (UK) Keyboard

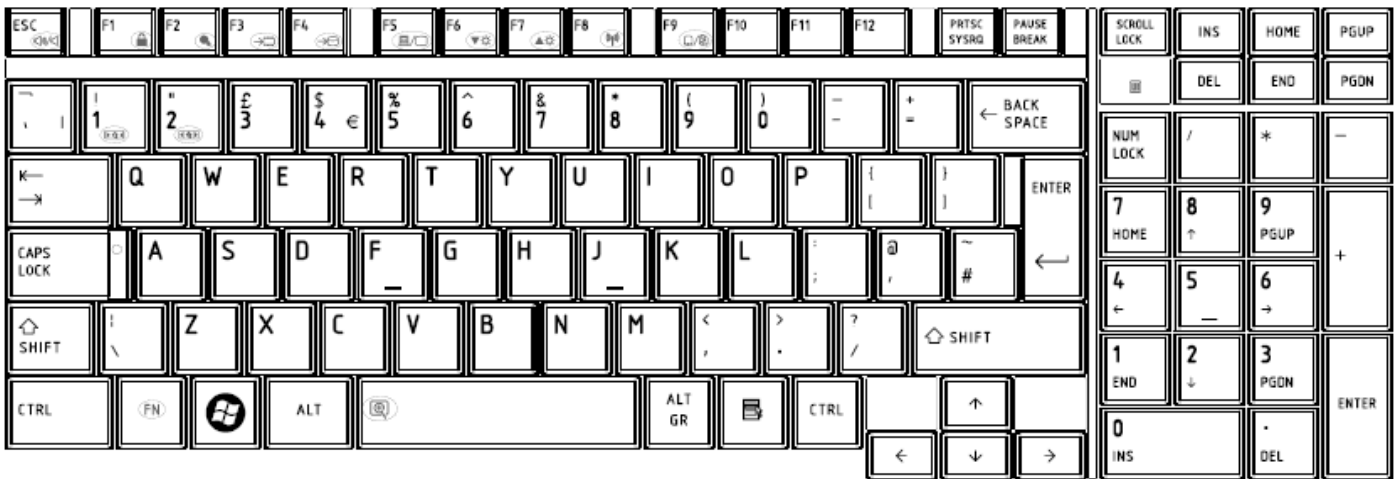

Figure UK keyboard

6. US International (UI) Keyboard

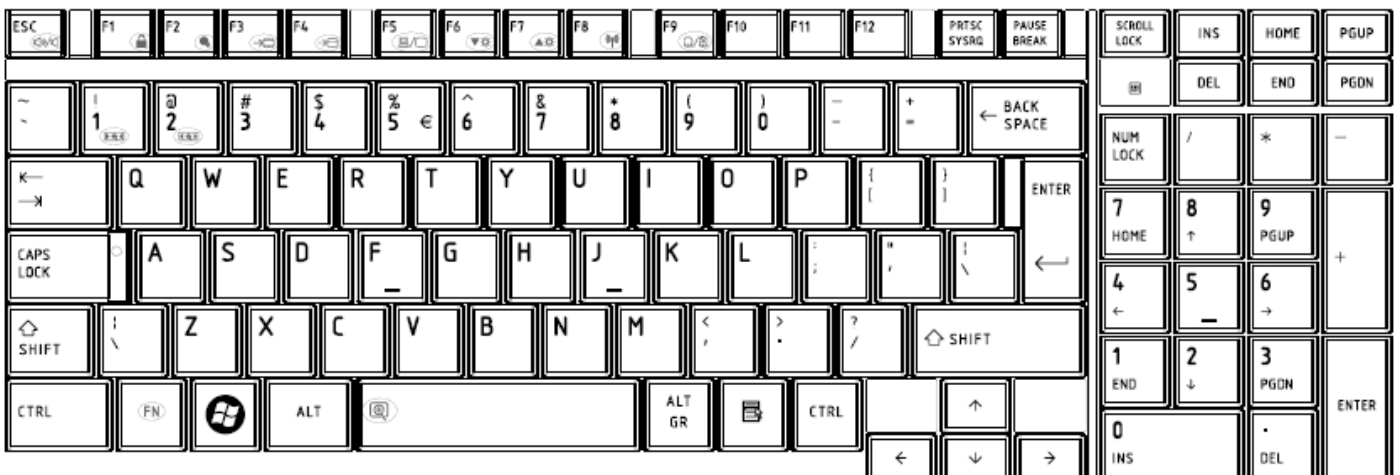

Figure UI keyboard

7. Hebrew (HB) Keyboard

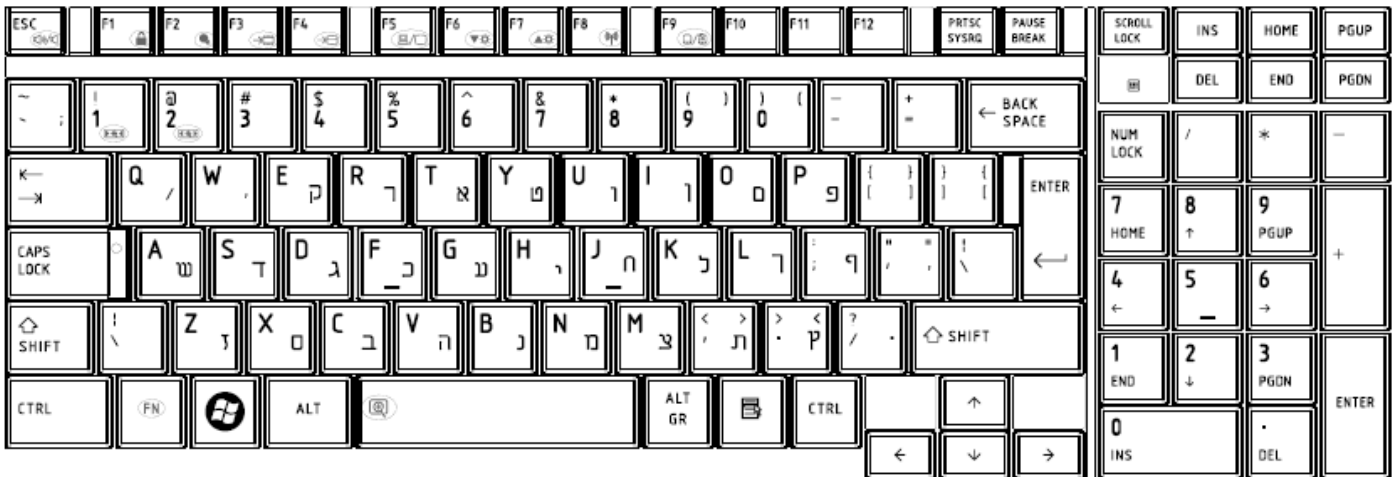

Figure HB keyboard

8. Danish (DM) Keyboard

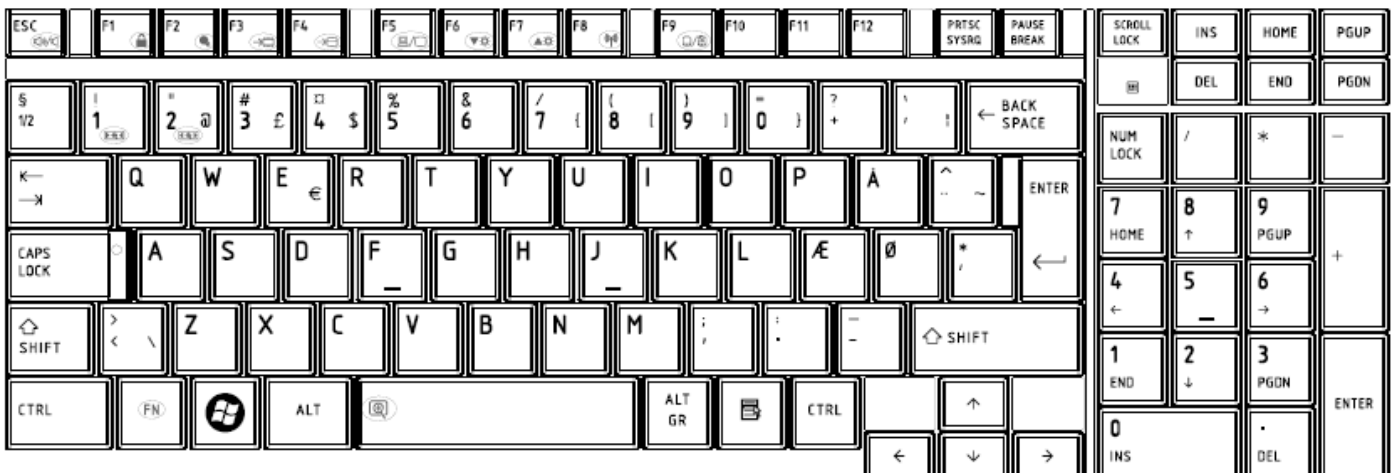

Figure DM keyboard

9. Swiss (SW) Keyboard

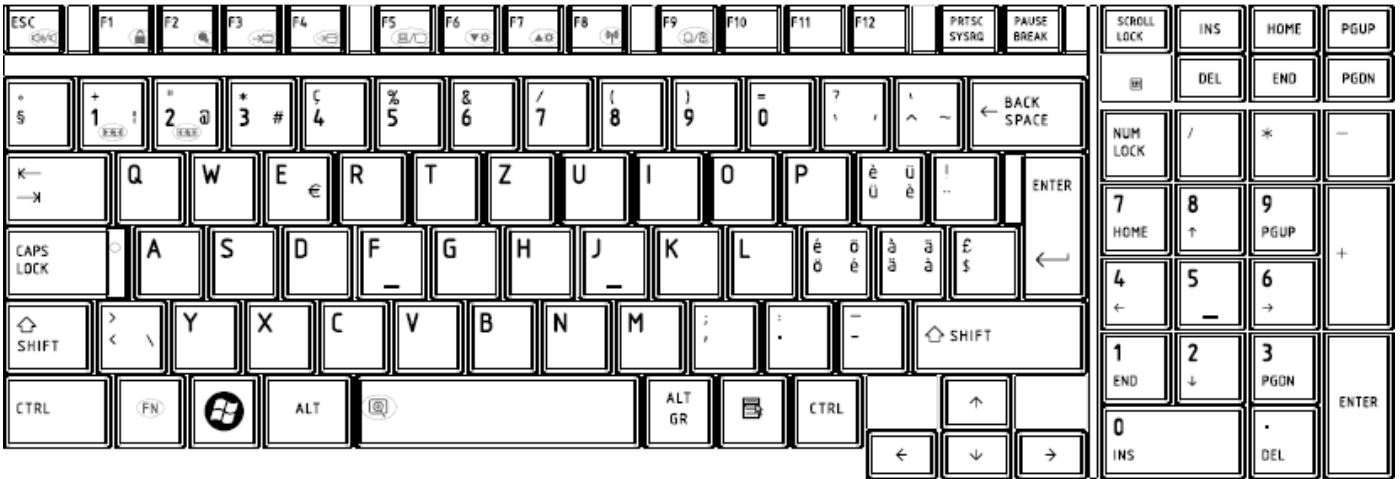

Figure SW keyboard

10. Arabic (ARE) Keyboard

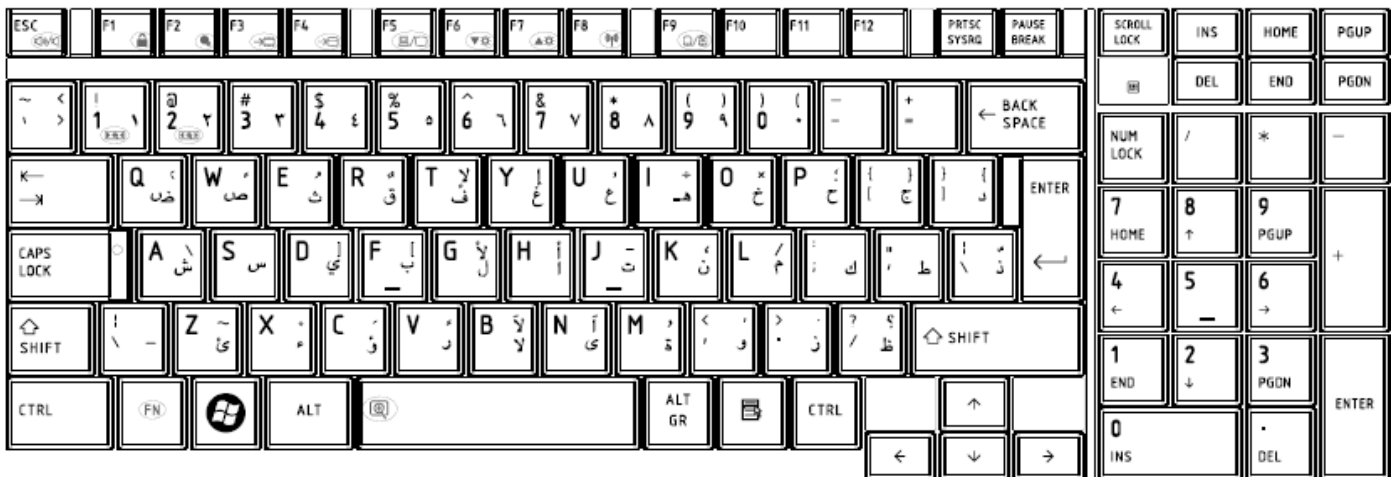

Figure ARE keyboard

11. Czech (CZ) Keyboard



Figure CZ keyboard

12. Russian (RU) Keyboard

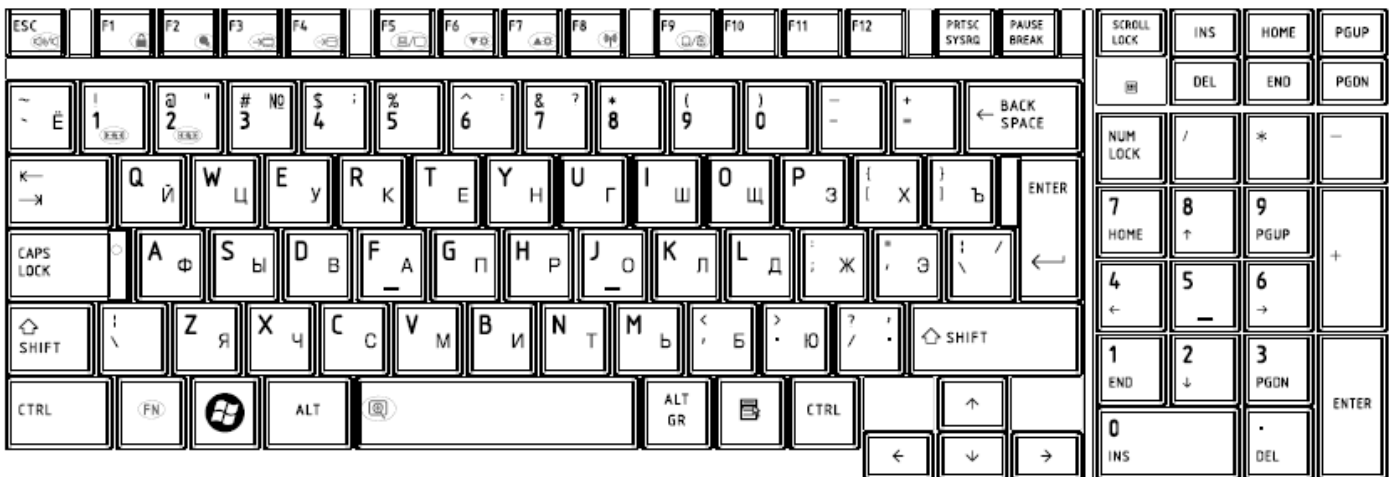

Figure RU keyboard

13. Portuguese (P0) Keyboard

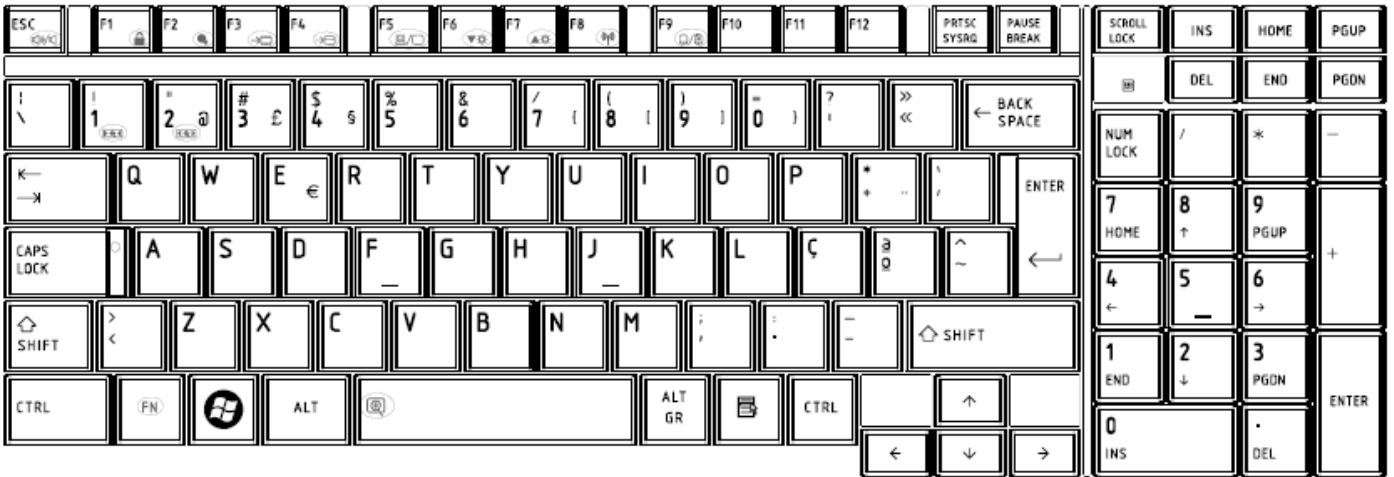

Figure PO keyboard

14.Slovakian (SL) Keyboard

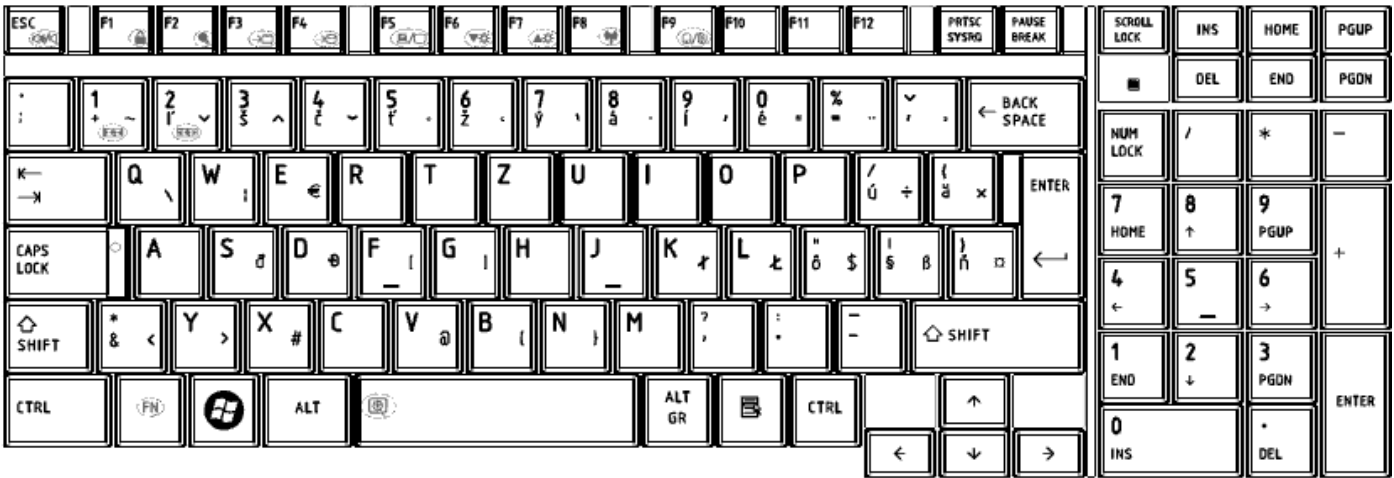

Figure SL keyboard

15.Italian (IT) Keyboard



Figure IT keyboard

16. French (FR) Keyboard

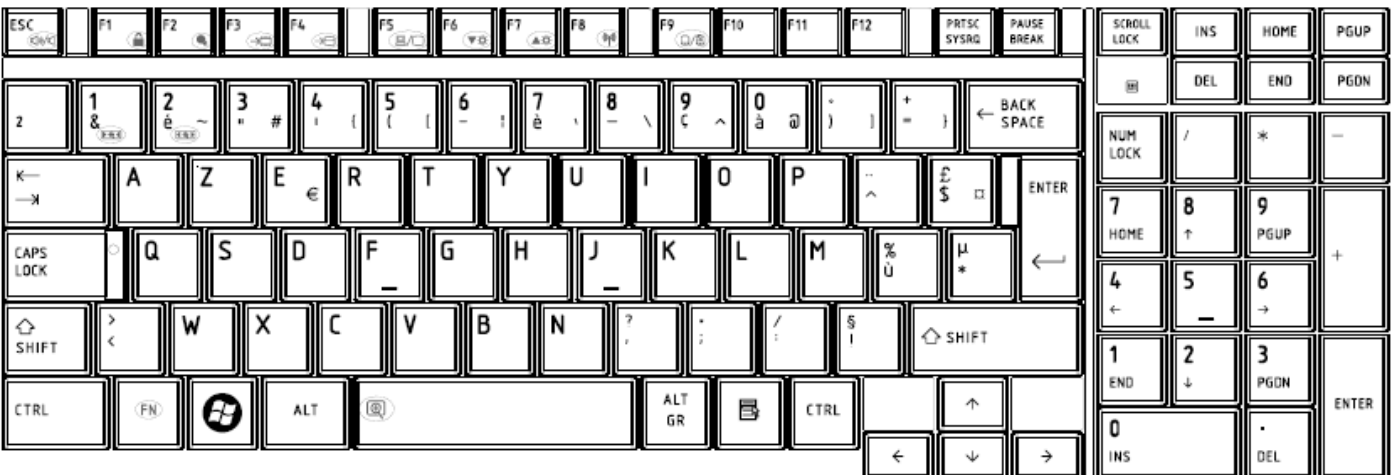

Figure FR keyboard

17. German (GR) Keyboard



Figure GR keyboard

18. Greek (GK) Keyboard



Figure GK keyboard

19. Hungarian (HG) Keyboard



Figure HG keyboard

20. Spanish (SP) Keyboard



Figure SP keyboard

21. Turkish (TR) Keyboard

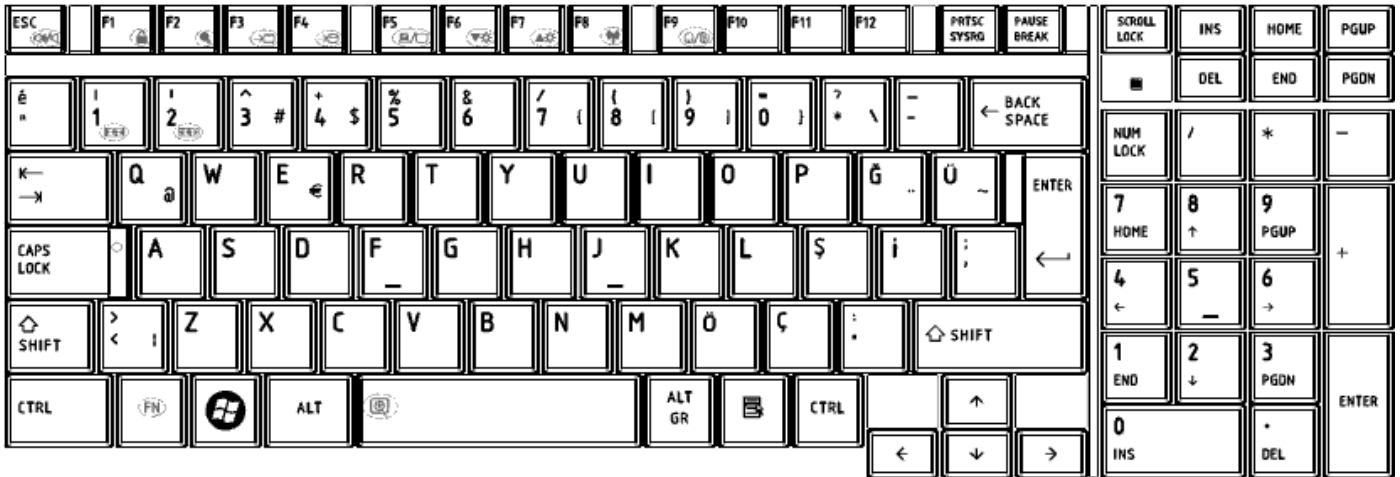

Figure TR keyboard

22. Turkish F (TF-F) Keyboard

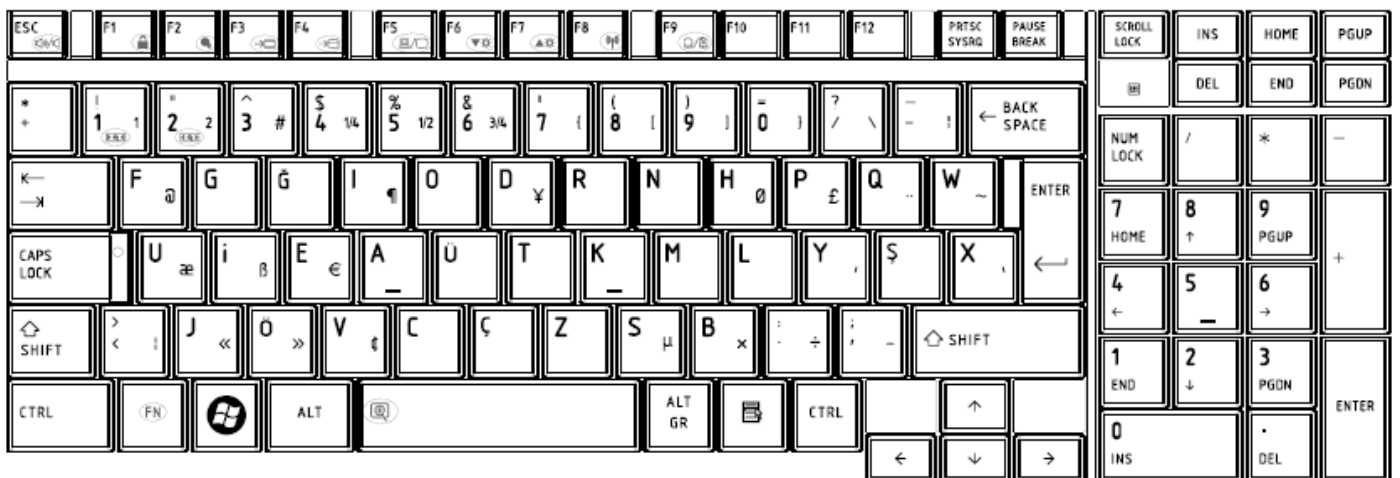

Figure TF-F keyboard

23. Swedish (SD) Keyboard

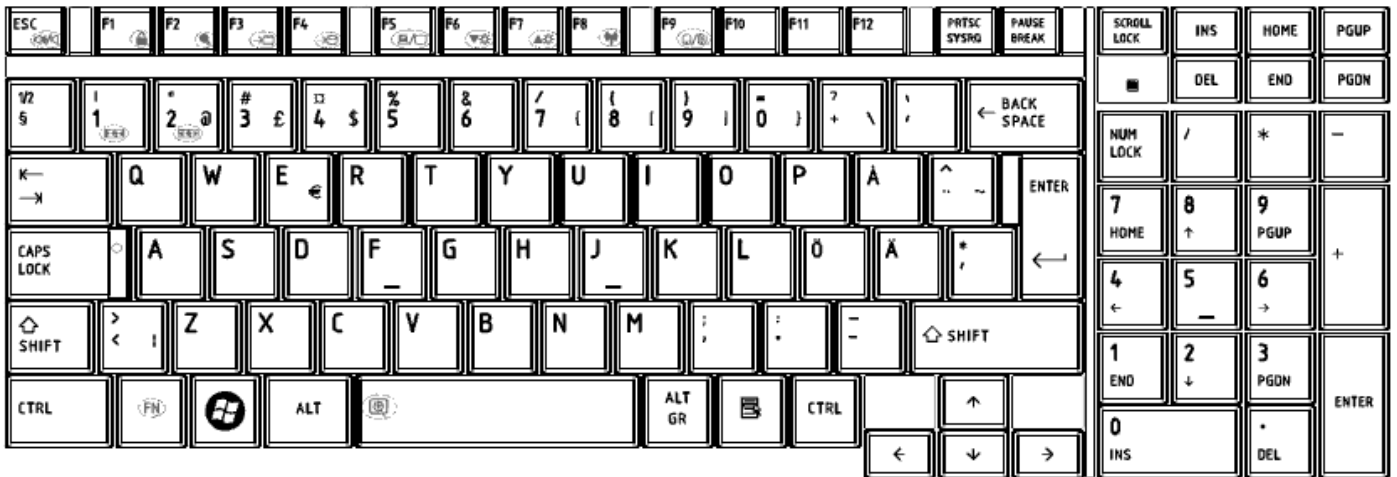

Figure SD keyboard

24. Belgian (BE) Keyboard

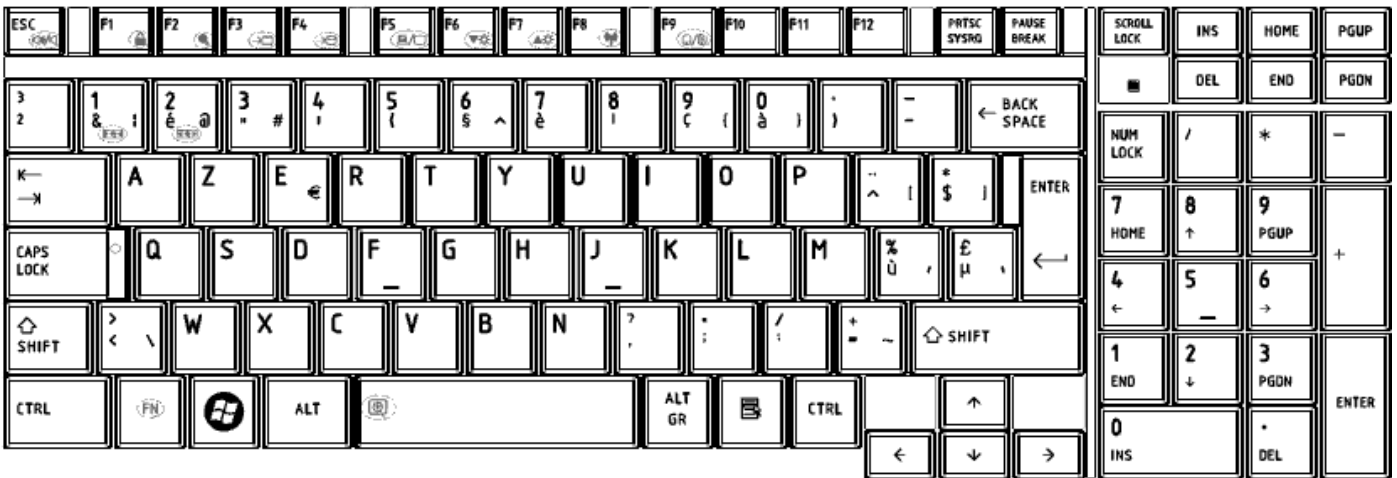

Figure BE keyboard

25. Yugoslavian (YU) Keyboard

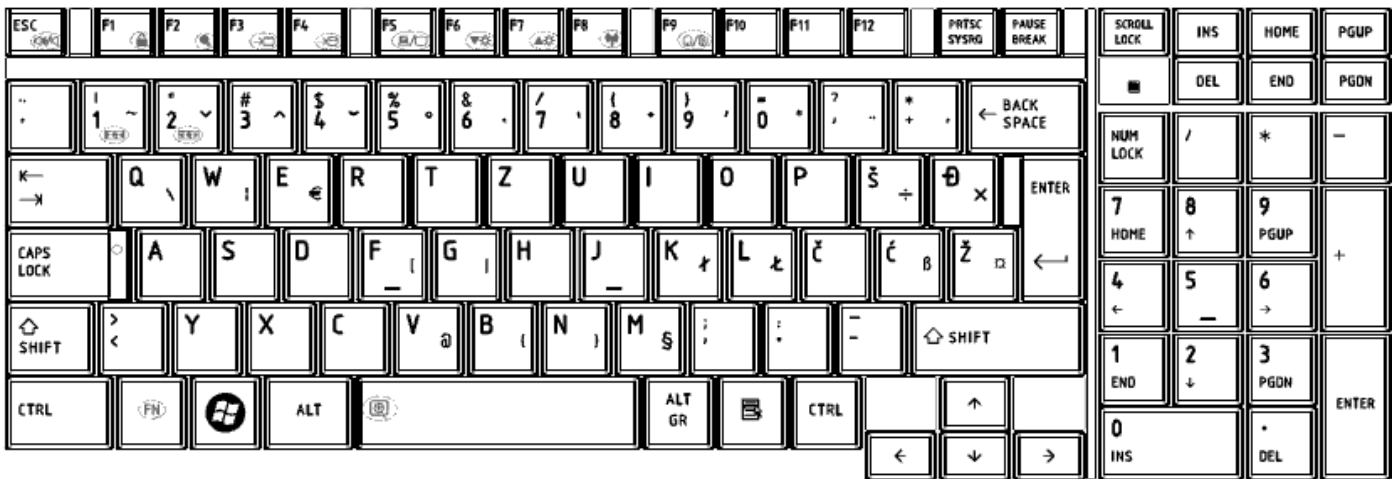

Figure YU keyboard

26. Norwegian (NW) Keyboard

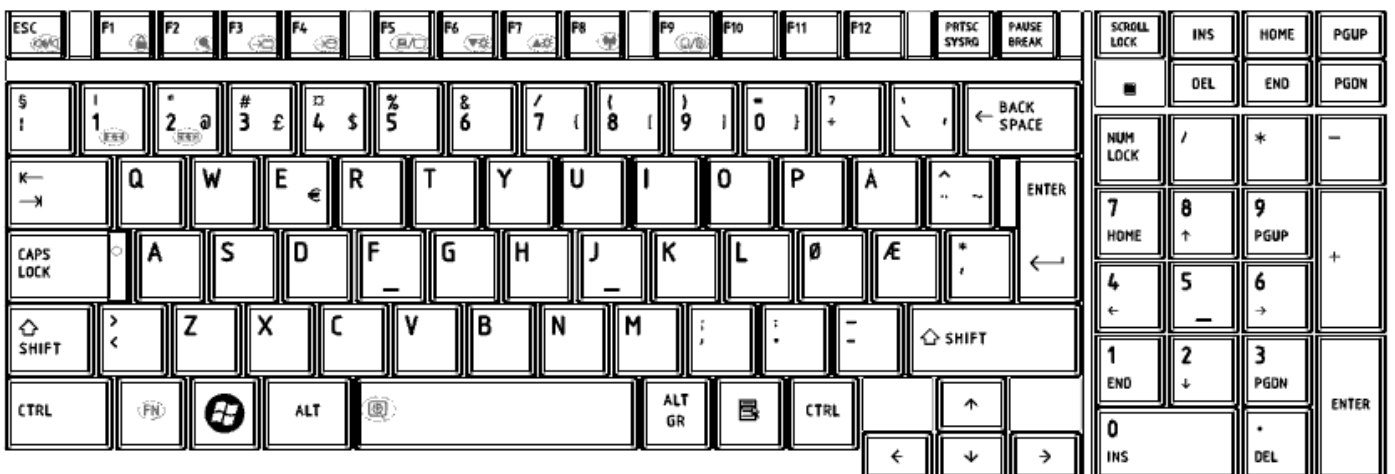

Figure NW keyboard

27. Scandinavian (ND) Keyboard

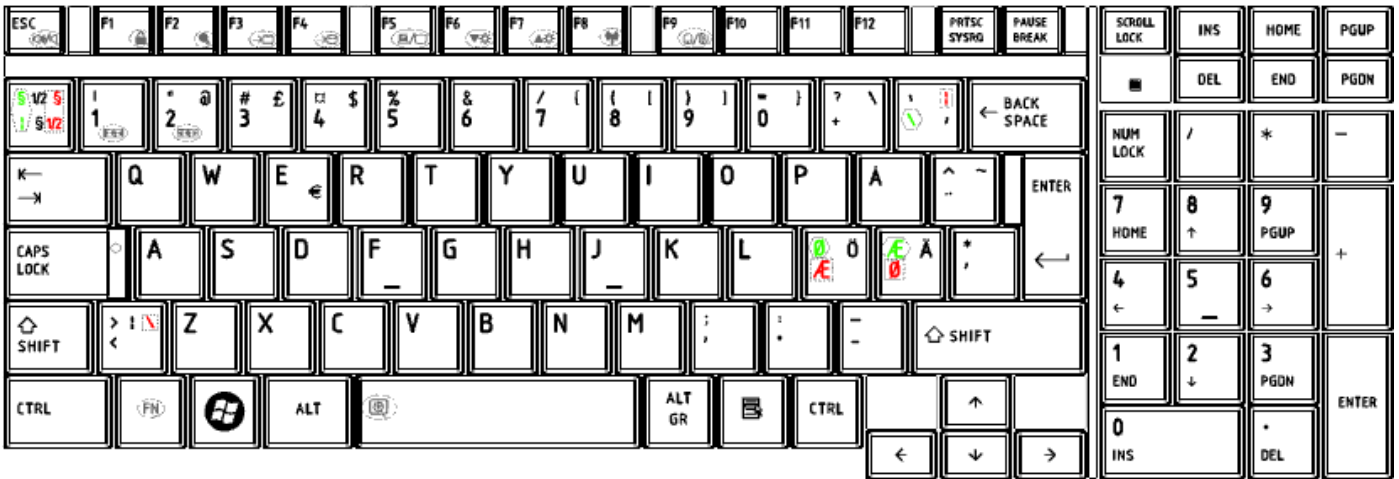

Figure ND keyboard

28. Canadian Multinational (AC) Keyboard

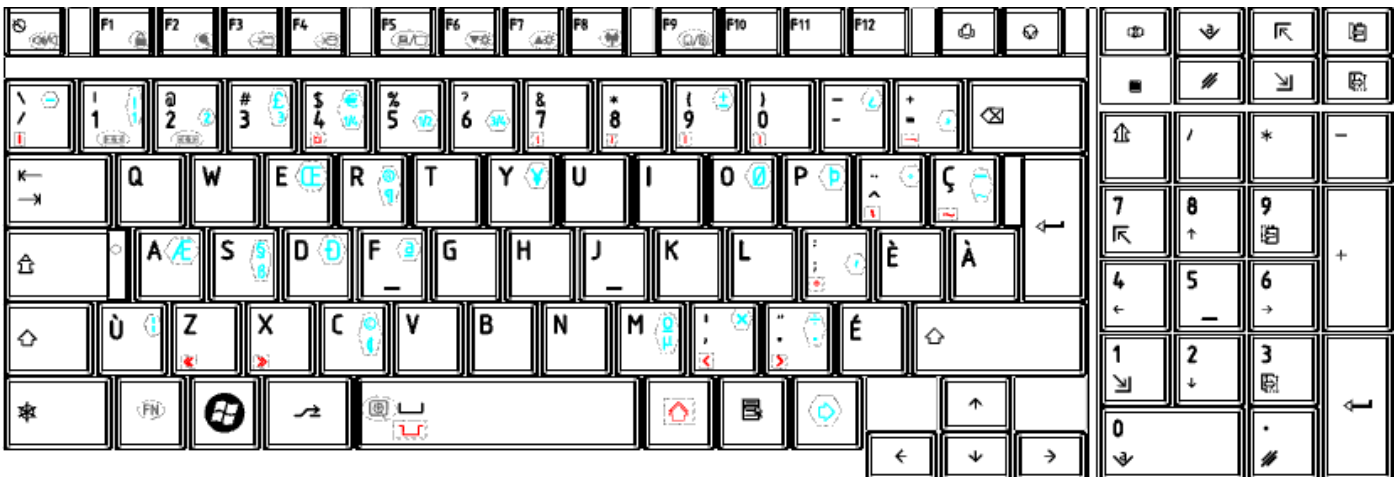

Figure AC keyboard

29. Canadian Bilingual (CB) Keyboard

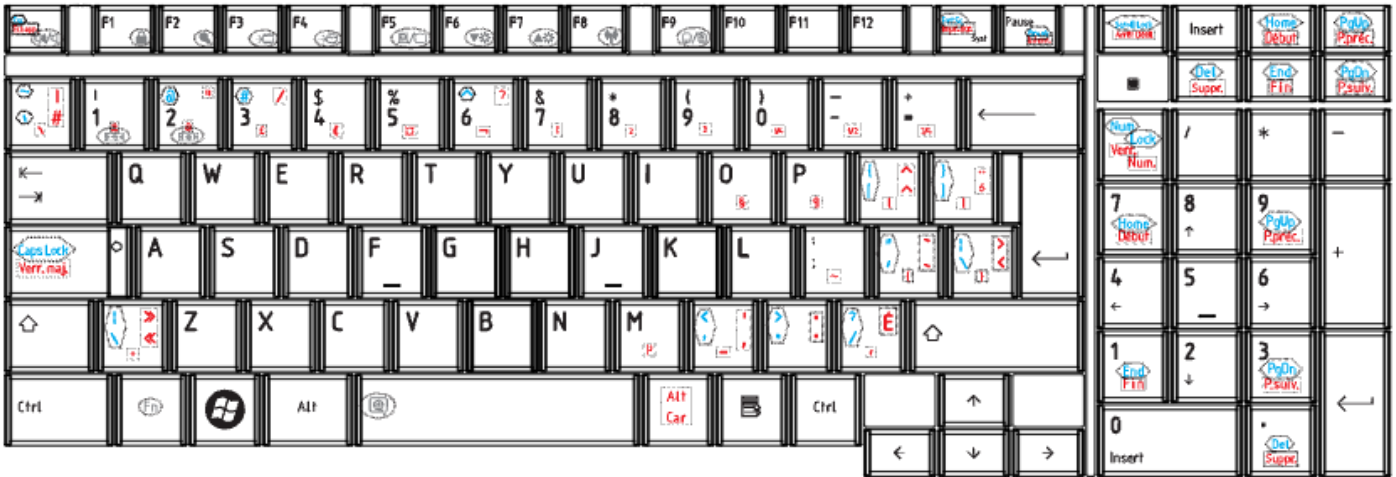

Figure CB keyboard

30. Romania (RO) Keyboard



Figure RO keyboard

31. Bulgaria (BU) Keyboard

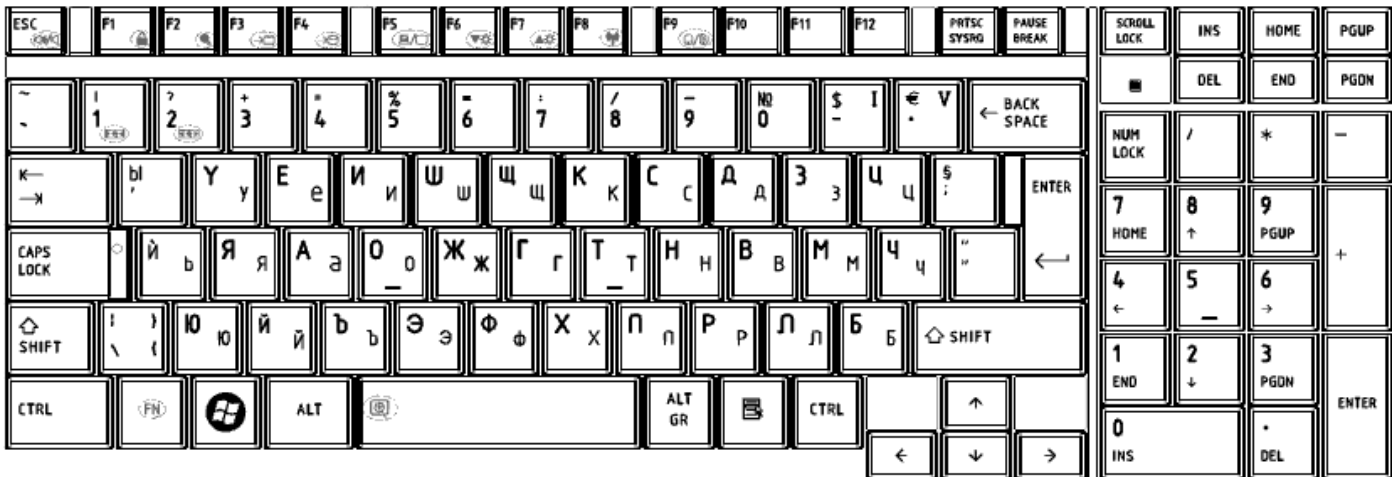

Figure BU keyboard

32. Japanese (JP) Keyboard

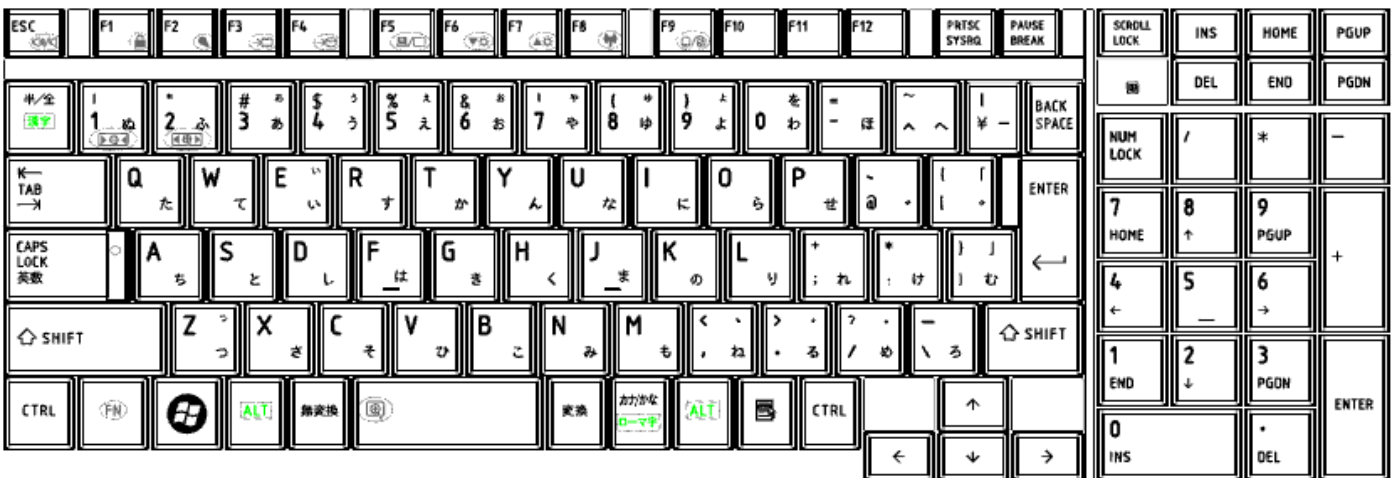

Figure JP keyboard

DISCRIPTION	Torque (kg-cm)	Part number	Q'ty
LCD PANEL TO LCD BREAKET(H/L)	1.2~1.5	MA0000060G0	6
LCD HINGE TO LCD COVER(H)	2.5~3.0	MA000007JG0	8
LCD HINGE TO LCD COVER(L)	2.5~3.0	MA000007JG0	6
LCD BEZEL TO LCD BRK TO LCD COVER(H)	2.5~3.0	MA0000062G0	2
LCD BEZEL TO LCD BRK TO LCD COVER(L)	2.5~3.0	MA0000062G0	4
INVERTER TO LCD COVER	1.5~2.0	MA0000060G0	1
ODD MODULE TO ODD BRK	1.5~2.0	MA0000060G0	2
HDD TO HDD BREAKET	2.5~3.0	MAAA03032G0	4
ODD CONN TO MB	1.5~2.0	MMCK20060G0	2
HDD CONN TO MB	1.5~2.0	MMCK20060G0	2
BATTERY CONN TO MB	1.5~2.0	MMCK20060G0	2
EXPRESS CARD SOCKET TO MB	1.5~2.0	MMCK20060G0	2
SPEAKER NET	2.5~3.0	MACK20030G0	2
SSD MODULE TO MB	1.5~2.0	MA0000060G0	4
SSD PCB TO BREAKET	1.5~2.0	MA0000025G0	4
POWER SW BOARD TO UPPER	2.5~3.0	MA000007JG0	2
TOUCH PAD SW BOARD TO UPPER	2.5~3.0	MA000007JG0	1
TOUCH PAD LED BOARD TO UPPER	2.5~3.0	MA000005WG0	1
TP BREAKET TO TOUCH PAD SW BOARD	2.5~3.0	MA000007JG0	1
TP BREAKET TO TOUCH PAD LED BOARD	2.5~3.0	MA000007JG0	1
TP BREAKET TO UPPER	2.5~3.0	MA000007JG0	2
Felica TO UPPER	1.5~2.0	MA000005WG0	1
SPEKAER L/R TO UPPER	2.5~3.0	MA000009KG0	4
SADDLE TO LOGIC LOWER	2.5~3.0	MA0000062G0	4
HDD DOOR TO LOGIC LOWER	2.5~3.0	MA0000035G0	2
HDD DOOR TO LOGIC LOWER	2.5~3.0	MA0000035G0	1
WIFI CARD TO MB MINI CARD	2.5~3.0	MA0000060G0	2
TV TUNNER / 3G / GPS MINI CARD	2.5~3.0	MA0000060G0	2
UWB MINI CARD	2.5~3.0	MA0000060G0	2
MODEM CARD TO MB	2.5~3.0	MA000005WG0	2
FM TUNNER CARD	2.5~3.0	MA000005WG0	2
FAN TO LOWER	2.5~3.0	MA0000062G0	1
LOWER TO UPPER	2.5~3.0	MA000005YG0	15
UPPER TO LOWER	2.5~3.0	MA000005YG0	5
		MACA25001G0	3
ODD ASSY TO LOWER	2.5~3.0	MA0000062G0	1
LCD ASSY TO LOWER	2.5~3.0	MA0000062G0	6

DISCRIPTION	Torque (kg-cm)	Part number	Q'ty
KEYBOARD TO LOGIC	1.5-2.0	MA0000060G0	4
KEYBOARD COVER TO LOGIC	1.5-2.0	MACA25001G0	2
SYSTEM LED BOARD TO LOGIC	2.5-3.0	MA000007JG0	1
L USB BOARD TO LOGIC	2.5-3.0	MA000007JG0	1
MB TO LOGIC	2.5-3.0	MA000005WG0	1
LOW BATTERY HOUSING TO UPPER	2.5-3.0	MA000007JG0	2
TV TUNER CABLER	2.5-3.0	MA000007JG0	1
CPU THERMAL MODULE	2.5-3.0	AM077000C00	4
VGA THERMAL MODULE	2.5-3.0	AM077000100	4
CPU WITH VGA THERMAL MODULE	2.5-3.0	AM077000C00	4
		MA0000096G0	2

Appendix G Reliability

The following table shows MTBF (Mean Time Between Failures) for each component.

Table G-1 MTBF

Component	Time (hours)
LCD	10,000
Keyboard	60,000
HDD	300,000
Optical (DVD/CD) drive	60,000
AC adaptor	60,000

Free Manuals Download Website

<http://myh66.com>

<http://usermanuals.us>

<http://www.somanuals.com>

<http://www.4manuals.cc>

<http://www.manual-lib.com>

<http://www.404manual.com>

<http://www.luxmanual.com>

<http://aubethermostatmanual.com>

Golf course search by state

<http://golfingnear.com>

Email search by domain

<http://emailbydomain.com>

Auto manuals search

<http://auto.somanuals.com>

TV manuals search

<http://tv.somanuals.com>