

**Toshiba Personal Computer
QOSMIO F30 series
Maintenance Manual**

TOSHIBA CORPORATION

File Number 960-555

[CONFIDENTIAL]

Copyright

© 2006 by Toshiba Corporation. All rights reserved. Under the copyright laws, this manual cannot be reproduced in any form without the prior written permission of Toshiba. No patent liability is assumed with respect to the use of the information contained herein.

Toshiba QOSMIO F30 series Maintenance Manual

First edition March 2006

Disclaimer

The information presented in this manual has been reviewed and validated for accuracy. The included set of instructions and descriptions are accurate for the QOSMIO F30 series at the time of this manual's production. However, succeeding computers and manuals are subject to change without notice. Therefore, Toshiba assumes no liability for damages incurred directly or indirectly from errors, omissions, or discrepancies between any succeeding product and this manual.

Trademarks

IBM is a registered trademark and IBM PC is a trademark of International Business Machines Corporation.

Intel, Intel SpeedStep, Intel Core and Centrino are trademarks or registered trademarks of Intel Corporation.

Windows and Microsoft are registered trademarks of Microsoft Corporation.

Photo CD is a trademark of Eastman Kodak.

Bluetooth is a trademark owned by its proprietor and used by TOSHIBA under license.

Memory Stick is a registered trademark and i.LINK is a trademark of Sony Corporation.

InterVideo and WinDVD are registered trademarks of InterVideo Inc.

WinDVD Creator is a trademark of InterVideo Inc.

Manufactured under license from Dolby Laboratories.

“Dolby” and the double-D symbol are trademarks of Dolby Laboratories.

Confidential unpublished works. Copyright 1992-1997 Dolby Laboratories.

All rights reserved.

EdgeMotion, PalmCheck, Touchpad and Synaptics are trademarks or registered trademarks of Synaptics Incorporated.

Other trademarks and registered trademarks not listed above may be used in this manual.

Preface

This maintenance manual describes how to perform hardware service maintenance for the Toshiba Personal Computer QOSMIO F30 series.

NOTE: *Each model of QOSMIO F30 series has a different configuration. For each model's configuration, refer to the parts list dedicated to it.*

The procedures described in this manual are intended to help service technicians isolate faulty Field Replaceable Units (FRUs) and replace them in the field.

SAFETY PRECAUTIONS

Four types of messages are used in this manual to bring important information to your attention. Each of these messages will be italicized and identified as shown below.

DANGER: *“Danger” indicates the existence of a hazard that could result in death or serious bodily injury, if the safety instruction is not observed.*

WARNING: *“Warning” indicates the existence of a hazard that could result in bodily injury, if the safety instruction is not observed.*

CAUTION: *“Caution” indicates the existence of a hazard that could result in property damage, if the safety instruction is not observed.*

NOTE: *“Note” contains general information that relates to your safe maintenance service.*

Improper repair of the computer may result in safety hazards. Toshiba requires service technicians and authorized dealers or service providers to ensure the following safety precautions are adhered to strictly.

- ❑ Be sure to fasten screws securely with the right screwdriver. Be sure to use the PH Point size “0” and “1” screwdrivers complying with the ISO/DIS 8764-1:1996. If a screw is not fully fastened, it could come loose, creating a danger of a short circuit, which could cause overheating, smoke or fire.
- ❑ If you replace the battery pack or RTC battery, be sure to use only the same model battery or an equivalent battery recommended by Toshiba. Installation of the wrong battery can cause the battery to explode.

The manual is divided into the following parts:

- Chapter 1 Hardware Overview describes the QOSMIO F30 series system unit and each FRU.
- Chapter 2 Troubleshooting Procedures explains how to diagnose and resolve FRU problems.
- Chapter 3 Test and Diagnostics describes how to perform test and diagnostic operations for maintenance service.
- Chapter 4 Replacement Procedures describes the removal and replacement of the FRUs.
- Appendices The appendices describe the following:
 - Handling the LCD module
 - Board layout
 - Pin assignment
 - Keyboard Scan/Character Codes
 - Key layout
 - Wiring diagrams
 - BIOS Rewrite procedures
 - EC/KBC Rewrite procedures
 - Reliability
 - Maintenance of TOSHIBA RAID

Conventions

This manual uses the following formats to describe, identify, and highlight terms and operating procedures.

Acronyms

On the first appearance and whenever necessary for clarification acronyms are enclosed in parentheses following their definition. For example:

Read Only Memory (ROM)

Keys

Keys are used in the text to describe many operations. The key top symbol as it appears on the keyboard is printed in **boldface** type.

Key operation

Some operations require you to simultaneously use two or more keys. We identify such operations by the key top symbols separated by a plus (+) sign. For example, **Ctrl + Pause (Break)** means you must hold down **Ctrl** and at the same time press **Pause (Break)**. If three keys are used, hold down the first two and at the same time press the third.

User input

Text that you are instructed to type in is shown in the boldface type below:

DISKCOPY A: B:

The display

Text generated by the QOSMIO F30 series that appear on its display is presented in the type face below:

```
Format complete
System transferred
```

Table of Contents

Chapter 1 Hardware Overview

1.1	Features	1-1
1.2	System Block Diagram	1-6
1.3	2.5-inch Hard Disk Drive.....	1-10
1.4	Optical Drive.....	1-12
1.5	Keyboard.....	1-14
1.6	TFT Color Display	1-15
1.7	Power Supply	1-17
1.8	Batteries	1-20
1.9	AC Adapter	1-23

Chapter 2 Troubleshooting Procedures

2.1	Troubleshooting	2-1
2.2	Troubleshooting Flowchart.....	2-3
2.3	Power Supply Troubleshooting.....	2-8
2.4	System Board Troubleshooting.....	2-18
2.5	USB FDD Troubleshooting	2-33
2.6	2.5" HDD Troubleshooting.....	2-37
2.7	Keyboard Troubleshooting	2-42
2.8	Touch pad Troubleshooting	2-44
2.9	Display Troubleshooting.....	2-46
2.10	Optical Disk Drive Troubleshooting.....	2-49
2.11	Modem Troubleshooting.....	2-50
2.12	LAN Troubleshooting	2-52
2.13	Wireless LAN Troubleshooting.....	2-53
2.14	Bluetooth Troubleshooting	2-56
2.15	Sound Troubleshooting.....	2-59
2.16	TV Tuner Troubleshooting	2-61

2.17	Bridge media Slot Troubleshooting	2-62
2.18	Fingerprint sensor	2-63

Chapter 3 Tests and Diagnostics

3.1	The Diagnostic Test	3-1
3.2	Executing the Diagnostic Test	3-4
3.3	Check of the RAID configuration.....	3-8
3.4	Setting of the hardware configuration.....	3-16
3.5	Heattrun Test.....	3-18
3.6	Subtest Names.....	3-19
3.7	System Test.....	3-21
3.8	Memory Test.....	3-23
3.9	Keyboard Test.....	3-24
3.10	Display Test	3-25
3.11	Floppy Disk Test.....	3-28
3.12	Printer Test.....	3-30
3.13	Async Test	3-32
3.14	Hard Disk Test	3-33
3.15	Real Timer Test.....	3-36
3.16	NDP Test.....	3-38
3.17	Expansion Test.....	3-39
3.18	CD-ROM/DVD-ROM Test	3-41
3.19	Error Code and Error Status Names.....	3-42
3.20	Hard Disk Test Detail Status.....	3-45
3.21	ONLY ONE TEST.....	3-47
3.22	Head Cleaning.....	3-54
3.23	Log Utilities	3-55
3.24	Running Test.....	3-57
3.25	Floppy Disk Drive Utilities.....	3-58
3.26	System Configuration	3-63
3.27	Wireless LAN Test Program (Atheros)	3-65
3.28	Wireless LAN Test Program (Intel-made a/b/g).....	3-72

3.29	Sound/LAN/Modem Test Program.....	3-76
3.30	IEEE1394 Test program	3-80
3.31	Bluetooth Test program	3-81
3.32	SETUP	3-91
3.33	Thermal Radiation Control Test	3-108

Chapter 4 Replacement Procedures

4.1	Overview.....	4-1
4.2	Battery pack	4-8
4.3	PC card/Bridge media.....	4-10
4.4	HDD.....	4-12
4.5	Memory module.....	4-16
4.6	Keyboard.....	4-18
4.7	MDC	4-21
4.8	Wireless LAN card	4-23
4.9	Bluetooth module.....	4-25
4.10	Cover assembly.....	4-27
4.11	Touch pad.....	4-33
4.12	LED board.....	4-37
4.13	Fingerprint sensor board	4-39
4.14	Volume board.....	4-41
4.15	Switch membrane.....	4-42
4.16	Wireless communication switch	4-44
4.17	Optical disk drive.....	4-45
4.18	RTC battery.....	4-49
4.19	Internal microphone	4-50
4.20	Jack board	4-51
4.21	System board/DC-IN jack.....	4-52
4.22	Speaker.....	4-54
4.23	Modem jack/F jack	4-55
4.24	GPU fan	4-57
4.25	Battery lock/Battery latch	4-58

4.26	Analog TV tuner	4-60
4.27	CPU fan/CPU heat sink/CPU.....	4-61
4.28	GPU heat sink	4-65
4.29	North bridge heat sink.....	4-67
4.30	PC card slot.....	4-68
4.31	LCD unit / FL inverter	4-70
4.32	LCD cable	4-77
4.33	Wireless LAN antennas/Bluetooth antenna	4-80
4.34	Latch assembly.....	4-82
4.35	Display rear cover	4-83
4.36	Hinge.....	4-85
4.37	Fluorescent lamp.....	4-87

Appendices

Appendix A	Handling the LCD Module	A-1
Appendix B	Board Layout	B-1
Appendix C	Pin Assignment	C-1
Appendix D	Keyboard Scan/Character Codes	D-1
Appendix E	Key Layout.....	E-1
Appendix F	Wiring Diagrams.....	F-1
Appendix G	BIOS Rewrite procedures	G-1
Appendix H	EC/KBC Rewrite procedures.....	H-1
Appendix I	Reliability.....	I-1
Appendix J	Maintenance of TOSHIBA RAID	J-1

Chapter 1

Hardware Overview

Chapter 1 Contents

1.1	Features	1-1
1.2	System Block Diagram	1-6
1.3	2.5-inch Hard Disk Drive.....	1-10
1.4	Optical Drive.....	1-12
1.4.1	DVD Super Multi Drive (supporting Double-Layer).....	1-12
1.5	Keyboard.....	1-14
1.6	TFT Color Display	1-15
1.6.1	LCD Module	1-15
1.6.2	FL Inverter Board.....	1-16
1.7	Power Supply	1-17
1.8	Batteries	1-20
1.8.1	Main Battery	1-20
1.8.2	Battery Charging Control	1-21
1.8.3	RTC battery	1-22
1.9	AC Adapter	1-23

Figures

Figure 1-1 Front of the computer and the system units configuration 1-5
Figure 1-2 System block diagram..... 1-6
Figure 1-3 2.5-inch HDD..... 1-10
Figure 1-4 DVD Super Multi drive (Double-Layer) 1-12
Figure 1-5 Keyboard..... 1-14
Figure 1-6 LCD module..... 1-15

Tables

Table 1-1 2.5-inch HDD dimensions 1-10
Table 1-2 2.5-inch HDD specifications..... 1-11
Table 1-3 DVD Super Multi drive (Double-Layer) outline dimensions 1-12
Table 1-4 DVD Super Multi drive (Double-Layer) specifications 1-13
Table 1-5 LCD module specifications..... 1-15
Table 1-6 FL inverter board specifications 1-16
Table 1-7 Power supply output rating 1-18
Table 1-8 Battery specifications..... 1-20
Table 1-9 Time required for charges of main battery 1-21
Table 1-10 Data preservation time 1-21
Table 1-11 Time required for charges of RTC battery..... 1-22
Table 1-12 AC adapter specifications 1-23

1.1 Features

The QOSMIO F30 series are high performance all-in-one PCs running an Intel® Core™ Duo/Solo or Intel® Celeron® M processor.

There some models and options. Refer to the Parts List for the configuration of each model and options.

The features are listed below.

Microprocessor

Microprocessor that is used will be different of the model.

Intel® Core™ Duo

Core™ Duo-2M	1.66GHz (Processor Number : T2300)
	1.83GHz (Processor Number : T2400)
	2.00GHz (Processor Number : T2500)
	2.16GHz (Processor Number : T2600)

Intel® Core™ Solo

Core™ Solo-1M	1.66GHz (Processor Number : T1300)
---------------	------------------------------------

Intel® Celeron® M

Celeron® M	1.60GHz (Processor Number : 420)
	1.73GHz (Processor Number : 430)

Chipset

Equipped with Intel 945GM/945PM as North Bridge, Intel ICH7-M as South Bridge and Texas Instrument PCI7412ZHK as Card Controller.

Memory

Two DDR2-533/DDR2-667 SDRAM slots. Memory modules can be installed to provide a maximum of 4GB. Memory modules are available in 256MB, 512MB, 1024MB and 2048MB sizes.

GPU

An nVIDIA G72M or G73M for 945PM models is mounted.

1st HDD

40GB, 60GB, 80GB, 100GB, 120GB serial-ATA drive. 2.5 inch x 9.5mm height or 160GB serial-ATA drive 2.5 inch x 12.5mm height.

2nd HDD

40GB, 60GB, 80GB, 100GB or 120GB serial-ATA drive. 2.5 inch x 9.5mm height.

 Optical devices

A slot-loading style DVD Super Multi drive (supporting double layer) is equipped.

 Keyboard

An-easy-to-use 85(US)/86(UK)-key keyboard provides a numeric keypad overlay for fast numeric data entry or for cursor and page control. The keyboard also includes two keys that have special functions in Microsoft® Windows® XP. It supports software that uses a 101- or 102-key enhanced keyboard.

 DisplayLCD

Built-in 15.4-inch, WXGA (1,280 x 800 dots) amorphous silicon TFT color display.

Interface

To external monitor via

- RGB connector
- S-video OUT connector
- D-port OUT connector

To internal monitor via

- S-video IN connector
- Monitor IN port

 Sound system

Harman/Kardon-made stereo speaker is equipped. An internal microphone, external monaural microphone jack and two stereo headphone jacks (one stereo headphone jack can be used also as S/PDIF connector) are also equipped.

 Battery

The RTC battery is equipped inside the computer.
The main battery is a detachable lithium ion battery (4,700mAh:Li-Ion, 6cell/
7,050mAh:Li-Ion, 9cell).

 TV-tuner (Mini PCI card)

This enables to watch TV and record it (Supporting world wide signal : NTSC, PAL and SECAM).

Wireless LAN (PCI Express Mini card)

The wireless LAN is equipped in the PCI Express Mini card slot.

 LAN/MODEM

Connectors for 10M/100M Ethernet or Gigabit Ethernet (1000M) LAN and Modem are mounted.

 Bluetooth

Depending on the model, the computer is equipped with a dedicated Bluetooth module. This enables a communication to devices that support Bluetooth Version 2.0. Adopting AFH (Adaptive Frequency Hopping), reduce the interference with the wireless communication in 2.4GHz. It can be switched on or off with a switch on the computer.

 Remote controller

A remote controller for easy operation from some distance.

 USB FDD

USB FDD supports 720KB and 1.44MB.

 PC card slot

The PC card slot (PCMCIA) accommodates one 5mm Type II card. (Based on PC Card Standard, supporting CardBus)

 USB (Universal Serial Bus)

Four USB ports are provided. The ports comply with the USB2.0 standard, which enables data transfer speeds 40 times faster than USB1.1 standard. USB1.1 is also supported.

 Bridge Media slot

One SD memory card/ SDIO card/Memory stick (PRO)/xD picture card/MultiMedia card slot. Data can be read and written by inserting each media to the slot.

 IEEE1394 port

The computer has one IEEE 1394 port. It enables high-speed data transfer directly from external devices such as digital video cameras.

S/PDIF

This port can send or receive the digital sound data with the equipment like CD, MD Player. (This port is also used for headphone I/F.)

Fingerprint sensor

The computer is equipped with a fingerprint sensor and fingerprint authentication utility. They enable only person who has registered his/her fingerprint to use the computer.

Figure 1-1 shows the front of the computer and the system units configuration.

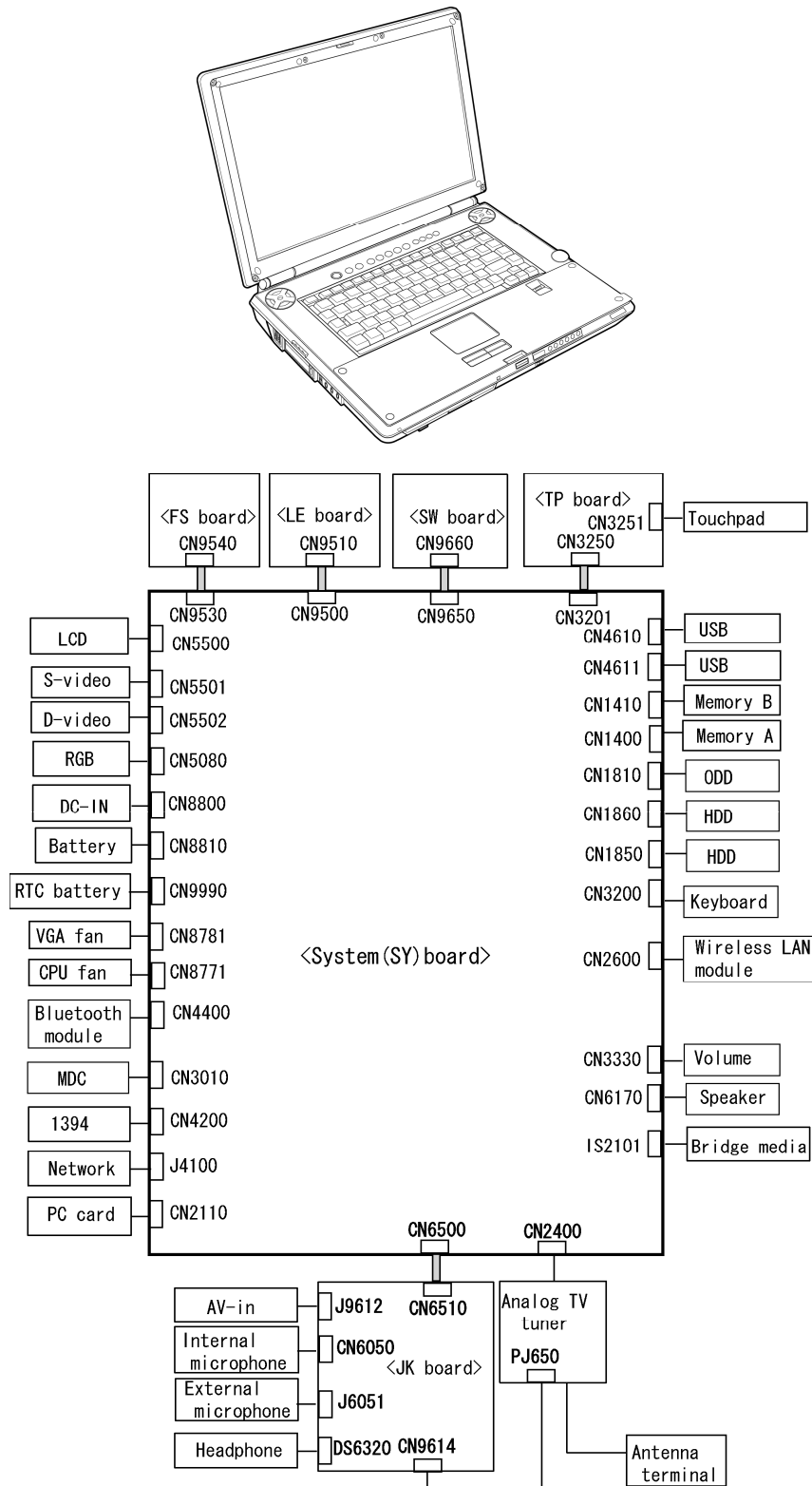

Figure 1-1 Front of the computer and the system units configuration

1.2 System Block Diagram

Figure 1-2 shows the system block diagram.

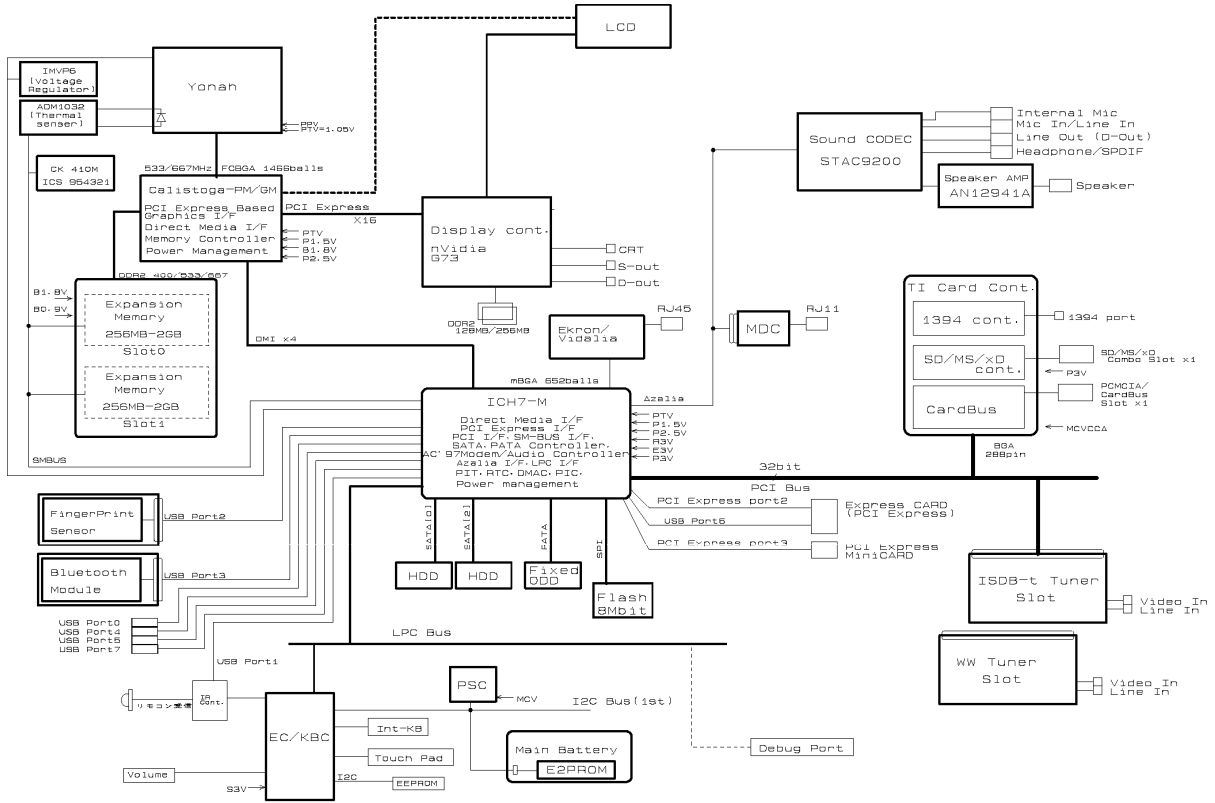

Figure 1-2 System block diagram

The PC contains the following components.

❑ CPU

Intel® Core™ Duo processor

Core™ Duo -2M 1.66GHz (Processor Number : T2300)
1.83GHz (Processor Number : T2400)
2.00GHz (Processor Number : T2500)
2.16GHz (Processor Number : T2600)

L1 cache : 64KB (32KB + 32KB)
L2 cache : 2MB
FSB : 667MHz Core voltage : 1.500~0.300V

Intel® Core™ Solo processor

Core™ Solo -1M 1.66GHz (Processor Number : T1300)

L1 cache : 64KB (32KB + 32KB)
L2 cache : 2MB
FSB : 667MHz Core voltage : 1.500~0.300V

Intel® Celeron® M processor

Celeron® M 1.60GHz (Processor Number : 420)
1.73GHz (Processor Number : 430)

L1 cache : 64KB (32KB + 32KB)
L2 cache : 1MB
FSB : 533MHz Core voltage : 1.500~0.300V

❑ Memory

Two memory slots capable of accepting DDR2-SDRAM 256MB, 512MB, 1024MB or 2048MB memory modules for a maximum of 4GB.

- 200-pin small-size DIMM
- 1.8V operation
- PC4200 (DDR2-533)/PC5300 (DDR2-667) support

❑ BIOS ROM (Flash memory)

- 8Mbit (512K×16-bit chip)

288KB used for system BIOS

64KB used for VGA-BIOS

64KB used for Finger Print

32KB used for ACPI

24KB used for booting

16KB used for Parameter Block

Others

❑ Chipset

This gate array has the following elements and functions.

• North Bridge (Intel 945PM/945GM)

- Support Yonah Processor System Bus

- System Memory Support : DDR2-400/DDR2-533/DDR2-667,
4GB(max)

- DMI (Direct Media Interface)

- ICH Support

- 1, 466-ball 37.5mm x 37.5mm x 2.56mm FC-BGA Package

• South Bridge (Intel 82801GBM (ICH7-M))

- DMI (Direct Media Interface)

- PCI Express I/F (4 ports)

- PCI Bus I/F Rev 2.3 (6 PCI REQ/GNT Pairs)

- Integrated Serial ATA Host Controller (2 ports, 150MB/S)

- Integrated IDE Controller (Ultra ATA 100/66/33)

- AC'97 Rev. 2.3 Controller

- USB 1.1/2.0 Controller 8 ports (EHCI: Enhanced Host Controller
Interface)

- Built-in LAN Controller (Wfm 2.0& IEEE802.3 compliance)

- Power Management (ACPI 2.0 compliance)

- SMBus2.0

- FWH interface (BIOS)

- Low Pin Count (LPC) interface (EC/KBC, Super I/O)

- IRQ controller

- Serial Interrupt Function

- Suspend/Resume control

- Built-in RTC

- GPIO

- 652-ball 31mm x 31mm x 2.51mm BGA Package

PC card controller (PCI7412ZHK, Texas Instrument-made)

- PCI Interface
- PC Card/Ultra Media Controller
- IEEE1394 Controller (2ports)
- SD/MMC, MemoryStick, xD card Controller
- 288-ball 16mm x 16mm x 1.4mm BGA Package

 GPU controller

nVIDIA G72/G73 (945PM models)

- VRAM DDR2 128MB (G72), DDR3 128MB/256MB (G73)
- PCI Express Interface
- LCD Interface LVDS 2ch
- Supports TV encoder, S-video, D-connector, HDMI

 Wireless LAN card (in PCI Express Mini card slot)

2.4GHz DSSS/OFDM, 5.0GHz OFDM wireless LAN card is equipped. Conformity with IEEE 802.11b/g or IEEE 802a/b/g. Transfer speed is maximum 54Mbit/sec. Supports 128/152 bit WEP.

 TV tuner (in Mini PCI card slot)

Some signals (NTSC, PAL and SECAM) are supported for worldwide use and MPEG2 hardware encoding function are also supported.

 LAN controller (Intel made Ekron)

Controls LAN and supports 1000Base-T (Gigabit Ethernet)/100BASE-TX (Fast Ethernet)/10BASE-T (Ethernet).

 MODEM (Askey-made MDC x 1)

Supported by Azallia MDC 1.5 using the Azallia link.

 Other main system chips

- PSC (Toshiba-made TMP86PM49UG x 1)
- Clock Generator (ICS-made 954321AGLFT x 1)
- EC/KBC (Renesas-made M306KAFCLRP U0 x 1)
- SPI Flash Memory (ST-Micro made M25PE80 ×1)

1.3 2.5-inch Hard Disk Drive

Compact, high-capacity Serial-ATA HDD with a height of 9.5mm/12.5mm containing a 2.5-inch magnetic disk and magnetic heads.

Figure 1-3 shows a view of the 2.5-inch HDD and Tables 1-1 and 1-2 list the dimensions and specifications.

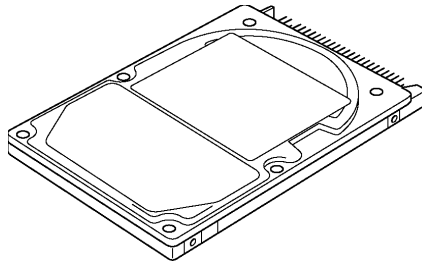

Figure 1-3 2.5-inch HDD

Table 1-1 2.5-inch HDD dimensions

Parameter		Standard value			
		FUJITSU G8BC0002W410	FUJITSU G8BC0002W610	FUJITSU G8BC0002W810	FUJITSU G8BC0002WA10
Outline dimensions	Width (mm)	70.0			
	Height (mm)	9.5			
	Depth (mm)	100.0			
	Weight (g)	101 (max)			

Parameter		Standard value			
		TOSHIBA HDD2D34BZK01	TOSHIBA HDD2D35BZK01	TOSHIBA HDD2D32BZK01	TOSHIBA HDD2D30BZK01
Outline dimensions	Width (mm)	69.85			
	Height (mm)	9.5			
	Depth (mm)	100.0			
	Weight (g)	98 (max)	102 (max)		

Parameter		Standard value		
		FUJITSU G8BC0002WC10	TOSHIBA HDD2D31BZK01	FUJITSU G8BC0002PG10
Outline dimensions	Width (mm)	70.0		
	Height (mm)	9.5	12.5	
	Depth (mm)	100.0		
	Weight (g)	101 (max)	102 (max)	135 (max)

Table 1-2 2.5-inch HDD Specifications

Parameter	Specification			
	FUJITSU G8BC0002W410	FUJITSU G8BC0002W610	FUJITSU G8BC0002W810	FUJITSU G8BC0002WA10
Storage size (formatted)	40GB	60GB	80GB	100GB
Speed (RPM)	5,400			
Data transfer rate To/From media (MB/s) To/From host (Gbps)	61.3 max. 1.5 (150 MB/s) max.			
Data buffer size (MB)	8			
Average seek time Read (ms)	12 typ.			
Motor startup time (s)	4 typ.			

Parameter	Specification			
	TOSHIBA HDD2D34BZK01	TOSHIBA HDD2D35BZK01	TOSHIBA HDD2D32BZK01	TOSHIBA HDD2D30BZK01
Storage size (formatted)	40GB	60GB	80GB	100GB
Speed (RPM)	5,400			
Data transfer rate (Mb/s)	218-429			236.1-456.0
Data buffer size (KB)	8,192			16,384
Average seek time Read (ms)	12			
Motor startup time (s)	4 typ.			

Parameter	Specification		
	FUJITSU G8BC0002WC10	TOSHIBA HDD2D31BZK01	FUJITSU G8BC0002PG10
Storage size (formatted)	120GB	120GB	160GB
Speed (RPM)	5,400	5,400	4,200
Data transfer rate To/From media (MB/s) To/From host (GBPS)	61.3 max. 1.5 (150 Mb/s)	42 max. 1.5 (150 Mb/s)	47.2 max. 1.5 (150 Mb/s)
Data buffer size (MB)	8	-	8
Average seek time Read (ms)	12 typ.	12.5 typ.	12 typ.
Motor startup time (s)	4 typ.	3.5 typ.	3.5 typ.

1.4 Optical Drive

1.4.1 DVD Super Multi Drive (supporting Double-Layer)

The DVD Super Multi drive (supporting Double Layer) accommodates 12 cm (4.72-inch) CD/DVD-ROM, CD-R/RW, DVD±R/±RW and DVD-RAM. It is a high-performance drive that reads DVD-ROM at maximum 8-speed and CD-ROM at maximum 24-speed. It writes CD-R at maximum 24-speed, CD-RW at maximum 16-speed (Ultra Speed), DVD-R and DVD+R at maximum 8-speed, DVD-RW and DVD+RW at maximum 4-speed, DVD-RAM at maximum 5-speed, DVD-R (Double Layer) at maximum 2-speed and DVD+R (Double Layer) at maximum 2.4-speed.

The DVD Super Multi drive is shown in Figure 1-4. The dimensions and specifications of the DVD Super Multi drive are described in Table 1-3, Table 1-4.

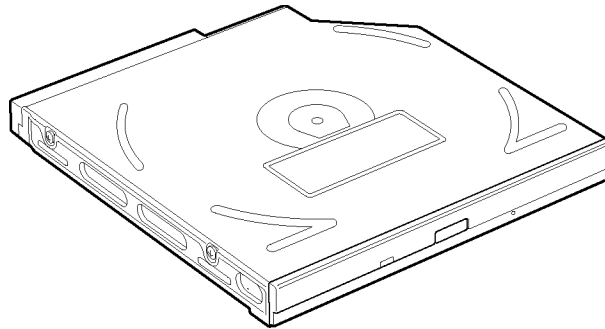

Figure 1-4 DVD Super Multi drive (Double-Layer)

Table 1-3 DVD Super Multi drive (Double-Layer) outline dimensions

Parameter		Standard value
Outline dimensions (excluding projections)	Maker	MATSUSHITA (G8CC0002PZ20)
	Width (mm)	128.0
	Height (mm)	12.7
	Depth (mm)	127.0
	Mass (g)	179 ±15

Table 1-4 DVD Super Multi drive (Double-Layer) specifications

Parameter		Drive Specification
		MATSUSHITA (G8CC0002PZ20)
Data transfer speed	Read	DVD-ROM MAX 8x CAV CD-ROM MAX 24x CAV
	Write (Maximum)	CD-R 24x (ZoneCLV) CD-RW 4x (CLV) High Speed CD-RW 10x (CLV) Ultra Speed CD-RW 16x (ZoneCLV) DVD-R 8x (ZoneCLV) DVD-R Dual Layer 2x (CLV) DVD-RW 4x (ZoneCLV) DVD+R 8x (ZoneCLV) DVD+R Dual Layer 2.4x (CLV) DVD+RW 4x (ZoneCLV) DVD-RAM 5x (ZoneCLV)
	ATAPI interface (MB/s)	PIO mode 16.67 MB/s (PIO MODE4 supported) DMA mode 16.67 MB/s (Multi-word MODE2 supported) Ultra DMA mode 33.33 MB/s (Ultra DMA MODE2 supported)
Access time (ms)	CD-ROM	150 (Random)
	DVD-ROM	180 (Random)
	DVD-RAM	280 (Random)
Buffer memory		-
Supported disk format	CD	CD-Audio, CD-ROM (mode1 and mode2), CD-ROM XA (mode2, form1 and form2), CD-I (mode2, form1 and form2), CD-I Ready, CD-I Bridge, CD-R, CD-RW, Photo CD, Video CD, Enhanced Music CD, CD-text
	DVD	DVD-5, DVD-9, DVD-10, DVD-18, DVD-R (3.95G/4.7G), DVD-RW, DVD+R, DVD+RW, DVD-RAM (4.7GB)

1.5 Keyboard

A keyboard which consists of 85(US)/86(UK) keys is mounted on the system unit. The keyboard is connected to membrane connector on the system board and controlled by the keyboard controller.

Figure 1-5 is a view of the keyboard.



Figure 1-5 Keyboard

See Appendix E for details of the keyboard layout.

1.6 TFT Color Display

The TFT color display is 15.4 inch and consists of LCD module and FL inverter board.

1.6.1 LCD Module

The LCD module used for the TFT color display uses a backlight as the light source and can display a maximum of 16M colors with 1,280 x 800 (WXGA) resolution.

Figure 1-6 shows a view of the LCD module and Table 1-5 lists the specifications.

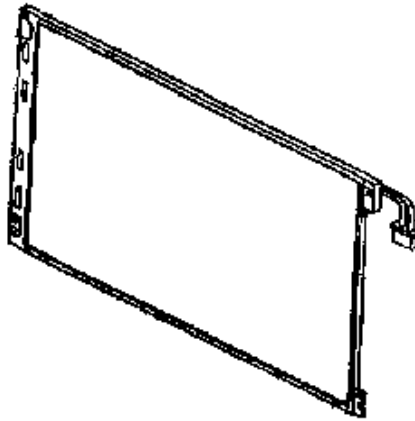

Figure 1-6 LCD module

Table 1-5 LCD module specifications

Item	Specifications (one lamp)
	Samsung (G33C0002S110)
Number of Dots	1,280(W) x 800(H)
Dot spacing (mm)	0.2588 (H) x 0.2588 (V)
Display range (mm)	331.2 (H) x 207.0 (V)
Outline dimensions	344.0 (W) x 222.0 (H) x 6.2 (D)

Item	Specifications
	Samsung (G33C0002X110)
Number of Dots	1,280(W) x 800(H)
Dot spacing (mm)	0.2588 (H) x 0.2588 (V)
Display range (mm)	331.2 (H) x 207.0 (V)
Outline dimensions	-

1.6.2 FL Inverter Board

The FL inverter board supplies a high frequency current to illuminate the LCD module FL.

Table 1-6 lists the FL inverter board specifications.

Table 1-6 FL inverter board specifications

Item		Specifications		
		G71C00011111 (One lamp)	G71C00011221 (One lamp)	G71C0004F410 (Two lamps)
Input	Voltage (V)	5 (DC)		
	Power (W)	7		18
Output	Voltage (V)	750 (rms)		900 (rms)
	Power (W/VA)	5 / 7		7 / 10 x 2 output
	Current (f=70KHz)(mA)	6 (rms)		7 (rms) x 2 output

1.7 Power Supply

The power supply supplies 31 different voltages to the system board.

The power supply microcontroller has the following functions.

1. Judges if the DC power supply (AC adapter) is connected to the computer.
2. Detects DC output and circuit malfunctions.
3. Controls the battery icon, and DC IN icon.
4. Turns the battery charging system on and off and detects a fully charged battery.
5. Turns the power supply on and off.
6. Provides more accurate detection of a low battery.
7. Calculates the remaining battery capacity.
8. Controls the transmission of the status signal of the main battery.

Table 1-7 lists the power supply output specifications.

Table 1-7 Power supply output rating (1/2)

Name	Power supply (Yes/No)				Object
	Voltage [V]	Power OFF (Suspend mode)	Power OFF (Boot mode)	No Battery	
PPV	1.500 - 0.300	No	No	No	CPU
PTV	1.05	No	No	No	CPU, MCH, GMCH, ICH7-M
1R5-P1V	1.5	No	No	No	CPU, MCH, GMCH, ICH7-M, PCI-e Mini Card
CRD1R5-P1V	1.5	No	No	No	Express Card
1R8-B1V	1.8	Yes	No	No	MCH, GMCH, DDR2-SDRAM
1R8-P1V	1.8	No	No	No	GPU, VRAM
2R5-P2V	2.5	No	No	No	MCH, GMCH, ICH7-M
LAN2R5-E2V	2.5	Yes	Yes / No	No	LAN
MR0R9-B0V	0.9	Yes	No	No	MCH, GMCH, DDR2-SDRAM
0R9-P0V	0.9	No	No	No	DDR2-SDRAM
P3V	3.3	No	No	No	Clock Generator, Thermal Sensor, MCH, GMCH, SDRAM(SPD), ICH7-M, HDD, PC-Card Cont., PC-Card Power, TV Tuner, PCI-e Mini Card, LED, LCD, GPU, STAC9200
E3V	3.3	Yes	Yes / No	No	ICH7-M, PCI-e Mini Card, MDC, SPI Flash
S3V	3.3	Yes	Yes	No	EC/KBC
CRD-E3V	3.3	Yes	Yes / No	No	Express Card
CRD-P3V	3.3	No	No	No	Express Card
FM-P3V	3.3	No	No	No	Flash Media
BT-P3V	3.3	No	No	No	Bluetooth
LAN-E3V	3.3	Yes	Yes / No	No	LAN
PGV	1.2	No	No	No	GPU
1R2-P1V	1.2	No	No	No	GPU
LAN1R2-E1V	1.2	Yes	Yes / No	No	LAN
P5V	5	No	No	No	ICH7-M, ODD, HDD, PC-Card Power, LED, TV Tuner, KB, PAD, CRT, FAN, FL-Inv
E5V	5	Yes	Yes / No	No	ICH7-M, USB Power

Table 1-7 Power supply output rating (2/2)

Name	Power supply (Yes/No)				
	Voltage [V]	Power OFF (Suspend mode)	Power OFF (Boot mode)	No Battery	Object
BCAS-P5V	5	No	No	No	BCAS
M5V	5	Yes	Yes	No	LED
MCV	5	Yes	Yes	No	PSC
TUNER-P5V	5	No	No	No	WW Tuner
TUNER2-P5V	5	No	No	No	ISDB-t Tuner
SND-P5V	5	No	No	No	AN12941A
A4R7-P4V	4.7	No	No	No	STAC9200, AN12941A
R3V	2.0 -3.5	Yes	Yes	Yes	ICH7-M (RTC)

1.8 Batteries

The PC has the following two batteries.

- Main battery
- Real time clock (RTC) battery

Table 1-8 lists the specifications for these two batteries.

Table 1-8 Battery specifications

Battery Name		Battery Element	Output Voltage	Capacity
Main battery	G71C00063210	Lithium ion 6 cell	10.8V	4,700mAh
	G71C00063110			
	G71C00064210	Lithium ion 9 cell	10.8V	7,050mAh
	G71C00064110			
Real time clock (RTC) battery	GDM710000041	Nickel hydrogen	2.4V	16mAh

1.8.1 Main Battery

The main battery is the primary power supply for the computer when the AC adapter is not connected. In Standby, the main battery maintains the current status of the computer.

1.8.2 Battery Charging Control

Battery charging is controlled by a power supply microprocessor. The power supply microprocessor controls power supply and detects a full charge when the AC adaptor and battery are connected to the computer.

Battery Charge

When the AC adapter is connected, normal charging is used while the system is turned on and quick charge is used while the system is turned off. Refer to the following Table 1-9.

Table 1-9 Time required for charges of main battery

Battery type	Quick charge	Normal charge
Battery 6cell (4,700mAh)	About 3.0 (hours)	About 3.0 to 3.5 or longer (hours)
Battery 9cell (7,050mAh)		About 3.0 to 5.0 or longer (hours)

Charge is stopped in the following cases.

1. The main battery is fully charged
2. The main battery is removed
3. Main battery or AC adapter voltage is abnormal
4. Charging current is abnormal

Data preservation time

When turning off the power in being charged fully, the preservation time is as following Table 1-10.

Table 1-10 Data preservation time

Condition	preservation time
Standby	About 5 days (Battery 6cell (4,700mAh)) About 8 days (Battery 9cell (7,050mAh))
Boot mode	About 20 days (Battery 6cell (4,700mAh)) About 35 days (Battery 9cell (7,050mAh))

1.8.3 RTC Battery

The RTC battery provides the power supply to maintain the date, time, and other system information in memory.

Table 1-11 lists the Time required for charges of RTC battery and data preservation time.

Table 1-11 Time required for charges of RTC battery

Condition	Time
Power ON (Lights Power LED)	About 8 hours
Data preservation tome (Full-charged)	About 30 days

1.9 AC Adapter

The AC adapter is used to charge the battery.

Table 1-12 lists the AC adapter specifications.

Table 1-12 AC adapter specifications

Item	Specification
	G71C00043310 (2-pin) / G71C00049410 (3-pin) / G71C00049510 (3-pin)
Power	75W (Peak 90W)
Input voltage	AC 100V/240V
Input frequency	50Hz/60Hz
Input current	1.5A or less
Output voltage	15.0V
Output current	0A~5A (At constant voltage mode) 5A~6A (At surge load mode)

Item	Specification
	G71C00058210 (2-pin) / G71C0005S210 (3-pin)
Power	90W (Peak 105W)
Input voltage	AC 100V/240V
Input frequency	50Hz/60Hz
Input current	1.5A or less
Output voltage	15.0V
Output current	0A to 6A (At constant voltage mode) 6A~7A (At surge load mode)

Item	Specification
	G71C0002R810 (2-pin) / G71C00067210 (3-pin)
Power	120W (Peak 150W)
Input voltage	AC 100V/240V
Input frequency	50Hz/60Hz
Input current	1.7A or less
Output voltage	15.0V
Output current	8.0A

Chapter 2

Troubleshooting Procedures

Chapter 2 Contents

2.1	Troubleshooting	2-1
2.2	Troubleshooting Flowchart.....	2-3
2.3	Power Supply Troubleshooting.....	2-8
	Procedure 1 Power Status Check	2-8
	Procedure 2 Error Code Check	2-10
	Procedure 3 Connection Check.....	2-16
	Procedure 4 Charging Check	2-16
	Procedure 5 Replacement Check	2-17
2.4	System Board Troubleshooting.....	2-18
	Procedure 1 Message Check	2-19
	Procedure 2 Debugging Port Check.....	2-21
	Procedure 3 Diagnostic Test Program Execution Check	2-32
	Procedure 4 Replacement Check	2-32
2.5	USB FDD Troubleshooting	2-33
	Procedure 1 FDD Head Cleaning Check	2-33
	Procedure 2 Diagnostic Test Program Execution Check	2-34
	Procedure 3 Connector Check and Replacement Check.....	2-35
2.6	2.5" HDD Troubleshooting.....	2-37
	Procedure 1 Partition Check.....	2-37
	Procedure 2 Message Check	2-38
	Procedure 3 Format Check.....	2-39
	Procedure 4 Diagnostic Test Program Execution Check	2-40
	Procedure 5 Connector Check and Replacement Check.....	2-41
2.7	Keyboard Troubleshooting	2-42
	Procedure 1 Diagnostic Test Program Execution Check	2-42
	Procedure 2 Connector Check and Replacement Check.....	2-43
2.8	Touch pad Troubleshooting	2-44
	Procedure 1 Diagnostic Test Program Execution Check	2-44
	Procedure 2 Connector Check and Replacement Check.....	2-45

2.9	Display Troubleshooting.....	2-46
	Procedure 1 External Monitor Check.....	2-46
	Procedure 2 Diagnostic Test Program Execution Check	2-46
	Procedure 3 Connector and Cable Check.....	2-47
	Procedure 4 Replacement Check	2-48
2.10	Optical Disk Drive Troubleshooting.....	2-49
	Procedure 1 Diagnostic Test Program Execution Check	2-49
	Procedure 2 Connector Check and Replacement Check.....	2-49
2.11	Modem Troubleshooting.....	2-50
	Procedure 1 Diagnostic Test Program Execution Check	2-50
	Procedure 2 Connector Check and Replacement Check.....	2-50
2.12	LAN Troubleshooting.....	2-52
	Procedure 1 Diagnostic Test Program Execution Check	2-52
	Procedure 2 Connector Check and Replacement Check.....	2-52
2.13	Wireless LAN Troubleshooting	2-53
	Procedure 1 Transmitting-Receiving Check	2-53
	Procedure 2 Antennas' Connection Check	2-54
	Procedure 3 Replacement Check	2-55
2.14	Bluetooth Troubleshooting	2-56
	Procedure 1 Transmitting-Receiving Check	2-56
	Procedure 2 Antennas' Connection Check	2-57
	Procedure 3 Replacement Check	2-58
2.15	Sound Troubleshooting.....	2-59
	Procedure 1 Diagnostic Test Program Execution Check	2-59
	Procedure 2 Connector Check.....	2-59
	Procedure 3 Replacement Check	2-60
2.16	TV Tuner Troubleshooting	2-61
	Procedure 1 Connector Check and Replacement Check.....	2-61
2.17	Bridge media Slot Troubleshooting	2-62
	Procedure 1 Check on Windows OS.....	2-62
	Procedure 2 Connector Check and Replacement Check.....	2-62

2.18	Fingerprint sensor	2-63
	Procedure 1 Setting Windows Log-ON password	2-64
	Procedure 2 Registration of fingerprint.....	2-64
	Procedure 3 Authentication of fingerprint	2-68
	Procedure 4 Connector Check and Replacement Check.....	2-69

Figures

Figure 2-1	Troubleshooting flowchart.....	2-4
Figure 2-2	A set of tool for debug port test	2-21

Tables

Table 2-1	Battery icon.....	2-8
Table 2-2	DC IN icon	2-9
Table 2-3	Error code	2-11
Table 2-4	Debug port (Boot mode) error status	2-22
Table 2-5	FDD error code and status	2-34
Table 2-6	2.5” Hard disk drive error code and status.....	2-40

2.1 Troubleshooting

Chapter 2 describes how to determine which Field Replaceable Unit (FRU) in the computer is causing the computer to malfunction. (The “FRU” means the replaceable unit in the field.) The FRUs covered are:

- | | | |
|-----------------|-----------------------|------------------------|
| 1. Power supply | 7. Display | 13. Sound |
| 2. System Board | 8. Optical Disk Drive | 14. TV Tuner |
| 3. USB FDD | 9. Modem | 15. Bridge Media slot |
| 4. 2.5” HDD | 10. LAN | 16. Fingerprint Sensor |
| 5. Keyboard | 11. Wireless LAN | |
| 6. Touch pad | 12. Bluetooth | |

The Test Program operations are described in Chapter 3. Detailed replacement procedures are described in Chapter 4.

NOTE: Before replacing the system board, it is necessary to execute the subtest 03 DMI Information save of the 3.4 Setting of the hardware configuration in Chapter 3.

After replacing the system board, it is necessary to execute the subtest 04 DMI Information recovery and subtest 08 System configuration display of the 3.4 Setting of the hardware configuration in Chapter 3. Also update with the latest EC/KBC as described in Appendix H “EC/KBC Rewrite Procedures”.

After replacing the LCD, update with the latest EC/KBC as described in Appendix H “EC/KBC Rewrite Procedures” to set the SVP parameter.

The implement for the Diagnostics procedures is referred to Chapter 3. Also, following implements are necessary:

1. Phillips screwdrivers (For replacement procedures)
2. Implements for debugging port check
 - Toshiba MS-DOS system FD
 - RS-232C cross cable
 - Test board with debug port test cable
 - PC for displaying debug port test result

There are following two types of connections in the figure of board and module connection in and after 2.3 Power Supply Troubleshooting.

(1) Cable connection is described in the figure as line.

(2) Pin connection is described in the figure as arrow.

<e.g> Connection of modem

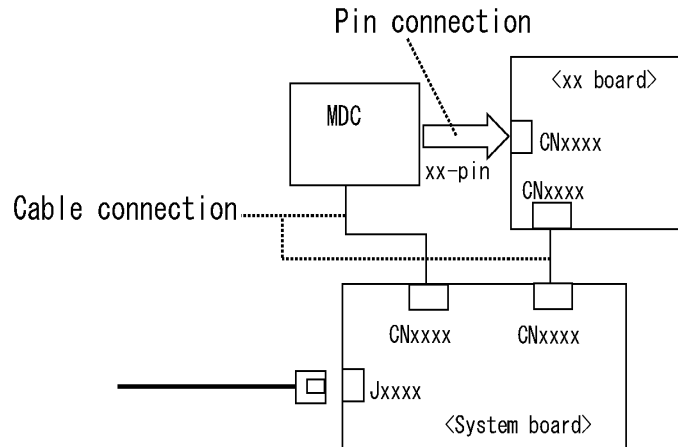

2.2 Troubleshooting Flowchart

Use the flowchart in Figure 2-1 as a guide for determining which troubleshooting procedures to execute. Before going through the flowchart steps, verify the following:

- Ask him or her to enter the password if a password is registered.
- Verify with the customer that Toshiba Windows OS is installed on the hard disk. Non-Windows operating systems can cause the computer to malfunction.
- Make sure all optional equipment is removed from the computer.

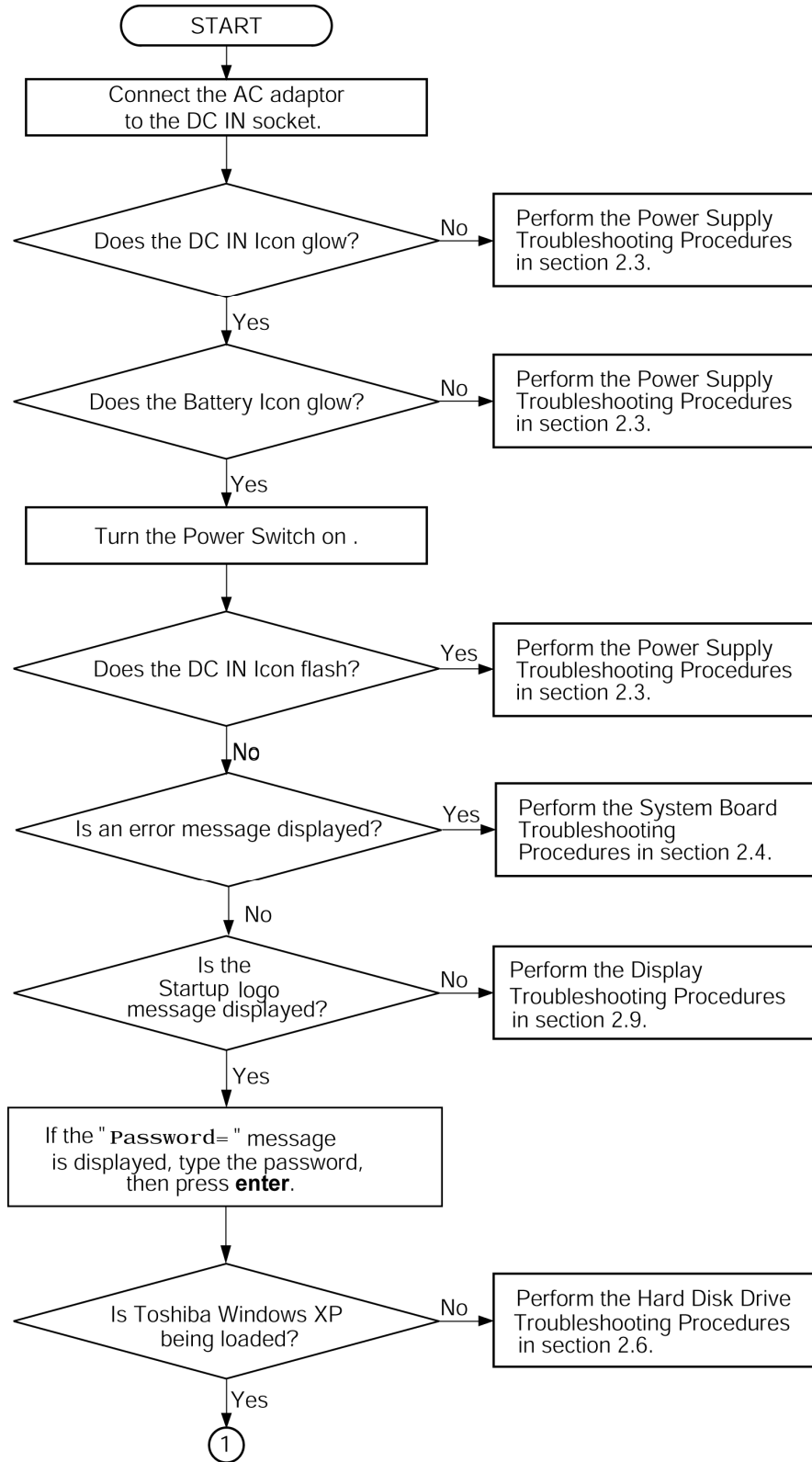

Figure 2-1 Troubleshooting flowchart (1/2)

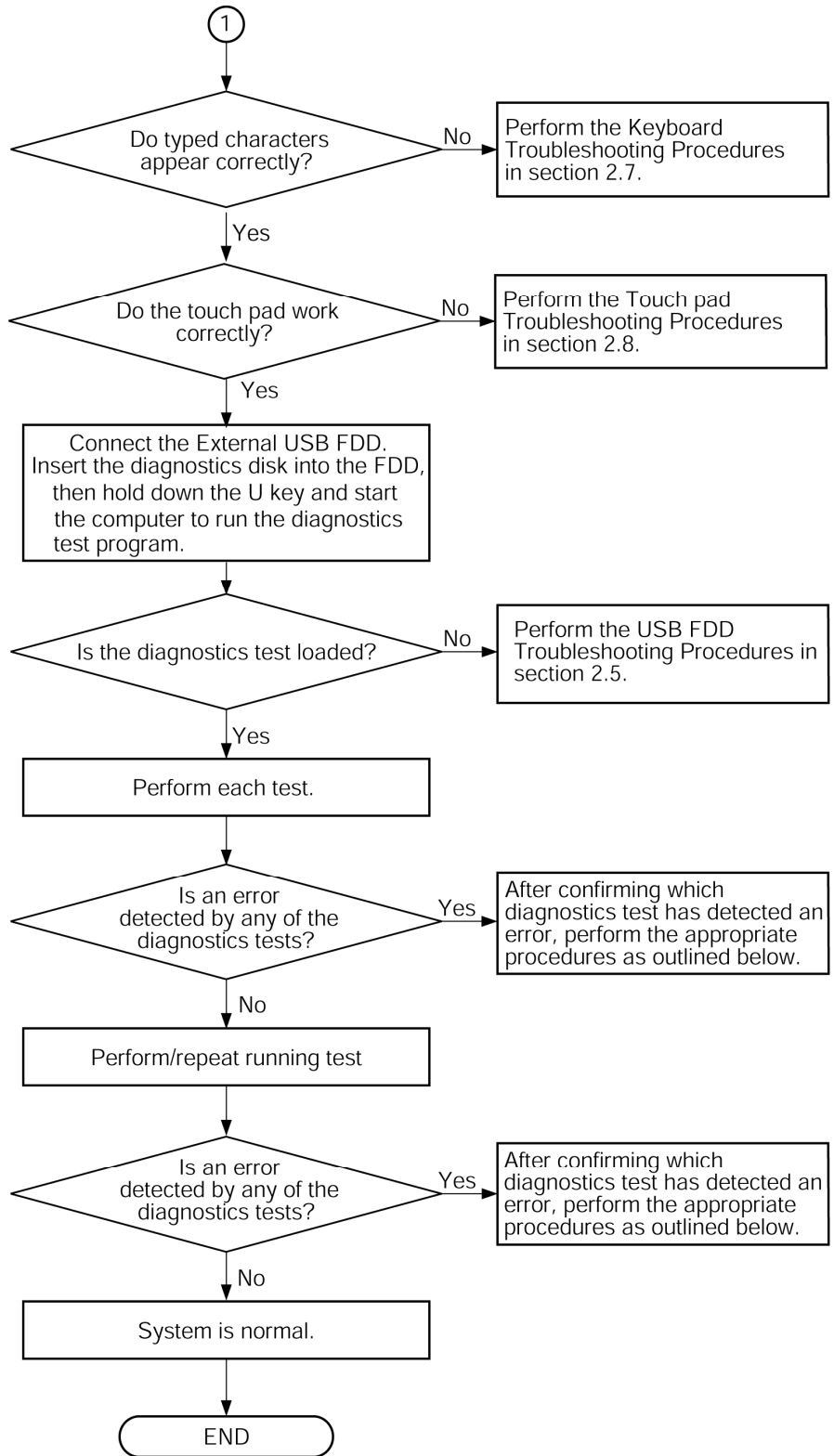

Figure 2-1 Troubleshooting flowchart (2/2)

If the diagnostics program cannot detect an error, the problem may be intermittent. The Test program should be executed several times to isolate the problem. Check the Log Utilities function to confirm which diagnostic test detected an error(s), then perform the appropriate troubleshooting procedures as follows:

1. If an error is detected on the system test, memory test, display test, CD-ROM/DVD-ROM test, expansion test, real timer test, Sound/LAN/Modem test, Bluetooth test or IEEE1394 test, perform the System Board Troubleshooting Procedures in Section 2.4.
2. If an error is detected on the floppy disk test, perform the USB FDD Troubleshooting Procedures in Section 2.5.
3. If an error is detected on the hard disk test, perform the HDD Troubleshooting Procedures in Section 2.6.
4. If an error is found on the keyboard test (DIAGNOSTICS TEST) and pressed key display test (ONLY ONE TEST), perform the Keyboard Troubleshooting Procedures in Section 2.7.
5. If an error is found on the touch pad test (ONLY ONE TEST), perform the touch pad Troubleshooting Procedures in Section 2.8.
6. If an error is detected on the display test, perform the Display Troubleshooting Procedures in Section 2.9.
7. If an error is detected on the CD-ROM/DVD-ROM test, perform the Optical Disk Drive Troubleshooting Procedures in Section 2.10.
8. If an error is detected on the modem test, perform the Modem Troubleshooting Procedures in Section 2.11.
9. If an error is detected on the LAN test, perform the LAN Troubleshooting Procedures in Section 2.12.
10. If an error is detected on the wireless LAN test, perform the Wireless LAN Troubleshooting Procedures in Section 2.13.
11. If an error is detected on the Bluetooth test, perform the Bluetooth Troubleshooting Procedures in Section 2.14.
12. If an error is detected on the sound test, perform the Sound Troubleshooting Procedures in Section 2.15.

If a malfunction is detected by the following items, perform the appropriate troubleshooting procedures follows.

1. If a malfunction is detected on the power supply, perform the Power Supply Troubleshooting Procedures in Section 2.3.
2. If a malfunction is detected on the TV tuner, perform the TV tuner Troubleshooting Procedures in Section 2.16.
3. If a malfunction is detected on the Bridge media, perform the Bridge media Slot Troubleshooting Procedures in Section 2.17.
4. If a malfunction is detected on the fingerprint sensor, perform the Fingerprint Sensor Troubleshooting Procedures in Section 2.18.

2.3 Power Supply Troubleshooting

The power supply controller controls many functions and components. To determine if the power supply is functioning properly, start with Procedure 1 and continue with the other Procedures as instructed. The procedures described in this section are:

- Procedure 1: Power Status Check
- Procedure 2: Error Code Check
- Procedure 3: Connection Check
- Procedure 4: Charging Check
- Procedure 5: Replacement Check

Procedure 1 Power Status Check

The following icons indicate the power supply status:

- Battery icon
- DC IN icon

The power supply controller displays the power supply status with the Battery icon and the DC IN icon as listed in the tables below.

Table 2-1 Battery icon

Battery icon	Power supply status
Lights orange	Battery is charged and the external DC is input. It has no relation with ON/OFF of the system power.
Lights green	Battery is fully charged and the external DC is input. It has no relation with ON/OFF of the system power.
Blinks orange (even intervals)	The battery level is low while the system power is ON.
Blinks orange once (at being switched on)	The system is driven by only a battery and the battery level is low.
Doesn't light	Any condition other than those above.

Table 2-2 DC IN icon

DC IN icon	Power supply status
Lights green	DC power is being supplied from the AC adapter.
Blinks orange	Power supply malfunction ^{*1}
Doesn't light	Any condition other than those above.

*1 When the power supply controller detects a malfunction, the DC IN icon blinks orange. It shows an error code.

When the icon is blinking, perform the following procedure.

1. Remove the battery pack and the AC adapter.
2. Re-attach the battery pack and the AC adapter.

If the icon is still blinking after the operation above, check the followings:

Check 1 If the DC IN icon blinks orange, go to Procedure 2.

Check 2 If the DC IN icon does not light, go to Procedure 3.

Check 3 If the battery icon does not light orange or blue, go to Procedure 4.

NOTE: Use a supplied AC adapter G71C00043310, G71C00058210, G71C0002R810 (2-pin)/G71C00049410, G71C00049510, G71C0005S210, G71C00067210 (3-pin).

Procedure 2 Error Code Check

If the power supply microprocessor detects a malfunction, the DC IN icon blinks orange. The blink pattern indicates an error as shown below.

- | | |
|---|---------------------|
| <input type="checkbox"/> Start | Off for 2 seconds |
| <input type="checkbox"/> Error code (8 bit) | |
| “1” | On for one second |
| “0” | On for half second |
| Interval between data bits | Off for half second |

The error code begins with the least significant digit.

Example: Error code 11h (Error codes are given in hexadecimal format.)

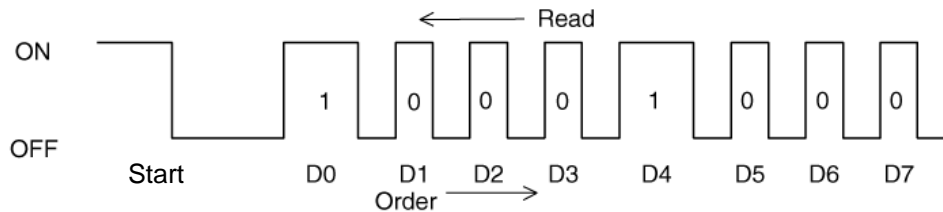

Check 1 Convert the DC IN icon blink pattern into the hexadecimal error code and compare it to the tables below. Then go to Check 2.

Table 2-3 Error code

Error code	Where error occurs
1*h	DC Power (AC Adapter)
2*h	Main battery
3*h	2nd battery
4*h	S3V output
5*h	E5V output
6*h	E3V output
7*h	1R5-E1V output
8*h	1R8-B1V output
9*h	PPV output
A*h	PTV output
B*h	1R5-E1V output
C*h	PGV/PTV output
D*h	1R5-P1V output
E*h	1R5-P1V output
F*h	-

DC power supply (AC adapter)

Error code	Meaning
10h	AC Adapter output voltage is over 16.5V.
11h	Common Dock output voltage is over 16.5V.
12h	Current from the DC power supply is over 12.0A.
13h	Current from the DC power supply is over 0.5A when there is no load.
14h	Abnormal current has been sensed.

Main Battery

Error code	Meaning
22h	Main battery discharge current is over 0.5A.
23h	Main battery charge current is over 4.3A.
24h	Abnormal current has been sensed.
25h	Main battery charge current is over 0.3A when the charging is off.

 2nd Battery

Error code	Meaning
32h	Second battery discharge current is over 0.5A.
33h	Second battery charge current is over 4.3A.
34h	Abnormal current has been sensed.
35h	Second battery charge current is over 0.3A when the charging is off.

 S3V output

Error code	Meaning
40h	S3V voltage is over 3.47V.
45h	S3V voltage is under 3.14V.
46h	S3V voltage is under 3.14V or less when the computer is booting up.

 E5V output

Error code	Meaning
50h	E5V voltage is over 6.00V.
51h	E5V voltage is under 4.50V when the computer is powered on.
52h	E5V voltage is under 4.50V when the computer is booting up.
54h	E5V voltage is under 4.50V when EV power is maintained.

E3V output

Error code	Meaning
60h	E3V voltage is over 3.96V.
61h	E3V voltage is under 2.81V when the computer is powered on.
62h	E3V voltage is under 2.81V when the computer is booting up.
64h	E3V voltage is under 2.81V when EV power is maintained.

1R5-E1V output

Error code	Meaning
70h	1R5-E1V voltage is over 1.80V.
71h	1R5-E1V voltage is under 1.275V when the computer is powered on.
72h	1R5-E1V voltage is under 1.275V when the computer is booting up.
73h	1R5-E1V voltage is over 1.275V when EV power is maintained.

1R8-B1V output

Error code	Meaning
80h	1R8-B1V voltage is over 2.16V.
81h	1R8-B1V voltage is under 1.53V when the computer is powered on.
82h	1R8-B1V voltage is under 1.53V when the computer is booting up.
84h	1R8-B1V voltage is under 1.53V when BV power is maintained.

PPV output

Error code	Meaning
90h	PPV voltage is over 1.80V.
91h	PPV voltage is under 0.32V when the computer is powered on.
92h	PPV voltage is under 0.32V when the computer is booting up.

PTV output

Error code	Meaning
A0h	PTV voltage is over 1.26V.
A1h	PTV voltage is under 0.89V when the computer is powered on.
A2h	PTV voltage is under 0.89V when the computer is booting up.

1R5-E1V output

Error code	Meaning
B0h	1R5-E1V voltage is over 1.80V.
B1h	1R5-E1V voltage is under 1.275V when the computer is powered on.
B2h	1R5-E1V voltage is under 1.275V when the computer is booting up.
B4h	1R5-E1V voltage is under 1.275V when EV power is maintained.

PGV/PTV output

Error code	Meaning
C0h	PGV voltage is over 1.62V when the computer is powered on/off. PTV voltage is over 1.26V when the computer is powered on/off.
C1h	PGV voltage is under 0.68V when the computer is powered on. PTV voltage is under 0.89V when the computer is powered on.
C2h	PGV voltage is under 0.68V when the computer is booting up. PTV voltage is under 0.89V when the computer is booting up.
C4h	PGV voltage is under 0.68V when EV power is maintained. PTV voltage is under 0.89V when EV power is maintained.

1R5-P1V output

Error code	Meaning
D0h	1R5-P1V voltage is over 1.80V.
D1h	1R5-P1V voltage is under 1.275V when the computer is powered on.
D2h	1R5-P1V voltage is under 1.275V when the computer is booting up.

1R5-P1V output

Error code	Meaning
E0h	1R5-P1V voltage is over 1.80V.
E1h	1R5-P1V voltage is under 1.248V when the computer is powered on.
E2h	1R5-P1V voltage is under 1.248V when the computer is booting up.

 Miscellaneous

Error code	Meaning
F0h	The sub clock does not oscillate.

Check 2 In the case of error code 10h or 12h:

- Make sure the AC adapter and AC power cord are firmly plugged into the DC IN 15 V socket and wall outlet. If the cables are connected firmly, go to the following step.
- Connect a new AC adapter and AC power cord. If the problem still occurs, go to Procedure 5.

Check 3 In the case of error code 21h:

- Go to Procedure 3.

Check 4 For any other errors, go to Procedure 5.

Procedure 3 Connection Check

The wiring diagram related to the power supply is shown below:

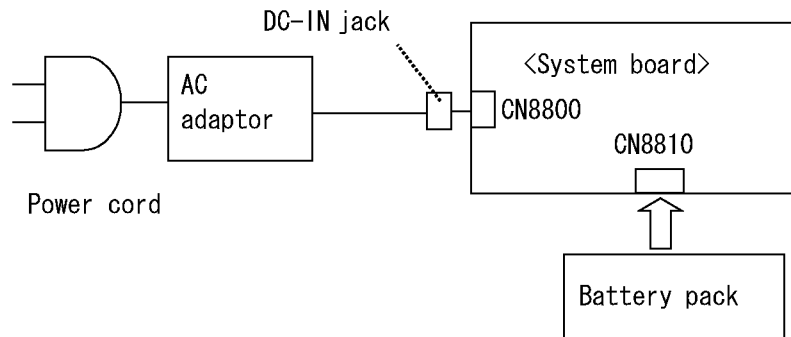

Any of the connectors may be disconnected. Perform Check 1.

- Check 1 Make sure the AC adaptor and the AC power cord are firmly plugged into the DC IN jack and wall outlet. If these cables are connected firmly, go to Check 2.
- Check 2 Replace the AC adaptor and the AC power cord with new ones.
- If the DC IN icon does not light, go to Procedure 5.
 - If the battery icon does not light, go to Check 3.
- Check 3 Make sure the battery pack is installed in the computer correctly. If the battery is properly installed and the battery icon still does not light, go to Procedure 4.

Procedure 4 Charging Check

Check if the power supply controller charges the battery pack properly. Perform the following procedures:

- Check 1 Make sure the AC adaptor is firmly plugged into the DC IN jack.
- Check 2 Make sure the battery pack is properly installed. If it is properly installed, go to Check 3.
- Check 3 The battery pack may be completely discharged. Wait a few minutes to charge the battery pack while connecting the battery pack and the AC adaptor. If the battery pack is still not charged, go to Check 4.
- Check 4 The battery's temperature is too high or low. Leave the battery for a while to adjust it in the right temperature. If the battery pack is still not charged, go to Check 5.
- Check 5 Replace the battery pack with a new one. If the battery pack is still not charged, go to Procedure 5.

Procedure 5 Replacement Check

The power is supplied to the system board by the AC adapter. If either the AC adapter or the system board was damaged, perform the following Checks.

To disassemble the computer, follow the steps described in Chapter 4, *Replacement Procedures*.

When AC adapter is connected:

- Check 1 AC adapter may be faulty. Replace the AC adapter with a new one. If the problem still occurs, perform Check 2.
- Check 2 System board may be faulty. Replace the system board with a new one.

When AC adapter is not connected:
(When driving with battery pack)

- Check 1 Battery pack may be faulty. Replace it with a new one. If the problem still occurs, perform Check 2.
- Check 2 System board may be faulty. Replace it with a new one.

2.4 System Board Troubleshooting

This section describes how to determine if the system board is malfunctioning or not. Start with Procedure 1 and continue with the other procedures as instructed. The procedures described in this section are:

Procedure 1: Message Check

Procedure 2: Debugging Port Check

Procedure 3: Diagnostic Test Program Execution Check

Procedure 4: Replacement Check

Procedure 1 Message Check

When the power is turned on, the system performs the Initial Reliability Test (IRT) installed in the BIOS ROM. The IRT tests each IC on the system board and initializes it.

- If an error message is shown on the display, perform Check 1.
- If there is no error message, go to Procedure 2.
- If MS-DOS or Windows OS is properly loaded, go to Procedure 4.

Check 1 If one of the following error messages is displayed on the screen, press the **F1** key as the message instructs. These errors occur when the system configuration preserved in the RTC memory (CMOS type memory) is not the same as the actual configuration or when the data is lost.

If you press the **F1** key as the message instructs, the **SETUP** screen appears to set the system configuration. If error message (b) appears often when the power is turned on, replace the RTC battery. If any other error message is displayed, perform Check 2.

- (a) *** Bad HDD type ***
Check system. Then press [F1] key
- (b) *** Bad RTC battery ***
Check system. Then press [F1] key
- (c) *** Bad configuration ***
Check system. Then press [F1] key
- (d) *** Bad memory size ***
Check system. Then press [F1] key
- (e) *** Bad time function ***
Check system. Then press [F1] key
- (f) *** Bad check sum (CMOS) ***
Check system. Then press [F1] key
- (g) *** Bad check sum (ROM) ***
Check system. Then press [F1] key

Check 2 If the following error message is displayed on the screen, press any key as the message instructs.

The following error message appears when data stored in RAM under the resume function is lost because the battery has become discharged or the system board is damaged. Go to Procedure 3.

```
WARNING: RESUME FAILURE.  
PRESS ANY KEY TO CONTINUE.
```

If any other error message displays, perform Check 3.

Check 3 The IRT checks the system board. When the IRT detects an error, the system stops or an error message appears.

If one of the following error messages (1) through (17), (23) or (24) is displayed, go to Procedure 4.

If error message (18) is displayed, go to the Keyboard Troubleshooting Procedures.

If error message (19), (20) or (21) is displayed, go to the 2.5" HDD Troubleshooting Procedures.

If error message (22) is displayed, go to the USB FDD Troubleshooting Procedures.

- (1) PIT ERROR
- (2) MEMORY REFRESH ERROR
- (3) TIMER CH.2 OUT ERROR
- (4) CMOS CHECKSUM ERROR
- (5) CMOS BAD BATTERY ERROR
- (6) FIRST 64KB MEMORY ERROR
- (7) FIRST 64KB MEMORY PARITY ERROR
- (8) VRAM ERROR
- (9) SYSTEM MEMORY ERROR
- (10) SYSTEM MEMORY PARITY ERROR
- (11) EXTENDED MEMORY ERROR
- (12) EXTENDED MEMORY PARITY ERROR
- (13) DMA PAGE REGISTER ERROR
- (14) DMAC #1 ERROR
- (15) DMAC #2 ERROR
- (16) PIC #1 ERROR
- (17) PIC #2 ERROR
- (18) KBC ERROR
- (19) HDC ERROR
- (20) HDD #0 ERROR
- (21) HDD #1 ERROR
- (22) NO FDD ERROR
- (23) TIMER INTERRUPT ERROR
- (24) RTC UPDATE ERROR

Procedure 2 Debugging Port Check

Check the D port status by a debug port test. The tool for debug port test is shown below.

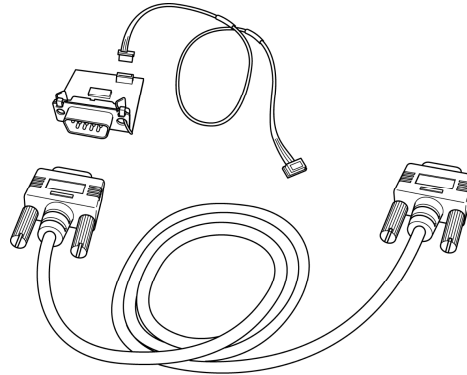
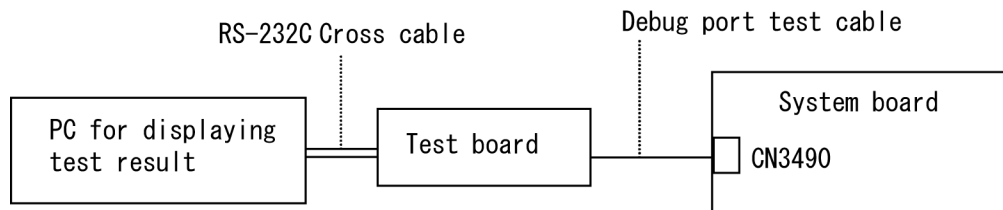

Figure 2-2 A set of tool for debug port test

The test procedures are follows:

1. Connect the debug port test cable to the connector CN3490 of the system board. For disassembling to connect the test cable, refer to Chapter 4.
2. Connect the debug port test cable and RS-232C cross-cable to the test board.
3. Connect the RS-232C cross-cable to the PC that displays the results.



4. Boot the computer in MS-DOS mode.
5. Execute GETDPORT.COM in the text menu in CPU REAL mode. (Insert the FD for starting D port into FDD and input “FD starting drive:>dport”.)

The D port status is displayed in the following form;

F100 : 000.000382	IRT_CHK_INI\SYSI_START
-----	-----
D port status	Contents of process
Time (second) to process	

6. When the D port status is FFFFh (normal status), go to Procedure 4.
7. When the D port status falls into any status in Table 2-4, execute Check 1.

Table 2-4 Debug port (Boot mode) error status (1/10)

D port status	Inspection items	Details
Boot block	Permission of A20 and Clear of software reset bit	
	Prohibition of APIC	
	Initialization of MCH and ICH	
	Initialization of Super I/O (For models supporting Super I/O)	
	Initialization of debug port (For models supporting debug port)	
	Dummy read of 3 rd Bus data	
	Setting of printer port (For models supporting printer port)	
F000h	Only PIT CH0 initialization (for HOLD_ON)	
	BIOS rewrite factor flag initialization	
	CHECK SUM CHECK	Transition to protected mode
		Boot block checksum (skip when returned to S3) (halts when error)
	Checksum other than boot block (skip when returned to S3)	
F001h	EC/KBC rewrite check	If "rewrite" is requested, go to "BIOS rewrite process".
F002h	Initialization of SC	HLT at DPORT=F003H or F004H, when error occurs
	Key input (skipped when returned from S3)	When a key is pressed, check if it is Tilde key or Tab key. (skipped when returned from S3)
F005h	Enables CPU cache	
F006h	Security check	
	BIOS rewrite request check	If Checksum check error occurred on except Boot Block or rewrite is required by user, go to "BIOS rewrite process".
F007	Transits to System BIOS IRT	
	BIOS rewrite process	Initialization of ICHM. D31
		DRAM configuration
		Permission of cache (L1 cache only)
		Memory clear
	Transition to real mode and copy of BIOS to RAM	

Table 2-4 Debug port (Boot mode) error status (2/10)

D port status	Inspection items	Details	
F009h	Saving key scan code		
	Setting TASK_1ms_TSC		
	Controlling fan		
	Initializing sound items (for BEEP)	Releasing mute	
		Making the volume max (model that can control volume)	
	When request BIOS, EC/KBC rewriting	Blinks green (cycle:2s, on:1s, off:1s)	
	When BIOS renewal is prohibited	Blinks orange (cycle:8s, on:4s, off:4s) HLT after BEEP is sounded for 30s (Dport=F00BH)	
	Key input	Prohibition of USB	
		BEEP	
		Waiting for key input	
	Reading CHGBIOSA.EXE / CHGFIRMA.EXE	FDC reset	
		Setting parameters for 2HD(1.44MB)	
		Reading of first sector, If it is the data of 1.44MB (2HD), the media type is definite.	
		Setting of parameters for 2DD (720KB)	
		Retrieval of "CHGBIOSA.EXE" from the root directory.	
		Directory start header and calculates the sector	
		Read 1 sector of the root directory	
		Retrieval of entry of "CHGBIOSA.EXE" /"CHGFIRMA.EXE" from the sector read.	
		Reading of EXE header of "CHGBIOSA.EXE" and "CHGFIRMA.EXE"	
		Key input when error occurred	
Execution of "CHGBIOSA.EXE" and "CHGFIRMA.EXE"			

Table 2-4 Debug port (Boot mode) error status (3/10)

D port status	Inspection items	Details	
F100h	Prohibition of cache		
	Permission of L1/L2 cache in Flash ROM area		
	Update of microcode		
	Initialization of H/W (before DRAM recognition)		Initialization of MCH
			Initialization of ICH.D30.Func0
			Initialization of ICH.D31.Func0
			Initialization of ICH.D31.Func1/2
			Initialization of USB Controller
			Initialization of ICH.D31.Func3
			Initialization of ICH Audio
			Initialization of TI Controller
Initialization of PIT channel 1	(Setting the refresh interval to "30μs")		
F101h	Check of DRAM type and size (at cold boot)	When unsupported memory is connected, becoming HLT after beep sound (HLT when DRAM size is 0)	
	SM-RAM stack area test	HLT When it can not be used as a stack	
F102h	Cache configuration		
	Cache permission (L1/L2 Cache)		
	CMOS access test (at cold boot)	(HLT when an error is detected)	
	Battery level check of CMOS		
	CMOS checksum check		
	Initialization of CMOS data (1)		
	Setting of IRT status	(Setting of boot status and IRT busy flag, The rest bits are 0)	
	Storing DRAM size in CMOS		
F103h	Resume branch (at cold boot)	Not resume when a CMOS error occurred	
		Not resume when resume status code is not set	
		Resume error check S3 returning error (1CH) (Resume error =F17AH) SM-RAM checksum check (Resume error =F173H) Check of memory configuration change (Resume error =F173H) RAM area checksum check in system BIOS (Resume error =F179H)	

Table 2-4 Debug port (Boot mode) error status (4/10)

D port status	Inspection items	Details
(F103h)		Expansion memory checksum check resume error (Resume error =F176H)
		PnP RAM checksum check (Resume error F177H)
		Transition to RESUME-MAIN
	Resume error process	Reset of CPU clock to low
		Prohibition of all SMI
		Clearance of resume status
		Return to ROM
		Turning area of C0000h to EFFFFh to PCI (Prohibition of DRAM)
	Setting of resume error request	
Copying ROM/RAM of system BIOS	(HLT, when error occurs)	
F104h	Security check	
F105h	SMRAM initialization	
	APIC initialization	
	WakeUp factor check	
	SMRAM base rewriting and CPU state map saving for BIOS	
	Permission of SMI based on ASMI	
F106h	Initialization of devices which need initialization before PCI bus initialization.	PIT test (Cold boot only) and initialization
		Setting of test pattern to channel 0 of PIT#0
		Check whether the set test pattern can be read
		Initialization of PIT channel 0, Setting of timer interruption interval to 55ms
		Initialization of PIT channel 2, Setting of the sound generator frequency to 664Hz
		Test of PIT channel 1 (Check whether the refresh signal works normally in 30 micro-s refresh interval.) HLT, when the time is out.
		Test of PIT channel 2 (Check whether the speaker gate works normally.)

Table 2-4 Debug port (Boot mode) error status (5/10)

D port status	Inspection items	Details
(F106h)		CPU clock measurement
		Check of parameter block A
		Permission of SMI except auto-off function
		Judging of destination (Japan or except Japan) based on DMI data
		Battery discharging current control (1CmA).
		Dividing procedures for time measuring by IRT
		Setting for clock generator
		Check of CMOS default setting (Default is set, when there are Bad Battery and Bad CheckSum (ROM, CMOS))
		Control of excess of rated input power
		AC adapter rated over current control
		CPU Initialization
F107h	Saving memory configuration to buffer	
	Reading of EC version	
	Update of flash ROM type	
	ACPI table initialization (for execution of option ROM)	
	Initialization of devices which need initialization before PCI bus initialization	Setting of IDE device operation mode
		Setting of AC'97/Azalia operation mode
		Initialization of temperature control information
		KBC initialization
		VGA display off, Reset control
		Control of built-in LAN permission/ prohibition
		PCI Express initialization
		Sound initialization
		PC multi-box status acquisition (For models supporting Select Bay)
HC initialization and Device recognition		
Recognition and initialization of SD memory card		

Table 2-4 Debug port (Boot mode) error status (6/10)

D port status	Inspection items	Details
(F107h)	PIC initialization	
	PIC test	
	Password Initialization	
F108h	PCI bus initialization (connection of DS Bus)	
	Initialization of LAN information	
	WakeUp factor check	
F109h	Task generation for waiting INIT_PCI completion	
	SVP initialization (For models supporting SVP)	
	CMOS data initialization (2)	
	PnP initialization	
	Setting of setup items	
	Waiting for the completion of Multi-box status check (For models supporting SVP)	
	H/W setting based on resource	
F10Ah	Task generation for waiting PnP resource making completion	
	PnP H/W initialization	PC card slot initialization
		SIO initialization (For models supporting SIO)
		FIR initialization (For models supporting FIR)
	PCI automatic configuration	Making of work for automatic configuration
		Acquisition of PCI IRQ
		Configuration
		Saving of VGA configuration result

Table 2-4 Debug port (Boot mode) error status (7/10)

D port status	Inspection items	Details
F10Bh	Task generation for waiting PCI_CONFIGURATION completion	
	Initialization of H/W needed after PCI configuration	Printer port setting (model supporting Printer port)
		HDD initialization sequence start
		FDD initialization sequence start (model supporting built-in FDD)
	Enabling power off	
Output code generation		
F10Ch	FIRST_64KB_CHECK	(Check of first 64KB memory)
F10Dh	INIT_INT_VECTOR	(Initialization of vectors)
F10Eh	INIT_NDP	(Initialization of NDP)
F10Fh	INIT_SYSTEM	(Initialization of system)
		Storing of CMOS error information to IRT_ERR_STS_BUF
		Controlling CD POWER SW (model supporting CD play)
		Timer initialization start
		EC initialization & Reading of battery information
		Update of system BIOS (Update EDID information for LCD)
F110h	INIT_DISPLAY	(Waiting for VGA chip initialization completion, VGA BIOS initialization)
		Waiting for VGA power-on
		Waiting for Display access completion
F111h	Calling VGA BIOS	
F113h	DISP_LOGO	(Logo displaying) (Starting of logo display waiting DPORT=F125H (unused))
F114h	SYS_MEM_CHECK	(Check of conventional memory) (Boot)
F115h	EXT_MEM_CHECK	(Exception check in protected mode) (Boot)
F116h	INIT_SYS_MEM	(Initialization of conventional memory) (Reboot) (DPORT=F117H if error occurred during exception check in protected mode)
F118h	CHK_DMA_PAGE	(Check of DMA Page Register) (Boot)

Table 2-4 Debug port (Boot mode) error status (8/10)

D port status	Inspection items	Details
F119h	CHECK_DMACH	(Check of DMACH) (Boot)
F11Ah	INIT_DMACH	(Initialization of DMACH) (Boot)
F11Bh	CHECK_PRT	(Check of printer existence) (For models supporting Printer port)
F11Ch	CHECK_SIO	(Check of SIO) (model supporting SIO)
F11Dh	Treatment of displaying the test results	(When DIAGNOSTIC mode is permitted)
F11Eh	BOOT_PASSWORD (In the case of "Reboot")	(Check of password)
		Waiting for FDD initialization completion (For models supporting built-in FDD)
		Waiting for HDD initialization completion
	(In the case of "Boot")	Check of key input during IRT (waiting for KBC initialization completion)
		I/O LOCK Processing (model supporting I/O LOCK)
		Initialization of ATA priority
		Check of key input during IRT (waiting for KBC initialization completion)
		Input of password (waiting for HDD initialization completion)
		I/O LOCK Processing (For models supporting I/O LOCK)
		TPM Initialization (For models supporting TPM)
F11Fh	EX_IO_ROM_CHECK	(Check of option I/O ROM)
F120h	PRE_BOOT_SETUP	Saving of value in 40:00h (For SIO saving/restoring)
		Setting of font address for resume password
		Setting of repeat parameter for USB KB
		Check of keys pressed during IRT
		Storing of T_SHADOW_RAM_SIZE
		Update of system resource before boot
		Rewriting of memory map data of INT15h E820h function
		Waiting for AC-Link initialization completion (For models supporting AC-Link)
Updating of table for DMI		

Table 2-4 Debug port (Boot mode) error status (9/10)

D port status	Inspection items	Details
(F120h)		Copy of ACPI table to top of expansion memory
		Waiting for writing of PSC version to BIOS completion
		Waiting for clock generator setting completion When error occurred, halts at DPORT=F121H
		Waiting for serial port initialization completion (For models supporting SIO)
		Cancel of NMI Mask
		Taking out TIT check sum
		Clear of the IRT flag on Runtime side
		Update of check sum on Runtime side
		Hibernation branch (For models supporting BIOS Hibernation)
		Initialization of Bluetooth (For models supporting Bluetooth)
		Check of existence of object maintenance cards
		Prohibition of unused PC cards
		Setting Wakeup status data for ACPI
		HW initialization before Boot, waiting for initialization completion
		Notifies the DVI connection status to VGA BIOS (For models supporting DVI)
		Setting of battery save mode
		Setting of date
		Waiting for Bluetooth initialization completion (For models supporting Bluetooth)
		PCI device configuration space close
		Cache control
Process for CPU (Make the CPU clock to be set by SETUP)		
Waiting of motor-off completion of disabled HDD		
Final setting of FDD information		

Table 2-4 Debug port (Boot mode) error status (10/10)

D port status	Inspection items	Details
(F120h)		Post processing of PRE_BOOT_SETUP Clears PWRBTN_STS Enables POWER Button
F122h	Initialization of SC	
F124h	Clearness of IRT status	
	Update of Checksum on Runtime side	
F1FFh	End	

NOTE: Status outputted by the test means the last error detected in the debug port test.

Check 1 If the D port is status F11Eh or F120h is displayed, go to “HDD Trouble shooting Procedure in Section 2.6.

Check 2 If any other D port status error code is displayed, perform Procedure 3.

D port error code is as follows:

Error code	Contents
F003h or F004h	SC initialization error
F00Bh	BIOS update error
F117h	Exception check error
F121h	Clock generator error

Procedure 3 Diagnostic Test Program Execution Check

Execute the following tests from the Diagnostic Test Menu. These tests check the system board. Refer to Chapter 3, *Tests and Diagnostic*, for more information on how to perform these tests.

1. System test
2. Memory test
3. Keyboard test
4. Display test
5. Floppy Disk test
6. Printer test [It is not supported]
7. Async test [It is not supported]
8. Hard Disk test
9. Real Timer test
10. NDP test
11. Expansion test
12. CD-ROM/DVD-ROM test
13. Only One test
14. Wireless LAN test
15. Sound/LAN/Modem test
16. Bluetooth test
17. IEEE 1394 test

If an error is detected during these tests, go to Procedure 4.

Procedure 4 Replacement Check

System board may be faulty. Disassemble the computer following the steps described in Chapter 4, *Replacement Procedures* and replace system board with a new one.

2.5 USB FDD Troubleshooting

To check if the USB FDD is malfunctioning or not, follow the troubleshooting procedures below as instructed.

Procedure 1: FDD Head Cleaning Check

Procedure 2: Diagnostic Test Program Execution Check

Procedure 3: Connector Check and Replacement Check

Procedure 1 FDD Head Cleaning Check

FDD head cleaning is one option available in the Diagnostic Program.

After connecting USB FDD, insert the Diagnostics Disk in the floppy disk drive. Turn on the computer and run the test. And then clean the FDD heads using the cleaning kit. If the FDD still does not function properly after cleaning, go to Procedure 2.

Detailed operation is given in Chapter 3, *Tests and Diagnostics*.

If the test program cannot be executed on the computer, go to Procedure 3.

Procedure 2 Diagnostic Test Program Execution Check

Insert the Diagnostics Disk in the USB FDD, turn on the computer and run the test. Refer to Chapter 3, *Tests and Diagnostics*, for more information about the diagnostics test procedures.

Make sure the floppy disk is formatted correctly and that the write protect tab is disabled. Floppy disk drive test error codes and their status names are listed in Table 2-5. If any other errors occur while executing the FDD diagnostics test, go to Check 1.

Table 2-5 FDD error code and status

Code	Status
01h	Bad command
02h	Address mark not found
03h	Write protected
04h	Record not found
06h	Media replaced
08h	DMA overrun error
09h	DMA boundary error
10h	CRC error
20h	FDC error
40h	Seek error
60h	FDD not drive
80h	Time out error (Not ready)
EEh	Write buffer error
FFh	Data compare error

Check 1 If the following message is displayed, disable the write protect tab on the floppy disk by sliding the write protect tab to “write enable”. If any other message appears, perform Check 2.

Write protected

Check 2 Make sure the floppy disk is formatted correctly. If it is, go to Procedure 3.

Procedure 3 Connector Check and Replacement Check

USB FDD is connected to USB port on system board. The connection of the cable and board may be defective. Otherwise, they may be faulty. Disassemble the computer following the steps described in Chapter 4, *Replacement Procedures* and perform the following checks.

USB FDD can be connected to the following 4 ports.
(System board x 4 ports)

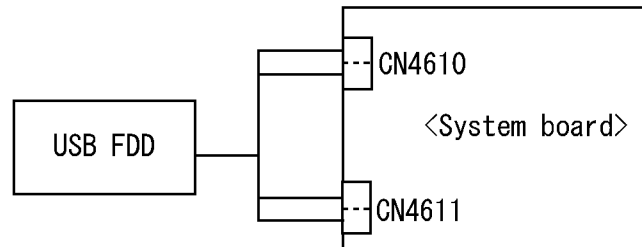

Check 1 Make sure USB FDD is firmly connected to USB port. If the connection is loose, connect firmly and repeat Procedure 2. If the problem still occurs, go to Check 2.

NOTE: When checking the connection, be sure to check it with care for the followings.

1. Cable can not be disconnected from the connector.
2. Cable is connected straight to the connector.
3. Cable is connected all the way seated in the connector.
4. Cable or connector can not be broken.

- Check 2 Connect USB FDD to other USB port and check if it works properly. If it does not work properly, perform Check 3
- Check 3 USB FDD may be faulty. Replace it with a new one. If the problem still occurs, perform Check 4
- Check 4 System board may be faulty. Replace it with a new one following the steps in Chapter 4, *Replacement Procedures*.

2.6 2.5" HDD Troubleshooting

To check if the 2.5" HDD is malfunctioning or not, follow the troubleshooting procedures below as instructed.

Procedure 1: Partition Check

Procedure 2: Message Check

Procedure 3: Format Check

Procedure 4: Diagnostic Test Program Execution Check

Procedure 5: Connector Check and Replacement Check

CAUTION: *The contents of the hard disk will be erased when the 2.5" HDD troubleshooting procedures are executed. Transfer the contents of the hard disk to floppy disks or other storage drive(s). For the backup, refer to the User's Manual.*

Procedure 1 Partition Check

Insert the Toshiba MS-DOS system disk and start the computer. Perform the following checks:

- Check 1 Input **C:** and press **Enter**. If you cannot change to drive C, go to Check 2. If you can change to drive C, go to Procedure 2.
- Check 2 Input **FDISK** and press **Enter**. Choose Display Partition Information from the FDISK menu. If drive C is listed in the Display Partition Information, go to Check 3. If drive C is not listed, return to the FDISK menu and choose the option to create a DOS partition or a logical DOS drive on drive C. If the problem still occurs, go to Procedure 2.
- Check 3 If drive C is listed as active in the FDISK menu, go to Check 4. If drive C is not listed as active, return to the FDISK menu and choose the option to set the active partition for drive C. Then go to Procedure 2.
- Check 4 Remove the system disk from the FDD and reboot the computer. If the problem still occurs, go to Procedure 2. Otherwise, the 2.5" HDD is operating normally.

Procedure 2 Message Check

When the power is turned on, the system performs the Initial Reliability Test (IRT) installed in the BIOS ROM. When the test detects an error, an error message is displayed on the screen.

Make sure no floppy disk is in the FDD. Turn on the computer and check the message on the screen. When an OS starts from the 2.5" HDD, go to Procedure 3. Otherwise, start with Check 1 below and perform the other checks as instructed.

Check 1 If any of the following messages appear, go to Procedure 3. If the following messages do not appear, perform Check 2.

HDC ERROR

or

HDD #X ERROR (After 5 seconds this message will disappear.)

Check 2 If either of the following messages appears, go to Check 3. If the following messages do not appear, perform Check 4.

Insert system disk in drive
Press any key when ready

or

Non-System disk or disk error
Replace and press any key when ready

Check 3 Using the SYS command of the MS-DOS, transfer the system to the 2.5" HDD. If the system is not transferred, go to Procedure 3. Refer to the MS-DOS Manual for detailed operation.

If the following message appears on the display, the system program has been transferred to the HDD.

System Transferred

If an error message appears on the display, perform Check 4.

Check 4 2.5" HDD(s) and the connector(s) of system board may be defective (Refer to the steps described in Chapter 4, *Replacement Procedures* for disassembling.). Insert HDD(s) to the connector(s) firmly. If it is (or they are) firmly connected, go to Procedure 3.

Procedure 3 Format Check

The computer's HDD is formatted using the MS-DOS FORMAT program or the physical format program of the test program. To format the HDD, start with Check 1 below and perform the other steps as required.

Refer to the MS-DOS Manual for the operation of MS-DOS. For the format by the test program, refer to the Chapter 3.

Check 1 Format the 2.5" HDD using MS-DOS FORMAT command. Type as **FORMAT C: /S/U**.

 If the 2.5" HDD can not be formatted, perform Check 2.

Check 2 Using the MS-DOS FDISK command, set the 2.5" HDD partition. If the partition is not set, go to Check 3. If it is set, format the 2.5" HDD using MS-DOS FORMAT command.

Check 3 Using the Diagnostic Disk, format the 2.5" HDD with a format option (physical format). If HDD is formatted, set the 2.5" HDD partition using MS-DOS FDISK command.

 If you cannot format the 2.5" HDD using the Tests and Diagnostic program, go to Procedure 4.

Procedure 4 Diagnostic Test Program Execution Check

The HDD test program is stored in the Diagnostics Disk. Perform all of the HDD tests in the Hard Disk Drive Test. Refer to Chapter 3, *Tests and Diagnostics*, for more information about the HDD test program.

If an error is detected during the HDD test, an error code and status will be displayed. The error codes and statuses are described in Table 2-6. If an error code is not displayed but the problem still occurs, go to Procedure 5.

Table 2-6 2.5" Hard disk drive error code and status

Code	Status
05	HDD - HDC NOT RESET ERROR
07	HDD - DRIVE NOT INITIALIZE
09	HDD - DMA BOUNDARY ERROR
0B	HDD - BAD TRACK ERROR
BB	HDD - UNDEFINED ERROR
08	HDD - OVERRUN ERROR (DRQ ON)
01	HDD - BAD COMMAND ERROR
02	HDD - ADDRESS MARK NOT FOUND
04	HDD - RECORD NOT FOUND ERROR
10	HDD - ECC ERROR
20	HDD - HDC ERROR
40	HDD - SEEK ERROR
80	HDD - TIME OUT ERROR
11	HDD - ECC RECOVER ENABLE
AA	HDD - DRIVE NOT READY
CC	HDD - WRITE FAULT
E0	HDD - STATUS ERROR
0A	HDD - BAD SECTOR
EE	HDD - ACCESS TIME ERROR
DA	HDD - NO HDD
12	HDD - DMA CRC ERROR

Procedure 5 Connector Check and Replacement Check

HDD(s) is/are connected to the connector(s) on the system board. The connection of HDD(s) and board may be defective. Otherwise, they may be faulty. Disassemble the computer following instructions in Chapter 4, *Replacement Procedures* and perform the following checks.

- Check 1 Make sure HDD(s) is/are firmly connected to the connector(s) on the system board.

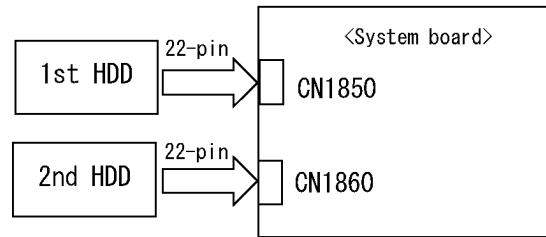

If any of the connections are loose, reconnect firmly and repeat Procedure 1. If the problem still occurs, go to Check 2.

- Check 2 (One of) HDD(s) may be faulty. Replace it with a new one following the instructions in Chapter 4, *Replacement Procedures* and check the operation. If the problem still occurs, perform Check 3.
- Check 3 System board may be faulty. Replace it with a new one following the instructions in Chapter 4, *Replacement Procedures*.

2.7 Keyboard Troubleshooting

To check if the computer's keyboard is malfunctioning or not, follow the troubleshooting procedures below as instructed.

Procedure 1: Diagnostic Test Program Execution Check

Procedure 2: Connector Check and Replacement Check

Procedure 1 Diagnostic Test Program Execution Check

Execute the Keyboard Test (DIAGNOSTIC TEST) and Pressed key display test (ONLY ONE TEST) in the Diagnostic Program. Refer to Chapter 3, *Tests and Diagnostics*, for more information on how to perform the test program.

If an error occurs, go to Procedure 2. If an error does not occur, keyboard is functioning properly.

Procedure 2 Connector Check and Replacement Check

The connection of cable and board may be defective. Otherwise, they may be faulty. Disassemble the computer following the steps described in Chapter 4, *Replacement Procedures*, and perform the following checks:

Check 1 Make sure keyboard cable is firmly connected to system board.

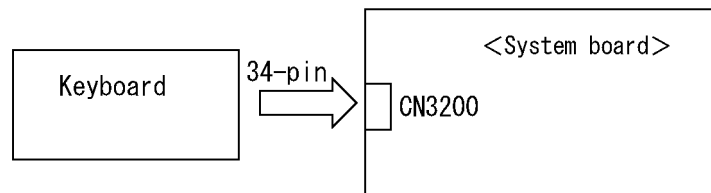

If the connection is loose, reconnect firmly and repeat Procedure 1. If the problem still occurs, go to Check 2.

Check 2 Keyboard may be faulty. Replace it with a new one following the instructions in Chapter 4, *Replacement Procedures*. If the problem still occurs, perform Check 3.

Check 3 System board may be faulty. Replace it with a new one following the instructions in Chapter 4, *Replacement Procedures*.

2.8 Touch pad Troubleshooting

To check if the computer's touch pad is malfunctioning or not, follow the troubleshooting procedures below as instructed.

Procedure 1: Diagnostic Test Program Execution Check

Procedure 2: Connector Check and Replacement Check

Procedure 1 Diagnostic Test Program Execution Check

Execute the Touch pad test (ONLY ONE TEST) in the Diagnostic Program. Refer to Chapter 3, *Tests and Diagnostics*, for more information on how to perform the test program.

If an error occurs, go to Procedure 2. If an error does not occur, touch pad is functioning properly.

Procedure 2 Connector Check and Replacement Check

The connection of the cable and board may be defective. Otherwise, they may be faulty. Disassemble the computer following the steps described in Chapter 4, *Replacement Procedures*, and perform the following checks:

Check 1 Make sure the cables are firmly connected to the TP board and system board.

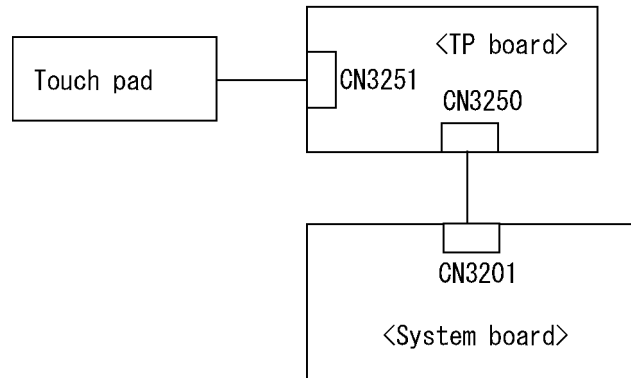

If the connection is loose, reconnect firmly and repeat Procedure 1. If the problem still occurs, go to Check 2.

- Check 2 Touch Pad or the cable may be faulty. Replace it with a new one following the instructions in Chapter 4, *Replacement Procedures*. If the problem still occurs, perform Check 3.
- Check 3 TP board or the cable may be faulty. Replace it with a new one following the instructions in Chapter 4, *Replacement Procedures*. If the problem still occurs, perform Check 4.
- Check 4 System board may be faulty. Replace it with a new one following the instructions in Chapter 4, *Replacement Procedures*.

2.9 Display Troubleshooting

To check if the computer's display is malfunctioning or not, follow the troubleshooting procedures below as instructed.

Procedure 1: External Monitor Check

Procedure 2: Diagnostic Test Program Execution Check

Procedure 3: Connector and Cable Check

Procedure 4: Replacement Check

Procedure 1 External Monitor Check

Connect an external monitor to the computer's external monitor port, then boot the computer. The computer automatically detects the external monitor.

If the external monitor works correctly, the internal LCD may be faulty. Go to Procedure 3.

If the external monitor appears to have the same problem as the internal monitor, system board may be faulty. Go to Procedure 2.

Procedure 2 Diagnostic Test Program Execution Check

The Display Test program is stored in Diagnostics disk. This program checks the display controller on system board. Insert the Diagnostics disk in the USB FDD, turn on the computer and run the test. Refer to Chapter 3, *Tests and Diagnostics* for details. If an error is detected, go to Procedure 3.

Procedure 3 Connector and Cable Check

LCD Module is connected to system board by an LCD/FL cable. FL inverter board is also connected to system board by an LCD/FL cable. In addition, fluorescent lamp is connected to FL inverter board by HV cable. Their cables may be disconnected from system board or FL inverter board. Disassemble the computer following the steps described in Chapter 4, *Replacement Procedures*.

If the connection is loose, reconnect firmly and restart the computer. If the problem still occurs, go to Procedure 4.

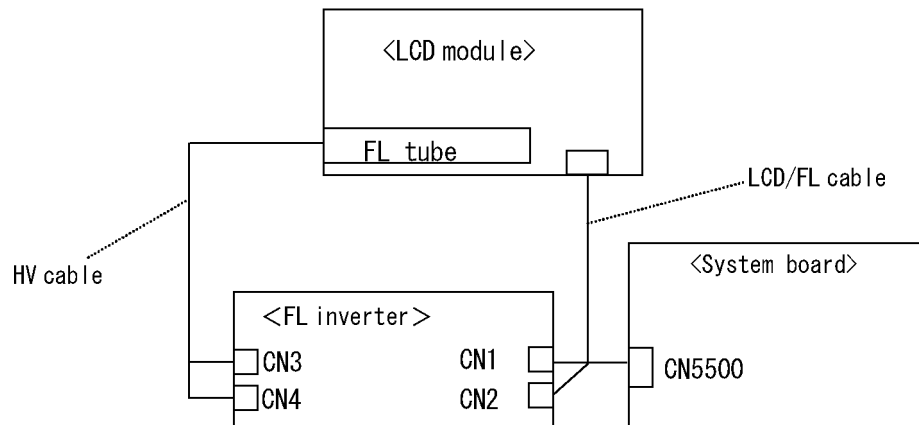

Procedure 4 Replacement Check

Fluorescent lamp, FL inverter, LCD module, HV cable and LCD/FL cable are connected to display circuits. Any of these components may be faulty. Refer to Chapter 4, *Replacement Procedures*, for instructions on how to disassemble the computer and then perform the following checks:

If fluorescent lamp does not light, perform Check 1.

If characters or graphics on the internal display are not displayed clearly, perform Check 4.

If some screen functions do not operate properly, perform Check 4.

If fluorescent lamp remains lit when the display is closed, perform Check 5.

- Check 1 Fluorescent lamp may be faulty. Replace fluorescent lamp with a new one following the instructions in Chapter 4, *Replacement Procedures* and test the display again. If the problem still occurs, perform Check 2.
- Check 2 LCD/FL cable may be faulty. Replace FL/LCD cable with a new one following the instructions in Chapter 4, *Replacement Procedure* and test the display again. If the problem still occurs, perform Check 3.
- Check 3 FL inverter may be faulty. Replace FL inverter with a new one following the instructions in Chapter 4, *Replacement Procedure* and test the display again. If the problem still occurs, perform Check 4.
- Check 4 LCD module may be faulty. Replace LCD module with a new one following the instructions in Chapter 4, *Replacement Procedure* and test the display again. If the problem still occurs, perform Check 5.
- Check 5 System board may be faulty. Replace it with a new one following the instructions in Chapter 4, *Replacement Procedure*.

2.10 Optical Disk Drive Troubleshooting

To check if optical disk drive is malfunctioning or not, follow the troubleshooting procedures below as instructed.

Procedure 1: Diagnostic Test Program Execution Check

Procedure 2: Connector Check and Replacement Check

Procedure 1 Diagnostic Test Program Execution Check

Execute the CD-ROM/DVD-ROM Test in the Diagnostic Program. Refer to Chapter 3, *Tests and Diagnostics* for more information on how to perform the test program.

Prepare the tools before the test.

If any error is detected by the test, go to Procedure 2.

Procedure 2 Connector Check and Replacement Check

The connection may be defective among the optical disk drive and system board. Otherwise, they may be faulty. Disassemble the computer following the steps described in Chapter 4, *Replacement Procedure* and perform the following checks:

Check 1 Make sure optical disk drive is firmly connected to the connector on system board.

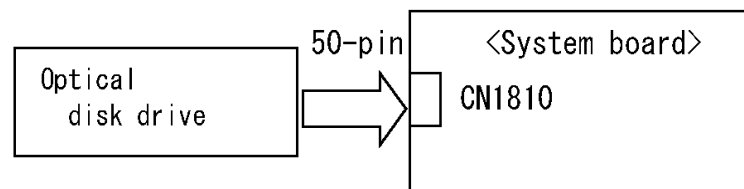

If the connection is loose, reconnect it firmly and return to Procedure 1. If the problem still occurs, perform Check 2.

Check 2 Optical disk drive may be faulty. Replace it with a new one following the steps in Chapter 4, *Replacement Procedure*. If the problem still occurs, perform Check 3.

Check 3 System board may be faulty. Replace it with new one following the instructions in Chapter 4, *Replacement Procedure*.

2.11 Modem Troubleshooting

To check if modem is malfunctioning or not, follow the troubleshooting procedures below as instructed.

Procedure 1: Diagnostic Test Program Execution Check

Procedure 2: Connector Check and Replacement Check

Procedure 1 Diagnostic Test Program Execution Check

Execute Modem test in the Sound/LAN/Modem test program. Refer to Chapter 3, *Tests and Diagnostics* for more information on how to perform the test program.

If any error is detected, perform Procedure 2.

Procedure 2 Connector Check and Replacement Check

MDC (Modem Daughter Card) is used as the modem for this computer. MDC is connected to the system board. If modem malfunctions, the connection of cable, board and module may be defective. Otherwise, they may be faulty.

Disassemble the computer following the steps described in Chapter 4, *Replacement Procedure* and perform the following checks:

Check 1 Make sure the following connections are firmly connected.

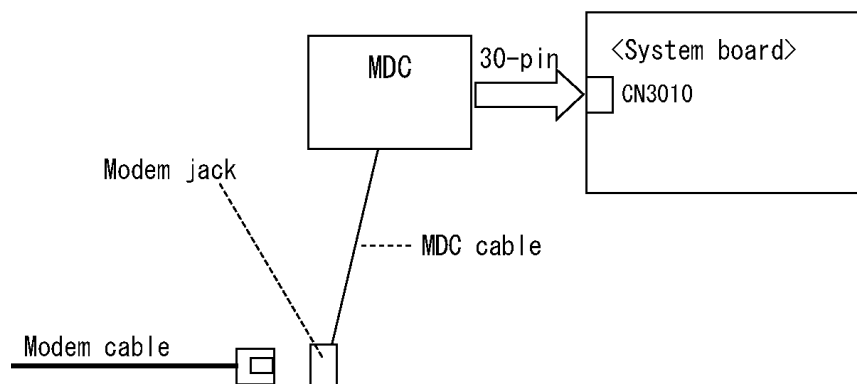

If any connector is disconnected, connect it firmly and return to Procedure 1. If the problem still occurs, perform Check 2.

- Check 2 Modem cable or MDC cable may be faulty. Replace it with a new one. If the problem still occurs, perform Check 3.
- Check 3 MDC may be faulty. Replace it with a new one following the steps in Chapter 4, *Replacement Procedure*. If the problem still occurs, perform Check 4.
- Check 4 System board may be faulty. Replace it with a new one following the instruction in Chapter 4, *Replacement Procedure*.

2.12 LAN Troubleshooting

To check if the computer's LAN is malfunctioning or not, follow the troubleshooting procedures below as instructed.

Procedure 1: Diagnostic Test Program Execution Check

Procedure 2: Connector Check and Replacement Check

Procedure 1 Diagnostic Test Program Execution Check

Execute LAN test in the Sound/LAN/Modem test program. Refer to Chapter 3, *Tests and Diagnostics* for more information on how to perform the test program.

If any error is detected by the test, go to Procedure 2.

Procedure 2 Connector Check and Replacement Check

LAN cable is connected to system board. If LAN malfunctions, the connection of the cable and board may be defective. Otherwise, they may be faulty.

Check 1 Make sure LAN cable is firmly connected to the LAN jack on the system board. If the problem still occurs, perform Check 2.

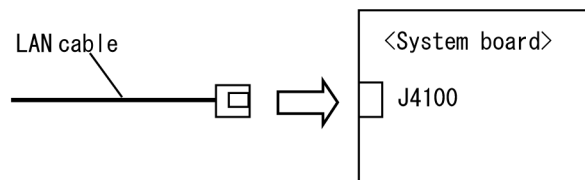

Check 2 LAN cable may be faulty. Replace it with a new one. If the problem still occurs, perform Check 3.

Check 3 System board may be faulty. Replace it with a new one following the instruction in Chapter 4, *Replacement Procedure*.

2.13 Wireless LAN Troubleshooting

To check if the computer's Wireless LAN is malfunctioning or not, follow the troubleshooting procedures below as instructed.

Procedure 1: Transmitting-Receiving Check

Procedure 2: Antennas' Connection Check

Procedure 3: Replacement Check

Procedure 1 Transmitting-Receiving Check

Before starting the test, make sure the wireless communication switch is set in the ON position.

Check 1 Execute Wireless LAN test program to check the transmitting-receiving function of wireless LAN. You will need a second computer that can communicate by wireless LAN. Perform the test following the instructions described in Chapter 3, *Tests and Diagnostics*.

If the computer passes the test, the function is correctly working. If the computer does not pass the test, perform Procedure 2.

Procedure 2 Antennas' Connection Check

The wireless LAN function-wiring diagram is shown below:

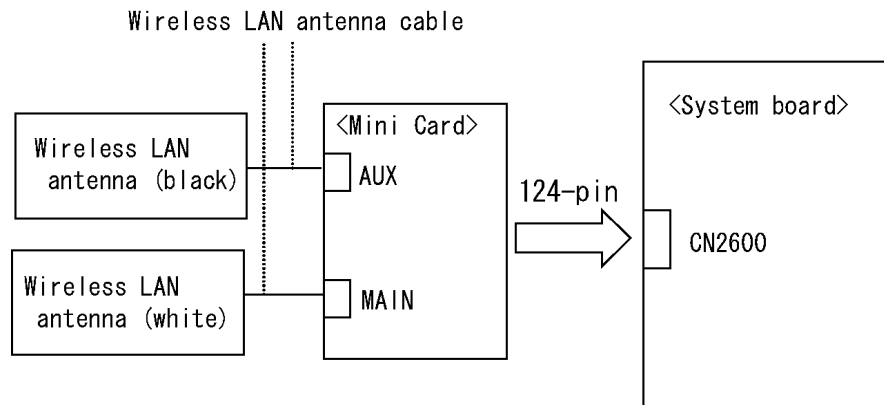

Any of the connections may be defective. Disassemble the computer following the steps described in Chapter 4, *Replacement Procedures*, and perform the following checks:

- Check 1 Make sure the wireless communication switch is “On”.
If the switch is “Off”, turn it “On”. If the problem still occurs, perform Check 2.
- Check 2 Make sure wireless LAN card (Mini-Card) is firmly connected to the CN2600 on the system board. If the connection is loose, connect it firmly and perform Procedure 1. If the problem still occurs, perform Check 3.
- Check 3 Make sure that wireless LAN antenna cables (black and white) are firmly connected to the connectors on Wireless LAN card. If wireless LAN antenna cables are not connected properly, connect them firmly and perform Procedure 1. If the problem still occurs, go to the procedure 3.

Procedure 3 Replacement Check

Wireless LAN card, wireless LAN antenna or system board may be faulty. Refer to Chapter 4, *Replacement Procedures*, for instructions on how to disassemble the computer and then perform the following checks:

- Check 1 Wireless LAN antenna may be faulty. Replace it with a new one following the instructions in Chapter 4, *Replacement Procedures*. If the problem still occurs, perform Check 2.
- Check 2 Wireless LAN card may be faulty. Replace it with a new one following the instructions in Chapter 4, *Replacement Procedures*. If the problem still occurs, perform Check 3.
- Check3 System board may be faulty. Replace it with a new one following the instructions in Chapter 4, *Replacement Procedures*.

2.14 Bluetooth Troubleshooting

To check if the Bluetooth is malfunctioning or not, follow the troubleshooting procedures below as instructed.

Procedure 1: Transmitting-Receiving Check

Procedure 2: Antennas' Connection Check

Procedure 3: Replacement Check

Procedure 1 Transmitting-Receiving Check

Before starting the test, make sure the wireless communication switch is set in the ON position. If the switch is "Off", turn it "On".

Check 1 Execute Bluetooth test program to check the transmitting-receiving function of Bluetooth. You will need a second computer that can communicate by Bluetooth. Perform the test following the instructions described in Chapter 3.

If the computer passes the test, the function is correctly working. If the computer does not pass the test, perform Procedure 2.

Procedure 2 Antennas' Connection Check

The Bluetooth function-wiring diagram is shown below:

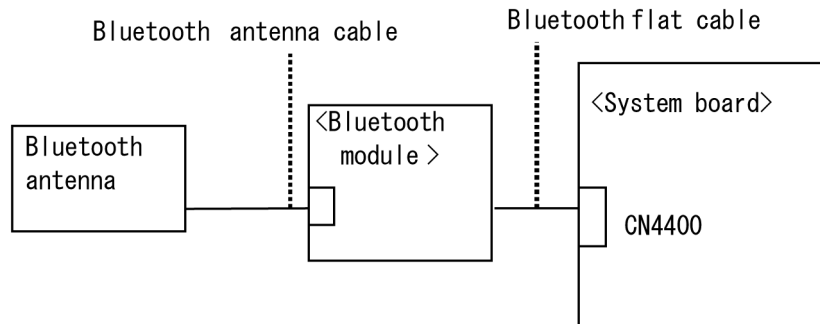

Any of the connections may be defective. Disassemble the computer following the steps described in Chapter 4, *Replacement Procedures*, and perform the following checks:

- Check 1 Make sure that the wireless communication switch is “On”.
If the switch is “Off”, turn it “On”. If the problem still occurs, perform Check 2.
- Check 2 Make sure that Bluetooth flat cable is firmly connected to the CN4400 on system board. If the connection is loose or disconnected, connect it firmly and perform Procedure 1. If the problem still occurs, perform Check 3.
- Check 3 Make sure that Bluetooth antenna cable is firmly connected to the connector on Bluetooth module. If Bluetooth antenna cable is not connected properly, connect them firmly and perform Procedure 1. If the problem still occurs, go to the procedure 3.

Procedure 3 Replacement Check

Bluetooth module, Bluetooth antenna or system board may be faulty. Refer to Chapter 4, *Replacement Procedures*, for instructions on how to disassemble the computer and then perform the following checks:

- Check 1 Bluetooth antenna may be faulty. Replace it with a new one following the instructions in Chapter 4, *Replacement Procedures*. If the problem still occurs, perform Check 2.
- Check 2 Bluetooth flat cable may be faulty. Replace it with a new one following the instructions in Chapter 4, *Replacement Procedures*. If the problem still occurs, perform Check 3.
- Check 3 Bluetooth module may be faulty. Replace it with a new one following the instructions in Chapter 4, *Replacement Procedures*. If the problem still occurs, perform Check 4.
- Check 4 System board may be faulty. Replace it with a new one following the instructions in Chapter 4, *Replacement Procedures*.

2.15 Sound Troubleshooting

To check if the sound function is malfunctioning or not, follow the troubleshooting procedures below as instructed.

Procedure 1: Diagnostic Test Program Execution Check

Procedure 2: Connector Check

Procedure 3: Replacement Check

Procedure 1 Diagnostic Test Program Execution Check

CAUTION: Sound test is not supported in this computer. So go to Procedure 2.

Execute the Sound test in Sound/LAN/Modem test program. Refer to Chapter 3, *Tests and Diagnostics* for more information on how to perform the test program.

If any error is detected in the test, go to Procedure 2.

Procedure 2 Connector Check

The connection of sound system is shown in the following figure.

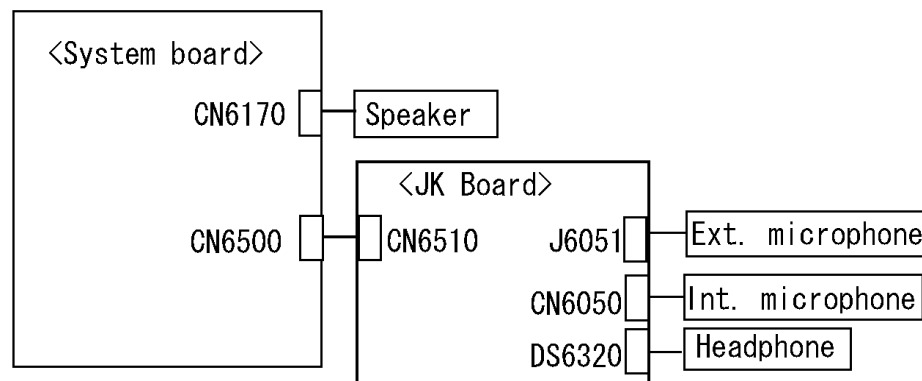

As the connection may be defective, disassemble the computer and check each connection.

If the problem still occurs, go to Procedure 3.

Procedure 3 Replacement Check

- If external microphone does not work properly, perform check 1.
- If headphone does not work properly, perform check 2.
- If internal microphone does not work properly, perform check 3.
- If speaker does not work properly, perform check 5.

Check 1 External microphone may be faulty. Replace it with a new one following the steps in Chapter 4, *Replacement Procedures*. If the problem still occurs, perform Check 4.

Check 2 Headphone may be faulty. Replace it with a new one following the steps in Chapter 4, *Replacement Procedures*. If the problem still occurs, perform Check 4.

Check 3 Internal microphone may be faulty. Replace it with a new one following the steps in Chapter 4, *Replacement Procedures*. If the problem still occurs, perform Check 4.

Check 4 JK board may be faulty. Replace it with a new one following the steps in Chapter 4, *Replacement Procedures*. If the problem still occurs, perform Check 6.

Check 5 Speaker may be faulty. Replace it with a new one following the steps in Chapter 4, *Replacement Procedures*. If the problem still occurs, perform Check 6.

Check 6 System board may be faulty. Replace it with a new one following the instructions in Chapter 4, *Replacement Procedures*.

2.16 TV tuner Troubleshooting

To check if TV tuner is malfunctioning or not, follow the troubleshooting procedures below as instructed.

Procedure 1: Connector Check and Replacement Check

Procedure 1 Connector Check and Replacement Check

The connection of cables, boards and module may be defective. Otherwise, they may be faulty. Disassemble the computer following the steps described in Chapter 4 and perform the following checks:

Check 1 Make sure the following connectors (cables) are firmly connected.

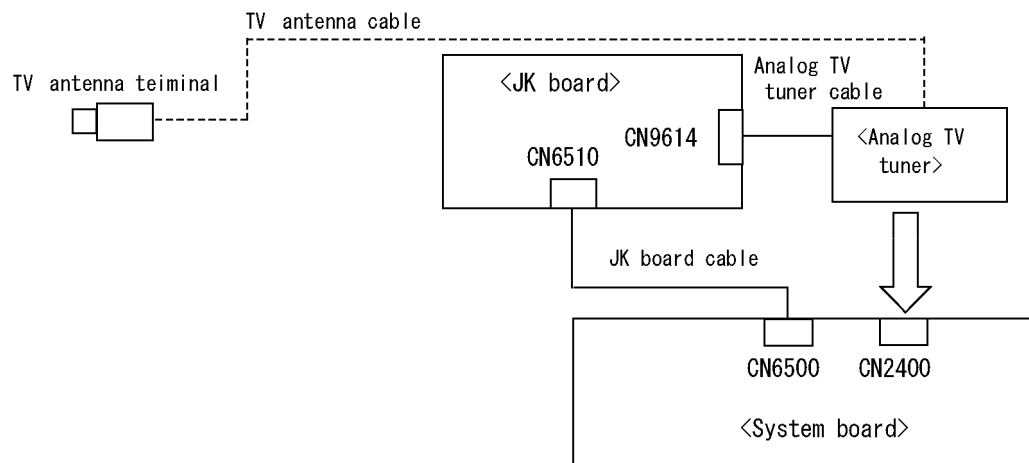

If the connection is loose, reconnect it firmly and check each connection. If the problem still occurs, perform Check 2.

- Check 2 TV antenna cable may be faulty. Replace it with a new one following the steps in Chapter 4. If the problem still occurs, perform Check 3.
- Check 3 Analog TV tuner may be faulty. Replace it with a new one following the steps in Chapter 4. If the problem still occurs, perform Check 4.
- Check 4 Analog TV tuner cable may be faulty. Replace it with a new one following the steps in Chapter 4. If the problem still occurs, perform Check 5.
- Check 5 JK board may be faulty. Replace it with a new one following the steps in Chapter 4. If the problem still occurs, perform Check 6.
- Check 6 JK board cable may be faulty. Replace it with a new one following the steps in Chapter 4. If the problem still occurs, perform Check 7.
- Check 7 System board may be faulty. Replace it with new one following the instructions in Chapter 4.

2.17 Bridge media Slot Troubleshooting

This section describes how to determine if the computer's Bridge media functions are functioning properly. Perform the steps below starting with Procedure 1 and continuing with the other procedures as required.

Procedure 1: Check on Windows OS

Procedure 2: Connector Check and Replacement Check

Procedure 1 Check on Windows OS

Insert a Bridge media (SD memory card/SDIO card/Memory stick/Memory stick Pro/xD Picture card/Multimedia card) into the slot. Check if the installed Windows recognizes automatically the Bridge media and the data in the Bridge media can be read.

If the card is not recognized or data are not read, go to Procedure 2.

Procedure 2 Connector Check and Replacement Check

The Bridge media is connected to IS2101 on the system board.

Bridge media supports SD memory card/SDIO card/Memory stick/Memory stick Pro/xD Picture card/Multimedia card.

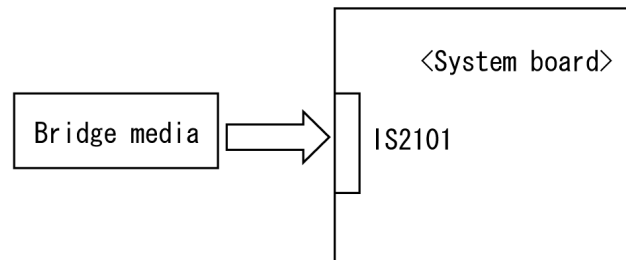

- Check 1 Bridge media and system board may be disconnected. Make sure the Bridge media is firmly inserted to IS2101 on the system board. If not, insert it firmly. If the Bridge media is still not functioning properly, perform Check 2.
- Check 2 Bridge media may be faulty. Replace it with a new one following the step in Chapter 4 *Replacement Procedures*. If the problem continues, perform Check 3.
- Check 3 System board may be faulty. Replace it with a new one following the step in Chapter 4 *Replacement Procedures*.

2.18 Fingerprint sensor

CAUTION: To delete the account for confirming the fingerprint operation, it is necessary to log on by the account with the management authority. If the password has been set to log on, ask the Log-ON password to the user.

To check if the Fingerprint sensor work correctly or not, follow the troubleshooting procedures below as instructed.

When failed in Procedure 1 to Procedure 3, execute Procedure 4.

Procedure 1: Setting Windows Log-ON password

Procedure 2: Registration of fingerprint

Procedure 3: Authentication of fingerprint

Procedure 4: Connector Check and Replacement Check

CAUTION: Scan your finger shown below.

1. Put your finger in parallel to the sensor.
2. Put your finger on the centerline of the sensor.
3. Make sure the first joint of your finger is on the sensor.
4. Slide slowly your finger from the first joint to fingertip at constant speed.
When not recognized, adjust the speed.

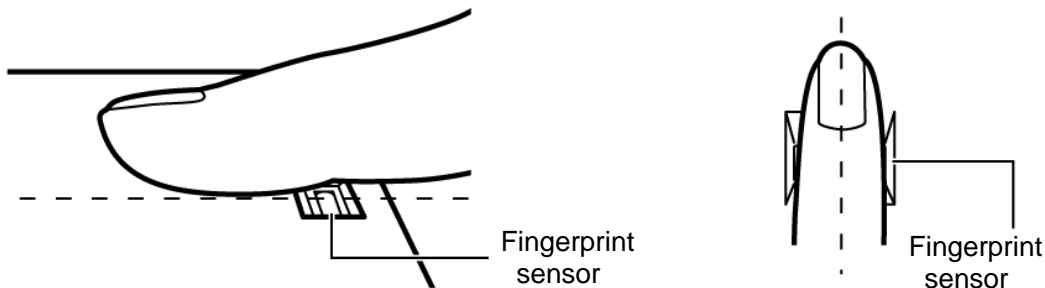

Procedure 1 Setting Windows Log-ON password

1. Open [User Account] from [Control Panel].
2. Select “Create a new account” in [User Account].
3. Input the name of Account (e.g. “TOSHIBA”) in [Name the new account] and click [NEXT] button.
4. Click “Create Account” button in the (default) condition that the “Computer administrator” is selected in [Pick an account type].
5. Select the icon of Account (e.g. “TOSHIBA”) that has been made in item 2 to item 4 in [User Accounts] display.
6. Select “Create a password” after displaying [What do you want to change about ****’s account?].
7. Input a password (e.g. “password”) in the box under the message of “Type a new password” and “Type the new password again to confirm” after displaying [Create a password for ****’s account]. Click [Create Password] button.
8. In the [Create a password for ****’s account] display, click  to close the window.

Procedure 2 Registration of fingerprint

1. Open [Start] → [All Programs] → [Protector Suite QL] → [User Enrollment].
2. After displaying [User Enrollment], click [Next].

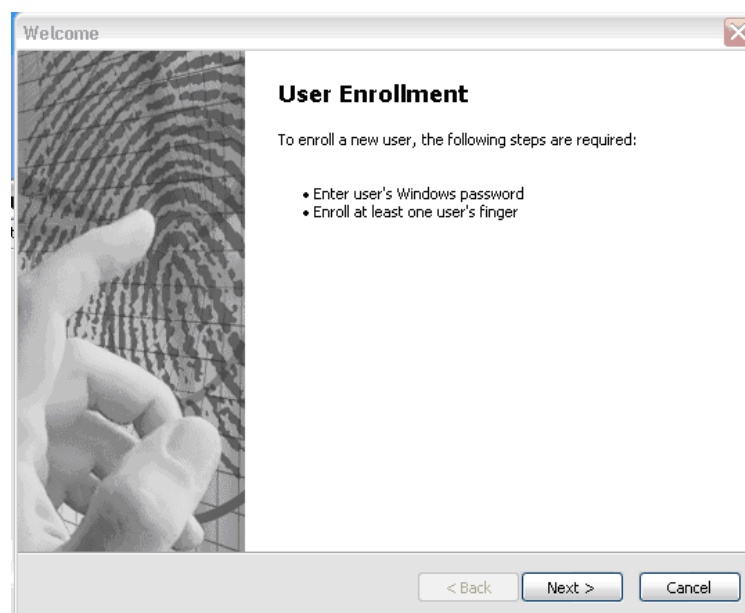

3. In the box of [Enter your password] on [User's Password] display, input the password (e.g. password) which has been input in item 7 of Procedure 1. Click [Next].

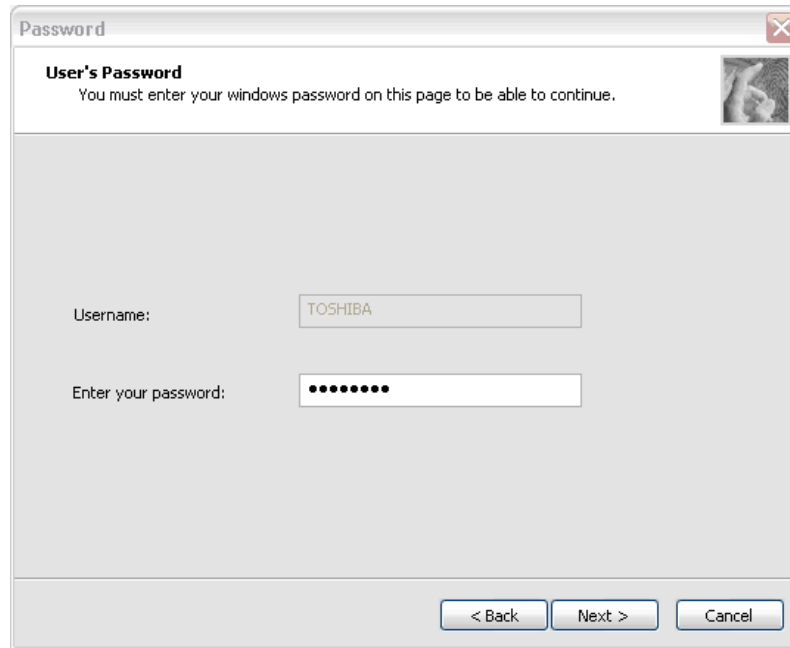

4. After displaying [Enrollment Hints], check off in the box of [Run interactive tutorial] (when proceeding without seeing Tutorial). The display of "if you want really skip or not the Tutorial" appears, and then click [Skip Tutorial].

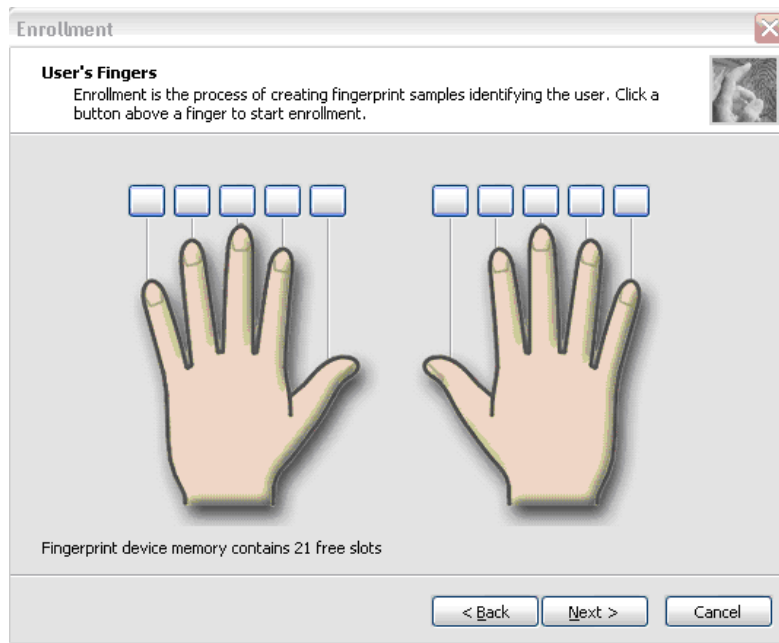

5. After displaying [User's Fingerprint], click the box of thumb of right hand. A small window of "Swipe finger" appears, then swipe three times.

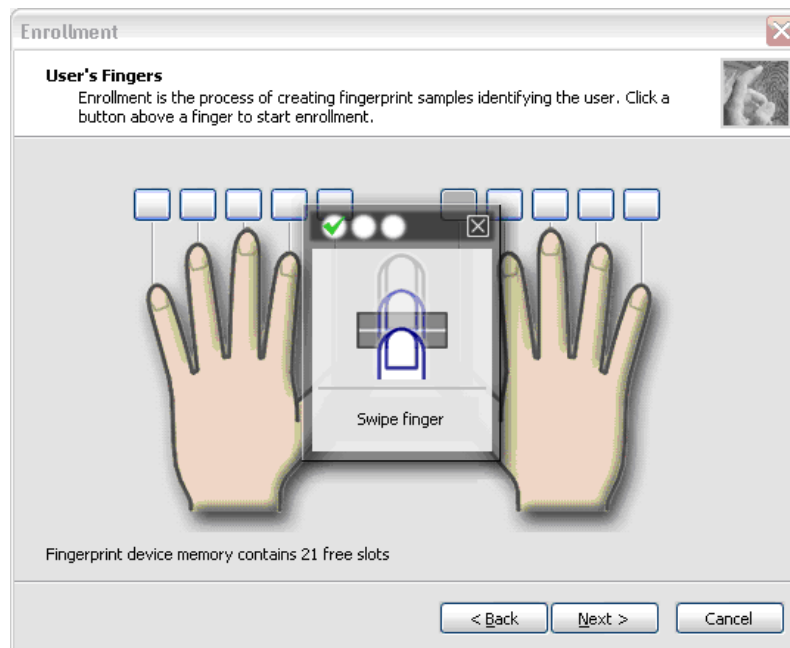

6. The display becomes as follows when the fingerprint is registered correctly. Click [Next].

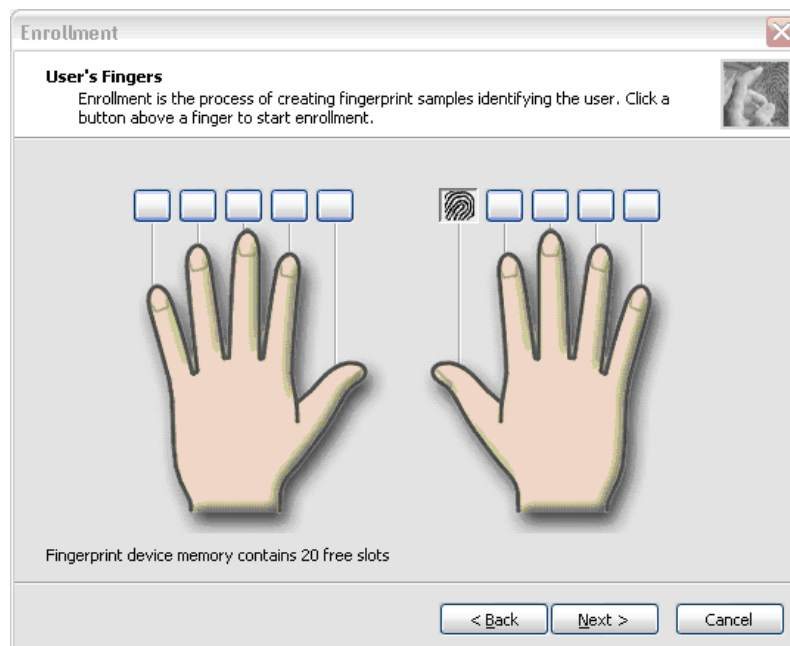

7. After displaying [User Enrollment] dialog, you are asked if you want to register one more finger. Click [No] when you do not want to register one more.
8. When [Advanced Security] is displayed, click [Next].

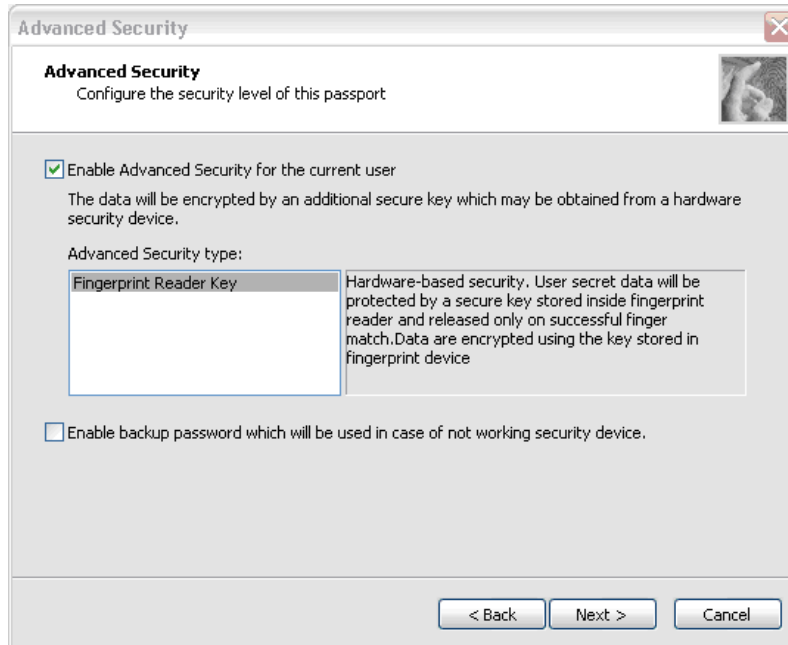

9. When [Finish] is displayed, click [Finish].

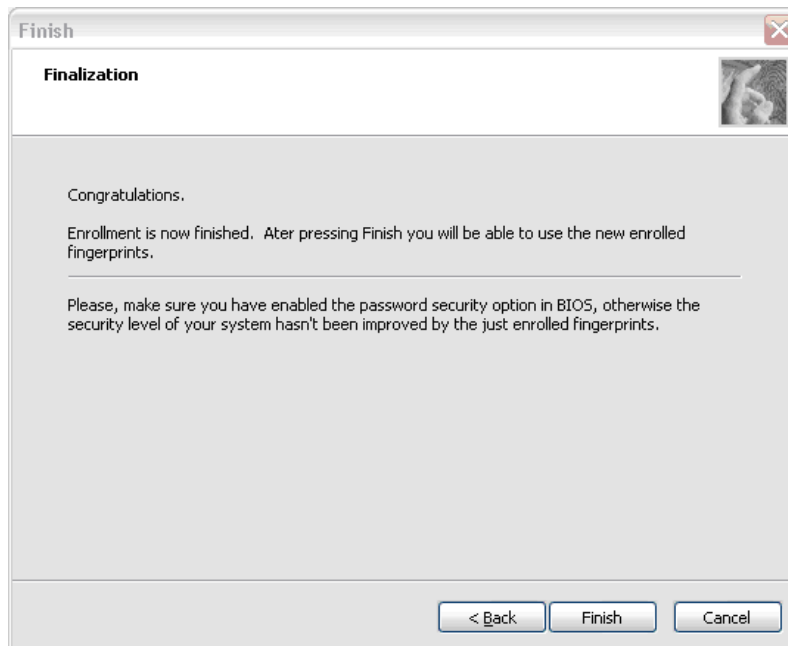

10. The display of “Protector Suite - QL Edition” appears in [Fingerprint Software] window, click [Close].

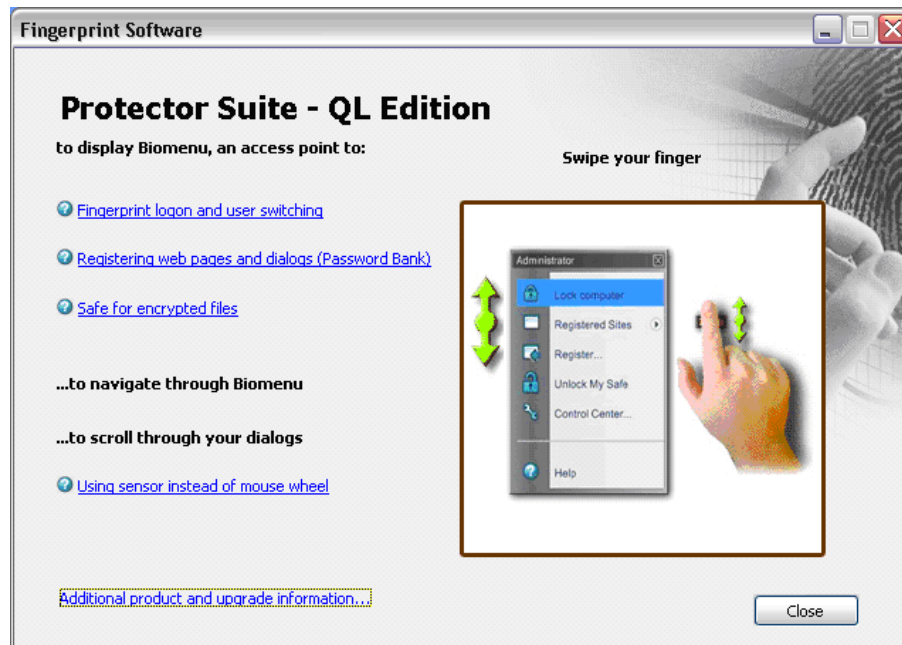

Procedure 3 Authentication of fingerprint

1. Turn on the computer. Windows starts up.
2. In the Windows Log-ON window, scan the fingerprint of registered finger. Make sure that a green check mark is displayed in the box (It means you have logged on).

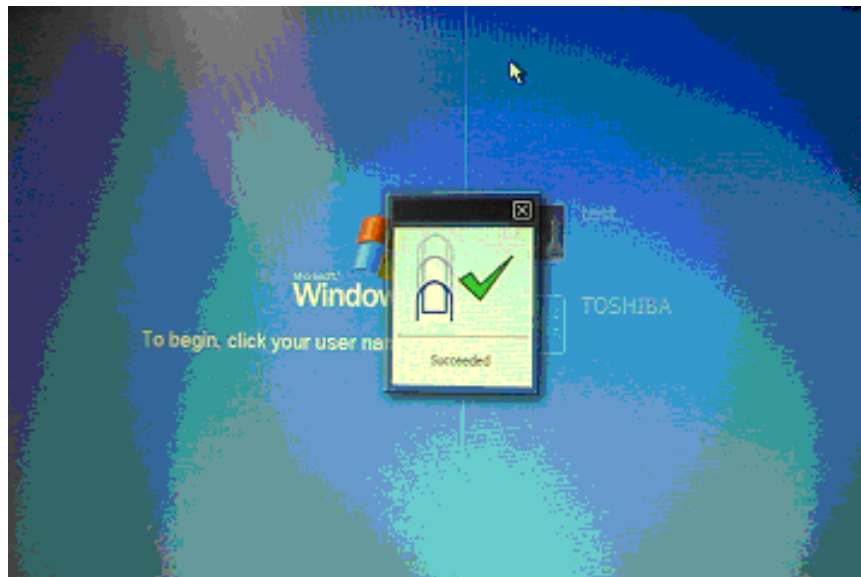

3. After starting Windows, make sure that the name of Account (e.g. "TOSHIBA"), which has been inputted in item 3 in Procedure 1 at the top of [Start].

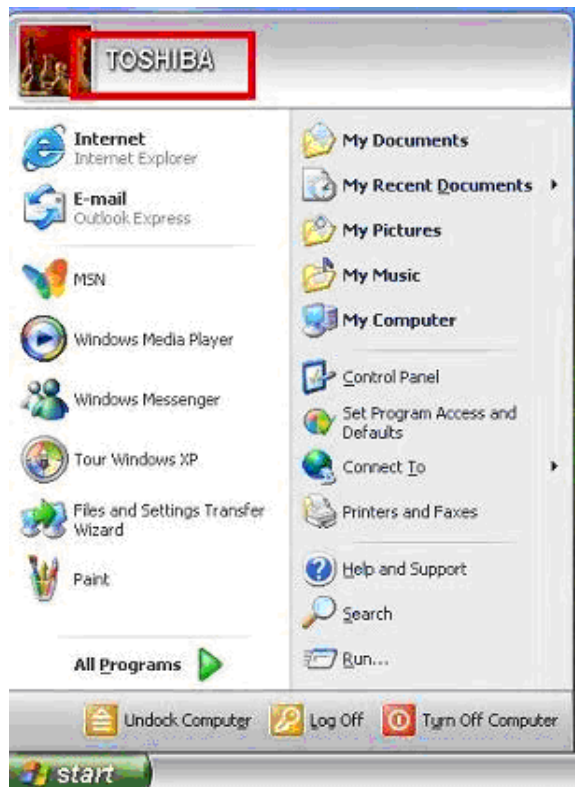

Procedure 4 Connector Check and Replacement Check

The connector CN9540 on the FS board is connected to the connector CN9530 on the system board.

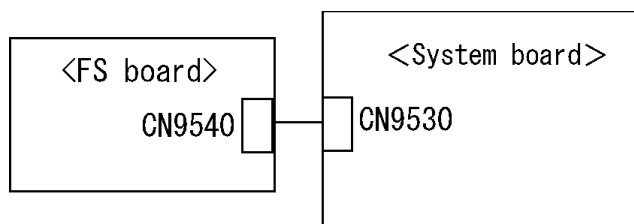

- Check 1 Check the FS cable is firmly connected to the connector CN9540 on the FS board and connector CN9530 on the system board. If not, connect it firmly. If the finger sensor is still not functioning properly, perform Check 2.
- Check 2 The FS cable may be faulty. Replace it with a new one. If the problem persists, perform Check 3.
- Check 3 The FS board may be faulty. Replace it with a new one. If the problem persists, perform Check 4.

Check 4 The system board may be faulty. Replace it with a new one.

Chapter 3

Tests and Diagnostics

Chapter 3 Contents

3.1	The Diagnostic Test	3-1
3.1.1	Diagnostics menu	3-1
3.1.2	H/W (Hardware) initial information setting tool.....	3-2
3.1.3	Heatrun test program.....	3-3
3.2	Executing the Diagnostic Test	3-4
3.2.1	Diagnostics menu (T&D)	3-5
3.2.2	H/W initial information setting tool	3-7
3.2.3	Heatrun test program.....	3-7
3.3	Check of the RAID configuration.....	3-8
3.3.1	Explanation of the screen display.....	3-8
3.3.2	Check of the screen display.....	3-10
3.3.3	Specification of the failed HDD	3-12
3.4	Setting of the hardware configuration.....	3-16
3.5	Heatrun Test.....	3-18
3.6	Subtest Names.....	3-19
3.7	System Test.....	3-21
3.8	Memory Test.....	3-23
3.9	Keyboard Test.....	3-24
3.10	Display Test	3-25
3.11	Floppy Disk Test.....	3-28
3.12	Printer Test.....	3-30
3.13	Async Test	3-32
3.14	Hard Disk Test	3-33
3.15	Real Timer Test.....	3-36
3.16	NDP Test.....	3-38
3.17	Expansion Test.....	3-39
3.18	CD-ROM/DVD-ROM Test	3-41
3.19	Error Code and Error Status Names.....	3-42
3.20	Hard Disk Test Detail Status.....	3-45

3.21	ONLY ONE TEST	3-47
	3.21.1 Program Description	3-47
	3.21.2 Operations	3-47
3.22	Head Cleaning.....	3-54
	3.22.1 Function Description	3-54
	3.22.2 Operations	3-54
3.23	Log Utilities	3-55
	3.23.1 Function Description	3-55
	3.23.2 Operations	3-56
3.24	Running Test.....	3-57
	3.24.1 Function Description	3-57
	3.24.2 Operations	3-57
3.25	Floppy Disk Drive Utilities.....	3-58
	3.25.1 Function Description	3-58
	3.25.2 Operations	3-59
3.26	System Configuration	3-63
	3.26.1 Function Description	3-63
	3.26.2 Operations	3-64
3.27	Wireless LAN Test Program (Atheros)	3-65
3.28	Wireless LAN Test Program (Intel-made a/b/g).....	3-72
3.29	Sound/LAN/Modem Test program.....	3-76
3.30	IEEE1394 Test program	3-80
3.31	Bluetooth Test program	3-81
3.32	SETUP	3-91
	3.32.1 Function Description	3-91
	3.32.2 Accessing the SETUP Program.....	3-93
3.33	Thermal Radiation Control Test	3-108

Tables

Table 3-1 Subtest names 3-19

Table 3-2 Error codes and error status names 3-42

Table 3-3 Hard disk controller status register contents 3-45

Table 3-4 HDC Error register contents 3-46

Table 3-5 Error message..... 3-83

Table 3-6 Error code for Bluetooth test (BD_ADDR) 3-84

Table 3-7 Error code for Bluetooth test (BD_ADDR of the DUT)..... 3-88

Table 3-8 Common Error code..... 3-90

3.1 The Diagnostic Test

This chapter explains how to use the Diagnostic Test programs to test the functions of the computer's hardware modules. The Diagnostics Programs are stored on some Diagnostic Disks. There are Service Program Modules (DIAGNOSTIC MENU) and the Test Program Modules (DIAGNOSTIC TEST MENU) on the Diagnostic Disk.

The Hardware Initial information Setting Tool consists of some programs that write the hardware information or displays the current information of the computer. It is also included in one of Diagnostic Disks.

The heatrun test is automatic test program that executes the some tests successively.

NOTE: Before starting the diagnostics, be sure to follow these steps:

1. Check all cables are connected firmly.
2. Exit any application and close Windows.
3. Check if [ALL Device] is selected in the "Device Config." in SET UP menu. After checking the diagnostics, be sure to select [Setup by OS] in the "Device Config."

3.1.1 Diagnostics menu

The DIAGNOSTIC MENU consists of the following functions.

- DIAGNOSTIC TEST
- ONLY ONE TEST
- HEAD CLEANING
- LOG UTILITIES
- RUNNING TEST
- FDD UTILITIES
- SYSTEM CONFIGURATION
- EXIT TO MS-DOS

The DIAGNOSTIC TEST MENU contains the following functional tests:

- SYSTEM TEST
- MEMORY TEST
- KEYBOARD TEST
- DISPLAY TEST
- FLOPPY DISK TEST
- PRINTER TEST
- ASYNC TEST
- HARD DISK TEST

- REAL TIMER TEST
- NDP TEST
- EXPANSION TEST
- CD-ROM/DVD-ROM TEST

Other tests are:

- Wireless LAN TEST (Wireless LAN TEST disk)
- Sound/LAN/Modem/ TEST (Sound/LAN/Modem TEST disk)
- Bluetooth TEST (Bluetooth TEST disk)
- IEEE1394 TEST (IEEE1394 TEST disk)

You will need the following equipment to perform some of the Diagnostic test programs.

- USB FDD
- The Diagnostic Disks (T&D for maintenance, LAN/Modem/Bluetooth/IEEE1394 for maintenance, wireless LAN for maintenance and Sound for maintenance)
- A formatted working disk (Floppy disk test)
- A cleaning kit to clean the floppy disk drive heads (Head Cleaning)
- An external display supporting monitor ID (Expansion test)
- A CD test media TOSHIBA CD-ROM TEST DISK or ABEX TEST CD-ROM (Sound test)
- A DVD test media (DVD-ROM TEST DISK TSD-1) (Sound test)
- A music CD (Sound test)
- A CD-RW test media (CD-ROM/DVD-ROM test)
- A USB test module (USB test)
- A USB cable (USB test)
- LAN wraparound connector (LAN test)
- RGB wraparound connector (Expansion test)
- Module cable and RJ11 connector checker (Modem test)
- Headphones (Sound test)
- A microphone (Sound test)
- A PC for wraparound test (Wireless LAN test/Bluetooth test/IEEE1394 test)
- PC card wraparound connector (Expansion test) [Not necessary for this model]

3.1.2 H/W (Hardware) initial information setting tool

The H/W initial information setting tool consists of the following programs.

- Initial configuration
- DMI information save
- DMI information recovery
- System configuration display
- E2PROM test (MAC/GUID/DMI)

You will need the following equipment to perform some of the programs.

- The Diagnostics Disk (Main T&D)

3.1.3 Heatrun test program

The heatrun test starts automatically after the selection.

You will need the following equipment to perform this program.

- The Diagnostics Disk (Main T&D)

3.2 Executing the Diagnostic Test

To start the DIAGNOSTIC PROGRAM, follow these steps:

1. Insert the Diagnostics disk in the floppy disk drive.
2. Release the lock of the power switch and turn on the computer with pressing the **F12**. Select the FDD in the display for selecting booting unit. Then, press **Enter** and the following menu appears.

```
Repair test program   (Qosmio F30)
-----

1. Repair Main (T&D)
2. Repair Initial config set
3. Repair Heatrun (T&D)

Select From Menu (1 2 3), or press [Enter] (selection=1)

Singlestepping [F8] is : OFF
```

When you press **1**, **2**, or **3**, “**RAID Configuration**” is displayed.

When you press **Enter** in the display, each menu is displayed.

To start the Diagnostics menu (T&D), press **1** or select 1 with arrow keys and press **Enter**.

To start the H/W initial information setting tool, press **2** or select 2 with arrow keys and press **Enter**.

To start the Heatrun test, press **3** or select 3 with arrow keys and press **Enter**.

CAUTION: Check if EMM386 resides. If resides, the following message displayed and the test program ends. (Because an error occurs in the memory test.)

Can not execute in a virtual 8086 mode.

If the EMM386 doesn't reside, execute each program module.

NOTE: When replacing the system board, be sure to execute the following procedures.

1. Before replacing the system board, execute subtest03 “DMI information save” in 3.4 Setting of the hardware configuration in order to save the DMI information from system board to floppy disk.
2. After replacing the system board, execute the subtest04 “DMI information recovery” and subtest08 “System configuration display” in 3.4 Setting of the hardware configuration in order to copy the DMI information and system information from the floppy disk.

3.2.1 Diagnostics menu (T&D)

Press **1** or select 1 with arrow keys and press **Enter** in the startup menu, and then the following menu appears.

```
TOSHIBA personal computer XXXXXX DIAGNOSTICS
version X.XX (c) copyright TOSHIBA Corp. 20XX
```

```
DIAGNOSTICS MENU :
1 - DIAGNOSTIC TEST
2 - ONLY ONE TEST
3 -
4 - HEAD CLEANING
5 - LOG UTILITIES
6 - RUNNING TEST
7 - FDD UTILITIES
8 - SYSTEM CONFIGURATION
9 - POWER OFF
```

```
↑↓→← : Select items
Enter  : Specify
Esc    : Exit
```

NOTE: To exit the **DIAGNOSTIC TEST MENU**, press the **Esc** key. If a test program is in progress, press **Ctrl + Break** to exit the test program. If a test program is in progress, press **Ctrl + C** to stop the test program.

Set the highlight bar to **1**, and press **Enter**. The following **DIAGNOSTIC TEST MENU** will appear:

```
TOSHIBA personal computer XXXXXX DIAGNOSTICS
version X.XX (c) copyright TOSHIBA Corp. 20XX
```

```
DIAGNOSTIC TEST MENU :
1 - SYSTEM TEST
2 - MEMORY TEST
3 - KEYBOARD TEST
4 - DISPLAY TEST
5 - FLOPPY DISK TEST
6 - PRINTER TEST           [It is not supported]
7 - ASYNC TEST             [It is not supported]
8 - HARD DISK TEST        [There is a second hard disk]
9 - REAL TIMER TEST
10 - NDP TEST
11 - EXPANSION TEST
12 - CD-ROM/DVD-ROM TEST
88 - ERROR RETRY COUNT SET [FDD & HDD]
99 - EXIT TO DIAGNOSTICS MENU
```

```
↑↓→← : Select items
Enter  : Specify
Esc    : Exit
```

NOTE: Only when a 2nd HDD is installed in the computer, [There is a second hard disk] message appears in the display.

Functions 1 through 12 are the Diagnostic Tests. Function 88 sets the floppy disk drive and hard disk drive error retry count (0-255).

To exit the submenu of the Diagnostic Test and returns to the Diagnostics Menu, set the highlight bar to function 99 and press **Enter**.

Select the option you want to execute and press **Enter**. When you select 1- SYSTEM TEST, the following message will appear:

```
SYSTEM TEST NAME      XXXXXXX  xxxxxxxx DIAGNOSTIC TEST VX.XX
                        [Ctrl]+[Break] : test end
                        [Ctrl]+[C]   : key stop
```

```
SUB-TEST      : XX
PASS COUNT    : XXXXX  ERROR COUNT: XXXXX
WRITE DATA   : XX     READ DATA  : XX
ADDRESS       : XXXXXXX STATUS       : XXX
```

SUB-TEST MENU :

```
01 - ROM checksum
02 - Fan ON/OFF
03 - Geyserville
04 - Quick charge
05 - DMI read
99 - Exit to DIAGNOSTIC TEST MENU
```

```
↑↓→← : Select items
Enter : Specify
Esc   : Exit
```

NOTE: The menu displayed by your computer may be slightly different from the one shown above.

Select the desired subtest number from the subtest menu and press **Enter**. The following message will appear:

```
TEST LOOP : YES (or NO)
ERROR STOP : YES (or NO)
```

Use the right and left arrow keys to move the cursor to the desired option.

Selecting **YES** of TEST LOOP increases the pass counter by one, each time the test cycle ends and restarts the test cycle.

Selecting **NO** returns the process to the subtest menu after the test is complete.

Use the up and down arrow keys to move the cursor to “ERROR STOP”.

Use the right and left arrow keys to move the cursor to the desired option and press **Enter**.

Selecting **YES** of ERROR STOP stops the test program when an error is found and displays the operation guide on the right side of the display screen as shown below:

```

ERROR STATUS NAME    [[ HALT OPERATION ]]

                                1: Test end
                                2: Continue
                                3: Retry

```

These three selections have the following functions respectively:

1. Terminates the test program and exits to the subtest menu.
2. Continues the test.
3. Restarts the test from the error.

Selecting **NO** keeps the test running even if an error is found. When an error occurred, the error status is displayed and one error is added to the error counter.

Table 3-1 in section 3.6 describes the function of each test on the subtest menu. Table 3-2 in section 3.19 describes the error codes and error status for each error.

3.2.2 H/W initial information setting tool

After selecting this test, the following menu appears in the display.

```

#####
#####   H/W initial information setting tool   VX.XX   #####
#####
*      1 ..... Initial configuration                *
*      3 ..... DMI information save                 *
*      4 ..... DMI information recovery             *
*      8 ..... System configuration display         *
*      9 ..... E2PROM test (MAC/GUID/DMI)          *
*****
... Press test number [1,3,4,8,9]?

```

For more details on this test, refer to the section 3.4.

3.2.3 Heatrun test program

Heatrun test starts executing the same subtest as 3.24 RUNNING TEST.

For more details on this test, refer to the section 3.5.

3.3 Check of the RAID configuration

Following screen is displayed for checking the RAID configuration and specifying a failed drive.

```
TOSHIBA RAID / RAID Information Display Rev xx.xx.xxxx
Copyright(c) 2005 TOSHIBA CORPORATION. All Rights Reserved.
```

```

Level   Status      Capacity
LD0 RAID-1 DEGRADE xxGB

Write cache      : Enable
Degrade Bootup   : Yes
MBR Protection   : Disable
S.M.A.R.T        : Enable

Port Assign  Status  Size  Model                      Rev
0  LD0-0     ONLINE xxGB  xxxxxxxx----- xxxxxxxx
1  LD0-1     FAILED  xxGB  xxxxxxxx----- xxxxxxxx

< RAID: not OPTIMAL >
```

3.3.1 Explanation of the screen display

Contents of the screen display are shown below.

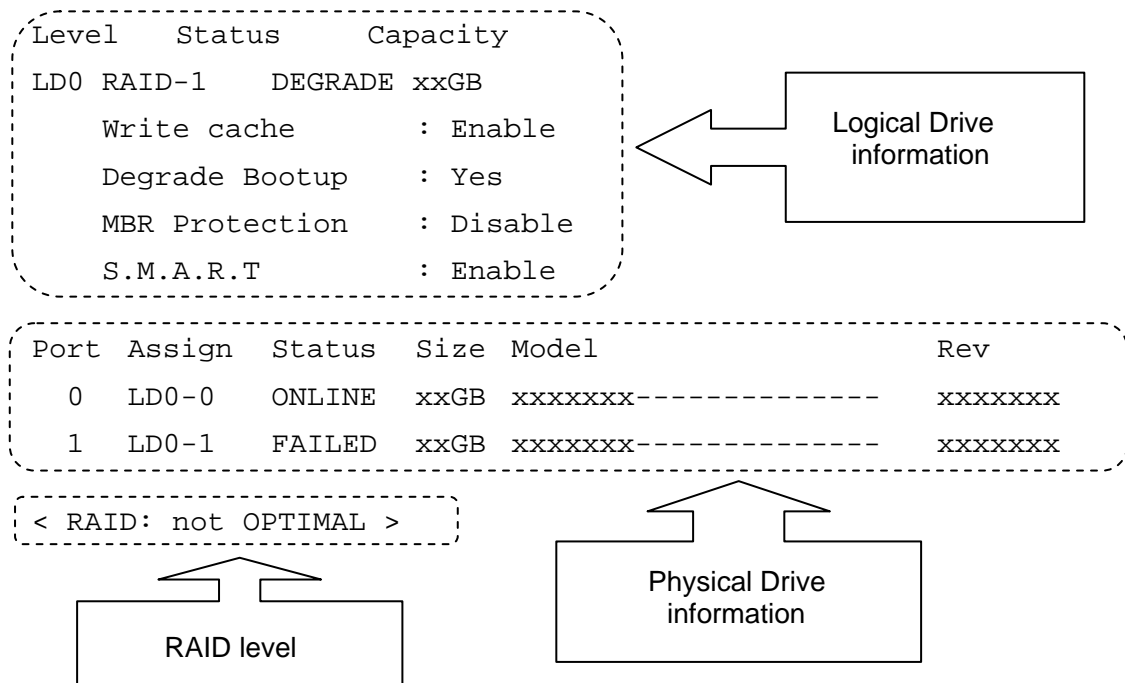

Logical Drive Information:

Displays logical drive number, RAID level, RAID status, contents and setting.

Physical Drive Information:

Displays port number, logical drive number belonged, status and disk information.

RAID level:

Displays RAID level configured.

NON:

Means that RAID is not configured. Confirming the physical drive information can check if a drive exists and check models of the drive.

RAID-0:

There are 1RAID-0 and 2RAID-0 (striping). When “RAID-0 OPTIMAL” is displayed in LD0 and LD1 in the logical drive information, it means 1RAID-0. When “RAID-0 OPTIMAL” is displayed only on the LD0, it means 2RAID-0 (striping). There is no problem in the RAID configuration, when “OPTIMAL” is displayed in the logical drive information.

RAID-1:

Indicates that 2RAID-1 (mirroring) is set. There is no problem in the RAID configuration, when “RAID-1 OPTIMAL” is displayed in the logical drive information.

not OPTIMAL:

Indicates that the RAID configuration is not optimal. See the logical drive information and physical drive information and check the condition of them.

3.3.1.1 Explanation of Logical drive condition

- (1) **OPTIMAL:** Indicates that all disks configuring RAID are normal and condition of the RAID is optimal.
- (2) **Degrade:** Indicates that one HDD failed in the RAID-1 that has redundancy.
- (3) **Critical:** Indicates critical condition that one HDD is failed in the RAID-0 that does not have redundancy.

“OPTIMAL” is displayed in the case of (1) and “not OPTIMAL” is displayed in the case of (2) and (3).

3.3.2 Check of the screen display

Contents of the screen displayed are shown below.

3.3.2.1 RAID-1

When the “RAID-1” is displayed in the shown below, it is judged that the RAID is configured by two drives.

```
TOSHIBA RAID / RAID Information Display  Rev xx.xx.xxxx
Copyright(c) 2005 TOSHIBA CORPORATION. All Rights Reserved.

      Level   Status   Capacity
LD0 RAID-1  DEGRADE  xxGB
      Write cache      : Enable
      Degradе Bootup   : Yes
      MBR Protection   : Disable
      S.M.A.R.T        : Enable

Port Assign Status   Size Model                      Rev
  0  LD0-0 ONLINE    xxGB FUJITSU----- xxxxxxxx
  1  LD0-1 FAILED    xxGB FUJITSU----- xxxxxxxx

< RAID: not OPTIMAL >
```

3.3.2.2 RAID-0 (1)

When there is one LD and “RAID-0 OPTIMAL” is displayed in the shown below, it is judged that the RAID is configured by two drives.

```
TOSHIBA RAID / RAID Information Display  Rev xx.xx.xxxx
Copyright(c) 2005 TOSHIBA CORPORATION. All Rights Reserved.

      Level   Status   Capacity
LD0 RAID-0 OPTIMAL  xxGB
      Write cache      : Enable
      Degradе Bootup   : Yes
      MBR Protection   : Disable
      S.M.A.R.T        : Enable

Port Assign Status   Size Model                      Rev
  0  LD0-0 ONLINE    xxGB xxxxxxxx----- xxxxxxxx
  1  LD0-1 FAILED    xxGB xxxxxxxx----- xxxxxxxx

< RAID: not OPTIMAL >
```

The RAID is not configured by two drives in the following display, because there are two LDs (LD0 and LD1).

```
TOSHIBA RAID / RAID Information Display  Rev xx.xx.xxxx
Copyright(c) 2005 TOSHIBA CORPORATION. All Rights Reserved.
```

```

      Level   Status   Capacity
LD0 RAID-0 OPTIMAL   xxGB
      Write cache       : Enable
      Degradе Bootup    : Yes
      MBR Protection    : Disable
      S.M.A.R.T         : Enable
LD1 RAID-0 OPTIMAL   xxGB
      Write cache       : Enable
      Degradе Bootup    : Yes
      MBR Protection    : Disable
      S.M.A.R.T         : Enable

Port Assign Status   Size Model                      Rev
  0  LD0-0 ONLINE    xxGB FUJITSU----- xxxxxxxx
  1  LD0-0 ONLINE    xxGB FUJITSU----- xxxxxxxx

< RAID: RAID-0 >
```

3.3.2.3 RAID-0 (2)

When there is one LD and “RAID-0 CRITICAL” is displayed in the shown below, it is judged that the RAID is configured by two drives.

```

      Level   Status   Capacity
LD0 RAID-0 CRITICAL xxGB
      Stripe Size       : 64KB
      Write cache       : Enable
      MBR Protection    : Disable
      S.M.A.R.T         : Enable

Port Assign Status   Size Model                      Rev
  0  LD0-0 ONLINE    xxGB FUJITSU----- xxxxxxxx
  1  NODRIVE

< RAID: not OPTIMAL >
```

3.3.3 Specification of the failed HDD

Check the RAID configuration condition from the shown below and specify a failed drive.

```
TOSHIBA RAID / RAID Information Display Rev xx.xx.xxxx
Copyright(c) 2005 TOSHIBA CORPORATION. All Rights Reserved.
```

```
Level Status Capacity
LD0 RAID-1 DEGRADE xxGB
Write cache : Enable
Degradate Bootup : Yes
MBR Protection : Disable
S.M.A.R.T : Enable
```

```
Port Assign Status Size Model Rev
0 LD0-0 ONLINE xxGB FUJITSU----- xxxxxxxx
1 LD0-1 FAILED xxGB FUJITSU----- xxxxxxxx
```

```
< RAID: not OPTIMAL >
```

3.3.3.1 RAID : OPTIMAL

When RAID is “OPTIMAL” (Both the two drives are normal), it is judged that RAID configuration is normal. There are the following reasons why the repair is requested.

Abnormal noise of the motor from the HDD:

Refer to the *2.5-HDD trouble shooting* in Chapter 2, *Troubleshooting Procedures*.

Access to the HDD is very slow:

Display the drive log by using Independent Utility of the DIAGNOSTIC PROGRAM. Check if ten or more continual logs of the message indicating retry such as “Write Error occurred, Retry the command.” or “Other Read Error occurred, Retry the command.” are recorded in the drive log of either HDD. If recorded, the drive is failed and should be repaired. Refer to *Independent Utility* in Appendix J.

In the other case above mentioned, it is judged that the MB side fails.

3.3.3.2 RAID : not OPTIMAL**ABSENT or OFFLINE is displayed**

When the “ABSENT” or “OFFLINE” is displayed as shown below, the drive is removed by the RAID console and installed again. When the drive is unlocked, “ABSENT” is displayed. When the drive is locked, “OFFLINE” is displayed. Repair is not needed in this case.

TOSHIBA RAID / RAID Information Display Rev xx.xx.xxxx
Copyright(c) 2005 TOSHIBA CORPORATION. All Rights Reserved.

```

      Level   Status      Capacity
LD0 RAID-1  DEGRADE    xxGB
      Write cache      : Enable
      Degrade Bootup   : Yes
      MBR Protection   : Disable
      S.M.A.R.T        : Enable

Port Assign  Status  Size Model          Rev
  0  LD0-0 ONLINE  xxGB FUJITSU----- xxxxxxxx
  1  LD0-1 ABSENT  xxGB FUJITSU----- xxxxxxxx

< RAID: not OPTIMAL >

```

NO DRIVE for one drive is displayed

When “NO DRIVE” is displayed and the HDD is connected to the port, follow the procedures below to check the HDD failure.

- (1) Install a new HDD.
When “NO DRIVE” is still displayed, It is judged that the MB or cable fails.
- (2) When a new HDD is recognized, It is judged that the HDD removed is failed.
Specify the reason by using the Independent Utility.

TOSHIBA RAID / RAID Information Display Rev xx.xx.xxxx
Copyright(c) 2005 TOSHIBA CORPORATION. All Rights Reserved.

```

      Level   Status   Capacity
LD0 RAID-1  DEGRADE  xxGB
      Write cache      : Enable
      Degrade Bootup   : Yes
      MBR Protection   : Disable
      S.M.A.R.T        : Enable

Port Assign Status   Size Model           Rev
  0 LD0-0  ONLINE  xxGB FUJITSU----- xxxxxxxx
  1          NODRIVE xxGB FUJITSU----- xxxxxxxx

< RAID: not OPTIMAL >

```

FAIL for one drive is displayed

One drive in the “RAID-1” is failed and degraded. This may look like failure by wrong operation. Specify the reason by using Independent Utility.

TOSHIBA RAID / RAID Information Display Rev xx.xx.xxxx
Copyright(c) 2005 TOSHIBA CORPORATION. All Rights Reserved.

```

Level      Status  Capacity
LD0 RAID-1  DEGRADE xxGB
Write cache      : Enable
Degraded Bootup  : Yes
MBR Protection   : Disable
S.M.A.R.T       : Enable

Port Assign Status Size Model                      Rev
0  LD0-0 ONLINE xxGB FUJITSU----- xxxxxxxx
1  LD0-1 FAILED  xxGB FUJITSU----- xxxxxxxx

< RAID: not OPTIMAL >

```

3.4 Setting of the hardware configuration

To execute this program, input **2** or select 1 with arrow keys in the startup menu. Then press **Enter** to select the (2)-Repair initial config set. The H/W initial information setting tool consists of four subtests. Input the number you want to execute and press **Enter**.

Subtest 01 Initial configuration

This subtest executes the following items and shows their contents in the display. When an item ends normally, the program proceeds automatically to the next one. When an error is found, the program stops and waits for key input. (After solving the problem, the program executes the item again.)

Setting of the CPU set table
Setting of the micro code
Setting of the EHSS
Inputting and writing of DMI information

When the DMI information is displayed, the following messages appear in order. Input each information. (If you do not replace the PCB, the DMI information should not be changed.)

1. "Enter Model Name?" is displayed. Input the computer's model name and press **Enter**. (e.g. DynaBook)
2. "Enter Version Number?" is displayed. Input the computer's version number and press **Enter**. (e.g. PC18070C313S)
3. "Enter Serial Number?" is displayed. Input the computer's serial number and press **Enter**. (e.g. 12345678)
4. "Enter Model Number?" is displayed. Input the computer's sales model number and press **Enter**. (e.g. PP200-AAAAA)
5. "Enter Bundle Number?" is displayed. Input the computer's PCN/Bundle number and press **Enter**. (e.g. PMSREQ3Q34H/S0123456789)
6. "Write data OK (Y/N)?" is displayed. To write the DMI information to the Flash ROM, press **Y**, and then **Enter**.
7. "Create DMIINFO TXT (Y/N)?" is displayed. Press **Y**, then the DMI information (text data) is written to the Floppy disk, etc.

Setting of the HWSC
Setting of the UUID
Display of the DMI information (including UUID)

After completion of the above settings, H/W configuration & DMI information are appeared in order. Check the contents and press **Enter**.

Subtest 03 DMI information save

NOTE: Before replacing the system board, be sure to execute this subtest and save the DMI information to the floppy disk.

This is one of tools to copy the DMI information to a new system board after replacing.

This subtest saves all the DMI data in a floppy disk.

Subtest 04 DMI information recovery

NOTE: 1. After replacing the system board, be sure to execute this subtest and copy the DMI information to a new system board.
2. Since the data of UUID is updated every time when this subtest, DMI information recovery, is done, the saved UUID data is not written

This is one of tools to copy the DMI information to a new system board after replacing.

This subtest writes all the DMI data in the floppy disk into the new system board.

Subtest 08 System configuration display

This subtest displays the information of the system configuration.

Confirm the contents and press **Enter**.

For more details on the system configuration information, refer to 3.26 "System configuration".

Subtest 09 E2PROM test (MAC/GUID/DMI)

It checks whether the MAC address, GUID of IEEE1394 and DMI information are written.

3.5 Heatrun Test

To execute this program, input **3** or select 3 with arrow keys in the startup menu. Then press **Enter** to select the (3)-Repair heatrun.

After selecting this test, the same subtests as 3.24 RUNNING TEST is executed successively.

For more details on the procedure and test content, refer to RUNNING TEST.

When the heatrun test ends, following message appears in the display.

```
*****  
HEATRUN TEST END  
*****  
Press any key to continue...
```

Press any key and return to the startup menu.

3.6 Subtest Names

Table 3-1 lists the subtest names for each test program in the DIAGNOSTIC TEST MENU.

Table 3-1 Subtest names (1/2)

No.	Test Name	Subtest No.	Subtest Name
1	SYSTEM	01	ROM checksum
		02	Fan ON/OFF
		03	Geyserville
		04	Quick charge
		05	DMI read
2	MEMORY	01	Conventional memory
		02	Protected Mode
		03	Protected Mode (cache off)
		04	Cache memory (on/off)
		05	Stress
3	KEYBOARD	01	Pressed key code display
4	DISPLAY	01	VRAM read/write for VGA
		02	Gradation for VGA
		03	Gradation for LCD
		04	Gradation & Mode test for VGA
		05	All dot on/off for LCD
		06	"H" pattern display
		07	LCD Brightness
5	FLOPPY DISK	01	Sequential read
		02	Sequential read/write
		03	Random address/data
		04	Write specified address
		05	Read specified address

Table 3-1 Subtest names (2/2)

No.	Test Name	Subtest No.	Subtest Name
6	PRINTER [Not supported]	01	Ripple pattern
		02	Function
		03	Wraparound
7	ASYNC [Not supported]	01	FIR/SIR point to point (send)
		02	FIR/SIR point to point (receive)
		03	Wraparound (board)
8	HARD DISK	01	Sequential read
		02	Address uniqueness
		03	Random address/data
		04	Cross talk & peak shift
		05	Partial Read
		06	Write specified address
		07	Read specified address
		08	Sequential write
		09	W-R-C specified address
9	REAL TIMER	01	Real time
		02	Backup memory
		03	Real time carry
10	NDP	01	NDP test
11	EXPANSION	01	PCMCIA wraparound [Not supported]
		02	RGB monitor ID
12	CD-ROM /DVD-ROM	01	Sequential read
		02	Read specified address
		03	Random address/data
		04	RW 1point W/R/C

3.7 System Test

To execute the System Test select **1** from the DIAGNOSTIC TEST MENU, press **Enter** and follow the directions on the screen. Move the highlight bar to the subtest you want to execute and press **Enter**.

Subtest 01 ROM checksum

This subtest executes a checksum test of the BIOS ROM (range: F0000h to FFFFFh, 64KB) on the System Board.

Subtest 02 Fan ON/OFF

This subtest turns on/off the fan motor by force with Fan ON/OFF commands.

The following message will appear.

```
Fan number select (1:FAN#1, 2:FAN#2, 0:FAN#1&#2) ?
```

To check the CPU fan, press **1** and **Enter**.

To check the VGA fan, press **2** and **Enter**.

To check both CPU fan and VGA fan, press **0** and **Enter**.

The following message will appear.

```
Fan test execute now ... (CPU:xxxxRpm / GPU:xxxxRpm)
```

```
*** Test Fan Revolution 0000RPM start
```

Make sure the specified fan does not rotate and the message of fan revolution is "0000Rpm". Then press **Enter**.

The following message will appear.

```
*** Test Fan Revolution Low speed Start
```

Make sure the fan rotates at low speed, then press **Enter**.

The following message will appear.

```
*** Test Fan Revolution High speed Start
```

Make sure the fan rotates at high speed, then press **Enter**.

After a while, the fan rotating will stop.

Subtest 03 Geyserville

If the CPU supports Gerserville (SpeedStep), this Subtest checks that the CPU operating clock speed can be changed.

If the CPU does not support Gerserville (SpeedStep), the following message is displayed and the test is ended.

```
This chip is not supported
```

Subtest 04 Quick Charge

This subtest checks the status for the quick charge.

Subtest 05 DMI read

This subtest displays the information in the Flash-ROM in the following format.

```
*** DMI Data Display Ver X.XX ***
Model Name       : XXXXXXXXXXXXX
Version Number  : XXXXXXXXXXXXXXX
Serial Number    : XXXXXXXXX
UUID Number     : XXXXXXXXXXXXXXXXXXXXXXXXXXXXXXXXXXXXXXX
Model Number    : XXXXXX-XXXXXX
PCN/BND Number  : XXXXXXXXXXXXX
Press [Enter] to EXIT
```

To exit this subtest and return to the SYSTEM test menu, press **Enter**.

3.8 Memory Test

To execute the Memory Test, select **2** from the DIAGNOSTIC TEST MENU, press **Enter** and follow the directions on the screen. Move the highlight bar to the subtest you want to execute and press **Enter**.

Subtest 01 Conventional memory

This subtest writes a constant data to conventional memory (0 to 640 KB), then reads the new data and compares the result with the original data.

Subtest 02 Protected Mode

NOTE: The CONFIG.SYS file must be configured without expanded memory manager programs such as EMM386.EXE, EMM386.SYS or QEMM386.SYS. Also, the HIMEM.SYS must be deleted from the CONFIG.SYS file.

This subtest writes constant data and address data (from 1MB to maximum MB), and reads the new data and compares the result with the original data.

Subtest 03 Protected Mode (cache off)

This subtest executes the same way as the subtest 02 with the cache off.

Subtest 04 Cache memory (on/off)

To test the cache memory, a pass-through write-read comparison of '5Ah' data is run repeatedly to the test area ('7000': 'Program' size to '7000': '7FFF' (32 KB)) to check the hit-miss ratio (on/off status) for CPU cache memory. One test takes 3 seconds.

Number of misses < Number of hits → OK

Number of misses ≥ Number of hits → Fail

Subtest 05 Stress

Write/Read buffer (1 size = B30h) is prepared in the conventional memory. The data is made in the Write Buffer, the data in Write Buffer is written in the area of address of 1MB or after. The data is red in the Read Buffer and data is compared in area up to the maximum size.

Data: FFh, FFh, FFh, FFh, FFh, 00h, 00h, 00h, 00h,
FFh, FFh, FFh, 00h, FFh, 00h, 00h, FFh, 00h,
00h, FFh, FFh, FFh, FFh, 00h, 00h, 00h, AAh

3.9 Keyboard Test

To execute the Keyboard Test, select **3** from the DIAGNOSTIC TEST MENU, press **Enter** and follow the directions on the screen. Move the highlight bar to the subtest you want to execute and press **Enter**.

Subtest 01 Pressed key code display

When a key is pressed, the scan code, character code, and key top name are displayed on the screen in the format shown below. The **Ins Lock, Caps Lock, Num Lock, Scroll Lock, Alt, Ctrl, Left Shift** and **Right Shift** keys are displayed in reverse screen mode when pressed. The scan codes, character codes, and key top names are shown in Appendix D.

```
KEYBOARD TEST IN PROGRESS 302000
```

```
Scan code      =
```

```
Character code =
```

```
Keytop        =
```

```
Ins Lock  Caps Lock  Num Lock  Scroll Lock
```

```
Alt       Ctrl       Left Shift  Right Shift
```

```
PRESS [Enter] KEY
```

3.10 Display Test

To execute the Display Test, select **4** from the DIAGNOSTIC TEST MENU, press **Enter** and follow the directions on the screen. Move the highlight bar to the subtest you want to execute and press **Enter**.

Subtest 01 VRAM read/write for VGA

This subtest writes the constant data (AAAAh and 5555h) to the video RAM. The data is read and compared to the original data.

Subtest 02 Gradation for VGA

This subtest displays four colors: red, green, blue and white from left to right across the screen from black to maximum brightness. The display below appears on the screen, when this subtest is executed.

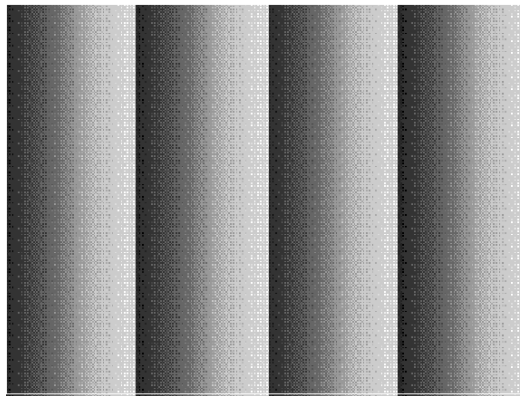

To exit this subtest and return to the DISPLAY TEST menu, press **Enter**.

Subtest 03 Gradation for LCD

This subtest displays bands of gradations for mixed colors, then for red, green, and blue. Next, it displays eight solid colors full screen: red, semi-red, green, semi-green, blue, semi-blue, white, and semi-white. Each color displays for three seconds.

Subtest 04 Gradation & Mode test for VGA

This subtest displays gradations for following modes. To change the mode, press **Enter**.

```
[Mode 12]
[Mode 13]
[Mode 3]
[Mode 111  640*480  64K]
[Mode 112  640*480  16M]
[Mode 114  800*600  64K]
[Mode 115  800*600  16M]
[Mode 117 1024*768  64K]
[Mode 118 1024*768  16M]
```

The display below appears on the screen when this subtest is executed.

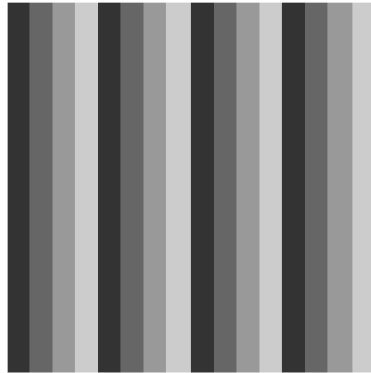

[Mode 12]

(Display example: Mode 12)

To exit this subtest and return to the DISPLAY TEST menu, press **Enter** after displaying the Mode 118.

Subtest 05 All dot on/off for LCD

This subtest displays an all-white screen then an all-black screen. The display changes automatically every three seconds, then returns to the DISPLAY TEST menu.

3.11 Floppy Disk Test

CAUTION: Before running the floppy disk test, prepare a formatted work disk. Remove the Diagnostics Disk and insert the work disk into the FDD. The contents of the floppy disk will be erased.

To execute the Floppy Disk Test, select **5** from the DIAGNOSTIC TEST MENU, press **Enter** and follow the directions displayed on the screen.

1. The following message will appear. Select the media mode and start track to be tested, then press **Enter**.

```
Test start track      (Enter:0/dd:00-79) ?
```

2. The Floppy Disk test contains five subtests that test the FDD. The floppy disk test menu will appear after you select FDD test parameters.

```
FLOPPY DISK          XXXXXXXX
```

```
XXX DIAGNOSTIC TEST VX.XX
[Ctrl]+[Break] : test end
[Ctrl]+[C]     : key stop
```

```
SUB-TEST      : XX
PASS COUNT    : XXXXX   ERROR COUNT   : XXXXX
WRITE DATA   : XX      READ DATA   : XX
ADDRESS       : XXXXXXX STATUS        : XXX
```

```
SUB-TEST MENU :
```

```
01 - Sequential read
02 - Sequential read/write
03 - Random address/data
04 - Write specified address
05 - Read specified address
99 - Exit to DIAGNOSTIC TEST MENU
```

```
↑↓→← : Select items
Enter : Specify
Esc   : Exit
```

Select the number of the subtest you want to execute and press **Enter**. The following message will appear during the floppy disk test.

```

FLOPPY DISK  IN PROGRESS  XXXXXXXX  xxx DIAGNOSTIC TEST VX.XX
                                         [Ctrl]+[Break] : test end
                                         [Ctrl]+[C]   : key stop

SUB-TEST      : XX
PASS COUNT    : XXXXX  ERROR COUNT   : XXXXX
WRITE DATA   : XX     READ DATA    : XX
ADDRESS       : XXXXXX  STATUS        : XXX
  
```

When the subtest 04 or 05 is selected, the following messages will appear on the screen. Select the test data (subtest 04 only), track number and head number you want to test.

```

Test data     ?? (subtest 04 only)
Track No.     ??
Head No.      ?
  
```

Subtest 01 Sequential read

This subtest performs a Cyclic Redundancy Check (CRC) that continuously reads all the tracks (track: 0 to 39/0 to 79) on a floppy disk.

Subtest 02 Sequential read/write

This subtest continuously writes data pattern B5ADADh to all the tracks (track: 0 to 39/0 to 79) on a floppy disk. The data is then read and compared to the original data.

Subtest 03 Random address/data

This subtest writes random data to random addresses on all tracks (track: 0 to 39/0 to 79) on a floppy disk. The data is then read and compared to the original data.

Subtest 04 Write specified address

This subtest writes the data specified by an operator to a specified track, head, and address.

Subtest 05 Read specified address

This subtest reads data from a track, head, and address specified by an operator.

CAUTION: When making the test data, make the data of the number of maximum sectors (18 sectors in 3 modes).

3.12 Printer Test

CAUTION: Printer Test is not supported for this model.

To execute the Printer Test, select **6** from the DIAGNOSTIC TEST MENU, press **Enter** and follow the directions on the screen.

NOTE: An IBM compatible printer must be connected to the system to execute this test. Also, printer port wraparound connector must be connected.

The following message will appear, after selecting the subtest 01 to 03 of the printer test:

```
channel#1 = XXXXh
channel#2 = XXXXh
channel#3 = XXXXh
```

Select the channel number (1-3) ?

The printer I/O port address is specified by the XXXXh number. The computer supports three printer channels. Select the printer channel number, and press **Enter** to execute the selected subtest.

Subtest 01 Ripple Pattern

This subtest prints characters for codes 20h through 7Eh line-by-line while shifting one character to the left at the beginning of each new line.

```
:"#$%E'()*+,-./0123456789:;<=>?@ABCDEFGHIJKLMNopqrstuvwxyz[\]^_`abcdefghijklmnop
:"#$%E'()*+,-./0123456789:;<=>?@ABCDEFGHIJKLMNopqrstuvwxyz[\]^_`abcdefghijklmnop
:"#$%E'()*+,-./0123456789:;<=>?@ABCDEFGHIJKLMNopqrstuvwxyz[\]^_`abcdefghijklmnop
:"#$%E'()*+,-./0123456789:;<=>?@ABCDEFGHIJKLMNopqrstuvwxyz[\]^_`abcdefghijklmnopqr
:"#$%E'()*+,-./0123456789:;<=>?@ABCDEFGHIJKLMNopqrstuvwxyz[\]^_`abcdefghijklmnopqrs
:"#$%E'()*+,-./0123456789:;<=>?@ABCDEFGHIJKLMNopqrstuvwxyz[\]^_`abcdefghijklmnopqrst
:"#$%E'()*+,-./0123456789:;<=>?@ABCDEFGHIJKLMNopqrstuvwxyz[\]^_`abcdefghijklmnopqrstu
:"#$%E'()*+,-./0123456789:;<=>?@ABCDEFGHIJKLMNopqrstuvwxyz[\]^_`abcdefghijklmnopqrstuv
:"#$%E'()*+,-./0123456789:;<=>?@ABCDEFGHIJKLMNopqrstuvwxyz[\]^_`abcdefghijklmnopqrstuvw
:"#$%E'()*+,-./0123456789:;<=>?@ABCDEFGHIJKLMNopqrstuvwxyz[\]^_`abcdefghijklmnopqrstuvwx
:"#$%E'()*+,-./0123456789:;<=>?@ABCDEFGHIJKLMNopqrstuvwxyz[\]^_`abcdefghijklmnopqrstuvwxy
```

Subtest 02 Function

This subtest is for IBM compatible printers, and tests the following functions:

Normal print
 Double-width print
 Compressed print
 Emphasized print
 Double-strike print
 All characters print

This subtest prints the various print types shown below:

```

PRINTER TEST
1. THIS LINE SHOWS NORMAL PRINT.
2. THIS LINE SHOWS DOUBLE-WIDTH PRINT.
3. THIS LINE SHOWS COMPRESSED PRINT.
4. THIS LINE SHOWS EMPHASIZED PRINT.
5. THIS LINE SHOWS DOUBLE-STRIKE PRINT.
6. ALL CHARACTERS PRINT
!"#$%&'()*+,-./0123456789:;<=>?@ABCDEFGHIJKLMN OPQRSTUVWXYZ [\]^_`abcdefghijklmnop
opqrstuvwxyz{|}~

```

Subtest 03 Wraparound

NOTE: To execute this subtest, a printer wraparound connector must be connected to the computer's printer port.

This subtest checks the output and bi-directional modes of the data control and status lines through the parallel port wraparound connector (34M741986G01). (Both output and bi-directional modes are tested.)

3.13 Async Test

CAUTION: Async Test is not supported for this model.

To execute the Async Test, select **7** from the DIAGNOSTIC TEST MENU, press **Enter** and follow the directions displayed on the screen. Move the highlight bar to the subtest you want to execute and press **Enter**.

Subtests 01 and 02 require the following data format:

Method: Asynchronous
Speed: 38400BPS
Data: 8 bits and one parity bit (EVEN)
Data pattern: 20h to 7Eh

Subtest 01 FIR/SIR point to point (send)

NOTE: To execute subtests 01 and 02, each computer must have access to the other computer's infrared port.

This subtest sends 20h through 7Eh data to the receive side, then receives the sent data and compares it to the original data through the FIR/SIR port.

Subtest 02 FIR/SIR point to point (receive)

This subtest is used with subtest 01 described above. This subtest receives the data from the send side, then sends the received data through the FIR/SIR port.

Subtest 03 Wraparound (board)

NOTE: To execute this subtest, a RS-232C wraparound connector must be connected to the RS-232C port.

This subtest checks the data send/receive function through the wraparound connector.

3.14 Hard Disk Test

To execute the Hard Disk Test, select **8** from the DIAGNOSTIC TEST MENU, press **Enter**, and follow the directions on the screen.

CAUTION: *The contents of the hard disk will be erased when subtest 02, 03, 04, 06, 08 or 09 is executed. Before running the test, the customer should transfer the contents of the hard disk to floppy disk or another hard disk. If the customer has not or cannot perform the back-up, create back-up disks as described below.*

Check to see if the Microsoft Create System Disks Tools (MSCSD.EXE) still exists in the System Tools Folder. (This tool can be used only once.) If it exists, use it to back up the pre-installed software, then use the Backup utility in the System Tools folder to back up the entire disk, including the user's files.

Refer to the operating system instructions.

When a 2nd HDD is installed, the following messages will appear after selecting the hard disk test from the DIAGNOSTIC TEST MENU.

Test drive number select (1:HDD#1, 2:HDD#2, 0:HDD#1&2) ?

↑↓→← : Select items
Enter : Specify
Esc : Exit

1. Input the number of HDD test and press **Enter**.
2. This message is used to select the error dump operation when a data compare error is detected. Select **1** or **2**.

Data compare error dump (1:no, 2:yes)

3. This message is used to select whether or not the HDD status is displayed on the screen. The HDC status is described in section 3.20. Select **1** or **2**.

Detail status display (1:no, 2:yes)

4. The Hard Disk Test message will appear after you respond to the Detail Status prompt. Select the number of the subtest you want to execute and press **Enter**. The following message will appear during each subtest.

```
HARD DISK TEST XXXXXXXX
```

```
XXX DIAGNOSTIC TEST VX.XX
[Ctrl]+[Break] : test end
[Ctrl]+[C]     : key stop
```

```
SUB TEST      : XX
PASS COUNT    : XXXXX      ERROR COUNT    : XXXXX
WRITE DATA   : XX         READ DATA   : XX
ADDRESS       : XXXXXXX    STATUS        : XXX
```

The first three digits of the ADDRESS indicate which cylinder is being tested, the fourth digit indicates the head and the last two digits indicate the sector.

The first digit of the STATUS number indicates the drive being tested and the last two digits indicate the error status code as explained in table 3-2 of the section 3.19.

Subtest 01 Sequential read

This subtest is a sequential reading of all the tracks on the HDD starting at track 0. When all the tracks on the HDD have been read, the test starts at the maximum track and reads the tracks on the HDD sequentially back to track 0.

Subtest 02 Address uniqueness

This subtest writes unique address data to each sector of the HDD track-by-track. The data written to each sector is then read and compared with the original data. There are three ways the HDD can be read:

1. Forward sequential
2. Reverse sequential
3. Random

Subtest 03 Random address/data

This subtest writes random data in a random length to random addresses. This data is then read and compared to the original data.

Subtest 04 Cross talk & peak shift

This subtest writes eight types of worst pattern data (listed below) to a cylinder, then reads the data while moving from cylinder to cylinder. (Test the data interference in the neighbor track)

Worst pattern data	Cylinder
'B5ADAD'	0 cylinder
'4A5252'	1 cylinder
'EB6DB6'	2 cylinder
'151149'	3 cylinder
'63B63B'	4 cylinder
'9C49C4'	5 cylinder
'2DB6DB'	6 cylinder
'D25114'	7 cylinder

Subtest 05 Partial Read

This subtest reads 1GB data that is in minimum, middle and maximum address of the HDD area.

Subtest 06 Write specified address

This subtest writes specified data to a specified cylinder and head on the HDD.

Subtest 07 Read specified address

This subtest reads data, which has been written to a specified cylinder and head on the HDD.

Subtest 08 Sequential write

This subtest writes specified 2-byte data to all of the cylinders on the HDD.

Subtest 09 W-R-C specified address

This subtest writes data to a specified cylinder and head on the HDD, then reads the data and compares it to the original data.

3.15 Real Timer Test

To execute the Real Timer Test, select **9** from the DIAGNOSTIC TEST MENU, press **Enter** and follow the directions on the screen. Move the highlight bar to the subtest you want to execute and press **Enter**.

Subtest 01 Real time

A new date and time can be input during this subtest. To execute the real time subtest, follow these steps:

1. Select subtest 01 and the following messages will appear:

```
Current date : XX-XX-XXXX
Current time : XX:XX:XX
```

```
Enter new date:
```

```
PRESS [ENTER] KEY TO EXIT TEST
```

2. If the current date is not correct, input the correct date at the “Enter new date” prompt and press **Enter**.

3. The following messages will appear:

```
Current date : XX-XX-XXXX
Current time : XX:XX:XX
```

```
Enter new time:
```

```
PRESS [ENTER] KEY TO EXIT TEST
```

4. If the current time is not correct, input the correct time in 24-hour format. To enter ":", press **Shift + ;**. The time is updated.

To exit the test, press **Enter**.

Subtest 02 Backup memory

This subtest checks the following backup memories:

Writes 1-bit of “on” data (01h through 80h) to address 0Eh through 7Fh

Writes 1-bit of “off” data (FEh through 7Fh) to address 0Eh through 7Fh

Writes the data pattern AAh and 55h to the address 0Eh to 7Fh

Then the subtest reads and compares this data with the original data.

Subtest 03 Real time carry

CAUTION: *When this subtest is executed, the current date and time are erased.*

This subtest checks the real time clock increments, making sure the date and time are displayed in the following format:

```
Current date : 12-31-1999
Current time : 23:59:58
```

The real time increments are automatically executed and the following is displayed:

```
Current date : 01-01-2000
Current time : 00:00:00
```

```
PRESS [Enter] KEY TO EXIT TEST
```

To exit the test, press **Enter**.

3.16 NDP Test

To execute the NDP test, select **10** from the DIAGNOSTICS TEST MENU, press **Enter** and follow the directions on the screen.

CAUTION: Judge the existence of high-speed operation processor by 1bit of the composition byte. If exists, the bit is "1". Test only when the high-speed operation processor exists.

Subtest 01 NDP test

This test checks the following functions of NDP:

- Control word
- Status word
- Bus
- Addition
- Multiplication

3.17 Expansion Test

To execute the expansion test, select **11** from the DIAGNOSTICS TEST MENU, press **Enter** and follow the directions on the screen.

Subtest 01 PCMCIA wraparound

CAUTION: PCMCIA wraparound test is not supported for this model.

NOTE: To execute this subtest, the PC card wraparound connector is required.

This subtest checks the following signal line of the PC card slot:

- Address line
- REG#, CE#1, CE#2 line
- Data line
- Speaker line
- Wait line
- BSY#, BVD1 line

This subtest is executed in the following order:

Sub#	Address	Good	Bad	Contents
01	00001 00001	nn nn	xx xx	Address line REG#, CE#1, CE#2 nn=A0, 90, 80, 00
02	00002	ww	rr	Data line ww=write data, rr=read data
03	00003	—	—	Speaker line
04	00004	40,80	xx	Wait line (40<xx<80)
05	00005	nn	xx	Other lines (BSY#, BVD1) NN=21, 00

NOTE: Select the subtest number 01, the following message will appear:
Test slot number select (1:slot0, 2:slot1, 0:slot0&1)?

Subtest 02 RGB monitor ID

NOTE: To execute this subtest, monitor supporting EDID (Extended Display Identification Data) is required.

Connect a wraparound connector to CRT monitor for the test of ID acquisition. This subtest is executed by using VESA command.

CAUTION: It becomes NG because the priority is given to the internal monitor in a simultaneous display mode.

3.18 CD-ROM/DVD-ROM Test

To execute the CD-ROM/DVD-ROM test, select **12** from the DIAGNOSTICS TEST MENU, press **Enter** and follow the directions on the screen.

NOTE: For the subtest 01, 02 and 03, use the TOSHIBA CD-ROM TEST DISK TDY-01 or ABEX TEST CD-ROM TCDR-702 and DVD-ROM TEST DISK TSD-1. For the subtest 04, use a CD-RW on the market.

Subtest 01 Sequential read

This subtest is a sequential reading of one-block units (2K bytes) of all the logical addresses.

Subtest 02 Read specified address

This subtest reads one-block data from a specified address.

Subtest 03 Random address/data

This subtest reads one-block data and multi-block data from random addresses 200 times.

Subtest 04 RW 1point W/R/C

This subtest writes, reads and compares data at one point on a CD/RW media.

3.19 Error Code and Error Status Names

Table 3-2 lists the error codes and error status names for the Diagnostic Test.

Table 3-2 Error codes and error status names (1/3)

Device name	Error code	Error status name
(Common)	FF	Data Compare Error
System	01 03 04 05 06 07 08 09 10	ROM - CHECKSUM ERROR ROM - SERIAL ID WRITE ERROR ROM - NOT SUPPORTED PS-SYSTEM ROM - SENSING ERROR(AC-ADAPT) ROM - SENSING ERROR(1st Batt) ROM - SENSING ERROR(2nd Batt) ROM - THORMISTOR ERROR(1) ROM - THORMISTOR ERROR(2) ROM - THORMISTOR ERROR(3)
Memory	01 02 DD	RAM - PARITY ERROR RAM - PROTECTED MODE NO CHANGE RAM - CACHE MEMORY ERROR
Keyboard	FE FD F0 F1 F2 F3 F4 F5 F6 F7 F8 F9 FA EF ED	USB - GET DESCR.ERROR (FIRST) USB - SET ADDRESS ERROR HUB - GET DESCR.ERROR(Top 8B) HUB - GET DESCR.ERROR (Whole) HUB - SET CONFIGURATION ERROR HUB - GET DESCR.ERROR(DESCR) HUB - SET FEATURE ERROR (P ON) HUB - GET STATUS ERROR HUB - SET FEATURE ERROR(RESET) HUB - CLEAR FEATURE ERROR HUB - CLEAR FEATURE1 ERROR HUB - SET FEATURE ERROR(Enab) HUB - CLEAR FEATURE2 ERROR USB - OVER CURRENT ERROR USB - GET DESCR.ERROR(SECOND)
Display	EE	VRAM SIZE NOT SUPPORT

Table 3-2 Error codes and error status names (2/3)

Device name	Error code	Error status name
FDD	01 02 03 04 08 09 10 20 40 80 60 06 EE	FDD - BAD COMMAND ERROR FDD - ADDRESS MARK NOT FOUND FDD - WRITE PROTECTED FDD - RECORD NOT FOUND FDD - DMA OVERRUN ERROR FDD - DMA BOUNDARY ERROR FDD - CRC ERROR FDD - FDC ERROR FDD - SEEK ERROR FDD - TIME OUT ERROR FDD - NOT DRIVE ERROR FDD - MEDIA REMOVED FDD - WRITE BUFFER ERROR
Printer	01 08 10 20 40 80	PRT - TIME OUT PRT - FAULT PRT - SELECT LINE PRT - OUT OF PAPER PRT - POWER OFF PRT - BUSY LINE
ASYNC	01 02 04 08 10 20 40 80 88 05 06	RS232C - [DTR ON] TIME OUT RS232C - [CTS ON] TIME OUT RS232C - [RX READY] TIME OUT RS232C - [TX FULL] TIME OUT RS232C - PARITY ERROR RS232C - FRAMING ERROR RS232C - OVERRUN ERROR RS232C - LINE STATUS ERROR RS232C - MODEM STATUS ERROR SIR - TIME OUT ERROR FIR - TIME OUT ERROR
HDD	05 07 09 0B BB 08 01 02 04 10 20 40 80 11 AA	HDD - HDC NOT RESET ERROR HDD - DRIVE NOT INITIALIZE HDD - DMA BOUNDARY ERROR HDD - BAD TRACK ERROR HDD - UNDEFINED ERROR HDD - OVERRUN ERROR (DRQ ON) HDD - BAD COMMAND ERROR HDD - ADDRESS MARK NOT FOUND HDD - RECORD NOT FOUND ERROR HDD - ECC ERROR HDD - HDC ERROR HDD - SEEK ERROR HDD - TIME OUT ERROR HDD - ECC RECOVER ENABLE HDD - DRIVE NOT READY

Table 3-2 Error codes and error status names (3/3)

Device name	Error code	Error status name
(HDD)	CC E0 0A EE DA 12	HDD - WRITE FAULT HDD - STATUS ERROR HDD - BAD SECTOR HDD - ACCESS TIME ERROR HDD - NO HDD HDD - DMA CRC ERROR
NDP	01 02 03 04 05 06	NDP - NO CO-PROCESSOR NDP - CONTROL WORD ERROR NDP - STATUS WORD ERROR NDP - BUS ERROR NDP - ADDITION ERROR NDP - MULTIPLAY ERROR
EXPANSION	C1 C3 C4 C5 C6 C7 C8 CB CC CE CF	ADDRESS LINE ERROR CE#1 LINE ERROR CE#2 LINE ERROR DATA LINE ERROR WAIT LINE ERROR BSY# LINE ERROR BVD1 LINE ERROR ZV-Port ERROR NO PCMCIA CARD TYPE ERROR ZV_CONT# ERROR
CD-ROM /DVD-ROM	01 02 03 04 05 06 09 11 20 40 80 90 B0	BAD COMMAND ILLEGAL LENGTH UNIT ATTENTION MEDIA CHANGE REQUEST MEDIA DETECTED ADDITIMAL SENSE BOUNDARY ERROR CORRECTED DATA ERROR DRIVE NOT READY SEEK ERROR TIME OUT RESET ERROR ADDRESS ERROR

3.20 Hard Disk Test Detail Status

When an error occurs in the hard disk test, the following message is displayed:

```
HDC status = XXXXXXXX
```

Detailed information about the hard disk test error is displayed on the screen by an eight-digit number. The first four digits represent the hard disk controller (HDC) error status number and the last four digits are not used.

The hard disk controller error status is composed of two bytes; the first byte displays the contents of the HDC status register in hexadecimal form and the second byte displays the HDC error register.

The contents of the HDC status register and error register are listed in Tables 3-3 and 3-4.

Table 3-3 Hard disk controller status register contents

Bit	Name	Description
7	BSY (Busy)	"0" ... HDC is ready. "1" ... HDC is busy.
6	DRY (Drive ready)	"0" ... Hard disk drive is not ready to accept any command. "1" ... Hard disk drive is ready.
5	DWF (Drive write fault)	"0" ... DWF error is not detected. "1" ... Write fault condition occurred.
4	DSC (Drive seek complete)	"0" ... The hard disk drive heads are not settled over a track. "1" ... The hard disk drive heads are settled over a track.
3	DRQ (Data request)	"0" ... Drive is not ready for data transfer. "1" ... Drive is ready for data transfer.
2	COR (Corrected data)	"0" ... Not used "1" ... Correctable data error is corrected.
1	IDX (Index)	"0" ... Not used "1" ... Index is sensed.
0	ERR (Error)	"0" ... Normal "1" ... The previous command was terminated with an error.

Tables 3-4 HDC Error register contents

Bit	Name	Description
7	BBK (Bad block mark)	"0" ... Not used "1" ... A bad block mark is detected.
6	UNC (Uncorrectable)	"0" ... There is no uncorrectable data error. "1" ... Uncorrectable data error has been detected.
5	—	Not used
4	IDN (Identification)	"0" ... Not used "1" ... There is no ID field in the requested sector.
3	—	Not used
2	ABT (Abort)	"0" ... Not used "1" ... Illegal command error or command abort.
1	TK0 (Track 0)	"0" ... The hard disk found track 0 during a recalibrate command. "1" ... The hard disk could not find track 0 during a recalibrate command.
0	—	Not used

3.21 ONLY ONE TEST

3.21.1 Program Description

This program tests the unique functions of this model.

3.21.2 Operations

Select test **2** from the DIAGNOSTIC MENU and press **Enter**. The following menu appears in the display.

```
#####
#####          ONLY ONE TEST Menu (QOSMIO F30)          #####
#####
*
*  1 ..... Pressed Key Display                            *
*  2 ..... Touch Pad                                       *
*  3 ..... Kill Switch                                     *
*  4 ..... USB                                             *
*  5 ..... LED                                             *
*  6 ..... Button                                          *
*  7 ..... Remocon (Remote control [AUDIO/STOP])         *
* 99 ..... Exit to Common Test                             *
*
*****
.... Press test number [1-99] ?
```

Select the subtest number you want to test and press **Enter**.

To return to the DIAGNOSTIC TEST menu, select **99** and press **Enter**.

Subtest 01 Pressed Key Display

When you execute this subtest, the keyboard layout is drawn on the display as shown below. When any key is pressed, the corresponding key on the screen changes to the key character that was pressed. Holding a key down enables the auto-repeat function that causes the key's display character to blink.

Press **Del + Enter** to end the test.

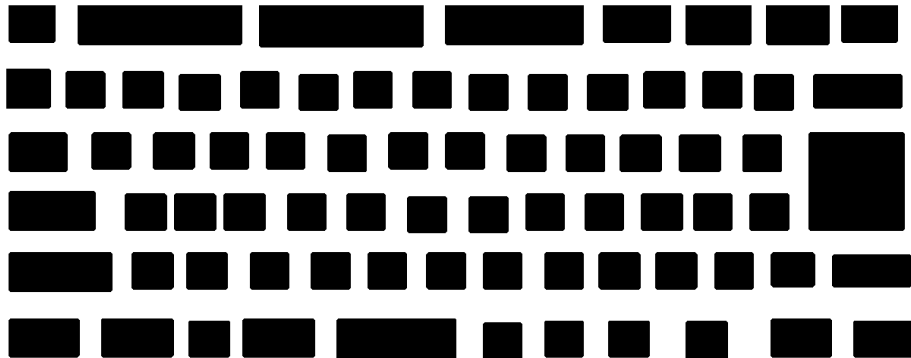

IF TEST OK, Press [Del][Enter]key

Subtest 02 Touch Pad

This subtest checks the functions of the touch pad as shown below.

- A) Direction and parameter
- B) Switching function check.

This test displays the response from the touch pad and touch pad switch. When moving your finger on the touch pad towards the upper left, the <POINTING> display changes according to the following illustration. If a touch pad switch is pressed, the <BUTTONS> displays appear on the right side one by one. The parameters appear above the <BUTTONS> (1) or (2) corresponding to the pressed touch pad switch highlights. To end this subtest, press two touch pad switches at the same time.

```

*** IPS (PAD) TEST PROGRAM (Vx.xx) ***

<POINTING>
<PARAMETER>
STATUS:0000h
X-RATE:0000h
Y-RATE:0000H

<BUTTON>
(1)    (2)

<< PRESS BUTTON1+BUTTON2 THEN END >>

*** IPS (PAD) TEST PROGRAM (Vx.xx) ***

< POINTING >
<PARAMETER>
STATUS: 0018h
X-RATE: OK
Y-RATE: OK

<BUTTON>
(1)    (2)

<< PRESS BUTTON1+BUTTON2 THEN END >>

```

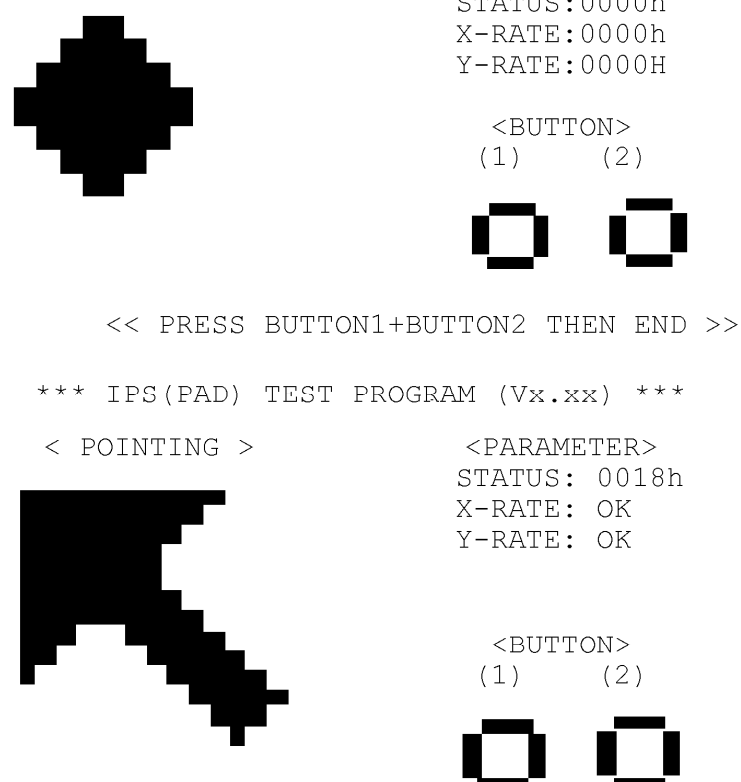

Subtest 03 Kill Switch

This subtest checks if the Wireless communication switch works properly.

If the test is started with the switch ON, following message appears in the display.

```
Kill switch is set to a start position (OFF)
```

Slide the switch to OFF position. Then, following message appears in the display.

```
KILL SWITCH ON !!
```

Slide the switch to ON position. Then, following message appears in the display.

```
KILL SWITCH OFF !!
```

After Sliding the switch to OFF position, return to the ONLY ONE TEST menu automatically.

Subtest 04 USB

NOTE: When executing this subtest, USB test module and USB cable must be connected.

This subtest checks if USB port works properly.

The following menu appears in the display.

```
#####
#####          USB Port Select (XXXXXXXX)          #####
#####
*
* 0 ..... Port 0 (Back side upper) *
* 1 ..... Port 1 (Back side lower) *
* 2 ..... Port 2 (Left side back) *
* 3 ..... Port 3 (Left side front) *
* 9 ..... EXIT to Only One Menu *
*
*****
.... Press test number[0-3, 9] ?
```

Connect the USB test module and USB cable to the computer.

Input the port test number and press **Enter**.

OK message appears in the display if the test ends without a defective.

NG message appears in the display if a defective is found during the test. Confirm the connection of cable, then execute the test again.

Press **9** and return to ONLY ONE TESST menu.

Subtest 05 LED

This subtest checks if each LED lights properly.

The following message appears in the display in order. Follow the instructions in the display to execute the test.

```
[HDD Access LED test]
```

Confirm the LED of HDD status blinks properly.

Press any key and following message appears in the display.

```
[Caps/Num/Overlay BT/W-LAN LED test]
```

Confirm each LED lights properly.

- (1) Press [Caps Lock] key ! ...Caps (on/off)
- (2) Press [Fn + F10] key ! ...Arrow (on/off)
- (3) Press [Fn + F11] key ! ...Num (on/off)
- (4) Slide [BT/W-LAN switch L&R]! (on/off)

Press **Enter** and following message appears in the display.

```
Check [Power SW-LED]= Green
```

Check if the Power Switch LED lights in the following order.
(Green -> Orange -> Blue -> OFF)

Press any key and following message appears in the display.

```
Check [DC-IN]&[Power]&[Main Battery]LED= Green
```

Check if the each LED lights in the same color as the message in the display
(Message switches Green <-> Orange).

Press **Enter** and return to the ONLY ONE TEST menu.

Subtest 06 Button

This subtest checks if the Operation buttons (11 buttons) work properly.

The following message appears in the display.

```

0 1 2 3 4 5 6 7 8 9 A
* * * * *

```

Press Function button !

Press the first Operation button from the left (The first * from the left is lighted in green.). The name of Operation button in the message is described as number (0-A) from the left side. (Refer to the following picture.)

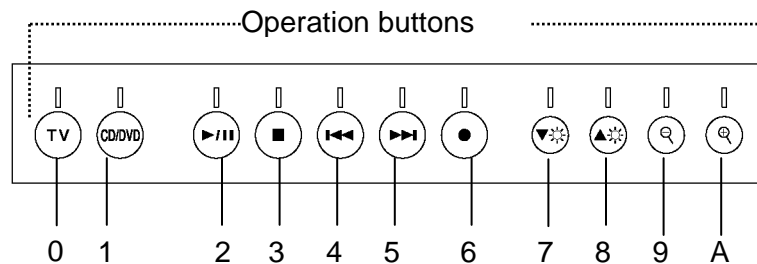

Press the indicated Operation button, following message will appear in the display.

```
Press Function button ! OK
```

As the same way, press the indicated touch sensor button and carry on the touch sensor button test.

If wrong key is pressed, following message will appear in the display.

```
Press Function button ! NG
```

```
Press any key !
```

Pressing any key, indication of pressing touch sensor button will appear in the display again. Unless the right touch sensor button is pressed, this operation is repeated.

After checking all touch sensor button, return to the ONLY ONE TEST menu automatically.

Subtest 07 Remocon (Remote control, [AUDIO/STOP])

This subtest checks if AUDIO/STOP button of attached remote controller works properly.

The following message appears in the display.

```
[[[Remote Control test]]]
```

Press [AUDIO/STOP] button!

Press AUDIO/STOP button of the remote controller and return to the ONLY ONE TEST menu.

3.22 Head Cleaning

3.22.1 Function Description

This function cleans the heads in the FDD by executing a series of head load/seek and read operations. A cleaning kit is necessary to perform this program.

3.22.2 Operations

1. Selecting test **4** from the DIAGNOSTIC MENU and pressing **Enter** displays the following messages:

```
DIAGNOSTICS - FLOPPY DISK HEAD CLEANING : VX.XX
```

```
Mount cleaning disk(s) on drive(s).
```

```
Press any key when ready.
```

2. Remove the Diagnostics Disk from the FDD, then insert the cleaning disk and press **Enter**.
3. When the “cleaning start” message appears, the FDD head cleaning has begun.
4. The display automatically returns to the DIAGNOSTIC MENU when the program is completed.

3.23 Log Utilities

3.23.1 Function Description

This function logs error information generated while a test is in progress and stores the results in RAM. This function can store data on a floppy disk or output the data to a printer.

The error information is displayed in the following order:

1. Error count (CNT)
2. Test name, Subtest number (TS-No)
3. Pass count (PASS)
4. Error status (STS)
5. FDD/HDD or memory address (ADDR)
6. Write data (WD)
7. Read data (RD)
8. HDC status (HSTS)
9. Error status name (ERROR STATUS NAME)

If the power switch is turned off, the error information will be lost.

3.24 Running Test

3.24.1 Function Description

Some devices are tested in an attended operation. The name of tested devices and subtest number are displayed on the screen while executing the test.

This function automatically executes the following tests in sequence:

1. System test (subtest 01)
2. Memory test (subtests 01, 02, 06)
3. Display test (subtest 01)
4. Real timer test (subtest 02)
5. HDD test (subtests 01)
6. FDD test (subtests 02)

The system automatically detects the number of floppy disk drives connected to the computer for the FDD test.

3.24.2 Operations

1. Select **6** from the Diagnostic Menu and press **Enter**, the following messages will appear in the display in order.
 - FDD write/read test (Y/N) ?
 - Printer wrap around test (Y/N) ?
 - Serial wrap around test (Y/N) ?
 - CD-ROM/DVD-ROM test (Y/N) ?

Y: The test is executed.
N: The test is not executed.
R: The sequential read is selected
W: The sequential read/write is selected
2. To execute the test, press **Y (yes)** and **Enter**. To cancel the test, press **N (no)** and **Enter**. If you execute the selectable test, follow the indication message in the display.
3. After setting the selectable test, the test starts automatically. To terminate the program, press **Ctrl + Break**.

3.25 Floppy Disk Drive Utilities

3.25.1 Function Description

This function formats the FDD, copies the floppy disk and displays the dump list for both the FDD and HDD.

1. FORMAT

NOTE: *This program is only for testing a floppy disk drive. The option is different from the Toshiba MS-DOS FORMAT command.*

This program can format a floppy disk in the following formats:

- (a) 2DD: Double-sided, double-density, double-track, 96/135 TPI, MFM mode, 512 bytes, 9 sectors/track.
- (b) 2HD: Double-sided, high-density, double-track, 96/135 TPI, MFM mode, 512 bytes, 18 sectors/track.

2. COPY

This program copies data from a source floppy disk to a target floppy disk.

3. DUMP

This program displays the contents of the floppy disk and the designated sectors of the hard disk on the display.

4. HDD ID READ

This program reads the hard disk ID and displays hard disk information.

3.25.2 Operations

1. Selecting **7** from the DIAGNOSTIC MENU and pressing **Enter** displays the following message:

```
[ FDD UTILITIES ]  
  
1 - FORMAT  
2 - COPY  
3 - DUMP  
4 - HDD-ID READ  
9 - EXIT TO DIAGNOSTICS MENU
```

2. FORMAT program

- (a) Selecting FORMAT displays the following message:

```
DIAGNOSTICS - FLOPPY DISK FORMAT : VX.XX  
Drive number select (1:A, 2:B) ?
```

- (b) Select a drive number to display the following message:

```
Type select (0:2DD, 3:2HD) ?
```

- (c) Select a media/drive type number and press **Enter**. A message similar to the one below will be displayed:

```
Warning : Disk data will be destroyed.  
Insert work disk into drive A:  
Press any key when ready.
```

- (d) Remove the Diagnostics Disk from the FDD, insert the work disk and press any key.

The following message will be displayed when the FDD format is executed:

```
[ FDD TYPE ] : TRACK   = XXX  
[ FDD TYPE ] : HEAD    = X  
[ FDD TYPE ] : SECTOR  = XX  
  
Format start  
[[track, head = XXX X]]
```

After the floppy disk is formatted, the following message will appear:

```
Format complete  
Another format (1:Yes/2:No) ?
```

- (e) Typing **1** displays the message from step (c) above. Typing **2** returns the test to the DIAGNOSTIC MENU.

3. COPY program

- (a) When COPY is selected, the following message appears:

```
FLOPPY DISK FORMAT & COPY : VX.XX
Type select (0:2DD,3:2HD) ?
```

- (b) Selecting a media/drive type number will display a message similar to the one below:

```
Insert source disk into drive A:
Press any key when ready.
```

- (c) Remove the Diagnostics Disk from the FDD, insert the source disk and press any key. The following message will appear, indicating the program has started.

```
[ FDD TYPE ] : TRACK      = XXX
[ FDD TYPE ] : HEAD       = X
[ FDD TYPE ] : SECTOR     = XX

Copy start
                [[ track, head = XXX X ]]
```

- (d) The following message will appear.

```
Insert target disk into drive A:
Press any key when ready.
```

- (e) Remove the source disk from the FDD, then insert a formatted work disk and press any key. The following message will appear and start copying to the target disk.

```
                [[ track, head = XXX X ]]
```

- (f) When the amount of data is too large to be copied in one operation, the message from step (b) is displayed again. After the floppy disk has been copied, the following message will appear:

```
Copy complete
Another copy (1:Yes/2:No) ?
```

- (g) To copy another disk, type **1** and the message from step (a) is displayed again. Entering **2** returns the test program to the DIAGNOSTIC MENU.

4. DUMP program

- (a) When DUMP is selected, the following message appears:

```
DIAGNOSTICS-HARD DISK & FLOPPY DISK DUMP : VX.XX
Drive type select (1:FDD, 2:HDD) ?
```

- (b) Select a drive type. If 2:HDD is selected, the display will go to step (h). If 1:FDD is selected, the following message will appear:

```
Select drive number (1:A, 2:B) ?
```

- (c) Select a drive number and the following message will be displayed.

```
Format type select (1:2DD, 3:2HD) ?
```

- (d) If 3:2HD is selected, the following message will appear. Select a media mode.

```
2HD media mode (1:1.20MB, 2:1.44MB, 3:1.23MB)?
```

- (e) The following message will appear:

```
Insert source disk into drive A:
Press any key when ready.
```

- (f) Insert a source disk and press any key and the following message will appear:

```
— Max. address —
[Track ] = XXXX
[Head  ] = XX
[Sector] = XX
Track number ?????
```

- (g) Set the track number, head number and sector number you want to dump. The system will access the disk and dump a list. Then the message shown in (k) will appear.

- (h) The following message will appear when selecting 2:HDD in (a).

```
Select drive number (1:C, 2:D) ?
```

- (i) Select a drive number and the following message will be displayed.

```
---Max. address ---
[LBA ] = XXXXXXXXXXXX
LBA number ??????????
```

- (j) Set the LBA number you want to dump. The system will access the disk and dump a list.

- (k) The following message will appear. To finish the dump, select **3**.

Press number key (1:up,2:down,3:end) ?

- (l) The following message will appear. Selecting **2** returns to the FDD UTILITIES MENU.

Another dump (1:Yes,2:No) ?

5. HDD ID READ program

Selecting HDD ID displays the following HDD ID configuration:

[HDD ID Read (VX.XX)]	[Drive #1]	[Drive #2]
Model No.	= XXXXXXXX	= XXXXXXXX

NOTE: Only when a 2nd HDD is installed, [Drive #2] message appears in the display.

Press **Enter** to return to the FDD UTILITIES MENU.

3.26 System Configuration

3.26.1 Function Description

The System Configuration program contains the following configuration information for the computer:

1. Processor Type [Code/L2 cache]
2. Chip set [VRAM]
3. BIOS ROM version [1st ID, 2nd ID]
4. Boot ROM version
5. EC/KBC version
6. PS Microprocessor version
7. SVP parameter version [Panel/Manufacture code/Product code]
8. Micro code revision [Processor number]
9. Total Memory Size [Conventional memory]
10. Battery code
11. HWSC
12. FSB [Voltage]
13. The number of printer ports
14. The number of ASYNC ports
15. Math co-processors
16. Floppy Disk Drive [Track/Head/Sector]
17. Hard Disk Drive [Sector/Drive size/Manufacture code]
18. Optical Disk Drive [Maker/Drive type/Manufacture code/Product code]
19. T&D total version
20. Date/Time

3.26.2 Operations

Select **8** from the DIAGNOSTIC MENU and press **Enter**. Then, the following system configuration appears in the display.

```
System Configuration Display: Ver X.XX [Machine Name???]

* - Processor Type      = XXXXXX-XXXXXXMHz      Code = XX      L2 Cache = XXXXXXKB
* - Chip set           = XXXXXX                      VRAM = XXXXMB
* - BIOS ROM Version   = VX.XX              1st ID = XXH, 2nd ID = XXH
* - BOOT ROM Version   = VX.XX
* - EC/KBC Version     = VX.XX
* - PS Micon Version   = VX.XX
* - SVP Par. Version   = VX.XX      (Panel=XXXXXXXX, Manu=XXXX, Prod=XXXX)
* - Micro code Revision = VX.XX      (Processor=XXXh)
* - Total Memory Size  = XXXXXXMB (Conventional Memory = XXXXKB)
* - Battery Code       = XXXXXXXXXXXX
* - HWSC               = XXXXXXXX
* - FSB                = XXXXXXMHz (Voltage = XEh)
* - X Printer Adapter  LPT1 = XXXX   LPT2 = XXXX   LPT3 = XXXX
* - X ASYNC Adapter    COM1 = XXXX   COM2 = XXXX   COM3 = XXXX
* - X Math CO-Processor
* - X Floppy Disk Drive(s)  Track = XX   Head = XX, Sector = XX
* - X Hard Disk Drive(s)   #1 Sectors = XXXXX, (XXXXX GB) [XXXXXXXXXXXXXXXXXXXX]
                          #2 Sectors = XXXXX, (XXXXX GB) [XXXXXXXXXXXXXXXXXXXX]
* - ODD                 = XXXX XXXXXXXX XXXXXXXX [XXXXXXXXXXXX]
* - T&D Total Version    = VX.XX

Press [Enter] Key      [Date = XXXX-YY-ZZ, XX:YY:ZZ]
```

Press **Enter** to return to the DIAGNOSTIC MENU.

3.27 Wireless LAN Test Program (Atheros)

This section describes how to perform the wireless LAN transmitting-receiving test with the test program.

NOTE: Use another computer (with Atheros 11a/g(MB44ag)/Atheros 11a/g(MB62HL)) that can communicate by the wireless LAN as a responder machine to perform this test.

The computer must be booted by the Responder T&D.

In this test, the following items are tested:

- (1) SKU check of Module
- (2) MAC Address Check
- (3) Communication test of 11a mode
- (4) Communication test of 11b mode
- (5) Communication test of 11g mode
- (6) SKU & MAC Check, 11a/b/g communication test

To start the Wireless LAN test program, follow the steps below:

NOTE: Before starting the wireless LAN test, make sure the Wireless Communication Switch on the left side of the computer is turned on. (The Wireless Communication LED lights orange.)

3.27.1 Setting the responder machine

1. MB44ag is installed
 - 1) Boot the computer by MB4x Responder media.
 - 2) The Responder T&D is automatically started.
2. MB6x is installed

As the capacity of MB6x T&D is over the one of a FD, a RAM drive is used.

- 1) Boot the computer by MB6x Responder media.
- 2) After starting the OS, following message is displayed. input **m** and press **Enter**.

```

*****
*
*      Atheros MB4x/MB5x/MB6x Maintenance T&D Menu      *
*
*      s : Atheros MB4x DUT mode                          *
*
*      Please exchange FD for MB4x DUT media             *
*
*      h : Atheros MB5x DUT mode                          *
*
*      Please exchange FD for MB5x DUT media             *
*
*      r : Atheros MB5x Responder mode                   *
*
*      Please exchange FD for MB5x Responder media       *
*
*      m : Atheros MB6x setup mode                       *
*
*****

```

Please input the (s / h / r / m) key and push the "Enter" key :

- 3) The RAM drive name which has been set at booting is displayed and command input is requested. Input **mb6x X** and press **Enter**. The part of X is the RAM drive name. In the following display, it is "C".

```

          1,440 (1K) C:      Installed Device=RAMDRIVE
Please input the following command. "mb6x X" > mb6x c [Enter]

```

- 4) The following message is displayed. Change the FD with "MB6x setup media 1" and press **Enter**. The file copy from the FD to the RAM drive is started.

```

Please exchange FD for "MB6x setup media 1"
Press any Key to continue . . .

```

- 5) The following message is displayed. Change the FD with "MB6x setup media 2" and press **Enter**. The file copy from the FD to the RAM drive is started.

```

Please exchange FD for "MB6x setup media 2"
Press any Key to continue . . .

```

- 6) When the file copy is completed, the following test menu is displayed. Press **r**. The Responder T&D is started.

```
*****
*
*   Atheros MB6x DUT mode Maintenance T&D Menu   *
*
*   d : DUT mode                                *
*
*   r : Responder mode                          *
*
*****

SELECT MODE No. (d or r) :
```

3.27.2 Test procedure

The following procedures show how to start the computer of DUT side.

- 1) Boot the computer by Atheros T&D boot media.
- 2) After displaying the following menu, input **m** and press **Enter**.

```
*****
*
*   Atheros MB4x/MB5x/MB6x Maintenance T&D Menu   *
*
*   s : Atheros MB4x DUT mode                      *
*
*   Please exchange FD for MB4x DUT media         *
*
*   h : Atheros MB5x DUT mode                      *
*
*   Please exchange FD for MB5x DUT media         *
*
*   r : Atheros MB5x Responder mode               *
*
*   Please exchange FD for MB5x Responder media   *
*
*   m : Atheros MB6x setup mode                   *
*
*****
```

Please input the (s / h / r / m) key and push the "Enter" key :

- 3) The following message is displayed. Change the FD with "MB6x setup media 1" and press **Enter**. The file copy from the FD to the RAM drive is started.

```
Please exchange FD for "MB6x setup media 1"
Press any Key to continue . . .
```

- 4) The following message is displayed. Change the FD with "MB6x setup media 2" and press **Enter**. The file copy from the FD to the RAM drive is started.

```
Please exchange FD for "MB6x setup media 2"
Press any Key to continue . . .
```

- 5) When the file copy is completed, the following test menu is displayed. Press **d**. The Responder T&D is started.

```
*****
*
*   Atheros MB6x DUT mode Maintenance T&D Menu
*
*   d : DUT mode
*
*   r : Responder mode
*
*****

SELECT MODE No. (d or r) :
```

- 6) The following test menu is displayed. Select the test number.

```
*****
*   Atheros MB6x DUT mode Maintenance T&D Menu
*
*   1 : SKU check of Module
*   2 : MAC Address Check
*   3 : Communication test of 11a mode
*   4 : Communication test of 11a mode(Main Antenna Only)
*   5 : Communication test of 11b mode
*   6 : Communication test of 11b mode(Main Antenna Only)
*   7 : Communication test of 11g mode
*   8 : Communication test of 11g mode(Main Antenna Only)
*   9 : All the tests of module
*       (SKU & MAC Check,11a/b/g communication test)
*   A : All the tests of module(Main Antenna Only)
*       (SKU & MAC Check,11a/b/g communication test)
*
*****

SELECT TEST No. (1-6) :
```

3.27.3 Contents of the test and errors

1. SKU check of Module

The SKU (destination) of the Wireless LAN card installed is displayed. Visually check it.

```
*****
*
*   Module   : Atheros MB62HL (MoW)
*   G-code   : G360001Q210
*
*****
```

When an error (read error of EEPROM date) has detected, the following is displayed.

```
-----ERROR-----
file bac.txt cannot be opened
```

2. MAC Address Check

The MAC address of the installed Wireless LAN card is checked. If it is not incorrect MAC address, the following is displayed.

```
*****
*                               *
*   MAC Address Check : OK !!   *
*                               *
*****
```

a. Case of All FF error

```
*****
*                               *
*   Mac Address Check NG       *
*                               *
*   FFFFFFF-FFFFFFh           *
*                               *
*****
```

b. Case of All 00 error

```
*****
*                               *
*   Mac Address Check NG       *
*                               *
*   000000-000000h            *
*                               *
*****
```

3. Communication test of 11a mode

The check of connection of 11a mode antenna and transmitting/receiving test are executed.

When the test has been finished normally, the following is displayed.

```
*****
*                               *
*   11a Communication Test : OK !!   *
*                               *
*****
```

When an error has detected, the following is displayed.

```

*****
*
* 11a Communication Test : NG !! *
*
* Please refer to log.txt *
*
*****

```

4. Communication test of 11b mode

The check of connection of 11b mode antenna and transmitting/receiving test are executed.

When the test has been finished normally, the following is displayed.

```

*****
*
* 11b Communication Test : OK !! *
*
*****

```

When an error has detected, the following is displayed.

```

*****
*
* 11b Communication Test : NG !! *
*
* Please refer to log.txt *
*
*****

```

5. Communication test of 11g mode

The check of connection of 11g mode antenna and transmitting/receiving test are executed.

When the test has been finished normally, the following is displayed.

```

*****
*
* 11g Communication Test : OK !! *
*
*****

```

When an error has detected, the following is displayed.

```

*****
*
* 11g Communication Test : NG !! *
*
* Please refer to log.txt *
*
*****

```

6. SKU & MAC Check 11a/b/g communication test

All the test is executed in the order of SKU check of Module, MAC Address Check, Communication test of 11a mode, Communication test of 11b mode and Communication test of 11g mode.

The check of connection of 11g mode antenna and transmitting/receiving test are executed.

3.28 Wireless LAN Test Program (Intel-made a/b/g)

This section describes how to perform the wireless LAN transmitting-receiving test (Intel-made 802.11a/b/g). To execute the wireless LAN test, use the Diagnostics disk for wireless LAN test. Finish the tests of the Main test program by selecting 99 - EXIT TO DIAGNOSTICS MENU in the DIAGNOSTIC TEST MENU. Then in the DIAGNOSTICS MENU, select 9 - EXIT TO MS-DOS.

Insert the Diagnostics disk for wireless LAN test into the Floppy Disk Drive. Turn on the power while pressing **U**.

The following menu appears in the display.

```
*****
*      Intel PRO/Wireless 3945ABG Network Connection      *
*                  Maintenance T&D Menu                  *
*                                                         *
*      1  : SKU check of Module                          *
*                                                         *
*      2  : MAC Address Check                            *
*                                                         *
*      3  : Antenna Check & communication test of 11b mode *
*                                                         *
*      4  : Communication test of 11a mode               *
*                                                         *
*      5  : Communication test of 11g mode               *
*                                                         *
*      6  : All the tests of 11a/g Card                  *
*      (SKU & MAC Check, 11a/b/g communication test)    *
*                                                         *
*****
```

SELECT TEST No, (1-6):

To execute the subtest, input the subtest number and press **Enter**.

Subtest01 SKU check of module

This subtest displays SKU information on the wireless LAN card installed. Selecting this subtest, following message will appear in the display. Confirm if the right information on the wireless LAN card is described.

```
*****
*
*      Module   : Module : Intel PRO/Wireless 3945ABG      *
*                  Network Connection (Mowl)              *
*      G-code   : G360001U110                            *
*      TA No.   : D26539                                  *
*
*****
```

Press any key and return to the test menu.

If a defective is found during the test, **NG** message will appear in the display.

Press any key and return to the test menu.

When a defective is detected in the test, following typical cause is considered.

- Connection of wireless LAN card
- Using a wrong wireless LAN card (Using unspecified card)
- Defective wireless LAN card

Checking the connection, execute the subtest again.

Subtest02 MAC Address Check

This subtest displays the MAC address. Selecting this subtest, following message will appear in the display.

```
*****
MAC = XXXXXXXXXXXX
*****
*****
*
* MAC Address Check : OK !!
*
*****
```

Press any key and return to the test menu.

If a defective is found during the test, following message will appear in the display.

```
*****
ERROR: MAC all F
MAC = XXXXXXXXXXXX
*****
*****
*
* MAC Address Check : NG !!
*
*****
```

Press any key and return to the test menu.

When a defective is detected in the test, following typical cause is considered.

- Connection of wireless LAN card
- Defective wireless LAN card
- Disappearance of MAC address data

Checking the connection, execute the subtest again.

Subtest03 Antenna check & communication test of 11b mode

This subtest execute transmitting/receiving test in 802.11b mode using the main antenna first. If a defective is not found during the test, transmitting/receiving test in 802.11b mode using the AUX antenna is automatically executed.

If a defective is not found during the test, **OK** message will appear in the display. Press any key and return to the test menu.

If a defective is found during the test, **NG** message will appear in the display. When pressing any key, the following message (which antenna is defective) is displayed

```

*****
*                                     *
*   Main Antenna Test : NG !!         *
*                                     *
*****
*****
*                                     *
*   Aux Antenna Test : NG !!         *
*                                     *
*****

```

Press any key and return to the test menu.

Subtest04 Communication test of 11a mode

This subtest execute transmitting/receiving test in 802.11a mode using the main antenna.

If a defective is not found during the test, **OK** message will appear in the display. Press any key and return to the test menu.

If a defective is found during the test, **NG** message will appear in the display. When pressing any key, the following message is displayed

```

*****
*                                     *
*           11a Communication Test :  NG !!         *
*                                     *
*****

```

When a defective is detected in the test, following typical cause is considered.

- Connection of wireless LAN card
- Defective wireless LAN card
- Disappearance of MAC address data

Checking the connection, execute the subtest again.

Subtest05 Communication test of 11g mode

This subtest execute transmitting/receiving test in 802.11g mode using the main antenna.

If a defective is not found during the test, **OK** message will appear in the display. Press any key and return to the test menu.

If a defective is found during the test, **NG** message will appear in the display. When pressing any key, the following message is displayed

```
*****
*                                     *
*           11g Communication Test :  NG !!   *
*                                     *
*****
```

When a defective is detected in the test, following typical cause is considered.

- Connection of wireless LAN card
- Defective wireless LAN card
- Disappearance of MAC address data

Checking the connection, execute the subtest again.

Subtest06 All the tests of 11a/b/g Card

All the tests is executed in the order of SKU check of Module, MAC Address Check, Communication test of 11b mode, Communication test of 11a mode and Communication test of 11g mode.

When any error has detected, the test finishes.

3.29 Sound/LAN/Modem Test Program

To execute the Sound/LAN/Modem Test, use the Sound/LAN/Modem test program disk. Finish the tests of the Diagnostics disk by selecting 99 - EXIT TO DIAGNOSTICS MENU in the DIAGNOSTIC TEST MENU. Then in the DIAGNOSTICS MENU, select 9 - EXIT TO MS-DOS.

Install the contents of Sound/LAN/Modem test program of the FDD into a HDD and make a dedicated test system that can boot from "C" drive.

The sound test makes a big capacity of wave data. It needs a big capacity high- speed device.

When the program starts, the following menu will appear.

```
#####
#####   XXXX DIAGNOSTICS PROGRAM (SOUND/LAN/MODEM TEST)   #####
#####
*
*  1 ..... (Microphoned recording&play) *
*  2 ..... (Sin wave) *
*  3 ..... (LAN) *
*  4 ..... (MODEM) *
*
*****
.... Press test number[1-4] ?
```

Press the number you want to test and press **Enter**.

NOTE: To execute Subtest 01, the external microphone is required. The system is capable of producing high volume sound, so when you use the headphones be careful to set the volume low and adjust it as necessary. Using the headphones at full volume could damage your ears.

Subtest 01 Microphoned recording & play

This subtest checks the function of the CODEC A/D D/A converter. Both the microphone and headphone terminal can be checked at the same time.

Before executing this subtest, connect an external microphone to the computer. If necessary, connect a headphone to the computer to check whether the headphone jack of the computer is working properly.

When the subtest is selected, the following message appears.

```
....Press test number[1-4] ? pause
Press any key to continue...
```

Press any key, and the following message appear.

The sound is recorded for five seconds automatically from the microphone.

```
....Press test number[1-4] ? call micrec
```

(Omission on the way)

```
Recorded from source name is MIC  
Requested Sampling Rate is 22025Hz  
Volume requested is 0.000 dB  
Record to buffer is BUFFER0  
Record Time requested is 5.0000 seconds  
Actual record time will be 5.000 seconds
```

After the recording is completed, the computer immediately plays back the sound recorded. When the playing is finished, a message similar to the one below appears.

```
Play to destination is LINEOUT  
Volume requested is X.XXX dB  
Play from buffer name is BUFFER0  
Requested play time is 5.000 seconds.  
Actual play time will be 5.000 seconds.
```

```
Completing SoundMAX/ICH play buffer to line out  
End Time XXX XXX XX :XX:XX XXXX  
System Status 0x0
```

```
Test completed at XXX XXX XX :XX:XX XXXX  
System completion code was 0x0
```

Then, the screen returns to the main menu.

NOTE: *The message displayed by your computer may be slightly different from the one shown above.*

Subtest 02 Sin wave

When the subtest is executed, the following message appears.

```
....Press test number[1-4] ? pause
Press any key to continue...
```

When the beep sound finished, the screen returns to the main menu and the following message appears.

```
....Press test number [1-4] ?
```

To execute a subtest continuously, select the test number and press **Enter**. To exit the Sound/Modem test, remove the test program disk from the USB FDD and turn the computer off.

Subtest 03 LAN

This subtest checks the operation of mini-PCI I/F by the loopback in the chip. When the subtest is executed, the following message appears. The large "OK" is displayed if no error occurred.

```
ICH4+8256ET LAN TEST Rev.XX
```

```
Repeat count = 00000
Error count = 00000
```

```
LOOPBACK TEST
```

```
100Mbps Auto-negotiation TxRx Test
Destination Address = xxxxxxxxxxxxxx
Source Address = xxxxxxxxxxxxxx
```

```
** 100Base-TX Full-Duplex **
< TRANSMIT >
< RECEIVE >
```

```

      ||||| | | | |
     ||  ||  ||  ||
    ||  ||  ||  ||
   ||  ||  ||  ||
  |||||  ||  ||

```

Subtest 04 MODEM

For this subtest, connect the modem PCB and RJ11 connector with a harness. This subtest contains the following tests. They are tested with the dedicated FAT-MODE inspection device (Product Code QE2000P01 made by Nittou Denki Seisakusyo).

- (a) Select **4** to execute and press **Enter**. The following message will appear:

```
[Modem loopback test!]
```

```
ICHX MDC Test Program with Modem Sound ( Line Test )  
Version X.X
```

```
* Scorpio Modem Initialize      :OK
```

```
* Digital Loopback Test        :OK
```

```
* Modem Sound Test              :( Operator's Check!! )
```

- (b) After a few seconds, the following message will appear:

```
...Press Key ( Y = OK , N =NG )
```

If you hear the modem sound from the speakers, press **Y**.
Otherwise, press **N**.

NOTE: *The message displayed by your computer may be slightly different from the one shown above.*

- (c) After you press **Y** or **N**, the RJ11 Connection Check (LED) test will execute, and the following message will appear:

```
...Press Key ( Y = OK , N =NG )
```

If the color in the LED of the connection checker is orange, press **Y**.
Otherwise, press **N**.

Press **Enter** to return to Main Menu.

3.30 IEEE 1394 Test Program

To execute the IEEE 1394Test, use the IEEE 1394 Test program disk. Finish the tests of the Diagnostics disk (No.1) by selecting 99 - EXIT TO DIAGNOSTICS MENU in the DIAGNOSTIC TEST MENU. Then in the DIAGNOSTICS MENU, select 9 - EXIT TO MS-DOS.

Insert the IEEE 1394 Test program disk in the floppy disk drive and turn on the power. The following message will appear:

```

*****
* -----*
*          IEEE1394 test menu (For repair)          *
* -----*
*          ===== Select test NO. and [Enter] =====*
*          *
*          1 ....Transmit & Receive test            *
*          2 ....Responder set                      *
*          3 ....1394 GUID Display                  *
*          *
*****
          .... Press test number [1-3] ?

```

Press the number you want to test and press **Enter**.

Subtest 01 Transmit & Receive test

This subtest tests the transmission/ reception function of the IEEE1394 port. Specifies the data size and transfer speed between the responder connected with an IEEE1394 cable, and sends, receives and compare data.

To execute this subtest, press **1** key and **Enter**.

Subtest 02 Responder set

Before executing Subtest 01, connect the target PC and responder PC with a IEEE1394 cable and execute this subtest to initialize the responder PC.

To execute this subtest, press **2** key and **Enter**.

Subtest 03 1394 GUID Display

GUID can be displayed.

To execute this subtest, press **3** key and **Enter**.

3.31 Bluetooth Test program

This section describes how to perform the Bluetooth test program to check if the Bluetooth functions of computer are working properly. To start the Bluetooth test program, follow the steps below:

NOTE: Use another computer that can communicate by the Bluetooth as a reference machine to perform this test.

Insert a floppy disk containing the test program into the target machine and turn on the target machine. The following Bluetooth test menu will appear:

```
#####
##### Bluetooth sub system test program VX.XX #####
#####
*
*          1...BD_ADDR check                               *
*
*          3... Communication test (DUT mode)               *
*
*          T...communication test (TEST mode)              *
*
*****
...Press test number [1, 3, T] ?
```

Press **1** or **3** key to perform the corresponding subtest. To quit the Bluetooth test program, eject the floppy disk and turn the computer off while the menu above is displayed.

Subtest 01 BD_ADDR check

This subtest checks the BD_ADDR functions. When the Bluetooth test menu is displayed, press **1** to select the test and press **Enter**. The following message will appear:

```

-----
Bluetooth Subsystem T&D for PCSE(BD_ADDR) VerX.XX Copyright (C) by TOSHIBA Co.
-----

Initializing ...

```

When the machine has passed the test, it displays **BD_ADDR**. If **BD_ADDR** has no problem, the following message is displayed.

```

-----
Bluetooth Subsystem T&D for PCSE(BD_ADDR) VerX.XX Copyright (C) by TOSHIBA Co.
-----

My BD_ADDR = XXXXXXXXXXXX [h]

PPPPPP  A    SSSSS  SSSSS
P  P  A A  S    S S  S
P  P  A  A  S      S
PPPPPP  A    A  SSSSS  SSSSS
P      AAAAAA  S      S
P      A  A  S    S S  S
P      A  A  SSSSS  SSSSS

```

If the target machine has any problem, it displays **Error CODE**. The following message is displayed.

```

-----
Bluetooth Subsystem T&D for PCSE(BD_ADDR) VerX.XX Copyright (C) by TOSHIBA Co.
-----

My BD_ADDR = XXXXXXXXXXXX [h]

FFFFFF      A      III  L
F           A A     I   L
F           A  A    I   L
FFFFFFF A      A    I   L
F           AAAAAA  I   L
F           A      A  I   L
F           A      A  III  LLLLLL

```

Table 3-5 Error message

Message	Contents
Invalid BD_ADDR (all 00)	0x000000000000
Invalid BD_ADDR (all FF)	0xFFFFFFFFFFFF
Invalid BD_ADDR (bit0=1)	bit40=1b
Invalid BD_ADDR (bit1=1)	bit41=1b
Invalid BD_ADDR (define in the file)	Defined BD_ADDR

If the machine detects a malfunction, it indicates the error code as shown below.
The error code begins with the least significant digit.

Error code

Table 3-6 Error code for Bluetooth test (BD_ADDR) (1/2)

Error code	Meaning
0x01	Unknown HCI Command.
0x02	No Connection.
0x03	Hardware Failure.
0x04	Page Timeout.
0x05	Authentication Failure.
0x06	Key Missing.
0x07	Memory Full.
0x08	Connection Timeout.
0x09	Max Number Of Connections.
0x0a	Max Number Of SCO Connections To A Device.
0x0b	ACL Connection already exists.
0x0c	Command Disallowed.
0x0d	Host Rejected due to limited resources.
0x0e	Host Rejected due to security reasons.
0x0f	Host Rejected due to remote device is only a personal device.
0x10	Host Timeout.
0x11	Unsupported Feature or Parameter Value.
0x12	Invalid HCI Command Parameters.
0x13	Other End Terminated Connection: Used Ended Connection.
0x14	Other End Terminated Connection: Low Resources.
0x15	Other End Terminated Connection: About to Power Off.
0x16	Connection Terminated by Local Host.
0x17	Repeated Attempts.
0x18	Paring Not Allowed.
0x19	Unknown LMP PDU.
0x1a	Unsupported Remote Feature.
0x1b	SCO Offset Rejected.
0x1c	SCO Interval Rejected.
0x1d	SCO Air Mode Rejected.
0x1e	Invalid LMP Parameters.
0x1f	Unspecified Error.

See the Specification of the Bluetooth System for details.

When the Bluetooth test menu is displayed, press **T** to select the test and press **Enter** in the test machine. The following message will appear:

```

-----
Bluetooth Subsystem T&D for PCSE(CS-Air) VerX.XX Copyright (C) by TOSHIBA Co.
-----
+-----+
|           |
|   Tester   |
|           |
+-----+

[ESC]:Finish Tester  [SPACE]:Start
Is DUT ready?

```

Then press **Space** to start the Bluetooth communication test.

When the machine has passed the test, it displays **BD_ADDR of the DUT**. If the connection with the tester is completed, the progress bar stops. The following message is shown.

```

-----
Bluetooth Subsystem T&D for PCSE(CS-Air) VerX.XX Copyright (C) by TOSHIBA Co.
-----
+-----+
|           | BD_ADDR of the DUT = XXXXXXXXXXXXX [h]
+-----+

  CCCC   OOO   M   M PPPPPP L   EEEEE TTTTTT EEEEE DDDD
C   C O   O MM  MM P   P L   E       T   E       D   D
C     O   O M M M M P   P L   E       T   E       D   D
C     O   O M M M PPPPPP L   EEEEE T   EEEEE D   D
C     O   O M   M P   L   E       T   E       D   D
C   C O   O M   M P   L   E       T   E       D   D
  CCCC   OOO   M   M P   LLLLLL EEEEE T   EEEEE DDDD

Testing is finished

A>_

```

If the target machine has any problem, the following message “INCOMPLETE” is displayed with the **Error Code**.

```

-----
Bluetooth Subsystem T&D for PCSE(CS-Air) VerX.XX Copyright (C) by TOSHIBA Co.
-----

+-----+
|           DUT           |   BD_ADDR of the DUT = XXXXXXXXXXXXX [h]
+-----+

III  N      N   CCCC   OOO  M      M  P P P P P P  L      EEEEE  TTTTTT  EEEEE
I   NN     N  C     C  O   O  MM   MM  P     P  L      E         T     E
I   N N    N  C         O   O  M M  M  M  P     P  L      E         T     E
I   N N    N  C         O   O  M   M   M  P P P P P P  L      EEEEE  T     EEEEE
I   N     N N C     C  O   O  M     M  P     L      E         T     E
I   N     NN  C     C  O   O  M     M  P     L      E         T     E
III  N      N   CCCC   OOO  M      M  P           L L L L L L  EEEEE  T     EEEEE

                                Testing is finished

_Press any key to continue. . .

```

If the machine detects a malfunction, it indicates the error code as shown below.

The error code begins with the least significant digit.

Error code

Table 3-7 Error code for Bluetooth test (BD_ADDR of the DUT) (1/2)

Error code	Meaning
0x01	Unknown HCI Command.
0x02	No Connection.
0x03	Hardware Failure.
0x04	Page Timeout.
0x05	Authentication Failure.
0x06	Key Missing.
0x07	Memory Full.
0x08	Connection Timeout.
0x09	Max Number Of Connections.
0x0a	Max Number Of SCO Connections To A Device.
0x0b	ACL Connection already exists.
0x0c	Command Disallowed.
0x0d	Host Rejected due to limited resources.
0x0e	Host Rejected due to security reasons.
0x0f	Host Rejected due to remote device is only a personal device.
0x10	Host Timeout.
0x11	Unsupported Feature or Parameter Value.
0x12	Invalid HCI Command Parameters.
0x13	Other End Terminated Connection: Used Ended Connection.
0x14	Other End Terminated Connection: Low Resources.
0x15	Other End Terminated Connection: About to Power Off.
0x16	Connection Terminated by Local Host.
0x17	Repeated Attempts.
0x18	Paring Not Allowed.
0x19	Unknown LMP PDU.
0x1a	Unsupported Remote Feature.
0x1b	SCO Offset Rejected.
0x1c	SCO Interval Rejected.
0x1d	SCO Air Mode Rejected.
0x1e	Invalid LMP Parameters.
0x1f	Unspecified Error.

Table 3-7 Error code for Bluetooth test (BD_ADDR of the DUT) (2/2)

Error code	Meaning
0x20	Unsupported LMP Parameter Value.
0x21	Role Change Not Allowed.
0x22	LMP Response Timeout.
0x23	LMP Error Transaction Collision.
0x24	LMP PDU Not Allowed.
0x25	Not Exist
0x26	Not Exist
0x27	Not Exist
0x28	Not Exist
0x29	Not Exist
0x2a	Not Exist
0x2b	Not Exist
0x2c	Not Exist
0x2d	Not Exist
0x2e	Not Exist
0x2f	Not Exist

See the Specification of the Bluetooth System in detail.

Table 3-8 Common Error code

Error code	Meaning
0x30	BT Control Status is not “Disable” .
0x31	BT Control Status is not “Enable” .
0x32	Power Status is not “OFF” .
0x33	Power Status is not “ON” .
0x34	USB I/F Status is not “Attach” .
0x35	USB I/F Status is not “Detach” .
0x36	Wake-up Status is “assert”
0x37	Wake-up Status is not “assert” .
0x38	Switch Status is “ON” .
0x39	Switch Status is “OFF” .
0x3a	Module does no exist.
0x3b	Module exists.
0x3c	Incorrect command line
0x3d	Sideband access driver does not exist always.
0x3e	DOS 用Bluetooth driver for DOS does not exist always.
0x3f	Get Status for Sideband access drive functions abnormally.
0x40	No response to Inquiry
0x41	Device Descriptor can not inquire abnormal USB I/F
0x42	Sideband Reset time our
0x43	Incorrect Descriptor type
0x44	Descriptor has been got despite of Detach condition
0x45	Abnormal setting file open
0x46	Incorrect contents of setting file
0x47	Incorrect BD_ADDR (00)
0x48	Incorrect BD_ADDR (FF)
0x49	Incorrect BD_ADDR (bit0=1)
0x4a	Incorrect BD_ADDR (bit1=1)
0x4b	Incorrect BD_ADDR (address defined as an error)
0x4c	Confirmation of hardware switch interrupted.
0x4d	RSSI is lower than specified value
0x4e	Interrupted
0x4f	(reserved)

The codes of 0x30 to 0x4f are common error code in the test program (IMCSXXXX)

3.32 SETUP

3.32.1 Function Description

This program displays the current system setup information as listed below:

1. Memory
2. System Date/Time
3. Battery
 - (a) Battery Save Mode
 - (b) PCI Express Link ASPM
 - (c) Enhanced C-States
4. Password
5. HDD Password
 - (a) HDD
 - (b) HDD Password Mode
 - (c) User Password
 - (d) Maser Password
6. Boot Priority
 - (a) Boot Priority
 - (b) HDD Priority
 - (c) Network Boot Protocol
7. Others
 - (a) Core Multi-Processing
 - (b) Dynamic CPU Frequency Mode
 - (c) Execute-Disable Bit Capability
 - (d) Virtualization Technology
 - (e) Auto Power On
 - (f) Diagnostic Mode
8. Configuration
9. Drives I/O
 - (a) Built-in HDD1
 - (b) Built-in HDD2
 - (c) CD-ROM
10. PCI Bus

11. Display

- (a) Power On Display
- (b) LCD Display Stretch
- (c) TV Type

12. Peripheral

- (a) Internal Pointing Device

13. Legacy Emulation

- (a) USB KB/Mouse Legacy Emulation
- (b) USB-FDD Legacy Emulation

14. PCI LAN

15. RAID ARRAY

- (a) Current State
- (b) Create State
- (c) Execute Creation

3.32.2 Accessing the SETUP Program

While pressing **ESC**, turn on the power. Then press **F1**. The following display appears.

SYSTEM SETUP (1/3) ACPI BIOS version = X.XX

<p style="text-align: center;">MEMORY</p> <p>Total = XXXXX MB</p>	<p style="text-align: center;">BOOT PRIORITY</p> <p>Boot Priorit = HDD → FDD → CD-ROM → LAN HDD Priority = Built in HDD1 → Built in HDD2 Network Boot Protocol = PXE</p>
<p style="text-align: center;">SYSTEM DATE/TIME</p> <p>Date(MM-DD-YY) = XX-XX-XXXX Time(HH:MM:SS) = XX:XX:XX</p>	<p style="text-align: center;">OTHERS</p> <p>Core Multi-Processing = Enabled Dynamic CPU Frequency Mode = Dynamically Switchable Execute-Disable Bit Capability = Not Available Virtualization Technology = Disabled Auto Power On = Disabled Diagnostic Mode = Disabled</p>
<p style="text-align: center;">BATTERY</p> <p>Battery Save Mode = Full Power PCI Express Link ASPM = Auto Enhanced C-States = Enabled</p>	
<p style="text-align: center;">PASSWORD</p> <p>Not Registered</p>	
<p style="text-align: center;">HDD PASSWORD</p> <p>HDD = Built-in HDD1 HDD Password Mode = Master+User User Password = Not Registered Mastere Password = Not registered</p>	

↓↑←→: Select items **Space, BkSp**: Change values **PgDn, PgUp**: Change pages
Esc: Exit without saving **Home**: Set default values **End**: Save changes and Exit

SYSTEM SETUP (2/3) ACPI BIOS version = X.XX

<p style="text-align: center;">CONFIGURATION</p> <p>Device Config. = Setup by OS</p>	<p style="text-align: center;">DISPLAY</p> <p>Power On Display = Auto-Selected LCD Display Stretch = Enabled TV Type = NTSC (JAPAN)</p>
<p style="text-align: center;">DRIVERS I/O</p> <p>Built-in HDD1 = Serial ATA Port0 Built-in HDD2 = Serial ATA Port2 CD-ROM = Primary IDE (1F0H/IRQ14)</p>	<p style="text-align: center;">PERIPHERAL</p> <p>Internal Pointing Device = Enabled</p>
<p style="text-align: center;">PCI BUS</p> <p>PCI BUS = IRQ10, IRQ11</p>	<p style="text-align: center;">LEGACY EMULATION</p> <p>USB KB/Mouse Legacy Emulation = Enabled USB-FDD Legacy Emulation = Enabled</p>
	<p style="text-align: center;">PCI LAN</p> <p>Built-in LAN = Enabled</p>

↓↑←→: Select items **Space, BkSp**: Change values **PgDn, PgUp**: Change pages
Esc: Exit without saving **Home**: Set default values **End**: Save changes and Exit

SYSTEM SETUP (3/3) ACPI BIOS version = X.XX

```

RAID ARRAY
Current State
  Built-in HDD1 = 1RAID-0
  Built-in HDD2 = JBOD
Create State
  Built-in HDD1 = 1RAID-0
  Built-in HDD2 = JBOD

```

	Level	Status	Capacity
LD0	1RAID-0	OPTIMAL	XXGB
LD1	JBOD	OPTIMAL	XXGB

Drive	Assign	Status	Size	Model	Rev
Built-in1	LD0-0	ONLINE	XXGB	XXXXXXXXXXXXXXXXXXXX	XXXXXXXX
Built-in2	LD1-0	ONLINE	XXGB	XXXXXXXXXXXXXXXXXXXX	XXXXXXXX

↑↓←→: Select items Space, BkSp: Change values PgDn, PgUp: Change pages
Esc: Exit without saving Home : Set default values End: Save changes and Exit

Moving Within the SETUP Menu and Changing Values

1. Press ← and → to move between the two columns. Press ↑ and ↓ to move between items in a column. Press **Fn+↑ (PgUp)** and **Fn + ↓ (PgDn)** to move between the two pages.
2. Press either the **Space bar** or **Back Space** to change the value.

Accepting Changes and Exiting the SETUP Window

1. Press **End** to accept the changes you made.

If the changed item does not require the system to reboot, the following message is displayed:

Are you sure? (Y/N)

If the changed item requires the system to reboot, the following message is displayed:

Are you sure? (Y/N)

The changes you made will cause the system to reboot.

2. To make other changes, press **N**. Repeat the steps above.
3. To accept the changes, press **Y**.

NOTE: You can press **Esc** to quit at any time without saving changes. *SETUP* asks you to confirm that you do not want to save your changes. When *SETUP* is displayed at the next time, the current configuration appears.

The Factory Preset Configuration

When you access *SETUP*, the current configuration is displayed.

1. To show the factory preset configuration, press **Home**.
2. To accept the default settings, press **End** and then press **Y**.

NOTE: When you execute the default setting, the following settings are not changed:

- (1) *HDD Mode*
- (2) *Password*
- (3) *Write Policy*

SETUP Options

The SETUP screen is divided into 15 functionally related groups. This section describes each group and its options.

1. Memory

This group of options displays the computer's memory.

This field displays the total amount of memory installed and is automatically calculated by the computer. You cannot change this value.

2. System Date/Time

Sets the date and time.

System Date Sets date.

System Time Sets time.

3. Battery

(a) Battery Save Mode

This option is used to select **Full Power**, **Low Power** or **User Setting** of the battery save mode. When you select the battery save mode, the followings will appear.

Full Power The following shows full power settings.

```

----- BATTERY SAVE OPTIONS -----
Processing Speed   = High
CPU Sleep Mode    = Enabled
LCD Brightness    = Bright (*1)
                  = Super-Bright (*2)
Cooling Method    = Maximum Performance
  
```

Low Power The following shows low power settings.

```

----- BATTERY SAVE OPTIONS -----
Processing Speed   = Low
CPU Sleep Mode    = Enabled
LCD Brightness    = Semi-Bright (*1)
                  = Bright (*2)
Cooling Method    = Battery Optimized
  
```

NOTE: Display of the LCD Brightness will be changed in the condition below:

(*1) Operating the battery

(*2) Using the AC adapter

User Setting Use this option to set the battery save parameters on the sub-window, **BATTERY SAVE OPTIONS**.

Battery Save Options

Processing Speed

This feature changes the CPU processing speed.

High CPU operates at high speed. (Default in Full Power Mode)

Low CPU operates at low speed. (Default in Low Power Mode)

CPU Sleep Mode

Use this option to enable or disable the CPU sleep function.

Enabled Enables sleep mode. (Default)

Disabled Disables sleep mode.

LCD Brightness

Use this option to set the level of LCD brightness.

Super-Bright Full brightness for maximum visibility.

Bright Full brightness for high visibility.

Semi-Bright Less than full brightness for saving power.

Cooling Method

Maximum Performance If the CPU becomes too hot, the fan turns on automatically in a high speed to cool down the CPU.

Performance If the CPU becomes too hot, the fan turns on automatically. When the CPU temperature falls to a normal range, the fan turns off.

Battery optimized

If the CPU becomes too hot, the processing speed is lowered. If the temperature is still too high, the fan turns on. When the CPU temperature falls to a normal range, the fan is turned off and the processing speed is increased.

NOTE: *Too hot condition may cause defect on the CPU. When the hot condition continues, the power is automatically turned off in resume mode.*

(b) PCI Express Link ASPM

This option set the power-saving function of PCI Express on the following conditions.

Auto

PCI Express devices are not used while battery operation. (Default)

Disabled

Disable the Power-saving function and drive with maximum performance.

Enabled

PCI Express devices are not used.

(c) Enhanced C-States

This option set the power-saving function of Enhanced C-States on the following conditions.

Enabled

This lowers the power consumption. (Default)

Disabled

This does not lower the power consumption.

4. Password

This option sets or resets the user password for power on and instant security (**Fn+F1**).

Registered

The user password has been registered.

Not registered

The user password has not been registered.

For details on setting the user password, refer to the User's Manual.

5. HDD Password

This option registers, resets or changes the HDD password.

(a) HDD

Hard disk for setting the password is selected.

When the second HDD is mounted, "Second HDD" can be selected.

Built-in HDD The password is set to Built-in HDD. (This cannot be changed, when the second HDD is not mounted.)

Second HDD The password is set to Second HDD.

(b) HDD Password Mode

This item registers HDD password and can be selected only for registering HDD password. To change HDD Password Mode when HDD password is registered, delete the registered HDD password first, and then register new password.

User Only Sets only User HDD Password (Default)

Master+User Sets Master HDD Password and User HDD Password

(c) User Password

This item sets User password.

For details on setting user password, refer to the User's Manual.

(d) Master Password

This item sets the Master HDD password.

This can be set, only when **Master+User** is set in the HDD password Mode. For details, refer to the User's Manual.

6. Boot Priority

(a) Boot Priority

Use this option to set the priority for booting of the computer and the priority for the HDD for booting.

FDD→HDD→CD-ROM→LAN: The computer looks for bootable files in the following order: FDD, HDD, CD-ROM (*1) and LAN

HDD→CD-ROM→LAN→FDD: The computer looks for bootable files in the following order: HDD, CD-ROM, LAN and FDD.

FDD→CD-ROM→LAN→HDD: The computer looks for bootable files in the following order: FDD, CD-ROM, LAN and HDD.

CD-ROM→LAN→HDD→FDD: The computer looks for bootable files in the following order: CD-ROM, LAN, HDD and FDD.

CD-ROM→LAN→FDD→HDD: The computer looks for bootable files in the following order: CD-ROM, LAN, FDD and HDD.

HDD→FDD→CD-ROM→LAN: The computer looks for bootable files in the following order: HDD, FDD, CD-ROM and LAN. (Default)

(*1) CD-ROM refers to a Optical Disk Drive.

(b) HDD Priority

Use this option to set the booting priority from HDD.

Built in HDD1→Built in HDD2 (Default)
: detecting boot-command from Built in HDD1

Built in HDD2→Built in HDD1
: detecting boot-command from Built in HDD2

NOTE: When 2nd HDD is not installed, this option does not appear in the menu.
If the boot command can not be detected from the prior HDD, booting target changes to other devices. (Not detected from the other one)

(c) Network Boot Protocol

Use this option to set the starting method via a network.

PXE Sets to PXE protocol. (Default)

RPL Sets to RPL protocol.

7. Others

Whether or not you need to configure the computer with these options depends primarily on the kind of software or peripherals you use.

(a) Core-Multi Processing

The Core Multi-Processing sets the CPU operating mode.

The configuration for the Core Multi - Processing is carried out in the BIOS setup program.

Enabled is Dual Core mode.

Disabled is Single Core mode.

Enabled Enables Core Multi-Processing functions. (Default)

Disabled Disables Core Multi - Processing functions.

(b) Dynamic CPU Frequency mode

Use this option to choose a setting from the followings.

Dynamically Switchable

Enables Intel® processor featuring Intel SpeedStep technology. (Default)

Always High Disables Intel® processor featuring Intel SpeedStep technology and always runs the processor at its maximum speed.

Always Low Disables Intel® processor featuring Intel SpeedStep technology and always runs the processor at its default speed.

(c) Execute-Disable Bit Capability

This option set the Execute-Disable Bit function of CPU to the operation system. Execute-Disable Bit gives higher security function preventing the PC from the computer viruses and buffer overflow problem on unauthorized access.

Available Enable the Execute-Disable Bit function.

Not Available Disable the Execute-Disable Bit function. (Default)

(d) Virtualization Technology

Virtualization Technology sets enable or disable of the Intel Virtualization Technology installed in the CPU.

Intel Virtualization Technology is the technique that allows one machine to operate as multiple virtual machines.

Enabled Enables Virtualization Technology.

Disabled Disables Virtualization Technology. (Default)

(e) Auto Power On

This option displays setting for Auto Power On.

Disabled Indicates auto power on is not set. (Default)

Enabled Indicates auto power on is set.

When “Enabled” is selected, the following sub-window appears.

OPTIONS	
Alarm Time	= 00:00:00
Alarm Date Option	= Disabled
Wake-up on LAN	= Disabled

Set the parameters for the Auto Power On (automatic power on) function in the “OPTIONS” window. To set the time, use **Space** or **BackSpace**. Press ↓ to move the cursor to the right and ↑ to move the cursor to the left when you set the date and time.

For the **Alarm Time**, set the time to turn on the power automatically. The “second” cannot be set. When it is set to “Disabled”, the time to turn on automatically is not set.

For the **Alarm Date Option**, set the date to turn on the power automatically. When it is set to “Disabled”, the time to turn on automatically is not set.

The **Wake-up on LAN** is a function to turn on the power automatically by the call from the administrator. It can be set to “Enabled” only when “Built-in LAN” is set to “Enabled”. To activate this function, use the AC adapter.

- NOTE:**
1. Do not remove the AC adaptor and battery pack at the same time when you use this feature. If you do so, data saved by the resume function will be lost. You must also reset this option.
 2. If you have set a password and the computer boots by the Auto Power On function and Standby is on, the computer will start with the instant security function enabled. The **password =** message is not displayed; however, you must enter the password to use the computer.
 3. This option is enabled only once, the setting is reset, after booting up.

(f) Diagnostic Mode

This option enables/disables the HW Diagnostic test function.

- | | |
|-----------------|---|
| Disabled | Disables the HW Diagnostic test function. (Default) |
| Enabled | Enables the HW Diagnostic test function. |

8. Configuration

This option lets you set the device configuration.

- | | |
|--------------------|---|
| All Devices | BIOS sets all devices. |
| Setup by OS | Initializes devices, which is needed to load an operating system. Operating system initializes other devices. (Default) |

- NOTE:**
1. When using installed OS, selecting “Setup by OS” is recommended.
 2. When executing test programs, be sure to select “ALL Device”. And after the test end, select “Setup by OS”.

9. Drives I/O

This option displays the address and interrupts level for hard disk drive and optical disk drive. It is for information only and cannot be changed.

Built-in HDD 1	Displays the setting of the HDD1 address. This cannot be changed.
Built-in HDD 2	Displays the setting of the HDD2 address. This cannot be changed.
CD-ROM	Displays the setting of the drive address and interrupt level. This cannot be changed.

10. PCI Bus

This option displays the interrupt level for the Card Bus in the computer. It is for information only and cannot be changed.

PCI BUS = IRQ10, IRQ11

11. Display

This group of options configures the computer's display.

(a) Power On Display

This option is used to select the display when booting up.

Auto-Selected Selects an external monitor if one is connected.
Otherwise it selects the internal LCD. (Default)

LCD+AnalogRGB Selects both the internal LCD and the external CRT for
simultaneous display.

NOTE: 1. When starting the computer in Standby or Hibernation, the last configuration is remembered. If data does not appear on the display you are using after starting in Standby or Hibernation, pressing **Fn+F5**.

2. Pressing **Fn+F5** changes the display setting as follows in order: the internal LCD, the external display, both the internal LCD and the external display.

3. When an external display, which does not support SVGA mode is connected and "LCD+AnalogRGB" is selected, the external display is not displayed.

(b) LCD Display Stretch

LCD Display Stretch enables or disables a larger display area of the screen.

Enabled Enables the LCD display stretch feature. (Default)

Disabled Disables the LCD display stretch feature.

(c) TV Type

This option allows you to select the type of TV.

NTSC (Japan) TV in Japanese system (Default)

NTSC (US) TV in the U.S. system

PAL (S-Video) TV in Europe system

525p (480p,D2) High Definition Television with 480 progressive scan

750p (720p,D4) High Definition Television with 720 progressive scan

1125i (1080i,D3) High Definition Television with 1080 interlace

525i (480i,D1) High Definition Television with 480 interlace

PAL (SCART) TV in Europe system with SCART

525p (480p,D2)、750p (720p,D4)、1125i(1080i,D3)、525i (480i,D1)、PAL (SCART) can be displayed in G73 models with "D terminal".

12. Peripheral

Use this option to select the peripheral's mode.

(a) Internal Pointing Device

This option enables or disables the touch pad

Enabled Enables the touch pad. (Default)

Disabled Disables the touch pad.

13. LEGACY EMULATION

(a) USB KB/Mouse Legacy Emulation

This option sets the Legacy support condition of the USB keyboard and the USB mouse.

Enabled Enables LEGACY support. (Default)
USB keyboard/USB mouse are available without the driver.

Disabled Disables LEGACY support

(b) USB-FDD Legacy Emulation

This option sets the Legacy support condition of the USB floppy disk drive. When a computer is FDD built-in model, this option is not displayed.

Enabled Enables LEGACY support. (Default)
USB floppy disk is available without the driver.

Disabled Disables LEGACY support

14. PCI LAN

This option sets the Enable / Disable of the built-in LAN functions.

Enabled Enables built-in LAN functions. (Default)

Disabled Disables built-in LAN functions.

15. RAID ARRAY

This option sets the RAID configuration.

(a) Current State

This option indicates the current hard disk condition. Content set in [Create State] is displayed, when booting BIOS setup next time.

Built in HDD1 Displays RAID configuration level of the built-in HDD1.

Built in HDD2 Displays RAID configuration level of the built-in HDD2.

(b) Create State

This option sets the RAID configuration level.

NOTE: *All data of the hard disk is deleted when setting of the RAID configuration is changed in the BIOS setup.
Therefore, it is recommended that the user password or the supervisor password is registered to prevent changing of setting the RAID configuration by the third party.
Moreover, registering the supervisor password can make add the restriction so that a user without the management authority can not change the setting of the BIOS setup.*

Built in HDD1 Sets RAID configuration level of the built-in HDD1.

Built in HDD2 Sets RAID configuration level of the built-in HDD2.

(c) Execute Creation

This option is displayed, only when the setting is changed in the “Create State”.

Set the cursor bar to “Execute Creation” and press **Space** or **Back Space**.
The following message will appear:

```
Warning: If you change RAID array, you need to install
OS again. Are you sure? All data on the HDD(s) will be
destroyed. Do you really want to do this? If "Yes",
please type the key string which is written in manual.
```

Input 1234 (press **1, 2, 3, 4** key) and press **Enter**.

The change of the RAID configuration will be reflected.

3.33 Thermal Radiation Control Test

This thermal radiation control test checks the temperature of the CPU and GPU. To execute this test, use the diagnostics disk (Thermal radiation control) and follow the procedures below.

1. Turn on the computer and start the Windows.
2. Insert the diagnostic disk for the thermal radiation control test to the USB FDD.
3. Open the [EXPLORE] window and double-click the [THERMAL.bat] file in the diagnostic disk.
4. The input field appears on the screen. Then, input the temperature around the computer and click [OK] button. The thermal radiation control test starts.
5. The test result is displayed 15 minutes later. When the test ends normally, the following message appears in the display.

[Status:pass]

When an error is found, the following message appears in the display.

[Status:CPU:FAIL GPU:FAIL]

When the error message appears in the display, there is a possibility of breakage of CPU, GPU or FAN.

Close the test menu to end the thermal radiation control test.

Chapter 4

Replacement Procedures

Chapter 4 Contents

4.1	Overview.....	4-1
4.2	Battery pack	4-8
4.3	PC card/Bridge media.....	4-10
	4.3.1 PC card.....	4-10
	4.3.2 Bridge media	4-11
4.4	HDD.....	4-12
4.5	Memory module.....	4-16
4.6	Keyboard.....	4-18
4.7	MDC	4-21
4.8	Wireless LAN card	4-23
4.9	Bluetooth module.....	4-25
4.10	Cover assembly.....	4-27
4.11	Touch pad.....	4-33
4.12	LED board.....	4-37
4.13	Fingerprint sensor board	4-39
4.14	Volume board.....	4-41
4.15	Switch membrane.....	4-42
4.16	Wireless communication switch	4-44
4.17	Optical disk drive.....	4-45
	4.17.1 Replacing the optical disk drive.....	4-45
	4.17.2 Ejecting the optical disk.....	4-47
4.18	RTC battery.....	4-49
4.19	Internal microphone	4-50
4.20	Jack board	4-51
4.21	System board/DC-IN jack.....	4-52
4.22	Speaker.....	4-54
4.23	Modem jack/F jack	4-55
4.24	GPU fan	4-57
4.25	Battery lock/Battery latch	4-58
4.26	Analog TV tuner	4-60

4.27	CPU fan/CPU heat sink/CPU	4-61
4.28	GPU heat sink	4-65
4.29	North bridge heat sink.....	4-67
4.30	PC card slot.....	4-68
4.31	LCD unit / FL inverter	4-70
4.32	LCD cable	4-77
4.33	Wireless LAN antennas/Bluetooth antenna	4-80
4.34	Latch assembly.....	4-82
4.35	Display rear cover.....	4-83
4.36	Hinge.....	4-85
4.37	Fluorescent lamp.....	4-87
	4.37.1 Replacing the 15.4-inch Samsung fluorescent lamp	4-88

 Figures

Figure 4-1	Removing the battery pack.....	4-8
Figure 4-2	Removing the battery	4-9
Figure 4-3	Removing the PC card	4-10
Figure 4-4	Removing the Bridge media.....	4-11
Figure 4-5	Removing the HDD-1 assembly	4-12
Figure 4-6	Removing the HDD-2 assembly	4-13
Figure 4-7	Removing the HDD.....	4-14
Figure 4-8	Removing the memory module.....	4-16
Figure 4-9	Removing the keyboard (1).....	4-18
Figure 4-10	Removing the keyboard (2)	4-19
Figure 4-11	Removing the MDC	4-21
Figure 4-12	Removing the wireless LAN card	4-23
Figure 4-13	Removing the Bluetooth module	4-25
Figure 4-14	Removing the cover assembly (1).....	4-27
Figure 4-15	Removing the cover assembly (2).....	4-28
Figure 4-16	Removing the cover assembly (3).....	4-29
Figure 4-17	Removing the cover assembly (4).....	4-30
Figure 4-18	Removing the cover assembly (5).....	4-31
Figure 4-19	Removing the touch pad assembly.....	4-33
Figure 4-20	Removing the cables	4-34
Figure 4-21	Removing the TP board	4-35
Figure 4-22	Removing the LED board	4-37
Figure 4-23	Removing the fingerprint sensor board.....	4-39
Figure 4-24	Removing the volume board	4-41
Figure 4-25	Removing the switch membrane (1)	4-42
Figure 4-26	Removing the switch membrane (2)	4-43
Figure 4-27	Removing the ODD assembly.....	4-45
Figure 4-28	Removing the ODD bracket.....	4-46
Figure 4-29	Ejecting the optical disk	4-47
Figure 4-30	Removing the RTC battery	4-49
Figure 4-31	Removing the internal microphone.....	4-50

Figure 4-32 Removing the Jack board	4-51
Figure 4-33 Removing the system board	4-52
Figure 4-34 Removing the DC-IN jack	4-53
Figure 4-35 Removing the speaker	4-54
Figure 4-36 Removing the modem jack.....	4-55
Figure 4-37 Removing the F jack	4-56
Figure 4-38 Removing the GPU fan	4-57
Figure 4-39 Removing the battery lock/battery latch	4-58
Figure 4-40 Removing the analog TV tuner	4-60
Figure 4-41 Removing the CPU heat sink and CPU fan	4-61
Figure 4-42 Separating the CPU fan and CPU heat sink	4-62
Figure 4-43 Removing the CPU	4-62
Figure 4-44 Installing the CPU	4-63
Figure 4-45 Applying silicon grease.....	4-64
Figure 4-46 Removing the GPU heat sink.....	4-65
Figure 4-47 Removing the North bridge heat sink	4-67
Figure 4-48 Removing the PC card slot.....	4-68
Figure 4-49 Removing the hinge cap.....	4-70
Figure 4-50 Removing the LCD mask.....	4-71
Figure 4-51 Removing the FL inverter	4-72
Figure 4-52 Removing the LCD unit (1)	4-73
Figure 4-53 Removing the LCD unit (2)	4-74
Figure 4-54 Removing the LCD support	4-75
Figure 4-55 Removing the harness hold plate	4-77
Figure 4-56 Removing the LCD hold plate	4-78
Figure 4-57 Removing the LCD cable.....	4-79
Figure 4-58 Removing the wireless LAN antenna/Bluetooth antenna (1)	4-80
Figure 4-59 Removing the wireless LAN antenna/Bluetooth antenna (2)	4-81
Figure 4-60 Removing the latch assembly.....	4-82
Figure 4-61 Removing the display rear cover (1).....	4-83
Figure 4-62 Removing the display rear cover (2).....	4-84
Figure 4-63 Removing the hinge	4-85

Figure 4-64 to 4-68 Replacing 15.4 inch Samsung fluorescent lamp.....4-88 to 4-91

4.1 Overview

This chapter describes the procedure for removing and replacing the field replaceable units (FRUs) in the PC. It may not be necessary to remove all the FRUs in order to replace one. The chart below provides a guide as to which other FRUs must be removed before a particular FRU can be removed. The numbers in the chart indicate the relevant section numbers in this manual.

In all cases when removing an FRU, the battery pack must also be removed. When repairing an FRU that is the potential cause of a computer fault, use the chart to determine the order in which FRUs need to be removed.

The tilt stand, if it is installed, can be removed without any other FRUs removed.

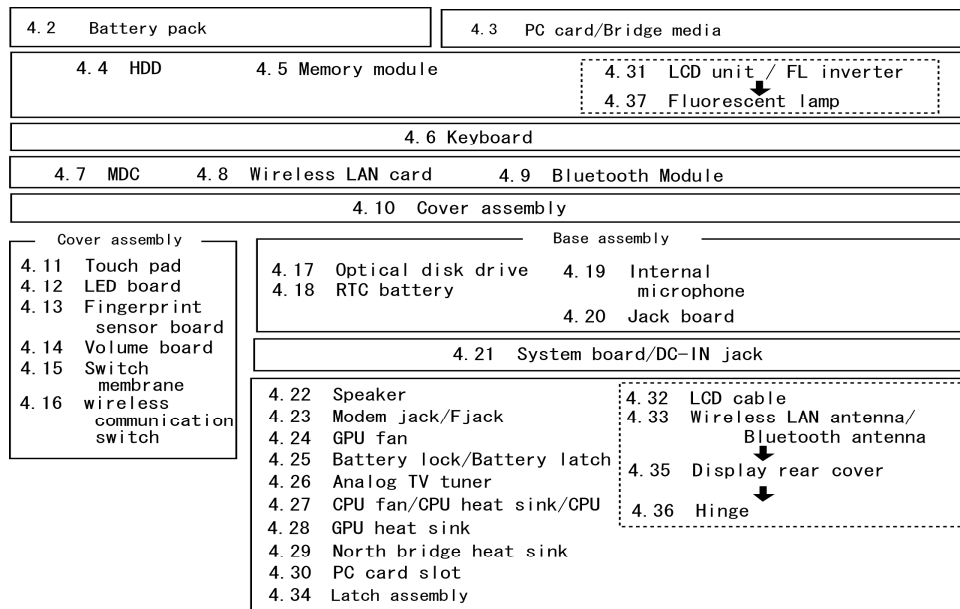

• Chart Notation

The chart shows the case for the following example:

• Removing a Touch pad

All FRUs down to the “4.2 Battery pack” to “4.10 Cover assembly” must be removed.

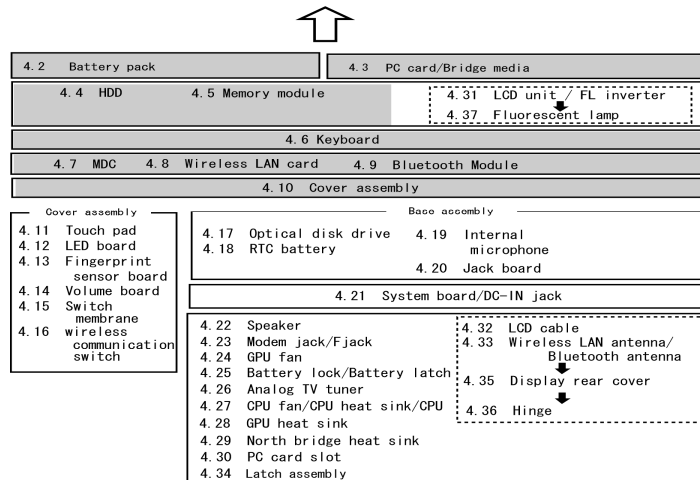

Safety Precautions

Please read the following safety instructions before disassembling the computer and always follow the instructions while working on the computer.

- DANGER:**
- 1. In the case of the battery, always use authentic parts or equivalent parts approved by Toshiba. Other batteries may have different specifications that are incompatible with the computer and may result in fire or explosion.
Due to the risk of alkali fluid leaks, never attempt to heat or disassemble the battery. Similarly, due to the risk of explosion, never expose the battery to flame.*
 - 2. Some parts including the power supply and FL inverter generate high voltages. If you need to turn on the power while disassembling the computer, do not touch any connectors or other components due to the risk of electric shock. Also, do not disassemble individual parts when performing routine maintenance.*

- WARNING:**
- 1. To prevent electric shock, turn off the power unplug the AC adapter from the power source.*
 - 2. As the battery installed to the computer is typically already charged, the risk of electric shock remains even when the AC adapter is unplugged from the socket. To prevent electric shock, always take off any metal jewelry or accessories such as necklaces, bracelets or rings before working on the computer. Never work with wet or moist hands.*
 - 3. Take care not to injury yourself on any edges or corners.*

- CAUTION:**
- 1. Confirm that replacement parts have compatible specifications before replacing on the computer. Never use incorrect parts as these may cause faults on the computer.*
 - 2. To prevent internal damage such as short circuits or burning, do not allow any screws, paper clips, or other metal objects to fall into the computer. When removing screws, always replace with the same size screw. Ensure that all screws are fully tightened. Loose screws may result in short circuits leading to overheating, smoke or flame.*
 - 3. To prevent electric shock, check that you have disconnected all cables from a part before removing the part.*
 - 4. When connecting to the AC power supply, use only an AC adapter and cable approved by Toshiba.*
 - 5. To prevent electric shock, ensure that all replacement parts are compatible with the computer and that all cables and connectors are securely connected.*

Before You Begin

Take note of the following points before starting work. Always remove the AC adapter and battery pack before commencing any of the procedures. The procedure for removing the battery pack is described in section “4.2 Battery Pack”.

1. Do not disassemble the computer unless it is operating abnormally.
2. Use the designated tools.
3. Ensure that the environment for working on and storing parts does not contain any of the following.
 - Dust or dirt
 - Static electricity
 - Extremely hot, cold or humid conditions
4. Perform the diagnostic tests described in Chapter 2 to determine which FRU is the cause of the fault.
5. Do not perform any unnecessary work. Always work in accordance with the disassembly and reassembly procedures in this manual.
6. Keep parts removed from the computer in a safe place away from the computer where they will not be damaged or interfere with your work.
7. Disassembling requires the removal of a large number of screws. Keep removed screws in a safe place such that you can determine which screws belong to which part.
8. When reassembling, ensure that you use the correct screws and fit parts in the correct position. Screw sizes are noted in the text and figures.
9. As all parts have sharp edges and corners, take care not to cut yourself.
10. After replacing an FRU, check that the computer and replaced part operate correctly.

Disassembly Procedure

Three main types of cable connector are used.

- Pressure plate connector
- Spring connector
- Normal pin connector

When disconnecting a pressure plate connector, lift up the tag on one side of the plastic pressure plate on the connector and pull the cable out from the connector. When reconnecting a cable to a pressure plate connector, lift up the pressure plate to a suitable height and insert the cable into the connector. Press down on both sides of the pressure plate such that both sides of the plate and connector are at the same height and that the cable is fixed in the correct position. Pull the cable to ensure that it is securely connected. If the cable is disconnected from the connector, reconnect it making sure that you lift the pressure plate high enough to insert fully the cable.

For spring connectors, lifting up the stopper frees the cable and allows it to be pulled out. To reconnect, hold the stopper in the up position and insert the cable, then lower the stopper to secure the cable.

Normal pin connectors are used for all other cables. Simply pull out or push in these connectors to disconnect or reconnect.

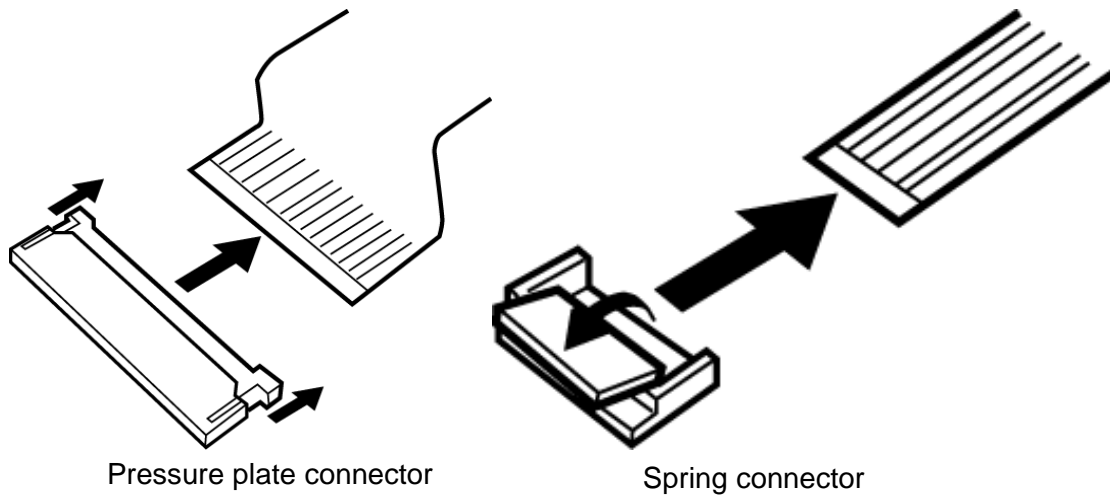

Assembly Procedure

After the computer has been disassembled and the part that caused the fault has been repaired or replaced, the computer must be reassembled.

Take note of the following general points when assembling the computer.

- Take your time and follow the instructions carefully. Hurrying the assembly work will only introduce new problems.
- Check that all cables and connectors are securely connected.
- Before fastening FRUs or other parts in place, ensure that no cables are caught on screws or the FRU.
- Check that all latches are securely closed.
- Ensure that you have installed all FRUs correctly and do not have any screws left over. Using an incorrect screw may damage the thread or screw head and result in the FRU not being securely fastened in place.

After installing FRUs, check that the computer operates correctly.

Tools and Equipment

For your safety and the safety of the people around you, it is important that you use Electrostatic Discharge (ESD) equipment. Correctly utilizing of the equipment increases the percentage of successful repairs and saves on the cost of damaged or destroyed parts. The following equipment is required for disassembly and assembly.

- One Philips screwdriver with type 0 bit (for thin head screws)
- One Philips screwdriver with type 1 bit (for screws other than above)
- One 4mm flat-blade screwdriver
- Screwdriver for TORX screw
- Tweezers (for lifting screws)
- ESD mats (lay on work table or floor)
- An ESD wrist strap and heel grounder
- Anti-static carpet or flooring

Screw Tightening Torque

Use the following torque when tightening screws.

CAUTION: Overtightening may damage screws or parts. Undertightening may allow screws to loosen (and possibly fall out) causing a short circuit or other damage.

NOTE: To tighten screws quickly and accurately, an electric screwdriver is recommended.

- M2 (2mm) 0.167 N·m (1.7 kgf·cm)
- M2.5 (2.5mm) 0.294 N·m (3.0 kgf·cm)
- M3.0 (3mm) 0.549 N·m (5.6 kgf·cm)

NOTE: To prevent damage to thin head screws, press along the axis of the screwdriver while turning the screw. This is because the contact area between the screw and driver is less than for a pan head screw (standard pan-shaped screw head).

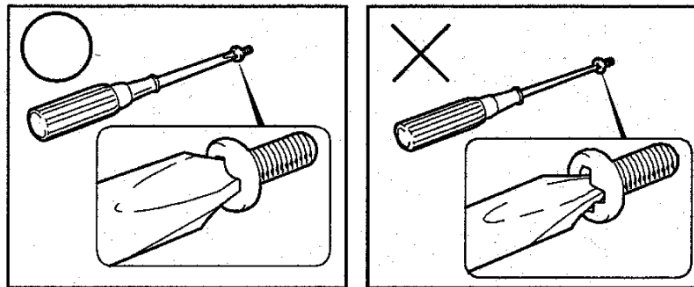

Grip Color

Some screws have a colored grip area to help you determine the length of the screw.

- Even numbered length screws: Brown
- Odd numbered length screws: White
- Special length screw: Blue



“Special length screw” means screws whose length is indicated in an integral number to the first decimal places such as 2.5 mm, 2.8 mm and so on.

Screw Notation

To make maintenance of the computer easier, markings of the kinds of the screws including the types and lengths of the screws are indicated on the computer body.

Format:

Screw shape + Screw length (mm)

Screw shape

B: Bind screw (BIND screw)

F: Flat head bind screw (FLAT BIND)

S: Super thin head screw (S-THIN HEAD)

T: Tapping screw

U: Other screws (Unique screws: pan head, stud, etc.)

Example: B6 ... 6mm bind screw

4.2 Battery pack

Removing the battery pack

The following describes the procedure for removing the battery pack (See Figure 4-1 and 4-2).

CAUTION: Take care not to short circuit the terminals when removing the battery pack. Similarly, do not drop, knock, scratch, disassemble, twist, or bend the battery pack.

1. Turn off the power of the computer.
2. Disconnect the AC adapter and all external devices from the computer.
3. Turn the computer upside down.
4. Release the **battery lock**.
5. Slide the **battery latch** in the direction of the arrow and pull up the **battery pack**.

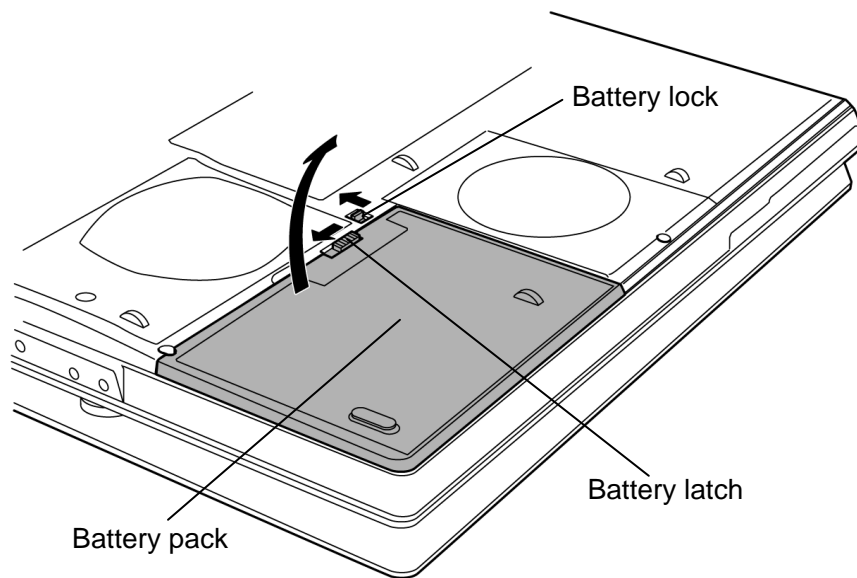

Figure 4-1 Removing the battery pack

6. Separate the **battery cover** and **battery** while releasing the **hooks** of the battery cover.

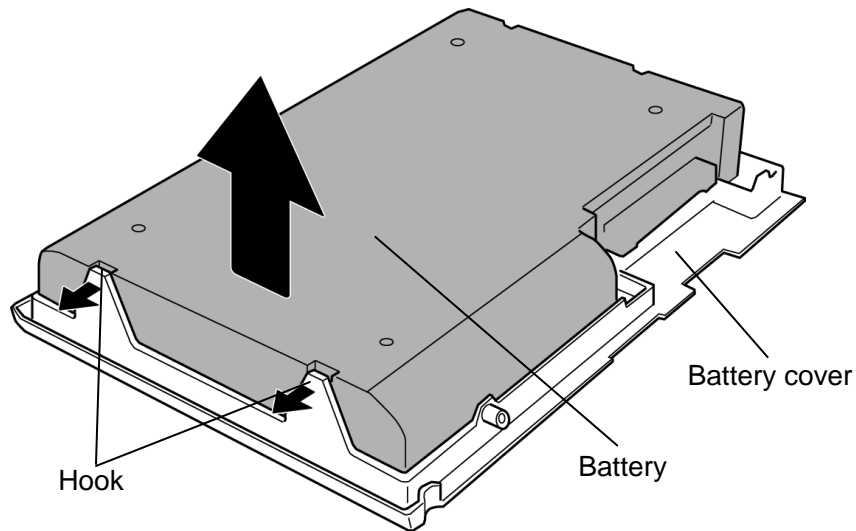

Figure 4-2 Removing the battery

NOTE: Dispose of the used battery pack in accordance with the laws and ordinances of your local authority.

Installing the battery pack

The following describes the procedure for installing the battery pack (See Figure 4-1 and 4-2).

CAUTION: There is a danger that the lithium ion battery pack may explode if not fitted, operated, handled, or disposed correctly. Dispose always the used battery pack in accordance with the laws and ordinances of your local authority. Use only the batteries approved by Toshiba.

NOTE: Check visually the battery terminals and clean off any dirt with a dry cloth.

1. Turn off the power of the computer.
2. Disconnect the AC adapter and all external devices from the computer.
3. Attach the **battery cover** to the **battery pack**.
4. Place the **battery pack assembly** into the slot and insert it carefully.
5. Slide the **battery lock** to the lock position. Make sure that the battery pack is securely in place and the battery lock is in the lock position.

4.3 PC card/Bridge media

4.3.1 PC card

Removing the PC card

The following describes the procedure for removing the PC card (See Figure 4-3).

CAUTION: Insert or remove the PC card in accordance with any instructions in their manual or the manuals of the computer system you are using.

1. Push the **eject button**. It will pop out when you release it, and then press the eject button once more to eject PC card.
2. Grasp the **PC card** and remove it.

NOTE: If a PC card is not inserted all the way, the eject button may not pop out. Be sure to push the PC card firmly and press the eject button again.

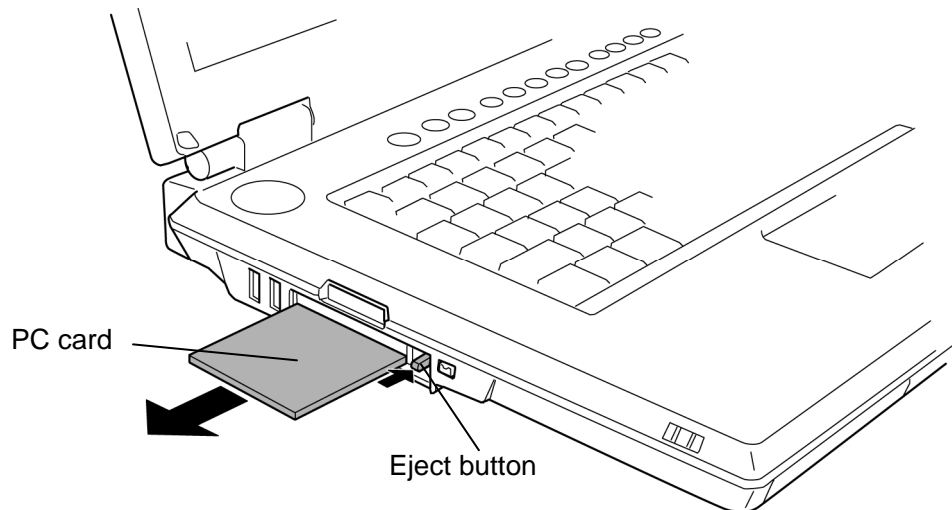

Figure 4-3 Removing the PC card

Installing the PC card

The following describes the procedure for installing the PC card (See Figure 4-3).

1. Make sure the **eject button** does not stick out.
2. Insert the **PC card** and press it until it is securely connected.

4.3.2 Bridge media (SD Card/Memory Stick/xDPicture Card/MultiMedia card)

Removing the Bridge media

The following describes the procedure for removing the Bridge media (See Figure 4-4).

CAUTION: Insert or remove a Bridge Media in accordance with any instructions in the each Bridge Media manual or the manuals of the computer system you are using.

1. Push the **Bridge media**. It will pop out partly when you release, so pull out the card. (For an instance, a SD card is described in the figure 4-4.)

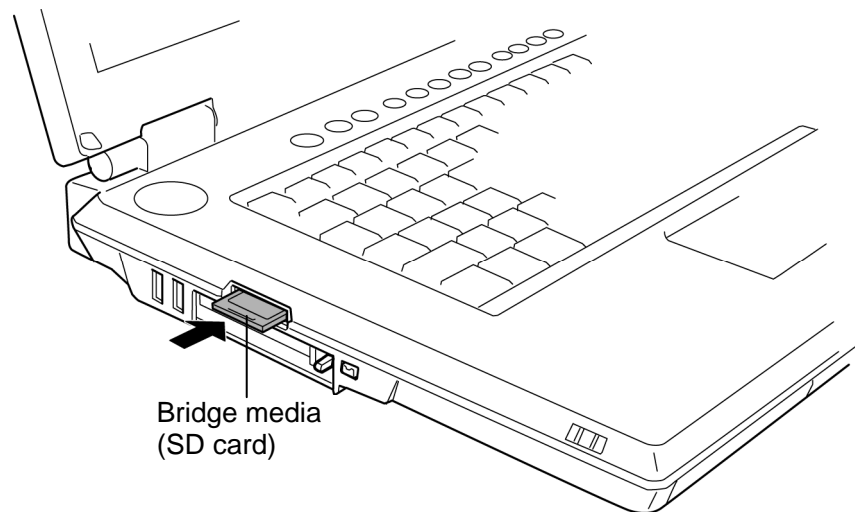

Figure 4-4 Removing the Bridge media

Installing the Bridge media

The following describes the procedure for installing the Bridge media (See Figure 4-4).

1. Insert the **Bridge media** and press it until it is securely connected.

4.4 HDD

Removing the HDD

The following describes the procedure for removing the HDD (See Figure 4-5 to 4-7).

CAUTION: Take care not to press on the top or bottom of a HDD. Pressure may cause data loss or damage to the device.

1. Turn the computer upside down.
2. Loosen the following **screw (with e-ring)** and remove the **HDD-1 slot cover**.
3. Remove the following **screw** securing the **HDD-1 assembly**.
 - M2.5×6B FLAT BIND screw × 1
4. With holding the **tab** of the HDD-1 assembly, lift **HDD-1 assembly** straight up and away from the connector on the system board.

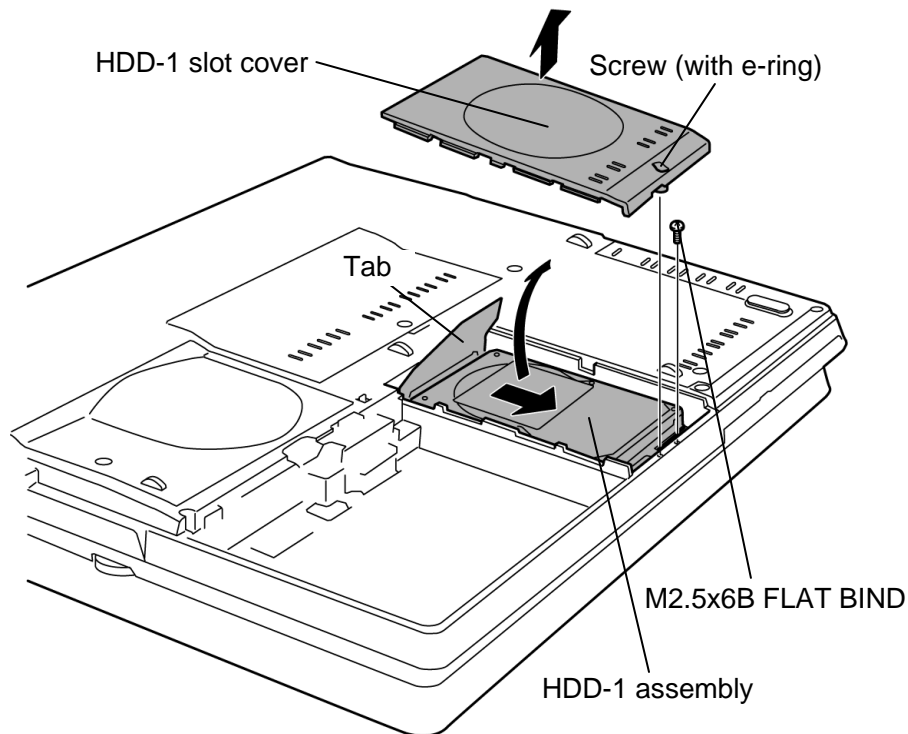

Figure 4-5 Removing the HDD-1 assembly

5. (When the HDD-2 is installed,) Loosen the **screw (with e-ring)** and remove the **HDD-2 slot cover**.
6. With holding the tab of the HDD-2 assembly, lift **HDD-2 assembly** straight up and away from the connector on the system board.

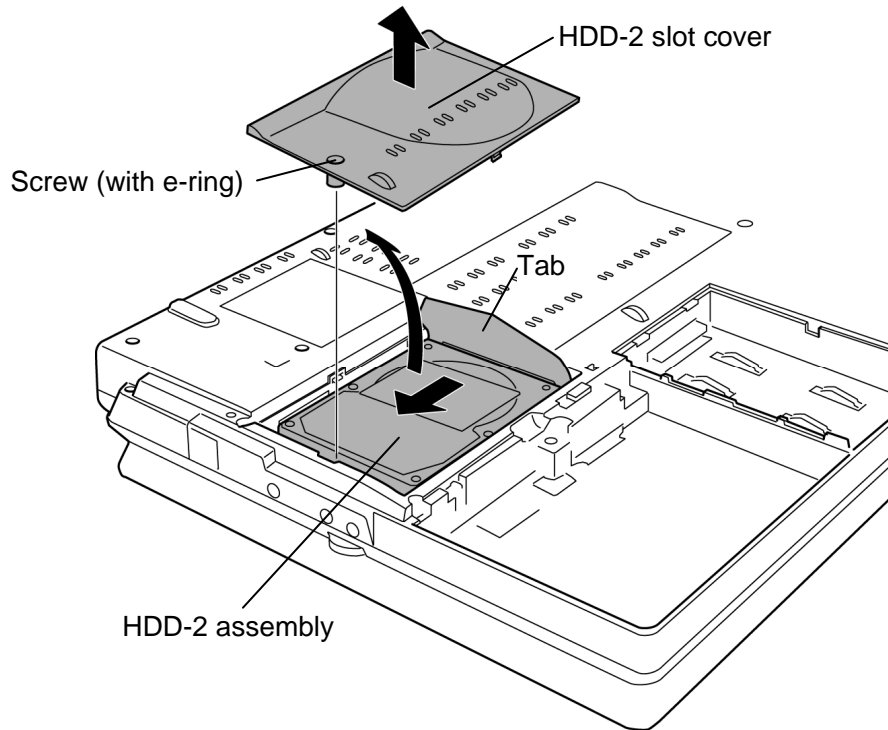

Figure 4-6 Removing the HDD-2 assembly

7. Remove the following screws and separate the **HDD holder** from the **HDD assembly**.

- M3.0×4S S-THIN HEAD screw ×4

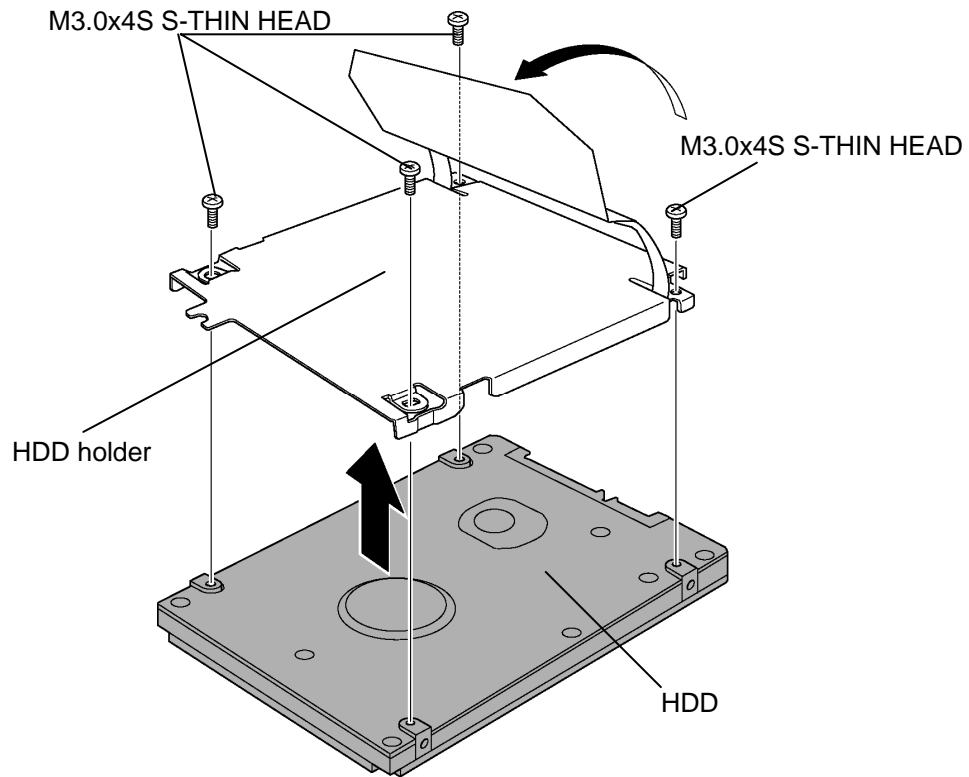

Figure 4-7 Removing the HDD

Installing the HDD

The following describes the procedure for installing the HDD (See Figure 4-5 to 4-7).

1. Install the **HDD** to the **HDD holder** and secure it with the following **screws**.

- M3.0×4S S-THIN HEAD screw ×4

NOTE: Although they are 3mm head screws, screw torque must be set in 0.294 N·m (3.0Kgf·cm) for four screws securing the HDD holder.

2. Insert the **HDD-2 assembly** into the HDD-2 slot and connect the connector carefully to the connector on the system board.
3. Install the **HDD-2 slot cover** and secure it with the **screw (with e-ring)**.
4. Insert the **HDD-1 assembly** into the HDD-1 slot and connect the connector carefully to the connector on the system board.
5. Secure the **HDD-1 assembly** with the following **screw**.
 - M2.5×6B FLAT BIND screw × 1
6. Install the **HDD-1 slot cover** and secure it with the **screw (with e-ring)**.

4.5 Memory module

CAUTION: The power of the computer must be turned off when you remove the memory module. Removing the memory module with the power on damages the module or the computer itself.

Do not touch memory module terminals. Any dirt on the terminals may cause memory access problems.

Never press hard or bend a memory module.

Removing the memory module

To remove the memory module, confirm that the computer is in boot mode. Then perform the following procedure (See Figure 4-8).

1. Loosen the **screw (with e-ring)** securing the **memory slot cover**.
2. Remove the **memory slot cover**.
3. Remove the **memory module** while opening the left and right **latches**.

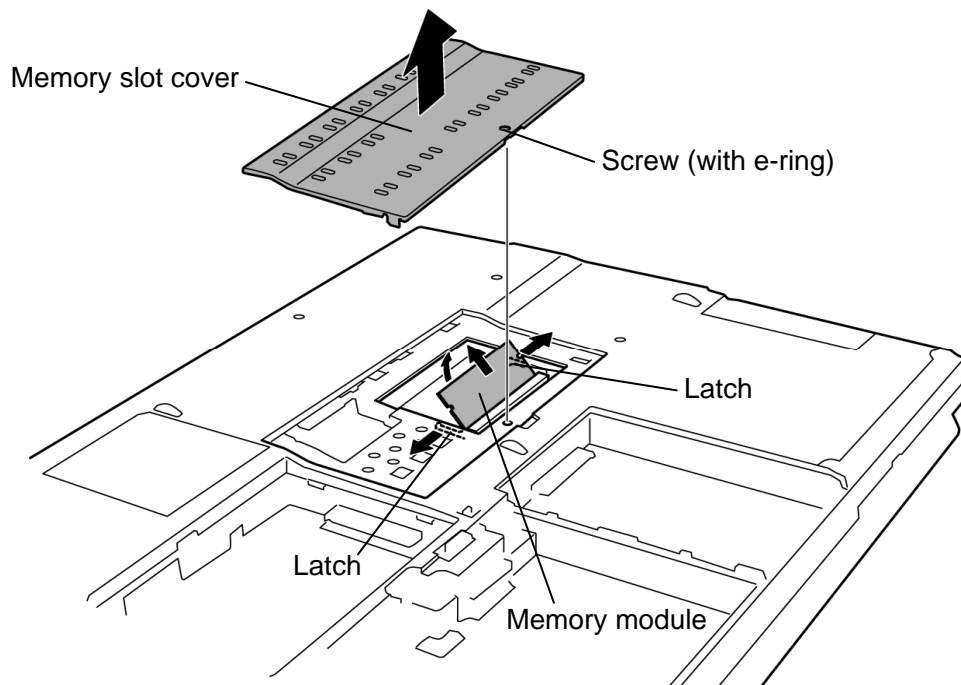

Figure 4-8 Removing the memory module

Installing the memory module

Before installing the memory module, confirm that the computer is in boot mode. Then perform the following procedure (See Figure 4-8).

1. Insert the **memory module** firmly into the connector of the computer slantwise and press down it.

CAUTION: *Be sure to install a memory module to slot A (CN1400). The computer does not boot when a memory module is installed into slot A.*

After installing the memory module, confirm that the memory module is secured with the left and right latches.

Never press hard or bend a memory module.

2. Install the **memory slot cover** and secure it with the **screw (with e-ring)**.

NOTE: *When the power of the computer is turned on, the computer checks automatically the memory size. Confirm that the new memory is detected correctly. If the memory is not detected, check that it is connected correctly.*

4.6 Keyboard

Removing the keyboard

The following describes the procedure for removing the keyboard (See Figure 4-9 and 4-10).

CAUTION: As the keytop may fall out, when handling the keyboard always hold it by the frame and do not touch the keytop.

1. Insert your finger into the slot between the keyboard holder and computer. Then lift up the **keyboard holder** while unlatching.
2. Remove the following **screw**.
 - M2.5x4B FLAT BIND screw ×2
3. Lift the upper side of the **keyboard** while releasing the **latch** and turn it face down on the palm rest.

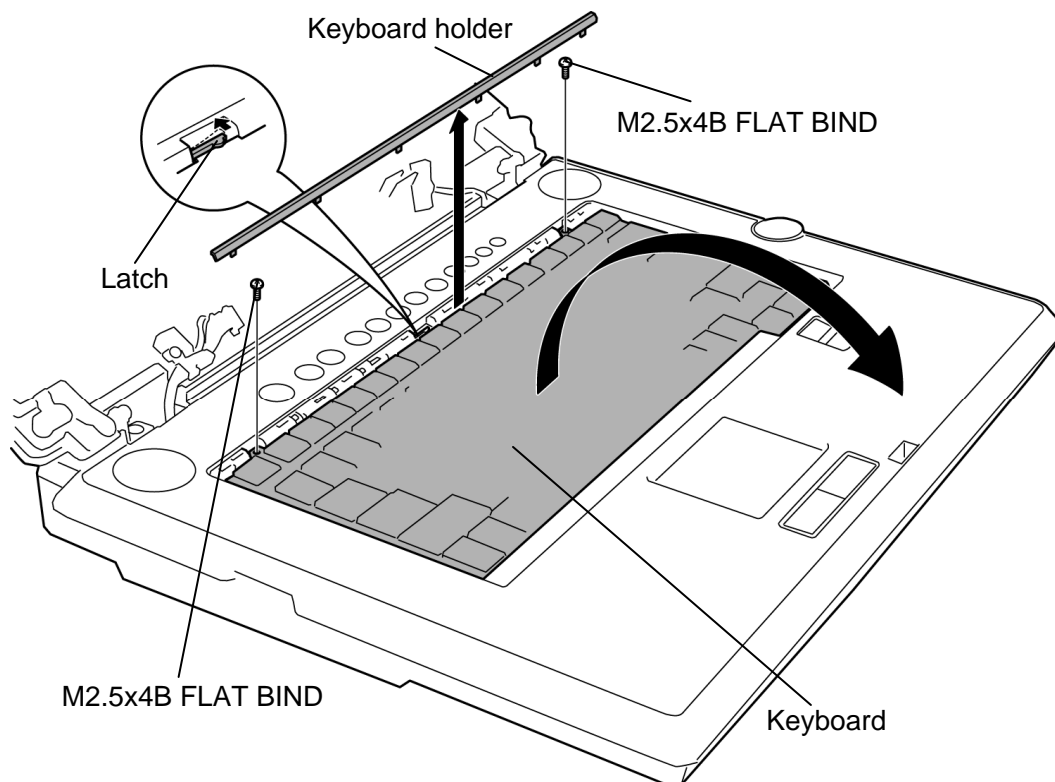

Figure 4-9 Removing the keyboard (1)

4. Remove the following **screw** and **keyboard support plate**.
 - M2.5×8B FLAT BIND screw ×1
5. Disconnect the **keyboard cable** from the connector **CN3200** on the system board and remove the **keyboard**.

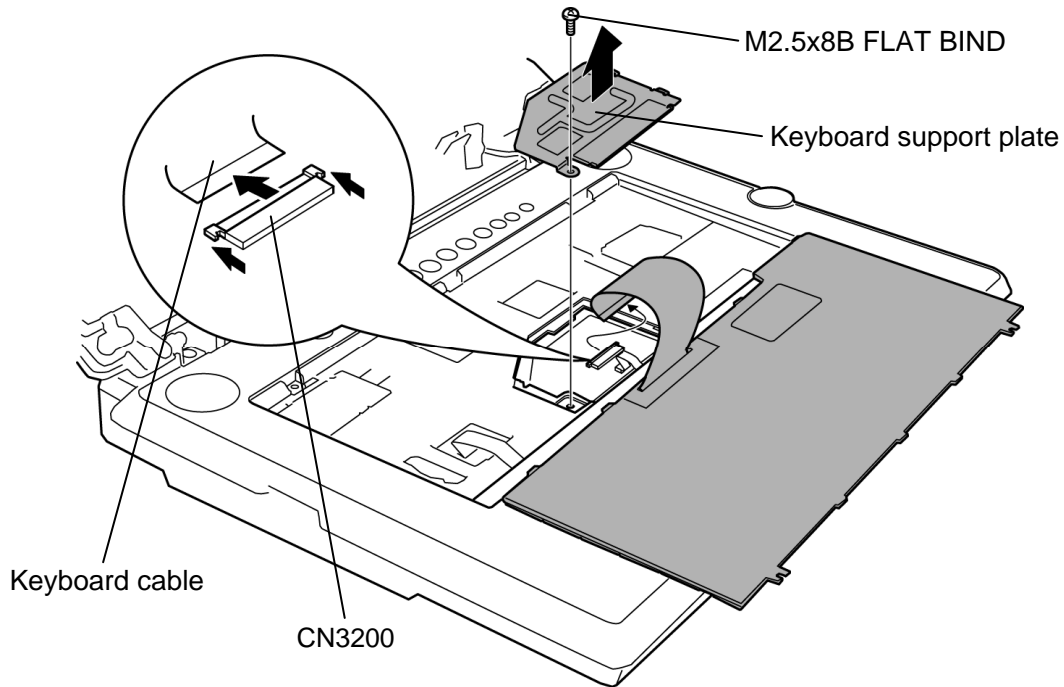

Figure 4-10 Removing the keyboard (2)

Installing the keyboard

The following describes the procedure for installing the keyboard (See Figure 4-9 to 4-10).

1. Place the keyboard on the palm rest with its face down. Connect the **keyboard cable** to the connector **CN3200** on the system board.
2. Install the **keyboard support plate** and secure it with the following **screw**.
 - M2.5×8B FLAT BIND screw ×1
3. Turn the **keyboard** face up and put it on the computer. Make sure that there is no space between the keyboard and computer.
4. Secure the keyboard with the following **screws**.
 - M2.5×4B FLAT BIND screw ×2
5. Install the **keyboard holder** (the topside first) and press it to latch.

4.7 MDC

Removing the MDC

The following describes the procedure for removing the MDC (See Figure 4-11).

1. Remove the following **screws** securing the MDC.
 - M2.0×4B BIND screw ×2
2. Pull the MDC straight up and disconnect the **MDC** from the connector **CN3010** on the system board.

CAUTION: *Be sure to pull the MDC straight up carefully, or the connector may be damaged.*

3. Disconnect the **modem cable** from the connector on the MDC.

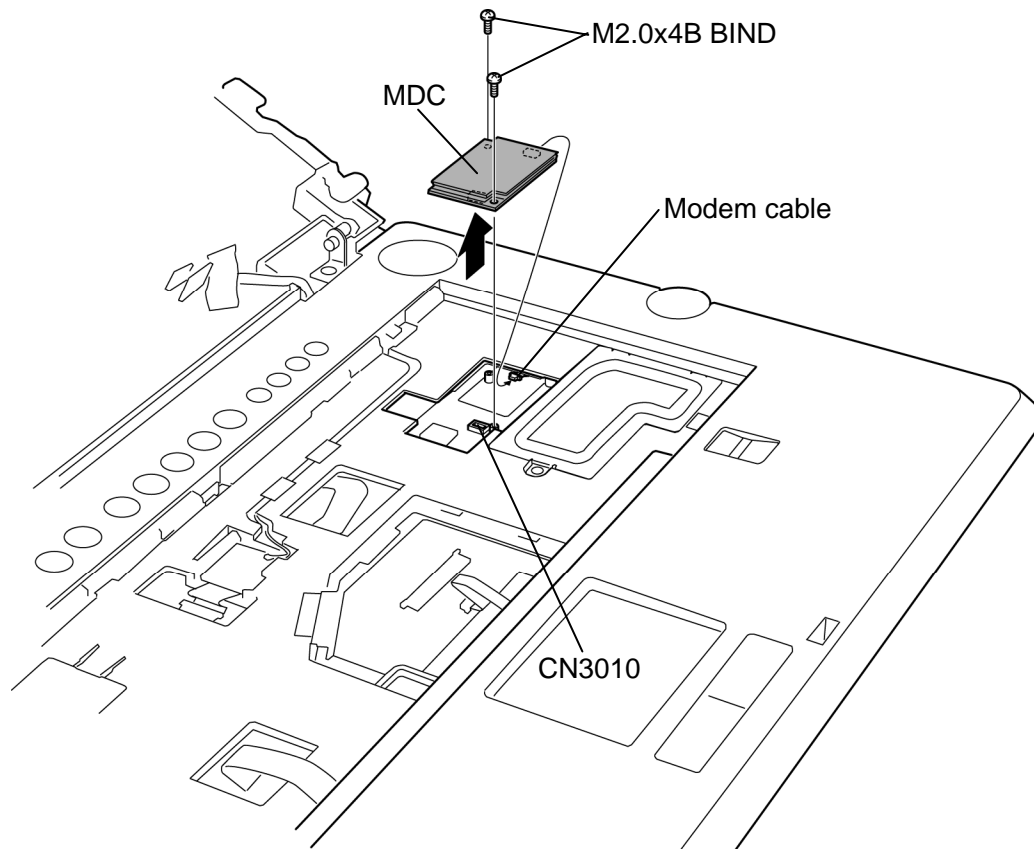

Figure 4-11 Removing the MDC

Installing the MDC

The following describes the procedure for installing the MDC (See Figure 4-11).

1. Connect the **modem cable** to the connector on the MDC.
2. Install the **MDC** and connect it to the connector **CN3010** on the system board.

CAUTION: *Be sure to install the MDC straight down carefully fitting the connectors of the MDC and system board, or the connectors may be damaged.*

3. Secure the MDC with the following **screws**.

- M2.0×4B BIND screw ×2

4.8 Wireless LAN card

Removing the wireless LAN card

The following describes the procedure for removing the wireless LAN card (See Figure 4-12).

1. Remove the following **screw** and **wireless LAN card hold plate**.
 - M2.0×4B TORX or BIND screw ×1
2. Disconnect the **wireless LAN antenna cables** (MAIN & AUX) from the terminals on the wireless LAN card.
3. Remove the following **screws** securing the wireless LAN card.
 - M2.0×4B BIND screw ×2
4. Disconnect the **wireless LAN card** from the connector **CN2600** on the system board.

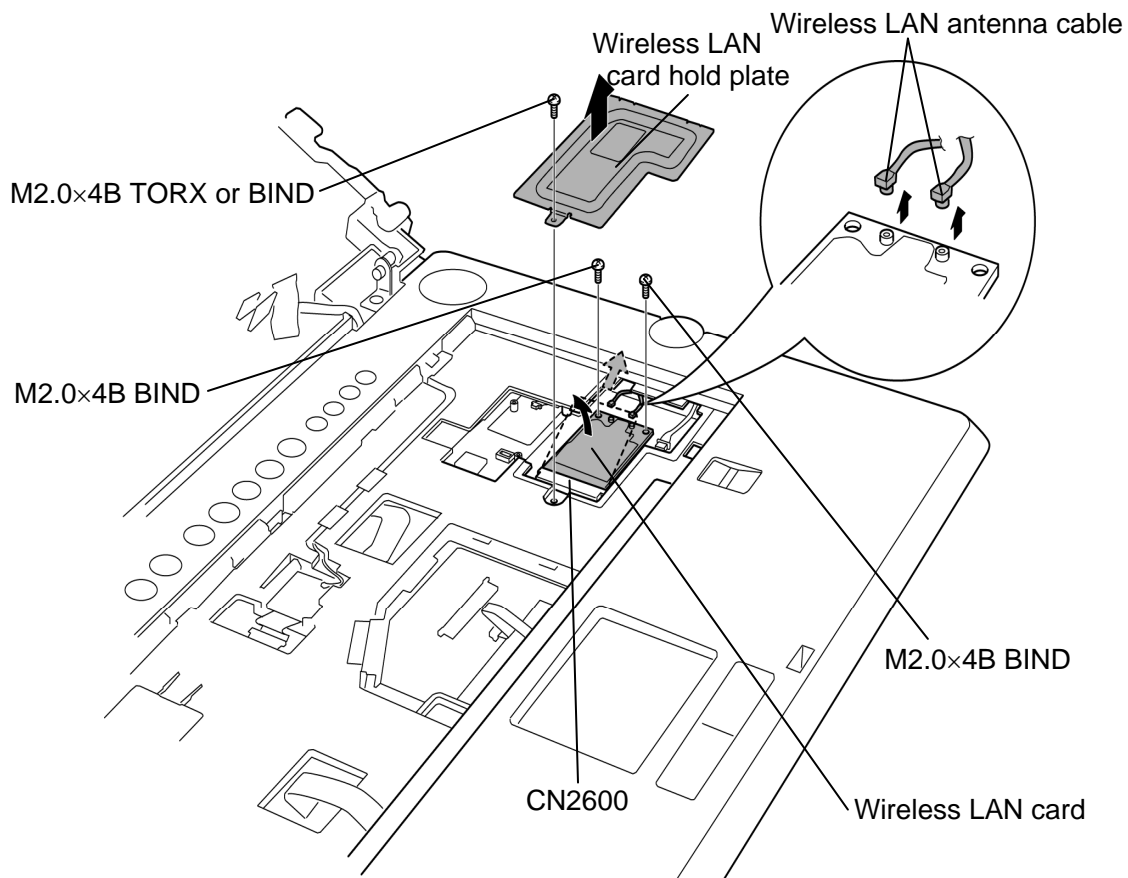

Figure 4-12 Removing the wireless LAN card

Installing the wireless LAN card

The following describes the procedure for installing the wireless LAN card (See Figure 4-12).

1. Insert slantwise the **wireless LAN card** firmly into the connector **CN2600** on the system board.
2. While holding down, secure the wireless LAN card with the following **screws**.
 - M2.0×4B BIND screw ×2
3. Connect the **wireless LAN antenna cables** to the terminals (White cable to MAIN, Black cable to AUX) on the wireless LAN card.
4. Install the **wireless LAN card hold plate** and secure it with the following **screw**.
 - M2.0×4B TORX or BIND screw ×1

4.9 Bluetooth module

Removing the Bluetooth module

The following describes the procedure for removing the Bluetooth module (See Figure 4-13).

1. Disconnect the **Bluetooth antenna cable** from the connector on the Bluetooth module.
2. Push the **stopper** in the direction of the arrow to unlatch and take out the **Bluetooth module** from the slot.
3. Disconnect the **Bluetooth flat cable** from the connector on the Bluetooth module.
4. Disconnect the **Bluetooth flat cable** from the connector **CN4400** on the system board.

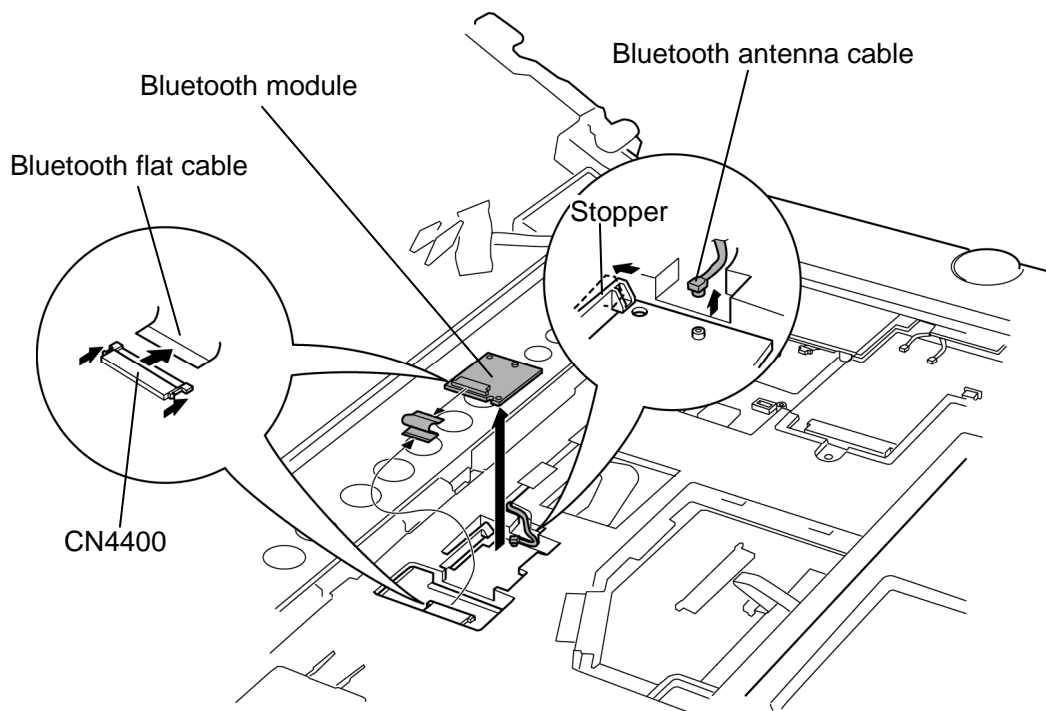

Figure 4-13 Removing the Bluetooth module

Installing the Bluetooth module

The following describes the procedure for installing the Bluetooth module (See Figure 4-13).

1. Connect the **Bluetooth flat cable** to the connector **CN4400** on the system board.
2. Connect the **Bluetooth flat cable** to the connector on the Bluetooth module.
3. Install the **Bluetooth module** to the slot.
4. Connect the **Bluetooth antenna cable** to the connector on the Bluetooth module.

4.10 Cover assembly

Removing the Cover assembly

The following describes the procedure for removing the cover assembly (See Figure 4-14 to 4-18).

1. Turn over the computer and disconnect the **GPU fan cable** from the connector **CN8781** on the system board.
2. Disconnect the **AV-IN cable** from the connector **PJ650** on the analog TV tuner.
3. Remove the following screws and **ODD slot bezel**.

- M2.5×4B FLAT BIND screw ×2

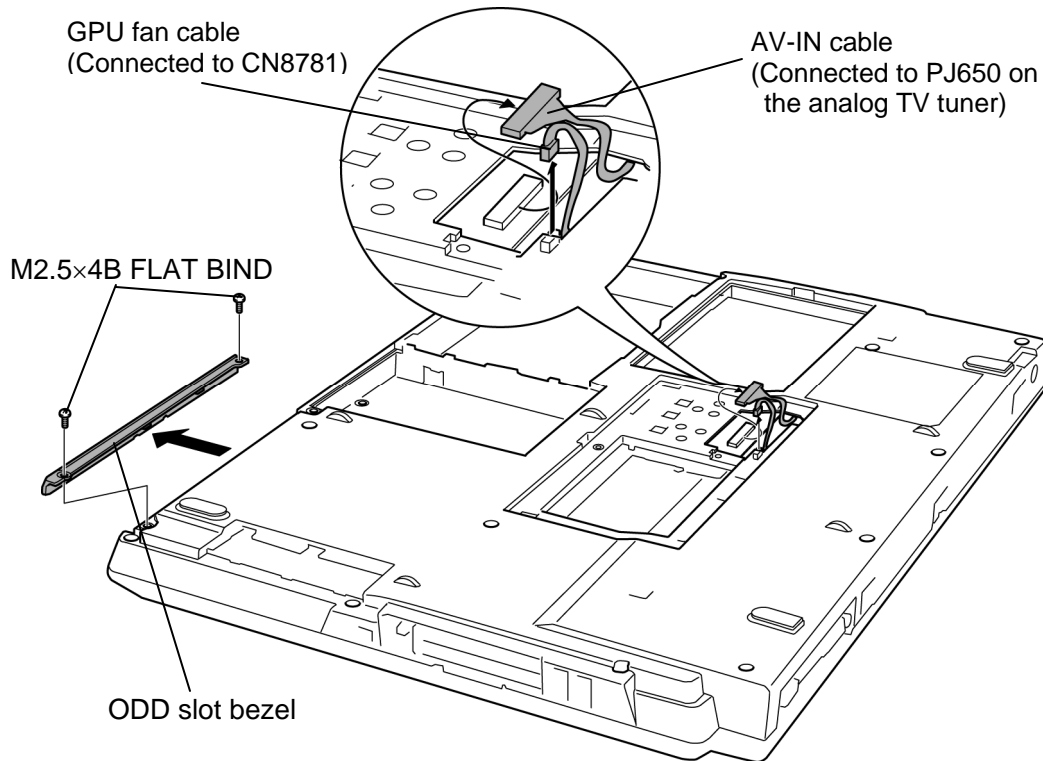

Figure 4-14 Removing the cover assembly (1)

4. Remove the following **screws** securing the cover assembly.

- M2.5×4B FLAT BIND screw ×3 (Described as "4" in the figure)
- M2.5×8B FLAT BIND screw ×4 (Described as "8" in the figure)
- M2.5×16B FLAT BIND screw ×10 (Described as "16" in the figure)

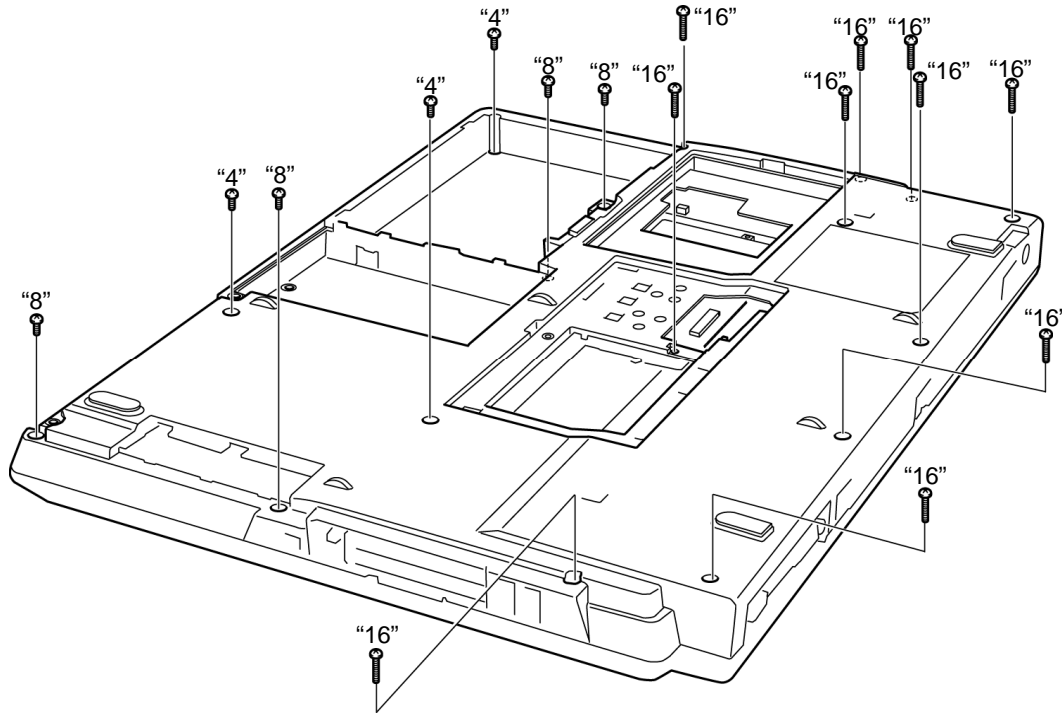

Figure 4-15 Removing the cover assembly (2)

5. Turn the computer face up and remove the **LCD connector cover**.
6. Disconnect the **LCD cable** from the connector **CN5500** on the system board.

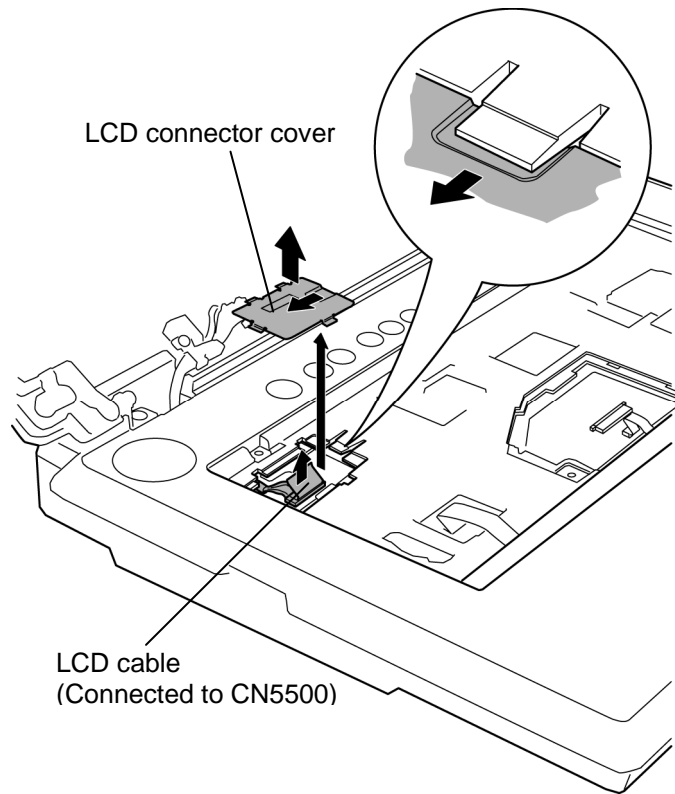

Figure 4-16 Removing the cover assembly (3)

7. Disconnect the **touch pad cable** from the connector **CN3201** on the system board.
8. Disconnect the **volume cable** from the connector **CN3330** on the system board.
9. Disconnect the **fingerprint sensor cable** from the connector **CN9530** on the system board.
10. Disconnect the **switch cable** from the connector **CN9650** on the system board.
11. Peel off the **insulator** and release the **Bluetooth antenna cable**.
12. Disconnect the **LED cable** from the connector **CN9500** on the system board.

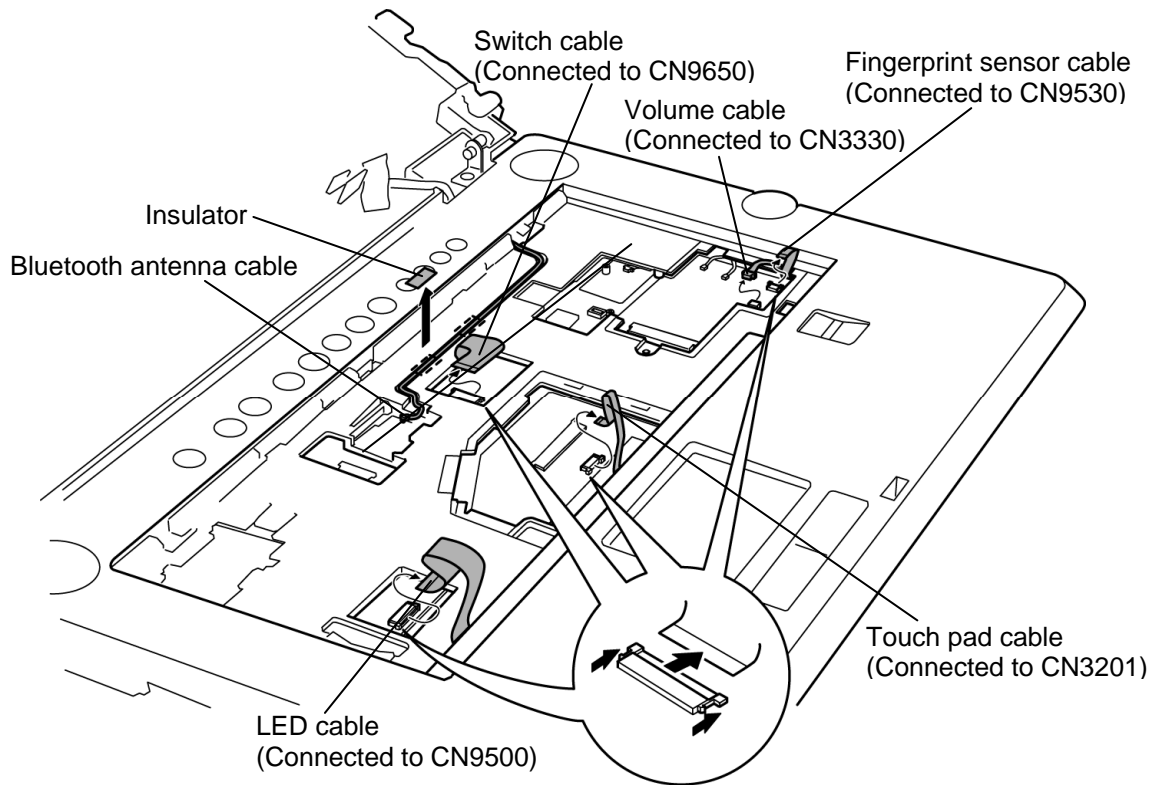

Figure 4-17 Removing the cover assembly (4)

13. Remove the **cover assembly** while releasing the latches.

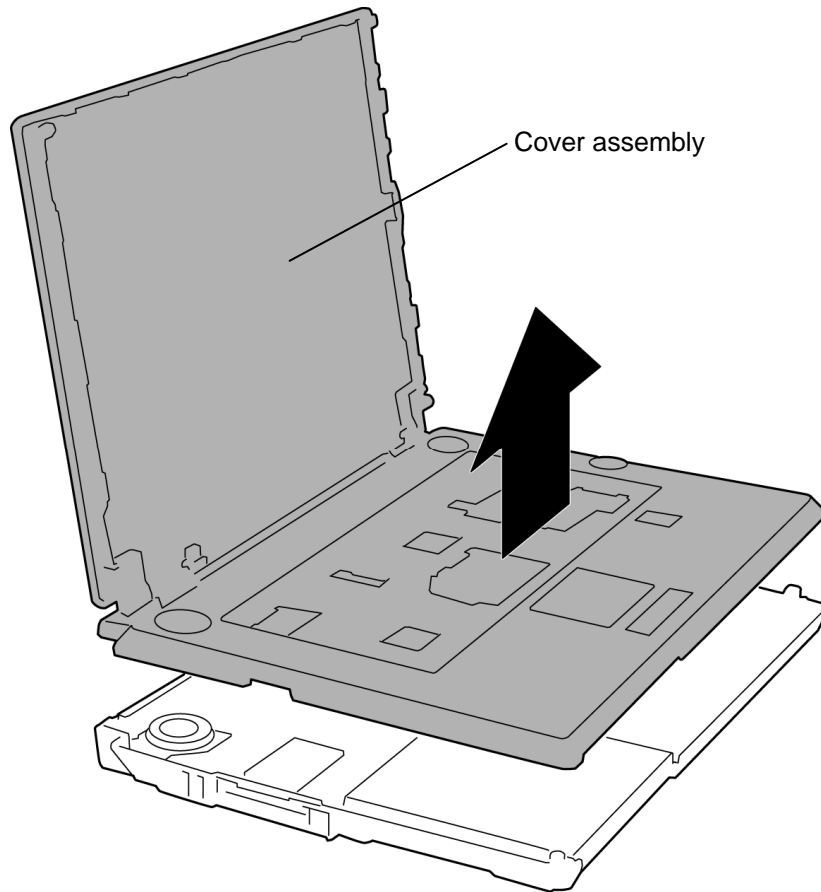

Figure 4-18 Removing the cover assembly (5)

Installing the cover assembly

The following describes the procedure for installing the cover assembly (See Figure 4-14 to 4-18).

1. Install the **cover assembly** to the base while engaging latches.
2. Connect the **LED cable** to the connector **CN9500** on the system board.
3. Arrange the **Bluetooth antenna cable** in place and stick the **insulator**.
4. Connect the **switch cable** to the connector **CN9650** on the system board.
5. Connect the **fingerprint sensor cable** to the connector **CN9530** on the system board.
6. Connect the **volume cable** to the connector **CN3330** on the system board.
7. Connect the **touch pad cable** to the connector **CN3201** on the system board.
8. Connect the **LCD cable** to the connector **CN5500** on the system board.
9. Install the **LCD connector cover** in place.
10. Turn over the computer.
11. Install the **ODD slot bezel** and secure it with the following **screws**.
 - M2.5×4B FLAT BIND screw ×2
12. Connect the **GPU fan cable** to the connector **CN8781** on the system board.
13. Connect the **AV-IN cable** to the connector **PJ650** on the analog TV tuner.
14. Secure the cover assembly with the following **screws**
 - M2.5×4B FLAT BIND screw ×3 (Described as "4" in the figure 4-15)
 - M2.5×8B FLAT BIND screw ×4 (Described as "8" in the figure 4-15)
 - M2.5×16B FLAT BIND screw ×10 (Described as "16" in the figure 4-15)

4.11 Touch pad

Removing the touch pad

The following describes the procedure for removing the touch pad (See Figure 4-19 to 4-21).

1. Remove the following **screw** on the back side of the cover assembly.
 - M2.5×4B FLAT BIND screw ×1
2. Remove the **touch pad assembly** while sliding it in the direction of the arrow.

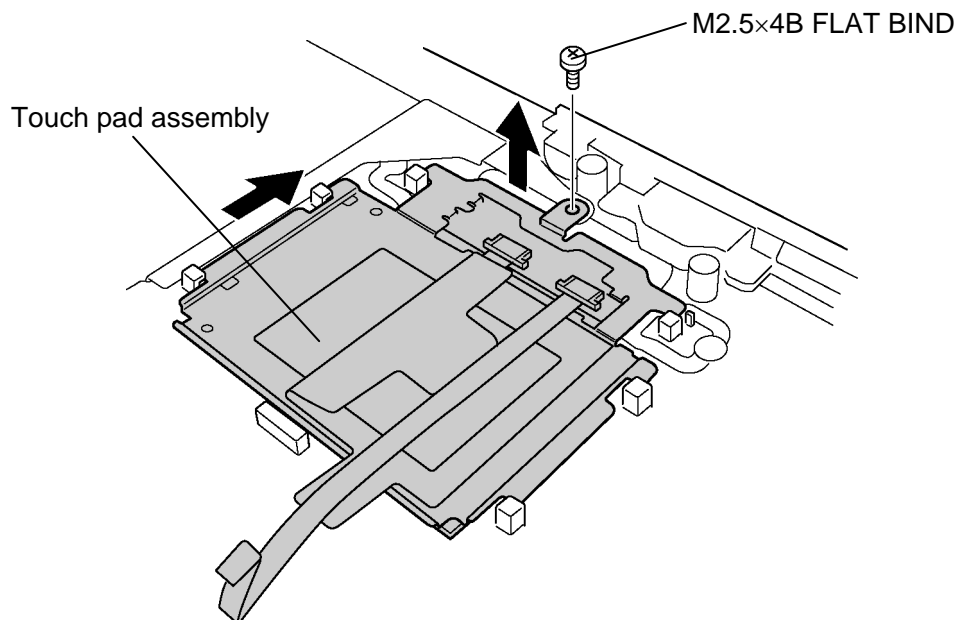

Figure 4-19 Removing the touch pad assembly

3. Open the **insulator A** to which the double-sided tape is stuck and disconnect the **touch pad cable** from the TP board.
4. Turn up the **insulator B** and disconnect the **button cable** from the touch pad assembly.
5. Disconnect the **button cable** from the TP board.

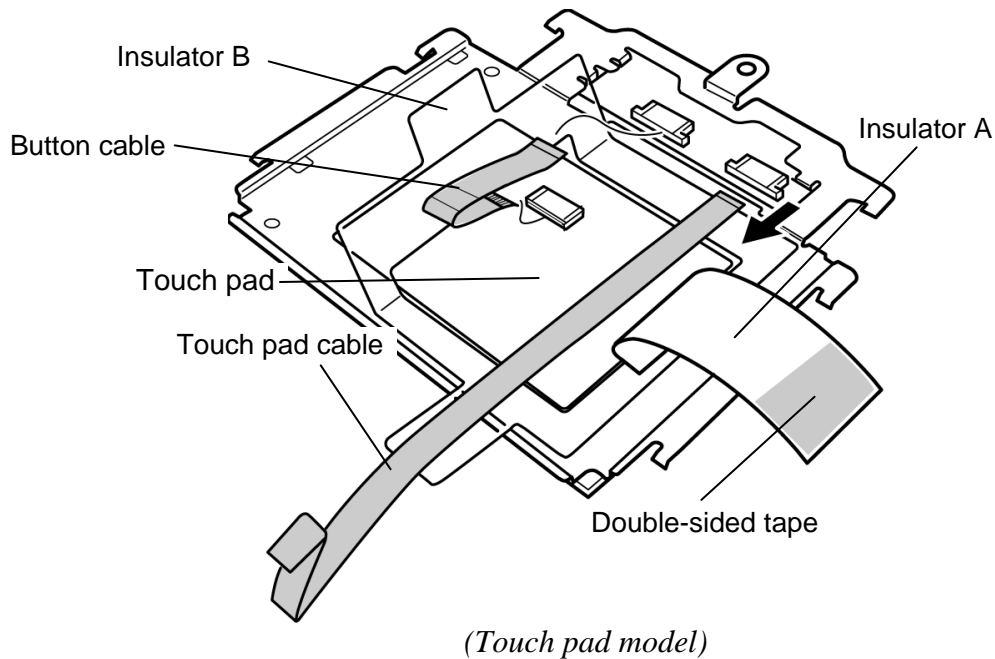
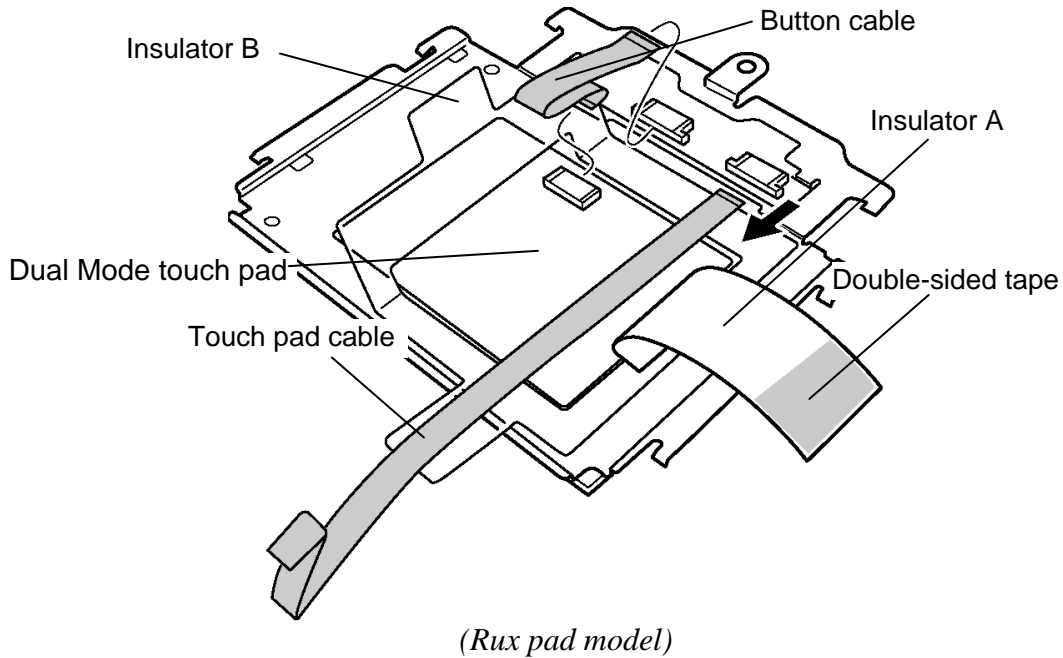

Figure 4-20 Removing the cables

6. Turn over the touch pad assembly and remove the following **screw** and **TP board**.

- M1.8×3S S-THIN HEAD screw ×1

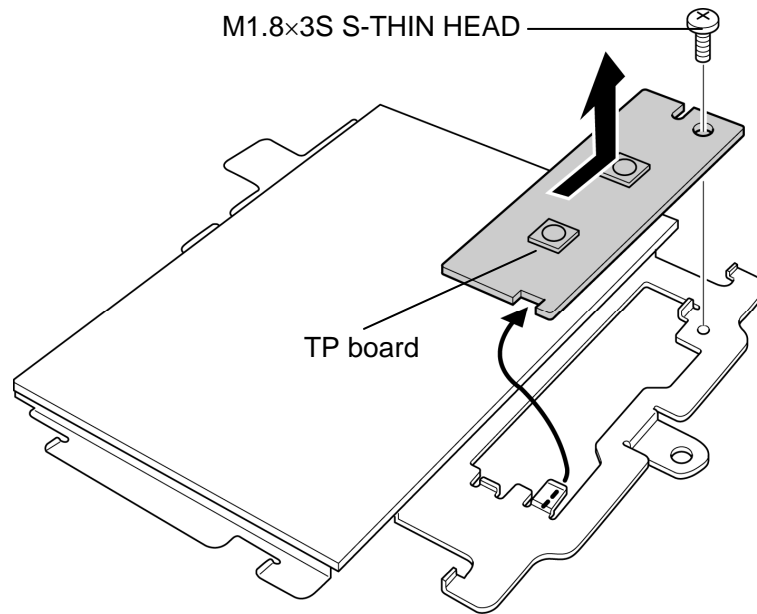

Figure 4-21 Removing the TP board

Installing the touch pad

The following describes the procedure for installing the touch pad (See Figure 4-19 to 4-21).

1. Install the **TP board** to the touch pad and secure it with the following screw.

- M1.8×3S S-THIN HEAD screw ×1

NOTE: When installing the TP board, insert the dent of the TP board under the guide and slide the TP board to the rib.

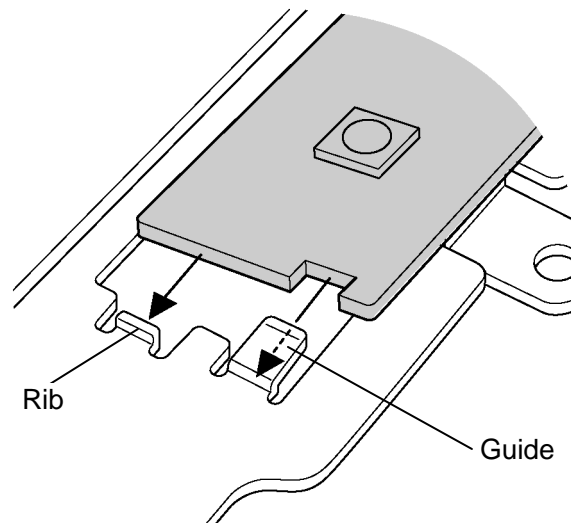

2. Turn up the **insulator B** and connect the **button cable** to the connector on the touch pad and TP board.
3. Turn up the **insulator A** and connect the **touch pad cable** to the connector on the TP board.

NOTE: Do not reuse the touch pad so that it can not be used after peeling off from the computer. Be sure to stick a new touch pad.

When installing the touch pad, be careful not to get the bubbles under the touch pad.

4. Install the **touch pad assembly** to the cover assembly while sliding it in the opposite direction of the arrow in Figure 4-19.
5. Secure the **touch pad assembly** with the following screw.

- M2.5×4B FLAT BIND screw ×1

4.12 LED board

Removing the LED board

The following describes the procedure for removing the sound board (See Figure 4-22).

1. Remove the following **screw** securing the LED board.
 - M2.5×4B FLAT BIND screw ×1
2. Remove the **LED board** upward from the cover assembly.
3. Disconnect the **LED cable** from the connector **CN9510** on the LED board.

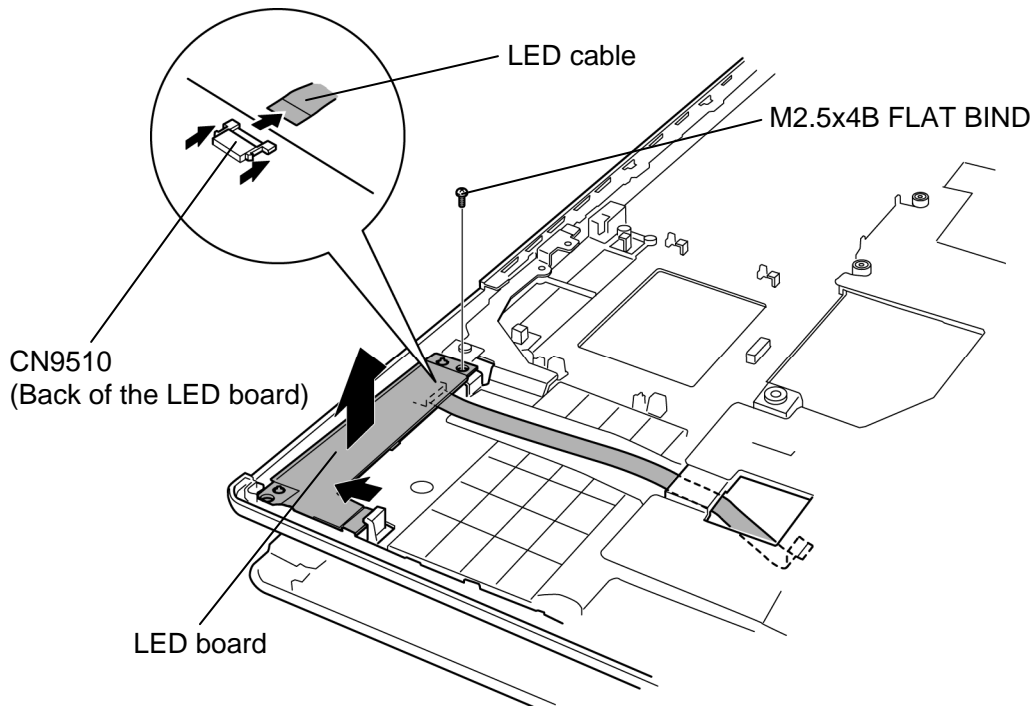

Figure 4-22 Removing the LED board

Installing the LED board

The following describes the procedure for installing the LED board (See Figure 4-22).

1. Connect the **LED cable** to the connector **CN9510** on the LED board.
2. Install the **LED board** to the cover assembly.

NOTE: Pass the LED cable through the hole of the cover assembly.

Install the LED board according to the position of the wireless communication switch.

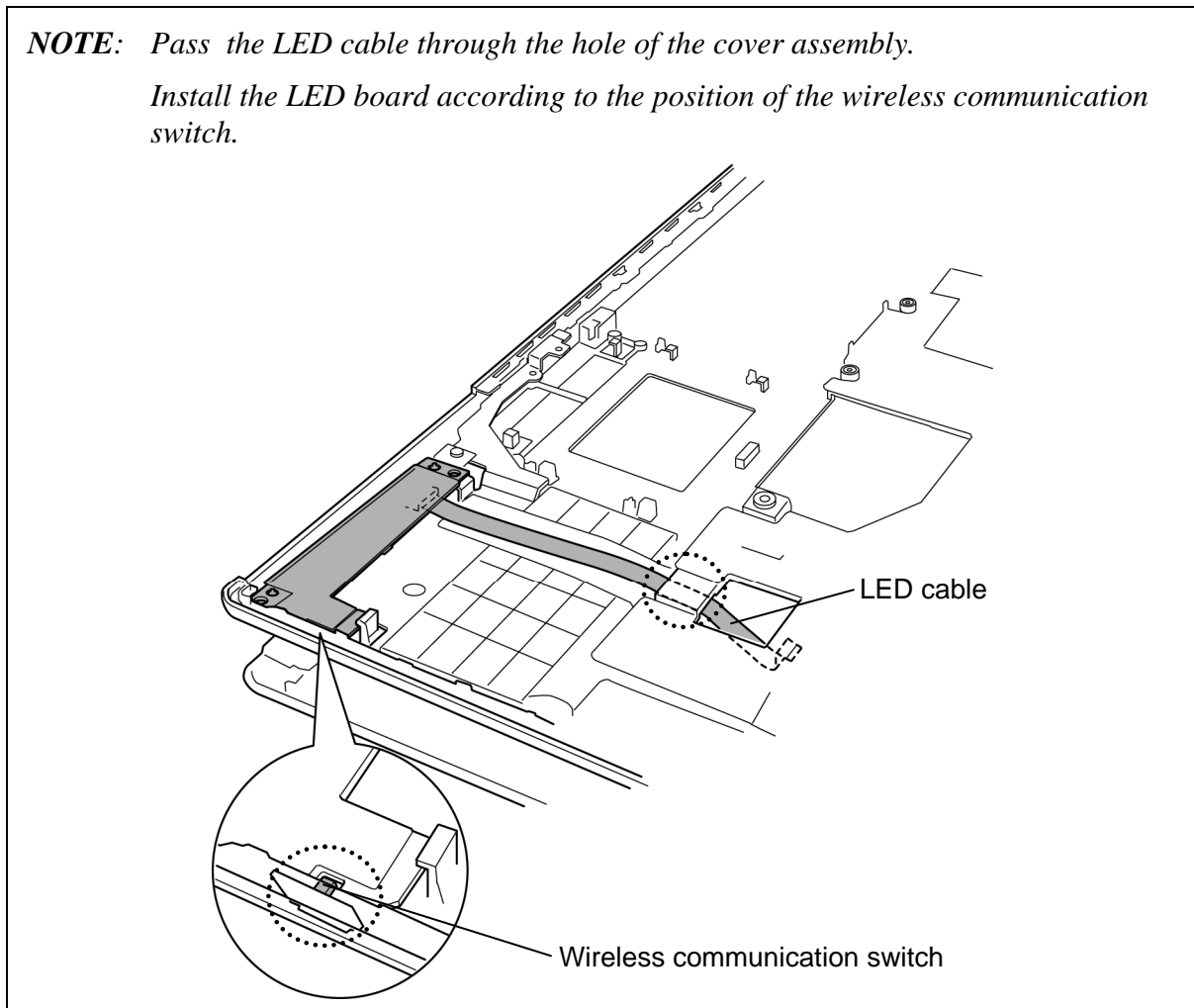

3. Secure the **LED board** with the following screw.

- M2.5×4B FLAT BIND screw ×1

4.13 Fingerprint sensor board

Removing the Fingerprint sensor board

The following describes the procedure for removing the fingerprint sensor board (See Figure 4-23).

1. Push down the **latch** and slide the **fingerprint sensor holder** in the direction of arrow in the following figure to remove it.
2. Remove the **fingerprint sensor board** from the cover assembly.
3. Disconnect the **fingerprint sensor cable** from the connector **CN9540** on the fingerprint sensor board.

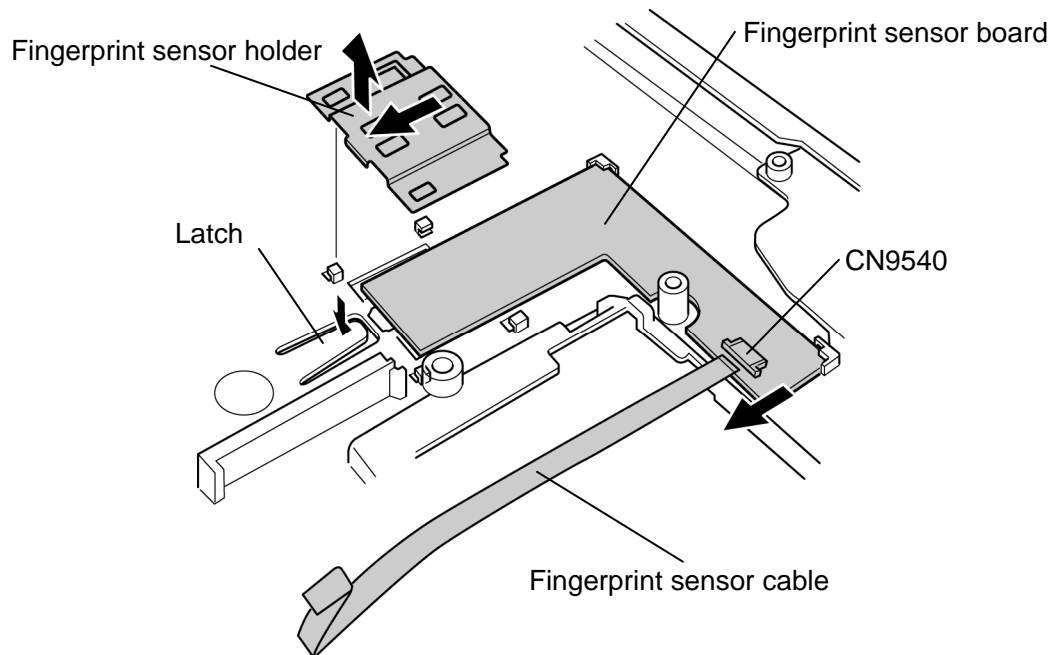

Figure 4-23 Removing the fingerprint sensor board

Installing the Fingerprint sensor board

The following describes the procedure for installing fingerprint sensor board (See Figure 4-23).

1. Connect the **fingerprint sensor cable** to the connector **CN9540** on the fingerprint sensor board.
2. Install the **fingerprint sensor board** to the cover assembly.
3. Install the **fingerprint sensor holder** in place and slide it in the opposite direction of arrow in the figure 4-23 while pushing down the latch.

4.14 Volume board

Removing the Volume board

The following describes the procedure for removing the volume board (See Figure 4-24).

1. Peel off the **glass tape** and remove the **volume holder** (with the **volume board**) from the cover assembly while expanding outward the **projections** of the volume holder.
2. Separate the **volume board** and **volume holder**.
3. Remove the **volume knob** under the base assembly while releasing two **latches**.

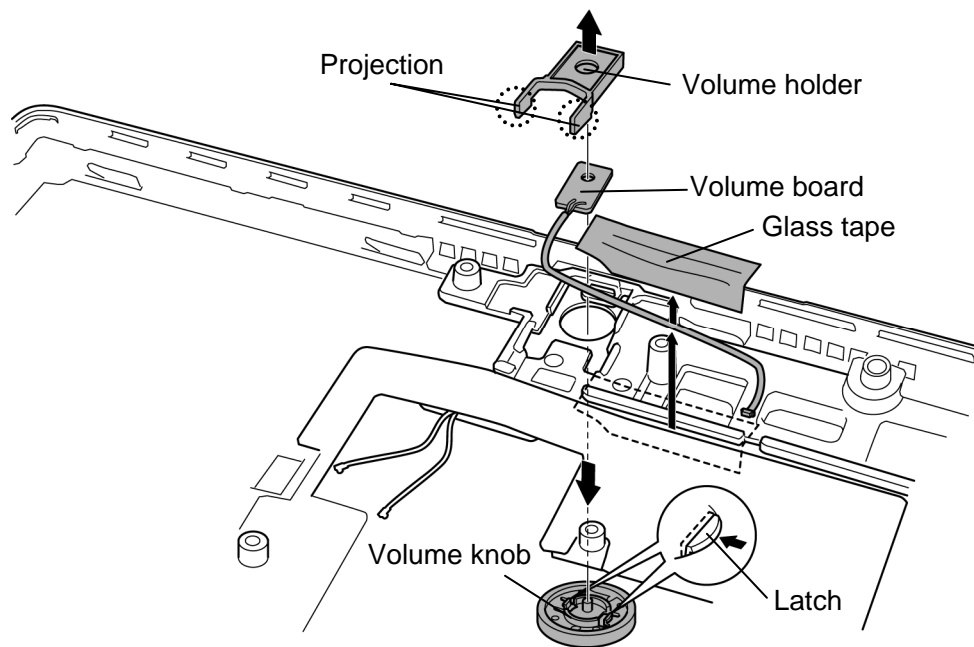

Figure 4-24 Removing the volume board

Installing the Volume board

The following describes the procedure for installing the volume board (See Figure 4-24).

1. Install the **volume knob** under the base assembly until it is latched.
2. Install the **volume holder** to the volume board.
3. Install the **volume board** (with the **volume holder**) to the cover assembly and arrange the volume cable in place.
4. Stick the **glass tape**.

4.15 Switch membrane

Removing the Switch membrane

The following describes the procedure for removing the switch membrane (See Figure 4-25 and 4-26).

1. Push the **projections** and remove the **switch membrane assembly** in the direction of the arrow in the following figure.

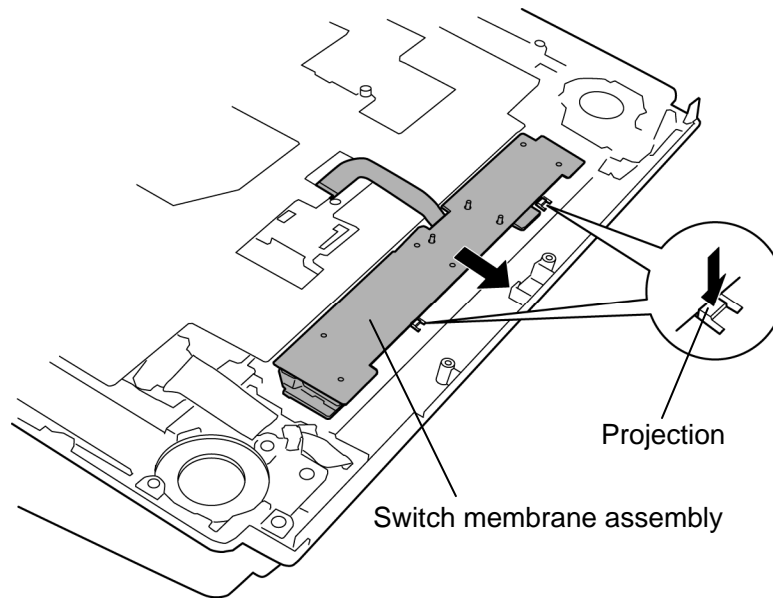

Figure 4-25 Removing the switch membrane (1)

2. Push the **latch** and slide the **switch membrane** in the direction of the arrow in the following figure to remove it from the **membrane frame assembly**.

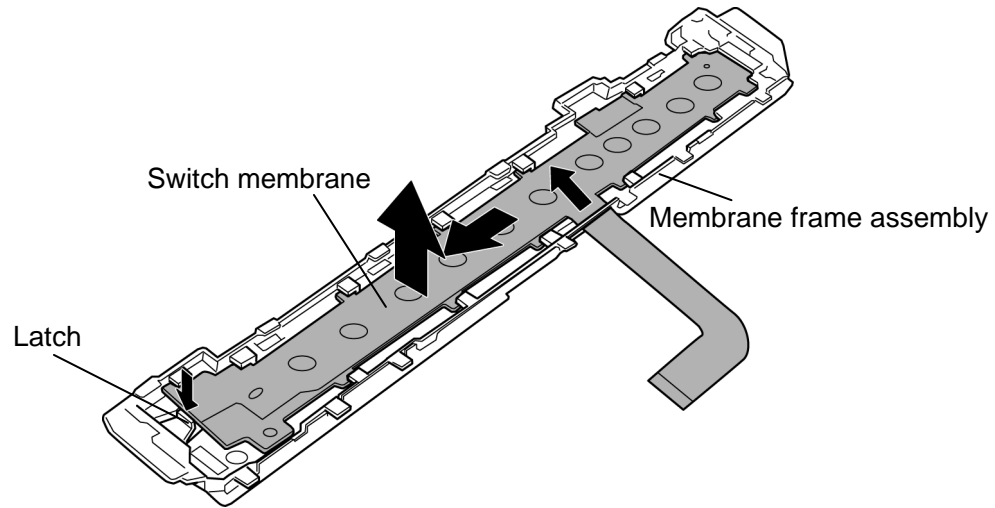

Figure 4-26 Removing the switch membrane (2)

Installing the Switch board

The following describes the procedure for installing the switch board (See Figure 4-25 and 4-26).

1. Set the **switch membrane** into the **membrane frame assembly** and slide it in the opposite direction of the arrow in the Figure 4-26.
2. Install the **switch membrane assembly** to the cover assembly in place.

4.16 Wireless communication switch

Removing the Wireless communication switch

The following describes the procedure for removing the wireless communication switch.

1. Remove the **wireless communication switch** from the cover assembly by pushing it from the inside of the cover assembly.

Installing the Wireless communication switch

The following describes the procedure for installing the wireless communication switch.

1. Install the **wireless communication switch** to the cover assembly.

4.17 Optical disk drive

CAUTION: Do not perform 4.17.2 “Ejecting the optical disk” except for the emergency ejection of optical disk inside ODD.

4.17.1 Replacing the optical disk drive

Removing the optical disk drive

The following describes the procedure for removing the optical disk drive (See Figure 4-27 and 4-28).

1. Pull out the **ODD assembly** from the connector **CN1810** on the system board.

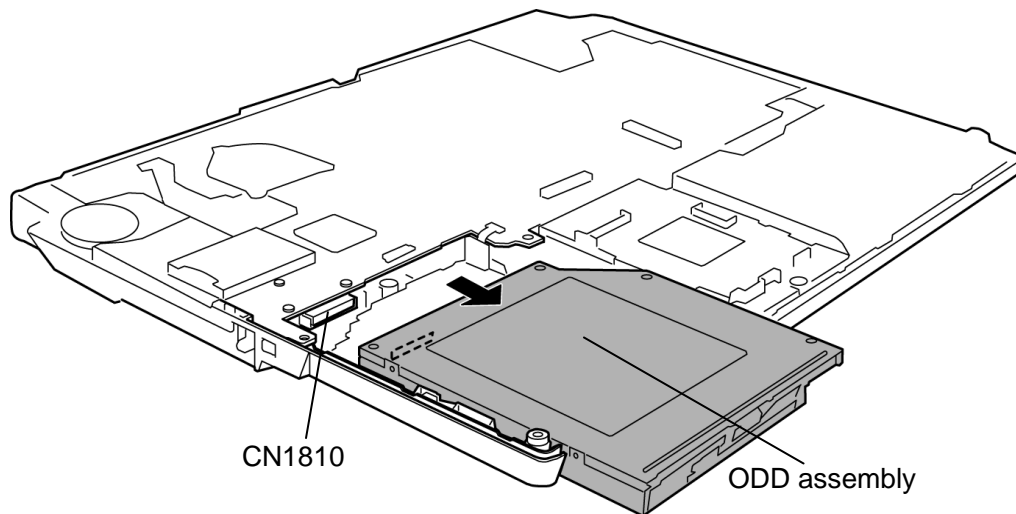

Figure 4-27 Removing the ODD assembly

2. Remove the following **screw** securing the ODD side bracket and remove the **ODD side bracket**.
 - M2.0×3S S-THIN HEAD screw ×1
3. Remove the following **screws** securing the ODD rear bracket.
 - M2.0×2.7B S-THIN HEAD screw ×2
4. Remove the **ODD rear bracket** from the ODD assembly.

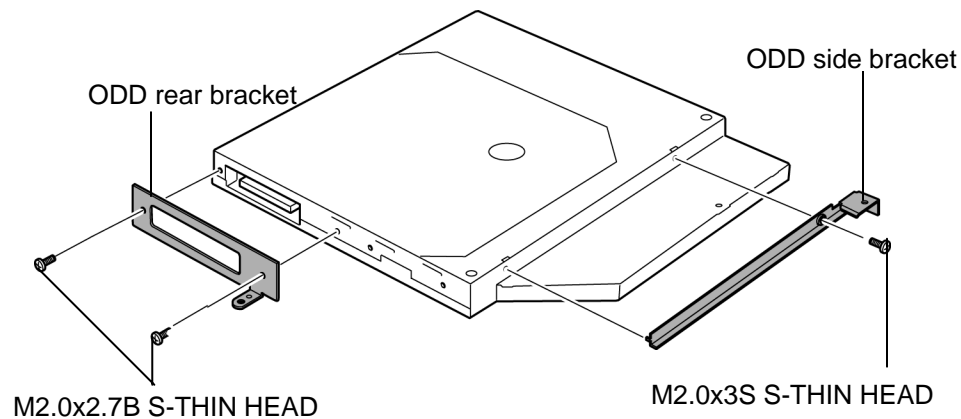

Figure 4-28 Removing the ODD bracket

Installing the optical disk drive

The following describes the procedure for installing the optical disk drive (See Figure 4-27 and 4-28).

1. Installing the **ODD rear bracket** to the ODD assembly and secure it with the following **screws**.
 - M2.0×2.7B S-THIN HEAD screw ×2
2. Installing the **ODD side bracket** to the ODD assembly and secure it with the following **screw**.
 - M2.0×3S S-THIN HEAD screw ×1
3. Connect the **ODD assembly** to the connector **CN1810** on the system board.

4.17.2 Ejecting the optical disk

CAUTION: The following procedure is emergency cope only when the optical disk inside ODD (here, refers DVD super multi drive to DVD) can not be ejected because of some failure.

Disassembling the ODD drive assembly

The following describes the procedure for ejecting the optical disk from the optical disk drive (See Figure 4-29).

1. Remove the following screws securing the ODD cover.
 - M1.8x2C S-THIN HEAD screw ×4
2. Open the **ODD cover** in the direction of the arrow to remove it from the ODD base assembly.
3. Hold the **optical disk** and lift it out.

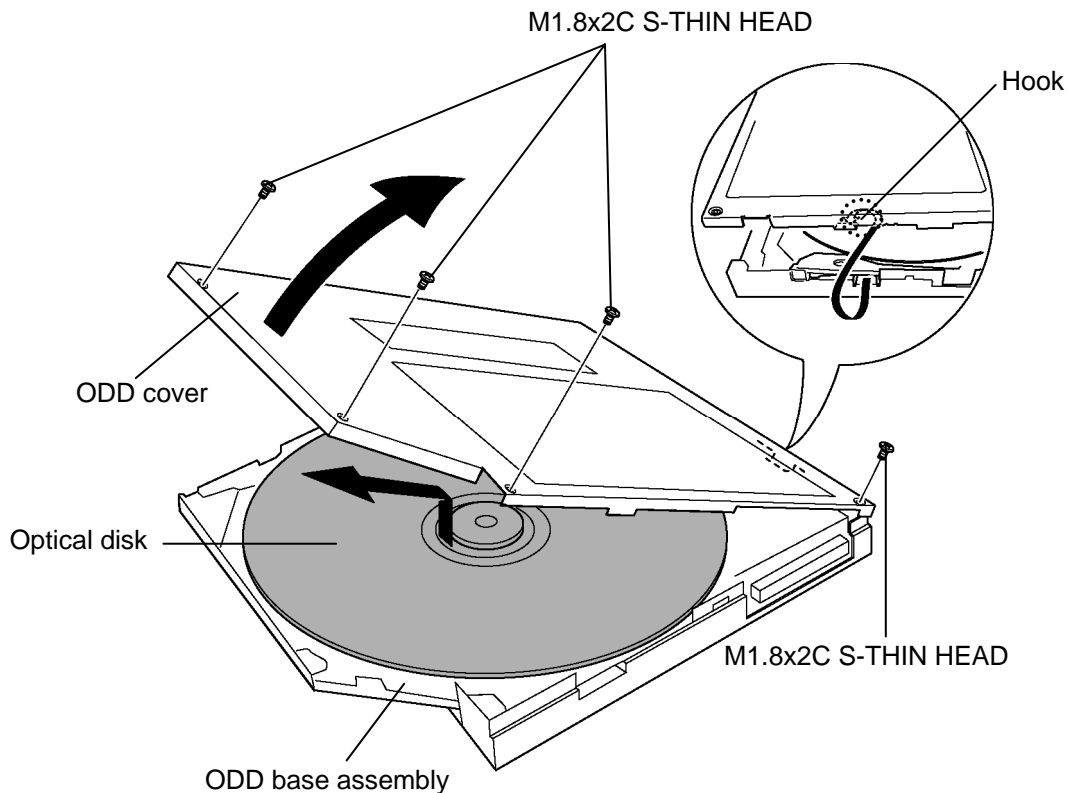

Figure 4-29 Ejecting the optical disk

Assembling the ODD assembly

The following describes the procedure for assembling the ODD assembly from the optical disk drive (See Figure 4-29).

1. Install the **ODD cover** to the ODD base assembly by sliding the **hook** into the slot of ODD base assembly.
2. Secure the ODD cover with the following **screws**.
 - M1.8×2C S-THIN HEAD screw ×4

4.18 RTC battery

Removing the RTC battery

The following describes the procedure for removing the RTC battery (See Figure 4-30).

1. Disconnect the **RTC battery cable** from the connector **CN9990** on the system board.
2. Peel off the **glass tape** and remove the **RTC battery** from the slot.

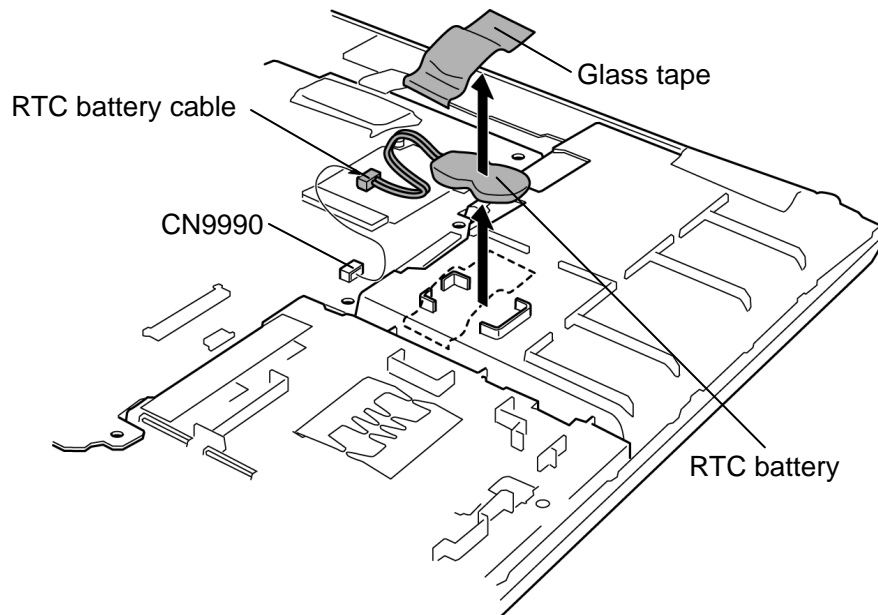

Figure 4-30 Removing the RTC battery

Installing the RTC battery

The following describes the procedure for installing the RTC battery (See Figure 4-30).

1. Connect the **RTC battery cable** to the connector **CN9990** on the system board.
2. Install the **RTC battery** to the slot and stick the **glass tape**.

4.19 Internal microphone

Removing the Internal microphone

The following describes the procedure for removing the internal microphone (See Figure 4-31).

1. Peel off the **glass tape**.
2. Disconnect the **microphone cable** from the connector **CN6050** on the jack board and remove the **internal microphone** from the **microphone holder**.

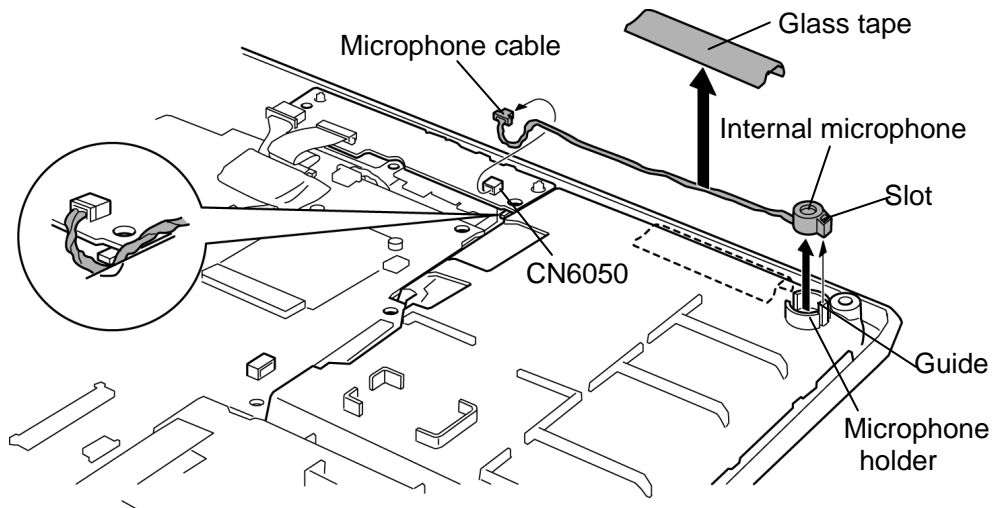

Figure 4-31 Removing the internal microphone

Installing the Internal microphone

The following describes the procedure for installing the internal microphone (See Figure 4-31).

1. Connect the **microphone cable** to the connector **CN6050** on the jack board and install the **internal microphone** into the **microphone holder**.

NOTE: Install the internal microphone while inserting the slot into the guide.

2. Arrange the **microphone cable** in place and stick the **glass tape**.

4.20 Jack board

Removing the Jack board

The following describes the procedure for removing the Jack board (See Figure 4-32).

1. Disconnect the **analog TV tuner cable** from the connector **CN9614** on the Jack board.
2. Disconnect the **Jack cable** from the connector **CN6500** on the system board and connector **CN6510** on the Jack board.
3. Take out the **Jack board** from the slot of the base assembly.

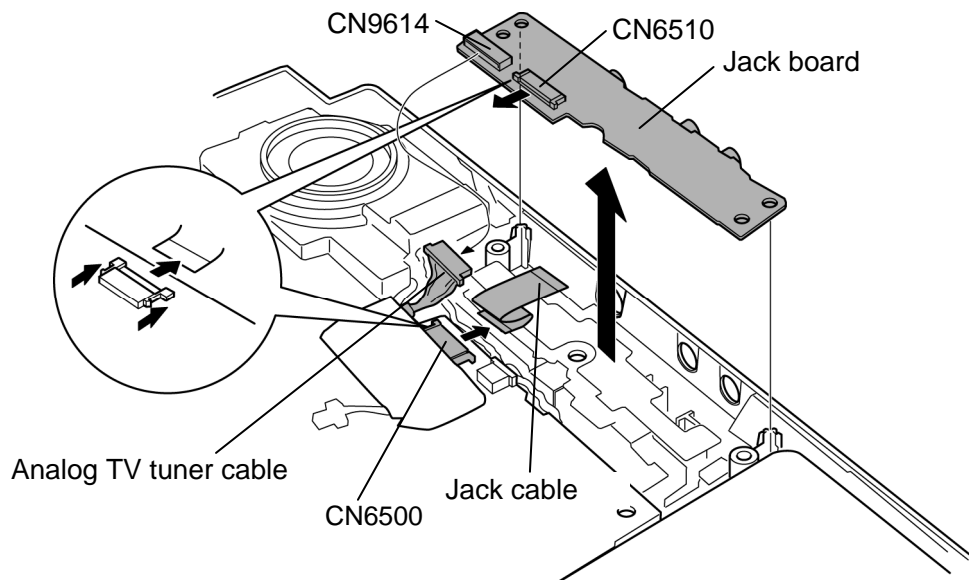

Figure 4-32 Removing the Jack board

Installing the Jack board

The following describes the procedure for installing the Jack board (See Figure 4-32).

1. Connect the **Jack cable** to the connector **CN6510** on the Jack board.
2. Install the **Jack board** into the slot of the base assembly.
3. Connect the **Jack cable** to the connector **CN6500** on the system board.
4. Connect the **analog TV tuner cable** to the connector **CN9614** on the Jack board.

4.21 System board/DC-IN jack

CAUTION: 1. When handling the system board, always hold by the edges. Do not touch the printed circuit face.

2. If replacing with a new system board, execute the substest01 Initial configuration in section 3.4 “Setting of the hardware configuration”. Also update with the latest BIOS and EC/KBC as described in Appendix G and in Appendix H.

Removing the system board/DC-IN jack

The following describes the procedure for removing the system board/DC-IN jack (See Figure 4-33 and 4-34).

1. Take out the **DC-IN jack** from the slot.
2. Disconnect the **speaker cable** from the connector **CN6170** the system board.
3. Peel off the **insulator** and remove the **system board** from the base assembly.

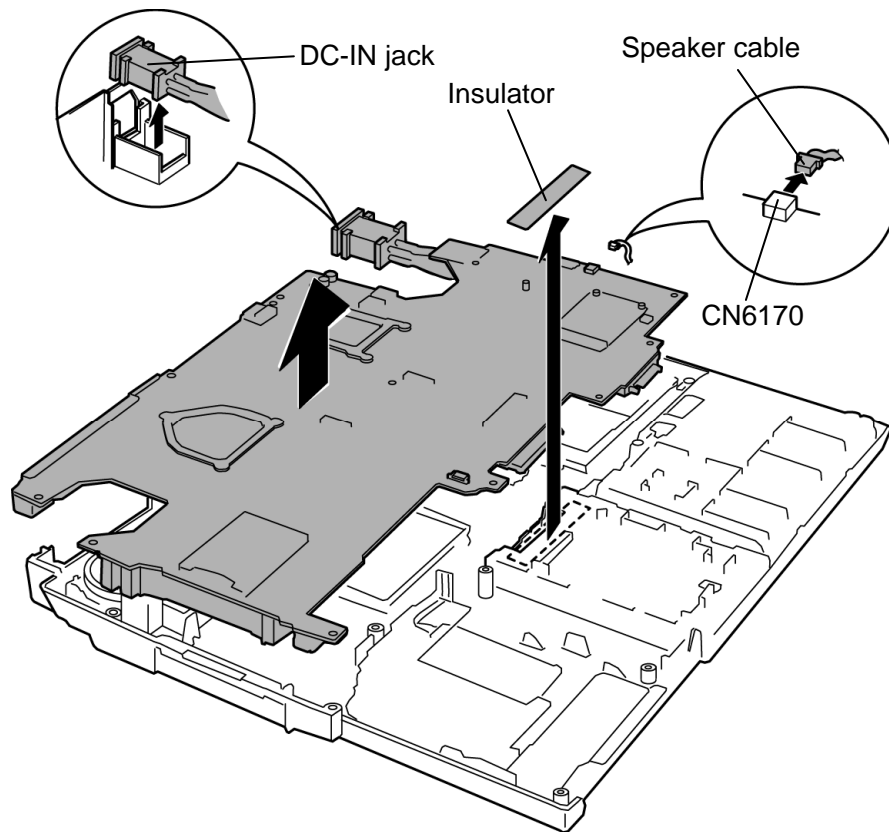

Figure 4-33 Removing the system board

4. Remove the **DC-IN jack** from the connector **CN8800** on the system board.

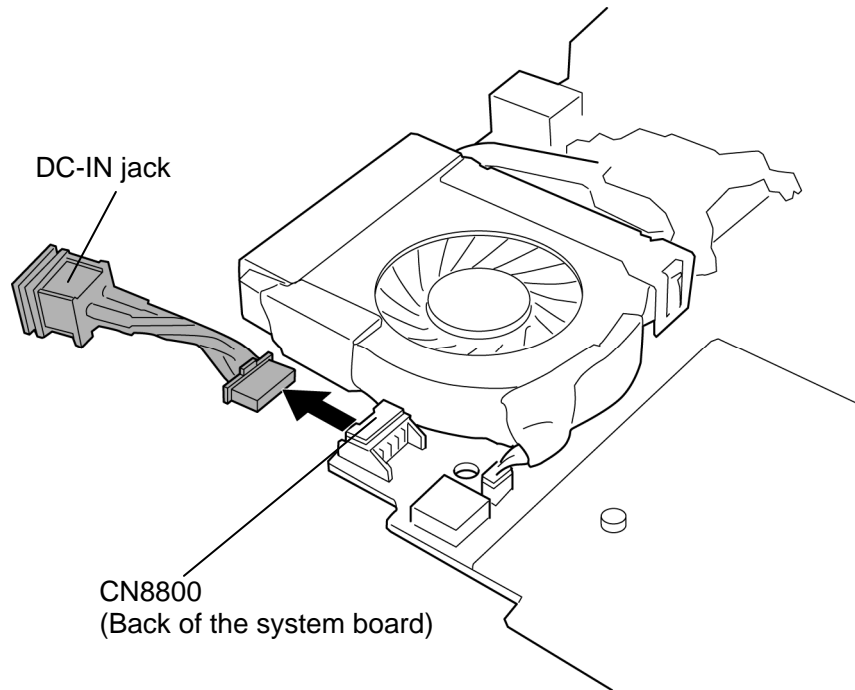

Figure 4-34 Removing the DC-IN jack

Installing the system board/DC-IN jack

The following describes the procedure for installing the system board/DC-IN jack (See Figure 4-33 and 4-34).

1. Connect the **DC-IN jack** to the connector **CN8800** on the system board.
2. Install the **system board** to the base assembly and stick the **insulator** in place.
3. Connect the **speaker cable** to the connector **CN6170** the system board.
4. Install the **DC-IN jack** to the slot.

4.22 Speaker

Removing the speaker

The following describes the procedure for removing the speaker (See Figure 4-35).

1. Take out the **analog TV tuner cable** from the slot.
2. Peel off five **glass tapes** and remove the **speakers** from the slot of the base assembly.

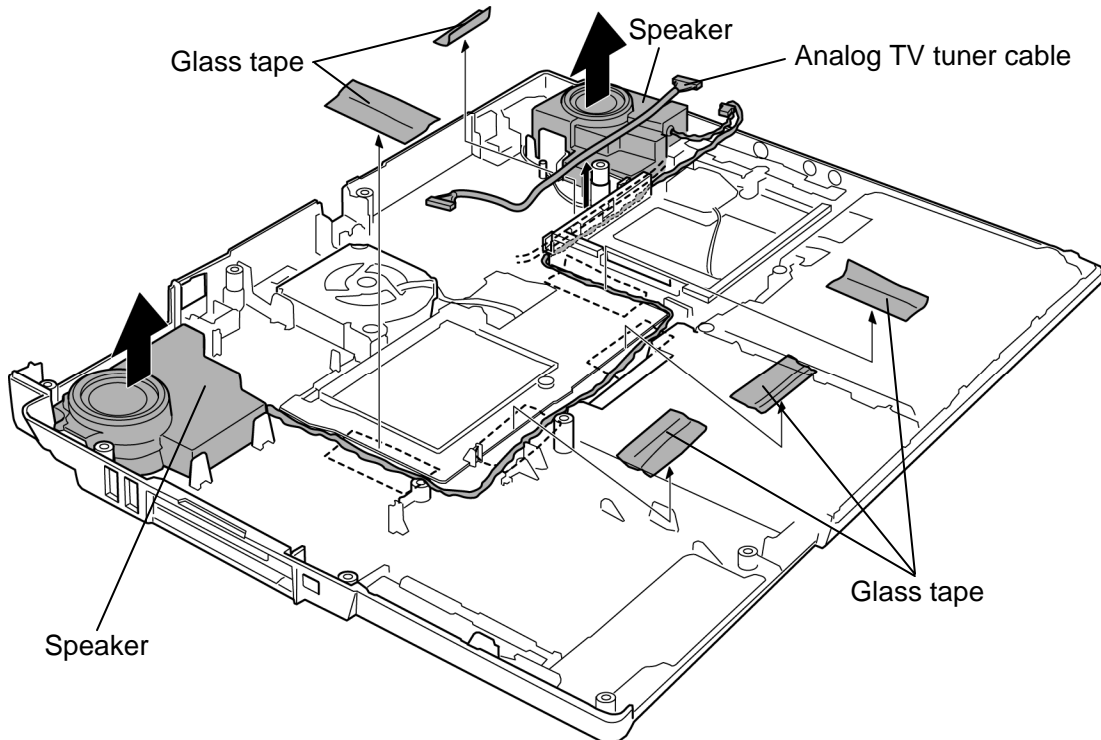

Figure 4-35 Removing the speaker

Installing the speaker

The following describes the procedure for installing the speaker (See Figure 4-35).

1. Install the **speaker** to the slot of the base assembly and arrange the **speaker cable** in place referring to the Figure 4-35.
2. Stick five **glass tapes**.
3. Install the **analog TV tuner cable** to the slot.

4.23 Modem jack/F jack

Removing the Modem jack/F jack

The following describes the procedure for removing the modem jack/F jack (See Figure 4-36 and 4-37).

1. Take out the **modem jack** from the slot.

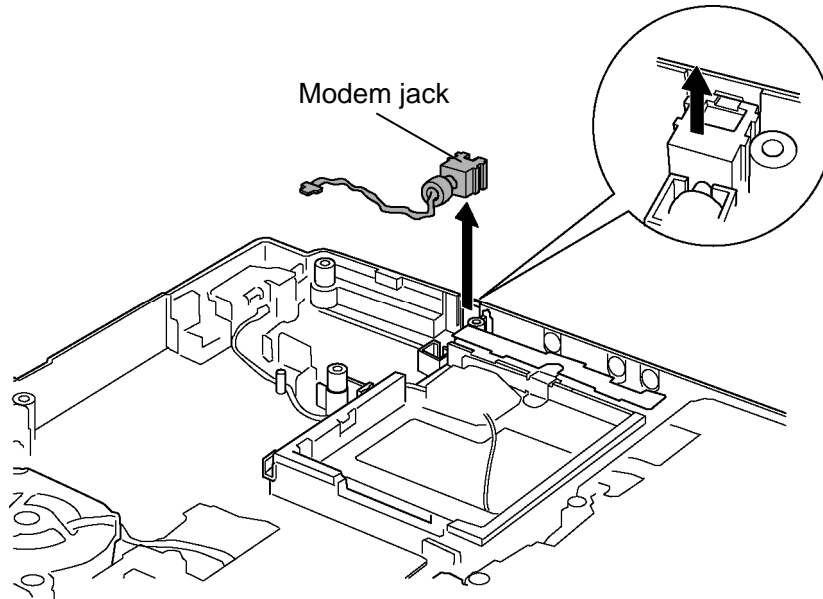

Figure 4-36 Removing the modem jack

2. Push the **F jack** in the direction of arrow in the following figure and take it out from the slot.
3. Disconnect the **TV antenna cable** from the F jack.

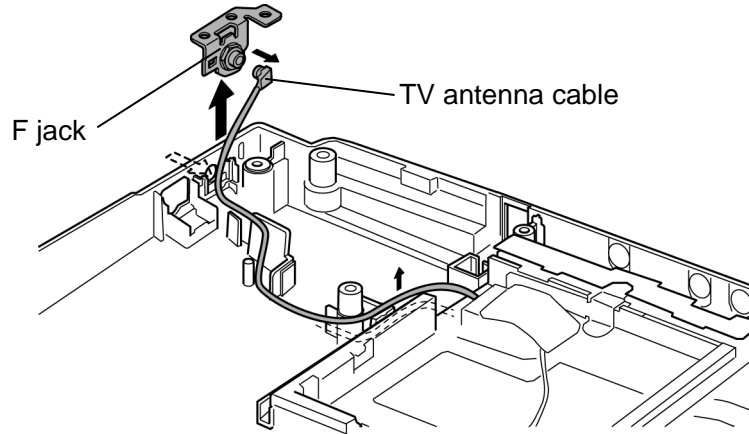

Figure 4-37 Removing the F jack

Installing the Modem jack/F jack

The following describes the procedure for installing the Modem jack/F jack (See Figure 4-36 and 4-37).

1. Connect the **TV antenna cable** to the F jack and install the **F jack** into the slot.
2. Arrange the **TV antenna cable** in place referring to Figure 4-37.
3. Install the **modem jack** to the slot.

4.24 GPU Fan

Removing the GPU fan

The following describes the procedure for removing the GPU fan (See Figure 4-38).

1. Remove the **GPU fan** from the slot of the base assembly.

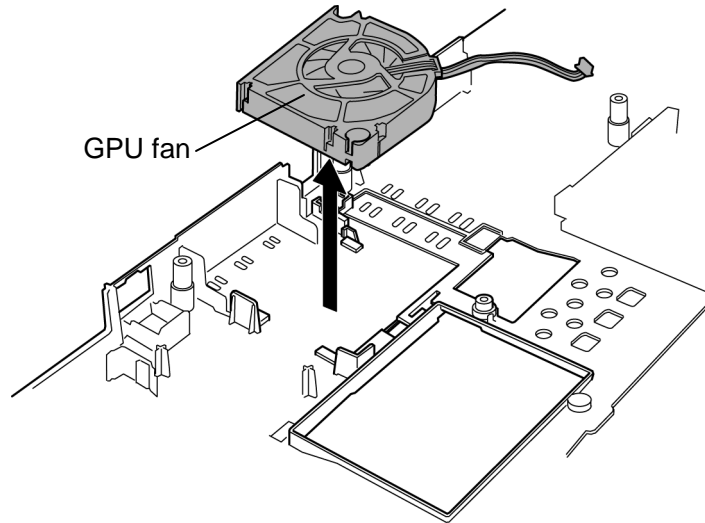

Figure 4-38 Removing the GPU fan

Installing the GPU fan

The following describes the procedure for installing the GPU fan (See Figure 4-38).

1. Install the **GPU fan** into the slot of the base assembly.

4.25 Battery lock/Battery latch

Removing the Battery lock/Battery latch

The following describes the procedure for removing the battery lock/battery latch (See Figure 4-39).

1. Remove the battery lock/latch assembly from the slot.
2. While unlatching the **latches**, separate the **battery lock**, **battery latch** and **knob**.

NOTE: When removing the battery latch, be careful not to lose the spring.

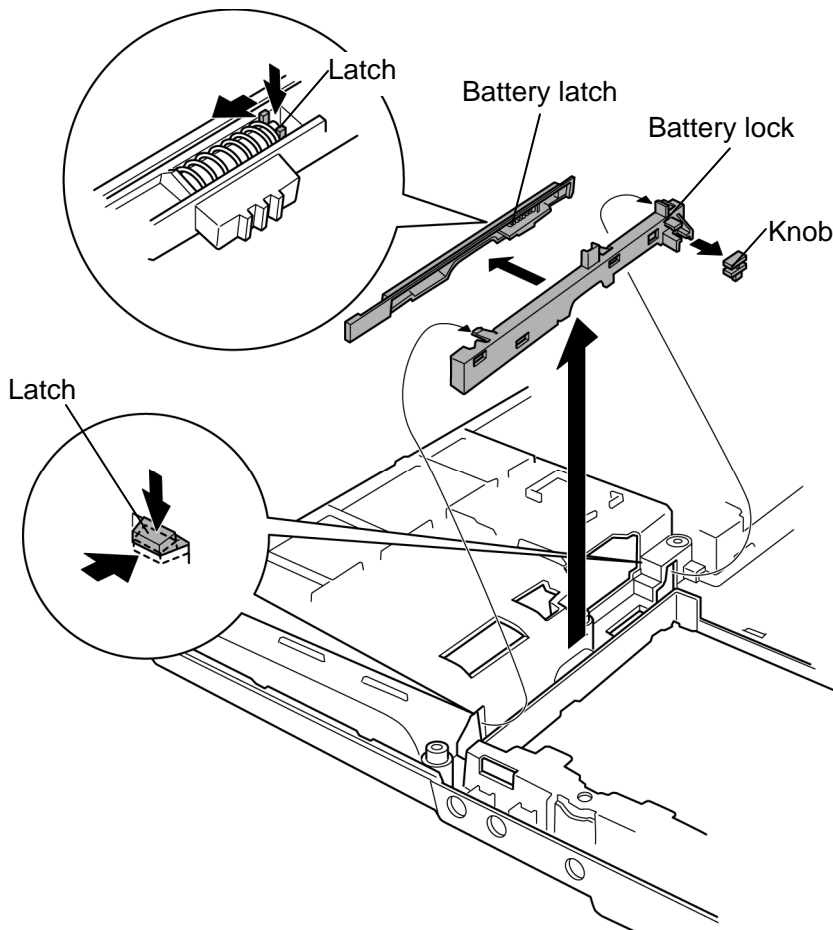

Figure 4-39 Removing the battery lock/battery latch

Installing the Battery lock/Battery latch

The following describes the procedure for installing the battery lock/battery latch (See Figure 4-39).

1. Install the **battery latch** and **knob** to the **battery lock**.

NOTE: When installing the battery latch, make sure that the spring is in correct position.

2. Install the battery lock/latch assembly into the slot.

4.26 Analog TV tuner

Removing the Analog TV tuner

The following describes the procedure for removing the analog TV tuner (See Figure 4-40).

1. Remove the following **screw** securing the analog TV tuner.
 - M2.0×4B BIND screw ×1
2. Open the left and right **latches** and remove the **analog TV tuner** from the connector **CN2400** on the system board.

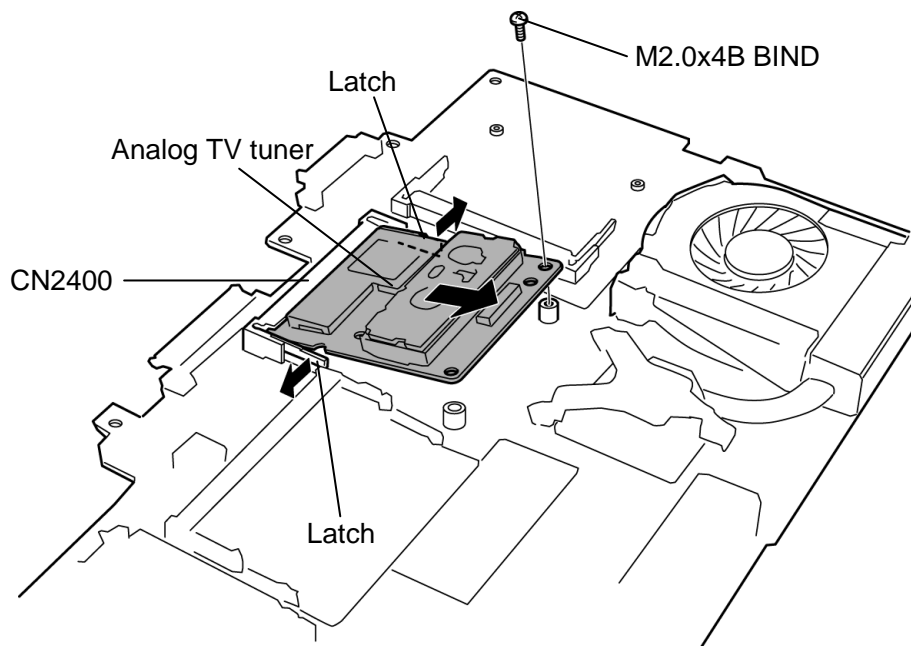

Figure 4-40 Removing the analog TV tuner

Installing the analog TV tuner

The following describes the procedure for installing the analog TV tuner (See Figure 4-40).

1. Insert the **analog TV tuner** firmly into the connector **CN2400** on the system board slantwise and press down it until it is latched.
2. Secure the analog TV tuner with the following **screw**.
 - M2.0×4 B BIND screw ×1

4.27 CPU fan/CPU heat sink/CPU

Removing the CPU fan/CPU heat sink/CPU

The following describes the procedure for removing the CPU fan/CPU heat sink/CPU (See Figure 4-41 to 4-43).

1. Remove the following **screws** securing the CPU holder.

- M2.0x4B BIND screw ×3

NOTE: When removing the CPU holder, be sure to remove the screws in the reverse order of the number marked on the holder.

2. Remove the **CPU holder**.
3. Disconnect the **CPU fan cable** from the connector **CN8771** on the system board and remove the **CPU heat sink** and **CPU fan** from the slot.

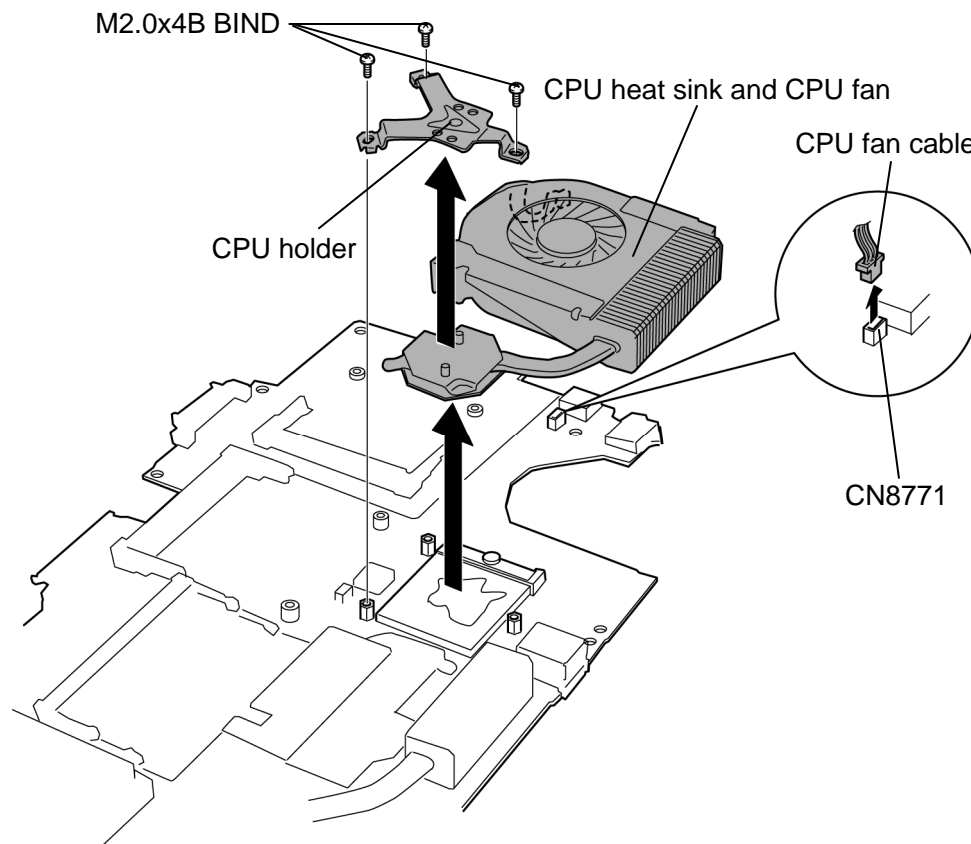

Figure 4-41 Removing the CPU heat sink and CPU fan

4. Remove the following **screw** and separate the **CPU fan** and **CPU heat sink**.

- M2.0x4B BIND screw ×1

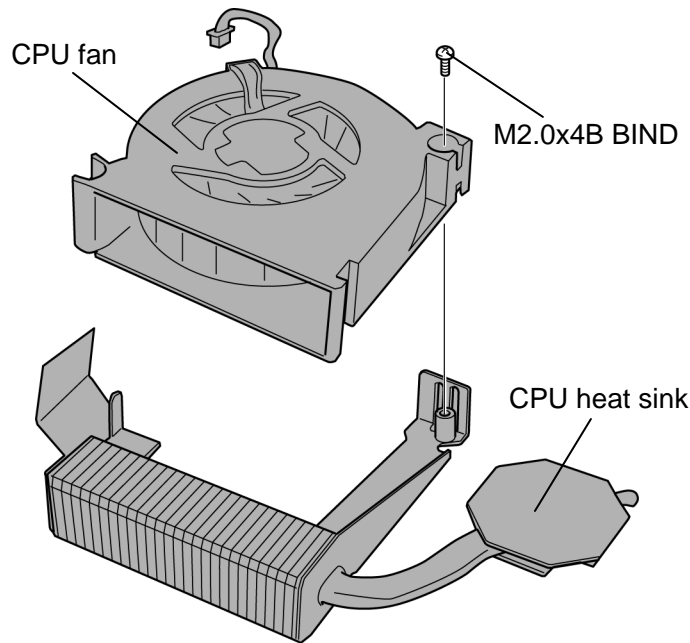

Figure 4-42 Separating the CPU fan and CPU heat sink

5. Unlock the **CPU** by rotating the **cam** on the CPU socket 90 degrees counterclockwise with a flat-blade screwdriver.

6. Remove the **CPU**.

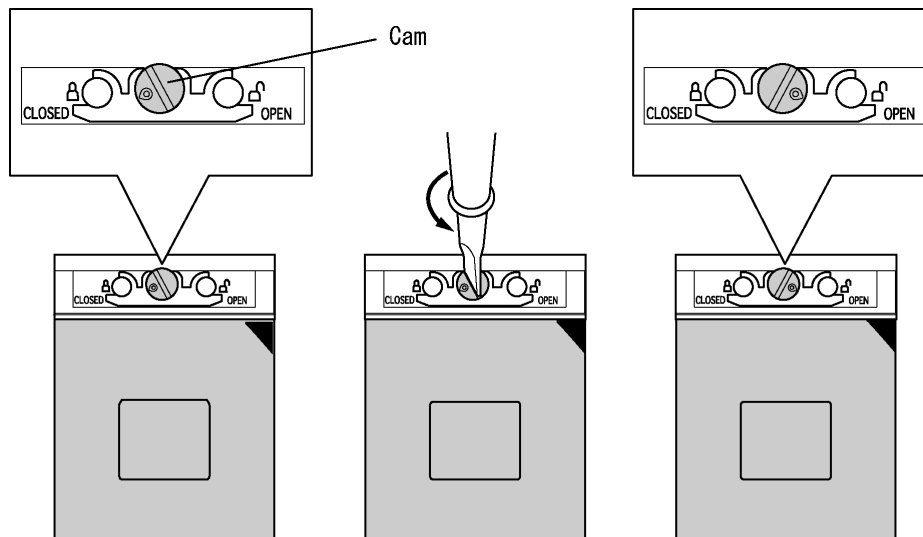

Figure 4-43 Removing the CPU

Installing the CPU fan/CPU heat sink/CPU

The following describes the procedure for installing the CPU fan/CPU heat sink/CPU (See Figure 4-41 to 4-45).

1. Check that the mark of the cam is in the unlocking position.
2. Install the **CPU** to the correct position in the **CPU socket**.
3. Fix the **CPU** by rotating the cam 90 degrees to the clockwise with a flat-blade screwdriver.

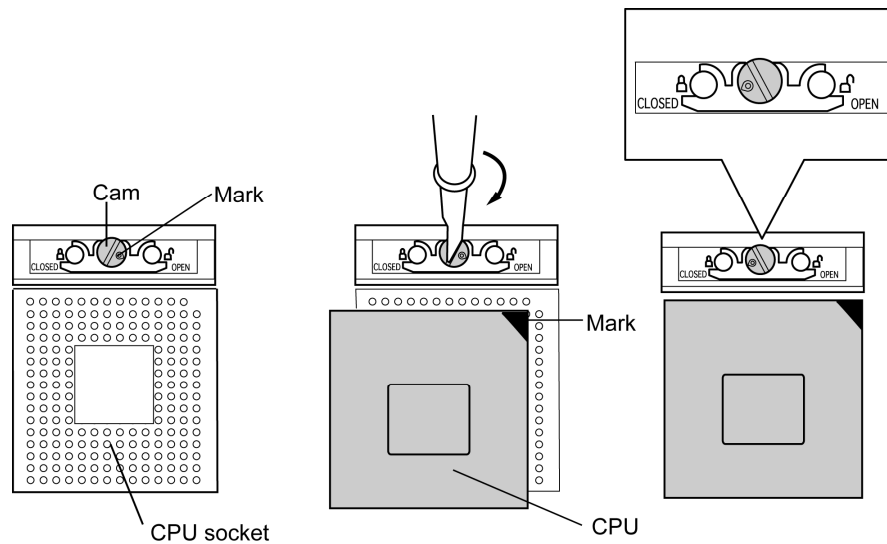

Figure 4-44 Installing the CPU

4. If there is already silicon grease on the CPU, clean it with a cloth.
Using a special applicator, apply silicon grease so that the CPU chip on the CPU is completely covered.

NOTE: Apply the silicon grease enough to cover the chip surface using the special applicator.

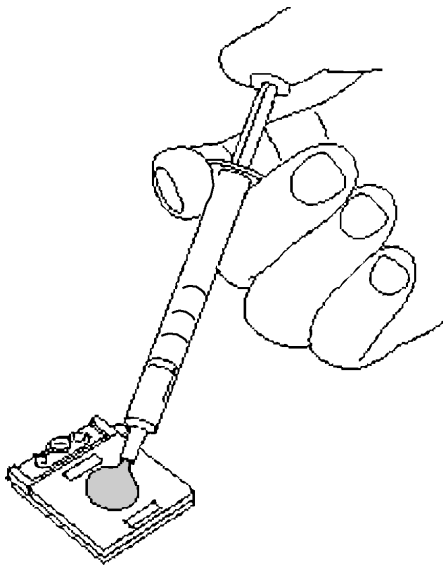

Figure 4-45 Applying silicon grease

5. Install the **CPU fan** to the **CPU heat sink** and secure them with the following **screw**.
 - M2.0×4B BIND screw ×1
6. Connect the **CPU fan cable** to the connector **CN8771** on the system board and install the **CPU heat sink** and CPU fan into the slot.
7. Install the **CPU holder** and secure it with the following **screws**.
 - M2.0×4B BIND screw ×3

NOTE: When securing the CPU holder, be sure to secure the screws in the order of the number marked on the holder.

4.28 GPU heat sink

Removing the GPU heat sink

The following describes the procedure for removing the GPU heat sink (See Figure 4-46).

1. Remove the following **screws** securing the GPU holder and GPU heat sink.
 - M2.0x4B BIND screw ×3
2. Remove the **GPU holder** and **GPU heat sink**.

NOTE: When removing the GPU holder, be sure to remove the screws in the reverse order of the number marked on the holder.

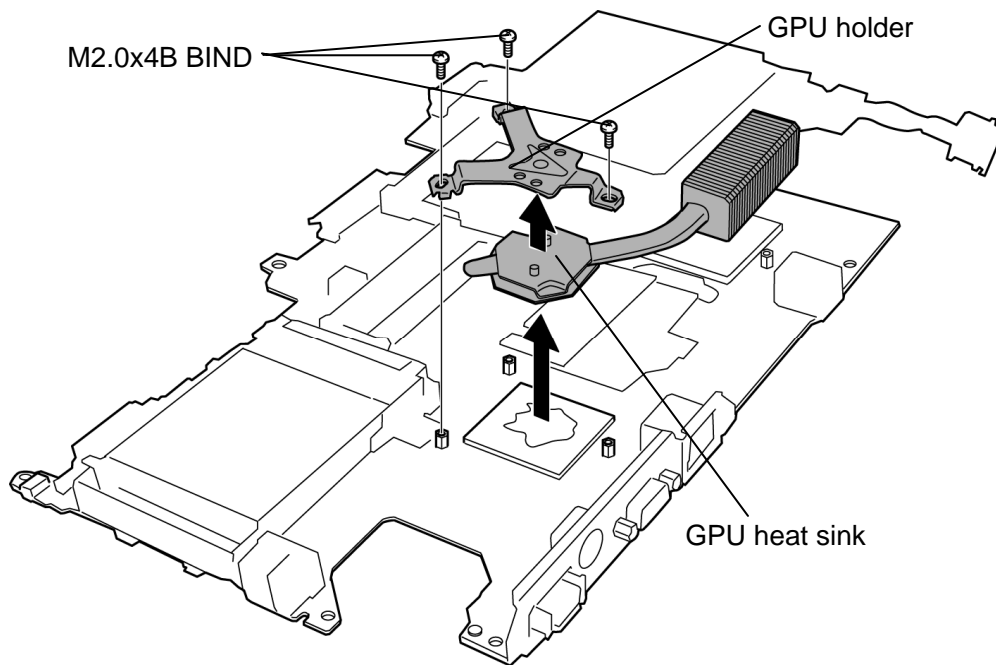

Figure 4-46 Removing the GPU heat sink

Installing the GPU heat sink

The following describes the procedure for installing the GPU heat sink (See Figure 4-46).

1. Install the **GPU heat sink** and **GPU holder**.

NOTE: For details on applying the silicon grease, refer to *Installing the CPU*.

2. Secure the **GPU heat sink** and **GPU holder** with the following screws.

- M2.0×4B BIND screw ×3

NOTE: When securing the GPU holder, be sure to secure the screws in the order of the number marked on the holder.

4.29 North bridge heat sink

Removing the North bridge heat sink

The following describes the procedure for removing the north bridge heat sink (See Figure 4-47).

1. Remove the following **screws** and **north bridge heat sink** from the system board.

- M2.0×3S S-THIN HEAD screw ×2

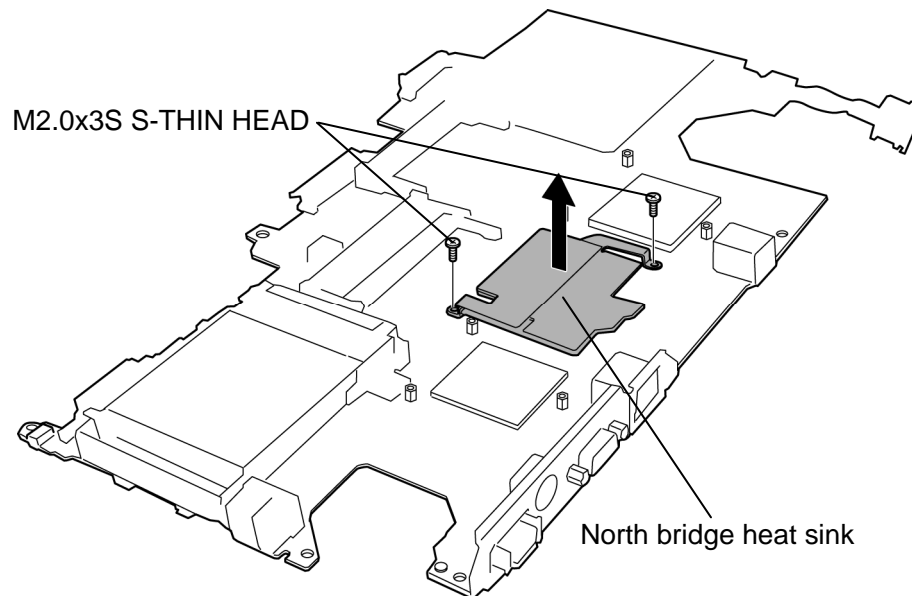

Figure 4-47 Removing the north bridge heat sink

Installing the North bridge heat sink

The following describes the procedure for installing the north bridge heat sink (See Figure 4-47).

1. Install the **north bridge heat sink** to the system board and secure it with the following screws.

- M2.0×3S S-THIN HEAD screw ×2

4.30 PC card slot

Removing the PC card slot

The following describes the procedure for removing the PC card slot (See Figure 4-48).

1. Remove the following **screws** securing the PC card slot.
 - M2.0×3S S-THIN HEAD screw ×2
 - M2.0×8S BIND screw ×2
2. Pull the **PC card slot** straight up and remove it from the system board.

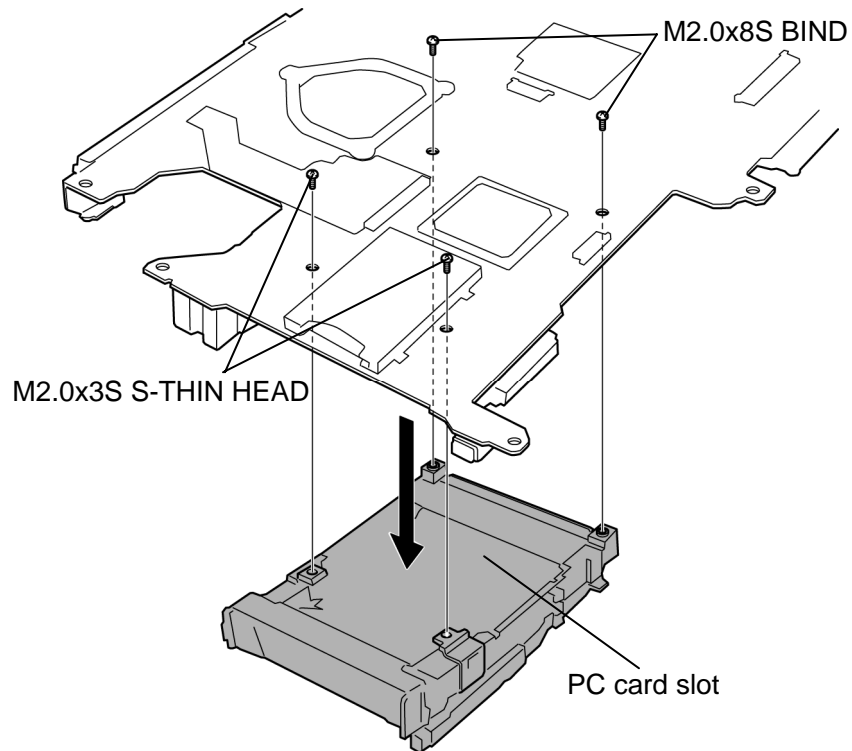

Figure 4-48 Removing the PC card slot

Installing the PC card slot

The following describes the procedure for installing the PC card slot (See Figure 4-48).

1. Install the PC card slot to the system board and secure it with the following **screws**.

- M2.0×3S S-THIN HEAD screw ×2
- M2.0×8S BIND screw ×2

4.31 LCD unit/FL inverter

CAUTION: When replacing a LCD, it is required that SVP parameter is set. Update with the latest EC/KBC as described in Appendix H “EC/KBC Rewrite Procedures”.

Removing the LCD unit/FL inverter

The following describes the procedure for removing the LCD unit and FL inverter (See Figure 4-49 to 4-54).

1. Remove the **hinge cap** from the slot while releasing latches.

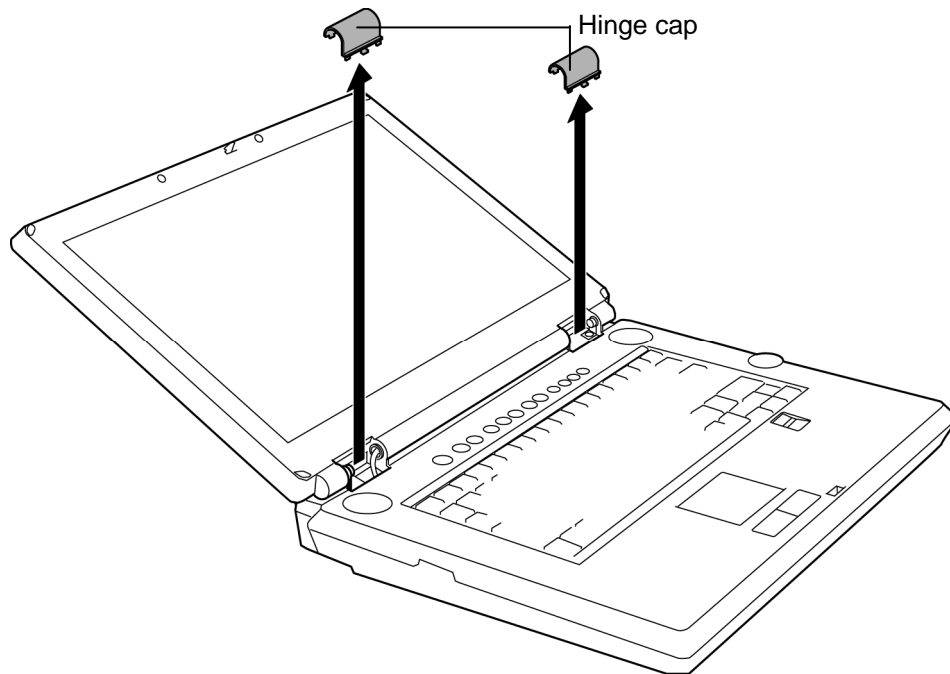

Figure 4-49 Removing the hinge cap

2. Peel off the **mask seals** and **mask pads** and remove the following **screws** securing the LCD mask.
 - M2.5×6B FLAT BIND screw ×6
3. Insert your finger between the edge of the LCD mask and LCD and remove the **LCD mask** while releasing the latches.

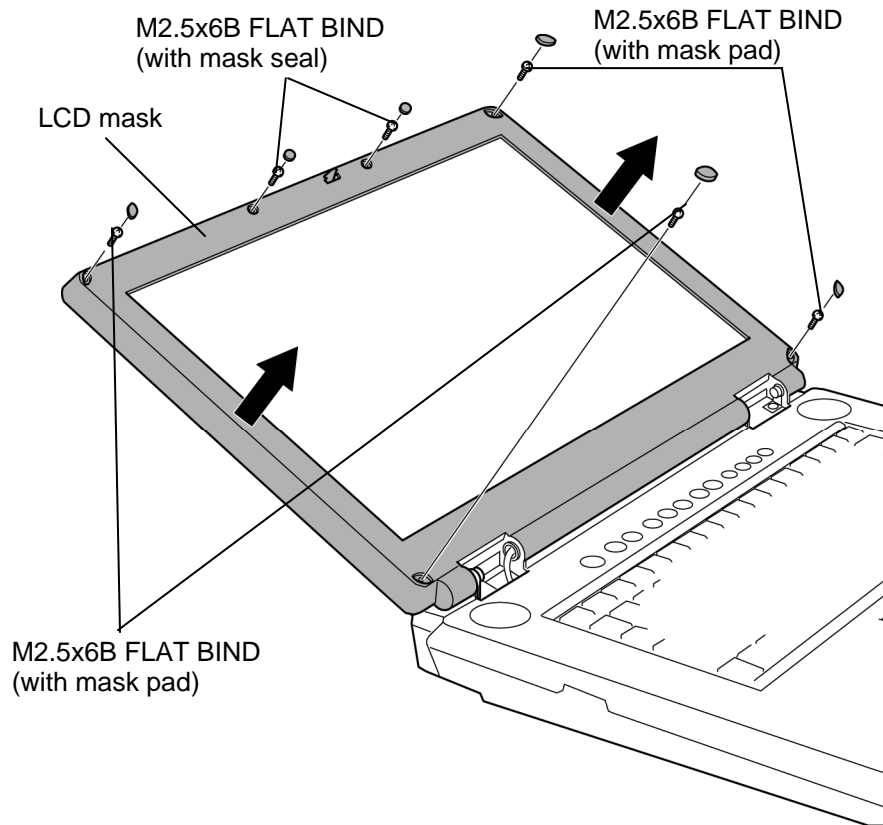

Figure 4-50 Removing the LCD mask

4. Remove the following **screw** securing the FL inverter.
 - M2.0×6S BIND screw ×1
5. Pull off one **insulator** from the FL inverter and take out the other one under the LCD unit.
6. Disconnect the **LCD cables** from the connectors on the FL inverter.
7. Disconnect the **HV cables** from the connectors on the FL inverter.
8. Remove the **FL inverter** from the display assembly.

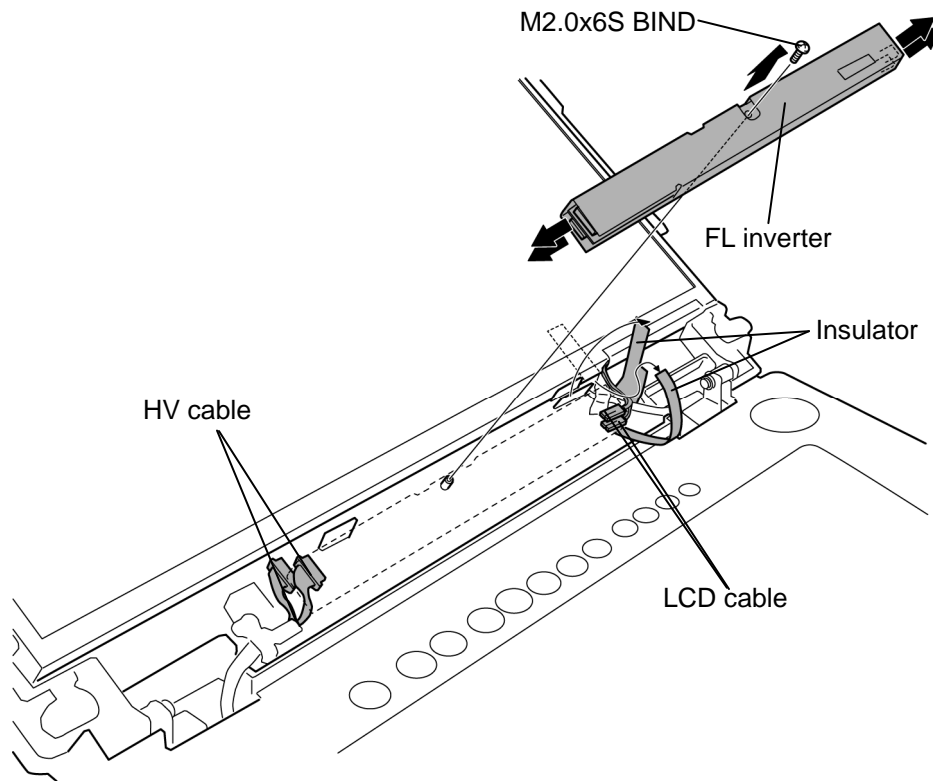

Figure 4-51 Removing the FL inverter

9. Remove the following **screws** securing the LCD unit.

- M2.0×6S BIND screw ×4

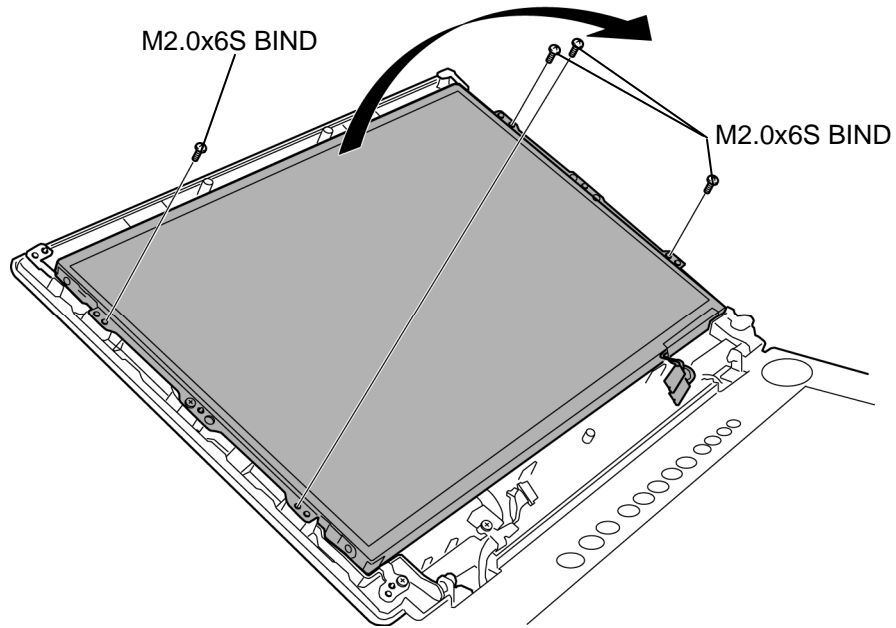

Figure 4-52 Removing the LCD unit (1)

10. With the bottom edge of the LCD unit on the display cover, lift up the top edge of the LCD unit. After peeling off the **glass tape**, disconnect the **LCD cable** from the connector on the back of the LCD.
11. Remove the **LCD unit**.

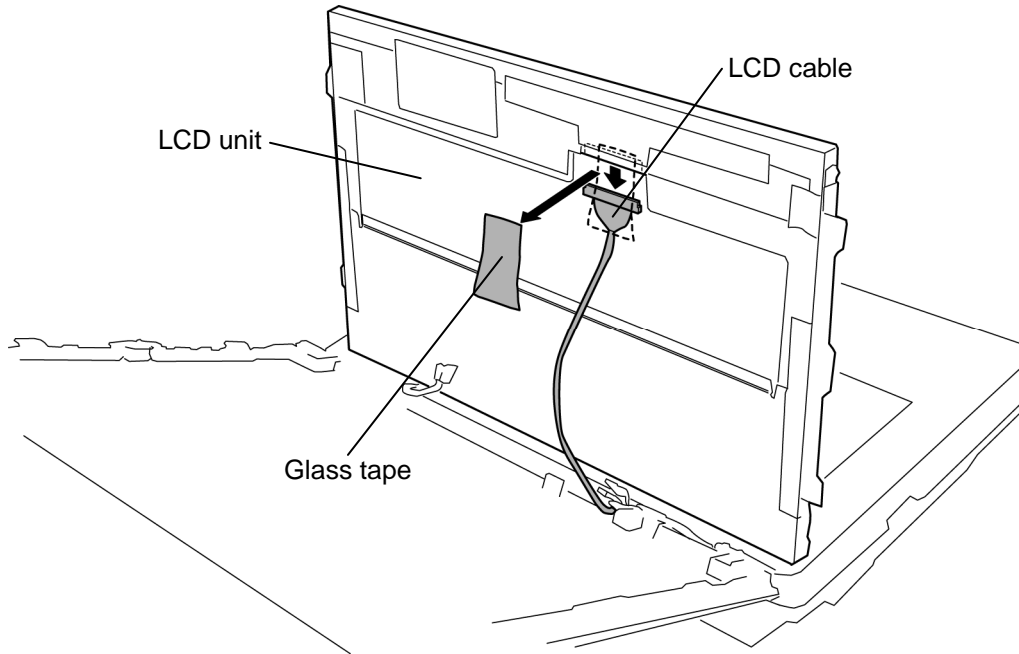

Figure 4-53 Removing the LCD unit (2)

12. Remove the following **screws** securing the LCD support and remove the **LCD supports** from the LCD unit.

- M2.0×3S S-THIN HEAD screw ×4

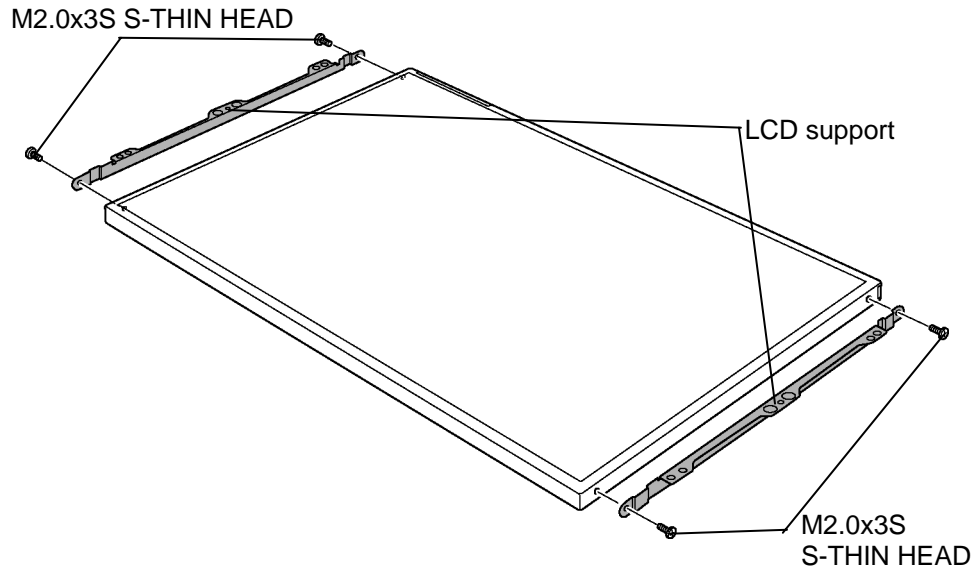

Figure 4-54 Removing the LCD support

Installing the LCD unit/FL Inverter

The following describes the procedure for installing the LCD unit and FL inverter (See Figure 4-49 to 4-54).

1. Install the **LCD support** to the LCD unit and secure them with the following **screws**.
 - M2.0×3S S-THIN HEAD screw ×4
2. Stand the **LCD unit** on the display cover and connect the **LCD cable** to the connector on the back of the LCD and stick the **glass tape** on it.
3. Secure the LCD unit with the following **screws**.
 - M2.0×6S BIND screw ×4
4. Connect the **LCD cables** to the connectors on the FL inverter.
5. Connect the **HV cables** to the connectors on the FL inverter.

CAUTION: *In a two-lamp LCD, be careful to connect the LCD/HV cables to the correct connectors of the FL inverter.*

6. Install the **FL inverter** and secure it with the following **screw**.
 - M2.0×6S BIND screw ×1
7. Stick one **insulator** on the FL inverter and insert one **insulator** under the LCD unit.
8. Install the **LCD mask** while latching.

NOTE: *When installing the display mask, make sure there is no gap between the LCD mask and the display rear cover.*

9. Secure the LCD mask with the following **screws**.
 - M2.5×6B FLAT BIND screw ×6
10. Stick the **mask seals** and **mask pads**.
11. Install the **hinge cap** while fitting the latches.

CAUTION: *When installing the hinge cap, do not mistake the left for the right and vice versa. “L” for the left and “R” for the right are marked on the hinge cap.*

4.32 LCD cable

Removing the LCD cable

The following describes the procedure for removing LCD cable (See Figure 4-55 to 4-57).

1. Peel off the **insulator** and remove the **harness hold plate** while unlatching.

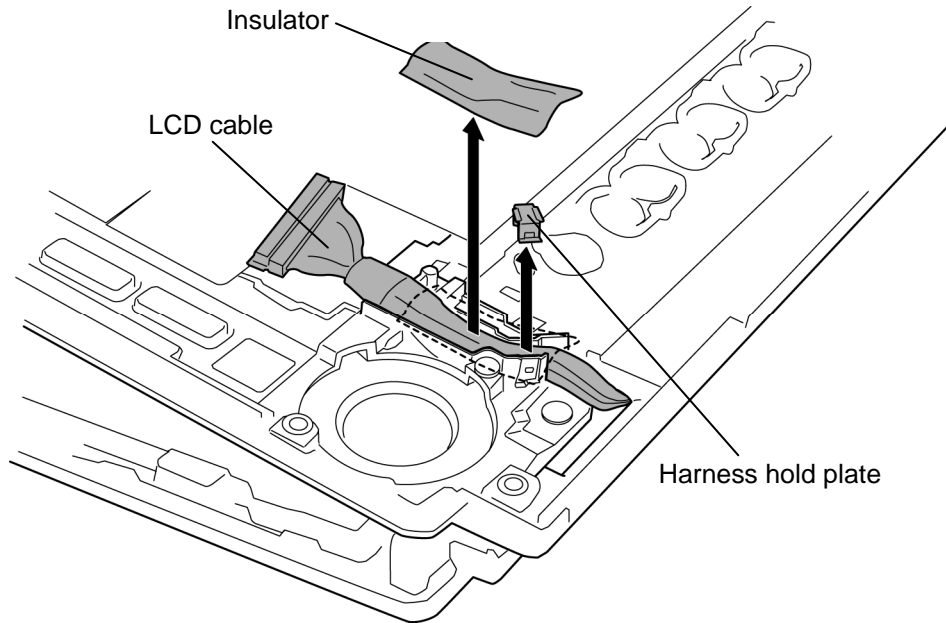

Figure 4-55 Removing the harness hold plate

2. Remove the following **screw** securing the LCD hold plate and remove the **LCD hold plate** from the cover assembly.

- M2.5×6S Tapping screw ×1

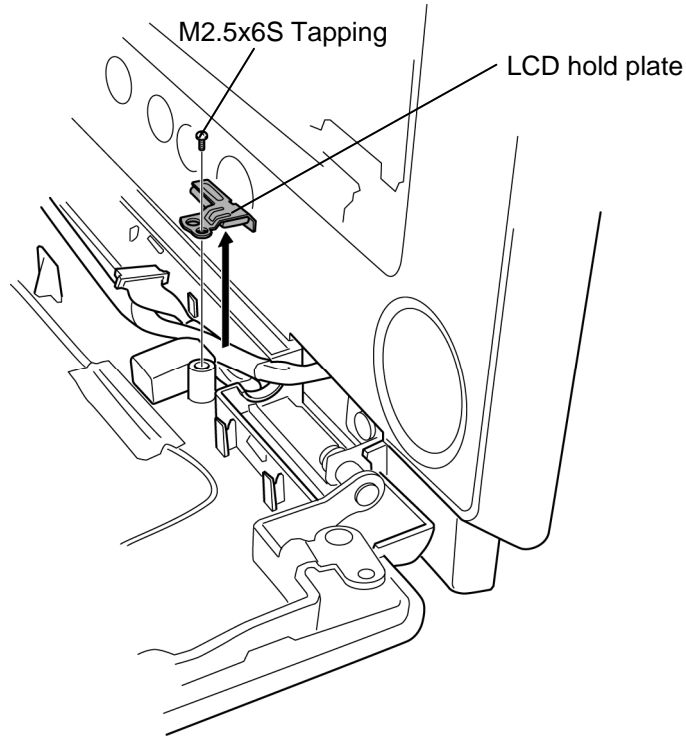

Figure 4-56 Removing the LCD hold plate

3. Pass the **LCD cable** through the hole of the cover assembly to remove it.

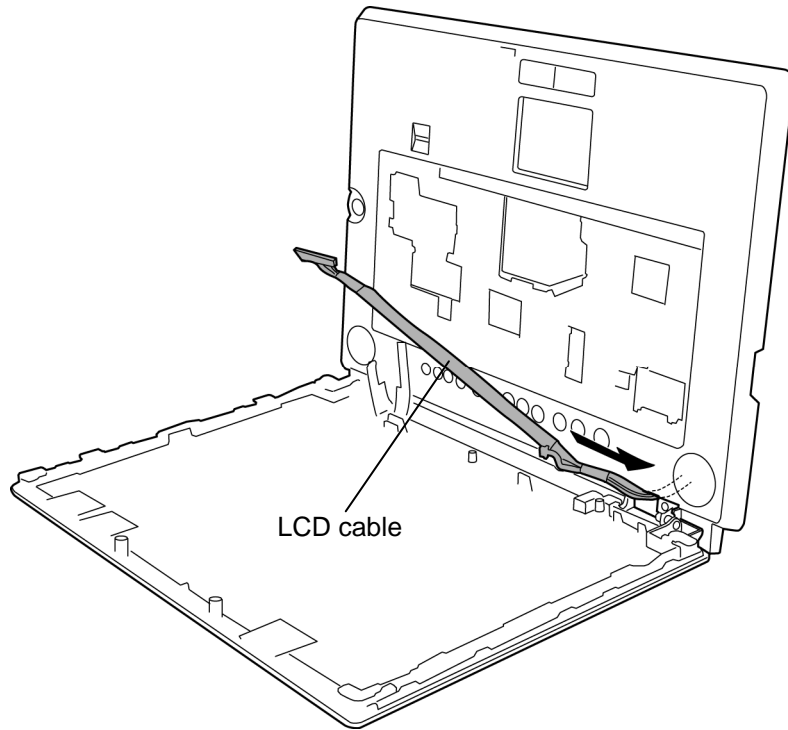

Figure 4-57 Removing the LCD cable

Installing the LCD cable

The following describes the procedure for installing the LCD cable (See Figure 4-55 to 4-57).

1. Arrange the **LCD cable** by passing it through the hole of the cover assembly.
2. Install the **LCD hold plate** and secure it with the following **screw**.
 - M2.5×6S Tapping screw ×1
3. Install the **harness hold plate** and stick the **insulator** in place.

4.33 Wireless LAN antenna/Bluetooth antenna

Removing the wireless LAN antenna/Bluetooth antenna

The following describes the procedure for removing the wireless LAN antennas/Bluetooth antenna (See Figure 4-58 and 4-59).

1. Peel off the **acetate tape** and draw out the **wireless LAN antenna cable** and **Bluetooth antenna cable**.

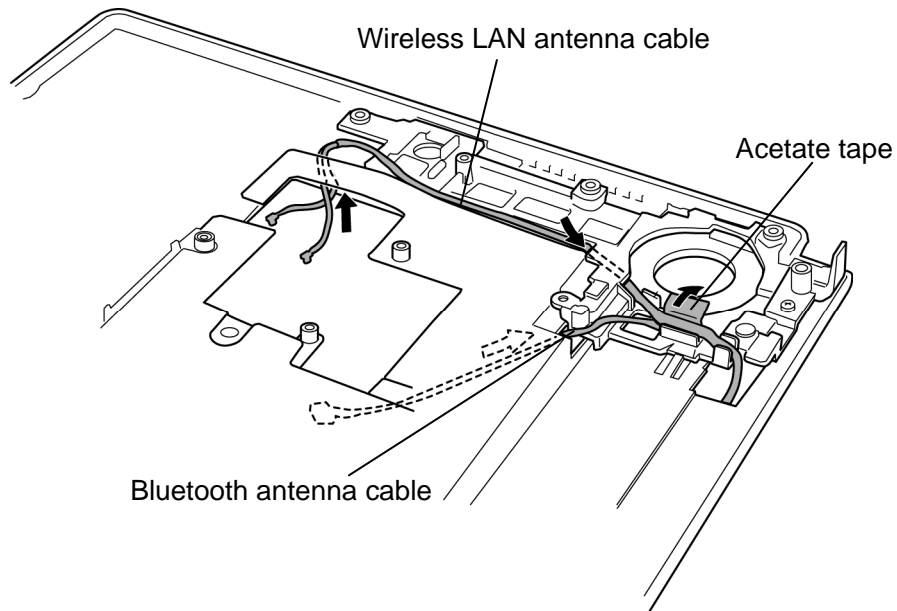

Figure 4-58 Removing the wireless LAN antenna/Bluetooth antenna (1)

2. Peel off the **acetate tapes** fixing the wireless LAN antenna cables and Bluetooth antenna cable and turn up **insulator**.
3. Peeling off the **wireless LAN antennas** and **Bluetooth antenna** from the display rear cover and remove the antennas from the display assembly.

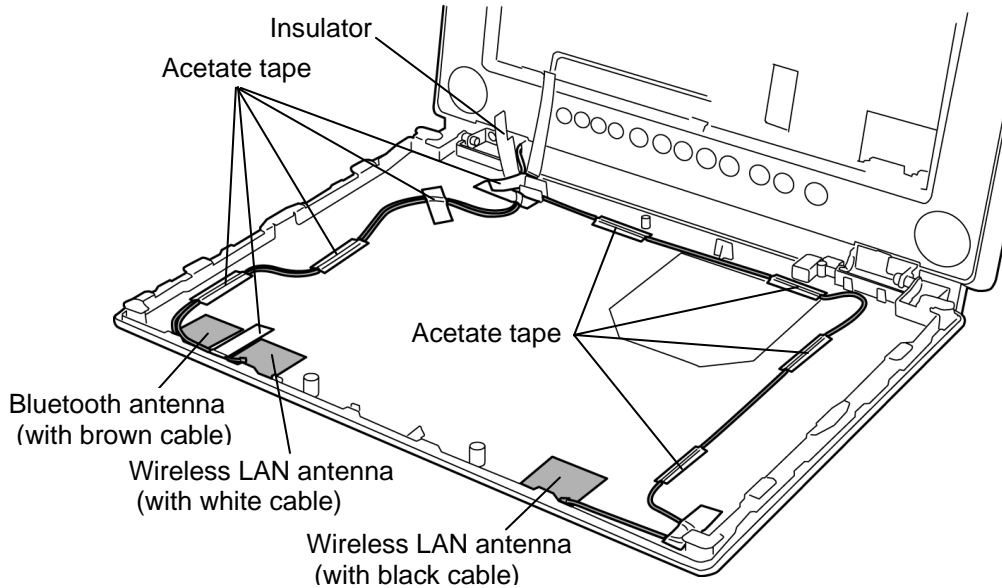

Figure 4-59 Removing the wireless LAN antenna/Bluetooth antenna (2)

Installing the wireless LAN antenna/Bluetooth antenna

The following describes the procedure for installing the wireless LAN antennas/Bluetooth antenna (See Figure 4-58 and 4-59).

1. Stick the **wireless LAN antennas** and **Bluetooth antenna** on the display rear cover.
2. Arrange the **wireless LAN antenna cables** and **Bluetooth antenna cable** on the display rear cover and fix them with **acetate tapes** and **insulator**.
3. Arrange the **wireless LAN antenna cables** and **Bluetooth antenna cable** on the back of the cover assembly and stick the **acetate tape** referring to Figure 4-58.

4.34 Latch assembly

Removing the Latch assembly

The following describes the procedure for removing the latch assembly (See Figure 4-60).

1. Remove the **LCD latch knob** while releasing **latches**.
2. Remove the **LCD latch hook** from the slot.

CAUTION: When removing the LCD latch hook, do not lose the spring.

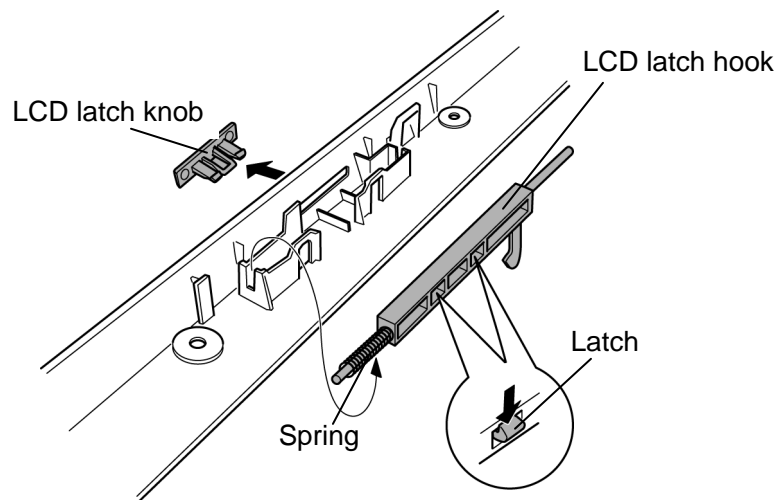

Figure 4-60 Removing the latch assembly

Installing the Latch assembly

The following describes the procedure for installing the latch assembly (See Figure 4-60).

1. Install the **LCD latch hook** to the display rear cover
2. Install the **LCD latch knob** until it is latched.

4.35 Display rear cover

Removing the display rear cover

The following describes the procedure for removing the display rear cover (See Figure 4-61 and 4-62).

1. Remove the following **screws** securing the display rear cover.

- M2.5×6S Tapping screw ×4

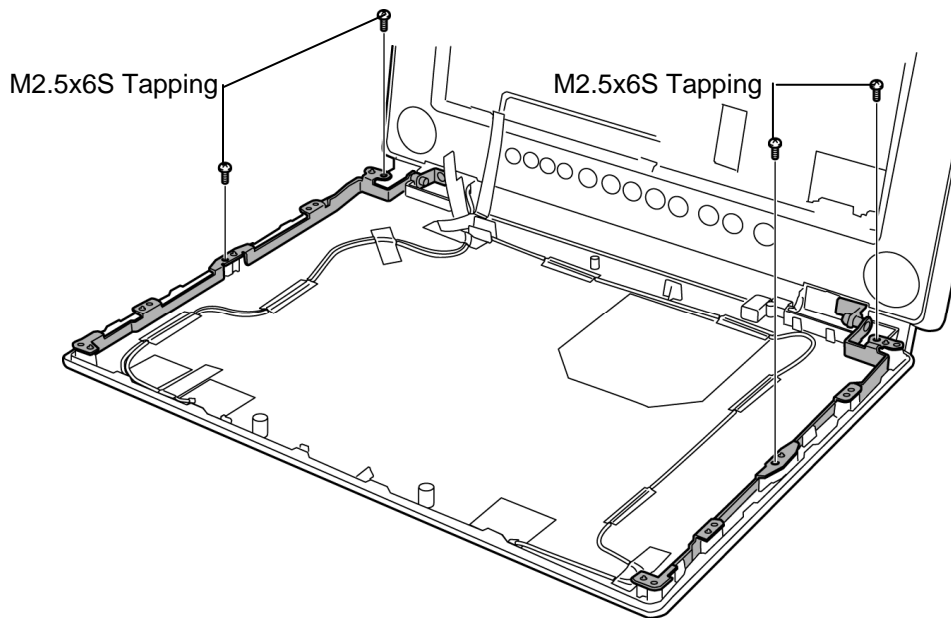

Figure 4-61 Removing the display rear cover (1)

- Incline the **cover assembly** a little as shown in the following figure and remove it from the **display rear cover**.

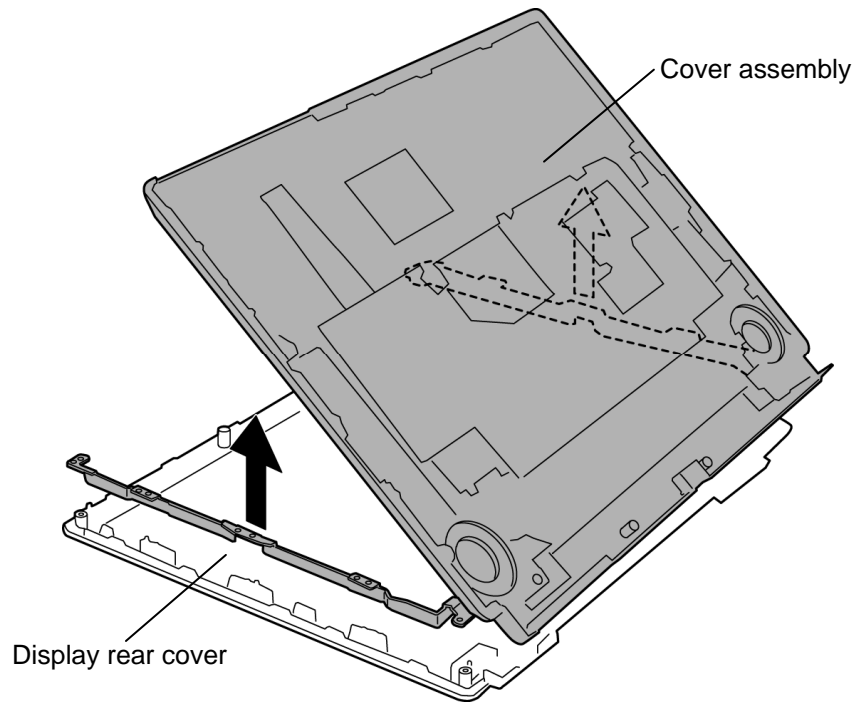

Figure 4-62 Removing the display rear cover (2)

Installing the display rear cover

The following describes the procedure for installing the display rear cover (See Figure 4-61 and 4-62).

- Incline the **cover assembly** and install it to the **display rear cover** while inserting the hinges on both sides in the slot of the display rear cover.
- Secure the **cover assembly** and **display rear cover** with the following **screws**.
 - M2.5×6S Tapping screw ×4

4.36 Hinge

Removing the hinge

The following describes the procedure for removing the hinge (See Figure 4-63).

1. Remove the following **screw** securing the hinge (L).
 - M2.5×6S Tapping screw ×1
2. Push down the latch and remove the **hinge (L)** by sliding it to the right.
3. Remove the following **screw** securing the hinge (R).
 - M2.5×6S Tapping screw ×1
4. Push down the latch and remove the **hinge (R)** by sliding it to the left.

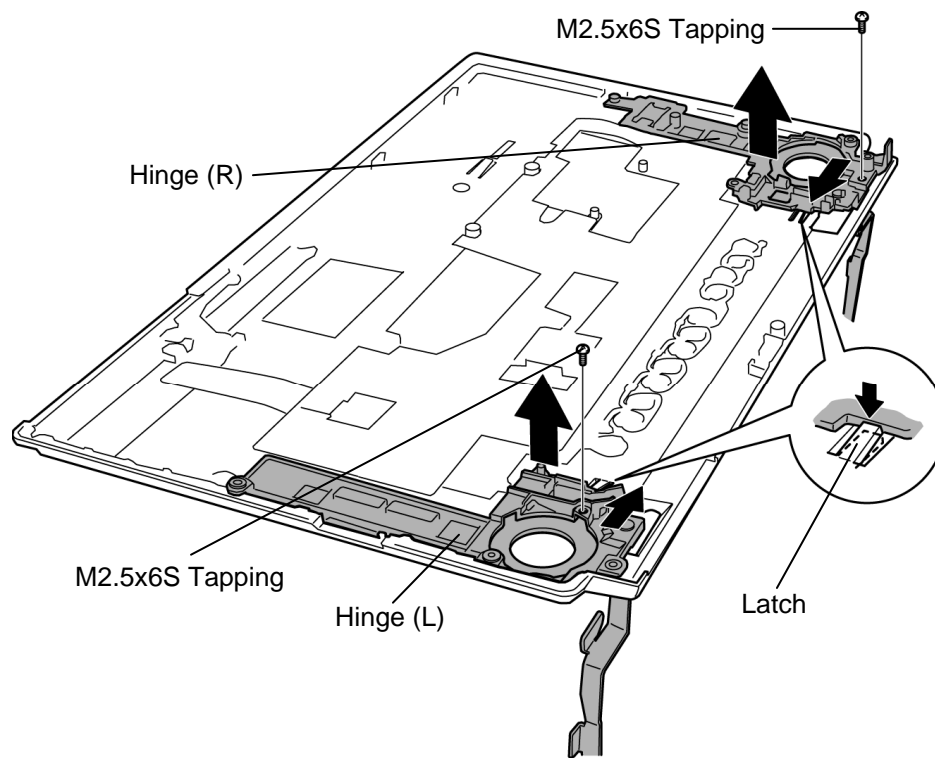

Figure 4-63 Removing the hinge

4.37 Fluorescent lamp

This system uses LCD module from the following supplier.

Type	Part No.	Supplier	Section
15.4 inch	G33C0002S110	Samsung	4.37.1
	G33C0002X110	Samsung	

- NOTE:**
- When working with a LCD module, always use a flat, grounded table.
 - Handle the backlight unit in the environment without dust, such as on the clean bench. Keep the worktable free from any screws or other material that may scratch the LCD surface.
 - Use an anti-static or protective sheet.
 - When replacing the FL unit, cover with a finger protector or similar to prevent dirtying or scratching the LCD panel.
 - Take care when handling the lamp. Excessive force may break the lamp.
 - Take care not to dirty or deform the lamp reflector.
 - Ensure always that the power of the LCD module is turned off before connecting or disconnecting cables and connectors.

4.37.1 Replacing the 15.4-inch Samsung Fluorescent lamp

CAUTION: When you replace the fluorescent lamp, wear finger covers or gloves to avoid contaminating or damaging the LCD module. Be careful not to let dust or other foreign substances into the LCD module.

Disassembling the 15.4-inch Samsung Fluorescent lamp

To disassemble the 15.4-inch WXGA Samsung Fluorescent Lamp, follow the steps below and refer to Figure 4-64 to 4-68.

The fluorescent lamp is assembled in the backlight unit. To replace the fluorescent lamp, replace the backlight unit.

1. Turn the LCD module face down, and remove the PCB cover.

CAUTION: Handle with care not to damage COF of S/D and G/D ICs.

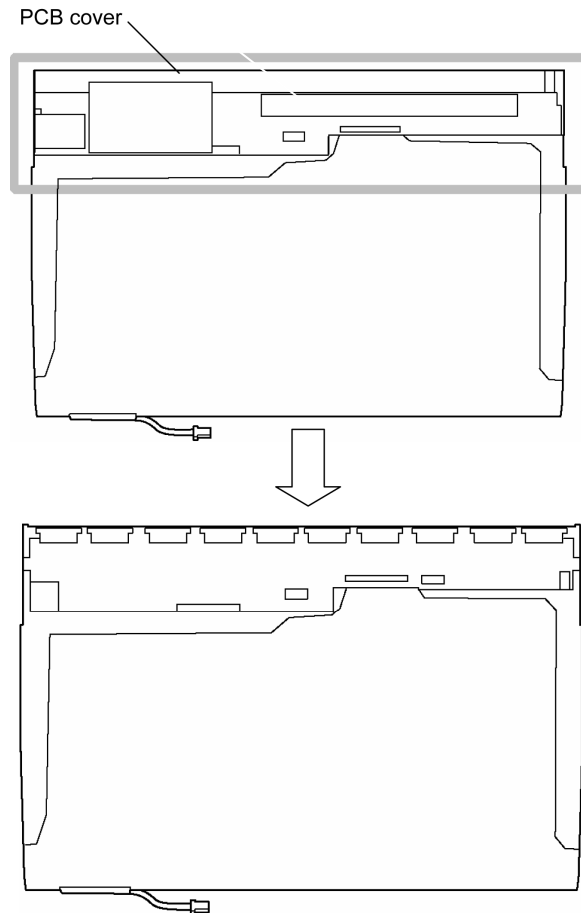

Figure 4-64 Replacing Samsung fluorescent lamp (WXGA) (1)

2. Remove white tapes stuck on the right and left sides.

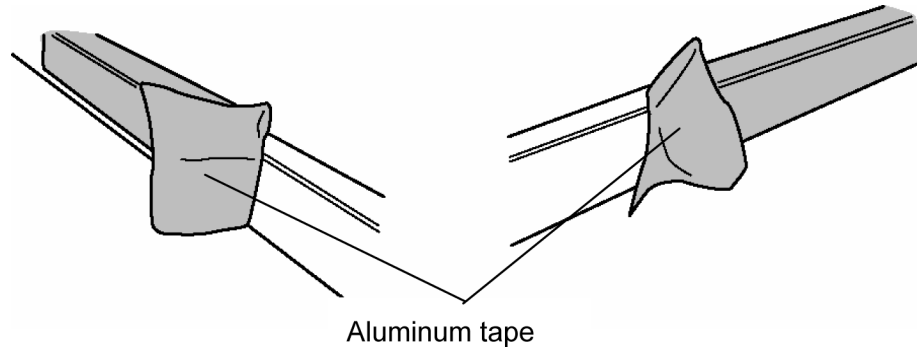

Figure 4-65 Replacing Samsung fluorescent lamp (WXGA) (2)

3. Remove the lamp wire tape and the aluminum tape stuck on the bottom.

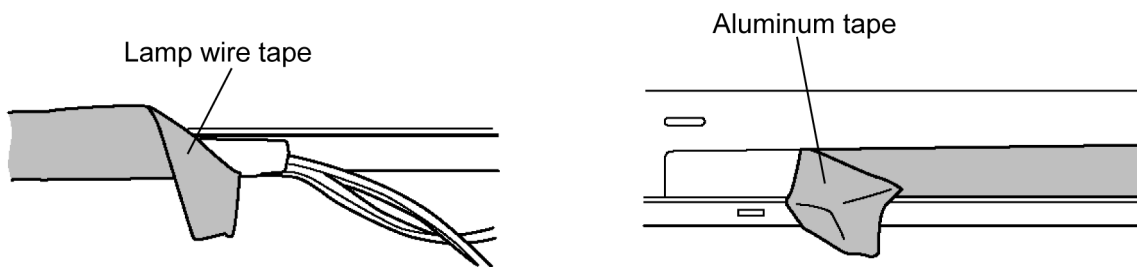

Figure 4-66 Replacing Samsung fluorescent lamp (WXGA) (3)

4. Unlatch the hooks on the bottom first and then the hooks on the right and left sides to remove the top chassis from the mold frame.

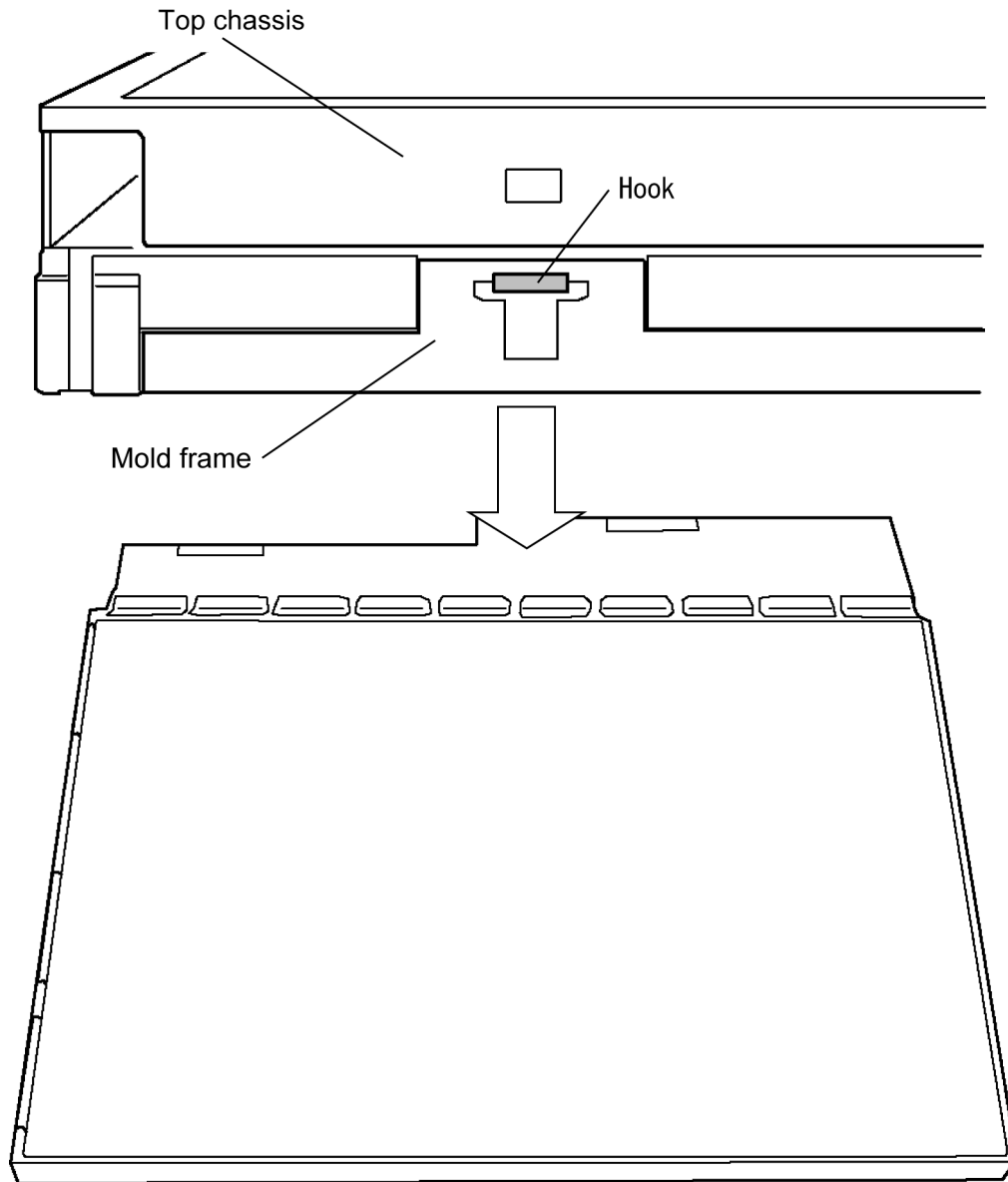

Figure 4-67 Replacing Samsung fluorescent lamp (WXGA) (4)

5. Remove the panel assembly from the backlight unit.

CAUTION: Handle with care not to damage the COF of S/D and G/D ICs.

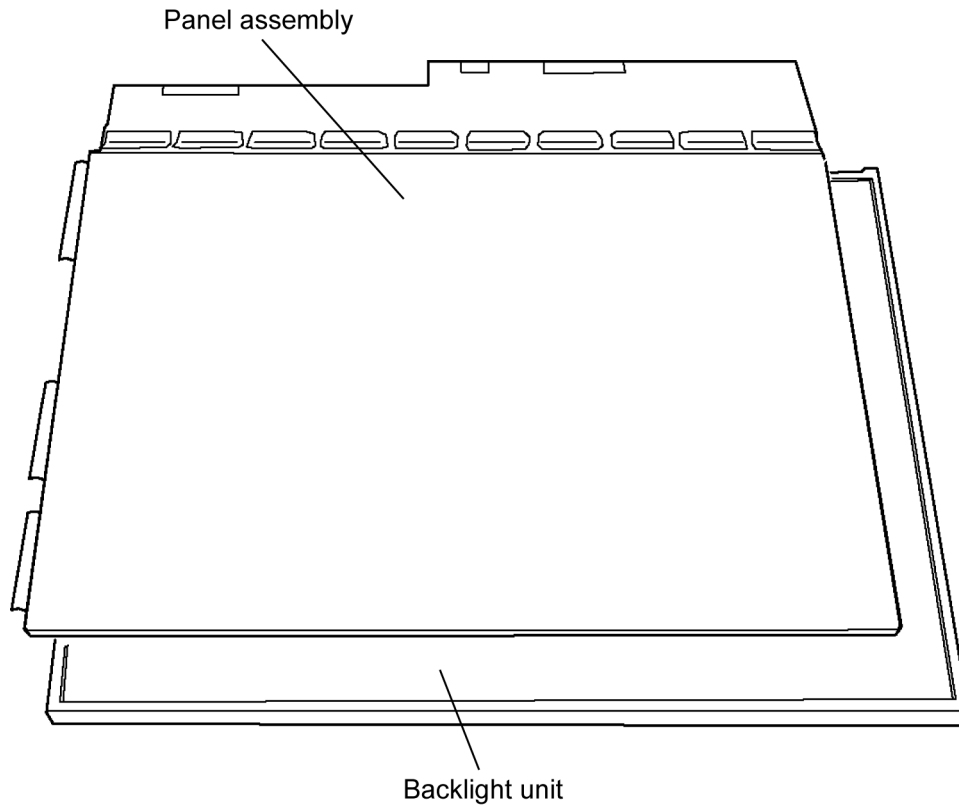

Figure 4-68 Replacing Samsung fluorescent lamp (WXGA) (5)

Assembling the 15.4-inch (W-XGA) Samsung fluorescent lamp

The assembly procedure is the reverse of the above disassembly procedure.

Appendices

Appendix Contents

Appendix A Handling the LCD Module..... A-1

Appendix B Board Layout..... B-1

B.1 System board (FUHSY*) Front View..... B-1

B.2 System board (FUHSY*) Back View B-3

B.3 BC board (FUHBC*) B-5

B.4 JK board (FUHJK*) B-6

B.5 LE board (FUHLE*) B-7

B.6 TP board (FUHTP*) B-8

B.7 FS board (FUHFS*) B-9

Appendix C Pin Assignment..... C-1

System board (FUHSY*)

C.1 CN1410 Memory B Connector (200-pin)..... C-1

C.2 CN1400 Memory A connector (200-pin) C-4

C.3 CN1810 ODD I/F connector (50-pin)..... C-7

C.4 CN1850 1st HDD I/F connector (22-pin) C-8

C.5 CN1860 2nd HDD I/F connector (22-pin)..... C-8

C.6 CN2110 PC card I/F connector (150-pin)..... C-9

C.7 IS2101 Bridge media I/F connector (42-pin)..... C-12

C.8 CN2400 WW Tuner I/F connector (124-pin) C-13

C.9 CN2450 BC board I/F connector (8-pin) C-15

C.10 CN2600 Wireless LAN card I/F connector (52-pin) C-15

C.11 CN3010 MDC I/F connector (12-pin) C-16

C.12 CN3200 Keyboard I/F connector (34-pin)..... C-17

C.13 CN3201 Touch Pad I/F connector (4-pin) C-17

C.14 CN3330 Volume I/F connector (3-pin)..... C-17

C.15 J4100 Network I/F connector (12-pin) C-18

C.16 CN4200 1394 I/F connector (4-pin) C-18

C.17	CN4400	Bluetooth I/F connector (20-pin).....	C-18
C.18	CN4610	USB I/F connector Port5/Port7 (8-pin)	C-19
C.19	CN4611	USB I/F connector Port0/Port4 (8-pin)	C-19
C.20	CN5500	LCD I/F connector (40-pin)	C-20
C.21	CN5080	RGB I/F connector (15-pin)	C-21
C.22	CN5501	S-video OUT connector (4-pin)	C-21
C.23	CN5502	D-video I/F connector (14-pin)	C-21
C.24	CN6170	Speaker connector (4-pin)	C-22
C.25	CN8800	DC IN connector (4-pin)	C-22
C.26	CN8810	Battery connector (10-pin)	C-22
C.27	CN9990	RTC battery connector (3-pin)	C-22
C.28	CN8771	CPU FAN connector (4-pin)	C-23
C.29	CN8781	VGA FAN connector (4-pin)	C-23
C.30	CN9500	LE board I/F connector (20-pin)	C-23
C.31	CN9530	FS board I/F connector (6-pin).....	C-24
C.32	CN6500	JK board I/F connector (20-pin).....	C-24
C.33	CN9650	SW board I/F connector (20-pin)	C-25

JK board (FUHJK*)

C.34	CN6510	System board I/F connector (20-pin).....	C-26
C.35	CN6050	Internal microphone connector (2-pin).....	C-26
C.36	J6051	External microphone connector (6-pin)	C-26
C.37	DS6320	Headphone connector (9-pin)	C-27
C.38	CN9612	TV-in connector (5-pin)	C-27
C.39	J9614	AV-in connector (12-pin).....	C-27

LE board (FUHLE*)

C.40	CN9510	System board I/F connector (20-pin).....	C-28
------	--------	--	------

TP board (FUHTP*)

C.41	CN3250	System board I/F connector (4-pin).....	C-29
C.42	CN3251	Touch pad I/F connector (12-pin)	C-29

SW board (FUHSW*)

C.43 CN9660 System board I/F connector (20-pin)..... C-30

FS board (FUHFS*)

C.44 CN9540 System board I/F connector (6-pin)..... C-31

Appendix D Keyboard Scan/Character Codes D-1

D.1 Scan Codes..... D-1

Appendix E Key Layout E-1

E.1 US Keyboard.....E-1

E.2 UK Keyboard.....E-1

Appendix F Wiring Diagrams..... F-1

F.1 RGB Monitor ID Wraparound Connector F-1

F.2 LAN loopbak Connector..... F-1

Appendix G BIOS Rewrite Procedures G-1

Appendix H EC/KBC Rewrite Procedures H-1

Appendix I Reliability.....I-1

Appendix J Maintenance of TOSHIBA RAID..... J-1

J.1 Outline of Maintenance (Repair) of TOSHIBA RAID.....J-1

J.2 Analysis and handling by Drive LogJ-2

J.3 Operation of Independent utility.....J-8

Figures

Figure B-1	System board layout (front)	B-1
Figure B-2	System board layout (back)	B-3
Figure B-3	BC board layout	B-5
Figure B-4	JK board layout	B-6
Figure B-5	LE board layout.....	B-7
Figure B-6	TP board layout.....	B-8
Figure B-7	FS board layout.....	B-9
Figure E-1	US Keyboard layout.....	E-1
Figure E-2	UK Keyboard layout.....	E-1
Figure F-1	RGB Monitor ID Wraparound connector (15PIN to 15PIN).....	F-1
Figure F-2	LAN loopback connector	F-1
Figure J-1	Flowchart of repairing TOSHIBA RAID	J-1
Figure J-2	Flowchart of Analysis and handling by Drive Log	J-2
Figure J-3	Drive Log	J-8
Figure J-4	Tree of menu of Independent Utility.....	J-13

Tables

Table B-1	System board IC and connectors (front)	B-2
Table B-2	System board ICs and connectors (back).....	B-4
Table B-3	BC board connectors.....	B-5
Table B-4	JK board connectors.....	B-6
Table B-5	LE board connector.....	B-7
Table B-6	TP board connectors	B-8
Table B-7	FS board connector	B-9

System board (FUHSY*)

Table C-1	Memory B connector (200-pin)	C-1
Table C-2	Memory A connector (200-pin).....	C-4
Table C-3	ODD I/F connector (50-pin)	C-7
Table C-4	1st HDD I/F connector (22-pin).....	C-8
Table C-5	2nd HDD I/F connector (22-pin)	C-8
Table C-6	PC card I/F connector (150-pin).....	C-9
Table C-7	Bridge media I/F connector (42-pin)	C-12
Table C-8	WW Tuner I/F connector (124-pin).....	C-13
Table C-9	BC board I/F connector (8-pin).....	C-15
Table C-10	Wireless LAN card I/F connector (52-pin).....	C-15
Table C-11	MDC I/F connector (12-pin).....	C-16
Table C-12	Keyboard I/F connector (34-pin)	C-17
Table C-13	Touch Pad I/F connector (4-pin).....	C-17
Table C-14	Volume I/F connector (3-pin)	C-17
Table C-15	Network I/F connector (12-pin)	C-18
Table C-16	1394 I/F connector (4-pin)	C-18
Table C-17	Bluetooth I/F connector (20-pin)	C-18
Table C-18	USB I/F connector Port5/Port7 (8-pin).....	C-19
Table C-19	USB I/F connector Port0/Port4 (8-pin).....	C-19
Table C-20	LCD I/F connector (40-pin)	C-20
Table C-21	RGB I/F connector (15-pin).....	C-21
Table C-22	S-video OUT connector (4-pin)	C-21

Table C-23	D-video I/F connector (14-pin).....	C-21
Table C-24	Speaker connector (4-pin).....	C-22
Table C-25	DC IN connector (4-pin).....	C-22
Table C-26	Battery connector (10-pin).....	C-22
Table C-27	RTC battery connector (3-pin).....	C-22
Table C-28	CPU FAN connector (4-pin).....	C-23
Table C-29	VGA FAN connector (4-pin).....	C-23
Table C-30	LE board I/F connector (20-pin).....	C-23
Table C-31	FS board I/F connector (6-pin).....	C-24
Table C-32	JK board I/F connector (20-pin).....	C-24
Table C-33	SW board I/F connector (20-pin).....	C-25
JK board (FUHJK*)		
Table C-34	System board I/F connector (20-pin).....	C-26
Table C-35	Internal microphone connector (2-pin).....	C-26
Table C-36	External microphone connector (6-pin).....	C-26
Table C-37	Headphone connector (9-pin).....	C-27
Table C-38	TV-in connector (5-pin).....	C-27
Table C-39	AV-in connector (12-pin).....	C-27
LE board (FUHLE*)		
Table C-40	System board I/F connector (20-pin).....	C-28
TP board (FUHTP*)		
Table C-41	System board I/F connector (4-pin).....	C-29
Table C-42	Touch pad I/F connector (12-pin).....	C-29
SW board (FUHSW*)		
Table C-43	System board I/F connector (20-pin).....	C-30
FS board (FUHFS*)		
Table C-44	System board I/F connector (6-pin).....	C-31
Table D-1	Scan codes (set 1 to set 2).....	D-1

Table D-2	Scan codes with left shift key	D-5
Table D-3	Scan codes with Numlock mode.....	D-6
Table D-4	Scan codes with Fn key.....	D-6
Table D-5	Scan codes in overlay mode.....	D-7
Table D-6	No. 124 key scan code	D-7
Table D-7	No. 126 key scan code	D-8
Table I-1	MTBF.....	I-1
Table J-1	List of Command	J-5
Table J-2	Displayed item in Logical Drive.....	J-10
Table J-3	Items displayed in Physical Drive	J-11
Table J-4	Item of Main Menu displayed	J-12
Table J-5	Item of parameter set	J-14
Table J-6	Item of array	J-20
Table J-7	Items set in View Drive Info.	J-23
Table J-8	Function of option and key	J-24
Table J-9	Content of Drive Log display	J-26
Table J-10	Content of View Drive Log menu	J-27
Table J-11	Function of key in View Drive Log.....	J-27

Appendix A Handling the LCD Module

Precautions for handling the LCD module

The LCD module can be easily damaged during assembly or disassembly. Observe the following precautions when handling the LCD module:

1. When installing the LCD module in the LCD cover, be sure to seat it so that it is properly aligned and maximum visibility of the display is maintained.

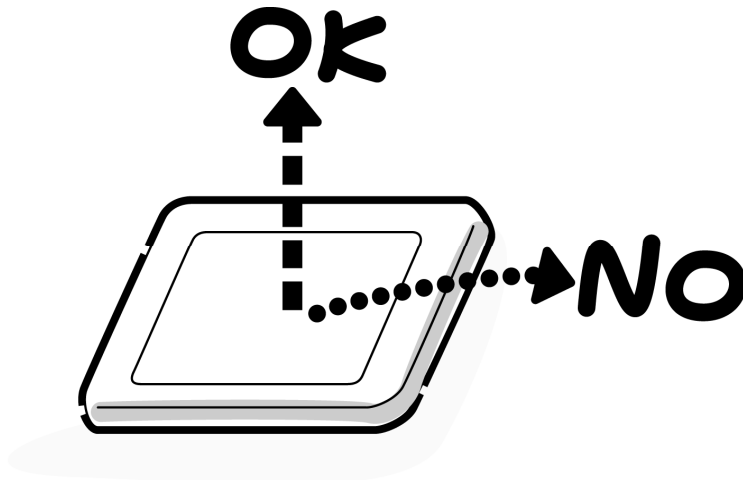

2. Be careful to align the holes at the four corners of the LCD module with the corresponding holes in the LCD cover before securing the module with screws. Do not force the module into place, because stress can affect its performance.

Also, the panel's polarized surface is easily scarred, so be careful when handling it.



3. If the panel's surface gets dirty, wipe it with cotton or a soft cloth. If it is still dirty, try breathing on the surface to create a light condensate and wipe it again.

If the surface is very dirty, we recommend a CRT cleaning agent. Apply the agent to a cloth and then wipe the panel's surface. Do not apply cleanser directly to the panel.



4. If water or other liquid is left on the panel's surface for a long period, it can change the screen's tint or stain it. Be sure to quickly wipe off any liquid.

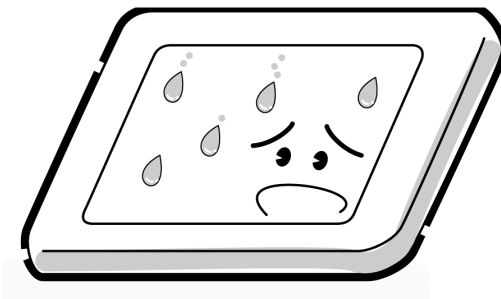

5. Glass is used in the panel, so be careful not to drop it or let it strike a hard object, which could cause breakage or cracks.

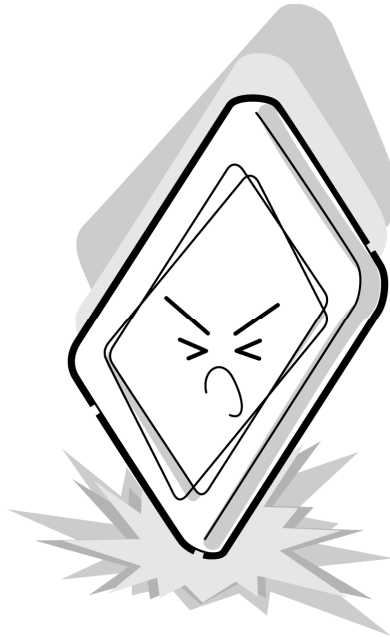

6. CMOS-LSI circuits are used in the module, so guard against damage from electrostatic discharge. Be sure to wear a wrist or ankle ground when handling the module.

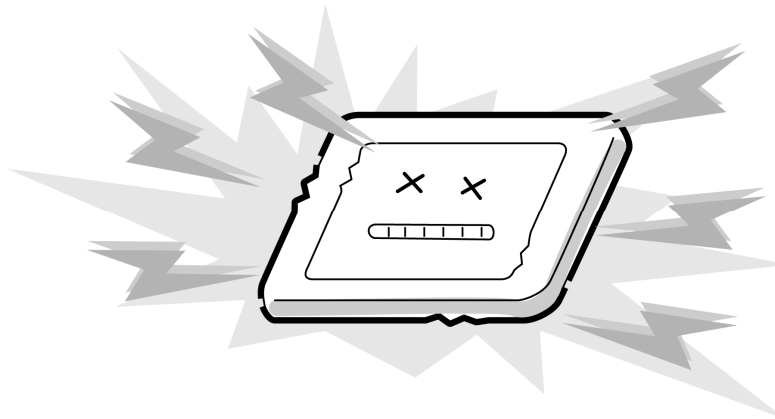

7. Do not expose the module to direct sunlight or strong ultraviolet rays for long periods.



8. Do not store the module at temperatures below specifications. Cold can cause the liquid crystals to freeze, lose their elasticity or otherwise suffer damage.

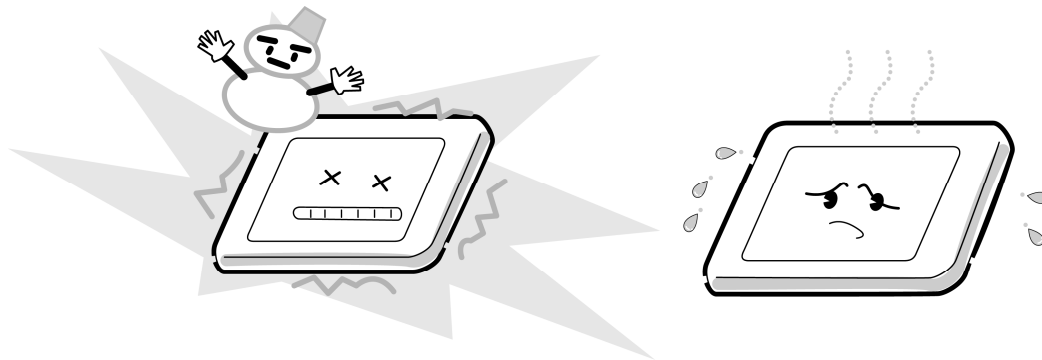

9. Do not disassemble the LCD module. Disassembly can cause malfunctions.

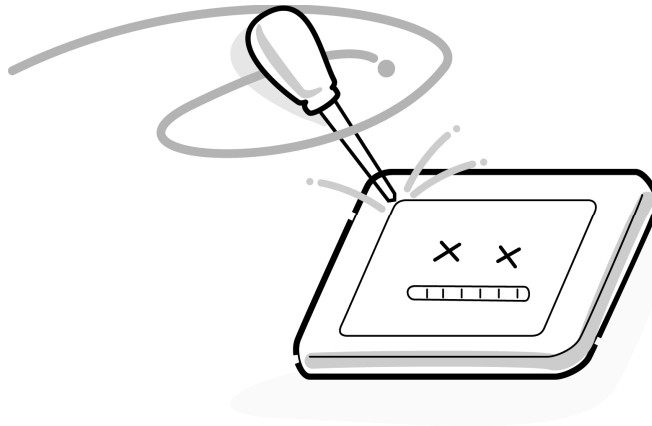

10. If you transport the module, do not use packing material that contains epoxy resin (amine) or silicon glue (alcohol or oxide). These materials can release gas that can damage the panel's polarization.

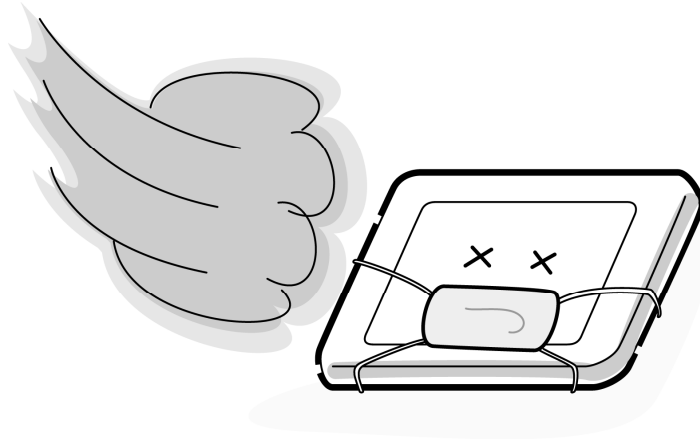

Appendix B Board Layout

B.1 System board (FUHSY*) Front View

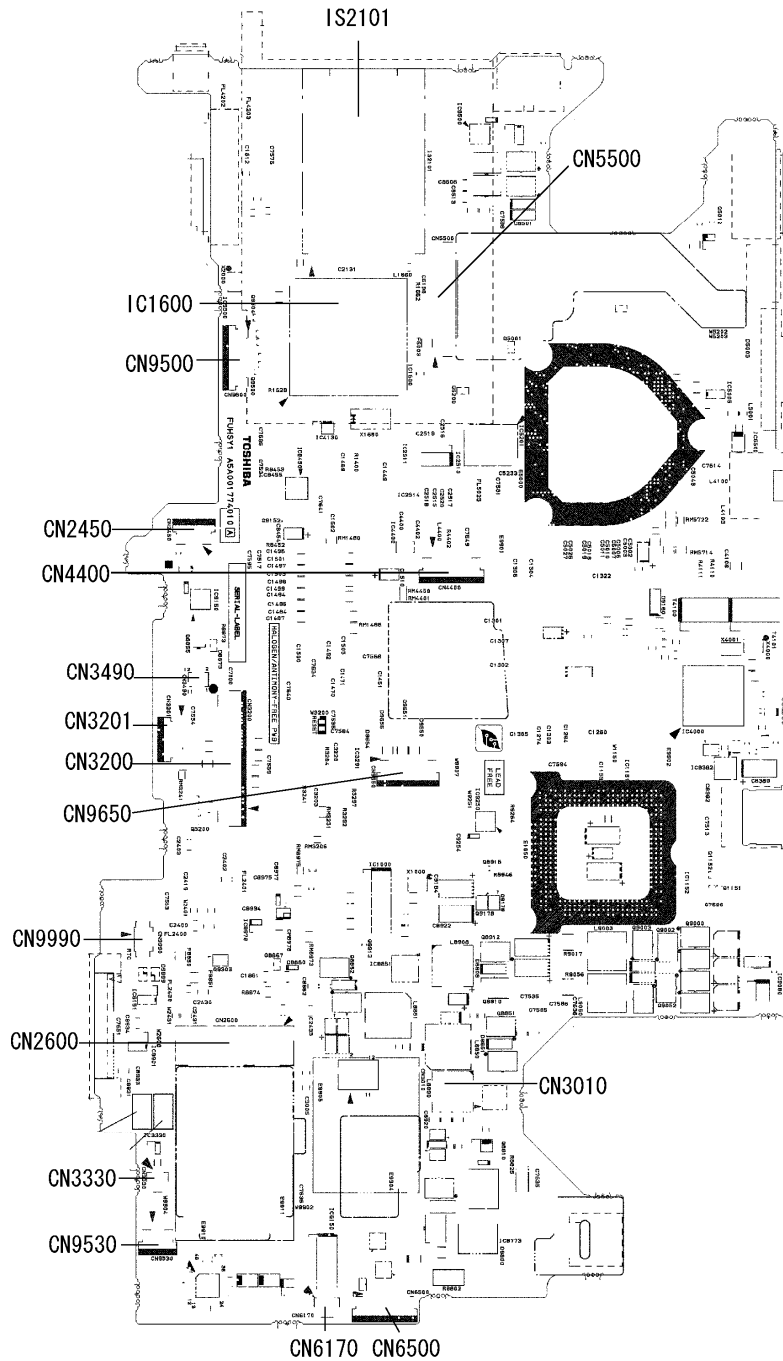

Figure B-1 System board layout (front)

Table B-1 System board connectors (front)

Number	Name
IS2101	Bridge media slot
CN6170	Internal speaker connector
CN6500	JK board I/F connector
CN9530	FS board I/F connector
CN9500	LE board I/F connector
CN9650	SW board I/F connector
CN2600	Wireless LAN card I/F connector
CN3490	Debugging port
CN3010	MDC I/F connector
CN5500	LCD I/F connector
CN2450	BC board I/F connector
CN4400	Bluetooth FFC connector
CN3330	Volume sensor cable connector
CN9990	RTC battery connector
CN3201	Touch pad FFC connector
CN3200	Keyboard I/F connector
IC1600	ICH7-M

B.2 System board (FUHSY*) Back View

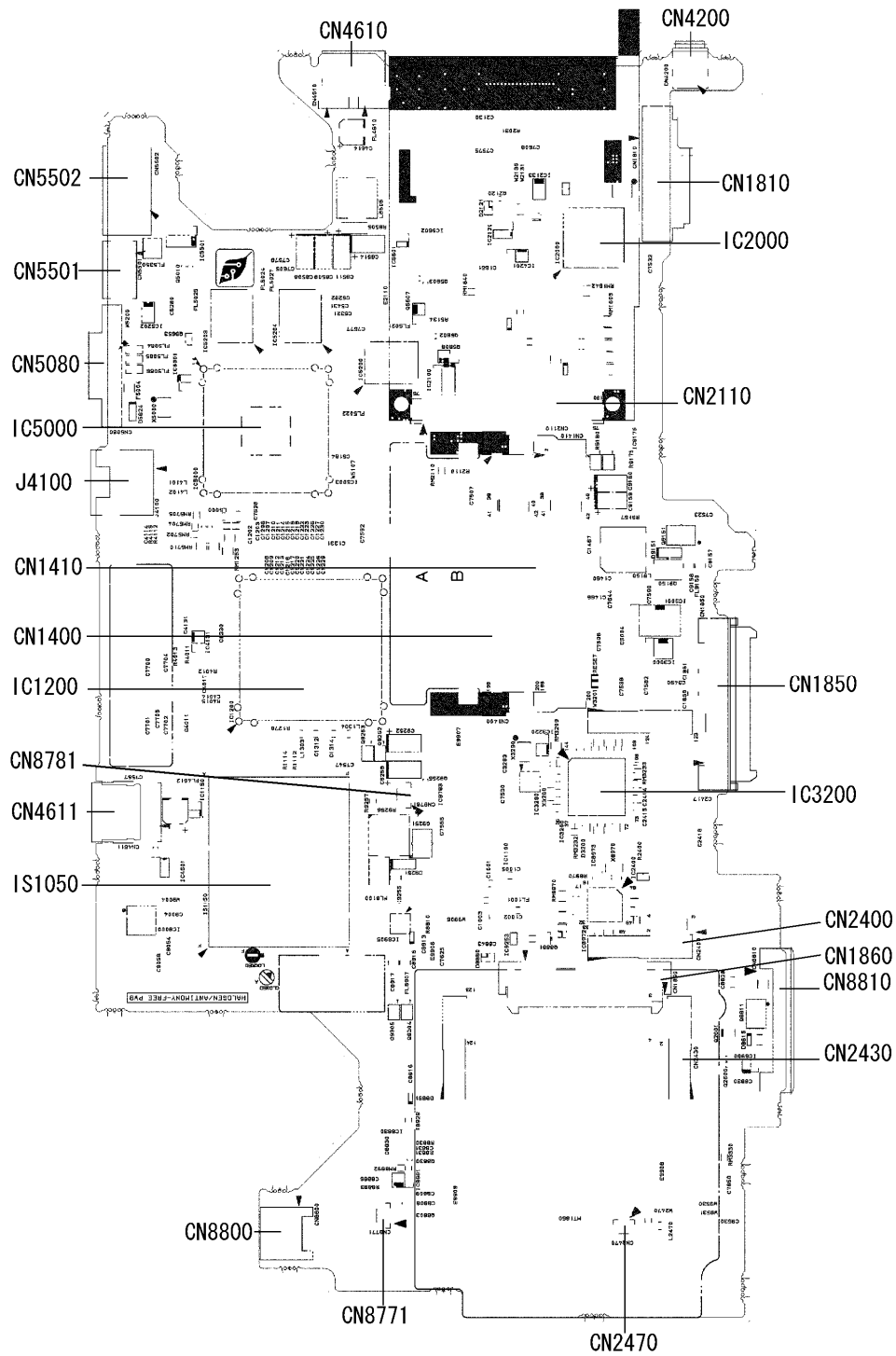

Figure B-2 System board layout (back)

Table B-2 System board ICs and connectors (back)

Number	Name
CN1400	Memory A I/F connector
CN1410	Memory B I/F connector
CN1850	HDD-1 I/F connector
CN5080	RGB I/F connector
CN5502	D-Video connector
CN5501	S-Video connector
CN1810	ODD connector
CN2110	PC card I/F connector
CN4200	i.LINK (IEEE1394) port
CN8771	CPU fan cable connector
CN8781	VGA fan cable connector
CN8800	DC-IN connector
CN8810	1 st battery connector
CN1860	HDD-2 I/F connector
IS1050	CPU
J4100	Network connector
CN4611	USB connector
CN6170	Speaker cable connector
CN4610	USB connector
CN2400	WW Tuner I/F connector
CN2430	ISDB-t Tuner I/F connector
CN2470	TV signal splitter connector
IC5000	GPU
IC1200	MCH
IC2000	Card controller
IC3200	EC/KBC

B.3 BC board (FUHBC*)

<Front layout>

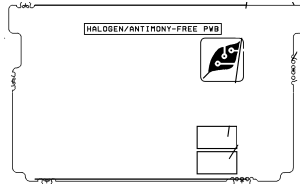

<Back layout>

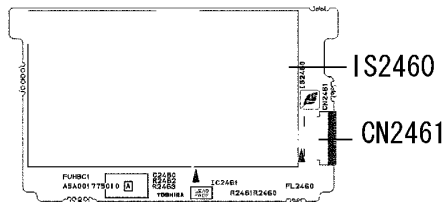

Figure B-3 BC board layout

Table B-3 BC board connectors

Number	Name
CN2461	System board I/F connector
IS2460	B-CAS card connector

B.4 JK board (FUHJK*)

<Front layout>

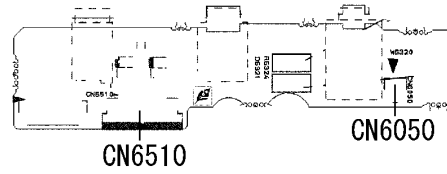

<Back layout>

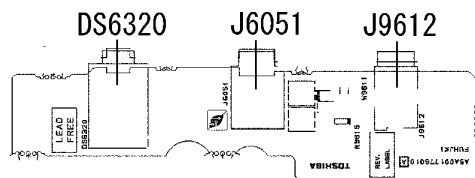

Figure B-4 JK board layout

Table B-4 JK board connectors

Number	Name
CN6510	System board I/F connector
CN6050	Internal microphone connector
J6051	External microphone connector
DS6320	Headphone connector
J6912	TV-in connector

B.5 LE board (FUHLE*)

<Front layout>

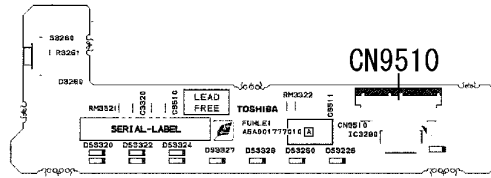

<Back layout>

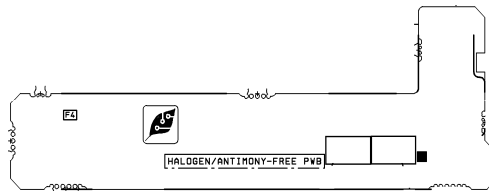

Figure B-5 LE board layout

Table B-5 LE board connector

Number	Name
CN9510	System board I/F connector

B.6 TP board (FUHTP*)

<Front layout>

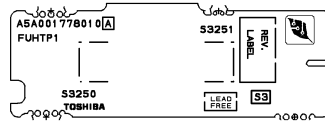

<Back layout>

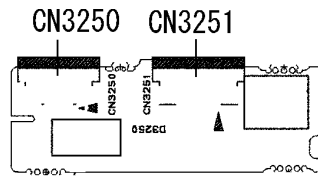

Figure B-6 TP board layout

Table B-6 TP board connectors

Number	Name
CN3250	System board I/F port
CN3251	Touch pad I/F port

B.7 FS board (FUHFS*)

<Front layout>

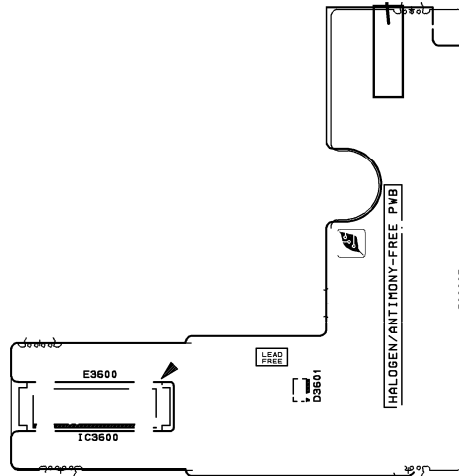

<Back layout>

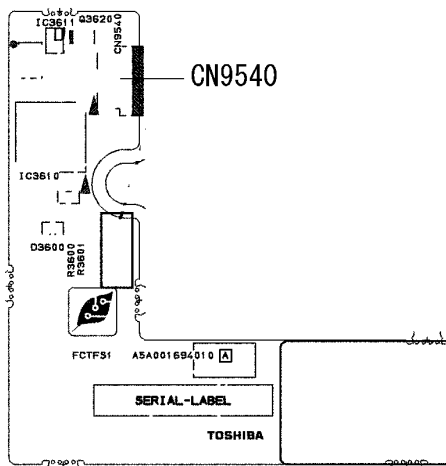

Figure B-7 FS board layout

Table B-7 FS board connector

Number	Name
CN9540	System board I/F connector

Appendix C Pin Assignment

System board (FUHSY*)

C.1 CN1410 Memory B Connector (200-pin)

Table C-1 Memory B connector (200-pin) (1/3)

PIN No.	Signal name	I/O	PIN No.	Signal name	I/O
1	MR0R9-B0V	I	2	GND	-
3	GND	-	4	BDQ01-B1P	I/O
5	BDQ07-B1P	I/O	6	BDQ04-B1P	I/O
7	BDQ06-B1P	I/O	8	GND	-
9	GND	-	10	BDM0-B1P	I
11	BDQS0-B1N	I/O	12	GND	-
13	BDQS0-B1P	I/O	14	BDQ05-B1P	I/O
15	GND	-	16	BDQ00-B1P	I/O
17	BDQ03-B1P	I/O	18	GND	-
19	BDQ02-B1P	I/O	20	BDQ12-B1P	I/O
21	GND	-	22	BDQ13-B1P	I/O
23	BDQ08-B1P	I/O	24	GND	-
25	BDQ09-B1P	I/O	26	BDM1-B1P	I
27	GND	-	28	GND	-
29	BDQS1-B1N	I/O	30	MCK3-B1P	I
31	BDQS1-B1P	I/O	32	MCK3-B1N	I
33	GND	-	34	GND	-
35	BDQ10-B1P	I/O	36	BDQ14-B1P	I/O
37	BDQ11-B1P	I/O	38	BDQ15-B1P	I/O
39	GND	-	40	GND	-
41	GND	-	42	GND	-
43	BDQ16-B1P	I/O	44	BDQ17-B1P	I/O
45	BDQ21-B1P	I/O	46	BDQ20-B1P	I/O
47	GND	-	48	GND	-
49	BDQS2-B1N	I/O	50	N.C.	-
51	BDQS2-B1P	I/O	52	BDM2-B1P	I
53	GND	-	54	GND	-
55	BDQ23-B1P	I/O	56	BDQ18-B1P	I/O
57	BDQ22-B1P	I/O	58	BDQ19-B1P	I/O
59	GND	-	60	GND	-

Table C-1 Memory B connector (200-pin) (2/3)

PIN No.	Signal name	I/O	PIN No.	Signal name	I/O
61	BDQ29-B1P	I/O	62	BDQ25-B1P	I/O
63	BDQ28-B1P	I/O	64	BDQ24-B1P	I/O
65	GND	-	66	GND	-
67	BDM3-B1P	I	68	BDQS3-B1N	I/O
69	N.C.	-	70	BDQS3-B1P	I/O
71	GND	-	72	GND	-
73	BDQ26-B1P	I/O	74	BDQ30-B1P	I/O
75	BDQ27-B1P	I/O	76	BDQ31-B1P	I/O
77	GND	-	78	GND	-
79	MCKE2-B1P	I	80	MCKE3-B1P	I
81	1R8-B1V	I	82	1R8-B1V	I
83	N.C.	-	84	N.C.	-
85	BBS2-B1P	I	86	N.C.	-
87	1R8-B1V	I	88	1R8-B1V	I
89	BMA12-B1P	I	90	BMA11-B1P	I
91	BMA09-B1P	I	92	BMA07-B1P	I
93	BMA08-B1P	I	94	BMA06-B1P	I
95	1R8-B1V	I	96	1R8-B1V	I
97	BMA05-B1P	I	98	BMA04-B1P	I
99	BMA03-B1P	I	100	BMA02-B1P	I
101	BMA01-B1P	I	102	BMA00-B1P	I
103	1R8-B1V	I	104	1R8-B1V	I
105	BMA10-B1P	I	106	BBS1-B1P	I
107	BBS0-B1P	I	108	BRAS-B1N	I
109	BWE-B1N	I	110	MCS2-B1N	I
111	1R8-B1V	I	112	1R8-B1V	I
113	BCAS-B1N	I	114	MODT2-B1P	I
115	MCS3-B1N	I	116	BMA13-B1P	I
117	1R8-B1V	I	118	1R8-B1V	I
119	MODT3-B1P	I	120	N.C.	-
121	GND	-	122	GND	-
123	BDQ32-B1P	I/O	124	BDQ36-B1P	I/O
125	BDQ33-B1P	I/O	126	BDQ37-B1P	I/O
127	GND	-	128	GND	-
129	BDQS4-B1N	I/O	130	BDM4-B1P	I

Table C-1 Memory B connector (200-pin) (3/3)

PIN No.	Signal name	I/O	PIN No.	Signal name	I/O
131	BDQS4-B1P	I/O	132	GND	-
133	GND	-	134	BDQ38-B1P	I/O
135	BDQ34-B1P	I/O	136	BDQ39-B1P	I/O
137	BDQ35-B1P	I/O	138	GND	-
139	GND	-	140	BDQ44-B1P	I/O
141	BDQ40-B1P	I/O	142	BDQ45-B1P	I/O
143	BDQ41-B1P	I/O	144	GND	-
145	GND	-	146	BDQS5-B1N	I/O
147	BMD5-B1P	I	148	BDQS5-B1P	I/O
149	GND	-	150	GND	-
151	BDQ47-B1P	I/O	152	BDQ46-B1P	I/O
153	BDQ42-B1P	I/O	154	BDQ43-B1P	I/O
155	GND	-	156	GND	-
157	BDQ48-B1P	I/O	158	BDQ53-B1N	I/O
159	BDQ52-B1P	I/O	160	BDQ49-B1N	I/O
161	GND	-	162	GND	-
163	N.C.	-	164	MCK2-B1P	I
165	GND	-	166	MCK2-B1N	I
167	BDQS6-B1N	I/O	168	GND	-
169	BDQS6-B1P	I/O	170	BDM6-B1P	I
171	GND	-	172	GND	-
173	BDQ51-B1P	I/O	174	BDQ50-B1P	I/O
175	BDQ54-B1P	I/O	176	BDQ55-B1P	I/O
177	GND	-	178	GND	-
179	BDQ57-B1P	I/O	180	BDQ56-B1P	I/O
181	BDQ61-B1P	I/O	182	BDQ60-B1P	I/O
183	GND	-	184	GND	-
185	BDM7-B1P	I	186	BDQS7-B1N	I/O
187	GND	-	188	BDQS7-B1P	I/O
189	BDQ58-B1P	I/O	190	GND	-
191	BDQ59-B1P	I/O	192	BDQ62-B1P	I/O
193	GND	-	194	BDQ63-B1P	I/O
195	SMBDAT-P3P	I/O	196	GND	-
197	SMBCLK-P3P	I/O	198	GND	-
199	P3V	I	200	P3V	I
1T	GND	-	2T	GND	-

C.2 CN1400 Memory A connector (200-pin)*Table C-2 Memory A connector (200-pin) (1/3)*

PIN No.	Signal name	I/O	PIN No.	Signal name	I/O
1	MR0R9-B0V	I	2	GND	-
3	GND	-	4	ADQ04-B1P	I/O
5	ADQ07-B1P	I/O	6	ADQ06-B1P	I/O
7	ADQ06-B1P	I/O	8	GND	-
9	GND	-	10	ADM0-B1P	I
11	ADQS0-B1N	I/O	12	GND	-
13	ADQS0-B1P	I/O	14	ADQ05-B1P	I/O
15	GND	-	16	ADQ01-B1P	I/O
17	ADQ03-B1P	I/O	18	GND	-
19	ADQ02-B1P	I/O	20	ADQ12-B1P	I/O
21	GND	-	22	ADQ13-B1P	I/O
23	ADQ14-B1P	I/O	24	GND	-
25	ADQ08-B1P	I/O	26	ADM1-B1P	I
27	GND	-	28	GND	-
29	ADQS1-B1N	I/O	30	MCK0-B1P	I
31	ADQS1-B1P	I/O	32	MCK0-B1N	I
33	GND	-	34	GND	-
35	ADQ15-B1P	I/O	36	ADQ10-B1P	I/O
37	ADQ09-B1P	I/O	38	ADQ11-B1P	I/O
39	GND	-	40	GND	-
41	GND	-	42	GND	-
43	ADQ21-B1P	I/O	44	ADQ17-B1P	I/O
45	ADQ20-B1P	I/O	46	ADQ16-B1P	I/O
47	GND	-	48	GND	-
49	ADQS2-B1N	I/O	50	N.C.	-
51	ADQS2-B1P	I/O	52	ADM2-B1P	I
53	GND	-	54	GND	-
55	ADQ23-B1P	I/O	56	ADQ18-B1P	I/O
57	ADQ19-B1P	I/O	58	ADQ22-B1P	I/O
59	GND	-	60	GND	-
61	ADQ25-B1P	I/O	62	ADQ29-B1P	I/O

Table C-2 Memory A connector (200-pin) (2/3)

PIN No.	Signal name	I/O	PIN No.	Signal name	I/O
63	ADQ28-B1P	I/O	64	ADQ24-B1P	I/O
65	GND	-	66	GND	-
67	ADM3-B1P	I	68	ADQS3-B1N	I/O
69	N.C.	-	70	ADQS3-B1P	I/O
71	GND	-	72	GND	-
73	ADQ30-B1P	I/O	74	ADQ27-B1P	I/O
75	ADQ26-B1P	I/O	76	ADQ31-B1P	I/O
77	GND	-	78	GND	-
79	MCKE0-B1P	I	80	MCKE1-B1P	I
81	1R8-B1V	I	82	1R8-B1V	I
83	N.C.	-	84	N.C	-
85	ABS2-B1P	I	86	N.C	-
87	1R8-B1V	I	88	1R8-B1V	I
89	AMA12-B1P	I	90	AMA11-B1P	I
91	VMA09-B1P	I	92	AMA07-B1P	I
93	VMA08-B1P	I	94	AMA06-B1P	I
95	1R8-B1V	I	96	1R8-B1V	I
97	AMA05-B1P	I	98	AMA04-B1P	I
99	AMA03-B1P	I	100	AMA02-B1P	I
101	AMA01-B1P	I	102	AMA00-B1P	I
103	1R8-B1V	I	104	1R8-B1V	I
105	AMA10-B1P	I	106	ABS1-B1P	I
107	ABS0-B1P	I	108	ARAS-B1N	I
109	AWE-B1N	I	110	MCS0-B1N	I
111	1R8-B1V	I	112	1R8-B1V	I
113	ACAS-B1N	I	114	MODT0-B1P	I
115	MCS1-B1N	I	116	AMA13-B1P	I
117	1R8-B1V	I	118	1R8-B1V	I
119	MODT1-B1P	I	120	N.C	-
121	GND	-	122	GND	-
123	ADQ34-B1P	I/O	124	ADQ36-B1P	I/O
125	ADQ33-B1P	I/O	126	ADQ37-B1P	I/O
127	GND	-	128	GND	-
129	ADQS4-B1N	I/O	130	ADM4-B1P	I

Table C-2 Memory A connector (200-pin) (3/3)

PIN No.	Signal name	I/O	PIN No.	Signal name	I/O
131	ADQS4-B1P	I/O	132	GND	-
133	GND	-	134	ADQ35-B1P	I/O
135	ADQ39-B1P	I/O	136	ADQ32-B1P	I/O
137	ADQ38-B1P	I/O	138	GND	-
139	GND	-	140	ADQ44-B1P	I/O
141	ADQ40-B1P	I/O	142	ADQ41-B1P	I/O
143	ADQ45-B1P	I/O	144	GND	-
145	GND	-	146	ADQS5-B1N	I/O
147	AMD5-B1P	I	148	ADQS5-B1P	I/O
149	GND	-	150	GND	-
151	ADQ42-B1P	I/O	152	ADQ46-B1P	I/O
153	ADQ43-B1P	I/O	154	ADQ47-B1P	I/O
155	GND	-	156	GND	-
157	ADQ48-B1P	I/O	158	ADQ52-B1N	I/O
159	ADQ49-B1P	I/O	160	ADQ53-B1N	I/O
161	GND	-	162	GND	-
163	N.C.	-	164	MCK1-B1P	I
165	GND	-	166	MCK1-B1N	I
167	ADQS6-B1N	I/O	168	GND	-
169	ADQS6-B1P	I/O	170	ADM6-B1P	I
171	GND	-	172	GND	-
173	ADQ55-B1P	I/O	174	ADQ54-B1P	I/O
175	ADQ51-B1P	I/O	176	ADQ50-B1P	I/O
177	GND	-	178	GND	-
179	ADQ56-B1P	I/O	180	ADQ60-B1P	I/O
181	ADQ57-B1P	I/O	182	ADQ61-B1P	I/O
183	GND	-	184	GND	-
185	ADM7-B1P	I	186	ADQS7-B1N	I/O
187	GND	-	188	ADQS7-B1P	I/O
189	ADQ58-B1P	I/O	190	GND	-
191	ADQ62-B1P	I/O	192	ADQ59-B1P	I/O
193	GND	-	194	ADQ63-B1P	I/O
195	SMBDAT-P3P	I/O	196	GND	-
197	SMBCL2-P3P	I/O	198	GND	-
199	P3V	I	200	GND	I
1T	GND	-	2T	GND	-

C.3 CN1810 ODD I/F connector (50-pin)*Table C-3 ODD I/F connector (50-pin)*

PIN No.	Signal name	I/O	PIN No.	Signal name	I/O
1	NC	-	2	NC	-
3	GND	-	4	NC	-
5	(PLTRS1+RST1DB)	O	6	PDD08-P3P	I/O
7	PDD07-P3P	I/O	8	PDD09-P3P	I/O
9	PDD06-P3P	I/O	10	PDD10-P3P	I/O
11	PDD05-P3P	I/O	12	PDD11-P3P	I/O
13	PDD04-P3P	I/O	14	PDD12-P3P	I/O
15	PDD03-P3P	I/O	16	PDD13-P3P	I/O
17	PDD02-P3P	I/O	18	PDD14-P3P	I/O
19	PDD01-P3P	I/O	20	PDD15-P3P	I/O
21	PDD00-P3P	I/O	22	PDDREQ-P3P	I
23	GND	-	24	PDIOR-P3N	O
25	PDIOW-P3N	O	26	GND	-
27	PIORDY-P3P	I	28	PDDACK-P3N	O
29	IDEIRQ-P3P	I	30	NC	-
31	PDA1-P3P	O	32	NC	-
33	PDA0-P3P	O	34	PDA2-P3P	O
35	PDCS1-P3P	O	36	PDCS3-P3N	O
37	CDRLED-P5N	I/O	38	P5V	O
39	P5V	O	40	P5V	O
41	P5V	O	42	P5V	O
43	GND	-	44	GND	-
45	GND	-	46	GND	-
47	NC	-	48	GND	-
49	NC	-	50	DISKIN-S3P	I

C.4 CN1850 1st HDD I/F connector (22-pin)*Table C-4 1st HDD I/F connector (22-pin)*

PIN No.	Signal name	I/O	PIN No.	Signal name	I/O
S1	GND	-	S2	ZSATT0-P1P	I
S3	ZSATT0-P1N	I	S4	GND	-
S5	ZSATR0-P1N	I	S6	ZSATR0-P1P	I
S7	GND	-			
P1	P3V	I	P2	P3V	I
P3	P3V	I	P4	GND	-
P5	GND	-	P6	GND	-
P7	P5V	I	P8	P5V	I
P9	P5V	I	P10	GND	-
P11	GND	-	P12	GND	-
P13	NC	-	P14	NC	-
P15	NC	-			

C.5 CN1860 2nd HDD I/F connector (22-pin)*Table C-5 2nd HDD I/F connector (22-pin)*

PIN No.	Signal name	I/O	PIN No.	Signal name	I/O
S1	GND	-	S2	ZSATT2-P1P	I
S3	ZSATT2-P1N	I	S4	GND	-
S5	ZSATR2-P1N	I	S6	ZSATR2-P1P	I
S7	GND	-			
P1	P3V	I	P2	P3V	I
P3	P3V	I	P4	GND	-
P5	GND	-	P6	GND	-
P7	P5V	I	P8	P5V	I
P9	P5V	I	P10	GND	-
P11	GND	-	P12	GND	-
P13	NC	-	P14	NC	-
P15	NC	-			

C.6 CN2110 PC card I/F connector (150-pin)*Table C-6 PC card I/F connector (150-pin) (1/3)*

PIN No.	Signal name	I/O	PIN No.	Signal name	I/O
1	GND	-	2	GND	-
3	ZUSBEX3-E3N	I/O	4	ZUSBEX-E3P	I/O
5	GND	-	6	CPUSB-E3N	O
7	N.C (Reserve)	-	8	NC (Reserve)	-
9	GND	-	10	NC (Reserve)	-
11	(CRD-E3V)	I	12	(CRD-E3V)	I
13	CRD1R5-P1V	I	14	CRD1R5-P1V	I
15	CRD1R5-P1V	I	16	PEWAKE-S3N	I
17	GND	-	18	CRD-E3V	I
19	CRD-E3V	I	20	CRDRST-E3N	-
21	CRD-P3V	I	22	CRD-P3V	I
23	CRD-P3V	I	24	CRD-P3V	I
25	GND	-	26	CRDCRQ-E3N	O
27	CPPE-E3N	O	28	GND	-
29	GND	-	30	GND	-
31	XPECRD-P3N	I	32	XPECRD-P3P	I
33	GND	-	34	ZERCRD-P1N	I
35	ZERCRD-P1P	I	36	GND	-
37	GND	-	38	GND	-
39	GND	-	40	GND	-
41	(ZETCRD-P1N)	I	42	(ZETCRD-P1P)	I
43	GND	-	44	NC	-
45	NC	-	46	NC	-
47	NC	-	48	NC	-
49	NC	-	50	NC	-
51	GND	-	52	NC	-
53	NC	-	54	NC	-
55	NC	-	56	NC	-
57	NC	-	58	NC	-
59	GND	-	60	NC	-
61	NC	-	62	NC	-
63	NC	-	64	NC	-
65	N.C	-	66	NC	-
67	GND	-	68	NC	-

Table C-6 PC card I/F connector (150-pin) (2/3)

PIN No.	Signal name	I/O	PIN No.	Signal name	I/O
69	NC	-	70	NC	-
71	NC	-	72	NC	-
73	NC	-	74	GND	-
75	GND	-	76	GND	-
77	GND	-	78	ACCD1-P3N	I/O
79	ACAD00-PYP	I/O	80	ACAD02-PYP	I/O
81	ACAD01-PYP	I/O	82	ACAD04-PYP	I/O
83	ACAD03-PYP	I/O	84	GND	-
85	ACAD06-PYP	I/O	86	ACAD05-PYP	I/O
87	ACD14-PYP	I/O	88	ACAD07-PYP	I/O
89	ACAD08-PYP	I/O	90	ACCB E0-PYN	I/O
91	ACAD10-PYP	I/O	92	GND	-
93	ACAD09-PYP	I/O	94	ACVS1-P3P	I/O
95	ACAD11-PYP	I/O	96	ACAD13-PYP	I/O
97	ACAD12-PYP	I/O	98	ACAD15-PYP	I/O
99	ACAD14-PYP	I/O	100	GND	-
101	ACAD16-PYP	I/O	102	ACCB E1-PYN	I/O
103	ACA18-PYP	I/O	104	ACPAR-PYP	I/O
105	ACLOCK-PYN	I/O	106	ACPERR-PYN	I/O
107	ACSTOP-PYN	I/O	108	GND	-
109	ACGNT-PYN	-	110	ACDEVS-PYN	I/O
111	ACINT-PYN	I/O	112	MCVCCA-PYV	I/O
113	MCVCCA-PYV	I/O	114	MCVPPA-PYV	I/O
115	ACCLK-PYP	I/O	116	ACTRDY-PYN	I/O
117	ACIRDY-PYN	I/O	118	GND	-
119	ACFRAM-PYN	I/O	120	ACCB E2-PYN	I/O
121	ACAD17-PYP	I/O	122	ACAD18-PYP	I/O
123	ACAD19-PYP	I/O	124	ACAD20-PYP	I/O
125	ACVS2-P3P	I/O	126	GND	-
127	ACAD21-PYP	I/O	128	ACRST-PYN	I/O
129	ACAD22-PYP	I/O	130	ACSERR-PYN	I/O
131	ACAD23-PYP	I/O	132	ACREQ-PYN	I/O
133	ACAD24-PYP	I/O	134	GND	-

Table C-6 PC card I/F connector (150-pin) (3/3)

PIN No.	Signal name	I/O	PIN No.	Signal name	I/O
135	ACCBE3-PYN	I/O	136	ACAD25-PYP	I/O
137	ACAUDI-PYP	I/O	138	ACAD26-PYP	I
139	ACSTSC-PYP	I/O	140	ACAD27-PYP	I/O
141	ACAD28-PYP	I/O	142	GND	-
143	ACAD29-PYP	I/O	144	ACAD30-PYP	I/O
145	ACD02-PYP	I/O	146	ACAD31-PYP	I/O
147	ACCLKR-PYN	I/O	148	ACCD2-P3N	I/O
149	GND	-	150	GND	-
1T	GND	-	2T	GND	-

C.7 IS2101 Bridge media I/F connector (42-pin)*Table C-7 Bridge media I/F connector (42-pin)*

PIN No.	Signal name	I/O	PIN No.	Signal name	I/O
1	MSDAT2-P3P	I/O	2	MSDAT3-P3P	I/O
3	MSBS-P3P	I/O	4	GND	-
5	GND	-	6	FM-P3V	I
7	MSCLK-P3P	I/O	8	MSDAT3-P3P	I/O
9	MSCD-P3N	O	10	MSDAT2-P3P	I/O
11	MSSDI0-P3P	I/O	12	MSDAT1-P3P	I/O
13	MSBS-P3P	I/O	14	GND	-
15	FM-P3V	I	16	MSCLK-P3P	I/O
17	GND	-	18	MSSDI0-P3P	I/O
19	MSSDAT1-P3P	I/O	20	FM-P3V	I
21	SDAT3-P3P	I/O	22	SDAT2-P3P	I/O
23	SDAT1-P3P	I/O	24	SDAT0-P3P	I/O
25	MSDAT3-P3P	I/O	26	MSDAT2-P3P	I/O
27	MSDAT1-P3P	I/O	28	MSSDI0-P3P	I/O
29	GND	-	30	MSCLK-P3P	I/O
31	XDWE-P3N	I	32	SDCMD-P3P	I/O
33	SMCLE-P3P	I/O	34	XDCE-P3N	I
35	XDRE-P3N	I	36	SMRDY-P3P	I
37	MXDCD-P3N	I	38	GND	-
39	GND	-	40	SDCD-P3N	O
41	GND	-	42	SDWP-P3P	O
1T	GND	-	2T	GND	-
2T	GND	-	4T	GND	-

C.8 CN2400 WW Tuner I/F connector (124-pin)*Table C-8 WW Tuner I/F connector (124-pin) (1/2)*

PIN No.	Signal name	I/O	PIN No.	Signal name	I/O
1	MSDAT2-P3P	I/O	2	MSDAT3-P3P	I/O
3	MSBS-P3P	I/O	4	GND	-
5	GND	-	6	FM-P3V	I
7	MSCLK-P3P	I/O	8	MSDAT3-P3P	I/O
9	MSCD-P3N	O	10	MSDAT2-P3P	I/O
11	MSSDI0-P3P	I/O	12	MSDAT1-P3P	I/O
13	MSBS-P3P	I/O	14	GND	-
15	FM-P3V	I	16	MSCLK-P3P	I/O
17	GND	-	18	MSSDI0-P3P	I/O
19	MSSDAT1-P3P	I/O	20	FM-P3V	I
21	SDAT3-P3P	I/O	22	SDAT2-P3P	I/O
23	SDAT1-P3P	I/O	24	SDAT0-P3P	I/O
25	MSDAT3-P3P	I/O	26	MSDAT2-P3P	I/O
27	MSDAT1-P3P	I/O	28	MSSDI0-P3P	I/O
29	GND	-	30	MSCLK-P3P	I/O
31	XDWE-P3N	I	32	SDCMD-P3P	I/O
33	SMCLE-P3P	I/O	34	XDCE-P3N	I
35	XDRE-P3N	I	36	SMRDY-P3P	I
37	MXDCD-P3N	I	38	GND	-
39	GND	-	40	SDCD-P3N	O
41	GND	-	42	SDWP-P3P	O
1T	GND	-	2T	GND	-
2T	GND	-	4T	GND	-
47	AD23-P3P	I/O	48	T1IDSL-P3P	I/O
49	GND	-	50	GND	-
51	AD21-P3P	I/O	52	AD22-P3P	I/O
53	AD19-P3P	I/O	54	AD20-P3P	I/O
55	GND	-	56	PAR-P3P	I/O
57	AD17-P3P	I/O	58	AD18-P3P	I/O
59	CBE2-P3N	I/O	60	AD16-P3P	I/O
61	IRDY-P3N	I/O	62	GND	-
63	T1-P3V	I	64	FRAME-P3N	I/O
65	CLKRUN-P3N	I/O	66	TRDY-P3N	I/O
67	SERR-P3N	I	68	STOP-P3N	I/O

Table C-8 WW Tuner I/F connector (124-pin) (2/2)

PIN No.	Signal name	I/O	PIN No.	Signal name	I/O
69	GND	-	70	T1-P3V	I
71	PERR-P3N	I/O	72	DEVSEL-P3N	I/O
73	CBE1-P3N	I/O	74	GND	-
75	AD14-P3P	I/O	76	AD15-P3P	I/O
77	GND	-	78	AD13-P3P	I/O
79	AD12-P3P	I/O	80	AD11-P3P	I/O
81	AD10-P3P	I/O	82	GND	-
83	GND	-	84	AD09-P3P	I/O
85	AD08-P3P	I/O	86	CBE0-P3N	I/O
87	AD07-P3P	I/O	88	T1-P3V	-
89	T1-P3V	I	90	AD06-P3P	I/O
91	AD05-P3P	I/O	92	AD04-P3P	I/O
93	BCRST-P3N	O	94	AD02-P3P	I/O
95	AD03-P3P	I/O	96	AD00-P3P	I/O
97	P5V	I	98	P5V	-
99	AD01-P3P	I/O	100	NC	-
101	GND	-	102	GND	-
103	BCIO-P5P	I/O	104	TMPTU1-SXP	I
105	NC	-	106	TMPMPG-SXP	I
107	NC	-	108	TMPCPL-SXP	I
109	NC	-	110	TMPTU3-SXP	I
111	BCCDET-P3N	I	112	(Aver EX_IN_R)	-
113	GND	-	114	GND	-
115	XBCCLK-P3P	O	116	GND	-
117	GND	-	118	GND	-
119	GND	-	120	GND	-
121	BCPWON-P3P	I	122	(TADCEN-P3P)	-
123	P5V	I	124	NC	-

C.9 CN2450 BC board I/F connector (8-pin)*Table C-9 BC board I/F connector (8-pin)*

PIN No.	Signal name	I/O	PIN No.	Signal name	I/O
1	BCAS-P5V	-	2	BCIO-P5P	I/O
3	BCRST-P3N	O	4	GND	-
5	XBCCLK-P3P	O	6	GND	-
7	BCCDET-P3N	I	8	GND	-
1T	GND	-	2T	GND	-

C.10 CN2600 Wireless LAN card I/F connector (52-pin)*Table C-10 Wireless LAN card I/F connector (52-pin) (1/2)*

PIN No.	Signal name	I/O	PIN No.	Signal name	I/O
1	PEWAKE-E3N	O	2	P3V	-
3	WCHDAT-P3P	O	4	GND	-
5	WCHCLK-P3P	O	6	1R5-P1V	-
7	MPEXRQ-P3N	I	8	NC	-
9	GND	-	10	NC	-
11	XPEMPE-P3N	O	12	NC	-
13	XPEMPE-P3P	O	14	NC	-
15	GND	-	16	NC	-
17	NC	-	18	GND	-
19	NC	-	20	(WLON-S3N)	O
21	GND	-	22	PLTRS2-E3N	-
23	ZPERWL-P1N	I	24	E3V	-
25	ZPERWL-P1P	I	26	GND	-
27	GND	-	28	1R5-P1V	-
29	GND	-	30	SMBCL1-P3P	O
31	ZPETWL-P1N	O	32	SMBDAT-P3P	O
33	ZPETWL-P1P	O	34	GND	-
35	GND	-	36	NC	-
37	NC	-	38	1R5-P1V	-
39	NC	-	40	GND	-
41	NC	-	42	NC	-
43	NC	-	44	NC	-
45	NC	-	46	NC	-
47	NC	-	48	1R5-P1V	-

Table C-10 Wireless LAN card I/F connector (52-pin) (2/2)

PIN No.	Signal name	I/O	PIN No.	Signal name	I/O
49	NC	-	50	GND	-
51	NC	-	52	P3V	-
1T	GND	-	2T	GND	-

C.11 CN3010 MDC I/F connector (12-pin)

Table C-11 MDC I/F connector (12-pin)

PIN No.	Signal name	I/O	PIN No.	Signal name	I/O
1	GND	-	2	NC	-
3	ACZOT1-P3P	I/O	4	NC	-
5	GND	-	6	E3V	-
7	ACZSY1-P3P	O	8	GND	-
9	ACZIN1-E3P	I/O	10	GND	-
11	ACZRS1-E3N	O	12	XAZBC1-P3P	O
1T	GND	-	2T	GND	-
3T	GND	-	4T	GND	-
5T	GND	-	6T	GND	-

C.12 CN3200 Keyboard I/F connector (34-pin)*Table C-12 Keyboard I/F connector (34-pin)*

PIN No.	Signal name	I/O	PIN No.	Signal name	I/O
1	NUMLED-P5N	I/O	2	ARWLED-P5N	I/O
3	CAPLED-P5N	I/O	4	P5V	-
5	KBSC00-S3N	O	6	KBSC01-S3N	O
7	KBSC02-S3N	O	8	KBSC03-S3N	O
9	KBSC04-S3N	O	10	KBSC05-S3N	O
11	KBSC06-S3N	O	12	KBRT00-S3N	O
13	KBSC07-S3N	O	14	KBSC08-S3N	O
15	KBSC09-S3N	O	16	KBRT01-S3N	O
17	KBRT02-S3N	O	18	KBRT03-S3N	O
19	KBSC10-S3N	O	20	KBSC11-S3N	O
21	KBRT04-S3N	O	22	KBRT05-S3N	O
23	KBSC12-S3N	O	24	KBSC13-S3N	O
25	KBRT06-S3N	O	26	KBRT07-S3N	O
27	KBSC14-S3N	O	28	KBSC15-S3N	O
29	P5V	-	30	N.C	-
31	N.C	-	32	N.C	-
33	N.C	-	34	P5V	-
1T	GND	-	2T	GND	-

C.13 CN3201 Touch Pad I/F connector (4-pin)*Table C-13 Touch Pad I/F connector (4-pin)*

PIN No.	Signal name	I/O	PIN No.	Signal name	I/O
1	GND	-	2	IPDCLK-P5P	I/O
3	IPDDAT-P5P	I/O	4	P5V	-

C.14 CN3330 Volume I/F connector (3-pin)*Table C-14 Volume I/F connector (3-pin)*

PIN No.	Signal name	I/O	PIN No.	Signal name	I/O
1	(ROTEA-S3N)	O	2	GND	-
3	(ROTEB-S3N)	O			

C.15 J4100 Network I/F connector (12-pin)*Table C-15 Network I/F connector (12-pin)*

PIN No.	Signal name	I/O	PIN No.	Signal name	I/O
1	ZMDIOP-EYP	I/O	2	ZMDION-EYN	I/O
3	ZMDI1P-EYP	I/O	4	ZMDI2P-EYP	I/O
5	ZMDI2N-EYP	I/O	6	ZMDI1N-EYP	I/O
7	ZMDI3P-EYP	I/O	8	ZMDI3N-EYP	I/O
9	(LAN-E3V)	-	10	LLINK-E3N	O
11	(LAN-E3V)	-	12	LACT-E3N	O
1T	GND	-	2T	GND	-

C.16 CN4200 1394 I/F connector (4-pin)*Table C-16 1394 I/F connector (4-pin)*

PIN No.	Signal name	I/O	PIN No.	Signal name	I/O
1	ZTPB0-P3N	I/O	2	ZTPB0-P3P	I/O
3	ZTPA0-P3N	I/O	4	ZTPA0-P3P	I/O
1T	GND	-	2T	GND	-
3T	GND	-	4T	GND	-

C.17 CN4400 Bluetooth I/F connector (20-pin)*Table C-17 Bluetooth I/F connector (20-pin)*

PIN No.	Signal name	I/O	PIN No.	Signal name	I/O
1	BT-P3V	-	2	NC	-
3	WCHDAT-P3P	O	4	ZUSBBT-E3N	I/O
5	ZUSBBT-E3P	I/O	6	NC	-
7	WCHCLK-P3P	O	8	(GND)	-
9	NC	-	10	GND.	-
11	NC	-	12	NC	-
13	BTRST-S3N	O	14	NC	-
15	NC	-	16	NC	-
17	NC	-	18	BTMDL-P3N	I
19	NC	-	20	GND	-
1T			2T		

C.18 CN4610 USB I/F connector Port5/Port7 (8-pin)*Table C-18 USB I/F connector Port5/Port7 (8-pin)*

PIN No.	Signal name	I/O	PIN No.	Signal name	I/O
A1	USB0PS-E5V	-	A2	ZUSBP5-E3N	I/O
A3	ZUSBP5-E3P	I/O	A4	GND	-
B1	USB0PS-E5V	-	B2	ZUSBP7-E3N	I/O
B3	ZUSBP7-E3P	I/O	B4	GND	-
1T	GND	-	2T	GND	-
3T	GND	-	4T	GND	-
5T	GND	-	6T	GND	-

C.19 CN4611 USB I/F connector Port0/Port4 (8-pin)*Table C-19 USB I/F connector Port0/Port4 (8-pin)*

PIN No.	Signal name	I/O	PIN No.	Signal name	I/O
1	USB1PS-E5V	-	2	ZUSBP4-E3N	I/O
3	ZUSBP4-E3P	I/O	4	GND	-
5	USB1PS-E5V	-	6	ZUSBP0-E3N	I/O
7	ZUSBP0-E3P	I/O	8	GND	-
1T	GND	-	2T	GND	-

C.20 CN5500 LCD I/F connector (40-pin)*Table C-20 LCD I/F connector (40-pin)*

PIN No.	Signal name	I/O	PIN No.	Signal name	I/O
1	FL-P5V	-	2	FL-P5V	-
3	FL-P5V	-	4	FL-P5V	-
5	FL-P5V	-	6	FL-P5V	-
7	PNL-P3V	-	8	PNL-P3V	-
9	GND	-	10	GND	-
11	GND	-	12	GND	-
13	GND	-	14	GND	-
15	GND	-	16	GND	-
17	GND	-	18	GND	-
19	BRT0-P5P	O	20	BRT1-P5P	O
21	BRT2DA-S3P	O	22	NC	-
23	NC	-	24	GND	-
25	GND	-	26	LCDSCL-P3P	O
27	P3V	-	28	LCSDA-P3N	O
29	GND	-	30	ZTXDA1-PYP	O
31	ZTXDA1-PYN	O	32	GND	-
33	ZTXDA1-PYP	O	34	ZTXDA1-PYN	O
35	GND	-	36	ZTXDA0-PYP	O
37	ZTXDA0-PYN	O	38	GND	-
39	XTXCKA -PYP	O	40	XTXCKA-PYN	O
1T	GND	-	2T	GND	-
3T	GND	-	4T	GND	-
5T	GND	-	6T	GND	-

C.21 CN5080 RGB I/F connector (15-pin)*Table C-21 RGB I/F connector (15-pin)*

PIN No.	Signal name	I/O	PIN No.	Signal name	I/O
1	SYSRED-PXP	O	2	SYSGRN-PXP	O
3	SYSBLU-PXP	O	4	NC	-
5	GND	-	6	GND	-
7	GND	-	8	GND	-
9	(P5V)	-	10	GND	-
11	NC	-	12	CRTSDA-P5P	O
13	(HSYNC+CR TEN)	O	14	(AVSYNC-P3P)	O
15	CRTSCL-P5P	O			
1T	GND	-	2T	GND	-

C.22 CN5501 S-video OUT connector (4-pin)*Table C-22 S-video OUT connector (4-pin)*

PIN No.	Signal name	I/O	PIN No.	Signal name	I/O
1	GND	-	2	GND	-
3	(LUMINA)	O	4	(CHROMA)	O
1T	GND	-	2T	GND	-
3T	GND	-	4T	GND	-

C.23 CN5502 D-video I/F connector (14-pin)*Table C-23 D-video I/F connector (14-pin)*

PIN No.	Signal name	I/O	PIN No.	Signal name	I/O
1	HDTVY-PXP	O	2	GND	-
3	HDTV PB-PXP	O	4	GND	-
5	HDTV PR-PXP	O	6	GND	-
7	LINOTL-PXP	O	8	DLINE1-P5P	I/O
9	DLINE2-P5P	I/O	10	LINOTR-PXP	O
11	DLINE3-P5P	I/O	12	(GND)	-
13	A-GND	-	14	DHPLUG-P5P	I/O

C.24 CN6170 Speaker connector (4-pin)*Table C-24 Speaker connector (4-pin)*

PIN No.	Signal name	I/O	PIN No.	Signal name	I/O
1	SPOTL-PXN	O	2	SPOTL-PXP	O
3	SPOTR-PXP	O	4	SPOTR-PXN	O

C.25 CN8800 DC IN connector (4-pin)*Table C-25 DC IN connector (4-pin)*

PIN No.	Signal name	I/O	PIN No.	Signal name	I/O
1	(ADPDC)	I	2	(ADPDC)	I
3	GND	-	4	GND	-

C.26 CN8810 Battery connector (10-pin)*Table C-26 Battery connector (10-pin)*

PIN No.	Signal name	I/O	PIN No.	Signal name	I/O
1	PVBL1	O	2	BTMP1	I/O
3	BATDCHG	-	4	(M5V)	-
5	PSCL-S5P	I	6	PSDA-S5P	I
7	GND	-	8	DBT10V-S5N	O
9	GND	-	10	GND	-

C.27 CN9990 RTC battery connector (3-pin)*Table C-27 RTC battery connector (3-pin)*

PIN No.	Signal name	I/O	PIN No.	Signal name	I/O
1	(R3V)	I	2	NC	-
3	GND	-			
1T	GND	-	2T	GND	-

C.28 CN8771 CPU FAN connector (4-pin)*Table C-28 CPU FAN connector (4-pin)*

PIN No.	Signal name	I/O	PIN No.	Signal name	I/O
1	P5V	-	2	FANGO-P3P	O
3	GND	-	4	(FPWMO-S3P)	O

C.29 CN8781 VGA FAN connector (4-pin)*Table C-29 VGA FAN connector (4-pin)*

PIN No.	Signal name	I/O	PIN No.	Signal name	I/O
1	P5V	-	2	FANG1-P3P	O
3	GND	-	4	(FPWM1-S3P)	O

C.30 CN9500 LE board I/F connector (20-pin)*Table C-30 LE board I/F connector (20-pin)*

PIN No.	Signal name	I/O	PIN No.	Signal name	I/O
1	GND	-	2	RCIRRX-S5P	I
3	(BTLED-P5N)	O	4	LERNLE-S3P	O
5	P5V	-	6	NC	-
7	GND	-	8	(FMLED-P5N)	O
9	BTSWON-S3N	I	10	GND	-
11	(ESTLED-S5N)	O	12	(SATLED-P3N)	O
13	BAT1GR-S5N	O	14	BAT1OR-S5N	O
15	M5V	-	16	(PWLEGR-S5N)	O
17	(PWLEOR-S5N)	O	18	DCINGR-S5N	O
19	DCINOR-S5N	O	20	GND	-
1T	GND	-	2T	GND	-

C.31 CN9530 FS board I/F connector (6-pin)*Table C-31 FS board I/F connector (6-pin)*

PIN No.	Signal name	I/O	PIN No.	Signal name	I/O
1	Power E3V	-	2	FGSPON-P3V	O
3	GND	-	4	ZUSBFS-E3N	I/O
5	ZUSBFS-E3P	I/O	6	GND	-
1T	GND	-	2T	GND	-

C.32 CN6500 JK board I/F connector (20-pin)*Table C-32 JK board I/F connector (20-pin)*

PIN No.	Signal name	I/O	PIN No.	Signal name	I/O
1	MICBIS-P2V	O	2	A-GND	-
3	MICIN-PXP	I	4	VREF1-P2V	-
5	LININL-PXP	I	6	A-GND	-
7	LININR-PXP	I	8	HEADL2-PXP	O
9	A-GND	-	10	HEADR2-PXP	O
11	SPKEN-P4N	I	12	A4R7-P4V	-
13	A4R7-P4V	-	14	NC	-
15	SPD3V-P3V	-	16	DETECT-P4N	I
17	SPDJIN-P3N	I	18	GND	-
19	DOUT-P3P	O	20	GND	-
1T	GND	-	2T	GND	-

C.33 CN9650 SW board I/F connector (20-pin)*Table C-33 SW board I/F connector (20-pin)*

PIN No.	Signal name	I/O	PIN No.	Signal name	I/O
1	PNLOFF-S3N	I	2	GNBTNE-S3N	I
3	GNBTND-S3N	I	4	GNBTNC-S3N	I
5	GNBTNB-S3N	I	6	GNBTNA-S3N	I
7	GND	-	8	GND	-
9	KBSC16-S3N	O	10	NC	-
11	KBRT00-S3N	I	12	KBRT01-S3N	I
13	KBRT02-S3N	I	14	KBRT03-S3N	I
15	CDBTN-S3N	I	16	TVBTN-S3N	I
17	PWRSW-S3N	I	18	NC	-
19	GND	-	20	P5V	-
1T	GND	-	2T	GND	-

JK board (FUHJK*)**C.34 CN6510 System board I/F connector (20-pin)***Table C-34 System board I/F connector (20-pin)*

PIN No.	Signal name	I/O	PIN No.	Signal name	I/O
1	GND	-	2	DOUT-P3P	I
3	GND	-	4	SPDJIN-P3N	O
5	DETECT-P4N	O	6	SPD3V-P3V	-
7	NC	-	8	A4R7-P4V	-
9	A4R7-P4V	-	10	SPKEN-P4N	O
11	HEADR2-PXP	I	12	A-GND	-
13	HEADL2-PXP	I	14	LININR-PXP	O
15	A-GND	-	16	LININL-PXP	O
17	VREF1-P2V	-	18	MICIN-PXP	O
19	A-GND	-	20	MICBIS-P2V	I
1T	GND	-	2T	GND	-

C.35 CN6050 Internal microphone connector (2-pin)*Table C-35 Internal microphone connector (2-pin)*

PIN No.	Signal name	I/O	PIN No.	Signal name	I/O
1	(MICIN)	I	2	A-GND	-

C.36 J6051 External microphone connector (6-pin)*Table C-36 External microphone connector (6-pin)*

PIN No.	Signal name	I/O	PIN No.	Signal name	I/O
1	A-GND	-	2	(MICIN-PXP)	I
3	(BIAS)	-	4	N.C.	-
5	NC	-	6	(MICIN)	I

C.37 DS6320 Headphone connector (9-pin)*Table C-37 Headphone connector (9-pin)*

PIN No.	Signal name	I/O	PIN No.	Signal name	I/O
1	(SPKEN-P4N)	O	2	HEADL2-PXP	I
3	HEADR2-PXP	I	4	A-GND	-
5	SPDJIN-P3N	-	6	NC	-
7	DOUT-P3P	I	8	SPD3V-P3V	-
9	GND	-			

C.38 CN9612 TV-in connector (5-pin)*Table C-38 TV-in connector (5-pin)*

PIN No.	Signal name	I/O	PIN No.	Signal name	I/O
1	(EXINR-PXP)	I	2	(TIF-GND)	-
3	EXCVBS-PXP	I	4	(EXINL-PXP)	I
5	(TIF-GND)	-			

C.39 J9614 AV-in connector (12-pin)*Table C-39 AV-in connector (12-pin)*

PIN No.	Signal name	I/O	PIN No.	Signal name	I/O
1	GND	-	2	TIF-GND	-
3	EXINR-PXP	O	4	TVA-P3V	-
5	EXINL-PXP	O	6	TIF-GND	-
7	EXCVBS-PXP	O	8	TIF-GND	-
9	CROMIN-PXP	O	10	TIF-GND	-
11	LUMAIN-PXP	O	12	GND	-

LE board (FUHLE*)**C.40 CN9510 System board I/F connector (20-pin)***Table C-40 System board I/F connector (20-pin)*

PIN No.	Signal name	I/O	PIN No.	Signal name	I/O
1	GND	-	2	RCIRRX-S5P	O
3	BTLED-M5N	I	4	LERNLE-S3P	I
5	P5V	-	6	LERNRX-P5N	O
7	LERNON-P5N	I	8	FMLED-P5N	I
9	BTSWON-S3N	I	10	GND	-
11	ESTLRD-S5N	I	12	SATLED-S5N	I
13	BAT1GR-S5N	I	14	BAT1OR-S5N	I
15	M5V	-	16	PWLEGR-S5N	I
17	PWLEOR-S5N	I	18	DCINGR-S5N	I
19	DCINOR-S5N	I	20	GND	-
1T	GND	-	2T	GND	-

TP board (FUHTP*)**C.41 CN3250 System board I/F connector (4-pin)***Table C-41 System board I/F connector (4-pin)*

PIN No.	Signal name	I/O	PIN No.	Signal name	I/O
1	GND	-	2	IPDCLK-P5P	I/O
3	IPDDAT-P6P	I/O	4	P5V	-
1T	GND	-	2T	GND	-

C.42 CN3251 Touch pad I/F connector (12-pin)*Table C-42 Touch pad I/F connector (12-pin)*

PIN No.	Signal name	I/O	PIN No.	Signal name	I/O
1	P5V	-	2	P5V	-
3	GND	-	4	GND	-
5	(Right SW)	I	6	(Right SW)	I
7	(Left SW)	I	8	(Left SW)	I
9	IPDDAT-P6P	I/O	10	IPDDAT-P6P	I/O
11	IPDCLK-P5P	I/O	12	IPDCLK-P5P	I/O
1T	GND	-	2T	GND	-

SW board (FUHSW*)

C.43 CN9660 System board I/F connector (20-pin)

Table C-43 System board I/F connector (20-pin)

PIN No.	Signal name	I/O	PIN No.	Signal name	I/O
1	LED	I	2	LED	O
3	NC	-	4	PWRSW-S3N	O
5	TVBTN-S3N	O	6	CDBTN-S3N	O
7	KBRT3-S3N	O	8	KBRT2-S3N	O
9	KBRT1-S3N	O	10	KBRT0-S3N	O
11	NC	-	12	KBSC16-S3N	I
13	GND	-	14	IPDCLK-P5P	I/O
15	GNBTNA-S3N	O	16	GNBTNB-S3N	O
17	GNBTNC-S3N	O	18	GNBTND-S3N	O
19	GNBTNE-S3N	O	20	PNLOFF-S3N	O
1T	GND	-	2T	GND	-

FS board (FUHFS*)**C.44 CN9540 System board I/F connector (6-pin)***Table C-44 System board I/F connector (6-pin)*

PIN No.	Signal name	I/O	PIN No.	Signal name	I/O
1	Power P3V	-	2	FGSPON-P3V	I
3	GND	-	4	ZUSBFS-E3N	I/O
5	ZUSBFS-E3P	I/O	6	GND	-
1T	GND	-	2T	GND	-

Appendix D Keyboard Scan/Character Codes

D.1 Scan Codes

Table D-1 Scan codes (set 1 and set 2) (1/4)

Cap No.	Keypop	Code set 1		Code set 2		Note	
		Make	Break	Make	Break		
01	' ~	29	A9	0E	F0	0E	
02	1 !	02	82	16	F0	16	
03	2 @	03	83	1E	F0	1E	
04	3 #	04	84	26	F0	26	
05	4 \$	05	85	25	F0	25	
06	5 %	06	86	2E	F0	2E	
07	6 ^	07	87	36	F0	36	
08	7 &	08	88	3D	F0	3D	*2
09	8 *	09	89	3E	F0	3E	*2
10	9 (0A	8A	46	F0	46	*2
11	0)	0B	8B	45	F0	45	
12	- _	0C	8C	4E	F0	4E	
13	= +	0D	8D	55	F0	55	
15	BkSp	0E	8E	66	F0	66	
16	Tab	0F	8F	0D	F0	0D	
17	Q	10	90	15	F0	15	
18	W	11	91	1D	F0	1D	
19	E	12	92	24	F0	24	
20	R	13	93	2D	F0	2D	
21	T	14	94	2C	F0	2C	
22	Y	15	95	35	F0	35	
23	U	16	96	3C	F0	3C	*2
24	I	17	97	43	F0	43	*2
25	O	13	98	44	F0	44	*2
26	P	19	99	4D	F0	4D	*2
27	[{	1A	9A	54	F0	54	
28] }	1B	9B	5B	F0	5B	

Table D-1 Scan codes (set 1 and set 2) (2/4)

Cap No.	Keytop	Code set 1		Code set 2			Note
		Make	Break	Make	Break		
29	\	2B	AB	5D	F0	5D	*5
30	Caps Lock	3A	BA	58	F0	58	
31	A	1E	9E	1C	F0	1C	
32	S	1F	9F	1B	F0	1B	
33	D	20	A0	23	F0	23	
34	F	21	A1	2B	F0	2B	
35	G	22	A2	34	F0	34	
36	H	23	A3	33	F0	33	
37	J	24	A4	3B	F0	3B	*2
38	K	25	A5	42	F0	42	*2
39	L	26	A6	4B	F0	4B	*2
40	; :	27	A7	4C	F0	4C	*2
41	' "	28	A8	52	F0	52	
43	Enter	1C	9C	5A	F0	5A	*3
44	Shift (L)	2A	AA	12	F0	12	
45	No.102 key	56	D6	61	F0	61	
46	Z	2C	AC	1A	F0	1A	
47	X	2D	AD	22	F0	22	
48	C	2E	AE	21	F0	21	
49	V	2F	AF	2A	F0	2A	
50	B	30	B0	32	F0	32	
51	N	31	B1	31	F0	31	
52	M	32	B2	3A	F0	3A	*2
53	, <	33	B3	41	F0	41	*2
54	. >	34	B4	49	F0	49	*2
55	/ ?	35	B5	4A	F0	4A	*2
57	Shift (R)	36	B6	59	F0	59	

Table D-1 Scan codes (set 1 and set 2) (3/4)

Cap No.	Keytop	Code set 1				Code set 2				Note	
		Make		Break		Make		Break			
58	Ctrl	1D		9D		14		F0	14	*3	
60	Alt (L)	38		B8		11		F0	11	*3	
61	Space	39		B9		29		F0	29		
62	ALT (R)	E0	38	E0	B8	E0	11	E0	F0	11	
75	Ins	E0	52	E0	D2	E0	70	E0	F0	70	*1
76	Del	E0	53	E0	D3	E0	71	E0	F0	71	*1
79	←	E0	4B	E0	CB	E0	6B	E0	F0	6B	*1
80	Home	E0	47	E0	C7	E0	6C	E0	F0	6C	*1
81	End	E0	4F	E0	CF	E0	69	E0	F0	69	*1
83	↑	E0	48	E0	C8	E0	75	E0	F0	75	*1
84	↓	E0	50	E0	D0	E0	72	E0	F0	72	*1
85	PgUp	E0	49	E0	C9	E0	7D	E0	F0	7D	*1
86	PgDn	E0	51	E0	D1	E0	7A	E0	F0	7A	*1
89	→	E0	4D	E0	CD	E0	74	E0	F0	74	*1
110	Esc	01		81		76		F0	76		
112	F1	3B		BB		05		F0	05		
113	F2	3C		BC		06		F0	06		
114	F3	3D		BD		04		F0	04		
115	F4	3E		BE		0C		F0	0C		
116	F5	3F		BF		03		F0	03		
117	F6	40		C0		0B		F0	0B		
118	F7	41		C1		83		F0	83		
119	F8	42		C2		0A		F0	0A		
120	F9	43		C3		01		F0	01		
121	F10	44		C4		09		F0	09	*3	

Table D-1 Scan codes (set 1 and set 2) (4/4)

Cap No.	Keytop	Code set 1				Code set 2				Note
		Make		Break		Make		Break		
122	F11	57	D7	78	F0	78			*3	
123	F12	58	D8	07	F0	07			*3	
124	PrintSc	*6	*6	*6	*6				*6	
126	Pause	*7	*7	*7	*7				*7	
202	Fn	—	—	—	—				*4	
203	Win	E0	5B	E0	DB	E0	1F	E0	F0	1F
204	App	E0	5D	E0	DD	E0	2F	E0	F0	2F

Notes:

1. * Scan codes differ by mode.
2. * Scan codes differ by overlay function.
3. * Combined with the **Fn** key makes different codes.
4. * **Fn** key does not generate a code by itself.
5. * This key corresponds to key No. 42 in a 102-key model.
6. * Refer to Table D-6, No. 124 key scan code.
7. * Refer to Table D-7, No. 126 key scan code.

Table D-2 Scan codes with left Shift key

Cap No.	Key top	Code set 1				Code set 2			
		Make		Break		Make		Break	
55	/	E0 AA E0 35	E0 B5 E0 2A	E0 F0 12 E0 4A	E0 F0 4A E0 12				
75	INS	E0 AA E0 52	E0 D2 E0 2A	E0 F0 12 E0 70	E0 F0 70 E0 12				
76	DEL	E0 AA E0 53	E0 D3 E0 2A	E0 F0 12 E0 71	E0 F0 71 E0 12				
79	←	E0 AA E0 4B	E0 CB E0 2A	E0 F0 12 E0 6B	E0 F0 6B E0 12				
80	Home	E0 AA E0 47	E0 C7 E0 2A	E0 F0 12 E0 6C	E0 F0 6C E0 12				
81	End	E0 AA E0 4F	E0 CF E0 2A	E0 F0 12 E0 69	E0 F0 69 E0 12				
83	↑	E0 AA E0 48	E0 C8 E0 2A	E0 F0 12 E0 75	E0 F0 75 E0 12				
84	↓	E0 AA E0 50	E0 D0 E0 2A	E0 F0 12 E0 72	E0 F0 72 E0 12				
85	PgUp	E0 AA E0 49	E0 C9 E0 2A	E0 F0 12 E0 7D	E0 F0 7D E0 12				
86	PgDn	E0 AA E0 51	E0 D1 E0 2A	E0 F0 12 E0 7A	E0 F0 7A E0 12				
89	→	E0 AA E0 4D	E0 CD E0 2A	E0 F0 12 E0 74	E0 F0 74 E0 12				
203	Win	E0 AA E0 5B	E0 DB E0 2A	E0 F0 12 E0 1F	E0 F0 1F E0 12				
204	App	E0 AA E0 5D	E0 DD E0 2A	E0 F0 12 E0 2F	E0 F0 2F E0 12				

Note : The table above shows scan codes with the left **Shift** key. In combination with the right **Shift** key, scan codes are changed as listed below:

	With left Shift	With right Shift
Set 1	E0 AA _____	E0 B6
	E0 2A _____	E0 36
Set 2	E0 F0 12 _____	E0 F0 59
	E0 12 _____	E0 59

Table D-3 Scan codes in Numlock mode

Cap No.	Key top	Code set 1				Code set 2			
		Make		Break		Make		Break	
75	INS	E0 2A E0 52	E0 D2 E0 AA	E0 12 E0 70	E0 F0 70 E0 F0 12				
76	DEL	E0 2A E0 53	E0 D3 E0 AA	E0 12 E0 71	E0 F0 71 E0 F0 12				
79	←	E0 2A E0 4B	E0 CB E0 AA	E0 12 E0 6B	E0 F0 6B E0 F0 12				
80	Home	E0 2A E0 47	E0 C7 E0 AA	E0 12 E0 6C	E0 F0 6C E0 F0 12				
81	End	E0 2A E0 4F	E0 CF E0 AA	E0 12 E0 69	E0 F0 69 E0 F0 12				
83	↑	E0 2A E0 48	E0 C8 E0 AA	E0 12 E0 75	E0 F0 75 E0 F0 12				
84	↓	E0 2A E0 50	E0 D0 E0 AA	E0 12 E0 72	E0 F0 72 E0 F0 12				
85	PgUp	E0 2A E0 49	E0 C9 E0 AA	E0 12 E0 7D	E0 F0 7D E0 F0 12				
86	PgDn	E0 2A E0 51	E0 D1 E0 AA	E0 12 E0 7A	E0 F0 7A E0 F0 12				
89	→	E0 2A E0 4D	E0 CD E0 AA	E0 12 E0 74	E0 F0 74 E0 F0 12				
203	Win	E0 2A E0 5B	E0 DB E0 AA	E0 12 E0 1F	E0 F0 1F E0 F0 12				
204	App	E0 2A E0 5D	E0 DD E0 AA	E0 12 E0 2F	E0 F0 2F E0 F0 12				

Table D-4 Scan codes with Fn key

Cap No.	Keytop	Code set 1		Code set 2	
		Make	Break	Make	Break
43	ENT	E0 1C	E0 9C	E0 5A	E0 F0 5A
58	CTRL	E0 1D	E0 9D	E0 14	E0 F0 14
60	LALT	E0 38	E0 B8	E0 11	E0 F0 11
121	ARROW	45	C5	77	F0 77
122	NUMERIC	45	C5	77	F0 77
123	Scrl	46	C5	7E	F0 7E

Table D-5 Scan codes in overlay mode

Cap No.	Keytop		Code set 1				Code set 2			
			Make		Break		Make		Break	
09	8	(8)	48		C8		75	F0	75	
10	9	(9)	49		C9		7D	F0	7D	
11	0	(*)	37		B7		7C	F0	7C	
23	U	(4)	4B		CB		6B	F0	6B	
24	I	(5)	4C		CC		73	F0	73	
25	O	(6)	4D		CD		74	F0	74	
26	P	(-)	4A		CA		7B	F0	7B	
37	J	(1)	4F		CF		69	F0	69	
38	K	(2)	50		D0		72	F0	72	
39	L	(3)	51		D1		7A	F0	7A	
40	;	(+)	4E		CE		79	F0	79	
52	M	(0)	52		D2		70	F0	70	
54	.	(.)	53		D3		71	F0	71	
55	/	(/)	E0 35		E0 B5		40 4A	E0 F0	4A	

Table D-6 No.124 key scan code

Key top	Shift	Code set 1				Code set 2			
		Make		Break		Make		Break	
Prt Sc	Common	E0 2A	E0 37	E0 B7	E0 AA	E0 12	E0 7C	E0 F0	7C E0 F0 12
	Ctrl +	E0 37		E0 B7		E0 7C		E0 F0	7C
	Shift +	E0 37		E0 B7		E0 7C		E0 F0	7C
	Alt +		54	D4		84		F0	B4

Table D-7 No.126 key scan code

Key top	Shift	Code set 1						Code set 2							
		Make						Make							
Pause	Common*	E1	1D	45	E1	9D	C5	E1	14	77	E1	F0	14	F0	77
	Ctrl*	E0	46	E0	C6			E0	7E	E0	F0	7E			

*: This key generates only make codes.

Appendix E Key Layout

E.1 US Keyboard



Figure E-1 US Keyboard layout

E.2 UK Keyboard



Figure E-2 UK Keyboard layout

Appendix F Wiring Diagrams

F.1 RGB Monitor ID Wraparound connector

(1) RED	_____	RED	(1)
(2) GREEN	_____	GREEN	(2)
(3) BLUE	_____	BLUE	(3)
(4) NC	_____	NC	(4)
(5) GND	_____	GND	(5)
(6) GND	_____	GND	(6)
(7) GND	_____	GND	(7)
(8) GND	_____	GND	(8)
(9) 5V	_____	5V	(9)
(10) GND	_____	GND	(10)
(11) NC	_____	NC	(11)
(12) SDA	_____	SDA	(12)
(13) HSYNC	_____	HSYNC	(13)
(14) VSYNC	_____	VSYNC	(14)
(15) SDL	_____	SCL	(15)

Figure F-1 RGB Monitor ID Wraparound connector (15PIN to 15PIN)

F.2 LAN loopback Connector

(1) BIBAP (TX+)	_____	(3) BIDBP (RX+)
(2) BIDAN (TX-)	_____	(4) BIDBN (RX-)

Figure F-2 LAN loopback connector

Appendix G BIOS Rewrite Procedures

This Appendix explains how to rewrite the system BIOS program when you update the system BIOS.

Tools

To rewrite the BIOS, you need the following tool:

- ❑ BIOS/EC/KBC rewriting disk

Rewriting the BIOS

1. Set the system to boot mode.
2. Turn off the power to the computer.
3. Remove the external cables and cards.
4. Connect an external FDD and insert the BIOS rewriting disk into the external FDD.
5. Turn on the power while holding down the tilde character key at the left of the **Space** key until beeps sound.

For example



(US Keyboard)



(UK Keyboard)

(Keep holding down the key.)

6. The BIOS rewriting starts.
7. When the process is completed, it beeps and the system automatically reboots.

NOTE:

1. Connect the AC adapter to the computer when you rewrite the BIOS.
2. Do not turn off the power while you are rewriting the BIOS.
If the rewrite fails, it might be impossible to start up the computer.
3. If you fail to rewrite BIOS, then when you next turn on the power, a message may be displayed that the contents of the BIOS have been erased. In this case, insert the BIOS rewriting disk and the BIOS will be rewritten.

Appendix H EC/KBC Rewrite Procedures

This Appendix explains how to rewrite the EC/KBC system program when you update the EC/KBC system.

It is necessary to rewrite the EC/KBC system program when the following changes are made.

1. Replacing of system board
2. Replacing of LCD

Tools

To rewrite the EC/KBC, you need the following tool:

- EC/KBC rewriting disk for the computer

Rewriting the EC/KBC

NOTE:

1. Rewrite the EC/KBC only when instructed by a diagnostic disk release notice.
2. Connect the AC adaptor to the computer when you rewrite the EC/KBC.
3. Do not turn off the power while you are rewriting the EC/KBC. If the rewrite fails, it might be impossible to start up the computer.
4. If you fail to rewrite EC/KBC, then when you next turn on the power, a message may be displayed that the contents of the EC/KBC have been erased. In this case, insert the EC/KBC rewriting disk, and the EC/KBC will be rewritten.
5. Normally it takes about 30 seconds to rewrite the EC/KBC. It may take 3 minutes (maximum), depending on the conditions of the computer or ICs. The computer is not hung up. Allow sufficient time. Never reboot or turn off the power to the computer before the rewriting is completed.

1. Set the system to boot mode.
2. Turn off the power to the computer.
3. Remove the external cables and cards.
4. Connect an external FDD and insert the EC/KBC rewriting disk into the external FDD.
5. Turn on the power while holding down the **Tab** key. (Keep holding down the key until a beep sounds.) The EC/KBC rewriting starts.
6. When the EC/KBC rewrite is completed, the system is automatically turned off.

Appendix I Reliability

The following table shows MTBF (Mean Time Between Failures) in maximum configuration.

Table I-1 MTBF

Component	Time (hours)
G73-HDD Model	7690

Appendix J Maintenance of TOSHIBA RAID

J.1 Outline of Maintenance (Repair) of TOSHIBA RAID

Follow the below procedures to repair TOSHIBA RAID

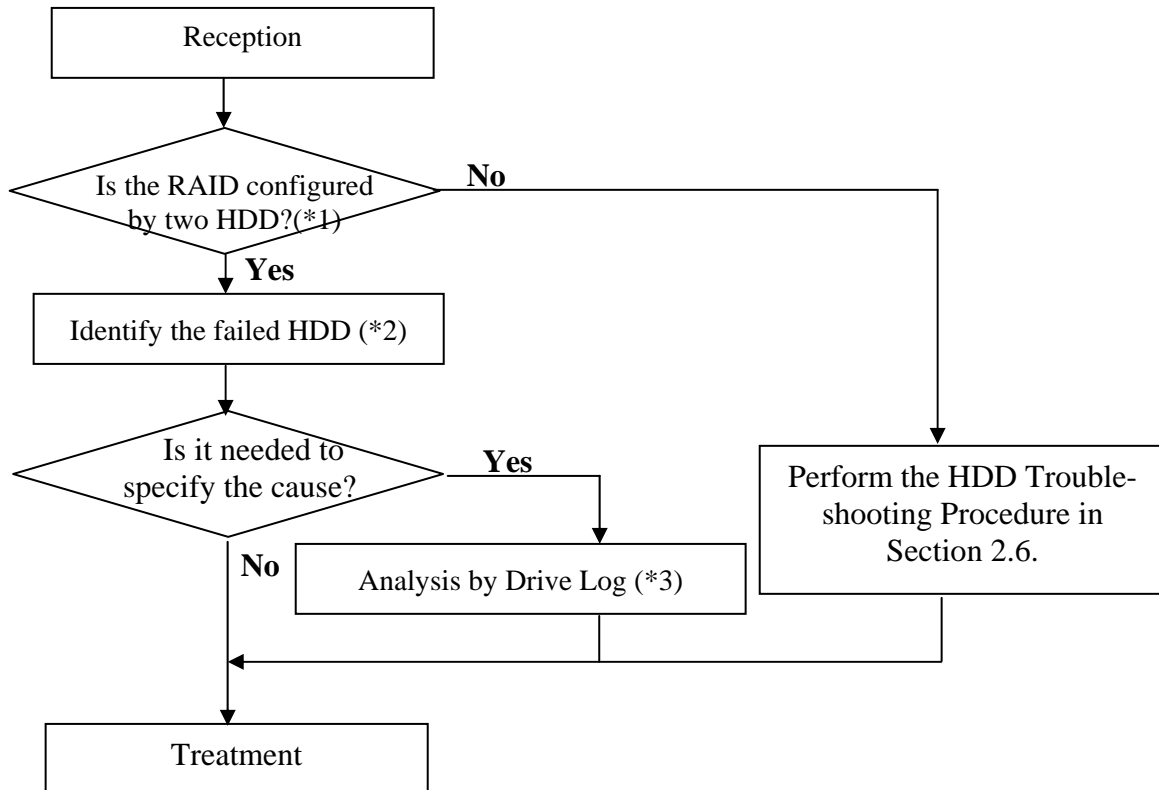

Figure J-1 Flowchart of repairing TOSHIBA RAID

*1: Refer to “Check of RAID configuration” in Section 3.2 in Chapter 3.

*2: Refer to “Identifying failed HDD” in Section 3.3.3 of Chapter 3.

*3: Refer to “Analysis by Drive Log” in section J.2.

J.2 Analysis and handling by Drive Log

Follow the below procedures to analyze.

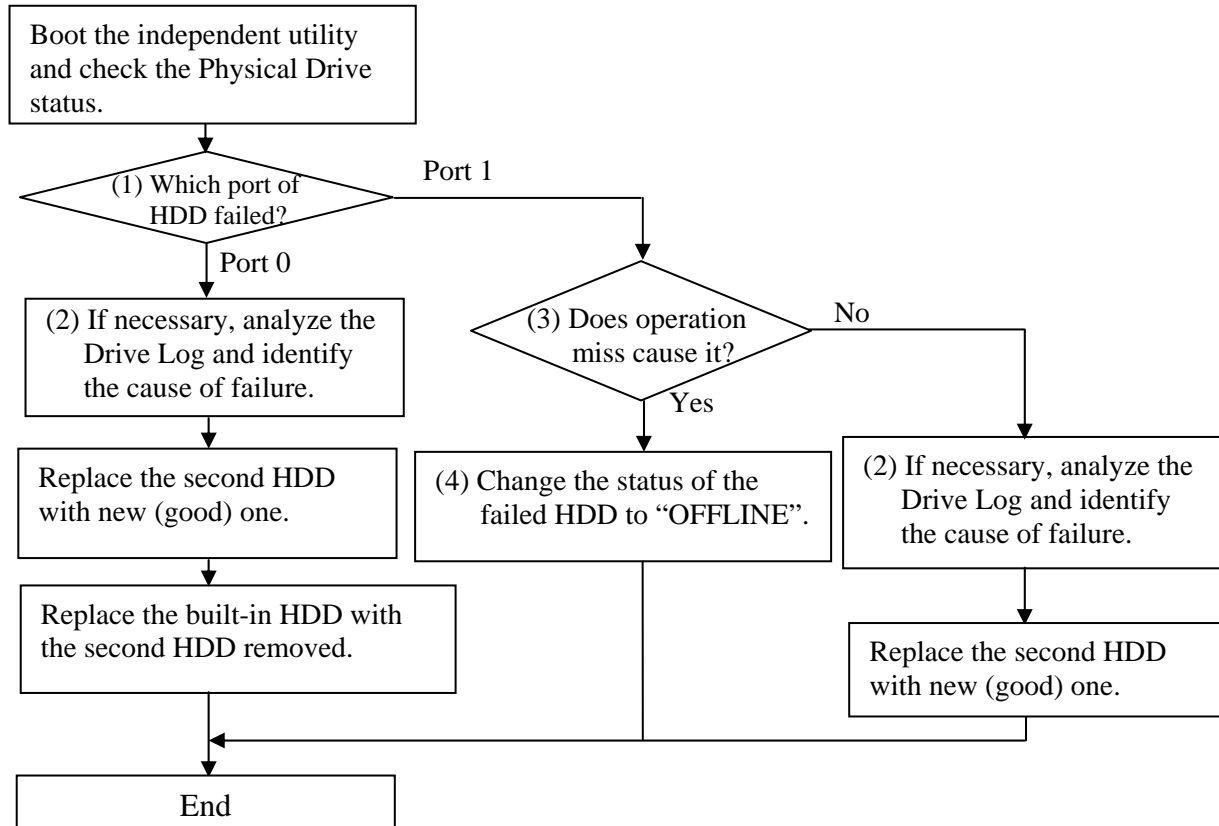

Figure J-2 Flowchart of Analysis and handling by Drive Log

How to identify the cause of failure

(1) When “Fail” or “NODRIVE” is displayed.

According to “Operation of Independent utility”, boot the independent utility to display the Drive Log.

To identify the failure cause of Port 0, analyze the Drive Log of [REDUNDANT] side of Port 1.

To identify the failure cause of Port 1, analyze the Drive Log of [REDUNDANT] side of Port 0.

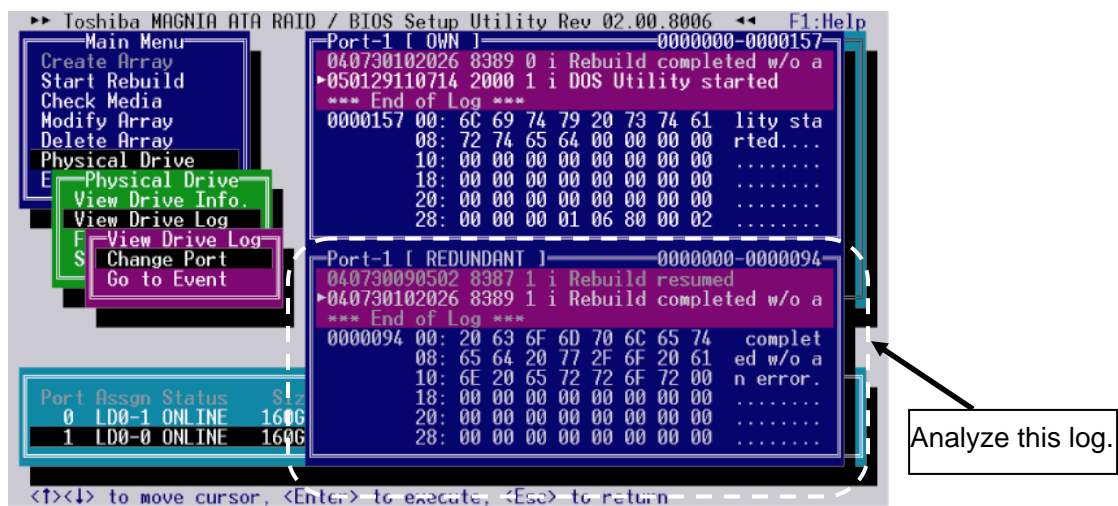

1. Find the log of message of “Fail this drive” last generated, using [PgUp] and [PgDn] keys.

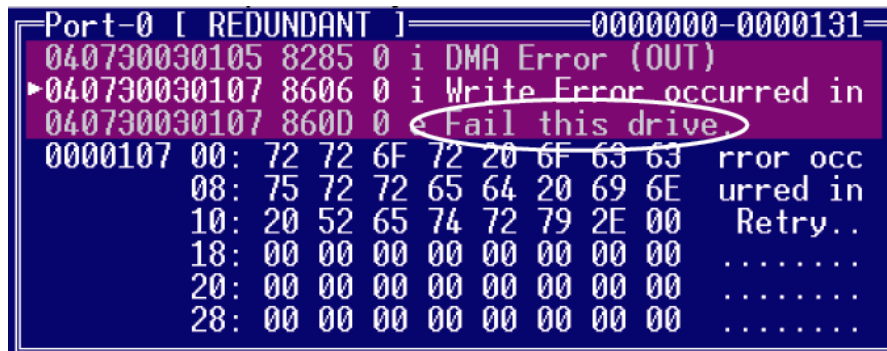

- Analyze the detailed date of the message of right before of “xxx Error (IN)”, “xxx Error (OUT)” (for example, “DMA Error (IN)”, “DMA Error (OUT)”) right before the log of “Fail this drive” message and identify the cause.

DMA Error (IN)

The screenshot shows a RAID controller log for Port-0 [REDUNDANT] with LBA range 00000000-0000131. The log entries are:

```

040730030105 8602 0 i Write Error occurred. R
▶040730030105 8284 0 i DMA Error (IN)
040730030105 8285 0 i DMA Error (OUT)
0000105 00: 6F 72 20 28 49 4E 29 00 or (IN).
08: 00 00 00 00 00 00 00 00 .....
10: 00 00 00 00 00 00 00 00 .....
18: 00 00 00 01 CD BC 85 01 .....
20: 00 00 41 00 35 00 00 00 ..A.5...
28: 00 00 00 00 71 76 9C 08 ....qv..
    
```

Annotations below the log:

- Sector Count**: Points to the value 41 in the 20th row.
- Command**: Points to the value 35 in the 20th row.
- LBA**: Points to the value 01 in the 18th row.

DMA Error (OUT)

The screenshot shows a RAID controller log for Port-0 [OWN] with LBA range 00000000-0000827. The log entries are:

```

041218234430 4284 0 i DMA Error (IN)
▶041218234430 4285 0 i DMA Error (OUT)
041218234430 4604 0 i Media Error occurred in
0000800 00: 6F 72 20 28 4F 55 54 29 or (OUT)
08: 00 00 00 00 00 00 00 00 .....
10: 00 00 00 00 00 00 00 00 .....
18: 40 00 01 00 01 00 50 01 @.....P.
20: 00 00 41 00 51 00 00 A0 ..A.Q...
28: 00 00 00 00 00 00 00 00 .....
    
```

Annotations below the log:

- Error**: Points to the value 40 in the 18th row.
- Status**: Points to the value 51 in the 20th row.

Command : Indicates Command code caused an error. The following list indicates the command

Table J-1 List of Command (1/2)

Protocol	Command	Devices not implementing the PACKET Command feature set	Devices implementing the PACKET Command feature set	Command code
ND	NOP	O	M	00h
ND	CFA REQUEST EXTENDED ERROR	O	N	03h
DR	DEVICE RESET	O	M	08h
PI	READ SECTOR(S)	M	N	20h
PI	READ SECTOR(S) EXT	O	N	24h
DM	READ DMA EXT	O	N	25h
DMO	READ DMA QUEUED EXT	O	N	26h
ND	READ NATIVE MAX ADDRESS EXT	O	N	27h
PI	READ MULTIPLE EXT	O	N	29h
PI	READ LOG EXT	O	O	2Fh
PO	WRITE SECTOR (S)	M	N	30h
PO	WRITE SECTOR (S) EXT	O	N	34h
DM	WRITE DMA EXT	O	N	35h
DMO	READ DMA QUEUED EXT	O	N	36h
ND	SET MAX ADDRESS EXT	O	N	37h
PO	CFA WRITE SECTORS W/OUT ERASE	O	N	38h
PO	WRITE MULTIPLE EXT	O	N	39h
PO	WRITE LOG EXT	O	O	3Fh
ND	READ VERIFY SECOTR(S)	M	N	40h
ND	READ VERIFY SECOTR(S) EXT	O	N	42h
ND	SEEK	M	N	70h
PI	CFA TRANSLATE SECTOR	O	N	87h
DD	EXECUTE DEVICE DIAGNOSTIC	M	M	90h
PO	DOWNLOAD MICROCODE	O	N	92h
P	PACKET	N	M	A0h
PI	IDENTIFY PACKET DEVICE	N	M	A1h
P	SERVICE	O	O	A2h
ND	SMART DISABLE OPERATIONS	O	N	B0h
ND	SMART ENABLE/DISABLE AUTOSAVE	O	N	B0h
ND	SMART ENABLE OPERATIONS	O	N	B0h
ND	SMART EXECUTE OFF LINE	O	N	B0h
PI	SMART READ DATA	O	N	B0h
PI	SMART READ LOG SECTOR	O	N	B0h
ND	SMART RETURNS STATUS	O	N	B0h
PO	SMART WRITE LOG SECTOR	O	N	B0h
ND	DEVICE CONFIGURATION FREEZE	O	O	B1h
PI	DEVICE CONFIGURATION IDENTIFY	O	O	B1h
ND	DEVICE CONFIGURATION RESTORE	O	O	B1h
PO	DEVICE CONFIGURATION SET	O	O	B1h
ND	CFA ERASE SECTORS	O	N	C0h
PI	READ MULTIPLE	M	N	C4h
PO	WRITE MULTIPLE	M	N	C5h
ND	SET MULTIPLE MODE	M	N	C6h
DMO	READ DMA QUEUED	O	N	C7h

Table J-1 List of Command (2/2)

Protocol	Command	Devices not implementing the PACKET Command feature set	Devices implementing the PACKET Command feature set	Command code
DM	READ DMA	M	N	C8h
DM	WRITE DMA	M	N	Cah
DMO	WRITE DMA QUEUED	O	N	CCh
PO	CFA WRITE MULTIPLE W/OUT ERASE	O	N	CDh
ND	CHECK MEDIA CARD TYPE	O	N	D1h
ND	GET MEDIA STATUS	O	O	DAh
ND	MEDIA LOCK	O	N	DEh
ND	MEDIA UNLOCK	O	N	DFh
ND	STANDBY IMMEDIATE	M	M	E0h
ND	IDLE IMMEDIATE	M	M	E1h
ND	STANDBY	M	O	E2h
ND	IDLE	M	O	E3h
PI	READ BUFFER	O	N	E4h
ND	CHECK POWER MODE	M	M	E5h
ND	SLEEP	M	M	E6h
ND	FLUSH CACHE	M	O	E7h
PO	WRITE BUFFER	O	N	E8h
ND	FLUSH CACHE EXT	O	N	Eah
PI	IDENTIFY DEVICE	M	N	EC0
ND	MEDIA EJECT	O	N	EDh
ND	SET FEATURES	M	M	Efh
PO	SECURITY SET PASSWORD	O	O	F1h
PO	SECURITY UNLOCK	O	O	F2h
ND	SECURITY ERASE PREPARE	O	O	F3h
PO	SECURITY ERASE UNIT	O	O	F4h
ND	SECURITY FREEZE LOCK	O	O	F5h
PO	SECURITY DISABLE PASSWORD	O	O	F6h
ND	READ NATIVE MAX ADDRESS	O	O	F8h
ND	SET MAX ADDRESS	O	O	F9h

LBA (Logical Block Address): First sector address caused an error.

Sector Count: Number of sectors transmitted from the address indicated by LBA.

STATUS: Status of command. The lowest bit becomes “1”, when an error occurs.

Error: Content of error. It indicates that an error occurs when the object bit is “1”.

Bit7:ICRC

Indicates that a CRC error occurs on the transmission bus (SATA) between Host and HDD.

Bit6:UNC

Indicates that an uncorrectable (media) error occurs.

Bit2:ABRT

Indicate that the command aborts.

(2) Check if it is caused by an operation miss or is a failure.

To check if the cause of failure of Port1 is an operation miss or not, analyze the Drive Log of Port0.

1. In [REDUNDANT] of Port-0, find a log of “Fail this drive” message by **[PgUp]** and **[PgDn]** key.
2. If no message of “Fail this drive” message, it is judged that the second HDD is removed without the operation of removal by TOSHIBA RAID console and installed again.

(3) How to change the status to OFF LINE

Release the status of “Fail”, using the menu of [Force OFFLINE]. This HDD is not necessary to be repaired.

J.3 Operation of Independent utility

J.3.1 Outline of Independent utility

This is a utility to display Drive Log of TOSHIBA RAID.

(1) Drive Log

TOSHIBA RAID can store about 7,000 logs of Drive Log.

TOSHIBA RAID makes Drive Log redundant and stores it. The drive has own log and other drive's log.

In TOSHIBA RAID, the log of own drive is called "Own Log" and the redundant log of other drive's drive is called "Redundant Log". Each port has "Own Log" and "Redundant Log". As shown in the following figure, the Port 0 has "Own Log" of Port0 and "Redundant Log" of Port1. The Port1 has "Own Log" of Port1 and "Redundant Log" of Port0.

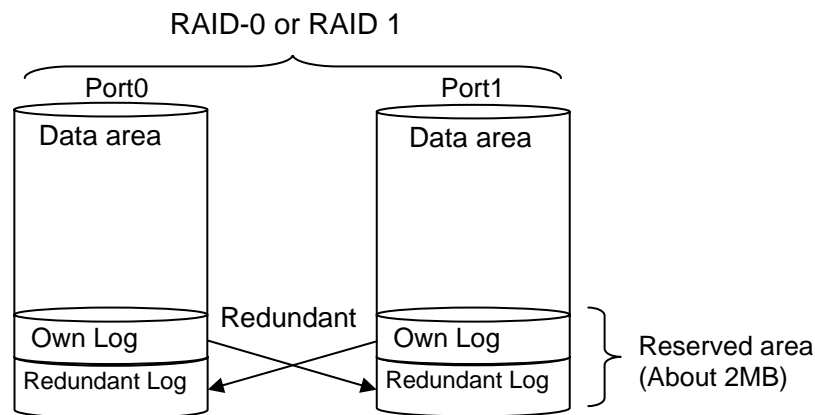

Figure J-3 Drive Log

(2) Information of Drive Log

TOSHIBA RAID writes the log when any change in RAID array or an error occurs. So, seeing the log can trace the history of the array or error information. In TOSHIBA RAID, about 7,000 logs can be stored and the past logs can be referred in detail.

J.3.2 How to operate the Independent Utility

(1) Booting PC

Connected the USB FDD to the PC to be repaired. Insert the FD storing the program of the Independent Utility in the FDD and boot the PC from the FD. The following display appears.

```

>> Toshiba MAGNIA ATA RAID / BIOS Setup Utility Rev 01.00.9030 << F1:Help
-----Main Menu-----
Create Array
Start Rebuild
Check Media
Modify Array
Delete Array
Physical Drive
Exit

-----Logical Drive-----
                LD0      LD1
Status
RAID Level
# of Drive
RAID ID
Capacity
Stripe Size
Write Cache
Degrade Bootup
MBR Protection
S.M.A.R.T.
Last MC

-----Physical Drive-----
Port Assgn Status   Size Model          Rev   Progress
0          OFFLINE 120GB ST3120023A     3.30
1          OFFLINE 40GB  ST340016A      3.19

<↑><↓> to move cursor, <Enter> to execute, <Esc> to return

```

In the Independent Utility, the cursor is moved by with [↑] key and [↓] key. Press [Enter] key to execute the option selected. Press [Esc] key to return to the previous menu.

Pressing [F1] key displays Help. Press [Esc] key to exit.

(2) Display of Logical/Physical Drive

Logical Drive

The status of RAID array is displayed in Logical Drive by array. The displayed items are follows.

Table J-2 Displayed item in Logical Drive

	Explanation
Status (Status of array)	Displays the status of array. The contents are follows. -OPTIMAL : The array works normally. -DEGRADE : The array is degraded. -CRITICAL : The array is failed. It can not be used.
RAID Level	Displays the RAID level.
# of Drive	Displays the number of physical drives incorporated in the array.
RAID ID	Displays peculiar ID by array.
Capacity	Displays the capacity of array.
Stripe Size	Item that is not set item.
Write Cache	Displays the setting of drive write cache. "Enable" or "Disable" is displayed. The default is "Enable". This option is displayed in RAID-1 (Mirroring).
Degrade Bootup	Displays if boot OS or not when the array is degraded. "Yes" (Boot up) or "No" (Not boot up) is displayed. The default is "Yes". This option is displayed in RAID-1 (Mirroring).
MBR Protection	Displays the setting of protection function of MBR (Master Boot Record). "Enable" (Protect) or "Disable" (Not protect) can be selected. The default is "Disable". When OS is installed by SetupInstructor, it is set automatically to "Enable". When OS is installed manually, it is set to "Enable". If necessary, change the setting.
S.M.A.R.T.	Displays the setting of failure prediction function of drive. "Enable" or "Disable" is displayed. The default is "Enable".
Last MC	Displays the date when checking of media or rebuilding of array executed last. It displays "00/00/00" right after making new array or when the rebuild limit is changed.

Physical Drive

In Physical Drive, the condition of RAID array is displayed by array. The following items are displayed.

Table J-3 Items displayed in Physical Drive

	Explanation
Port	Displays the port number of Serial ATA connected to the drive.
Assign	Displays the array number and drive number of array that the drive is incorporated. The display format is LD [Array number] [Drive number]. For example, [LD0-1] means the disk drive 1 of Array 0.
Status	Displays the drive status. The followings are displayed. -ONLINE: The drive is working normally. -OFFLINE: The drive is not configured as array and is not used. -FAIL: The drive is failed and dose not work. -REBUILDING: The drive is been rebuilding by data of normal drive or the rebuilding is suspended. -UNKNOWN: There is controversy in the RAID information of other drive and the status is not decided. It is displayed when this drive was removed and used in the past. When this drive has been found good one, setting to OFFLINE is possible by executing [Force Offline].
Size	Displays the capacity of drive.
Model	Displays the model number of drive.
Rev	Displays the firmware revision of drive.
Progress	Displays the progress of rebuilding and Check media.

(3) Explanation of Main Menu

The Independent Utility has following Main Menu.

Table J-4 Item of Main Menu displayed

	Explanation
Create Array	Builds RAID array.
Start Rebuild	Rebuilds RAID-1. While the rebuild is suspended, the message of "Resume Rebuild" is displayed.
Check Media	Checks if any error in drives configuring array. This is available for the RAID-1 in the "Optimal" condition.
Modify Array	Changes the setting of array.
Delete Array	Delete array.
Physical Drive	Changes the setting of physical drive.
Exit	Exits from the utility.

CAUTION: Do not use the following item of the Independent Utility for maintenance.

[Create Array]

This changes the current RAID configuration or information, and delete user's data. Do not use for maintenance.

[Start Rebuild (Resume Rebuild)]

This changes the current RAID configuration or information, and delete user's data. Do not use for maintenance.

[Modify Array]

This changes the current RAID configuration or information, and delete user's data. Do not use for maintenance.

[Check Media]

This changes the current RAID configuration or information, and delete user's data. Do not use for maintenance.

[Delete Array]

This changes the current RAID configuration or information, and delete user's data. Do not use for maintenance.

The tree of Independent Menu is as follows.

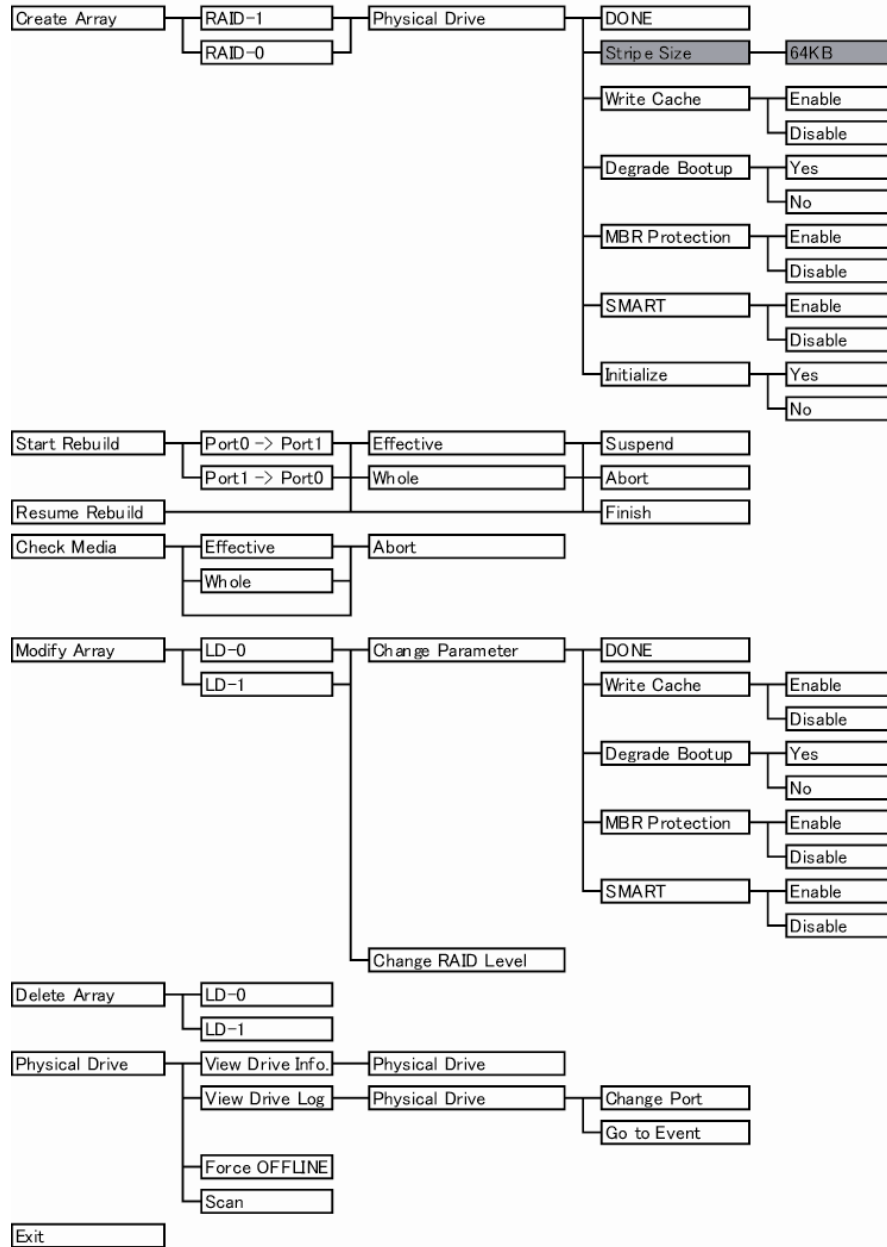

Figure J-4 Tree of menu of Independent Utility

Create Array

This section explains how to select option and build array. The [Create Array] option can be selected only when there is a drive not assigned. To build array, follow the procedure below.

1. Put the cursor on [Create Array] in [Main Menu] and press **[Enter]** key.
2. Select RAID level. Put the cursor on [RAID-1] or [RAID-0] and press **[Enter]** key.
3. Put the cursor on the drive to be incorporated in [Physical Drive] and press **[Space]** key to select a drive. When a drive selected, the status of [Physical Drive] changes to “ON LINE”. When selecting plural, repeat the same operation.
4. After selecting a drive, press **[Enter]** key.
5. The [RAID Parameter] is displayed. The setting of parameter in the following table can be made.
Put the cursor on the item to be set and press **[Enter]** key. Put the cursor on the value to be set and press **[Enter]** key.

Table J-5 Item of parameter set

Option	Explanation
DONE	When this option is selected after completing of setting in [Create Array] menu, building of RAID is decided.
Stripe Size	Designates the size of segment written in each disk of RAID-0 (Striping). The Stripe Size is only 64KB. This parameter can be set only in the RAID-0 configured by two drives.
Write Cache	Displays the setting of Write Cache of drive. This can select “Enable (use)” or “Disable (not use)”. The default is “Enable (use)”.
Degrade Bootup	Displays if boot up OS or not When the array is degraded. “Yes (boot up)” or “No (not boot up)” is selected. The default is “Yes (boot up)”. This option can be selected in RAID-1 (Mirroring).
MBR Protection	Displays the setting of protection function of MBR (Master Boot Record). “Enable (protect)” or “Disable (not protect)” is selected. The default is “Disable (not protect)”.
S.M.A.R.T.	Displays the setting of failure prediction function of drive. “Enable” or “Disable” is displayed. The default is “Enable”.
Initialize	Initialize the MBR of array. Normally, it is done when the array is made newly. For details, refer to “ Initializing array”. Initializing sets the rebuild limit to 10GB.

After completing the detailed setting, array is initialized. Put the cursor on “Initialize” and press **[Enter]** key. Put the cursor on the “Yes” and press **[Enter]** key. If the array is initialized, date of array is lost. Selecting “No” dose not initialize.

- Put the cursor on the “DONE” and press **[Enter]** key. Pressing “OK” in [Confirmation] store the change.

CAUTION: When the array is initialized, the data of drive is lost.

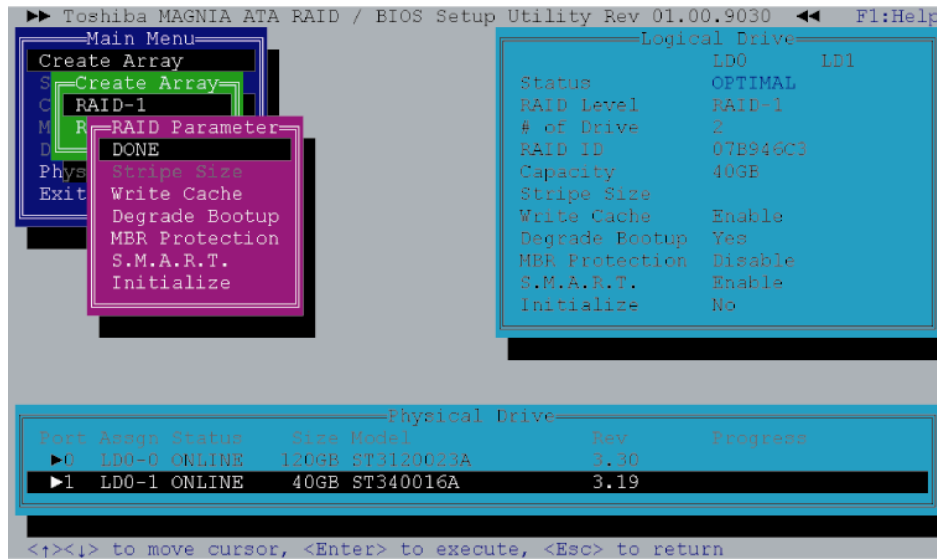

Start Rebuild

Selecting of this option starts rebuilding. [Start Rebuild] is displayed only in the RAID-1 condition of with “OFFLINE” drive that has same or more size of capacity as the array in the condition of “Optimal” or “Degraded”.

During halt of rebuilding, [Resume Rebuild] is displayed instead of [Start Rebuild].

The procedure to rebuild drives is as follows.

- Put the cursor to the [Start Rebuild] in the main menu of Indent Utility and press **[Enter]** key.
- Select the direction to rebuild in [Rebuild Direction] menu and press **[Enter]** key. When the array is “Degraded”, the choice is only is one.

3. When [Rebuild Range] menu is displayed, the range to be rebuilt is designated. When [Effective] is selected, rebuild limit becomes valid and it rebuilds up to the rebuild limit. When [Whole] is selected, it rebuilds maximum capacity of array. The [Rebuild Range] menu is not displayed when the rebuild limit is not set or the rebuild limit is the same as the maximum capacity of array. Normally designation of [Effective] is adequate.
4. Put the cursor on “OK” in [Confirmation] and press **[Enter]** key. The rebuild starts.

CAUTION: When the rebuild starts, the data of drive rebuilt is lost.

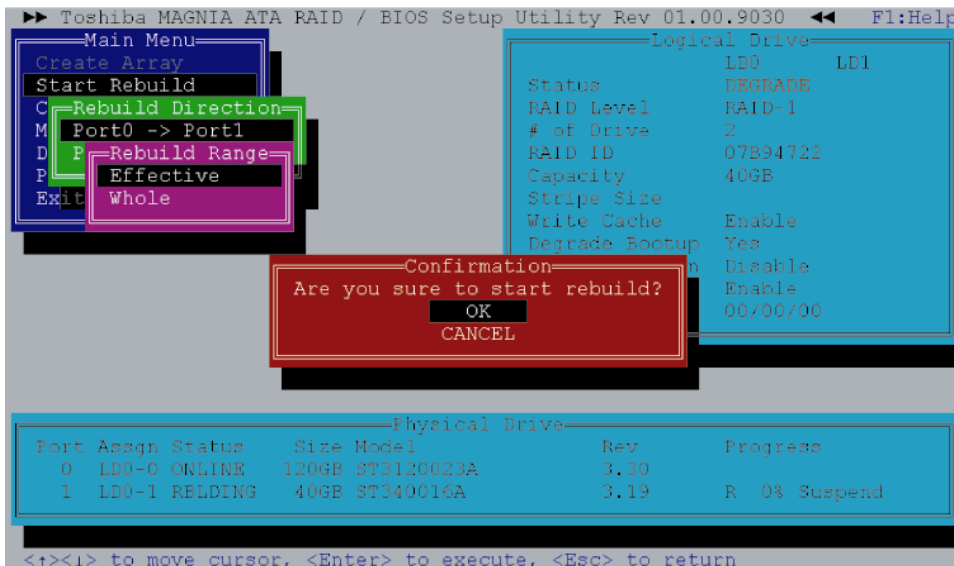

5. During rebuilding, [Status] of [Physical Drive] becomes “Rebuilding” and the progress rate, expected remaining time and the number of errors are displayed. During rebuilding, the [Rebuilding] dialog to select [Suspend] or [Abort] is displayed. It may take time depending on the drive capacity.
6. To suspend the rebuilding, put the cursor on [Suspend] (when aborting, on the [Abort]) and press **[Enter]** key. When [Confirmation] is displayed, put the cursor on [OK] and press **[Enter]** key. During being suspended, [Suspend] is displayed in [Progress] of [Physical Drive].
7. When “Rebuild Limit” is set and [Rebuild Range] is set to [Whole], only [Finish] is can be selected after exceeding the Rebuild Limit. When [Finish] is selected and “OK” is selected in [Confirmation], the rebuilding is completed at the time. When OS is booted after exceeding the Rebuild Limit, the rebuild is completed.

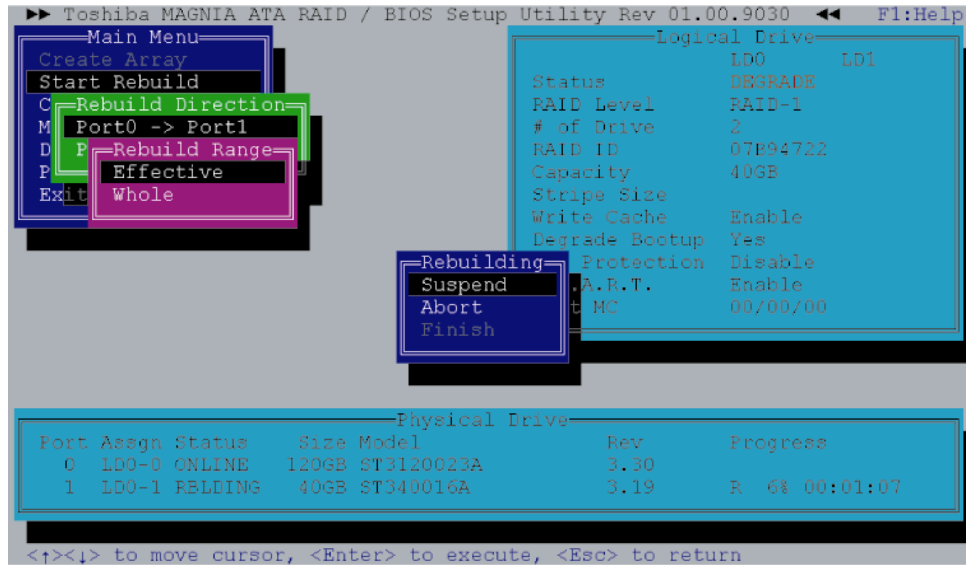

8. When completing the rebuild, press “OK” to return to the main menu of Independent Setup Utility.

Resume Rebuild

During being suspended, [Resume Rebuild] is displayed in [Main Menu]. To start rebuilding suspended, follow the procedure below.

1. Put the cursor to the [Resume Rebuild] in the main menu of Indent Utility and press **[Enter]** key.
2. When [Rebuild Range] menu is displayed, the range to be rebuilt is designated. When [Effective] is selected, rebuild limit becomes valid and it rebuilds up to the rebuild limit. When [Whole] is selected, it rebuilds maximum capacity of array. The [Rebuild Range] menu is not displayed when the rebuild limit is not set or the rebuild limit is the same as the maximum capacity of array. Normally designation of [Effective] is adequate.
3. Put the cursor on “OK” in [Confirmation] and press **[Enter]** key. The rebuild starts.
4. During rebuilding, [Status] of [Physical Drive] becomes [REBUILDING] and the progress rate, expected remaining time and the number of errors are displayed. During rebuilding, the [Rebuilding] dialog to select [Suspend] or [Abort] is displayed. It may take time depending on the drive capacity.
5. To suspend the rebuilding, put the cursor on [Suspend] (when aborting, on the [Abort]) and press **[Enter]** key. When [Confirmation] is displayed, put the cursor on [OK] and press **[Enter]** key.

- When completing the rebuild, press “OK” to return to the main menu of Independent Setup Utility.

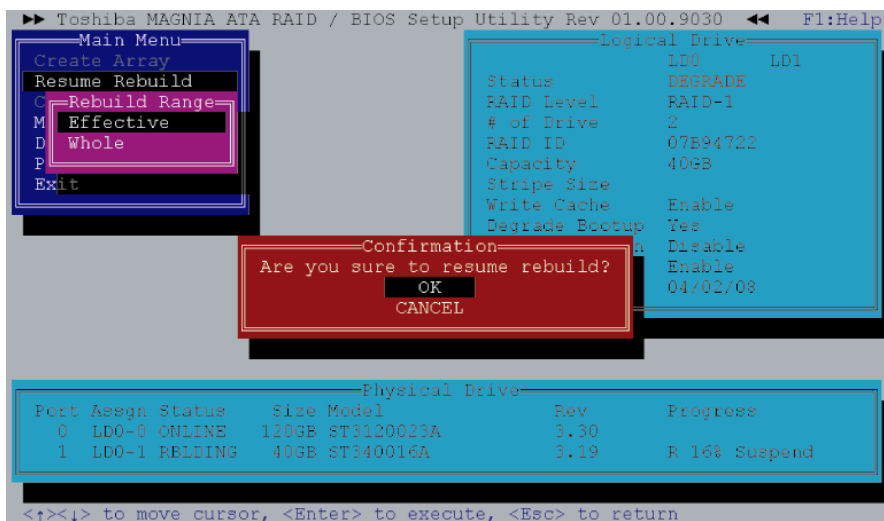

- When “Rebuild Limit” is set and [Rebuild Range] is set to [Whole], only [Finish] is can be selected after exceeding the Rebuild Limit. When [Finish] is selected and “OK” is selected in [Confirmation], the rebuilding is completed at the time. When OS is booted after exceeding the Rebuild Limit, the rebuild is completed.

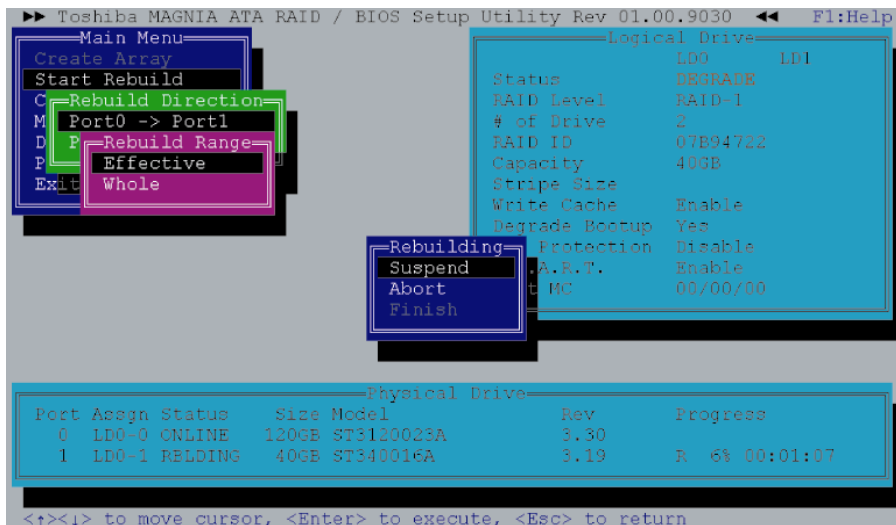

When completing the rebuild, press “OK” to return to the main menu of Independent Setup Utility.

Check Media

This option can check if there is an error in the HDD of array. The Check Media can be done only in RAID-1. To execute Check Media, follow the procedure below.

1. Put the cursor to the [Check Media] in [Main Menu] and press **[Enter]** key.
2. When [Check Range] is displayed, designate the range to be checked. When [Effective] is limited, it makes the rebuild limit effective and execute [Check Media] up to the rebuild limit. When [Whole] is selected, execute [Check Media] up to the maximum capacitor of RAID array. The [Rebuild Range] menu is not displayed when the rebuild limit is not set or the rebuild limit is the same as the maximum capacity of array. Normally designation of [Effective] is adequate.
3. To start the Check Media, put the cursor to the [Confirmation] and press **[Enter]** key. When an error is detected, it automatically corrects.
4. During [Check Media], the progress rate, expected remaining time and the number of errors are displayed in [Progress] of [Physical Drive], [Check Media] may take time depending on the drive capacity.

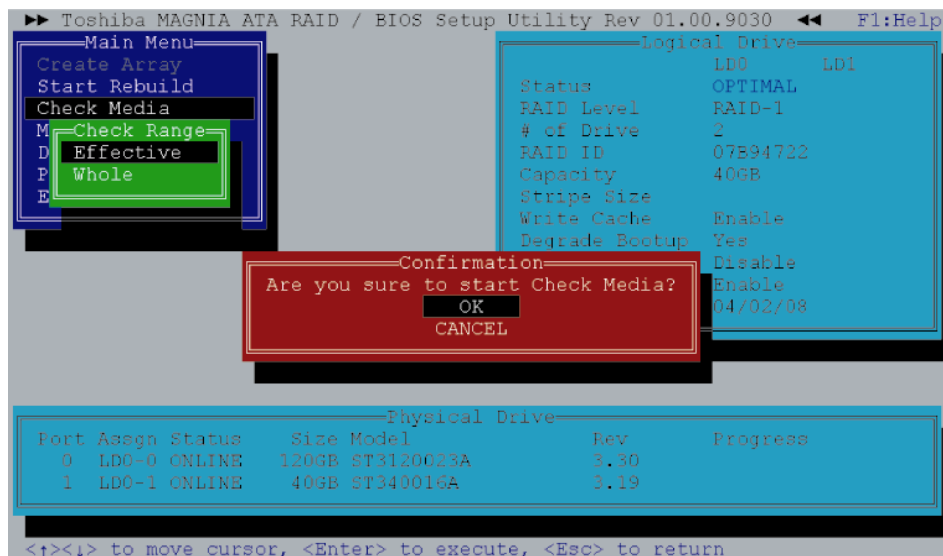

5. When [Check Media] is completed, put the cursor on [OK] and press **[Enter]** key to return to the menu of Independent Utility.

The date when the [Check Media] was done last is displayed in [Last MC] of [Logical Drive]. [Last MC] is renewed when rebuilding is done. When "Rebuild Limit" is changed or right after building RAID array, the value of [Last MC] becomes [00/00/00].

Modify Array

This option changes the setting of array.

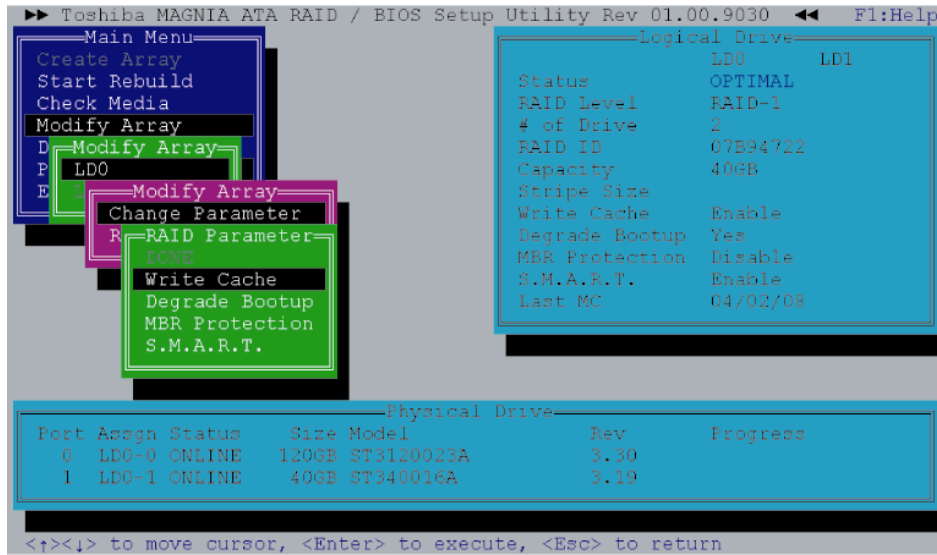

Change Parameter

Select [Change Parameter] in [Modify Array] menu. The following items can be set.

Table J-6 Item of array

Option	Explanation
Write Cache	Displays the setting of drive write cache. "Enable (use)" or "Disable (not use)" is displayed. The default is "Enable (use)".
Degrade Bootup	Displays if boot OS or not when the array is degraded. "Yes" (Boot up) or "No" (Not boot up) is displayed. The default is "Yes". This option is displayed in RAID-1 (Mirroring).
MBR Protection	Displays the setting of protection function of MBR (Master Boot Record). "Enable" (Protect) or "Disable" (Not protect) can be selected. The default is "Disable".
S.M.A.R.T.	Displays the setting of failure prediction function of drive. "Enable" or "Disable" is displayed. The default is "Enable".

Change RAID Level

To change RAID level, select [Modify Array] menu. When changing RAID-1 (Mirroring) to RAID-0 (Striping), refer “Changing RAID-1 to RAID-0”. When changing RAID-0 to RAID-1, refer “Changing RAID-0 to RAID-1”.

Changing RAID-1 to RAID-0 working by one drive

When changing RAID-1 array working by two drives to RAID-0 working by one drive, follow the procedure below.

1. Select [Modify Array] in [Main Menu].
2. In [Modify Array], select array [LDx] that you want to change.
3. In [Modify Array], select [RAID-1 -> RAID-0].
4. In [Physical Drive] select one drive, which is used as RAID-0, and press **[Space]** key
5. After selecting a drive, press **[Enter]** key. When [Confirmation] is displayed, select “OK” to store the setting.

Changing RAID-0 working by one drive to RAID-1

To change RAID-1 working by one drive to RAID-1 working by two drives, follow the procedure below.

1. Select [Modify Array] in [Main Menu].
2. In [Modify Array], select array [LDx] that you want to change.
3. In [Modify Array], select [RAID-0 -> RAID-1].
4. Select a drive in the condition of [OFFLINE] in [Physical Drive], which is expanded as RAID-1 with **[Space]** key. After selecting drive, [Status] changes to [REBUILDING]. The capacity of drive that is newly added must be same/more as/than original drive. The drive in the condition of [Fail] can not be incorporated.
5. After selecting a drive, press **[Enter]** key. When [Confirmation] is displayed, select “OK” to store the setting.
6. Select [Resume Rebuild] in [Main Menu], or select [Exit] to exit from Independent Utility. When automatic rebuilding is set in OS, rebuilding starts automatically after booting OS.
7. During rebuilding, the progress is displayed in [Physical Drive]. Suspending or aborting is possible.
8. When the rebuilding is completed, message is displayed, the select “OK”.

Delete Array

Selects [Delete Array] of Setup Utility and delete array. Put the cursor on the array you want to delete and press **[Enter]** key.

When [Confirmation] is displayed, select “OK” to store the setting.

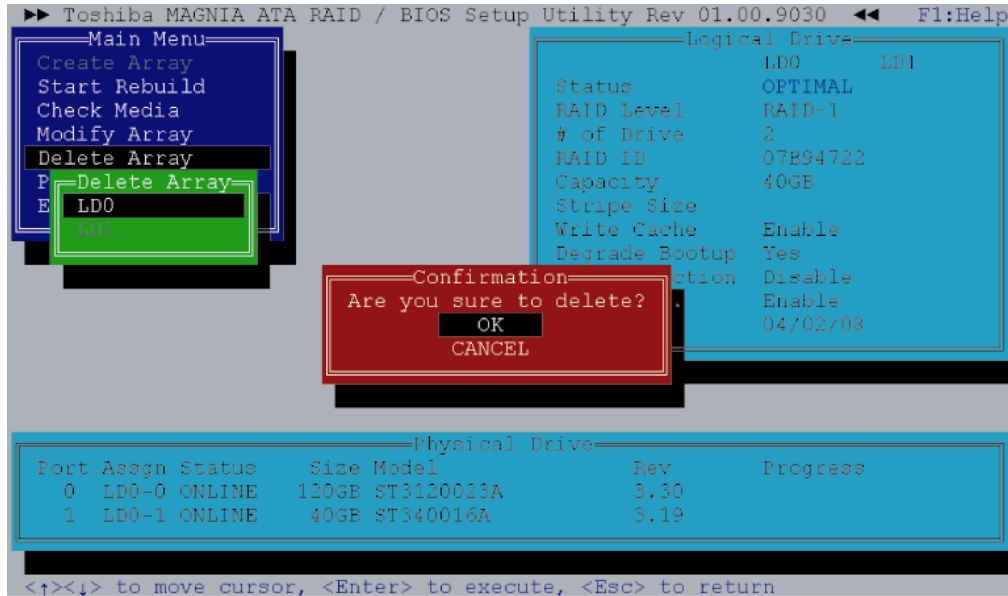

Physical Drive

Select [Physical Drive] in Setup Utility to set physical drive.

View Drive Info.

Select this option in [Physical Drive] to display information of physical drive. Select the drive that you want to display in [Physical Drive] at the lower of display and press **[Enter]** key. In the server with fault lamp (lamp displaying disk condition), the fault lamp of corresponded drive blinks while [Drive Information] display appears. Press **[Esc]** key to close the display. The following information is displayed.

Table J-7 Items set in View Drive Info.

Option	Explanation
Assignment	Displays Array number and drive number of array incorporated. The display format is LD [Array number] [Drive number]. For example, [LD0-1] means Disk drive 1 of array 0.
Status	Displays the drive status. The followings are displayed. -ONLINE: The drive is working normally. -OFFLINE : The drive is not configured as array and is not used. -FAIL: The drive is failed and dose not work. -REBUILDING: The rebuilding is suspended. -UNKNOWN: There is controversy in the RAID information of other drive and the status is not decided. It is displayed when this drive was removed and used in the past. When this drive has been found good one, setting to OFFLINE is possible by executing [Force Offline].
S.M.A.R.T.	Displays the setting of failure prediction function of drive. "Enable" or "Disable" is displayed. The default is "Enable". When the level reach to worming level, [Alert] is displayed. When [S.M.A.R.T.] is set to [Disable], [Normal] is displayed.
Model	Displays Model number of drive.
FW Rev	Displays the firmware revision of drive.
Serial	Displays the serial number of drive.
ATA/UDMA	Displays ATA standard and transmission mode that the drive corresponds to.
Max LBA	Displays the total number of sectors of drive in hexadecimal mode. (1 sector = 512B)
Uncopied Blk	In rebuilding, display the address of area that can not be used because of error in the original drive. When an error has been displayed in [Uncopied Blk], check if any error in the file system in the Windows scan disk. It is not necessary to check all the sectors. When any error is detected, any file is damaged. It is recommended to back up the data and rebuild RAID and restore.

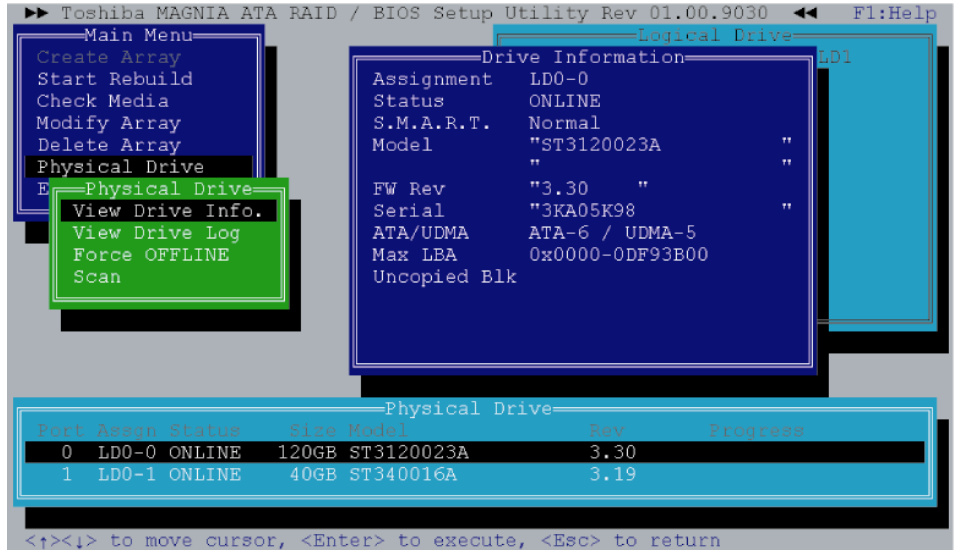

View Drive Log

Select this option in [Physical Drive] menu and select the drive that you want to display the log. At the beginning, the latest log is displayed. The 7,168 logs from the latest are recorded in detail. For the older log, only ID is recorded. The options and functions of key in [View Drive Log] are as follows.

Table J-8 Function of option and key

Option	Explanation
Change Port	Changes log's port displayed and port's own log or redundant log.
Go to Event	Inputting the log number in this number moves to the log of the number.

Key	Function
[PageUp]	Scrolls upward one by one.
[PageDown]	Scrolls downward one by one.
[Home]	Jumps to oldest log in the latest 7,168 logs.
[End]	Jumps to the latest log.
[Ctrl]+[Home]	Jumps to the oldest log that is older than 7,168 logs and the identification ID is recorded.
[Tab]	Switches [OWN] window and [REDUNDANT] window.

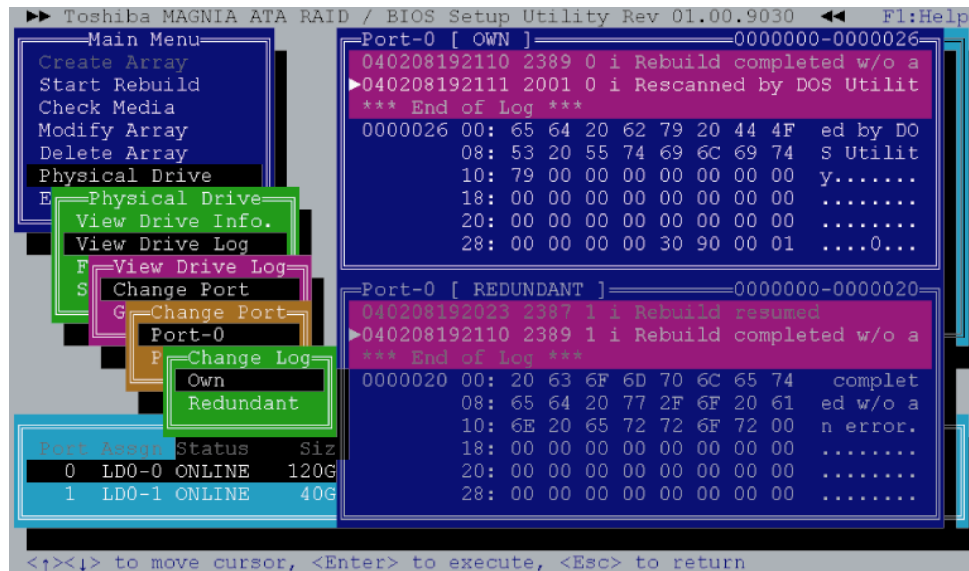

Execute the following procedures to see the drive log in the independent utility.

1. Put on the cursor on [Physical Drive] in [Main Menu] and press **[Enter]** key.
2. Put on the cursor on [View Drive Log] and press **[Enter]** key.
3. Select drive that you want to display the log in [Physical Drive] at the lower of display with a cursor key and press **[Enter]** key.
4. The drive log is displayed. Press **[PageUp]** or **[PageDown]** key to scroll the drive log upward or downward.
5. To change log displayed, put the cursor on [Change Port] and press **[Enter]** key.
6. Select Drive log port to be displayed and [Own/Redundant]. For Example, [Own] log means the drive log of Port-0 own, [Redundant] log of Port-0 means the backup copy of the drive log of Port-1.
7. To switch the upper and lower of drive log frame, press **[Tab]** key. The selected frame is displayed more lightly than the other frame.
8. To move to the drive log with arbitrary log number, put the cursor on the [Go to Event] and press **[Enter]** key. Next, input the log number you want to move to and press **[Enter]** key.

The 7,168 logs from the latest are recorded in detail. For the older than that, only identification ID is recorded.

The following is displayed.

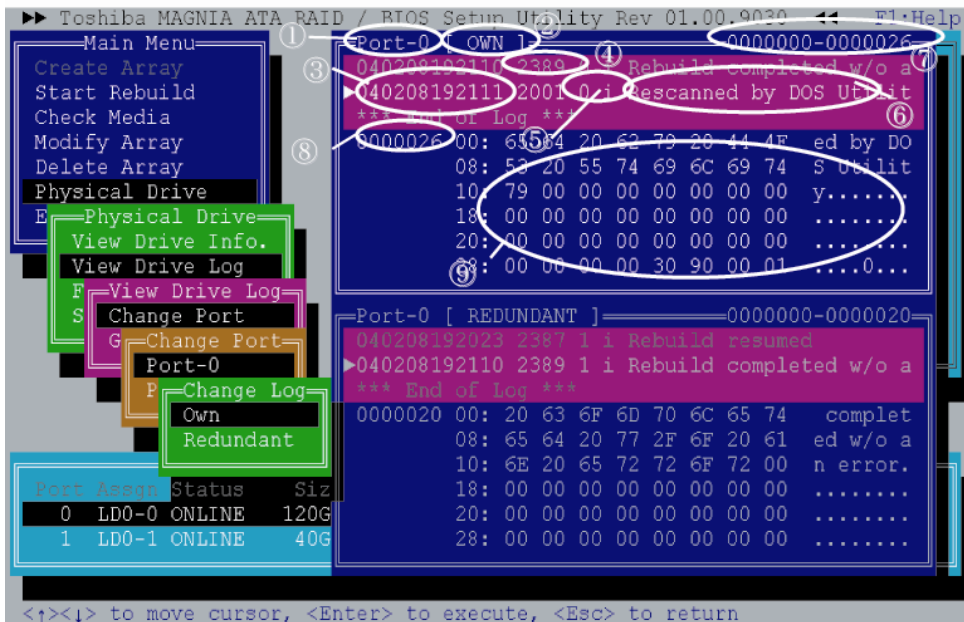

Table J-9 Content of Drive Log display

No.	Option	Explanation
1	Port	Displays the port number of log displayed.
2	Own/Redundant	Displays if the displayed log is a log of own port (Own) or a copy of other port log (Redundant).
3	Time	Displays the time when the log is recorded in six digits. The format is [Year Month Day Hour Minute Second].
4	ID	Displays identification ID of log.
5	Port and Degree of importance	The number displays the port that the drive is connected when the log is recorded. The alphabet displays the degree of importance. [i] means information, [W] means warning and [e] means an error.
6	Message	Displays the content of log. When the log is too much and it can not displayed in the area, the remaining is displayed in [Detail] area.
7	Range of log	Displays the range of log number stored. In this case, it means that logs with the number of 0 to 26 are stored.
8	Log number	Displays the log number that is being displayed.
9	Detail	Displays the detailed contents and codes of log. When the number of logs is 7,168 or more, the details of old log is not displayed.

[View Drive Log] menu is as follows

Table J-10 Content of View Drive Log menu

Option	Explanation
Change Port	Changes the display of the own log and redundant log. At the beginning, the Port-0's own log and the redundant log are displayed.
Go to Event	When this option selected, it moves to the log with designated number.

The key function in [View Drive Log] key is as follows.

Table J-11 Function of key in View Drive Log

Key	Function
[PageUp]	Scrolls upward step one by one.
[PageDown]	Scrolls downward step one by one.
[Home]	Jumps to the oldest log in the latest 7,168 logs.
[End]	Jumps to the latest log.
[Ctrl]+[Home]	Jumps to the oldest log that is older than 7,168 logs and the identification ID is recorded.
[Tab]	Switches [OWN] window and [REDUNDANT] window.

Force OFFLINE

Selecting this option in [Physical Drive] menu of Setup Utility can set the physical drive to offline by force. Follow the procedure below.

1. Select [Physical Drive] in [Main Menu].
2. Select [Force OFFLINE] in [Physical Drive].
3. Select the drive that you want to set it to offline with **[Space]** key in [Physical Drive] and press **[Enter]** key.
4. Selecting "OK" in [Confirmation] stores the setting.

Scan

When [Scan] in [Physical Drive] menu is selected, it scans physical drive. This is used to recognize the drive after replacing failed drive.

Exit

When this option is selected, the utility is finished. When [Confirmation] is displayed, select "OK".

Free Manuals Download Website

<http://myh66.com>

<http://usermanuals.us>

<http://www.somanuals.com>

<http://www.4manuals.cc>

<http://www.manual-lib.com>

<http://www.404manual.com>

<http://www.luxmanual.com>

<http://aubethermostatmanual.com>

Golf course search by state

<http://golfingnear.com>

Email search by domain

<http://emailbydomain.com>

Auto manuals search

<http://auto.somanuals.com>

TV manuals search

<http://tv.somanuals.com>