

**Toshiba Personal Computer
Satellite M60
Maintenance Manual**

TOSHIBA CORPORATION

[CONFIDENTIAL]

Copyright

© 2004 by Toshiba Corporation. All rights reserved. Under the copyright laws, this manual cannot be reproduced in any form without the prior written permission of Toshiba. No patent liability is assumed with respect to the use of the information contained herein.

Toshiba Personal Computer Satellite M60 Maintenance Manual

First edition May 2005

Disclaimer

The information presented in this manual has been reviewed and validated for accuracy. The included set of instructions and descriptions are accurate for the M60 Series at the time of this manual's production. However, succeeding computers and manuals are subject to change without notice. Therefore, Toshiba assumes no liability for damages incurred directly or indirectly from errors, omissions, or discrepancies between any succeeding product and this manual.

Trademarks

IBM is a registered trademark, and OS/2 and PS/2 are trademarks of IBM Corporation. Microsoft, MS-DOS, Windows, DirectSound and DirectMusic are registered trademarks of Microsoft Corporation.

Intel and Pentium are registered trademarks, and SpeedStep is a trademark of Intel Corporation. Sound Blaster is a registered trademark of Creative Technology Ltd.

Centronics is a registered trademark of Centronics Data Computer Corporation.

Photo CD is a trademark of Eastman Kodak.

All other properties are trademarks or registered trademarks of their respective holders.

Preface

This maintenance manual describes how to perform hardware service maintenance for the Toshiba Personal Computer Satellite SATELLITE M60, referred to as the M60 Series in this manual.

The procedures described in this manual are intended to help service technicians isolate faulty Field Replaceable Units (FRUs) and replace them in the field.

SAFETY PRECAUTIONS

Four types of messages are used in this manual to bring important information to your attention. Each of these messages will be italicized and identified as shown below.

DANGER: “Danger” indicates the existence of a hazard that could result in death or serious bodily injury if the safety instruction is not observed.

WARNING: “Warning” indicates the existence of a hazard that could result in bodily injury if the safety instruction is not observed.

CAUTION: “Caution” indicates the existence of a hazard that could result in property damage if the safety instruction is not observed.

NOTE: “Note” contains general information that relates to your safe maintenance service.

Improper repair of the computer may result in safety hazards. Toshiba requires service technicians and authorized dealers or service providers to ensure the following safety precautions are adhered to strictly.

- Be sure to fasten screws securely with the right screwdriver. If a screw is not fully fastened, it could come loose, creating a danger of a short circuit, which could cause overheating, smoke or fire.
- If you replace the battery pack or RTC battery, be sure to use only the same model battery or an equivalent battery recommended by Toshiba. Installation of the wrong battery can cause the battery to explode.

The manual is divided into the following parts:

- Chapter 1 Hardware Overview describes the M60 Series system unit and each FRU.
- Chapter 2 Troubleshooting Procedures explains how to diagnose and resolve FRU problems.
- Chapter 3 Test and Diagnostics describes how to perform test and diagnostic operations for maintenance service.
- Chapter 4 Replacement Procedures describes the removal and replacement of the FRUs.
- Appendices The appendices describe the following:

- Handling the LCD module
- Board layout
- Pin assignments
- Keyboard scan/character codes
- Key layout
- Screw torque list
- Reliability

Conventions

This manual uses the following formats to describe, identify, and highlight terms and operating procedures.

Acronyms

On the first appearance and whenever necessary for clarification acronyms are enclosed in parentheses following their definition. For example:

Read Only Memory (ROM)

Keys

Keys are used in the text to describe many operations. The key top symbol as it appears on the keyboard is printed in **boldface** type.

Key operation

Some operations require you to simultaneously use two or more keys. We identify such operations by the key top symbols separated by a plus (+) sign. For example, **Ctrl + Pause (Break)** means you must hold down **Ctrl** and at the same time press **Pause (Break)**. If three keys are used, hold down the first two and at the same time press the third.

User input

Text that you are instructed to type in is shown in the boldface type below:

DISKCOPY A: B:

The display

Text generated by the computer that appears on its display is presented in the type face below:

```
Format complete
System transferred
```

Table of Contents

Chapter 1 Hardware Overview

1.1	Features	Error! Bookmark not defined.
1.2	System Unit.....	Error! Bookmark not defined.
1.3	2.5-inch Hard Disk Drive.....	Error! Bookmark not defined.
1.4	Optical device Drives.....	Error! Bookmark not defined.
1.4.1	CD-RW & DVD-ROM.....	Error! Bookmark not defined.
1.4.2	DVD Super Multi Double Layer	Error! Bookmark not defined.
1.5	Power Supply	Error! Bookmark not defined.
1.6	Batteries	Error! Bookmark not defined.
1.6.1	Main Battery	Error! Bookmark not defined.
1.6.2	RTC battery.....	Error! Bookmark not defined.

Chapter 2 Troubleshooting Procedures

2.1	Troubleshooting Introduction	Error! Bookmark not defined.
2.2	Troubleshooting Flowchart.....	Error! Bookmark not defined.
2.3	Power Supply Troubleshooting	Error! Bookmark not defined.
2.4	Display Troubleshooting.....	Error! Bookmark not defined.
2.5	Keyboard Troubleshooting	<u>2-15</u>
2.6	External USB Devices Troubleshooting.....	2-17
2.7	TV-Out Failure Troubleshooting	2-19
2.8	TouchPad Troubleshooting.....	<u>2-21</u>
2.9	Speaker Troubleshooting	<u>2-23</u>
2.10	Optical drive troubleshooting.....	2-27
2.11	Modem Troubleshooting.....	2-30
2.12	PCMCIA Troubleshooting.....	2-32
2.13	IEEE 1394 Troubleshooting	2-34
2.14	Wireless LAN Troubleshooting.....	2-36

2.15 Express card troubleshooting2-38
2.16 Bluetooth Troubleshooting.....2-40

Chapter 3 Test and Diagnostic Operation Handbook

3.1	The Diagnostic Test	3-1
3.2	Executing the Diagnostic Test	3-2
3.3	Config Check Test	3-6
3.4	DMI Check Test.....	3-7
3.5	PIO Loopback Test	3-8
3.6	IEEE 1394 Test	3-9
3.7	Speaker Audio Test.....	3-10
3.8	Fan ON/OFF Test	3-11
3.9	Main Battery Charge Test.....	3-12
3.10	FDD Test.....	3-13
3.11	CD-ROM Test.....	3-14
3.12	Keyboard Test.....	3-15
3.13	Mouse (Pad) Test	3-17
3.14	LCD Pixels Mode Test	3-19
3.15	Lid Switch Test	3-20
3.16	HDD R/W Test	3-21
3.17	LAN Test	3-23
3.18	RTC Test.....	3-25
3.19	CD Control Button Test.....	3-26

Chapter 4 Replacement Procedures

4.1	General	Error! Bookmark not defined.
4.2	Battery	Error! Bookmark not defined.
4.3	PC Card	Error! Bookmark not defined.
4.4	HDD	Error! Bookmark not defined.
4.5	Optical Drive Module.....	Error! Bookmark not defined.
4.6	Optical Drive	Error! Bookmark not defined.
4.7	Keyboard	Error! Bookmark not defined.
4.8	Wireless LAN Unit.....	Error! Bookmark not defined.
4.9	Expansion Memory	Error! Bookmark not defined.
4.10	Modem.....	Error! Bookmark not defined.
4.11	Display Assembly.....	Error! Bookmark not defined.
4.12	Top Cover.....	Error! Bookmark not defined.
4.13	TouchPad.....	Error! Bookmark not defined.
4.14	Speakers.....	Error! Bookmark not defined.
4.15	System Board	Error! Bookmark not defined.
4.16	Fan & CPU	Error! Bookmark not defined.
4.17	Display Mask.....	Error! Bookmark not defined.
4.18	LCD Module.....	Error! Bookmark not defined.
4.19	FL Inverter Board.....	Error! Bookmark not defined.

Appendices

Appendix A	Handling the LCD Module	A-1
Appendix B	Board Layout	B-1
Appendix C	Pin Assignments.....	C-1
Appendix D	Keyboard Scan/Character Codes	D-1
Appendix E	Key Layout.....	E-1
Appendix F	Series Screw Torque List.....	F-1
Appendix G	Reliability.....	G-1

Chapter 1

Hardware Overview

Chapter 1 Contents

1.1	Features	1-5
1.2	System Unit.....	1-10
1.3	2.5-inch Hard Disk Drive.....	1-12
1.4	Optical device Drives.....	1-13
1.4.1	CD-RW & DVD-ROM	1-13
1.4.2	DVD Super Multi Double Layer	1-14
1.5	Power Supply	1-15
1.6	Batteries	1-17
1.6.1	Main Battery.....	1-18
1.6.2	RTC battery	1-19

Figures

Figure 1-1 2.5-inch HDD 1-12

Table

Table 1-1 2.5-inch HDD specifications 1-12
Table 1-2 DVD-ROM & CD-RW drive specifications 1-13
Table 1-3 DVD Super Multi Double Layer drive specifications..... 1-14

1.1 Features

The Satellite M60 Series Personal Computer uses extensive Large Scale Integration (LSI), and Complementary Metal-Oxide Semiconductor (CMOS) technology extensively to provide compact size, minimum weight and high reliability. This computer incorporates the following features and benefits:

❑ CPU

- Intel® Celeron® M Processor 350 or higher
- Intel® Pentium® M Processor 730 or higher

❑ Chipset

- Mobile Intel® 915PM Express Chipset (400/533 MHz FSB supported) for external graphics controller
- Mobile Intel® 915GM Express Chipset (400/533 MHz FSB supported) for integrated graphics controller
- Mobile Intel® 910GML Express Chipset (400MHz FSB supported) for integrated graphics controller
- ATI MOBILITY™ RADEON® X600SE
- ATI MOBILITY™ RADEON® X700
- NVIDIA® GeForce™ GO 6600
- ENE KB910 for Keyboard Controller, Battery management Unit, and RTC
- ENE CB714 controller with Multiple Digital Media Card Slot support
- IEEE 1394 controller
- ALC250 for AC97 CODEC
- Realtek RTL8100CL for 10M/100M LAN or RTL8110SBL for Gigabit LAN

Memory

- DDRII-400/533MHz specification compliant
- Dual channel support
- No On board memory
- Two DDRII SODIMM with 256MB/512MB/1GB ,
- Max. upgrade to 2GB with 2 DDRII SODIMM Socket

 BIOS

- MB Flash ROM for system BIOS.
- Suspend to RAM/Disk.
- Password protection (System).
- Various hot key for system control.
- Refreshable
- Complete ACPI 1.0B Function

 Power

- 8 cells Li-Ion 18650 size smart battery Pack with 64Wh capacity
- Approximately 4-12 hours or longer charge time to 100% battery capacity with the system on
- Approximately 4 hours charge time to 100% battery capacity with the system off
- Discharge time in shutdown mode is approximately 1 month

 HDD

- 9.5mm, 2.5" HDD up to 120 GB
- Bus Master IDE
- 9.5mm, 2.5" HDD Support
- Support Ultra 100 synchronous DMA

 Fixed Device Drivers

- 5.25" 12.7mm height CD-RW & DVD-ROM drive
- 5.25" 12.7mm height DVD Super Multi drive

Optional Devices

- 256/512/1024MB SO-DIMM DDRII modules
- Li-ION Battery Pack
- AC adapter
- USB FDD Kit

 Keyboard

The computer's keyboard layout is that of a 101/102-key enhanced keyboard.

There are four types of keys: typewriter keys, function keys, soft keys and cursor control keys. The typewriter keys are gray. The other keys are dark gray.

 TouchPad

This pointing control device, located in the center of the keyboard palm-rest, provides convenient control of the cursor without requiring desk space for a mouse. The TouchPad incorporates two mouse buttons.

 Display

- 17" TFT screen with a resolution of 1440 horizontal x 900 vertical pixels WXGA
- 17" High Brightness TFT screen with a resolution of 1440 horizontal x 900 vertical pixels WXGA
- 17" TFT screen with a resolution of 1680 horizontal x 1050 vertical pixels WSXGA+

 I/O Ports

- One 15 pins CRT port
- One TV-out (S-Video) port
- One MIC In port
- One headphone-out
- One 2pins AC Adapter Jack
- Type II PCMCIA Card Bus slot with shutter door
- ExpressCard/54 slot with shutter door
- Three 4 pins USB 2.0 ports
- One RJ11 Port
- One RJ45 Port
- One IEEE 1394
- Multiple Digital Media Card Slot with rubber cover

PC Card Slot

- One type II card socket
- 1.8" 10.5mm removable ATA Device
- Card bus card or PC Card with hot insertion and removal
- ACPI 1.1 Compliant.
- Support 5V/3.3V PC Cards and 3.3V Cardbus cards.
- Supports PCMCIA-ATA Specification.

 Express Card Slot

- One ExpressCard/54 slot

 Multiple Digital Media Card Slot

- ENE CB714 Cardbus/MediaReader Controller
- Support xD, SD, SM, MS, MS Pro and MMC

 Communication

- Modem: V90 (V.92)/56K bps specification compliant and 14.4K bps Send/Receive Fax with MDC solution
- V92/56K bps (US/Canada/UK/GR/FR)
- V90/56K bps (other countries)
- LAN: Realtek 8100CL (On Board 10/100Mbps) RTL8110SBL(BTO)
- WOL from S3 on AC/Battery mode and S4/S5 on AC adapter mode only.

 Bluetooth

- Taiyo Yuden V2.0
- Wireless communication killer switch

 Wireless LAN

- 802.11g: Atheros (MB43/MB51/MB51L), Intel Calexico2.
- 802.11a/g: Atheros (MB44), Intel Calexico2.
- 802.11a/g+HighBand: Intel Calexico2
- Module integrated for Mini-PCI interface.
- Easy service for WLAN.
- Wireless communication killer switch (BTO)
- Support MiniPCI IIIB
- Support Intel Wireless Coexistence system with Taiyo Yuden V2.0

- ❑ **Universal Serial Bus (USB)**

The computer has three Universal Serial Bus (USB) ports that comply with the USB 2.0 standard, which enable data transfer speeds more than 40 times faster than USB 1.1 (which this computer also supports.) The USB drives may be used to transfer data at Low, Full, and high speeds.
- ❑ **External monitor port**

A 15-pin CRT port supporting DDC 2B enables connection of an external monitor, which is recognized automatically by Video Electronics Standards Association (VESA) Display Data Channel (DDC) compatible functions.
- ❑ **Sound system**

Windows® Operating System compatible sound system provides internal speakers as well as jacks for an external microphone and headphone.
- ❑ **TV-out (S-Video) port**

Plug a 4-pin S-video cable into this connector for output of NTSC or PAL signal.
- ❑ **LAN port**

The computer comes with an RJ-45 Local Area Network (LAN) port. The LAN port provides connectivity for LAN.

1.2 System Unit

The system unit is composed of the following major components:

❑ Processor

- Intel® Celeron® M CPU up to 1.5GHZ 0.09u, 1M L2, FSB 400MHz
- Intel® Pentium® M CPU up to 2.13GHZ 0.09u, 2M L2, FSB 533MHz
- Micro FC-PGA package CPU

❑ System Logic

- Mobile Intel® 915PM Express Chipset (Alviso-PM 400/533MHz FSB supported) / Mobile Intel® 915GM Express Chipset (Alviso-GM 400/533MHz FSB supported) or Mobile Intel® 910GML Express Chipset (Alviso-GML 400MHz FSB supported)
- Intel® 82801FBM (ICH6-M)
- ENE KB910 for Keyboard Controller, Battery management Unit, and RTC
- ENE714 for Card Bus PCMCIA, Multiple Digital Media Card Slot.
- TI TSB43AB21A IEEE1394 Controller
- Integrated VGA solution for 915GM/910GML / External VGA card for 915PM
- ALC250 for AC97 Codec
- Marvell 88SA8040 for SATA to PATA HDD support.
- RTL8110SBL for Gigabit LAN / RTL8100CL for 10/100M LAN

❑ Keyboard Controller

- ENE KB910 is use as Keyboard Controller and Battery management unit.

❑ Memory

- On board with two 200-pin +1.8V DDRII SO-DIMM connector, supporting, DDRII memories card. Maximum up gradable to 2GB by two 1GB SO-module
- Support 64MB/128MB VGA memory for the ATI MOBILITY™ RADEON® X600SE/X700
- Support 64MB/128MB VGA memory for the NVIDIA® GeForce™ GO 6600
- Adjustable 128MB UMA VGA memory share from North Bridge

□ Audio subsystem

- Realtek ALC250 for CODEC
- 20-bit Stereo Digital-to-Analog Converters.
- 18-bit Stereo Analog-to- Digital Converters.
- Built-in 7 Bands of Digital Hardware Equalizer for Optimizing Speaker Response.
- Supports double sampling rate(96KHz) of DVD audio playback.
- Meets Microsoft WHQL/WLP 2.0 audio requirements.
- HRTF 3D positional audio.
- 3D Stereo Enhancement.

1.3 2.5-inch Hard Disk Drive

The internal HDD is a random access non-volatile storage device. It has a non-removable 2.5-inch magnetic disk and mini-Winchester type magnetic heads. The computer supports HDDs up to 120 GB.

The HDD is shown in Figure 1-1. Specifications are listed in Table 1-1

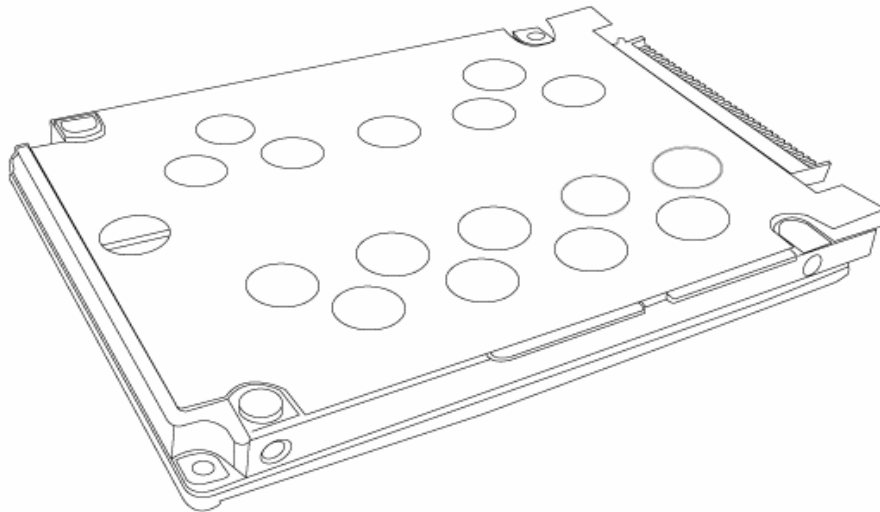

Figure 1-1 2.5-inch HDD

Items	40GB	60GB	80GB	100GB
Formatted capacity (GB)	37.26	55.89	74.52	93.15
Logical Blocks (LBA)	78,125,000	117,187,500	156,301,488	195,371,568
Rotational speed (rpm)	4,200/5400	4,200/5400	4200/5400	4200/5400
Toshiba HDD Buffer (MB)	8/16	8/16	8/16	8/16
Hitachi HDD Buffer (MB)	2/8	8/8	8/8	NA/8
Bytes per sector	512	512	512	512

Table 1-1 2.5-inch HDD specifications

1.4 Optical device Drives

- DVD-ROM & CD-RW drive
- DVD Super Multi drive

1.4.1 CD-RW & DVD-ROM

The combo drive accepts 12-cm (4.72-inch) and 8-cm (3.15-inch) discs. At maximum, the drive can play back a DVD at 8x speed, read CD-ROM at 24x speed, and write CD-R at 24x speed and CD-RW at 4x speed or High speed CD-RW at 10X or Ultra speed CD-RW at 24X speed.

The specifications of the DVD-ROM & CD-RW drive are listed in Table 1-2.

Item	DVD-ROM mode	CD-ROM mode
Data transfer rate (Mbytes/s)	33.3 (U-DMA transfer mode 2) 16.6 (PIO mode 4, Multiword DMA mode 2)	
Access time (ms) Average random access	180	150
Data buffer size (Mbytes)	2MB	
Formats supported	DVD: DVD-VIDEO, DVD-ROM, DVD-R (3.9G,4.7G), DVD-RW (Ver.1.1), DVD-RAM, DVD+R, DVD+RW, DVD+R DL. CD: CD-DA, CD-ROM, CD-R, CD-RW, CD-ROMXA, PhotoCD (multiSession), Video CD, CD-Extra (CD+), CD-Text	

Table 1-2 DVD-ROM & CD-RW drive specifications

1.4.2 DVD Super Multi Double Layer

The DVD Super Multi drive accepts 12-cm (4.72-inch) and 8-cm (3.15-inch) discs. At maximum, the drive can play back a DVD at 8x speed, read CD-ROM at 24x speed, and write CD-R at 24x speed and CD-RW at 4x speed or Ultra and High speed CD-RW at 10x speed and DVD-R at 8x speed and DVD-RW at 4x speed and DVD+R at 8x speed and DVD+RW at 4x speed and DVD-RAM at 3x speed and DVD+R DL at 2.4x speed.

The specifications of the DVD Super Multi Double Layer drive are listed in Table 1-4

Item	DVD-ROM mode	CD-ROM mode
Data transfer rate (Mbytes/s)	33.3 (U-DMA transfer mode 2) 16.6 (PIO mode 4, Multiword DMA mode 2)	
Access time (ms) Average random access	180	150
Data buffer size (Mbytes)	2MB	
Formats supported	DVD: DVD-VIDEO, DVD-ROM, DVD-R (3.9G,4.7G), DVD-RW (Ver.1.1), DVD-RAM, DVD+R, DVD+RW, DVD+R DL. CD: CD-DA, CD-ROM, CD-R, CD-RW, CD-ROMXA, PhotoCD (multiSession), Video CD, CD-Extra (CD+), CD-Text	

Table 1-3 DVD Super Multi Double Layer drive specifications

1.5 Power Supply

This specification defines the performance and characteristic of 65W and 75W AC adapter power supply. It supplies a constant voltage 19V output source for M60 series notebook computer.

- ❑ A/D conversion
 - The EC uses 10-bit sampling for A/D conversion to determine the following values:
 - AC adaptor current
 - Battery and temperature

- ❑ AC adaptor and battery check
 - The EC checks the following by A/D converted values:
 - Battery installed
 - The EC checks the following by GPIO values:
 - AC adaptor connected

- ❑ Abnormal check
 - The EC determines whether the condition is abnormal, and if so, stores an error code into the error register.

- ❑ Input port management
 - The EC monitors the following input signal status:
 - System power ON/OFF status
 - Direct CD power ON/OFF status

- ❑ Beep and LED control
 - Beep is caused by the low battery status.
 - The EC controls the following two kinds of LED
 - DC IN LED (one color: green)
 - Green = indicates AC adaptor is connected
 - Battery LED (two colors: orange and green)
 - Green solid = The battery is fully charged.
 - Orange = The computer is quick-charging the battery / The battery is low.

- ❑ Power ON/OFF sequence
 - When power is turned on or off, the EC starts the power on or off sequence.
 - SQ0-4 = power ON sequence
 - SQ5-B = power OFF sequence

Battery charging control

- The EC controls the following.
 - The quick charging ON/OFF
 - The detection of full charge

 Detection of the low battery

- The EC detects the low battery point by the gas gauge.
 - LB10M = The system will be driven by the battery for 12 more minutes.
 - LB0 = The battery won't be able to drive the system after 3 minutes.
 - LB1 = The battery can drive the system only during the suspend process.
 - LB2 = The battery cannot drive the system.

 New battery installation

- When a new battery is installed, the EC communicates with the E²PROM in the battery to read information of the newly installed battery.

 Battery capacity calculation

- The EC reads battery remaining and percentage capacity from the battery through SMBus.

1.6 Batteries

The computer has two types of battery:

- Main battery pack (18650 size)
- RTC battery

The removable main battery pack is the computer's main power source when the AC adaptor is not attached.

The battery specifications are listed in the table below.

Battery name	Material	Output voltage	Capacity
Main battery	Lithium-Ion	14.8 V	4300mAH
RTC battery	Lithium	3.0 V	15 mAh

1.6.1 Main Battery

Battery charging is controlled by a power supply microprocessor that is mounted on the system board. The power supply microprocessor controls whether the charge is on or off and detects a full charge when the AC adaptor and battery are attached to the computer. The system charges the battery using quick charge or trickle charge.

Quick Battery Charge

When the AC adaptor is attached, there are two types of quick charge: quick charge when the system is powered off and normal charge when the system is powered on.

The times required for charges are listed in the table below.

Status	Charging time
Normal charge (power on)	12 hours or longer
Quick charge (power off)	About 4 hours

NOTES

1. *The time required for normal charge is affected by the amount of power the system is consuming. Use of the fluorescent lamp and frequent disk access diverts power and lengthens the charge time.*
2. *Using quick charge, the power supply microprocessor automatically stops the charge after eight hours regardless of the condition of the battery. Overcharging could cause the battery to explode.*

If any of the following occurs, the battery quick charge process stops.

1. The battery becomes fully charged.
2. The AC adaptor or battery is removed.
3. The battery or output voltage is abnormal.
4. The battery temperature is abnormal.
5. The battery SMBus communication fails.
6. The battery cell is bad.

Detection of full charge

A full charge is detected from the battery pack through SMBus when the battery is charging.

1.6.2 RTC battery

The RTC battery provides power to keep the current date, time and other setup information in memory while the computer is turned off. The table below lists the charging time and data preservation period of the RTC battery. The RTC battery is charged by the adaptor or main battery, while the computer is powered on.

Status	Time
Charging Time (power on)	About 24 hours
Data preservation period (full charge)	1 month

Chapter 2

Troubleshooting Procedures

Chapter 2 Contents

2.1	Troubleshooting Introduction.....	2-1
2.2	Troubleshooting Flowchart	2-2
2.3	Power Supply Troubleshooting.....	2-7
2.4	Display Troubleshooting	2-12
2.5	Keyboard Troubleshooting.....	2-15
2.6	External USB Devices Troubleshooting	2-17
2.7	TV-Out Failure Troubleshooting.....	2-19
2.8	TouchPad Troubleshooting	2-21
2.9	Speaker Troubleshooting.....	2-23
2.10	Optical drive troubleshooting	2-27
2.11	Modem Troubleshooting	2-30
2.12	PCMCIA Troubleshooting	2-32
2.13	IEEE 1394 Troubleshooting.....	2-34
2.14	Wireless LAN Troubleshooting	2-36
2.15	Express card troubleshooting	2-38
2.16	Bluetooth Troubleshooting.....	2-40

Figures

Figure 2-1	Troubleshooting flowchart (1/2).....	2-3
Figure 2-1	Troubleshooting flowchart (2/2).....	2-4
Figure 2-2	Power Supply Troubleshooting Process	2-7
Figure 2-3	Display troubleshooting process	2-12
Figure 2-4	Keyboard troubleshooting process.....	2-15
Figure 2-5	External USB device troubleshooting process.....	2-17
Figure 2-6	TV-out troubleshooting process.....	2-19
Figure 2-7	TouchPad troubleshooting process	2-21
Figure 2-8	Speaker troubleshooting process.....	2-23
Figure 2-9	Optical drive troubleshooting process	2-27
Figure 2-10	Modem troubleshooting process	2-30
Figure 2-11	PCMCIA troubleshooting process	2-32
Figure 2-12	IEEE 1394 troubleshooting process.....	2-34
Figure 2-13	Wireless LAN troubleshooting process	2-36
Figure 2-14	Express card troubleshooting process.....	2-38
Figure 2-15	Bluetooth troubleshooting.....	2-40

Tables

Table 2-1	Battery LED.....	2-8
Table 2-2	DC-IN LED.....	2-9

2.1 Troubleshooting Introduction

Chapter 2 describes how to determine if a Field Replaceable Unit (FRU) in the computer is causing the computer to malfunction. The FRUs covered are:

- | | | |
|----------------------------|-------------------------|--------------------------------|
| <u>1. Display</u> | <u>6. TouchPad</u> | <u>11. IEEE 1394 port</u> |
| <u>2. USB Floppy Drive</u> | <u>7. Speaker</u> | <u>12. Wireless LAN system</u> |
| <u>3. Keyboard</u> | <u>8. Optical drive</u> | <u>13. Express card unit.</u> |
| <u>4. USB ports</u> | <u>9. Modem</u> | <u>14. Bluetooth</u> |
| <u>5. TV-out port</u> | <u>10. PCMCIA unit</u> | |

The Diagnostics Disk operations are described in Chapter 3. Detailed replacement procedures are given in Chapter 4.

The following tools are necessary for implementing the troubleshooting procedures:

1. Diagnostics Disk (Repair and Sound Repair)
2. Phillips screwdriver (2 mm)
3. 6mm nut driver (for the helix screw nuts on the rear ports for CPU door)
4. 2DD or 2HD formatted work disk for floppy disk drive testing
5. Sycard (PCMCIA test card)
6. Cleaning kit for floppy disk drive troubleshooting
7. Cleaning kit for optical drive troubleshooting
8. Multimeter
9. External monitor
10. USB compatible keyboard
11. Multimedia sound system with line-in and line-out ports
12. Headphones
13. USB test module and USB cable
14. Music CD

2.2 Troubleshooting Flowchart

If you know the location of the malfunction, turn directly to the appropriate section of this chapter. If the problem is unspecified, use the flowchart in Figure 2-1 as a guide for determining which troubleshooting procedures to execute. Before performing any troubleshooting procedures, verify the following:

- Ask the user if a password is registered and, if it is, ask him or her to enter the password.
- Verify with the customer that Toshiba Windows XP is installed on the hard disk. Operating systems that were not preinstalled by Toshiba can cause the computer to malfunction.
- Make sure all optional equipment is removed from the computer.
- Make sure the floppy disk drive, if installed, is empty. If no FDD module is installed, you should use an external FDD to run the diagnostics tests

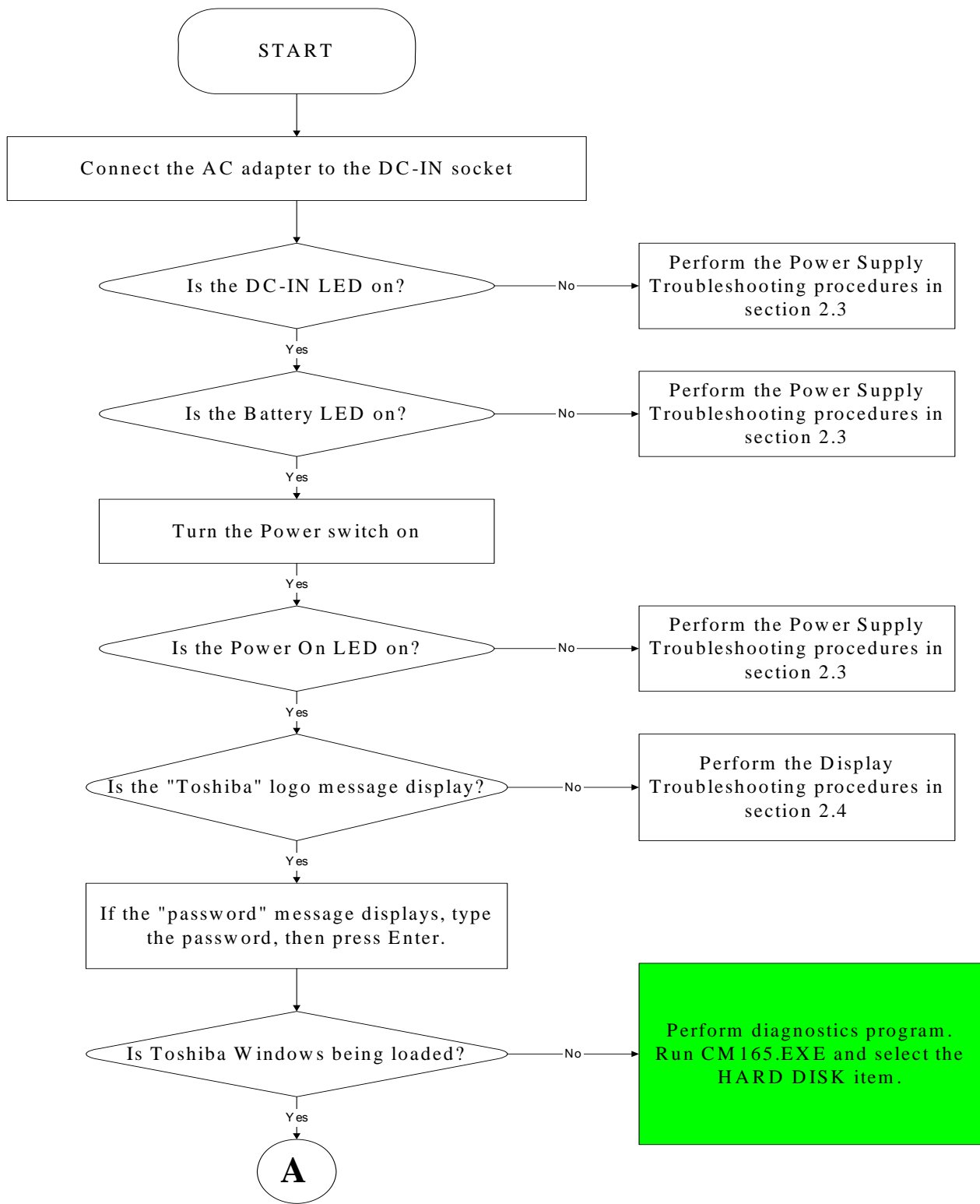

Figure 2-1 Troubleshooting flowchart (1/2)

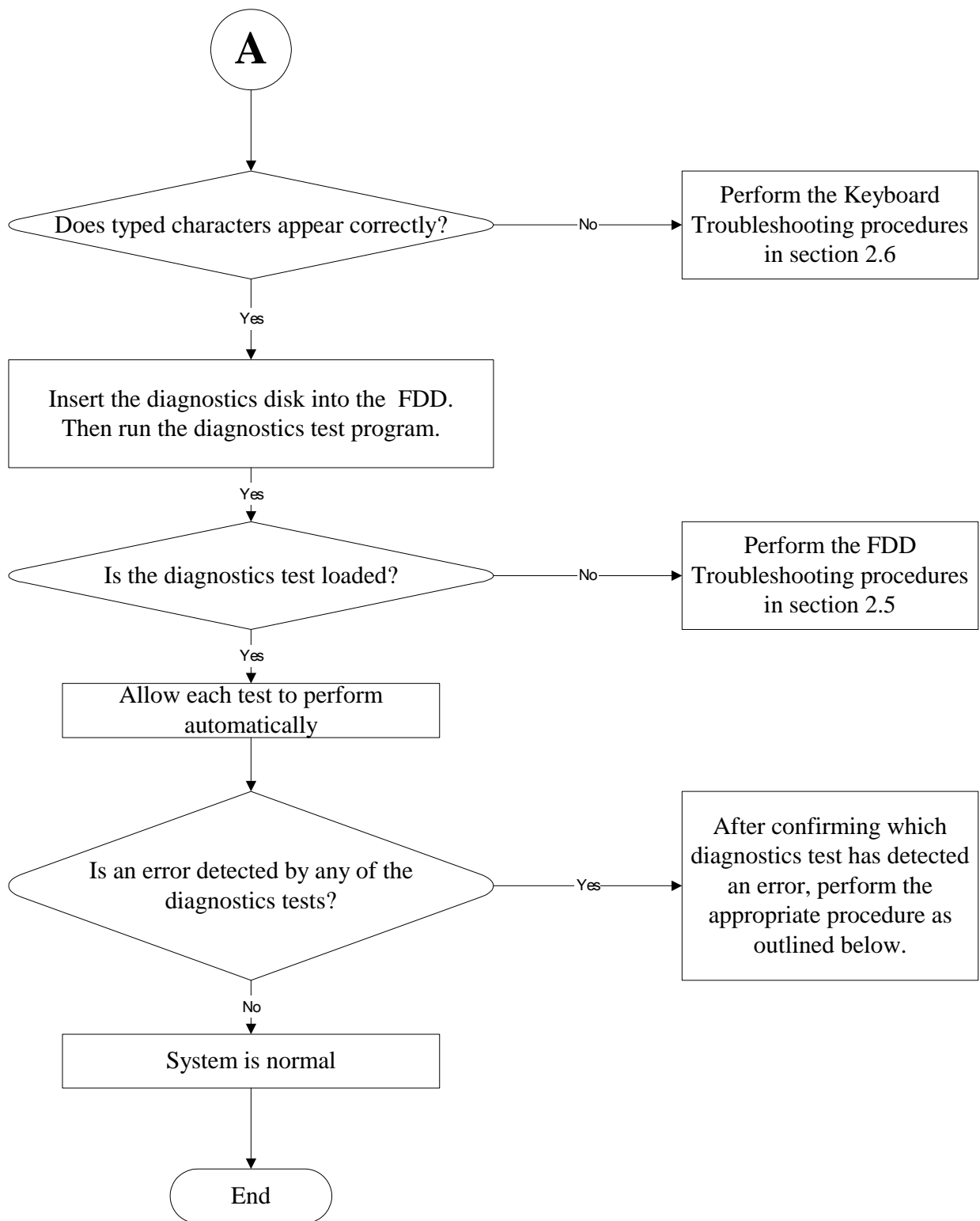

Figure 2-1 Troubleshooting flowchart (2/2)

If the diagnostics program cannot detect an error, the problem may be intermittent. The test program should be executed several times to isolate the problem. When a problem has been located, perform the appropriate troubleshooting procedures as follows:

1. If an error is detected by the battery test, perform the Power Supply Troubleshooting procedures in Section 2.3.
2. If an error is detected by the display test, perform the Display Troubleshooting procedures in Section 2.4.
3. If an error is detected by the keyboard test, perform the Keyboard Troubleshooting procedures in Section 2.5.
4. If an error is detected by the TouchPad test, perform the TouchPad Troubleshooting procedures in Section 2.8.
5. If an error is detected by the audio test, perform the Speaker Troubleshooting procedures in Section 2.9 and the Optical Drive Troubleshooting Procedures in Section 2.9.
6. If an error is detected by the modem test, perform the Modem Troubleshooting Procedures in Section 2.10.

Other problems that are not covered by the diagnostics program may be discovered by a user.

1. If an error is detected when using an external USB device, perform the External USB Devices Troubleshooting procedures in Section 2.6.
2. If an error is detected when using the TV-out connection, perform the TV-Out Failure Troubleshooting procedures in Section 2.7.
3. If an error is detected when using the speakers, perform the Speaker Troubleshooting procedures in Section 2.10.
4. If an error is detected when using the modem, perform the Modem Troubleshooting procedures in Section 2.12.
5. If an error is detected when using the PCMCIA unit, perform the PCMCIA Troubleshooting procedures in Section 2.13.
6. If an error is detected when using the IEEE1394 device, perform the IEEE1394 device Troubleshooting procedures in Section 2.14.
7. If an error is detected when using the Wireless LAN, perform the Wireless LAN Troubleshooting procedures in Section 2.15.

2.3 Power Supply Troubleshooting

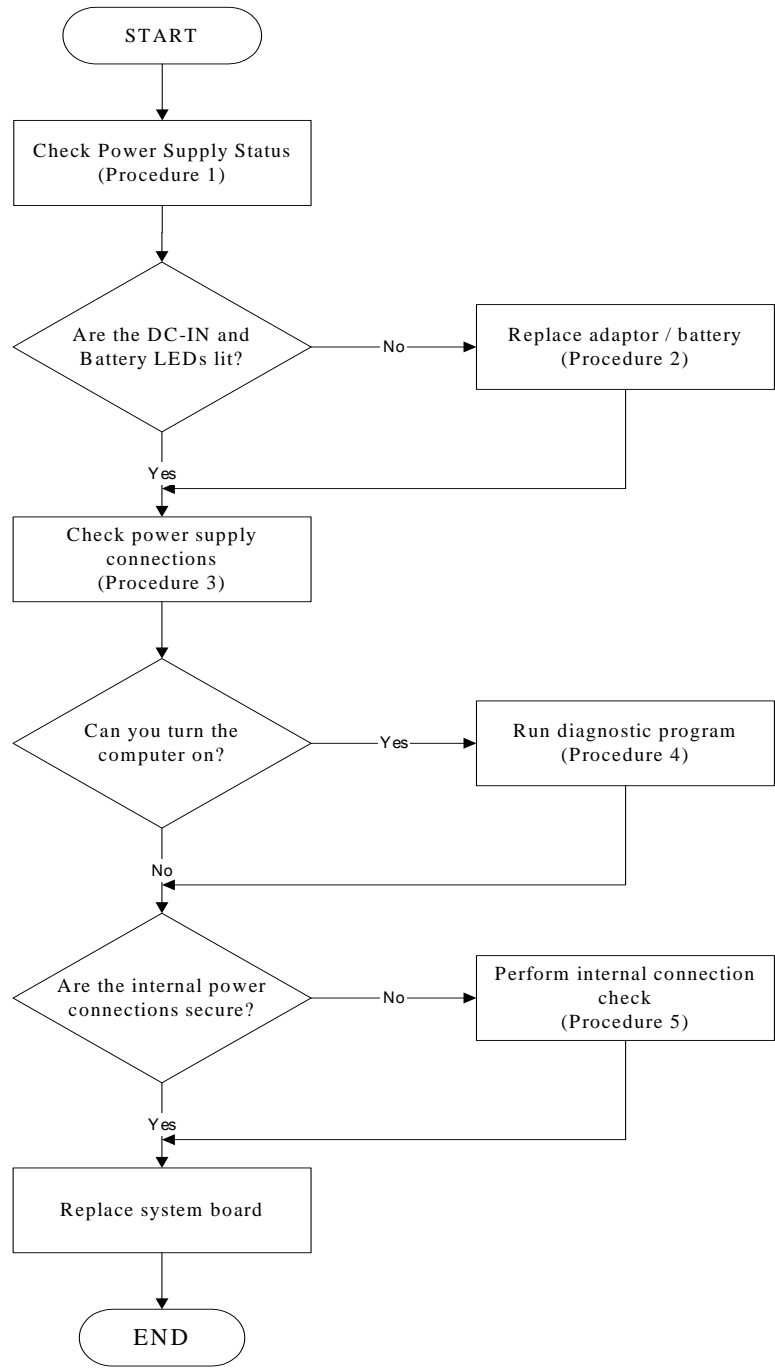

Figure 2-2 Power Supply Troubleshooting Process

The power supply controls many functions and components. To determine if the power supply is functioning properly, start with Procedure 1 and continue with the other Procedures as instructed. The flowchart in Figure 2-2 gives a summary of the process. The procedures described in this section are:

- Procedure 1: Power status check
- Procedure 2: Adaptor / battery replacement
- Procedure 3: Power supply connection check
- Procedure 4: Diagnostic check
- Procedure 5: Internal connection check

Procedure 1 Power Status Check

The following LEDs indicate the power supply status:

 Battery LED

 DC-IN LED

The power supply controller displays the power supply status through the Battery and the DC-IN LEDs as listed in the tables below.

Table 2-1 Battery LED

Battery State	LED colors	Definition
Charging	Amber, solid on	Battery charging with AC .
	Green, solid on	Battery fully charged by AC
	Green color off	Battery abnormal stop charging with AC (Bad cell/ Overheated)
Discharging	Amber, blinking (LED on for 1 second every 4 seconds)	Battery within low state: 12 minutes remaining
	Amber, blinking (LED on for 1 second every 2 seconds)	Battery within critical low state: 3 minutes remaining. The system is protected and cannot be re-powered on without the AC power connected.
	Amber color off	Battery not in low or critical low state; It's in discharging state

Table 2-2 DC-IN LED

AC-IN LED	Power supply status
Solid on	AC power exists (LED is solid green).
Off	No AC power exists.

To check the power supply status, install a battery pack and connect an AC adaptor to the DC-IN port on the computer and to a power supply.

If the DC-IN LED or Battery LED is not lit, go to Procedure 2.

Procedure 2 Adaptor / battery replacement

A faulty adaptor may not supply power or may not charge the battery. Perform Check 1.

Check 1 Connect a new AC adaptor. If the problem is not resolved, go to Check 2.

Check 2 Insert a new battery. If the problem is still not resolved, go to Procedure 3.

Procedure 3 Power supply connection check

The power supply wiring diagram is shown below:

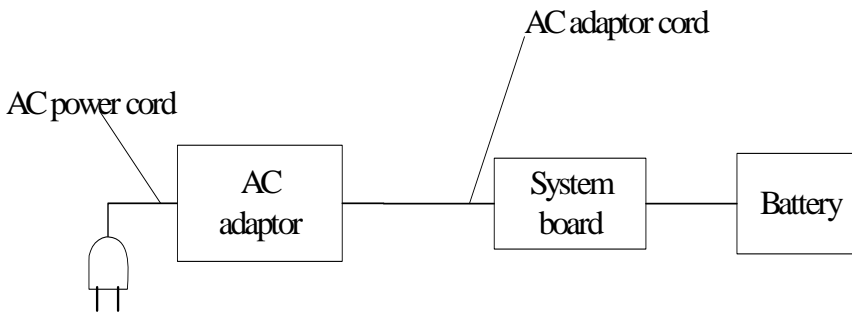

Any of the connectors may be disconnected. Perform Check 1.

- Check 1 Disconnect the AC power cord from wall outlet. Check the power cable for breaks. If the power cord is damaged, connect a new AC power cord. If there is no damage, go to Check 2.
- Check 2 Make sure the AC adaptor cord and AC power cord are firmly plugged into the DC-IN socket, AC adaptor inlet and wall outlet. If these cables are connected correctly, go to Check 3.
- Check 3 Make sure that the DC-IN input port socket is firmly secured to the system board of the computer.
- If the DC-IN input socket is loose, go to Procedure 5.
 - If it is not loose, go to Check 4.
- Check 4 Use a multi-meter to make sure that the AC adaptor output voltage is close to 19 V. If the output is several percent lower than 19 V, go to Check 5. If the output is close to 19 V, go to Check 6.
- Check 5 Connect a new AC adaptor or AC power cord.
- If the DC-IN LED does not light, go to Procedure 4.
 - If the battery LED does not light, go to Check 6.
- Check 6 Make sure the battery pack is installed in the computer correctly. If the battery is properly installed and the battery LED still does not light, go to Procedure 4.

Procedure 4 Diagnostic check

The power supply may not charge the battery pack. Perform the following procedures:

1. Reinstall the battery pack.
2. Attach the AC adaptor and turn on the power. If you cannot turn on the power, go to Procedure 5.
3. Run the Diagnostic test following the procedures described in Chapter 3, Tests and Diagnostics. If no problem is detected, the battery is functioning normally.

Procedure 5 Replacement check

The system board may be disconnected or damaged. Disassemble the computer following the steps described in Chapter 4, *Replacement Procedures*. Check the connection between the AC adaptor and the system board. After checking the connection, perform Check 1:

- Check 1 Use a multi-meter to make sure that the fuses on the system board are not blown. If a fuse is not blown, go to Check 2. If a fuse is blown, go to Check 3.
- Check 2 Make sure that the battery cable is firmly connected to the system board. If it is connected firmly, go to Check 3.
- Check 3 The system board may be damaged. Replace it with a new one following the instructions in Chapter 4.

2.4 Display Troubleshooting

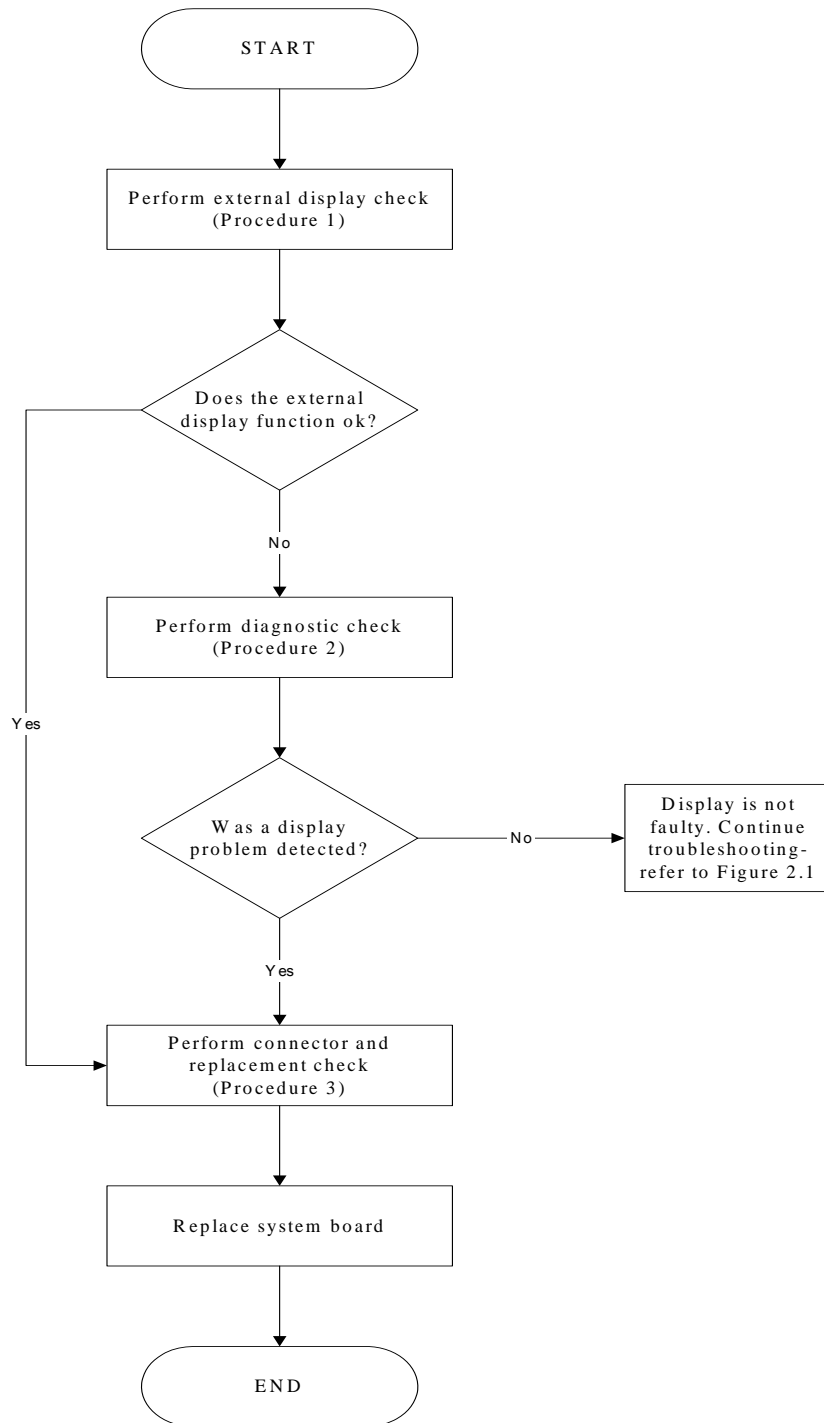

Figure 2-3 Display troubleshooting process

This section describes how to determine if the computer's display is functioning properly. The process is outlined in Figure 2-3. Start with Procedure 1 and continue with the other procedures as instructed.

Procedure 1: External display check

Procedure 2: Diagnostic check

Procedure 3: Connector and replacement check

Procedure 1 External display check

Connect an external display to the computer's external monitor port, then boot the computer. The computer automatically detects the external display.

If the external display works correctly, the internal LCD may be damaged. Go to Procedure 3.

If the external monitor appears to have the same problem as the internal monitor, the system board may be damaged. Go to Procedure 2.

Procedure 2 Diagnostic check

The Display Test program is stored on the computer's Diagnostics disk. This program checks the display controller on the system board. Insert the Diagnostics disk in the computer's floppy disk drive, turn on the computer and run the test. Refer to Chapter 3, *Tests and Diagnostics* for details.

If an error is detected, go to Procedure 3. If an error is not detected, the display is functioning properly.

Procedure 3 Connector and replacement check

The FL inverter board, LCD module, and system board are connected to the display circuits. Any of these components may be damaged. Refer to Chapter 4, *Replacement Procedures*, for instructions on how to disassemble the computer and then perform the following checks:

- Check 1 Make sure the DDR RAM module is seated properly. Test display again. If the problem still exists, replace the DDR RAM module. If the problem still exists, perform Check 2.
- Check 2 Replace the FL inverter board with a new one and test display again. If the problem still exists, perform Check 3.
- Check 3 Replace the LCD module with a new one and test display again. If the problem still exists, perform Check 4.
- Check 4 Replace the LCD/FL cable with a new one and test display again. If the problem still exists, perform Check 5.
- Check 5 Replace the CPU with another of the same specifications. If the problem still exists, perform Check 6.
- Check 6 The system board may be damaged. Replace it with a new one.

2.5 Keyboard Troubleshooting

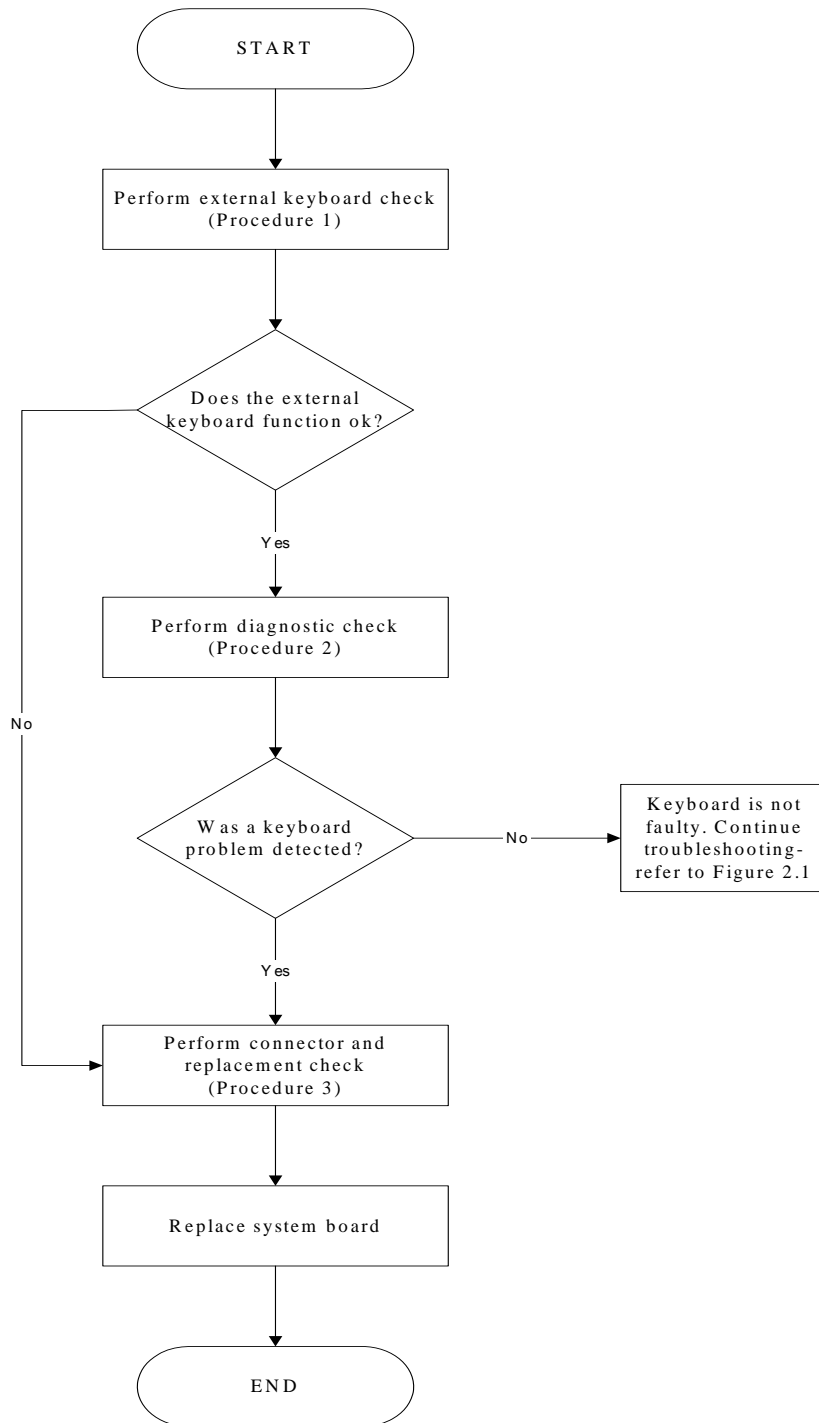

Figure 2-4 Keyboard troubleshooting process

To determine if the computer's keyboard is functioning properly, perform the following procedures. Figure 2-5 outlines the process. Start with Procedure 1 and continue with the other procedures as instructed.

Procedure 1: External keyboard check

Procedure 2: Diagnostic check

Procedure 3: Connector and replacement check

Procedure 1 External keyboard check

Connect a USB keyboard to one of the computer's USB ports, then boot the computer. The computer automatically detects the external keyboard.

If the external keyboard works correctly, the internal keyboard or its connections may be faulty. Go to Procedure 2.

If the external keyboard appears to have the same problem as the internal keyboard, the system board may be damaged. Replace it with a new one following the instructions in Chapter 4.

Procedure 2 Diagnostic check

Run the Diagnostic Program, which will automatically execute the Keyboard Test. Refer to Chapter 3, *Tests and Diagnostics* for more information on how to run the program.

If an error is located, go to Procedure 3. If an error does not occur, the keyboard is functioning properly.

Procedure 3 Connector and replacement check

The keyboard and/or system board may be disconnected or damaged. Disassemble the computer following the steps described in Chapter 4, *Replacement Procedures* and perform the following checks.

Check 1 Make sure the keyboard cable is firmly connected to the system board.

If the connection is loose, reconnect firmly and repeat Procedure 2. If there is still an error, go to Check 2.

Check 2 The keyboard may be damaged. Replace it with a new one following the instructions in Chapter 4.

If the problem still exists, perform Check 3.

Check 3 The system board may be damaged. Replace it with a new one following the instructions in Chapter 4.

2.6 External USB Devices Troubleshooting

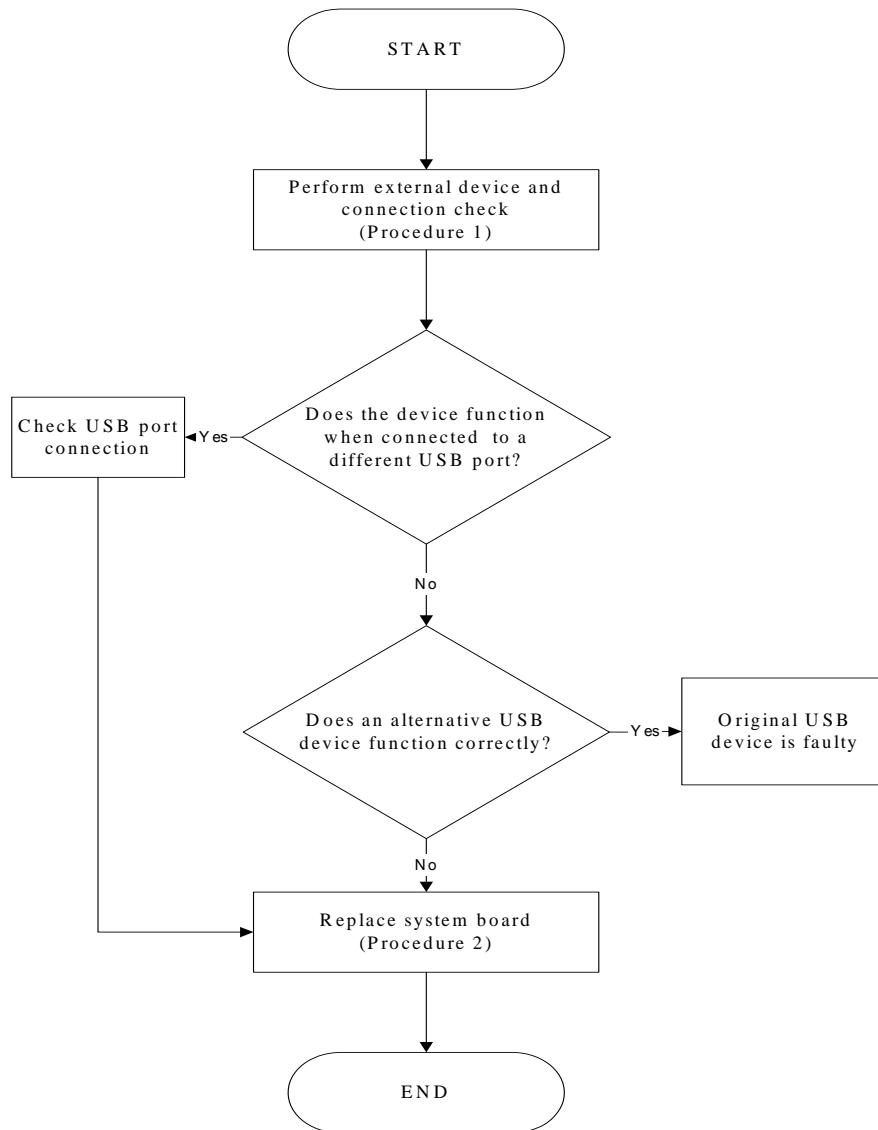

Figure 2-5 External USB device troubleshooting process

To determine if the computer's external USB devices are functioning properly, perform the following procedures. Figure 2-6 outlines the process. Start with Procedure 1 and continue as instructed.

Procedure 1: External device and connection check

Procedure 2: Replace system board

Procedure 1 External device and connection check

The USB device may be damaged or the connection may be faulty. Perform Check 1.

Check 1 Make sure USB device cable is firmly plugged into one of the USB sockets. If the cable is connected correctly, go to Check 2.

Check 2 Plug the USB device into another USB socket (there are three in all). If the USB device still does not work, go to Check 4.

If the device functions correctly when connected to another USB port, go to Check 3.

Check 3 Make sure that the USB socket is firmly secured to the system board of the computer. If the malfunction remains, the system board may be damaged. Go to Procedure 2.

Check 4 Connect an alternative USB device to one of the computer's USB ports, and then boot the computer. The computer automatically detects the external device.

If the alternative USB device works correctly, the original device may be damaged and should be replaced.

If the alternative USB device appears to have the same problem as the original device, the system board may be damaged. Go to Procedure 2.

Procedure 2 Replace system board

If the error persists, the system board may be damaged. Replace it with a new one following the instructions in Chapter 4.

2.7 TV-Out Failure Troubleshooting

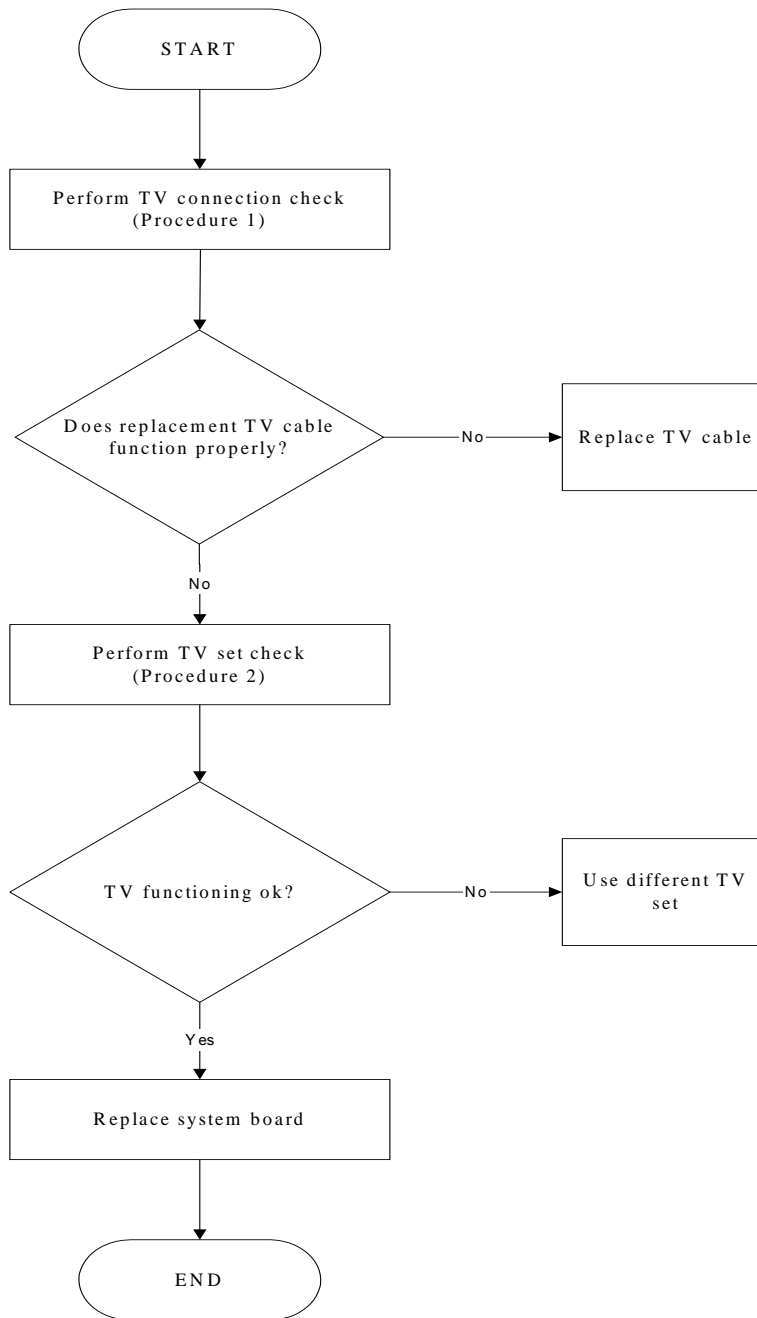

Figure 2-6 TV-out troubleshooting process

To determine if the computer's TV-out port is functioning properly, perform the following procedures. Figure 2-7 outlines the process. Start with Procedure 1 and continue as instructed.

Procedure 1: TV connection check

Procedure 2: TV set check

Procedure 1 TV connection check

The TV cable may be damaged or the connections may be loose. Perform Check 1:

- Check 1 Make sure TV cable is firmly plugged into both the TV set and the TV-out port of the computer. If the cable is connected correctly, go to Check 2.
- Check 2 Make sure the TV-out port is firmly secured to the system board of the computer. If the malfunction remains, go to Check 3.
- Check 3 The TV cable may be damaged. Replace with a good cable. If the malfunction remains, go to Procedure 2.

Procedure 2 TV set check

The TV set may be faulty. Perform Check 1:

- Check 1 Try using the set for television reception. If it does not work, the set may be damaged. If the set does work, perform Check 2.
- Check 2 Try connecting a different television to the computer. If the replacement television works, the original set may be damaged. If the replacement set does not work the system board may be damaged. Replace it with a new one following the instructions in Chapter 4.

2.8 TouchPad Troubleshooting

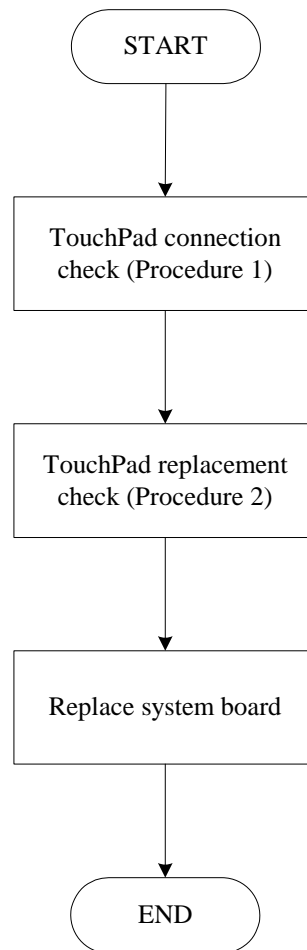

Figure 2-7 TouchPad troubleshooting process

To determine if the computer's built-in TouchPad is functioning properly, perform the following procedures. Figure 2-9 outlines the process. Start with Procedure 1 and continue as instructed.

Procedure 1: TouchPad connection check

Procedure 2: TouchPad replacement check

Procedure 1 TouchPad connection check

The TouchPad is connected via the TouchPad FPC to the system board. Make sure the TouchPad FPC cable is firmly connected to the TouchPad and system board. Refer to Chapter 4, *Replacement Procedures*, for instructions on how to disassemble the computer and then perform the following checks.

If any of the connections are loose, reconnect firmly. If any of the connections is damaged, or there is still an error, go to Procedure 2.

Procedure 2 TouchPad replacement check

The TouchPad unit or FPC may be defective or damaged. Replace each with a new one following the steps in Chapter 4. If the FDD is still not functioning properly, replace the system board with a new one following the steps in Chapter 4.

2.9 Speaker Troubleshooting

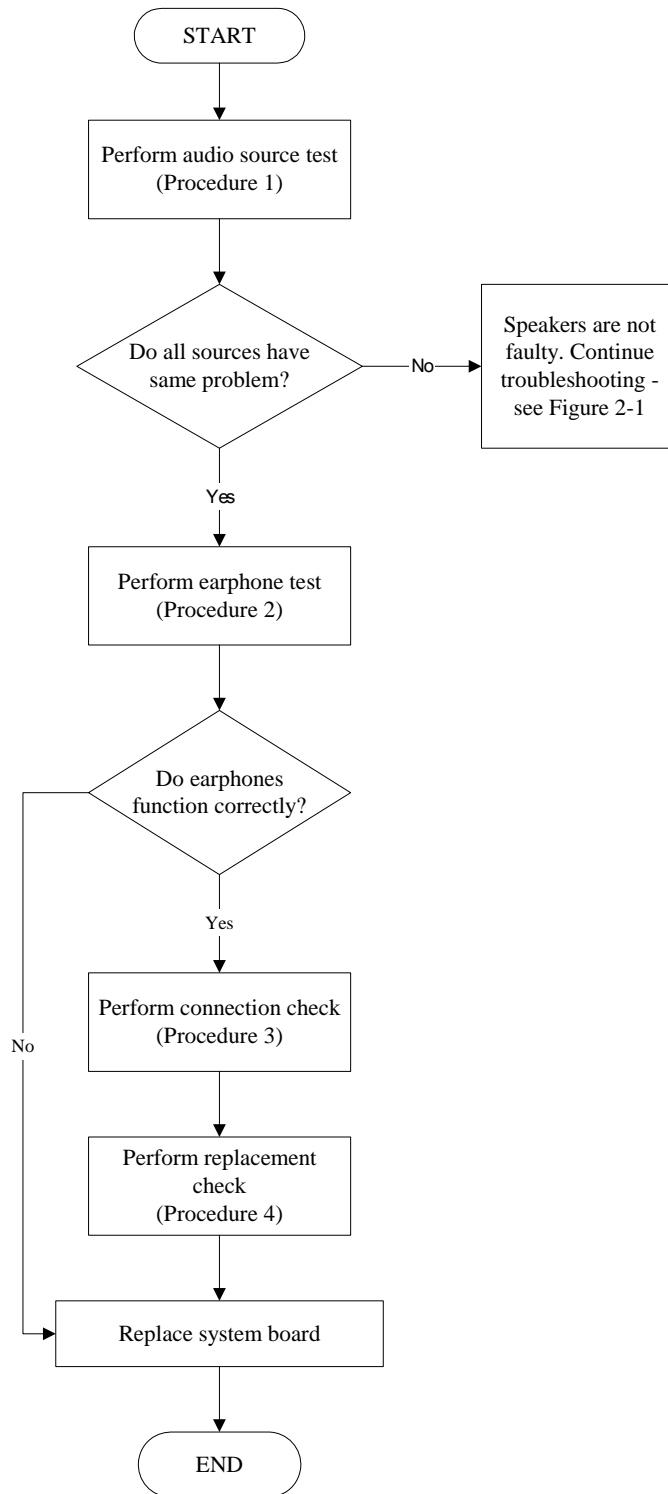

Figure 2-8 Speaker troubleshooting process

To determine if the computer's built-in speakers are functioning properly, perform the following procedures. Figure 2-10 outlines the process. First adjust the speaker volume to an appropriate level. Start with Procedure 1 and continue as instructed.

- Procedure 1: Audio source test
- Procedure 2: Earphone test
- Procedure 3: Connection check
- Procedure 4: Replacement check

Procedure 1 Audio source test

Try different audio sources (e.g. an audio CD and digital music file) to determine whether the fault is in the speaker system or not. If not all sources have sound problem, the problem is in the source devices. If all have the same problem, continue with Procedure 2.

Procedure 2 Earphone test

Connect a set of earphones or external speakers. If these function correctly, go to Procedure 3. If they do not function correctly, the system board may be defective or damaged. Replace it with a new one.

Procedure 3 Connection check

Disassemble the computer following the steps described in Chapter 4, *Replacement Procedures* and make sure the speaker cable is firmly connected to the audio board. If the stereo speakers are still not functioning properly, go to Procedure 4.

Procedure 4 Replacement check

If the stereo speakers don't sound properly, the stereo speakers may be defective or damaged. Replace them with new ones. If the stereo speakers still do not work properly, try replacing in turn the audio board and system board.

2.10 Optical Drive Troubleshooting

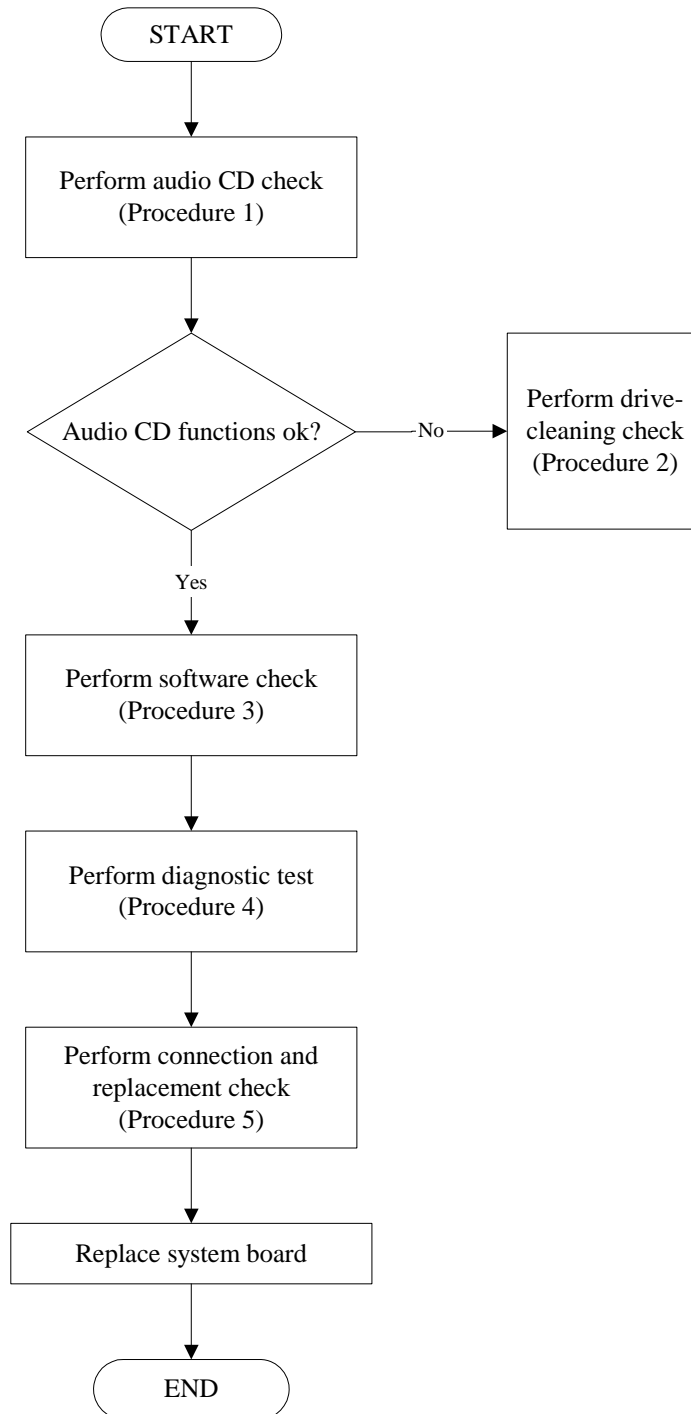

Figure 2-9 Optical drive troubleshooting process

This section describes how to determine if the computer's internal optical drive is functioning properly. The Satellite P10 module bays can accommodate the following optical drives:

- DVD-R/RW device
- DVD-ROM device
- DVD Multi-drive device
- COMBO device

Figure 2-11 outlines the process. Perform the steps below starting with Procedure 1 and continue with the other procedures as required.

Procedure 1: Audio CD test

Procedure 2: Drive cleaning check

Procedure 3: Software check

Procedure 4: Diagnostic test

Procedure 5: Connection and replacement check

Procedure 1 Audio CD check

First, insert an audio CD into the CD/DVD drive. If it works, the problem is not with the drive. Go to Procedure 3. If the audio CD does not work, go to Procedure 2. If the CD/DVD LED on the front panel does not light when the disc is played and the drive gives no response, go straight to Procedure 3.

Procedure 2 Drive cleaning check

Insert a CD/DVD drive-cleaning disk into the drive clean according to the drive-cleaning product instructions. If the problem persists, go to Procedure 3.

Procedure 3 Software check

Ensure that the appropriate driver has been installed on the computer for the CD/DVD drive.

Procedure 4 Diagnostic test

The audio test program stored in the Diagnostics Disk will test the drive's ability to play an audio CD. See Chapter 3 for details.

If any errors occur while executing the diagnostic program, go to Procedure 5.

Procedure 5 Connection check and replacement check

The optical drive connects to the system board. The drive may be disconnected, or the drive or system board may be damaged. Disassemble the computer following the steps described in Chapter 4, *Replacement Procedures*, and perform the following checks:

- Check 1 Make sure the drive is firmly connected to the system board. If the connection is good and there is still an error, go to Check 2.
- Check 2 The drive or drive cable may be defective or damaged. Replace each with a new one following the steps in Chapter 4, *Replacement Procedures*. If the drive is still not functioning properly, perform Check 3.
- Check 3 The system board may be damaged. Replace it with new one following the instructions in Chapter 4, *Replacement Procedures*.

2.11 Modem Troubleshooting

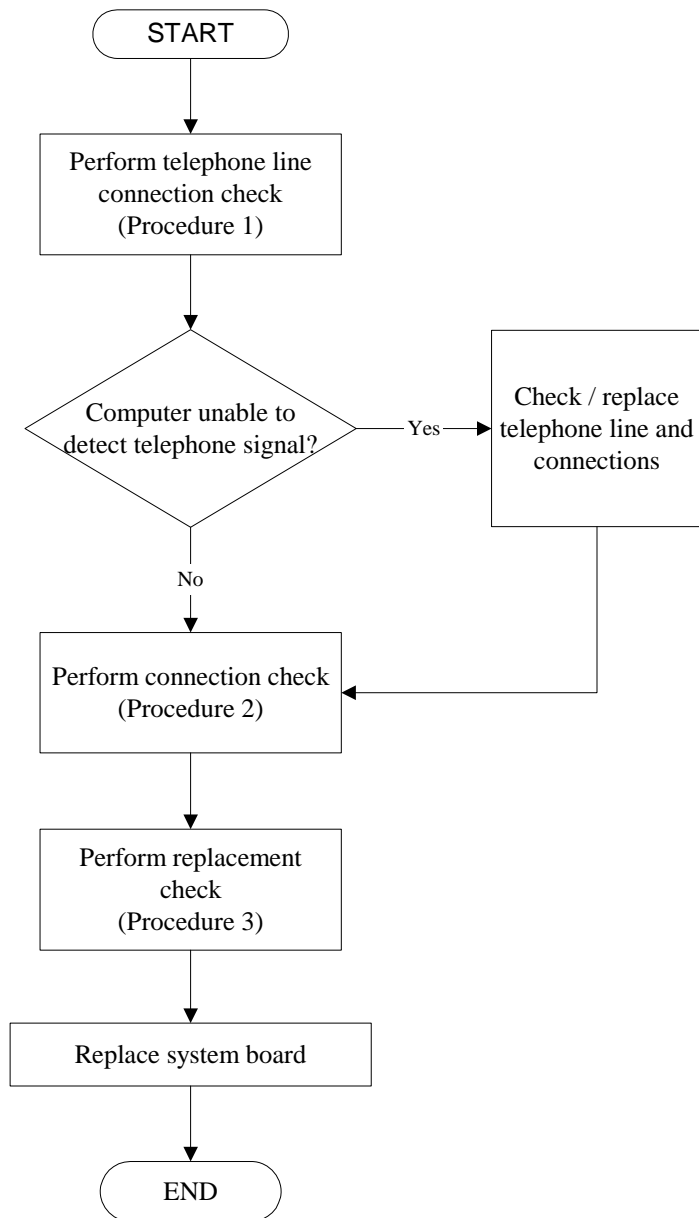

Figure 2-10 Modem troubleshooting process

This section describes how to determine if the computer's modem is functioning properly. Figure 2-12 outlines the process. Perform the steps below starting with Procedure 1 and continuing with the other procedures as required.

Procedure 1: Telephone line connection check

Procedure 2: Modem card connection check

Procedure 3: Modem card replacement check

Procedure 1 Telephone line connection check

The telephone cable may be damaged or the connections may be loose. Attempt to connect the computer to a network through using the modem. If the modem does not function at all, go to Procedure 3. If the attempt fails because the computer detects no telephone signal, the fault may be in the telephone cable, the wall socket or the modem port. Perform Check 1:

Check 1 Make sure telephone cable is firmly plugged into both the telephone wall socket and the modem port of the computer. If the cable is connected correctly, go to Check 2.

Check 2 Make sure the modem port is firmly secured to the system board of the computer. If the malfunction remains, go to Check 3.

Check 3 The telephone cable may be damaged. Replace with a good cable. If the malfunction remains, go to Procedure 2.

Procedure 2 Modem card connection check

Disassemble the computer following the steps described in Chapter 4, *Replacement Procedures* and ensure that the modem card is well connected to the system board. If the problem persists, perform Procedure 3.

Procedure 3 Modem replacement check

The modem card or RJ-11 jack may be faulty. Try replacing them. If the problem persists, the system board may be defective or damaged. Replace the System Board with a new one following the steps in Chapter 4, *Replacement Procedures*.

2.12 PCMCIA Troubleshooting

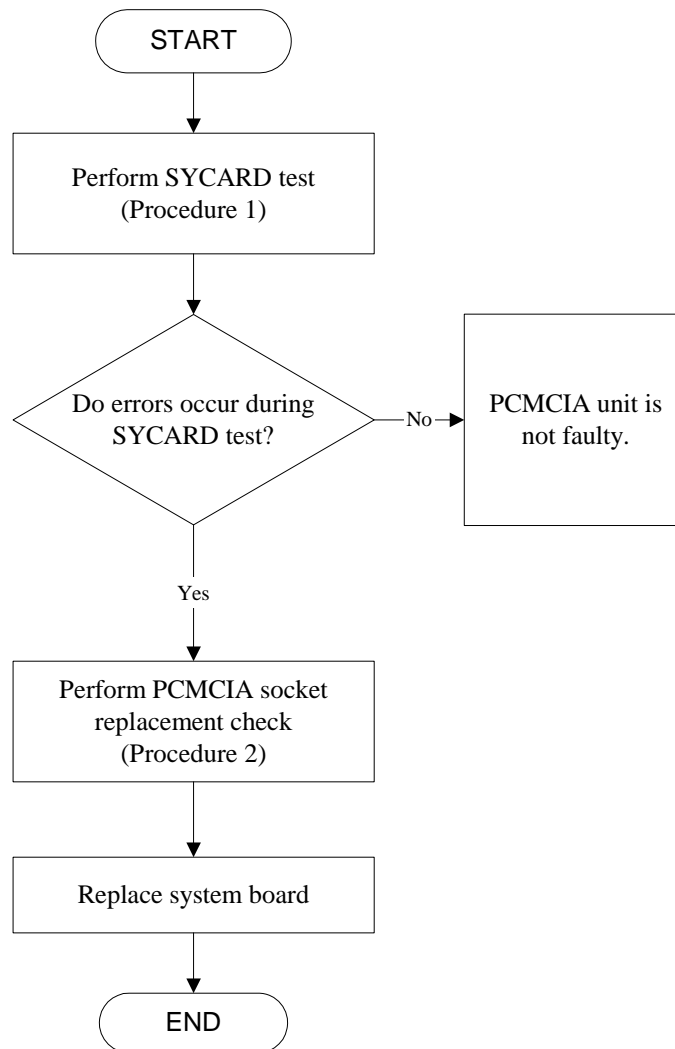

Figure 2-11 PCMCIA troubleshooting process

This section describes how to determine if the PCMCIA card player is functioning properly. The process is summarized in Figure 2-13. Perform the steps below starting with Procedure 1 and continuing with the other procedures as required.

Procedure 1: Sycard test

Procedure 2: PCMCIA socket replacement check

Procedure 1 SYCARD test

The SYCARD test card contains a PCMCIA test program. Ensure the card is fully inserted into the socket before running the program.

If an error occurs during the SYCARD test, perform Procedure 2. If no error occurs, it is likely that the original PC card was faulty.

Procedure 2 PCMCIA socket replacement check

The PCMCIA socket may be damaged or defective, for instance the socket pins can be bent. Disassemble the computer following the steps described in Chapter 4, Replacement Procedures and replace the socket. If the problem persists, the system board may be defective or damaged. Replace the system board with a new one following the steps in Chapter 4.

2.13 IEEE 1394 Troubleshooting

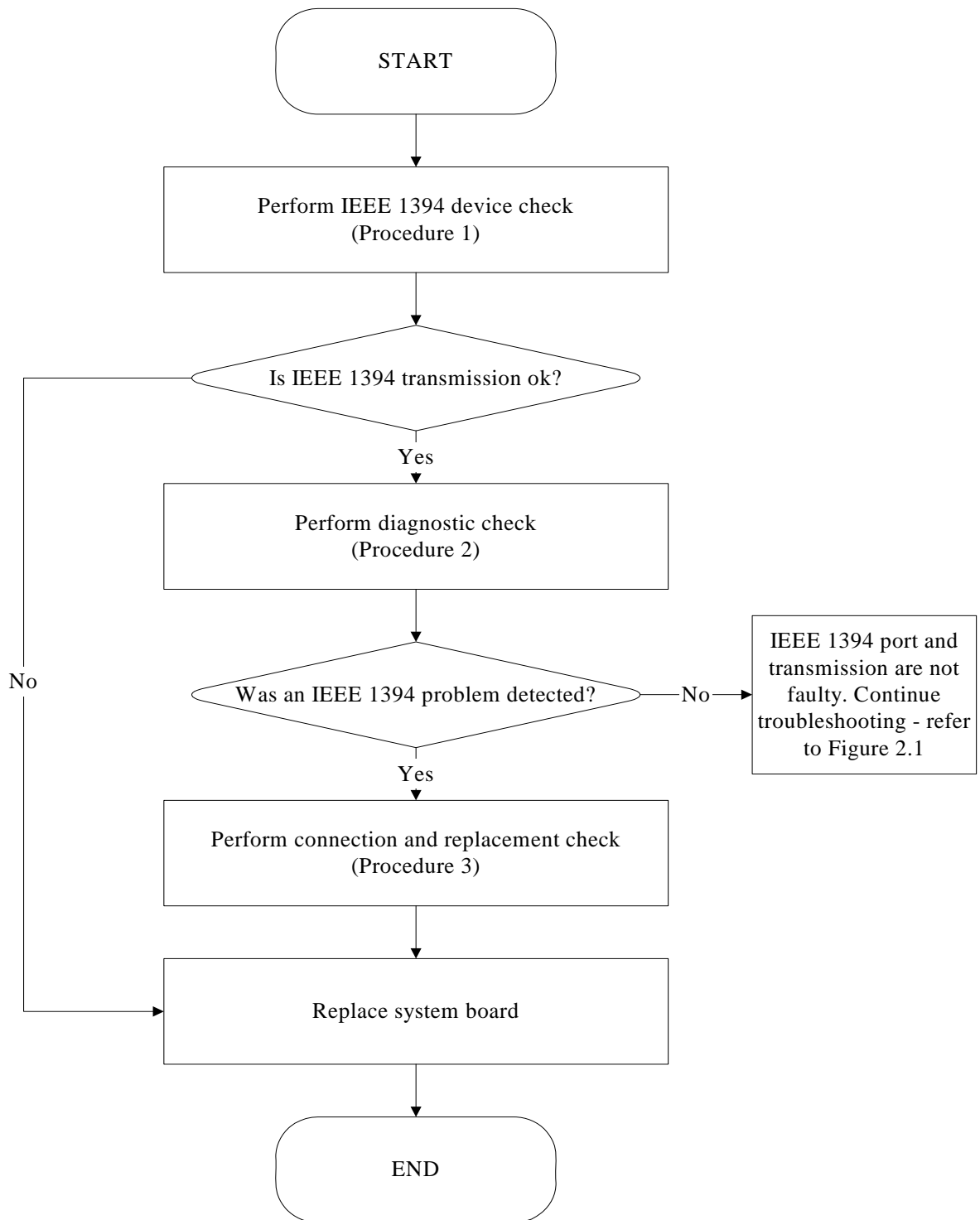

Figure 2-12 IEEE 1394 troubleshooting process

To determine if the computer's IEEE 1394 system is functioning properly, perform the following procedures. Figure 2-14 outlines the process. Start with Procedure 1 and continue with the other procedures as instructed.

Procedure 1: IEEE 1394 device check

Procedure 2: Diagnostic check

Procedure 3: Connection and replacement check

Procedure 1 IEEE 1394 device check

Connect an IEEE 1394 device to the computer's IEEE 1394 port, then boot the computer for Windows XP. The computer should automatically detect the 1394 device. Check whether the device can transmit data to the computer.

If the device is able to communicate with the computer, the problem may be intermittent or connections may be faulty. Go to Procedure 2.

If communication is impaired, there may be a faulty connection. Go to Procedure 3.

Procedure 2 Diagnostic check

Run the Diagnostic Program, which will automatically execute the IEEE 1394 port test for transmission. Refer to Chapter 3, Tests and Diagnostics for more information on how to run the program.

If an error is located, go to Procedure 3. If an error does not occur, the 1394 port is functioning properly.

Procedure 3 Connection and replacement check

The transmission cable may be damaged or the connections may be loose. Perform Check 1:

- Check 1 Make sure the transmission cable is firmly plugged into both the IEEE 1394-compatible device and the IEEE 1394 port of the computer. If the cable is connected correctly, go to Check 2.
- Check 2 Make sure the IEEE 1394 port is firmly secured to the system board of the computer. If the malfunction persists, go to Check 3.
- Check 3 The transmission cable may be damaged. Replace with a good cable. If the malfunction persists, go to Check 4.
- Check 4 The system board may be damaged. Replace it with a new one following the instructions in Chapter 4.

2.14 Wireless LAN Troubleshooting

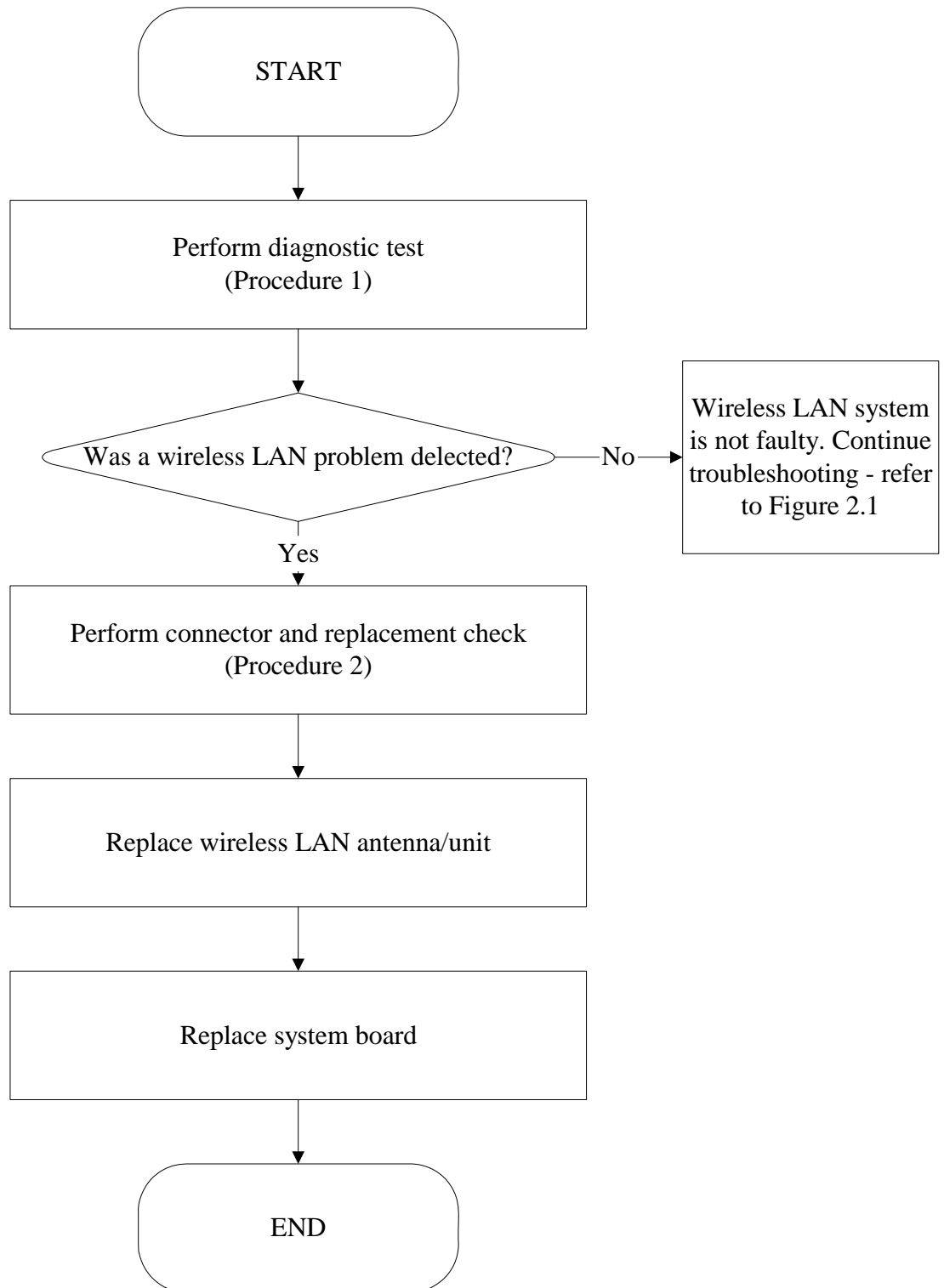

Figure 2-13 Wireless LAN troubleshooting process

The wireless LAN antenna wire, wireless LAN unit or system board may each be the source of a wireless LAN fault. Any of these components may be damaged. To determine if the computer's wireless LAN system is functioning properly, perform the following procedures. Figure 2-15 outlines the process. Start with Procedure 1 and continue with the other procedures as instructed.

Procedure 1: Diagnostic test

Procedure 2: Connector and replacement check

Procedure 1 Diagnostic test

Run the Diagnostic Program, which will automatically execute the wireless LAN test. Refer to Chapter 3, Tests and Diagnostics for more information on the program.

If an error is located, go to Procedure 2. If an error is not located, the wireless LAN system is functioning properly.

Procedure 2 Connector and replacement check

The wireless LAN antenna, wireless LAN unit or system board may be disconnected or damaged. Disassemble the computer following the steps described in Chapter 4, *Replacement Procedures*, and perform the following checks.

- Check 1 Make sure that the wireless LAN antenna is firmly connected to the wireless LAN unit (refer to Chapter 4 for instructions) and that the wireless LAN unit is securely slotted into the system board. If the problem persists, go to Check 2.
- Check 2 Check that the wireless communication switch is turned to "On", then make sure that the wireless communication LED on the front panel is lit. If the LED is lit but the wireless LAN function is still faulty, the antenna may be damaged. Replace with a new antenna following the steps in Chapter 4, *Replacement Procedures*. If the problem persists, or if the wireless LAN LED is not lit when the wireless communication switch is turned to "On", go to Check 3.
- Check 3 The wireless LAN unit may be damaged. Replace it with a new one following the instructions in Chapter 4. If the problem still exists, perform Check 4.
- Check 4 The system board may be damaged. Replace it with a new one following the instructions in Chapter 4.

2.15 Express Card Troubleshooting

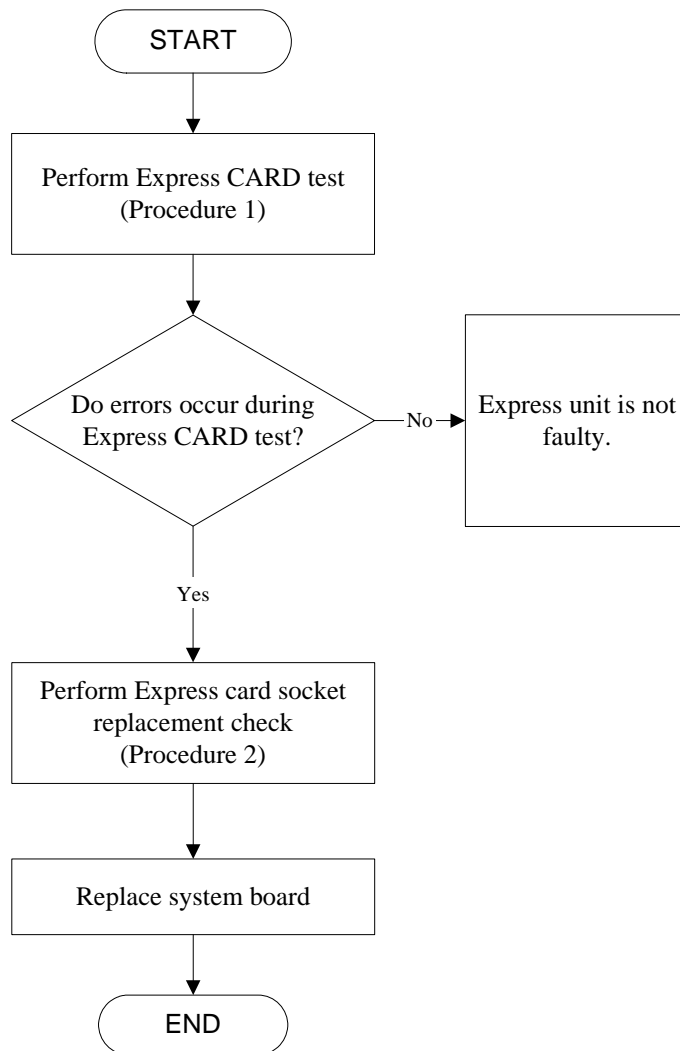

Figure 2-14 Express card troubleshooting process

This section describes how to determine if the Express card player is functioning properly. The process is summarized in Figure 2-14. Perform the steps below starting with Procedure 1 and continuing with the other procedures as required.

Procedure 1: Express card test

Procedure 2: Express socket replacement check

Procedure 1 Express card test

The Express test card contains a Express test program. Ensure the card is fully inserted into the socket before running the program.

If an error occurs during the Express card test, perform Procedure 2. If no error occurs, it is likely that the original Express card was faulty.

Procedure 2 Express card socket replacement check

The Express card socket may be damaged or defective, for instance the socket pins can be bent. Disassemble the computer following the steps described in Chapter 4, Replacement Procedures and replace the socket. If the problem persists, the system board may be defective or damaged. Replace the system board with a new one following the steps in Chapter 4.

2.12 Bluetooth Troubleshooting

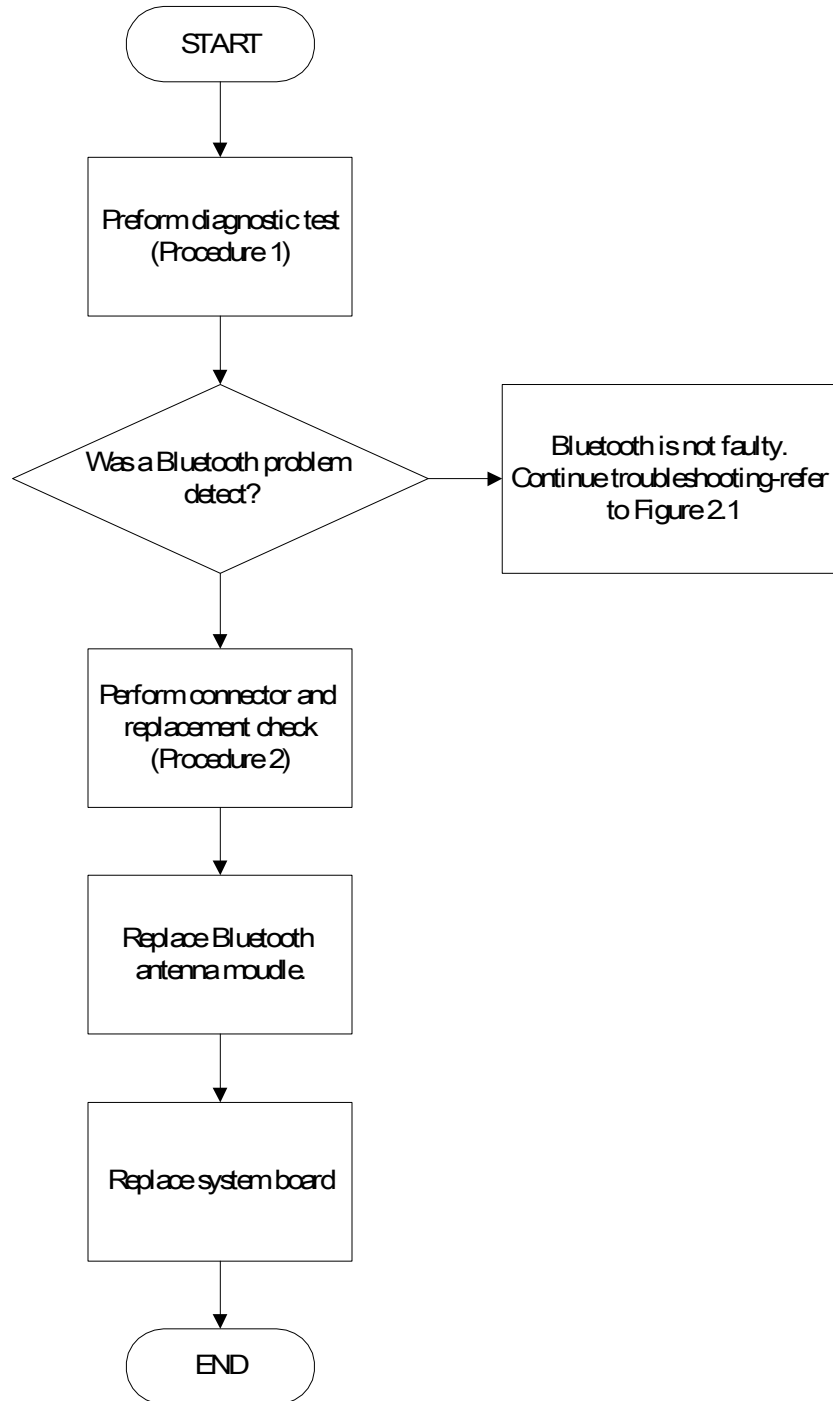

Figure 2-16 Bluetooth troubleshooting process

The Bluetooth antenna wire, Bluetooth module or system board may be the reason of a Bluetooth fault. Any of these components may be damaged. To determine if the computer's Bluetooth is functioning properly, perform the following procedures. Figure 2-16 outlines the process. Start with Procedure 1 and continue with the other procedures as instructed.

Procedure 1: Diagnostic test

Procedure 2: Connector and replacement check

Procedure 1 Diagnostic test

Run the Diagnostic Program, which will automatically execute the Bluetooth test. Refer to Chapter 3, Tests and Diagnostics for more information on the program.

If an error is located, go to Procedure 2. If an error is not located, the Bluetooth system is functioning properly.

Procedure 2 Connector and replacement check

The Bluetooth, antenna module or system board may be disconnected or damaged. Disassemble the computer following the steps described in Chapter 4, *Replacement Procedures*, and perform the following checks.

- Check 1 Make sure that the Bluetooth antenna is firmly connected to the Bluetooth module (refer to Chapter 4 for instructions) and that the Bluetooth FFC is securely slotted into the system board. If the problem persists, go to Check 2.
- Check 2 Check that the Bluetooth communication switch is turned to "On", then make sure that the communication LED on the left panel is lit. If the LED is lit but the Bluetooth function is still faulty, the antenna module may be damaged. Replace with a new antenna following the steps in Chapter 4, *Replacement Procedures*. If the problem persists, or if the Bluetooth communication LED is not lit when the Bluetooth communication switch is turned to "On", go to Check 3.
- Check 3 The Bluetooth module may be damaged. Replace it with a new one following the instructions in Chapter 4. If the problem still exists, perform Check 4.
- Check 4 The system board may be damaged. Replace it with a new one following the instructions in Chapter 4.

Chapter 3

Test and Diagnostic Operation Handbook

Version 1.0

Write by: Handsome

May. 20 2005 released

Contents

1.	The Diagnostic Test	1
2.	Executing the Diagnostic Test	2
2.1	Config Check Test	6
2.2.	DMI Chech Test.....	8
2.3.	Speaker Audio Test.....	8
2.4.	Fan ON/OFF Test	9
2.5.	Main Battery Charge Test.....	10
2.6.	FDD Test.....	11
2.7.	CD-ROM Test.....	12
2.8.	Keyboard Test.....	13
2.9.	Mouse (Pad) Test	16
2.10.	LCD Pixels Mode Test	18
2.11.	Lid Switch Test.....	19
2.12.	HDD R/W Test	20
2.13.	LAN Test	22
2.14.	RTC Test.....	24
2.15.	CD Control Button Test.....	25
2.16.	Speaker EQ Check&Rewrite	26
2.17.	Read 1394 GUID	28

1. The Diagnostic Test

This chapter explains how to use the Test & Diagnostic program (**based on Charlotte10 T&D Version: 1.0**) to test the functions of the computer's hardware modules. The Test & Diagnostic Program is stored on the T&D diskettes. The program consists of a series of tests that run automatically when the Diagnostics Program items are selected and executed.

NOTES: To start the diagnostics, follow these steps

1. Check all cables for loose connections.
2. Exit this program when you are at Main Menu.

The TEST & DIAGNOSTIC PROGRAM contains the following functional tests:

- CONFIG CHECK TEST
- DMI CHECK TEST
- SPEAKER AUDIO TEST
- FAN ON/OFF TEST
- MAIN BATTERY CHARGE TEST
- FDD TEST
- CD-ROM TEST
- KEYBOARD TEST
- MOUSE(PAD) TEST
- LCD PIXELS MODE TEST
- LID SWITCH TEST
- HDD R/W TEST
- LAN TEST
- RTC TEST
- BUTTON TEST
- Speaker EQ Check/Write
- Read 1394 GUID

You will need the following equipment to perform some of the Diagnostic test programs.

- The diagnostics diskette (2 pcs)
- A formatted working diskette for the floppy disk drive test (Floppy Disk Drive Test)
- A data CD disc (CD-ROM Test)
- A LAN loopback connector (LAN Test)

The following sections explain how to execute the Test & Diagnostic Program and detail the tests within the program.

2. Executing the Diagnostic Test

Toshiba MS-DOS is required to run the DIAGNOSTICS PROGRAM. To start the DIAGNOSTIC PROGRAM, follow these steps:

1. Insert the diagnostics diskette #1 in the floppy disk drive and turn on the computer. (The diagnostics diskette contains the MS-DOS boot files.) And then follow the instructions to swap with the diagnostics diskette #2 for T&D program installed in RAM driver.

NOTE: *To execute the CD test, make sure the CD is installed in the ODD drive.*

The T&D Program can run by single test item when you press corresponsive English letter of test item, or run two or more test items what you like if you choose them by “Arrow cursors” and “Space Bar” – the wonderful thing is you can setup test loop by “Enter” button. And it also asks you if you like to copy test log file to diskette as reference at the end of test(s).

The test list is as the following:

- A. CONFIG CHECK TEST
- B. DMI CHECK TEST
- C. RTC TEST
- D. SPEAKER AUDIO TEST
- E. LAN TEST
- F. FAN ON/OFF TEST
- G. MAIN BATTERY CHARGE TEST
- H. FDD TEST
- I. CD-ROM TEST
- J. KEYBOARD TEST
- K. MOUSE (PAD) TEST
- L. LCD PIXELS MODE TEST
- M. LID SWITCH TEST
- N. HDD R/W TEST
- O. BUTTON TEST
- P. Speaker EQ Check/Rewrite
- Q. Read 1394 GUID

The below display will show up at the beginning of T&D program.

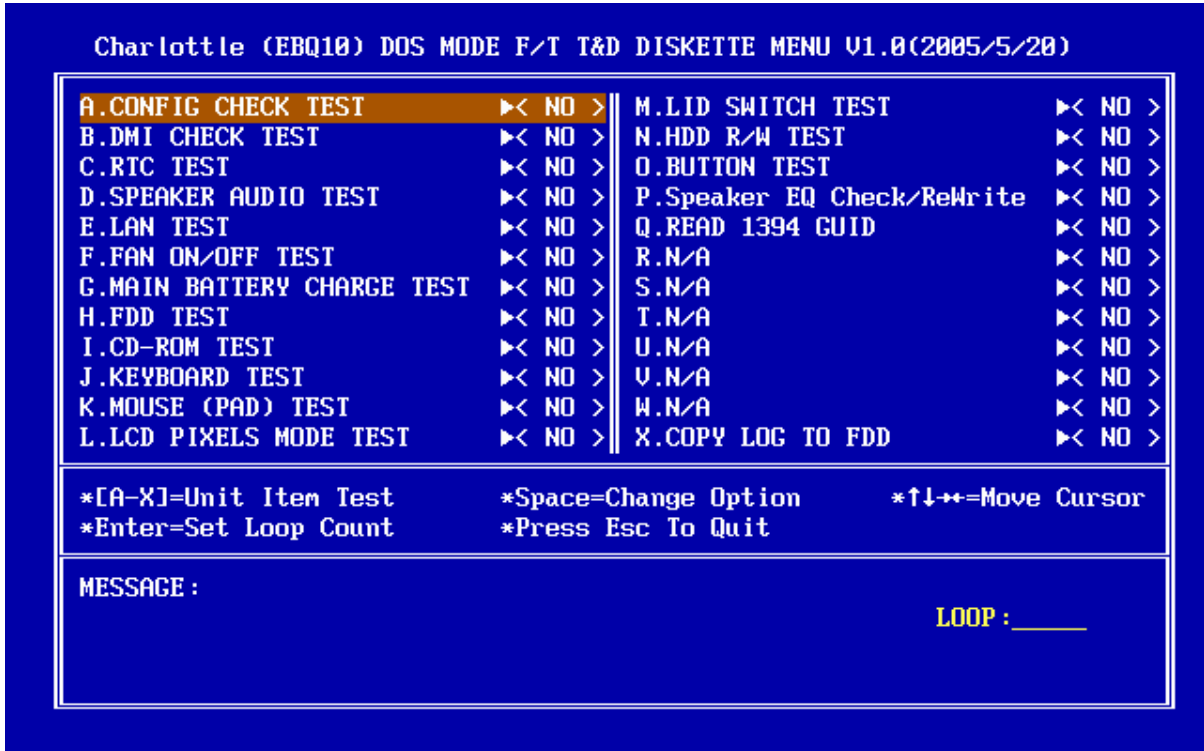

If the test result passes, the following display will show up:



If an error is detected and a test fails, the following message displays:



Then press any key for next actions – the below display presented if copying test log file onto diskette is necessary. This action will be executed when “Y” key pressed.

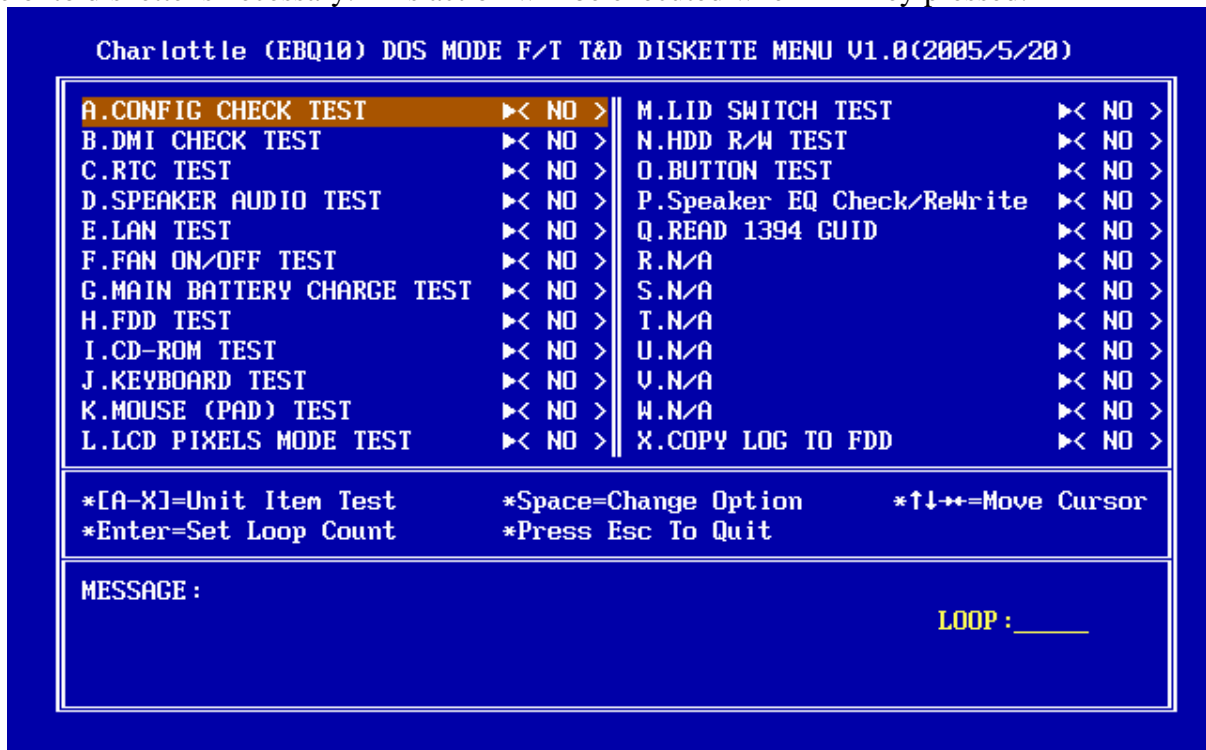

It will skip this process if “N” key pressed.

And then it will check if it’s necessary to leave this program. Program will quit when “Y” key pressed and it will go back main menu for next test if “N” key pressed.

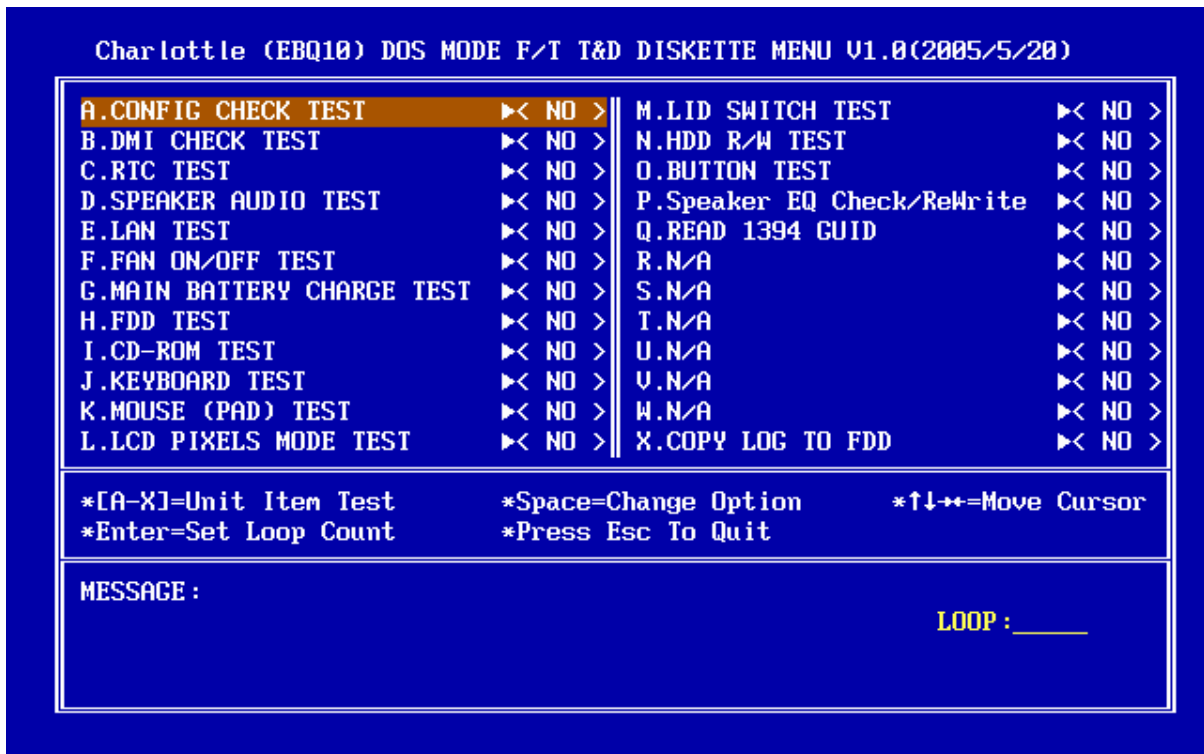

NOTE: Press **Pause** to pause a test and **Enter** to resume.

2.1. Config Check Test

The config check test checks unit configuration. It includes:

- ◆ CPU type (P4/CEL; Dothan; Cache ; CPU speed ;CPU FSB)
- ◆ System memory size (*** MB)
- ◆ ODD type (DVD-SuperMulti; COMBO; ...)
- ◆ LCD Type (AU&LG/17.0WXGA&17.0WSXGA)
- ◆ HDD type & capacity (VENDER_ID;M ODEL;FIRMWARE)
- ◆ VRAM&VGA Type (VRAM Size & intel910GML; NV43; ATIM24C; ATIM26P)
- ◆ Battery cell
- ◆ Wireless type
- ◆ LAN Type (LAN10/100; GigaLAN)
- ◆ With/Without Bluetooth (BLUE/NONE)

This test needs input unit Part Number by manual to make comparison with known SKU data.

NOTE: To execute this test, you must input unit **Part Number** as “**Uppercase Character**”.

Then it will show its configuration is correct (in **green** color) or failed (in **red** color).

The screen should display as below, indicating whether the test is passed or failed after comparison.

```
<Neil Fu> <2002/6/18> <Ver 1.0>
Command Line: cfgchk TabFileName SKU
Example      : cfgchk btw10tab.txt PS110E-0002S-GR

                Please input the SKU: PSM60E-01S01CGR

CURRENT SPEC IS :
P4 Dothan 2048 1.73GHZ 533MHZ 512 DVD-SuperMulti LG17.0WXGA 80G54HDD 16MBATIM26P
8cell Intel_G11 LAN100 NONE
Press any key to continue . . .
```

2.2. DMI Check Test

This test will check if the computer's Desktop Management Interface (DMI) is correct.

DMI includes:

- ◆ Manufacturer
- ◆ Production Name
- ◆ Version
- ◆ Serial Number
- ◆ UUID
- ◆ OEM String

It needs to input unit Part Number by manual, then show this unit DMI information and makes comparison with SKU data.

NOTE: To execute this test, you must input unit *Part Number* as “*Uppercase Character*”.

The screen should display as below, indicating whether the test is passed or failed after comparison.



```

      PASS

■ Compal DMI String R/W Utility V3.1 ■
Manufacturer(Type1, Offset04h) : TOSHIBA
Product Name(Type1, Offset05h) : Satellite M60-S8112TD
Version(Type1, Offset06h) : PSM60U-01Y014
Serial Number(Type1, Offset07h): U01Y014001
UUID(Type1, Offset08h) : F7402765-C094-11D9-BDB5-000FB083415B
OEM Strings(Part Number,SW Number)(Type11, Offset05h):
=>PSM60U-01Y014,U01Y014001

Press any key to continue . . .
```

2.3. Speaker Audio Test

The speaker audio test allows the user to aurally confirm the speaker functions. And check both speakers if they are OK within 3 times “Beep” sound generated.

NOTE: Remember to tune up the volume as “*Maximum*” before this test starts.

The screen should display as below, indicating whether the test is passed or failed after the question.

```

** FATBUZER test version 1.07 **
Please listen for speaker being sound
      1.0 Sec by 3 times

Test over, no errors found

Do you hear Beep sound ?
[Y,N]?
```

2.4. Fan ON/OFF Test

The fan test allows the user to test aurally whether the fan is working. And follow the below procedures for this test:

- ◆ The computer will let the fan be “ON” after any key pressed. Listen to check whether the fan is working.

NOTE: Remember to approach fan outlet that is near right side of unit whether fan is “ON”.

- ◆ The computer will stop the fan working after any key pressed. Listen to check if the fan is “OFF” – it means no rotating sound.

The screen should display as below, indicating whether the test is passed or failed after the question.

```
*** Fan ON/OFF Test ,Please Listen To The FAN Sound !!  
Press Any Key To Start Test ..  
FAN On Test :  
  
FAN Off Test :  
  
Do you hear FAN rotating sound?  
  
[Y,N]?
```

2.5. Main Battery Charge Test

NOTE: The AC adaptor (75W, 19V) should be connected to successfully run this test.

This test shows and measures the main battery:

- ◆ Battery type (Lion)
- ◆ Manufacturer (Sanyo)
- ◆ Remain charge capacity (0 ~ 100%)
- ◆ Charge function (PASS/FAIL)
 - “Battery Is Full” showed when “remain charge capacity” is 100%

The screen should display as below, indicating whether the test is passed or failed when finished.

```
ONLY FOR 87591 T&D Series Battery Test Program.[591] V1.0 2002/07/23
MAIN Battery

Battery Type: Lion
Manufacturer: Sanyo
Remain charge capacity : 17.9%

Charge Test-> [ PASS ]

Press any key to continue . . .
```

2.6. FDD Test

NOTE: Before running the FDD test, prepare a formatted work diskette (1.44 MB). Remove the diagnostics diskette and insert the work diskette into the FDD. The contents of the floppy diskette maybe erased.

The Floppy Disk Test includes three subtests of the:

1. Sequential seek/verify function (Range: Track 0 ~ 79)
2. Funnel code seek/verify function (Range: Track 0 ~ 79)
3. Write/Read/Compare pattern function (Range: Track 75 ~ 79)

NOTE: The write-protected device of this formatted diskette should be "Disable".

The subtests run automatically.

NOTE: Press "Esc" key can skip the current subtest.

The screen should display as below, indicating whether the subtests pass or fail when finished.

```
***** Fdd Test Program V1.3 *****  
Testing Driver A: [1.44 MByte (Cyl:00, Head:2, Sec:18)]...  
Testing Seq. seek/verify... Head: 01, Track: 79... [ PASS ]  
Testing Fun. seek/verify... Head: 01, Track: 06...
```

2. 7. CD-ROM Test

The CD-ROM test allows a user to aurally confirm the CD-ROM functions.

NOTE: A CD disc (including data file) must be inserted into the CD-ROM drive before this test starts.

The CD-ROM test includes two subtests of the:

1. Random read/partial sequential read function
2. Sequential read function (for all surface)

Each item can be chosen by manual. When each test item finished, the CD-ROM tray will open. Check whether the tray can open automatically.

NOTE: Press “Esc” key can skip the current subtest.

The screen should display as below, indicating whether the subtests pass or fail when finished.

```
CDROM Utility (for Testing only) Ver 1.0
-----
Testing CDROM Information ..... Press [ESC] key to skip testing
-----
CD ROM Drive Z:, MSCDEX ver.: 2.23, Driver name: TSYCD1 , Vol.: 020329_1105
Total 198960 sectors(2352 bytes/sector) = 467953920 bytes
Testing CD ROM reset function...

Partial sequential read ..... 198950
Random read ..... 95496 PASS

Please remove CD Media, then close CD tray ...

Press any key to continue . . .
```

2. 8. Keyboard Test

The keyboard test checks the all keys function.

NOTE: The *Num Lock* and the *Overlay* mode must be off to execute the keyboard test.

When you execute this test, the keyboard layout is drawn on the display. When any key is pressed, the corresponding key on the screen changes to black as shown below.

It will indicate whether the subtest is passed or failed after the question.

NOTE: The “Fn” & “Pause” key cannot be tested in the keyboard test. To determine whether the “Fn” key is working correctly, press “Fn+F6 ” or “Fn+F7 ” keys to check if LCD display brightness change gradually.

```
=====KEYBOARD TEST=====
1.Please press all of the KEYBOARD BUTTONS except the [Fn] and [Pause] key.
2.[Fn] key test status that please see the LCD backlight when you
  adjust LCD brightness.
3.If the letter color of K/B changes from white to black on screen
  that the result is pass.
4.If the letter color of K/B is no action on screen that the result
  is fail.
5.Quit test progarm must used [Ctrl]+[Scroll] key.
Press any key to continue . . .
```

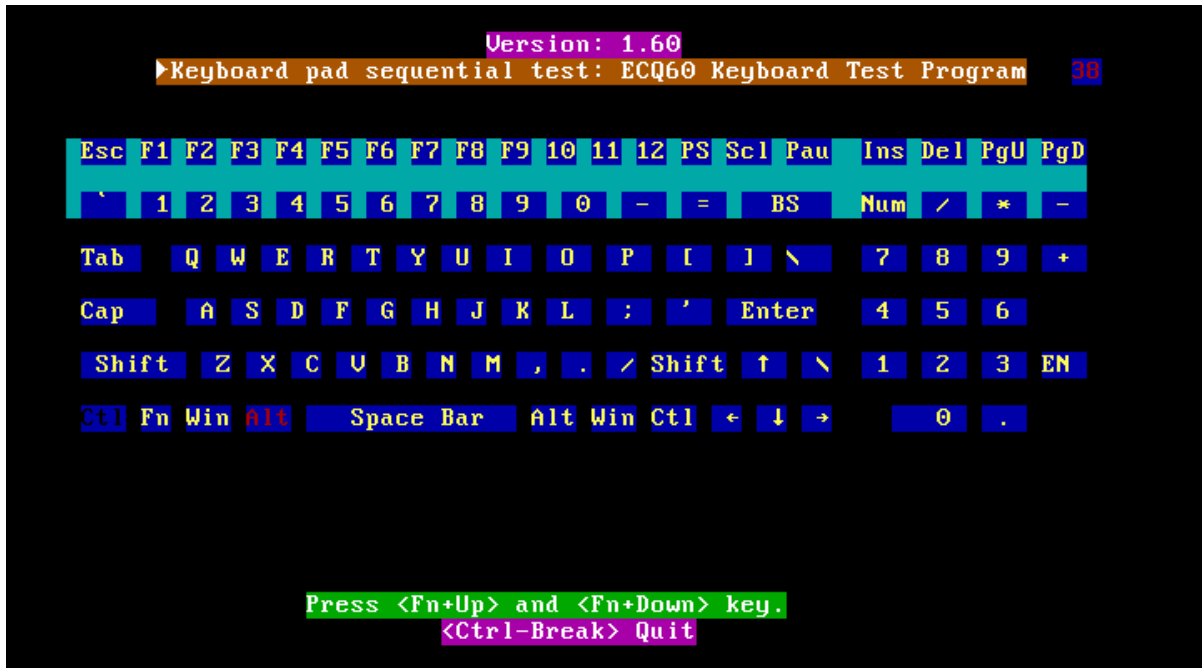

Pressing a key also reveals that key's **scan codes** in the upper right hand corner of the screen. When the key is depressed, its **make code** is displayed. When the key is released, the **break code** is shown.

2. 9. Mouse (Pad) Test

The Mouse test allows the user to select and assign values to the following, using the Touch Pad or “**Tab**” key to move between selections:

1. Mouse Speed (on a scale from slow to fast)
2. Acceleration (Off, Low, Medium, High)
3. Button Assignments (Left + Right / Right button, either Unassigned or Drag Lock)
4. Swap Buttons (Left /Right)

NOTE: The Touch Pad test cannot be used to test an external USB mouse.

The Touch Pad button subtest allows users to test their Touch Pad buttons. If the buttons are clicked, the cursors should appear in the corresponding box of the button figure that is displayed on the screen as below.



After checking T/Pad buttons and cursor’s function, use “Tab” key or use T/Pad cursor to click the “OK” column will end this test.

It will indicate whether the subtests pass or fail after three questions.

NOTE: *The above figure has three compartments although the Touch Pad installed may only have two buttons. In this case, the central compartment in the figure does not correspond to any button.*

2. 10. LCD Pixels Mode Test

This LCD pixels mode test checks whether video display is fine.

This test includes two modes of the test:

1. Text Mode
 - including 40*25 (16 colors) and 80*25 (2/16colors).
2. VGA Mode
 - including 320*200 (4/16/256 colors), 640*200 (2/16 colors), 640*350 (2/16 colors), 640*480 (2/16/256 colors), 800*600 (256 colors) and 1024*768 (256 colors).

The screen should display as below, indicating whether the test is passed or failed after the question.

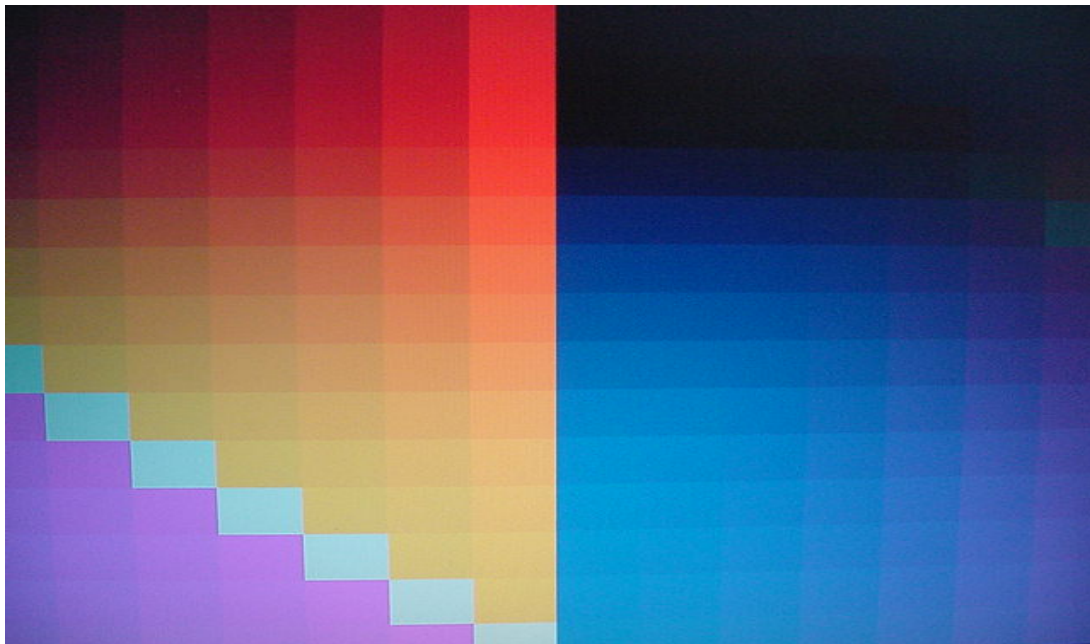

2. 11. Lid Switch Test

The lid switch test checks the lid function of the unit. When LCD cover closed, the lid should enable to turn off the display.

NOTE: Remember to tune up the volume as “**Maximum**” before this test starts.

Follow below steps to run this test:

1. Close the LCD cover.
2. Heard 3 “Beep” sound happened during LCD closed.
3. Open the LCD.

Then it will indicate whether the test is passed or failed.

```
***** Lid Switch Test Program V1.1 2002/08/15 *****  
Please Close LCD,Continue 3 Sec ,Or keyin <ESC> To Quit !!
```

2. 12. HDD R/W Test

The HDD R/W test allows the user to test aurally HDD read/write function. For data security concern, it is necessary to input password - “**hard disk**” before HDD write test starts.

The HDD test includes three subtests of the:

1. Sequential read (all surface)
2. Sequential write (all surface)
3. Partial W/R + Random W/R

After the choice is made, HDD information will show as below:

- ◆ Model name
- ◆ Firmware revision
- ◆ Serial number
- ◆ CHR (Cylinder High Register) mode – including cylinders, heads, sectors and sizes.
- ◆ LBA (Logical Block Addressing) mode – including sectors and sizes.
- ◆ Support Ultra DMA Mode
- ◆ Support PIO Mode

```

HDD Utility (for Testing only) Ver 1.1
-----
Testing HDD Information ... Press [ESC] key to stop testing
-----
Model name           = HTS541080G9AT00
Firmware revision    = MB40A56J
Serial number        =          MPB410X6G03B3B
CHR Mode cylinders   = 16383
CHR Mode heads       = 16
CHR Mode sectors     = 63
CHR Mode sizes       = 8063 MB
LBA Mode sectors     = 156301488
LBA Mode sizes       = 76319 MB
Support Ultra DMA Mode = 3f
Support PIO Mode     = 1f
-----

Begin Testing ..... Sequential read (all surface)
--->
    
```

NOTE: Press “**Ctrl + Break**” keys can terminate the current subtest.

The screen should display as previous picture, indicating whether the subtest is passed or failed when finished.

NOTE: The AC adaptor should be connected to successfully run this test.

2. 13. LAN Test

The LAN test checks the LAN full-duplex environment.

NOTE: LAN loopback needs to plug in before test begins.

And LAN information will show on the test screen:

- ◆ IO Base – Port: 3000H
- ◆ IRQ – AH, it's "IRQ 10".
- ◆ Node – it is "MAC Address".
- ◆ Line Frame – 1514 Bytes.
- ◆ Line Speed – 1000Mbps or 100Mbps or 10 Mbps.
- ◆ Bus ID – it's "4".

The LAN test includes two subtests of the:

1. Speed100
 - including Ethernet_802.2, Ethernet_II, Ethernet_SNAP and Ethernet_802.3.
All test items are in LSB mode.
2. Speed10
 - including Ethernet_802.2 in LSB mode.
3. Speed1000
 - including Ethernet_802.2, Ethernet_II, Ethernet_SNAP and Ethernet_802.3. All test items are in LSB mode.

The subtests run automatically.

The screen should display as below, indicating whether the subtests pass or fail when finished.

```
2.N_Way_Test=false           none
3.Boot_Rom=false            none
4.Speed100=true             testing
5.Speed10=true              testing

                                     Press any key to exit

Realtek RTL8139(A/B) Fast Ethernet MLID v3.62 (000112)
(c) Copyright 1999, by Realtek Semiconductor Corp. All rights reserved.

Full duplex environment,  IRQ 10, Port 3000, Node Address 23F7993AA L
Max Frame 1514 bytes, Line Speed 100 Mbps, Bus ID 4
Board 1, Frame ETHERNET_802.2, LSB Mode
Board 2, Frame ETHERNET_II, LSB Mode
Board 3, Frame ETHERNET_SNAP, LSB Mode
Board 4, Frame ETHERNET_802.3, LSB Mode
```

2. 14. RTC Test

Checks the computer's RTC (Real Time Clock) and calendar functions by comparing the DOS and CMOS values.

The test runs automatically.

The screen should display as below, indicating whether the test is passed or failed when finished.

```
====RTC TEST====

Please Check the result after test.

Press any key to continue . . .

Wait for zero counter...
Testing...
DOS TIME = 22:33:48.04(8122804), CMOS TIME = 22:33:48(8122800)
DOS DATE: 09/19/2002, CMOS DATE: 09/19/2002
DATE & TIME test [ PASS ]

Press any key to continue . . .
```

.2. 15. CD Control Button Test

The CD control button test allows the user to manually test each of the five CD control buttons and one Internet button.

Key "WWW" need to press first. One will hear one "bi" sound when press "WWW" or "Audio" sound, and continuously "bi" sound for another key test.

The figure below will be displayed:

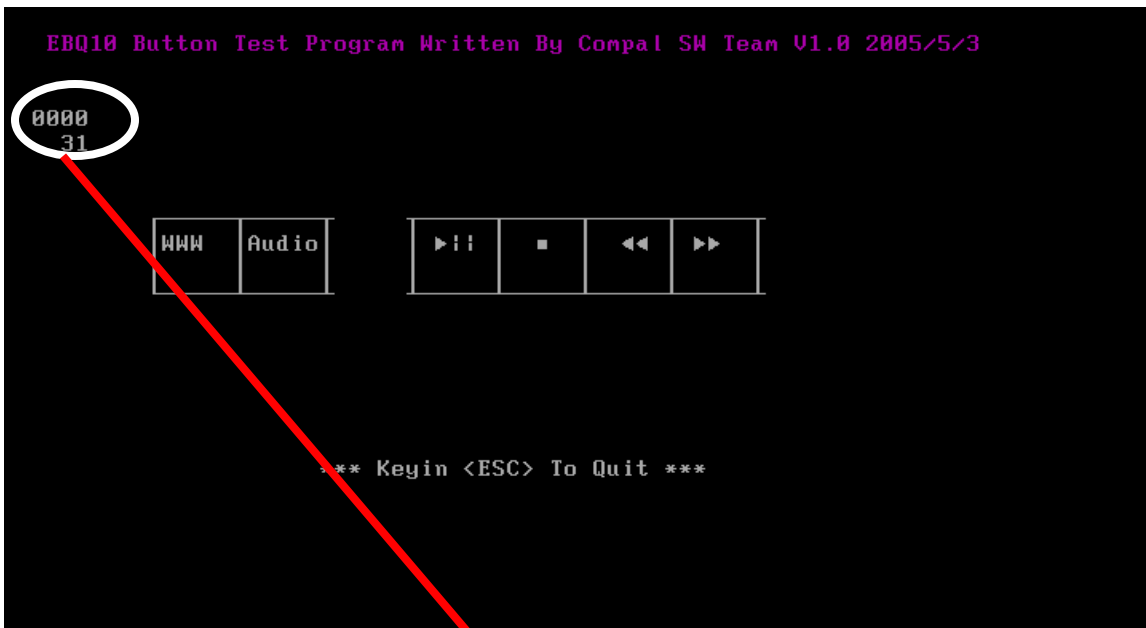

NOTE: 1. Must wait test program show "0000" code before press button key.
2. WWW button necessary the first testing.

Press each of the buttons on the front panel in turn. A yellow bar will appear on the relevant section of the figure if the button passes the test.

Press **Esc** to quit the test.

2. 16. Speaker EQ Type Check&Re-Write

This test will check if the computer's EEPROM EQ type is correct.

The EQ Type test includes two subtests of the:

1. Read EQ Type from EEPROM
2. Re-Write EQ Type to EEPROM

NOTE: To execute this test, you must select speaker type (Harman or No brand).

The Item1 figure below will be displayed:

```
Please select read or write EQ
1. Read EQ Type from EEPROM
2. Write EQ Type to EEPROM

[1,2]?1

=====EQ CHECK TEST=====

Please check upper left side mark then Select Speaker type
1: Harman/kardon
2: No brand
[1,2]?
```

The Item2 figure below will be displayed

```
Please select read or write EQ
1. Read EQ Type from EEPROM
2. Write EQ Type to EEPROM

[1,2]?2

=====Write EQ to EEPROM =====

Please Select Speaker type (1=Harman;2=No brand)
[1,2]?
```

NOTE: Write speaker EQ must reboot to enable EQ.

```
1. Read EQ Type from EEPROM
2. Write EQ Type to EEPROM

[1,2]?2

=====Write EQ to EEPROM =====

Please Select Speaker type (1=Harman;2=No brand)
[1,2]?1

      0 uS: C 4D
      900 uS: D EF
     1200 uS: D 01
     3600 uS: I 00
    114900 uS: I 82

Harman EQ Type Re-Write OK
Need remove AC-adapter firstly then reboot to enable EQ.

Press any key to continue . . .
```

2. 17. Read 1394 GUID

This test will check if the computer's EEPROM 1394GUID code is correct.

NOTE: Must open the RAM Door to see RAM connector GUID bar code before test item begins.

The figure below will be displayed

```
=====guid read=====
```

```
Please check RAM Connector GUID bar code.
```

```
R1394 Code Check Program 1.0 PE/SW  
1394code=00023F557640016D
```

```
Are you check OK? [Y,N]?
```

Chapter 4

Replacement Procedures

Chapter 4 Contents

4.1	General.....	4-5
4.2	Battery.....	4-11
4.3	PC Card.....	4-13
4.4	HDD.....	4-15
4.5	Optical Drive Module.....	4-18
4.6	Optical Drive.....	4-20
4.7	Keyboard.....	4-22
4.8	Wireless LAN Unit.....	4-25
4.9	Expansion Memory.....	4-27
4.10	Modem.....	4-29
4.11	Display Assembly.....	4-31
4.12	Top Cover.....	4-34
4.13	TouchPad.....	4-37
4.14	Speakers.....	4-39
4.15	System Board.....	4-41
4.16	Fan & CPU.....	4-43
4.17	Display Mask.....	4-46
4.18	LCD Module.....	4-48
4.19	FL Inverter Board.....	4-51

Figures

Figure 4-1	Removing the battery pack.....	4-11
Figure 4-2	Pressing the eject button.....	4-13
Figure 4-3	Installing the PC card	4-14
Figure 4-4	HDD	4-15
Figure 4-5	Removing the HDD door	4-16
Figure 4-6	Removing the optical drive module	4-18
Figure 4-7	Removing the optical drive bracket	4-20
Figure 4-8	Removing the strip cover	4-22
Figure 4-9	Removing the keyboard.....	4-23
Figure 4-10	Disconnecting the keyboard cable.....	4-24
Figure 4-11	Removing the wireless LAN card	4-25
Figure 4-12	Removing the wireless LAN unit.....	4-26
Figure 4-13	Removing the expansion memory	4-27
Figure 4-14	Installing the expansion memory	4-28
Figure 4-15	Removing the modem module.....	4-29
Figure 4-16	Disconnecting the LCD cable	4-31
Figure 4-17	Removing the display assembly	4-32
Figure 4-18	Removing the top cover-1	4-34
Figure 4-19	Removing the top cover-2	4-35
Figure 4-20	Removing the TouchPad	4-37
Figure 4-21	Removing the speakers.....	4-39
Figure 4-22	Removing the system board	4-41
Figure 4-23	Removing the hexagonal screws	4-41
Figure 4-24	Removing the hexagonal screws	4-43
Figure 4-25	Removing the CPU.....	4-44
Figure 4-26	Removing the display mask	4-46
Figure 4-27	Removing the LCD module-1	4-48
Figure 4-28	Removing the FL inverter board	4-51

4.1 General

This chapter explains how to disassemble the computer and replace Field Replaceable Units (FRUs). It may not be necessary to remove all the FRUs in order to replace one. The chart below is a guide to which FRUs need to be removed in order to remove others. Always start by removing the battery pack, next, optional items such as the optional PC Card, then follow the chart downward removing only those FRUs necessary to reach the one you think is causing the computer to operate improperly. Refer to the example on the following page.

Battery pack				
Expansion Memory Module	HDD	Keyboard	Wireless LAN	
	ODD	Modem	Display Assembly	
	Top Cover			Display Mask
System Board	Direct Play Button Board	Speakers	Touch Pad	LCD Module
Fan & Heat Sink				FL Inverter Board
CPU				

4 Replacement Procedures

The example below shows FRUs to be removed before the Direct Play button board can be removed and repaired or replaced. The Direct Play button board is overlapped by the top cover which must be removed before the Direct Play button board can be reached. The removable HDD, keyboard, wireless LAN, ODD, modem, and display assembly in turn overlap the top cover. Always starts the disassembly process by removing the battery pack.

Battery pack				
Expansion Memory Module	HDD	Keyboard	Wireless LAN	
	ODD	Modem	Display Assembly	
	Top Cover			Display Mask
System Board	Direct Play Button Board	Speakers	Touch Pad	LCD Module
Fan & Heat Sink				FL Inverter Board
CPU				

Safety Precautions

Before you begin disassembly, read the following safety precautions and observe them carefully as you work.

DANGER:

1. *Always use the lithium ion battery pack or backup battery that is authorized by Toshiba or compatible with the unit. Since other battery packs have different specifications, they may be incompatible with the unit, and may burst or explode. Heating or disassembling the battery pack could cause leakage of alkaline solution. Throwing the battery pack into a fire could cause the battery pack to explode.*
2. *The power supply, FL inverter and other components carry high voltages. To avoid the risk of electric shock when you need to turn on the power of a partially disassembled computer to check its operation, be very careful not to touch connectors or components. Also, do not disassemble individual components in first-level maintenance.*

WARNING: To avoid the risk of electric shock or other injury:

1. *Always turn the power off and disconnect the AC adaptor from the power source.*
2. *Remove any metal jewelry or accessories such as necklaces, bracelets, or rings. Batteries in the computer retain an electrical charge so there is danger of electrical shock even when the computer is disconnected from an AC power source.*
3. *Never work with wet or damp hands.*
4. *The computer contains sharp edges and corners: be careful not to injure yourself.*
5. *Make sure that all replacement components meet the specifications for the computer and that all cables and connectors are securely fastened.*

CAUTION: To avoid damage to the computer:

1. *When you change a component, be sure the replacement component meets the required specifications. Never use foreign parts.*
2. *Metal objects such as screws or paper clips which fall into the unit can cause a short-circuit, fire, or other internal damage.*
3. *When assembling the computer, make sure you use the correct screws to secure the various pieces in place. Screw sizes are listed in their corresponding figure. Make sure all screws are securely fastened. Loose screws can cause short circuits, resulting in heat, smoke, or fire.*
4. *Before removing an FRU or other component, make sure all cables to the component have been disconnected.*
5. *If you use AC power, be sure to use the cable that came with the computer or one recommended by Toshiba.*

Before You Begin

Look over the procedures in this section before you begin disassembling the computer. Familiarize yourself with the disassembly and reassembly steps. Begin each procedure by removing the AC adaptor and the battery pack as instructed in section 4.2.

1. Do not disassemble the computer unless it is operating abnormally.
2. Use only the correct and approved tools.
3. Make sure the working environment is free from the following elements whether you are using or storing the computer.
 - Dust and contaminants
 - Static electricity
 - Extreme heat, cold and humidity
4. Make sure the FRU you are replacing is causing the abnormal operation by performing the necessary troubleshooting and diagnostics tests described in chapters 2 and 3 of this manual.
5. Do not perform any operations that are not necessary and use only the described procedures for disassembling and installing FRUs in the computer.
6. After removing parts from the computer, place them in a safe place away from the computer so they will not be damaged and will not interfere with your work.
7. You will remove and replace many screws when you disassemble the computer. When you remove screws, make sure they are placed in a safe place and identified with the correct parts.
8. When assembling the computer make sure you use the correct screws to secure the various pieces. Screw sizes are listed in their corresponding figures.
9. The computer contains many sharp edges and corners, so be careful not to injure yourself.
10. After you have replaced an FRU, make sure the computer is functioning properly by performing the appropriate test on the FRU you have fixed or replaced.

Disassembly Procedures

The computer has two basic types of cable connectors:

- Pressure Plate Connectors
- Standard Pin Connectors

To disconnect a Pressure Plate connector, lift up the tabs on either side of the connector's plastic pressure plate and slide the cable out of the connector. To connect the cable to a Pressure Plate connector, make sure the pressure plate is fully lifted and slide the cable into the connector. Secure the cable in place by pushing the sides of the pressure plate down so the plate is flush with the sides of the connector. Gently pull on the cable to make sure the cable is secure. If you pull out the connector, connect it again making sure the connector's pressure plate is fully lifted when you insert the cable.

Standard pin connectors are used with all other cables. These connectors can be connected and disconnected by simply pulling them apart or pushing them together.

Assembly Procedures

After you have disassembled the computer and fixed or repaired the problem that was causing the computer to operate abnormally, you will need to reassemble the computer.

Install all the removed FRUs following the steps described in the corresponding sections in this chapter.

While assembling the computer, remember the following general points:

- Take your time, making sure you follow the instructions closely. Most problems arise when you get in a hurry assembling the computer.
- Make sure all cables and connectors are securely fastened.
- Before securing the FRU or other parts, make sure that no cables will be pinched by screws or the FRU.
- Check that all latches are closed securely.
- Make sure all the correct screws are used to secure all FRUs. Using the wrong screw can either damage the threads on the screw or the head of the screw and may prevent proper seating of an FRU.

After installing an FRU in the computer, confirm that the FRU and the computer are functioning properly.

Tools and Equipment

The use of Electrostatic Discharge (ESD) equipment is very important for your safety and the safety of those around you. Proper use of these devices will increase the success rate of your repairs and lower the cost for damaged or destroyed parts. The following equipment is necessary to disassemble and reassemble the computer:

- One M2 Phillips screwdriver to remove and replace screws.
- One T5 security screwdriver.
- Tweezers, to lift out screws that you cannot grasp with your fingers.
- ESD mats for the floor and the table you are working on.
- ESD wrist strap or heel grounder.
- Anti-static carpeting or flooring.
- Air-ionizers in highly static sensitive areas.

4.2 Battery

Removing the Battery Pack

To remove the battery pack from the battery bay, follow the steps below.

1. Turn the computer upside down.
2. Unlock the battery double lock and slide the battery bay latch to release the battery pack. Then you can remove it from the bay.

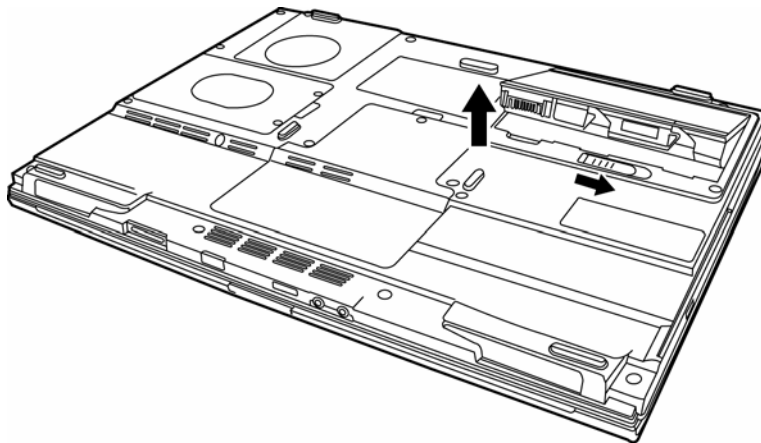

Figure 4-1 Removing the battery pack

NOTE: For environmental reasons, do not throw away a spent battery pack. Please return spent battery packs to Toshiba.

Installing the Battery Pack

To install the battery pack in the battery bay, follow the steps below and refer to the figure in the preceding section.

WARNING: *The battery is a lithium ion battery and can explode if not properly replaced, used, handled or disposed of. Use only batteries recommended by Toshiba as replacements.*

1. Slide the battery pack into the battery bay. The battery bay latch will click automatically.

4.3 PC Card

Removing a PC Card

To remove a PC Card, follow the steps below.

1. Click the Safely Remove Hardware icon on the Task Bar.
2. Click the PC Card you want to remove.
3. Press the eject button of the PC Card to extend it.
4. Press the extended eject button to pop the card out slightly.
5. Grasp the PC Card and remove it.

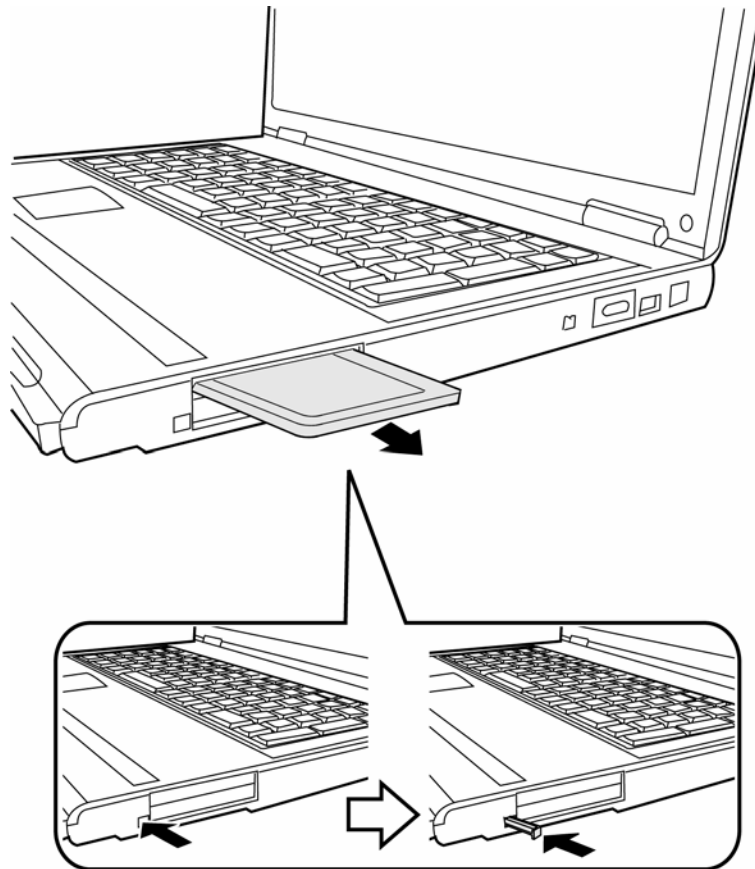

Figure 4-2 Pressing the eject button

Installing the PC Card

To install the PC Card, follow the steps below and refer to the figures in the preceding section.

1. Insert the PC Card.
2. Press gently to ensure a firm connection.

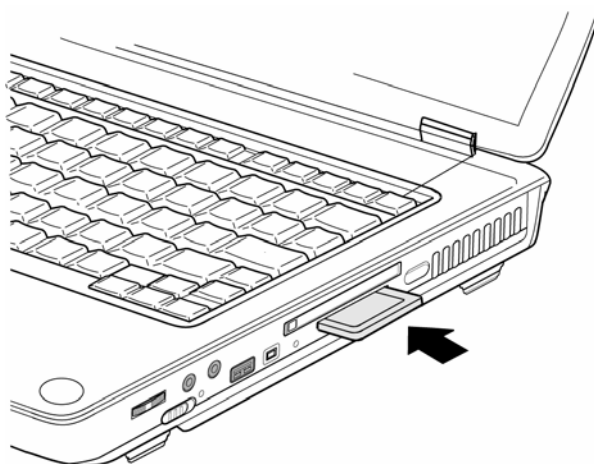

Figure 4-3 Installing the PC card

4.4 HDD

CAUTION: When handling the HDD, do not press the top surface as shown by the arrow. Hold it by the sides.

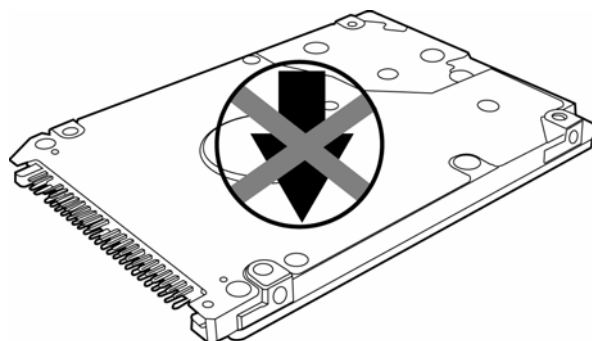

Figure 4-4 HDD

Removing the HDD Module

Follow the steps below to remove HDD module:

1. Turn the computer upside down
2. Remove two black M2.5x4 security screws to release the HDD door.
3. Pull on the tab to remove the HDD unit.

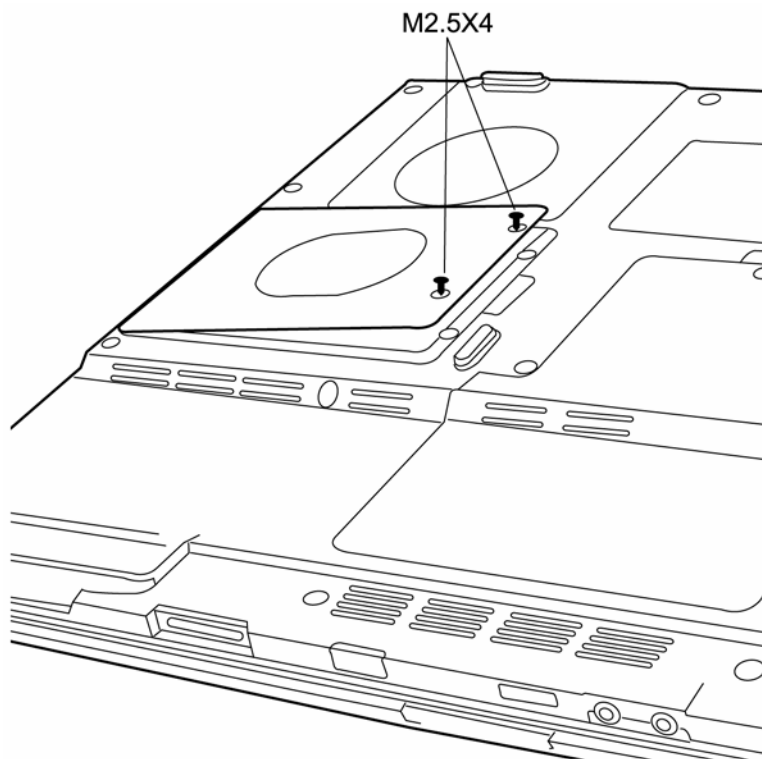

Figure 4-5 Removing the HDD door

4. Remove four M3x3 silver screws that secure the HDD case and bracket to the HDD.
5. Remove the HDD from the HDD case.

Installing the HDD

To install the HDD, follow the steps below and refer to the figures in the preceding section.

1. Seat the HDD in the HDD case and bracket, and secure it with two M3×3 black screws.
2. Insert the HDD unit into the HDD slot.
3. Secure the HDD door with two black M2.5×4 security screws.

4.5 Optical Drive Module

Removing the Optical Drive Module

To remove the optical drive module, you need to remove the keyboard first. Follow the steps below:

1. Turn the computer upside down.
2. Remove the screw M2.5x4 securing the optical drive module.
3. Use your hand to pull the module and then you can slide the module from the bay.

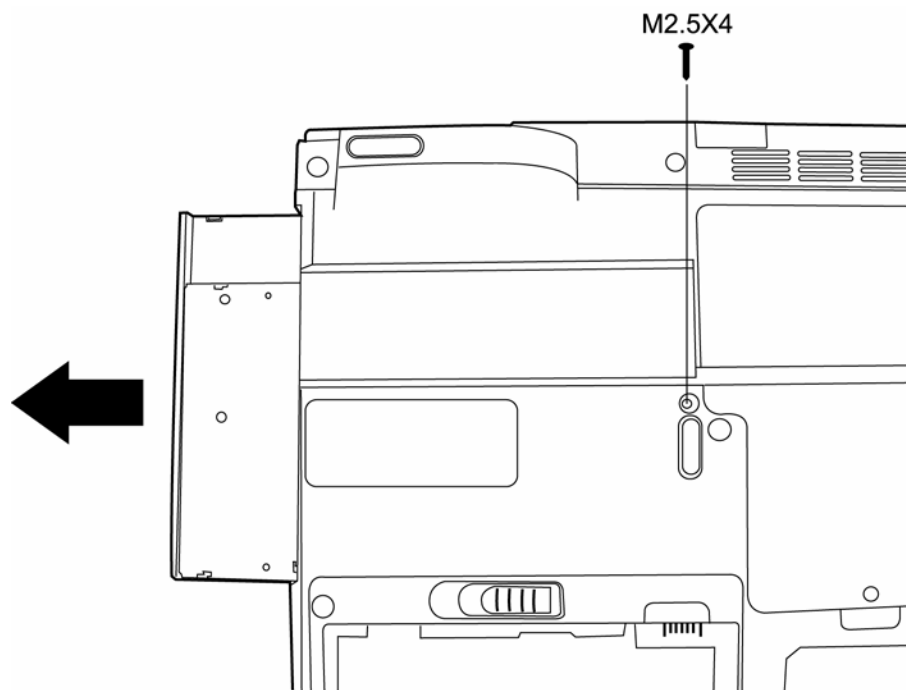

Figure 4-6 Removing the optical drive module

Installing the Optical Drive Module

To install a device in the optical drive module bay, follow the steps below and refer to the figure in the preceding section.

1. Slide the device into the optical drive module bay.
2. Use the screw M2.5x4 to secure the optical drive module.

4.6 Optical Drive

This computer may be fitted with a:

- CD-RW/DVD-ROM device
- DVD dual device
- DVD Super Multi device

Disassembling the Optical Drive

To disassemble the optical drive, first remove the drive from its module bay, then follow the steps below.

1. Remove two M2x3 screws from the bracket plate. Remove the bracket plate.

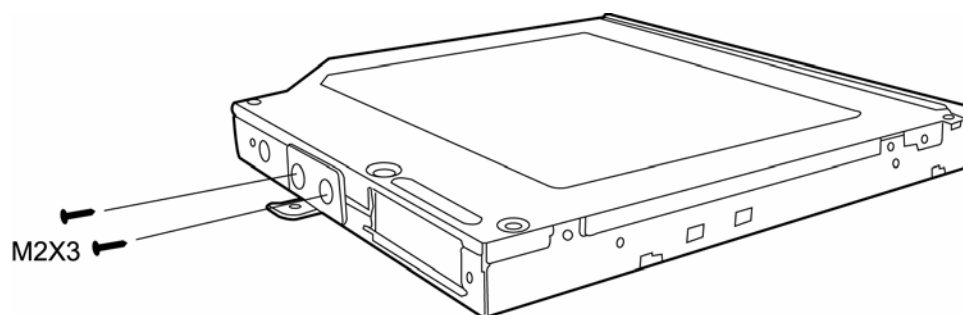

Figure 4-7 Removing the optical drive bracket

Reassembling the Optical Drive

To reassemble an optical drive, follow the steps below and refer to the figure in the preceding section.

1. Position the optical drive bracket plate to the rear panel of optical drive.
2. Secure the optical drive bracket plate with two black M2×3 screws.
3. Install the optical drive module into the bay and secure with one M2.5x5 screw.

4.7 Keyboard

Removing the Keyboard

Follow the steps below to remove the keyboard:

1. Open the display panel.
2. Insert a thin tool into the gap between the strip cover and keyboard to lever the strip cover up and then release the strip cover.

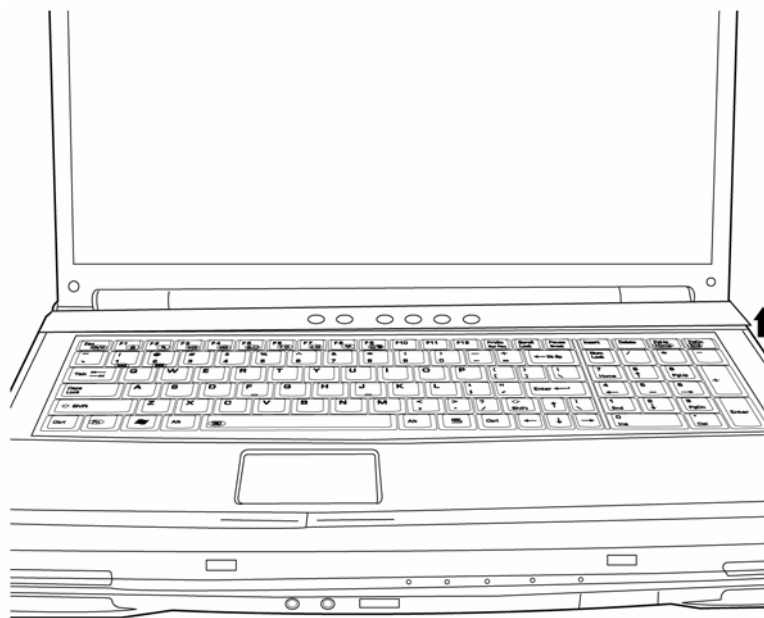

Figure 4-8 Removing the strip cover

3. Remove four M2.5 x 3 black screws securing the keyboard. Push the center of the strip cover and lift the keyboard out and place over the display hinges, revealing the keyboard cable. (Note: There are 6 screw holes, but only 4 are used.)

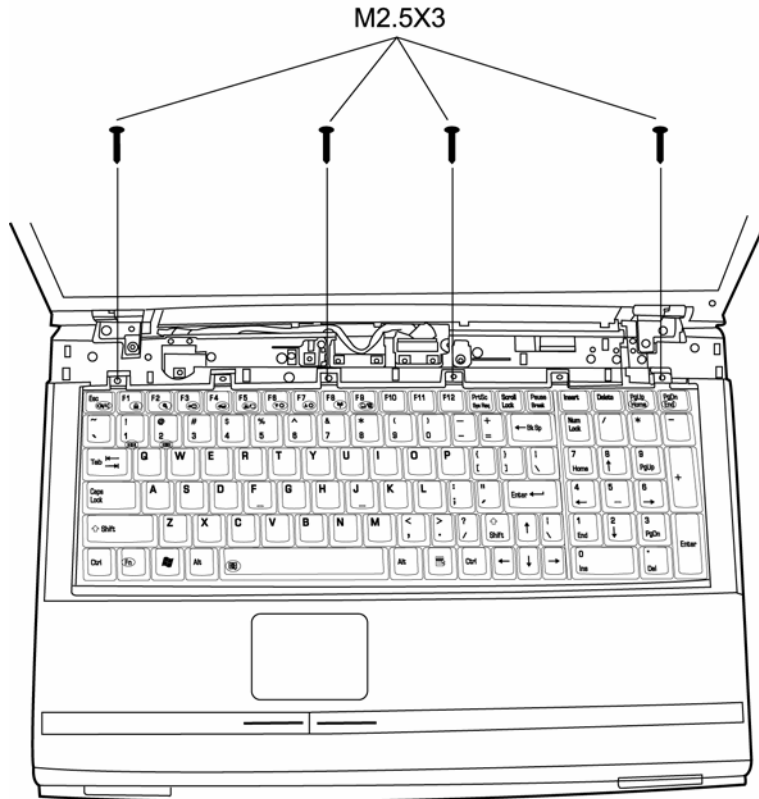

Figure 4-9 Removing the keyboard

4. Disconnect the keyboard cable and remove the keyboard.

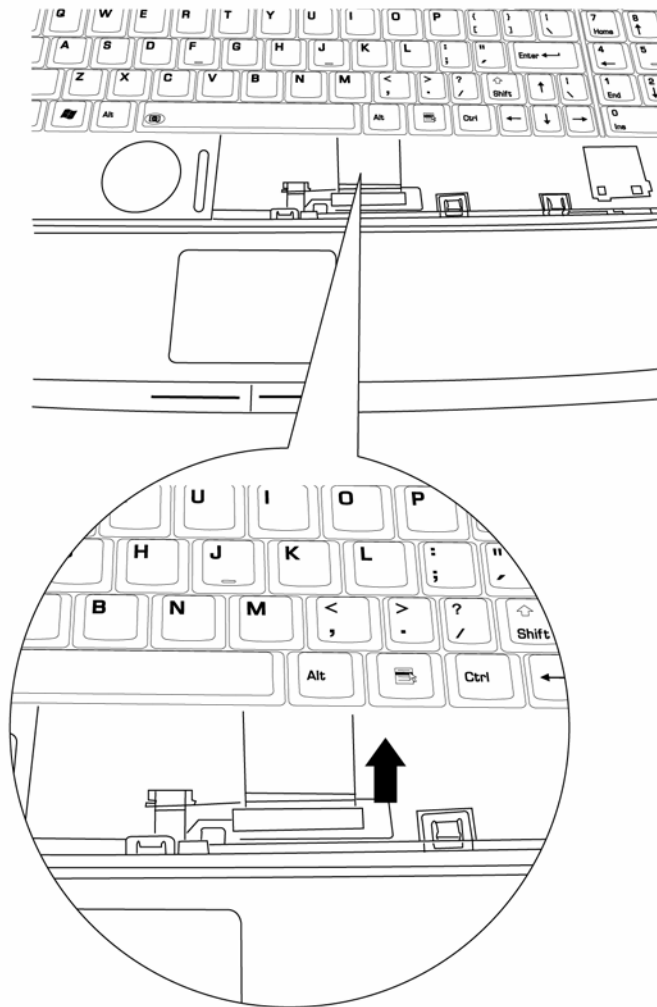

Figure 4-10 Disconnecting the keyboard cable

Installing the Keyboard

To install the keyboard, follow the steps below and refer to the figures in the preceding section.

1. Connect the keyboard cable to the system board.
2. Set the keyboard in place and secure it with four M2.5 x 3 black screws.
3. Set the strip cover and press down to secure the strip cover latches engage.

4.8 Wireless LAN Unit

Removing the Wireless LAN Unit

To remove wireless LAN unit, you must remove strip cover and keyboard first, then follow the steps below to remove wireless LAN unit.

1. Remove the embedded M2.5x4 screw securing the wireless LAN door, and then remove it.
2. Remove one M2x3 screw securing the Mini-PCI Shelter Bracket over the wireless LAN card.

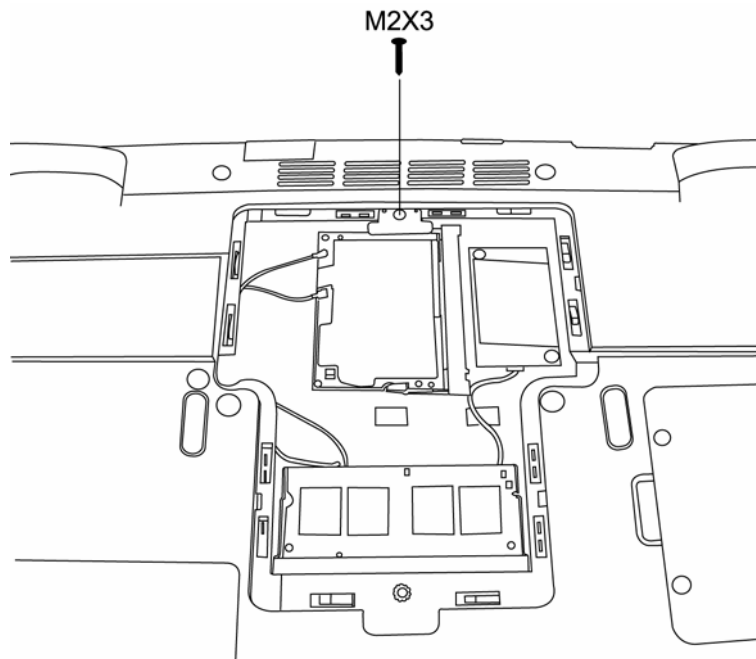

Figure 4-11 Removing the wireless LAN card

3. Detach the two ends of LAN antenna.
4. Use your fingers to press the two latches of LAN unit container. The LAN unit will pop up.
5. Grasp the wireless LAN unit and pull it out.

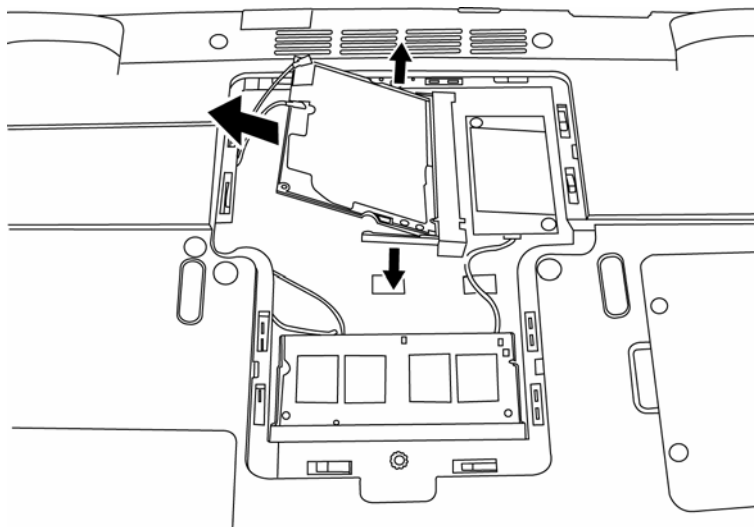

Figure 4-12 Removing the wireless LAN unit

CAUTION: Do not touch the connectors on the wireless LAN unit or on the computer. Debris on the connectors may cause malfunction.

Installing the Wireless LAN Unit

To install the wireless LAN unit, follow the steps below and refer to the figures in the preceding section.

1. Remove strip cover and keyboard.
2. Remove the embedded screw securing the wireless LAN door, and then remove it.

CAUTION: Do not touch the connectors on the wireless LAN unit or on the computer. Debris on the connectors may cause malfunction.

3. Gently, push the wireless LAN unit into the wireless LAN container. The two latches of container will automatically close up.
4. Secure the gray support tooth over the wireless LAN card with one M2x3 screw.
5. Attach the white antenna to the main connector, and the black antenna to the Aux connector.
6. Use the embedded screw to secure the wireless LAN door.

4.9 Expansion Memory

Removing the Expansion Memory

To remove the memory module, make sure the computer is in boot mode then remove the wireless LAN compartment cover:

1. Push the latches securing the memory module to the outside to release it. A spring will force one end of the module up.
2. Grasp the module and pull it out.
3. Seat the cover and secure its screws.

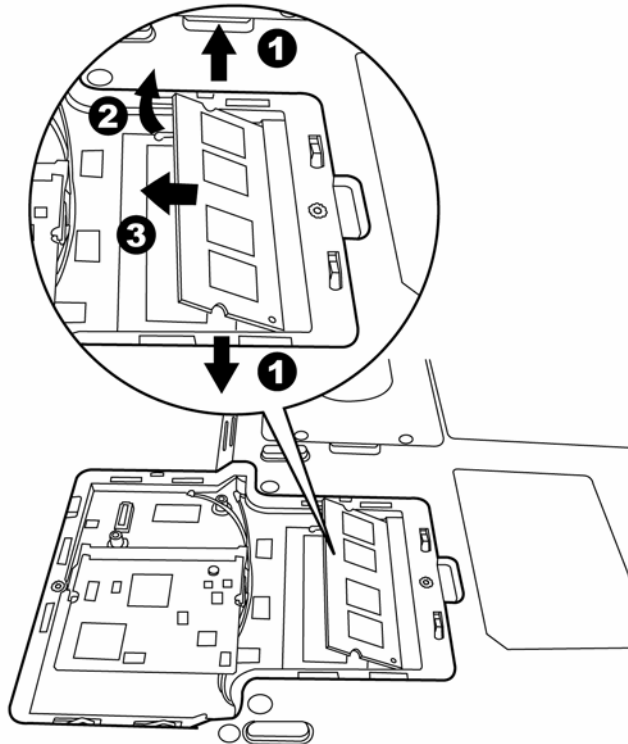

Figure 4-13 Removing the expansion memory

CAUTION: Do not touch the connectors on the expansion memory or on the computer. Debris on the connectors may cause memory access problems.

Installing the Expansion Memory

CAUTION: Do not touch the connectors on the expansion memory or on the computer. Debris on the connectors may cause memory access problems.

To install a memory module, follow the steps below and refer to the figures in the preceding section:

1. Fit the module's connectors into the computer's connectors at about a 45-degree angle and press the module carefully to ensure a firm connection.
2. Push the module down so it lies flat. Latches on either side will click into place to secure the module.

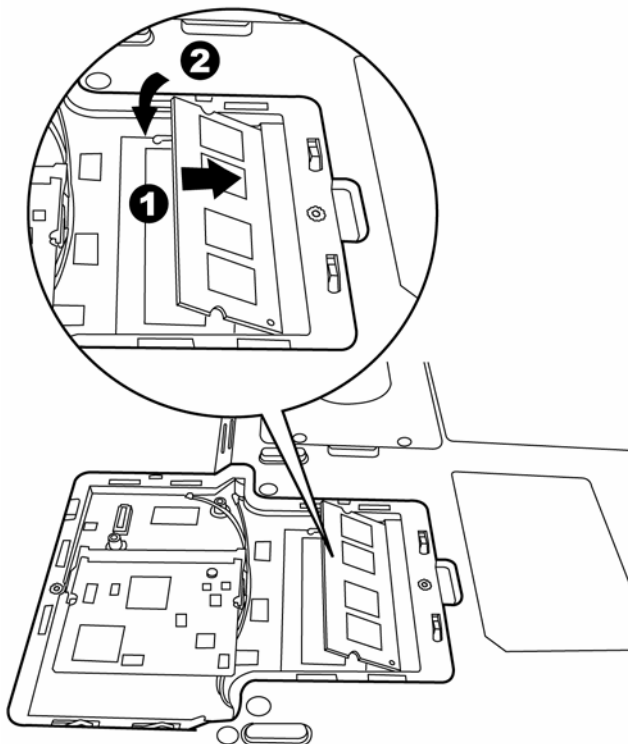

Figure 4-14 Installing the expansion memory

4.10 Modem

Removing the Modem

To remove the installed modem, first remove the wireless LAN compartment cover, then follow the steps below:

1. Remove two M2x3 screws securing the modem module.
2. Carefully lift the unit off its connector
3. Disconnect the modem cable from the modem module.

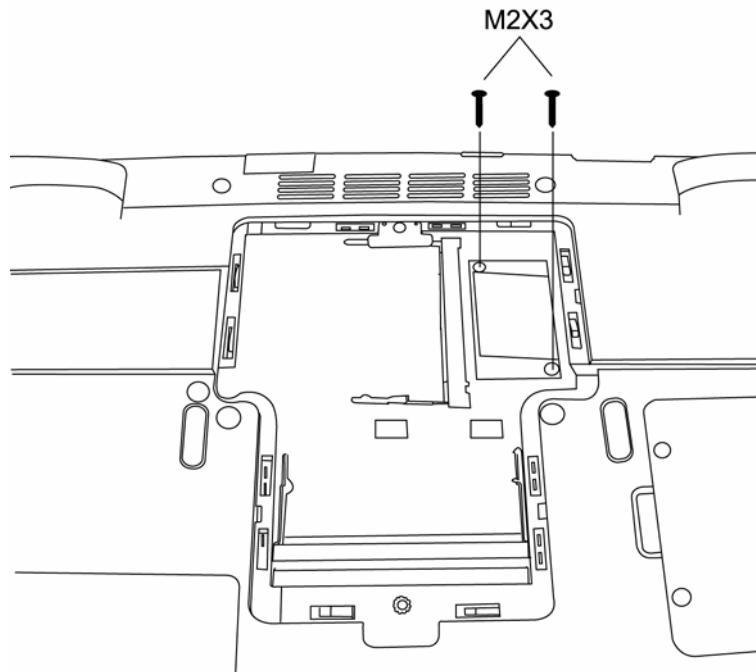

Figure 4-15 Removing the modem module

Installing the Modem

To install a modem, follow the steps below and refer to the figures in the preceding section.

1. Connect the modem cable to the modem module.
2. Fit the modem onto its connector and secure it with two black M2x3 screws.

4.11 Display Assembly

Removing the Display Assembly

To remove the display assembly, first remove the keyboard and wireless LAN, then follow the steps below:

1. Disconnect the LCD power cable from the top chassis.

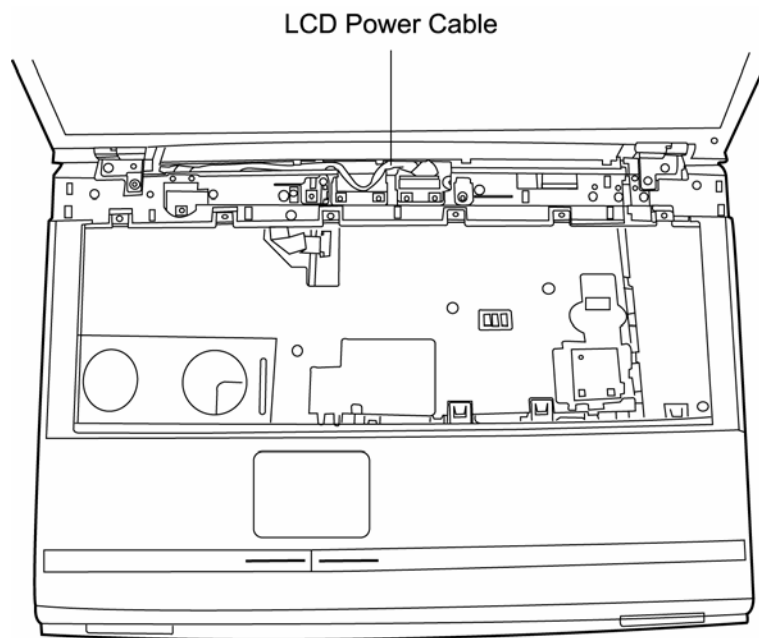

Figure 4-16 Disconnecting the LCD cable

2. From the backside, remove two M2.5x6 screws securing the LCD.
3. Remove four M2.5x4 screws securing LCD to the top cover.

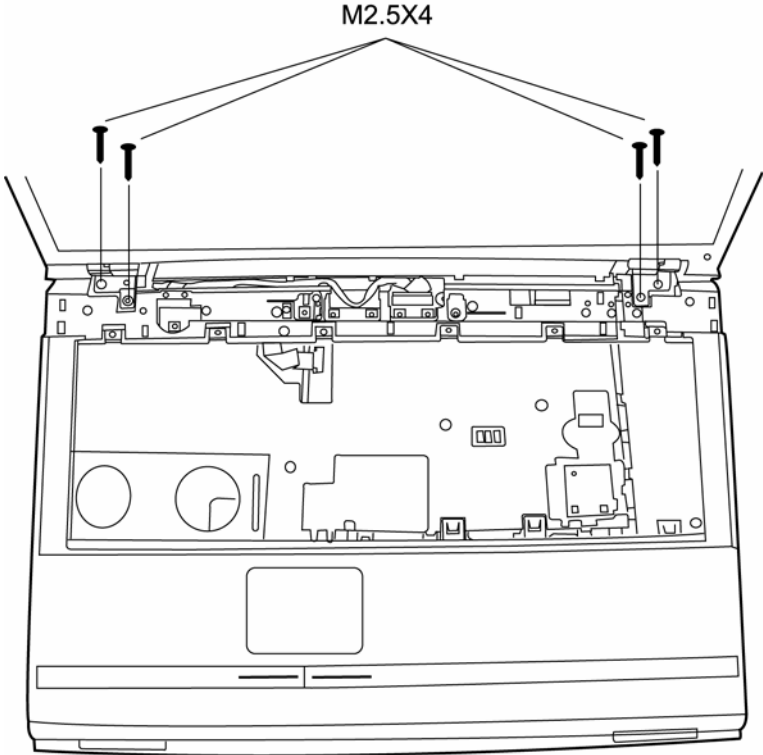

Figure 4-17 Removing the display assembly

Installing the Display Assembly

To install the display assembly, follow the steps below and refer to the figures in the preceding section.

1. Seat the display assembly taking care not to crush to the LCD display cable, the LCD power cable, or wireless LAN antenna.
2. Secure four M2.5x4 black screws to each hinge.
3. Secure two M2.5x6 black screws to the computer's backside.
4. Connect the LCD power cable to the top chassis.

4.12 Top Cover

Removing the Cover

To remove the top cover, first remove the battery pack, keyboard, display assembly, optical drive module, HDD, and memory module and wireless LAN as described in the preceding sections, then follow the steps below:

1. Remove three M2.5x15 screws and one M2.5x6 screw securing top cover.

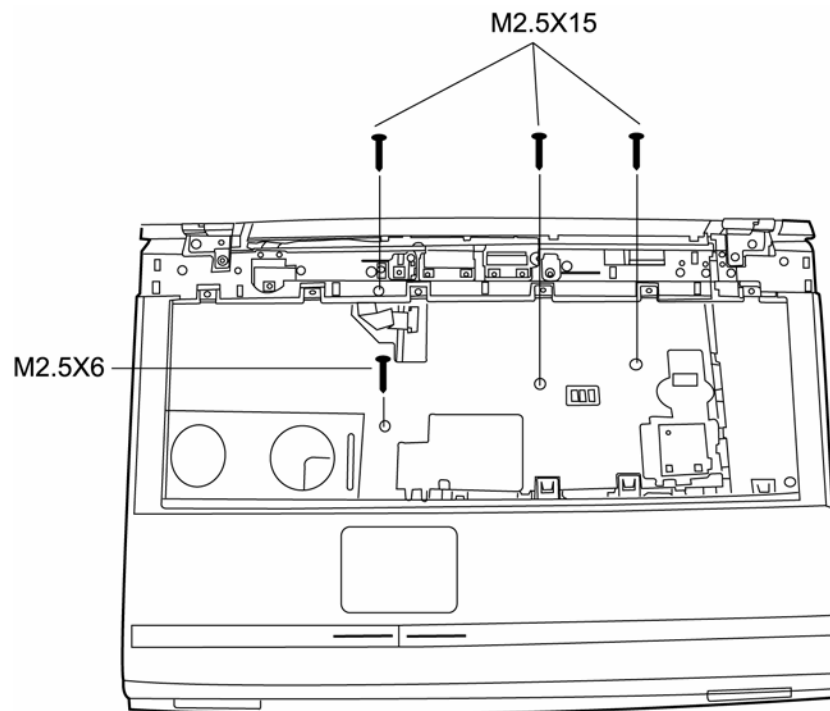

Figure 4-18 Removing the top cover-1

2. Detach the upper FFC cable and TouchPad FFC cable on the top chassis.
3. Turn the computer upside down and remove sixteen M2.5x6 screws.

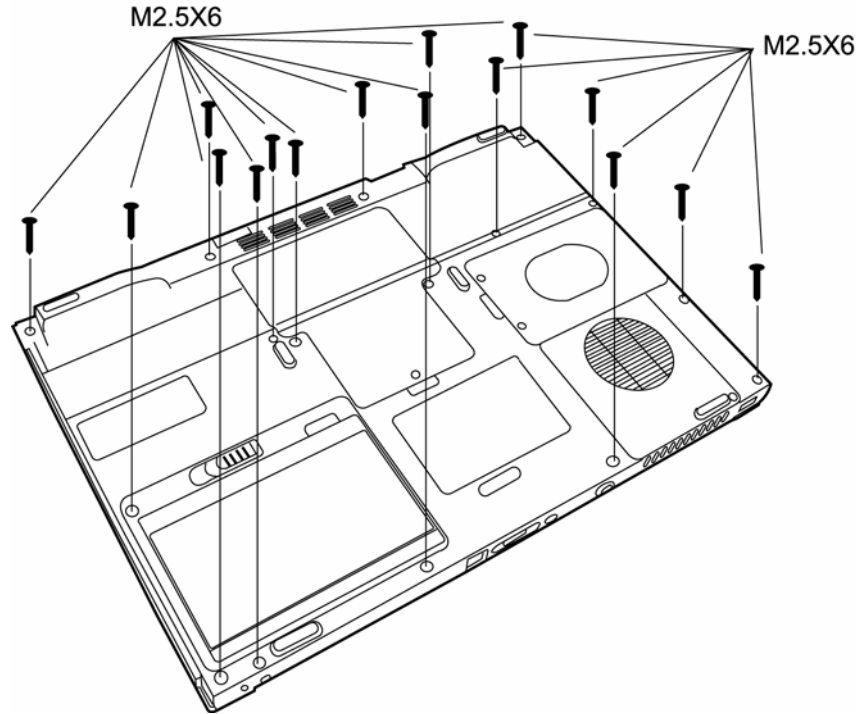

Figure 4-19 Removing the top cover-2

4. Turn the computer upright to lift off the top cover.

Installing the Top Cover

To install the top cover, follow the steps below and refer to the figures in the preceding section.

1. Seat the top cover and secure the upper FFC cable and Touch pad FFC cable to the computer's top chassis.
2. Secure the top cover with three M2.5x15 screws and one M2.5x6 screw.
3. Turn the computer upside down and secure fourteen M2.5x6 screws.

4.13 TouchPad

Removing the TouchPad

To remove the TouchPad, first remove the top cover, then follow the steps below:

1. Disconnect the TouchPad FFC cable from the TouchPad.
2. Remove two M2.5x3 black screws securing the control button board. Slide it and lift it out.
3. Remove one M2.5x3 screw securing the TrackPad Bracket. Slide it and lift out the Track Pad Bracket.

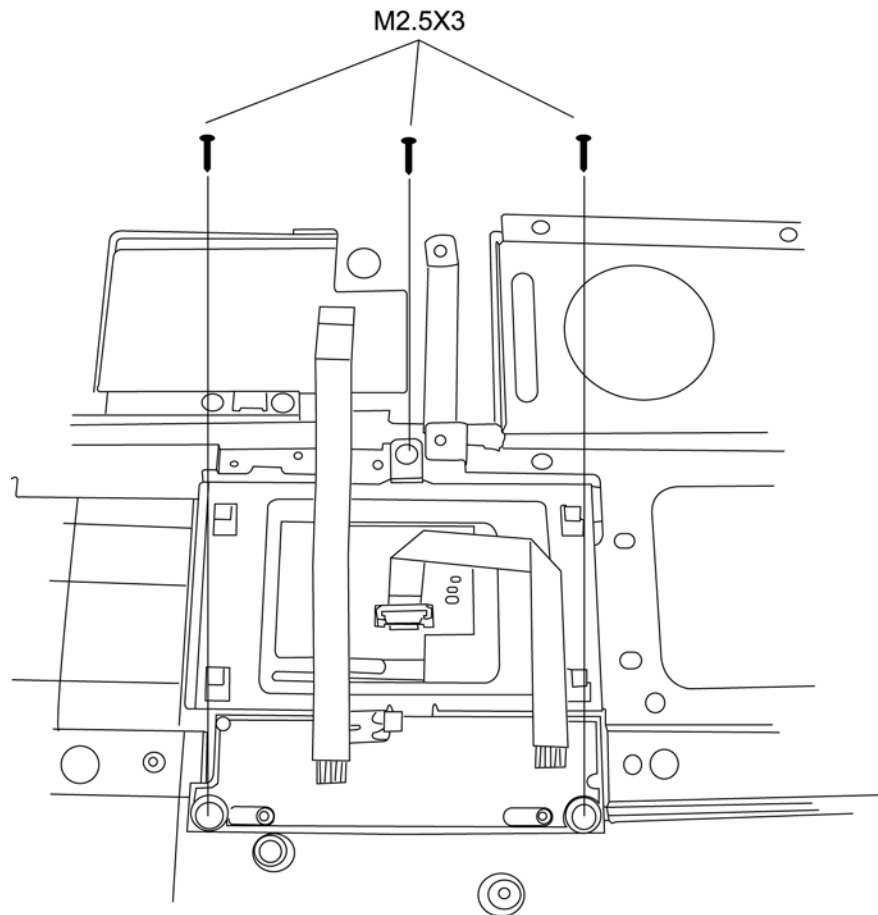

Figure 4-20 Removing the TouchPad

Installing the TouchPad

To install the TouchPad, follow the steps below and refer to the figures in the preceding section:

1. With the top cover upside down, place the TouchPad, the Track Pad Bracket, and control button board in position.
2. Secure the Track Pad Bracket with one M2.5x3 screw.
3. Secure the control button board with two M2.5x3 silver screws.
4. Connect the TouchPad LED FFC cable to the TouchPad.

4.14 Speakers

Removing the Speakers

To remove the speakers, first remove the top cover, then follow the steps below:

1. Remove the four M2.5x4 screws.
2. Disconnect the speaker cable from the system board.

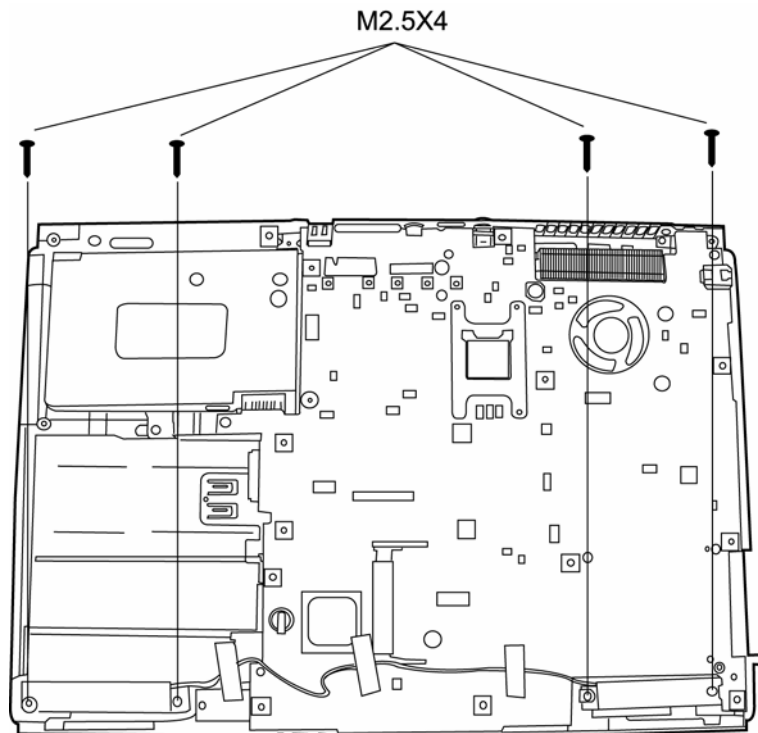

Figure 4-21 Removing the speakers

3. Lift out the speakers.

Installing the Speakers

To install the speakers, follow the steps below and refer to the figure in the preceding section:

1. Seat each speaker.
2. Secure each speaker with four M2.5x4 screws.

3. Attach the speaker cable to the system board.

4.15 System Board

Removing the System Board

To remove the system board, first remove the LCD assembly, top cover and HDD, then follow the steps below:

1. Remove two M2.5x4 screws from the system board.

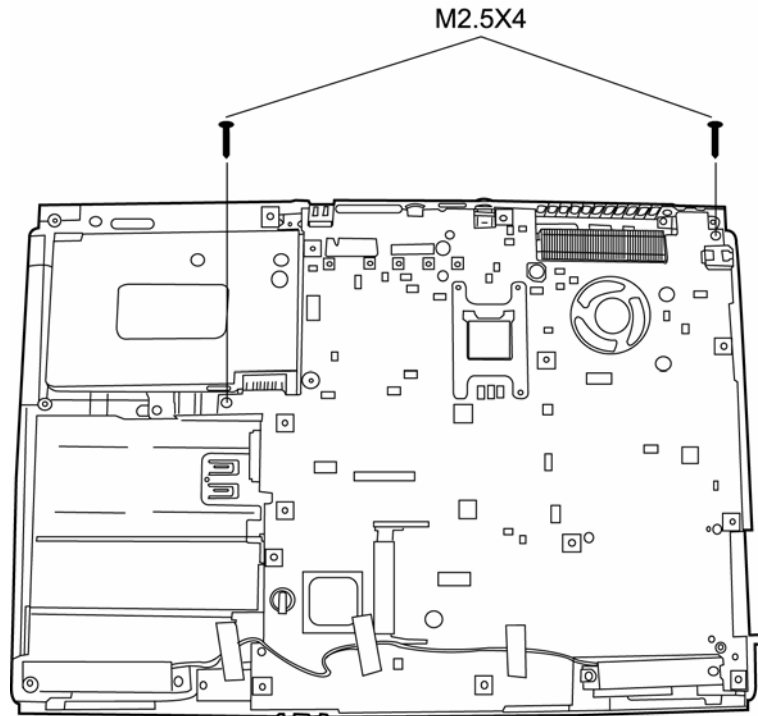

Figure 4-22 Removing the system board

2. Remove two hexagonal screws from the back of the system board.

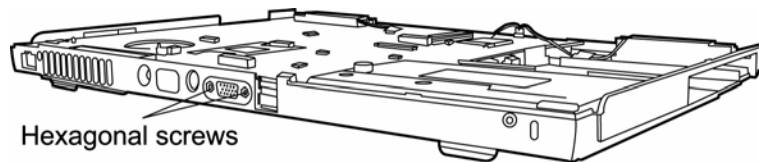

Figure 4-23 Removing the hexagonal screws

3. Lift it out.

Installing the System Board

To install the system board, follow the steps below and refer to the figures in the preceding section.

1. Seat the system board in the chassis.
2. Secure two hexagonal screws to the back of the system board.
3. Secure two M2.5x4 screws to the system board.

4.16 Fan & CPU

Removing the Fan & CPU

To remove the Fan, Heat Sink, and CPU, you must first remove the panel, keyboard, top cover and bottom chassis to reveal the system board, then follow the steps below:

1. Remove two M2.5x4 fan screws and then lift out the fan.

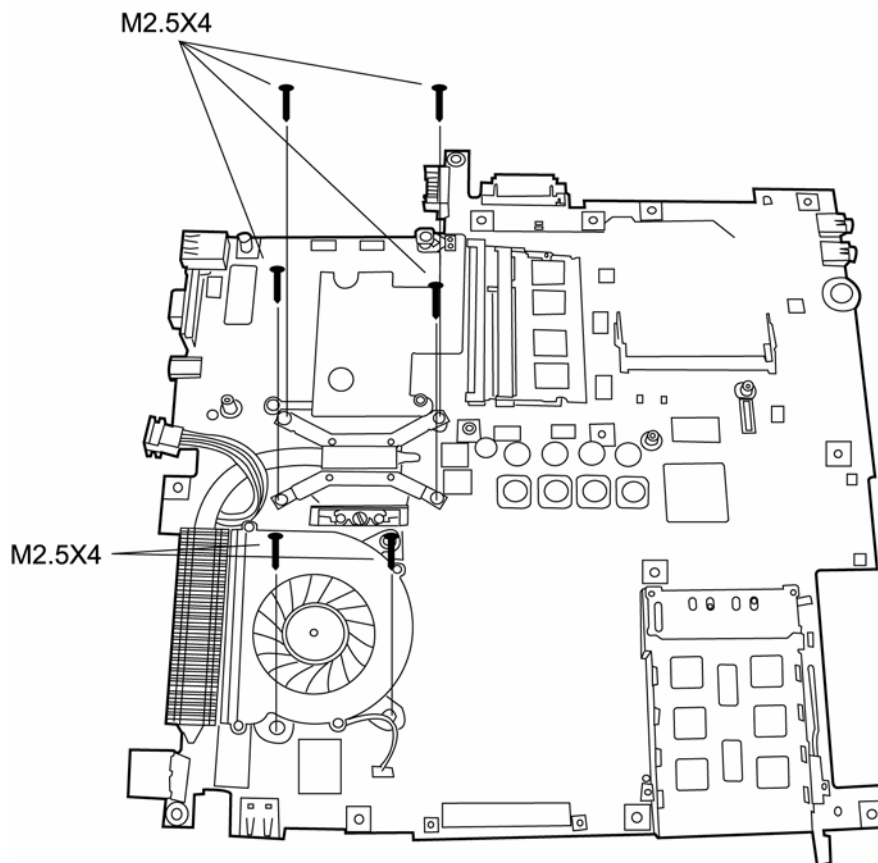

Figure 4-24 Removing the hexagonal screws

2. Remove four M2.5x4 screws securing the CPU bracket and heat sink, then lift them out.

- 3. Turn the CPU screw cam to loosen it, then lift it out.

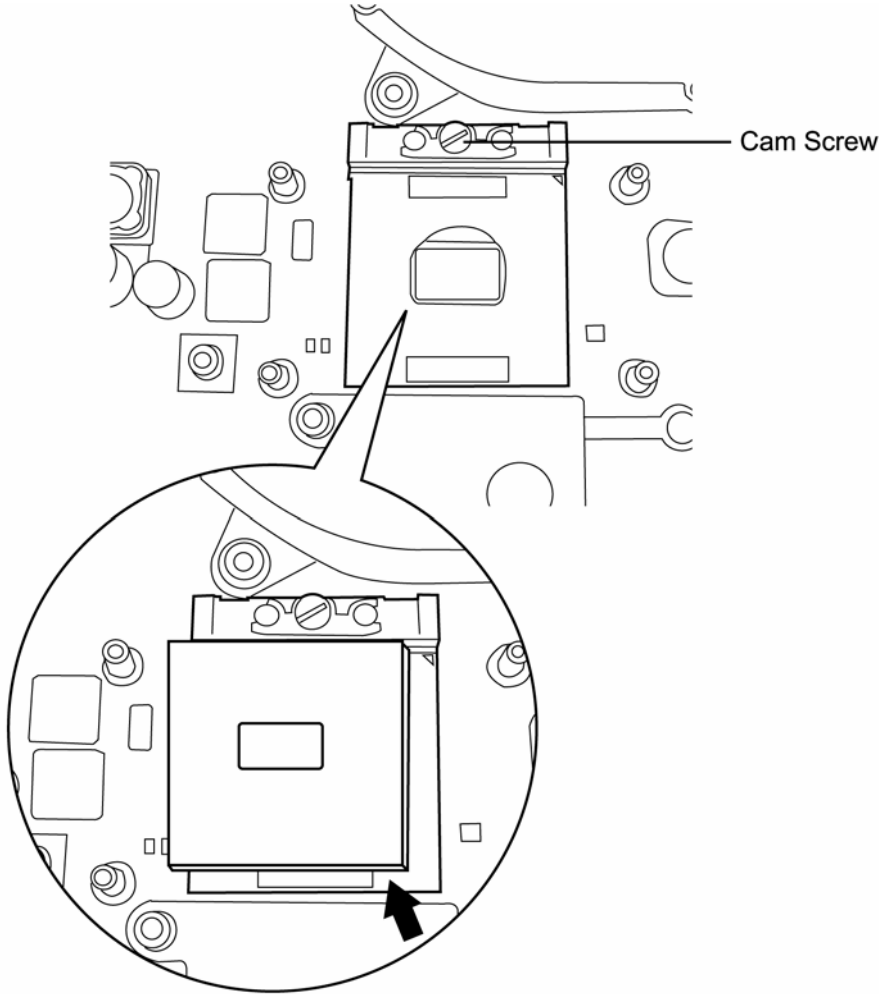

Figure 4-25 Removing the CPU

Installing the CPU

To install the CPU, follow the steps below and refer to the figures in the preceding section.

CAUTION: *If you remove the heat sink, you should use the CPU grease tool to remove the grease on the CPU and heat sink. Reapply fresh grease before installing the heat sink.*

1. Seat the CPU, then turn the screw cam to lock it in place.
2. Secure the CPU bracket and heat sink with four M2.5x4 screws.
3. Secure the fan with M2.5x4 fan screws.

4.17 Display Mask

Removing the Display Mask

To remove the display mask, first remove the display assembly as described earlier, then follow the steps below:

1. Remove the mask seals to expose four lower inner corner screws securing the display mask.
2. Remove four M2.5x4 black screws from the corners that were previously covered by the mask seals.
3. Carefully insert your fingers between the mask and the LCD panel and pry open the snaps. Start with the four snaps at the top of the display mask. Continue unsnapping the display mask along the two sides and the bottom edge to remove display.

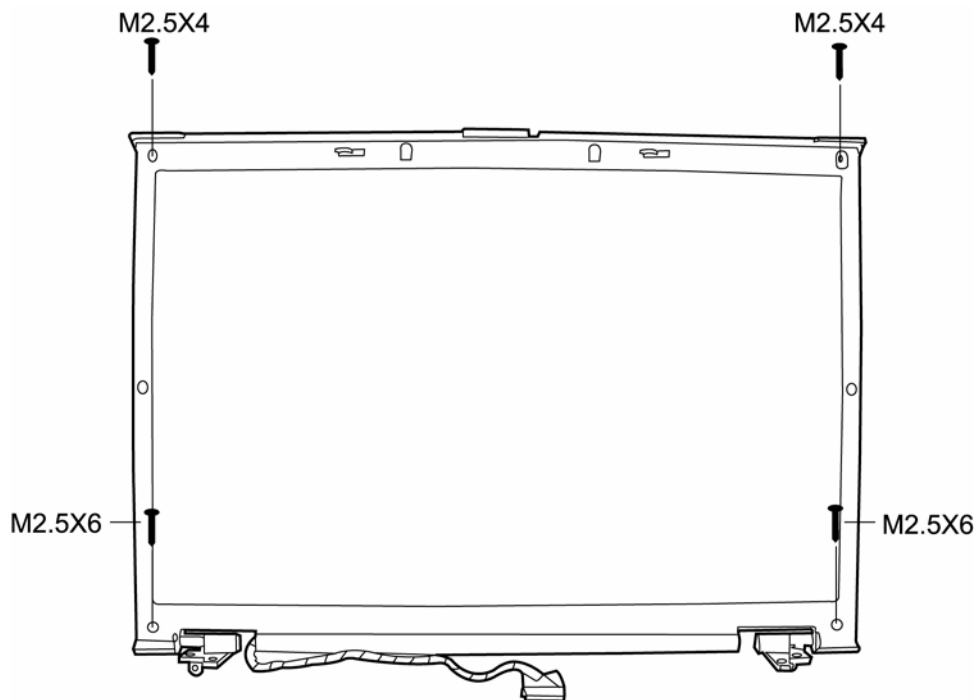

Figure 4-26 Removing the display mask

Installing the Display Mask

To install the display mask, follow the steps below and refer to the figures in the preceding section.

1. Seat the display mask and secure the snaps on each side.
2. Secure the display mask with four M2.5x4 screws at the bottom inner corner.
3. Cover the secured screws with mask seals.

4.18 LCD Module

Removing the LCD Module

To remove the LCD module, first remove the display assembly and display mask, then follow the steps below.

1. Remove two M2x3 black screws securing the LCD cable and FL inverter board.
2. Disconnect the LCD cable from the FL inverter board.
3. Remove two M2.5x6 black screws securing the LCD module bracket to LCD cover.
4. Lift it out.

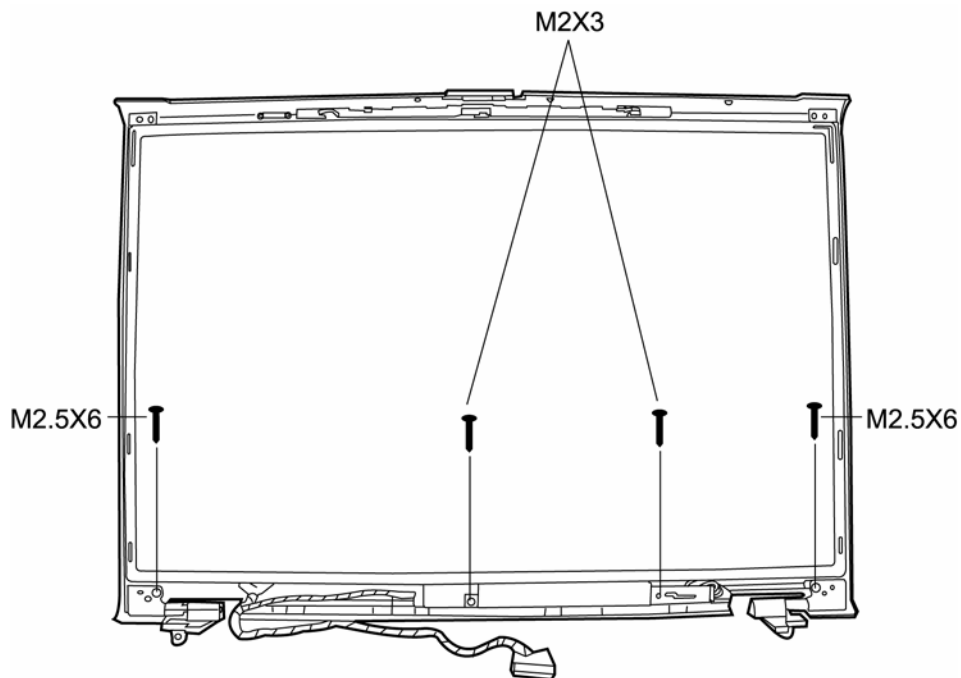

Figure 4-27 Removing the LCD module-1

5. Remove six M2x3 screws securing LCD module bracket to LCD module. Remove LCD cable.

NOTE: *If the LCD module malfunctions, remove the LCD cable and LCD bracket. Then replace the whole LCD module unit.*

Installing the LCD Module

To install the LCD module, follow the steps below and refer to the figures in the preceding section.

1. Set the LCD module in the display assembly.
2. Connect the FL cable and the HV cable to the FL inverter board.
3. Seat the LCD module in the display assembly with the LCD module bracket and six M2x3 black screws. Secure the LCD module with four M2.5x6 black screws.
4. Secure one M2x3 black screws holding the left HV cable and FL inverter board in place.

4.19 FL Inverter Board

Removing the FL Inverter Board

To remove the FL inverter board, first remove the battery pack, the display assembly, display mask, and LCD module, then follow the steps below.

1. Remove one M2x3 black screw securing the FL invert board to the LCD display assembly.

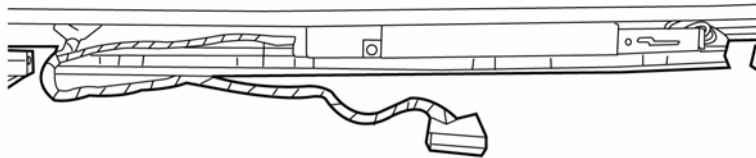

Figure 4-28 Removing the FL inverter board

Installing the FL Inverter Board

To install the FL inverter board, follow the steps below and refer to the figure in the preceding section..

1. Secure one M2x3 black screw connecting the FL inverter board to the LCD display assembly.
2. Reassemble the computer.

Appendices

Appendices

Appendix Contents

Appendix A Handling the LCD Module.....	A-1
Appendix B Board Layout.....	B-1
B.1 System Board (FRDSY*) Top View	B-1
B.2 System Board (FRDSY*) Bottom View.....	B-2
Appendix C Pin Assignments	C-1
C.1 JP23/JP26 SODIMM I/F (200-PIN)	C-1
C.2 JP13 RGB I/F (15-pin).....	C-5
C.3 JP24 HDD I/F (44-pin)	C-6
C.4 JP27 ODD Module I/F (60-pin).....	C-7
C.5 JP12 PC Card I/F (84-pin)	C-8
C.6 JP30 MIN1 PCI I/F pin assignments (124-pin)	C-10
C.7 JP1 LVDS I/F pin assignments (30-pin).....	C-12
C.8 JP32 4 in 1 conn	C-13
C.9 JP21 I/F pin assignments (3-pin)	C-14
C.10 PJP1 AC Adaptor Connector pin assignments (6-pin)	C-14
C.11 JP14 S-Video Connector pin assignments (6-pin).....	C-14
C.12 JP15 RJ11-45 Connector pin assignments (16-pin).....	C-14
C.13 JP16 Double USB Connector pin assignments (12-pin).....	C-15
C.14 JP18 Single USB Connector pin assignments (4-pin)	C-15
C.15 JP33 MDC Connector pin assignments (30-pin)	C-15
C.16 JP2 PW/LED Connector pin assignments (14-pin)	C-16
C.17 JP4 T/P Connector pin assignments (12-pin).....	C-16
C.18 JP5 KB Connector pin assignments (38-pin).....	C-16
C.19 JP22 1394 Connector pin assignments (4-pin)	C-17
C.20 JP9 SPK Connector pin assignments (4-pin)	C-17
C.21 JP8 NEWCARD Connector pin assignments (12-pin).....	C-17
C.22 PJP2 BATT Connector pin assignments (7-pin).....	C-18

Appendix D Keyboard Scan/Character Codes.....D-1

Appendix E Key Layout.....E-1

Appendix F Series Screw Torque List F-1

Appendix G ReliabilityG-1

Appendix A Handling the LCD Module

Precautions for handling the LCD module

The LCD module can be easily damaged during assembly or disassembly. Therefore, please observe the following precautions when handling it:

1. When installing the LCD module in the LCD cover, be sure to seat it so that it is properly aligned and maximum visibility of the display is maintained.

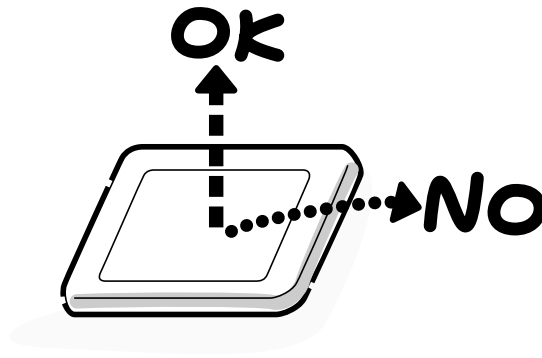

2. Be careful to align the holes at the four corners of the LCD module with the corresponding holes in the LCD cover before securing the module with screws. Do not force the module into place, because stress can affect its performance.

Note: The panel's polarized surface is easily scarred, so handle it carefully.



3. If the panel's surface gets dirty, wipe it with cotton or a soft cloth. If it is still dirty, try breathing on the surface to create a light condensate and wipe it again.

If the surface is very dirty, we recommend a CRT cleaning agent. Apply the agent to a cloth and then wipe the panel's surface. Do not apply cleanser directly to the panel.



4. If water or other liquid is left on the panel's surface for a long period, it can change the screen's tint or stain it. Be sure to quickly wipe off any liquid.



5. Glass is used in the panel, so be careful not to drop it or let it strike a hard object, which could cause breakage or cracks.

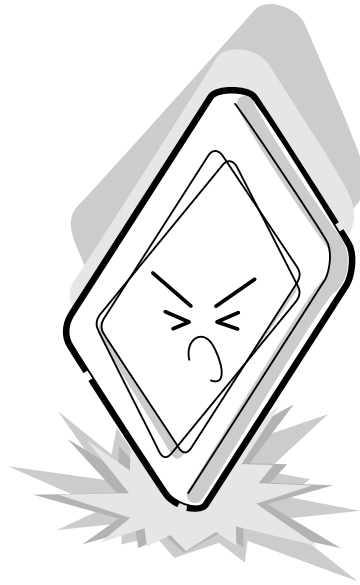

6. CMOS-LSI circuits are used in the module, so guard against damage from electrostatic discharge. Be sure to wear a wrist or ankle ground when handling the module.

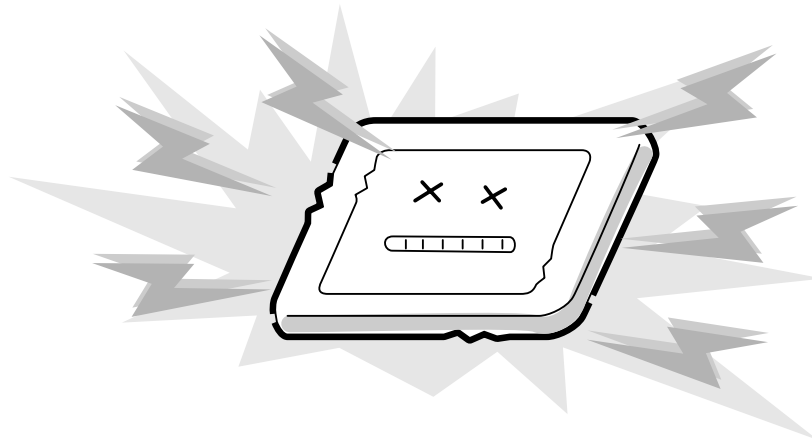

7. Do not expose the module to direct sunlight or strong ultraviolet rays for long periods.

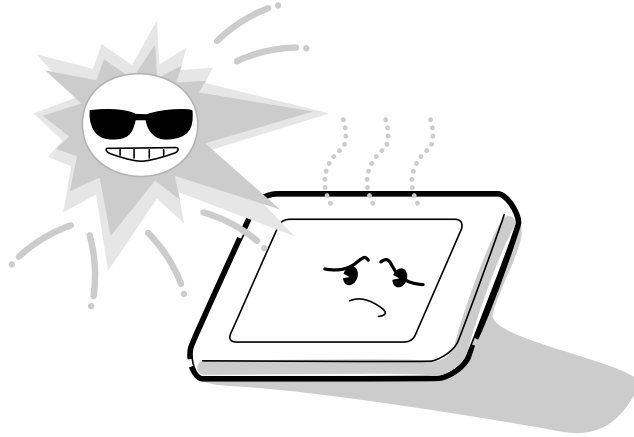

8. Do not store the module at temperatures below specifications. Cold can cause the liquid crystals to freeze, lose their elasticity or otherwise suffer damage.

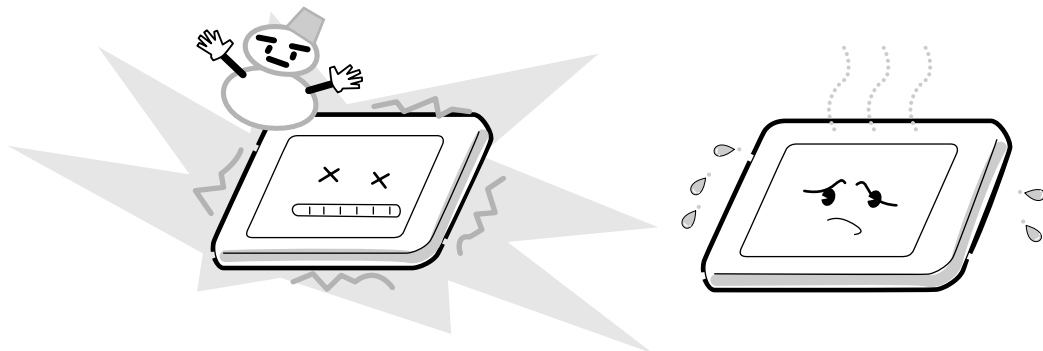

9. Do not disassemble the LCD module. Disassembly can cause malfunctions.

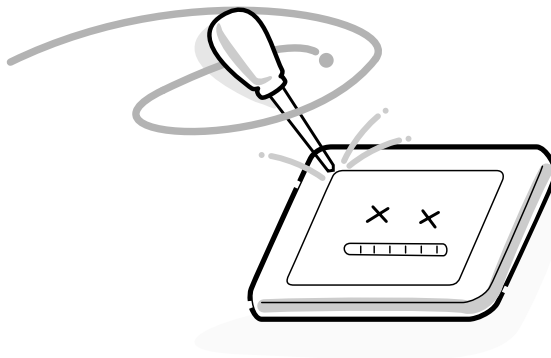

10. If you transport the module, do not use packing material that contains epoxy resin (amine) or silicon glue (alcohol or oxime). These materials can release gas that can damage the panel's polarization.

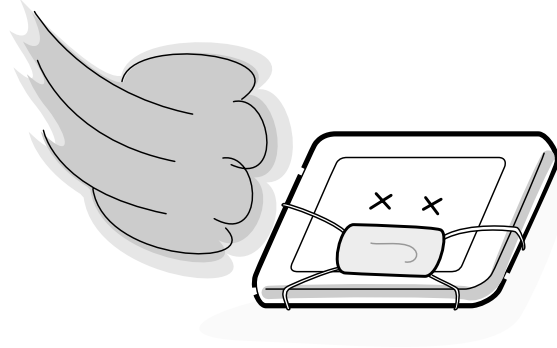

Appendix B Board Layout

B.1 System Board (FRDSY*) TOP View

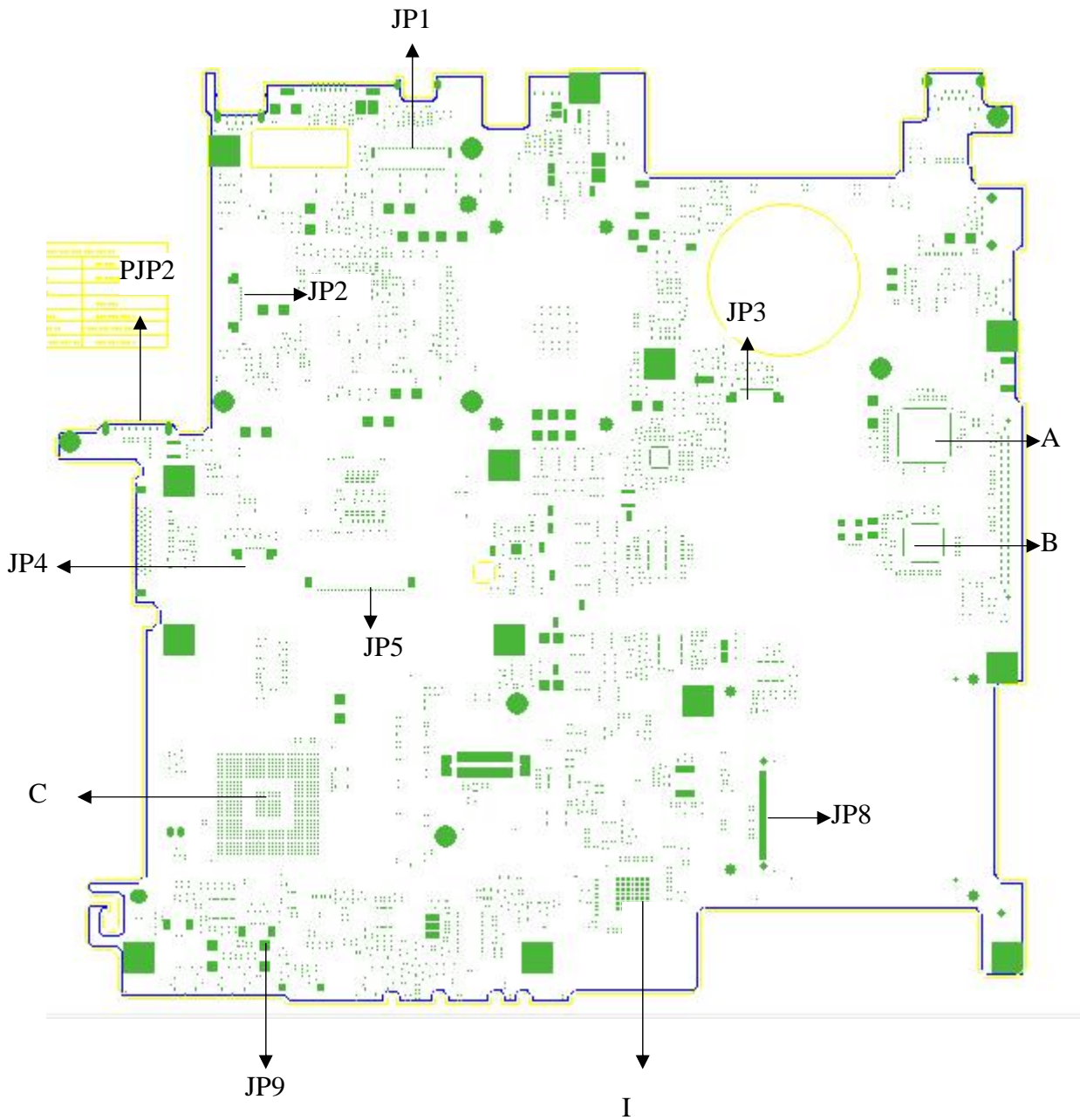

B.2 System Board (FRDSY*) BUTTOM View

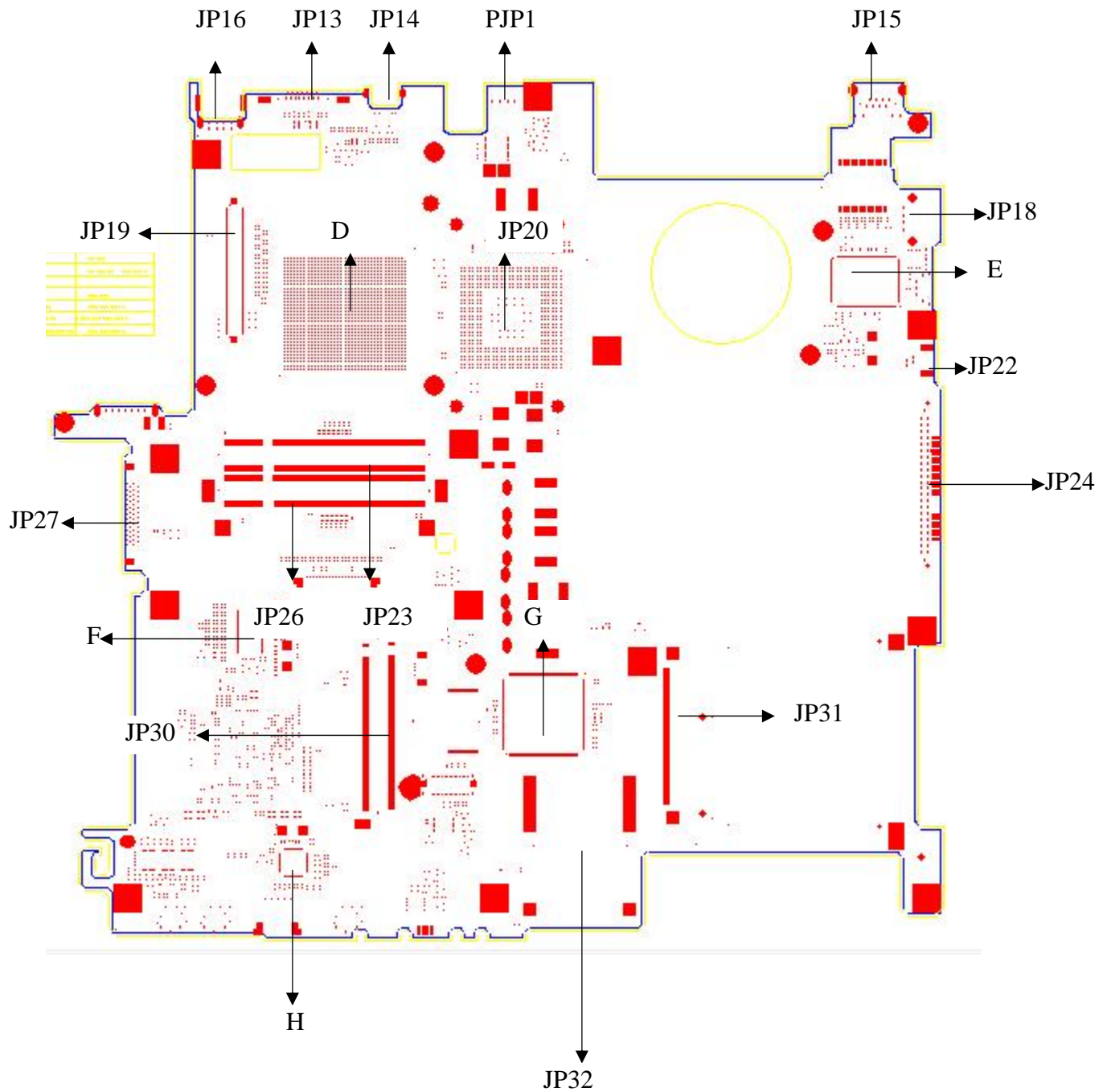

Table B-1 System board ICs (top and bottom)

Mark	Number	Name
A	U4	1394 TSB43AB21
B	U7	Marrell 8036
C	U18	Intel ICH6
D	U34	Intel 915PM
E	U32	LAN CHIP
F	U38	ICS95226
G	U40	Kb 910
H	U43	AC97 CODEC ALC250-VD
I	U21	ENE 714

Table B-2 System board connectors (top and bottom)

Number	Name
JP1	LVDS Connector
JP2	POWER/B Connector
JP3	FAN Connector
JP4	T/P Connector
JP5	KB Connector
JP8	NEWCARD Connector
JP9	AUDIO Connector
JP10	HDD Connector
JP13	CRT Connector
JP14	Tv-out Connector
JP15	LAN Connector
JP16	USB Connector
JP18	USB Connector
JP19	VGA Connector
JP22	1394 Connector
JP23, JP26	SODIMM Socket
JP27	ODD Connector
JP30	MINI PCI
JP31	CARDBUS
JP32	5IN1 CARD BUS
PJP1	DC-in Connector
PJP2	Battery Connector

Appendix C Pin Assignments

System Board

C.1 JP23, JP26

Table C-1 SODIMM I/F pin assignments (200-PIN) (1/4)

Pin No.	Signal name	I/O	Pin No.	Signal Name	I/O
1	VREF	O	2	GND	O
3	GND	O	4	DDRA_SDQ4	I/O
5	DDRA_SDQ0	I/O	6	DDRA_SDQ2	I/O
7	DDRA_SDQ1	I/O	8	GND	O
9	GND	O	10	DDRA_SDM0	I/O
11	DDRA_SDQS0#	I/O	12	GND	O
13	DDRA_SDQS0	I/O	14	DDRA_SDQ6	I/O
15	GND	O	16	DDRA_SDQ7	I/O
17	DDRA_SDQ2	I/O	18	GND	O
19	DDRA_SDQ3	I/O	20	DDRA_SDQ12	I/O
21	GND	O	22	DDRA_SDQ13	I/O
23	DDRA_SDQ8	I/O	24	GND	I/O
25	DDRA_SDQ9	I/O	26	DDRA_SDM1	O
27	GND	O	28	GND	O
29	DDRA_SDQS1#	I/O	30	DDRA_CLK0	I/O
31	DDRA_SDQS1	I/O	32	DDRA_CLK0#	I/O
33	GND	O	34	GND	O
35	DDRA_SDQ10	I/O	36	DDRA_SDQ14	I/O
37	DDRA_SDQ11	I/O	38	DDRA_SDQ15	I/O
39	GND	O	40	GND	O
41	GND	O	42	GND	O
43	DDRA_SDQ16	I/O	44	DDRA_SDQ20	I/O
45	DDRA_SDQ17	I/O	46	DDRA_SDQ21	I/O
47	GND	O	48	GND	O
49	DDRA_SDQS2#	I/O	50	NC	-

Table C-1 SODIMM I/F pin assignments (200-PIN) (2/4)

Pin No.	Signal name	I/O	Pin No.	Signal Name	I/O
51	DDRA_SDQS2	I/O	52	DDRA_SDM2	I/O
53	GND	O	54	GND	O
55	DDRA_SDQ18	I/O	56	DDRA_SDQ22	I/O
57	DDRA_SDQ19	I/O	58	DDRA_SDQ23	I/O
59	GND	O	60	GND	O
61	DDRA_SDQ24	I/O	62	DDRA_SDQ28	I/O
63	DDRA_SDQ25	I/O	64	DDRA_SDQ29	I/O
65	GND	O	66	GND	O
67	DDRA_SDM3	I/O	68	DDRA_SDQS3#	I/O
69	NC	-	70	DDRA_SDQS3	I/O
71	GND	O	72	GND	O
73	DDRA_SDQ26	I/O	74	DDRA_SDQ30	I/O
75	DDRA_SDQ27	I/O	76	DDRA_SDQ31	I/O
77	GND	O	78	GND	O
79	DDRA_CKE0	I/O	80	DDRA_CKE1	I/O
81	+1.8V	O	82	+1.8V	O
83	NC	-	84	NC	-
85	DDRA_SBS2#	I/O	86	NC	-
87	+1.8V	O	88	+1.8V	O
89	DDRA_SMA12	I/O	90	DDRA_SMA11	I/O
91	DDRA_SMA9	I/O	92	DDRA_SMA7	I/O
93	DDRA_SMA8	I/O	94	DDRA_SMA9	I/O
95	+1.8V	O	96	+1.8V	O
97	DDRA_SMA5	I/O	98	DDRA_SMA4	I/O
99	DDRA_SMA3	I/O	100	DDRA_SMA2	I/O
101	DDRA_SMA1	I/O	102	DDRA_SMA0	I/O
103	+1.8V	O	104	+1.8V	O
105	DDRA_SMA10	I/O	106	DDRA_SBS1#	I/O
107	DDRA_SBS0#	I/O	108	DDRA_SRAS#	I/O
109	DDRA_SWE#	I/O	110	DDRA_SCS#0	I/O
111	+1.8V	O	112	+1.8V	O
113	DDRA_SCAS#	I/O	114	DDRA_ODT0	I/O

Table C-1 SODIMM I/F pin assignments (200-PIN) (3/4)

Pin No.	Signal name	I/O	Pin No.	Signal Name	I/O
115	DDRA_SCS#1	I/O	116	DDRA_SMA13	I/O
117	+1.8V	O	118	+1.8V	O
119	DDRA_ODT1	I/O	120	NC	-
121	GND	O	122	GND	O
123	DDRA_SDQ32	I/O	124	DDRA_SDQ36	I/O
125	DDRA_SDQ33	I/O	126	DDRA_SDQ37	I/O
127	GND	O	128	GND	O
129	DDRA_SDQS4#	I/O	130	DDRA_SDM4	I/O
131	DDRA_SDQS4	I/O	132	GND	O
133	GND	O	134	DDRA_SDQ38	I/O
135	DDRA_SDQ34	I/O	136	DDRA_SDQ39	I/O
137	DDRA_SDQ35	I/O	138	GND	O
139	GND	O	140	DDRA_SDQ44	I/O
141	DDRA_SDQ40	I/O	142	DDRA_SDQ45	I/O
143	DDRA_SDQ41	I/O	144	GND	O
145	GND	O	146	DDRA_SDQS5#	I/O
147	DDRA_SDM5	I/O	148	DDRA_SDQS5	I/O
149	GND	O	150	GND	O
151	DDRA_SDQ42	I/O	152	DDRA_SDQ46	I/O
153	DDRA_SDQ43	I/O	154	DDRA_SDQ47	I/O
155	GND	O	156	GND	O
157	DDRA_SDQ48	I/O	158	DDRA_SDQ52	I/O
159	DDRA_SDQ49	I/O	160	DDRA_SDQ53	I/O
161	GND	O	162	GND	O
163	NC	-	164	DDRA_CLK1	I/O
165	GND	O	166	DDRA_CLK1#	I/O
167	DDRA_SDQS6#	I/O	168	GND	O
169	DDRA_SDQS6	I/O	170	DDRA_SDM6	I/O
171	GND	O	172	GND	O
173	DDRA_SDQ50	I/O	174	DDRA_SDQ54	I/O
175	DDRA_SDQ51	I/O	176	DDRA_SDQ55	I/O
177	GND	O	178	GND	O
179	DDRA_SDQ56	I/O	180	DDRA_SDQ60	I/O

Table C-1 SODIMM I/F pin assignments (200-PIN) (4/4)

Pin No.	Signal name	I/O	Pin No.	Signal Name	I/O
181	DDRA_SDQ57	I/O	182	DDRA_SDQ61	I/O
183	GND	O	184	GND	O
185	DDRA_SDM7	I/O	186	DDRA_SDQS7 #	I/O
187	GND	O	188	DDRA_SDQS7	I/O
189	DDRA_SDQ58	I/O	190	GND	O
191	DDRA_SDQ59	I/O	192	DDRA_SDQ62	I/O
193	GND	O	194	DDRA_SDQ63	I/O
195	D_CK_SDATA	I/O	196	GND	O
197	D_CK_SCLK	I/O	198	GND	O
199	+3VS	O	200	GND	O

C.2 JP13

Table C-3 RGB I/F pin assignments (15-pin)

Pin No.	Signal name	I/O	Pin No.	Signal Name	I/O
1	CRT_R_L	O	2	CRT_G_L	O
3	CRT_B_L	O	4	GND	-
5	GND	-	6	GND	-
7	GND	-	8	GND	-
9	+CRT_VCC	-	10	GND	-
11	NC	-	12	DSUB_12	I/O
13	HSYNC_L	O	14	VSYNC_L	O
15	DSUB_15	I/O			

C.3 JP24

Table C-4 HDD I/F pin assignments (44-pin)

Pin No.	Signal name	I/O	Pin No.	Signal Name	I/O
1	PIDE_HRESET#	O	2	GND	-
3	PIDE_HDD7	I/O	4	PIDE_HDD8	I/O
5	PIDE_HDD6	I/O	6	PIDE_HDD9	I/O
7	PIDE_HDD5	I/O	8	PIDE_HDD10	I/O
9	PIDE_HDD4	I/O	10	PIDE_HDD11	I/O
11	PIDE_HDD3	I/O	12	PIDE_HDD12	I/O
13	PIDE_HDD2	I/O	14	PIDE_HDD13	I/O
15	PIDE_HDD1	I/O	16	PIDE_HDD14	I/O
17	PIDE_HDD0	I/O	18	PIDE_HDD15	I/O
19	GND	-	20	NC	-
21	PIDE_HDREQ	I	22	GND	-
23	PIDE_HDIOW#	O	24	GND	-
25	PIDE_HDIOR#	O	26	GND	-
27	PIDE_HIORDY	I	28	SEC_CSEL	O
29	PD_DACK#	O	30	GND	-
31	PIDE_HINTRQ	I	32	GND	-
33	PIDE_HDA1	O	34	GND	-
35	PIDE_HDA0	O	36	PIDE_HDA2	O
37	PIDE_HCS0#	O	38	PIDE_HCS1#	O
39	+5VS	-	40	GND	-
41	+5VS	-	42	+5VS	-
43	GND	-	44	NC	-

C.4 JP27

Table C-5 ODD I/F pin assignments (52-pin)

Pin No.	Signal name	I/O	Pin No.	Signal Name	I/O
1	INT_CD_L	I	2	INT_CD_R	I
3	CD_AGND	-	4	GND	-
5	SIDE_RST#	O	6	SD_D8	I/O
7	SD_D7	I/O	8	SD_D9	I/O
9	SD_D6	I/O	10	SD_D10	I/O
11	SD_D5	I/O	12	SD_D11	I/O
13	SD_D4	I/O	14	SD_D12	I/O
15	SD_D3	I/O	16	SD_D13	I/O
17	SD_D2	I/O	18	SD_D14	I/O
19	SD_D1	I/O	20	SD_D15	I/O
21	SD_D0	I/O	22	SD_DREQ	I
23	GND	-	24	SD_IOR#	O
25	IDE_DIOW#	O	26	GND	O
27	IDE_DIORDY	I	28	IDE_DDACK#	O
29	IDE_IRQ	I	30	NC	O
31	IDE_DA1	O	32	+5VCD	I
33	IDE_DA0	O	34	IDE_DA2	I
35	SW_SD_CS#1	O	36	SW_SD_CS#3	-
37	SHDD_LED#	I	38	+5VCD	O
39	+5VCD	-	40	+5VCD	-
41	+5VCD	-	42	+5VCD	-
43	GND	-	44	GND	-
45	GND	-	46	GND	-
47	GND	-	48	GND	-
49	NC	-	50	+5VCD	-
51	GND		52	GND	

C.5 JP12

Table C-7 PC Card I/F pin assignments (84-pin) (1/2)

Pin No.	Signal name	I/O	Pin No.	Signal Name	I/O
1	GND	-	2	S1_D3	-
3	S1_D4	I/O	4	S1_D5	O
5	S1_D6	I/O	6	S1_D7	I/O
7	S1_CE1#	I/O	8	S1_A10	I/O
9	S1_OE#	I/O	10	S1_A11	I/O
11	S1_A9	I/O	12	S1_A8	I/O
13	S1_A13	I/O	14	S1_A14	I/O
15	S1_WE#	I	16	S1_RDY#	I/O
17	+S1_VCC	I/O	18	+S1_VPP	I
19	S1_A16	I	20	S1_A15	I/O
21	S1_A12	I	22	S1_A7	I
23	S1_A6	I	24	S1_A5	I
25	S1_A4	I	26	S1_A3	I
27	S1_A2	I	28	S1_A1	I
29	S1_A0	I	30	S1_D0	I
31	S1_D1	O	32	S1_D2	I
33	S1_WP	-	34	GND	-
35	GND	-	36	S1_CD1#	-
37	S1_D11	I	38	S1_D12	I
39	S1_D13	I	40	S1_D14	I
41	S1_D15	I	42	S1_CE2#	I
43	S1_VS1	I	44	S1_IORD#	I
45	S1_IOWR#	I	46	S1_A17	I
47	S1_A18	I	48	S1_A19	I
49	S1_A20	I	50	S1_A21	I
51	+S1_VCC	I	52	+S1_VPP	O
53	S1_A22	I	54	S1_A23	I
55	S1_A24	I	56	S1_A25	O
57	S1_VS2	I	58	S1_RST	I
59	S1_WAIT#	I	60	S1_INPACK#	I/O

Table C-7 PC Card I/F pin assignments (84-pin) (2/2)

Pin No.	Signal name	I/O	Pin No.	Signal Name	I/O
61	S1_REG#	I/O	62	S1_BVD2	I/O
63	S1_BVD1	I/O	64	S1_D8	I/O
65	S1_D9	I/O	66	S1_D10	I
67	S1_CD2#	-	68	GND	-

C.6 JP30

Table C-8 Mini PCI I/F pin assignments (124-pin) (1/2)

Pin No.	Signal name	I/O	Pin No.	Signal Name	I/O
1	NC	-	2	NC	-
3	NC	-	4	NC	-
5	NC	-	6	NC	-
7	NC	-	8	NC	-
9	NC	-	10	NC	-
11	NC	-	12	NC	-
13	SWITCH	O	14	NC	-
15	NC	-	16	NC	-
17	PCI_PIRQH#	I	18	+5VS	-
19	+3VS	O	20	PCI_PIRQG#	I
21	NC	-	22	NC	-
23	GND	-	24	+3V	O
25	CLK_PCI_MINI	O	26	PCI_RST#	O
27	GND	-	28	+3VS	O
29	PCI_REQ#1	I	30	PCI_GNT#1	O
31	+3.3V	O	32	GND	-
33	AD31	I/O	34	WLANME#	I
35	AD29	I/O	36	NC	-
37	GND	-	38	AD30	I/O
39	AD27	I/O	40	+3.3V	O
41	AD25	I/O	42	AD28	I/O
43	NC	-	44	AD26	I/O
45	CBE3#	I/O	46	AD24	I/O
47	AD23	I/O	48	MINI_IDSEL	I/O
49	GND	-	50	GND	-
51	AD21	I/O	52	AD22	I/O
53	AD19	I/O	54	AD20	I/O
55	GND	-	56	PAR	I/O
57	AD17	I/O	58	AD18	I/O
59	CBE2#	I/O	60	AD16	I/O

Table C-8 Mini PCI I/F pin assignments (124-pin)(2/2)

Pin No.	Signal name	I/O	Pin No.	Signal Name	I/O
61	IRDY#	I/O	62	GND	-
63	+3.3V	O	64	FRAME#	I/O
65	PM_CLKRUN#	I/O	66	TRDY#	I/O
67	PCI_SERR#	I/O	68	STOP#	I/O
69	GND	-	70	+3.3V	O
71	PCI_PERR#	O	72	DEVSEL#	I/O
73	C/BE1#	I/O	74	GND	-
75	AD14	I/O	76	AD15	I/O
77	GND	-	78	AD13	I/O
79	AD12	I/O	80	AD11	I/O
81	AD10	I/O	82	GND	-
83	GND	-	84	AD09	I/O
85	AD08	I/O	86	C/BE0#	I/O
87	AD07	I/O	88	+3.3V	O
89	+3.3V	O	90	AD06	I/O
91	AD05	I/O	92	AD04	I/O
93	NC	-	94	AD02	I/O
95	AD03	I/O	96	AD00	I/O
97	+5VS_MINIPCI	O	98	NC	-
99	AD01	I/O	100	NC	-
101	GND	-	102	GND	-
103	NC	-	104	NC	-
105	NC	-	106	NC	-
107	NC	-	108	NC	-
109	NC	-	110	NC	-
111	NC	I	112	NC	-
113	GND	-	114	GND	-
115	NC	-	116	NC	-
117	GND	-	118	GND	-
119	GND	-	120	GND	-
121	NC	-	122	NC	-
123	+5VS_MINIPCI	-	124	+3.3V	-

C.7 JP1

Table C-9 LVDS I/F pin assignments (30-pin)

Pin No.	Signal name	I/O	Pin No.	Signal Name	I/O
1	B+	-	2	B+	-
3	NC	-	4	+3VS	-
5	LCD_CLK	-	6	LCD_DATA	-
7	GND	-	8	TZOUT0-	-2
9	TZOYT0+	-	10	GND	-
11	TZOUT1+	-	12	TZOUT1-	-
13	GND	O	14	TZOUT2+	-
15	TZOUT2-	-	16	GND	-
17	TZCLK-	I	18	TZCLK+	-
19	GND	O	20	LCD_ID#	I
21	DAC_BRIG	-	22	INVT_PWM	-
23	DISPOFF#	-	24	+LCDVDD	O
25	+LCDVDD	O	26	+LCDVDD	O
27	GND	-	28	TXOUT0-	O
29	TXOUT0+	I	30	GND	O
31	TXOUT1-	-	32	TXOUT1-	-
33	GND	-	34	TXOUT2+	O
35	TXOUT2-	O	36	GND	O
37	TXCLK-	-	28	TXCLK+	O
39	GND	I	40	NC	O

C.8**JP32 4IN1 CONN**

Pin No.	Signal name	I/O	Pin No.	Signal Name	I/O
1	GND		2	MSBS_XDD1	
3	MSD1_XDD6		4	MSD0_XDD2	
5	MSD2_XDD5		6	MSINS#	
7	MSD3_XDD3		8	MSCLK_XDRE #	
9	VCC		10	GND	
11	SDDA2_XDCL		12	SDDA3_XDD4	
13	SDCM_XDALE		14	GND	
15	VCC		16	SDCK_XDWE #	
17	GND		18	NC	
19	SDDA0_XDD7		20	SDDA1_XDD0	
21	SDCD#		22	GND	
23	XDCD#		24	GND	
25	XDBSY#		26	MSCLK_XDRE #	
27	XDCE#		28	SDDA2_XDCL	
29	SDCM_XDALE		30	SDCK_XDWE #	
31	XDWP#		32	GND	
33	SDDA1_XDD0		34	MSBS_XDD1	
35	MSD0_XDD2		36	MSD3_XDD3	
37	SDDA3_XDD4		38	MSD2_XDD5	
39	MSD1_XDD6		40	SDDA0_XDD7	
41	VCC		42	NC	
43	SDWP		44	GND	

C.9 JP21

Table C-9-1 JP21 Fan I/F pin assignments (3-pin)

Pin No.	Signal name	I/O	Pin No.	Signal Name	I/O
1	FAN1_VOUT	I	2	FAN-SPEED1	O
3	GND	-			

C.10 PJP1

Table C-10 AC Adaptor Connector pin assignments (6-pin)

Pin No.	Signal name	I/O	Pin No.	Signal Name	I/O
1	DC_IN_S1	I	2	GND	-
3	GND	-	4	GND	-
5	GND	-	6	GND	-

C.11 JP14

Table C-11 S-Video Connector pin assignments (6-pin)

Pin No.	Signal name	I/O	Pin No.	Signal Name	I/O
1	GND	-	2	GND	-
3	LUMA_1	I	4	CRMA_1	I
5	GND	-	6	GND	-

C.12 JP15

Table C-12 RJ11-45 Connector pin assignments (16-pin)

Pin No.	Signal name	I/O	Pin No.	Signal Name	I/O
1	RJ45_MDI0+	I	2	RJ45_MDI0-	I
3	RJ45_MDI1+	I	4	RJ45_MDI2+	-
5	RJ45_MDI2-	-	6	RJ45_MDI1-	I
7	RJ45_MDI3+	-	8	RJ45_MDI3-	-
9	+3VALW	I	10	GND	-
11	GND	-	12	+3VALW	I
13	GND	-	14	GND	-

C.13 JP16

Table C-13 Double USB Connector pin assignments (12-pin)

Pin No.	Signal name	I/O	Pin No.	Signal Name	I/O
1	+USB_VCCA	I	2	USB20_N0	I
3	USB20_P0	I	4	GND	-
5	+USB_VCCA	-	6	USB20_N2	I
7	USB20_P2	-	8	GND	-
9	GND	I	10	GND	-
11	GND	-	12	GND	I

C.14 JP18

Table C-14 Single USB Connector pin assignments (4-pin)

Pin No.	Signal name	I/O	Pin No.	Signal Name	I/O
1	+USB_VCCC	I	2	USB20_N4	I/O
3	USB20_P4	I/O	4	GND	-

C.15 JP33

Table C-15 MDC Connector pin assignments (30-pin)

Pin No.	Signal name	I/O	Pin No.	Signal Name	I/O
1	NC	-	2	NC	-
3	GND	-	4	NC	I
5	NC	-	6	NC	-
7	NC	-	8	GND	-
9	NC	-	10	+5VS_MDC	I
11	NC	-	12	NC	-
13	NC	-	14	NC	-
15	GND	-	16	+3VS_MDC_R	I
17	+3V_MDC	I	18	NC	-
19	GND	-	20	GND	-
21	+3VS_MDC	I	22	AC97_SYNC	O
23	AC97_SDOOUT	O	24	AC97_SDIN1	O
25	AC97_RST#	O	26	AC97_SDIN1	I

27	GND	-	28	GND	-
29	GND	-	30	AC97_BITCLK	I

C.16 JP2

Table C-16 PW/LED Connector pin assignments (14-pin)

Pin No.	Signal name	I/O	Pin No.	Signal Name	I/O
1	NC	-	NC	MODE_LED#	O
3	DINBTN#	O	4	PWR_LED0#	O
5	PWR_SUSPLED0#	O	6	NC	I
7	MOBELLED#	I	8	ON/OFFBTN#	I
9	GND	I	10	NC	I

C.17 JP4

Table C-17 T/P Connector pin assignments (12-pin)

Pin No.	Signal name	I/O	Pin No.	Signal Name	I/O
1	+5VS	-	2	NC	I
3	TP_DATA	I	4	TP_CLK	I
5	NC	I	6	GND	I

C.18 JP5

Table C-18 KB Connector pin assignments (38-pin)

Pin No.	Signal name	I/O	Pin No.	Signal Name	I/O
1	KSI3	I	2	KSI2	-
3	KSI1	-	4	KSI0	-
5	KS14	-	6	KSO17	I
7	KSI5	O	8	KS6I	O
9	KSI7	O	10	KSO16	O
11	KSO0	O	12	KSO1	O
13	KSO15	O	14	KSO14	O
15	KSO13	O	16	KSO12	O

17	KSO11	O	18	KSO10	O
19	KSO9	O	20	KSO8	O
21	KSO7	O	22	KSO6	O
23	KSO5	O	24	KSO2	O
25	KSO4	O	26	KSO3	O

C.19 JP22

Table C-19 1394 Connector pin assignments (4-pin)

Pin No.	Signal name	I/O	Pin No.	Signal Name	I/O
1	TPB0-	I/O	2	TPB0+	I/O
3	TPA0-	I/O	4	TPA0+	I/O
5	GND	-	6	GND	-

C.20 JP9

Table C-20 SPK Connector pin assignments (4-pin)

Pin No.	Signal name	I/O	Pin No.	Signal Name	I/O
1	SPKR-	I/O	2	SPKR+	I/O
3	SPKL-	I/O	4	SPKL+	I/O

C.21 JP8

Table C-21 NEWCARD Connector pin assignments (12-pin)

Pin No.	Signal name	I/O	Pin No.	Signal Name	I/O
1	GND	I	2	USB_N6	I/O
3	USB_P6	I/O	4	CP_USB#	
5	NC		6	NC	
7	CK_CLK		8	CK_SDATA	
9	+1.5VS		10	+1.5VS	
11	ICH_PCIE_WAKE#		12	+3VALW	
13	PERST#		14	+3VS	
15	+3VS		16	CLKREQ#	
17	EXP_CPPE#		18	CLK_PCIE_CARD#	

19	CLK_PCIE_CARD		20	GND
21	PCIE_PTX_C_IRX_N2		22	PCIE_PTX_C_IRX_P2
23	GND		24	PCIE_ITX_C_PRX_N2
25	PCIE_ITX_C_PRX_P2		26	GND
27	GND		28	GND

C.22 PJP2

Table C-22 BATT Connector pin assignments (7-pin)

Pin No.	Signal name	I/O	Pin No.	Signal Name	I/O
1	BATT_S1	I	2	ALI/NIMH#	I
3	AB/I	I	4	TS_A	O
5	EC_SMDA	O	6	EC_SMCA	O
7	GND	-			

Appendix D Keyboard Scan/Character Codes

Table D-1 Scan codes (set 1 and set 2) (1/4)

Cap No.	Keytop	Code set 1		Code set 2		Note	
		Make	Break	Make	Break		
01	' ~	29	A9	0E	F0	0E	
02	1 !	02	82	16	F0	16	
03	2 @	03	83	1E	F0	1E	
04	3 #	04	84	26	F0	26	
05	4 \$	05	85	25	F0	25	
06	5 %	06	86	2E	F0	2E	
07	6 ^	07	87	36	F0	36	
08	7 &	08	88	3D	F0	3D	*2
09	8 *	09	89	3E	F0	3E	*2
10	9 (0A	8A	46	F0	46	*2
11	0)	0B	8B	45	F0	45	
12	- _	0C	8C	4E	F0	4E	
13	= +	0D	8D	55	F0	55	
15	BkSp	0E	8E	66	F0	66	
16	Tab	0F	8F	0D	F0	0D	
17	Q	10	90	15	F0	15	
18	W	11	91	1D	F0	1D	
19	E	12	92	24	F0	24	
20	R	13	93	2D	F0	2D	
21	T	14	94	2C	F0	2C	
22	Y	15	95	35	F0	35	
23	U	16	96	3C	F0	3C	*2
24	I	17	97	43	F0	43	*2
25	O	18	98	44	F0	44	*2
26	P	19	99	4D	F0	4D	*2
27	[{	1A	9A	54	F0	54	
28] }	1B	9B	5B	F0	5B	

Table D-1 Scan codes (set 1 and set 2) (2/4)

Cap No.	Keytop	Code set 1		Code set 2			Note
		Make	Break	Make	Break		
29	\	2B	AB	5D	F0	5D	*5
30	Caps Lock	3A	BA	58	F0	58	
31	A	1E	9E	1C	F0	1C	
32	S	1F	9F	1B	F0	1B	
33	D	20	A0	23	F0	23	
34	F	21	A1	2B	F0	2B	
35	G	22	A2	34	F0	34	
36	H	23	A3	33	F0	33	
37	J	24	A4	3B	F0	3B	*2
38	K	25	A5	42	F0	42	*2
39	L	26	A6	4B	F0	4B	*2
40	; :	27	A7	4C	F0	4C	*2
41	' "	28	A8	52	F0	52	
43	Enter	1C	9C	5A	F0	5A	*3
44	Shift (L)	2A	AA	12	F0	12	
45	No.102 key	56	D6	61	F0	61	
46	Z	2C	AC	1A	F0	1A	
47	X	2D	AD	22	F0	22	
48	C	2E	AE	21	F0	21	
49	V	2F	AF	2A	F0	2A	
50	B	30	B0	32	F0	32	
51	N	31	B1	31	F0	31	
52	M	32	B2	3A	F0	3A	*2
53	, <	33	B3	41	F0	41	*2
54	. >	34	B4	49	F0	49	*2
55	/ ?	35	B5	4A	F0	4A	*2
57	Shift (R)	36	B6	59	F0	59	

Table D-1 Scan codes (set 1 and set 2) (3/4)

Cap No.	Keypop	Code set 1		Code set 2			Note
		Make	Break	Make	Break		
58	Ctrl(L)	1D	9D	14	F0	14	*3
60	Alt (L)	38	B8	11	F0	11	*3
61	Space	39	B9	29	F0	29	
62	ALT (R)	E0 38	E0 B8	E0 11	E0 F0	11	
64	Ctrl(R)	E0 1D	E0 9D	E0 14	E0 F0	14	
75	Ins	E0 52	E0 D2	E0 70	E0 F0	70	*1
76	Del	E0 53	E0 D3	E0 71	E0 F0	71	*1
79	←	E0 4B	E0 CB	E0 6B	E0 F0	6B	*1
80	Home	E0 47	E0 C7	E0 6C	E0 F0	6C	*1
81	End	E0 4F	E0 CF	E0 69	E0 F0	69	*1
83	↑	E0 48	E0 C8	E0 75	E0 F0	75	*1
84	↓	E0 50	E0 D0	E0 72	E0 F0	72	*1
85	PgUp	E0 49	E0 C9	E0 7D	E0 F0	7D	*1
86	PgDn	E0 51	E0 D1	E0 7A	E0 F0	7A	*1
89	→	E0 4D	E0 CD	E0 74	E0 F0	74	*1
110	Esc	01	81	76	F0	76	
112	F1	3B	BB	05	F0	05	
113	F2	3C	BC	06	F0	06	
114	F3	3D	BD	04	F0	04	
115	F4	3E	BE	0C	F0	0C	
116	F5	3F	BF	03	F0	03	
117	F6	40	C0	0B	F0	0B	
118	F7	41	C1	83	F0	83	
119	F8	42	C2	0A	F0	0A	
120	F9	43	C3	01	F0	01	
121	F10	44	C4	09	F0	09	*3

Table D-1 Scan codes (set 1 and set 2) (4/4)

Cap No.	Keytop	Code set 1				Code set 2				Note
		Make		Break		Make		Break		
122	F11	57		D7		78		F0 78		*3
123	F12	58		D8		07		F0 07		*3
124	PrintSc	*6		*6		*6		*6		*6
126	Pause	*7		*7		*7		*7		*7
X	Fn	—		—		—		—		*4
X	Win	E0	5B	E0	DB	E0	1F	E0	F0 1F	
x	App	E0	5D	E0	DD	E0	2F	E0	F0 2F	

Notes:

1. * Scan codes differ by mode.
2. * Scan codes differ by overlay function.
3. * Combination with the **Fn** key gives different codes.
4. * The **Fn** key does not generate a code by itself.
5. * This key corresponds to key No. 42 in a 102-key model.
6. * Refer to Table D-6, No. 124 key scan code.
7. * Refer to Table D-7, No. 126 key scan code.

Table D-2 Scan codes with left Shift key

Cap No.	Key top	Code set 1		Code set 2	
		Make	Break	Make	Break
55	/	E0 AA E0 35	E0 B5 E0 2A	E0 F0 12 E0 4A	E0 F0 4A E0 12
75	INS	E0 AA E0 52	E0 D2 E0 2A	E0 F0 12 E0 70	E0 F0 70 E0 12
76	DEL	E0 AA E0 53	E0 D3 E0 2A	E0 F0 12 E0 71	E0 F0 71 E0 12
79	←	E0 AA E0 4B	E0 CB E0 2A	E0 F0 12 E0 6B	E0 F0 6B E0 12
80	Home	E0 AA E0 47	E0 C7 E0 2A	E0 F0 12 E0 6C	E0 F0 6C E0 12
81	End	E0 AA E0 4F	E0 CF E0 2A	E0 F0 12 E0 69	E0 F0 69 E0 12
83	↑	E0 AA E0 48	E0 C8 E0 2A	E0 F0 12 E0 75	E0 F0 75 E0 12
84	↓	E0 AA E0 50	E0 D0 E0 2A	E0 F0 12 E0 72	E0 F0 72 E0 12
85	PgUp	E0 AA E0 49	E0 C9 E0 2A	E0 F0 12 E0 7D	E0 F0 7D E0 12
86	PgDn	E0 AA E0 51	E0 D1 E0 2A	E0 F0 12 E0 7A	E0 F0 7A E0 12
89	→	E0 AA E0 4D	E0 CD E0 2A	E0 F0 12 E0 74	E0 F0 74 E0 12
X	Win	E0 AA E0 5B	E0 DB E0 2A	E0 F0 12 E0 1F	E0 F0 1F E0 12
X	App	E0 AA E0 5D	E0 DD E0 2A	E0 F0 12 E0 2F	E0 F0 2F E0 12

Note : The table above shows scan codes with the left **Shift** key. In combination with the right **Shift** key, scan codes are changed as listed below:

	With left Shift	With right Shift
Set 1	E0 AA _____	E0 B6
	E0 2A _____	E0 36
Set 2	E0 F0 12 _____	E0 F0 59
	E0 12 _____	E0 59

Table D-3 Scan codes in Numlock mode

Cap No.	Key top	Code set 1				Code set 2			
		Make		Break		Make		Break	
75	INS	E0 2A	E0 52	E0 D2	E0 AA	E0 12	E0 70	E0 F0	70 E0 F0 12
76	DEL	E0 2A	E0 53	E0 D3	E0 AA	E0 12	E0 71	E0 F0	71 E0 F0 12
79	←	E0 2A	E0 4B	E0 CB	E0 AA	E0 12	E0 6B	E0 F0	6B E0 F0 12
80	Home	E0 2A	E0 47	E0 C7	E0 AA	E0 12	E0 6C	E0 F0	6C E0 F0 12
81	End	E0 2A	E0 4F	E0 CF	E0 AA	E0 12	E0 69	E0 F0	69 E0 F0 12
83	↑	E0 2A	E0 48	E0 C8	E0 AA	E0 12	E0 75	E0 F0	75 E0 F0 12
84	↓	E0 2A	E0 50	E0 D0	E0 AA	E0 12	E0 72	E0 F0	72 E0 F0 12
85	PgUp	E0 2A	E0 49	E0 C9	E0 AA	E0 12	E0 7D	E0 F0	7D E0 F0 12
86	PgDn	E0 2A	E0 51	E0 D1	E0 AA	E0 12	E0 7A	E0 F0	7A E0 F0 12
89	→	E0 2A	E0 4D	E0 CD	E0 AA	E0 12	E0 74	E0 F0	74 E0 F0 12
X	Win	E0 2A	E0 5B	E0 DB	E0 AA	E0 12	E0 1F	E0 F0	1F E0 F0 12
X	App	E0 2A	E0 5D	E0 DD	E0 AA	E0 12	E0 2F	E0 F0	2F E0 F0 12

Table D-4 Scan codes with Fn key

Cap No.	Keytop	Code set 1		Code set 2	
		Make	Break	Make	Break
43	ENT	E0 1C	E0 9C	E0 5A	E0 F0 5A
58	L-CTRL	E0 1D	E0 9D	E0 14	E0 F0 14
60	L-ALT	E0 38	E0 B8	E0 11	E0 F0 11
121	ARROW	45	C5	77	F0 77
122	NUMERIC	45	C5	77	F0 77
123	ScrL	46	C6	7E	F0 7E

Table D-5 Scan codes in overlay mode

Cap No.	Keytop	Code set 1		Code set 2	
		Make	Break	Make	Break
09	8 (8)	48	C8	75	F0 75
10	9 (9)	49	C9	7D	F0 7D
11	0 (*)	37	B7	7C	F0 7C
23	U (4)	4B	CB	6B	F0 6B
24	I (5)	4C	CC	73	F0 73
25	O (6)	4D	CD	74	F0 74
26	P (-)	4A	CA	7B	F0 7B
37	J (1)	4F	CF	69	F0 69
38	K (2)	50	D0	72	F0 72
39	L (3)	51	D1	7A	F0 7A
40	; (+)	4E	CE	79	F0 79
52	M (0)	52	D2	70	F0 70
54	. (.)	53	D3	71	F0 71
55	/ (/)	E0 35	E0 B5	E0 4A	E0 F0 4A

Table D-6 No.124 key scan code

Key top	Shift	Code set 1				Code set 2			
		Make		Break		Make		Break	
Prt Sc	Common	E0 2A	E0 37	E0 B7	E0 AA	E0 12	E0 7C	E0 F0 7C	E0 F0 12
	Ctrl +	E0 37		E0 B7		E0 7C		E0 F0 7C	
	Shift +	E0 37		E0 B7		E0 7C		E0 F0 7C	
	Alt +		54	D4		84		F0 84	

Table D-7 No.126 key scan code

Key top	Shift	Code set 1						Code set 2							
		Make						Make							
Pause	Common	E1	1D	45	E1	9D	C5	E1	14	77	E1	F0	14	F0	77
	Ctrl	E0	46	E0	C6			E0	7E	E0	F0	7E			

*: This key generates only make codes.

Appendix E Key Layout

E.1 United Kingdom (UK) Keyboard

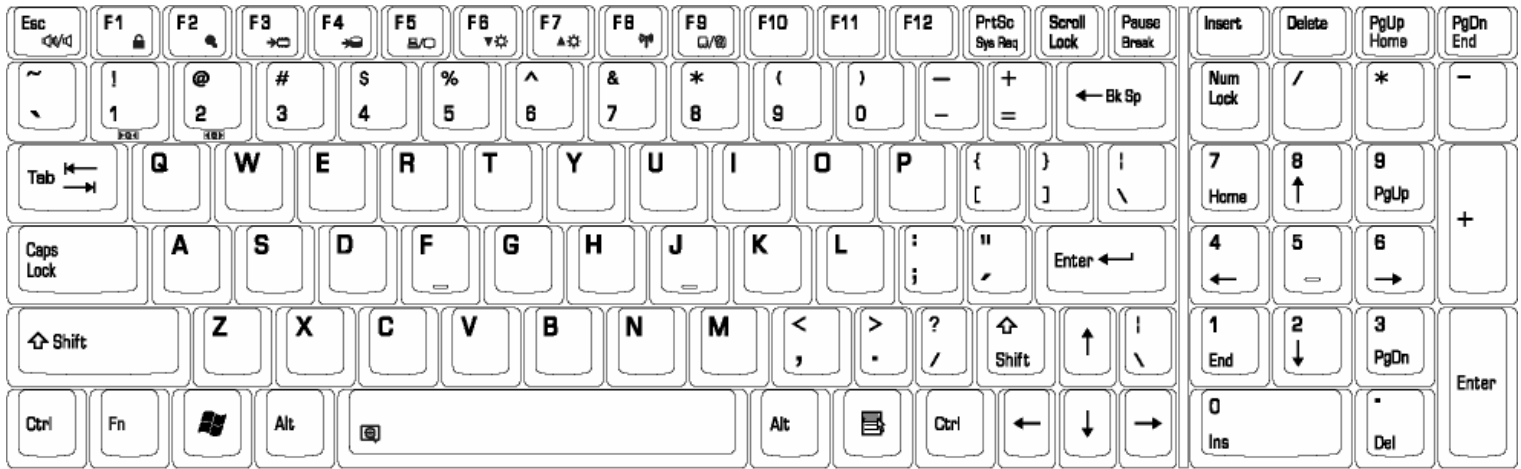

Figure E-1 UK-English_keyboard

E.2 United States (US) Keyboard

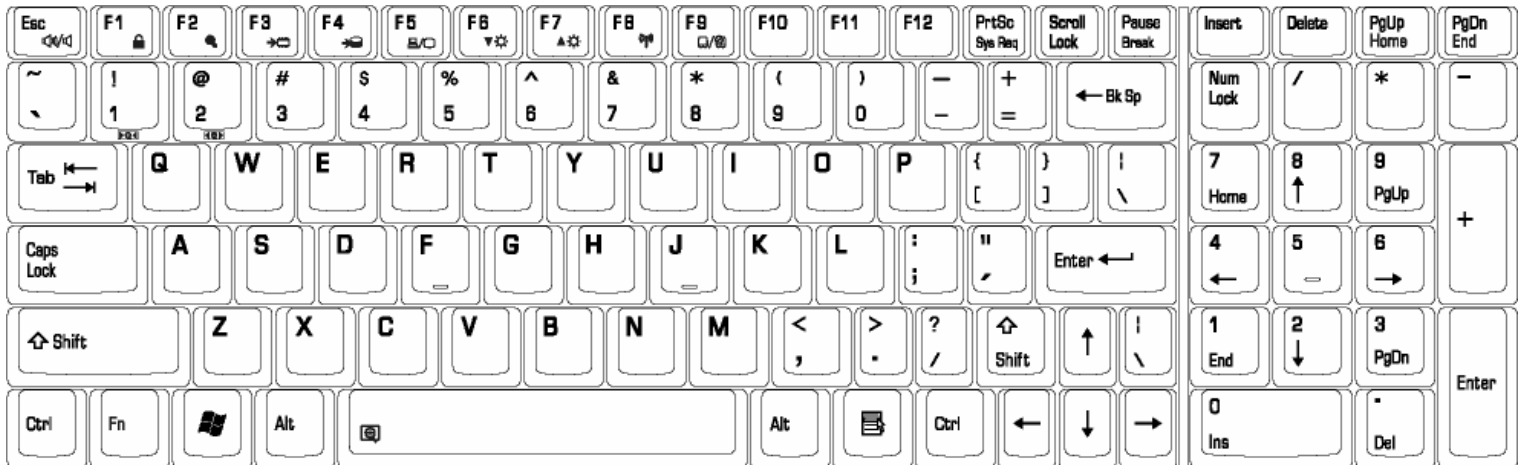

Figure E- US_keyboard

E.3 Spanish (SP) Keyboard

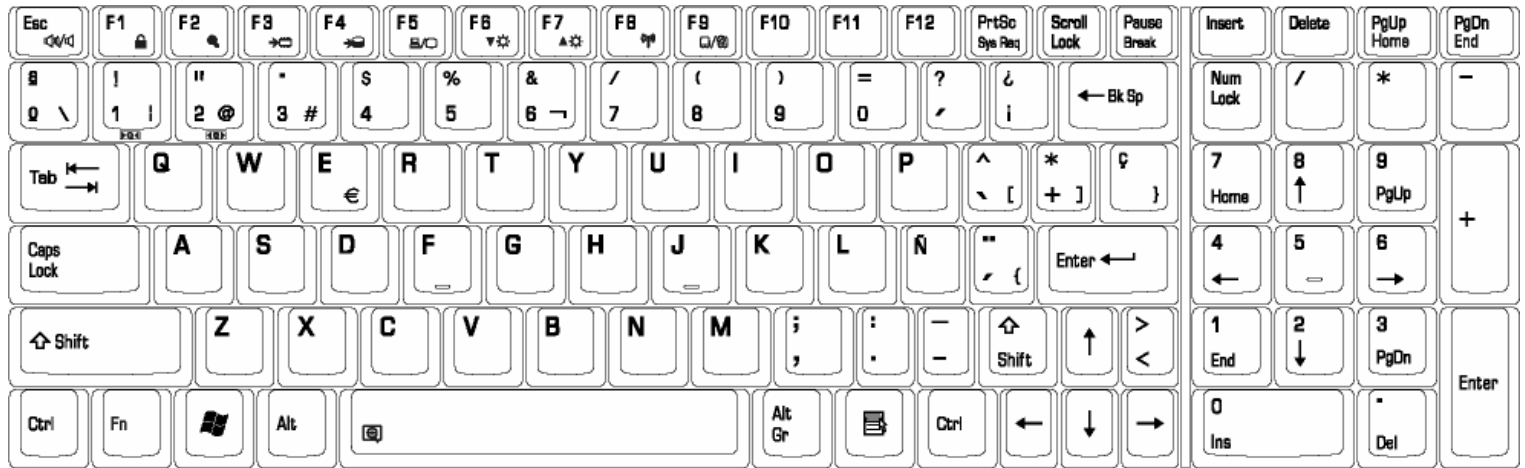

Figure E-3 SP keyboard

E.4 Turkish (TR) Keyboard



Figure E-4 TK keyboard

E.5 Korean (KO) Keyboard



Figure E-5 KO keyboard

E.6 Canada France (CF) Keyboard

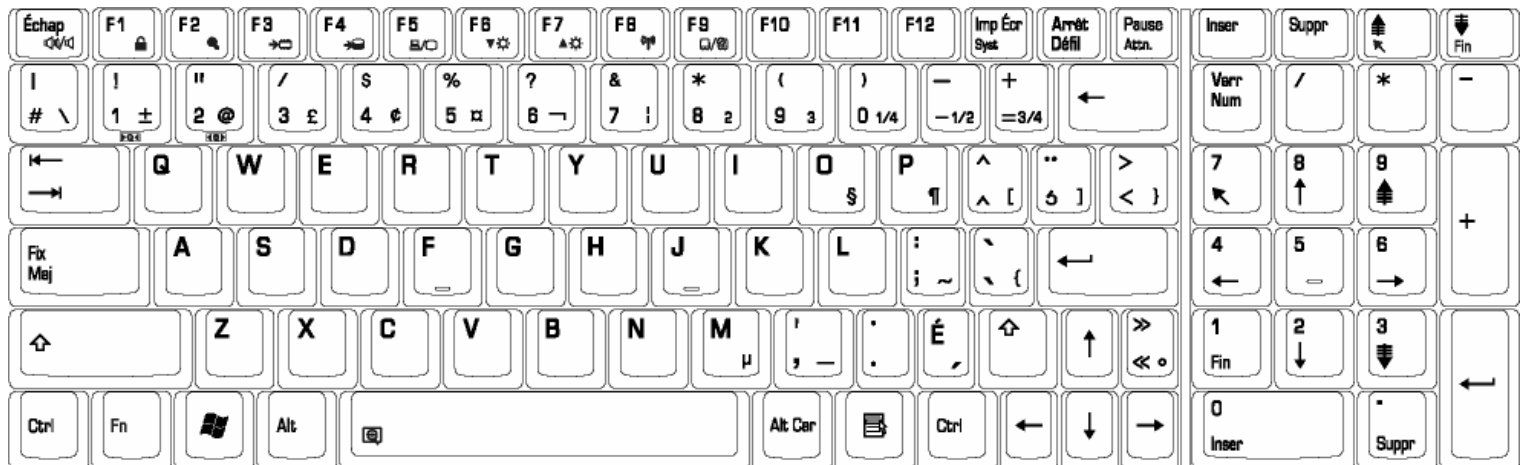

Figure E-6 CF keyboard

E.7 Portuguese (PO) Keyboard

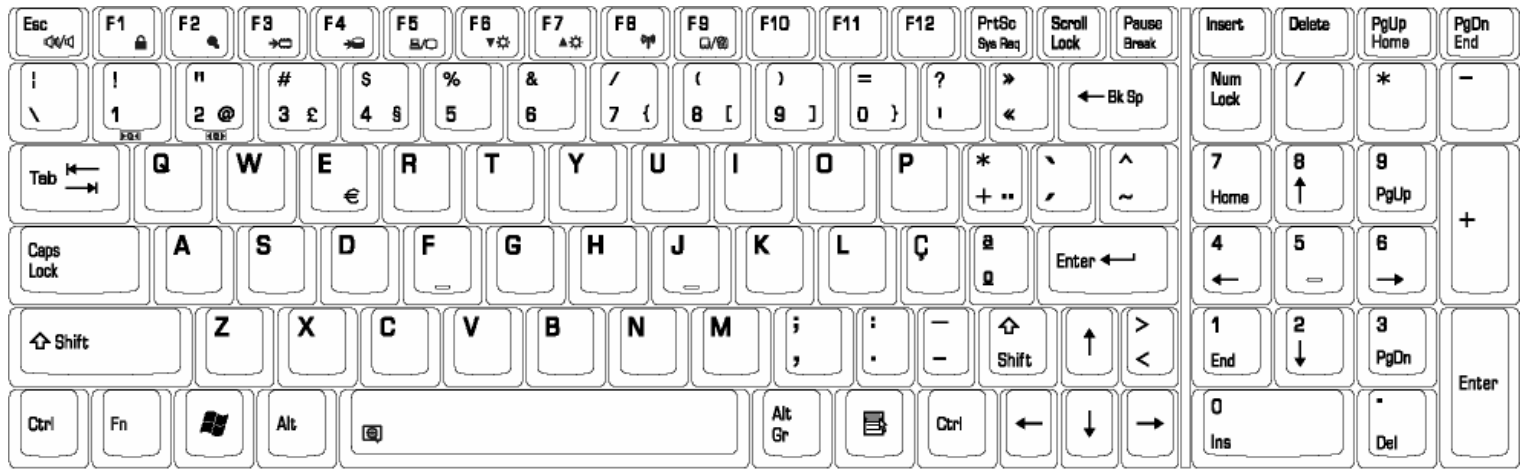

Figure E-7 PO keyboard

E.8 US-INTE (INTE) Keyboard

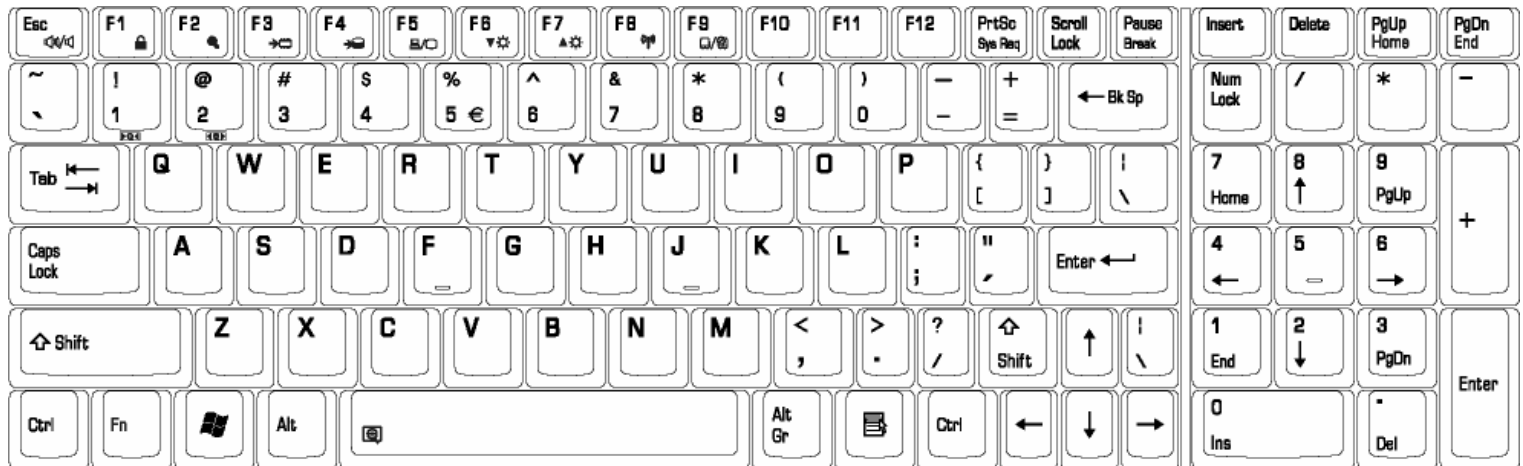

Figure E-7 Intrnational English_KB

E.9 Germanic (GR) Keyboard

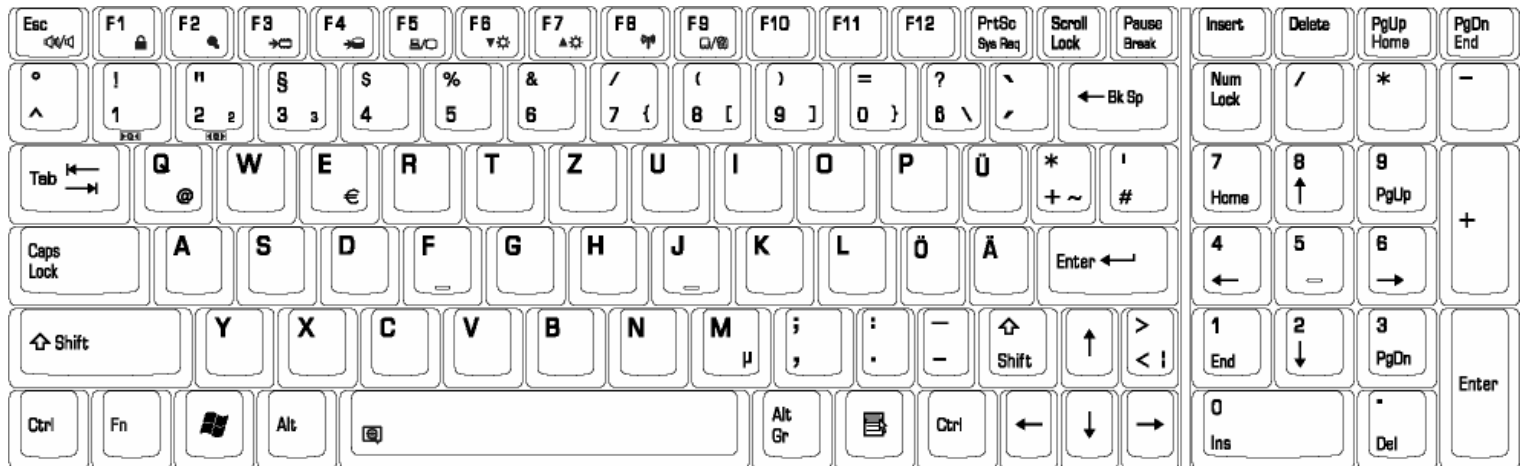

Figure E-9 GR keyboard

E.10 France (FR) Keyboard

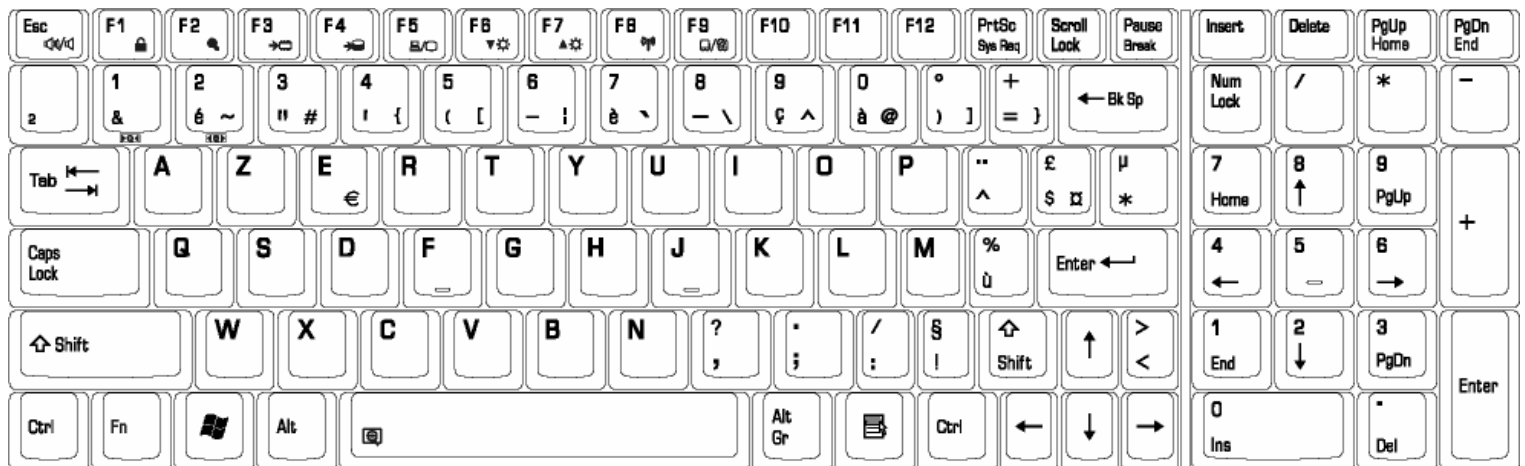

Figure E-10 FR keyboard

E.11 Chinese (CH) Keyboard

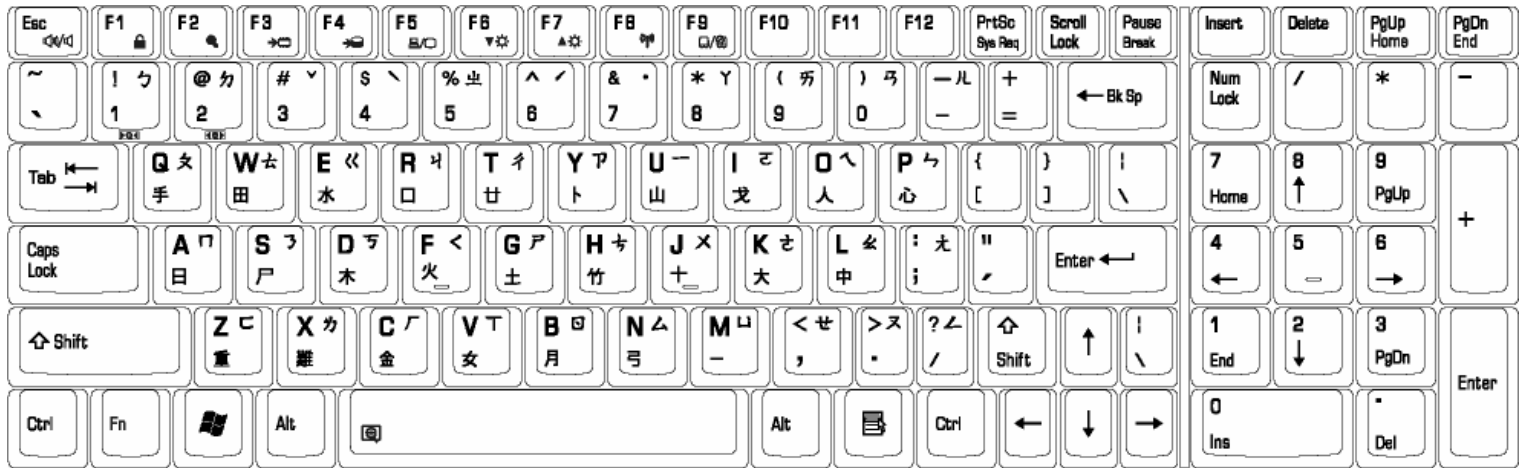

Figure E-11 CH keyboard

E.12 Swiss-Germanic (SW) Keyboard

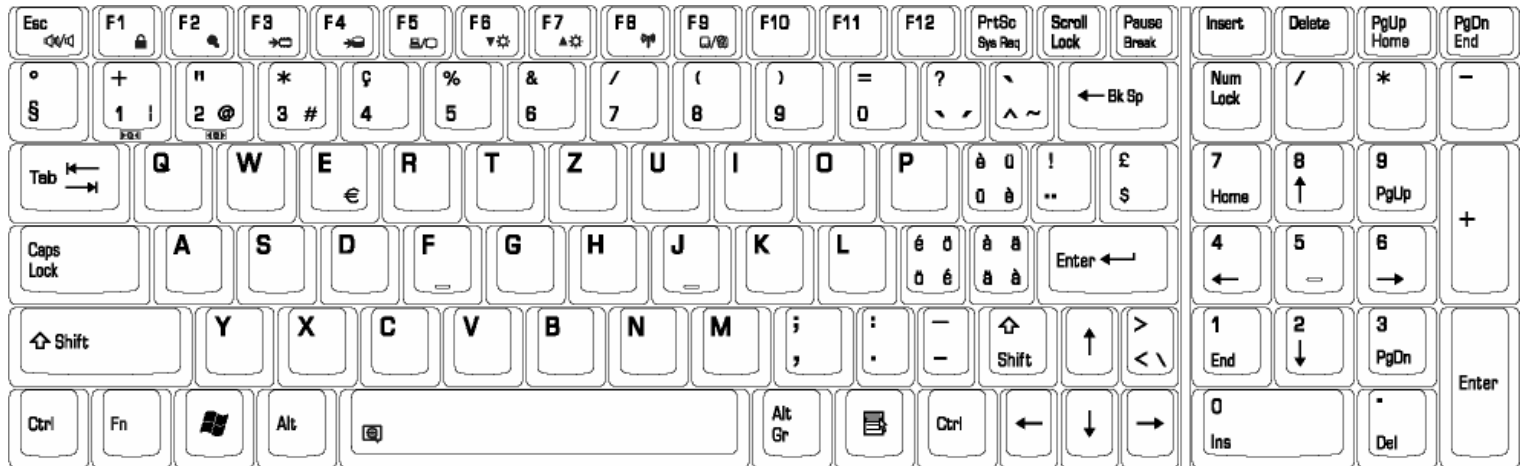

Figure E-12 Swiss- Germanic keyboard

E.13 Italian (IT) Keyboard

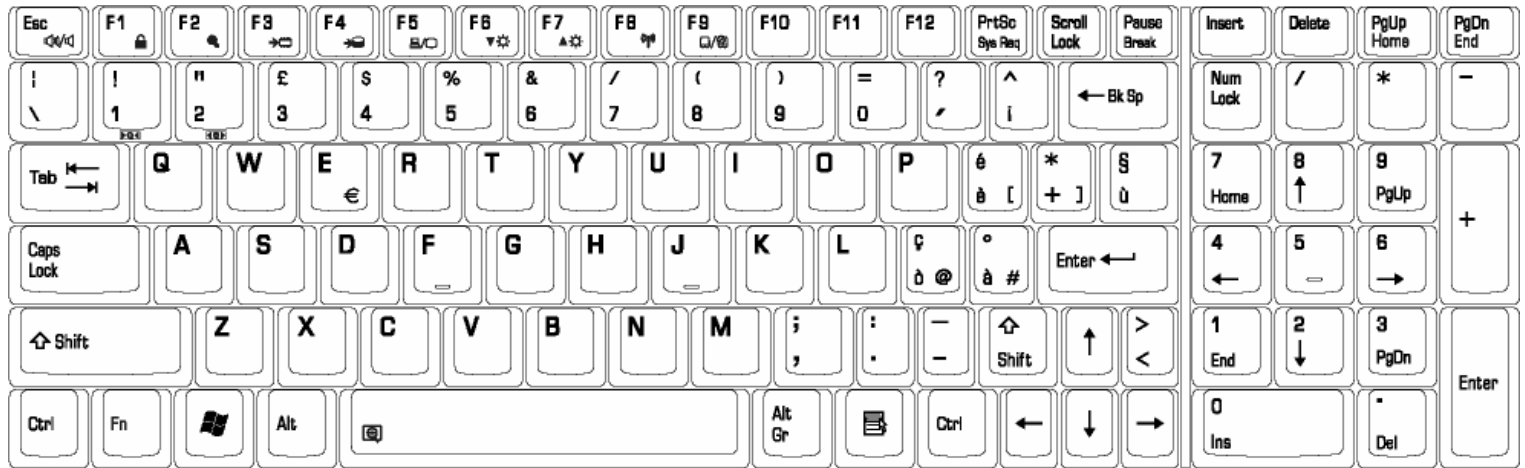

Figure E-13 IT keyboard

E.14 Belgium (BE) Keyboard

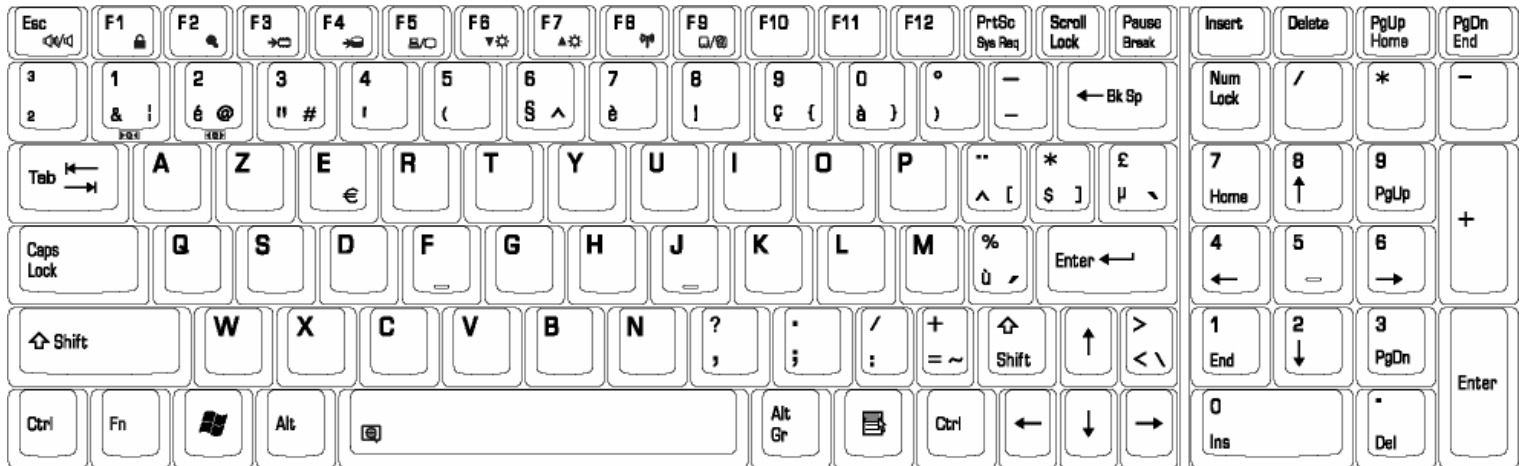

Figure E-14 BE keyboard

E.15 Arabic (AR-E) Keyboard

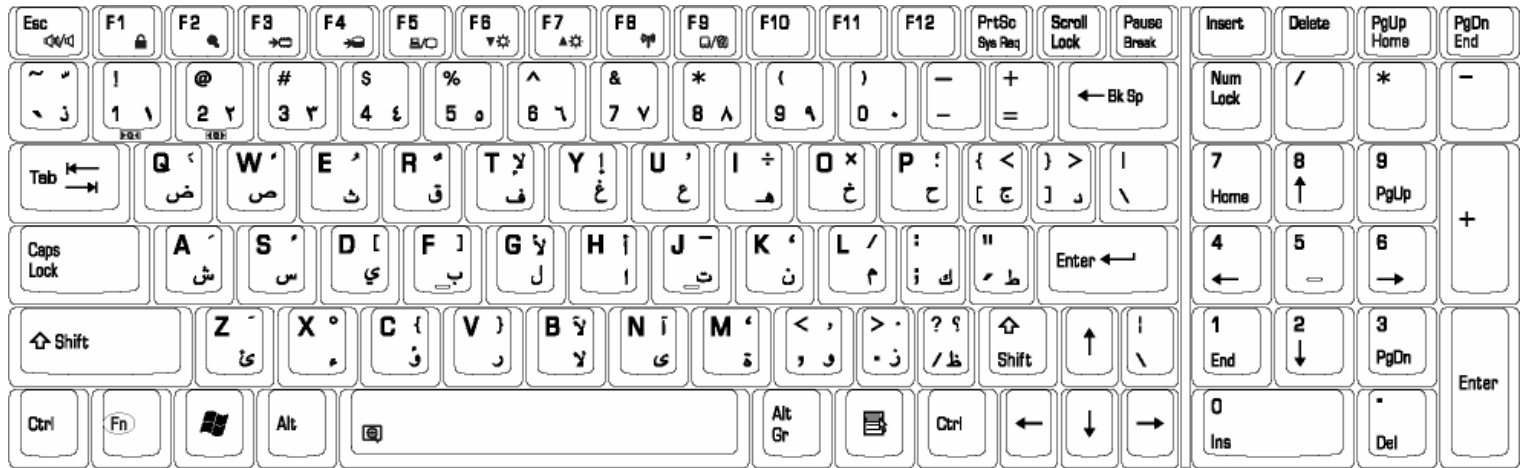

Figure E-15 AR-E keyboard

E.16 Czech (CZ) Keyboard

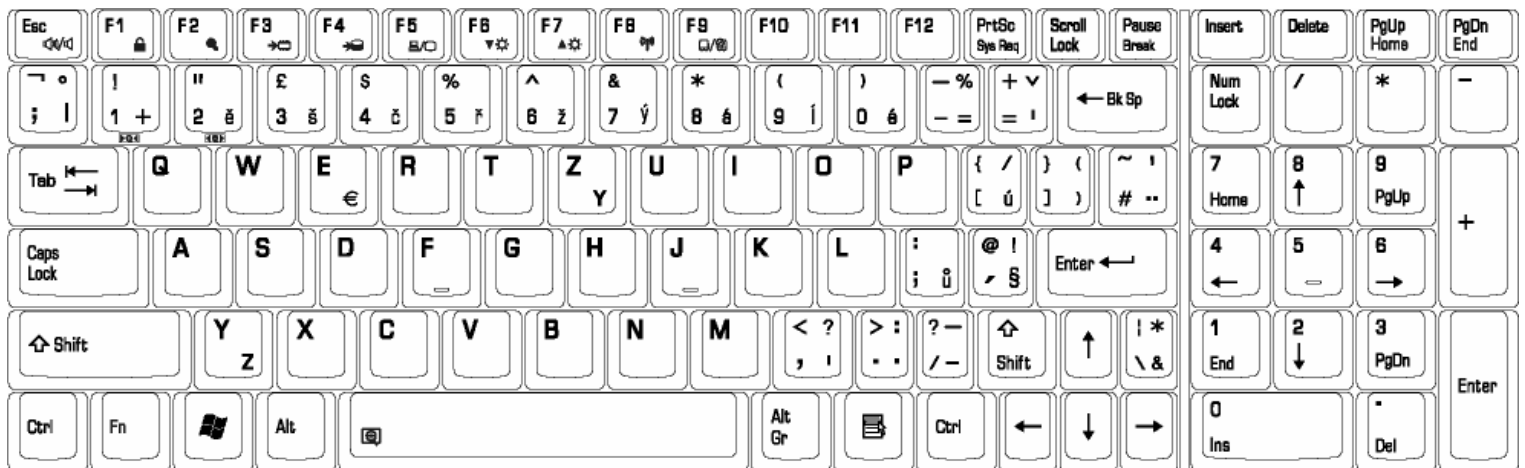

Figure E-16 CZ keyboard

E.17 Swedish (SD) Keyboard

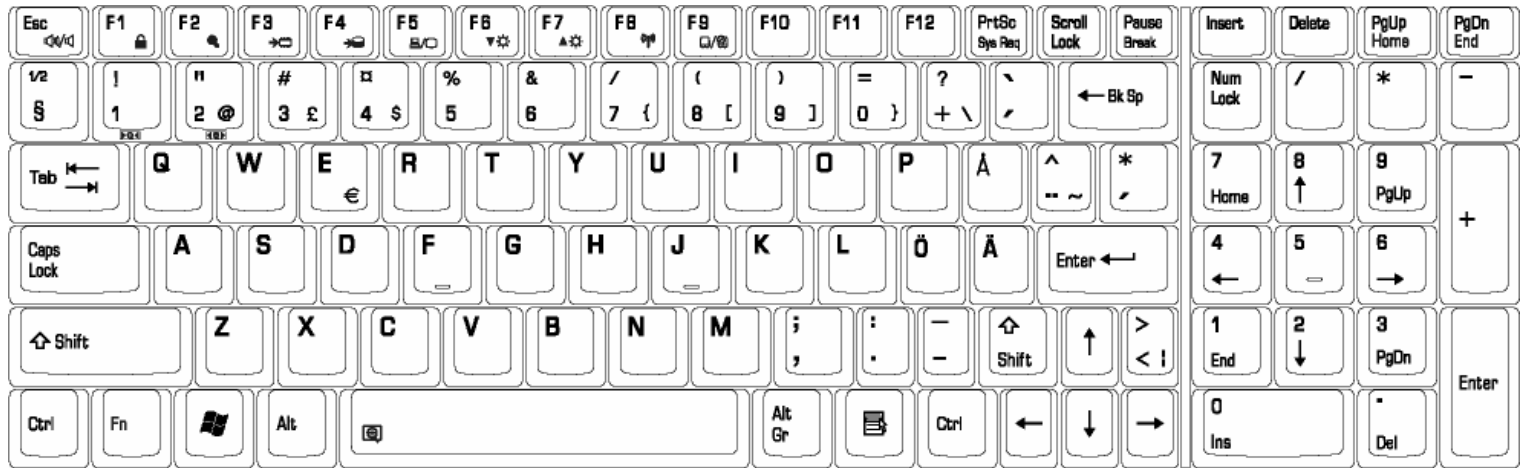

Figure E-17 SWE keyboard

E.18 Greece (GK) Keyboard

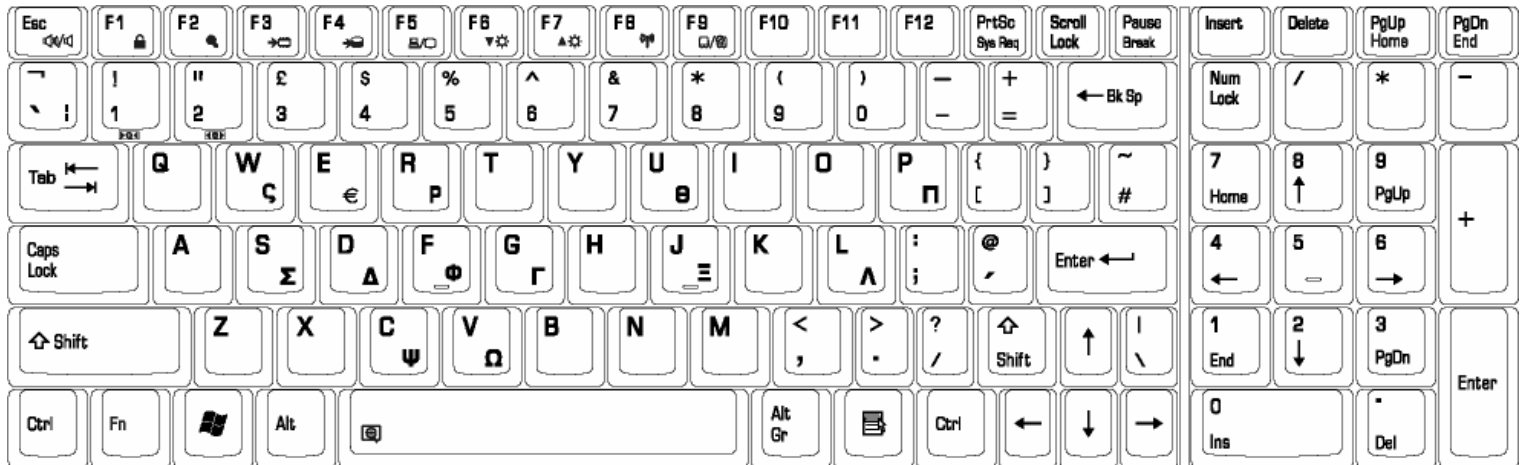

Figure E-18 GR keyboard

E.19 Hebrew (HB) Keyboard

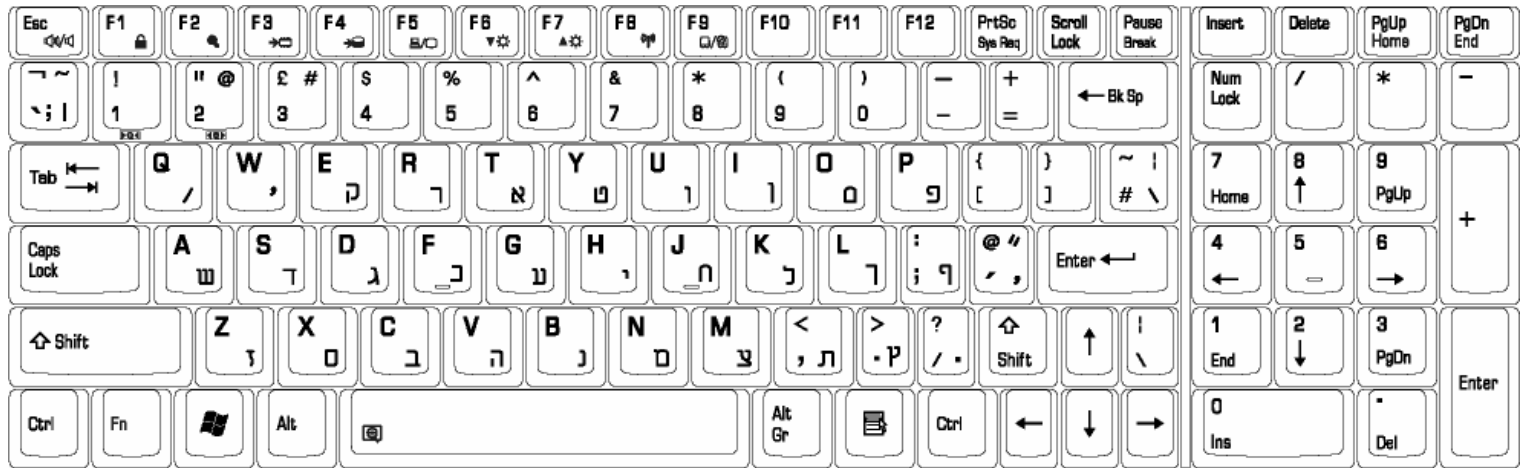

Figure E-19 HB keyboard

E.20 Hungary (HG) Keyboard

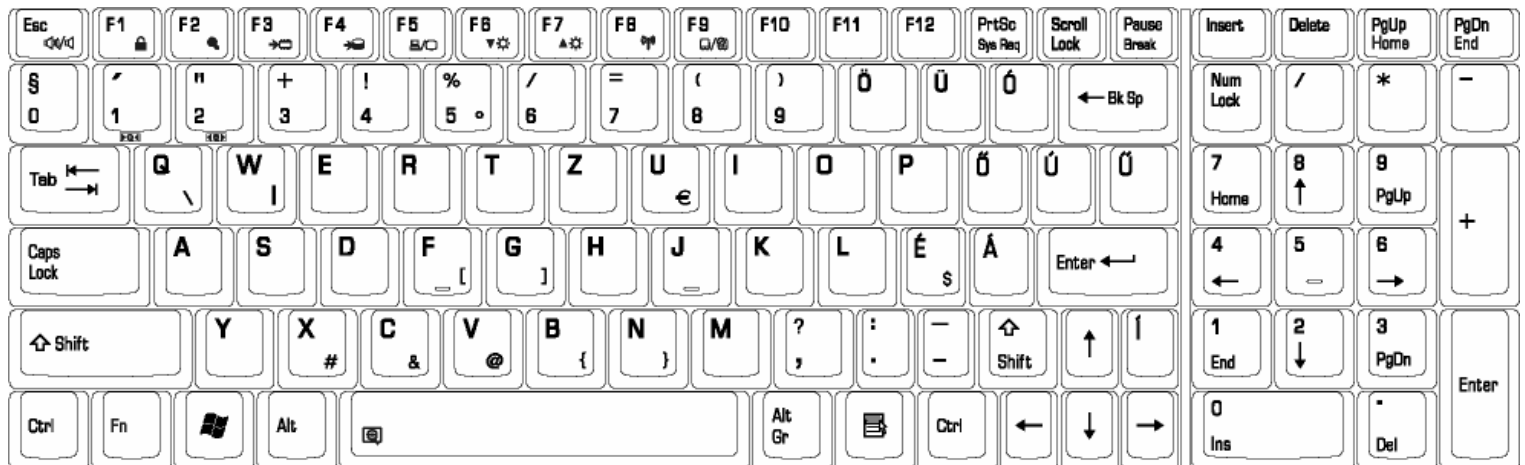

Figure E-20 HG Keyboard

E.21 Norwegian (NW) Keyboard

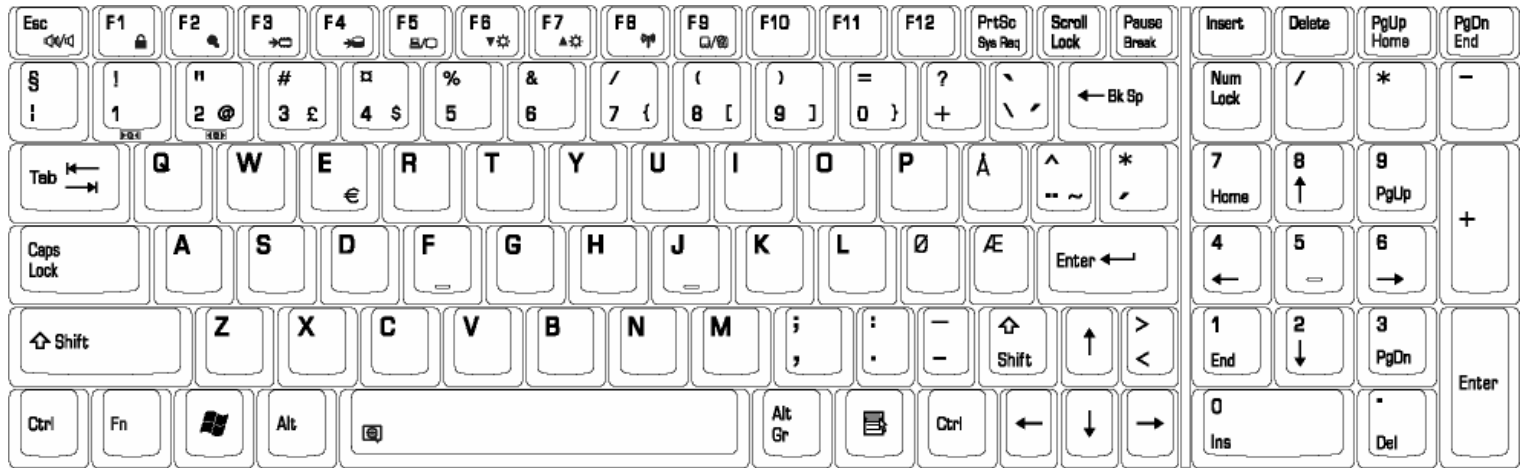

Figure E-21 NW keyboard

E.22 Danish (DM) Keyboard

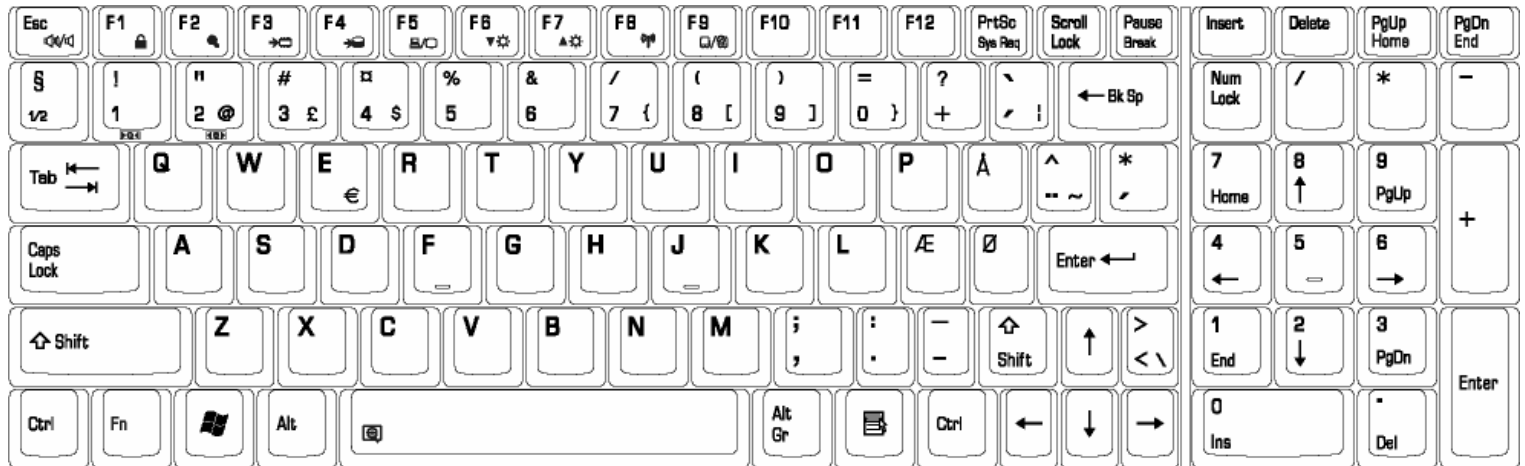

Figure E-22 DN keyboard

E. 23 Russian (RU) Keyboard

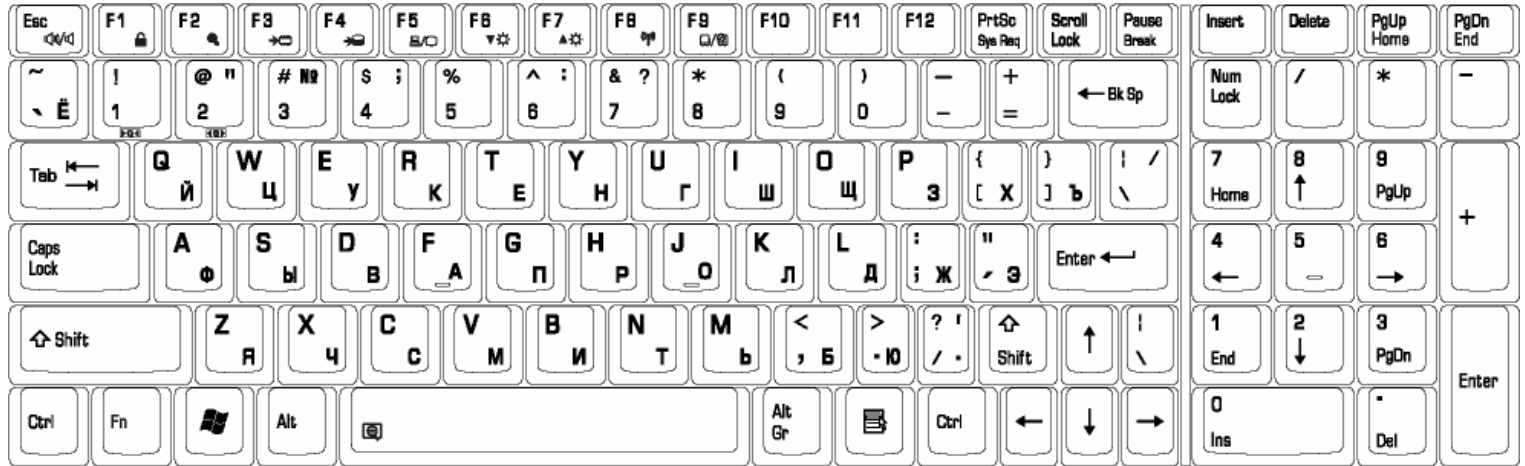

Figure E-24 RU keyboard

Appendix F Series Screw Torque List

Table F-1 Series Screw Torque List

SCREW P/N	SCREW SPEC	Q'ty	LOCATION	SCREW TORQUE
MAC925003Z0	M2.5*3(NL)NI (銀白)	1	TRACK PAD BRKT TO LOGIC UP	2.0~2.5kgfcm
MAC925003Z0	M2.5*3(NL)NI (銀白)	1	BATT LATCH TO BAT KNOB	2.0~2.5kgfcm
MAC925003Z0	M2.5*3(NL)NI (銀白)	4	K/B TO LOGIC UP	2.0~2.5kgfcm
MAC925003Z0	M2.5*3(NL)NI (銀白)	1	NB THERMAL ASSY TO MB	2.0~2.5kgfcm
MMCK25040Z2	M2.5*4(NL)NI	2	LCD BEZEL TO COVER-17" LCD SCREW	2.5~3.0kgfcm
MMCK25040Z2	M2.5*4(NL)NI	4	R&L SADDLE TO LOGIC UP(OUT SIDE ASSY)	2.5~3.0kgfcm
MMCK25040Z2	M2.5*4(NL)NI	2	POWER PCB TO LOGIC UP	2.5~3.0kgfcm
MMCK25040Z2	M2.5*4(NL)NI	2	TRACK PAD BOARD TO LOGIC UP	2.5~3.0kgfcm
MMCK25040Z2	M2.5*4(NL)NI	2	MB TO LOGIC LOWER	2.5~3.0kgfcm
MMCK25040Z2	M2.5*4(NL)NI	4	R/L SPK ASSY TO LOG LOW	2.5~3.0kgfcm
MMCK25040Z2	M2.5*4(NL)NI	2	HINGE TO SADDLE RH.(TOP)	2.5~3.0kgfcm
MMCK25040Z2	M2.5*4(NL)NI	2	HINGE TO SADDLE	2.5~3.0kgfcm

SCREW P/N	SCREW SPEC	Q'ty	LOCATION	SCREW TORQUE
MMCK25040Z2	M2.5*4(NL)NI	2	VGA BOARD TO M/B	2.5~3.0kgfcm
MMCK25040Z2	M2.5*4(NL)NI	2	FAN TO MB	2.5~3.0kgfcm
MMCK25040Z2	M2.5*4(NL)NI	4	CPU THERMAL MODULE TO MB	2.5~3.0kgfcm
MMCK25040Z2	M2.5*4(NL)NI	3	VGA THERMAL MODULE TO VGA BOARD	2.5~3.0kgfcm
MAC925006Z0	M2.5*6(NL)	2	LCD brk(R/L) TO LCD COVER	
MAC925006Z0	M2.5*6(NL)	2	LCD BEZEL TO COVER	
MAC925006Z0	M2.5*6(NL)	2	LOG LOW TO HINGE SADDLE(R/L BOTTOM)	
MAC925006Z0	M2.5*6(NL)	2	LOG LOW TO HINGE SADDLE(R/L BACK)	
MAC925006Z0	M2.5*6(NL)	14	LOGIC LOWER TO UP(BOTTOM)	
MAC925006Z0	M2.5*6(NL)	1	ODD TO LOG LOW	
MAC925006Z0	M2.5*6(NL)	1	LOGIC UP TO LOGIC LOWER	
MAC925018Z0	M2.5*15(NL)	3	LOGIC UP TO LOGIC LOWER	
MAAA0015320	M2*3(NL)	8	LCD brk(R/L) TO LCD PANEL	2.5~3.0kgfcm
MAAA0015320	M2*3(NL)	1	INVERTER TO LCD	2.5~3.0kgfcm

SCREW P/N	SCREW SPEC	Q'ty	LOCATION	SCREW TORQUE
MAAA0015320	M2*3(NL)	2	COVER CARD BUS TO MLB	2.5~3.0kgfcm
MAAA0015320	M2*3(NL)	2	EXPRESS CARD TO MLB	2.5~3.0kgfcm
MAAA0015320	M2*3(NL)	2	MDC BOARD TO MDC STANDOFF	2.5~3.0kgfcm
MAAA0015320	M2*3(NL)	2	ODD brk to ODD Module	2.5~3.0kgfcm
MA000001N00	M2*5(NL)	2	EXPRESS CARD TO MLB	2.5~3.0kgfcm
MA000001N00	M2*5(NL)	2	HDD CONN TO MLB	2.5~3.0kgfcm
MAA2T027200	M2*7(B)&NI	2	CARD BUS TO MLB	4.0~4.5kgfc
MAAA0303208	M3*3	4	HDD BRK to HDD Module	
MA000001S00	M2*4	1	SHELTER BRKT TO LOGIC LOWER	
MAFA94001N0	D-SUB NUT	2	VGA SCREW TO LOGIC LOWER	

Appendix G Reliability

The following table shows MTBF (Mean Time Between Failures) for each component.

Table G-1 MTBF

Component	Time (hours)
LCD	50,000
Keyboard	40,000
HDD	300,000
Removable FDD	30,000
Optical (DVD/CD) drive	60,000
AC adaptor	60,000

Free Manuals Download Website

<http://myh66.com>

<http://usermanuals.us>

<http://www.somanuals.com>

<http://www.4manuals.cc>

<http://www.manual-lib.com>

<http://www.404manual.com>

<http://www.luxmanual.com>

<http://aubethermostatmanual.com>

Golf course search by state

<http://golfingnear.com>

Email search by domain

<http://emailbydomain.com>

Auto manuals search

<http://auto.somanuals.com>

TV manuals search

<http://tv.somanuals.com>