

Toshiba Personal Computer
Satellite U400, Satellite Pro U400 and Portégé M800
Maintenance Manual
PPM80A, PSU40A

TOSHIBA CORPORATION

Copyright

© 2003 by Toshiba Corporation. All rights reserved. Under the copyright laws, this manual cannot be reproduced in any form without the prior written permission of Toshiba. No patent liability is assumed with respect to the use of the information contained herein.

Toshiba Personal Computer Satellite U400 and Satellite Pro U400 and PORTEGE M800 Series Maintenance Manual

First edition Feb 2008

Disclaimer

The information presented in this manual has been reviewed and validated for accuracy. The included set of instructions and descriptions are accurate for the Satellite U400 and Satellite Pro U400 and PORTEGE M800 Series at the time of this manual's production. However, succeeding computers and manuals are subject to change without notice. Therefore, Toshiba assumes no liability for damages incurred directly or indirectly from errors, omissions, or discrepancies between any succeeding product and this manual.

Trademarks

Intel, Intel SpeedStep, Pentium and Celeron are trademarks or registered trademarks of Intel Corporation or its subsidiaries in the United States and other countries/regions.

Windows and Microsoft are registered trademarks of Microsoft Corporation.

Photo CD is a trademark of Eastman Kodak.

i Link is a trademark of Sony Corporation.

TruSurround XT, Trubass, Dialog Clarity, SRS and (●)symbol are trademarks of SRS Labs, Inc.

TruSurround XT technology is incorporated under license from SRS Labs, Inc.

Other trademarks and registered trademarks not listed above may be used in this manual.

Preface

This maintenance manual describes how to perform hardware service maintenance for the Toshiba Personal Computer Satellite U400 and Satellite Pro U400 Series.

The procedures described in this manual are intended to help service technicians isolate faulty Field Replaceable Units (FRUs) and replace them in the field.

SAFETY PRECAUTIONS

Four types of messages are used in this manual to bring important information to your attention. Each of these messages will be italicized and identified as shown below.

DANGER: “Danger” indicates the existence of a hazard that could result in death or serious bodily injury, if the safety instruction is not observed.

WARNING: “Warning” indicates the existence of a hazard that could result in bodily injury, if the safety instruction is not observed.

CAUTION: “Caution” indicates the existence of a hazard that could result in property damage, if the safety instruction is not observed.

NOTE: “Note” contains general information that relates to your safe maintenance service.

Improper repair of the computer may result in safety hazards. Toshiba requires service technicians and authorized dealers or service providers to ensure the following safety precautions are adhered to strictly.

- ❑ Be sure to fasten screws securely with the right screwdriver. If a screw is not fully fastened, it could come loose, creating a danger of a short circuit, which could cause overheating, smoke or fire.
- ❑ If you replace the battery pack or RTC battery, be sure to use only the same model battery or an equivalent battery recommended by Toshiba. Installation of the wrong battery can cause the battery to explode.

The manual is divided into the following parts:

- Chapter 1 Hardware Overview describes the Satellite U400 and Satellite Pro U400 system unit and each FRU.
- Chapter 2 Troubleshooting Procedures explains how to diagnose and resolve FRU problems.
- Chapter 3 Test and Diagnostics describes how to perform test and diagnostic operations for maintenance service.
- Chapter 4 Replacement Procedures describes the removal and replacement of the FRUs.
- Appendices The appendices describe the following:
 - Handling the LCD Module
 - Board layout
 - Pin assignments
 - Keyboard scan/character codes
 - Key layout
 - Wiring diagrams
 - BIOS Rewrite Procedures
 - EC/KBC Rewrite Procedures
 - Reliability

Conventions

This manual uses the following formats to describe, identify, and highlight terms and operating procedures.

Acronyms

On the first appearance and whenever necessary for clarification acronyms are enclosed in parentheses following their definition. For example:

Read Only Memory (ROM)

Keys

Keys are used in the text to describe many operations. The key top symbol as it appears on the keyboard is printed in **boldface** type.

Key operation

Some operations require you to simultaneously use two or more keys. We identify such operations by the key top symbols separated by a plus (+) sign. For example, **Ctrl + Pause (Break)** means you must hold down **Ctrl** and at the same time press **Pause (Break)**. If three keys are used, hold down the first two and at the same time press the third.

User input

Text that you are instructed to type in is shown in the boldface type below:

DISKCOPY A: B:

The display

Text generated by the computer that appears on its display is presented in the typeface below:

```
Format complete
System transferred
```

Table of Contents

Chapter 1 Hardware Overview

1.1	Features	1
1.2	System Block Diagram	6
1.3	2.5-inch Hard Disk Drive.....	11
1.4	Optical Drive.....	15
	1.4.1DVD-ROM & CD-R/RW Drive	15
	1.4.2DVD Super Multi Drive	17
1.5	Keyboard.....	19
1.6	TFT Color Display	20
	1.6.1LCD Module	20
	1.6.2FL Inverter Board	23
	1.6.3CCFL Invertor Board.....	24
1.7	Power Supply	25
1.8	Batteries	27
	1.8.1Main Battery	27
	1.8.2Battery Charging Control.....	28
	1.8.3RTC battery.....	29
1.9	AC Adapter	30

Chapter 2 Troubleshooting Procedures

2.1	Troubleshooting	1
2.2	Troubleshooting Flowchart.....	3
2.3	Power Supply Troubleshooting	7
	Procedure 1 Power Status Check	7
	Procedure 2 Error Code Check	9
	Procedure 3 Connection Check.....	10
	Procedure 4 Charging Check	11
	Procedure 5 Replacement Check	12
2.4	System Board Troubleshooting	13
	Procedure 1 Message Check	14

	Procedure 2	Debugging Port Check	16
	Procedure 3	Diagnostic Test Program Execution Check	21
	Procedure 4	Replacement Check	21
2.5	USB FDD Troubleshooting		22
	Procedure 1	FDD Head Cleaning Check	22
	Procedure 2	Diagnostic Test Program Execution Check	23
	Procedure 3	Connector Check and Replacement Check.....	24
2.6	2.5" HDD Troubleshooting.....		26
	Procedure 1	Partition Check.....	26
	Procedure 2	Message Check	27
	Procedure 3	Format Check.....	28
	Procedure 4	Diagnostic Test Program Execution Check	29
	Procedure 5	Connector Check and Replacement Check.....	30
2.7	Keyboard Troubleshooting		31
	Procedure 1	Diagnostic Test Program Execution Check	31
	Procedure 2	Connector Check and Replacement Check.....	32
2.8	Touch pad Troubleshooting		33
	Procedure 1	Diagnostic Test Program Execution Check	33
	Procedure 2	Connector Check and Replacement Check.....	34

2.9	Display Troubleshooting.....	35
	Procedure 1 External Monitor Check.....	35
	Procedure 2 Diagnostic Test Program Execution Check	35
	Procedure 3 Connector and Cable Check	36
	Procedure 4 Replacement Check	37
2.10	Optical Disk Drive Troubleshooting.....	38
	Procedure 1 Diagnostic Test Program Execution Check	38
	Procedure 2 Connector Check and Replacement Check.....	38
2.11	Modem Troubleshooting.....	39
	Procedure 1 Diagnostic Test Program Execution Check	39
	Procedure 2 Connector Check and Replacement Check.....	39
2.12	LAN Troubleshooting.....	41
	Procedure 1 Diagnostic Test Program Execution Check	41
	Procedure 2 Connector Check and Replacement Check.....	41
2.13	Wireless LAN Troubleshooting	42
	Procedure 1 Transmitting-Receiving Check	42
	Procedure 2 Antennas' Connection Check	43
	Procedure 3 Replacement Check	44
2.14	Sound Troubleshooting.....	45
	Procedure 1 Connector Check.....	45
	Procedure 2 Replacement Check	46
2.15	VGA Troubleshooting.....	47
	Procedure 1 Diagnostic Test Program Execution Check	47
	Procedure 2 Connector Check and Replacement Check.....	47
2.16	Fingerprint Troubleshooting.....	49
	Procedure 1 Diagnostic Test Program Execution Check	49
	Procedure 2 Connector Check and Replacement Check.....	49
2.17	Bluetooth Troubleshooting	50
	Procedure 1 Diagnostic Test Program Execution Check	50
	Procedure 2 Connector Check and Replacement Check.....	50

Chapter 3 Test Program for Field

3.1	Tests and Diagnostics Software Overview	3-3
3.2	Executing the Diagnostic Test	3-4
3.3	Subtest names.....	3-8

3.4	System Test.....	3-11
3.5	Memory Test.....	3-13
3.6	Keyboard Test.....	3-16
3.7	Display Test	3-19
3.8	Floppy Disk Test.....	3-34
3.9	Hard Disk Test	3-36
3.10	Real Time Clock Test	3-39
3.11	Cache Memory Test.....	3-41
3.12	High Resolution Display Test.....	3-43
3.13	Multimedia Test	3-49
3.14	MEMORY2 Test.....	3-50
3.15	Error Codes and Error Status Names	3-52
3.16	Running Test.....	3-54
3.17	DMI INFORMATION.....	3-55
3.17.1	Check DMI Information.....	3-55
3.17.2	Write DMI Information.....	3-55
3.18	Log Utilities	3-57
3.18.1	Operations.....	3-57
3.19	System Configuration	3-59
3.20	Running Test Edit Item.....	3-60
3.20.1	Function Description.....	3-60
3.20.2	Operation Description.....	3-60
3.21	Common Tests an Operation	3-62
3.21.1	How to operate a window	3-62
3.21.2	How to Stop the Test Program	3-62
3.21.3	Test Status Screen	3-62
3.21.4	Test Stop Display.....	3-64
3.21.5	How to enter data	3-64

Chapter 4 Replacement Procedures

4.1	Overview.....	4-1
	Safety Precautions.....	4-2
	Before You Begin	4-3
	Disassembly Procedure.....	4-4

Assembly Procedure	4-5
Tools and Equipment	4-5
Screw Tightening Torque	4-6
Grip Color	4-6
Screw Notation	4-7
4.2 Battery pack	4-8
4.3 PC card.....	4-10
4.4 HDD	4-12
4.5 Wireless LAN card	4-16
4.6 Memory module.....	4-18
4.7 Keyboard.....	4-21
4.8 LED Board	4-24
4.9 Optical disk drive.....	4-26
4.10 Display assembly	4-28
4.11 Bluetooth assembly.....	4-33
4.12 Cover assembly	4-38
4.13 Touch pad.....	4-40
4.14 Audio board	4-40
4.15 Fingerprint board	4-41
4.16 USB board.....	4-42
4.17 System board.....	4-45
4.18 CPU.....	4-47
4.19 VGA heat sink.....	4-50
4.20 LCD unit / FL inverter	4-52

Appendices

Appendix A	Handling the LCD Module	A-1
Appendix B	Board Layout	B-1
Appendix C	Pin Assignments.....	C-1
Appendix D	Display Codes	D-1
Appendix E	Key board Layout.....	E-1
Appendix F	Wiring Diagrams.....	F-1
Appendix G	BIOS Rewrite Procedures	G-1
Appendix H	EC/KBC Rewrite Procedures.....	H-1
Appendix I	Reliability.....	I-1

Chapter 1

Hardware Overview

1.1	Features	1
1.2	System Block Diagram	5
1.3	2.5-inch Hard Disk Drive.....	9
1.4	Optical Drive.....	12
	1.4.1 DVD-ROM & CD-R/RW Drive	12
	1.4.2 DVD Super Multi Drive.....	14
1.5	Keyboard.....	16
1.6	TFT Color Display.....	17
	1.6.1 LCD Module	17
	1.6.2 FL Inverter Board	19
	1.6.3.....CCFL Invertor Board.....	21
1.7	Power Supply	22
1.8	Batteries	23
	1.8.1 Main Battery.....	23
	1.8.2 Battery Charging Control.....	24
	1.8.3 RTC battery	25
1.9	AC Adapter	25

Figures

Figure 1-1	Front of the computer.....	4
Figure 1-2	System block diagram.....	5
Figure 1-3	2.5-inch HDD.....	9
Figure 1-4	DVD-ROM & CD-R/RW drive	12
Figure 1-5	DVD Super Muti drive.....	14
Figure 1-6	Keyboard for US style	16
Figure 1-7	Keyboard for JP style.....	16
Figure 1-8	LG-Philips LCD Module	17
Figure 1-9	AUO LCD Module	18
Figure 1-10	Samsung Module	18
Figure 1-11	CMO LCD Module.....	19
Figure 1-12	TMD LED Backlight Module.....	20
Figure 1-13	LCD module.....	22

Tables

Table 1-1	2.5-inch HDD dimensions	9
Table 1-2	2.5-inch HDD specifications.....	10
Table 1-3	DVD-ROM & CD-R/RW drive outline dimensions.....	12
Table 1-4	DVD-ROM & CD-R/RW drive specifications	13
Table 1-5	DVD Super Multi drive outline dimensions	14
Table 1-6	DVD Super Multi drive specifications	15
Table 1-7	LCD module specifications.....	19
Table 1-8	LED backlight module specifications	20
Table 1-9	FL inverter board specifications	21
Table 1-10	Power supply output rating	22
Table 1-11	Battery specifications.....	23
Table 1-12	Time required for charges of main battery	24
Table 1-13	Data preservation time	24
Table 1-14	Time required for charges of RTC battery.....	25
Table 1-15	AC adapter specifications	26

1.1 Features

The Satellite U400/PROTEGE M800 (Intel Platform) series are 2 spindle PCs running
Intel® Celeron® Processor 540 or higher.
Intel® Core™ 2 Duo Processor (800MHz) T8100 or higher.
Intel® Core™ 2 Duo Processor (667MHz) T5450 or higher.

The features are listed below.

θ Microprocessor

Microprocessor that is used will be different by the model.

It supports processors as follows

Intel® Core™ 2 Duo

FSB : 667 MHz	T5450(1.67GHz)
	T5550(1.83GHz)
	T5750(2.0GHz)

Intel® Core™ 2 Duo

FSB: 800MHz	T8100(2.1GHz)
	T8300(2.4GHz)
	T9300(2.5GHz)
	T9500(2.6GHz)

Intel Celeron

FSB : 533MHz	540 (1.86GHz)
	550 (2.0GHz)
	560(2.13GHz)

θ Memory

Two DDRII SO-DIMM (667/800MHz specification compliant) used can up to 4GB.
But to GL960, can only up to 2GB. Maximum upgradeable system memory may depend on the model.

θ VRAM

Shared with System RAM for Intel GL960/GM965

θ HDD

80GB, 120GB, 160GB, 200GB, 250GB, 320GB internal drives. 2.5 inch x 9.5mm height.

θ USB FDD (Option)

Toshiba external USB FDD for option

θ Display

LCD (CCFL)

13.3-inch, 1,280 (H) x 800 (V) WXGA 262,144 colors + CCFL, High-brightness, CSV, amorphous silicon TFT color display.

LCD (LED)

13.3-inch, 1,280 (H) x 800 (V) WXGA + LED Backlight, High-brightness, CSV, amorphous silicon TFT color display.

CRT

Supported via a RGB connector.

θ Keyboard

Toshiba Standard keyboard with 86-88 keys (desktop-style), Support Windows keys & Application keys. (Toshiba standard layout) Standard pitch, 2.5mm travel length. Multi-langue support

θ PC card slot / New card slot

The PC card slot (PCMCIA) accommodates one 5mm Type II card. The slot support 16-bit PC cards and Card Bus PC cards. Card Bus supports 32-bit PC cards.

ExpressCard/34 and ExpressCard/54 are supported.

θ Optical devices

A DVD Super Multi drive is equipped.

θ Battery

The RTC battery is equipped inside the computer.
It is good with no external power source for 1month on average.

The main battery is a detachable lithium ion battery.

6 cell Li-Ion 3700mAh/4800mAh

9 cell Li-Ion 7200mAh

θ USB (Universal Serial Bus)

3 USB ports are provided. The ports comply with the USB2.0 standard, which enables data transfer speeds 40 times faster than USB1.1 standard. USB1.1 is also supported.

θ Sound system

Internal stereo speaker, Internal MIC (Option) external monaural microphone connector, stereo headphone connector.

θ Wireless LAN

The wireless LAN is equipped on the mini card slot.

θ LAN/MODEM

Connectors for LAN and Modem are separately mounted.

θ 1394

One 1394 port is equipped.

θ Multiple Digital Media Card Slot

XD/MS/MS pro/SD/MMC are supported

θ Bluetooth

USB Bluetooth Module (BTO) V2.1 & EDR(Enhanced Data Rate) equipped

θ Security

Kensington Lock,

Fingerprint –Enhanced Lock is also equipped.

HDD Password

3D Accelerometer for HDD

Front with display open

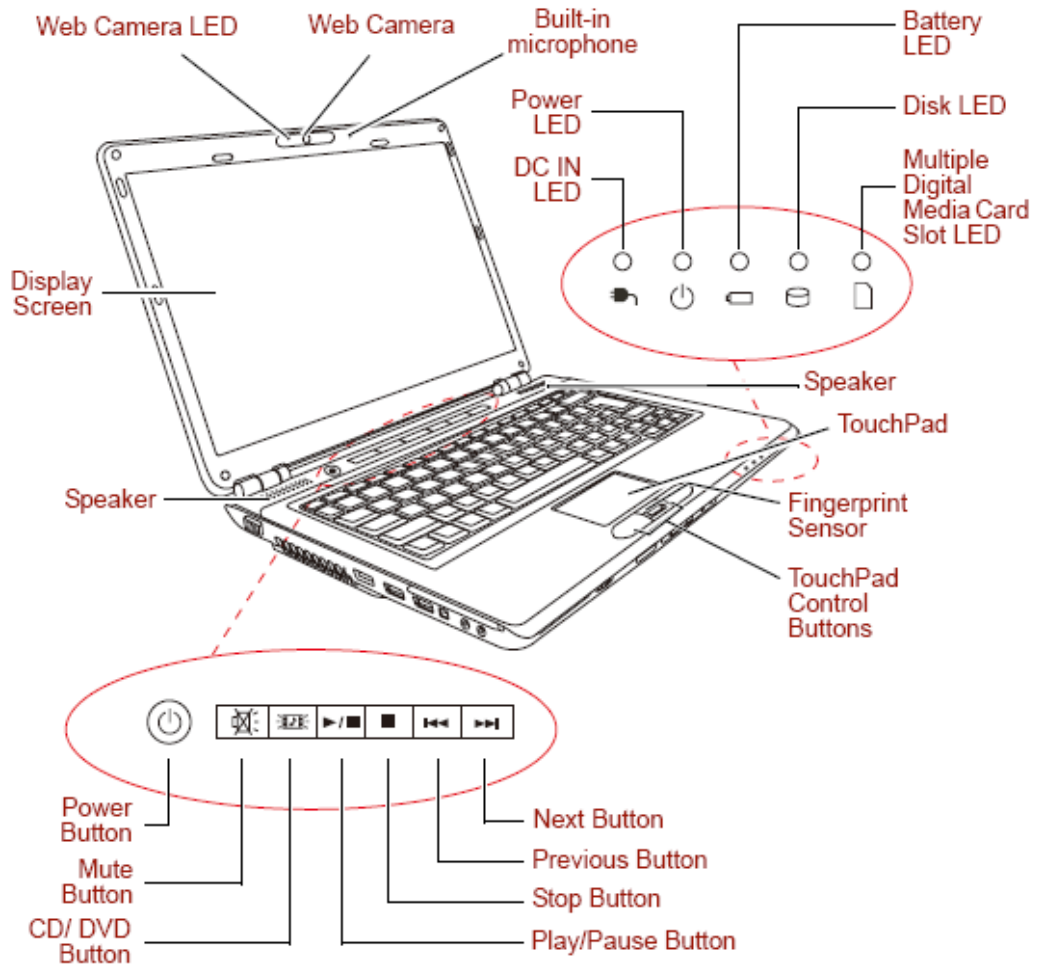

Figure 1-1 Front of the computer

- DRAM Controller : DDRII 533/667 support
 - DMI
 - 1299-ball 35 x 35mm Mirco FC-BGA Package

- South Bridge (Intel 82801HBM ICH8-M)
 - Direct Media Interface (DMI)
 - PCI Express
 - Serial ATA (SATA) Controller
 - PCI Interface
 - IDE Interface
 - Low Pin count (LPC) interface
 - Serial Peripheral Interface (SPI)
 - DMA controller
 - Advanced Programmable Interrupt Controller (APIC)
 - USB Controllers
 - Gigabit Ethernet Controller
 - RTC
 - GPIO
 - Enhanced Power Management
 - SMBus 2.0
 - High Definition Audio Controller
 - 676-pin 31mmx31mm mBGA Package

- θ PC card controller (CB1410, ENE Technology INC.)
 - PCI Interface (PCI Rev. 2.2)
 - PC Card Controller

- θ Other main system chips
 - Clock Generator (Santa Rosa Platform: ICS9LPRS365BGLFT)

 - EC/KBC (Winbond WPCE775C)
 - HD Audio (Connexant CX20561-12Z)
 - Audio AMP (Panasonic ISL6262ACRZ-T)
 - Card Reader controller (O2Micro OZ129)
 - 10/100 LAN controller (Marvell 88E8040T)

θ Mini Card

Wireless LAN card (BTO)

2.4 GHz DSSS/OFDM LAN card is equipped. Conformity with IEEE 802.11b/g and IEEE 802.11a/b/g.. Transfer speed maximum is 54Mbit/sec. supports 128bit WEP.

θ MODEM (Conexant x 1)

Supported by on board Modem + DAA daughter card.

Data and FAX transmission is available.

Supports ITU-TV.90.

The transfer speed of data receiving is 56kbps, of data sending is 33.6kbps and of FAX is 14.4kbps. Actual speed depends on the quality of the line used.

Connected to telephone line through RJ11 MOD

θ Blue tooth

Mini USB Bluetooth Module (BTO) V2.1.

1.3 2.5-inch Hard Disk Drive

A compact, high-capacity HDD with a height of 9.5mm. Contains a 2.5-inch magnetic disk and magnetic heads.

Figure 1-3 shows a view of the 2.5-inch HDD and Tables 1-1 and 1-2 list the specifications.

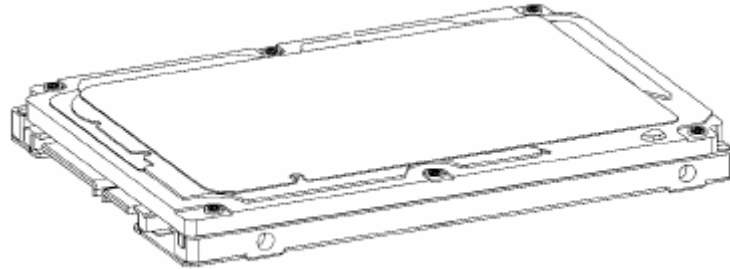

Figure 1-3 2.5-inch HDD

Table 1-1 2.5-inch HDD dimensions

Parameter		Standard value					
		TOSHIBA MK8046GSX	TOSHIBA MK1246GSX	TOSHIBA MK1646GSX	TOSHIBA MK2046GSX	TOSHIBA MK2546GSX	TOSHIBA MK3252GSX
Outline Dimensions	Width (mm)	69.8					
	Height (mm)	9.5					
	Depth (mm)	100					
	Weight (g)	98	98	102	102	102	102

Parameter		Standard value					
		Fujitsu MHY2080BH	Fujitsu MHY2120BH	Fujitsu MHY2160BH	Fujitsu MHY2200BH	Fujitsu MHY2250BH	Fujitsu MHY2320BH
Outline Dimensions	Width (mm)	100					
	Height (mm)	9.5					
	Depth (mm)	70					
	Weight (g)	96	96	101	101	101	101

Parameter		Standard value					
		Hitachi HTS542508 k9SA00	Hitachi HTS542512 k9SA00	Hitachi HTS542516 k9SA00	Hitachi HTS542520 K9SA00	Hitachi HTS542525 k9SA00	Hitachi HTS542532 k9SA00
Outline Dimensions	Width (mm)	69.85 +/- 0.25					
	Height (mm)	9.5 +/- 0.2					
	Depth (mm)	100.2 +/- 0.25					
	Weight (g)	95 max	95 max	102 max	102 max	102 max	102 max

Table 1-2 2.5-inch HDD specifications

Parameter	Specification					
	TOSHIBA MK8046GSX	TOSHIBA MK1246GSX	TOSHIBA MK1646GSX	TOSHIBA MK1246GSX	TOSHIBA MK2546GSX	TOSHIBA MK3252GSX
storage size(formatted)	80GB	120GB	160GB	200GB	250GB	320GB
Speed (RPM)	5400					
Data transfer Rate - To/From Media - T0/From Host	730Mbits Media 300MBytes Host				794Mbits Media 3GBytes Host	
bus transfer rate (MB/s)	ATA8/SATA 2.6					
Average random seek time (read) (ms)	12ms					
Power-on-to- ready (sec)	3.5 sec<typical> 9.5 sec <Max>					

Parameter	Specification					
	Fujitsu MHY2080BH	Fujitsu MHY2120BH	Fujitsu MHY2160BH	Fujitsu MHY2200BH	Fujitsu MHY2250BH	Fujitsu MHY2320BH
storage size(formatted)	80GB	120GB	160GB	200GB	250GB	320GB
Speed (RPM)	5400					
Data transfer Rate - To/From Media - T0/From Host	84.6MB/s					
bus transfer rate (MB/s)	1.5Gbps(150MB/s)					
Average random seek time (read) (ms)	12.0ms/14.0ms					
Power-on-to-ready	4.0s					

Parameter	Specification					
	Hitachi HTS542508 k9SA00	Hitachi HTS542512 k9SA00	Hitachi HTS542516 K9SA00	Hitachi HTS542520 K9SA00	Hitachi HTS542525 k9SA00	Hitachi HTS542532 k9SA00
storage size(formatted)	80GB	120GB	160GB	200GB	250GB	320GB
Speed (RPM)	5400					
Data transfer Rate - To/From Media - T0/From Host	~ 665 (Mb/s), (max)					
bus transfer rate (MB/s)	~~ 150 (MB/S)					
Average random seek time (read) (ms)	~~ 11 ms					
Power-on-to-ready (sec)	~~ 3.5 sec					

1.4 Optical Drive

1.4.1 DVD-ROM & CD-R/RW Drive

The DVD-ROM & CD-R/RW drive accommodates either 12 cm (4.72-inch) or 8 cm (3.15-inch) CD/DVD-ROM and CD-R/RW. It is a high-performance drive that reads DVD at maximum 8-speed and CD at maximum 24-speed.

The DVD-ROM & CD-R/RW drive is shown in Figure 1-4. The dimensions and specifications of the DVD-ROM & CD-R/RW drive are described in Table 1-3, Table 1-4.



Figure 1-4 DVD-ROM & CD-R/RW drive

Table 1-3 DVD-ROM & CD-R/RW drive outline dimensions

Parameter		Standard value
Outline dimension	Maker	TEAC DW-224E-VT7
	Width (mm)	127.7
	Height (mm)	12.7
	Depth (mm)	126.1
	Mass (g)	173 or less

Table 1-4 DVD-ROM & CD-R/RW drive specifications (1/3)

Parameter		Drive Specification
		TEAC DW-224E-VT7
Data transfer speed	Read (KB/s)	1,545 to 3,600(KB/s) CD-ROM model 4,469 to 10,816(KB/s) DVD-ROM
	Write	CD-R:24x CAV,16x CAV, 10x CLV, 4x CLV MS CD-RW:4x CLV HS CD-RW:10x CAV, 10x CLV, 4x CLV US CD-RW:24x CAV, 10x CLV US+ CD-RW:Not supported
	ATAPI interface (MB/s)	Programmed I/O 16.7MB/sec max(Mode 0 to 4) Multi-word DMA 16.7MB/sec max(Mode 0 to 2) Ultra DMA 33.3MB/sec max
Access time (ms) (Random)	CD-ROM	90msc
	DVD-ROM	110msc
Buffer memory		2MB
Supported disk format	CD	CD-DA CD-ROM (MODE1, MODE2) CD-ROM XA MODE2 (Form1, Form2) Photo CD (Single/Multi-session) CD-I Video-CD CD-Extra (CD-Plus) CD-Text
	DVD	DVD-ROM DVD-Video DVD-R (Single/Multi-border) DVD-R DL (Single/Multi/border) DVD-RW (Single/Multi-border) DVD+R (Single/Multi-session) DVD+R DL (Single/Multi-session) DVD+RW (Single/Multi-session) DVD-ROM (4.7GB, 2.6GB)

1.4.2 DVD Super Multi Drive

The DVD Super Multi drive accommodates either 12 cm (4.72-inch) or 8 cm (3.15-inch) CD/DVD-ROM, CD-R/RW, DVD±R/±RW and DVD-RAM. It is a high-performance drive that reads DVD-ROM at maximum 8-speed and CD at maximum 24-speed. Write speed of DVD±R/±RW and DVD-RAM is different depending on the drive.

The DVD Super Multi drive is shown in Figure 1-5. The dimensions and specifications of the DVD Super Multi drive are described in Table 1-5, Table 1-8.



Figure 1-5 DVD Super Multi drive

Table 1-5 DVD Super Multi drive outline dimensions

Parameter		Standard value	
Outline dimensions	Maker	Panasonic (UJ-852B)	Panasonic (UJ-852M)
	Width (mm)	128	
	Height (mm)	9.5	
	Depth (mm)	129	
	Mass (g)	140g	103g

Table 1-6 DVD Super Multi drive specifications (1/4)

Parameter		Drive Specification
		Panasonic (UJ-852B/ UJ-852M)
Data transfer speed	Read (KB/s)	DVD-ROM MAX 8X CAV (MAX 10800 KB/s) CD-ROM MAX 24X CAV (MAX 3600 KB/s)
	Write	CD-R MAX. 24X(CAV) CD-RW 4X (CLV) High Speed CD-RW 10X (CLV) Ultra Speed CD-RW MAX. 24X (CAV)
	ATAPI interface (MB/s)	16.6 MB/s :PIO mode4 16.6 MB/s :Multi word mode2 33.3 MB/s :Ultra DMA mode2
Access time (ms) (Random)	CD-ROM	150ms (Typ.)
	DVD-ROM	170ms (Typ.)
Buffer memory		2MB
Supported disk format	CD	CD-DA, CD-ROM, CD-R, CD-RW CD-ROM XA(except ADPCM) PhotoCD(Multi Session) Video CD,CD-Extra(CD+),CD-text
	DVD	DVD-ROM, DVD-Video DVD-R, DVD-RW (Ver. 1.1) DVD+R, DVD+RW DVD+R DL DVD-R DL DVD-RAM(2.6GB/4.7GB)

1.5 Keyboard

The Hampton 10/10S keyboard has two different kinds of placement, one is for JP style and the other is for US style.

Figure 1-6 is a view of the keyboard for US style



Figure 1-6 Keyboard for US style

Figure 1-7 is a view of the keyboard for JP style



Figure 1-7 Keyboard for JP style

See Appendix E for details of the keyboard layout.

1.6 TFT Color Display

The Hampton 10/10S Panel has two different kinds of model, one is CCFL backlight and the other is LED backlight.

1.6.1 LCD Module with CCFL Backlight

Figure 1-8 ~ 1-11 shows a view of the LCD module and Table 1-7 lists the specifications.

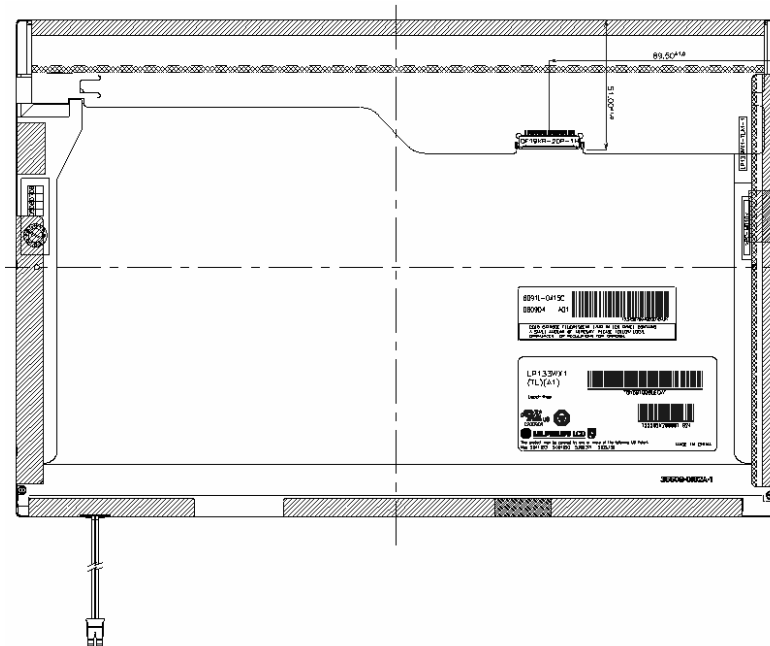

Figure 1-8 LG-Philips LCD Module

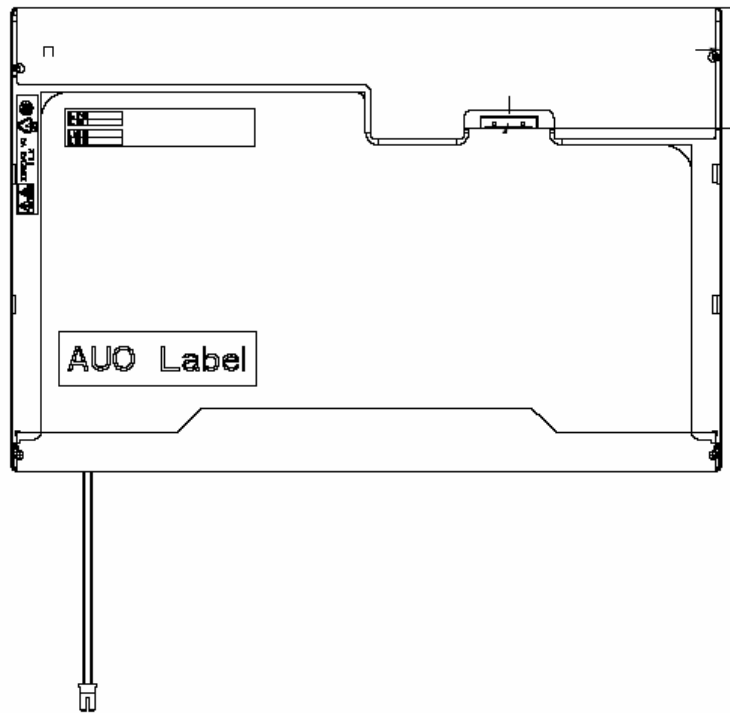

Figure 1-9 AUO LCD Module

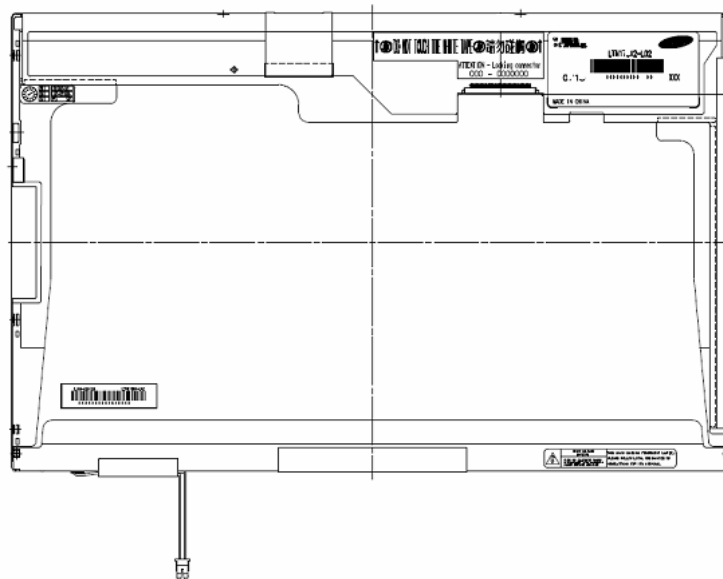

Figure 1-10 Samsung Module

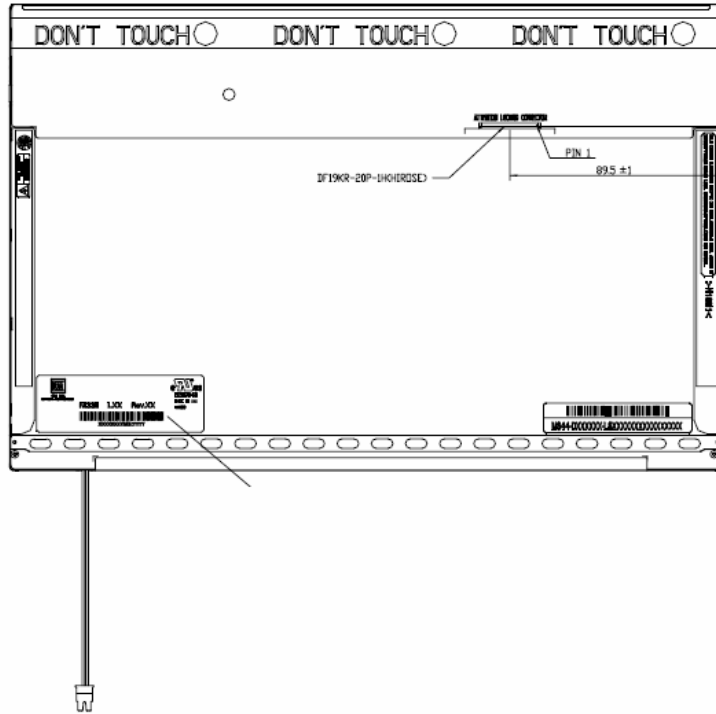

Figure 1-11 CMO LCD Module

Table 1-7 LCD module specifications

Item	Specifications(WXGA)			
	LG LP133WX3-TLN3	AUO B133EW01 V3	Samsung LTN133AT07-G01	CMO N133I1-L01
Number of Dots	1,280x 800			
Dot spacing (mm)	0.2235(H)× 0.2235(V)			

1.6.2 LCD Module with LED Backlight

Figure 1-12 shows a view of the LED backlight module and Table 1-8 lists the specifications.

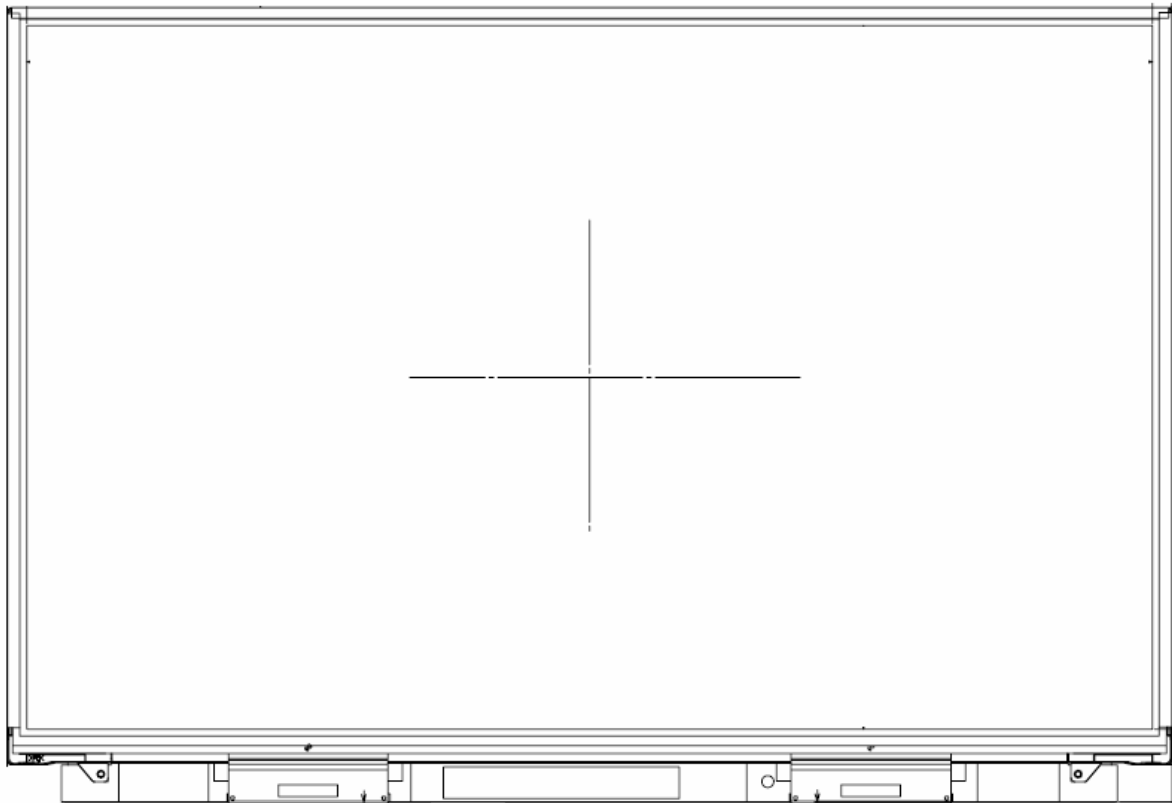

Figure 1-12 TMD LED Backlight Module

Table 1-8 LED backlight module specifications

Item	Specifications(WXGA)
	TMD LTD133EWHK
Number of Dots	1,280x 800
Dot spacing (mm)	0.2235(H)× 0.2235(V)

1.6.3 CCFL Inverter Board

Table 1-9 lists the FL inverter board specifications.

Table 1-9 FL inverter board specifications

Item		Specifications			
		Foxconn T181095.00	Delta DAC-08N035 AF	SUMIDA TWS-449-308	TDK TBD485NR
Input	Voltage (V)	8~20	8~20	8~20	8~20
	Power (W)	7.5W	7.5W	7.5W	7.5W
Output	Voltage (Vrms)	612~945	612~945	612~945	612~945
	Current (f=55KHz)(mA _{rms})	2.3±0.4 ~ 6.5±0.3			

1.7 Power Supply

Table 1-10 lists the power rail output specifications of Santa Rosa platform.

Table 1-10 Santa Rosa Power supply output rating

Name	Power supply (Yes/No)			
	Voltage [V]	Power OFF Suspend mode	Power OFF Boot mode	No Battery
+5VPCU	5	Yes	Yes	No
+5V_S5	5	Yes	No	No
+5V	5	No	No	No
+5VSATA	5	No	No	No
USBPWR	5	No	No	No
+5V_TP	5	No	No	No
VCCRTC	3.3	Yes	Yes	Yes
TH_FAN_POWER	3.1~5	No	No	No
+3VPCU	3.3	Yes	Yes	No
+3V_S5	3.3	Yes	No	No
+3VSUS	3.3	Yes	No	No
+3V	3.3	No	No	No
CCD_POWER	3.3	No	No	No
+5V_Felica	5	No	No	No
VCC_XD	3.3	No	No	No
+1.8VSUS	1.8	Yes	No	No
+1.8V	1.8	No	No	No
+1.5V	1.5	No	No	No
+1.25V	1.25	No	No	No
+1.05V	1.05	No	No	No
+SMDDR_VREF	0.9	Yes	No	No
+SMDDR_VTERM	0.9	No	No	No
VCC_CORE	0.55~1.575	No	No	No

1.8 Batteries

The PC has the following two batteries.

- θ Main battery
- θ Real time clock (RTC) battery

Table 1-11 lists the specifications for these two batteries.

Table 1-11 Battery specifications

Battery Name		Battery Element	Lithium ion	Capacity
Main battery	Sanyo 6 Cells	Lithiumion	11.1v	3700mAh
	Sanyo 6 cells		11.1v	4800mAh
	Panasonic 6cells		11.1v	3700mAh
	Sanyo 9 cell		11.1v	7200mAh
Real time clock (RTC) battery	VARTA ML1220	Lithiumion	3V	16mAh

1.8.1 Main Battery

The main battery is the primary power supply for the computer when the AC adapter is not connected. In Standby, the main battery maintains the current status of the computer.

1.8.2 Battery Charging Control

Battery charging is controlled by a power supply microprocessor. The power supply microprocessor controls power supply and detects a full charge when the AC adaptor and battery are connected to the computer.

θ Battery Charge

When the AC adapter is connected, normal charging is used while the system is turned on and quick charge is used while the system is turned off. Refer to the following Table 1-12.

Table 1-12 Time required for charges of main battery

Condition	Charging Time
Power On Charge	About 12 hours-
Power Off Charge	About 4 hours

Charge is stopped in the following cases.

1. The main battery is fully charged
2. The main battery is removed
3. Main battery or AC adapter voltage is abnormal
4. Charging current is abnormal

θ Data preservation time

When turning off the power in being charged fully, the preservation time is as following Table 1-13.

Table 1-13 Data preservation time

Condition		preservation time
Standby		About 3 days
Hibernation		About 1 month
Battery Pack	3 cell	Approximately 1.5 days(sleep mode)
	6 cell	Approximately 3 days(sleep mode)
	9 cell	Approximately 5 days(sleep mode)
Approximately 1 month(shutdown mode, All type of battery pack)		

1.8.3 RTC Battery

The RTC battery provides the power supply to maintain the date, time, and other system information in memory.

Table 1-14 lists the Time required for charges of RTC battery and data preservation time.

Table 1-14 Time required for charges of RTC battery

Condition	Time
Power ON (Lights Power LED)	About 24 hours
Data preservation tome (Full-charged)	About a month

1.9 AC Adapter

The AC adapter is used to charge the battery.

Table 1-15 lists the AC adapter specifications.

Table 1-15 AC adapter specifications

Parameter	Specification
With Led	DELTA/ LITE-ON
Power	75W
Input voltage	AC 100V/240V
Input frequency	50Hz/60Hz
Input current	1.5A
Output voltage	DC 19V
Output current	3.95A

Chapter 2

Troubleshooting Procedures

2.1	Troubleshooting	1
2.2	Troubleshooting Flowchart.....	3
2.3	Power Supply Troubleshooting.....	7
	Procedure 1 Power Status Check	7
	Procedure 2 Error Code Check	8
	Procedure 3 Connection Check.....	10
	Procedure 4 Charging Check	11
	Procedure 5 Replacement Check	12
2.4	System Board Troubleshooting.....	13
	Procedure 1 Message Check	14
	Procedure 2 Debugging Port Check.....	16
	Procedure 3 Diagnostic Test Program Execution Check	21
	Procedure 4 Replacement Check	21
2.5	USB FDD Troubleshooting	22
	Procedure 1 FDD Head Cleaning Check	22
	Procedure 2 Diagnostic Test Program Execution Check	23
	Procedure 3 Connector Check and Replacement Check.....	24
2.6	2.5" HDD Troubleshooting.....	26
	Procedure 1 Partition Check.....	26
	Procedure 2 Message Check	27
	Procedure 3 Format Check.....	28
	Procedure 4 Diagnostic Test Program Execution Check	29
	Procedure 5 Connector Check and Replacement Check.....	30
2.7	Keyboard Troubleshooting	31
	Procedure 1 Diagnostic Test Program Execution Check	31
	Procedure 2 Connector Check and Replacement Check.....	32
2.8	Touch pad Troubleshooting	33
	Procedure 1 Diagnostic Test Program Execution Check	33
	Procedure 2 Connector Check and Replacement Check.....	34

2.9	Display Troubleshooting.....	35
	Procedure 1 External Monitor Check.....	35
	Procedure 2 Diagnostic Test Program Execution Check	35
	Procedure 3 Connector and Cable Check.....	36
	Procedure 4 Replacement Check	37
2.10	Optical Disk Drive Troubleshooting.....	38
	Procedure 1 Diagnostic Test Program Execution Check	38
	Procedure 2 Connector Check and Replacement Check.....	38
2.11	Modem Troubleshooting.....	39
	Procedure 1 Diagnostic Test Program Execution Check	39
	Procedure 2 Connector Check and Replacement Check.....	39
2.12	LAN Troubleshooting.....	41
	Procedure 1 Diagnostic Test Program Execution Check	41
	Procedure 2 Connector Check and Replacement Check.....	41
2.13	Wireless LAN Troubleshooting.....	43
	Procedure 1 Transmitting-Receiving Check	43
	Procedure 2 Antennas' Connection Check	44
	Procedure 3 Replacement Check	45
2.14	Sound Troubleshooting.....	46
	Procedure 1 Connector Check.....	46
	Procedure 2 Replacement Check	47
2.15	Fingerprint Troubleshooting	48
	Procedure 1 Diagnostic Test Program Execution Check	48
	Procedure 2 Connector Check and Replacement Check.....	48
2.16	Bluetooth Troubleshooting	49
	Procedure 1 Diagnostic Test Program Execution Check	49
	Procedure 2 Connector Check and Replacement Check.....	49

2.1 Troubleshooting

Chapter 2 describes how to determine which Field Replaceable Unit (FRU) in the computer is causing the computer to malfunction.

The FRUs covered are:

- | | | |
|-----------------|-----------------------|------------------------|
| 1. Power supply | 6. Touch pad | 11. Wireless LAN |
| 2. System Board | 7. Display | 12. Sound |
| 3. USB FDD | 8. Optical Disk Drive | 13. Finger Print Board |
| 4. 2.5" HDD | 9. Modem | 14. Bluetooth |
| 5. Keyboard | 10. LAN | |

The Test Program operations are described in Chapter 3. Detailed replacement procedures are described in Chapter 4.

NOTE: After replacing the system board or CPU, it is necessary to execute the subtest 01 initial configuration of the 3.3 Setting of the hardware configuration in Chapter 3. Also update with the latest BIOS as described in Appendix G "BIOS Rewrite Procedures"

After replacing the LCD, update with the latest EC/KBC as described in Appendix H "EC/KBC Rewrite Procedures" to set the SVP parameter.

The implement for the Diagnostics procedures is referred to Chapter 3. Also, following implements are necessary:

1. Phillips screwdrivers (For replacement procedures)
2. Implements for debugging port check
 - Toshiba MS-DOS system FD
 - RS-232C cross cable
 - Test board with debug port test cable
 - PC for displaying debug port test result

There are following two types of connections in the figure of board and module connection in and after 2.3 Power Supply Troubleshooting.

- (1) Cable connection is described in the figure as line.
 - (2) Pin connection is described in the figure as arrow.
- <e.g.> Connection of modem

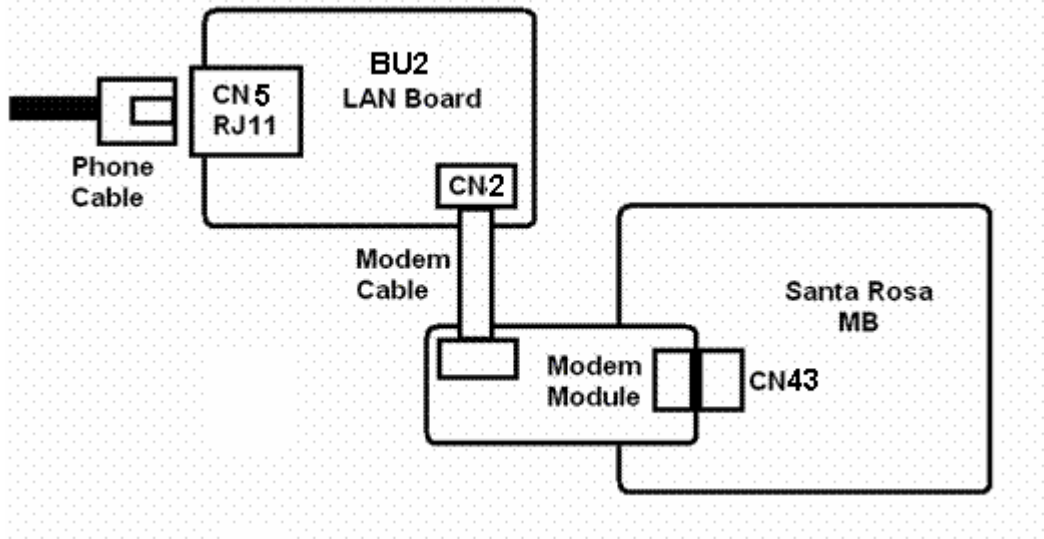

2.2 Troubleshooting Flowchart

Use the flowchart in Figure 2-1 as a guide for determining which troubleshooting procedures to execute. Before going through the flowchart steps, verify the following:

- Ask him or her to enter the password if a password is registered.
- Verify with the customer that Toshiba Windows is installed on the hard disk. Non-Windows operating systems can cause the computer to malfunction.
- Make sure all optional equipment is removed from the computer.

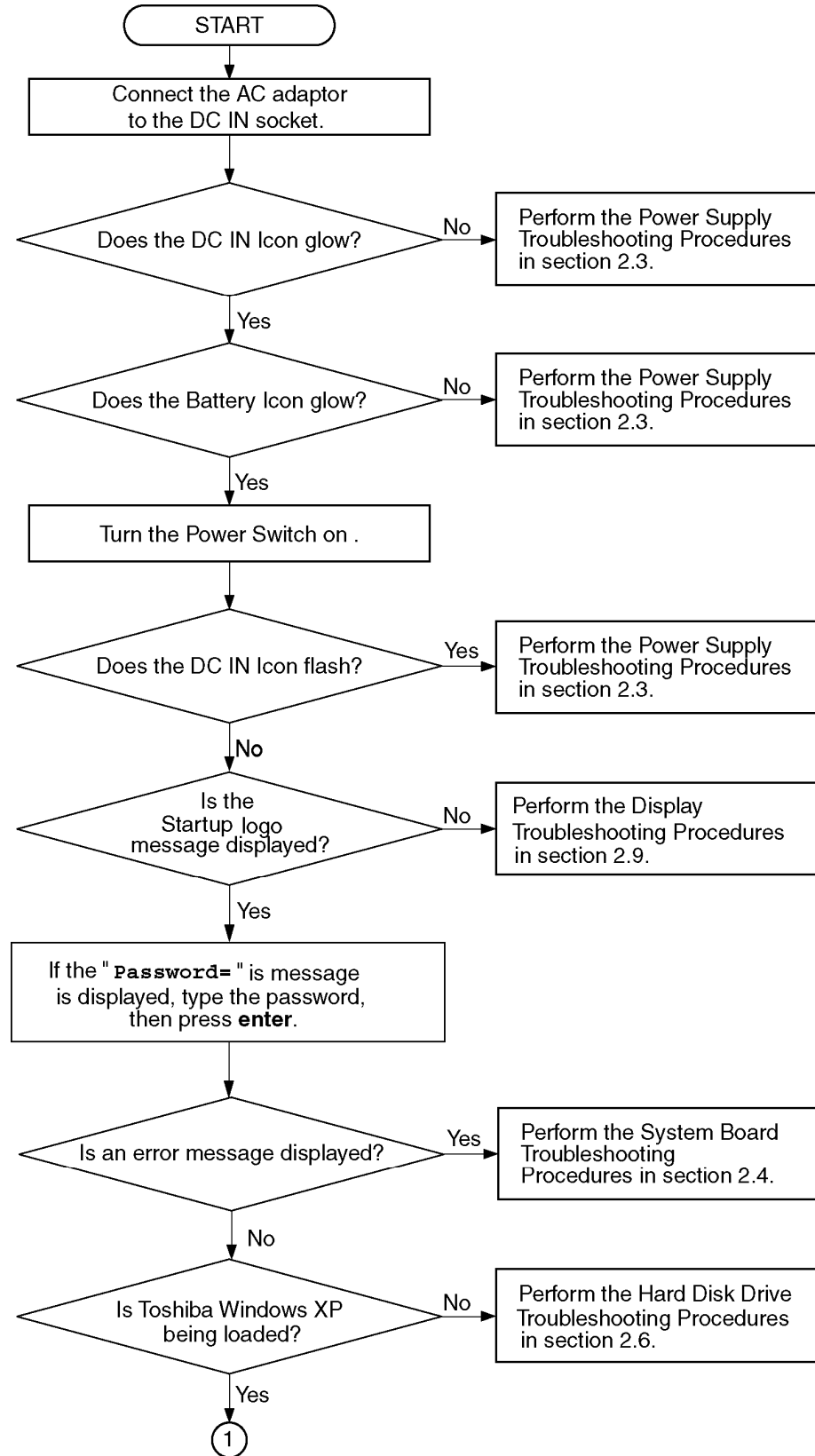

Figure 2-1 Troubleshooting flowchart (1/2)

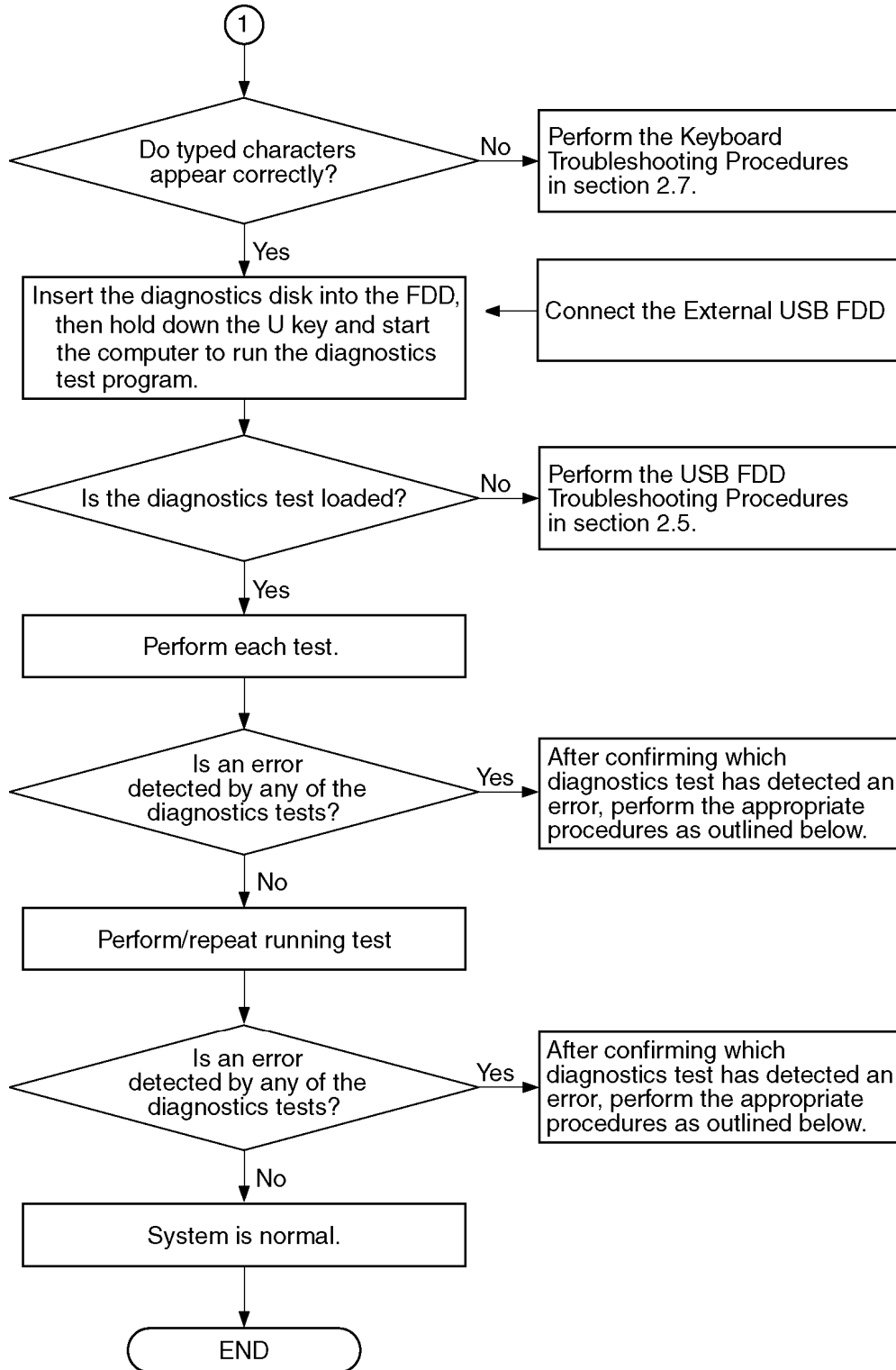

Figure 2-1 Troubleshooting flowchart (2/2)

If the diagnostics program cannot detect an error, the problem may be intermittent. The Test program should be executed several times to isolate the problem. Check the Log Utilities function to confirm which diagnostic test detected an error(s), and then perform the appropriate troubleshooting procedures as follows:

1. If an error is detected on the system test, memory test, display test, CD-ROM/DVD-ROM test, expansion test, real timer test, sound test or Modem/LAN/Bluetooth /IEEE1394 test, perform the System Board Troubleshooting Procedures in Section 2.4.
2. If an error is detected on the floppy disk test, perform the USB FDD Troubleshooting Procedures in Section 2.5.
3. If an error is detected on the hard disk test, perform the HDD Troubleshooting Procedures in Section 2.6.
4. If an error is found on the keyboard test (DIAGNOSTICS TEST) and pressed key display test (ONLY ONE TEST), perform the Keyboard Troubleshooting Procedures in Section 2.7.
5. If an error is found on the touch pad test (ONLY ONE TEST), perform the touch pad Troubleshooting Procedures in Section 2.8.
6. If an error is detected on the display test, perform the Display Troubleshooting Procedures in Section 2.9.
7. If an error is detected on the CD-ROM/DVD-ROM test, perform the Optical Disk Drive Troubleshooting Procedures in Section 2.10.
8. If an error is detected on the modem test, perform the Modem Troubleshooting Procedures in Section 2.11.
9. If an error is detected on the LAN test, perform the LAN Troubleshooting Procedures in Section 2.12.
10. If an error is detected on the wireless LAN test, perform the Wireless LAN Troubleshooting Procedures in Section 2.13.
11. If an error is detected on the sound test, perform the Sound Troubleshooting Procedures in Section 2.14.
12. If an error is detected on the VGA daughter card test, perform the VGA Troubleshooting Procedures in Section 2.15.
13. If an error is detected on the fingerprint test, perform the fingerprint Troubleshooting Procedures in Section 2.16.
14. If an error is detected on the Bluetooth test, perform the Bluetooth Troubleshooting Procedures in Section 2.17.

2.3 Power Supply Troubleshooting

The power supply controller controls many functions and components. To determine if the power supply is functioning properly, start with Procedure 1 and continue with the other Procedures as instructed. The procedures described in this section are:

- Procedure 1: Power Status Check
- Procedure 2: Error Code Check
- Procedure 3: Connection Check
- Procedure 4: Charging Check
- Procedure 5: Replacement Check

Procedure 1 Power Status Check

The following LED indicates the power supply status:

- Battery LED
- DC IN LED

The Power Supply control displays the power supply status with the Battery LED and the DC IN LED as listed in the tables below.

Table 2-1 Battery icon

Battery icon	Power supply status
Lights orange	Battery is charged and the external DC is input. It has no relation with ON/OFF of the system power.
Lights blue or white	Battery is fully charged and the external DC is input. It has no relation with ON/OFF of the system power.
Blinks orange (even intervals)	The battery level is low while the system power is ON.
Blinks orange once (at being switched on)	The system is driven by only a battery and the battery level is low.
Doesn't light	Any condition other than those above.

Table 2-2 DC IN icon

DC IN icon	Power supply status
Lights blue or white	DC power is being supplied from the AC adapter.
Blinks orange	Power supply malfunction ^{*1}
Doesn't light	Any condition other than those above.

*1 when the power supply controller detects a malfunction, the DC IN icon blinks orange. It shows an error code.

When the icon is blinking, perform the following procedure.

1. Remove the battery pack and the AC adapter.
2. Re-attach the battery pack and the AC adapter.

If the icon is still blinking after the operation above, check the followings:

Check 1 If the DC IN icon blinks orange, go to Procedure 2.

Check 2 If the DC IN icon does not light, go to Procedure 3.

Check 3 If the battery icon does not light orange or green, go to Procedure 4.

NOTE: Use a supplied AC adapter.

Procedure 2 Error Code Check

Device Name	Error Code	Error Status Name
(Common)	FF	Data Compare Error
Memory	2	Protected Mode Not Changed
	??	Other Error
FDD	1	Bad Command Error
	2	Address Mark Not Found
	3	Write Protected
	4	Record Not Found
	6	Media Change Line Error
	8	DMA Overrun Error
	9	DMA Boundary Error
	0C	Select Media Error
	10	CRC Error
	20	FDC Error
40	Seek Error	

	80	Time Out Error
	??	Other Error
HDD	1	Bad Command Error
	2	Bad Address Mark Error
	4	Record Not Found
	5	HDC Not Reset Error
	7	Drive Not Initialized
	9	DMA Boundary Error
	0A	Bad Sector
	0B	Bad Track Error
	10	ECC Error
	11	ECC Recover Enabled
	20	HDC Error
	40	Seek Error
	80	Time Out Error
AA	Drive Not Ready	
HDD	BB	Undefined Error
	CC	Write Fault
	E0	Status Error
	F0	No Sense Error
	??	Other Error
Cache Memory	2	Protect Mode Error
	3	Caching Error
	??	Other Error
Multimedia	1	Write Error
	0F	Invalid Drive
	15	Drive Not Ready
	??	Other Error

Procedure 3 Connection Check

The wiring diagram related to the power supply is shown below:

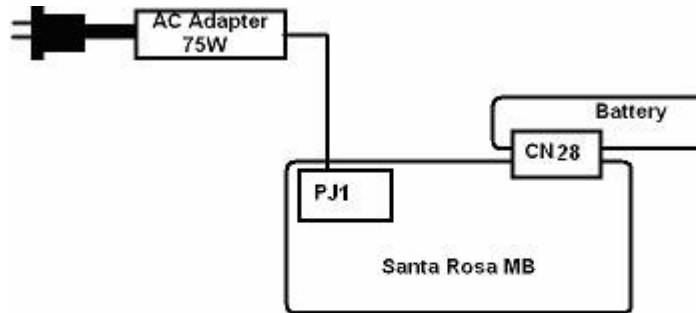

Any of the connectors may be disconnected. Perform Check 1.

Check 1 Make sure the AC adapter and the AC power cord is firmly plugged into the DC IN connector PCN1 and wall outlet. If these cables are connected firmly, go to Check 2.

Check 2 Replace the AC adapter and the AC power cord with new ones.

- If the DC IN icon does not light, go to Procedure 5.
- If the battery icon does not light, go to Check 3.

Check 3 Make sure the battery pack is installed in the computer correctly. If the battery is properly installed and the battery icon still does not light, go to Procedure 4.

Procedure 4 Charging Check

Check if the power supply controller charges the battery pack properly. Perform the following procedures:

Check 1 Make sure the AC adapter is firmly plugged into the DC IN socket (W8800).

Check 2 Make sure the battery pack is properly installed. If it is properly installed, go to Check 3.

Check 3 The battery pack may be completely discharged. Wait a few minutes to charge the battery pack while connecting the battery pack and the AC adapter. If the battery pack is still not charged, go to Check 4.

Check 4 The battery's temperature is too high or low. Leave the battery for a while to adjust it in the right temperature. If the battery pack is still not charged, go to Check 5.

Check 5 Replace the battery pack with a new one. If the battery pack is still not charged, go to Procedure 5.

Procedure 5 Replacement Check

The power is supplied to the system board by the AC adapter. If either the AC adapter or the system board was damaged, perform the following Checks.

To disassemble the computer, follow the steps described in Chapter 4, *Replacement Procedures*.

When AC adapter is connected;

Check 1 AC adapter may be faulty. Replace the AC adapter with a new one. If the problem still occurs, perform Check 2.

Check 2 System board may be faulty. Replace the system board with a new one.

When AC adapter is not connected ;
(When driving with battery pack)

Check 1 Battery pack may be faulty. Replace it with a new one. If the problem still occurs, perform Check 2.

Check 2 System board may be faulty. Replace it with a new one.

2.4 System Board Troubleshooting

This section describes how to determine whether the system board is malfunctioning or not. Start with Procedure 1 and continue with the other procedures as instructed. The procedures described in this section are:

Procedure 1: Message Check

Procedure 2: Debugging Port Check

Procedure 3: Diagnostic Test Program Execution Check

Procedure 4: Replacement Check

Procedure 1 Message Check

When the power is turned on, the system performs the Power On Self Test (POST) installed in the BIOS ROM. The POST tests each IC on the system board and initializes it.

- If an error message is shown on the display, perform Check 1.
- If there is no error message, go to Procedure 2.
- If MS-DOS or Windows XP is properly loaded, go to Procedure 4.

Check 1 If one of the following error messages is displayed on the screen, press the **F1** key as the message instructs. These errors occur when the system configuration preserved in the RTC memory (CMOS type memory) is not the same as the actual configuration or when the data is lost.

If you press the **F1** key as the message instructs, the SETUP screen appears to set the system configuration. If error message (b) appears often when the power is turned on, replace the RTC battery. If any other error message is displayed, perform Check 2.

- (a) *** Bad HDD type ***
 Check system. Then press [F1] key
- (b) *** Bad RTC battery ***
 Check system. Then press [F1] key
- (c) *** Bad configuration ***
 Check system. Then press [F1] key
- (d) *** Bad memory size ***
 Check system. Then press [F1] key
- (e) *** Bad time function ***
 Check system. Then press [F1] key
- (f) *** Bad check sum (CMOS) ***
 Check system. Then press [F1] key
- (g) *** Bad check sum (ROM) ***
 Check system. Then press [F1] key

Check 2 If the following error message is displayed on the screen, press any key as the message instructs.

The following error message appears when data stored in RAM under the resume function is lost because the battery has become discharged or the system board is damaged. Go to Procedure 3.

```
WARNING: RESUME FAILURE.  
PRESS ANY KEY TO CONTINUE.
```

If any other error message displays, perform Check 3.

Check 3 The IRT checks the system board. When the IRT detects an error, the system stops or an error message appears.

If one of the following error messages (1) through (17), (24) or (25) is displayed, go to Procedure 4.

If error message (18) is displayed, go to the Keyboard Troubleshooting Procedures.

If error message (19), (20) or (21) is displayed, go to the 2.5" HDD Troubleshooting Procedures.

If error message (22) or (23) is displayed, go to the USB FDD Troubleshooting Procedures.

- (1) PIT ERROR
- (2) MEMORY REFRESH ERROR
- (3) TIMER CH.2 OUT ERROR
- (4) CMOS CHECKSUM ERROR
- (5) CMOS BAD BATTERY ERROR
- (6) FIRST 64KB MEMORY ERROR
- (7) FIRST 64KB MEMORY PARITY ERROR
- (8) VRAM ERROR
- (9) SYSTEM MEMORY ERROR
- (10) SYSTEM MEMORY PARITY ERROR
- (11) EXTENDED MEMORY ERROR
- (12) EXTENDED MEMORY PARITY ERROR
- (13) DMA PAGE REGISTER ERROR
- (14) DMAC #1 ERROR
- (15) DMAC #2 ERROR
- (16) PIC #1 ERROR
- (17) PIC #2 ERROR
- (18) KBC ERROR
- (19) HDC ERROR
- (20) HDD #0 ERROR
- (21) HDD #1 ERROR
- (22) NO FDD ERROR
- (23) FDC ERROR
- (24) TIMER INTERRUPT ERROR
- (25) RTC UPDATE ERROR

Procedure 2 Debugging Port Check

Check the MiniPCI Debug board. The tool for debug port test is shown below.

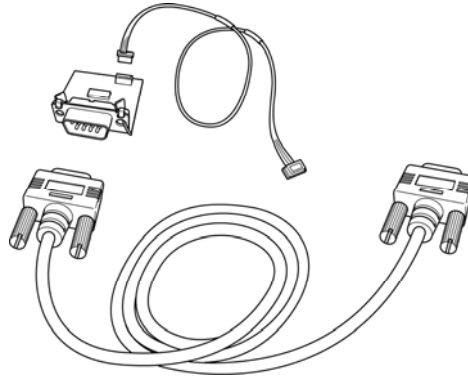

Figure 2-2 A set of tool for debug port test

The test procedures are follows:

1. Replace Mini PCI debug port with Wireless LAN card, check LED in the Mini PCI debug board

The following is a list of the Test Point codes written to port 80h at the start of each routine, the beep codes issued for terminal errors, and a description of the POST routine. Unless otherwise noted, these codes are valid for Phoenix BIOS 4.0 Release 6.0.

NOTE: The following routines are sorted by their test point numbers were assigned in the BIOS code. Their actual order as executed during POST can Be quite different.

Code Beeps POST Routine Description

02h	Verify Real Mode
03h	Disable Non-Maskable Interrupt (NMI)
04h	Get CPU type
06h	Initialize system hardware
08h	Initialize chipset with initial POST values
09h	Set IN POST flag
0Ah	Initialize CPU registers
0Bh	Enable CPU cache
0Ch	Initialize caches to initial POST values
0Eh	Initialize I/O component
0Fh	Initialize the local bus IDE
10h	Initialize Power Management
11h	Load alternate registers with initial POST values
12h	Restore CPU control word during warm boot
13h	Initialize PCI Bus Mastering devices

Code Beeps POST Routine Description

14h	Initialize keyboard controller
16h1-2-2-3	BIOS ROM checksum
17h	Initialize cache before memory autosize
18h	8254 timer initialization
1Ah	8237 DMA controller initialization
1Ch	Reset Programmable Interrupt Controller
20h1-3-1-1	Test DRAM refresh
22h1-3-1-3	Test 8742 Keyboard Controller
24h	Set ES segment register to 4 GB
26h	Enable A20 line
28h	Autosize DRAM
29h	Initialize POST Memory Manager
2Ah	Clear 512 KB base RAM
2Ch1-3-4-1	RAM failure on address line xxxx*
2Eh1-3-4-3	RAM failure on data bits xxxx* of low byte of memory bus
2Fh	Enable cache before system BIOS shadow
30h1-4-1-1	RAM failure on data bits xxxx* of high byte of memory bus
32h	Test CPU bus-clock frequency
33h	Initialize Phoenix Dispatch Manager
36h	Warm start shut down
38h	Shadow system BIOS ROM
3Ah	Autosize cache
3Ch	Advanced configuration of chipset registers
3Dh	Load alternate registers with CMOS values
42h	Initialize interrupt vectors
45h	POST device initialization
46h2-1-2-3	Check ROM copyright notice
48h	Check video configuration against CMOS
49h	Initialize PCI bus and devices
4Ah	Initialize all video adapters in system
4Bh	QuietBoot start (optional)
4Ch	Shadow video BIOS ROM
4Eh	Display BIOS copyright notice
50h	Display CPU type and speed
51h	Initialize EISA board
52h	Test keyboard
54h	Set key click if enabled
58h2-2-3-1	Test for unexpected interrupts
59h	Initialize POST display service
5Ah	Display prompt "Press F2 to enter SETUP"
5Bh	Disable CPU cache
5Ch	Test RAM between 512 and 640 KB
60h	Test extended memory
62h	Test extended memory address lines

- 64h Jump to UserPatch1
- 66h Configure advanced cache registers
- 67h Initialize Multi Processor APIC
- 68h Enable external and CPU caches
- 69h Setup System Management Mode (SMM) area
- 6Ah Display external L2 cache size
- 6Bh Load custom defaults (optional)
- 6Ch Display shadow-area message
- 6Eh Display possible high address for UMB recovery
- 70h Display error messages
- 72h Check for configuration errors
- 76h Check for keyboard errors
- 7Ch Set up hardware interrupt vectors
- 7Eh Initialize coprocessor if present
- 80h Disable onboard Super I/O ports and IRQs
- 81h Late POST device initialization
- 82h Detect and install external RS232 ports
- 83h Configure non-MCD IDE controllers
- 84h Detect and install external parallel ports
- 85h Initialize PC-compatible PnP ISA devices
- 86h Re-initialize onboard I/O ports.
- 87h Configure Motheboard Configurable Devices (optional)
- 88h Initialize BIOS Data Area
- 89h Enable Non-Maskable Interrupts (NMIs)
- 8Ah Initialize Extended BIOS Data Area
- 8Bh Test and initialize PS/2 mouse
- 8Ch Initialize floppy controller (optional)
- 8Fh Determine number of ATA drives (optional)
- 90h Initialize hard-disk controllers
- 91h Initialize local-bus hard-disk controllers
- 92h Jump to UserPatch2
- 93h Build MPTABLE for multi-processor boards
- 95h Install CD ROM for boot
- 96h Clear huge ES segment register
- 97h Fixup Multi Processor table
- 98h1-2 Search for option ROMs. One long, two short beeps on checksum failure
- 99h Check for SMART Drive (optional)
- 9Ah Shadow option ROMs
- 9Ch Set up Power Management
- 9Dh Initialize security engine (optional)
- 9Eh Enable hardware interrupts
- 9Fh Determine number of ATA and SCSI drives
- A0h Set time of day
- A2h Check key lock
- A4h Initialize Typematic rate
- A8h Erase F2 prompt

Code Beeps POST Routine Description

AAh	Scan for F2 key stroke
ACh	Enter SETUP
A Eh	Clear Boot flag
B0h	Check for errors
B2h	POST done - prepare to boot operating system
B4h	One short beep before boot
B5h	Terminate QuietBoot (optional)
B6h	Check password (optional)
B9h	Prepare Boot
Bah	Initialize DMI parameters
BBh	Initialize PnP Option ROMs
BCh	Clear parity checkers
BDh	Display MultiBoot menu
BEh	Clear screen (optional)
BFh	Check virus and backup reminders
C0h	Try to boot with INT 19
C1h	Initialize POST Error Manager (PEM)
C2h	Initialize error logging
C3h	Initialize error display function
C4h	Initialize system error handler
C5h	PnPnd dual CMOS (optional)
C6h	Initialize notebook docking (optional)
C7h	Initialize notebook docking late
C8h	Force check (optional)
C9h	Extended checksum (optional)
D2h	Unknown interrupt

Code Beeps For Boot Block in Flash ROM

E0h	Initialize the chipset
E1h	Initialize the bridge
E2h	Initialize the CPU
E3h	Initialize system timer
E4h	Initialize system I/O
E5h	Check force recovery boot
E6h	Checksum BIOS ROM
E7h	Go to BIOS
E8h	Set Huge Segment
E9h	Initialize Multi Processor
EAh	Initialize OEM special code
EBh	Initialize PIC and DMA
ECh	Initialize Memory type
EDh	Initialize Memory size
EEh	Shadow Boot Block
EFh	System memory test
F0h	Initialize interrupt vectors
F1h	Initialize Run Time Clock
F2h	Initialize video
F3h	Initialize System Management Mode
F4h	1 Output one beep before boot
F5h	Boot to Mini DOS
F6h	Clear Huge Segment
F7h	Boot to Full DOS

Procedure 3 Diagnostic Test Program Execution Check

Execute the following tests from the Diagnostic Test Menu. These tests check the system board. Refer to Chapter 3, *Tests and Diagnostic*, for more information on how to perform these tests.

1. System test
2. Memory test
3. Keyboard test
4. Display test
5. Floppy Disk test
6. VGA test
7. VGA Memory test
8. Hard Disk test
9. CPU Temperature test
10. Main Battery test
11. BIOS test
12. CD-ROM/DVD-ROM test
13. System Status LED test
14. Wireless LAN test
15. LAN/Modem/Sound test
16. UUID test-DMI Information (Write DMI)

If an error is detected during these tests, go to Procedure 4.

Procedure 4 Replacement Check

System board may be faulty. Disassemble the computer following the steps described in Chapter 4, *Replacement Procedures* and replace system board with a new one.

2.5 USB FDD Troubleshooting

To check whether the USB FDD is malfunctioning or not, follow the troubleshooting procedures below as instructed.

Procedure 1: FDD Head Cleaning Check

Procedure 2: Diagnostic Test Program Execution Check

Procedure 3: Connector Check and Replacement Check

Procedure 1 FDD Head Cleaning Check

FDD head cleaning is one option available in the Diagnostic Program.

After connecting USB FDD, insert the Diagnostics Disk in the floppy disk drive. Turn on the computer and run the test. And then clean the FDD heads using the cleaning kit. If the FDD still does not function properly after cleaning, go to Procedure 2.

Detailed operation is given in Chapter 3, *Tests and Diagnostics*.

If the test program cannot be executed on the computer, go to Procedure 3.

Procedure 2 Diagnostic Test Program Execution Check

Insert the Diagnostics Disk in the USB FDD, turn on the computer and run the test. Refer to Chapter 3, *Tests and Diagnostics*, for more information about the diagnostics test procedures.

Make sure the floppy disk is formatted correctly and that the write protect tab is disabled. Floppy disk drive test error codes and their status names are listed in Table 2-7. If any other errors occur while executing the FDD diagnostics test, go to Check 1.

Table 2-7 FDD error code and status

Code	Status
01h	Bad command
02h	Address mark not found
03h	Write protected
04h	Record not found
06h	Media replaced
08h	DMA overrun error
09h	DMA boundary error
10h	CRC error
20h	FDC error
40h	Seek error
60h	FDD not drive
80h	Time out error (Not ready)
EEh	Write buffer error
FFh	Data compare error

Check 1 If the following message is displayed, disable the write protect tab on the floppy disk by sliding the write protect tab to “write enable”. If any other message appears, perform Check 2.

Write protected

Check 2 Make sure the floppy disk is formatted correctly. If it is, go to Procedure 3.

Procedure 3 Connector Check and Replacement Check

USB FDD is connected to USB port on system board and US board. US board is also connected to system board by cable. The connection of cable and board may be defective. Otherwise, they may be faulty. Disassemble the computer following the steps described in Chapter 4, *Replacement Procedures* and perform the following checks.

Check 1 Make sure USB FDD is firmly connected to USB port. If the connection is loose, connect firmly and repeat Procedure 2. If the problem still occurs, go to Check 2.

NOTE: *When checking the connection, be sure to check it with care for the followings.*

- 1. Cable can not be disconnected from the connector.*
- 2. Cable is connected straight to the connector.*
- 3. Cable is connected all the way seated in the connector.*
- 4. Cable can not be broken.*

Check 2 USB FDD may be faulty. Replace it with a new one. If the problem still occurs, perform Check 3.

Check 3 Connect USB FDD to each port embedded on system board.

If it does not work properly when connected to CN12, CN19, CN20 or all ports, perform Check 4.

Check 4 System board may be faulty. Replace it with a new one following the steps in Chapter 4, *Replacement Procedures*.

2.6 2.5” HDD Troubleshooting

To check if 2.5” HDD is malfunctioning or not, follow the troubleshooting procedures below as instructed.

Procedure 1: Partition Check

Procedure 2: Message Check

Procedure 3: Format Check

Procedure 4: Diagnostic Test Program Execution Check

Procedure 5: Connector Check and Replacement Check

CAUTION: *The contents of the hard disk will be erased when the 2.5” HDD troubleshooting procedures are executed. Transfer the contents of the hard disk to floppy disks or other storage drive(s). For the backup, refer to the User’s Manual.*

Procedure 1 Partition Check

Insert the Toshiba MS-DOS system disk and start the computer. Perform the following checks:

- Check 1 Input **C:** and press **Enter**. If you cannot change to drive C, go to Check 2. If you can change to drive C, go to Procedure 2.
- Check 2 Input **FDISK** and press **Enter**. Choose Display Partition Information from the FDISK menu. If drive C is listed in the Display Partition Information, go to Check 3. If drive C is not listed, return to the FDISK menu and choose the option to create a DOS partition or a logical DOS drive on drive C. If the problem still occurs, go to Procedure 2.
- Check 3 If drive C is listed as active in the FDISK menu, go to Check 4. If drive C is not listed as active, return to the FDISK menu and choose the option to set the active partition for drive C. Then go to Procedure 2.
- Check 4 Remove the system disk from the FDD and reboot the computer. If the problem still occurs, go to Procedure 2. Otherwise, the 2.5” HDD is operating normally.

Procedure 2 Message Check

When the power is turned on, the system performs the Initial Reliability Test (IRT) installed in the BIOS ROM. When the test detects an error, an error message is displayed on the screen.

Make sure no floppy disk is in the FDD. Turn on the computer and check the message on the screen. When an OS starts from the 2.5" HDD, go to Procedure 3. Otherwise, start with Check 1 below and perform the other checks as instructed.

Check 1 If any of the following messages appear, go to Procedure 3. If the following messages do not appear, perform Check 2.

HDC ERROR

or

HDD #X ERROR (After 5 seconds this message will disappear.)

Check 2 If either of the following messages appears, go to Check 3. If the following messages do not appear, perform Check 4.

Insert system disk in drive
Press any key when ready

or

Non-System disk or disk error
Replace and press any key when ready

Check 3 Using the SYS command of the MS-DOS, transfer the system to the 2.5" HDD. If the system is not transferred, go to Procedure 3. Refer to the MS-DOS Manual for detailed operation.

If the following message appears on the display, the system program has been transferred to the HDD.

System Transferred

If an error message appears on the display, perform Check 4.

Check 4 2.5" HDD(s) and the connector(s) of system board may be defective (Refer to the steps described in Chapter 4, *Replacement Procedures* for disassembling.). Insert HDD(s) to the connector(s) firmly. If it is (or they are) firmly connected, go to Procedure 3.

Procedure 3 Format Check

The computer's HDD is formatted using the MS-DOS FORMAT program or the physical format program of the test program. To format the HDD, start with Check 1 below and perform the other steps as required.

Refer to the MS-DOS Manual for the operation of MS-DOS. For the format by the test program, refer to the Chapter 3.

Check 1 Format an 2.5" HDD using MS-DOS FORMAT command. Type as **FORMAT C:/S/U**.

 If 2.5" HDD can not be formatted, perform Check 2.

Check 2 Using the MS-DOS FDISK command, set the 2.5" HDD partition. If the partition is not set, go to Check 3. If it is set, format 2.5" HDD using MS-DOS FORMAT command.

Check 3 Using the Diagnostic Disk, format 2.5" HDD with a format option (physical format). If HDD is formatted, set the 2.5" HDD partition using MS-DOS FDISK command.

 If you cannot format 2.5" HDD using the Tests and Diagnostic program, go to Procedure 4.

Procedure 4 Diagnostic Test Program Execution Check

The HDD test program is stored in the Diagnostics Disk. Perform all of the HDD tests in the Hard Disk Drive Test. Refer to Chapter 3, *Tests and Diagnostics*, for more information about the HDD test program.

If an error is detected during the HDD test, an error code and status will be displayed. The error codes and statuses are described in Table 2-8. If an error code is not displayed but the problem still occurs, go to Procedure 5.

Table 2-8 2.5" Hard disk drive error code and status

Code	Status
05	HDD - HDC NOT RESET ERROR
07	HDD - DRIVE NOT INITIALIZE
09	HDD - DMA BOUNDARY ERROR
0B	HDD - BAD TRACK ERROR
BB	HDD - UNDEFINED ERROR
08	HDD - OVERRUN ERROR (DRQ ON)
01	HDD - BAD COMMAND ERROR
02	HDD - ADDRESS MARK NOT FOUND
04	HDD - RECORD NOT FOUND ERROR
10	HDD - ECC ERROR
20	HDD - HDC ERROR
40	HDD - SEEK ERROR
80	HDD - TIME OUT ERROR
11	HDD - ECC RECOVER ENABLE
AA	HDD - DRIVE NOT READY
CC	HDD - WRITE FAULT
E0	HDD - STATUS ERROR
0A	HDD - BAD SECTOR
EE	HDD - ACCESS TIME ERROR
DA	HDD - NO HDD
12	HDD - DMA CRC ERROR

Procedure 5 Connector Check and Replacement Check

HDD(s) is/are connected to the connector(s) on the system board. The connection of HDD(s) and board may be defective. Otherwise, they may be faulty. Disassemble the computer following instructions in Chapter 4, *Replacement Procedures* and perform the following checks.

Check 1 Make sure HDD(s) is/are firmly connected to the connector(s) on the system board.

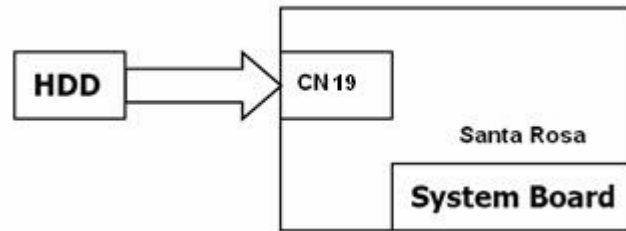

If any of the connections are loose, reconnect firmly and repeat Procedure 1. If the problem still occurs, go to Check 2.

Check 2 (One of) HDD(s) may be faulty. Replace it with a new one following the instructions in Chapter 4, *Replacement Procedures* and check the operation. If the problem still occurs, perform Check 3.

Check 3 System board may be faulty. Replace it with a new one following the instructions in Chapter 4, *Replacement Procedures*.

2.7 Keyboard Troubleshooting

To check if the computer's keyboard is malfunctioning or not, follow the troubleshooting procedures below as instructed.

Procedure 1: Diagnostic Test Program Execution Check

Procedure 2: Connector and Replacement Check

Procedure 1 Diagnostic Test Program Execution Check

Execute the Keyboard Test (DIAGNOSTIC TEST) and Pressed key display test (ONLY ONE TEST) in the Diagnostic Program. Refer to Chapter 3, *Tests and Diagnostics*, for more information on how to perform the test program.

If an error occurs, go to Procedure 2. If an error does not occur, keyboard is functioning properly.

Procedure 2 Connector and Replacement Check

The connection of cable and board may be defective. Otherwise, they may be faulty. Disassemble the computer following the steps described in Chapter 4, *Replacement Procedures*, and perform the following checks:

Check 1 Make sure keyboard cable is firmly connected to system board.

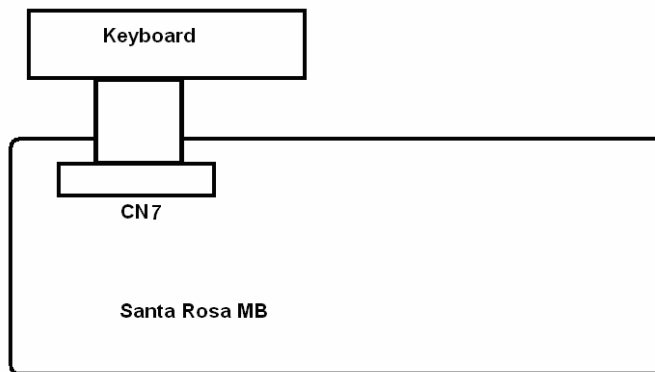

If the connection is loose, reconnect firmly and repeat Procedure 1. If the problem still occurs, go to Check 2.

Check 2 Keyboard may be faulty. Replace it with a new one following the instructions in Chapter 4, *Replacement Procedures*. If the problem still occurs, perform Check 3.

Check 3 System board may be faulty. Replace it with a new one following the instructions in Chapter 4, *Replacement Procedures*.

2.8 Touch pad Troubleshooting

To check if the computer's touch pad is malfunctioning or not, follow the troubleshooting procedures below as instructed.

Procedure 1: Diagnostic Test Program Execution Check

Procedure 2: Connector and Replacement Check

Procedure 1 Diagnostic Test Program Execution Check

Execute the Touch pad test (ONLY ONE TEST) in the Diagnostic Program. Refer to Chapter 3, *Tests and Diagnostics*, for more information on how to perform the test program.

If an error occurs, go to Procedure 2. If an error does not occur, touch pad is functioning properly.

Procedure 2 Connector and Replacement Check

The connection of cable and board may be defective. Otherwise, they may be faulty. Disassemble the computer following the steps described in Chapter 4, *Replacement Procedures*, and perform the following checks:

Check 1 Make sure the cable is firmly connected to system board.

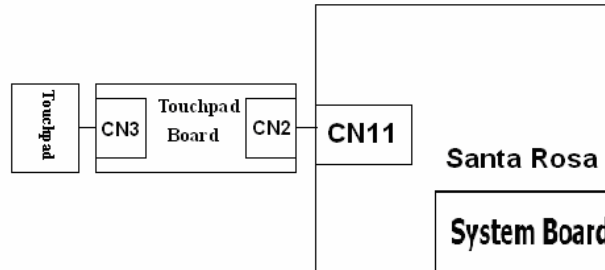

If the connection is loose, reconnect firmly and repeat Procedure 1. If the problem still occurs, go to Check 2.

Check 2 Touch Pad or the cable may be faulty. Replace it with a new one following the instructions in Chapter 4, *Replacement Procedures*. If the problem still occurs, perform Check 3.

Check 3 System board may be faulty. Replace it with a new one following the instructions in Chapter 4, *Replacement Procedures*

2.9 Display Troubleshooting

To check if the computer's display is malfunctioning or not, follow the troubleshooting procedures below as instructed.

Procedure 1: External Monitor Check

Procedure 2: Diagnostic Test Program Execution Check

Procedure 3: Connector and Cable Check

Procedure 4: Replacement Check

Procedure 1 External Monitor Check

Connect an external monitor to the computer's external monitor port, then boot the computer. The computer automatically detects the external monitor.

If the external monitor works correctly, the internal LCD may be faulty. Go to Procedure 3.

If the external monitor appears to have the same problem as the internal monitor, system board may be faulty. Go to Procedure 2.

Procedure 2 Diagnostic Test Program Execution Check

The Display Test program is stored in Diagnostics disk. This program checks the display controller on system board. Insert the Diagnostics disk in the USB FDD, turn on the computer and run the test. Refer to Chapter 3, *Tests and Diagnostics* for details. If an error is detected, go to Procedure 3.

Procedure 3 Connector and Cable Check

LCD Module is connected to system board by an LCD/FL cable. FL inverter board is also connected to system board by an LCD/FL cable. And, fluorescent lamp is connected to FL inverter board by HV cable. Their cables may be disconnected from system board or FL inverter board. Disassemble the computer following the steps described in Chapter 4, *Replacement Procedures*.

If the connection is loose, reconnect firmly and restart the computer. If the problem still occurs, go to Procedure 4.

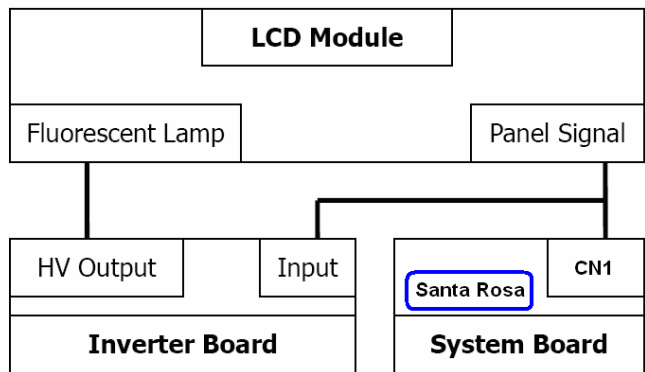

Procedure 4 Replacement Check

Fluorescent lamp, FL inverter, LCD module, HV cable and LCD/FL cable are connected to display circuits. Any of these components may be faulty. Refer to Chapter 4, *Replacement Procedures*, for instructions on how to disassemble the computer and then perform the following checks:

If fluorescent lamp does not light, perform Check 1.

If characters or graphics on the internal display are not displayed clearly, perform Check 4.

If some screen functions do not operate properly, perform Check 4.

If fluorescent lamp remains lit when the display is closed, perform Check 5.

- Check 1 Replace fluorescent lamp with a new one following the instructions in Chapter 4, *Replacement Procedures* and test the display again. If the problem still occurs, perform Check 2.
- Check 2 LCD/FL cable may be faulty. Replace FL/LCD cable with a new one following the instructions in Chapter 4, *Replacement Procedure* and test the display again. If the problem still occurs, perform Check 3.
- Check 3 FL inverter may be faulty. Replace FL inverter with a new one following the instructions in Chapter 4, *Replacement Procedure* and test the display again. If the problem still occurs, perform Check 4.
- Check 4 LCD module may be faulty. Replace LCD module with a new one following the instructions in Chapter 4, *Replacement Procedure* and test the display again. If the problem still occurs, perform Check 5.
- Check 5 System board may be faulty. Replace it with a new one following the instructions in Chapter 4, *Replacement Procedure*.

2.10 Optical Disk Drive Troubleshooting

To check if optical disk drive is malfunctioning or not, follow the troubleshooting procedures below as instructed.

Procedure 1: Diagnostic Test Program Execution Check

Procedure 2: Connector Check and Replacement Check

Procedure 1 Diagnostic Test Program Execution Check

Execute the CD-ROM/DVD-ROM Test in the Diagnostic Program. Refer to Chapter 3, *Tests and Diagnostics* for more information on how to perform the test program.

Prepare the tools before the test.

If any error is detected by the test, go to Procedure 2.

Procedure 2 Connector Check and Replacement Check

The connection of optical disk drive and system board may be defective. Otherwise, they may be faulty. Disassemble the computer following the steps described in Chapter 4 and perform the following checks:

Check 1 Make sure optical disk drive is firmly connected to the connector on system board.

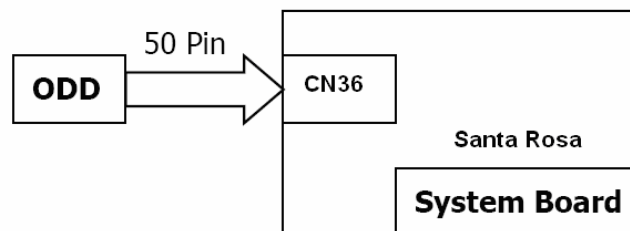

If the connection is loose, reconnect it firmly and return to Procedure 2. If the problem still occurs, perform Check 2.

Check 2 Optical disk drive may be faulty. Replace it with a new one following the steps in Chapter 4. If the problem still occurs, perform Check 3.

Check 3 System board may be faulty. Replace it with new one following the instructions in Chapter 4.

2.11 Modem Troubleshooting

To check if modem is malfunctioning or not, follow the troubleshooting procedures below as instructed.

Procedure 1: Diagnostic Test Program Execution Check

Procedure 2: Connector Check and Replacement Check

Procedure 1 Diagnostic Test Program Execution Check

Execute Modem test in the LAN/Modem/Bluetooth/IEEE1394 test program. Refer to Chapter 3, *Tests and Diagnostics* for more information on how to perform the test program.

If any error is detected, perform Procedure 2.

Procedure 2 Connector Check and Replacement Check

MDC (Modem Daughter Card) is used as the modem for this computer. MDC is connected to system board by connector CN31 (Santa Rosa) or CN29 (NAPA). And also, MDC is connected to system and LAN board by modem cable. If modem malfunctions, the connection of cable, board and module may be defective. Otherwise, they may be faulty.

Disassemble the computer following the steps described in Chapter 4 and perform the following checks:

Check 1 Make sure the following connections are firmly connected.

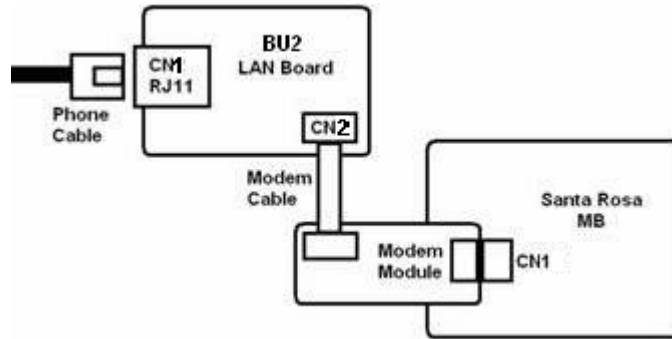

If any connector is disconnected, connect it firmly and return to Procedure 1. If the problem still occurs, perform Check 2.

- Check 2 Modem cable may be faulty. Replace it with a new one. If the problem still occurs, perform Check 3.
- Check 3 MDC may be faulty. Replace it with a new one following the steps in Chapter 4. If the problem still occurs, perform Check 4.
- Check 4 Cable between MDC and system board may be faulty. Replace it with a new one following the instructions in Chapter 4. If the problem still occurs, perform Check 5.
- Check 6 System board may be faulty. Replace it with a new one following the instruction in Chapter 4.

2.12 LAN Troubleshooting

To check if the computer's LAN is malfunctioning or not, follow the troubleshooting procedures below as instructed.

Procedure 1: Diagnostic Test Program Execution Check

Procedure 2: Connector Check and Replacement Check

Procedure 1 Diagnostic Test Program Execution Check

Execute LAN test in the LAN/Modem test program. Refer to Chapter 3, *Tests and Diagnostics* for more information on how to perform the test program.

If any error is detected by the test, go to Procedure 2.

Procedure 2 Connector Check and Replacement Check

The LAN function is embedded on system board. If LAN malfunctions, its connection is defective or LAN cable and system board may be faulty.

Check 1 Make sure LAN cable is firmly connected to the connector CN9. If the problem still occurs, perform Check 2.

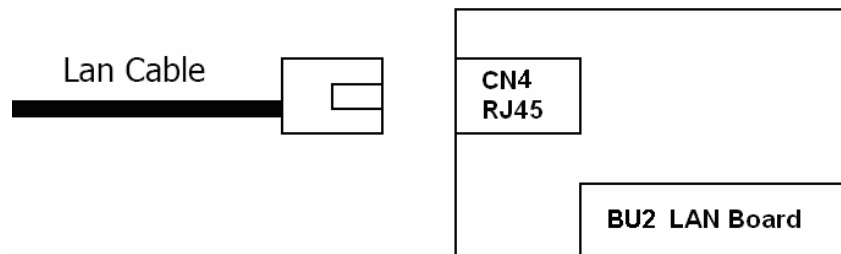

Check 2 LAN cable may be faulty. Replace it with a new one. If the problem still occurs, perform Check 3.

Check 3 System board may be faulty. Replace it with a new one following the instruction in Chapter 4.

2.13 Wireless LAN Troubleshooting

To check if the computer's Wireless LAN is malfunctioning or not, follow the troubleshooting procedures below as instructed.

Procedure 1: Transmitting-Receiving Check

Procedure 2: Antennas' Connection Check

Procedure 3: Replacement Check

Procedure 1 Transmitting-Receiving Check

Before starting the test, make sure the wireless communication switch is set in the ON position.

Check 1 Execute Wireless LAN test program to check the transmitting-receiving function of wireless LAN. You will need a second computer that can communicate by wireless LAN. Perform the test following the instructions described in Chapter 3.

If the computer passes the test, the function is correctly working. If the computer does not pass the test, perform Procedure 2.

Procedure 2 Antennas' Connection Check

The wireless LAN function-wiring diagram is shown below:

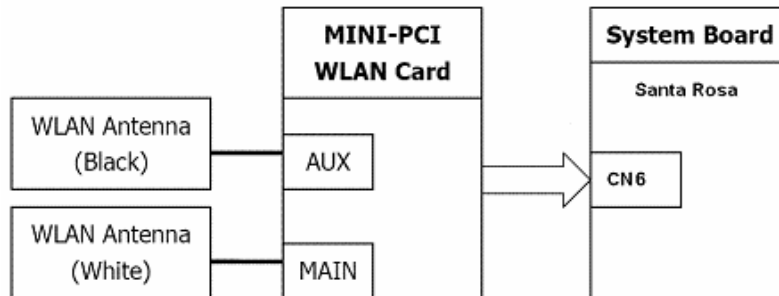

Any of the connections may be defective. Disassemble the computer following the steps described in Chapter 4, *Replacement Procedures*, and perform the following checks:

- Check 1 Make sure the wireless communication switch is “On”.
If the switch is “Off”, turn it “On”. If the problem still occurs, perform Check 2.
- Check 2 Make sure wireless LAN card (Mini-PCI) is firmly connected to the CN2200 on system board. If the connector is defective, connect it firmly and perform Procedure 1. If the problem still occurs, perform Check 3.
- Check 3 Make sure that wireless LAN antenna cables (black and white) are firmly connected to the connectors on Wireless LAN card. If wireless LAN antenna cables are not connected properly, connect them firmly and perform Procedure 1. If the problem still occurs, go to the procedure 3.

Procedure 3 Replacement Check

Wireless LAN card, wireless LAN antenna or system board may be faulty. Refer to Chapter 4, *Replacement Procedures*, for instructions on how to disassemble the computer and then perform the following checks:

- Check 1 Wireless LAN antenna may be faulty. Replace it with a new one following the instructions in Chapter 4, *Replacement Procedures*. If the problem still occurs, perform Check 2.

- Check 2 Wireless LAN card may be faulty. Replace it with a new one following the instructions in Chapter 4, *Replacement Procedures*. If the problem still occurs, perform Check 3.

- Check 3 System board may be faulty. Replace it with a new one following the instructions in Chapter 4, *Replacement Procedures*.

2.14 Sound Troubleshooting

To check if the sound function is malfunctioning or not, follow the troubleshooting procedures below as instructed.

Procedure 1: Connector Check

Procedure 2: Replacement Check

Procedure 1 Connector Check

As the connection may be defective, disassemble the PC and check each connection.

If the problem still occurs, go to Procedure 2.

Procedure 2 Replacement Check

- If External microphone/Headphone does not work properly, perform check 1.
- If Internal microphone /Speaker does not work properly, perform check 2.
- If HP out does not work properly, perform check 3.
- If Volume control does not work properly, perform check 4.

Check 1 External microphone/Headphone may be faulty. Replace it with a new one following the steps in Chapter 4. If the problem still occurs, perform Check 5.

Check 2 Internal microphone /Speaker may be faulty. Replace it with a new one following the steps in Chapter 4. If the problem still occurs, perform Check 5.

Check 3 HP out may be faulty. Replace it with a new one following the steps in Chapter 4. If the problem still occurs, perform Check 5.

Check 4 Volume control may be faulty. Replace it with a new one following the steps in Chapter 4. If the problem still occurs, perform Check 6.

Check 5 Flat cable between AD board/Speaker and system board may be faulty. Replace it with new cable following the instructions in Chapter 4. If the problem still occurs, perform Check 6.

Check 6 Audio board/System board may be faulty. Replace it with a new one following the instructions in Chapter 4.

2.15 Fingerprint Troubleshooting

To check if the computer's Fingerprint is malfunctioning or not, follow the troubleshooting procedures below as instructed.

Procedure 1: Connector Check and Replacement Check

Procedure 1 Diagnostic Test Program Execution Check

Execute Fingerprint test in the test program. Refer to Chapter 3, *Tests and Diagnostics* for more information on how to perform the test program.

If any error is detected, perform Procedure 2.

Procedure 2 Connector Check and Replacement Check

The Fingerprint function is embedded on system board. If Fingerprint malfunctions, its connection is defective or Fingerprint cable and system board may be faulty.

Check 1 Make sure Fingerprint cable is firmly connected to the connector CN14(**Santa Rosa**) or CN8(**NAPA**). If the problem still occurs, perform Check 2.

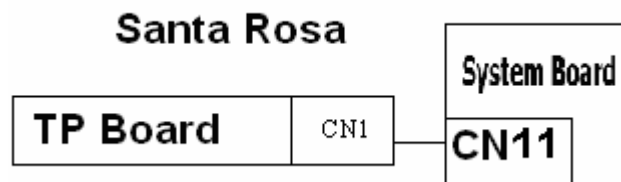

Check 2 Fingerprint cable may be faulty. Replace it with a new one. If the problem still occurs, perform Check 4.

Check 3 Fingerprint may be faulty. Replace it with a new one following the steps in Chapter 4. If the problem still occurs, perform Check 4.

Check 4 System board may be faulty. Replace it with a new one following the instruction in Chapter 4.

2.16 Bluetooth Troubleshooting

To check if the computer's **Bluetooth** is malfunctioning or not, follow the troubleshooting procedure below as instructed.

Procedure 1 Diagnostic Test Program Execution Check

Procedure 2 Connector Check and Replacement Check

The **Bluetooth** function is connected to system board. If **Bluetooth** malfunctions, its connection is defective or **Bluetooth** cable and system board may be faulty.

Check 1 Make sure **Bluetooth** cable is firmly connected to the connector **CN9(Santa Rosa)** or **CN13(NAPA)**. If the problem still occurs, perform Check 2.

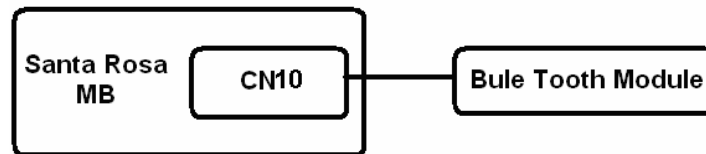

Check 2 **Bluetooth** cable may be faulty. Replace it with a new one. If the problem still occurs, perform Check 3.

Check 3 **Bluetooth** may be faulty. Replace it with a new one following the steps in Chapter 4. If the problem still occurs, perform Check 4.

Check 4 System board may be faulty. Replace it with a new one following the instruction in Chapter 4.

Chapter 3

Diagnostic Programs

Chapter 3 Contents

3.1	Tests and Diagnostics Software Overview	3
3.2	Executing the Diagnostic Test	4
3.3	Subtest names.....	8
3.4	System Test.....	11
3.5	Memory Test.....	18
3.6	Keyboard Test.....	22
3.7	Display Test	25
3.8	Floppy Disk Test.....	40
3.9	Hard Disk Test	42
3.10	Real Time Clock Test	45
3.11	Cache Memory Test.....	47
3.12	High Resolution Display Test.....	49
3.13	Multimedia Test	55
3.14	MEMORY2 Test.....	56
3.15	Error Codes and Error Status Names	58
3.16	Running Test.....	60
3.17	DMI INFOEMATION	61
3.17.1	Check DMI Information	61
3.17.2	Write DMI Information.....	61
3.17.3	Computrace Disabled.....	63
3.18	Log Utilities	64
3.18.1	Operations	64
3.19	System Configuration	66
3.20	Running Test Edit Item.....	67
3.20.1	Function Description.....	67
3.20.2	Operation Description.....	67
3.21	Common Tests and Operation	69
3.21.1	How to operate a window	69
3.21.2	How to Stop the Test Program.....	69
3.21.3	Test Status Screen	69
3.21.4	Test Stop Display	71
3.21.5	How to enter data	71

3.1 Tests and Diagnostics Software Overview

This chapter explains how to use the Tests and Diagnostics Software for the Satellite U400 and Satellite Pro U400 computer systems.

NOTES: *Before starting the Tests and Diagnostics software:*

- 1. Check all cables for loose connections.*
- 2. Exit any application and close Windows.*

The Diagnostics Menu consists of the following options:

- Diagnostic Test
- Running Test
- DMI Information
- Log Utilities
- System Configuration
- Option

The Diagnostic Test Menu consists of the following functional tests:

- System Test
- Memory Test
- Keyboard Test
- Display Test
- Floppy Disk Test
- Hard Disk Test
- Real Time Clock Test
- Cache Memory Test
- High Resolution Display Test
- Multimedia Test
- Memory2 Test
- FDD & HDD Error Retry Count Set

The following equipment is required to perform some of the diagnostic test programs:

- The Diagnostics Disk (all tests)
- A formatted working disk for the floppy disk drive test (all tests)
- A CD test media (Toshiba Backup CD ROM for the CD-ROM test)

The following sections detail the tests contained within the Diagnostic Test Menu. Refer to Sections 3.18, 3.19, 3.20 and, 3.21 for detailed information on the remaining functions of the Tests and Diagnostics software.

3.2 Executing the Diagnostic Test

DOS is required to run the Diagnostics Program. To start the programs follow these steps:

1. Create a DOS bootable disk and copy all the files from the Tests and Diagnostics software to the disk.
2. Insert the boot disk into the computer's floppy disk drive and turn on the computer.

The following screen displays:

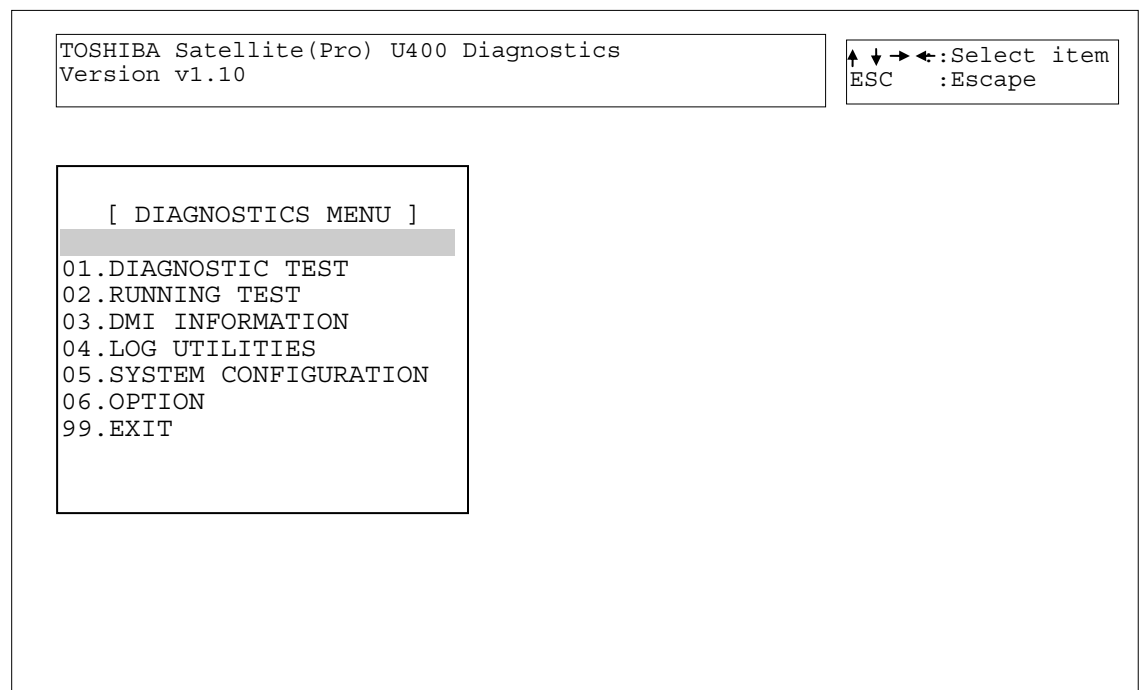

3. To select the Diagnostic Test from the Diagnostics Menu use the arrow keys to set the highlight bar to **01** and press **Enter**.

The following menu displays:

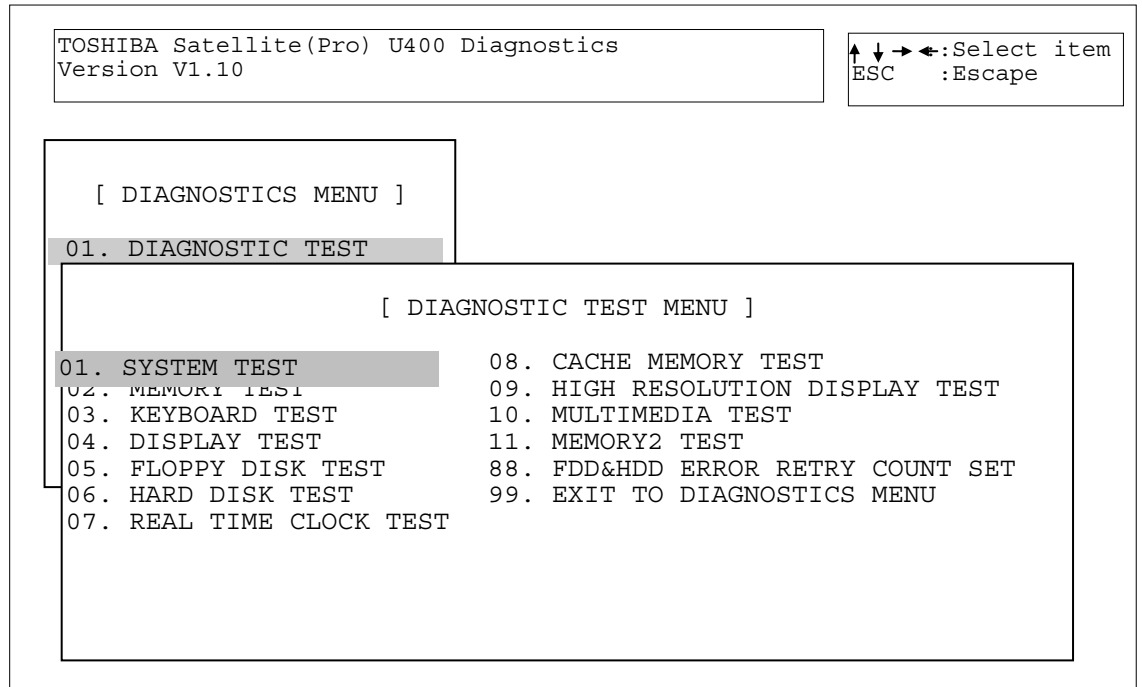

Refer to Sections 3.4 through 3.14 for detailed descriptions of Diagnostics Tests 1 through 11. Item 88 sets the floppy disk drive and hard disk drive error retry count. Item 99 exits the submenu of the Diagnostic Test and returns to the Diagnostics Menu.

4. Select the subtest you want to execute and press **Enter**. The following menu displays:

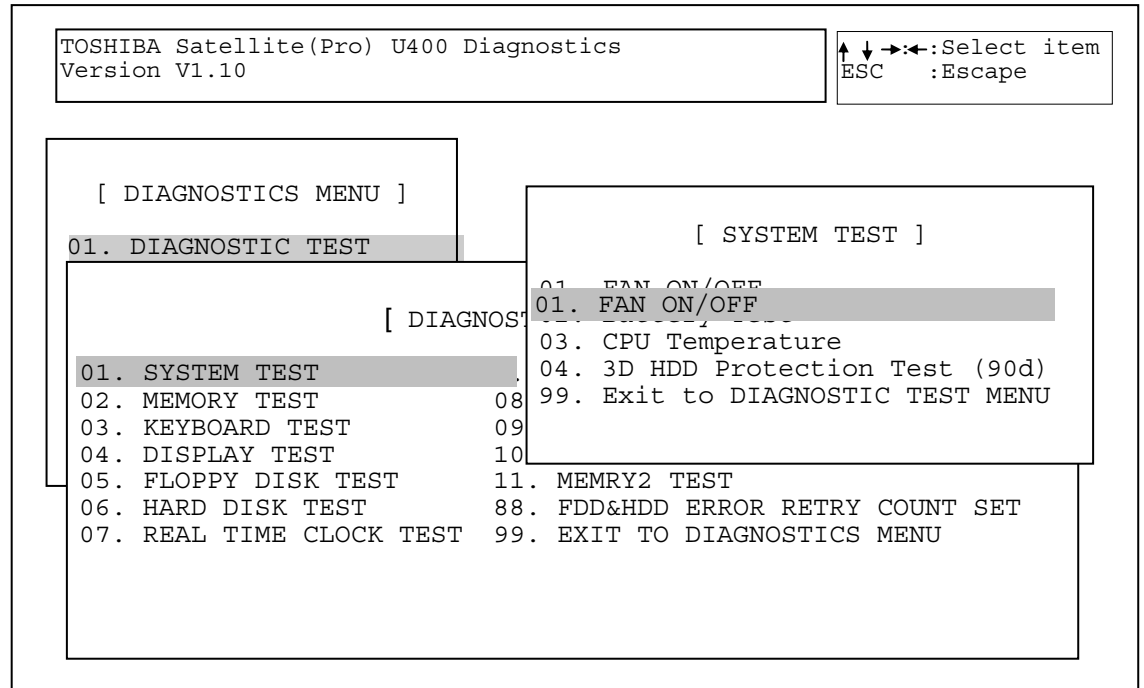

5. Select the desired test from the subtest menu and press **Enter**. The following Test Parameter menu displays:

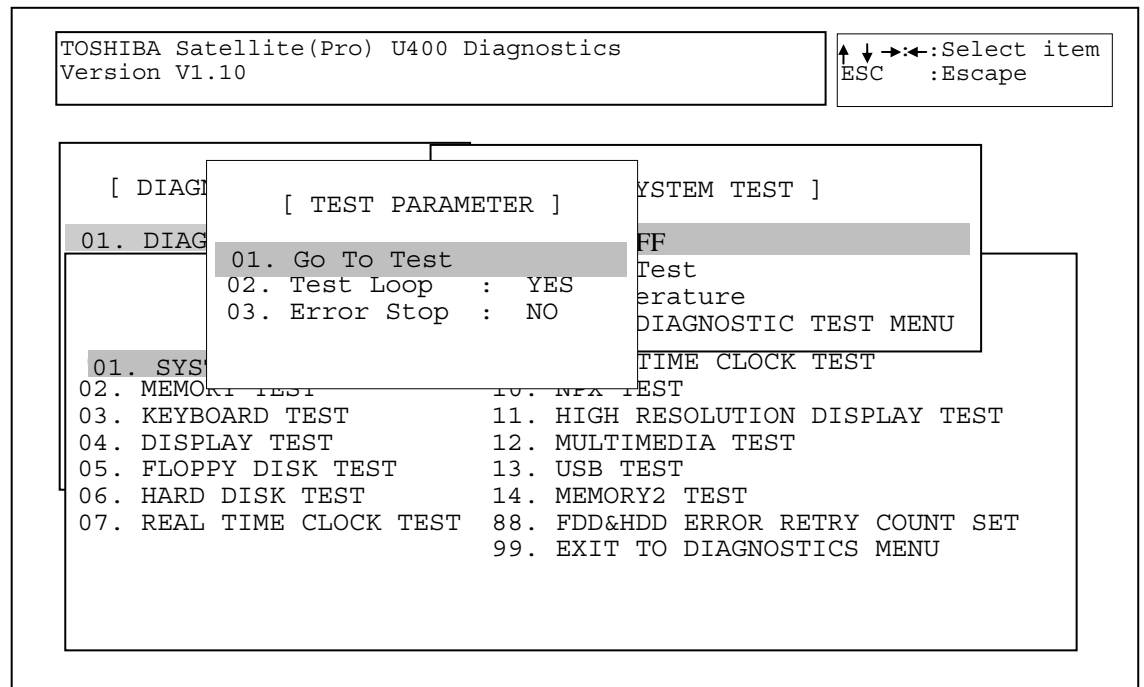

Use the arrow keys to highlight the desired option and press **Enter**.

NOTES: *The Item2 and 3 of Test Parameter are not used by some tests.*

Go To Test

Move the highlight bar to *Go To Test* and press **Enter** to start executing the test.

Test Loop

Select **NO** to return the screen to the subtest menu after the test is complete.

Select **YES** to set the test to run continuously until it is halted by the user.

Error Stop

Select **NO** to keep the test running even if an error is found.

Select **YES** to stop the test program when an error is found and display the HALT OPERATION screen as shown below:

```
[ [ HALT OPERATION ] ]
  1: Test end
  2: Continue
  3: Retry
```

These three selections have the following functions:

- 1: Terminates the test program and exits to the subtest menu.
- 2: Continues the test from the error.
- 3: Restarts the test from the beginning.

Use the arrow keys to move the cursor to the desired option and press **Enter**.

Table 3-1 in Section 3.3 lists the function of each test on the subtest menu. Table 3-2 in Section 3.15 lists the error codes and error status for each error.

3.3 Subtest names

Table 3-1 lists the subtest names for each test program in the Diagnostic Test menu.

Table 3-1 Subtest Names(1/3)

No.	Test Name	No.	Subtest Name
01	SYSTEM TEST	01	FAN ON/OFF check
		02	Battery TEST
		03	CPU Temperature
		04	3D HDD Protection Test (90d)
02	MEMORY TEST	01	Conventional Memory
		02	Protected Mode
		03	Protected Mode (32MB-MAX)
		04	RAM Refresh
		05	Stress Test
03	KEYBOARD TEST	01	Pressed Key Display [87 KBD]
		02	Pressed Key Display [86 KBD]
		03	Pressed Key Display [85 KBD]
		04	Hot Key Display [7 KBD]
		05	Hot Key Display [1 KBD]
		06	PS/2 Mouse (Pointing 2Button)
04	DISPLAY TEST	01	Character Attributes
		02	Character Set
		03	80* 25 Character Display
		04	320* 200 Graphics Display
		05	640* 200 Graphics Display
		06	640* 480 Graphics Display
		07	Display Page
		08	"H" Pattern Display
		09	Video DAC Register W/R/C
		10	Color Graphics Display
		11	Color Attributes Display
		12	Color Tiling

Table 3-1 Subtest Names(2/3)

No.	Test Name	No.	Subtest Name
05	FLOPPY DISK TEST	01	Sequential Read
		02	Sequential W/R/C
		03	Random Address/Data
		04	Write Specified Address
		05	Read Specified Address
06	HARD DISK TEST	01	Sequential Read
		02	Address Uniqueness
		03	Random Address Data
		04	Cross Talk and Peek Shift
		05	Write Specified Address
		06	Read Specified Address
		07	Sequential Write
		08	W-R-C Specified Address
07	REAL TIME CLOCK TEST	01	Real Time Test
		02	Backup Memory Test
		03	Real Time Carry Test
08	CACHE MEMORY TEST	01	Constant Data Test
		02	Address Pattern Test
		03	Increment/Decrement Test
		04	Bit Shift Pattern Test
		05	*Write Disturb Test
		06	Checker Board Test
		07	Marching Test
		08	Working Data Test
09	HIGH RESOLUTION DISPLAY TEST	01	VRAM W/R/C Test
		02	640* 480 Mode Display
		03	800* 600 Mode Display
		04	1024* 768 Mode Display
		05	"H" Pattern Display
		06	Focus Test ("E" Pattern)

Table 3-1 Subtest Names(3/3)

No.	Test Name	No.	Subtest Name
10	MULTIMEDIA TEST	01	Sequential Read Test
		02	Random Read Test
		03	Read Specified Address Test
		04	1 point W/R/C Test
11	MEMORY2	01	All one/zero Test
		02	Walking 1/Walking 0 Test(Left)
		03	Walking 1/Walking 0 Test(Right)
		04	Walking 1/Walking 0 Test(Left /Right)

**This test cannot support.*

3.4 System Test

To execute the System Test select **01** from the Diagnostic Test Menu, press **Enter** and follow the directions on the screen. The System Test contains three subtests. Move the highlight bar to the subtest you want to execute and press **Enter**.

Subtest 01 FAN ON/OFF Checking

Select 1,2,3 to control FAN on/off , 1=Fan on , 2=Fan off , 3=Exit .

[BU1FAN.EXE] Program Version : 1.0

1: Fan On 2: Fan Off 3: Exit

Fan1 Status On Fan1RPM : 5000 or Fan1 Status OFF Fan1RPM : 0

Subtest 02 Battery Test

This will display battery information for check , press [ESC] to exit .

[BOIPCU.EXE] Program Version : 1.0 03-27-2007

voltage	: 12522 mV	Remaining capacity alarm	: 400 mAh
temperature	: 24.4 'C	Remaining time alarm	: 10 min
current	: 1330 mA	Battery mode	: 0
average current	: 1327 mA	AtRate	: 0 mA
relative state of charge	: 93 %	At rate time to full	: 65535 min
absolute state of charge	: 89 %	At rate time to empty	: 65535 min
remaining capacity	: 3546 mAh	At rate O. K.	: FFFF
full charge capacity	: 3800 mAh	Maximun error	: 2 %
run time to empty	: -1 min.	Charging current	: 2800 mA
average time to empty	: -1 min.	Charging voltage	: 12600 mA
average time to full	: 101 min.	Manufacturer name	: SANYO
cycle count	: 10 times	Device name	: NS2P3SZDENVWR
design capacity	: 4000 mAh	Device chemistry	: LION
design voltage	: 11100 mV	Manufacturer data	: 0
specification information	: 2.1	Manufacture date	: 9/13/2005
serial no.	: 32009		
STATUS	: INIT		

Press [ESC] KEY to exit

Subtest 03 CPU Temperature

This will display CPU Temperature for check , press [ESC] to exit .

[CPU_TEMP.EXE] Program Version : 1.0 03-27-2007

CPU Temperature : XX

Subtest 04 3D HDD Protection Test (90d)

1. For Field inspection T&D.

This program judges by sampling five kinds of data shown below.

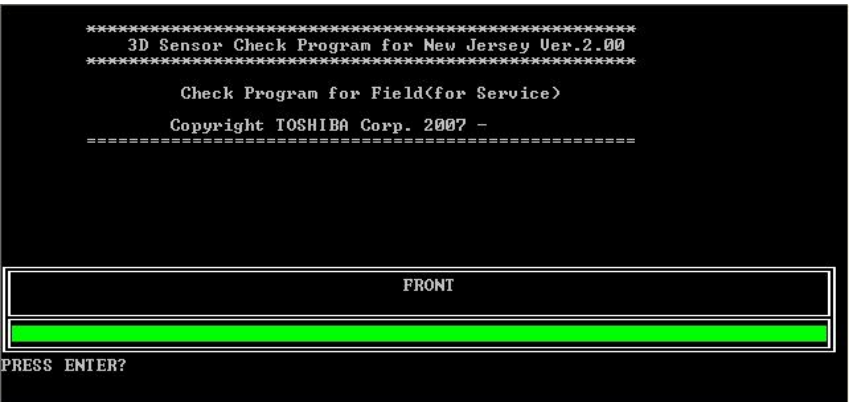
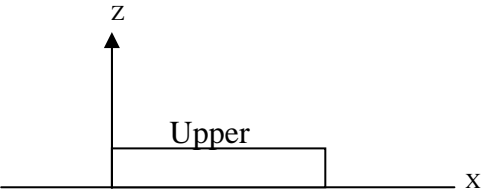
No	Item	Contents
1	Access platform.	An access platform is leveling.
2	Test Fixture	The Fixture which fixes PC by 90 degree inclination is used. Vibration/shock doesn't take a PCB at the time of T&D inspection.
3	Test1	<p>The display of a test program and the set method of PC are shown below.</p> <p>Display of a Test Program The portion which PC and Test-Fixture contact is green.</p>  <p>Set method of PC</p> 

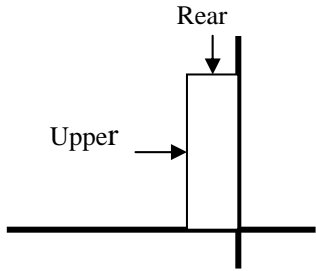
		Judgment If all data is less than ranges, it will be OK.
4	Test2	<p>The display of a test program and the set method of PC are shown below.</p> <p>Display of a Test Program</p>  <p>Set method of PC</p>  <p>Judgment If all data is less than ranges, it will be OK.</p>

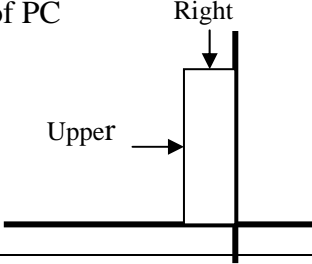
5	Test3	<p>The display of a test program and the set method of PC are shown below.</p> <p>Display of a Test Program</p>  <p>Set method of PC</p>  <p>Judgment</p> <p>If all data is less than ranges, it will be OK.</p>
---	-------	---

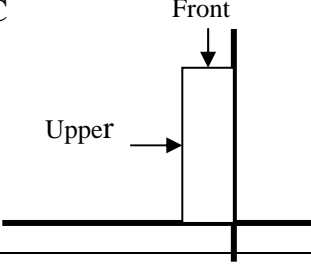
6	Test4	<p>The display of a test program and the set method of PC are shown below.</p> <p>Display of a Test Program</p>  <p>Set method of PC</p>  <p>Judgment</p> <p>If all data is less than ranges, it will be OK.</p>
---	-------	---

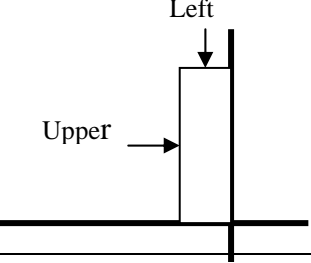
7	Test5	<p>The display of a test program and the set method of PC are shown below.</p> <p>Display of a Test Program</p>  <p>Set method of PC</p>  <p>Judgment If all data is less than ranges, it will be OK.</p>
8	Inspection	<p>Judgment If all data is less than ranges, it will be OK.</p>
9	Setting Calibration data	<p>When an inspection result is O.K., calibration at HPC.</p>

2. Test Result

A test result is displayed when a test is completed. A display of result is O.K. or NG.

And an error flag is returned at the end of a program.

OK is 0.

NG is 1.

3.5 Memory Test

To execute the Memory Test select **02** from the Diagnostic Test Menu, press **Enter** and follow the directions on the screen. The Memory Test contains five subtests that test the computer's memory. Move the highlight bar to the subtest you want to execute and press **Enter**.

***NOTE:** If **NO** is selected for Test Loop on the Test Parameter menu, the Test Status screen displays while the test is executing. When the test is complete the Memory Test menu displays.*

*If **YES** is selected for Test Loop on the Test Parameter menu, the Test Status screen displays while the test is executing. Press **Ctrl + break** to return to the Memory Test menu.*

Subtest 01 Conventional Memory

This subtest first writes test data patterns to conventional memory (0 to 640 KB), then reads the new data and compares the result with the original data patterns.

If a compare error occurs, the write data, read data, and test address display on the screen. Addresses are displayed in 4KB increments during the test.

Test Process:

1. Byte Enable Test
One bit write/ 8 bit read" is executed and the new data is compared with the original data.
Test data = CCAA5533H, 80000000H
2. Byte Enable Test
"One bit write/16 bit read" is executed and the new data is compared with the original data.
Test data = CCAA5533H, 80000000H
3. Data bus test
"One bit write/16 bit read" is executed and the new data is compared with the original data.
Test data = 1H, 2H, 4H, 8H, 10H, through 80000000H.
4. Fixed data test
"16 bit write/ 16 bit read" is executed and the new data is compared to the original data.
Test data = FFFFFFFFH, 00000000H, 80018001H

5. Address pattern test
“16 bit write and 16 bit read” of address pattern data is executed and the new data is compared with the original data.
Test data = 0000H, 0004H, 0008H, 000CH,...8000H, 8004H, through FFECH

Subtest 02 Protected Mode

This subtest first writes data patterns and address data from 1 to 32 MB, then reads the new data and compares the result with the original data patterns. Addresses are displayed in 64KB increments during the test.

Test Process:

1. Byte Enable Test
“One bit write/ 8 bit read” is executed and the new data is compared with the original data.
Test data = CCAA5533H, 80000000H
2. Byte Enable Test
“One bit write/16 bit read” is executed and the new data is compared with the original data.
Test data = CCAA5533H, 80000000H
3. Data bus test
“One bit write/16 bit read” is executed and the new data is compared with the original data.
Test data = 1H, 2H, 4H, 8H, 10H, through 80000000H.
4. Fixed data test
“16 bit write/ 16 bit read” is executed and the new data is compared to the original data.
Test data = FFFFFFFFH, 00000000H, 80018001H
5. Address pattern test
“16 bit write and 16 bit read” of address pattern data is executed and the new data is compared with the original data.
Test data = 0000H, 0004H, 0008H, 000CH,...8000H, 8004H, through FFECH

Subtest 03 Protected Mode [32MB - MAX]

This subtest first writes data patterns and address data from 32MB to the maximum installed memory, reads the new data, and then compares the result

with the original data patterns. Addresses are displayed in 64KB increments during the test.

Test Process:

1. Byte Enable Test
“One bit write/ 8 bit read” is executed and the new data is compared with the original data.
Test data = CCAA5533H, 80000000H
2. Byte Enable Test
“One bit write/16 bit read” is executed and the new data is compared with the original data.
Test data = CCAA5533H, 80000000H
3. Data bus test
“One bit write/16 bit read” is executed and the new data is compared with the original data.
Test data = 1H, 2H, 4H, 8H, 10H, through 80000000H.
4. Fixed data test
“16 bit write/ 16 bit read” is executed and the new data is compared to the original data.
Test data = FFFFFFFFH, 00000000H, 80018001H
5. Address pattern test
“16 bit write and 16 bit read” of address pattern data is executed and the new data is compared with the original data.
Test data = 0000H, 0004H, 0008H, 000CH,...8000H, 8004H, through FFECH

Subtest 04 RAM Refresh

This subtest writes a data pattern (CCAA5533H) in 4KB from 0 to the maximum installed memory, then waits for a memory refresh cycle (16 ms or more), reads the new data, and compares the result with the original data pattern.

Test Process:

1. Checks the memory size to determine the maximum size of installed memory.
2. Tests memory addresses 0 to the maximum installed.
3. Writes, reads, and compares test data after a memory refresh cycle (16ms or more).

***NOTE:** There may be a short delay between write and read operations, depending on the memory size.*

Subtest 05 Stress Test

This subtest writes the following 16KB data patterns to the Write/Read Buffer in conventional memory.

```
data:  FFFFFFFFFFFFFFFFFF0000000000000000
       5555555555555555AAAAAAAAAAAAAAAA
       CCCCCCCCCCCCCCCC3333333333333333
       0000000000000000FFFFFFFFFFFFFFFF
       AAAAAAAAAAAAAAAAAA55555555555555
       3333333333333333CCCCCCCCCCCCCCCC
       FFFFFFFFFFFFFFFFFF0000000000000000
       0000000000000000FFFFFFFFFFFFFFFF
       5555555555555555AAAAAAAAAAAAAAAA
       AAAAAAAAAAAAAAAAAA55555555555555
       CCCCCCCCCCCCCCCC3333333333333333
       3333333333333333CCCCCCCCCCCCCCCC
```

3.6 Keyboard Test

To execute the Keyboard Test select **03** from the Diagnostic Test Menu, press **Enter** and follow the directions on the screen. The Keyboard Test contains five subtests that test the computer's keyboard and mouse actions. Move the highlight bar to the subtest you want to execute and press **Enter**.

***NOTE:** The Test Loop and Error Stop parameters are not enabled for the Keyboard test.*

Subtest 01 Pressed Key Display [87 Keyboard]

When you execute this subtest, the keyboard layout is drawn on the display. When any key is pressed, the corresponding key on the screen changes from light to dark. Holding a key down enables the auto-repeat function which causes the key's display character to blink.

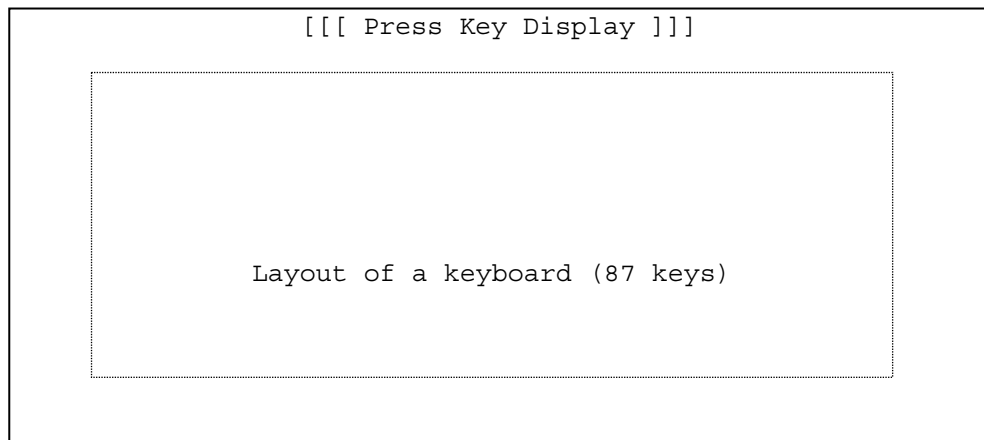

Subtest 02 Pressed Key Display [86 Keyboard]

This subtest is used for the 86 keyboard and functions the same as Subtest 1.

Subtest 03 Pressed Key Display [85 Keyboard]

This subtest is used for the 85 keyboard and functions the same as Subtest 1.

Subtest 04 Hot Key Display [7 Key]

This subtest is used for the 7 hot key and functions the same as Subtest 1.

MUTE MUSIC PLAY STOP BACK NEXT WLAN

Subtest 05 Hot Key Display [1 Key]

This subtest is used for the 1 hot key and functions the same as Subtest 1.

WLAN

Subtest 06 PS/2 Mouse (Pointing)

This subtest checks the function of mouse as shown below.

- A) Pointing device (mouse)
- B) Mouse buttons

Please move cursor to upper left and press left button , screen will display <PRESS> in left rectangle , move cursor to lower right and press right button , screen will display <PRESS> in right rectangle , the program exit .

If left and right button short , screen will display <Left and Right Button maybe short > , the program exit .

LEFT
PRESS



TOUCH_PAD TEST

RIGHT
PRESS

Please Do Not Press the Left and Right Button At The Same Time

Subtest 03 80 * 25 Character Display

This subtest uses 80*25 video resolution to display character codes 20H - 7EH using Mode 03H (80*25). The data displayed is shifted 1 byte to the left for each line as shown below.

```
80*25 CHARACTER DISPLAY
0123456789012345678901234567890123456789012345678901234567890123456789
!"#$%&'()*+,-./0123456789:;<?@ABCDEFGHIJKLMN OPQRSTUVWXYZ[\]^_`abcdefghijklmnop
!"#$%&'()*+,-./0123456789:;<?@ABCDEFGHIJKLMN OPQRSTUVWXYZ[\]^_`abcdefghijklmnop
!"#$%&'()*+,-./0123456789:;<?@ABCDEFGHIJKLMN OPQRSTUVWXYZ[\]^_`abcdefghijklmnop
!"#$%&'()*+,-./0123456789:;<?@ABCDEFGHIJKLMN OPQRSTUVWXYZ[\]^_`abcdefghijklmnopqr
!"#$%&'()*+,-./0123456789:;<?@ABCDEFGHIJKLMN OPQRSTUVWXYZ[\]^_`abcdefghijklmnopqrs
!"#$%&'()*+,-./0123456789:;<?@ABCDEFGHIJKLMN OPQRSTUVWXYZ[\]^_`abcdefghijklmnopqrst
!"#$%&'()*+,-./0123456789:;<?@ABCDEFGHIJKLMN OPQRSTUVWXYZ[\]^_`abcdefghijklmnopqrstu
!"#$%&'()*+,-./0123456789:;<?@ABCDEFGHIJKLMN OPQRSTUVWXYZ[\]^_`abcdefghijklmnopqrstu
```

Shifted to the left one letter by one letter.

```
23456789:;<?@ABCDEFGHIJKLMN OPQRSTUVWXYZ[\]^_`abcdefghijklmnop gh I j k l mnopqrst
3456789:;<?@ABCDEFGHIJKLMN OPQRSTUVWXYZ[\]^_`abcdefghijklmnop gh I j k l mnopqrst
456789:;<?@ABCDEFGHIJKLMN OPQRSTUVWXYZ[\]^_`abcdefghijklmnop gh I j k l mnopqrst
```

Press [Enter] KEY

To exit this subtest and return to the Display Test menu:

Press **Enter** if **NO** was selected for *Test Loop* on the Test Parameter Menu.
Press **Ctrl + break** if **YES** was selected for *Test Loop* on the Test Parameter Menu.

Subtest 04 320 * 200 Character Display

This subtest uses 320*200 video resolution to display green, red and yellow followed by cyan, magenta, and white. The screen below shows the displays when this subtest is executed.

320 * 200 GRAPHICS DISPLAY

COLOR SET 0 : [4]

GREEN
CYAN

RED
MAGENTA

YELLOW
WHITE



Press **ENTER** to display the following sixteen colors: black, blue, green, cyan, red, magenta, brown, white, dark gray, light blue, light green, light cyan, light red, light magenta, yellow, and intensified white.

Test Program for Field.

320*200 GRAPHICS DISPLAY : [D]

BLACK	<input type="text"/>	<input type="text"/>	D GRAY
BLUE	<input type="text"/>	<input type="text"/>	L BLUE
GREEN	<input type="text"/>	<input type="text"/>	L GREEN
CYAN	<input type="text"/>	<input type="text"/>	L CYAN
RED	<input type="text"/>	<input type="text"/>	L RED
MAGENTA	<input type="text"/>	<input type="text"/>	L MAGENTA
BROWN	<input type="text"/>	<input type="text"/>	YELLOW
WHITE	<input type="text"/>	<input type="text"/>	I WHITE

Press [Enter] KEY

<input type="text"/>	<input type="text"/>
----------------------	----------------------

Press **ENTER** to display 64 gradations of red, green, blue and white on the screen

320*200 GRAPHICS DISPLAY : [13]

64 gradations of red are displayed.
64 gradations of green are displayed.
64 gradations of blue are displayed.
64 gradations of white are displayed.

Press [Enter] KEY

To exit this subtest and return to the Display Test menu:

Press **Enter** if **NO** was selected for *Test Loop* on the Test Parameter Menu.
Press **Ctrl + break** if **YES** was selected for *Test Loop* on the Test Parameter Menu.

Subtest 05 640 * 200 Character Display

This subtest uses 640*200 video resolution to display three windows, each window drives a different set of dots: even dots, odd dots and all dots. The screen below displays when this subtest is executed.

640 * 200 GRAPHICS DISPLAY : [6]

EVEN DOTS DRIVEN	ODD DOTS DRIVEN	ALL DOTS DRIVEN

Press **ENTER** to display the following 16 colors: black, blue, green, cyan, red, magenta, brown, white, dark gray, light blue, light green, light cyan, light red, light magenta, yellow, and intensified white.

640*200 GRAPHICS DISPLAY : [E]

BLACK	<input type="text"/>	<input type="text"/>	DARK GRAY
BLUE	<input type="text"/>	<input type="text"/>	LIGHT BLUE
GREEN	<input type="text"/>	<input type="text"/>	LIGHT GREEN
CYAN	<input type="text"/>	<input type="text"/>	LIGHT CYAN
RED	<input type="text"/>	<input type="text"/>	LIGHT RED
MAGENTA	<input type="text"/>	<input type="text"/>	LIGHT MAGENTA
BROWN	<input type="text"/>	<input type="text"/>	YELLOW
WHITE	<input type="text"/>	<input type="text"/>	INTENSIFIED WHITE
	<input type="text"/>	<input type="text"/>	

Press [Enter] KEY

To exit this subtest and return to the Display Test menu:

Press **Enter** if **NO** was selected for *Test Loop* on the Test Parameter Menu.
Press **Ctrl + break** if **YES** was selected for *Test Loop* on the Test Parameter Menu.

Test Program for Field.

Subtest 06 640 * 480 Character Display

This subtest uses 640*350 video resolution to display 16 colors: black, blue, green, cyan, red, magenta, brown, white, dark gray, light blue, light green, light cyan, light red, light magenta, yellow, and intensified white. The screen below displays when this subtest is executed.

640*350 GRAPHICS DISPLAY : [10]

BLACK	<input type="text"/>	<input type="text"/>	DARK GRAY
BLUE	<input type="text"/>	<input type="text"/>	LIGHT BLUE
GREEN	<input type="text"/>	<input type="text"/>	LIGHT GREEN
CYAN	<input type="text"/>	<input type="text"/>	LIGHT CYAN
RED	<input type="text"/>	<input type="text"/>	LIGHT RED
MAGENTA	<input type="text"/>	<input type="text"/>	LIGHT MAGENTA
BROWN	<input type="text"/>	<input type="text"/>	YELLOW
WHITE	<input type="text"/>	<input type="text"/>	INTENSIFIED WHITE
Press [Enter]	<input type="text"/>	<input type="text"/>	

Press **ENTER** to display the following 16 colors: black, blue, green, cyan, red, magenta, brown, white, dark gray, light blue, light green, light cyan, light red, light magenta, yellow, and intensified white using 640*480 video resolution.

640*480 GRAPHICS DISPLAY : [12]

BLACK	<input type="text"/>	<input type="text"/>	DARK GRAY
BLUE	<input type="text"/>	<input type="text"/>	LIGHT BLUE
GREEN	<input type="text"/>	<input type="text"/>	LIGHT GREEN
CYAN	<input type="text"/>	<input type="text"/>	LIGHT CYAN
RED	<input type="text"/>	<input type="text"/>	LIGHT RED
MAGENTA	<input type="text"/>	<input type="text"/>	LIGHT MAGENTA
BROWN	<input type="text"/>	<input type="text"/>	YELLOW
WHITE	<input type="text"/>	<input type="text"/>	INTENSIFIED WHITE
	<input type="text"/>	<input type="text"/>	

Press [Enter] ~~RET~~

To exit this subtest and return to the Display Test menu:

Press **Enter** if **NO** was selected for *Test Loop* on the Test Parameter Menu.
Press **Ctrl + break** if **YES** was selected for *Test Loop* on the Test Parameter Menu.

Subtest 10 Color Graphics Display

This subtest displays three colors, cyan, white and yellow on the screen as shown below.

640 * 480 GRAPHICS DISPLAY

CYAN

WHITE

YELLOW

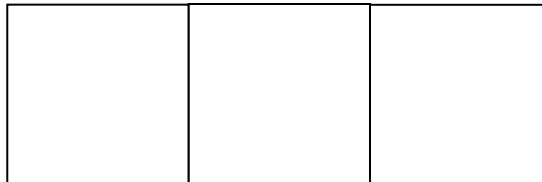

To exit this subtest and return to the Display Test menu:

Press **Enter** if **NO** was selected for *Test Loop* on the Test Parameter Menu.
Press **Ctrl + break** if **YES** was selected for *Test Loop* on the Test Parameter Menu.

Subtest 11 Color Attributes Display

This subtest displays 16 colors: black, blue, green, cyan, red, magenta, brown, white, dark gray, light blue, light green, light cyan, light red, light magenta, yellow, and intensified white. The screen below displays when this subtest is executed.

640*480 COLOR ATTRIBUTE DISPLAY

0	1	2	3	4	5	6	7	8	9	A	B	C	D	E	F
---	---	---	---	---	---	---	---	---	---	---	---	---	---	---	---

Press [Enter] Key

Pressing **Enter** executes VRAM mapping test which indicates vertical lines

Press **Enter** to execute the VRAM mapping test which displays a horizontal line at one dot intervals using Mode 12.

NOTE: *The following screen does not display correctly. It will be amended in the next version.*



Press **Enter** to execute the VRAM mapping test which displays a vertical line at four dot intervals using Mode 12.

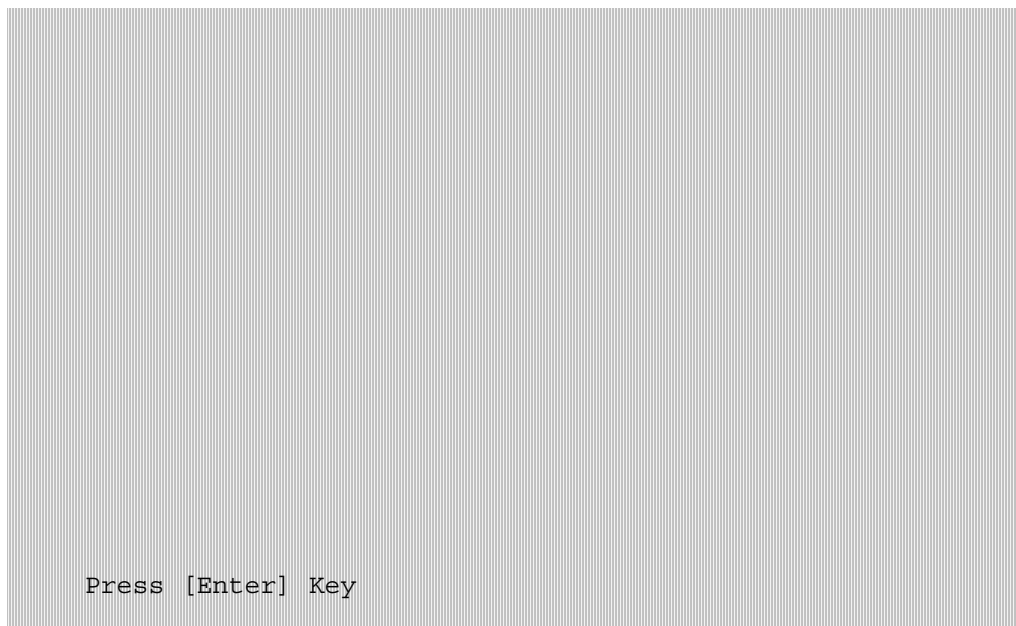

Press **Enter** to display VRAM mapping test using the all dots Mode.

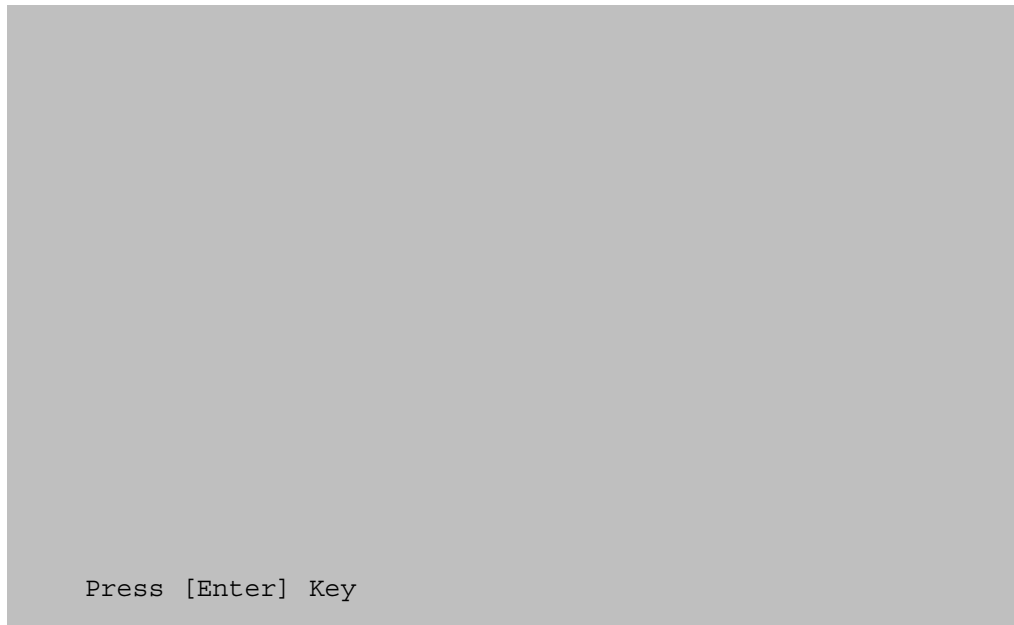

To exit this subtest and return to the Display Test menu:

Press **Enter** if **NO** was selected for *Test Loop* on the Test Parameter Menu.
Press **Ctrl + break** if **YES** was selected for *Test Loop* on the Test Parameter Menu.

Subtest 12 Color Tiling

This subtest displays black, gray, white, and 3 gradations of red, green, and blue as shown in the following display.

Black	Red	Green	Blue
Gray	Red Gradation	Green Gradation	Blue Gradation
White	Red Gradation	Green Gradation	Blue Gradation

To exit this subtest and return to the Display Test menu:

Press **Enter** if **NO** was selected for *Test Loop* on the Test Parameter Menu.
Press **Ctrl + break** if **YES** was selected for *Test Loop* on the Test Parameter Menu.

3.8 Floppy Disk Test

CAUTION: Before running the floppy disk test, prepare a formatted work disk. Remove the diagnostics disk and insert the work disk into the FDD. The contents of the floppy disk will be erased.

To execute the Floppy Disk Test select **05** from the Diagnostic Test Menu, press **Enter** and follow the directions on the screen. The Floppy Disk Test contains five subtests that test the FDD. Move the highlight bar to the subtest you want to execute and press **Enter**.

Subtest 01 Sequential Read

This subtest sequentially reads all the tracks (Tracks 0 to 79) on the floppy disk.

Subtest 02 Sequential W/R/C

This subtest continuously writes the data pattern B5ADADh to all the specified tracks selected in Subtest 01. The data pattern is then read and compared to the original data.

Subtest 03 Random Address/Data

This subtest writes random data to random addresses on all tracks defined in Subtest 01. The data is then read and compared to the original data.

Subtest 04 Write Specified Address

NOTE: The first two digits of the ADDRESS indicate which track is being tested, the next two digits indicates the head, and the last two digits indicate the sector.

This subtest allows you to verify the errors from Subtest 02. It writes specified data to a specified track and head. Use the Log Utilities (see Section 3.21) to specify the track number and head number where the error(s) occurred during Subtest 02. The following message displays on the screen to enter the test data, track number, and head number.

```
TEST DATA ??  
TRACK NO (00~79) ??  
HEAD NO (0~1) ?
```

Subtest 05 Read Specified Address

This subtest reads data from a specified track and head.

The following message displays on the screen to enter the test track number and head number.

```
TRACK NO (00~79) ??  
HEAD NO (0~1) ?
```

3.9 Hard Disk Test

To execute the Hard Disk Test select **06** from the Diagnostic Test Menu, press **Enter** and follow the directions on the screen. The Hard Disk Test contains eight subtests that test the functions of the hard disk drive. Move the highlight bar to the subtest you want to execute and press **Enter**.

NOTES:** The contents of the hard disk will be erased when subtest 02, 03, 04, 05, 07 or 08 is executed. Before running the test, transfer the contents of the hard disk to other disk. A password is necessary to execute the Hard Disk Test. The password is: **hard disk

Subtest 01 Sequential Read

This subtest sequentially reads all the tracks on the HDD starting at track 0. When all tracks have been read, the test starts at the maximum track and reads sequentially back to track 0.

Subtest 02 Address Uniqueness (This subtest need very long time)

This subtest writes unique address data to each sector of the HDD track-by-track. The data written to each sector is then read and compared with the original data. There are three ways the HDD can be read:

- Forward sequential
- Reverse sequential
- Random

Subtest 03 Random Address Data

This subtest writes random data to 1000 different random addresses on the HDD. This data is then read and compared to the original data.

Subtest 04 Cross Talk and Peak Shift

This subtest writes eight of the most likely to fail data patterns (shown below) to a cylinder on the HDD, then reads the data while moving from cylinder to cylinder.

Data Pattern

B5ADADH
4A5252H
EB6DB6H
149249H
63B63BH
9C49C4H
2DB6DBH
D24924H

Subtest 05 Write Specified Address

NOTE: This subtest is designed to run with the Test Loop set to **NO**. This subtest is a debug tool and the operator should enter the Test Parameters each time.

This subtest allows you to verify the errors from Subtest 01. It writes specified data to a specified LBA. Use the Log Utilities (see Section 3.18) to specify the LBA number where the error(s) occurred during Subtest 01. The following message displays on the screen to enter the test data, and Sector count.

```
TEST DATA          ??  
SECTOR COUNT (01~39) ??  
START ADDRESS (00000000~MAX Address) ?
```

Subtest 06 Read Specified Address

NOTE: This subtest is designed to run with the Test Loop set to **NO**. This subtest is a debug tool and the operator should enter the Test Parameters each time.

This subtest allows you to verify the errors from Subtest 01. It reads specified data (Subtest 06) from a specified LBA. Use the Log Utilities (see Section 3.18) to specify the LBA number where the error(s) occurred during Subtest 01. The following message displays on the screen to enter the test sector count.

```
SECTOR COUNT (01~39) ??  
START ADDRESS (00000000~MAX Address) ?
```

Subtest 07 Sequential Write

This subtest writes specified data to all cylinders on the HDD. The following message displays on the screen to enter the test data.

TEST DATA ????? (=37b3H)

Subtest 08 W-R-C Specified Address

This subtest writes specified data to a specified sector count, then reads and compares the result. The following message displays on the screen to enter the test data, sector count.

TEST DATA ????? (=37b3H)
SECTOR COUNT (01~39) ??
START ADDRESS (00000000~Max Address) ?

3.10 Real Time Clock Test

To execute the Real Time Clock Test select **07** from the Diagnostic Test Menu, press **Enter** and follow the directions on the screen. The Real Time Clock Test contains three subtests that test the computer's real time functions. Move the highlight bar to the subtest you want to execute and press **Enter**.

Subtest 01 Real Time

This subtest allows you to change the date and time. To execute the Real Time Subtest, follow these steps:

1. Select Subtest **01** and the following displays:

```
[ REAL TIME TEST ]  
  
Current date : mm-dd-yyyy  
Current time : hh:mm:ss  
  
Enter new date : mm-dd-yyyy  
Enter new time : hh:mm:ss  
  
Press [Enter] key to exit test
```

2. If the current date is not correct, enter the correct date at the "Enter new date" prompt and press **Enter**. The following prompt displays:

```
Enter new time :
```
3. If the current time is not correct, enter the correct time using a 24-hour format and press **Enter**.

NOTE: If **NO** is selected for Test Loop on the Test Parameter menu, the Real Time Clock Test menu displays.
If **YES** is selected for Test Loop on the Test Parameter menu, the screen above displays and the test is executed again. Press **Ctrl + break** to return to the Real Time Clock Test menu.

Subtest 02 Backup Memory

This subtest writes 50 bytes of test data (FFH, AAH, 55H, and 00H) to the CMOS 14th address, then reads the new data and compares it to the original data.

Subtest 03 Real Time Carry

CAUTION: *When this subtest is executed, the current date and time are reset.*

This subtest checks the clock's carry function.

```
                [ REAL TIME CARRY TEST ]  
  
Current date : 12-31-1999  
Current time : 23:59:55  
  
Press [Enter] key to exit test
```

The following is the display after the date carry function is executed.

```
                [ REAL TIME CARRY TEST ]  
  
Current date : 01-01-2000  
Current time : 00:00:01  
  
Press [Enter] key to exit test
```

To exit this subtest and return to the Real Time Clock menu:

Press **Enter** if **NO** was selected for *Test Loop* on the Test Parameter Menu.
Press **Ctrl + break** if **YES** was selected for *Test Loop* on the Test Parameter Menu.

3.11 Cache Memory Test

To execute the Cache Memory Test select **08** from the Diagnostic Test Menu, press **Enter** and follow the directions on the screen. The Cache Memory Test contains eight subtests that test the computer's cache memory. Move the highlight bar to the subtest you want to execute and press **Enter**.

***NOTE:** If **NO** is selected for Test Loop on the Test Parameter menu, the screen will remain blank while the subtest is executing. When the test is complete the Cache Memory Test menu displays.*

*If **YES** is selected for Test Loop on the Test Parameter menu, the Test Status screen displays while the subtest is executing. Press **Ctrl + break** to return to the Cache Memory Test menu.*

Subtest 01 Constant Data Test

This subtest reads the contents of cache memory and saves it into RAM. The subtest then writes constant data (FFFFH, AAAAH, 5555H, 0101H, 0000H), reads the new data and compares the result with the original data pattern. The original cache memory content is then restored to the cache memory.

Subtest 02 Address Pattern Test

This subtest reads the contents of cache memory and saves it into RAM. The subtest then writes address data patterns (0000H, 0001H, 0002H, through 3FFDH, 3FFEH, 3FFFH), reads the new data and compares the result with the original data. The original cache memory content is then restored to the cache memory.

Subtest 03 Increment/Decrement Test

This subtest reads the contents of cache memory and saves it into RAM. The subtest then writes the increment data (00H, 01H, 02H, through FDH, FEH, FFH), reads the new data and compares the result with the original data. After comparing the incremental data, decrement data (FFH, FEH, FEH, through 02H, 01H, 00H) is written and the new data is read and compared with the original data. The original cache memory content is then restored to the cache memory.

Subtest 04 Bit Shift Pattern Test

This subtest reads the contents of cache memory and saves it into RAM. The subtest then writes the bit shift data patterns (1 bit shifted every 4 bytes), reads the new data and compares the result with the original data. The original cache memory content is then restored to the cache memory.

Subtest 05 Write Disturb Test (We can't support this time)

This subtest reads the contents of cache memory and saves it into RAM. The subtest then writes the "write disturb data," reads the new data and compares the result with the original data. The original cache memory content is then restored to the cache memory.

Subtest 06 Checker Board Test

This subtest reads the contents of cache memory and saves it into RAM. The subtest then writes the "checker board data," (data which is inverted front/back and left/right) reads the new data and compares the result with the original data. The original cache memory content is then restored to the cache memory.

Subtest 07 Marching Test

This subtest reads the contents of cache memory and saves it into RAM. The subtest then writes the "marching data," (00H through 01H and 01H through 00H) reads the new data and compares the result with the original data. The original cache memory content is then restored to the cache memory.

Subtest 08 Working Data Test

This subtest reads the contents of cache memory and saves it into RAM. The subtest then writes the "working data," reads the new data and compares the result with the original data. The original cache memory content is then restored to the cache memory.

3.12 High Resolution Display Test

To execute the High Resolution Display Test select **09** from the Diagnostic Test Menu, press **Enter** and follow the directions on the screen. The High Resolution Display Test contains six subtests that test the computer's high resolution video display. Move the highlight bar to the subtest you want to execute and press **Enter**.

Subtest 01 VRAM W/R/C Test

This subtest writes address and data patterns to Video RAM, then reads the values from the Video RAM and compares them to the original test patterns. During the execution of this test 13 different color screens display: black, green, green, blue, blue, red, red, red, black, white, pink, cyan, and black.

Test Process:

1. Sets the video display to 1024*768 mode
2. Bank change test
Writes 1 byte data in order 0, 1, through Fh, and compares the result, at every bank, to the original data patterns.
3. Bit shift data test
Writes 01h data into addresses A000:0000h through A000:FFFFh for each bank, reads the new data and, then compares the results with the original data. Data is then shifted 1 bit to the left, and all bits (01h, 02h, 04h, 08h, through 80h) are tested again.
4. Fixed data test
Writes test data (in order FFh, AAh, 55h, 00h) into addresses A000:0000h through A000:FFFFh for each bank by, reads the new data and, then compares the results with the original data. Data is then shifted 1 bit to the left, and all bits are tested again

NOTE: *If **NO** is selected for Test Loop on the Test Parameter menu, the screen displays the colors listed above and then the High Resolution Display Test menu displays.*

*If **YES** is selected for Test Loop on the Test Parameter menu, the screen displays the colors listed above. Press **Ctrl + break** to return to the High Resolution Display Test menu.*

Subtest 02 640*480 Mode Display

This subtest uses 640*480 video resolution to display a high resolution white frame, 256 letter types (8*16 pixels) and 64 gradations of white, red, green, and blue as shown below.

[640*480 256]

Press [Enter] key

256 letter types indication

	0---+---1---+---2---+---3---+---4---+---5---+---6---
WHITE	64 gradations
RED	64 gradations
GREEN	64 gradations
BLUE	64 gradations

To exit this subtest and return to the High Resolution Display Test menu:

Press **Enter** if **NO** was selected for *Test Loop* on the Test Parameter Menu.
 Press **Ctrl + break** if **YES** was selected for *Test Loop* on the Test Parameter Menu.

Test Program for Field.

Subtest 03 800 * 600 Mode Display

This subtest uses 800*600 video resolution to display a high resolution white frame, 256 letter types (8*16 pixels) and 256 gradations of white, red, green, and blue as shown below.

[800*600 256]

Press [Enter] key

256 letter types indication

	0---+---1---+---2---+---3---+---4---+---5---+---6---
WHITE	64 gradations
RED	64 gradations
GREEN	64 gradations
BLUE	64 gradations

To exit this subtest and return to the High Resolution Display Test menu:

Press **Enter** if **NO** was selected for *Test Loop* on the Test Parameter Menu.
 Press **Ctrl + break** if **YES** was selected for *Test Loop* on the Test Parameter Menu

Subtest 04 1024* 768 Mode Display

This subtest uses 1024*768 video resolution to display a high resolution white frame, 256 letter types (8*16 pixels) and 64 gradations of white, red, green, and blue as shown below.

[1024*768 256]

Press [Enter] key

256 letter types indication

0-----1-----2-----3-----4-----5-----6-----

WHITE	64 gradations
RED	64 gradations
GREEN	64 gradations
BLUE	64 gradations

To exit this subtest and return to the High Resolution Display Test menu:

Press **Enter** if **NO** was selected for *Test Loop* on the Test Parameter Menu.
 Press **Ctrl + break** if **YES** was selected for *Test Loop* on the Test Parameter Menu.

Subtest 06 Focus Test ("E" Pattern)

This subtest sets the 1024*768 Mode and displays "E" patterns (18*18 dot fonts), at 56 letters *42 lines surrounded by a high resolution white frame.

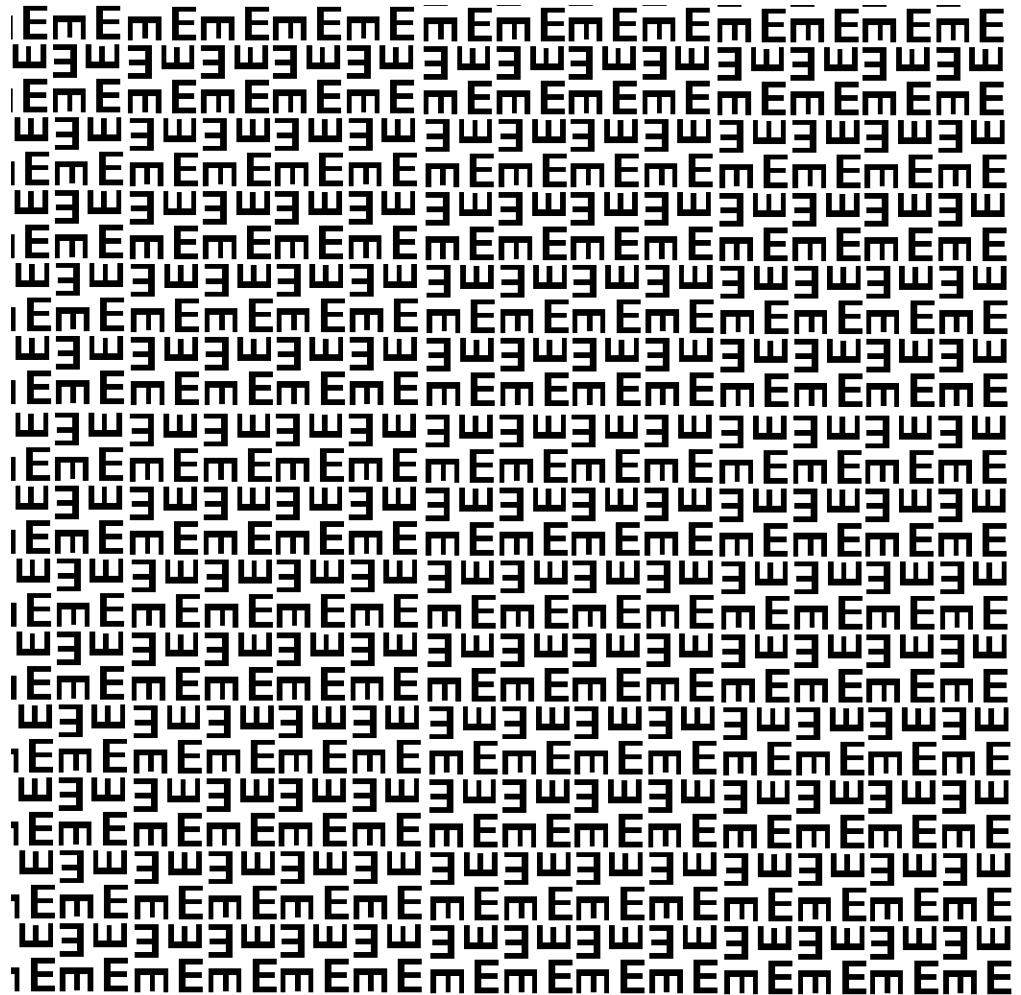

To exit this subtest and return to the High Resolution Display Test menu:

Press **Enter** if **NO** was selected for *Test Loop* on the Test Parameter Menu.
Press **Ctrl + break** if **YES** was selected for *Test Loop* on the Test Parameter Menu.

3.13 Multimedia Test

To execute the Multimedia Test select **10** from the Diagnostic Test Menu, press **Enter** and follow the directions on the screen. The Multimedia Test contains four subtests that test the computer's multimedia functions. Move the highlight bar to the subtest you want to execute and press **Enter**.

NOTE: Use the Toshiba Backup CD-ROM for Subtests 01, 02, and 03.

Subtest 01 Sequential Read Test

This subtest sequentially reads one block unit (2K bytes) of all logical addresses from the test CD.

NOTE: If **NO** is selected for Test Loop on the Test Parameter Menu, the screen will remain blank while the subtest is executing. When the test is complete the Multimedia Test menu displays.

If **YES** is selected for Test Loop on the Test Parameter Menu, the Test Status screen displays while the subtest is executing. Press **Ctrl + break** to return to the Multimedia Test menu.

Subtest 02 Random Read Test

This subtest randomly reads all addresses.

Subtest 03 Read Specified Address Test

This subtest reads data from a specified block of addresses.

The following message displays on the screen to enter the start and end block addresses:

```
START BLOCK ADDRESS ?  
END BLOCK ADDRESS  ?
```

Subtest 04 1 Point W/R/C (R/RW Media)

NOTE: Use CD-R or CD-RW, the CD-ROM and DVD cannot be used for this subtest, and some DVD-dual can't support this test.

This subtest writes specified data to a specified block count, then reads and compares the result.

3.14 MEMORY2 Test

To execute the Expansion Test select **11** from the Diagnostic Test Menu, press **Enter** and follow the directions on the screen. The MEMORY2 Test contains four subtests that test the computer's. Move the highlight bar to the subtest you want to execute and press **Enter**.

***NOTE:** If **NO** is selected for Test Loop on the Test Parameter menu, the Test Status screen displays while the test is executing. When the test is complete the Memory Test menu displays.*

*If **YES** is selected for Test Loop on the Test Parameter menu, the Test Status screen displays while the test is executing. Press **Ctrl + break** to return to the Memory Test menu*

Subtest 01 All one/All zero test

This subtest performs pseudorandom data read/write. The data consists of “all ones”/”all zero” patterns produced by pseudorandom sequence generator. The test checks address error.

```
FFFFFFFFFFFFFFFFF0000000000000000000
0000000000000000FFFFFFFFFFFFFFFFF
```

Subtest 02 Walking 1/Walking 0 test (Left)

This subtest uses “running one”/”running zero” patterns. This test sequence allows also to checking system bus in maximum noise conditions. The following test sequence is written.

```
7FFF7FFF7FFF7FFF8000800080008000
BFFFBFFFBFFFBFFF4000400040004000
```

After all the memory being tested is filled with the pattern, it is read in descending direction and compared with reference data. As the memory is read, the data is replaced with inverse test pattern. After all the memory is read and replaced with inverted pattern, it is read in descending direction and compare with new reference data. As the memory is read, the data is replaced with next pattern, which is like first one shifted to right.

Subtest 03 Walking 1/Walking 0 test (Right)

The test method is the same as Subtest2. However, the data to be used differs.

```
80008000800080007FFF7FFF7FFF7FFF
4000400040004000BFFFBFFFBFFFBFFF
```

Subtest 04 Walking 1/Walking 0 test (Left/ Right)

The test method is the same as Subtest2. However, the data to be used differs.

```
7FFF7FFF7FFF7FFF8000800080008000  
BFFFBFFFBFFFBFFF4000400040004000  
DFFFDFFFDFFFDFFF2000200020002000
```

```
FFFBFFFBFFFBFFFB0004000400040004  
FFFDFFFDFFFDFFFD0002000200020002  
FFFFFFFFFFFEE0001000100010001  
80008000800080007FFF7FFF7FFF7FFF  
4000400040004000BFFFBFFFBFFFBFFF
```

```
0004000400040004FFFBFFFBFFFBFFFB  
0002000200020002FFFDFFFDFFFDFFFD  
0001000100010001FFFFFFFFFFFEE
```

3.15 Error Codes and Error Status Names

The following table lists the error codes and error status names for the Diagnostic Tests.

Table 3-2 Error codes and error status names (1/2)

Device Name	Error Code	Error Status Name
(Common)	FF	Data Compare Error
Memory	02	Protected Mode Not Changed
	??	Other Error
FDD	01	Bad Command Error
	02	Address Mark Not Found
	03	Write Protected
	04	Record Not Found
	06	Media Change Line Error
	08	DMA Overrun Error
	09	DMA Boundary Error
	0C	Select Media Error
	10	CRC Error
	20	FDC Error
	40	Seek Error
	80	Time Out Error
??	Other Error	
HDD	01	Bad Command Error
	02	Bad Address Mark Error
	04	Record Not Found
	05	HDC Not Reset Error
	07	Drive Not Initialized
	09	DMA Boundary Error
	0A	Bad Sector
	0B	Bad Track Error
	10	ECC Error
	11	ECC Recover Enabled
	20	HDC Error
	40	Seek Error
	80	Time Out Error
	AA	Drive Not Ready

Table 3-2 Error codes and error status names (2/2)

Device Name	Error Code	Error Status Name
HDD	BB	Undefined Error
	CC	Write Fault
	E0	Status Error
	F0	No Sense Error
	??	Other Error
Cache Memory	02	Protect Mode Error
	03	Caching Error
	??	Other Error
Multimedia	01	Write Error
	0F	Invalid Drive
	15	Drive Not Ready
	??	Other Error

NOTE: If error status name is ***Other Error*** , please reference the ***Error Code*** for error information

3.16 Running Test

NOTES:

1. *You may add or delete subtests using the Running Test Edit Item function, see Section 3.20.*
2. *Do not forget to insert a work disk in the FDD. If a work disk is not inserted an error will be generated during the Floppy Disk Test.*
3. *If the test completes successfully an “PASS” sign with blue letters displays on the screen.*
4. *If the test fails or is interrupted before completion an “FAIL” sign with red letters displays on the screen.*
5. *If running item not select an “NOITEM” sign with green letters display on the screen.*
6. *All errors which occur during execution of the Running Test are logged in the Log File.*
7. *This program is executed according to the Count Loop number selected in the Running Test Edit Item, see Section 3.20. To terminate the program, press **Ctrl + Break**.*

- 9. Project Identifier [1]LCD13”[2]LCD14”[3]LCD15”[4]LCD17”
 - a. SLP2.0 Build Sig [1]Non OS [2]OS
 - b. Wireless LAN ID (001E4CXXXXXX)

Select 1 ~ b to keyin new data , select 0 to exit program , program will compare input data length with the max length , if over will retry keyin

Note : Please Check New DMI Information After System Restart !! V2.6

- 1. **** Manufacture Name (TOSHIBA) - (15)
- 2. **** Product Name (Satellite XXXXXX) - (31)
- 3. **** Part Number (PSL20X-XXXXXX) - (15)
- 4. **** Serial Number (12345678W) - (9)
- 5. **** OEM String (PSL20X-XXXXX,SXXXXXXXXXXXX) - (31)
- 6. **** Model Select [1]Dyn-Jpn [2]Tos-Jpn [3]Tos-Eng [4]Tos-FR – (2)
- 7. **** Write UUID (XXXXXXXXXXXXXXXXXXXX) – (16)
- 8. **** Brightness Write (XXXXXXXX) – (8)
- 9. **** Project Identifier [1]LCD13”[2]LCD14”[3]LCD15”[4]LCD17”-(1)
 - a. **** SLP2.0 Build Sig [1]Non OS [2]OS-(2)
 - b. **** Wireless LAN ID (001E4CXXXXXX) –(6)
- 0. **** Exit

Please Select (1 ~ b) To Modify DMI String :

Current Data of EEPROM : Toshiba

1. Enter the Manufacture Name : TOSHIBA

Your Keyin is : TOSHIBA This is your keyin data

EEPROM return : TOSHIBA This is read from eeprom back

Press any key to continue

Note : Please Check New DMI Information After System Restart !!

If Keyin length too long will retry :

Current Data of EEPROM : 12345678W

4. Enter the Serial Number : 12345678901234

Your Keyin String Length Not Correct 14 > 9 !!!

Current Data of EEPROM : 12345678W

4. Enter the Serial Number :

NOTE: The SLP2.0 is Microsoft SPEC , call “System Locked Pre-Installation” or “SLP”, It is for OEM pre install Windows and no need to Active , If you select Non OS , then you need to Active your OS before you use .

3.17.3 Computrace Disabled

The Write Computrace Information to disabled computrace function before ship :

The information as below :

```
dmiStorageBase = df010h
dmiStorageSize = 841h
NVR 72h/0ah
*** Setting SMBIOS data! ***
Type 11 base 26h
UUID = "e0f43ec347f4db118688001b24f463c5"
Type 12 DSN: Serial Number: "      Y7KFT037T"
Type 12 DSN: Serial Number: "00000590"
Type 12 DSN: Serial Number: "SANYO002A2007/12/14"
*** Setting SMBIOS data! ***
Type 11 Length: 5 Handle : 0009h
String 1: "PSU400-123321,S123456789      ", 0
String 2: "XQMG1hLoEhYLF", 0
String 3: "GKpncOhAIONam", 0
String 4: "Z87E-Kr8+kIg8", 0, 0
*** Disabled! ***
```

Press Any Key To Return!

2. Error information displayed on the screen can be manipulated with the following number keys:

The **1** key scrolls the display to the next page.
The **2** key scrolls the display to the previous page.
The **3** key returns to the Diagnostics Menu.
The **4** key erases all error log information in RAM.
The **5** key reads the log information from a floppy disk.
The **6** key writes the log information to a floppy disk.
The **7** key save the log information to a floppy disk.

The following are the test abbreviations for each Diagnostics Test.

Test Name	Test Abbreviations
System Test	ROM
Memory Test	RAM
Keyboard Test	KBD
Display Test	CRT
Floppy Disk Test	FDD
Hard Disk Test	HDD
Real Time Clock Test	RTM
Cache Memory Test	CAH
Height Resolution Display Test	KIF
Multimedia Test	MLT
Memory2 Test	RAM

3.19 System Configuration

Select **05** from the Diagnostics Menu and press **Enter** to display the following system configuration:

```
SYSTEM CONFIGURATION :

* - BIOS VER = VX.XX  KBC VER = XXXX
* - MAC ADDRESS : XXXXXXXXXXXXX
* - 0 ASYNC ADAPTER
* - 1 HDD DRIVE(S):XXXXXXXXXXXXXXXXXXXXXXXXXXXX
      FW Rev.:XXXXXXXX
      CUR LBA:XXXXXXXX  ORG LBA:XXXXXXXX
* - BATTERY TYPE:XXXXXXXX
* - XXXMB MEMORY SIZE
* - XXX CPU
* - 1 Vedio Chip XXXXXXXXXXXXXXX
* - 1 ODD DRIVE(S):XXXXXXXX
      FW Rev.:XXXX
```

Press **Enter** to return to the Diagnostics Menu.

3.20 Running Test Edit Item

3.20.1 Function Description

Function description lets you add or delete the subtests used to execute the Running Test. The following screen displays after pressing the **Tab** key to edit an item in the Running Test.

KEY OPERATION

↓	Cursor Down
↑	Cursor Up
PgDn	Page Down
PgUp	Page Up
Home	Top of ITEM
End	End of ITEM
Ins	Insert ITEM
Del	Delete ITEM
Enter	End

3.20.2 Operation Description

Select **05** from the Diagnostics Menu and press **Enter** to display the following:

```

                                Test Item Editor                                [RUNNING TEST]
Loop Count (1-65535, 0 = infinity)  Error Stop 

```

T-No	Test Name	S-No	Subtest Name
01	System Test	Subtest 01	ROM Checksum
02	Memory Test	Subtest 01	Conventional Memory
02	Memory Test	Subtest 02	Protect Mode
02	Memory Test	Subtest 03	Protect Mode (32MB Max)
02	Memory Test	Subtest 04	RAM Refresh
04	Display Test	Subtest 01	VRAM W/R/C
04	Display Test	Subtest 02	Character Attribute Set
04	Display Test	Subtest 03	Character Set
04	Display Test	Subtest 04	80 * 25 Character Display
04	Display Test	Subtest 05	320 * 200 Graphics Display
04	Display Test	Subtest 06	640 * 200 Graphics Display
04	Display Test	Subtest 07	640 * 480 Graphics Display
04	Display Test	Subtest 08	Display Page
05	Floppy Disk Test	Subtest 02	Sequential W/R/C
08	Hard Disk Test	Subtest 01	Sequential Read
08	Real Time Clock Test	Subtest 02	Backup Memory Test

Tab: HELP (Key Operation)

1. Enter a **number** or **0** for **Loop Count** and press **Enter**.

Select a number from 1 to 65535 to define the number of times the Running Test executes.

Select 0 to run the test continuously until halted by the user.

2. Select the **NO** or **YES** for **Error Stop** and press **Enter**.

Select **NO** to keep the test running even if an error is found.

Select **YES** to stop the test program when an error is found.

***NOTE:** All errors which occur during execution of the Running Test are logged in the Log File.*

3. Press **Insert** to add a subtest.
4. Press **Delete** to remove the selected subtest.
5. Press **Enter** when you have finished editing the Running Test list.
6. The following message displays:

Do you want to save the data?

Save to disk
Do not save

7. Select the option and press **Enter**.
8. Select **03** from the Diagnostics Menu and press **Enter** to execute the Running Test.

***NOTE:** If press **Ctrl+break** in the runin process, please press more one any key to exit.*

3.21 Common Tests and Operation

3.21.1 How to operate a window

To input parameters, or open a window use the following keys.

- ↑ ↓ → ← key : to move a highlight bar
- [Enter] key : to select an item at the highlight bar
- [Esc] key : to close the current window and go back to the previous window

3.21.2 How to Stop the Test Program

To stop a test:

[Ctrl]+[Break] Press the Ctrl key and the Break key simultaneously.

3.21.3 Test Status Screen

***NOTE:** The Test Status Screen does not display during all the tests. See the specific test description Sections 3.4 through 3.14.*

The following Test Status screen displays during most tests. See the description of each test Sections 3.4 through 3.14 for specific screen information.

Test Name			
Sub Test	:0101		
Pass Count	:00000	Error Count	:00000
Write Data	:00	Read Data	:00
Address	:00000000	Status	:00

Test Name Displays the name of the test being executed.

Subtest No. Displays the Subtest number in the following format:

ffgg

ff = Subtest No.

gg = Step Number (Will be blank if the test does not have a Step Number.)

Pass Count	Displays the number of times the test has been executed.
Error Count	Displays the number of errors which have occurred during the test.
Write Data	Displays only the test data that has failed to compare during the test while being written during the test.
Read Data	Displays test data that has failed to compare during the test while being read during the test.
Test Address	Displays the Test Address. (The format differs for each test.)
Error Status	Displays the error status.
Error Name	Displays the name of the error.

3.21.4 Test Stop Display

If an error occurs during a Subtest and YES is selected for Error Stop, the following message displays:

```
[HALT OPERATION]

  1. Test end
  2. Continue
  3. Retry
```

* Select 1, 2, or 3

The three selections have the following functions:

- 1: Terminates the test program and exits to the subtest menu.
- 2: Continues the test from the error.
- 3: Restarts the test from the beginning.

Use the arrow keys to move the cursor to the desired option and press Enter.

3.21.5 How to enter data

Letters which must be entered are always shown in []. Simultaneous entries are displayed by a “+” mark. For example:

[a] [Enter]

Press the “a” key, then press the [Enter] key.

[Ctrl] + [c]

Press the [Ctrl] key and the “c” key simultaneously.

Chapter 4

Replacement Procedures

Chapter 4 Contents

4.1	Overview.....	4-1
	Safety Precautions.....	4-2
	Before You Begin.....	4-3
	Disassembly Procedure.....	4-4
	Assembly Procedure.....	4-5
	Tools and Equipment.....	4-5
	Screw Tightening Torque.....	4-6
	Grip Color.....	4-6
	Screw Notation.....	4-7
4.2	Battery pack.....	4-8
4.3	Express card.....	4-10
4.4	HDD.....	4-12
4.5	Wireless LAN card.....	4-16
4.6	Memory module.....	4-18
4.7	Keyboard.....	4-21
4.8	Optical disk drive.....	4-25
4.9	Display assembly.....	4-28
4.10	Cover assembly.....	4-32
4.11	Touch pad.....	4-36
4.12	LAN board.....	4-38
4.13	System board.....	4-39
4.14	CPU.....	4-42
4.15	LCD unit / FL inverter.....	4-45
4.16	Application for Thermal Pad on North Bridge.....	4-50

Figures

Figure 4-1	Remove the battery pack.....	4-8
Figure 4-2	Install the battery pack	4-9
Figure 4-3	Remove Express card.....	4-10
Figure 4-4	Insert Express card	4-11
Figure 4-5	Remove the HDD assembly	4-13
Figure 4-6	Remove HDD.....	4-14
Figure 4-7	Remove wireless LAN card	4-16
Figure 4-8	Remove memory module	4-19
Figure 4-9	Insert memory module	4-20
Figure 4-10	Remove screws for KBD cover/keyboard.....	4-22
Figure 4-11	Remove the keyboard/KBD cover	4-23
Figure 4-12	Remove optical disk drive.....	4-25
Figure 4-13	Disassemble the side bracket	4-26
Figure 4-14	Remove the screws from bottom side	4-28
Figure 4-15	Remove the screws from top side	4-29
Figure 4-16	Remove Wireless lan and LCD cable	4-29
Figure 4-17	Remove the hinge screw	4-30
Figure 4-18	Remove the screws(back)	4-32
Figure 4-19	Disconnect the touch pad flat cable/Fingerprint cable/Bluetooth Cable.....	4-33
Figure 4-20	Remove the screws (front) and cover assy.....	4-34
Figure 4-21	Remove the touch pad.....	4-36
Figure 4-22	Remove the LAN board	4-38
Figure 4-23	Disconnect the power cable	4-39
Figure 4-24	Remove the system board	4-40
Figure 4-25	Remove the CPU heat sink	4-42
Figure 4-26	Remove the CPU.....	4-43
Figure 4-27	Applying silicon grease.....	4-44
Figure 4-28	Remove the display mask.....	4-45
Figure 4-29	Remove the FL inverter	4-46
Figure 4-30	Remove the LCD unit	4-47
Figure 4-31	Remove the LCD supports	4-48

4.1 Overview

This chapter describes the procedure **of** removing and replacing the field replaceable units (FRUs) in the PC. It may **be unnecessary** to remove all the FRUs in order to make a replacement. The chart below provides a guide as to which other FRUs must be removed before a particular FRU can be removed. The numbers in the chart indicate the relevant section numbers in this manual.

In all cases when removing an FRU, the battery pack must also be removed. And 4.2, 4.3 can be removed without removing any other FRU.

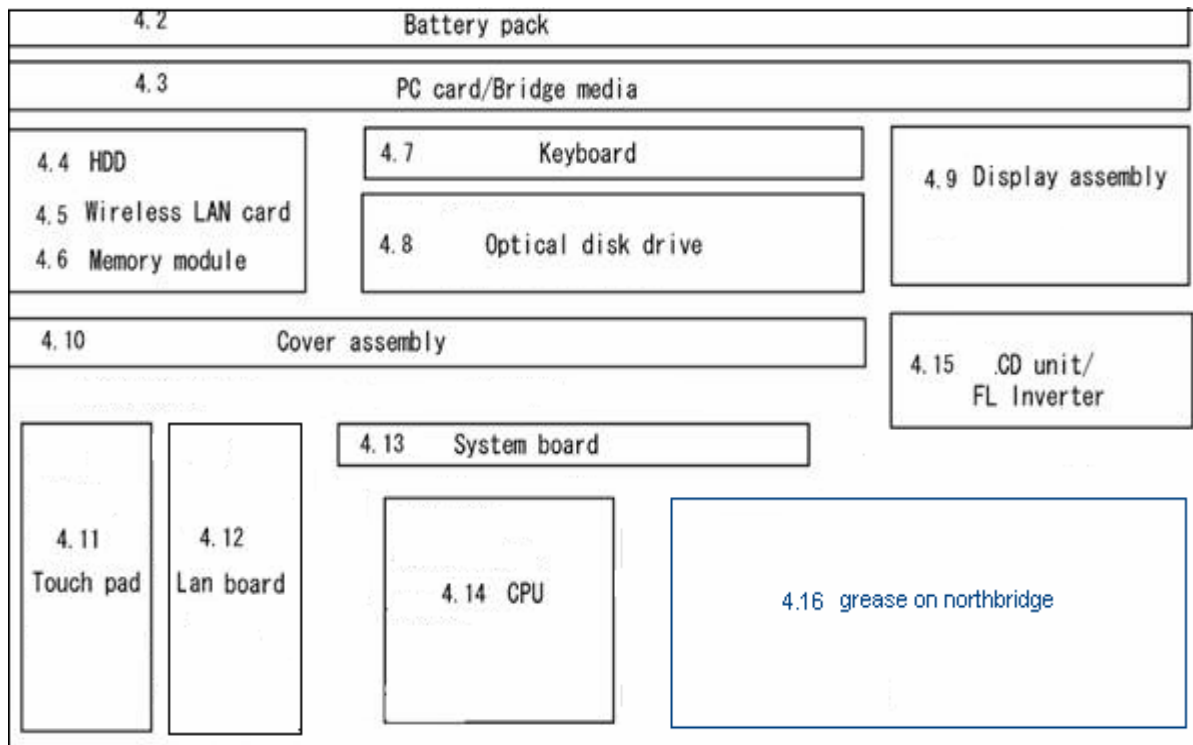

Safety Precautions

Please read the following safety instructions before disassembling the computer and always follow the instructions while working on the computer.

- DANGER:**
- 1. In the case of the battery, always use authentic parts or equivalent parts approved by Toshiba. Other batteries may have different specifications that are incompatible with the computer and may result in fire or explosion.
Due to the risk of alkali fluid leaks, never attempt to heat or disassemble the battery. Similarly, due to the risk of explosion, never expose the battery to flame.*
 - 2. Some parts including the power supply and FL inverter generate high voltages. If you need to turn on the power while disassembling the computer, do not touch any connectors or other components due to the risk of electric shock. Also, do not disassemble individual parts when performing routine maintenance.*

- WARNING:**
- 1. To prevent electric shock, turn off the power unplug the AC adapter from the power source.*
 - 2. As the battery installed to the computer is typically already charged, the risk of electric shock remains even when the AC adapter is unplugged from the socket. To prevent electric shock, always take off any metal jewelry or accessories such as necklaces, bracelets or rings before working on the computer. Never work with wet or moist hands.*
 - 3. Take care not to injury yourself on any edges or corners.*

- CAUTION:**
- 1. Confirm that replacement parts have compatible specifications before replacing on the computer. Never use incorrect parts as these may cause faults on the computer.*
 - 2. To prevent internal damage such as short circuits or burning, do not allow any screws, paper clips, or other metal objects to fall into the computer. When removing screws, always replace with the same size screw. Ensure that all screws are fully tightened. Loose screws may result in short circuits leading to overheating, smoke or flame.*
 - 3. To prevent electric shock, check that you have disconnected all cables from a part before removing the part.*
 - 4. When connecting to the AC power supply, use only an AC adapter and cable approved by Toshiba.*
 - 5. To prevent electric shock, ensure that all replacement parts are compatible with the computer and that all cables and connectors are securely connected.*

Before You Begin

Take note of the following points before starting work. Always remove the AC adapter and battery pack before commencing any of the procedure. The procedure of removing the battery pack is described in section “4.2.1 Battery Pack”.

1. Do not disassemble the computer unless it is operating abnormally.
2. Use the designated tools.
3. Ensure that the environment for working or storing does not contain any of the following things.
 - Dust or dirt
 - Static electricity
 - Extremely hot, cold or humid conditions
4. Perform the diagnostic tests described in Chapter 2 to determine which FRU is the cause of the fault.
5. Do not perform any unnecessary work. Always work in accordance with the disassembly and reassembly procedures in this manual.
6. Keep parts removed from the computer to a safe place away from the computer. So that they will not be damaged or interfere with your work.
7. Disassembling requires removal of a large number of screws. Keep these screws separately will make you easily judge where they come from.
8. When reassembling, ensure that you are using the correct screws and fit parts in the correct positions. Screw sizes are noted in the text.
9. As all parts have sharp edges and corners, take care not to cut yourself.
10. After replacing an FRU, check that the computer and replaced part operate correctly.

Disassembly Procedure

Three main types of cable connector are used.

- Pressure plate connector
- Spring connector
- Normal pin connector

When disconnecting a pressure plate connector, lift up the tag on one side of the plastic pressure plate and pull the cable out from the connector. When reconnecting a cable, lift up the pressure plate to a suitable height and insert the cable into the connector. Press down on both sides of the pressure plate so that both sides and connector are at the same height, then the cable will be fixed in the correct position. Pull the cable to ensure that it is securely connected. If the cable is disconnected from the connector, reconnect it. Make sure that you lift the pressure plate high enough to fully insert the cable.

For spring connectors, lift up the stopper to free the cable. To reconnect it, you just need to hold the stopper in the up position and insert the cable, lower the stopper to secure the cable.

Normal pin connectors are used for all other cables. Simply pull out or push in these connectors to disconnect or reconnect.

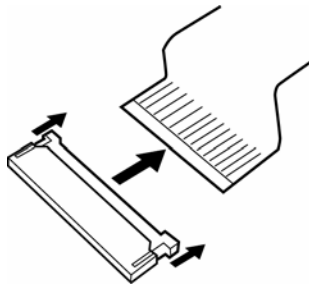

Pressure plate connector

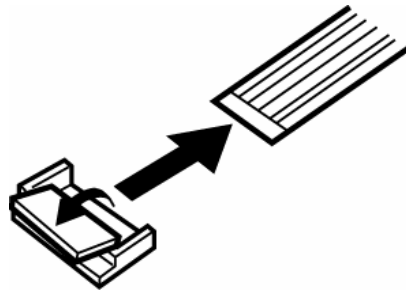

Spring connector

Assembly Procedure

After the part that caused the fault has been repaired or replaced, the computer need to be reassembled again.

Take note of the following general points when assembling the computer.

- Take your time and follow the instructions carefully. Hurry the assembly work will only introduce new problems.
- Check that all cables and connectors are securely connected.
- Before fastening parts in place, ensure that no cables are caught on screws or the FRU.
- Check that all latches are securely closed.
- Ensure that you have installed all FRUs correctly and do not have any screws left over. Using an incorrect screw may damage the thread or screw head and result in the FRU not being securely fastened in place.

After installing, check that the computer operates correctly.

Tools and Equipment

For your safety and the safety of the people around you, it is important **for you to** use Electrostatic Discharge (ESD) equipment. Correctly utilizing of the equipment increases the percentage of successful repairs and saves the cost. The following equipment is required for disassembly and assembly.

- One Philips screwdriver with type 0 bit (for THIN HEAD screws)
- One Philips screwdriver with type 1 bit (for screws other than above)
- Tweezers (for lifting screws)
- ESD mats (lay on work table or floor)
- An ESD wrist strap and heel grounder
- Anti-static carpet or flooring

Screw Tightening Torque

Use the following torque when tightening screws.

CAUTION: *Overtightening may damage screws or parts. Undertightening may allow screws to loosen (and possibly fall out) causing a short circuit or other damage.*

NOTE: *To tighten screws quickly and accurately, an electric screwdriver is recommended.*

- M2 (2mm) 0.167 N·m (1.7 kgf·cm)
- M2.5 (2.5mm) 0.245 N·m(2.5 kgf·cm)
- M2.5 (2.5mm) 0.392 N·m(4.0 kgf·cm) for Hinge support
- M3.0 (3mm) 0.245 N·m (2.5 kgf·cm)

NOTE: *To prevent damage to THIN HEAD screws, press along the axis of the screwdriver while turning the screw. This is because the contact area between the screw and driver is less than for a pan head screw (standard pan-shaped screw head).*

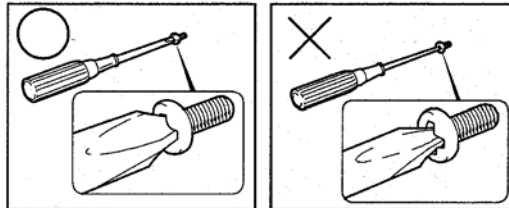

Grip Color

Some screws have a colored grip area to help you determine the length of the screw.

- Even numbered length screws: Brown
- Odd numbered length screws: White
- Special length screw: Blue



“Special length screw” means screws whose length is indicated in an integral number to the first decimal places such as 2.5 mm, 2.8 mm and so on.

Screw Notation

To make maintenance of the computer easier, markings of the kinds of the screws including the types and lengths of the screws are indicated on the computer body.

Format:

Screw shape + Screw length (mm)

Screw shape

B: Bind screw

F: Thin head screw

S: Super thin head screw

T: Tapping screw

U: Other screws (Unique screws: pan head, stud, etc.)

Example: B6 ... 6mm bind screw

4.2 Battery pack

Removing the battery pack

The following describes the procedure of removing the battery pack (Figure 4-1).

CAUTION: Take care not to short circuit the terminals when removing the battery pack. Similarly, do not drop, knock, scratch, disassemble, twist, or bend the battery pack.

1. Turn off the power of the computer.
2. Disconnect AC adapter and all external devices from computer.
3. Turn the computer upside down.
4. Slide and hold latch (2) to free the battery pack after moving lock (1) to unlock position – pick the battery pack out of the computer from fillister.

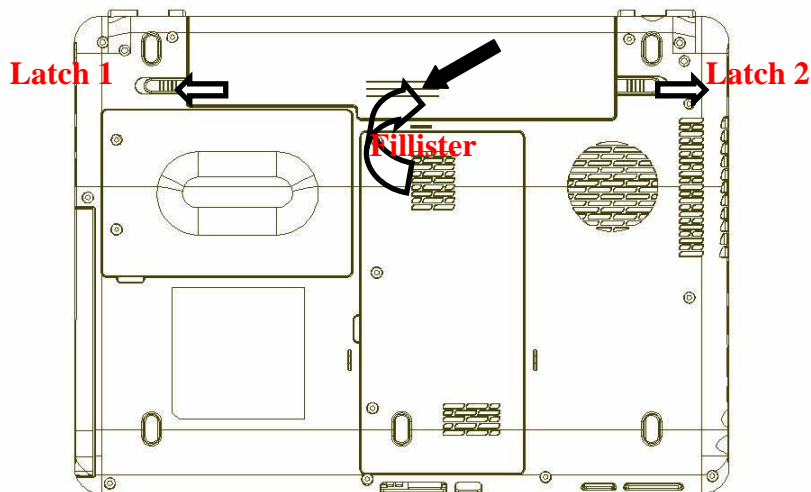

Figure 4-1 Remove battery pack

NOTE: *Dispose of the used battery pack in accordance with the laws and ordinances of your local authority.*

Installing the battery pack

The following describes the procedure of installing the battery pack (Figure 4-2).

CAUTION: *The lithium ion battery pack may explode if not fitted, operated, handled, or disposed correctly. Dispose the used battery pack in accordance with the laws and ordinances of your local authority. Use only the batteries approved by Toshiba.*

NOTE: *Check visually the battery terminals and clean off any dirt with a dry cloth.*

1. Turn off the power of the computer.
2. Disconnect the AC adapter and all external devices from the computer.
3. Insert the battery pack
4. Ensure the battery release lock (1) is moved into its locked position

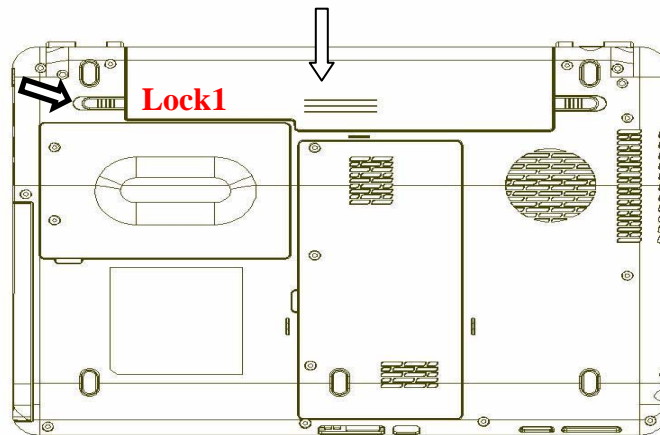

Figure 4-2 Install battery pack

4.3 Express card

Removing Express card

The following procedures show the way of removing an Express card (Figure 4-3).

CAUTION: *Insert or remove a EXPRESS card in accordance with any instructions in an Express card manual or the manuals of the computer system you are using.*

1. Push the **eject button**. It will pop out. Push it again, and the card will pop out
2. Grasp **Express card** and remove it.

NOTE: *If an Express card is not inserted all the way, the eject button may not pop out. Be sure to push a EXPRESS card firmly and press the eject button again.*

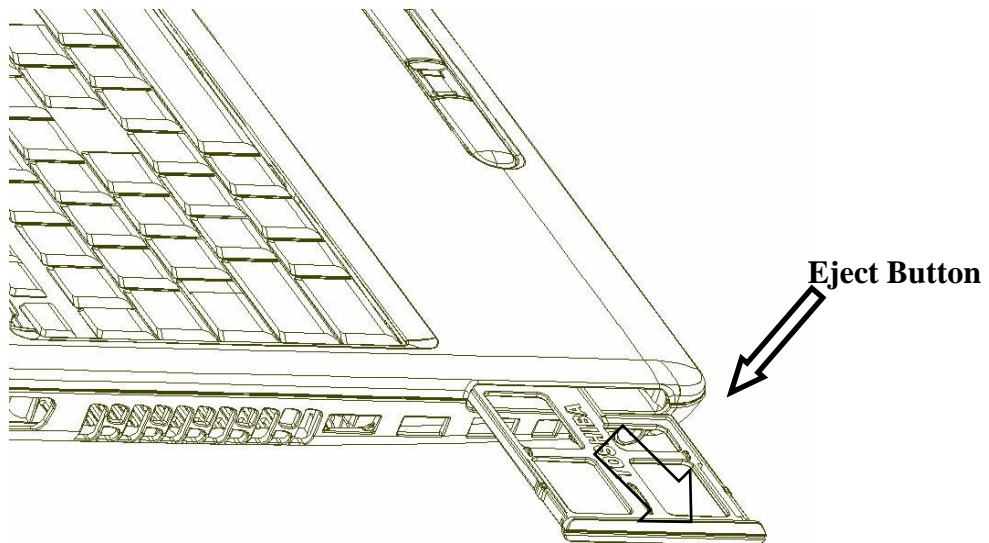

Figure 4-3 Remove Express card

Installing a Express card

The following describes the procedure for inserting a EXPRESS card (Figure 4-4).

1. Make sure the **eject button** does not stick out.
2. Insert an **Express card** and press it until it is securely connected.

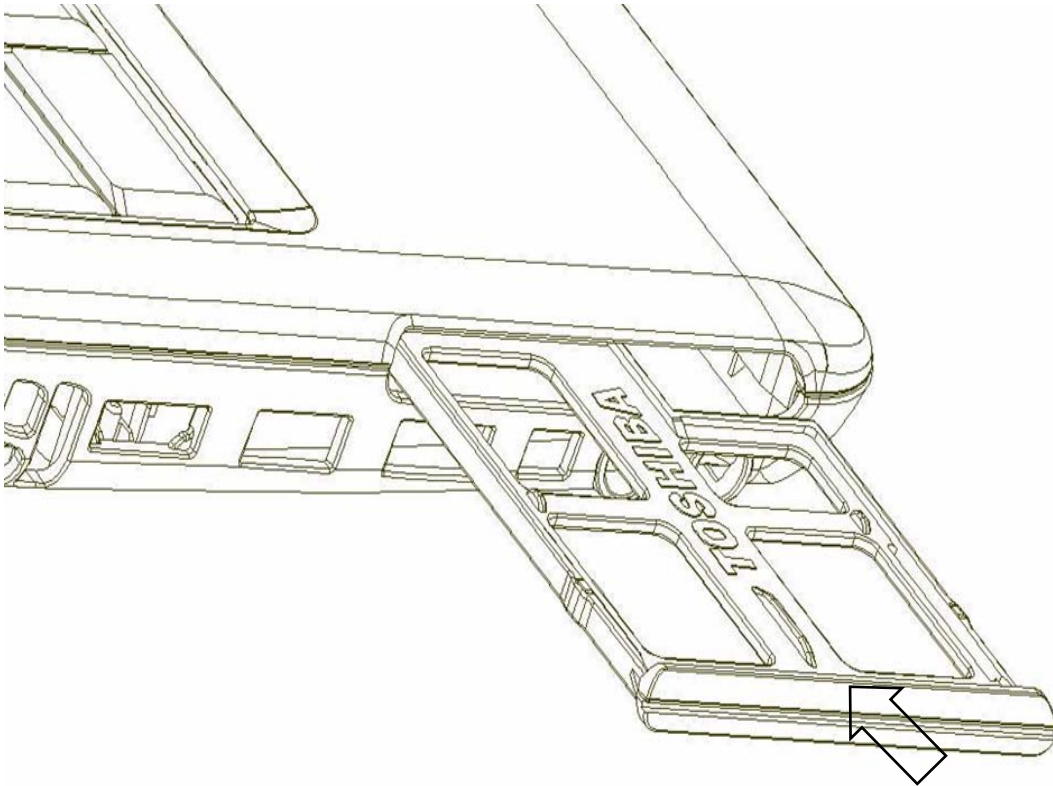

Figure 4-4 Insert Express card

4.4 HDD

Removing HDD

The following describes the procedure of removing a HDD.

CAUTION: *Take care not to press on the top or bottom of a HDD. Pressure may cause data loss or damage to the device.*

1. Turn the computer upside down.
2. Remove the following **screws** securing the **HDD assembly**.
 - M2.0×3.0B FLAT BIND screw x2
3. Disconnect the **HDD assembly** from the connector on the system board.

CAUTION: When a HDD is installed, it should be installed in the position as below.

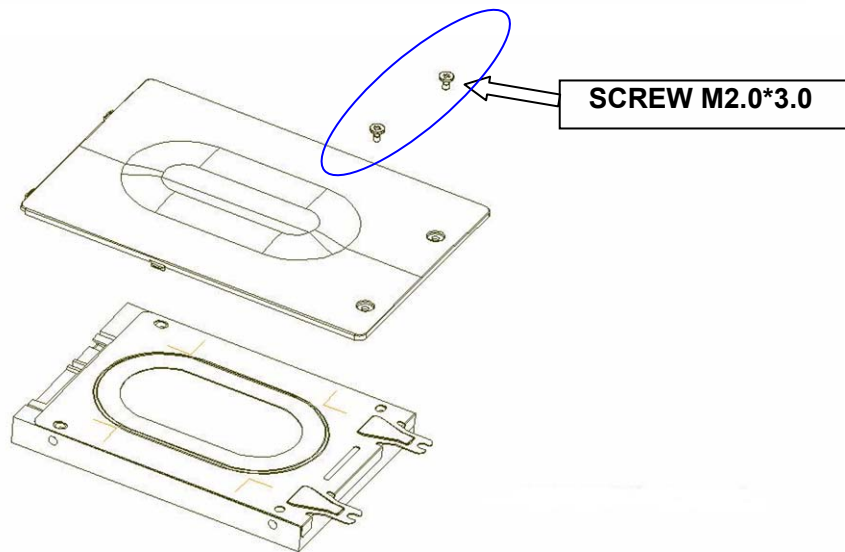
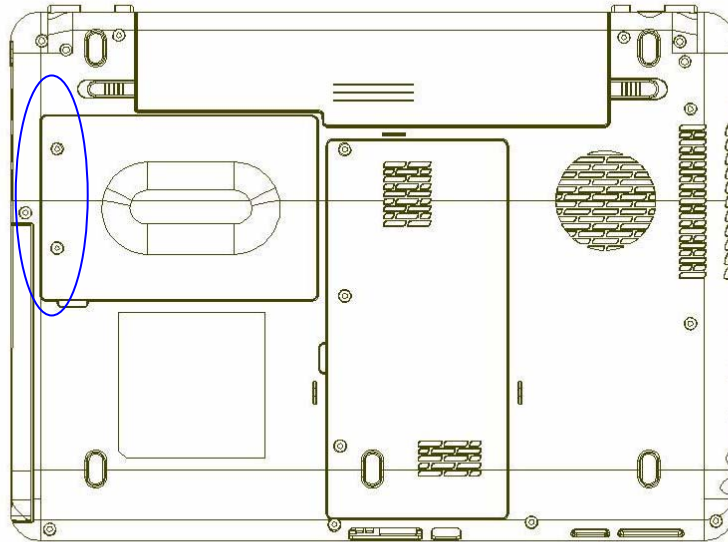

Figure 4-5 Remove HDD assembly

4. Remove the following **screws** securing the HDD holder and remove the **HDD holder**.

- M3.0×0.5+3.5I B FLAT BIND screw x4

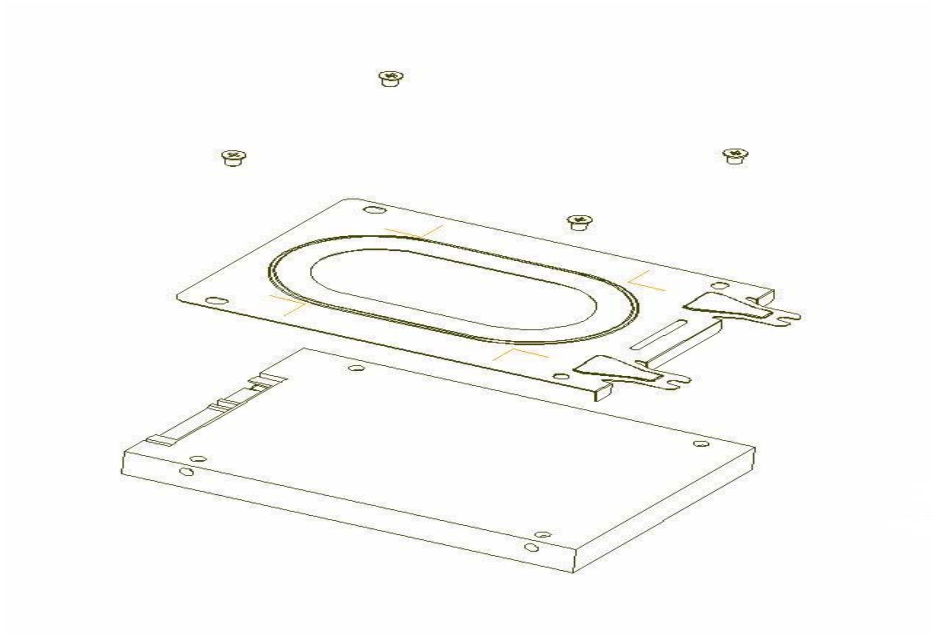

Figure 4-6 Remove HDD

Installing HDD

The following procedures describe the way of installing a HDD

Install a HDD to the **HDD bracket** and secure it with the following **screws**.

- M3.0×0.5+3.5I B FLAT BIND screw x4

NOTE: *Although they are 3mm head screws, screw torque must be set in 2.5kg-cm for four screws securing the HDD holder.*

1. Insert the **HDD assembly** into the HDD slot and connect it carefully to the system board.
2. Secure the **HDD assembly** with the following **screw**.

- M2.0×3.0B FLAT BIND screw x2

4.5 Wireless LAN card

Removing Wireless LAN card

The following procedures describe the way of removing Wireless LAN card.

1. Remove the following **screws** of wireless cover securing **wireless LAN card**. And then, remove screws of wireless board
 - 2.0 x 3.0B BIND screw x3
2. Disconnect the **wireless LAN antenna cable** from the wireless LAN card.
3. Remove **wireless LAN card** from the **connector** on the system board.

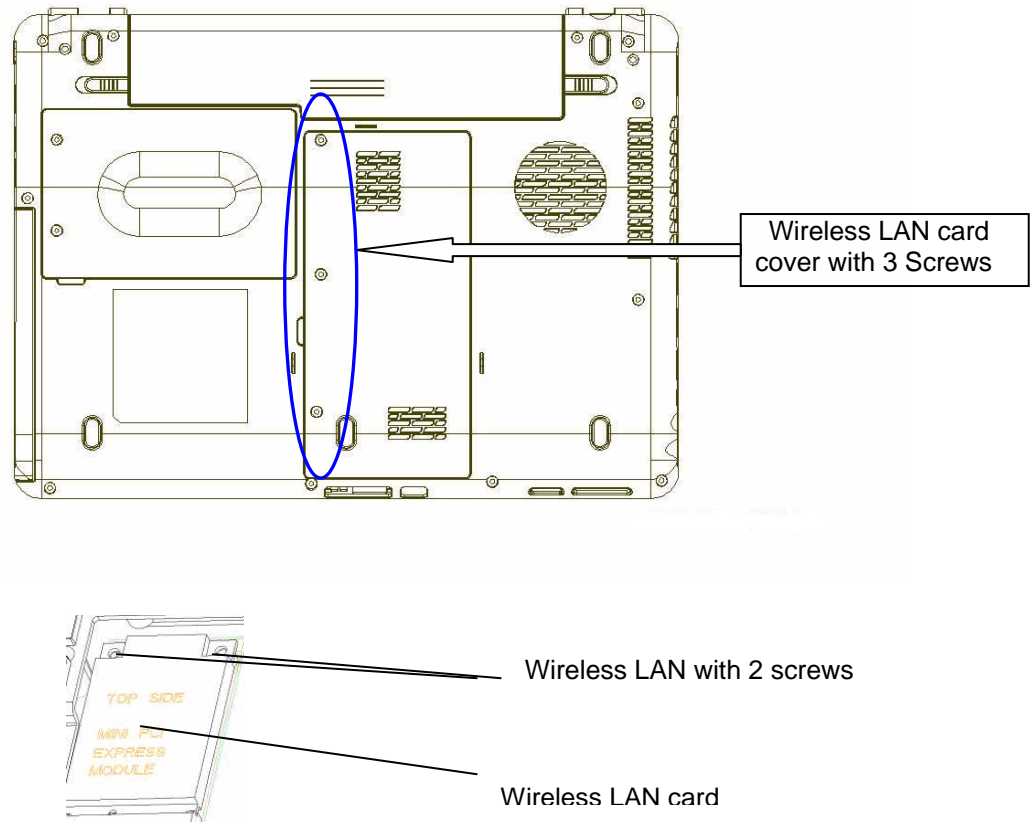

Figure 4-7 Remove wireless LAN card

Installing Wireless LAN card

The following procedure shows the way of installing Wireless LAN card

1. Insert **wireless LAN card** into the connector, press it and lock the secure screws.
2. Connect the **wireless LAN antenna cables** to the terminals.
3. Install the **wireless LAN card cover** and lock it with **screws**.

4.6 Memory module

CAUTION: *The power of the computer must be turned off when you remove the memory module. Removing memory module with power will bring risk of damaging the module or the computer itself.*

Do not touch memory module terminals. Any dirt on the terminals may cause memory access problems.

Never press hard or bend memory module.

Removing memory module

To remove a memory module, please confirm that the computer is in boot mode. Then perform the following procedure.

1. Loosen the **screw** securing the **memory slot cover**.
2. Remove the **memory slot cover**.
3. Open the left and right **latches** and remove **memory module**.

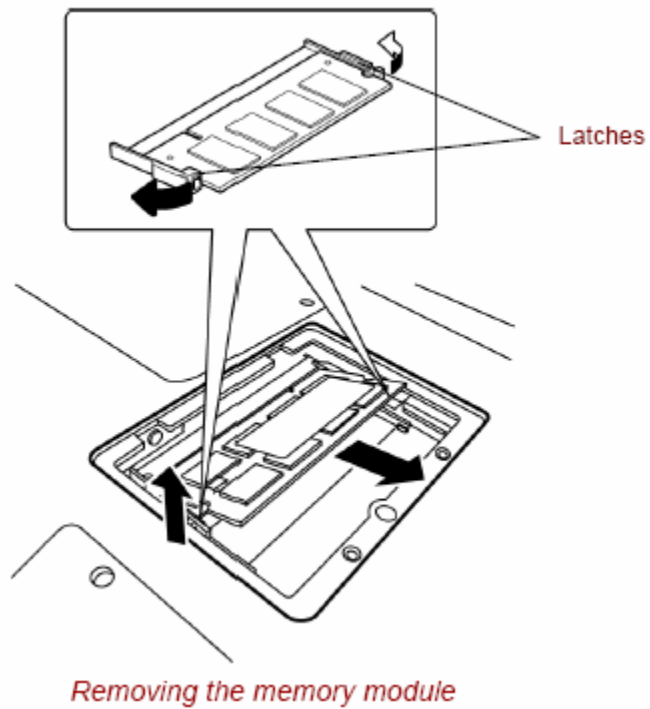
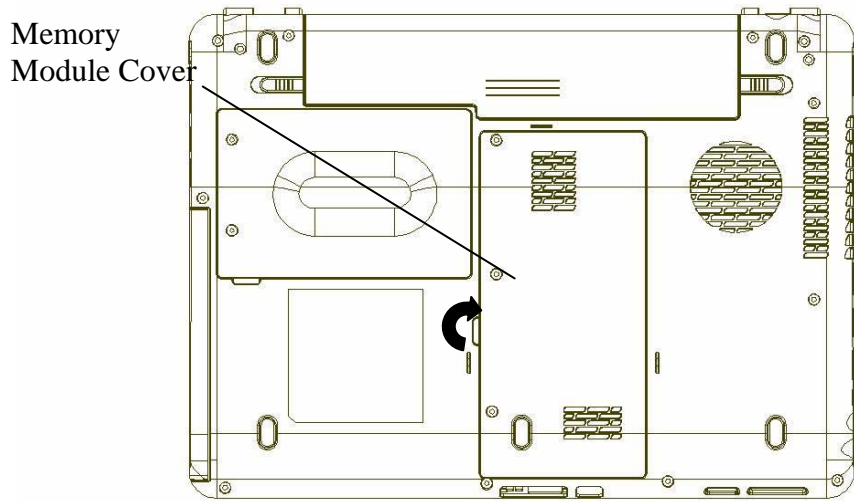

Figure 4-8 Remove memory module

Installing memory module

To install a memory module, please confirm that the computer is in boot mode. Then perform the following procedure.

1. Insert **memory module** into the connector of the computer slantwise (terminal side first) and press it to connect firmly.

CAUTION: *The power must be turned off when you insert a memory module. Inserting a memory module with the power on might damage the module or the computer itself.*

Never press hard or bend a memory module.

2. Install the **memory slot cover** and secure it with **screw**.
3. When the power of the computer is turned on, the computer checks automatically the memory size. Confirm that the new memory is detected correctly.
4. If the memory is not detected, check that it is connected correctly.

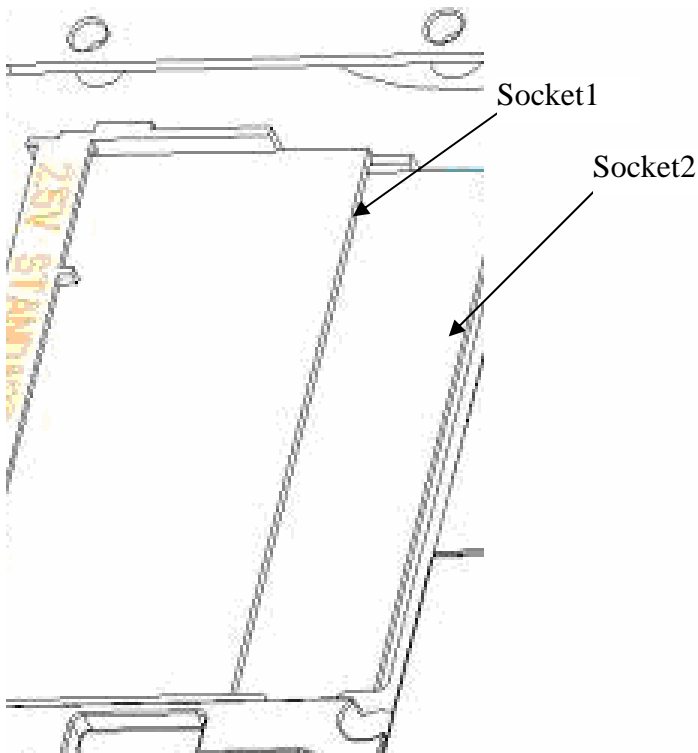

Figure 4-9 Insert memory module

4.7 Keyboard

Removing the keyboard

The following procedures describe the way of removing the keyboard.

CAUTION: *As the keycap may fall out, when handling the keyboard, you shall always hold it by the frame and do not touch the keycap.*

1. Turn the computer upside down and remove the battery
2. Loose the **screw** securing KB Holder.
M2.0x2-I Flat BIND screws x2
3. **Turn** the computer **over** again.
4. Open the LCD cover
5. Remove KB holder and remove below screws.
2.0 x 3.0B BIND screw x2
6. Insert your finger into the keyboard slot and keyboard. Then lift up the keyboard to remove it.
7. Disconnect keyboard cable.

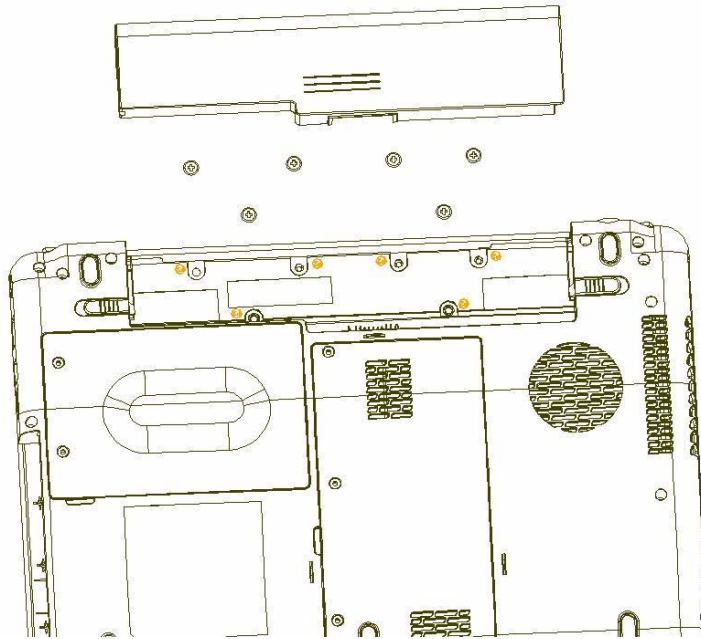

Figure 4-10 Remove screws for KB Holder

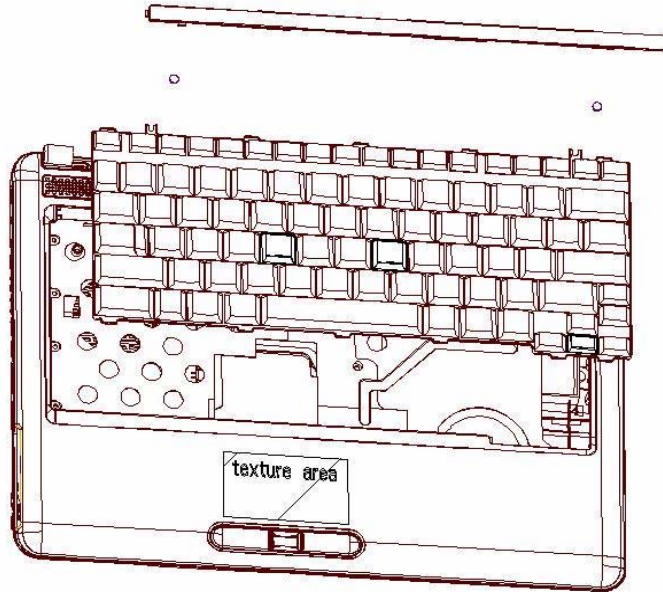

Figure 4-11 Remove the keyboard/KB Holder

Installing the keyboard

The following describes the procedure **of** installing the keyboard.

1. Put **keyboard** on the **Top** and connect the **keyboard flexible cable** to the connector on the system board.
2. Lock the screws and install the **keyboard holder** by pressing it from the topside.
3. Turn the PC over and screw **keyboard holder** from bedside.

4.8 Optical disk drive

NOTE: Do not apply excessive force to the top of an optical disk drive.
Do not touch the shaded portion of the figure below, when the drive is removed or installed.

Removing optical disk drive

The following describes the procedure of removing an optical disk drive (Figure 4-12 and 4-13).

1. Remove the following **screws** securing an optical disk drive.
 - M2.0×5.0B FLAT BIND screw x1
2. Disconnect an **optical disk drive** toward the arrow direction from the connector on the system board.
3. Take the side screws and disassemble the side bracket

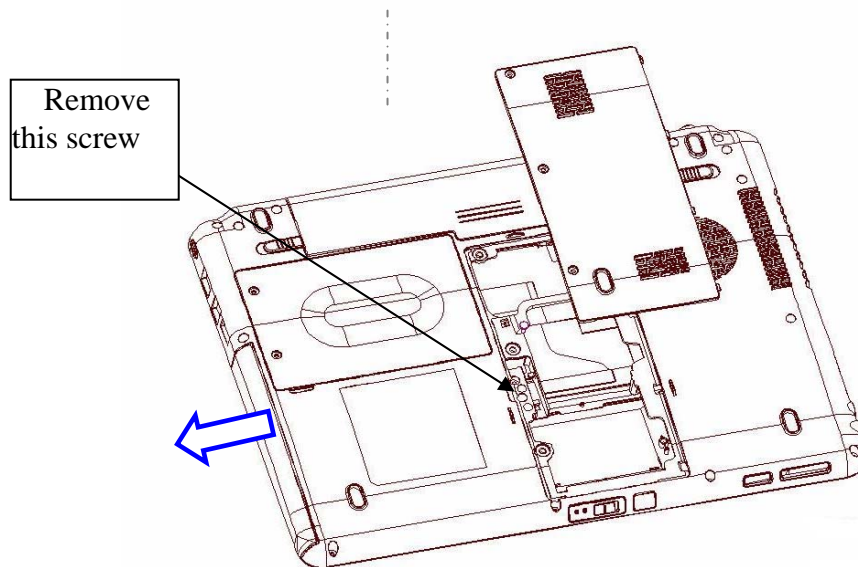

Figure 4-12 Remove optical disk drive

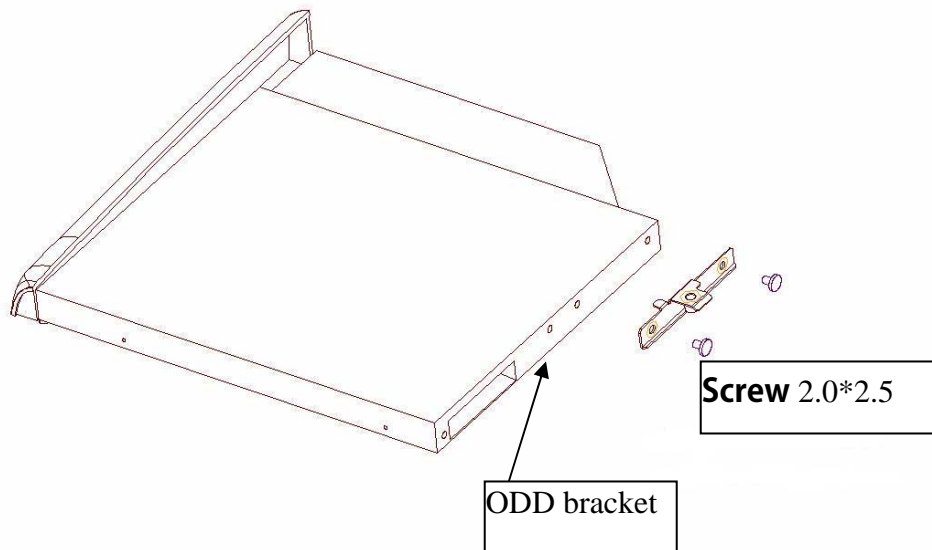

Figure 4-13 Disassemble the side bracket

Installing optical disk drive

The following describes the procedure **of** installing an optical disk drive.

1. Attach the **ODD bracket** to an optical disk drive and secure it with the following **screws**.

- M2.0×**2.5** Flat BIND screw x2

2. Insert an optical disk drive assembly into the slot and connect it to the connector on the system board.
3. Secure the ODD drive with the following **screw**.

- **M2.0X5.0** Flat BIND screw x1

4.9 Top assembly

Removing the Top assembly

The following describes the procedure of removing the cover assembly.

1. Turn over the computer.
2. Remove the following **screws** securing the cover assembly from the back and bottom of computer.

- M2.0×5.0 FLAT BIND screw Back x9
- M2.5×8 FLAT BIND screw Back x4

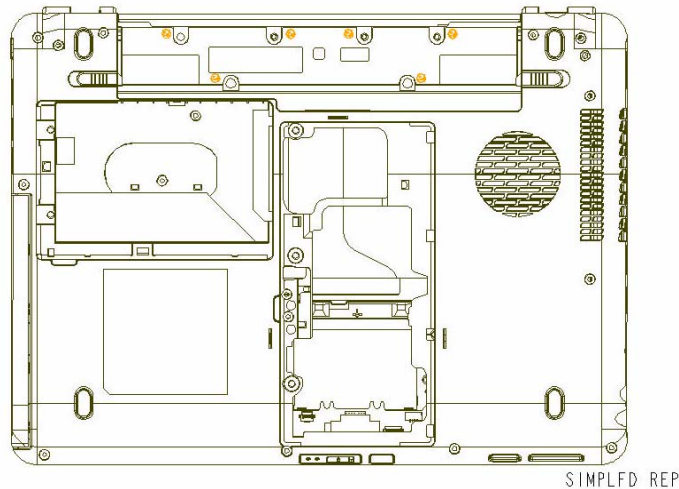

Figure 4-14 remove the screws (back)

3. Disconnect the **touch pad flat cable/Fingerprint cable/Bluetooth Cable** from the connector on the system board.

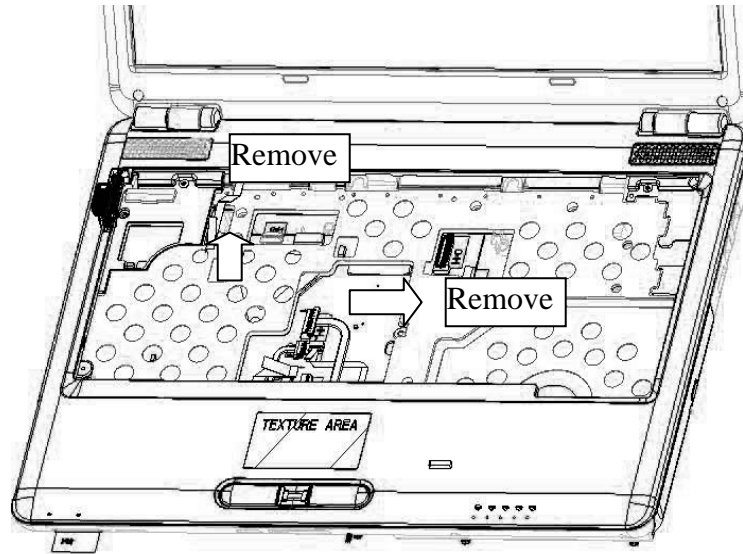
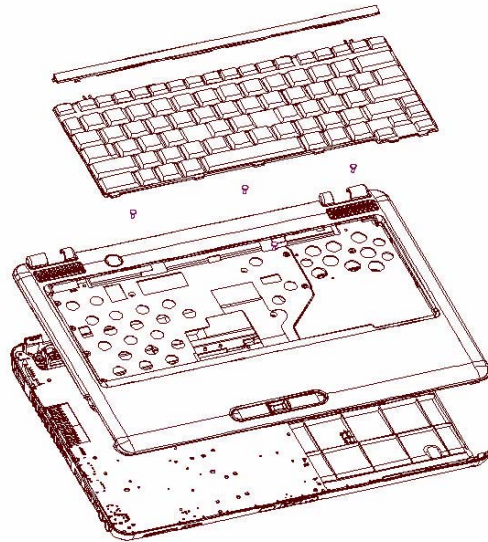

Figure 4-15 Disconnect the touch pad flat cable/Fingerprint cable/Bluetooth Cable

Replacement Procedures

4. Remove the following **screws** securing the cover assembly from the front of computer. Pull up and remove the **cover assembly** from the **base assembly**.

M2.0×5.0 FLAT BIND screw Front x4



EXPLD STATE: EXP0001
SIMPLFD REP: REP0005

Figure 4-16 Remove the screws (front) and cover assy

Installing the Top assembly

The following describes the procedure of installing the cover assembly.

1. Install the **Top assembly** to the base assembly.

NOTE: *Be careful not to catch the cables between cover assembly and base assembly.*

2. Connect the **touch pad flat cable** to the connector on the system board.
3. Secure the cover assembly with the following **screws** from the back and bottom of computer.
 - M2.0×5.0 FLAT BIND screw Back x9
 - M2.5×8 FLAT BIND screw Back x4
4. Free the cable from cable-drain when through the antenna cable to PCB hole.

4.10 Display assembly

Removing the display assembly

The following describes the procedure **of** removing the display assembly.

1. Turn the PC over, remove battery and base screws.
2. Turn the PC upside. Open the LCD cover and removing the **K/B holder** and **keyboard**.
3. Disassemble TOP ASSY

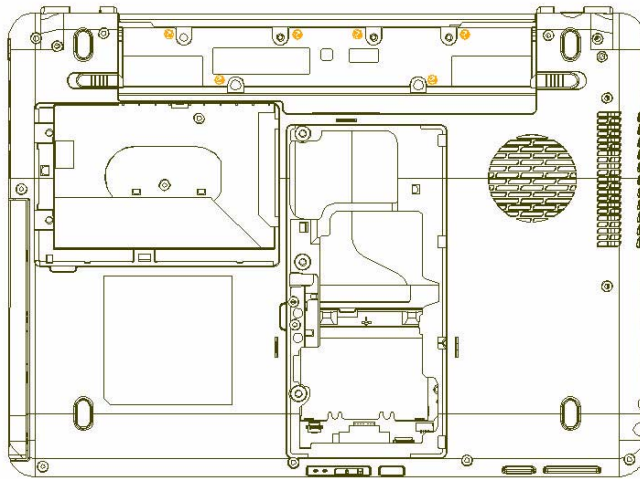

SIMPLFD REP: REP0005

Figure 4-17 Remove the screws (from bottom side)



Figure 4-18 Remove the screws (from top side)

4. Removing LAN board ASSY and pull out the wireless LAN antenna and LCD cables

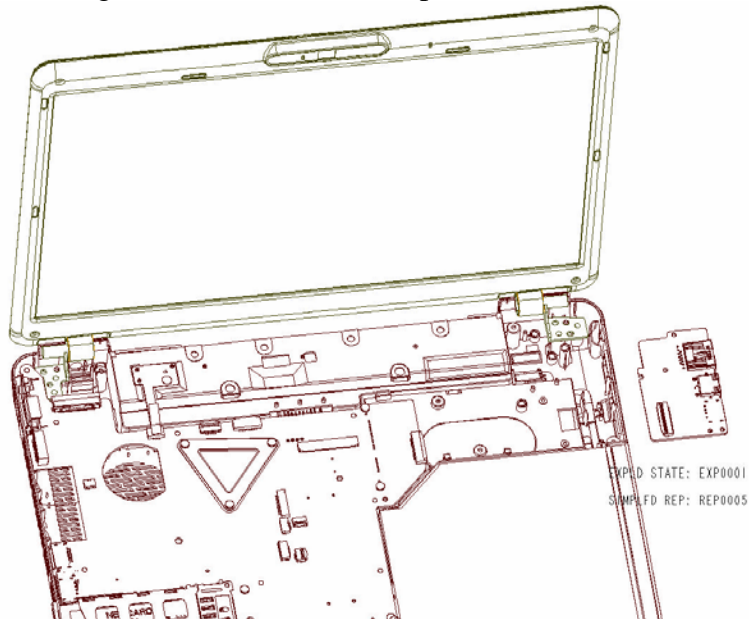

Figure 4-19 Remove the Wireless Antenna and LCD cable

5. Open the display to 90 degree, and remove the hinge screw.

M2.5×5.0 FLAT BIND screw x2

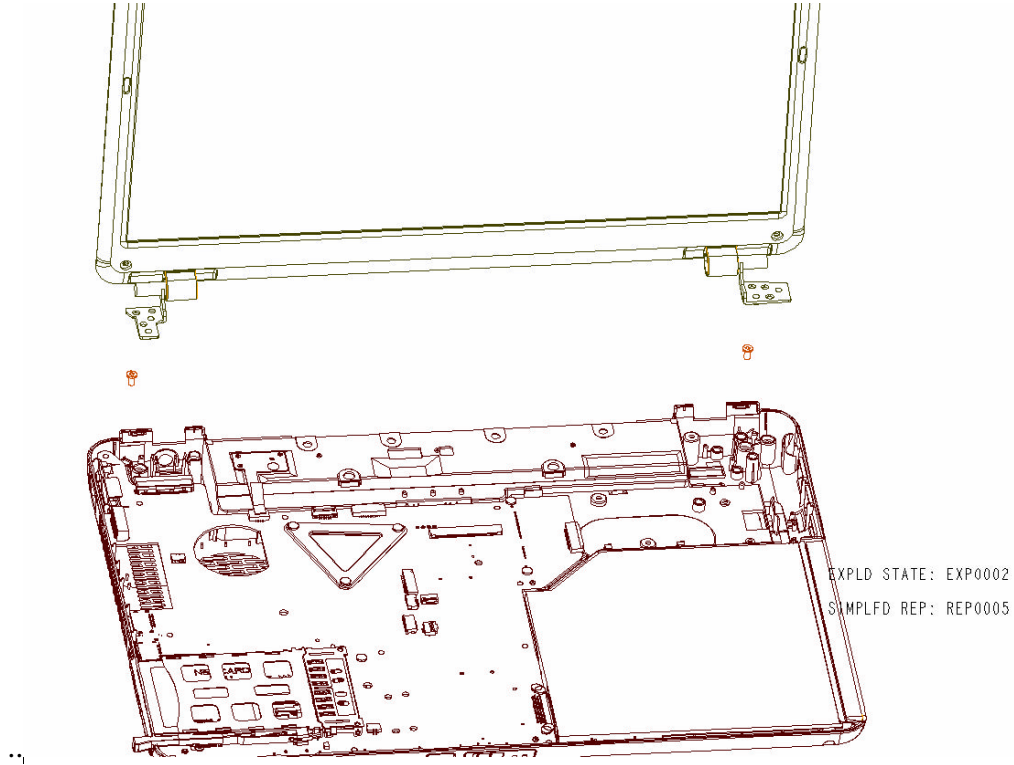

Figure 4-20 Remove the hinge screw

Install the display assembly

The following describes the procedure of installing the display assembly.

1. Insert the **pole of hinge** to the **hole** of hinge assembly, set the **display assembly** on the base assembly.

2. Screw the **hinges**

M2.5×5.0B FLAT BIND screw x2

3. Connect the **LCD harness** to the connector on the system board.
4. Arrange the wireless antenna cables along the guide (front) and secure them with **guide**.
5. Arrange the **wireless LAN antenna** along the guide and contact with the connector.
6. Install cover ASSY of the system.

4.11 Touch pad

Removing the touch pad

The following describes the procedure of removing the touch pad.

1. Peel off the **glass tape** and disconnect the **touch pad flat cable, finger print cable** from the connector on the touch pad.
2. Remove the following **screws** securing the touch pad plate.
 - M2.0×2.0B SUPER THIN HEAD screw x4
3. Remove the **touch pad board and touch pad plate**.
4. Peel off and remove the **touch pad** from the cover assembly.

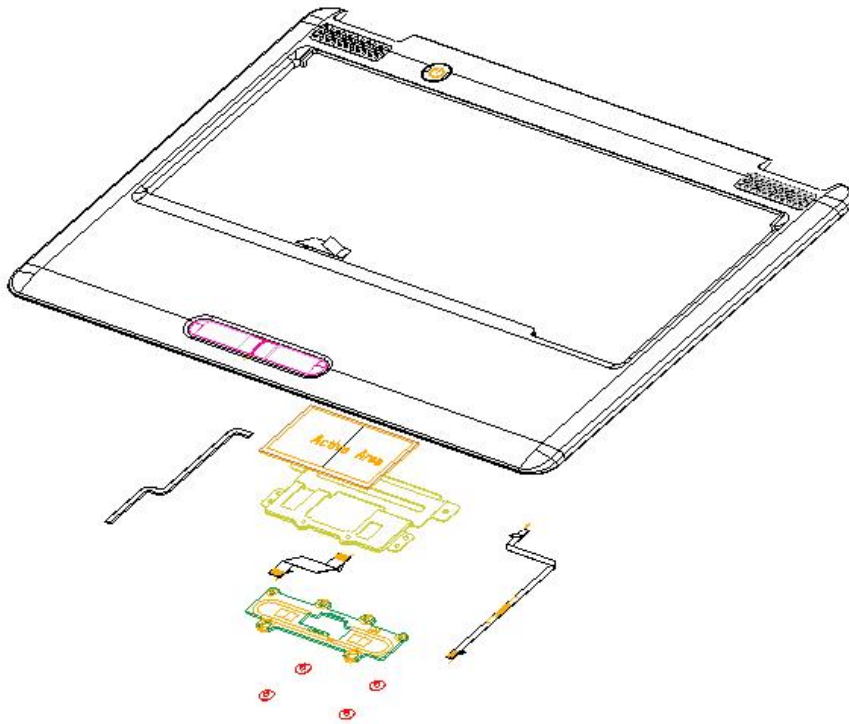

Figure 4-21 Remove the touch pad

Installing the touch pad

The following describes the procedure of installing the touch pad.

1. Peel off the separator covering on the sensor portion of a new touch pad.

NOTE: *Do not reuse the touch pad for it can not be used after peeling off from the computer. Be sure to stick a new touch pad.*

When sticking the touch pad, be careful not to get the bubbles under the touch pad.

2. Stick and install the **touch pad** on the cover assembly.
3. Install the **touch pad plate** and secure it with the following **screws**.
 - M2.0×2.0B SUPER THIN HEAD screw x4
4. Stick the **insulator** on the touch pad plate.
5. Connect the **touch pad flat cable** to the connector on the touch pad and stick the **glass tape** on the connector.

4.12 LAN Board

Removing LAN board

The following describes **of** removing the LAN board.

1. Remove the modern cable
2. Loose below screw from USB board then incline pull out **LAN Board**

- M2.0x5.0 FLAT BIND screw x1

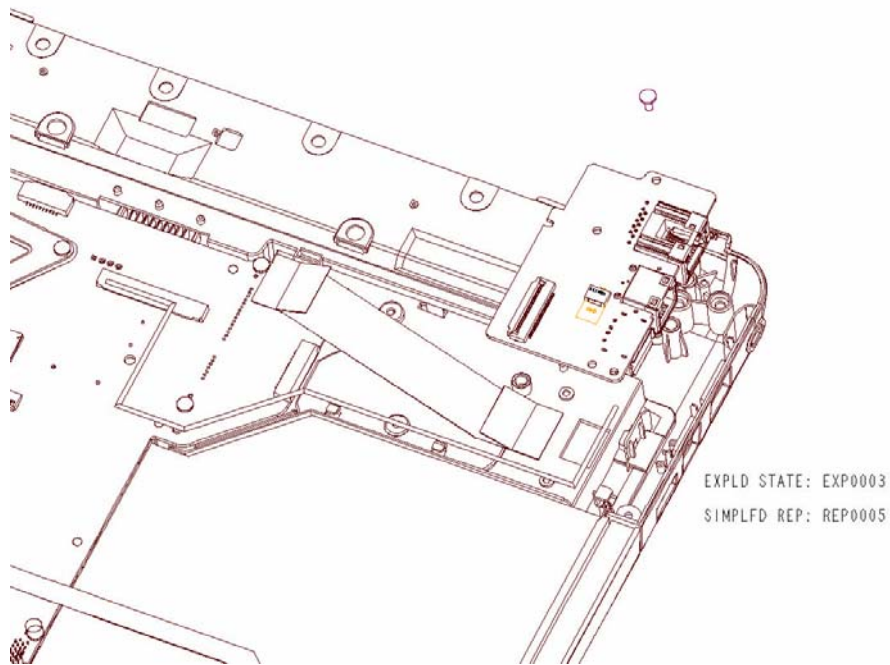

Figure 4-22 Remove the LAN board

Installing the LAN Board

1. Put LAN board in correct location and fix below screw

- M2.0x5.0 FLAT BIND screw x1

2. Connect the modern cable

4.13 System Board

CAUTION: 1. When handling the system board, always hold the edges. Do not touch the printed circuit face.

2. If replacing with a new system board, pls refer to section “Setting of the hardware configuration”. Also update with the latest BIOS as described in Appendix “BIOS Rewrite Procedures” and with the latest EC/KBC as described in “EC/KBC Rewrite Procedures”.

Removing the system board

The following describes the procedure **of** removing the system board.

1. Disconnect the power cable from the system board

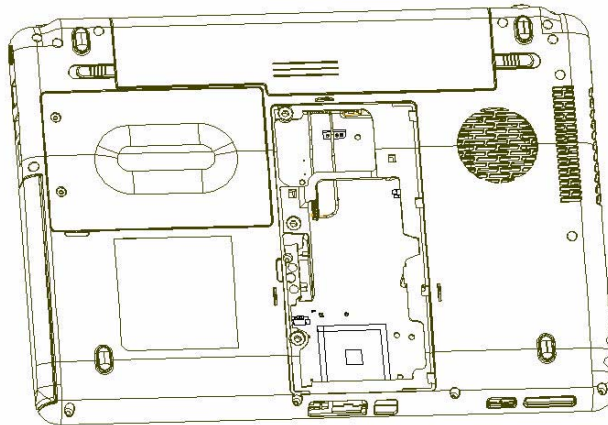

SIMPLFD REP: REP0005

Figure 4-23 Disconnect the power cable

2. Disconnect the **speaker cable, USB cable, modem cable** from the connector on the system board.

3. Remove the following **screws** securing the system board and remove the **system board**.

- M2.0×5.0 BIND screw x2

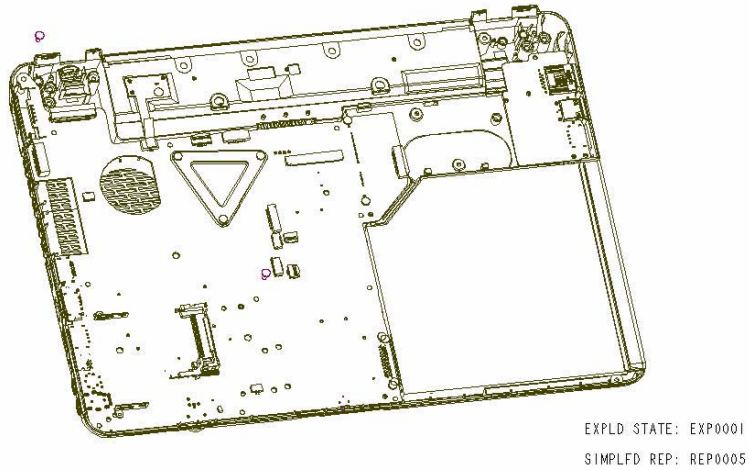

Figure 4-24 Remove the system board

Installing the system board

The following describes the procedure **of** installing the system board.

1. Secure the system board with the following **screws**.
 - M2.0×5.0 BIND screw x**2**
2. Connect the **speaker cable, USB cable, modem cable** to the connector on the system board.
3. Connect the power cable to the connector on the system board

4.14 CPU

Removing the CPU heat sink

The following describes the procedure of removing the CPU heat sink.

1. Disconnect the **Heat sink cable** from the connector on the system board
2. Remove the following **screws** securing the heat sink holder.

- M2.0×3.0 BIND screw x3

NOTE: *When removing the heat sink holder, be sure to remove the screws in the reverse order of the number marked on the holder.*

3. Remove the **CPU heat sink**.

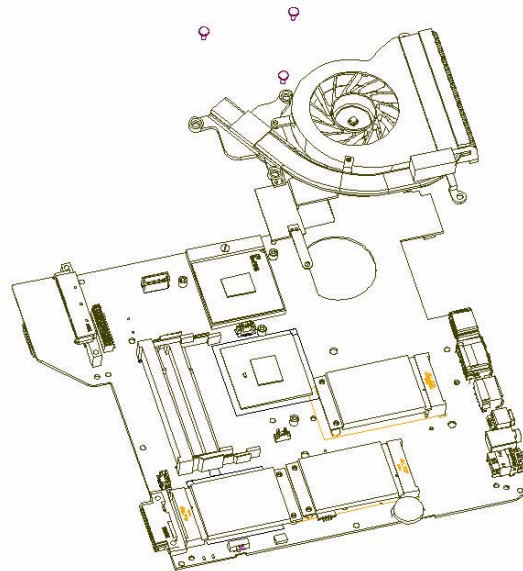

EXPLD STATE: EXP0002
SIMPLFD REP: REP0005

Figure 4-25 Remove the CPU heat sink

4. Unlock the **CPU** by rotating the **cam** on the CPU socket 120 degrees to the counterclockwise with a flat-blade screwdriver.
5. Remove the **CPU**.

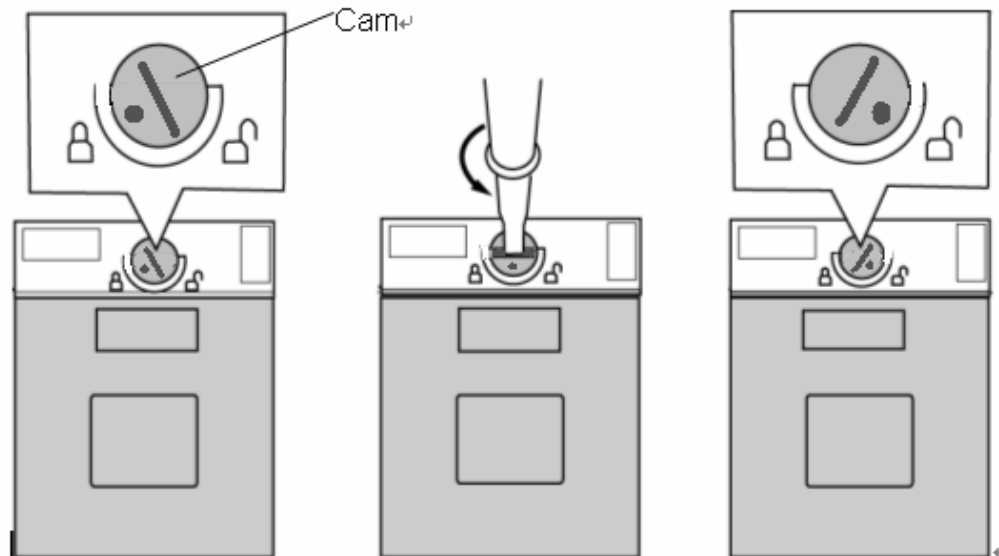

Figure 4-26 Remove the CPU

Installing the CPU

The following describes the procedure of installing the CPU.

1. Check that the mark of cam is in the unlocking position.
2. Attach the **CPU** to the correct position in the **CPU socket**.
3. Fix the **CPU** by rotating the cam 120 degrees to the clockwise with a flat-blade screwdriver.
4. If there is already silicon grease on the CPU, clean it with a cloth. Using a special applicator, apply silicon grease so that the CPU chip on the CPU is completely covered.
5. Please apply 0.1cc silicon grease ([Shinetsu7762](#)) for each repair.

NOTE: *Apply the silicon grease enough to cover the chip surface using the special applicator.*

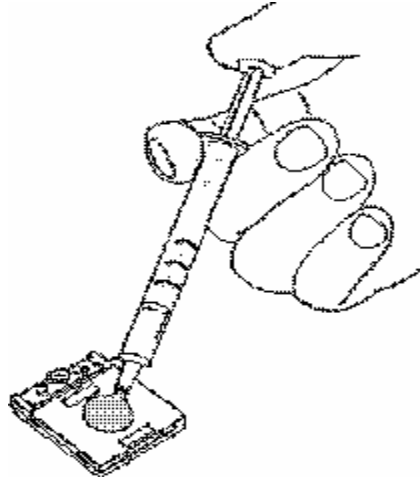

Figure 4-27 Applying silicon grease

6. Install the **CPU heat sink** and **heat sink holder** and secure them with the following **screws** along 1 to 6.

M2.0×3.0BIND screw x6

7. Connect the **Heat sink cable** to the connector on the system board

NOTE: *When securing the heat sink holder, be sure to secure the screws in the order of the number marked on the holder.*

4.15 LCD unit / FL inverter

CAUTION: When replacing a LCD, it is required that SVP parameter is set. Update with the latest EC/KBC as described in Appendix H “EC/KBC Rewrite Procedures”.

Removing the LCD unit / FL inverter

The following describes the procedure of removing the LCD unit and FL inverter

Remove Screw rubber cover

1. Remove the following **screws** securing the display mask

M2.5×5.0 BIND screw X11

2. Insert your finger between the edge of the display mask and the **LCD**, and remove the **display mask** while releasing the latches of display mask.

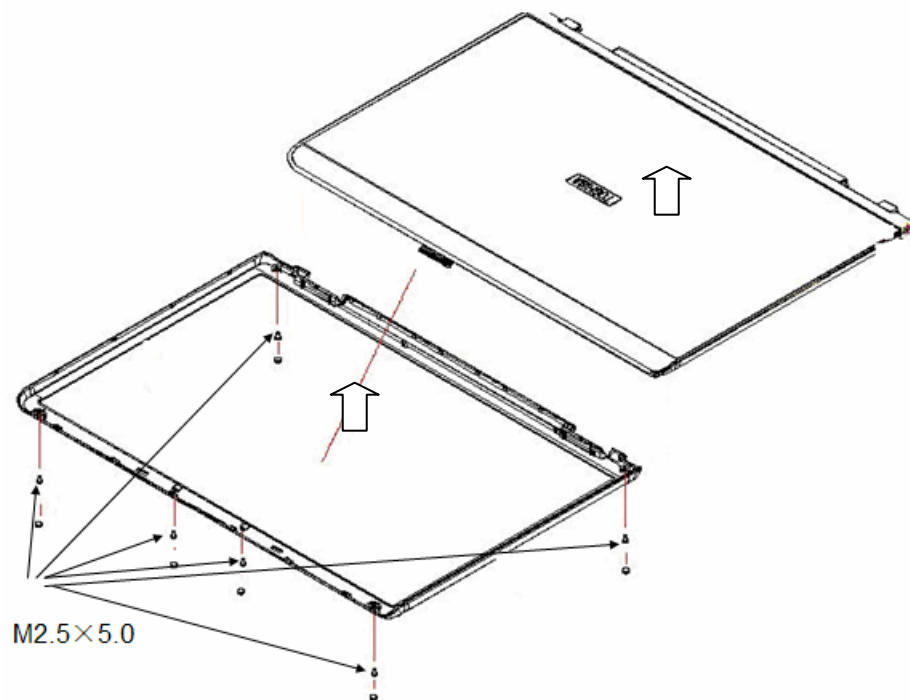

Figure 4-28 Remove the display mask

3. Pull out one **insulator** and peel off the other one adhered to the FL inverter.

4. Disconnect the **LCD harnesses** from the connectors **CN1** on the FL inverter.
5. Disconnect the **HV harnesses** from the connectors **CN2** on the FL inverter.
6. Remove the **FL inverter** while peeling off the **double-sided tape**.

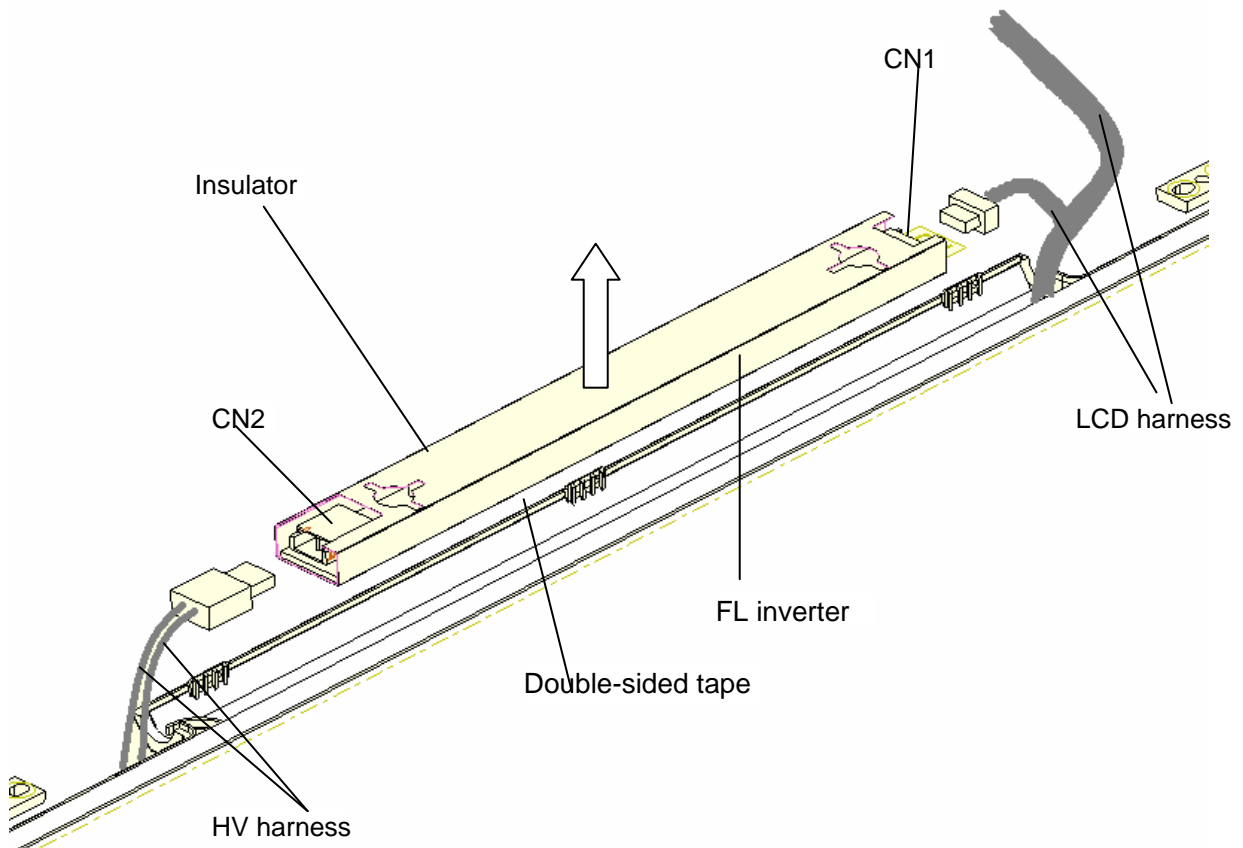

Figure 4-29 Remove the FL inverter

Replacement Procedures

7. Remove the following **screws** securing the LCD unit.
 - M2.5x4.0 BINK HEAD screw x2
8. With the bottom edge of the LCD unit on the display cover, lift only the top edge of the LCD unit. After peeling off the **CONDUCTIVE tape**, disconnect the LCD harness from the connector on the back of the LCD.
9. Remove the **LCD unit**.

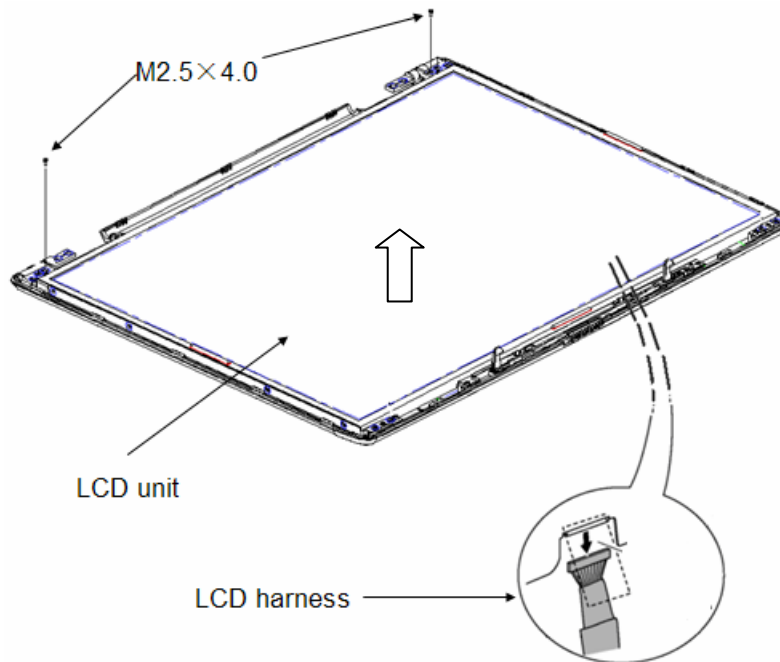

Figure 4-30 Remove the LCD unit

10. Remove the following **screws** securing the LCD support (LCD unit side) and remove the **LCD supports** from the LCD unit.

- M2.0x2.5 BINK screw x4

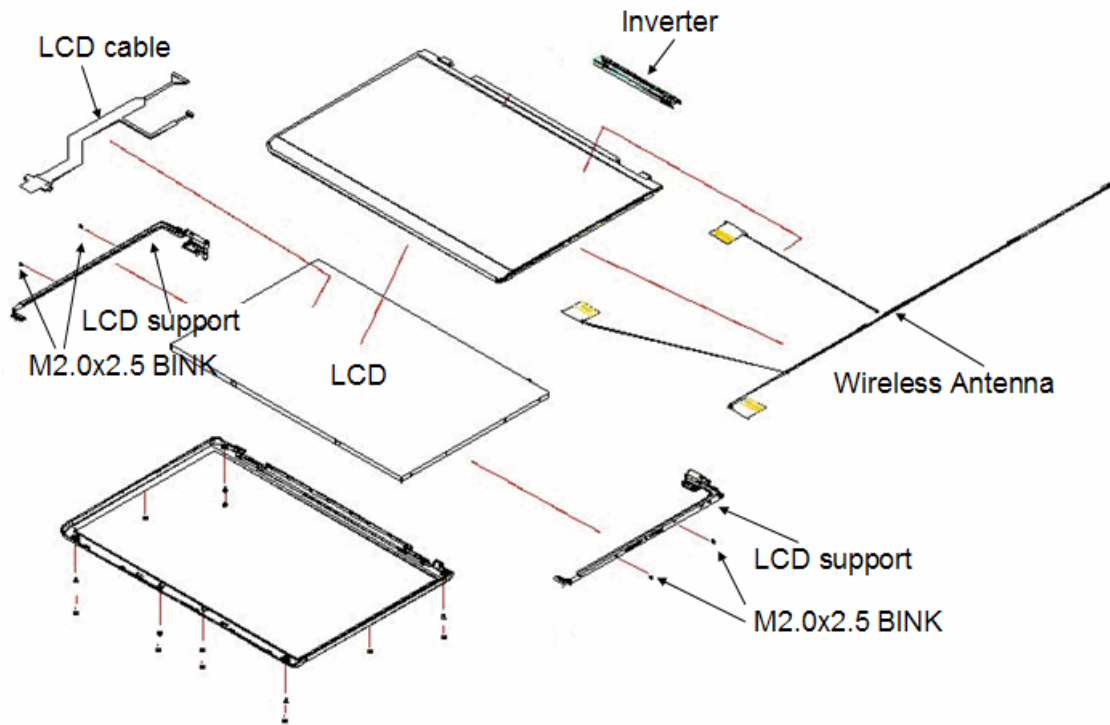

Figure 4-31 Remove the LCD supports

Installing the LCD unit/FL Inverter

The following describes the procedure **of** installing the LCD unit and FL inverter.

1. Install the LCD supports (LCD unit side) to the LCD and secure them with the following **screws**.
 - M2.0×2.5 BINK screw x4
2. Stand the **LCD unit** on the display cover and connect the **LCD harness** to the connector on the back of LCD.
3. Stick the **conductive tape** on the connector of LCD harness.
4. Secure the LCD unit with the following **screws**.
 - M2.5×4.0 BINK screw x2
5. Connect **LCD harnesses** to the connector **CN1** of the FL inverter.

CAUTION: *Be careful not to connect the LCD harnesses to the wrong connectors of FL inverter.*

6. Connect **HV harnesses** to the connector **CN2** of the FL inverter.
7. Install the **display mask** while fitting the latches.
8. Secure the display mask with following **screws**
 - M2.5×5.0 BIND screw X6
9. Cover screws with Screw rubber cover X6

NOTE: *When installing the display mask, make sure there is no gap between the display mask and the display cover.*

4.16 Application for Thermal Pad on North Bridge

For Satellite U400/Satellite Pro U400/PROTÉGÉ M800 (Intel without VGA board) use Thermal Pad FSL-BS75 on North Bridge

1. Thermal Pad FSL-BS75
2. one Syringe contains 12mmX14mmX0.75mm

TSB P/N	Raw Material	Classification	Description
A000026940	JXBU2013010	NORTH BRIDGE THERMAL PAD	THERMAL PAD UMA FSL-BS BU2(JXBU2013,R3A)

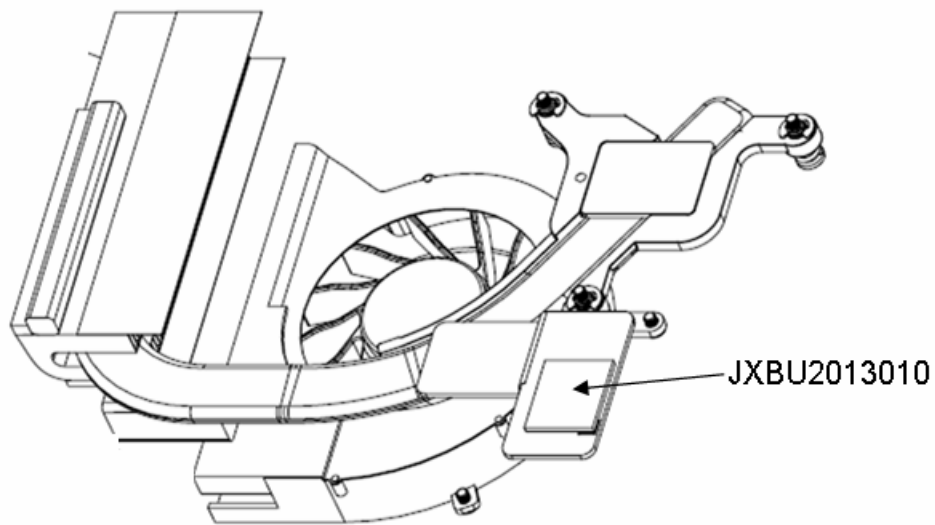

NOTE: Thermal pad is fixed for each one, no need special applicator and can re-use.

Appendix A Handling the LCD Module

Precautions for handling the LCD module

The LCD module can be easily damaged during assembly or disassembly. Observe the following precautions when handling the LCD module:

1. When installing the LCD module in the LCD cover, be sure to seat it so that it is properly aligned and maximum visibility of the display is maintained.

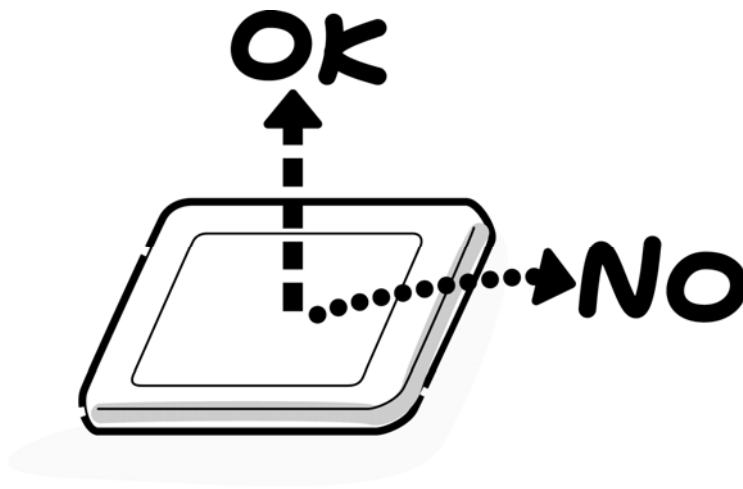

2. Be careful to align the holes at the four corners of the LCD module with the corresponding holes in the LCD cover before securing the module with screws. Do not force the module into place, because stress can affect its performance.

Also, the panel's polarized surface is easily scarred, so be careful when handling it.



3. If the panel's surface gets dirty, wipe it with cotton or a soft cloth. If it is still dirty, try breathing on the surface to create a light condensate and wipe it again.

If the surface is very dirty, we recommend a CRT cleaning agent. Apply the agent to a cloth and then wipe the panel's surface. Do not apply cleanser directly to the panel.



4. If water or other liquid is left on the panel's surface for a long period, it can change the screen's tint or stain it. Be sure to quickly wipe off any liquid.



5. Glass is used in the panel, so be careful not to drop it or let it strike a hard object, which could cause breakage or cracks.

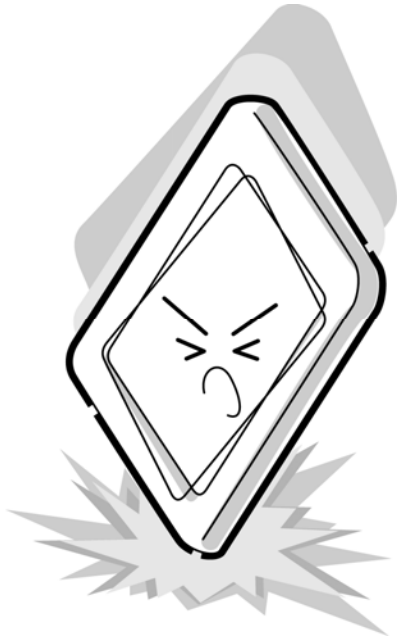

6. CMOS-LSI circuits are used in the module, so guard against damage from electrostatic discharge. Be sure to wear a wrist or ankle ground when handling the module.

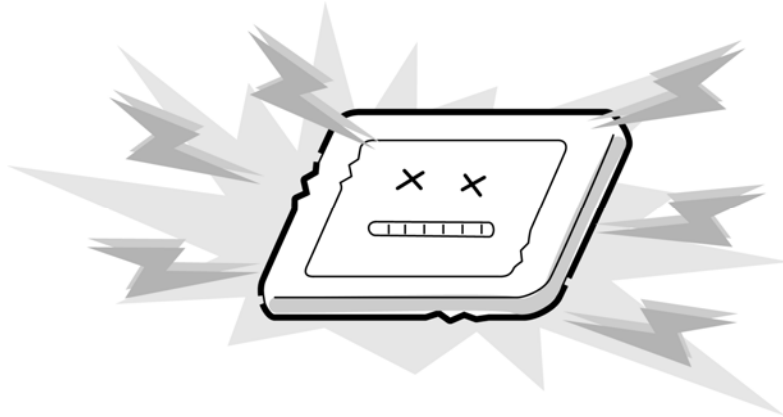

7. Do not expose the module to direct sunlight or strong ultraviolet rays for long periods.



8. Do not store the module at temperatures below specifications. Cold can cause the liquid crystals to freeze, lose their elasticity or otherwise suffer damage.

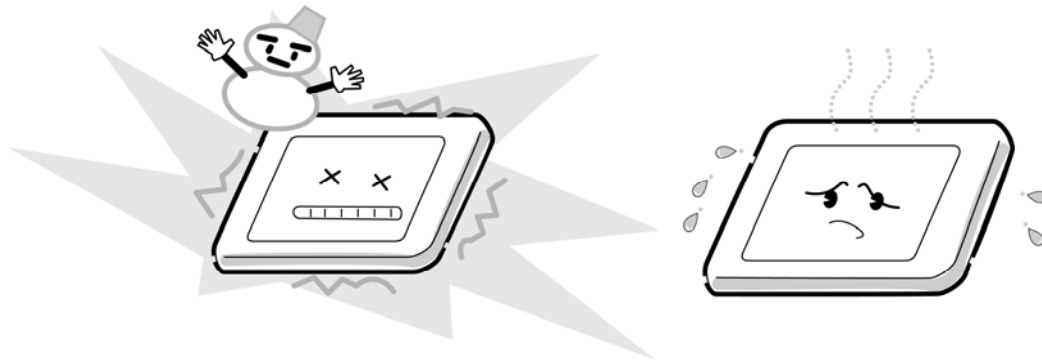

9. Do not disassemble the LCD module. Disassembly can cause malfunctions.

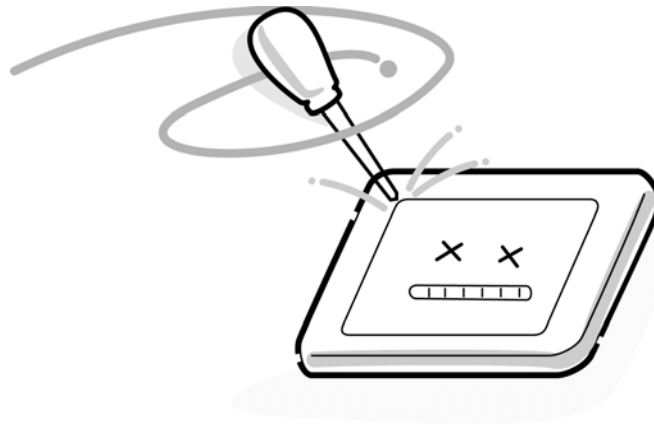

10. If you transport the module, do not use packing material that contains epoxy resin (amine) or silicon glue (alcohol or oxide). These materials can release gas that can damage the panel's polarization.

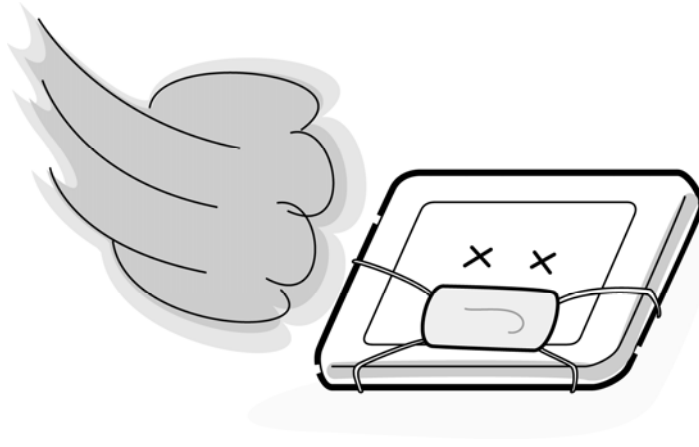

Appendix B Board Layout

B.1 System Board

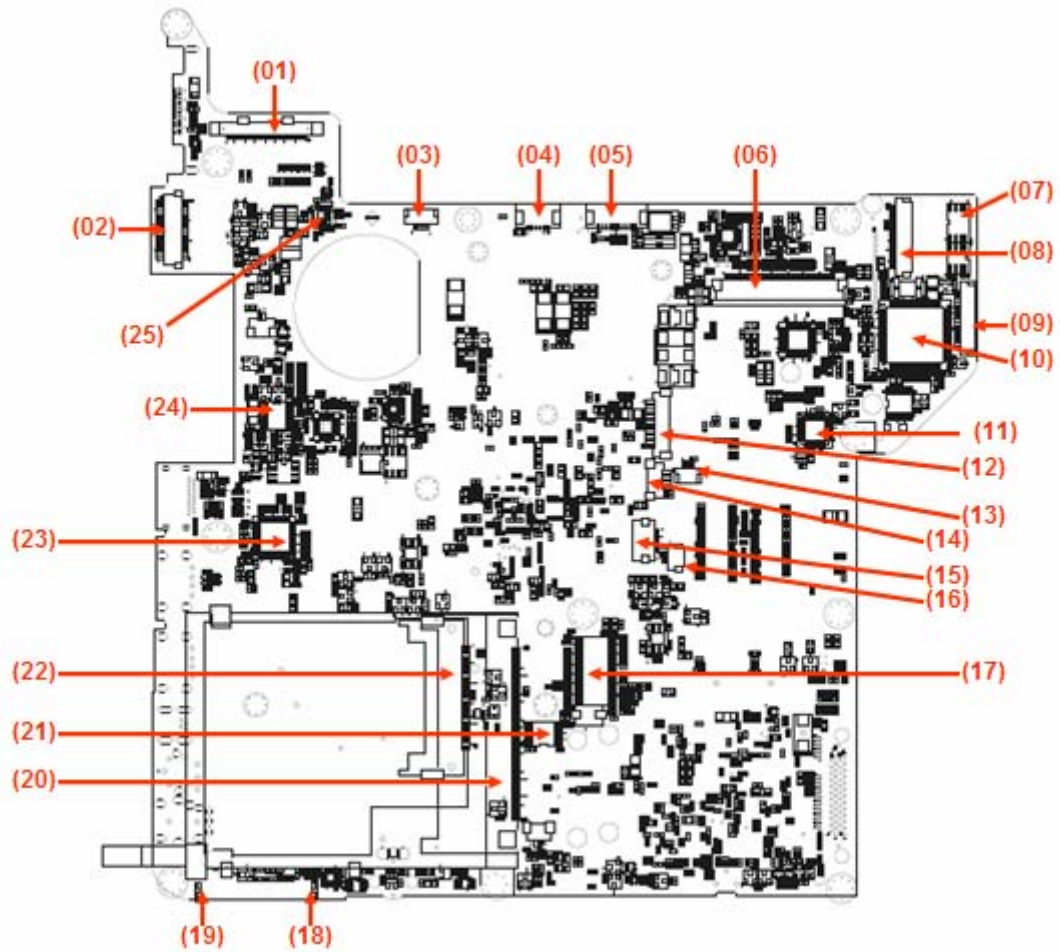

Figure B-1-1 System board layout (front)

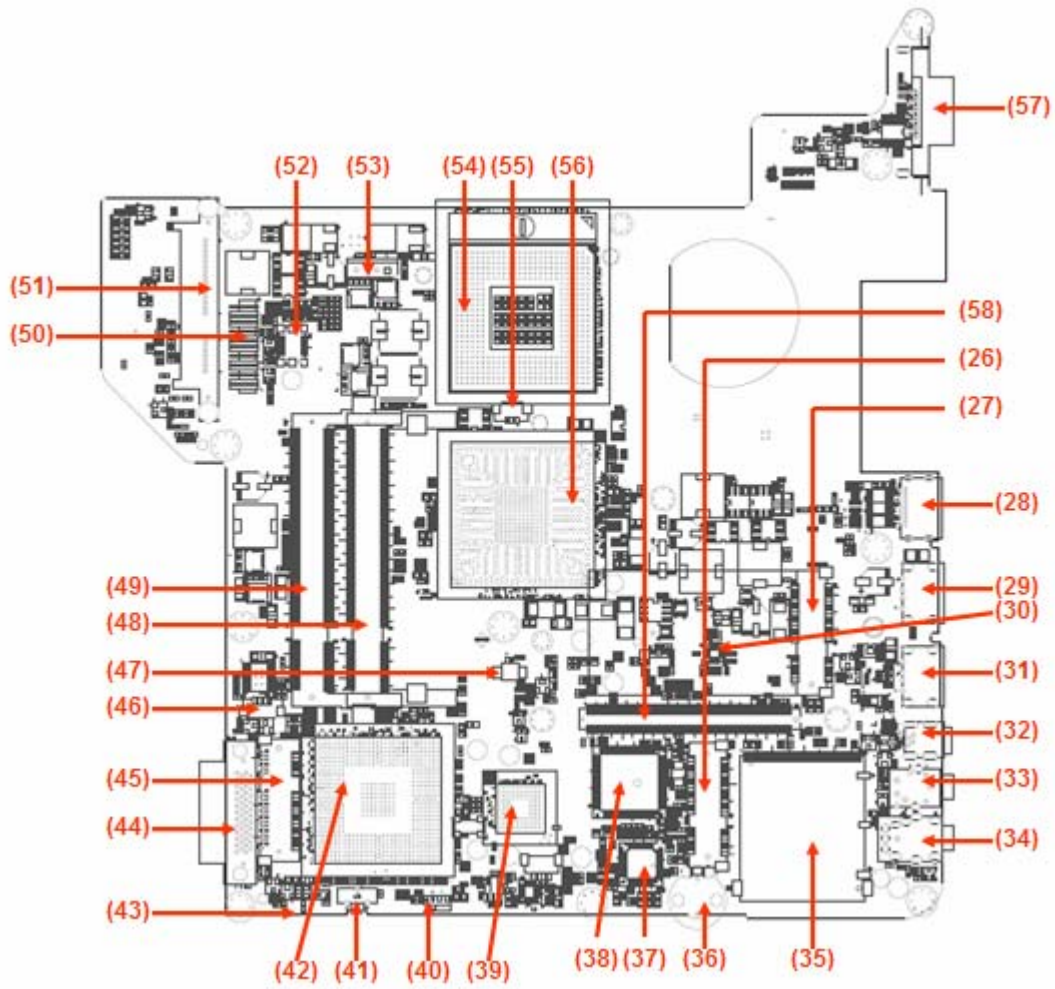

Figure B-1-2 System board layout (Back)

Table B-1 System board ICs and connectors

	Location	Function
(01)	CN1	M/B to LED type panel connector
(02)	CN5	M/B to CCFL type panel connector
(03)	CN4	M/B to Power Board connector
(04)	CN2	M/B to Mainstream Function board connector
(05)	CN3	M/B to Low Cost Function board connector
(06)	CN7	External Keyboard connector
(07)	U2	BIOS IC
(08)	CN6	M/B to LAN Board connector
(09)	CN8	M/B to External MINI card slot connector
(10)	U5	Embedded Controller IC (Winbond WPCE775C)
(11)	U33	G-sensor IC LIS3L02AQ3
(12)	CN10	M/B to Bluetooth module connector
(13)	CN11	M/B to Touch pad board connector
(14)	CN12	M/B to Touch pad with Fingerprint board connector
(15)	CN13	M/B to LED board connector
(16)	CN14	M/B to Ferica module connector
(17)	U13	Clock Gen IC ICS9LPRS365BGLFT
(18)	LED2	Satellite LED
(19)	LED1	Satellite LED
(20)	CN16	Card Bus connector
(21)	U16	Card Bus power switch IC ENE CP-2211
(22)	CN15	New Card connector
(23)	U12	Internal HDMI transmitter IC Sil1392
(24)	U9	CEC control IC R5F211A4SP
(25)	U1	LED Panel Drive IC
(26)	CN34	Internal MINI card slot
(27)	CN27	Internal MINI card slot
(28)	CN23	HDMI connector
(29)	CN26	USB connector
(30)	U17	New Card power switch IC OZ27C10LN-B1
(31)	CN29	USB connector
(32)	CN32	1394 connector
(33)	CN33	External MIC jack connector
(34)	CN38	HP/SPDIF jack connector
(35)	CN37	Card Reader connector
(36)	VR1	Volume wheel
(37)	U39	Codec IC CX20561-12Z
(38)	U36	Card reader/1394 control IC OZ129T
(39)	U38	Card Bus control IC CB1410

(40)	U42	CIR controller IR-IRM-V538-TR1
(41)	SW2	Kill SW
(42)	U37	South Bridge ICH8
(43)	LED3	W-LAN&BT LED
(44)	CN36	ODD connector
(45)	CN35	Internal MINI card slot
(46)	CN30	Internal speaker connector
(47)	CN28	RTC battery connector
(48)	CN25	DDR SO-DIMM(200P) slot
(49)	CN24	DDR SO-DIMM(200P) slot
(50)	CN21	Battery cable connector
(51)	CN19	HDD connector
(52)	CN20	Modem module connector
(53)	PJ1	AC cable connector
(54)	U26	CPU socket
(55)	CN22	FAN connector
(56)	U29	North Bridge
(57)	CN18	CRT connector
(58)	CN31	VGA board connector

B.2 Function Button board

<Front layout>

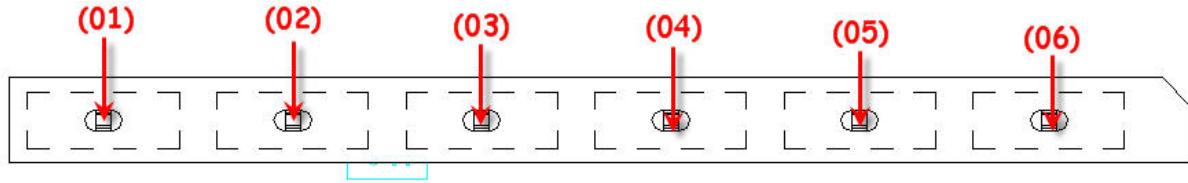

Figure B-2-1-1 Function Button board layout Mainstresam (Front)

<Back layout>

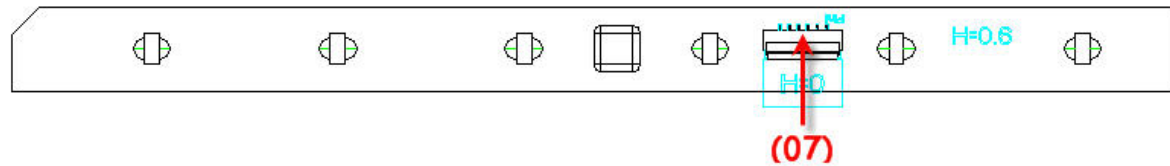

Figure B-2-1-2 Function Button board layout Mainstream (Back)

Table B-2-1 Function Button board connectors

	Location	Function
(01)	SW1	Music Silence Button
(02)	SW2	Media Player Button
(03)	SW3	Music Play / Pause Button
(04)	SW4	Music Stop Button
(05)	SW5	Music Backward
(06)	SW6	Music Forward
(07)	J1	MMB board (Mainstream) to M/B connector

<Front layout>

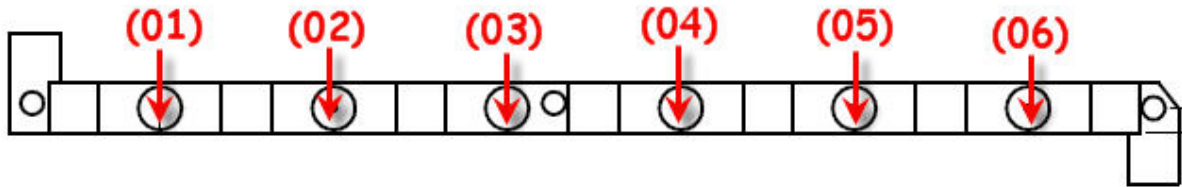

Figure B-2-2-1 Function Button board layout Lowcost (Front)

<Back layout>

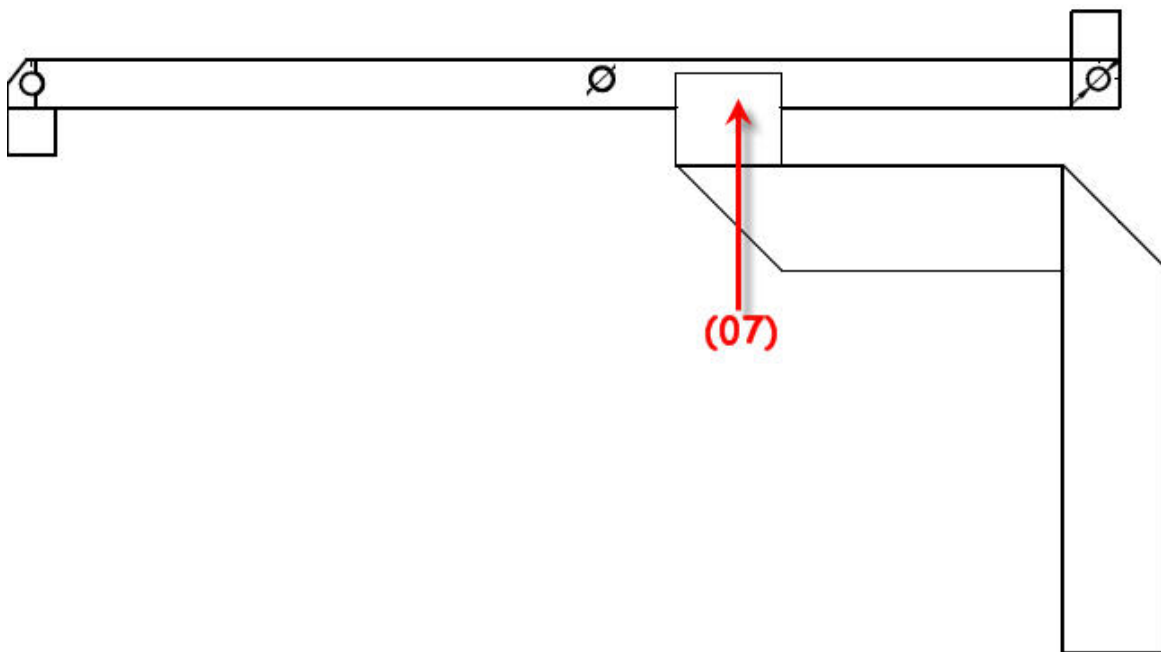

Figure B-2-2-2 Function Button board layout Lowcost (Back)

Table B-2-2 Function Button board connectors

	Location	Function
(01)	SW1	Music Silence Button
(02)	SW2	Media Player Button
(03)	SW3	Music Play / Pause Button
(04)	SW4	Music Stop Button
(05)	SW5	Music Backward
(06)	SW6	Music Forward
(07)	CN1	MMB board (Lowcost) to M/B connector (no mount connector, only with Hotbar)

B.3 Power Board

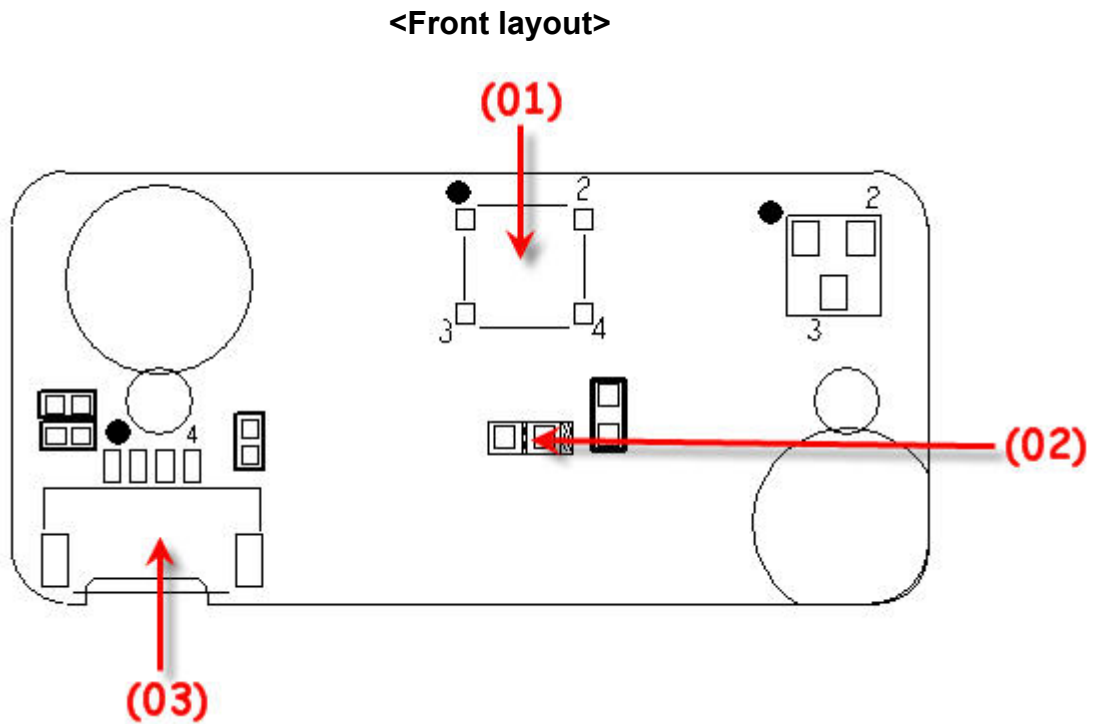

Figure B-3 Power board layout

Table B-3 Power board connectors

	Location	Function
(01)	SW1	Power Button Switch
(02)	LED1	Power LED
(03)	CN1	Power board to M/B connector

B.4 Touch Pad Board

<Front layout>

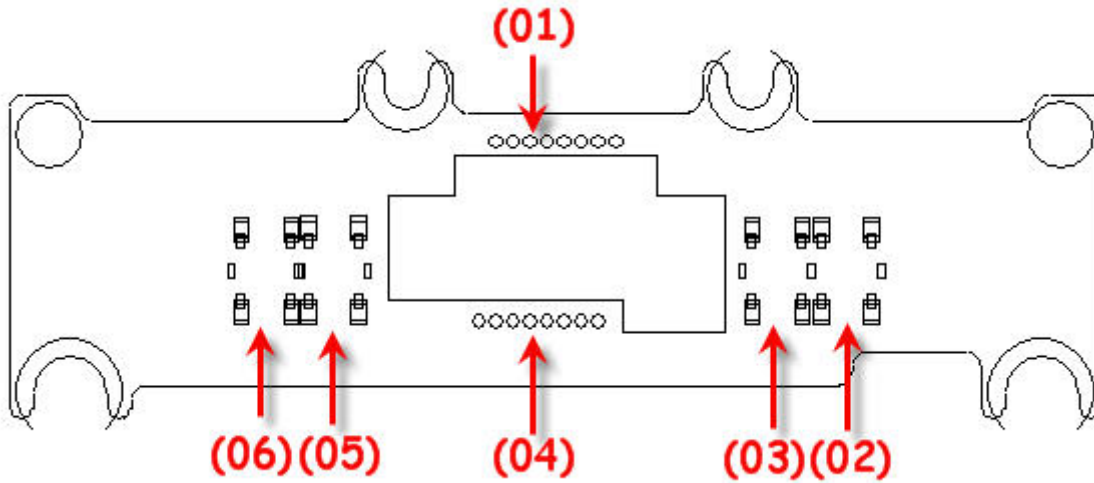

Figure B-4-1 Touch Pad board layout (Front)

Table B-4-1 Touch Pad board connectors (Front)

	Location	Function
(01)	CN4	Touch Pad board to Fingerprint board connector(Upper)
(02)	SW4	Mouse Button Right key
(03)	SW2	Mouse Button Right key
(04)	CN5	Touch Pad board to Fingerprint board connector(Lower)
(05)	SW3	Mouse Button Left key
(06)	SW1	Mouse Button Left key

<Back layout>

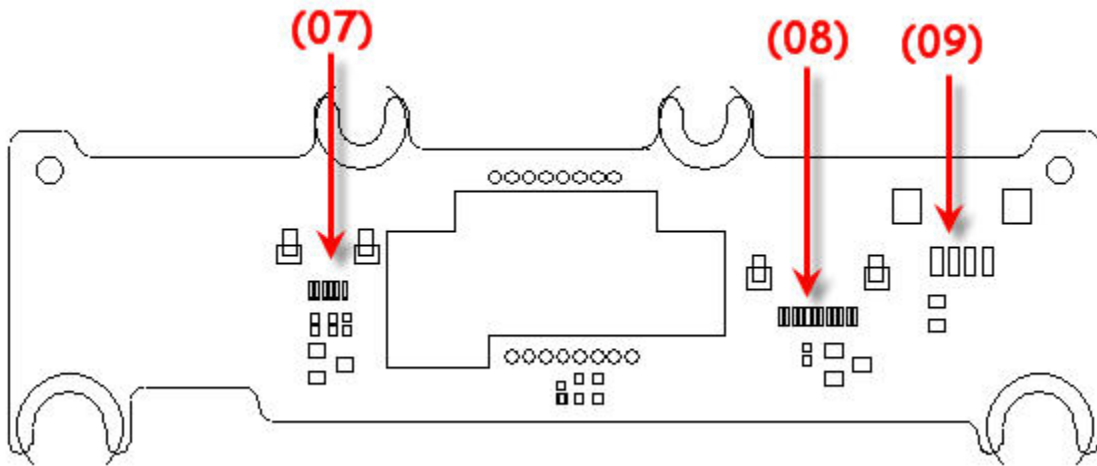

Figure B-4-2 Touch pad board layout (Back)

Table B-4-2 Touch pad board connectors (Back)

	Location	Function
(07)	CN1	Touch Pad board to M/B connector for Module use
(08)	CN3	Touch Pad board to Touch Pad Module connector
(09)	CN2	Touch Pad board to M/B connector for Fingerprint board use

B.5 LAN Board – 10/100/Giga RJ11 Modem Board

<Front layout>

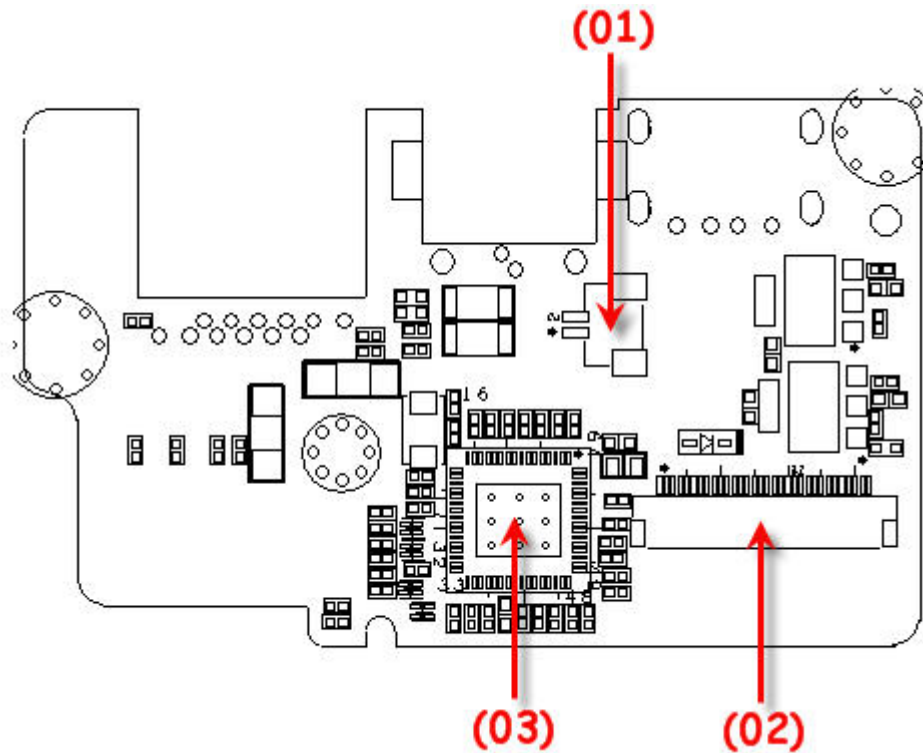

Figure B-5-1 LAN board 10/100 RJ11 layout (Front)

Table B-5-1 LAN board 10/100 RJ11 layout (Front)

	Location	Function
(01)	CN1	Modem signal to MDC connector
(02)	CN2	LAN board to M/B connector
(03)	U1	LAN board Marvell controller IC 88E8040T for 10/100 88E8072 for Giga

<Back layout>

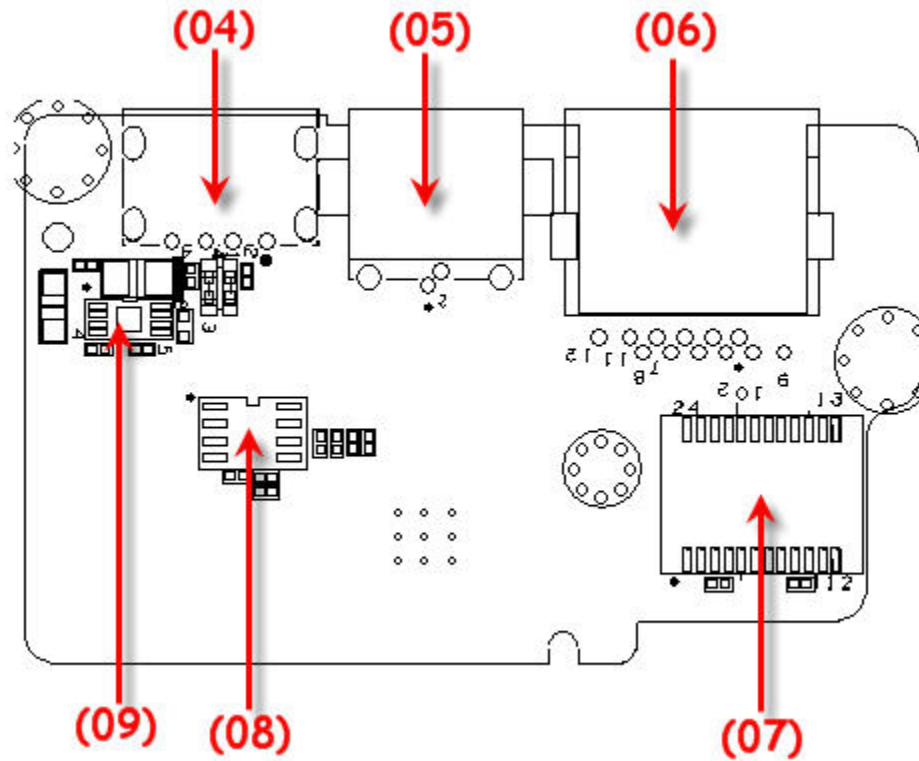

Figure B-5-2 LAN board 10/100 RJ11 layout (Back)

Table B-5-2 LAN board 10/100 RJ11 layout (Back)

	Location	Function
(04)	CN3	USB connector
(05)	CN5	RJ11 connector
(06)	CN4	RJ45 connector
(07)	U4	LAN transformer IC
(08)	U3	LAN EEPROM IC
(09)	U2	LAN board USB power switch

B.6 LAN Board – Giga FM Board

<Front layout>

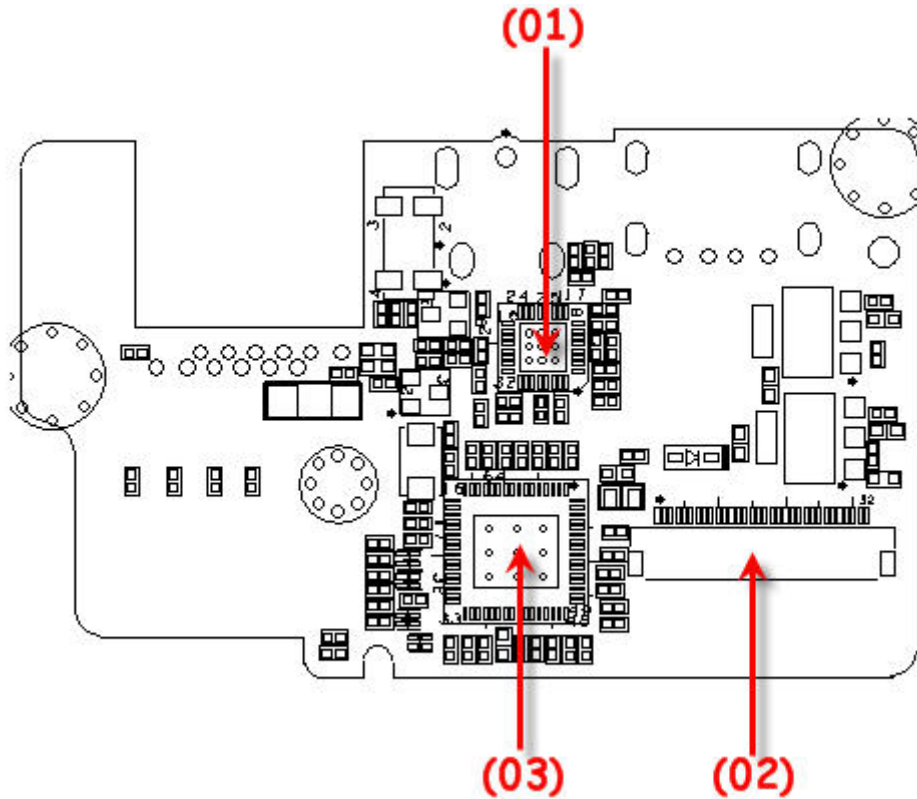

Figure B-6-1 LAN board Giga FM layout (Front)

Table B-6-1 LAN board Giga FM layout (Front)

	Location	Function
(01)	U1	FM tuner controller IC
(02)	CN2	LAN board to M/B connector
(03)	U2	LAN board Marvell controller IC 88E8072 for Giga

<Back layout>

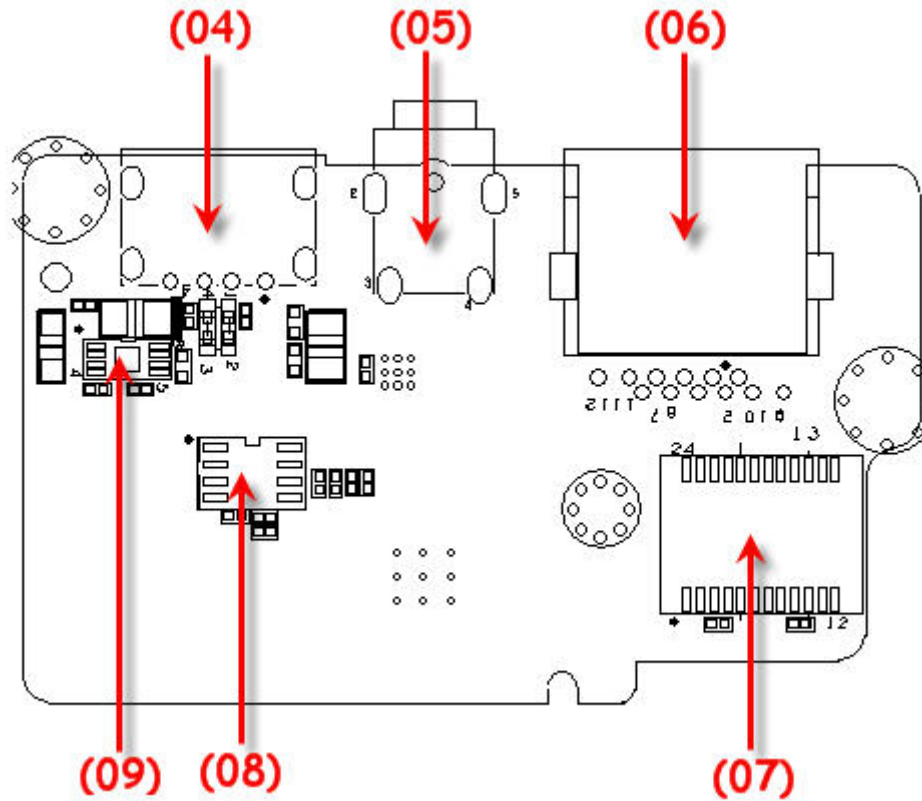

Figure B-6-2 LAN board Giga FM layout (Back)

Table B-6-2 LAN board Giga FM layout (Back)

	Location	Function
(04)	CN2	USB connector
(05)	CN3	FM RF connector
(06)	CN4	RJ45 connector
(07)	U5	LAN transformer IC
(08)	U4	LAN Flash IC
(09)	U3	LAN board USB power switch

B.7 Fingerprint Board

<Front layout>

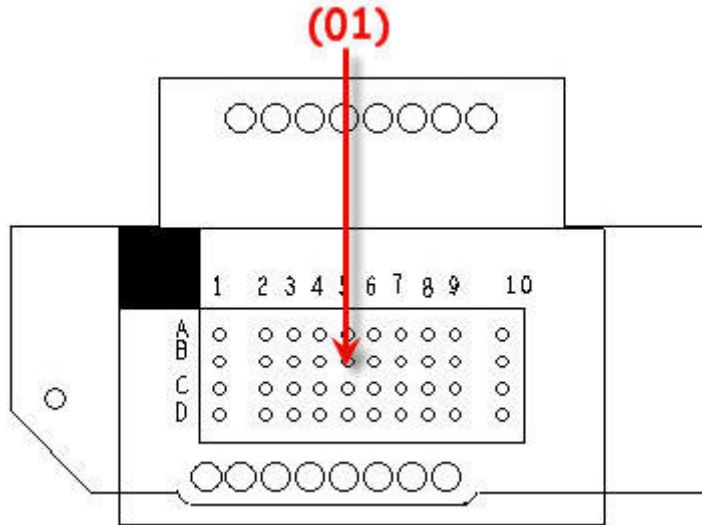

Figure B-7-3 Fingerprint board layout (Front)

Table B-7-1 Fingerprint board layout (Front)

	Location	Function
(01)	U1	Finger Printer IC AES1610

<Back layout>

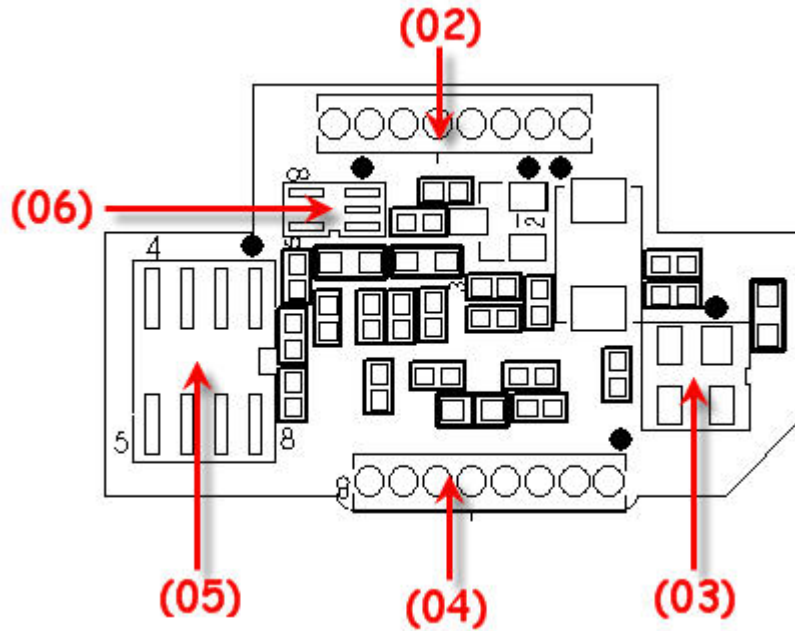

Figure B-7-2 Fingerprint board layout (Back)

Table B-7-2 Fingerprint board layout (Back)

	Location	Function
(02)	CN2	Fingerprint board to Touch Pad Board connector (Upper)
(03)	U2	Fingerprint Sensor ESD protect IC
(04)	CN3	Fingerprint board to Touch Pad Board connector (Lower)
(05)	U5	Fingerprint Flash IC
(06)	U3	Fingerprint current limited IC

B.8 Modem Board

<Front layout>

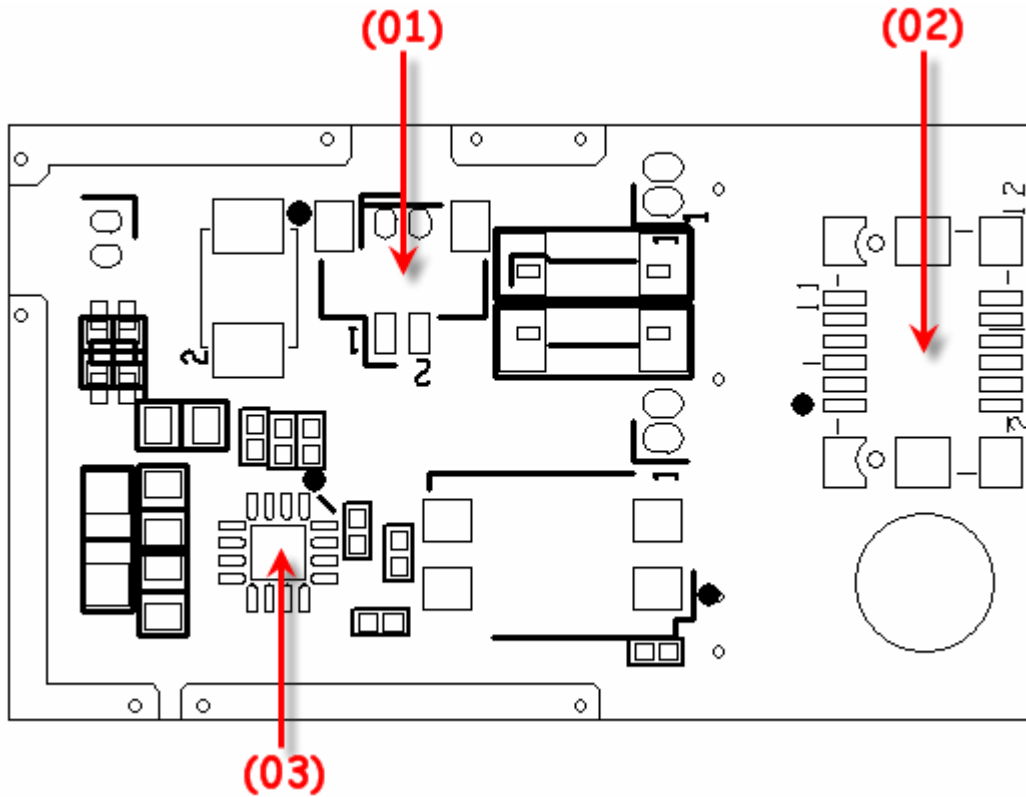

Figure B-8 Modem board layout

Table B-8 Modem board layout

	Location	Function
(01)	MJ2	Modem board to LAN board modem connector
(02)	CN1	Modem board to M/B connector
(03)	MU1	Modem board controller IC

B.9 LED Board

<Front layout>

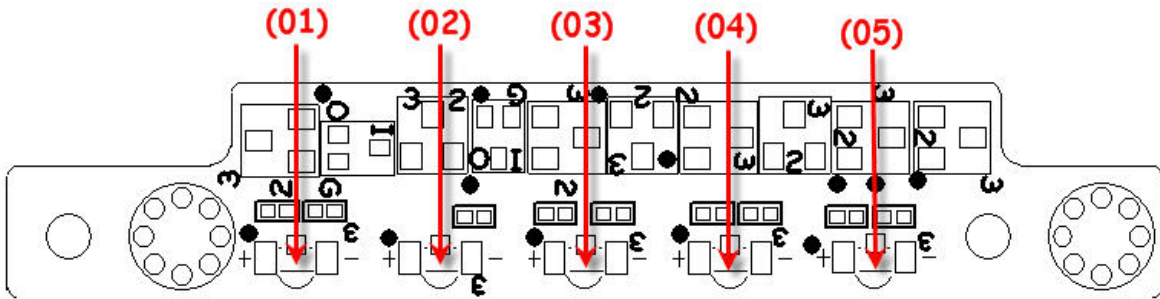

Figure B-9-4 LED board layout (Front)

Table B-9-1 LED board layout (Front)

	Location	Function
(01)	LED7	ACIN signal detected light
(02)	LED3	Power signal detected light
(03)	LED1	Battery signal detected light
(04)	LED8810	HDD signal detected light
(05)	LED2	Card Reader signal detected light

<Back layout>

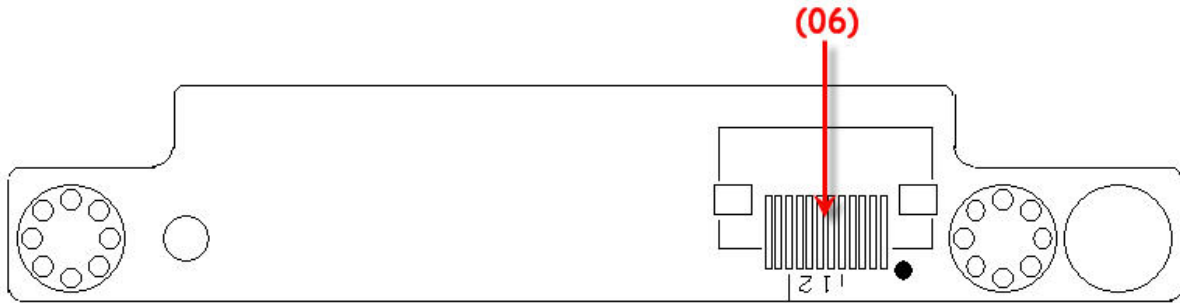

Figure B-9-2 LED board layout (Back)

Table B-9-2 LED board layout (Back)

	Location	Function
(06)	CN1	LED board to M/B connector (no mount connector, only with Hotbar)

Appendix C Pin Assignment

CN1 LED Panel Connector

P/N : DFHS40FS736 CONN SMD HOUSING 40P 2R FS(P0.5,H2.6)

PIN No.	Signal name	I/O	PIN No.	Signal name	I/O
1	MIC_DATA	I/O	2	ADOGND	---
3	GND	---	4	NC	---
5	LED_PWR	---	6	LED_PWR	---
7	LED_PWR	---	8	LED_PWR	---
9	LED_PWR	---	10	LED_PWR	---
11	NC	---	12	LED_GND6	---
13	LED_GND5	---	14	LED_GND4	---
15	LED_GND3	---	16	LED_GND2	---
17	LED_GND1	---	18	GND	---
19	LED_EDIDCLK	I/O	20	LED_EDIDDATA	I/O
21	GND	---	22	LED_TXLCLKOUT-	I/O
23	LED_TXLCLKOUT+	I/O	24	GND	---
25	LED_TXLOUT0-	I/O	26	LED_TXLOUT0+	I/O
27	GND	---	28	LED_TXLOUT1-	I/O
29	LED_TXLOUT1+	I/O	30	GND	---
31	LED_TXLOUT2-	I/O	32	LED_TXLOUT2+	I/O
33	GND	---	34	USBP3+_LED	I/O
35	USBP3-_LED	I/O	36	GND	---
37	LCDVCC	---	38	LCDVCC	---

39	+3V	---	40	CCD_POWER	---
41	GND	---	42	GND	---
43	GND	---	44	GND	---
45	NC	---	46	NC	---

CN2 Mainstream Function board connector

P/N : DFFC06FR013 CONN SMD FFC 6P 1R FR(P1.0,H2.02)

PIN No.	Signal name	I/O	PIN No.	Signal name	I/O
1	+3VPCU	---	2	+5VPCU	---
3	KEY_INT	---	4	GND	---
5	3ND_MBDATA	I/O	6	3ND_MBCLK	I/O
7	GND	---	8	GND	---

CN3 Low Cost Function board connector

P/N : DFFC10FR012 CONN SMD FFC 10P 1R FR(P1.0,H2.02)

PIN No.	Signal name	I/O	PIN No.	Signal name	I/O
1	+3VPCU	---	2	MX5	I
3	MX2	I	4	MY1	I
5	GND	---	6	MX3	I
7	LOW_DET	I	8	MX4	I
9	FN0#	O	10	FN1#	O

CN4 Power Board connector

P/N : DFFC04FR012 CONN SMD FFC 4P 1R FR(P1.0,H1.5)

PIN No.	Signal name	I/O	PIN No.	Signal name	I/O
1	GND	---	2	PWRLED#	I
3	NBSWON#	I	4	+5VPCU	---

CN5 CCFL type panel connector

P/N : DFHS30FSB28 CONN SMD HOUSING 30P 2R FS (P1.0,H3.9)

PIN No.	Signal name	I/O	PIN No.	Signal name	I/O
1	INVCC0	---	2	LCDVCC	---
3	INVCC0	---	4	LCDVCC	---
5	NC	---	6	NC	---
7	+3V	---	8	GND	---
9	CCD_POWER	---	10	LCD_TXLCLKOUT+	I/O
11	ADOGND	---	12	LCD_TXLCLKOUT-	I/O
13	MIC_DATA	I	14	GND	---
15	DISPON	---	16	LCD_TXLOUT0+	I/O
17	LCD_VADJ	---	18	LCD_TXLOUT0-	I/O
19	LCD_EDIDCLK	I/O	20	GND	---
21	LCD_EDIDDATA	I/O	22	LCD_TXLOUT1+	I/O
23	GND	---	24	LCD_TXLOUT1-	I/O
25	USBP3+_LCD	---	26	GND	---

27	USBP3-_LCD	---	28	LCD_TXLOUT2+	I/O
29	GND	I/O	30	LCD_TXLOUT2-	I/O
31	GND	---	32	GND	---

CN6 LAN Board connector

P/N:DFFC32FR003 CONN SMD FPC 32P 1R FR(P0.5,H2.13)

PIN No.	Signal name	I/O	PIN No.	Signal name	I/O
1	+5VPCU	---	2	+5VPCU	---
3	+5VPCU	---	4	+5VPCU	---
5	USB_EN#0	I	6	USBOC#0	O
7	+3V_S5	---	8	+3V_S5	---
9	FM_RIGHT	O	10	FM_LEFT	O
11	SB_GPIO7	I	12	FM_INT	O
13	SB_GPIO27	I	14	LOM_DISABLE#	O
15	GND	---	16	USBP0-	I/O
17	USBP0+	I/O	18	GND	---
19	CLK_PCIE_LAN	O	20	CLK_PCIE_LAN#	O
21	GND	---	22	PCIE_TXN5	O
23	PCIE_TXP5	O	24	GND	---
25	PCIE_RXP5	I	26	PCIE_RXN5	I
27	GND	---	28	PLTRST#	O
29	PCIE_WAKE#	I	30	+3V	---
31	FM_DET	I	32	GND	---

CN7 External Keyboard connector

P/N:DFFC34FR003 CONN SMD FFC 34P,1R,FR(P0.8,H2.0)

PIN No.	Signal name	I/O	PIN No.	Signal name	I/O
1	K_LED_P	I	2	MY16	O
3	NC	---	4	MY17	O
5	NC	---	6	K_LED_P	I
7	MY2	O	8	MY1	O
9	MY0	O	10	MY4	O
11	MY3	O	12	MY5	O
13	MY14	O	14	MY6	O
15	MY6	O	16	MY13	O
17	MY8	O	18	MY9	O
19	MY10	O	20	MY11	O
21	MY12	O	22	MY15	O
23	MX7	O	24	MX2	O
25	MX3	O	26	MX4	O
27	MX0	O	28	MX5	O
29	MX6	O	30	MX1	O
31	K_LED_P	I	32	CAPSLED	I
33	FN_F10	I	34	NUMLED	I
35	GND	---	36	GND	---

CN8 External MINI card slot connector

P/N:DFFC14FR009 CONN SMD FFC 14P 1R FR(P1.0,H1.5)

PIN No.	Signal name	I/O	PIN No.	Signal name	I/O
1	PLTRST#	---	2	NC	---
3	GND	---	4	CLK_PCIE_MINI4#	I
5	CLK_PCIE_MINI4	I	6	GND	---
7	PCIE_RXN4	I	8	PCIE_RXP4	I
9	GND	---	10	PCIE_TXN4	O
11	PCIE_TXP4	O	12	GND	---
13	+1.5V	---	14	+3V	---

CN10 Bluetooth module connector

P/N: DFHD10MR008 CONN SMD HEADER 10P 1R MR(P1.25,H1.9)

PIN No.	Signal name	I/O	PIN No.	Signal name	I/O
1	GND	---	2	USBP2+	I/O
3	USBP2-	I/O	4	WCS_CLK	I
5	GND	---	6	BT_RESET	---
7	WCS_DAT	O	8	+3V	---
9	USB_DETACH	---	10	GND	---
11	GND	---	12	GND	---

CN11 Touch pad board connector

P/N:DFFC06FR019 CONN SMD FFC 6P 1R FR(P0.5,H2.0)

PIN No.	Signal name	I/O	PIN No.	Signal name	I/O
1	+5V_TP	---	2	TPDATA	I/O
3	TPCLK	I/O	4	TP_LED_ON	I
5	GND	---	6	GND	---

CN12 Touch pad with Fingerprint board connector

P/N:DFHD04MRA75 CONN SMD HEADER 4P 1R MR(P1.25,H1.95)

PIN No.	Signal name	I/O	PIN No.	Signal name	I/O
1	+3V_Fingerprint	---	2	USBP1-	I/O
3	USBP1+	I/O	4	GND	---

CN13 LED board connector

P/N:DFFC12FR285 CONN SMD FFC 12P 1R FR (P0.5,H2.2)

PIN No.	Signal name	I/O	PIN No.	Signal name	I/O
1	GND	---	2	GND	---
3	+5VPCU	---	4	+5VPCU	---
5	+5V	---	6	BATLED1#	I
7	BATLED0#	I	8	PWRLED#	I
9	SUSLED_EC	I	10	IDE_LED#	---

11	TP_XD_LED	I	12	ACIN	---
----	-----------	---	----	------	-----

CN14 Ferica module connector

P/N: DFFC06FR003 CONN SMD FPC 6P 1R FR(P0.5,H1.5)

PIN No.	Signal name	I/O	PIN No.	Signal name	I/O
1	+5V_Felica	---	2	USBP4-	I/O
3	USBP4+	I/O	4	GND	---
5	NC	---	6	Test point	---

CN15 New Card connector

P/N:DFHD26MR074 CONN SMD HEADER 26P 1R MR (P1.0,H5.4)

PIN No.	Signal name	I/O	PIN No.	Signal name	I/O
1	GND	---	2	USBP9-_R	I/O
3	USBP9+_R	I/O	4	CPUSB#	O
5	NC	---	6	NC	---
7	NEW_SMCLK	O	8	NEW_SMDATA	O
9	+NEW_1.5V	---	10	+NEW_1.5V	---
11	PCIE_WAKE#	---	12	+NEW_3VAUX	---
13	PERST#	O	14	+NEW_3V	---
15	+NEW_3V	---	16	NEW_CLKREQ#	O
17	CPPE#	O	18	CLK_PCIE_NEW#	I
19	CLK_PCIE_NEW	I	20	GND	---
21	PCIE_RXN1	I	22	PCIE_RXP1	I
23	GND	---	24	PCIE_TXN1	O

Pin Assignment

25	PCIE_TXP1	O	26	GND	---
27	GND	---	28	GND	---
29	GND	---	30	GND	---

CN16 Card Bus connector

P/N:DFHD68MR710 CONN SMD HEADER 68P 2R MR(P0.635,H5.5)

PIN No.	Signal name	I/O	PIN No.	Signal name	I/O
1	GND	---	2	A_CAD0	I/O
3	A_CAD1	I/O	4	A_CAD3	I/O
5	A_CAD5	I/O	6	A_CAD7	I/O
7	A_CC/BE0#	O	8	A_CAD9	I/O
9	A_CAD11	I/O	10	A_CAD12	I/O
11	A_CAD14	I/O	12	A_CC/BE1#	O
13	A_CPAR	I/O	14	A_CPERR#	O
15	A_CGNT#	I	16	A_CINT#	O
17	AVCC	---	18	AVPP	---
19	A_CCLK	I	20	A_CIRDY#	O
21	A_CC/BE2#	O	22	A_CAD18	I/O
23	A_CAD20	I/O	24	A_CAD21	I/O
25	A_CAD22	I/O	26	A_CAD23	I/O
27	A_CAD24	I/O	28	A_CAD25	I/O
29	A_CAD26	I/O	30	A_CAD27	I/O
31	A_CAD29	I/O	32	A_CRSVD/D2	I/O
33	A_CCLKRUN#	I	34	GND	---

35	GND	---	36	A_CCD1#	I/O
37	A_CAD2	I/O	38	A_CAD4	I/O
39	A_CAD6	I/O	40	A_CRVSD/D14	I/O
41	A_CAD8	I/O	42	A_CAD10	I/O
43	A_CVS1#	O	44	A_CAD13	I/O
45	A_CAD15	I/O	46	A_CAD16	I/O
47	A_CRVSD/A18	I/O	48	A_CBLOCK#	I
49	A_CSTOP#	O	50	A_CDEVSEL#	I
51	AVCC	---	52	AVPP	---
53	A_CTRDY#	O	54	A_CFRAME#	I
55	A_CAD17	I/O	56	A_CAD19	I/O
57	A_CVS2#	O	58	A_CRST#	I
59	A_CSERR#	I	60	A_CREQ#	I
61	A_CC/BE3#	O	62	A_CAUDIO	I
63	A_CSTSCHG	I	64	A_CAD28	I/O
65	A_CAD30	I/O	66	A_CAD31	I/O
67	A_CCD2#	I/O	68	GND	---

CN18 CRT connector

P/N:DFDS15FR581 CONN DIP D-SUB 15P 2R FR(H10,P1.145)

PIN No.	Signal name	I/O	PIN No.	Signal name	I/O
1	CRT_R1	I	2	CRT_G1	I
3	CRT_B1	I	4	NC	---
5	GND	---	6	GND	---

Pin Assignment

7	GND	---	8	GND	---
9	5V_CRT2	---	10	GND	---
11	CRT_SENSE#	O	12	CRTDDAT	I
13	CRTHSYNC	I	14	CRTVSYNC	I
15	CRTDCLK	I	16	GND	---
17	GND	---			

CN19 HDD connector

P/N:DFHS22FR056 CONN DIP HOUSING 22P 1R FR(P1.27,H12.15)

PIN No.	Signal name	I/O	PIN No.	Signal name	I/O
1	GND	---	2	SATA_TXP0	O
3	SATA_TXN0	O	4	GND	---
5	SATA_RXN0	I	6	SATA_RXP0	I
7	GND	---	8	+3.3VSATA	---
9	+3.3VSATA	---	10	+3.3VSATA	---
11	GND	---	12	GND	---
13	GND	---	14	+5VSATA	---
15	+5VSATA	---	16	+5VSATA	---
17	GND	---	18	NC	---
19	GND	---	20	NC	---
21	NC	---	22	NC	---
23	GND	---	24	GND	---

CN20 Modem module connector

P/N:DFHS12FS002 CONN SMD HOUSING 12P 2R FS(P0.8,H8.35)

PIN No.	Signal name	I/O	PIN No.	Signal name	I/O
1	NC	---	2	NC	---
3	NC	---	4	NC	---
5	NC	---	6	NC	---
7	DIB_P	I	8	NC	---
9	DIB_N	I	10	NC	---
11	NC	---	12	NC	---

CN21 Battery cable Connector

P/N: DFHD14MS014 CONN SMD HEADER 14P 2R MS(P1.5,H19.5)

PIN No.	Signal name	I/O	PIN No.	Signal name	I/O
1	GND	---	2	GND	---
3	GND	---	4	GND	---
5	MBCLK	I/O	6	MBDATA	I/O
7	TEMP_MBAT	O	8	GND	---
9	ID	O	10	NC	---
11	MBAT+	---	12	MBAT+	---
13	MBAT+	---	14	MBAT+	---

CN22 FAN connector

Pin Assignment

P/N:DFWF03MS000 CONN SMD WAFER,3P,1R,MS(P1.25,H4.7)

PIN No.	Signal name	I/O	PIN No.	Signal name	I/O
1	TH_FAN_POWER	---	2	GND	---
3	+3V/ FANSIG	---			

CN23 HDMI connector

P/N:DFHD19MR011 CONN SMD HDMI 19P 2R MR(P1.0,H6.53)

PIN No.	Signal name	I/O	PIN No.	Signal name	I/O
1	HDMITX2P	O	2	GND	---
3	HDMITX2N	O	4	HDMITX1P	O
5	GND	---	6	HDMITX1N	O
7	HDMITX0P	O	8	GND	---
9	HDMITX0N	O	10	HDMICLK+	I/O
11	GND	---	12	HDMICLK-	I/O
13	CEC	---	14	NC	---
15	HDMI_DDCCLK	I/O	16	HDMI_DDCDATA	I/O
17	GND	---	18	DDC5V	---
19	HDMI_HP	---	20	GND	---
21	GND	---	22	GND	---
23	GND	---			

CN24 DDR2 SO-DIMM(200P) slot

P/N:DGMK0000040 IC SOCKET DDR2 SO-DIMM(200P,H10.5,RVS)

PIN No.	Signal name	I/O	PIN No.	Signal name	I/O
1	SMDDR_VREF_DIMM	---	2	GND	---
3	GND	---	4	M_B_DQ4	I/O
5	M_B_DQ0	I/O	6	M_B_DQ1	I/O
7	M_B_DQ5	I/O	8	GND	---
9	GND	---	10	M_B_DM0	I
11	M_B_DQS#0	I/O	12	GND	---
13	M_B_DQS0	I/O	14	M_B_DQ2	I/O
15	GND	---	16	M_B_DQ6	I/O
17	M_B_DQ7	I/O	18	GND	---
19	M_B_DQ3	I/O	20	M_B_DQ12	I/O
21	GND	---	22	M_B_DQ13	I/O
23	M_B_DQ9	I/O	24	GND	---
25	M_B_DQ8	I/O	26	M_B_DM1	I
27	GND	---	28	GND	---
29	M_B_DQS#1	I/O	30	M_CLK_DDR3	I
31	M_B_DQS1	I/O	32	M_CLK_DDR#3	I
33	GND	---	34	GND	---
35	M_B_DQ11	I/O	36	M_B_DQ14	I/O
37	M_B_DQ10	I/O	38	M_B_DQ15	I/O
39	GND	---	40	GND	---
41	GND	---	42	GND	---

Pin Assignment

43	M_B_DQ20	I/O	44	M_B_DQ16	I/O
45	M_B_DQ17	I/O	46	M_B_DQ21	I/O
47	GND	---	48	GND	---
49	M_B_DQS#2	I/O	50	PM_EXTTTS#1	O
51	M_B_DQS2	I/O	52	M_B_DM2	I
53	GND	---	54	GND	---
55	M_B_DQ22	I/O	56	M_B_DQ18	I/O
57	M_B_DQ23	I/O	58	M_B_DQ19	I/O
59	GND	---	60	GND	---
61	M_B_DQ29	I/O	62	M_B_DQ24	I/O
63	M_B_DQ28	I/O	64	M_B_DQ25	I/O
65	GND	---	66	GND	---
67	M_B_DM3	I	68	M_B_DQS#3	I/O
69	NC	---	70	M_B_DQS3	I/O
71	GND	---	72	GND	---
73	M_B_DQ26	I/O	74	M_B_DQ30	I/O
75	M_B_DQ27	I/O	76	M_B_DQ31	I/O
77	GND	---	78	GND	---
79	M_CKE3	I	80	M_CKE4	I
81	+1.8VSUS	---	82	+1.8VSUS	---
83	NC	---	84	NC	---
85	M_B_BS#2	I	86	M_B_A14	---
87	+1.8VSUS	---	88	+1.8VSUS	---
89	M_B_A12	I/O	90	M_B_A11	I/O

91	M_B_A9	I/O	92	M_B_A7	I/O
93	M_B_A8	I/O	94	M_B_A6	I/O
95	+1.8VSUS	---	96	+1.8VSUS	---
97	M_B_A5	I/O	98	M_B_A4	I/O
99	M_B_A3	I/O	100	M_B_A2	I/O
101	M_B_A1	I/O	102	M_B_A0	I/O
103	+1.8VSUS	---	104	+1.8VSUS	---
105	M_B_A10	I/O	106	M_B_BS1	I
107	M_B_BS0	I	108	M_B_RAS#	I
109	M_B_WE#	I	110	M_CS#2	I
111	+1.8VSUS	---	112	+1.8VSUS	---
113	M_B_CAS#	I	114	M_ODT2	I
115	M_CS#3	I	116	M_B_A13	I/O
117	+1.8VSUS	---	118	+1.8VSUS	---
119	M_ODT3	I	120	NC	---
121	GND	---	122	GND	---
123	M_B_DQ37	I/O	124	M_B_DQ32	I/O
125	M_B_DQ38	I/O	126	M_B_DQ36	I/O
127	GND	---	128	GND	---
129	M_B_DQS#4	I/O	130	M_B_DM4	I
131	M_B_DQS4	I/O	132	GND	---
133	GND	---	134	M_B_DQ39	I/O
135	M_B_DQ34	I/O	136	M_B_DQ33	I/O
137	M_B_DQ35	I/O	138	GND	---

Pin Assignment

139	GND	---	140	M_B_DQ44	I/O
141	M_B_DQ40	I/O	142	M_B_DQ45	I/O
143	M_B_DQ41	I/O	144	GND	---
145	GND	---	146	M_B_DQS#5	I/O
147	M_B_DM5	I	148	M_B_DQS5	I/O
149	GND	---	150	GND	---
151	M_B_DQ46	I/O	152	M_B_DQ42	I/O
153	M_B_DQ43	I/O	154	M_B_DQ47	I/O
155	GND	---	156	GND	---
157	M_B_DQ53	I/O	158	M_B_DQ52	I/O
159	M_B_DQ49	I/O	160	M_B_DQ48	I/O
161	GND	---	162	GND	---
163	NC	---	164	M_CLK_DDR4	I
165	GND	---	166	M_CLK_DDR#4	I
167	M_B_DQS#6	I/O	168	GND	---
169	M_B_DQS6	I/O	170	M_B_DM6	I
171	GND	---	172	GND	---
173	M_B_DQ51	I/O	174	M_B_DQ55	I/O
175	M_B_DQ54	I/O	176	M_B_DQ50	I/O
177	GND	---	178	GND	---
179	M_B_DQ56	I/O	180	M_B_DQ60	I/O
181	M_B_DQ57	I/O	182	M_B_DQ61	I/O
183	GND	---	184	GND	---
185	M_B_DM7	I	186	M_B_DQS#7	I/O

187	GND	---	188	M_B_DQS7	I/O
189	M_B_DQ59	I/O	190	GND	---
191	M_B_DQ62	I/O	192	M_B_DQ63	I/O
193	GND	---	194	M_B_DQ58	I/O
195	CGDAT_SMB	I/O	196	GND	---
197	CGCLK_SMB	I/O	198	GND	---
199	+3V	---	200	+3V	---

CN25 DDR2 Connector

P/N: DGMK0000037 IC SOCKET DDR2 SO-DIMM(200P,H6,RVS)

PIN No.	Signal name	I/O	PIN No.	Signal name	I/O
1	SMDDR_VREF_DIMM	---	2	GND	---
3	GND	---	4	M_A_DQ4	I/O
5	M_A_DQ6	I/O	6	M_A_DQ0	I/O
7	M_A_DQ5	I/O	8	GND	---
9	GND	---	10	M_A_DM0	I
11	M_A_DQS#0	I/O	12	GND	---
13	M_A_DQS0	I/O	14	M_A_DQ7	I/O
15	GND	---	16	M_A_DQ1	I/O
17	M_A_DQ2	I/O	18	GND	---
19	M_A_DQ3	I/O	20	M_A_DQ13	I/O
21	GND	---	22	M_A_DQ12	I/O

Pin Assignment

23	M_A_DQ9	I/O	24	GND	---
25	M_A_DQ8	I/O	26	M_A_DM1	I
27	GND	---	28	GND	---
29	M_A_DQS#1	I/O	30	M_CLK_DDR0	I
31	M_A_DQS1	I/O	32	M_CLK_DDR#0	I
33	GND	---	34	GND	---
35	M_A_DQ14	I/O	36	M_A_DQ10	I/O
37	M_A_DQ11	I/O	38	M_A_DQ15	I/O
39	GND	---	40	GND	---
41	GND	---	42	GND	---
43	M_A_DQ17	I/O	44	M_A_DQ16	I/O
45	M_A_DQ20	I/O	46	M_A_DQ21	I/O
47	GND	---	48	GND	---
49	M_A_DQS#2	I/O	50	PM_EXTTTS#0	O
51	M_A_DQS2	I/O	52	M_A_DM2	I
53	GND	---	54	GND	---
55	M_A_DQ23	I/O	56	M_A_DQ18	I/O
57	M_A_DQ19	I/O	58	M_A_DQ22	I/O
59	GND	---	60	GND	---
61	M_A_DQ28	I/O	62	M_A_DQ29	I/O
63	M_A_DQ25	I/O	64	M_A_DQ24	I/O
65	GND	---	66	GND	---
67	M_A_DM3	I	68	M_A_DQS#3	I/O
69	NC	---	70	M_A_DQS3	I/O

71	GND	---	72	GND	---
73	M_A_DQ26	I/O	74	M_A_DQ30	I/O
75	M_A_DQ27	I/O	76	M_A_DQ31	I/O
77	GND	---	78	GND	---
79	M_CKE0	I	80	M_CKE1	I
81	+1.8VSUS	---	82	+1.8VSUS	---
83	NC	---	84	NC	---
85	M_A_BS#2	I	86	M_A_A14	---
87	+1.8VSUS	---	88	+1.8VSUS	---
89	M_A_A12	I/O	90	M_A_A11	I/O
91	M_A_A9	I/O	92	M_A_A7	I/O
93	M_A_A8	I/O	94	M_A_A6	I/O
95	+1.8VSUS	---	96	+1.8VSUS	---
97	M_A_A5	I/O	98	M_A_A4	I/O
99	M_A_A3	I/O	100	M_A_A2	I/O
101	M_A_A1	I/O	102	M_A_A0	I/O
103	+1.8VSUS	---	104	+1.8VSUS	---
105	M_A_A10	I/O	106	M_A_BS1	I
107	M_A_BS0	I	108	M_A_RAS#	I
109	M_A_WE#	I	110	M_CS#0	I
111	+1.8VSUS	---	112	+1.8VSUS	---
113	M_A_CAS#	I	114	M_ODT0	I
115	M_CS#1	I	116	M_A_A13	I/O
117	+1.8VSUS	---	118	+1.8VSUS	---

Pin Assignment

119	M_ODT1	I	120	NC	---
121	GND	---	122	GND	---
123	M_A_DQ36	I/O	124	M_A_DQ32	I/O
125	M_A_DQ37	I/O	126	M_A_DQ33	I/O
127	GND	---	128	GND	---
129	M_A_DQS#4	I/O	130	M_A_DM4	I
131	M_A_DQS4	I/O	132	GND	---
133	GND	---	134	M_A_DQ35	I/O
135	M_A_DQ39	I/O	136	M_A_DQ38	I/O
137	M_A_DQ34	I/O	138	GND	---
139	GND	---	140	M_A_DQ44	I/O
141	M_A_DQ40	I/O	142	M_A_DQ45	I/O
143	M_A_DQ41	I/O	144	GND	---
145	GND	---	146	M_A_DQS#5	I/O
147	M_A_DM5	I	148	M_A_DQS5	I/O
149	GND	---	150	GND	---
151	M_A_DQ42	I/O	152	M_A_DQ43	I/O
153	M_A_DQ46	I/O	154	M_A_DQ47	I/O
155	GND	---	156	GND	---
157	M_A_DQ53	I/O	158	M_A_DQ48	I/O
159	M_A_DQ49	I/O	160	M_A_DQ52	I/O
161	GND	---	162	GND	---
163	NC	---	164	M_CLK_DDR1	I
165	GND	---	166	M_CLK_DDR#1	I

167	M_A_DQS#6	I/O	168	GND	---
169	M_A_DQS6	I/O	170	M_A_DM6	I
171	GND	---	172	GND	---
173	M_A_DQ50	I/O	174	M_A_DQ54	I/O
175	M_A_DQ51	I/O	176	M_A_DQ55	I/O
177	GND	---	178	GND	---
179	M_A_DQ56	I/O	180	M_A_DQ61	I/O
181	M_A_DQ60	I/O	182	M_A_DQ57	I/O
183	GND	---	184	GND	---
185	M_A_DM7	I	186	M_A_DQS#7	I/O
187	GND	---	188	M_A_DQS7	I/O
189	M_A_DQ62	I/O	190	GND	---
191	M_A_DQ63	I/O	192	M_A_DQ58	I/O
193	GND	---	194	M_A_DQ59	I/O
195	CGDAT_SMB	I/O	196	GND	---
197	CGCLK_SMB	I/O	198	GND	---
199	+3V	---	200	GND	---

CN26 USB connector

P/N:DFHS04FRB11 CONN DIP USB HOUSING 4P 1R FR(H7.6)

PIN No.	Signal name	I/O	PIN No.	Signal name	I/O
1	GND	---	2	BUSBP7+	I/O

Pin Assignment

3	BUSBP7-	I/O	4	USBPWR	---
---	---------	-----	---	--------	-----

CN27 Internal MINI card slot

P/N:DFHD52MS146 CONN SMD HEADER,52P,2R,MS(P0.8,H9)

PIN No.	Signal name	I/O	PIN No.	Signal name	I/O
1	NC	---	2	+3V	---
3	NC	---	4	GND	---
5	NC	---	6	+1.5V	---
7	NC	I	8	NC	---
9	GND	O	10	NC	---
11	CLK_PCIE_MINI3#	I	12	NC	---
13	CLK_PCIE_MINI3	I	14	NC	---
15	GND	---	16	NC	---
17	NC	---	18	GND	---
19	NC	---	20	NC	---
21	GND	---	22	PLTRST#	I
23	PCIE_RXN2	I	24	NC	---
25	PCIE_RXP2	I	26	GND	---
27	GND	---	28	+1.5V	---
29	GND	---	30	NC	---
31	PCIE_TXN2	O	32	NC	---
33	PCIE_TXP2	O	34	GND	---
35	GND	---	36	NC	---

37	NC	---	38	NC	---
39	NC	---	40	GND	---
41	NC	---	42	NC	---
43	NC	---	44	NC	---
45	NC	---	46	NC	---
47	NC	---	48	+1.5V	---
49	NC	---	50	GND	---
51	NC	---	52	+3V	---

CN28 RTC battery connector

P/N:DFWF02MS000 CONN SMD WAFER 2P 1R MS(P1.25)

PIN No.	Signal name	I/O	PIN No.	Signal name	I/O
1	VCCRTC_4	---	2	GND	---

CN29 USB connector

P/N: DFHS04FRB11 CONN DIP USB HOUSING 4P 1R FR(H7.6)

PIN No.	Signal name	I/O	PIN No.	Signal name	I/O
1	GND	---	2	BUSBP6+	I/O
3	BUSBP6-	I/O	4	USBPWR	---

CN30 Internal speaker connector

P/N:DFWF04MS002 CONN SMD WAFER,4P,1R,MS(P1.25,H4.7)

PIN No.	Signal name	I/O	PIN No.	Signal name	I/O
---------	-------------	-----	---------	-------------	-----

Pin Assignment

1	INSPKR-N	---	2	INSPKR+N	---
3	INSPKL-N	---	4	INSPKL+N	---
5	NC	---	6	NC	---

CN31 VGA board connector

P/N:DFHSK0FS001 CONN SMD HOUSING 200P FS(P5.15,H8.65)

PIN No.	Signal name	I/O	PIN No.	Signal name	I/O
1	PEG_RXN15	I	2	PEG_TXN15	O
3	PEG_RXP15	I	4	PEG_TXP15	O
5	GND	---	6	GND	---
7	PEG_RXN14	I	8	PEG_TXN14	O
9	PEG_RXP14	I	10	PEG_TXP14	O
11	GND	---	12	GND	---
13	PEG_RXN13	I	14	PEG_TXN13	O
15	PEG_RXP13	I	16	PEG_TXP13	O
17	GND	---	18	GND	---
19	PEG_RXN12	I	20	PEG_TXN12	O
21	PEG_RXP12	I	22	PEG_TXP12	O
23	GND	---	24	GND	---
25	PEG_RXN11	I	26	PEG_TXN11	O
27	PEG_RXP11	I	28	PEG_TXP11	O
29	GND	---	30	GND	---
31	PEG_RXN10	I	32	PEG_TXN10	O

33	PEG_RXP10	I	34	PEG_TXP10	O
35	GND	---	36	GND	---
37	PEG_RXN9	I	38	PEG_TXN9	O
39	PEG_RXP9	I	40	PEG_TXP9	O
41	GND	---	42	GND	---
43	PEG_RXN8	I	44	PEG_TXN8	O
45	PEG_RXP8	I	46	PEG_TXP8	O
47	GND	---	48	GND	---
49	PEG_RXN7	I	50	PEG_TXN7	O
51	PEG_RXP7	I	52	PEG_TXP7	O
53	GND	---	54	GND	---
55	PEG_RXN6	I	56	PEG_TXN6	O
57	PEG_RXP6	I	58	PEG_TXP6	O
59	GND	---	60	GND	---
61	PEG_RXN5	I	62	PEG_TXN5	O
63	PEG_RXP5	I	64	PEG_TXP5	O
65	GND	---	66	GND	---
67	PEG_RXN4	I	68	PEG_TXN4	O
69	PEG_RXP4	I	70	PEG_TXP4	O
71	GND	---	72	GND	---
73	PEG_RXN3	I	74	PEG_TXN3	O
75	PEG_RXP3	I	76	PEG_TXP3	O
77	GND	---	78	GND	---
79	PEG_RXN2	I	80	PEG_TXN2	O

Pin Assignment

81	PEG_RXP2	I	82	PEG_TXP2	O
83	GND	---	84	GND	---
85	PEG_RXN1	I	86	PEG_TXN1	O
87	PEG_RXP1	I	88	PEG_TXP1	O
89	GND	---	90	GND	---
91	PEG_RXN0	I	92	PEG_TXN0	O
93	PEG_RXP0	I	94	PEG_TXP0	O
95	GND	---	96	GND	---
97	CLK_MXM#	I	98	EXT_CRT_DDCCLK	I/O
99	CLK_MXM	I	100	EXT_CRT_DDCDAT	I/O
101	GND	---	102	GND	---
103	GFXRST#	I	104	EXT_HDMI_DDCCLK	I/O
105	SYSFANON#	O	106	EXT_HDMI_DDCDATA	I/O
107	MAINON	I	108	GND	---
109	GFXPG	O	110	EXT_LVDS_PNLCLK	I/O
111	3ND_MBDATA	I/O	112	EXT_LVDS_PNLDAT	I/O
113	3ND_MBCLK	I/O	114	GND	---
115	EXT_LVDS_BLON	O	116	EXT_VGA_RED	O
117	EXT_DISP_ON	O	118	GND	---
119	DVI_HPD	I	120	EXT_VGA_GRN	O
121	GND	---	122	GND	---
123	EXT_HSYNC	O	124	EXT_VGA_BLU	O
125	EXT_VSYNC	O	126	GND	---
127	GND	---	128	EXT_LVDS_TXL#2	---

129	NC	---	130	EXT_LVDS_TXL2	
131	NC	---	132	GND	---
133	GND	---	134	EXT_LVDS_TXL#1	
135	NC	---	136	EXT_LVDS_TXL1	
137	NC	---	138	GND	---
139	GND	---	140	EXT_LVDS_TXL#0	
141	NC	---	142	EXT_LVDS_TXL0	
143	NC	---	144	GND	---
145	GND	---	146	EXT_LVDS_TXLCK#	
147	NC	---	148	EXT_LVDS_TXLCK	
149	NC	---	150	GND	---
151	GND	---	152	NC	---
153	GND	---	154	GND	---
155	GND	---	156	NC	---
157	GND	---	158	GND	---
159	GND	---	160	NC	---
161	NC	---	162	GND	---
163	+5V	---	164	EXT_HDMICLK-	O
165	+5V	---	166	EXT_HDMICLK+	O
167	NC	---	168	GND	---
169	GND	---	170	EXT_HDMITX2N	O
171	NC	---	172	EXT_HDMITX2P	O
173	+3V	---	174	GND	---
175	+3V	---	176	EXT_HDMITX1N	O

Pin Assignment

177	+3V	---	178	EXT_HDMITX1P	O
179	+3V	---	180	GND	---
181	+3V	---	182	EXT_HDMITX0N	O
183	NC	---	184	EXT_HDMITX0P	O
185	GND	---	186	GND	---
187	NC	---	188	NC	---
189	VIN_VGA	---	190	VIN_VGA	---
191	VIN	---	192	VIN	---
193	VIN	---	194	VIN	---
195	VIN	---	196	VIN	---
197	VIN	---	198	VIN	---
199	VIN	---	200	VIN	---

CN32 1394 connector

P/N:DFHS04FR109 CONN DIP 1394 4P FR(P0.8,H6.6)

PIN No.	Signal name	I/O	PIN No.	Signal name	I/O
1	L1394_TPB0-	O	2	L1394_TPB0+	O
3	L1394_TPA0-	O	4	L1394_TPA0+	O
5	GND	---	6	GND	---
7	GND	---	8	GND	---

CN33 External MIC jack connector

P/N:DFTJ06FR102 CONN DIP PHONE JACK 6P 1R FR(H6.6)BLACK

PIN No.	Signal name	I/O	PIN No.	Signal name	I/O
1	ADOGND	---	2	MIC1-L1	O
3	MIC1-R1	O	4	Port_B#	O
5	ADOGND	---	6	NC	---
7	ADOGND	---	8	ADOGND	---

CN34 Internal MINI card slot

P/N:DFHS52FR011 CONN SMD HOUSING 52P 2R FR(P0.8,H7.5) VGA

P/N:DFHS52FR010 CONN SMD HOUSING 52P 2R FR(P0.8,H5.6) UMA

PIN No.	Signal name	I/O	PIN No.	Signal name	I/O
1	NC	---	2	+3V	---
3	NC	---	4	GND	
5	NC	---	6	+1.5V	---
7	NC	---	8	LAD0_PCIE	I/O
9	GND	---	10	LAD1_PCIE	I/O
11	CLK_PCIE_MINI2#	I	12	LAD2_PCIE	I/O
13	CLK_PCIE_MINI2	I	14	LAD3_PCIE	I/O
15	GND	---	16	LFRAME#_PCIE	I
17	NC	---	18	GND	---
19	NC	---	20	NC	---
21	GND	---	22	PLTRST#	I

Pin Assignment

23	PCIE_RXN3	I	24	NC	---
25	PCIE_RXP3	I	26	GND	---
27	GND	---	28	+1.5V	---
29	GND	---	30	NC	---
31	PCIE_TXN3	O	32	NC	---
33	PCIE_TXP3	O	34	GND	---
35	GND	---	36	Test point	---
37	NC	---	38	Test point	---
39	NC	---	40	GND	---
41	NC	---	42	NC	---
43	NC	---	44	NC	---
45	PCLK__debug	I	46	NC	---
47	PLTRST#_debug	I	48	+1.5V	---
49	LDRQ#1__debug	O	50	GND	---
51	SERIRQ_debug	O	52	+3V	---

CN35 Internal MINI card slot

P/N:DFHS52FR016 CONN DIP HOUSING 52P 2R FR(P0.8,H6.5)

PIN No.	Signal name	I/O	PIN No.	Signal name	I/O
1	WLAN_WAKE#	O	2	+3V	---
3	WCS_DATR	I/O	4	GND	---

5	WCS_CLKR	I/O	6	+1.5V	---
7	NC	---	8	NC	---
9	GND	---	10	NC	---
11	CLK_PCIE_MINI#	I	12	NC	---
13	CLK_PCIE_MINI	I	14	NC	---
15	GND	---	16	NC	---
17	NC	---	18	GND	
19	NC	---	20	RF_EN_WLAN	I
21	GND	---	22	PLTRST#	I
23	PCIE_RXN6	I	24	+3V_S5	---
25	PCIE_RXP6	I	26	GND	---
27	GND	---	28	+1.5V	---
29	GND	---	30	WL_SMCLK	I/O
31	PCIE_TXN6	O	32	WL_SMDATA	I/O
33	PCIE_TXP6	O	34	GND	---
35	GND	---	36	USBP5-_C	I/O
37	GND	---	38	USBP5+_C	I/O
39	NC	---	40	GND	---
41	NC	---	42	WiMAX_LED#_B	O
43	GND	---	44	NC	---
45	CL_CLK1_WLAN	I/O	46	NC	---
47	PLTRST#_PCIE	I/O	48	+1.5V	---
49	CL_RST#1_WLAN	I	50	GND	---
51	NC	---	52	+3V	---

CN36 ODD connector

P/N: DFHS50FR034 CONN DIP HOUSING 50P 2R FR(P0.8,H3.45)

PIN No.	Signal name	I/O	PIN No.	Signal name	I/O
1	NC	---	2	NC	---
3	NC	---	4	GND	---
5	-IDERST	O	6	PDD8	I/O
7	PDD7	I/O	8	PDD9	I/O
9	PDD6	I/O	10	PDD10	I/O
11	PDD5	I/O	12	PDD11	I/O
13	PDD4	I/O	14	PDD12	I/O
15	PDD3	I/O	16	PDD13	I/O
17	PDD2	I/O	18	PDD14	I/O
19	PDD1	I/O	20	PDD15	I/O
21	PDD0	I/O	22	PDDREQ	O
23	GND	---	24	PDIOR#	I
25	PDIOW#	I	26	GND	---
27	PDIORDY	O	28	PDDACK#	I
29	IRQ14	O	30	NC	---
31	PDA1	I/O	32	DIAG#	---
33	PDA0	I/O	34	PDA2	I/O
35	PDCS1#	I	36	PDCS3#	O

37	ODD_LED#	O	38	+5V	---
39	+5V	---	40	+5V	---
41	+5V	---	42	+5V	---
43	GND	---	44	GND	---
45	GND	---	46	GND	---
47	GND	---	48	GND	---
49	NC	---	50	NC	---
51	GND	---	52	GND	---

CN37 Card Reader connector

P/N:DFHD42MS005 CONN SMD HEADER 42P 1R MS(P0.76,H5.6)

PIN No.	Signal name	I/O	PIN No.	Signal name	I/O
1	GND	---	2	XD_CD#	O
3	XD_R/B#	I	4	XD_RE#	I/O
5	XD_CE#	I	6	XD_CLE	O
7	XD_ALE	I	8	XD_WE#	I
9	GND	I/O	10	GND	---
11	SD_D3	I/O	12	VCC_XD	---
13	XD_WPO#	O	14	SD/MS_CLK_C	---
15	SD_CMD	I	16	MS_D3/XD_D0	I/O
17	GND	---	18	MS_CD#	---
19	GND	---	20	MS_D2/XD_D1	I/O

Pin Assignment

21	VCC_XD	---	22	MS_D0/XD_D2	I/O
23	MS_D3/XD_D0_C	I/O	24	MS_D1/XD_D7	I/O
25	SD/MS_CLK	I/O	26	MS_BS/XD_D3	I
27	MS_D2/XD_D1_C	I/O	28	GND	---
29	GND	---	30	MS_D0/XD_D2_C	I/O
31	SD_D0	I/O	32	MS_BS/XD_D3_C	I/O
33	XD_D4	I/O	34	SD_D1	I/O
35	XD_D5	I/O	36	XD_D6	I/O
37	MS_D1/XD_D7_C	I/O	38	VCC_XD	---
39	SD_CD#	I/O	40	GND	---
41	SM_WPI#/SD_WP	I	42	GND	---
43	GND	---	44		---

CN38 HP/SPDIF jack connector

P/N:DFTJ05FR015 CONN DIP PHONE JACK 5P 1R FR(H6.6)BLACK

PIN No.	Signal name	I/O	PIN No.	Signal name	I/O
1	ADOGND	---	2	HPR_SYS	I
3	HPL_SYS	I	4	ADOGND	---
5	HP_JD	---	6	GND	---
7	+3V_SPD	---	8	SPDIF_OUT	I
9	NC	---	10	NC	---

Appendix D Display Codes

D.1 Display Codes

Table D-1 Scan codes (set 1 and set 2) (1/4)

Cap No.	Keytop	Code set 1		Code set 2			Note
		Make	Break	Make	Break		
01	‘ ~	29	A9	0E	F0	0E	
02	1 !	02	82	16	F0	16	
03	2 @	03	83	1E	F0	1E	
04	3 #	04	84	26	F0	26	
05	4 \$	05	85	25	F0	25	
06	5 %	06	86	2E	F0	2E	
07	6 ^	07	87	36	F0	36	
08	7 &	08	88	3D	F0	3D	*2
09	8 *	09	89	3E	F0	3E	*2
10	9 (0A	8A	46	F0	46	*2
11	0)	0B	8B	45	F0	45	
12	- _	0C	8C	4E	F0	4E	
13	= +	0D	8D	55	F0	55	
15	BkSp	0E	8E	66	F0	66	
16	Tab	0F	8F	0D	F0	0D	
17	Q	10	90	15	F0	15	
18	W	11	91	1D	F0	1D	
19	E	12	92	24	F0	24	
20	R	13	93	2D	F0	2D	
21	T	14	94	2C	F0	2C	
22	Y	15	95	35	F0	35	
23	U	16	96	3C	F0	3C	*2
24	I	17	97	43	F0	43	*2
25	O	13	98	44	F0	44	*2
26	P	19	99	4D	F0	4D	*2
27	[{	1A	9A	54	F0	54	
28] }	1B	9B	5B	F0	5B	

Table D-1 Scan codes (set 1 and set 2) (2/4)

Cap No.	Keytop	Code set 1		Code set 2		Note	
		Make	Break	Make	Break		
29	\	2B	AB	5D	F0	5D	*5
30	Caps Lock	3A	BA	58	F0	58	
31	A	1E	9E	1C	F0	1C	
32	S	1F	9F	1B	F0	1B	
33	D	20	A0	23	F0	23	
34	F	21	A1	2B	F0	2B	
35	G	22	A2	34	F0	34	
36	H	23	A3	33	F0	33	
37	J	24	A4	3B	F0	3B	*2
38	K	25	A5	42	F0	42	*2
39	L	26	A6	4B	F0	4B	*2
40	; :	27	A7	4C	F0	4C	*2
41	' "	28	A8	52	F0	52	
43	Enter	1C	9C	5A	F0	5A	*3
44	Shift (L)	2A	AA	12	F0	12	
45	No.102 key	56	D6	61	F0	61	
46	Z	2C	AC	1A	F0	1A	
47	X	2D	AD	22	F0	22	
48	C	2E	AE	21	F0	21	
49	V	2F	AF	2A	F0	2A	
50	B	30	B0	32	F0	32	
51	N	31	B1	31	F0	31	
52	M	32	B2	3A	F0	3A	*2
53	, <	33	B3	41	F0	41	*2
54	. >	34	B4	49	F0	49	*2
55	/ ?	35	B5	4A	F0	4A	*2
57	Shift (R)	36	B6	59	F0	59	

Table D-1 Scan codes (set 1 and set 2) (3/4)

Cap No.	Keytop	Code set 1				Code set 2				Note
		Make		Break		Make		Break		
58	Ctrl	1D		9D		14		F0 14		*3
60	Alt (L)	38		B8		11		F0 11		*3
61	Space	39		B9		29		F0 29		
62	ALT (R)	E0	38	E0	B8	E0	11	E0	F0 11	
75	Ins	E0	52	E0	D2	E0	70	E0	F0 70	*1
76	Del	E0	53	E0	D3	E0	71	E0	F0 71	*1
79	←	E0	4B	E0	CB	E0	6B	E0	F0 6B	*1
80	Home	E0	47	E0	C7	E0	6C	E0	F0 6C	*1
81	End	E0	4F	E0	CF	E0	69	E0	F0 69	*1
83	↑	E0	48	E0	C8	E0	75	E0	F0 75	*1
84	↓	E0	50	E0	D0	E0	72	E0	F0 72	*1
85	PgUp	E0	49	E0	C9	E0	7D	E0	F0 7D	*1
86	PgDn	E0	51	E0	D1	E0	7A	E0	F0 7A	*1
89	→	E0	4D	E0	CD	E0	74	E0	F0 74	*1
110	Esc	01		81		76		F0 76		
112	F1	3B		BB		05		F0 05		
113	F2	3C		BC		06		F0 06		
114	F3	3D		BD		04		F0 04		
115	F4	3E		BE		0C		F0 0C		
116	F5	3F		BF		03		F0 03		
117	F6	40		C0		0B		F0 0B		
118	F7	41		C1		83		F0 83		
119	F8	42		C2		0A		F0 0A		
120	F9	43		C3		01		F0 01		
121	F10	44		C4		09		F0 09		*3

Table D-1 Scan codes (set 1 and set 2) (4/4)

Cap No.	Keytop	Code set 1				Code set 2				Note
		Make		Break		Make		Break		
122	F11	57	D7	78	F0	78			*3	
123	F12	58	D8	07	F0	07			*3	
124	PrintSc	*6	*6	*6	*6				*6	
126	Pause	*7	*7	*7	*7				*7	
202	Fn	—	—	—	—				*4	
203	Win	E0	5B	E0	DB	E0	1F	E0	F0	1F
204	App	E0	5D	E0	DD	E0	2F	E0	F0	2F

Notes:

1. * Scan codes differ by mode.
2. * Scan codes differ by overlay function.
3. * Combined with the **Fn** key makes different codes.
4. * **Fn** key does not generate a code by itself.
5. * This key corresponds to key No. 42 in a 102-key model.
6. * Refer to Table D-6, No. 124 key scan code.
7. * Refer to Table D-7, No. 126 key scan code.

Table D-2 Scan codes with left Shift key

Cap No.	Key top	Code set 1				Code set 2					
		Make		Break		Make		Break			
55	/	E0 AA	E0 35	E0 B5	E0 2A	E0 F0	12 E0	E0 4A	E0 F0	4A E0	E0 12
75	INS	E0 AA	E0 52	E0 D2	E0 2A	E0 F0	12 E0	E0 70	E0 F0	70 E0	E0 12
76	DEL	E0 AA	E0 53	E0 D3	E0 2A	E0 F0	12 E0	E0 71	E0 F0	71 E0	E0 12
79	←	E0 AA	E0 4B	E0 CB	E0 2A	E0 F0	12 E0	E0 6B	E0 F0	6B E0	E0 12
80	Home	E0 AA	E0 47	E0 C7	E0 2A	E0 F0	12 E0	E0 6C	E0 F0	6C E0	E0 12
81	End	E0 AA	E0 4F	E0 CF	E0 2A	E0 F0	12 E0	E0 69	E0 F0	69 E0	E0 12
83	↑	E0 AA	E0 48	E0 C8	E0 2A	E0 F0	12 E0	E0 75	E0 F0	75 E0	E0 12
84	↓	E0 AA	E0 50	E0 D0	E0 2A	E0 F0	12 E0	E0 72	E0 F0	72 E0	E0 12
85	PgUp	E0 AA	E0 49	E0 C9	E0 2A	E0 F0	12 E0	E0 7D	E0 F0	7D E0	E0 12
86	PgDn	E0 AA	E0 51	E0 D1	E0 2A	E0 F0	12 E0	E0 7A	E0 F0	7A E0	E0 12
89	→	E0 AA	E0 4D	E0 CD	E0 2A	E0 F0	12 E0	E0 74	E0 F0	74 E0	E0 12
203	Win	E0 AA	E0 5B	E0 DB	E0 2A	E0 F0	12 E0	E0 1F	E0 F0	1F E0	E0 12
204	App	E0 AA	E0 5D	E0 DD	E0 2A	E0 F0	12 E0	E0 2F	E0 F0	2F E0	E0 12

Note : The table above shows scan codes with the left **Shift** key. In combination with the right **Shift** key, scan codes are changed as listed below:

	With left Shift	With right Shift
Set 1	E0 AA _____	E0 B6
	E0 2A _____	E0 36
Set 2	E0 F0 12 _____	E0 F0 59
	E0 12 _____	E0 59

Table D-3 Scan codes in Numlock mode

Cap No.	Key top	Code set 1				Code set 2			
		Make		Break		Make		Break	
75	INS	E0 2A	E0 52	E0 D2	E0 AA	E0 12	E0 70	E0 F0	70 E0 F0 12
76	DEL	E0 2A	E0 53	E0 D3	E0 AA	E0 12	E0 71	E0 F0	71 E0 F0 12
79	←	E0 2A	E0 4B	E0 CB	E0 AA	E0 12	E0 6B	E0 F0	6B E0 F0 12
80	Home	E0 2A	E0 47	E0 C7	E0 AA	E0 12	E0 6C	E0 F0	6C E0 F0 12
81	End	E0 2A	E0 4F	E0 CF	E0 AA	E0 12	E0 69	E0 F0	69 E0 F0 12
83	↑	E0 2A	E0 48	E0 C8	E0 AA	E0 12	E0 75	E0 F0	75 E0 F0 12
84	↓	E0 2A	E0 50	E0 D0	E0 AA	E0 12	E0 72	E0 F0	72 E0 F0 12
85	PgUp	E0 2A	E0 49	E0 C9	E0 AA	E0 12	E0 7D	E0 F0	7D E0 F0 12
86	PgDn	E0 2A	E0 51	E0 D1	E0 AA	E0 12	E0 7A	E0 F0	7A E0 F0 12
89	→	E0 2A	E0 4D	E0 CD	E0 AA	E0 12	E0 74	E0 F0	74 E0 F0 12
203	Win	E0 2A	E0 5B	E0 DB	E0 AA	E0 12	E0 1F	E0 F0	1F E0 F0 12
204	App	E0 2A	E0 5D	E0 DD	E0 AA	E0 12	E0 2F	E0 F0	2F E0 F0 12

Table D-4 Scan codes with Fn key

Cap No.	Keytop	Code set 1		Code set 2	
		Make	Break	Make	Break
43	ENT	E0 1C	E0 9C	E0 5A	E0 F0 5A
58	CTRL	E0 1D	E0 9D	E0 14	E0 F0 14
60	LALT	E0 38	E0 B8	E0 11	E0 F0 11
121	ARROW	45	C5	77	F0 77
122	NUMERIC	45	C5	77	F0 77
123	Scrl	46	C5	7E	F0 7E

Table D-5 Scan codes in overlay mode

Cap No.	Keytop		Code set 1				Code set 2			
			Make		Break		Make		Break	
09	8	(8)	48		C8			75	F0	75
10	9	(9)	49		C9			7D	F0	7D
11	0	(*)	37		B7			7C	F0	7C
23	U	(4)	4B		CB			6B	F0	6B
24	I	(5)	4C		CC			73	F0	73
25	O	(6)	4D		CD			74	F0	74
26	P	(-)	4A		CA			7B	F0	7B
37	J	(1)	4F		CF			69	F0	69
38	K	(2)	50		D0			72	F0	72
39	L	(3)	51		D1			7A	F0	7A
40	;	(+)	4E		CE			79	F0	79
52	M	(0)	52		D2			70	F0	70
54	.	(.)	53		D3			71	F0	71
55	/	(/)	E0 35		E0 B5			40 4A	E0 F0	4A

Table D-6 No.124 key scan code

Key top	Shift	Code set 1				Code set 2			
		Make		Break		Make		Break	
Prt Sc	Common	E0 2A	E0 37	E0 B7	E0 AA	E0 12	E0 7C	E0 F0	7C E0 F0 12
	Ctrl +	E0 37		E0 B7		E0 7C		E0 F0	7C
	Shift +	E0 37		E0 B7		E0 7C		E0 F0	7C
	Alt +		54	D4		84		F0	B4

Table D-7 No.126 key scan code

Key top	Shift	Code set 1						Code set 2							
		Make						Make							
Pause	Common*	E1	1D	45	E1	9D	C5	E1	14	77	E1	F0	14	F0	77
	Ctrl*	E0	46	E0	C6			E0	7E	E0	F0	7E			

*: This key generates only make codes.

Appendix E Keyboard Layout

E.1 United States (US) Keyboard



Figure US keyboard (L300mm x W131.3mm)

E.1 Traditional Chinese (CH) Keyboard

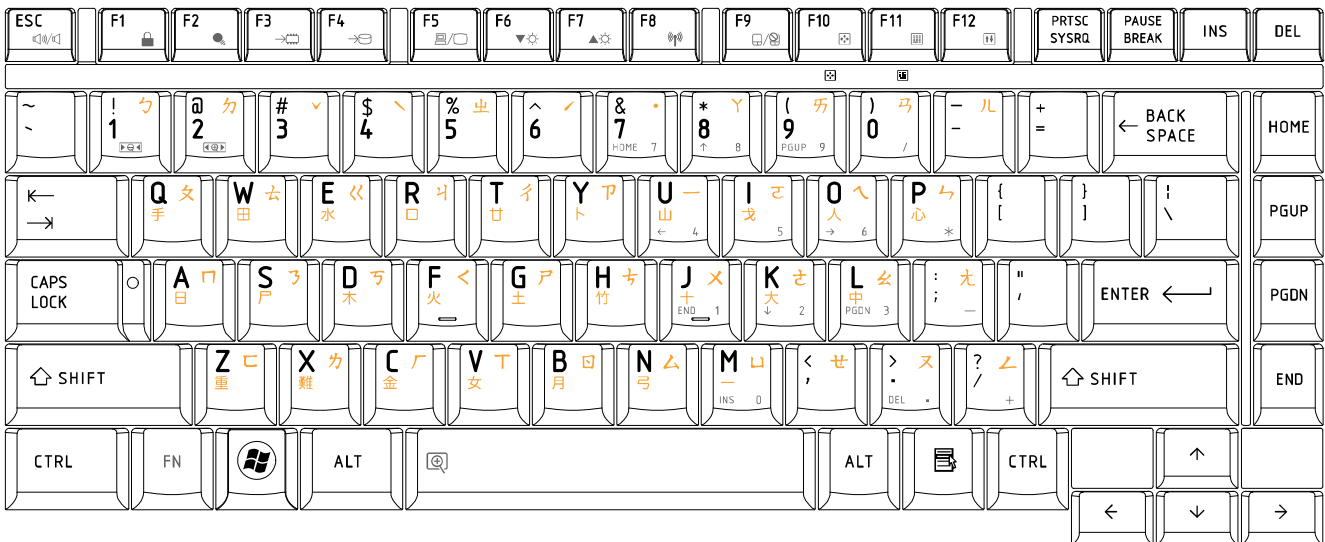

Figure CH keyboard (L300mm x W131.3mm)

E.2 Thai (TI) Keyboard

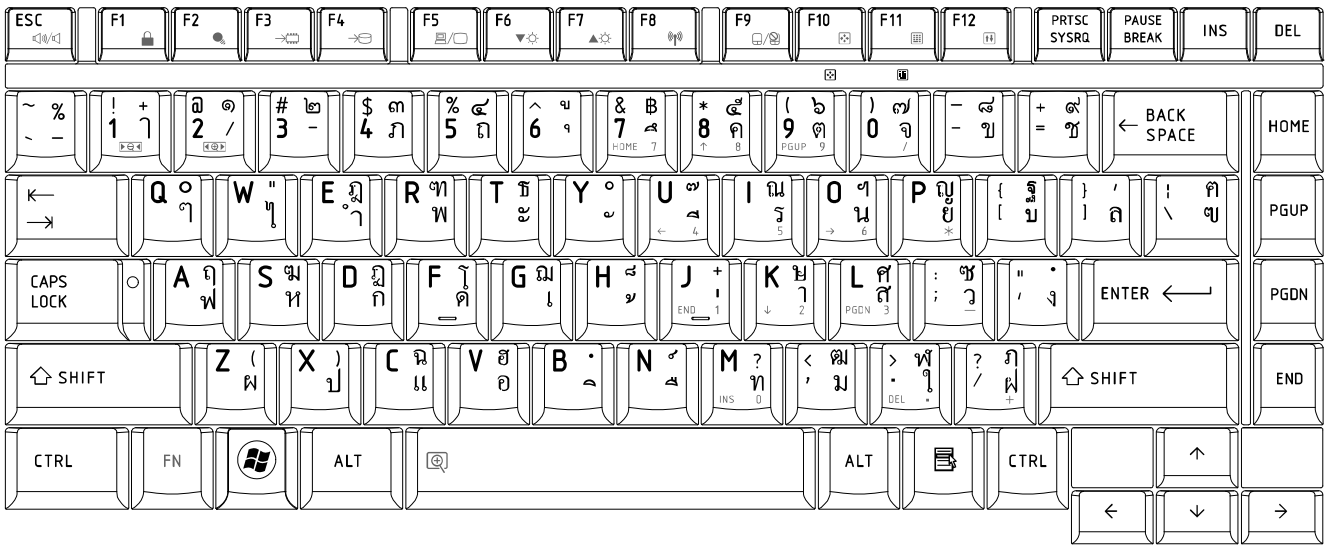

Figure TI keyboard (L300mm x W131.3mm)

E.3 Korean (KO) Keyboard

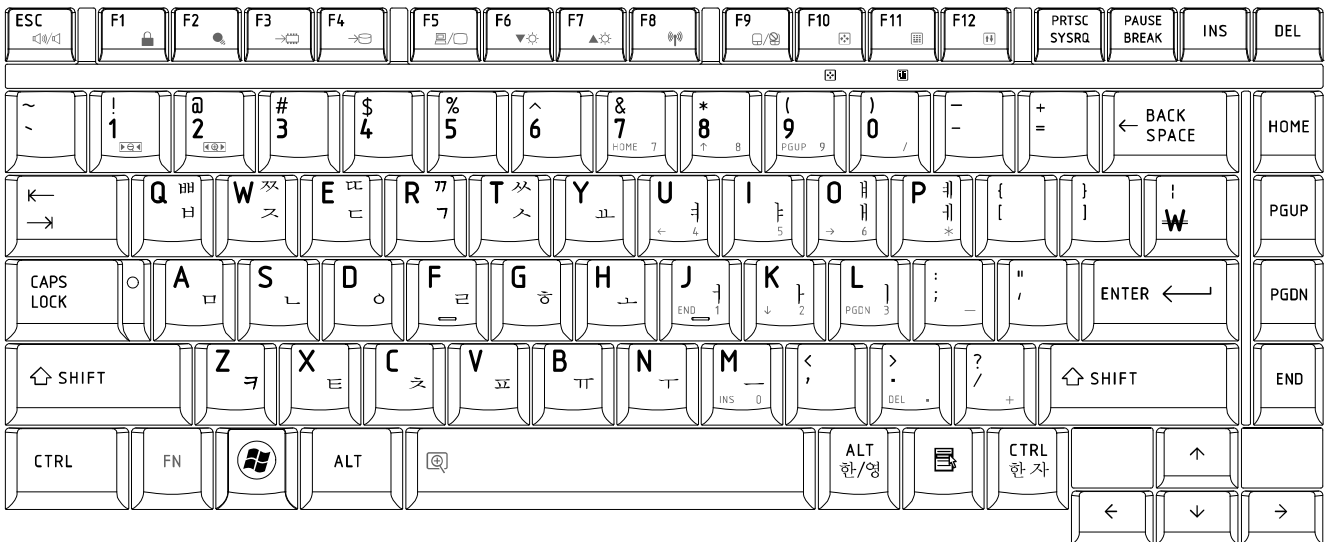

Figure KO keyboard (L300mm x W131.3mm)

E.4 United Kingdom (UK) Keyboard

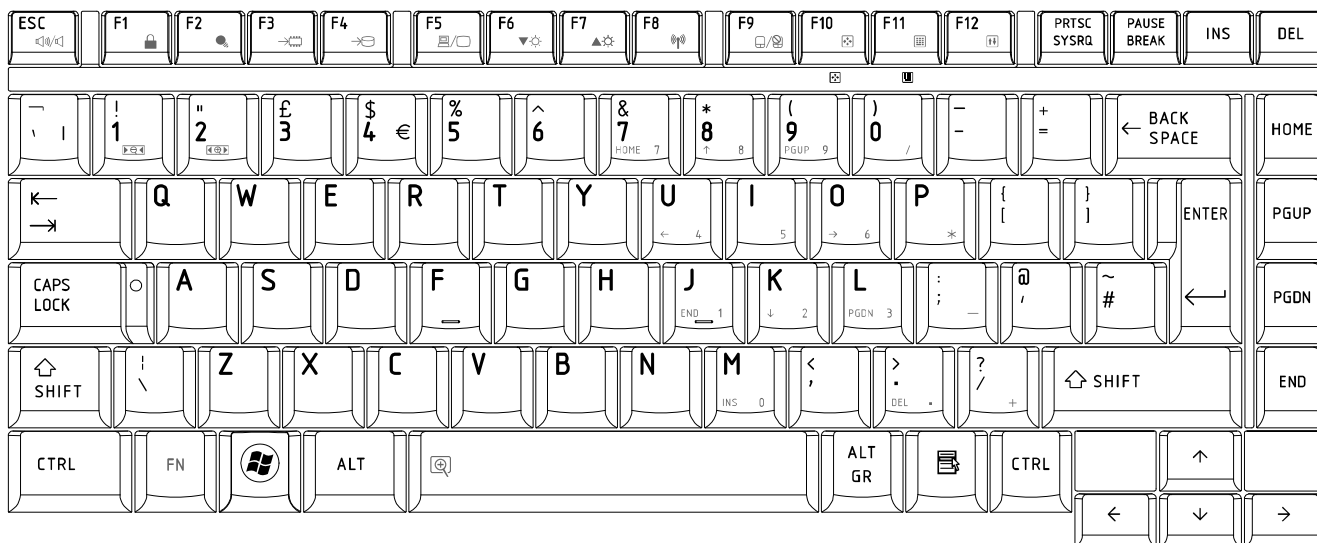

Figure UK keyboard (L300mm x W131.3mm)

E.5 US International (UI) Keyboard

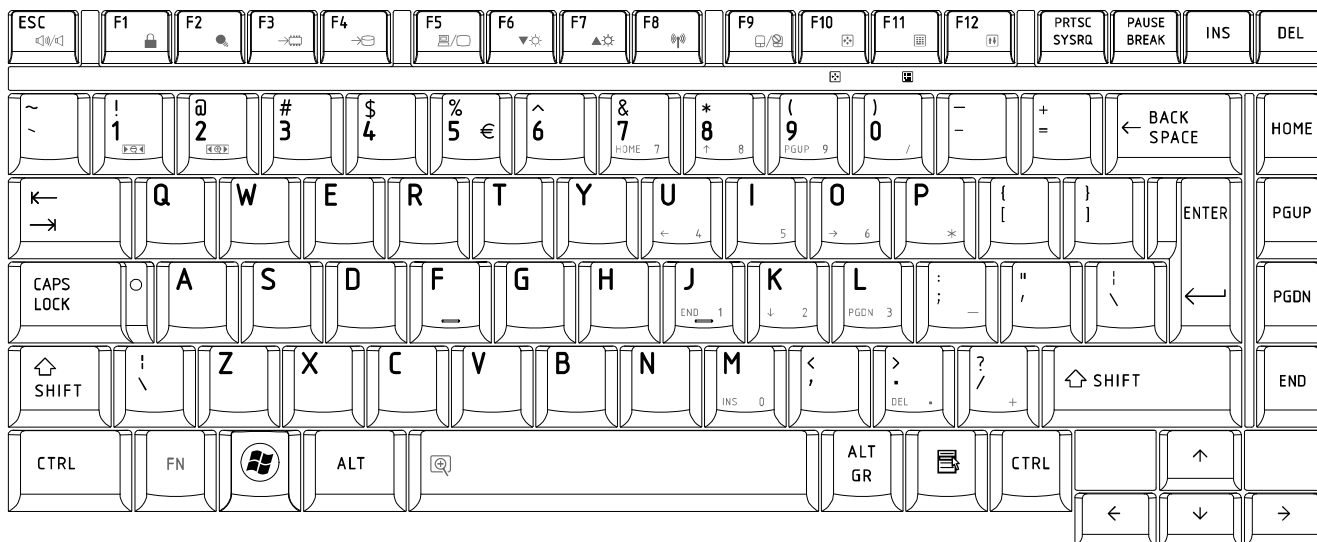

Figure UI keyboard (L300mm x W131.3mm)

E.6 Hebrew (HB) Keyboard

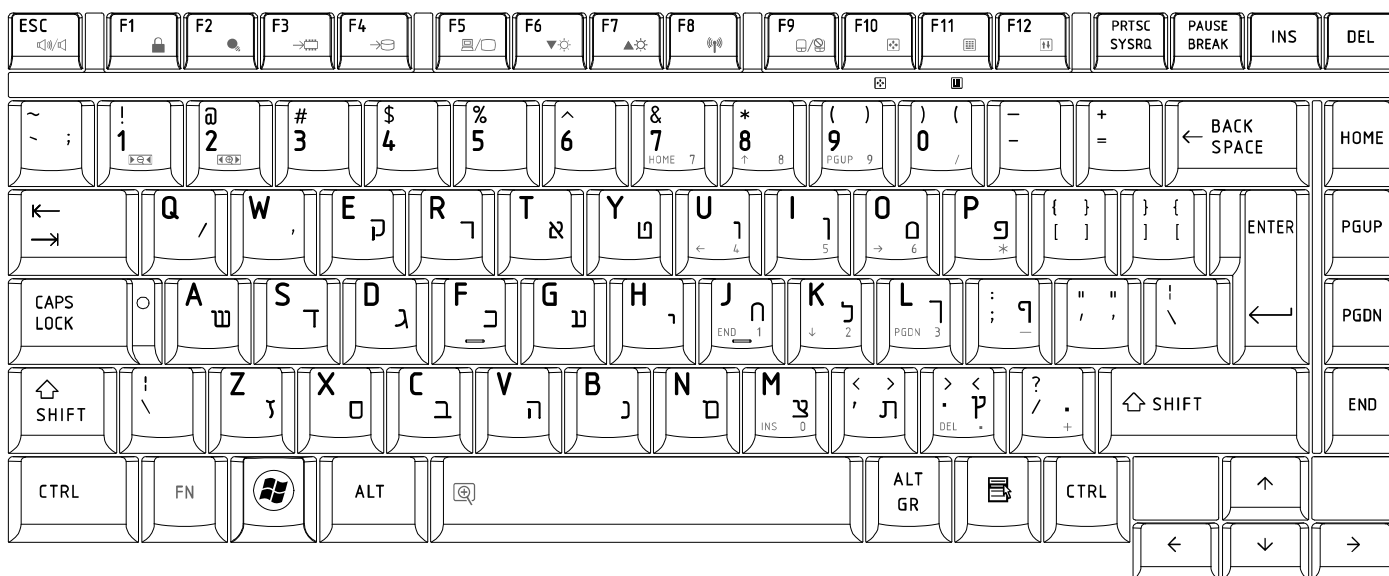

Figure HB keyboard (L300mm x W131.3mm)

E.7 Danish (DM) Keyboard

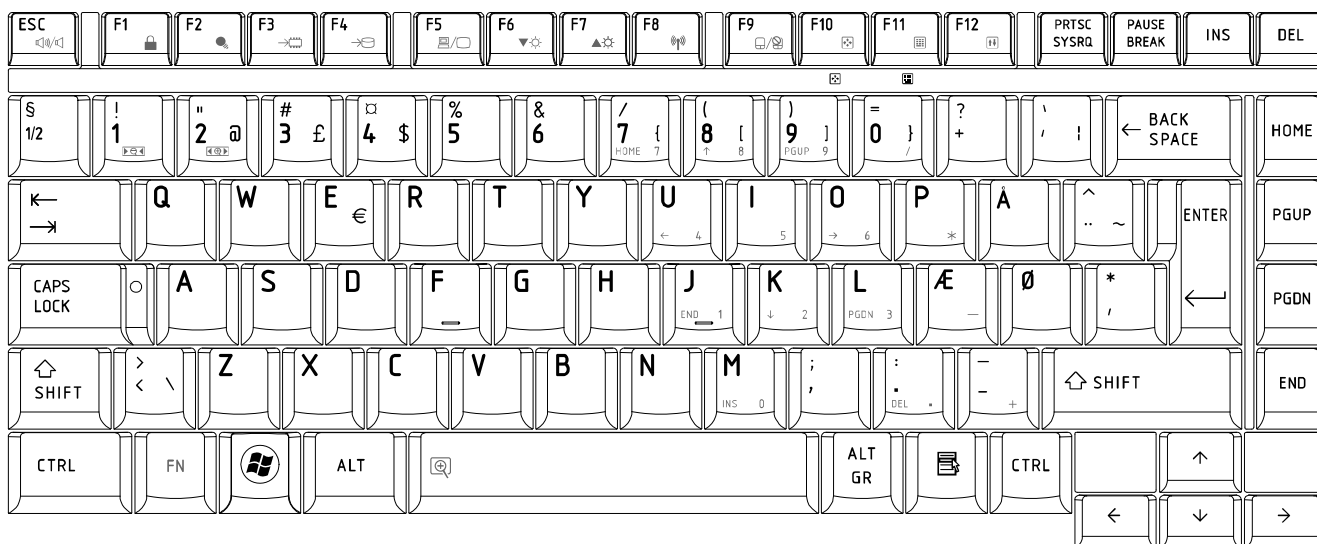

Figure DM keyboard (L300mm x W131.3mm)

E.8 Swiss (SW) Keyboard

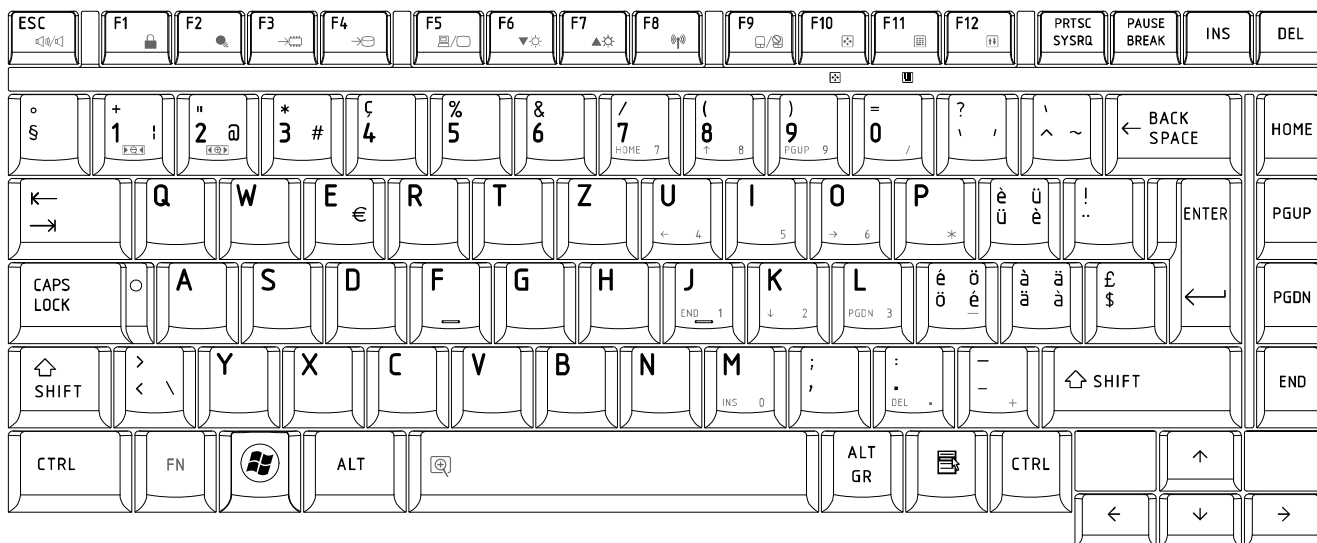

Figure SW keyboard (L300mm x W131.3mm)

E.9 Arabic (ARE) Keyboard

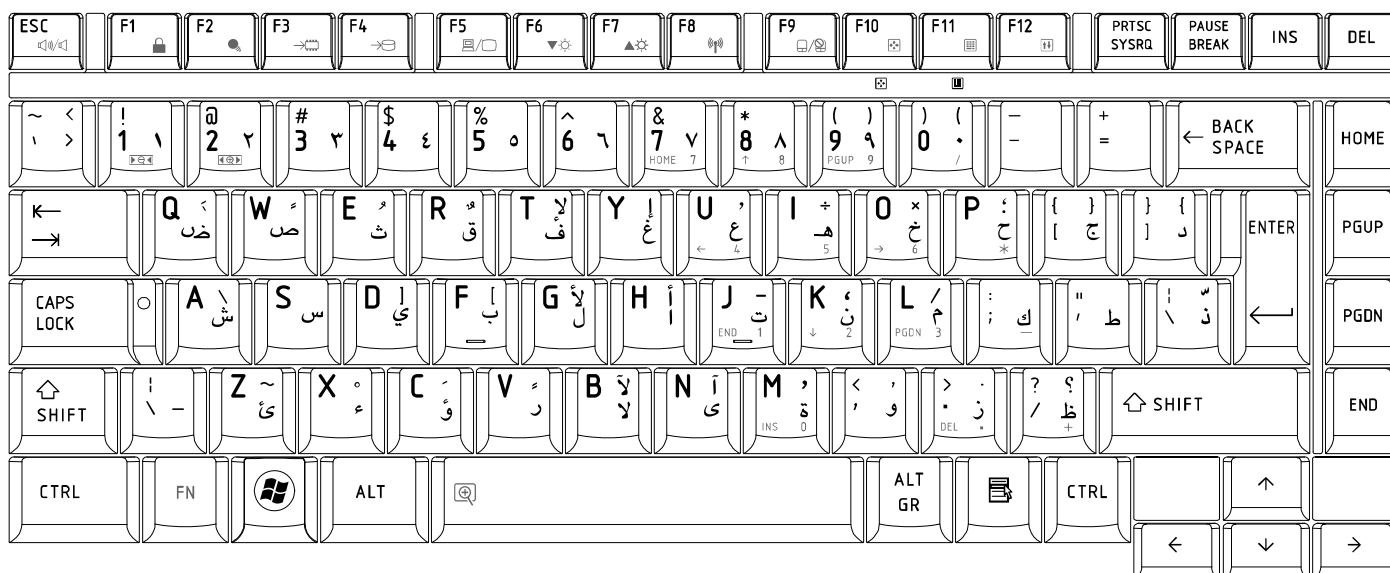

Figure ARE keyboard (L300mm x W131.3mm)

E.10 Czech (CZ) Keyboard

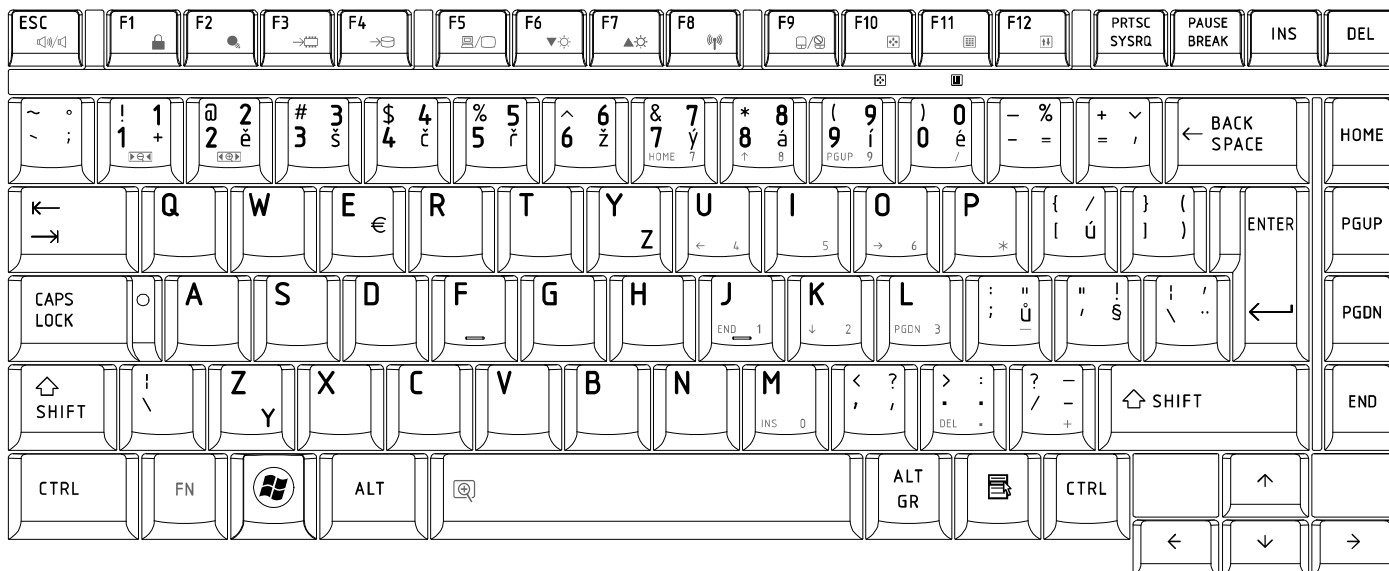

Figure CZ keyboard (L300mm x W131.3mm)

E.11 Russian (RU) Keyboard

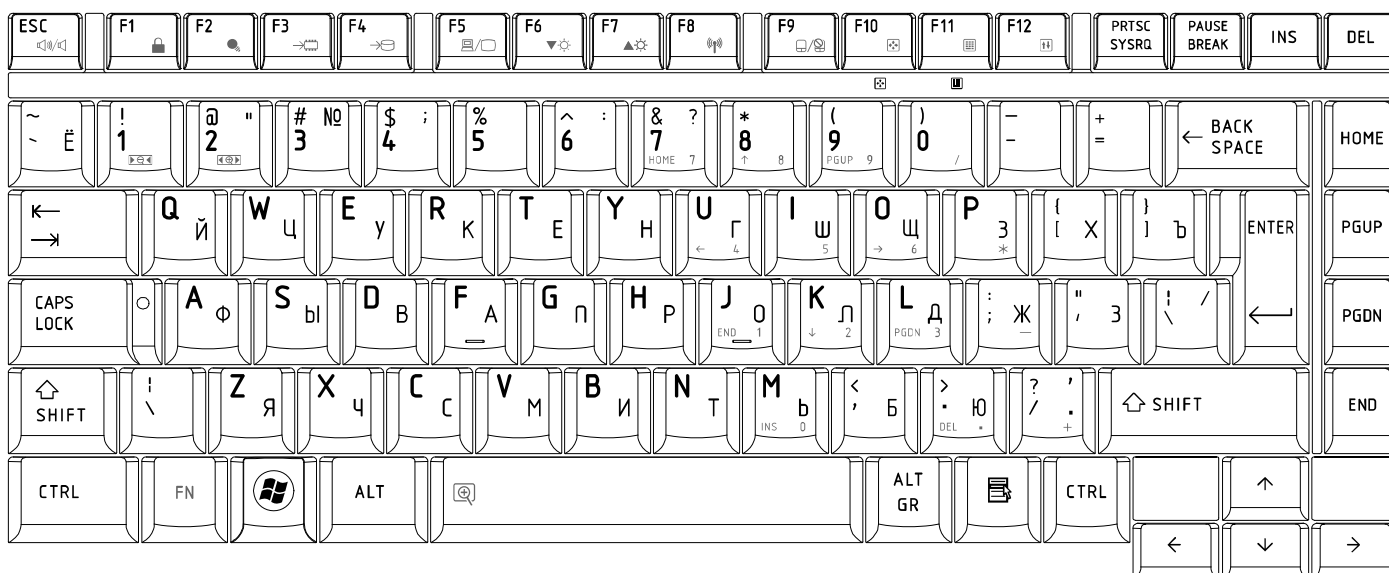

Figure RU keyboard (L300mm x W131.3mm)

E.12 Portuguese (PO) Keyboard

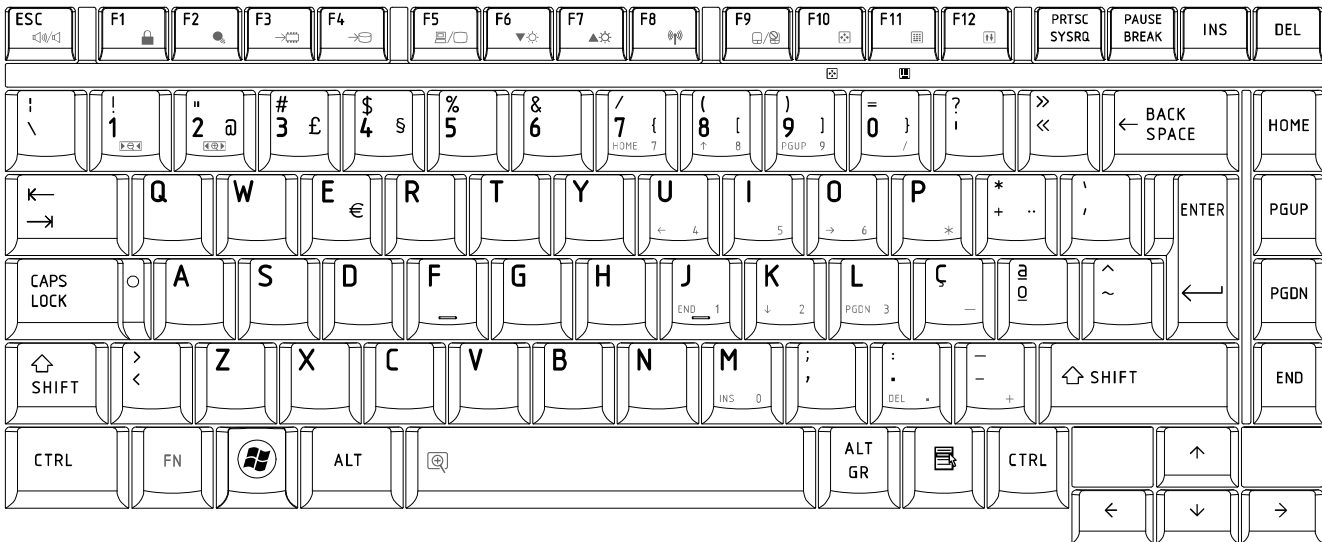

Figure PO keyboard (L300mm x W131.3mm)

E.13 Slovakian (SL) Keyboard

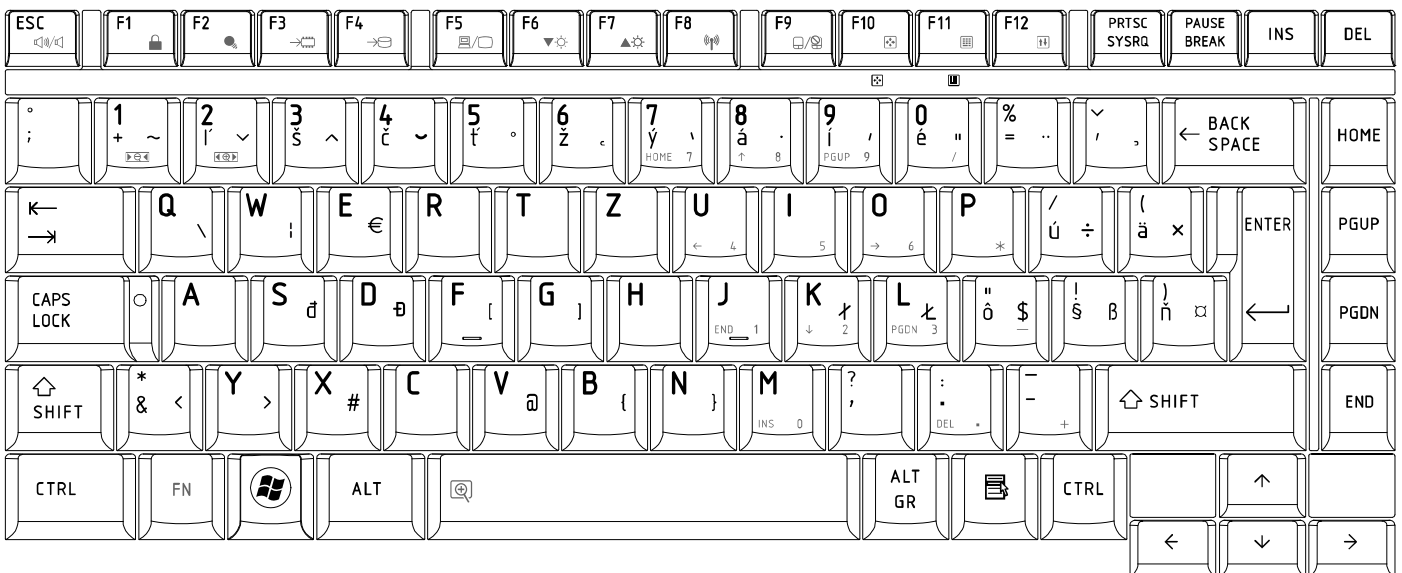

Figure SL keyboard (L300mm x W131.3mm)

E.14 Italian (IT) Keyboard

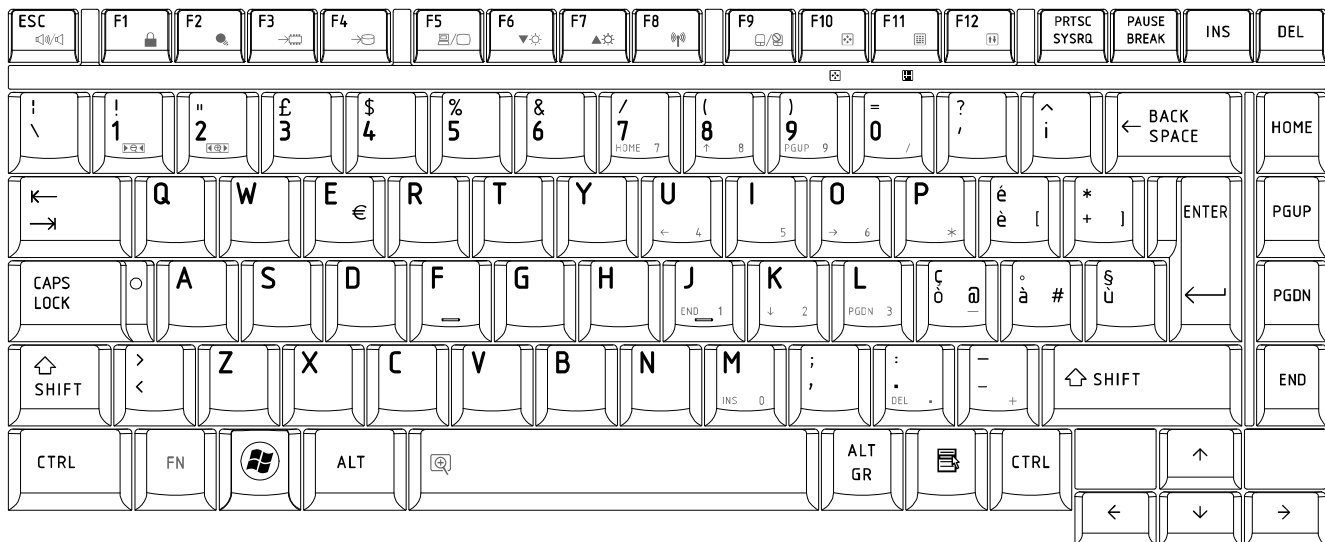

Figure IT keyboard (L300mm x W131.3mm)

E.15 French (FR) Keyboard

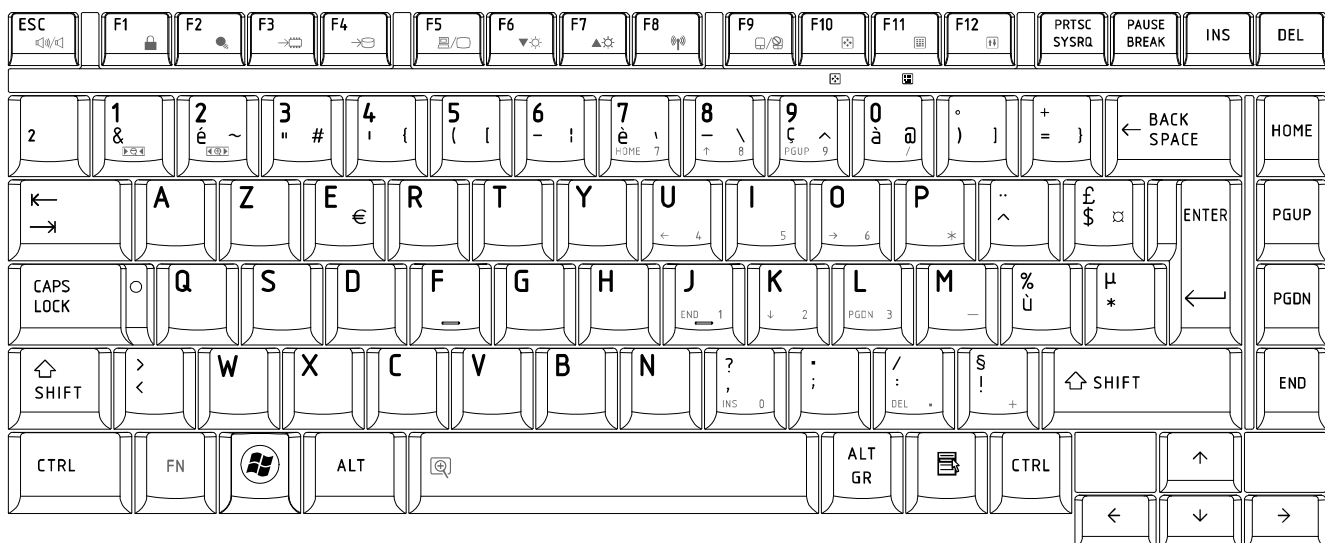

Figure FR keyboard (L300mm x W131.3mm)

E.16 German (GR) Keyboard

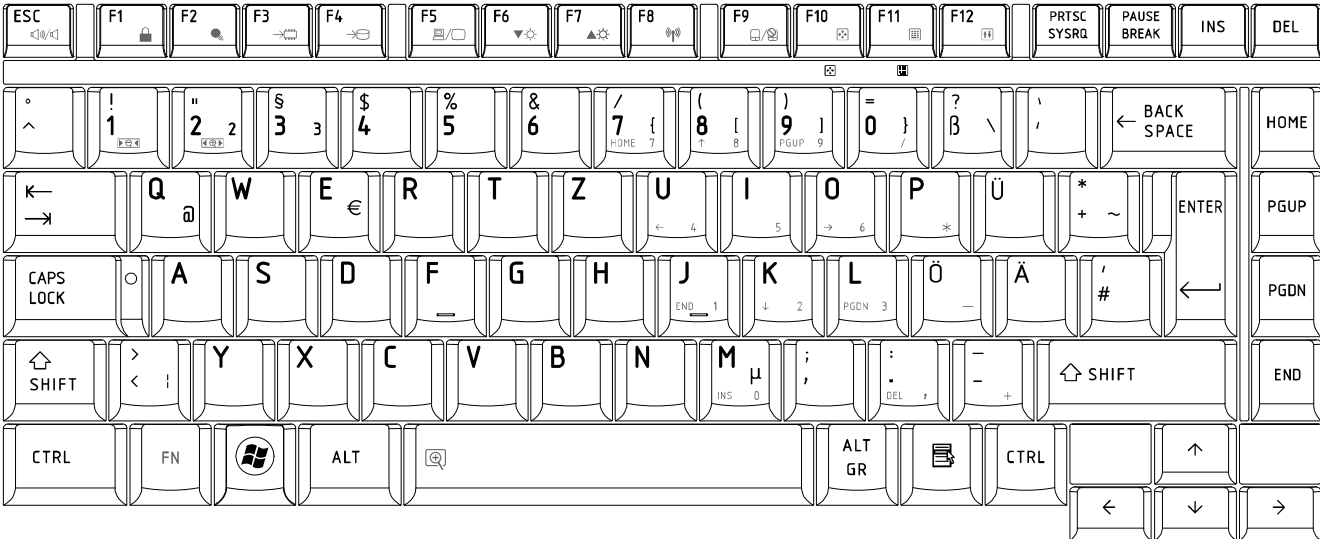

Figure GR keyboard (L300mm x W131.3mm)

E.17 Greek (GK) Keyboard

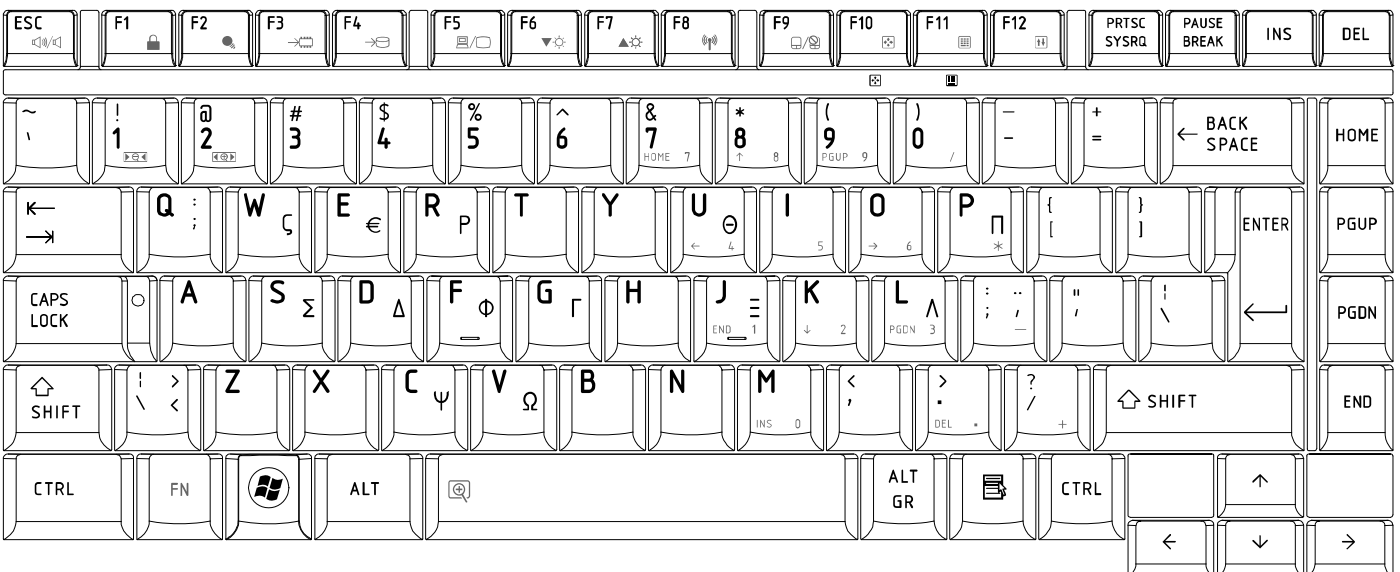

Figure GK keyboard (L300mm x W131.3mm)

E.18 Canada French (CF) Keyboard

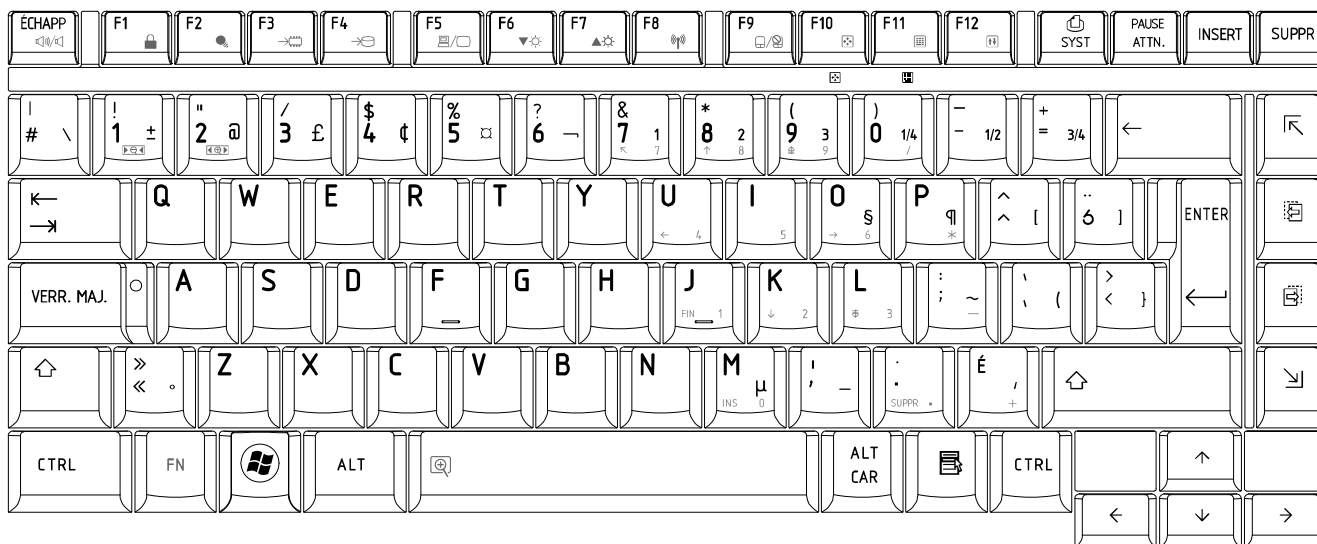

Figure CF keyboard (L300mm x W131.3mm)

E.19 Hungarian (HG) Keyboard

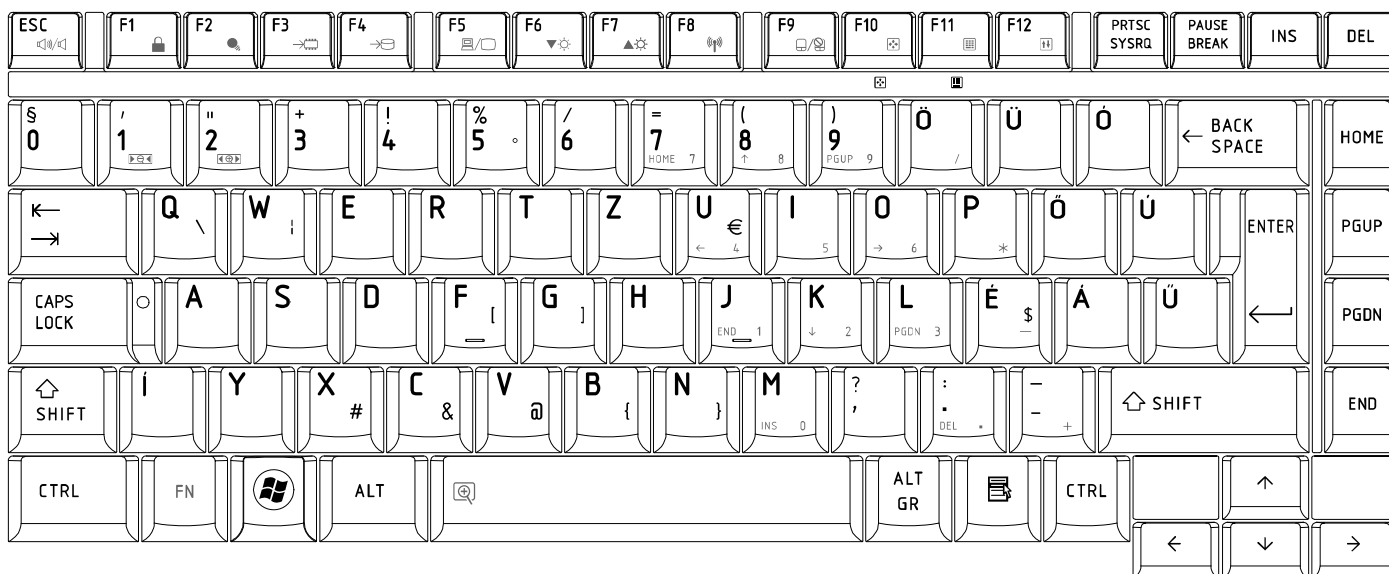

Figure HG keyboard (L300mm x W131.3mm)

E.20 Spanish (SP) Keyboard

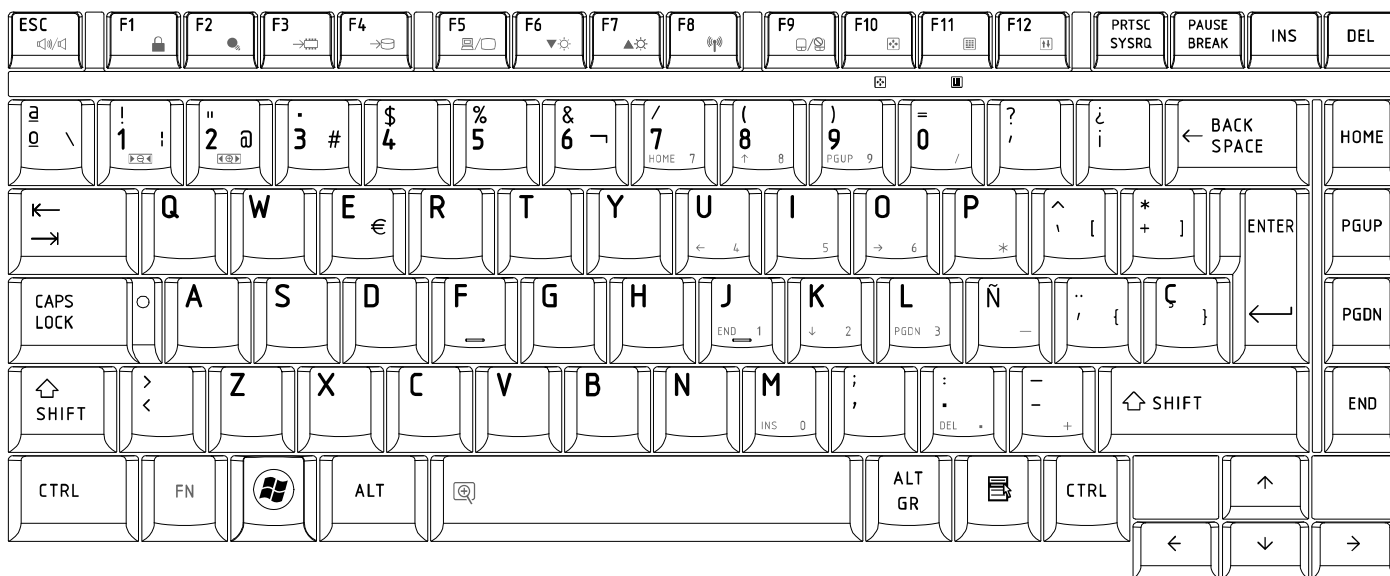

Figure SP keyboard (L300mm x W131.3mm)

E.21 Turkish (TR) Keyboard

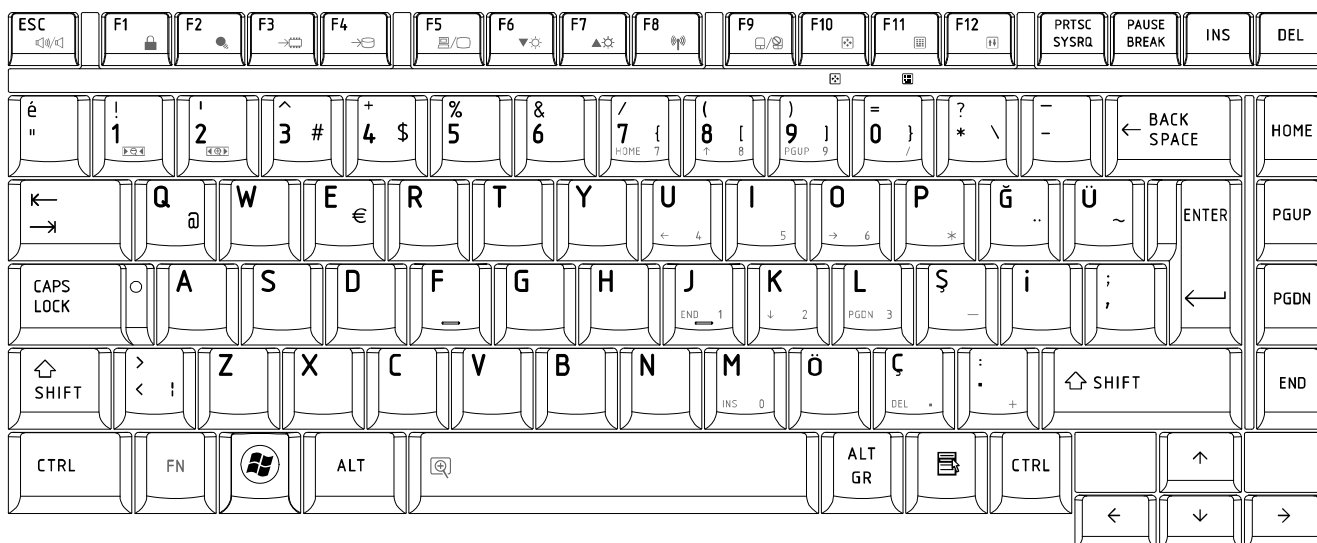

Figure TR keyboard (L300mm x W131.3mm)

E.22 Turkish F (TF-F) Keyboard

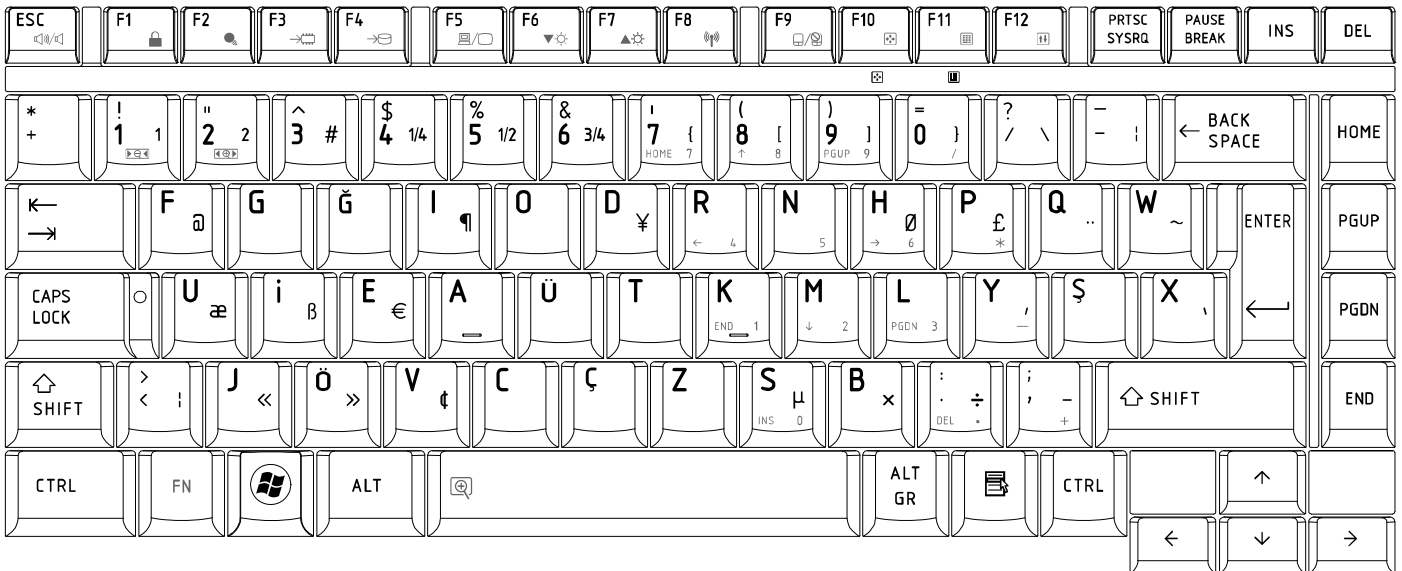

Figure TF-F keyboard (L300mm x W131.3mm)

E.23 Swedish (SD) Keyboard

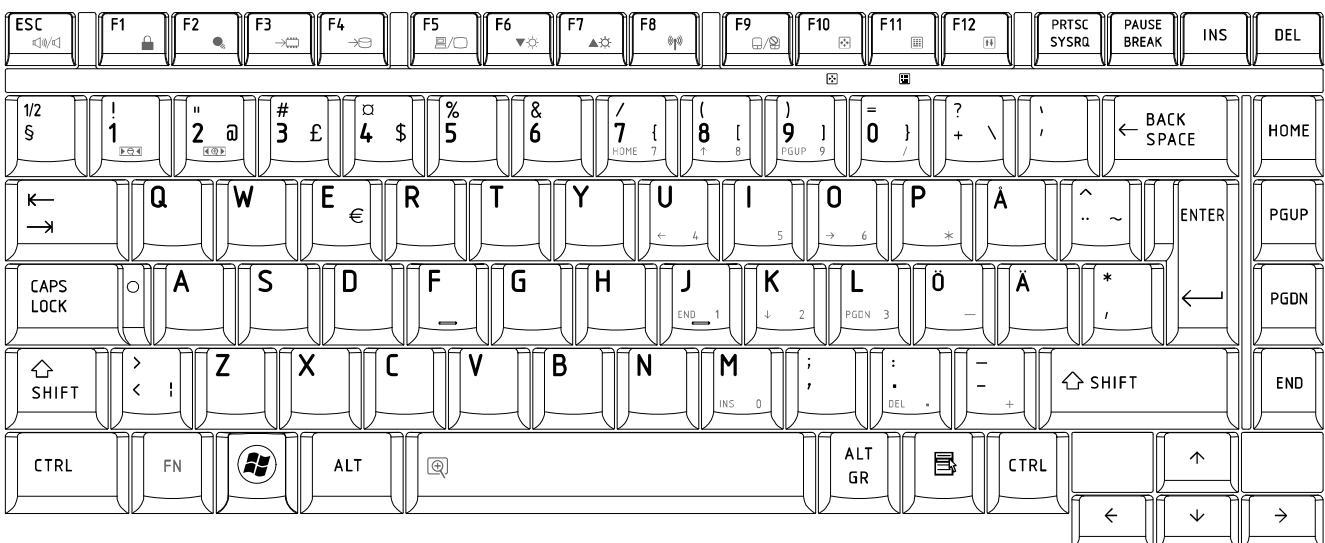

Figure SD keyboard (L300mm x W131.3mm)

E.26 Norwegian (NW) Keyboard

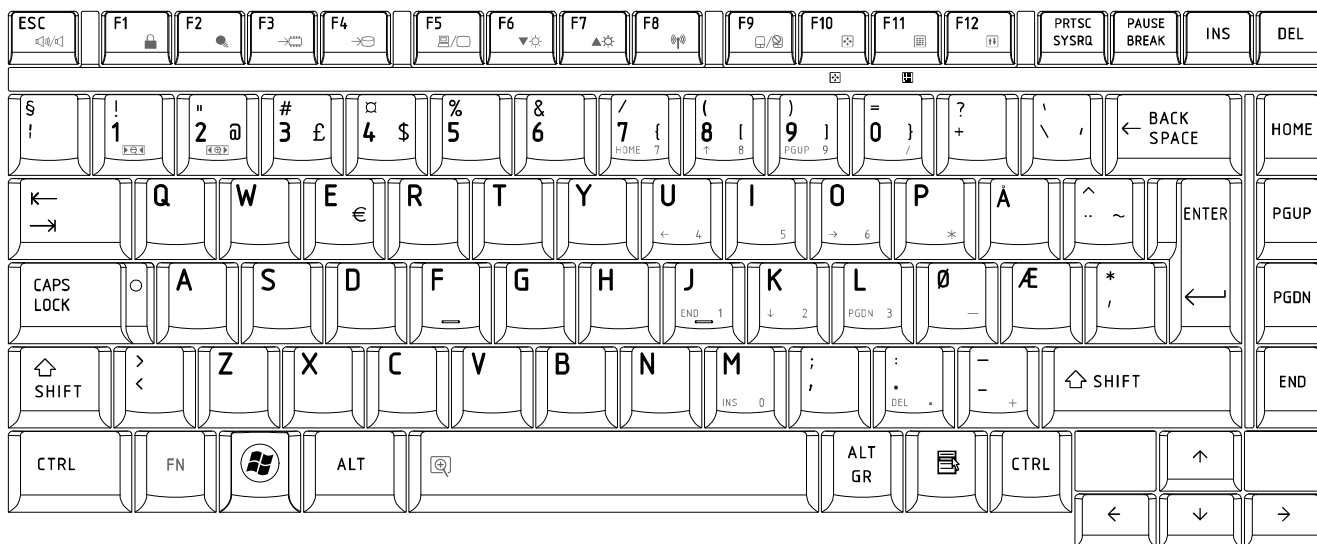

Figure NW keyboard (L300mm x W131.3mm)

E.27 Scandinavian (ND) Keyboard

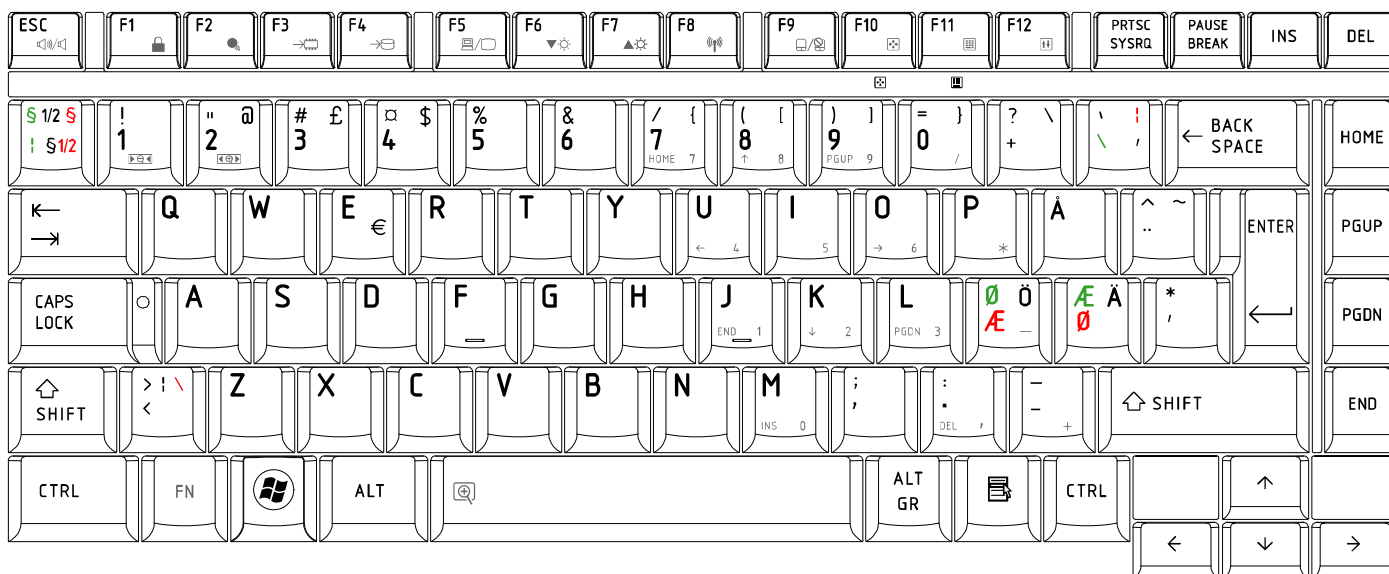

Figure ND keyboard (L300mm x W131.3mm)

E.28 Canadian Multinational (AC) Keyboard

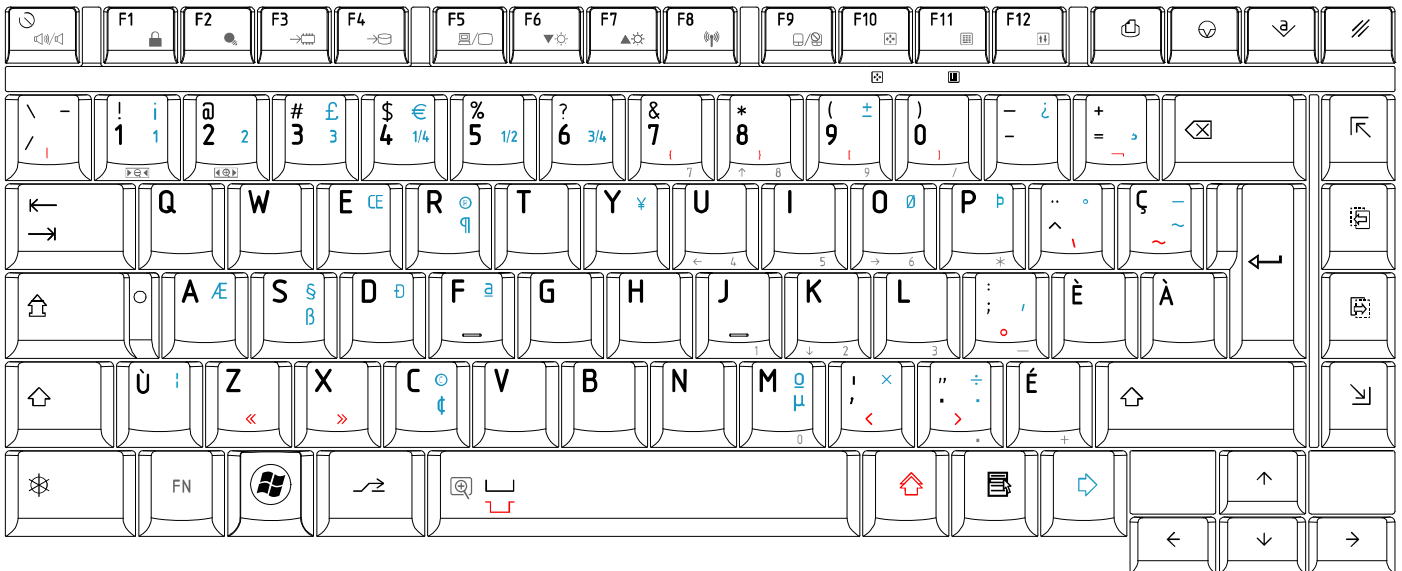

Figure AC keyboard (L300mm x W131.3mm)

E.29 Canadian Bilingual (CB) Keyboard



Figure CB keyboard (L300mm x W131.3mm)

E.30 Japanese (JP) Keyboard

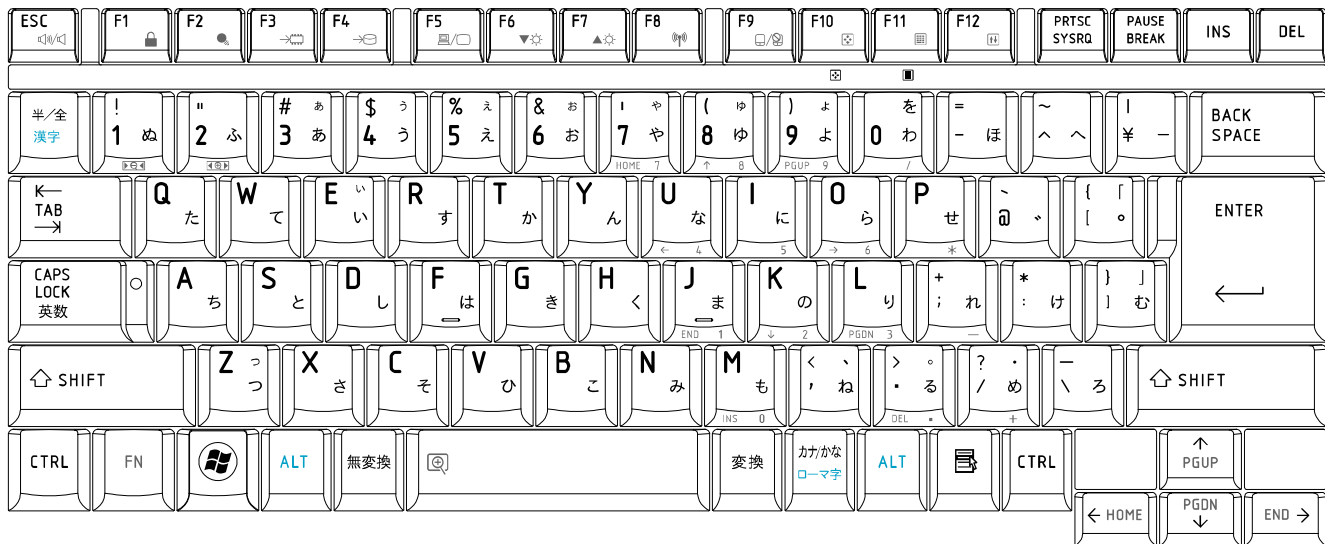

Figure JP keyboard (L300mm x W131.3mm)

Appendix F Wiring Diagrams

F.1 RGB Monitor ID Wraparound connector

(1) RED	_____	RED	(1)
(2) GREEN	_____	GREEN	(2)
(3) BLUE	_____	BLUE	(3)
(4) NC	_____	NC	(4)
(5) GND	_____	GND	(5)
(6) GND	_____	GND	(6)
(7) GND	_____	GND	(7)
(8) GND	_____	GND	(8)
(9) 5V	_____	5V	(9)
(10) GND	_____	GND	(10)
(11) NC	_____	NC	(11)
(12) SDA	_____	SDA	(12)
(13) HSYNC	_____	HSYNC	(13)
(14) VSYNC	_____	VSYNC	(14)
(15) SDL	_____	SCL	(15)

Figure F-1 RGB Monitor ID Wraparound connector (15PIN to 15PIN)

F.2 LAN Loopback Connector

(1) BIBAP (TX+)	_____	(3) BIDBP (RX+)
(2) BIDAN (TX-)	_____	(4) BIDBN (RX-)

Figure F-2 LAN loopback connector

Appendix G BIOS Rewrite Procedures

This Appendix explains how to rewrite the system BIOS program when you update the system BIOS.

Tools

To rewrite the BIOS, you need the following tool:

- BIOS/EC/KBC rewriting disk
- USB doggle

Rewriting the BIOS

1. Turn off the power to the computer.
2. Remove the external cables and cards.
3. Connect an external FDD and insert the BIOS rewriting disk into the external FDD.
4. Connect the USB doggle special for BIOS rewrite
5. Turn on the power
6. The BIOS rewriting starts.
7. When the process is completed, it beeps and the system automatically reboots.

NOTE:

1. *Connect the AC adaptor to the computer when you rewrite the BIOS.*
2. *Do not turn off the power while you are rewriting the BIOS. If the rewrite fails, it might be impossible to start up the computer.*
3. *If you fail to rewrite BIOS, then when you next turn on the power, a message may be displayed that the contents of the BIOS have been erased or system can not boot . In this case, insert the BIOS rewriting disk, and the BIOS will be rewritten.*

Appendix H EC/KBC Rewrite Procedures

Same as BIOS rewrite Procedures, please refer appendix G

Appendix I Reliability

The following table shows MTBF (Mean Time Between Failures) in maximum configuration.

Table I-1 MTBF

Component	Time (hours)
System	4138.00

Free Manuals Download Website

<http://myh66.com>

<http://usermanuals.us>

<http://www.somanuals.com>

<http://www.4manuals.cc>

<http://www.manual-lib.com>

<http://www.404manual.com>

<http://www.luxmanual.com>

<http://aubethermostatmanual.com>

Golf course search by state

<http://golfingnear.com>

Email search by domain

<http://emailbydomain.com>

Auto manuals search

<http://auto.somanuals.com>

TV manuals search

<http://tv.somanuals.com>