

Toshiba Personal Computer
TECRA S3
TECRA S4
Maintenance Manual

TOSHIBA CORPORATION

File Number 960-532

[CONFIDENTIAL]

Copyright

© 2005 by Toshiba Corporation. All rights reserved. Under the copyright laws, this manual cannot be reproduced in any form without the prior written permission of Toshiba. No patent liability is assumed with respect to the use of the information contained herein.

Toshiba Personal Computer TECRA S3 Maintenance Manual

First edition August 2005

Disclaimer

The information presented in this manual has been reviewed and validated for accuracy. The included set of instructions and descriptions are accurate for the TECRA S3 at the time of this manual's production. However, succeeding computers and manuals are subject to change without notice. Therefore, Toshiba assumes no liability for damages incurred directly or indirectly from errors, omissions, or discrepancies between any succeeding product and this manual.

Trademarks

IBM is a registered trademark and IBM PC is a trademark of International Business Machines Corporation.

Intel, Intel SpeedStep, Pentium and Centrino are trademarks or registered trademarks of Intel Corporation or its subsidiaries in the United States and other countries/regions.

Windows and Microsoft are registered trademarks of Microsoft Corporation.

Photo CD is a trademark of Eastman Kodak.

Sonic RecordNow! is a registered trademark of Sonic Solutions.

Bluetooth is a trademark owned by its proprietor and used by TOSHIBA under license.

i.LINK is trademark and registered trademark of Sony Corporation.

OmniPass is the trademark of Softex Incorporated.

InterVideo and WinDVD are registered trademarks of InterVideo Inc.

WinDVD Creator is trademark of InterVideo Inc.

Other trademarks and registered trademarks not listed above may be used in this manual.

Preface

This maintenance manual describes how to perform hardware service maintenance for the Toshiba Personal Computer TECRA S3.

The procedures described in this manual are intended to help service technicians isolate faulty Field Replaceable Units (FRUs) and replace them in the field.

SAFETY PRECAUTIONS

Four types of messages are used in this manual to bring important information to your attention. Each of these messages will be italicized and identified as shown below.

DANGER: “*Danger*” indicates the existence of a hazard that could result in death or serious bodily injury, if the safety instruction is not observed.

WARNING: “*Warning*” indicates the existence of a hazard that could result in bodily injury, if the safety instruction is not observed.

CAUTION: “*Caution*” indicates the existence of a hazard that could result in property damage, if the safety instruction is not observed.

NOTE: “*Note*” contains general information that relates to your safe maintenance service.

Improper repair of the computer may result in safety hazards. Toshiba requires service technicians and authorized dealers or service providers to ensure the following safety precautions are adhered to strictly.

- Be sure to fasten screws securely with the right screwdriver. If a screw is not fully fastened, it could come loose, creating a danger of a short circuit, which could cause overheating, smoke or fire.
- If you replace the battery pack or RTC battery, be sure to use only the same model battery or an equivalent battery recommended by Toshiba. Installation of the wrong battery can cause the battery to explode.

The manual is divided into the following parts:

- Chapter 1 Hardware Overview describes the TECRA S3 system unit and each FRU.
- Chapter 2 Troubleshooting Procedures explains how to diagnose and resolve FRU problems.
- Chapter 3 Test and Diagnostics describes how to perform test and diagnostic operations for maintenance service.
- Chapter 4 Replacement Procedures describes the removal and replacement of the FRUs.
- Appendices The appendices describe the following:
 - Handling the LCD module
 - Board layout
 - Pin assignments
 - Keyboard scan/character codes
 - Key layout
 - Wiring diagrams
 - BIOS rewrite procedures
 - EC/KBC rewrite procedures
 - Reliability
 - Maintenance of TOSHIBA RAID

Conventions

This manual uses the following formats to describe, identify, and highlight terms and operating procedures.

Acronyms

On the first appearance and whenever necessary for clarification acronyms are enclosed in parentheses following their definition. For example:

Read Only Memory (ROM)

Keys

Keys are used in the text to describe many operations. The key top symbol as it appears on the keyboard is printed in **boldface** type.

Key operation

Some operations require you to simultaneously use two or more keys. We identify such operations by the key top symbols separated by a plus (+) sign. For example, **Ctrl + Pause (Break)** means you must hold down **Ctrl** and at the same time press **Pause (Break)**. If three keys are used, hold down the first two and at the same time press the third.

User input

Text that you are instructed to type in is shown in the boldface type below:

DISKCOPY A: B:

The display

Text generated by the computer that appears on its display is presented in the type face below:

```
Format complete
System transferred
```

Table of Contents

Chapter 1 Hardware Overview

| | | |
|-----|-------------------------------|------|
| 1.1 | Features | 1-1 |
| 1.2 | 2.5-inch Hard Disk Drive..... | 1-11 |
| 1.3 | Keyboard..... | 1-13 |
| 1.4 | Optical Drive..... | 1-14 |
| 1.5 | TFT Color Display | 1-16 |
| 1.6 | Power Supply | 1-18 |
| 1.7 | Batteries | 1-20 |
| 1.8 | AC Adapter | 1-22 |

Chapter 2 Troubleshooting Procedures

| | | |
|------|--|------|
| 2.1 | Troubleshooting | 2-1 |
| 2.2 | Troubleshooting Flowchart..... | 2-2 |
| 2.3 | Power Supply Troubleshooting..... | 2-6 |
| 2.4 | System Board Troubleshooting..... | 2-15 |
| 2.5 | USB FDD Troubleshooting | 2-38 |
| 2.6 | HDD Troubleshooting | 2-41 |
| 2.7 | Keyboard/Touch pad Troubleshooting | 2-46 |
| 2.8 | Display Troubleshooting..... | 2-48 |
| 2.9 | Optical Drive Troubleshooting | 2-50 |
| 2.10 | Modem Troubleshooting..... | 2-51 |
| 2.11 | LAN Troubleshooting | 2-53 |
| 2.12 | Sound Troubleshooting..... | 2-54 |
| 2.13 | SD Card Slot Troubleshooting..... | 2-57 |
| 2.14 | Wireless LAN Troubleshooting..... | 2-58 |
| 2.15 | Bluetooth Troubleshooting | 2-60 |
| 2.16 | PCI ExpressCard slot | 2-63 |
| 2.17 | Fingerprint sensor | 2-64 |

Chapter 3 Tests and Diagnostics

| | | |
|------|---|-------|
| 3.1 | The Diagnostic Test | 3-1 |
| 3.2 | Executing the Diagnostic Test | 3-4 |
| 3.3 | Check of the RAID configuration..... | 3-9 |
| 3.4 | Setting of the hardware configuration | 3-17 |
| 3.5 | Heatron Test..... | 3-20 |
| 3.6 | Subtest Names..... | 3-21 |
| 3.7 | System Test..... | 3-23 |
| 3.8 | Memory Test..... | 3-25 |
| 3.9 | Keyboard Test..... | 3-26 |
| 3.10 | Display Test | 3-27 |
| 3.11 | Floppy Disk Test..... | 3-30 |
| 3.12 | Printer Test..... | 3-32 |
| 3.13 | Async Test | 3-34 |
| 3.14 | Hard Disk Test | 3-35 |
| 3.15 | Real Timer Test..... | 3-38 |
| 3.16 | NDP Test..... | 3-40 |
| 3.17 | Expansion Test..... | 3-41 |
| 3.18 | CD-ROM/DVD-ROM Test | 3-43 |
| 3.19 | Error Code and Error Status Names..... | 3-44 |
| 3.20 | Hard Disk Test Detail Status | 3-47 |
| 3.21 | ONLY ONE TEST | 3-49 |
| 3.22 | Head Cleaning..... | 3-59 |
| 3.23 | Log Utilities | 3-60 |
| 3.24 | Running Test..... | 3-62 |
| 3.25 | Floppy Disk Drive Utilities..... | 3-63 |
| 3.26 | System Configuration | 3-68 |
| 3.27 | Wireless LAN Test Program (Intel-made b/g)..... | 3-70 |
| 3.28 | Wireless LAN Test Program (Intel-made a/g)..... | 3-74 |
| 3.29 | LAN/Modem/Bluetooth/IEEE1394 Test Program | 3-79 |
| 3.30 | Sound Test program..... | 3-94 |
| 3.31 | SETUP | 3-100 |

Chapter 4 Replacement Procedures

| | | |
|------|---|------|
| 4.1 | General | 4-1 |
| 4.2 | Battery pack | 4-8 |
| 4.3 | PC card..... | 4-10 |
| 4.4 | SD card..... | 4-11 |
| 4.5 | Memory module..... | 4-12 |
| 4.6 | HDD | 4-14 |
| 4.7 | Wireless LAN card | 4-17 |
| 4.8 | Slim select bay module | 4-19 |
| 4.9 | Keyboard..... | 4-22 |
| 4.10 | Touch pad..... | 4-25 |
| 4.11 | Bluetooth module..... | 4-27 |
| 4.12 | Switch membrane..... | 4-29 |
| 4.13 | Display assembly | 4-31 |
| 4.14 | RTC battery..... | 4-35 |
| 4.15 | Modem Daughter Card (MDC)..... | 4-36 |
| 4.16 | USB board..... | 4-39 |
| 4.17 | Internal microphone | 4-41 |
| 4.18 | SR board/DC-IN jack..... | 4-43 |
| 4.19 | Fan..... | 4-45 |
| 4.20 | CPU | 4-47 |
| 4.21 | GFX board | 4-50 |
| 4.22 | System board..... | 4-52 |
| 4.23 | FP board | 4-56 |
| 4.24 | LCD unit/FL inverter | 4-58 |
| 4.25 | Cover latch | 4-65 |
| 4.26 | Wireless LAN antenna/Bluetooth antenna..... | 4-66 |
| 4.27 | Hinge..... | 4-68 |
| 4.28 | Speaker..... | 4-72 |
| 4.29 | Battery slider..... | 4-73 |
| 4.30 | Fluorescent Lamp..... | 4-75 |

Appendices

| | | |
|------------|-------------------------------------|-----|
| Appendix A | Handling the LCD Module | A-1 |
| Appendix B | Board Layout | B-1 |
| Appendix C | Pin Assignments..... | C-1 |
| Appendix D | Keyboard Scan/Character Codes | D-1 |
| Appendix E | Key Layout..... | E-1 |
| Appendix F | Wiring Diagrams..... | F-1 |
| Appendix G | BIOS rewrite Procedures | G-1 |
| Appendix H | EC/KBC rewrite Procedures | H-1 |
| Appendix I | Reliability..... | I-1 |
| Appendix J | Maintenance of TOSHIBA RAID | J-1 |

Chapter 1

Hardware Overview

Chapter 1 Contents

| | | |
|-----|--|------|
| 1.1 | Features..... | 1-1 |
| 1.2 | 2.5-inch Hard Disk Drive | 1-11 |
| 1.3 | Keyboard | 1-13 |
| 1.4 | Optical Drive | 1-14 |
| | 1.4.1 DVD-ROM & CD-R/RW Drive | 1-14 |
| | 1.4.2 DVD Super Multi (DVD±R/±RW/-RAM) Drive | 1-15 |
| 1.5 | TFT Color Display | 1-16 |
| | 1.5.1 LCD Module | 1-16 |
| | 1.5.2 FL Inverter Board | 1-17 |
| 1.6 | Power Supply..... | 1-18 |
| 1.7 | Batteries | 1-20 |
| | 1.7.1 Main Battery | 1-20 |
| | 1.7.2 RTC battery..... | 1-21 |
| 1.8 | AC Adapter..... | 1-22 |

Figures

Figure 1-1 Front of the computer1-5
Figure 1-2 System unit configuration.....1-6
Figure 1-3 System unit block diagram1-7
Figure 1-4 2.5-inch HDD1-11
Figure 1-5 Keyboard1-13
Figure 1-6 LCD module1-16

Tables

Table 1-1 2.5-inch HDD specifications1-11
Table 1-2 DVD-ROM & CD-R/RW drive specifications.....1-14
Table 1-3 DVD Super Multi (DVD±R/±RW/-RAM) drive specifications.....1-15
Table 1-4 LCD module specifications1-16
Table 1-5 FL inverter board specifications.....1-17
Table 1-6 Power supply output rating.....1-19
Table 1-7 Battery specifications1-20
Table 1-8 Time required for charges of main battery1-20
Table 1-9 RTC battery charging/data preservation time.....1-21
Table 1-10 AC adapter specifications.....1-22

1.1 Features

The Toshiba TECRA S3 Personal Computer uses extensive Large Scale Integration (LSI), and Complementary Metal-Oxide Semiconductor (CMOS) technology extensively to provide compact size, minimum weight, low power usage and high reliability. This computer incorporates the following features and benefits:

Microprocessor

The PC comes in with one of the followings:

- Intel Mobile Pentium-M Processor
1.73GHz/1.86GHz/2.0AGHz (0.748-1.356V)/2.13GHz (0.748-1.372V)
/2.26GHz (0.748-1.404V)

These processors operate at 533MHz bus clock.

Cache memory

Intel Mobile Pentium-M Processor has 64KB primary cache and 2MB secondary cache.

Memory

The computer comes with two PC2-3200/PC2-4200 compatible DDR2 SO-DIMM slots. Two memory modules of 256GB, 512MB or 1GB(1,024MB) can be installed.

Video Controller

The computer has a NV43 VGA controller. The internal VRAM is 64MB or 128MB.

HDD

The computer has a 2.5-inch, 9.5mm SATA HDD. The following capacities are available.

- 40/60/80/100GB

USB FDD

Supports a USB 3.5-inch FDD, which connected via a USB port, supports 720KB, 1.2MB and 1.44MB formats and enables booting from system FD.

Batteries

The RTC battery (NiMH 2.4V 16mAh) is mounted inside the computer.

The main battery is a detachable lithium-ion main battery (10.8V-4,700mAh/8,800mAh) .

Universal Serial Bus (USB2.0)

Three USB ports are provided. The ports comply with the USB2.0 standard.

Display

LCD

The PC comes in with one of the following two types:

- 15.0" XGA-TFT color display, resolution 1,024×768, 16M colors
- 15.0" SXGA+-TFT color display, resolution 1,400×1,050, 16M colors

External monitor

Supported via a RGB connector.

 Slim Select Bay

A DVD-ROM & CD-R/RW drive, DVD Super Multi drive (DVD±R/±RW/-RAM) or 2nd HDD can be installed in the Slim Select Bay.

 Keyboard

An-easy-to-use 85-key (US) or 86-key (UK) keyboard provides a numeric keypad overlay for fast numeric data entry or for cursor and page control. The keyboard supports a Windows key and an application key.

 Touch pad

Touch pad (dual point) is installed as a pointing device.

 PC card slot

The PC card slot (PCMCIA) accommodates one 5mm Type II card. (Based on PC Card Standard, supporting CardBus)

 SD Card

The SD Card Slot can accommodate Secure Digital flash memory cards with various capacities. SD cards let you easily transfer data from devices, such as digital cameras and Personal Digital Assistants, which use SD Card flash-memory.

 Sound system

The sound system is equipped with the following features:

- Stereo speakers
- Built-in microphone
- Stereo headphone jack
- External microphone jack
- Supports VoIP

Toshiba Assist button

When this button is pressed during power-on, the PC is connected to “Toshiba Assist”. When this button is pressed during power-off, the PC is turned on and connected to “Toshiba Assist”.

 Toshiba Presentation button

This button switches the display between internal display, external display, simultaneous display and multi-monitor display.

 Internal modem

The internal modem is equipped as a modem daughter card (MDC).

The internal modem provides capability for data and fax communication and supports V.90/92. For data reception it operates at 56,000bps and for data transmission it operates at 33,600bps. For fax transmission it operates at 14,400bps. It is also equipped with Speakerphone and TAM (Telephony Answering Machine) function. The speed of data transfer and fax depends on analog telephone line conditions. It has a RJ11 modem jack for connecting to a telephone line.

 Internal LAN

The computer is equipped with LAN circuits that support 1,000Mbit (Gigabit) Ethernet LAN. It also supports Wakeup on LAN (WOL), Magic Packet and LED.

 Mini PCI card slot (Wireless LAN)

The computer is equipped with a mini-PCI Type III wireless LAN card that supports 802.11 b/g or 802.11a/b/g (Intel made Freeville). It also supports kill switch.

 Bluetooth

Bluetooth module can be equipped. This enables a communication to devices that support Bluetooth Version 2.0. Adopting AFH (Adaptive Frequency Hopping), reduce the interference with the wireless communication in 2.4GHz.

 IEEE 1394 port

The computer comes with one IEEE 1394 port. It enables high-speed data transfer directly from external devices such as digital video cameras.

 Infrared port

The infrared port is compatible with Fast InfraRed (FIR) standards enabling cableless 4 Mbps (max.) data transfer with Infrared Data Association (IrDA) 1.1 compatible external devices.

Fingerprint sensor

The computer is equipped with a fingerprint sensor and fingerprint authentication utility. They enable only person who has registered his/her fingerprint to use the computer.

The front of the computer is shown in figure 1-1.

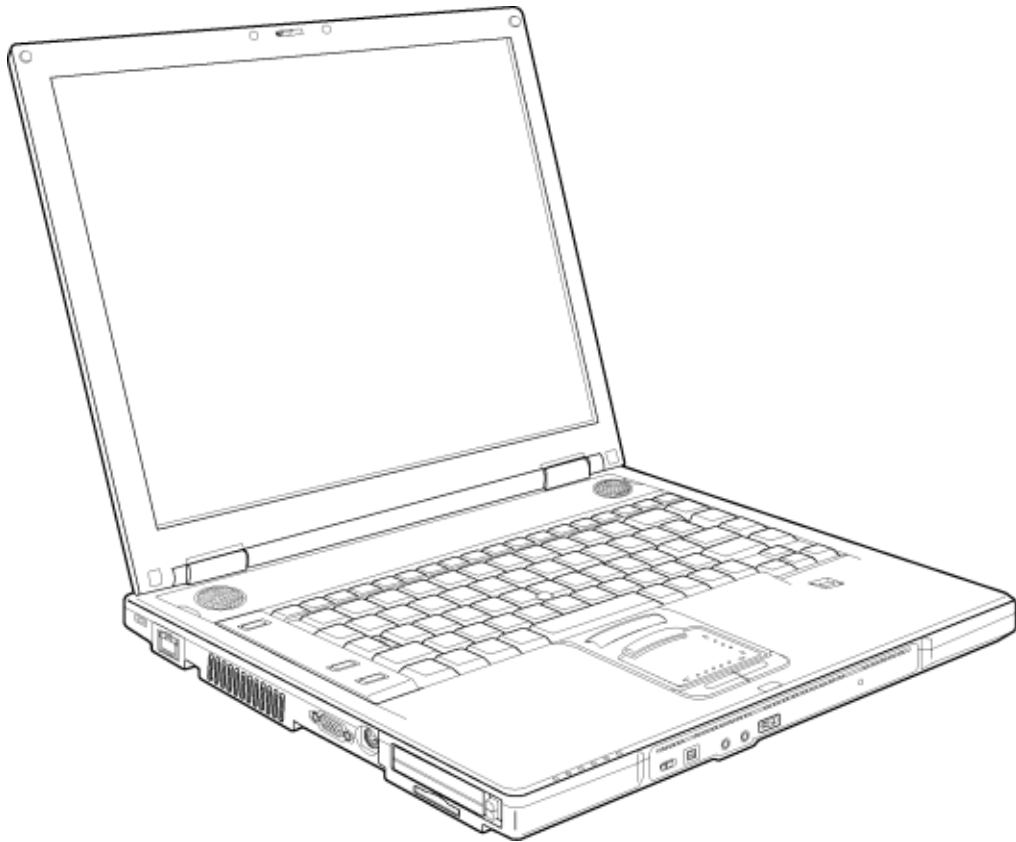

Figure 1-1 Front of the computer

The system unit configuration is shown in figure 1-2.

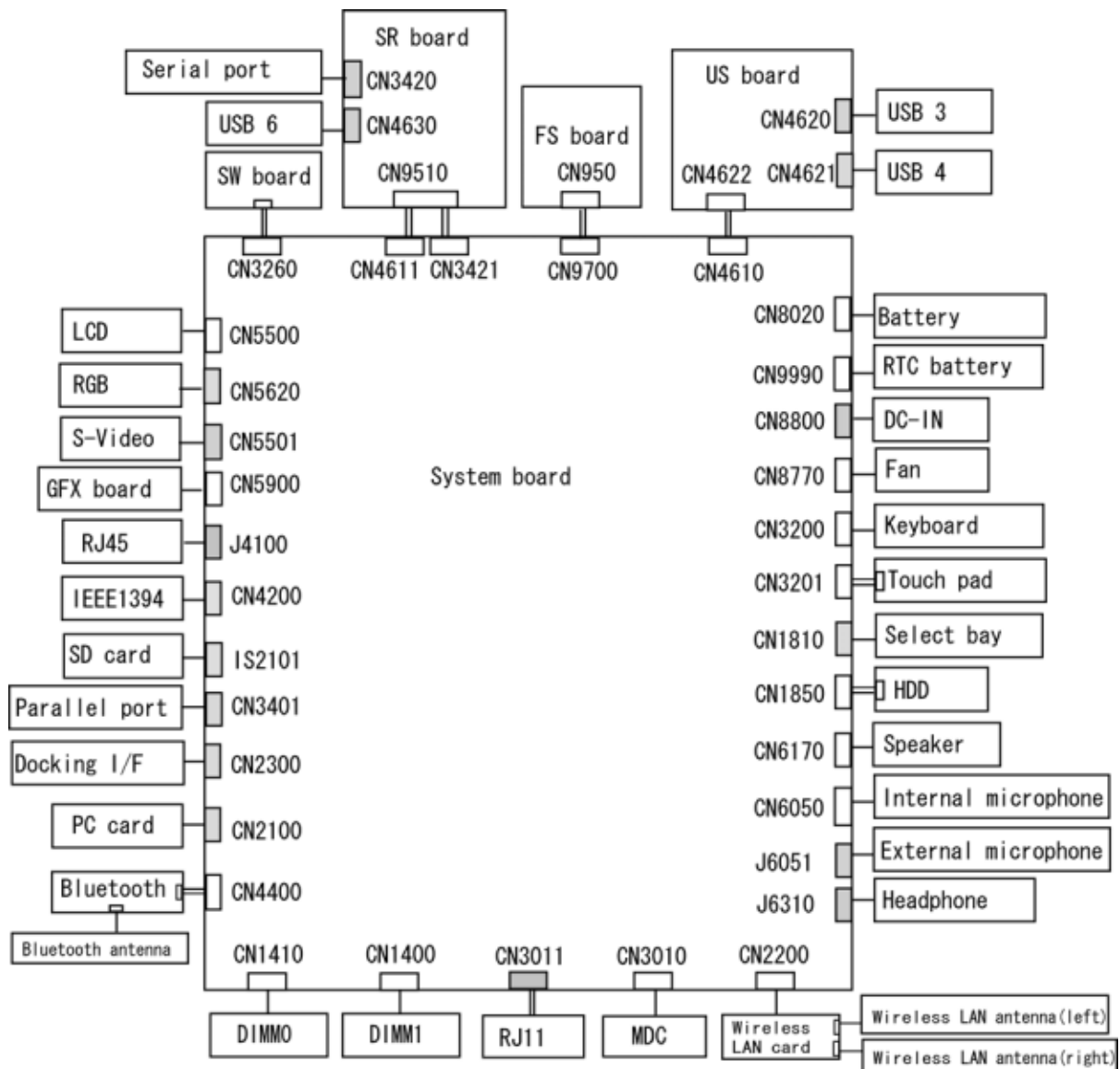

Figure 1-2 System unit configuration

Figure 1-3 is a block diagram of the system unit.

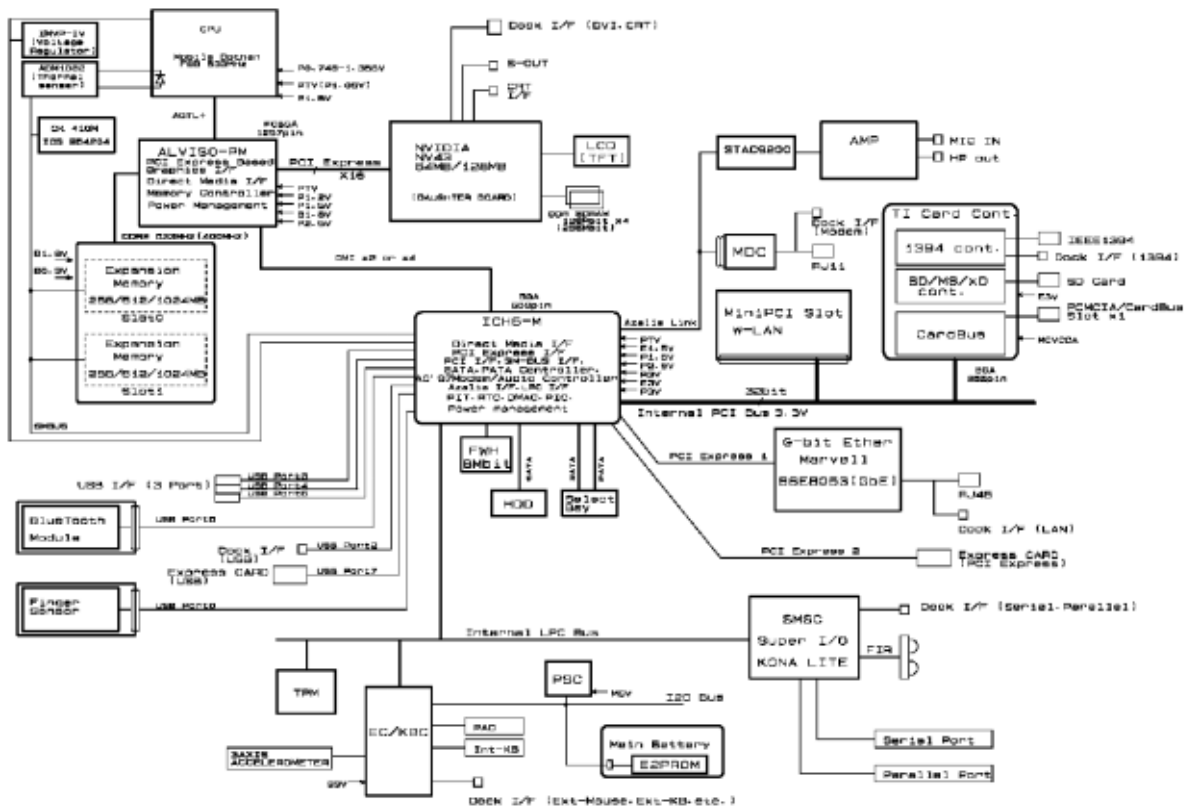

Figure 1-3 System unit block diagram

The system unit is composed of the following major components:

Processor

- Intel Mobile Pentium-M Processor
 - Processor core speed: 1.73GHz/1.86GHz/2.0AGHz/2.13GHz/2.26GHz
 - Processor bus speed: 533MHz
 - Integrated L1 cache memory: 32KB instruction cache and 32KB write-back data cache
 - Integrated L2 cache memory: 2MB
 - Integrated NDP

Memory

Two memory slots are provided. Expansion up to 2GB (2,048MB) is available.

Memory

- DDR2-SDRAM
- DDR400 or DDR533 memory
- 1.8 volt operation
- FBGA

Memory Module

- 240 pin, SO Dual In-line Memory Module (SO-DIMM)
- PC2-3200 or PC2-4200
- 256MB/512MB/1GB
 - 256 MB 256Mb×8
 - 512 MB 512Mb×8
 - 1GB 512Mb×16

Firmware Hub (FWH)

- One STMicro M50FW080N is used.
- 8Mbits of flash memory are used.

PCI chipset

This gate array incorporates the following elements and functions.

- North Bridge (Intel GMCH, AlvisoPM)
 - Dothan Processor System Bus Support
 - System memory interface
 - DRAM Controller: DDR333, DDR2-400/DDR2-533 Support, 2GB max
 - X16 PCI Express Graphics Interface
 - DMI (Direct Media Interface)
 - 1257-ball, 40.0×40.0 mm, FC-BGA package

- South Bridge (Intel ICH6)
 - DMI (Direct Media Interface)
 - PCI Express 2 Interface (4ports)
 - PCI Bus Rev2.3 Interface (7 PCI REQ/GNT Pairs)
 - Integrated Serial ATA Host Controller (2ports, 150MB/S)
 - Integrated IDE Controller (Ultra ATA 100/66/33)
 - AC'97 2.3 Interface
 - USB 1.1/2.0 Controller 8 Ports (EHCI: Enhanced Host Controller)
 - Internal LAN Controller (WfM 2.0 and IEEE 802.3)
 - Power Management Controller (ACPI 2.0)
 - SMBus2.0 Controller
 - FWH Interface
 - LPC Interface (EC/KBC, Super I/O)
 - IRQ Controller
 - Serial Interrupt Controller
 - Suspend/Resume Control
 - Internal RTC
 - GPIO
 - 609-ball, 31.0×31.0mm, BGA Package

❑ PC Card Controller

- One TI PC7411ZHK gate array is used.
- This gate array has the following functions and components.
 - PCI interface
 - CardBus/Ultra Media (1 socket)
 - SD/MMC, Memory Stick, XD Card Controller
 - 1394 Controller (2 ports)
 - 208-ball, 16.0×16.0×1.4mm, BGA Package

❑ Other main system chips

- Clock Generator (ICS950812CG)
- Super I/O (SMSC Kona-Life)
- EC/KBC (Mitsubishi M306KA)
- PSC (TOSHIBA TMP87PM48U)
- LCD Sensor (NRS-701-1015T)
- Thermal Sensor (ADM1032×2)
- AXIS accelerometer (STMicro LIS3L02AQ)

❑ Modem Controller

Supported by Azallia MDC 1.5 using the Azallia link.

- ❑ Internal LAN Controller (Marvell maid)
Controls LAN and supports Gigabit Ethernet.
Gigabit is connected to PCI-Express.
- ❑ Sound Controller
Azallia and CODEC (STAC9200) are used.

1.2 2.5-inch Hard Disk Drive

The HDD is a random access non-volatile storage device. The computer supports a 40GB, 60GB, 80GB and 100GB HDD.

The HDD is shown in figure 1-4. Specifications are listed in Table 1-1.

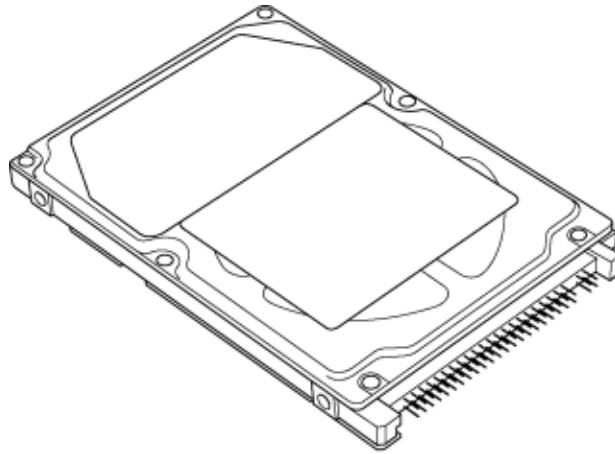

Figure 1-4 2.5-inch HDD

Table 1-1 2.5-inch HDD specifications (1/2)

| Items | | Specifications | | | |
|---|-------------|----------------------------------|-------------------------|-------------------------|-----------------------------|
| | | FUJITSU G8BC00028410 | FUJITSU G8BC00028610 | FUJITSU G8BC00028810 | FUJITSU G8BC00028A1 0 |
| Outline dimensions | Width (mm) | 70 | | | |
| | Height (mm) | 9.5 | | | |
| | Depth (mm) | 100 | | | |
| | Weight (g) | 96 max. | 101 max. | | |
| Storage size (formatted) | | 40GB | 60GB | 80GB | 100GB |
| Speed (RPM) | | 5,400 | | | |
| Data transfer rate To/From media (MB/s) To/From host (Gbps) | | 64.0 max. 1.5 (150 MB/s) max. | | | |
| Data buffer size (MB) | | 8 | | | |
| Average seek time Read (ms) | | 12 typ. | | | |
| Motor startup time (s) | | 4 typ. | | | |

Table 1-1 2.5-inch HDD specifications (2/2)

| Items | | Specifications | | | |
|--------------------------------|-------------|-------------------------|-------------------------|-------------------------|-------------------------|
| | | TOSHIBA HDD2D34BZK01 | TOSHIBA HDD2D33BZK01 | TOSHIBA HDD2D32BZK01 | TOSHIBA HDD2D30BZK01 |
| Outline dimensions | Width (mm) | 69.85 | | | |
| | Height (mm) | 9.5 | | | |
| | Depth (mm) | 100 | | | |
| | Weight (g) | 98 max. | 102 max. | | |
| Storage size (formatted) | | 40GB | 60GB | 80GB | 100GB |
| Speed (RPM) | | 5,400 | | | |
| Data transfer rate (Mb/s) | | 218-429 | | | 236.1-456.0 |
| Data buffer size (kb) | | 8,192 | | | 16,384 |
| Average seek time Read (ms) | | 12 | | | |
| Motor startup time (s) | | 4 | | | |

| Items | | Specifications | | | |
|---|-------------|----------------------------|----------------------------|----------------------------|----------------------------|
| | | HITACH GST G8BC00029410 | HITACH GST G8BC00029610 | HITACH GST G8BC00029810 | HITACH GST G8BC00029A10 |
| Outline dimensions | Width (mm) | 69.85±0.25 | | | |
| | Height (mm) | 9.5±0.2 | | | |
| | Depth (mm) | 100.2±0.25 | | | |
| | Weight (g) | 95 max. | 102 max. | | |
| Storage size (formatted) | | 40GB | 60GB | 80GB | 100GB |
| Speed (RPM) | | 5,400 | | | |
| Data transfer rate To/From media (Mb/s) To/From host (Gbps) | | 493 max. | | | 1.5 |
| Data buffer size (MB) | | 8 | | | |
| Average seek time Read (ms) | | 12 typ. | | | |
| Motor startup time (s) | | 3.5 | | | |

1.3 Keyboard

The keyboard is mounted 85(US)/86(UK) keys that consist of character key and control key. The keyboard is connected to membrane connector on the system board and controlled by the keyboard controller.

Figure 1-5 is a view of the keyboard.

See Appendix E about a layout of the keyboard.



Figure 1-5 Keyboard

1.4 Optical Drive

1.4.1 DVD-ROM & CD-R/RW Drive

The DVD-ROM & CD-R/RW drive accommodates either 12 cm (4.72-inch) or 8 cm (3.15-inch) CDs, CD-R/RW and DVDs. It is a high-performance drive that writes CD-R at maximum 24-speed and CD-RW at maximum 24-speed (Ultra Speed CD-RW) and reads DVD-ROM at maximum 8-speed and CD-ROM at maximum 24-speed.

DVD-ROM & CD-R/RW drive specifications are listed in Table 1-2.

Table 1-2 DVD-ROM & CD-R/RW drive specifications

| Item | | Specifications |
|--|--|--|
| | | MATSUSHITA G8CC00025A20 |
| Outline Dimensions | Width (mm) | 128 (The projection part is excluded) |
| | Height (mm) | 9.5 (The projection part is excluded) |
| | Depth (mm) | 129 (The projection part is excluded) |
| Date transfer speed READ Write | DVD-ROM CD-ROM | Max. 8x CAV Max. 24x CAV |
| | CD-R CD-RW High Speed CD-RW Ultra Speed CD-RW | Max. 24x CAV Max. 4x CLV Max. 10x CLV Max. 24x CAV |
| ATAPI Burst (MB/s) PIO Mode DMA Mode Ultra DMA Mode | | 16.6 (PIO MODE4) 16.6 (Multi Word Mode2) 33.3 (Ultra DMA Mode2) |
| Average access time (msec) | CD-ROM DVD-ROM | 150 typ. 170 typ. |
| Data Buffer Capacity | | 2MB |
| Supported Disks | | CD: CD/CD-ROM (12cm, 8cm), CD-R, CD-RW DVD: DVD-ROM, DVD-R, DVD-RW, DVD+R, DVD+RW, DVD+RAM, DVD+R DL |
| Supported Formats | | CD: CD-DA, CD-ROM, CD-ROM XA, PHOTO CD, CD-Extra(CD+), CD-text DVD: DVD-R, DVD-RW (Ver.1.2), DVD-Video, DVD+R, DVD+RW, DVD-RAM (2.6GB/4.7GB) |

1.4.2 DVD Super Multi (DVD±R/±RW/-RAM) Drive

The DVD Super Multi drive is capable of driving either 12cm (4.72-inch) or 8cm (3.15-inch) DVD and CD without using an adaptor. This drive reads DVD-ROM at maximum 8-speed, reads CD-ROM at maximum 24-speed, writes CD-R at maximum 24-speed, writes CD-RW at maximum 10-speed, writes DVD-R at maximum 4-speed, writes DVD-RW at maximum 2-speed, writes DVD+R at maximum 4-speed, writes DVD+R DL at maximum 2.4-speed, writes DVD+RW at maximum 2.4-speed and writes DVD-RAM at maximum 2-speed.

The DVD Multi drive specifications are listed in Table 1-3.

Table 1-3 DVD Super Multi (DVD±R/±RW/-RAM) drive specifications

| Item | | Specifications |
|--|---|---|
| | | MATSUSHITA G8CC0002Q120 |
| Outline Dimensions | Width (mm) | 128 (The projection part is excluded) |
| | Height (mm) | 9.5 (The projection part is excluded) |
| | Depth (mm) | 129 (The projection part is excluded) |
| Date transfer speed READ | DVD-ROM CD-ROM | Max. 8x CAV Max. 24x CAV |
| Write | CD-R CD-RW High Speed CD-RW Ultra Speed CD-RW DVD-R DVD-RW DVD+R DVD+R DL DVD+RW DVD-RAM | Max. 24x ZCLV Max. 4x CLV Max. 10x CLV Max. 10x CLV Max. 4x ZCLV Max. 2x CLV Max. 4x ZCLV Max. 2.4x CLV Max. 2.4x CLV Max. 2x ZCLV |
| ATAPI Burst (MB/s) PIO Mode DMA Mode Ultra DMA Mode | | 16.6 (PIO MODE4) 16.6 (Multi Word Mode2) 33.3 (Ultra DMA Mode2) |
| Average access time (msec) | CD-ROM DVD-ROM | 150 typ. 180 typ. |
| Data Buffer Capacity | | 2MB |
| Supported Formats | | CD: CD-DA, CD-ROM, CD-R, CD-RW, CD-ROM XA, PHOTO CD, Video CD, CD-Extra(CD+), CD-text DVD: DVD-VIDEO, DVD-ROM, DVD-R(3.9GB/4.7GB), DVD-RW(Ver. 1.1), DVD-RAM(2.6GB/4.7GB/9.4GB), DVD+R, DVD+R DL, DVD+RW |

1.5 TFT Color Display

The TFT color display consists of 15.0-inch XGA/SXGA+ LCD module and FL inverter board.

1.5.1 LCD Module

The LCD module used for the TFT color display uses a backlight as the light source and can display a maximum of 16M colors with 1,024 x 768 or 1,400x 1,050 resolution. The NVIDIA-made NV43 can control both internal and external XGA/SXGA+ support displays simultaneously.

Figure 1-6 shows a view of the LCD module and Table 1-4 lists the specifications.

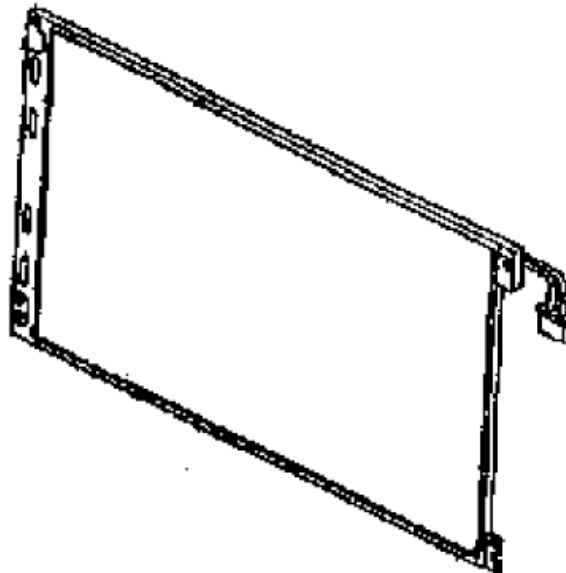

Figure 1-6 LCD module

Table 1-4 LCD module specifications (1/2)

| Item | Specifications (15.0-inch XGA TFT) | | |
|--------------------|------------------------------------|-----------------------|-------------------------|
| | LG Philips G33C00030110 | SHARP G33C0002Y110 | Samsung G33C0002W110 |
| Number of Dots | 1,024(W) × 768(H) | | |
| Dot spacing (mm) | 0.297(H) × 0.297(V) | | |
| Display range (mm) | 304.128(H) × 228.096(V) | | |

Table 1-4 LCD module specifications (2/2)

| Item | Specifications (15.0-inch SXGA+ TFT) |
|--------------------|--------------------------------------|
| | LG Philips G33C0001X210 |
| Number of Dots | 1,400(W) x 1,050 (H) |
| Dot spacing (mm) | 0.2175 (H) x 0.2175 (V) |
| Display range (mm) | 304.5 (W) x 228.38 (H) |

1.5.2 FL Inverter Board

The FL inverter board supplies a high frequency current to illuminate the LCD module FL. Table 1-5 lists the FL inverter board specifications.

Table 1-5 FL inverter board specifications

| Item | | Specifications |
|--------|-----------------|----------------|
| | | G71C00011221 |
| Input | Voltage (VDC) | 5 |
| | Power (W) | 7 |
| Output | Voltage (Vrms) | 750 |
| | Current (mArms) | 6.00 |
| | Power (W/VA) | 5/7 |

1.6 Power Supply

The power supply supplies many different voltages to the system board and performs the following functions:

1. Judges that the DC power supply (AC adapter) is connected to the computer.
2. Detects DC output and circuit malfunctions.
3. Controls the battery icon, and DC IN icon.
4. Turns the battery charging system on and off and detects a fully charged battery.
5. Turns the power supply on and off.
6. Provides more accurate detection of a low battery.
7. Calculates the remaining battery capacity.
8. Controls the transmission of the status signal of the main battery.

The power supply output rating is specified in Table 1-6.

Table 1-6 Power supply output rating

| Name | Voltage (V) | Use |
|------------|-------------|--|
| PPV | 1.404-0.748 | CPU |
| PTV | 1.05 | CPU, MCH, ICH6-M |
| PGV | 1.056 | GPU |
| 1R5-P1V | 1.5 | CPU, MCH, ICH6-M, Express Card |
| 1R8-B1V | 1.8 | MCH, DDR2-SDRAM |
| VG1R8-P1V | 1.8 | GPU |
| 2R5-P2V | 2.5 | MCH, ICH6-M |
| MR0R9-B0V | 0.9 | MCH, DDR2-SDRAM |
| 0R9-P0V | 0.9 | DDR2-SDRAM |
| P3V | 3.3 | Clock Generator, Thermal Sensor, SDRAM(SPD), ICH6-M, Super I/O, GPU, Mini-PCI, TPM, LCD, Express Card, FWH, FIR, STAC9200, HDD (SATA), Finger Print Sensor |
| E3V | 3.3 | ICH6-M, TI CARD Cont., PC Card Power, Mini-PCI, Express Card, MDC, RS-232C |
| SD-E3V | 3.3 | SD Card |
| LAN-E3V | 3.3 | LAN Power |
| LAN2R5-E2V | 2.5 | LAN Power |
| BT-P3V | 3.3 | Bluetooth |
| USB0PS-E5V | 5 | USB |
| USB1PS-E5V | 5 | USB |
| S3V | 3.3 | EC/KBC, PSC, 3 AXIS Accerelometer |
| P5V | 5 | CRT, ICH6-M, FL inverter, LEDs, HDD (SATA), ODD, KB, PAD, Bluetooth Power, Parallel |
| 1R5-E1V | 1.5 | ICH6-M |
| SND-P5V | 5 | AN12941 |
| A4R7-P4V | 4.7 | STAC9200, AN12941 |
| E5V | 5 | ICH6-M, PC Card Power, USB Power |
| M5V | 5 | Docker, MAX6501, LED |
| MCV | 5 | PSC |
| R3V | 2.0 - 3.5 | ICH6-M(RTC) |

1.7 Batteries

The computer has two types of batteries as follows:

- Main battery pack
- RTC battery

The battery specifications are listed in Table 1-7.

Table 1-7 Battery specifications

| Battery name | | Material | Output voltage | Capacity |
|--------------|------------------------------|-------------|----------------|-----------|
| Main battery | G71C0003W510 G71C0003W610 | Lithium-Ion | 10.8 V | 8,800 mAh |
| | G71C0004G510 G71C0004G610 | | | 4,700 mAh |
| RTC battery | GDM710000041 | NiMH | 2.4 V | 16 mAh |

1.7.1 Main Battery

The removable main battery pack is the computer's main power source when the AC adaptor is not attached. The main battery maintain the state of the computer when the computer enters in resume mode.

- Battery Charge

When the AC adapter is connected, normal charging is used while the system is turned on and quick charge is used while the system is turned off or in suspend mode.
(See Table 1-8)

Table 1-8 Time required for charges of main battery

| | Power ON | Power OFF |
|--------------------|-------------------------|-----------------|
| Battery (8,800mAh) | About 5.0 to 21.5 hours | About 4.5 hours |
| Battery (4,700mAh) | About 3.5 to 13.0 hours | About 3.0 hours |

Charge is stopped in the following cases.

1. The main battery is fully charged.
2. The main battery is removed.
3. Main battery or AC adapter voltage is abnormal.
4. Charging current is abnormal.

RTC battery

The RTC battery provides power to keep the current date, time and other setup information in memory while the computer is turned off. Table 1-9 lists the charging time and data preservation period of the RTC battery.

Table 1-9 RTC battery charging/data preservation time

| Status | Time |
|--|-------------|
| Charging Time (power on) | 8 hours |
| Data preservation period (full charge) | 30 days |

1.8 AC Adapter

The AC adapter is used to charge the battery.

Table 1-10 lists the AC adapter specifications.

Table 1-10 AC adapter specifications

| Parameter | Specification | |
|-----------------|--|------------------------------|
| | G71C00043310 (two-pins) | G71C00049410 (three-pins) |
| Voltage | 75W (Peak 90W) | |
| Input voltage | 100V/240V | |
| Input frequency | 47Hz to 63Hz | |
| Input power | 1.5A or less (100V) 1.125A or less (240V) | |
| Output voltage | DC15V | |
| Output current | 0A to 5A (At constant voltage mode) 5A to 6A (At surge load mode) | |

Chapter 2

Troubleshooting Procedures

Chapter 2 Contents

| | | |
|-----|---|------|
| 2.1 | Troubleshooting..... | 2-1 |
| 2.2 | Troubleshooting Flowchart | 2-2 |
| 2.3 | Power Supply Troubleshooting | 2-6 |
| | Procedure 1 Icons in the LCD Check..... | 2-6 |
| | Procedure 2 Error Code Check | 2-8 |
| | Procedure 3 Connection Check..... | 2-13 |
| | Procedure 4 Charge Check..... | 2-13 |
| | Procedure 5 Replacement Check..... | 2-14 |
| 2.4 | System Board Troubleshooting | 2-15 |
| | Procedure 1 Message Check | 2-16 |
| | Procedure 2 Printer Port LED Check on Boot Mode..... | 2-18 |
| | Procedure 3 Printer Port LED Check on Suspend/Resume Mode | 2-29 |
| | Procedure 4 Diagnostic Test Program Execution Check | 2-37 |
| | Procedure 5 Replacement Check..... | 2-37 |
| 2.5 | USB FDD Troubleshooting..... | 2-38 |
| | Procedure 1 USB FDD Head Cleaning Check..... | 2-38 |
| | Procedure 2 Diagnostic Test Program Execution Check | 2-39 |
| | Procedure 3 Connector Check and Replacement Check..... | 2-40 |
| 2.6 | HDD Troubleshooting | 2-41 |
| | Procedure 1 Partition Check..... | 2-41 |
| | Procedure 2 Message Check | 2-42 |
| | Procedure 3 Format Check..... | 2-43 |
| | Procedure 4 Diagnostic Test Program Execution Check | 2-44 |
| | Procedure 5 Connector Check and Replacement Check..... | 2-45 |
| 2.7 | Keyboard/Touch pad Troubleshooting..... | 2-46 |
| | Procedure 1 Diagnostic Test Program Execution Check | 2-46 |
| | Procedure 2 Connector Check and Replacement Check..... | 2-46 |

| | | |
|------|---|------|
| 2.8 | Display Troubleshooting | 2-48 |
| | Procedure 1 Diagnostic Test Program Execution Check | 2-48 |
| | Procedure 2 Connector Check and Cable Check | 2-48 |
| | Procedure 3 Replacement Check..... | 2-49 |
| 2.9 | Optical Drive Troubleshooting..... | 2-50 |
| | Procedure 1 Diagnostic Test Program Execution Check | 2-50 |
| | Procedure 2 Connector Check and Replacement Check..... | 2-50 |
| 2.10 | Modem Troubleshooting | 2-51 |
| | Procedure 1 Diagnostic Test Program Execution Check | 2-51 |
| | Procedure 2 Connector Check and Replacement Check..... | 2-52 |
| 2.11 | LAN Troubleshooting | 2-53 |
| | Procedure 1 Diagnostic Test Program Execution Check | 2-53 |
| | Procedure 2 Connector Check and Replacement Check..... | 2-53 |
| 2.12 | Sound Troubleshooting | 2-54 |
| | Procedure 1 Diagnostic Test Program Execution Check | 2-54 |
| | Procedure 2 Connector Check..... | 2-55 |
| | Procedure 3 Replacement Check..... | 2-56 |
| 2.13 | SD Card Slot Troubleshooting | 2-57 |
| | Procedure 1 Check on Windows XP | 2-57 |
| | Procedure 2 Connector Check and Replacement Check..... | 2-57 |
| 2.14 | Wireless LAN Troubleshooting | 2-58 |
| | Procedure 1 Transmitting-Receiving Check | 2-58 |
| | Procedure 2 Antenna Connection Check | 2-59 |
| | Procedure 3 Replacement Check..... | 2-59 |
| 2.15 | Bluetooth Troubleshooting..... | 2-60 |
| | Procedure 1 Transmitting-Receiving Check | 2-60 |
| | Procedure 2 Antenna Connection Check | 2-61 |
| | Procedure 3 Replacement Check..... | 2-62 |
| 2.16 | PCI ExpressCard slot..... | 2-63 |

| | | |
|------|---|------|
| 2.17 | Fingerprint sensor | 2-64 |
| | Procedure 1 Setting Windows Log-ON password | 2-65 |
| | Procedure 2 Registration of fingerprint..... | 2-65 |
| | Procedure 3 Authentication of fingerprint | 2-69 |
| | Procedure 4 Connector Check and Replacement Check..... | 2-70 |

Figures

| | | |
|------------|-------------------------------------|------|
| Figure 2-1 | Troubleshooting flowchart | 2-3 |
| Figure 2-2 | Printer port LED board | 2-18 |
| Figure 2-3 | Printer port LED board status | 2-18 |

Tables

| | | |
|-----------|---|------|
| Table 2-1 | Battery icon..... | 2-6 |
| Table 2-2 | DC IN icon..... | 2-7 |
| Table 2-3 | Error code | 2-8 |
| Table 2-4 | Printer port LED boot mode status | 2-20 |
| Table 2-5 | Printer port LED suspend mode error status..... | 2-30 |
| Table 2-6 | Printer port LED resume mode error status..... | 2-33 |
| Table 2-7 | FDD error code and status | 2-39 |
| Table 2-8 | HDD error code and status | 2-44 |

2.1 Troubleshooting

Chapter 2 describes how to determine if a Field Replaceable Unit (FRU) in the computer is causing the computer to malfunction. The FRUs covered are:

- | | | |
|--------------------------|------------------|------------------------|
| 1. Power Supply | 6. Display | 11. SD Card Slot |
| 2. System Board | 7. Optical Drive | 12. Wireless LAN |
| 3. USB Floppy Disk Drive | 8. Modem | 13. Bluetooth |
| 4. Hard Disk Drive | 9. LAN | 14. PCI ExpressCard |
| 5. Keyboard/Touch pad | 10. Sound | 15. Fingerprint Sensor |

The Diagnostics Disk operations are described in Chapter 3. Detailed Replacement Procedures are given in Chapter 4, *Replacement Procedures*.

The following tools are necessary for implementing the troubleshooting procedures:

The following tools are necessary for implementing the Diagnostics procedures:

For tools required for executing the Test Program, refer to the Chapter 3. For tools required for disassembling/assembling, refer to the Chapter 4.

1. Toshiba MS-DOS system FD
2. LED board
3. Headphone (for Sound troubleshooting)
4. An external microphone (for Sound troubleshooting)
5. A SD card (for SD card slot troubleshooting)

2.2 Troubleshooting Flowchart

Use the flowchart in Figure 2-1 as a guide for determining which FRU malfunctions. Before going through the flowchart steps, check the following:

- Ask the user if a password is registered and if it is, ask him or her to enter the password.
- Make sure that Toshiba Windows[®] XP/ Windows[®] 2000 is installed on the hard disk. Non-Toshiba operating systems can cause the computer malfunction.
- Make sure all optional equipment is removed from the computer.
- Make sure the USB FDD is empty.

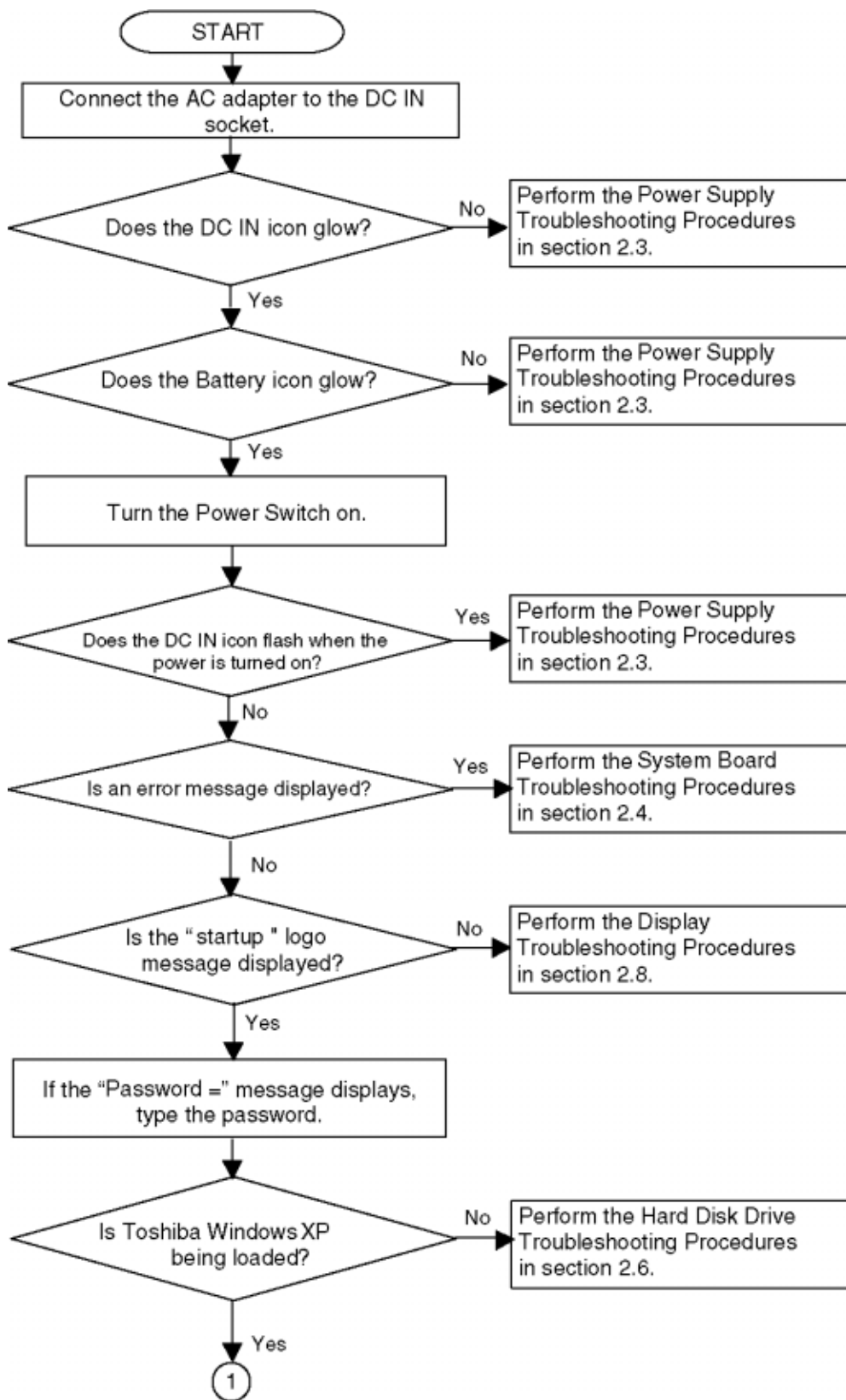

Figure 2-1 Troubleshooting flowchart (1/2)

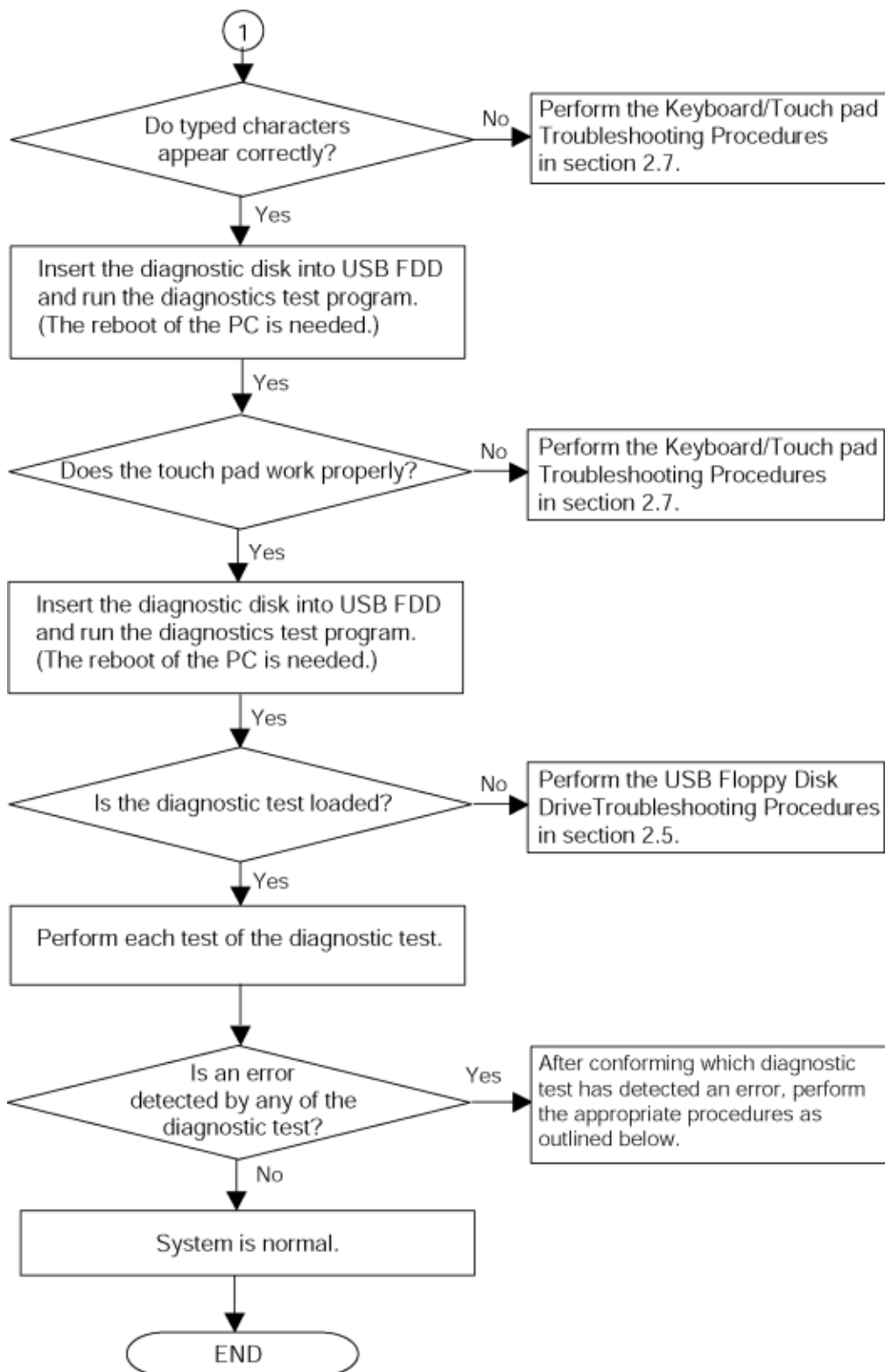

Figure 2-1 Troubleshooting flowchart (2/2)

If the diagnostics program cannot detect an error, the problem may be intermittent. The Running Test program should be executed several times to isolate the problem. Check the Log Utilities function to confirm which diagnostic test detected an error, then perform the appropriate troubleshooting procedures as follows:

1. If an error is detected on the system test, memory test, real timer test, perform the System Board Troubleshooting Procedures in Section 2.4.
2. If an error is detected on the floppy disk test, perform the USB FDD Troubleshooting Procedures in Section 2.5.
3. If an error is detected on the hard disk test, perform the HDD Troubleshooting Procedures in Section 2.6.
4. If an error is detected on the keyboard/touch pad test, perform the Keyboard Troubleshooting Procedures in Section 2.7.
5. If an error is detected on the display test, perform the Display Troubleshooting Procedures in Section 2.8.
6. If an error is detected on the optical drive test, perform the Optical Drive Troubleshooting Procedures in Section 2.9.
7. If an error is detected on the modem test, perform the Modem Troubleshooting Procedures in Section 2.10.
8. If an error is detected on the LAN test, perform the LAN Troubleshooting Procedures in Section 2.11.
9. If an error is detected on the sound test, perform the Sound Troubleshooting Procedures in Section 2.12.
10. If an error is detected on SD card slot, perform the SD Card Slot Troubleshooting Procedures in Section 2.13.
11. If an error is detected on the Wireless LAN test, perform the Wireless LAN Troubleshooting Procedures in Section 2.14.
12. If an error is detected on the Bluetooth test, perform the Bluetooth Troubleshooting Procedures in Section 2.15.
13. If a malfunction is detected on the PCI ExpressCard, perform the PCI ExpressCard Troubleshooting Procedures in Section 2.16.
14. If a malfunction is detected on the Fingerprint sensor, perform the Fingerprint Sensor Troubleshooting Procedures in Section 2.17.

2.3 Power Supply Troubleshooting

The power supply controls many functions and components. To determine if the power supply is functioning properly, start with Procedure 1 and continue with the other Procedures as instructed. The procedures described in this section are:

Procedure 1: Icons in the LCD Check

Procedure 2: Error Code Check

Procedure 3: Connection Check

Procedure 4: Charge Check

Procedure 5: Replacement Check

Procedure 1 Icons in the LCD Check

The following Icons in the LCD indicate the power supply status:

- Battery icon
- DC IN icon

The power supply controller displays the power supply status through the Battery icon and the DC IN icon in the LCD as listed in the tables below. To check the power supply status, install a battery pack and connect an AC adaptor.

Table 2-1 Battery icon

| Battery icon | Power supply status |
|--------------------------------|--|
| Lights orange | Battery has been charging and AC adapter is connected. |
| Lights green | Battery is fully charged and AC adapter is connected. |
| Blinks orange (even intervals) | Battery charge is low while system power is ON. |
| Flashes orange | Battery charge is low. AC adaptor must be connected to recharge the battery. |
| Doesn't light | Any condition other than those above. |

Table 2-2 DC IN icon

| DC IN icon | Power supply status |
|---------------|---|
| Lights green | DC power is being supplied from the AC adapter. |
| Blinks orange | There is a problem with the power supply.*1 |
| Doesn't light | Any condition other than those above. |

*1 When the power supply controller detects a malfunction, the DC IN LED blinks orange and an error code is displayed.

If the icon blinks, execute the followings:

1. Remove the battery and AC adapter to cut power supply to the computer.
2. Reinstall the battery and AC adapter.

If the LED still blinks, perform the followings:

- Check 1 If the DC IN icon blinks orange, go to Procedure 2.
- Check 2 If the DC IN icon does not light, go to Procedure 3.
- Check 3 If the battery icon does not light orange or green, go to Procedure 4.

CAUTION: Use a recommended AC adapter (G71C00043310/G71C00049410).

Procedure 2 Error Code Check

If the power supply microprocessor detects a malfunction, the DC IN icon blinks orange. The blink pattern indicates an error as shown below.

- Start Off for 2 seconds
- Error code (8 bit)
 - “1” On for one second
 - “0” On for half second
 - Interval between data bits Off for half second

The error code begins with LSB (Least Significant bit).

Example: Error code 11h (Error codes are given in hexadecimal format.)

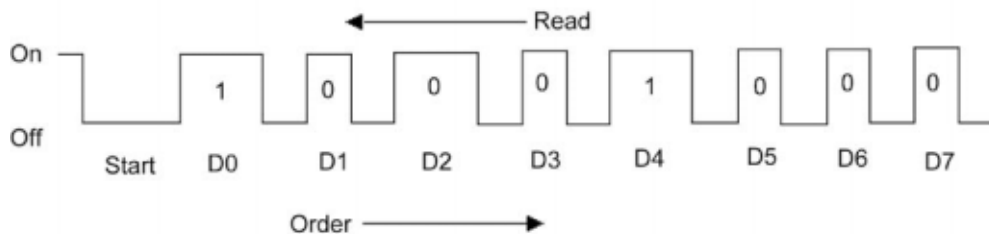

- Check 1 Convert the DC IN icon blink pattern into the hexadecimal error code and compare it to the tables below. Then go to Check 2.

Table 2-3 Error code

| Error code | Where Error occurs |
|------------|-------------------------|
| 1*h | DC IN (AC Adapter) |
| 2*h | 1 st battery |
| 3*h | 2 nd battery |
| 4*h | S3V output |
| 5*h | E5V output |
| 6*h | E3C output |
| 7*h | 1R5-E1V output (CH0) |
| 8*h | 1R8-B1V output |
| 9*h | PPV output |
| A*h | PTV output (CH0) |
| B*h | 1R5-E1V output (CH1) |
| C*h | PGV output |
| D*h | VG1R8-P1V output |
| E*h | PTV output (CH1) |
| F*h | - |

❑ DC IN

| Error code | Meaning |
|------------|--|
| 10h | AC Adaptor output voltage is over 16.5V. |
| 11h | Common Dock voltage is over 16.5V. |
| 12h | Current from the DC power supply is over 7.00A. |
| 13h | Current from the DC power supply is over 0.5A when there is no load. |
| 14h | Current sensing IC is not normal. |

❑ 1st Battery

| Error code | Meaning |
|------------|---|
| 22h | Main battery discharge current is over 0.5A. |
| 23h | Main battery charge current is over 3.9A when the battery is charged. |
| 24h | Current sensing IC is not normal. |
| 25h | Main battery charge current is over 0.3A when the battery is not charged. |

❑ 2nd Battery

| Error code | Meaning |
|------------|--|
| 32h | Secondary battery discharge current is over 0.5A. |
| 33h | Secondary battery charge current is over 3.9A when the battery is charged. |
| 34h | Current sensing IC is not normal. |
| 35h | Secondary battery charge current is over 0.3A when the battery is not charged. |

❑ S3V output

| Error code | Meaning |
|------------|---|
| 40h | S3V voltage is over 3.47V when the computer is powered on/off. |
| 45h | S3V voltage is under 3.14V when the computer is powered on/off. |
| 46h | S3V voltage is under 3.14V when the computer is booting up. |

❑ E5V output

| Error code | Meaning |
|------------|--|
| 50h | E5V voltage is over 6.00V when the computer is powered on/off. |
| 51h | E5V voltage is under 4.50V when the computer is powered on. |
| 52h | E5V voltage is under 4.50V when the computer is booting up. |
| 53h | E5V voltage is over 4.50V when the computer is powered off. |
| 54h | E5V voltage is under 4.50V when the EV power supply is maintained. |

❑ E3V output

| Error code | Meaning |
|------------|--|
| 60h | E3V voltage is over 3.96V when the computer is powered on/off. |
| 61h | E3V voltage is under 2.81V when the computer is powered on. |
| 62h | E3V voltage is under 2.81V when the computer is booting up. |
| 63h | E3V voltage is over 2.81V when the computer is powered off. |
| 64h | E3V voltage is under 2.81V when the EV power supply is maintained. |

❑ 1R5-E1V output (CH0)

| Error code | Meaning |
|------------|--|
| 70h | 1R5-E1V voltage is over 1.80V when the computer is powered on/off. |
| 71h | 1R5-E1V voltage is under 1.275V when the computer is powered on. |
| 72h | 1R5-E1V voltage is under 1.275V when the computer is booting up. |
| 73h | 1R5-E1V voltage is over 1.275V when the computer is powered off. |

❑ 1R8-B1V output

| Error code | Meaning |
|------------|--|
| 80h | 1R8-B1V voltage is over 3.00V when the computer is powered on/off. |
| 81h | 1R8-B1V voltage is under 1.53V when the computer is powered on. |
| 82h | 1R8-B1V voltage is under 1.53V when the computer is booting up. |
| 83h | 1R8-B1V voltage is over 1.53V when the computer is powered off. |
| 84h | 1R8-B1V voltage is under 1.53V when the BV power supply is maintained. |

PPV output

| Error code | Meaning |
|------------|--|
| 90h | PPV voltage is over 1.80V when the computer is powered on/off. |
| 91h | PPV voltage is under 0.56V when the computer is powered on. |
| 92h | PPV voltage is under 0.56V when the computer is booting up. |
| 93h | PPV voltage is over 0.56V when the computer is powered off. |

PTV output (CH0)

| Error code | Meaning |
|------------|--|
| A0h | PTV voltage is over 1.26V when the computer is powered on/off. |
| A1h | PTV voltage is under 0.89V when the computer is powered on. |
| A2h | PTV voltage is under 0.89V when the computer is booting up. |
| A3h | PTV voltage is over 0.89V when the computer is powered off. |

1R5-E1V output (CH1)

| Error code | Meaning |
|------------|---|
| B0h | 1R5-E1V voltage is over 1.80V when the computer is powered on/off. |
| B1h | 1R5-E1V voltage is under 1.275V when the computer is powered on. |
| B2h | 1R5-E1V voltage is under 1.275V when the computer is booting up. |
| B3h | 1R5-E1V voltage is over 1.275V when the computer is powered off. |
| B4h | 1R5-E1V voltage is under 1.275V when the EV power supply is maintained. |

PGV output

| Error code | Meaning |
|------------|--|
| C0h | PGV voltage is over 1.62V when the computer is powered on/off. |
| C1h | PGV voltage is under 0.68V when the computer is powered on. |
| C2h | PGV voltage is under 0.68V when the computer is booting up. |
| C3h | PGV voltage is over 0.68V when the computer is powered off. |
| C4h | PGV voltage is under 0.68V when the BV power supply is maintained. |

VG1R8-P1V output

| Error code | Meaning |
|------------|--|
| D0h | VG1R8-P1V voltage is over 2.16V when the computer is powered on/off. |
| D1h | VG1R8-P1V voltage is under 0.89V when the computer is powered on. |
| D2h | VG1R8-P1V voltage is under 0.89V when the computer is booting up. |
| D3h | VG1R8-P1V voltage is over 0.89V when the computer is powered off. |

PTV output (CH1)

| Error code | Meaning |
|------------|--|
| E0h | PTV voltage is over 1.26V when the computer is powered on/off. |
| E1h | PTV voltage is under 0.89V when the computer is powered on. |
| E2h | PTV voltage is under 0.89V when the computer is booting up. |
| E3h | PTV voltage is over 0.89V when the computer is powered off. |

Miscellaneous

| Error code | Meaning |
|------------|-----------------------------------|
| F0h | The sub clock does not oscillate. |

Check 2 In the case of error code 10h or 12h:

- Make sure the AC adaptor cord and AC power cord are firmly plugged into the DC IN 15 V socket and wall outlet. If the cables are connected correctly, go to the following step.
- Connect a new AC adaptor and/or AC power cord, if necessary. If the error still exists, go to Procedure 5.

Check 3 In the case of error code 21h:

- Go to Procedure 3.

Check 4 For any other error, go to Procedure 5.

Procedure 3 Connection Check

The power supply wiring diagram is shown below:

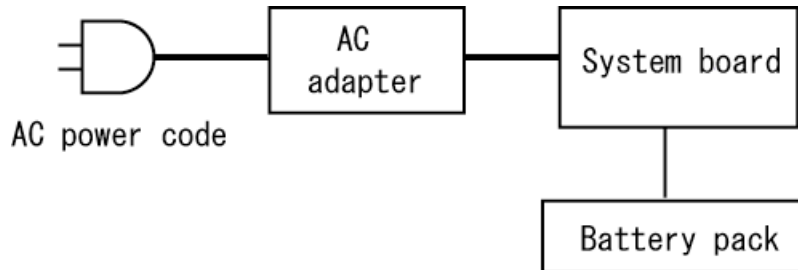

Any of the connectors may be disconnected. Perform Check 1.

Check 1 Disconnect the AC power cord from the wall outlet. Check the power cable for breaks. If the power cord is damaged, connect a new AC power cord. If there is no damage, go to Check 2.

Check 2 Connect a new AC adaptor or AC power cord.

- If the DC IN icon does not light, go to Procedure 5.
- If the battery icon does not light, go to Check 3.

Check 3 Make sure the battery pack is installed in the computer correctly. If the battery is properly installed and the battery icon still does not light, go to Procedure 4.

Procedure 4 Charge Check

The power supply may not charge the battery pack. Perform the following procedures:

Check 1 Make sure the AC adaptor and AC power cord are firmly plugged into the DC IN socket and the wall outlet.

Check 2 Make sure the battery is properly installed. If the battery is properly installed, go to Check 3.

Check 3 The battery pack may be completely discharged. Wait a few minutes to charge the battery pack. If the battery pack is still not charged, go to Check 4.

Check 4 The battery's temperature is too hot or cold. Return the temperature to a normal operating condition. If the battery pack still is not charged, go to Check 5.

Check 5 Replace the battery pack with a new one. If the battery pack still is not charged, go to Procedure 5.

Procedure 5 Replacement Check

The system board processor module may be disconnected or damaged. Disassemble the computer following the steps described in Chapter 4, *Replacement Procedures*. Check the connection between the AC adaptor and system board. After checking the connections, perform the following Check 1:

- Check 1 Replace the AC adaptor with a new one. If the AC adaptor is still not functioning properly, perform Check 2.
- Check 2 Replace the system board with a new one following the steps described in Chapter 4, *Replacement Procedures*.

2.4 System Board Troubleshooting

This section describes how to determine if the system board and CPU are defective or not functioning properly. Start with Procedure 1 and continue with the other procedures as instructed.

The procedures described in this section are:

Procedure 1: Message Check

Procedure 2: Printer Port LED Check on Boot Mode

Procedure 3: Printer Port LED Check on Suspend/Resume Mode

Procedure 4: Diagnostic Test Program Execution Check

Procedure 5: Replacement Check

Procedure 1 Message Check

When the power is turned on, the system performs the Initial Reliability Test (IRT) installed in the BIOS ROM. The IRT tests each IC on the system board and initializes it.

- If an error message is shown on the display, perform Check 1.
- If there is no error message, go to Procedure 2.
- If Toshiba MS-DOS or Windows XP is properly loaded, go to Procedure 4.

Check 1 If one of the following error messages appears on the screen, press **F1** as the message instructs. These errors occur when the system configuration preserved in the RTC memory (CMOS type memory) is not the same as the actual configuration or when the data is lost.

If you press the **F1** key as the message instructs, the SETUP screen appears to set the system configuration. If any other error message is displayed, perform Check 2.

- (a) *** Bad HDD type ***
Check system. Then press [F1] key
- (b) *** Bad configuration ***
Check system. Then press [F1] key
- (c) *** Bad memory size ***
Check system. Then press [F1] key
- (d) *** Bad time function ***
Check system. Then press [F1] key
- (e) *** Bad check sum (CMOS) ***
Check system. Then press [F1] key
- (f) *** Bad check sum (ROM) ***
Check system. Then press [F1] key
- (g) *RTC battery is low or CMOS checksum is inconsistent
Press [F1] key to set Date/Time

Check 2 If the following error message is displayed on the screen press any key as the message instructs.

The following error message appears when data stored in RAM under the resume function is lost because the battery has become discharged or the system board is damaged. Go to Procedure 3.

```
WARNING: RESUME FAILURE.  
PRESS ANY KEY TO CONTINUE.
```

If any other error message is displayed, perform Check 3.

Check 3 The IRT checks the system board. When the IRT detects an error, the system stops or an error message appears.

If one of the following error messages (1) through (17), (22) or (23) is displayed, go to Procedure 4.

If error message (18) is displayed, go to the Keyboard/Touch pad Troubleshooting Procedures in Section 2.7.

If error message (19), (20) or (21) is displayed, go to the 2.5" HDD Troubleshooting Procedures in Section 2.6.

- (1) PIT ERROR
- (2) MEMORY REFRESH ERROR
- (3) TIMER CH.2 OUT ERROR
- (4) CMOS CHECKSUM ERROR
- (5) CMOS BAD BATTERY ERROR
- (6) FIRST 64KB MEMORY ERROR
- (7) FIRST 64KB MEMORY PARITY ERROR
- (8) VRAM ERROR
- (9) SYSTEM MEMORY ERROR
- (10) SYSTEM MEMORY PARITY ERROR
- (11) EXTENDED MEMORY ERROR
- (12) EXTENDED MEMORY PARITY ERROR
- (13) DMA PAGE REGISTER ERROR
- (14) DMAC #1 ERROR
- (15) DMAC #2 ERROR
- (16) PIC #1 ERROR
- (17) PIC #2 ERROR
- (18) KBC ERROR
- (19) HDC ERROR
- (20) Built-in HDD ERROR
- (21) Select Bay ERROR
- (22) TIMER INTERRUPT ERROR
- (23) RTC UPDATE ERROR

Procedure 2 Printer Port LED Check on Boot Mode

The printer port LED displays the IRT status and test status by turning lights on and off as an eight-digit binary value for boot mode. Figure 2-2 shows the printer port LED.

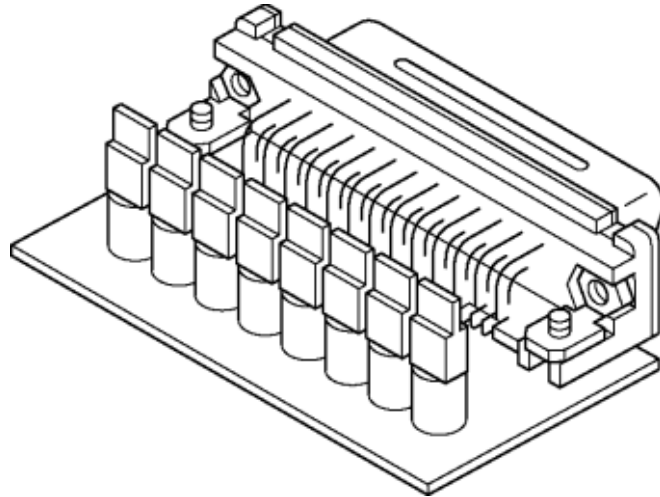

Figure 2-2 Printer port LED board

Figure 2-3 shows the function of the printer port LED board.

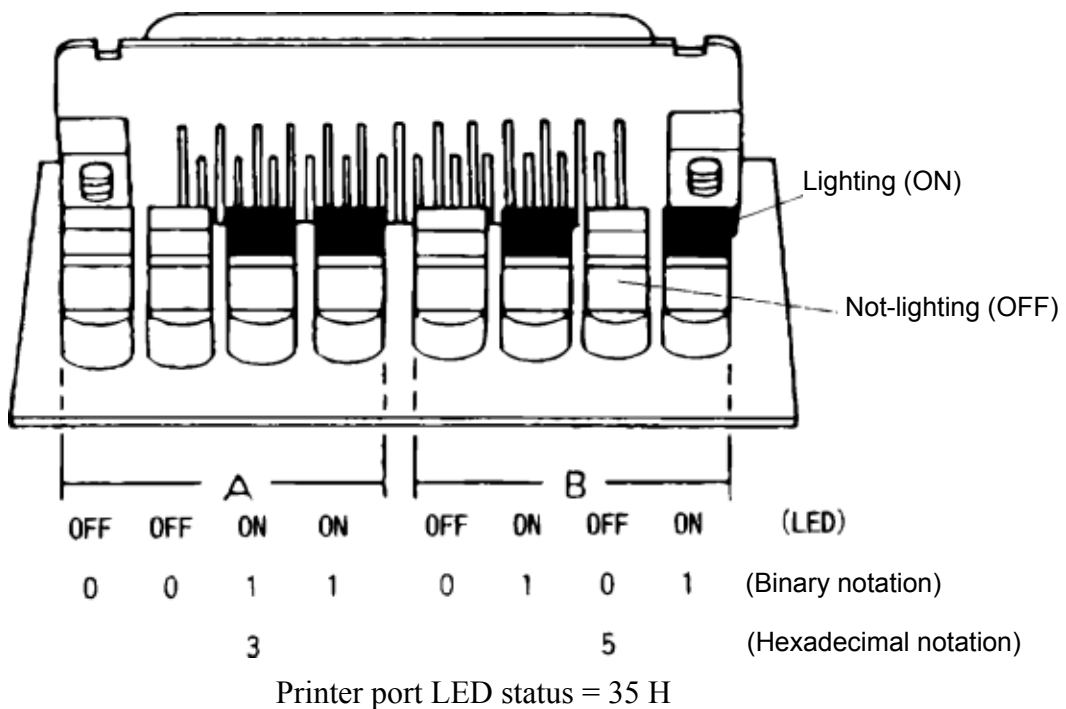
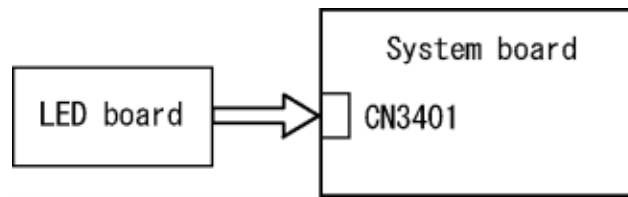

Figure 2-3 Printer port LED board status

To use the printer port LED, follow the steps below:



1. Turn on the computer's power and set it to boot mode.
2. Turn off the computer's power.
3. Plug the printer port LED into the parallel port.
4. While holding down the space bar, turn on the computer's power.
5. Read the LED status from left to right.
6. Convert the status from binary to hexadecimal notation.
7. If the final LED status is FFh (normal status), go to Procedure 4.

Table 2-4 Printer port LED boot mode status (1/9)

| LED Status | Test item | Contents |
|------------|---|---|
| | Permission of A20 and clear of software reset bit | |
| | Prohibition of APIC | |
| | Initialization of MCH, ICH | |
| | Initialization of Super I/O | |
| | Initialization of debug port (For models supporting debug port) | |
| | Dummy read of 3 rd Bus data | |
| | Setting of printer port (For models supporting printer port) | |
| B0h | PIT CH0 initialization (for HOLD_ON) | |
| | BIOS rewrite factor flag initialization | |
| | CHECK SUM CHECK | Transition to protected mode |
| | | Boot block checksum (skipped when returned from S3) Halts when error occurs |
| | | Checksum other than boot block (skipped when returned from S3) |
| B1h | EC/KBC rewrite check | If "rewrite" is requested, go to "BIOS rewrite process". |
| B2h | Initialization of SC | HLT at LED=B3H or B4, when error occurs |
| | Key input (skipped when returned from S3) | When a key is pressed, check if it is Tilde key or Tab key. (skipped when returned from S3) |
| B5h | Enables CPU cache | |
| B6h | Security check | |
| | BIOS rewrite request check | If Checksum check error occurred on except Boot Block or rewrite is required by user, go to "BIOS rewrite process". |
| B7h | Transits to System BIOS IRT | |
| | BIOS rewrite process | |
| | Initialization of ICH. D31 | |
| | DRAM configuration | |
| | Permission of cache (L1 cache only) | |
| | Memory clear | |
| | Transition to real mode and copy of BIOS to RAM | |

Table 2-4 Printer port LED boot mode status (2/9)

| LED Status | Test item | Contents |
|---|---|---|
| B9h | Saving of key scan code | |
| | Setting of TASK_1ms_TSC | |
| | FAN control | |
| | Sound initialization (for BEEP sound) | Cancel of sound mute Setting of volume to max (model that can control volume) |
| | When BIOS, EC/KBC rewriting is requested | Blinks green (cycle:2s, on:1s, off:1s) |
| | When BIOS renewal is prohibited | Blinks orange (cycle:8s, on:4s, off:4s) HLT after BEEP is sounded for 30s (LED=BBH)) |
| | When BIOS ROM is abnormal | Blinks orange (cycle:2s, on:1s, off:1s) |
| | Key input | Prohibition of USB |
| | | BEEP |
| | | Waiting for Key input |
| | Reading of CHGBIOSA.EXE/CHGFIRMA.EXE | FDC RESET |
| | | Setting of parameters for 2HD (1.44MB) |
| | | Reading of first sector, If it is the data of 1.44MB (2HD), the media type is definite. |
| Setting of parameters for 2DD (720KB) | | |
| Retrieval of "CHGBIOSA.EXE" from the root directory. Calculation of directory start head and sector Read 1 sector of the root directory Retrieval of entry of "CHGBIOSA.EXE" /"CHGFIRMA.EXE" from the sector read. | | |
| | Reading of EXE header of "CHGBIOSA.EXE" and "CHGFIRMA.EXE" Key input when error occurred | |
| | Execution of "CHGBIOSA.EXE" and "CHGFIRMA.EXE" | |

Table 2-4 Printer port LED boot mode status (3/9)

| LED Status | Test item | Message | |
|---------------------------------|---|---|--|
| 00h | Prohibition of cache | | |
| | Permission of L1/L2 cache in FlashROM area | | |
| | Initialization of H/W (before DRAM recognition) | Initialization of MCH | |
| | | Initialization of ICH.D30.Func0 | |
| | | Initialization of ICH.D31.Func0 | |
| | | Initialization of ICH.D31.Func1/2 | |
| | | Initialization of USB Controller | |
| | | Initialization of ICH.D31.Func3 | |
| | | Initialization of ICH Audio | |
| | | Initialization of TI Controller | |
| Initialization of PIT channel 1 | (Setting the refresh interval to "30 μ s") | | |
| 01h | Check of DRAM type and size (at cold boot) | When unsupported memory is connected, becoming HLT after beep sound | |
| | SM-RAM stack area test | HLT when DRAM size is 0 HLT When it can not be used as a stack | |
| 02h | Cache configuration | | |
| | Cache permission | | |
| | CMOS access test (at cold boot) | (HLT when an error is detected) | |
| | Battery level check of CMOS | | |
| | CMOS checksum check | | |
| | Initialization of CMOS data (1) | | |
| | Setting of IRT status | (Setting of boot status and IRT busy flag, The rest bits are 0) | |
| | Storing DRAM size in CMOS | | |
| 03h | Resume branch (at cold boot) | Not resume when a CMOS error occurred | |
| | | Not resume when resume status code is not set | |
| | | Resume error check S3 returning error (1CH) (Resume error LED=7AH) SM-RAM checksum check (Resume error LED=73H) Check of memory configuration change (Resume error LED=73H) RAM area checksum check in system BIOS (Resume error LED=79H) | |
| | | | |

Table 2-4 Printer port LED boot mode status (4/9)

| LED Status | Test item | Contents |
|---------------------------------|--|--|
| (03h) | | Expansion memory checksum check resume error (Resume error LED=76H) PnP RAM checksum check (Resume error LED=77H) |
| | | Transition to RESUME-MAIN |
| | Resume error process | Reset of CPU clock to low |
| | | Prohibition of all SMI |
| | | Clearance of resume status |
| | | Return to ROM |
| | | Turning area of C0000h to EFFFFh to PCI (Prohibition of DRAM) |
| Setting of resume error request | | |
| Copying ROM/RAM of system BIOS | (HLT, when error occurs) | |
| 04h | Security check | |
| 05h | SMRAM initialization | |
| | APIC initialization | |
| | WakeUp factor check | |
| | SMRAM base rewriting and CPU state map saving for BIOS | |
| | Permission of SMI based on ASMI | |
| 06h | Initialization of devices which need initialization before PCI bus initialization. | PIT test (Cold boot only) and initialization |
| | | Setting of test pattern to channel 0 of PIT#0 |
| | | Check whether the set test pattern can be read |
| | | Initialization of PIT channel 0, Setting of timer interruption interval to 55ms |
| | | Initialization of PIT channel 2, Setting of the sound generator frequency to 664Hz |
| | | Test of PIT channel 1 (Check whether the refresh signal works normally in 30 micro-seconds refresh interval.) HLT, when the time is out. |
| | | Test of PIT channel 2 (Check whether the speaker gate works normally.) |
| | | CPU clock measurement |
| | | Check of parameter block A |
| | | Permission of SMI except auto-off function |
| | | Judging of destination (Japan or except Japan) based on DMI data |

Table 2-4 Printer port LED boot mode status (5/9)

| LED Status | Test item | Contents | |
|-------------------------|---|---|--|
| (06h) | | Battery discharging current control (1CmA). | |
| | | Dividing procedures for time measuring by IRT | |
| | | Setting for clock generator | |
| | | Check of CMOS default setting Default is set, when there are Bad Battery and Bad CheckSum (ROM, CMOS). | |
| | | Control of excess of rated input power | |
| | | AC adapter rated over current control | |
| | | CPU Initialization Micro code update Judging of CPU type Geyserville support check Setting of CPU clock to "high" | |
| 07h | Saving memory configuration to buffer | | |
| | Reading of EC version | | |
| | Update of flash ROM type | | |
| | ACPI table initialization (for execution of option ROM) | | |
| | Initialization of devices which need initialization before PCI bus initialization | Setting of IDE device operation mode | |
| | | Setting of AC'97/Azalia operation mode | |
| | | Initialization of temperature control information | |
| | | KBC initialization | |
| | | VGA display off, Reset control | |
| | | Control of built-in LAN permission/prohibition | |
| | | PCI Express initialization | |
| | | Sound initialization | |
| | | PC multi-box status acquisition (For models supporting Select Bay) | |
| | | HC initialization and Device recognition | |
| PIC initialization | | | |
| PIC test | | | |
| Password Initialization | | | |

Table 2-4 Printer port LED boot mode status (6/9)

| LED Status | Test item | Contents | |
|------------------------|--|---|--|
| 08h | PCI bus initialization (connection of DS Bus) | | |
| | Initialization of LAN information | | |
| | WakeUp factor check | | |
| 09h | Task generation for waiting INIT_PCI completion | | |
| | CMOS data initialization (2) | | |
| | PnP initialization | | |
| | Setting of setup items | | |
| | Waiting for the completion of Multi-box status check | | |
| | H/W setting based on resource | | |
| 0Ah | Task generation for waiting PnP resource making completion | | |
| | PnP H/W initialization | | PC card slot initialization |
| | | | SIO initialization (For models supporting SIO) |
| | | | FIR initialization (For models supporting FIR) |
| | PCI automatic configuration | | Making of work for automatic configuration |
| | | | Acquisition of PCI IRQ |
| | | | Configuration |
| | | | Saving of VGA configuration result |
| 0Bh | | Task generation for waiting PCI_CONFIGURATION completion | |
| | Initialization of H/W needed after PCI configuration | Printer port setting (model supporting Printer port) | |
| | | HDD initialization sequence start | |
| | | FDD initialization sequence start (model supporting built-in FDD) | |
| | Enabling power off | | |
| Output code generation | | | |
| 0Ch | FIRST_64KB_CHECK | (Check of first 64KB memory) | |
| 0Dh | INIT_INT_VECTOR | (Initialization of vectors) | |
| 0Eh | INIT_NDP | (Initialization of NDP) | |

Table 2-4 Printer port LED boot mode status (7/9)

| LED Status | Test item | Contents |
|------------|---|--|
| 0Fh | INIT_SYSTEM | (Initialization of system) |
| | | Storing of CMOS error information to IRT_ERR_STS_BUF |
| | | Controlling CD POWER SW (model supporting CD play) |
| | | Timer initialization start |
| | | EC initialization & Reading of battery information |
| | | Update of system BIOS (Update EDID information for LCD) |
| 10h | INIT_DISPLAY | (Waiting for VGA chip initialization completion, VGA BIOS initialization) |
| | | Waiting for VGA power-on |
| | | Waiting for Display access completion |
| 11h | Calling VGA BIOS | |
| 13h | DISP_LOGO | (Logo displaying) (Starting of logo display waiting LED=25H (unused)) |
| 14h | SYS_MEM_CHECK | (Check of conventional memory) (Boot) |
| 15h | EXT_MEM_CHECK | (Exception check in protected mode) (Boot) |
| 16h | INIT_SYS_MEM | (Initialization of conventional memory) (Reboot) (LED=17h if error occurred during exception check in protected mode) |
| 18h | CHK_DMA_PAGE | (Check of DMA Page Register) (Boot) |
| 19h | CHECK_DMAC | (Check of DMAC) (Boot) |
| 1Ah | INIT_DMAC | (Initialization of DMAC) (Boot) |
| 1Bh | CHECK_PRT | (Check of printer existence) (For models supporting Printer port) |
| 1Ch | CHECK_SIO | (Check of SIO) (model supporting SIO) |
| 1Dh | Process of DIAGNOSTIC inspection result display | (When DIAGNOSTIC mode is permitted) |
| 1Eh | BOOT_PASSWORD | (Check of password) |
| | | Waiting for FDD initialization completion (For models supporting built-in FDD) |
| | (In the case of "Reboot") | Waiting for HDD initialization completion |
| | | Check of key input during IRT (waiting for KBC initialization completion) |
| | | I/O LOCK Processing (model supporting I/O LOCK) |
| | | Initialization of ATA priority |

Table 2-4 Printer port LED boot mode status (8/9)

| LED Status | Test item | Contents |
|---|-------------------------|---|
| 1Eh | (In the case of "Boot") | Check of key input during IRT (waiting for KBC initialization completion) |
| | | Input of password (waiting for HDD initialization completion) |
| | | I/O LOCK Processing (For models supporting I/O LOCK) |
| | | TPM Initialization (model supporting TPM) |
| 1Fh | EX_IO_ROM_CHECK | (Check of option I/O ROM) |
| 20h | PRE_BOOT_SETUP | Saving of value in 40:00h (For SIO saving/restoring) |
| | | Setting of font address for resume password |
| | | Setting of repeat parameter for USB KB |
| | | Acquisition of keys pressed during IRT |
| | | Storing of T_SHADOW_RAM_SIZE |
| | | Update of system resource before boot |
| | | Rewriting of memory map data of INT15h E820h function |
| | | Waiting for AC-Link initialization completion (For models supporting AC-Link) |
| | | Updating of table for DMI |
| | | Copy of ACPI table to top of expansion memory |
| | | Waiting for writing of PSC version to BIOS completion |
| | | Waiting for clock generator setting completion When error occurred, halts at LED=21H |
| | | Waiting for serial port initialization completion (For models supporting SIO) |
| | | Cancel of NMI Mask |
| | | Taking out TIT check sum |
| | | Clear of the IRT flag on Runtime side |
| | | Update of check sum on Runtime side |
| | | Hibernation branch (For models supporting BIOS Hibernation) |
| Initialization of Bluetooth (For models supporting Bluetooth) | | |
| Check of existence of object maintenance cards | | |
| Prohibition of unused PC cards | | |
| Setting Wakeup status data for ACPI | | |

Table 2-4 Printer port LED boot mode status (9/9)

| LED Status | Test item | Contents |
|------------|------------------------------------|---|
| (20h) | | HW initialization before Boot, Waiting for initialization completion |
| | | Notifies the DVI connection status to VGA BIOS (For models supporting DVI) |
| | | Setting of battery save mode |
| | | Setting of date |
| | | Waiting for Bluetooth initialization completion (For models supporting Bluetooth) |
| | | Update of DMI Wakeup factor, Update of SM-BIOS structure table |
| | | PCI device configuration space close |
| | | Cache control |
| | | Process for CPU (Make the CPU clock to be set by SETUP) |
| | | Waiting of motor-off completion of disabled HDD |
| | | Final setting of FDD information |
| | | Post processing of PRE_BOOT_SETUP Clears PWRBTN_STS Enables POWER Button |
| 22h | Initialization of SC | |
| 24h | Clearness of IRT status | |
| | Update of Checksum on Runtime side | |
| FFh | End | |

Check 1 If error code 1Eh or 20h is displayed, go to the following Sections:
Section 2.6 “2.5” HDD Troubleshooting”

Check 2 If the final status of the LED are the followings, perform Procedure 4.

Printer port LED error status

| Error | Content |
|------------|---------------------------------|
| B3H or B4H | Initialization of SC error |
| BBH | Prohibition of BIOS update (*1) |
| 17H | Exception check error |
| 20H | Clock generator setting error |

(*1) Check the situation of security because the setting of security may prohibit the renewal of BIOS when the LED status is BBh.

Procedure 3 Printer Port LED Check on Suspend/Resume Mode

The printer port LED displays the IRT status and error status by turning lights on and off as an eight-digit binary value after turning on of the power.

To use the printer port LED, follow the steps below:

1. Turn on the computer's power and set it to the resume mode.
2. Turn off the computer's power.
3. Plug the printer port LED into the parallel port (printer port).
4. Read the LED status from left to right as you face the computer.
5. Convert the status from binary to hexadecimal notation.
6. If the final LED status is FFh (normal status), go to Procedure 4.
7. If the final LED status matches any of the test status values in Table 2-5, 2-6 perform Procedure 5.

Table 2-5 Printer port LED suspend mode error status (1/3)

| LED Status | Test item | Contents |
|------------|--|---|
| | | Sets the parallel port to D0 state. (For models supporting PRT port) |
| 36h | When powering-off request from OS is required, waiting for the completion of dividing process because waiting in SUSPEND of Runtime returns the process to OS. | |
| | Forced execution of dividing (Permission of SMI for dividing) | |
| | Waiting for completion of dividing | |
| 37h | After prohibiting of all SMI, permits I/O trap (EHC1) and external SMI. | |
| | Starts dividing to transmit periodically extension command (every 25 seconds) not to generate time-out of power-off. | |
| | Clears resume/power-off status. | |
| | Storing and initializing of special PCI configuration register | |
| | Prohibits clock control. | |
| | Recognition of suspending for boot/ resume | |
| | Branch of resume mode (LED=38H) or boot mode (LED=3DH) | |
| 38h | Powering-off during resuming | Halts HC. |
| | | Starts sequence for storing display system. |

Table 2-5 Printer port LED suspend mode error status (2/3)

| LED Status | Test item | Contents |
|--|---|--|
| 39h | Resume error check in suspend mode. | Check if IRT process is being executed |
| | | Check if external option ROM exists |
| | | Check if FDD motor is rotating (For models supporting built-in FDD) |
| | Execution of driver for suspend | |
| | Clearing of data for Remote Lockout | |
| | Storing of FDD register | (For models supporting built-in FDD) |
| | Storing of USB register | |
| | Halt of HC | |
| | Storing CPU register | |
| | Permission of system area and memory cache | (to work at high-speed) |
| | Suspending of HDD | |
| | Storing KBC,SCC and MOUSE | |
| | Storing of PCI device | |
| | Storing of PIT | |
| | Starts sequence for storing display system. | |
| | Storing of PIC | |
| | Storing of DMAC | |
| | Storing of system status command port | |
| | Storing of SIO | (For models supporting SIO) |
| | Storing of PCMCIA card | |
| Storing of RTC | | |
| Processing of system peculiar HW preservation | | |
| Calculation of check sum (conventional memory) | | |
| 3Ah | Suspending for boot mood | |
| 3Dh | Processing of VGA –off (boot) | |
| | Suspending of HDD (boot) | |
| | Transition to S5 of Bluetooth (boot) | (For models supporting Bluetooth) |
| 3Eh | Suspending of boot/ resume for PnP | (Stores PnP resource information into Flash ROM.) |
| | Suspending of boot /resume for password | (Stores password information into Flash ROM.) |
| 3Fh | Waiting for completion of suspending for HDD password | |

Table 2-5 Printer port LED suspend mode error status (3/3)

| LED Status | Test item | Contents |
|------------|--|---|
| 40h | Prohibition of PCI arbiter | |
| | Setting of Wakeup event | |
| | Power-off of PC card | |
| | Re-setting backup current | |
| | Forced off of fan | |
| | Checks whether off-process for resume is needed | |
| | Power LED control during suspending | |
| | Isolates built-in LAN. | |
| | Makes the power of sound off. | |
| | Makes the power of Dock off. | (For models supporting Dock) |
| 41h | Model-unique processing just before suspending | |
| | Waiting for completion of dividing for suspending | |
| | Stops dividing of extension command for power off. | |
| 42h | Measure for USB over current | |
| | Calculation of check sum of PnP RAM area | (Not work in suspending for boot) |
| | Acquires how to turn the power off | |
| | Resets by EC. | (when required) |
| | Makes not to send Eject Power Off command when turn the power off by the date check of alarm power on. | |
| | Prohibition of all SMI | |
| | Initializing of special register in suspending | |
| 43h | Calculates the checksum of system BIOS in the IRT side | (Checksum does not match during IRT) |
| | Setting status of suspend completion | |
| | Prohibition of L1&L2 | |
| | Power off process | (BIOS process is end because of reaching P-OFF) |

Table 2-6 Printer port LED resume mode error status (1/4)

| LED Status | Test item | Contents |
|-----------------------------------|---|---|
| 00h | Refer to IRT printer LED error status. | |
| 01h | Refer to IRT printer LED error status. | |
| 02h | Refer to IRT printer LED error status. | |
| 03h | Refer to IRT printer LED error status. | |
| | Clears flag for SMI control. | |
| 27h(not used) | Renewal of Resume counter | |
| 26h | Checks the WakeUp factors. | |
| | Rewriting of SMRAM BASE | |
| 28h | Initializing devices necessary for initialization before initializing PCI bus | Initializing of PIT |
| | | Initializing of PIT channel 0 (Sets the interval of timer interruption to 55ms) |
| | | Initializing of PIT channel 2 (Sets the sound generator frequency to 664Hz) |
| | | Measuring CPU clock |
| | | Check of parameter block A |
| | | Permission of SMI other than auto-off function |
| | | Control of excess of rated input power |
| | | Control of battery discharging current (1CmA) |
| | | AC adapter rated over current control |
| | | Dividing for measuring of IRT time |
| | | Setting to clock generator |
| | Initializing of CPU Updating micro-code Judgment of CPU type Check of supporting Geyserville Sets the CPU clock to High | |
| | Recovery of PIC register | |
| | Initialization of devices necessary for initialization before initializing PCI bus 2 | Setting of IDE device operation mode |
| | | Setting of AC'97/Azalia operation mode |
| | | Initializing of temperature control information |
| Initializing of KBC | | |
| VGA display-off and Reset control | | |
| | Control of built-in LAN permission/ prohibition | |

Table 2-6 Printer port LED resume mode error status (2/4)

| LED Status | Test item | Contents | |
|-------------------------------------|--|--|--|
| (28h) | | Initializing of sound | |
| | | Initializing of PCI Express | |
| | | Acquires the multi-box status (For models supporting Select bay) | |
| | | Initializing of HC and recognizing of devices | |
| | | Initializing and recognizing of SD card | |
| | Check of the checksum of conventional memory | Resume error LED=74H | |
| 29h | Initializing of PCI devices | | |
| | Check of WakeUp factors after initializing PCI bus | | |
| 2Ah | Resume process of IEEE1394 | (For models supporting IEEE1394) | |
| | Waiting for initializing of devices which have to be initialized before setting HW by PnP resource | Waiting for completion of MultiBox status check (For models supporting Select bay) | |
| | Recovery of each device (1) | Processing of RESUME for PnP | |
| | | Tentative initialization of printer port (For models supporting printer port) | |
| | | Waiting for the completion of VGA power-down control (because the VGA configuration can not be seen) | |
| | | Processing of RESUME for PCI | |
| | | Recovery of FDC (For models supporting internal FDD) | |
| | | Recovery of PCMCIA card | |
| | | Error when an ATA card is pulled out (For models supporting ATA card) Resume error LED=7BH | |
| | | Executing of dividing process of device detection of PC card | |
| | | Initializing COM (For models supporting SIO) | |
| | | Initializing FIR (For models supporting FIR) | |
| | Check of HDD pack connection | Resume error when HDD is mounted LED=72H | |
| Start of IDE device resume sequence | | | |
| 2Bh | Recovery of user alarm setting and cancel of alarm power-on function | (only one time) | |
| | Enabling power off switch | | |
| | Initializing EC and start of reading battery information | | |
| | Recovery of each device (2) | Setting items to be set up | |
| Initializing DMAC | | | |

Table 2-6 Printer port LED resume mode error status (3/4)

| LED status | Test item | Contents |
|---------------------------------------|---|--|
| (2Bh) | | Initializing printer mode (For models supporting Printer port) |
| | Initializing VGA BIOS, when resume | Waiting for VGA power on |
| 2Ch | Calling VGA BIOS | |
| 2Eh | Processing of password for RESUME | |
| 2Fh | Recovery of each device(3) | Recovery of COM register (For models supporting SIO) |
| | | Recovery of DMAC register |
| | | PnP Resume processing 2 |
| | Turns the disabled HDD motor off | |
| 30h | Waiting for completion of KBC initializing | (not in ACPI mode) |
| | Waiting for completion of USB initializing | |
| | Recovery of USB register | |
| | Recovery of CPU register | |
| | Processing of SIO dummy-reading | (For models supporting SIO) |
| | Resetting NDP interruption | |
| | Recovery of system, status, command and port | |
| | Wakeup check | Notifies the device change status to the high rank. |
| | | Setting WAKEUP status data for ACPI |
| | Initializing HW just before booting or waiting for the completion | Notifies the DVI connection status to VGA BIOS (For models supporting DVI) |
| | | Setting battery saving mode |
| | | Setting date |
| | | Waiting for the completion of Bluetooth initializing (For models supporting Bluetooth) |
| | | Renewal of Wakeup factor of DMI and SM-BIOS structure table |
| | | Closing PCI device configuration area |
| | | Cache control |
| | | Process related to CPU |
| | | Setting of CPU to SETUP designation |
| | | Waiting for motor-off of disabled HDD |
| Final decision of USB FDD information | | |
| After process of PRE_BOOT_SETUP | | |
| Clears PWRBTN_STS. | | |
| Enables Power Button. | | |

Table 2-6 Printer port LED resume mode error status (4/4)

| LED status | Test item | Contents |
|------------|--|--|
| 30h | Waiting for the completion of recovery of VGA register | |
| | Recovery of PIT register | |
| | Recovery of PCI configuration register | |
| | Recovery of PIC MASK | |
| | Executing of driver for RESUME | |
| | Waiting for the completion of recovery of FDD | (For models supporting built-in FDD) |
| 31h | Checks if the power-off switch is pressed or not during resume processing/ | Suspends if pressed. |
| | Executes HOTKEY F1 when booting in instant security | |
| 32h | (Not in ACPI mode) | Clears key buffer |
| 33h | (In ACPI mode) | Clears IRT status. |
| 34h | (In ACPI mode) | Clears flag in Resume process |
| | | Acquires Wake Up Vector address. |
| | | Clears key buffer. |
| | | Renewal of date/time |
| | | ACPI mode on |
| | | Recovery of write-protected status before. |
| FFh | (In ACPI mode / not in ACPI mode) | Initializing printer port (For models supporting printer port) |
| | | Returning to the main process |

Procedure 4 Diagnostic Test Program Execution Check

Execute the following tests from the Diagnostic Test Menu. Refer to Chapter 3, *Tests and Diagnostics*, for more information on how to perform these tests.

1. System test
2. Memory test
3. Keyboard test
4. Display test
5. Floppy Disk test
6. ASYNC test
7. Hard Disk test
8. Real Timer test
9. NDP test
10. Expansion test
11. CD-ROM/DVD-ROM test
12. Wireless LAN test
13. LAN/Modem/Bluetooth/IEEE1394 test
14. Sound test

If an error is detected during these tests, go to Procedure 5.

Procedure 5 Replacement Check

The system board connectors may be disconnected. Disassemble the computer following the steps described in Chapter 4, *Replacement Procedures* and perform Check 1.

Check 1 Visually check for the following:

- a) Cracked or broken connector housing
- b) Damaged connector pins

If their connectors are in good condition, but there is still a problem, go to Check 2.

Check 2 The system board may be damaged. Replace the system board with a new one following the steps described in Chapter 4, *Replacement Procedures*.

2.5 USB FDD Troubleshooting

This section describes how to determine if the USB FDD is functioning properly. Perform the steps below starting with Procedure 1 and continuing with the other procedures as required.

Procedure 1: USB FDD Head Cleaning Check

Procedure 2: Diagnostic Test Program Execution Check

Procedure 3: Connector Check and Replacement Check

Procedure 1 USB FDD Head Cleaning Check

USB FDD head cleaning operation details are given in Chapter 3, *Tests and Diagnostics*.

Insert the Diagnostics Disk in the USB FDD, turn on the computer and run the test. Clean the USB FDD heads using the cleaning kit. If the USB FDD still does not function properly after cleaning, go to Procedure 2.

Detailed operation is given in Chapter 3, *Tests and Diagnostics*.

If the test program cannot be executed, go to Procedure 3.

Procedure 2 Diagnostic Test Program Execution Check

Insert the Diagnostics Disk in the USB FDD, turn on the computer and run the test. Refer to Chapter 3, *Tests and Diagnostics*, for more information about the diagnostics test procedures.

Floppy disk drive test error codes and their status names are listed in Table 2-7. Make sure the floppy disk is formatted correctly and that the write protect tab is disabled. If any other errors occur while executing the FDD diagnostics test, go to Check 1.

Table 2-7 FDD error code and status

| Code | Status |
|------|------------------------|
| 01h | Bad command error |
| 02h | Address mark not found |
| 03h | Write protected |
| 04h | Record not found |
| 06h | Media removed |
| 08h | DMA overrun error |
| 09h | DMA boundary error |
| 10h | CRC error |
| 20h | FDC error |
| 40h | Seek error |
| 60h | Not drive error |
| 80h | Time out error |
| EEh | Write buffer error |
| FFh | Data compare error |

Check 1 If the following message appears, disable the write protect tab on the floppy disk. If any other message appears, perform Check 2.

Write protected

Check 2 Make sure the floppy disk is formatted correctly. If it is, go to Procedure 3.

Procedure 3 Connector Check and Replacement Check

The USB FDD is connected to the US board or SR board via the USB port.

- Check 1 Make sure the USB FDD cable is firmly connected to the connector CN4620/CN4621 on the US board or CN4630 on the SR board. The USB FDD can be connected to any of three USB ports. (Two ports are installed on the UA board and one is on the USB board.)

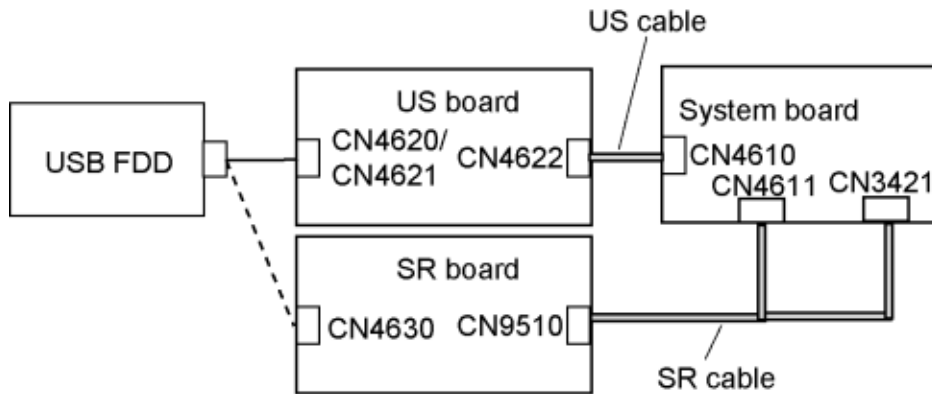

If any of the connections are loose, reconnect firmly and repeat Procedure 2.
If any of the connections is damaged, or there is still an error, go to Check 2.

- Check 2 Make sure the US cable is firmly connected to the connector CN4622 on the US board and CN4610 on the system board.
If any of the connections are loose, reconnect firmly and repeat Procedure 2.
If any of the connections is damaged, or there is still an error, go to Check 3.
- Check 3 Make sure the SR cable is firmly connected to the connector CN9510 on the SR board and CN4611 or CN3421 on the system board.
If any of the connections are loose, reconnect firmly and repeat Procedure 2.
If any of the connections is damaged, or there is still an error, go to Check 4.
- Check 4 The USB FDD or USB FDD cable may be defective or damaged. Replace it with a new one. If the USB FDD is still not functioning properly, go to Check 5.
- Check 5 Replace the System board with a new one following the steps in Chapter 4, *Replacement Procedures*.

2.6 HDD Troubleshooting

This section describes how to determine if the HDD is functioning properly. Perform the steps below starting with Procedure 1 and continuing with the other procedures as required.

Procedure 1: Partition Check

Procedure 2: Message Check

Procedure 3: Format Check

Procedure 4: Diagnostic Test Program Execution Check

Procedure 5: Connector Check and Replacement Check

CAUTION: *The contents of the hard disk will be erased when you execute the HDD troubleshooting procedures. Transfer the contents of the hard disk to floppy disks or other storage media.*

Procedure 1 Partition Check

Insert the Toshiba MS-DOS system disk and start the computer. Perform the following checks:

- Check 1 Type C : and press **Enter**. If you cannot change to drive C, go to Check 2. If you can change to drive C, go to Check 3.
- Check 2 Type **FDISK** and press **Enter**. Choose Display Partition Information from the FDISK menu. If drive C is listed, go to Check 3. If drive C is not listed, return to the FDISK menu and choose the option to create a DOS partition on drive C. Restart the computer from the Toshiba MS-DOS system disk. If the problem still exists, go to Procedure 2.
- Check 3 If drive C is listed as active in the FDISK menu, go to Check 4. If drive C is not listed as active, return to the FDISK menu and choose the option to set the active partition for drive C. Restart the computer and then go to Procedure 2.
- Check 4 Remove the FD and restart the computer. If the problem still exists, go to Procedure 2.

Procedure 2 Message Check

When the power is turned on, the system performs the Initial Reliability Test (IRT) installed in the BIOS ROM. When the test detects an error, an error message is displayed on the screen.

Make sure of no floppy disk in the FDD. Turn on the computer and check the message on the screen. When an OS starts from the 2.5" HDD, go to Procedure 3. Otherwise, start with Check 1 below and perform the other checks as instructed.

Check 1 If any of the following messages appear, go to Procedure 3. If the following messages do not appear, perform Check 2.

```
Built-in HDD ERROR
OR
Select Bay ERROR (After 5 seconds this message will disappear.)
```

Check 2 If either of the following messages appears, go to Check 3. If the following messages do not appear, perform Check 5.

```
Insert system disk in drive
Press any key when ready .....
OR
Non-System disk or disk error
Replace and press any key when ready
```

Check 3 Check SETUP to see whether the Hard Disk option is set to "Not used". If it is set to "Not used", choose another setting and return to Check 1. If it is not set to "Not used", go to Check 4.

Check 4 Using the **SYS** command on the Toshiba MS-DOS system disk, install system files on the HDD. If it is not installed, go to procedure 3. Refer to MS-DOS manual.

If the following message appears on the display, the system files have been transferred to the HDD. Restart the computer. If the problem still exists, go to Check 5.

```
System transferred
```

Check 5 The connection of the HDD and system board may loose. Reconnect firmly (refer to the instructions in Chapter 4, *Replacement Procedures*). If they connect firmly, go to procedure 3.

Procedure 3 Format Check

The computer's 2.5" HDD is formatted using the MS-DOS FORMAT program or the physical format program of the test program. To format the 2.5" HDD, start with Check 1 below and perform the other steps as required.

Refer to the MS-DOS Manual for the operation of MS-DOS. For the format by the test program, refer to the Chapter 3.

- Check 1 Format the 2.5" HDD using MS-DOS FORMAT command. Type as `FORMAT C: /S/U`. If the 2.5" HDD can not be formatted, perform Check 2.
- Check 2 Using the MS-DOS FDISK command, set the 2.5" HDD partition. If the partition is not set, go to Check 3. If it is set, format the 2.5" HDD using MS-DOS FORMAT command.
- Check 3 Using the Diagnostic Disk, format the 2.5" HDD with a format option (physical format). If the 2.5" HDD is formatted, set the 2.5" HDD partition using MS-DOS FDISK command. If you cannot format the 2.5" HDD using the Tests and Diagnostic program, go to Procedure 4.

Procedure 4 Diagnostic Test Program Execution Check

The HDD test program is stored in the Diagnostics Disk. Perform all of the HDD tests in the Hard Disk Drive Test. Refer to Chapter 3, *Tests and Diagnostics*, for more information about the HDD test program.

If an error is detected during the HDD test, an error code and status will be displayed. Replace the HDD with a new one following the instructions in Chapter 4, *Replacement Procedures*. The error codes and statuses are listed in Table 2-8. If an error code is not generated or the problem still exists, go to Procedure 5.

Table 2-8 HDD error code and status

| Code | Status |
|------|------------------------|
| 01h | Bad command error |
| 02h | Address mark not found |
| 04h | Record not found |
| 05h | HDC not reset |
| 07h | Drive not initialized |
| 08h | Overrun error (DRQ) |
| 09h | DMA boundary error |
| 0Ah | Bad sector error |
| 0Bh | Bad track error |
| 10h | ECC error |
| 11h | ECC recover enable |
| 20h | HDC error |
| 40h | Seek error |
| 80h | Time out error |
| AAh | Drive not ready |
| BBh | Undefined error |
| CCh | Write fault |
| E0h | Status error |
| EEh | Access time error |
| DAh | No HDD |

Procedure 5 Connector Check and Replacement Check

The HDD may be disconnected, or the HDD or the system board may be damaged. Disassemble the computer following the steps described in Chapter 4, *Replacement Procedures* and perform the following checks:

Check 1 Make sure the HDD is firmly connected to CN1850 on the system board.

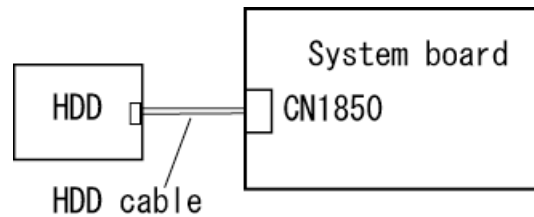

If the connection is loose, reconnect firmly and repeat Procedure 1. If there is still an error, go to Check 2.

Check 2 The HDD may be damaged. Replace it with a new one following the instructions in Chapter 4, *Replacement Procedures*. If the problem still exists, perform Check 3.

Check 3 The system board may be damaged. Replace it with a new one following the instructions in Chapter 4, *Replacement Procedures*.

2.7 Keyboard/Touch pad Troubleshooting

To determine if the computer's keyboard or touch pad is functioning properly, perform the following procedures. Start with Procedure 1 and continue with the other procedures as instructed.

Procedure 1: Diagnostic Test Program Execution Check

Procedure 2: Connector Check and Replacement Check

Procedure 1 Diagnostic Test Program Execution Check

Execute the Keyboard Test in the Diagnostic Program. Refer to Chapter 3, *Tests and Diagnostics*, for more information on how to perform the test program.

If an error occurs, go to Procedure 2. If an error does not occur, the keyboard is functioning properly.

Procedure 2 Connector Check and Replacement Check

The keyboard or touch pad may be disconnected or damaged. Disassemble the computer following the steps described in Chapter 4, *Replacement Procedures*, and perform the following checks:

1. When checking the keyboard, perform Check 1.
2. When checking the touch pad, perform Check 3.
3. When checking the SW board, perform Check 6.

Check 1 Make sure the keyboard cable is securely connected to the connector CN3200 on the system board.

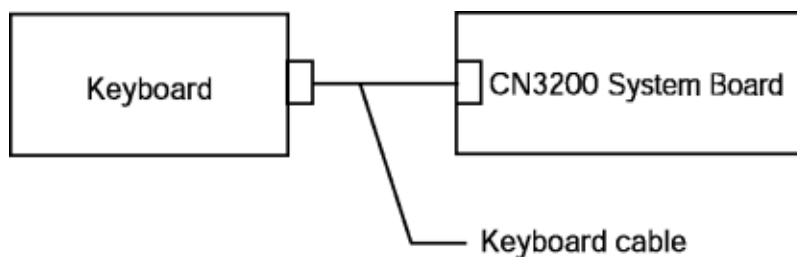

If the connection is loose, reconnect firmly and repeat Procedure 1. If there is still an error, go to Check 2.

Check 2 The keyboard or its cable may be damaged. Replace it with a new one following the instructions in Chapter 4, *Replacement Procedures*. If the problem still exists, perform Check 9.

- Check 3 Make sure the touch pad cable is securely connected to the touch pad and connector CN3201 on the system board.

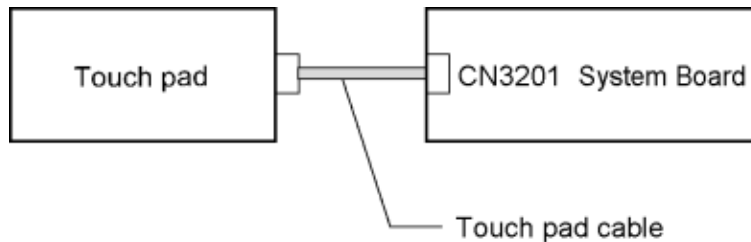

If the connection is loose, reconnect firmly and repeat Procedure 1. If there is still an error, go to Check 4.

- Check 4 The touch pad cable may be damaged. Replace it with a new one following the instructions in Chapter 4, *Replacement Procedures*. If the problem still exists, perform Check 5.
- Check 5 The touch pad may be damaged. Replace it with a new one following the instructions in Chapter 4, *Replacement Procedures*. If the problem still exists, perform Check 9.
- Check 6 Make sure the SW cable is securely connected to the SW board and connector CN3260 on the system board.

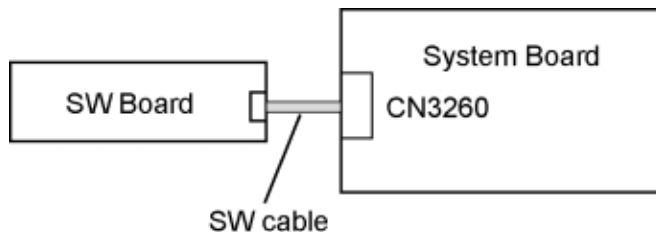

If the connection is loose, reconnect firmly and repeat Procedure 1. If there is still an error, go to Check 7.

- Check 7 The SW cable may be damaged. Replace it with a new one following the instructions in Chapter 4, *Replacement Procedures*. If the problem still exists, perform Check 8.
- Check 8 The SW board may be damaged. Replace it with a new one following the instructions in Chapter 4, *Replacement Procedures*. If the problem still exists, perform Check 9.
- Check 9 The system board may be damaged. Replace it with a new one following the instructions in Chapter 4, *Replacement Procedures*.

2.8 Display Troubleshooting

This section describes how to determine if the computer's display is functioning properly. Start with Procedure 1 and continue with the other procedures as instructed.

Procedure 1: Diagnostic Test Program Execution Check

Procedure 2: Connector Check and Cable Check

Procedure 3: Replacement Check

Procedure 1 Diagnostic Test Program Execution Check

The Display Test program is stored on the computer's Diagnostics disk. This program checks the display controller on the system board. Insert the Diagnostics disk in the USB floppy disk drive, turn on the computer and run the test. Refer to Chapter 3, *Tests and Diagnostics* for details. If an error is detected, go to Procedure 3.

Procedure 2 Connector Check and Cable Check

The LCD module is connected to the system board by an LCD/FL cable. The FL inverter board is also connected to the system board by an LCD/FL cable. The connectors may be disconnected from the system board or may be damaged. Disassemble the computer following the steps described in Chapter 4, *Replacement Procedures*.

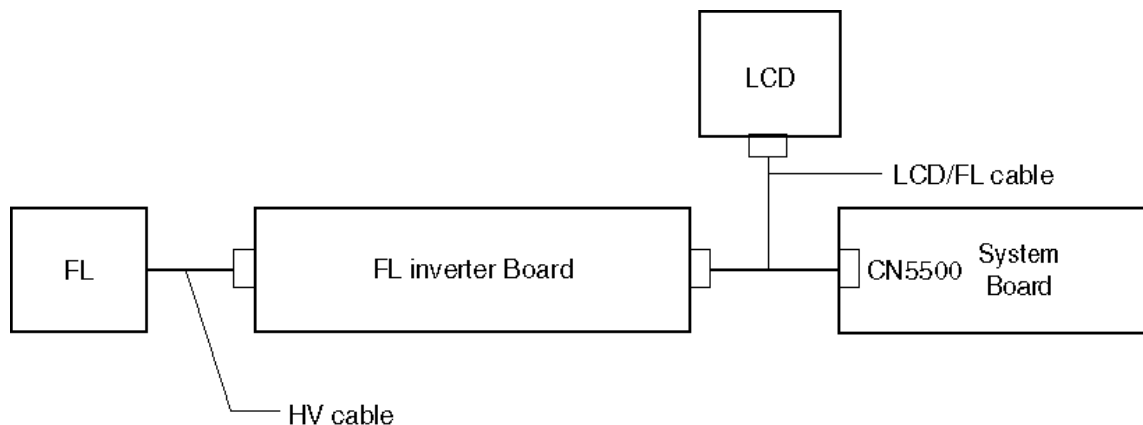

If the connection is loose, reconnect firmly and restart the computer. If there is still an error, go to Procedure 3.

Procedure 3 Replacement Check

Units related to display are a FL inverter board, Display module, System board, LCD/FL cable and display ON/OFF sensor. Any of the components may be damaged. Disassemble the computer following the steps described in Chapter 4, *Replacement Procedures*, then perform the following checks:

- (1) If the FL does not light, perform Check 1.
- (2) If characters are displayed on the internal display but the display is not normal, perform Check 2.
- (3) If the FL lights even if the display cover is closed, perform Check 5.

Check 1 Open the display and check the display on/off sensor. If the sensor works properly, display switch may be damaged. Replace the switch with a new one. If there is still an error, go to Check 2.

Check 2 The LCD/FL cable may be damaged. Replace the cable with a new one. If there is still an error, go to Check 3.

Check 3 The LCD module may be damaged. Replace it with a new one and repeat Procedure 1. If there is still an error, go to Check 4.

Check 4 The FL inverter board may be damaged. Replace it with a new one and repeat Procedure 1. If there is still an error, go to Check 5.

Check 5 The system board may be damaged. Replace it with a new one following the instructions in Chapter 4, *Replacement Procedures*.

2.9 Optical drive Troubleshooting

This section describes how to determine if the optical drive in the Slim Select Bay is functioning properly. Perform the steps below starting with Procedure 1 and continue with the other procedures as required.

Procedure 1: Diagnostic Test Program Execution Check

Procedure 2: Connector Check and Replacement Check

Procedure 1 Diagnostic Test Program Execution Check

The CD-ROM/DVD-ROM test program is stored in the Diagnostics Disk.

Prepare the tools before the test.

Then insert the Diagnostics Disk in the USB floppy disk drive, turn on the computer and run the test. Refer to Chapter 3, *Tests and Diagnostics*, for more information about the diagnostics test procedures.

If any errors occur while executing the CD-ROM/DVD-ROM test, go to Procedure 2.

Procedure 2 Connector Check and Replacement Check

The optical drive is connected to the system board. The connectors may be disconnected from the system board or may be damaged. Disassemble the computer following the steps described in Chapter 4, *Replacement Procedures* and perform the following checks:

Check 1 Make sure the drive to test is firmly connected to CN1810 on the system board.

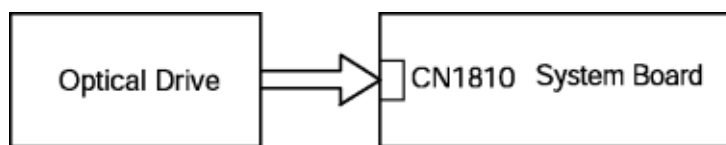

If the connection is loose, reconnect firmly and repeat Procedure 1. If there is still an error, go to Check 2.

Check 2 The optical drive may be defective or damaged. Replace it with a new one. If there is still an error, go to Check 3.

Check 3 Replace the system board with a new one following the steps in Chapter 4, *Replacement Procedures*.

2.10 Modem Troubleshooting

This section describes how to determine if the computer's modem is functioning properly. Perform the steps below starting with Procedure 1 and continuing with the other procedures as required.

Procedure 1: Diagnostic Test Program Execution Check

Procedure 2: Connector Check and Replacement Check

Procedure 1 Diagnostic Test Program Execution Check

Execute the Modem test program available as part of the LAN/Modem/Bluetooth/IEEE1394 test program. This program checks the modem. Refer to Chapter 3, *Tests and Diagnostics* for more information on how to perform the test program.

If any error is detected by the test, go to Procedure 2.

Procedure 2 Connector Check and Replacement Check

The Modem is installed as a Modem Daughter Card (MDC). If the modem malfunctions, there may be a bad connection between the MDC and the system board or their connectors might be damaged.

Disassemble the computer following the steps described in Chapter 4, *Replacement Procedures* and perform the following checks:

- Check 1 Make sure the MDC is firmly connected to CN3010 on the system board, and the modem/jack cable is connected to CN3011 on the system board and the connector of the MDC.

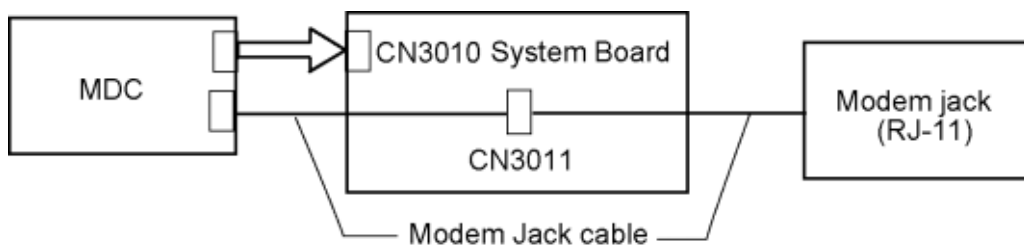

If any of the connector is disconnected, connect it firmly and repeat Procedure 1. If the modem is still not functioning properly, perform Check 2.

- Check 2 The modem jack or modem jack cable may be defective or damaged. Replace it with a new one following the steps in Chapter 4, *Replacement Procedures*. If the modem is still not functioning properly, perform Check 3.
- Check 3 The MDC may be defective or damaged. Replace it with a new one following the steps in Chapter 4, *Replacement Procedures*. If the modem is still not functioning properly, perform Check 4.
- Check 4 The system board may be defective or damaged. Replace it with a new one following the steps in Chapter 4, *Replacement Procedures*.

2.11 LAN Troubleshooting

This section describes how to determine if the computer's LAN is functioning properly. Perform the steps below starting with Procedure 1 and continue with the other procedures as required.

Procedure 1: Diagnostic Test Program Execution Check

Procedure 2: Connector Check and Replacement Check

Procedure 1 Diagnostic Test Program Execution Check

Execute the LAN test program available as part of the LAN/Modem/Bluetooth/IEEE1394 test program. Refer to Chapter 3, *Tests and Diagnostics* for more information on how to perform the test program.

If any error is detected by the test, go to Procedure 2.

Procedure 2 Connector Check and Replacement Check

LAN function of this computer is mounted on the system board. If the LAN malfunctions, the LAN cable or system board might be damaged.

Disassemble the computer following the steps described in Chapter 4, *Replacement Procedures* and perform the following check:

Check 1 Make sure the LAN cable is firmly connected to J4100 on the system board.

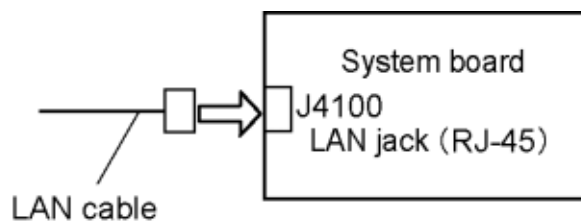

If the connector is disconnected, connect it firmly and repeat Procedure 1. If the LAN port is still not functioning properly, perform Check 2.

Check 2 The LAN cable may be defective or damaged. Replace it with a new one. If the LAN port is still not functioning properly, perform Check 3.

Check 3 The system board may be defective or damaged. Replace it with a new one following the steps in Chapter 4, *Replacement Procedures*.

2.12 Sound Troubleshooting

This section describes how to determine if the computer's sound functions are functioning properly. Perform the steps below starting with Procedure 1 and continuing with the other procedures as required.

Procedure 1: Diagnostic Test Program Execution Check

Procedure 2: Connector Check

Procedure 3: Replacement Check

Procedure 1 Diagnostic Test Program Execution Check

Execute the Sound test program. Refer to Chapter 3, *Tests and Diagnostics* for more information on how to perform the test program.

If any error is detected by the test, go to Procedure 2.

Procedure 2 Connector Check

The sound function-wiring diagram is shown below:

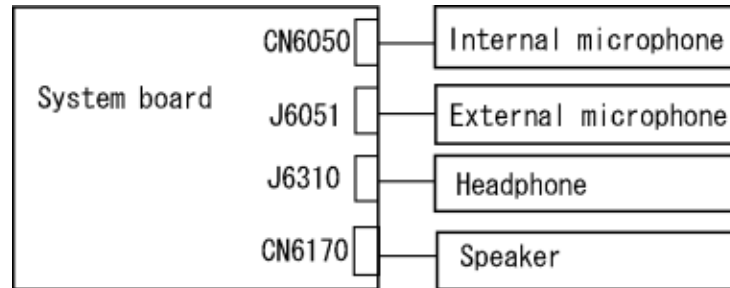

Any of the connections may be disconnected. Disassemble the computer following the steps described in Chapter 4, *Replacement Procedures* and perform the following checks:

1. If the stereo speaker or internal microphone does not work correctly, perform Check 1.
2. If the external microphone or headphone does not work correctly, perform Check 2.

Check 1 If the stereo speaker or internal microphone does not work properly, the speaker cable or internal microphone cable may be disconnected. Make sure the speaker cable is firmly connected to CN6170 on the system board and the internal microphone is firmly connected to CN6050 on the system board. If the stereo speaker or internal microphone is still not functioning properly, go to procedure 3.

Check 2 If the external microphone or headphone does not work properly, the external microphone cable or headphone jack may be disconnected. Make sure the external microphone cable is firmly connected to J6051 on the system board and the headphone jack is firmly connected to J6310 on the system board. If the external microphone or headphone is still not functioning properly, go to procedure 3.

Procedure 3 Replacement Check

- Check 1 If the stereo speaker or internal microphone does not sound properly, the stereo speaker or internal microphone may be defective or damaged. Replace it with a new one. If the stereo speaker or internal microphone still does not work properly, go to Check 3.
- Check 2 If the external microphone or headphone does not sound properly, go to Check 3.
- Check 3 The system board may be defective or damaged. Replace it with a new one following the step in Chapter 4 *Replacement Procedures*.

2.13 SD Card Slot Troubleshooting

This section describes how to determine if the computer's SD card functions are functioning properly. Perform the steps below starting with Procedure 1 and continuing with the other procedures as required.

Procedure 1: Check on Windows XP

Procedure 2: Connector Check and Replacement Check

Procedure 1 Check on Windows XP

Insert a SD card into the slot. Check if the installed Windows recognizes automatically the SD card and the data in the SD card can be read.

If the card is not recognized or data are not read, go to Procedure 2.

Procedure 2 Connector Check and Replacement Check

The SD card is connected to IS2101 on the system board.

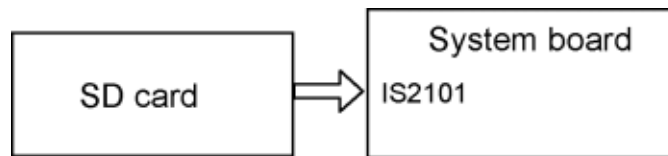

- Check 1 Make sure the SD card is firmly inserted to the slot (IS2101) on the system board. If not, insert it firmly. If the SD card is still not functioning properly, perform Check 2.
- Check 2 The SD card may be defective or damaged. Replace it with a new one following the step in Chapter 4 *Replacement Procedures*. If the problem continues, perform Check 3.
- Check 3 The system board may be defective or damaged. Replace it with a new one following the step in Chapter 4 *Replacement Procedures*.

2.14 Wireless LAN Troubleshooting

This section describes how to determine if the computer's Wireless LAN is functioning properly. Perform the steps below starting with Procedure 1 and continuing with the other procedures as required.

Procedure 1: Transmitting-Receiving Check

Procedure 2: Antenna Connection Check

Procedure 3: Replacement Check

Procedure 1 Transmitting-Receiving Check

Before starting the test, make sure the wireless communication switch is set in the "ON" position.

Refer to Chapter 3, *Tests and Diagnostics* for more information on how to perform the test program.

Check 1 Execute the test program for the wireless LAN function to check the transmitting-receiving function of the wireless LAN. You will need a second computer that can communicate by the wireless LAN.

If the computer passes the test, the function is correctly working.

If the computer does not pass the test, perform Procedure 2.

Procedure 2 Antenna Connection Check

The wireless LAN wiring diagram is shown below:

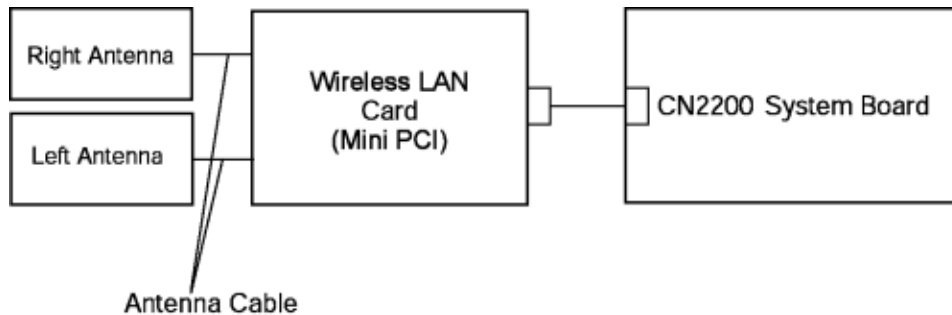

Any of the connections may be disconnected. Disassemble the computer following the steps described in Chapter 4, *Replacement Procedures*, and perform the following checks:

Check 1 Make sure the wireless LAN card is firmly connected to CN2200 on the system board.

If the connector is disconnected, connect it firmly and perform Procedure 1. If the wireless LAN card is still not functioning properly, perform Check 2.

Check 2 Make sure the wireless LAN antenna cables (black and white) are firmly connected to the wireless LAN card.

If the wireless LAN antenna cables are disconnected, connect them firmly and perform Procedure 1. If the wireless LAN function is still not functioning properly, go to Procedure 3.

Procedure 3 Replacement Check

The wireless LAN antenna, wireless LAN card and system board are connected to the circuits. Any of these components may be damaged. Refer to Chapter 4, *Replacement Procedures*, for instructions on how to disassemble the computer and then perform the following checks:

Check 1 The wireless LAN card may be defective or damaged. Replace it with a new one following the steps in Chapter 4, *Replacement Procedures*. If the problem still exists, perform Check 2.

Check 2 The wireless LAN antenna may be defective or damaged. Replace it with a new one following the steps in Chapter 4, *Replacement Procedures*. If the problem still exists, perform Check 3.

Check 3 The system board may be defective or damaged. Replace it with a new one following the instructions in Chapter 4, *Replacement Procedures* and test the display again.

2.15 Bluetooth Troubleshooting

To check if the Bluetooth is malfunctioning or not, follow the troubleshooting procedures below as instructed.

Procedure 1: Transmitting-Receiving Check

Procedure 2: Antenna Connection Check

Procedure 3: Replacement Check

Procedure 1 Transmitting-Receiving Check

Before starting the test, make sure the wireless communication switch is set in the “ON” position.

Check 1 Execute the Bluetooth test program as part of the LAN/Modem/ Bluetooth/ IEEE1394 test program to check the transmitting-receiving function of Bluetooth. You will need a second computer that can communicate by Bluetooth. Perform the test following the instructions described in Chapter 3 *Tests and Diagnostics*.

If the computer passes the test, the function is correctly working. If the computer does not pass the test, perform Procedure 2.

Procedure 2 Antenna Connection Check

The Bluetooth function-wiring diagram is shown below:

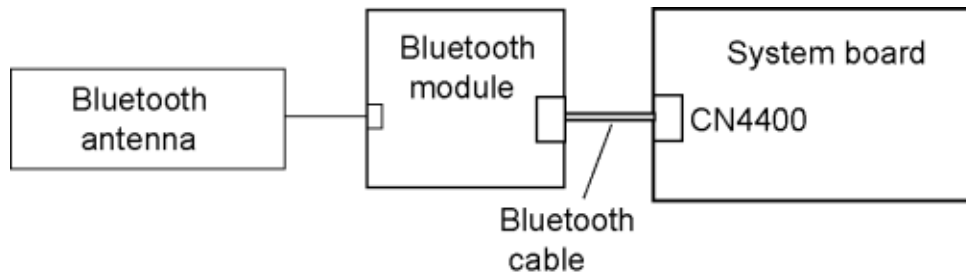

Any of the connections may be defective. Disassemble the computer following the steps described in Chapter 4, *Replacement Procedures*, and perform the following checks:

- Check 1 Make sure that the wireless communication switch is “On”.
If the switch is “Off”, turn it “On”. If the problem still occurs, perform Check 2.
- Check 2 Make sure that Bluetooth cable is firmly connected to the Bluetooth module and CN4400 on system board. If the connections are defective, connect them firmly and perform Procedure 1. If the problem still occurs, perform Check 3.
- Check 3 Make sure that Bluetooth antenna cable is firmly connected to the connector on the Bluetooth module. If Bluetooth antenna cable is not connected properly, connect it firmly and perform Procedure 1. If the problem still occurs, go to the procedure 3.

Procedure 3 Replacement Check

Bluetooth module, Bluetooth antenna or system board may be faulty. Refer to Chapter 4, *Replacement Procedures*, for instructions on how to disassemble the computer and then perform the following checks:

- Check 1 The Bluetooth antenna may be faulty. Replace it with a new one following the instructions in Chapter 4, *Replacement Procedures*. If the problem still occurs, perform Check 2.
- Check 2 The Bluetooth module may be faulty. Replace it with a new one following the instructions in Chapter 4, *Replacement Procedures*. If the problem still occurs, perform Check 3.
- Check3 The system board may be faulty. Replace it with a new one following the instructions in Chapter 4, *Replacement Procedures*.

2.16 PCI ExpressCard slot

This section describes how to check PCI ExpressCard slot by inspecting a card with PCI Express interface and a card with USB 2.0 interface.

1. Gigabit Ether ExpressCard
2. USB2.0 5in1 ExpressCard

1. Gigabit Ether ExpressCard

- (1) Insert the Gigabit Ether ExpressCard into the ExpressCard slot.
- (2) On Windows, open System Property → Hardware → Device Manager window.
- (3) Make sure that the following device is recognized on the Device Manager window.

Marvell Yukon 88E8053E PCI-E Gigabit Ethernet Controller #2

(“#2” is displayed in the PC with a built-in LAN of Gigabit, because the controller is the same one. “#2” is not displayed in the PC with a built-in LAN of 10/100 Megabit.)

- (4) After making sure, take a “Safety Remove” procedure and pull out the Gigabit Ether ExpressCard

2. USB2.0 5in1 ExpressCard

- (1) Insert the USB2.0 5in1 ExpressCard into the ExpressCard slot.
- (2) On Windows, open System Property →Hardware → Device Manager window.
- (3) Make sure that the following device is recognized on the Device Manager window.

USB 2.0 5in1 ExpressCard USB Device

- (4) After making sure, take a “Safety Remove” procedure and pull out the USB2.0 5in1 ExpressCard.

2.17 Fingerprint sensor

CAUTION: To delete the account for confirming the fingerprint operation, it is necessary to log on by the account with the management authority. If the password has been set to log on, ask the Log-ON password to the user.

To check if the Fingerprint sensor work correctly or not, follow the troubleshooting procedures below as instructed.

When failed in Procedure 1 to Procedure 3, execute Procedure 4.

Procedure 1: Setting Windows Log-ON password

Procedure 2: Registration of fingerprint

Procedure 3: Authentication of fingerprint

Procedure 4: Connector Check and Replacement Check

CAUTION: Scan your finger shown below.

1. Put your finger in parallel to the sensor.
2. Put your finger on the centerline of the sensor.
3. Make sure the first joint of your finger is on the sensor.
4. Slide slowly your finger from the first joint to fingertip at constant speed.
When not recognized, adjust the speed.

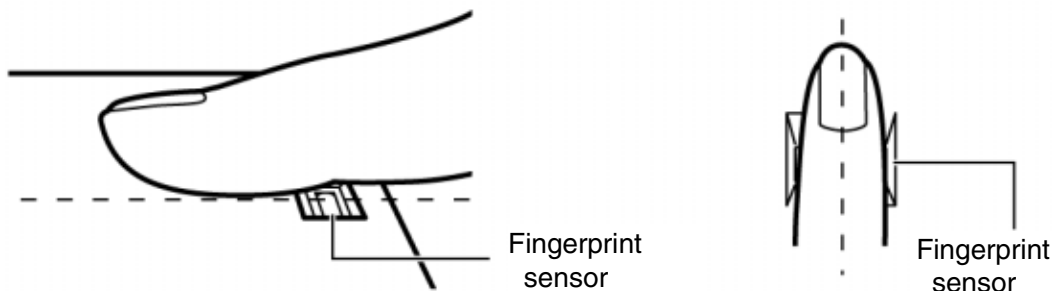

Procedure 1 Setting Windows Log-ON password

1. Open [User Account] from [Control Panel].
2. Select “Create a new account” in [User Account].
3. Input the name of Account (e.g. “TOSHIBA”) in [Name the new account] and click [NEXT] button.
4. Click “Create Account” button in the (default) condition that the “Computer administrator” is selected in [Pick an account type].
5. Select the icon of Account (e.g. “TOSHIBA”) that has been made in item 2 to item 4 in [User Accounts] display.
6. Select “Create a password” after displaying [What do you want to change about ****’s account?].
7. Input a password (e.g. “password”) in the box under the message of “Type a new password” and “Type the new password again to confirm” after displaying [Create a password for ****’s account]. Click [Create Password] button.
8. In the [Create a password for ****’s account] display, click  to close the window.

Procedure 2 Registration of fingerprint

1. Open [Start] → [All Programs] → [Softex] → [Omnipass Enrollment Wizard].
2. After displaying [Omnipass Enrollment Wizard], click [Enroll] button.



- Input the name of Account (e.g. “TOSHIBA”), which has been inputted in item 3 in Procedure 1, in the box at the right of [User Name:] on the [Verify Username and Password]. In addition, input the password, which has been inputted in item 7 in Procedure 1, in the box at the right of name (e.g. “password”) of [Password]. Click [Next] button.



- After displaying [Choose Finger], check at the dotted square of right index finger with a mouse and make sure that a red arrow appears. Click [Next] button.

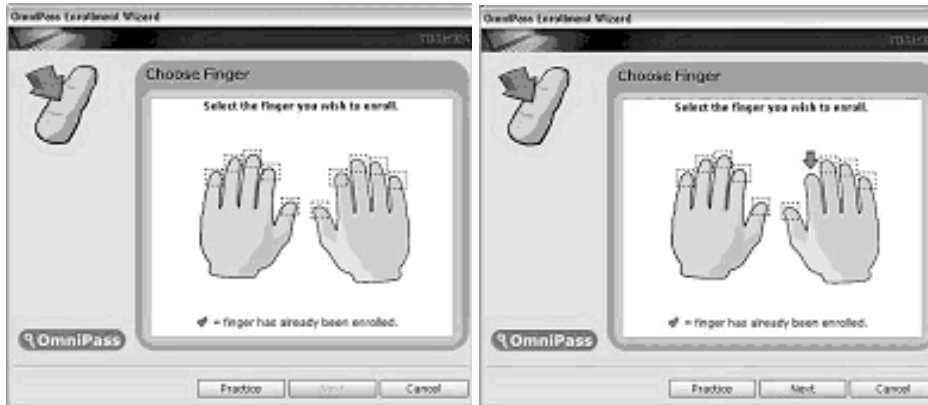

5. After displaying [Capture Fingerprint], scan the fingerprint of your right index finger on the finger sensor. When it succeeds the number at the center of display of display changes to “2”, then scan again. When it succeeds the number changes to “3”, again scan (total three times).



6. After displaying [Verify Fingerprint], scan the fingerprint of your right index finger on the finger sensor again. The message of “Verification Successful” is displayed. Click [Next] button.



7. When [OmniPass Enrollment Wizard] is displayed, you are asked if you want to register one more finger. Click [No].

8. When [Audio and Taskbar Settings] is displayed, click [Next].



9. When [Congratulations] is displayed, click [Done].



10. When [OmniPass-Logon New User?] is displayed, click [Yes].



11. Close all applications and power off the computer.

Procedure 3 Authentication of fingerprint

1. Turn on the computer and start up the Windows.
2. In the Windows Log-ON window, scan the fingerprint of your right index finger. Make sure that scanned fingerprint is displayed on the frame of [Logon Authentication] in red and you can not log on.



3. In the Windows Log-ON window, scan the fingerprint of your right index finger. Make sure that scanned fingerprint is displayed on the frame of [Logon Authentication] in green and you can log on.



4. After starting Windows, Make sure that the name of Account (e.g. "TOSHIBA"), which has been inputted in item 3 in Procedure 1 at the top of [Start].
5. Open [User Accounts] from [Control Panel]. Select [Delete an Account] in [Change an Account] and delete the account registered for fingerprint authentication.

Procedure 4 Connector Check and Replacement Check

The connector CN950 on the FS board is connected to the connector CN9700 on the system board.

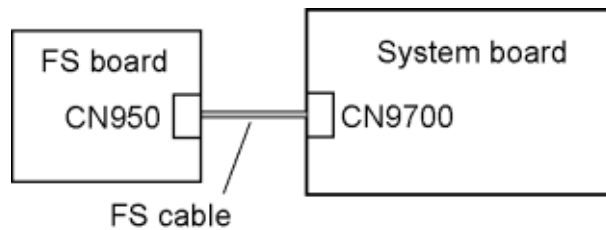

- Check 1 Check the FS cable is firmly connected to the connector CN950 on the FS board and connector CN9700 on the system board. If not, connect it firmly. If the finger sensor is still not functioning properly, perform Check 2.
- Check 2 The FS cable may be faulty. Replace it with a new one. If the problem persists, perform Check 3.
- Check 3 The FS board may be faulty. Replace it with a new one. If the problem persists, perform Check 4.
- Check 4 The system board may be faulty. Replace it with a new one.

Chapter 3

Tests and Diagnostics

Chapter 3 Contents

| | | |
|-------|--|------|
| 3.1 | The Diagnostic Test | 3-1 |
| 3.1.1 | Diagnostics menu | 3-1 |
| 3.1.2 | H/W (Hardware) initial information setting tool..... | 3-3 |
| 3.1.3 | Heatrunk test program..... | 3-3 |
| 3.2 | Executing the Diagnostic Test | 3-4 |
| 3.2.1 | Diagnostics menu (T&D) | 3-5 |
| 3.2.2 | H/W initial information setting tool | 3-8 |
| 3.2.3 | Heatrunk test program..... | 3-8 |
| 3.3 | Check of the RAID configuration..... | 3-9 |
| 3.3.1 | Explanation of the screen display..... | 3-9 |
| 3.3.2 | Check of the screen display..... | 3-11 |
| 3.3.3 | Specification of the failed HDD..... | 3-13 |
| 3.4 | Setting of the hardware configuration..... | 3-17 |
| 3.5 | Heatrunk Test..... | 3-20 |
| 3.6 | Subtest Names..... | 3-21 |
| 3.7 | System Test..... | 3-23 |
| 3.8 | Memory Test..... | 3-25 |
| 3.9 | Keyboard Test..... | 3-26 |
| 3.10 | Display Test | 3-27 |
| 3.11 | Floppy Disk Test..... | 3-30 |
| 3.12 | Printer Test..... | 3-32 |
| 3.13 | Async Test | 3-34 |
| 3.14 | Hard Disk Test | 3-35 |
| 3.15 | Real Timer Test..... | 3-38 |
| 3.16 | NDP Test..... | 3-40 |
| 3.17 | Expansion Test..... | 3-41 |
| 3.18 | CD-ROM/DVD-ROM Test | 3-43 |
| 3.19 | Error Code and Error Status Names..... | 3-44 |
| 3.20 | Hard Disk Test Detail Status | 3-47 |

| | | |
|--------|---|------|
| 3.21 | ONLY ONE TEST..... | 3-49 |
| 3.21.1 | Program Description | 3-49 |
| 3.21.2 | Operations | 3-49 |
| 3.22 | Head Cleaning..... | 3-59 |
| 3.22.1 | Function Description | 3-59 |
| 3.22.2 | Operations | 3-59 |
| 3.23 | Log Utilities | 3-60 |
| 3.23.1 | Function Description | 3-60 |
| 3.23.2 | Operations | 3-61 |
| 3.24 | Running Test..... | 3-62 |
| 3.24.1 | Function Description | 3-62 |
| 3.24.2 | Operations | 3-62 |
| 3.25 | Floppy Disk Drive Utilities..... | 3-63 |
| 3.25.1 | Function Description | 3-63 |
| 3.25.2 | Operations | 3-64 |
| 3.26 | System Configuration | 3-68 |
| 3.26.1 | Function Description | 3-68 |
| 3.26.2 | Operations | 3-69 |
| 3.27 | Wireless LAN Test Program (Intel-made b/g)..... | 3-70 |
| 3.28 | Wireless LAN Test Program (Intel-made a/g)..... | 3-74 |
| 3.29 | LAN/Modem/Bluetooth/IEEE1394 Test Program | 3-79 |
| 3.29.1 | LAN test | 3-79 |
| 3.29.2 | Modem test..... | 3-82 |
| 3.29.3 | Bluetooth test..... | 3-83 |
| 3.29.4 | IEEE1394 test..... | 3-93 |
| 3.30 | Sound Test program..... | 3-94 |
| 3.30.1 | Sound (Standard) test | 3-94 |
| 3.30.2 | Sound (Legacy) test..... | 3-96 |
| 3.30.3 | CD Sound (Standard) test..... | 3-97 |
| 3.30.4 | CD Sound (Legacy) test | 3-99 |

| | | |
|--------|----------------------------------|-------|
| 3.31 | SETUP | 3-100 |
| 3.31.1 | Function Description | 3-100 |
| 3.31.2 | Accessing the SETUP Program..... | 3-102 |

Tables

| | | |
|-----------|---|------|
| Table 3-1 | Subtest names | 3-21 |
| Table 3-2 | Error codes and error status names | 3-44 |
| Table 3-3 | Hard disk controller status register contents | 3-47 |
| Table 3-4 | Error register contents..... | 3-48 |
| Table 3-5 | Error message..... | 3-85 |
| Table 3-6 | Error code for Bluetooth test (BD_ADDR) | 3-86 |
| Table 3-7 | Error code for Bluetooth test (BD_ADDR of the DUT)..... | 3-90 |
| Table 3-8 | Common error code | 3-92 |

3.1 The Diagnostic Test

This chapter explains how to use the Diagnostic Test programs to test the functions of the computer's hardware modules. The Diagnostics Programs are stored on some Diagnostic Disks. There are Service Program Modules (DIAGNOSTIC MENU) and the Test Program Modules (DIAGNOSTIC TEST MENU) on the Diagnostic Disk.

The Hardware Initial information Setting Tool consists of some programs which write the hardware information or displays the current information of the computer. It is also included in one of Diagnostic Disks.

The heatrun test is automatic test program which executes the some tests successively.

NOTE: Before starting the diagnostics, be sure to follow these steps:

1. Check all cables are connected firmly.
2. Exit any application and close Windows.
3. Check if [All Devices] is selected in the "Device Config." in SETUP menu.
4. Check if [Not Used] is not selected in the "Serial" and "Parallel" in SETUP menu.

3.1.1 Diagnostics menu

The DIAGNOSTIC MENU consists of the following functions.

- DIAGNOSTIC TEST
- ONLY ONE TEST
- HEAD CLEANING
- LOG UTILITIES
- RUNNING TEST
- FDD UTILITIES
- SYSTEM CONFIGURATION
- EXIT TO MS-DOS

The DIAGNOSTIC TEST MENU contains the following functional tests.

- SYSTEM TEST
- MEMORY TEST
- KEYBOARD TEST
- DISPLAY TEST
- FLOPPY DISK TEST
- PRINTER TEST
- ASYNC TEST

- HARD DISK TEST
- REAL TIMER TEST
- NDP TEST
- EXPANSION TEST
- CD-ROM/DVD-ROM TEST

Other tests are:

- Wireless LAN TEST (Wireless LAN TEST disk)
- LAN/Modem/Bluetooth/IEEE1394 TEST (LAN/Modem/Bluetooth/IEEE1394 TEST disk)
- Sound TEST (Sound TEST disk)

You will need the following equipment to perform some of the Diagnostic test programs.

- The Diagnostic Disks (T&D for maintenance for Main, LAN/Modem/Bluetooth/IEEE1394, wireless LAN and Sound)
- A formatted working disk (Floppy disk test)
- USB FDD (for all tests)
- A USB test module (USB test)
- A USB cable (USB test)
- An external monitor (Expansion test)
- A CD test media TOSHIBA CD-ROM TEST DISK or ABEX TEST CD-ROM (Sound test)
- A DVD test media (DVD-ROM TEST DISK TSD-1) (Sound test)
- A music CD (Sound test)
- A store-bought CD-RW media (CD-ROM/DVD-ROM test)
- A microphone (Sound test)
- Headphones (Sound test)
- A cleaning kit to clean the floppy disk drive heads (Head Cleaning)
- An exclusive modem test jig (Nitto Electric Manufacture Co.Ltd-made QE2000P01) (Modem test)
- A module cable and RJ11 connector checker (Modem test)
- A LAN wraparound connector (LAN test)
- A display with monitor ID function (Expansion test)
- RS232C wraparound connector (Async test)
- A PC for wraparound test (Wireless LAN test/Bluetooth test/IEEE1394 test)

3.1.2 H/W (Hardware) initial information setting tool

The H/W initial information setting tool consists of the following programs.

- Initial configuration
- DMI information save
- DMI information recovery
- System configuration display
- E2PROM test (MAC/GUID/DMI)

You will need the following equipment to perform some of the programs.

- The Diagnostics Disk (Main T&D)

3.1.3 Heatrun test program

The heatrun test starts automatically after the selection.

You will need the following equipment to perform this program.

- The Diagnostics Disk (Main T&D)

3.2 Executing the Diagnostic Test

To start the DIAGNOSTIC PROGRAM, follow these steps:

1. Insert the Diagnostics disk in the USB floppy disk drive.
2. Turn on the computer with pressing the **F12**. Select the FDD in the display for selecting booting unit. Then, press **Enter** and the following menu appears.

```
Microsoft Windows XX Startup Menu
```

```
-----
```

1. Repair Main (T&D)
2. Repair initial config set
3. Repair Heatrun (T&D)

```
Enter a choice: 1
```

Select the program you want to execute and press **Enter**. The RAID configuration check screen will be displayed. Refer to 3.3 RAID configuration Check.

When any key is pressed, the RAID configuration check screen is completed and the program selected is executed.

To start the Diagnostics menu (T&D), press **1** and **Enter**.

To start the H/W initial information setting tool, press **2** and **Enter**.

To start the Heatrun test, press **3** and **Enter**.

NOTE: After replacing the system board or CPU, it is necessary to execute the subtest 01 Initial configuration in 3.4 Setting of the hardware configuration.

3.2.1 Diagnostics menu (T&D)

To execute this program, select 1- Repair Main (T&D) in the startup menu, press **Enter**. The following menu appears.

```
TOSHIBA personal computer XXXXXX DIAGNOSTICS
version X.XX (c) copyright TOSHIBA Corp. 20XX
```

```
DIAGNOSTICS MENU :
```

- 1 - DIAGNOSTIC TEST
- 2 - ONLY ONE TEST
- 3 -
- 4 - HEAD CLEANING
- 5 - LOG UTILITIES
- 6 - RUNNING TEST
- 7 - FDD UTILITIES
- 8 - SYSTEM CONFIGURATION
- 9 - EXIT TO MS-DOS

```
↑↓→← : Select items
Enter  : Specify
Esc    : Exit
```

NOTE: To exit the *DIAGNOSTIC TEST MENU*, press the **Esc** key. If a test program is in progress, press **Ctrl + Break** to exit the test program. If a test program is in progress, press **Ctrl + C** to stop the test program.

Set the highlight bar to **1**, and press **Enter**. The following DIAGNOSTIC TEST MENU will appear:

```
TOSHIBA personal computer XXXXXX DIAGNOSTICS
version X.XX (c) copyright TOSHIBA Corp. 20XX

DIAGNOSTIC TEST MENU :

 1 - SYSTEM TEST
 2 - MEMORY TEST
 3 - KEYBOARD TEST
 4 - DISPLAY TEST
 5 - FLOPPY DISK TEST
 6 - PRINTER TEST
 7 - ASYNC TEST
 8 - HARD DISK TEST  * [There is a second hard disk]
 9 - REAL TIMER TEST
10 - NDP TEST
11 - EXPANSION TEST
12 - CD-ROM/DVD-ROM TEST
88 - ERROR RETRY COUNT SET [FDD & HDD]
99 - EXIT TO DIAGNOSTICS MENU
```

```
↑↓→← : Select items
Enter  : Specify
Esc    : Exit
```

NOTE: When the two HDD are mounted, the message of [There is a second hard disk] is displayed.

Functions 1 through 12 are the Diagnostic Tests. Function 88 sets the floppy disk drive and hard disk drive error retry count (0-255).

To exit the submenu of the Diagnostic Test and returns to the Diagnostics Menu, set the highlight bar to function 99 and press **Enter**.

Select the option you want to execute and press **Enter**. When you select 1 - SYSTEM TEST, the following message will appear:

```

SYSTEM TEST NAME      XXXXXX
                        xxxxxxxx DIAGNOSTIC TEST VX.XX
                        [Ctrl]+[Break] : test end
                        [Ctrl]+[C]    : key stop

SUB-TEST      : XX
PASS COUNT   : XXXXX      ERROR COUNT : XXXXX
WRITE DATA  : XX        READ DATA   : XX
ADDRESS      : XXXXXX    STATUS       : XXX

SUB-TEST MENU :
01 - ROM checksum
02 - Fan ON/OFF
03 - Geyserville
04 - Quick charge
05 - DMI read
99 - Exit to DIAGNOSTIC TEST MENU

                        ↑↓← : Select items
                        Enter : Specify
                        Esc   : Exit

```

NOTE: The menu displayed by your computer may be slightly different from the one shown above.

Select the desired subtest number from the subtest menu and press **Enter**. The following message will appear:

```

TEST LOOP : YES (or NO)
ERROR STOP : YES (or NO)

```

Use the right and left arrow keys to move the cursor to the desired option.

Selecting **YES** of TEST LOOP increases the pass counter by one, each time the test cycle ends and restarts the test cycle.

Selecting **NO** returns the process to the subtest menu after the test is complete.

Use the up and down arrow keys to move the cursor to “ERROR STOP”.

Use the right and left arrow keys to move the cursor to the desired option and press **Enter**.

Selecting **YES** of ERROR STOP stops the test program when an error is found and displays the operation guide on the right side of the display screen as shown below:

```

ERROR STATUS NAME      [[ HALT OPERATION ]]
                        1: Test end
                        2: Continue
                        3: Retry

```

These three selections have the following functions respectively:

1. Terminates the test program and exits to the subtest menu.
2. Continues the test.
3. Restarts the test from the error.

Selecting **NO** keeps the test running even if an error is found. When an error occurred, the error status is displayed and one error is added to the error counter.

Table 3-1 in section 3.6 describes the function of each test on the subtest menu. Table 3-2 in section 3.19 describes the error codes and error status for each error.

Details of tests in DIAGNOSTIC TEST MENU are described on and after section 3.7. As for other service programs, refer to section 3.21 to 3.26.

3.2.2 H/W initial information setting tool

After selecting this test, the following menu appears in the display.

```

#####
#####   H/W initial information setting tool   VX.XX   #####
#####
*      1 ..... Initial configuration                *
*      3 ..... DMI information save                 *
*      4 ..... DMI information recovery             *
*      8 ..... System configuration display         *
*      9 ..... E2PROM test (MAC/GUID/DMI)          *
*****
... Press test number [1,3,4,8,9] ?

```

For more details on this test, refer to the section 3.4.

3.2.3 Heatrun test program

After selecting this test, the heatrun test starts executing the same subtest as 3.24 RUNNING TEST.

For more details on this test, refer to the section 3.5.

3.3 Check of the RAID configuration

Following screen is displayed for checking the RAID configuration and specifying a failed drive.

```
TOSHIBA RAID / RAID Information Display Rev xx.xx.xxxx
Copyright(c) 2005 TOSHIBA CORPORATION. All Rights Reserved.

      Level      Status      Capacity
LD0 RAID-1  DEGRADE xxGB
      Write cache          : Enable
      MBR Protection       : Disable
      S.M.A.R.T            : Enable

Port  Assgn Status   Size   Model                      Rev
  0   LD0-0 ONLINE  xxGB  FUJITSU-----            xxxxxxxx
  1   LD0-1 FAILED  xxGB  FUJITSU-----            xxxxxxxx

< RAID : not OPTIMAL >
```

3.3.1 Explanation of the screen display

Contents of the screen display are shown below.

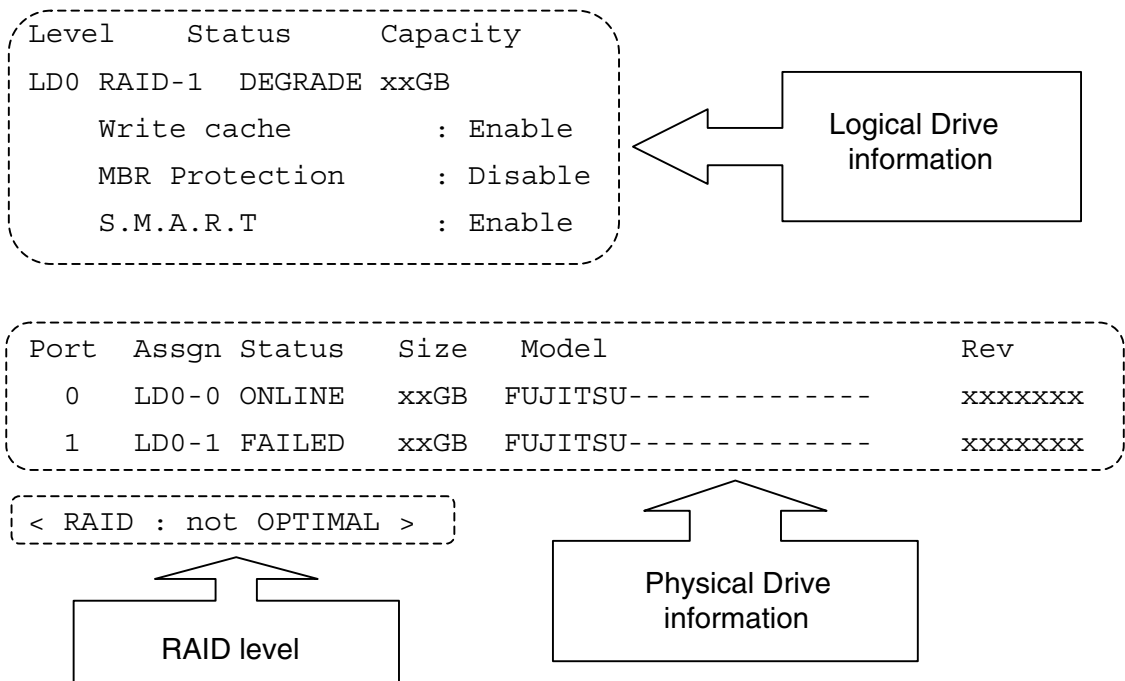

Logical Drive Information:

Displays logical drive number, RAID level, RAID status, contents and setting.

Physical Drive Information:

Displays port number, logical drive number belonged, status and disk information.

RAID level:

Displays RAID level configured.

NON:

Means that RAID is not configured. Confirming the logical drive information can check if a drive exists and check models of the drive.

RAID-0:

There are 1RAID-0 and 2RAID-0 (striping). When “RAID-0 OPTIMAL” is displayed in LD0 and LD1 in the logical drive information, it means 1RAID-0. When “RAID-0 OPTIMAL” is displayed only on the LD0, it means 2RAID-0 (striping). There is no problem in the RAID configuration, when “OPTIMAL” is displayed in the logical drive information.

RAID-1:

Indicates that 2RAID-1 (mirroring) is set. There is no problem in the RAID configuration, when “RAID-1 OPTIMAL” is displayed in the logical drive information.

not OPTIMAL:

Indicates that the RAID configuration is not optimal. See the logical drive information and physical drive information and check the condition of them.

3.3.1.1 Explanation of Logical drive condition

- (1) **OPTIMAL:** Indicates that all disks configuring RAID are normal and condition of the RAID is optimal.
- (2) **Degrade:** Indicates that one HDD failed in the RAID-1 that has redundancy.
- (3) **Critical:** Indicates critical condition that one HDD is failed in the RAID-0 that does not have redundancy.

“OPTIMAL” is displayed in the case of (1) and “not OPTIMAL” is displayed in the case of (2) and (3).

3.3.2 Check of the screen display

Contents of the screen displayed are shown below.

3.3.2.1 RAID-1

When the “RAID-1” is displayed in the shown below, it is judged that the RAID is configured by two drives.

```
TOSHIBA RAID / RAID Information Display Rev xx.xx.xxxx
Copyright(c) 2005 TOSHIBA CORPORATION. All Rights Reserved.
```

```

      Level      Status      Capacity
LD0 RAID-1  DEGRADE  xxGB
      Write cache           : Enable
      MBR Protection        : Disable
      S.M.A.R.T             : Enable

Port  Assgn Status   Size   Model                      Rev
  0   LD0-0 ONLINE  xxGB  FUJITSU-----  xxxxxxxx
  1   LD0-1 FAILED  xxGB  FUJITSU-----  xxxxxxxx

< RAID : not OPTIMAL >
```

3.3.2.2 RAID-0 (1)

When there is one LD and “RAID-0 OPTIMAL” is displayed in the shown below, it is judged that the RAID is configured by two drives.

```
TOSHIBA RAID / RAID Information Display Rev xx.xx.xxxx
Copyright(c) 2005 TOSHIBA CORPORATION. All Rights Reserved.
```

```

      Level      Status      Capacity
LD0 RAID-0 OPTIMAL  xxGB
      Write cache           : Enable
      MBR Protection        : Disable
      S.M.A.R.T             : Enable

Port  Assgn Status   Size   Model                      Rev
  0   LD0-0 ONLINE  xxGB  FUJITSU-----  xxxxxxxx
  1   LD0-1 FAILED  xxGB  FUJITSU-----  xxxxxxxx

< RAID : not OPTIMAL >
```

The RAID is not configured by two drives in the following display, because there are two LDs (LD0 and LD1).

TOSHIBA RAID / RAID Information Display Rev xx.xx.xxxx
 Copyright(c) 2005 TOSHIBA CORPORATION. All Rights Reserved.

| Level | Status | Capacity | | | |
|-------|----------------|----------|-----------|--------------|---------|
| LD0 | RAID-0 | OPTIMAL | xxGB | | |
| | Write cache | | : Enable | | |
| | MBR Protection | | : Disable | | |
| | S.M.A.R.T | | : Enable | | |
| LD1 | RAID-0 | OPTIMAL | xxGB | | |
| | Write cache | | : Enable | | |
| | MBR Protection | | : Disable | | |
| | S.M.A.R.T | | : Enable | | |
| Port | Assgn | Status | Size | Model | Rev |
| 0 | LD0-0 | ONLINE | xxGB | FUJITSU----- | xxxxxxx |
| 1 | LD0-0 | ONLINE | xxGB | FUJITSU----- | xxxxxxx |

< RAID : **RAID-0** >

3.3.2.3 RAID-0 (2)

When there is one LD and “RAID-0 Critical” is displayed in the shown below, it is judged that the RAID is configured by two drives.

| Level | Status | Capacity | | | |
|------------|----------------|-----------------|-----------|--------------|---------|
| LD0 | RAID-0 | Critical | xxGB | | |
| | Stripe Size | | : 64KB | | |
| | Write cache | | : Enable | | |
| | MBR Protection | | : Disable | | |
| | S.M.A.R.T | | : Enable | | |
| Port | Assgn | Status | Size | Model | Rev |
| 0 | LD0-0 | ONLINE | xxGB | FUJITSU----- | xxxxxxx |
| 1 | NODRIVE | | | | |

< RAID : not OPTIMAL >

3.3.3 Specification of the failed HDD

Check the RAID configuration condition from the shown below and specify a failed drive.

TOSHIBA RAID / RAID Information Display Rev xx.xx.xxxx
 Copyright(c) 2005 TOSHIBA CORPORATION. All Rights Reserved.

| Level | Status | Capacity |
|----------------|---------|-----------|
| LD0 RAID-1 | DEGRADE | xxGB |
| Write cache | | : Enable |
| MBR Protection | | : Disable |
| S.M.A.R.T | | : Enable |

| Port | Assgn | Status | Size | Model | Rev |
|------|-------|--------|------|--------------|---------|
| 0 | LD0-0 | ONLINE | xxGB | FUJITSU----- | xxxxxxx |
| 1 | LD0-1 | FAILED | xxGB | FUJITSU----- | xxxxxxx |

< RAID : not OPTIMAL >

3.3.3.1 RAID : OPTIMAL

When RAID is “OPTIMAL” (Both the two drives are normal), it is judged that RAID configuration is normal. There are the following reasons why the repair is requested.

Abnormal noise of the motor from the HDD:

Refer to the *2.5-HDD trouble shooting* in Chapter 2, *Troubleshooting Procedures*.

Access to the HDD is very slow :

Display the drive log by using Independent Utility of the DIAGNOSTIC PROGRAM. Check if ten or more continual logs of the message indicating retry such as “Write Error occurred, Retry the command.” or “Other Read Error occurred, Retry the command.” is recorded in the drive log of either HDD. If recorded, the drive is failed and should be repaired. Refer to *Independent Utility* in Appendix J.

In the other case above mentioned, it is judged that the MB side fails.

3.3.3.2 RAID : not OPTIMAL**ABSENT or OFFLINE is displayed**

When the “ABSENT” or “OFFLINE” is displayed as shown below, the drive is removed by the RAID console and installed again. When the drive is unlocked, “ABSENT” is displayed. When the drive is locked, “OFFLINE” is displayed. Repair is not needed in this case.

TOSHIBA RAID / RAID Information Display Rev xx.xx.xxxx
Copyright(c) 2005 TOSHIBA CORPORATION. All Rights Reserved.

```

      Level      Status      Capacity
LD0 RAID-1  DEGRADE xxGB
      Write cache          : Enable
      MBR Protection       : Disable
      S.M.A.R.T           : Enable

Port  Assgn Status   Size   Model              Rev
  0   LD0-0 ONLINE  xxGB  FUJITSU-----  xxxxxxxx
  1   LD0-1 ABSENT  xxGB  FUJITSU-----  xxxxxxxx

< RAID : not OPTIMAL >

```

NO DRIVE for one drive is displayed

When “NO DRIVE” is displayed and the HDD is connected to the port, follow the procedures below to check the HDD failure. When the HDD is not connected to the port, removing of the drive causes the failure. It is not necessary to repair.

- (1) Install a new HDD.
When “NO DRIVE” is still displayed, It is judged that the MB or cable fails.
- (2) When a new HDD is recognized, It is judged that the HDD removed is failed.
Specify the reason by using the Independent Utility.

TOSHIBA RAID / RAID Information Display Rev xx.xx.xxxx
Copyright (c) 2005 TOSHIBA CORPORATION. All Rights Reserved.

```

      Level      Status      Capacity
LD0 RAID-1  DEGRADE    xxGB
      Write cache      : Enable
      MBR Protection   : Disable
      S.M.A.R.T       : Enable

Port  Assgn Status   Size   Model              Rev
  0   LD0-0 ONLINE  xxGB  FUJITSU-----  xxxxxxxx
  1           NODRIVE xxGB  FUJITSU-----  xxxxxxxx

< RAID : not OPTIMAL >

```

FAIL for one drive is displayed

One drive in the “RAID-1” is failed and degraded. This may look like failure by wrong operation. Specify the reason by using Independent Utility.

TOSHIBA RAID / RAID Information Display Rev xx.xx.xxxx
Copyright(c) 2005 TOSHIBA CORPORATION. All Rights Reserved.

```

      Level      Status      Capacity
LD0 RAID-1  DEGRADE xxGB
      Write cache          : Enable
      MBR Protection       : Disable
      S.M.A.R.T            : Enable

Port  Assgn Status  Size  Model                      Rev
  0   LD0-0 ONLINE xxGB  FUJITSU----- xxxxxxxx
  1   LD0-1 FAILED xxGB  FUJITSU----- xxxxxxxx

< RAID : not OPTIMAL >

```

3.4 Setting of the hardware configuration

To execute this program, select `2-Repair initial config set` in the startup menu, press **Enter** and follow the directions on the screen. The H/W initial information setting tool consists of six subtests. Move the highlight bar to the subtest you want to execute and press **Enter**.

Subtest 01 Initial configuration

This subtest executes the following items and shows their contents in the display. When an item ends normally, the program proceeds automatically to the next one. When an error is found, the program stops and waits for key input. (After solving the problem, the program executes the item again.)

Setting of the CPU set table
Setting of the micro code
Setting of the EHSS
Inputting and writing of DMI information

When the DMI information is displayed, the following messages appear in order. Input each information. (If you do not replace the system board, the DMI information should not be changed.)

1. "Enter Model Name ?" is displayed. Input the computer's model name and press **Enter**. (e.g. DynaBook)
2. "Enter Version Number ?" is displayed. Input the computer's version number and press **Enter**. (e.g. PC18070C313S)
3. "Enter Serial Number ?" is displayed. Input the computer's serial number and press **Enter**. (e.g. 12345678)
4. "Enter Model Number ?" is displayed. Input the computer's sales model number and press **Enter**. (e.g. PP200-AAAAA)
5. "Enter PCN/BND (Bundle) Number ?" is displayed. Input the computer's PCN/Bundle number and press **Enter**. (e.g. PMSREQ3Q34H/S0123456789)
6. "Write data OK (Y/N) ?" is displayed. To write the DMI information to the Flash ROM, press **Y**, and then **Enter**.
7. "Create DMIINFO TXT (Y/N) ?" is displayed. Press **Y**, then the DMI information (text data) is written to the Floppy disk, etc.

- Setting of the HWSC
- Setting of the UUID
- Display of the DMI information (including UUID)

After completion of the above settings, H/W configuration & DMI information are appeared in order. Check the contents and press **Enter**.

Subtest 03 DMI information save

NOTE: *Before replacing the system board, be sure to execute this subtest and save the DMI information to the floppy disk.*

This is one of tools to copy the DMI information to a new system board after replacing.

This subtest saves all the DMI data in a floppy disk.

Subtest 04 DMI information recovery

NOTE: *1. After replacing the system board, be sure to execute this subtest and copy the DMI information to a new system board.*
2. Since the data of UUID is updated every time when this subtest, DMI information recovery, is done, the saved UUID data is not written.

This is one of tools to copy the DMI information to a new system board after replacing.

This subtest writes all the DMI data in the floppy disk into the new system board.

Subtest 08 System configuration display

This subtest displays the information of the system configuration.

When the following message appears, confirm the contents and press **Enter**.

Press [Enter] key

For more details on the system configuration information, refer to “3.26 System configuration”.

Subtest 09 E2PROM test (MAC/GUID/DMI)

It checks whether the MAC address, GUID of IEEE1394 and DMI information are written.

3.5 Heatrun Test

To execute this program, select 3-Repair heatrun in the startup menu, press **Enter**.

When selecting the option you want to execute, the message shown below will appear and 01-ROM Checksum of the SYSTEM test will be executed.

```

SYSTEM TEST NAME   XXXXXX   xxxxxxxx DIAGNOSTIC TEST VX.XX
                               [Ctrl]+[Break] : test end
                               [Ctrl]+[C]      : key stop

SUB-TEST          : XX
PASS COUNT       : XXXXX   ERROR COUNT : XXXXX
WRITE DATA      : XX      READ DATA  : XX
ADDRESS         : XXXXXX   STATUS       : XXX

```

After selecting this test, the same subtests as 3.24 Running Test are executed successively. For more details on the procedure and test content, refer to Running Test.

When the heatrun test ends, following message appears in the display.

```

*****
HEATRAN TEST END
*****
Press any key to continue...

```

Press any key and return to the startup menu.

NOTE: The test result (*Errorlog.txt*) is stored in the floppy disk. The result is displayed in the same format as *Log Utilities*. For more details of the format, refer to 3.23 *Log Utilities*.

3.6 Subtest Names

Table 3-1 lists the subtest names for each test program in the DIAGNOSTIC TEST MENU.

Table 3-1 Subtest names (1/2)

| No. | Test Name | Subtest No. | Subtest Name |
|-----|-------------|-------------|----------------------------------|
| 1 | SYSTEM | 01 | ROM checksum |
| | | 02 | Fan ON/OFF |
| | | 03 | Geyserville |
| | | 04 | Quick charge |
| | | 05 | DMI read |
| 2 | MEMORY | 01 | Conventional memory |
| | | 02 | Protected mode |
| | | 03 | Protected mode (cache off) |
| | | 04 | Cache memory (on/off) |
| | | 05 | Stress |
| 3 | KEYBOARD | 01 | Pressed key code display |
| 4 | DISPLAY | 01 | VRAM read/write for VGA |
| | | 02 | Gradation for VGA |
| | | 03 | Gradation for LCD |
| | | 04 | Gradation & Mode test for VGA |
| | | 05 | All dot on/off for LCD |
| | | 06 | "H" pattern display |
| | | 07 | LCD Brightness |
| 5 | FLOPPY DISK | 01 | Sequential read |
| | | 02 | Sequential read/write |
| | | 03 | Random address/data |
| | | 04 | Write specified address |
| | | 05 | Read specified address |
| 6 | PRINTER | 01 | Ripple pattern |
| | | 02 | Function |
| | | 03 | Wraparound |
| 7 | ASYNC | 01 | FIR/SIR Point to point (send) |
| | | 02 | FIR/SIR Point to point (receive) |
| | | 03 | Wraparound (board) |

Table 3-1 Subtest names (2/2)

| No. | Test Name | Subtest No. | Subtest Name |
|-----|--------------------|-------------|-----------------------------------|
| 8 | HARD DISK | 01 | Sequential read |
| | | 02 | Address uniqueness |
| | | 03 | Random address/data |
| | | 04 | Cross talk & peak shift |
| | | 05 | Partial Read |
| | | 06 | Write specified address |
| | | 07 | Read specified address |
| | | 08 | Sequential write |
| | | 09 | W-R-C specified address |
| 9 | REAL TIMER | 01 | Real time |
| | | 02 | Backup memory |
| | | 03 | Real time carry |
| 10 | NDP | 01 | NDP |
| 11 | EXPANSION | 01 | PCMCIA wraparound [Not supported] |
| | | 02 | RGB monitor ID |
| 12 | CD-ROM /DVD-ROM | 01 | Sequential read |
| | | 02 | Read specified address |
| | | 03 | Random address/data |
| | | 04 | RW 1point W/R/C |

3.7 System Test

To execute the System Test, select **1** from the DIAGNOSTIC TEST MENU, press **Enter** and follow the directions on the screen. Move the highlight bar to the subtest you want to execute and press **Enter**.

Subtest 01 ROM checksum

This subtest executes a checksum test of the BIOS ROM (range: F0000h to FFFFFh, 64KB) on the System Board.

Subtest 02 Fan ON/OFF

This subtest turns on/off the fan motor by force with Fan ON/OFF commands.

The following message will appear.

```
Fan number select (1;FAN#1, 2;FAN#2, 0;FAN#1&#2)?
```

To check the CPU fan, press **1** and **Enter**.

To check the VGA fan, press **2** and **Enter**.

To check both CPU fan and VGA fan, press **0** and **Enter**.

The following message will appear.

```
*** Test Fan Revolution 0000RPM start
```

Make sure the specified fan does not rotate and the message of fan revolution for it is "0000Rpm". Then press **Enter**.

The following message will appear.

```
*** Test Fan Revolution Low speed Start
```

Make sure the fan rotates at low speed and the message of fan revolution for it changes. Then press **Enter**.

The following message will appear.

```
*** Test Fan Revolution High speed Start
```

Make sure the fan rotates at high speed and the message of fan revolution for it changes. Then press **Enter**.

After a while, the fan rotating will stop.

NOTE: FAN#2(GPU) is not supported in this model.

Subtest 03 Geyserville

If the CPU supports Geyserville (SpeedStep), this Subtest checks that the CPU operating clock speed can be changed.

Subtest 04 Quick charge

This subtest checks the status for the quick charge.

Subtest 05 DMI read

This subtest displays the information in the Flash-ROM in the following format.

```
*** DMI Data Display Ver X.XX ***
Model Name       : XXXXXXXXXXXXX
Version Number   : XXXXXXXXXXXXX
Serial Number    : XXXXXXXXX
Model Number     : XXXXXX-XXXXX
PCN/BND Number   : XXXXXXXXXXXXX/XXX
UUID Number      : XXXXXXXXXXXXXXXXXXXXXXXXXXXXXXXXXXXX
Press [Enter] to EXIT
```

To exit this subtest and return to the SYSTEM test menu, press **Enter**.

3.8 Memory Test

To execute the Memory Test, select **2** from the DIAGNOSTIC TEST MENU, press **Enter** and follow the directions on the screen. Move the highlight bar to the subtest you want to execute and press **Enter**.

Subtest 01 Conventional memory

This subtest writes a constant data to conventional memory (0 to 640 KB), then reads the new data and compares the result with the original data.

Subtest 02 Protected mode

NOTE: The *CONFIG.SYS* file must be configured without expanded memory manager programs such as *EMM386.EXE*, *EMM386.SYS* or *QEMM386.SYS*. Also, the *HIMEM.SYS* must be deleted from the *CONFIG.SYS* file.

This subtest writes constant data and address data (from 1MB to maximum MB), and reads the new data and compares the result with the original data.

Subtest 03 Protected mode (cache off)

This subtest executes the same way as the subtest 02 with the cache off.

Subtest 04 Cache memory (on/off)

To test the cache memory, a pass-through write-read comparison of '5Ah' data is run repeatedly to the test area ('7000': 'Program' size to '7000': '7FFF' (32 KB)) to check the hit-miss ratio (on/off status) for CPU cache memory. One test takes 3 seconds.

Number of misses < Number of hits → OK

Number of misses ≥ Number of hits → Fail

Subtest 05 Stress

Data (from 1MB to the maximum MB) is written from the 16KB write buffer to the 16KB read buffer and compared the data in the buffers. The read buffer starts from 0001 and the comparison is continued with the following read buffer addresses: 0001, 0003, 0005, 0007, 0009, 000b, 000d and 000f.

3.9 Keyboard Test

To execute the Keyboard Test, select **3** from the DIAGNOSTIC TEST MENU, press **Enter** and follow the directions on the screen. Move the highlight bar to the subtest you want to execute and press **Enter**.

Subtest 01 Pressed key code display

When a key is pressed, the scan code, character code, and key top name are displayed on the screen in the format shown below. The **Ins Lock, Caps Lock, Num Lock, Scroll Lock, Alt, Ctrl, Left Shift** and **Right Shift** keys are displayed in reverse screen mode when pressed. The scan codes, character codes and key top names are shown in Appendix D.

```
KEYBOARD TEST    IN PROGRESS    302000
```

```
          Scan code            =
          Character code       =
          Keytop                =
```

```
Ins Lock    Caps Lock    Num Lock    Scroll Lock
Alt            Ctrl            Left Shift    Right Shift
```

```
PRESS [Enter] KEY
```

3.10 Display Test

To execute the Display Test, select **4** from the DIAGNOSTIC TEST MENU, press **Enter** and follow the directions on the screen. Move the highlight bar to the subtest you want to execute and press **Enter**.

Subtest 01 VRAM read/write for VGA

This subtest writes the constant data (AAh and 55h) to the video RAM. The data is read and compared to the original data.

Subtest 02 Gradation for VGA

This subtest displays four colors: red, green, blue and white from left to right across the screen from black to maximum brightness. The display below appears on the screen, when this subtest is executed.

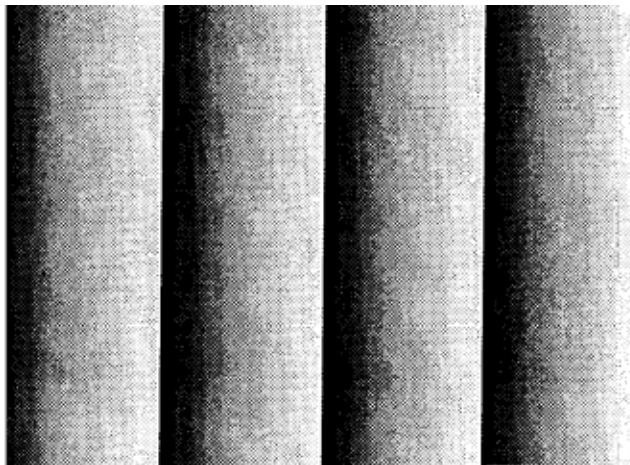

To exit this subtest and return to the DISPLAY TEST menu, press **Enter**.

Subtest 03 Gradation for LCD

This subtest displays bands of gradations for mixed colors, then for red, green, and blue. Next, it displays eight solid colors full screen: red, semi-red, green, semi-green, blue, semi-blue, white and semi-white. Each color displays for three seconds.

Subtest 04 Gradation & Mode test for VGA

This subtest displays gradations for following modes. To change the mode, press **Enter**.

```
[Mode 12]
[Mode 13]
[Mode 3 ]
[Mode 111 640*480 64K]
[Mode 112 640*480 16M]
[Mode 114 800*600 64K]
[Mode 115 800*600 16M]
[Mode 117 1024*768 64K]
[Mode 118 1024*768 16M]
```

The display below appears on the screen when this subtest is executed.



(Display example: Mode 12)

To exit this subtest and return to the DISPLAY TEST menu, press **Enter** after displaying the Mode 118.

Subtest 05 All dot on/off for LCD

This subtest displays an all-white screen then an all-black screen. The display changes automatically every three seconds and the screen returns to the DISPLAY TEST menu.

3.11 Floppy Disk Test

CAUTION: Before running the floppy disk test, prepare a formatted work disk. Remove the Diagnostics Disk and insert the work disk into the FDD because the contents of the floppy disk will be erased.

To execute the Floppy Disk Test, select **5** from the DIAGNOSTIC TEST MENU, press **Enter** and follow the directions displayed on the screen.

1. The following message will appear. Select the media mode and start track to be tested and press **Enter**.

```
Test start track      (Enter:0/dd:00-79)?
```

2. The Floppy Disk test contains five subtests that test the FDD. The Floppy Disk test menu will appear after you select FDD test parameters.

```
FLOPPY DISK          XXXXXXXX
```

```
XXX DIAGNOSTIC TEST VX.XX
[Ctrl]+[Break] : test end
[Ctrl]+[C]     : key stop
```

```
SUB-TEST      : XX
PASS COUNT    : XXXXX   ERROR COUNT   : XXXXX
WRITE DATA   : XX      READ DATA   : XX
ADDRESS       : XXXXXXX STATUS        : XXX
```

```
SUB-TEST MENU :
```

```
01 - Sequential read
02 - Sequential read/write
03 - Random address/data
04 - Write specified address
05 - Read specified address
99 - Exit to DIAGNOSTIC TEST MENU
```

```
↑↓→← : Select items
Enter : Specify
Esc   : Exit
```

Select the number of the subtest you want to execute and press **Enter**. The following message will appear during the floppy disk test.

```

FLOPPY DISK  IN PROGRESS  XXXXXXXX  xxx DIAGNOSTIC TEST VX.XX
                                         [Ctrl]+[Break] : test end
                                         [Ctrl]+[C]   : key stop

SUB-TEST      : XX
PASS COUNT    : XXXXX   ERROR COUNT    : XXXXX
WRITE DATA   : XX      READ DATA     : XX
ADDRESS       : XXXXXXX  STATUS         : XXX
  
```

When the subtest 04 or 05 is selected, the following messages will appear on the screen. Select the test data (subtest 04 only), track number and head number you want to test.

```

Test data ?? (subtest 04 only)
Track No. ??
Head No.   ?
  
```

Subtest 01 Sequential read

This subtest performs a Cyclic Redundancy Check (CRC) that continuously reads all the tracks (track: 0 to 39/0 to 79) on a floppy disk.

Subtest 02 Sequential read/write

This subtest continuously writes data pattern B5ADADh to all the tracks (track: 0 to 39/0 to 79) on a floppy disk. The data is then read and compared to the original data.

Subtest 03 Random address/data

This subtest writes random data to random addresses on all tracks (track: 0 to 39/0 to 79) on a floppy disk. The data is then read and compared to the original data.

Subtest 04 Write specified address

This subtest writes the data specified by an operator to a specified track, head, and address.

Subtest 05 Read specified address

This subtest reads data from a track, head, and address specified by an operator.

3.12 Printer Test

To execute the Printer Test, select **6** from the DIAGNOSTIC TEST MENU, press **Enter** and follow the directions on the screen.

NOTE: An IBM compatible printer must be connected to the system to execute this test. Also, printer port wraparound connector must be connected.

The following message will appear, after selecting the subtest 01 to 03 of the printer test:

```
channel#1 = XXXXh
channel#2 = XXXXh
channel#3 = XXXXh

Select the channel number (1-3) ?
```

The printer I/O port address is specified by the XXXXh number. The computer supports three printer channels. Select the printer channel number, and press **Enter** to execute the selected subtest.

Subtest 01 Ripple pattern

This subtest prints characters for codes 20h through 7Eh line-by-line while shifting one character to the left at the beginning of each new line.

```
:"#$%&'()*+,-./0123456789:;<=>?@ABCDEFGHIJKLMNPOQRSTUVWXYZ[\]^_`abcdefghijklmnop
:"#$%&'()*+,-./0123456789:;<=>?@ABCDEFGHIJKLMNPOQRSTUVWXYZ[\]^_`abcdefghijklmnop
:"#$%&'()*+,-./0123456789:;<=>?@ABCDEFGHIJKLMNPOQRSTUVWXYZ[\]^_`abcdefghijklmnop
#$%&'()*+,-./0123456789:;<=>?@ABCDEFGHIJKLMNPOQRSTUVWXYZ[\]^_`abcdefghijklmnopqr
#$%&'()*+,-./0123456789:;<=>?@ABCDEFGHIJKLMNPOQRSTUVWXYZ[\]^_`abcdefghijklmnopqr
&'()*+,-./0123456789:;<=>?@ABCDEFGHIJKLMNPOQRSTUVWXYZ[\]^_`abcdefghijklmnopqrst
&'()*+,-./0123456789:;<=>?@ABCDEFGHIJKLMNPOQRSTUVWXYZ[\]^_`abcdefghijklmnopqrstu
'()*+,-./0123456789:;<=>?@ABCDEFGHIJKLMNPOQRSTUVWXYZ[\]^_`abcdefghijklmnopqrstuv
()*+,-./0123456789:;<=>?@ABCDEFGHIJKLMNPOQRSTUVWXYZ[\]^_`abcdefghijklmnopqrstuvw
()*+,-./0123456789:;<=>?@ABCDEFGHIJKLMNPOQRSTUVWXYZ[\]^_`abcdefghijklmnopqrstuvwx
*+,-./0123456789:;<=>?@ABCDEFGHIJKLMNPOQRSTUVWXYZ[\]^_`abcdefghijklmnopqrstuvwxy
```

Subtest 02 Function

This subtest is for IBM compatible printers, and tests the following functions:

Normal print
 Double-width print
 Compressed print
 Emphasized print
 Double-strike print
 All characters print

This subtest prints the various print types shown below:

```

PRINTER TEST
1.  THIS LINE SHOWS NORMAL PRINT.
2.  THIS LINE SHOWS DOUBLE-WIDTH PRINT.
3.  THIS LINE SHOWS COMPRESSED PRINT.
4.  THIS LINE SHOWS EMPHASIZED PRINT.
5.  THIS LINE SHOWS DOUBLE-STRIKE PRINT.
6.  ALL CHARACTERS PRINT
   !"#$%&'()*+,-./0123456789:;<=>?@ABCDEFGHIJKLMN OPQRSTUVWXYZ[\]^_`abcdefghijklmnopqrstu
vwxyz{|}~

```

Subtest 03 Wraparound

NOTE: *To execute this subtest, a printer wraparound connector must be connected to the computer's printer port.*

This subtest checks the output and bi-directional modes of the data control and status lines through the parallel port wraparound connector (34M741986G01). (Both output and bi-directional modes are tested.)

3.13 Async Test

To execute the Async Test, select **7** from the DIAGNOSTIC TEST MENU, press **Enter** and follow the directions displayed on the screen. Move the highlight bar to the subtest you want to execute and press **Enter**.

Subtest 01 and 02 require the following data format:

Method: Asynchronous
Speed: 38400BPS
Data: 8 bits and one parity bit (EVEN)
Data pattern: 20h to 7Eh

Subtest 01 FIR/SIR Point to point (send)

NOTE: To execute subtests 01 and 02, each computer must have access to the other computer's infrared port.

This subtest sends 20h through 7Eh data to the receive side, then receives the sent data and compares it to the original data through the FIR/SIR port.

Subtest 02 FIR/SIR Point to point (receive)

This subtest is used with subtest 01 described above. This subtest receives the data from the send side, then sends the received data through the FIR/SIR port.

Subtest 03 Wraparound (board)

NOTE: To execute this subtest, a RS-232C wraparound connector must be connected to the RS-232C port.

This subtest checks the data send/receive function through the wraparound connector.

3.14 Hard Disk Test

To execute the Hard Disk Test, select **8** from the DIAGNOSTIC TEST MENU, press **Enter** and follow the directions on the screen.

CAUTION: *The contents of the hard disk will be erased when subtest 02, 03, 04, 06, 08 or 09 is executed. Before running the test, the customer should transfer the contents of the hard disk to floppy disk or another hard disk. If the customer has not or cannot perform the back-up, create back-up disks as described below.*

Check to see if the Microsoft Create System Disks Tools (MSCSD.EXE) still exists in the System Tools Folder. (This tool can be used only once.) If it exists, use it to back up the pre-installed software, then use the Backup utility in the System Tools folder to back up the entire disk, including the user's files.

Refer to the operating system instructions.

The following messages will appear after selecting the hard disk test from the DIAGNOSTIC TEST MENU.

```
Test drive number select      (1:HDD#1, 2:HDD#2, 0:HDD#1&2)?
```

```
↑↓→← : Select items
Enter  : Specify
Esc    : Exit
```

1. Select the drive number and press **Enter**.
2. The following message appears for the error dump operation when a data compare error is detected. Select **1** or **2**.

```
Data compare error dump (1:no, 2:yes)
```

3. The following message appears for whether or not the HDD status is displayed on the screen. The HDC status is described in section 3.20. Select **1** or **2**.

```
Detail status display (1:no, 2:yes)
```

4. The Hard Disk Test message will appear after you respond to the Detail Status prompt. Select the number of the subtest you want to execute and press **[Enter]**. The following message will appear during each subtest.

HARD DISK TEST XXXXXXXX

| |
|---------------------------|
| XXX DIAGNOSTIC TEST VX.XX |
| [Ctrl]+[Break] : test end |
| [Ctrl]+[C] : key stop |

| | | | | | |
|------------|---|--------|-------------|---|-------|
| SUB TEST | : | XX | | | |
| PASS COUNT | : | XXXXX | ERROR COUNT | : | XXXXX |
| WRITE DATA | : | XX | READ DATA | : | XX |
| ADDRESS | : | XXXXXX | STATUS | : | XXX |

The first three digits of the ADDRESS indicate which cylinder is being tested, the fourth digit indicates the head number and the last two digits indicate the sector number.

The first digit of the STATUS indicates the drive being tested and the last two digits indicate the error status code as explained in the table 3-2 of the section 3.19.

Subtest 01 Sequential read

This subtest is a sequential reading of all the tracks on the HDD starting at track 0. When all the tracks on the HDD have been read, the test starts at the maximum track and reads the tracks on the HDD sequentially back to track 0.

Subtest 02 Address uniqueness

This subtest writes unique address data to each sector of the HDD track-by-track. The data written to each sector is then read and compared with the original data. There are three ways the HDD can be read:

1. Forward sequential
2. Reverse sequential
3. Random

Subtest 03 Random address/data

This subtest writes random data in a random length to random addresses. This data is then read and compared to the original data.

Subtest 04 Cross talk & peak shift

This subtest writes eight types of worst pattern data (listed below) to a cylinder and then reads the data while moving from cylinder to cylinder. (Tests the data interference in the neighbor track.)

| Worst pattern data | Cylinder |
|---------------------------|-----------------|
| 'B5ADAD' | 0 cylinder |
| '4A5252' | 1 cylinder |
| 'EB6DB6' | 2 cylinder |
| '149249' | 3 cylinder |
| '63B63B' | 4 cylinder |
| '9C49C4' | 5 cylinder |
| '2DB6DB' | 6 cylinder |
| 'D24924' | 7 cylinder |

Subtest 05 Partial Read

This subtest reads 1GB data which is in minimum, middle and maximum address of the HDD area.

Subtest 06 Write specified address

This subtest writes specified data to a specified cylinder and head on the HDD.

Subtest 07 Read specified address

This subtest reads data, which has been written to a specified cylinder and head on the HDD.

Subtest 08 Sequential write

This subtest writes specified 2-byte data to all of the cylinders on the HDD.

Subtest 09 W-R-C specified address

This subtest writes data to a specified cylinder and head on the HDD, then reads the data and compares it to the original data.

3.15 Real Timer Test

To execute the Real Timer Test, select **9** from the DIAGNOSTIC TEST MENU, press **Enter** and follow the directions on the screen. Move the highlight bar to the subtest you want to execute and press **Enter**.

Subtest 01 Real time

A new date and time can be input during this subtest. To execute the real time subtest, follow these steps:

1. Select subtest 01 and the following messages will appear:

```
Current date : XX-XX-XXXX
Current time : XX:XX:XX
Enter new date:

PRESS [ENTER] KEY TO EXIT TEST
```

2. If the current date is not correct, input the correct date at the “Enter new date” prompt and press **Enter**.

3. The following messages will appear:

```
Current date : XX-XX-XXXX
Current time : XX:XX:XX
Enter new time:

PRESS [ENTER] KEY TO EXIT TEST
```

4. If the current time is not correct, input the correct time in 24-hour format and press **Enter**. The time is updated. (To enter “:”, press **Shift + ;**.)

To exit the test, press **Enter**.

Subtest 02 Backup memory

This subtest checks the following backup memories:

Writes 1-bit of “on” data (01h through 80h) to address 0Eh through 7Fh

Writes 1-bit of “off” data (FEh through 7Fh) to address 0Eh through 7Fh

Writes the data pattern AAh and 55h to the address 0Eh to 7Fh

Then the subtest reads and compares this data with the original data.

Subtest 03 Real time carry

CAUTION: *When this subtest is executed, the current date and time are erased.*

This subtest checks the real time clock increments, making sure the date and time are displayed in the following format:

```
Current date : 12-31-1999
Current time : 23:59:58
```

The real time increments are automatically executed and the following is displayed:

```
Current date : 01-01-2000
Current time : 00:00:00
```

```
PRESS [Enter] KEY TO EXIT TEST
```

To exit the test, press **Enter**.

3.16 NDP Test

To execute the NDP test, select **10** from the DIAGNOSTICS TEST MENU, press **Enter** and follow the directions on the screen.

Subtest 01 NDP

This test checks the following functions of NDP:

- Control word
- Status word
- Bus
- Addition
- Multiplication

3.17 Expansion Test

To execute the expansion test, select **11** from the DIAGNOSTICS TEST MENU, press **Enter** and follow the directions on the screen.

Subtest 01 PCMCIA wraparound [not supported]

CAUTION: PCMCIA wraparound test is not supported for this model.

NOTE: To execute this subtest, the PC card wraparound connector is required.

This subtest checks the following signal line of the PC card slot:

- Address line
- REG#, CE#1, CE#2 line
- Data line
- Speaker line
- Wait line
- BSY#, BVD1 line

This subtest is executed in the following order:

| Sub# | Address | Good | Bad | Contents |
|------|----------------|----------|----------|---|
| 01 | 00001 00001 | nn nn | xx xx | Address line REG#, CE#1, CE#2 nn=A0, 90, 80, 00 |
| 02 | 00002 | ww | rr | Data line ww=write data, rr=read data |
| 03 | 00003 | — | — | Speaker line |
| 04 | 00004 | 40,80 | xx | Wait line (40<xx<80) |
| 05 | 00005 | nn | xx | Other lines (BSY#, BVD1) NN=21, 00 |

NOTE: Select the subtest number 01, The following message will appear:
Test slot number select (1:slot0, 2:slot1, 0:slot0&1)?

Subtest 02 RGB monitor ID

NOTE: To execute this subtest, monitor supporting EDID is required.

Connect the external monitor supporting EDID to the PC for the test of ID acquisition.

This test is executed by VESA command.

3.18 CD-ROM/DVD-ROM Test

To execute the CD-ROM/DVD-ROM test, select **12** from the DIAGNOSTICS TEST MENU, press **Enter** and follow the directions on the screen.

NOTE: For the subtest 01, 02 and 03, use the TOSHIBA CD-ROM TEST DISK TDY-01 or ABEX TEST CD-ROM TCDR-702 and DVD-ROM TEST DISK TSD-1. For the subtest 04, use a CD-RW on the market.

Subtest 01 Sequential read

This subtest is a sequential reading of one-block units (2K bytes) of all the logical addresses.

Subtest 02 Read specified address

This subtest reads one-block data from a specified address.

Subtest 03 Random address/data

This subtest reads one-block data and multi-block data from random addresses 200 times.

Subtest 04 RW 1point W/R/C

This subtest writes, reads and compares data at one point on a CD/RW media.

3.19 Error Code and Error Status Names

Table 3-2 lists the error codes and error status names for the Diagnostic Test.

Table 3-2 Error codes and error status names (1/3)

| Device name | Error code | Error status name |
|-------------|--|---|
| (Common) | FF | Data Compare Error |
| System | 01 03 04 05 06 07 08 09 10 | ROM - CHECKSUM ERROR ROM - SERIAL ID WRITE ERROR ROM - NOT SUPPORTED PS-SYSTEM ROM - SENSING ERROR(AC-ADAPT) ROM - SENSING ERROR(1st Batt) ROM - SENSING ERROR(2nd Batt) ROM - THORMISTOR ERROR(1) ROM - THORMISTOR ERROR(2) ROM - THORMISTOR ERROR(3) |
| Memory | 01 02 DD | RAM - PARITY ERROR RAM - PROTECTED MODE NO CHANGE RAM - CACHE MEMORY ERROR |
| Keyboard | FE FD F0 F1 F2 F3 F4 F5 F6 F7 F8 F9 FA EF ED | USB - GET DESCR.ERROR (FIRST) USB - SET ADDRESS ERROR HUB - GET DESCR.ERROR(Top 8B) HUB - GET DESCR.ERROR (Whole) HUB - SET CONFIGURATION ERROR HUB - GET DESCR.ERROR(DESCR.) HUB - SET FEATURE ERROR(P ON) HUB - GET STATUS ERROR HUB - SET FEATURE ERROR(RESET) HUB - CLEAR FEATURE ERROR HUB - CLEAR FEATURE1 ERROR HUB - SET FEATURE ERROR(Enab.) HUB - CLEAR FEATURE2 ERROR USB - OVER CURRENT ERROR USB - GET DESCR.ERROR(SECOND) |
| Display | EE | VRAM SIZE NOT SUPPORT |

Table 3-2 Error codes and error status names (2/3)

| Device name | Error code | Error status name |
|-------------|--|---|
| FDD | 01 02 03 04 08 09 10 20 40 80 60 06 EE | FDD - BAD COMMAND ERROR FDD - ADDRESS MARK NOT FOUND FDD - WRITE PROTECTED FDD - RECORD NOT FOUND FDD - DMA OVERRUN ERROR FDD - DMA BOUNDARY ERROR FDD - CRC ERROR FDD - FDC ERROR FDD - SEEK ERROR FDD - TIME OUT ERROR FDD - NOT DRIVE ERROR FDD - MEDIA REMOVED FDD - WRITE BUFFER ERROR |
| Printer | 01 08 10 20 40 80 | PRT - TIME OUT PRT - FAULT PRT - SELECT LINE PRT - OUT OF PAPER PRT - POWER OFF PRT - BUSY LINE |
| ASYNC | 01 02 04 08 10 20 40 80 88 05 06 | RS232C - [DTR ON] TIME OUT RS232C - [CTS ON] TIME OUT RS232C - [RX READY] TIME OUT RS232C - [TX FULL] TIME OUT RS232C - PARITY ERROR RS232C - FRAMING ERROR RS232C - OVERRUN ERROR RS232C - LINE STATUS ERROR RS232C - MODEM STATUS ERROR SIR - TIME OUT ERROR FIR - TIME OUT ERROR |
| HDD | 05 07 09 0B BB 08 01 02 04 10 20 40 80 11 AA | HDD - HDC NOT RESET ERROR HDD - DRIVE NOT INITIALIZE HDD - DMA BOUNDARY ERROR HDD - BAD TRACK ERROR HDD - UNDEFINED ERROR HDD - OVERRUN ERROR (DRQ ON) HDD - BAD COMMAND ERROR HDD - ADDRESS MARK NOT FOUND HDD - RECORD NOT FOUND ERROR HDD - ECC ERROR HDD - HDC ERROR HDD - SEEK ERROR HDD - TIME OUT ERROR HDD - ECC RECOVER ENABLE HDD - DRIVE NOT READY |

Table 3-2 Error codes and error status names (3/3)

| Device name | Error code | Error status name |
|--------------------|----------------|--------------------------|
| HDD | CC | HDD - WRITE FAULT |
| | E0 | HDD - STATUS ERROR |
| | 0A | HDD - BAD SECTOR |
| | EE | HDD - ACCESS TIME ERROR |
| | DA | HDD - NO HDD |
| | 12 | HDD - DMA CRC ERROR |
| NDP | 01 | NDP - NO CO-PROCESSOR |
| | 02 | NDP - CONTROL WORD ERROR |
| | 03 | NDP - STATUS WORD ERROR |
| | 04 | NDP - BUS ERROR |
| | 05 | NDP - ADDITION ERROR |
| | 06 | NDP - MULTIPLY ERROR |
| EXPANSION | C1 | ADDRESS LINE ERROR |
| | C3 | CE#1 LINE ERROR |
| | C4 | CE#2 LINE ERROR |
| | C5 | DATA LINE ERROR |
| | C6 | WAIT LINE ERROR |
| | C7 | BSY# LINE ERROR |
| | C8 | BVD1 LINE ERROR |
| | CB | ZV-Port ERROR |
| | CC | NO PCMCIA |
| | CE | CARD TYPE ERROR |
| CF | ZV_CONT# ERROR | |
| CD-ROM /DVD-ROM | 01 | BAD COMMAND |
| | 02 | ILLEGAL LENGTH |
| | 03 | UNIT ATTENTION |
| | 04 | MEDIA CHANGE REQUEST |
| | 05 | MEDIA DETECTED |
| | 06 | ADDITIMAL SENSE |
| | 09 | BOUNDARY ERROR |
| | 11 | CORRECTED DATA ERROR |
| | 20 | DRIVE NOT READY |
| | 40 | SEEK ERROR |
| | 80 | TIME OUT |
| | 90 | RESET ERROR |
| B0 | ADDRESS ERROR | |

3.20 Hard Disk Test Detail Status

When an error occurs in the hard disk test, the following message is displayed:

```
HDC status = XXXXXXXX
```

Detailed information about the hard disk test error is displayed on the screen by an eight-digit number. The first four digits represent the Hard Disk Controller (HDC) error status number and the last four digits are not used.

The hard disk controller error status is composed of two bytes; the first byte displays the contents of the HDC status register in hexadecimal form and the second byte displays the HDC error register.

The contents of the HDC status register and error register are listed in Tables 3-3 and 3-4.

Table 3-3 Hard disk controller status register contents

| Bit | Name | Description |
|-----|------------------------------|--|
| 7 | BSY (Busy) | "0" ... HDC is ready. "1" ... HDC is busy. |
| 6 | DRY (Drive ready) | "0" ... Hard disk drive is not ready to accept any command. "1" ... Hard disk drive is ready. |
| 5 | DWF (Drive write fault) | "0" ... DWF error is not detected. "1" ... Write fault condition occurred. |
| 4 | DSC (Drive seek complete) | "0" ... The hard disk drive heads are not settled over a track. "1" ... The hard disk drive heads are settled over a track. |
| 3 | DRQ (Data request) | "0" ... Drive is not ready for data transfer. "1" ... Drive is ready for data transfer. |
| 2 | COR (Corrected data) | "0" ... Not used "1" ... Correctable data error is corrected. |
| 1 | IDX (Index) | "0" ... Not used "1" ... Index is sensed. |
| 0 | ERR (Error) | "0" ... Normal "1" ... The previous command was terminated with an error. |

Table 3-4 Error register contents

| Bit | Name | Description |
|-----|-------------------------|---|
| 7 | BBK (Bad block mark) | "0" ... Not used "1" ... A bad block mark is detected. |
| 6 | UNC (Uncorrectable) | "0" ... There is no uncorrectable data error. "1" ... Uncorrectable data error has been detected. |
| 5 | — | Not used |
| 4 | IDN (Identification) | "0" ... Not used "1" ... There is no ID field in the requested sector. |
| 3 | — | Not used |
| 2 | ABT (Abort) | "0" ... Not used "1" ... Illegal command error or command abort. |
| 1 | TK0 (Track 0) | "0" ... The hard disk found track 0 during a recalibrate command. "1" ... The hard disk could not find track 0 during a recalibrate command. |
| 0 | — | Not used |

3.21 ONLY ONE TEST

3.21.1 Program Description

This program tests the unique functions of this model.

3.21.2 Operations

Select test **2** from the DIAGNOSTIC MENU and press **Enter**. The following menu appears in the display.

```
#####
#####          ONLY ONE TEST Menu (XXXXXXXX)          #####
#####
*
*  1 .....      Pressed Key Display                    *
*  2 .....      Touch Pad                               *
*  3 .....      GP Button                               *
*  4 .....      Kill Switch                             *
*  5 .....      USB                                     *
*  6 .....      Docker Dock/Undock                     *
*  7 .....      LED                                     *
*  8 .....      PC-Card Device Lock                    *
*  A .....      Acceleration sensor                    *
*
*  9 .....      Exit to Common Test                    *
*
*****
.... Press test number [1-A] ?
```

Select the subtest number you want to test and press **Enter**.

To return to the DIAGNOSTIC TEST menu, select **9** and press **Enter**.

Subtest 01 Pressed Key Display

When you execute this subtest, the keyboard layout is drawn on the display as shown below. When any key is pressed, the corresponding key on the screen changes to the key character that was pressed. Holding a key down enables the auto-repeat function that causes the key's display character to blink.

Press **Del + Enter** to end the test.

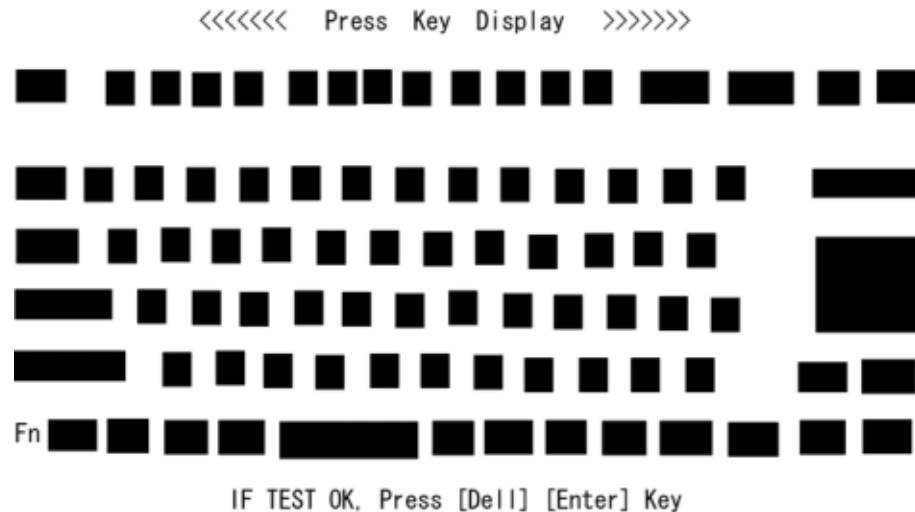

NOTE: The screen displayed on your computer may be slightly different from the one shown above.

Subtest 02 Touch Pad

This subtest checks the functions of the touch pad as shown below.

A) Direction and parameter

B) Switching function check



This test displays the response from the touch pad and touch pad switch. When moving your finger on the touch pad towards the upper left, the <POINTING> display changes according to the following illustration. If a touch pad switch is pressed, the <BUTTONS> displays appear on the right side one by one. The parameters appear above the <BUTTONS> (1) or (2) corresponding to the pressed touch pad switch highlights. To end this subtest, press two touch pad switches at the same time.

```

*** IPS TEST PROGRAM (Vx.xx) ***
<POINTING>

<PARAMETER>
STATUS:0000h
X-RATE:0000h
Y-RATE:0000h
<BUTTON>
(1) (2)

<< PRESS BUTTON1+BUTTON2 THEN END >>

*** IPS TEST PROGRAM (Vx.xx) .***
< POINTING >

<PARAMETER>
STATUS:0018h
X-RATE:OK
Y-RATE:OK
<BUTTON>
(1) (2)

<< PRESS BUTTON1+BUTTON2 THEN END >>

```

Subtest 03 GP Button

This subtest checks moving of the front operation panel button.

Press the Toshiba Presentation button after the following message appears.

Press [Assist] button

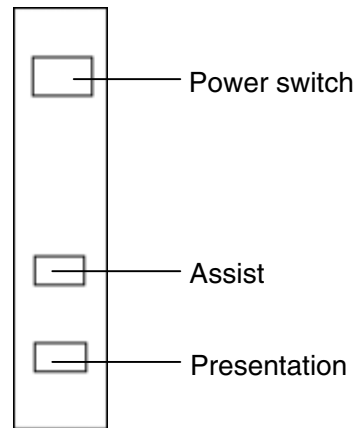

Press the Toshiba Assist button after the following message appears.

Press [Presentation] button

If the test ends successfully, the display returns to the ONLY ONE TEST menu.

Subtest 04 Kill Switch

This subtest checks if the Wireless communication switch works properly.

If the test is started with the switch ON, following message appears in the display.

Kill switch is set to a start position (OFF)

Slide the switch to OFF position. Then, following message appears in the display.

KILL SWITCH ON !!

Slide the switch to ON position. Then, following message appears in the display.

KILL SWITCH OFF !!

After sliding the switch to OFF position, return to the ONLY ONE TEST menu automatically.

Subtest 05 USB

NOTE: When executing this subtest, USB test module and USB cable must be connected.

This subtest checks if USB port works properly.

The following menu appears in the display.

```
#####
#####          ONLY ONE TEST Menu (XXXXXXXX)          #####
#####
*
*  0 .....      Port 0
*  1 .....      Port 1
*  2 .....      Port 2
*  9 .....      EXIT
*
*****
.... Press test number[0-2, 9] ?
```

Connect the USB test module and USB cable to the computer.

Input the port test number and press **Enter**.

OK message appears in the display if the test ends without fail.

NG message appears in the display if an error is found during the test.
Confirm the connection of cable, and then execute the test again.

Press **9** and **Enter** to return to ONLY ONE TESST menu.

Subtest 06 Docker Dock/Undock

This subtest is executed with Common Dock 3 installed.

Press **Enter** while pushing the eject button of the Common Dock 3 after the following message appears.

Slide Eject-SW, and press [Enter] Key

Press **Enter** without pushing the eject button of the Common Dock 3 after the following message appears.

Release Eject-SW, and press [Enter] Key

If the test ends successfully, the display returns to the ONLY ONE TEST menu.

When the display returns to the ONLY ONE TEST menu, remove the Common Dock 3 from the computer.

Subtest 07 LED

This subtest checks if each LED lights properly.

The following message appears in the display in order. Follow the instructions in the display to execute the test.

[HDD Access LED test]

Press any key and following message appears in the display.

[Caps/Num/Overlay BT/W-LAN LED test]

- (1) Press [Caps Lock] key ! ...Caps (on/off)
- (2) Press [Fn + F10] key ! ...Arrow (on/off)
- (3) Press [Fn + F11] key ! ...Num (on/off)
- (4) Slide [BT/W-LAN switch L&R] ! (on/off)

Confirm corresponding LED lights properly.

Press any key and following message appears in the display.

Check [DC-IN] & [Power] & [Main Battery] LED = Green/Orange

Check if the each LED lights in the same color shown in the display (Message switches Green ↔ Orange).

Press **Enter** and return to the ONLY ONE TEST menu.

Subtest 08 PC-Card Device Lock

This subtest checks the device lock function. This test needs a PC card, not a PC wraparound card. Before this test, inset a PC card.

Turn on the computer and select **8** from the only one test menu.

When it passes the test, following message appears.

Device Lock TEST OK

When a PC card is not inserted or a PC wraparound card is inserted, following message appears.

PC Card Not Inserted

When it does not pass the test, following message appears.

Device Lock TEST NG

Press **Enter** and return to the ONLY ONE TEST menu.

| |
|--|
| <p>CAUTION: <i>PC card wraparound test is not tested on this subtest.</i></p> |
|--|

Subtest 0A Acceleration sensor

This subtest detects and corrects the each axis (X, Y, Z).

NOTE: Make sure that this subtest is executed on the following condition:

1. Flat desk with vertical plane to get the stability of machine.
2. Prevent the machine from shake or shock.

<Example>

Set the machine
against the vertical plane
with the Front upward

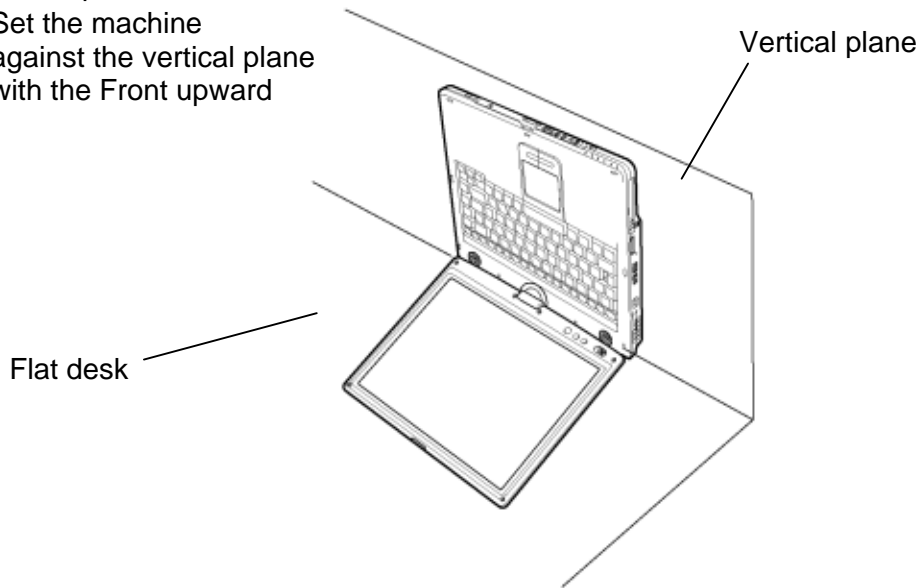

The figure below shows the name and position of each side.

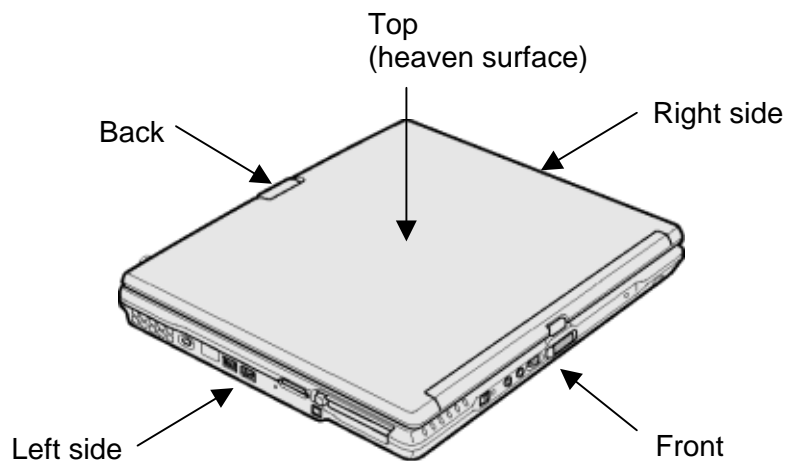

When this subtest is selected, the following message appears in the display.

The heaven surface establishes in the upper direction
Press [Enter] key

NOTE: *Be sure to execute the test with the display panel opened.*

Set the machine on the flat desk. Then press **Enter** to detect the data on this setting of machine. The following message appears in the display.

The back establishes in the upper direction
Press [Enter] key

Set the machine against the vertical plane on the flat desk with the back of machine upward. Then press **Enter** to detect the data on this setting of machine. The following message appears in the display.

The right establishes in the upper direction
Press [Enter] key

Set the machine against the vertical plane on the flat desk with the right side of machine upward. Then press **Enter** to detect the data on this setting of machine. The following message appears in the display.

The front establishes in the upper direction
Press [Enter] key

Set the machine against the vertical plane on the flat desk with the front of machine upward. Then press **Enter** to detect the data on this setting of machine. The following message appears in the display.

The left establishes in the upper direction
Press [Enter] key

Set the machine against the vertical plane on the flat desk with the left side of machine upward. Then press **Enter** to detect the data on this setting of machine.

When there is no defective during the all checks above, the following message appears in the display. Then press **Enter** and return to the Only One Test menu.

** Setting OK! **
Press [Enter] key

When any trouble in the above setting is found, the following message appears and the test halts. Then press **Enter** and return to the Only One Test menu.

** Setting ERROR! **
Press [Enter] key

3.22 Head Cleaning

3.22.1 Function Description

This function cleans the heads in the FDD by executing a series of head load/seek and read operations. A cleaning kit is necessary to perform this program.

3.22.2 Operations

1. Selecting test **4** from the DIAGNOSTIC MENU and pressing **Enter** displays the following messages:

```
DIAGNOSTICS - FLOPPY DISK HEAD CLEANING : VX.XX  
Mount cleaning disk(s) on drive(s).  
Press any key when ready.
```

2. Remove the Diagnostics Disk from the FDD, then insert the cleaning disk and press **Enter**.
3. When the “cleaning start” message appears, the FDD head cleaning has begun.
4. The display automatically returns to the DIAGNOSTIC MENU when the program is completed.

3.23 Log Utilities

3.23.1 Function Description

This function logs error information generated while a test is in progress and stores the results in RAM. This function can store data on a floppy disk, or output the data to a printer or the display.

The error information is displayed in the following order:

1. Error count (CNT)
2. Test name, Subtest number (TS-No)
3. Pass count (PASS)
4. Error status (STS)
5. FDD/HDD or memory address (ADDR)
6. Write data (WD)
7. Read data (RD)
8. HDC status (HSTS)
9. Error status name (ERROR STATUS NAME)

If the power switch is turned off, the error information will be lost.

3.24 Running Test

3.24.1 Function Description

This function automatically executes the following tests in sequence:

1. System test (subtest 01)
2. Memory test (subtests 01, 02, 06)
3. Display test (subtest 01)
4. Real timer test (subtest 02)
5. HDD test (subtest 01)

The system automatically detects the number of floppy disk drives connected to the computer for the FDD test.

3.24.2 Operations

1. Select **6** from the DIAGNOSTIC MENU and press **Enter**, the following messages for selectable tests will appear in the display in order.

```
FDD write/read test      (Y/N) ?  
Printer wrap around test (Y/N) ?  
Serial wrap around test  (Y/N) ?  
CD-ROM/DVD-ROM test     (Y/N) ?
```

2. To execute the test, press **Y** and **Enter**. To cancel the test, press **N** and **Enter**. If you select the selectable tests, follow the instruction message in the display.
3. After selecting the selectable tests, the running test starts automatically. To terminate the program, press **Ctrl + Break**.

3.25 Floppy Disk Drive Utilities

3.25.1 Function Description

This function formats the FDD, copies the floppy disk and displays the dump list for both the FDD and HDD.

1. FORMAT

NOTE: *This program is only for testing a floppy disk drive. It is different from the Toshiba MS-DOS FORMAT command.*

This program can format a floppy disk in the following formats:

- (a) 2D : Double-sided
- (b) 2DD: Double-sided, double-density, double-track, 96/135 TPI, MFM mode, 512 bytes, 9 sectors/track.
- (c) 2HD: Double-sided, high-density, double-track, 96/135 TPI, MFM mode, 512 bytes, 18 sectors/track.

2. COPY

This program copies data from a source floppy disk to a target floppy disk.

3. DUMP

This program displays the contents of the floppy disk and the designated sectors of the hard disk on the display.

4. HDD ID READ

This program reads the hard disk ID and displays hard disk information.

3.25.2 Operations

1. Selecting **7** from the DIAGNOSTIC MENU and pressing **Enter** displays the following message.

```
[ FDD UTILITIES ]  
  
1 - FORMAT  
2 - COPY  
3 - DUMP  
4 - HDD-ID READ  
9 - EXIT TO DIAGNOSTICS MENU
```

2. FORMAT program

- (a) Selecting FORMAT displays the following message.

```
DIAGNOSTICS - FLOPPY DISK FORMAT : VX.XX  
Drive number select (1:A, 2:B) ?
```

- (b) Select a drive number to display the following message.

```
Type select (0:2DD, 3:2HD) ?
```

- (c) Select a media/drive type number and press **Enter**. A message similar to the one below will be displayed.

```
Warning : Disk data will be destroyed.  
Insert work disk into drive A:  
Press any key when ready.
```

- (d) Remove the Diagnostics Disk from the FDD, insert the work disk and press any key.

The following message will be displayed when the FDD format is executed.

```
[ FDD TYPE ] : TRACK   = XXX  
[ FDD TYPE ] : HEAD    = X  
[ FDD TYPE ] : SECTOR  = XX
```

```
Format start
```

```
[[track, head = XXX X]]
```

After the floppy disk is formatted, the following message will appear.

```
Format complete  
Another format (1:Yes/2:No) ?
```

- (e) Typing **1** displays the message from step (c) above. Typing **2** returns the test to the DIAGNOSTIC MENU.

3. COPY program

- (a) When COPY is selected, the following message appears.

```
FLOPPY DISK FORMAT & COPY : VX.XX
Type select (0:2DD,3:2HD) ?
```

- (b) Selecting a media/drive type number will display a message similar to the one below.

```
Insert source disk into drive A:
Press any key when ready.
```

- (c) Remove the Diagnostics Disk from the FDD, insert the source disk and press any key. The following message will appear, indicating the program has started.

```
[ FDD TYPE ] : TRACK      = XXX
[ FDD TYPE ] : HEAD       = X
[ FDD TYPE ] : SECTOR     = XX

Copy start
[[ track,head = XXX X ]]
```

- (d) The following message will appear.

```
Insert target disk into drive A:
Press any key when ready.
```

- (e) Remove the source disk from the FDD, then insert a formatted work disk and press any key. The following message will appear and start copying to the target disk.

```
[[ track,head = XXX X ]]
```

- (f) When the amount of data is too large to be copied in one operation, the message from step (b) is displayed again. After the floppy disk has been copied, the following message will appear.

```
Copy complete
Another copy (1:Yes/2:No) ?
```

- (g) To copy another disk, type **1** and the message from step (a) is displayed again. Entering **2** returns the test program to the DIAGNOSTIC MENU.

4. DUMP program

- (a) When DUMP is selected, the following message appears.

```
DIAGNOSTICS-HARD DISK & FLOPPY DISK DUMP : VX.XX
Drive type select (1:FDD, 2:HDD) ?
```

- (b) Select a drive type. If 2:HDD is selected, the display will go to step (h).
-
- If 1:FDD is selected, the following message will appear.

```
Select drive number (1:A, 2:B) ?
```

- (c) Select a drive number and the following message will be displayed.

```
Format type select (1:2DD, 3:2HD) ?
```

- (d) If 3:2HD is selected, the following message will appear. Select a media mode.

```
2HD media mode (1:1.20MB, 2:1.44MB, 3:1.23MB)?
```

- (e) The following message will appear.

```
Insert source disk into drive A:
Press any key when ready.
```

- (f) Insert a source disk and press any key and the following message will appear.

```
— Max. address —
[Track ] = XXXX
[Head  ] = XX
[Sector] = XX
Track number ????
```

- (g) Set the track number, head number and sector number you want to dump. The system will access the disk and dump a list. Then the message shown in (k) will appear.

- (h) The following message will appear when selecting 2:HDD in (a).

```
Select drive number (1:C, 2:D) ?
```

- (i) Select a drive number and the following message will be displayed.

```
---Max. address ---
[LBA ] = XXXXXXXXX
LBA number ????????
```

- (j) Set the LBA number you want to dump. The system will access the disk and dump a list.

- (k) The following message will appear. To finish the dump, select **3**.

Press number key (1:up,2:down,3:end) ?

- (l) The following message will appear. Selecting **2** returns to the FDD UTILITIES MENU.

Another dump (1:Yes,2:No) ?

5. HDD ID READ program

Selecting HDD ID displays the following HDD ID configuration.

[HDD ID Read (VX.XX)] [Drive #X]

Model No. = XXXXXXXX

Press [Enter] key

Press **Enter** to return to the FDD UTILITIES MENU.

3.26 System Configuration

3.26.1 Function Description

***NOTE:** To display the system configuration, the write protect tab should be OFF position. If the tab is ON position, move the tab to OFF position and restart the test. Otherwise the correct information cannot be acquired.*

The System Configuration program contains the following configuration information for the computer:

1. Processor Type [Code/L2 cache]
2. Chip set [VRAM]
3. BIOS ROM version [1st ID/2nd ID]
4. BOOT ROM version
5. EC Total version
6. PS Microprocessor version
7. Micro code revision [Processor number]
8. Total Memory Size [Conventional memory]
9. Battery code
10. HWSC
11. FSB [Voltage]
12. The number of printer ports
13. The number of ASYNC ports
14. Math co-processors
15. Floppy Disk Drive [Track/Head/Sector]
16. Hard Disk Drive [Sector/Drive size/Manufacture code]
17. T&D Total version
18. Date/Time

3.26.2 Operations

Select **8** from the DIAGNOSTIC MENU and press **Enter**. Then, the following system configuration appears in the display.

System Configuration Display : Ver X.XX [Machine Name ???]

```
* - Processor Type      = XXXXXX-XXXXXMHz      Code = XX      L2 Cache = XXXXXKB
* - Chip set           = XXXXXX                      VRAM = XXXXMB
* - BIOS ROM Version   = VX.XX      1st ID = XXH, 2nd ID = XXH
* - BOOT ROM Version   = VX.XX
* - EC Total Version   = VX.XX
* - PS Micon Version   = VX.XX
* - Micro code Revision = VX.XX      (Processor=XXXh)
* - Total Memory Size  = XXXXXXMB (Conventional Memory = XXXKB)
* - Battery Code       = XXXXXXXXXXXXX
* - HWSC               = XXXXXXXX
* - FSB                = XXXXXMHz (Voltage = XEh)
* - X Printer Adapter  LPT1 = XXXX LPT2 = XXXX LPT3 = XXXX
* - X ASYNC Adapter    COM1 = XXXX COM2 = XXXX COM3 = XXXX
* - X Math CO-Processor

* - X Floppy Disk Drive(s)  Track = XX Head = XX, Sector = XX
* - X Hard Disk Drive(s)   #1 Sectors = XXXXX, (XXXXX GB) [XXXXXXXXXXXXXXXXXXXX]
                           #2 Sectors = XXXXX, (XXXXX GB) [XXXXXXXXXXXXXXXXXXXX]
* - T&D Total Version     = VX.XX

Press [Enter] Key      [Date = XXXX-YY-ZZ, XX:YY:ZZ]
```

Press **Enter** to return to the DIAGNOSTIC MENU.

3.27 Wireless LAN Test Program (Intel-made b/g)

This section describes how to perform the wireless LAN transmitting-receiving test (Intel-made Calexico 802.11b/g). To execute the wireless LAN test, use the Diagnostics disk for wireless LAN test. Finish the tests of the Main test program by selecting 99 - EXIT TO DIAGNOSTICS MENU in the DIAGNOSTIC TEST MENU. Then in the DIAGNOSTICS MENU, select 9 - EXIT TO MS-DOS.

Insert the Diagnostics disk for wireless LAN test into the Floppy Disk Drive. Turn on the power while pressing **U**.

The following menu appears in the display.

```
*****Intel Calexico 11b/g Card Maintenance test Menu*****
*
*   1 : SKU check of Module                               *
*
*   2 : MAC Address Check                                 *
*
*   3 : Antenna Check & communication test of 11b mode  *
*
*   4 : Communication test of 11g mode                   *
*
*   5 : All the tests of Calexico 11b/g Card             *
*       (SKU & MAC Check, 11b/g communication test)     *
*
*****
SELECT TEST No. (1-5) :
```

To execute the subtest, input the subtest number and press **Enter**.

Subtest01 SKU check of Module

This subtest displays SKU information on the wireless LAN card installed. When selecting this subtest, following message will appear in the display. Confirm if the right information on the wireless LAN card is described.

```
*****
*
*   Module   : Intel Calexico 802.11b/g (MoW)           *
*   G-code   : G36C0000X310                             *
*   PBA No.  : C55369                                    *
*
*****
```

If a defective is found during the test, **NG** message will appear in the display.

Press any key to return to the test menu.

When a defective is detected in the test, following typical cause is considered.

- Bad connection of wireless LAN card
- Using a wrong wireless LAN card (Using unspecified card)
- Defective wireless LAN card

Check the connection and execute the subtest again.

Subtest02 MAC Address Check

This subtest displays the MAC address. When selecting this subtest, following message will appear in the display.

```
*****MAC CHECK*****
MAC = XXXXXXXXXXXX
*****
*****
*
*   MAC Address Check : OK !!
*
*****
```

Press any key to return to the test menu.

If a defective is found during the test, following message will appear in the display.

```
*****MAC CHECK*****
ERROR: MAC all 0
MAC = XXXXXXXXXXXX
*****
*****
*
*   MAC Address Check : NG !!
*
*****
```

Press any key to return to the test menu.

When a defective is detected in the test, following typical cause is considered.

- Bad of wireless LAN card
- Defective wireless LAN card
- Disappearance of MAC address data

Check the connection and execute the subtest again.

Subtest03 Antenna Check & communication test of 11b mode

CAUTION: *To execute subtest 03-05, use another computer (with Callexico wireless LAN card) that can communicate by the wireless LAN as a responder machine. Access points are also required. (Access point for 802.11b and 802.11g)*

Be sure to turn the wireless communication switch ON before executing wireless LAN communication test. (The wireless communication LED lights orange.)

Release the write-protection of floppy disk for the test.

Turn on the responder machine before selecting subtest 03-05.

Setting the responder machine

Connect the responder machine to the access points (for 802.11b and 802.11g) with a cross cable and turn on the access points.

Insert the floppy disk containing the wireless LAN test program into the FDD of the responder machine and turn on the responder machine.

This subtest checks the connection and communication of wireless LAN antenna of Callexico 802.11b mode.

After finishing the test, **OK** message will appear in the display. Press any key to return to the test menu.

When a defective is found during the test, **NG** message will appear in the display. Press any key and following message will appear in the display. Check which antenna (Main/Aux) is defective.

```
*****
*
*           Main Antenna Test : NG !!
*
*****
```

Press any key to return to the test menu.

When a defective is detected in the test, following typical cause is considered.

- Bad connection of wireless LAN card
- Bad connection of wireless LAN antenna cable (Main/Aux)
- Bad environment for wireless LAN communication (Interference/obstruction)
- Defective wireless LAN card

Check the connection and condition, and execute the subtest again.

Subtest04 Communication test of 11g mode

This subtest checks the communication of wireless LAN antenna of Callexico 802.11g mode.

After finishing the test, **OK** message will appear in the display. Press any key to return to the test menu.

When a defective is found during the test, **NG** message will appear in the display. Press any key and following message will appear in the display.

```
*****
*
*           11g Communication Test : NG !!
*
*****
```

Press any key to return to the test menu.

When a defective is detected in the test, following typical cause is considered.

- Bad connection of wireless LAN card
- Bad connection of wireless LAN antenna cable (Main)
- Bad environment for wireless LAN communication (Interference/obstruction)
- Defective wireless LAN card

Check the connection and condition, and execute the subtest again.

Subtest05 All the tests of Callexico 11b/g Card

This subtest checks SKU information, MAC address, connection and communication of wireless LAN antenna of Callexico 802.11b/g card. The test stops at when a defective is found. For more details, refer to each subtest.

3.28 Wireless LAN Test Program (Intel-made a/g)

This section describes how to perform the wireless LAN transmitting-receiving test (Intel-made Calexico 802.11a/g). To execute the wireless LAN test, use the Diagnostics disk for wireless LAN test. Finish the tests of the Main test program by selecting 99 - EXIT TO DIAGNOSTICS MENU in the DIAGNOSTIC TEST MENU. Then in the DIAGNOSTICS MENU, select 9 - EXIT TO MS-DOS.

Insert the Diagnostics disk for wireless LAN test into the Floppy Disk Drive. Turn on the power while pressing **U**.

The following menu appears in the display.

```
*****
*      Intel Calexico2 11a/g Maintenance T&D Menu      *
*
*      1 : SKU check of Module                          *
*
*      2 : MAC Address Check                            *
*
*      3 : Antenna Check & communication test of 11b mode *
*
*      4 : Communication test of 11a mode               *
*
*      5 : Communication test of 11g mode               *
*
*      6 : All the tests of Calexico2 11a/g Card        *
*      (SKU & MAC Check, 11a/b/g communication test)   *
*
*****
```

SELECT TEST No, (1-6) :

To execute the subtest, input the subtest number and press **Enter**.

Subtest01 SKU check of Module

This subtest displays SKU information on the wireless LAN card installed. Selecting this subtest, following message will appear in the display. Confirm if the right information on the wireless LAN card is described.

```
*****
*
*      Module   : Intel Calexico 802.11a/g (MoW)      *
*      G-code   : G36C00018510                       *
*      PBA No.  : C67287                               *
*
*****
```

Press any key and return to the test menu.

If a defective is found during the test, **NG** message will appear in the display.

Press any key and following message will appear in the display.

```
*****
*
*           SKU NG !!
*
*       Other Card or Module not found
*
*****
```

Press any key and return to the test menu.

When a defective is detected in the test, following typical cause is considered.

- Connection of wireless LAN card
- Using a wrong wireless LAN card (Using unspecified card)
- Defective wireless LAN card

Checking the connection, execute the subtest again.

Subtest02 MAC Address Check

This subtest displays the MAC address. Selecting this subtest, following message will appear in the display.

```
*****
*
*       MAC = XXXXXXXXXXXX
*
*****
*
*       MAC Address Check : OK !!
*
*****
```

Press any key and return to the test menu.

If a defective is found during the test, following message will appear in the display.

```
*****
*
*       ERROR: MAC all F
*       MAC = XXXXXXXXXXXX
*
*****
*
*       MAC Address Check : NG !!
*
*****
```

Press any key and return to the test menu.

When a defective is detected in the test, following typical cause is considered.

- Connection of wireless LAN card
- Defective wireless LAN card
- Disappearance of MAC address data

Checking the connection, execute the subtest again.

Subtest03 Antenna Check & communication test of 11b mode

CAUTION: To execute subtest 03-06, use another computer (with Calexico wireless LAN card) that can communicate by the wireless LAN as a responder machine to perform those tests. Access points are also required. (Access point for 802.11a, 802.11b and 802.11g)

Be sure to turn the wireless communication switch ON before executing wireless LAN communication test. (The wireless communication LED lights orange.)

Release the write-protection of floppy disk for the test.

Setting the responder machine

Connect the responder machine to the access points (for 802.11a, 802.11b and 802.11g) with a cross cable and turn on the access points.

Insert the floppy disk containing the wireless LAN test program into the FDD of the responder machine and turn on the responder machine.

This subtest checks the connection and communication of wireless LAN antenna of Calexico 802.11b mode.

After finishing the test, **OK** message will appear in the display. Press any key and return to the test menu.

When a defective is found during the test, **NG** message will appear in the display. Press any key and following message will appear in the display. Check which antenna (Main/Aux) is defective.

```
*****
*
*           Aux Antenna Test : NG !!
*
*****
```

Press any key and return to the test menu.

When a defective is detected in the test, following typical cause is considered.

- Connection of wireless LAN card
- Connection of wireless LAN antenna cable (Main/Aux)
- Condition of wireless LAN communication (Interference/obstruction)
- Defective wireless LAN card

Checking the connection and condition, execute the subtest again.

Subtest04 Communication test of 11a mode

This subtest checks the communication of wireless LAN antenna of Calexico 802.11a mode.

After finishing the test, **OK** message will appear in the display. Press any key and return to the test menu.

When a defective is found during the test, **NG** message will appear in the display. Press any key and following message will appear in the display.

```
*****
*
*           11a Communication Test : NG !!
*
*****
```

Press any key and return to the test menu.

When a defective is detected in the test, following typical cause is considered.

- Connection of wireless LAN card
- Connection of wireless LAN antenna cable (Main)
- Condition of wireless LAN communication (Interference/obstruction)
- Defective wireless LAN card

Checking the connection and condition, execute the subtest again.

Subtest05 Communication test of 11g mode

This subtest checks the communication of wireless LAN antenna of Calexico 802.11g mode.

For more details on procedure and contents of this subtest, refer to Subtest04 Communication test of 11a mode.

Subtest06 All the tests of Calexico 11a/b/g Card

This subtest checks SKU information, MAC address of Calexico 802.11a/b/g card, antenna connection and communication test of Calexico 802.11b card and communication test of Calexico 802.11a and Calexico 802.11g. The test stops at when a defective is found. For more details, refer to each subtest.

3.29 LAN/Modem/Bluetooth/IEEE1394 Test Program

This section describes how to perform the LAN/Modem/Bluetooth/IEEE1394 test with the test program.

Insert the test program disk for LAN/Modem/Bluetooth/IEEE1394 test in FDD and turn on the power. The following message will appear.

```
Microsoft Windows XX Startup Menu
-----
```

1. LAN
2. Modem
3. Bluetooth
4. IEEE1394

Enter a choice:

Press the number you want to test and press **Enter**.

NOTE: *It is impossible to go back to startup menu once you choose the test. Therefore, LAN/Modem/Bluetooth/IEEE1394 test can not be executed successively.*

3.29.1 LAN test

To execute LAN test, press **1** and **Enter**. The following message will appear:

```
#####
#####      i82562 ICHx Gbe (i82540) Diagnostics program      #####
#####
*
* 1 ..... (i82562 + ICHx) *
*
* 2 ..... (GbE) *
*
*****
.... Press test number [1-2] ?
```

Press the number you want to test and press **Enter**.

Subtest01 (i82562 + ICHx)

NOTE: *i82562 + ICHx test is not supported for this model.*

This subtest checks the operation of mini-PCI I/F by the loopback test in the chip.

The following message will appear.

```
[LAN transmit & receive test !]
                                     COMPLETED Repeat count =      00000
                                     Error count   =      00000

LOOPBACK TEST
100Mbps Auto-negotiation TxRx Test
Destination Address   = xxxxxxxxxxxxxx
Source Address       = xxxxxxxxxxxxxx
  ** 100Base-TX Full-Duplex **
< TRANSMIT >
< RECEIVE >
```

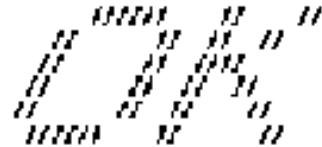

NOTE: *The menu displayed by your computer may be slightly different from the one shown above.*

If a defective is found, **NG** message will appear in the display.

Subtest02 (GbE)

This subtest checks the operation of mini-PCI I/F by the loopback test in the chip. Select **2** to execute and press **Enter**.

The following message will appear.

```
Testing adapter...hit <ESC> to abort.
*
External Loopback Test...PASSED
Testing completed.
*
*
Loopback Test Complete
*
*
* 1000Base Auto-negotiation TxRx Test
*
* CE Test Complete
```

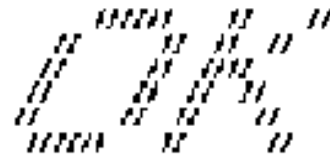

NOTE: The menu displayed by your computer may be slightly different from the one shown above.

If a defective is found, **NG** message will appear in the display.

3.29.2 Modem test

For this subtest, connect the modem PCB and RJ11 connector with a harness. Use the dedicated “FAT-MODE inspection device (product code: QE2000P01 made by Nitto Electric Manufacture Co.Ltd)” for the tests.

To execute Modem test, press **2** and **Enter**. Following message will appear.

```
[Modem loopback test !]
ICHx MDC Test Program with Modem Sound (Line Test)
Version X.X
* Scorpio Modem Initialize      :OK
* Digital Loopback Test        :OK
* RJ11 Connector Check (LED)   :(Operator's Check!!)
```

NOTE: *The menu displayed by your computer may be slightly different from the one shown above.*

RJ11 Connection Check (LED) (Operator's Check LED) test will be executed, and the following message will appear.

```
...Press Key (Y = OK , N =NG)
```

If the color in the LED of the connection checker is orange, press **Y**, otherwise, press **N**.

3.29.3 Bluetooth test

To execute this test, input **3** and press **Enter**.

NOTE: Use another computer that can communicate by the Bluetooth as a reference machine to perform this test.

Insert a floppy disk containing the test program into the target machine and turn on the target machine. The following Bluetooth test menu will appear.

```
#####
##### Bluetooth sub system test program VX.XX #####
#####
*
*          1....BD_ADDR check                               *
*
*          3....Communications test (DUT mode)              *
*
*          T....communications test (TEST mode)            *
*
*****
....Press test number [1, 3, T] ?
```

Press **1** or **3** key to perform the corresponding subtest. To quit the Bluetooth test program, eject the floppy disk and turn the computer off while the menu above is displayed.

Subtest01 BD_ADDR check

This subtest checks the BD_ADDR functions. When the Bluetooth test menu is displayed, press **1** to select the test and press **Enter**. The following message will appear:

```

-----
Bluetooth Subsystem T&D for PCSE(BD_ADDR) VerX.XX Copyright (C) by TOSHIBA Co.
-----

Initializing ...

```

When the machine has passed the test, it displays BD_ADDR. If BD_ADDR has no problem, the following message is displayed.

```

-----
Bluetooth Subsystem T&D for PCSE(BD_ADDR) VerX.XX Copyright (C) by TOSHIBA Co.
-----

My BD_ADDR = XXXXXXXXXXXX [h]

PPPPPP  A    SSSSS  SSSSS
P  P  A A  S    S  S    S
P  P  A  A  S      S
PPPPPP  A    A  SSSSS  SSSSS
P      AAAAAA  S      S
P      A    A  S    S  S    S
P      A    A  SSSSS  SSSSS

```

If the target machine has any problem, it displays Error message. The following message is displayed.

```

-----
Bluetooth Subsystem T&D for PCSE(BD_ADDR) VerX.XX Copyright (C) by TOSHIBA Co.
-----

My BD_ADDR = XXXXXXXXXXXX [h]

FFFFFF  A      III  L
F        A A    I    L
F        A  A    I    L
FFFFFF  A      A    I    L
F        AAAAAA I    L
F        A  A    I    L
F        A  A    III  LLLLLL
    
```

Table 3-5 Error message

| Message | Contents |
|--------------------------------------|-----------------|
| Invalid BD_ADDR (all 00) | 0x000000000000 |
| Invalid BD_ADDR (all FF) | 0xFFFFFFFFFFFF |
| Invalid BD_ADDR (bit0=1) | bit40=1b |
| Invalid BD_ADDR (bit1=1) | bit41=1b |
| Invalid BD_ADDR (define in the file) | Defined BD_ADDR |

If the machine detects a malfunction, it indicates the error code as shown below.

The error code begins with the least significant digit.

Error code

Table 3-6 Error code for Bluetooth test (BD_ADDR) (1/2)

| Error code | Meaning |
|------------|---|
| 0x01 | Unknown HCI Command. |
| 0x02 | No Connection. |
| 0x03 | Hardware Failure. |
| 0x04 | Page Timeout. |
| 0x05 | Authentication Failure. |
| 0x06 | Key Missing. |
| 0x07 | Memory Full. |
| 0x08 | Connection Timeout. |
| 0x09 | Max Number Of Connections. |
| 0x0a | Max Number Of SCO Connections To A Device. |
| 0x0b | ACL Connection already exists. |
| 0x0c | Command Disallowed. |
| 0x0d | Host Rejected due to limited resources. |
| 0x0e | Host Rejected due to security reasons. |
| 0x0f | Host Rejected due to remote device is only a personal device. |
| 0x10 | Host Timeout. |
| 0x11 | Unsupported Feature or Parameter Value. |
| 0x12 | Invalid HCI Command Parameters. |
| 0x13 | Other End Terminated Connection: Used Ended Connection. |
| 0x14 | Other End Terminated Connection: Low Resources. |
| 0x15 | Other End Terminated Connection: About to Power Off. |
| 0x16 | Connection Terminated by Local Host. |
| 0x17 | Repeated Attempts. |
| 0x18 | Paring Not Allowed. |
| 0x19 | Unknown LMP PDU. |
| 0x1a | Unsupported Remote Feature. |
| 0x1b | SCO Offset Rejected. |
| 0x1c | SCO Interval Rejected. |
| 0x1d | SCO Air Mode Rejected. |
| 0x1e | Invalid LMP Parameters. |
| 0x1f | Unspecified Error. |

** See the Specification of the Bluetooth System for details.

Table 3-6 Error code for Bluetooth test (BD_ADDR) (2/2)

| Error code | Meaning |
|------------|----------------------------------|
| 0x20 | Unsupported LMP Parameter Value. |
| 0x21 | Role Change Not Allowed. |
| 0x22 | LMP Response Timeout. |
| 0x23 | LMP Error Transaction Collision. |
| 0x24 | LMP PDU Not Allowed. |
| 0x25 | Not Exist |
| 0x26 | Not Exist |
| 0x27 | Not Exist |
| 0x28 | Not Exist |
| 0x29 | Not Exist |
| 0x2a | Not Exist |
| 0x2b | Not Exist |
| 0x2c | Not Exist |
| 0x2d | Not Exist |
| 0x2e | Not Exist |
| 0x2f | Not Exist |

** See the Specification of the Bluetooth System in detail.

Subtest03 Communications test (DUT mode)

Subtest T Communications test (TEST mode)

This subtest checks the Bluetooth communication functions. Set the responder machine to DUT mode and tester machine to TEST mode.

Insert a floppy disk containing the test program into the responder machine and turn on the power. The Bluetooth test menu will appear.

Press **3** to select the test and press **Enter** of the responder machine. The following message will appear:

When the communication test has been completed without fail, the DUT machine displays BD_ADDR. If the connection with the tester is completed, the progress bar stops. The following message is shown.

```

-----
Bluetooth Subsystem T&D for PCSE(CS-Air) VerX.XX Copyright (C) by TOSHIBA Co.
-----
+-----+
|          DUT          |   BD_ADDR of the DUT = XXXXXXXXXXXXX [h]
+-----+

  CCCC   OOO   M     M PPPPPP L     EEEEEE TTTTTTTT EEEEEEE DDDDD
C   C   O   O MM   MM P     P L     E         T     E         D     D
C     O     O M M M M P     P L     E         T     E         D     D
C     O     O M M M PPPPPP L     EEEEEE   T     EEEEEEE D     D
C     O     O M     M P     L     E         T     E         D     D
C   C   O   O M     M P     L     E         T     E         D     D
  CCCC   OOO   M     M P     LLLLLL EEEEEE   T     EEEEEEE DDDDD

                                Testing is finished

A>_

```

If the DUT machine has any problem or **S** of the DUT machine is pressed before connection to tester machine, the following message “INCOMPLETE” is displayed.

```

-----
Bluetooth Subsystem T&D for PCSE(CS-Air) VerX.XX Copyright (C) by TOSHIBA Co.
-----
+-----+
|          DUT          |   BD_ADDR of the DUT = XXXXXXXXXXXXX [h]
+-----+

III N     N   CCCC   OOO   M     M PPPPPP L     EEEEEE TTTTTTTT EEEEEEE
I  NN    N C   C O   O MM   MM P     P L     E         T     E
I  N N   N C     O     O M M M M P     P L     E         T     E
I  N N N C     O     O M M M PPPPPP L     EEEEEE   T     EEEEEEE
I  N   N N C     O     O M     M P     L     E         T     E
I  N     NN C   C O   O M     M P     L     E         T     E
III N     N   CCCC   OOO   M     M P     LLLLLL EEEEEE   T     EEEEEEE

                                Testing is finished

A>

```

If any problem is detected during the test, the message **FAIL** is displayed on the tester machine with the error code as shown below.

The error code begins with the least significant digit.

Error code

Table 3-7 Error code for Bluetooth test (BD_ADDR of the DUT) (1/2)

| Error code | Meaning |
|------------|---|
| 0x01 | Unknown HCI Command. |
| 0x02 | No Connection. |
| 0x03 | Hardware Failure. |
| 0x04 | Page Timeout. |
| 0x05 | Authentication Failure. |
| 0x06 | Key Missing. |
| 0x07 | Memory Full. |
| 0x08 | Connection Timeout. |
| 0x09 | Max Number Of Connections. |
| 0x0a | Max Number Of SCO Connections To A Device. |
| 0x0b | ACL Connection already exists. |
| 0x0c | Command Disallowed. |
| 0x0d | Host Rejected due to limited resources. |
| 0x0e | Host Rejected due to security reasons. |
| 0x0f | Host Rejected due to remote device is only a personal device. |
| 0x10 | Host Timeout. |
| 0x11 | Unsupported Feature or Parameter Value. |
| 0x12 | Invalid HCI Command Parameters. |
| 0x13 | Other End Terminated Connection: Used Ended Connection. |
| 0x14 | Other End Terminated Connection: Low Resources. |
| 0x15 | Other End Terminated Connection: About to Power Off. |
| 0x16 | Connection Terminated by Local Host. |
| 0x17 | Repeated Attempts. |
| 0x18 | Paring Not Allowed. |
| 0x19 | Unknown LMP PDU. |
| 0x1a | Unsupported Remote Feature. |
| 0x1b | SCO Offset Rejected. |
| 0x1c | SCO Interval Rejected. |
| 0x1d | SCO Air Mode Rejected. |
| 0x1e | Invalid LMP Parameters. |
| 0x1f | Unspecified Error. |

** See the Specification of the Bluetooth System in detail.

Table 3-7 Error code for Bluetooth test (BD_ADDR of the DUT) (2/2)

| Error code | Meaning |
|------------|----------------------------------|
| 0x20 | Unsupported LMP Parameter Value. |
| 0x21 | Role Change Not Allowed. |
| 0x22 | LMP Response Timeout. |
| 0x23 | LMP Error Transaction Collision. |
| 0x24 | LMP PDU Not Allowed. |
| 0x25 | Not Exist |
| 0x26 | Not Exist |
| 0x27 | Not Exist |
| 0x28 | Not Exist |
| 0x29 | Not Exist |
| 0x2a | Not Exist |
| 0x2b | Not Exist |
| 0x2c | Not Exist |
| 0x2d | Not Exist |
| 0x2e | Not Exist |
| 0x2f | Not Exist |

** See the Specification of the Bluetooth System in detail.

Table 3-8 Common error code

| Error code | Meaning |
|------------|---|
| 0x30 | BT Control Status should be "Disable", but it is "Enable". |
| 0x31 | BT Control Status should be "Enable", but it is "Disable". |
| 0x32 | Power Status should be "OFF", but it is "ON". |
| 0x33 | Power Status should be "ON", but it is "OFF". |
| 0x34 | USB I/F Status should be "Attach", but it is "Detach". |
| 0x35 | USB I/F Status should be "Detach", but it is "Attach". |
| 0x36 | Wake-up Status should be non-"Assert", but it is "Assort". |
| 0x37 | Wake-up Status should be "Assert", but it is non-"Assort". |
| 0x38 | Switch Status should be "OFF", but it is "ON". |
| 0x39 | Switch Status should be "ON", but it is "OFF". |
| 0x3a | Module dose not exist. |
| 0x3b | Module exists. (not error) |
| 0x3c | Command Line is wrong. |
| 0x3d | Side band access driver is not resident. |
| 0x3e | Bluetooth driver for DOS is not resident. |
| 0x3f | Get Status function of Side band access driver is not normal. |
| 0x40 | No reply to inquiry |
| 0x41 | Device Descriptor can not be acquired. USB I/F is not normal. |
| 0x42 | Sideband reset timeout occurs. |
| 0x43 | Descriptor type is wrong. |
| 0x44 | Descriptor is acquired in spite of Detach condition. |
| 0x45 | Configuration file open is not normal. |
| 0x46 | Contents of Configuration file are wrong. |
| 0x47 | BD_ADDR is wrong (00) |
| 0x48 | BD_ADDR is wrong (FF) |
| 0x49 | BD_ADDR is wrong (bit0=1) |
| 0x4a | BD_ADDR is wrong (bit1=1) |
| 0x4b | BD_ADDR is wrong (address defined as an error) |
| 0x4c | Suspended during Hard ware switch confirmation. |
| 0x4d | RSSI value is less than the standard value. |
| 0x4e | Holts |
| 0x4f | (reserved) |

** Number 0x30 to 0x40 are common error codes of the test program.

3.29.4 IEEE1394 test

To execute this test, input **4** and press **Enter**.

NOTE: Use another computer that can communicate by IEEE1394 (i. Link) cable as a reference machine to perform this test.

The following menu will appear:

```

*****
*****      IEEE1394 [XXXXX] Diagnostics program      *****
*****
*
*      1 ....(Transmit & Receive test)                  *
*
*      2 ....(Responder set)                            *
*
*      3 ....(1394 GUID Display)                        *
*
*****
.... Press test number [1-3] ?

```

To execute the TEST, select the test number you want to execute and press **Enter**.

Subtest01 (Transmit & Receive test)

NOTE: Before executing subtest 01, be sure to execute subtest 02 in the responder machine.

This program checks the data transporting between responder machine and target machine and compare them with the original data through the IEEE1394 cable.

Subtest02 (Responder set)

This program is executed in the responder machine to initialize the responder machine with the IEEE1394 cable connected to the target machine before executing subtest 01.

Subtest03 (1394 GUID Display)

This program checks the GUID of IEEE1394.

3.30 Sound Test program

This section describes how to perform the Sound test. To execute the sound test, refer to the following description.

Insert the test program disk for Sound test in the floppy disk drive and turn on the power. The following message will appear:

```
#####
#####      WSS, Sound blaster pro Diagnostics program      #####
#####
*
*      1 .....      Sound (Standard)      *
*
*      2 .....      Sound (Legacy)      *
*
*      3 .....      CD Sound (Standard)   *
*
*      4 .....      CD Sound (Legacy)    *
*
*      ---It outputs at the speaker and lineout---
*
*****
.... Press test number[1-4] ?
```

Input the test number and press **Enter**.

3.30.1 Sound (Standard) test

To execute the Sound (Standard) test, press **1** and **Enter**. The following menu will appear in the display.

```
#####
#####      ICH4-M + AD1981A Diagnostics program      #####
#####
*
*      1 .....      ( Microphone recording & play )      *
*
*      2 .....      ( Sine wave )      *
*
*      3 .....      ( Line IN recording & play )      *
*
*
*      9 .....      Exit to Main      *
*
*****
.... Press test number[1-3,9] ?
```

To return to the Sound test menu, Press **9** and **Enter**. Then following message will appear in the display.

```
*****  
*****  May I Restart ?  *****  
*****  
Press any key to continue...
```

After pressing any key, the machine starts rebooting and sound test menu will appear in the display.

Subtest01 (Microphone recording & play)

This subtest checks the function of the CODEC A/D, D/A converter.

When this subtest is selected, the following message will appear.

```
[Recording & play test !]
```

And the following message will appear.

```
DOS/4GW Protected Mode Run-time Version X.XX  
Copyright (c) Tenberry Software, Inc. XXXX
```

After this message appears, display stops briefly. In this timing, sound is recorded from internal microphone.

After the recording is completed, the computer plays back the sound recorded after the following message.

```
STACWAVE Version X.XX  
Build data: XXX XX XXXX at XX:XX:XX  
Loading "mic.wav".
```

NOTE: *The message in the display might have slight difference from those above.*

The display returns to the Sound (Standard) test menu after the test ends.

Subtest02 (Sine Wave)

This subtest is executed by loading the COM file (ADSIN.COM). The program expands sine wave data table from 16KB to 64KB, and creates the play data. Then it transfers the data between the DMA and the CODEC to play the sine wave. (It sounds like a continuous beep.) By using wave measurable devices such as an oscilloscope, the data can be measured as a sine wave.

When the subtest is executed, the sine wave is played while expanding sine wave from 16KB to 64KB.

The display returns to the Sound (Standard) test menu after the test ends.

Subtest03 (Line IN recording & play)

This subtest executes the same test as the subtest01 by recorded sound from the different port (Line-in port).

For more details on the subtest, refer to the subtest01 Microphone recording & play.

The display returns to the Sound (Standard) test menu after the test ends.

3.30.2 Sound (Legacy) test

To execute the Sound (Legacy) test, select **2** and press **Enter**.

| |
|---|
| NOTE: <i>Sound (Legacy) test is not supported in this model.</i> |
|---|

3.30.3 CD Sound (Standard) test

To execute the CD Sound (Standard) test, press **3** and **Enter**. Insert the test media (TOSHIBA TEST CD-ROM or ABEX TEST CD-ROM) or music CD on the market (if the test media can not be prepared). Following menu appears in the display.

For details on use of test media, refer to 3.30.3.1 Test media (Toshiba-made test media).
For details on use of audio CD on the market, refer to 3.30.3.2 Audio CD.

3.30.3.1 Test media (Toshiba-made test media)

CD/DVD TEST IN PROGRESS XXXXXXXX

| |
|--|
| <pre> xxxxxxxx DIAGNOSTIC TEST VX.XX [Ctrl]+[Break] : test end [Ctrl]+[C] : key stop </pre> |
|--|

```

SUB-TEST      : XX
PASS COUNT    : XXXXX      ERROR COUNT : XXXXX
WRITE DATA   : XX         READ DATA  : XX
ADDRESS       : XXXXXXX    STATUS        : XXX

```

```

01 - Japanese Narration
02 - English Narration
03 - Test Tone A (100Hz - 20Hz)
04 - Test Tone B (400Hz - 3KHz L-R)

```

```

Drive # = 0, ATAPI status =00
Command = XX
[[Block address = XXXXXXXXX]]
[[Block length  = XXXXXXXXX]]
Final : Block address = XXXXXXXXX

```

Subtest01 Japanese Narration

Selected this subtest, narration in Japanese starts and following message appears in the display.

```

Play start CD sound !
Press any key <Play stop>.

```

Press any key and stop the narration. Then return to the CD Sound (Standard) test menu.

Subtest02 English Narration

Selected this subtest, narration in English starts.

For more details on the procedure, refer to the subtest01.

Subtest03 Test Tone A

CAUTION: Before starting subtest03, be sure to set the sound at proper volume.

This subtest plays sine wave while changing its table from 100Hz to 20Hz.

The test returns to the CD Sound (Standard) menu after the test ends.

Subtest 04 Test Tone B

This subtest plays sine wave while changing its table from 400Hz to 3KHz and also changing the channel from left speaker to right speaker.

The test returns to the CD Sound (Standard) menu after the test ends.

3.30.3.2 Audio CD

Insert an audio CD and the following menu appears in the display.

```

CD/DVD TEST  IN PROGRESS XXXXXXXX

```

```

xxxxxxx DIAGNOSTIC TEST VX.XX
[Ctrl]+[Break] : test end
[Ctrl]+[C]     : key stop

```

```

SUB-TEST      : XX
PASS COUNT   : XXXXX      ERROR COUNT : XXXXX
WRITE DATA  : XX         READ DATA  : XX
ADDRESS     : XXXXXXXX   STATUS       : XXX

```

CD Sound track number (01-98 : Track) ?

```

Drive # = 0, ATAPI status =00
Command = XX
[[Block address = XXXXXXXXX]]
[[Block length  = XXXXXXXXX]]
Final : Block address = XXXXXXXXX

```

Select the track number you want to test and press **Enter** twice.

The following message appears in the display and selected track is played.

```

Play start CD sound !
Press any key <play stop>

```

After pressing any key, the music stops and the display returns to the selection menu of the track number.

NOTE: When the CD-ROM test is executed, [ALL DEVICE] must be selected in the "Device Config.=" of the BIOS SETUP. If the "ALL DEVICE" is not selected, music can not be played.

3.30.4 CD Sound (Legacy) test

To execute the CD Sound (Legacy) test, select **4** and press **Enter**.

CAUTION: Sound (Legacy) test is not supported in this model.

3.31 SETUP

3.31.1 Function Description

This program displays the current system setup information as listed below:

1. Memory
 - (a) Total
2. System Date/Time
 - (a) Date (MM-DD-YYYY)
 - (b) Time (HH:MM:SS)
3. Battery
 - (a) Battery Save Mode
 - (b) PCI Express Link ASPM
4. Password
5. HDD Password
 - (a) HDD
 - (b) HDD Password Mode
 - (c) User Password
 - (d) Master Password
6. Boot Priority
 - (a) Boot Priority
 - (b) HDD Priority
7. Display
 - (a) Power On Display
 - (b) LCD Display Stretch
 - (c) TV type
8. Others
 - (a) Dynamic CPU Frequency Mode
 - (b) Execute-Disable Bit Capability
 - (c) Auto Power On
 - (d) Diagnostic Mode
 - (e) Language During Bootup
9. Configuration

10. I/O Ports

- (a) Serial
- (b) Parallel

11. Drives I/O

- (a) Built-in HDD
- (b) Select Bay

12. PCI Bus

13. Security Controller

- (a) TPM
- (b) Clear TPM Owner

14. Peripheral

- (a) Internal Pointing Device
- (b) Ext keyboard “Fn”
- (c) Parallel Port Mode

15. Legacy Emulation

- (a) USB KB/Mouse Legacy Emulation
- (b) USB-FDD Legacy Emulation
- (c) USB Memory BIOS Support Type

16. PCI LAN

17. RAID ARRAY

- (a) Current State
- (b) Create State
- (c) Execute Creation

3.31.2 Accessing the SETUP Program

Select 0-SETUP in the Main Menu and press **Enter** key. The following display appears.

```

SYSTEM SETUP (1/3)  ACPI BIOS version = X.XX

```

| | |
|--|---|
| <pre> MEMORY Total = XXXXXX MB </pre> | <pre> BOOT PRIORITY Boot Priority = HDD→FDD→CD-ROM→LAN HDD Priority = Built-in HDD → Second HDD → USB </pre> |
| <pre> SYSTEM DATE/TIME Date(MM-DD-YYYY) = XX-XX-XXXX Time(HH:MM:SS) = XX:XX:XX </pre> | <pre> DISPLAY Power On Display = Auto-Selected LCD Display Stretch = Enabled TV Type = NTSC(US) </pre> |
| <pre> BATTERY Battery Save Mode = Full Power PCI Express Link ASPM = Enabled </pre> | <pre> Others Dynamic CPU Frequency Mode = Dynamically Switchable Execute-Disable Bit Capability = Not Available Auto Power On = Disabled Diagnostic Mode = Disabled Language During Bootup = English </pre> |
| <pre> PASSWORD Not Registered </pre> | |
| <pre> HDD PASSWORD HDD = Built-in HDD HDD Password Mode = User Only User Password = Not Registered </pre> | |

↑↓←→: Select items Space, BkSp: Change values PgDn, PgUp: Change pages
Esc: Exit without saving Home : Set default values End: Save changes and Exit

```

SYSTEM SETUP (2/3)  ACPI BIOS version = X.XX

```

| | |
|--|--|
| <pre> CONFIGURATION Device Config. = Setup by OS </pre> | <pre> PERIPHERAL Internal Pointing Device = Enabled Ext Keyboard "Fn" = Disabled Parallel Port Mode = ECP </pre> |
| <pre> I/O PORTS Serial = COM1(3F8H/IRQ4) Parallel = LPT1(378H/IRQ7/CH3) </pre> | <pre> LEGACY EMULATION USB KB/Mouse Legacy Emulation = Enabled USB-FDD Legacy Emulation = Enabled USB Memory BIOS Support Type =HDD </pre> |
| <pre> DRIVES I/O Built-in HDD = Serial ATA Port0 Select Bay = Primary IDE(1F0H/IRQ14) </pre> | <pre> PCI LAN Built-in LAN = Enabled </pre> |
| <pre> PCI BUS PCI BUS = IRQ10, IRQ11 </pre> | |
| <pre> SECURITY CONTROLLER TPM = Disabled </pre> | |

↑↓←→: Select items Space, BkSp: Change values PgDn, PgUp: Change pages
Esc: Exit without saving Home : Set default values End: Save changes and Exit

SYSTEM SETUP (3/3) ACPI BIOS version = X.XX

```

----- CONFIGURATION -----
Current State
  Built-in HDD = 1RAID-0
  Second HDD  = No Drive
Create State
  Built-in HDD = 1RAID-0
  Second HDD  = No Drive

```

```

      Level  Status  Capacity
L00   1RAID-0  OPTIMAL   XXGB

```

```

Drive  Assign  Status  Size  Model  Rev
Built-in L00-0  ONLINE  XXGB  XXXXXXX XXXXXXXXXXXX XXXXXXX
Second                NO Drive

```

↑↓←→: Select items Space, BkSp: Change values PgDn, PgUp: Change pages
 Esc: Exit without saving Home : Set default values End: Save changes and Exit

Moving Within the SETUP Menu and Changing Values

1. Press **←** and **→** to move between the two columns. Press **↑** and **↓** to move between items in a column. Press **Fn+↑ (PgUp)** and **Fn + ↓ (PgDn)** to move between the two pages.
2. Press either the **Space bar** or **Back Space** to change the value.

Accepting Changes and Exiting the SETUP Window

1. Press **End** to accept the changes you made.

If the changed item does not require the system to reboot, the following message is displayed:

Are you sure? (Y/N)

If the changed item requires the system to reboot, the following message is displayed:

Are you sure? (Y/N)
The changes you made will cause the system to reboot.

2. To make other changes, press **N**. Repeat the steps above.
3. To accept the changes, press **Y**.

NOTE: You can press **Esc** to quit at any time without saving changes. **SETUP** asks you to confirm that you do not want to save your changes. When **SETUP** is displayed at the next time, the current configuration appears.

The Factory Preset Configuration

When you access **SETUP**, the current configuration is displayed.

1. To show the factory preset configuration, press **Home**.
2. Press **End** and then press **Y** to accept the factory preset settings.

NOTE: When you execute the default setting, the following settings are not changed:
(1) Password
(2) Execute-Disable Bit Capability

SETUP Options

The SETUP screen is divided into functionally related groups. This section describes each group and its options.

1. Memory

This group of options displays the computer's memory.

(a) Total

This field displays the total amount of memory installed and is automatically calculated by the computer. You cannot change this value.

2. System Date/Time

Sets the date and time.

Date Sets date.

Time Sets time.

3. Battery

(a) Battery Save Mode

This option is used to select **Full Power**, **Low Power** or **User Setting** of the battery save mode. When you select the battery save mode, the following sub-window will appear.

Full Power The following shows full power settings.

```

Full Power (Default)
Processing Speed = High
CPU Sleep Mode  = Enabled
LCD Brightness  = Bright *1
                  Super-Bright *2
Cooling Method  = Maximum Performance
  
```

Low Power The following shows low power settings.

```

Low Power
Processing Speed = Low
CPU Sleep Mode  = Enabled
LCD Brightness  = Semi-Bright *1
                  Bright *2
Cooling Method  = Battery Optimized
  
```

NOTE: Display of the LCD Brightness will be changed in the condition below:

(*1) Operating the battery

(*2) Using the AC adapter

User Setting Use this option to set the battery save parameters on the sub-window, **BATTERY SAVE OPTIONS**.

Processing Speed

This feature changes the CPU processing speed.

High CPU operates at high speed. (Default in Full Power Mode)

Low CPU operates at low speed. (Default in Low Power Mode)

CPU Sleep Mode

Use this option to enable or disable the CPU sleep function.

Enabled Enables sleep mode. (Default)

Disabled Disables sleep mode.

LCD Brightness

Use this option to set the level of LCD brightness.

Super-Bright Full brightness for maximum visibility.

Bright Full brightness for high visibility.

Semi-Bright Less than full brightness for saving power.

Cooling Method

If the CPU becomes too hot, the fan turns on or the processing speed is lowered automatically. When the CPU temperature falls to a normal range, the fan turns off.

| | |
|----------------------------|---|
| Maximum performance | If the CPU becomes too hot, the fan turns on automatically in a high speed to cool down the CPU. Gives priority to the decrease of noise. |
| Performance | If the CPU becomes too hot, the fan turns on automatically. When the CPU temperature falls to a normal range, the fan turns off. |
| Battery optimized | If the CPU becomes too hot, the processing speed is lowered. If the temperature is still too high, the fan turns on. When the CPU temperature falls to a normal range, the fan is turned off and the processing speed is increased. |
| Cooling Optimized | If the CPU becomes too hot, the fan turns on automatically in a high speed to cool down the CPU. Gives priority to the decrease of temperature at the bottom of the PC. |

NOTE: *Too hot condition may cause defect on the CPU. When the hot condition continues, the power is automatically turned off.*

(b) PCI Express Link ASPM

This option sets the power saving function of the PCI Express.

| | |
|-----------------|--|
| Auto | Saves power consumption, when the PCI Express device is not used while the battery is working. |
| Disabled | Disables the power saving function and gives priority to the performance. |
| Enabled | Saves power consumption, when the PCI Express device is not used. (Default) |

4. Password

This option sets or resets the user password for power on and instant security (**Fn+F1**).

| | |
|-----------------------|--|
| Registered | The user password has been registered. |
| Not Registered | The user password has not been registered. |

For details on setting the user password, refer to the User's Manual.

5. HDD Password

This option registers, resets or changes the HDD password.

(a) HDD

Hard disk for setting the password.

When the second HDD is mounted, "Second HDD" can be selected.

Built-in HDD The password is set to Built-in HDD. (This cannot be changed, when the second HDD is not mounted.)

Second HDD The password is set to Second HDD.

(b) HDD Password Mode

This item registers HDD password and can be selected only for registering HDD password. To change HDD Password Mode when HDD password is registered, delete the registered HDD password first, and then register new password.

User Only Sets only User HDD Password (Default)

Master+User Sets Master HDD Password and User HDD Password

(c) User Password

This item sets User password.

For details on setting user password, refer to the User's Manual.

(d) Master Password

This item sets the Master HDD password.

This can be set, only when **Master+User** is set in the HDD password Mode.

For details, refer to the User's Manual.

6. Boot Priority

This tab sets the priority for booting the computer and the priority for the built-in HDD or optional secondary HDD.

(a) Boot Priority

| | |
|---------------------------|---|
| HDD→FDD→CD-ROM→LAN | The computer looks for bootable files in the following order: HDD, FDD, CD-ROM and LAN. (Default) |
| FDD→HDD→CD-ROM→LAN | The computer looks for bootable files in the following order: FDD, HDD, CD-ROM and LAN. |
| HDD→CD-ROM→LAN→FDD | The computer looks for bootable files in the following order: HDD, CD-ROM, LAN and FDD. |
| FDD→CD-ROM→LAN→HDD | The computer looks for bootable files in the following order: FDD, CD-ROM, LAN and HDD. |
| CD-ROM→LAN→HDD→FDD | The computer looks for bootable files in the following order: CD-ROM, LAN, HDD and FDD. |
| CD-ROM→LAN→FDD→HDD | The computer looks for bootable files in the following order: CD-ROM, LAN, FDD and HDD. |

NOTE: *CD-ROM refers to an Optical drive.*

(b) HDD Priority

This option enables to select the priority for the Built-in HDD, optional second HDD or PC card.

Built-in HDD → Second HDD→USB

The priority is set as Built-in HDD → Second HDD→USB. (Default)

Second HDD → Built-in HDD→USB

The priority is set as Second HDD → Built-in HDD→USB.

Built-in HDD → USB → Second HDD

The priority is set as Built-in HDD → USB → Second HDD.

Second HDD → USB → Built-in HDD

The priority is set as Second HDD → USB → Built-in HDD.

USB → Built-in HDD → Second HDD

The priority is set as USB → Built-in HDD → Second HDD.

USB → Second HDD → Built-in HDD

The priority is set as USB → Second HDD → Built-in HDD.

NOTE: When the boot command can not be found in the specified HDD, the PC is booted from other devices, not but from the other HDD.

7. Display

This group of options configures the computer's display.

(a) Power On Display

This option is used to select the display when booting up.

Auto-Selected Selects an external monitor if one is connected. Otherwise it selects the internal LCD. (Default)

LCD+AnalogRGB Selects both the internal LCD and the external monitor for simultaneous display.

(b) LCD Display Stretch

LCD Display Stretch enables or disables a larger display area of the screen.

Enabled Enables the LCD display stretch feature. (Default)

Disabled Disables the LCD display stretch feature.

(c) TV Type

This option allows you to select the type of TV.

| | |
|---------------------|----------------------------------|
| NTSC (Japan) | TV in Japanese system. |
| NTSC (US) | TV in the U.S. system. (Default) |
| PAL | TV in Europe and China system. |

8. Others

Whether or not you need to configure the computer with these options depends primarily on the kind of software or peripherals you use.

(a) Dynamic CPU Frequency Mode

Use this option to choose a setting from the followings.

Dynamically Switchable

Enables Intel SpeedStep technology. When the computer is in use, the CPU power consumption and clock speed are automatically switched when necessary. (Default)

Always High Disables Intel SpeedStep technology and always runs the processor at its fastest speed.

Always Low Disables Intel SpeedStep technology and always runs the processor at low power consumption and low speed.

(b) Execute-Disable Bit Capability

Selects the function to reports whether the CPU Execute-Disable Bit is available or not to OS. The Execute-Disable Bit Capability is a function that strengthens the security to protect PC from the buffer overflow attack by a computer virus and an illegal access.

Available Makes the processor's Execute-Disable Bit Capability available for use.

Not Available Disables the processor's Execute-Disable Bit Capability so that it is not available for use. (Default).

(c) Auto Power On

The Auto Power On has two functions. The result of setting in the sub-window (OPTIONS) is indicated as follows.

| | |
|-----------------|--|
| Disabled | Indicated when “Alarm time” set to “Disabled and “Wake-up on LAN” set to “Disabled”. |
| Enabled | Indicated when “Alarm time” set to “xx:xx:xx” or “Wake-up on LAN” set to “Enabled”. |

| OPTIONS | |
|-------------------|------------|
| Alarm Time | = 00:00:00 |
| Alarm Date Option | = Disabled |
| Wake-up on LAN | = Disabled |

Set the parameters for the Auto Power On (automatic power on) function and the Wake-up on LAN in the “OPTIONS” window. To set the time, use **Space** or **BackSpace**. Press ↓ to move the cursor to the right and ↑ to move the cursor to the left when you set the date and time.

For the **Alarm Time**, set the time to turn on the power automatically. The “second” cannot be set. When it is set to “Disabled”, the time to turn on automatically is not set.

For the **Alarm Date Option**, set the date to turn on the power automatically. When it is set to “Disabled”, the time to turn on automatically is not set.

The **Wake-up on LAN** is a function to turn on the power automatically by the call from the administrator. It can be set to “Enabled” only when “Built-in LAN” is set to “Enabled”. To activate this function, use the AC adapter.

- NOTE:**
1. Do not remove the AC adaptor and battery pack at the same time when you use this feature. If you do so, data saved by the resume function will be lost. You must also reset this option.
 2. If you have set a password and the computer boots by the Auto Power On function and Resume is on, the computer will start with the instant security function enabled. The **password** = message is not displayed; however, you must enter the password to use the computer.
 3. This option is enabled only once, the setting is reset, after booting up.

(d) Diagnostic Mode

This option enables/disables the HW Diagnostic test function.

| | |
|-----------------|---|
| Disabled | Disables the HW Diagnostic test function. (Default) |
| Enabled | Enables the HW Diagnostic test function. |

(e) Language During Bootup

This option selects the language during bootup. This message appears only on the model for TCL(Canada).

English The message is displayed in English. (Default)

French The message is displayed in French.

9. Configuration

This option displays the configuration method.

(a) Device Config.

The devices are initialized when the PNP OS loads.

Setup by OS Initializes devices necessary for loading the OS.
The OS will initialize other devices. (Default)

All Devices BIOS sets all devices.

NOTE: When using installed OS, select “Setup by OS”. But, when executing the test program, select “All Devices”.

10. I/O ports

This option controls settings for serial/parallel port.

NOTE: Do not assign the same interrupt request level and I/O address to the serial port and PC card.

(a) Serial

Use this option to set the COM level for the serial port.

- | | |
|---------------------|---|
| Not used | Does not assign the serial port. |
| COM1 | Assign the serial port specified. (Default) |
| COM2 to COM4 | Assign the serial port specified. |

(b) Parallel

This option sets the interrupt request level (IRQ) and I/O port base address for the parallel port.

When **ECP** is selected in “Parallel Port Mode” and an option except for **Not Used** is selected in “Parallel”, an option window to set DMA appears.

11. Drives I/O

This option displays the address and interrupt level for hard disk drive and select bay. It is for information only and cannot be changed.

(a) Built-in HDD

This option displays the address and interrupt level for hard disk drive. This cannot be changed.

(b) Select Bay

This option displays the address and interrupt level for select bay. This cannot be changed.

12. PCI Bus

This item displays the interrupt level for the Card Bus. It is for information only and cannot be changed.

PCI BUS = IRQ10, IRQ11

13. Security controller

(a) **TPM**

Disables the security controller called TPM (Trusted Platform Module). When the cursor is on the **Enable (Disable)** and the **Space** is pressed, message is displayed and the PC waits **Y** or **N** key input by the user. When **Y** is pressed, it is sets to **Enable (Disable)**. After changing, the cursor could not be moved on the **TPM** tem. This option can be changed after rebooting.

Disabled Disables the TPM. (Default)

Enabled Enables the TPM.

(b) **Clear TPM Owner**

This is not displayed when the **TPM** is set to **Disabled**. This is executed, when the PC is disposed or the owner of the PC changes. When the cursor is on this item and the **Space** is pressed, message is displayed and the PC waits **Y, E, S** and **Enter** key inputs by the user. When **Y, E, S** and **Enter** keys are pressed, the data is disposed. After changing, the display of **TPM** item is changed to **Disabled** and this item becomes not displayed and the cursor could not be moved on the **TPM** item.

14. Peripheral

Use this option to select the parallel port mode and hard disk mode.

(a) Internal Pointing Device

This option enables and disables the Touch Pad.

Enabled Enables the Touch Pad. (Default)

Disabled Disables the Touch Pad.

(b) Ext Keyboard “Fn”

Use this option to set the Fn key equivalent when you are using an external keyboard. Selecting this option displays the following subwindow.

Enabled Enables the feature.

Disabled Disables the feature. (Default)

When “Enabled” is selected, the following sub-window appears.

| KEYBOARD |
|--|
| Ext Keyboard "Fn" key equivalent = Left Ctrl + Left Alt |

Use this option to set a key combination on an external keyboard to emulate the **Fn** key on the computer’s internal keyboard. Setting a **Fn** key equivalent will enable you to use “Hotkeys” by pressing the set combination in place of the **Fn** key. The following items can be selected for this option:

- Left Ctrl + Left Alt***
- Right Ctrl + Right Alt***
- Left Alt + Left Shift**
- Right Alt + Right Shift**
- Left Alt + Caps Lock**

*If these selections are made, you cannot warm boot the system by pressing **Ctrl + Alt + Del**.

(c) Parallel Port Mode

The option selects Parallel Port Mode.

- ECP** Sets the port mode to ECP (Extended Capabilities Port). For most printers, the port should be set to ECP. (Default)
- Std. Bi-Direct.** Sets the bi-directional setting. This setting should be used with some other parallel devices.

15. Legacy Emulation.

(a) USB KB/Mouse Legacy Emulation.

This option sets the Legacy support condition of the USB keyboard and the USB mouse.

- Enabled** USB Legacy Support can be used. (Default)
USB keyboard/USB mouse are available without a driver.
- Disabled** USB Legacy Support cannot be used.

(b) USB-FDD Legacy Emulation.

This option sets the Legacy support condition of the USB floppy disk drive.

- Enabled** USB Legacy Support can be used. (Default)
USB floppy disk is available without the driver.
- Disabled** USB Legacy Support cannot be used.

(c) USB-FDD Legacy Emulation.

This option sets the type of the USB memory as a startup device.

| | |
|-----------------|--|
| HDD | Sets the type of the USB memory to be equivalent to the HDD (Default). |
| Disabled | Sets the type of the USB memory to be equivalent to the FDD. |

16. PCI LAN

This option enables/disables the Built-in LAN functions.

(a) Built-in LAN

| | |
|-----------------|---|
| Enabled | Enables Built-in LAN functions. (Default) |
| Disabled | Disables Built-in LAN functions. |

17. RAID ARRAY

This option sets the RAID configuration.

(a) Current State

This option indicates the current hard disk condition. Content set in [Create State] is displayed, when booting BIOS setup next time.

| | |
|---------------------|--|
| Built in HDD | Displays RAID configuration level of the built-in HDD. |
| Second HDD | Displays RAID configuration level of the second HDD. |

(b) Create State

This option sets the RAID configuration level.

NOTE: *All data of the hard disk is deleted when setting of the RAID configuration is changed in the BIOS setup. Therefore, it is recommended that the user password or the supervisor password is registered to prevent changing of setting the RAID configuration by the third party. Moreover, registering the supervisor password can make add the restriction so that a user without the management authority can not change the setting of the BIOS setup.*

| | |
|---------------------|--|
| Built in HDD | Sets RAID configuration level of the built in HDD. |
| Second HDD | Sets RAID configuration level of the second HDD. |

(c) Execute Creation

This option is displayed, only when the setting is changed in the “Create State”.

Set the cursor bar to “Execute Creation” and press **Space** or **Back Space**. The following message will appear:

```
Warning: If you change RAID array, you need to install
OS again. Are you sure? All data on the HDD(s) will be
destroyed. Do you really want to do this? If "Yes",
please type the key string which is written in manual.
```

Input 1234 (press **1, 2, 3, 4** key) and press **Enter**.

The change of the RAID configuration will be reflected.

Chapter 4

Replacement Procedures

Chapter 4 Contents

| | | |
|------|---|------|
| 4.1 | General..... | 4-1 |
| 4.2 | Battery pack..... | 4-8 |
| 4.3 | PC card..... | 4-10 |
| 4.4 | SD card..... | 4-11 |
| 4.5 | Memory module..... | 4-12 |
| 4.6 | HDD..... | 4-14 |
| 4.7 | Wireless LAN card..... | 4-17 |
| 4.8 | Slim select bay module..... | 4-19 |
| 4.9 | Keyboard..... | 4-22 |
| 4.10 | Touch pad..... | 4-25 |
| 4.11 | Bluetooth module..... | 4-27 |
| 4.12 | Switch membrane..... | 4-29 |
| 4.13 | Display assembly..... | 4-31 |
| 4.14 | RTC battery..... | 4-35 |
| 4.15 | Modem Daughter Card (MDC)..... | 4-36 |
| 4.16 | USB board..... | 4-39 |
| 4.17 | Internal microphone..... | 4-41 |
| 4.18 | SR board/DC-IN jack..... | 4-43 |
| 4.19 | Fan..... | 4-45 |
| 4.20 | CPU..... | 4-47 |
| 4.21 | GFX board..... | 4-50 |
| 4.22 | System board..... | 4-52 |
| 4.23 | FP board..... | 4-56 |
| 4.24 | LCD unit/FL inverter..... | 4-58 |
| 4.25 | Cover latch..... | 4-65 |
| 4.26 | Wireless LAN antenna/Bluetooth antenna..... | 4-66 |
| 4.27 | Hinge..... | 4-68 |
| 4.28 | Speaker..... | 4-72 |
| 4.29 | Battery slider..... | 4-73 |

| | | |
|--------|---|-------|
| 4.30 | Fluorescent Lamp..... | 4-75 |
| 4.30.1 | Replacing the 15.0-inch XGA LG Philips Fluorescent Lamp | 4-76 |
| 4.30.2 | Replacing the 15.0-inch XGA Sharp Fluorescent Lamp..... | 4-85 |
| 4.30.3 | Replacing the 15.0-inch XGA Samsung Fluorescent Lamp | 4-106 |
| 4.30.4 | Replacing the 15.0-inch SXGA+ LG Philips Fluorescent Lamp | 4-111 |

Figures

| | | |
|-------------|--|------|
| Figure 4-1 | Removing the battery pack | 4-8 |
| Figure 4-2 | Removing the PC card | 4-10 |
| Figure 4-3 | Removing the SD card | 4-11 |
| Figure 4-4 | Removing the memory module..... | 4-12 |
| Figure 4-5 | Removing the HDD assembly | 4-14 |
| Figure 4-6 | Separating the HDD..... | 4-15 |
| Figure 4-7 | Removing the Wireless LAN card..... | 4-17 |
| Figure 4-8 | Removing the slim select bay module | 4-19 |
| Figure 4-9 | Detaching the optical drive assembly | 4-20 |
| Figure 4-10 | Removing the speaker cover..... | 4-22 |
| Figure 4-11 | Turning over the keyboard..... | 4-23 |
| Figure 4-12 | Removing the keyboard support plate | 4-23 |
| Figure 4-13 | Removing the keyboard | 4-24 |
| Figure 4-14 | Removing the touch pad assembly | 4-25 |
| Figure 4-15 | Removing the touch pad | 4-26 |
| Figure 4-16 | Removing the Bluetooth module | 4-27 |
| Figure 4-17 | Removing the SW membrane | 4-29 |
| Figure 4-18 | Removing the display assembly (1)..... | 4-31 |
| Figure 4-19 | Removing the display assembly (2)..... | 4-32 |
| Figure 4-20 | Removing the display assembly (3)..... | 4-33 |
| Figure 4-21 | Removing the RTC battery | 4-35 |
| Figure 4-22 | Removing the Modem Daughter Card (MDC) | 4-36 |
| Figure 4-23 | Removing the modem jack and modem cable | 4-37 |
| Figure 4-24 | Installing the modem jack and modem cable..... | 4-38 |

| | | |
|-------------|--|------|
| Figure 4-25 | Removing the USB board | 4-39 |
| Figure 4-26 | Removing the internal microphone..... | 4-41 |
| Figure 4-27 | Removing the SR board/DC-IN jack | 4-43 |
| Figure 4-28 | Connecting the SR/USB cable | 4-44 |
| Figure 4-29 | Removing the fan..... | 4-45 |
| Figure 4-30 | Removing the CPU heat sink..... | 4-47 |
| Figure 4-31 | Removing the CPU | 4-48 |
| Figure 4-32 | Applying silicon grease | 4-49 |
| Figure 4-33 | Removing the GPU heat sink..... | 4-50 |
| Figure 4-34 | Removing the GFX board..... | 4-51 |
| Figure 4-35 | Removing the HDD cable holder..... | 4-52 |
| Figure 4-36 | Removing the modem jack | 4-53 |
| Figure 4-37 | Removing the HDD cable..... | 4-53 |
| Figure 4-38 | Removing the PC card slot | 4-54 |
| Figure 4-39 | Removing the north bridge IC heat sink..... | 4-54 |
| Figure 4-40 | Removing the FP board | 4-56 |
| Figure 4-41 | Removing the display mask..... | 4-58 |
| Figure 4-42 | Removing the FL inverter..... | 4-59 |
| Figure 4-43 | Removing the LCD unit (1) | 4-60 |
| Figure 4-44 | Removing the LCD unit (2) | 4-61 |
| Figure 4-45 | Removing the LCD bracket | 4-62 |
| Figure 4-46 | Peeling off the insulator..... | 4-62 |
| Figure 4-47 | Removing the LCD cable holder | 4-63 |
| Figure 4-48 | Removing the cover latch | 4-65 |
| Figure 4-49 | Removing the wireless LAN antenna cable..... | 4-66 |
| Figure 4-50 | Removing the wireless LAN antenna/Bluetooth antenna..... | 4-67 |
| Figure 4-51 | separating the display cover and middle frame | 4-68 |
| Figure 4-52 | Removing the hinge (right)..... | 4-69 |
| Figure 4-53 | Removing the hinge (left) | 4-70 |
| Figure 4-54 | Removing the speaker..... | 4-72 |
| Figure 4-55 | Removing the battery slider A | 4-73 |
| Figure 4-56 | Removing the battery slider B | 4-74 |

4 Replacement Procedures

| | | |
|---------------------|---|----------------|
| Figure 4-57 to 4-64 | Replacing LG.Philips fluorescent lamp (XGA) (1) to (8)..... | 4-77 to 4-84 |
| Figure 4-65 to 4-87 | Replacing Sharp fluorescent lamp (XGA) (1) to (23)..... | 4-85 to 4-105 |
| Figure 4-88 to 4-91 | Replacing Samsung fluorescent lamp (XGA) (1) to (4) | 4-106 to 4-109 |
| Figure 4-92 to 4-99 | Replacing LG.Philips fluorescent lamp (SXGA+) (1) to (8) | 4-112 to 4-121 |

4.1 General

This section explains how to disassemble the computer and replace Field Replaceable Units (FRUs). It may not be necessary to remove all the FRUs in order to replace one. The chart below is a guide to which FRUs need to be removed in order to remove others. Always start by removing the battery pack, next, optional items such as the optional PC card and optional SD card, then follow the line on the chart to determine which FRU you must remove next in order to repair the one you think is causing the computer to operate improperly. Refer to the example at the bottom of the page.

| | | |
|----------------------------|--------------------------|---|
| 4.2 Battery pack | | |
| 4.3 PC card | 4.4 SD card | 4.23 LCD unit/FL inverter |
| 4.5 Memory module | | 4.24 Cover latch |
| 4.6 HDD | 4.7 Wireless LAN card | 4.30 Fluorescent lamp |
| 4.8 Slim select bay module | | |
| 4.9 Keyboard | | |
| 4.10 Touch pad | 4.11 Bluetooth module | |
| 4.12 Switch membrane | | |
| 4.13 Display assembly | | |
| 4.14 RTC battery | 4.15 MDC | 4.26 Wireless LAN antenna/ Bluetooth antenna |
| 4.16 USB board | 4.17 Internal microphone | |
| 4.18 SR board/DC-IN jack | 4.19 Fan | 4.27 Hinge 4.28 Speaker |
| 4.20 CPU 4.21 GFX board | | 4.29 Battery slider |
| 4.21 System board | | |
| 4.22 FP board | | |

How to See the Chart

Example of referring to the chart is shown below.

•Removing the Touch pad

4.2 Battery pack to 4.9 Keyboard must be removed.

| | | |
|----------------------------|--------------------------|---|
| 4.2 Battery pack | | |
| 4.3 PC card | 4.4 SD card | 4.23 LCD unit/FL inverter |
| 4.5 Memory module | | 4.24 Cover latch |
| 4.6 HDD | 4.7 Wireless LAN card | 4.30 Fluorescent lamp |
| 4.8 Slim select bay module | | |
| 4.9 Keyboard | | |
| 4.10 Touch pad | 4.11 Bluetooth module | |
| 4.12 Switch membrane | | |
| 4.13 Display assembly | | |
| 4.14 RTC battery | 4.15 MDC | 4.26 Wireless LAN antenna/ Bluetooth antenna |
| 4.16 USB board | 4.17 Internal microphone | |
| 4.18 SR board/DC-IN jack | 4.19 Fan | 4.27 Hinge 4.28 Speaker |
| 4.20 CPU 4.21 GFX board | | 4.29 Battery slider |
| 4.21 System board | | |
| 4.22 FP board | | |

Safety Precautions

Before you begin disassembly, read the following safety precautions and observe them carefully as you work.

- DANGER:**
- 1) Always use the genuine battery that is authorized by Toshiba or compatible with the unit. Since other battery packs have different specifications, they may be incompatible with the unit, and may burst or explode.
Never heat or disassemble the battery pack, as that could cause leakage of alkaline solution. Never throw the battery pack into a fire, as that could cause the battery pack to explode.
 - 2) The power supply, FL inverter and other components carry high voltages. If you need to turn on the power of a partially disassembled computer to check its operation, be very careful not to touch connectors or components, in order to avoid the risk of electric shock. Also, do not disassemble individual components in first-level maintenance.

- WARNING:**
- 1) Turn off the power and disconnect the AC adaptor from the power source, to avoid exposure to electric shock.
 - 2) Batteries in the computer retain an electrical charge, so there is danger of electrical shock even when the computer is disconnected from an AC power source. Remove any metal jewelry or accessories such as necklaces, bracelets or rings, in order to reduce the risk of electric shock. Never work with wet or damp hands.
 - 3) Be careful of edges and corners as these may cut.

- CAUTION:**
- 1) When you change a component, be sure the replacement component meets the required specifications. Never use foreign parts, to avoid any risk of damage to the computer.
 - 2) To avoid any risk of short-circuit, fire or other internal damage, never allow any metal objects such as screws or paper clips to fall into the unit. Be sure to replace screws with the same size as those removed. Make sure all screws are securely fastened. Loose screws can cause short circuits, resulting in heat, smoke or fire.
 - 3) Before lifting out an FRU or other component, make sure all cables to the component have been disconnected, in order to reduce the risk of accidental electric shock.
 - 4) If you use AC power, be sure to use the cable that came with the computer or one recommended by Toshiba.
 - 5) Make sure that all replacement components meet the specifications for the computer and that all cables and connectors are securely fastened, in order to avoid the risk of electric shock.
 - 6) Some parts inside the computer, such as the CPU and cooling module, become very hot during operation. Conduct repair work after they have cooled. Be careful around the CPU and cooling module to avoid burns.

Before You Begin

Look over the procedures in this section before you begin disassembling the computer. Familiarize yourself with the disassembly and reassembly steps. Begin each procedure by removing the AC adapter and the battery pack as instructed in this section:

1. Do not disassemble the computer unless it is operating abnormally.
2. Use only the correct and approved tools.
3. Make sure the working environment is free from the following elements whether you are using or storing the computer.
 - Dust and contaminants
 - Static electricity
 - Extreme heat, cold and humidity
4. Make sure the FRU you are replacing is causing the abnormal operation by performing the necessary diagnostics tests described in this manual.
5. Do not perform any operations that are not necessary and use only the described procedures for disassembling and installing FRUs in the computer.
6. After removing parts from the computer, place them in a safe place away from the computer so they will not be damaged and will not interfere with your work.
7. You will remove and replace many screws when you disassemble the computer. When you remove screws, make sure they are placed in a safe place and identified with the correct parts.
8. When assembling the computer make sure you use the correct screws to secure the various pieces in place. Screw sizes are listed in their corresponding figures.
9. The computer contains many sharp edges and corners, so be careful not to injure yourself.
10. After you have replaced an FRU, make sure the computer is functioning properly by performing the appropriate test on the FRU you have fixed or replaced.

Disassembly Procedures

The computer has four basic types of cable connectors:

- Pressure Plate connector
- Spring connector
- Coaxial connector
- Normal Pin connector

To disconnect a Pressure Plate connector, lift up the tabs on either side of the connector's plastic pressure plate and slide the cable out of the connector. To connect the cable to a Pressure Plate connector, make sure the pressure plate is fully lifted and slide the cable into the connector. Secure the cable in place by pushing the sides of the pressure plate down so the plate is flush with the sides of the connector. Gently pull on the cable to make sure the cable is secure. If you pull out the connector, connect it again making sure the connector's pressure plate is fully lifted when you insert the cable.

For spring connectors, lifting up the stopper frees the cable and allows it to be pulled out. To reconnect, hold the stopper in the up position and insert the cable, then lower the stopper to secure the cable.

Coaxial cables should be disconnected with an antenna coaxial disconnecter.

Standard pin connectors are used with all other cables. These connectors can be connected and disconnected by simply pulling them apart or pushing them together.

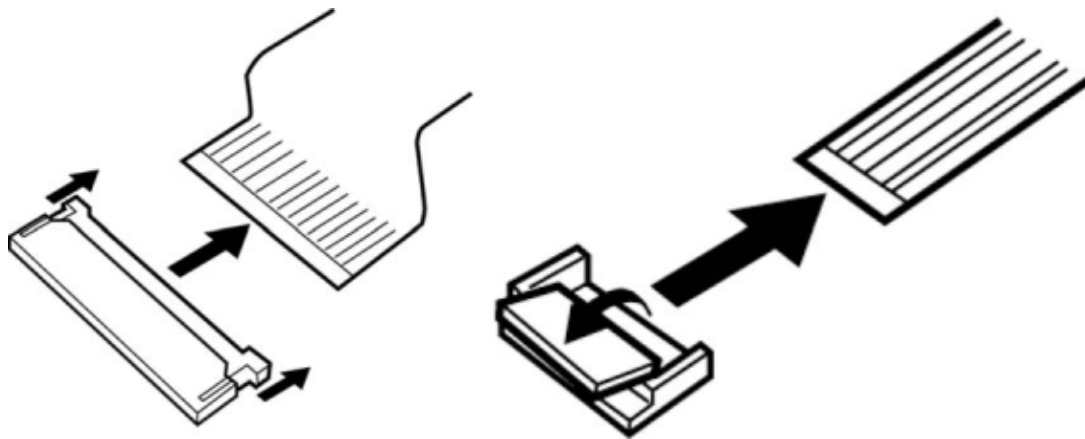

Pressure Plate Connector

Spring Connector

Assembly Procedures

After you have disassembled the computer and fixed or repaired the problem that was causing the computer to operate abnormally, you will need to reassemble the computer.

Install all the removed FRUs following the steps described in the corresponding sections in this chapter.

While assembling the computer, remember the following general points:

- Take your time, making sure you follow the instructions closely. Most problems arise when you get in a hurry assembling the computer.
- Make sure all cables and connectors are securely fastened.
- Before securing the FRU or other parts, make sure that screws or the FRU will pinch no cables.
- Check that all latches are closed securely in place.
- Make sure all the correct screws are used to secure all FRUs. Using the wrong screw can either damage the threads on the screw or the head of the screw and may prevent proper seating of an FRU.

After installing an FRU in the computer, confirm that the FRU and the computer are functioning properly.

Tools and Equipment

The use of Electrostatic Discharge (ESD) equipment is very important for your safety and the safety of those around you. Proper use of these devices will increase the success rate of your repairs and lower the cost for damaged or destroyed parts. The following equipment is necessary to disassemble and reassemble the computer:

- One M2 point size 0 Phillips screwdriver
- One M2.5/M3 point size 1 Phillips screwdriver
- One screw driver for stick screw
- One flat-blade screwdriver
- Tweezers, to lift out screws that you cannot grasp with your fingers
- ESD mats for the floor and the table you are working on
- An ESD wrist strap or heel grounder
- Anti-static carpeting or flooring
- Air ionizers in highly static sensitive areas
- Antenna coaxial cable disconnecter

Screw Tightening Torque

When you fasten screws, be sure to follow the torque list below.

CAUTION: Overtightening can damage components and screws; undertightening can result in electrical shorts or other damage if screws or components come loose.

NOTE: Toshiba recommends that you use an electric screw driver for quick and easy operations.

- M2 0.167 N·m (1.7 kgf·cm)
- M2.5 0.294 N·m (3.0 kgf·cm)
- M3 0.549 N·m (5.6 kgf·cm)

NOTE: The computer contains several flat head screws. These screws have less contact area with the screwdriver, so be careful to press firmly enough to prevent the screwdriver from slipping out and damaging the screw head.

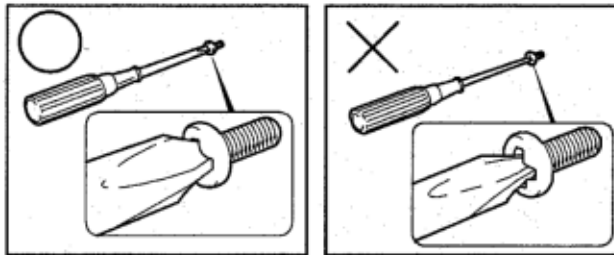

Color of Screw Shaft

To avoid mistakes on the screw length, screw shafts are colored as follows:

- Even number length screw: yellow
- Odd number length screw: pink
- Special length screw: green

Screws whose lengths are indicated to one or more decimal places such as 2.5 mm or 2.6 mm.



Marking of Screws on the Computer Body

To make maintenance of the computer easier, markings of the kinds of the screws including the types and lengths of the screws are indicated on the computer body.

| Color/Material of screws | Symbol |
|--|--------|
| <input type="checkbox"/> Black | B |
| <input type="checkbox"/> Silver | S |
| <input type="checkbox"/> Zinc | Z |
| <input type="checkbox"/> Other screws (Unique screws, STUD, etc.) | U |

Examples:

| | |
|---|----|
| <input type="checkbox"/> 6 mm Black screw | 6B |
|---|----|

Kind of screws

- BIND screw
- FLAT HEAD screw
- SUPER FLAT HEAD screw
- TAPPING screw
- Other screws
(Unique screws, STUD, etc.)

4.2 Battery pack

Removing the Battery pack

To remove the battery pack, follow the steps below and refer to Figure 4-1.

CAUTION: When handling battery packs, be careful not to short circuit the terminals. Also do not drop, hit or apply impact; do not scratch, break, twist or bend the battery pack.

1. Turn off the power of the computer.
2. Disconnect the AC adapter and other external devices from the computer.
3. Turn the computer face down.
4. Release the **battery lock**, then remove the **battery pack** while sliding the **battery latch**.

NOTE: For environmental reasons, do not throw away a spent battery pack. Collect the spent battery packs.

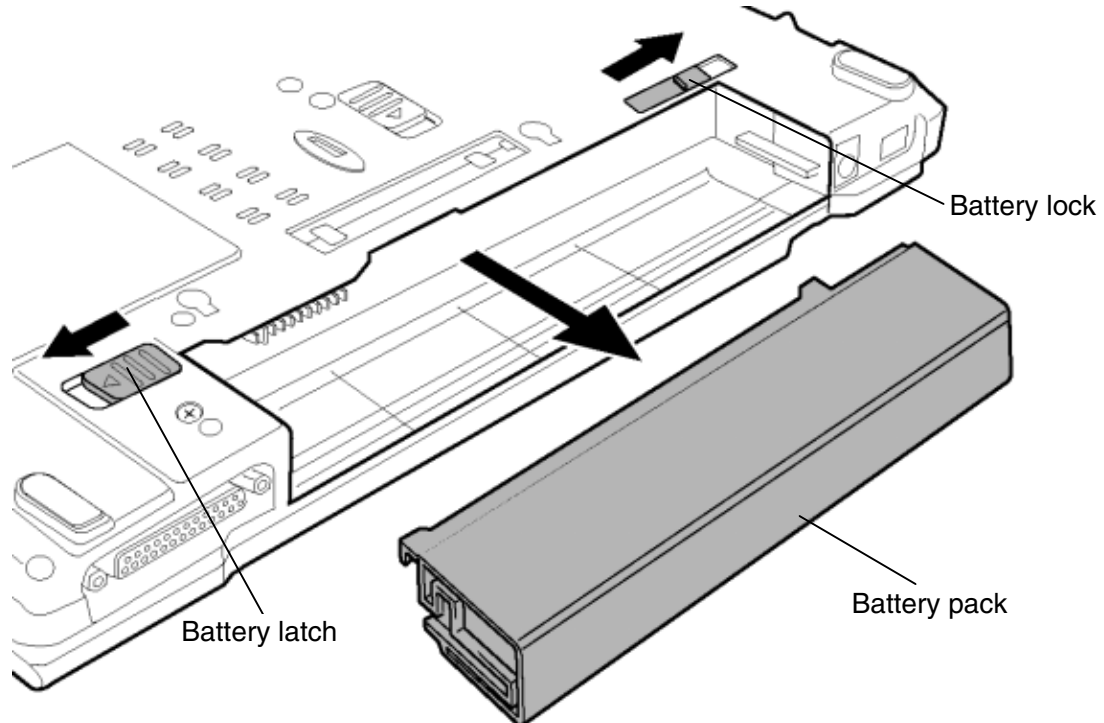

Figure 4-1 Removing the battery pack

Installing the Battery pack

To install the battery pack, follow the steps below and refer to Figure 4-1.

CAUTION: *The battery pack is a lithium ion battery, which can explode if not properly replaced, used, handled or disposed of. For environmental reasons, collect the spent battery packs. Use only batteries recommended by Toshiba as replacements.*

NOTE: *Check the battery's terminals visually. If they are dirty, wipe them clean with a dry cloth.*

1. Turn off the power of the computer.
2. Disconnect the AC adapter and all other external devices to the computer.
3. Insert the **battery pack** all the way to the end.
4. Make sure that the battery pack is securely in place and the **battery lock** is in the lock position.

4.3 PC card

Removing the PC card

To remove the PC card, follow the steps below and refer to Figure 4-2.

CAUTION: Before you remove a PC card, refer to the card's documentation and to your operating system documentation for proper procedures and precautions.

1. Turn the computer face up.
2. Press the PC card **eject button** to extend it.
3. Press the extended eject button to pop the PC card out slightly.
4. Grasp the **PC card** and pull it out.

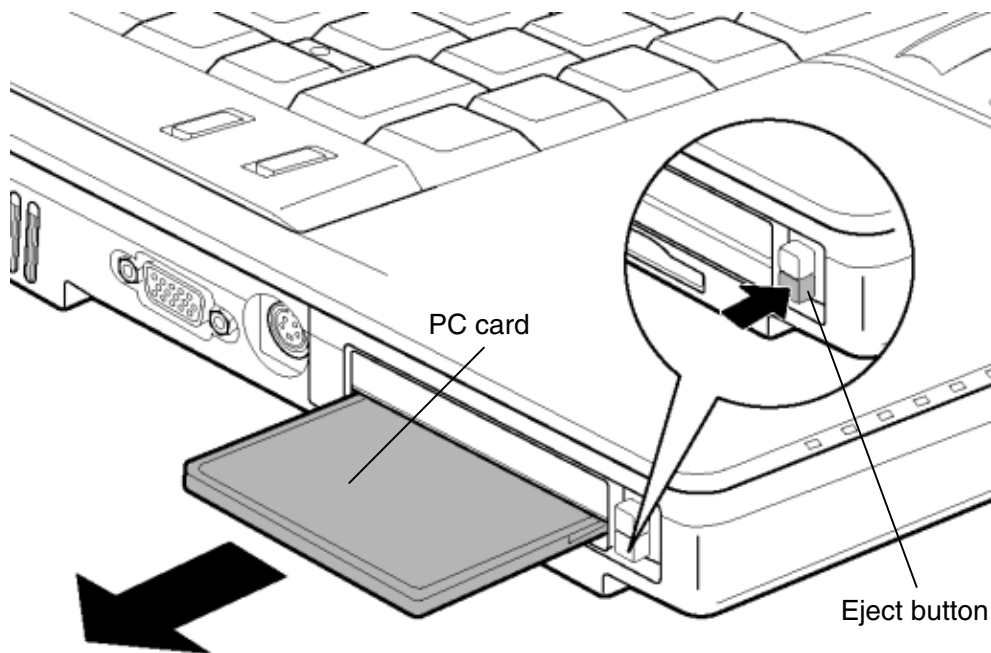

Figure 4-2 Removing the PC card

Installing the PC card

To install the PC card, follow the steps below and refer to Figure 4-2.

1. Insert the **PC card** in the PC card slot.
2. Push it carefully to ensure a firm connection.

4.4 SD card

Removing the SD card

To remove the SD card, follow the steps below and refer to Figure 4-3.

CAUTION: Before you remove the SD card, refer to the card's documentation and to your operating system documentation for proper procedures and precautions.

1. Push in the **SD card** (indicated as "1" in the figure below) and release it to pop the card out slightly.
2. Grasp the **SD card** and pull it out (indicated as "2" in the figure below).

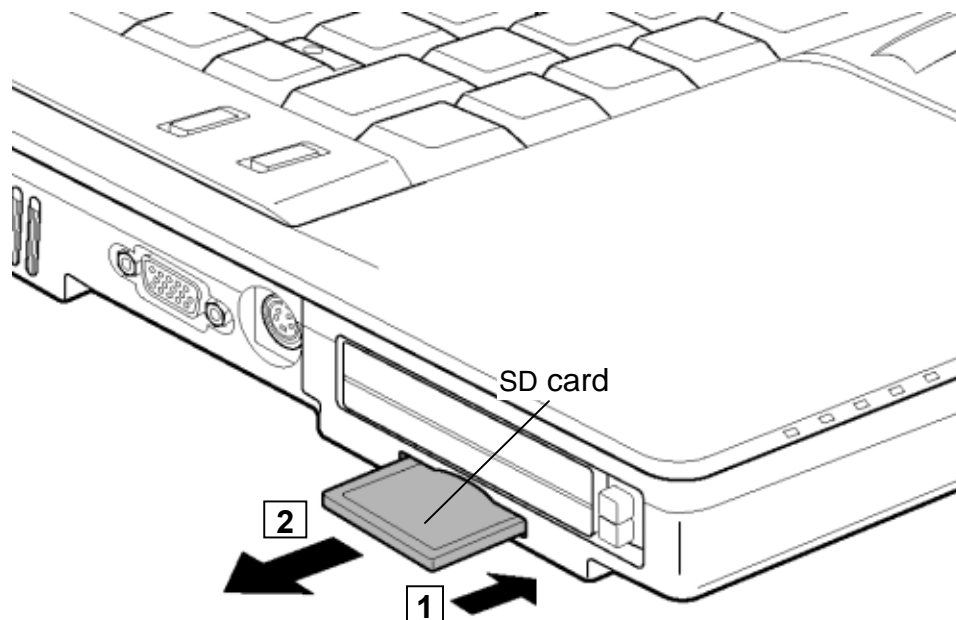

Figure 4-3 Removing the SD card

Installing the SD card

To install the SD card, follow the steps below and refer to Figure 4-3.

1. Insert the **SD card** in the SD card slot.
2. Push it carefully to ensure a firm connection.

4.5 Memory module

Removing the Memory module

To remove the memory module, make sure the computer is in boot mode and powered off, follow the steps below and refer to Figure 4-4.

CAUTION: *The power must be turned off when you remove/insert the memory module. Removing/inserting a memory module with the power on might damage the module or the computer itself.*

Never press hard or bend the memory module.

1. Turn over the computer.
2. Loosen the **screw** (with e-ring) fixing the memory slot cover.
3. Slide your finger under the **memory slot cover** and lift it up to remove.
4. Press the **latches** outward and remove the **memory module**.

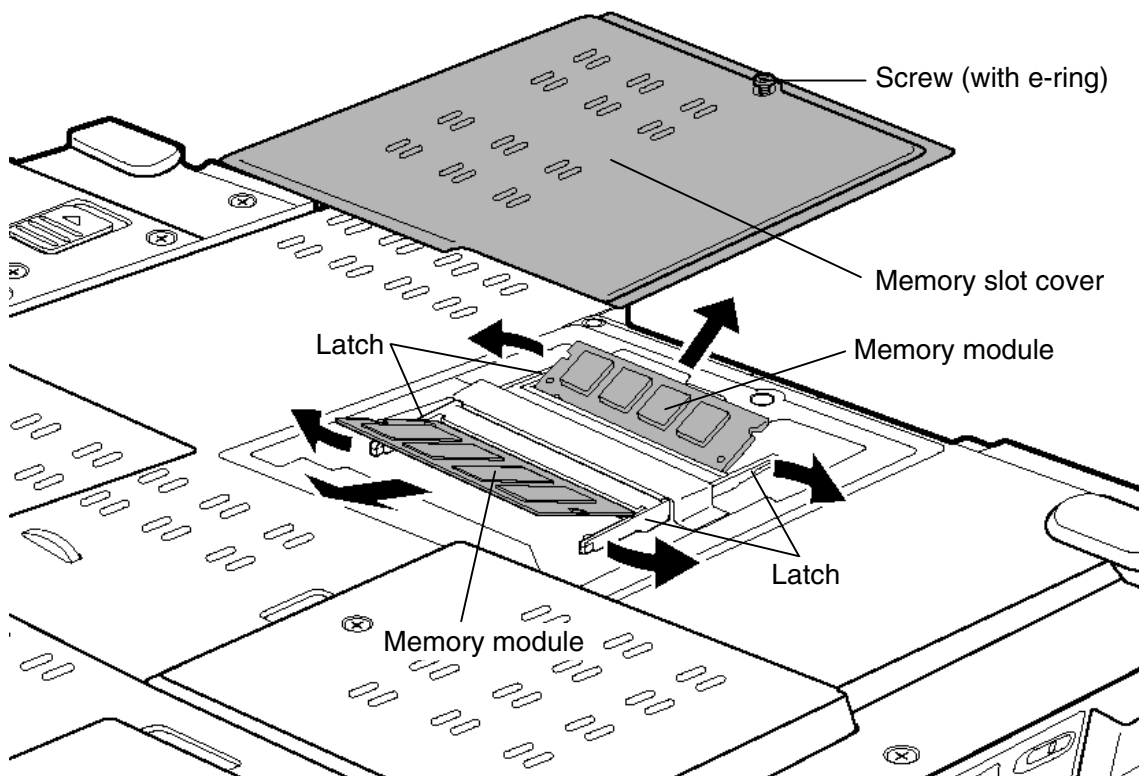

Figure 4-4 Removing the memory module

Installing the Memory module

To install the memory module, make sure the computer is in boot mode and powered off, follow the steps below and refer to Figure 4-4.

CAUTION: *Do not touch the connectors on the memory module or on the computer. Dust and stains on the connectors may cause memory access problems.*

1. Insert the **memory module** into the connector slantwise (terminal side first) and press it to connect firmly.

CAUTION: *After installing the memory module, confirm that the memory module is fixed with the left and right latches.*

2. Seat the **memory slot cover** and secure it with the **screw** (with e-ring).
3. When the power of the computer is turned on, the computer checks automatically the memory size. Confirm that the new memory is detected correctly.
4. If the memory is not detected, check that it is connected correctly.

4.6 HDD

CAUTION: When handling the HDD, do not press the top surface as shown by the arrow. Hold it by the sides.

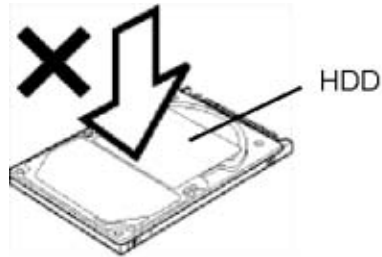

Removing the HDD

To remove the HDD, follow the steps below and refer to Figure 4-5 and 4-6.

1. Loosen the **screw** (with e-ring) fixing the HDD cover and slide your finger under the **HDD cover** and lift it up to remove.
2. Hold the tub to raise the HDD assembly straight and pull out the **HDD assembly** from the connector of the **HDD cable**.

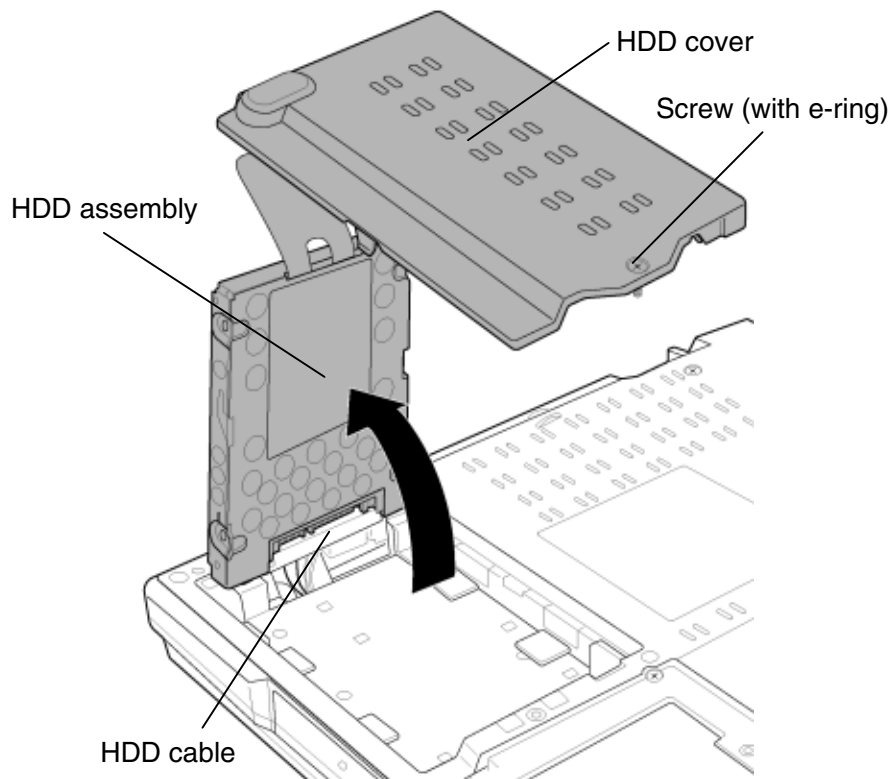

Figure 4-5 Removing the HDD assembly

NOTE: The following steps describe how to disassemble the HDD assembly; however, do not disassemble if the HDD is working properly.

3. Place the HDD assembly on a flat surface, and remove the following screws.

- M3×4S FLAT HEAD screw ×4

4. Separate the **HDD** and the **HDD bracket**.

CAUTION: Do not apply pressure to the top or bottom of the HDD.

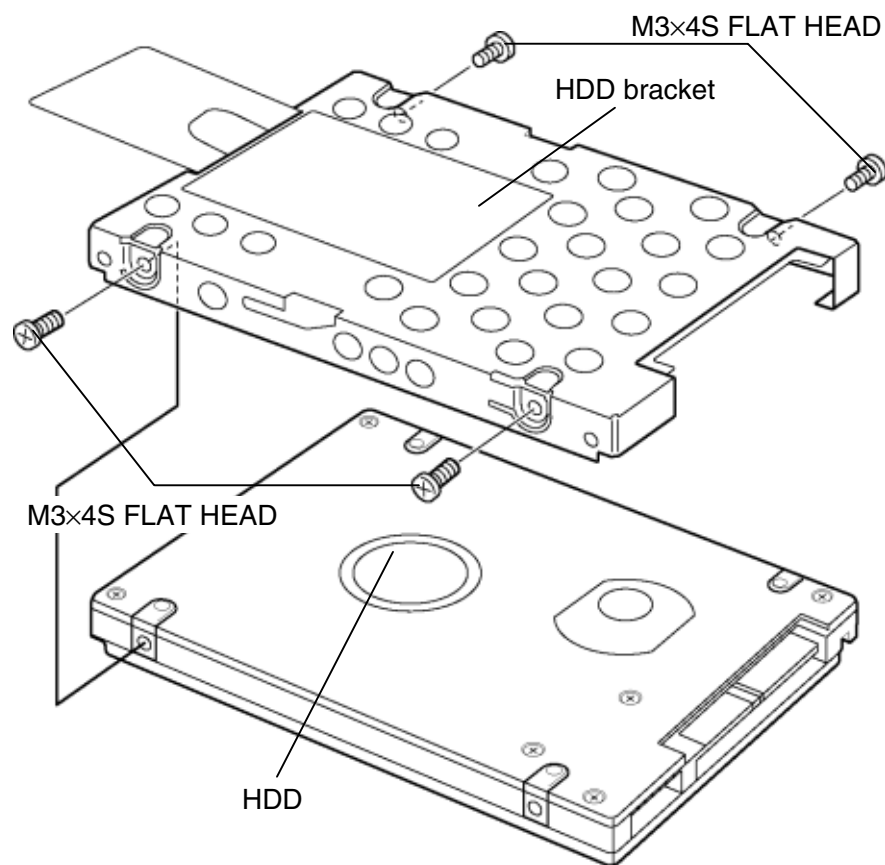

Figure 4-6 Separating the HDD

Installing the HDD

To install the HDD, follow the steps below and refer to Figure 4-5 and 4-6.

CAUTION: Do not hold the HDD by its top and bottom flat surfaces. It may damage the HDD.

1. Seat the **HDD** in the **HDD bracket** and secure them with the following **screws**.

- M3×4S FLAT HEAD screw ×4

CAUTION: Do not apply pressure to the middle of the HDD pack. It may damage the HDD assembly. Hold the HDD assembly by its corners.

2. Set the connector of the **HDD cable** upward and connect the **HDD assembly** to the connector. Press to ensure a firm connection.
3. Set the **HDD assembly** into the slot.
4. Seat the **HDD cover** and secure it with the **screw** (with e-ring).

4.7 Wireless LAN card

Removing the Wireless LAN card

To remove the wireless LAN card, make sure the computer is in boot mode and powered off, follow the steps below and refer to Figure 4-7.

CAUTION: Do not try to remove the wireless LAN card with the computer turned on. The computer or the wireless LAN card can be damaged. Do not touch the connectors on the wireless LAN card on the computer. Debris on the connectors may cause the wireless LAN card access problems.

1. Remove the following **screw** securing the wireless LAN card cover.
 - M2×4B BIND screw ×1
2. Slide your finger under the **wireless LAN card cover** and lift it up to remove.
3. Peel off the **insulator** and disconnect the **wireless LAN antenna cables** (black and white) from the wireless LAN card using an antenna coaxial cable disconnecter.
4. Press two **latches** outward to release the wireless LAN card.
5. Disconnect the **wireless LAN card** from the connector on the system board.

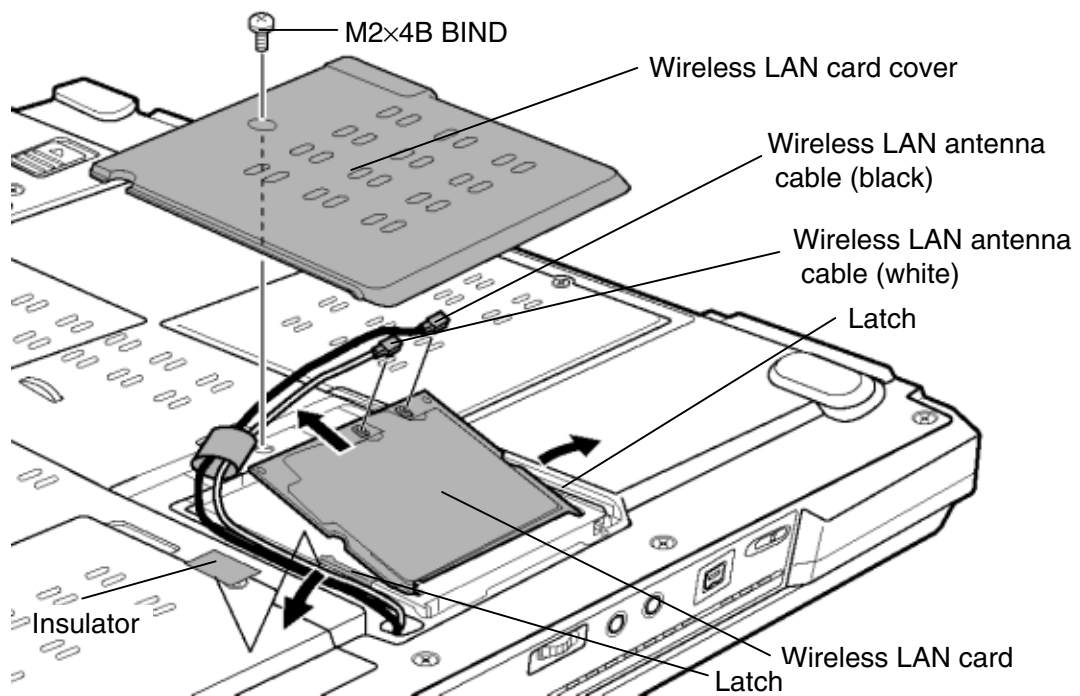

Figure 4-7 Removing the Wireless LAN card

Installing the Wireless LAN card

To install the wireless LAN card, make sure the computer is in boot mode and powered off, follow the steps below and refer to Figure 4-7.

CAUTION: *Be sure to switch the computer off before installing the wireless LAN card. Otherwise, the computer or the wireless LAN card may be damaged.*

1. Insert the **wireless LAN card** into the connector of the slot slantwise and press it to connect firmly.

CAUTION: *Match the ditch of the wireless LAN card to the guide of the slot.*

2. Gently push the wireless LAN card down until the **latches** on the both sides are engaged.
3. Connect the **wireless LAN antenna cables** (black AUX and white MAIN) to the connectors on the wireless LAN card and stick the **insulator** in place.
4. Seat the **wireless LAN card cover** and secure it with the following screw.
 - M2×4B BIND screw ×1

4.8 Slim select bay module

Removing the Slim select bay module

To remove the slim select bay module, follow the steps below and refer to Figure 4-8 and 4-9. The explanation and figure shown below are the optical drive removing/installing. As for other module, the procedure is same.

CAUTION: Do not put fingers in the slim select bay module. It may cause injury.

1. Remove the following **screw** securing the latch and drive the removed **screw** into the **screw hole**. (The slim select bay is unlocked.)
 - M2.5×4B FLAT HEAD screw ×1
2. While sliding the **latch** toward the arrow direction in the Figure 4-8, pull out the slim select bay module to disconnect it from the system board.

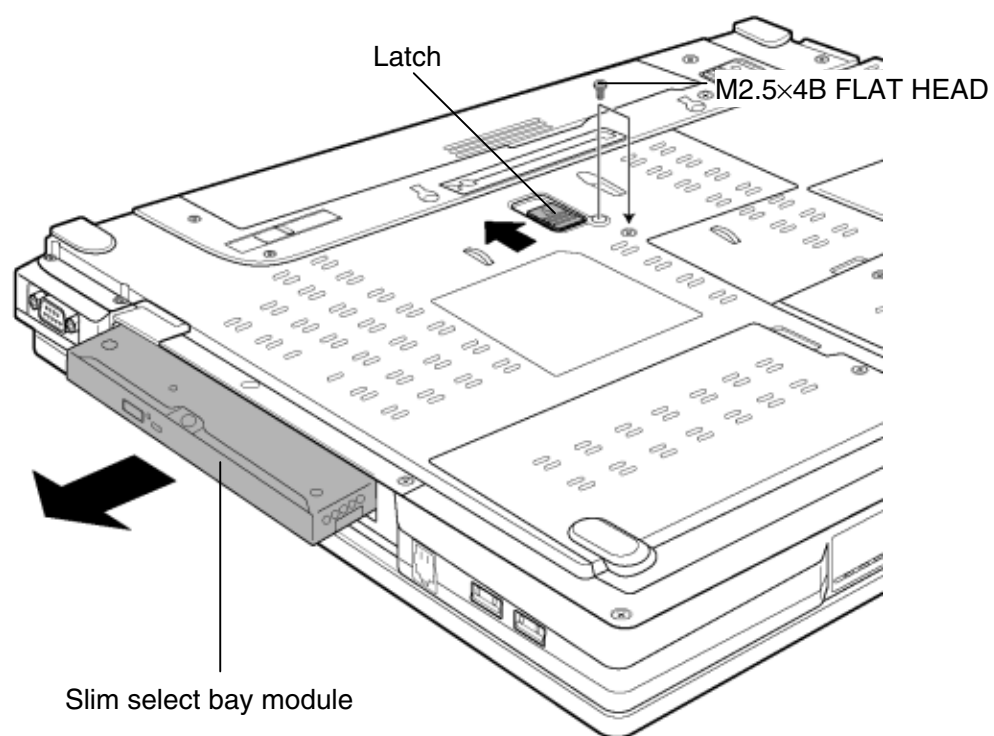

Figure 4-8 Removing the slim select bay module

CAUTION: When using the DVD super multi drive as the slim select bay module, the removed drive must be kept in an ultra slim bay case.

3. Remove the following **screws**, **connector cover** and **connector** from the optical drive assembly.

- M2×6S BIND screw ×2

4. Remove the following **screw** and **connector cover** from the optical drive assembly.

- M2×3S S-FLAT HEAD screw ×1

5. Remove the following **screws** and **connector cover holder** from the optical drive assembly.

- M2×6S BIND screw ×1

- M2×22S BIND screw ×1

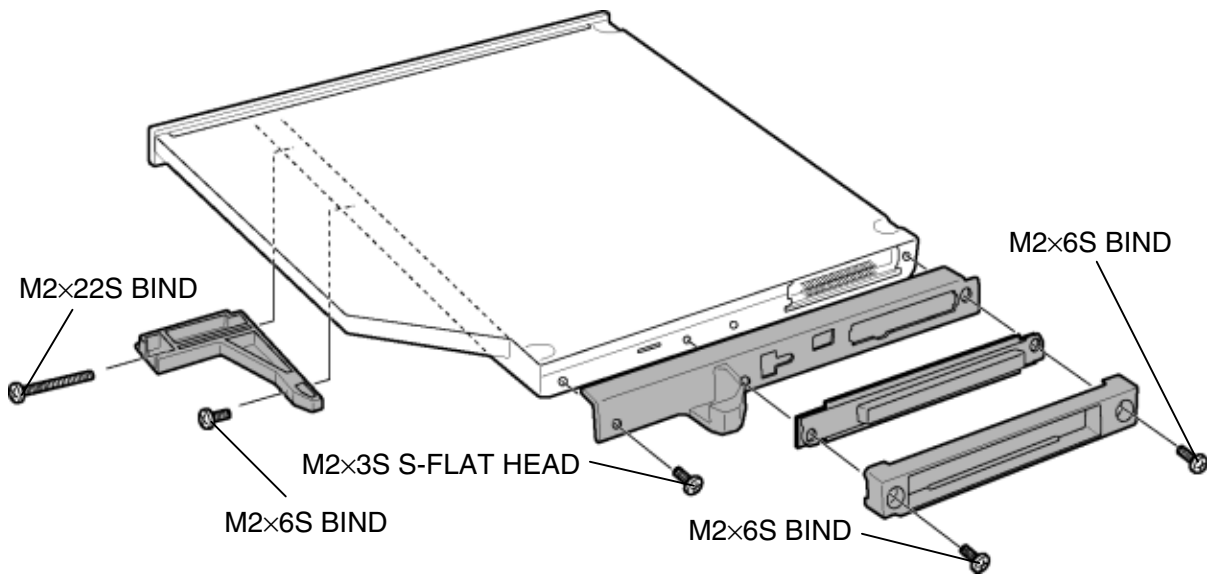

Figure 4-9 Detaching the optical drive assembly

Installing the Slim select bay module

To install the slim select bay module, follow the steps below and refer to Figure 4-8 and 4-9.

1. Install the **connector cover holder** to the optical drive assembly and secure it with the following **screws**.

- M2×6S BIND screw ×1
- M2×22S BIND screw ×1

2. Install the **connector cover** to the optical drive assembly and secure it with the following **screw**.

- M2×3S S-FLAT HEAD screw ×1

3. Install the **connector cover** and **connector** to the optical drive assembly and secure it with the following **screws**.

- M2×6S BIND screw ×2

4. Insert the **slim select bay module** into the computer to connect it to the connector on the system board. Press to ensure a firm connection.

5. Remove the following **screw** from the screw hole. Then secure the latch with the **removed screw**. (The slim select bay is locked.)

- M2.5×4B FLAT HEAD screw ×1

4.9 Keyboard

Removing the Keyboard

To remove the keyboard, follow the steps below and refer to Figure 4-10 to 4-13.

1. Turn the computer face up.
2. Open the display and make it flat.
3. Insert your finger into the latches of the both sides and lift up the **speaker cover** to remove.
4. Remove the following screws.
 - M2.5×4B FLAT HEAD screw ×2

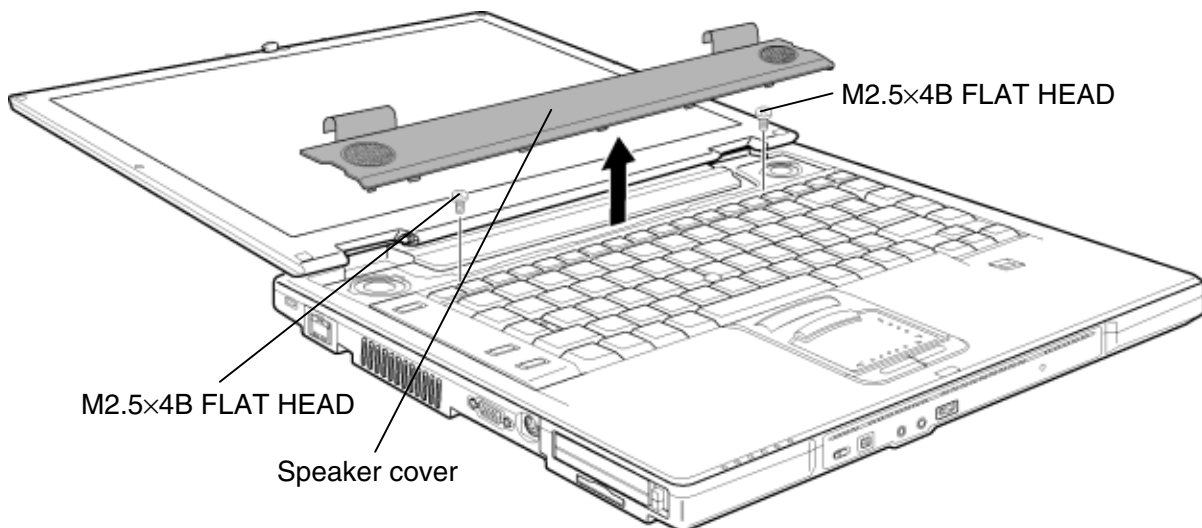

Figure 4-10 Removing the speaker cover

5. Lift the upper side of the **keyboard** while releasing three latches and turn it face down on the palm rest.

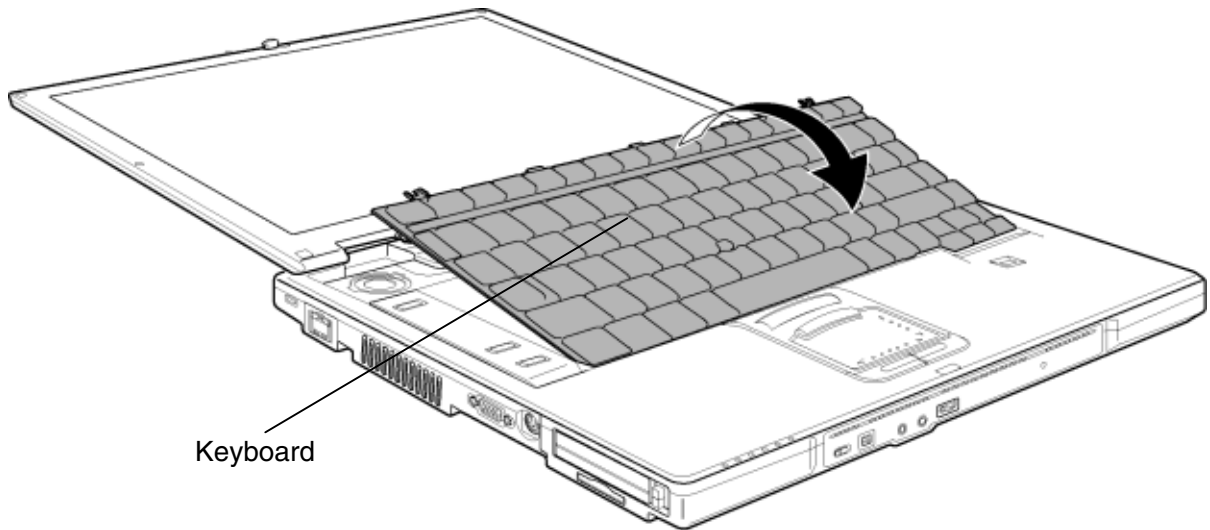

Figure 4-11 Turning over the keyboard

6. Remove the following **screw**.
 - M2.5×4B FLAT HEAD screw ×1
7. Peel off the adhered portion (adhered to the CPU holder) of the **keyboard support plate** and slide it to the direction indicated in the figure below to remove.

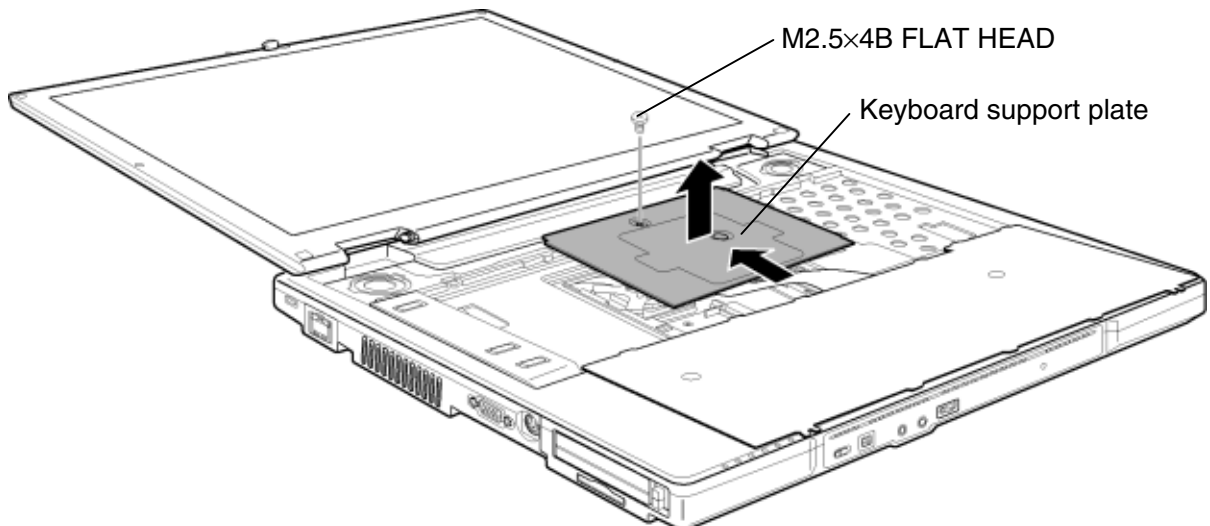

Figure 4-12 Removing the keyboard support plate

8. Disconnect the **keyboard cable** from the connector **CN3200** on the system board and remove the keyboard.

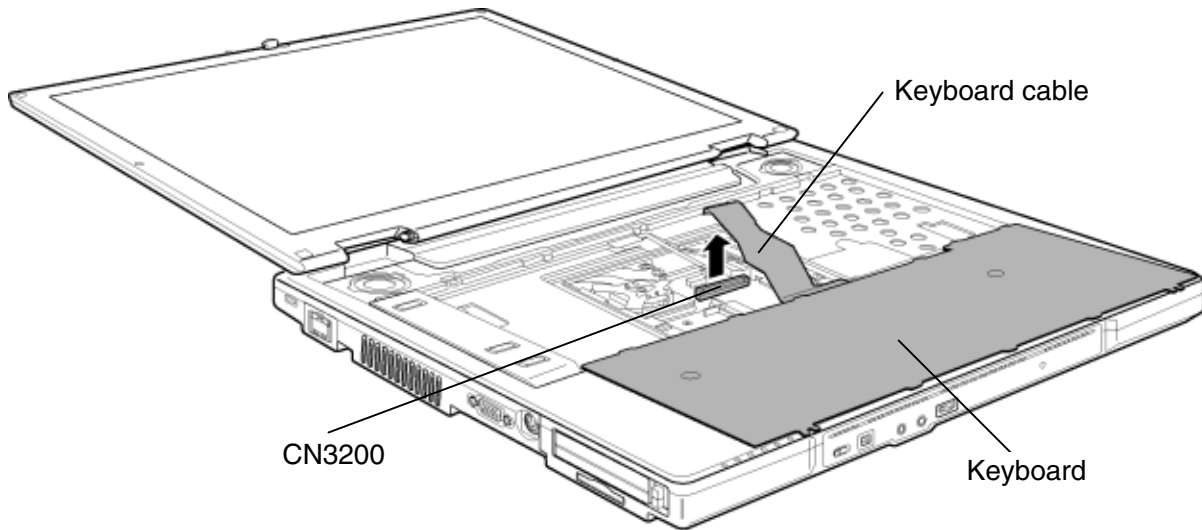

Figure 4-13 Removing the keyboard

Installing the Keyboard

To install the keyboard, follow the steps below and refer to Figure 4-10 to 4-13.

1. Place the keyboard face down on the palm rest.
2. Connect the **keyboard cable** to the connector **CN3200** on the system board.
3. Extra portion of the keyboard cable must be put under the keyboard support.
4. Slide the **keyboard support plate** to the below and set it while sticking the adhered portion on the CPU holder.
5. Secure the **keyboard support plate** with the following **screw**.
 - M2.5×4B FLAT HEAD screw ×1
6. Turn the **keyboard** face up and set it while engaging three latches. Make sure that there is no gap between the keyboard and edge of the palm rest.
7. Secure the **keyboard** with the following **screws**.
 - M2.5×4B FLAT HEAD screw ×2
8. Install the **speaker cover**.

4.10 Touch pad

Removing the Touch pad

To remove the touch pad, follow the steps below and refer to Figure 4-14 and 4-15.

1. Disconnect the **touch pad cable** from the connector **CN3201** on the system board.
2. Remove the **touch pad assembly** while releasing the latches.

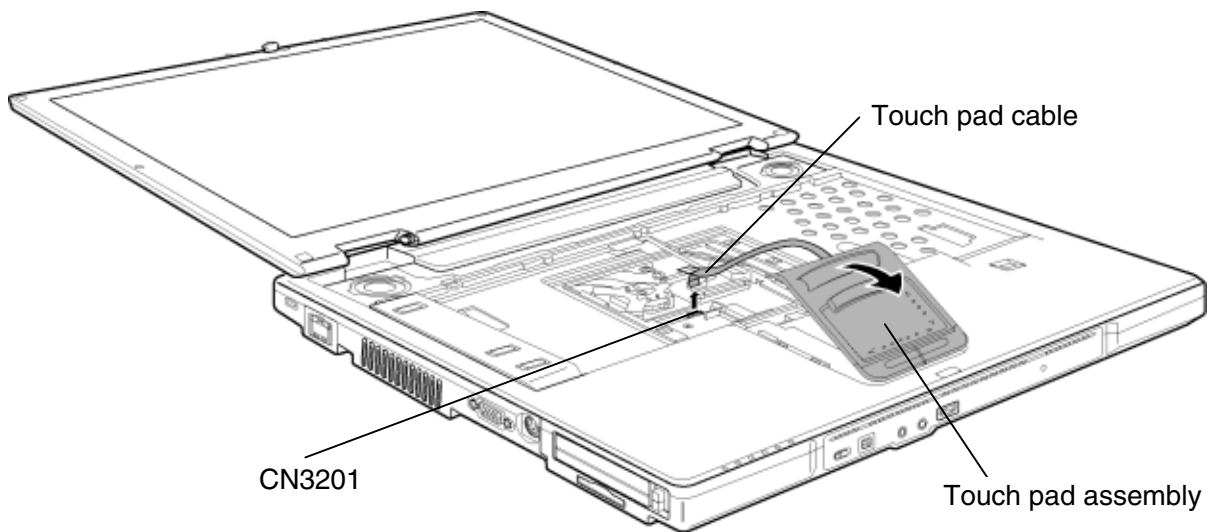

Figure 4-14 Removing the touch pad assembly

3. Peel off the **glass tape** and disconnect the **touch pad cable** from the connector on the touch pad.
4. Remove the following **screws** and **touch pad**.
 - M2.5×4B FLAT HEAD screw ×2

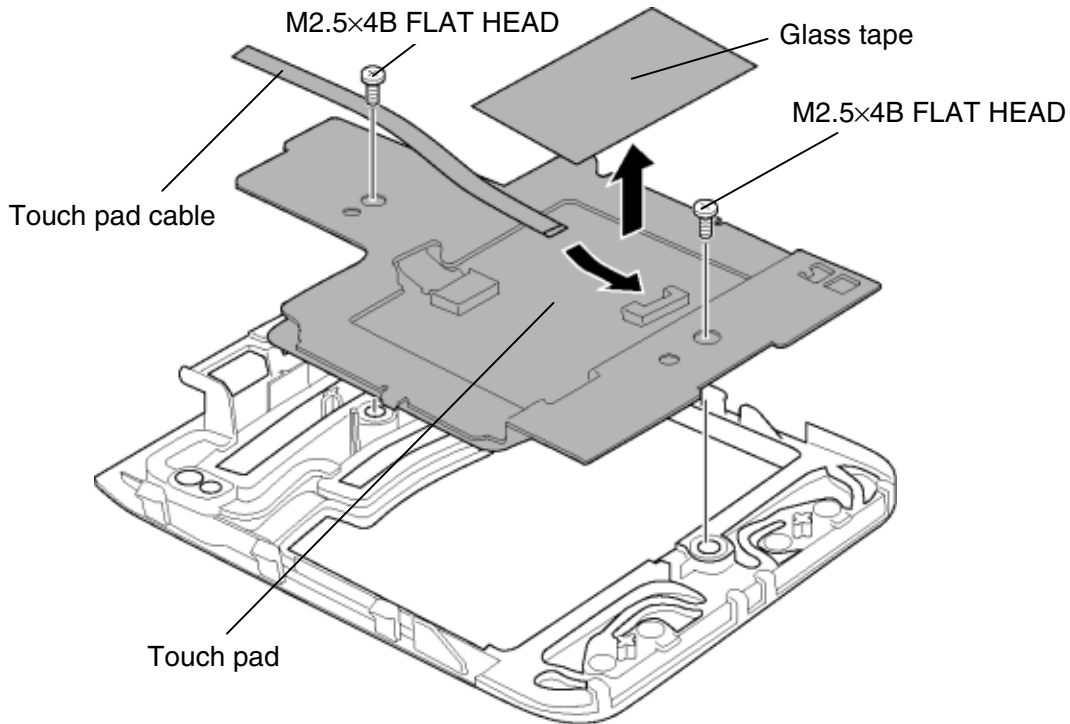

Figure 4-15 Removing the touch pad

Installing the Touch pad

To install the touch pad, follow the steps below and refer to Figure 4-14 and 4-15.

1. Install the **touch pad** and secure it with the following **screws**.
 - M2.5×4B FLAT HEAD screw ×2
2. Connect the **touch pad cable** to the connector on the touch pad and stick the **glass tape**.
3. Install the **touch pad assembly** to the slot of the palm rest while engaging the latches.
4. Connect the **touch pad cable** to the connector **CN3201** on the system board.

4.11 Bluetooth module

Removing the Bluetooth module

To remove the Bluetooth module, follow the steps below and refer to Figure 4-16.

1. Disconnect the **Bluetooth antenna cable** from the connector on the Bluetooth module.
2. Disconnect the **Bluetooth cable** from the connector **CN4400** on the system board.
3. Remove the **Bluetooth module** from the slot and disconnect the **Bluetooth cable** from the connector on the Bluetooth module.

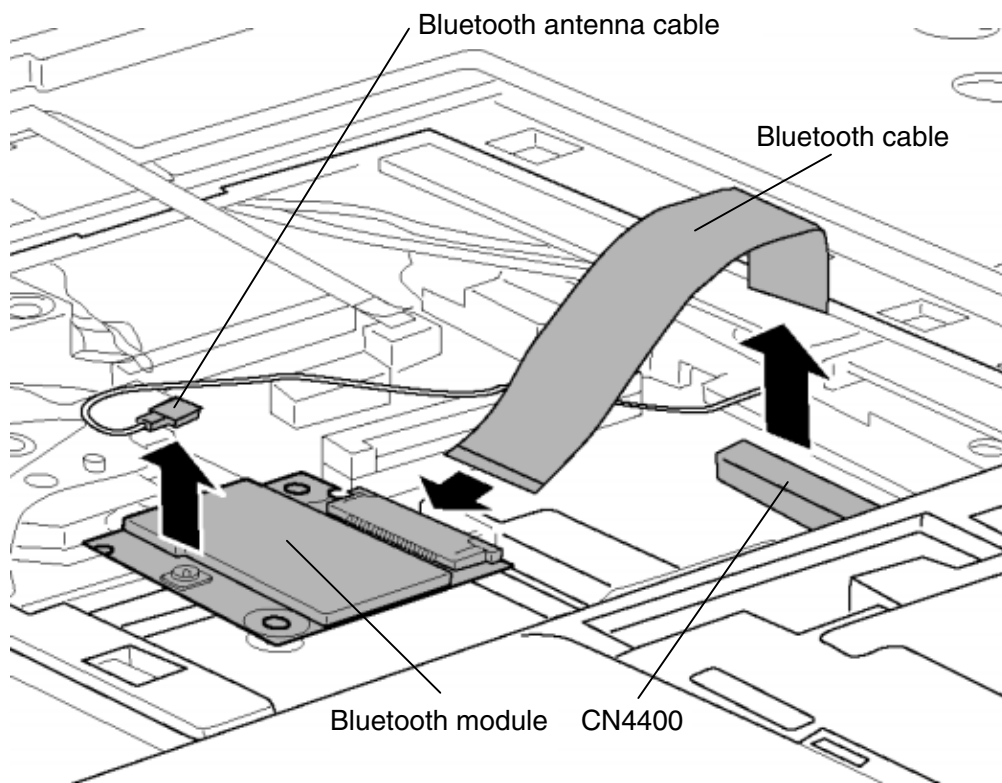

Figure 4-16 Removing the Bluetooth module

Installing the Bluetooth module

To install the Bluetooth module, follow the steps below and refer to Figure 4-16.

1. Connect the **Bluetooth cable** to the connector on the Bluetooth module and set the **Bluetooth module** to the slot in place.
2. Connect the **Bluetooth cable** to the connector **CN4400** on the system board.
3. Connect the **Bluetooth antenna cable** to the connector on the Bluetooth module.

4.12 Switch membrane

Removing the Switch membrane

To remove the switch membrane, follow the steps below and refer to Figure 4-17.

1. Remove the following **screw** and lift up the upper part of the right side of the **switch cover** to remove.

- M2.5×4B FLAT HEAD x1

2. Peel off the **insulator** and disconnect the **switch cable** from the connector **CN3260** on the system board.

3. Remove the following **screw** and slide the **switch membrane** to the right to remove.

- M2.5×4B FLAT HEAD x1

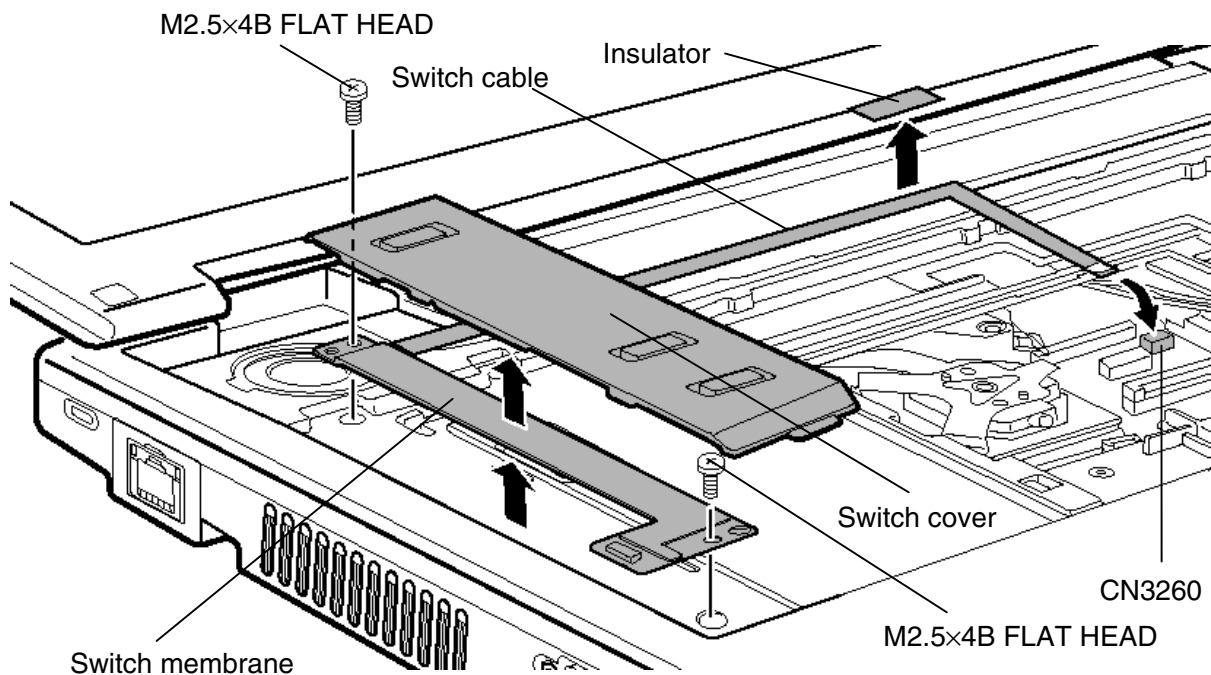

Figure 4-17 Removing the SW membrane

Installing the Switch membrane

To install the switch membrane, follow the steps below and refer to Figure 4-17.

1. Install the **switch membrane** in place and secure it with the following **screw**.
 - M2.5×4B FLAT HEAD screw x1
2. Connect the **switch cable** to the connector **CN3260** on the system board.
3. Slide the **switch cover** to the below to install and secure it with the following **screw**.
 - M2.5×4B FLAT HEAD screw x1

4.13 Display assembly

Removing the Display assembly

To remove the display assembly, follow the steps below and refer to Figure 4-18 to 4-20.

1. Peel off the **insulator** and disconnect the **finger print sensor cable** from the connector **CN9700** on the system board.
2. Disconnect the **speaker cable** from the connector **CN6170** on the system board.
3. Turn up the **black tape** and disconnect the **LCD cable** from the connector **CN5500** on the system board.
4. Remove the following **screws**.
 - M2.5×8B FLAT HEAD screw ×1
 - M2×6S BIND screw ×1

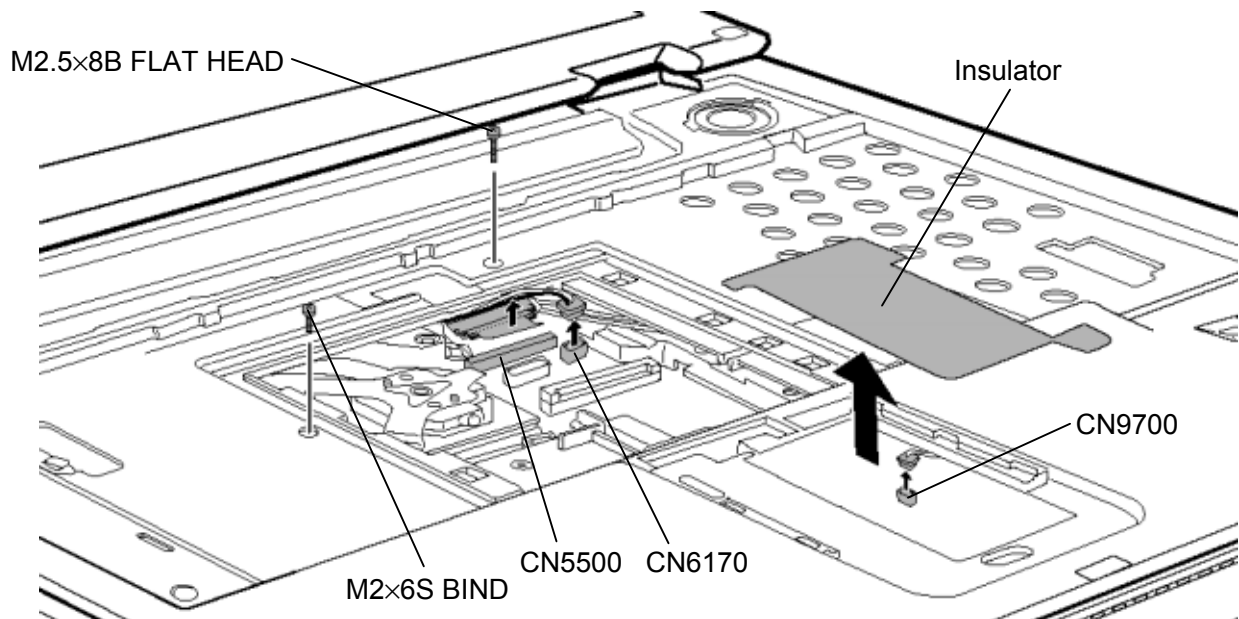

Figure 4-18 Removing the display assembly (1)

5. Turn the computer face down and remove the following **screws**.

- M2.5×16B FLAT HEAD screw ×8 (“16” in the figure below)
- M2.5×8B FLAT HEAD screw ×7 (“8” in the figure below)
- M2.5×4B FLAT HEAD screw ×1 (“4” in the figure below)

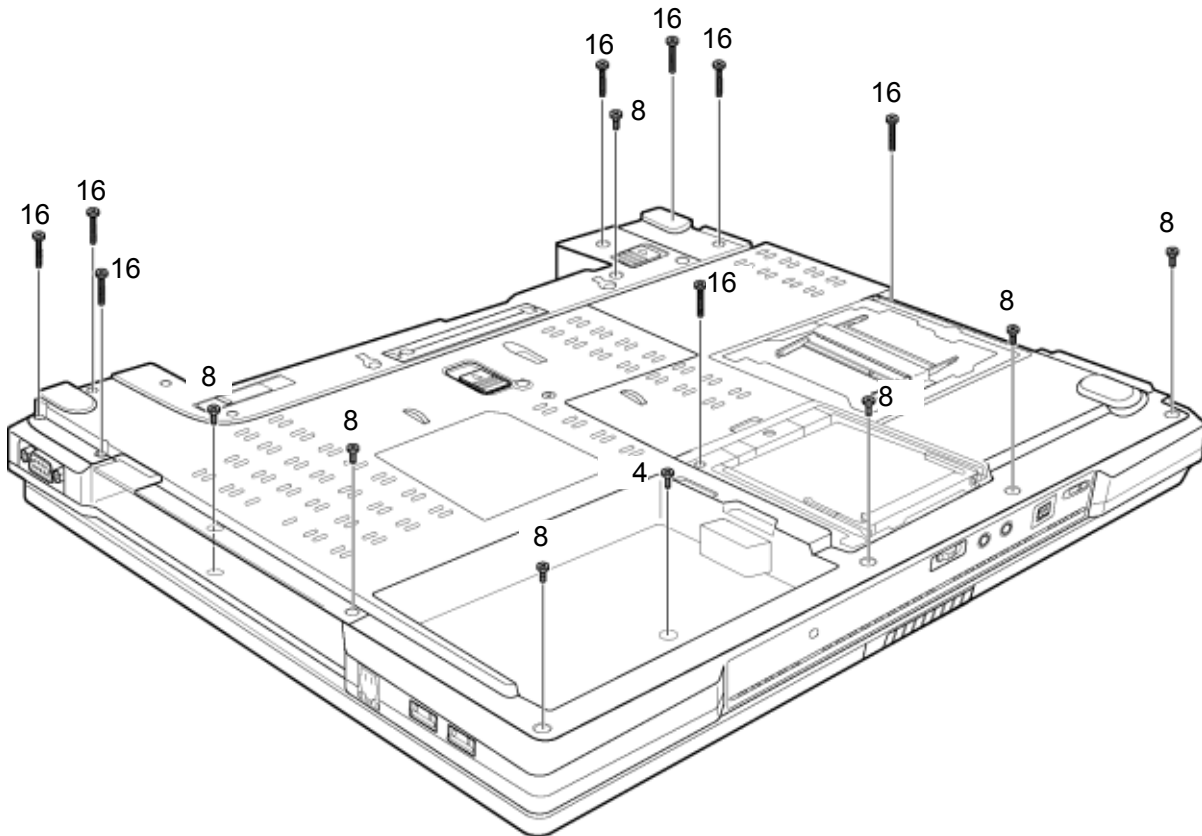

Figure 4-19 Removing the display assembly (2)

6. Turn the computer face up and open the display.
7. Lift the **display assembly** up to remove while releasing the latches.

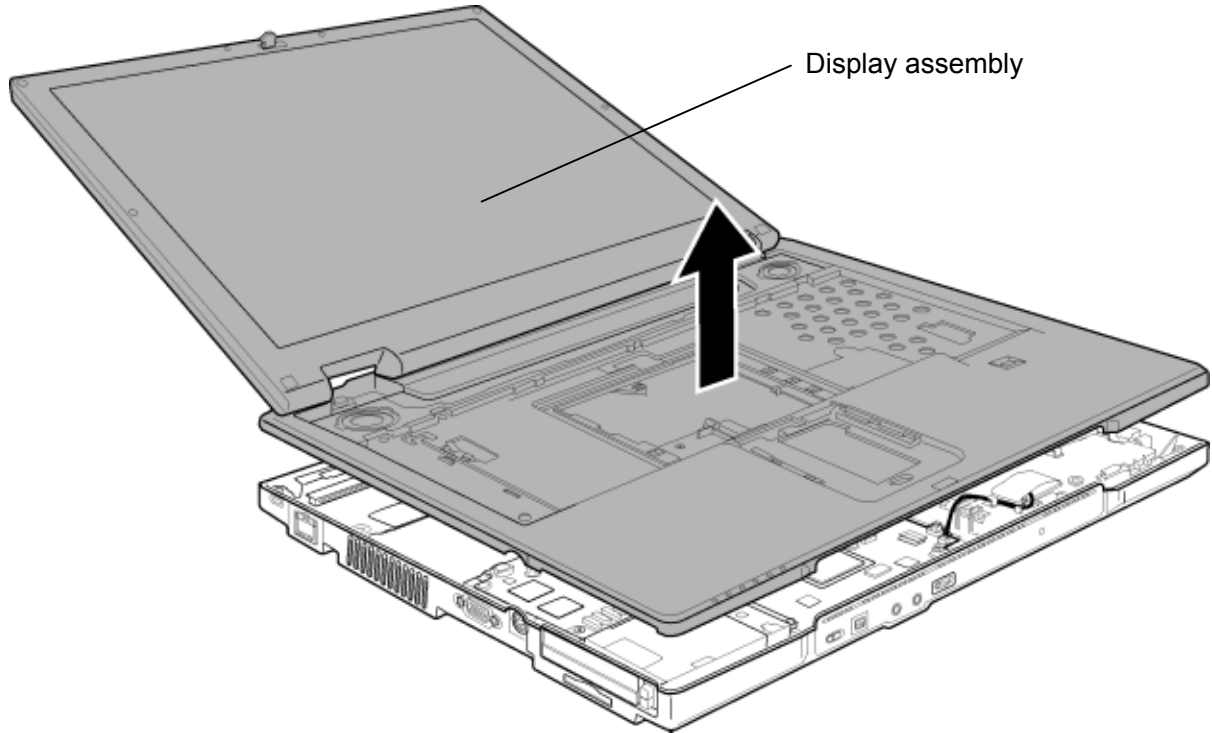

Figure 4-20 Removing the display assembly (3)

Installing the Display assembly

To install the display assembly, follow the steps below and refer to Figure 4-18 to 4-20.

1. Place the **display assembly** to the base assembly while engaging the latches.
2. Secure the display assembly (front) with the following **screws**.
 - M2.5×8B FLAT HEAD screw ×1
 - M2×6S BIND screw ×1
3. Turn up the **black tape** and connect the **LCD cable** to the connector **CN5500** on the system board.
4. Connect the **speaker cable** to the connector **CN6170** on the system board.
5. Connect the **finger print sensor cable** to the connector **CN9700** on the system board and stick the **insulator**.
6. Close the display and turn the computer face down. Secure the following **screws**.
 - M2.5×16B FLAT HEAD screw ×8 (“16” in the figure 4-19)
 - M2.5×8B FLAT HEAD screw ×7 (“8” in the figure 4-19)
 - M2.5×4B FLAT HEAD screw ×1 (“4” in the figure 4-19)

4.14 RTC battery

Removing the RTC battery

To remove the RTC battery, follow the steps below and refer to Figure 4-21.

1. Disconnect the **RTC battery cable** from the connector **CN9990** on the system board.
2. Turn up the battery holder and remove the **RTC battery** from the holder.

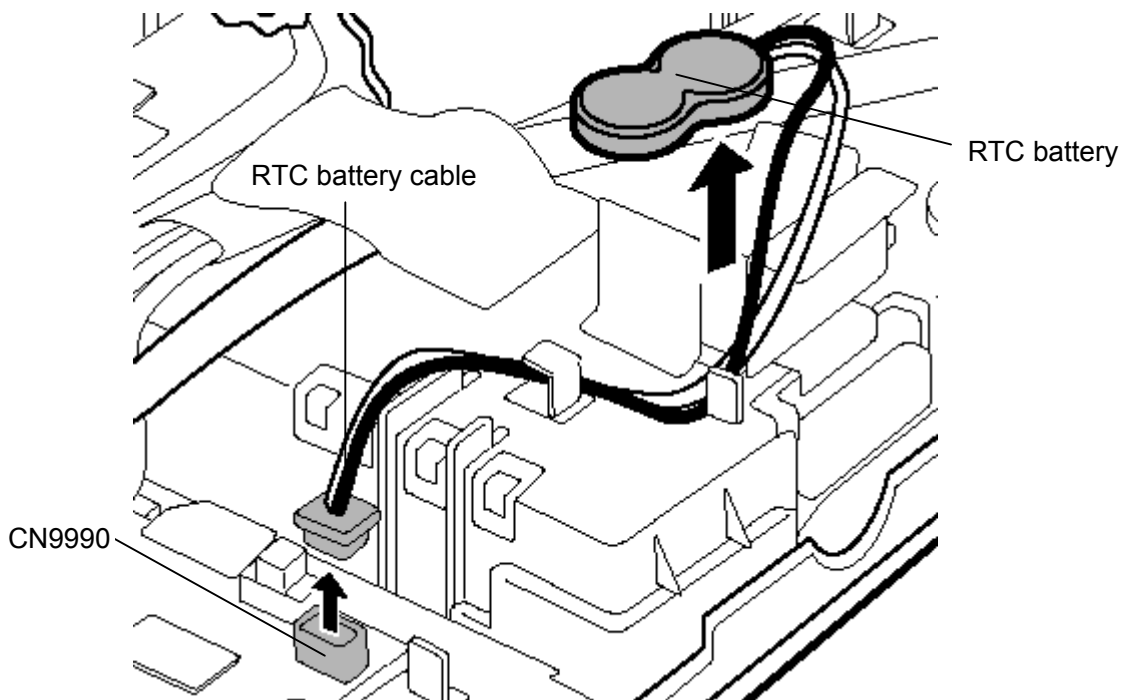

Figure 4-21 Removing the RTC battery

Installing the RTC battery

To install the RTC battery, follow the steps below and refer to Figure 4-21.

1. Connect the **RTC battery cable** to the connector **CN9990** on the system board.
2. Seat the **RTC battery** in place while matching the RTC battery cable to the guide.
3. Wrap the **RTC battery** by the battery holder.

4.15 Modem Daughter Card (MDC)

Removing the Modem Daughter Card

To remove the modem daughter card, follow the steps below and refer to Figure 4-22 and 4-23.

1. Remove the following **screws** securing the modem daughter card.
 - M2×4B BIND screw ×2
2. Lift up the **modem daughter card** to disconnect it from the connector **CN3010** on the system board.
3. Disconnect the **modem cable** from the connector on the modem daughter card.

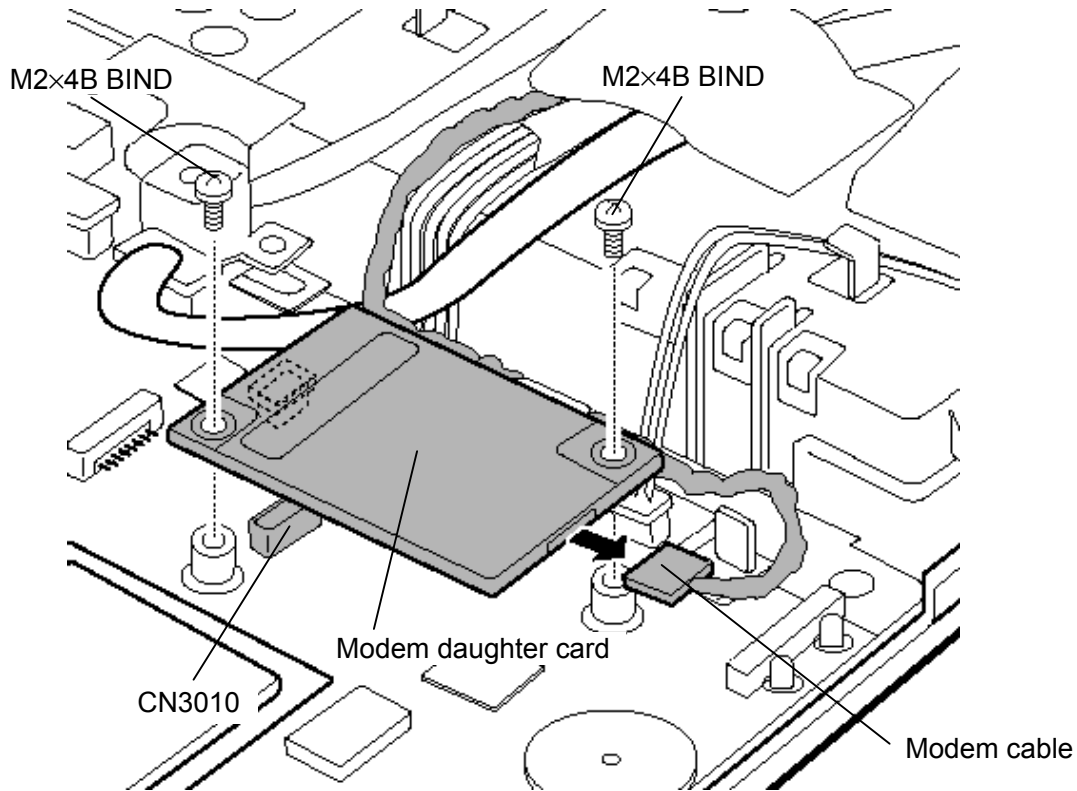

Figure 4-22 Removing the Modem Daughter Card (MDC)

4. Turn up the **insulator** and remove the **modem jack** from the slot.
5. Peel off the **glass tape** and turn up the **insulator (cable holder)**.
6. Disconnect the **modem cable** from the connector **CN3011** on the system board.

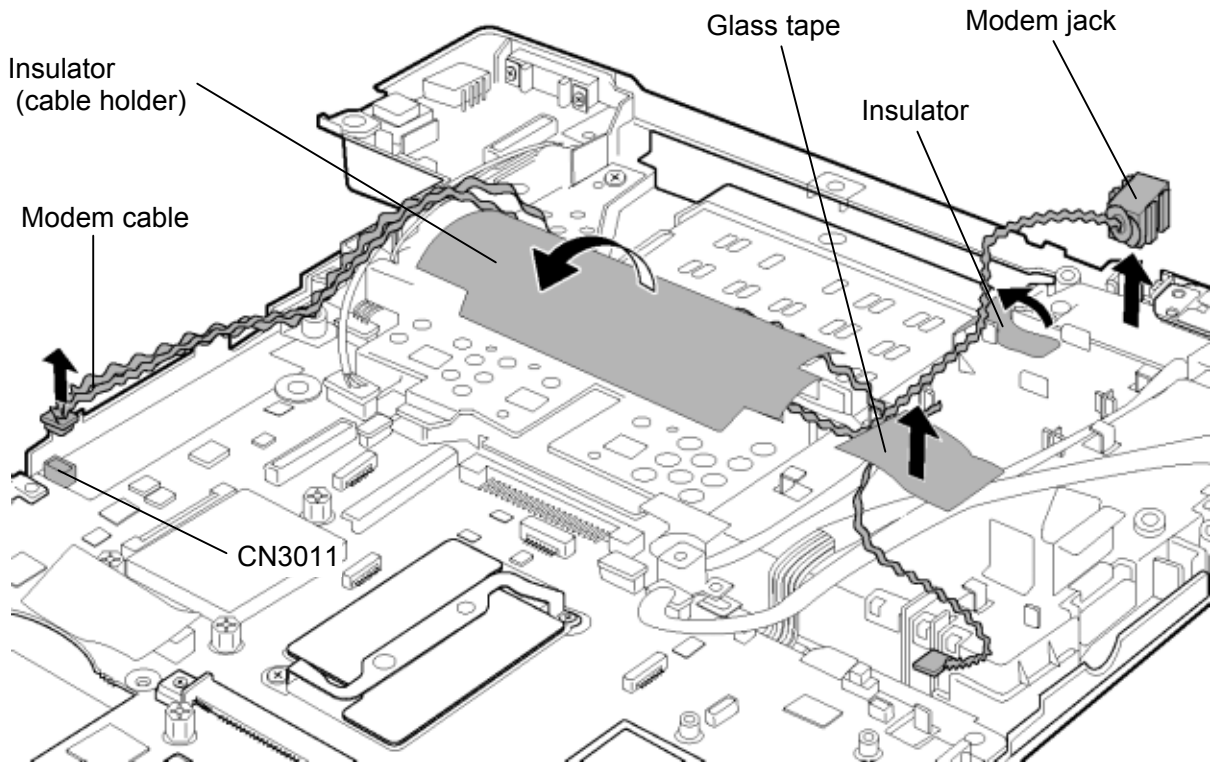

Figure 4-23 Removing the modem jack and modem cable

Installing the Modem Daughter Card (MDC)

To install the modem daughter card, follow the steps below and refer to Figure 4-22 to 4-24.

1. Turn up the **insulator (cable holder)** and connect the **modem cable** to the connector **CN3011** on the system board. Stick the **glass tape** on the cable.
2. Turn up the **insulator** and install the **modem jack** to the slot.

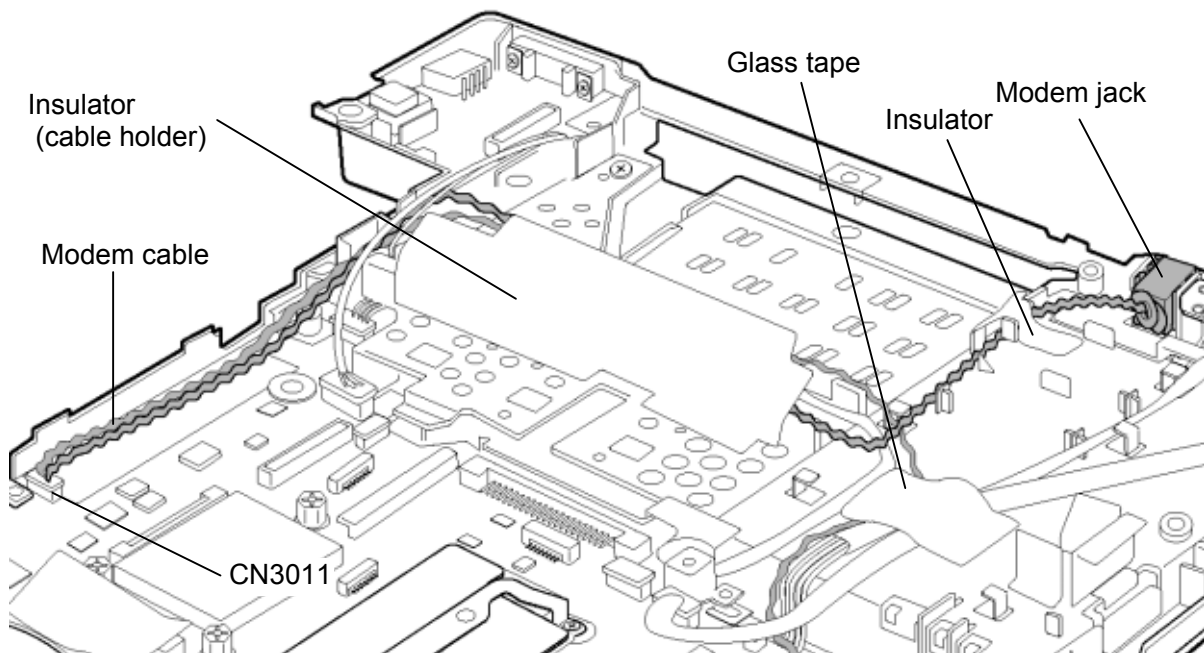

Figure 4-24 Installing the modem jack and modem cable

3. Connect the **modem cable** to the connector on the modem daughter card.
4. Seat the **modem daughter card** in place and press carefully on the card to connect it to the connector **CN3010** on the system board. Be careful not to damage the card and connector.
5. Secure the modem daughter card with the following **screws**.
 - M2×4B BIND screw ×2

4.16 USB board

Removing the USB board

To remove the USB board, follow the steps below and refer to Figure 4-25.

1. Remove the following screw and lift up the **USB board** to the left above.
 - M2.5×6S Tapping screw ×1
2. Disconnect the **USB cable** from the connector **CN4622** on the USB board.
3. Disconnect the **USB cable** from the connector **CN4610** on the system board and take it out.

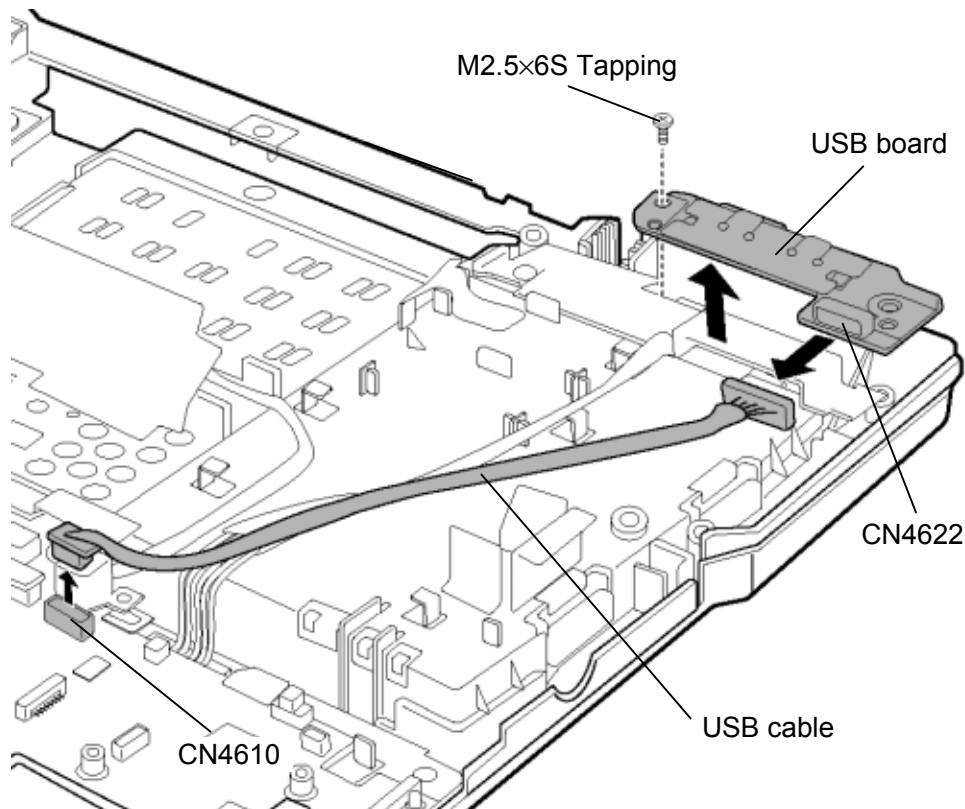

Figure 4-25 Removing the USB board

Installing the USB board

To install the USB board, follow the steps below and refer to Figure 4-25.

1. Connect the **USB cable** to the connector **CN4610** on the system board.
2. Connect the **USB cable** to the connector **CN4622** on the USB board.
3. Install the **USB board** in place and secure it with the following **screw**.
 - M2.5×6S Tapping screw ×1

4.17 Internal microphone

Removing the Internal microphone

To remove the internal microphone, follow the steps below and refer to Figure 4-26.

1. Remove the following **screws and front panel**.
 - M2.5×6S Tapping screw ×2
2. Disconnect the **microphone cable** from the connector **CN6050** on the system board.
3. Take out the **internal microphone** from the slot of the front panel.

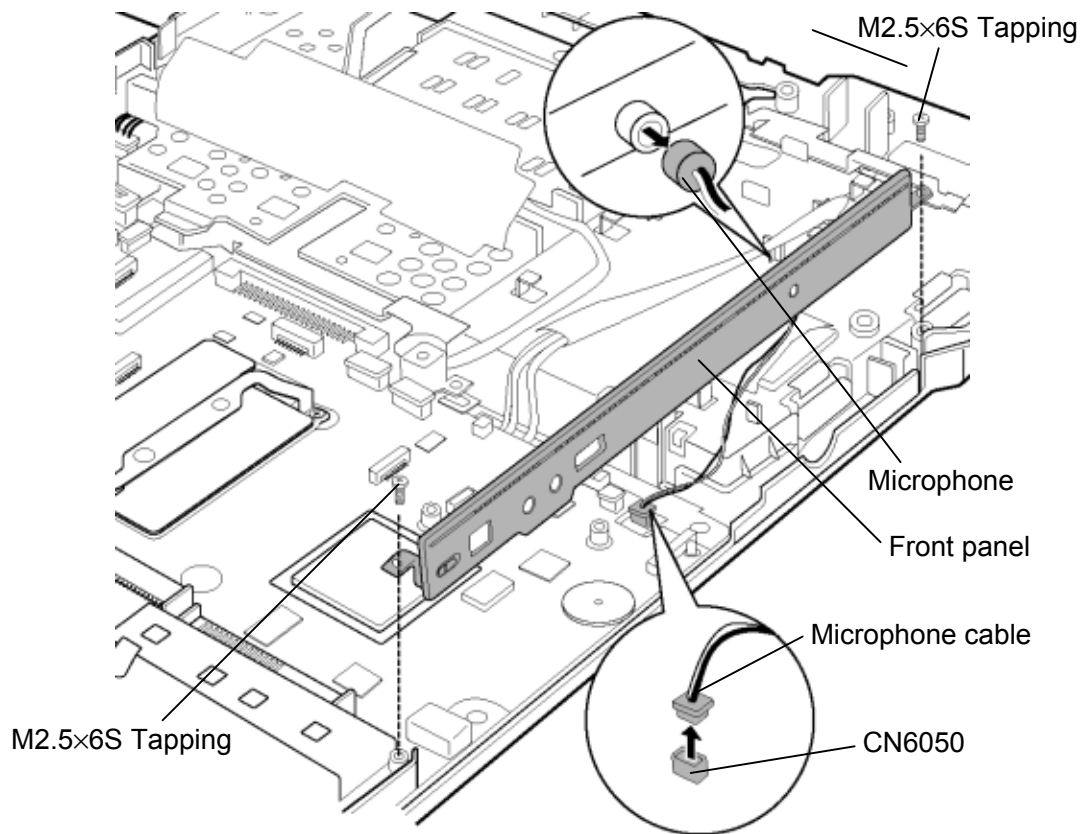

Figure4-26 Removing the internal microphone

Installing the Internal microphone

To install the internal microphone, follow the steps below and refer to Figure 4-26.

1. Install the **internal microphone** to the slot of the front panel. (Pass the hole of the microphone rubber through the guide.)
2. Connect the **microphone cable** to the connector **CN6050** on the system board.
3. Install the **front panel** in place and secure it with the following **screws**.
 - M2.5×6S Tapping screw ×2

4.18 SR board/DC-IN jack

Removing the SR board/DC-IN jack

To remove the SR board/DC-IN jack, follow the steps below and refer to Figure 4-27.

1. Remove the following **screw** and take out the **SR board** from the slot.
 - M2.5×6S Tapping screw ×1
2. Disconnect the **SR/USB cable** from the connector **CN9510** on the SR board.
3. Remove the following **screw** and **serial harness holder**.
 - M2.5×6S Tapping screw ×1
4. Disconnect the **SR/USB cable** from the connectors **CN3421** and **CN4611** on the system board.
5. Take out the **DC-IN jack** from the slot and disconnect the **DC-IN jack cable** from the connector **CN8800** on the system board.

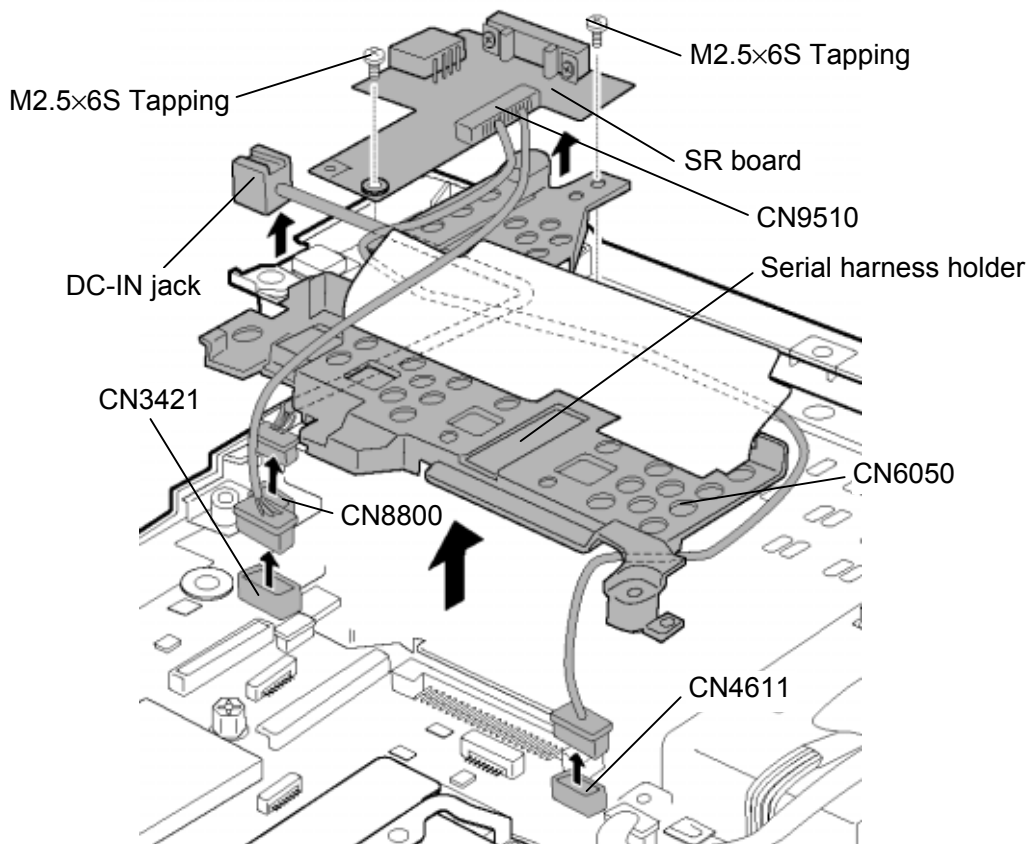

Figure 4-27 Removing the SR board/DC-IN jack

Installing the SR board/DC-IN jack

To install the SR board/DC-IN jack, follow the steps below and refer to Figure 4-27 and 4-28.

1. Connect the **DC-IN jack cable** to the connector **CN8800** on the system board (Pass the cable under the guide) and install the **DC-IN jack** to the slot.
2. Connect the **SR/USB cable** to the connectors **CN3421** and **CN4611** on the system board.
3. Install the **serial harness holder** and secure it with the following screw.
 - M2.5×6S Tapping screw ×1
4. Connect the **SR/USB cable** to the connector **CN9510** on the SR board.

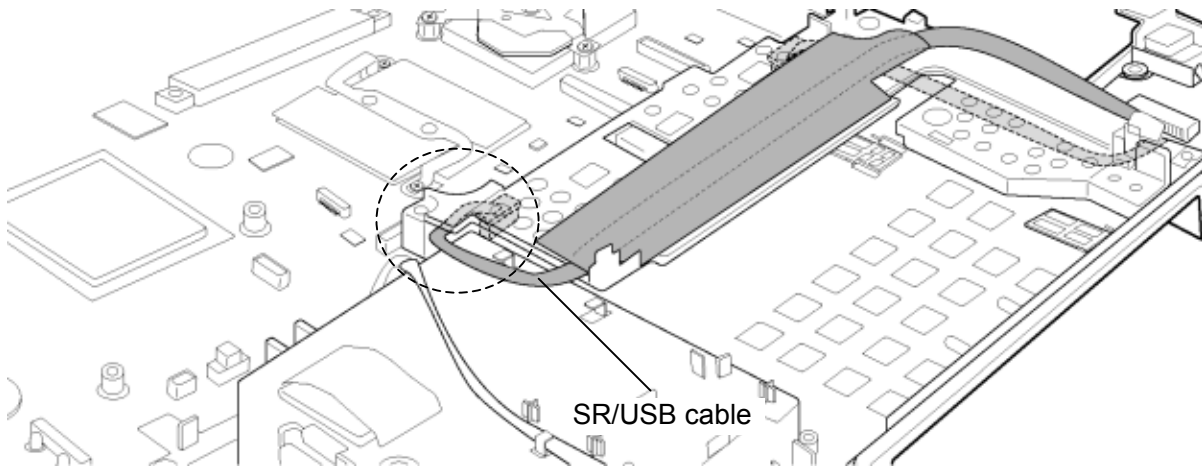

Figure 4-28 Connecting the SR/USB cable

5. Install the **SR board** to the slot and secure it with the following screw.
 - M2.5×6S Tapping screw ×1

4.19 Fan

Removing the Fan

To remove the fan, follow the steps below and refer to Figure 4-29.

1. Peel off the **glass tape**.
2. Disconnect the **fan cable** from the connector **CN8770** on the system board.
3. Remove the following **screws and fan**.
 - M2.5×4B FLAT HEAD screw ×2

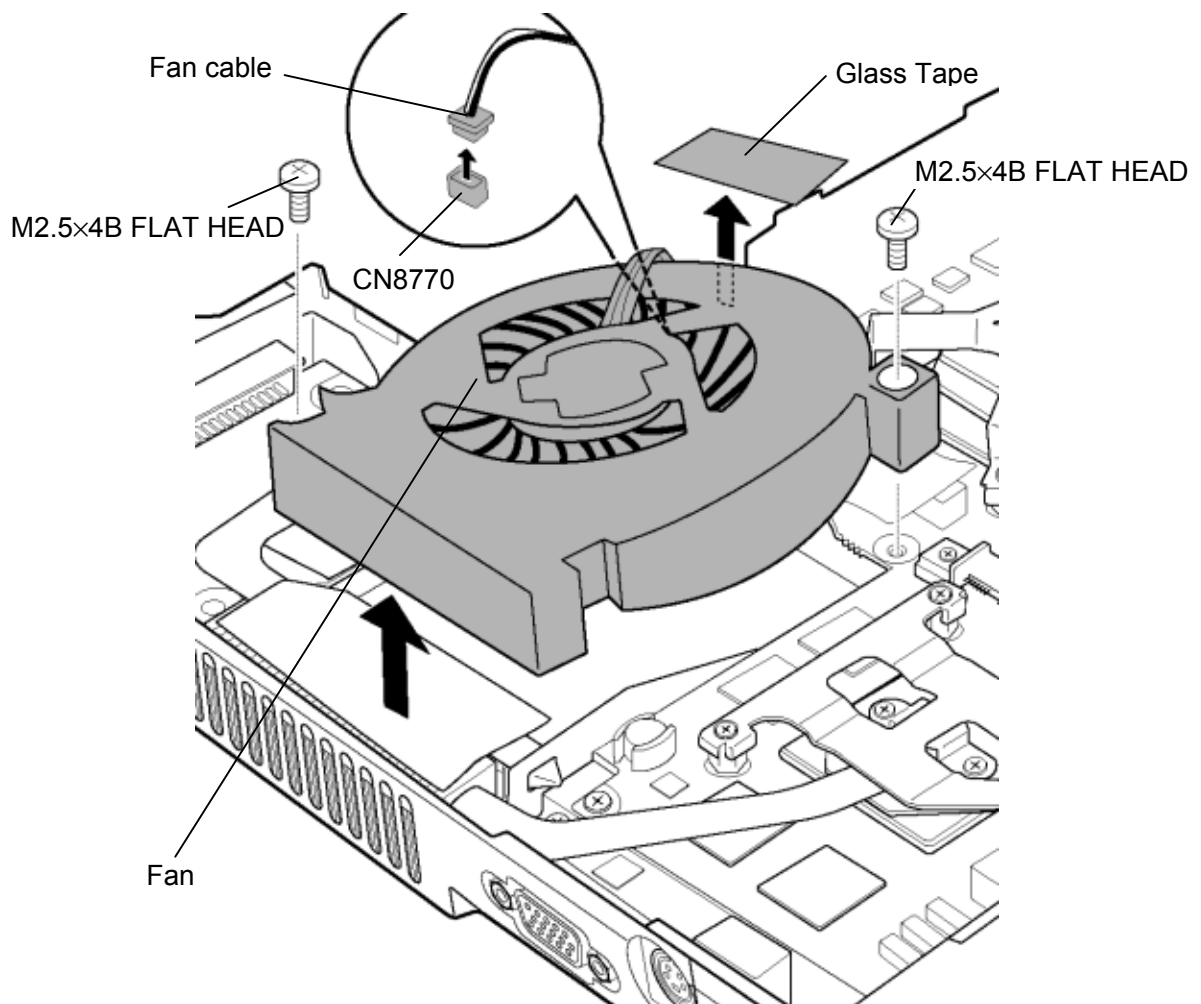

Figure 4-29 Removing the fan

Installing the Fan

To install the Fan, follow the steps below and refer to Figure 4-29.

1. Install the **fan** and secure it with the following **screws**.
 - M2.5×4B FLAT HEAD screw ×2
2. Connect the **fan cable** to the connector **CN8770** on the system board.
3. Stick the **glass tape** in place.

CAUTION: When sticking the glass tape, do not let the tape over the CPU heat sink.

4.20 CPU

Removing the CPU

To remove the CPU, follow the steps below and refer to Figure 4-30 and 4-31.

1. Remove the following **screws** securing the CPU holder, in the reverse order of the number marked on the holder.
 - M2×4B BIND screw ×3
2. Remove the **CPU holder** and **CPU heat sink**.

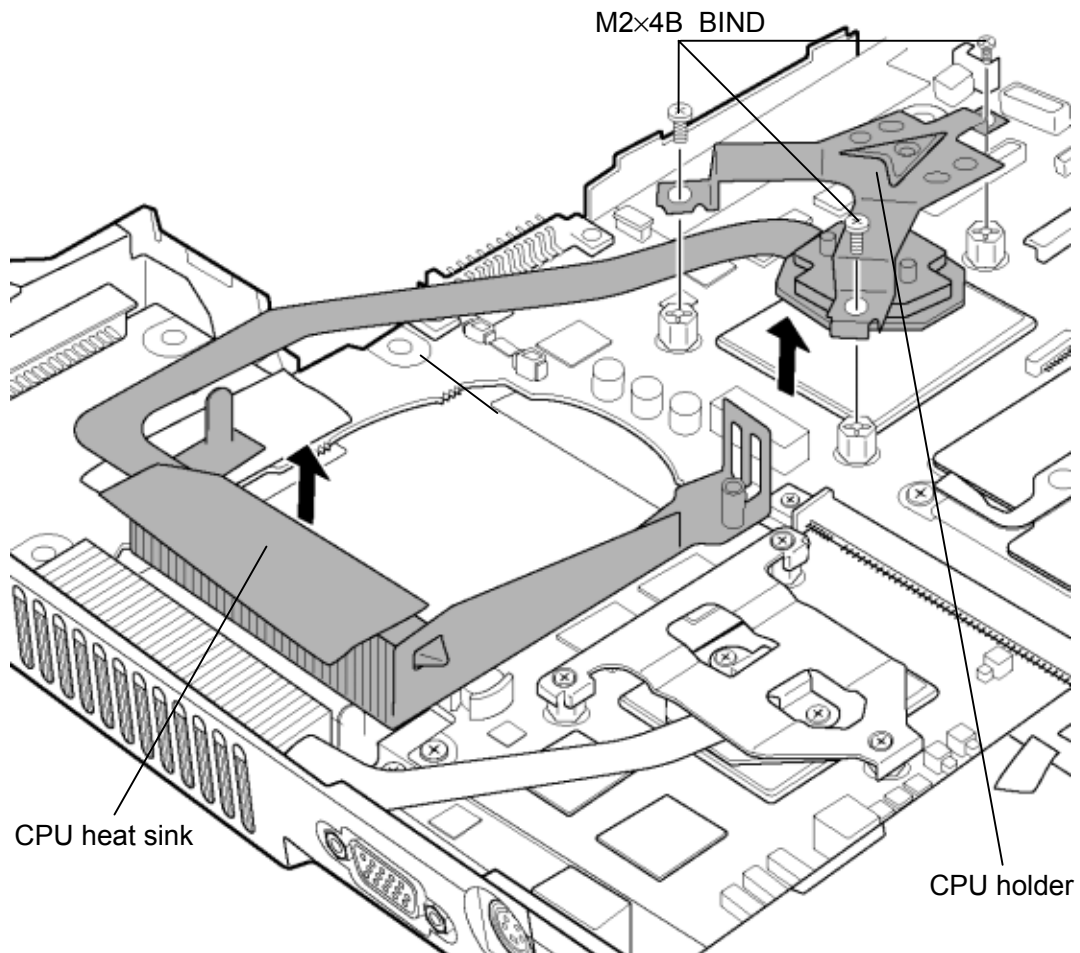

Figure 4-30 Removing the CPU heat sink

3. Unlock the **CPU** by rotating the **cam** on the CPU socket 90 degrees to the counterclockwise with a flat-blade screwdriver (in the order shown in the figure below).
4. Remove the **CPU**.

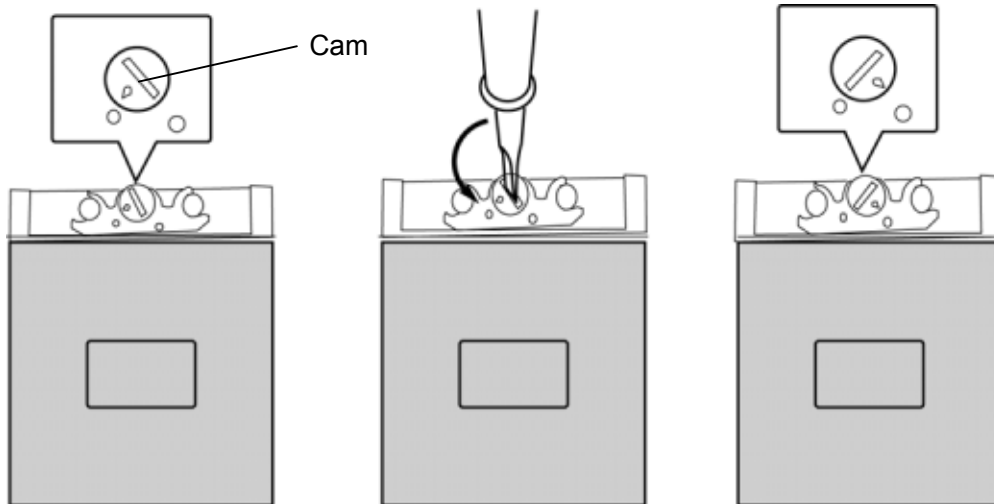

Figure 4-31 Removing the CPU

Installing the CPU

To install the CPU, follow the steps below and refer to Figure 4-30 to 4-32.

1. Check that the triangle on the cam is in the unlocking position.
2. Install the **CPU** to the correct position in the CPU socket.
3. Fix the CPU by rotating the cam 90 degrees to the clockwise with a flat-blade screwdriver.
4. If there is already silicon grease on the CPU, clean it with a cloth. Using a special applicator, apply silicon grease so that the CPU chip on the CPU is completely covered.

NOTE: *Apply the silicon grease enough to cover the chip surface using the special applicator.*

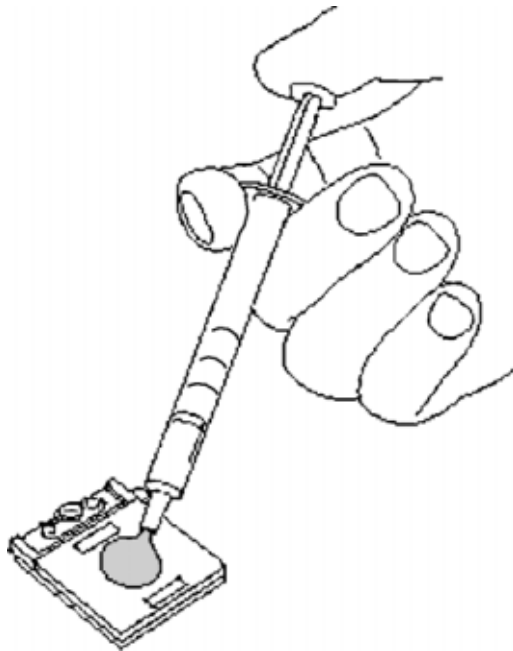

Figure 4-32 Applying silicon grease

5. Install the **CPU heat sink** in place.
6. Seat the **CPU holder** and secure it with the following **screws** in the order of the number marked on the holder.
 - M2×4B BIND screw ×3

4.21 GFX board

Removing the GFX board

To remove the GFX board, follow the steps below and refer to Figure 4-33 and 4-34.

1. Remove the following screws securing the GPU heat sink, in the reverse order of the number marked on the heat sink.

- M2×4B S-FLAT HEAD screw ×3

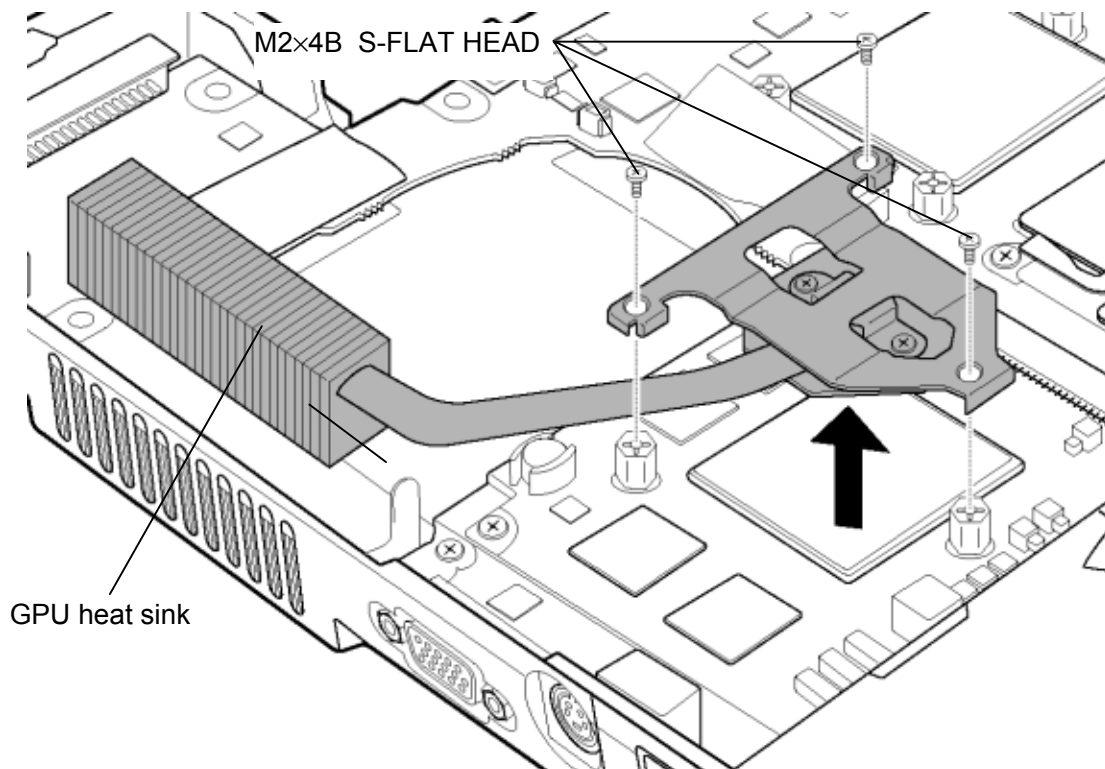

Figure 4-33 Removing the GPU heat sink

2. Remove the following **screws** and disconnect the **GFX board** from the connector **CN5900** on the system board.

- M2×4B S-FLAT HEAD screw ×2

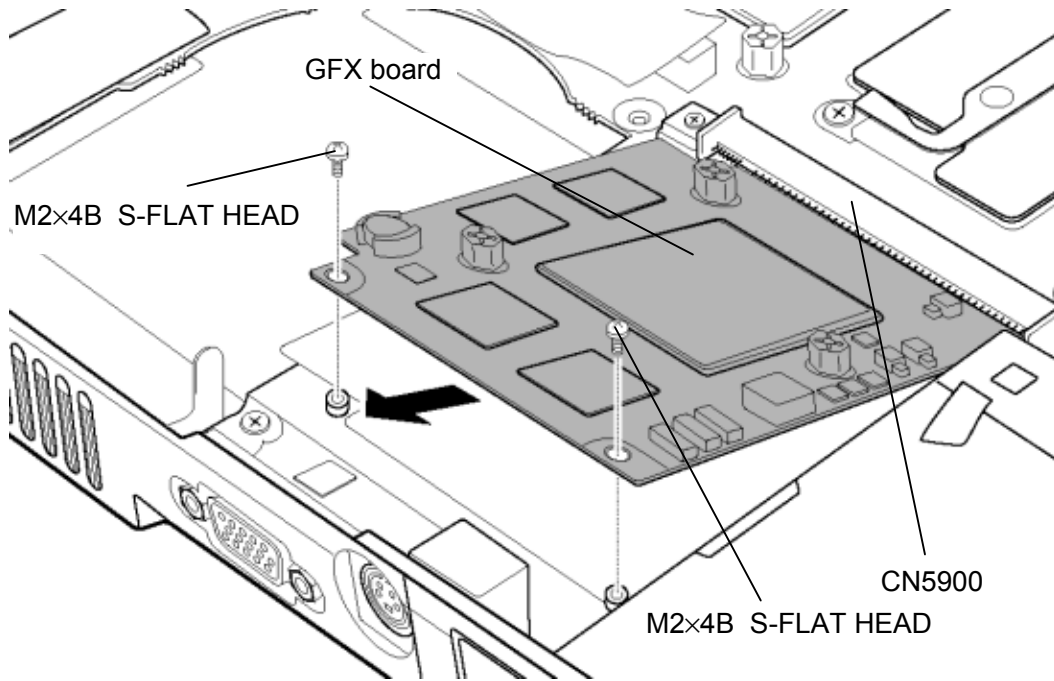

Figure 4-34 Removing the GFX board

Installing the GFX board

To install the GFX board, follow the steps below and refer to Figure 4-33 and 4-34.

1. Insert the **GFX board** into the connector **CN5900** on the system board slantwise and press it to connect firmly.

2. Secure the GFX board with the following **screws**.

- M2×4B S-FLAT HEAD screw ×2

3. Install the **GPU heat sink** in place and secure it with the following **screws** in the order of the number marked on the heat sink.

- M2×4B S-FLAT HEAD screw ×3

4.22 System board

Removing the System board

To remove the system board, follow the steps below and refer to Figure 4-35 to 4-39.

1. Remove the following screw and **HDD cable holder**.
 - M2.5×6S Tapping screw ×1
2. Take out the **HDD cable** of the HDD connector side from the slot.

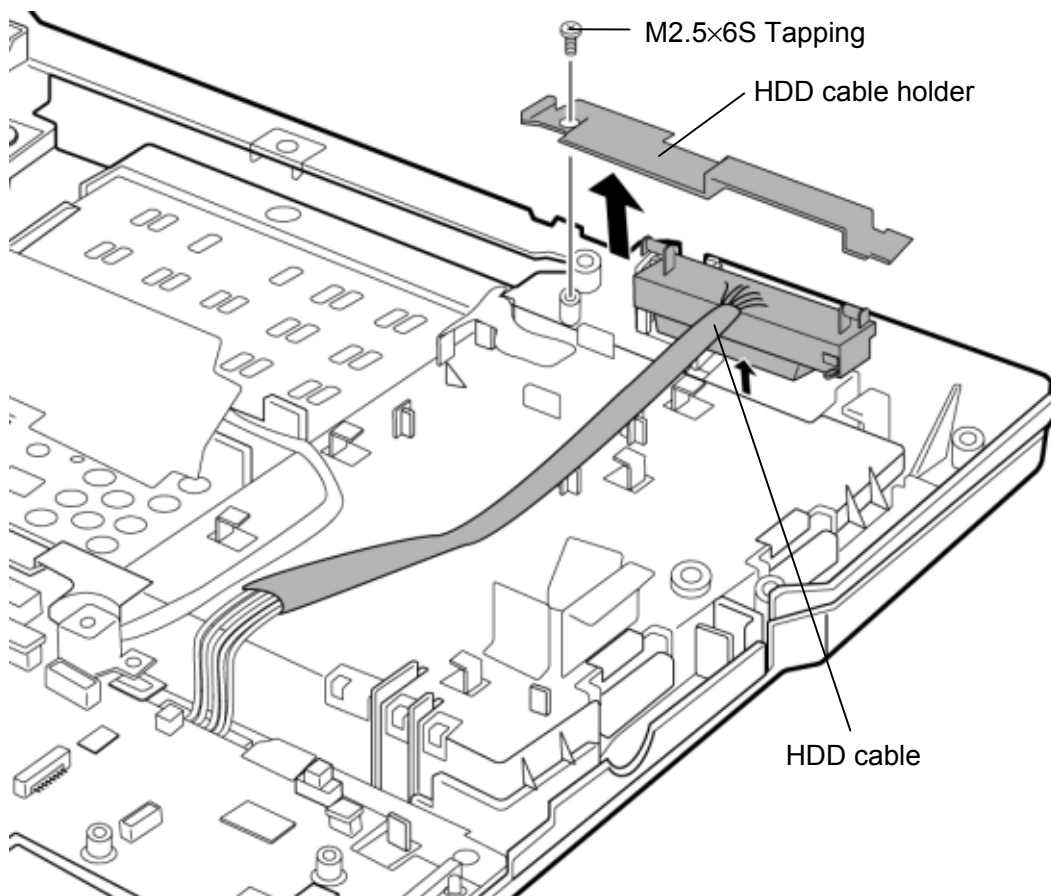

Figure 4-35 Removing the HDD cable holder

3. Remove the following **screw** and **system board**.

- M2.5×6S Tapping screw ×1

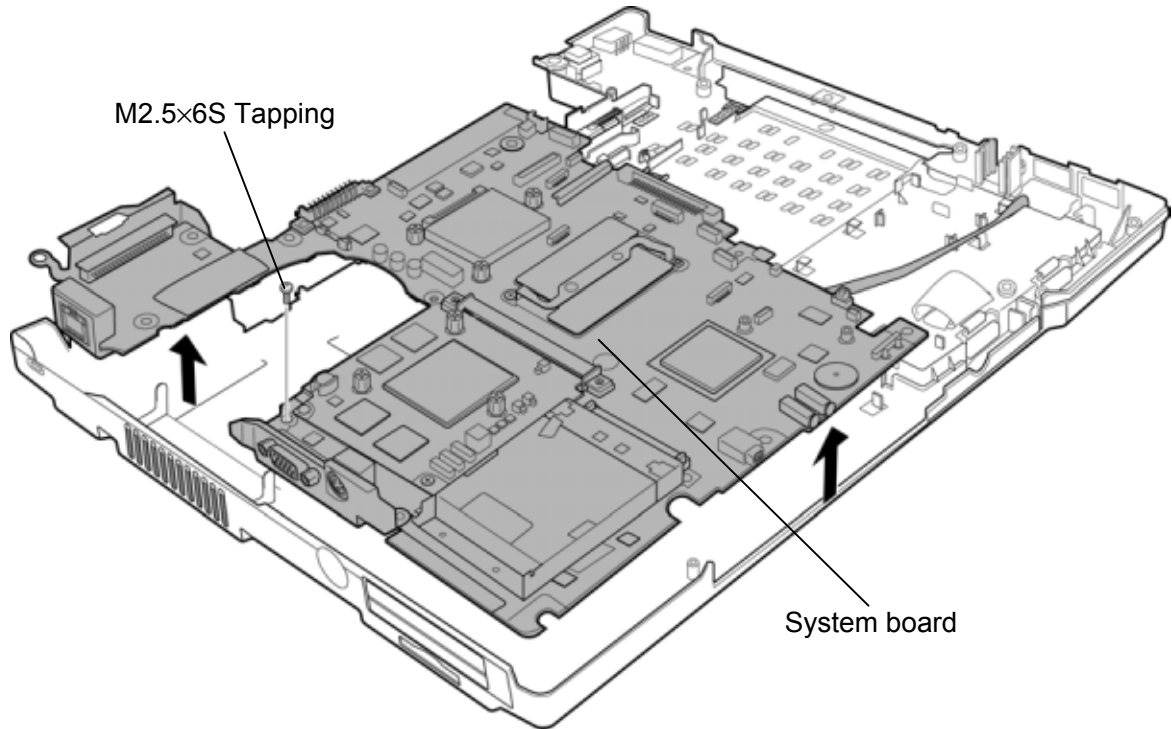

Figure 4-36 Removing the modem jack

4. Peel off the **insulator** and disconnect the **HDD cable** from the connector **CN1850** on the back of the system board.

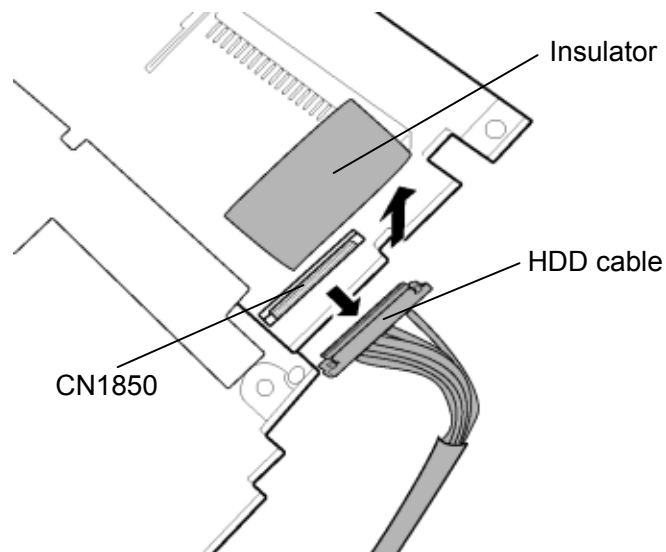

Figure 4-37 Removing the HDD cable

5. Remove the following **screws** and **PC card slot** from the back of the system board.

- M2×8B S-FLAT HEAD screw ×2
- M2×3S S-FLAT HEAD screw ×2

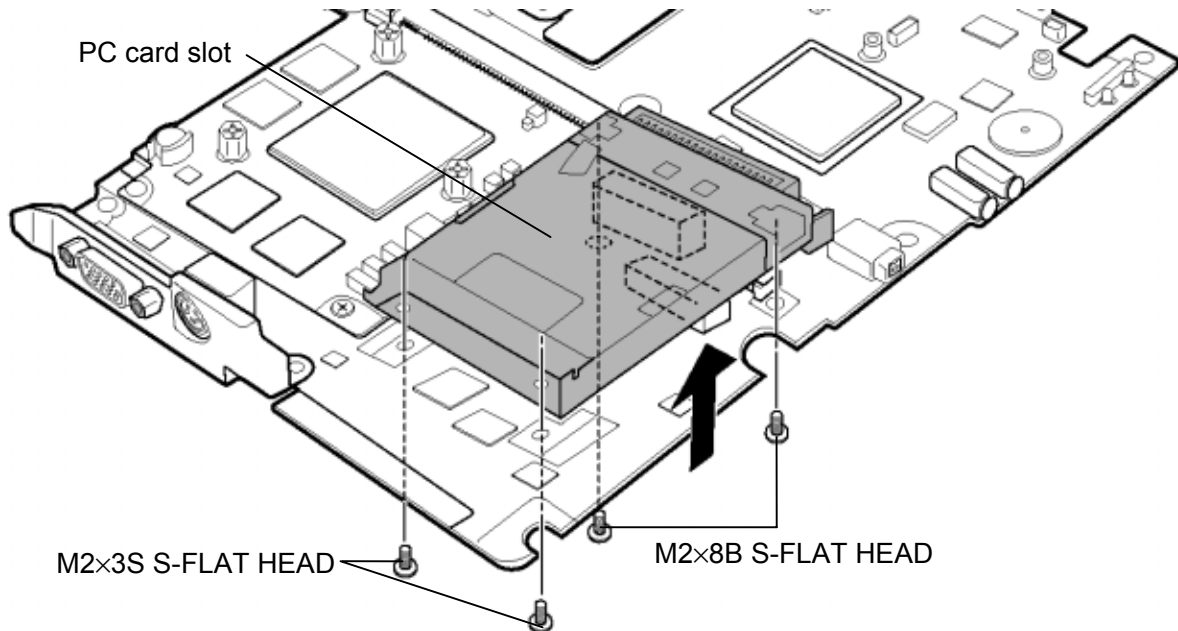

Figure 4-38 Removing the PC card slot

6. Remove the following **screws** and **north bridge IC heat sink** from the back of the system board.

- M2×4S S-FLAT HEAD screw ×2

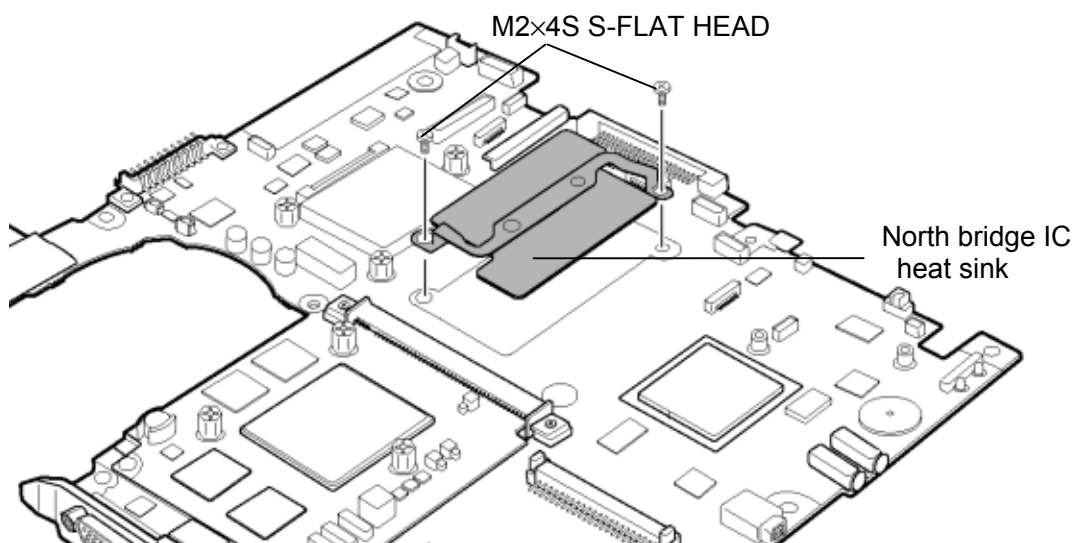

Figure 4-39 Removing the north bridge IC heat sink

Installing the System board

To install the system board, follow the steps below and refer to Figure 4-35 to 4-39.

1. Install the **north bridge IC heat sink** in place (back of the system board) and secure it with the following **screws**.
 - M2×4S S-FLAT HEAD screw ×2
2. Install the **PC card slot** in place (back of the system board) and secure it with the following **screws**.
 - M2×8B S-FLAT HEAD screw ×2
 - M2×3S S-FLAT HEAD screw ×2
3. Connect the **HDD cable** to the connector **CN1850** on the back of the system board.
4. Install the **system board** from the left side and secure it with the following **screw**.
 - M2.5×6S Tapping screw ×1
5. Install the **HDD cable** of the HDD connector side to the slot. (Pass the HDD cable under the guide.)
6. Install the **HDD cable holder** and secure it with the following **screw**.
 - M2.5×6S Tapping screw ×1

4.23 FP board

Removing the FP board

To remove the FP board, follow the steps below and refer to Figure 4-40.

1. Peel off the **glass tape** (back of the middle assembly).
2. Remove the following **screws** and **FP board**.
 - M2×3S S-FLAT HEAD screw ×2
3. Disconnect the **FP cable** from the connector **CN950** on the FP board.

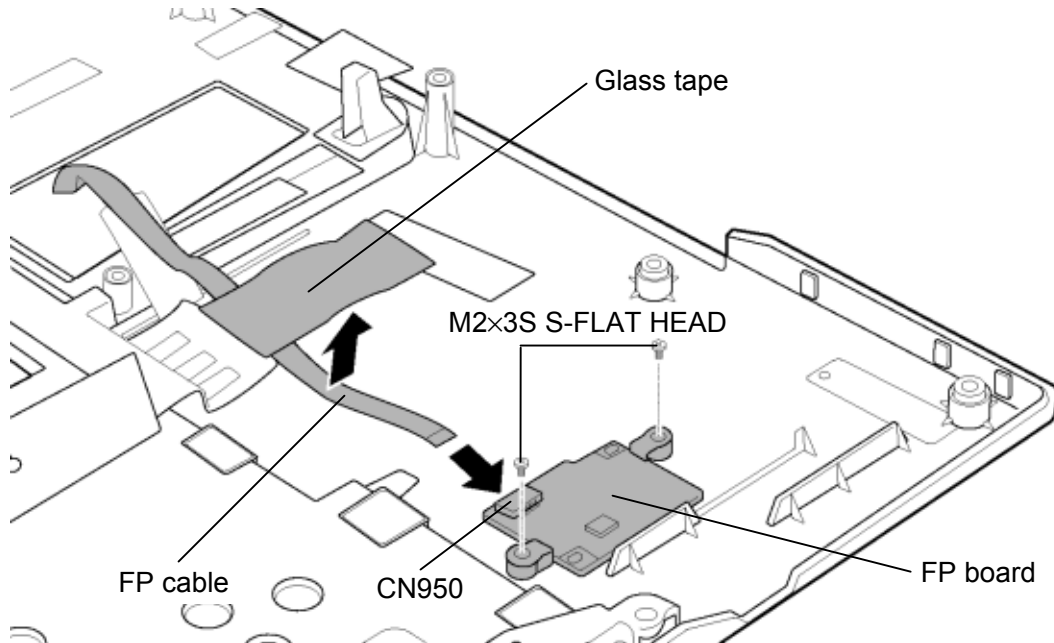

Figure4-40 Removing the FP board

Installing the FP board

To install the FP board, follow the steps below and refer to Figure 4-40.

1. Connect the **FP cable** to the connector **CN950** on the FP board.
2. Install the FP board in place and secure it with the following **screws**.
 - M2×3S S-FLAT HEAD screw ×2
3. Stick the **glass tape** on the FP cable.

4.24 LCD unit/FL inverter

Removing the LCD unit/FL inverter

To remove the LCD unit/FL inverter, follow the steps below and refer to Figure 4-41 to 4-47.

1. Peel off two **mask rubbers** and two **mask seals** and remove the following **screws** securing the display mask.
 - M2.5×4B FLAT HEAD screw ×2
 - M2×4B S-FLAT HEAD screw ×2
2. Remove the **display mask** while releasing the latches.

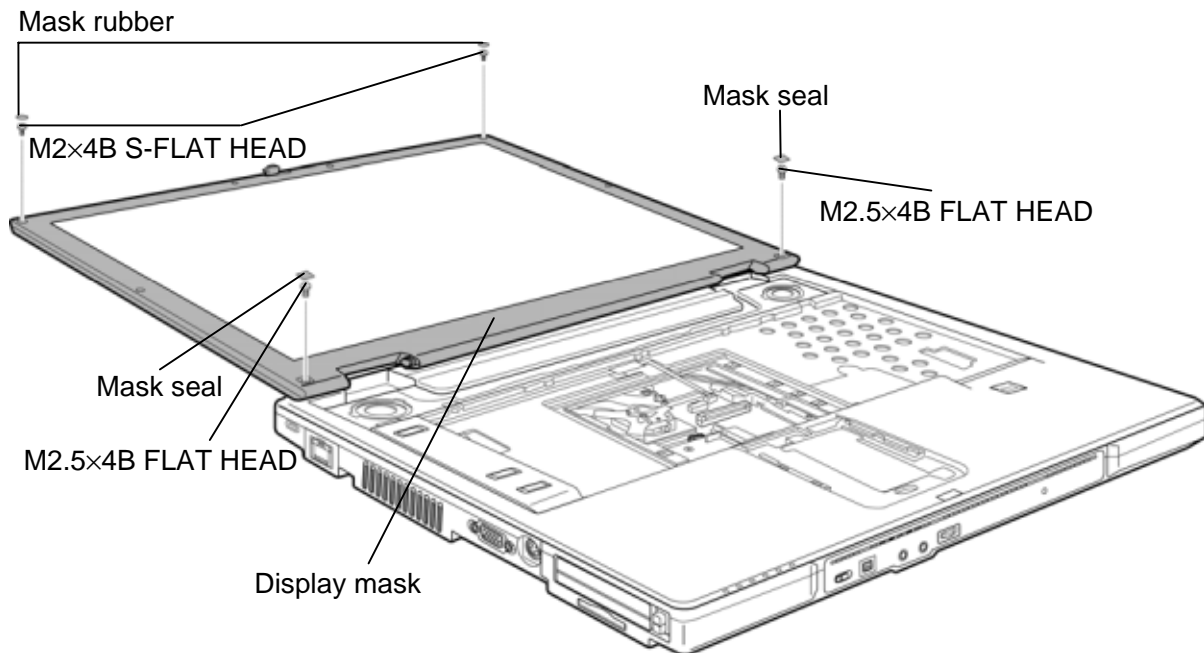

Figure 4-41 Removing the display mask

3. Peel off one **insulator** from the FL inverter and take out the **other one** under the LCD unit.
4. Remove the following **screw** securing the FL inverter.
 - M2×4B S-FLAT HEAD screw ×1
5. Disconnect two **cables** from the FL inverter and remove the **FL inverter** from the slot.

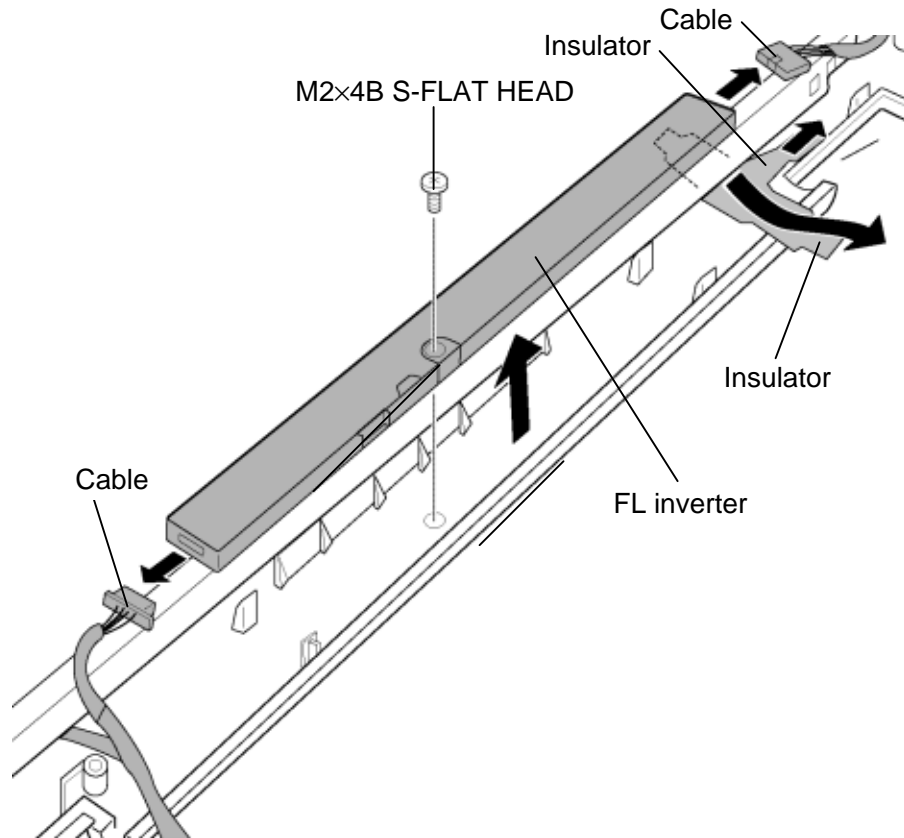

Figure 4-42 Removing the FL inverter

6. Remove the following **screws** securing the LCD unit.

- M2×4B S-FLAT HEAD screw ×2

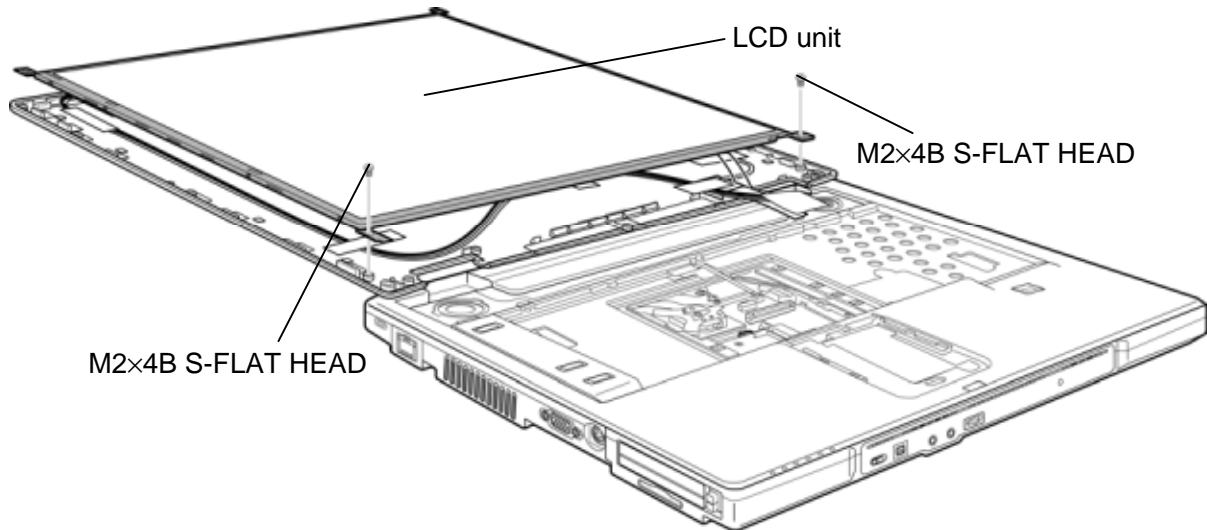

Figure 4-43 Removing the LCD unit (1)

7. Carefully lift up the top of the **LCD unit** to access the LCD cable.

NOTE: When lifting up the top of the LCD unit, hold the corners of the LCD unit. The top edge of the LCD unit is sensitive area.

8. Remove the **glass tape** securing the LCD cable.
9. Disconnect the **LCD cable** and remove the **LCD unit**.

CAUTION: When removing the LCD cable, be careful not to damage the connector.

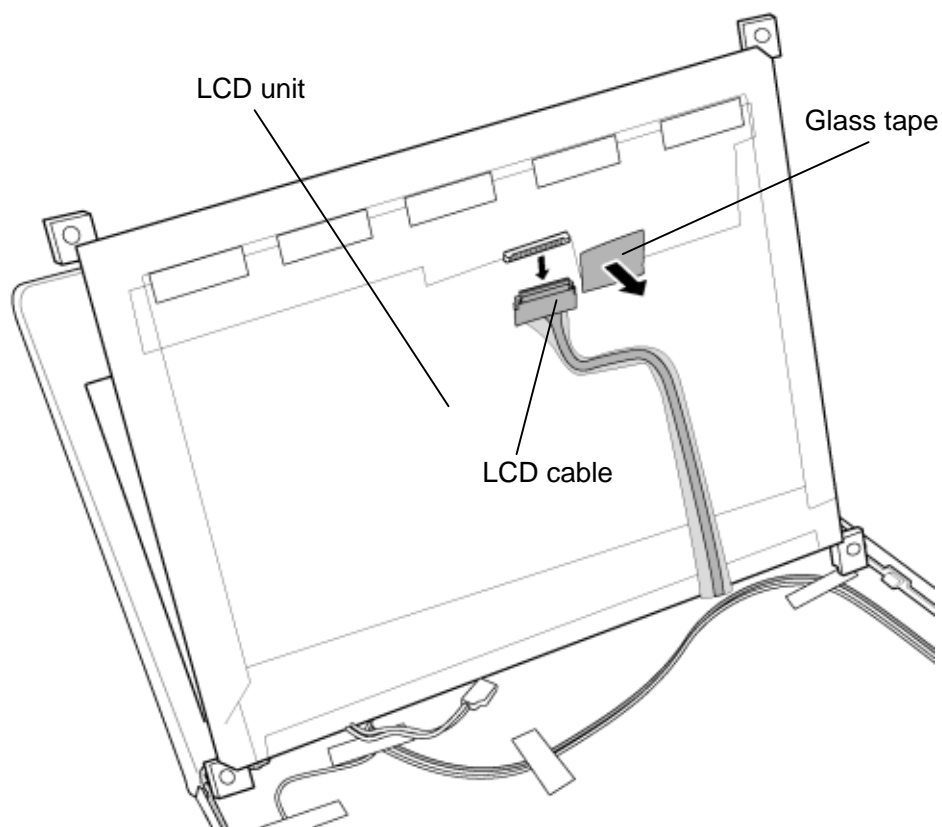

Figure 4-44 Removing the LCD unit (2)

10. Remove the following **screws** and detach two **LCD brackets** from the **LCD unit**.

- M2×3S S-FLAT HEAD screw ×8

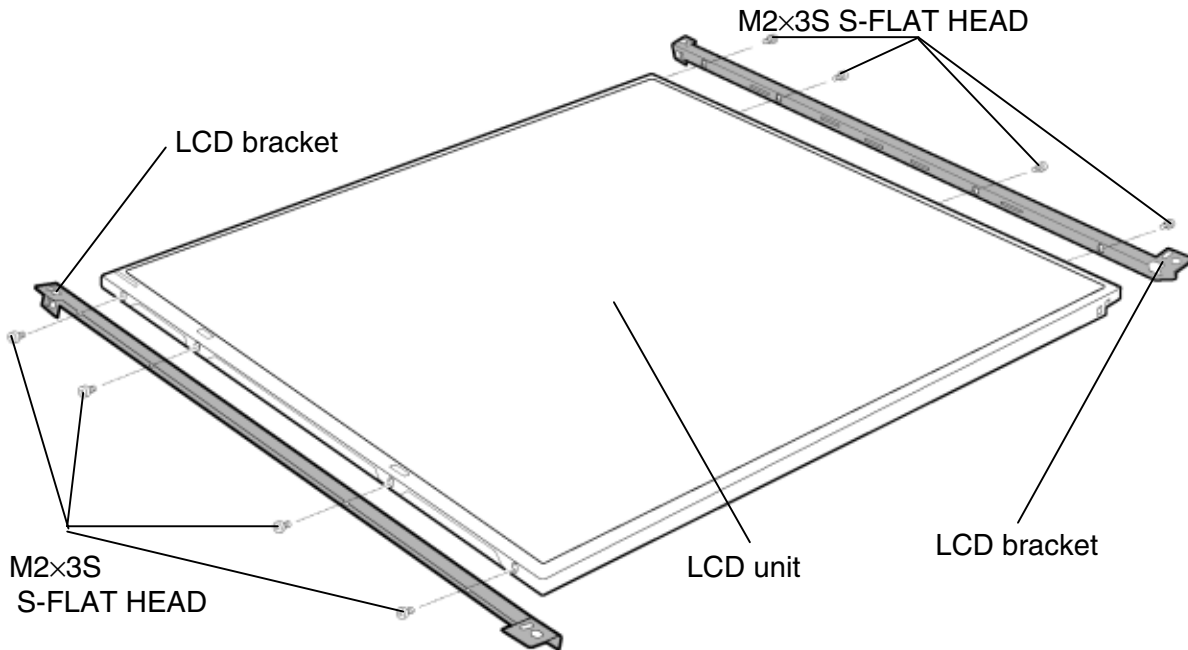

Figure 4-45 Removing the LCD bracket

11. Peel off the **insulator** from the back of the middle cover.

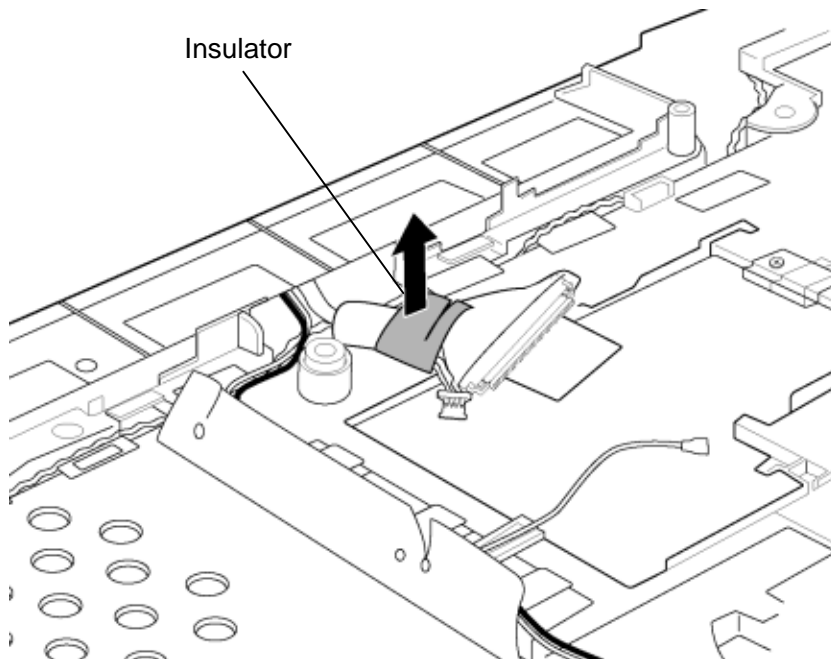

Figure 4-46 Peeling off the insulator

12. Peel off two **insulators** (front of the middle assembly).

13. Remove the following **screw** and **LCD cable holder A**.

- M2.5×4S Tapping screw ×1

14. Remove the following **screw** and **LCD cable holder B**.

- M2.5×6S Tapping screw ×1

15. Take out the **LCD cable** from the hole of the middle assembly.

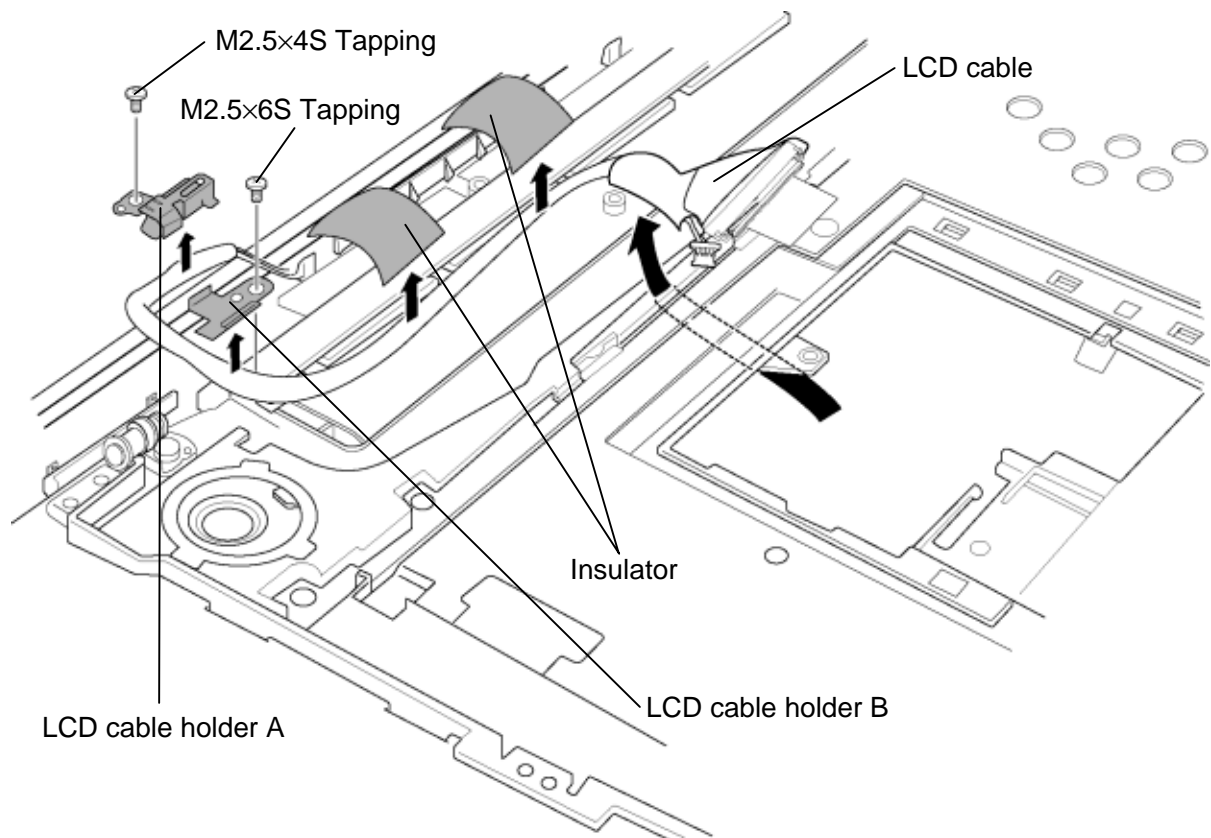

Figure 4-47 Removing the LCD cable holder

Installing the LCD unit/FL inverter

To install the LCD unit/FL inverter, follow the steps below and refer to Figure 4-41 to 4-47.

1. Pass the **LCD cable** through the hole of the middle frame and set it in place.
2. Install the **LCD cable holder B** to the slot and secure it with the following **screw**.
 - M2.5×6S Tapping screw ×1
3. Install the **LCD cable holder A** to the slot and secure it with the following **screw**.
 - M2.5×4S Tapping screw ×1
4. Stick two **insulators** to the middle assembly (front).
5. Stick the **insulator** to the middle assembly (back).
6. Install two **LCD brackets** to the LCD unit and secure them with the following **screws**.
 - M2×3S S-FLAT HEAD screw ×8

CAUTION: When installing the LCD bracket, do not mistake the left for the right and vice versa. "L" for the left, "R" for the right and "UP" for the up of the bracket are marked on the bracket.

7. Connect the **LCD cable** to the connector on the back of the LCD unit. Stick the **glass tape** on the connected portion.
8. Seat the **LCD unit** to the display cover and secure it with the following **screws**.
 - M2×4B S-FLAT HEAD screw ×2
6. Connect two **cables** to the FL inverter.
7. Seat the **FL inverter** to the slot and secure it with the following **screw**.
 - M2×4B S-FLAT HEAD screw ×1
8. Stick one **insulator** on the FL inverter and insert one **insulator** under the LCD unit.
9. Install the **display mask** while hooking the latches.
10. Secure the display mask with the following **screws** and stick two **mask rubbers** and two **mask seals**.
 - M2.5×4B FLAT HEAD screw ×2
 - M2×4B S-FLAT HEAD screw ×2

4.25 Cover latch

Removing the Cover latch

To remove the cover latch, follow the steps below and refer to Figure 4-48.

1. Remove the **cover cap**.
2. Remove the **cover latch** to the direction in the figure below. Be careful not lose the spring

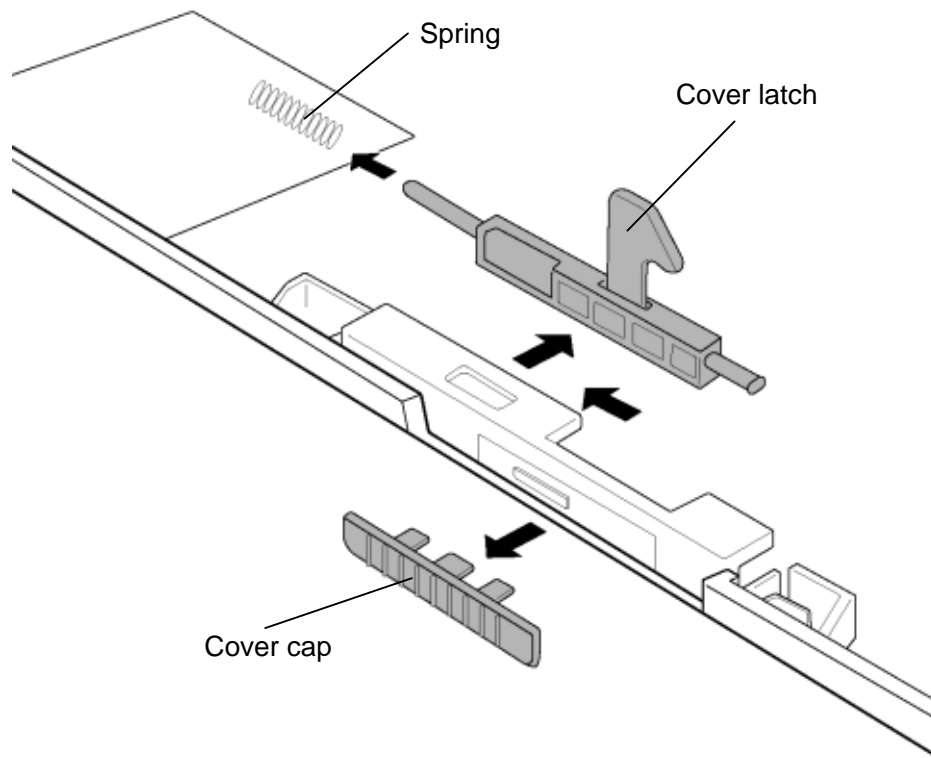

Figure 4-48 Removing the cover latch

Installing the Cover latch

To install the cover latch, follow the steps below and refer to Figure 4-48.

1. Install the **cover latch** in place.
2. Install the **cover cap**.

4.26 Wireless LAN antenna/Bluetooth antenna

Removing the Wireless LAN antenna/Bluetooth antenna

To remove the wireless LAN antenna/Bluetooth antenna, follow the steps below and refer to Figure 4-49 and 4-50.

1. Peel off one **acetate tape** and four **insulators** from the back of the middle assembly.
2. Take out the **wireless LAN antenna cables** from the hole of the middle frame.

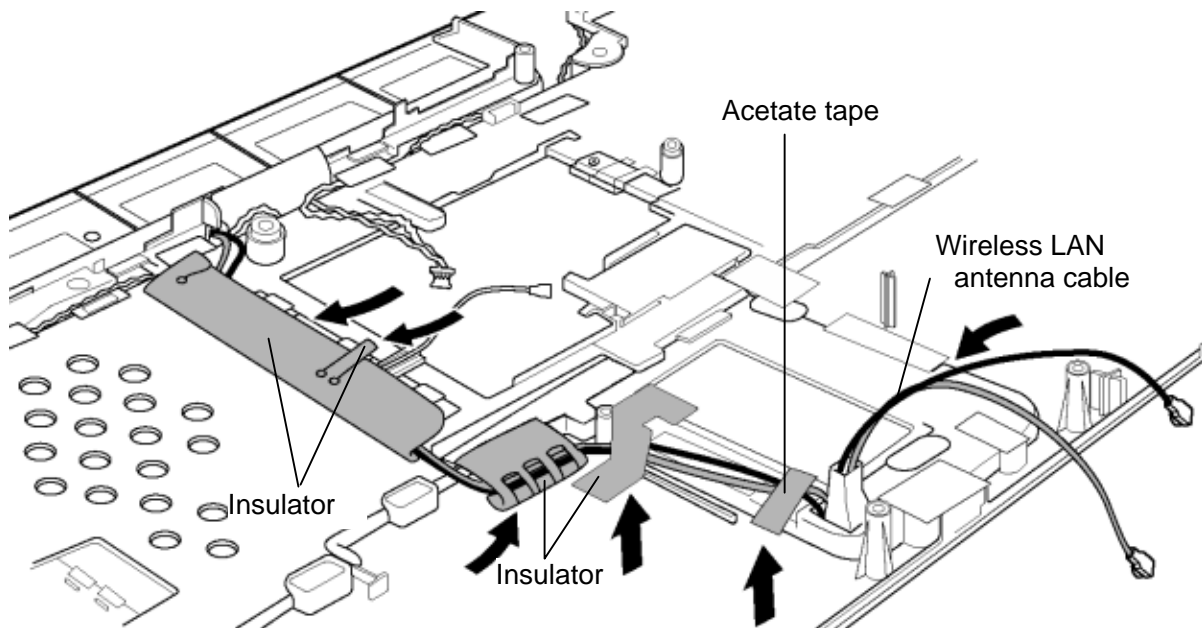

Figure 4-49 Removing the wireless LAN antenna cable

3. Peel off eight **acetate tapes** and one **insulator**.
4. Peel off the **wireless LAN antennas** and **Bluetooth antenna** from the top cover and take them out.

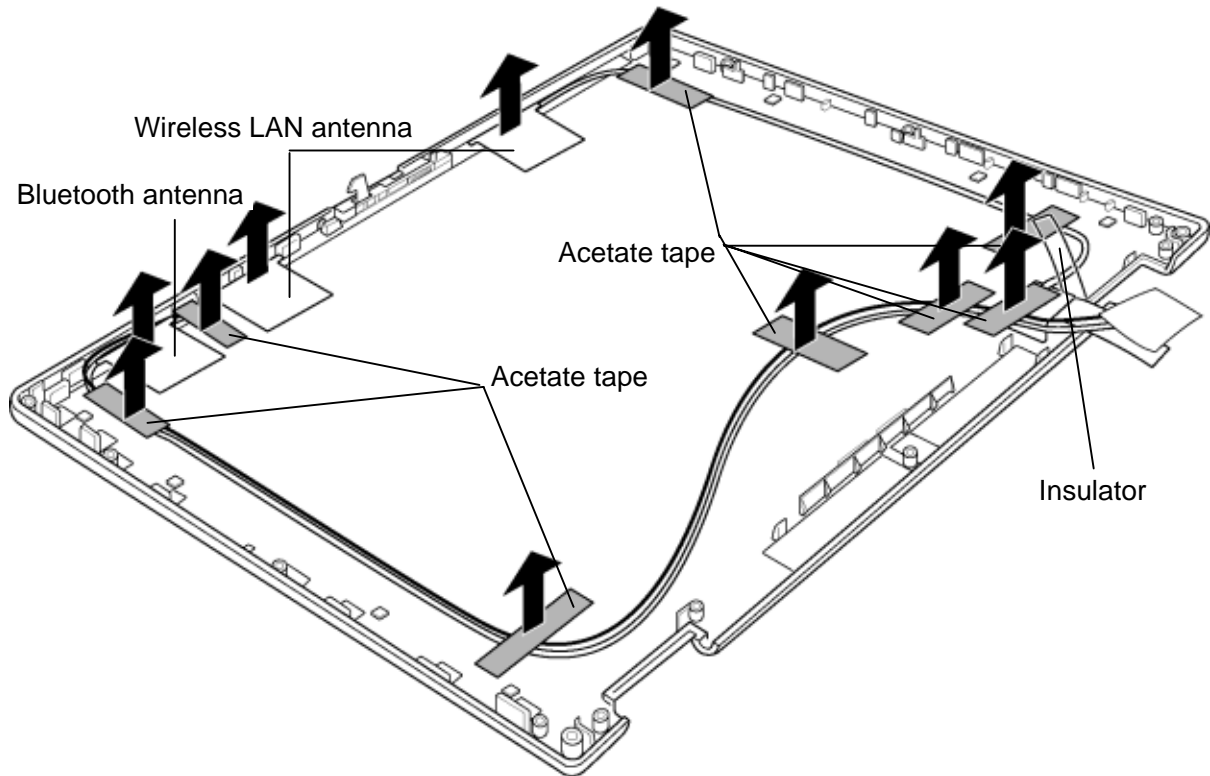

Figure 4-50 Removing the wireless LAN antenna/Bluetooth antenna

Installing the Wireless LAN antenna/Bluetooth antenna

To install the wireless LAN antenna/Bluetooth antenna, follow the steps below and refer to Figure 4-49 and 4-50.

1. Stick the **wireless LAN antennas** and **Bluetooth antenna** to the top cover in place.
2. Seat the **wireless LAN antenna cables** and **Bluetooth antenna cable** on the top cover and stick eight **acetate tapes** and one **insulator** to fix them.
3. Pass the **wireless LAN antenna cables** through the hole of the middle frame and seat them in place.
4. Stick four **insulators** and one **acetate tape** on the back of the middle assembly.

4.27 Hinge

Removing the Hinge

To remove the hinge, follow the steps below and refer to Figure 4-51 to 4-53.

1. Remove the following screws and separate the **display cover** and **middle frame**.

- M2×4B BIND screw ×4
- M2.5×6S Tapping screw ×2

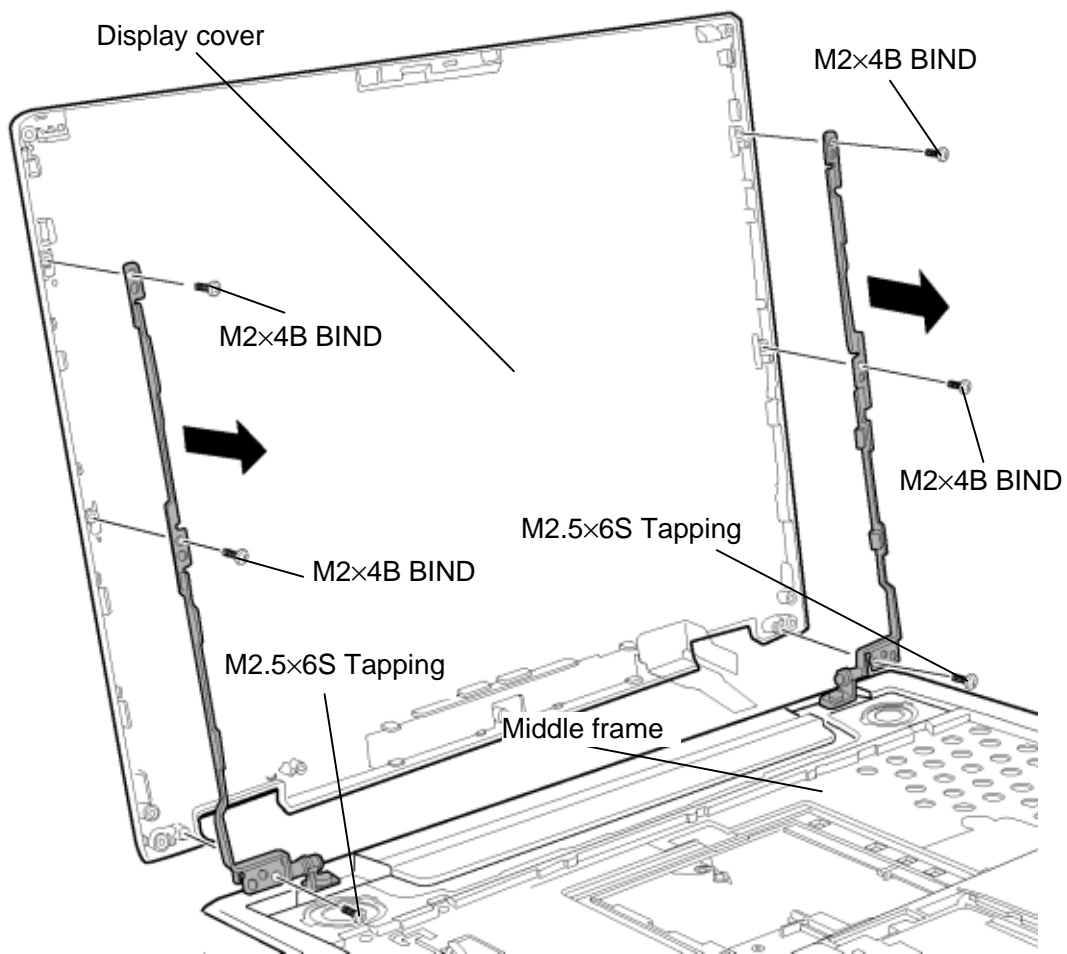

Figure 4-51 separating the display cover and middle frame

2. Remove the following **screw** and **SPG GND VGA fin**.

- M2×3S S-FLAT HEAD screw ×1

3. Remove the following **screws** and take out the **right hinge** from the hole of the middle frame by moving it to the left.

- M2.5×6S Tapping screw ×2

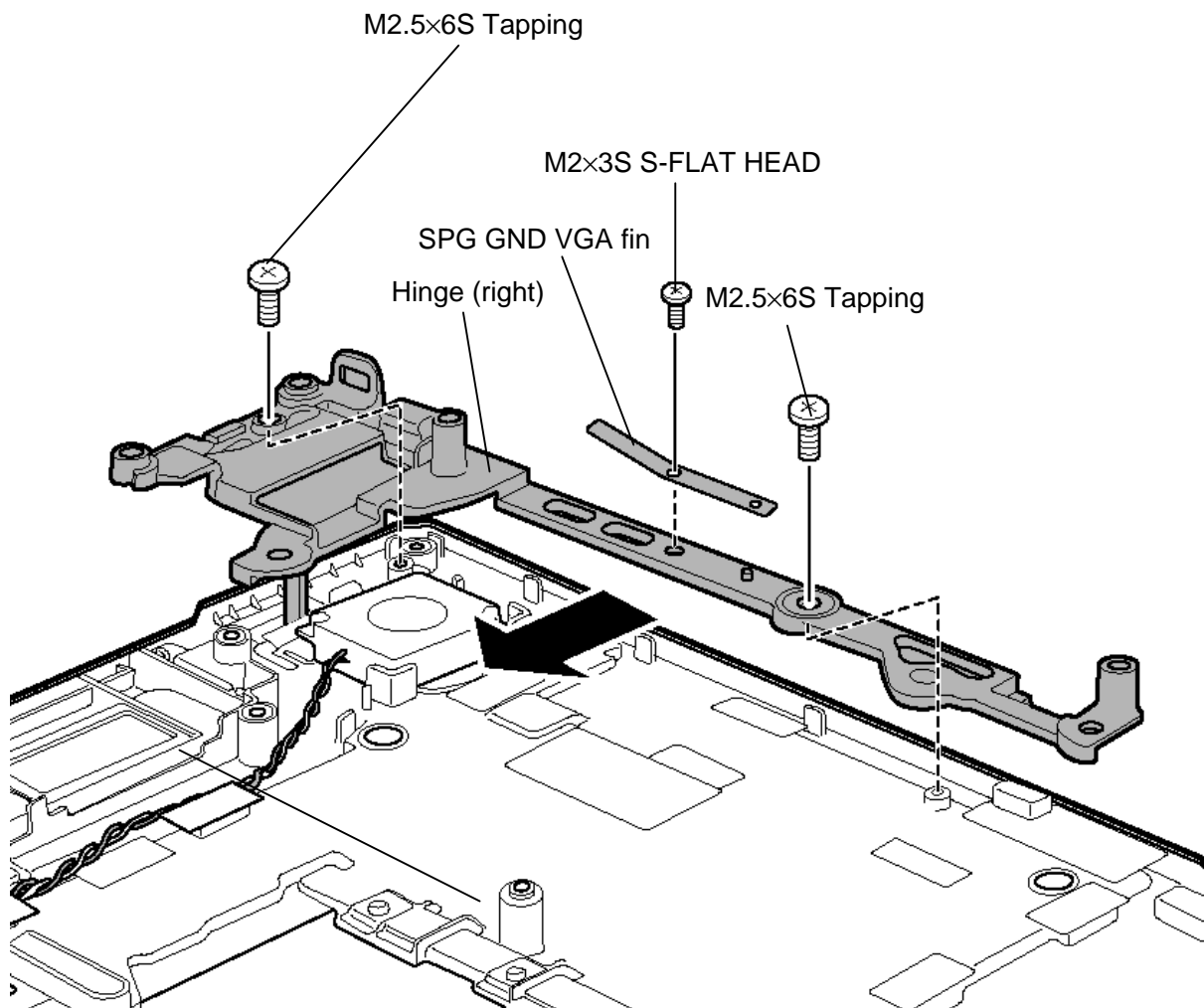

Figure 4-52 Removing the hinge (right)

4. Remove the following **screw** and take out the **left hinge** from the hole of the middle frame by moving it to the right.

- M2.5×6S Tapping screw ×1

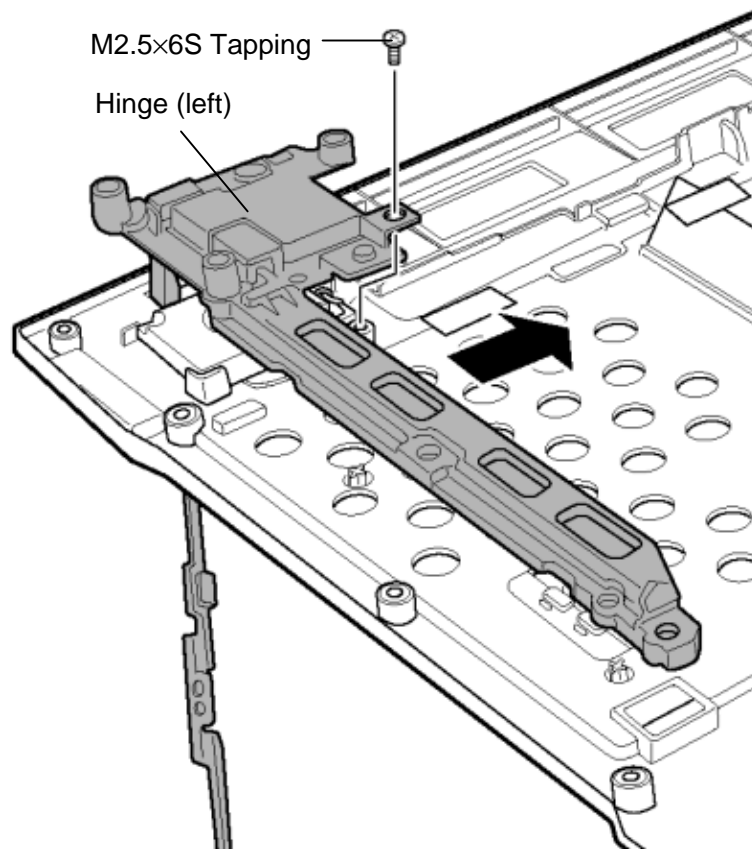

Figure 4-53 Removing the hinge (left)

Installing the Hinge

To install the hinge, follow the steps below and refer to Figure 4-51 to 4-53.

1. Install the left **hinge** and secure it with the following **screw**.
 - M2.5×6S Tapping screw ×1
2. Install the right **hinge** and secure it with the following **screws**.
 - M2.5×6S Tapping screw ×2
3. Install the SPG GND VGA fin and secure it with the following **screw**.
 - M2×3S S-FLAT HEAD screw ×1
4. Set the **middle frame** in place on the **display cover** and secure them with the following **screws**.
 - M2×4B BIND screw ×4
 - M2.5×6S Tapping screw ×2

4.28 Speaker

Removing the Speaker

To remove the speaker, follow the steps below and refer to Figure 4-54.

1. Peel off four **insulators**.
2. Remove the left and right **speakers** from the slots.

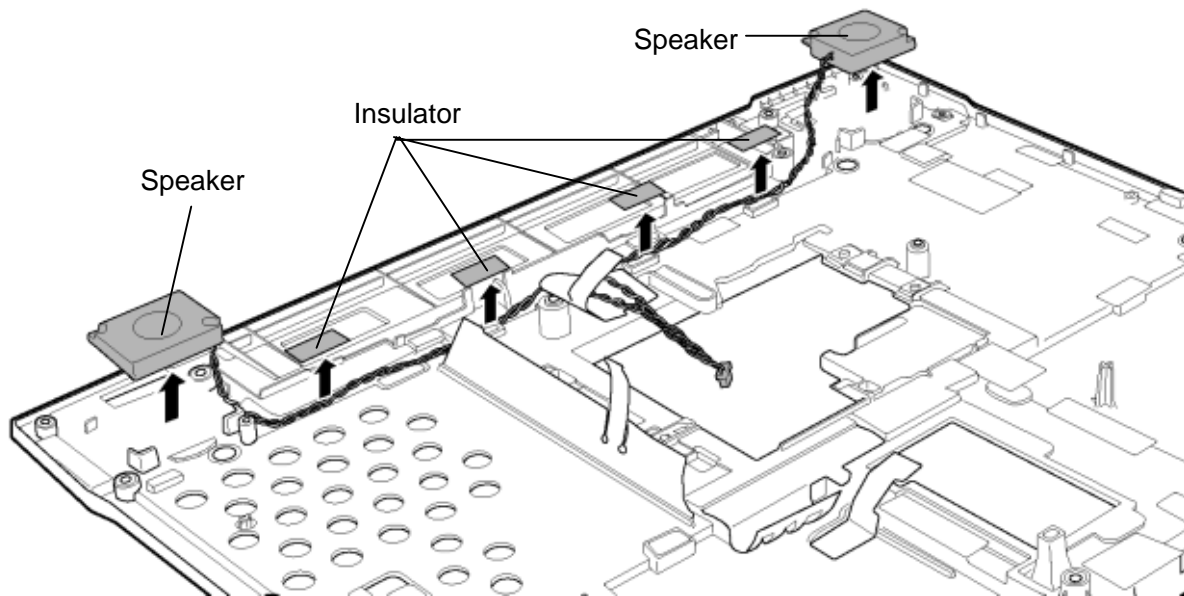

Figure 4-54 Removing the speaker

Installing the Speaker

To install the speaker, follow the steps below and refer to Figure 4-54.

1. Install the **speakers** (right and left) to the each slot.
2. Seat the **speaker cables** in place and stick four **insulators**.

4.29 Battery slider

Removing the Battery slider

To remove the battery slider, follow the steps below and refer to Figure 4-55 and 4-56.

1. Release the latches of the battery slider A and remove the **slider cap** from the bottom of the computer.
2. Take out the **battery slider A** from the base cover.

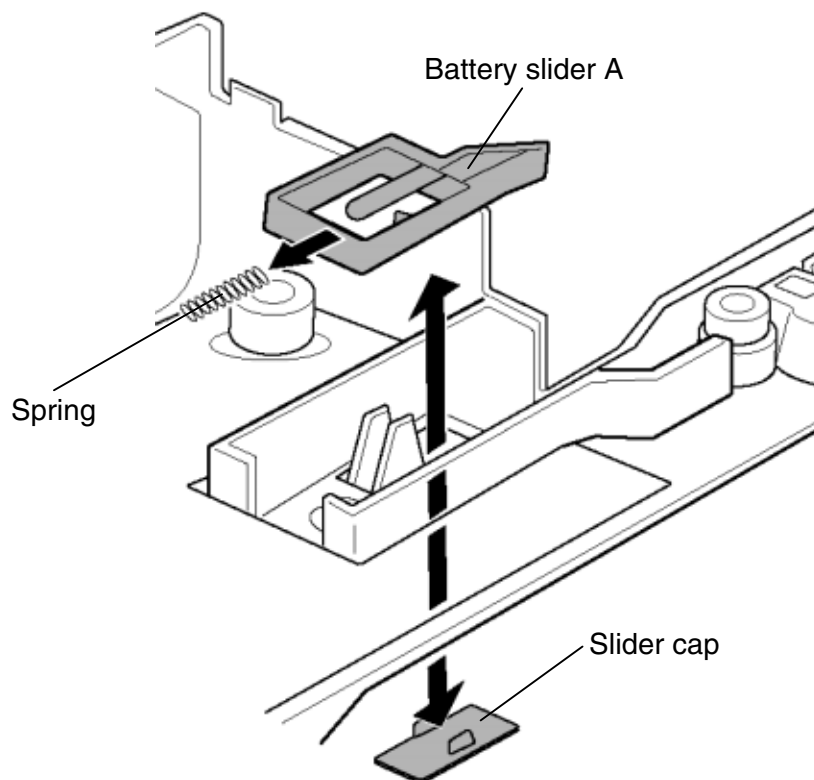

Figure 4-55 Removing the battery slider A

3. Release the latches of the battery slider B and remove the **slider cap** from the bottom of the computer.
4. Take out the **battery slider B** from the base cover.

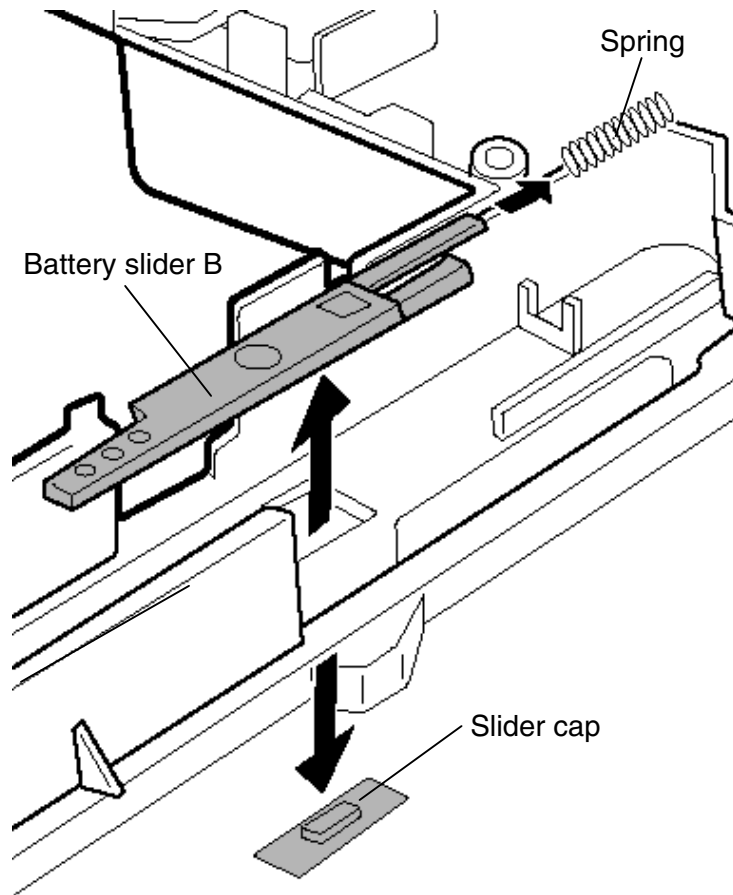

Figure 4-56 Removing the battery slider B

Installing the Battery slider

To install the Battery slider, follow the steps below and refer to Figure 4-55 and 4-56.

1. Install the **spring** to the **battery slider B** and set them to the base assembly.
2. Install the **slider cap** to the base cover from the bottom of the computer.
3. Install the **spring** to the **battery slider A** and set them to the base assembly.
4. Install the **slider cap** to the base cover from the bottom of the computer.

4.30 Fluorescent Lamp

This system uses LCD modules from the following suppliers. The procedure for replacing the fluorescent lamp is different for each LCD module. Refer to the appropriate procedure.

| Type | Part No. | Supplier | Section |
|-------------------|--------------|------------|---------|
| 15.0-inch (XGA) | G33C00030110 | LG Philips | 4.30.1 |
| | G33C0002Y110 | SHARP | 4.30.2 |
| | G33C0002W110 | Samsung | 4.30.3 |
| 15.0-inch (SXGA+) | G33C0001X210 | LG Philips | 4.30.4 |

- NOTE:**
- When working with a LCD module, always use a flat, grounded table.
 - Handle the backlight unit in the environment without dust, such as on the clean bench. Keep the worktable free from any screws or other material that may scratch the LCD surface.
 - Use an anti-static or protective sheet.
 - When replacing the FL unit, cover with a finger protector or similar to prevent soiling or scratching the LCD panel.
 - Be careful when handling the lamp. Excessive force may break the lamp.
 - Be careful not to soil or deform the lamp reflector.
 - Make sure that the power of the LCD module is turned off before connecting or disconnecting cables and connectors.

4.30.1 Replacing the 15.0-inch XGA LG Philips Fluorescent Lamp

CAUTION: When replacing the fluorescent lamp, wear finger covers or gloves to avoid contaminating or damaging the LCD panel. Be careful not to let dust or other foreign substance into the module.

Disassembling the 15.0-inch XGA LG Philips Fluorescent Lamp

To disassemble the 15.0-inch XGA LG Philips fluorescent lamp, follow the steps below and refer to Figure 4-57 to 4-64.

Disassembly of outside tape / Cover shield

1. Disassembly of Cover shield (S).

CAUTION: Pressure or stress should not be given on Source PCB.
Usage of gloves with anti-electric discharge coating is recommended.
To eliminate possible damage on circuits occurred by ESC.

2. Disassembly of Cover shield (G).

CAUTION: Pressure or stress should not be given on Gate COF.

3. Disassembly of Tape Adhesive used for Top case fixing.
Disassembly of Tape Adhesive used for B/L Wire fixing.

CAUTION: Pressure or stress should not be given on Top case during this process.

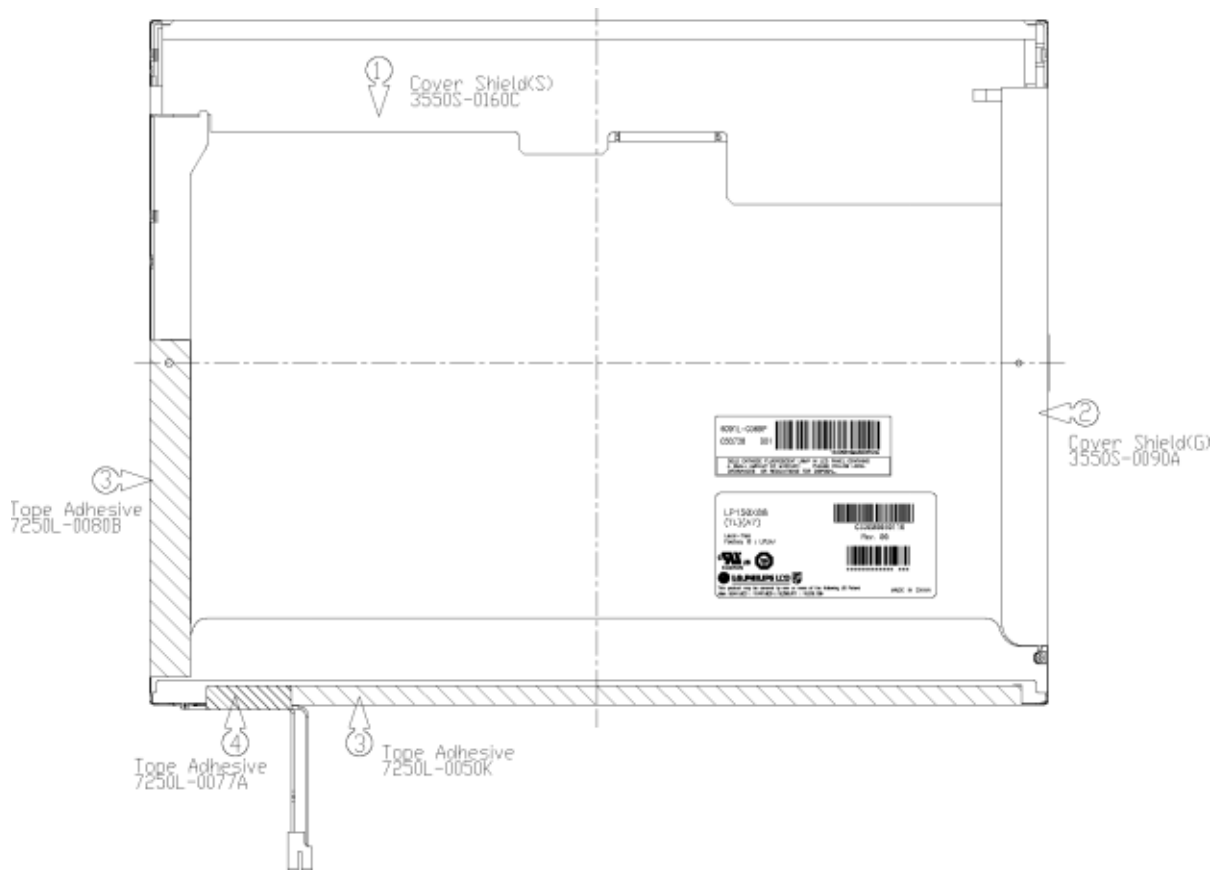

Figure 4-57 Replacing LG.Philips fluorescent lamp (XGA) (1)

Disassembly of Top Case

1. Disassembly of Top Case.

CAUTION: Pressure or stress should not be given on Source TCP and Gate COF.

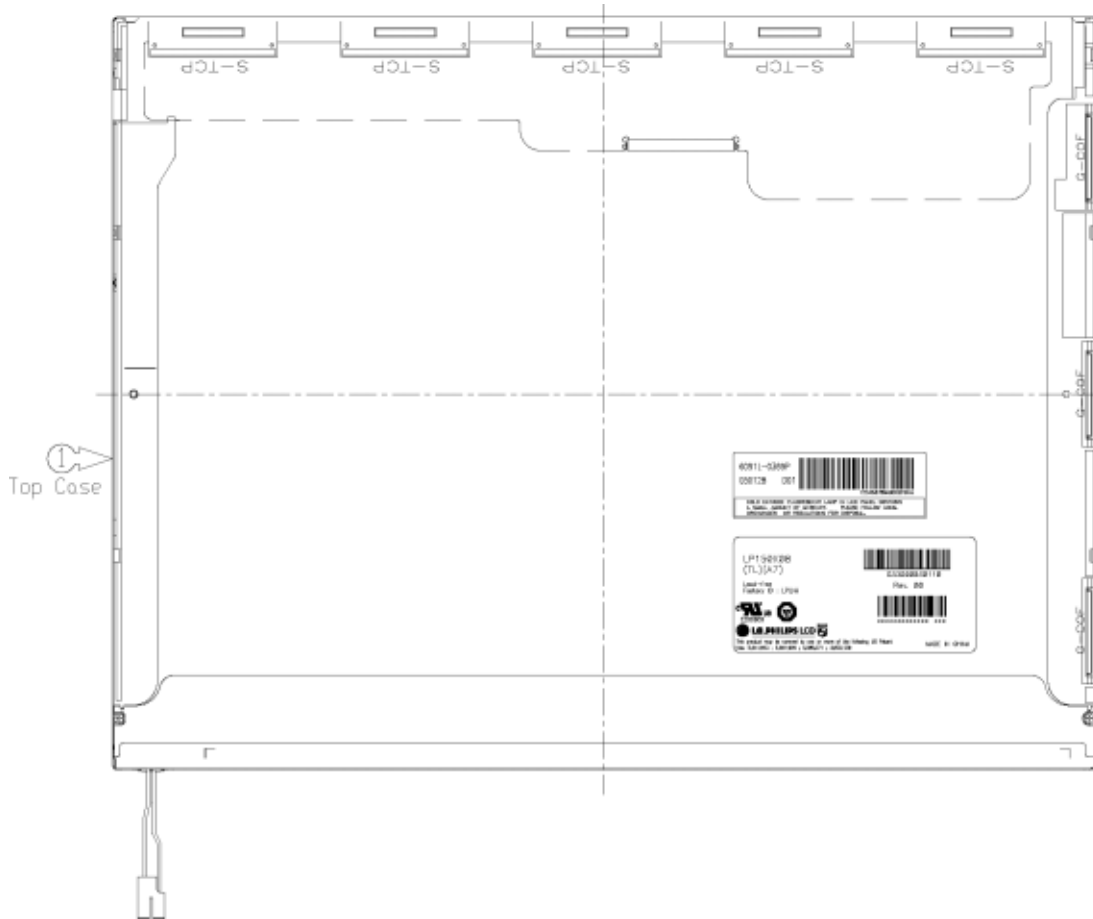

Figure 4-58 Replacing LG.Philips fluorescent lamp (XGA) (2)

Disassembly of Source PCB

1. Disassembly of Source PCB.

CAUTION: Pressure or stress should not be given on PCB and TCP.

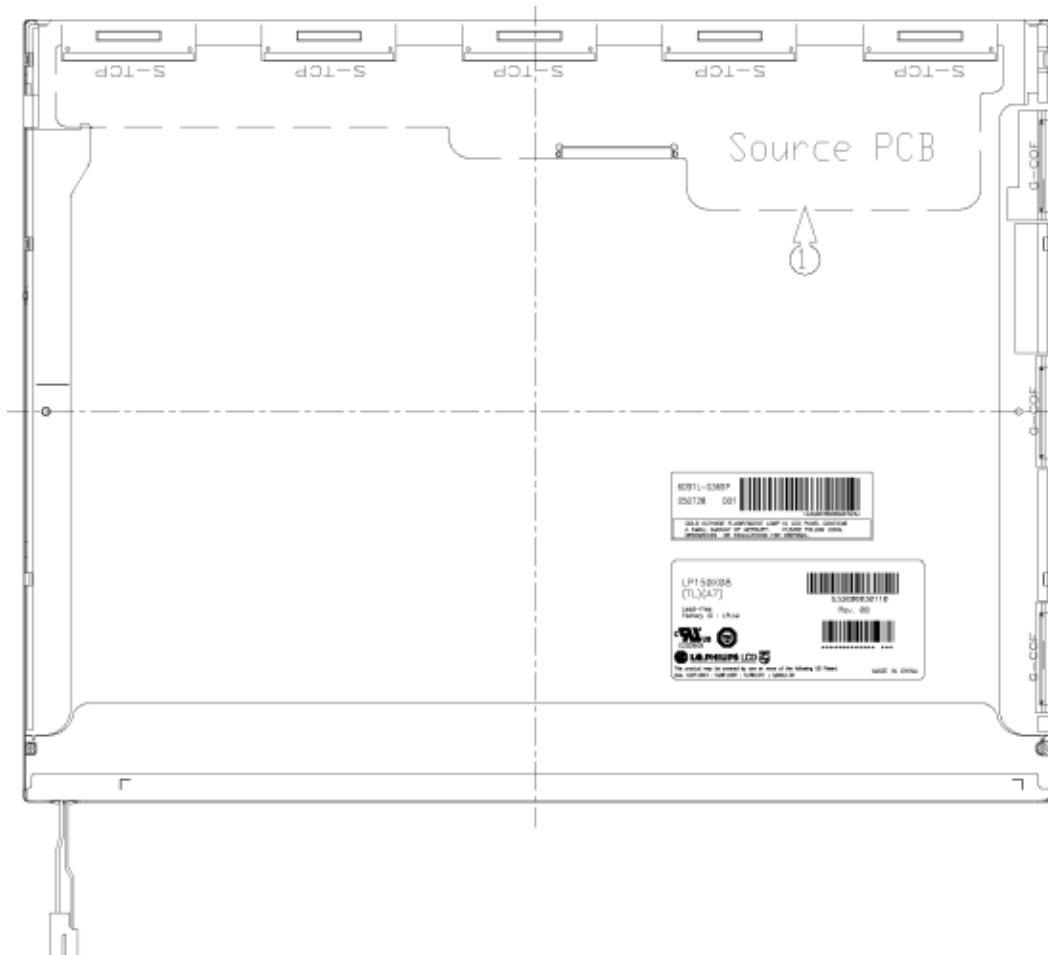

Figure 4-59 Replacing LG.Philips fluorescent lamp (XGA) (3)

Disassembly of Board Ass'y, Tape Adhesive, Light guide, Cover Ass'y Bottom (L)

1. Disassembly of Board Ass'y.

CAUTION: This process should be made in Clean room with no scratch nor particle on Polarizer and B/L Ass'y.

2. Disassembly of Tape Adhesive used for Sheets fixing (4 Points).
3. Disassembly of Sheets and Light guide.

CAUTION: No penetration of foreign body is indispensable with no scratch on the surface of each Sheet.

4. Disassembly of Screw (2 Points) and Cover Ass'y Bottom.

CAUTION: Maximum value of torque with Screw should be below 1.5kg.

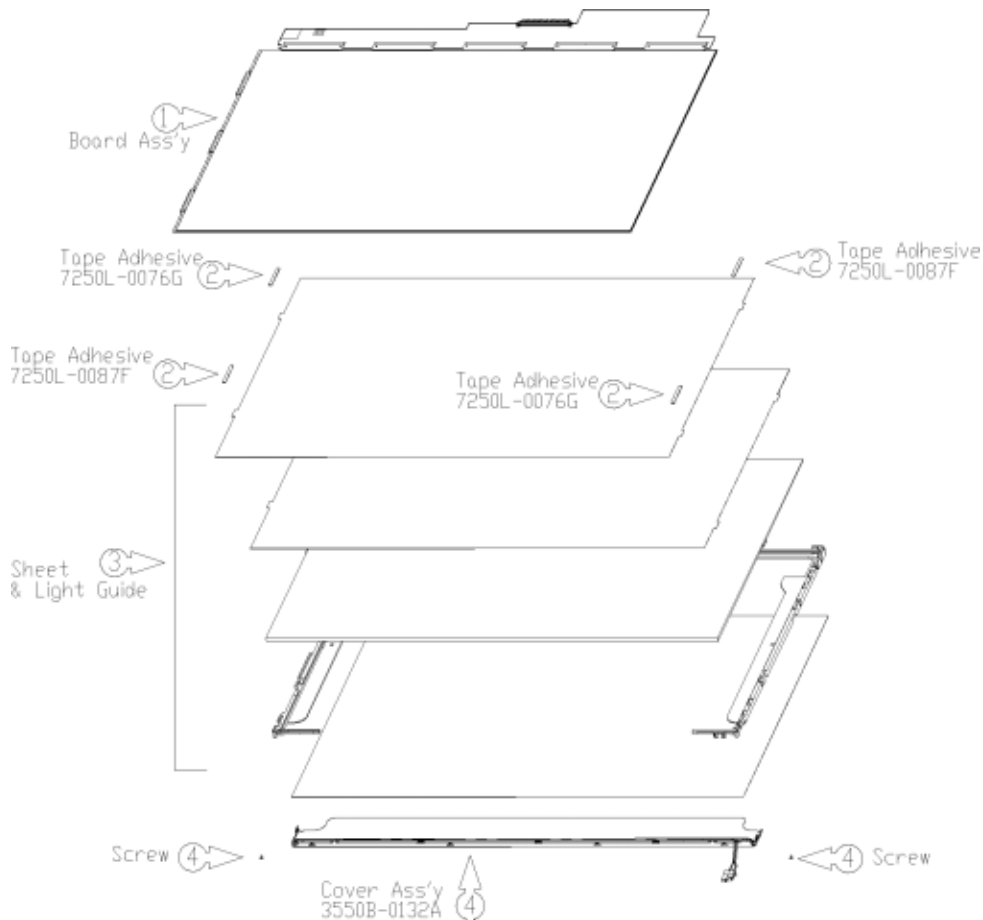

Figure 4-60 Replacing LG.Philips fluorescent lamp (XGA) (4)

Assembly of Cover Ass'y Bottom (L), Sheets, Light guide, Tape Adhesive and Board Ass'y.

1. Assembly of Cover Ass'y Bottom and Screw (2 Point).

CAUTION: Maximum value of torque with Screw should be below 2.0kgf.cm.

2. Assembly of Light Guide and Sheets. (Reflector Sheet fixing with one Double Tape, Diffuser Sheet fixing with one Double Tape.)

CAUTION: No penetration of foreign body is indispensable with no scratch on the surface of each Sheet and Light guide.

3. Assembly of Tape adhesive used for Sheets fixing (4 Points).
4. Assembly of Board Ass'y.

CAUTION: Pressure or stress should not be given on PCB and TCP.

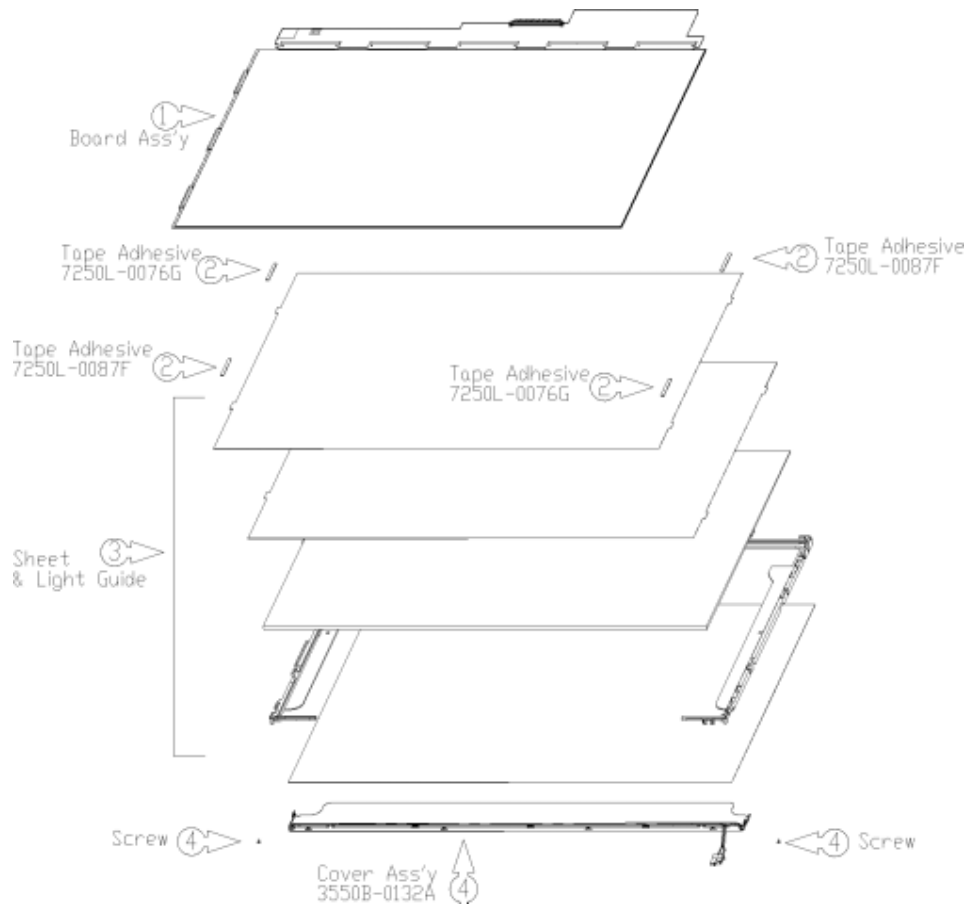

Figure 4-61 Replacing LG.Philips fluorescent lamp (XGA) (5)

Assembly of Source PCB

1. Assembly of Source PCB.

CAUTION: Stress should not be given on TCP.

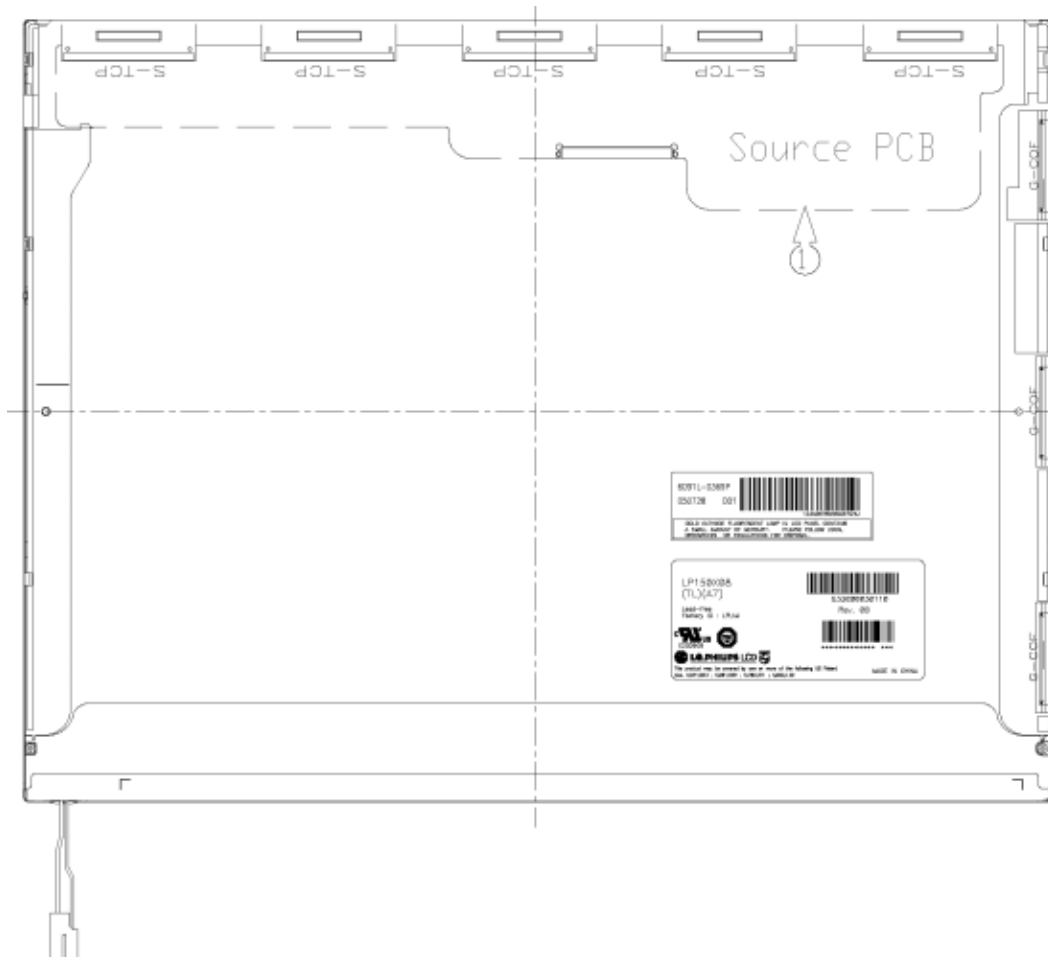

Figure 4-62 Replacing LG.Philips fluorescent lamp (XGA) (6)

Assembly of Top Case

1. Assembly of Top Case.

CAUTION: Pressure should not be given on Source TCP and Gate COF.

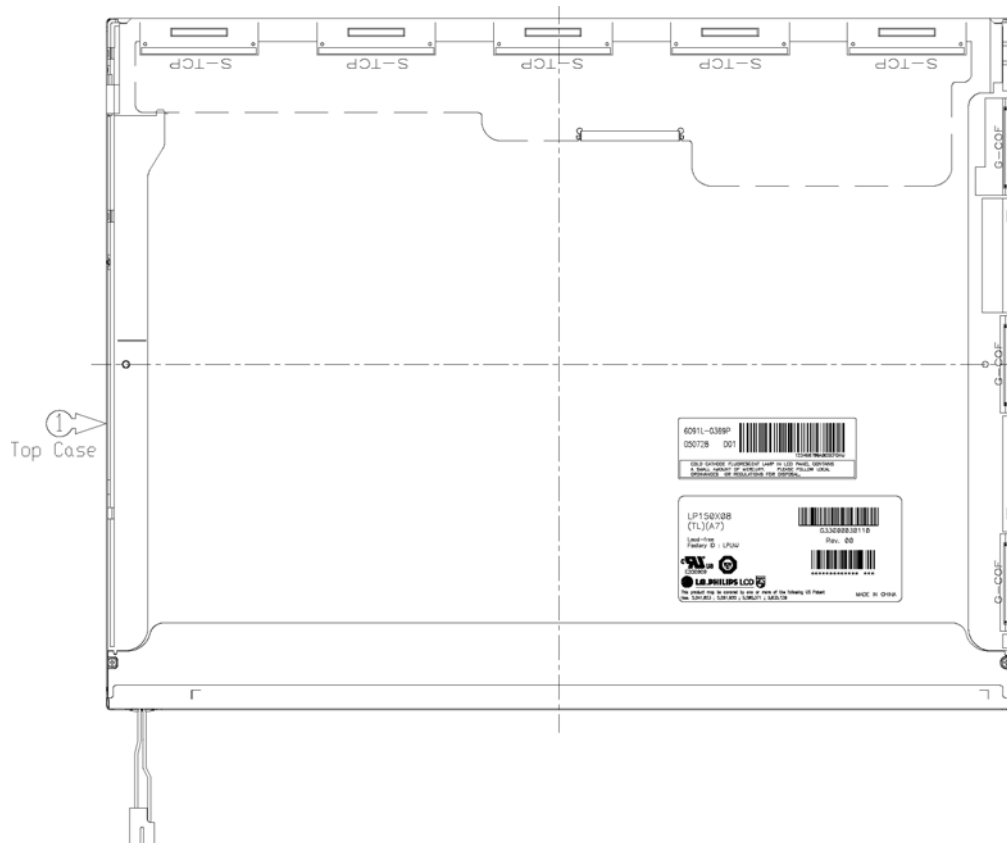

Figure 4-63 Replacing LG.Philips fluorescent lamp (XGA) (7)

Assembly of outside Tape and Cover shield

1. Assembly of Cover shield (S).

CAUTION: Pressure or stress should not be given on Source PCB.
Usage of gloves with anti-electric discharge coating is recommended.
To eliminate possible damage on circuits occurred by ESC.

2. Assembly of Cover shield (G).

CAUTION: Pressure or stress should not be given on Gate TCP.

3. Assembly of Tape Adhesive used for Top case fixing.
Assembly of Tape Adhesive used for B/L Wire fixing.

CAUTION: Pressure or stress should not be given on Top case during this process.

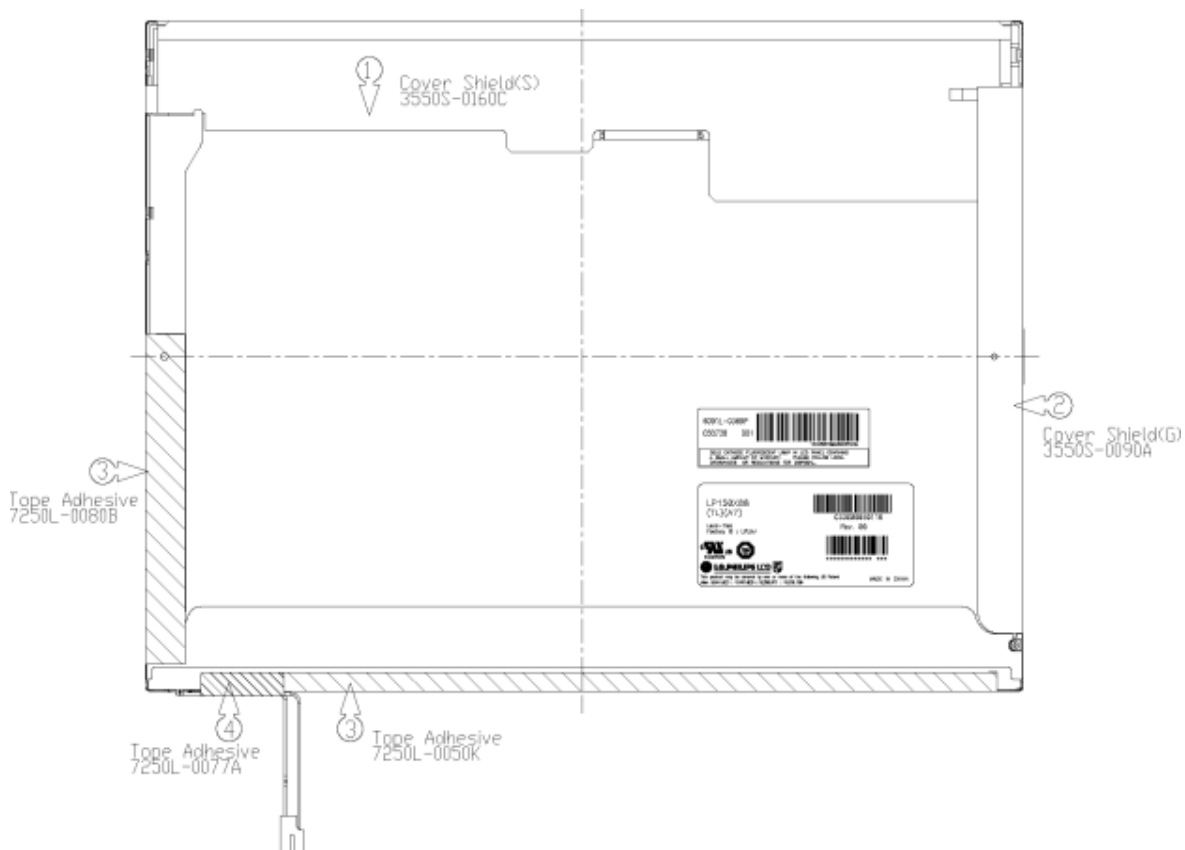

Figure 4-64 Replacing LG.Philips fluorescent lamp (XGA) (8)

4.30.2 Replacing the 15.0-inch XGA Sharp Fluorescent Lamp

CAUTION: When replacing the fluorescent lamp, wear finger covers or gloves to avoid contaminating or damaging the LCD panel. Be careful not to let dust or other foreign substance into the module.

Removing the 15.0-inch XGA Sharp fluorescent lamp

To remove the 15.0-inch XGA Sharp Fluorescent Lamp, follow the steps below and refer to Figures 4-65 to 4-74.

1. Turn the LCD module face down, and remove the protection cover SC (A), protection cover G (B) and two fixing tapes (C) and (D).

CAUTION: 1) Be careful not to damage the TCP and chip.
2) Discard the tapes(A, C, D) removed.
3) The protection cover G (B) is reused. Do not peel off the place stuck to the bezel.

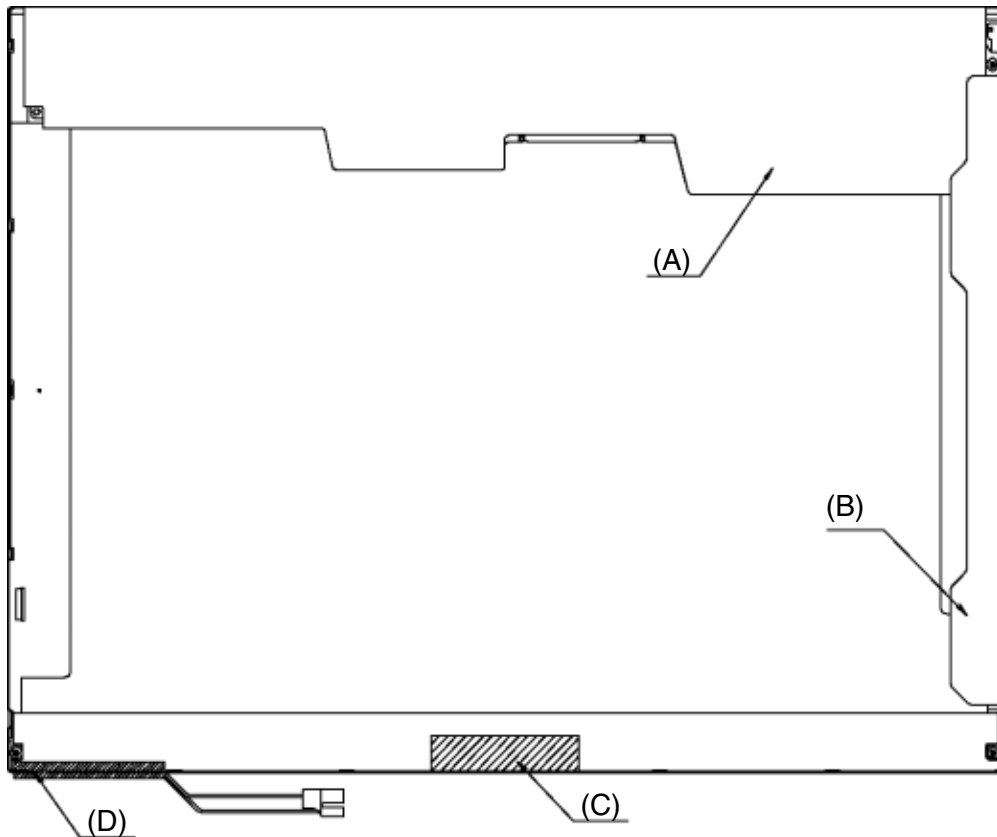

Figure 4-65 Replacing Sharp fluorescent lamp (XGA) (1)

2. Remove the four screws (E) on the both sides.

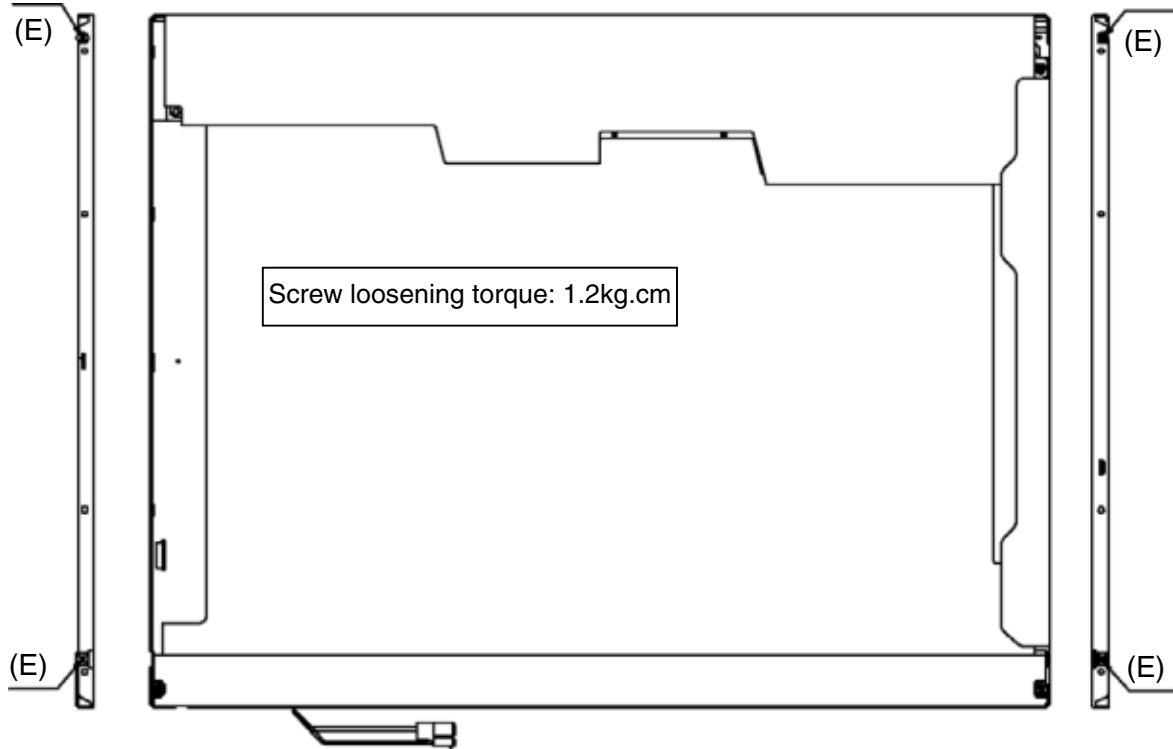

Figure 4-66 Replacing Sharp fluorescent lamp (XGA) (2)

3. Turn the LCD module face up and remove the bezel (F).

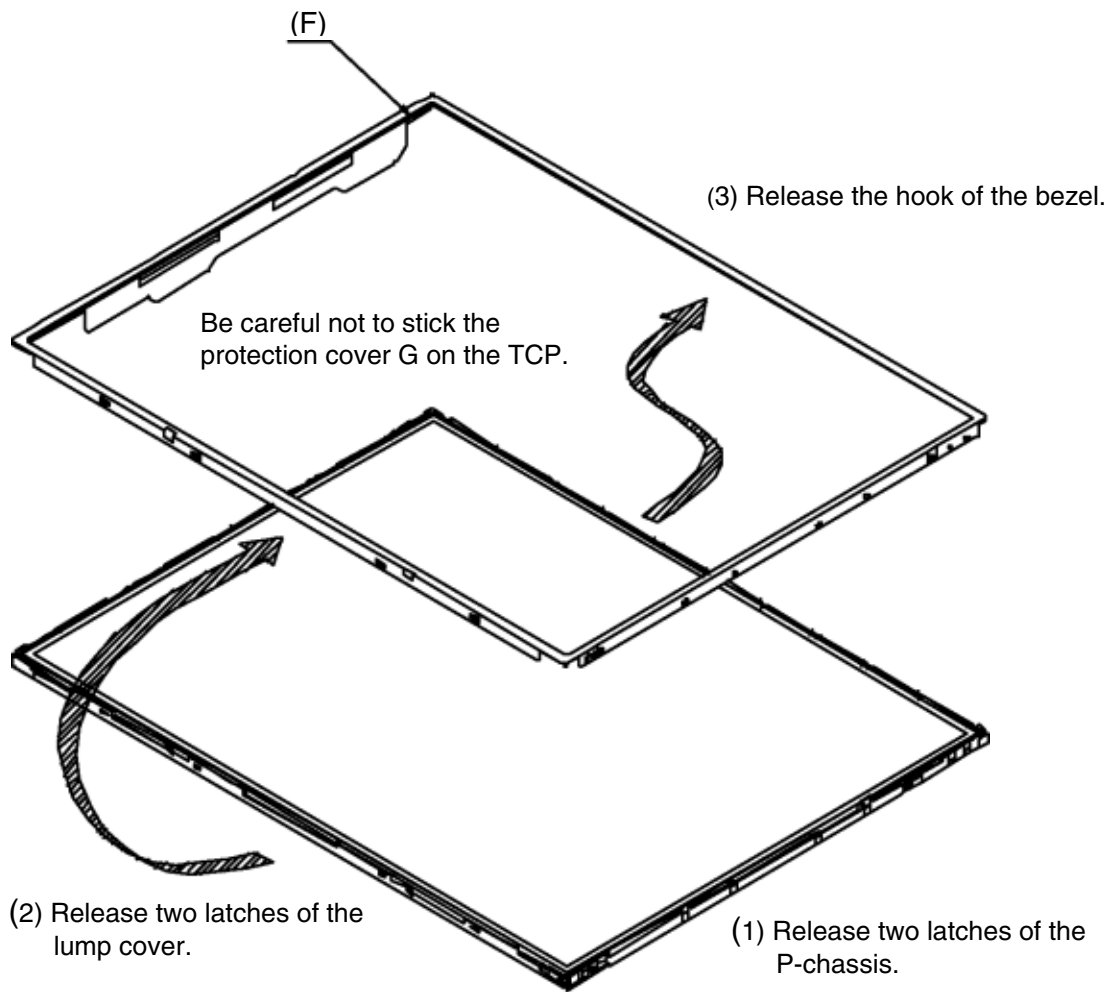

Figure 4-67 Replacing Sharp fluorescent lamp (XGA) (3)

4. Turn the LCD module face down and remove the screw (E) fixing the board. Then open the bent portion of the TCP of the board and remove the backlight.

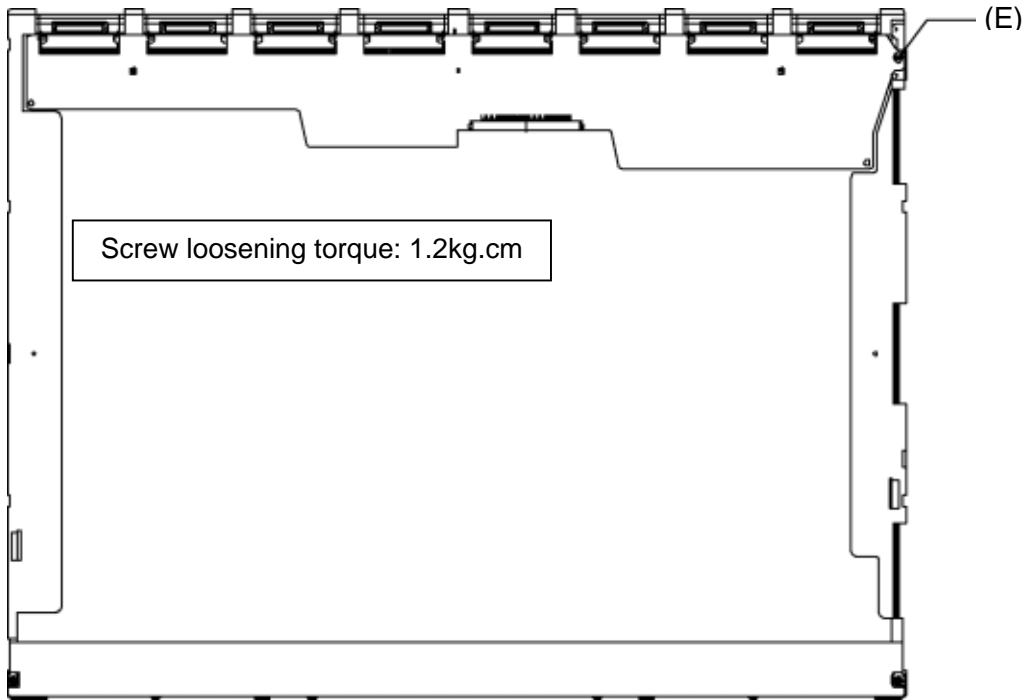

Figure 4-68 Replacing Sharp fluorescent lamp (XGA) (4)

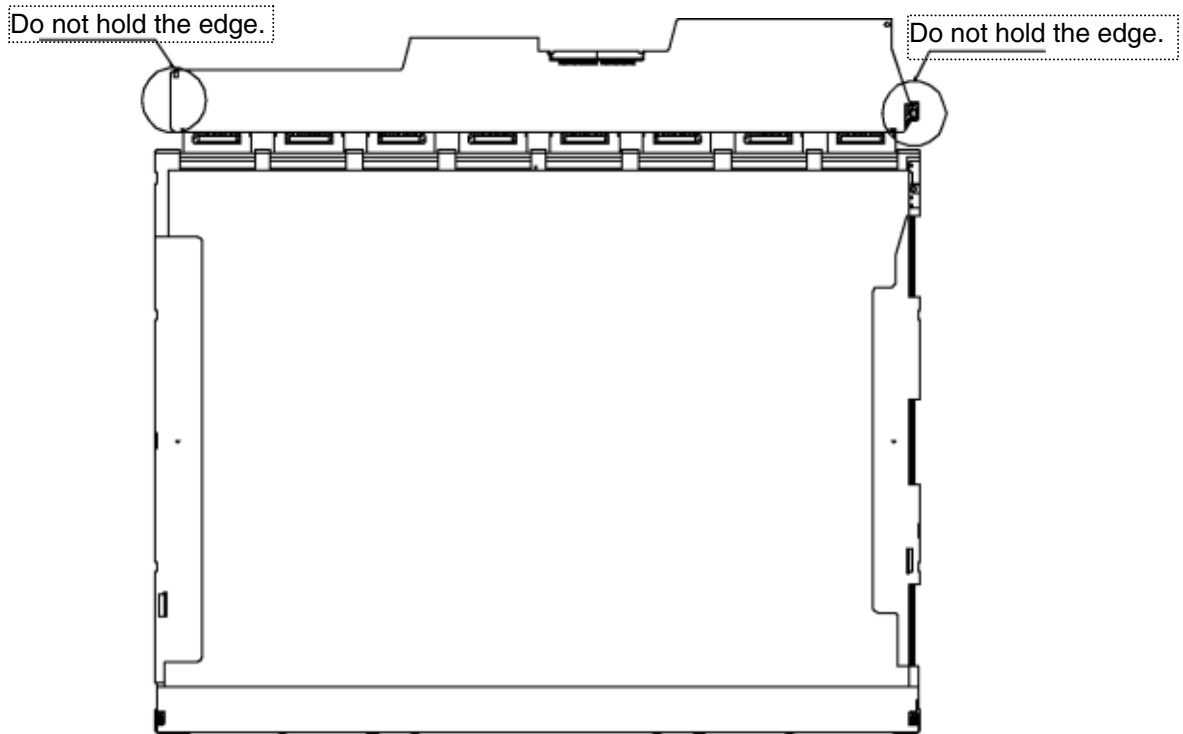

Figure 4-69 Replacing Sharp fluorescent lamp (XGA) (5)

5. Turn the LCD module face up and remove the LCD panel (G) from the backlight unit (H).

CAUTION: Wear finger sacks or gloves during the work not to soil or scratch the LCD panel or backlight unit.

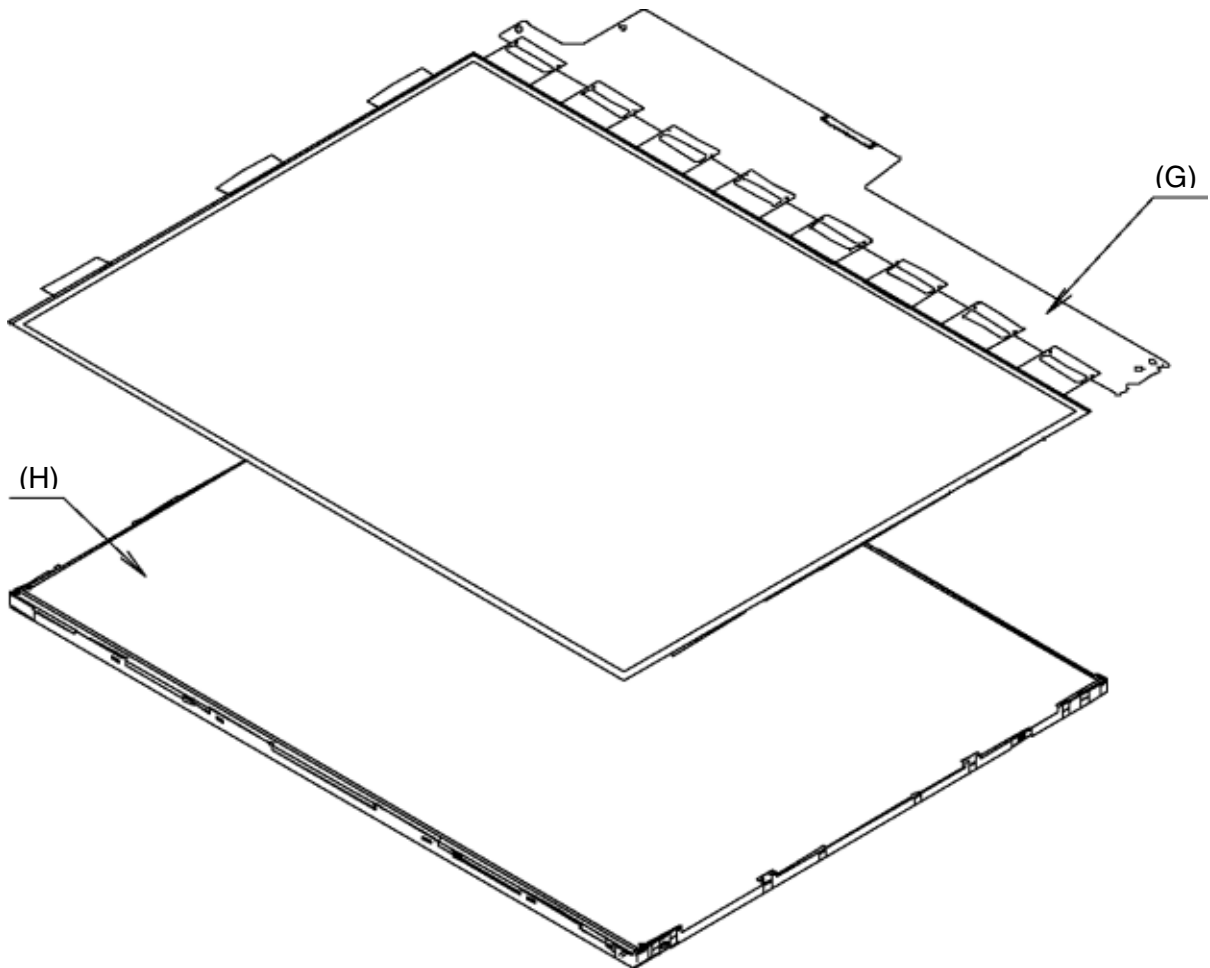

Figure 4-70 Replacing Sharp fluorescent lamp (XGA) (6)

6. Peel off four fixing tapes (P).

CAUTION: Keep the removed fixing tapes (P) to reuse.



Figure 4-71 Replacing Sharp fluorescent lamp (XGA) (7)

7. Remove the lens sheet (M), diffusion sheet (N) and light guide plate (O).

CAUTION: Be careful not to scratch or soil the removed sheets and light guide to reuse them.

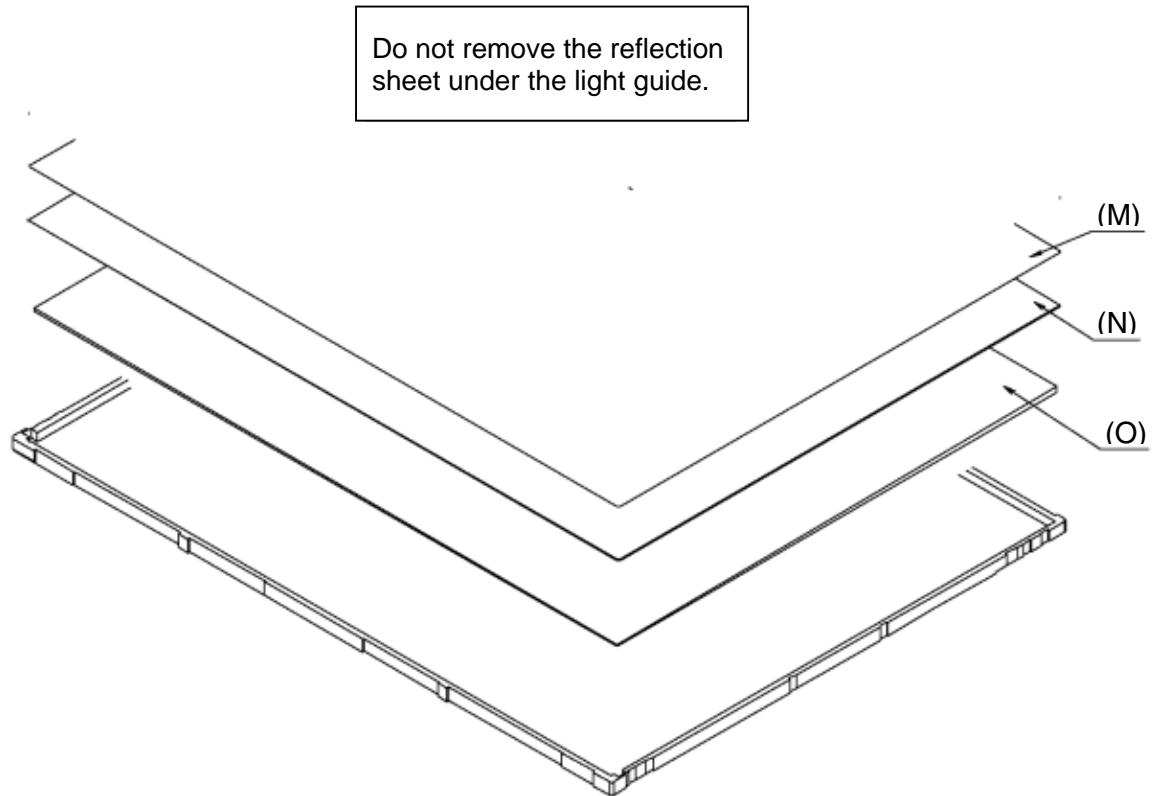

Figure 4-72 Replacing Sharp fluorescent lamp (XGA) (8)

- Turn the back light unit (G) face down and remove two screws (I), lump cover (J), metal fitting A (K) and metal fitting B (L).

CAUTION: Be careful not to scratch or soil the back light unit.

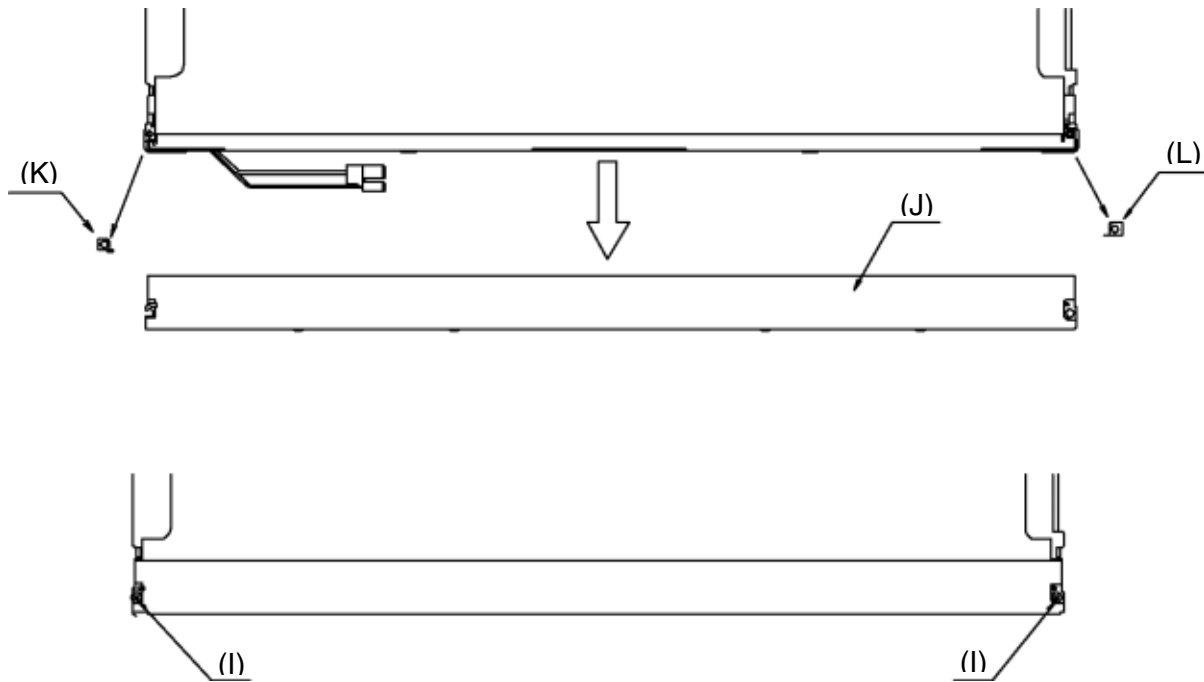

Figure 4-73 Replacing Sharp fluorescent lamp (XGA) (9)

9. Remove the lamp unit (Q) from the P-chassis.

CAUTION: When removing the lamp unit, be careful not to break the lamp, or bend the reflection sheet.

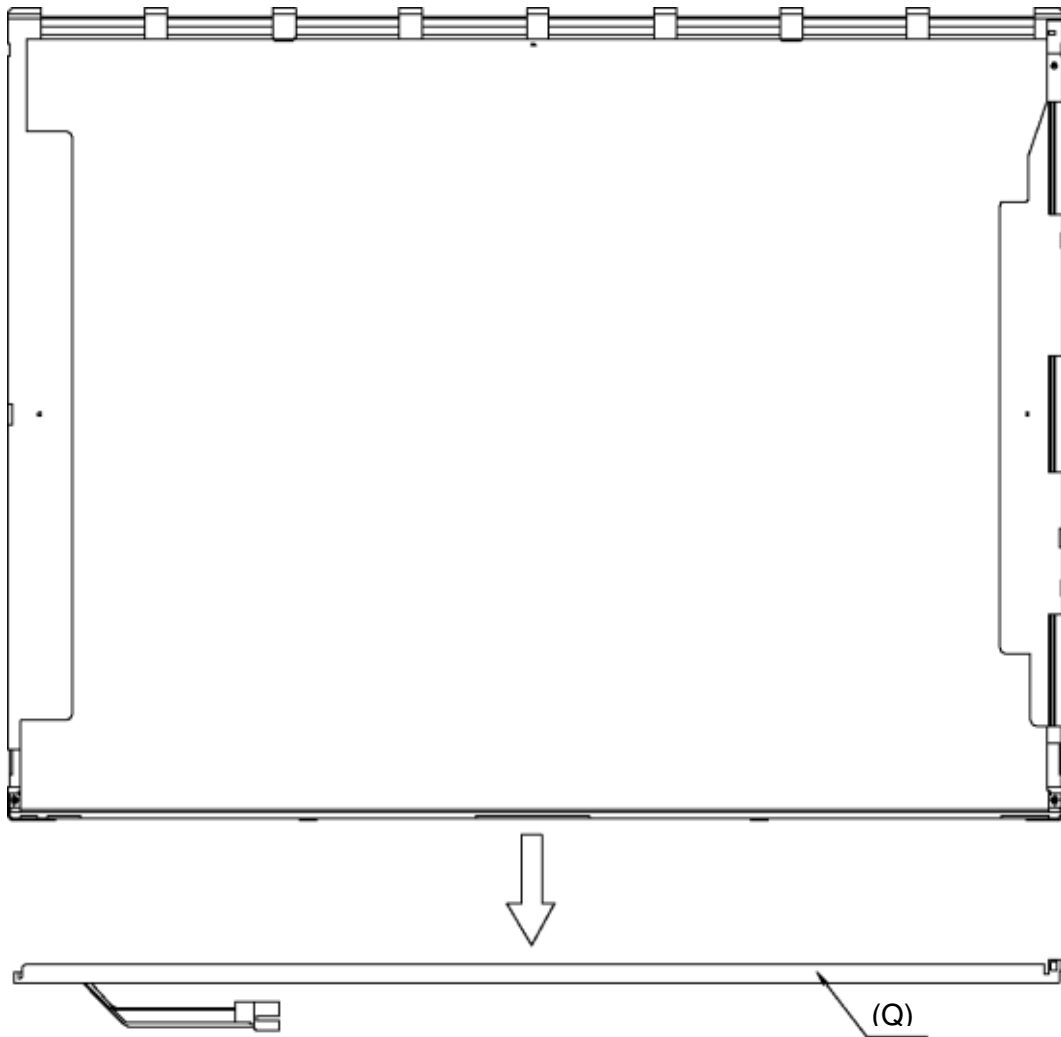

Figure 4-74 Replacing Sharp fluorescent lamp (XGA) (10)

Assembling the 15.0-inch XGA Sharp fluorescent lamp

To assemble the 15.0-inch Sharp XGA fluorescent lamp, follow the steps below and refer to figures 4-75 to 4-87.

1. Install a new lamp unit (Q) on the P-chassis.

CAUTION: When install the lamp unit (Q), be careful not to bend or damage the reflection sheet.

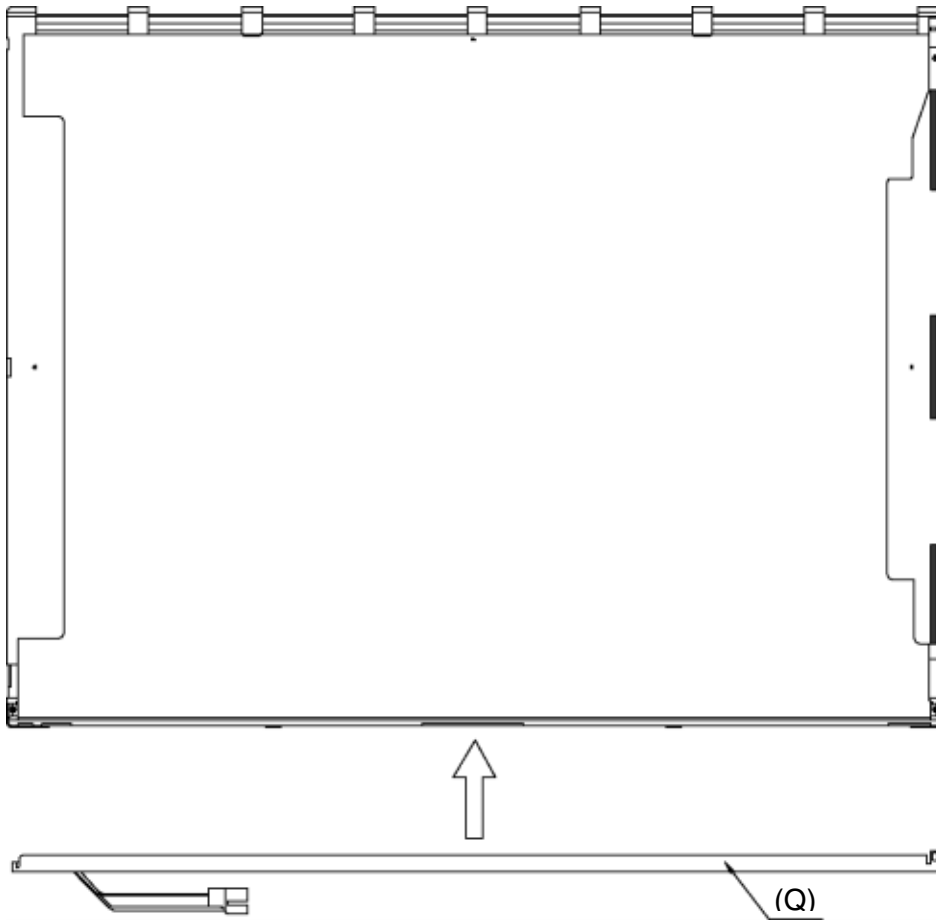
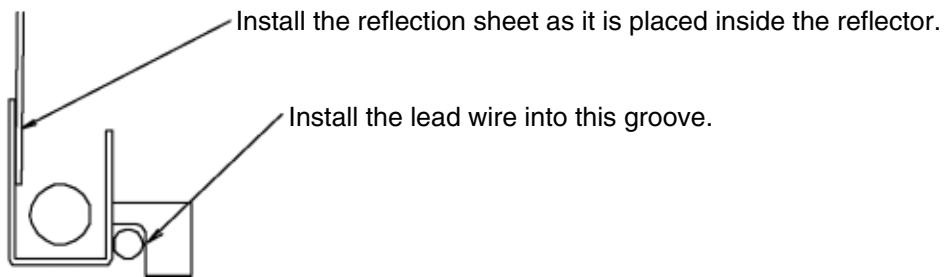
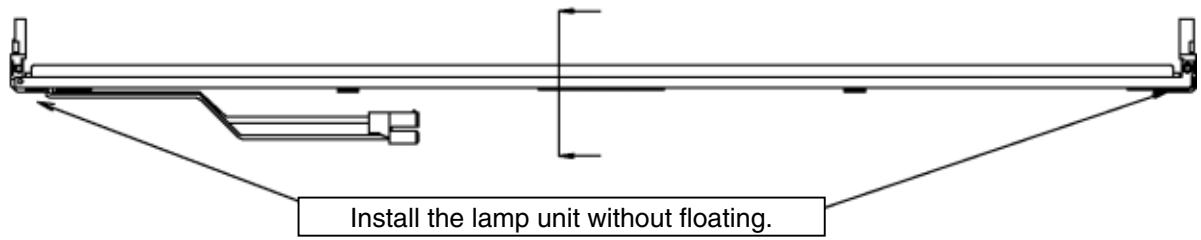

Figure 4-75 Replacing Sharp fluorescent lamp (XGA) (11)



Cross-section drawing of Z-Z

Figure 4-76 Replacing Sharp fluorescent lamp (XGA) (12)

2. Install the metal fitting A (K), metal fitting B (L) and lump cover (J) on the backlight unit and secure the two screws (I).

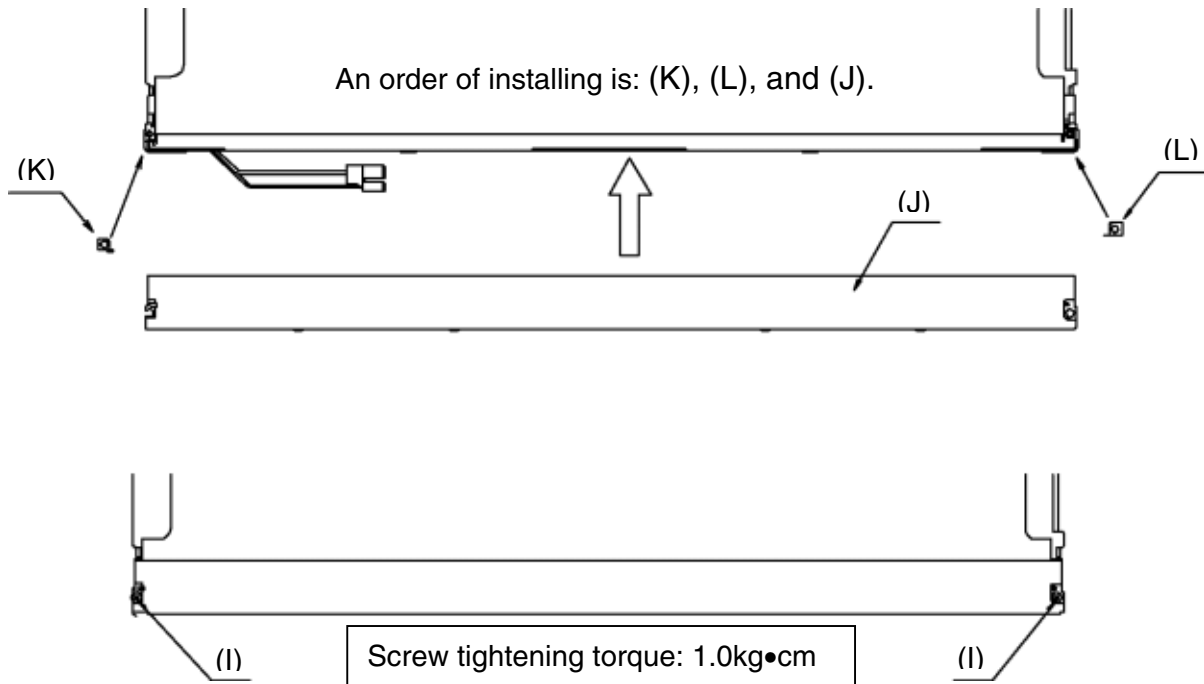

Figure 4-77 Replacing Sharp fluorescent lamp (XGA) (13)

3. Install the light guide plate (O) on the backlight unit. (Insert the thick side of the light guiding plate in the lamp unit.)

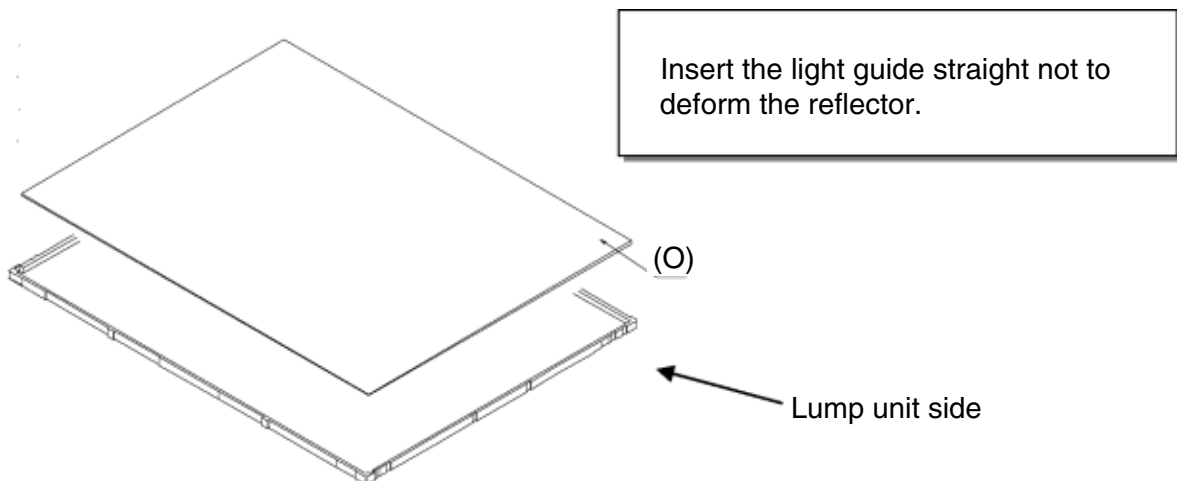

Figure 4-78 Replacing Sharp fluorescent lamp (XGA) (14)

- Place the diffusion sheet (N) and lens sheet (M) on the backlight unit with light guide plate.

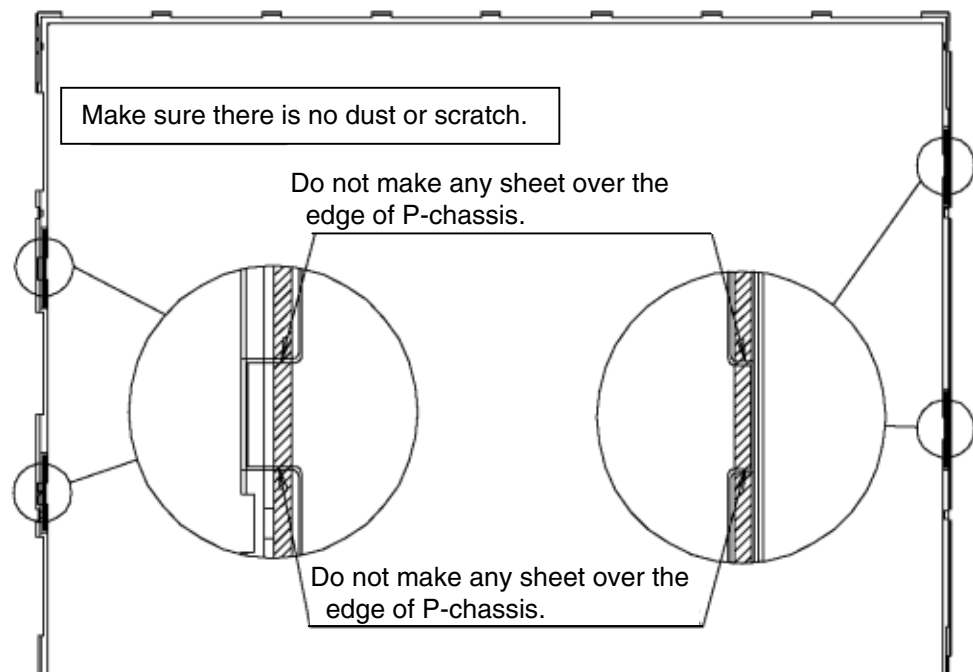
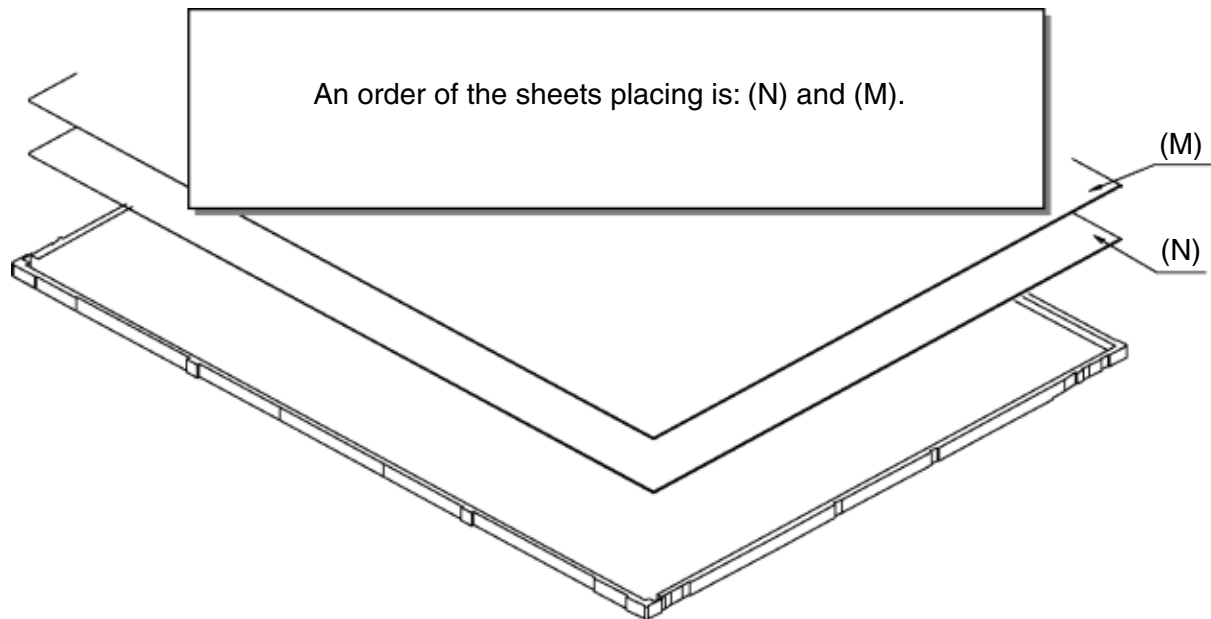

Figure 4-79 Replacing Sharp fluorescent lamp (XGA) (15)

- 5. Stick four fixing tapes (P).

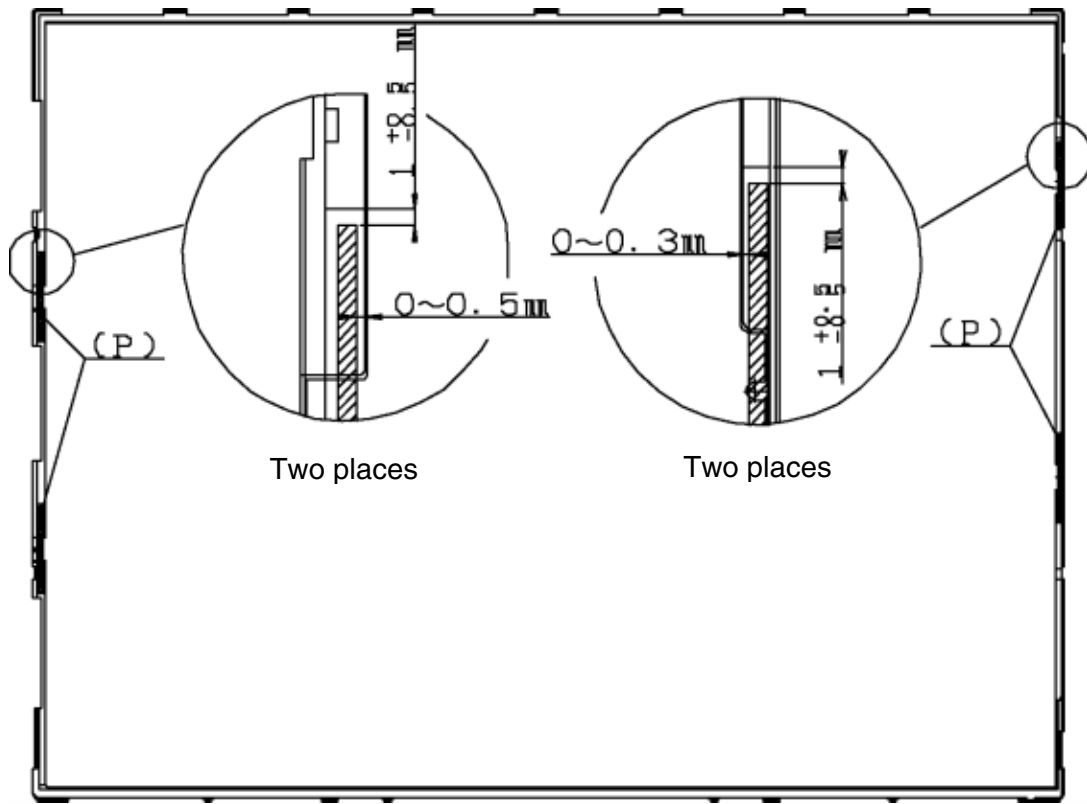
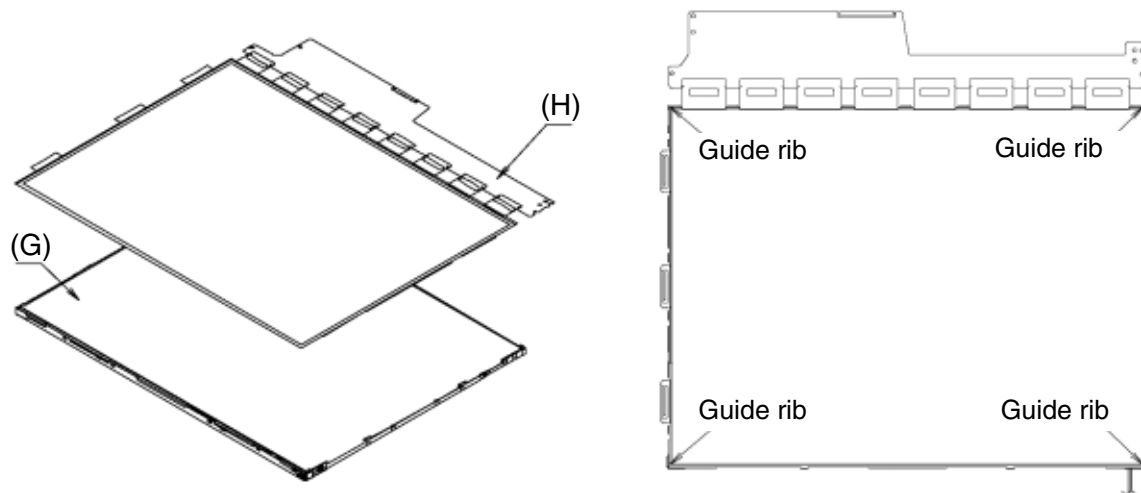

Figure 4-80 Replacing Sharp fluorescent lamp (XGA) (16)

6. Place the LCD panel (H) on the backlight unit (G).

CAUTION: Make sure there is no dust between the LCD panel and backlight unit. If any dust is found, remove it with crepe tape or others, which has no remaining of paste.



Make sure the LCD panel is installed in the guide rib surely.

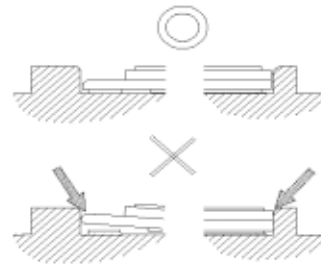

Figure 4-81 Replacing Sharp fluorescent lamp (XGA) (17)

7. Bend the TCP attaching to the source board and secure the screw (E).

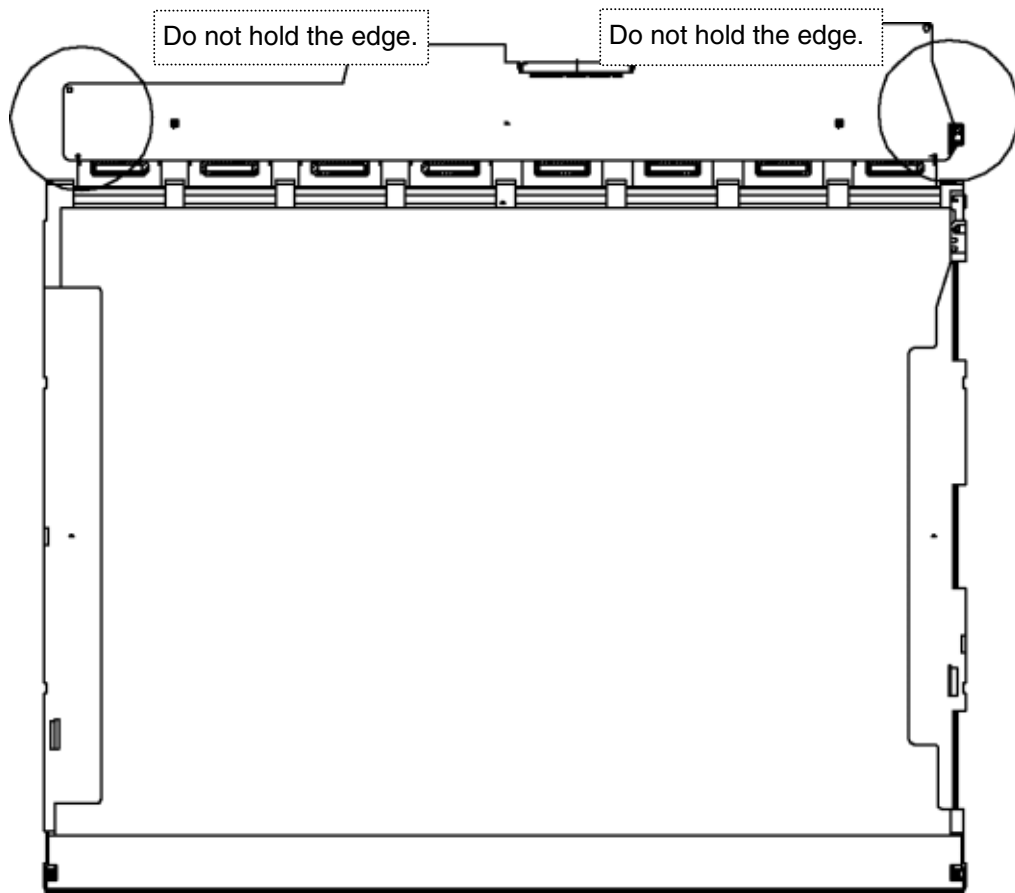

Figure 4-82 Replacing Sharp fluorescent lamp (XGA) (18)

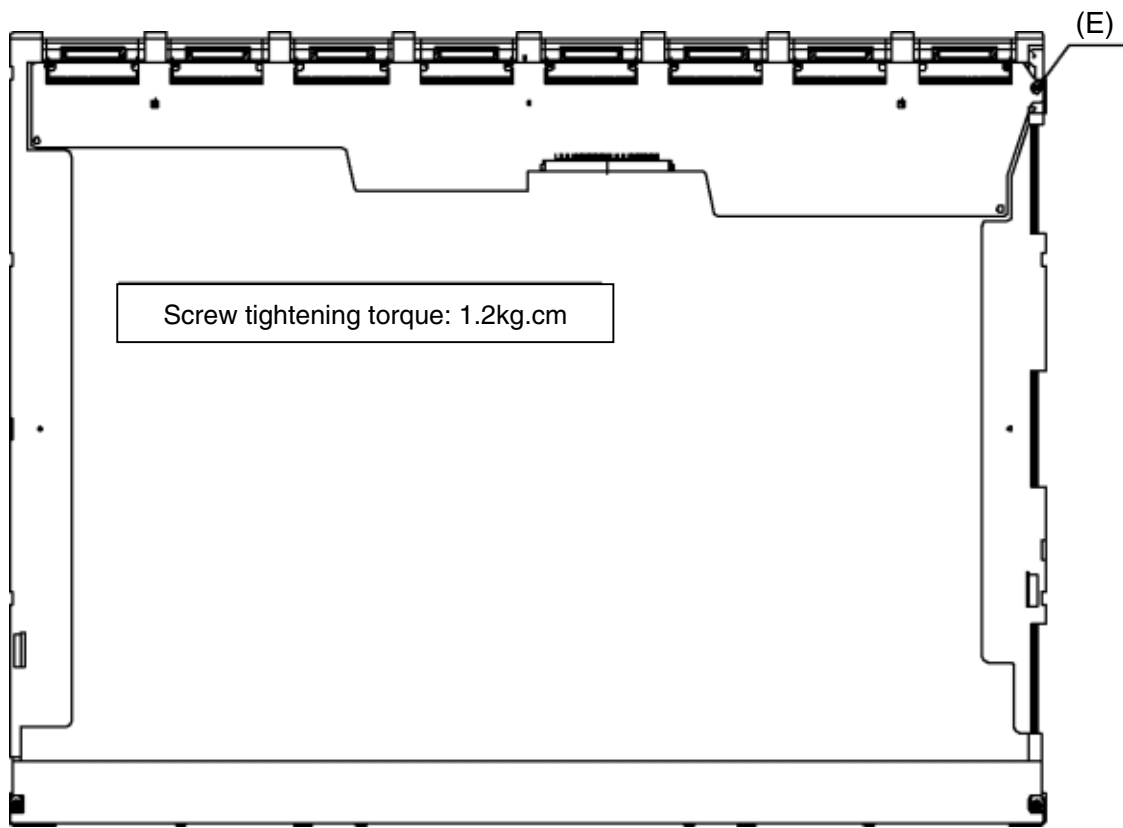

Figure 4-83 Replacing Sharp fluorescent lamp (XGA) (19)

8. Install the bezel (F) on the lamp cover and hook four latches on the lamp cover and two latches on the P-chassis.

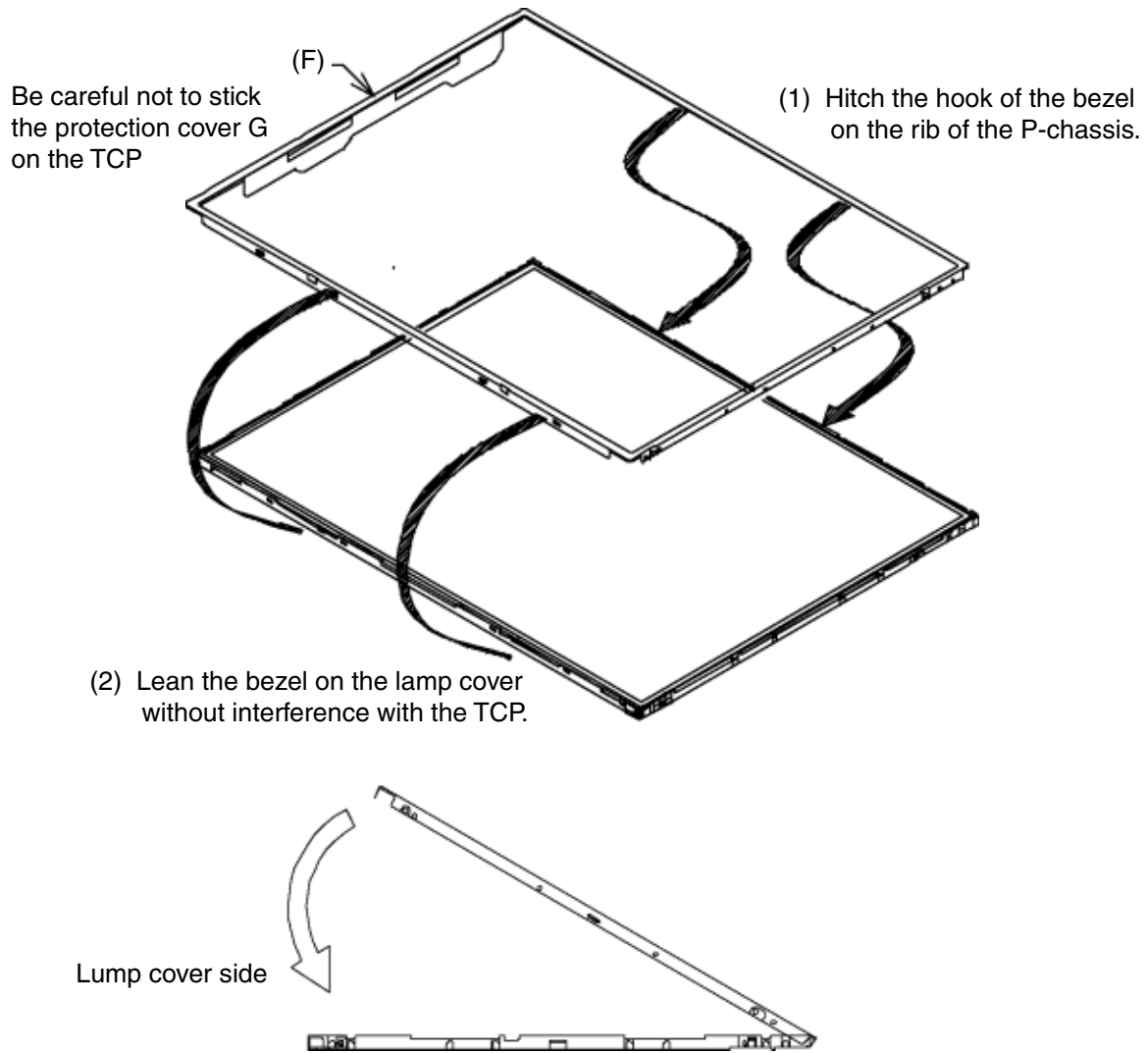

Figure 4-84 Replacing Sharp fluorescent lamp (XGA) (20)

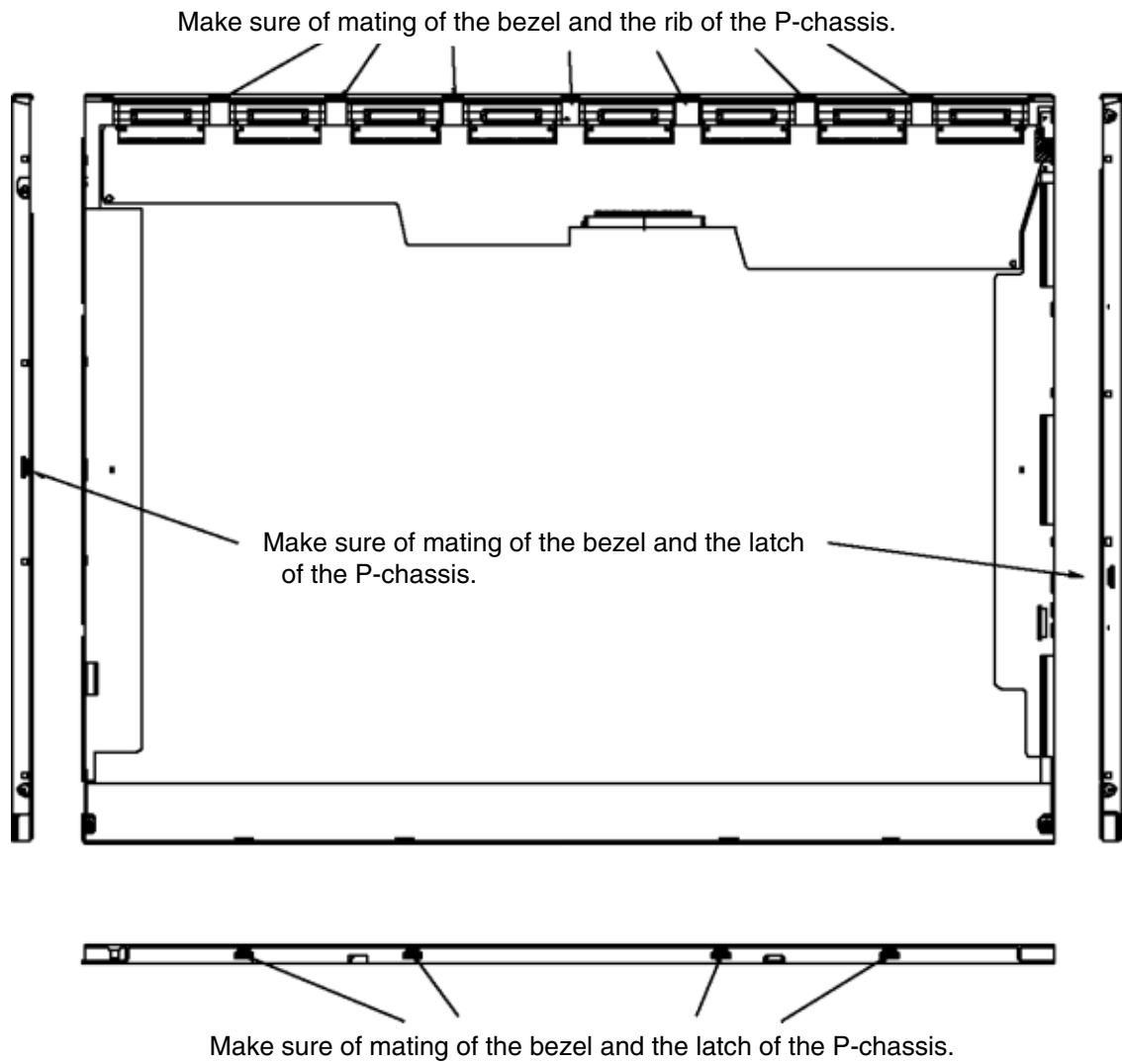

Figure 4-85 Replacing Sharp fluorescent lamp (XGA) (21)

9. Secure the four screws (E) on the both sides.

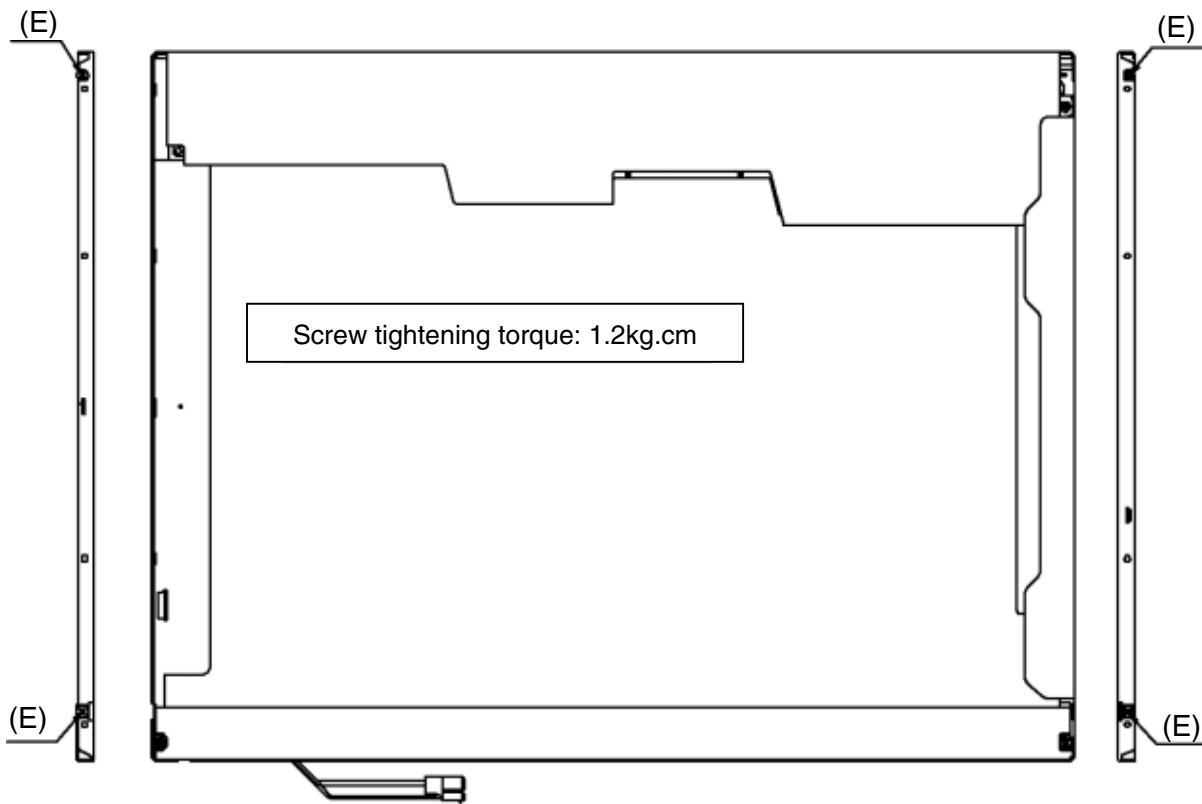

Figure 4-86 Replacing Sharp fluorescent lamp (XGA) (22)

10. Stick the protection cover G (B), protection cover SC (A) and two fixing tapes (C) and (D).

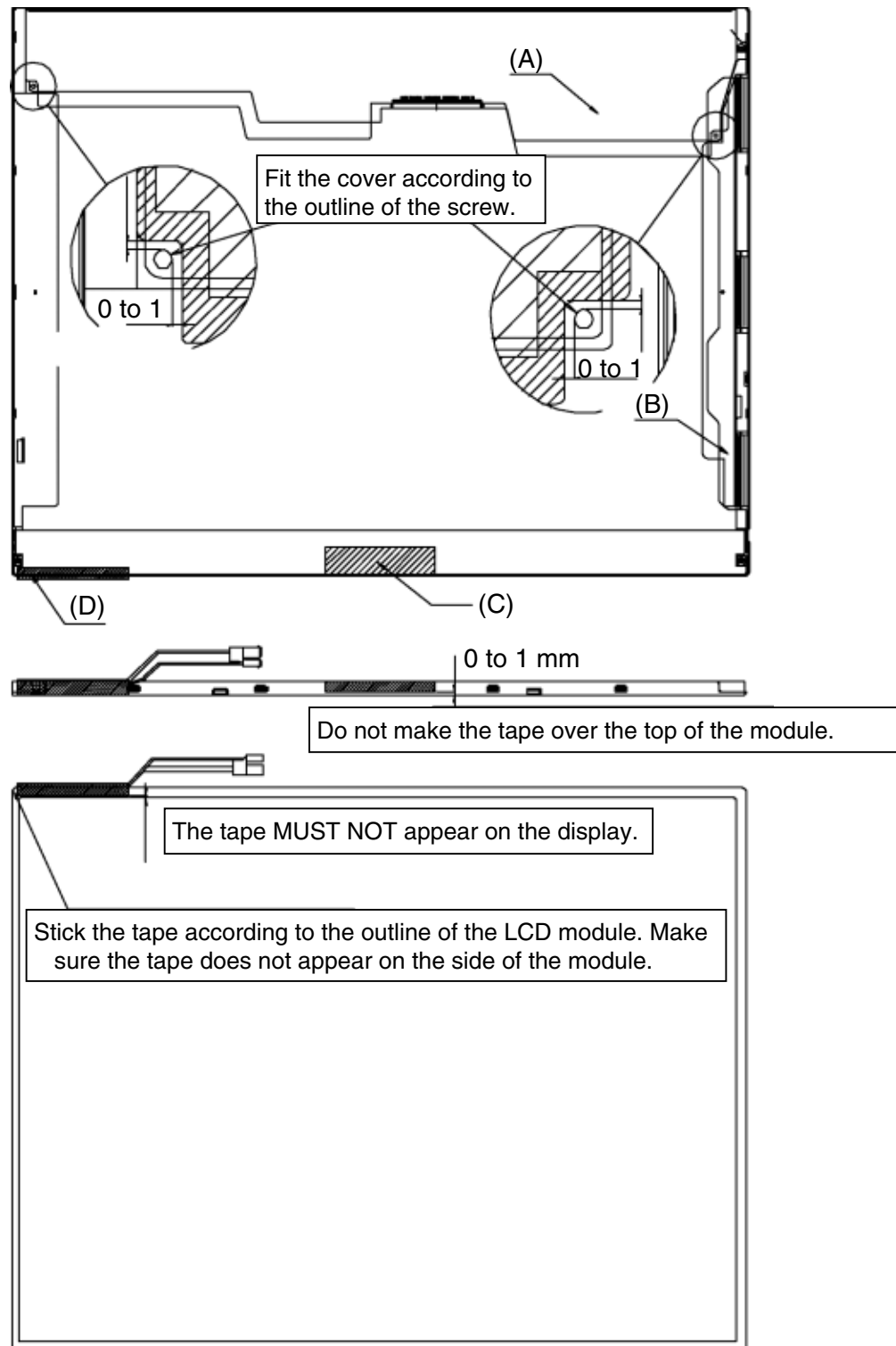

Figure 4-87 Replacing Sharp fluorescent lamp (XGA) (23)

4.30.3 Replacing the 15.0-inch XGA Samsung Fluorescent Lamp

CAUTION: When replacing the fluorescent lamp, wear finger covers or gloves to avoid contaminating or damaging the LCD panel. Be careful not to let dust or other foreign substance into the module.

Disassembling the 15.0-inch XGA Samsung Fluorescent Lamp

To disassemble the 15.0-inch XGA Samsung fluorescent lamp, follow the steps below and refer to Figure 4-88 to 4-91.

1. Remove the PCB.

CAUTION: Handle with care not to damage the COF of S/D and G/D ICs.

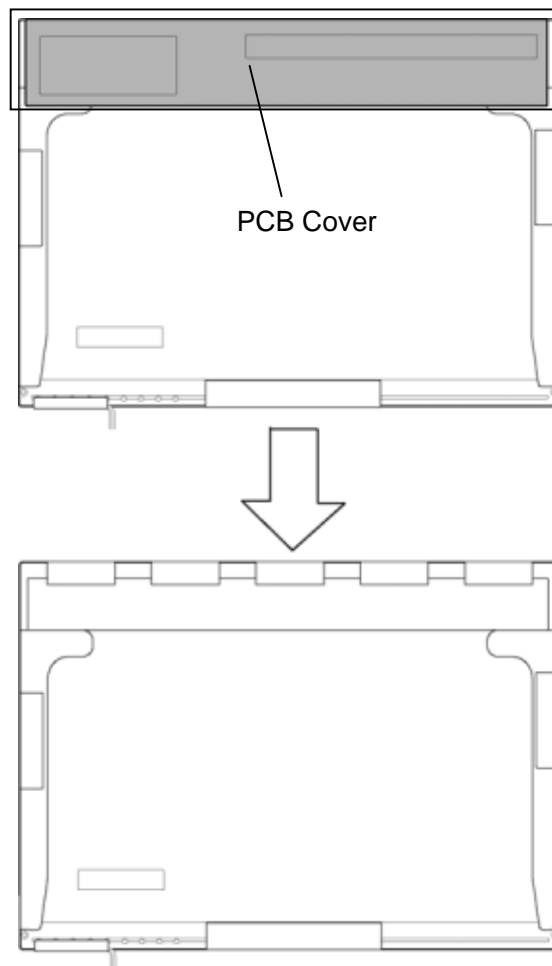

Figure 4-88 Replacing Samsung fluorescent lamp (XGA) (1)

2. Remove the white tapes, lamp-wire tape and aluminum tape.

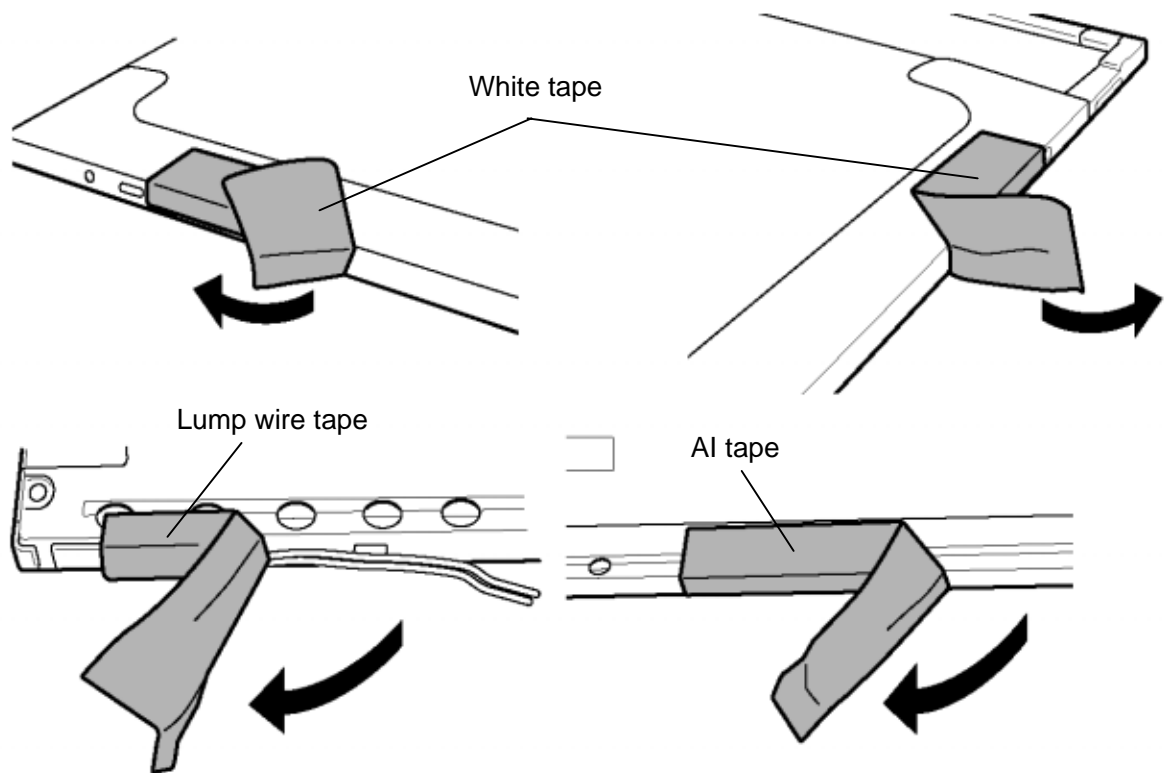

Figure 4-89 Replacing Samsung fluorescent lamp (XGA) (2)

3. Separate the Top Chassis from the Mold frame.

CAUTION: The order : Bottom hook \Rightarrow Side hook [Left & Right]

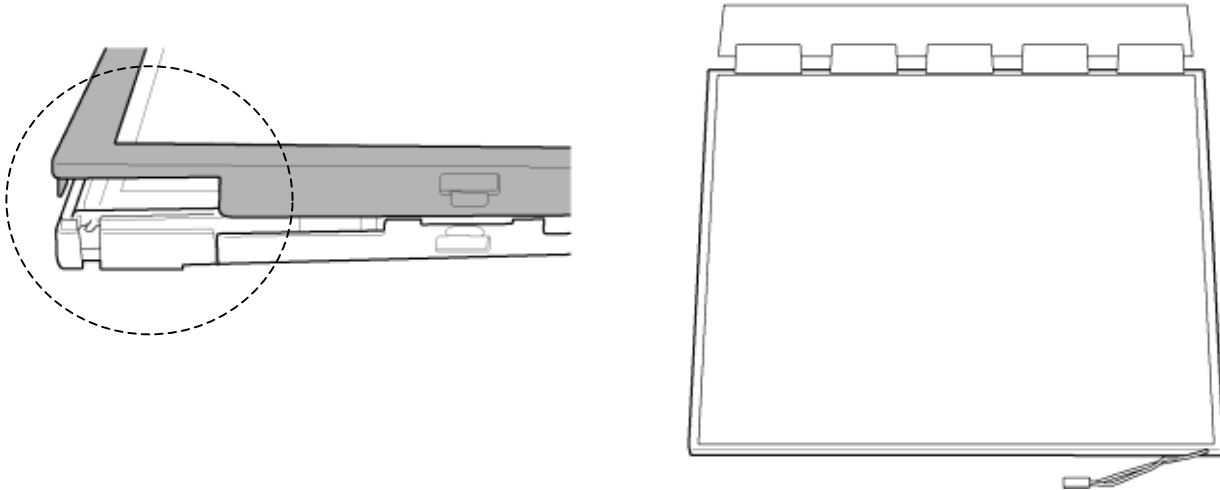

Figure 4-90 Replacing Samsung fluorescent lamp (XGA) (3)

4. Separate the Panel assembly from the BLU

CAUTION: Handle with care not to damage the COF of S/D and G/D ICs.

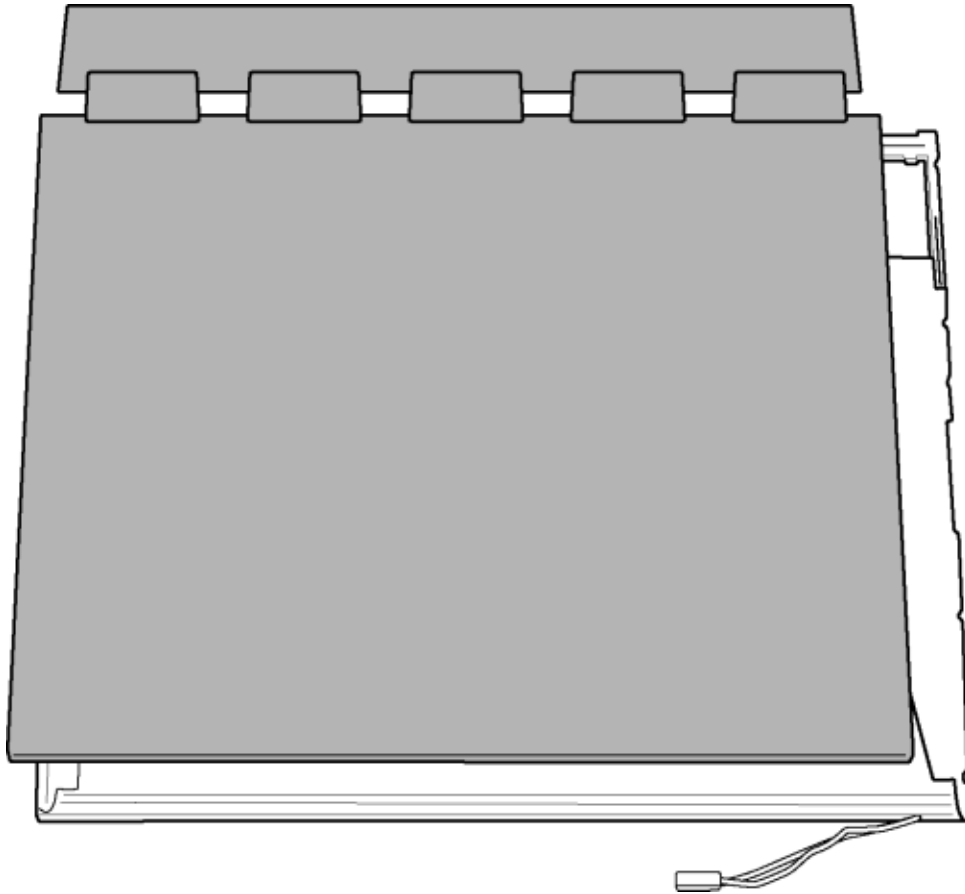

Figure 4-91 Replacing Samsung fluorescent lamp (XGA) (4)

Assembling the 15.0-inch XGA Samsung Fluorescent Lamp

To assemble the 15.0-inch XGA Samsung fluorescent lamp, follow the steps below and refer to Figure 4-88 to 4-91.

Assembling is the opposite order of the disassembling.

4.30.4 Replacing the 15.0-inch SXGA+ LG Philips Fluorescent Lamp

CAUTION: When replacing the fluorescent lamp, wear finger covers or gloves to avoid contaminating or damaging the LCD panel. Be careful not to let dust or other foreign substance into the module.

Disassembling the 15.0-inch SXGA+ LG Philips Fluorescent Lamp

To disassemble the 15.0-inch SXGA+ LG Philips fluorescent lamp, follow the steps below and refer to Figure 4-92 to 4-95.

Disassembly of outside tape / Cover shield

1. Disassembly of Tape Filament used for B/L Wire fixing.

CAUTION: Pressure or stress should not be given on B/L Wire.

2. Disassembly of Tape Adhesive used for Top case fixing.

CAUTION: Pressure or stress should not be given on Top case during this process.

3. Disassembly of Cover shield (G).

CAUTION: Pressure or stress should not be given on Gate COF.

4. Disassembly of Cover shield (S).

CAUTION: Pressure or stress should not be given on Source PCB.
Usage of gloves with anti-electric discharge coating is recommended.
To eliminate possible damage on circuits occurred by ESC.

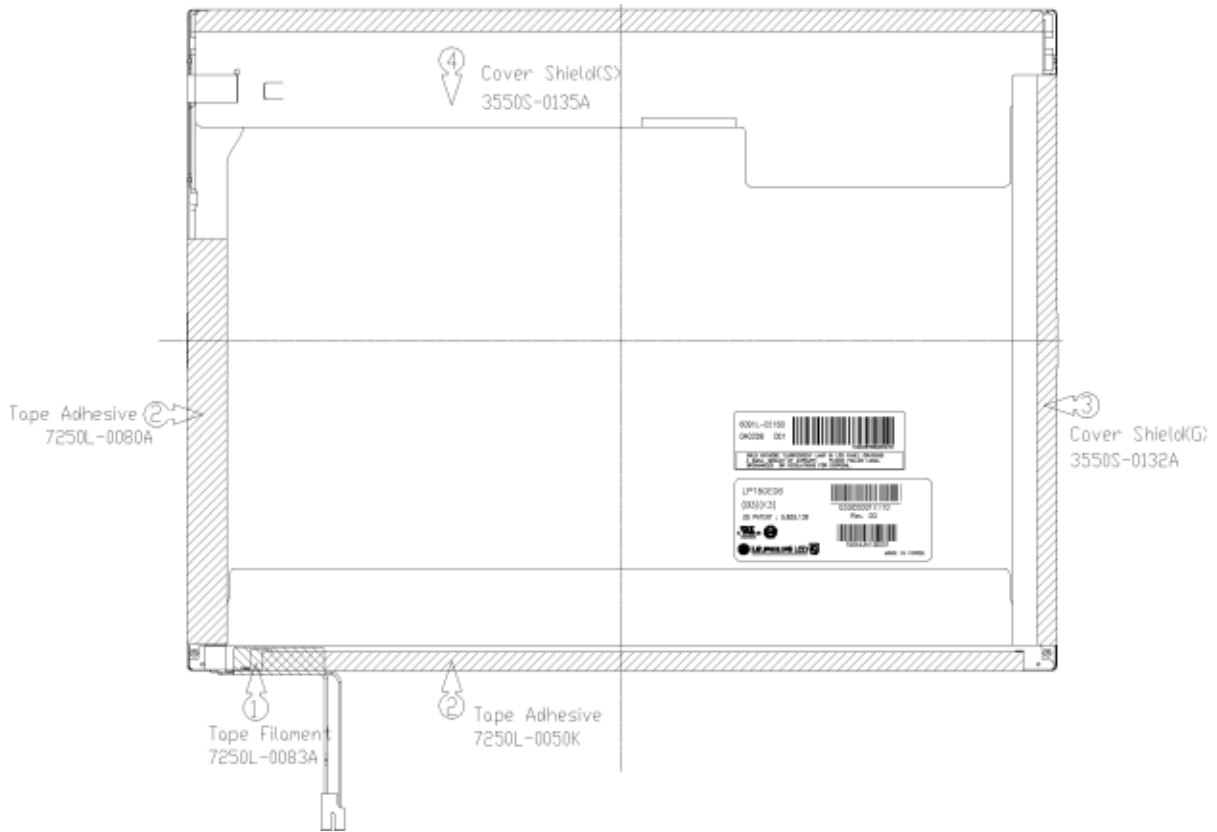

Figure 4-92 Replacing LG Philips fluorescent lamp (SXGA+) (1)

Disassembly of Top Case

1. Disassembly of Top Case.

CAUTION: Pressure or stress should not be given on Source COF and Gate COF.

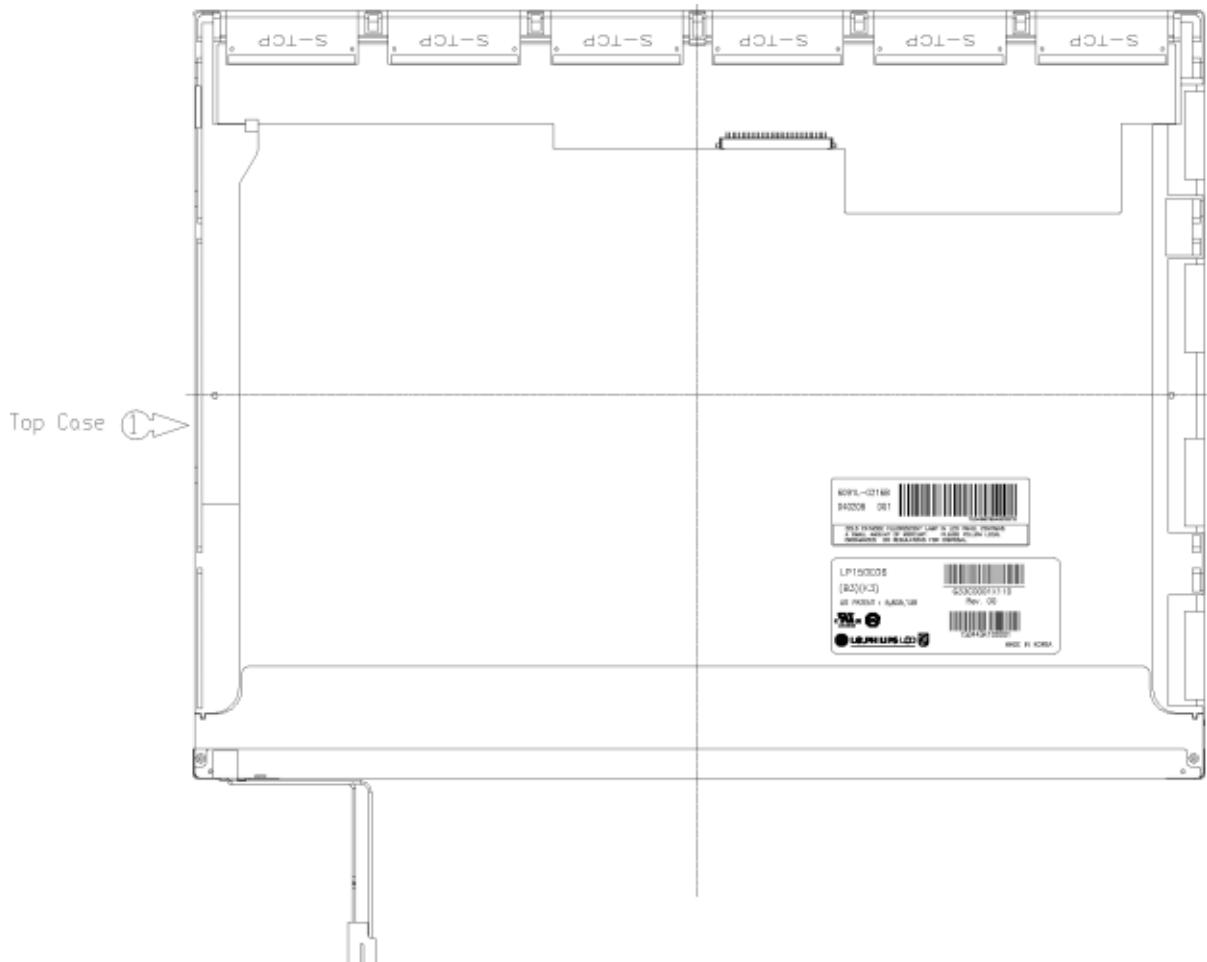

Figure 4-93 Replacing LG Philips fluorescent lamp (SXGA+) (2)

Disassembly of Source PCB

1. Disassembly of Source PCB.

CAUTION: Pressure or stress should not be given on PCB and COF.

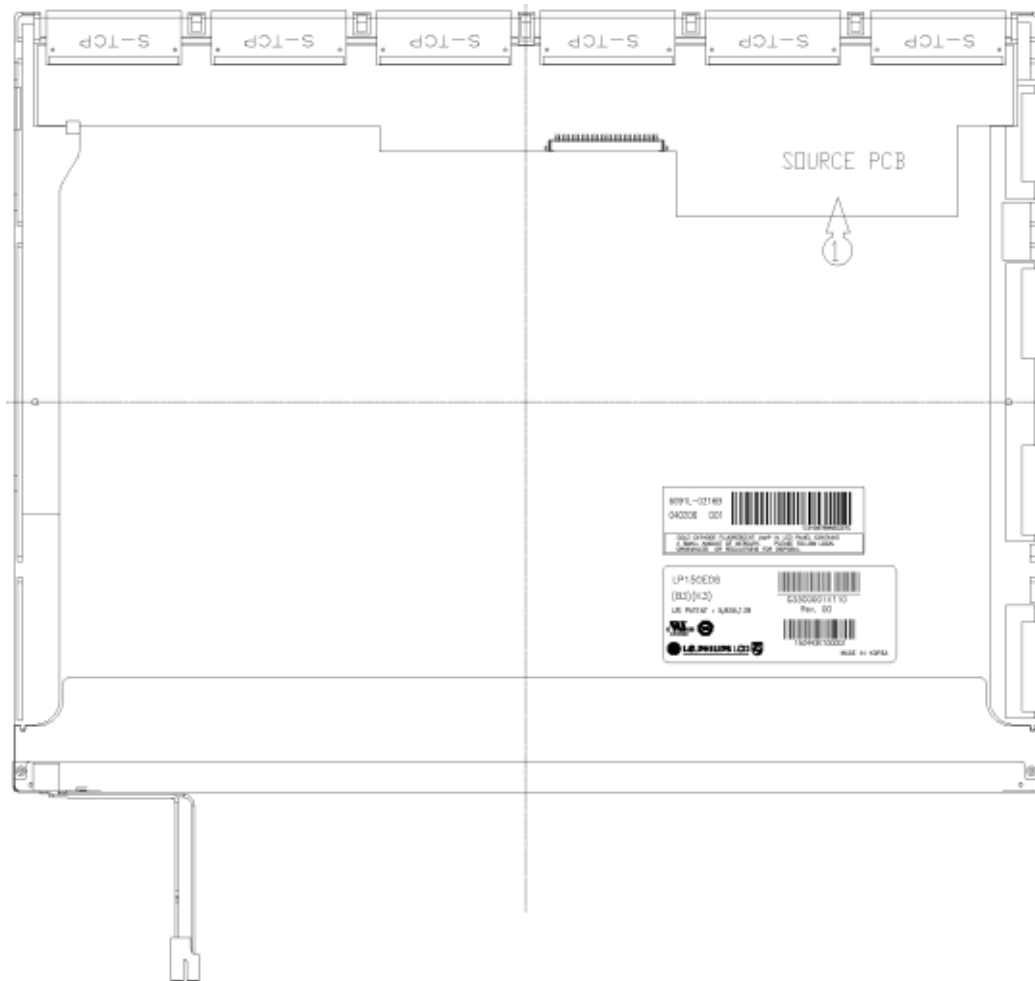

Figure 4-94 Replacing LG Philips fluorescent lamp (SXGA+) (3)

Disassembly of Board Ass'y, Tape Adhesive, Light guide, Cover Ass'y Bottom (L)

1. Disassembly of Board Ass'y.

CAUTION: *This process should be made in Clean room with no scratch nor particle on Polarizer and B/L Ass'y.*

2. Disassembly of Tape Adhesive used for Sheets fixing (4 Points).
3. Disassembly of Sheets and Light guide.

CAUTION: *No penetration of foreign body is indispensable with no scratch on the surface of each Sheet.*

4. Disassembly of Screw (2 Points) and Cover Ass'y Bottom.

CAUTION: *Maximum value of torque with Screw should be below 1.5kg.*

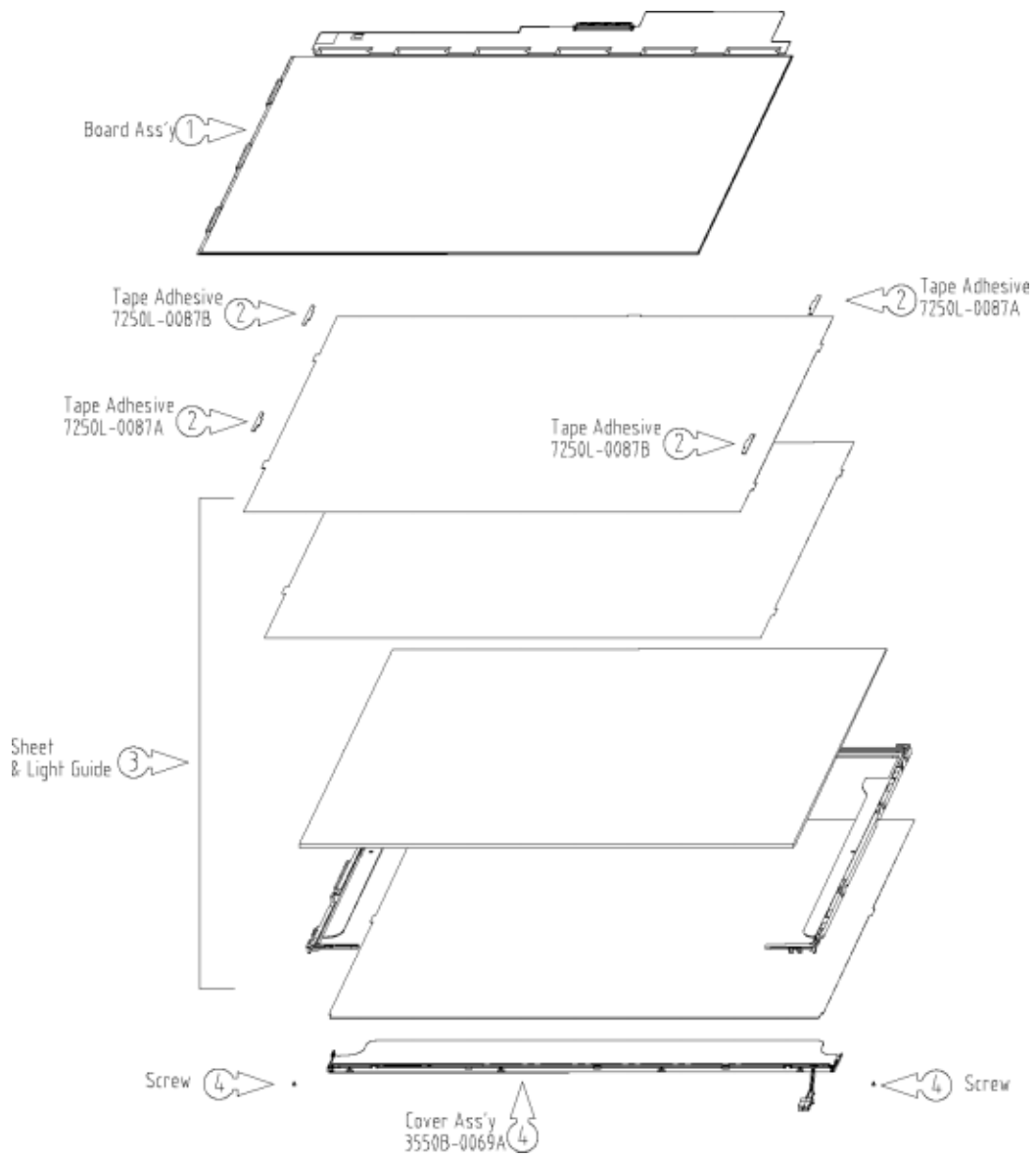

Figure 4-95 Replacing LG Philips fluorescent lamp (SXGA+) (4)

Assembling the 15.0-inch SXGA+ LG Philips Fluorescent Lamp

To assemble the 15.0-inch SXGA+ LG Philips fluorescent lamp, follow the steps below and refer to Figure 4-96 to 4-99.

Assembly of Cover Ass'y Bottom (L), Sheets, Light guide, Tape Adhesive and Board Ass'y

1. Assembly of Cover Ass'y Bottom and Screw (2 Point).

CAUTION: Maximum value of torque with Screw should be below 2.0kgf.cm.

2. Assembly of Light Guide and Sheets. (Reflector Sheet fixing with one Double Tape, Diffuser Sheet fixing with one Double Tape.)

CAUTION: No penetration of foreign body is indispensable with no scratch on the surface of each Sheet and Light guide.

3. Assembly of Tape adhesive used for Sheets fixing (4 Points).
4. Assembly of Board Ass'y.

CAUTION: Pressure or stress should not be given on PCB and TCP.

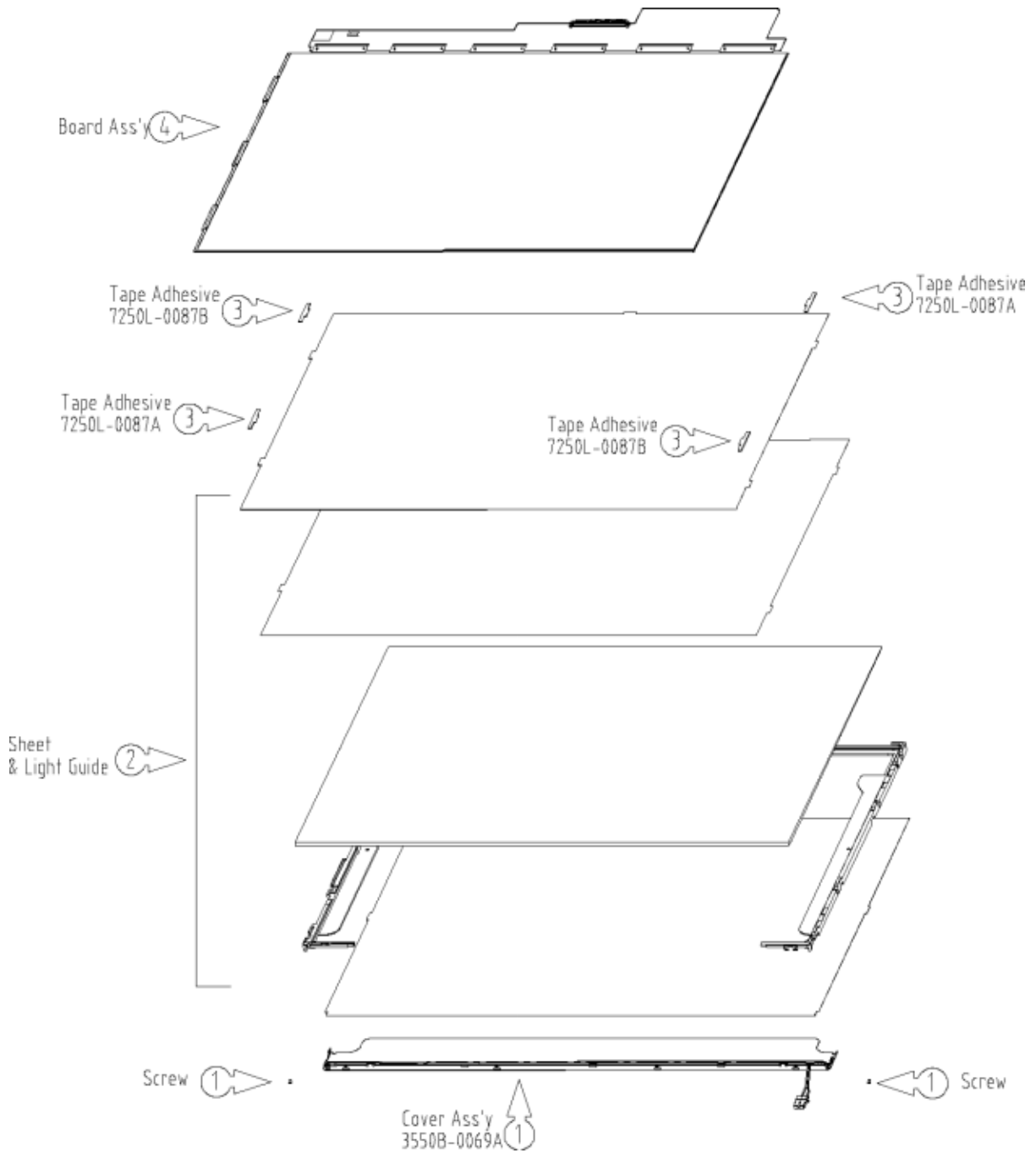

Figure 4-96 Replacing LG Philips fluorescent lamp (SXGA+) (5)

Assembly of Source PCB

1. Assembly of Source PCB.

CAUTION: Stress should not be given on COF.

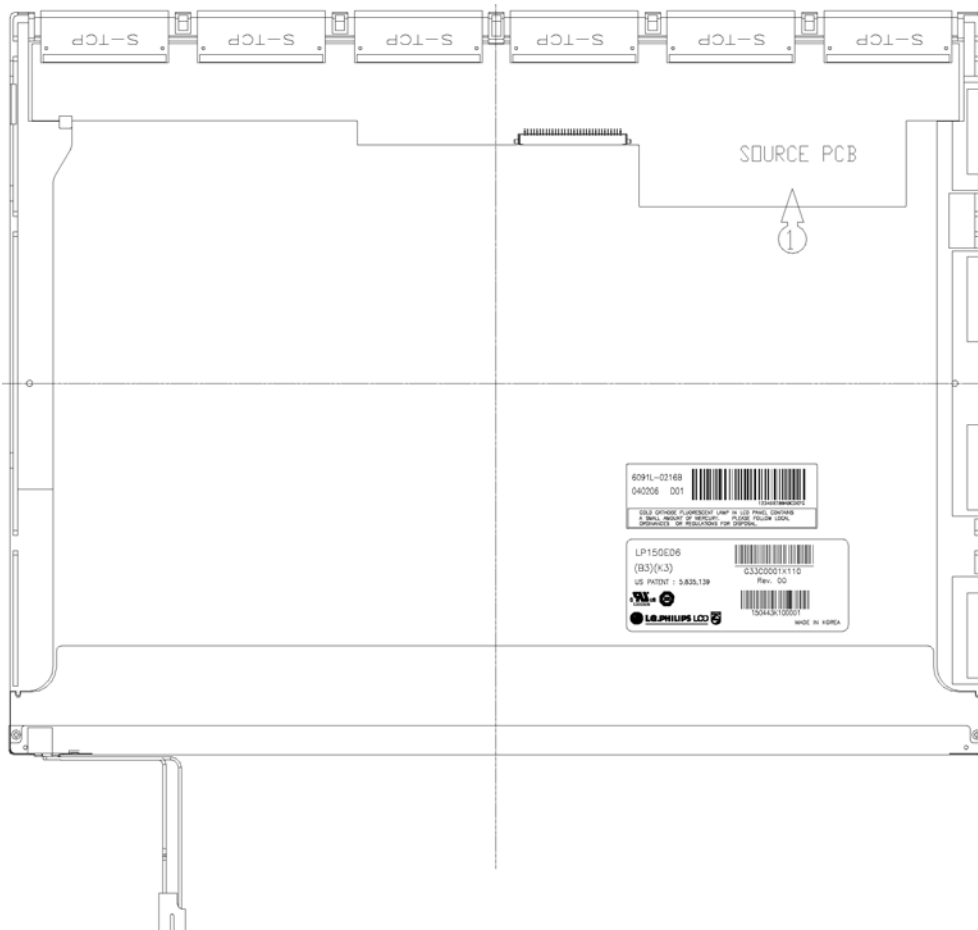

Figure 4-97 Replacing LG Philips fluorescent lamp (SXGA+) (6)

Assembly of Top Case

1. Assembly of Top Case.

CAUTION: Pressure should not be given on Source COF and Gate COF.

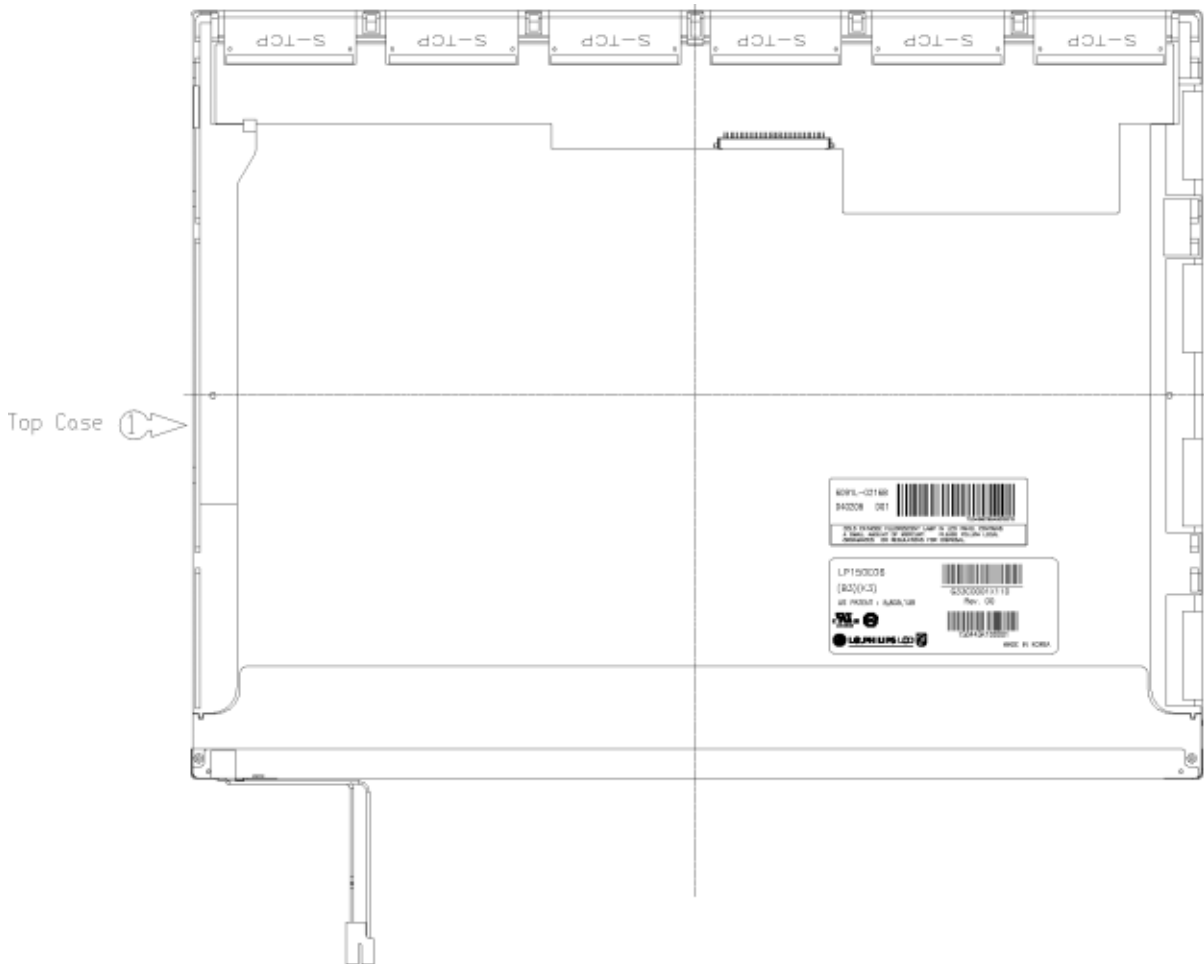

Figure 4-98 Replacing LG Philips fluorescent lamp (SXGA+) (7)

Assembly of outside Tape and Cover shield

1. Assembly of Cover shield (S).

CAUTION: Pressure or stress should not be given on Source PCB.
Usage of gloves with anti-electric discharge coating is recommended.
To eliminate possible damage on circuits occurred by ESC.

2. Assembly of Cover shield (G).

CAUTION: Pressure or stress should not be given on Gate COF.

3. Assembly of Tape Adhesive used for Top case fixing.

CAUTION: Pressure or stress should not be given on Top case during this process.

4. Assembly of Tape Adhesive used for B/L Wire fixing.

CAUTION: Pressure or stress should not be given on B/L Wire.

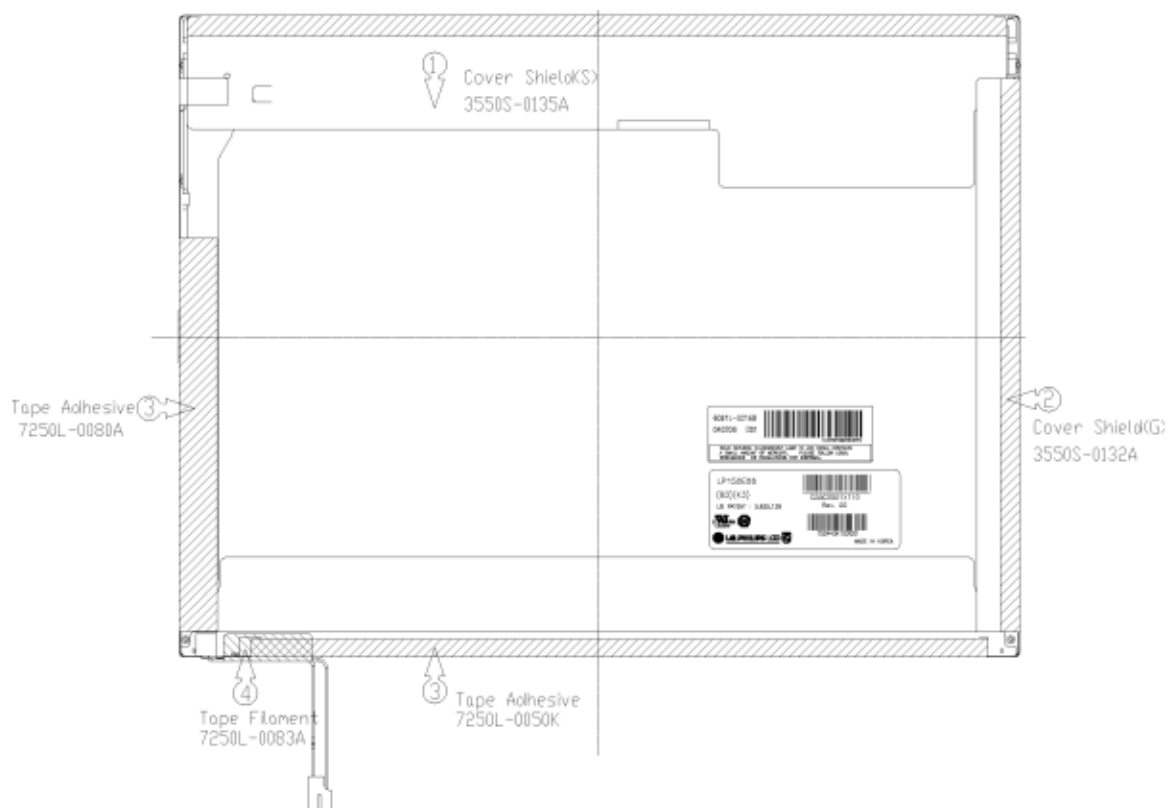

Figure 4-99 Replacing LG Philips fluorescent lamp (SXGA+) (8)

Appendices

Appendix Contents

| | |
|---|------------|
| Appendix A Handling the LCD Module | A-1 |
| Appendix B Board Layout | B-1 |
| B.1 System Board (FDRSY*) Front View | B-1 |
| B.2 System Board (FDRSY*) Back View | B-3 |
| B.3 US Board (FDRUS*) Front and Back View | B-5 |
| B.4 SR Board (FDRSR*) Front and Back View..... | B-6 |
| B.5 FS Board (FDRFS*) Front and Back View | B-7 |
| Appendix C Pin Assignments..... | C-1 |
| C.1 CN1410 SO-DIMM0 connector (200-pin)..... | C-1 |
| C.2 CN1400 SO-DIMM1 connector (200-pin)..... | C-4 |
| C.3 CN1850 SATA interface connector (11-pin)..... | C-7 |
| C.4 CN1810 Select bay interface connector (72-pin)..... | C-7 |
| C.5 CN2100 PC card interface connector (150-pin)..... | C-9 |
| C.6 IS2101 SD card interface connector (12-pin) | C-11 |
| C.7 CN2200 Mini PCI interface connector (124-pin) | C-12 |
| C.8 CN2300 Docking interface connector (240-pin)..... | C-14 |
| C.9 CN3011 Modem relay connector (4-pin)..... | C-17 |
| C.10 CN3010 Modem connector (12-pin) | C-17 |
| C.11 CN3200 Keyboard interface connector (34-pin)..... | C-18 |
| C.12 CN3201 Touch pad interface connector (8-pin) | C-18 |
| C.13 CN3260 SW board interface connector (13-pin) | C-19 |
| C.14 CN3421 SR board interface connector (12-pin) | C-19 |
| C.15 CN3401 Parallel port interface connector (25-pin)..... | C-20 |
| C.16 J4100 LAN jack (12-pin) | C-20 |
| C.17 CN4200 IEEE 1394 interface connector (4-pin)..... | C-20 |
| C.18 CN4400 Bluetooth interface connector (20-pin)..... | C-21 |
| C.19 CN4610 US board I/F connector (10-pin)..... | C-21 |
| C.20 CN4611 SR board I/F connector (8-pin)..... | C-21 |
| C.21 CN5500 LCD interface connector (40-pin) | C-22 |

| | | |
|------|--|------|
| C.22 | CN5620 RGB connector (15-pin) | C-23 |
| C.23 | CN5501 S-VIDEO connector (4-pin) | C-23 |
| C.24 | CN5900 GFX board interface connector (230-pin) | C-24 |
| C.25 | CN6050 Internal microphone connector (2-pin)..... | C-28 |
| C.26 | J6051 External microphone connector (5-pin)..... | C-28 |
| C.27 | CN6170 Speaker connector (4-pin)..... | C-28 |
| C.28 | J6310 Headphone connector (5-pin) | C-28 |
| C.29 | CN8800 DC-IN connector (4-pin) | C-28 |
| C.30 | CN8020 Main Battery connector (10-pin) | C-29 |
| C.31 | CN9990 RTC Battery connector (3-pin)..... | C-29 |
| C.32 | CN8770 FAN connector (3-pin) | C-29 |
| C.33 | CN9700 FS board interface connector (8-pin)..... | C-29 |
| C.34 | CN9510 System board interface connector (20-pin)..... | C-30 |
| C.35 | CN4630 USB6 connector (4-pin)..... | C-30 |
| C.36 | CN3420 Serial port (9-pin) | C-30 |
| C.37 | CN950 System board interface connector (8-pin)..... | C-31 |
| C.38 | CN5901 System board interface connector (230-pin)..... | C-32 |
| C.39 | CN4622 System board interface connector (12-pin)..... | C-36 |
| C.40 | CN4620 USB Port 3 connector (4-pin) | C-36 |
| C.41 | CN4622 USB Port 4 connector (4-pin) | C-36 |

Appendix D Keyboard Scan/Character Codes..... D-1

Appendix E Key LayoutE-1

| | | |
|-----|-----------------------------------|-----|
| E.1 | United Kingdom (UK) Keyboard..... | E-1 |
| E.2 | United States (US) Keyboard..... | E-1 |

Appendix F Wiring DiagramsF-1

| | | |
|-----|---|-----|
| F.1 | LAN Loopback Connector | F-1 |
| F.2 | Printer Loopback Connector | F-1 |
| F.3 | RS232C Loopback Connector..... | F-2 |
| F.4 | RGB monitor Loopback Connector | F-2 |
| F.5 | RS232C direct-connection cable (9-pin to 9-pin) | F-3 |

| | | |
|--|--|------------|
| F.6 | RS232C direct-connection cable (9-pin to 25-pin) | F-3 |
| Appendix G BIOS rewrite Procedures | | G-1 |
| Appendix H EC/KBC rewrite Procedures..... | | H-1 |
| Appendix I Reliability | | I-1 |
| Appendix J Maintenance of TOSHIBA RAID..... | | J-1 |

Figures

| | | |
|------------|--|------|
| Figure B-1 | System board (FDRSY*) layout (front) | B-1 |
| Figure B-2 | System board (FDRSY*) layout (back) | B-3 |
| Figure B-3 | US board (FDRUS*) layout (front/back) | B-5 |
| Figure B-4 | SR board (FDRSR*) layout (front/back) | B-6 |
| Figure B-5 | FS board (FDRFS*) layout (front/back) | B-7 |
| | | |
| Figure E-1 | UK keyboard | E-1 |
| Figure E-2 | US keyboard..... | E-1 |
| | | |
| Figure F-1 | LAN loopback connector | F-1 |
| Figure F-2 | Printer loopback connector | F-1 |
| Figure F-3 | RS232C Loopback Connector..... | F-2 |
| Figure F-4 | RGB monitor Loopback Connector | F-2 |
| Figure F-5 | RS232C direct-connection cable (9-pin to 9-pin) | F-3 |
| Figure F-6 | RS232C direct-connection cable (9-pin to 25-pin) | F-3 |
| | | |
| Figure J-1 | Flowchart of repairing TOSHIBA RAID..... | J-1 |
| Figure J-2 | Flowchart of Analysis and handling by Drive Log..... | J-2 |
| Figure J-3 | Drive Log | J-8 |
| Figure J-4 | Tree of menu of Independent Utility..... | J-13 |

Tables

| | | |
|------------|---|------|
| Table B-1 | System board (FDRSY*) ICs and connectors (front)..... | B-2 |
| Table B-2 | System board (FDRSY*) ICs and connectors (back)..... | B-4 |
| Table B-3 | US board (FDRUS*) connectors | B-5 |
| Table B-4 | SR board (FDRSR*) connectors | B-6 |
| Table B-5 | FS board (FDRFS*) connectors | B-7 |
| | | |
| Table C-1 | SO-DIMM0 connector (200-pin)..... | C-1 |
| Table C-2 | SO-DIMM1 connector (200-pin)..... | C-4 |
| Table C-3 | SATA interface connector (11-pin) | C-7 |
| Table C-4 | Select bay interface connector (72-pin)..... | C-7 |
| Table C-5 | PC card interface connector (150-pin)..... | C-9 |
| Table C-6 | SD card interface connector (12-pin)..... | C-11 |
| Table C-7 | Mini PCI interface connector (124-pin)..... | C-12 |
| Table C-8 | Docking interface connector (240-pin)..... | C-14 |
| Table C-9 | Modem relay connector (4-pin) | C-17 |
| Table C-10 | Modem connector (12-pin) | C-17 |
| Table C-11 | Keyboard interface connector (34-pin)..... | C-18 |
| Table C-12 | Touch pad interface connector (8-pin)..... | C-18 |
| Table C-13 | SW board interface connector (13-pin) | C-19 |
| Table C-14 | SR board interface connector (12-pin)..... | C-19 |
| Table C-15 | Parallel port interface connector (25-pin)..... | C-20 |
| Table C-16 | LAN jack (12-pin) | C-20 |
| Table C-17 | IEEE 1394 interface connector (4-pin)..... | C-20 |
| Table C-18 | Bluetooth interface connector (20-pin)..... | C-21 |
| Table C-19 | US board I/F connector (10-pin)..... | C-21 |
| Table C-20 | SR board I/F connector (8-pin)..... | C-21 |
| Table C-21 | LCD interface connector (40-pin)..... | C-22 |
| Table C-22 | RGB connector (15-pin) | C-23 |
| Table C-23 | S-VIDEO connector (4-pin)..... | C-23 |
| Table C-24 | GFX board interface connector (230-pin) | C-24 |

| | | |
|------------|---|------|
| Table C-25 | Internal microphone connector (2-pin) | C-28 |
| Table C-26 | External microphone connector (5-pin) | C-28 |
| Table C-27 | Speaker connector (4-pin)..... | C-28 |
| Table C-28 | Headphone connector (5-pin) | C-28 |
| Table C-29 | DC-IN connector (4-pin) | C-28 |
| Table C-30 | Main Battery connector (10-pin) | C-29 |
| Table C-31 | RTC Battery connector (3-pin)..... | C-29 |
| Table C-32 | FAN connector (3-pin)..... | C-29 |
| Table C-33 | FS board interface connector (8-pin) | C-29 |
| Table C-34 | System board interface connector (20-pin)..... | C-30 |
| Table C-35 | USB6 connector (4-pin)..... | C-30 |
| Table C-36 | Serial port (9-pin)..... | C-30 |
| Table C-37 | System board interface connector (8-pin)..... | C-31 |
| Table C-38 | System board interface connector (230-pin)..... | C-32 |
| Table C-39 | System board interface connector (12-pin)..... | C-36 |
| Table C-40 | USB Port 3 connector (4-pin) | C-36 |
| Table C-41 | USB Port 4 connector (4-pin) | C-36 |
| | | |
| Table D-1 | Scan codes (set 1 and set 2) | D-1 |
| Table D-2 | Scan codes with left Shift key | D-5 |
| Table D-3 | Scan codes in Numlock mode..... | D-6 |
| Table D-4 | Scan codes with Fn key | D-6 |
| Table D-5 | Scan codes in overlay mode | D-7 |
| Table D-6 | No.124 key scan code | D-7 |
| Table D-7 | No.126 key scan code | D-8 |
| | | |
| Table I-1 | MTBF | I-1 |
| | | |
| Table J-1 | List of Command | J-5 |
| Table J-2 | Displayed item in Logical Drive | J-10 |
| Table J-3 | Items displayed in Physical Drive | J-11 |
| Table J-4 | Item of Main Menu displayed | J-12 |

| | | |
|------------|---|------|
| Table J-5 | Item of parameter set | J-14 |
| Table J-6 | Item of array | J-20 |
| Table J-7 | Items set in View Drive Info. | J-23 |
| Table J-8 | Explanation of option and Function of key | J-24 |
| Table J-9 | Content of Drive Log display | J-26 |
| Table J-10 | Content of View Drive Log menu | J-27 |
| Table J-11 | Function of key in View Drive Log..... | J-27 |

Appendix A Handling the LCD Module

Precautions for handling the LCD module

The LCD module can be easily damaged during assembly or disassembly. Observe the following precautions when handling the LCD module:

1. When installing the LCD module in the LCD cover, be sure to seat it so that it is properly aligned and maximum visibility of the display is maintained.

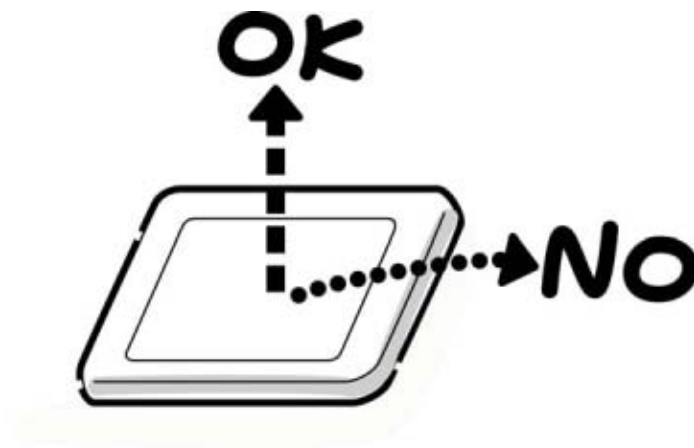

2. For the LCD module, be careful to align the four holes at the right side and left side of the LCD module with the corresponding holes in the LCD cover before securing the module with four screws.

Do not force the module into place, because stress can affect its performance. Also, the panel's polarized surface is easily scarred, so be carefully when handling it.



3. If the panel's surface gets dirty, wipe it with cotton or a soft cloth. If it is still dirty, try breathing on the surface to create a light condensate and wipe it again.

If the surface is very dirty, we recommend a CRT cleaning agent. Apply the agent to a cloth and then wipe the panel's surface. Do not apply cleanser directly to the panel.



4. If water or other liquid is left on the panel's surface for a long period, it can change the screen's tint or stain it. Be sure to quickly wipe off any liquid.



5. Glass is used in the panel, so be careful not to drop it or let it strike a hard object, which could cause breakage or cracks.



6. CMOS-LSI circuits are used in the module, so guard against damage from electrostatic discharge. Be sure to wear a wrist or ankle ground when handling the module.

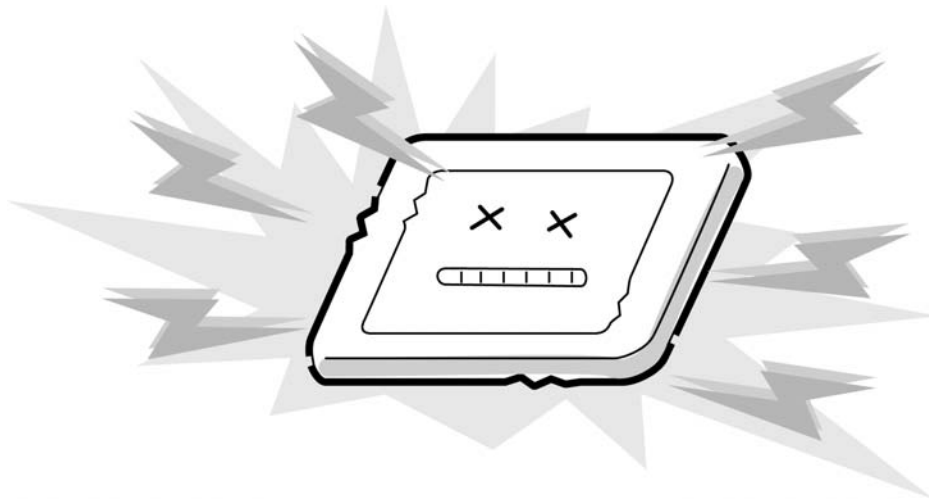

7. Do not expose the module to direct sunlight or strong ultraviolet rays for long periods.



8. Do not store the module at temperatures below specifications. Cold can cause the liquid crystals to freeze, lose their elasticity or otherwise suffer damage.



9. Do not disassemble the LCD module. Disassembly can cause malfunctions.

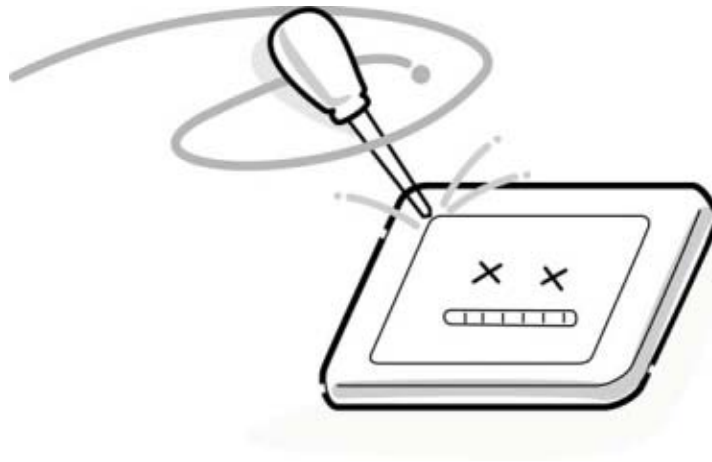

10. If you transport the module, do not use packing material that contains epoxy resin (amine) or silicon glue (alcohol or oxime). These materials can release gas that can damage the panel's polarization.

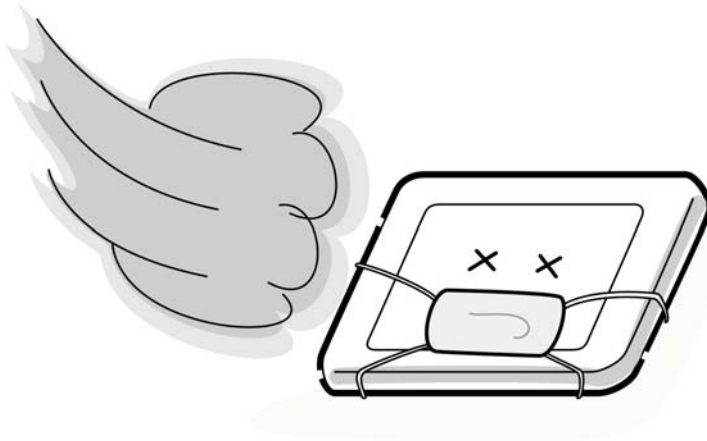

Appendix B Board Layout

B.1 System Board (FDRSY*) Front View

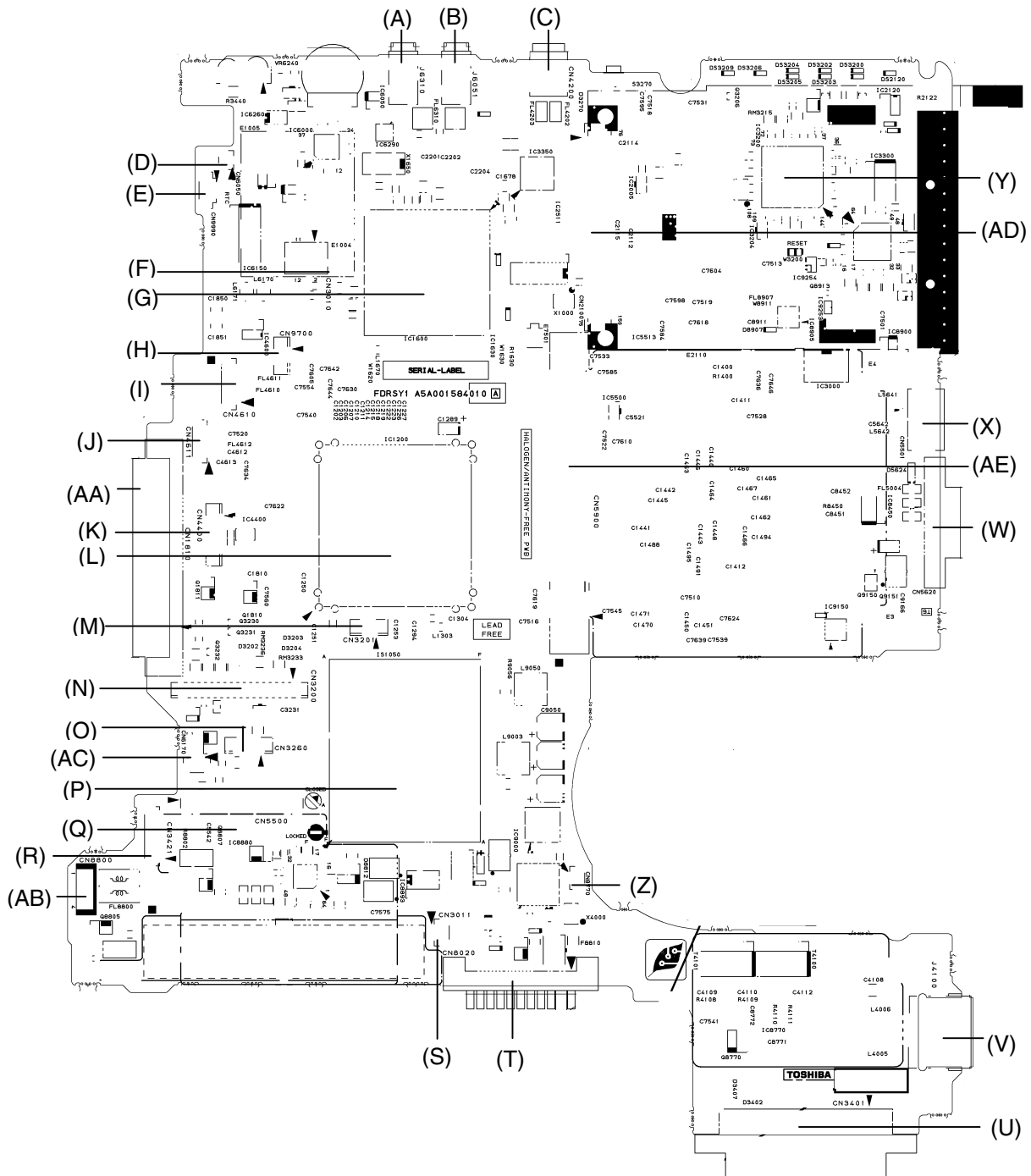

Figure B-1 System board (FDRSY*) layout (front)

Table B-1 System board (FDRSY*) ICs and connectors (front)

| Mark | Number | Name |
|------|--------|-------------------------------|
| (A) | J6310 | Headphone connector |
| (B) | J6051 | External microphone connector |
| (C) | CN4200 | IEEE1394 connector |
| (D) | CN6050 | Internal microphone connector |
| (E) | CN9990 | RTC battery connector |
| (F) | CN3010 | MDC I/F connector |
| (G) | IC1600 | ICH6-M |
| (H) | CN9700 | FS Board I/F connector |
| (I) | CN4610 | US Board I/F connector |
| (J) | CN4611 | SR Board I/F connector |
| (K) | CN4400 | Bluetooth I/F connector |
| (L) | IC1200 | MCH |
| (M) | CN3201 | Touch-pad I/F connector |
| (N) | CN3200 | Keyboard I/F connector |
| (O) | CN3260 | SW Board I/F connector |
| (P) | IS1050 | CPU socket |
| (Q) | CN5500 | LCD I/F connector |
| (R) | CN3421 | SR Board I/F connector |
| (S) | CN3011 | Modem jack |
| (T) | CN8020 | Main battery connector |
| (U) | CN3401 | Parallel port |
| (V) | J4100 | LAN jack |
| (W) | CN5620 | RGB port |
| (X) | CN5501 | S-VIDEO port |
| (Y) | IC3200 | EC/KBC |
| (Z) | CN8770 | Fan connector |
| (AA) | CN1810 | Select-bay I/F connector |
| (AB) | CN8800 | DC-IN jack |
| (AC) | CN6170 | Speaker connector |
| (AD) | CN2100 | PC card I/F connector |
| (AE) | CN5900 | GFX board I/F connector |

Table B-2 System board (FDRSY*) ICs and connectors (back)

| Mark | Number | Name |
|-------------|---------------|---------------------------------|
| (A) | CN2300 | Docking I/F connector |
| (B) | CN1850 | SATA (HDD) I/F connector |
| (C) | CN2200 | Wireless LAN card I/F connector |
| (D) | IC2000 | PC card controller |
| (E) | IS2101 | SD card connector |
| (F) | CN1400 | DIMM1 connector |
| (G) | CN1410 | DIMM0 connector |

B.3 US Board (FDRUS*) Front and Back View

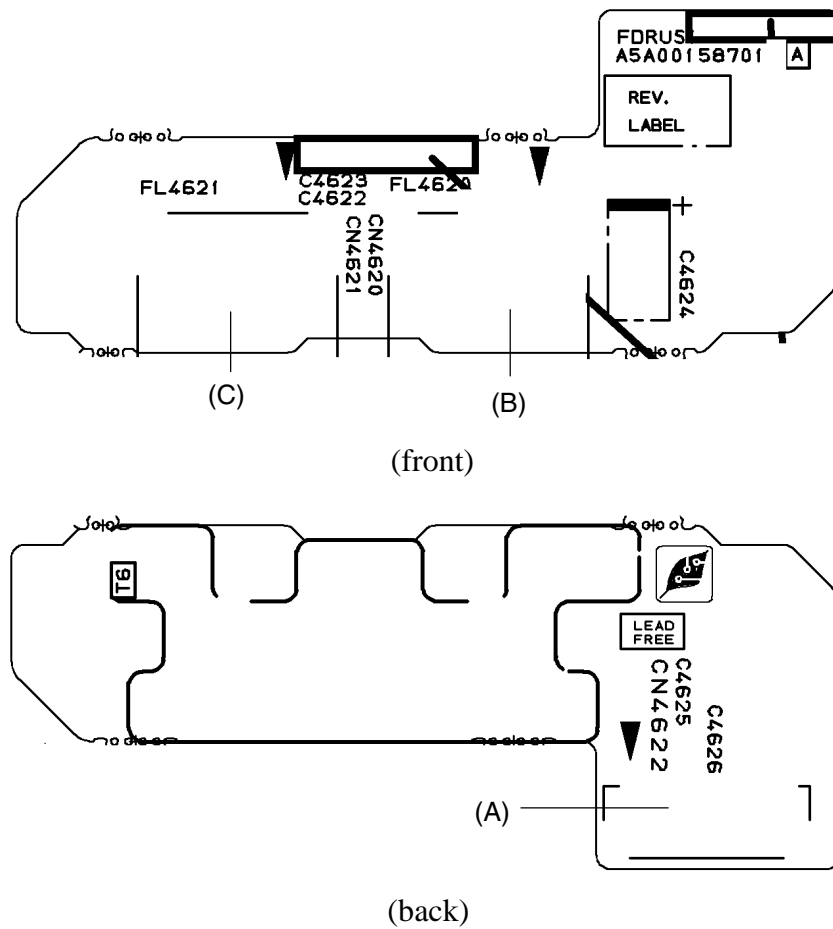

Figure B-3 US Board (FDRUS*) layout (front/back)

Table B-3 US Board (FDRUS*) connectors

| Mark | Number | Name |
|------|--------|----------------------------|
| (A) | CN4622 | System board I/F connector |
| (B) | CN4620 | USB 3 connector |
| (C) | CN4621 | USB 4 connector |

B.4 SR Board (FDRSR*) Front and Back View

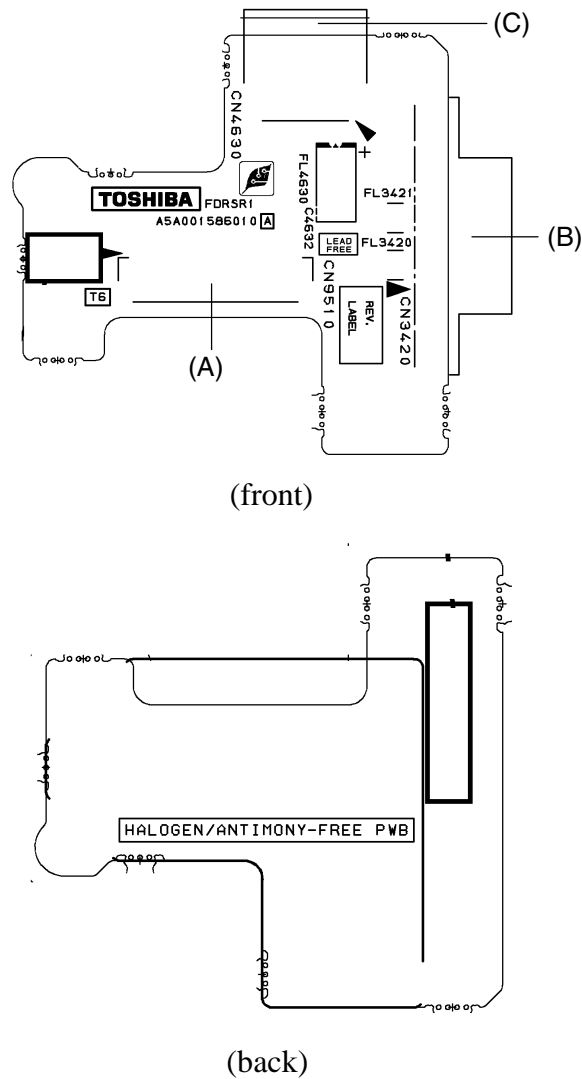

Figure B-4 SR Board (FDRSR*) layout (front/back)

Table B-4 SR Board (FDRSR*) connectors

| Mark | Number | Name |
|------|--------|----------------------------|
| (A) | CN9510 | System board I/F connector |
| (B) | CN3420 | Serial port |
| (C) | CN4630 | USB 6 connector |

B.5 FS Board (FDRFS*) Front and Back View

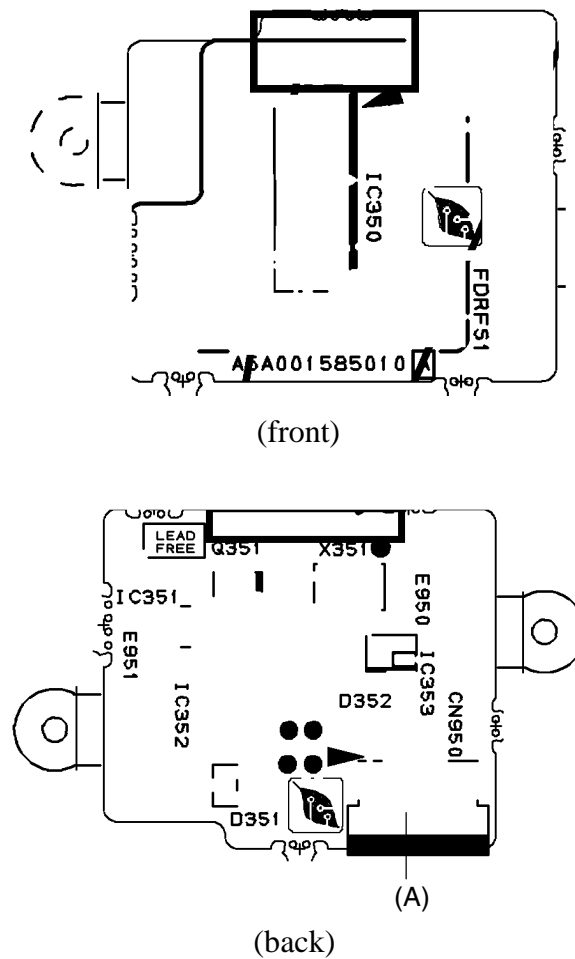

Figure B-5 FS Board (FDRFS*) layout (front/back)

Table B-5 FS Board (FDRFS*) connectors

| Mark | Number | Name |
|------|--------|----------------------------|
| (A) | CN950 | System board I/F connector |

Appendix C Pin Assignments

System board

C.1 CN1410 SO-DIMM0 connector (200-pin)

Table C-1 SO-DIMM0 connector (200-pin) (1/3)

| Pin No. | Signal Name | I/O | Pin No. | Signal Name | I/O |
|---------|-------------|-----|---------|-------------|-----|
| 1 | MRVREF-B0V | - | 2 | GND | - |
| 3 | GND | - | 4 | ADQ04-B1P | I/O |
| 5 | ADQ01-B1P | I/O | 6 | ADQ05-B1P | I/O |
| 7 | ADQ00-B1P | I/O | 8 | GND | - |
| 9 | GND | - | 10 | ADM0-B1P | I/O |
| 11 | ADQS0-B1N | I/O | 12 | GND | - |
| 13 | ADQS0-B1P | I/O | 14 | ADQ02-B1P | I/O |
| 15 | GND | - | 16 | ADQ07-B1P | I/O |
| 17 | ADQ03-B1P | I/O | 18 | GND | - |
| 19 | ADQ06-B1P | I/O | 20 | ADQ08-B1P | I/O |
| 21 | GND | - | 22 | ADQ09-B1P | I/O |
| 23 | ADQ12-B1P | I/O | 24 | GND | - |
| 25 | ADQ13-B1P | I/O | 26 | ADM1-B1P | I/O |
| 27 | GND | - | 28 | GND | - |
| 29 | ADQS1-B1N | I/O | 30 | MCK0-B1P | O |
| 31 | ADQS1-B1P | I/O | 32 | MCK0-B1N | O |
| 33 | GRD | - | 34 | GND | - |
| 35 | ADQ14-B1P | I/O | 36 | ADQ11-B1P | I/O |
| 37 | ADQ15-B1P | I/O | 38 | ADQ10-B1P | I/O |
| 39 | GND | - | 40 | GND | - |
| 41 | GND | - | 42 | GND | - |
| 43 | ADQ17-B1P | I/O | 44 | ADQ20-B1P | I/O |
| 45 | ADQ16-B1P | - | 46 | ADQ21-B1P | I/O |
| 47 | GND | - | 48 | GND | - |
| 49 | ADQS2-B1N | I/O | 50 | NC | - |
| 51 | ADQS2-B1P | I/O | 52 | ADM2-B1P | I/O |
| 53 | GND | - | 54 | GND | - |
| 55 | ADQ19-B1P | I/O | 56 | ADQ23-B1P | I/O |
| 57 | ADQ18-B1P | I/O | 58 | ADQ22-B1P | I/O |
| 59 | GND | - | 60 | GND | - |
| 61 | ADQ24-B1P | I/O | 62 | ADQ29-B1P | I/O |

Table C-1 SO-DIMM0 connector (200-pin) (2/3)

| Pin No. | Signal Name | I/O | Pin No. | Signal Name | I/O |
|---------|-------------|-----|---------|-------------|-----|
| 63 | ADQ25-B1P | I/O | 64 | ADQ28-B1P | I/O |
| 65 | GND | - | 66 | GND | - |
| 67 | ADM3-B1P | I/O | 68 | ADQS3-B1N | I/O |
| 69 | NC | - | 70 | ADQS3-B1P | I/O |
| 71 | GND | - | 72 | GND | - |
| 73 | ADQ26-B1P | I/O | 74 | ADQ30-B1P | I/O |
| 75 | ADQ27-B1P | I/O | 76 | ADQ31-B1P | I/O |
| 77 | GND | - | 78 | GND | - |
| 79 | MCKE0-B1P | O | 80 | MCKE1-B1P | O |
| 81 | 1R8-B1V | - | 82 | 1R8-B1V | - |
| 83 | NC | - | 84 | NC | - |
| 85 | ABS2-B1P | O | 86 | NC | - |
| 87 | 1R8-B1V | - | 88 | 1R8-B1V | - |
| 89 | AMA12-B1P | O | 90 | AMA11-B1P | O |
| 91 | AMA09-B1P | O | 92 | AMA07-B1P | O |
| 93 | AMA08-B1P | O | 94 | AMA06-B1P | O |
| 95 | 1R8-B1V | - | 96 | 1R8-B1V | I |
| 97 | AMA05-B1P | O | 98 | AMA04-B1P | O |
| 99 | AMA03-B1P | O | 100 | AMA02-B1P | O |
| 101 | AMA01-B1P | O | 102 | AMA00-B1P | O |
| 103 | 1R8-B1V | - | 104 | 1R8-B1V | - |
| 105 | AMA10-B1P | O | 106 | ABS1-B1P | O |
| 107 | ABS0-B1P | O | 108 | ARAS-B1N | I |
| 109 | AWE-B1N | I | 110 | MCS0-B1N | O |
| 111 | 1R8-B1V | - | 112 | 1R8-B1V | - |
| 113 | ACAS-B1N | O | 114 | MODT0-B1P | O |
| 115 | MCS1-B1N | O | 116 | AMA13-B1P | I/O |
| 117 | 1R8-B1V | - | 118 | 1R8-B1V | - |
| 119 | MODT1-B1P | O | 120 | NC | - |
| 121 | GND | - | 122 | GND | - |
| 123 | ADQ37-B1P | I/O | 124 | ADQ32-B1P | I/O |
| 125 | ADQ36-B1P | I/O | 126 | ADQ33-B1P | I/O |
| 127 | GND | - | 128 | GND | - |
| 129 | ADQS4-B1N | I/O | 130 | ADM4-B1P | O |
| 131 | ADQS4-B1P | I/O | 132 | GND | - |
| 133 | GND | - | 134 | ADQ39-B1P | I/O |
| 135 | ADQ35-B1P | I/O | 136 | ADQ34-B1P | I/O |
| 137 | ADQ38-B1P | I/O | 138 | GND | - |

Table C-1 SO-DIMM0 connector (200-pin) (3/3)

| Pin No. | Signal Name | I/O | Pin No. | Signal Name | I/O |
|---------|-------------|-----|---------|-------------|-----|
| 139 | GND | - | 140 | ADQ41-B1P | I/O |
| 141 | ADQ44-B1P | I/O | 142 | ADQ40-B1P | I/O |
| 143 | ADQ45-B1P | I/O | 144 | GND | - |
| 145 | GND | - | 146 | ADQS5-B1N | I/O |
| 147 | ADM5-B1P | O | 148 | ADQS5-B1P | I/O |
| 149 | GND | - | 150 | GND | - |
| 151 | ADQ46-B1P | I/O | 152 | ADQ42-B1P | I/O |
| 153 | ADQ47-B1P | I/O | 154 | ADQ43-B1P | I/O |
| 155 | GND | - | 156 | GND | - |
| 157 | ADQ53-B1P | I/O | 158 | ADQ49-B1P | I/O |
| 159 | ADQ48-B1P | I/O | 160 | ADQ52-B1P | I/O |
| 161 | GND | - | 162 | GND | - |
| 163 | NC | - | 164 | MCK1-B1P | O |
| 165 | GND | - | 166 | MCK1-B1N | O |
| 167 | ADQS6-B1N | I/O | 168 | GND | - |
| 169 | ADQS6-B1P | I/O | 170 | ADM6-B1P | O |
| 171 | GND | - | 172 | GND | - |
| 173 | ADQ50-B1P | I/O | 174 | ADQ55-B1P | I/O |
| 175 | ADQ54-B1P | I/O | 176 | ADQ51-B1P | I/O |
| 177 | GND | - | 178 | GND | - |
| 179 | ADQ61-B1P | I/O | 180 | ADQ56-B1P | I/O |
| 181 | ADQ60-B1P | I/O | 182 | ADQ57-B1P | I/O |
| 183 | GND | - | 184 | GND | - |
| 185 | ADM7-B1P | O | 186 | ADQS7-B1N | I/O |
| 187 | GND | - | 188 | ADQS7-B1P | I/O |
| 189 | ADQ63-B1P | I/O | 190 | GND | - |
| 191 | ADQ62-B1P | I/O | 192 | ADQ58-B1P | I/O |
| 193 | GND | - | 194 | ADQ59-B1P | I/O |
| 195 | SMBDAT-P3P | I/O | 196 | GND | - |
| 197 | SMBCLK-P3P | I/O | 198 | GND | - |
| 199 | P3V | - | 200 | GND | - |
| 1T | GND | - | 2T | GND | - |

C.2 CN1400 SO-DIMM1 connector (200-pin)

Table C-2 SO-DIMM1 connector (200-pin) (1/3)

| Pin No. | Signal Name | I/O | Pin No. | Signal Name | I/O |
|---------|-------------|-----|---------|-------------|-----|
| 1 | MRBREF-B0V | - | 2 | GND | - |
| 3 | GND | - | 4 | BDQ01-B1P | I/O |
| 5 | BDQ05-B1P | I/O | 6 | BDQ00-B1P | I/O |
| 7 | BDQ04-B1P | I/O | 8 | GND | - |
| 9 | GND | - | 10 | BDM0-B1P | I/O |
| 11 | BDQS0-B1N | I/O | 12 | GND | - |
| 13 | BDQS0-B1P | I/O | 14 | BDQ02-B1P | I/O |
| 15 | GND | - | 16 | BDQ06-B1P | I/O |
| 17 | BDQ07-B1P | I/O | 18 | GND | - |
| 19 | BDQ03-B1P | I/O | 20 | BDQ12-B1P | I/O |
| 21 | GND | - | 22 | BDQ13-B1P | I/O |
| 23 | BDQ08-B1P | I/O | 24 | GND | - |
| 25 | BDQ09-B1P | I/O | 26 | BDM1-B1P | I/O |
| 27 | GND | - | 28 | GND | - |
| 29 | BDQS1-B1N | I/O | 30 | MCK3-B1P | O |
| 31 | BDQS1-B1P | I/O | 32 | MCK3-B1N | O |
| 33 | 2R5-B2V | - | 34 | GND | - |
| 35 | BDQ15-B1P | I/O | 36 | BDQ10-B1P | I/O |
| 37 | BDQ14-B1P | I/O | 38 | BDQ11-B1P | I/O |
| 39 | GND | - | 40 | GND | - |
| 41 | GND | - | 42 | GND | - |
| 43 | BDQ16-B1P | I/O | 44 | BDQ20-B1P | I/O |
| 45 | BDQ17-B1P | - | 46 | BDQ21-B1P | I/O |
| 47 | GND | - | 48 | GND | - |
| 49 | BDQS2-B1N | I/O | 50 | NC | - |
| 51 | BDQS2-B1P | I/O | 52 | BDM2-B1P | I/O |
| 53 | GND | - | 54 | GND | - |
| 55 | BDQ23-B1P | I/O | 56 | BDQ18-B1P | I/O |
| 57 | BDQ22-B1P | I/O | 58 | BDQ19-B1P | I/O |
| 59 | GND | - | 60 | GND | - |
| 61 | BDQ28-B1P | I/O | 62 | BDQ29-B1P | I/O |

Table C-2 SO-DIMM1 connector (200-pin) (2/3)

| Pin No. | Signal Name | I/O | Pin No. | Signal Name | I/O |
|---------|-------------|-----|---------|-------------|-----|
| 63 | BDQ30-B1P | I/O | 64 | BDQ25-B1P | I/O |
| 65 | GND | - | 66 | GND | - |
| 67 | BDM3-B1P | I/O | 68 | BDQS3-B1N | I/O |
| 69 | NC | - | 70 | BDQS3-B1P | I/O |
| 71 | GND | - | 72 | GND | - |
| 73 | BDQ27-B1P | I/O | 74 | BDQ29-B1P | I/O |
| 75 | BDQ26-B1P | I/O | 76 | BDQ31-B1P | I/O |
| 77 | GND | - | 78 | GND | - |
| 79 | MCKE2-B1P | O | 80 | MCKE3-B1P | O |
| 81 | 1R8-B1V | - | 82 | 1R8-B1V | - |
| 83 | NC | - | 84 | NC | - |
| 85 | BBS2-B1P | O | 86 | NC | - |
| 87 | 1R8-B1V | - | 88 | 1R8-B1V | - |
| 89 | BMA12-B1P | O | 90 | BMA11-B1P | O |
| 91 | BMA09-B1P | O | 92 | BMA07-B1P | O |
| 93 | BMA08-B1P | O | 94 | BMA06-B1P | O |
| 95 | 1R8-B1V | - | 96 | 1R8-B1V | I |
| 97 | BMA05-B1P | O | 98 | BMA04-B1P | O |
| 99 | BMA03-B1P | O | 100 | BMA02-B1P | O |
| 101 | BMA01-B1P | O | 102 | BMA00-B1P | O |
| 103 | 1R8-B1V | - | 104 | 1R8-B1V | - |
| 105 | BMA10-B1P | O | 106 | BBS1-B1P | O |
| 107 | BBS0-B1P | O | 108 | BRAS-B1N | I |
| 109 | BWE-B1N | I | 110 | MCS2-B1N | O |
| 111 | 1R8-B1V | - | 112 | 1R8-B1V | - |
| 113 | BCAS-B1N | - | 114 | MODT2-B1P | O |
| 115 | MCS3-B1N | O | 116 | BMA13-B1P | I/O |
| 117 | 1R8-B1V | - | 118 | 1R8-B1V | - |
| 119 | MODT3-B1P | O | 120 | NC | - |
| 121 | GND | - | 122 | GND | - |
| 123 | BDQ37-B1P | I/O | 124 | BDQ33-B1P | I/O |
| 125 | BDQ35-B1P | I/O | 126 | BDQ32-B1P | I/O |
| 127 | GND | - | 128 | GND | - |
| 129 | BDQS4-B1N | I/O | 130 | BDM4-B1P | O |
| 131 | BDQS4-B1P | I/O | 132 | GND | - |
| 133 | GND | - | 134 | BDQ35-B1P | I/O |
| 135 | BDQ38-B1P | I/O | 136 | BDQ34-B1P | I/O |
| 137 | BDQ39-B1P | I/O | 138 | GND | - |

Table C-2 SO-DIMM1 connector (200-pin) (3/3)

| Pin No. | Signal Name | I/O | Pin No. | Signal Name | I/O |
|---------|-------------|-----|---------|-------------|-----|
| 139 | GND | - | 140 | BDQ41-B1P | I/O |
| 141 | BDQ45-B1P | I/O | 142 | BDQ40-B1P | I/O |
| 143 | BDQ44-B1P | I/O | 144 | GND | - |
| 145 | GND | - | 146 | BDQS5-B1N | I/O |
| 147 | BDM5-B1P | O | 148 | BDQS5-B1P | I/O |
| 149 | GND | - | 150 | GND | - |
| 151 | BDQ42-B1P | I/O | 152 | BDQ42-B1P | I/O |
| 153 | BDQ43-B1P | I/O | 154 | BDQ43-B1P | I/O |
| 155 | GND | - | 156 | GND | - |
| 157 | BDQ53-B1P | I/O | 158 | BDQ49-B1P | I/O |
| 159 | BDQ52-B1P | I/O | 160 | BDQ52-B1P | I/O |
| 161 | GND | - | 162 | GND | - |
| 163 | NC | - | 164 | MCK1-B1P | O |
| 165 | GND | - | 166 | MCK1-B1N | O |
| 167 | BDQS6-B1N | I/O | 168 | GND | - |
| 169 | BDQS6-B1P | I/O | 170 | BDM6 | O |
| 171 | GND | - | 172 | GND | - |
| 173 | BDQ51-B1P | I/O | 174 | BDQ55-B1P | I/O |
| 175 | BDQ49-B1P | I/O | 176 | BDQ51-B1P | I/O |
| 177 | GND | - | 178 | GND | - |
| 179 | BDQ57-B1P | I/O | 180 | BDQ56-B1P | I/O |
| 181 | BDQ60-B1P | I/O | 182 | BDQ57-B1P | I/O |
| 183 | GND | - | 184 | GND | - |
| 185 | BDM7-B1P | O | 186 | BDQS7-B1N | I/O |
| 187 | GND | - | 188 | BDQS7-B1P | I/O |
| 189 | BDQ62-B1P | I/O | 190 | GND | - |
| 191 | BDQ63-B1P | I/O | 192 | BDQ58-B1P | I/O |
| 193 | GND | - | 194 | BDQ59-B1P | I/O |
| 195 | SMBDAT-P3P | I/O | 196 | GND | - |
| 197 | SMBCK1-P3P | I/O | 198 | GND | - |
| 199 | P3V | - | 200 | P3V | - |
| 1T | GND | - | 2T | GND | - |

C.3 CN1850 SATA interface connector (11-pin)*Table C-3 SATA interface connector (11-pin)*

| Pin No. | Signal Name | I/O | Pin No. | Signal Name | I/O |
|---------|-------------|-----|---------|-------------|-----|
| 1 | SATAT0-P3P | O | 2 | SATAT0-P3N | O |
| 3 | GND | - | 4 | SATAR0-P3N | I |
| 5 | SATAR0-P3P | I | 6 | GND | - |
| 7 | P3V | - | 8 | GND | - |
| 9 | P5V | - | 10 | GND | - |
| 11 | GND | - | | | |
| 1T | GND | - | 2T | GND | - |
| 3T | GND | - | 4T | GND | - |

C.4 CN1810 Select bay interface connector (72-pin)*Table C-4 Select bay interface connector (72-pin) (1/2)*

| Pin No. | Signal Name | I/O | Pin No. | Signal Name | I/O |
|---------|-------------|-----|---------|-------------|-----|
| 1 | SB-P3V | - | 2 | SB-P3V | - |
| 3 | SB-P3V | - | 4 | SB-P3V | - |
| 5 | SB-P3V | - | 6 | SB-P3V | - |
| 7 | NC | - | 8 | NC | - |
| 9 | MBSTS0-S3N | I | 10 | MBSTS1-S3N | I |
| 11 | MBSTS2-S3N | I | 12 | GND | - |
| 13 | GND | - | 14 | SATSR2-P3P | I |
| 15 | GND | - | 16 | SATSR2-P3N | I |
| 17 | GND | - | 18 | GND | - |
| 19 | GND | -I | 20 | SATAT2-P3N | I |
| 21 | GND | - | 22 | SATAT2-P3P | I |
| 23 | GND | - | 24 | GND | - |
| 25 | NC | - | 26 | NC | - |
| 27 | GND | - | 28 | GND | - |
| 29 | PDCS1-P3N | O | 30 | PDCS3-P3N | O |
| 31 | PDA0-P3P | O | 32 | PDA2-P3P | O |
| 33 | PDA0-P3P | O | 34 | PDDACK-P3N | O |
| 35 | IDEIRQ-P3P | I | 36 | GND | - |
| 37 | GND | - | 38 | PDA1-P3N | O |
| 39 | PIORDY-P3P | I | 40 | PDDREQ-P3P | I |
| 41 | PDIOW-P3N | O | 42 | GND | - |
| 43 | GND | - | 44 | PDD15-P3P | I/O |

Table C-4 Select bay interface connector (72-pin) (2/2)

| Pin No. | Signal Name | I/O | Pin No. | Signal Name | I/O |
|---------|-------------|-----|---------|-------------|-----|
| 45 | PDD00-P3P | I/O | 46 | PDD14-P3P | I/O |
| 47 | PDD01-P3P | I/O | 48 | PDD13-P3P | I/O |
| 49 | GND | - | 50 | GND | - |
| 51 | GND | - | 52 | PDD12-P3P | I/O |
| 53 | PDD02-P3P | I/O | 54 | PDD11-P3P | I/O |
| 55 | PDD03-P3P | I/O | 56 | PDD08-P3P | I/O |
| 57 | PDD04-P3P | I/O | 58 | GND | - |
| 59 | GND | - | 60 | PDD10-P3P | I/O |
| 61 | PDD05-P3P | I/O | 62 | PDD09-P3P | I/O |
| 63 | PDD06-P3P | I/O | 64 | PDD07-P3P | I/O |
| 65 | GND | - | 66 | IDRSTB-P5N | O |
| 67 | GND | - | 68 | GNDNC | - |
| 69 | GND | - | 70 | GND | - |
| 71 | SB-P5V | - | 72 | GND | - |

C.5 CN2100 PC card interface connector (150-pin)*Table C-5 PC card interface connector (150-pin) (1/3)*

| Pin No. | Signal Name | I/O | Pin No. | Signal Name | I/O |
|---------|-------------|-----|---------|-------------|-----|
| 1 | GND | - | 2 | GND | - |
| 3 | NC | - | 4 | NC | - |
| 5 | NC | - | 6 | NC | -I |
| 7 | NC | - | 8 | NC | - |
| 9 | GND | - | 10 | NC | - |
| 11 | NC | - | 12 | NC | - |
| 13 | NC | - | 14 | NC | - |
| 15 | NC | - | 16 | NC | - |
| 17 | GND | - | 18 | GND | - |
| 19 | GND | - | 20 | GND | - |
| 21 | GND | - | 22 | GND | - |
| 23 | PETCRD-P3P | O | 24 | PETCRD-P3N | O |
| 25 | GND | - | 26 | GND | -I |
| 27 | PERCRD-P3P | I | 28 | PERCRD-P3N | I |
| 29 | GND | - | 30 | GND | - |
| 31 | GND | - | 32 | GND | - |
| 33 | GND | - | 34 | XPERD-P3P | O |
| 35 | XPECRD-P3N | O | 36 | GND | - |
| 37 | GND | -I | 38 | GND | - |
| 39 | GND | - | 40 | GND | - |
| 41 | GND | - | 42 | CPPE-E3N | I |
| 43 | GND | - | 44 | CRDCRQ-E3N | I |
| 45 | CRD-P3V | - | 46 | CRD-P3V | - |
| 47 | CRD-P3V | - | 48 | CRD-P3V | - |
| 49 | CRD-P3V | - | 50 | CRDRST-E3N | O |
| 51 | GND | - | 52 | CRD-E3V | - |
| 53 | CRD-E3V | -O | 54 | CRD-E3V | - |
| 55 | PEWAKE-S3N | O | 56 | CRD1R5-P1V | - |
| 57 | CRD1R5-P1V | - | 58 | CRD1R5-P1V | - |
| 59 | GND | - | 60 | CRD-E3V | - |
| 61 | CRD-E3V | - | 62 | GND | - |
| 63 | NC | - | 64 | GND | - |
| 65 | NC | - | 66 | GND | - |
| 67 | GND | - | 68 | NC | - |
| 69 | GND | - | 70 | CPUSB-E3N | I |

Table C-5 PC card ard interface connector (150-pin) (2/3)

| Pin No. | Signal Name | I/O | Pin No. | Signal Name | I/O |
|---------|-------------|-----|---------|-------------|-----|
| 71 | GND | - | 72 | USBP6-S3P | I/O |
| 73 | USBP6-S3N | I/O | 74 | GND | - |
| 75 | GND | - | 76 | GND | - |
| 77 | GND | - | 78 | ACCD2-E3N | I |
| 79 | ACCLKR-EYN | I/O | 80 | ACAD31-EYP | I/O |
| 81 | ACD02-EYP | I/O | 82 | ACAD30-EYP | I/O |
| 83 | ACAD29-EYP | I/O | 84 | GND | - |
| 85 | ACAD28-EYP | I/O | 86 | ACAD27-EYP | I/O |
| 87 | ACSTSC-EYP | I | 88 | ACAD26-EYP | I/O |
| 89 | ACAUDI-EYP | I | 90 | ACAD25-EYP | I/O |
| 91 | ACCBE3-EYN | I/O | 92 | GND | - |
| 93 | ACAD24-EYP | I/O | 94 | ACREQ-EYN | I |
| 95 | ACAD23-EYP | I/O | 96 | ACSERR-EYN | I/O |
| 97 | ACAD22-EYP | I/O | 98 | ACRST-EYN | I/O |
| 99 | ACAD21-EYP | I/O | 100 | GND | - |
| 101 | ACVS2-E3P | I/O | 102 | ACAD20-EYP | I/O |
| 103 | ACAD19-EYP | I/O | 104 | ACAD18-EYP | I/O |
| 105 | ACAD17-EYP | I/O | 106 | ACCBE2-EYN | I/O |
| 107 | ACFRAM-EYN | I/O | 108 | GND | - |
| 109 | ACIRDY-EYN | I/O | 110 | ACTRDY-EYN | I/O |
| 111 | ACCLK-EYP | I/O | 112 | MCVPPB-EYV | - |
| 113 | MCVCCB-EYV | - | 114 | MCVCCB-EYV | - |
| 115 | ACINT-EYN | I | 116 | ACDEVS-EYN | I/O |
| 117 | ACGNT-EYN | O | 118 | GND | - |
| 119 | ACSTOP-EYN | I/O | 120 | ACPERR-EYN | I/O |
| 121 | ACLOCK-EYN | I/O | 122 | ACPAR-EYP | I/O |
| 123 | ACA18-EYP | I/O | 124 | ACCBE1-EYN | I/O |
| 125 | ACAD16-EYP | I/O | 126 | GND | - |
| 127 | ACAD14-EYP | I/O | 128 | ACAD15-EYP | I/O |
| 129 | ACAD12-EYP | I/O | 130 | ACAD13-EYP | I/O |
| 131 | ACAD11-EYP | I/O | 132 | ACVS1-E3P | I/O |
| 133 | ACAD09-EYP | I/O | 134 | GND | - |
| 135 | ACAD10-EYP | I/O | 136 | ACCBE0-EYN | I/O |
| 137 | ACAD08-EYP | I/O | 138 | ACAD07-EYP | I/O |
| 139 | ACD14-EYP | I/O | 140 | ACAD05-EYP | I/O |
| 141 | ACAD06-EYP | I/O | 142 | GND | - |
| 143 | ACAD03-EYP | I/O | 144 | ACAD04-EYP | I/O |

Table C-5 PC card interface connector (150-pin) (3/3)

| Pin No. | Signal Name | I/O | Pin No. | Signal Name | I/O |
|---------|-------------|-----|---------|-------------|-----|
| 145 | ACAD01-EYP | I/O | 146 | ACAD02-EYP | I/O |
| 147 | ACAD00-EYP | I/O | 148 | ACCD1-E3N | I |
| 149 | GND | - | 150 | GND | - |
| 1T | GND | - | 2T | GND | - |

C.6 IS2101 SD card interface connector (12-pin)

Table C-6 SD card interface connector (12-pin)

| Pin No. | Signal Name | I/O | Pin No. | Signal Name | I/O |
|---------|-------------|-----|---------|-------------|-----|
| 1 | SDAT3-E3P | I/O | 2 | SDCMD-E3P | I/O |
| 3 | GND | - | 4 | SD-E3V | - |
| 5 | SDCLK-E3P | I | 6 | GND | - |
| 7 | SDAT0-E3P | I/O | 8 | SDAT1-E3P | I/O |
| 9 | SDAT2-E3P | I/O | 10 | SDCD-E3N | I |
| 11 | GND | - | 12 | SDWP-E3P | I |
| 1T | GND | - | 2T | GND | - |
| 3T | GND | - | 4T | GND | - |

C.7 CN2200 Mini PCI interface connector (124-pin)

Table C-7 Mini PCI interface connector (124-pin) (1/2)

| Pin No. | Signal Name | I/O | Pin No. | Signal Name | I/O |
|---------|--------------|-----|---------|-------------|-----|
| 1 | NC | - | 2 | NC | - |
| 3 | NC | - | 4 | NC | - |
| 5 | NC | - | 6 | NC | - |
| 7 | NC | - | 8 | NC | - |
| 9 | NC | - | 10 | NC | - |
| 11 | NC | - | 12 | NC | - |
| 13 | (WLN-S3N) | O | 14 | NC | - |
| 15 | GND | - | 16 | NC | - |
| 17 | PIRQF-P3N | I | 18 | P5V | - |
| 19 | P3V | - | 20 | PIRQG-P3N | I |
| 21 | NC | - | 22 | NC | - |
| 23 | GND | - | 24 | E3V | - |
| 25 | X33MPC-P3P | I | 26 | PCIRST-S3N | O |
| 27 | GND | - | 28 | P3V | - |
| 29 | PREQ2-P3N | O | 30 | PGNT2-P3N | I |
| 31 | P3V | - | 32 | GND | - |
| 33 | AD31-P3P | I/O | 34 | PME-E3N | I/O |
| 35 | AD29-P3P | I/O | 36 | NC | - |
| 37 | GND | - | 38 | AD30-P3P | I/O |
| 39 | AD27-P3P | I/O | 40 | P3V | - |
| 41 | AD25-P3P | I/O | 42 | AD28-P3P | I/O |
| 43 | NCWCHDAT-P3P | -O | 44 | AD26-P3P | I/O |
| 45 | CBE3-P3N | I/O | 46 | AD24-P3P | I/O |
| 47 | AD23-P3P | I/O | 48 | AD26-P3P | I/O |
| 49 | GND | - | 50 | GND | - |
| 51 | AD21-P3P | I/O | 52 | AD22-P3P | I/O |
| 53 | AD19-P3P | I/O | 54 | AD20-P3P | I/O |
| 55 | GND | - | 56 | PAR-P3P | I/O |
| 57 | AD17-P3P | I/O | 58 | AD18-P3P | I/O |
| 59 | CBE2-P3N | I/O | 60 | AD16-P3P | I/O |
| 61 | IRDY-P3N | I/O | 62 | GND | - |
| 63 | P3V | - | 64 | FRAME-P3N | I/O |
| 65 | CLKRUN-P3N | I/O | 66 | TRDY-P3N | I/O |
| 67 | SERR-P3N | I | 68 | STOP-P3N | I/O |

Table C-7 Mini PCI interface connector (124-pin) (2/2)

| Pin No. | Signal Name | I/O | Pin No. | Signal Name | I/O |
|---------|-------------|-----|---------|-------------|-----|
| 69 | GND | - | 70 | P3V | - |
| 71 | PERR-P3N | I/O | 72 | DEVSEL-P3N | I/O |
| 73 | CBE1-P3N | I/O | 74 | GND | - |
| 75 | AD14-P3P | I/O | 76 | AD15-P3P | I/O |
| 77 | GND | - | 78 | AD13-P3P | I/O |
| 79 | AD12-P3P | I/O | 80 | AD11-P3P | I/O |
| 81 | AD10-P3P | I/O | 82 | GND | - |
| 83 | GND | - | 84 | AD09-P3P | I/O |
| 85 | AD08-P3P | I/O | 86 | CBE0-P3N | I/O |
| 87 | AD07-P3P | I/O | 88 | P3V | - |
| 89 | P3V | - | 90 | AD06-P3P | I/O |
| 91 | AD05-P3P | I/O | 92 | AD04-P3P | I/O |
| 93 | NC | - | 94 | AD02-P3P | I/O |
| 95 | AD03-P3P | I/O | 96 | AD00-P3P | I/O |
| 97 | P5V | - | 98 | NC | - |
| 99 | AD01-P3P | I/O | 100 | NC | - |
| 101 | GND | - | 102 | GND | - |
| 103 | NC | - | 104 | GND | - |
| 105 | NC | - | 106 | NC | - |
| 107 | NC | - | 108 | NC | - |
| 109 | NC | - | 110 | NC | - |
| 111 | NC | - | 112 | NC | - |
| 113 | GND | - | 114 | GND | - |
| 115 | NC | - | 116 | NC | - |
| 117 | GND | - | 118 | NC | - |
| 119 | GND | - | 120 | GND | - |
| 121 | NC | - | 122 | NC | - |
| 123 | NC | - | 124 | E3V | - |
| 1T | GND | - | 2T | GND | - |

C.8 CN2300 Docking interface connector (240-pin)

Table C-8 Docking interface connector (240-pin) (1/4)

| Pin No. | Signal Name | I/O | Pin No. | Signal Name | I/O |
|---------|--------------|-----|---------|--------------|-----|
| A1 | DSKDC | - | A2 | GND | - |
| 1 | DCOUT | - | 2 | DCOUT | - |
| 3 | DOCDT1-S3N | I | 4 | IF-P5V | - |
| 5 | EXMSCK-P5P | I/O | 6 | EXKBCK-P5P | I/O |
| 7 | GND | - | 8 | (PHYRST-E3N) | O |
| 9 | DPCONF-S5P | I | 10 | GND | - |
| 11 | GND | - | 12 | NVASCL-P3P | I/O |
| 13 | CDKRED-PXP | O | 14 | CDKGRN-PXP | O |
| 15 | CDKBLU-PXP | O | 16 | DVSYNC-P35P | O |
| 17 | NVBSCCL-P35P | I/O | 18 | NC | - |
| 19 | GND | - | 20 | NC | - |
| 21 | NC | - | 22 | DVITX2-P3P | O |
| 23 | DVITX2-P3N | O | 24 | DVITX1-P3P | O |
| 25 | DVITX1-P3N | O | 26 | DVITX0-P3P | O |
| 27 | DVITX0-P3N | O | 28 | GND | - |
| 29 | GND | - | 30 | DVITXC-P3P | O |
| 31 | DVITXC-P3N | O | 32 | DVIDET-S3N | O |
| 33 | NC | - | 34 | NC | - |
| 35 | NC | - | 36 | NC | - |
| 37 | GND | - | 38 | NC | - |
| 39 | NC | - | 40 | NC | - |
| 41 | GND | - | 42 | NC | - |
| 43 | NC | - | 44 | NC | - |
| 45 | GND | - | 46 | NC | - |
| 47 | NC | - | 48 | NC | - |
| 49 | GND | - | 50 | NC | - |
| 51 | NC | - | 52 | NC | - |
| 53 | Not Mount | - | 54 | Not Mount | - |
| 55 | BIDDP-EXP | O | 56 | BIDDN-EXN | O |
| 57 | Not Mount | - | 58 | Not Mount | - |
| 59 | MDMRNG-E3P | I/O | 60 | MDMTIP-E3P | I/O |
| 61 | DCOUT | - | 62 | DCOUT | - |
| 63 | EJCTRQ-S3N | I/O | 64 | IF-P5V | - |
| 65 | EXMSDT-P5P | I/O | 66 | EXKBDT-P5P | I/O |
| 67 | GND | - | 68 | GND | - |
| 69 | DILSON-S3P | O | 70 | NC | - |

Table C-8 Docking interface connector (240-pin) (2/4)

| Pin No. | Signal Name | I/O | Pin No. | Signal Name | I/O |
|---------|-------------|-----|---------|-------------|-----|
| 71 | GND | - | 72 | NVASDA-P3P | I/O |
| 73 | GND | - | 74 | GND | - |
| 75 | GND | - | 76 | DHSYNC-P3P | O |
| 77 | NVBSDA-P3P | I/O | 78 | NC | - |
| 79 | GND | - | 80 | NC | - |
| 81 | NC | - | 82 | NC | - |
| 83 | NC | - | 84 | NC | - |
| 85 | NC | - | 86 | NC | - |
| 87 | NC | - | 88 | GND | - |
| 89 | GND | - | 90 | NC | - |
| 91 | NC | - | 92 | NC | - |
| 93 | NC | - | 94 | NC | - |
| 95 | NC | - | 96 | NC | - |
| 97 | GND | - | 98 | NC | - |
| 99 | NC | - | 100 | NC | - |
| 101 | GND | - | 102 | NC | - |
| 103 | NC | - | 104 | NC | - |
| 105 | GND | - | 106 | NC | - |
| 107 | NC | - | 108 | NC | - |
| 109 | GND | - | 110 | NC | - |
| 111 | NC | - | 112 | NC | - |
| 113 | Not Mount | - | 114 | Not Mount | - |
| 115 | BIDCN-EXN | - | 116 | Not Mount | - |
| 117 | BIDCP-EXP | - | 118 | Not Mount | - |
| 119 | Not Mount | - | 120 | Not Mount | - |
| 121 | DCOUT | - | 122 | DCOUT | - |
| 123 | DSSCL-S5P | I/O | 124 | IF-P5V | - |
| 125 | (M5V) | - | 126 | DTPA-E3P | I/O |
| 127 | GND | - | 128 | DTPB-E3P | I/O |
| 129 | NC | - | 130 | NC | - |
| 131 | GND | - | 132 | NC | - |
| 133 | NC | - | 134 | SNDMUT-S3N | O |
| 135 | NC | - | 136 | NC | - |
| 137 | NC | - | 138 | NC | - |
| 139 | GND | - | 140 | PWRSW-S3N | O |
| 141 | DCD-PYP | I | 142 | DSR-PYP | I |
| 143 | TXD-EYN | O | 144 | RING-PYP | I |
| 145 | PE-P5P | I | 146 | PDB07-P5P | I/O |

Table C-8 Docking interface connector (240-pin) (3/4)

| Pin No. | Signal Name | I/O | Pin No. | Signal Name | I/O |
|---------|-------------|-----|---------|-------------|-----|
| 147 | PDB06-P5P | I/O | 148 | GND | - |
| 149 | GND | - | 150 | PDB04-P5P | I/O |
| 151 | PDB01-P5P | I/O | 152 | PDB02-P5P | I/O |
| 153 | PDB00-P5P | I/O | 154 | STROB-P5N | O |
| 155 | NC | - | 156 | NC | - |
| 157 | GND | - | 158 | NC | - |
| 159 | NC | - | 160 | NC | - |
| 161 | GND | - | 162 | NC | - |
| 163 | NC | - | 164 | NC | - |
| 165 | GND | - | 166 | NC | - |
| 167 | NC | - | 168 | NC | - |
| 169 | GND | - | 170 | NC | - |
| 171 | NC | - | 172 | NC | - |
| 173 | GND | - | 174 | Not Mount | - |
| 175 | LAN-E3V | - | 176 | Not Mount | - |
| 177 | Not Mount | - | 178 | NC | - |
| 179 | BIDAP-EXP | I | 180 | BIDAN-EXN | I |
| 181 | DCOUT | - | 182 | DCOUT | - |
| 183 | DSSDA-S5P | I/O | 184 | IF-P5V | - |
| 185 | NC | - | 186 | DTPA-E3N | I/O |
| 187 | GND | - | 188 | DTPB-E3N | I/O |
| 189 | USBP2-E3P | I/O | 190 | USBP2-E3N | I/O |
| 191 | GND | - | 192 | NC | - |
| 193 | NC | - | 194 | NC | - |
| 195 | NC | - | 196 | NC | - |
| 197 | NC | - | 198 | NC | - |
| 199 | GND | - | 200 | RXD-PYN | I |
| 201 | RTS-EYP | O | 202 | CTS-PYP | I |
| 203 | DTR-EYP | O | 204 | SELCT-P5P | I |
| 205 | BUSY-P5P | I | 206 | ACK-P5N | I |
| 207 | PDB05-P5P | I/O | 208 | GND | - |
| 209 | GND | - | 210 | PDB03-P5P | I/O |
| 211 | SLIN-P5N | O | 212 | PINIT-P5N | O |
| 213 | ERROR-P5N | I | 214 | AUTFD-P5N | O |
| 215 | NC | - | 216 | NC | - |
| 217 | GND | - | 218 | NC | - |
| 219 | NC | - | 220 | NC | - |
| 221 | GND | - | 222 | NC | - |

Table C-8 Docking interface connector (240-pin) (4/4)

| Pin No. | Signal Name | I/O | Pin No. | Signal Name | I/O |
|---------|-------------|-----|---------|-------------|-----|
| 223 | NC | - | 224 | NC | - |
| 225 | GND | - | 226 | NC | - |
| 227 | NC | - | 228 | NC | - |
| 229 | GND | - | 230 | NC | - |
| 231 | NC | - | 232 | NC | - |
| 233 | GND | - | 234 | ACT-E3N | I |
| 235 | LINK-E3N | I | 236 | DOCDT2-S3N | I |
| 237 | Not mounted | - | 238 | Not mounted | - |
| 239 | BIDBP-EXP | O | 240 | BIDBN-EXN | O |
| 1T | GND | - | 2T | GND | - |
| 3T | GND | - | 4T | GND | - |
| 5T | GND | - | 6T | GND | - |
| 7T | GND | - | 8T | GND | - |
| 9T | GND | - | 10T | GND | - |

C.9 CN3011 Modem relay connector (4-pin)

Table C-9 Modem relay connector (4-pin)

| Pin No. | Signal Name | I/O | Pin No. | Signal Name | I/O |
|---------|-------------|-----|---------|-------------|-----|
| 1 | MDMRNG-E3P | I/O | 2 | MDMRNG-E3P | I/O |
| 3 | MDMIP-E3P | I/O | 4 | MDMIP-E3P | I/O |

C.10 CN3010 Modem connector (12-pin)

Table C-10 Modem connector (12-pin)

| Pin No. | Signal Name | I/O | Pin No. | Signal Name | I/O |
|---------|-------------|-----|---------|-------------|-----|
| 1 | GND | - | 2 | NC | - |
| 3 | ACZOT2-P3P | I/O | 4 | NC | - |
| 5 | GND | - | 6 | E3V | - |
| 7 | ACZSY2-P3P | - | 8 | GND | - |
| 9 | ACZIN2-E3P | I/O | 10 | GND | - |
| 11 | ACZRS2-E3N | - | 12 | XAZBCM-P3P | I |
| 1T | GND | - | 2T | GND | - |
| 3T | GND | - | 4T | GND | - |
| 5T | GND | - | 6T | GND | - |

C.11 CN3200 Keyboard interface connector (34-pin)*Table C-11 Keyboard interface connector (34-pin)*

| Pin No. | Signal Name | I/O | Pin No. | Signal Name | I/O |
|---------|-------------|-----|---------|-------------|-----|
| 1T | GND | - | 2T | GND | - |
| 1 | P5V | - | 2 | SPY-PXP | O |
| 3 | SP-GND | - | 4 | SPX-PXP | O |
| 5 | SP-P5V | - | 6 | P5V | - |
| 7 | KBSC15-S3N | O | 8 | KBSC14-S3N | O |
| 9 | KBRT07-S3N | I | 10 | KBRT06-S3N | I |
| 11 | KBSC13-S3N | O | 12 | KBSC12-S3N | O |
| 13 | KBRT05-S3N | I | 14 | KBRT04-S3N | I |
| 15 | KBSC11-S3N | O | 16 | KBSC10-S3N | O |
| 17 | KBRT03-S3N | I | 18 | KBRT02-S3N | I |
| 19 | KBRT01-S3N | I | 20 | KBSC09-S3N | O |
| 21 | KBSC08-S3N | O | 22 | KBSC07-S3N | O |
| 23 | KBRT00-S3N | I | 24 | KBSC06-S3N | O |
| 25 | KBSC05-S3N | O | 26 | KBSC04-S3N | O |
| 27 | KBSC03-S3N | O | 28 | KBSC02-S3N | O |
| 29 | KBSC01-S3N | O | 30 | KBSC00-S3N | O |
| 31 | P5V | - | 32 | CAPLED-P5N | O |
| 33 | ARWLED-P5N | O | 34 | NUMLED-P5N | O |

C.12 CN3201 Touch pad interface connector (8-pin)*Table C-12 Touch pad interface connector (8-pin)*

| Pin No. | Signal Name | I/O | Pin No. | Signal Name | I/O |
|---------|-------------|-----|---------|-------------|-----|
| 1 | SP-P5V | - | 2 | SPX-PXP | O |
| 3 | SPY-PXP | O | 4 | SP-GND | - |
| 5 | GND | - | 6 | IPDCLK-P5P | I/O |
| 7 | IPDDAT-P5P | I/O | 8 | P5V | - |
| 1T | GND | - | 2T | GND | - |

C.13 CN3260 SW board interface connector (13-pin)*Table C-13 SW board interface connector (13-pin)*

| Pin No. | Signal Name | I/O | Pin No. | Signal Name | I/O |
|---------|-------------|-----|---------|-------------|-----|
| 1 | GPBTNB-S3W | I | 2 | NC | - |
| 3 | NC | - | 4 | GPBTNA-S3N | I |
| 5 | NC | - | 6 | NC | - |
| 7 | PWRSW-S3N | I | 8 | NC | - |
| 9 | NC | - | 10 | GND | - |
| 11 | NC | - | 12 | NC | - |
| 13 | PNLOFF-S3N | I | | | |
| 1T | GND | - | 2T | GND | - |

C.14 CN3421 SR board interface connector (12-pin)*Table C-14 SR board interface connector (12-pin)*

| Pin No. | Signal Name | I/O | Pin No. | Signal Name | I/O |
|---------|-------------|-----|---------|-------------|-----|
| 1 | GND | - | 2 | DCD-PYP | I |
| 3 | RXD-PYN | I | 4 | TXD-EYN | O |
| 5 | DTR-EYP | O | 6 | GND | - |
| 7 | DSR-PYP | I | 8 | RTS-EYP | O |
| 9 | CTS-PYP | I | 10 | RING-PYP | I |
| 11 | GND | - | 12 | NC | - |

C.15 CN3401 Parallel port interface connector (25-pin)*Table C-15 Parallel port interface connector (25-pin)*

| Pin No. | Signal Name | I/O | Pin No. | Signal Name | I/O |
|---------|-------------|-----|---------|-------------|-----|
| 1 | STROB-P5N | O | 2 | PDB00-P5P | I/O |
| 3 | PDB01-P5P | I/O | 4 | PDB02-P5P | I/O |
| 5 | PDB03-P5P | I/O | 6 | PDB04-P5P | I/O |
| 7 | PDB05-P5P | I/O | 8 | PDB06-P5P | I/O |
| 9 | PDB07-P5P | I/O | 10 | ACK-P5N | I |
| 11 | BUSY-P5P | I | 12 | PE-P5P | I |
| 13 | SELCT-P5P | I | 14 | AUTFD-P5N | O |
| 15 | ERROR-P5N | I | 16 | PINIT-P5N | O |
| 17 | SLIN-P5N | O | 18 | GND | - |
| 19 | GND | - | 20 | GND | - |
| 21 | GND | - | 22 | GND | - |
| 23 | GND | - | 24 | GND | - |
| 25 | GND | - | | | |

C.16 J4100 LAN jack (12-pin)*Table C-16 LAN jack (12-pin)*

| Pin No. | Signal Name | I/O | Pin No. | Signal Name | I/O |
|---------|-------------|-----|---------|-------------|-----|
| 1 | MDI0-EXP | I/O | 2 | MDI0-EXN | I/O |
| 3 | MDI1-EXP | I/O | 4 | MDI1-EXN | I/O |
| 5 | MDI2-EXN | I/O | 6 | MDI2-EXN | I/O |
| 7 | MDI3-EXP | I/O | 8 | MDI3-EXN | I/O |
| 9 | LINK-E3N | O | 10 | (LAN-E3V) | - |
| 11 | ACT-E3N | O | 12 | (LAN-E3V) | - |
| 1T | GND | - | 2T | GND | - |

C.17 CN4200 IEEE 1394 interface connector (4-pin)*Table C-17 IEEE 1394 interface connector (4-pin)*

| Pin No. | Signal Name | I/O | Pin No. | Signal Name | I/O |
|---------|-------------|-----|---------|-------------|-----|
| 1 | TPB0-E3N | I/O | 2 | TPB0-E3P | I/O |
| 3 | TPA0-E3N | I/O | 4 | TPA0-E3P | I/O |

C.18 CN4400 Bluetooth interface connector (20-pin)*Table C-18 Bluetooth interface connector (20-pin)*

| Pin No. | Signal Name | I/O | Pin No. | Signal Name | I/O |
|---------|-------------|-----|---------|-------------|-----|
| 1 | GND | - | 2 | NC | - |
| 3 | BTMDL-P3N | I | 4 | NC | - |
| 5 | NC | - | 6 | NC | - |
| 7 | NC | - | 8 | BTRST-S3N | O |
| 9 | NC | - | 10 | NC | - |
| 11 | GND | - | 12 | NC | - |
| 13 | (GND) | - | 14 | WCHCLK-P3P | O |
| 15 | NC | - | 16 | USBP4-E3P | I/O |
| 17 | USBP4-E3N | I/O | 18 | NC | - |
| 19 | NC | - | 20 | BT-P3V | - |

C.19 CN4610 US board I/F connector (10-pin)*Table C-19 US board I/F connector (10-pin)*

| Pin No. | Signal Name | I/O | Pin No. | Signal Name | I/O |
|---------|-------------|-----|---------|-------------|-----|
| 1 | GND | - | 2 | GND | - |
| 3 | USBP3-E3N | I/O | 4 | USBP3-E3P | I/O |
| 5 | USB0PS-E5V | O | 6 | USB0PS-E5V | O |
| 7 | USBP4-E3N | I/O | 8 | USBP4-E3P | I/O |
| 9 | GND | - | 10 | GND | - |

C.20 CN4611 SR board I/F connector (8-pin)*Table C-20 SR board I/F connector (8-pin)*

| Pin No. | Signal Name | I/O | Pin No. | Signal Name | I/O |
|---------|-------------|-----|---------|-------------|-----|
| 1 | USB1PS-E5V | O | 2 | USB1PS-E5V | O |
| 3 | USBP6-E3N | I/O | 4 | USBP6-E3P | I/O |
| 5 | GND | - | 6 | GND | - |
| 7 | GND | - | 8 | NC | - |

C.21 CN5500 LCD interface connector (40-pin)*Table C-21 LCD interface connector (40-pin)*

| Pin No. | Signal Name | I/O | Pin No. | Signal Name | I/O |
|---------|-------------|-----|---------|-------------|-----|
| 1 | BRT2DA-S3P | O | 2 | BRT1-P5P | O |
| 3 | BRT0-P5P | O | 4 | FL-P5V | - |
| 5 | FL-P5V | - | 6 | FL-P5V | - |
| 7 | NC | - | 8 | GND | - |
| 9 | GND | - | 10 | GND | - |
| 11 | NC | - | 12 | PNL-P3V | - |
| 13 | PNL-P3V | - | 14 | PNL1-P3P | I |
| 15 | PNL0-P3P | I | 16 | GND | - |
| 17 | TXDT4-P3N | O | 18 | TXDT4-P3P | O |
| 19 | GND | - | 20 | TXDT5-P3N | O |
| 21 | TXDT5-P3P | O | 22 | GND | - |
| 23 | TXDT6-P3N | O | 24 | TXDT6-P3P | O |
| 25 | GND | - | 26 | TXCK1-P3N | O |
| 27 | TXCK1-P3P | O | 28 | GND | - |
| 29 | TXDT0-P3N | O | 30 | TXDT0-P3P | O |
| 31 | GND | - | 32 | TXDT1-P3N | O |
| 33 | TXDT1-P3P | O | 34 | GND | - |
| 35 | TXDT2-P3N | O | 36 | TXDT2-P3P | O |
| 37 | GND | - | 38 | TXCK0-P3N | O |
| 39 | TXCK0-P3P | O | 40 | GND | - |
| 1T | GND | - | 2T | GND | - |
| 3T | GND | - | 4T | GND | - |
| 5T | GND | - | 6T | GND | - |

C.22 CN5620 RGB connector (15-pin)*Table C-22 RGB connector (15-pin)*

| Pin No. | Signal Name | I/O | Pin No. | Signal Name | I/O |
|---------|-------------|-----|---------|-------------|-----|
| 1 | SYSRED-PXP | O | 2 | SYSGRN-PXP | O |
| 3 | SYSBLU-PXP | O | 4 | NC | - |
| 5 | GND | - | 6 | GND | - |
| 7 | GND | - | 8 | GND | - |
| 9 | DDC-P5V | - | 10 | GND | - |
| 11 | NC | - | 12 | CRTSDA-P5P | I/O |
| 13 | SHSYNC-P5P | O | 14 | SVSYNC-P5P | O |
| 15 | CRTSCL-P5P | I/O | | | |
| 1T | GND | - | 2T | GND | - |

C.23 CN5501 S-VIDEO connector (4-pin)*Table C-23 S-VIDEO connector (4-pin)*

| Pin No. | Signal Name | I/O | Pin No. | Signal Name | I/O |
|---------|-------------|-----|---------|-------------|-----|
| 1 | GND | - | 2 | GND | - |
| 3 | LUMINA-PYP | O | 4 | CHROMA-PYP | O |
| 1T | GND | - | 2T | GND | - |
| 3T | GND | - | 4T | GND | - |

C.24 CN5900 GFX board interface connector (230-pin)

Table C-24 GFX board interface connector (230-pin) (1/4)

| PIN No. | Signal name | I/O | PIN No. | Signal name | I/O |
|---------|--------------|-----|---------|--------------|-----|
| 1 | PVT-EFV | - | 2 | 1R5-P1V | - |
| 3 | PVT-EFV | - | 4 | 1R5-P1V | - |
| 5 | PVT-EFV | - | 6 | 1R5-P1V | - |
| 7 | PVT-EFV | - | 8 | 1R5-P1V | - |
| 9 | PVT-EFV | - | 10 | 1R5-P1V | - |
| 11 | PVT-EFV | - | 12 | 1R5-P1V | - |
| 13 | PVT-EFV | - | 14 | (L1INE1-PXP) | - |
| 15 | PVT-EFV | - | 16 | GND | - |
| 17 | N.C. | - | 18 | GND | - |
| 19 | (L1INE2-PXP) | - | 20 | GND | - |
| 21 | (L1INE3-PXP) | - | 22 | GND | - |
| 23 | PGN | - | 24 | GND | - |
| 25 | GND | - | 26 | GND | - |
| 27 | TXCK1-P3N | I | 28 | TXCK0-P3N | I |
| 29 | TXCK1-P3P | I | 30 | TXCK0-P3P | I |
| 31 | GND | - | 32 | GND | - |
| 33 | TXDT4-P3N | I | 34 | TXDT0-P3P | I |
| 35 | TXDT4-P3P | I | 36 | TXDT0-P3N | I |
| 37 | TXDT5-P3N | I | 38 | TXDT1-P3P | I |
| 39 | TXDT5-P3P | I | 40 | TXDT1-P3N | I |
| 41 | GND | - | 42 | GND | - |
| 43 | TXDT6-P3N | I | 44 | TXDT2-P3P | I |
| 45 | TXDT6-P3P | I | 46 | TXDT2-P3N | I |
| 47 | (TXDT7-P3N) | - | 48 | (TXDT3-P3P) | - |
| 49 | (TXDT7-P3P) | - | 50 | (TXDT3-P3N) | - |
| 51 | GND | - | 52 | GND | - |
| 53 | GND | - | 54 | GND | - |
| 55 | PEGC15-P1N | I | 56 | PEGC15-P1N | O |
| 57 | PEGC15-P1P | I | 58 | PEGC15-P1P | O |

Table C-24 GFX board interface connector (230-pin) (2/4)

| PIN No. | Signal name | I/O | PIN No. | Signal name | I/O |
|---------|-------------|-----|---------|-------------|-----|
| 59 | GND | - | 60 | GND | - |
| 61 | PEGC14-P1N | I | 62 | PECG14-P1N | O |
| 63 | PEGC14-P1P | I | 64 | PECG14-P1P | O |
| 65 | GND | - | 66 | GND | - |
| 67 | PEGC13-P1N | I | 68 | PECG13-P1N | O |
| 69 | PEGC13-P1P | I | 70 | PECG13-P1P | O |
| 71 | GND | - | 72 | GND | - |
| 73 | PEGC12-P1N | I | 74 | PECG12-P1N | O |
| 75 | PEGC12-P1P | I | 76 | PECG12-P1P | O |
| 77 | GND | - | 78 | GND | - |
| 79 | PEGC11-P1N | I | 80 | PECG11-P1N | O |
| 81 | PEGC11-P1P | I | 82 | PECG11-P1P | O |
| 83 | GND | - | 84 | GND | - |
| 85 | PEGC10-P1N | I | 86 | PECG10-P1N | O |
| 87 | PEGC10-P1P | I | 88 | PECG10-P1P | O |
| 89 | GND | - | 90 | GND | - |
| 91 | PEGC09-P1N | I | 92 | PECG09-P1N | O |
| 93 | PEGC09-P1P | I | 94 | PECG09-P1P | O |
| 95 | GND | - | 96 | GND | - |
| 97 | PEGC08-P1N | I | 98 | PECG08-P1N | O |
| 99 | PEGC08-P1P | I | 100 | PECG08-P1P | O |
| 101 | GND | - | 102 | GND | - |
| 103 | PEGC07-P1N | I | 104 | PECG07-P1N | O |
| 105 | PEGC07-P1P | I | 106 | PECG07-P1P | O |
| 107 | GND | - | 108 | GND | - |
| 109 | PEGC06-P1N | I | 110 | PECG06-P1N | O |
| 111 | PEGC06-P1P | I | 112 | PECG06-P1P | O |
| 113 | GND | - | 114 | GND | - |
| 115 | PEGC05-P1N | I | 116 | PECG05-P1N | O |
| 117 | PEGC05-P1P | I | 118 | PECG05-P1P | O |
| 119 | GND | - | 120 | GND | - |
| 121 | PEGC04-P1N | I | 122 | PECG04-P1N | O |

Table C-24 GFX board interface connector (230-pin) (3/4)

| PIN No. | Signal name | I/O | PIN No. | Signal name | I/O |
|---------|--------------|-----|---------|-------------|-----|
| 123 | PEGC04-P1P | I | 124 | PECG04-P1P | O |
| 125 | GND | - | 126 | GND | - |
| 127 | PEGC03-P1N | I | 128 | PECG03-P1N | O |
| 129 | PEGC03-P1P | | 130 | PECG03-P1P | O |
| 131 | GND | - | 132 | GND | - |
| 133 | PEGC02-P1N | I | 134 | PECG02-P1N | O |
| 135 | PEGC02-P1P | I | 136 | PECG02-P1P | O |
| 137 | GND | - | 138 | GND | - |
| 139 | PEGC01-P1N | I | 140 | PECG01-P1N | O |
| 141 | PEGC01-P1P | I | 142 | PECG01-P1P | O |
| 143 | GND | - | 144 | GND | |
| 145 | PEGC00-P1N | I | 146 | PECG00-P1N | O |
| 147 | PEGC00-P1P | I | 148 | PECG00-P1P | O |
| 149 | GND | - | 150 | GND | |
| 151 | XPEPEG-P3N | O | 152 | SYSRED-PXP | I |
| 153 | XPEPEG-P3P | O | 154 | A-GND | - |
| 155 | GND | | 156 | SYSGRN-PXP | I |
| 157 | RSTVGA-P3N | | 158 | A-GND | - |
| 159 | (PDNVGA-P3N) | - | 160 | SYSBLU-PXP | I |
| 161 | DVIDET-S3N | I | 162 | A-GND | - |
| 163 | GND | | 164 | AHSYNC-P3P | I/O |
| 165 | GND | | 166 | AVSYNC-P3P | I/O |
| 167 | DVITX0-P3P | I | 168 | A-GND | - |
| 169 | DVITX0-P3N | I | 170 | CHROMA-PYP | O |
| 171 | GND | | 172 | A-GND | - |
| 173 | DVITX1-P3P | I | 174 | LUMINA-PYP | O |
| 175 | DVITX1-P3N | I | 176 | A-GND | - |
| 177 | GND | - | 178 | (NVBBLU) | - |
| 179 | DVITX2-P3P | I | 180 | GND | - |

Table C-24 GFX board interface connector (230-pin) (4/4)

| PIN No. | Signal name | I/O | PIN No. | Signal name | I/O |
|---------|---------------|-----|---------|-------------|-----|
| 181 | DVATX2-P3N | I | 182 | TSDA-P3P | I/O |
| 183 | GND | | 184 | TSCL-P3P | I/O |
| 185 | DVITXC-P3P | - | 186 | GALERT-P3N | I |
| 187 | DVACK-P3N | - | 188 | GTHERM-P3N | I |
| 189 | GND | | 190 | GPUHOT-S5N | O |
| 191 | NVASCL-P3P | I/O | 192 | GND | - |
| 193 | NVASDA-P3P | I/O | 194 | (SVSCL) | - |
| 195 | NVBSCCL-P3P | | 196 | (SVSDA) | - |
| 197 | NVBSDA-P3P | | 198 | (SVRST) | - |
| 199 | (NVCSCCL-P3P) | - | 200 | (VDMDD) | - |
| 201 | (NVCSDA-P3P) | - | 202 | (SVRXPDP) | - |
| 203 | GND | - | 204 | (SVTXPD) | - |
| 205 | LCDVEN-P3P | I | 206 | A-GND | - |
| 207 | FLVEN-P3P | I | 208 | CDKRED-PXP | O |
| 209 | GND | | 210 | A-GND | - |
| 211 | GPON-E3P | O | 212 | CDKGRN-PXP | O |
| 213 | VG1R8-P1V | I | 214 | A-GND | - |
| 215 | PVON-S5P | I | 216 | CDKBLU-PXP | O |
| 217 | 10-EAV | - | 218 | P3V | - |
| 219 | CHSYNC-P3P | O | 220 | P3V | - |
| 221 | E5V | - | 222 | P3V | - |
| 223 | CVSYNC-P3P | I | 224 | P3V | - |
| 225 | M5V | - | 226 | P3V | - |
| 227 | DPCONF-P5P | I | 228 | P3V | - |
| 229 | P5V | - | 230 | P3V | - |

C.25 CN6050 Internal microphone connector (2-pin)*Table C-25 Internal microphone connector (2-pin)*

| Pin No. | Signal Name | I/O | Pin No. | Signal Name | I/O |
|---------|-------------|-----|---------|-------------|-----|
| 1 | MICIN | I | 2 | A-GND | - |

C.26 J6051 External microphone connector (5-pin)*Table C-26 External microphone connector (5-pin)*

| Pin No. | Signal Name | I/O | Pin No. | Signal Name | I/O |
|---------|-------------|-----|---------|-------------|-----|
| 1 | A-GND | - | 2 | MICIN | I |
| 3 | VREF1 | - | 4 | (MICIN) | I |
| 5 | NC | - | | | |

C.27 CN6170 Speaker connector (4-pin)*Table C-27 Speaker connector (4-pin)*

| Pin No. | Signal Name | I/O | Pin No. | Signal Name | I/O |
|---------|-------------|-----|---------|-------------|-----|
| 1 | SPOTL-PXN | O | 2 | SPOTL-PXP | O |
| 3 | SPOTR-PXP | - | 4 | SPOTR-PXN | O |

C.28 J6310 Headphone connector (5-pin)*Table C-28 Headphone connector (5-pin)*

| Pin No. | Signal Name | I/O | Pin No. | Signal Name | I/O |
|---------|-------------|-----|---------|-------------|-----|
| 1 | A-GND | - | 2 | HEADL-PXP | O |
| 3 | HEADR-PXP | O | 4 | NC | - |
| 5 | (SPKEN) | O | | | |

C.29 CN8800 DC-IN connector (4-pin)*Table C-29 DC-IN connector (4-pin)*

| Pin No. | Signal Name | I/O | Pin No. | Signal Name | I/O |
|---------|-------------|-----|---------|-------------|-----|
| 1 | ADPDC | O | 2 | ADPDC | O |
| 3 | GND | - | 4 | GND | - |

C.30 CN8020 Main Battery connector (10-pin)*Table C-30 Main Battery connector (10-pin)*

| Pin No. | Signal Name | I/O | Pin No. | Signal Name | I/O |
|---------|-------------|-----|---------|-------------|-----|
| 1 | PVBL1 | - | 2 | BTMP1 | I |
| 3 | (DCHG) | - | 4 | M5V | - |
| 5 | PSCL-S5P | I/O | 6 | PSDA-S5P | I/O |
| 7 | GND | - | 8 | DBT10V-S5N | O |
| 9 | GND | - | 10 | GND | - |

C.31 CN9990 RTC Battery connector (3-pin)*Table C-31 RTC Battery connector (3-pin)*

| Pin No. | Signal Name | I/O | Pin No. | Signal Name | I/O |
|---------|-------------|-----|---------|-------------|-----|
| 1 | ZS-PWCHKF | O | 2 | NC | - |
| 3 | GND | - | | | |
| 1T | GND | - | 2T | GND | - |

C.32 CN8770 FAN connector (3-pin)*Table C-32 FAN connector (3-pin)*

| Pin No. | Signal Name | I/O | Pin No. | Signal Name | I/O |
|---------|-------------|-----|---------|-------------|-----|
| 1 | (P5V) | O | 2 | GND | - |
| 3 | FANG-P3P | I | | | |

C.33 CN9700 FS board interface connector (8-pin)*Table C-33 FS board interface connector (8-pin)*

| Pin No. | Signal Name | I/O | Pin No. | Signal Name | I/O |
|---------|-------------|-----|---------|-------------|-----|
| 1 | GND | - | 2 | USBP0-E5P | I/O |
| 3 | USBP0-E3N | I/O | 4 | GND | - |
| 5 | FGSPON-S3N | - | 6 | P3V | - |
| 7 | NC | - | 8 | NC | - |
| 1T | GND | - | 2T | GND | - |

FDRSR Board

C.34 CN9510 System board interface connector (20-pin)

Table C-34 System board interface connector (20-pin)

| Pin No. | Signal Name | I/O | Pin No. | Signal Name | I/O |
|---------|-------------|-----|---------|-------------|-----|
| 1 | USB1PS-E5V | I | 2 | USB1PS-E5V | I |
| 3 | USB1PS-E5V | I/O | 4 | USBP6-E3P | I/O |
| 5 | GND | - | 6 | E5V | - |
| 7 | NC | - | 8 | NC | - |
| 9 | NC | - | 10 | GND | - |
| 11 | DCD1:110 | I | 12 | RD1:010 | I |
| 13 | SD1:O10 | O | 14 | DTR1:110 | O |
| 15 | GND | - | 16 | DSR1:110 | I |
| 17 | RTS1:110 | O | 18 | CTS1:110 | I |
| 19 | RT1:110 | I | 20 | GND | - |
| 1T | GND | - | 2T | GND | - |

C.35 CN4630 USB6 connector (4-pin)

Table C-35 USB6 connector (4-pin)

| Pin No. | Signal Name | I/O | Pin No. | Signal Name | I/O |
|---------|-------------|-----|---------|-------------|-----|
| 1 | USB1PS-E5V | I | 2 | USBP6-E3N | I/O |
| 3 | USBP6-E3P | I/O | 4 | GND | - |
| 1T | GND | - | 2T | GND | - |
| 3T | GND | - | | | |

C.36 CN3420 Serial port (9-pin)

Table C-36 Serial port (9-pin)

| Pin No. | Signal Name | I/O | Pin No. | Signal Name | I/O |
|---------|-------------|-----|---------|-------------|-----|
| 1 | DCD1:110 | I | 2 | RD1:010 | I |
| 3 | SD1:O10 | O | 4 | DTR1:110 | O |
| 5 | GND | - | 6 | DSR1:110 | I |
| 7 | RTS1:110 | O | 8 | CTS1:110 | I |
| 9 | RT1:110 | I | | | |
| 1T | GND | - | 2T | GND | - |

FDRFS Board**C.37 CN950 System board interface connector (8-pin)***Table C-37 System board interface connector (8-pin)*

| Pin No. | Signal Name | I/O | Pin No. | Signal Name | I/O |
|---------|-------------|-----|---------|-------------|-----|
| 1 | NC | - | 2 | NC | - |
| 3 | P3V | - | 4 | FGSPON-S3N | I |
| 5 | GND | - | 6 | USBFS-E3N | I/O |
| 7 | USBFS-E3P | I/O | 8 | GND | - |
| 1T | GND | - | 2T | GND | - |

FDRVG Board**C.38 CN5901 System board interface connector (230-pin)***Table C-38 System board interface connector (230-pin)(1/4)*

| PIN No. | Signal name | I/O | PIN No. | Signal name | I/O |
|---------|--------------|-----|---------|--------------|-----|
| 1 | PVT-EFV | - | 2 | 1R5-P1V | - |
| 3 | PVT-EFV | - | 4 | 1R5-P1V | - |
| 5 | PVT-EFV | - | 6 | 1R5-P1V | - |
| 7 | PVT-EFV | - | 8 | 1R5-P1V | - |
| 9 | PVT-EFV | - | 10 | 1R5-P1V | - |
| 11 | PVT-EFV | - | 12 | 1R5-P1V | - |
| 13 | PVT-EFV | - | 14 | (L1INE1-PXP) | - |
| 15 | PVT-EFV | - | 16 | GND | - |
| 17 | N.C. | - | 18 | GND | - |
| 19 | (L1INE2-PXP) | - | 20 | GND | - |
| 21 | (L1INE3-PXP) | - | 22 | GND | - |
| 23 | PGN | - | 24 | GND | - |
| 25 | GND | - | 26 | GND | - |
| 27 | TXCK1-P3N | O | 28 | TXCK0-P3N | O |
| 29 | TXCK1-P3P | O | 30 | TXCK0-P3P | O |
| 31 | GND | - | 32 | GND | - |
| 33 | TXDT4-P3N | O | 34 | TXDT0-P3P | O |
| 35 | TXDT4-P3P | O | 36 | TXDT0-P3N | O |
| 37 | TXDT5-P3N | O | 38 | TXDT1-P3P | O |
| 39 | TXDT5-P3P | O | 40 | TXDT1-P3N | O |
| 41 | GND | - | 42 | GND | - |
| 43 | TXDT6-P3N | O | 44 | TXDT2-P3P | O |
| 45 | TXDT6-P3P | O | 46 | TXDT2-P3N | O |
| 47 | (TXDT7-P3N) | - | 48 | (TXDT3-P3P) | - |
| 49 | (TXDT7-P3P) | - | 50 | (TXDT3-P3N) | - |
| 51 | GND | - | 52 | GND | - |
| 53 | GND | - | 54 | GND | - |
| 55 | PEGC15-P1N | O | 56 | PEGC15-P1N | I |
| 57 | PEGC15-P1P | O | 58 | PEGC15-P1P | I |

Table C-38 System board interface connector (230-pin)(2/4)

| PIN No. | Signal name | I/O | PIN No. | Signal name | I/O |
|---------|-------------|-----|---------|-------------|-----|
| 59 | GND | - | 60 | GND | |
| 61 | PEGC14-P1N | O | 62 | PECG14-P1N | I |
| 63 | PEGC14-P1P | O | 64 | PECG14-P1P | I |
| 65 | GND | - | 66 | GND | - |
| 67 | PEGC13-P1N | O | 68 | PECG13-P1N | I |
| 69 | PEGC13-P1P | O | 70 | PECG13-P1P | I |
| 71 | GND | - | 72 | GND | - |
| 73 | PEGC12-P1N | O | 74 | PECG12-P1N | I |
| 75 | PEGC12-P1P | O | 76 | PECG12-P1P | I |
| 77 | GND | - | 78 | GND | - |
| 79 | PEGC11-P1N | O | 80 | PECG11-P1N | I |
| 81 | PEGC11-P1P | O | 82 | PECG11-P1P | I |
| 83 | GND | - | 84 | GND | - |
| 85 | PEGC10-P1N | O | 86 | PECG10-P1N | I |
| 87 | PEGC10-P1P | O | 88 | PECG10-P1P | I |
| 89 | GND | - | 90 | GND | - |
| 91 | PEGC09-P1N | O | 92 | PECG09-P1N | I |
| 93 | PEGC09-P1P | O | 94 | PECG09-P1P | I |
| 95 | GND | - | 96 | GND | - |
| 97 | PEGC08-P1N | O | 98 | PECG08-P1N | I |
| 99 | PEGC08-P1P | O | 100 | PECG08-P1P | I |
| 101 | GND | - | 102 | GND | - |
| 103 | PEGC07-P1N | O | 104 | PECG07-P1N | I |
| 105 | PEGC07-P1P | O | 106 | PECG07-P1P | I |
| 107 | GND | - | 108 | GND | - |
| 109 | PEGC06-P1N | O | 110 | PECG06-P1N | I |
| 111 | PEGC06-P1P | O | 112 | PECG06-P1P | I |
| 113 | GND | - | 114 | GND | - |
| 115 | PEGC05-P1N | O | 116 | PECG05-P1N | I |
| 117 | PEGC05-P1P | O | 118 | PECG05-P1P | I |
| 119 | GND | - | 120 | GND | - |
| 121 | PEGC04-P1N | O | 122 | PECG04-P1N | I |

Table C-38 System board interface connector (230-pin) (3/4)

| PIN No. | Signal name | I/O | PIN No. | Signal name | I/O |
|---------|--------------|-----|---------|-------------|-----|
| 123 | PEGC04-P1P | O | 124 | PECG04-P1P | I |
| 125 | GND | - | 126 | GND | - |
| 127 | PEGC03-P1N | O | 128 | PECG03-P1N | I |
| 129 | PEGC03-P1P | | 130 | PECG03-P1P | I |
| 131 | GND | - | 132 | GND | - |
| 133 | PEGC02-P1N | O | 134 | PECG02-P1N | I |
| 135 | PEGC02-P1P | O | 136 | PECG02-P1P | I |
| 137 | GND | - | 138 | GND | - |
| 139 | PEGC01-P1N | O | 140 | PECG01-P1N | I |
| 141 | PEGC01-P1P | O | 142 | PECG01-P1P | I |
| 143 | GND | - | 144 | GND | |
| 145 | PEGC00-P1N | O | 146 | PECG00-P1N | I |
| 147 | PEGC00-P1P | O | 148 | PECG00-P1P | I |
| 149 | GND | - | 150 | GND | |
| 151 | XPEPEG-P3N | I | 152 | SYSRED-PXP | O |
| 153 | XPEPEG-P3P | I | 154 | A-GND | - |
| 155 | GND | | 156 | SYSGRN-PXP | O |
| 157 | RSTVGA-P3N | | 158 | A-GND | - |
| 159 | (PDNVGA-P3N) | - | 160 | SYSBLU-PXP | O |
| 161 | DVIDET-S3N | O | 162 | A-GND | - |
| 163 | GND | | 164 | AHSYNC-P3P | I/O |
| 165 | GND | | 166 | AVSYNC-P3P | I/O |
| 167 | DVITX0-P3P | O | 168 | A-GND | - |
| 169 | DVITX0-P3N | O | 170 | CHROMA-PYP | I |
| 171 | GND | | 172 | A-GND | - |
| 173 | DVITX1-P3P | O | 174 | LUMINA-PYP | I |
| 175 | DVITX1-P3N | O | 176 | A-GND | - |
| 177 | GND | - | 178 | (NVBBLU) | - |
| 179 | DVITX2-P3P | O | 180 | GND | - |

Table C-38 System board interface connector (230-pin) (4/4)

| PIN No. | Signal name | I/O | PIN No. | Signal name | I/O |
|---------|---------------|-----|---------|-------------|-----|
| 181 | DVATX2-P3N | O | 182 | TSDA-P3P | I/O |
| 183 | GND | - | 184 | TSCL-P3P | I/O |
| 185 | DVITXC-P3P | - | 186 | GALERT-P3N | O |
| 187 | DVACK-P3N | - | 188 | G THERM-P3N | O |
| 189 | GND | - | 190 | GPUHOT-S5N | I |
| 191 | NVASCL-P3P | I/O | 192 | GND | - |
| 193 | NVASDA-P3P | I/O | 194 | (SVSCL) | - |
| 195 | NVB SCL-P3P | - | 196 | (SVSDA) | - |
| 197 | NVBSDA-P3P | - | 198 | (SVRST) | - |
| 199 | (NVC SCL-P3P) | - | 200 | (VDMDD) | - |
| 201 | (NVCSDA-P3P) | - | 202 | (SVRXP D) | - |
| 203 | GND | - | 204 | (SVTXPD) | - |
| 205 | LCDVEN-P3P | O | 206 | A-GND | - |
| 207 | FLVEN-P3P | O | 208 | CDKRED-PXP | I |
| 209 | GND | - | 210 | A-GND | - |
| 211 | GPON-E3P | I | 212 | CDKGRN-PXP | I |
| 213 | VG1R8-P1V | O | 214 | A-GND | - |
| 215 | PVON-S5P | O | 216 | CDKBLU-PXP | I |
| 217 | 10-EAV | - | 218 | P3V | - |
| 219 | CHSYNC-P3P | O | 220 | P3V | - |
| 221 | E5V | - | 222 | P3V | - |
| 223 | CVSYNC-P3P | O | 224 | P3V | - |
| 225 | M5V | - | 226 | P3V | - |
| 227 | DPCONF-P5P | O | 228 | P3V | - |
| 229 | P5V | - | 230 | P3V | - |

FDRUS Board**C.39 CN4622 System board interface connector (12-pin)***Table C-39 System board interface connector (12-pin)*

| Pin No. | Signal Name | I/O | Pin No. | Signal Name | I/O |
|---------|-------------|-----|---------|-------------|-----|
| 1 | GND | - | 2 | GND | - |
| 3 | D- (Port 3) | I/O | 4 | D+ (Port 3) | I/O |
| 5 | USB Power | - | 6 | USB Power | - |
| 7 | D- (Port 4) | I/O | 8 | D+ (Port 4) | I/O |
| 9 | GND | - | 10 | GND | - |
| 11 | NC | - | 12 | NC | - |

C.40 CN4620 USB Port 3 connector (4-pin)*Table C-40 USB Port 3 connector (4-pin)*

| Pin No. | Signal Name | I/O | Pin No. | Signal Name | I/O |
|---------|-------------|-----|---------|-------------|-----|
| 1 | USB Power | - | 2 | D- | I/O |
| 3 | D+ | I/O | 4 | GND | - |
| 1T | GND | - | 2T | GND | - |
| 3T | NC | - | - | - | - |

C.41 CN4622 USB Port 4 connector (4-pin)*Table C-41 USB Port 4 connector (4-pin)*

| Pin No. | Signal Name | I/O | Pin No. | Signal Name | I/O |
|---------|-------------|-----|---------|-------------|-----|
| 1 | USB Power | - | 2 | D- | I/O |
| 3 | D+ | I/O | 4 | GND | - |
| 1T | GND | - | 2T | GND | - |
| 3T | NC | - | - | - | - |

Appendix D Keyboard Scan/Character Codes

Table D-1 Scan codes (set 1 and set 2) (1/4)

| Cap No. | Keytop | Code set 1 | | Code set 2 | | Note | |
|---------|--------|------------|-------|------------|-------|------|----|
| | | Make | Break | Make | Break | | |
| 01 | ' ~ | 29 | A9 | 0E | F0 | 0E | |
| 02 | 1 ! | 02 | 82 | 16 | F0 | 16 | |
| 03 | 2 @ | 03 | 83 | 1E | F0 | 1E | |
| 04 | 3 # | 04 | 84 | 26 | F0 | 26 | |
| 05 | 4 \$ | 05 | 85 | 25 | F0 | 25 | |
| 06 | 5 % | 06 | 86 | 2E | F0 | 2E | |
| 07 | 6 ^ | 07 | 87 | 36 | F0 | 36 | |
| 08 | 7 & | 08 | 88 | 3D | F0 | 3D | *2 |
| 09 | 8 * | 09 | 89 | 3E | F0 | 3E | *2 |
| 10 | 9 (| 0A | 8A | 46 | F0 | 46 | *2 |
| 11 | 0) | 0B | 8B | 45 | F0 | 45 | |
| 12 | - _ | 0C | 8C | 4E | F0 | 4E | |
| 13 | = + | 0D | 8D | 55 | F0 | 55 | |
| 15 | BkSp | 0E | 8E | 66 | F0 | 66 | |
| 16 | Tab | 0F | 8F | 0D | F0 | 0D | |
| 17 | Q | 10 | 90 | 15 | F0 | 15 | |
| 18 | W | 11 | 91 | 1D | F0 | 1D | |
| 19 | E | 12 | 92 | 24 | F0 | 24 | |
| 20 | R | 13 | 93 | 2D | F0 | 2D | |
| 21 | T | 14 | 94 | 2C | F0 | 2C | |
| 22 | Y | 15 | 95 | 35 | F0 | 35 | |
| 23 | U | 16 | 96 | 3C | F0 | 3C | *2 |
| 24 | I | 17 | 97 | 43 | F0 | 43 | *2 |
| 25 | O | 13 | 98 | 44 | F0 | 44 | *2 |
| 26 | P | 19 | 99 | 4D | F0 | 4D | *2 |
| 27 | [{ | 1A | 9A | 54 | F0 | 54 | |
| 28 |] } | 1B | 9B | 5B | F0 | 5B | |

Table D-1 Scan codes (set 1 and set 2) (2/4)

| Cap No. | Keytop | Code set 1 | | Code set 2 | | Note |
|---------|------------|------------|-------|------------|-------|------|
| | | Make | Break | Make | Break | |
| 29(42) | \ | 2B | AB | 5D | F0 5D | *5 |
| 30 | Caps Lock | 3A | BA | 58 | F0 58 | |
| 31 | A | 1E | 9E | 1C | F0 1C | |
| 32 | S | 1F | 9F | 1B | F0 1B | |
| 33 | D | 20 | A0 | 23 | F0 23 | |
| 34 | F | 21 | A1 | 2B | F0 2B | |
| 35 | G | 22 | A2 | 34 | F0 34 | |
| 36 | H | 23 | A3 | 33 | F0 33 | |
| 37 | J | 24 | A4 | 3B | F0 3B | *2 |
| 38 | K | 25 | A5 | 42 | F0 42 | *2 |
| 39 | L | 26 | A6 | 4B | F0 4B | *2 |
| 40 | ; : | 27 | A7 | 4C | F0 4C | *2 |
| 41 | ' " | 28 | A8 | 52 | F0 52 | |
| 43 | Enter | 1C | 9C | 5A | F0 5A | *3 |
| 44 | Shift (L) | 2A | AA | 12 | F0 12 | |
| 45 | No.102 key | 56 | D6 | 61 | F0 61 | |
| 46 | Z | 2C | AC | 1A | F0 1A | |
| 47 | X | 2D | AD | 22 | F0 22 | |
| 48 | C | 2E | AE | 21 | F0 21 | |
| 49 | V | 2F | AF | 2A | F0 2A | |
| 50 | B | 30 | B0 | 32 | F0 32 | |
| 51 | N | 31 | B1 | 31 | F0 31 | |
| 52 | M | 32 | B2 | 3A | F0 3A | *2 |
| 53 | , < | 33 | B3 | 41 | F0 41 | |
| 54 | . > | 34 | B4 | 49 | F0 49 | *2 |
| 55 | / ? | 35 | B5 | 4A | F0 4A | *2 |
| 57 | Shift (R) | 36 | B6 | 59 | F0 59 | |

Table D-1 Scan codes (set 1 and set 2) (3/4)

| Cap No. | Keytop | Code set 1 | | | | Code set 2 | | | Note |
|---------|---------|------------|-------|-------|-------|------------|----|-------|-------|
| | | Make | | Break | | Make | | Break | |
| 58 | Ctrl | 1D | | 9D | | 14 | F0 | 14 | *3 |
| 60 | Alt (L) | 38 | | B8 | | 11 | F0 | 11 | *3 |
| 61 | Space | 39 | | B9 | | 29 | F0 | 29 | |
| 62 | ALT (R) | E0 38 | E0 B8 | E0 11 | E0 F0 | 11 | | | |
| 75 | Ins | E0 52 | E0 D2 | E0 70 | E0 F0 | 70 | | | *1 |
| 76 | Del | E0 53 | E0 D3 | E0 71 | E0 F0 | 71 | | | *1 |
| 79 | ← | E0 4B | E0 CB | E0 6B | E0 F0 | 6B | | | *1 |
| 80 | Home | E0 47 | E0 C7 | E0 6C | E0 F0 | 6C | | | *1 *9 |
| 81 | End | E0 4F | E0 CF | E0 69 | E0 F0 | 69 | | | *1 *9 |
| 83 | ↑ | E0 48 | E0 C8 | E0 75 | E0 F0 | 75 | | | *1 |
| 84 | ↓ | E0 50 | E0 D0 | E0 72 | E0 F0 | 72 | | | *1 |
| 85 | PgUp | E0 49 | E0 C9 | E0 7D | E0 F0 | 7D | | | *1 |
| 86 | PgDn | E0 51 | E0 D1 | E0 7A | E0 F0 | 7A | | | *1 |
| 89 | → | E0 4D | E0 CD | E0 74 | E0 F0 | 74 | | | *1 |
| 110 | Esc | 01 | 81 | 76 | F0 | 76 | | | |
| 112 | F1 | 3B | BB | 05 | F0 | 05 | | | |
| 113 | F2 | 3C | BC | 06 | F0 | 06 | | | |
| 114 | F3 | 3D | BD | 04 | F0 | 04 | | | |
| 115 | F4 | 3E | BE | 0C | F0 | 0C | | | |
| 116 | F5 | 3F | BF | 03 | F0 | 03 | | | |
| 117 | F6 | 40 | C0 | 0B | F0 | 0B | | | |
| 118 | F7 | 41 | C1 | 83 | F0 | 83 | | | |
| 119 | F8 | 42 | C2 | 0A | F0 | 0A | | | |
| 120 | F9 | 43 | C3 | 01 | F0 | 01 | | | |
| 121 | F10 | 44 | C4 | 09 | F0 | 09 | | | *3 |

Table D-1 Scan codes (set 1 and set 2) (4/4)

| Cap No. | Keytop | Code set 1 | | | | Code set 2 | | | | Note | |
|---------|---------|------------|----|-------|----|------------|----|-------|-------|------|----|
| | | Make | | Break | | Make | | Break | | | |
| 122 | F11 | 57 | D7 | 78 | F0 | 78 | | | *3 | | |
| 123 | F12 | 58 | D8 | 07 | F0 | 07 | | | *3 | | |
| 124 | PrintSc | *6 | *6 | *6 | *6 | | | | *6 | | |
| 126 | Pause | *7 | *7 | *7 | *7 | | | | *7 *8 | | |
| 202 | Fn | — | — | — | — | | | | *4 | | |
| 203 | Win | E0 | 5B | E0 | DB | E0 | 1F | E0 | F0 | 1F | *1 |
| 204 | App | E0 | 5D | E0 | DD | E0 | 2F | E0 | F0 | 2F | *1 |

Notes:

- *1: Scan codes differ by mode.
- *2: Scan codes differ by overlay function.
- *3: Combined with the **Fn** key makes different codes.
- *4: **Fn** key does not generate a code by itself.
- *5: This key corresponds to key No. 42 in a 102-key model.
- *6: Refer to Table D-6, No. 124 key scan code.
- *7: Refer to Table D-7, No. 126 key scan code.
- *8: This key is not in the B5 arrangement.
- *9: The scan code of this key varies in the combination with Fn key in the B5 arrangement.

Table D-2 Scan codes with left Shift key

| Cap No. | Key top | Code set 1 | | Code set 2 | |
|---------|---------|-------------|-------------|----------------|----------------|
| | | Make | Break | Make | Break |
| 55 | / | E0 AA E0 35 | E0 B5 E0 2A | E0 F0 12 E0 4A | E0 F0 4A E0 12 |
| 75 | INS | E0 AA E0 52 | E0 D2 E0 2A | E0 F0 12 E0 70 | E0 F0 70 E0 12 |
| 76 | DEL | E0 AA E0 53 | E0 D3 E0 2A | E0 F0 12 E0 71 | E0 F0 71 E0 12 |
| 79 | ← | E0 AA E0 4B | E0 CB E0 2A | E0 F0 12 E0 6B | E0 F0 6B E0 12 |
| 80 | Home | E0 AA E0 47 | E0 C7 E0 2A | E0 F0 12 E0 6C | E0 F0 6C E0 12 |
| 81 | End | E0 AA E0 4F | E0 CF E0 2A | E0 F0 12 E0 69 | E0 F0 69 E0 12 |
| 83 | ↑ | E0 AA E0 48 | E0 C8 E0 2A | E0 F0 12 E0 75 | E0 F0 75 E0 12 |
| 84 | ↓ | E0 AA E0 50 | E0 D0 E0 2A | E0 F0 12 E0 72 | E0 F0 72 E0 12 |
| 85 | PgUp | E0 AA E0 49 | E0 C9 E0 2A | E0 F0 12 E0 7D | E0 F0 7D E0 12 |
| 86 | PgDn | E0 AA E0 51 | E0 D1 E0 2A | E0 F0 12 E0 7A | E0 F0 7A E0 12 |
| 89 | → | E0 AA E0 4D | E0 CD E0 2A | E0 F0 12 E0 74 | E0 F0 74 E0 12 |
| 203 | Win | E0 AA E0 5B | E0 DB E0 2A | E0 F0 12 E0 1F | E0 F0 1F E0 12 |
| 204 | App | E0 AA E0 5D | E0 DD E0 2A | E0 F0 12 E0 2F | E0 F0 2F E0 12 |

Note: The table above shows scan codes with the left **Shift** key. In combination with the right **Shift** key, scan codes are changed as listed below.

| | With left Shift | With right Shift |
|-------|------------------------|-------------------------|
| Set 1 | E0 AA _____ | E0 B6 _____ |
| | E0 2A _____ | E0 36 _____ |
| Set 2 | E0 F0 12 _____ | E0 F0 59 _____ |
| | E0 12 _____ | E0 59 _____ |

No. 55 key: only in the overlay mode (including a temporary overlay mode)

Table D-3 Scan codes in Numlock mode

| Cap No. | Key top | Code set 1 | | | | Code set 2 | | | |
|---------|---------|------------|-------|-------|-------|------------|-------|-------|-------|
| | | Make | | Break | | Make | | Break | |
| 75 | INS | E0 2A | E0 52 | E0 D2 | E0 AA | E0 12 | E0 70 | E0 F0 | E0 12 |
| 76 | DEL | E0 2A | E0 53 | E0 D3 | E0 AA | E0 12 | E0 71 | E0 F0 | E0 12 |
| 79 | ← | E0 2A | E0 4B | E0 CB | E0 AA | E0 12 | E0 6B | E0 F0 | E0 12 |
| 80 | Home | E0 2A | E0 47 | E0 C7 | E0 AA | E0 12 | E0 6C | E0 F0 | E0 12 |
| 81 | End | E0 2A | E0 4F | E0 CF | E0 AA | E0 12 | E0 69 | E0 F0 | E0 12 |
| 83 | ↑ | E0 2A | E0 48 | E0 C8 | E0 AA | E0 12 | E0 75 | E0 F0 | E0 12 |
| 84 | ↓ | E0 2A | E0 50 | E0 D0 | E0 AA | E0 12 | E0 72 | E0 F0 | E0 12 |
| 85 | PgUp | E0 2A | E0 49 | E0 C9 | E0 AA | E0 12 | E0 7D | E0 F0 | E0 12 |
| 86 | PgDn | E0 2A | E0 51 | E0 D1 | E0 AA | E0 12 | E0 7A | E0 F0 | E0 12 |
| 89 | → | E0 2A | E0 4D | E0 CD | E0 AA | E0 12 | E0 74 | E0 F0 | E0 12 |
| 203 | Win | E0 2A | E0 5B | E0 DB | E0 AA | E0 12 | E0 1F | E0 F0 | E0 12 |
| 204 | App | E0 2A | E0 5D | E0 DD | E0 AA | E0 12 | E0 2F | E0 F0 | E0 12 |

Table D-4 Scan codes with Fn key

| Cap No. | Key top | Code set 1 | | Code set 2 | |
|---------|---------|------------|-------|------------|----------|
| | | Make | Break | Make | Break |
| 43 | ENT | E0 1C | E0 9C | E0 5A | E0 F0 5A |
| 58 | CTRL | E0 1D | E0 9D | E0 14 | E0 F0 14 |
| 60 | LALT | E0 38 | E0 B8 | E0 11 | E0 F0 11 |
| 121 | ARROW | 45 | C5 | 77 | F0 77 |
| 122 | NUMERIC | 45 | C5 | 77 | F0 77 |
| 123 | Scrl | 46 | C5 | 7E | F0 7E |

Note: No. 121key and No. 122 key generate a scan code when the NUMLOCK flag changes.

Table D-5 Scan codes in overlay mode

| Cap No. | Keytop | Code set 1 | | Code set 2 | |
|---------|--------|------------|-------|------------|----------|
| | | Make | Break | Make | Break |
| 09 | 8 (8) | 48 | C8 | 75 | F0 75 |
| 10 | 9 (9) | 49 | C9 | 7D | F0 7D |
| 11 | 0 (*) | 37 | B7 | 7C | F0 7C |
| 23 | U (4) | 4B | CB | 6B | F0 6B |
| 24 | I (5) | 4C | CC | 73 | F0 73 |
| 25 | O (6) | 4D | CD | 74 | F0 74 |
| 26 | P (-) | 4A | CA | 7B | F0 7B |
| 37 | J (1) | 4F | CF | 69 | F0 69 |
| 38 | K (2) | 50 | D0 | 72 | F0 72 |
| 39 | L (3) | 51 | D1 | 7A | F0 7A |
| 40 | ; (+) | 4E | CE | 79 | F0 79 |
| 52 | M (0) | 52 | D2 | 70 | F0 70 |
| 54 | . (.) | 53 | D3 | 71 | F0 71 |
| 55 | / (/) | E0 35 | E0 B5 | 40 4A | E0 F0 4A |

Note: The scan code of No. 55 key changes in Shift.

Table D-6 No.124 key scan code

| Key top | Shift | Code set 1 | | | | Code set 2 | | | |
|---------|---------|------------|-------|-------|-------|------------|-------|----------|----------|
| | | Make | | Break | | Make | | Break | |
| Prt Sc | Common | E0 2A | E0 37 | E0 B7 | E0 AA | E0 12 | E0 7C | E0 F0 7C | E0 F0 12 |
| | Ctrl + | E0 37 | | E0 B7 | | E0 7C | | E0 F0 7C | |
| | Shift + | E0 37 | | E0 B7 | | E0 7C | | E0 F0 7C | |
| | Alt + | 54 | | D4 | | 84 | | F0 B4 | |

Table D-7 No.126 key scan code

| Key top | Shift | Code set 1 | | | | | | Code set 2 | | | | | | | |
|---------|----------|------------|----|----|----|----|----|------------|----|----|----|----|----|----|----|
| | | Make | | | | | | Make | | | | | | | |
| Pause | Common * | E1 | 1D | 45 | E1 | 9D | C5 | E1 | 14 | 77 | E1 | F0 | 14 | F0 | 77 |
| | Ctrl* | E0 | 46 | E0 | C6 | | | E0 | 7E | E0 | F0 | 7E | | | |

*: This key generates only make codes.

Appendix E Key Layout

E.1 United Kingdom (UK) Keyboard

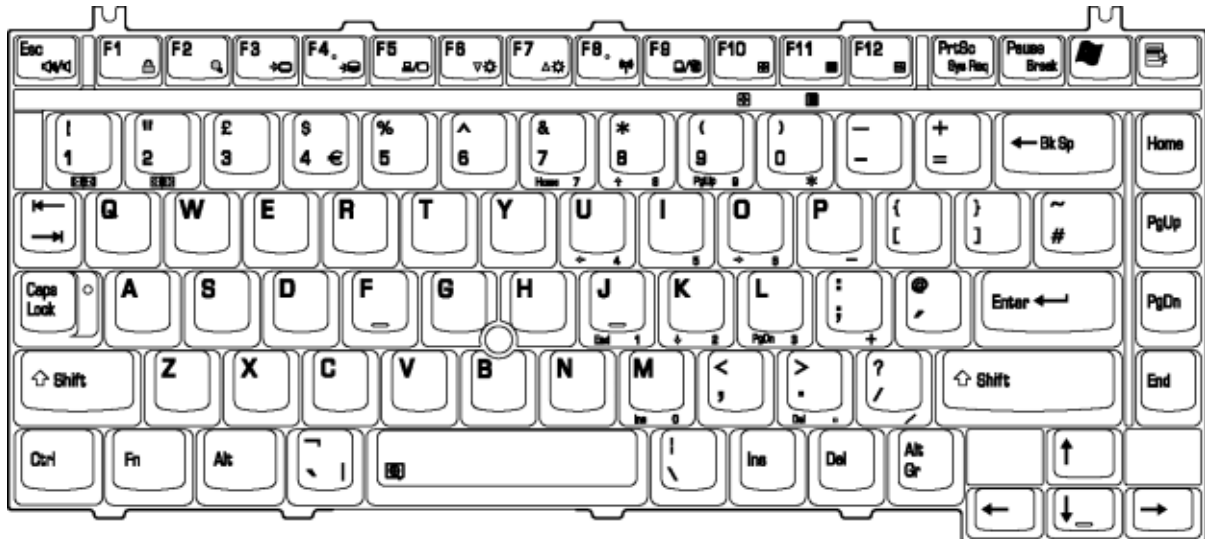

Figure E-1 UK keyboard

E.2 United States (US) Keyboard

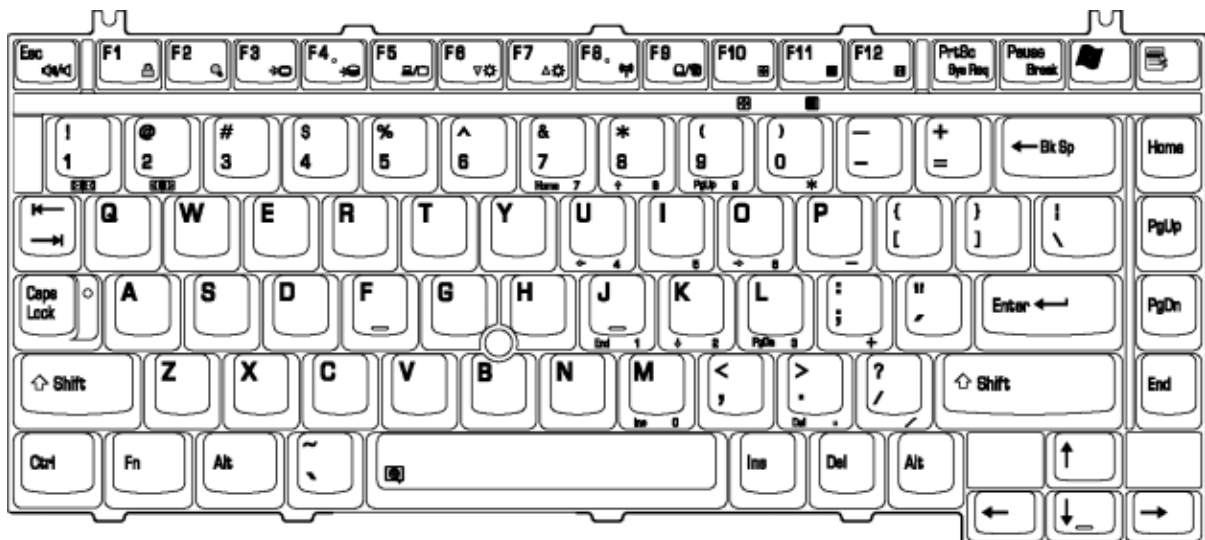

Figure E-2 US keyboard

Appendix F Wiring diagrams

F.1 LAN Loopback Connector

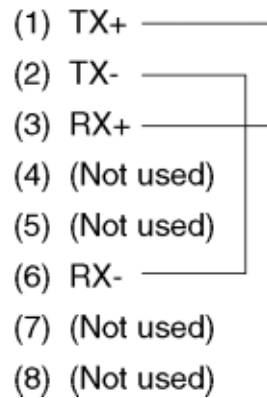

Figure F-1 LAN loopback connector

F.2 Printer Loopback Connector

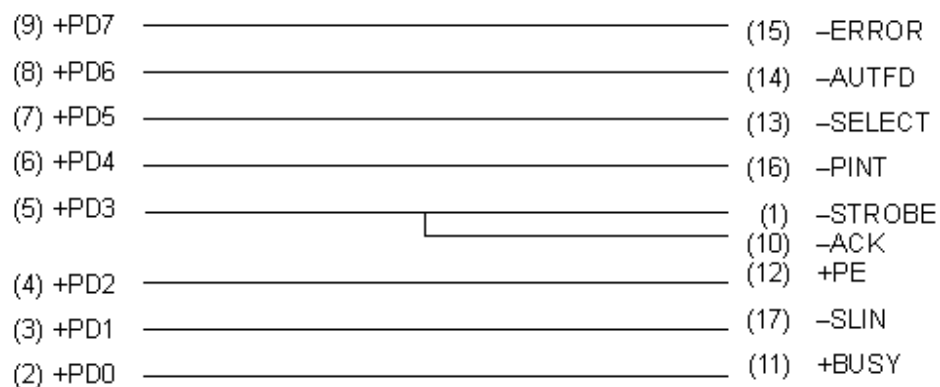

Figure F-2 Printer loopback connector

F.3 RS232C Loopback Connector

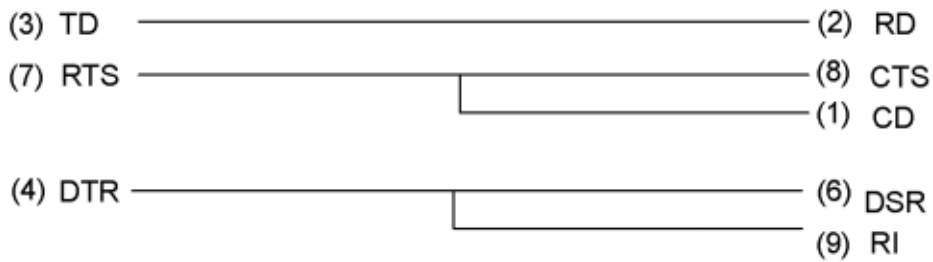

Figure F-3 RS232C loopback connector

F.4 RGB monitor Loopback Connector

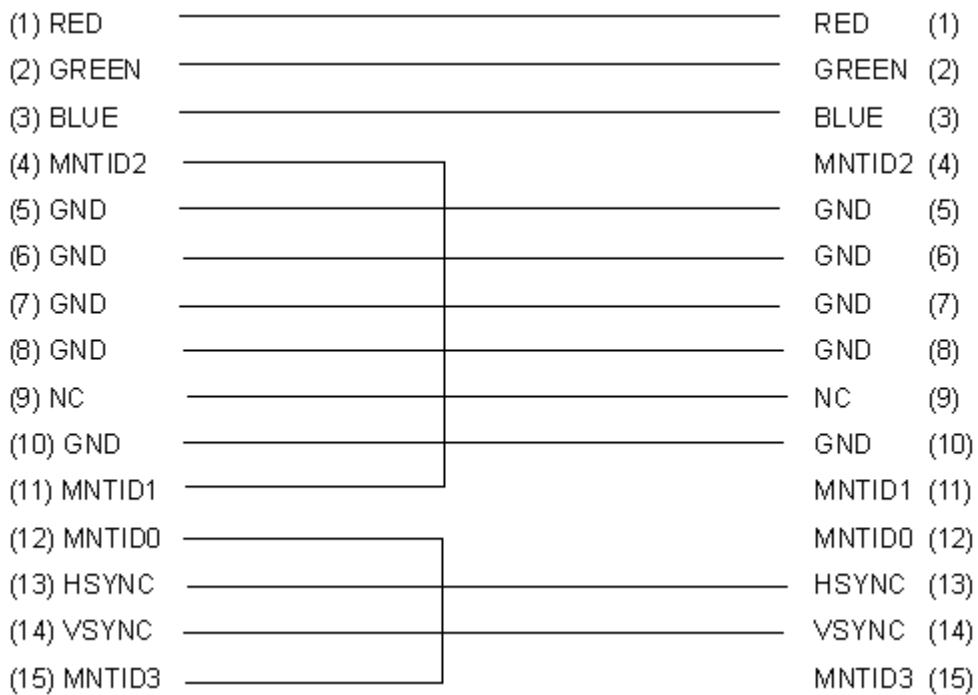

Figure F-4 RGB monitor loopback connector

F.5 RS232C direct-connection cable (9-pin to 9-pin)

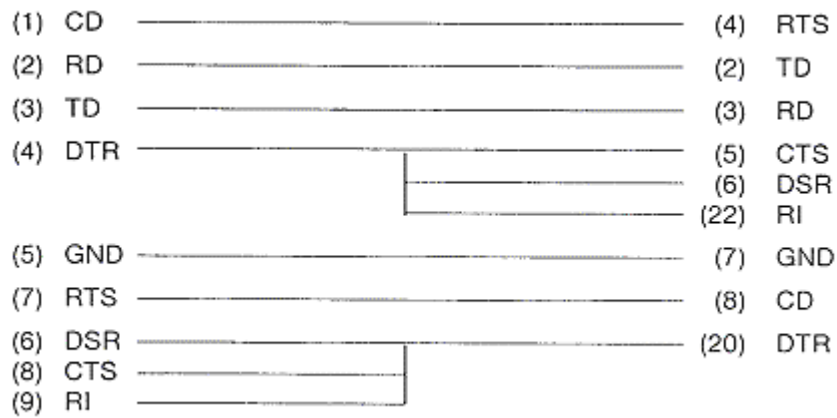

Figure F-5 RS232C direct-connection cable (9-pin to 9-pin)

F.6 RS232C direct-connection cable (9-pin to 25-pin)

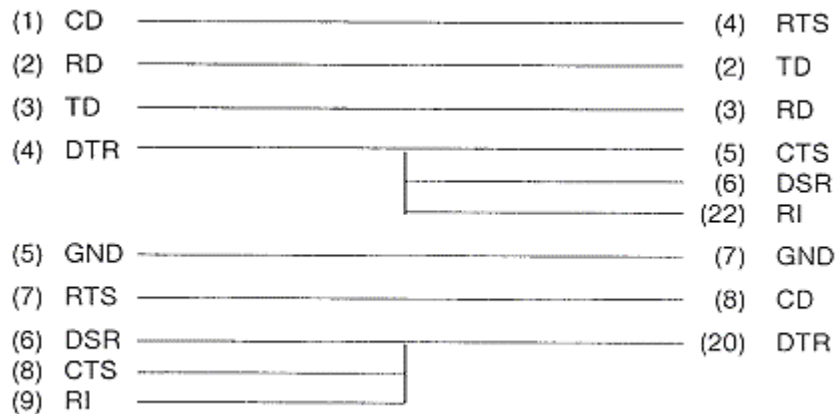

Figure F-6 RS232C direct-connection cable (9-pin to 25-pin)

Appendix G BIOS rewrite procedures

This Appendix explains how to rewrite the system BIOS program when you update the system BIOS.

Tools

To rewrite the BIOS, you need the following tool:

- ❑ BIOS/EC/KBC rewriting disk for the computer that has renewed BIOS data.

Rewriting the BIOS

1. Set the system to boot mode.
2. Turn off the power to the computer.
3. Remove the external cable and PC card.
4. Connect an USB FDD and insert the BIOS/EC/KBC rewriting disk into the USB FDD.
5. Turn on the power while holding down the No. 01 key.

For example



(US Keyboard)



(UK Keyboard)

(Keep holding down the key until beep sounds.)

The BIOS rewriting starts.

6. When the process is completed, the system is automatically rebooted.

NOTE:

1. Connect the AC adapter to the computer when you rewrite the BIOS.
2. Do not turn off the power while you are rewriting the BIOS.
If the rewrite fails, it might be impossible to start up the computer.
3. If you fail to rewrite BIOS, then when you next turn on the power, a message may be displayed that the contents of the BIOS have been erased.
In this case, insert the BIOS/EC/KBC rewriting disk and the BIOS will be rewritten.

Appendix H EC/KBC rewrite procedures

This Appendix explains how to rewrite the EC/KBC system program when you update the EC/KBC system.

Tools

To rewrite the EC/KBC, you need the following tool:

- ❑ BIOS/EC/KBC rewriting disk for the computer

Rewriting the EC/KBC

1. Set the system to boot mode.
2. Turn off the power to the computer.
3. Remove the external cable and PC Card.
4. Connect an USB FDD and insert the BIOS/EC/KBC rewriting disk into the USB FDD.
5. Turn on the power while holding down the **Tab** key. (Keep holding down the key until a beep sounds.)
6. When the EC/KBC rewrite is completed, the system is automatically rebooted.

NOTE:

1. Rewrite the EC/KBC only when instructed by a diagnostic disk release notice.
2. Connect the AC adapter to the computer when you rewrite the EC/KBC.
3. Do not turn off the power while you are rewriting the EC/KBC. If the rewrite fails, it might be impossible to start up the computer.
4. If you fail to rewrite EC/KBC, then when you next turn on the power, a message may be displayed that the contents of the EC/KBC have been erased. In this case, insert the BIOS/EC/KBC rewriting disk and the EC/KBC will be rewritten.
5. Normally it takes about 30 seconds to rewrite the EC/KBC. It may take 3 minutes (maximum), depending on the conditions of the computer or ICs. The computer is not hung up. Allow sufficient time. Never reboot or turn off the power to the computer before the rewriting is completed.

Appendix I Reliability

The following table shows MTBF (Mean Time Between Failures).

Table I-1 MTBF

| | Time (hours) |
|------|---------------------|
| MTBF | 5,514 |

Appendix J Maintenance of TOSHIBA RAID

J.1 Outline of Maintenance (Repair) of TOSHIBA RAID

Follow the below procedures to repair TOSHIBA RAID.

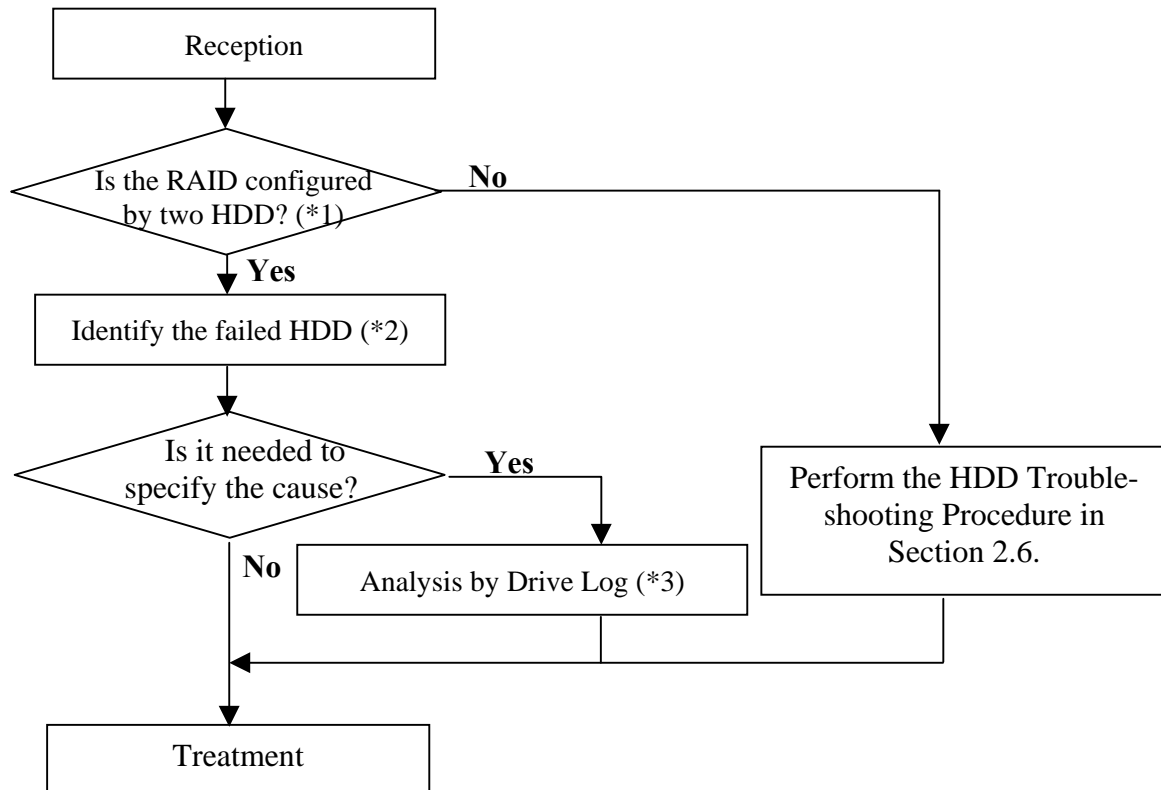

Figure J-1 Flowchart of repairing TOSHIBA RAID

*1: Refer to “Check of RAID configuration” in Section 3.3 in Chapter 3.

*2: Refer to “Identifying failed HDD” in Section 3.3.3 of Chapter 3.

*3: Refer to “Analysis by Drive Log” in section J.2.

J.2 Analysis and handling by Drive Log

Follow the below procedures to analyze.

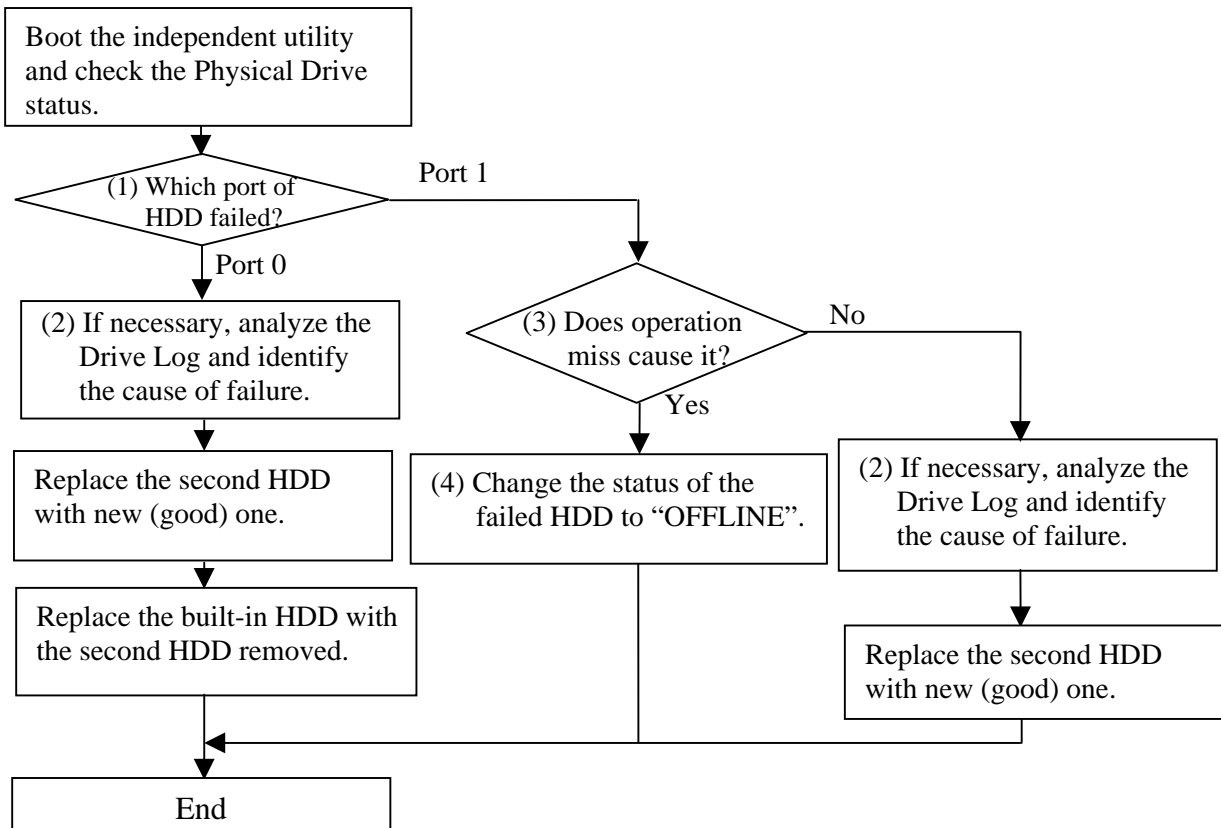

Figure J-2 Flowchart of Analysis and handling by Drive Log

J.2.1 How to identify the cause of failure

(1) When “Fail” or “NODRIVE” is displayed.

According to “Operation of Independent utility”, boot the independent utility to display the Drive Log.

To identify the failure cause of Port 0, analyze the Drive Log of [REDUNDANT] side of Port 1.

To identify the failure cause of Port 1, analyze the Drive Log of [REDUNDANT] side of Port 0.

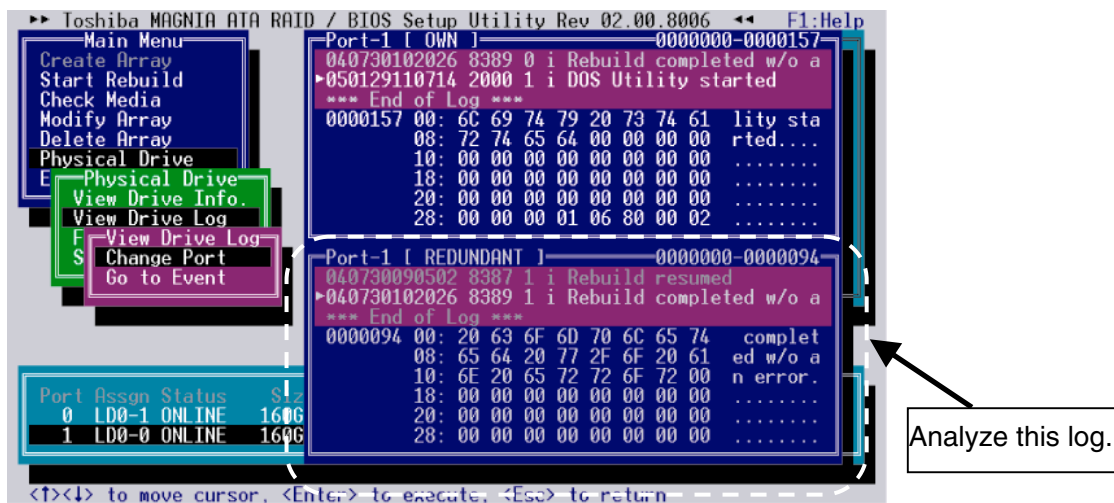

1. Find the log of message of “Fail this drive” last generated, using **PgUp** and **PgDn** keys.

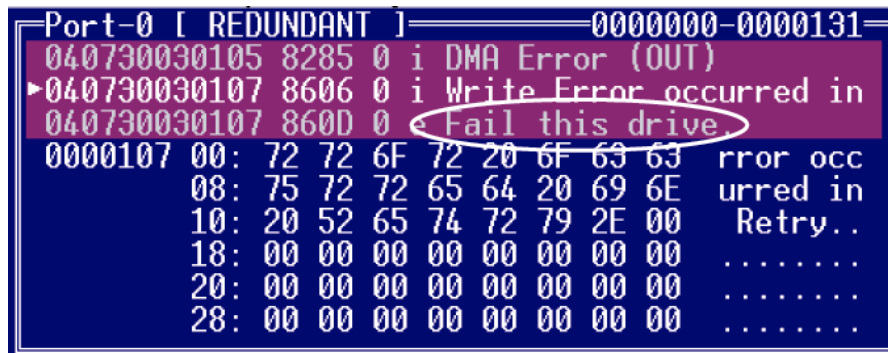

- Analyze the detailed data of the message of right before of “xxx Error (IN)”, “xxx Error (OUT)” (for example, “DMA Error (IN)”, “DMA Error (OUT)”) right before the log of “Fail this drive” message and identify the cause.

DMA Error (IN)

Port-0 [REDUNDANT] 0000000-0000131

```

040730030105 8602 0 i Write Error occurred. R
▶040730030105 8284 0 i DMA Error (IN)
040730030105 8285 0 i DMA Error (OUT)
0000105 00: 6F 72 20 28 49 4E 29 00 or (IN).
08: 00 00 00 00 00 00 00 00 .....
10: 00 00 00 00 00 00 00 00 .....
18: 00 00 00 01 CD BC 85 01 .....
20: 00 00 41 00 35 00 00 00 ..A.5...
28: 00 00 00 00 71 76 9C 08 ....qv..
    
```

Annotations:

- Sector Count: 01 (at row 18)
- Command: 35 (at row 20)
- LBA: 00 (at row 20)

DMA Error (OUT)

Port-0 [OWN] 0000000-0000827

```

041218234430 4284 0 i DMA Error (IN)
▶041218234430 4285 0 i DMA Error (OUT)
041218234430 4604 0 i Media Error occurred in
0000800 00: 6F 72 20 28 4F 55 54 29 or (OUT)
08: 00 00 00 00 00 00 00 00 .....
10: 00 00 00 00 00 00 00 00 .....
18: 40 00 01 00 01 00 50 01 @.....P.
20: 00 00 41 00 51 00 00 A0 ..A.Q...
28: 00 00 00 00 00 00 00 00 .....
    
```

Annotations:

- Error: 40 (at row 18)
- Status: 51 (at row 20)

Command: Indicates Command code caused an error. The following list indicates the command.

Table J-1 List of Command (1/2)

| protocol | Command | Devices not implementing the PACKET Command feature set | Devices implementing the PACKET Command feature set | Command code |
|----------|----------------------------------|---|---|--------------|
| ND | NOP | O | M | 00h |
| ND | CFA REQUEST EXTENDED ERROR | O | N | 03h |
| DR | DEVICE RESET | O | M | 08h |
| PI | READ SECTOR(S) | M | N | 20h |
| PI | READ SECTOR(S) EXT | O | N | 24h |
| DM | READ DMA EXT | O | N | 25h |
| DMO | READ DMA QUEUED EXT | O | N | 26h |
| ND | READ NATIVE MAX ADDRESS EXT | O | N | 27h |
| PI | READ MULTIPLE EXT | O | N | 29h |
| PI | READ LOG EXT | O | O | 2Fh |
| PO | WRITE SECTOR(S) | M | N | 30h |
| PO | WRITE SECTOR(S) EXT | O | N | 34h |
| DM | WRITE DMA EXT | O | N | 35h |
| DMO | WRITE DMA QUEUED EXT | O | N | 36h |
| ND | SET MAX ADDRESS EXT | O | N | 37h |
| PO | CFA WRITE SECTORS W/OUT ERASE | O | N | 38h |
| PO | WRITE MULTIPLE EXT | O | N | 39h |
| PO | WRITE LOG EXT | O | O | 3Fh |
| ND | READ VERIFY SECTOR(S) | M | N | 40h |
| ND | READ VERIFY SECTOR(S) EXT | O | N | 42h |
| ND | SEEK | M | N | 70h |
| PI | CFA TRANSLATE SECTOR | O | N | 87h |
| DD | EXECUTE DEVICE DIAGNOSTIC | M | M | 90h |
| PO | DOWNLOAD MICROCODE | O | N | 92h |
| P | PACKET | N | M | A0h |
| PI | IDENTIFY PACKET DEVICE | N | M | A1h |
| P | SERVICE | O | O | A2h |
| ND | SMART DISABLE OPERATIONS | O | N | B0h |
| ND | SMART ENABLE/DISABLE AUTOSAVE | O | N | B0h |
| ND | SMART ENABLE OPERATIONS | O | N | B0h |
| ND | SMART EXECUTE OFF LINE | O | N | B0h |
| PI | SMART READ DATA | O | N | B0h |
| PI | SMART READ LOG SECTOR | O | N | B0h |
| ND | SMART RETURN STATUS | O | N | B0h |
| PO | SMART WRITE LOG SECTOR | O | N | B0h |
| ND | DEVICE CONFIGURATION FREEZE LOCK | O | O | B1h |
| PI | DEVICE CONFIGURATION IDENTIFY | O | O | B1h |
| ND | DEVICE CONFIGURATION RESTORE | O | O | B1h |
| PO | DEVICE CONFIGURATION SET | O | O | B1h |

Table J-1 List of Command (2/2)

| protocol | Command | Devices not implementing the PACKET Command feature set | Devices implementing the PACKET Command feature set | Command code |
|----------|--------------------------------|---|---|--------------|
| ND | CFA ERASE SECTORS | O | N | C0h |
| PI | READ MULTIPLE | M | N | C4h |
| PO | WRITE MULTIPLE | M | N | C5h |
| ND | SET MULTIPLE MODE | M | N | C6h |
| DMO | READ DMA QUEUED | O | N | C7h |
| DM | READ DMA | M | N | C8h |
| DM | WRITE DMA | M | N | CAh |
| DMO | WRITE DMA QUEUED | O | N | CCh |
| PO | CFA WRITE MULTIPLE W/OUT ERASE | O | N | CDh |
| ND | CHECK MEDIA CARD TYPE | O | N | D1h |
| ND | GET MEDIA STATUS | O | O | DAh |
| ND | MEDIA LOCK | O | N | DEh |
| ND | MEDIA UNLOCK | O | N | DFh |
| ND | STANDBY IMMEDIATE | M | M | E0h |
| ND | IDLE IMMEDIATE | M | M | E1h |
| ND | STANDBY | M | O | E2h |
| ND | IDLE | M | O | E3h |
| PI | READ BUFFER | O | N | E4h |
| ND | CHECK POWER MODE | M | M | E5h |
| ND | SLEEP | M | M | E6h |
| ND | FLUSH CACHE | M | O | E7h |
| PO | WRITE BUFFER | O | N | E8h |
| ND | FLUSH CACHE EXT | O | N | EAh |
| PI | IDENTIFY DEVICE | M | N | ECh |
| ND | MEDIA EJECT | O | N | EDh |
| ND | SET FEATURES | M | M | EFh |
| PO | SECURITY SET PASSWORD | O | O | F1h |
| PO | SECURITY UNLOCK | O | O | F2h |
| ND | SECURITY ERASE PREPARE | O | O | F3h |
| PO | SECURITY ERASE UNIT | O | O | F4h |
| ND | SECURITY FREEZE LOCK | O | O | F5h |
| PO | SECURITY DISABLE PASSWORD | O | O | F6h |
| ND | READ NATIVE MAX ADDRESS | O | O | F8h |
| ND | SET MAX ADDRESS | O | O | F9h |

LBA (Logical Block Address): First sector address caused an error.

Sector Count: Number of sectors transmitted from the address indicated by LBA.

STATUS: Status of command. The lowest bit becomes “1”, when an error occurs.

Error: Content of error. It indicates that an error occurs when the object bit is “1”.

Bit7:ICRC

Indicates that a CRC error occurs on the transmission bus (SATA) between Host and HDD.

Bit6:UNC

Indicates that an uncorrectable (media) error occurs.

Bit2:ABRT

Indicate that the command aborts.

(2) Check if it is caused by an operation miss or is a failure.

To check if the cause of failure of Port1 is an operation miss or not, analyze the Drive Log of Port0.

1. In [REDUNDANT] of Port-0, find a log of “Fail this drive” message by **PgUp** and **PgDn** key.
2. If no message of “Fail this drive” message, it is judged that the second HDD is removed without the operation of removal by TOSHIBA RAID console and installed again.

(3) How to change the status to OFF LINE

Release the status of “Fail”, using the menu of [Force OFFLINE]. This HDD is not necessary to be repaired.

J.3 Operation of Independent Utility

J.3.1 Outline of Independent Utility

This is a utility to display Drive Log of TOSHIBA RAID.

(1) Drive Log

TOSHIBA RAID can store about 7,000 logs of Drive Log.

TOSHIBA RAID make Drive Log redundant and store it. The drive has own log and other drive's log.

In TOSHIBA RAID, the log of own drive is called "Own Log" and the redundant log of other drive's drive is called "Redundant Log". Each port has "Own Log" and "Redundant Log". As shown in the following figure, the Port 0 has "Own Log" of Port0 and "Redundant Log" of Port1. The Port1 has "Own Log" of Port1 and "Redundant Log" of Port0.

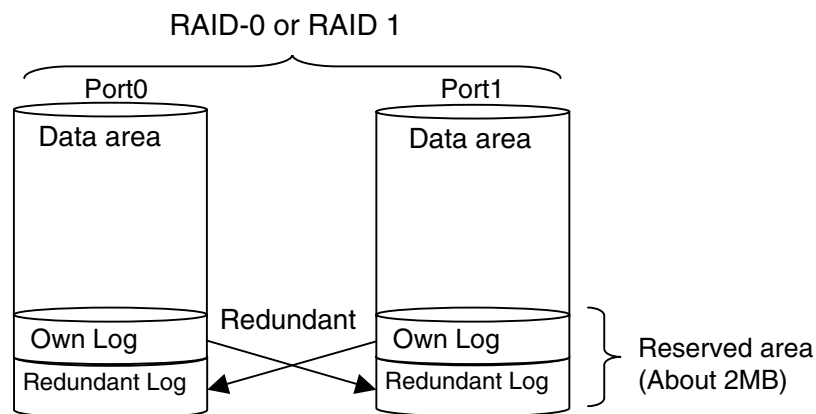

Figure J-3 Drive Log

(2) Information of Drive Log

TOSHIBA RAID writes the log when any change in RAID array or an error occurs. So, seeing the log can trace the history of the array or error information. In TOSHIBA RAID, about 7,000 logs can be stored and the past logs can be referred in detail.

J.3.2 How to operate the Independent Utility

(1) Booting PC

Connected the USB FDD to the PC to be repaired. Insert the FD storing the program of the Independent Utility in the FDD and boot the PC from the FD. The following display appears.

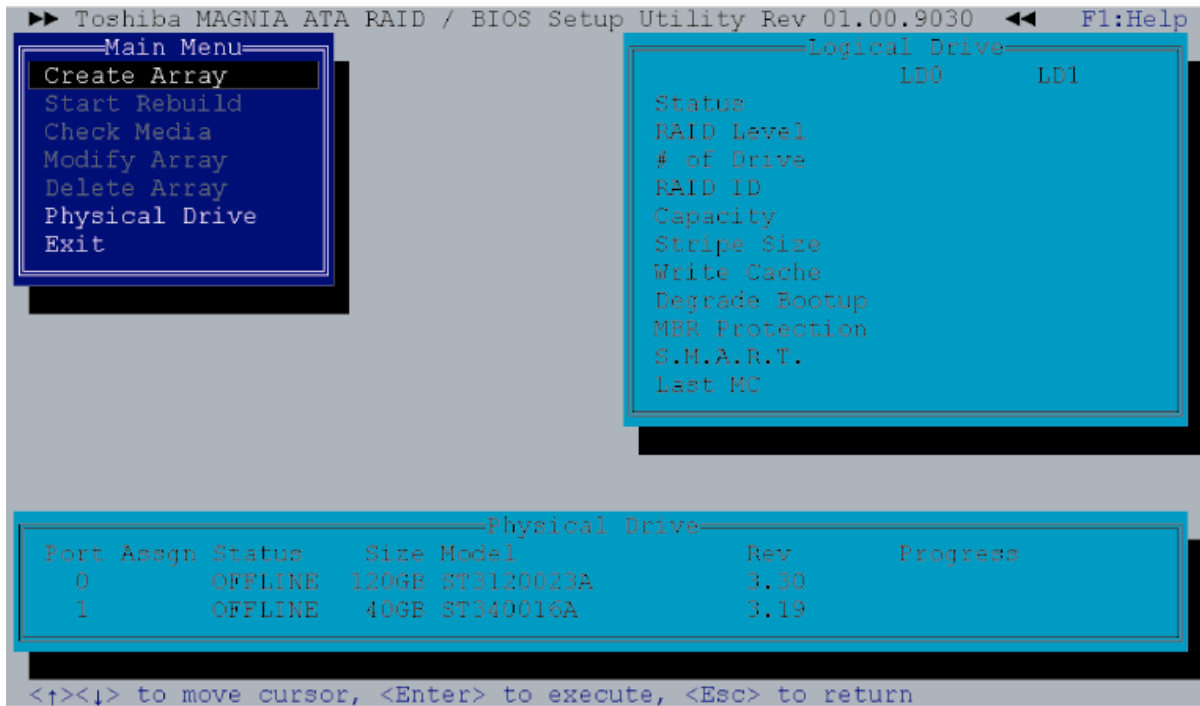

In the Independent Utility, the cursor is moved by with ↑ key and ↓ key. Press **Enter** key to execute the option selected. Press **Esc** key to return to the previous menu.

Pressing **F1** key displays Help. Press **Esc** key to exit.

(2) Display of Logical/Physical Drive

Logical Drive

The status of RAID array is displayed in Logical Drive by array. The displayed items are follows.

Table J-2 Displayed item in Logical Drive

| | Explanation |
|-----------------------------|---|
| Status (Status of array) | Displays the status of array. The contents are follows. -OPTIMAL: The array works normally. -DEGRADE: The array is degraded. -CRITICAL: The array is failed. It can not be used. |
| RAID Level | Displays the RAID level. |
| # of Drive | Displays the number of physical drives incorporated in the array. |
| RAID ID | Displays peculiar ID by array. |
| Capacity | Displays the capacity of array. |
| Stripe Size | Item that is not set. |
| Write Cache | Displays the setting of drive write cache. "Enable" or "Disable" is displayed. The default is "Enable". This option is displayed in RAID-1 (Mirroring). |
| Degrade Bootup | Displays if boot OS or not when the array is degraded. "Yes" (Boot up) or "No" (Not boot up) is displayed. The default is "Yes". This option is displayed in RAID-1 (Mirroring). |
| MBR Protection | Displays the setting of protection function of MBR (Master Boot Record). "Enable" (Protect) or "Disable" (Not protect) can be selected. The default is "Disable". When OS is installed by SetupInstructor, it is set automatically to "Enable". When OS is installed manually, it is set to "Disable". If necessary, change the setting. |
| S.M.A.R.T. | Displays the setting of failure prediction function of drive. "Enable" or "Disable" is displayed. The default is "Enable". |
| Last MC | Displays the date when checking of media or rebuilding of array executed last. It displays "00/00/00" right after making new array or when the rebuild limit is changed. |

Physical Drive

In Physical Drive, the condition of RAID array is displayed by array. The following items are displayed.

Table J-3 Items displayed in Physical Drive

| | Explanation |
|----------|--|
| Port | Displays the port number of Serial ATA connected to the drive. |
| Assign | Displays the array number and drive number of array that the drive is incorporated. The display format is LD [Array number] [Drive number]. For example, [LD0-1] means the disk drive 1 of Array 0. |
| Status | Displays the drive status. The followings are displayed. -ONLINE: The drive is working normally. -OFFLINE: The drive is not configured as array and is not used. -FAIL: The drive is failed and dose not work. -REBUILDING: The drive is been rebuilding by data of normal drive or the rebuilding is suspended. -UNKNOWN: There is controversy in the RAID information of other drive and the status is not decided. It is displayed when this drive was removed and used in the past. When this drive has been found good one, setting to OFFLINE is possible by executing [Force Offline]. |
| Size | Displays the capacity of drive. |
| Model | Displays the model number of drive. |
| Rev | Displays the firmware revision of drive. |
| Progress | Displays the progress of rebuilding and Check media. |

(3) Explanation of Main Menu

The Independent Utility has following Main Menu.

Table J-4 Item of Main Menu displayed

| | Explanation |
|----------------|---|
| Create Array | Builds RAID array. |
| Start Rebuild | Rebuilds RAID-1. While the rebuild is suspended, the message of "Resume Rebuild" is displayed. |
| Check Media | Checks if any error in drives configuring array. This is available for the RAID-1 in the "Optimal" condition. |
| Modify Array | Changes the setting of array. |
| Delete Array | Delete array. |
| Physical Drive | Changes the setting of physical drive. |
| Exit | Exits from the utility. |

CAUTION: Do not use the following item of the Independent Utility for maintenance.

[Create Array]

This changes the current RAID configuration or information, and delete user's data. Do not use for maintenance.

[Start Rebuild (Resume Rebuild)]

This changes the current RAID configuration or information, and delete user's data. Do not use for maintenance.

[Modify Array]

This changes the current RAID configuration or information, and delete user's data. Do not use for maintenance.

[Check Media]

This changes the current RAID configuration or information, and delete user's data. Do not use for maintenance.

[Delete Array]

This changes the current RAID configuration or information, and delete user's data. Do not use for maintenance.

The tree of Independent Menu is as follows.

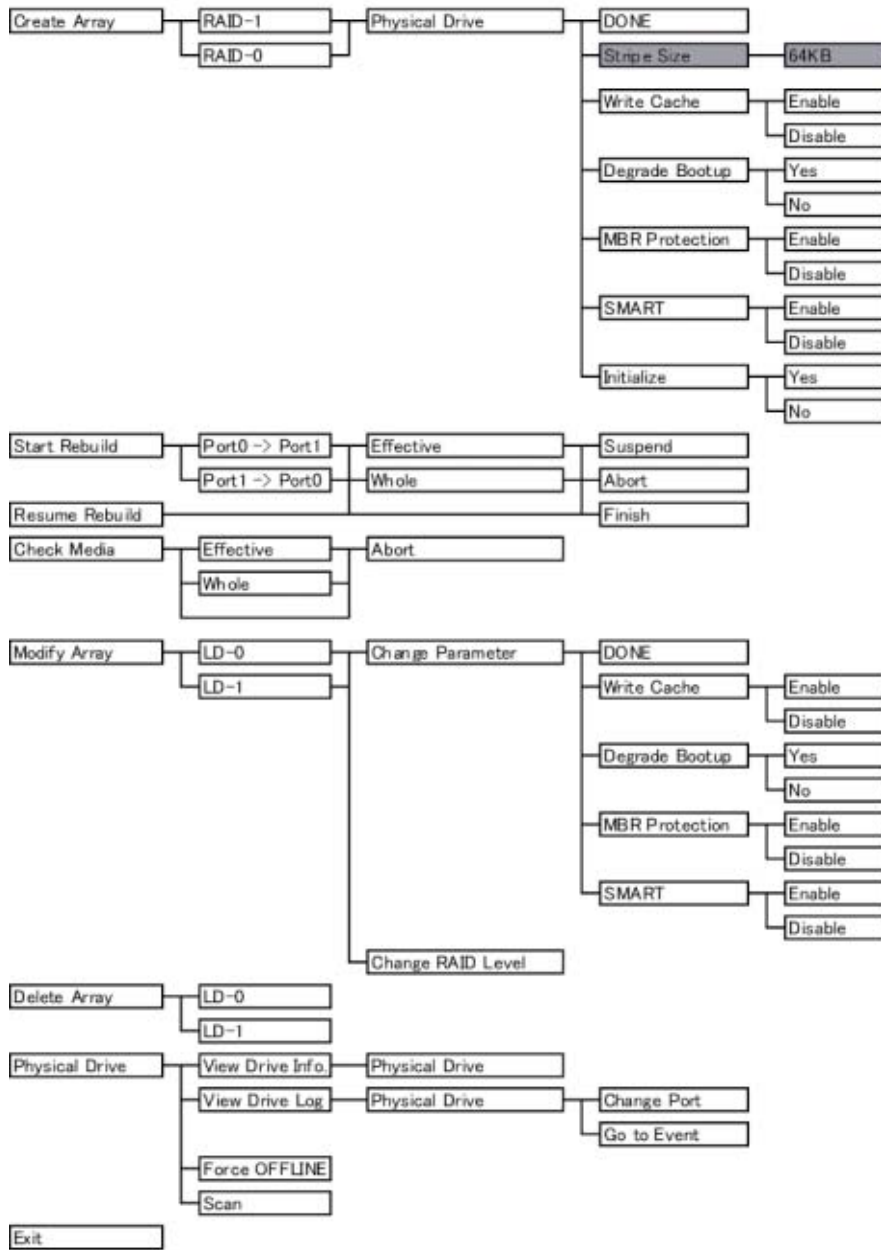

Figure J-4 Tree of menu of Independent Utility

Create Array

This section explains how to select option and build array. The [Create Array] option can be selected only when there is a drive not assigned. To build array, follow the procedure below.

1. Put the cursor on [Create Array] in [Main Menu] and press **Enter** key.
2. Select RAID level. Put the cursor on [RAID-1] or [RAID-0] and press **Enter** key.
3. Put the cursor on the drive to be incorporated in [Physical Drive] and press **Space** key to select a drive. When a drive selected, the status of [Physical Drive] changes to "ON LINE". When selecting plural, repeat the same operation.
4. After selecting a drive, press **Enter** key.
5. The [RAID Parameter] is displayed. The setting of parameter in the following table can be made.
Put the cursor on the item to be set and press **Enter** key. Put the cursor on the value to be set and press **Enter** key.

Table J-5 Item of parameter set

| Option | Explanation |
|----------------|---|
| DONE | When this option is selected after completing of setting in [Create Array] menu, building of RAID is decided. |
| Stripe Size | Designates the size of segment written in each disk of RAID-0 (Striping). The Stripe Size is only 64KB. This parameter can be set only in the RAID-0 configured by two drives. |
| Write Cache | Displays the setting of Write Cache of drive. This can select "Enable (use)" or "Disable (not use)". The default is "Enable (use)". |
| Degrade Bootup | Displays if boot up OS or not When the array is degraded. "Yes (boot up)" or "No (not boot up)" is selected. The default is "Yes (boot up)". This option can be selected in RAID-1 (Mirroring). |
| MBR Protection | Displays the setting of protection function of MBR (Master Boot Record). "Enable (protect)" or "Disable (not protect)" is selected. The default is "Disable (not protect)". |
| S.M.A.R.T. | Displays the setting of failure prediction function of drive. "Enable" or "Disable" is displayed. The default is "Enable". |
| Initialize | Initialize the MBR of array. Normally, it is done when the array is made newly. For details, refer to "Initializing array". Initializing sets the rebuild limit to 10GB. |

After completing the detailed setting, array is initialized. Put the cursor on "Initialize" and press **Enter** key. Put the cursor on the "Yes" and press **Enter** key. If the array is initialized, date of array is lost. Selecting "No" dose not initialize.

- Put the cursor on the “DONE” and press **Enter** key. Pressing “OK” in [Confirmation] store the change.

CAUTION: When the array is initialized, the data of drive is lost.

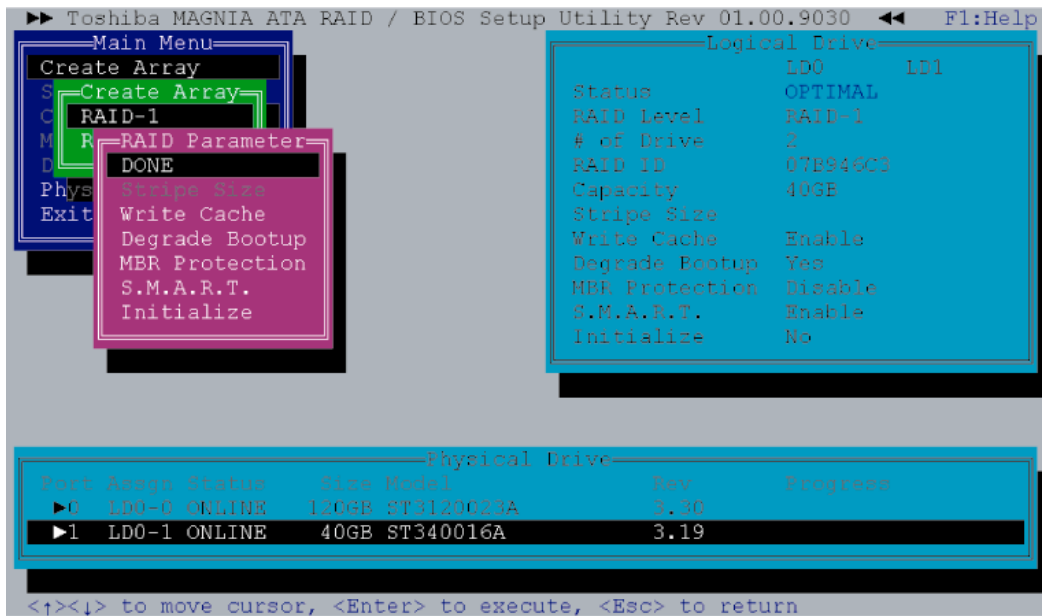

Start Rebuild

Selecting of this option starts rebuilding. [Start Rebuild] is displayed only in the RAID-1 condition of with “OFFLINE” drive that has same or more size of capacity as the array in the condition of “Optimal” or “Degraded”.

During halt of rebuilding, [Resume Rebuild] is displayed instead of [Start Rebuild]. The procedure to rebuild drives is as follows.

- Put the cursor to the [Start Rebuild] in the main menu of Indent Utility and press **Enter** key.
- Select the direction to rebuild in [Rebuild Direction] menu and press **Enter** key. When the array is “Degraded”, the choice is only one.

3. When [Rebuild Range] menu is displayed, the range to be rebuilt is designated. When [Effective] is selected, rebuild limit becomes valid and it rebuilds up to the rebuild limit. When [Whole] is selected, it rebuilds maximum capacity of array. The [Rebuild Range] menu is not displayed when the rebuild limit is not set or the rebuild limit is the same as the maximum capacity of array. Normally designation of [Effective] is adequate.
4. Put the cursor on “OK” in [Confirmation] and press **Enter** key. The rebuild starts.

CAUTION: When the rebuild starts, the data of drive rebuilt is lost.

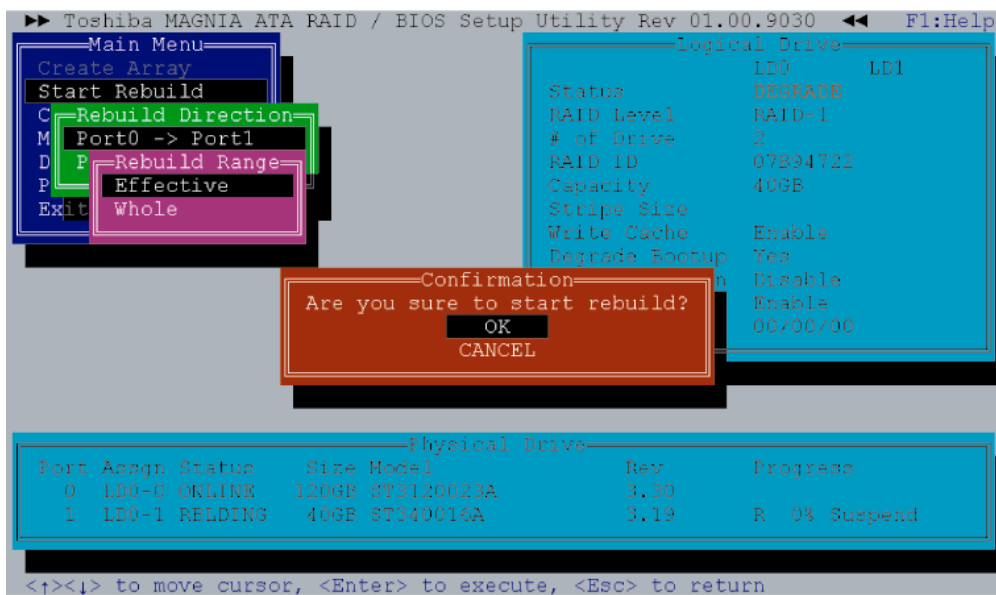

5. During rebuilding, [Status] of [Physical Drive] becomes “Rebuilding” and the progress rate, expected remaining time and the number of errors are displayed. During rebuilding, the [Rebuilding] dialog to select [Suspend] or [Abort] is displayed. It may take time depending on the drive capacity.
6. To suspend the rebuilding, put the cursor on [Suspend] (when aborting, on the [Abort]) and press **Enter** key. When [Confirmation] is displayed, put the cursor on [OK] and press **Enter** key. During being suspended, [Suspend] is displayed in [Progress] of [Physical Drive].
7. When “Rebuild Limit” is set and [Rebuild Range] is set to [Whole], only [Finish] is can be selected after exceeding the Rebuild Limit. When [Finish] is selected and “OK” is selected in [Confirmation], the rebuilding is completed at the time. When OS is booted after exceeding the Rebuild Limit, the rebuild is completed.

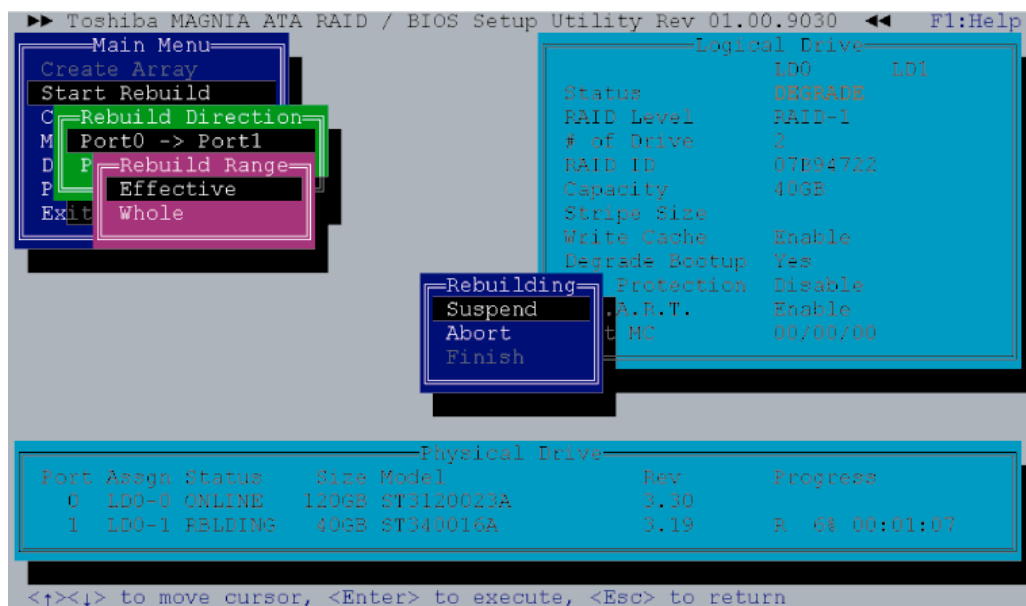

- When completing the rebuild, press “OK” to return to the main menu of Independent Setup Utility.

Resume Rebuild

During being suspended, [Resume Rebuild] is displayed in [Main Menu]. To start rebuilding suspended, follow the procedure below.

- Put the cursor to the [Resume Rebuild] in the main menu of Indent Utility and press **Enter** key.
- When [Rebuild Range] menu is displayed, the range to be rebuilt is designated. When [Effective] is selected, rebuild limit becomes valid and it rebuilds up to the rebuild limit. When [Whole] is selected, it rebuilds maximum capacity of array. The [Rebuild Range] menu is not displayed when the rebuild limit is not set or the rebuild limit is the same as the maximum capacity of array. Normally designation of [Effective] is adequate.
- Put the cursor on “OK” in [Confirmation] and press **Enter** key. The rebuild starts.
- During rebuilding, [Status] of [Physical Drive] becomes [REBUILDING] and the progress rate, expected remaining time and the number of errors are displayed. During rebuilding, the [Rebuilding] dialog to select [Suspend] or [Abort] is displayed. It may take time depending on the drive capacity.
- To suspend the rebuilding, put the cursor on [Suspend] (when aborting, on the [Abort]) and press **Enter** key. When [Confirmation] is displayed, put the cursor on [OK] and press **Enter** key.

- When completing the rebuild, press “OK” to return to the main menu of Independent Setup Utility.



- When “Rebuild Limit” is set and [Rebuild Range] is set to [Whole], only [Finish] is can be selected after exceeding the Rebuild Limit. When [Finish] is selected and “OK” is selected in [Confirmation], the rebuilding is completed at the time. When OS is booted after exceeding the Rebuild Limit, the rebuild is completed.

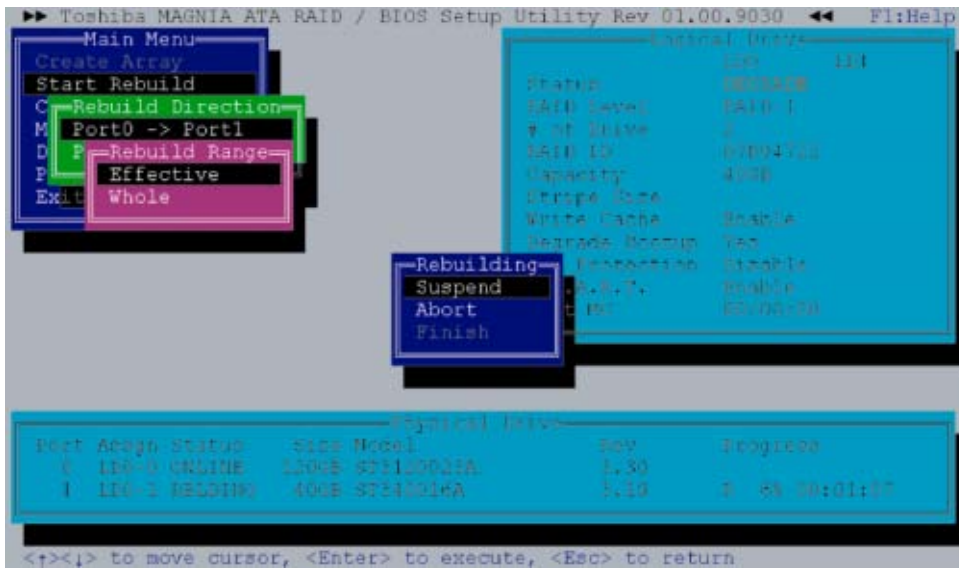

When completing the rebuild, press “OK” to return to the main menu of Independent Setup Utility.

Check Media

This option can check if there is an error in the HDD of array. The Check Media can be done only in RAID-1. To execute Check Media, follow the procedure below.

1. Put the cursor to the [Check Media] in [Main Menu] and press **Enter** key.
2. When [Check Range] is displayed, designate the range to be checked. When [Effective] is limited, it makes the rebuild limit effective and execute [Check Media] up to the rebuild limit. When [Whole] is selected, execute [Check Media] up to the maximum capacitor of RAID array. The [Rebuild Range] menu is not displayed when the rebuild limit is not set or the rebuild limit is the same as the maximum capacity of array. Normally designation of [Effective] is adequate.
3. To start the Check Media, put the cursor to the [Confirmation] and press **Enter** key. When an error is detected, it automatically correct.
4. During [Check Media], the progress rate, expected remaining time and the number of errors are displayed in [Progress] of [Physical Drive], [Check Media] may take time depending on the drive capacity.

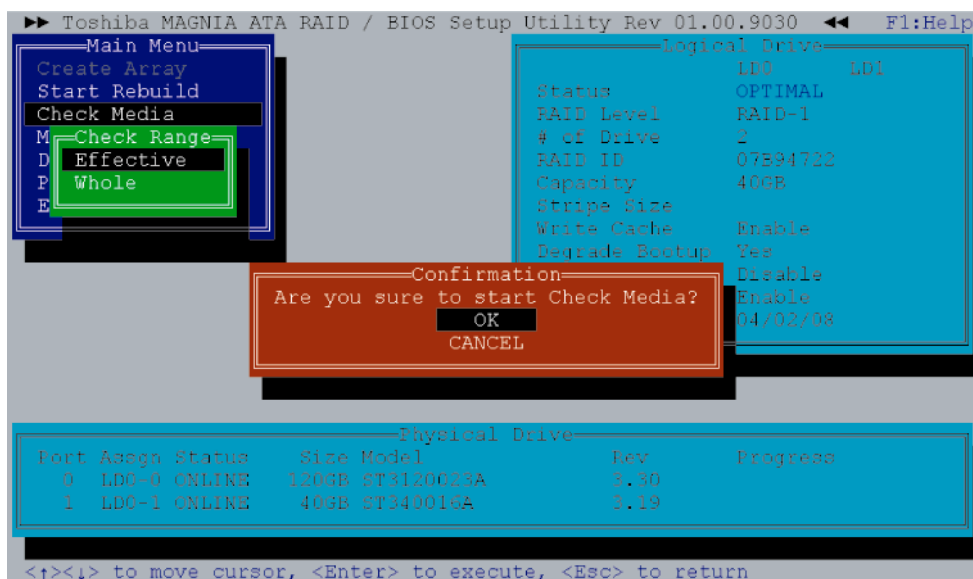

5. When [Check Media] is completed, put the cursor on “OK” and press **Enter** key to return to the menu of Independent Utility.

The date when the [Check Media] was done last is displayed in [Last MC] of [Logical Drive]. [Last MC] is renewed when rebuilding is done. When “Rebuild Limit” is changed or right after building RAID array, the value of [Last MC] becomes [00/00/00].

Modify Array

This option changes the setting of array.

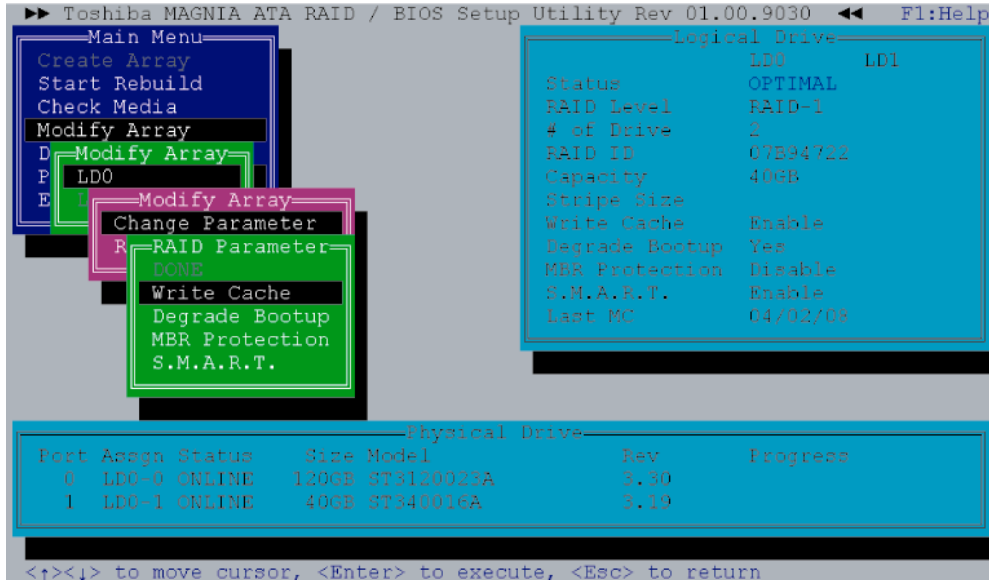

Change Parameter

Select [Change Parameter] in [Modify Array] menu. The following items can be set.

Table J-6 Item of array

| Option | Explanation |
|-----------------|--|
| Write Cache | Displays the setting of drive write cache. "Enable (use)" or "Disable (not use)" is displayed. The default is "Enable (use)". |
| Degraded Bootup | Displays if boot OS or not when the array is degraded. "Yes" (Boot up) or "No" (Not boot up) is displayed. The default is "Yes". This option is displayed in RAID-1 (Mirroring). |
| MBR Protection | Displays the setting of protection function of MBR (Master Boot Record). "Enable" (Protect) or "Disable" (Not protect) can be selected. The default is "Disable". |
| S.M.A.R.T. | Displays the setting of failure prediction function of drive. "Enable" or "Disable" is displayed. The default is "Enable". |

Change RAID Level

To change RAID level, select [Modify Array] menu. When changing RAID-1 (Mirroring) to RAID-0 (Striping), refer “Changing RAID-1 to RAID-0”. When changing RAID-0 to RAID-1, refer “Changing RAID-0 to RAID-1”.

Changing RAID-1 to RAID-0 working by one drive

When changing RAID-1 array working by two drives to RAID-0 working by one drive, follow the procedure below.

1. Select [Modify Array] in [Main Menu].
2. In [Modify Array], select array [LDx] that you want to change.
3. In [Modify Array], select [RAID-1 -> RAID-0].
4. In [Physical Drive] select one drive, which is used as RAID-0, and press **Space** key
5. After selecting a drive, press **Enter** key. When [Confirmation] is displayed, select “OK” to store the setting.

Changing RAID-0 working by one drive to RAID-1

To change RAID-0 working by one drive to RAID-1 working by two drives, follow the procedure below.

1. Select [Modify Array] in [Main Menu].
2. In [Modify Array], select array [LDx] that you want to change.
3. In [Modify Array], select [RAID-0 -> RAID-1].
4. Select a drive in the condition of [OFFLINE] in [Physical Drive], which is expanded as RAID-1 with **Space** key. After selecting drive, [Status] changes to [REBUILDING]. The capacity of drive that is newly added must be same/more as/than original drive. The drive in the condition of [Fail] can not be incorporated.
5. After selecting a drive, press **Enter** key. When [Confirmation] is displayed, select “OK” to store the setting.
6. Select [Resume Rebuild] in [Main Menu], or select [Exit] to exit from Independent Utility. When automatic rebuilding is set in OS, rebuilding starts automatically after booting OS.
7. During rebuilding, the progress is displayed in [Physical Drive]. Suspending or aborting is possible.
8. When the rebuilding is completed, message is displayed. Select “OK”.

Delete Array

Selects [Delete Array] of Setup Utility and delete array. Put the cursor on the array you want to delete and press **Enter** key.

When [Confirmation] is displayed, select “OK” to store the setting.



Physical Drive

Select [Physical Drive] in Setup Utility to set physical drive.

View Drive Info.

Select this option in [Physical Drive] to display information of physical drive. Select the drive that you want to display in [Physical Drive] at the lower of display and press **[Enter]** key. In the server with fault lamp (lamp displaying disk condition), the fault lamp of corresponded drive blinks while [Drive Information] display appears. Press **[Esc]** key to close the display. The following information is displayed.

Table J-7 Items set in View Drive Info.

| Option | Explanation |
|--------------|--|
| Assignment | Displays Array number and drive number of array incorporated. The display format is LD [Array number] [Drive number]. For example, [LD0-1] means Disk drive 1 of array 0. |
| Status | Displays the drive status. The followings are displayed. -ONLINE: The drive is working normally. -OFFLINE: The drive is not configured as array and is not used. -FAIL: The drive is failed and dose not work. -REBUILDING: The rebuilding is suspended. -UNKNOWN: There is controversy in the RAID information of other drive and the status is not decided. It is displayed when this drive was removed and used in the past. When this drive has been found good one, setting to OFFLINE is possible by executing [Force Offline]. |
| S.M.A.R.T. | Displays the setting of failure prediction function of drive. [normal] is displayed usually. When the level reach to warning level, [Alert] is displayed. When [S.M.A.R.T.] is set to [Disable], [Normal] is displayed. |
| Model | Displays Model number of drive. |
| FW Rev | Displays the firmware revision of drive. |
| Serial | Displays the serial number of drive. |
| ATA/UDMA | Displays ATA standard and transmission mode that the drive corresponds to. |
| Max LBA | Displays the total number of sectors of drive in hexadecimal mode. (1 sector = 512B) |
| Uncopied Blk | In rebuilding, display the address of area that can not be used because of error in the original drive. When an error has been displayed in [Uncopied Blk], check if any error in the file system in the Windows scan disk. It is not necessary to check all the sectors. When any error is detected, any file is damaged. It is recommended to back up the data and rebuild RAID and restore. |

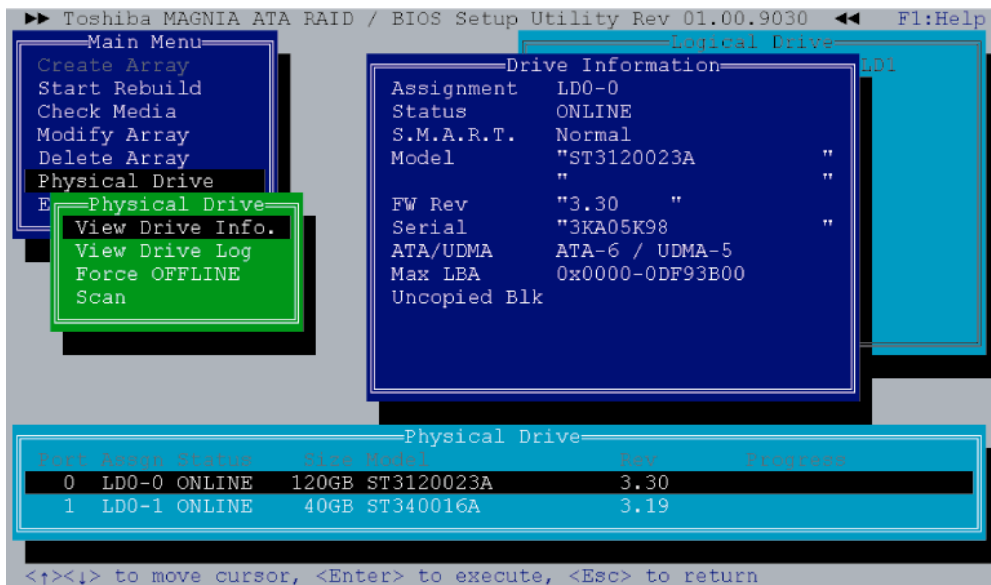

View Drive Log

Select this option in [Physical Drive] menu and select the drive that you want to display the log. At the beginning, the latest log is displayed. The 7,168 logs from the latest are recorded in detail. For the older log, only ID is recorded. The options and functions of key in [View Drive Log] are as follows.

Table J-8 Explanation of option and Function of key

| Option | Explanation |
|-------------|---|
| Change Port | Changes log's port displayed and port's own log or redundant log. |
| Go to Event | Inputting the log number in this number moves to the log of the number. |

| Key | Function |
|-----------------|--|
| [PageUp] | Scrolls upward one by one. |
| [PageDown] | Scrolls downward one by one. |
| [Home] | Jumps to oldest log in the latest 7,168 logs. |
| [End] | Jumps to the latest log. |
| [Ctrl] + [Home] | Jumps to the oldest log that is older than 7,168 logs and the identification ID is recorded. |
| [Tab] | Switches [OWN] window and [REDUNDANT] window. |

```

Toshiba MAGNIA ATA RAID / BIOS Setup Utility Rev 01.00.9030  F1:Help
Main Menu
Create Array
Start Rebuild
Check Media
Modify Array
Delete Array
Physical Drive
E Physical Drive
View Drive Info.
View Drive Log
F View Drive Log
S Change Port
G Change Port
Port-0
P Change Log
Own
Redundant
Port-0 [ OWN ]-----0000000-0000026
040208192110 2389 0 i Rebuild completed w/o a
040208192111 2001 0 i Rescanned by DOS Utilit
*** End of Log ***
0000026 00: 65 64 20 62 79 20 44 4F ed by DO
08: 53 20 55 74 69 6C 69 74 S Utilit
10: 79 00 00 00 00 00 00 00 y.....
18: 00 00 00 00 00 00 00 00 .....
20: 00 00 00 00 00 00 00 00 .....
28: 00 00 00 00 30 90 00 01 ....0...

Port-0 [ REDUNDANT ]-----0000000-0000020
040208192023 2387 1 i Rebuild resumed
040208192110 2389 1 i Rebuild completed w/o a
*** End of Log ***
0000020 00: 20 63 6F 6D 70 6C 65 74 complet
08: 65 64 20 77 2F 6F 20 61 ed w/o a
10: 6E 20 65 72 72 6F 72 00 n error.
18: 00 00 00 00 00 00 00 00 .....
20: 00 00 00 00 00 00 00 00 .....
28: 00 00 00 00 00 00 00 00 .....

View Drive Status Siz
0 LD0-0 ONLINE 120G
1 LD0-1 ONLINE 40G

<↑><↓> to move cursor, <Enter> to execute, <Esc> to return

```

Execute the following procedures to see the drive log in the Independent Utility.

1. Put on the cursor on [Physical Drive] in [Main Menu] and press **Enter** key.
2. Put on the cursor on [View Drive Log] and press **Enter** key.
3. Select drive that you want to display the log in [Physical Drive] at the lower of display with a cursor key and press **Enter** key.
4. The drive log is displayed. Press **PageUp** or **PageDown** key to scroll the drive log upward or downward.
5. To change log displayed, put the cursor on [Change Port] and press **Enter** key.
6. Select Drive log port to be displayed and [Own/Redundant]. For Example, [Own] log means the drive log of Port-0 own, [Redundant] log of Port-0 means the backup copy of the drive log of Port-1.
7. To switch the upper and lower of drive log frame, press **Tab** key. The selected frame is displayed more lightly than the other frame.
8. To move to the drive log wit arbitrary log number, put the cursor on the [Go to Event] and press **Enter** key. Next, input the log number you want to move to and press **Enter** key.

The 7,168 logs from the latest are recorded in detail. For the older than that, only identification ID is recorded.

The following is displayed.

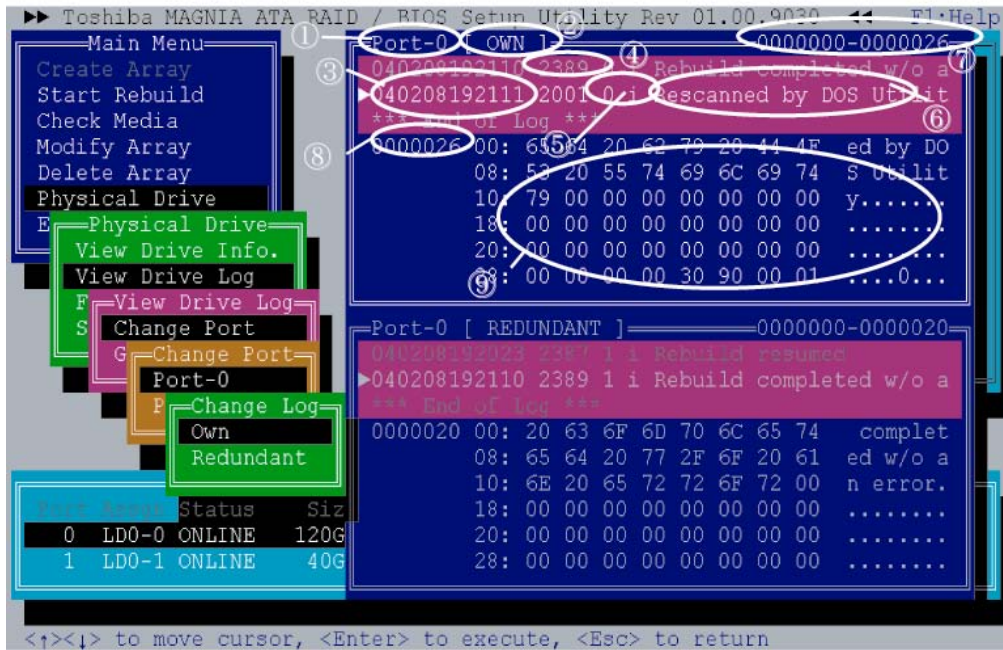

Table J-9 Content of Drive Log display

| No. | Option | Explanation |
|-----|-------------------------------|---|
| 1 | Port | Displays the port number of log displayed. |
| 2 | Own/Redundant | Displays if the displayed log is a log of own port (Own) or a copy of other port log (Redundant). |
| 3 | Time | Displays the time when the log is recorded in six digits. The format is [Year Month Day Hour Minute Second]. |
| 4 | ID | Displays identification ID of log. |
| 5 | Port and Degree of importance | The number displays the port that the drive is connected when the log is recorded. The alphabet displays the degree of importance. [i] means information, [W] means warning and [e] means an error. |
| 6 | Message | Displays the content of log. When the log is too much and it can not be displayed in the area, the remaining is displayed in [Detail] area. |
| 7 | Range of log | Displays the range of log number stored. In this case, it means that logs with the number of 0 to 26 are stored. |
| 8 | Log number | Displays the log number that is being displayed. |
| 9 | Detail | Displays the detailed contents and codes of log. When the number of logs is 7,168 or more, the details of old log are not displayed. |

[View Drive Log] menu is as follows

Table J-10 Content of View Drive Log menu

| Option | Explanation |
|-------------|---|
| Change Port | Changes the display of the own log and redundant log. At the beginning, the Port-0's own log and the redundant log are displayed. |
| Go to Event | When this option selected, it moves to the log with designated number. |

The key function in [View Drive Log] key is as follows.

Table J-11 Function of key in View Drive Log

| Key | Function |
|----------------|--|
| [PageUp] | Scrolls upward step one by one. |
| [PageDown] | Scrolls downward step one by one. |
| [Home] | Jumps to the oldest log in the latest 7,168 logs. |
| [End] | Jumps to the latest log. |
| [Ctrl] +[Home] | Jumps to the oldest log that is older than 7,168 logs and the identification ID is recorded. |
| [Tab] | Switches [OWN] window and [REDUNDANT] window. |

Force OFFLINE

Selecting this option in [Physical Drive] menu of Setup Utility can set the physical drive to offline by force. Follow the procedure below.

1. Select [Physical Drive] in [Main Menu].
2. Select [Force OFFLINE] in [Physical Drive].
3. Select the drive that you want to set it to offline with **Space** key in [Physical Drive] and press **Enter** key.
4. Selecting "OK" in [Confirmation] stores the setting.

Scan

When [Scan] in [Physical Drive] menu is selected, it scans physical drive. This is used to recognize the drive after replacing failed drive.

Exit

When this option is selected, the utility is finished. When [Confirmation] is displayed, select "OK".

Free Manuals Download Website

<http://myh66.com>

<http://usermanuals.us>

<http://www.somanuals.com>

<http://www.4manuals.cc>

<http://www.manual-lib.com>

<http://www.404manual.com>

<http://www.luxmanual.com>

<http://aubethermostatmanual.com>

Golf course search by state

<http://golfingnear.com>

Email search by domain

<http://emailbydomain.com>

Auto manuals search

<http://auto.somanuals.com>

TV manuals search

<http://tv.somanuals.com>