

---

---

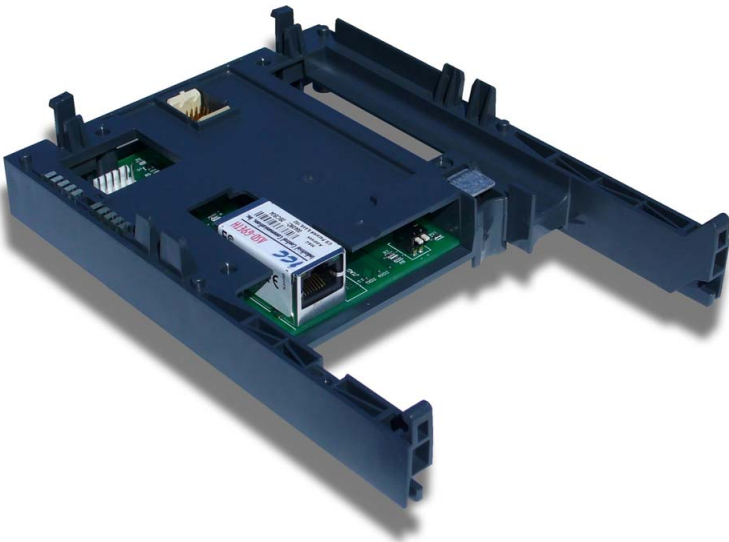
## **ASD INTERFACE SERIES**

---

---



**INDUSTRIAL CONTROL COMMUNICATIONS, INC.**



---

---

## **ASD-G9ETH**

**MULTIPROTOCOL ETHERNET INTERFACE FOR  
TOSHIBA G9 / VFAS1 ADJUSTABLE SPEED DRIVES**

---

---



## **ASD-G9ETH Multiprotocol Ethernet Interface User's Manual**

Part Number 10639-2.300-000

Printed in U.S.A.

©2007-2011 Industrial Control Communications, Inc.

All rights reserved

### **NOTICE TO USERS**

Industrial Control Communications, Inc. reserves the right to make changes and improvements to its products without providing notice.

Industrial Control Communications, Inc. shall not be liable for technical or editorial omissions or mistakes in this manual, nor shall it be liable for incidental or consequential damages resulting from the use of information contained in this manual.

INDUSTRIAL CONTROL COMMUNICATIONS, INC.'S PRODUCTS ARE NOT AUTHORIZED FOR USE AS CRITICAL COMPONENTS IN LIFE-SUPPORT DEVICES OR SYSTEMS. Life-support devices or systems are devices or systems intended to sustain life, and whose failure to perform, when properly used in accordance with instructions for use provided in the labeling and user's manual, can be reasonably expected to result in significant injury.

No complex software or hardware system is perfect. Bugs may always be present in a system of any size. In order to prevent danger to life or property, it is the responsibility of the system designer to incorporate redundant protective mechanisms appropriate to the risk involved.

This user's manual may not cover all of the variations of interface applications, nor may it provide information on every possible contingency concerning installation, programming, operation, or maintenance.

The contents of this user's manual shall not become a part of or modify any prior agreement, commitment, or relationship between the customer and Industrial Control Communications, Inc. The sales contract contains the entire obligation of Industrial Control Communications, Inc. The warranty contained in the contract between the parties is the sole warranty of Industrial Control Communications, Inc., and any statements contained herein do not create new warranties or modify the existing warranty.

Any electrical or mechanical modifications to this equipment without prior written consent of Industrial Control Communications, Inc. will void all warranties and may void any UL/cUL listing or other safety certifications. Unauthorized modifications may also result in equipment damage or personal injury.

## Usage Precautions

### ***Operating Environment***

- Please use the interface only when the ambient temperature of the environment into which the unit is installed is within the following specified temperature limits:  
Operation: -10 ~ +50°C (+14 ~ +122°F)  
Storage: -40 ~ +85°C (-40 ~ +185°F)
- Avoid installation locations that may be subjected to large shocks or vibrations.
- Avoid installation locations that may be subjected to rapid changes in temperature or humidity.

### ***Installation and Wiring***

- Proper ground connections are vital for both safety and signal reliability reasons. Ensure that all electrical equipment is properly grounded.
- Route all communication cables separate from high-voltage or noise-emitting cabling (such as ASD input/output power wiring).

### ***ASD Connections***

- Do not touch charged parts of the drive such as the terminal block while the drive's CHARGE lamp is lit. A charge will still be present in the drive's internal electrolytic capacitors, and therefore touching these areas may result in an electrical shock. Always turn the drive's input power supply OFF, and wait at least 5 minutes after the CHARGE lamp has gone out before connecting communication cables.
- For further drive-specific precaution, safety and installation information, please refer to the appropriate documentation supplied with your drive.
- Internal ASD EEPROMs have a limited life span of write cycles. Observe all precautions contained in this manual and your ASD manual regarding which drive registers safely may and may not be repetitively written to.

# TABLE OF CONTENTS

<b>1. Introduction .....</b>	<b>6</b>
<b>2. Features .....</b>	<b>7</b>
<b>3. Precautions and Specifications .....</b>	<b>9</b>
3.1 Installation Precautions .....	9
3.2 Maintenance Precautions .....	10
3.3 Inspection .....	11
3.4 Storage.....	11
3.5 Warranty.....	11
3.6 Disposal .....	11
3.7 Environmental Specifications .....	12
<b>4. Interface Board Overview .....</b>	<b>13</b>
<b>5. Installation .....</b>	<b>14</b>
5.1 Installation Procedure.....	14
5.2 Installing Multiple Option Cards.....	16
<b>6. LED Indicators .....</b>	<b>17</b>
6.1 Front Panel.....	17
6.2 Ethernet Jack .....	18
<b>7. Configuring the IP Address .....</b>	<b>19</b>
7.1 Via the Finder Utility .....	19
7.2 Via the Drive's Keypad .....	20
7.3 Via the Web Page .....	20
<b>8. Using the ICC Finder Utility .....</b>	<b>21</b>
<b>9. Parameter Numbering .....</b>	<b>22</b>
<b>10. Embedded Web Server.....</b>	<b>24</b>
10.1 Overview .....	24
10.2 Authentication .....	25
10.3 Page Select Tabs.....	25
10.4 Monitor Tab.....	26
10.4.1 Information Window.....	26
10.4.2 Parameter Group Selection List.....	26
10.4.3 Parameter Subgroup Selection List .....	27
10.4.4 Parameter List .....	27

10.4.5	Parameter List Filter .....	28
10.4.6	Radix Selection.....	29
10.5	PROFINET Tab.....	30
10.5.1	Information Window.....	30
10.5.2	Device Identification and Configuration .....	31
10.5.3	I/O Data Configuration Arrays .....	31
10.5.4	Submitting Changes .....	32
10.6	BACnet Tab.....	33
10.6.1	Information Window.....	33
10.6.2	Device Identifiers.....	34
10.6.3	Submitting Changes .....	34
10.7	Config Tab.....	35
10.7.1	Information Window.....	35
10.7.2	Drive Configuration Parameter Write Selection .....	36
10.7.3	Authentication Configuration.....	36
10.7.4	IP Address Configuration.....	37
10.7.5	Timeout Configuration .....	37
10.7.6	Submitting Changes .....	38
10.8	EtherNet/IP Tab .....	39
10.8.1	Information Window.....	39
10.8.2	Device Identification .....	40
10.8.3	Run/Idle Flag Behavior .....	40
10.8.4	Class 1 (I/O) Data Configuration Arrays .....	40
10.8.5	Submitting Changes .....	41
10.9	Alarm Tab.....	43
10.9.1	Information Window.....	44
10.9.2	Email Configuration .....	44
10.9.3	Alarm Configuration.....	45
10.9.4	Submitting Changes .....	47
10.10	Modbus Tab.....	48
10.10.1	Information Window.....	48
10.10.2	Supervisory Timer Selection.....	49
10.10.3	Register Remap Configuration .....	49
10.10.4	Submitting Changes .....	50
10.11	Dashboard Tab.....	51
10.11.1	Information Window.....	52
10.11.2	Gauge Window Navigation .....	52
10.11.3	Gauge Window Configuration.....	52
10.11.4	Submitting Changes .....	56
<b>11.</b>	<b>Interacting With the Filesystem.....</b>	<b>57</b>
11.1	Initiating FTP via the Finder Utility.....	58

11.2	Using FTP with Windows Explorer .....	59
11.3	Using FTP with a Windows Command Prompt.....	60
11.4	Using FTP with Core FTP LE .....	62
<b>12.</b>	<b>Loading New Application Firmware .....</b>	<b>64</b>
<b>13.</b>	<b>Protocol-Specific Information .....</b>	<b>66</b>
13.1	Modbus/TCP .....	66
13.1.1	Overview .....	66
13.1.2	Coil & Discrete Input Mappings .....	67
13.2	EtherNet/IP.....	69
13.2.1	Overview .....	69
13.2.2	ODVA AC/DC Drive Profile.....	70
13.2.3	ControlLogix Examples: Setup .....	73
13.2.4	ControlLogix Example: I/O Messaging .....	75
13.2.5	ControlLogix Example: Generic Default I/O Add-On Instruction .	78
13.2.6	ControlLogix Example: AC/DC Drive Profile Add-On Instruction	81
13.2.7	Explicit Messaging Tag Reference .....	83
13.2.8	ControlLogix Example: Read a Register Block.....	85
13.2.9	ControlLogix Example: Read a Single Register.....	91
13.2.10	ControlLogix Example: Multiple MSG Instructions.....	91
13.2.11	ControlLogix Example: Reading and Writing .....	92
13.3	Allen Bradley CSP.....	94
13.3.1	Tag Reference.....	94
13.3.2	SLC-5/05 Example: Read a Register Block.....	95
13.3.3	SLC-5/05 Example: Read a Single Register.....	100
13.3.4	SLC-5/05 Example: Multiple MSG Instructions.....	101
13.3.5	SLC-5/05 Example: Reading and Writing .....	102
13.4	BACnet.....	104
13.4.1	Overview .....	104
13.4.2	Protocol Implementation Conformance Statement .....	104
13.4.3	Supported Objects.....	108
13.4.4	Supported Object Details.....	110
13.5	PROFINET IO .....	113
13.5.1	Overview .....	113
13.5.2	PROFdrive Profile.....	114

# 1. Introduction

Congratulations on your purchase of the ICC Multiprotocol Ethernet Interface for the Toshiba G9, H9, Q9 and VFAS1 families of Adjustable Speed Drives (ASDs). This interface allows information to be transferred seamlessly between the drive and several different Ethernet-based fieldbus networks with minimal configuration requirements. The interface installs directly into the drive enclosure and presents a standard 10/100BaseT Ethernet port for connection to the Ethernet network. In addition to the supported fieldbus protocols, the interface also hosts an embedded web server, which provides access to all drive information via a standard web browser for remote monitoring, configuration and control.

Before using the interface, please familiarize yourself with the product and be sure to thoroughly read the instructions and precautions contained in this manual. In addition, please make sure that this instruction manual is delivered to the end user of the interface and ASD, and keep this instruction manual in a safe place for future reference or unit inspection.

For the latest information, support software and firmware releases, please visit <http://www.iccdesigns.com>.

Before continuing, please take a moment to ensure that you have received all materials shipped with your kit. These items are:

- Ethernet interface in plastic housing
- Documentation CD-ROM

Note that different interface firmware versions may provide varying levels of support for the various protocols. When using this manual, therefore, always keep in mind that the firmware version running on your interface must match this manual's respective revision in order for all documented aspects to apply.

This manual will primarily be concerned with the interface board's hardware specifications, installation, wiring, configuration and operational characteristics. For more advanced ASD application-level information, please contact Toshiba's ASD Marketing Department for copies of available application notes.

To maximize the abilities of your new ASD interface, a working familiarity with this manual will be required. This manual has been prepared for the interface installer, user, and maintenance personnel. With this in mind, use this manual to develop a system familiarity before attempting to install or operate the interface or ASD.

## 2. Features

### **Ethernet Port**

IEEE 802.3 10/100BaseT Ethernet compliant. Shielded RJ45 connector accepts standard CAT5-type 8-conductor unshielded twisted-pair (UTP) patch cables. Supports multiple simultaneous protocols.

### **Supported Protocols**

The interface currently provides server support for the following fieldbus protocols:

- Modbus TCP
- EtherNet/IP
- Allen Bradley CSP (also known as “PCCC” and “AB Ethernet”)
- BACnet/IP
- PROFINET IO

Note that use of PROFINET IO is mutually exclusive of the other supported protocols. In order to use PROFINET IO, a separate application firmware file must be loaded into the interface (refer to section 12).

### **Adobe® Flash-Enabled Embedded Web Server**

Interface configuration and real-time drive parameter monitoring & control are provided via an embedded web server. The interface's web server feature provides direct data access and control via standard web browsers such as Microsoft Internet Explorer and Mozilla Firefox. The latest version of Adobe Flash Player browser plug-in is required. Refer to section 10.

### **XML Configuration File Upload/Download**

All interface configuration files are stored in the unit's internal filesystem in XML format. These files can be transferred to/from a PC via the FTP protocol, which provides the capability for PC-based file backup and easy configuration copying to multiple units. Configuration files can also be viewed and edited via standard text editors, XML editors and web browsers. Refer to section 11.

### **Email-Based Alarm Notifications**

Up to 20 configurable alarm conditions can be programmed into the interface. Value, logical comparison and time-based conditions can be provided for the interface to autonomously monitor any available drive register. When an alarm condition is triggered, a notification email can be sent to up to four destination email addresses. Refer to section 10.9.

### **Dashboard GUI**

A dashboard tab on the embedded web server provides 10 gauge windows, each of which can be configured to display any available drive register in a variety of meter, graph and gauge formats. Refer to section 10.11.



## **Network Timeout Action**

A configurable network timeout action can be programmed that allows registers to have their own unique "fail-safe" conditions in the event of a network interruption. Refer to section 10.7.5.

## **Field-Upgradeable**

As new firmware becomes available, the interface can be upgraded in the field by the end-user. Refer to section 12 for more information.

## **EtherNet/IP Data Access Options**

The EtherNet/IP protocol provides access to inverter data via explicit messaging, user-defined I/O assembly instances, and the ODVA AC/DC drive profile. Refer to section 13.2 for more information.

## **PROFINET Data Access Options**

The PROFINET protocol provides access to drive data via acyclic services, user-defined cyclic I/O modules, and the PROFIdrive profile. Refer to section 13.5 for more information.

### 3. Precautions and Specifications

**DANGER!**



Rotating shafts and electrical equipment can be hazardous. Installation, operation, and maintenance of the ASD and interface board shall be performed by **Qualified Personnel** only.

**Qualified Personnel** shall be:

- Familiar with the construction and function of the ASD and interface board, the equipment being driven, and the hazards involved.
- Trained and authorized to safely clear faults, ground and tag circuits, energize and de-energize circuits in accordance with established safety practices.
- Trained in the proper care and use of protective equipment in accordance with established safety practices.

Installation of ASD systems and associated interface boards should conform to all applicable **National Electrical Code (NEC) Requirements For Electrical Installations**, all regulations of the **Occupational Safety and Health Administration**, and any other applicable national, regional, or industry codes and standards.

**DO NOT** install, operate, perform maintenance, or dispose of this equipment until you have read and understood all of the following product warnings and user directions. Failure to do so may result in equipment damage, operator injury, or death.

#### 3.1 Installation Precautions

**DANGER!**



- Use lockout/tagout procedures on the branch circuit disconnect before installing the interface board into the ASD.
- Avoid installation in areas where vibration, heat, humidity, dust, metal particles, or high levels of electrical noise (EMI) are present.
- Do not install the ASD or interface board where it may be exposed to flammable chemicals or gasses, water, solvents, or other fluids.
- Where applicable, always ground the interface board appropriately to prevent electrical shock to personnel and to help reduce electrical noise. The ASD's input, output, and control power cables are to be run separately from the interface board's associated cables.

**Note:** *Conduit is not an acceptable ground.*

- Turn the power on only after attaching the front cover.

- Follow all warnings and precautions and do not exceed equipment ratings.
- The ASD maintains a residual charge for a while after turning supply power off. After turning supply power off, wait at least ten minutes before servicing the ASD or interface board. Ensure that the **Charge LED** is off prior to beginning installation.
- For further ASD-specific precaution, safety and installation information, please refer to the applicable *Adjustable Speed Drive Operation Manual* supplied with your ASD.

## 3.2 Maintenance Precautions

**DANGER!**



- Use lockout/tagout procedures on the branch circuit disconnect before servicing the ASD or installed interface board.
- The ASD maintains a residual charge for a while after turning supply power off. After turning supply power off, wait at least ten minutes before servicing the ASD or interface board. Ensure that the **Charge LED** is off prior to beginning maintenance.
- **Do Not** attempt to disassemble, modify, or repair the interface board. Contact your ICC or Toshiba sales representative for repair or service information.
- Turn the power on only after attaching the front cover and **Do Not** remove the front cover of the ASD when the power is on.
- If the ASD should emit smoke or an unusual odor or sound, turn the power off immediately.
- The ASD heat sink and discharge resistors may become extremely hot to the touch. Allow the unit to cool before coming into contact or performing service on the ASD or interface board.
- The system should be inspected periodically for damaged or improperly functioning parts, cleanliness, and to determine that all connectors are tightened securely.

### **3.3 Inspection**

Upon receipt, perform the following checks:

- Inspect the unit for shipping damage.
- Check for loose, broken, damaged or missing parts.

Report any discrepancies to your ICC or Toshiba sales representative.

### **3.4 Storage**

- Store the device in a well ventilated location (in its shipping carton, if possible).
- Avoid storage locations with extreme temperatures, high humidity, dust, or metal particles.

### **3.5 Warranty**

This communication interface is covered under warranty by ICC, Inc. for a period of 12 months from the date of installation, but not to exceed 18 months from the date of shipment from the factory. For further warranty or service information, please contact Industrial Control Communications, Inc. or your local distributor.

### **3.6 Disposal**

- Contact the local or state environmental agency in your area for details on the proper disposal of electrical components and packaging.
- Do not dispose of the unit via incineration.

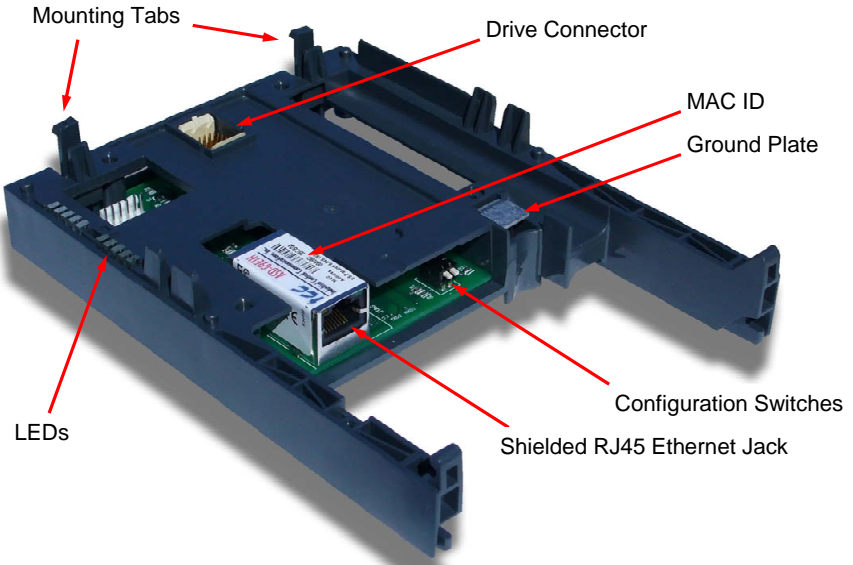
### 3.7 Environmental Specifications

Item	Specification
Operating Environment	Indoors, less than 1000m above sea level, do not expose to direct sunlight or corrosive / explosive gasses
Operating Temperature	-10 ~ +50°C (+14 ~ +122°F)
Storage Temperature	-40 ~ +85°C (-40 ~ +185°F)
Relative Humidity	20% ~ 90% (without condensation)
Vibration	5.9m/s <sup>2</sup> (0.6G) or less (10 ~ 55Hz)
Grounding	Non-isolated, referenced to ASD control power ground
Cooling Method	Self-cooled
Communication Speed	10/100BaseT auto sensing



The ASD-G9ETH interface is lead-free / RoHS-compliant. *Lead Free*

## 4. Interface Board Overview






**Note:** The configuration switches are used for factory test only, and should remain in the OFF (up) position at all times.

## 5. Installation

This interface card has been designed for quick and simple installation. The card is connected to the drive's control board via a 30-pin rectangular connector, and is mechanically supported via an integral housing that seamlessly mates with the drive's enclosure. The only tool required for installation is a flat-blade screwdriver.

Before opening the drive, please observe all safety precautions as outlined on the drive's front cover and in the operation manual.

### 5.1 Installation Procedure

1.  **CAUTION!** Verify that all input power sources to the drive have been turned OFF and are locked and tagged out.
2.  **DANGER!**  Wait at least 5 minutes for the drive's electrolytic capacitors to discharge before proceeding to the next step. **Do not touch any internal parts with power applied to the drive, or for at least 5 minutes after power to the drive has been removed. A hazard exists temporarily for electrical shock even if the source power has been removed.** Verify that the CHARGE LED has gone out before continuing the installation process.
3. Remove the drive's display panel and front cover by inserting a flat-blade screwdriver into each of the two mounting tab access openings at the top of the front cover and depressing each of the mounting tabs (Figure 1). Rotate the top of the front cover outward and remove the cover (Figure 2).

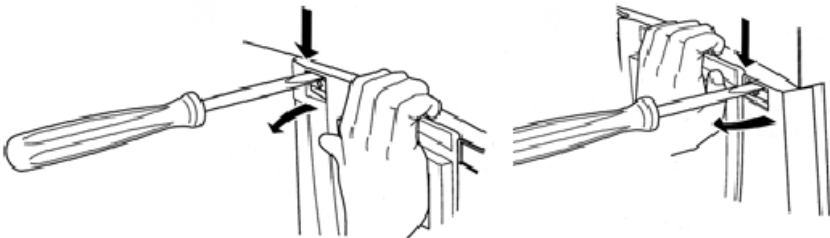
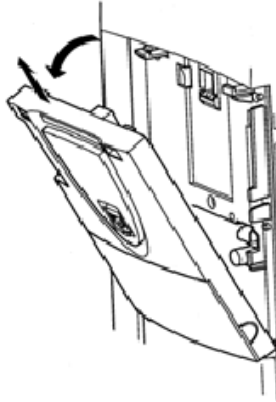
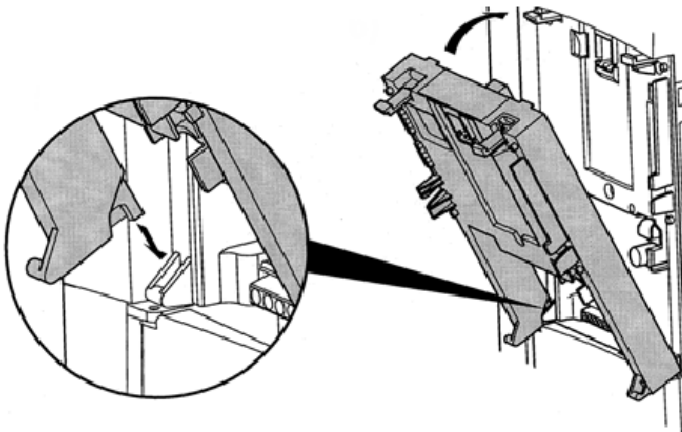


Figure 1: Releasing the Drive's Front Cover



**Figure 2: Removing the Drive's Front Cover**

4. Install the interface card into the drive by inserting the tabs on the lower legs of the interface housing into the corresponding slots on the drive's enclosure. Rotate the interface housing up and press it onto the drive enclosure's mounting tabs, depressing firmly until the housing snaps into place (Figure 3). Double-check that the plastic bosses located on the left and right side of the drive enclosure are properly inserted into the corresponding recesses on the back of the interface housing, and that the interface housing is overall secure and flush with the drive enclosure.

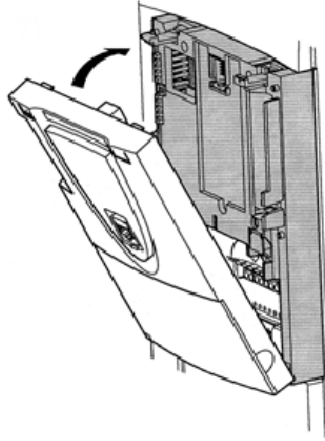


**Figure 3: Installing the Interface Card**

5. Reinstall the drive's front cover by inserting the tabs on the bottom part of the front cover into the corresponding slots on the interface housing. Rotate the front cover up and press it onto the interface housing's mounting tabs,



depressing firmly until the front cover snaps into place (Figure 4). Double-check that the plastic bosses located on the left and right side of the interface housing are properly inserted into the corresponding recesses on the back of the front cover, and that the front cover is overall secure and flush with the interface housing.



**Figure 4: Reinstalling the Drive's Front Cover**

6. Insert the network cable into the Ethernet jack. Ensure that the connector is fully seated into the jack, and route the cable such that it is located well away from any electrical noise sources, such as drive's input power or motor wiring. Also take care to route the cable away from any sharp edges or positions where it may be pinched.
7. Turn the power source to the drive ON, and verify that it functions properly. If the drive does not appear to power up, or does not function properly, immediately turn power OFF. **Repeat steps 1 and 2 to remove all power from the drive.** Then, verify all connections. Contact ICC or your local Toshiba representative for assistance if the problem persists.

## **5.2 Installing Multiple Option Cards**

When this communication interface is installed into a drive in conjunction with an I/O option card, the I/O option card must be installed first (adjacent to the drive's enclosure), and the communication interface must be installed last (adjacent to the drive's front panel).

## 6. LED Indicators

### 6.1 Front Panel

The interface board has 5 bicolor (red/green) LEDs that are visible through the ASD's front cover (labeled 2.1 through 2.5).



Interface Status	2.1
EIP Module Status / Reserved	2.2
EIP Network Status / PROFINET Cnxn Status	2.3
Ethernet Activity	2.4
Heartbeat	2.5



**Interface Status:** Normally solid green during operation. If a fatal error occurs, this LED will flash a red error code. The number of sequential blinks (followed by 3s of OFF time) indicates the error code.

**EIP Module Status / Reserved:** When the multi-protocol firmware image (with EtherNet/IP support) is loaded, this LED conforms to the prescribed “module status LED” behavior as dictated in the EtherNet/IP specification, Volume 2, Chapter 9. When the PROFINET IO firmware image is loaded, this LED is reserved, and therefore always OFF.

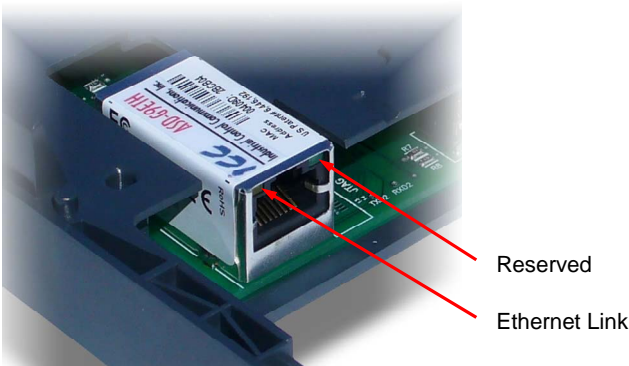
**EIP Network Status / PROFINET IO Connection Status:** When the multi-protocol firmware image (with EtherNet/IP support) is loaded, this LED conforms to the prescribed “network status LED” behavior as dictated in the EtherNet/IP specification, Volume 2, Chapter 9. When the PROFINET IO firmware image is loaded, this LED is on solid green when the controller has established a link with the interface board and is communicating with it.

**Ethernet Activity:** Blinks green briefly when network packets are sent or received.

**Heartbeat:** Blinks green to indicate communication between the interface card and the drive. Contact ICC technical support if a blinking red error code is observed.

## 6.2 Ethernet Jack

The Ethernet jack also contains two embedded LEDs.



**Ethernet Link:** This amber LED is lit whenever a viable Ethernet network is connected to the port.

**Reserved:** This green LED is currently unused and is therefore always OFF.

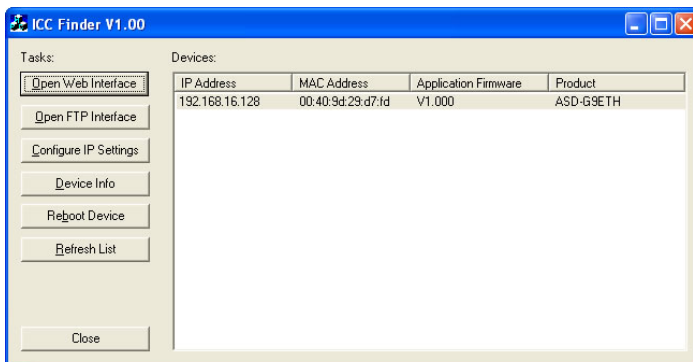
## 7. Configuring the IP Address

Before you can access the interface from your web browser or begin using it as a part of your automation network, you must know its IP address. The interface comes from the factory configured to obtain an IP address dynamically (DHCP/BOOTP). You can determine the interface's current IP address using the discovery software included on the CD provided with the interface, or available from the ICC homepage at <http://www.iccdesigns.com>.

### 7.1 Via the Finder Utility

To configure the interface to use a static IP address:

1. Connect the interface to your network and apply power to the ASD. When the interface boots up, it will attempt to obtain an IP address from a DHCP server or, failing that, will fallback to either the last static IP address assigned, or a default static IP address of 192.168.16.102 if no static IP address has yet been assigned.
2. To determine the initial IP address of your interface, start the `ICC_FINDER.EXE` discovery utility.
3. The discovery utility scans the network for ICC devices and then lists each device's **IP Address**, **MAC Address**, **Firmware Version** and **Product ID**. Identify your device by its MAC address (printed on a label on the top of the Ethernet network jack). Refer to Figure 5.



**Figure 5: ICC Finder Discovery Utility**

4. To change the IP address, select the device in the list of detected devices and click the **Configure IP Settings** button.
5. In the dialog that appears, select **Manually configure network settings**.

6. Enter the desired **IP Address**, **Subnet Mask** and **Default Gateway** in the appropriate boxes, then click **Apply**.
7. Enter the case-sensitive system password (default is “icc”) in the Authentication dialog box, then click **Submit**.
8. A popup dialog box will prompt you to reboot. Click **Reboot**. Rebooting may require 30s or more to complete. When the device status indicates “Ready”, click **Close**.
9. The discovery utility will automatically rescan the network. Confirm that the new IP address has been accepted by the device.

## 7.2 Via the Drive’s Keypad

This section applies to G9 (drive control board firmware V203R5 and later) and H9 (drive control board firmware V204R4) drives only.

The interface card’s IP Address, Subnet Mask, Default Gateway, and DHCP/Static IP mode can be viewed and modified via the drive’s keypad by navigating to *Program...Communications...Ethernet Settings*. Additionally, the interface card’s unique MAC ID can be viewed (but not modified) in this screen.

Note that these parameter values are read by the interface card only during initial boot-up. Therefore, be sure to power cycle the drive whenever any of these values are changed to allow the changes to take effect.

## 7.3 Via the Web Page

Once an initial IP address has been assigned to the device and the configuration web page can be accessed, the IP address-related parameters can also be modified via the web page. Refer to section 10.7.4.

## 8. Using the ICC Finder Utility

The “ICC Finder” utility is a simple Windows PC program (just a single .exe file, no installations, DLL’s etc.), which when executed discovers all ICC communication interfaces on the current Ethernet subnet, regardless of whether or not their network parameters are currently compatible with the subnet upon which they reside. Refer to Figure 5 on page 19.

In order for the Finder application to discover devices, certain UDP Ethernet traffic must be allowed in and out of the computer, and firewall applications (such as Windows Firewall) are often configured to block such traffic by default. If the Finder is unable to discover any devices on the current subnet, be sure to check the computer’s firewall settings during troubleshooting, and add an exception to the firewall configuration if necessary.

All discovered devices can be organized in ascending or descending order by clicking on the desired sort header (IP Address, MAC Address, Application Firmware or Product). The buttons on the left side of the window perform the following actions:

**Open Web Interface:** Opens a web browser page of the selected device. Refer to section 10.

**Open FTP Interface:** Opens the computer’s default FTP application, which could be either Windows Explorer, a web browser, or a 3<sup>rd</sup>-party FTP program (whatever the computer/operating system is configured for by default). This allows you to interact directly with the unit’s on-board flash filesystem, enabling you to drag and drop files to/from the unit and upload new firmware. Refer to section 11.

**Configure IP Settings:** Allows configuration of whether the device will use static IP parameters or will obtain its IP parameters via DHCP. Refer to section 7 for more information.

**Device Info:** Opens a dialog box containing relevant device information.

**Reboot Device:** Opens a dialog box which prompts for a password to reboot the interface. Enter the case-sensitive system password (default is “icc”), then click **Reboot**. The reboot cycle has completed when the displayed status changes from “Rebooting” to “Ready” (note that this may require 30s or more to complete.) Clicking **Close** will then close the dialog box and cause the discovery utility to automatically rescan the network.

**Refresh List:** Causes the discovery utility to rescan the network.

**Close:** Closes the discovery utility.

## 9. Parameter Numbering

Inspection of the Toshiba ASD user's manual reveals that the ASD's parameters are organized as hexadecimal numbers ranging from F000 to FFFF. These parameters are made accessible to the interface board as "registers", and are numerically remapped to present a more natural interface to the communications user. There are 1500 total registers available via the interface board, and their mappings are as shown in Table 1.

**Table 1: ASD Parameter-to-Register Mapping**

Hexadecimal ASD Parameter Numbers...	...Map to Decimal Register Numbers
F000 - F999	1 - 1000
FA00 - FA99	1001 - 1100
FB00 - FB99	1101 - 1200
FC00 - FC99	1201 - 1300
FD00 - FD99	1301 - 1400
FE00 - FE99	1401 - 1500

This mapping is easier to understand if one just uses the interface's web page as a guide (refer to Figure 6 and section 10.4.4). The "parameter" numbers (ASD references) and "register" numbers (network references) for all available parameters are shown in the first two columns. Commanding the drive over the network therefore entails writing to registers 1007 (option board command 1) and 1008 (option board frequency command), which correspond to ASD parameters FA06 and FA07, respectively.

Parameter	Register	Description
FA00	1001	Command 1 (2-wire RS485)
FA01	1002	Frequency command value
FA03	1004	Operation panel operation
FA04	1005	Command 1 (4-wire RS485)
FA05	1006	Frequency command value
FA06	1007	Command 1 (internal op)
FA07	1008	Frequency Command (internal op)
FA09	1010	Acceleration/deceleration
FA10	1011	Panel key selection
FA11	1012	External communication
FA20	1021	Command 2 (2-wire RS485)
FA22	1023	Command 2 (4-wire RS485)
FA23	1024	Command 2 (internal op)
FA30	1031	Torque command value
FA32	1033	Torque command value
FA33	1034	Torque command value
FA50	1051	Terminal output data
FA51	1052	FM analog output data
FA52	1053	AM analog output data

**Figure 6: Web Page Register Assignment Reference**

To avoid confusion, when this user's manual uses the term "parameter", it will be referring to the ASD's hexadecimal number as documented in the ASD user's manual. Similarly, when this user's manual uses the term "register", it will be referring to the decimal number as it is exposed to the network interface.

Note that although 1500 total registers are available in the register space, not all of those registers have corresponding parameters that exist in the drive. In other words, if a read from or write to a register that does not correspond to an existing drive parameter takes place, the read/write will be successful, but the data will have no meaning. This feature is beneficial in situations where the accessing of non-contiguous registers can be made more efficient by accessing an all-inclusive block of registers (some of which correspond to drive parameters and some of which do not), while only manipulating those in your local programming that are known to exist.

For a complete listing of all available drive parameters, their bit mappings, scaling values etc., please refer to the Toshiba "TOSVERT VF-AS1 Series RS485 Communication Function Instruction Manual" (Toshiba document #E6581315). As a user convenience, the structure of the commonly-used "option board command 1" word (drive parameter FA06 / register 1007) is replicated here (refer to Table 2).

**Table 2: Structure of "Command 1" Word (Drive Parameter FA06)**

bit	Specifications	0	1	Remarks
0	Preset speed operation frequencies 1	Preset speed operation is disabled or preset speed operation frequencies (1-15) are set by specifying bits for preset speed operation frequencies 1-4.  (0000: Preset speed operation OFF, 001-1111: Setting of preset speed operation frequencies (1-15))		
1	Preset speed operation frequencies 2			
2	Preset speed operation frequencies 3			
3	Preset speed operation frequencies 4			
4	Motor selection (1 or 2) (THR 2 selection)	Motor 1 (THR 1)	Motor2 (THR2)	THR1 : <i>EHr</i> THR2 : <i>F173</i>
5	PI control	Normal operation	PI OFF	
6	Acceleration/deceleration pattern selection (1 or 2) (AD2 selection)	Acceleration/deceleration pattern 1 (AD1)	Acceleration/deceleration pattern 2 (AD2)	AD1 : <i>ACC, dEC</i> AD2 : <i>F500, F501</i>
7	DC braking	OFF	Forced DC braking	
8	Jog run	OFF	Jog run	
9	Forward/reverse run selection	Forward run	Reverse run	
10	Run/stop	Stop	Run	
11	Coast stop command	Standby	Coast stop	
12	Emergency stop	OFF	Emergency stop	Always enabled, "E" trip
13	Fault reset	OFF	Reset	No data is returned from the inverter.
14	Frequency priority selection	OFF	Enabled	Enabled regardless of the setting of <i>FADd</i>
15	Command priority selection	OFF	Enabled	Enabled regardless of the setting of <i>CADd</i>



# 10. Embedded Web Server

## 10.1 Overview

The interface contains an embedded web server (also known as an HTTP server), which allows users to access the drive's internal data in a graphical manner with web browsers such as Microsoft Internet Explorer or Mozilla Firefox. In this way, the drive can be monitored, configured and controlled from across the room or from across the globe.

In order to view the interface's web page, the free Adobe Flash Player browser plug-in is required. If the plug-in is not already installed on your computer, then your browser will automatically be redirected to the appropriate Adobe download web site when you initially attempt to access the interface's web page. Alternatively, the plug-in can be downloaded directly by going to <http://www.adobe.com>, and choosing the "get Adobe Flash Player" link. Always ensure that you have the latest version of the Flash Player installed: if some aspect of the web page does not appear to be displayed properly, installing the latest Flash Player update usually resolves the problem.

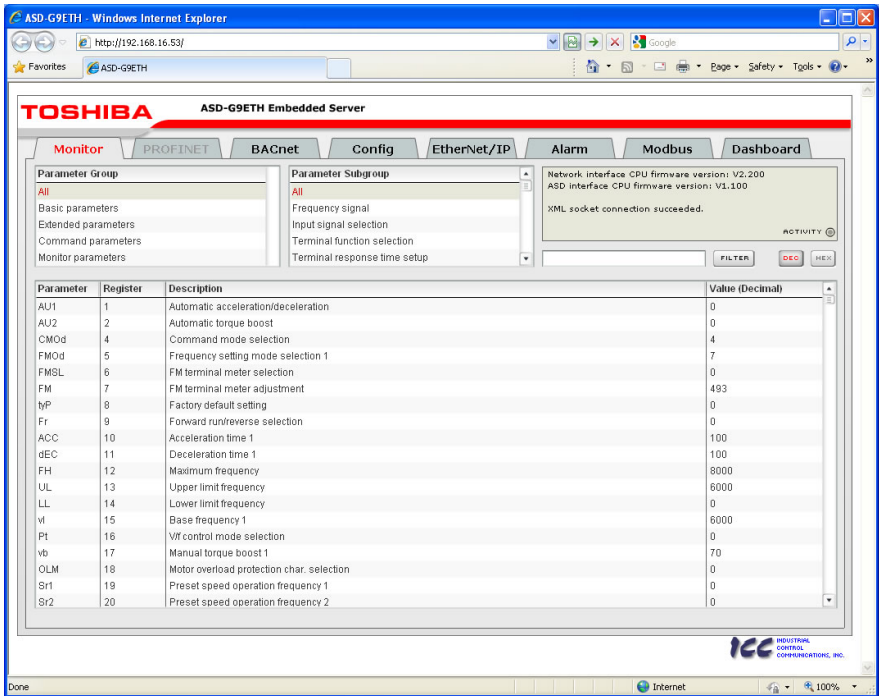


Figure 7: Embedded Web Server

To access an interface's embedded web server, either use the finder utility (refer to section 8) and select the "Open Web Interface" button when the target unit is highlighted, or just directly enter the target unit's IP address into the address (URL) field of your web browser. Refer to Figure 7 for a representative screenshot of the web server interface.

In order to access the web server and view the parameter values, destination TCP ports 80 and 2000 must be accessible from the client computer. If an "XML socket connection failed" error message is displayed in the information window, and no parameter values are shown, this is typically indicative of port 2000 being blocked by a firewall or Ethernet router situated between the client computer and the interface card.

## 10.2 Authentication

For security, the interface requires valid user authentication whenever the web page is accessed. The authentication request will appear as a browser popup box that will request entry of a user name and password. Refer to Figure 8.

The factory-default user name is "root", and the password is "icc". Note that the username and password are case-sensitive, and that once authenticated, the authentication will remain in effect from that point until all browser windows are closed. The authentication credentials can also be changed from their default settings (refer to section 10.7.3.)



Figure 8: Web Server Authentication

## 10.3 Page Select Tabs

The web interface is subdivided into several different "tabs" of associated information, much the same as how folders in a filing cabinet are arranged. Refer to Figure 9. To change tabs, just click on the tab you wish to view. The title of the currently-selected tab is red. Note that because different protocols are supported by the interface with different firmware images, not all tabs may be accessible with the firmware image currently loaded. The titles of tabs that are not accessible are grayed-out, and clicking them has no effect.



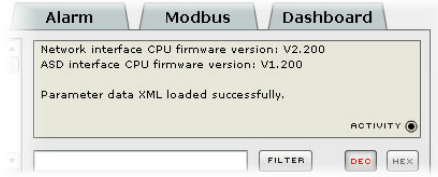
Figure 9: Page Select Tabs

## 10.4 Monitor Tab

### 10.4.1 Information Window

Figure 10 shows the Information Window, which is located in the upper-right hand corner of the monitor tab.

This window displays various informational messages regarding the status of the interface card or web browser session. There is also an “activity” indicator located in the lower-right hand corner of the Information Window, which blinks periodically to show the status of data communication between the web browser and the interface card. If you do not observe the activity indicator blink at all for several seconds or more, it is possible that the web browser may have lost contact to the web server due to a drive reset or a network problem: to reestablish communications, select “refresh” on your web browser.



**Figure 10: Monitor Tab Information Window**

### 10.4.2 Parameter Group Selection List

The Parameter Group Selection List is located in the upper-left hand corner of the Monitor Tab. Refer to Figure 11. Individual groups can be selected by clicking on the group name. Multiple groups may also be selected by holding down the CTRL key while clicking on the group names, or a range of groups can be selected by first selecting the starting group, and then holding down the SHIFT key while selecting the last group in the range. When a parameter group is selected, the parameter subgroups (if any) contained in that parameter group are displayed in the Parameter Subgroup Selection List (refer to section 10.4.3), and the corresponding parameters are displayed in the Parameter List (refer to section 10.4.4). The following parameter groups are available:



**Figure 11: Parameter Group Selection List**

**All:** All parameters are available (configuration, command and monitor parameters).

**Basic Parameters:** The configuration parameters most commonly used for drive setup are available.

**Extended Parameters:** All other configuration parameters that are not “basic parameters” are available.

**Command Parameters:** Drive command parameters are available. Note that although all parameters associated with drive control are available in this selection, only those parameters that are identified as being for the “internal option board” can

be used to actually control the drive via the option board: all other drive command parameters can only be monitored via the option board.

**Monitor Parameters:** Drive monitor parameters are available.

### 10.4.3 Parameter Subgroup Selection List

Subgroups can be used to further filter the parameters of a group that are to be displayed in the Parameter List. Refer to Figure 12.



**Figure 12: Parameter Subgroup Selection List**

If the group currently selected in the Parameter Group Selection List (refer to section 10.4.2) has subgroups available, then choosing one or more desired subgroups will further filter the parameters that are displayed in the Parameter List. If the currently-selected group does not have any available subgroups, then only the “All” subgroup will be shown, and all parameters in that group will be shown in the Parameter List.

### 10.4.4 Parameter List

The bottom half of the Monitor tab contains the parameter list (refer to Figure 13). The parameters that are displayed in the list at any given time depend on the groups/subgroups selected, as well as whether or not any filters have been applied (refer to section 10.4.5).

Parameter	Register	Description	Value (Decimal)
AU1	1	Automatic acceleration/deceleration	0
AU2	2	Automatic torque boost	0
CMOd	4	Command mode selection	1
FMOd	5	Frequency setting mode selection 1	4
FMSL	6	FM terminal meter selection	509
FM	7	FM terminal meter adjustment	0
tYP	8	Factory default setting	0
Fr	9	Forward run/reverse selection	0
ACC	10	Acceleration time 1	178
dEC	11	Deceleration time 1	30
FH	12	Maximum frequency	8000
UL	13	Upper limit frequency	6000
LL	14	Lower limit frequency	0
vf	15	Base frequency 1	6000

**Figure 13: Parameter List**

The first two columns of the Parameter List show the parameter name and the register number that provides access to that parameter, and were discussed in detail in section 9. The third column contains the parameter descriptions, which are used by the filter function. The last column performs two functions: it displays the current

value of the parameter, and also allows changing the parameter's value by clicking on the number in the value column and entering the new value.

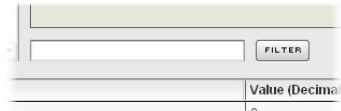
Some items to keep in mind when interacting with the Parameter List are:

- When entering new parameter values, be sure that the number being entered is appropriate for the currently-selected radix (refer to section 10.4.6): for example, an entered value of "1000" in hexadecimal is equal to 4096 in decimal.
- If desired, the column widths can be changed by dragging the vertical bars that separate the header row's cells to a different position.
- If you begin changing a parameter value and then decide to abandon the change, pressing the ESC key on your keyboard will abandon the change and redisplay the current parameter value.
- When editing a parameter value, clicking someplace off the entry cell is equivalent to hitting the ENTER key.

## 10.4.5 Parameter List Filter

A filter function provides Parameter List search capabilities. To use the filter function, simply type a word or portion of a word into the filter entry box and then click the "filter" button. Refer to Figure 14.

The filter will then display only those parameters currently available in the Parameter List that satisfy the search criteria. For example, to find all monitor parameters that contain some derivative of the word "volt" (such as "voltage" or "volts"), select the "Monitor Parameters" group, the "All" subgroup, enter "volt" in the filter entry box, and then click the "filter" button.



**Figure 14: Parameter List Filter**

Once a filter has been entered, it will continue to be applied to all information normally displayed in the Parameter List for as long as the filter term is left in the filter entry box. Continuing the previous example where we filtered on the root term "volt" in the monitor parameters, we can then easily apply this filter to all parameters (configuration, command or monitor) simply by selecting the "All" parameter group. The Parameter List will now display all configuration, command or monitor parameters that contain the root term "volt".

To remove the filter, delete any characters contained in the filter entry box and then click the "filter" button.

### 10.4.6 Radix Selection

Figure 15 shows the radix selection buttons. These selection buttons allow changing the Parameter List “value” column data display and entry radix between decimal and hexadecimal formats.



**Figure 15: Radix Selection**

When “DEC” is selected, the “value” column heading will be “*Value (Decimal)*”, current parameter values will be displayed in decimal, and values to be written to parameters must be entered in decimal format. For example, to change the drive’s frequency command to 40.00Hz, enter the decimal value 4000.

Similarly, when “HEX” is selected, the “value” column heading will be “*Value (Hexadecimal)*”, current parameter values will be displayed in hexadecimal, and values to be written to parameters must be entered in hexadecimal format. For example, to turn on bits #15, #14 and #10 in the drive’s “command 1” word, enter the hexadecimal number C400.

## 10.5 PROFINET Tab

This section is only applicable when the PROFINET firmware is loaded onto the interface card. The PROFINET tab provides for the configuration of the device on a PROFINET network. Refer to Figure 16.

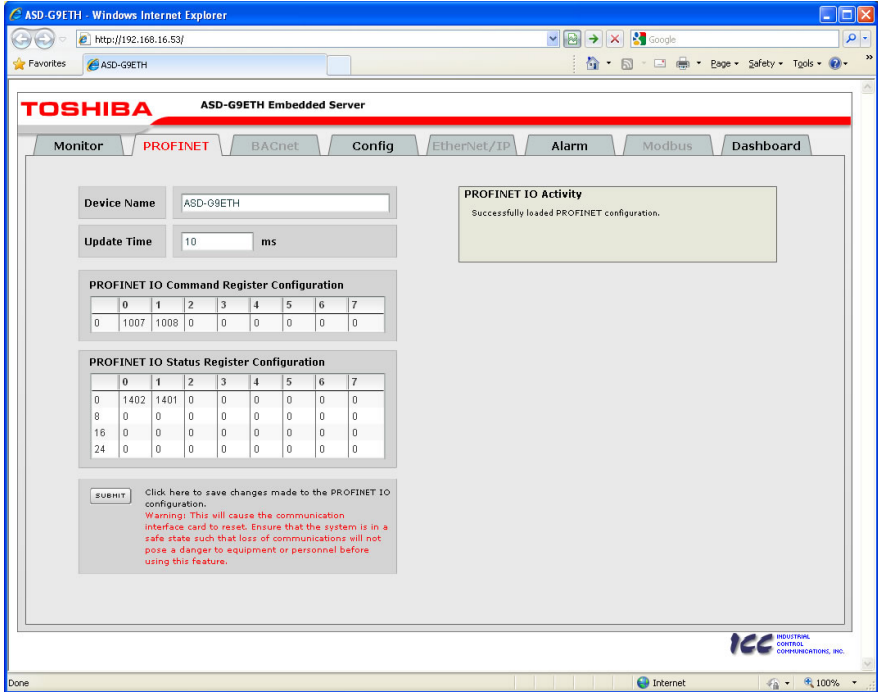


Figure 16: PROFINET Tab

### 10.5.1 Information Window

Figure 17 shows the Information Window, which is located in the upper-right hand corner of the PROFINET tab. This window displays various informational messages regarding the status of the PROFINET configuration (loading or submitting).



Figure 17: PROFINET Tab Information Window

## 10.5.2 Device Identification and Configuration

There are several identification and configuration items available for setting various characteristics of the PROFINET device. These items are shown in Figure 18 and are explained in further detail below.

**Figure 18: PROFINET Device Identification and Configuration**

A PROFINET device's name (station name) must be unique across the entire PROFINET network because it is used by controllers to uniquely identify PROFINET devices. The **Device Name** text entry box is used to configure this unique device identifier on every drive.

The **Update Time** field is a configuration item which changes the frequency with which command and status data updates take place internally in the device. This setting is not related to the frequency with which data communications take place on the Ethernet network. This time setting is a 32-bit value adjustable in 1ms increments. Typically, this value should not need to be changed from its default value of 10ms. Please note that this setting is not related and should not be confused with the I/O Cycle Update Time (in Step 7 or an equivalent hardware configuration tool).

## 10.5.3 I/O Data Configuration Arrays

The interface card supports two different types of PROFINET data transfer. One type is included with the implementation of the PROFIdrive profile, and requires no user configuration (refer to section 13.5 for more information). The other type, however, is entirely user-configurable, and is utilized when a standard "IN: XX, OUT:YY" I/O module is chosen during network configuration.

	0	1	2	3	4	5	6	7
0	1007	1008	0	0	0	0	0	0

	0	1	2	3	4	5	6	7
0	1402	1401	0	0	0	0	0	0
8	0	0	0	0	0	0	0	0
16	0	0	0	0	0	0	0	0
24	0	0	0	0	0	0	0	0

**Figure 19: I/O Data Configuration**

The I/O data configuration arrays consist of two separate elements (refer to Figure 19.) The command register configuration defines the structure of the command data sent from the PROFINET controller to the drive, and the status register configuration defines the structure of the status data sent from the drive back to the controller. These arrays allow the creation of custom-built I/O data. Up to 8 command registers can be sent to the drive, and up to 32 status registers can be sent back to the controller. Each box in an array is capable of containing a register number. Because all drive registers are



16-bit data elements, each box therefore represents two bytes of input or output data.

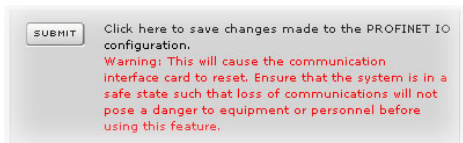
The command register array locations are numbered 0-7, and traverse from left to right. The status register array locations are numbered 0-31, and traverse from left to right across each row, and then increment to the left-most position on the next row. Clicking on a box in an array allows the user to enter a register number that will be referenced at that location when data is either received from or sent to the controller. A value of 0 indicates that no register is referenced at that location, which will cause corresponding command data to be ignored and status data to be a default value of 0.

As an example, looking at the default configuration shown in Figure 19, we can see that each array contains two defined registers. Therefore, up to 4 “meaningful” bytes of data can be both received and sent (the qualifier “meaningful” is used here because the module currently selected by the controller may require larger input and/or output data sizes, but all unreferenced command data will be ignored, and all unreferenced status data will contain dummy “0” values). The first word (two bytes) of command data will be written to register 1007 (command 1) and the second word will be written to register 1008 (frequency command). Similarly, the first word of status data will contain the value of register 1402 (status 1) and the second word will contain the value of register 1401 (output frequency).

## 10.5.4 Submitting Changes

Whenever any of the PROFINET configuration elements (I/O array configuration, Device Name, etc.) have been changed, the “submit” button located in the lower left-hand portion of the web page must be clicked in order to write these settings to the interface card’s filesystem.

Note that because these configuration elements are read from the filesystem only when the interface card boots up, the act of submitting configuration changes will also reset the interface card. Please allow 30 seconds for the interface card to reboot, at which time it will then be operating with the recently-submitted configuration. Refer to Figure 20.



**Figure 20: Submit PROFINET Changes**

## 10.6 BACnet Tab

The BACnet tab provides for the configuration of the device on a BACnet/IP network. Refer to Figure 21.

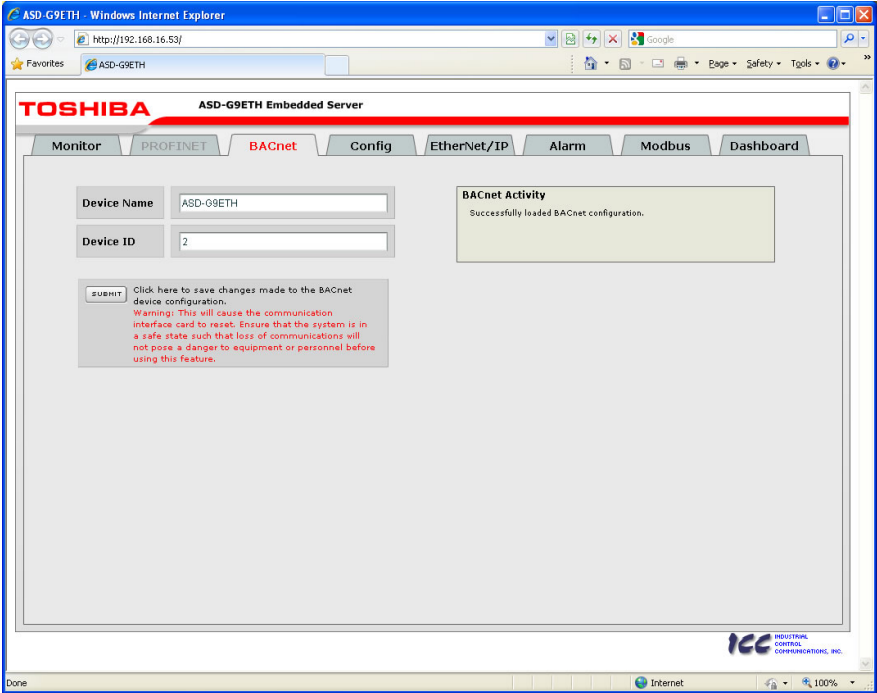


Figure 21: BACnet Tab

### 10.6.1 Information Window

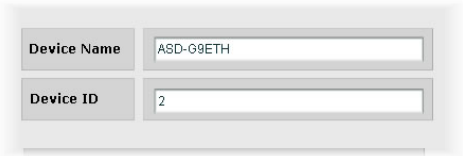
Figure 22 shows the Information Window, which is located in the upper-right hand corner of the BACnet tab. This window displays various informational messages regarding the status of the BACnet configuration (loading or submitting).



Figure 22: BACnet Tab Information Window

## 10.6.2 Device Identifiers

A BACnet device's name and ID (the Object\_Name and Object\_Identifier properties, respectively, of the Device Object) must be unique across the entire BACnet network because they are used to uniquely identify BACnet devices. The text entry boxes shown in Figure 23 are used to configure these unique device identifiers on every drive.



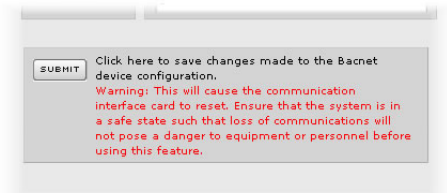
The image shows a web form with two input fields. The first field is labeled "Device Name" and contains the text "ASD-09ETH". The second field is labeled "Device ID" and contains the number "2".

**Figure 23: BACnet Device Identifiers**

## 10.6.3 Submitting Changes

Whenever either of the BACnet configuration elements (Device Name or Device ID) has been changed, the “submit” button located in the left-hand portion of the web page must be clicked in order to write these settings to the interface card's filesystem.

Note that because these configuration elements are read from the filesystem only when the interface card boots up, the act of submitting configuration changes will also reset the interface card. Please allow 30 seconds for the interface card to reboot, at which time it will then be operating with the recently-submitted configuration. Refer to Figure 24.



The image shows a dialog box with a "SUBMIT" button on the left. To the right of the button is a warning message: "Click here to save changes made to the Bacnet device configuration. Warning: This will cause the communication interface card to reset. Ensure that the system is in a safe state such that loss of communications will not pose a danger to equipment or personnel before using this feature."

**Figure 24: Submit BACnet Changes**

## 10.7 Config Tab

The Config tab provides access to various configuration items. Refer to Figure 25.

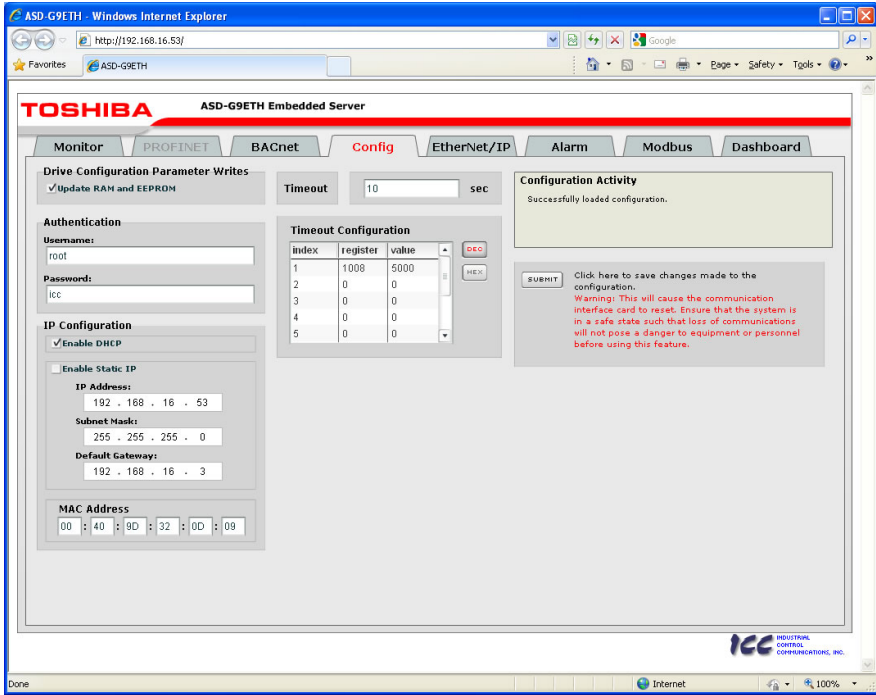


Figure 25: Config Tab

### 10.7.1 Information Window

Figure 26 shows the Information Window, which is located in the upper-right hand corner of the Config tab. This window displays various informational messages regarding the status of the configuration parameters (loading or submitting).



Figure 26: Config Tab Information Window

## 10.7.2 Drive Configuration Parameter Write Selection

Figure 27 shows the check box selection that determines whether drive configuration parameters (registers 1..1000) will be written only to the drive's RAM, or to both the drive's RAM and EEPROM when they are changed via the interface card.



**Figure 27: RAM Only or RAM/EEPROM Write Selection**

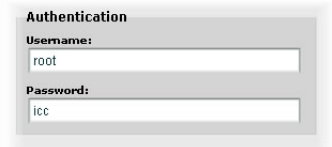
If written to RAM only, then parameter value changes will be lost when the drive is power cycled or otherwise reset. If written to both RAM and EEPROM, then parameter value changes will be retained. When enabling writes to EEPROM, be sure to always observe Toshiba's restrictions on the number of times a configuration parameter may be written to EEPROM before possible EEPROM damage occurs.

This selection affects all configuration parameters, and applies regardless of the interface card mechanism used to modify the parameters (control protocol data write, modification via the web page "monitor" tab, timeout configuration setting etc.)

Note that ASD Interface CPU firmware version V1.100 or later is required for this feature to be supported (refer to Figure 10 on page 26 for how to determine the ASD interface CPU version.)

## 10.7.3 Authentication Configuration

Figure 28 shows the entry boxes used to modify the authentication credentials. The case-sensitive username and password can contain letters ("a".."z" and "A".."Z") and numbers ("0".."9"), and can each be up to 80 characters in length.

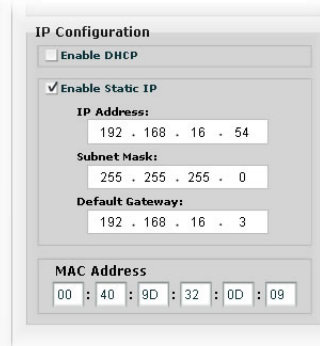


**Figure 28: Authentication Configuration**

Be sure to make a note of the new settings whenever these credentials are changed, as they must be entered whenever the web page is accessed, an FTP session is initiated, or when a configuration change is performed via the Finder utility. Contact ICC for assistance if you have forgotten your customized credentials.

## 10.7.4 IP Address Configuration

Figure 29 shows the configuration items used to modify the IP address-related parameters. Modification of these settings is consistent with the technique used with the Finder utility (refer to section 7.1). Figure 29 also shows the text entry boxes that are used to view and/or modify the unique MAC address of the interface card. The MAC address should not be changed without first consulting ICC Technical Support.



**Figure 29: IP Address Configuration**

## 10.7.5 Timeout Configuration

The interface can be configured to perform a specific set of actions when network communications are lost. Support for this feature varies depending on the protocol: refer to the protocol-specific section of this manual for further information.

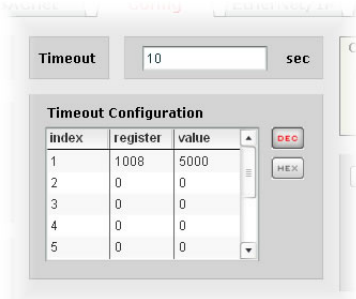
There are two separate elements that comprise the timeout configuration (refer to Figure 30):

- The timeout time
- The timeout configuration array

The **timeout time** is a floating-point number which allows adjustment down to 1/100<sup>th</sup> of a second (0.01 second increments). This time setting is used by certain protocols in order to determine abnormal loss-of-communications conditions and, optionally, to trigger a timeout processing event. The default timeout time is 10s.

The **timeout configuration array** allows up to 10 register/value pairs to be designated by the user. When a timeout event is triggered by a protocol, the timeout configuration array indexes are parsed. If the “register” field for an index is set to 0, then this index is “disabled” and therefore ignored. If, on the other hand, the “register” field is non-zero, then the value contained in the “value” field is automatically written to the designated register. This flexible mechanism allows up to 10 designated drive registers to have their own unique “fail-safe” conditions in the event of a network interruption.

For example, Figure 30 shows a timeout time of 10s, and one timeout entry assignment. If a protocol that makes use of timeout processing triggers a timeout event, then a value of 5000 will automatically be written to drive register 1008 (the frequency command). Provided the drive has a valid “run” command and is currently



**Figure 30: Timeout Configuration**

configured to use the network frequency command as its master frequency command, it will ramp to 50.00Hz.

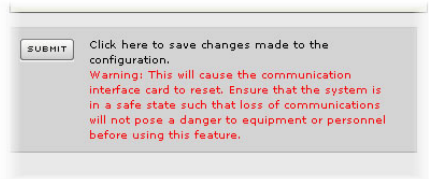
If timeout/failsafe processing is not desired, just set the “register” fields for all indexes to 0 (disabled). This is the default condition.

“DEC” and “HEX” selection buttons are also available, and allow changing the “value” column data display and entry radix between decimal and hexadecimal formats, respectively. These buttons provide the ability to interact with the various drive registers in their most natural radix (e.g. a hexadecimal command word vs. a decimal frequency command value).

## 10.7.6 Submitting Changes

Whenever any of the configuration elements has been changed, the “submit” button located in the right-hand portion of the web page must be clicked in order to write these settings to the interface card’s filesystem.

Note that because these configuration elements are read from the filesystem only when the interface card boots up, the act of submitting configuration changes will also reset the interface card. Please allow 30 seconds for the interface card to reboot, at which time it will then be operating with the recently-submitted configuration. Refer to Figure 31.



**Figure 31: Submit Configuration Changes**

## 10.8 EtherNet/IP Tab

The EtherNet/IP tab provides access to configuration items related to communication on an EtherNet/IP network. Refer to Figure 32.

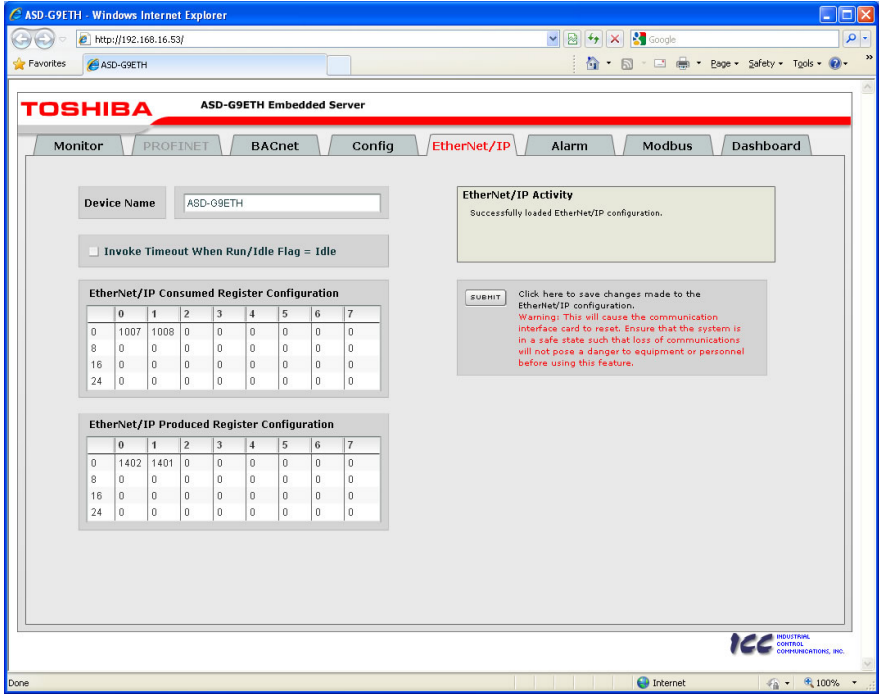


Figure 32: EtherNet/IP Tab

### 10.8.1 Information Window

Figure 33 shows the Information Window, which is located in the upper-right hand corner of the EtherNet/IP tab. This window displays various informational messages regarding the status of the EtherNet/IP configuration parameters (loading or submitting).



Figure 33: EtherNet/IP Tab Information Window



## 10.8.2 Device Identification

A text entry box is available which allows customization of the device's name for identification on the EtherNet/IP network. This string is accessible as the "product name" attribute of the identity object. Refer to Figure 34.



**Figure 34: EtherNet/IP Device Identification**

## 10.8.3 Run/Idle Flag Behavior

EtherNet/IP clients (such as PLCs) have the option of adding a 32-bit "run/idle" header to all class 1 (I/O) data packets sent to devices. Bit 0 of this header is called the "run/idle flag" by the EtherNet/IP specification, and is intended to signify when the client is in a "running" state or an "idle" state.

A running state (run/idle flag = Run) is indicated whenever the client is performing its normal processing (e.g. scanning its ladder logic). An idle state (run/idle flag = Idle) is indicated otherwise. For example, Allen Bradley ControlLogix PLCs will set their run/idle flag to Idle whenever their processor keyswitch is placed in the "PROG" position, presumably in preparation to receive a new application program from RSLogix.



**Figure 35: Run/Idle Flag Behavior Selection**

The behavior of EtherNet/IP devices when they receive I/O data from a controller with the run/idle flag set to Idle is not specified in the EtherNet/IP specification. The interface card allows the option of two different behavioral responses when a run/idle flag = Idle condition is received, depending on the state of the checkbox indicated in Figure 35.

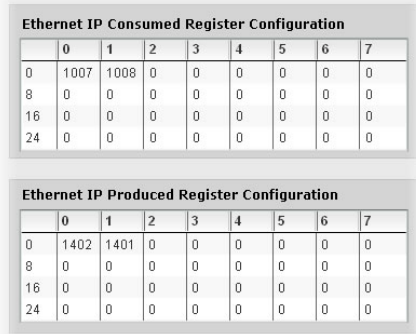
- If the checkbox is cleared (default setting), then the interface card will maintain the last I/O data values received from the client. For example, if the inverter was being commanded to run prior to the run/idle flag being set to Idle, then it will continue to run.
- If the checkbox is checked, then the interface card will invoke its user-configured timeout processing (refer to section 10.7.5). This setting allows the user to determine any inverter behavior they may desire (stop the inverter, fault the inverter, ramp to a preset speed, etc.)

## 10.8.4 Class 1 (I/O) Data Configuration Arrays

The interface card supports two different types of EtherNet/IP class 1 (I/O) data transfer. One type is included with the implementation of the AC/DC drive profile, and requires no user configuration. The other type, however, is entirely user-

configurable, and is utilized when the client opens a connection to the interface using assembly instances 100 and 150.

The user-configurable data arrays consist of two separate elements (refer to Figure 36.) The consumed register configuration defines the structure of the command data sent from the EtherNet/IP controller (for example, a ControlLogix PLC) to the drive, and the produced register configuration defines the structure of the status data sent from the drive back to the controller. These arrays allow the creation of custom-built I/O data. Up to 32 command registers can be sent to the drive, and up to 32 status registers can be sent back to the controller. Each box in an array is capable of containing a register number. Because all drive registers are 16-bit data elements, each box therefore represents two bytes of consumed or produced data.



**Figure 36: EtherNet/IP Class 1 (I/O) Data Configuration**

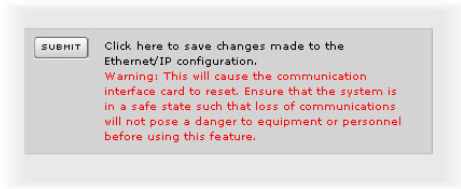
Each of the register array locations are numbered 0-31, and traverse from left to right across each row, and then increment to the left-most position on the next row. Clicking on a box in an array allows the user to enter a register number that will be referenced at that location when data is either consumed from the controller or produced to the network. A value of 0 indicates that no register is referenced at that location, which will cause the corresponding consumed data to be ignored and produced data to be a default value of 0.

As an example, looking at the default configuration shown in Figure 36, we can see that each array contains two defined registers. Therefore, up to 4 “meaningful” bytes of data can be both received and sent (the qualifier “meaningful” is used here because the connection sizes configured in the controller may request larger consumed and/or produced data sizes, but all unreferenced consumed data will be ignored, and all unreferenced produced data will contain dummy “0” values). The first word (two bytes) of consumed data will be written to register 1007 (command 1) and the second word will be written to register 1008 (frequency command). Similarly, the first word of produced data will contain the value of register 1402 (status 1) and the second word will contain the value of register 1401 (output frequency).

### 10.8.5 Submitting Changes

Whenever any of the EtherNet/IP configuration elements (Device Name or I/O array configurations) have been changed, the “submit” button located in the right-hand portion of the web page must be clicked in order to write these settings to the interface card’s filesystem.

Note that because these configuration elements are read from the filesystem only when the interface card boots up, the act of submitting configuration changes will also reset the interface card. Please allow 30 seconds for the interface card to reboot, at which time it will then be operating with the recently-submitted configuration. Refer to Figure 37.



**Figure 37: Submit Configuration Changes**

## 10.9 Alarm Tab

The Alarm tab provides a configurable mechanism by which the interface card can autonomously monitor any available drive register and send emails to up to four recipients when a certain condition is detected. The alarm conditions have both value and time constraints, and can be configured to retrigger at a fixed interval as long as the alarm condition continues to be satisfied. Twenty individually-configurable alarms are available. Refer to Figure 38.

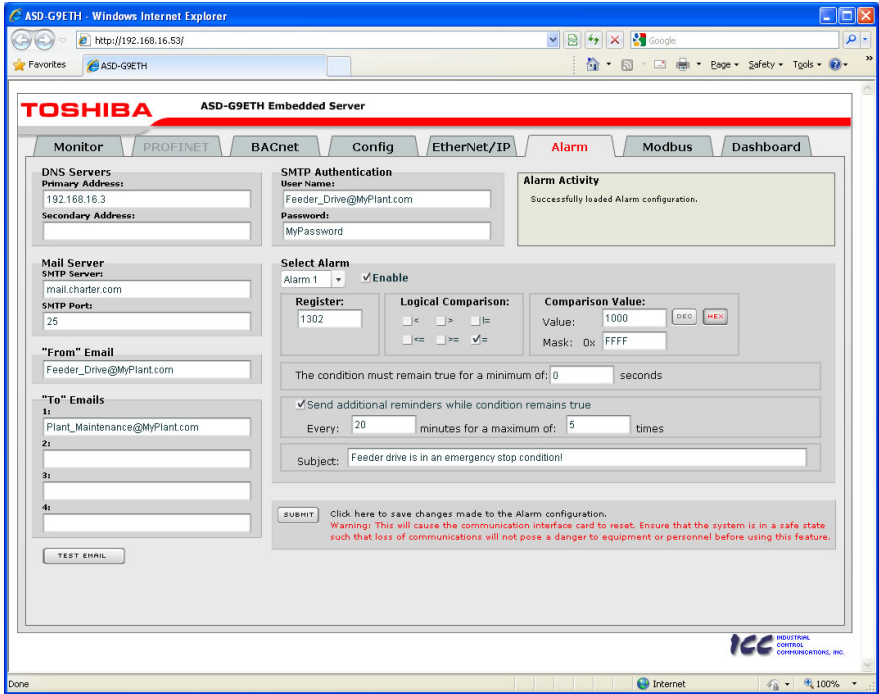


Figure 38: Alarm Tab

## 10.9.1 Information Window

Figure 39 shows the Information Window, which is located in the upper-right hand corner of the Alarm tab. This window displays various informational messages regarding the status of the Alarm configuration parameters (loading or submitting) and test emails.



**Figure 39: Alarm Tab Information Window**

## 10.9.2 Email Configuration

In order for an alarm trigger to successfully send a notification email, some network settings must first be configured properly (refer to Figure 40 and Figure 41.)

**DNS Servers:** Enter the dotted-decimal IP addresses of the primary and secondary DNS servers which will be used to resolve the configured SMTP server name. Only the primary DNS server is required, but if a secondary DNS server is entered, then it will be used if the primary server is inaccessible.

**Mail Server:** Enter the SMTP server address as a name or as a dotted-decimal IP address, and the SMTP port (default=25) that the SMTP server listens for incoming emails on.

**“From” Email:** Enter the email address that will appear as the sender’s email address in the email headers.

**“To” Emails:** Up to four recipients can be designated to receive alarm emails. Blank entries will not be processed by the interface.

**“Test Email” Button:** When the “Test Email” button is pressed, the interface card will use the information currently entered in the above-mentioned fields to send a test email. Note that you do not have to first “submit” the settings to the interface card’s filesystem (refer to section 10.9.4) in order to test them: fields can be changed and retested on-the-fly without affecting the operation of the interface card’s control protocols. When the correct settings have been confirmed with a successfully-sent test email, “submit” the changes at that time to commit them to the interface card’s filesystem: any changes made prior to submitting as described in section 10.9.4 are temporary only and will be lost if a different configuration tab is selected or if the web browser is closed.

The screenshot shows the following configuration fields:

- DNS Servers:**
  - Primary Address: 192.168.16.3
  - Secondary Address: (empty)
- Mail Server:**
  - SMTP Server: mail.charter.com
  - SMTP Port: 25
- “From” Email:** Feeder\_Drive@MyPlant.com
- “To” Emails:**
  - 1: Plant\_Maintenance@MyPlant.com
  - 2: (empty)
  - 3: (empty)
  - 4: (empty)
- TEST EMAIL:** (button)

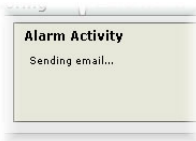
**Figure 40: Email Configuration**

**SMTP Authentication:** Some email servers require that clients wishing to send emails first authenticate themselves. If the email server in use requires authentication, then enter the user name and password as indicated in Figure 41. If the email server in use does not require authentication, then these entries can be disregarded.

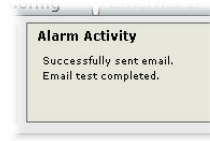


**Figure 41: SMTP AUTH Configuration**

When a test email transmission is initiated, completes successfully, or fails due to an error, the information window (refer to section 10.9.1) will display appropriate messages such as those shown in Figure 42 and Figure 43.



**Figure 42: Information Window at Test Email Initiation**

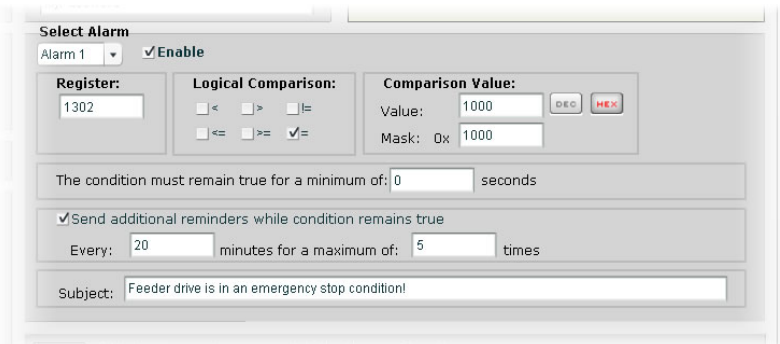


**Figure 43: Information Window at Test Email Successful Completion**

Although the test email is sent immediately, note that due to internet and/or email server delays, it may take several minutes to receive test emails.

### 10.9.3 Alarm Configuration

The interface supports twenty independently-configurable alarms. As shown in Figure 44, each alarm has a variety of configuration elements, which will be explained further below.



**Figure 44: Alarm Configuration Box**

**Alarm Selection:** This drop-down box allows the selection of one of the twenty available alarms. When an alarm is selected, that alarm's current configuration parameters will be populated in the alarm configuration box.

**"Enable" Check Box:** If checked, this alarm is active and will be evaluated every second. If unchecked, this alarm is inactive and will therefore not be evaluated.

**Register:** Enter the drive register number that this alarm will continuously monitor. For example, the alarm displayed in Figure 44 is configured to monitor register 1302, which is "inverter status 1".

**Logical Comparison:** Choose a comparison operator which will be used to compare the current value of the indicated "Register" with the reference "Comparison Value". Available selections are "less than" (<), "less than or equal to" (<=), "greater than" (>), "greater than or equal to" (>=), "not equal to" (!=), and "equal to" (=).

**Comparison Value:** The reference comparison value is comprised of two subcomponents: a "Mask" field and a "Value" field. Each time the alarm is evaluated, the current value of the indicated "Register" is first bit-wise "AND"ed with the "Mask" field. The resulting derived value is then compared with the "Value" field by way of the "Logical Comparison" operator. While the "Mask" field is always a hexadecimal number, the display and entry radix of the "Value" field can be changed between decimal and hexadecimal with the associated "DEC" and "HEX" buttons.

Registers that correspond to "analog" process variables (e.g. frequencies, voltages, etc.) should typically have their "Mask" fields set to 0xFFFF, which causes all data bits to be retained for the "Value" field comparison. For registers that correspond to "enumerated" process variables (e.g. status words where each bit of the register indicates a different item), however, the "Mask" can be chosen to single out one or more specific data bits of the register. For example, the "Mask" value of 0x1000 displayed in Figure 44 isolates bit #12 of "inverter status 1", which indicates whether or not the drive is in an emergency stop condition. The "Value" field is also set to a hexadecimal value of 0x1000, so the alarm condition will be evaluated as "true" when the emergency stop bit equals 1.

**The Condition Must Remain True For A Minimum Of:** Alarm analysis processing is performed by the interface card once per second. Enter the number of seconds that the condition must be continuously evaluated as "true" for the alarm to be triggered. A time of 0 seconds means that just a single evaluation of "true" will immediately trigger the alarm.

**Send Additional Reminders While The Condition Remains True:** If this check box is unchecked, then only one email transmission event will occur when an alarm condition is triggered: further email transmissions will not be attempted for this alarm unless the alarm condition is first evaluated as "false" (which resets the alarm), and then once again is triggered by a subsequent event.

If this check box is checked, then as long as the alarm condition continues to be evaluated as "true", subsequent email transmissions will be automatically retriggered every indicated number of minutes for a maximum of the indicated number of times.

If at any time during the subsequent transmissions the alarm condition is evaluated as “false”, then the alarm will be reset and email transmissions for this alarm will stop (until the next time the alarm is triggered, of course).

**Subject:** Enter a string of up to 128 characters in length which will appear in the “subject” line of the alarm email. The body of the alarm email is empty.

## 10.9.4 Submitting Changes

Whenever any of the Alarm configuration elements (alarm settings or email configuration parameters) have been changed, the “submit” button located in the lower right-hand portion of the web page must be clicked in order to write these settings to the interface card’s filesystem.

Note that because these configuration elements are read from the filesystem only when the interface card boots up, the act of submitting configuration changes will also reset the interface card. Please allow 30 seconds for the interface card to reboot, at which time it will then be operating with the recently-submitted configuration. Refer to Figure 45.



**Figure 45: Submit Configuration Changes**



## 10.10 Modbus Tab

The Modbus tab provides access to configuration items related to communication on a Modbus TCP network. Refer to Figure 46.

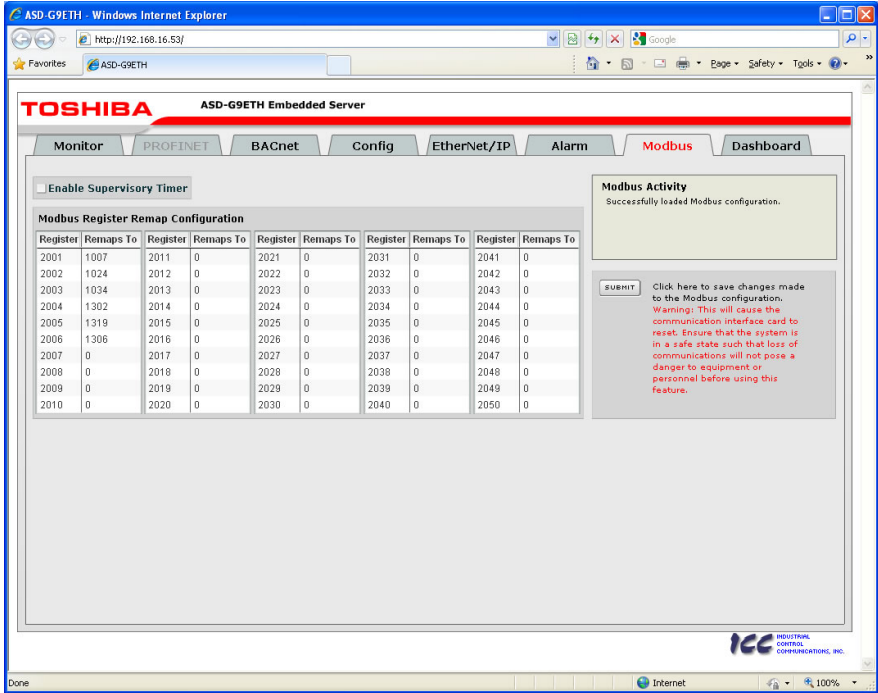


Figure 46: Modbus Tab

### 10.10.1 Information Window

Figure 47 shows the Information Window, which is located in the upper-right hand corner of the Modbus tab. This window displays various informational messages regarding the status of the Modbus configuration parameters (loading or submitting).

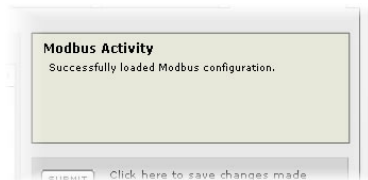


Figure 47: Modbus Tab Information Window

## 10.10.2 Supervisory Timer Selection

Figure 48 shows the checkbox which enables the interface card's Modbus "supervisory timer" function. This timer provides the ability for the interface card to monitor timeout occurrences between successive Modbus TCP socket connections, as opposed to the standard timeout functionality (refer to section 10.7.5), which monitors timeout occurrences only within the scope of each client socket connection. While this feature provides an additional level of fail-safe functionality for those applications that require it, there are several ramifications that must be understood prior to enabling this capability. Before enabling this timer, therefore, it is suggested that users read the ICC whitepaper titled "*A Discussion of Modbus/TCP Server-Side Timeout Processing*", which can be found in the documents section at <http://www.iccdesigns.com>.



**Figure 48: Supervisory Timer Selection**

## 10.10.3 Register Remap Configuration

At times, it may be convenient to access inverter registers in bulk Modbus transactions. This may be especially true in situations where it is desired to access certain registers that are natively non-contiguous. For example, if it were desired to read the inverter's status 1 word (register 1302), torque (register 1319) and output voltage (register 1306), this could be accomplished in two different ways:

1. Implement three separate Modbus read transactions, each one reading one register only, or
2. Implement one single Modbus read transaction, starting at register 1302 for a quantity of 18 registers. Then, pick out the registers of interest and ignore the rest of the response data.

While both of these methods will certainly work, neither one of them is optimized for the task at hand, which is to access three specific register values. A fully optimized solution can be realized, however, by making use of the interface card's Modbus register remapping capabilities. This mechanism operates by allocating a block of 50 user-configurable registers (2001..2050) that remap to other inverter registers. In this way, non-contiguous inverter registers can be grouped together in any order and accessed efficiently via the Modbus TCP "read multiple registers" and "write multiple registers" function codes. The net effect is one of being able to transfer larger blocks of registers using fewer Modbus transactions, which results in improved network utilization and simpler data manipulation code on the Modbus master device.

Figure 49 shows the register remap configuration array. Clicking on an entry field in the "Remaps To" column allows the user to enter an inverter register number that will then be accessible at the register indicated in the adjacent "Register" column. An assignment of 0 in the "Remaps To" column indicates that no inverter register is remapped at that location, which results in written values being ignored and read values returned as a default value of 0. Note that remapped inverter registers are still accessible at their original locations: remapping simply provides an additional means of accessing the original register's value.

Modbus Register Remap Configuration									
Register	Remaps To	Register	Remaps To	Register	Remaps To	Register	Remaps To	Register	Remaps To
2001	1007	2011	0	2021	0	2031	0	2041	0
2002	1024	2012	0	2022	0	2032	0	2042	0
2003	1034	2013	0	2023	0	2033	0	2043	0
2004	1302	2014	0	2024	0	2034	0	2044	0
2005	1319	2015	0	2025	0	2035	0	2045	0
2006	1306	2016	0	2026	0	2036	0	2046	0
2007	0	2017	0	2027	0	2037	0	2047	0
2008	0	2018	0	2028	0	2038	0	2048	0
2009	0	2019	0	2029	0	2039	0	2049	0
2010	0	2020	0	2030	0	2040	0	2050	0

**Figure 49: Modbus TCP Register Remap Configuration**

As an example, the configuration shown in Figure 49 reveals that a total of six inverter registers have been remapped: register 1007 (command 1 word) has been remapped to register 2001, register 1024 (command 2 word) has been remapped to register 2002, register 1034 (torque command) has been remapped to register 2003, register 1302 (inverter status 1) has been remapped to register 2004, register 1319 (torque) has been remapped to register 2005, and register 1306 (output voltage) has been remapped to register 2006. With this configuration, it is now possible to efficiently interact with these six non-contiguous inverter registers via just two Modbus “read/write multiple registers” transactions. Writing to the command 1 word, command 2 word and torque command can be accomplished with a single “write multiple registers” transaction by writing a quantity of three registers starting at register 2001. Similarly, reading the inverter status 1 word, torque and output voltage (in that order) can be accomplished with a single “read multiple registers” transaction by reading a quantity of three registers starting at register 2004.

### 10.10.4 Submitting Changes

Whenever the Modbus configuration has been changed, the “submit” button located on the right-hand portion of the web page must be clicked in order to write these settings to the interface card’s filesystem. Refer to Figure 50.

Note that because these configuration elements are read from the filesystem only when the interface card boots up, the act of submitting configuration changes will also reset the interface card. Please allow 30 seconds for the interface card to reboot, at which time it will then be operating with the recently-submitted configuration.



**Figure 50: Submit Configuration Changes**

## 10.11 Dashboard Tab

The Dashboard Tab provides access to a variety of gauges, meters and graphs that can be configured to provide an at-a-glance graphical overview of critical application variables in real-time. A total of 10 gauge windows are available (four at a time), and each gauge window can be configured to display any scanned register's value via one of six different gauge types. User-defined engineering units, scaling and range limits are also configurable. Refer to Figure 51.

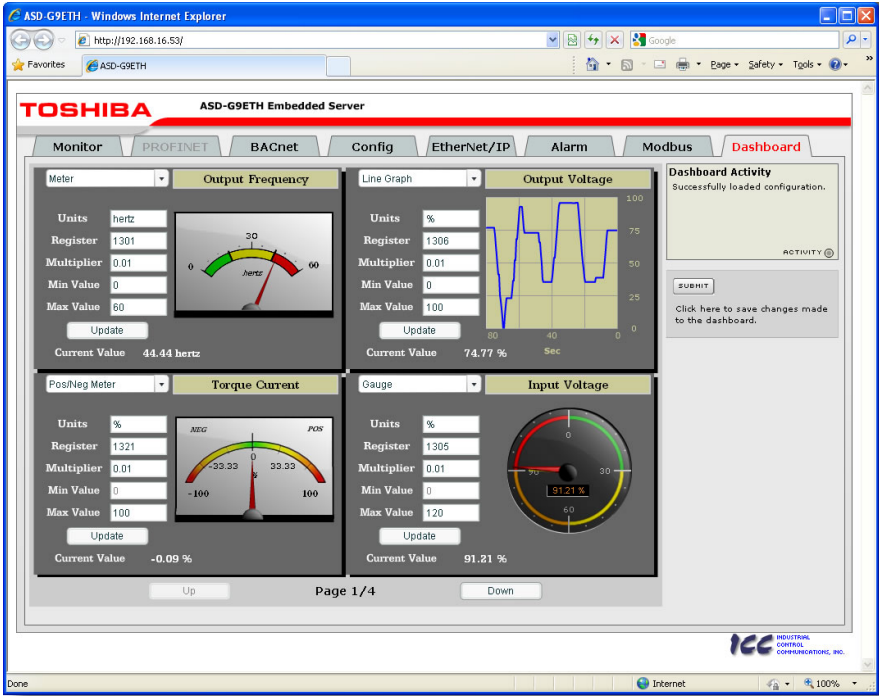
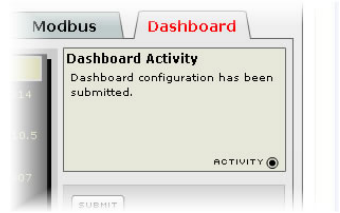


Figure 51: Dashboard Tab

## 10.11.1 Information Window

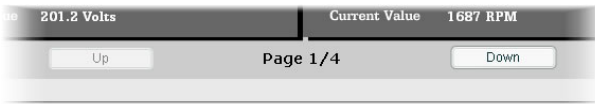
Figure 52 shows the Information Window, which is located in the upper-right hand corner of the Dashboard Tab. This window displays various informational messages regarding the status of the Dashboard configuration parameters (loading or submitting).



**Figure 52: Dashboard Tab Information Window**

## 10.11.2 Gauge Window Navigation

Figure 53 shows the two buttons that provide for navigation of the gauge windows. Gauge windows are displayed four at a time in the Dashboard Tab, and by clicking the “Up” or “Down” buttons, the gauge windows will scroll in the corresponding direction, two at a time.



**Figure 53: Gauge Window Navigation**

## 10.11.3 Gauge Window Configuration

Each of the gauge windows can be independently configured to display a user-defined register with a variety of flexible configuration options. While the behavior and presentation may vary slightly depending on the specific gauge chosen, all of the gauges share the following common elements (refer to Figure 54 for an example):

**Gauge Selector:** A drop-down selection box in the upper left-hand corner of the gauge window, which allows the user to select the type of gauge that will be displayed.

**Title:** A text entry box located above the gauge, in which the user can enter a descriptive gauge title comprised of up to 16 characters.

**Units:** A text entry box in which the user can enter an engineering units string comprised of up to 8 characters. This units string will be appended to all locations in the gauge window that display the designated register’s current value.

**Register:** The designated register whose value is to be reflected on the gauge.

**Multiplier:** The multiplier value is a floating-point number that is used to scale the raw value of a register. As its name suggests, the multiplier value is multiplied by the

designated register's current raw value in order to calculate the gauge's indicated value. Negative values can also be used if desired.

**Min Value:** The gauge's minimum indicated value. Negative values can be used if desired (e.g. if a negative Multiplier attribute is used to generate a negative indicated value). Not all gauges allow adjustment of the min value.

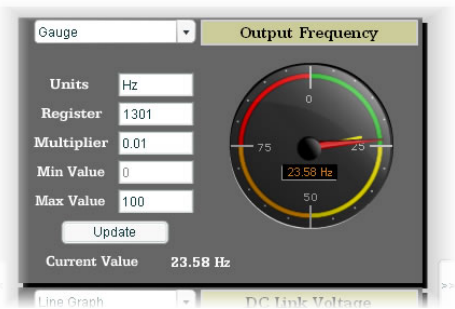
**Max Value:** The gauge's maximum indicated value. Similar to the Min Value attribute, negative values can be used if desired. Indicated value characteristics can even be inverted by setting the Max Value attribute to a value less than the Min Value attribute.

**Update Button:** Clicking the update button will apply the current configuration attribute settings to the gauge. Note, however, that simply updating the gauge's current display properties does not write these settings to the interface card's filesystem. To save the current configuration of all the gauge windows to the filesystem, the Dashboard tab's "submit" button must be selected (refer to section 10.11.4).

**Current Value:** The current indicated value of the designated register is numerically displayed with the configured Units string at the bottom of each gauge window.

The following is a summary of the different available gauge types:

**Gauge:** Refer to Figure 54. This type of meter implements a rotary dial-type display format. The indicated value and units are shown numerically on the face of the gauge, and via the red indicator needle. The yellow needle shows the previous indicated value, thereby providing a simple historical reference. The "Min Value" attribute is not configurable; this gauge always starts at 0.



**Figure 54: Gauge**

**BarGraph:** Refer to Figure 55. This type of meter implements a linear bar graph display format. Hovering the mouse pointer over the red portion of the graph pops up a tooltip which displays the current indicated value and units.

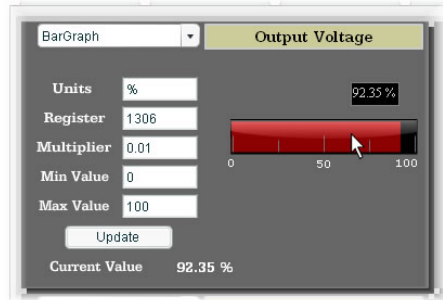


Figure 55: BarGraph

**Meter:** Refer to Figure 56. This type of meter implements a common panel meter-type display format. The units string is shown on the face of the meter. All raw register values are interpreted as positive numbers (i.e. 0..0xFFFF equates to 0..65535<sub>10</sub>.)

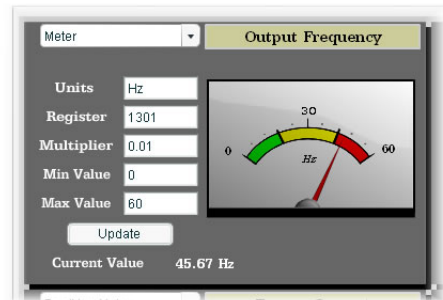


Figure 56: Meter

**Pos/Neg Meter:** Refer to Figure 57. Similar to the “meter” gauge, this type of meter also implements a common panel meter-type display format, but in this instance the indicated value can be positive or negative (two’s complement interpretation). In other words, raw register values between 0..0x7FFF equate to 0..32767<sub>10</sub>, and values between 0x8000..0xFFFF equate to -32768..-1. Because the meter placard is always centered around zero, the “Min Value” attribute is not configurable, and the “Max Value” attribute is used for both the maximum positive indicated value as well as the maximum negative indicated value.

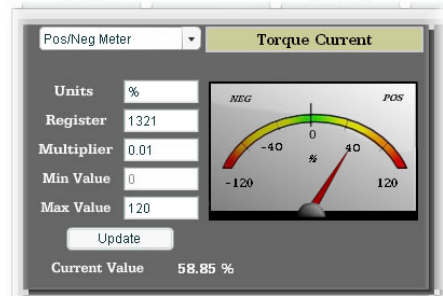


Figure 57: Pos/Neg Meter

**Thermometer:** Refer to Figure 58. This type of meter implements the universally-identifiable thermometer display format. Hovering the mouse pointer over the red “mercury” portion of the graph pops up a tooltip which displays the current indicated value and units.

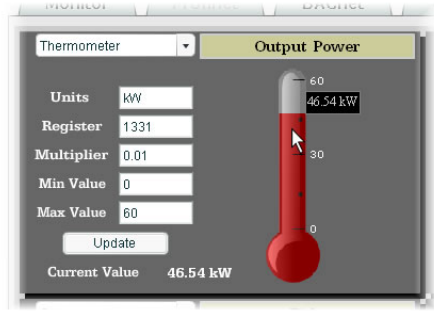


Figure 58: Thermometer

**Line Graph:** Refer to Figure 59. This type of graph implements a continuously-scrolling historical data logging line graph. Up to 80 seconds worth of historical data is available. Hovering the mouse pointer anywhere on the graph displays a vertical reference line at the corresponding time, and pops up a tooltip which displays the current indicated value at that time.

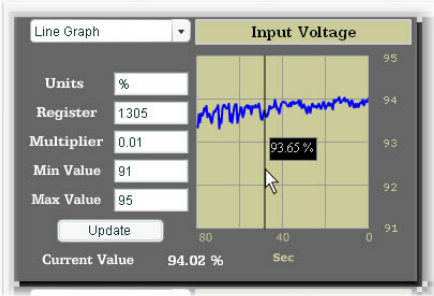


Figure 59: Line Graph

**Gauge Usage Tip**

At times, it may be convenient to zoom in on a particular gauge or meter in order to more clearly see the indicator, or to fill the computer screen with a particular gauge’s image. This can be easily accomplished with the web browser’s Flash Player plug-in by right-clicking on the gauge and selecting the desired zoom level (refer to Figure 60).

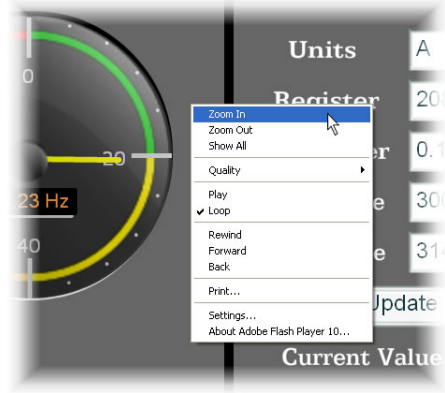
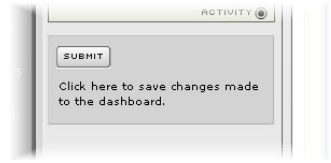


Figure 60: Zooming



## 10.11.4 Submitting Changes

Whenever any of the gauge window configuration items in the Dashboard Tab have been changed, the “submit” button located on the right-hand portion of the web page must be selected in order to write these settings to the interface card’s filesystem. Refer to Figure 61. Note that submitting the Dashboard Tab configuration does not require rebooting of the interface card: the changes take effect immediately, and the interface card continues its operation without interruption.



**Figure 61: Submit Dashboard Changes**

## 11. Interacting With the Filesystem

The interface card's on-board filesystem is used to store files for use by the application firmware. Currently, the application firmware's main use of the filesystem is to store XML-encoded configuration files that dictate the characteristics of the various protocols. Each protocol that requires configuration will have its own XML file stored on the filesystem. For easy identification, the filename will begin with the corresponding protocol which it configures. For example, a BACnet configuration file's filename will begin with "bacnet", and a PROFINET I/O file will begin with "pnio".

Whenever the configuration for a specific protocol is completed, it is suggested that a backup copy of the configuration file be downloaded from the unit to a PC. One reason for this is in case it becomes necessary to restore a previous configuration at a later time. Another reason is that it may be desirable to load multiple units with the same configuration, as a downloaded configuration file can be uploaded again to any compatible unit, allowing the user to easily clone multiple units with the same configuration.

Each time the interface card boots up, it will search the filesystem for the configuration files required by the protocols currently operating in the unit. If it does not find a required file, it will create one and initialize it with factory-default values. Therefore, if it is ever desired to reset a protocol's configuration to factory-default values, this can be easily accomplished by simply deleting the appropriate configuration file from the filesystem and rebooting the unit.

Note that the application firmware uses specific filenames for the configuration files. This means that if a file with a different filename is loaded onto the unit, it will be stored correctly, but will not be used by the application firmware. Similarly, if an existing configuration file's filename is changed, then the unit will again create a default configuration file at next boot-up, which will be stored in the filesystem alongside the file with the changed name.

Configuration files are only read by the protocol drivers at unit boot-up. Therefore, if a new configuration file is loaded onto a unit's filesystem, that unit must be rebooted for the configuration file's settings to take effect. Rebooting a unit can be performed by:

- power-cycling the drive in which the card is installed,
- setting drive parameter F899 (register 900) to a value of "1" either via the keypad, a communication protocol or the web server interface, or
- selecting the "Reboot Device" button in the Finder utility.

Interacting with the filesystem is performed by use of the File Transfer Protocol (FTP). Using FTP allows the user to interact with the files on the interface card's filesystem in the same manner as though they were traditional files stored on a local or remote PC. While there are many different FTP applications available, the following sections will provide general examples of using some of the most commonly-available ones.

## 11.1 Initiating FTP via the Finder Utility

After discovering all interface cards on the current subnet as described in section 8, select the target interface card and then click on the “Open FTP Interface” button. This will open the computer’s default FTP application, which could be Windows Explorer, a web browser, or a 3<sup>rd</sup>-party FTP program (whatever the computer/operating system is configured for by default). This example will assume that a web browser (Microsoft Internet Explorer) is configured as the default FTP application.

An authentication dialog will appear (refer to Figure 62.) Enter the currently-configured user name and case-sensitive password (defaults are “root” and “icc”, respectively), then click “Log On.”



Figure 62: FTP Authentication

The web browser will then display the filesystem’s contents (refer to Figure 63.) FTP access via a web browser allows viewing and downloading files to a computer, but does not allow advanced file manipulation such as cut, paste, drag-and-drop, etc. For advanced file manipulation, use of a different FTP application is required.

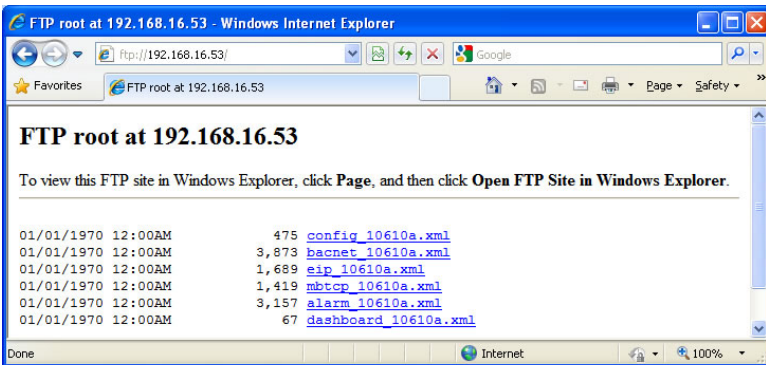
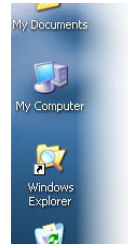


Figure 63: FTP Navigation with Internet Explorer

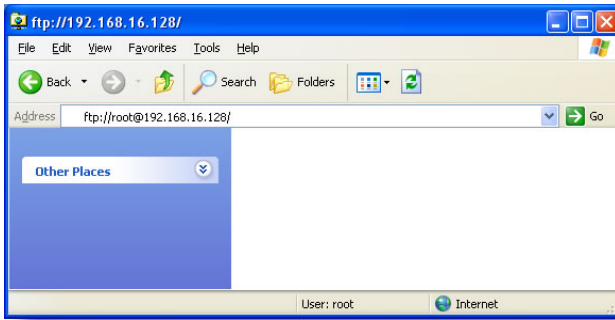
## 11.2 Using FTP with Windows Explorer

To use FTP with Microsoft Windows Explorer, first open either “Windows Explorer” or “My Computer”. Refer to Figure 64. Please note that the indicated procedure, prompts and capabilities outlined here can vary depending on such factors as the installed operating system, firewalls and service packs.



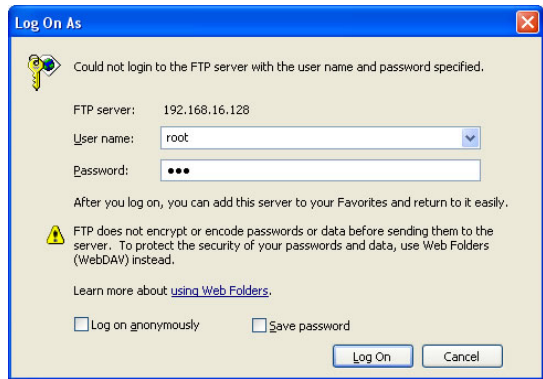
**Figure 64: Accessing Windows Explorer**

In the “Address” field, type in “ftp://root@” and then the IP address of the target interface card (if the user name has been changed from its default, then replace “root” in “ftp://root@” with the new user name.) Refer to Figure 65.

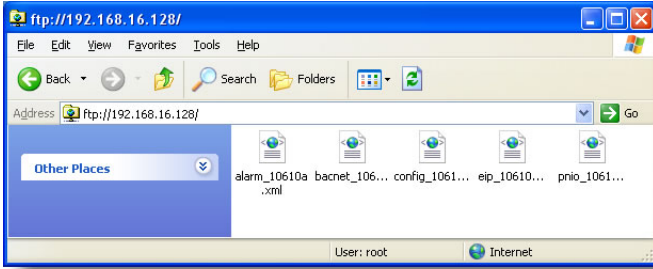


**Figure 65: FTP Navigation with Windows Explorer**

You will then be presented with an authentication dialog (refer to Figure 66.) The user name will already be filled-in. Enter the case-sensitive password (default is “icc”) and click “Log On.” Windows Explorer will then display the filesystem’s contents (refer to Figure 67.) You can now perform normal file manipulation actions on the available files (cut, copy, paste, open, rename, drag-and-drop transfers etc.) in the same manner as though you were manipulating any traditional file stored on your computer’s hard drive.



**Figure 66: FTP Authentication**



**Figure 67: File Access with Windows Explorer**

## 11.3 Using FTP with a Windows Command Prompt

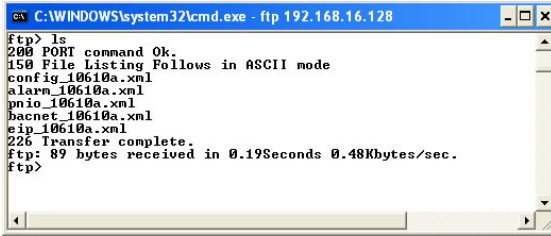
To use FTP with a Windows command (DOS) prompt, first open a command prompt by either selecting *Start...All Programs...Accessories...Command Prompt*, or by selecting *Start...Run* and typing “cmd” in the “Run” dialog.

Once the command prompt opens, type “ftp” and the IP address of the target interface card. The FTP client will connect to the unit and then prompt for the username and case-sensitive password (defaults are “root” and “icc”, respectively). Upon successful entry of the authentication information, you will be presented with an “ftp>” prompt. Refer to Figure 68.



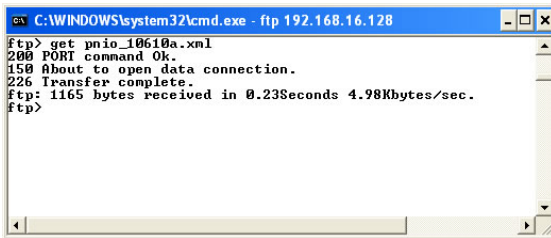
**Figure 68: FTP Initiation and Authentication**

At this point, you can use standard Unix-style file and directory manipulation commands to perform such actions as listing files (Figure 69), copying files to your computer (Figure 70), and copying files to the unit (Figure 71).



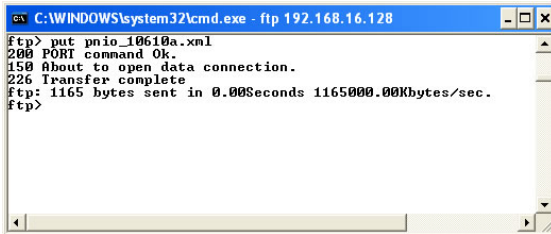
```
C:\WINDOWS\system32\cmd.exe - ftp 192.168.16.128
ftp> ls
200 PORT command Ok.
150 File Listing Follows in ASCII mode
config_10610a.xml
alarm_10610a.xml
pnio_10610a.xml
bacnet_10610a.xml
eip_10610a.xml
226 Transfer complete.
ftp> 89 bytes received in 0.19Seconds 0.48Kbytes/sec.
ftp>
```

Figure 69: Listing Files with "ls" Command



```
C:\WINDOWS\system32\cmd.exe - ftp 192.168.16.128
ftp> get pnio_10610a.xml
200 PORT command Ok.
150 About to open data connection.
226 Transfer complete.
ftp> 1165 bytes received in 0.23Seconds 4.98Kbytes/sec.
ftp>
```

Figure 70: Copying a File from the Unit With "get" Command



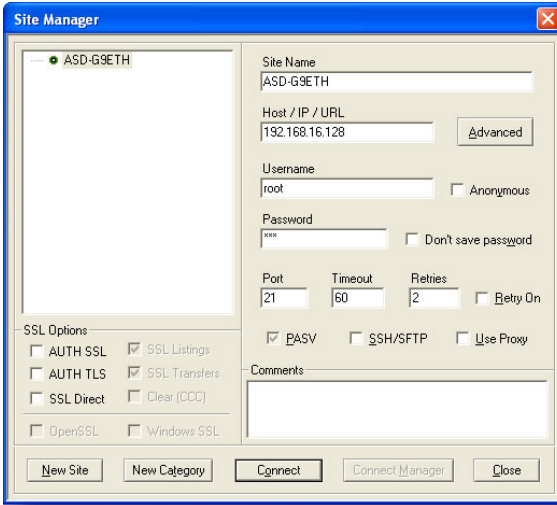
```
C:\WINDOWS\system32\cmd.exe - ftp 192.168.16.128
ftp> put pnio_10610a.xml
200 PORT command Ok.
150 About to open data connection.
226 Transfer complete
ftp> 1165 bytes sent in 0.00Seconds 1165000.00Kbytes/sec.
ftp>
```

Figure 71: Copying a File to the Unit With "put" Command

## 11.4 Using FTP with Core FTP LE

Core FTP LE (Lite) is a 3<sup>rd</sup>-party FTP application that can be downloaded for free from <http://www.coreftp.com>. Core FTP is just one example of the various commercial and freeware FTP client applications available on the internet.



After installing Core FTP LE, run the program. If the “Site Manager” window (Figure 72) does not automatically open, open it by choosing “File...connect”.



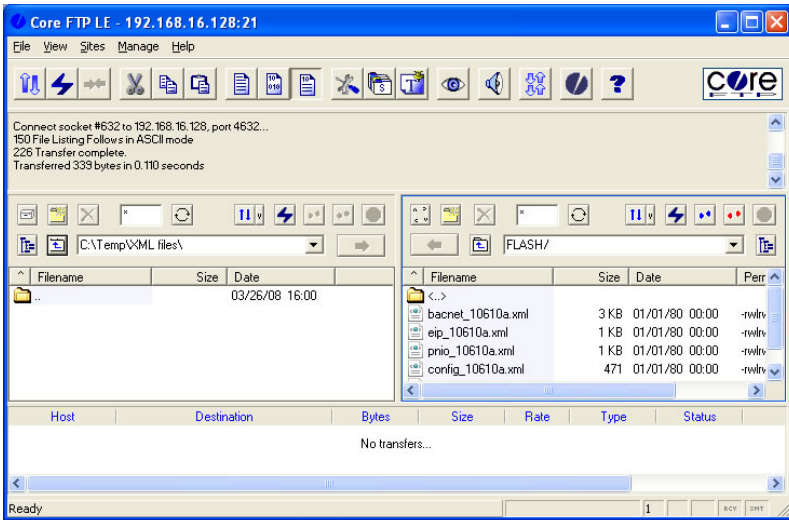
**Figure 72: Core FTP Site Manager**

Click on the “New Site” button, then enter a Site Name, IP Address, user name (default is “root”) and case-sensitive password (default is “icc”). The “Port”, “Timeout”, and “Retries” fields should already contain the default values. Click the “Connect” button when done.

Core FTP LE will then try to connect and authenticate to the FTP server, and if successful, will populate the right-hand side of the main page with the unit’s filesystem contents. Refer to Figure 73.

Files can be easily downloaded from the unit by choosing the appropriate destination folder on your computer in the left-hand side of the main page, choosing the file to download, and then clicking the “download”  button in the right-hand (source) side. Similarly, files can be easily uploaded to the unit by choosing the file to upload and then clicking the “upload”  button in the left-hand (source) side of the main page.

Like most 3<sup>rd</sup>-party FTP client applications, Core FTP LE has a wide array of configuration and file management capabilities, which are beyond the scope of this manual. Refer to the program's Help file for more detailed instructions.



**Figure 73: Core FTP in "Connected" State**



## 12. Loading New Application Firmware

The interface card's embedded firmware resides in flash memory that can be updated in the field. Firmware updates may be released for a variety of reasons, such as custom firmware implementations, firmware improvements and added functionality as a result of user requests. Additionally, it may be necessary to load different firmware onto the unit in order to support various protocols (such as PROFINET I/O).

ICC is continually striving to enhance the functionality and flexibility of our products, and we therefore periodically release new embedded firmware to achieve these goals and meet customer requests. Flash firmware files and all related documentation (such as updated user manuals) can be downloaded from <http://www.iccdesigns.com>. It is suggested that users check this Internet site prior to installation, and then periodically afterwards to determine if new firmware has been released and is available to upgrade their units.

Besides the new firmware file, firmware updates require only a PC with the same FTP client capabilities as described in section 11. The new firmware is loaded on the unit via the FTP protocol in the same manner as uploading a configuration (.XML) file. Some notes on uploading new firmware via FTP are:

- Please be sure to read the firmware release notes and updated user's manual for any important notices, behavior precautions or configuration requirements prior to updating your firmware. For example, upgrading to a new firmware version may affect user-defined configuration files: prior to starting an update procedure always back up your configuration file to a PC for later recovery if necessary.
- Because the FTP application firmware in the unit distinguishes application firmware files from XML configuration files by virtue of the filename, don't change the default name of the firmware file to be uploaded to the unit.
- Although the firmware file is uploaded from your PC to the unit in the same manner as configuration files are uploaded, the firmware cannot be downloaded from the unit, because the firmware does not reside in the unit's filesystem like configuration files do.
- After the firmware upload process has been completed (typically requiring 30-45 seconds), the unit will reset automatically 5s after the FTP connection is closed. When the unit boots up again, it will be running the new application firmware, which can be confirmed by observing the version displayed in the web server's information window (refer to section 10.4.1).
- Because the transferred firmware file is not written to the unit's flash memory until the FTP connection is closed, be sure to close the connection in order to trigger the write process. The method of closing an FTP connection differs depending on the FTP transfer mechanism used. For example, if using Windows Explorer, it is necessary to click "refresh" after the file has completed downloading, and then close the window. If using the command prompt method,

type “quit” to close the connection. If using Core FTP, click on the “disconnect” button, etc.

- Because the interface’s web pages may have changed with the new firmware version, it is recommended to clear your web browser’s cache memory before accessing the web server after the firmware update. This will ensure that your web browser will load the updated web server pages directly from the interface, instead of just loading the local (old) copy stored in your computer’s cache memory. To accomplish this in Internet Explorer, go to *Tools...Internet Options...Browsing History...Delete*, and delete all temporary internet files.

## 13. Protocol-Specific Information

This section will discuss topics that are specific to each of the supported protocols.

### 13.1 Modbus/TCP

#### 13.1.1 Overview

The interface card supports Schneider Electric’s Modbus TCP protocol, release 1.0. The interface is conformance class 0 and partial class 1 and class 2 compliant, and allows up to 8 simultaneous Modbus TCP client connections (sockets). Other notes of interest are:

- Supported Modbus slave functions are indicated in Table 3.

**Table 3: Supported Modbus TCP Functions**

Function Code	Function	Modbus TCP Class
1	Read coils	1
2	Read input status	1
3	Read multiple registers	0
4	Read input registers	1
5	Write coil	1
6	Write single register	1
15	Force multiple coils	2
16	Write multiple registers	0

- Drive registers can be addressed as either holding registers (4X references) or input registers (3X references). For example, accessing the output frequency involves accessing holding register 41301 or input register 31301 (i.e. offset 1301).
- Specific bits within drive registers can be accessed as either coils (0X references) or discrete inputs (1X references).
- Because the transaction is handled locally within the interface card, write data checking is not available. For example, if a write is performed to a register with a data value that is out-of-range of the corresponding parameter object, no Modbus exception will be immediately returned.
- The “unit identifier” (UI) field of the request packets is ignored.
- The socket timeout time is determined by the “timeout” setting on the web server’s “Config” tab (refer to section 10.7.5). This means that if a particular open socket experiences no activity for more than the timeout time setting, then

the interface assumes that the client or network has experienced some sort of unexpected problem, and will close that socket.

- Because the socket timeout determination is performed on a per-socket basis, note that a certain degree of caution must be exercised when using the network timeout feature to avoid “nuisance” timeouts from occurring. Specifically, do not perform inadvisable behavior such as sending a request from the master device to the interface, and then closing the socket prior to successfully receiving the unit’s response. The reason for this is because the interface will then experience an error when attempting to respond via the now-closed socket, which will immediately trigger the timeout action. Always be sure to manage socket life cycles “gracefully”, and do not abandon outstanding requests.
- If a socket timeout occurs (regardless of whether it was due to a communication lapse or abnormal socket error), the driver will trigger a timeout event as described in section 10.7.5.

### 13.1.2 Coil & Discrete Input Mappings

The Modbus TCP driver provides read/write support for coils (0X references) and read-only support for discrete inputs (1X references). These will collectively be referred to from here on out as simply “discretes”. Accessing discretes does not reference any new physical data: discretes are simply indexes into various bits of existing registers. What this means is that when a discrete is accessed, that discrete is resolved by the interface into a specific register, and a specific bit within that register. The pattern of discrete-to-register/bit relationships can be described as follows:

Discrete 1...16 map to register #1, bit0...bit15 (bit0=LSB, bit15=MSB)  
 Discrete 17...32 map to register #2, bit0...bit15, and so on.

Arithmetically, the discrete-to-register/bit relationship can be described as follows: For any given discrete, the register in which that discrete resides can be determined by:

$$register = \left\lfloor \frac{discrete + 15}{16} \right\rfloor \tag{Equation 1}$$

Where the bracket symbols “ $\lfloor \ ]$ ” indicate the “floor” function, which means that any fractional result (or “remainder”) is to be discarded, with only the integer value being retained.

Also, for any given discrete, the targeted bit in the register in which that discrete resides can be determined by:

$$bit = (discrete - 1) \% 16 \tag{Equation 2}$$

Where “discrete”  $\in [1...65535]$ , “bit”  $\in [0...15]$ , and “%” is the modulus operator, which means that any fractional result (or “remainder”) is to be retained, with the integer value being discarded (i.e. it is the opposite of the “floor” function).

For clarity, let's use Equation 1 and Equation 2 in a calculation example. Say, for instance, that we are going to read coil #34. Using Equation 1, we can determine that coil #34 resides in register #3, as  $\lfloor 3.0625 \rfloor = \lfloor 3 r1 \rfloor = 3$ . Then, using Equation 2, we can determine that the bit within register #3 that coil #34 targets is  $(34-1)\%16 = 1$ , as  $33\%16 = \text{mod}(2 r1) = 1$ . Therefore, reading coil #34 will return the value of register #3, bit #1.

## 13.2 EtherNet/IP

### 13.2.1 Overview

The EtherNet/IP protocol is an application-level protocol implemented on top of the Ethernet TCP/IP and UDP/IP layers. It shares its object model with ControlNet and DeviceNet through the Common Industrial Protocol (CIP). This protocol allows the transfer of data and I/O over Ethernet.

EtherNet/IP incorporates both the TCP and UDP layers of Ethernet in the transmission of data. Because TCP/IP is a point-to-point topology, EtherNet/IP uses this layer only for explicit messaging; i.e. those messages in which the data field carries both protocol information and instructions for service performance. With explicit messaging, nodes must interpret each message, execute the requested task and generate responses. These types of messages can be used to transmit configuration, control and monitor data.

The UDP/IP protocol layer, which has the ability to multi-cast, is used for implicit (I/O) messaging. With I/O messaging, the data field contains only real-time I/O data; no protocol information is sent because the meaning of the data is pre-defined at the time the connection is established, which in turn minimizes the processing time of the node during run-time. I/O messages are short and have low overhead, which allows for the time-critical performance needed by controllers.

The interface card supports both explicit and I/O messaging. Further, two different types of I/O messaging are supported. One type (invoked when the client opens a connection to the interface using assembly instances 20 & 70 or 21 & 71) is included with the implementation of the AC/DC drive profile, and requires no user configuration. The other type, however, is entirely user-configurable, and is invoked when the client opens a connection to the interface using assembly instances 100 and 150.

The following sections demonstrate specific examples of how to use EtherNet/IP to transfer data between the drive and Allen-Bradley Logix-brand PLCs.

#### Some other notes of interest are:

- The interface card supports the EtherNet/IP protocol (release 1.0), administered by the Open DeviceNet Vendor Association (ODVA).
- This product has been self-tested by ICC, Inc. and found to comply with ODVA EtherNet/IP Conformance Test Software Version A-5.
- I/O connection sizes for assembly instances 100 and 150 are adjustable between 0 and 64 bytes (32 registers max @ 2 bytes per register = 64 bytes). Because registers are 16-bit elements, however, connection sizes cannot be odd (i.e. 1, 3, 5 etc.)
- The interface card's product type code is 2 (AC drive.)
- Supports unconnected messages (UCMM), and up to 16 simultaneous class 1 (I/O) or class 3 (explicit) connections.

- Assembly instances 100 and 150: if a register entry in the consumed data configuration array is 0, then any consumed data that corresponds to that location will be ignored. Conversely, if a register entry in the produced data configuration array is 0, then any produced data that corresponds to that location will be a default value of 0. Refer to section 10.8.4 for further information on the data configuration arrays.
- Class 1 implicit I/O supports both multicast and point-to-point (unicast) when producing data in the T→O direction.
- Point-to-point class 1 connected messages will be produced targeting the IP address of the device that instantiated the connection, UDP port 0x08AE (UDP port 2222).
- If a class 1 point-to-point connection is established in the (T→O) direction, no more class 1 connections can be established.
- If a class 1 connection’s consuming half (O→T) times out, then the producing half (T→O) will also time-out and will stop producing.
- If a class 1 or class 3 connection timeout occurs, the driver will trigger a timeout event as described in section 10.7.5. The timeout value is dictated by the scanner/client and is at a minimum, four times the scan rate (Requested Packet Interval) for class 1. The typical timeout value for class 3 messaging is usually much larger and is also dictated by the scanner/client.

## 13.2.2 ODVA AC/DC Drive Profile

The interface card supports the ODVA AC/DC drive profile. No special Ethernet/IP configuration of the interface card is required when using the AC/DC drive profile: all that is needed is that the controller must target either assembly instances 20 & 70 or 21 & 71 in its connection parameters.

The AC/DC drive profile implementation provides support for several required CIP objects, which are specified in Table 4. While the various supported attributes of all of these objects are accessible via explicit messaging, the main intent of using the AC/DC drive profile is to interact with the predefined input and output assembly instances via an I/O connection. The structure of these assembly instances is defined by the Ethernet/IP specification in order to engender interoperability among different vendor’s products. This section will focus primarily on the format of the AC/DC drive profile I/O assemblies supported by the interface card, and the inverter data which their various constituent elements map to.

**Table 4: AC/DC Drive Profile-Related Objects**

Class Code	Object Name
0x04	Assembly Object
0x28	Motor Data Object
0x29	Control Supervisor Object
0x2A	AC Drive Object

## Output Instances 20 and 21 Detail

Instance	Byte	Bit 7	Bit 6	Bit 5	Bit 4	Bit 3	Bit 2	Bit 1	Bit 0
20	0						Fault Reset		Run Fwd
	1								
	2	Speed Reference (Low Byte)							
	3	Speed Reference (High Byte)							
21	0		NetRef	NetCtrl			Fault Reset	Run Rev	Run Fwd
	1								
	2	Speed Reference (Low Byte)							
	3	Speed Reference (High Byte)							

### Mapping Detail

**Run Fwd:** forward rotation command (0=forward rotation off, 1=forward rotation on). Maps to inverter register 1007, bits 9 and 10. Run Fwd = 1 translates to inverter register 1007 bit 9 (direction) = 0 and bit 10 (run/stop) = 1. Note that if both the “Run Fwd” and “Run Rev” bits are on, then inverter register 1007 will not be changed from its previous value.

**Run Rev:** reverse rotation command (0=reverse rotation off, 1=reverse rotation on). Maps to inverter register 1007, bits 9 and 10. Run Rev = 1 translates to inverter register 1007 bit 9 (direction) = 1 and bit 10 (run/stop) = 1. Note that if both the “Run Fwd” and “Run Rev” bits are on, then inverter register 1007 will not be changed from its previous value.

**Fault Reset:** Inverter reset command (0=no action, 0→1 rising edge=reset). Maps to inverter register 1007, bit 13 (fault reset).

**NetCtrl:** Run/stop control source selection (0=local control, 1=network control). Maps to inverter register 1007, bit 15 (command priority).

**NetRef:** Speed reference source selection (0=local control, 1=network control). Maps to inverter register 1007, bit 14 (frequency priority).

**Speed Reference:** Inverter speed reference in RPM. Maps to inverter register 1008 (frequency command). Because the inverter always requires a frequency command value in units of Hz, the interface card applies an RPM-to-Hz conversion equation. The general RPM-to-Hz conversion equation is  $[RPM \times \text{number of motor poles} / 120]$ . However, for simplicity the interface card always assumes that a 4-pole motor is in use, thereby reducing the applied conversion equation to  $[\text{frequency command value} = RPM / 30]$ .



## Input Instances 70 and 71 Detail

Instance	Byte	Bit 7	Bit 6	Bit 5	Bit 4	Bit 3	Bit 2	Bit 1	Bit 0
70	0						Running 1		Fault
	1								
	2	Speed Actual (Low Byte)							
	3	Speed Actual (High Byte)							
71	0	At Ref	Ref From Net	Ctrl From Net	Rdy	Running 2 (REV)	Running 1 (FWD)	Warn	Fault
	1	Drive State							
	2	Speed Actual (Low Byte)							
	3	Speed Actual (High Byte)							

### Mapping Detail

**Faulted:** Inverter fault signal (0=not faulted, 1=faulted). Maps to inverter register 1302 (status 1 word), bit 0.

**Warning:** This bit is not used (it is always 0).

**Running1 (FWD):** Running forward status signal (0=not running forward, 1=running forward). Maps to inverter register 1302 (status 1 word), bits 9 and 10. The Running1 bit will be 1 whenever inverter register 1302 bit 9 (direction) is 0 and bit 10 (running/stopped) is 1, and will be 0 otherwise.

**Running2 (REV):** Running reverse status signal (0=not running reverse, 1=running reverse). Maps to inverter register 1302 (status 1 word), bits 9 and 10. The Running2 bit will be 1 whenever inverter register 1302 bit 9 (direction) is 1 and bit 10 (running/stopped) is 1, and will be 0 otherwise.

**Ready:** Inverter ready signal (0=not ready, 1=ready). The Ready bit will be 1 whenever the Drive State attribute (see below) is in the Ready, Enabled or Stopping state.

**CtrlFromNet:** Inverter command reference status (0=command reference is not from network, 1=command reference is from network). Maps to inverter register 1007, bit 15 (command priority). In other words, CtrlFromNet always reflects the status of the NetCtrl attribute.

**RefFromNet:** Inverter speed reference status (0=speed reference is not from network, 1=speed reference is from network). Maps to inverter register 1007, bit 14 (frequency priority). In other words, RefFromNet always reflects the status of the NetRef attribute.

**AtReference:** Up-to-speed signal (0=not up-to-speed, 1=up-to-speed). Maps to inverter register 1350 (status 3 word), bit 12 (RCH).

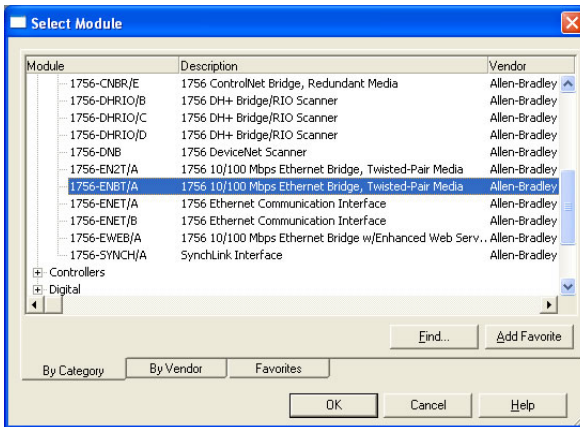
**Drive State:** Indicates the current state of the Control Supervisor Object state machine. Refer to the ODVA Ethernet/IP specification (object library) for detailed information on the Control Supervisor Object state machine.

**Speed Actual:** Inverter operating speed in RPM. Maps to inverter register 1301 (output frequency). Because the inverter always provides its output frequency in units of Hz, the interface card applies a Hz-to-RPM conversion equation. The general Hz-to-RPM conversion equation is  $[output\ frequency \times 120 / number\ of\ motor\ poles]$ . However, for simplicity the interface card always assumes that a 4-pole motor is in use, thereby reducing the applied conversion equation to  $[RPM = output\ frequency\ value \times 30]$ .

### 13.2.3 ControlLogix Examples: Setup

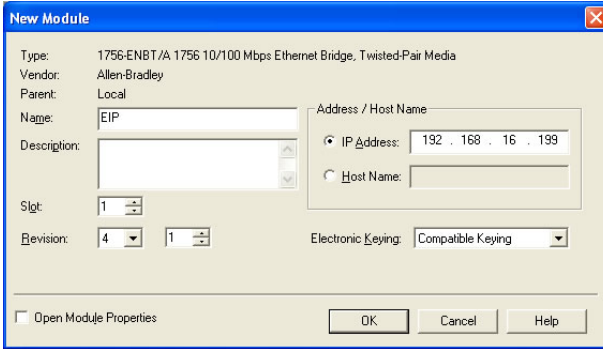
This section will demonstrate how to initially setup a ControlLogix PLC (such as a 1756-L61) coupled with a 1756-ENBT/A communication interface (adjust this procedure according to your specific equipment). Later sections will provide specific read/write examples using this configuration with I/O or explicit messaging.

- 1) Run RSLogix 5000, and create a new configuration.
- 2) To add a 1756-ENBT/A to your I/O configuration, first switch to offline mode.
- 3) Right click on the I/O Configuration node in the controller organizer view and choose “New Module...”
- 4) The “Select Module” window will open.
- 5) Under “Communications”, select “1756-ENBT/A”, and click OK. Refer to Figure 74.



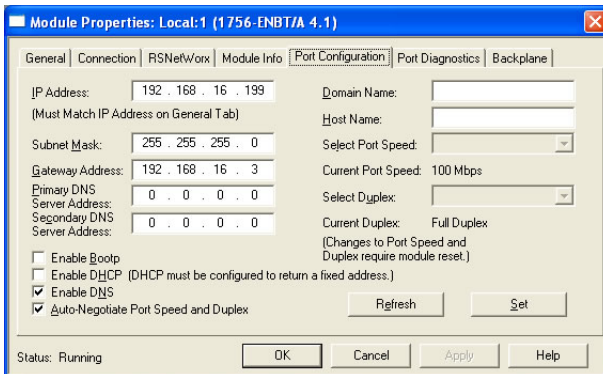
**Figure 74: Adding a New Module**

- 6) The “New Module” window will open. Refer to Figure 75.
- 7) Assign the Ethernet module a name (we will use “EIP”) and an IP address, deselect “Open Module Properties”, and click OK.



**Figure 75: Identifying the New Module**

- 8) Download the configuration.
- 9) Switch to online mode. Right click on the 1756-ENBT/A module in the I/O Configuration and choose “Properties”.
- 10) Select the Port Configuration tab from the Module Properties dialog box.
- 11) Confirm that the IP Address, Subnet Mask and Gateway Address fields are configured correctly. The IP Address must match the IP Address entered when the new module was first created. Refer to Figure 76.



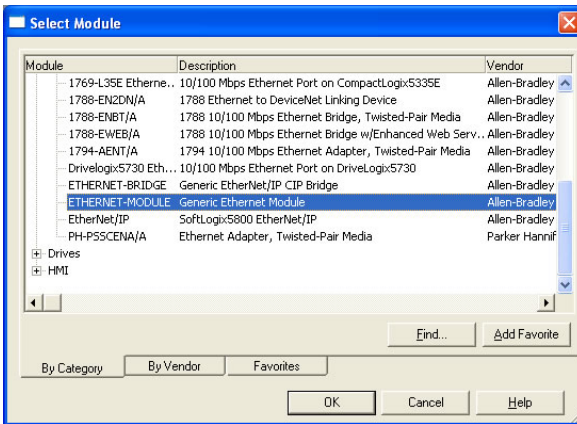
**Figure 76: Confirming the Module's Properties**

- 12) Apply the settings using the “Set” button.
- 13) You should now be able to confirm that the 1756-ENBT/A module is configured properly by (for example) opening the module’s web interface in a web browser.

## 13.2.4 ControllLogix Example: I/O Messaging

This section will demonstrate how to setup and use an EtherNet/IP I/O connection via vendor-specific assembly instances 100 & 150. EtherNet/IP I/O messaging allows the drive's registers to be directly mapped into tags in the ControllLogix PLC. Once an I/O connection is established, it is automatically synchronized at an interval defined by the Requested Packet Interval (RPI).

- 1) Switch to offline mode.
- 2) Right click on the 1756-ENBT/A node under the I/O Configuration in the controller organizer view and choose "New Module..."
- 3) Choose "Generic Ethernet Module" in the Select Module dialog box and click "OK". Refer to Figure 77.



**Figure 77: Adding a New Generic Ethernet Module**

- 4) The module properties dialog box will open (refer to Figure 78). Enter a Name and Description which will allow easy identification of the drive on the network (the tags created in RSLogix 5000 will be derived from this Name). Because all drive data is stored as 16-bit registers, change the "Comm Format" selection to "Data-INT". Enter the IP address of the targeted interface card.

In the "Connection Parameters" portion of the dialog box, enter the following information:

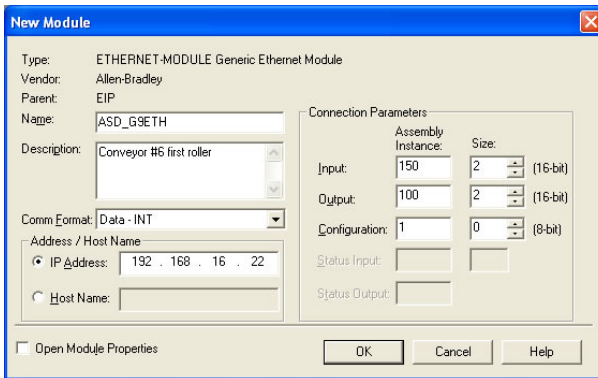
**Input:** The Input Assembly is the collection of monitor data that is produced by the interface card and is received as an input to the PLC. Its structure is defined by the Produced Register Configuration as described in section 10.8.4. The Input Assembly Instance must be set to 150 when connecting to the vendor-specific I/O assembly instances (or 70/71 when using the ODVA AC/DC drive profile), and the size must be set to the number of 16-bit registers that we wish to receive from the interface card. For the purposes of this example, we are

assuming that the produced configuration array is defined as shown in Figure 36, with two relevant registers (1402 and 1401). We therefore set the Input Size to 2.

**Output:** The Output Assembly is the collection of command & configuration data that is sent as an output from the PLC and consumed by the interface card. Its structure is defined by the Consumed Register Configuration as described in section 10.8.4. The Output Assembly Instance must be set to 100 when connecting to the vendor-specific I/O assembly instances (or 20/21 when using the ODVA AC/DC drive profile), and the size must be set to the number of 16-bit registers that we wish to send to the interface card. For the purposes of this example, we are assuming that the consumed configuration array is defined as shown in Figure 36, with two relevant registers (1007 and 1008). We therefore set the Output Size to 2.

**Configuration:** The Configuration Assembly Instance is unused, and its instance number and size are therefore irrelevant (you can just enter “1” and “0”, respectively).

When done, click “OK”.

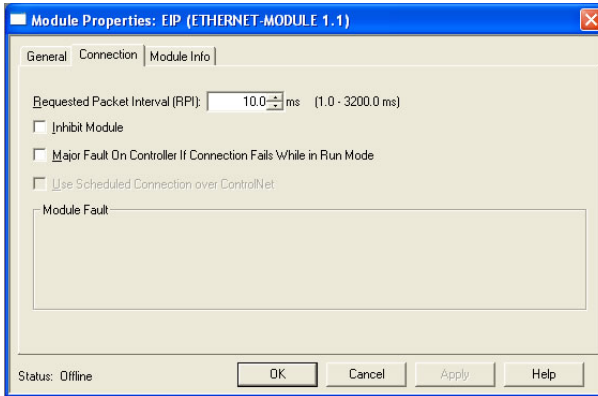


**Figure 78: Interface Card Module Properties**

- 5) You should now see the new module (named “ETHERNET-MODULE ASD\_G9ETH”) in the 1756-ENBT/A branch under the I/O Configuration in the controller organizer view. Right click on this new module, choose “Properties”, and select the Connection tab. Refer to Figure 79.

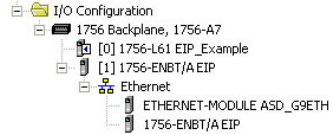
Confirm the setting of the Requested Packet Interval (RPI). The RPI defines the amount of time (in milliseconds) between data exchanges across an I/O connection. The smallest RPI supported by the interface card is 10ms.

Click OK when done.



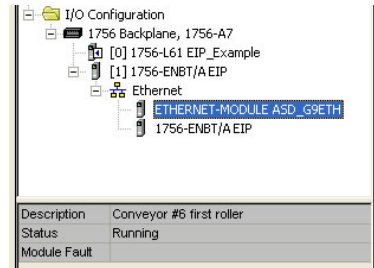
**Figure 79: Module Properties Connection Tab**

6) After adding the I/O Module to the configuration, the full I/O Configuration tree should appear similar to Figure 80.



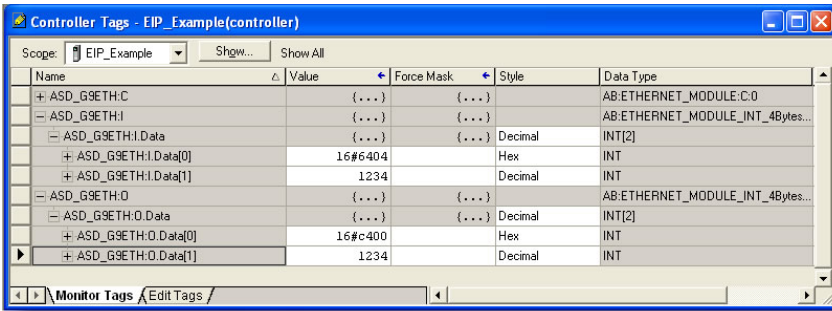
**Figure 80: I/O Configuration Tree**

7) Switch to online mode and download the project to the PLC. Verify that the newly-added drive is available and operating correctly by observing any indications shown on the drive's icon. When the drive's icon is selected, its status and any available error messages will be displayed in the area below the project tree. Refer to Figure 81. Also confirm that the interface card's "Network Status" LED should be solid green, indicating an "online/connected" state.



**Figure 81: Online Module Status**

8) By double-clicking "Controller Tags" in the project tree, it is possible to view the newly-added tags. Refer to Figure 82. The ASD\_G9ETH:C configuration tag is unused, the ASD\_G9ETH:I tag allows viewing of the input data, and the ASD\_G9ETH:O tag allows modification of the output data. These tags will be synchronized with the drive at whatever rate was established for the module's RPI.



**Figure 82: Controller Tags for I/O Access**

We can directly interact with these tags in order to control and monitor the drive. In Figure 82, we can see that the first 16-bit word of output data (ASD\_G9ETH:O.Data[0]) has been set to a hexadecimal value of 0xC400. Referring back to Figure 36, we can see that the first element of the consumed register configuration references register 1007, which is the drive's option board Command 1 register. A value of 0xC400, therefore, means that the frequency priority, command priority, and run bits have been turned ON.

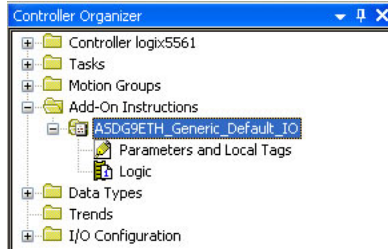
Similarly, we can see that the second 16-bit word of output data (ASD\_G9ETH:O.Data[1]) has been set to a decimal value of 1234. Once again referring back to Figure 36, we can see that the second element of the consumed register configuration references register 1008, which is the drive's option board frequency command register. A value of 1234, therefore, equates to a frequency command of 12.34Hz.

The input data from the drive shows similar expected results. Values of 0x6404 and 1234 corresponding to registers 1402 (inverter status 1) and 1401 (output frequency), respectively, are consistent with the drive running at the parameters commanded by the output tag.

### 13.2.5 ControlLogix Example: Generic Default I/O Add-On Instruction

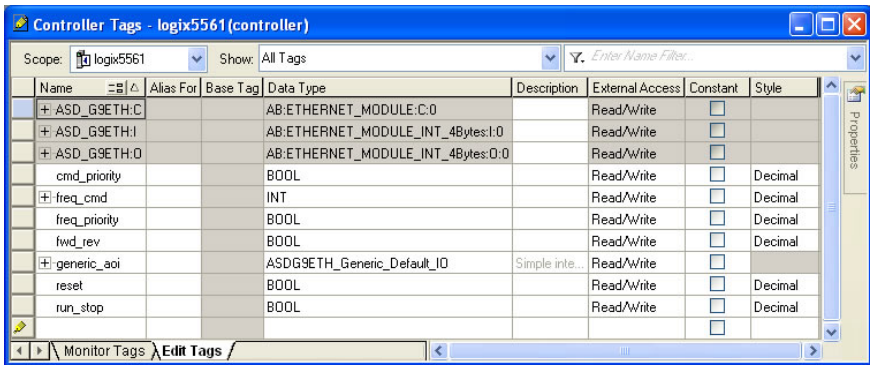
The generic default I/O Add-On Instruction (AOI) is a simple interface to command and monitor the inverter. It is based on vendor-specific I/O assembly instances 100 & 150 and the default produce and consume data configuration arrays (refer to section 10.8.4).

- 1) Complete all the steps in section 13.2.4.
- 2) Right click on "Add-On Instructions" in the controller organizer view and select "Import Add-On Instruction". Browse and import the generic default I/O AOI. Refer to Figure 83.



**Figure 83: Generic Default I/O AOI**

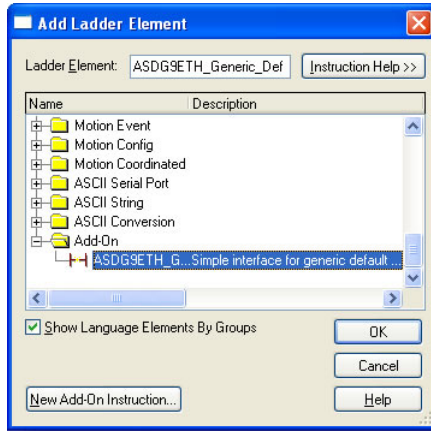
- 3) Double click “Controller Tags” in the controller organizer view and select the “Edit Tags” tab at the bottom.
- 4) Create the tags in Figure 84.



**Figure 84: Create Generic Default AOI Tags**

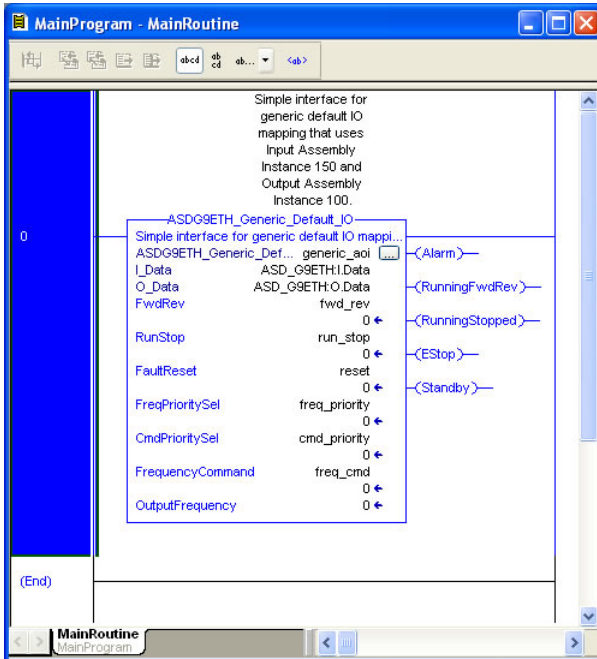
- 5) Double click “MainRoutine” under Tasks ...MainTask ...MainProgram in the controller organizer view.
- 6) Right click on the first ladder logic rung in the MainRoutine window and select “Add Ladder Element...”
- 7) The “Add Ladder Element” window appears.
- 8) Select the generic default I/O AOI in the Add-On folder. Refer to Figure 85.





**Figure 85: Add Generic Default AOI**

- 9) Click OK.
- 10) Edit the AOI according to Figure 86.



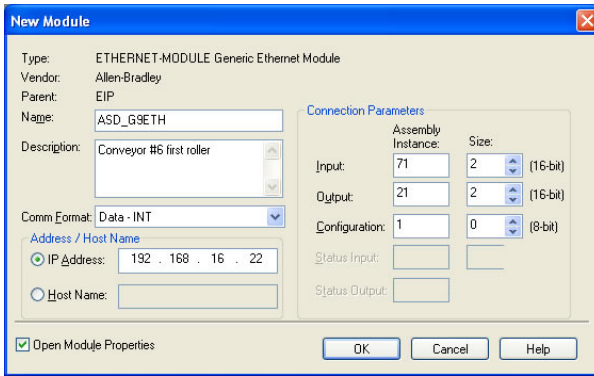
**Figure 86: Configure Generic Default AOI**

- 11) The program is now complete.
- 12) Save, download and run the program.

## 13.2.6 ControlLogix Example: AC/DC Drive Profile Add-On Instruction

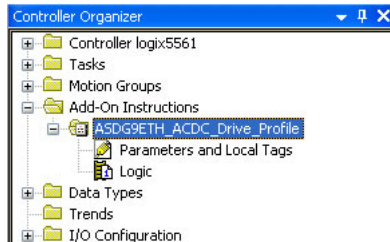
The AC/DC drive profile Add-On Instruction (AOI) is a simple interface to command and monitor the inverter. It is based on I/O assembly instances 21 & 71.

- 1) Complete all the steps in section 13.2.4. Please note that the Assembly Input Instance must be changed to 71 and the Assembly Output Instance must be changed to 21. Refer to Figure 87.



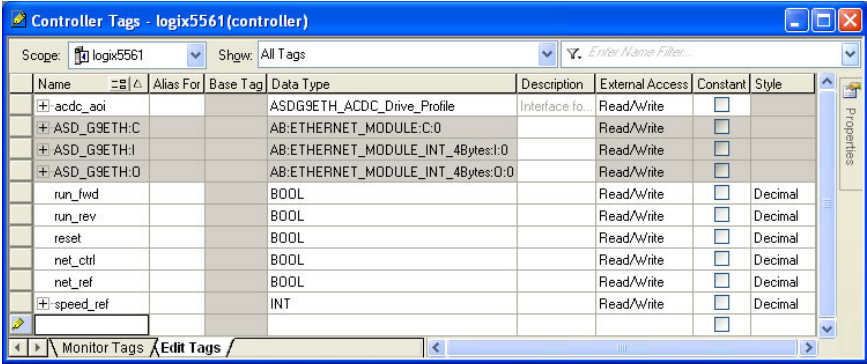
**Figure 87: AC/DC Drive Profile Generic Ethernet Module Configuration**

- 2) Right click on “Add-On Instructions” in the controller organizer view and select “Import Add-On Instruction”. Browse and import the AC/DC drive profile AOI. Refer to Figure 88.



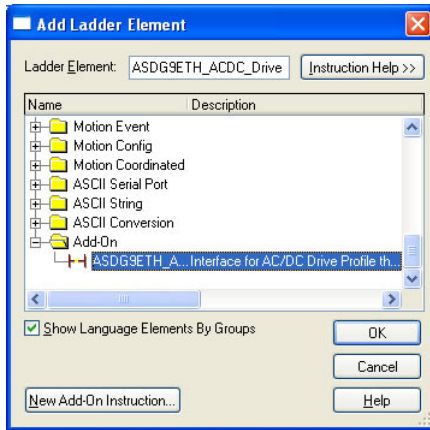
**Figure 88: AC/DC Drive Profile AOI**

- 3) Double click “Controller Tags” in the controller organizer view and select the “Edit Tags” tab at the bottom.
- 4) Create the tags in Figure 89.



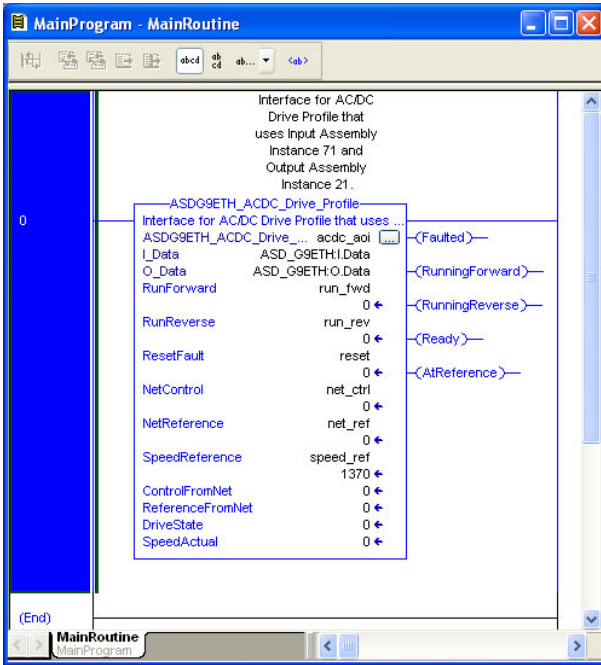
**Figure 89: Create AC/DC Drive Profile AOI Tags**

- 5) Double click “MainRoutine” under Tasks ...MainTask ...MainProgram in the controller organizer view.
- 6) Right click on the first ladder logic rung in the MainRoutine window and select “Add Ladder Element...”
- 7) The “Add Ladder Element” window appears.
- 8) Select the AC/DC drive profile AOI in the Add-On folder. Refer to Figure 90.



**Figure 90: Add AC/DC Drive Profile AOI**

- 9) Click OK.
- 10) Edit the AOI according to Figure 91.



**Figure 91: Configure AC/DC Drive Profile AOI**

- 11) The program is now complete.
- 12) Save, download and run the program.

### 13.2.7 Explicit Messaging Tag Reference

When class 3 (explicit messaging) connections are used, register contents are read from and written to the interface card via EtherNet/IP by reference to “tag names”. Tags are read via the EtherNet/IP “data table read” service, and tags are written via the EtherNet/IP “data table write” service. Different tags exist for reading vs. writing.

Any given register can be accessed with its own unique tag name, or an array tag can be used to access a group of registers with one PLC instruction. Tag names are generated according to the following structure:

**[action prefix][\_reg\_][register number]**

#### Where

**[action prefix]** is a 2-character field, and is equal to either “rd” for read tags, or “wr” for write tags. Although commonly followed for naming clarity, this “read vs. write” naming convention is not strictly enforced by the interface card, however: it is

perfectly acceptable to write to a tag that starts with “rd” and read from a tag that starts with “wr”.

[\_reg\_] is just the 5-character sequence “\_reg\_”.

[register number] is a 1- to 4-character field (“1”, “2”...“1484”, “1485”) corresponding to the referenced register number.

Examples

- Read “acceleration time 1” (register #10) ..... rd\_reg\_10
- Write “option frequency command” (register #1008) ..... wr\_reg\_1008
- Read “inverter status 1” (register #1402)..... rd\_reg\_1402

Additionally, a few special tags exist which provide backward-compatibility with V1.000 network interface CPU firmware. These are specified in Table 5.

**Table 5: Special Tag Reference**

Service	Tag Name	Register Start	Same As...
Data table read	rd_reg_basic	1	rd_reg_1
Data table read	rd_freq_out	1401	rd_reg_1401
Data table read	rd_inv_stat1	1402	rd_reg_1402
Data table read	rd_torq_out	1419	rd_reg_1419
Data table read	rd_inv_stat2	1443	rd_reg_1443
Data table write	wr_reg_basic	1	wr_reg_1
Data table write	wr_cmd1	1007	wr_reg_1007
Data table write	wr_freq_cmd	1008	wr_reg_1008
Data table write	wr_cmd2	1024	wr_reg_1024
Data table write	wr_torq_cmd	1034	wr_reg_1034

To read data from the interface card, the application PLC program must reference a “source element” from which to start reading and the “number of elements” to read. The “source element” will be a tag name constructed according to the naming convention shown above, or a special tag as shown in Table 5. The “source element” can be either a base tag (such as “rd\_reg\_1301”, which starts at register 1301), or an offset from a base tag (such as “rd\_reg\_1301[4]”, which starts at register 1301+4 = register 1305, the drive’s input voltage monitor register).

In a similar manner, to write data to the interface card, the application PLC program must reference a “destination element” to which to start writing and the “number of elements” to write. Again, the “destination element” will be a tag name constructed according to the naming convention shown above, or a special tag as shown in Table 5.

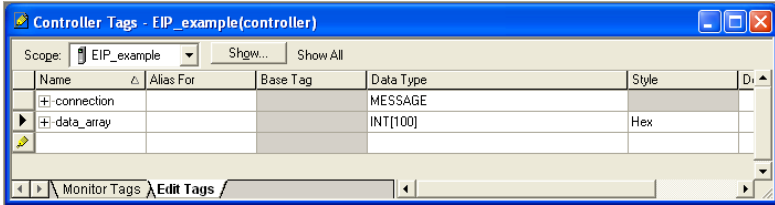
Whether reading or writing, the “number of elements” can be any quantity of registers from 1 to the maximum allowable length (1485).

## 13.2.8 ControllLogix Example: Read a Register Block

This example program will show how to continuously read a block of registers from the drive with a single MSG instruction. Only one read request is outstanding at any given time.

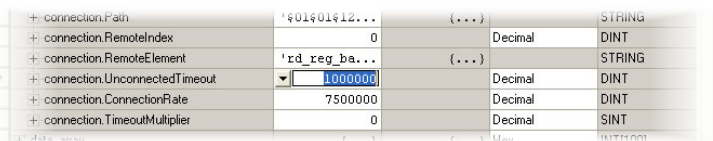
### 1) Create new Tags.

- a) Double click “Controller Tags” in the controller organizer view.
- b) The “Controller Tags” window appears. Refer to Figure 92.



**Figure 92: Create New Tags**

- c) Select the “Edit Tags” tab at the bottom.
- d) Create a new tag by entering “connection” in the first blank Name field, and change its Data Type to “MESSAGE”. This tag will contain configuration information for the MSG instruction.
- e) Select the “Monitor Tags” tab. Expand the “connection” tag by clicking on the “+” sign next to the tag name. Scroll down to the connection.UnconnectedTimeout field and change its value from the default 30000000 (30s in 1uS increments) to 1000000 (1s). This value determines how long to wait before timing out and retransmitting a connection request if a connection failure occurs. Refer to Figure 93.



**Figure 93: Reduce the UnconnecteTimeout Value**

- f) Collapse the “connection” tag again by clicking on the “-” sign next to the tag name.
- g) Select the “Edit Tags” tab again. Create another new tag by entering “data\_array” in the next blank Name field, and change its Data Type by typing in “INT[100]” in the Data Type field. This tag is an array of INTs that will be able to hold up to 100 16-bit registers from the drive. Always make sure that the destination tag size is large enough to hold all elements to be read.

## 2) Add a MSG instruction to the main program.

- Double click “MainRoutine” under Tasks ...MainTask ...MainProgram in the controller organizer view.
- Right click on the first ladder logic rung in the MainRoutine window and select “Add Ladder Element...”
- The “Add Ladder Element” window appears.
- Select the “MSG” instruction in the Input/Output folder. Refer to Figure 94.
- Click OK.

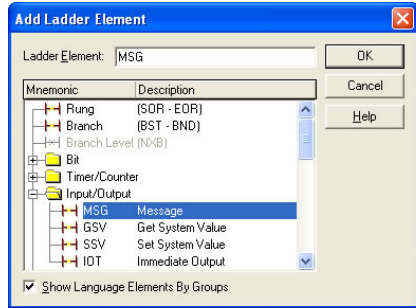


Figure 94: Adding a MSG Instruction

## 3) Add an XIO element to the main program.

- Right click on the ladder logic rung containing the MSG instruction in the MainRoutine window and select “Add Ladder Element...” again.
- The “Add Ladder Element” window appears.
- Select the “XIO” element in the Bit folder. Refer to Figure 95.
- Click OK.

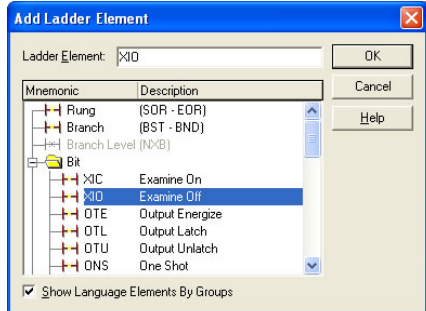
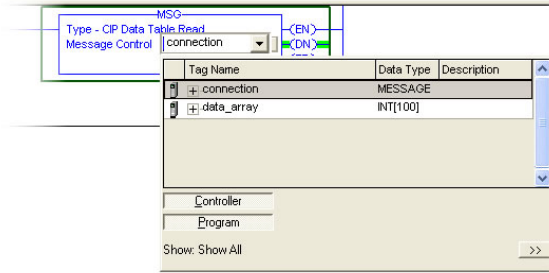


Figure 95: Adding an XIO Element

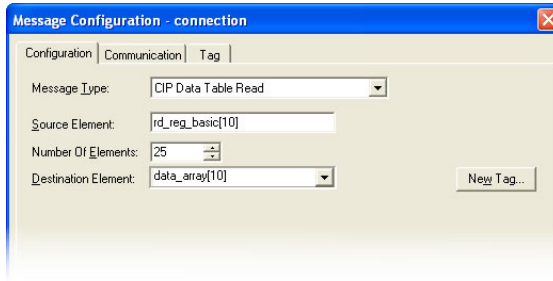
## 4) Configure the MSG instruction.

- Edit the “Message Control” field on the MSG instruction to use the previously-created “connection” tag. Refer to Figure 96.



**Figure 96: MSG Instruction Tag Assignment**

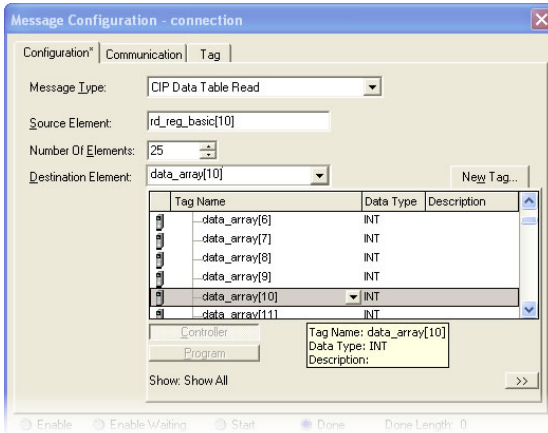
- b) Click the message configuration button (“...”) in the MSG instruction. The “Message Configuration” window will open. Refer to Figure 97.



**Figure 97: MSG Instruction Configuration**

- c) “Configuration” tab settings:
  - i) Change the “Message Type” to “CIP Data Table Read”.
  - ii) In the “Source Element” field, enter the read tag you wish to access (refer to section 13.2.5.) In this example, we will be reading a total of 25 registers beginning at rd\_reg\_basic[10]. Offset 10 in the interface card’s rd\_reg\_basic root tag (which starts at register 1) refers to 1+10 = register 11 (deceleration time 1). If we wish, we could also use the tag name which references deceleration time 1 directly (rd\_reg\_11) to achieve the same results.
  - iii) Enter the Number Of Elements to read. In this example, we will read 25 registers.
  - iv) For the Destination Element, either directly type in “data\_array[10]”, or select element #10 in the data\_array tag via the drop-down box (refer to Figure 98). The destination could be any offset in the data\_array tag, as long as the offset plus the Number Of Elements (25) does not exceed the tag’s defined size (100).



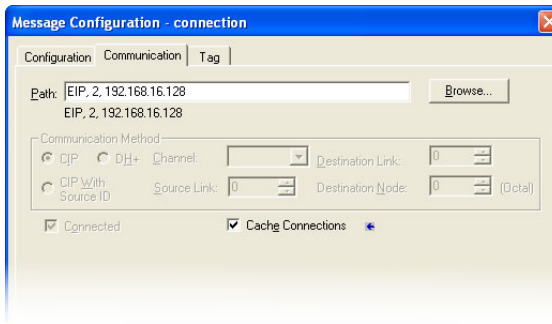


**Figure 98: Selecting the Destination Element**

d) “Communication” tab settings (refer to Figure 99):

- i) Enter the Path to the interface card. A typical path is formatted as “*Local\_ENB,2,target\_IP\_address*”, where:
  - *Local\_ENB* is the name of the 1756-ENBx module in the local chassis (we named ours “EIP” in section 13.2.3),
  - 2 is the Ethernet port of the 1756-ENBx module in the local chassis, and
  - *target\_IP\_address* is the IP address of the target node.

In our example, this path would be entered as “EIP,2,192.168.16.128”.

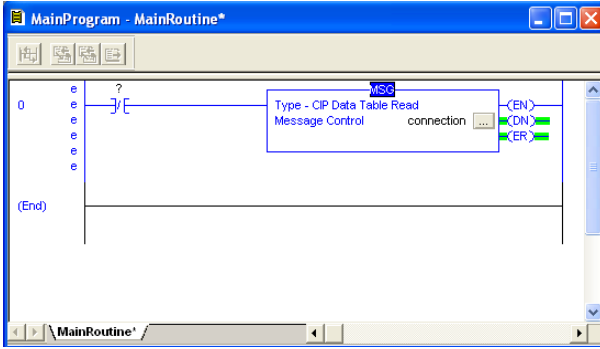


**Figure 99: Setting the Communication Path**

- ii) If “Cache Connections” is enabled (checked), the connection remains open after transmission. If disabled (unchecked), the connection is

opened before and closed after every transmission. For efficiency, it is recommended to enable “Cache Connections”.

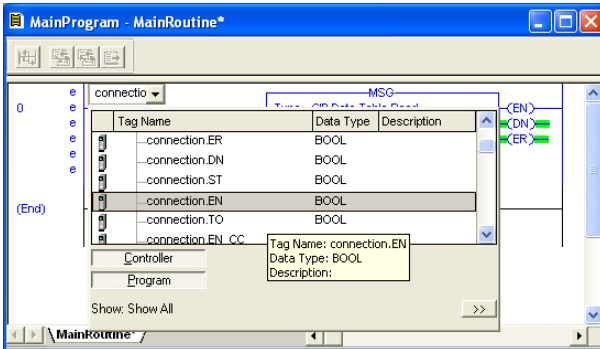
- e) Click “OK” to close the MSG Configuration dialog. At this stage, MainRoutine should look like Figure 100.



**Figure 100: MainRoutine**

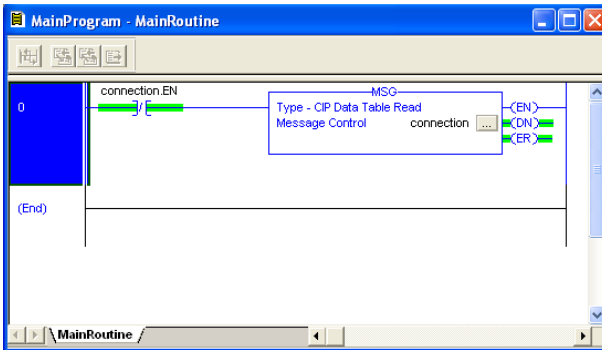
**5) Assign a tag to the XIO element.**

- a) Double-click on the XIO element located to the left of the MSG block. In the drop-down box, double-click on the “connection.EN” field. Refer to Figure 101. This configuration causes the MSG instruction to automatically retrigger itself when it completes. While this is acceptable for the purposes of this example, it can produce high network utilization. In actual practice, it may be desirable to incorporate additional logic elements to allow triggering the MSG instruction at a specific rate or under specific conditions.



**Figure 101: Configure XIO Element**

- 6) The program is now complete. Refer to Figure 102.



**Figure 102: Complete Program**

**7) Save, download and run the program.**

- a) To view the values of the registers being read from the interface card, double-click “Controller Tags” in the controller organizer view.

Name	Value	Force Mask	Style	Data Type
connection	{...}	{...}		MESSAGE
data_array	{...}	{...}	Decimal	INT[100]
data_array[0]	0		Decimal	INT
data_array[1]	0		Decimal	INT
data_array[2]	0		Decimal	INT
data_array[3]	0		Decimal	INT
data_array[4]	0		Decimal	INT
data_array[5]	0		Decimal	INT
data_array[6]	0		Decimal	INT
data_array[7]	0		Decimal	INT
data_array[8]	0		Decimal	INT
data_array[9]	0		Decimal	INT
data_array[10]	100		Decimal	INT
data_array[11]	8000		Decimal	INT
data_array[12]	6000		Decimal	INT
data_array[13]	0		Decimal	INT
data_array[14]	6000		Decimal	INT
data_array[15]	0		Decimal	INT
data_array[16]	60		Decimal	INT
data_array[17]	0		Decimal	INT
data_array[18]	0		Decimal	INT
data_array[19]	0		Decimal	INT
data_array[20]	0		Decimal	INT

**Figure 103: Viewing the Register Values**

- b) Select the “Monitor Tags” tab.
- c) Expand the data\_array tag. Refer to Figure 103.
- d) 25 register values starting at register #11 are being continuously read from the interface card and placed in the 25 sequential offsets of data\_array starting at the 11<sup>th</sup> offset (data\_array[10]). In Figure 103, we can see that

data\_array[10] (deceleration time #1) has a value of 100 (10.0s),  
 data\_array[11] (maximum frequency) has a value of 8000 (80.00Hz) etc.

### 13.2.9 ControlLogix Example: Read a Single Register

The configuration and execution for reading a single register is in general identical to that required for reading a block of registers as detailed in section 13.2.8. The only difference is in the configuration of the MSG instruction. Figure 104 shows an example MSG instruction's Configuration tab, which will read a single tag (rd\_reg\_1402, which corresponds to the drive's "inverter status 1" register) and place it in the first element (offset 0) of data\_array.

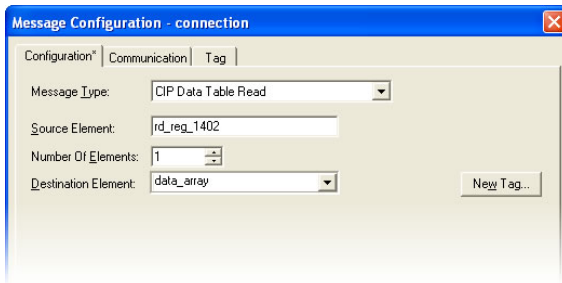
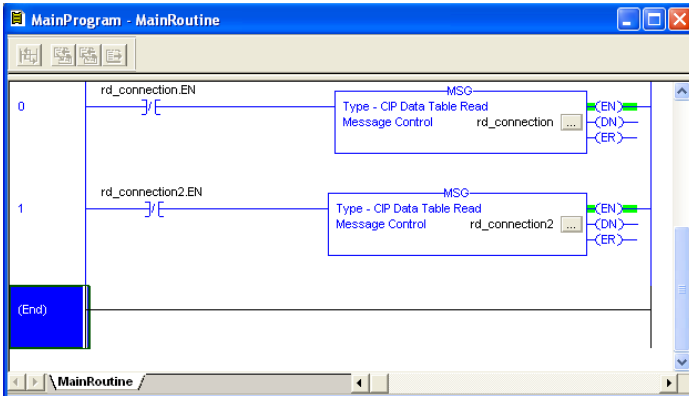


Figure 104: Read the Drive's Status Register

### 13.2.10 ControlLogix Example: Multiple MSG Instructions

At times, reading from different groups of registers may be necessary. For example, a specific application may require some registers located in various disjoint locations in the register map. To accomplish this task efficiently, multiple MSG instructions can be implemented in the PLC program.

The configuration and execution for implementing multiple MSG instructions is in general identical to that required for implementing just one MSG instruction. Each MSG instruction will require its own message controller tag. In the case of read MSG instructions, more than one instruction may use the same Destination Element tag, but the storage locations must not overlap. Figure 105 shows an example of two MSG instructions, each accessing different read tags. It is evident from this logic that "rd\_connection" and "rd\_connection2" are the two independent message controller tags created for these instructions.



**Figure 105: Reading Via Multiple MSG Instructions**

### 13.2.11 ControlLogix Example: Reading and Writing

Often times, applications may need to both read data from and write data to the drive. At a minimum, this will require two MSG instructions and two message controller tags. Figure 106 shows an example of two MSG instructions, one for reading and one for writing. The only item of note that differentiates this example from the multiple-read example in section 13.2.10 is the addition of the `en_wr` XIC element. The reason for the addition of this element is that while reading from a remote device is often continuously performed (monitoring), data is typically written to the remote device only when necessary (i.e. when the value to write has changed). This conserves both network bandwidth and potentially EEPROM lifespans on the target device. The `en_wr` element in this example, therefore, would typically be replaced in an actual application program by user-provided logic which controls the conditions under which a write operation would be performed.

Figure 107 shows the configuration details of the example `wr_connection` MSG instruction. Note that the chosen “Message Type” is “CIP Data Table Write”, and that this instruction will only be writing to one drive register: namely, the frequency command (Destination Element is `wr_reg_1008`). The Source Element in this case is the 8<sup>th</sup> element (starting from index 0) of an INT array tag named “`wr_data_array`”.

Note that when writing data via explicit messaging, use caution to ensure that the commanded registers are not also simultaneously being commanded in the background via I/O messaging. Indeterminate behavior can occur if MSG instructions and background I/O data transfers are both writing to the same registers. In other words, if the I/O messaging example procedure detailed in section 13.2.4 has already been implemented, and the same program is now being modified to implement explicit messaging, then it is recommended to inhibit the target module by selecting the “Inhibit Module” checkbox in the Connection tab of the Module Properties dialog.

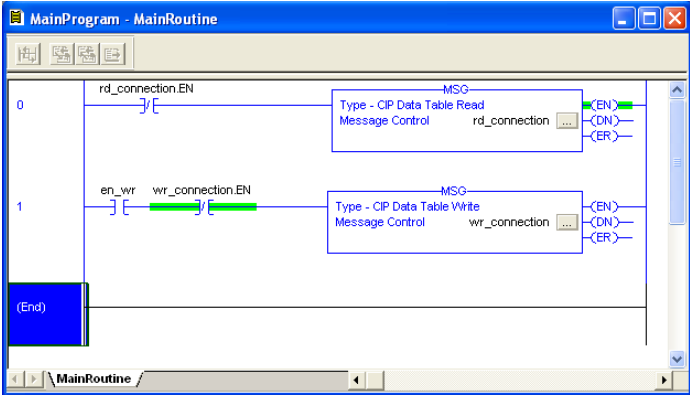


Figure 106: Reading and Writing via MSG Instructions

The 'Message Configuration - wr\_connection' dialog box has three tabs: 'Configuration', 'Communication', and 'Tag'. The 'Configuration' tab is active. It contains the following fields:

- Message Type: CIP Data Table Write
- Source Element: wr\_data\_array[7]
- Number Of Elements: 1
- Destination Element: wr\_reg\_1008

A 'New Tag...' button is located to the right of the Source Element field.

Figure 107: MSG Configuration for Writing

## 13.3 Allen Bradley CSP

Ethernet-enabled Allen-Bradley legacy PLCs (such as the PLC5E and SLC-5/05 series) use a protocol called CSP (Client Server Protocol) to communicate over the Ethernet network. The flavor of CSP used by these PLCs is also known as “PCCC” (Programmable Controller Communication Commands) and “AB Ethernet”. The interface card supports CSP for direct connectivity to these PLCs.

If a connection timeout or socket-level error occurs, the driver will trigger a timeout event as described in section 10.7.5.

### 13.3.1 Tag Reference

Register contents are read from and written to the interface card via CSP by reference to an integer “file/section number” and an “offset/element” within that file. Reading is performed via the CSP “PLC5 Read” (DF1 protocol typed read) service, and writing is performed via the CSP “PLC5 Write” (DF1 protocol typed write) service.

The formula to calculate which register is targeted in the interface card is provided in Equation 3.

$$\text{target register} = (\text{file number} - 10) \times 100 + \text{offset} \qquad \text{Equation 3}$$

In Equation 3, “target register”  $\in [1 \dots 1485]$ , “file number”  $\in [10 \dots 24]$  (which means N10...N24), and “offset” is restricted only by the limitations of the programming software (but is a value of 1485 max). Table 6 provides some examples of various combinations of file/section numbers and offsets/elements which can be used to access drive registers. Note that there are multiple different combinations of file/section numbers and offsets/elements that will result in the same drive register being accessed.

**Table 6: CSP Target Register Examples**

File/Section Number	Offset/Element	Start Target Register
N10	1	1
N12	99	299
N11	199	299
N20	7	1007
N24	85	1485
N10	1485	1485

In addition to providing access to the drive registers in their “standard” numerical locations as mentioned above, the registers can also be accessed in a special “assembly object” type format by targeting integer file N50. What this means is that when N50 is targeted for reading, what is actually returned by the interface card is the user-defined register data as ordered by the EtherNet/IP produced register

configuration array (refer to section 10.8.4). Similarly, when N50 is targeted for writing, the written data is disseminated to the drive's registers according to the definition contained in the EtherNet/IP consumed register configuration array. By appropriate configuration of the EtherNet/IP consumed and produced register configuration arrays, therefore, bulk access to non-contiguous but frequently-used drive registers can be conveniently provided by performing only one read and/or write instruction targeting file N50.

Because both the EtherNet/IP consumed and produced register configuration arrays are comprised of 32 register definitions, the targeted "offset/element" must be within the range of 0 to 31 inclusive. Refer to Table 7 for some examples of N50 accesses.

**Table 7: Examples of EtherNet/IP-Style Bulk Access via File N50**

Offset/Element	Start Target Register of Configuration Array	Max Number of Accessible Elements
0	1st	32
:	:	:
15	16th	16
:	:	:
31	32nd	1

The application PLC program uses a MSG instruction that is configured with a "Data Table Address" from which to start the access and a "Size in Elements" which determines the number of items to access (read or write). The "Data Table Address" is constructed by selecting a "File/Section Number" and an "Offset/Element" according to Equation 3. For example, a "File/Section Number" of N23 and "Offset/Element" of 5 = N23:5, which corresponds to register 1305 (the drive's input voltage monitor register).

### 13.3.2 SLC-5/05 Example: Read a Register Block

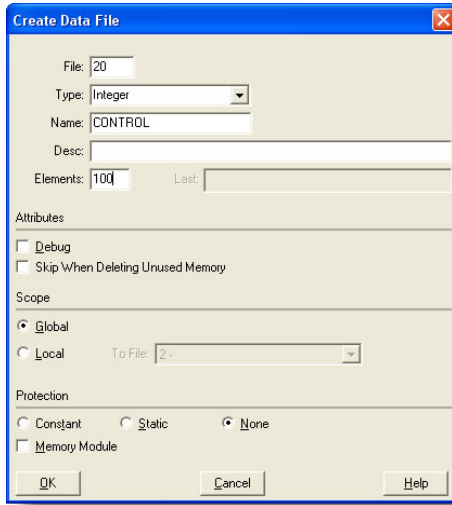
This example program will show how to continuously read a block of registers from the drive with a single MSG instruction. Only one read request is outstanding at any given time.

**1) Run RSLogix 500, and create a new configuration.**

**2) Create a control and a data file.**

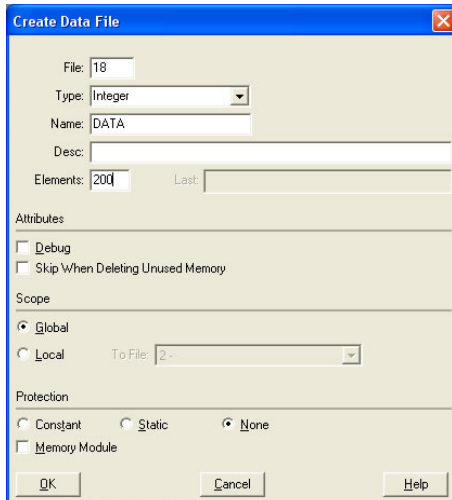
- a) Right click Data Files and select New... The "Create Data File" dialog box appears (refer to Figure 108).
- b) To create a control file, enter a file number (e.g. 20), set the type to "Integer", enter a descriptive name (e.g. "CONTROL"), and enter a number of elements (e.g. 100). Click OK to create the file. The control file is used to store configuration information pertaining to the functionality of the MSG instruction which will perform the data read.





**Figure 108: Creating a Control File**

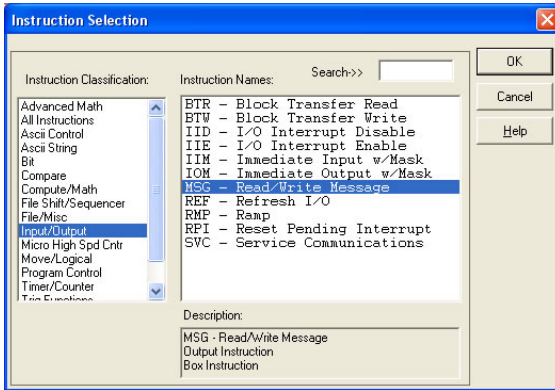
- c) Follow the same procedure to create a data file. This file will be used to store the incoming data read from the interface card. Enter a file number (e.g. 18), set the type to "Integer", enter a descriptive name (e.g. "DATA"), and enter a number of elements (e.g. 200). Refer to Figure 109. Click OK to create the file.



**Figure 109: Creating a Data File**

### 3) Add a MSG instruction to the program.

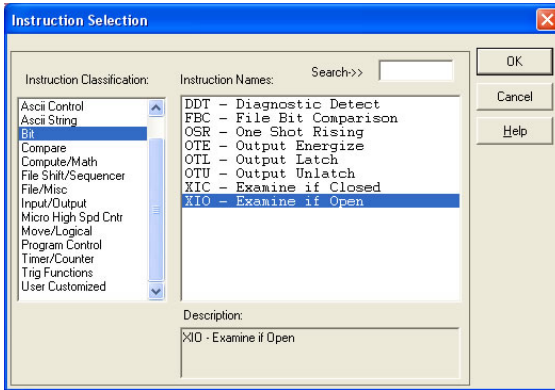
- a) If not already visible, double-click “LAD2” under Project...Program Files in the controller organizer view to bring up the ladder logic program.
- b) Right click on the default rung number on the left-hand side of the LAD2 window and select “Insert Rung”.
- c) Right click on the rung number of the new editable rung and select “Append Instruction”.
- d) Select the “MSG” instruction from the “Input/Output” classification, then click OK. Refer to Figure 110.



**Figure 110: MSG Instruction Selection**

### 4) Add an XIO element to the program.

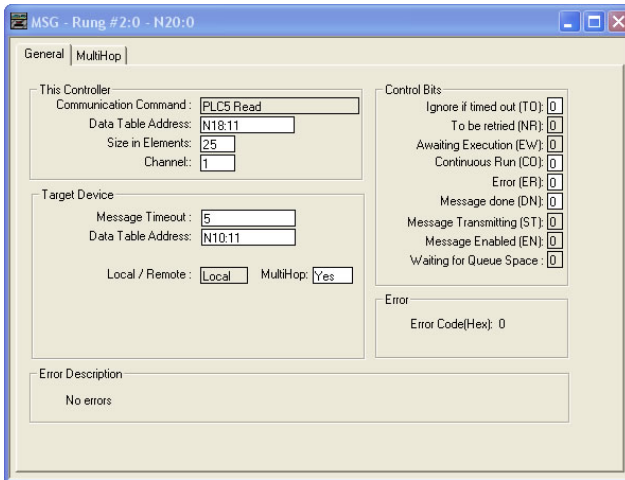
- a) Right click on the rung number of the rung currently being edited and select “Append Instruction” again.
- b) Select the “XIO” instruction from the “Bit” classification, then click OK. Refer to Figure 111.



**Figure 111: XIO Instruction Selection**

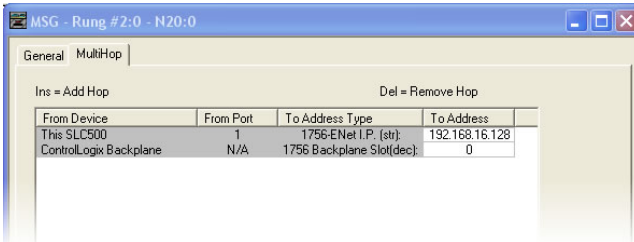
**5) Configure the MSG instruction.**

- a) Set the "Read/Write" field to "Read", "Target Device" field to "PLC5", "Local/Remote" field to "Local", and "Control Block" to "N20:0".
- b) Upon hitting the <ENTER> key while in the "Control Block" entry box, the MSG Properties dialog box should appear (or it can be opened by clicking on the "Setup Screen" button at the bottom of the MSG instruction). Refer to Figure 112.



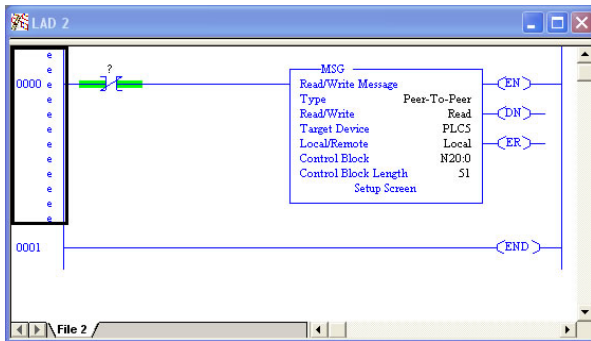
**Figure 112: MSG Configuration, "General" Tab**

- c) In this example, we will be reading a total of 25 registers beginning at N10:11 (register 11, the drive's "deceleration time 1" parameter). To configure this, under "This Controller" set the "Data Table Address" field to N18:11, set the "Size in Elements" field to 25, and set the "Channel" field to 1 (Ethernet).
- d) Under "Target Device", set the "Data Table Address" field to N10:11 (starting target register=11) and set the "MultiHop" field to Yes to cause the "MultiHop" tab to appear.
- e) Under the "MultiHop" tab settings, set the "To Address" in the first row to the drive's IP address, and the "To Address" in the second row to 0. Refer to Figure 113.



**Figure 113: MSG Configuration, "MultiHop" Tab**

- f) Close the dialog box. At this point, the program should appear as shown in Figure 114.



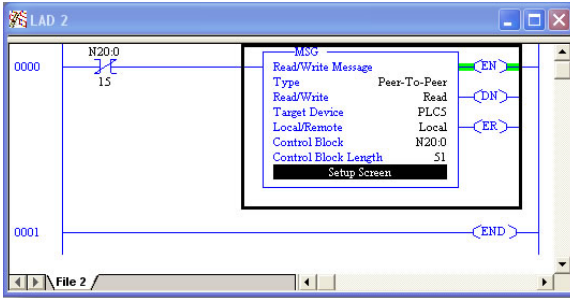
**Figure 114: PLC Program after MSG Instruction Configuration**

## 6) Assign a tag to the XIO element.

- a) Double-click on the XIO element located to the left of the MSG block. Type in N20:0/15 (MSG instruction's enable bit). This configuration causes the MSG instruction to automatically retrigger itself when it completes. While this is acceptable for the purposes of this example, it can produce high network utilization. In actual practice, it may be desirable to incorporate

additional logic elements to allow triggering the MSG instruction at a specific rate or under specific conditions.

**7) The program is now complete. Refer to Figure 115.**



**Figure 115: Completed PLC Program**

**8) Save, download, and run the program.**

- a) To view the registers being read from the interface card, double-click the data file N18 under "Data Files" in the controller organizer view. 25 register values starting at register #11 are being continuously read from the interface card and placed in the 25 sequential offsets of N18 starting at N18:11. Refer to Figure 116. We can see that N18:11 (deceleration time #1) has a value of 100 (10.0s), N18:12 (maximum frequency) has a value of 6000 (60.00Hz), etc.

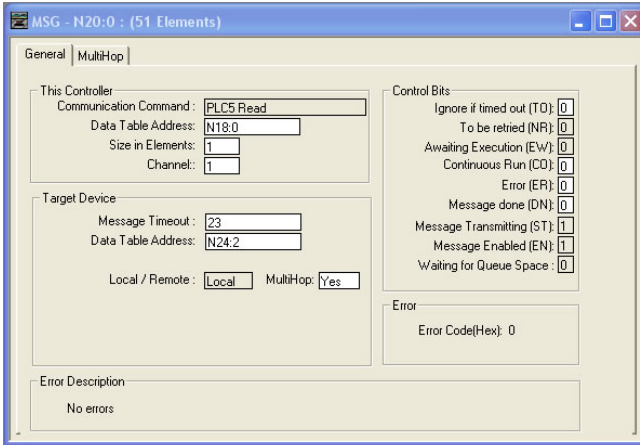
Offset	0	1	2	3	4	5	6	7	8	9
N18:0	0	0	0	0	0	0	0	0	0	0
N18:10	0	100	6000	6000	0	6000	0	70	0	0
N18:20	0	0	0	0	0	0	0	0	0	0
N18:30	0	0	0	0	0	0	0	0	0	0
N18:40	0	0	0	0	0	0	0	0	0	0
N18:50	0	0	0	0	0	0	0	0	0	0

**Figure 116: Monitoring the Data Being Read from the Drive**

### 13.3.3 SLC-5/05 Example: Read a Single Register

The configuration and execution for reading a single register is in general identical to that required for reading a block of registers as detailed in section 13.3.2. The only

difference is in the configuration of the MSG instruction. Figure 117 shows an example MSG instruction's General tab, which will read a single element (N24:2, which corresponds to the drive's "inverter status 1" register) and place it in the first element (offset 0) of N18.

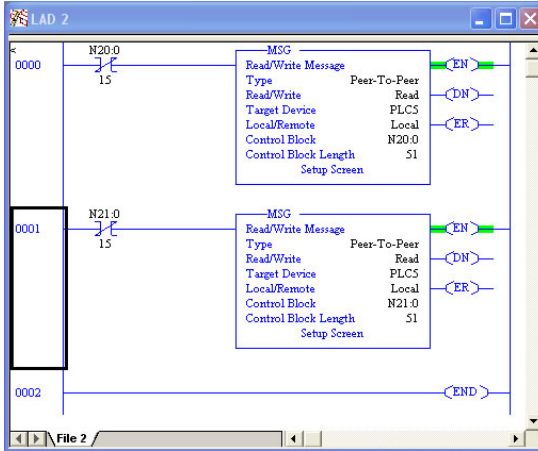


**Figure 117: Read the Drive's Status Register**

### 13.3.4 SLC-5/05 Example: Multiple MSG Instructions

At times, reading from different groups of registers may be necessary. For example, a specific application may require some registers located in various disjoint locations in the register map. To accomplish this task efficiently, multiple MSG instructions can be implemented in the PLC program.

The configuration and execution for implementing multiple MSG instructions is in general identical to that required for implementing just one MSG instruction. Each MSG instruction will require its own message control file. In the case of read MSG instructions, more than one instruction may use the same data file to store the received register values, but the storage locations must not overlap. Figure 118 shows an example of two MSG instructions, each accessing different target integer files. It is evident from this logic that N20 and N21 are the two independent message control files created for these instructions.



**Figure 118: Reading Via Multiple MSG Instructions**

### 13.3.5 SLC-5/05 Example: Reading and Writing

Often times, applications may need to both read data from and write data to the drive. At a minimum, this will require two MSG instructions and two message control files. Figure 119 shows an example of two MSG instructions, one for reading and one for writing. Note that the “Read/Write” field of each of the MSG instructions is set according to their function.

Figure 120 shows the configuration details of the “write” MSG instruction. Note that this instruction will only be writing to one drive register: namely, the frequency command (Target Data Table Address is N20:8, which equates to drive register 1008). The source Data Table Address in this case is N18:7.

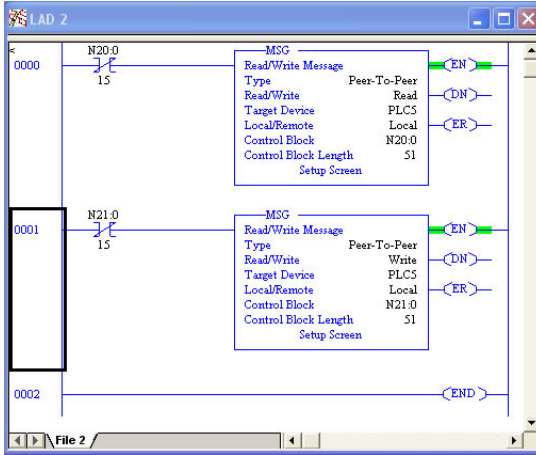


Figure 119: Reading and Writing via MSG Instructions

The screenshot shows the configuration dialog for the MSG instruction N21:0. The General tab is active. Under 'This Controller', the Communication Command is 'PLC5 Write', Data Table Address is 'N18.7', Size in Elements is '1', and Channel is '1'. Under 'Target Device', the Message Timeout is '23', Data Table Address is 'N20.8', Local / Remote is 'Local', and MultiHop is 'Yes'. The Control Bits section includes: Ignore if timed out (TO): 0, To be retried (NR): 0, Awaiting Execution (EW): 0, Continuous Run (CO): 0, Error (ER): 0, Message done (DN): 0, Message Transmitting (ST): 1, Message Enabled (EN): 1, and Waiting for Queue Space: 0. The Error Code (Hex) is 0, and the Error Description is 'No errors'.

Figure 120: MSG Configuration for Writing



## 13.4 BACnet

### 13.4.1 Overview

- The interface card supports the BACnet/IP (Annex J) protocol over Ethernet via UDP port 47808.
- The BACnet driver does not trigger timeout events (section 10.7.5).

### 13.4.2 Protocol Implementation Conformance Statement

#### BACnet Protocol

Date: June 1, 2011  
Vendor Name: ICC, Inc.  
Product Name: Ethernet interface for Toshiba G9/AS1 ASD  
Product Model Number: ASD-G9ETH  
Applications Software Version: V2.300  
Firmware Revision: V2.300  
BACnet Protocol Revision: 2  
Product Description:

The Toshiba G9/AS1 is an advanced inverter featuring reduced high-frequency noise, reduced harmonics, and high-precision and high-speed torque control with or without sensors.

#### BACnet Standard Device Profile (Annex L):

- BACnet Operator Workstation (B-OWS)
- BACnet Building Controller (B-BC)
- BACnet Advanced Application Controller (B-AAC)
- BACnet Application Specific Controller (B-ASC)
- BACnet Smart Sensor (B-SS)
- BACnet Smart Actuator (B-SA)

#### BACnet Interoperability Building Blocks Supported (Annex K):

- Data Sharing – ReadProperty-B (DS-RP-B)
- Data Sharing – ReadPropertyMultiple-B (DS-RPM-B)
- Data Sharing – WriteProperty-B (DS-WP-B)
- Device Management – Dynamic Device Binding-B (DM-DDB-B)
- Device Management – Dynamic Object Binding-B (DM-DOB-B)

#### Segmentation Capability:

None

Segmented requests supported

Window Size \_\_\_\_\_

Segmented responses supported

Window Size \_\_\_\_\_

**Standard Object Types Supported:**

See "Object Types/Property Support Table".

**Data Link Layer Options:**

- BACnet IP, (Annex J)
- BACnet IP, (Annex J), Foreign Device
- ISO 8802-3, Ethernet (Clause 7)
- ANSI/ATA 878.1, 2.5 Mb. ARCNET (Clause 8)
- ANSI/ATA 878.1, RS-485 ARCNET (Clause 8), baud rate(s) \_\_\_\_\_
- MS/TP master (Clause 9), baud rate(s): 9600, 19200, 38400, 76800
- MS/TP slave (Clause 9), baud rate(s): \_\_\_\_\_
- Point-To-Point, EIA 232 (Clause 10), baud rate(s): \_\_\_\_\_
- Point-To-Point, modem, (Clause 10), baud rate(s): \_\_\_\_\_
- LonTalk, (Clause 11), medium: \_\_\_\_\_
- Other: \_\_\_\_\_

**Device Address Binding:**

Is static device binding supported? (This is currently for two-way communication with MS/TP slaves and certain other device.)  Yes  No

**Networking Options:**

- Router, Clause 6 - List all routing configurations
- Annex H, BACnet Tunneling Router over IP
- BACnet/IP Broadcast Management Device (BBMD)  
Does the BBMD support registrations by Foreign Devices?  Yes  No

**Character Sets Supported:**

Indicating support for multiple character sets does not imply that they can all be supported simultaneously.

- ANSI X3.4
- IBM™/Microsoft™ DBCS
- ISO 8859-1
- ISO 10646 (UCS-2)
- ISO 10646 (UCS-4)
- JIS C 6226

If this product is a communication gateway, describe the types of non-BACnet equipment/networks(s) that the gateway supports: N/A

## Datatypes Supported:

The following table summarizes the datatypes that are accepted (in the case of a write property service) and returned (in the case of a read property service) when targeting the present value property of each supported object type.

Object Type	Service	
	Read Property	Write Property
<b>Analog Output</b>	Real	Real, Unsigned, Integer, Null
<b>Analog Input</b>	Real	N/A
<b>Binary Output</b>	Enumerated	Enumerated, Boolean, Real, Unsigned, Integer, Null
<b>Binary Input</b>	Enumerated	N/A

### Notes:

- The Null data type is used to relinquish a previously-commanded entry at the targeted priority in the priority array.
- When writing to Binary Output objects, all non-zero values are interpreted as a "1".

## Object Types/Property Support Table

The following table summarizes the Object Types/Properties supported.

Property	Object Type				
	Device	Binary Input	Binary Output	Analog Input	Analog Output
Object Identifier	R	R	R	R	R
Object Name	R	R	R	R	R
Object Type	R	R	R	R	R
System Status	R				
Vendor Name	R				
Vendor Identifier	R				
Model Name	R				
Firmware Revision	R				
Appl Software Revision	R				
Protocol Version	R				
Protocol Revision	R				
Services Supported	R				
Object Types Supported	R				
Object List	R				
Max APDU Length	R				
Segmentation Support	R				
APDU Timeout	R				
Number APDU Retries	R				
Max Master					
Max Info Frames					
Device Address Binding	R				
Database Revision	R				
Present Value		R	W	R	W
Status Flags		R	R	R	R
Event State		R	R	R	R
Reliability		R	R	R	R
Out-of-Service		R	R	R	R
Units				R	R
Priority Array			R		R
Relinquish Default			R		R
Polarity		R	R		
Active Text		R	R		
Inactive Text		R	R		

R – readable using BACnet services

W – readable and writable using BACnet services

### 13.4.3 Supported Objects

#### Binary Input Object Instance Summary

Instance ID	Object Name	Description	Active/ Inactive Text
BI1	RUN_STOP_STATUS	Run/stop status	running/ stopped
BI2	FWD_REV_STATUS	Forward/reverse status	reverse/ forward
BI3	F_PIT_STATUS	"F" programmable input terminal status	on/off
BI4	R_PIT_STATUS	"R" programmable input terminal status	on/off
BI5	ST_PIT_STATUS	"ST" programmable input terminal status	on/off
BI6	RES_PIT_STATUS	"RES" programmable input terminal status	on/off
BI7	S1_PIT_STATUS	"S1" programmable input terminal status	on/off
BI8	S2_PIT_STATUS	"S2" programmable input terminal status	on/off
BI9	S3_PIT_STATUS	"S3" programmable input terminal status	on/off
BI10	S4_PIT_STATUS	"FS4" programmable input terminal status	on/off
BI11	OUT1_POT_STATUS	"OUT1" programmable input terminal status	on/off
BI12	OUT2_POT_STATUS	"OUT2" programmable input terminal status	on/off
BI13	FL_POT_STATUS	"FL" programmable input terminal status	on/off

## Binary Output Object Instance Summary

Instance ID	Object Name	Description	Active/ Inactive Text
BO1	RUN_STOP_CMD	Run/stop command	run/stop
BO2	FWD_REV_SEL	Forward/reverse command	reverse/forward
BO3	EMERGENCY_OFF	Emergency off command	emergency off/ no action
BO4	FAULT_RESET	Fault reset command	reset/no action
BO5	FEEDBACK_CTRL_SEL	Feedback enable/ disable selection	enable/disable
BO6	FREQ_PRIORITY	Frequency priority	on/off
BO7	COMMAND_PRIORITY	Command priority	on/off
BO8	DATA_OUT1_TERMINAL	Output terminal "selected data out 1"	on/off
BO9	DATA_OUT2_TERMINAL	Output terminal "selected data out 2"	on/off
BO10	DATA_OUT3_TERMINAL	Output terminal "selected data out 3"	on/off

## Analog Input Object Instance Summary

Instance ID	Object Name	Description	Units
AI1	OUTPUT_FREQ	Output frequency	Hz
AI2	LOAD_CURRENT	Output current	Percent
AI3	OUTPUT_VOLTAGE	Output voltage	Percent
AI4	INPUT_POWER_CONSUME	Input power	KW
AI5	RR_ANALOG_INPUT	RR/S4 input	Percent
AI6	VI_II_ANALOG_INPUT	VI/II input	Percent
AI7	RX_ANALOG_INPUT	RX input	Percent
AI8	TRIP_CODE	Trip code information	None

## Analog Output Object Instance Summary

Instance ID	Object Name	Description	Units
AO1	FREQ_CMD_REG	Frequency command	Hz
AO2	FM_ANALOG OUTPUT	FM output value	None
AO3	AM_ANALOG OUTPUT	AM output value	None

## 13.4.4 Supported Object Details

### Binary Input Objects

- BI1..... Indicates whether the drive is running or stopped. ASD parameter FE01, bit#10.
- BI2..... Indicates whether the drive is running in the forward or reverse direction. ASD parameter FE01, bit #9.
- BI3..... Indicates the status of the "F" programmable input terminal. ASD parameter FE06, bit#0.
- BI4..... Indicates the status of the "R" programmable input terminal. ASD parameter FE06, bit#1.
- BI5..... Indicates the status of the "ST" programmable input terminal. ASD parameter FE06, bit#2.
- BI6..... Indicates the status of the "RES" programmable input terminal. ASD parameter FE06, bit#3.
- BI7..... Indicates the status of the "S1" programmable input terminal. ASD parameter FE06, bit#4.
- BI8..... Indicates the status of the "S2" programmable input terminal. ASD parameter FE06, bit#5.
- BI9..... Indicates the status of the "S3" programmable input terminal. ASD parameter FE06, bit#6.
- BI10..... Indicates the status of the "S4" programmable input terminal. ASD parameter FE06, bit#7.
- BI11..... Indicates the status of the "OUT1" programmable output terminal. ASD parameter FE07, bit#0.
- BI12..... Indicates the status of the "OUT2" programmable output terminal. ASD parameter FE07, bit#1.
- BI13..... Indicates the status of the "FL" programmable output terminal. ASD parameter FE07, bit#2.

### Binary Output Objects

Note that the drive will only use the commands indicated in BO1, BO2 and BO5 if the *Command Mode* parameter is set to "Communication Interface Input Enabled", or if the "command override" bit (BO7) is ON.

- BO1..... Run/stop command. ASD parameter FA06, bit#10.
- BO2..... Forward/reverse command. ASD parameter FA06, bit#9.
- BO3..... Forces the drive to fault "Emergency Off". ASD parameter FA06, bit#12.
- BO4..... Resets the drive when it is faulted. ASD parameter FA06, bit#13.

- BO5..... Enables or disables process (PID) feedback control. Note that this object does not activate (turn on) feedback control. It only enables or disables feedback control once it has already been activated. ASD parameter FA06, bit#5.
- BO6..... Communication interface frequency priority selection. Allows the frequency command from the interface card to be used by the drive without having to set the *Frequency Mode* parameter. Refer to the Toshiba documentation regarding "Command Mode and Frequency Mode Control" for detailed information pertaining to the frequency source hierarchy and the use of overrides. ASD parameter FA06, bit#14.
- BO7..... Communication interface command priority selection. Allows commands (BO1, BO2, and BO5) from the interface card to be used by the drive without having to explicitly set the *Command Mode* parameter. Refer to the Toshiba documentation regarding "Command Mode and Frequency Mode Control" for detailed information pertaining to the command source hierarchy and the use of overrides. ASD parameter FA06, bit#15.
- BO8..... Output terminal data out 1. Any programmable output terminals that are configured to output "specified data output 1" will follow the value of this BO. ASD parameter FA50, bit#0.
- BO9..... Output terminal data out 2. Any programmable output terminals that are configured to output "specified data output 2" will follow the value of this BO. ASD parameter FA50, bit#1.
- BO10.... Output terminal data out 3. Any programmable output terminals that are configured to output "specified data output 3" will follow the value of this BO. ASD parameter FA50, bit#2.

## **Analog Input Objects**

- AI1..... Output frequency in 0.01Hz units. ASD parameter FD00.
- AI2..... Load current in 0.01% units (10000=100.00%=drive's rated current). ASD parameter FE03.
- AI3..... Output voltage in 0.01% units (10000=100.00%=drive's rated voltage). ASD parameter FE05.
- AI4..... Input power consumption (drive+motor) in 0.01kW units. ASD parameter FE29.
- AI5..... Indicates the signal level currently being applied to the ASD's RR analog input terminal. This can be used to monitor such items as feedback sensor outputs and other process variables. Expressed in 0.01% units (10000=100.00%=input rated value). ASD parameter FE35.
- AI6..... Similar to AI5, this object indicates the signal level currently being applied to the ASD's VI/II analog input terminal. ASD parameter FE36.
- AI7..... Similar to AI5, this object indicates the signal level currently being applied to the ASD's RX analog input terminal. ASD parameter FE37.



AI8..... Indicates the present fault code. Under normal operation (no faults), this value will be 0. ASD parameter FC90.

## **Analog Output Objects**

- AO1 ..... Sets the drive's frequency command in 0.01Hz units (e.g. 4000 = 40.00Hz). Note that the drive will only use this value as its active frequency command if the *Frequency Mode* parameter is set to "Communication Option Input Enabled", or if the "frequency override" bit (BO6) is ON. Although the adjustment range for this object is 0-40000 (0.00Hz-400.00Hz), the actual frequency command will be internally limited by the *Upper Limit Frequency* and *Lower Limit Frequency* parameters. ASD parameter FA07.
- AO2 ..... Adjusts the FM analog output voltage if the "FM terminal meter selection" parameter is set to a value of 31 (communication data output). Range is 0-2047 = 0-100%. ASD parameter FA51.
- AO3 ..... Adjusts the AM analog output voltage if the "AM terminal meter selection" parameter is set to a value of 31 (communication data output). Range is 0-2047 = 0-100%. ASD parameter FA52.

## 13.5 PROFINET IO

### 13.5.1 Overview

The interface card supports two different types of PROFINET data transfer. One type is entirely user-configurable, and is utilized when a standard I/O module is chosen during network configuration. The other type is a module that is compliant with the PROFIdrive profile.

Some other notes of interest are:

- Supports real time (RT) communication.
- A total of 85 modules are available for selection by the controller (84 standard I/O modules and one PROFIdrive module). The standard I/O modules follow the naming conventions of “IN:XX, OUT:YY”, where XX is the number of input (status) registers to be sent to the controller, and YY is the number of output (command) registers to be sent to the drive. The single PROFIdrive profile-compliant module is named “Standard Telegram 1”. Refer to the GSDML file for specific module information.
- When using standard I/O modules, up to 8 command registers can be sent to the drive, and up to 32 status registers can be retrieved from the drive.
- No explicit module selection is required on the interface card: the module will be selected automatically according to the controller’s configuration.
- The lowest recommended I/O Cycle Update Time (in Step 7 or an equivalent hardware configuration tool) is 8ms. Lower update times are possible but determinism may vary depending on the interface’s processing load. Note that this setting is not related to, and should therefore not be confused with, the Update Time setting on the embedded web server’s PROFINET tab.
- If the RT connection timeout occurs, the driver will trigger a timeout event as described in section 10.7.5. The timeout value is dictated by the PROFINET controller and is at least three times the IO Cycle update time. The timeout value is also known as the “IO Cycle Watchdog” time.
- The interface card supports PROFIdrive profile V4.1. For more information on PROFIdrive communications, refer to the [PROFIdrive Profile Drive Technology Technical Specification for Profibus and PROFINET](#) (Profibus International order #3.172.)
- Any available drive register can be accessed via PROFINET acyclic services. The record index (unless reserved) directly corresponds to a register number (section 9).
- Standard I/O module configuration: if a register entry in the command data configuration array is 0, then any commanded data that corresponds to that location will be ignored. Conversely, if a register entry in the status data configuration array is 0, then any status data that corresponds to that location will be a default value of 0. Refer to section 10.5.3 for further information on the data configuration arrays.

## 13.5.2 PROFIdrive Profile

For optimal interoperability, the interface card supports the PROFIdrive profile. No special configuration of the interface card is required when using the PROFIdrive profile: all that is needed is that the controller must be configured to target the “Standard Telegram 1” module on the interface card.

- Implements Application Class 1 (standard drive)
- Supports only Standard Telegram 1 (ST1, PZD-2/2) on slot 1 (similar to Profibus PPO type 3)
- Supports only Speed Control Mode
- The maximum motor speed (in RPM) =  $[maximum\ frequency \times 120] / number\ of\ motor\ poles$ , where “maximum frequency” equates to the value of register 13 / parameter “UL” (upper limit frequency), and “number of motor poles” is assumed to be a constant value of 4.
- The speed setpoint value is the commanded speed reference (in RPM) sent from the controller to the drive. Similarly, the speed actual value is the actual operating speed (in RPM) of the drive sent back to the controller. As the drive natively operates in units of Hz, the following conversion equations are applied within the interface card:

Speed Setpoint: drive speed reference in RPM. Maps to inverter register 1008 (parameter FA07 / internal option board frequency command). The speed setpoint component of the PROFIdrive profile is always in units of RPM. Therefore, the interface card applies the RPM-to-Hz conversion indicated in Equation 4 in order to determine the appropriate frequency command value (in units of Hz) to be written to register 1008.

$$Hz = \frac{RPM \times number\ of\ motor\ poles}{120} \qquad \text{Equation 4}$$

The “number of motor poles” term which appears in the numerator of Equation 4 is assumed to be a constant value of 4.

Speed Actual: drive operating speed in RPM. Maps to drive register 1301 (parameter FD00 / output frequency). The speed actual component of the PROFIdrive profile is always in units of RPM. Therefore, the interface card applies the Hz-to-RPM conversion indicated in Equation 5 in order to determine the appropriate operating speed (in units of RPM) to be written to the network.

$$RPM = \frac{Hz \times 120}{number\ of\ motor\ poles} \qquad \text{Equation 5}$$

The “number of motor poles” term which appears in the denominator of Equation 5 is assumed to be a constant value of 4.



**INDUSTRIAL CONTROL COMMUNICATIONS, INC.**

**Madison Office**

1600 Aspen Commons, Suite 210  
Middleton, WI USA 53562-4720  
Tel: [608] 831-1255 Fax: [608] 831-2045

<http://www.iccdesigns.com>

Printed in U.S.A

## Free Manuals Download Website

<http://myh66.com>

<http://usermanuals.us>

<http://www.somanuals.com>

<http://www.4manuals.cc>

<http://www.manual-lib.com>

<http://www.404manual.com>

<http://www.luxmanual.com>

<http://aubethermostatmanual.com>

Golf course search by state

<http://golfingnear.com>

Email search by domain

<http://emailbydomain.com>

Auto manuals search

<http://auto.somanuals.com>

TV manuals search

<http://tv.somanuals.com>