



E X R 2 4 8 0

OWNER'S MANUAL

2.4 GHz Cordless
Phone with Digital
Answering System

Caller ID and
Call Waiting

3-Way Conference

Uniden®

INTRODUCTION

TO YOUR NEW PHONE

Introduction

Thank you for choosing the Uniden EXR 2480 cordless telephone. This phone is designed to exacting standards that provide reliability, long life and outstanding performance.

Note: Some illustrations in this manual may differ from the actual unit for explanation purposes.

Features

- 2.4 GHz Spread Spectrum Technology
- Secure Digital Transmission
- Integrated Telephone Answering Device (ITAD)
- Caller ID and Call Waiting Caller ID (CIDCW)
- 50 Number Caller ID Memory
- 10 Enhanced Memory Dial Locations
- 32 Digit Redial
- Lighted Keypad
- 3-Line, 16 Character Backlit LCD Handset Display
- Redial, Flash and Pause
- Pulse / Tone Dialing
- 4 Hour Talk Time
- 7 Day Standby Battery Life
- Handset Earpiece and Ringer Volume Control
- Speakerphone
- 3-Way Conference Operation
- 20 Channel Auto Scan
- Back-up Power Supply for Optional Battery Pack
- 2-Way Page / Intercom

Digital Spread Spectrum Technology utilizes a “wider frequency band” vs. a “single narrow band” used in standard digital transmissions. The result is a more secure conversation with the clarity of digital sound, extended range, and minimal interference from other cordless phones.

Random Code™ digital security automatically selects one of over 65,000 codes for the handset and base. This feature prevents unauthorized calls as a result of your phone being activated by other equipment.

Controls and functions

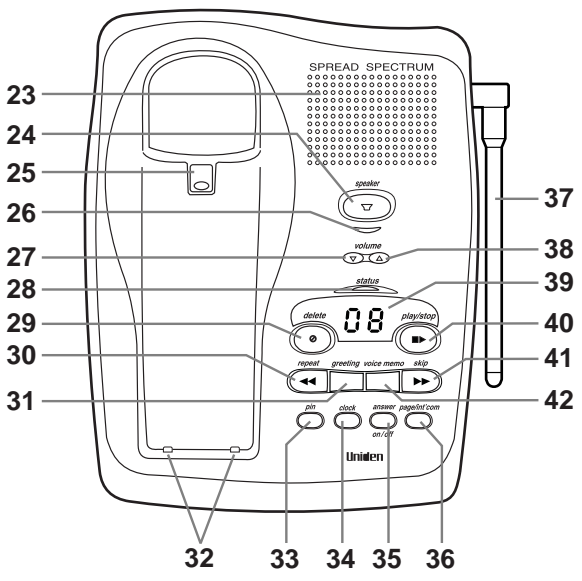
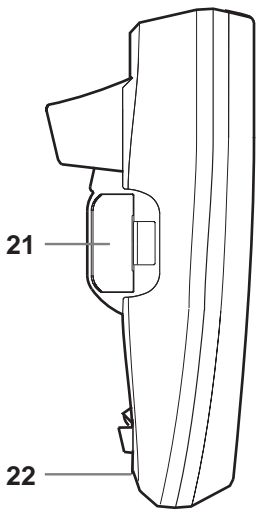
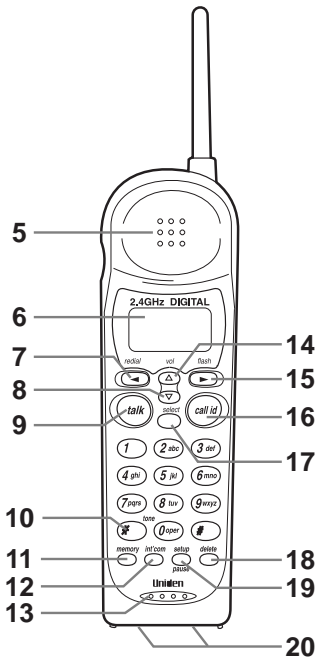
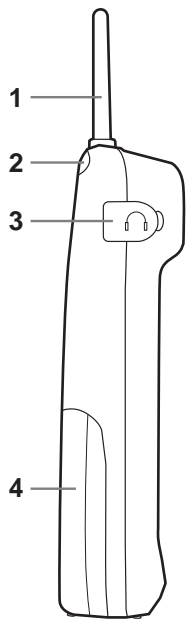

1. Handset antenna
2. Beltclip cover
3. Headset jack cover
4. Handset battery compartment
5. Handset earpiece
6. LCD display
7. Redial/Backspace key
8. Volume/Cursor down key
9. Talk key
10. Tone key
11. Memory key
12. Intercom key
13. Handset microphone
14. Volume/Cursor up key
15. Flash/Cursor forward key
16. Call ID key
17. Select key
18. Delete key
19. Setup/Pause key
20. Battery charge contact
21. Spare battery compartment
22. Base microphone
23. Base speaker
24. Speaker key
25. Handset clip storage
26. Speaker LED
27. Volume down key
28. Status LED
29. Delete key
30. Repeat key
31. Greeting key
32. Base charging contact
33. Pin code key
34. Clock key
35. Answer on/off key
36. Page/Intercom key
37. Base antenna
38. Volume up key
39. Message counter display
40. Play/Stop key
41. Skip key
42. Voice memo key
43. Desktop/Wall mount adapter
44. Record time switch
45. Ring time switch
46. Reset button
47. Ringer off-on switch
48. Pulse-Tone switch
49. DC power input
50. Phone jack

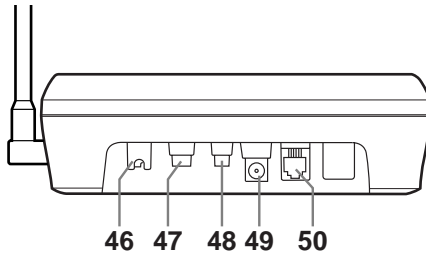
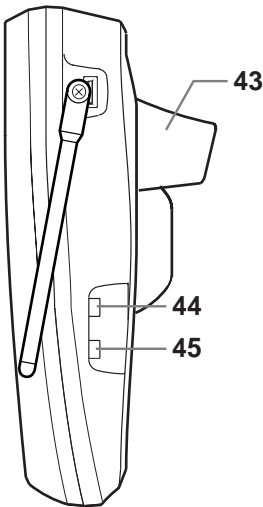

CONTENTS

OF YOUR OWNER'S MANUAL

Contents

Introduction / Features.....	inside front cover
Controls and Functions	inside front cover
Getting Started	
Read this first.....	2
Step 1: Checking the package contents.....	3
Step 2: Setting up the base unit	4
Mounting the base unit on a wall	7
Step 3: Preparing the battery pack.....	9
Step 4: Setting the Caller ID options.....	11
Entering your area code	12
Basics	
Making a call	13
Receiving a call	15
Adjusting ringer and earpiece volume.....	16
Redialing a call	17
Using the speaker phone	18
Using your EXR 2480 intercom	19
Transferring a call.....	20
Memory Dialing	
Storing phone numbers and names.....	21
Making calls with memory dialing.....	23
Editing a stored name and/or phone number	25
Erasing a stored name and phone number.....	27
3-Way Conference Feature	
3-way conferencing.....	29
Caller ID features	
Caller ID service.....	30
When the telephone rings	31
Viewing the Caller ID Message list	32
Deleting information from Caller ID list.....	33
Using the Caller ID list	35
Using "Caller ID with call waiting" service	37
The Integrated Answering Device	
Features.....	38
Setting up your answering system	39
Using your answering system	43
Additional Information	
Changing the digital security code.....	48
Headset installation.....	48
Installing the beltclip.....	49
Note on power sources	50
Maintenance.....	50
Troubleshooting	51
Specifications	53
Index	54

Getting Started

Basics

Memory Dialing

3-way
Conference
Features

Caller ID
Features

The Integrated
Answering
Device

Additional
Information

Read this first

This cordless telephone must be set up before use. Follow these steps;

Step 1 (page 3)

Unpack and check the telephone and accessories.

Step 2 (page 4 to 8)

Next, choose the best location to set up the base unit.



Base unit

Step 3 (page 9 to 10)

Then, insert the battery pack into the handset. You must charge the battery pack for at least 17 hours before using the phone.



Handset

Step 4 (page 11 to 12)

Finally, set Caller ID options and store your area code in memory for use with Caller ID service.

Note: Skip the setting of area code if your calling area requires 10 digit dialing.



Handset

Checking the package contents

Make sure you have received the following items in the package. If any of these items are missing or damaged, contact the **Uniden Parts Department** (see below).

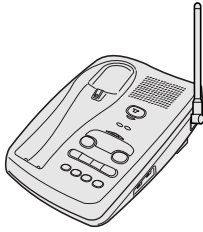

• Base unit



• Handset

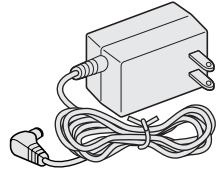

• AC adapter (AD-9500)

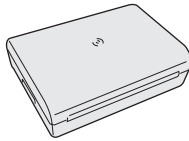

• Rechargeable battery pack (BT-2499)

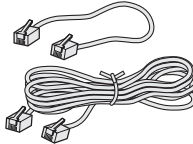

• Telephone line cord (2)

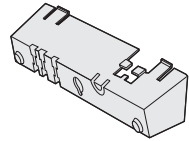

• Wall mount adapter

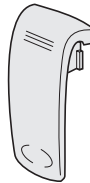

• Beltclip

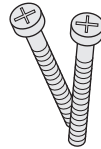

• Wall mounting screws (2)

- This Owner's Manual
- Quick Reference Guide
- Precautions and Important Safety Instructions
- Registration Card

Uniden Parts Department

(800) 554-3988

Hours: M-F 8:30 AM to 5:00 PM CST.

We can also be reached on the web at www.uniden.com.

Setting up the base unit

Do the following steps.

- Choose the best location
- Connect the base unit
- Choose the dialing mode

Choose the best location

Before choosing a location for your new phone, read the INSTALLATION CONSIDERATIONS included in the PRECAUTIONS AND IMPORTANT SAFETY INSTRUCTIONS brochure. Here are some important guidelines you should consider:

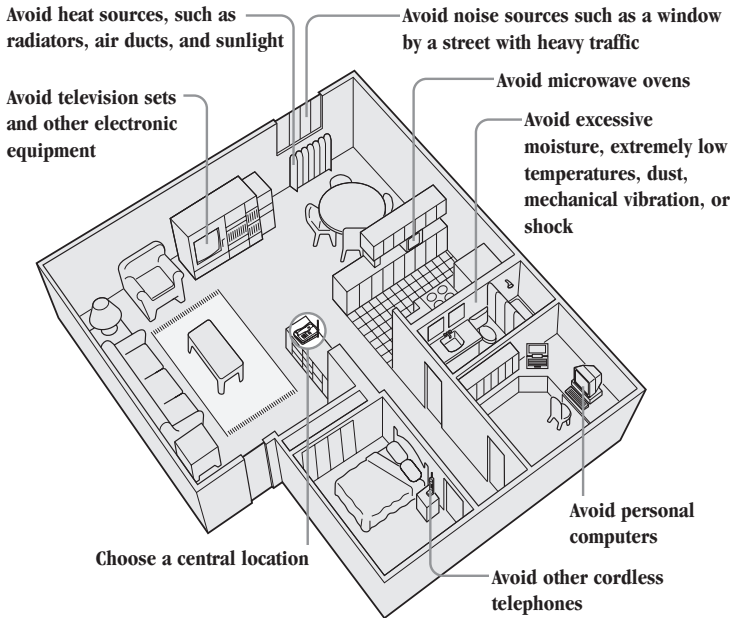

- You should charge your handset for more than 17 hours before using the phone.
- The location should be close to both a phone jack and a continuous power outlet which is not switchable.
- Keep the base and handset away from sources of electrical noise such as motors and fluorescent lighting.
- Be sure there is sufficient space to raise the base antenna fully vertical.
- The base can be placed on a desk, tabletop or mounted on a standard wall plate.

Connect the base unit

If you want to install the base unit on the wall, see page 7.

NOTE

Place the power cord so it does not create a trip hazard, or where it could become chafed and create a fire or electrical hazard.

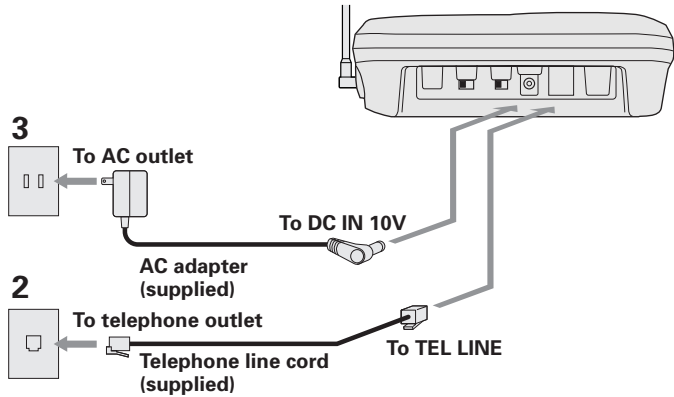

- 1** Snap the desktop/wall mount adapter into the top of the base as shown.

Route the AC adapter cord

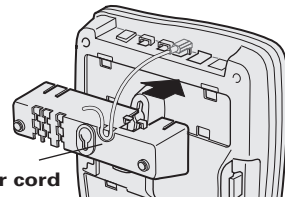

- 2** Connect the telephone line cord to the **TEL LINE** jack and to a telephone outlet.

- 3** Connect the AC adapter to the **DC IN 10V** jack and to a standard 120V AC wall outlet.

- 4** Set the base unit on a desk or tabletop and place the handset on the base unit. Then raise the antenna to a vertical position.

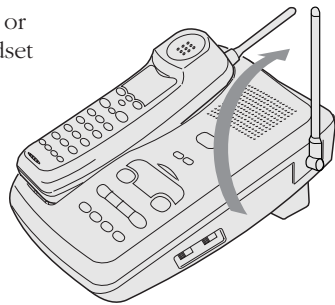



Use only the supplied AD-9500 AC adapter. Do not use any other AC adapter.

Polarity of the plug

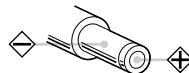

Connect the AC adapter to a continuous power supply.



Place the base unit close to the AC outlet so that you can unplug the AC adapter easily.



If your telephone outlet isn't modular, contact your telephone company for assistance.

Modular



Choose the dialing mode

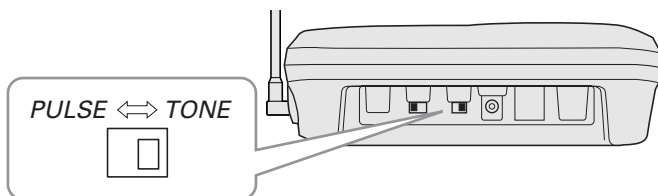

Depending on your dialing system, set the **PULSE-TONE** switch as follows:

If your dialing system is	Set the switch to
Tone	<i>TONE</i>
Pulse	<i>PULSE</i>

If you aren't sure of your dialing system

Make a trial call with the **PULSE-TONE** switch set to ***TONE***. If the call connects, leave the switch as is; otherwise, set to ***PULSE***.

Mounting the base unit on a wall

Standard wall plate mounting

This phone can be mounted on any standard telephone wall plate.

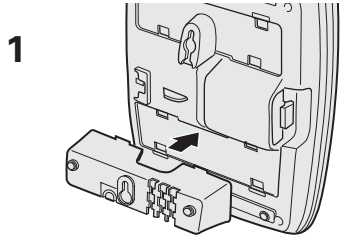

1 Snap the desktop/wall mount adapter into the bottom of base as shown.

2 Plug the telephone line cord to the **TEL LINE** jack and the AC adapter to the **DC IN 10V** jack.

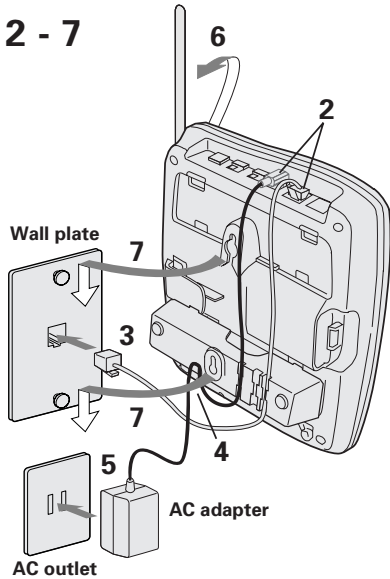

3 Plug the telephone line cord into the telephone outlet.

4 Wrap the AC adapter cord inside the molded wiring channel. Then wrap the cord around the strain relief notch.

5 Plug the AC adapter into a standard 120V AC wall outlet.

6 Raise the antenna to a vertical position.

7 Align the mounting slots on the base, with the mounting posts on the wall. Push in and down until the phone is firmly seated.



If the handset beltclip is attached, you cannot charge the handset facing forward when the phone is mounted on the wall (See page 49).

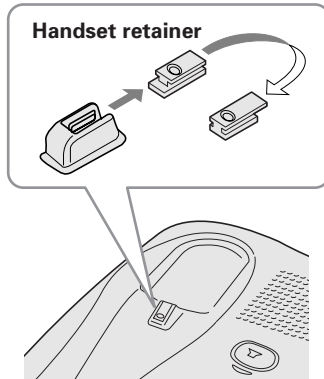

- 8** On the base unit, pull the handset retainer out of the slot. Rotate it clockwise 180 degrees.
- 9** Flip the retainer from front to back. Slide it back into the slot so that the lip of the retainer is up and the oval is down. The retainer holds the handset in place.

Direct wall plate mounting

If you don't have a standard wall plate, you can mount your phone directly to the wall. Before doing this, consider the following:

- Avoid electrical cables, pipes, or other items behind the mounting location, that could cause a hazard when inserting screws into the wall.
- Try to mount your phone within 10 - 15 feet of a working phone jack to avoid excessive cord lengths.
- Make sure the wall material is capable of supporting the weight of the base and handset.
- Use #10 screws with anchoring devices suitable for the wall material where the base unit will be placed.

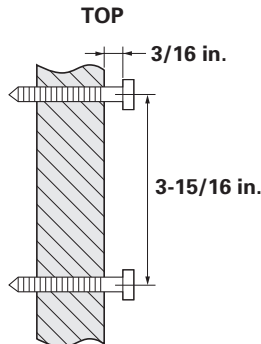

- 1** Insert two mounting screws into the wall, (with their appropriate anchoring device), 3-15/16 inches apart. Allow about 3/16 of an inch between the wall and screwheads for mounting the phone.
- 2** Refer to steps 1 through 9 on page 7 and 8 to mount the telephone.

Preparing the battery pack

Charge the battery pack for more than 17 hours before you start using your phone.

NOTE

Use only Uniden Battery BT-2499 supplied with your phone.

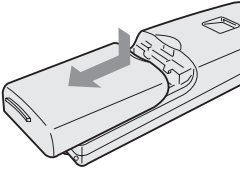
- 

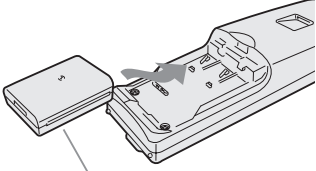
1 Remove the battery cover.
- 

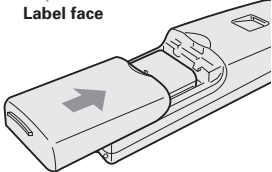
2 Install the battery pack with the label down.
- 

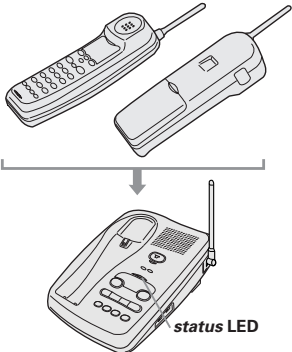
3 Slide the battery cover forward until it snaps into place.
- 

4 Place the handset on the base.
Make sure that the "**status**" LED of the base unit lights, and charging begins. Charge the battery for at least 17 hours.
You can place the handset either side up for charging the battery.

NOTE

Even when the battery pack is not being used, it will gradually discharge over a long period. For optimum performance, be sure to return the handset to the base unit after a telephone call for charging the battery.

NOTE

Rechargeable batteries have a memory effect that reduces standby and talk time. To avoid this memory effect, on a monthly basis, use the phone until "Low Battery" appears. Then charge the battery for more than 17 hours.

NOTE

Please visit your authorized Uniden dealer to obtain an extra battery pack or contact the Uniden parts department at (800) 554 - 3988. Hours are from 8:30 a.m. to 5:00 p.m. Central time, Monday through Friday.

Battery use time (per charge)

From fully charged

- Four hours continuous use.
- Seven days when the handset is in the standby mode.

When the battery charge becomes low

When the voltage of battery pack in the handset is very low and needs to be charged, the phone is programmed to eliminate functions in order to save power. If the battery charge becomes "Low Battery" appears on the LCD, and if the phone is in use, the handset beeps. Complete your conversation as quickly as possible and return the handset to the base unit for charging.

Cleaning the battery contacts

To maintain a good charge, it is important to clean the battery contacts on the handset and base unit about once a month. Use a pencil eraser or other contact cleaner.

Do not use liquids or solvents.

Charging optional battery packs

The base of your phone is equipped with a compartment for charging an extra battery pack for use in your handset.

You can obtain an extra battery pack from your authorized Uniden dealer.

1. Position the battery pack so the charging contacts are facing up.
2. Slide the battery pack into the charging compartment until it locks into place.
3. Charge the battery for more than 24 hours.

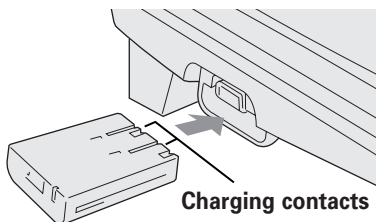

NOTE

In the event of a power failure, your spare battery pack temporarily provides power for the base so you can still use your phone.

Setting the Caller ID options

There are three Caller ID options, Auto Talk, CIDCW (Caller ID with Call Waiting), and Area Code.

AutoTalk allows you to answer the phone without pressing the **talk** button. If the phone rings when AutoTalk is on, simply remove the handset from the cradle and the phone automatically answers the call. If the phone rings when AutoTalk is off, you must press **talk** to answer the call.

CIDCW performs the same as regular Caller ID on a call waiting number.

You must be subscribed to CIDCW from your phone company in order to use this feature.

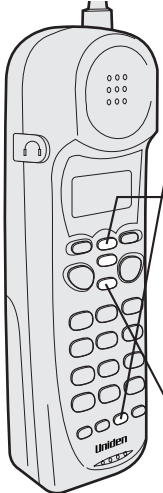

1 In the standby mode, press **setup/pause**.

```
1# Auto Talk:Off
2 CIDCW      :On
3 Area Code:
```

2 Press **▲** or **▼** to move the cursor to the item that is to be set.

Example: To select CIDCW

```
1 Auto Talk:Off
2#CIDCW      :On
3 Area Code:
```

3 For Auto Talk and CIDCW, press **select** to set on or off. For the Area Code setting, see page 12.

4 To complete the settings, press **setup/pause** and return the handset to the base, then the handset returns to standby mode.

Entering your area code



If your calling area requires 10-digit dialing, do not program this option.

If you enter your 3-digit area code number in the Area Code option, your local area code does not appear in Caller ID messages. When reviewing Caller ID messages, you will see only the local seven digit number. For calls received from outside your local area code, you will see a full 10-digit number.

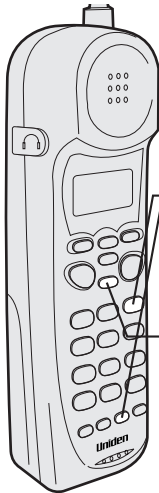

- 1** When the phone is in the standby mode, press **(setup/pause)**.

```
1 Auto Talk:Off
2 CIDCW      :On
3 Area Code:
```

- 2** Press **(3)** to select "Area Code".

```
1 Auto Talk:Off
2 CIDCW      :On
3 Area Code:
```

- 3** Press **(select)**.

```
1 Auto Talk:Off
2 CIDCW      :On
3 Area Code:█
```

- 4** Use the dial buttons (**(0)** to **(9)**) to enter the 3-digit area code.

- 5** Press **(select)**.

A beep sounds and the displayed area code is entered.

- 6** Press **(setup/pause)** to complete the setting. Or return the handset to the base unit to complete the setting mode and set the handset to the standby mode.



When the area code has already been stored in memory, the stored area code will be displayed. To change it, use the **(delete)** and keypad to enter the new area code.

```
1 Auto Talk:Off
2 CIDCW      :On
3 Area Code:█17
```

To complete the setting, press **(setup/pause)** or return the handset to the base unit.

Making a call

NOTE

Press **(delete)** if you enter a wrong number at the step 1.

NOTE

You must press a key within 20 seconds or the phone will return to standby.

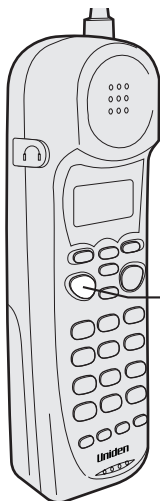

On-hook dialing

- 1 Enter the phone number. (Up to 32 digits.)

Example: Enter 8178583300

8178583300

- 2 Press **(talk)**. "Talk" flashes on the display.

Talk
8178583300

Then the volume setting is displayed. For example, if the volume is set to high the display shows.

Talk
<High>

- 3 The number is dialed. After about 5 seconds, the call-time display appears.

Talk 0:00
8178583300

- 4 To hang up, press **(talk)** or place the handset on the base. The call-time will be displayed for about 5 seconds.

5:15

Other Operations

To	Do this
To adjust the earpiece volume	Press (▲) or (▼) during the call.
To temporarily switch to tone dial (When the base is set to pulse mode)	Press (*/tone) . The following numbers dialed will be sent as tone dialing.
To enter a pause within dialing sequence dialed	Press (setup/pause) .

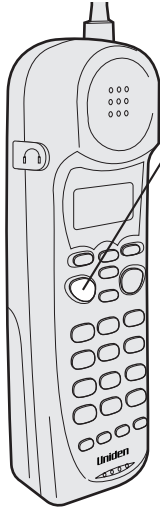

Off-hook dialing

- 1** Press **(talk)**. "Talk" flashes on the display.



Then the volume setting is displayed.
For example, if the volume is set to high
the display shows:



- 2** Dial the phone number.

Example: Enter 8178583300



- 3** To hang up, press **(talk)** or place the handset in the base. The call-time will be displayed for about 5 seconds.

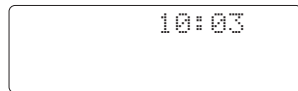

Receiving a call

From the handset

NOTE

When AutoTalk is on, simply lift the handset from the base, or press any key if the handset is off the base to answer the call.

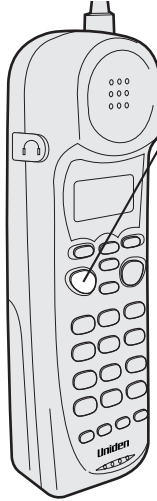

- 1 Phone rings. "Calling" appears on the display.
- 2 Press **(talk)**. "Talk" appears on the display. Then the earpiece volume is displayed for 2 seconds.
- 3 The call-time display starts.
- 4 To hang up, press **(talk)** or place the handset on the base. The call time will be displayed for about 5 seconds.

From the base

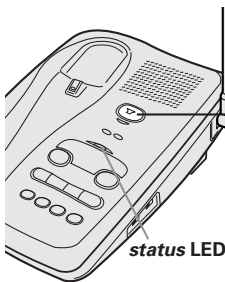

- 1 The phone rings. The **status** LED on the base flashes.
- 2 Press **(speaker)**.
- 3 To finish the call, press **(speaker)**.

Adjusting the ringer and earpiece volume

Handset ringer volume

In the standby mode, press **▲** or **▼** on the handset to set the handset ringer volume High or Low.

Ringer High
▼ ↓ ↑ **▲**
Ringer Low

Handset earpiece volume

Pressing **▲** or **▼** during a telephone call will change the earpiece volume of the handset. This setting will remain in effect even if you hang up the phone.

<Loud> **▼** > <High> **▼** > <Medium> **▼** > <Normal>
▲ < **▲** < **▲** <

When you press **▲** in Loud mode or press **▼** in Normal mode, error sound beeps.

Base ringer switch

This switch turns the base ringer on or off.

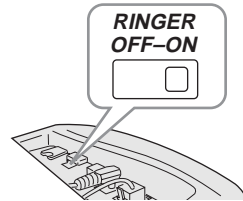

Base speaker volume

To control the speaker volume of the base, adjust the **volume ▲** and **volume ▼** button as desired. The volume setting from 1 (lowest) to 10 (highest) appears in the message counter display.

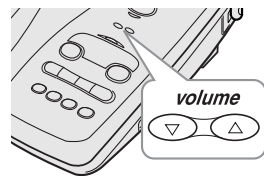

Redialing a call

The last phone number entered can be quickly redialed.

NOTE

If the recently dialed number exceeds 32 digits, only the first 32 digits are retained for redialing.

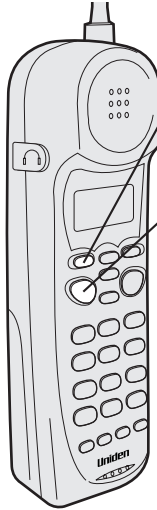

On-hook redialing

- 1** Press **redial/◀**.
The phone number that was last dialed appears on the display.
- 2** Press **talk**. “Talk” appears flashing on the display, then the volume setting is displayed.
- 3** Then the selected number is dialed. After about 5 seconds, the call-time display appears.
- 4** To hang up, press **talk** or place the handset on the base. The call-time will be displayed for about 5 seconds.

Off-hook redialing

- 1** Press **talk**.
- 2** Press **redial/◀**.
The last number dialed will be dialed.
- 3** To hang up, press **talk** or place the handset on the base. The call-time will be displayed for about 5 seconds.

Using the speakerphone

You may use the phone as speaker phone to answer calls by pressing the **(speaker)** button on the base. To hang up, press **(speaker)** again.

The base microphone is located under the phone. Position yourself approximately 12 inches away from the base and speak clearly.

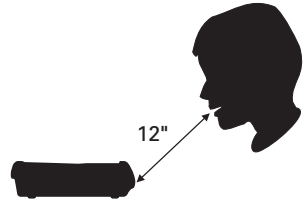

Using your EXR 2480 Page/Intercom

Page/Intercom from the base to handset

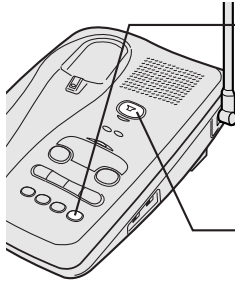

- 1** Press **page/int'com** on the base. The handset beeps.
- 2** Press **int'com** or **talk** on the handset. Speak into the mouthpiece to answer the base.
- 3** To turn off the intercom, press **talk** on the handset or **speaker** on the base.

Page/Intercom from the handset to base

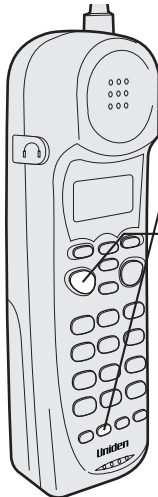

- 1** Press **int'com** on the handset. The base beeps.
- 2** At the base, press **page/int'com** or **speaker**. Speak into the base microphone to answer the page.
- 3** To turn off the intercom, press **talk** on the handset or **speaker** on the base.

Transferring a call

To transfer from the handset to the base

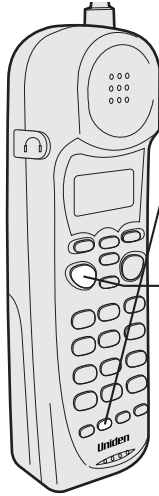

- 1** Press **int'com** on the handset while speaking on the handset. The line will be held, and the inter'com tone will be sounded on the base.
- 2** Press **page/int'com** or **speaker** on the base. The intercom mode is activated and the line is held.
- 3** To transfer to the base, press **talk** on the handset.
To cancel the transfer, press **speaker** on the base.

To transfer from the base to the handset

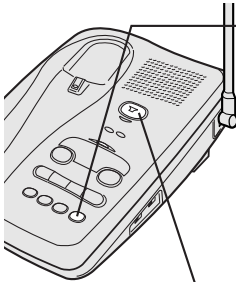

- 1** Press **page/int'com** on the base while speaking on the speaker phone. The line will be held, and the intercom tone will be sounded on the handset.
- 2** Press **int'com** or **talk** on the handset. The intercom mode is activated and the line is held.
- 3** To transfer to the handset, press **speaker** on the base.
To cancel the transfer, press **talk** on the handset.

Storing phone numbers and names

Your EXR 2480 stores up to 10 name/numbers in the handset.

NOTE

You must press a key within 20 seconds or the phone will return to standby. You may also press **(memory)** to quit a storing operation at any time.

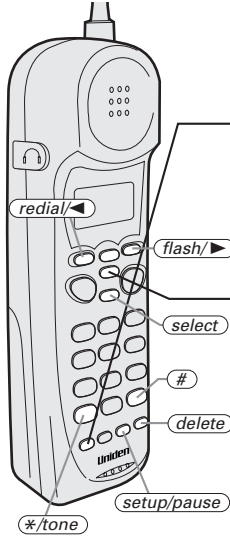

Example: To store a name (MOM AND DAD) and number (8175553300) in memory location 3.

1 Press and hold **(memory)** until "Memory Store" is displayed.

```
Memory Store
1 UNIDEN CORP
2 JOHN DOE
```

2 Press **(▲)** or **(▼)** to scroll to the memory number where you would like to store the number.

```
Memory Store
2 JOHN DOE
3
```

Or press the keypad (**(0)** to **(9)**) to select the memory location (0 - 9) where you would like to store the number.

3 Press **(select)**.
When an empty memory location is selected, "Store Name" is displayed. The cursor flashes indicating that the display is ready for the name to be entered.

```
Store Name
█
```

If this screen appears, the selected memory location is already stored. Then you must either change the entry in this location, clear the location, or select "Go Back" to choose another location.

```
Edit Memory 3
Delete Memory 3
Go Back
```

MEMORY

DIALING

- 4** Use the **▲** , **▼** , **flash/▶** , **redial/◀** , or **delete** keys to enter the name. The name cannot exceed 14 characters.
- Use the **▲** and **▼** key to scroll through the character menu. It contains upper and lower case letters, numbers, punctuation marks and various characters.
 - Use **flash/▶** and **redial/◀** to move the cursor to the desired location.
 - Use **delete** key to delete characters as needed.

- 5** Press **select** .
 “Store Number” is displayed. The cursor flashes indicating that the display is ready for the number to be entered.

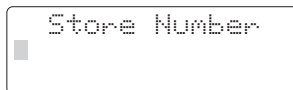

- 6** Use the number keypad or *** /tone** , **#** , or **setup/pause** keys to enter the phone number.



- The phone number cannot exceed 20 digits.
- Use the **setup/pause** key to enter pause in the dialing sequence. The display shows a “P”.



The pause feature is useful for long distance calling, credit card dialing, or sequences that require a pause between digits.

- Use the **delete** key to delete digits as needed.

- 7** Press **select** .
 The handset beeps and displays the confirmation screen. Memory storage is complete.

For example, if you store a name and number into memory location number 3, the display shows “Memory 3 Stored”.

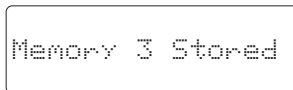

After about 2 seconds, “Memory Store” is displayed.

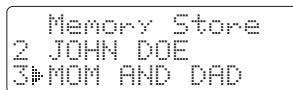

- 8** Press **memory** to return to standby mode.

Making calls with memory dialing

NOTE

You must press key within 20 seconds or the phone will return to standby.

NOTE

If you press **(select)** before **(talk)**, you can confirm the name and number stored in the selected memory location.

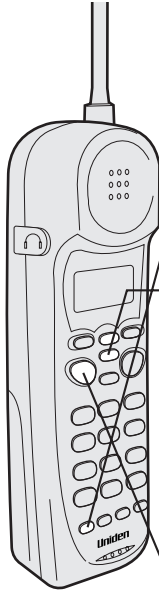

On-hook memory dialing

- 1 Press **(memory)**.
The handset displays your programmed memory locations.

```
1 UNIDEN CORP
2 JOHN DOE
3 MOM AND DAD
```

- 2 Press the number keypad or **(down arrow)** and **(up arrow)** to select the memory location (0 - 9) of the desired phone number.

For example, if you pressed 5 on the keypad, the display shows memory location number 5 with the cursor in that line.

```
5 JOHN SMITH
6 <Memory 6>
7
```

- 3 Press **(talk)**. "Talk" flashes and the volume setting appears on the display. Then the displayed number is dialed.

```
-Talk-
0123456789012
```

Display a Programmed Number

Use the **flash/▶** and **redial/◀** keys to toggle between the names display and the numbers display.

Program name		Program number
1 UNIDEN CORP	==▶→	1 8178583300
2 JOHN DOE		2 5452930
3▶MOM AND DAD	←◀==	3▶8175551212



When the stored phone number has 15 or more digits, “▶” is displayed next to the 13th digit. Press **flash/▶** to see the extra digits and **redial/◀** to return.

```
5 01234567890123
6▶0118135543293+
7
```

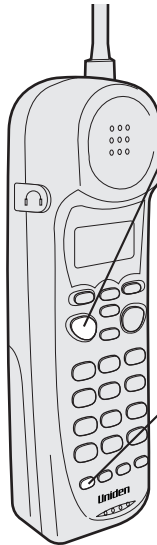

Off-hook memory dialing

- 1 Press **talk**.
“Talk” flashes and the volume setting appears.

```
>Talk<
```



```
Talk
<High>
```

- 2 Press **memory**.

```
Talk 0:00
```

- 3 Press the number keypad to select the memory location (0 - 9) of the desired phone number.
The selected phone number is displayed. Then the number is dialed.

```
Talk 0:35
0123456789012
```

Editing a stored name and/or phone number

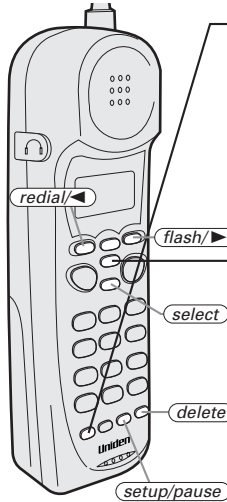

- 1** Press and hold **(memory)** for 2 seconds. The display shows the memory screen and any saved name/number.

```
Memory Store
1 UNIDEN CORP
2 JOHN DOE
```

- 2** Press the **(▲)** or **(▼)** keys or number keypad to select the memory location (0 - 9) you would like to edit.

```
Memory Store
1 UNIDEN CORP
2 JOHN DOE
```

- 3** Press **(select)**.
The following screen appears with the memory location number that you have selected in the display.
For example, if you selected memory location number 1, the display shows options for Memory 1 location.

```
Edit Memory 1
Delete Memory 1
Go Back
```

- 4** Press the **(▲)** or **(▼)** key to select "Edit Memory 1", then press **(select)**.
The following screen appears.
The cursor flashes indicating that the display is ready for the name to be edited. When a name has not been stored, the cursor appears at the beginning of the second line.

```
Store Name
UNIDEN CORP█
```

- 5** Press **(▲)**, **(▼)**, **(flash/▶)**, **(redial/◀)**, or **(delete)** to edit the name. (See page 22.)
To edit only the phone number, skip this step.

6 Press **(select)**.
The following screen appears.
The cursor flashes indicating that the display is ready for the number to be edited.

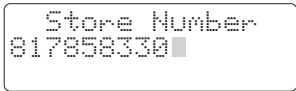

7 Use the dial keypad, **(setup/pause)**, or **(delete)** key to edit the phone number.
The phone number cannot exceed 20 digits. (See page 22.)
If you don't want to change the phone number, skip this step.

8 Press **(select)**.
The handset beeps and displays the confirmation screen. The memory storage is complete.

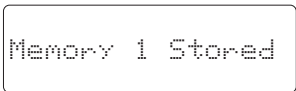

For example, if you store a name and number into memory location number 1, the display shows "Memory 1 stored".

After about 2 seconds, "Memory Store" is displayed.

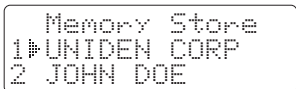

9 Press **(memory)** to return to standby mode.

Erasing a stored name and phone number

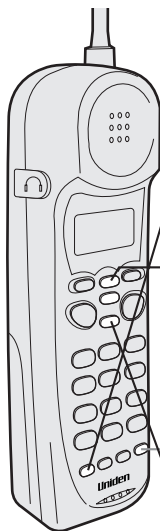

1 Press and hold **(memory)** for 2 seconds. The display shows the memory screen and any saved name/number.

```
Memory Store
1 UNIDEN CORP
2 JOHN DOE
```

2 Press the **(▲)** or **(▼)** keys or number keypad to select the memory location (0 - 9) you would like to edit.

```
Memory Store
1 UNIDEN CORP
2 JOHN DOE
```

3 Press **(select)**.
The following screen appears with the memory location number that you have selected in the display.
For example, if you selected memory location number 2, the display shows options for Memory 2 location.

```
Edit Memory 2
Delete Memory 2
Go Back
```

4 Press **(▼)** to move the cursor down to "Delete Memory 2" command line.

```
Edit Memory 2
Delete Memory 2
Go Back
```

5 Press **(select)**. The following confirmation screen appears.

```
Delete Memory 2?
Yes
No
```

6 Press **(▲)** to move the cursor to "Yes".

7 Press **(select)** or **(delete)**.
There is a confirmation tone and the entry is deleted. The following screen appears.

For example, if memory location number 2 is selected for deletion, the following display appears as the confirmation screen.

```
Memory 2 Deleted
```

- 8** After 2 seconds the display returns to the "Memory Store" screen. You may select another number to delete (return to step 2).

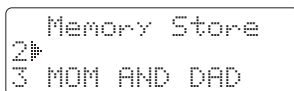

```
Memory Store
2 →
3 MOM AND DAD
```

- 9** Press **memory** to return to standby.

NOTE

Dialing is possible only from the handset during the 3-way conferencing.

3-way conferencing

The Uniden EXR 2480 permits 3-way conversations between the handset, base, and outside line.

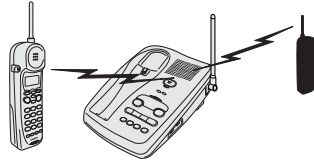

When speaking on the handset

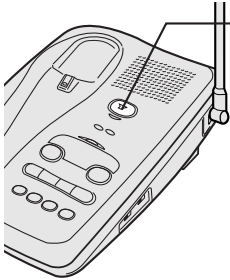

- 1 Press **speaker** on the base to join the 3-way conversation. This will set the 3-way conversation mode.
- 2 Press **speaker** on the base to hang up. The handset remains connected to the outline call.

When speaking on the base with the handset off the base

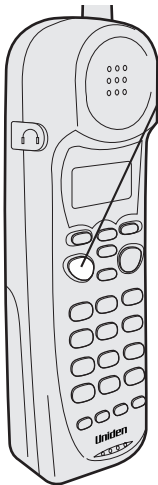

- 1 Press **talk** on the handset to join the 3-way conversation.
- 2 Press **talk** on the handset to hang up.

Caller ID service

You must subscribe to the Caller ID service from your telephone company to use this feature.

When the telephone rings, the Caller ID feature allows you to view the caller's name and phone number on the display before you answer the phone.

The handset displays the phone number of the incoming call, the name, time, and the number of calls. Additionally, you can dial the displayed number, and store the information for memory dialing.

When the telephone rings

NOTE

If you answer a call before the Caller ID message is received (Example: before the second ring), the Caller ID message will not appear.

NOTE

When the call is received via a telephone company that does not offer Caller ID service, the caller's phone number and name do not appear. (This includes international calls.)

NOTE

When the call is via a private branch exchange (PBX), the caller's phone number and name may not appear.

- 1 When the Caller ID message is received, the display shows the caller's phone number along with the date and time. The incoming call information is stored in Caller ID record. If the Caller ID service includes the caller's name, the caller's name appears on the display (up to 15 letters).

The date and time received — 5/11 12:30PM 01
Caller's name — UNIDEN CORP
Caller's phone number — 817-858-3300

Here are some typical displays;

When the phone number and name data are received

```
5/11 12:30PM 01
UNIDEN CORP
817-858-3300
```

When a private name is received

```
5/11 12:30PM 01
Private Name
817-858-3300
```

When an unknown name is received

```
5/11 12:30PM 01
Unknown Name
817-858-3300
```

When invalid data is received

```
Incomplete Data
```

When a private number is received

```
5/11 12:30PM 01
UNIDEN CORP
Private Number
```

When an unknown number is received

```
5/11 12:30PM 01
UNIDEN CORP
Unknown Number
```

- 2 When the telephone is answered, the display changes to "Talk".

NOTE

Data errors appear as "■ ■".

```
5/11 12:30PM 01
UNI■EN CORP
813-8■-3300
```

Viewing the Caller ID Message list

The Caller ID list stores information for up to 50 incoming calls - even unanswered calls.

NOTE

If a call comes in via a telephone system that does not offer Caller ID service, no information is stored.

NOTE

"End" appears when you have reviewed all messages in the Caller ID list.

NOTE

Press  to return to the summary screen.

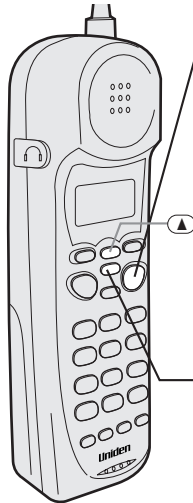



- 1** Press **call id**.

When there are new messages you have not reviewed, "New" and the number of calls are displayed. The summary screen shows how many new calls are stored, along with the total of new calls and old calls stored in the list.

```
New :01
Total:02
```

- 2** Press  to display the latest caller ID message.

```
5/17 12:30PM 03
UNIDEN CORP
817-858-3300
```

- 3** Press  to see the next message.
Or press  to see previous message.

- 4** Press **call id** to return to standby.

Deleting information from the Caller ID list

The EXR 2480 stores up to 50 messages. If more new calls are received, messages stored in the list are deleted beginning with the oldest message in the list.

Caller ID data can also be deleted manually.

Deleting a Caller ID message

NOTE

If no key is pressed for more than 20 seconds during the deleting operation, an error tone sounds and the telephone returns to standby.

NOTE

If you get an incoming call, the deleting operation is cancelled.

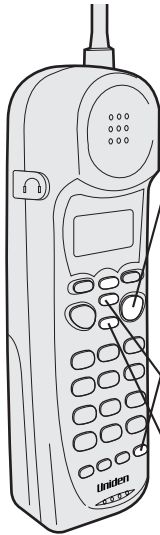

- 1** Press **call id** .
Display the message to be deleted from the Caller ID list by pressing **▼** or **▲** .

```
5/17 12:30PM 03
UNIDEN CORP
817-858-3300
```

- 2** Press **delete** .

```
Delete Message ?
# Yes
No
```

- 3** Press **▲** or **▼** to select "Yes" or "No".

- 4** Press **select** or **delete** .

When the pointer is at "Yes":
A beep tone sounds and the next Caller ID message displayed.

When the pointer is at "No":
The display returns to the Caller ID display.

Deleting all Caller ID name/numbers

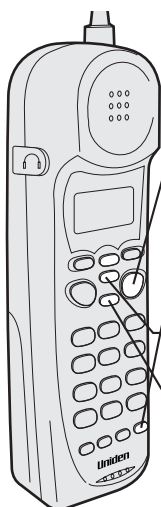

1 Press **call id**.

```
New :01
Total:02
```

2 Press **delete**.

```
Delete All ?
Yes
#No
```

3 Press **▲** or **▼** to select "Yes" or "No".

4 Press **select** or **delete**

When the pointer is at "Yes":
A beep tone sounds and all stored Caller ID messages are deleted.

```
Total:00
```

When the pointer is at "No":
The display returns to the summary screen.

```
New :01
Total:02
```

Using the Caller ID list

Calling a party from the Caller ID list

You can place a call from the Caller ID list.
The EXR 2480 stores up to 50 messages.

NOTE

You cannot make a call from the Caller ID list if your EXR 2480 is connected to private branch exchange (PBX).

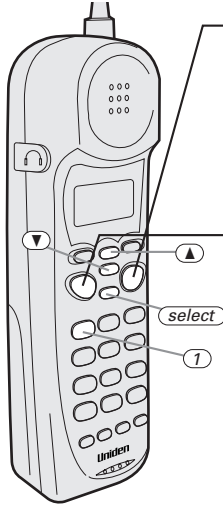

1 Press **call id**.
Select the phone number that you want to dial by pressing **▲** or **▼**.

```
5/17 12:30PM 03
UNIDEN CORP
817-858-3300
```

2 Press **talk**.

```
Talk
8178583300 ■
```

The displayed phone number dials automatically.

NOTE

When a long distance call has been set, "1" appears in the display.

Long Distance calls

Pressing **1** while the incoming call information is displayed (in step 1) will set or cancel a long distance call.

Dial edit

You can edit the phone number of Caller ID data when you press **select** after the step 1.

```
UNIDEN CORP
8178583300 ■
```

Storing Caller ID messages in Memory dialing

Messages shown in the Caller ID list can be stored in memory dialing.

Using the incoming call information (i.e., Caller ID list), the phone number of the party on the Caller ID list can be stored in memory dialing.

NOTE

You can not store a Caller ID message if no phone number appears in the message.

NOTE

If no key is pressed for more than 20 seconds, an error tone sounds and the telephone returns to the standby mode.

NOTE

If there is an incoming call or page, memory storage is cancelled and the telephone is set to receive the incoming call or page.

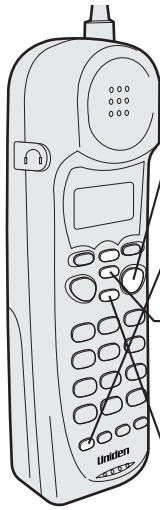

- 1** Press **call id**.
Select the phone number to be stored from the Caller ID list by pressing **▼** or **▲**.

```
5/17 12:30PM 03
UNIDEN CORP
817-858-3300
```

- 2** Press **memory**.

- 3** Press **▼**, **▲** or the dial button (**0** to **9**) to select the memory location.

```
Select Location
1 UNIDEN CORP
2 JOHN DOE
```

- 4** Press **select**.
A beep tone will sound. The number is stored in memory, and the display returns to the Caller ID list.

```
5/17 12:30PM 03
UNIDEN CORP
817-858-3300
```

NOTE

If a message has already been stored in the selected memory numbers location, a confirmation screen is displayed. Press **▲** to select "Yes". Press **select** to overwrite. The display returns to the Caller ID list.

```
Replace Memory ?
Yes
No
```

Using "Caller ID with call waiting" service

"Caller ID" and "Call Waiting" are separate services. CIDCW (Caller ID on Call Waiting) performs the same as regular Caller ID on a call waiting number. You must subscribe to the "Caller ID with call waiting (CIDCW)" service from your telephone company before you can use the following features. The "Call Waiting" service can also be used independently. Please contact your telephone company for details.

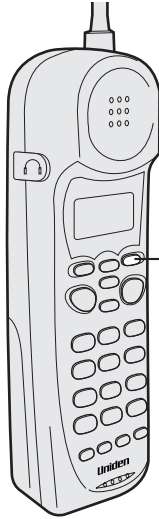

- 1** When a new incoming call arrives during your current telephone call, the phone number and the name of the caller is displayed.

```
Talk 10:30  
UNIDEN CORP  
817-858-3300
```

- 2** Press **flash/▶**.
You will be able to talk with the person that has just called. The first caller will be put on hold.
- 3** To return to the first caller, press **flash/▶** again.

The integrated answering device

The EXR 2480 has a built-in answering system that answers and records incoming calls.

You can also use your answering system to record a conversation, leave a voice memo message for others who use the phone, or to announce a special message to callers when you're away from your phone.

Features

- Digital Tapeless Recording
- 13 minutes of Recording Time
- Selective Outgoing Message (Greeting)
- Time and Day Stamp
- Remote Message Retrieval and Room Monitor
- Toll Saver
- Conversation Recording

Digital Tapeless Recording allows you to quickly review, save or delete the messages. You'll never have to worry about a tape wearing out, jamming, or resetting improperly.

The Integrated Answering System is easy and convenient to use, but please read through all of the instructions carefully.

Setting up your answering system

Turning the answering system on/off

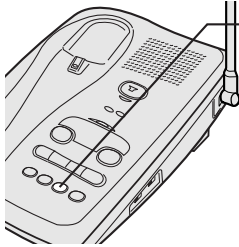

- 1 To turn the answering system on, press **(answer on/off)**. The current greeting message is played and a tone will sound.
- 2 To turn the answering system off, press **(answer on/off)** again.

Setting the clock

The clock on EXR 2480 Answer System starts when power is applied to the base. Follow these steps to set the clock to the correct time.

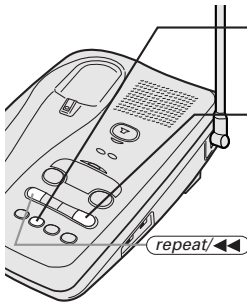

- 1 Press and hold **(clock)** until a tone sounds.
- 2 First, press **(skip/next)** or **(repeat/previous)** until the correct day of the week is announced. (Number 0 through 6 displays on the base as each day is announced.) Press **(clock)** again to select the day.
- 3 Next, press **(skip/next)** or **(repeat/previous)** until you hear the correct hour setting. Numbers 1 through 12 display on the base as each hour is announced. Press **(clock)** again to select the correct hour.
- 4 Press **(skip/next)** or **(repeat/previous)** until you hear the correct time setting. Numbers 0 through 59 display on the base as each minute is announced. Press **(clock)** again to select the correct time.
- 5 The LED displays A or P. Press **(skip/next)** or **(repeat/previous)** until you hear the correct AM/PM setting.
- 6 Press **(clock)** again to end the time/day setting. The EXR 2480 announces the time that you have set.

NOTE

Press and hold **(skip/next)** or **(repeat/previous)** to scroll through days, hours, minutes, etc.

NOTE

If you do not press a next key within 15 seconds, the system returns to standby.

Setting your greeting

When you receive a call, the answering system automatically plays either a preset message or your own greeting.

▼ Preset Message

The following message is prerecorded:

"Hello, no one is available to take your call. Please leave a message after the tone."

▼ Recording your personal greeting

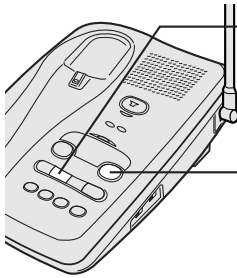

1 Press and hold **(greeting)** until you hear a long tone. Start recording your message immediately after you hear the long tone end.

2 When you finish recording your message, press **(greeting)** or **(play/stop)**. A long tone sounds and your message plays back on the phone.

NOTE

You can record a greeting up to 30 second.

NOTE

Stand within 12 inches in front of the microphone and speak clearly when recording your greeting.

▼ Choosing between two greetings

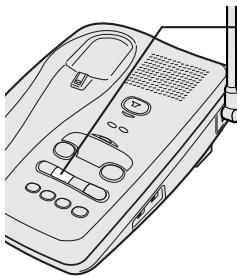

1 Press **(greeting)** to play the greeting.

2 While the message is playing, press **(greeting)** again to select between your personal greeting and the prerecorded message.

Selecting the message record time

You can set your answering system to record messages up to one or four minutes long.

One minute option:
move the **REC TIME** switch to **1**.

Four minutes option:
move the **REC TIME** switch to **4**.



▼ Announce only feature:

The announce only feature plays an outgoing message, but it will not allow the caller to leave a message. Move the **REC TIME** switch to the **ANN** position.

The message counter LED displays “**9**” when system is on. Prerecorded outgoing message for Announce only feature is:

“Hello, no one is available to take your call.” (twice)

Selecting a PIN code

To play your messages from a remote location, you will need to enter a two-digit Personal Identification Number (PIN) code (00-99). To select a PIN, perform the following steps.

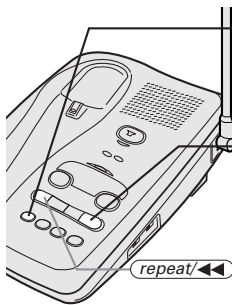

- 1** On the base, press and hold **(pin)** button until a tone sounds, and the LED displays 00.
- 2** To set the first number, press **(skip/▶▶)** or **(repeat/◀◀)** to scroll from 0 to 9. When the desired number appears in the display, press **(pin)**. This selects the first number.
- 3** To set the second number, press **(skip/▶▶)** or **(repeat/◀◀)** to scroll from 0 to 9. When the desired number appears in the display, press **(pin)**. This selects the second number and then the entered number is announced.

NOTE

Press **(skip/▶▶)** or **(repeat/◀◀)** multiple times to scroll through numbers on the display.

Setting ring time switch

The ring time/toll saver switch allows you to set the number of rings the caller hears before the answering system plays your outgoing message. You can set the switch to answer after two rings or after four rings. In the

TS (Toll Saver) position, the answering system picks up after two rings if you have new messages, and after four rings if there are none. This way, if you call long distance to check your messages, you can hang up after the third ring to avoid billing charges.

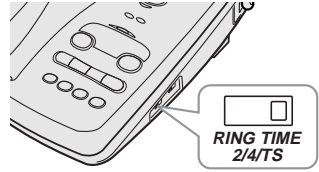

Using your answering system

NOTE

To stop playing your messages, press **play/stop** again.

NOTE

Pressing **repeat/◀◀** before 2 seconds (4 seconds from remote) of the message has played causes the system to scan back one message.

NOTE

If you have several messages, press **repeat/◀◀** until you return to the message you want to replay.

Playing your message

The base LED shows the number of total messages on the display. If the display is blinking, then there are new messages waiting for you. The EXR 2480 is designed to play your new messages first. After you play your new messages you can then play your old messages.

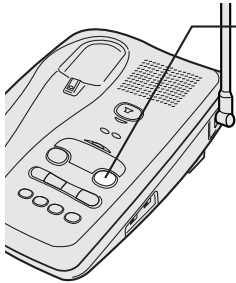

- 1** Press **play/stop**. The system announces the number of new and old messages, then the incoming messages are played. The time and day each message was received is announced after the message is played.
- 2** When all new messages have played, a long tone is heard. The message counter LED stops flashing to indicate that all of the new messages have been reviewed.
- 3** After you have reviewed all your messages, you can play your old messages again. Press **play/stop** and follow the instructions above.

Repeating a message

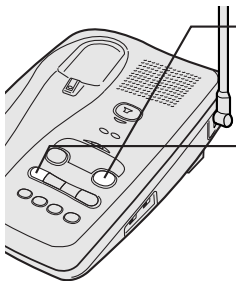

- 1** Press **play/stop** to review your message. The number of stored messages is announced.
- 2** After a message has played for a few seconds, press **repeat/◀◀** to repeat the message.
- 3** Press **play/stop** at any time to stop reviewing messages and return to standby. The message counter LED shows the total number of messages still on the system.

NOTE

Each time **skip/▶▶** is pressed, the system scans forward one message.

NOTE

If you have several messages, press and hold **skip/▶▶** to find the message you want to play.

NOTE

When you press delete, you are permanently deleting the message. Once deleted, the message cannot be replayed.

Skipping a message

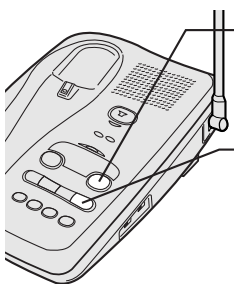

- 1 Press **play/stop** to review your messages. The number of messages is announced.
- 2 Press **skip/▶▶** at anytime to skip to the next message.
- 3 Press **play/stop** at any time to stop reviewing your messages and return to standby. The message counter LED shows the total number of messages on the system.

Deleting a message

▼ Deleting individual message

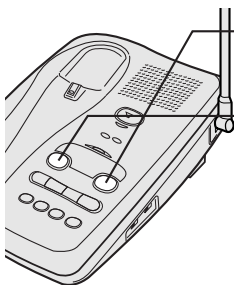

- 1 Press **play/stop** to review your message.
- 2 If you decide to delete a message, press **delete** anytime during the message. The system beeps and immediately goes to the next message.
- 3 After you have played all of your messages, a long tone sounds on the base speaker.

▼ Deleting all messages

Press and hold **delete** while the system is standby.

A tone sounds when all messages are cleared.

If there is a message you have not reviewed, you cannot delete all messages at once.

NOTE

The voice memo function is completely independent of the outgoing message. It's handy for leaving others a quick message.

NOTE

A memo message is treated as a typical recorded message and will be added to the stored messages.

NOTE

A recorded conversation is treated as a typical message and will be added to the stored messages.

NOTE

You cannot record a conversation while speaking on the base.

Voice memo

The voice memo function allows the user to record a message on the base.

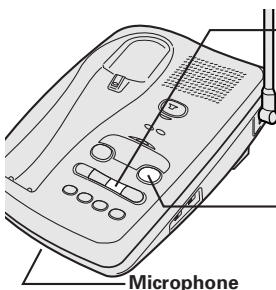

- 1 Press and hold **voice memo**, until you hear a long beep. The message counter LED blinks.
- 2 Speak into the microphone.
- 3 When you have finished, press **voice memo** or **play/stop** to stop recording. The system returns to standby.

Recording a conversation

You can record of conversation while you are making your call from the handset.

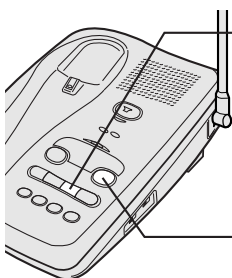

- 1 During the conversation from the handset, press and hold **voice memo** on the base. The unit begins recording and the LED blinks. A beep that can be heard by both parties sounds every 15 seconds.
- 2 To stop the recording, press **voice memo** or **play/stop**.

Remote access away from home

You can operate your answering system from a remote location using any touch-tone telephone. Use this function to check for recorded messages, to play or delete messages, even to record a new greeting, and to monitor sounds in the room.

- 1** Call your telephone number.
- 2** While the answering machine is activated, press **#** and your PIN code.
- 3** The answering system announces the time and day stamp and the number of messages stored in memory. Then the message playback automatically begins.
- 4** You may continue to listen to your message, or you may select a command from the following chart.

Command (Press a number within 2 seconds after #)	Function
# then 1	Repeat a message
# then 2	Playing your messages
# then 3	Skipping a message
# then 4	Deleting a message
# then 5	Stop message playback
# then 6	Answering system on
# then 7	Voice memo record/stop
# then 8	Greeting record/stop
# then 9	Answer system off
# then *	Room monitor

NOTE

The system will only playback messages for four minutes. To continue playing your message, press **#** then **2** again within 15 seconds.

NOTE

Enter a next command within 15 seconds, or the answering system automatically hangs up and returns to standby.

- 5** After all of your messages have played, or the playback time exceeds 4 minutes, you will hear that the intermittent beeps indicating that the system is in the command waiting mode. You may enter another command at this time from the chart above.
- 6** When you finish, hang up to exit the system. The answering system automatically returns to standby.

Remote room monitor

You can call your answering system from any touch-tone phone and monitor sounds in the room where your base is installed.

- 1** Call your telephone number.
- 2** While the answering machine is activated, press **#** and your PIN code.
- 3** The answering system begins announcing the time and day.
- 4** Press **#** then **5** to stop the message.
- 5** Press **#** then *****. You hear sounds in the room where your phone is installed. After 15 seconds, the answering system stops monitoring.
- 6** Press **#** then ***** to monitor the room for another 15 seconds. Or select another remote function. Or hang up to exit the system. The answering system automatically returns to standby.

Changing the digital security code

NOTE

If the handset battery pack is completely discharged or the battery pack is removed, the digital security code will be lost. If this happens, a new security code is set automatically next time the battery pack is charged.

The digital security code is an identification code used to connect the handset and the base unit. Normally, setting the code is not necessary.

The first time you charge your handset, the security code is automatically set.

In the rare situation that you suspect another cordless telephone is using the same security code, you can change the code.

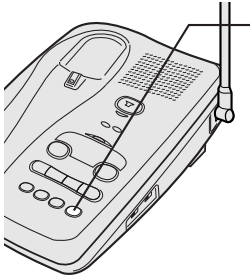

- 1 Remove the handset from the base unit. Press and hold **page/int'com**.
- 2 While the handset is emitting the paging sound, place the handset on the base unit holding **page/int'com**. The paging tone stops. Leave the handset on the base longer than 5 seconds. A random, new security code is set.

Headset installation

Your phone may be used with an optional headset. To use this feature, simply plug any standard 2.5mm headset plug into the headset jack. Your phone is ready for hands-free conversation.

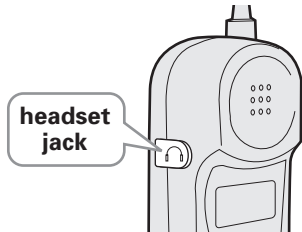

Installing the beltclip

To attach the beltclip

- 1 Remove the slot cover.

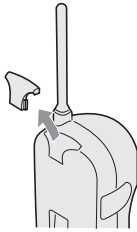

- 2 Insert the beltclip into the empty slot. Press down until it clicks.

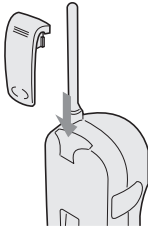

To remove the beltclip

- 1 Pull back on the release tab. Lift the beltclip.

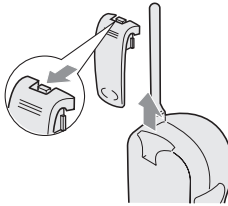

- 2 Replace the slot cover. You can store either the beltclip, or the slot cover, on the bottom of the base.

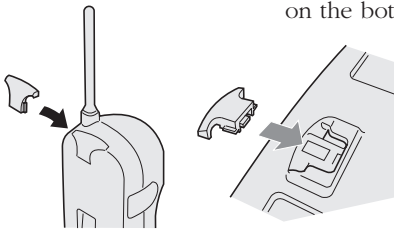

Note on power sources

Battery replacement and handling

When the operating time becomes short, even after a battery is recharged, please replace the battery.

With normal usage, your battery should last about one year.

Please contact your place of purchase for a replacement battery.

Power Failure
During the period that the power is off, you will not be able to make or receive calls with the telephone.

Caution

- Use the specified battery pack.
- Do not remove the battery from the handset to charge it.
- Never throw the battery into a fire, disassemble it, or heat it.
- Do not remove or damage the battery casing.

Maintenance

When slightly dirty
Wipe with a soft, dry cloth.

When very dirty
Wipe with a soft cloth that has been dampened with diluted, neutral detergent. Dry with a dry cloth.

When the charging terminals become dirty
Wipe with a pencil eraser or other contact cleaner.

RECYCLING NICKEL-CADMIUM BATTERIES



NICKEL-CADMIUM BATTERIES MUST BE DISPOSED OF PROPERLY.

Nickel-cadmium cells are used in the battery pack. Please take your used nickel-cadmium battery packs to a store that recycles nickel-cadmium batteries.

Caution
Do not use paint thinner, benzene, alcohol, or other chemical products. Doing so may discolor the surface of the telephone and damage the finish.

Troubleshooting

If your phone is not performing to your expectations, please try these simple steps first.

Symptom	Suggestion
The status LED won't come on when the handset is placed in the base unit.	<ul style="list-style-type: none"> • Make sure the AC adapter is plugged into the base unit and wall outlet. • Make sure the handset is properly seated in the base unit. • Make sure the charging contacts on the handset and base unit are clean.
The audio sounds weak and/or scratchy.	<ul style="list-style-type: none"> • Make sure that the base unit antenna is in a vertical position. • Move the handset and or base unit to a different location away from metal objects or appliances and try again. • Make sure that you are not too far from the base.
Can't make or receive calls.	<ul style="list-style-type: none"> • Check both ends of the base unit telephone line cord. • Make sure the AC adapter is plugged into the base unit and wall outlet. • Disconnect the AC adapter for a few minutes, then reconnect it. • Reset the digital security code (See page 48). • Make sure (talk) is pressed.
The handset doesn't ring or receive a page.	<ul style="list-style-type: none"> • The battery pack may be weak. Charge the battery on the base unit for 15-20 hours. • The handset may be too far away from the base unit. • Place the base unit away from appliances or metal objects. • Reset the digital security code (See page 48).
Severe noise interference.	<ul style="list-style-type: none"> • Keep the handset away from computers, remote control toys, wireless microphones, alarm systems, intercoms, room monitors, fluorescent lights and electrical appliance. • Move to another location or turn off the source of interference.

Symptom	Suggestion
The caller ID does not display	<ul style="list-style-type: none"> • The handset was picked up before the second ring. • The call was placed through a switch board. • Call your local telephone company to verify your Caller ID service is current.
The answering system does not work.	<ul style="list-style-type: none"> • Make sure the base unit is plugged in. • Make sure that the answering system is turned on. • Make sure that the message record time is not set to ANN (See page 41).
Messages are incomplete.	<ul style="list-style-type: none"> • The incoming messages may be too long. Remind callers to leave a brief message. • The memory may be full. Delete some or all of the saved messages.
The outgoing message is deleted.	<ul style="list-style-type: none"> • Record your greeting again. The preset messages should remain.
No sounds on the base unit speaker during call monitoring or message playback.	<ul style="list-style-type: none"> • Adjust the speaker volume on the base unit.
Cannot access remote call-in features from another touch-tone phone.	<ul style="list-style-type: none"> • Make sure you are using the correct PIN number. • Make sure that the touch-tone phone you're using can transmit the tone. If it cannot, you may have to use another phone to access your message.

Specifications

General

The EXR 2480 complies with FCC Parts 15 and 68.
 Frequency control: PLL
 Modulation: Phase shift keying
 Operating temperature: 0°C to +50°C (+32°F to +122°F)

Base unit

Frequency: 2400.0 MHz to 2483.5 MHz (20 channel)
 Power requirements: 10V 500mA (from AC adapter)
 Size: 8-49/64 in. (W) x 6-57/64 in. (D) x 2-37/64 in. (H)
 (222.5 mm (W) x 175 mm (D) x 65.3 mm (H))
 Weight: Approx. 21 oz. (Approx. 594 g)

Handset

Frequency: 2400.0 MHz to 2483.5 MHz (20 channel)
 Power requirements: Rechargeable Nickel-Cadmium battery pack
 Size (without antenna): 7 in. (W) x 2-17/64 in. (D) x 2 in. (H)
 (178 mm (W) x 57.6 mm (D) x 51 mm (H))
 Weight: Approx. 9 oz. (254 g) (including battery)
 Battery: BT-2499
 Capacity: 800 mAh, 3.6V
 Talk mode: 4 hours TYP
 Standby mode: 7 days TYP

Specifications, features, and availability of optional accessories are all subject to change without prior notice.

At Uniden, we'll take care of you!

If you need any assistance with this product, please call our Customer Hotline at

1-800-297-1023

PLEASE DO NOT RETURN THIS PRODUCT TO THE PLACE OF PURCHASE.

Our Uniden representatives will be happy to help you with any matters regarding the operation of this unit, available accessories, or any other related matters.

Thank you for purchasing a Uniden product.
 Hours: M-F 7:00 AM to 7:00 PM CST.

Index

0 - 9

3-way conferencing.....29

A

Answering device

Features.....38

Setting up.....37

Using.....43

B

Base ringer switch.....15

Battery pack

Preparing and charging...9

Replacement and handling.....50

C

Caller ID

Caller ID service.....30

Call Waiting.....37

Deleting.....33

Using.....35

Viewing.....32

Connection.....5

D

Dialing mode.....6

Digital security code.....48

E, F, G

Earpiece volume.....16

H

Handset ringer volume.....16

Headset installation.....48

I, J, K, L

Intercom.....19

Installing the beltclip.....49

M, N, O

Maintenance.....50

Making a call.....13

Memory dialing

Making calls with memory dialing.....23

Erasing a stored name and phone number.....27

Storing phone

numbers and names.....21

Mounting the base unit

on a wall.....7

P, Q

Package contents.....3

R

Receiving a call.....15

Redialing a call.....17

S

Setting up your answering system

Selecting a PIN code.....41

Selecting the

message record time.....41

Setting the clock.....39

Setting ring time switch.....42

Setting your greeting.....40

Turning the answering

system on/off.....39

Setting up the Base unit.....4

Setting up the Handset.....9

Specifications.....53

T

Transferring a call.....20

Troubleshooting.....51

U, V, W, X, Y, Z

Using your answering system

Deleting a message.....44

Playing your message.....43

Recording a

conversation.....45

Remote access

away from home.....46

Remote room monitor.....47

Repeating a message.....43

Skipping a message.....44

Voice memo.....45

THANK YOU

FOR PURCHASING A UNIDEN PHONE!

Uniden®

Covered under one or more of the following U.S. patents:

4,511,761 4,523,058 4,595,795 4,797,916 5,381,460
5,426,690 5,434,905 5,491,745 5,533,010 5,574,727
5,650,790 5,660,269 5,661,780 5,663,981 5,671,248
5,717,312 5,754,407 5,768,345 5,787,356 5,838,721

© August 1999 Uniden America Corporation

All rights reserved • Printed in China UCZZ01651BZ

Free Manuals Download Website

<http://myh66.com>

<http://usermanuals.us>

<http://www.somanuals.com>

<http://www.4manuals.cc>

<http://www.manual-lib.com>

<http://www.404manual.com>

<http://www.luxmanual.com>

<http://aubethermostatmanual.com>

Golf course search by state

<http://golfingnear.com>

Email search by domain

<http://emailbydomain.com>

Auto manuals search

<http://auto.somanuals.com>

TV manuals search

<http://tv.somanuals.com>