

PEQ-200

5-BAND CROSSOVER AND EQUALIZER

**Owner's
Manual**

CONTENTS

Precautions/Specifications..... 3

Installation Procedures..... 4

Wiring Instructions..... 4

Typical System Wiring Diagram.....6

Operating Instructions..... 7-9

Warranty.....11

PRECAUTIONS

IMPORTANT - READ THIS SECTION CAREFULLY

1. This unit does not contain a power amplifier and must be used with a compatible external amplifier. The output of this unit is not designed for, and is not capable of driving speakers directly.
2. The input of this unit operates at a low level (120 mV to 4.0 V) and must be connected to the low-level (pre-amp level) outputs of the car stereo.

CAUTION: DO NOT attempt to directly connect the speaker level outputs of the car stereo to this unit or damage to the car stereo and/or equalizer may result.

3. This unit is designed for 12V dc negative-ground electrical systems, only.

SPECIFICATIONS:

Pre-Amplifier Input Level:	0.12V to 4.0V	Cut/Boost:	+/-12dB
Input Impedance:	10K Ohms	Subwoofer Level Control:	-6dB to +10dB
Frequency Response:	10Hz to 30kHz, +1dB	Crossover Subwoofer Output:	50Hz, 80Hz, 100Hz, 120Hz
THD:	0.03%	Slope:	18dB/Octave
Channel Separation:	Greater than 82dB	Rear Output:	80Hz, 100Hz, 150Hz, FULL
Signal-to-Noise Ratio:	Greater than 92dB	Slope:	12dB/Octave
Maximum Output:	7.5V rms	Front Output:	100Hz, 150Hz, 200Hz, FULL
Equalizer Frequencies:	40Hz, 150Hz, 400Hz, 2kHz, 10kHz	Slope:	12dB/Octave

HELP!

1-800-645-4994

Monday - Friday 8:30am - 7:00pm Eastern
Saturday 9:00am - 5:00pm Eastern

INSTALLATION PROCEDURES

The PEQ-200 should be easily accessible to the operator, and is intended for in-dash (if a location is available), console, or under-dash mounting as shown. To install the unit, proceed as follows:

1. Carefully choose a favorable mounting location prior to wiring the unit. Before deciding on the mounting location, consider these points:
 - a. Will the unit be accessible for easy operation while driving?
 - b. Is it a good solid mounting surface?
 - c. How will the wiring be routed to reach the unit?
 - d. Will it obstruct or interfere with passengers or other controls?
2. After choosing the location, position the mounting bracket and mark the location of the four screws on the surface, two at each end.
3. Remove the bracket and drill a 3/32" hole at the four locations.

CAUTION: Do not use any screws other than those provided with this unit. Use of longer screws may short-circuit or damage internal components of the unit.

4. Place the bracket in position and secure it to the mounting surface using the four self-tapping screws, flat washers and lockwashers provided.
5. Attach the PEQ-200 to the mounting bracket using two machine screws through the bracket into each side of the unit. Since the mounting bracket holes are elongated vertically, the unit can be secured in a tilted fashion to enhance control accessibility.

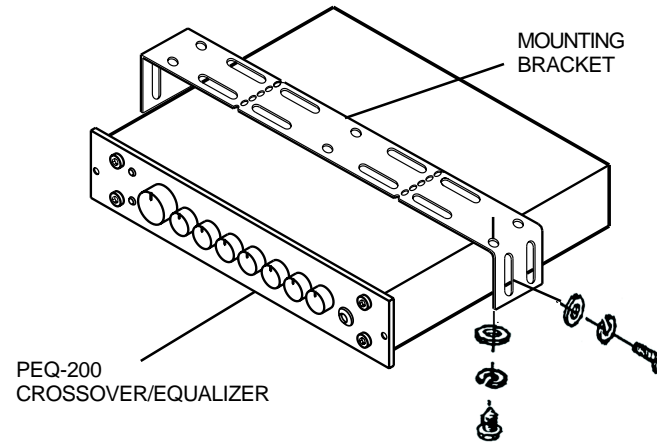

Under-Dash Installation

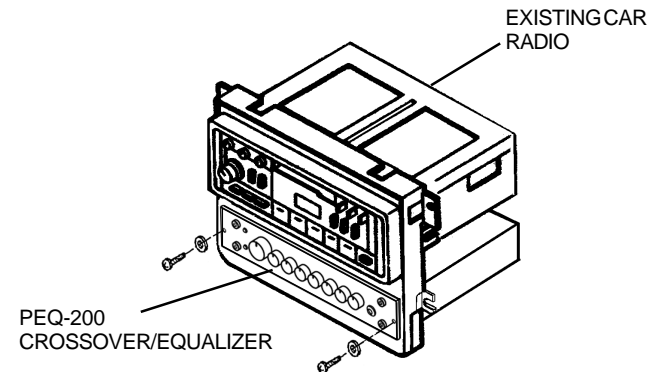

Typical In-Dash Installation

WIRING INSTRUCTIONS

The wiring of your crossover equalizer will depend on the system and speakers you are using but will either be a 2-way (bass and midrange/high) or 3-way (bass, midrange and high) application using 2 or 4 channels of input from the car stereo. The following pages illustrate the input and output wiring for these types. Please refer to the appropriate diagram for the system configuration you are using.

The power connections for this unit are accomplished using the supplied modular 4-pin connector wiring harness (item 18). The wiring harness contains three color-coded wires.

Connecting these wires should not be overly difficult if the following guidelines are adhered to: (See the installation diagram.)

1. *Power Connection (Red wire)*

Pull the source unit (radio, amplifier, etc.) out from the dash far enough until the wires are exposed at the rear of the unit. Using a digital voltmeter, find a constant +12Vdc lead for the radio, and splice into this wire. Splice or solder the red wire from the wiring harness and connect it inline with the +12Vdc wire using a barrel connector of appropriate size.

2. *Ground Connection (Black wire)*

Locate the ground wire supplied to the source unit and splice into it. Take the black wire from the wiring harness and connect it in line with the ground wire by splicing and or soldering.

NOTE: If ground wire to the source is not available, you will need to find your own grounding point. Locate a metal area close to the PEQ-200 that provides a good ground point (preferably the floor). Eliminate unwanted paint and other contaminants using a wire brush or sandpaper. Terminate the black wire using the correct size of ring terminal and attach it to the bare metal. Spread Silicone over the screw and bare metal to prevent rust and corrosion.

3. *Remote Turn-On Connection (Orange wire)*

The PEQ-200 is turned on by applying +12 volts to the remote turn-on terminal (REM) of the cable 4-Pin connector harness. The wire lead to this terminal should be connected either to the "Auto-Antenna" lead from the car stereo, or to some other point which will provide a +12 V dc supply only when the car stereo is turned on. If the car stereo does not provide an Auto-Antenna lead, the remote turn-on lead may be wired to an "Accessory" or "Radio" terminal in the car's fuse block. This will turn the PEQ-200 on and off with the ignition key, regardless of whether the car stereo is on or off. The remote turn-on lead of the cable harness does not have to carry large currents, so #20 gauge wire may be used for this application. After the remote connection has been made, insert the cable connector into the 4-pin jack at the rear of the unit while pressing the key tab; it will snap into place.

TYPICAL WIRING DIAGRAM

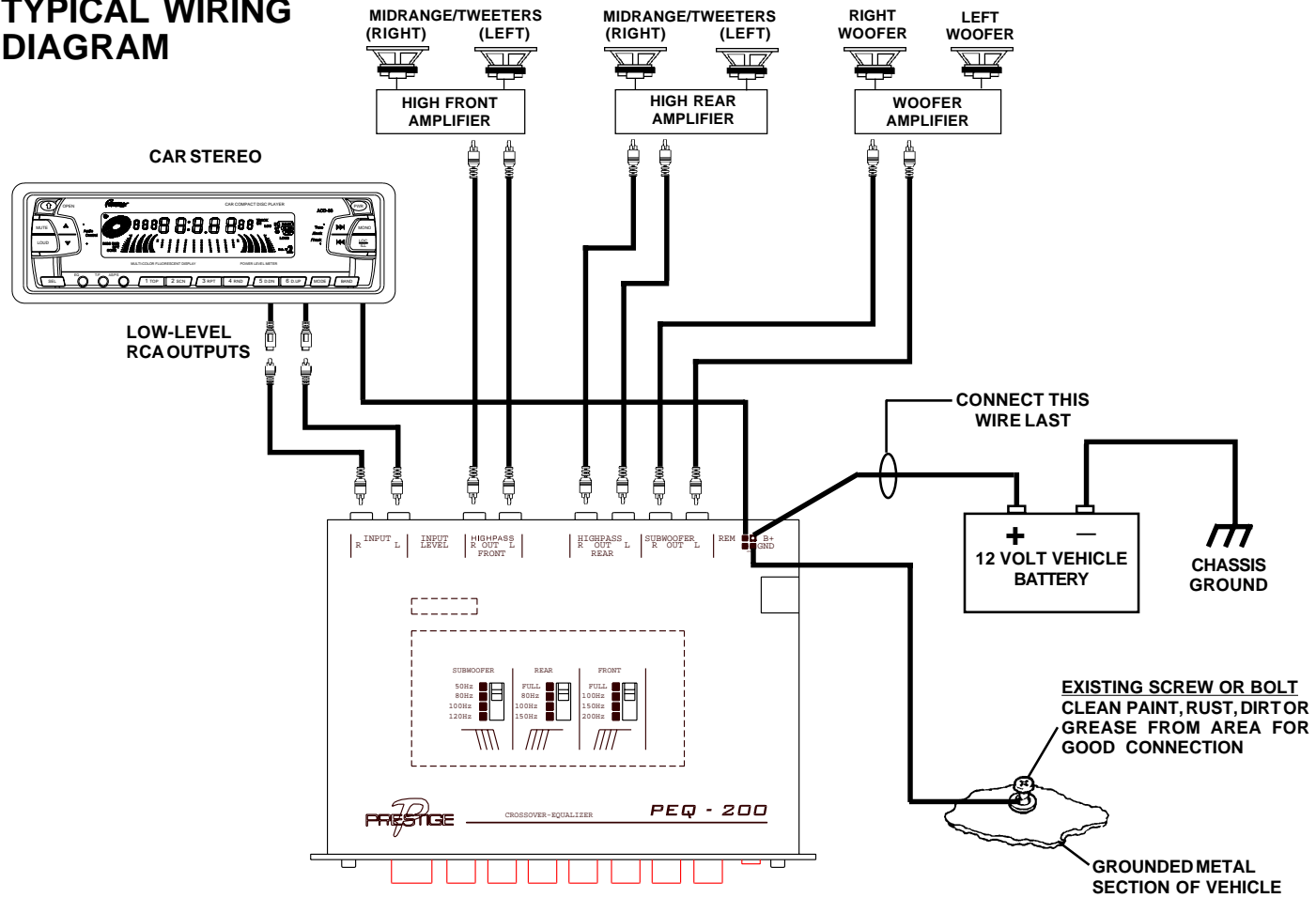

OPERATING INSTRUCTIONS

4. *Input Connections*

This crossover features low-level input capability and can accommodate two channels of low-level output from the car stereo, which is connected to the INPUT R/L jacks (item 12) on the rear panel as shown on the wiring diagram.

5. *Output Connections*

Connect the low-level output jacks from the PEQ-200 to the low-level inputs of the amplifier(s) in the system as shown on the wiring diagram. For 2-way systems, use the SUBWOOFER OUT R/L and HIGH PASS OUT REAR R/L jacks. For 3-way systems, use the SUBWOOFER OUT R/L, HIGH PASS OUT REAR R/L and HIGH PASS OUT FRONT R/L jacks.

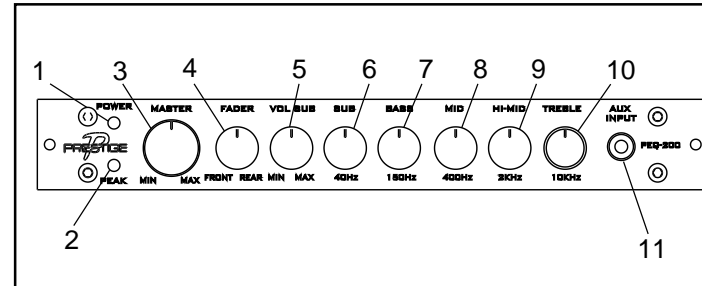

① POWER INDICATOR

This LED indicator lights green when power is applied to the unit from a remote source, such as the radio and/or the vehicle ignition switch, and provided the remote terminal is connected to +12Vdc.

② PEAK INDICATOR

This LED indicator lights red when the equalizer input signal exceeds the input range, thereby causing saturation or overloading to take place. The indicator will also light when the input signal itself is overdriven or clipped.

③ MASTER MIN/MAX CONTROL

Rotate this control clockwise (MAX) or counterclockwise (MIN) to adjust the overall system volume after the source radio or amplifier volume output has been set to the desired level.

④ FADER FRONT/REAR CONTROL

Rotate this control clockwise (REAR) or counterclockwise (FRONT) to favor the output from the rear or front speakers, respectively; the sound output from the front or rear speakers is thereby subdued. The control is detented at the center position which provides equal front and rear speaker outputs.

⑤ VOL SUB MIN/MAX CONTROL

Rotate this control clockwise (MAX) or counterclockwise (MIN) to adjust the subwoofer (SUB) output level at or below the crossover frequency selected by the SUBWOOFER four-position slide switch (item 20).

⑥ SUB 40Hz CONTROL

Rotate this control counterclockwise (minimum) or clockwise (maximum) to adjust the subwoofer cut or boost between -12dB and 12dB, respectively, at the frequency of 40Hz.

⑦ BASS 150Hz CONTROL

Rotate this control counterclockwise (minimum) or clockwise (maximum) to adjust the system bass cut or boost between -12dB and 12dB, respectively, at the frequency of 150Hz.

⑧ MID 400Hz CONTROL

Rotate this control counterclockwise (minimum) or clockwise (maximum) to adjust the system mid-range cut or boost between -12dB and 12dB, respectively, at the frequency of 400Hz.

⑨ HI-MID 2kHz CONTROL

Rotate this control counterclockwise (minimum) or clockwise (maximum) to adjust the system high mid-range cut or boost, respectively, between -12dB and 12dB at the frequency of 2kHz.

⑩ TREBLE 10kHz CONTROL

Rotate this control counterclockwise (minimum) or clockwise (maximum) to adjust the system treble cut or boost, respectively, between -12dB and 12dB at the frequency of 10kHz.

⑪ AUX INPUT JACK

This jack can be used with a portable CD (or MP3) stereo player by connecting an audio patch cable with a standard 1/8" phono plug (available at most radio supply stores). Attach the audio output from the CD/MP3 player to the AUX IN jack. This external input will automatically override the input from the existing stereo source. To resume play of the existing stereo, simply remove the patch cable from the AUX IN jack.

⑫ INPUT R/L CONNECTORS

These connectors accept the stereo output signal from the external audio source, such as a radio.

⑬ INPUT LEVEL ADJUSTMENT

This rear panel control provides a sensitivity screwdriver adjustment which matches the input sensitivity of the unit to the level of the output signal from the stereo source.

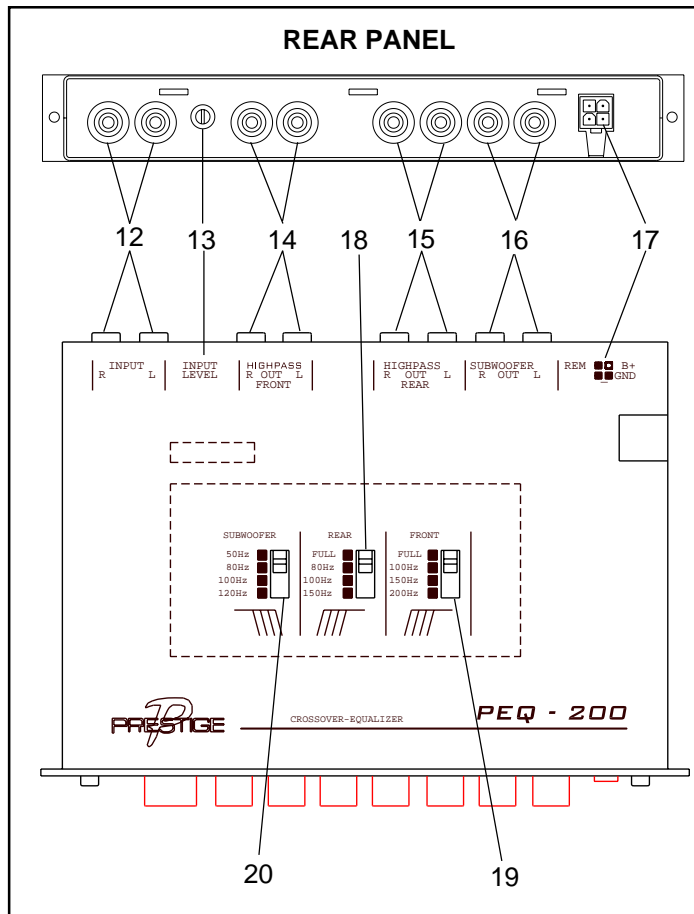

⑭ HIGH PASS OUT FRONT R/L CONNECTORS

These connector ports provide the high-pass crossover stereo output signal to the front speaker amplifier. The crossover equalization frequency of this signal is selected by the FRONT crossover selector switch (item 19).

⑮ HIGH PASS OUT REAR R/L CONNECTORS

These connector ports provide the high-pass crossover stereo output signal to the rear speaker amplifier. The crossover equalization frequency of this signal is selected by the REAR crossover selector switch (item 18).

⑯ SUBWOOFER OUT R/L CONNECTORS

These connector ports provide the subwoofer crossover stereo output signal to the subwoofer amplifier. The crossover equalization frequency of this signal is selected by the SUBWOOFER selector switch (item 20).

⑰ INPUT POWER CONNECTOR

This 4-pin connector accepts vehicle input power of 12Vdc and ground, along with the remote turnon, via the supplied harness.

⑱ REAR HIGH-PASS CROSSOVER SWITCH

This 4-position slide switch allows you to select the high-pass crossover point for the rear speakers at 150Hz, 100Hz, 80Hz or FULL (Full Range) during 2-way and 3-way operation. The frequencies above the setting of this control will be passed through the crossover to the HIGH PASS OUT REAR R/L jacks. Make this selection as appropriate for the woofer-to-midrange frequency of the speaker system being used.

①9 FRONT HIGH-PASS CROSSOVER SWITCH

This 4-position slide switch allows you to select the high-pass crossover point for the front speakers at 200Hz, 150Hz, 100Hz or FULL (Full Range) during 2-way and 3-way operation. The frequencies above the setting of this control will be passed through the crossover to the HIGH PASS OUT FRONT R/L jacks. Make this selection as appropriate for the midrange-to-tweeter crossover frequency of the speaker system being used.

②0 SUBWOOFER LOW-PASS CROSSOVER SWITCH

This 4-position slide switch allows you to select the low-pass crossover point for the subwoofer speakers at 120Hz, 100Hz, 80Hz or 50Hz. The frequencies below the setting of this control will be passed through the crossover to the SUBWOOFER OUT R/L jacks. Make this selection as appropriate for the subwoofer crossover frequency of the speaker system being used.

②1 IN-LINE POWER FUSE

The circuitry of the PEQ-200 is protected from damage by a 1-Amp automotive-type fuse in-line with the constant +12V dc power input, and housed within the fuse box of the power harness assembly. The use of fuses with incorrect ratings may cause serious damage to the unit. If the fuse blows constantly, carefully check all electrical connections to the unit.



12 / 24 MONTH LIMITED WARRANTY

Applies to automotive radios, radio/tape players, radio/CD players, CD changers, power amplifiers, equalizers and accessories.

AUDIOVOX CORPORATION (the Company) warrants to the original retail purchaser of this product that should this product or any part thereof, under normal use and conditions, be proven defective in material or workmanship within 12 months from the date of original purchase, such defect(s) will be repaired or replaced with new or reconditioned product (at the Company's option) without charge for parts and repair labor.

To obtain repair or replacement within the terms of this Warranty, the product is to be delivered with proof of warranty coverage (e.g. dated bill of sale), specification of defect(s), transportation prepaid, to an approved warranty station or the Company at the address shown below.

The warranty period will be extended to 24 months from the date of original purchase if the product is installed by an authorized Prestige Audio dealer. To claim warranty service during this extended period, the bill of sale must specify that the product was installed by an authorized Prestige Audio dealer.

This Warranty does not extend to the elimination of externally generated static or noise, to correction of antenna problems, to costs incurred for installation, removal or reinstallation of the product, or to damage to tapes, compact discs, speakers, accessories, or vehicle electrical systems.

This Warranty does not apply to any product or part thereof which, in the opinion of the Company, has suffered or been damaged through alteration, improper installation, mishandling, misuse, neglect, accident, or by removal or defacement of the factory serial number/bar code label(s). THE EXTENT OF THE COMPANY'S LIABILITY UNDER THIS WARRANTY IS LIMITED TO THE REPAIR OR REPLACEMENT PROVIDED ABOVE AND, IN NO EVENT, SHALL THE COMPANY'S LIABILITY EXCEED THE PURCHASE PRICE PAID BY PURCHASER FOR THE PRODUCT.

This Warranty is in lieu of all other express warranties or liabilities. ANY IMPLIED WARRANTIES, INCLUDING ANY IMPLIED WARRANTY OF MERCHANTABILITY, SHALL BE LIMITED TO THE DURATION OF THIS WRITTEN WARRANTY. ANY ACTION FOR BREACH OF ANY WARRANTY HEREUNDER INCLUDING ANY IMPLIED WARRANTY OF MERCHANTABILITY MUST BE BROUGHT WITHIN A PERIOD OF 30 MONTHS FROM DATE OF ORIGINAL PURCHASE. IN NO CASE SHALL THE COMPANY BE LIABLE FOR ANY CONSEQUENTIAL OR INCIDENTAL DAMAGES FOR BREACH OF THIS OR ANY OTHER WARRANTY, EXPRESS OR IMPLIED, WHATSOEVER. No person or representative is authorized to assume for the Company any liability other than expressed herein in connection with the sale of this product.

Some states do not allow limitations on how long an implied warranty lasts or the exclusion or limitation of incidental or consequential damage so the above limitations or exclusions may not apply to you. This Warranty gives you specific legal rights and you may also have other rights which vary from state to state.

U.S.A. : AUDIOVOX CORPORATION, 150 MARCUS BLVD., HAUPPAUGE, NEW YORK 11788 • 1-800-645-4994

CANADA : CALL 1-800-645-4994 FOR LOCATION OF WARRANTY STATION SERVING YOUR AREA

128-5543

Free Manuals Download Website

<http://myh66.com>

<http://usermanuals.us>

<http://www.somanuals.com>

<http://www.4manuals.cc>

<http://www.manual-lib.com>

<http://www.404manual.com>

<http://www.luxmanual.com>

<http://aubethermostatmanual.com>

Golf course search by state

<http://golfingnear.com>

Email search by domain

<http://emailbydomain.com>

Auto manuals search

<http://auto.somanuals.com>

TV manuals search

<http://tv.somanuals.com>