

# **XEROX 5915 SERVICE MANUAL**

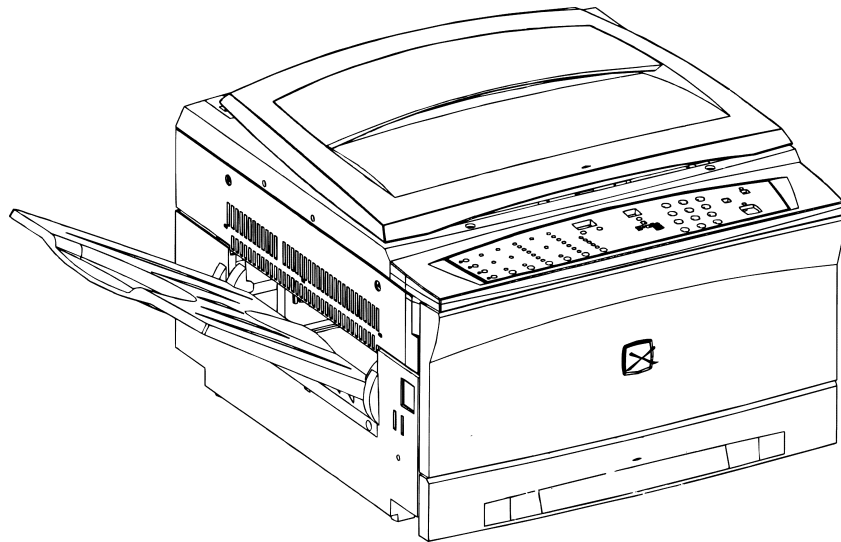

**Issued by : Overseas Technical Group,  
Xerox of Shanghai Limited.  
7<sup>th</sup>. July 200**

**XEROX**

**Issued: JUNE 2000**

## **THE DOCUMENT COMPANY**

### **XEROX 5915**

#### **Service Manual 1st Edition**

- **This service manual covers the following models:**

Electrostatic Copier XEROX 5915 manufactured by SHANGHAI XEROX.

- **Related Materials**

No related materials are issued other than this service manual.

- **Confidentiality**

- This service manual is issued intending use by maintenance service personal authorized by XEROX. Copying, transferring or leasing this manual without prior consent by XEROX is prohibited.
- Whenever a paper is eliminated because of issuance of a replacement page containing changes modifications, burn it or take the necessary action including cutting by a shredder.
- Be careful of handing the manual to avoid missing or damaging it.

- **Revision and Modification Information**

When design changes or revisions relating to this service manual occur, overseas technical information or overseas service bulletins may be issued as supplementary information until such change will be accommodated in the updated version of this service manual.

**CAUTION:** Important changes including revisions of spare part numbers and adjustment specifications must immediately be reflected on the respective pages of this service manual upon reception of such information.

## Introduction

### 1. Scope and Comment Sheet

This service manual is prepared to specify service standards for the XEROX 5915.

#### • Service Manual Comment Sheet

When you have comments or corrections, or discover wrong descriptions in the XEROX 5915 service manual, enter these items on the comment sheet and send it to:  
Overseas Support Group,  
Technical Services Department,  
Xerox of Shanghai Ltd.

Via your company's Technical Department.

### 2. How to Use the Service Manual

This service manual covers standard maintenance servicing procedures for the XEROX 5915. Observe Section 1 Service Procedure for efficient work during maintenance calls.

#### 2.1 Service Manual Composition

This manual is divided into the following 9 sections:

#### Section 1 Service Procedure

This section describes general and servicing procedures required to carry out maintenance of the XEROX 5915.

#### Section 2 Troubleshooting

This section specifies troubleshooting procedures, except those on the image or copy quality. How to use the diagnostic mode and programs are also contained in this section.

#### Section 3 Image Troubleshooting (Under preparation)

This section describes troubleshooting procedures relating to image quality problems.

#### Section 4 Disassembly, Assembly and Adjustment

This section instructs the disassembly, assembly, adjustment and replacement procedures for components of the XEROX 5915.

#### Section 5 Parts List

This section lists the component parts of the XEROX 5915.

#### Section 6 General

The following pieces of information relating to the XEROX 5915 are contained in this section:

- Specifications
- Tools and servicing supplies
- Consumables
- Information relating to modifications
- Installation and removal procedures

#### Section 7 Wiring Information

This section contains information relating to electrical wiring of the XEROX 5915.

- Wiring connectors list
- Wiring connectors positions
- PWBS reference materials

#### Section 8 Information of Related Products

(Not to be issued as the 5915 is unique)

#### Section 9 Block Schematic Diagrams (BSD)

This section contains the following Block Schematic Diagrams (BSD) of Chains 1 to 9 and other wiring information on the XEROX 5915.

- Chain 1. STANDBY POWER
- Chain 2. MODE SELECTION, MACHINE RUN CONTROL START PRINT POWER
- Chain 3. DOCUMENT TRANSPORTATION OPTICS NO.1
- Chain 4. DOCUMENT TRANSPORTATION OPTICS NO.2
- Chain 5. PAPER SUPPLYING AND TRANSPORTATION NO.1
- Chain 6. PAPER SUPPLYING AND TRANSPORTATION NO.2
- Chain 7. XEROGRAPHIC, COPY TRANSPORTATION AND FUSING

### 2.2 Revision Information

This manual will be revised as specified below and the necessary information sent to all customer engineers. Revisions must be incorporated correctly in order to keep the manual up-to-date.

#### Revision Procedure:

- When the entire manual is revised, the Revision 1 on the front cover will be renewed to Revision 2, Revision 3 and so on.
- When the manual is partially revised, Revision A, B, C and after will be issued. Each revised page will carry Revision A, B, C and up in order to clarify the revision history.
- Change bar:  
When a paragraph, table or figure is revised, a change bar will be inserted into respective revisions in order to clearly indicate that a change or addition is made.

Example: 

When the same page is changed a second time, the previous change bar will be deleted.

### 3. Warning, Cautions and Notes

#### WARNING

**A Warning is used whenever an operating or maintenance procedure, practice, condition or statement, if not strictly observed, could result in personal injury.**

#### CAUTION

**A Caution is used whenever an operating or maintenance procedure, practice, condition or statement, if not strictly observed, could result in damage to the equipment.**

#### NOTE

*NOTE:* A Note is used where it is essential to highlight a procedure, practice, condition or statement.

### 4. Symbols

The following symbols are used throughout this manual:

- **PL:** This indicates you should refer to the parts list.

## **Section 1 Service Procedure**

## **Section 1 Service Procedure**

### **1.1 Precautions**

- 1.1.1 Safety..... 1-2
- 1.1.2 Other precautions.....1-2

### **1.2 Work Process When Making Calls ..... 1-2**

### **1.3 Detailed Explanation of Work**

- When Making Calls..... 1-3**
- 1.3.1 What to do first.....1-3
- 1.3.2 Check for repeatability of the problem.....1-3
- 1.3.3 Check the image quality.....1-3
- 1.3.4 Feed Counter Check ..... 1-3
- 1.3.5 Paper Jam Status Check ..... 1-4
- 1.3.6 TRIM .....1-4

Intentional bank page

## 1. Service Call Procedure

### FIRST CALL ACTIONS

Perform the following:

1. Discuss with the customer the required and agreed configuration for the copier. Check that all required hardware and software is installed and/or enabled to meet this specification.
2. If the copier is configured with either a sorter or ADF, check the alignment of the output device.

### NORMAL CALL ACTIONS

1. **Ask the operator about the reason for the call.** Obtain the operators description of the reason for the call and any other problems that may be occurring. Review any defective copies to determine what actions need to be taken.
2. **First Call?** If this is the first call, carry out the first call actions.
3. **Switch on the copier...** Observe the user interface panel <Note to author add initialising sequence of events>
4. **System initialisation...** Confirm that the < Note to author add initialising sequence of events eg drives moving etc>
5. **Check the service log.** Review the copier service log book for any previous actions that may be relevant to the call.
6. **Check and record copy counters.** Check and record copy counters in the XXX book. Enter the diagnostic Mode and check the number of sheets of copy paper fed from Trays and that of originals fed from Document Feeders.
7. **Enter Diagnostic Mode.** Perform the following
  - Make a note of any faults recorded.
  - Make a note of the High Frequency Service Items (H.F.S.I) requiring attention.
8. **Verify and classify the fault.** Use the information obtained in the previous steps to determine the cause of the fault. If the previous steps do not determine the fault, fully exercise the copier utilising all options until the fault is determined.
9. **Plan the call.** Using the information noted in previous steps, structure the call:
  - Check all H.F.S.I required are available. Any items unavailable shall be ordered at this point.

- When troubleshooting or repairing a fault in a particular subsystem, resolve any workaround and overthreshold faults and replace any noted H.F.S.I applicable to that subsystem.
- Perform any subsystem maintenance actions applicable to that system.

### FINAL ACTIONS

1. **Perform any remaining maintenance actions.** Check that all maintenance actions noted during the call have been completed.
2. Carry out TRIM procedure.
3. **Make a copy of the customer document. Clean the document glass and make a copy. Ensure that the customer is satisfied with the copy quality.**
4. **Reset any H.F.S.I counters where items have been replaced.**
5. **Clean the copier and clean the service area.**
  - Remove any toner spillage's.
  - Use "Formula A" cleaner to clean the covers.

**WARNING**  
Do not use solvents.

**CAUTION**  
Take care when cleaning the control panel to not use an excessive amount of the cleaner.

6. **Provide customer with training (if required)**
7. **Make a note of the copy credits** and record copy counters in the XXX book.
8. Complete the copier log book. Record all service actions performed in the copier log book and record any other relevant information.

**HIGH FREQUENCY SERVICE ITEMS**

Component	Indication	Replacement threshold	Parts list	Replacement Procedure
<b>Photoreceptor drum</b>	With the Drum Unit replacement due, the Control Panel display turns on at 50K copies indicating its replacement is required. After "Replace Drum Cartridge" is displayed, J7 is displayed at 5K copies and copying is <u>prohibited</u> from this point.	<b>50K</b>	<b>673S50211</b>	<b>REP 5.1.1</b>
<b>Toner Cartridge</b>	When the Toner Cartridge runs short of toner, "Supply Toner" is flashing. When approx. 100 copies have been made since the display began flashing, J1 is displayed and copying is <u>prohibited</u> from this point.	<b>6K</b> The above copy quantities apply to A4 originals with an area coverage of 6% .	<b>6R01020</b>	
Half-Moon Feed Roll		67K	<b>59K03261</b>	<b>REP 2.5.1</b>
MSI Feed Roller		60K	<b>6S50220</b>	<b>REP 2.3.2</b>
MSI Retard Pad		60K	<b>19S50212</b>	<b>REP 2.2.2</b>
Ozone Filter		50K	<b>53E91510</b>	<b>REP 8.5.2</b>

**TRIM**

- The XEROX 5915 TRIM procedure shall be performed at all maintenance calls., unless the procedure has been carried out within the last 10 days.

TRIM work items are listed in the TRIM table. The work is categorized into the following:

▼:Check at calls. ▽: Make sure to clean

< TRIM Check List

▼:Check at calls.  
 ▽: Make sure to clean  
 ○: Make sure to replace at given intervals.

	Work Item	Category	Main Points
1	Check the overall M/C operation before work.	▼	<ul style="list-style-type: none"> <li>Check on paper feeding, copy quality, abnormal noise, etc.</li> </ul>
2	Clean Platen Glass(top/bottom surfaces), Platen Cushion and Mirrors.	▽	<ul style="list-style-type: none"> <li>Clean Platen Glass top/bottom surfaces with silicon cloth and lens cleaning liquid.</li> <li>Clean Platen Cushion with wet cloth.</li> <li>Clean Mirrors 1-4 and Lamp Reflector with optics cleaning cloth.</li> </ul>
3	Clean Transfer/Detach/Pre-transfer Corotrons.	▽	<ul style="list-style-type: none"> <li>Clean Wire Shield and Guide with a clean brush, and wipe them with dry cloth if necessary.</li> </ul>
4	Clean Paper Transport Assy.	▽	<ul style="list-style-type: none"> <li>Clean Transport Belt and its surrounding area with a brush, and wipe them with a dry cloth if necessary.</li> </ul>
5	Charge Corotron, Seal Glass, and I.S.I.L.	▽	<ul style="list-style-type: none"> <li>Wipe Charge Corotron, Seal Glass, and I.S.I.L. with dry cloth.</li> </ul>
6	Check clean parts subject to wear.	▼○	<ul style="list-style-type: none"> <li>Check lives of the parts and replace/clean if necessary.</li> <li>Ozone Filter (50k)</li> <li>MSI Feed/Retard Roller/Pad (60k)</li> <li>Half-Moon Feed Roller (67k)</li> </ul>
7	Check on safety.	▼	<ul style="list-style-type: none"> <li>Carry out earth continuity check on mains cable.</li> <li>Check Power Plug for damage(cracks/exposed core)</li> </ul>
8	Check the overall M/C operation after work.	▼	<ul style="list-style-type: none"> <li>Enable all the operations and check paper feeding, copy quality, abnormal noise, etc.</li> <li>Check counters.</li> <li>Update the History Card and service report.</li> </ul>

- NOTE:**
- The Drum doesn't normally need cleaning.
  - When you can't help cleaning the Drum because of fingerprints, etc., clean its surface with the XEROX 5915 toner slightly and then wipe it with dry cloth. (Clean it while rotating it in the Drum rotating direction.)
  - Never use Drum Cleaner or Refiner.



## **Section 2 Troubleshooting**

## Section 2 Troubleshooting

### 2.1 Preface

- 2.1.1 How to Troubleshoot..... 2-2
- 2.1.2 Terminology.....2-2

### 2.2 Diagnostic(C/E) Mode

- 2.2.1 How to Enter Diagnostic (C/E) Mode..... 2-4
- 2.2.2 Entries of Chain Codes, Function Codes & Set Values.....2-4
- 2.2.3 How to Exit Diagnostic (C/E) Mode.....2-4
- 2.2.4 Diagnostic Functions and Operating Procedures .....2-4

### 2.3 Level 1 Troubleshooting

- 2.3.1 Level 1 FIP.....2-12
- 2.3.2 Chart of Jam Status Codes .....2-13
- 2.3.3 A List of Status Codes .....2-15

### 2.4 Level 2 Troubleshooting

- 2.4.1 General FIPs.....2-16
- 2.4.2 U Code F.I.P.'s .....2-19
- 2.4.3 Misfeed Jams .....2-25

## 2.1 Preface

### 2.1.1 How to Troubleshoot

#### Level 1 Troubleshooting

- Level 1 Troubleshooting (Level 1 F.I.P.) is the first step toward the diagnosis of a problem. Level 1 F.I.P. asks you whether or not any Status Code and other problems exist, guiding you to Level 2 Troubleshooting.

#### Level 2 Troubleshooting

- Level 2 Troubleshooting is a diagnostic procedure of isolating one problem by classified Status Codes, Misfeed Jams and various problematic symptoms. Performing a F.I.P. or an appropriate procedure in the check list enables you to discover causes of a problem in a short period of time.
- Status Code  
When a Status Code alerts you to a machine failure, perform appropriate troubleshooting items, referring to the list of Status Codes listing problem contents and corrective actions or troubleshooting items.

#### How to Troubleshoot and Notes

- First perform Level 1 F.I.P. to isolate one problem. Then go to an appropriate Level 2 Troubleshooting, BSD, or Disassembly/Assembly/Adjustment procedure to resolve the problem. When you try to find a cause of a problem using a F.I.P. or Check Chart, you should read its procedure carefully and perform it properly. When there are a number of possible causes, you may perform a F.I.P. of the same title again, because it is impossible to find all causes at once. In this case, pay attention to different judgments made in the process of the same F.I.P.
- When taking voltage measurements or performing operation tests of electric appliances, you should check their Interlock Switches.
- When replacing PWBs, you should check connectors on them for proper connections before replacements.

### 2.1.2 Terminology

Troubleshooting uses the following terms. You need to understand these terms in analyzing failures.

#### Common Terminology

Status Code	The message "Report XX." appears when the machine discovers a problem. This XX is called Status Code.
Actuate	Mechanically press or release the Switch Actuator or the linking Mechanical Linkage.
Block	Place a document or a sheet of paper against the Photo Sensor to make the Sensor detect one.
Check	Visually Check parts such as the Relay or Mechanical Linkage for its proper operation or check to see if parts are defective.
Enter Diagnostic Mode.	Enter Diagnostic Mode following the procedure indicated in Diagnostic(C/E) Mode.
Check for a short circuit.	Power off. Measure the resistances between the wire and the frame with the tester Ohm range.
Check for an open circuit	Power off. Measure the resistance on the both ends of the wire with the tester Ohm range.
Set [*.*] to ON	Enter Diagnostic Mode following the procedure indicated in Diagnostic(C/E) Mode. Then enter [Chain Code & Function Code]. Once you have entered Diagnostic Mode, you must not exit it until you are instructed by the message to "Exit Diagnostic Mode" or you don't need to check any more because an area where a failure has occurred is found.
Stop [*.*]	Press the <b>Stop</b> button to set the drive signal for the output component being tested to OFF.
Exit Diagnostic Mode	Exit Diagnostic Mode following the procedure described in Diagnostic Mode/Program.
Check Voltage Levels + 5VDC	<ul style="list-style-type: none"> <li>• + 5.2VDC <math>\pm</math> 0.25VDC</li> </ul> <p><b>NOTE:</b> The voltage values may exceed their ranges a little due to varying AC powers or loads.</p>
+ 24VDC	<ul style="list-style-type: none"> <li>• + 24VDC <math>\pm</math> 2.4VDC</li> </ul>
<u>Breakaway from Failure Analysis Procedure</u>	
Mechanical Problem	This is used when you should move to mechanical adjustments and parts replacements. Read all items (describing main causes) and find causes of a problem in comparison with symptoms the machine shows.
PL 4.2	Refer to Parts List PL 4.2, Section 5.
BSD 6	Refer to BSD 6, Section 9.
④4.1.3	Refer to 4.1.3, Section 4 Disassembly/Assembly/Adjustment.
Replace parts in order	When it is impossible to further analyze causes of a problem, replace parts in order. Replacement parts are described in order of highest possible replacement items.

Intentional blank page

**2.2 Diagnostic(C/E) Mode****2.2.1 How to Enter Diagnostic(C/E) Mode**

Power on while pressing "0" on the keyboard.

- All the LEDs on Console Panel turn on.  
When you press the key pad or the **Stop Clear** button, the three LEDs: "EI JAM", "E3 JAM" and "TONER EMPTY" starts flashing while the other LEDs turn off.

**2.2.2 Entries of Chain Codes, Function Codes and Set Values**

If you enter a wrong Chain Code or Function Code, press the **Stop Clear** button and re-enter a correct one.

- If you enter an unspecified Chain Code, Function Code or Set Value, "Er" appears.

**2.2.3 How to Exit Diagnostic(C/E) Mode**

Set the Power to OFF/ON.

**2.2.4 Diagnostic Functions & Operating Procedures****Input Check****Function:**

This displays the input voltage level from the Sensor or the Switch with "H" or "L"

**Procedure:**

1. Enter Diagnostic (C/E) Mode.
2. Enter the Chain Code for a part to be checked and press the **Start** button.
3. Enter the Function Code for a part to be checked and press the **Start** button.
4. Operate the part to be checked.
  - When the voltage level is high, "H" is displayed. When it is low, "L" is displayed.
5. When you press the **Stop Clear** button once during the check, the Function Code Entry awaiting status is initiated, while you press it twice, the Chain Code Entry awaiting status is initiated.

**A/D Input Check****Function:**

This displays the input voltage level from the Sensor with a digital value.

**Procedure:**

1. Enter Diagnostic (C/E) Mode.
2. Enter the Chain Code for a part to be checked and press the **Start** button.
3. Enter the Function Code for a part to be checked and press the **Start** button.
  - The voltage levels are displayed with the digital values of 0-FF.  
The varying voltage level will change the display.
4. When you press the **Stop Clear** button once during the check, the Function Code Entry awaiting status is initiated, while you press it twice, the Chain Code Entry awaiting status is initiated.

**Console Button Check (2-1)****Function:**

This checks any other button than the **Stop Clear** one on the Console Panel.

**Procedure:**

1. Enter Diagnostic (C/E) Mode.
2. Enter Chain Code "2" and press the **Start** button.
3. Enter Function Code "1" and press the **Start** button.
4. Set any other button than the **Stop Clear** one to ON/OFF, then + 2 is added to the displayed value.
5. When you press the **Stop Clear** button once during the check, the Function Code Entry awaiting status is initiated, while you press it twice, the Chain Code Entry awaiting status is initiated.

## 2.2 Diagnostic(C/E) Mode

### 2.2.4 Diagnostic Functions & Operating procedures

#### Input Check

CHAIN CODE	FUNCTION CODE	PART/SIGNAL	DIS-PLAY	REF. BSD
1	1	Front Interlock Switch	H/L	1
	2	RH Upper Interlock Switch	H/L	5
2	1	Console Button	+1	2
3	10	Option Set	H/L	2
	11	Option Start	H/L	2
	12	Option Stop	H/L	2
6	1	Lens Sensor	H/L	3
	2	Optical Regi Sensor	H/L	3
	8	Exposure Monitor Signal	A/D	3
	17	Fuser Thermistor	A/D	7
	18	Fuser Thermistor Open Circuit	A/D	7
7	1	Tray 1 Size Sensor	H/L	5
	6	Tray 1 No Paper Sensor	H/L	5
	10	MSI No Paper Sensor	H/L	5
8	8	Regi Gate Sensor	H/L	5
	9	Fuser Exit Switch	H/L	7
	10	MSI Size Sensor	H/L	5
9	9	Toner Empty Sensor	H/L	7

Output Check
--------------

**Function:**

This operates parts such as the Solenoid, the Clutch and the Motor. You can set parts within the same Chain to the ON positions simultaneously.

**Procedure:**

1. Enter Diagnostic(C/E) Mode.
  2. Enter the Chain Code for a part to be operated. Press the **Start** button.
  3. Enter the Function Code and press the **Start** button.
    - The designated part starts operating.
  4. When you operate parts simultaneously, enter the Function Codes for the parts you will operate successively. Press the **Start** button.
  5. When you stop operating a part simultaneously, press the **Stop Clear** button.
    - When parts are operating, stop them simultaneously.
    - The following parts stop automatically after respective specified periods of time:
      - All Solenoids/Clutches ..... 1 sec.
      - Lamp Carriage Motor ..... 1 sec.
      - Exposure Lamp ..... 30 sec.
- REF.:** When you press the **Start** button again after the above parts stop automatically, they start operating again.

**Output Check**

CHAIN	FUNCTION	PART/SIGNAL	ON TIME	REF. BSD
4	1	Main Motor(& Erase Lamp)		2,7
6	3	Lamp Carriage Motor(Scan)	1sec	3
	4	Lamp Carriage Motor(Return)	1sec	3
	7	Exposure Lamp(& Erase Lamp)	30sec	2,3,7
8	1	Main Motor (& Erase Lamp)		2,7
	2	Tray 1 Feed Solenoid		5
	6	Regi Gate Solenoid		5
	7	MSI Feed Clutch		5
9	1	Main Motor (& Erase Lamp)		2,7
	2	DEVE Bias		7
	3	ISIL		7
10	1	Optical Cooling Fan Motor		3
	4	Fuser fan Motor		7



**Parameter (NVM Value) Adjustment****Function:**

This performs the Parameter (NVM Value) Adjustment.

**Procedure:**

1. Enter Diagnostic(C/E) Mode.
2. Enter Chain Code "20" and press the **Start** button.
3. Enter the Function Code for the parameter to be adjusted. Press the **Start** button.
  - The current value is displayed flashing on the Quantity Display.
4. Enter a new set value with the key pad and press the **Start** button.
  - The flashing display comes to remain on. Then the old set value has been changed to the new one.
5. When you press the **Stop Clear** button once, the Function Code Entry awaiting status is initiated, while you press it twice, the Chain Code Entry awaiting status is initiated.

**NVM Initialization (20-96)****Function:**

This initializes all NVM contents.

**Procedure:**

1. Enter Diagnostic(C/E) Mode.
2. Enter Chain Code "20" and Function Code "96." Press the **Start** button.
  - The Quantity is displayed as follows: "55" →→ "Ed"
  - Initialize the following NVM items:
    - 1) Set initial values in all Functions in Chain 20.
    - 2) Reset all Counters in Chains 30/40.
    - 3) Set set-values in all Functions in Chain 50.
    - 4) Set initial values in all programs in Specification Setup.
3. To exit this mode, press the **Stop Clear** button twice.

**Chain Code 20 Table**

CHAIN CODE	FUNCTION CODE	SETUP ITEM	MIN. VALUE	INITIAL VALUE	MAX.VALUE	1 STEP CHANGE	ADJ
20	1	Registration Adjustment	16(-4.13mm)	32	64(+4.13mm)	0.2564mm	⊘ 2.7.6
	2	Light Quantity Adj. 100%	0	30	80	0.8%	5.1.4-⊘
		Enlargement/Reduction	0	50	99	0.8%	5.1.4-⊘
	3	Paper Loop Amount Adjustment	0(-8.27mm)	32	64(+8.27mm)	0.2584mm	
	4	ISIL Lead Edge Erase Amount Adjustment	0(-8.27mm)	32	64(+8.27mm)	0.2584mm	⊘ 5.1.6
	5	ISIL Trail Edge Erase Amount Adjustment	0(-8.27mm)	32	64(+8.27mm)	0.2584mm	⊘ 5.1.6
	6	Fine Tuning of 100% Horizontal Magnification	0(-2.272%)	32	64(+2.272%)	0.071%	⊘ 4.3.4
	7	Fine Tuning of 100% Vertical Magnification	0(-3.16%)	32	64(+3.16%)	0.099%	⊘ 4.3.4
	10	MSI Paper Loop Amount Adjustment	0(-8.27mm)	32	64(+8.27mm)	0.2584mm	-
	11	Registration Adjustment (MSI)	16(-4.13mm)	32	64(+4.13mm)	0.2564mm	
	14	Selection of Exposure Photoreceptor Sensitivity Correction	0(OFF)	1(ON)	1(ON)		-
	16	Bias Curve Selection 1	0	4	8		-
	17	Bias Curve Selection 2	0(slot)	1(Flat)	1(Flat)		-
	20	Exposure Lamp Adj.	0	50	99		5.1.4-⊘
	23	Drum Photoreceptor Sensitivity Correction Constant	0(0)	11(1.1)	40(4.0)	0.1	-
	30	Fuser Temperature Adjustment (Stand-by)	0(-23°C)	32	39(+5°C)	0.72°C	-
	31	Fuser Temp. Adjustment (Copy cycle)	0(-23°C)	32	39(+5°C)	0.72°C	-
	41	Density Correction Light 6	0(0V)	52(-413V)	64(-500V)	-7.8125V	-
	42	Density Correction Dark 6	0(0V)	16(-125V)	64(-500V)	-7.8125V	-
	45	Density Correction Photo Light 6	0(0V)	50(-388V)	64(-500V)	-7.8125V	-
46	Density Correction Photo Dark 6	0(0V)	24(-184V)	64(-500V)	-7.8125V	-	
96	NVM Initialization	This initializes all NVM values.					
50	9	Black band Function Time 1	0(-5.168mm)	20(+9.56mm)	64(+5.168mm)	0.2584mm	
	10	Black band Function Time 2	0(-6.732mm)	64(+10.3mm)	64(+6.732mm)	0.2584mm	

**Feed Counter Check/Clearance.**

**Function:**

This displays or clears Feed Counters for all trays .

**Procedure:**

1. Enter Diagnostic(C/E) Mode.
2. Enter Chain Code "30" and press the **Start** button.
3. Enter the Function Code for the Feed Counter to be checked. Press the **Start** button.
  - The counter value is displayed by the unit of k on the Quantity Display.
  - When not clearing the counter value, go to Step 5.
4. Enter "0" with the keyboard and press the **Start** button.
  - The counter value is cleared.
  - If you enter any other value than "0," "Er" appears.
5. Pressing the **Stop Clear** button once will initiate the Function Code Entry awaiting status, while pressing it twice will initiate the Chain Code Entry awaiting status.

**REF.:** Counter Value is countable within the range of 0~99k feeds, but uncountable when it exceeds 99k.

CHAIN CODE	FUNCTION CODE	COMPONENT COUNTER
30	1	Tray 1 Feed Counter
	4	MSI Feed Counter

**JAM Counter Check.**

**Function:**

This counts Original/Paper Jams and display their counts for every component where they occur.

**Procedure:**

1. Enter Diagnostic(C/E) Mode.
2. Enter Chain Code "40" and press the **Start** button.
3. Enter the Function Code for the counter to be checked. Press the **Start** button.
  - The counter value is displayed on the Quantity Display.
5. To exit this mode, press the **Stop Clear** button twice.

**NOTE:** Counter Value is countable within the range of 0~99 feeds, but uncountable when it exceeds 99K.

CHAIN CODE	FUNCTION CODE	COMPONENT COUNTER
40	1	E1 JAM Counter
	2	E3 JAM Counter
	5	C1 JAM Counter
	10	C9 JAM Counter
	21	E1 JAM Counter Reset
	22	E3 JAM Counter Reset
	25	C1 JAM Counter Reset
	30	C9 JAM Counter Reset

**Jam Counter Reset.**

**Function:**

This clears Original/Paper Jam Counters.

**Procedure:**

1. Enter Diagnostic(C/E) Mode.
2. Enter Chain Code "40" and press the **Start** button.
3. Enter the Function Code for the counter to be checked. Press the **Start** button.
4. To exit this mode, press the **Stop Clear** button twice.

### Individual Mode Setup

#### Function:

This sets up the execution/ inhibition of certain functions for individual users.

#### Procedure:

1. Enter Diagnostic(C/E) Mode.
2. Enter Chain Code "50" and press the **Start** button.
3. Enter the Function Code for the mode (function) to be set up. Press the **Start** button.
  - The present value appears on the Quantity Display.
  - When not changing the set value, go to Step 5.
4. Enter a new set value with the key pad and press the **Start** button.
  - The old set value is rewritten into the new one.
5. Pressing the **Stop Clear** button once will initiate the Function Code Entry awaiting status, while pressing it twice will initiate the Chain Code Entry awaiting status.

### U4-6 Failure Clearance

#### Function:

When U4-6(Fuser Over Heat Fail) occurs, clear U4-6 by executing [50-20] in Diagnostic (C/E) Mode.

#### Procedure:

1. Open the Front Interlock and enter Diagnostic(C/E) Mode.
  - NOTE:** During the occurrence of U4-6, you cannot enter Diagnostic (C/E) Mode without opening the Front Interlock.
2. Enter Chain Code "50" and press the **Start** button.
3. Enter Function Code "20" and press the **Start** button.
  - The Quantity Display displays "Ed" indicating the clearance is complete.
4. Close the Front Interlock.
5. Set the power to OFF/ON.

### U8-7 Failure Clearance

#### Function:

When U8-7(Exposure Lamp mistakenly turns on) occurs, clear U8-7 by executing [50-21] in Diagnostic(C/E) Mode.

#### Procedure:

1. Open the Front Interlock and enter Diagnostic(C/E) Mode.
2. Enter Chain Code "50" and press the **Start** button.
3. Enter Function Code "21" and press the **Start** button.
  - The Quantity Display displays "Ed" indicating the clearance is complete.
4. Close the Front Interlock.
5. Set the power to OFF/ON.

CHAIN CODE	FUNCTION CODE	SETUP ITEM	SET VALUE	CONTENT	EXPLANATION
50	1	Toner Touch Up Function	0	inhibit	Only when the new Drum unit is installed, this sets up Toner Touch Up Function at the start of copying to prevent Talc Deletion.
			*1	execute	
	2	Nation Configuration Setup	0	XE	This supplements a lack of exposure light quantity by the Deve. Bias when it doesn't reach its target value.
			1	KX	
			*2	AP	
	4	Black Band Creation Function	0	Execute	Create a black band of Toner on the Drum to prevent Talc Deletion.
			*1	Execute	
			2	execute	
			3	inhibit	
	6	Related Products' L6 Detection	*0	No	This temporarily inhibits the detection of L6 when changes are made to specification setups of the machine with related products.
			1	Yes	
	7	Fuser Warm Up Function	*0	Inhibit	At the start of an initial copy with the power on, this warms up the Fuser by rotating the Main Motor for 20 sec .
			1	execute	
	8	Copy density selection	0	13Phase	In case of KX
			*1	7Phase	In case of AP
	9	Black Band Function Time1	0~40	20	
10	Black Band Function Time2	0~40	20		
20	Fuser Over Heat Failure Clearance	0	Cancellation	U4-6(Fuser Over Heat Fail) will be cleared.	
		1	Cancellation		
21	Exposure Lamp Failure Clearance	0	Cancellation	U8-7(Exposure Lamp mistakenly turns on) will be cleared.	
		1	Cancellation		
86	Machine Administrator Reset	-	-	Set to "1111".	

**NOTE:** Set Value with \* indicates that the value is its initial one at the execution of [20-96] .

2.3 Level 1 Troubleshooting

2.3.1 Level 1 F.I.P

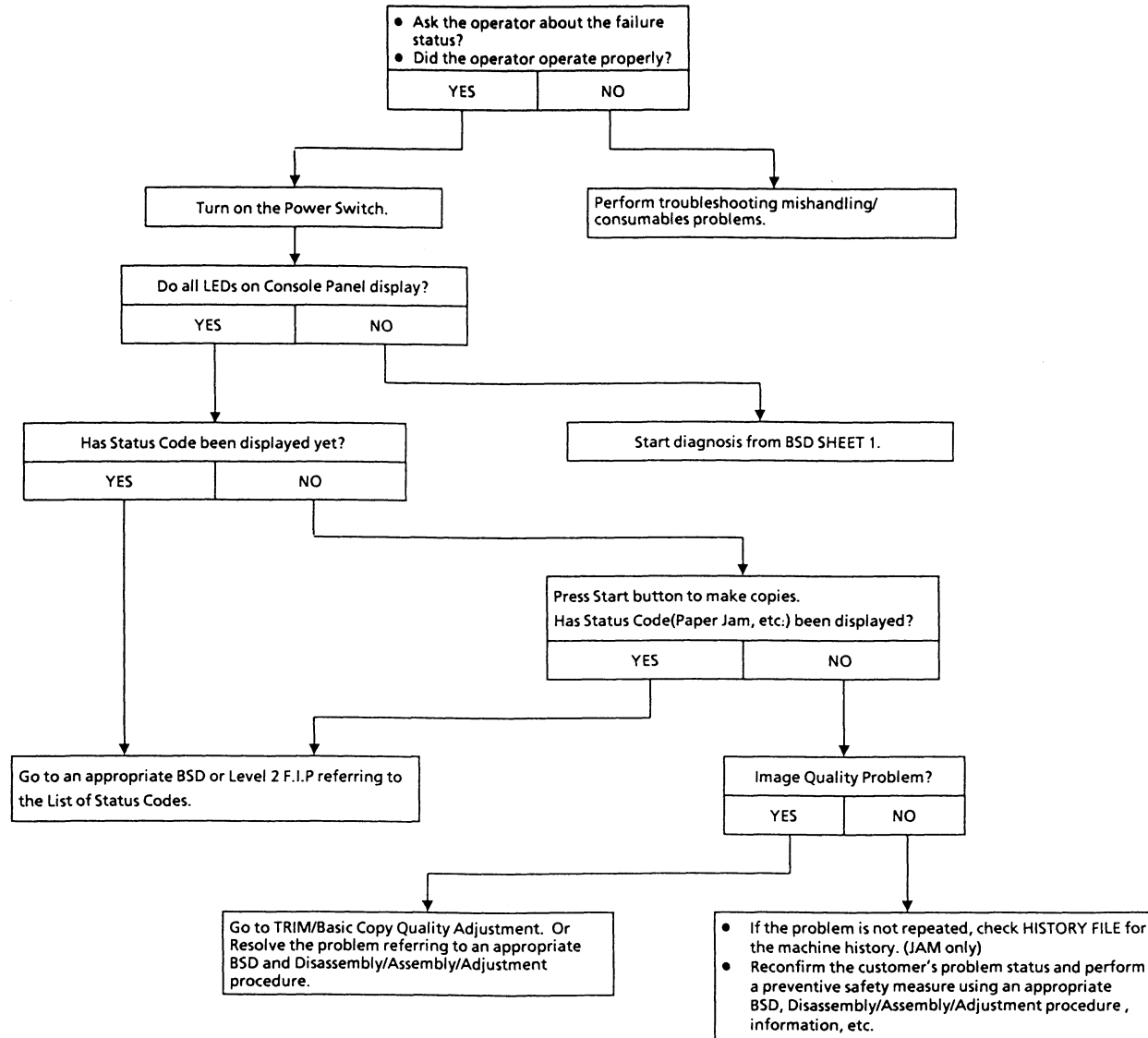

### 2.3.2 Chart of JAM Status Codes

Machine

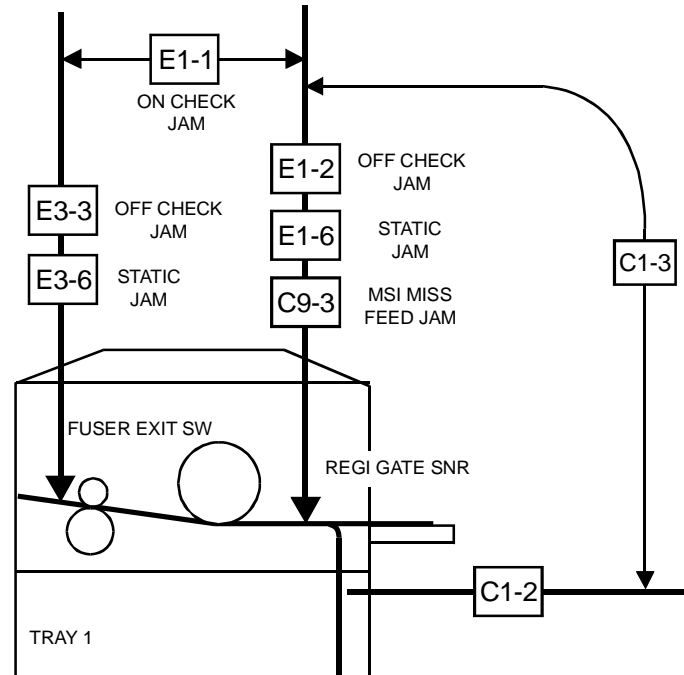

## 2.3.3 Status Code List

STATUS CODE	NAME	PROBLEM	CORRECTIVE ACTION	REF. BSD
U1-1	M/C CLOCK FAIL	M/C clock fails to input the signal to Main PWB even once for 0.47 sec., while copying	• Refer to the U-Code F.I.P.	2
U2-1	LAMP CARRIAGE FAIL-STAND-BY	Lamp carriage doesn't actuate Optical Registration Sensor for 6.5 sec., during stand-by.	• Refer to the U-Code F.I.P.	3
U2-2	LAMP CARRIAGE FAIL-POSITION	1: Optical Registration Sensor isn't turned on within 0.05 sec., after the initial operation of Lamp Carriage after copying is finished. 2: Optical Registration sensor isn't turned on within 0.05 sec., after the start of copying.	• Refer to the U-Code F.I.P.	3
U2-3	LAMP CARRIAGE FAIL-SCAN	Optical Registration sensor isn't turned on within 0.46 sec., after Lamp Carriage starts scanning.	• Refer to the U-Code F.I.P.	3
U2-4	LAMP CARRIAGE FAIL-RETURN	Optical Registration sensor isn't turned on within 2.5 sec., after Lamp Carriage starts scanning.	• Refer to the U-Code F.I.P.	3
U3-1	LENS POSITION FAIL	Lens Sensor isn't turned on within 3.1 sec., after the initial operation of Lens. (i.e. Lens starts moving)	• Refer to the U-Code F.I.P.	3
U4-1	FUSER THERMISTOR OPEN FAIL	Open or defective circuit of Fuser Thermistor	• Refer to the U-Code F.I.P.	5
U4-2	FUSER WARM UP FAIL	Fuser Ready is not initiated within 1 min. After the power is on or Front interlock Switch is turned OFF/ON.	• Refer to the U-Code F.I.P.	5
U4-3	FUSER OVER HEAT FAIL 1	Heater Rod has been on for 10 sec. or more after Fuser Ready	• Refer to the U-Code F.I.P.	5
U4-4	FUSER OVER HEAT FAIL 2	Heater Rod has been on for 20sec. or more after Cycle Down	• Refer to the U-Code F.I.P.	5
U4-6	FUSER OVER HEAT SAFETY FAIL	Fuser Thermistor has detected 240°C or a higher temperature for straight 0.5sec. or more	• Enter Diagnostic(C/E) Mode and execute [5-20]	5
U6-4	NVM FAIL	NVM READ/WRITE VERIFY ERROR	• Refer to the U-Code F.I.P.	2
U8-1	EXPOSURE CONTROL FAIL	Control Mode is not initiated within 0.5 sec., after Exposure Lamp turns on.	• Refer to the U-Code F.I.P.	3
U8-2	NO ZERO CROSS FAIL	During Fuse Control, no Zero Cross is input for straight 3 sec.	• Refer to the U-Code F.I.P.	5
U8-4	EXPOSURE VOLTAGE OVER FAIL	Exposure Sensor signal voltage level is over 2.9V when Exposure Lamp is on.	• Refer to the U-Code F.I.P.	3
U8-5	EXPOSURE VOLTAGE UNDER FAIL	Exposure Sensor signal voltage level is under 0.5V at Standard Reflection Plate.	• Refer to the U-Code F.I.P.	3

STATUS CODE	NAME	PROBLEM	CORRECTIVE ACTION	REF. BSD
C1-2	TRAY 1 MIS FEED JAM	Regi-gate Sensor isn't turned on within 2.7sec. after paper starts to be fed.	• Refer to the MISFEED JAM.	4
C9-3	MSI MISFEED JAM	Regi-gate Sensor isn't turned on within 2.3 sec. after paper starts to be fed.	• Refer to the MISFEED JAM	4
E1-1	FUSER EXIT SWITCH ON CHECK JAM	Fuser Exit Switch isn't turned on within 3.7 sec. After Regi-Gate is open.	• Refer to BSD Sheet 5	5
E1-2	REGI-GATE SENSOR OFF CHECK JAM	Regi-Gate Sensor isn't turned off (remains ON) a preset period of time (which varies with paper sizes) after Regi-Gate is open.	• Refer to BSD Sheet 5	5
E1-6	REGI-GATE SENSOR STATIC JAM	Regi-Sensor is on during Power On or Stand-by. (Paper remains)	• Remove the paper • Check the Regi-Gate sensor circuit.	4
E3-3	FUSER EXIT SWITCH OFF CHECK JAM	Fuser Exit isn't turned off (remains ON) a preset period of time (which varies with paper sizes) after Fuser Exit Switch is turned on.	• Refer to BSD Sheet 5	5
E3-6	FUSER EXIT SWITCH STATIC JAM	Fuser Exit Switch is on during Power On or Stand-by. (Paper remains)	• Remove the paper • Check the Fuser Exit Switch circuit.	5
E5-1	FRONT INTLK OPEN FAIL	Front Cover is open, or Front Interlock Switch is defective.	• Close Front Cover. • Check the Front Interlock Switch circuit.	4
E6-1	R/H UPPER INTLK OPEN FAIL	R/H Upper Cover is open, or R/H Upper Interlock Switch is defective.	• Check R/H Upper Cover. • Check the R/H Upper Interlock switch circuit.	4
J1-1	TONER EMPTY FAIL	Number of copies reaches 100 after toner empty sensor sensed toner end condition.	• Supply toner. • Check the Toner Empty Sensor circuit.	5
J1-2	TONER LIFE END	The counter value of toner unit reaches the default value 7700.	• Replace the Toner Cartridge.	5
J3-1	DRUM UNIT SET FAIL	Drum unit is not set, or is set incorrectly to the machine.	• Ensure to install the Drum Unit to the machine properly.	5
J3-2	Toner Cartridge SET FAIL	Toner unit is not set, or is set incorrectly to the machine.	• Ensure to install the Toner Unit to the machine properly.	5
J3-3	Counter SET FAIL	Total counter is corrected improperly.	• Ensure to install the Total Copy Count Unit to the machine	5
J6-1	DRUM UNIT ID FAIL	Drum unit Read/Write is in error.	• Replace the Drum Unit.	5
J6-2	Toner Cartridge ID FAIL	Toner unit Read/Write is in error.	• Replace the Toner Unit.	5
J6-3	Counter ID FAIL	Total Counter Read/Write is in error.	• Replace the Total Copy Count Unit.	5
J7-1	DRUM UNIT LIFE END	Copy Value has become 50K (sheets of paper)	• Replace the Drum Unit.	5
J8-1	DRUM UNIT TYPE NO. FAIL	Type No. stored in ID of Drum Unit is not the same as that stored in NVM of the Main PWB.	• Replace with correct type Drum Unit	5
J8-2	Toner Cartridge TYPE NO. FAIL	Type No. stored in ID of Toner Unit does not match with that saved in NVM on main PWB.	• Replace with correct type Toner Unit	5
J8-3	Counter TYPE NO. FAIL	Type No. stored in ID of Total Counter does not match with that saved in NVM on main PWB.	• Replace with correct type Total Copy Count Unit	5
J9-1	<b>DRUM UNIT ID No. FAIL</b>	Identification No. of Drum Unit is not of Xerox origin.	• Replace with Xerox Drum Unit	5
J9-2	<b>TONER UNIT ID No. FAIL</b>	Identification No. of Toner Unit is not of Xerox origin.	• Replace with Xerox Toner Unit	5
J9-3	<b>TOTAL COUNTER ID No. FAIL</b>	Identification No. of Total Copy Count is not of Xerox origin.	• Replace with Xerox Total Copy Count Unit	5



2.4 Level 2 Troubleshooting

2.4.1 General F.I.P (General F.I.P for Defective Parts)

• Reflective Sensor F.I.P [SENSED(L)]  
ORIGINAL SIZE Sensors 1-4

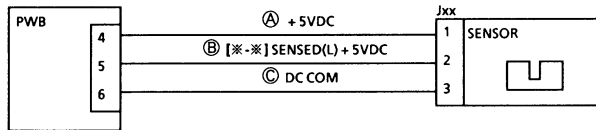

**Preparation:** • Remove any remaining paper (if there is any).

**Procedure**

Enter Diag. [ \* - \* ].

Make the Sensor turn ON/OFF with a blank sheet of paper.

Does the display repeat (L) and (H) alternately?

- Y N Does the display remain (H)?
  - Y N It remains (L).
    - Check with the tester the harness from Pin 2 of the Sensor to Pin 5 of PWB for a short circuit. If it is good, replace the Sensor.
  - Can the tester lead wire be inserted in Jxx of the Sensor?
    - Y N
      - Check Pins 4/5/6 for improper connections or Harnesses a b c for open circuits. If they are good, replace the Sensor.
      - \* You can also check by exchanging the Sensor with another Sensor of the same type if one is available.
- Place the tester wire between Pin 2(+) of the Sensor and COM(-) .
  - Make the Sensor turn ON/OFF with blank paper.
  - Does the voltage repeat (L) and (H) alternately?
    - Y N
      - Is the voltage from Pin 1(+) to Pin 3 of the Sensor +5VDC?
        - Y N
          - Check Pins 4/6 for improper connections or Harnesses a c for open circuits.
          - Replace the Sensor.
- Check to see if the document detecting position on Platen Glass is contaminated. If not, replace the PWB.
- Check outer light/check the sensor for its installation and (signal) chattering. If no problem exists, replace the PWB.

• Permeable Sensor F.I.P [SENSOR(H)]  
OTHER SENSORS with 3  
Wiring

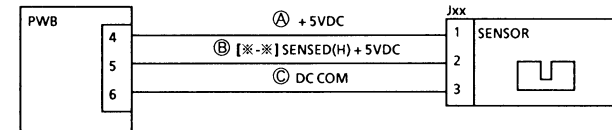

**Preparation:** • Remove any remaining paper (if there is any).

**Procedure**

Enter Diag. [ \* - \* ].

Make Actuator turn ON/OFF manually or with paper. (If necessary, use Output Check.)

- Y N Does the display remain (H)?
  - Y N It remains (L).
    - Check with the tester the harness a from Pin 2 of the Sensor to Pin 5 of PWB for a short circuit. If it is good, replace the Sensor.
  - Can the tester lead wire be inserted in Jxx of the Sensor?
    - Y N
      - Check Pins 4/5/6 for improper connections or Harnesses a b c for open circuits. If they are good, replace the Sensor.
      - \* You can also check by exchanging the Sensor with another Sensor of the same type if one is available.
- Place the tester wire between Pin 2(+) of the Sensor and COM(-) .
  - Make Actuator turn ON/OFF manually or with paper.
  - Does the voltage repeat (L) and (H) alternately?
    - Y N
      - Is the voltage from Pin 1(+) to Pin 3 of the Sensor +5VDC?
        - Y N
          - Check Pins 4/6 for improper connections or Harnesses a c for open circuits.
          - Replace the Sensor.
          - Replace the PWB.
  - Check the Sensor for its installation and (signal) chattering. If no problem exists, replace the PWB.

• Switch F.I.P

**PLATEN INTLK SWITCH  
R/H UPPER INTLK SWITCH**

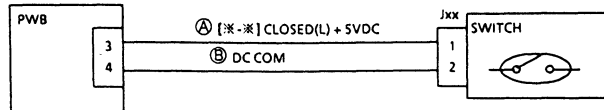

Does the display remain (H)?  
**Y** **N** It remains (L).  
 Turn the power off.  
 Disconnect Connector Jxx of the Switch.  
 Enter Diag. [\* - \*].  
 Does the display remain (L)?  
**Y** **N** The display has been changed to(H)  
 Replace the Switch.  
 Check shorted areas(i.e. a wire caught in the frame) of  
 Harness a and repair them.  
 Can the tester lead wire be inserted in Jxx of the Switch?  
**Y** **N**  
 Check Harnesses A, B for open circuits. If they are  
 good, replace the Switch.  
 \* You can also check by exchanging the Switch with  
 another Switch of the same type if one is available.  
 Is the voltage from Pin 1(+) to COM +5VDC with the Switch  
 off?  
**Y** **N**(0V)  
 Check Pin 1 of the Switch or Pin 3 of PWB for an  
 improper connection or Harness a for an open circuit.  
 Check Pin 2 of the Switch for an improper connection or  
 Harness b for an open wire. If no problem exists, replace the  
 Switch.  
 Check the Panel, etc. for end play or recheck Switch Leads 1/2. If no  
 problem exists, replace PWB.

• Solenoid/Clutch/Motor F.I.P

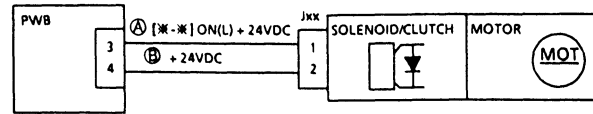

1. Solenoid or Clutch doesn't energize. Motor doesn't rotate.

**Procedure**

Enter Diag. [\* - \*]. (**NOTE:** All you have to do here is enter Diag.  
 Don't start.)

Is the voltage from Pin 3(+) of PWB to COM(-) +24VDC?

**Y** **N**  
 Is the voltage from Pin 1(+) of Solenoid/Clutch/Motor to GND  
 (-) +24VDC?  
**Y** **N**  
 Is the voltage from Pin 2(+) of Solenoid/Clutch/Motor to  
 GND(-) +24VDC?  
**Y** **N**  
 Go to 1. STANDBY POWER, BSD to check DC  
 power(+24VDC).  
 Replace the Solenoid/Clutch/Motor.  
 Check the circuit from Pin 3 of PWB to Pin 1 Solenoid/Clutch/  
 Motor for an improper connection/open circuit.

Start (or Actuate).

Has Power level dropped to (L)?

**Y** **N** It remains (H).  
 Replace the PWB.  
 Repair the binding Plunger or clear the inside of the Solenoid of  
 contamination. Don't clean the Clutch.  
 If necessary, replace the Solenoid/Clutch/Motor.

2. Solenoid/Clutch keeps energized. Motor keeps rotating.

**Procedure**

Power off.

Is the resistance value from Connector Pin 3 of PWB to the frame  
 0~some hundred Ω?

**Y** **N** (~)  
 Replace the PWB.

Repair shorted areas of the circuit from Connector Pin 3 to Pin 1 of  
 Solenoid/Clutch/Motor. If no problem(such as a wire caught in the  
 frame) exists, replace the Solenoid/Clutch/Motor.

• Switch F.I.P

R/H UPPER INTLK SWITCH

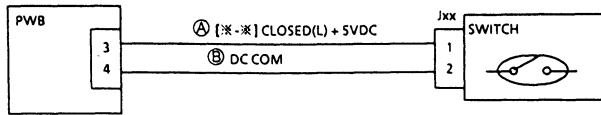

**Procedure**

Enter Diag. [\* - \*].  
Make the Switch turn ON/OFF(Cover open/close). If necessary, use Output Check.  
Does the display repeat (L) and (H) alternately?

Y N  
Does the display remain (H)?  
Y N It remains (L).  
Power off.  
Disconnect Connector Jxx of the Switch.  
Enter Diag. [\* - \*].  
Does the display remain (L)?  
Y N The display has been changed to (H)  
Replace the Switch.  
Check shorted areas(i.e. a wire caught in the frame) of Harness a and repair them.  
Can the tester lead wire be inserted in Jxx of the Switch?  
Y N  
Check Harnesses A B for open circuits. If they are good, replace the Switch.  
\* You can also check by exchanging the Switch with another Switch of the same type if one is available.  
Is the voltage from Pin 1(+) to COM +5VDC with the Switch off?  
Y N(0V)  
Check Pin 1 of the Switch or Pin 3 of PWB for an improper connection or Harness a for an open circuit.  
Check Pin 2 of the Switch for an improper connection or Harness b for an open wire. If no problem exists, replace the Switch.

Check the Panel, etc. for end play or recheck Switch Leads 1/2. If no problem exists, replace PWB.

• Solenoid/Clutch/Motor F.I.P

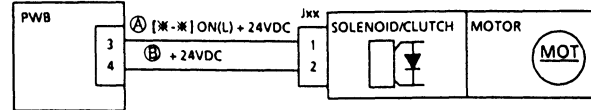

1. Solenoid or Clutch doesn't energize. Motor doesn't rotate.

**Procedure**

Enter Diag. [\* - \*]. (NOTE: All you have to do here is enter Diag. Don't start.)  
Is the voltage from Pin 3(+) of PWB to COM(-) +24VDC?

Y N  
Is the voltage from Pin 1(+) of Solenoid/Clutch/Motor to GND(-) +24VDC?  
Y N  
Is the voltage from Pin 2(+) of Solenoid/Clutch/Motor to GND(-) +24VDC?  
Y N  
Go to 1. STANDBY POWER, BSD to check DC power(+24VDC).  
Replace the Solenoid/Clutch/Motor.  
Check the circuit from Pin 3 of PWB to Pin 1 Solenoid/Clutch/Motor for an improper connection/open circuit.

Start (or Actuate).

Has Power level dropped to (L)?

Y N It remains (H).  
Replace the PWB.

Repair the binding Plunger or clear the inside of the Solenoid of contamination. Don't clean the Clutch.

If necessary, replace the Solenoid/Clutch/Motor.

2. Solenoid/Clutch keeps energized. Motor keeps rotating.

**Procedure**

Power off.  
Is the resistance value from Connector Pin 3 of PWB to the frame 0~some hundred Ω?

Y N (~)  
Replace the PWB.

Repair shorted areas of the circuit from Connector Pin 3 to Pin 1 of Solenoid/Clutch/Motor. If no problem(such as a wire caught in the frame) exists, replace the Solenoid/Clutch/Motor.

## 2.4 Level 2 Troubleshooting

### 2.4.2 U-Code F.I.P's

#### U1-1 M/C CLOCK FAIL

Ref. BSD: 2

**Preparation:** Ensure that the following connector is securely connected.

- P/J404 of Main PWB

#### Procedure

Open the Front Cover and cheat the Front Interlock. Enter Diag. (C/E) Mode. Enter Code[4-1] and rotate the Main Motor.

Does the Main Motor keep stopping?

Y N  
Does the Main Motor stop after rotating for 1-2 seconds?

Y N  
Open the ClamShell and restart the Main Motor. Do abnormal noises occur or does the Main Motor rotate irregularly?

Y N  
**WARNING:** Power off the machine and disconnect the **power cord**.  
Check the mechanics (Gear, Bearing, etc.) of the following and replace parts if necessary.  
Fuser Assy(PL8.4)  
Regi. Roller Gear(PL2.7)

Slide out the Drum Unit and restart the Main Motor. Do abnormal noises occur or does the Main Motor rotate irregularly?

Y N  
Check the Drum Unit for its drive mechanics. If any load or abnormal noise exists, replace the Drum Unit.

**WARNING:** Power off the machine and disconnect the **power cord**

Check the mechanics(Gear, Bearing, etc.) of the following and replace parts if necessary.  
Deve Assy(PL6.2)  
Main Drives(PL1.1/1.2/1.3)

A B

A B  
Is the voltage from J404-5 of Main PWB to COM +5VDC?  
Y N  
Replace the Main Motor(PL1.1/1.2)/Main PWB(PL9.1) in order.  
Replace the Main PWB.  
Is the voltage from J404-1 of Main PWB to COM +24VDC?  
Y N  
Check +24VDC circuit in the DC Wiring Diagram.  
Is the voltage from J404-3 of Main PWB to COM +5VDC?  
Y N  
Check +5VDC circuit in the DC Wiring Diagram.  
Is the voltage from J404-6 of Main PWB to COM +5VDC?  
Y N  
Replace the Main PWB.  
Replace the Main Motor.

- U2-1 LAMP CARRIAGE FAIL-STAND-BY**
- U2-2 LAMP CARRIAGE FAIL-POSITION**
- U2-3 LAMP CARRIAGE FAIL-SCAN**
- U2-4 LAMP CARRIAGE FAIL-RETURN**

REF. BSD: 3

**Preparation:** Ensure that the following connectors are securely connected.

- P/J404 of Main PWB.
- P/J405 of Lamp Carriage Motor.
- Gently move the Lamp Carriage fro and back by hand, Check it for the mechanical jam.
- Ensure that the following Connectors are securely connected.
- Check the Scan Cable for disengagement, binding, load, etc.

**Procedure**

Power on, enter Diag. Mode and enter (6-3). Press the start button. Does the Lamp Carriage scan?

```

Y      N
|      |
|      | Are voltages from P/J 405-7,P/J 405-8 to COM +24VDC?
|      | Y      N
|      | |      |
|      | |      | Check +24VDC INTLK circuit.
|      | |      | Power off and disconnect P/J 605.
|      | |      | Are J605-1 to -3,J605-1 to-4, J605-2 to -5,J605-2 to -6
|      | |      | resistance values approx. 6.3Ω each?
|      | Y      N
|      | |      |
|      | |      | Replace the Lamp Carriage Motor.
|      | |      | Replace the Main PWB.
    
```

Enter [6-4] and press the **start** button.

Does the Lamp Carriage return?

```

Y      N
|      |
|      | Replace the Main PWB.
    
```

Using the Permeable Sensor F.I.P., General F.I.P. and the wiring diagram, perform the diagnosis of Optical Regi Sensor. If no problem exists, replace the Main PWB.

**U3-1 LENS POSITION FAIL**

Ref. BSD: 3

**Preparation:** Ensure that the following connectors are securely connected.

- P/J405 of Main PWB
- Relay Connector P/J604 of Lens Motor
- Remedy the mechanical jam
- Check the Lens Cable for disengagement, binding, load, etc.

**Procedure**

Power on.

Does the Lens Assy move?(Does it perform its initial operation?)

```

Y      N
|      |
|      | Are voltages from P/J 405-1,P/J 405-2 to COM +24VDC?
|      | Y      N
|      | |      |
|      | |      | Check +24VDC circuit
|      | |      | Power off and disconnect P/J604.Are J604-1 to - 3,J604-1 to
|      | |      | -5,J604-2 to -4,J604-2 to -6 resistance values approx. 100Ω
|      | |      | each?
|      | Y      N
|      | |      |
|      | |      | Check P405-3,4,5,6 of Main PWB and P604-3,4,5,6 of
|      | |      | Lens Motor for an open circuit or a short circuit to
|      | |      | ground.
|      | |      |
|      | |      | If the harness is good, replace the lens Motor.
|      | |      | Replace the main PWB.
    
```

Using the Permeable Sensor F.I.P., General F.I.P. and the wiring diagram, perform the diagnosis of Lens Sensor. If no problem exists, replace the Main PWB.

## U4-1 FUSER THERMISTOR OPEN FAIL

Ref. BSD: 7

**Preparation:** Ensure that the following connectors are securely connected.

- P/J410 of Main PWB
- P/J118 of Fuser Thermistor

### Procedure

**WARNING:** Power off the machine and disconnect the power cord.

WARNING: Fuser surfaces are hot, allow the fuser to cool down before attempting service procedure. Fuser lubricant can cause discomfort to eyes. Do not allow fuser lubricant to touch eyes

Disconnect P/J118.

Measure the resistance from J118-1 to J118-2.

- Fuser is hot: approx. 13k $\Omega$
- Fuser is cool: approx. 236k $\Omega$

Does the resistance value satisfy the above spec. ?

Y N( $\infty$ )

Check the wire from P/J118-1 to P/J410-3, and the wire from P/J118-2 to P/J410-4. If no problem exists, replace the Fuser Thermistor.

Replace the Main PWB.

## U4-2 FUSER WARM UP FAIL

Ref. BSD: 7

**Preparation:** Ensure that the following connectors are securely connected.

- P/J410 of Main PWB
- P/J430/T111/T110 of AC Drive PWB
- P/J 12/13 of Main Heater Rod
- Relay Connector P/J14

**NOTE:** This is sometimes displayed when C/E visits the customer and switches the m/c on after the power has been off after the occurrences of U4-3, U4-4 & U4-6. Therefore, the diagnosis of Thermostat is first performed.

### Procedure

**WARNING:** Power off the machine and disconnect the power cord.

WARNING: Fuser surfaces are hot, allow the fuser to cool down before attempting service procedure. Fuser lubricant can cause discomfort to eyes. Do not allow fuser lubricant to touch eyes

Remove the Fuser Cover.

Is there continuity between the Fuser Thermostat leads?

Y N( $\infty$ )

Press the **Manual Reset** button of the Fuser Thermostat.

Is there continuity between the Fuser Thermostat leads?

Y N

Replace the Fuser Thermostat. Proceed with the diagnosis using U4-3/U4-4/U4-6 Over Heat FIPs.

Proceed with the diagnosis using U4-3/U4-4/U4-6 Over Heat FIPs.

Disconnect J12/J13 of Heater Rod?

Is there continuity between J12 and J13?

Y N

Replace the Heater Rod.

Remove the Fuser Cover.

Cheat the Front Interlock Switch.

Power on.

Does the Main Heater Rod turn on?

Y N

Is the voltage form T110 to T111 of AC Drive PWB 220VAC?

Y N

A B C

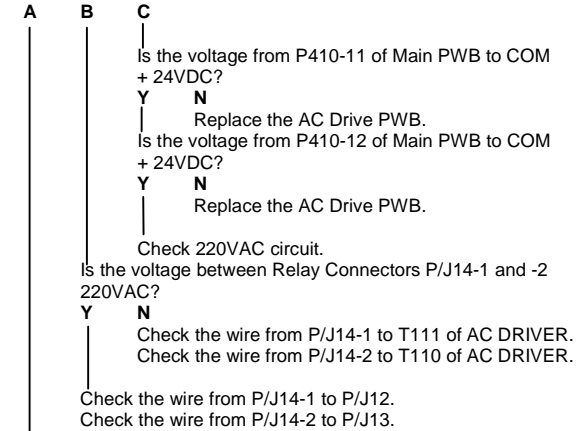

Power off.

Check for the scraped Heat Roll surface, the raised-off Fuser Thermistor, the deteriorated Heater Rod. If no problem exists, replace the Fuser Thermistor.

**U4-3** FUSER OVER HEAT FAIL 1**U4-4** FUSER OVER HEAT FAIL 2**U4-6** FUSER OVER HEAT SAFETY FAIL

Ref. BSD: 7

**NOTE:** At the occurrence of U4-6, open the Front Cover, enter Diagnostic(C/E) Mode and clear U4-6 by executing [50-20].

**Procedure**

Power on. Check the starting signal of Fuser. Does the level between P/J410-12 to COM remain low(L)?

Y

N

**WARNING:** Power off the machine and disconnect the power cord.

WARNING: Fuser surfaces are hot, allow the fuser to cool down before attempting service procedure. Fuser lubricant can cause discomfort to eyes. Do not allow fuser lubricant to touch eyes

Disconnect P/J14.

Check the circuit continuity from T111 to T110. (AC DRIVER)

Y

N

Check the following harnesses for short circuits.

- from P/J12 to COM.
- from P/J13 to COM.

Replace the AC Drive PWB.

Replace the Main PWB.

## U6-4 NVM FAIL

Ref. BSD: 2

- Preparation:**
- Install the ground wire.
  - Ensure that the power voltage hasn't dropped 10% or more (with Power ON or Power OFF).
  - Ensure that there is neither operating power sources nor devices generating high frequencies around the installation site.
  - Ensure that no high voltage wires such as the Corotron have burnt out or have leakage.

### Procedure

Power OFF/ON.

Has the display of Status Code disappeared?

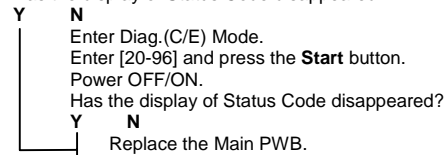

Make copies. Confirm that the machine operates properly and monitor the machine operation for several days.  
If the problem reoccurs, replace the Main PWB.



**U8-1 EXPOSURE CONTROL FAIL**

Ref. BSD: 3

**Problem Area:** Initial Light Quantity Control(Optics)**Cause/Corrective Action**

- Defective Main PWB
- Defective AC Drive PWB
- Open harnesses or improper P/J connections of the circuits controlling the above PWB's.

**U8-2 NO ZERO CROSS FAIL**

Ref. BSD: 7

**Preparation:** Ensure that P/J410 of Main PWB is securely connected to P/J430 of AC Drive PWB.**WARNING:** Hazardous voltage. Use extreme care.**Procedure**

Power on. Detect the zero cross signal.

Is the level from P/J410-9 to COM +0.5VDC?

Y      N

| Is the voltage from P/J437-1 to P/J437-2 220VAC?

Y      N

| Check 220VAC input circuit.

| Is the Front INTLK switch close?

| Is the voltage from J431 to COM +24VDC?

Y      N

| Check the trouble chain E5.

| Check the start signal of the INTLK Power Relay.

| Is the level from P/J410-11 to com 0v?

Y      N

| Replace the Main PWB.

| Check the wire from P/J430-4 of AC DRIVER to P/J410-11 of Main PWB for an open circuit, short circuit or improper connection. If no problem exists, replace the Main PWB

Replace the Main PWB.

**U8-4 EXPOSURE VOLTAGE OVER FAIL**

Ref. BSD: 3

**Problem Area:** Light Quantity/Voltage Control(Optics)**Procedure**

check the wire from P/J430-1 of AC DRIVER to P/J410-10 of Main PWB.

Power on. Detect the Exposure Sensor Signal level.

Is the level from P/J410-10 to COM over 2.9VDC?

Y      N

| Replace Main PWB.

Replace AC DRIVER.

**U8-5 EXPOSURE LIGHT QTY/VOLTAGE UNDER FAIL**

Ref. BSD: 3

**Problem Area:** Light Quantity/Voltage Control(Optics)**Preparation:** Ensure that P/J410-10 of Main PWB is securely connected to P/J430-1 of AC Drive PWB.**Procedure**

Enter Diag. Mode. Enter [6-7],[6-8].

Check the A/D value, A5-A7.

Is the voltage from P/J430-1 to COM  $\leq$  0.5V?

Y      N

| Replace the Main PWB.

Replace the AC DRIVER.

### 2.4.3 MISFEED JAM

#### C1-3 TRAY 1 MISFEED JAM

##### Preparation:

- Ensure that no paper jam occurred.
- Ensure that the Feed Roller has not worn out and the friction is proper.

##### Procedure

Clear paper jam, start copying.

Does the Feed Roller rotate?

Y | N  
 | | Enter Diag. (C/E) Mode. Enter [8-2], and check the operation of Feed Solenoid.  
 | | Y | N  
 | | | | Check the start signal of Feed Solenoid. Does the voltage from P/J406-10 to com go high correctly?  
 | | | | Y | N  
 | | | | | | Replace the Main PWB  
 | | | | | | Remedy the mechanical jam, then check the operation of Solenoid. If it cannot turn on, replace it.  
 | | | | | | Check the tension of the pick up gear spring. If the tension is weak, replace the spring.

Clean the Feed Roller and the Pinch Roller. Check them for the deterioration.

Y | N  
 | | Did the lead edge of paper reach the Regi-Gate.  
 | | Y | N  
 | | | | Replace the Feed Roller, Clean the paper path.  
 | | | | Check the Regi-Gate sensor. Enter [8-8], check the level from P/J407-8 to com, does it go high(H) and go low(L)? If no change is the voltage from P/J600-1 to P/J600-3 +5VDC?  
 | | | | Y | N  
 | | | | | | Check the +5VDC circuit.  
 | | | | | | Replace the Regi-Gate Sensor.

- Replace the Feed Roller.
- Clean the paper path.

#### C9-3 MSI MISFEED JAM

##### Procedure:

Start the copying in by in by pass Mode.

Does the MSI feed Roller operate?

Y | N  
 | | Does the MSI Solenoid operate?  
 | | Y | N  
 | | | | Enter Diag. Mode, Enter [8-7], does MIS Solenoid turn on?  
 | | | | Y | N  
 | | | | | | Replace the Main PWB.  
 | | | | | | Check the wire from P406-2 to P/J210-2.  
 | | | | | | Remedy mechanical trouble. Check the operation of Solenoid again. If it does not turn on , replace it.  
 | | | | | | Replace the pick up Gear Spring.

- Clean MSI Feed Roller and paper path.
- If necessary, replace MSI Feed Roller, or adjust / replace the Retard Pad.

## **Section 4 Disassembly/Assembly/Adjustment**

## Section 4 Disassembly/ Assembly/ Adjustment

### 1. Main Drive

- 1.1.1 Main Motor Replacement ..... 4-3

### 2. Paper Handling

- 2.1.1 Side Registration Adjustment ..... 4-3
- 2.2.1 MSI Feeder Assy Removal/Installation ..... 4-4
- 2.2.2 MSI Retard Pad Replacement ..... 4-4
- 2.3.2 MSI Feed Roller Replacement ..... 4-5
- 2.3.3 MSI Size Sensor Replacement ..... 4-5
- 2.3.4 MSI No Paper Sensor Replacement ..... 4-5
- 2.5.1 Feed Roller Replacement ..... 4-6
- 2.5.3 No Paper Sensor Replacement ..... 4-6
- 2.5.4 Right Cover Intlk switch Replacement ..... 4-8
- 2.5.5 Tray1 Intlk Switch Replacement ..... 4-9
- 2.5.6 Tray1 Intlk Switch Adjustment ..... 4-9
- 2.7.1 Registration Assy Removal/Installation ..... 4-10
- 2.7.2 Registration Gate Solenoid Replacement ..... 4-10
- 2.7.3 Regi-Gate Sensor Replacement ..... 4-10
- 2.7.4 Registration Roller Replacement ..... 4-10
- 2.7.6 Lead Edge Registration Adjustment ..... 4-11

### 3. Paper Transport

- 3.1.1 Vacuum Transport Belt Replacement ..... 4-12

### 4. Optics

- 4.1.1 Plate Glass Replacement ..... 4-13
- 4.1.2 Optical Cooling Fan Replacement ..... 4-13
- 4.2.1 Optical Regi-Sensor Replacement ..... 4-14
- 4.2.2 Lamp Carriage Motor Replacement ..... 4-14
- 4.2.3 Carriage Cable Replacement ..... 4-15
- 4.3.1 Full-Rate & Half-Rate Carriages Parallel Adjustment ..... 4-16
- 4.3.2 Exposure Lamp Replacement ..... 4-18
- 4.3.3 Optical Skew Adjustment ..... 4-18
- 4.3.4 Size-for-Size Fine Tuning ..... 4-19
- 4.5.3 Lens Cable Replacement ..... 4-20
- 4.5.4 Lens Motor Replacement ..... 4-22

### 5. Xerographic

- 5.1.1 Drum Unit Replacement ..... 4-23
- 5.1.2 Drum Finger Replacement ..... 4-23
- 5.1.3 Charge Corotron Wire Replacement ..... 4-24

- 5.1.4 Basic Copy Quality Adjustment ..... 4-24
- 5.1.5 ISIL Assembly Replacement ..... 4-26
- 5.1.6 ISIL Copy Edge Erase Amount Adjustment ... 4-26

### 6. Development

- 6.2.1 Deve. Unit Removal/Installation ..... 4-27
- 6.2.2 Mag. Roll Blade Replacement ..... 4-27
- 6.2.3 Toner Empty Sensor Replacement ..... 4-27

### 8. Fuser

- 8.1.1 Fuser Thermostat Replacement ..... 4-28
- 8.1.2 Fuser Thermistor Replacement ..... 4-28
- 8.2.1 Heater Rod Replacement ..... 4-29
- 8.2.2 Heat Roller Replacement ..... 4-30
- 8.2.3 Pressure Roller Replacement ..... 4-31
- 8.2.4 Contact Arc Adjustment ..... 4-32
- 8.3.1 Heat Roller Fingers Replacement ..... 4-33
- 8.3.2 Pressure Roller Fingers Replacement ..... 4-33
- 8.5.1 Fuser Fan Motor Assy Replacement ..... 4-34
- 8.5.2 Ozone Filter (Fuser Fan) Replacement ..... 4-34

### 9. Electrical

- 9.1.2 Main PWB Replacement ..... 4-35
- 9.1.3 LVPS Replacement ..... 4-38
- 9.1.4 AC Drive PWB Replacement ..... 4-38

### 10. Covers L Frame

- 10.1.1 Front Gas Spring Replacement ..... 4-39
- 10.1.2 Rear Gas Spring Replacement ..... 4-39
- 10.2.1 Console Assembly Replacement ..... 4-40
- 10.2.2 Top Cover Removal/Installation ..... 4-40

### How to Use the Disassembly/Assembly/Adjustment Manual

1. Specific removal/installation procedures are not described for parts for which those procedures are at first sight understood.
2. Installation procedures refer only to items requiring your attention.
2. Install parts with their protrusions, if any, fitted into half-punched dents.
3. Circled numbers such as ①/②/③ in each Figure indicate the order of a procedure and parts applicable.

**Intentional blank page**

### 1.1.1 Main Motor Replacement

#### Removal

1. **WARNING:** Power off the machine and disconnect the **power cord**.
2. Open the Front Cover and the machine.
3. Remove the Drum Unit ..... (5.1.1)
4. Remove the Rear Upper Cover.
5. (Fig. 1): Remove the Main Motor.

- ①. Disconnect P/J404.
- ②. Remove screws (3).
- ③. Remove Main Motor

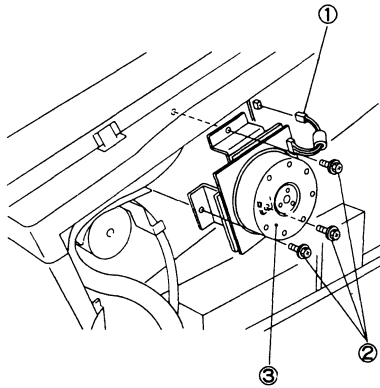

(Fig. 1)

#### Installation

1. Perform the installation in the reverse order of the removal.

### 2.1.1 Side Registration Adjustment

**Purpose** To adjust the position of the Cassette Tray to align the document image transferred onto the Drum with paper (in the Drum axis direction).

**Reference** The Tray positions in front/rear directions are each adjustable by 2mm (4mm in total) .

#### Adjustment

1. Slide out the Cassette Tray from the machine.
2. (Fig. 1): Perform the Side Registration Adjustment as follows.

- NOTE:** • The Right/Left Stoppers should be moved by the same distance.
- ①. Remove Screws.
  - ②. Install Screws to slots of both Stoppers respectively.
  - ③. Change the positions of Stoppers. A direction (Front): X will widen. B direction (Rear): X will narrow.
  - ④. Tighten Screws.

3. (Fig. 1): After adjustment make a copy-if it is NOT OK, repeat Steps 1~3.

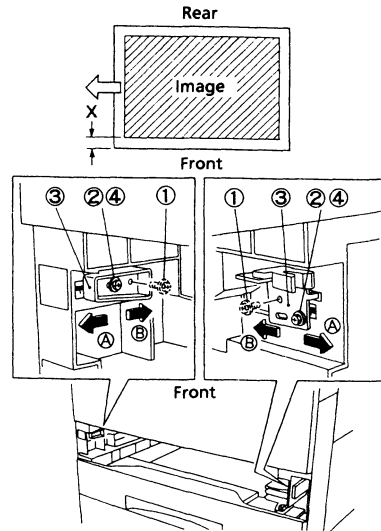

(Fig. 1)

**2.2.1 MSI Feeder Assy  
Removal/Installation**

**Removal**

1. **WARNING:** Power off the machine and disconnect the **power cord**.
2. Open the Rear Upper Cover.
3. Open the Right Upper Cover.
4. (Figs. 1 & 2): Remove the MSI Tray.

- ①. Open MSI Tray.
- ②. Remove Screw and then open MSI Tray slide it toward rear and remove it.

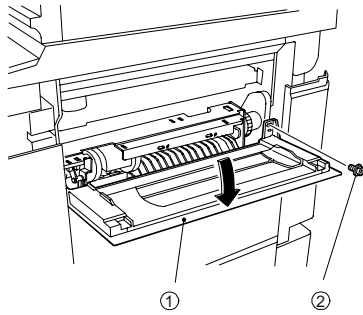

(Fig. 1)

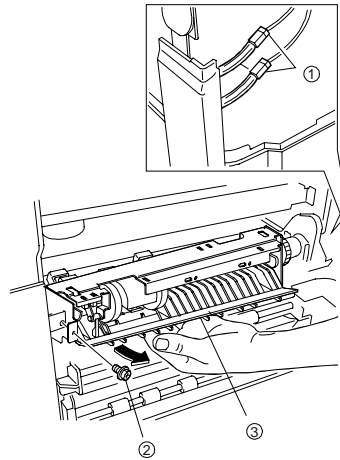

(Fig. 2)

**Installation**

1. Perform the installation in the reverse order of removal.

5. Open the Right Transport Cover.
6. (Fig. 2): Remove the MSI Feeder Assembly.

- ①. Disconnect P/J616 and P/J210 .
- ②. Remove Screw.
- ③. Remove MSI Feeder Assembly.

**2.2.2 MSI Retard Pad Replacement**

- NOTE:**
- You should replace the Retard Pad, the Feed Roller(2.3.2).
  - You should clear the Feed Counter in Diag. Mode [30-4].

**Removal**

1. **WARNING:** Power off the machine and disconnect the **power cord**.
2. Remove the MSI Feeder Assembly ..... (2.2.1)
3. (Fig.1): Remove the Tie Plate Assembly.

- ①. Remove Screws (2).
- ②. Remove Tie Plate Assembly.

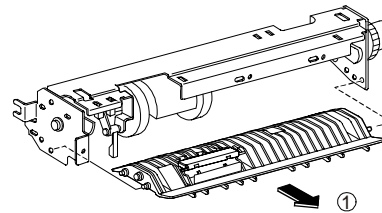

(Fig. 1)

4. (Fig. 2): Remove the Retard Pad.

- ①. Turn over Tie Plate Assy.
- ②. Release locking of the Retard Pad.

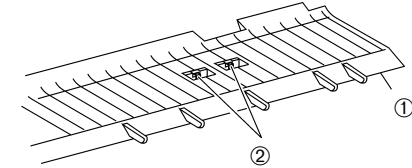

(Fig. 2)

- ③. Remove Retard Pad.

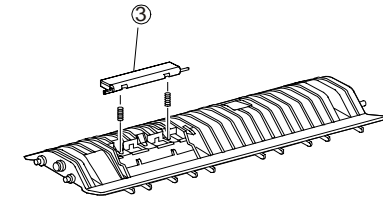

(Fig. 3)

**Installation**

1. Perform the installation in the reverse order of removal.

### 2.3.2 MSI Feed Roller Replacement

**NOTE:** • You should clear the Feed Counter in Diag. Mode [30-4] at the time of replacement.

#### Removal

1. **WARNING:** Power off the machine and disconnect the **power cord**.
2. Remove the MSI Feeder Assy..... (2.2.1)
3. (Fig. 1): Remove the MSI Feed Roller.

- ①. Remove E Clip.
- ②. Remove bearing.
- ③. Slide MSI Roll Assy.
- ④. Push up hook and then slide Core Roll.
- ⑤. Remove MSI Feed Roller.

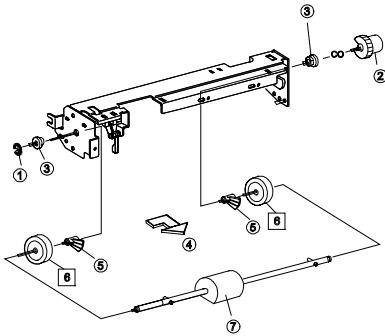

(Fig. 1)

#### Installation

1. Perform the installation in the reverse order of removal.

### 2.3.3 MSI Size Sensor Replacement

#### Removal

1. **WARNING:** Power off the machine and disconnect the **power cord**.
2. Remove the MSI Feeder Assembly ..... (2.2.1)
3. (Fig.1): Remove the MSI Size Sensor.

- ①. Disconnect P/J110.
- ②. Remove Size Sensor.
- ③. Remove Size Sensor Actuator .

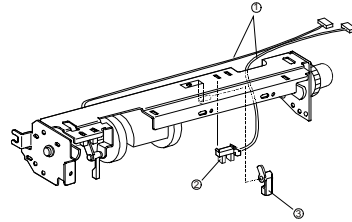

(Fig. 1)

#### Installation

1. Perform the installation in the reverse order of removal.
2. Perform an Input Check of the MSI Size Sensor in Diag. Mode[8-10].

### 2.3.4 MSI No Paper Sensor Replacement

#### Removal

1. **WARNING:** Power off the machine and disconnect the **power cord**.
2. Remove the MSI Feeder Assembly ..... (2.2.1)
3. (Fig.1): Remove the MSI No Paper Sensor.

- ①. Remove Cover.
- ②. Disconnect P/J111.
- ③. Remove MSI No Paper Sensor.

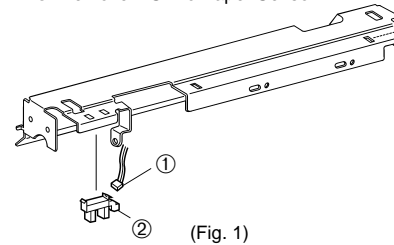

(Fig. 1)

#### Installation

1. Perform the installation in the reverse order of removal.
2. Perform an Input Check of the MSI No Paper Sensor in Diag. Mode[7-10].



2.5.1 Feed Roller Replacement  
2.5.3 No Paper Sensor Replacement

**NOTE:** • When replacing the Feed Roller, clear the Feed Counter of the appropriate Tray, using the Diag. Mode applicable:

Content	Diag Mode
Tray 1 Feed Counter	30-1

Replacement Procedure Common to the Above

**Removal**

1. **WARNING:** Power off the machine and disconnect the **power cord**.
2. Slide out the appropriate Tray.
3. Remove the Transport Cover.
  - ①. Remove Screw.
  - ②. Push Transport Cover to rear side.
  - ③. Remove Transport Cover by sliding away Pin on its front side.

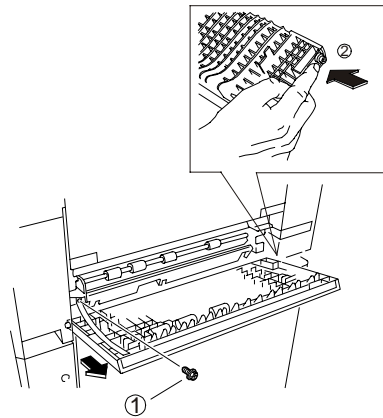

(Fig. 1)

4. (Fig. 2): Remove the Chute.

- ①. Remove Chute from Pins by pulling its rear side.
- ②. Slide Chute to rear and remove it.

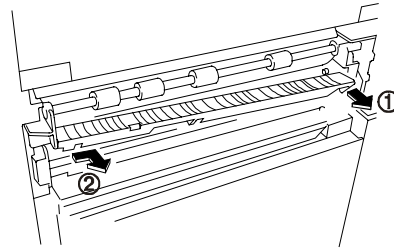

(Fig. 2)

5. (Fig. 3): Remove the Feeder Assy.

- ①. Disconnect P/J610 (Tray 1) and the Ground wire.
- ②. Remove Screws (2). (Wire Guard disengages together.)
- ③. Lift No Paper Sensor Actuator manually.
- ④. Remove Feeder Assy.

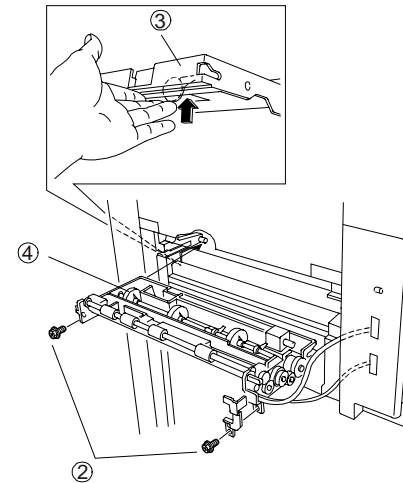

(Fig.4)

Replacement Procedure for Feed Roller only

6. (Fig. 5): Remove the Feed Roller.

**NOTE:** • Do not contaminate the Roller surface with grease, etc. Clean the contaminated Roller surface with the Drum Cleaner.

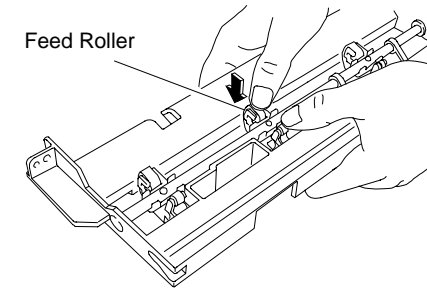

(Fig. 5)

**Replacement Procedure  
For Pick Up Gear only**

6. (Fig. 5): Remove the Pick Up Gear.
- ①. Remove the Spring.
  - ②. Keep pushing the hook of the pick up gear using the small screw gear.
  - ③. Remove the pick up gear.

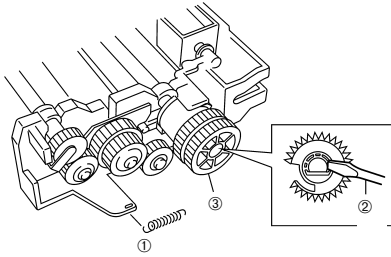

(Fig. 5)

**Replacement Procedure  
for No Paper Sensor only**

6. (Fig. 6): Remove the No Paper Sensor.
- ①. Remove No Paper Sensor tab.
  - ②. Lift Actuator.
  - ③. Remove No Paper Sensor.
  - ④. Remove Connector.

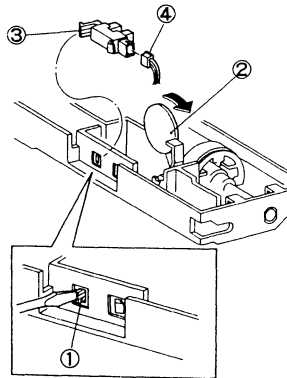

(Fig.6)

**Common Procedure**

**Installation**

1. Perform the installation in the reverse order of removal.

**NOTE:** • (Fig.7): Install the Feeder Assy to the machine with the Feed Roller half-moon shaped facing upwards.

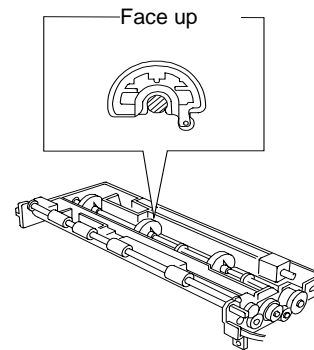

(Fig. 7)

- When installing the Feeder Assembly to the machine, take great care not to damage the No Paper Sensor Actuator.

- (Fig. 8): Install the Feeder Assy to the machine with the Assy cutouts hooked on the machine pins.

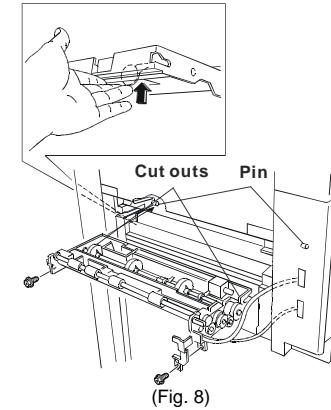

(Fig. 8)

- Reconfirm that the Feed Roller half-moon shape faces upwards before installing the appropriate Tray.

**NOTE:** • After the replacement of the No Paper Sensor, check the Sensors using the following Diag Codes.

Sensor	Diag. Code
Tray 1 No Paper Sensor	7-6

## 2.5.4 Transport Cover INTLK Switch Replacement

**Remove**

1. **WARNING:** Power off the machine and disconnect the **power cord**.
2. Open the Transport Cover.
3. Remove the Transport Cover.
  - ①. Remove Screw.
  - ②. Push Transport Cover to rear side.
  - ③. Remove Transport Cover by sliding away Pin on its front side.

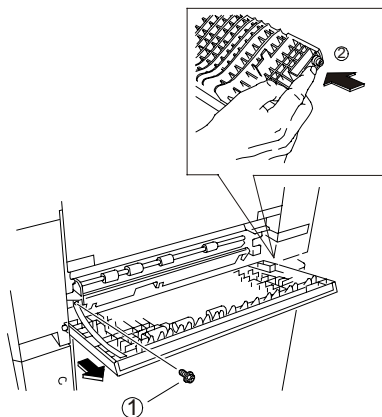

(Fig. 1)

4. (Fig.2) Remove Transport Cover INTLK Switch.

- ①. Push up the hook that fixes INTLK Switch.
- ②. Slide out INTLK switch then disconnect.

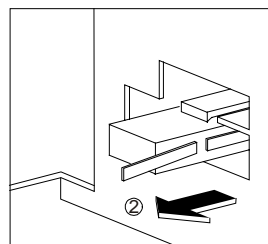
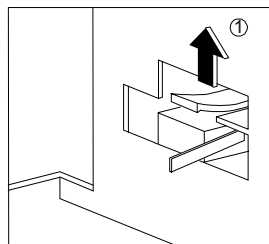

(Fig.2)

**Installation:**

1. Perform the installation in the reverse order of removal.

## 2.5.5 TRAY 1 Switch Replacement

### Removal

1. **WARNING:** Power off the machine and disconnect the **power cord**.
2. Remove the Rear Lower Cover.
3. Remove the LVPS
4. (Fig1) Remove the Switch Bracket.

① Remove screw.

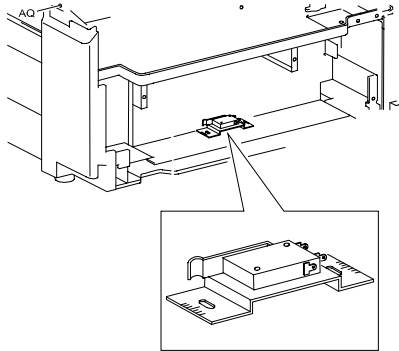

(Fig.1)

### Installation

1. Perform the installation in the reverse order of the removal.

## 2.5.6 TRAY 1 Switch Adjustment

**Purpose:** To prevent the Tray from hitting the Tray Switch, as deformation of the Switch Actuator will lead to poor contact.

1. **WARNING:** Power off the machine and disconnect the **power cord**.
2. Remove the Rear Lower Cover.
3. Remove the LVPS.....9.1.3
4. (Fig.1) Loosen two fixing screws of Tray 1 Switch Bracket.

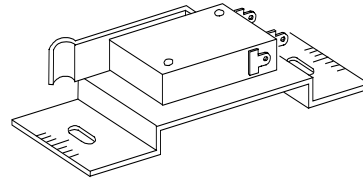

(Fig.1)

5. Tighten two fixing screws of Tray 1 Switch Bracket.

**2.7.1 Registration Assy  
Removal/Installation**

**Removal**

1. Power off the machine and disconnect the Power Plug.
2. Remove the Drum Unit and place a black bag over it ..... (5.1.1)
3. Remove the Deve. Unit. .... (6.2.1)
4. Remove the TC/DTC Assy.
5. Remove the following Covers:
  - Right Upper Cover
  - Rear Upper Cover
  - Rear Lower Cover
6. Remove the MSI Feeder Assy. .... (2.2.1)
7. (Fig. 1): Remove the Upper Chute Assy.
  - ①. Loosen Screw and remove Chute Bias resistance.
  - ②. Remove Spring.
  - ③. Open Registration Assy pin-installed bracket.
  - ④. Remove Upper Chute Assy.

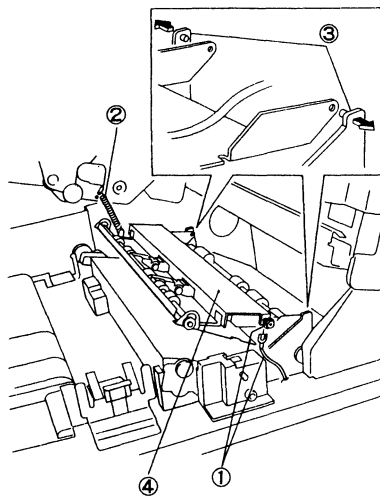

(Fig. 1)

8. (Fig. 2): Remove the Registration Assy.
  - ①. Disconnect P/J116 (for Regi-Sensor) & P/J214 (for Regi-Gate Solenoid).
  - ②. Remove Screws(2).
  - ③. Remove Registration Assy.

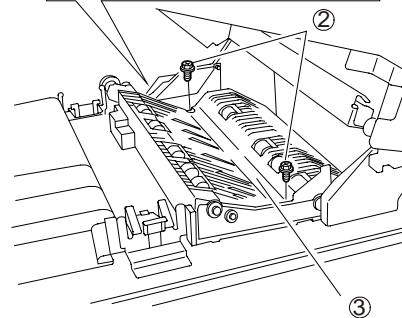
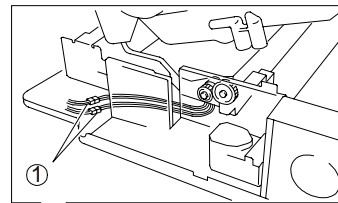

(Fig. 2)

**Installation**

1. Reinstall the Registration Assy by reversing Step 8, Removal.
2. Restore the machine to its original state in the reverse order of the removal.

**2.7.2 Registration Gate Solenoid  
Replacement**

**2.7.3 Regi-Gate Sensor Replacement**

- Replace both by removing the Registration Assy..... (2.7.1)
- The Solenoid/Sensor can now be replaced.

**2.7.4 Registration Roller Replacement**

**Removal**

1. Power off the machine and disconnect the Power Plug.
2. Remove the Registration Assembly ..... (2.7.1)
3. Remove the Registration Roller.

- ①. (Fig.1): Remove E Clip and then Bearing.

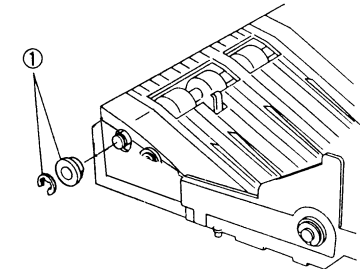

(Fig. 1)

- ②. (Fig.2): Remove Screw and then Gear.

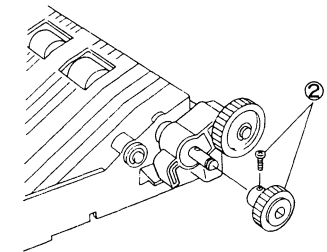

(Fig. 2)

- ③. (Fig. 3): Remove One-Way Clutch and Gear. (Spring disengages together.)
- ④. Remove E Clip and then Bearing.

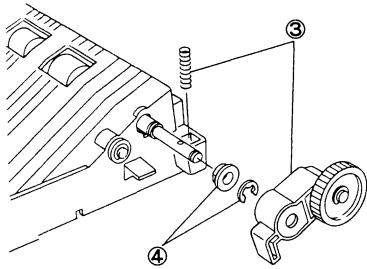

(Fig. 3)

- ⑤. (Fig. 4): Turn over Registration Assy.
- ⑥. Push in Registration Gate Solenoid plunger with your finger.
- ⑦. Remove Registration Roller (with plunger pushed in).

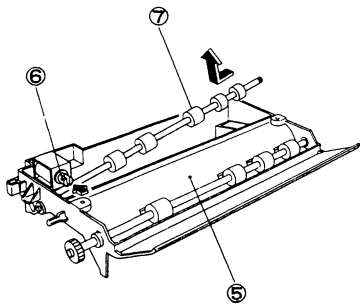

(Fig. 4)

### Installation

1. Perform the installation in the reverse order of the removal.

### 2.7.6 Lead Edge Registration Adjustment

**Purpose** To properly align the copy image on the Drum with the lead edge of paper.

#### Check

1. In 100% Mode, align Test Chart(499T247 or 248) with Regi-Guide and make a copy.
2. (Fig. 1): Check that there is  $10 \pm 1.6$ mm from the copy's lead edge to the reference line.

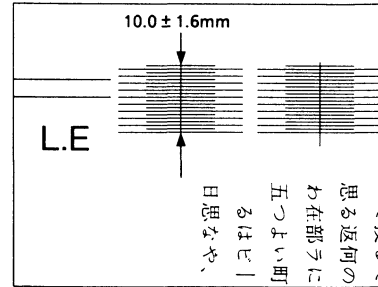

(Fig. 1)

#### Adjustment

- **Fast Paper Feed**(The distance is more than  $10 \pm 1.6$ mm from the copy's lead edge to the reference line.)

1. Key in Diag. [20-1].
2. Increase data.

**NOTE:** • Changing the data by 1 will change the distance by 0.2584mm.

- **Slow Paper Feed**(The distance is less than  $10 \pm 1.6$ mm from the copy's lead edge to the reference line.)

1. Key in Diag. [20-1].
2. Decrease data.

**NOTE:** • Changing the data by 1 will change the distance by 0.2584mm.

3. Make a copy and check it.

4. Perform the ISIL Copy Edge Erase Amount Adjustment ..... (5.1.6)

3.1.1 Vacuum Transport Belt Replacement

Removal

1. Power off the machine and disconnect the Power Plug.
2. Open the Front Cover and then the machine.
3. Remove the Drum Unit and place a black bag over it ..... (5.1.1)
4. Remove the Rear Upper Cover.
5. Remove the TC/DTC Assembly.
6. (Fig. 1): Remove the Main Switch Cover.

- ①. Remove Screw.
- ②. Remove Main Switch Cover.

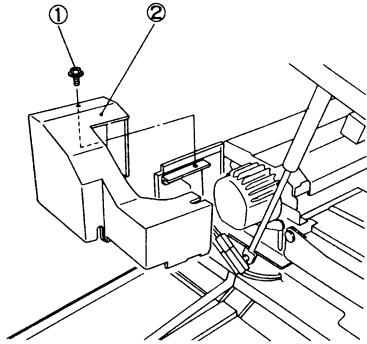

(Fig. 1)

7. (Fig. 2): Remove AC DRIVE PWB.

- ①. Remove Screw.
- ②. Remove AC Drive PWB Cover.
- ③. Disconnect the plug and remove AC Drive PWB,

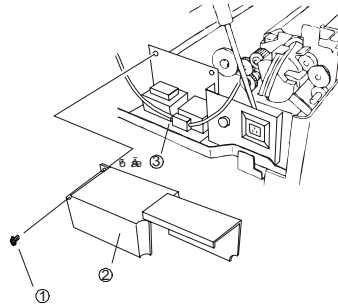

(Fig. 2)

8. (Fig. 3): Remove the Vacuum Transport Assembly.

- ①. Remove Screw.
- ②. Remove Vacuum Transport Assy.

**NOTE:** • Pushing the rear pin with a screw driver as shown in Fig. 3 makes it easier to remove.

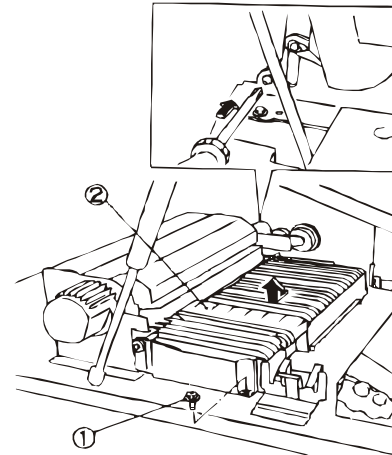

(Fig. 3)

9. (Fig. 4): Remove the Transport Belt.

- ①. Remove E Clip and then Bearing.
- ②. Slide Shaft.
- ③. Remove Transport Belt.

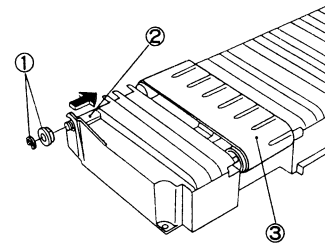

(Fig. 4)

Installation

1. Perform the installation in the reverse order of removal.

**NOTE:** • (Fig. 5): Pay attention to the Belt direction.

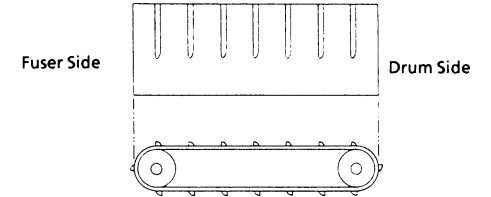

(Fig. 5)

#### 4.1.1 Platen Glass Replacement

##### Removal

1. Power off the machine and disconnect the Power Plug.
2. Open the Platen Cover.
3. (Fig. 1): Remove the Platen Glass.

- ①. Remove Screws (2).
- ②. Remove Platen Glass Support.
- ③. Remove Platen Glass.

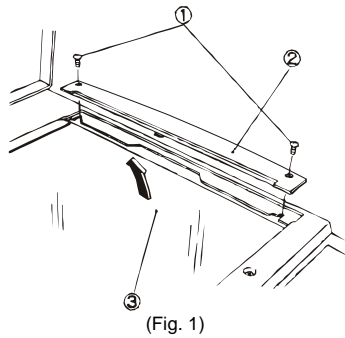

##### Installation

1. Perform the installation in the reverse order of removal.

#### 4.1.2 Optical Cooling Fan Replacement

##### Removal

1. Power off the machine and disconnect the Power Plug.
2. Remove the Left Upper/Rear Upper Covers.
3. (Fig. 1): Remove the Optical Cooling Fan.

- ①. Disconnect P/J408.
- ②. Remove Screws(2).
- ③. Remove Optical Cooling Fan.

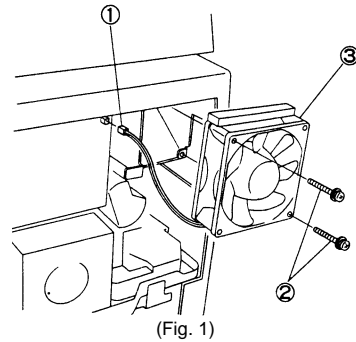

##### Installation

1. Perform the installation in the reverse order of removal.

- Reference**
- This Fan cools the Optics by taking air into the machine.
  - Do not turn the Fan over when installing it.



4.2.1 Optical Regi-Sensor Replacement

**Removal**

1. Power off the machine and disconnect the Power Plug.
2. Remove the Platen Glass. .... (4.1.1)
3. Open the Front Cover and remove the Console Assy. .... (10.2.1)
4. (Fig. 1): Loosen the Top Cover.

- ①. Remove Front Screws(2) to enable Top Cover Front to be raised.

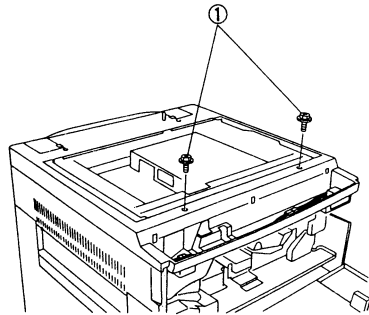

(Fig. 1)

5. (Fig. 2): Remove Optical Regi-Sensor.

- ①. Raise Top Cover a little.
- ②. Remove Screw.
- ③. Remove Regi-Sensor.
- ④. Disconnect P/J100.

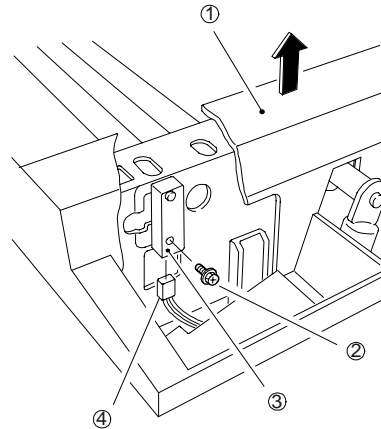

(Fig. 2)

**Installation**

1. Perform the installation in the reverse order of removal.

**NOTE:** • While pushing the Regi-Sensor toward the lower right to eliminate end play, tighten the Screw.

4.2.2 Lamp Carriage Motor Replacement

**Removal**

1. Power off the machine and disconnect the Power Plug.
2. Remove Rear Upper Covers.
3. (Fig. 1): Remove Lamp Carriage Motor.
  - ①. Disconnect P/J605.
  - ②. Remove Screws(2).
  - ③. Remove the Motor.

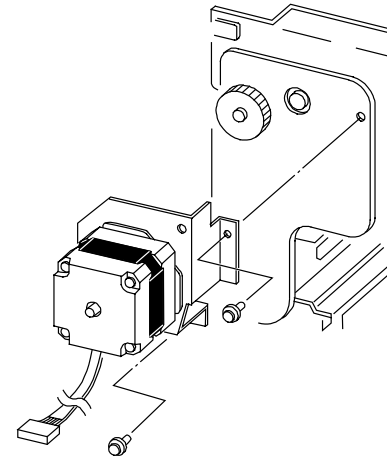

(Fig. 1)

**Installation**

1. Perform the installation in the reverse order of removal.
2. Make a copy of Test Chart(499T247 or 248) and check that it exhibits no skip, that no abnormal noises are heard, etc.

### 4.2.3 Carriage Cable Replacement

**NOTE:** • The Cable winding procedure is described only for the Front Cable because the Front and Rear Cables are symmetrically wound.

- Prepare Scotch tape.
  - Replace Cables one by one.
- Refer to the location of the installed wiring for the correct Cable routing.

**Reference** The Rear Cable is painted in black.

#### Removal

1. Power off the machine and disconnect the Power Plug.
2. Remove the Platen Cover .
3. Remove the Platen Glass. .... (4.1.1)
4. Remove the Top Cover. .... (10.2.2)
5. Remove the Regi-Guide.
6. (Fig. 1): Gently move the Full-Rate Carriage manually up to the frame hole at the right of the Regi-Sensor.

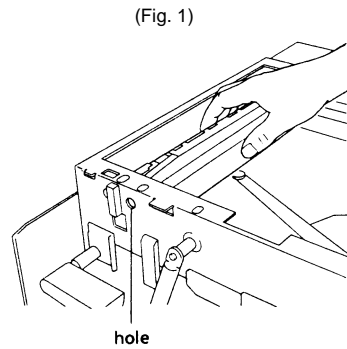

7. (Fig. 2): Loosen the Cable Mounting Screw for the Full-Rate Carriage.

**NOTE:** • When replacing the Rear Cable, remove the Optical Cooling Fan. .... (4.1 2)

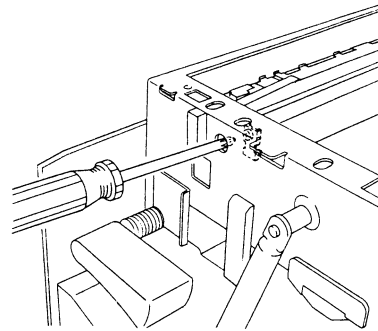

8. (Fig. 3): To make the rest of this procedure easier, gently move the Full-Rate Carriage up to the frame cutout.

**NOTE:** • Move the Carriage by holding at the rear keeping it perpendicular to the frame because its front is not fixed to the Cable.

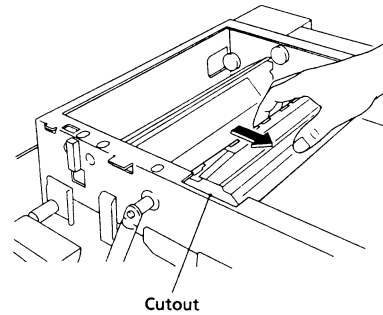

9. (Fig. 4): Remove the Cable from the spring and then the whole Cable from the machine.

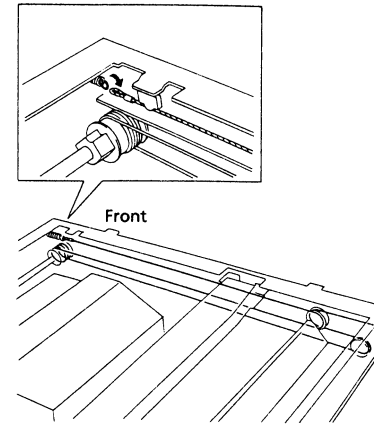

#### Installation

1. (Figs. 5 & 6): Wind the Cable on the Capstan Pulley.

- ①. (Fig. 5): Determine the Cable direction.
- ②. Wind Cable on Capstan Pulley shaft nine turns.

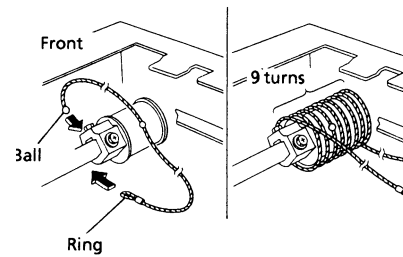

**NOTE:** • The Full-Rate Carriage should be positioned at the frame cutout in Fig.3.

- ③. (Fig. 6): With the Cable-centering ball in the Capstan Pulley hole, wind the Cable five turns on the front side and three turns on the rear side centering on the ball. The total number of winds is nine, including one wind at the central ball. (Overlap of the cable windings is allowed here.)

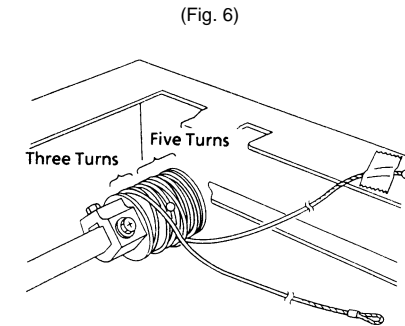

2. (Fig. 7): Route the ball-attached side of Cable to the Pulley via the far left Pulley as shown in Fig. 7, then fasten the ball into the left-hand Frame hole.

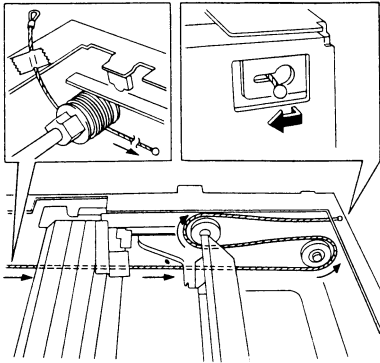

(Fig. 7)

3. (Fig. 8): Route the ring-attached side of cable to the Pulley via the Full-Rate Carriage and, then hook the ring on the right-hand-Frame spring.

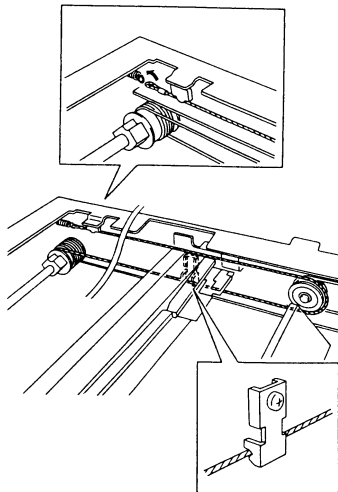

(Fig. 8)

4. (Fig. 9): Finger tighten the Cable Mounting Screw for the Full-Rate Carriage.

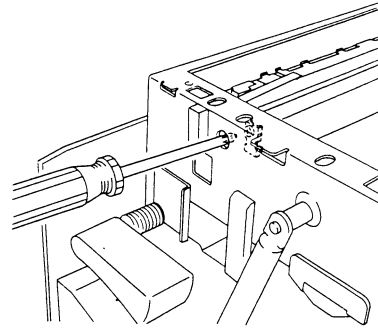

(Fig. 9)

5. (Fig. 10): Arrange the cable windings on the Capstan Pulley by holding the Full-Rate Carriage with your hand and gently moving it right and left.

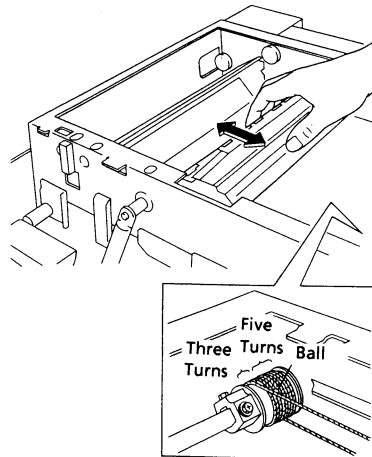

(Fig. 10)

6. Perform the Full-Rate & Half-Rate Carriage Parallel Adjustment. .... (4.3.1)  
7. Reinstall all the parts and make a copy. Check that the copy exhibits no optical skew, etc.

**4.3.1 Full-Rate & Half-Rate Carriages Parallel Adjustment**

**Purpose** To set the Carriages parallel so that the Front/Rear Light Paths are the same in length.

**NOTE:** • This adjustment should be performed when the following problem occurs or after the work is complete:  
1. Optical Skew (Skewed image)  
2. Carriage Cable Removal/Installation (4.2.3)

- Check**
1. Power off the machine and disconnect the Power Plug.
  2. Remove the Platen Cover.
  3. Remove the Platen Glass. .... (4.1.1)
  4. Remove the Left Upper Cover.
  5. Remove the Top Cover. .... (10.2.2)
  6. Remove the Regi-Guide.

7. Remove the Blocks for Parallel Adjustment from the Left-Hand Frame by moving the Full-Rate & Half-Rate Carriages manually to the Right.

①. (Fig. 1): Push Block A convex from the frame hole and turn Block A through 180 degrees. (Both front and rear).

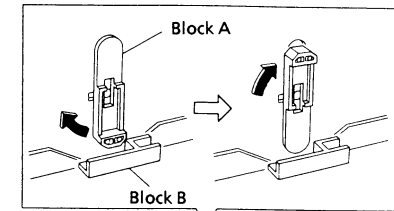

(Fig. 1)

②. (Fig. 2): Remove Block B's and install them to Full-Rate Carriage front/rear.

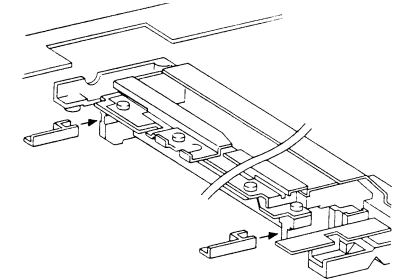

(Fig. 2)

8. (Fig. 3): Move gently the Full/Half-Rate Carriages toward their home positions by rotating the Capstan Pulley shaft manually to check the following:
- The Half-Rate Carriage convex contacts Block A's at its front and rear.
  - Block B's installed to the Full-Rate Carriage contact the Left-Hand Frame at its front and rear.

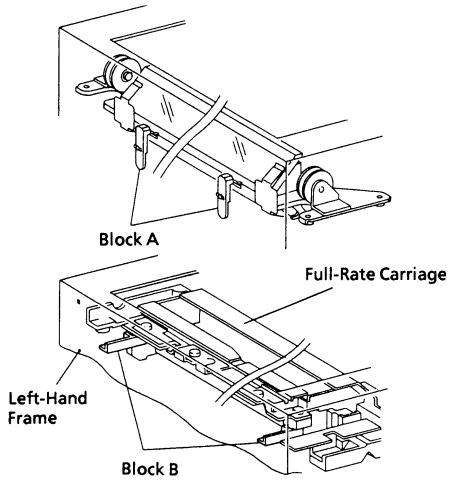

(Fig. 3)

**Adjustment**

**Half-Rate Carriage Adjustment**

1. (Fig. 4): Make the Half-Rate Carriage convex contact (Front/Rear) Block A's.
  - ①. Loosen screws(2) for Front Capstan Pulley.
  - ②. Adjust by rotating Capstan Pulley or Shaft.
  - ③. Tighten Screws(2).

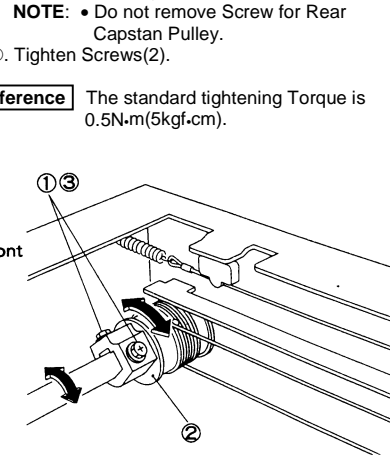

(Fig. 4)

**Reference** The standard tightening Torque is 0.5N·m(5kgf·cm).

2. (Fig. 5): Remove the end play in the Drive Shaft axis direction and tighten the screws for the Capstan Pulley.

- ①. Insert 0.5mm Thickness Gauge between Capstan Pulley and Bearing.
- ②. Push Capstan Pulley to front and Shaft to rear and tighten screws(2).

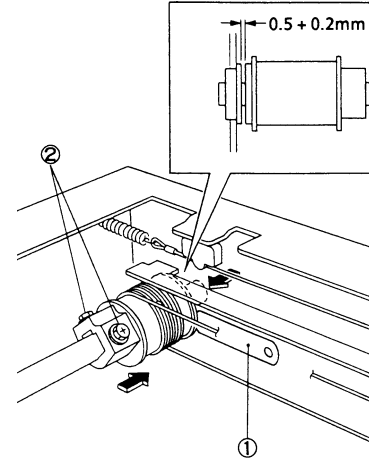

(Fig. 5)

**Full-Rate Carriage Adjustment**

1. (Fig. 6): Make (Front/Rear) Block B's installed to the Carriage contact the Left-Hand Frame.
  - ①. Loosen the Carriage Wire Mounting Screw.

**NOTE:** • For the adjustment of Rear Block B, remove the Optical Cooling Fan.  
..... (4.1.2)

- ②. Adjust by moving the Carriage.
- ③. Tighten Screw.

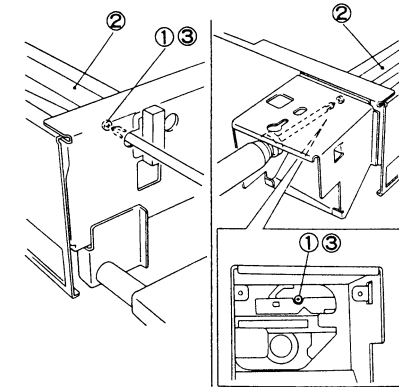

(Fig. 6)

4.3.2 Exposure Lamp Replacement

**NOTE:**

- Do not touch the Exposure Lamp glass tube with your hand. If you touch it, wipe it with the Drum Cleaner.
- Take care not to hit the Exposure Lamp glass tube. It is fragile.

**Removal**

1. Power off the machine and disconnect the Power Plug.
2. Open the Platen Cover.
3. Remove the Platen Glass. .... (4.1.1)
4. (Fig. 1): Move the Full-Rate Carriage gently to the frame cutout and remove the Lamp.

- ①. Remove Screw.
- ②. Remove Front/Rear Side Reflectors.
- ③. Remove Cover.
- ④. Push open Front Contact Plate with your fingers.
- ⑤. Remove Lamp.

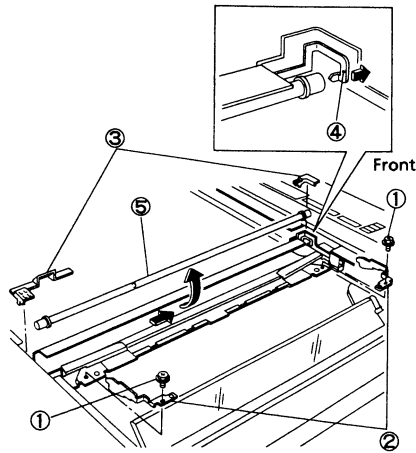

(Fig. 1)

**Installation**

1. Perform the installation in the reverse order of removal.

**NOTE:**

- (Fig. 2): Install the Lamp with its protrusion facing the Reflector opening approx. 45° from the Platen Glass surface .

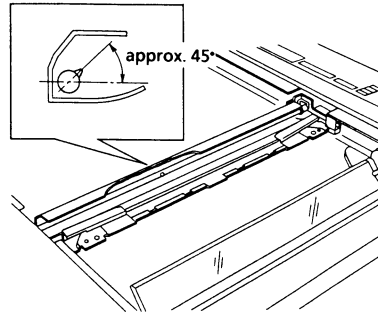

(Fig. 2)

2. Key in Diag. Mode [6-7] and check that the Lamp is on.
3. Perform the Basic Copy Quality Adjustment. .... (5.1.4)

4.3.3 Optical Skew Adjustment

**Purpose** To correct the optical image skew in the Drum axis and paper feed directions.

**NOTE:**

- Ensure that the following are functioning correctly:

1. Paper is fed properly.
  - a. There is no difference in skew level between Trays.
  - b. There is no difference in skew level between continuously-made copies.
2. The Regi-Guide(or Gate) and the Platen Glass are positioned properly.
3. The Full-Rate/Half-Rate Carriages Parallel Adjustment is properly performed. .... (4.3.1)
4. There is no difference in skew level between A4 & A3 ( or between B5 & B4).
  - \* If there is some difference, check to see if the bottom half of A3(or B4) paper skews due to the uneven transporting force of the Fuser owing to a defective P Roll. Replace the P Roll if necessary.
  - \* The Regi-Roll is deteriorated or worn out.
5. Do not adjust paper skew by this means.
6. After this adjustment, make sure to record in the Machine History Card that it has been performed.

**Adjustment Flow chart**

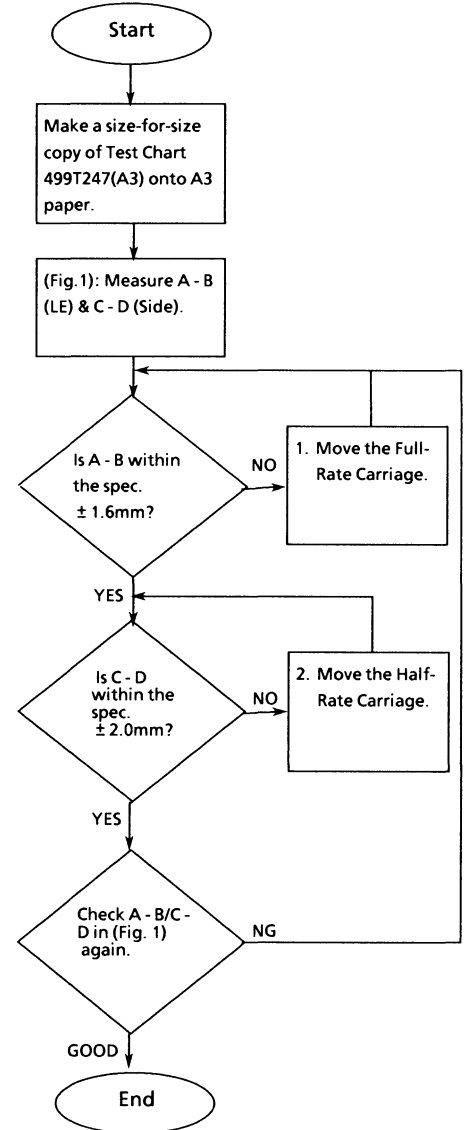

**Check**

1. Align Test Chart(499T247) with the Regi-Guide and make a size- for-size copy of it on A3 paper.
2. (Fig. 1): Measure A, B, C & D each. Check that the values each obtained by subtracting B from A and D from C are in the specifications below:  
 A - B → within ± 1.6mm  
 C - D → within ± 2.0mm

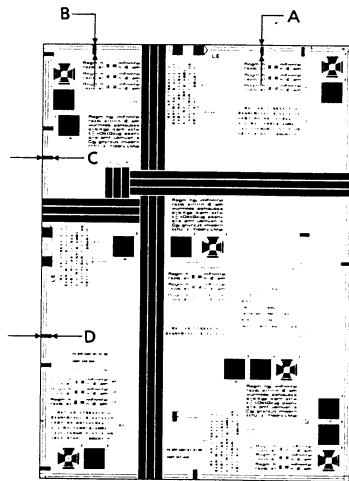

(Fig. 1)

**Adjustment**

**A - B is out of spec.**

1. Power off the machine and disconnect the Power Plug.
2. Remove the Platen Glass. .... (4.1.1)
3. Remove the Optical Cooling Fan. .... (4.1.2)
4. (Fig. 2): Move the Full-Rate Carriage holding it at its rear.

- NOTE:**
- Do not move the Carriage right and left more than 2mm; otherwise, there could occur problems such as poor resolution and the Carriage slamming on the frame.
  - ①. Remove Carriage Wire Mounting Screw.
  - ②. Adjust by moving Full-Rate Carriage with Carriage Cable still.

- A > B  
Move the Carriage to the right.
- A < B  
Move the Carriage to the left.

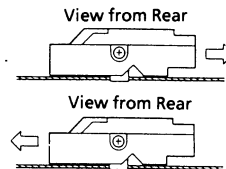

③. Tighten Screw.

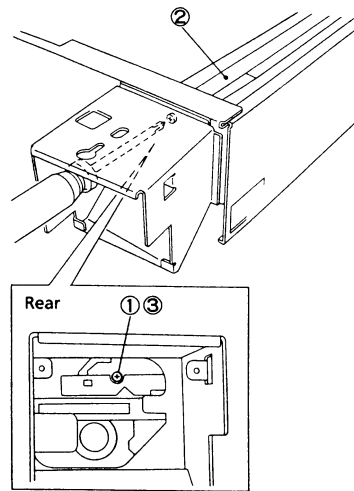

(Fig. 2)

**C - D is out of spec.**

1. Power off the machine and disconnect the Power Plug.
2. Remove the Platen Glass. .... (4.1.1)
3. Remove the Right Upper Cover.
4. (Fig. 3): Move the Half-Rate Carriage holding it at its front.

- NOTE:**
- Do not move the Carriage right and left more than 2mm; otherwise, there could occur problems such as poor resolution and the Carriage slamming on the frame.
  - ①. Loosen Front Capstan Pulley screws(2).
  - ②. (Fig. 3): To adjust, move the Half-Rate Carriage by rotating the Capstan Pulley.

- NOTE:**
- Do not remove the screw for the Rear Capstan Pulley.
  - Do not rotate the Carriage Drive Shaft.
  - In the case of C > D, rotate the Capstan in the ⤵ direction.
  - In the case of C < D, rotate the Capstan in the ⤴ direction.

③. Tighten Screw.

**Reference** The standard tightening torque is 0.5N · m(5kgf · cm).

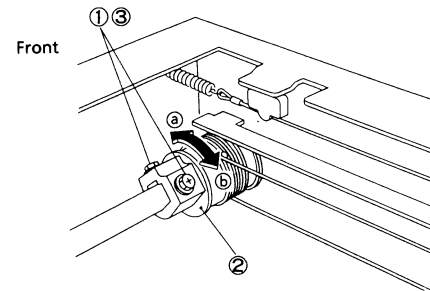

(Fig. 3)

**4.3.4 Size-for-Size Fine Tuning**

**Purpose** To set the vertical magnification (Scan direction) and horizontal magnification(Drum axis direction).

**Reference** When the machine is shipped out from the plant, its copy magnification is set to 100% ± 0.8%.

**Check**

1. Make a size-for-size A3 copy of Test Chart (499T247).
2. (Fig. 1): Check that designated locations are the same in length by comparing Test Chart with the copy as follows:
  - Vertical Magnification  
Check on ② to ④, ② to ⑤ and ④ to ⑤.
  - Horizontal Magnification  
Check on ① to ②, ② to ③ and ① to ③.

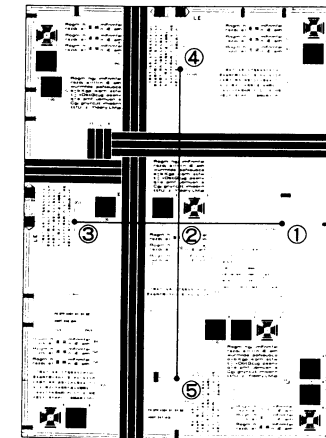

(Fig. 1)

Adjustment

- Vertical Magnification  
Change the vertical magnification (Scan direction) referring to Table 1.
- Horizontal Magnification  
Change the horizontal magnification (Drum axis direction) referring to Table 1.

Chain	Code	Content	Min.	Initial Value	Max.
20	6	100% Horizontal Mag. Fine Tuning	0 (-2%)	32 (±0%)	64 (+2%)
	7	100% Vertical Mag. Fine Tuning	0 (-3%)	32 (±0%)	64 (+3%)

4.5.3 Lens Cable Replacement

Removal

1. Select 100% Magnification. After the Lens stops, power off the machine and disconnect the Power Plug.
2. Open the Platen Cover and remove the Platen Glass. .... (4.1.1)
3. (Fig. 1): Remove the Optical Shield.

- ①. Loosen Screws(2)
- ②. Raise the rear side of Mirror Carriage and

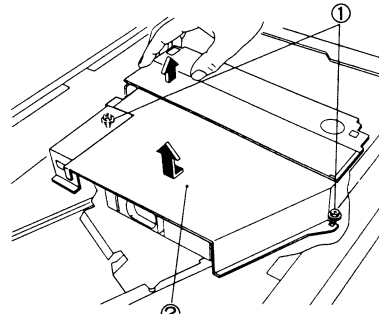

remove Optical Shield.

(Fig. 1)

4. (Fig. 2): Remove the Lens Carriage Shield.

- ①. Remove Screw.
- ②. Remove Lens Carriage Shield.

**NOTE:** • Take care not to break the film

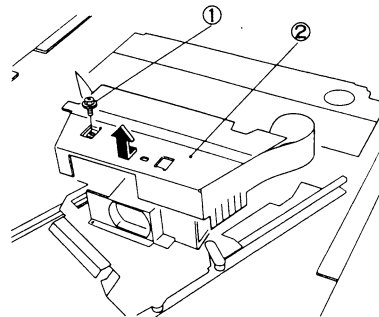

attached to the Shield.

(Fig. 2)

5. Check the following:

- (Fig. 3): The Lens Carriage timing hole should align with the Rail timing hole.

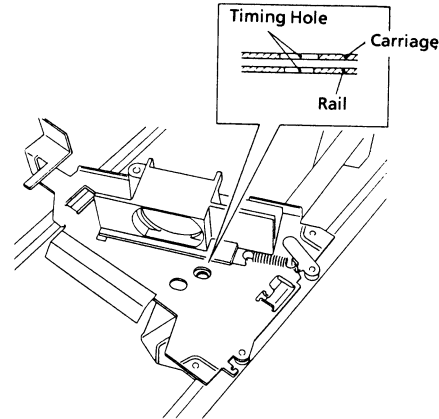

(Fig. 3)

6. (Fig. 4): Remove the Lens Cable.

- First unhook the spring-attached side of Cable.

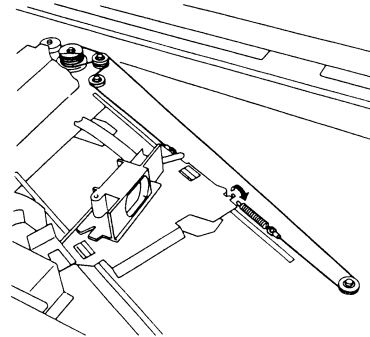

(Fig. 4)

### Installation

1. (Fig. 5): Check that the Lens Carriage timing hole aligns with the Rail timing hole. Tape the Lens Carriage to the frame.

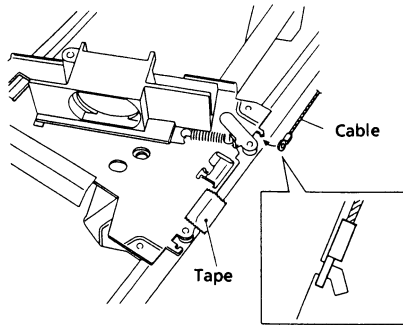

(Fig. 5)

2. Hook the shorter side of Cable from its ball on the Lens Carriage.  
**NOTE:** • (Fig. 5): Hook the Cable with the flat side of the hook toward the Carriage.

3. (Fig. 6): Route the Cable to shaft of Pulley A, then to the Pulley B, and finally wind it on the Gear Pulley. Wind the Cable five turns in total, inserting the ball into the Gear

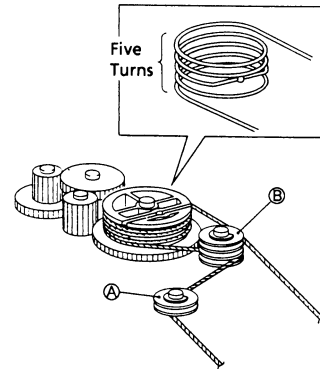

inserting the ball into the Gear Pulley hole.

(Fig. 6)

4. (Fig. 7): Route the longer side of Cable from its ball to the Pulley, then hook it on the Lens Carriage with the spring.

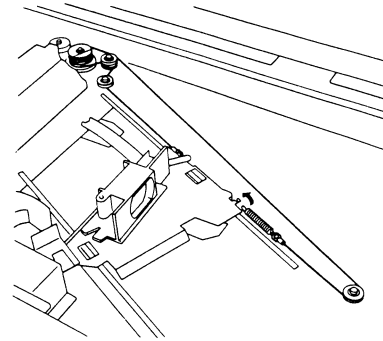

(Fig. 7)

5. Remove the tape fixing the Lens Carriage and route the Cable to the Pulley A.
6. Power on the machine. Check that the Lens Carriage timing hole aligns with the Rail timing hole (Step 5, Removal) when the Lens is set to 100%. If the holes don't align with each other, check the installation procedure again. Check, in particular, that the Cable ball is in the Gear Pulley hole.
7. Select 61%/163% Magnifications respectively. Check the following:
  - The Lens Carriage moves smoothly.
  - The Cable windings on the Gear Pulley are not overlapped.
8. Restore the machine to its original state. Make copies using Enlargement/100%/Reduction Modes respectively. Check that the copies are good. Perform the Size-for-Size Fine Tuning (4.3.4) if necessary.



4.5.4 Lens Motor Replacement

Removal

1. Select 100%. After the Lens stops, power off the machine and disconnect the Power Plug.
2. Remove the Right/Rear Upper Covers.
3. Open the Front Cover, and then the machine.
4. Remove the Drum Unit and place a black bag over it. (5.1.1)
5. Remove the Deve. Unit. (6.2.1)
6. Close the machine.
7. Remove the Platen Glass. (4.1.1)
8. (Fig. 1): Remove the Optical Shield.

- ①. Loosen Screws(2).
- ②. Raise the rear side of Mirror Carriage and remove Optical Shield.

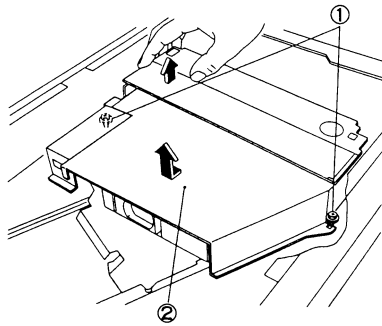

(Fig. 1)

9. (Fig. 2): Disconnect Connector P/J604 from the Lens Motor.

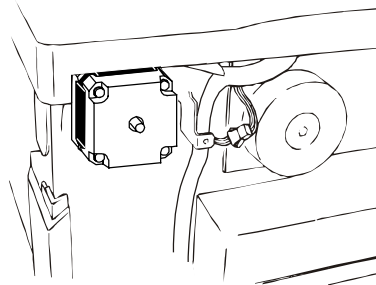

(Fig. 2)

10. Remove the Motor wire from each Cable clamp.
11. (Fig. 3): To fix the Mirror Carriage position at 100%, insert the Phillips Screwdriver through the Worm Wheel timing hole to the frame timing hole. (The screwdriver goes through the frame hole.)

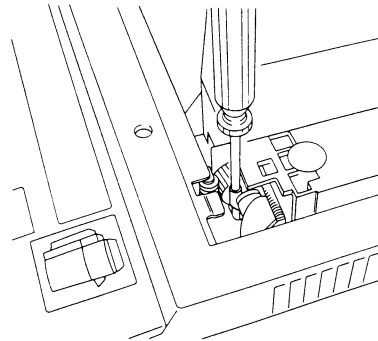

(Fig. 3)

12. (Fig. 4): Remove the Gear.

- ①. Remove E Clip.
- ②. Remove Gear.

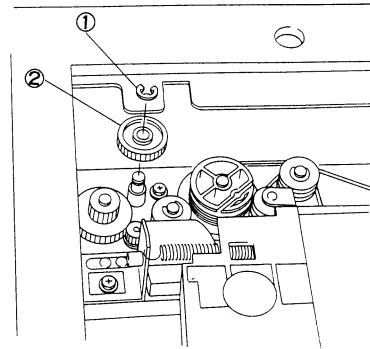

(Fig. 4)

13. (Fig. 5): Remove the Lens Motor.

- ①. Remove Screws (2).
- ②. Remove Lens Motor.

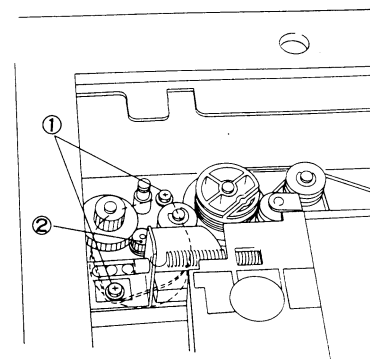

(Fig. 5)

Installation

1. Perform the installation in the reverse order of removal. Pay attention to the following:

**NOTE:** • (Fig. 6): When installing the Lens Motor, check that the Lens Carriage is set to 100%.

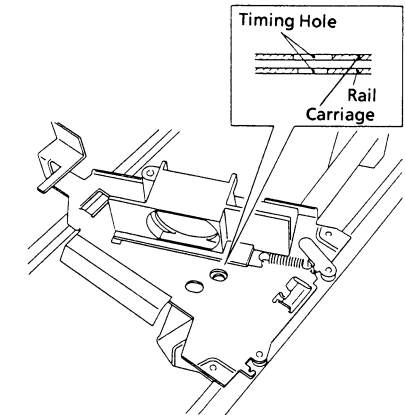

(Fig. 6)

2. Make copies using 100%, 70% and 141% Magnifications respectively. Check that the copies are good.

### 5.1.1 Drum Unit Replacement

- NOTE:**
- Be careful of the following in handling the Drum Unit:
    - a. Place the removed Unit on a flat surface.
    - b. Keep the Drum away from direct strong light. Put a protective cover over it.
    - c. Do not rotate the Drum anti -- clockwise.
    - e. Do not touch the Drum surface with your bare hand(s).

#### Removal

1. Power off the machine and disconnect the Power Plug.
2. Open the Front Cover and then the machine.
3. (Fig. 3): Remove the Drum Unit.

- ①. Push Lock Lever.
- ②. Pull out Drum Unit.

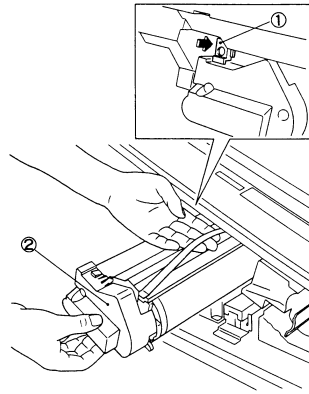

(Fig. 1)

#### Installation

1. Install the Drum Unit securely. Its improper installation will cause J3 to be displayed. Put the plug ID into the socket.
2. Perform the Basic Copy Quality Adjustment. .... (5.1.4)

#### Reference • Drum Unit

- a. When replacing the Drum, replace the whole Drum Unit. (It is impossible to replace the Drum alone.) The Drum Unit contains the Drum Cleaning Blade, Film Seal and Charge Corotron.
- b. Max. Copy Output Quantity When the Drum Unit is shipped out of the plant, the max. copy output quantity is set on ID as below:

M/C Type	Max. Copy Output Qty on ID (Initial Value)
5915	50,000

#### c. "Drum Cartridge(Unit) Replacement" Display

Remaining Copy Output Qty	Drum Cartridge Replacement Display	Status Code	Copy
5,000	ON	--	Possible
500	Flash	--	Possible
0	Flash (continuously)	J7-1	Not possible

When the cartridge reaches the end of its service life, the Replace copy cartridge lamp flashes and the Copy Quantity display shows "J7".

- d. Remaining Copy Output Qty The remaining copy output quantity is stored in EPROM incorporated into the Drum Unit. You can check on the remaining copy output quantity in [81] of "Performance Spec."

### 5.1.2 Drum Finger Replacement

#### Removal

1. Power off the machine and disconnect the Power Plug.
2. Open the Front Cover and then the machine.
3. Remove the Drum Unit..... (5.1.1)
4. (Figs. 1 & 2): Remove the Finger Assembly.

- ①. (Fig. 1): Remove Stopper preventing the disengagement of Finger Assy.

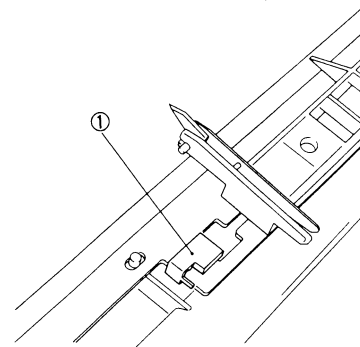

(Fig. 1)

- ②. (Fig. 2): Remove Finger Assy from Bracket by sliding it to the front of Drum Unit.

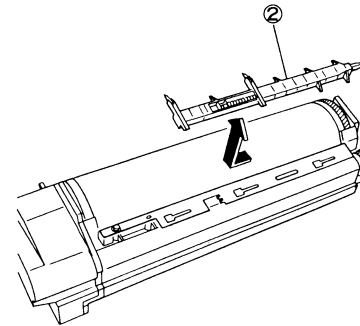

(Fig. 2)

5. (Fig. 3): Remove the Drum Finger.

**WARNING:** • Take care not to hurt yourself in removing the Finger. Its tip is sharp.

- ①. Remove Spring.
- ②. Remove Drum Finger.

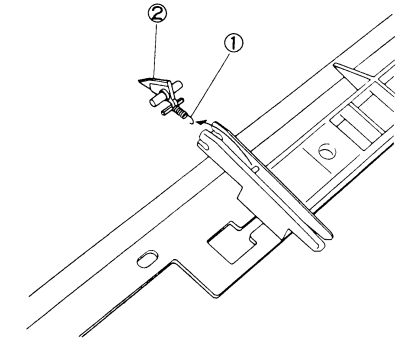

(Fig. 3)

#### Installation

1. Perform the installation in the reverse order of removal.

**CAUTION:**

- Check that the Drum Finger tip is not damaged.
- Take care not to damage the Drum surface in installing the Finger Assy.
- Install the Stopper in the proper direction referring to Fig. 1.

5.1.3 Charge Corotron Wire Replacement

Removal

1. Power off the machine and disconnect the Power Plug.
2. Open the Front Cover and then the machine.
3. Remove the Drum Unit. .... (5.1.1)
4. (Fig. 1): Remove the Charge Corotron Assembly.

- ①. Remove Screw.

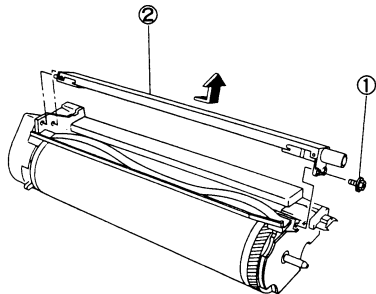

- ②. Remove Charge Corotron Assy.

(Fig. 1)

5. (Fig. 2): Remove the Charge Corotron Wire.

- ①. Remove Front/Rear Arc Shields.
- ②. Remove Spring.
- ③. Remove Corotron Wire.

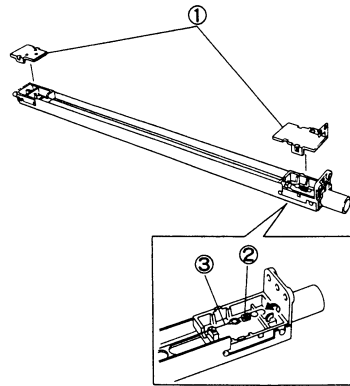

(Fig. 2)

Installation

1. Perform the installation in the reverse order of removal.

**NOTE:** • The copy edge erase amount changes according to the Front Arc Shield installing position. Install the Arc Shield so that the copy edge erase amount after replacement is the same as before.

5.1.4 Basic Copy Quality Adjustment

**Purpose** To determine the correction values of Exposure Light Quantity and Deve. Bias to obtain copy densities appropriate to various types of original.

- NOTE:** • Copy Quality Adjustment should be performed when copy quality problems occur or the following are replaced:
- ①. Drum Unit Replacement ..... (5.1.1)
  - ②. Exposure Lamp Replacement ..... (4.3.2)
  - ③. Main PWB Replacement ..... (9.1.2)

**NOTE:** • Perform TRIM before making the Copy Quality Adjustment.

Adjustment Flow

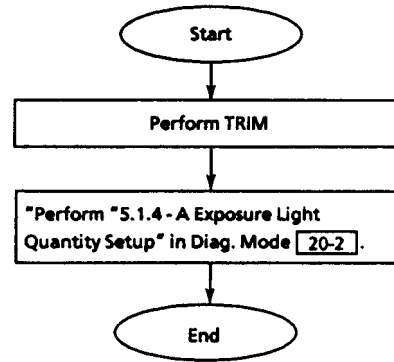

5.1.4-A Exposure Light Quantity Setup

**Purpose** To adjust light quantities applicable to each magnification and store the values in NVM.

Check

1. Enter Diag. Mode [20-2].  
The Control Panel displays the following:  
Set/Count 30
2. Check that the magnification is 100%.
3. Set Test Chart(499T247 or 499T248) and select A3 or B4.
4. Press the **Start** button and make three straight copies. (Press the **Stop** button when the third copy has been made.)

**NOTE:** • Because pressing the **Start** button in Diag. [20-2] will allow ten straight copies to be made, press the **Stop** button at the completion of the third copy.

• This Diag Mode detects paper jams and counts.

5. Evaluate the third copy.  
Spec: At the target in the center of the copy.

- (Fig. 1): 0.1 gray vertical/horizontal lines disappear.
- 0.2 gray vertical/horizontal lines are reproduced.

(Fig. 1)

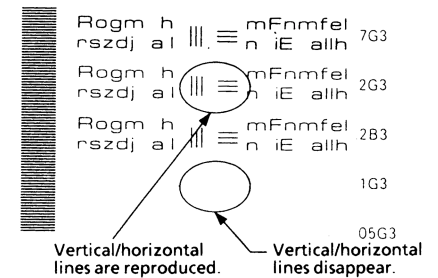

6. Go to one of the following steps per the result of the evaluation.
- Within Spec. → Perform Steps 3 through 5 in 70%/141% magnification modes.
- Out of Spec. → Proceed with the adjustment procedure.

### Adjustment

- Reference** The Exposure Light Quantity can be set up by changing the NVM value.
- Normally adjust by the [20-2] value.
  - Adjust by [20-20] in the cases below:
    - Light Quantity is unadjustable by the NVM value.
    - The Main PWB has been replaced.

**NOTE:** • Make sure to first perform the adjustment in 100% mode.

### Adjustment Flow

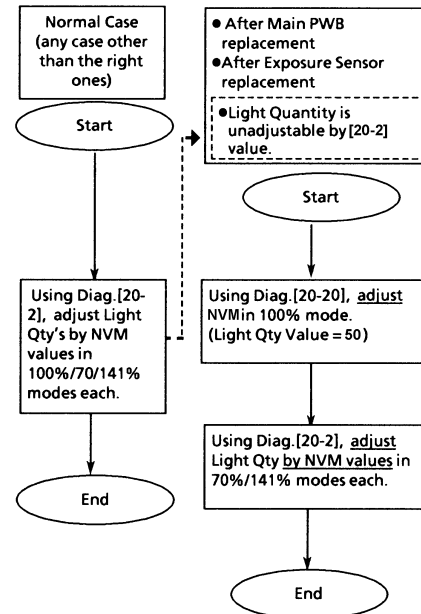

### Adjustment by NVM Value (Normal Adjustment)

- Enter Diag. Mode [20-2].
- Select 100% Magnification.
- The exposure setting is adjusted by pressing the following buttons on the keyboard:
  - Button 6 to decrease the Exposure.
  - Button 9 to increase the Exposure.
- While making the copies, adjust the exposure so that the .20 gray lines are reproduced clearly and the .10 gray lines disappear.
- When the correct setting has been achieved, press the **Start** button and make three straight copies.
- Repeat Steps 3, 4 & 5 until the results satisfy the spec. in Step 5, Check.
- When the reproduced copies meet the spec, press the **Start** button while the machine is running in Diag. Mode[20-2]. This enables the light quantity to be stored in NVM.
- Perform Steps 3 through 7 in 70%/141% modes.

### Adjustment by [20-20]

- Enter Diag. Mode [20-20].  
The Control Panel displays the following:  
Set/ Count 50
- Select 100% Magnification
- Using the keyboard, enter number:  
Increasing the number increases the exposure  
Decreasing the number decreases the exposure.
- Check the copy meets the spec in step 5 of "check" .
- Perform steps 3 to 7 of Adjustment by NVM [20-2] Value Process Normal Value.

5.1.5 ISIL Assembly Replacement

Removal

1. **WARNING:** Power off the machine and disconnect the **power cord**.
2. Open the Front Cover and then the machine.
3. Remove the Drum Unit and place a black bag over it. .... (5.1.1)
4. Remove the Deve. Unit. .... (6.2.1)
5. (Fig. 1): Remove the ISIL Assembly.

- ①. Remove P/J200.
  - ②. Remove Screw.
- NOTE:** • Do not lose Spring.
- ③. Remove ISIL.

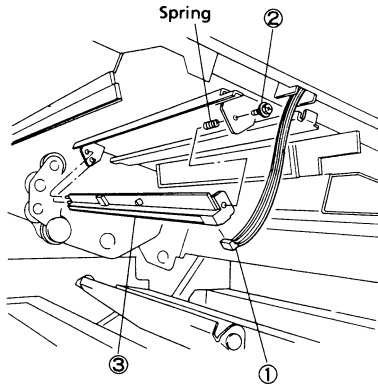

(Fig. 1)

Installation

1. Perform the installation in the reverse order of removal.
2. Perform the Rear Side Edge Erase Amount Check of the ISIL Copy Edge Erase Amount Adjustment. .... (5.1.6)

5.1.6 ISIL Copy Edge Erase Amount Adjustment

- NOTE:** • Ensure that the following adjustment is properly performed before making this adjustment:  
Lead Edge Registration Adjustment ..... (2.7.6)

Check

1. Make three size-for-size copies of Test Chart(499T247) onto A3. Check the third copy.
2. (Fig. 1): Check the erase amount.
  - 4mm along lead/trail edges
  - 4mm or less at rear

- NOTE:** • Front Side Edge Erase Amount is set by moving the Front Shield Cover of the Charge Corotron.

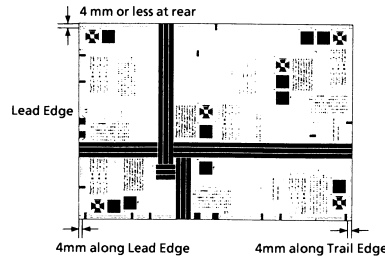

(Fig. 1)

Adjustment

Lead Edge

1. Enter Diag. Mode and key in [20-4].
2. The current set value appears.
3. Key in a new set value and press the **Start** button.

Increase the value. → The erase amount decreases.

Decrease the value. → The erase amount increases.

- The adjustable range in the Diag. Mode is 0~64.
- A step of "1" will change the erase amount by 0.2584mm.
- The initial value is 32.

Trail Edge

1. Enter Diag. Mode and key in [20-5].
2. The current set value appears.
3. Key in a new set value and press the **Start** button.

Increase the value. → The erase amount decreases.

Decrease the value. → The erase amount increases.

- The adjustable range in the Diag. Mode is 0~64.
- A step of "1" will change the erase amount by 0.2584mm.
- The initial value is 32.

Rear Side

1. Open the Front Cover.
2. (Fig. 2): Perform the ISIL Positioning Adjustment.
  - A . The erase amount decreases.
  - B . The erase amount increases.

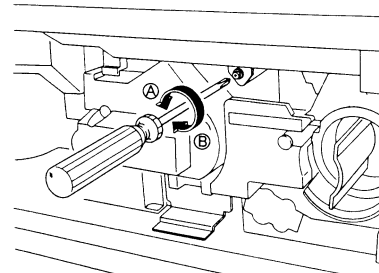

(Fig. 2)

### 6.2.1 Deve. Unit Removal/Installation

#### Removal

1. **WARNING:** Power off the machine and disconnect the **power cord**.
  2. Open the Front Cover and then the machine.
  3. (Fig. 1): Remove the Deve. Unit.
- NOTE:** • Ensure before the work that the Deve. Unit separates fully from the Drum. When you open the machine, the Deve. Unit will separate from the Drum.

- ①. Remove Screw.
- ②. Remove Deve. Unit.

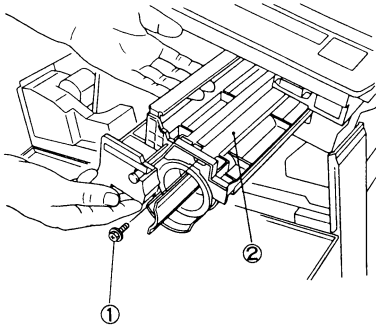

(Fig. 1)

#### Installation

1. Perform the installation in the reverse order of removal.

### 6.2.2 Mag. Roll Blade Replacement 6.2.3 Toner Empty Sensor Replacement

#### Common Procedure

#### Removal

1. **WARNING:** Power off the machine and disconnect the **power cord**.
2. Open the Front Cover and then the machine.
3. (Fig. 1): Remove the Deve. Unit. .... (6.2.1)

#### Replacement Procedure Exclusively For Mag. Roll Blade

4. (Fig. 1): Remove the Deve. Housing Upper Cover and then the Mag. Roll Blade.
- NOTE:** • Do not rotate the Mag. Roll after removing the Mag. Roll Blade, otherwise; a large quantity of toner will be spilled.

- ①. Remove Screws (5).
- ②. Remove Upper Cover.
- ③. Remove Screws(2).
- ④. Remove Mag. Roll Blade.

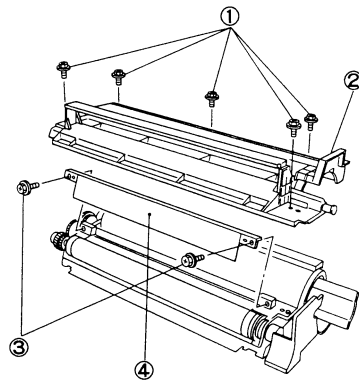

(Fig. 1)

#### Installation

1. Perform the installation in the reverse order of removal. Pay attention to the following:

- NOTE:** • Ensure that the Blade and the Mag. Roll have no foreign objects on their surfaces.
- Install the Blade flat.
  - (Fig.2): After the assembly, ensure that there are no white streaks, etc. in the Mag. Roll rotating direction, by turning the Mag. Roll Gear in the direction of arrow. If any white streaks, etc. exist, find their cause such as mixed foreign objects and remove them.

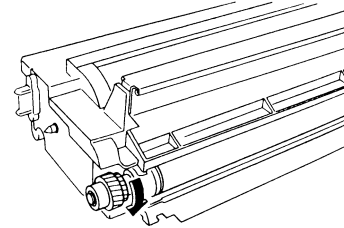

(Fig. 2)

#### Replacement Procedure for Toner Empty Sensor only

4. (Fig. 3): Remove the Toner Empty Sensor.
- NOTE:** • Take care not to cause any pressure or shock to the detection surface of the Empty Sensor.

- ①. Remove Deve. Housing Front Cover.
- ②. Remove Screws (2).
- ③. Remove Toner Empty Sensor, then disconnect P/J122.

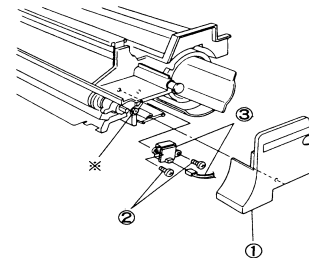

(Fig. 3)

- NOTE:** • When loosening or removing the Screw with \*, put the MSA Plate ① against the protrusion ↑ and tighten the screw ③ as shown in Fig. 4.

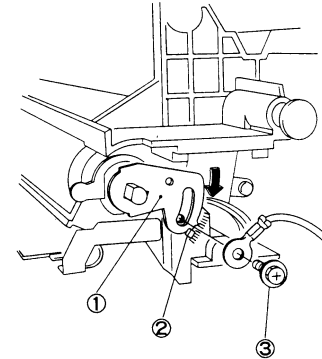

(Fig. 4)

#### Installation

1. Perform the installation in the reverse order of removal.

8.1.1 Fuser Thermostat Replacement  
8.1.2 Fuser Thermistor Replacement

Common Procedure

Removal

1. **WARNING:** Power off the machine and disconnect the **power cord**.

**WARNING**

Fuser surfaces are hot, allow the fuser to cool down before attempting service procedure. Fuser lubricant can cause discomfort to eyes. Do not allow fuser lubricant to touch eyes.

2. Open the Front Cover and then the machine:
3. Remove the Drum Unit and place a black cover over it. .... (5.1.1)
4. Remove the Left Upper Cover.
5. (Fig. 1): Remove the Main Switch Cover.

- ①. Remove Screw.
- ②. Remove Main Switch Cover.

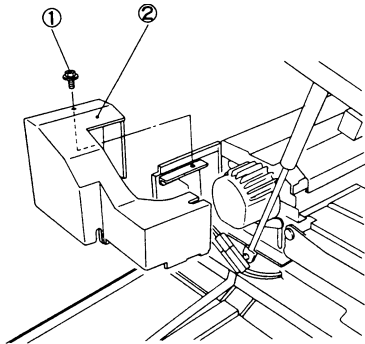

(Fig. 1)

6. (Fig. 2): Remove the Fuser Cover.

- ①. Loosen Screw.
- ②. Remove Fuser Cover.

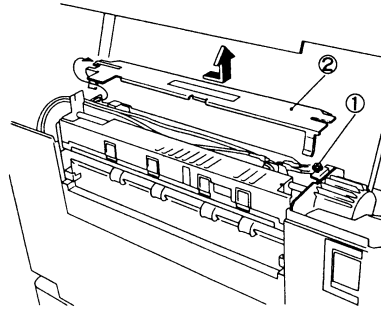

(Fig. 2)

Replacement Procedure for Thermostat only

7. (Fig. 3): Remove the Thermostat.

- ①. Remove Wire going to Thermostat.
- ②. Loosen Screws (2) and remove Sensor Bracket.
- ③. Remove Thermostat.

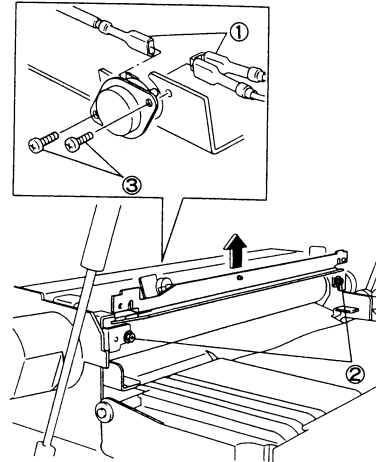

(Fig. 3)

Replacement Procedure for Thermistor only

7. (Fig. 4): Remove the Thermistor.

- ①. Disconnect P/J118.
- ②. Remove Screw and then Thermistor.

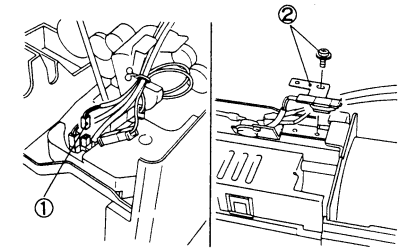

(Fig. 4)

Common Procedure

Installation

1. Perform the installation in the reverse order of removal.

### 8.2.1 Heater Rod Replacement

- NOTE:** a. Take great care in handling the Heater Rod glass tube. It is fragile.  
 b. Do not touch the Heater Rod glass tube with your bare hand(s). If you touch it, wipe it with Drum Cleaner.

#### Removal

1. **WARNING:** Power off the machine and disconnect the **power cord**.

#### WARNING

Fuser surfaces can be hot. Fuser lubricant can cause discomfort to eyes. Do not allow fuser lubricant to touch eyes.

2. Open the Front Cover and then the machine.  
 3. Remove the Drum Unit and place a black bag over it. .... (5.1.1)  
 4. Remove the Left/Rear Upper Covers.  
 5. (Fig. 1): Remove the Main Switch Cover.

- ①. Remove Screw.  
 ②. Remove Main Switch Cover.

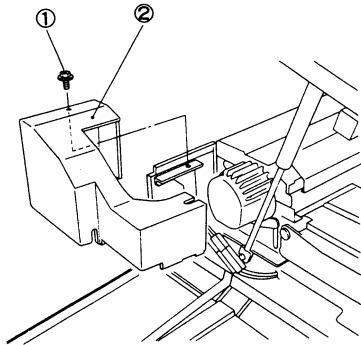

(Fig. 1)

6. Disconnect P/J's 12, & 13 from the Heater Rod.

7. (Fig. 2): Remove the Front/Rear Heater Rod Covers each.

- ①. Loosen Screw.

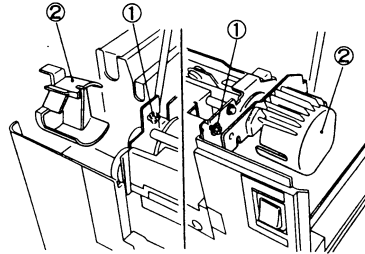

- ②. Remove Front/Rear Heater Rod Covers.

(Fig. 2)

8. (Fig. 3): Remove the Heater Rod.

- ①. Loosen Screw.  
 ②. Remove Front Support Bracket.  
 ③. Remove Heater Rod.

- NOTE:** • Hold the insulator and take out the Heater Rod.

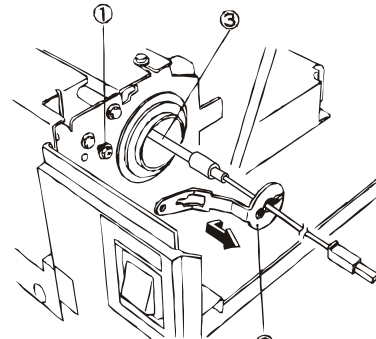

(Fig. 3)

#### Installation

1. Perform the installation in the reverse order of removal.

- NOTE:** • Determine which way(front or rear) the Heater faces by the color of the connector.



8.2.2 Heat Roller Replacement

Removal

1. **WARNING:** Power off the machine and disconnect the **power cord**.

**WARNING**

Fuser surfaces are hot, allow the fuser to cool down before attempting service procedure. Fuser lubricant can cause discomfort to eyes. Do not allow fuser lubricant to touch eyes.

2. Open the Front Cover and then the machine.
3. Remove the Drum Unit and place a black bag over it. .... (5.1.1)
4. Remove the Left/Rear Upper Covers.
5. (Fig. 1): Remove the Main Switch Cover.

- ①. Remove Screw.
- ②. Remove Main Switch Cover.

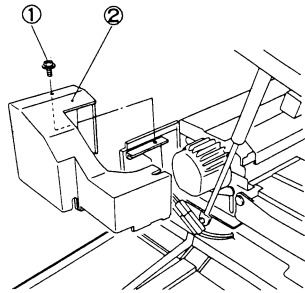

(Fig. 1)

6. (Fig. 2): Disconnect P/J117 (for Fuser Exit Switch) at rear. Remove the Fuser Cover and the Finger Assy.

- ①. Disconnect P/J117.
- ②. Loosen Screw and Remove Fuser Cover.
- ③. Loosen Screw and Remove Finger Assy.

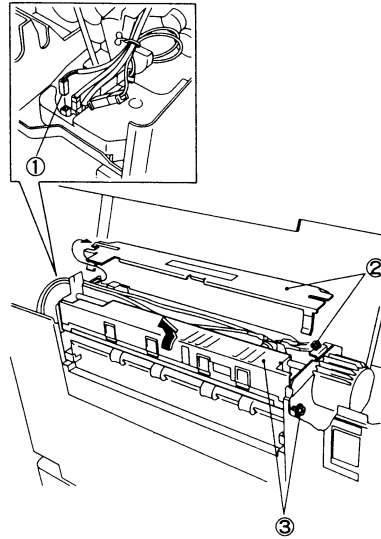

(Fig. 2)

7. (Fig. 3): Remove the Sensor Bracket.

- ①. Loosen Screws (2).
- ②. Remove Sensor Bracket.

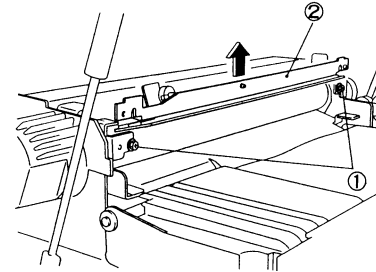

(Fig. 3)

8. Remove the Heater Rod. .... (8.2.1)
9. (Fig. 4): Remove the Heat Roller.

- ①. Remove Front/Rear Heat Roller Rings
- ②. Remove Web Washer.
- ③. Remove Heat Roller Collar.
- ④. Remove Bearing.
- ⑤. Remove Heat Roller. (Rear Gear will also be disengaged.)

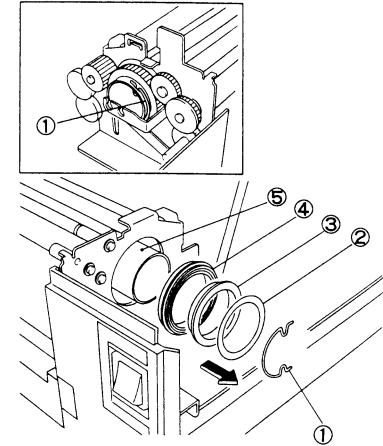

(Fig. 4)

**Installation**

1. Perform the installation in the reverse order of removal.

### 8.2.3 Pressure Roller Replacement

#### Removal

1. **WARNIN: Power off the machine and disconnect the power cord.**

#### WARNING

Fuser surfaces are hot, allow the fuser to cool down before attempting service procedure.  
Fuser lubricant can cause discomfort to eyes.  
Do not allow fuser lubricant to touch eyes.

2. Open the Front Cover and then the machine.
3. Remove the Heat Roller.....(8.2.2)
4. (Fig.1):Remove the Pressure Roller Finger Assy.
  - ①. Remove Screw (2).
  - ②. Remove the Pressure Roller Finger Assy.

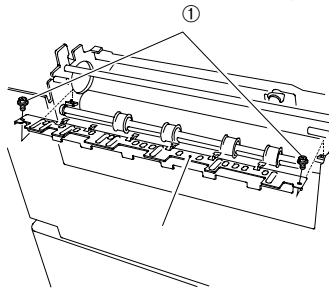

(Fig. 1)

5. (Fig.2):Remove the Pressure Roller.

- ①. Remove the Pressure Roller Finger Assy.

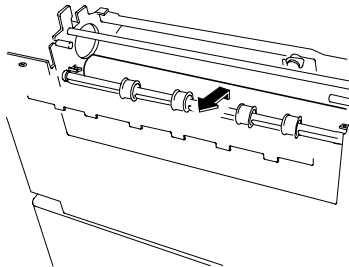

(Fig.2)

## 8.2.4 Contact Arc Adjustment

**Purpose** To obtain the appropriate fusing level.

**NOTE:** A narrow contact arc would cause improper fusing. Wide contact arc or a great difference in contact arc between front and rear would cause wrinkled or curled copies.

Check

- (Fig. 1): Make two or three copies of A4(LEF) paper with their halves solid black. Regard the copies as the measurement paper.

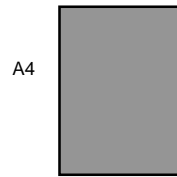

(Fig. 1)

- Make fifteen copies of Test Chart onto A3 paper to even the temperatures of the Heat Roller and the Pressure Roller.
- Put the black copy obtained from procedure No.1 on the MSI face down
- Hold the measurement paper so that it copy reaches the Heat Roll & the Pressure Roll.
- Take out the measurement paper after closing the machine for approx. 8-10 seconds
- (Fig. 2): Open the measurement paper gently. Take measurements at the positions 75 mm from the both sides of the paper respectively (at two positions on the fold made when the paper is folded into quarters with its lead edge aligning to its trail edge.)

- **Proper width of NIP**  
 $5.5 \pm 0.15 \text{ mm}$

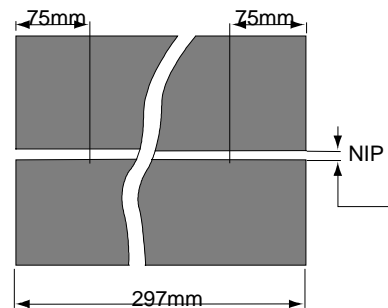

measurement paper A4LEF

(Fig. 2)

**Adjustment**

- (Fig. 3): Adjust by rotating the Adjustment Screws(at front/rear).

- Loosen Lock Nut.
- Slide the bracket.
- Tighten Lock Nut.

**NOTE:** Width of NIP increases: Slide the bracket to inside.  
Width of NIP decreases: Slide the bracket to outside.

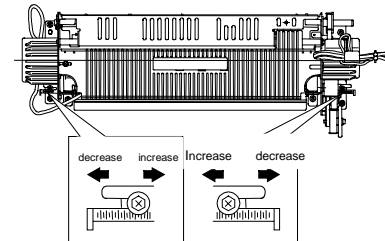

(Fig. 3)

- Adjust by repeating Check Steps 1 through 6.

**8.3.1 Heat Roller Fingers Replacement**  
**8.3.2 Pressure Roller Fingers Replacement**

**Common Procedure**

**Removal**

**1. WARNING: Power off the machine and disconnect the power cord.**

**WARNING**

Fuser surfaces are hot, allow the fuser to cool down before attempting service procedure. Fuser lubricant can cause discomfort to eyes. Do not allow fuser lubricant to touch eyes.

2. Open the Front Cover and then the machine.
3. (Fig. 1): Remove the Main Switch Cover.

- ①. Remove Screw.
- ②. Remove Main Switch Cover.

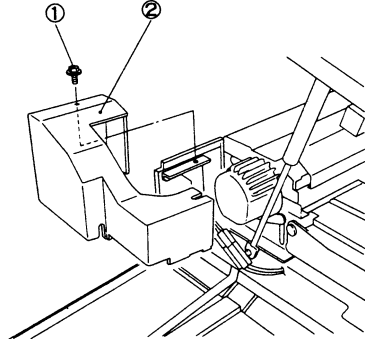

(Fig. 1)

4. (Fig. 2): Disconnect P/J117 (for Fuser Exit Switch) at rear and remove the Fuser Cover and the Finger Assy.

- ①. Disconnect P/J117.
- ②. Loosen Screw and remove Fuser Cover.
- ③. Loosen Screw and remove Finger Assy.

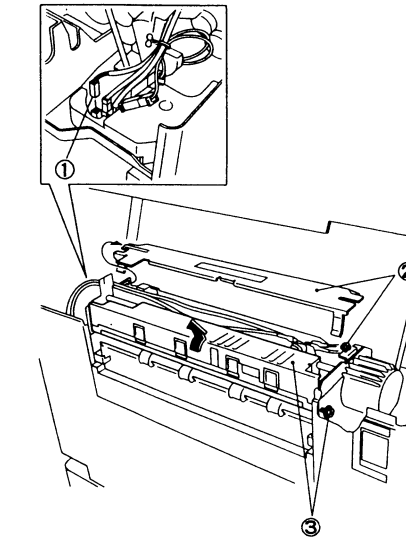

(Fig. 2)

**Replacement Procedure for Heat Roller Fingers only**

5. (Fig. 3): Remove the Heat Roller Fingers.

- ①. Remove Screws(4).
- ②. Remove KL Clips(2).
- ③. Remove Heat Roller Fingers along with their shafts.

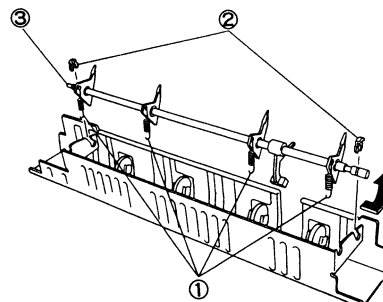

(Fig. 3)

**Installation**

1. Perform the installation in the reverse order of removal.

**NOTE:** • (Fig. 4): When installing the Shaft to the Finger Assy, pay attention to the following:

- ①. the position of the Exit Sensor actuator.
- ②. The longer hook of the spring should be installed to the Finger Assy.

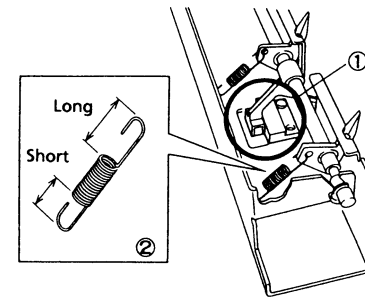

(Fig. 4)

**Replacement Procedure for Pressure Roller Fingers only**

5. (Fig. 5): Remove the Heat Roller Fingers.

- ①. Remove Screws (2).
- ②. Remove Pressure Roller Finger Assy.

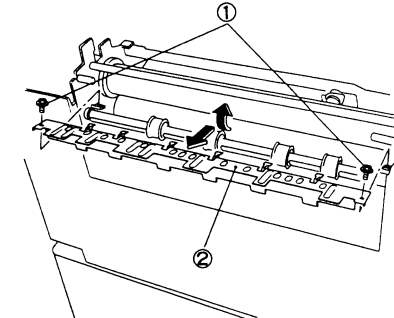

(Fig. 5)

6. (Fig. 6): Remove the Pressure Roller Fingers.

- ①. Unhook the spring end.
- ②. Pull out the Shaft
- ③. Remove the Finger.

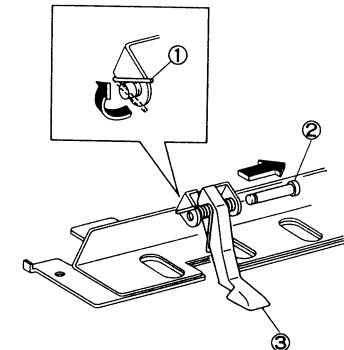

(Fig. 6)

**Installation**

1. Perform the installation in the reverse order of removal.

**NOTE:** • (Fig. 7): Install the Finger with the both ends of the Spring under the Shaft.

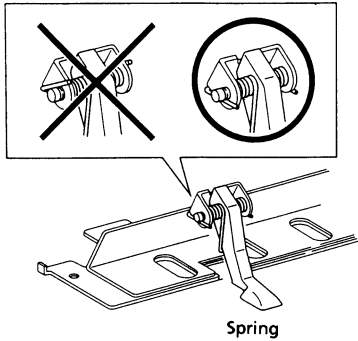

(Fig. 7)

**8.5.1 Fuser Fan Motor Assembly Replacement**

**Removal**

1. **WARNING:** Power off the machine and disconnect the **power cord**.
2. Remove the Platen Glass. .... (4.1.1)
3. Open the Front Cover and then the machine.
4. Remove the Left/Rear Upper Covers.
5. Remove the Drum Unit and place a black bag over it. .... (5.1.1)
6. Move the Full-Rate Carriage slowly to the right.
7. (Fig. 1): Loosen the Fuser Fan Motor Assy Mounting Screw.

**NOTE:** • (Fig. 2): The Vibration Preventing Damper Tapes are attached to the Fan Motor Assy securing areas. If the screws are not loose enough, you may not be able to remove the Fan Motor Assy.

- ①. Loosen Screws enough.
- ②. Remove Screw.

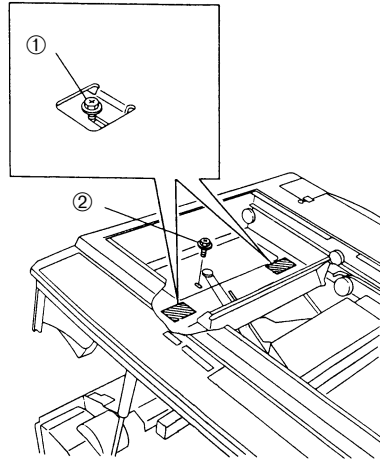

(Fig. 1)

8. (Fig. 2): Remove the Fuser Fan Motor Assy.

- ①. Disconnect P/J409 from Main PWB.
- ②. Remove Fuser Fan Motor Assy.

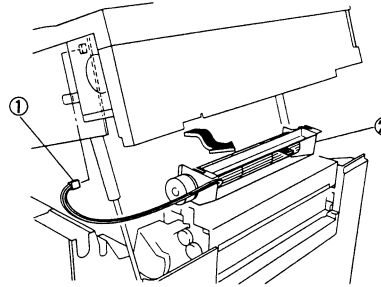

(Fig. 2)

**Installation**

1. Perform the installation in the reverse order of removal.

**CAUTION:** • Put the shock absorber of the Fan Motor. Assy against the Ozone Filter securely.

**8.5.2 Ozone Filter(Fuser Fan) Replacement**

**Removal**

1. **WARNING:** Power off the machine and disconnect the power cord.
2. Open the Front Cover and then the machine.
3. (Fig. 1): Remove the Ozone Filter.

①. Put the Filter at front by pushing the rear end of the Ozone Filter.

**NOTE:** • When you can't push out the Filter by Step ①, remove the Fuser Fan Motor Assy. .... (8.5.1)

②. Using the screwdriver in an upright position, prise out the Ozone Filter.

**NOTE:** • When removing the Ozone Filter alone without replacing it with a new one, do not use Step ②. Remove the Filter by removing the Fuser Fan Motor Assy instead.

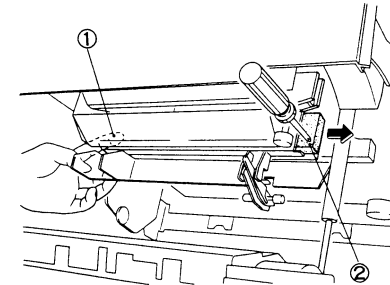

(Fig. 1)

**Installation**

1. Insert the new Filter into the area from which the old one has been removed.

### 9.1.2 Main PWB Replacement

#### Removal

1. If the machine is ready, make a copy of Table Diag. Modes from the succeeding pages.
2. Enter Diag. Mode and record the data of Chain Codes into Table Diag. Mode.

**NOTE:** • If there is any unreadable data, perform its appropriate adjustment after the replacement of the Main PWB.

3. **WARNING:** Power off the machine and disconnect the **power cord**.
4. Open the Front Cover and then machine.
5. Remove the Rear Upper Cover.
6. Disconnect all connectors from the Main PWB.
7. (Fig. 1): Remove the Main PWB.

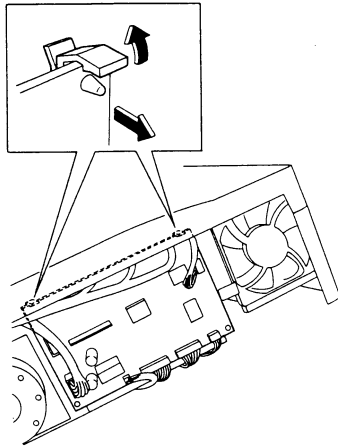

(Fig. 1)

#### Installation

1. Install the Main PWB.
2. (Fig. 2): Perform the Dip Switch(SW2) Setup.
3. Enter Diag. Mode and key in [20-96]. Perform the initialization.

**NOTE:** • The initialization is required because the new Main PWB's NVM values are unstable.

Items to be Initialized:

- ①. Set the initial value in each item of Reference Chain 20.
- ②. Set the initial value in each item of Chain 50.
- ③. Reset counters of Chain 30.
- ④. Reset the jam histories of Chain 40.

**Reference** NVM stands for Nonvolatile Memory.

4. Key-in to NVM the data recorded in the table in Removal Step 2.
5. Perform the Basic Copy Quality Adjustment.  
..... (5.1.4)

**CHAIN CODE 20 TABLE**

\* The list below deletes Function which do not need recording.

CHAIN CODE	FUNCTION CODE	SETUP ITEM	MIN. VALUE	INITIAL VALUE	MAX.VALUE	1 STEP CHANGE	ADJ
20	1	Registration Adjustment	16(-4.13mm)	32	64(+4.13mm)	0.2584mm	⊘ 2.7.6
	2	Light Quantity Adj. 100%	0	30	80	0.8%	5.1.4-A ⊘
		Enlargement/Reduction	0	50	99	0.8%	5.1.4-A ⊘
	3	Paper Loop Amount Adjustment	0(-8.27mm)	32	64(+8.27mm)	0.2584mm	
	4	ISIL Lead Edge Erase Amount Adjustment	0(-8.27mm)	32	64(+8.27mm)	0.2584mm	⊘ 5.1.6
	5	ISIL Trail Edge Erase Amount Adjustment	0(-8.27mm)	32	64(+8.27mm)	0.2584mm	⊘ 5.1.6
	6	Fine Tuning of 100% Horizontal Magnification	0(-2.272%)	32	64(+2.272%)	0.071%	⊘ 4.3.4
	7	Fine Tuning of 100% Vertical Magnification	0(-3.16%)	32	64(+3.16%)	0.099%	⊘ 4.3.4
	10	MSI Paper Loop Amount Adjustment	0(-8.27mm)	32	64(+8.27mm)	0.2584mm	-
	11	MSI Registration Adjustment	16(-4.13mm)	32	48(+4.13mm)	0.2584mm	
	14	Selection of Exposure Photoreceptor Sensitivity Correction	0(OFF)	1(ON)	1(ON)		-
	16	Bias Curve Selection 1	0	4	8		-
	17	Bias Curve Selection 2	0(slot)	1(Flat)	1(Flat)		-
	20	Light Quantity Adj.	0	50	99		5.1.4-A ⊘
	23	Drum Photoreceptor Sensitivity Correction Constant	0(0)	11(1.1)	40(4.0)	0.1	-
	30	Fuser Temperature Adjustment (Stand-by)	0(-23°C)	32	39(+5°C)	0.72°C	-
	31	Fuser Temp. Adjustment (Copy cycle)	0(-23°C)	32	39(+5°C)	0.72°C	-
	41	Density Correction Light 6	0(0V)	52(-413V)	64(-500V)	-7.8125V	-
	42	Density Correction Dark 6	0(0V)	16(-125V)	64(-500V)	-7.8125V	-
	45	Density Correction Photo Light 6	0(0V)	50(-388V)	64(-500V)	-7.8125V	-
46	Density Correction Photo Dark 6	0(0V)	24(-184V)	64(-500V)	-7.8125V	-	
96	NVM Initialization	This initializes all NVM values.					
50	9	Black band Function Time 1	0(-5.168mm)	20(+9.56mm)	64(+5.168mm)	0.2584mm	
	10	Black band Function Time 2	0(-6.732mm)	64(+10.3mm)	64(+6.732mm)	0.2584mm	

**CHAIN 30 CODE TABLE**

CHAIN CODE	FUNCTION CODE	CURRENT VALUE	COMPONENT COUNTER
30	1		Tray 1 Feed Counter
	4		MSI Feed Counter

**CHAIN 40 CODE TABLE**

CHAIN CODE	FUNCTION CODE	CURRENT VALUE	COMPONENT COUNTER
40	1		E1 JAM Counter
	2		E3 JAM Counter
	5		C1 JAM Counter
	10		C9 JAM Counter
	21		E1 JAM Counter Reset
	22		E3 JAM Counter Reset
	25		C1 JAM Counter Reset
	30		C9 JAM Counter Reset

**CHAIN 50 CODE TABLE**

CHAIN CODE	FUNCTION CODE	SETUP ITEM	SET VALUE	CONTENT	EXPLANATION
50	1	Toner Touch Up Function	0	inhibit	Only when the new Drum unit is installed, this sets up Toner Touch Up Function at the start of copying to prevent Talc Deletion.
			*1	execute	
	2	Nation Configuration Setup	0	XC	This supplements a lack of the exposure light quantity by the Deve. Bias when it doesn't reach its target value.
			1	KX	
			*2	AP	
	4	Black Band Creation Function	0	execute	Create a black band of Toner on the Drum to prevent Talc Deletion.
			*1	execute	
			2	execute	
			3	inhibit	
	6	Related Products' L6 Detection	*0	No	This temporarily inhibits the detection of L6 when changes are made to specification setups of the machine.
			1	Yes	
	7	Fuser Warm Up Function	*0	Inhibit	At the start of an initial copy with the power on, this warms up the Fuser by rotating the Main Motor for 20 sec .
			1	execute	
	8	Copy density selection	0	13Phase	In case of KX
			*1	7Phase	In case of AP
	9	Black Band Function Time1	0~40	20	
10	Black Band Function Time2	0~40	20		
20	Fuser Over Heat Failure Clearance	0	Cancellation	U4-6(Fuser Over Heat Fail) will be cleared.	
		1	Cancellation		
		1	Cancellation		
86	Machine Administrator Reset	-	-	Set to "1111".	



## 9.1.3 LVPS Replacement

**Removal**

1. **WARNING:** Power off the machine and disconnect the **power cord**.
2. Remove the Rear Lower Cover.
3. (Fig. 1): Remove LVPS.

- ①. Disconnect all connectors from LVPS.
- ②. Remove Screws(2).
- ③. Remove LVPS.

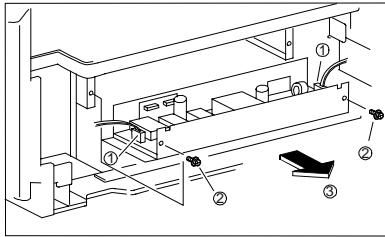

(Fig. 1)

**Installation**

1. Perform the installation in the reverse order of removal.

## 9.1.4 AC Drive PWB Replacement

**Removal**

1. **WARNING:** Power off the machine and disconnect the **power cord**.
2. Remove the Rear Upper Covers.
3. (Fig. 1): Remove AC Drive PWB .

- ①. Remove Screws(2).
- ②. Remove AC Drive PWB Cover.
- ③. Disconnect all connectors from AC Drive PWB and Remove it.

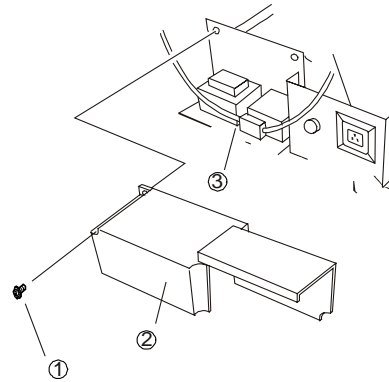

(Fig. 1)

**Installation**

1. Perform the installation in the reverse order of removal.

### 10.1.1 Front Gas Spring Replacement

#### Removal

1. Power off the machine and disconnect the Power Plug.
2. Remove the Console Assembly. .... (10.2.1)
3. Open the machine.
4. (Fig. 1): Remove the Main Switch Cover.
  - ①. Loosen Screw and remove Cover.

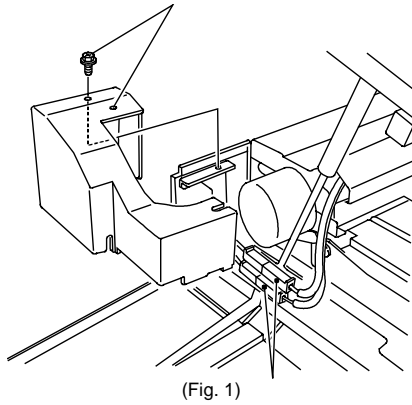

5. (Fig. 2): Set the Stopper under the Rear Gas Spring.

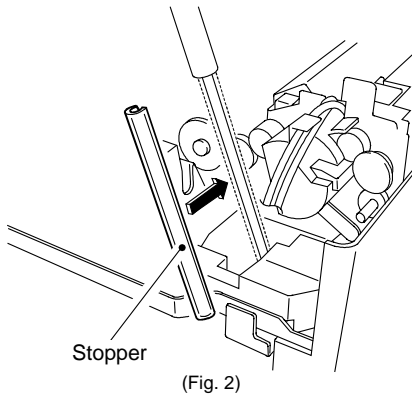

7. (Fig. 3): Remove the Front Gas Spring.

- ①. Remove E Clip from bottom end of Gas Spring.
- ②. Remove E Clip from top end of Gas Spring.
- ③. Remove Gas Spring.

**WARNING:** • Never lift the upper part of the machine after removing the Front Gas Spring. Because the Rear Gas Spring is not secured either at top or at bottom, the Spring would unhook, causing the M/C upper part to fall down, thus resulting in a possible injury.

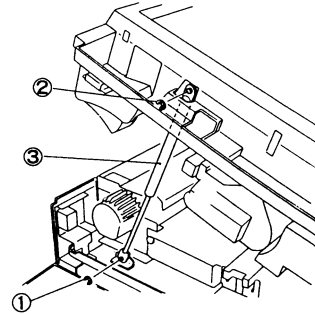

#### Installation

1. Perform the installation in the reverse order of removal.

### 10.1.2 Rear Gas Spring Replacement

#### Removal

1. Power off the machine and disconnect the Power Plug.
2. Open the Front Cover and then machine.
3. (Fig. 1): Set the Stopper under the Front Gas Spring

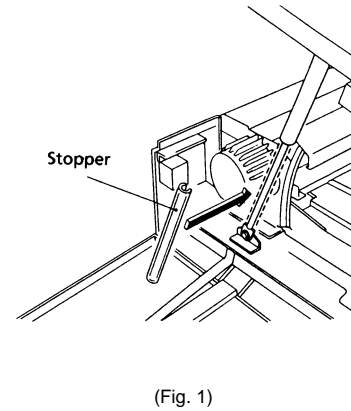

4. Remove the Left/Rear Upper Covers.
5. Disconnect P/J14 (for Heater Rod), P/J117 (for Fuser Exit Switch) and P/J118 (for Fuser Thermistor) from the AC Drive Chassis.

6. (Fig. 2): Remove the Rear Gas Spring.

- ①. Remove the top end of Gas Spring while lifting the M/C upper part.
- ②. Pull out the bottom end of Gas Spring and remove Gas Spring from M/C.

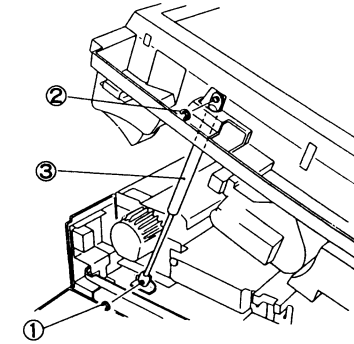

#### Installation

1. Insert the Rear Gas Spring top end at the back of Main PWB while lifting the M/C upper part. Do not install the top end of the Shaft here.
2. Insert the Gas Spring bottom end into the Gas Spring hole.
3. Install the Gas Spring top end in the Shaft.
4. Restore the machine to its original state by reversing the removal procedure.

10.2.1 Console Assembly Replacement

Removal

1. **WARNING:** Power off the machine and disconnect the **power cord**.
2. Open the Front Cover.
3. (Fig. 1): Remove the Console Assembly.
  - ①. Remove Screws(3).
  - ②. Disconnect P/J's 417/418.
  - ③. Remove Console Assy.

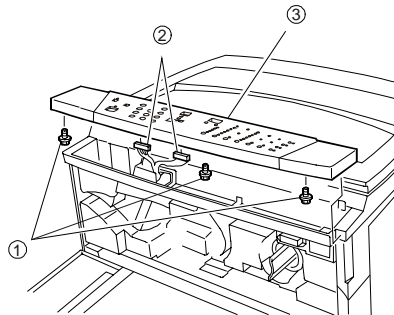

(Fig. 1)

Installation

1. Perform the installation in the reverse order of removal.

10.2.2 Top Cover Removal/Installation

Removal

1. **WARNING:** Power off the machine and disconnect the **power cord**.
2. Remove the Platen Cover .
3. Remove the Platen Glass. .... (4.1.1)
4. Remove the Console Assy. .... (10.2.1)
5. Remove the Drum Unit and place a black bag over it. .... (5.1.1)
6. Remove the Deve. Unit. .... (6.2.1)
7. Disconnect P/J200 from ISIL.
8. (Fig. 1): Remove the Top Cover.

- ①. Remove Screws(4).
- ②. Disconnect the following:  
P/J209  
T64,T65(for Front Interlock Switch)  
P/J100(for Optical Regi. Sensor)
- ③. Remove Screw and Ground Wire.
- ④. Remove Top Cover.

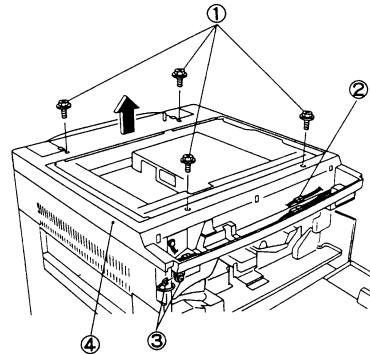

(Fig. 1)

Installation

1. Perform the installation in the reverse order of removal.

## **Section 5 Parts List**

## Section 5 Parts List

**Preface** ..... 5-2

### **PL-1 DRIVE**

- 1.1 Main Drives(1) ..... 5-3
- 1.2 Main Drives(2) ..... 5-4

### **PL-2 PAPER HANDLING**

- 2.1 Paper Cassettes Assembly ..... 5-5
- 2.2 Multi Sheet Inserter Assembly ..... 5-6
- 2.3 MSI Upper Assembly ..... 5-7
- 2.4 RH Transport Cover & Paper Chute ..... 5-8
- 2.5 Feeder Assembly ..... 5-9
- 2.6 Upper Chute Assembly ..... 5-10
- 2.7 Registration Chute Assembly ..... 5-11

### **PL-3 PAPER TRANSPORT**

- 3.1 Vacuum Transport Assembly ..... 5-12

### **PL-4 OPTICAL**

- 4.1 Optical Assembly ..... 5-13
- 4.2 Optical Drive ..... 5-14
- 4.3 Full Rate & Half Rate Carriage ..... 5-15
- 4.4 Mirror Carriage ..... 5-16
- 4.5 Lens Carriage ..... 5-17

### **PL-5 XEROGRAPHIC**

- 5.1 XERO Module Assembly ..... 5-18
- 5.2 TC/DTC Corotron ..... 5-19

### **PL-6 DEVELOPMENT**

- 6.1 Deve Mechanism ..... 5-20
- 6.2 Deve Assembly ..... 5-21

### **PL-8 FUSER**

- 8.1 Inlet Chute & Temperature Control ..... 5-22
- 8.2 Heat Roller ..... 5-23
- 8.3 Paper Exit ..... 5-24
- 8.4 Upper Frame & Receiving Tray ..... 5-25
- 8.5 Fuser Fan Motor & Ozone Filter ..... 5-26

### **PL-9 ELECTRICAL**

- 9.1 Rear Side (1) ..... 5-27
- 9.2 Rear Side (2) ..... 5-28

### **PL-10 FRAME & COVER**

- 10.1 Gas Spring & Latch Lever ..... 5-29
- 10.2 Console & Top, Platen Cover ..... 5-30
- 10.3 Front & Left Hand ..... 5-31
- 10.4 Rear & Right Hand ..... 5-32

Hardware ..... 5-33

Parts number index ..... 5-35

5.1 Preface

5.1.1

Section 5 Parts List contains information on XEROX 5915 main Processor and Spare Parts.  
Use this section for applying for replacement spare parts and entering area codes.

5.1.2 Plate Structure

Each plate is constructed as follows:

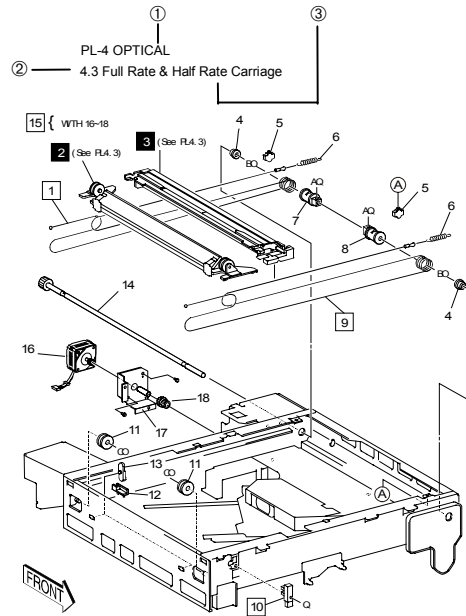

- ① PLATE NAME            MODULE NAME
- ② SUB PLATE No. .... Parts List reference No. as described in each Section.
- ③ SUB PLATE NAME ..... Art title of the Plate dividing the module.
- ④ ITEM ..... Shows the number in the Art for the same plate.
- ⑤ PART No. .... Nos. to be used for ordering parts and entering the Service Report.
- ⑥ DESCRIPTION ..... Describes the Part Name, V code and Note.

④ ITEM	⑤ PART NO	⑥ DESCRIPTION
1	12E 93380	REAR CARRIAGE CABLE (CABLE SCAN IN)
2	41S 50210	HALF RATE CARRIAGE ASSY (SEE PL4.3)
3	41S 50211	FULL RATE CARRIAGE ASSY (SEE PL4.3)
4	413W 77559	BEARING
5	113E 16680	HOLDER CABLE
6	8P 20224	SPRING EXT
7	20E 21721	PULLEY CAPSTAN
8	20E 22063	PULLEY CAPSTAN OUT
9	12E 93390	CABLE SCAN OUT
10	130E 80970	SENSOR REGI OPT
11	20K 94411	PULLEY IDLER METAL
12	- -	FULL RATE ADJUST BLOCK (REF ONLY)
13	- -	HALF RATE ADJUST BLOCK (REF ONLY)
14	6K 82301	SHAFT ASSY DRIVE
15	68S 50270	MOT SCAN ASSY (WITH 16-18)
16	127S 50222	MOT SCAN
17	68S 50269	BRKT MOT SCAN
18	7E 94981	GEAR

5.1.3 Symbols and Marks

Symbols Marks	
With 2~10	Shows assembly parts containing "Item 2~10".
DETAIL "A"	Shows detailed illustration of "A".
SEE PLxx	For a part item related, indicates to refer to an appropriate PL No.
1	Shows that removal and installation procedure are included in the Service Manual.
1	Shows that the adjustment procedure is included in the Service Manual.
12	Shows that the removal, installation, and adjustment procedure are included in the Service Manual.
	Shows that the leader lines a is connected to another leader lines a as described.
(P/O Item)	Shows correction part for Item 1. Replace Item 1 as required.

**PL-1 DRIVE**  
**1.1 Main Drive(1)**

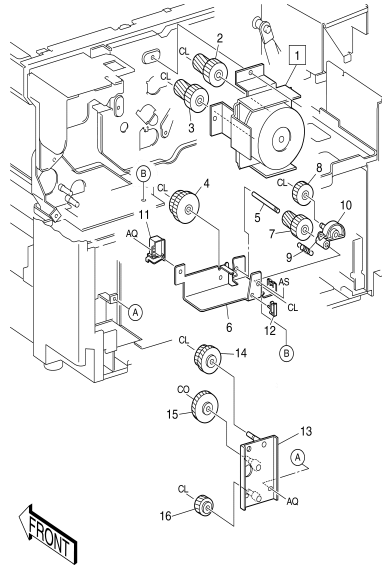

ITEM	PART NO.	DESCRIPTION
1	127K 87031	MOTOR ASSY MAIN (WITH 2,3)
2	7E 35210	DRUM GEAR
3	7E 35200	MAIN MOTOR GEAR
4	7E 27680	GEAR HELICAL T36/T41
5	- -	SHAFT (REF ONLY)
6	- -	BRACKET (REF ONLY)
7	7E 41270	GEAR T18/34
8	7E 41280	GEAR T22
9	9E 76500	SPRING EXTENSION
10	12E 97580	LINK ASSY
11	121E 84454	MSI SOLENOID ASSY
12	- -	SADDLE (REF ONLY)
13	- -	BRACKET
14	7E 27970	GEAR SPUR T35/28
15	7E 32890	GEAR T40
16	7E 28000	GEAR-T21

PL-1 Drive  
1.2 Main Drive (2)

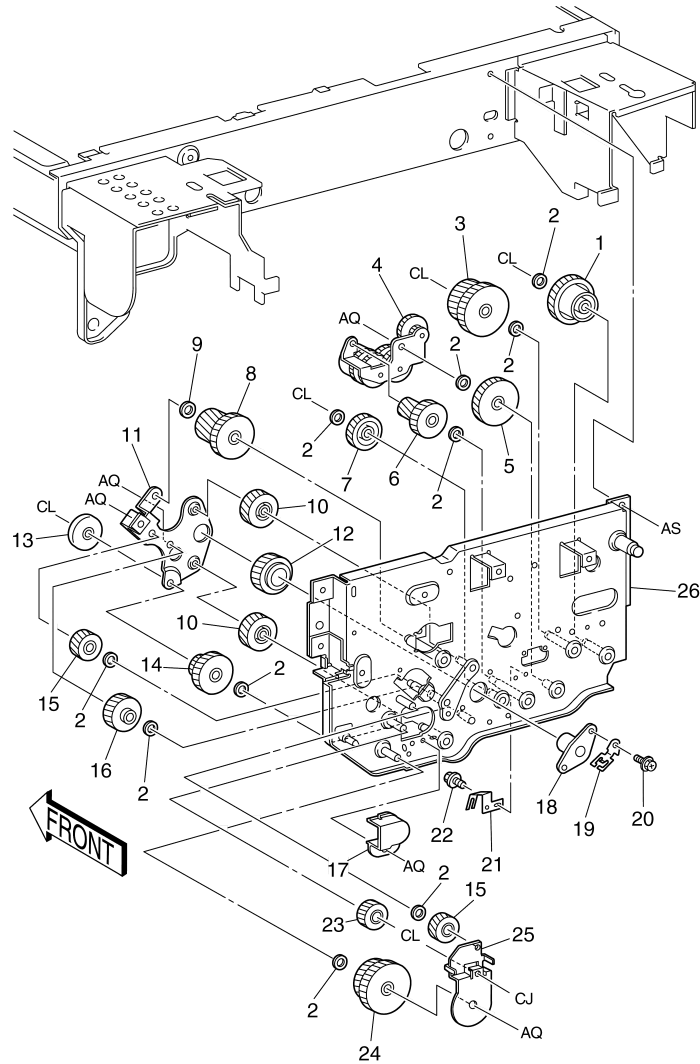

ITEM	PART NO.	DESCRIPTION
1	7E 32461	GEAR T36
2	- -	WASHER(REF ONLY)
3	7E 30530	GEAR-SPUR.T41/35
4	68K 85541	BRACKET ASSY (REF ONLY)
5	7E 32961	GEAR T36
6	7E 28881	GEAR-T25/16
7	7E 32981	GEAR T27
8	7E 22910	GEAR-T37/23
9	- -	WASHER(REF ONLY)
10	7E 33020	GEAR SPUR T25
11	- -	GEAR BRACKET(REF ONLY)
12	7E 32450	GEAR T28
13	22E 83690	ROLLER
14	7E 32970	GEAR T18/32
15	7E 32951	GEAR HELICAL T19R
16	7E 33010	GEAR HELICAL T25
17	- -	SUPPORT BRACKET(REF ONLY)
18	13E 92520	BEARING-DRUM
19	- -	EARTH PLATE(REF ONLY)
20	- -	SCREW M3x8 (REF ONLY)
21	- -	EARTH PLATE(REF ONLY)
22	- -	SCREW(REF ONLY)
23	7E 32990	GEAR T23
24	7E 33000	GEAR T30/T44
25	- -	GEAR BRACKET
26	- -	DRIVE FRAME(REF ONLY)



**PL-2 PAPER HANDLING**  
**2.1 Paper Cassette Assembly**

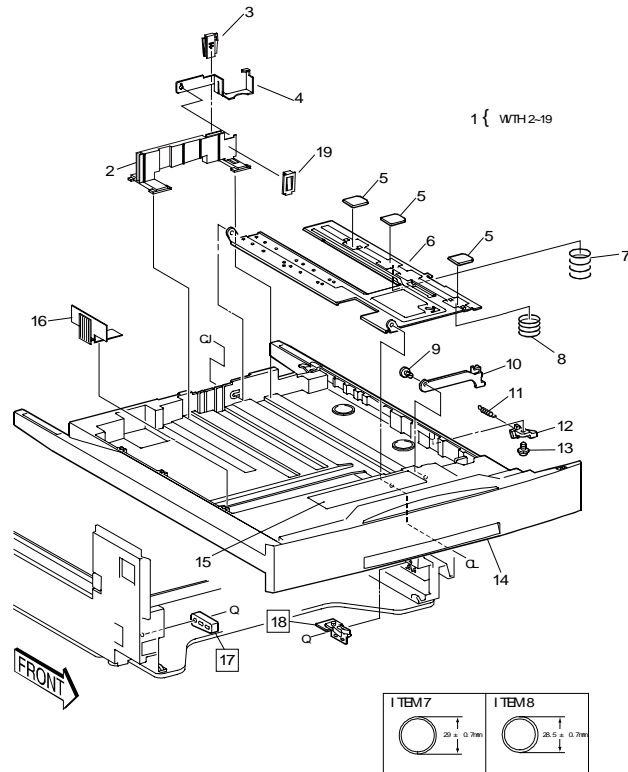

ITEM	PART NO.	DESCRIPTION
1	50S 20240	CASSETTE ASSY
2	38P 50216	GUIDE ASSY-SIDE
3	9P 50223	SPRING
4	19P 50218	SNUBBER-R
5	19E 93480	PAD-SIDE
6	49P 50212	PLATE BOTTOM
7	9P 50222	SPRING-N/F
8	9P 50221	SPRING-N/F
9	3P 63172	STOPPER
10	19P 50217	SNUBBER-F
11	- -	SPRING(REF ONLY)
12	12E 93400	LINK
13	- -	TAPPING SCREW(REF ONLY)
14	50P 50237	CASSETTE
15	- -	INSTRUCTION LABEL
16	38P 50217	GUIDE-END
17	3E 30040	STOPPER CASSETTE
18	68K 85602	BRKT ASSY
19	9P 50213	SPRING

**PL-2 PAPER HANDLING**  
**2.2 Multi Sheet Inserter Assembly**

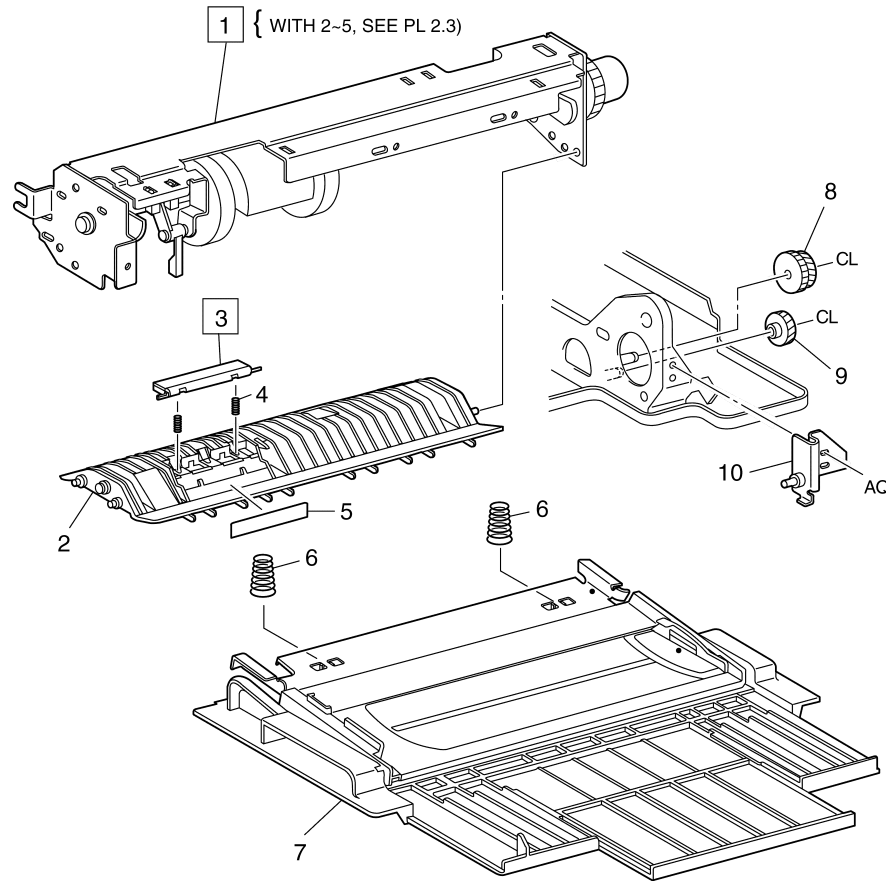

ITEM	PART NO.	DESCRIPTION
1	22S 50256	MSI FEEDER ASSY (WITH 2-5) (SEE PL2.3)
2	54E 09243	CHUTE-MSI AP 220V
3	19S 50212	PAD ASSY RETARD
4	9E 78271	SPRING
5	19E 42170	FILM CHUTE
6	9E 78782	SPRING N/F MSI
7	50S 50238	TRAY ASSY MSI
8	7E 32871	GEAR-T29/28
9	7E 27521	GEAR-SKEW T22
10	- -	SUPPORT(REF ONLY)

**PL-2 PAPER HANDLING**  
**2.3 MSI Upper Assembly**

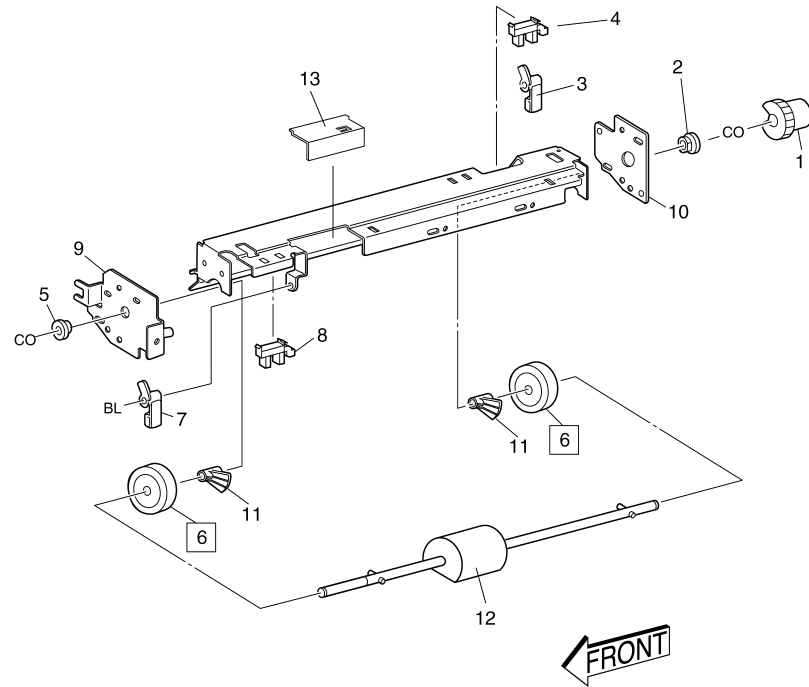

ITEM	PART NO.	DESCRIPTION
1	7K 85620	GEAR PICK UP
2	13E 84520	BEARING
3	120E 13150	MSI ACTUATOR
4	107E 06650	MSI SIZE SENSOR
5	13E 84490	BEARING
6	22E 84350	ROLL CORE
7	120E 09921	ACTUATOR N.P
8	107E 06650	SENSOR
9	- -	FRONT BRACKET ASSY(REF ONLY)
10	- -	REAR BRACKET ASSY (REF ONLY)
11	8E 93751	CAM PICK-UP
12	6S 50220	SHAFT ASSY PICK UP
13	802E 05051	COVER ROLL

**PL-2 PAPER HANDLING**  
**2.4 RH Transport Cover & Paper Chute**

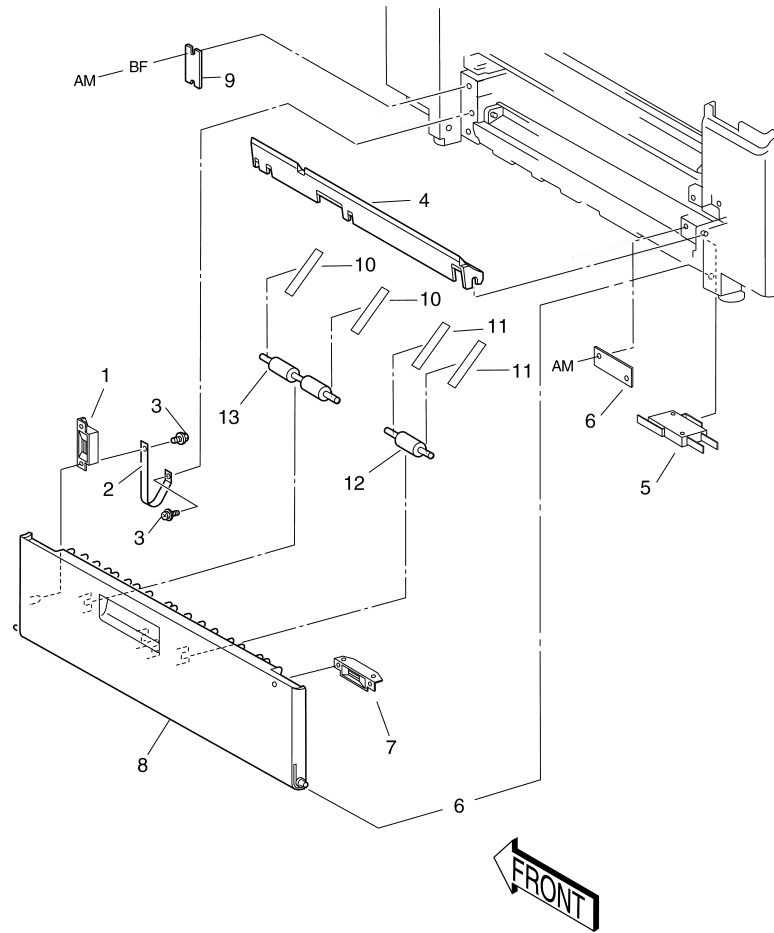

ITEM	PART NO.	DESCRIPTION
1	121E 83330	MAGNET CATCH
2	63P 50206	TAPE STOPPER
3	- -	SCREW(REF ONLY)
4	54E 82040	CHUTE-FEED
5	110P 50202	SWITCH-SPOT MINIATURE
6	- -	PLATE COVER(REF ONLY)
7	121E 83312	MAGNET CATCH
8	48P 50237	COVER R/H
9	- -	PLATE COVER(REF ONLY)
10	9P 50214	SPRING FRONT
11	9P 50215	SPRING BACK
12	22E 81851	ROLLER-PINCH
13	22E 81861	ROLLER-PINCH

**PL-2 PAPER HANDLING**  
**2.5 Feeder Assembly**

<b>ITEM</b>	<b>PART NO.</b>	<b>DESCRIPTION</b>
1	22S 50260	FEEDER ASSY H/M (WITH 2-21)
2	22K 46310	ROLLER ASSY-TRANS
3	13E 84490	BEARING
4	59K 03261	ROLL ASSY FEED
5	- -	WASHER(REF ONLY)
6	7E 41593	GEAR PICK UP-FEED
7	9E 76810	SPRING PICK-UP
8	7E 41571	GEAR-T28
9	3E 35531	STOPPER
10	13E 84490	BEARING
11	6P 50236	SHAFT FEED ROLL
12	9E 65960	SPRING
13	12E 97890	LINK-SOL
14	121K 16860	SOLENOID ASSY
15	107E 06650	PHOTO INTERRUPT
16	120E 99400	ACTUATOR-SNR
17	- -	COVER(REF ONLY)
18	- -	FRAME ASSY(REF ONLY)
19	7K 83521	DRIVE ASSY
20	7E 34950	GEAR IDLER T17
21	22P 50262	PINCH

PL-2 PAPER HANDLING  
2.6 Upper Chute Assembly

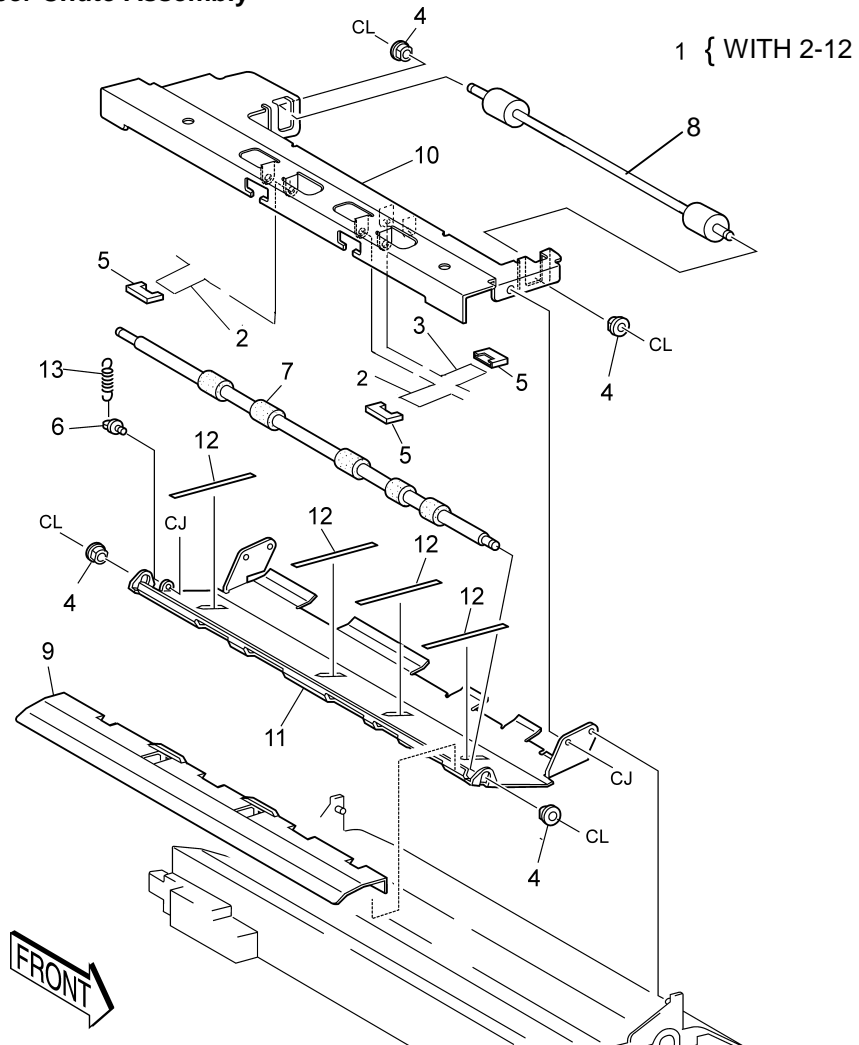

ITEM	PART NO.	DESCRIPTION
1	54K 08210	UPPER CHUTE ASSEMBLY (WITH 2~12)
2	- -	TORSION SPRING
3	- -	TORSION SPRING
4	13E 80030	BEARING
5	13E 93670	BEARING
6	- -	HOOK (REF ONLY)
7	22K 49970	ROLL ASSY-REGI PINCH
8	22K 47662	ROLL ASSY PRE-REGI PINCH
9	32E 99342	CHUTE-GUIDE
10	- -	PINCH SUPPORT (REF ONLY)
11	- -	CHUTE UP (REF ONLY)
12	- -	FILM CHUTE (REF ONLY)
13	9E 65760	SPRING

**PL-2 PAPER HANDLING**  
**2.7 Registration Chute Assembly**

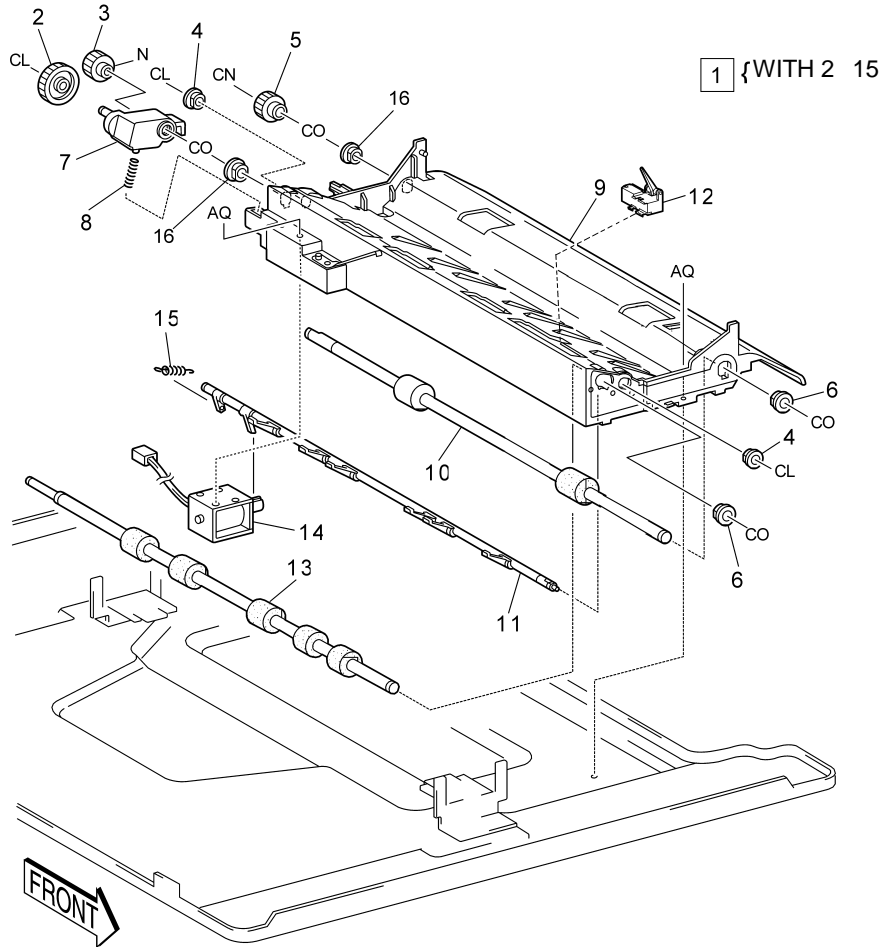

ITEM	PART NO.	DESCRIPTION
1	54K 16331	REGISTRATION LOW CHUTE ASSY (WITH 2-15)
2	7E 32360	GEAR-T27
3	7E 32940	GEAR-T18
4	13E 80030	BEARING
5	7E 32930	GEAR-18
6	13E 84520	BEARING
7	12K 93160	LINK-STUD
8	9E 65810	SPRING
9	54E 08345	CHUTE-LOW REGI
10	22K 47222	ROLL ASSY-PRE,REGI
11	50K 28751	GATE ASSY-REGI
12	130K 56130	SENSOR REGI
13	22K 47211	ROLL ASSY-REGI
14	121K 22340	SOLENOID ASSY
15	9E 65800	SPRING GATE
16	13E 84490	BEARING

**PL-3 PAPER TRANSPORT**  
**3.1 Vacuum Transport Assembly**

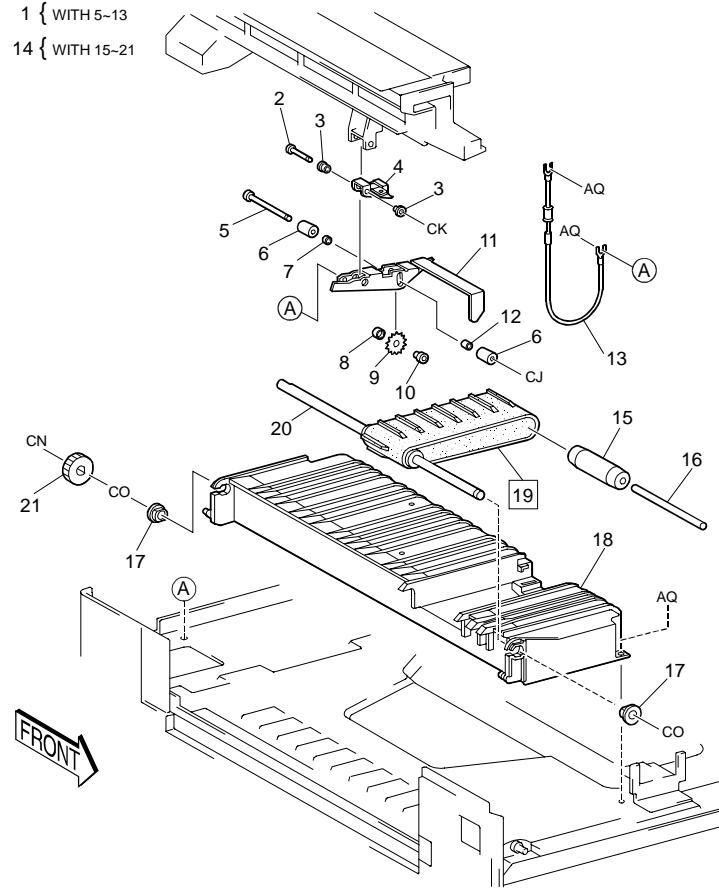

ITEM	PART NO.	DESCRIPTION
1	20K 94292	WHEEL ASSY(WITH 5-13)
2	6E 47160	SHAFT WHEEL
3	13E 84130	BEARING
4	49E 40130	BRKT STOPPER
5	- -	WHEEL SHAFT (P/O ITEM 1)
6	- -	WHEEL WEIGHT (P/O ITEM 1)
7	- -	SPACER (P/O ITEM 1)
8	- -	TUBE (P/O ITEM 1)
9	20E 21860	WHEEL METAL
10	- -	TUBE (P/O ITEM 1)
11	- -	WHEEL SUPPORT (P/O ITEM 1)
12	- -	SPACER (P/O ITEM 1)
13	103K 80361	REGISTOR ASSY
14	1S 50286	FRAME ASSY-TRANSPORT (WITH15-21)
15	22E 19430	ROLL IDLER
16	- -	SHAFT (P/O ITEM 14)
17	13E 84490	BEARING
18	- -	VACUUM TRANSPORT ASSEMBLY (P/O ITEM 14)
19	23E 12250	VACUUM TRANSPORT BELT
20	- -	SHAFT(P/O ITEM 14)
21	7E 32421	GEAR-24T



**PL-4 OPTICAL**  
**4.1 Optical Assembly**

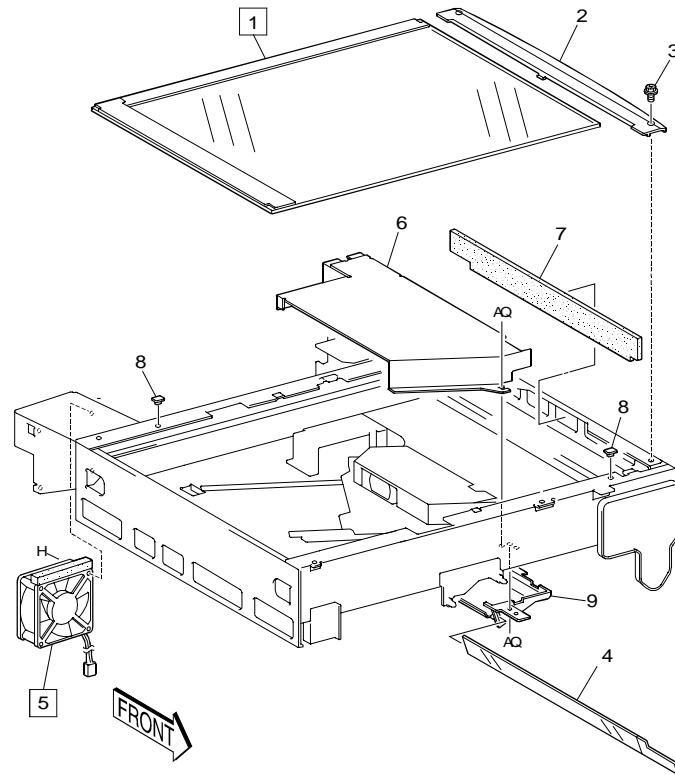

ITEM	PART NO.	DESCRIPTION
1	90S 50209	GLASS ASSY PLATEN
2	15P 50249	PLATE GLASS
3	- -	SCREW(REF ONLY)
4	57K 90521	SEAL GLASS
5	127S 50224	FAN ASSY OPT
6	55K 20881	SHIELD ASSY OPTIC
7	53E 91530	FILTER-RIGHT
8	14P 61844	PLATEN SPACER
9	48E 17460	COVER GLASS SEAL

PL-4 OPTICAL  
4.2 Optical Drive

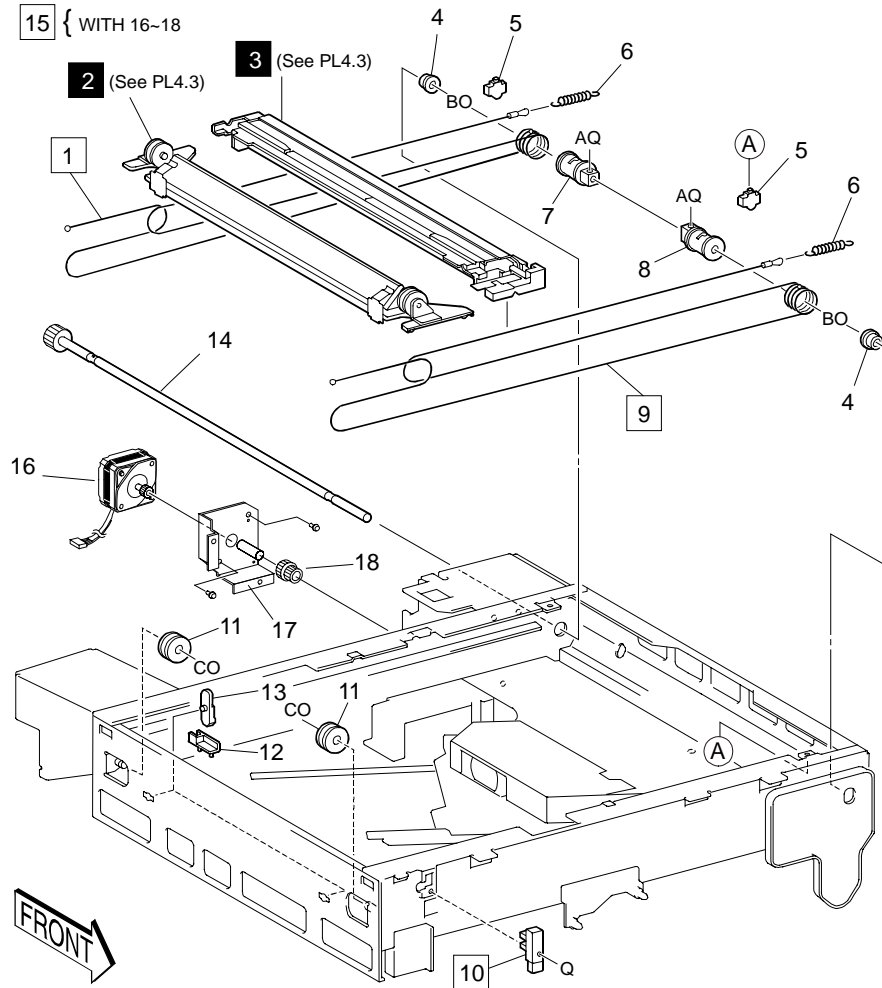

ITEM	PART NO.	DESCRIPTION
1	12E 93380	REAR CARRIAGE CABLE (CABLE SCAN IN)
2	41S 50210	HALF RATE CARRIAGE ASSY (SEE PL4.3)
3	41S 50211	FULL RATE CARRIAGE ASSY (SEE PL4.3)
4	413W 77559	BEARING
5	113E 16680	HOLDER CABLE
6	9P 20224	SPRING EXT
7	20E 21721	PULLEY CAPSTAN
8	20E 22063	PULLEY CAPSTAN OUT
9	12E 93390	CABLE SCAN OUT
10	130E 80970	SENSOR REGI OPT
11	20K 94411	PULLEY IDLER METAL
12	- -	FULL RATE ADJUST BLOCK (REF ONLY)
13	- -	HALF RATE ADJUST BLOCK (REF ONLY)
14	6K 82301	SHAFT ASSY DRIVE
15	68S 50270	MOT SCAN ASSY (WITH 16-18)
16	127S 50222	MOT SCAN
17	68S 50269	BRKT MOT SCAN
18	7E 94981	GEAR

**PL-4 OPTICAL**

**4.3 Full Rate & Half Rate Carriage**

**1** { WITH 2-7

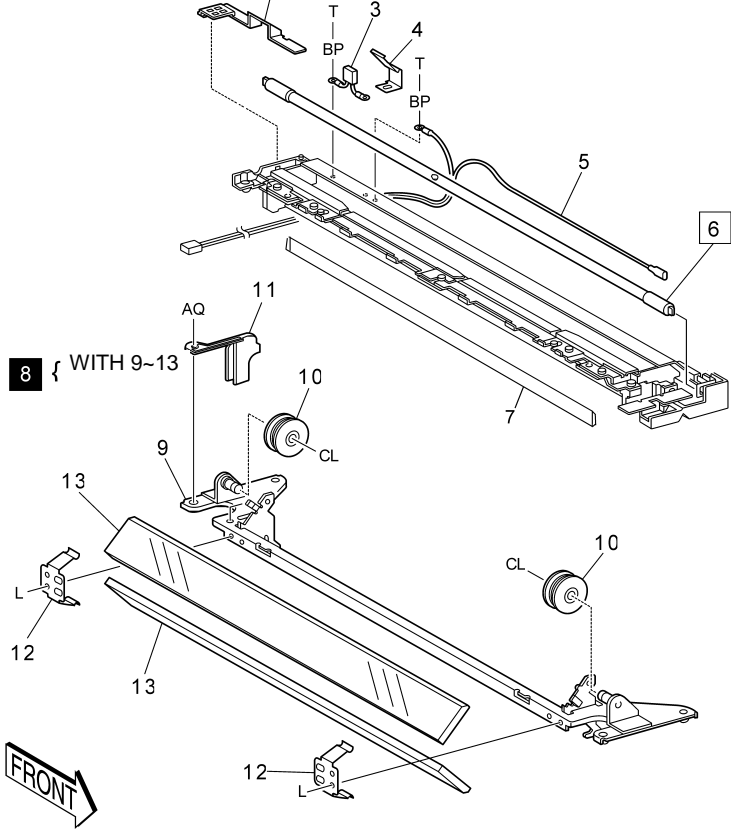

ITEM	PART NO.	DESCRIPTION
1	41S 50211	FULL RATE CARRIAGE ASSY (WITH 2-7)
2	48E 20972	COVER CONTACT IN
3	108K 90710	FUSE ASSY EXP
4	9E 65820	SPRING FUSE
5	162K 12611	CABLE ASSY
6	122P 50201	LAMP HALOGEN
7	62E 93400	MIRROR # 1
8	41S 50210	HALF RATE CARRIAGE ASSY (WITH 2-7)
9	- -	HALF RATE CARRIAGE (P/O ITEM 8)
10	20K 94441	CARRIAGE CABLE PULLEY
11	113E 16410	CORD PULLEY
12	- -	MIRROR SPRING (P/O ITEM 8)
13	62E 93420	NO.2,3 MIRROR

PL-4 OPTICAL  
4.4 Mirror Carriage

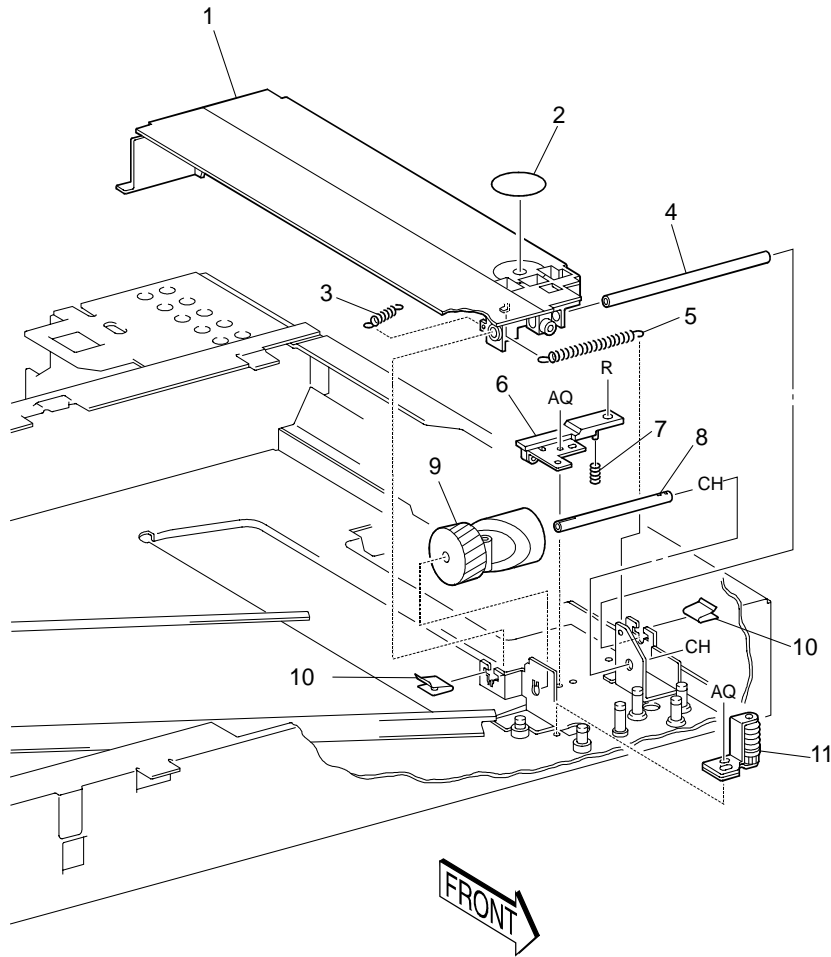

ITEM	PART NO.	DESCRIPTION
1	- -	NO.4 MIRROR ASSY (REF ONLY)
2	35E 30190	SEAL
3	9E 65650	SPRING NO. 4 HSG
4	- -	SHAFT (REF ONLY)
5	9E 65360	SPRING EXTENSION
6	- -	ANGLE PLATE (REF ONLY)
7	9E 65610	SPRING
8	6E 57190	SHAFT CAM
9	20E 24480	WORM WHEEL
10	9E 65600	SPRING NO. 4 SHAFT
11	15K 87900	WORM GEAR

**PL-4 OPTICAL**  
**4.5 Lens Carriage**

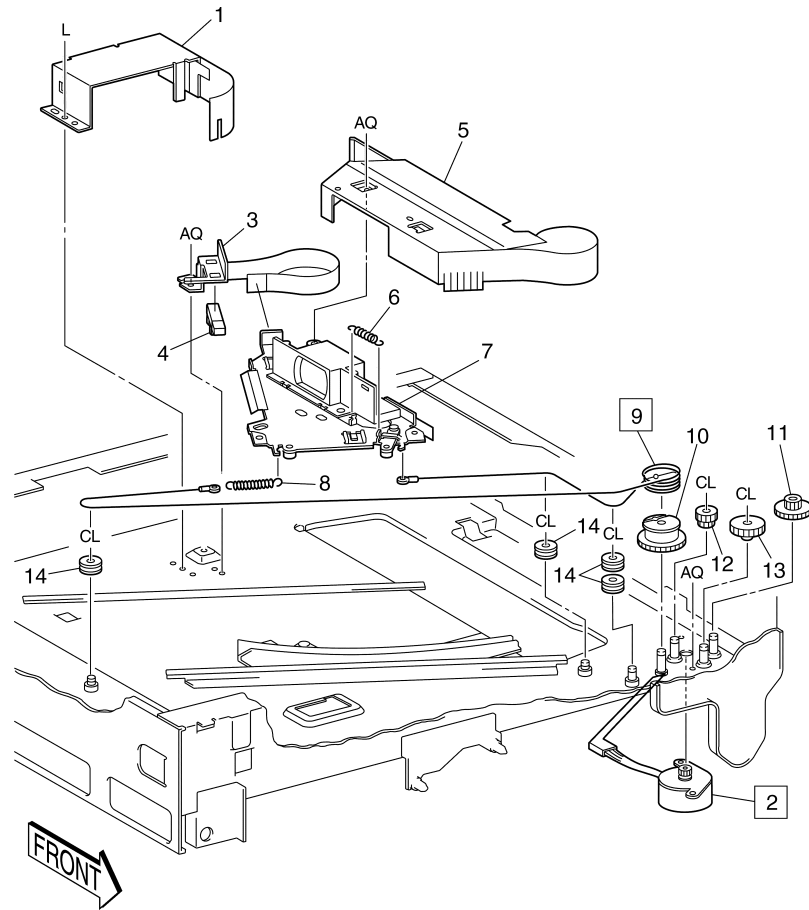

ITEM	PART NO.	DESCRIPTION
1	- -	SENSOR BRACKET(REF ONLY)
2	127K 84530	LENS MOTOR ASSY
3	- -	SENSOR BRACKET(REF ONLY)
4	107E 06650	LENS SENSOR
5	- -	LENS CARRIAGE SHIELD(REF ONLY)
6	9E 65630	SPRING EXTENSION
7	41K 93880	LENS CARRIAGE ASSY
8	9E 65460	SPRING EXTENSION
9	12E 93370	LENS CABLE
10	7E 32820	CABLE GEAR PULLEY
11	7E 32830	GEAR-24/50T
12	7E 32840	GEAR-24/32T
13	7E 32850	GEAR-48T
14	20E 21710	PULLEY IDLER

**PL-5 XEROGRAPHIC**  
**5.1 XERO Module Assembly**

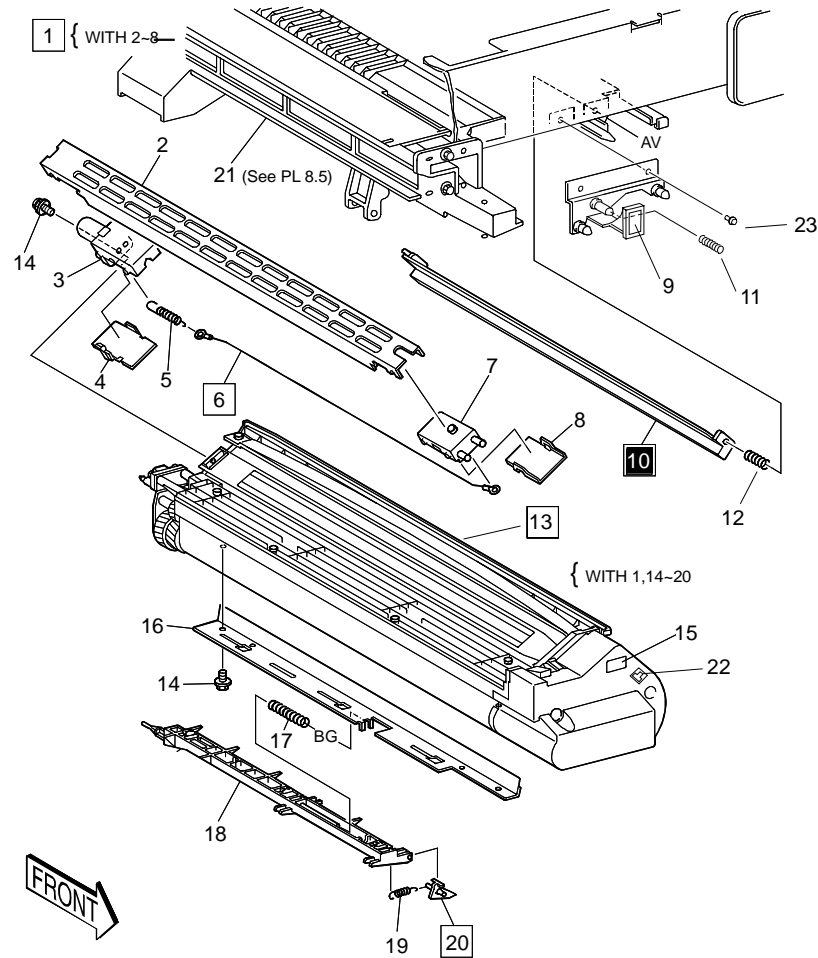

ITEM	PART NO.	DESCRIPTION
1	125K 92513	COROTRON ASSY-CC(WITH 2-8)
2	55E 27511	SHIELD-CC
3	118K 91572	REAR INSULATOR BLOCK
4	55K 18323	REAR ARC SHIELD
5	9E 65900	WIRE SPRING
6	117K 19220	COROTRON WIRE
7	118E 12000	FRONT INSULATOR BLOCK
8	55E 27391	FRONT ARC SHIELD
9	15K 34621	PLATE CRU ASSY
10	122S 50203	ISIL LAMP ASSY
11	9P 50220	SPRING COMPRESSION
12	9E 65710	SPRING
13	- -	XERO MODULE
14	- -	TAPPING SCREW (REF ONLY)
15	91E 71050	LABEL VOLTAGE(REF ONLY)
16	- -	TONER SEAL (REF ONLY)
17	- -	SPRING (REF ONLY)
18	19K 92822	FINGER-ASSY
19	- -	SPRING (REF ONLY)
20	19E 93200	DRUM FINGER
21	- -	COOLING DUCT & ERASELAMP (SEE PL8.5)
22	- -	ID ASSY

**PL-5 XEROGRAPHIC**  
**5.2 TC/DTC Corotron**

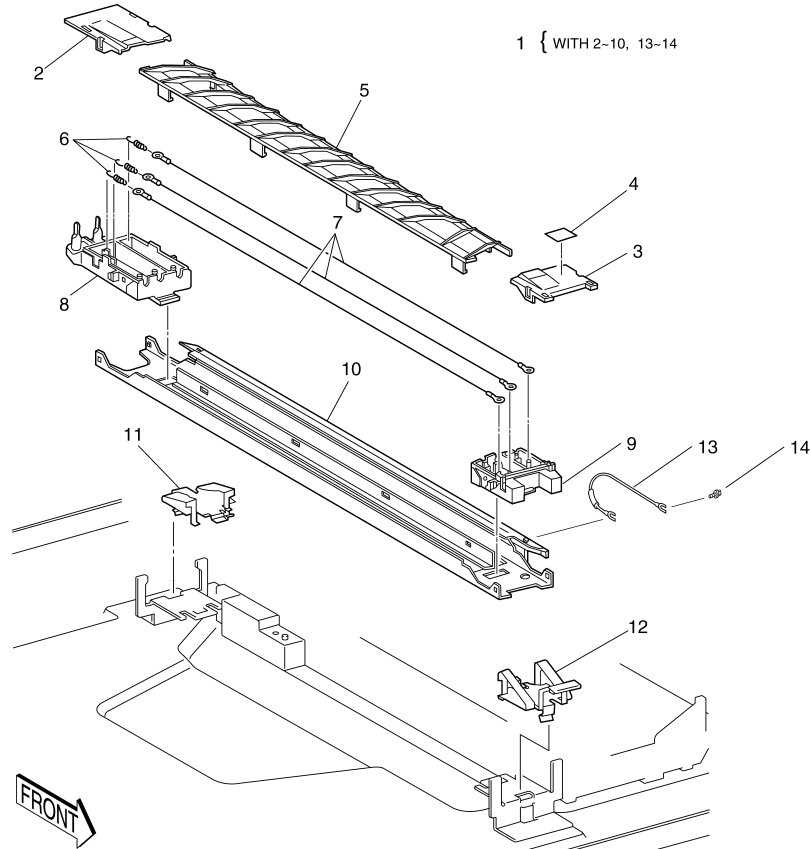

ITEM	PART NO.	DESCRIPTION
1	125S 50201	TRANSFER & DETACH COROTRON ASSY (WITH 2-10 13-14)
2	55E 27650	REAR ARC SHIELD
3	55E 29550	FRONT ARC SHIELD
4	- -	VOLTAGE LABEL
5	32E 05740	DTC GUIDE
6	9E 65900	WIRE SPRING
7	117K 19220	COROTRON WIRE
8	118K 91591	REAR INSULATOR BLOCK
9	118E 98610	FRONT INSULATOR BLOCK
10	- -	TC/TDC SHIELD(P/O ITEM 1)
11	9E 65722	REAR TC/DTC SPRING
12	9E 65732	FRONT TC/DTC SPRING
13	55S 50204	EARTH SPRING
14	- -	SCREW(REF ONLY)

PL-6 DEVELOPMENT  
6.1 Deve Mechanism

ITEM	PART NO.	DESCRIPTION
1	1K 49781	DEVE RAIL ASSY (WITH 2-5)
2	1K 51861	RAIL ASSY
3	- -	PLATE FRONT (REF ONLY)
4	- -	PLATE REAR (REF ONLY)
5	9E 65630	SPRING
6	68K 11652	BRACKET SUPPORT ASSY
7	- -	ROLL (P/O ITEM 6)
8	- -	STUD ROLL (P/O ITEM 6)
9	48S 50267	DEVE ASSY (SEE PL 6.2)
10	- -	TONER CARTRIDGE

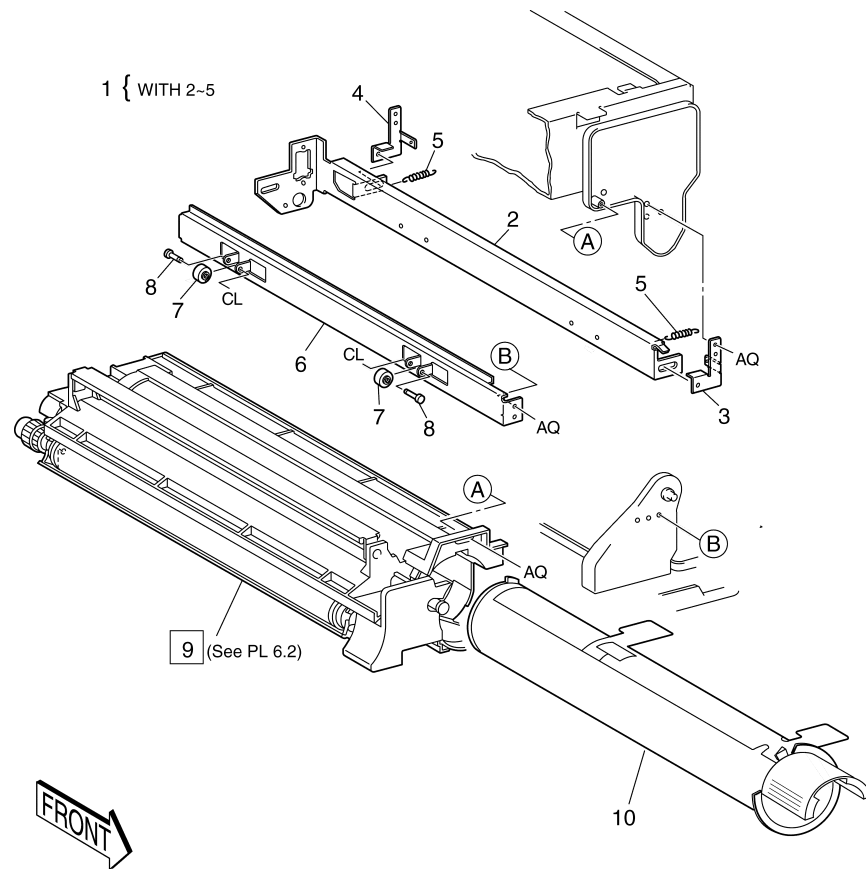



**PL-6 DEVELOPMENT**  
**6.2 Deve Assembly**

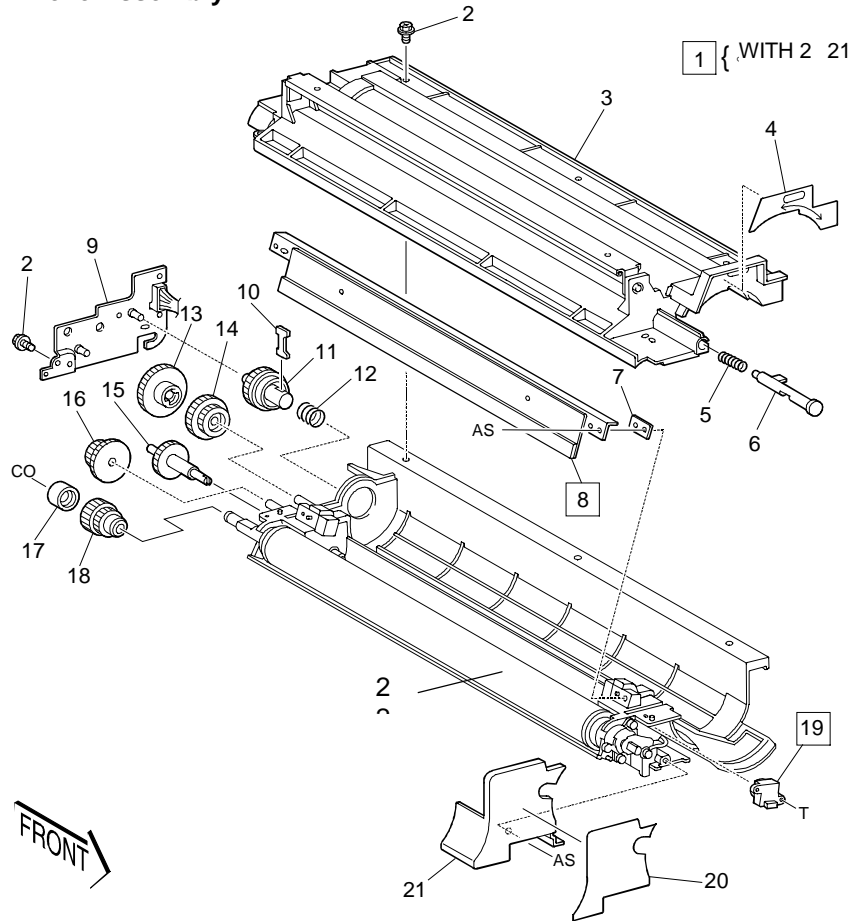

ITEM	PART NO.	DESCRIPTION
1	48S 50267	DEVE ASSY (WITH 2 21)
2	- -	SCREW (P/O ITEM 1)
3	48K 49550	UPPER DEVE COVER(P/O ITEM 1)
4	- -	LABEL (P/O ITEM 1)
5	9E 65870	SPRING COMPRESSION
6	3E 36350	CARTRIDGE STOPPER (P/O ITEM 1)
7	- -	PLATE (P/O ITEM 1)
8	33K 91570	MAG ROLLER BLADE (P/O ITEM 1)
9	- -	COVER PLATE
10	49E 37860	COUPLING PLATE
11	7K 82601	GEAR-27T (WITH 10 12)
12	9E 65850	SPRING
13	7E 32480	IDLER GEAR-40T
14	7E 41250	GEAR-22/31T
15	7E 41240	GEAR-27T
16	7E 34880	IDLER GEAR-32/21T (P/O ITEM 1)
17	- -	ROLLER ASSY MAG (P/O ITEM 1)
18	7E 88070	GEAR-24/20T
19	130E 80990	TONER EMPTY SENSOR
20	48E 62480	COVER
21	121K 86670	MAG ROLLER

**PL-8 FUSER**

**8.1 Inlet Chute & Temperature Control**

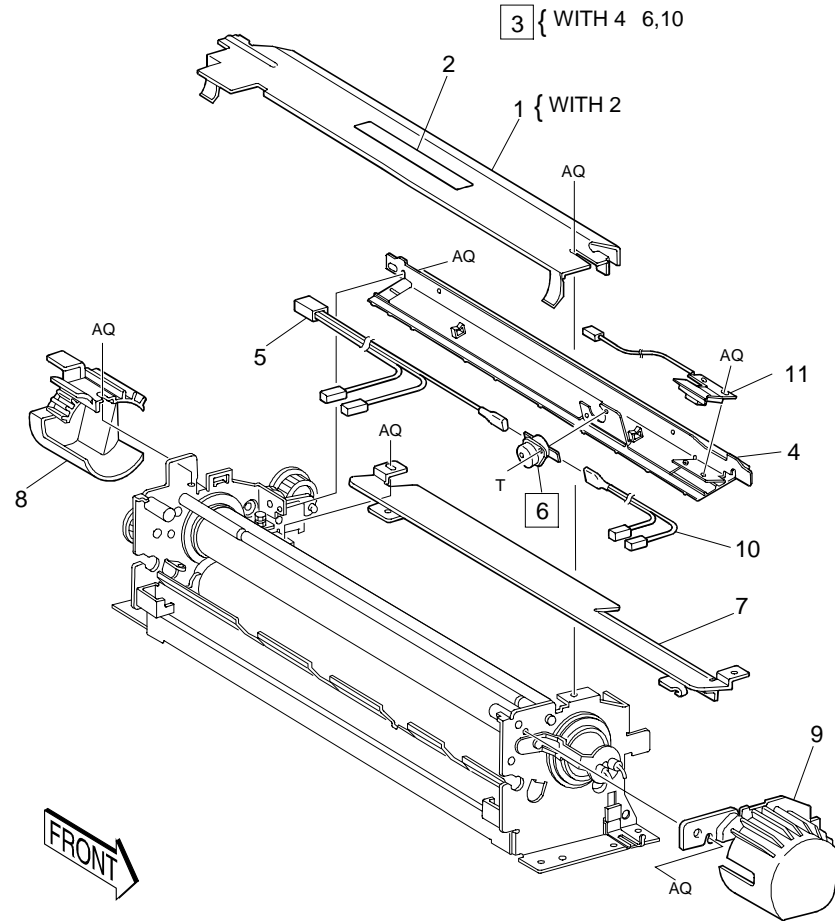

ITEM	PART NO.	DESCRIPTION
1	48K 75880	FUSER COVER (WITH 2)
2	- -	CAUTION LABEL
3	130K 85732	FUSER SENSOR ASSY (WITH 4 6,10)
4	- -	SENSOR BRACKET(REF ONLY)
5	- -	HARNESS (REF ONLY)
6	130P 08241	FUSER THERMOSTAT
7	54E 11970	INLET CHUTE
8	21E 93630	REAR HEATER ROD COVER
9	21K 91341	FRONT HEATER ROD COVER
10	- -	HARNESS (REF ONLY)
11	130K 85790	FUSER THERMISTOR

**PL-8 FUSER**  
**8.2 Heat Roller**

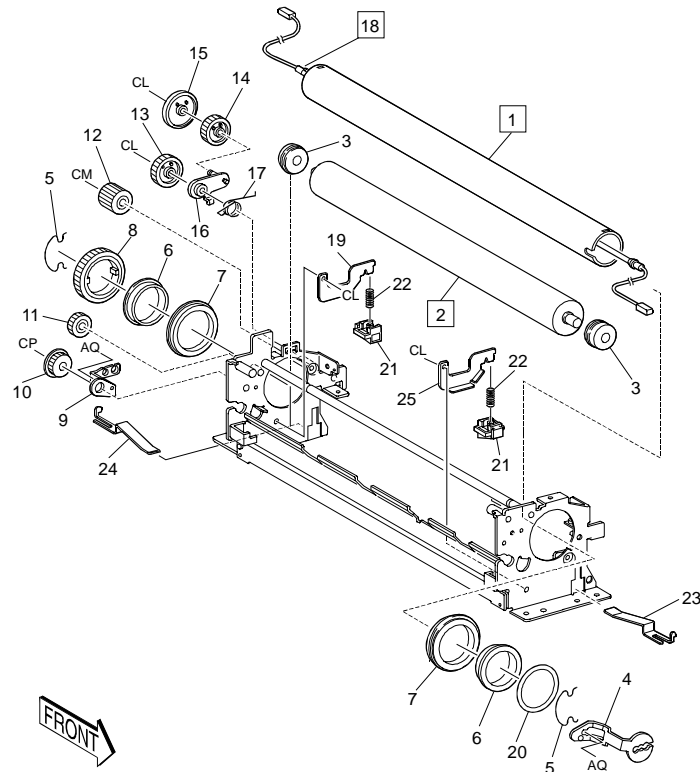

ITEM	PART NO.	DESCRIPTION
1	22P 50261	HEAT ROLLER
2	59S 50200	PRESSURE ROLLER
3	13P 61059	BEARING
4	49E 40170	FRONT HEATER ROD SUPPORT
5	28E 93121	HEAT ROLLER RING
6	5J 90590	COLLAR
7	13E 82160	BEARING
8	7E 34910	GEAR-48T
9	49E 40190	REAR HEATER ROD SUPPORT
10	7E 34921	IDLER GEAR-22T
11	7K 82230	IDLER GEAR-22T
12	7K 82220	IDLER GEAR-23T
13	7E 32431	IDLER GEAR-24T
14	7E 32441	IDLER GEAR-31T
15	- -	ROLLER (REF ONLY)
16	12E 90560	LINK
17	9E 65930	SPRING
18	126K 97451	HEATER ROD (220V)
19	- -	REAR LEVER (REF ONLY)
20	- -	WAVE WASHER
21	10E 91872	SLIDE
22	9E 76490	SPRING LEVER
23	49E 63961	FRONT SLIDE BRACKET
24	49E 63971	REAR SLIDE BRACKET
25	- -	FRONT LEVER (REF ONLY)

PL-8 FUSER  
8.3 Paper Exit

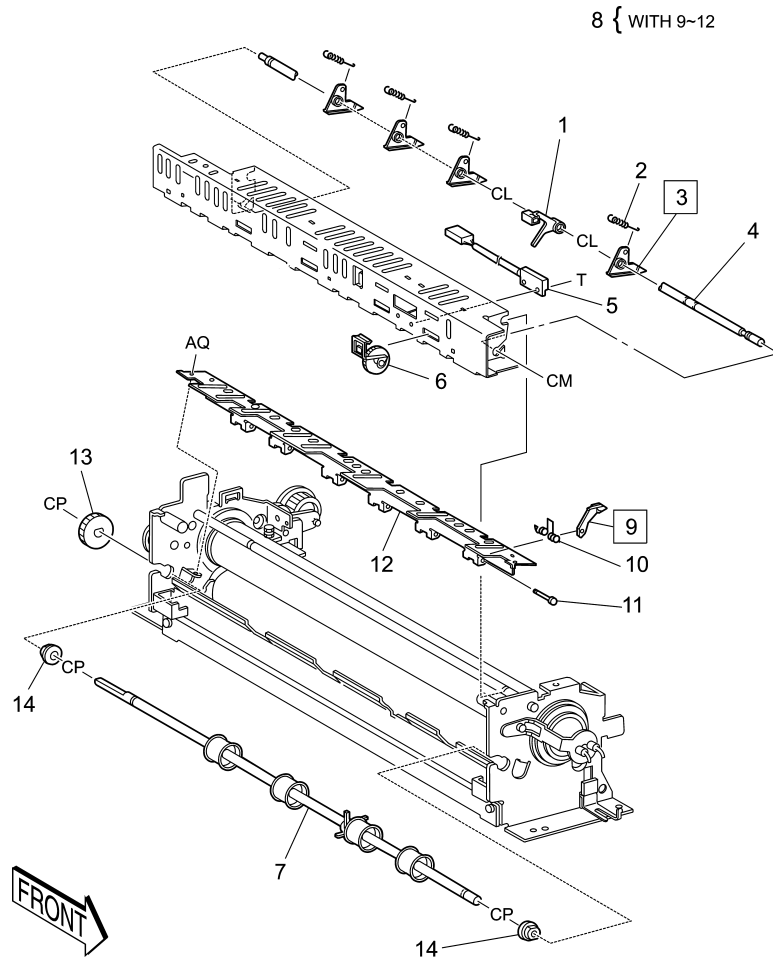

ITEM	PART NO	DESCRIPTION
1	120K 91080	EXIT SWITCH ACTUATOR ASSY
2	9E 65940	SPRING
3	19E 22120	HEAT ROLLER FINGER
	19E 92740	HEAT ROLLER FINGER (ALT)
4	- -	SHAFT (REF ONLY)
5	110K 91880	EXIT SWITCH ASSY
6	22K 39321	EXIT PINCH ROLLER ASSY
7	59K 09000	FUSER EXIT ROLLER ASSY
8	54K 09470	CHUTE ASSEMBLY (WITH 9~12)
9	19E 22130	PERSSURE ROLLER FINGER (P/O ITEM 8)
10	9E 65950	TORSION SPRING (P/O ITEM 8)
11	26E 56030	STUD (P/O ITEM 8)
12	- -	CHUTE (P/O ITEM 8)
13	7E 34931	GEAR-25T
14	13E 84490	BEARING

**PL-8 FUSER**  
**8.4 Upper Frame & Receiving Tray**

ITEM	PART NO.	DESCRIPTION
1	126S 50225	FUSER ASSEMBLY
2	50P 50247	EXIT TRAY ASSY

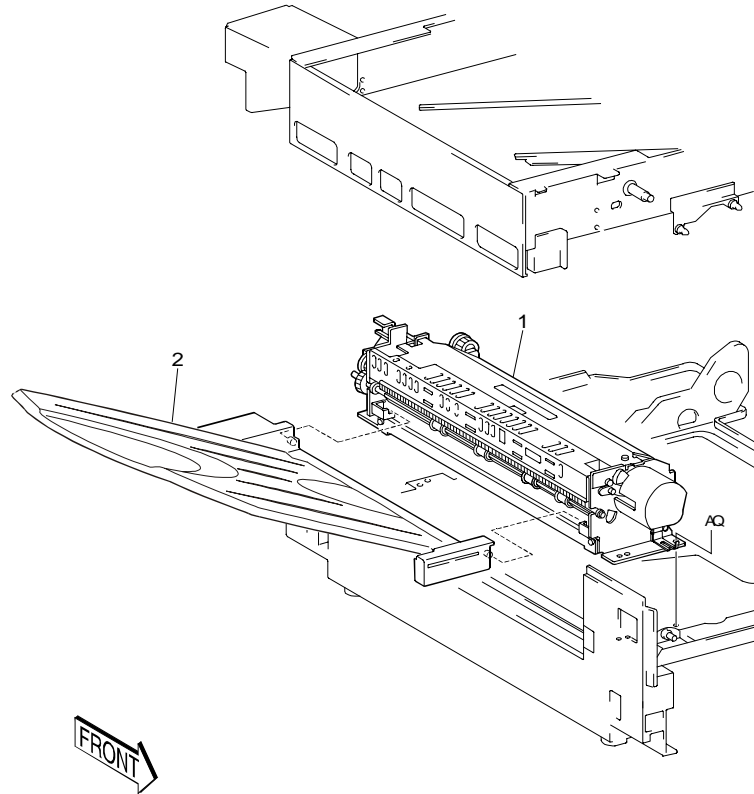

**PL-8 FUSER**  
**8.5 Fuser Fan Motor & Ozone Filter**

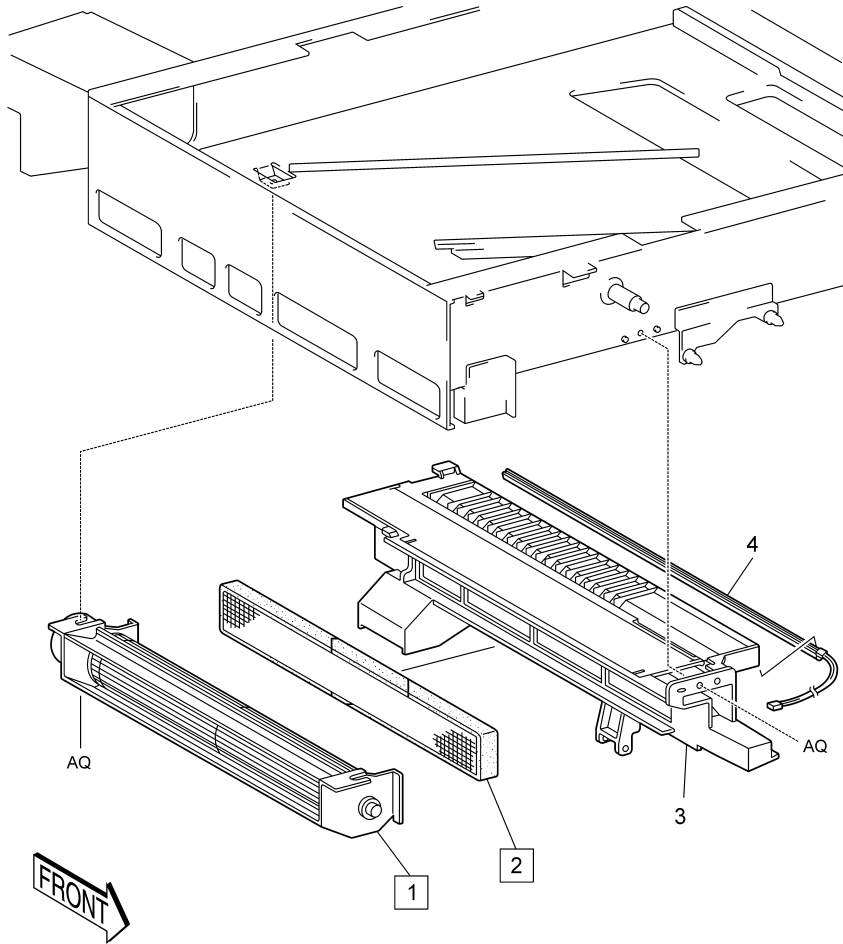

ITEM	PART NO.	DESCRIPTION
1	127K 84431	FUSER FAN MOTOR
2	53E 91510	OZONE FILTER
3	54E 08552	DUCT (REF ONLY)
4	122K 92080	ERASE LAMP

**PL-9 ELECTRICAL**  
**9.1 Rear Side (1)**

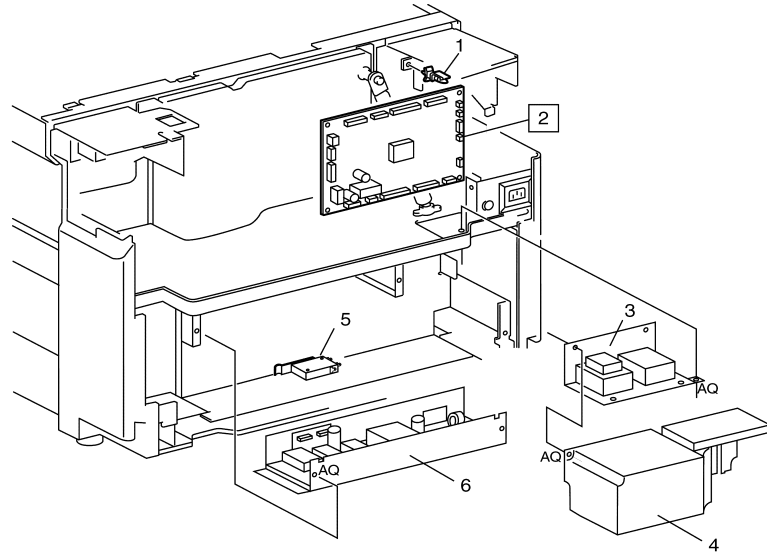

ITEM	PART NO.	DESCRIPTION
1	- -	PWB SUPPORT
2	140S 50182	MAIN PWB
3	140S 50191	AC DRIVE PWB
4	48P 50261	AC DRIVE PWB COVER
5	110P 50203	TRAY 1 SWITCH
6	105S 50209	LVPS
7	- -	SCREW
8	- -	POWER CORD (220V)

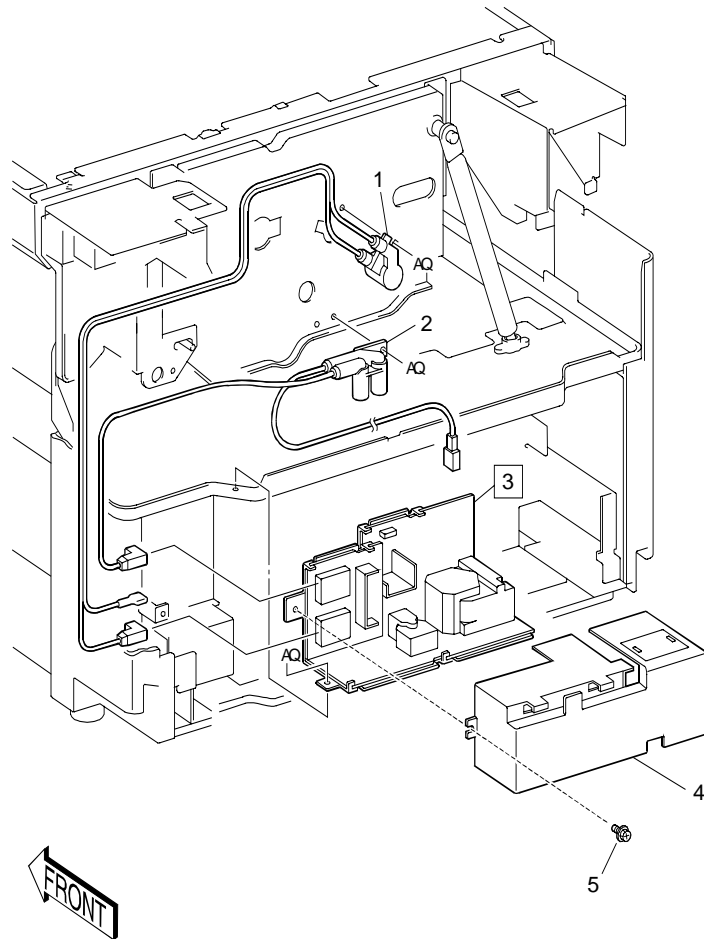
PL-9 ELECTRICAL  
9.2 Rear Side (2)

ITEM	PART NO.	DESCRIPTION
1	113S 50217	CHARGE COROTRON HOLDER
2	113S 50218	TC/TDC COROTRON HOLDER
3	105S 50210	HVPS
4	48P 50273	HVPS COVER
5	26P 62407	SCREW



**PL-10 FRAME & COVER**  
**10.1 Gas Spring & Latch Lever**

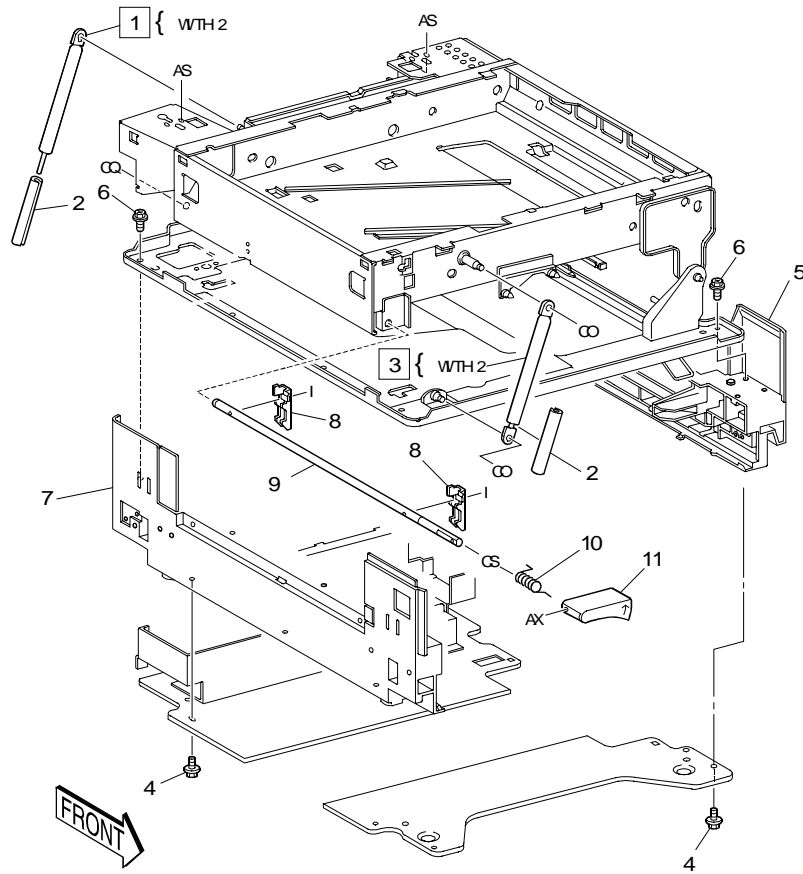

ITEM	PART NO.	DESCRIPTION
1	9P 50208	REAR GAS SPRING KIT (WITH 2)
2	- -	STOPPER (P/O ITEM 1)
3	9P 50209	FRONT GAS SPRING KIT
4	26E 82620	TAPPING SCREW
5	1P 50264	RIGHT FRAME
6	- -	TAPPING SCREW (REF ONLY)
7	1P 50263	LEFT FRAME
8	49E 37471	LATCH
9	6E 47133	SHAFT
10	9E 65670	SPRING
11	3P 50208	LATCH LEVER

## PL-10 FRAME &amp; COVER

## 10.2 Console &amp; Top, Platen Cover

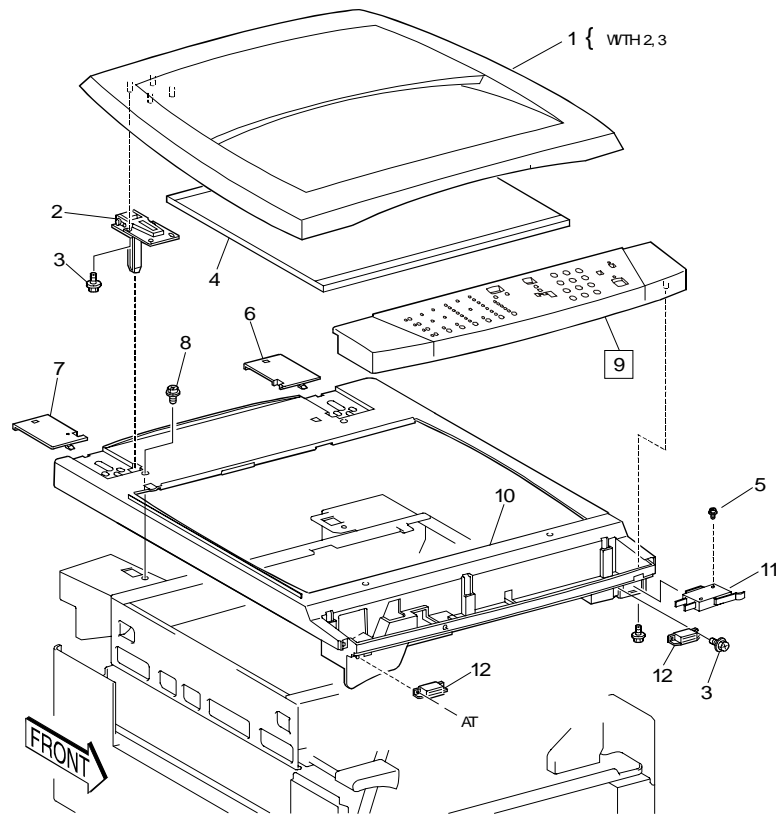

ITEM	PART NO.	DESCRIPTION
1	48S 50214	PLATEN COVER (WITH 2,3)
2	36K 90941	COUNTER BALANCE (P/O ITEM 1)
3	26E 46630	TAPPING SCREW
4	4K 92320	PLATEN CUSHION
5	26P 50221	SCREW
6	302P 50329	RIGHT BLIND COVER
7	302P 50330	LEFT BLIND COVER
8	26E 93961	SCREW M4x8
9	48S 50281	CONSOLE ASSEMBLY
10	48P 50236	TOP COVER
11	110P 50202	FRONT INTERLOCK SWITCH
12	121E 83330	MAGNET CATCH

**PL-10 FRAME & COVER**  
**10.3 Front & Left Hand**

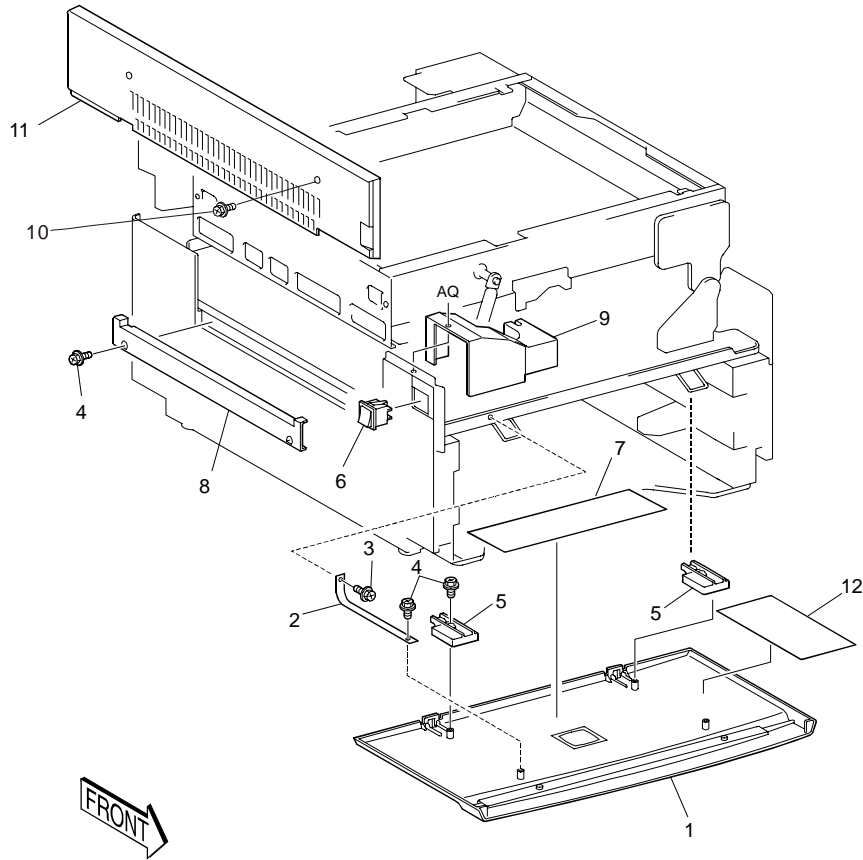

ITEM	PART NO.	DESCRIPTION
1	48P 50294	FRONT COVER
2	63E 93100	STOPPER TAPE
3	112W 27659	SCREW DEL M3x8
4	26E 46630	TAPPING SCREW
5	3E 35414	HINGE
6	110P 50208	MAIN POWER SWITCH
7	96P 50345	LEBEL DEVE
8	48P 01440	LEFT LOWER COVER
9	2E 60560	MAIN POWER SWITCH COVER
10	- -	SCREW
11	48P 50232	LEFT COVER
12	- -	LABEL NVM

**PL-10 FRAME & COVER**  
**10.4 Rear & Right Hand Cover**

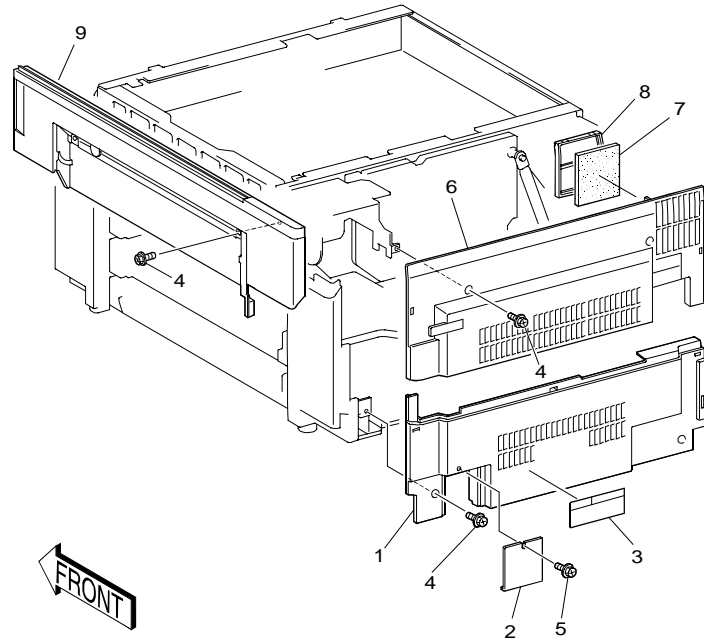

ITEM	PART NO	DESCRIPTION
1	48P 50238	REAR LOWER COVER
2	302P 50322	REAR CONNECTER COVER
3	- -	DATE PLATE (REF ONLY)
4	26E 93961	SCREW DEL M4x8
5	26E 14060	TAPPING SCREW
6	48P 50251	REAR UPPER COVER
7	53P 50204	FILTER
8	48P 50268	FILTER HOUSING
9	48P 50231	RIGHT COVER

	<b>PART NO</b>	<b>DESCRIPTION</b>		<b>PART NO</b>	<b>DESCRIPTION</b>
A	102W 27651	SCREW	BB	220W 21250	NUT-FLANGE
B	102W 28251	SCREW	BC	220W 24350	NUT
C	112W 27651	SCREW	BD	232W 26250	NUT CLINCHING
D	112W 27659	SCREW DEL SEMS	BE	236W 21250	NUT-SPEED
E	112W 27851	SCREW	BF	251W 21251	WASHER
F	112W 27859	SCREW (M3x8)	BG	251W 24251	WASHER
G	112W 28451	SCREW	BH	251W 24451	WASHER
H	112W 29751	SCREW WASHER	BI	252W 24250	WASHER NYLON
I	112W 36259	SCREW-DEL SEMS	BJ	252W 24350	WASHER
J	113W 15651	SCREW	BK	252W 27250	WASHER PLAIN
K	113W 15851	SCREW	BL	252W 27350	WASHER
L	113W 20457	SCREW TP	BM	252W 27450	WASHER-NYLON
M	113W 20557	SCREW-TP	BN	252W 29350	WASHER-NYLON
N	113W 20651	SCREW	BO	252W 29450	WASHER-NYLON
O	113W 20657	SCREW TP	BP	256W 21251	WASHER SPRING
P	113W 20857	SCREW TP	BQ	258W 21250	WASHER LOCK
Q	113W 21057	SCREW TP	BR	258W 24250	WASHER LOCK
R	113W 21257	SCREW-TP	BS	271W 16250	PIN DOWEL
S	113W 27451	SCREW	BT	271W 21250	PIN DOWEL
T	113W 27651	SCREW	BU	271W 21650	PIN-DOWEL
U	113W 27656	SCREW TP	BV	285W 15651	PIN SPRING
V	113W 27851	SCREW	BW	285W 15851	PIN SPG
W	113W 28056	SCREW-TP	BX	285W 16251	PIN SPRING
X	113W 28251	SCREW	BY	285W 16653	PIN SPRING
Y	113W 28451	SCREW	BZ	285W 21051	PIN SPRING
Z	113W 29751	SCREW PAN HEAD	CA	285W 28051	PIN-SPRING
AA	113W 35557	SCREW HEX HEAD	CB	285W 28251	PIN
AB	113W 35657	SCREW-TP	CC	285W 28651	PIN SPRING
AC	113W 35851	SCREW	CD	285W 28851	PIN SPRING
AD	113W 36051	SCREW M4x10	CE	285W 37151	PIN SPRING
AE	113W 36057	SCREW	CF	286W 16050	PIN-SPRING
AF	113W 36851	SCREW	CG	351W 29250	RING
AG	131W 63851	SCREW-MACHINE	CH	354W 10655	RING-M
AH	141W 27651	SCREW-SET	CI	354W 15251	RING-E
AI	141W 35651	SCREW-SET	CJ	354W 21251	RING-E 3
AJ	153W 27650	SCREW TAPPING	CK	354W 21254	RING KL
AK	153W 27850	SCREW TAPPING	CL	354W 24251	RING E
AL	153W 28050	SCREW L10	CM	354W 24254	RING KL
AM	153W 28250	SCREW TAPPING	CN	354W 26251	RING-E
AN	153W 35850	SCREW	CO	354W 27251	RING-E
AO	153W 36250	SCREW	CP	354W 27254	RING KL
AP	158W 27651	SCREW FORMING	CQ	354W 29251	RING E
AQ	158W 27655	SCREW DELTITE	CR	354W 30251	E-RING
AR	158W 27851	SCREW-FORMING	CS	356W 29251	RING RETAINING
AS	158W 27855	SCREW DEL	CT	358W 27251	RING-E
AU	158W 28255	SCREW-DELTITE	CU	252W 26350	WASHER NYLON
AV	158W 28655	SCREW			
AW	158W 35655	SCREW M4x6			
AX	158W 35855	SCREW-DEL			
AY	158W 36255	SCREW DELTITE T			
AZ	180W 65850	SCREW WING			
BA	201W 21251	NUT			

## **Section 6 GENERAL**

## Section 6 GENERAL

### 6.1 XEROX 5915 Specifications

6.1.1 Product Code .....	6-2
6.1.2 Dimensions .....	6-2
6.1.3 Space required for installation .....	6-3
6.1.4 Levels .....	6-3
6.1.5 Electrical Specification .....	6-3
6.1.6 Calorific power .....	6-3
6.1.7 Noise .....	6-3
6.1.8 Ozone Emission .....	6-3
6.1.9 Environment .....	6-3
6.1.10 Magnification ratio .....	6-3
6.1.11 Time required for changing magnification .....	6-4
6.1.12 Copy speed .....	6-4
6.1.13 Document size .....	6-4
6.1.14 Image size .....	6-4
6.1.15 Paper .....	6-4
6.1.16 Compatibility .....	6-4
6.1.17 Image loss .....	6-4
6.1.18 Copy capacity .....	6-4
6.1.19 Warm up time .....	6-4
6.1.20 Copy quality .....	6-5

### 6.2 Tools and consumables for servicing

6.2.1 Tools .....	6-6
6.2.2 Consumables for servicing .....	6-6

### 6.3 Consumables .....

6-6

### 6.4 Modification

6.4.1 Symbology .....	6-6
6.4.2 Relevant area .....	6-6
6.4.3 Modification list .....	6-6

### 6.5 Installation / Removal

6.5.1 Installation .....	6-7
6.5.2 Installation/Removal .....	6-7

### 6.6 Program Setting

6.6.1 Entering the Program Mode .....	6-9
6.6.2 Entering the program number and setup value .....	6-9
6.6.3 Exiting the Program Mode.....	6-9
6.6.4 Program operation procedure .....	6-9
6.6.5 Operation procedure to display the number of copies made .....	6-9
6.6.6 Setting start modes .....	6-10
6.6.7 Setting single-password mode .....	6-11
6.6.8 Changing Password.....	6-12

6.1 XEROX 5915 Specifications

6.1.1 Product Code

Model	M/C No	Product Code
5915 (220V) SEA TRANSPORT	350100001X	G3L
5915 (220V) AIR TRANSPORT	350500001X	G4L

X: Check Digit

6.1.2 Dimensions

XEROX 5915  
(Unit: mm)

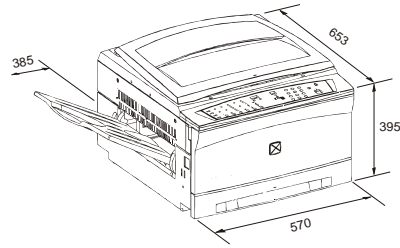

	Width (mm)	Depth (mm)	Height (mm)	Weight (kg)
5915	570	653	395	41



### 6.1.3 Space required for installation

XEROX 5915  
(Unit: mm)

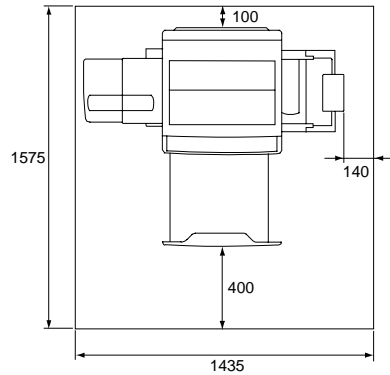

### 6.1.4 Levels

- Front & Rear directions: Moves freely for less than 5mm.
- Horizontal directions: Moves freely for less than 10mm.

### 6.1.5 Electrical Specifications

- Frequency ..... 50Hz/60Hz ±0.5%  
(All models are the same Hz)
  - Input voltage ... 220 ± 10%  
230 ± 10%  
240 ± 6%
  - Cord ..... The standard 2.5m
  - Operational current ..... 15A or less at 100V full system
  - Overload protection ..... The current breaker is built-in
  - Leakage protection ..... Grounding wire is available as standard.
  - Electrical noise in conformity with VCCI, Class 2
  - Power consumption
    1. Maximum power consumption ..... 1.5kw or less
    2. Power consumption (To be included in the Technical Information as disclosed)
      - At warm up (30.0 sec) ..... Wh/job
      - At standby ..... Wh/hr
      - At copying ..... Wh/sheet
    3. Monthly power consumption ..... kWh  
(Conditions): XEROX 5915, A4 LEF, No optional, No Stand-by mode
      - Run length =
      - Monthly average C/V = 2,000 sheets . (V)
      - Power ON/OFF = 1/day .....(N)
      - Workdays/monthly = 21 days .....
- (D)
- Workhours/day = 8 hours ..... (T)
  - Warm-up time (23°C) = 30.0 (SEC)

Calculation for power consumption (Wh/Mo)  
=  $\frac{7.29ND}{*1} + \frac{176.49[TD-1/3600x(3.81V + 30.0ND)]}{*2}$

$$+ \frac{1.18V}{*3}$$

- \*1: At warm up
- \*2: At standby
- \*3: In operation

### 6.1.6 Calorific power

(Power consumption x 0.86kcal)

- At warm up (30.0sec) ..... 6.27 kcal
- At stand by ..... 151.78kcal
- At copying ..... 1.01kcal/sheet

### 6.1.7 Noise

- The maximum levels of noise are as shown in the table.

	Main Processor Copy cycle
Noise	55

Unit: db(A)

### 6.1.8 Ozone emission .....0.02PPM or less

### 6.1.9 Environment

- Temperature 10-35°C
- Humidity 15-85%
- Height above sealevel 1800m or less

### 6.1.10 Magnification ratio

	Mag. Ratio	Tolerance
Preset zoom ratio(%)	70.7	± 1.3
	81.6	± 1.3
	86.5	± 1.3
	100.0	± 0.8
	141.4	± 1.8

	Mag. Ratio	Tolerance
Variable ratio adjustable 1%	61~109	± 1.3
	110~119	± 1.5
	120~129	± 1.6
	130~139	± 1.7
	140~149	± 1.8
	150~156	± 1.9
	157~163	± 2.0
	100%	± 0.8

**6.1.11 Time required for changing magnification ratio**

- A ratio can be changed in less than 6 seconds within the magnification of 70-141%. (Less than 9 seconds for 61% → 163% or 163% → 61%)

**6.1.12 Copy speed**

- FCOT:  
XEROX 5915-6.7sec(A4LEF,Using the No.1 tray)

- For making size-for-size copy (Tray 1)

Paper size	5915
A3	10
B4	12
A4 SEF	13
A4 LEF	15
B5	13
B5 LEF	15

**6.1.13 Document size**

- Max. size: 297 x 432mm
- Min. size: Not limited

**6.1.14 Image Size**

- Max. image size: 297 x 432mm
- Min. image size: Not limited

**6.1.15 Paper**

Type	Weight g/m <sup>2</sup>	Thickness mm/100	Size
M Paper	68 ± 3.0	99 ± 3	A3,B4, A4,B5
L Paper	64 ± 3.0	85 ± 3	A3,A4, B5,A5
P Paper	65 ± 2.0	91 ± 3	A3,B4, A4,B5
S Paper	56 ± 3.0	80 ± 3	A3,B4, A4,B5

\* Other than the above types, paper of other manufacturers (52-82g/m<sup>2</sup>), onion skin paper and special paper are also usable.

**Ref:** • For converting into kg, use the calculation of g/m<sup>2</sup> x 0.86 = (coefficient)

e.g.: L paper 64g/m<sup>2</sup> x 0.86 = 55(kg)

The following paper is applicable:

- Trays 1:  
:SEF-A3, B4, A4, B5  
:LEF-A4, B5
- Bypass Tray: A3-A6 SEF
- Tray capacity  
Trays 1..... 250 sheets (L)  
Bypass Tray .....100 sheets (L)

**6.1.16 Compatibility (Platen Mode)**

Alignment to the 95% copies	Tolerance at 1:1 copies	Tolerance at reduction/enlargement
Feeding direction (Lead Edge) Registration	± 1.6mm or less	± 2.7mm or less (± 4.0mm or less)
Side Registration	± 2.1mm or less	± 3.3mm or less (± 4.5mm or less)
Skew at Lead Edge	200mm long paper ± 1.6mm or less	200mm long paper ± 2.3mm or less (± 2.6mm or less)
Skew at Side Edge	200mm long paper ± 2.0mm	200mm long paper ± 2.0mm or less
Right (90 degree) Angle	200mm long paper ± 1.0mm or less	200mm long paper ± 1.5mm or less

( ) Applicable to over 142%

**6.1.17 Image Loss**

	Lead edge/Tail edge	Left edge/Right edge
• At magnification • At 1:1 • At reduction	4mm or less	4mm or less

Test Chart 499T247(A3)

**6.1.18 Copy capacity**

	Tray/Bin	Capacity
Main Processor	Receiving Tray	Approx. 100 sheets

**6.1.19 Warm up time**

- Less than 35 seconds in an environment of temperature: 20°C, humidity: 60%.

6.1.20 Copy quality

-- : Not specified

	item	Mag. Ratio (%)	Test Chart	Test Chart Checked at	Copy quality		
					Copy density		
					Normal	Light	Dark
I.D (Density)	Density	100	499T247(A3)	0.7 gray	Over 1.08	--	--
	Uniformity				Tolerance less than 0.2	--	--
Low contrast (Light image)	Reproducibility	100	499T247	0.2 gray	Over 0.17	--	Over 0.46
	Uniformity				Below 0.4	--	Below 0.40
	Reproducibility			0.1 gray	--	Not confirmed	--
Blue	Reproducibility	100	499T247	0.2 Blue	Over 0.17	--	Over 0.57
	Uniformity				--	--	Below 0.40
Solid	Reproducibility	100	499T247	1.0 solid	Over 1.2	--	--
	Uniformity				Below 0.3	--	--
Low contrast (Light image)	Reproducibility	100	499T247	0.2 gray	--	--	Over 0.57
	Uniformity				--	--	Below 0.40
	Reproducibility			0.1 gray	--	Not confirmed	--
B.G.D (Background)		100	499T247		Below 1.2	--	--
Resolution		100	499T247(A3)	Resolution target	Over 4.3(L/mm)	--	--
		70			Over 3.0(L/mm)		
		141			Over 4.3(L/mm)		
Focus depth		100	499T247	Resolution target	Over 3.0(L/mm)	--	--
		70			--		
		141			--		
Skip / Smear		100	499T247	Ladder	Over 2.5(L/mm)	--	--
		70			Over 1.8(L/mm)		
		141			Over 2.5(L/mm)		

#### 6.2 Tools and Consumables for servicing

##### 6.2.1 Tools

No.	TOOL No.	TOOL NAME
1	499T225	TEST PATTERN(CAM-II)
2	499T7002	TEST PATTERN CASE
3	499T247	TEST PATTERN (A3):10
4	499T248	TEST PATTERN (B4):10
5	499T301	MINI DRIVER(-)
6	499T355	SCREW DRIVER(+)
7	499T1423	BOX DRIVER 5.5
8	499T1901	SIDE CUTTING NIPPER
9	499T2004	ROUND NOSE PLIER
10	499T2320	C/E TESTER SET
11	499T6025	C/E TOOLS CASE
12	499T8104	FLASH LIGHT(UM-2)
13	499T8902	BRUSH
14	499T9583	TESTER LEAD WIRE(RED)
15	499T451	SPANNER AND WRENCH 5.5×5.5
16	499T2601	SILVER SCALE(150mm)
17	499T6402	MAGNETICS SCREW PICK UP TOOL
18	606T50206	CHEAT

##### 6.2.2 Consumables for servicing

- There are no unique consumables for this model.  
In case any servicing arises requiring a particular consumable unique to this model, the case will be handled separately.

#### 6.3 Consumables

The consumables available with this model are:

Name	Prod. Code	Capacity	Ref. Life
Drum Unit	673S50211		50K
Toner Cartridge (black)	6R01020	500g	6K

\* 6% Area coverage is assumed on A4 size documents.

#### 6.4 Modification

##### 6.4.1 Symbology

When there are differences by modification in the Manual, the modification code will be shown by symbols or marks as below.



The arrow points out the information which modification (shown by the No.) has been introduced.



The arrow points out the information which modification (shown by the No.) has not been introduced yet.

##### 6.4.2 Relevant Area

Modification is Implemented relative to the following areas:

- Reliability
- Safety
- Market Requirement
- Maintainability
- Operability

##### 6.4.3 Modification List

Lists not issued: Technical Information will be issued as necessary, using the formally recognise procedures

## 6.5 Installation/Removal

### 6.5.1 Installation

#### XEROX 5915 Installation Procedure

**Note:** To comply IEC 950, IEC 950 Brackets (YJ-68) is required as mandatory. See procedure No 9.

#### 1. Introduction

- Tick (V) the "Check column of the table below as you proceed with the installation.

**Note:** Prepare the Phillips head screwdriver (⊕).

#### 2. Check accessories (in the accessory box)

Check	Name	Qty
<input type="checkbox"/>	User guide	1
<input type="checkbox"/>	Copy Output Tray	1
<input type="checkbox"/>	Tray Pad	1
<input type="checkbox"/>	Paper	1
<input type="checkbox"/>	Drum Cover (Black plastic bag)	1
<input type="checkbox"/>	Service Record Card	1
<input type="checkbox"/>	Warranty record	1

#### 3. Remove the Tape

- 1) Peel off the tapes from the main Processor.

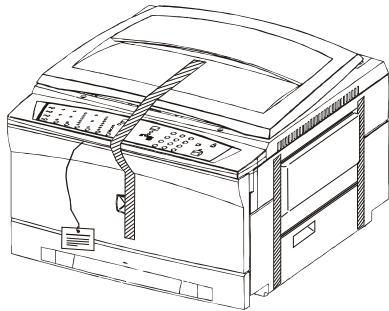

#### 4. Remove the Packing material that secures the part.

- 1) Remove the cushion from fuser exit.
- 2) Open the Front Cover, then open the machine.
- 3) Pull the label to remove the packing material from the four areas of the machine.
- 4) Close the machine.

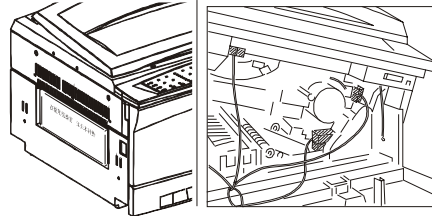

#### 5. Peel off the tapes from the optical area. (air ship only)

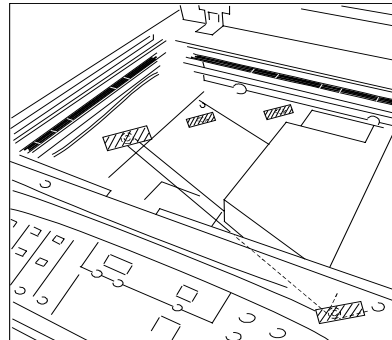

#### 6. Load the toner Cartridge.

- 1) Open the Front Cover.
- 2) Spread a sheet of paper to protect the back of the cover from toner spillage.
- 3) Remove the dummy Cartridge (tube) toward the front side. Put the it in the empty box for disposal.

- 4) Shake the Toner Cartridge more than 10 times.

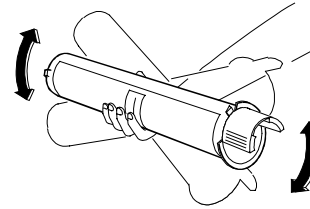

- 5) Fit the claw of the new Toner Cartridge to the groove and push the Cartridge. Pull the tape towards you & remove. Place in the empty box for disposal.

- 6) Press in the Toner Cartridge as much as possible, then turn it counterclockwise until it clicks.

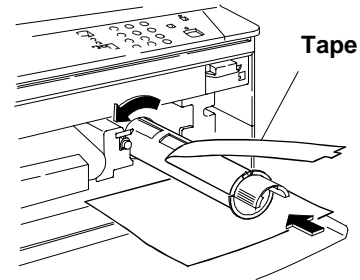

- 7) Press in the Toner Cartridge and engage the ID socket on to the cartridge

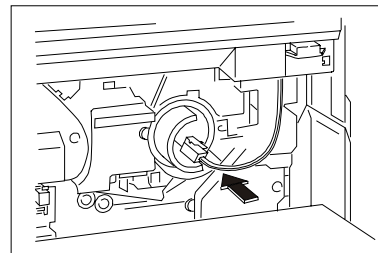

#### 7. Install the Copy Output Tray.

- 1) Set the Copy Output Tray by placing the protrusion on the arrow make of the main processor.

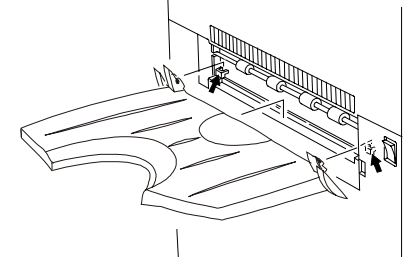

#### 8. Turn on the power switch.

- 1) Make a copy from each tray .
- 2) Check that no paper is jammed and copy image quality is good.

#### 9. Perform the Operator Initial Training Program.

**6.5.2 Removal**

Removal as described in this Manual applies to field clearance activity only

Perform the removal procedure in the reverse order of installation.

Customer Service Engineers should check the final destination of the machine prior to field clearance.

For removal, the following are required:

1. Category Check List
2. Sticker indicating M/C destination
3. Installation Procedure
4. Packaging Tapes and Clothes
5. Plastic Bag (Drum Cover)

**Removal Procedure**

1. Check if any consumable or wear parts require replacement by referring to the service record card. (See the "Trim" section of the Manual.)

**Note:** If any parts are installed wrongly, correct, before removal.

2. If any adjustment has been made based on the customers desire, put it back to the original status.
3. Perform Trim operation and clean inside of the machine.
4. Turn on the power, make copies, and check copy quality, paper feed and copy count.
5. Switch off the machine and unplug the power cord.
6. Remove paper from the Paper Tray.
7. Remove the Copy Output Tray.
8. Remove the Tray Module and unplug the connector from the Main Processor.
9. Clean the machine surroundings.
10. Enter relevant data in the service record card and store it along with the Category Check List.
11. Affix the return delivery sticker on the Top Cover.
12. Place the Drum Cover for consumables on the Platen Cover.
13. Log in the Service Report.

## 6.6 Program Setting

### 6.6.1 Entering the Program Mode

Press the Program button as "Ready to Copy" is on display.

**Note:** Inapplicable in the Interrupt Mode.

### 6.6.2 Entering the program number and setup value.

- If you enter an inappropriate Program number or setup value, "Er" appears. Press the Clear button to enter a new value.
- Enter a Program number using the keypad, or select setup values using the Reduce /Enlarge button or by moving the Paper Supply button . See "Entry" of the Program List.

### 6.6.3 Exiting the Program Mode

- Press the Program button.
- Press the All Clear button.
- The machine automatically exits the Program mode if no buttons have been pressed for more than a minute.

### 6.6.4 Program operation procedure

**Note:** Operational procedure is different for the Program Number 81/83/84.  
See 6.6.5 Operational Procedure for displaying the number of copies made.

1. Enter the Program Mode
2. Select the Program number to set up and press the Start button.
  - Current values flash on the displays of Magnification, Tray, or Number of copies.
3. If you don't change the current values, press the Start button and go to Step 5.
4. Select or enter a new setup values and press the Start button.

**Note:** See the Program List for entering setup values.

- Setup values will be changed.
5. If you have other features to set up, go back to Step 2.
  6. Exit the Program Mode.

### 6.6.5 Operation procedure to display the number of copies made.

**Note:** This applies only to the Program Number 81/83/84.

1. Enter the Program Mode.
2. Enter Program Number "81" and press the Start button.
  - LCD shows the copy volume made by the Drum cartridge.
3. Enter Program Number "83" and press the Start button.
  - LCD shows the copy volume made by the Customer.
4. Enter Program Number "84" and press the Start button.
  - LCD shows the copy volume made by the Toner cartridge.
5. Press the Clear button and the display goes back to the display ready to enter Program Number.
6. Exit the Program Mode.

Program No.	Item	Value	Description	Default Value
21	Auto Clear	0	Disable	1
		1	Enable	
24	Auto Tray Shut off	1: 2min 4: 16min 7: 2hrs 2: 4min 5: 30min 8: 4hrs 3: 8min 6: 1hrs 9: 8hrs 0: Disable		5 (30 Min)
25	Magnification priority	100% → 70% → 81% → 86% → 141% → 100%		100
45	Priority of setting up a Copy Mode	0	Newspaper	1
		1	Text	
		2	Photo	
51	Setting up Edge Erase amount	0 16mm	By 1mm	10mm
52	Margin Shift	0 16mm	By 1mm	10mm
53	Setting up Center Erase amount	6 16mm	By 1mm	10mm
81	Display the CV made by the Drum Cartridge	Shows the number of copies that have been made on the Drum cartridge. Unchangeable.		
83	Display the CV made by the machine	Shows the number of copies that have been made on the machine. Unchangeable.		
84	Display the CV made by the Toner Cartridge	Shows the number of copies that have been made on the Toner cartridge. Unchangeable.		
85	Check the serial No. of the machine	Check the serial No. of the machine		
86	Setting Start Modes	0	No-password mode	0
		1	Single-password mode	

**6.6.6 Setting start mode**

The start mode can be set and changed as required.

**Procedure**

1. Press **Custom Presets**.

**Note** Custom Presets is cleared if no button is pressed within 60 seconds.

2. Enter 86, using the Numeric Keyboard and the start mode is set.
3. Press **Start**, and the current value of the program code (0 is factory-set) will be displayed in the Copy Quantity display.
4. Enter one of the numbers 0,1, which represent respectively as follows:
  - 0-- No-password mode. The machine will enter directly the ready to copy state when it is turned on.
  - 1-- Single-password mode. The information presenting state   will be displayed when the machine is turned on, and a password has to be entered before copies can be made.
5. When the selected value is displayed in the Quantity display, press **Start** for the setting to be memorized. There is no display in the Copy Quantity display, indicating the entered code is correct. If a wrong code is entered and "Er" displayed in the Quantity display, press **Start/Clear** and re-enter a correct code.
6. Press **Custom Presets** to make the machine exit the customizing state and return to the normal copy state.



### 6.6.7 Setting Single-Password Mode

To prevent the machine from being incorrectly used, the machine administrator can exercise control by setting a password after turning the machine on.

#### Procedure

1. Press **Custom Presets**.

**Note** • Custom Presets is cleared if no button is pressed within 60 seconds since the **Custom Presets** button was pressed.

2. Enter 86, using the Numeric Keyboard and the start mode is set.

3. Press **Start**, and "0", the initial value of the code, is displayed in the Copy Quantity display.

4. Enter 1. When the selected value is displayed in the Copy Quantity display, re-press **Start** for the setting to be memorized. Meanwhile, there is no display in the Copy Quantity display on the panel, indicating the entered value is correct.

5. Press **Custom Presets** to make the machine exit the customizing state and return to the normal copy state.

6. Press "\*" or turn off the machine and turn it on again to make it enter the information presenting state  .

7. Enter a 4-digit password using number keys, the initial one being "1111". For security, each number is displayed in the Quantity display as    . If you want to re-enter a password, press **Clear** before confirmation to clear the entered number and then re-enter a desired one. After finishing the entry, press "\*" to make the machine enter the waiting state.

**Note** • To ensure the safe use of the machine by its administrator, the initial password should be changed into another 4-digit password.

**See:** 6.6.8 Changing Passwords.

- The machine will enter the power-saving state automatically if no operation is done within 1 minute. Press key on the control panel, and the machine will re-enter the information presenting state.

### 6.6.8 Changing Passwords

This function enables the machine administrator or the account users to modify passwords.

#### Procedure

1. Modifying passwords under single-password mode

- (1). Turn the machine power switch on, and the information presenting state   is displayed.
- (2). Enter the original user password using number keys and the machine enters the waiting state.
- (3). Press **Custom Presets**, and the machine enters the customizing state.
- (4). Press the number key "0" and then the **Start** button. There is   displayed on the panel and the lamp in the Quantity display will keep flashing. Re-enter a 4-digit password and the lamp in the Quantity display will stop flashing. Re-press **Start**. There is no display on the panel, indicating the entry is correct.
- (5). Press **Custom Presets** to make the machine exit the customizing state and return to the normal copy state.

## **Section 7 Wiring Data**

## Section 7 Wiring Data

- Plug/Jack List .....7-2
- Connector Configuration ..... 7-5

**Plug/Jack List**

How to read the Plug/Jack List:

Fig ..... • Indicates a figure or BSD where the respective plug/jack are shown.

Number of pins ..... • Indicates the number of pins, which does not necessarily match with the number of wires.

Destination ..... • Indicates to which component or module the plug/jack is connected.

P/J No.	Fig.No.	Number Of pins	Destination
1	2	3	LVPS
12	BSD7	1	HEATER ROD(FRONT)
13	BSD7	1	HEATER ROD (REAR)
14	9,4	3	FUSER THERMOSTAT ↔ AC DRIVE PWB
15	2	2	EXPOSURE LAMP↔AC DRIVE PWB
16	2	2	EXPOSURE LAMP
40	2	8	LVPS
100	5,8	3	OPTICAL REGI. SENSOR
105	8	3	LENS SENSOR
110	9-14	3	MSI SIZE SENSOR
111	9-14	3	MSI NO PAPER SENSOR

P/J NO.	Fig. No.	Number of Pins	Destination
114	BSD5	3	TRAY1 NO PAPER SENSOR
116	9,4	3	FEED REGI. SENSOR
117	9,4	2	FUSER EXIT SENSOR
118	BSD7	2	FUSER THERMISTOR
122	BSD7	3	TONER EMPTY SENSOR
200	5,8	10	ISIL
202	5	2	ERASE LAMP
203		2	COUNTER↔MAIN PWB
204		3	MAIN PWB↔DRUM UNIT ID
205		2	MAIN ↔TONER CARTRIDGE ID
206		2	DRUM UNIT ID
207		2	TONER CARTRIDGE ID
209	3	3	AC DRIVE PWB↔M/C INTLK SWITCH
210	BSD5	2	MSI SOLENOLD
211	BSD5	2	TRAY1 FEED SOLENOLD
214	9	2	FEED SOLENOLD
400	2	8	MAIN PWB
401	2	28	MAIN PWB
402	2	10	MAIN PWB
403	2	14	MAIN PWB
404	2	6	MAIN PWB
405	2	12	MAIN PWB
406	2	16	MAIN PWB
407	2	18	MAIN PWB
408	2	2	MAIN PWB
409	2	4	MAIN PWB
410	2	14	MAIN PWB
413	2	4	MAIN PWB
417	8	16	CONTRAL CONSOLE

P/J NO.	Fig. No.	Number of Pins	Destination
418	8	12	CONTROL CONSOLE
430	2,4	10	AC DRIVE PWB
431	4	3	AC DRIVE PWB
437		2	AC DRIVE PWB
500	9	8	HVPS
600	9	3	MAIN PWB↔ REGI GATE SENSOR
604	2	6	LENS MOTER
605		6	LAMP CARRIAGE PWB
610	1	6	MAIN PWB↔TRAY1 NO PAPER TRAY1 FEED SOLENOLD
616	3,9	8	MAIN PWB↔MSI NO PAPER SENSOR MSI SIZE SENSOR MSI SOLENOLD
620	2	12	TONER EMPTY SENSOR
T11	5,BSD1		MAIN SWITCH
T12	5,BSD1		MAIN SWITCH
T13	5,BSD1		MAIN SWITCH
T14	5,BSD1		MAIN SWITCH
T24	BSD7		FUSER THERMOSTAT
T25			EXPOSURE LAMP
T26			EXPOSURE LAMP
T27			EXPOSURE LAMP THERMOSTAT
T28			EXPOSURE LAMP THERMOSTAT
T32			GROUND WIRE
T33	BSD1		LVPS GROUND WIRE
T34	BSD7		FUSER THERMOSTAT
T50			DEVE BIAS
T58	3, 2, BSD6		TRAY1 SWITCH

<b>P/J NO.</b>	<b>Fig. No.</b>	<b>Number of Pins</b>	<b>Destination</b>
T59	3,2, BSD2 BSD6		TRAY1 SWITCH
T60			UP CHUTE ASSY GROUND WIRE
T61			UP CHUTE ASSY GROUND WIRE
T62	3 6 BSD6		RIGHT COVER SWITCH
T63	3 6 BSD3 BSD6		RIGHT COVER SWITCH
T64	BSD1 BSD2		FRONT COVER INTLK SWITCH
T65	BSD1		FRONT COVER INTLK SWITCH

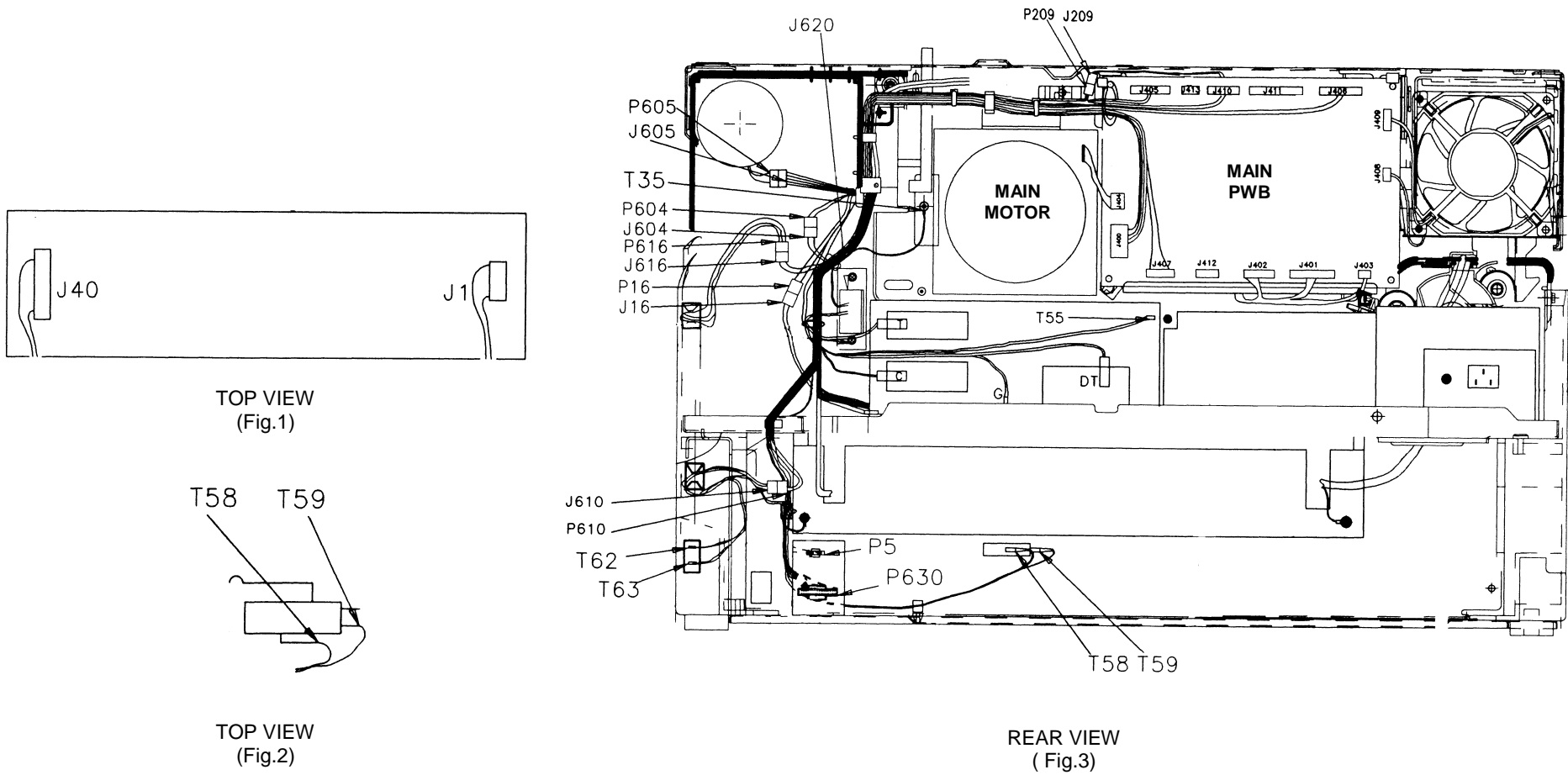



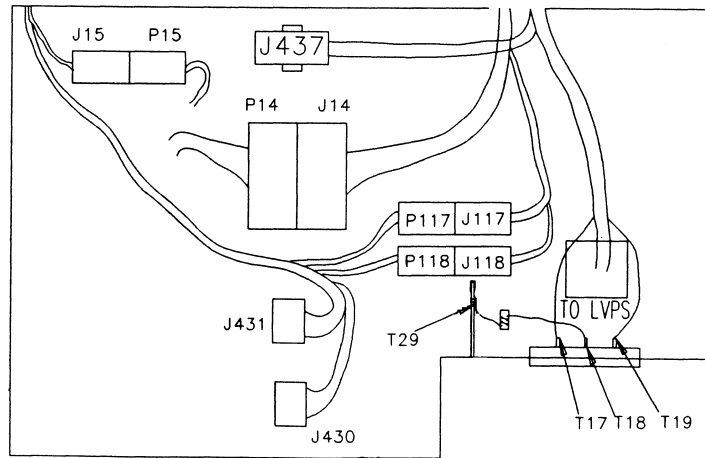

TOP VIEW  
(Fig. 4)

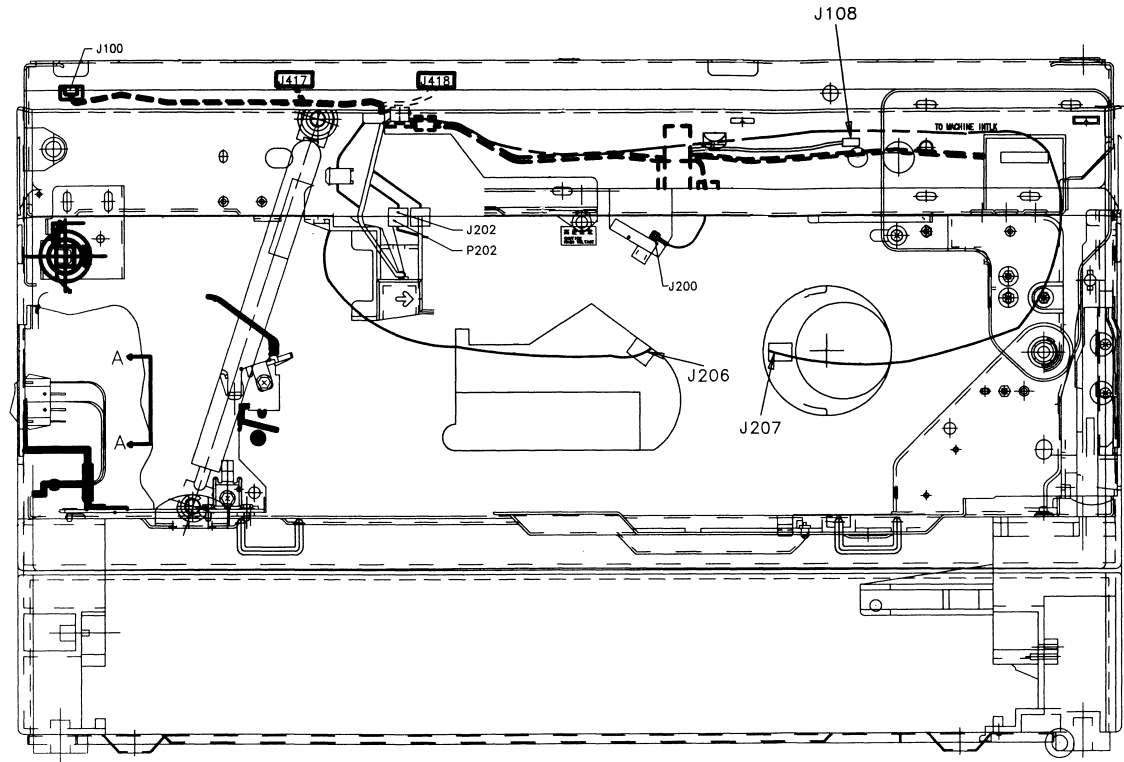

FRONT VIEW  
(Fig. 5)

A A Details (MAIN SW)

Terminal No	Wire Color	Wire Color	Terminal No
T13	BRN	2 5	BLU T14
T11	BRN	1 4	BLU T12

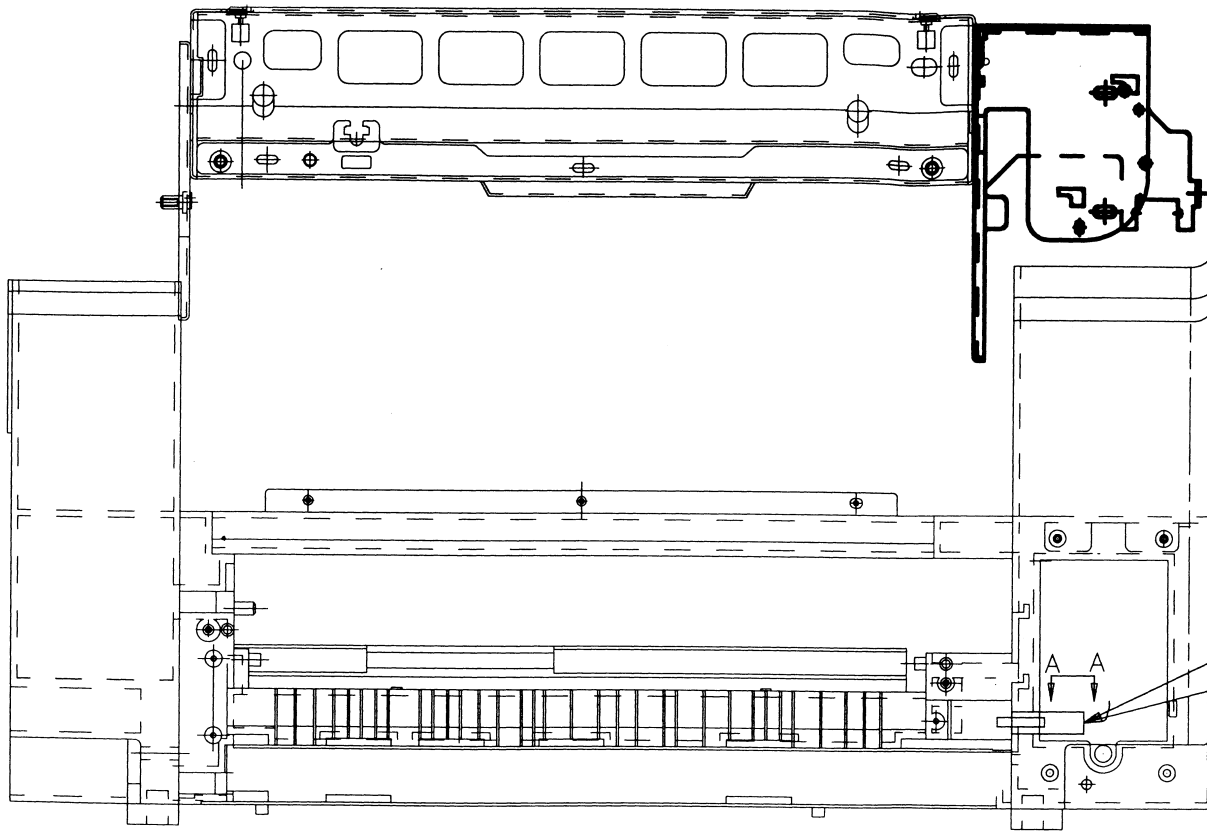

R/H VIEW  
(Fig. 6)

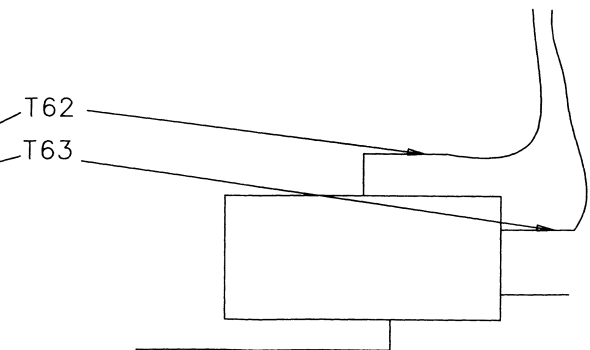

A-A DETAILS TOP VIEW  
(Fig. 7)

Section 7 Wiring Data  
Connector Configuration

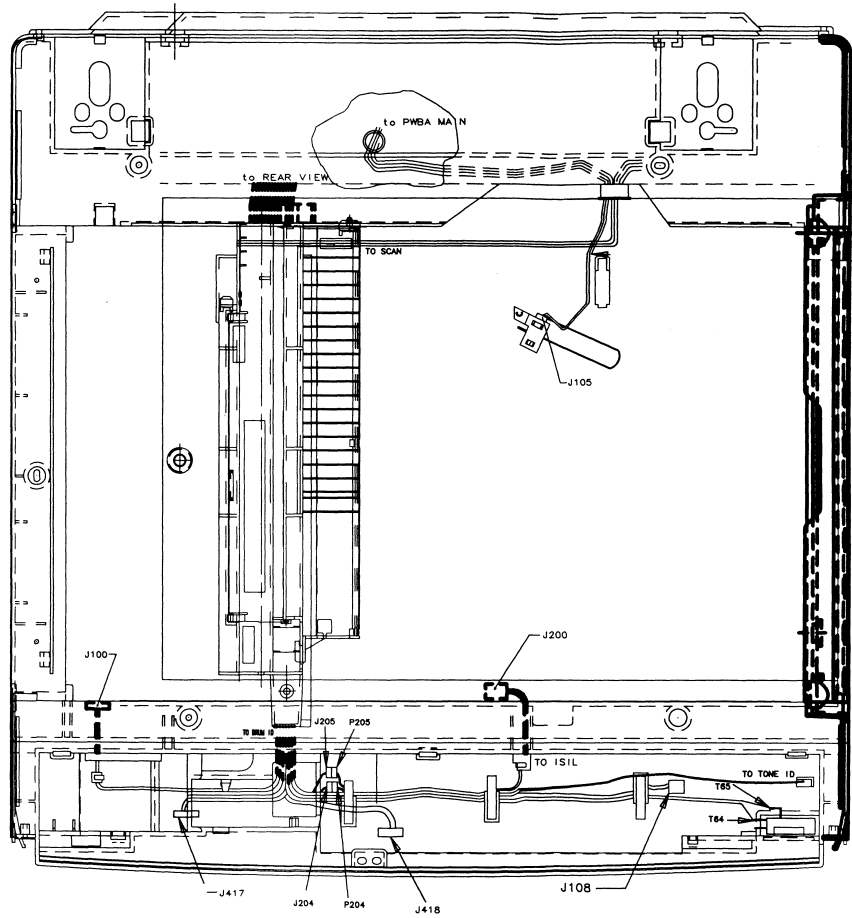

TOP VIEW  
(Fig. 8)

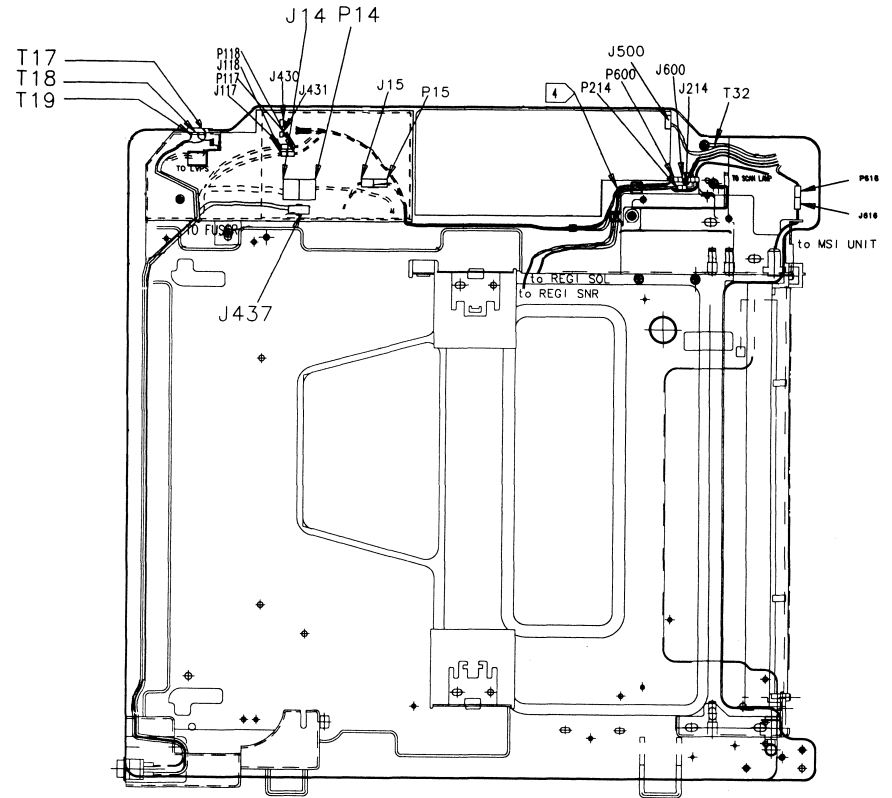

BASE FRAME TOP VIEW  
(Fig.9)

## **Section 9 BSD (Block Schematic Diagram)**

## Section 9 BSD (Block Schematic Diagram)

### 9.1 Symbol/Signal Nomenclature

- 9.1.1 Symbols ..... 9-2
- 9.1.2 Signal nomenclature ..... 9-2

### 9.2 BSD

- 1. STANDBY POWER ..... 9-3
- 2. MODE SELECTION, MACHINE RUN CONTROL  
START PRINT POWER ..... 9-6
- 3. OPTICS .....9-7
- 4. PAPER SUPPLYING AND TRANSPORTATION  
.....9-9
- 5. XEROGRAPHICS, COPY TRANSPORTATION  
AND FUSING ..... 9-11

### How to use the BSD

- Refer to this chapter containing 9 BSDs during troubleshooting which is normally begun from the Level 1 FIP or status code list.
- Function parts are indicated on each BSD is being Supplemented by text data notes.
- Troubleshooting using the BSD is carried out using a combination of the necessary text data and diagnostic modes.
- Adjustment (ADJ No.) and parts list (PL) number are indicated on each BSD, indicating where to refer to disassembly, replacement and adjustment procedure.

9.1 Symbol/Signal Nomenclature

9.1.1 Symbols

Following symbols are used in BSDs.

• Test data



This symbol on a BSD indicates that test data must always be referred to check existence of the signal.

• NOTE



Instructs to refer to the NOTE on the same page.

• Adjustment



3.1.11

Instructs to refer to the adjustment procedure in Service Manual. In this example, 3.1.11 is the adjustment number of the Service Manual to be referred to.



3.1.11

This symbol is used to instruct reference of an electrical adjustment procedure using a control on PWB instructed in the Service Manual.

• Parts list

PL7-1

Instructs to refer to the parts list. This example indicates that the part is listed at PL7-1 of the parts list.

• Diagnostic code

[4-1]

This symbol is indicated on above a signal name or in the main PWB on a BSD. "4" in this example represents the chain code No. while "1", the function No.

• I/O flag

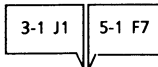

This symbol indicates I/O to or from the BSD. Figures in a flag represent the original or destination BSD No. of the I/O signal.

9.1.2 Signal nomenclature

• Output signal

REGI GATE SOL. ON

Signal name

(L) + 24VDC

Voltage level when the signal is high (H).

Voltage level necessary to activate the electrical part.

\* For certain signals, the activating voltage level is high.

• Input signal

REGI SENSOR SENSED

Signal name



(L) +25VDC

Voltage level when the signal is high (H).

Voltage level when the switch or sensor is activated or energized.

\* For certain signals, the activating voltage level is high.

• DC voltage

Unless otherwise specified by test data  or NOTE , the + 5V and + 24V DC voltage levels must be within the following ranges when measured between test points and DC COM:

- + 5VDC : + 5.2 ± 0.2VDC
- + 24VDC : + 24.5 ± 2.5VDC

• AC voltage

- 220VAC : 220V ± 10%
- 240VAC : 240V ± 6%

The above 220/240VACs are represented by 220VAC in the BSD.

• Wiring colors

Abbreviation	Color	Description
BRN	BROWN	220VAC LINE
BLU	BLUE	AC RETURN (220VAC)
GRN	GREEN	GROUND(EARTH)
GRN/YEL	GREEN/YELLOW	GROUND(EARTH)
RED	RED	HIGH-VOLTAGE LINE
ORG	ORANGE	+ 24VDC VOLTAGE LINE
GRY	GRAY	+ 5VDC VOLTAGE LINE
BLU	BLUE	OUTPUT SIGNAL LINE FOR DRIVING PARTS AT + 24VDC VOLTAGE
YEL	YELLOW	INPUT SIGNAL LINE FROM SWITCH OR SENSOR OPERATING AT + 5VDC
VIO	VIOLET	DC COMMON

• Wiring colors are different around the heat roller since heat resistance wires must be used.

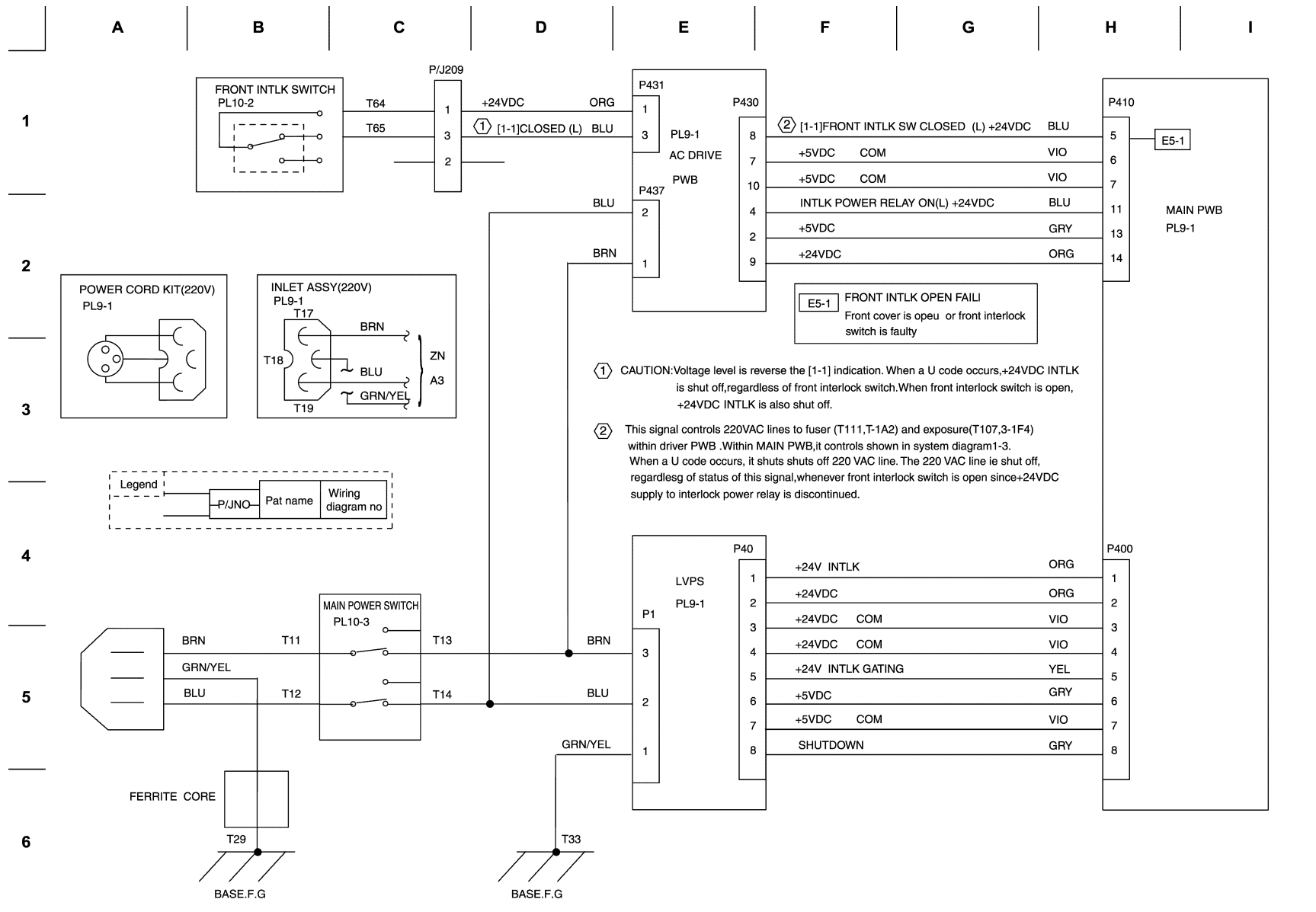

Section 9 BSD (Block Schematic Diagram)  
1.1 STANDBY POWER

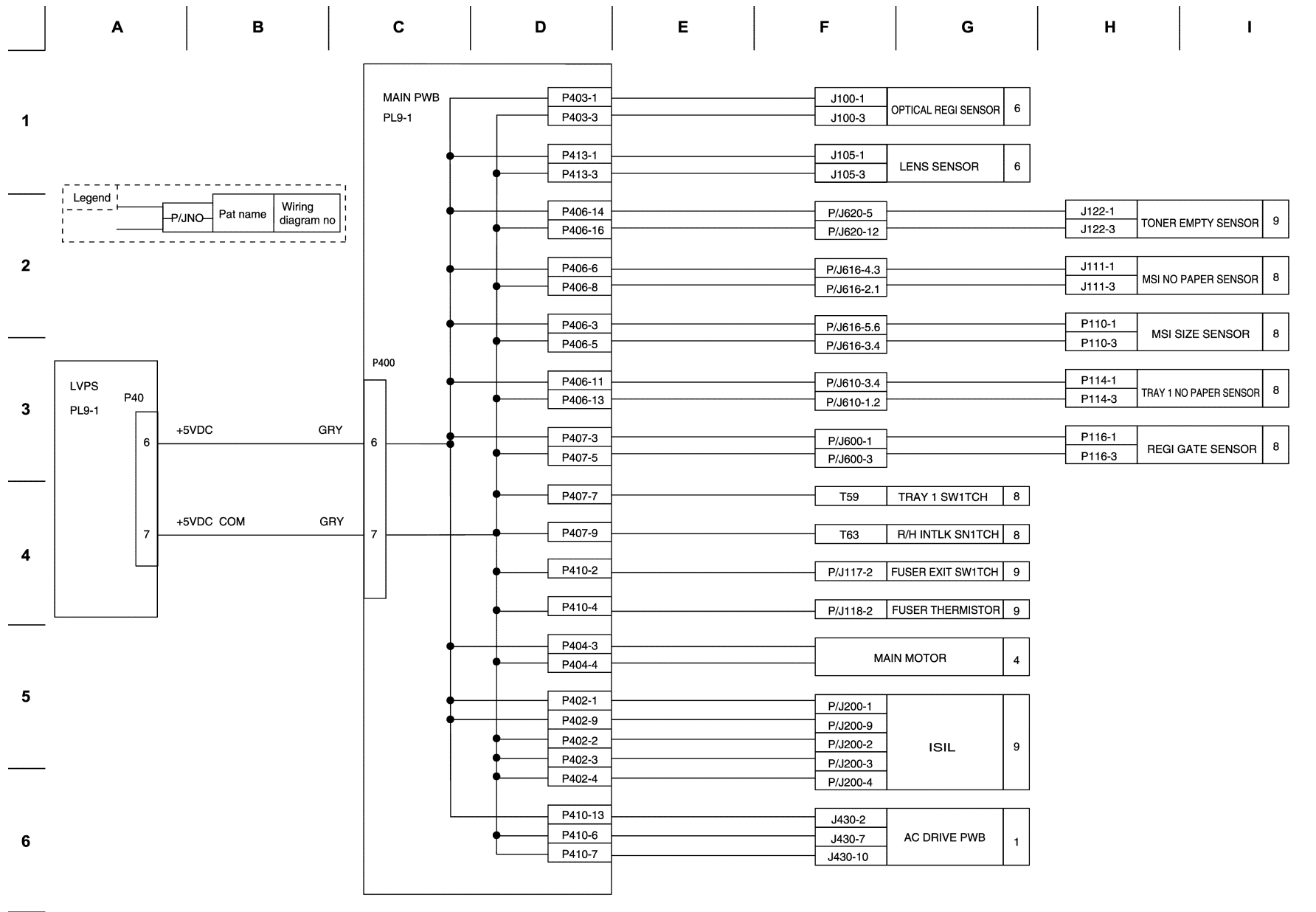



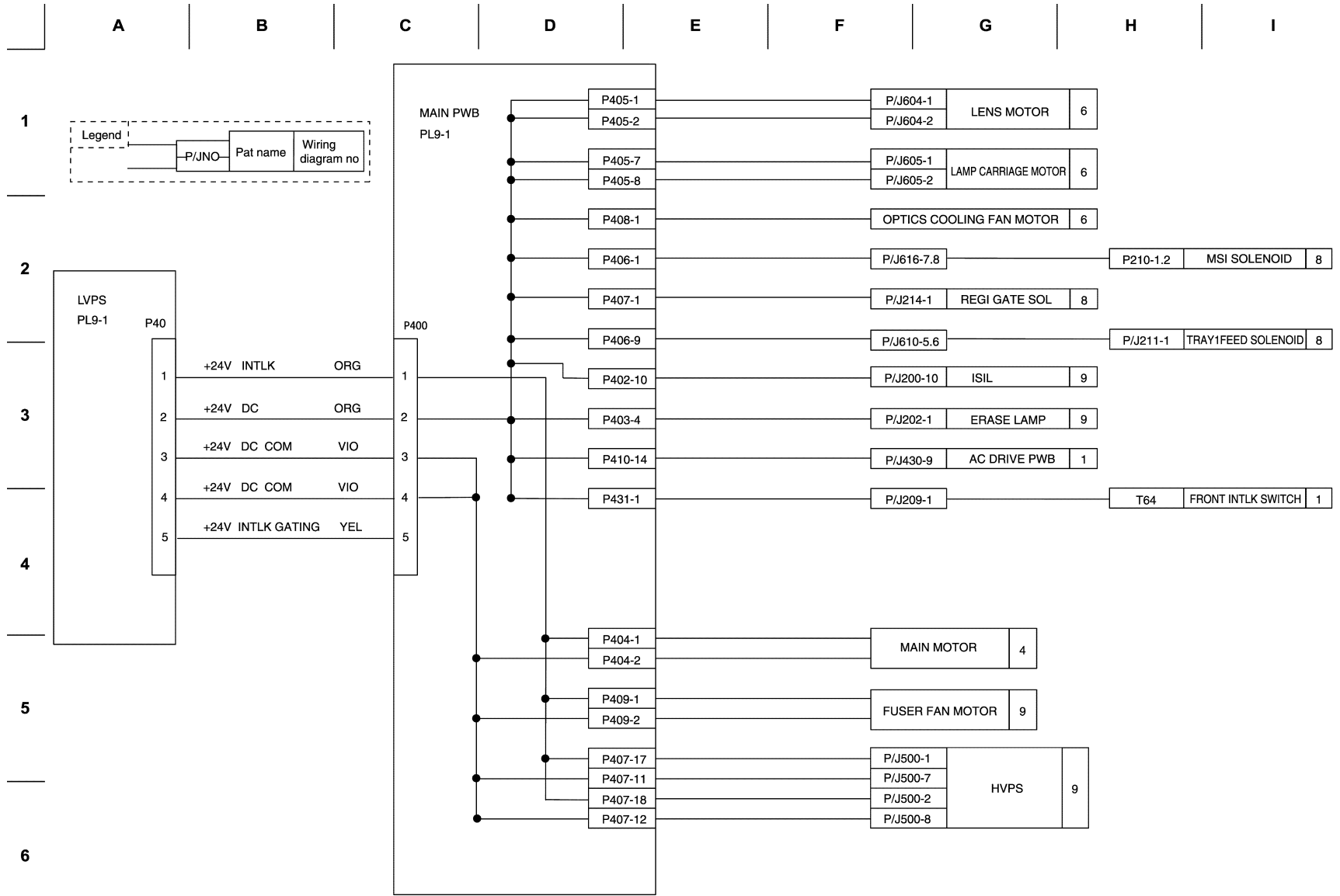

Section 9 BSD (Block Schematic Diagram)  
 2. MODE SELECTION, MACHINE RUN CONTROL, START PRINT POWER

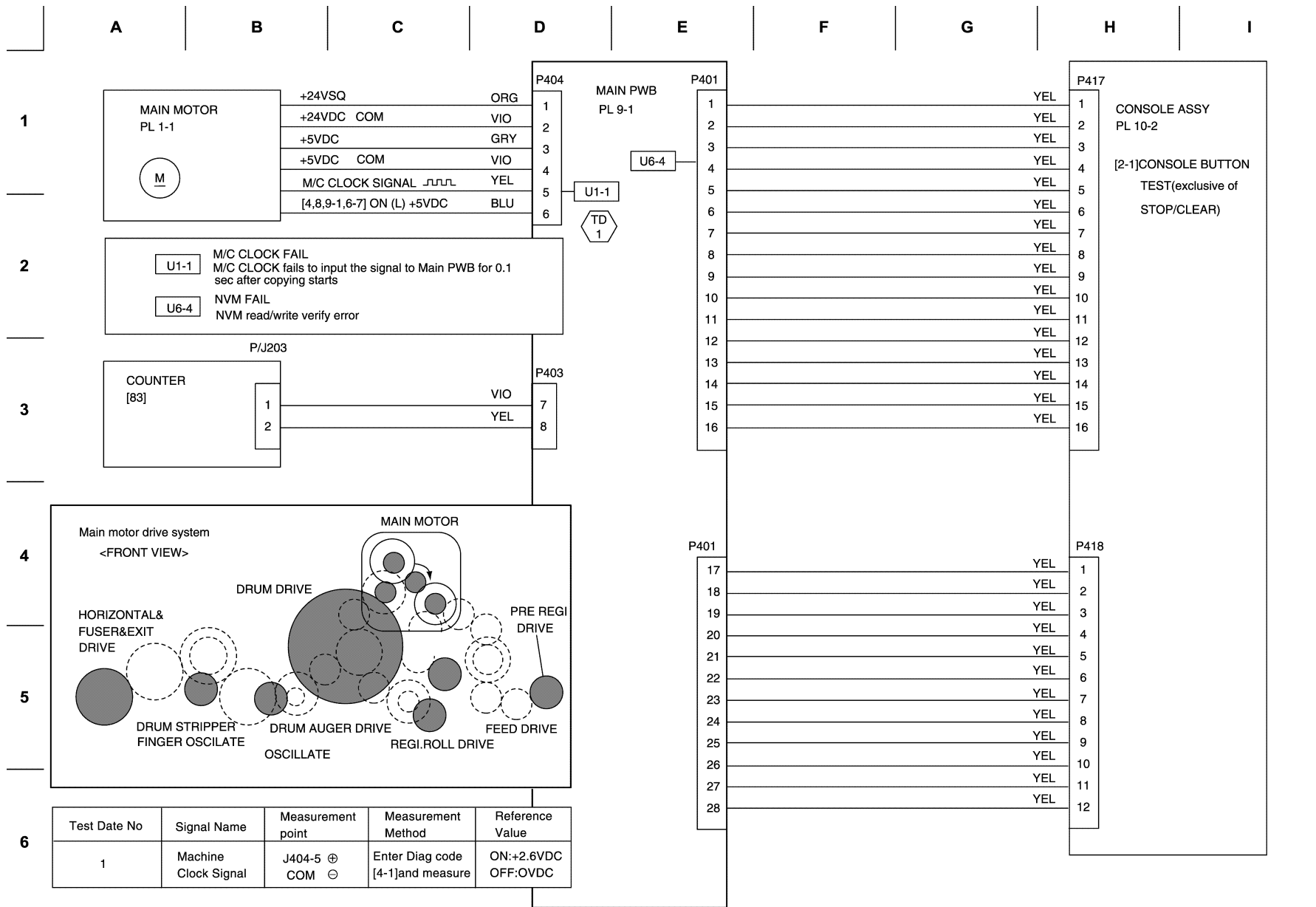

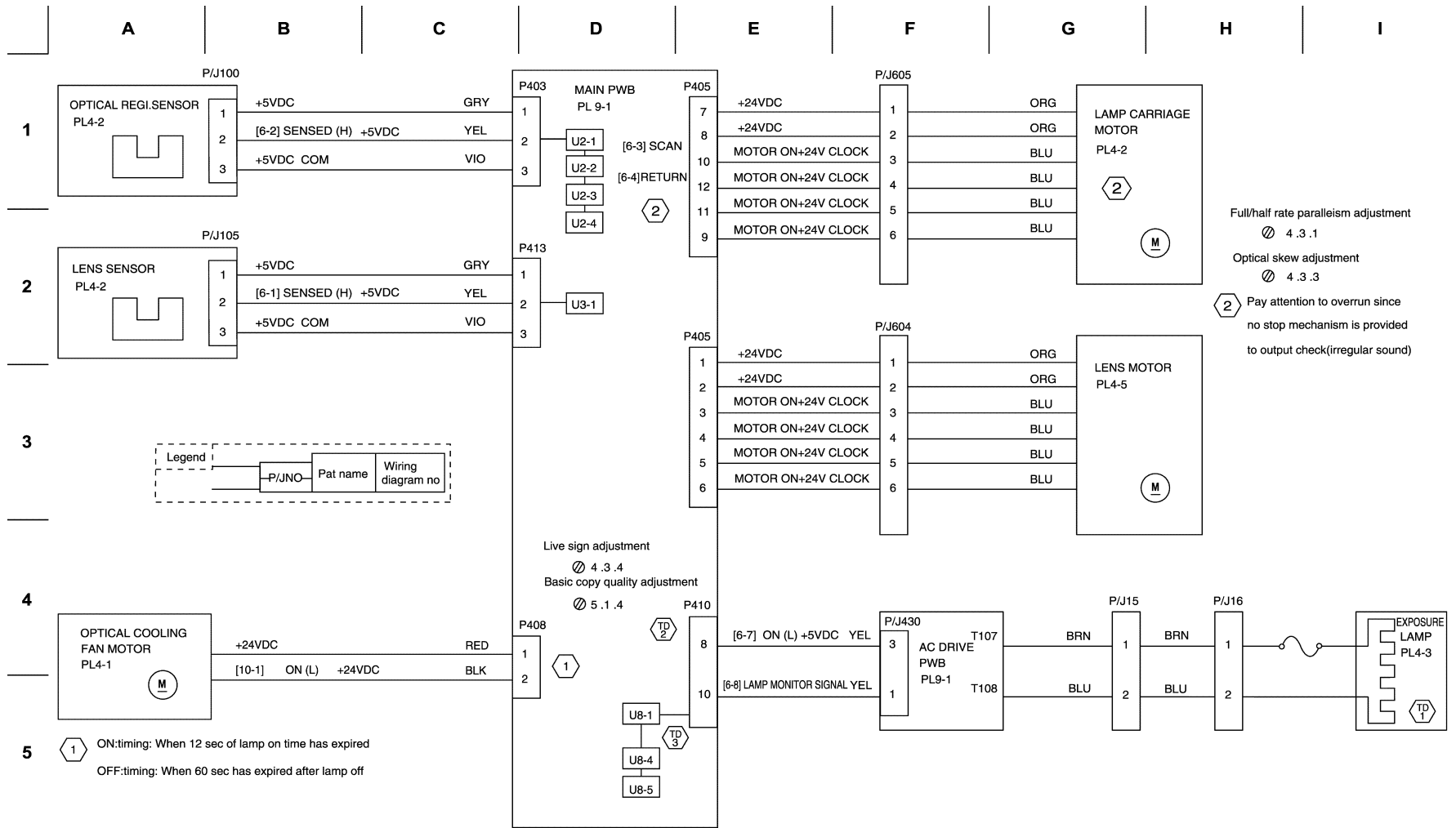

<b>U2-1</b>	<u>LAMP CARRIAGE FAIL - STANDBY</u> Lamp carriage fails to activate optical registration sensor for 6.5 sec during standby.
<b>U2-2</b>	<u>LAMP CARRIAGE FAIL - POSITION</u> Case 1: Optical registration sensor fails to turn on within 0.65 sec at lamp carriage initialization after end of copying. Case 2: Optical registration sensor fails to turn off within 0.65 sec at start of copy.
<b>U2-3</b>	<u>LAMPCARRIAGE FAIL-SCAN</u> Optical registration sensor fails to turn on within 0.46 sec after lamp carriage initiated scanning.
<b>U2-4</b>	<u>LAMP CARRIAGE FAIL - RETURN</u> Optical registration sensor fails to turn on within 2.5 sec after lamp carriage initiated return.
<b>U3-1</b>	<u>LENS POSITION FAIL</u> Lens sensor fails to turn on within 3.1 sec after lens initialization was initiated (start of movement).
<b>U8-1</b>	<u>EXPOSURE CONTROL FAIL</u> Control mode is not set within 0.5 sec after exposure lamp turned on.
<b>U8-4</b>	<u>EXPOSURE VOLTAGE OVER FAIL</u> Voltage level of exposure signal intensity level already exceeds 2.9 V when exposure lamp turns on.
<b>U8-5</b>	<u>EXPOSURE VOLTAGE UNDER FAIL</u> Voltage level of exposure signal intensity level is already below 0.5 V when exposure lamp turns on.

Test data No.	Signal name	Measurement point	Measurement method	Reference value
1	EXPOSURE LAMP TERMINAL VOLTAGE	P/J16-1 ⊕ P/J16-2 ⊖	•Enter diag code [6-7] •Start a copy cycle in normal mode.	100VAC 60-70VAC
2	EXPOSURE LAMP STARTING SIGNAL	P410-12 ⊕ COM ⊖	Enter diag code [6-7] measure	ON: +10.2VDC OFF: 22.3VDC
3	LAMP VOLTAGE MONITOR SIGNAL	Enter diag code [6-7] and then [6-8] to check A/D value		A/D VALUE: B4 to B6 (reference: +19VDC)
4	LAMP CARRIAGE MOTOR ON 24V CLOCK	J605-3,4,5,6 ⊕ COM ⊖	Enter diag code [6-3] or [6-4] and measure	ON: +24.0VDC OFF: +24.5VDC

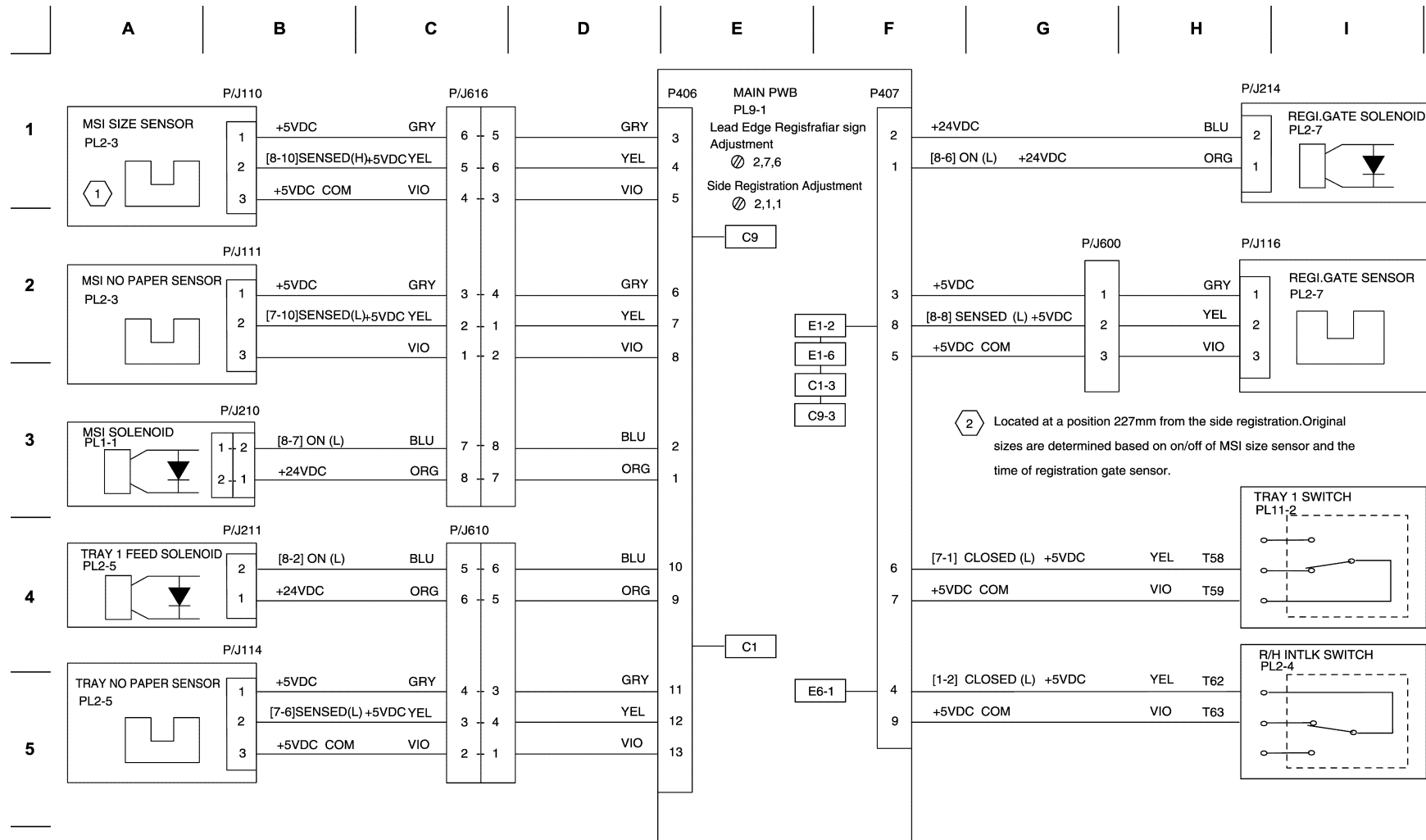

## Section 9 BSD (Block Schematic Diagram)

### 4.2 PAPER SUPPLYING AND TRANSPORTATION

<b>C1-2</b>	<b>TRAY 1 MISFEED JAM</b> Feed sensor fails to turn on within 2.7 sec after feed was initiated.
<b>C9-3</b>	<b>MSI MISFEED JAM</b> Registration gate sensor fails to turn on within 2.3 seconds after initiation of feed.
<b>E1-2</b>	<b>REGI-GATE SENSOR OFF CHECK JAM</b> Registration gate sensor fails to turn off (remains on) at the end of the specified time (varies by paper size) after registration gate opened.
<b>E1-6</b>	<b>REGI-GATE SENSOR STATIC JAM</b> Registration gate sensor remains on at power on or standby. (Remaining paper)
<b>E6-1</b>	<b>R/H UPPER INTLK OPEN FAIL</b> Right upper cover is open or right upper interlock switch is faulty.

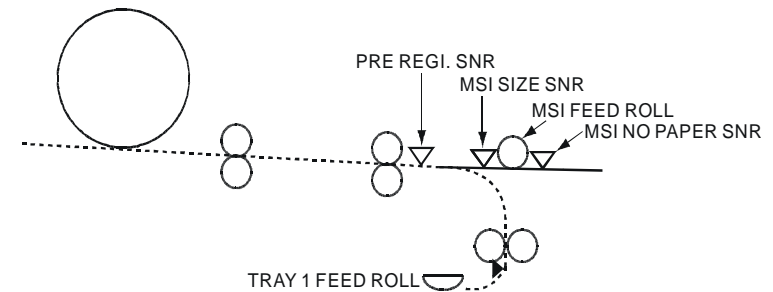

#### MSI size detection

- The MSI paper size is detected for the following purposes:
  - a. Lamp scan control
  - b. Fuser temperature control
  - c. Detection of FUSER EXIT JAM [E3-3].
    1. Width is detected by the MSI size sensor by measuring time from start of 1st paper feed to registration gate sensor ON.
    2. Length is detected by measuring the time from registration gate open to registration gate sensor OFF.
- Since length cannot be detected for the 1st paper, control is carried out using that for A3.

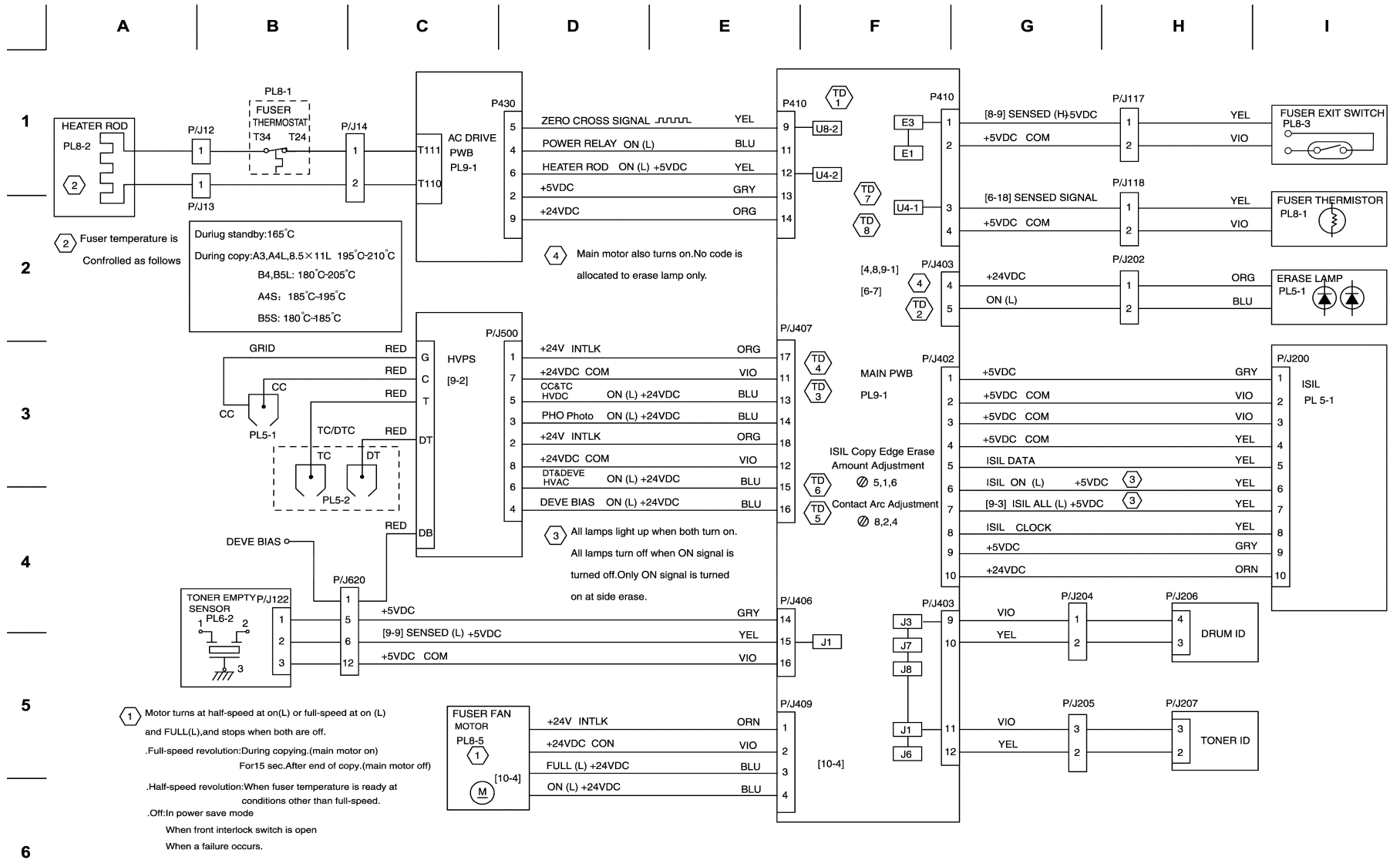

<b>U4-1</b>	<b>FUSER THERMISTOR OPEN FAIL</b> Electrical discontinuation of fuser thermistor or faulty fuser thermistor circuit.
<b>U4-2</b>	<b>FUSER WARM UP FAIL</b> Fuser is not ready 1 minute after power on or front interlock switch is turned off and then on.
<b>U4-3</b>	<b>FUSER OVERHEAT FAIL 1</b> Heater rod remains on for 10 sec or more after fuser is ready.
<b>U4-4</b>	<b>FUSER OVERHEAT FAIL 2</b> Heater rod remains on for 20 sec or more after cycle down.
<b>U4-6</b>	<b>FUSER OVERHEAT SAFETY FAIL</b> Fuser thermistor detected 240°C or more continuously for 0.5 sec or more.
<b>U8-2</b>	<b>NO ZERO CROSS FAIL</b> No zero cross is input for 2 sec or more during fuser control.
<b>E1-1</b>	<b>FUSER EXIT SWITCH ON CHECK JAM</b> Fuser exit switch fails to turn on 3.7 sec after registration gate opened.
<b>E3-3</b>	<b>FUSER EXIT SWITCH OFF CHECK JAM</b> Fuser exit switch fails to turn off (remains on) the specified time (which varies according to paper size) after fuser exit switch turned on.
<b>E3-6</b>	<b>FUSER EXIT SWITCH STATIC JAM</b> Fuser exit switch is on at power on or standby (paper is remaining).
<b>J1-1</b>	<b>TONER EMPTY FAIL</b> Number of copies reaches 100 after toner empty sensor sensed toner end condition.
<b>J1-2</b>	<b>TONER UNIT LIFE END</b> The counter value of toner unit reaches the default value 7700.
<b>J3-1</b>	<b>DRUM UNIT SET FAIL</b> Drum unit is not set, or is set incorrectly to the machine.
<b>J3-2</b>	<b>TONER UNIT SET FAIL</b> Toner unit is not set, or is set incorrectly to the machine.
<b>J3-3</b>	<b>TOTAL COUNTER SET FAIL</b> Total counter is corrected improperly.
<b>J7-1</b>	<b>DRUM UNIT LIFE END</b> CV counter value reaches 50K.
<b>J6-1</b>	<b>DRUM UNIT ID FAIL</b> Drum unit Read/Write is in error.
<b>J6-2</b>	<b>TONER UNIT ID FAIL</b> Toner unit Read/Write is in error.
<b>J6-3</b>	<b>TOTAL COUNTER ID FAIL</b> Total Counter Unit Read/Write is in error.
<b>J8-1</b>	<b>DRUM UNIT TYPE NO. FAIL</b> Type No. stored in ID of drum unit does not match with that saved in NVM on main PWB.

<b>J8-2</b>	<b>TONER UNIT TYPE NO. FAIL</b> Type No. stored in ID of toner unit does not match with that saved in NVM on main PWB.
<b>J8-3</b>	<b>TOTAL COUNTER TYPE NO. FAIL</b> Type No. stored in ID of total counter does not match with that saved in NVM on main PWB.
<b>J9-1</b>	<b>DRUM UNIT ID No. FAIL</b> Identification No. of drum unit is not of Xerox origin.
<b>J9-2</b>	<b>TONER UNIT ID No. FAIL</b> Identification No. of toner unit is not of Xerox origin.
<b>J9-3</b>	<b>TOTAL COUNTER ID No. FAIL</b> Identification No. of total copy count is not of Xerox origin.



Test data No.	Signal name	Measurement Point	Measurement method	Reference value
1	ZERO CROSS SIGNAL	J410-9 ⊕ COM ⊖	Measure in standby mode. (close front cover)	+0.5VDC
2	ERASE LAMP ON(L) +24VDC	J403-5 ⊕ COM ⊖	Enter diag code [4-1] and measure.	ON: +0.75VDC OFF: +12.5VDC
3	PHOTO MODE ON(L) +24VDC	J407-14 ⊕ COM ⊖	Select Photo mode during standby and start a copy cycle.	ON: 0V OFF: +13VDC-14VDC (Auto and variable modes)
4	CC&TC ON(L) +24VDC	J407-13 ⊕ COM ⊖	Start a copy cycle in normal mode.	ON: 0V OFF: +13VDC-14VDC
5	DEVE BIAS ON(L) +5VDC	J407-16 ⊕ COM ⊖	Enter diag. code [9-2] and start a copy cycle.	ON: 0V OFF: +13VDC-14VDC
6	DTC&DEVE BIAS ON(L) +24VDC	J407-15 ⊕ COM ⊖	Start a copy cycle in normal mode.	ON: 0V OFF: +13VDC-14VDC
7	FUSER THERMISTOR SENSED SIGNAL	Enter diag code [6-18] and check A/D value.		A/D VALUE: 9C to 93
8	FUSER THERMISTOR discontinuation check	Enter diag code [6-19] and check A/D value.		A/D VALUE: Normal: 00 to 01 Discontinuous: FF

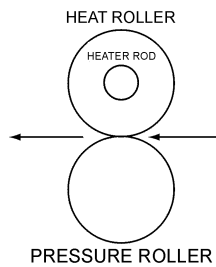

**XEROX**

**Issued: JUNE 2000**

## **THE DOCUMENT COMPANY**

### **XEROX 5915**

#### **Service Manual 1st Edition**

- **This service manual covers the following models:**

Electrostatic Copier XEROX 5915 manufactured by SHANGHAI XEROX.

- **Related Materials**

No related materials are issued other than this service manual.

- **Confidentiality**

- This service manual is issued intending use by maintenance service personal authorized by XEROX. Copying, transferring or leasing this manual without prior consent by XEROX is prohibited.
- Whenever a paper is eliminated because of issuance of a replacement page containing changes modifications, burn it or take the necessary action including cutting by a shredder.
- Be careful of handing the manual to avoid missing or damaging it.

- **Revision and Modification Information**

When design changes or revisions relating to this service manual occur, overseas technical information or overseas service bulletins may be issued as supplementary information until such change will be accommodated in the updated version of this service manual.

**CAUTION:** Important changes including revisions of spare part numbers and adjustment specifications must immediately be reflected on the respective pages of this service manual upon reception of such information.

## Free Manuals Download Website

<http://myh66.com>

<http://usermanuals.us>

<http://www.somanuals.com>

<http://www.4manuals.cc>

<http://www.manual-lib.com>

<http://www.404manual.com>

<http://www.luxmanual.com>

<http://aubethermostatmanual.com>

Golf course search by state

<http://golfingnear.com>

Email search by domain

<http://emailbydomain.com>

Auto manuals search

<http://auto.somanuals.com>

TV manuals search

<http://tv.somanuals.com>