

Xerox WorkCentre C226 User Guide

Warranty

While every effort has been made to make this operation manual as accurate and helpful as possible, Xerox Corporation makes no warranty of any kind with regard to its content. All information included herein is subject to change without notice. Xerox is not responsible for any loss or damages, direct or indirect, arising from or related to the use of this operation manual.

© Copyright Xerox Corporation 2005. All rights reserved. Reproduction, adaptation or translation without prior written permission is prohibited, except as allowed under copyright laws.

Trademark information

- Microsoft Windows operating system is a registered trademark or trademark of the Microsoft Corporation in the U.S.A. and other countries.
- Windows 98, Windows Me, Windows NT 4.0, Windows 2000, and Windows XP are registered trademarks or trademarks of Microsoft Corporation in the U.S.A. and other countries.
- Netscape Navigator is a trademark of Netscape Communications Corporation.
- Adobe® Reader Copyright© 1987-2005 Adobe Systems Incorporated. All rights reserved.
- Adobe, the Adobe logo, Acrobat, and the Acrobat logo are trademarks of Adobe Systems Incorporated.
- All other company names and product names appearing in this manual are the trademarks of their respective owners.

Table of contents

Introduction

Safety Notes xv

WARNING - Electrical Safety Information	xvi
Operational Safety Information	xvii
Maintenance Information	xviii
Ozone Safety Information	xviii
For Consumables	xviii
Radio Frequency Emissions	xix
Product Safety Certification	xix

Regulatory Information for Fax Function xx

USA	xx
FAX Send Header Requirements:	xx
Data Coupler Information	xxi
Canada	xxii
Europe	xxii
Certification to 1999/5/EC Radio Equipment & Telecommunications Terminal Equipment Directive	xxii

Environmental Compliance xxiii

USA - Energy Star	xxiii
Canada - Environmental Choice	xxiii
Europe - Energy	xxiv

Illegal Copies xxiv

USA	xxiv
Canada	xxv
Other countries	xxvi

Product Recycling and Disposal xxvi

1 General Information

Before Using the Product	1-1
Installation Requirements	1-1
Moving this machine	1-3
Cautions	1-4
Introduction	1-5
Main Features	1-7
Energy saving features	1-8
Part Names and Functions	1-9
Exterior	1-9
Interior	1-11
Part names and functions of peripheral devices	1-12
Other optional equipment	1-13
Operation panel	1-14
Touch panel	1-16
Auditing Mode	1-18
Managing the Machine	1-21
Loading Paper	1-21
Loading paper in Paper Tray 1	1-21
Changing the paper size in Paper Tray 1	1-22
Loading paper in the Bypass Tray	1-23
Setting envelopes or postcards	1-26
Loading paper in the stand/1-Tray Unit/3-Tray Unit	1-28
Specifications (stand/1-Tray Unit/3-Tray Unit)	1-29
Loading paper in the Duplex Module/2-Tray Unit	1-29
Specifications (Duplex Module/2-Tray Unit)	1-30
Specifications for paper trays	1-30
More information on plain paper	1-32
More information on special media that can be used	1-32
Paper that can be used for automatic two-sided printing	1-33
Setting the paper type (except the Bypass Tray)	1-33
Setting the paper size when an extra size is loaded	1-34
Setting the paper type and paper size in the Bypass Tray	1-35
Custom Settings	1-37
Operation procedure common to all custom settings	1-39
About the settings	1-40
Replacing the Toner Cartridges	1-42
Storing Supplies	1-45

Proper storage	1-45
Misfeed Removal	1-46
Misfeed Removal Guidance	1-47
Misfeed in the paper feed area	1-47
Misfeed in the transport area, fusing area, and exit area	1-49
Misfeed in the stand/1-Tray Unit	1-52
Misfeed in the 3-Tray Unit	1-53
Misfeed in the Duplex Bypass/Inverter Unit and Duplex Module/2-Tray Unit	1-53
Misfeed in the upper or lower tray	1-55
Troubleshooting	1-56

Peripheral Devices 1-59

Saddle Stitch Finisher	1-59
Part names and functions	1-59
Using the Saddle Stitch Finisher	1-60
Staple cartridge replacement and staple jam removal	1-61
Staple cartridge replacement	1-61
Staple jam removal	1-63
Disposal of hole punch scrap (when the punch unit is installed)	1-66
Misfeed in the Saddle Stitch Finisher	1-67
Troubleshooting Saddle Stitch Finisher problems	1-70
Stapling position quick reference guide for duplex output	1-72
Relation between print image and saddle stitch	1-73
High Capacity Feeder	1-74
Part name	1-74
Loading paper in the High Capacity Feeder	1-74
Misfeed in the High Capacity Feeder	1-75

2 Copier Operation

Before Making Copies 2-1

Part Names and Functions (The DADF)	2-1
Exterior	2-1
Touch Panel (main screen of copy mode)	2-2
DADF	2-3
Acceptable originals	2-3
Size and weight of acceptable originals	2-4
Setting Originals	2-4

When using the DADF	2-4
When using the document glass	2-5
Standard original setting orientation	2-7
Automatic copy image rotation - rotation copying	2-8
Selecting the Original Size	2-8
Storing, Deleting, and Using Original Sizes	2-10
Storing or deleting an original size	2-10
Using a Stored Original Size	2-12

Basic Procedure for Making Copies 2-13

Normal Copying	2-13
Copying from the DADF	2-13
1-sided copies of 1-sided originals	2-13
Automatic two-sided copying from the DADF	2-19
Copying from the document glass	2-21
1-sided copies of 1-sided originals	2-21
Automatic two-sided copying from the document glass	2-24
Exposure Adjustments	2-25
Reduction/Enlargement/Zoom	2-28
Automatic selection (auto image)	2-28
Manual selection	2-30
XY Zoom	2-33
Special Papers	2-35

Convenient Copy Functions 2-37

Special Modes	2-37
Common operation procedure for using the special functions	2-38
Margin shift	2-39
Erase	2-41
Dual page copy	2-42
Centring	2-44
Transparency film with insert sheets	2-45
Covers	2-47
Copying onto a cover	2-47
Not copying onto a cover	2-48
B/W reverse	2-50
Colour Adjustments Menu	2-51
RGB Adjust	2-52
Sharpness	2-53
Suppress background	2-54
Colour balance	2-55

Brightness	2-57
Intensity	2-58
Image Edit Menu	2-59
Single colour	2-60
Mirror image	2-61
Photo Repeat	2-62
Multi shot	2-64
A3 (11" x 17") Full-bleed	2-66
Multi-page enlargement	2-68
Pamphlet copy	2-71
Job Program Memory	2-73
Storing a job program	2-73
Recalling a job program	2-74
Deleting a stored job program	2-75
Interrupting a Copy Run	2-77

Machine Maintenance (for Copying) 2-79

Removing an Original Misfeed	2-79
Removing a misfed original from the DADF	2-79
User Maintenance (for copying)	2-81
Cleaning the Original Scanning Area	2-82
Troubleshooting	2-83

3 Printer Operation

Basic Printing Procedures 3-1

Setting the Printer Drivers	3-1
Printer driver settings in Windows (selecting and setting print conditions)	3-1
Windows 95 / 98 / Me	3-1
Windows NT4.0 / 2000 / XP / Server 2003	3-2
Selecting a Color Mode setting	3-2
Using the Help file to view explanations of the settings	3-3
Opening Help in Windows	3-3
Printing in black and white	3-4
Automatic switching between colour and black and white	3-7
Printing in colour	3-10
Printing using optional peripheral equipment	3-12

Setting the Printer Driver Properties 3-15

Selecting Printing Functions	3-15
Frequently used settings	3-16
Saddle stitch function	3-20
Staple sort mode	3-20
Hole punching (only if a Hole Punch Module is installed)	3-22
Offset mode	3-22
Paper settings	3-26
Advanced settings	3-29
PCL5c	3-29
PostScript	3-31
Watermark settings	3-33
Color settings	3-35
Web Pages in the Printer	3-40
Printer Configuration Through the Network	3-40
Environment required for accessing Web pages	3-40
Accessing Web pages and displaying help	3-40
Items and outline of menu frame of Web pages	3-42
System Information	3-42
Device Setup	3-43
Network Setup	3-44
Printer Configuration Settings	3-44
Making Configuration Settings	3-44
Operation procedure common to all printer configuration settings	3-45
Default settings	3-46
Copies	3-46
Orientation	3-46
Default paper size	3-46
Default output tray	3-46
Default paper type	3-47
PCL settings	3-47
PCL symbol set setting	3-47
PCL font settings	3-47
Printing from the Operation Panel	3-48
Hold Job List	3-48
Key Operator Programs	3-50
Key operator program list	3-50
Procedure for using key operator programs	3-52

Key operator program menu	3-54
Description of Setting Programs	3-55
Printer settings	3-55
Default settings	3-55
Interface settings	3-56
Network settings	3-57
Colour adjustments	3-58
Initialize and/or store settings	3-59

Troubleshooting..... 3-61

Additional information on selecting the paper type for the Bypass Tray when using the printer function	3-63
Checking the IP address	3-64

Appendix..... 3-65

Notice Page Printing	3-65
Print Area	3-66

4 Network Scanner Operation

Introduction	4-1
About the Network Scanner Function	4-3

Settings and Programming Required for the Network Scanner

Feature	4-4
Accessing Web Pages	4-4
About the Web Page	4-5
Basic Settings for Network Scanning	4-6
Enable scanner delivery methods ("Enable Scanner Delivery to")	4-6
Enabling user authentication ("Advanced Setup")	4-6
Select the method for assigning a file name to a scanned image ("File Naming")	4-7
Selecting an e-mail subject ("E-mail Subject": only used for Scan to E-mail)	4-7
E-mail Server and DNS Server Settings	4-7
Setting Up Destination Information	4-10
Storing destinations for Scan to E-mail	4-11
Storing destinations for Scan to FTP	4-12
Storing Groups (Scan to E-mail)	4-14
Editing and deleting programmed transmission destinations	4-15

Storing Sender Information (Scan to E-mail)	4-16
Editing and deleting programmed sender's information.	4-17
Storing a Custom Directory	4-17
Protecting Information Programmed in the Web Page ("Passwords")	4-18
Condition Setting Screen of Scanner Mode	4-18
Condition setting screen	4-19
Address directory screen	4-21
Sending an Image	4-23
Basic Transmission Method	4-23
Destination Input Methods	4-27
Destination address manual entry	4-27
Destination address entry with global address search.	4-30
Scanning and Transmitting a Two-sided Original.	4-32
Scanning Settings	4-34
Manually Setting the Scanning Size.	4-34
Selecting the Exposure.	4-36
Change the exposure.	4-36
Selecting the Resolution.	4-37
Change the resolution	4-37
Selecting the File Format	4-38
Cancelling an E-Mail/FTP Transmission	4-41
Storing, Editing, and Deleting from the Touch Panel	4-42
Storing One-Touch Keys (Only Addresses for Scan to E-mail)	4-42
Editing and Deleting One-Touch Keys	4-46
Programming a Group Key.	4-48
Editing and Deleting Group Keys	4-50
Storing Sender Information.	4-52
Editing and Deleting Sender Information	4-53
Storing a Group Index	4-54
Printing Programmed Information.	4-55
Troubleshooting.	4-57
If Your E-Mail Is Returned	4-59
If a Transmission Error Occurs.	4-59
Error Code Table	4-59
Checking the IP Address	4-60
Important Points When Using Scan to E-Mail	4-62

Key Operator Programs.	4-63
Key Operator Program List.	4-63
Using the Key Operator Programs	4-64
Setting Programs	4-65
Network scanner settings.	4-65
Default display settings	4-66
The number of direct address keys displayed setting	4-66
Initial resolution setting	4-66
Scan complete sound setting	4-67
Default sender set	4-67
Compression mode at broadcasting	4-67
Initial file format setting	4-67
Maximum size of e-mail attachments	4-68
Scanner mode timeout after last scan	4-68
Default exposure settings	4-68
Disable of address direct entry	4-69
Specifications.	4-70
Scanning margins.	4-71

5 Fax Unit

To Use this Product Correctly as a Fax Device	5-1
Important Safety Information	5-2
Before Using the FAX Feature	5-3
Points to Check and Program After Installation	5-3
Connecting an Extension Phone	5-4
A Look at the Operation Panel	5-5
Fax Mode (Condition Settings Screen).	5-6
Originals that Can Be Faxed	5-10
Loading a Document	5-11
Using the DADF	5-11
Using the Document Glass	5-11
Checking the Size of a Loaded Original.	5-12
Manually Setting the Scanning Size.	5-13
Selecting Resolution and Exposure Settings	5-14
Selecting the Resolution	5-14
Selecting the Exposure	5-16

Convenient Dialing Methods	5-17
Basic Operations	5-19
Sending a Fax	5-19
Basic Procedure for Sending Faxes	5-19
Transmission by Auto-Dialing (One-Touch Dialing and Group Dialing)	5-22
Faxing a Two-Sided Original	5-23
Priority Transmission of a Stored Job	5-26
Cancelling a Fax Transmission	5-27
Cancelling On-Hook Dialing	5-27
Receiving Faxes	5-28
Advanced Transmission Methods	5-29
Sending the Same Document to Multiple Destinations in a Single Operation (Broadcast Transmission)	5-29
Using Broadcast Transmission	5-30
Automatic Transmission at a Specified Time (Timer Transmission)	5-32
Setting Up a Timer Transmission	5-33
Transmission and Reception Using the Polling Function	5-34
Using the Polling Function	5-36
Using Polling Memory	5-38
Own Number Sending	5-42
Faxing a Divided Original (Dual Page Scan)	5-43
Programming Frequently Used Operations	5-44
Using a Program	5-45
Transferring Received Faxes to Another Machine When Printing Is Not Possible (Forwarding Function)	5-46
Using the Transfer Function	5-47
Transmission Using F-Codes	5-49
Transmission Between Machines Supporting F-codes	5-49
Memory Boxes and Sub-Addresses/Passcodes Required for F-code Transmission	5-49
Entering (Dialing) a Fax Number with a Sub-Address and Passcode	5-51
Creating a Memory Box for F-Code Transmission	5-52
F-Code Polling Memory	5-52
Using F-Code Polling Memory	5-53
Procedure for F-Code Polling	5-54
F-Code Confidential Transmission	5-56

F-Code Confidential Transmission	5-57
Printing a Document Received to an F-Code Confidential Memory Box.	5-57
F-Code Relay Broadcast Transmission	5-59
Using the F-Code Relay Broadcast Function.	5-60
Using the F-Code Relay Request Function	5-61
Convenient Methods of Use	5-61
Using an Extension Phone	5-61
Sending a Fax after Talking (Manual Transmission)	5-62
Using an Extension Phone to Receive a Fax.	5-63
Receiving a Fax After Talking (Manual Reception)	5-64
Programming	5-66
Storing, Editing, and Deleting Auto Dial Keys and Programs.	5-66
Storing One-Touch Keys	5-68
Editing and Deleting One-Touch Keys.	5-72
Storing a Group Key	5-74
Editing and Deleting Group Keys.	5-76
Storing a Program	5-78
Editing and Deleting Programs	5-80
Storing a Group Index	5-80
Programming, Editing, and Deleting F-Code Memory Boxes.	5-81
Programming an F-Code Memory Box	5-82
Setting for F-Code Polling Memory Boxes (Polling Times)	5-84
Setting for F-Code Confidential Transmission Memory Boxes (Print PIN)	5-85
Setting for F-Code Relay Broadcast Memory Boxes (Recipient).	5-86
Editing and Deleting a Memory Box.	5-88
Printing Programmed Information.	5-89
Entering Characters	5-90
Entering alphabetical characters	5-90
Entering numbers and symbols	5-93
Troubleshooting.	5-95
When a Transaction Report Is Printed	5-95
Viewing the Communication Activity Report.	5-98
When an Alarm Sounds and a Warning Message Is Displayed.	5-98
Problems and Solutions	5-100
Index	I-1

Introduction

Safety Notes

Read these safety notes carefully before using this product to ensure you operate the equipment safely. Your Xerox product and recommended supplies have been designed and tested to meet strict safety requirements. These include safety agency approval, and compliance to established environmental standards. Please read the following instructions carefully before operating the product and refer to them as needed to ensure the continued safe operation of your product.

The safety and environment testing and performance of this product have been verified using Xerox materials only.

WARNING: Any unauthorized alteration, which may include the addition of new functions or connection of external devices, may impact the product certification. Please contact your authorized local dealer for more information.

Warning Markings

All warning instructions marked on or supplied with the product should be followed.



Warning

This WARNING alerts users to areas of the product where there is the possibility of personal injury.



Warning

This WARNING alerts users to areas of the product where there are heated surfaces, which should not be touched.

Electrical Supply

This product shall be operated from the type of electrical supply indicated on the product's data plate label. If you are not sure that your electrical supply meets the requirements, please consult your local power company for advice.



WARNING

This product must be connected to a protective earth circuit.

This product is supplied with a plug that has a protective earth pin. This plug will fit only into an earthed electrical outlet. This is a safety feature. To avoid risk of electric shock, contact your electrician to replace the electrical outlet if you are unable to insert the plug into it. Never use an earthed adapter plug to connect the product to an electrical outlet that lacks an earth connection terminal.

Operator Accessible Areas

This equipment has been designed to restrict operator access to safe areas only. Operator access to hazardous areas is restricted with covers or guards, which would require a tool to remove. Never remove these covers or guards.

Maintenance

Any operator product maintenance procedures will be described in the user documentation supplied with the product. Do not to carry out any maintenance on this product, which is not described in the customer documentation.

Cleaning Your Product

Before cleaning this product, unplug the product from the electrical outlet. Always use materials specifically designated for this product, the use of other materials may result in poor performance and may create a hazardous situation. Do not use aerosol cleaners, they may be explosive and flammable under certain circumstances.

WARNING - Electrical Safety Information

- Use only power cord supplied with this equipment.
- Plug the power cord directly into a grounded electrical outlet. Do not use an extension cord. If you do not know whether or not an outlet is grounded, consult a qualified electrician.
- This equipment is to be operated from the type of electrical supply indicated on the product data plate label. If this machine needs to be moved to a different location, contact a Xerox service representative or your authorized local representative or service support organization.
- Improper connection of the equipment-grounding conductor can result in electrical shock.
- Do not place this equipment where people might step on or trip on the power cord.
- Do not place objects on the power cord.

-
- Do not override or disable electrical or mechanical interlocks.
 - Do not obstruct the ventilation openings.
 - Never push objects of any kind into slots or openings on this equipment
 - If any of the following conditions occur, switch off the power to the machine immediately and disconnect the power cord from the electrical outlet. Call an authorized local service representative to correct the problem.
 - The equipment emits unusual noise or odors.
 - The power cord is damaged or frayed.
 - A wall panel circuit breaker, fuse, or other safety device has been tripped.
 - Liquid is spilled into the copier/printer.
 - The equipment is exposed to water.
 - Any part of the equipment is damaged.

Disconnect Device

The power cable is the disconnect device for this equipment. It is attached to the back of the machine as a plug-in device. To remove all electrical power from the equipment, disconnect the power cable from the electrical outlet.

Operational Safety Information

To ensure the continued safe operation of your Xerox equipment, follow these safety guidelines at all times.

Do These:

- Always connect equipment to a correctly grounded power outlet. If in doubt, have the outlet checked by a qualified electrician.
- This equipment must be connected to a protective earth circuit.

This equipment is supplied with a plug that has a protective earth pin. This plug will fit only into an earthed electrical outlet. This is a safety feature. To avoid risk of electric shock, contact your electrician to replace the electrical outlet if you are unable to insert the plug into it. Never use a plug that lacks an earth connection terminal to connect the product to an electrical outlet.

 - Always follow all warnings and instructions that are marked on or supplied with the equipment.
 - Always exercise care when moving or relocating equipment. Please contact your local Xerox Service Department, or your local support organization to arrange relocation of the product to a location outside of your building.
 - Always locate the equipment in an area that has adequate ventilation, and the room for servicing. See Install guide for minimum dimensions.
 - Always use materials and supplies specifically designed for your Xerox equipment. Use of unsuitable materials may result in poor performance.
 - Always unplug this equipment from the electrical outlet before cleaning.

Do Not Do These:

- Never use a plug that lacks an earth connection terminal to connect the product to an electrical outlet.
- Never attempt any maintenance function that is not specifically described in this documentation.
- This equipment should not be placed in a built-in installation unless proper ventilation is provided, please contact your Authorized local dealer for further information.
- Never remove covers or guards that are fastened with screws. There are no operator serviceable areas within these covers.
- Never locate the equipment near a radiator or any other heat source.
- Never push objects of any kind into the ventilation openings.
- Never override or "cheat" any of the electrical or mechanical interlock devices.
- Never operate the equipment if you notice unusual noises or odors. Disconnect the power cord from the electrical outlet and contact your local Xerox Service Representative or Service Provider immediately.

Maintenance Information

Do not attempt any maintenance procedure that is not specifically described in the documentation that is supplied with your copier/printer.

- Do not use aerosol cleaners. The use of cleaners that are not approved may cause poor performance of the equipment, and could create a dangerous condition.
- Use supplies and cleaning materials only as directed in this manual. Keep all of these materials out of the reach of children.
- Do not remove covers or guards that are fastened with screws. There are no parts behind these covers that you can maintain or service.
- Do not perform any maintenance procedures unless you have been trained to do them by an authorized local dealer or unless a procedure is specifically described in the user manuals.

Ozone Safety Information

This product will produce ozone during normal operation. The ozone produced is heavier than air and is dependent on copy volume. Providing the correct environmental parameters as specified in the Xerox installation procedure will ensure that the concentration levels meet safe limits.

If you need additional information about ozone, please request the Xerox publication Ozone by calling 1-800-828-6571 in the United States and Canada. In other markets please contact your authorized local dealer or Service Provider.

For Consumables

Store all consumables in accordance with the instructions given on the package or container.

- Keep all consumables away from the reach of children.
- Never throw toner, toner cartridges or toner containers into an open flame

Radio Frequency Emissions

United States, Canada, Europe

Note: This equipment has been tested and found to comply with the limits for a class A digital device, pursuant to Part 15 of the FCC Rules. These limits are designed to provide reasonable protection against harmful interference when the equipment is operated in a commercial environment. This equipment generates, uses, and can radiate radio frequency energy and, if not installed and used in accordance with the instruction manual, may cause harmful interference to radio communications. Operation of this equipment in a residential area is likely to cause harmful interference in which case the user will be required to correct the interference at his own expense.

Changes and modifications to this equipment not specifically approved by Xerox may void the user's authority to operate this equipment.

Shielded interface cables must be used with this equipment to maintain compliance with worldwide EMC regulations."

Product Safety Certification

This product is certified by the following Agency using the Safety standards listed.

Agency	Standard
Underwriters Laboratories Inc.	UL60950 3 rd Edition (USA/Canada)
NEMKO	IEC60950 3 rd Edition (1999)

This product was manufactured under a registered ISO9001 Quality system.

Regulatory Information for Fax Function

CE Mark

The CE mark applied to this product symbolizes Xerox's declaration of conformity with the following applicable Directives of the European Union as of the dates indicated:

January 1, 1995: Council Directive 72/23/EEC amended by Council directive 93/68/EEC, approximation of the laws of the member states related to low voltage equipment.

January 1, 1996: Council directive 89/336/EEC, approximation of the laws of the member states related to electromagnetic compatibility.

March 9, 1999: Council Directive 99/5/EC, on radio equipment and telecommunications terminal equipment and the mutual recognition of their conformity.

A full declaration of conformity, defining the relevant directives and referenced standards, can be obtained from your Authorized local dealer.

WARNING: In order to allow this equipment to operate in proximity to Industrial Scientific and Medical (ISM) equipment, the external radiation from the ISM equipment may have to be limited or special mitigation measures taken.

WARNING: This is a Class A product. In a domestic environment the product may cause radio frequency interference, in which case the user may be required to take adequate measures.

USA

FAX Send Header Requirements:

The Telephone Consumer Protection Act of 1991 makes it unlawful for any person to use a computer or other electronic device, including FAX machines, to send any message unless such message clearly contains in a margin at the top or bottom of each transmitted page or on the first page of the transmission, the date and time it is sent and an identification of the business or other entity, or other individual sending the message and the telephone number of the sending machine or such business, other entity, or individual. (The telephone number provided may not be a 900 number or any other number for which charges exceed local or long-distance transmission charges.)

In order to program this information into your FAX machine refer to "Own number and name set" in the "Fax Unit" section of your Xerox WorkCentre C226 System Administration Guide and follow the steps provided.

Data Coupler Information

This equipment complies with Part 68 of the FCC rules and the requirements adopted by the Administrative Council for Terminal Attachments (ACTA). On the rear of this equipment is a label that contains, among other information, a product identifier in the format US:XRMM07BZSA1. If requested, this number must be provided to the Telephone Company.

A plug and jack used to connect this equipment to the premises wiring and telephone network must comply with the applicable FCC Part 68 rules and requirements adopted by the ACTA.

A compliant telephone cord and modular plug is provided with this product. It is designed to be connected to a compatible modular jack that is also compliant.

WARNING: **Ask your local Telephone Company for the modular jack type installed on your line. Connecting this machine to an unauthorized jack can damage Telephone Company equipment. You, not Xerox, assume all responsibility and/or liability for any damage caused by the connection of this machine to an unauthorized jack.**

You may safely connect the machine to the following standard modular jack: USOC RJ-11C using the compliant telephone line cord (with modular plugs) provided with the installation kit.

The Ringer Equivalence Number (or REN) is used to determine the number of devices that may be connected to a telephone line. Excessive RENs on a telephone line may result in the devices not ringing in response to an incoming call. In most but not all areas, the sum of RENs should not exceed five (5.0). To be certain of the number of devices that may be connected to a line, as determined by the total RENs, contact the local Telephone Company. For products approved after July 23, 2001, the REN for this product is part of the product identifier that has the format US:XRMM07BZSA1. The digits 07 are the REN without a decimal point (e.g., 07 is a REN of 0.7). For earlier products, the REN is separately shown on the label.

If this Xerox equipment causes harm to the telephone network, the Telephone Company will notify you in advance that temporary discontinuance of service may be required. But if advance notice isn't practical, the Telephone Company will notify the customer as soon as possible. Also, you will be advised of your right to file a complaint with the FCC if you believe it is necessary.

The Telephone Company may make changes in its facilities, equipment, operations or procedures that could affect the operation of the equipment. If this happens the Telephone Company will provide advance notice in order for you to make necessary modifications to maintain uninterrupted service.

If trouble is experienced with this Xerox equipment, for repair or warranty information, please contact the Xerox Welcome Center telephone number 800-821-2797. If the equipment is causing harm to the telephone network, the Telephone Company may request that you disconnect the equipment until the problem is resolved.

Repairs to the machine should be made only by a Xerox representative or an authorized Xerox service agency. This applies at any time during or after the service warranty period. If unauthorized repair is performed, the remainder of the warranty period is null and void.

This equipment must not be used on party lines. Connection to party line service is subject to state tariffs. Contact the state public utility commission, public service commission or corporation commission for information.

If your office has specially wired alarm equipment connected to the telephone line, ensure the installation of this Xerox equipment does not disable your alarm equipment. If you have questions about what will disable alarm equipment, consult your Telephone Company or a qualified installer.

Canada

This product meets the applicable Industry Canada technical specifications.

The Ringer Equivalence Number (REN) is an indication of the maximum number of devices allowed to be connected to a telephone interface. The termination on an interface may consist of any combination of devices subject only to the requirement that the sum of the RENs of all the devices does not exceed five.

The REN value may be found on the label located on the rear of the equipment.

Repairs to certified equipment should be made by an authorized Canadian maintenance facility designated by the supplier. Any repairs or alterations made by the user to this equipment, or equipment malfunctions, may give the telecommunications company cause to request the user to disconnect the equipment.

Users should ensure for their own protection the electrical ground connections of the power utility, telephone lines and internal metallic water pipe system, if present, are connected together. This precaution may be particularly important in rural areas.

CAUTION: *Users should not attempt to make such connections themselves, but should contact the appropriate electric inspection authority or electrician, as appropriate.*

Europe

Certification to 1999/5/EC Radio Equipment & Telecommunications Terminal Equipment Directive

This Xerox product has been self-certified by Xerox for pan-European single terminal connection to the analogue public switched telephone network (PSTN) in accordance with Directive 1999/5/EC.

The product has been designed to work with the national PSTNs and compatible PBXs of the following countries:

Austria	Germany	Luxembourg	Sweden
Belgium	Greece	Netherlands	Switzerland
Denmark	Iceland	Norway	United Kingdom
France	Ireland	Portugal	Finland
Italy	Spain	Czech Republic	Poland
Bulgaria	Romania		

In the event of problems, you should contact your local Xerox representative in the first instance.

This product has been tested to and is compliant with TBR21, a technical specification for terminal equipment for use on analogue-switched telephone networks in the European Economic Area.

The product may be configured to be compatible with other country networks. Please contact your Xerox representative if it needs to be reconnected to another country's network. There are no user-adjustable settings in the product.

NOTE: *Although this product can use either loop disconnect (pulse) or DTMF (tone) signaling it is recommended that it is set to use DTMF signaling. DTMF signaling provides reliable and faster call setup.*

Modification, connection to external control software or to external control apparatus not authorized by Xerox, will invalidate its certification.

Environmental Compliance

USA - Energy Star



As an ENERGY STAR partner, Xerox Corporation has determined that (the basic configuration of) this product meets the ENERGY STAR guidelines for energy efficiency.

The ENERGY STAR and ENERGY STAR MARK are registered United States trademarks.

The ENERGY STAR Office Equipment Program is a team effort between U.S., European Union and Japanese governments and the office equipment industry to promote energy-efficient copiers, printers, fax, multifunction machine, personal computers, and monitors. Reducing product energy consumption helps combat smog, acid rain and long-term changes to the climate by decreasing the emissions that result from generating electricity.

Xerox ENERGY STAR equipment is preset at the factory to enter a "low power" state and/or shut off completely after a specified period of use. These energy-saving features can reduce product energy consumption in half when compared to conventional equipment.

Canada - Environmental Choice



Terra Choice Environmental Serviced, Inc. of Canada has verified that this product conforms to all applicable Environmental Choice EcoLogo requirements for minimized impact to the environment.

As a participant in the Environmental Choice program, Xerox Corporation has determined that this product meets the Environmental Choice guidelines for energy efficiency.

Environment Canada established the Environmental Choice program in 1988 to help consumers identify environmentally responsible products and services. Copier, printer, digital press and fax products must meet energy efficiency and emissions criteria, and exhibit compatibility with recycled supplies. Currently, Environmental Choice has more than 1600 approved products and 140 licensees. Xerox has been a leader in offering EcoLogo approved products.

Europe - Energy

Xerox Corporation has designed and tested this product to meet the energy restrictions required to establish Group for Efficient Appliances (GEA) compliance and have notified the registration authorities.

Illegal Copies

USA

Congress, by statute, has forbidden the reproduction of the following subjects under certain circumstances. Penalties of fine or imprisonment may be imposed on those guilty of making such reproductions.

1. Obligations or Securities of the United States Government, such as:

Certificates of Indebtedness National Bank Currency

Coupons from Bonds Federal Reserve Bank Notes

Silver Certificates Gold Certificates

United States Bonds Treasury Notes

Federal Reserve Notes Fractional Notes

Certificates of Deposit Paper Money

Bonds and Obligations of certain agencies of the government, such as FHA, etc.

Bonds. (U.S. Savings Bonds may be photographed only for publicity purposes in connection with the campaign for the sale of such bonds.)

Internal Revenue Stamps. (If it is necessary to reproduce a legal document on which there is a canceled revenue stamp, this may be done provided the reproduction of the document is performed for lawful purposes.)

Postage Stamps, canceled or uncanceled. (For philatelic purposes, Postage Stamps may be photographed, provided the reproduction is in black and white and is less than 75% or more than 150% of the linear dimensions of the original.)

Postal money Orders.

Bills, Checks, or Draft of money drawn by or upon authorized officers of the United States.

Stamps and other representatives of value, of whatever denomination, which have been or may be issued under any Act of Congress.

2. Adjusted Compensation Certificates for Veterans of the World Wars.
3. Obligations or Securities of any Foreign Government, Bank, or Corporation.
4. Copyrighted materials, unless permission of the copyright owner has been obtained or the reproduction falls within the "fair use" or library reproduction rights provisions of the copyright law. Further information of these provisions may be obtained from the Copyright Office, Library of Congress, Washington, D.C. 20559. Ask for Circular R21.

-
5. Certificates of Citizenship or Naturalization. (Foreign Naturalization Certificates may be photographed.)
 6. Passports. (Foreign Passports may be photographed.)
 7. Immigration Papers.
 8. Draft Registration Cards.
 9. Selective Service Induction Papers that bear any of the following Registrant's information:

Earnings or Income	Dependency Status
Court Record	Previous military service
Physical or mental condition	

Exception: United States military discharge certificates may be photographed.
 10. Badges, Identification Cards, Passes, or Insignia carried by military personnel, or by members of the various Federal Departments, such as FBI, Treasury, etc. (unless photograph is ordered by the head or such department or bureau.)

Reproducing the following is also prohibited in certain states:

Automobile Licenses - Drivers' Licenses - Automobile Certificates of Title.
- The above list is not all inclusive, and no liability is assumed for its completeness or accuracy. In case of doubt, consult your attorney.

Canada

Parliament, by statute, has forbidden the reproduction of the following subjects under certain circumstances. Penalties of fine or imprisonment may be imposed on those guilty of making such reproductions.

1. Current bank notes or current paper money.
2. Obligations or securities of a government or bank.
3. Exchequer bill paper or revenue paper.
4. The public seal of Canada or of a province, or the seal of a public body or authority in Canada, or of a court of law.
5. Proclamations, orders, regulations or appointments, or notices thereof (with intent to falsely cause same to purport to have been printed by the Queen's Printer for Canada, or the equivalent printer for a province).
6. Marks, brands, seals, wrappers or designs used by or on behalf of the Government of Canada or of a province, the government of a state other than Canada or a department, board, Commission or agency established by the Government of Canada or of a province or of a government of a state other than Canada.
7. Impressed or adhesive stamps used for the purpose of revenue by the Government of Canada or of a province or by the government of a state other than Canada.
8. Documents, registers or records kept by public officials charged with the duty of making or issuing certified copies thereof, where the copy falsely purports to be a certified copy thereof.
9. Copyrighted material or trademarks of any manner or kind without the consent of the copyright or trademark owner.

The above list is provided for your convenience and assistance, but it is not all-inclusive, and no liability is assumed for its completeness accuracy. In case of doubt, consult your solicitor.

Other countries

Copying certain documents may be illegal in your country. Penalties of fine or imprisonment may be imposed on those found guilty of making such reproductions.

- Currency notes
- Bank notes and cheques
- Band and government bonds and securities
- Passports and identification cards
- Copyright material or trademarks without the consent of the owner
- Postage stamps and other negotiable instruments

This list is not inclusive and no liability is assumed for either its completeness or accuracy. In case of doubt, contact your legal counsel.

Product Recycling and Disposal

Xerox operates a worldwide equipment takeback and reuse/recycle program. Contact your Xerox sales representative (1-800-ASK-XEROX) to determine whether this Xerox product is part of the program. For more information about Xerox environmental programs, visit www.xerox.com/environment.

If you are managing the disposal of your Xerox product, please note that the product contains lead other materials whose disposal may be regulated due to environmental considerations. The presence of Lead is fully consistent with global regulations applicable at the time that the product was placed on the market. For recycling and disposal information, contact your local authorities. In the United States, you may also refer to the Electronic Industries Alliance web site: www.eiae.org."

1 General Information

Before Using the Product

This section contains basic information that should be read before using the product.

- NOTES:**
- *Considerable care has been taken in preparing this manual. If you have any comments or concerns about the manual, please contact your nearest Xerox Representative.*
 - *This product has undergone strict quality control and inspection procedures. In the unlikely event that a defect or other problem is discovered, please contact your dealer or nearest Xerox Representative.*
 - *Aside from instances provided for by law, Xerox is not responsible for failures occurring during use of the product or its options, or failures due to incorrect operation of the product and its options, or other failures, or for any damage that occurs due to use of the product.*
 - *The display screens, messages, and key names shown in the manual may differ from those on the actual machine due to product improvements and modifications.*

Installation Requirements

Improper installation may damage this product. Please note the following during initial installation and whenever the machine is moved.

1. The machine should be installed near an accessible power outlet for easy connection.
2. Be sure to connect the power cord only to a power outlet that meets the specified voltage and current requirements. Also make certain the outlet is properly grounded.

For the power supply requirements, see the name plate on the main unit.

3. Do not install your machine in areas that are:

- damp, humid, or very dusty



- exposed to direct sunlight

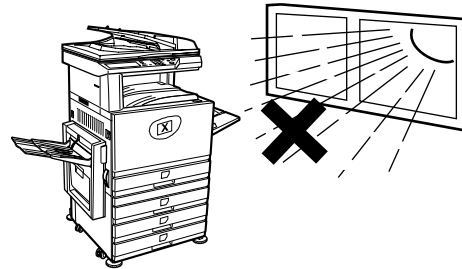

- poorly ventilated

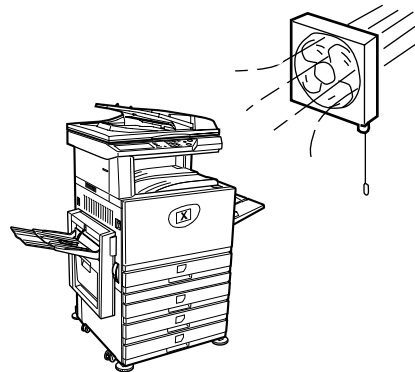

- subject to extreme temperature or humidity changes, e.g., near an air conditioner or heater.

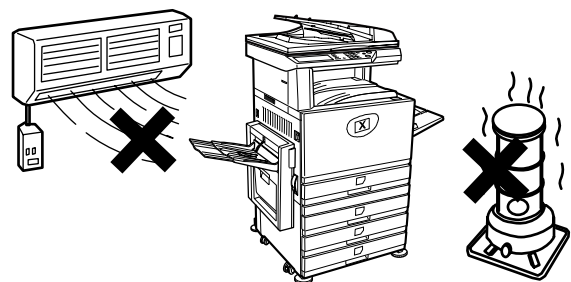

- Be sure to allow the required space around the machine for servicing and proper ventilation.

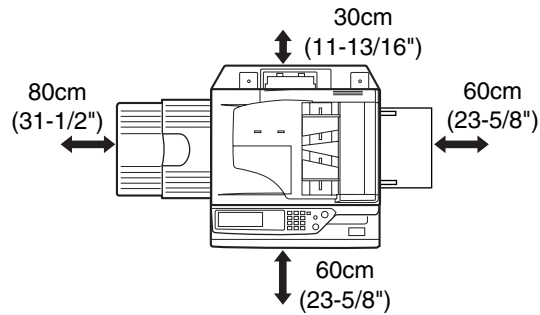

A small amount of ozone is produced within the copier during operation. The emission level is insufficient to cause any health hazard.

NOTE: *The present recommended long term exposure limit for ozone is 0.1 ppm (0.2 mg/m³) calculated as an 8 hr. time-weighted average concentration.*

However, since the small amount that is emitted may have an objectionable odor, it is advisable to place the copier in a ventilated area.

Moving this machine

Pull out the four handles as shown below, grasp them firmly, and keep the machine horizontal while moving it.

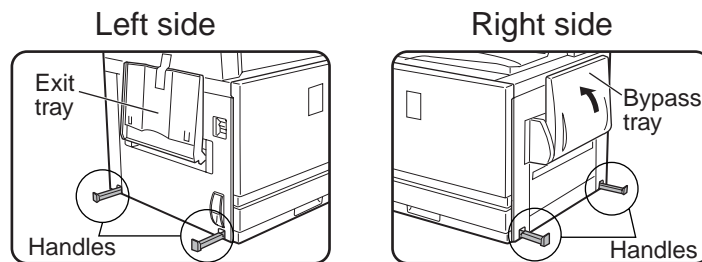

Before lifting the machine, fold up the exit tray and tape it securely to the machine.

Before lifting the machine, fold up the Bypass Tray and tape it securely to the machine.

CAUTION: *Two people are required to lift and carry this machine.*

If the machine has been placed on a stand/1-Tray Unit:

The stand/1-Tray Unit is on casters for moving. Unlock the casters and the adjusters of the stand/1-Tray Unit and gently move the machine taking care to steady it to prevent it from toppling.

For locking and unlocking the casters and the adjusters, see page 1-4.

If the machine is to be left unused for a long time

If the machine is to be left unused for a month or longer, follow the procedure on page 1-27 to release the pressure on the fusing roller.

Cautions

1. Do not touch the photoconductive drum. Scratches or smudges on the drum will cause dirty prints.
2. The fusing unit is extremely hot. Exercise care in this area.

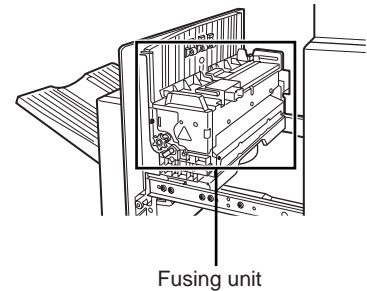

3. Do not look directly at the light source. Doing so may damage your eyes.

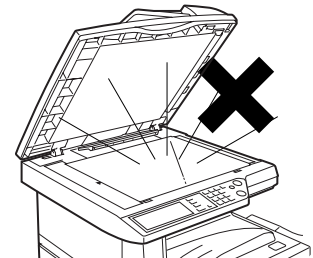

4. Four adjusters are provided on all optional stand/paper tray units. These adjusters should be lowered until they contact the floor.

When moving the machine with the optional stand/paper tray, be sure to raise the adjusters. Also, unlock the two casters at the front of the optional stand/paper tray. After moving the machine, lower the four adjusters until they reach the floor and lock the two casters.

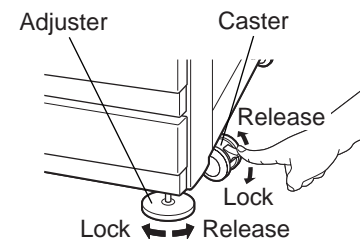

5. Do not make any modifications to this machine. Doing so may result in personal injury or damage to the machine.
6. Since this machine is heavy, it is recommended that it be moved by more than one person to prevent injury.
7. When connecting this machine to a computer, be sure to first turn both the computer and the machine off.

8. Do not make copies of anything which is prohibited from copying by law. The following items are normally prohibited from printing by national law. Other items may be prohibited by local law.
- Money
 - Stamps
 - Bonds
 - Stocks
 - Bank drafts
 - Checks
 - Passports
 - Driver's licences

BATTERY DISPOSAL

THIS PRODUCT CONTAINS A LITHIUM PRIMARY MEMORY BACK-UP BATTERY THAT MUST BE DISPOSED OF PROPERLY. PLEASE CONTACT YOUR LOCAL XEROX DEALER OR AUTHORISED SERVICE REPRESENTATIVE FOR ASSISTANCE IN DISPOSING OF THIS BATTERY.

This product utilizes tin-lead solder, and a fluorescent lamp containing a small amount of mercury.

Disposal of these materials may be regulated due to environmental considerations.

For disposal or recycling information, please contact your local authorities or the Electronics Industries Alliance: www.eia.org.

Introduction

To gain the maximum benefits in using this product, it is recommended that the user read this section to become familiar with all the features and functions of the basic product and the precautionary information contained in the manual.

This product is a high speed Digital full colour copier/printer that can be expanded to become multifunctional through the installation of optional peripheral devices. The product can be extended to include printer, network scanning or network printing capabilities. This section describes the basic use of the product as a copier and does not contain information on using any of the optional peripheral devices. Separate operation manuals are included with each of the optional peripheral devices. Refer to these manuals for their operation.

Original and paper sizes

This machine allows use of standard sizes in both the AB and inch systems.

These are shown in the tables below.

Sizes in the AB system
A3
B4
A4
B5
A5

Sizes in the inch system
11" x 17" (LEDGER)
8-1/2" x 14" (LEGAL)
8-1/2" x 13" (FOOLSCAP)
8-1/2" x 11" (LETTER)
7-1/4" x 10-1/2" (EXECUTIVE)
5-1/2" x 8-1/2" (INVOICE)

The meaning of "R" in original and paper size indications

Some original and paper sizes can be placed in either the portrait or landscape orientations. To differentiate between landscape and portrait, the landscape orientation size indication will contain an "R". These are indicated as A4R, B5R, 8-1/2" x 11"R, 5-1/2" x 8-1/2"R, etc. Sizes that can be placed only in the landscape orientation (A3, B4, 11" x 17", 8-1/2" x 14", 8-1/2" x 13") do not contain the "R" in their size indication.

Size indication with "R"

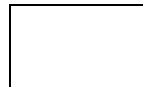

Landscape orientation

Size indication without "R"

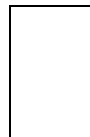

Portrait orientation

Main Features

1. Full-colour copies with vivid colours based on digital technology

Photos, colour text, and other originals are scanned by full-colour CCD sensors, and the acquired image information is output in vivid full colour at a resolution of 600 dpi using digital image processing technology.

The machine can also be used as a full-colour network printer, and a network scanner function can further be added as an option.
2. A range of optional units to enhance productivity

A range of optional equipment is available to enhance productivity, such as duplex units for producing two-sided output, additional paper tray units to increase the number of available paper sizes and paper capacity, and paper output units that are capable of stapling and saddle stitch binding.
3. Advanced image processing features based on digital technology

The scanned image data is converted to digital data, enabling the following advanced image processing features:

 - Photo Repeat :
Up to 24 full-size copies of a photo image can be made on a single sheet of paper (page 2-62).
 - Multi shot :
Up to four original pages can be copied onto a single sheet (page 2-64).
 - Pamphlet copy* :
Copies of original pages are arranged in proper order for copying so that the copies can be centre-stapled and folded into a pamphlet (page 2-71).

* Pamphlet copy requires the Duplex Module/2-Tray Unit and Duplex Bypass/Inverter Unit options. If a Saddle Stitch Finisher is installed, copies can be stapled in two positions along the centre of copies and folded at the centre.
4. Image processing manual exposure adjustment for optimal copying

Image processing is optimized for the type of original being copied (text, photo, mixed text and photo or map). This along with the ability to manually adjust exposure makes it possible to obtain copies that are faithful to the original.
5. Standard offset function makes it easy to distinguish between sets of copies

As sets of copies are delivered to the centre tray, each set is offset from the previous set for easy separation.

6. PostScript compatible

Installation of an optional PS kit gives PostScript compatibility (PostScript 3).

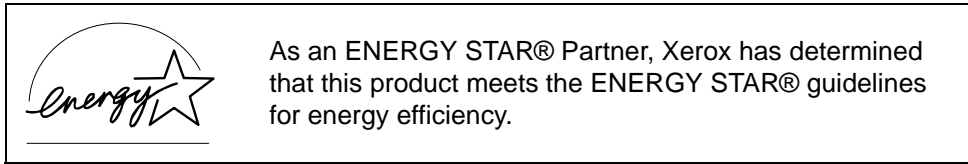

Energy saving features

This product has the following two power reducing modes to help conserve natural resources and reduce environmental pollution.

Preheat mode

Preheat mode automatically reduces the temperature of the fusing unit after the time set in the key operator programs elapses when the machine is on standby. This allows the machine to use less power while on standby. The machine automatically returns to normal operation when a key is pressed on the operation panel, or when an original is placed to make a copy or send a fax.

Auto power shut-off mode

Auto power shut-off mode automatically shuts off power to the fusing unit after the time set in the key operator programs elapses when the machine is on standby. This minimizes the power used by the machine while on standby. When this mode activates, the touch panel screen turns off.

To return the machine to normal operation, press the mode select key (the indicator of this key will be lit).

Auto power shut-off mode can be configured in the key operator programs. The mode is initially set (factory default setting) to activate after 60 seconds elapses.

If a print job or fax is received while auto power shut-off mode or preheat mode is activated, the machine automatically returns to normal operation.

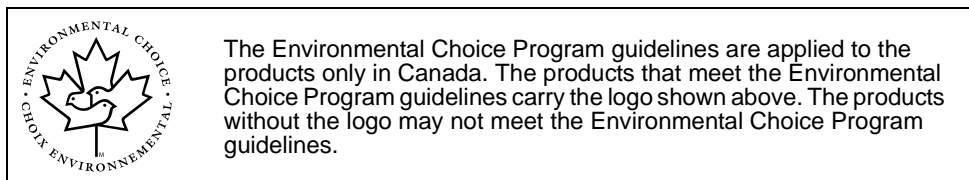

Part Names and Functions

Exterior

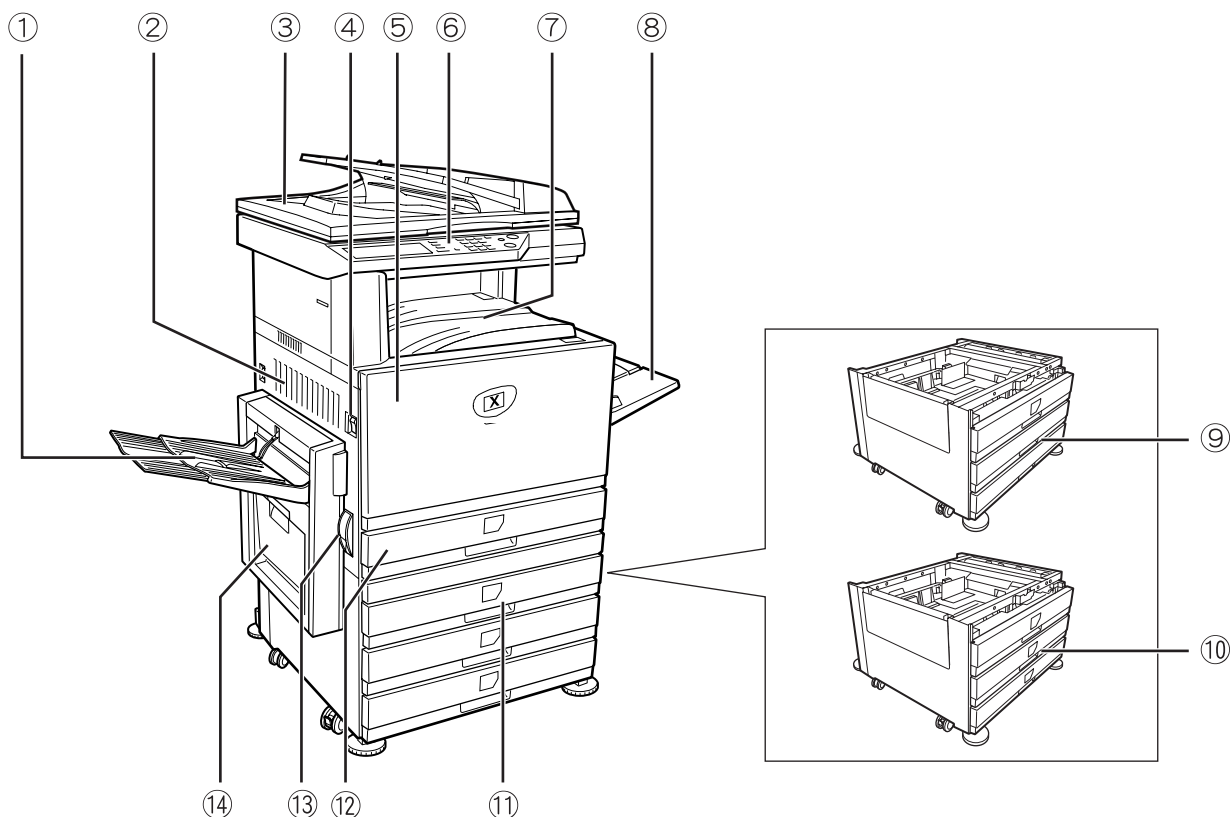

- ① **Left tray** Finished sheets are deposited here (see page 2-18).
- ② **Left side cover** Open this cover when a paper misfeed occurs in the fusing unit or the transfer unit.
- ③ **DADF** Duplex Automatic Document Feeder. This automatically feeds originals to be scanned. The feeder can turn the original over and scan the back side as well as the front side for support of two-sided originals.
- ④ **Power switch** Press to turn power on and off.
- ⑤ **Front cover** Open to replace toner cartridge.
- ⑥ **Operation panel**
- ⑦ **Centre tray** Finished sheets are deposited here (see page 2-18).

- ⑧ **Bypass Tray** Special papers (including transparency film) and copy paper can be fed from the Bypass Tray.

- ⑨ **Stand/1-Tray Unit*** (See page 1-28)

- ⑩ **3-Tray Unit*** (See page 1-28)

- ⑪ **Duplex Module/2-Tray Unit*** (See page 1-30)

- ⑫ **Paper tray** Each tray can hold approximately 500 sheets of the recommended paper for colour (80 g/m² or 21 lbs.), or approximately 500 sheets of Xerox standard paper (80 g/m² or 21 lbs.).

- ⑬ **Left side cover release** Push this release up to open the left side cover.

- ⑭ **Duplex Bypass/Inverter Unit and exit tray*** (See page 1-10.)

* ⑨, ⑩, ⑪, and ⑭ are peripheral devices. For a description of these devices, see page 1-10.

Interior

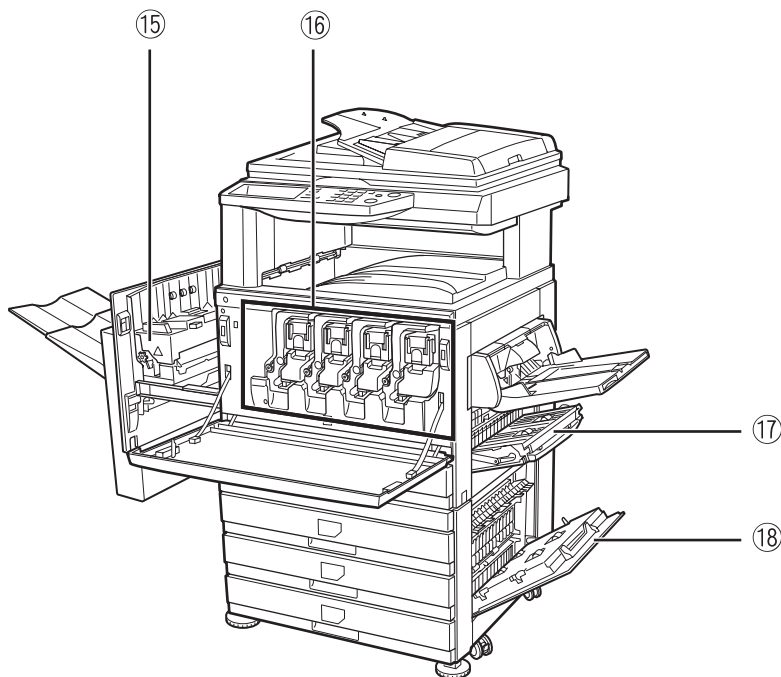

⑮ **Fusing unit** Toner images are fused here.

CAUTION *The fusing unit is hot. Take care in removing misfed paper.*

⑯ **Toner cartridge** The toner cartridge must be replaced when indicated on the operation panel (see page 1-42).

⑰ **Right side cover** Open when a misfeed has occurred in the paper feed area.

⑱ **Right cover of paper tray** Open this cover to remove paper misfed in the paper tray.

Part names and functions of peripheral devices

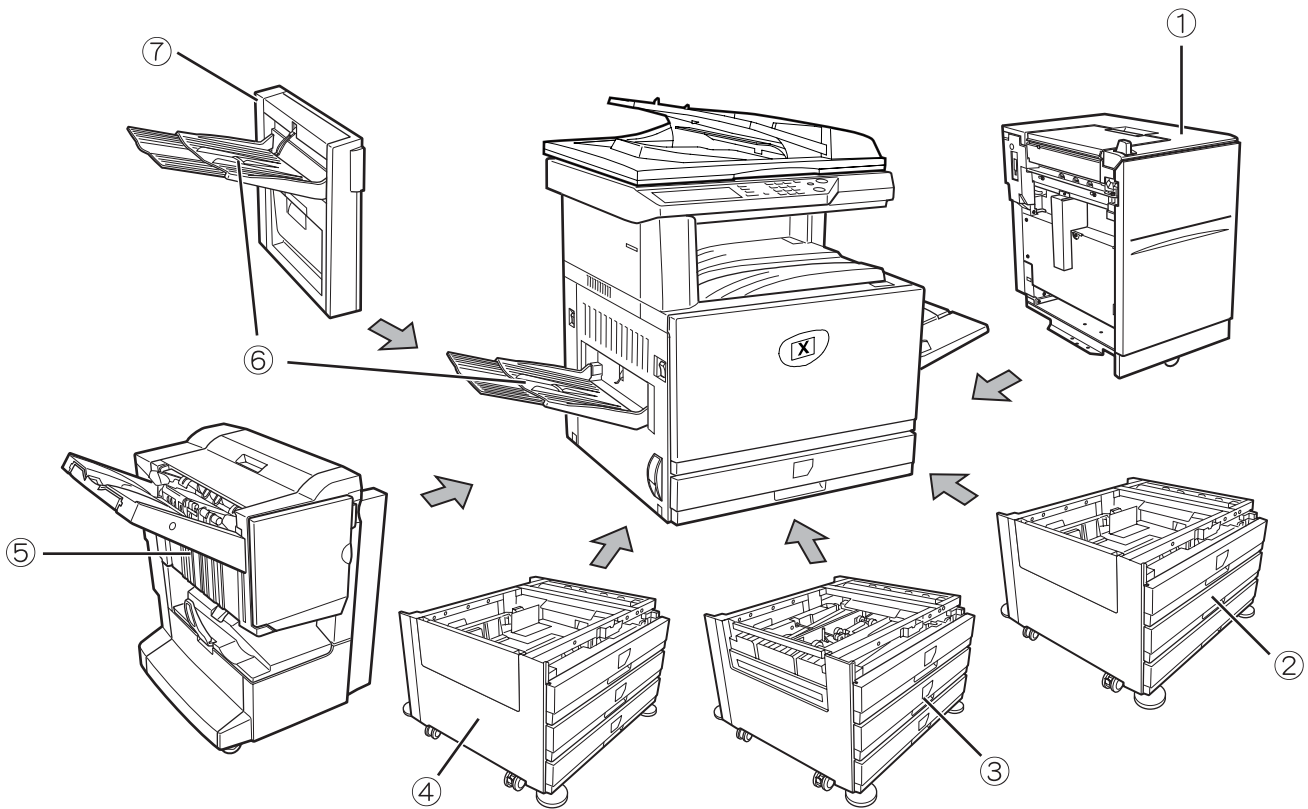

- ① **High Capacity Feeder** The High Capacity Feeder provides the added convenience of having 3,500 sheets of A4 or 8-1/2" x 11" paper (80 g/m² or 21 lbs.) available.
- ② **Stand/1-Tray Unit** This stand has one paper tray. It can hold approximately 500 sheets of the recommended paper for colour (80 g/m² or 21 lbs.), or approximately 500 sheets of Xerox standard paper (80 g/m² or 21 lbs.).
- ③ **Duplex Module/2-Tray Unit** This stand includes a module for automatic two-sided printing and two paper trays. The two trays can hold approximately 500 sheets of the recommended paper for colour (80 g/m² or 21 lbs.), or approximately 500 sheets of Xerox standard paper (80 g/m² or 21 lbs.). To perform two-sided printing, a Duplex Bypass/Inverter Unit is required.
- ④ **3-Tray Unit** This stand has three paper trays. Each tray can hold approximately 500 sheets of the recommended paper for colour (80 g/m² or 21 lbs.), or approximately 500 sheets of Xerox standard paper (80 g/m² or 21 lbs.).
- ⑤ **Saddle Stitch Finisher** The finisher can deliver sets saddle stitched and folded at the paper centreline to form a pamphlet, edge stapled in three different modes or unstapled. For two-hole or three-hole output, a hole Punch Module must be installed.

- ⑥ **Exit tray** The exit tray is installed on the output outlet of the machine or the Duplex Tray / Inverter Unit.
- ⑦ **Duplex Bypass/ Inverter Unit** This module is required to automatically turn paper over within the machine for automatic two-sided printing.

Other optional equipment

Scan Kit

This kit is required to add the network scanner function*.

* To use the network scanner function, the scan kit, scanner interface board, and 256 MB or more of optional memory must be installed.

PS Kit

This kit provides compatibility of PostScript level 3 to the printer.

To use this function, 256 MB x2 optional memory must be installed.

Fax Unit

This kit must be installed to use the fax function.

Fax Expansion Memory (8 MB)

This adds memory for use by the fax function.

256 MB Memory Kit

This adds memory that is used for the copy function, printer function, and scanner function.

Face-up and face-down output

After printing, the paper is delivered to the exit tray. This product has two exit trays (centre tray and left tray). The paper specifications and output conditions differ for each tray; however, if the paper and output conditions are such that the paper can be delivered to either tray, you can select the tray to which the paper will go.

- Paper exits to the centre tray face-down only.
- Paper exits to the left tray face-up only. However, if a Duplex Bypass/Inverter Unit has been installed, face-down output is also possible. In this case, face-up or face-down output is automatically selected according to the paper and output conditions (it is not possible to manually select face-up or face-down.)

Operation panel

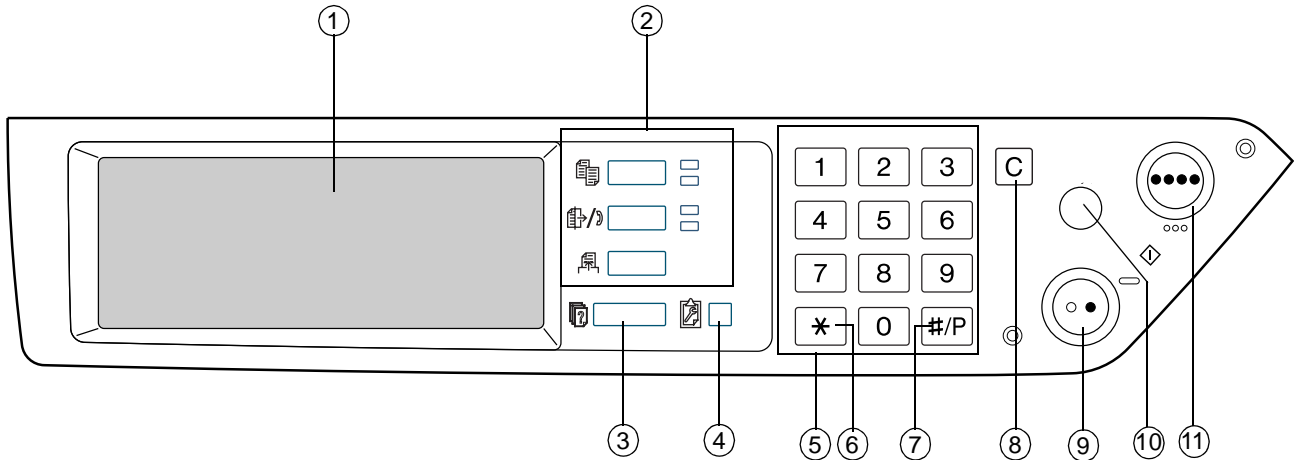

- ① **Touch panel** The machine status, messages and touch keys are displayed on the panel. Selections made with the keys are confirmed by a "beep"* that is sounded when a key is touched, and highlighting of the selection key.

* If a key that cannot be selected is touched, double-beep will sound.

Keys that are greyed out cannot be selected.

When using the touch panel, first change the display to the mode that you wish to use: printer mode, copy mode, network scanner mode*¹, or fax mode*². For details see page 1-16.

- ② **Mode select keys and indicators** Use to change modes and the corresponding display on the touch panel.

 **[PRINT] key/
READY indicator/
DATA indicator**

Press to enter the printer mode.



READY indicator Print data can be received when this indicator is lit.

DATA indicator Lights up or blinks when print data is being received. Also lights up or blinks when the machine is printing.

 **[IMAGE SEND]
key/LINE indicator/
DATA indicator**

Press this key to switch the display between network scanner mode*¹ and fax mode*². (See the sections for network scanner and fax.)

 **[COPY] key** Press to select the copy mode. If this key is pressed and held while the main screen of the copy mode is displayed, the total output count will be displayed.

-
- ③ **[JOB STATUS] key** Press to display the current job status. (See page 1-17.)
- ④ **[CUSTOM SETTINGS] key** Use to adjust the contrast of the touch panel or to set key operator programs. (See page 1-37.)
- ⑤ **Numeric keys** Use to select the number of copies and to make numerical entries for setting operations.
- ⑥ **[*] key ([ACC.#-C] key)** This is used when the copy, network scan*¹, and fax*² functions are used. If the auditing mode has been set, press this key to close an open account after finishing a copy job. For setting of the auditing mode, see page 1-18.
- ⑦ **[#/P] key** This is used as a program key when using the copy function, and to dial when using the fax function*².
- ⑧ **[C] key** Press to clear a copy quantity entry. If this key is pressed while the DADF is being used, any originals in progress will be automatically output.
This key is used in copy mode, network scanner mode*¹, and fax mode*².
- ⑨ **[BLACK COPY START ()] key** This is used to make black and white copies and to scan a black and white original when the network scan function is used. This is also used to scan an original to be faxed using the fax function*².
- ⑩ **[CLEAR ALL] key** This key is used in copy mode, network scanner mode*¹, and fax mode*². This returns all copy mode settings to the default settings. However, the touch panel display mode will not be changed. When beginning a copy job, press this key.
- ⑪ **[COLOUR COPY START ()] key** This is used to make full-colour or single-colour copies and to scan a colour original when the network scanner function is used.

*1 When the network scanner option is installed.

*2 When the fax option is installed.

Touch panel

Using the touch panel

[Example 1]

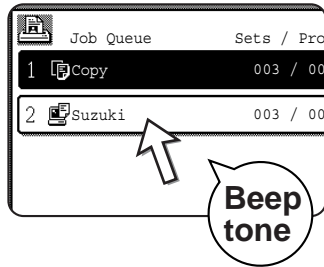

Items on the touch panel are easily selectable by touching the key associated with the item with a finger. Selection of an item will be accompanied with a beep tone to confirm the item was selected. Also, the key area for the item will be highlighted for visual confirmation.

[Example 2]

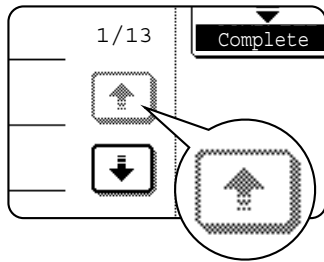

Keys which are greyed out on any screen are not selectable. If a greyed out key is touched, a double beep will be sounded.

The confirmation beeps can be disabled by a key operator program.

The touch panel screens shown in this manual are printed images, and may appear different from the actual screens.

Selection of function

[Example 1]

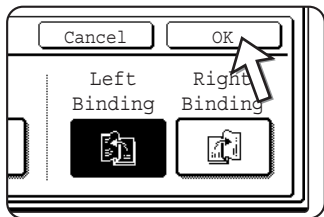

Items which are highlighted at the time a screen appears are already selected and will be registered to function if the [OK] key is touched.

[Example 2]

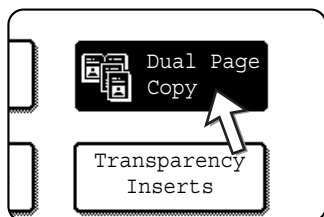

When the machine is used in the copy mode, the functions shown below can only be set or cancelled on the special feature screen by alternate touches of the function keys on the panel.

Copier feature

- Dual page copy
- Centring
- Transparency inserts
- Mirror image
- A3 (11"x17") Full-bleed
- B/W Reverse

Job status screen (common to print, copy, network scan and fax)

This screen is displayed when the [JOB STATUS] key on the operation panel is pressed.

A job list showing the current job at the top of the job queue or a list showing completed jobs can be displayed. The contents of jobs can be viewed or jobs can be deleted from the queue. (The screen below is an example and differs from actual screens.)

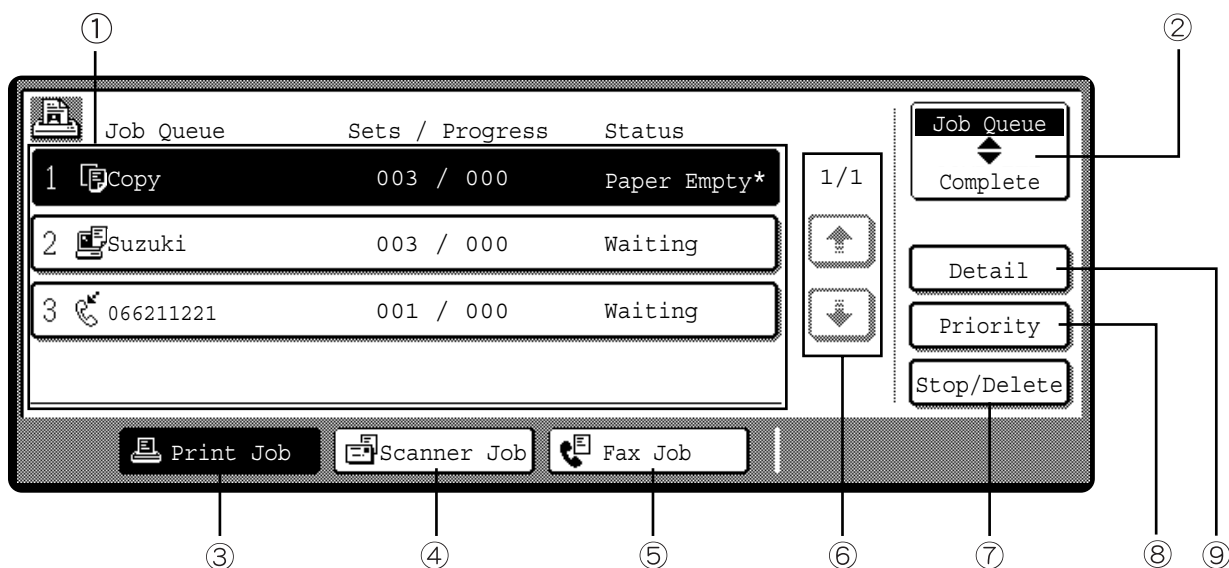

- ① **Job list** This shows the current job and the jobs waiting to be run. The icons to the left of the jobs in the queue show the job mode.

 Copy mode  Printer mode

 Network scanner mode

 Fax send job  Fax reception job

The displayed jobs in the job list are themselves operation keys. To cancel printing or to give a job the highest print priority, touch the relevant job key to select the job and execute the desired operation using the keys described in 5 and 6.

- * **"PAPER EMPTY" in the job status display** When a job status display indicates "PAPER EMPTY", the specified paper size for the job is not loaded in any of the trays.
When the [DETAIL] key appears, the key of a job in the job queue can be touched followed by the [DETAIL] key to change the paper size selection to a different paper size (only in printer mode).
- ② **Mode select key** This only appears in the job status screen of fax mode. The key is used to switch the job list display between "JOB QUEUE" and "COMPLETE".
"JOB QUEUE": Shows stored jobs and the job in progress.
"COMPLETE": Shows finished jobs.
- ③ **[PRINT JOB] key** Use to display the print job list for printer, copy and fax mode.
- ④ **[SCANNER JOB] key** This displays a list of jobs that only used the network scanner function. (Only when the network scanner function is added.)
- ⑤ **[FAX JOB] key** This displays the transmission/reception status and finished jobs of fax mode when the fax option is installed.
- ⑥ **Display switching keys** Use to switch the page of the displayed job list.
- ⑦ **[STOP/DELETE] key** Use to cancel or delete the current job or delete the selected reserved job. Note that a fax print job cannot be cancelled or deleted.
- ⑧ **[PRIORITY] key** This only appears in the job status screen of fax mode. Touch this key to give priority to a job that has been selected in the job queue.
- ⑨ **[DETAIL] key** The key is only effective for computer print jobs and only appears in the job status screen of the printer mode. It is used to display detailed information of a selected print job and to change the paper size for the print job.

Auditing Mode

When the account counter function is turned on, a count is kept of the number of copy sheets used by each account (maximum of 200 accounts). The counts can be displayed and totaled as needed.

The key operator programs can be used to enable auditing mode separately for copy mode, fax mode, network scanner mode, and printer mode.

Using the machine when the auditing mode is enabled

The procedure for using the machine for copying functions when the Auditing Mode has been enabled for the copier functions is explained below.

- NOTES:**
- When the account counter is turned on for fax or network scanner functions, a message will appear prompting you to enter your account number each time the touch panel is changed to the main screen of the function. Enter your account number as explained below and then proceed with the job.
 - When the account counter is turned on for the printer function, you must enter your account number in the setting screen of the printer driver on your computer in order to print.

When the account counter is turned on, the following messages appear on the touch panel. There are two types of prompts, depending on whether the account counter was turned on for both the colour copy and the black and white copy modes, or only for colour copy mode.

Account counter enabled for both the colour copy and the black and white copy modes

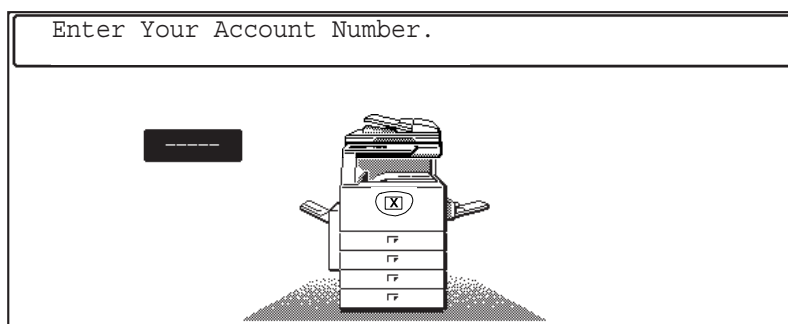

The account counter is enabled only for the colour copy mode

When the [✖] key ([ACC.#-C] key) or the [COLOUR COPY START] key is pressed, this message appears.

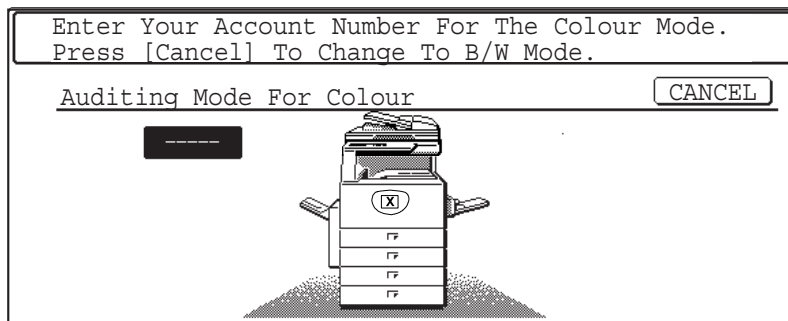

In this case, enter your 5-digit account number as explained on page 1-20 to gain access to the copier functions.

7. Enter your account number (5 digits) with the numeric keys.

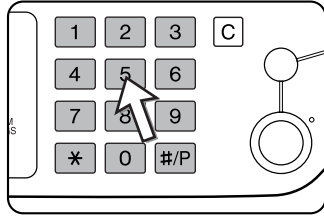

As you enter your account number, the hyphens (—) change to asterisks (*). If you enter an incorrect digit, press the **C** key and re-enter the correct digit.

When a correct account number is entered, the following message will appear.

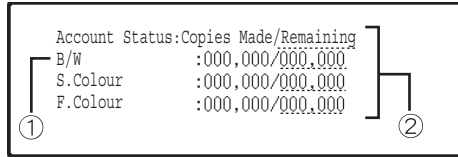

① This does not appear if the account counter has only been set for colour copy mode.

② If a limit has been set by key operator program for the number of copies that can be made by the account, the remaining number that can be made is displayed.

This message appears for several seconds and then changes to the following message.

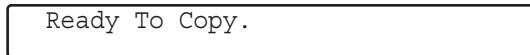

NOTE: *If "Account number security" is turned on in the key operator programs, the following message will appear in the event that an incorrect account number is entered three times in a row.*

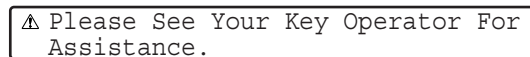

While this message appears (for about one minute), no other operations can be performed.

8. Follow the appropriate steps to perform the copy job.

When copying is begun, the following message will appear.



In the case of interrupt copying (page 2-77), the following message will appear.

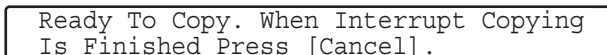

9. When the copy job is finished, press the **[*]** key ([ACC.#-C] key)

Managing the Machine

Loading Paper

The message "ADD PAPER" or "OPEN TRAY AND ADD PAPER" will appear when paper runs out during operation.

Follow the procedure below to load paper.

- NOTES:**
- Do not use curled or folded paper. Doing so may cause a misfeed.
 - For best results use paper supplied by Xerox. (See pages 1-30, 1-45.)
 - When you change the paper type and size in Paper Tray 1, you must change the paper type and size settings as explained in "Setting the paper type (except the Bypass Tray)" on page 1-33).
 - Do not place heavy objects or press hard on any tray which is pulled out.

Loading paper in Paper Tray 1

1. Pull out Paper Tray 1.

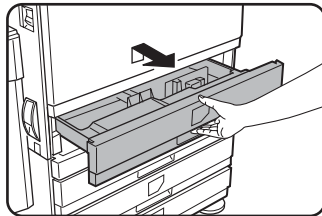

Gently pull the tray out until it stops.

2. Load paper into the tray.

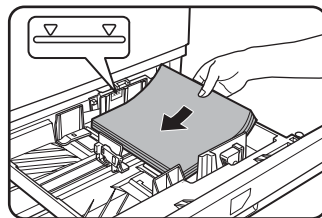

Load a stack of paper no higher than the indicator line (about 500 sheets of the recommended paper for colour (80 g/m² or 21 lbs.), or approximately 500 sheets of Xerox standard paper (80 g/m² or 21 lbs.)).

3. Gently push tray 1 into the machine.

Push the tray firmly all the way into the machine.

4. Set the paper type.

If you change the paper type, be sure to set the paper type refer to "Setting the paper type (except the Bypass Tray)" on page 1-33.

NOTE: *If you load a different size of the same type of paper, you only need to change the position of the size slide (see step 2 below); you do not need to change the paper type.*

5. Loading paper in Paper Tray 1 is now complete.

Changing the paper size in Paper Tray 1

The following paper size settings are available for Paper Tray 1: A3 to A5 (11" x 17" to 8-1/2" x 5-1/2"), and "EXTRA"*1. Use the following procedure to change the size as needed.

*1 This is limited to square or rectangular paper, A3 to A5 (11" x 17" to 8-1/2" x 5-1/2") size.

1. Pull out Paper Tray 1.

If paper remains in the tray, remove it.

2. Adjust the paper size slide to the paper size.

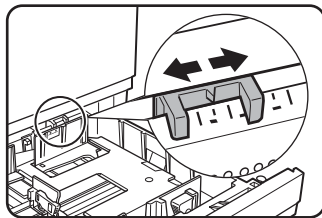

Move the paper size slide right or left to indicate the paper size being loaded.

If a special size paper is loaded in the paper tray, set the size slide to "EXTRA" to inform the machine that a special size paper has been loaded. (When INCH-based size paper is loaded, move the size slide to "EXTRA".)

Note that setting the size slide to "EXTRA" only informs the machine that a special size of paper has been loaded; it does not inform the machine of the specific size. If you wish to inform the machine of the specific size, follow the steps in "Setting the paper size when an extra size is loaded" on page 1-34. (If you do not set a size, part or all of the image may not print.)

3. Adjust the guide plates A and B by squeezing their lock levers and sliding them to the paper size to be loaded.

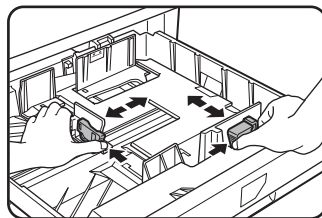

The guide plates A and B are slidable. Adjust them to the paper size to be loaded while squeezing their lock levers.

4. Load paper into the tray.

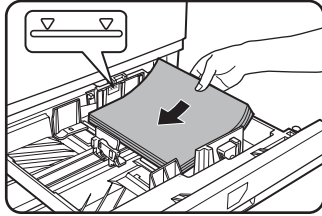

5. Gently push tray 1 into the machine.

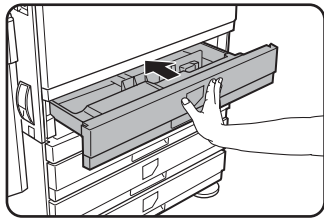

Push the tray firmly all the way into the machine.

6. Set the paper type of the paper that was loaded in the 1st tray.

If you loaded a different type of paper from the previous paper, be sure to set the new paper type as explained in "Setting the paper type (except the Bypass Tray)" on page 1-33.

Changing paper size in Paper Tray 1 is now complete.

NOTE: *If the size slide position (step 2 of page 1-22) is not set correctly after changing the paper size, or if the paper type (page 1-33) is not set correctly, incorrect paper selection or paper misfeeding may occur.*

Loading paper in the Bypass Tray

The Bypass Tray can be used to feed the same paper specified for Paper Tray 1 or for special papers. For paper types that can be used in the Bypass Tray, see the specifications for the Bypass Tray in the paper tray specifications (page 1-30).

Up to 250 sheets of Xerox standard paper or up to 100 postcards can be set in the Bypass Tray.

- NOTES:**
- *After loading the paper in the Bypass Tray, be sure to set the paper type and size (step 4) if these were changed.*
 - *Do not use inkjet paper. This may cause misfeeds in the fusing unit.*

1. Open the Bypass Tray.

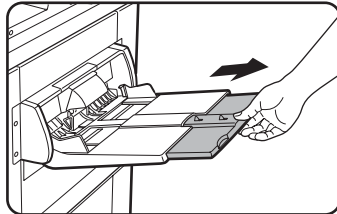
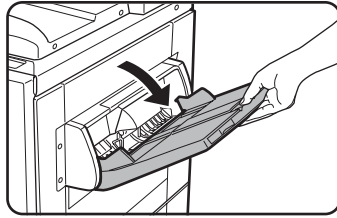

When loading paper that will extend past the end of the tray, pull out the tray extension to support the paper and to allow the paper sensors to properly sense the paper size.

Be sure to pull the tray extension all the way out. If the tray extension is not pulled all the way out, the size of the paper loaded in the Bypass Tray may not display correctly.

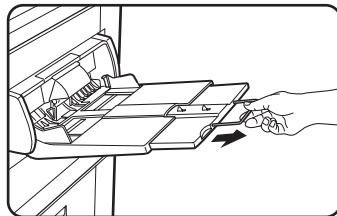

To support papers that extend past the tray extension, pull out the wire extension.

2. Set the Bypass Tray guides to the width of the copy paper.

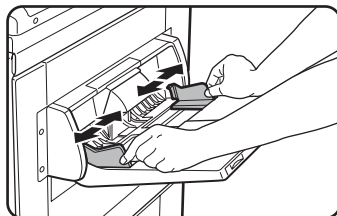

3. Insert the copy paper all the way into the Bypass Tray. (Do not force the paper in.)

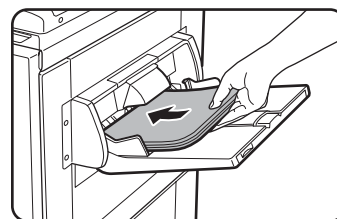

Place the copy paper face up. If the Bypass Tray guides are set wider than the copy paper, the inside of the machine may become soiled, resulting in smudges on succeeding copies.

Special purpose papers other than Xerox-recommended transparency film must be fed individually. Multiple sheets of Xerox-recommended transparency film can be loaded in the Bypass Tray.

4. Set the type and size of the paper loaded in the Bypass Tray.

If you loaded a different type of paper from the previous paper, be sure to set the new paper type as explained in "Setting the paper type and paper size in the Bypass Tray" on page 1-35. If you loaded a special size of paper in the Bypass Tray, set the paper size as explained in "Setting the paper type and paper size in the Bypass Tray" on page 1-35.

(If you do not set a size, part or all of the image may not print.)

This completes the procedure for loading paper in the Bypass Tray.

NOTE:

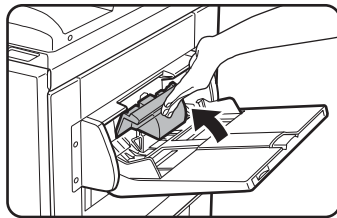

When loading paper in the Bypass Tray or closing the tray, close the paper cover as shown.

NOTES:

- Be sure to load A6 paper, A5 paper, 5-1/2" x 8-1/2" paper, and postcards as shown in the diagram below.

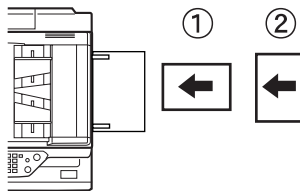

- ① A6 paper, post cards.
- ② A5 paper, 5-1/2" x 8-1/2" paper.
- When loading plain paper other than paper recommended for colour, Xerox standard paper, special media other than postcards, Xerox-recommended transparency film, or paper to be printed on the back, the paper must be loaded one sheet at a time. Loading more than one sheet at a time will cause misfeeds.
- Before loading heavy paper, straighten any curling in the paper.
- When adding paper, remove any paper remaining in the tray, combine it with the paper to be added, and reload as a single stack.
- Do not use paper that has already been printed on by a plain paper fax machine or a laser printer. This may cause printed images to become dirty.
- When printing on transparency film, be sure to remove each sheet as it exits the machine. Allowing sheets to stack in the output tray may cause curling.

- Use only Xerox-recommended transparency film. Insert the film so that the rounded corner is on the left for horizontal loading, or on the right for vertical loading.

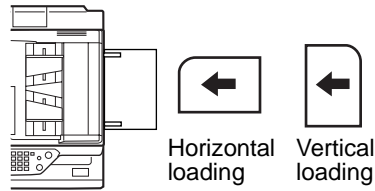

- When loading multiple sheets of transparency film in the Bypass Tray, fan the sheets several times before loading.

Setting envelopes or postcards

When setting envelopes or postcards in the Bypass Tray, set them in the orientation shown below.

Loading postcards

Insert the postcard with the side to be printed on facing up. The postcard should be oriented as shown in the diagram.

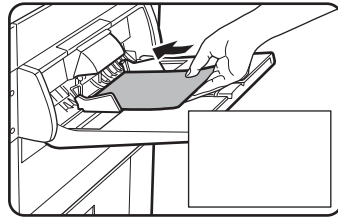

Loading envelopes

Only the front side of envelopes can be printed. Insert the envelope with the front side facing up.

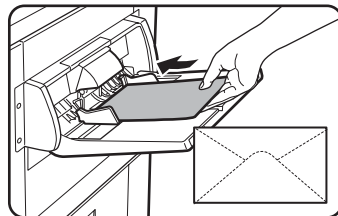

Printing onto envelopes or postcards

- Attempting to print onto both sides of envelopes or postcards may result in misfeeds or poor prints.
- Do not use pre-printed envelopes.
- Before inserting a postcard or envelope, straighten any curled edges. Curled edges may cause creases, colour deviations, misfeeds, and poor quality images.

Printing onto envelopes

- Attempting to print on envelopes that have metal clasps, plastic snaps, string closures, windows, linings, self-adhesive patches or synthetic materials may cause misfeeds, inadequate toner adherence or other trouble.
- Envelopes with embossed surfaces may cause the prints to become smudged.
- Use only envelopes which are flat and crisply folded. Curled or poorly formed envelopes may be poorly printed or may cause misfeeds.
- Print quality is not guaranteed in the area 10 mm or 13/32" from the edges of the envelope.
- Print quality is not guaranteed on parts of envelopes where there is a large step-like change of thickness, such as on three-layer or four-layer envelopes.
- Print quality is not guaranteed on envelopes having peel off flaps for sealing the envelopes.

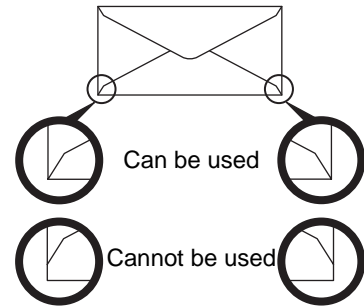

Fusing unit pressure adjusting levers

In some cases damage to the envelopes, colour deviations, or smudging may occur even if envelopes within the specifications are used. This problem may be reduced by shifting the fusing unit pressure adjusting levers from their normal pressure position to the lower pressure position. Follow the procedure on page 1-28.)

NOTE: *Be sure to return the lever to the normal position when you have finished feeding envelopes. If not, inadequate toner adherence, paper misfeeds or other trouble may occur.*

1. Unlatch the Duplex Bypass/Inverter Unit and slide it to the left.

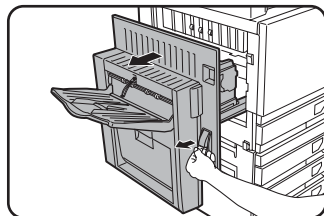

Unlatch the unit and gently move it away from the machine. If the machine is not equipped with a Duplex Bypass/Inverter Unit, open the side cover similarly.

2. Lower the two fusing unit pressure adjusting levers marked A and B in the illustration.

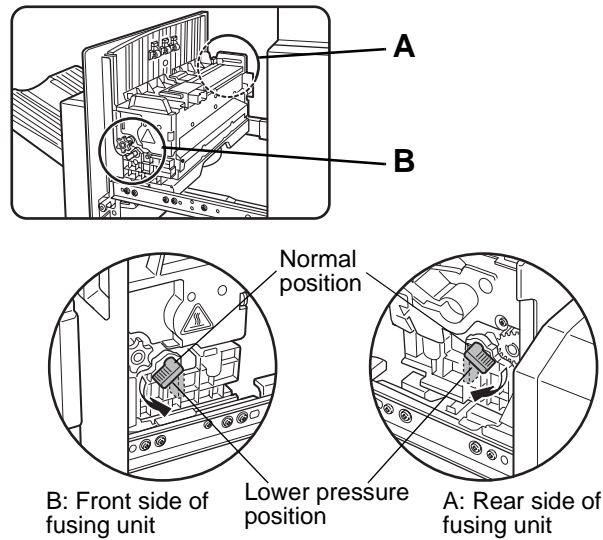

3. Gently close the Duplex Bypass/Inverter Unit.

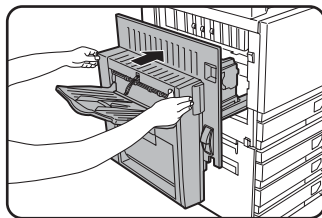

If the machine is not equipped with a Duplex Bypass/Inverter Unit, close the side cover.

Loading paper in the stand/1-Tray Unit/3-Tray Unit

Upper tray / middle tray / lower tray*

Up to 500 sheets of paper recommended for colour or Xerox-recommended plain paper can be loaded in these trays. The method of loading paper is the same as for Paper Tray 1 in the main unit (see the explanation on page 1-21).

* The stand/1-Tray Unit only has the upper tray.

NOTE: *If the size of paper being loaded is different from the previous size, or is an extra size, or if the paper type is different from the previous type, you must change the paper tray settings in the custom settings. Change the settings as explained in "Setting the paper type (except the Bypass Tray)" on page 1-33 and "Setting the paper size when an extra size is loaded" on page 1-34.*

Specifications (stand/1-Tray Unit/3-Tray Unit)

Name	Stand/1-Tray Unit	3-Tray Unit
Paper size/weight	A3, B4, A4, A4R, B5, B5R, A5, Extra. (11" x 17", 8-1/2" x 14", 8-1/2" x 13", 8-1/2" x 11", 8-1/2" x 11"R, 7-1/4" x 10-1/2"R, 5-1/2" x 8-1/2") / 64 to 105 g/m2 or 17 to 28 lbs.	
Paper capacity	Paper recommended for colour (80 g/m2 or 21 lbs.): 500 sheets; Xerox standard paper (80 g/m2 or 21 lbs.): 500 sheets	
Power supply	Supplied from the main unit	
Dimensions	600 mm (W) x 642 mm (D) x 403 mm (H) (23-5/8" (W) x 25-9/32" (D) x 15-7/8" (H)) (not including the adjuster)	
Weight	Approximately 22.5 kg or 49.6 lbs.	Approximately 29.5 kg or 65.0 lbs.

Specifications are subject to change for improvement without notice.

Loading paper in the Duplex Module/2-Tray Unit

Upper tray:

The upper tray contains a Duplex Module that automatically turns print paper over for automatic two-sided printing.

Middle and lower paper trays:

The middle and lower trays are paper trays.

Up to 500 sheets of paper recommended for colour or Xerox-recommended plain paper can be loaded in these trays. The method of loading paper is the same as for Paper Tray 1 in the main unit. See the explanation on page 1-21.

NOTE: *If the size of paper being loaded is different from the previous size, or is an extra size, or if the paper type is different from the previous type, you must change the paper tray settings in the custom settings. Change the settings as explained in "Setting the paper type (except the Bypass Tray)" on page 1-33 and "Setting the paper size when an extra size is loaded" on page 1-34.*

Specifications (Duplex Module/2-Tray Unit)

Name	Duplex Module/2-Tray Unit
Paper size/weight	A3, B4, A4, A4R, B5, B5R, A5, Extra. (11" x 17", 8-1/2" x 14", 8-1/2" x 13", 8-1/2" x 11", 8-1/2" x 11"R, 7-1/4" x 10-1/2"R, 5-1/2" x 8-1/2") / 64 to 105 g/m2 or 17 to 28 lbs.
Paper capacity	Paper recommended for colour (80 g/m2 or 21 lbs.): 500 sheets; Xerox standard paper (80 g/m2 or 21 lbs.): 500 sheets
Power supply	Supplied from the main unit
Dimensions	600 mm (W) x 642 mm (D) x 403 mm (H) (23-5/8" (W) x 25-9/32" (D) x 15-7/8" (H)) (not including the adjuster)
Weight	Approximately 31 kg or 68.3 lbs.
Duplex Module	
Size of plain paper	A3, B4, A4, A4R, B5, B5R, A5, 11" x 17", 8-1/2" x 14", 8-1/2" x 13", 8-1/2" x 11", 8-1/2" x 11"R, 7-1/4" x 10-1/2"R, 5-1/2" x 8-1/2"
Weight of plain paper	64 to 200 g/m2 or 17 to 54 lbs.
Number of sheets	One sheet (single pass type)

Specifications are subject to change for improvement without notice.

Specifications for paper trays

The specifications for the types and sizes of paper that can be loaded in the paper trays are shown below.

	Paper tray type	Tray No. (tray name)	Applicable paper types	Applicable paper sizes	Remarks
A	Paper Tray 1	Tray 1	Paper recommended for colour	A3, B4, A4, A4R, B5, B5R, A5, Extra. (11"x17", 8-1/2"x14", 8-1/2"x13", 8-1/2"x11", 8-1/2"x11"R, 5-1/2"x8-1/2", 7-1/4"x10-1/2"R)	See "Storing Supplies" on page 1-45.
			Plain paper	A3, B4, A4, A4R, B5, B5R, A5, Extra. (11"x17", 8-1/2"x14", 8-1/2"x13", 8-1/2"x11", 8-1/2"x11"R, 5-1/2"x8-1/2", 7-1/4"x10-1/2"R)	See "More information on plain paper" on page 1-32.

	Paper tray type	Tray No. (tray name)	Applicable paper types	Applicable paper sizes	Remarks		
B	Bypass Tray	Bypass Tray	Same as paper types and sizes in row A * Paper size A3W (12" x 18") and A6R can also be used in the Bypass Tray.			See "More information on special media that can be used" on page 1-32.	
			Special paper (Refer to page 1-32 for applicable special papers.)	Heavy paper	Heavy paper 1		A6R - A3W (5-1/2"x8-1/2" - 12"x18"), Special (paper weight: 106 to 200 g/m2 (28 to 54 lbs.)), Postcard
					Heavy paper 2		A6R - A3W (5-1/2"x8-1/2" - 12"x18"), Special (paper weight: 201 to 300 g/m2 (54 to 80 lbs.))
			Transparency film		Transparency film		
Envelopes		Standard-size envelopes that can be used: COM10, Monarch, DL, C5					
C	Stand/1-Tray Unit	Tray 2	Same as paper types and sizes in row A				
D	Stand/3-Tray Unit	Upper				Tray 2	
		Middle				Tray 3	
		Lower	Tray 4				
E	Duplex Module/2-Tray Unit	Upper	Duplex	Duplex Module (See page 1-30 for paper sizes and weights that can be used.)			
		Middle	Tray 2	Same as paper types and sizes in row A			
		Lower	Tray 3				
F	High Capacity Feeder	Tray 4* ¹ or Tray 5* ²	Same as paper types in row A	A4 (8-1/2"x11")	See the specifications in "High Capacity Feeder" on page 1-74, and "More information on plain paper" on page 1-32.		

*1 When the Duplex Module/2-Tray Unit is installed.

*2 When the 3-Tray Unit is installed.

More information on plain paper

The following restrictions apply to plain paper. Be sure to load the paper correctly. Incorrect loading may result in skewed feeding or misfeeds.

		Paper in AB system	Paper in inch system
		A6R - A3W*	5-1/2"x8-1/2" - 12"x18"*
Plain paper	Xerox standard paper	80g/m2	21 lbs.
	Restrictions on paper other than Xerox standard paper	64 to 105g/m2 or 17 to 28 lbs.	
Recycled, coloured, pre-punched, pre-printed and letterhead papers must conform to the same conditions as above.			

* In the High Capacity Feeder, only A4 size paper can be used when using AB sizes, and only 8-1/2" x 11" can be used when using inch sizes.

More information on special media that can be used

The following restrictions apply to special media. The use of incorrect media may result in fusing problems (weak adhesion of toner to paper or toner smudging when rubbed), skewed feeding, misfeeds, or other failures.

		Type	Remarks
Special paper	Heavy paper	heavy paper 1	For paper sizes from A6R to A3W (5-1/2" x 8-1/2" to 12" x 18"), paper weights from 106 to 200 g/m2 (28 to 54 lbs.) can be used. Postcards can be used. Do not use folded postcards, picture postcards, or postcards with a coated front. These may cause misfeeds or a dirty printed image.
		heavy paper 2	For paper sizes from A6R to A3W (5-1/2" x 8-1/2" to 12" x 18"), paper weights from 201 to 300 g/m2 (54 to 80 lbs.) can be used.
	Transparency film		Use Xerox recommended transparencies.
	Envelopes		Applicable standard envelopes: COM-10, Monarch, DL, C5 Envelopes can only be fed from the Bypass Tray. Applicable paper stock weight for envelopes is 75 to 90 g/m2 or 20 to 23 lbs.

- Special paper such as heavy paper 2, transparency film, and envelopes cannot be output to the centre tray.
- Paper that cannot be output to the centre tray is output face-up to the left tray.

Paper that can be used for automatic two-sided printing

Paper used for automatic two-sided printing (paper that can be fed through the Duplex Module) must meet the following conditions:

Paper type: Plain paper as specified on page 1-30.

Paper size: Must be one of the following standard sizes: A3, B4, A4, A4R, B5, B5R or A5 (11" x 17", 8-1/2" x 14", 8-1/2" x 13", 8-1/2" x 11", 8-1/2" x 11"R, 7-1/4" x 10-1/2" or 5-1/2" x 8-1/2")

Paper weight: 64 to 200 g/m² or 17 to 54 lbs.

- NOTES:**
- *Special papers as described above cannot be used for automatic two-sided printing. Heavy paper up to 200 g/m² (54 lbs.) can be used.*
 - *The image quality and toner fusibility of special papers may change due to ambient conditions, operating conditions, and paper characteristics, resulting in image quality inferior to that of Xerox standard paper.*
 - *Various types of plain paper and special paper are sold. Some of these cannot be used in the machine. Please consult your retailer or your dealer when buying paper.*

Setting the paper type (except the Bypass Tray)

Follow these steps to change the paper type setting when the paper type has been changed in a paper tray. For the paper types that can be used in each tray, see page 1-30. To change the paper type setting for the Bypass Tray, see page 1-35.

1. Press the [CUSTOM SETTINGS] key.

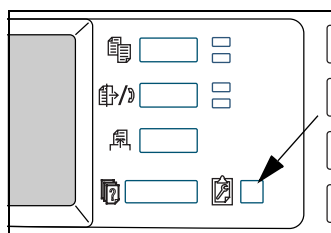

The custom setting menu screen will appear.

2. Touch the [TRAY SETTINGS] key.

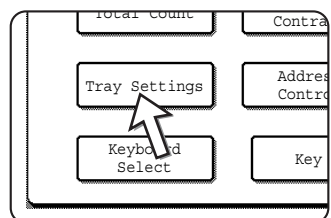

The paper tray selection screen will appear.

3. Select the paper tray for which the setting is to be made. (For the tray numbers, see the tray specifications on page 1-30.)

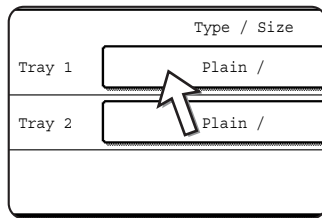

If the desired tray is not on the display, use or key to scroll the display until it appears.

4. Select the type of paper that was loaded in the tray.

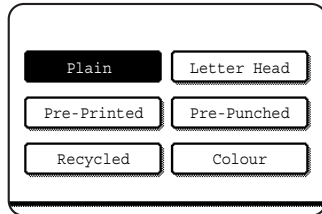

The currently selected paper type will be highlighted. To change the setting, touch the desired type.

NOTE: *Special paper such as transparency film, envelopes, and postcards can only be used in the Bypass Tray.*

5. Touch the [OK] key to complete the setting.

Setting the paper size when an extra size is loaded

When a paper tray is set to "extra", this informs the machine that an extra size is being used. It does not inform the specific size. To enter the specific size of the paper loaded, follow the steps below.

For example, if 8-1/2" x 11" size paper is loaded in the tray (with the size slide set to "extra"), you can use this procedure to set the paper size recognized by the machine to 8-1/2" x 11" size. If you loaded an irregular size of paper, you can enter the dimensions of the paper.

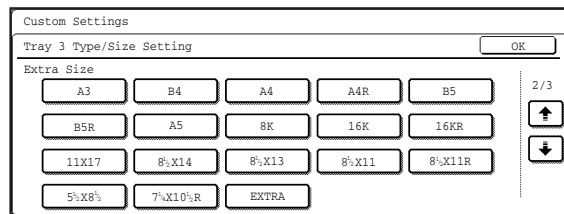

To set the paper size when an extra size of paper is loaded in the Bypass Tray, see page 1-35.

1. Perform steps 1 through 4 of "Setting the paper type" at left.
2. Touch the key to display the paper size setting screen.



- When the loaded paper size appears in the display (if you loaded an INCH-based size such as 8-1/2" x 11"), touch the size key to highlight it, and then touch the [OK] key to complete the procedure.
- If an irregular size of paper was loaded after the [EXTRA] key was touched, touch the  key in the screen of step 2 to display the following screen.



When the screen opens the X key will be highlighted. Use the  and  touch keys to enter the X dimension. Next touch the Y key to highlight it and enter the dimensions for Y.

The permitted range for the X dimension is 139 to 432 mm (5-1/2 to 17 inches), and the permitted range for the Y dimension is 182 to 297 mm (7-1/4 to 11-3/4 inches).

When both have been entered, touch the [OK] to complete the operation.

Setting the paper type and paper size in the Bypass Tray

Follow the steps below to set the type and size of the paper loaded in the Bypass Tray.

- For copy mode or printer mode, touch the appropriate key.

(When copy mode is selected)

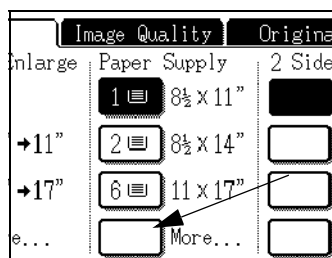

Touch the [More...] key in the Paper Select display of the main screen of copy mode.

(When printer mode is selected)

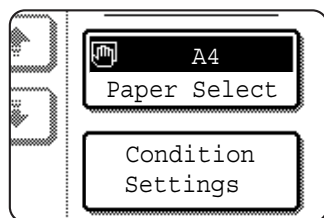

Touch the [PAPER SELECT] key in the main screen of printer mode.

2. Touch the key for the desired paper type.

(When copy mode is selected)

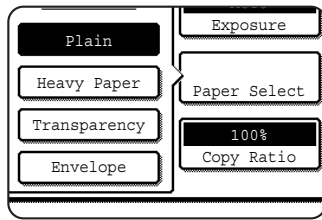

The key for the selected paper type will be highlighted.

(When printer mode is selected)

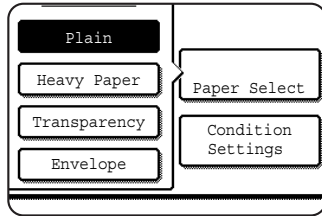

The steps that follow differ depending on the paper type selected. Follow the steps for the selected type.

- If you touched [PLAIN], go to step 6.
 - If you touched [HEAVY PAPER], go to step 3.
 - If you touched [TRANSPARENCY], go to step 4.
 - If you touched [ENVELOPE], go to step 5.
3. Touch [HEAVY PAPER 1] or [HEAVY PAPER 2], and go to step 6.

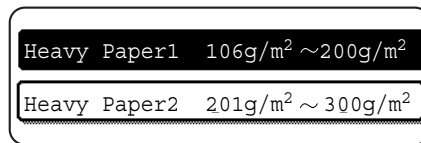

For the types of heavy paper that can be used, see page 1-32.

4. Touch [SPEED MODE] or [QUALITY MODE] for the transparency film, and go to step 7.

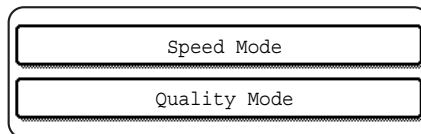

- SPEED MODE is for fast printing.
- QUALITY MODE is for a high quality image.

5. Touch the type of envelope, and go to step 7.

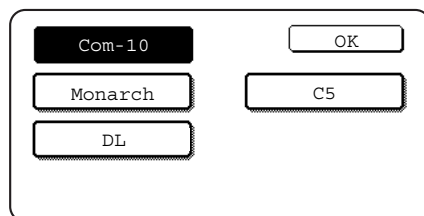

6. If you inserted a non-standard size of paper in the Bypass Tray, remove the checkmark from "ENABLE AUTO SIZE DETECTION" and then touch the [EXTRA SIZE] tab. When the screen opens, the X key will be highlighted. Use the and touch keys to enter the X dimension. If you inserted a standard size of paper in the Bypass Tray, make sure that a checkmark appears in the [ENABLE AUTO SIZE DETECTION] checkbox.

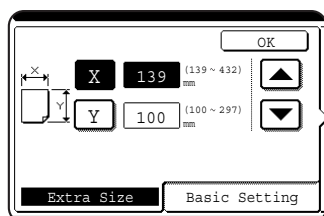

Next touch the key to highlight it and enter the dimensions for Y.

The permitted range for the X dimension is 139 to 432 mm (5-1/2 to 17 inches), and the permitted range for the Y dimension is 100 to 297 mm (4 to 11-3/4 inches).

7. Touch the [OK] key to complete the setting.

Custom Settings

The items that can be set with the custom settings are shown below.

Total count	The number of pages processed by the machine and optional equipment can be displayed. (See page 1-40.)
Display contrast	Used to adjust the contrast of the operation panel display. (See page 1-41.)
List print	Used to print a list of machine settings. (See page 1-41)
Clock adjust	Used to set the date and time of the built-in clock of the machine. (See page 1-39.)

Tray settings

The paper type, paper size and automatic tray switching can be set for each tray. Automatic tray switching allows feeding to switch between trays loaded with the same type and size of paper. If one tray runs out of paper during printing, printing will continue from the other tray. (See page 1-41.)

For the detailed descriptions and use of the settings listed below, see Chapter 5, "Fax Unit" and Chapter 4, "Network Scanner Operation".*

Address control	Use this to store fax destinations (fax numbers). This is also used to store groups, memory boxes, and user indexes. If the network scanner function is available, e-mail addresses, user indexes, and scanner senders can also be stored.
Receive mode	Use this to configure fax reception settings (auto/manual).
Fax data forward	Faxes received to memory can be forwarded to another destination.
Keyboard select	When using the fax function or network scanner function, you can switch the arrangement of the letter keys in the display keyboard used for storing and editing destinations in the English character entry screen.

Key operator program These are programs that are used by the key operator (administrator of the machine) to configure machine settings. A key appears for these settings in the custom settings menu screen. For information on these settings, see "Key Operator Programs" in the WorkCentre C226 System Administration Guide.

* These settings can be configured if the fax function or network scanner function is available.

Operation procedure common to all custom settings

1. Press the [CUSTOM SETTINGS] key.

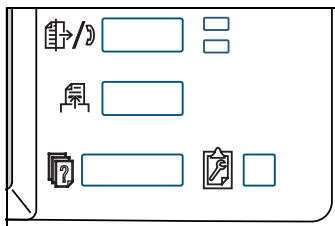

The custom setting menu screen will appear.

More information on setting procedures

In the following type of screen, a setting is turned on when a checkmark (☑) appears next to the key. A checkmark will appear or disappear by alternate touches of the checkmark box. In the following screen, Tray 1 can be used in print, copy, and fax modes. Tray 2 can only be used in the copy mode.

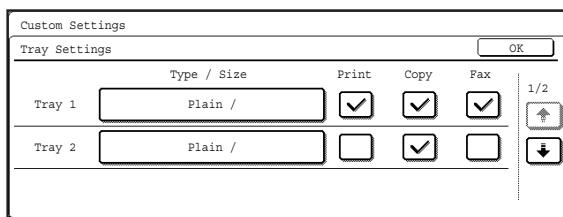

2. Touch the key of the desired item to display its setting screen.

The settings accessed by touching the [CLOCK] key are explained here.

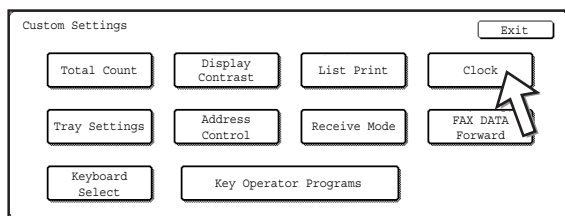

Detailed descriptions for program settings start on page 1-40.

The procedure for setting the clock is shown below as an example.

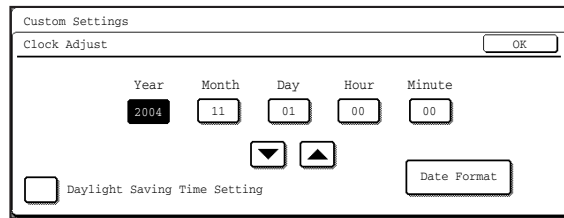

3. Touch the year, month, day, hour or minute key, and then use the \uparrow or \downarrow key to adjust the setting.
 - If you select a non-existent date (for example, Feb. 30), the [OK] key will grey out to prevent entry of the date.
 - Select [DAYLIGHT SAVING TIME SETTING] checkbox to have the time automatically change at the beginning and end of daylight saving time.
4. Touch the [OK] key.
5. To finish the setting operation, touch the [EXIT] key.

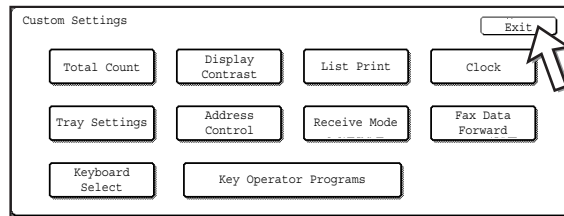

About the settings

Total count

This displays the following sheet counts:

- ① The number of sheets printed in copy, print, and fax modes.
- ② The number of sheets transmitted using the fax function and scanned using the network scanner function.
- ③ The number of sheets used by optional equipment such as the DADF and the Duplex Module of the Duplex Module/2-Tray Unit, and the number of sheets stapled by the Saddle Stitch Finisher.

In the case of ① only:

- Each sheet of paper that is A3 (11" x 17") size or larger is counted as two sheets.
- Each sheet of paper used for automatic two-sided copying is counted as two sheets (A3 (11" x 17") paper is counted as four sheets). (When an optional Duplex Module/2-Tray Unit and a Duplex Bypass/Inverter Unit are installed.)

Display contrast

Screen contrast adjustment is used to make the LCD touch panel easier to view under various lighting conditions. Touch the [LIGHTER] key to make the screen lighter, or the [DARKER] key to make the screen darker.

List print

Used to print a list of the settings configured in the fax, printer and network scanner function.

Clock adjust

Use this to set the date and time in the machine's built-in clock. This clock is used by functions that require date and time information. The format of the printed date can also be changed.

Tray settings

The paper type, paper size, enabled modes and automatic tray switching can set for each tray. See page 1-33 for details on setting the paper type and paper size. Automatic tray switching to another paper tray is used to automatically switch to another tray with the same size and type of paper in the event that the paper runs out during continuous printing. This requires that the trays be loaded with the same size of paper. To enable any function, touch the check box key so that a checkmark (☑) appears.

Keyboard select

When using the fax function or network scanner function, you can switch the arrangement of the letter keys in the display keyboard that appear in the character entry screen when storing or editing destinations. Select the arrangement of the letter keys that you find easiest to use.

The following three alphabet keyboard configurations are available:

- Keyboard 1 (QWERT... configuration)*
- Keyboard 2 (AZERTY...configuration)
- Keyboard 3 (ABCDEF...configuration)

* The default setting is "Keyboard 1".

(Example: Character entry screen when Keyboard 3 is selected)

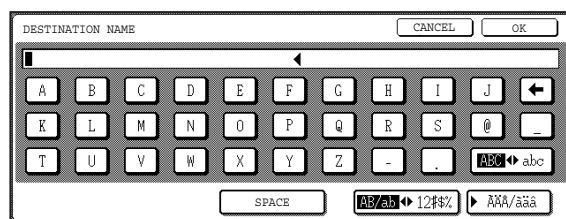

Replacing the Toner Cartridges

When toner runs low, "[□□□□] TONER SUPPLY IS LOW" appears in the display. It is recommended that you keep a set of new toner cartridges so that you can replace them quickly when toner runs out.

Ready To Copy.
([□□□□] Toner Supply Is Low.)



If you continue to use the toner cartridge, the toner will eventually run out, the machine will stop and the following message will appear.

△ Change The Toner Cartridge.
([□□□□])

This indicates the colour of toner that is low.

- Y = Yellow toner
- M = Magenta toner
- C = Cyan toner
- Bk = Black toner

- NOTES:**
- *There may be cases that copy images become light or uneven before the message is displayed, depending on the way the machine is used. If this occurs, take out the toner cartridge by following the same steps as replacement, shake it horizontally to even out the toner in the cartridge, and re-insert the toner cartridge. If copy images do not improve even after following this procedure, replace the toner cartridge with a new cartridge.*
 - *If one of the toners is out, including black toner, colour copying will not be possible. If Y, M, or C runs out but BK toner remains, black and white copying will still be possible.*

Follow these steps to replace the toner cartridge that is out of toner.

1. Open the front cover.

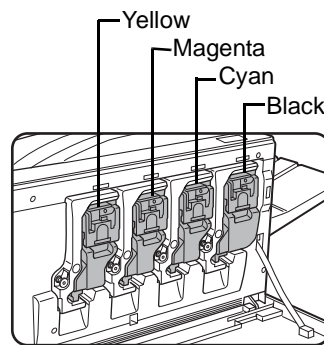
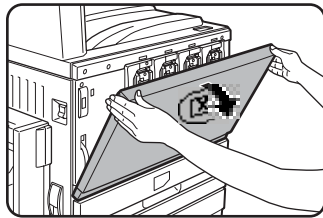

Arrangement of colour toner cartridges

2. Lift the cartridge lock lever toward you.

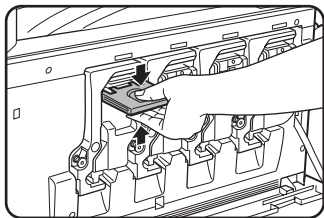

Example: Replacing the yellow toner cartridge

3. While holding the lock lever on the toner cartridge, pull the toner cartridge toward you.

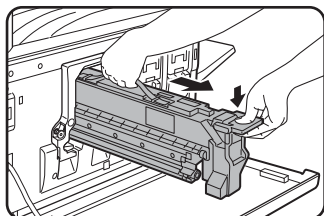

Hold the toner cartridge with both hands as shown in the illustration, and pull it out of the machine.

4. Remove a new toner cartridge from the package and shake it horizontally five or six times.

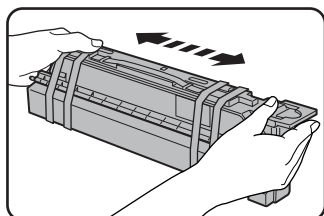

NOTE:

Shake the toner cartridge well to ensure that the toner flows well and will not stick to the inside of the cartridge.

5. Remove the protective material from the new toner cartridge.

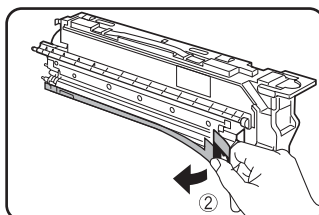
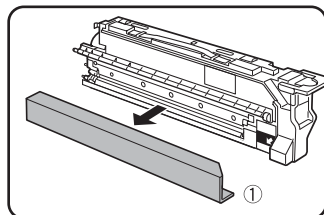

6. Insert the new toner cartridge.

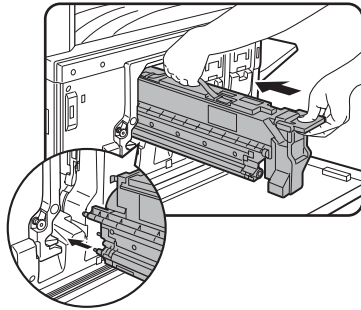

Align the insert holes as shown and then push the cartridge in.

NOTE: A toner cartridge of a different colour cannot be installed. For instance, a yellow cartridge cannot be installed in the cyan position.

7. Push the cartridge in until it locks securely in place.

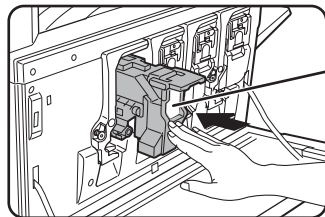

NOTE:

Do not push the white area shown in the illustration. The lock lever may come down.

8. Return the cartridge lock lever.

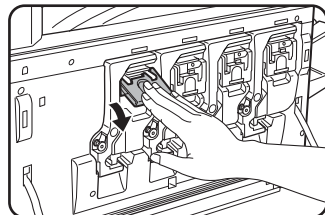

9. Close the front cover.

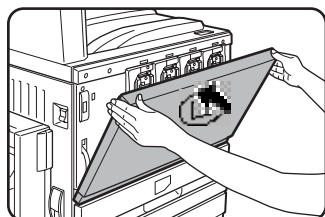

After the toner cartridge is replaced, the machine automatically enters resolution adjustment mode. (In some cases, this may take about 5 minutes.)

CAUTION:

- Do not throw the toner cartridge into a fire. Toner may fly and cause burns.
- Store toner cartridges out of the reach of small children.

Storing Supplies

Standard supplies for this product that can be replaced by the user include paper, toner cartridges, and staple cartridges for the finisher.

For best copying results, be sure to use only Xerox Genuine Supplies which are designed, engineered, and tested to maximize the life and performance of Xerox products. Look for the Genuine Supplies label on the toner package.

Proper storage

1. Store the supplies in a location that is:
 - clean and dry,
 - at a stable temperature,
 - not exposed to direct sunlight.
2. Store paper in the wrapper and lying flat.
3. Paper stored in packages standing up or out of the wrapper may curl or become damp, resulting in paper misfeeds.
4. Store a new toner cartridge box horizontally. Do not store it standing on end. If stored standing on end, the toner may not distribute well even after shaking the cartridge vigorously, and will remain inside the cartridge without flowing out.

Supply and Consumables

The supply of spare parts for a repair of the appliance is guaranteed for at least 7 years following the termination of production. Spare parts are those parts of the apparatus which may break down within the scope of the ordinary use of the product - whereas those parts which normally exceed the life of the product are not to be considered as spare parts. Consumables too, are available for 7 years following the termination of production.

Misfeed Removal

When a misfeed has occurred during printing, the message "MISFEED HAS OCCURRED." will appear in the touch panel display of the operation panel and printing output will stop. The approximate locations of possible misfeeds are indicated by "▼" in the illustration below. The page numbers for detailed information for misfeed removal for each are also shown.

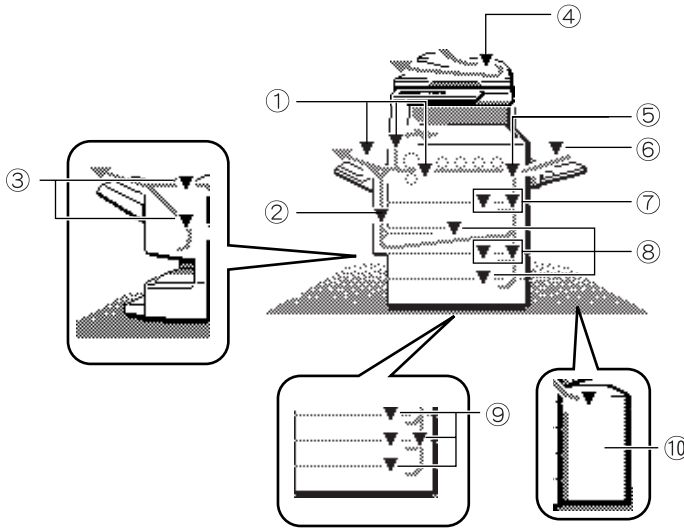

- ① Misfeed in the fusing area, and exit area (page 1-50)
- ② Misfeed in the Duplex Bypass /Inverter Unit (page 1-53)
- ③ Misfeed in the Saddle Stitch Finisher (page 1-67)
- ④ Misfeed in the DADF (see page 2-79 in the "Copier Operation" section)
- ⑤ Misfeed in the transport area (page 1-49)
- ⑥ Misfeed in the Bypass Tray (page 1-48)
- ⑦ Misfeed in the 1-Tray Unit (page 1-47)
- ⑧ Misfeed in the Duplex Module/2-Tray Unit (page 1-55)
- ⑨ Misfeed in the stand/1-Tray Unit or the 3-Tray Unit (page 1-53)
- ⑩ Misfeed in the High Capacity Feeder (page 1-75)

NOTE: *Received faxes are all temporarily stored in memory. If a paper misfeed occurs, received faxes cannot be printed. When the misfeed is removed, the received faxes will print out automatically.*

- NOTES:**
- *Be careful not to tear the misfed paper during removal.*
 - *If paper is accidentally torn during removal, be sure to remove all pieces.*
 - *Take care not to damage or leave fingerprints on the transfer belt when removing the misfed paper.*

CAUTION

The fusing unit is hot. Take care in removing paper.

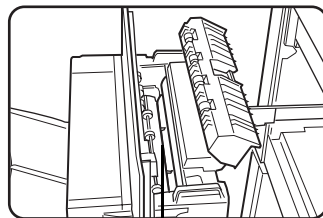

Upper fusing unit

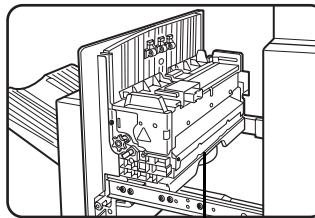

Fusing unit paper guide

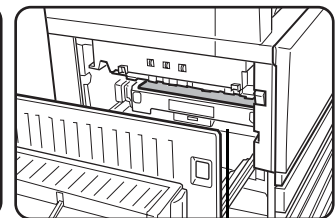

Transfer belt

Misfeed Removal Guidance

Misfeed removal guidance can be displayed by touching the [INFORMATION] key on the touch panel after a misfeed has occurred.

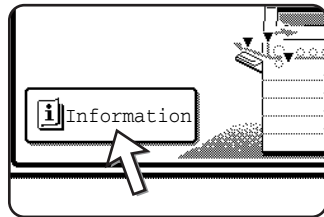

Misfeed in the paper feed area

NOTE: Paper misfed from a paper tray may be extending out of the tray into the right side cover area. In this case if the tray is drawn out of the machine, the paper may become torn and difficult to remove. To prevent this from happening, always open the right side cover first and remove the misfed paper if it is extending into that area.

Misfeed in Tray 1

1. Open the upper side cover.

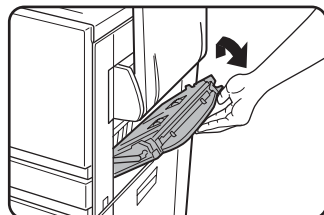

Push the lever upward and gently open the cover.

NOTE: If paper is loaded in the Bypass Tray, temporarily remove the paper and close the Bypass Tray before opening the side cover.

2. Remove the misfed paper.

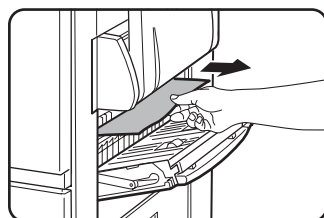

Be careful not to tear the misfed paper during removal.

NOTE: The misfeed may have occurred inside the machine. Check carefully and remove it.

3. If misfed paper is not found in step 2, pull out Paper Tray 1 and remove the misfed paper.

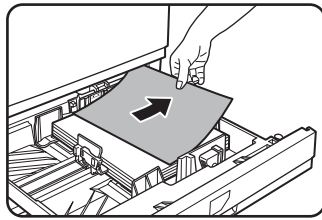

Be careful not to tear the misfed paper during removal.

4. Gently close the paper tray.

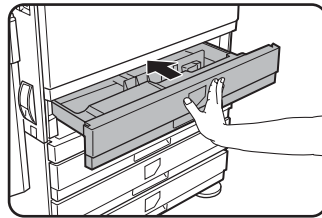

Push the tray firmly all the way into the machine.

5. Gently close the upper side cover.

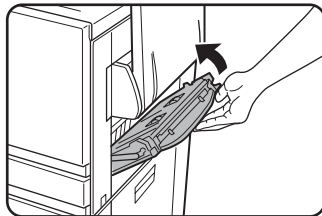

After closing, confirm that the misfeed message has been cleared and the normal display appears.

Misfeed in the Bypass Tray

1. Remove the misfed paper from the Bypass Tray.

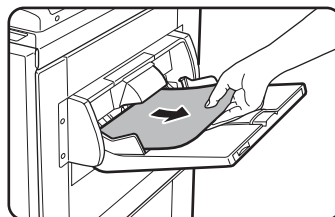

Be careful not to tear the misfed paper during removal.

2. After removing the misfed paper, open and close the Duplex Bypass/Inverter Unit to reset.

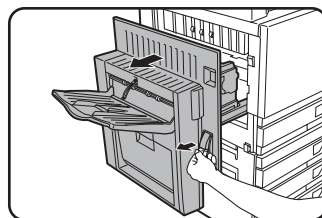

Grasp the finger hold and gently open the unit.

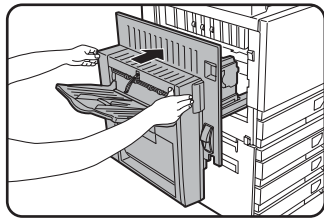

After closing, confirm that the misfeed message has been cleared and the normal display appears. If the Duplex Bypass/Inverter Unit is not installed, close the side cover in the same way.

Misfeed in the transport area, fusing area, and exit area

Transport area

1. Open the upper side cover and check for a misfeed.

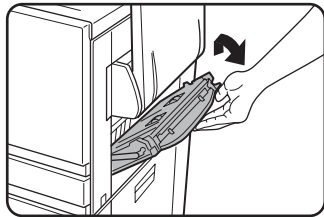

- ① Push the lever upward and gently open the cover.

NOTE: *If paper is loaded in the Bypass Tray, temporarily remove the paper and close the Bypass Tray before opening the side cover.*

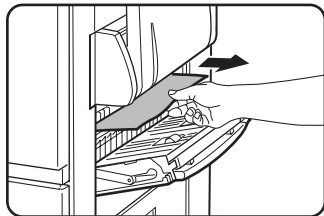

- ② Be careful not to tear the misfed paper during removal.

NOTE: *The misfeed may have occurred inside the machine. Check carefully and remove it.*

2. Gently close the upper side cover.

NOTE: *Even after clearing a misfeed, paper may remain inside the machine on the transfer belt where it is not visible. In this case, after visible misfeeds are removed, the paper on the transfer belt will be automatically moved to a position where it is visible and a misfeed will be indicated once again on the display. Clear the misfeed as explained in "Misfeed in the transfer unit" (step 3 on page 1-51). For this reason, it may be necessary to perform the "Misfeed in the transfer unit" procedure twice.*

Exit area

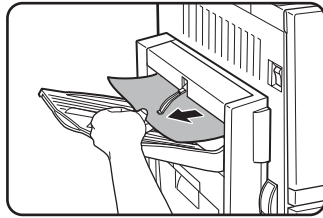

Models with an exit tray attached to the Duplex Bypass/Inverter Unit:

Gently remove the misfed paper as shown in the illustration, taking care not to tear the paper.

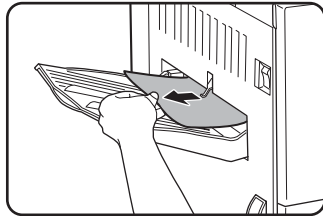

Models without the Duplex Bypass/Inverter Unit:

Gently remove the misfed paper as shown in the illustration, taking care not to tear the paper.

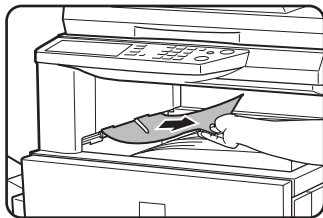

Upper exit tray:

Gently remove the misfed paper as shown in the illustration, taking care not to tear the paper.

Fusing area

1. Open the Duplex Bypass/Inverter Unit.

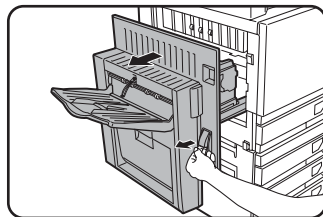

Grasp the finger hold and gently open the unit.

2. Remove the misfed paper as shown in the illustrations below.

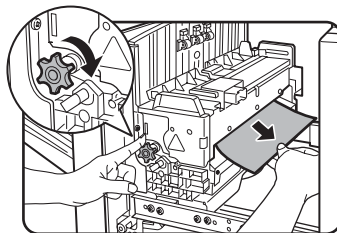

If paper is misfed in the transport area, turn roller rotating knob A in the direction of the arrow to remove the misfed paper.

⚠ CAUTION

The fusing unit is hot. Take care in removing paper. (Do not touch any metal parts.)

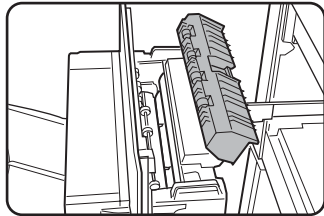

If you do not find a misfeed, open the cover of the fusing unit and check for a misfeed inside the fusing unit.

⚠ CAUTION

The fusing unit is hot. Take care in removing paper. (Do not touch any metal parts.)

3. Misfeed in the transfer unit

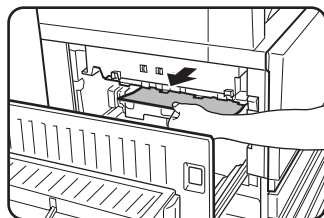

If paper is misfed on the transfer belt, remove it gently without touching the transfer belt. Do not pull out the transfer unit.

⚠ CAUTION

The transfer unit is hot. Take care in removing paper. (Do not touch any metal parts.)

4. Gently close the Duplex Bypass/Inverter Unit.

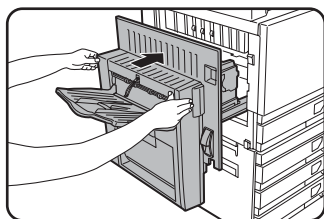

After closing, confirm that the misfeed message has been cleared and the normal display appears. If the Duplex Bypass/Inverter Unit is not installed, close the side cover in the same way.

Misfeed in the stand/1-Tray Unit

NOTE: Paper misfed from a paper tray may be extending out of the tray into the right side cover area. In this case if the tray is drawn out of the machine, the paper may become torn and difficult to remove. To prevent this from happening, always open the right side cover first and remove the misfed paper if it is extending into that area.

1. Open the upper and lower side covers.

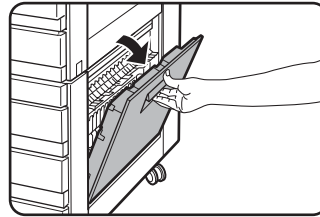
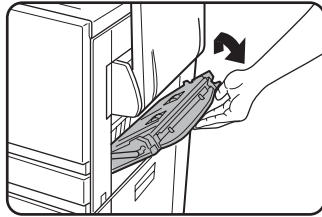

Push the lever upward and gently open the cover.

NOTE: If paper is loaded in the Bypass Tray, temporarily remove the paper and close the Bypass Tray before opening the side cover.

2. Remove the misfed paper.

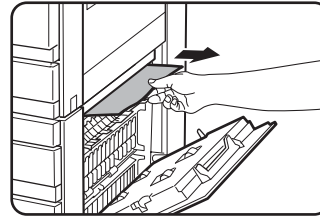
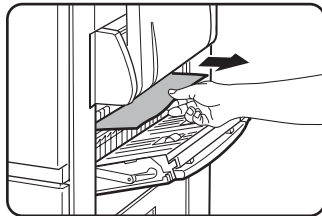

Be careful not to tear the misfed paper during removal.

NOTE: The misfeed may have occurred inside the machine. Check carefully and remove it.

3. If misfed paper is not found in step 2, pull out Paper Tray 1 and remove the misfed paper.

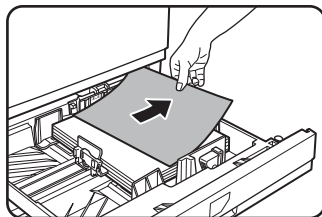

Be careful not to tear the misfed paper during removal.

4. Gently push the paper tray into the machine.
Push the tray firmly all the way into the machine.

5. Gently close the upper and lower side covers.

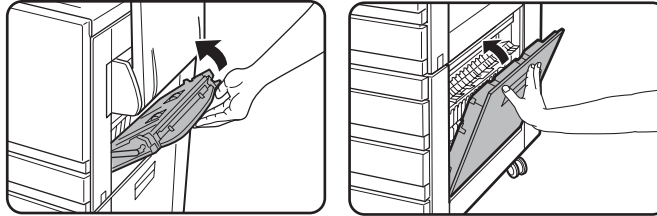

After closing, confirm that the misfeed message has been cleared and the normal display appears.

Misfeed in the 3-Tray Unit

To remove a misfeed in the upper, middle, or lower tray, follow steps 1 through 5 above of “Misfeed in the stand/1-Tray Unit”.

Misfeed in the Duplex Bypass/Inverter Unit and Duplex Module/2-Tray Unit

NOTE: Paper misfed from a paper tray may be extending out of the tray into the right side cover area. In this case if the tray is drawn out of the machine, the paper may become torn and difficult to remove. To prevent this from happening, always open the right side cover first and remove the misfed paper if it is extending into that area.

1. Perform steps 1 and 2 of “Misfeed in the stand/1-Tray Unit” on page 1-52.
2. Open the upper cover of the Duplex Bypass/Inverter Unit.

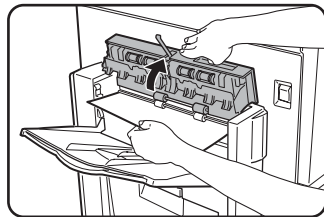

3. Remove the misfeed from the upper part of the Duplex Bypass/Inverter Unit.

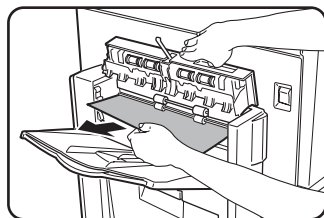

Hold the upper cover of the unit open while removing the misfed paper.

4. Close the upper cover of the Duplex Bypass/Inverter Unit.

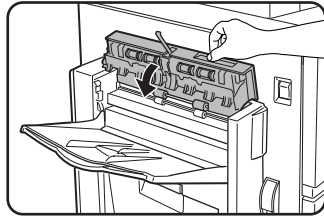

5. Lift the exit tray if one is installed and open the cover of the Duplex Bypass/Inverter Unit.

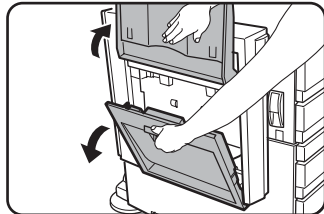

6. Remove the misfed paper.

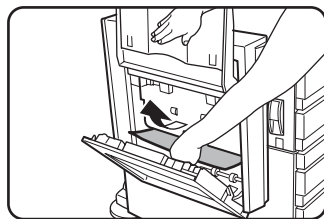

While holding the exit tray up, remove the misfed paper as shown in the illustration. Be careful not to tear the misfed paper during removal.

7. Close the cover of the Duplex Bypass/Inverter Unit and return the exit tray to its original position.

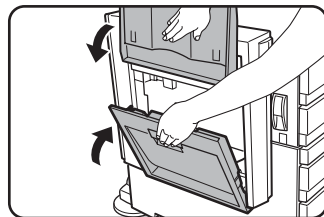

8. Remove a misfeed from the bottom of the Duplex Bypass/Inverter Unit.

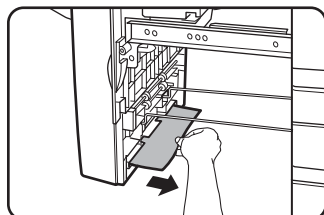

Gently remove the misfed paper from the bottom of the Duplex Bypass/Inverter Unit as shown in the illustration, taking care not to tear the paper.

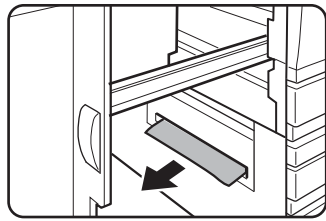

Make sure that there is no misfed paper in the machine.

9. Pull out the Duplex Module of the Duplex Module/2-Tray Unit.

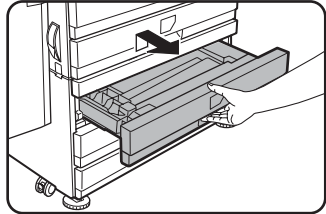

10. Remove the misfed paper from the Duplex Module.

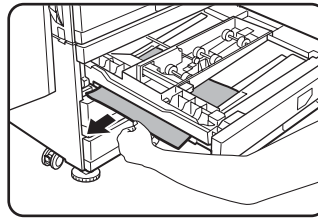
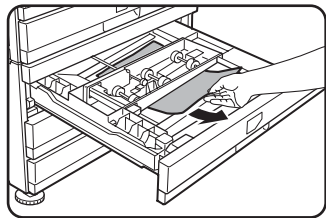

Be careful not to tear the misfed paper during removal.

11. Gently close the Duplex Module.

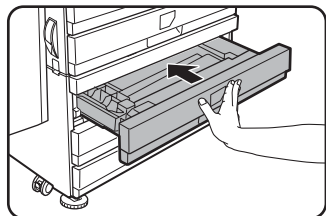

Push the tray firmly all the way into the machine.

12. Gently close the Duplex Bypass /Inverter Unit.

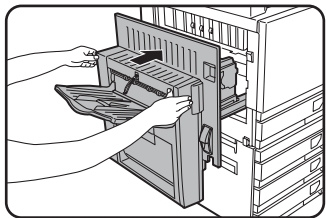

Misfeed in the upper or lower tray

To remove misfed paper from the upper tray or lower tray, follow steps 1 through 5 of "Misfeed in the stand/1-Tray Unit" beginning on page 1-52.

Troubleshooting

Check the following troubleshooting list before requesting service as many problems can be fixed by the user. If you are unable to solve the problem by checking the list, turn off the power switch, unplug the power cord.

Problems related to general use of the machine are described below. For problems related to the copy function, see page 2-83. For fax, printer, and network scanner problems, see the manuals for those functions. For peripheral device problems, see the explanation of the device.

If the message "CALL FOR SERVICE. CODE:**-***" appears in the touch panel, turn off the power switch, wait about 10 seconds, and then turn the power switch back on. If the message still appears after turning the switch off and on several times, it is likely that a failure has occurred and maintenance would be required. In this event, stop using the machine, unplug the power cord, and contact your Xerox dealer.

Note: Letters and numbers appear in "***-***" above. When you contact your Xerox dealer, please tell your dealer what letters and numbers appear.

Problem	Check	Solution or cause
The machine does not operate.	Printer plugged in?	Plug the printer into a grounded outlet.
	Power switch on?	Turn on the power switch.
	READY indicator off?	The printer is warming up. (Warm-up time is approximately 99 seconds.) Wait until the READY indicator lights up.
	Message indicating need to load paper displayed?	Load paper. (page 1-21)
	Message indicating need to replace the toner cartridge displayed?	Replace the toner cartridge.(page 1-42)
	Message indicating a paper misfeed displayed?	Remove misfed paper. (page 1-46)
	A message appears saying that the power must be turned off and then turned on.	Turn off the power switch, wait about 10 seconds, and then turn on the switch again. If the same message appears after turning the power switch off and on several times, it is possible that the machine needs service. In this event, contact your dealer.
Copying/printing is not possible.	A message appears saying that this type of paper cannot be used for two-sided copying.	Two-sided printing is not possible on special paper. Use paper that can be used for automatic two-sided printing. (page 1-33)
Incorrect Bypass Tray paper size.	Incorrect display of paper sizes A3W, A3, B4, A4R, 12" x 18", 11" x 17", 8-1/2" x 14", 8-1/2" x 13", or 8-1/2" x 11"R only.	When loading sizes A3W, A3, B4, A4R, 12" x 18", 11" x 17", 8-1/2" x 14", 8-1/2" x 13", or 8-1/2" x 11"R, be sure to open the tray extension.

Problem	Check	Solution or cause
Copying/printing on paper from the Bypass Tray is skewed.	The number of sheets placed on the Bypass Tray exceeds the maximum number.	Do not place more than the maximum number of sheets.
	The Bypass Guide is not adjusted to the size of the loaded paper.	Adjust the Bypass Guide to the size of the loaded paper.
Paper from the Bypass Tray mis-feeds.	The paper size and paper type have not been set.	Be sure to set the paper size and paper type when using special size or special type papers. (page 1-35)
	The number of sheets placed on the Bypass Tray exceeds the maximum number.	Do not place more than the maximum number of sheets.
	The Bypass Guide is not adjusted to the size of the loaded paper.	Adjust the Bypass Guide to the size of the loaded paper.
Printing stops before the job is finished.	If too many pages collect on the output tray, the tray full sensor activates and stops printing.	Remove the paper from the output tray.
	You have run out of paper.	Load paper. (page 1-21)
Smudges on printed sheets.	Does a message appear indicating the need for maintenance?	Please contact the your dealer as soon as possible.
Colour deviations occur.	When printing in colour, character and colour deviations appear.	Perform colour registration as explained in the “Key Operator Programs” section of the WorkCentre C226 System Administration Guide.
The displayed paper size differs from the loaded paper size.	The display of the tray's paper size slide differs from the paper size in the tray.	When you change the paper size in the tray, be sure to adjust the paper size slide on the tray to the new paper size. (page 1-22)
When printing on a special size of paper, part of the printed image is missing.	The paper size setting is not set correctly in the paper tray settings of the custom settings.	When using a special size of paper, set the correct paper size in millimetres in the paper tray settings of the custom settings (see page 1-33). If the paper size setting is not correct, part or all of the image may not print (this depends on the options installed).
When printing on a special size of paper using the Bypass Tray, part of the printed image is missing.	The paper size is not set correctly in the special size settings for the Bypass Tray.	When using a special size of paper, set the correct paper size in millimetres as explained in step 6 on page 1-37. If the paper size setting is not correct, part or all of the image may not print (this depends on the options installed).

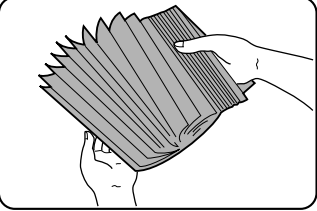
Problem	Check	Solution or cause
Paper misfeeds frequently.	Is paper other than Xerox-recommended paper being used?	Use Xerox-recommended paper.
	Paper curled or damp?	Do not use curled or crimped paper. If you do not use paper for a long time, store paper in the wrapper in a dry location.
	Is the paper curled and does it frequently misfeed in the Duplex Module/2-Tray Unit or Saddle Stitch Finisher?	Paper may be curled when output depending on the paper type and quality. In some cases turning the paper over in the tray will reduce misfeeding due to curling.
	Multiple sheets of paper fed simultaneously?	 <p>Remove the paper from the paper tray or the Bypass Tray, fan the paper as shown in the illustration, and then load it again.</p>
Printed paper is wrinkled or the image rubs off easily.	Is paper other than Xerox-recommended paper being used?	Use Xerox-recommended paper.
	Is paper size or weight out of the allowable range?	Use paper in the allowable range.
	Do wrinkles appear when printing envelopes?	Moving the pressure adjusting levers of the fusing unit from the normal position to a weaker pressure position may help alleviate this problem. (page 1-27)
	Is the pressure adjustment lever of the fusing unit out of position?	Return the pressure adjusting levers of the fusing unit to the normal position. (page 1-28)
	Paper damp?	Be sure to store paper in the wrapper in a dry location and do not store paper in a location that is humid at a high temperature or an extremely low temperature.
The contrast on the touch panel is too high or too low.	Is LCD contrast properly adjusted?	Adjust the contrast using "DISPLAY CONTRAST" of custom settings. (page 1-37)

Peripheral Devices

This section explains procedures for using the peripheral devices such as the Saddle Stitch Finisher.

Saddle Stitch Finisher

The Saddle Stitch Finisher can automatically place two staples for centreline binding of prints or copies and fold them along the centreline. An optional hole punching unit is available for installation into the finisher.

Part names and functions

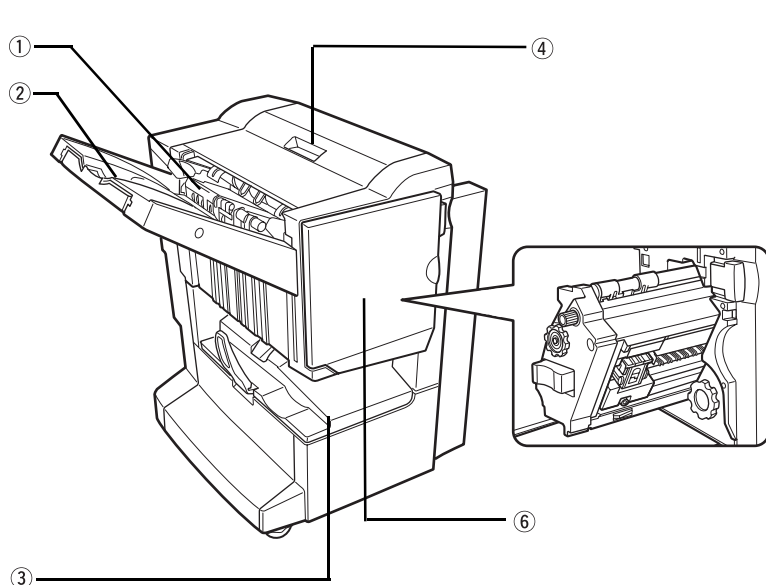

① Stapler compiler
Paper to be stapled is stacked temporarily. When printing on post cards or envelopes, remove the output from here.

④ Top cover
Open for misfeed removal.

② Offset tray
Output which is stapled or offset will be delivered to this tray.

⑤ Stapler section
Open the front cover and pull out this section to replace the staple cartridge or to remove jammed staples.

③ Saddle stitch tray
Saddle stitched output is delivered here.

⑥ Front cover
Open to replace the staple cartridge, to remove the misfed paper, or to remove jammed staples.

- NOTES:**
- Do not press on the Saddle Stitch Finisher (particularly the offset tray).
 - Use caution when near the offset tray during printing as the tray moves up and down.
 - To install the Saddle Stitch Finisher, a Duplex Bypass/Inverter Unit and either a stand/1-Tray Unit, a 3-Tray Unit, or a Duplex Module/2-Tray Unit must also be installed.

Using the Saddle Stitch Finisher

Touch the [More...] key in the Output display on the main screen of copy mode to display the screen that allows selection of sort, staple sort, centreline stapling, group function, and the output tray.

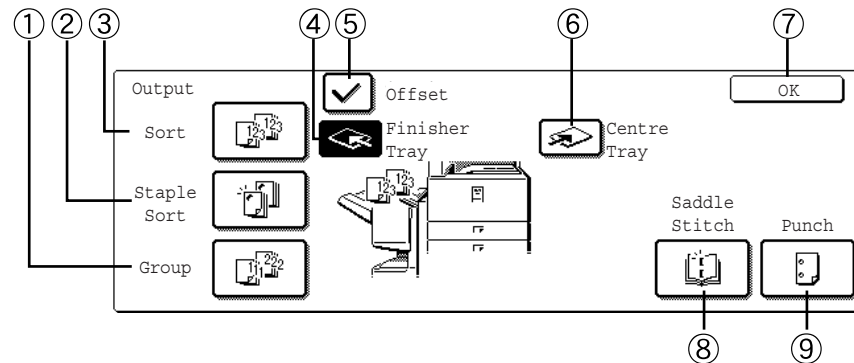

- ① **[GROUP] key** When Group is selected, all copies of the same original will be grouped.
- ② **[STAPLE SORT] key** When Staple Sort is selected, sorted sets will be stapled and delivered to the offset tray. (They will not be offset stacked.)
- ③ **[SORT] key** When Sort is selected, sets of copies will be sequentially delivered.
- ④ **[FINISHER TRAY] key** When the offset function is selected, output goes to the offset tray. (The offset tray is automatically selected when the staple sort function is turned on.)
- ⑤ **[OFFSET] key** The offset function operates when "Yes" is selected, and doesn't operate when "No" is selected. (The offset checkmark is automatically cleared when the staple sort function is turned on.)
- ⑥ **[CENTRE TRAY] key** If the centre tray is selected, output paper will be delivered to the exit tray located above the main unit.
- ⑦ **[OK] key** Touch to close the [OUTPUT] screen and to return to the main screen.
- ⑧ **[SADDLE STITCH] key** When saddle stitching is selected, the copies will be stapled at the centre and delivered to the saddle stitch tray.
Touch this key to display the pamphlet copy setting screen (page 2-71). (This is only possible when a checkmark appears in the checkbox of the [AUTOMATIC SADDLE STITCH] key operator program)
- ⑨ **[PUNCH] key** If the Saddle Stitch Finisher is equipped with a hole Punch Module, printed paper can be hole punched and delivered to the offset tray.

* When one of the functions is selected, it is highlighted.

Staple cartridge replacement and staple jam removal

When the staple cartridge becomes empty or staples become jammed, a message will appear in the message display of the operation panel.

Follow the procedure below to replace the staple cartridge or remove jammed staples.

Staple cartridge replacement

1. Open the front cover.

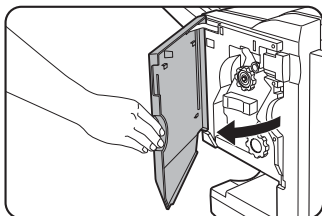

2. Pull out the stapler section.

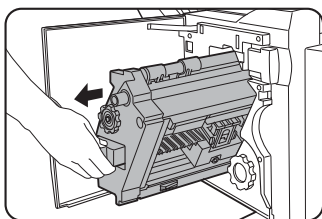

3. Turn roller rotating knob A in the direction of the arrow to move the staple unit to the front.

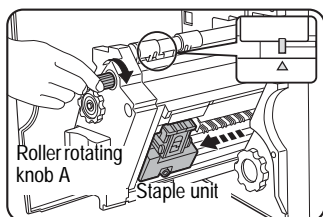

Turn the roller rotating knob until the triangle mark is aligned with the index.

4. Remove the empty staple box.

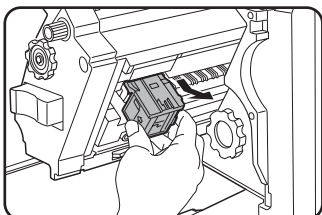

5. Remove the empty staple cartridge.

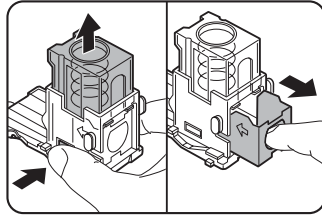

Press the lock button to unlock the staple box cover and remove the staple cartridge.

NOTE: *If staples remain, the staple cartridge cannot be removed.*

6. Insert a new staple cartridge into the staple box.

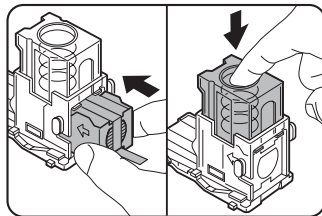

After inserting the staple cartridge, press down on the staple box cover to lock the cartridge in place.

- NOTES:**
- *Do not remove the tape from the cartridge before inserting the staple cartridge into the box.*
 - *Make sure that the new staple cartridge is locked securely in the staple box. Press down on the staple box cover until you hear a "click" indicating that the staple cartridge is locked.*

7. Remove the tape from the staple cartridge by pulling it straight.

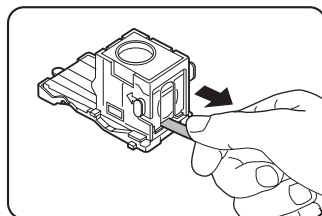

8. Insert the staple box.

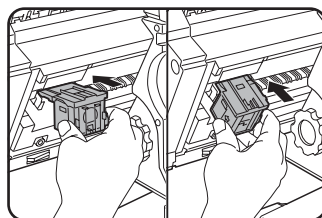

Push the staple box in until it clicks into place.

9. Push the stapler section back into the finisher.

10. Close the front cover.

NOTE: *Make a test print or copy in the staple sort mode to ensure that stapling is performed properly.*

Staple jam removal

1. Unlatch the Saddle Stitch Finisher and slide it away from the main unit.

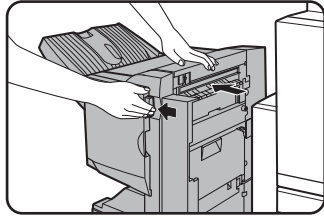

2. Open the front cover.

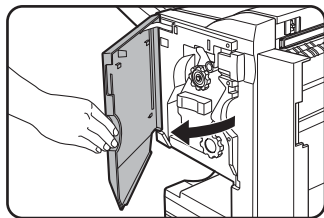

3. Turn roller rotating knob C as shown in the illustration until the blue indication is seen.

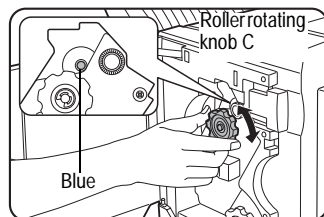

4. Remove the paper from the stapler compiler.

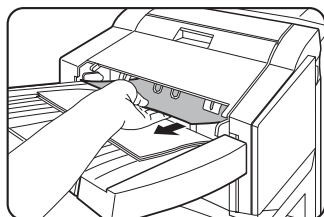

5. If saddle stitching was selected, open the saddle stitch section cover.

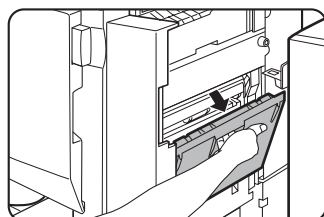

6. Remove the misfed paper.

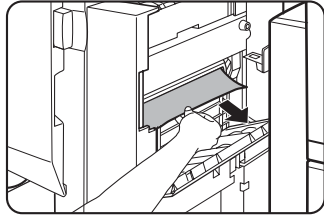

Be careful not to tear the misfed paper during removal.

7. Close the saddle stitch section cover.

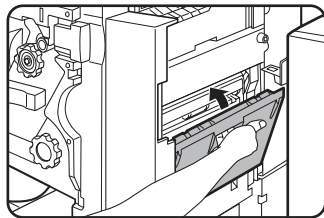

8. Pull out the stapler section.

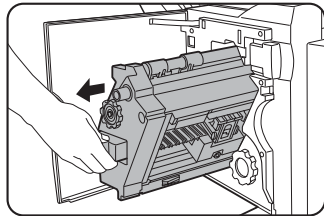

9. Turn roller rotating knob A in the direction of the arrow to move the staple unit to the front.

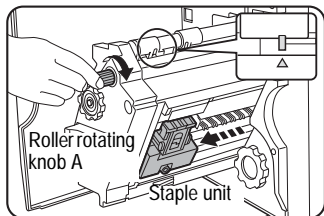

Turn the roller rotating knob until the triangle mark is aligned with the index.

10. Remove the staple box.

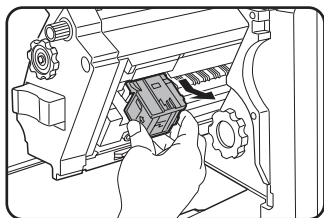

11. Raise the lever at the end of the staple box.

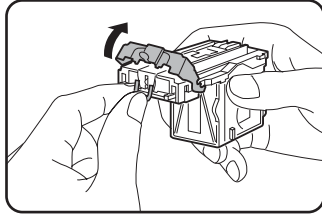

Remove the top staple if it is bent. If bent staples remain, a staple jam will occur again.

12. Return the lever to its original position.

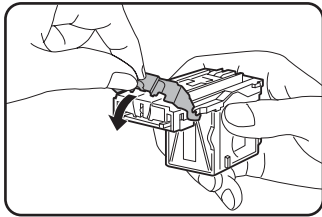

13. Reinstall the staple box.

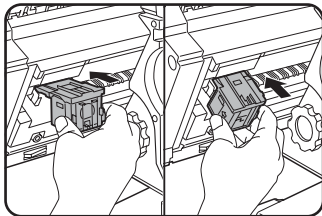

Push the staple box in until it clicks into place.

14. Push the stapler section back into the finisher.

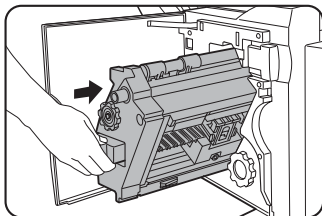

15. Close the front cover.

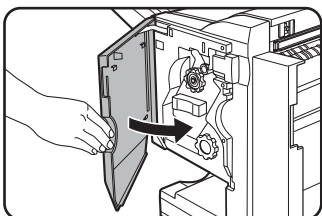

16. Push the Saddle Stitch Finisher back against the main unit.

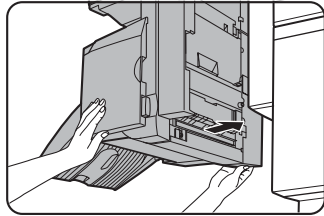

NOTE: *Make a test print or copy in the staple sort mode to ensure that stapling is performed properly.*

Disposal of hole punch scrap (when the punch unit is installed)

1. Unlatch the Saddle Stitch Finisher and slide it away from the main unit.

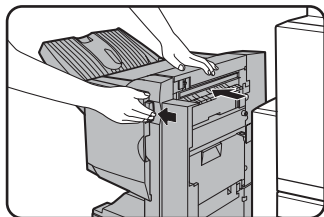

2. Pull out the punch scrap collecting container and empty it.

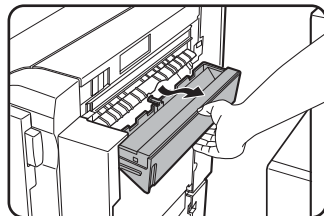

Discard the punch scraps in a plastic bag or other container, taking care not to let the scraps scatter.

3. Return the punch scrap collecting container to its original position.

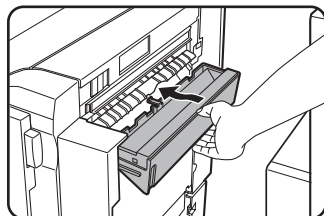

4. Push the Saddle Stitch Finisher back against the main unit.

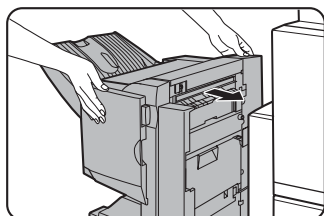

Misfeed in the Saddle Stitch Finisher

When a misfeed occurs in the Saddle Stitch Finisher, remove the misfed paper following the procedure below.

1. Unlatch the Saddle Stitch Finisher and slide it away from the main unit.

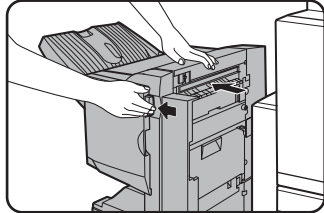

NOTE: *The Saddle Stitch Finisher and the machine are connected at the rear. Exercise caution when pulling them apart.*

2. Remove the misfed paper from the main unit.

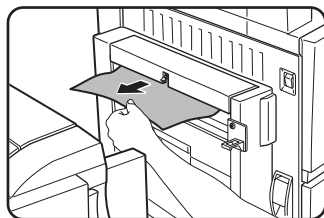

After removing the misfed paper, open and close the Duplex Bypass/Inverter Unit to reset the jam indicator. ("Misfeed in the transport area, fusing area, and exit area" step 1 of "Fusing area" on page 1-50 or step 4 on page 1-51.)

3. If there was no misfed paper in step 2, pull roller rotating knob B on the punch unit towards you and rotate it. (Only when an optional punch unit is installed.)

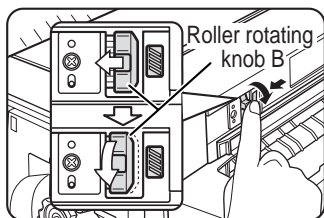

Rotating roller rotating knob B releases the caught paper.

4. Open the top cover.

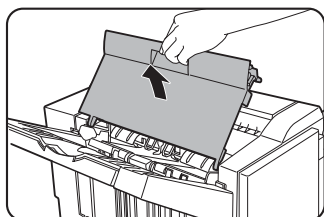

5. Remove the misfed paper.

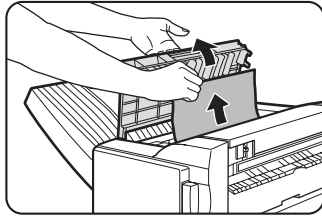

Remove the paper gently, taking care not to tear it.

6. Close the top cover.

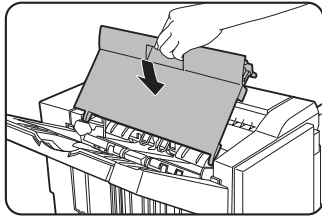

7. Remove the misfed paper from the stapler compiler.

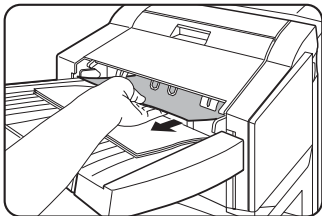

Be careful not to tear the misfed paper during removal.

8. Open the saddle stitch section cover.

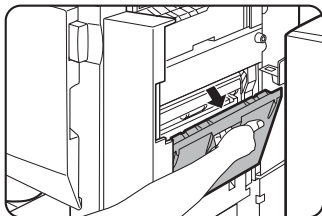

9. Remove the misfed paper.

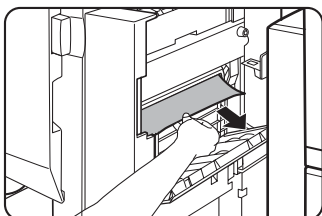

Be careful not to tear the misfed paper during removal.

10. Open the front cover.

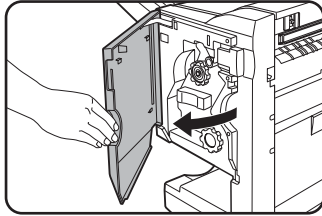

11. Turn roller rotating knob in the direction of the arrow.

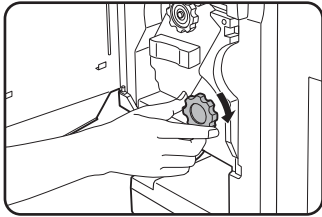

12. Remove any misfed paper from the saddle stitch tray.

Be careful not to tear the misfed paper during removal.

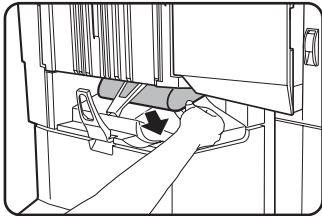

13. Close the saddle stitch section cover.

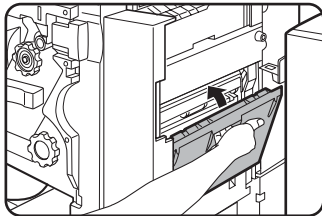

14. Close the front cover.

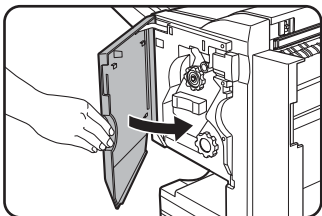

15. Push the Saddle Stitch Finisher back against the main unit.

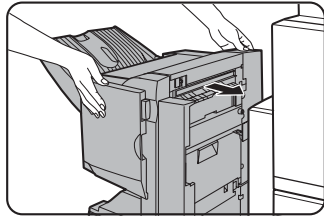

Troubleshooting Saddle Stitch Finisher problems

Check the list below before calling for service.

Problem	Check	Solution or cause
Stapling position is not correct (including saddle stitch).	Stapling position not set properly?	Check the stapling position setting. (See pages 1-72 and 1-73.)
The Saddle Stitch Finisher does not operate.	Are any Saddle Stitch Finisher covers open?	Close all covers. (See pages 1-68 and 1-69.)
	Message indicating need to remove paper from the stapler compiler displayed?	Remove all remaining paper from the stapler compiler referring to step 4 on page 1-63.
Stapling cannot be performed (including saddle stitch).	Message to check the staple unit displayed?	Remove jammed staples. (See page 1-63.)
	Message to add staples displayed?	Replace the staple cartridge. (See page 1-61.) Check that a staple cartridge has been installed. (See page 1-61.)
	Different size paper included?	Stapling cannot be performed onto different size paper.
	Is the paper badly curled, preventing stapling?	Differences in paper quality and type may result in bad curling of output paper. Take the paper out of the tray or Bypass Tray, turn it around, and reload it so that the top and bottom edges are reversed.
The punch hole positions are not correct* ¹	The punch function is not set to the correct punch positions.	Check the allowed hole punch positions.

Problem	Check	Solution or cause
Cannot be punched.*	Message to check the Punch Module displayed?	Dispose of punch scraps. (See page 1-66.)
	Mixed paper sizes?	Punching is not possible when different paper sizes are mixed together.
	Paper is badly curled and the output paper is not punched.	Differences in paper quality and type may result in bad curling of output paper. Take the paper out of the tray or Bypass Tray, turn it around, and reload it so that the top and bottom edges are reversed.

* When a hole Punch Module is installed









Stapling position quick reference guide for duplex output

The orientation of the copy paper, original, scanned original data, and binding position selection are all interrelated. The table below shows these relationships.

		Orientation of original or original data			Output result	
		Page 1	Page 2	Page 1 & Page 2 Duplexed	One-position stapling	Two-position stapling
Portrait orientation printing	Left binding					
	Top binding					<p>Two-position stapling along the shorter edge is not possible.</p>
	Right binding					<p>Two-position stapling along the shorter edge is not possible.</p>
Landscape orientation printing	Left binding					<p>Left binding with two-position stapling is not possible.</p>
	Top binding					<p>Two-position stapling along the shorter edge is not possible.</p>
	Right binding					<p>Right binding with two-position stapling is not possible.</p>

Relation between print image and saddle stitch

The orientation of the copy paper, original, scanned original data, and binding position selection are all interrelated. The table below shows these relationships.

		Orientation of original or original data			Output result
Portrait orientation printing	Left binding	Page 1 	Page 2 	Page 1 & Page 2 Duplexed 	
	Right binding	Same as above			
Landscape orientation printing	Left binding	Page 1 	Page 2 	Page 1 & Page 2 Duplexed 	
	Right binding	Same as above			

High Capacity Feeder

The High Capacity Feeder can hold approximately 3,500 sheets (80 g/m² (21 lbs.)) of A4 (8-1/2" x 11") size paper.

(For the types of paper that can be loaded in the High Capacity Feeder, see "High Capacity Feeder" in the tray specifications (page 1-31).)

Part name

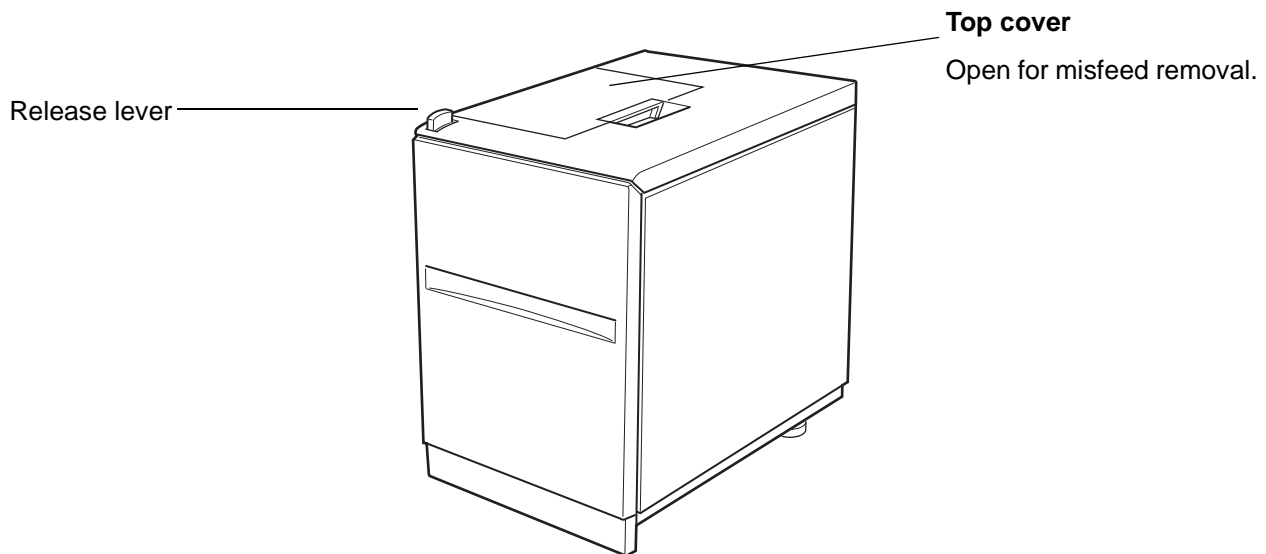

- NOTES:**
- Do not place heavy objects on the High Capacity Feeder or press down hard on the tray.
 - To install the High Capacity Feeder, the optional Duplex Module/2-Tray Unit or the 3-Tray Unit must also be installed.

Loading paper in the High Capacity Feeder

1. Pull the tray out until it stops.

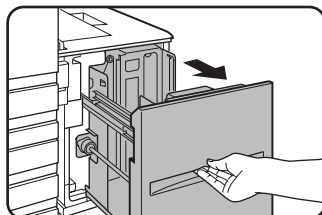

When the tray is in operation, do not use excessive force to pull the tray out. This may damage the tray.

- Place the paper in the centre of the paper table.

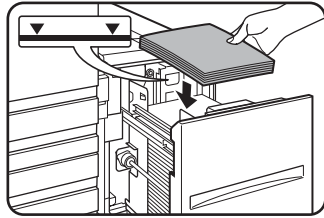

The paper stack must not be higher than the indicator line (up to 3,500 sheets of Xerox standard paper (80 g/m² (21 lbs.))

If the paper type was changed, be sure to change the appropriate settings as explained in "Setting the paper type (except the Bypass Tray)" (See page 1-33).

- Push the tray firmly all the way into the machine.

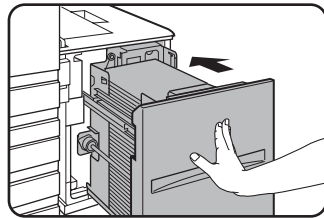

The paper table will automatically rise to the paper feed position.

Misfed in the High Capacity Feeder

When a misfeed occurs in the High Capacity Feeder, remove the misfed paper, following the procedure below.

- While holding the tray release lever, carefully slide the High Capacity Feeder away from the main unit until it stops.

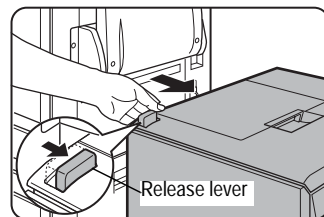

- Remove any misfed paper from the main unit and the High Capacity Feeder.

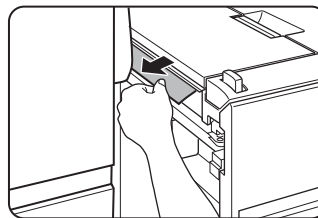
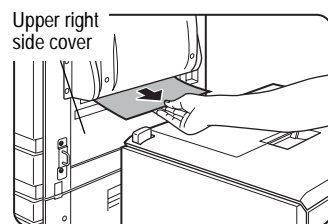

If the misfed paper is stuck inside the machine and cannot be removed, open the side cover and then remove the misfed paper. (See "Misfeed in the transport area, fusing area, and exit area" on page 1-49.)

3. Open the top cover.

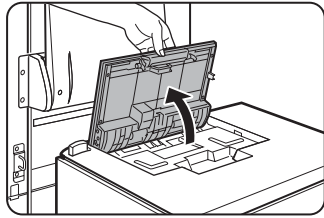

4. Remove the misfed paper.

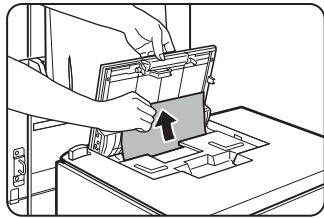

Be sure not to tear the misfed paper during removal.
After removing the misfed paper, close the top cover.

5. Push the High Capacity Feeder towards the main unit and latch it into place.

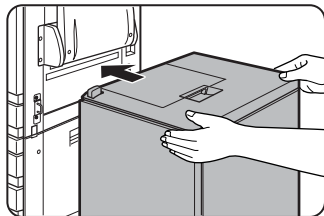

Gently push the High Capacity Feeder back in until it stops.

6. If misfed paper is not found in step 2, pull the tray out.

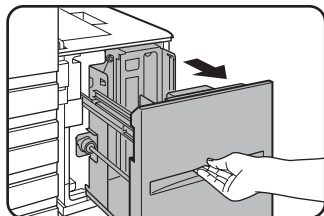

7. Remove the misfed paper.

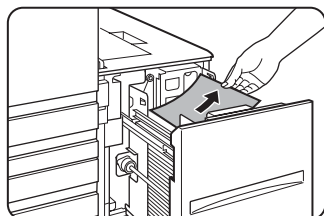

8. Gently push the tray back into place.

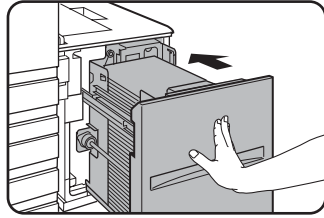

The paper feed table automatically rises to the paper feed position. Make sure that the paper misfeed screen is cleared and the normal message screen appears.

2 Copier Operation

Before Making Copies

This chapter provides basic information necessary for using the copier functions of the machine. Please read this chapter before making copies.

Part Names and Functions (The DADF)

Exterior

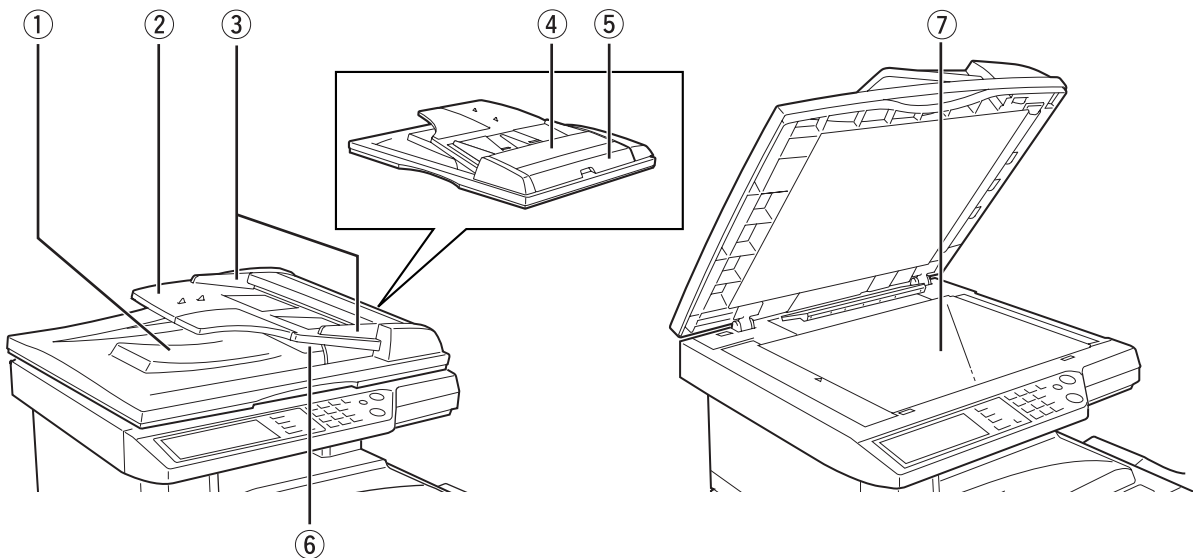

- ① **DADF exit area** Finished originals are output here.
- ② **DADF tray** Set the originals here for automatic feeding (page 2-4).

- ③ **Original guides** Adjust to the size of the originals (page 2-4).
- ④ **Document feeding area cover** Open to remove misfed originals in this area (page 2-79).
- ⑤ **DADF right side cover** Open to remove misfed originals (page 2-79).
- ⑥ **Reversing tray** Pull out to remove misfed originals.
- ⑦ **Document glass** All originals which cannot be copied from the DADF tray must be copied here.

Touch Panel (main screen of copy mode)

The main screen of copy mode shows messages and keys necessary for copying and settings that can be selected. Touch a key to make a selection. The main screen of the copy mode will be displayed when the [COPY] key is pressed.*

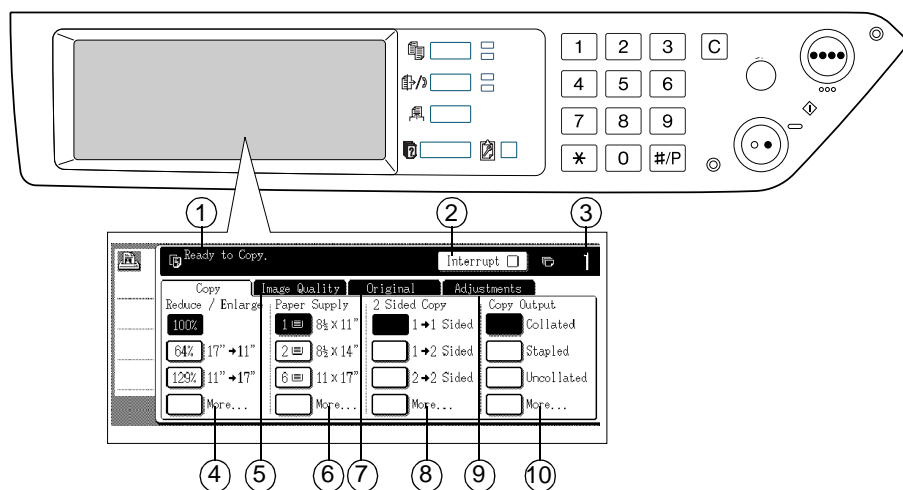

* Except when the custom settings screen is displayed.

The screen at left shows the machine with the Duplex Module/2-Tray Unit and the Duplex Bypass/Inverter Unit installed.

The image will vary depending on the equipment installed.

- ① **Message display** Basic status messages are displayed here.
- ② **[INTERRUPT] key display area** When interrupt copy is available, the [INTERRUPT] key will be displayed here. When an interrupt copy job is being run, a [CANCEL] key will be displayed here to be used for cancelling the interrupt copy job.

- ③ **Copy quantity display** Displays the selected number of copies before the [START] key is pressed or the number of remaining copies after the [START] key is pressed. A single copy can be made when "0" displayed.
- ④ **Copy Ratio display** Use to select the copy ratio (page 2-30).
- ⑤ **Exposure tab** Touch to adjust the copy exposure (page 2-25).
- ⑥ **Paper Select display** Use to select the paper size (page 2-14, 2-22). The display shows the location of the paper trays, the size of the paper in the trays and the approximate amount of paper loaded in each tray. The approximate amount of paper in a tray is indicated by .
- ⑦ **Original tab** Touch this tab to manually enter the original size (page 2-8).
- ⑨ **2-Sided Copy display** Use to select the duplex copy mode setting (pages 2-19, 2-24).
- ⑩ **Special Modes tab** Touch to display the Special Modes screen (page 2-37).
- ⑪ **Output display** Use to select sort, group, and staple sort, (pages 2-14, 2-23).

NOTE: *For a description of the Operation Panel, see page 1-14.*

DADF

The DADF can be used to automatically feed originals for continuous copying. Both sides of two-sided sheet originals can be scanned without having to manually turn the originals over. This feature is convenient for making copies of a large number of originals.

Acceptable originals

When the DADF is used, up to 40 originals of the same size can be set in the feeder (maximum stack thickness of 4 mm (11/64"), or 30 originals of weight 90 g/m² (24 lbs.)).

Size and weight of acceptable originals

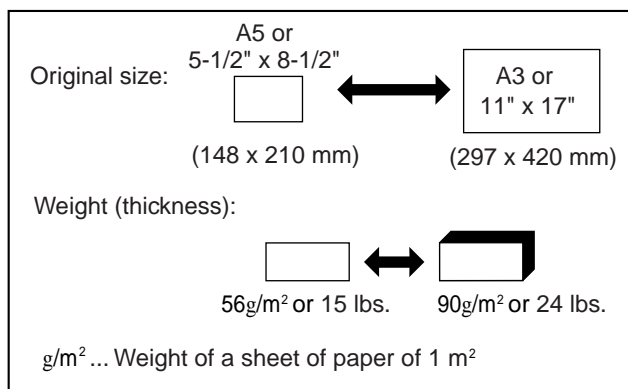

Notes on use of the DADF

- Use originals within the specified size and weight ranges. Use of originals out of the specified range may cause an original misfeed.
- Before loading originals into the DADF tray, be sure to remove any staples or paper clips.
- If originals have damp spots from correction fluid, ink or glue from pasteups, be sure they are dried before they are fed. If not, the interior of the DADF or the document glass may be soiled.
- To prevent incorrect original size detection, original misfeeds or smudges on copies, use the following as a guide for feeding originals.

Transparency film, tracing paper, carbon paper, thermal paper or originals printed with thermal transfer ink ribbon should not be fed through the DADF. Originals to be fed through the feeder should not be damaged, crumpled or folded or have loosely pasted paper on them or cutouts in them.

Setting Originals

When using the DADF

1. Adjust the original guides to the size of the originals.

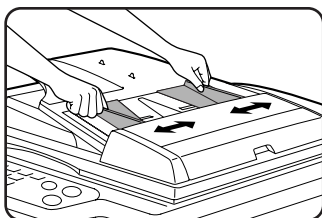

- Place the originals face up in the DADF tray.

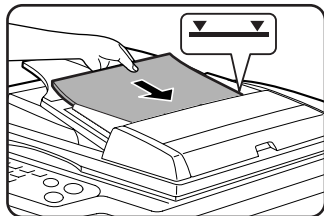

Set the originals all the way into the feed slot. Do not exceed the maximum height line marked on the original guide.

When using the document glass

Open the document cover, place the original face down on the document glass, and then gently close the document cover.

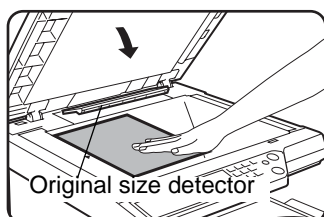

- NOTES:**
- Do not place any objects under the original size detector, because they may damage it or the original size may not be detected properly.
 - If an original has been placed in the DADF tray of the DADF, remove it. Otherwise the original in the DADF tray will be scanned instead of the original on the document glass.

[How to place the original]

Place the original in the appropriate position shown below according to its size. (Centre the original on the centring scale.)

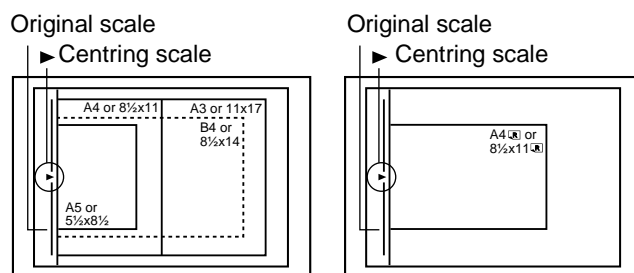

NOTE: Original size detection function

One of the four groups of standard original sizes shown below can be selected for detection by the original size detection function. The factory default setting is "AB-1 (INCH-1)". The setting can be changed using "Original size detector setting" in the key operator programs.

	Group	Detectable original sizes
		DADF tray (for reversing single pass feeding) or document glass
1	INCH - 1	11" x 17", 8-1/2" x 14", 8-1/2" x 11", 8-1/2" x 11"R, 5-1/2" x 8-1/2"*
2	INCH - 2	11" x 17", 8-1/2" x 13", 8-1/2" x 11", 8-1/2" x 11"R, 5-1/2" x 8-1/2"*
3	AB - 1	A3, A4, A4R, A5, B4, B5, B5R
4	AB - 2	A3, A4, A4R, A5, B5, B5R, 8-1/2" x 13"

* When the DADF is used, these sizes are only supported for one-sided originals.

Standard original setting orientation

Place originals in the DADF tray or on the document glass so that the top and bottom of the original is positioned as shown in the illustration. If not, staples will be incorrectly positioned and some special features may not give the expected result.

[Example 1]

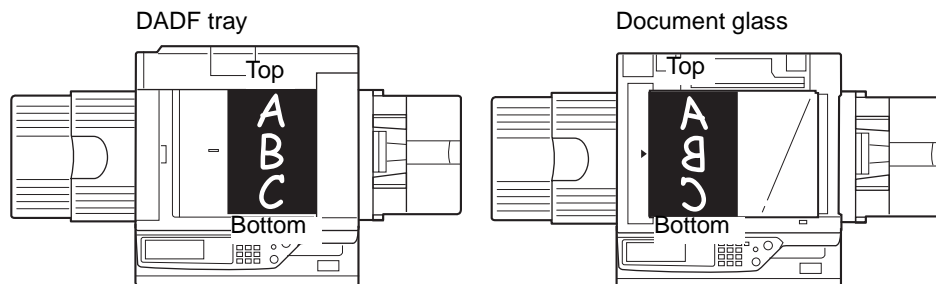

[Example 2]

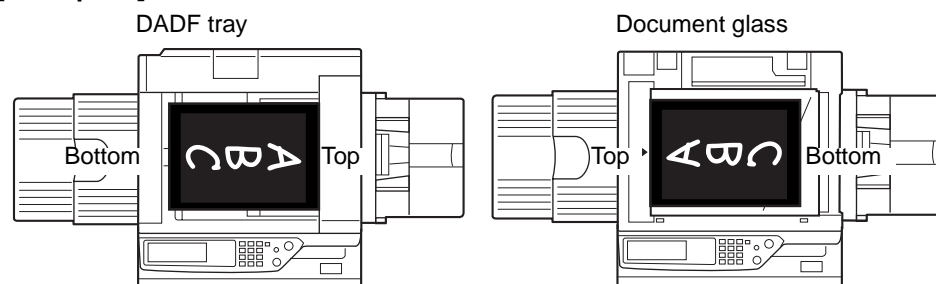

*When the original is placed as shown in example 2 and stapling is to be performed, orient the top of the original as shown below.

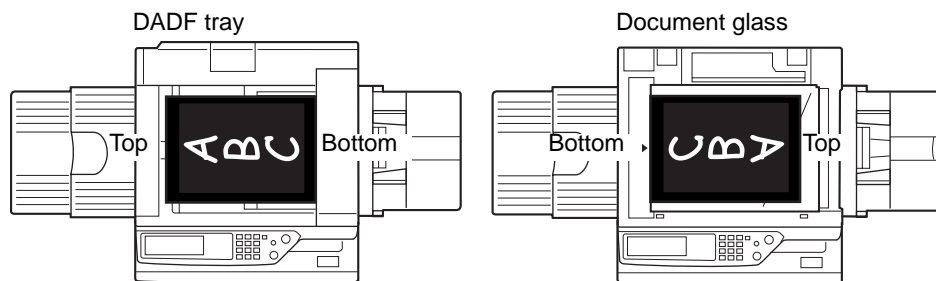

Automatic copy image rotation - rotation copying

If the orientation of the originals and copy paper are different, the original image will be automatically rotated 90° and copied. (When an image is rotated, a message will be displayed.) If a function is selected that is not suitable for rotation, such as enlarging the copy to greater than A4 (8-1/2" x 11") size or staple sorting with the Saddle Stitch Finisher, rotation will not be possible.

[Example]

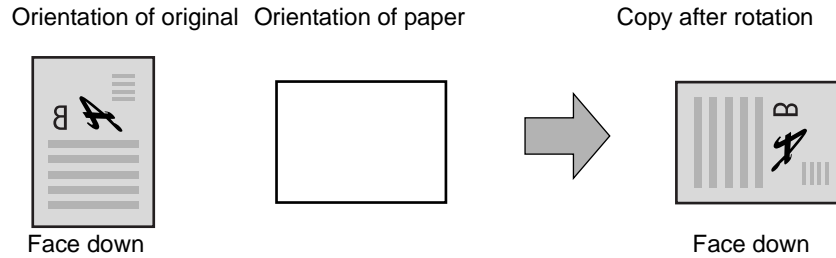

This function operates in both the auto paper select or auto image mode. (Rotation copying can be disabled with a key operator program.)

Selecting the Original Size

When the correct original size is not detected or the original size is not displayed, you can manually specify the original size.

By causing the machine to recognize the original size, you can have the automatic ratio selection function (page 2-28) automatically set a suitable enlargement or reduction ratio for the selected paper size.

Place the original in the DADF tray or on the document glass and then follow the steps below.

1. Touch the Original tab.

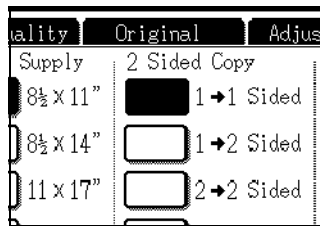

2. Enter the original size.

If the original size is a standard size, touch the appropriate original size key.

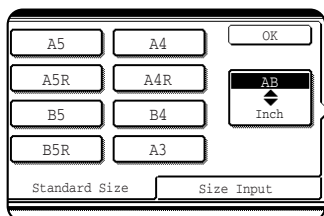

[MANUAL] and the original size key you touched are highlighted.

If you wish to select an inch size, touch the [AB/INCH] key and then touch the desired original size key.

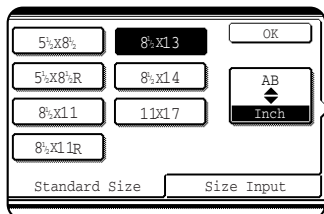

[INCH] is highlighted and inch size keys are displayed. To return to the AB palette, touch the [AB/INCH] key once again.

If the original size is a non-standard size, touch the [SIZE INPUT] tab and then enter the X (width) and Y (length) dimensions of the original with the ▲ or ▼ key.

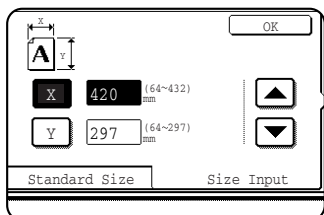

The X dimension (width) is initially selected.

Touch the Y (Y) key and enter the Y dimension (length).

The range of original sizes that can be entered is as follows.

	Using the DADF	Using the document glass
X (horizontal direction)	143 to 432 mm (5-3/4" to 17")	64 to 432 mm (2-1/2" to 17")
Y (vertical direction)	130 to 297 mm (5-1/8" to 11-3/4")	64 to 297 mm (2-1/2" to 11-3/4")

3. Touch the [OK] key.

You will return to the initial screen.

Storing, Deleting, and Using Original Sizes

Up to 9 special original sizes can be stored. Stored sizes can be easily called up and are not erased if the power is turned off. Storing a frequently used original size saves you the trouble of manually setting the size each time you copy that size of document.

To cancel an original size storing, using, or deleting operation, press the [CLEAR ALL] key.

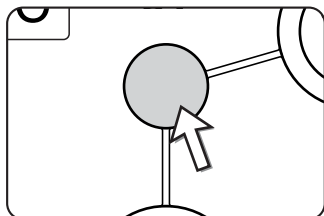

Storing or deleting an original size

1. Touch the Original tab.

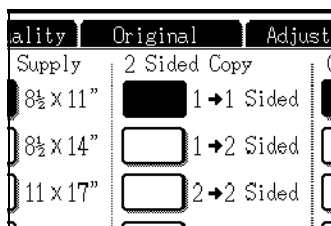

2. Touch the [CUSTOM SIZE] key.

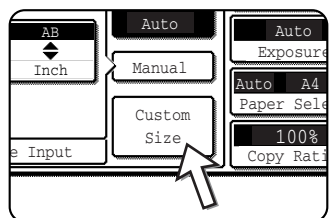

3. Touch the [STORE/DELETE] key.

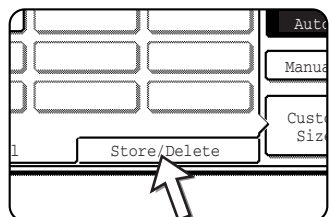

4. Touch the original size key () that you wish to store or delete.

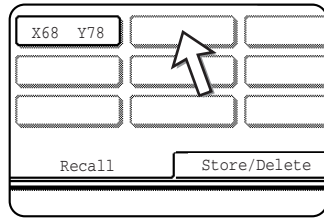

To store an original size, touch a key that does not show a size ().

Keys that already have an original size stored will show the stored size (X68 Y78).

To delete or change a stored size, touch the key that shows the size that you wish to delete or change.

- If you are storing an original size, go to step 5.
- To delete or change an original size, go to step 7.

5. Enter the X (width) and Y (length) dimensions of the original with the keys.

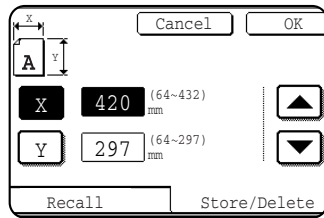

X (width) is initially selected.

Enter X and then touch the () key to enter Y. A width of 64 to 432 mm can be entered in X, and a length of 64 to 297 mm can be entered in Y.

6. Touch the [OK] key.

The original size entered in step 5 is stored in the key selected in step 4.

To exit, touch the [OK] key.

7. When you touch a key that shows an original size in step 4, a message screen appears that contains the keys [CANCEL], [DELETE], and [STORE].

- To cancel the procedure, touch the [CANCEL] key.
- To delete the selected original size, touch the [DELETE] key.
- To change the original size stored in the key, touch the [STORE] key. The screen of step 5 will appear to let you change the size.

8. To exit, touch the [OK] key.

Using a Stored Original Size

1. Follow steps 1 to 2 of “Storing or deleting an original size”.
2. Touch the original size key that you wish to use.

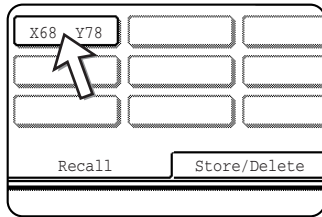

3. Touch the [OK] key.
The stored original size is called up.

Basic Procedure for Making Copies

This section explains the procedures for using basic copy functions, including making normal copies and enlarging/reducing copies.

Normal Copying

This section describes the normal copying procedure.

Copying from the DADF

NOTE: *Certain restrictions exist depending on the amount of memory installed and the copy settings. (See “Copy mode output restrictions” on page 2-16 and “Guidelines for the number of scannable originals during sort copying” on page 2-17.)*

1-sided copies of 1-sided originals

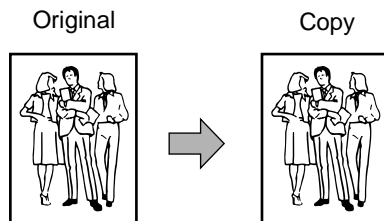

1. Place the originals in the DADF tray. (pages 2-4 to 2-10)

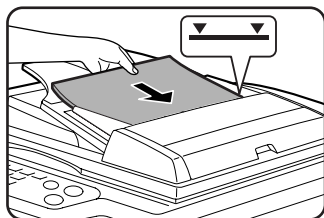

2. Ensure that the 1 → 1 Sided copy mode is selected.

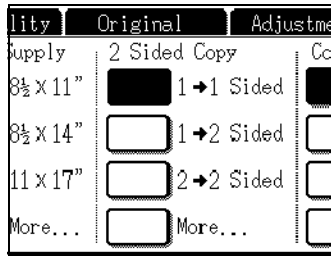

3. Ensure that paper of the same size as the originals is automatically selected.
(*Note)

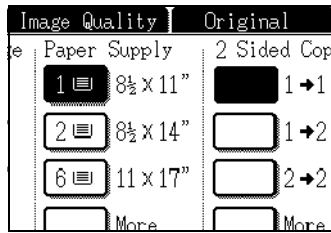

The selected tray will be highlighted or the message "LOAD xxxxxx PAPER." will appear. If the message appears, load paper in a paper tray with paper of the required size.

Even if the message above is displayed, copying can be performed onto the currently selected paper.

(*Note) The following requirements must be satisfied:

Originals of a standard size (A3, B4, A4, A4R, B5, B5R or A5 (11" x 17", 8-1/2" x 14", 8-1/2" x 11", 8-1/2" x 11"R or 5-1/2" x 8-1/2")) are set and the auto paper select function is enabled.

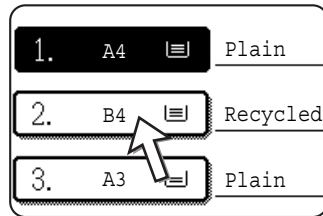

If originals of a size other than the sizes above are to be copied, manually select the desired paper size by touching the [More...] key in the Paper Select display, and then touching the desired paper size selection key.

The selected key will be highlighted and the paper selection screen will close. To close the paper selection screen without making a selection, touch the [OK] key.

4. Select the desired output mode (see page 2-18).

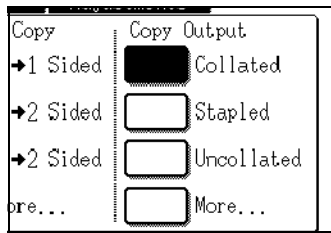

The sort mode is the default mode.

5. Use the numeric keys to set the desired number of copies.

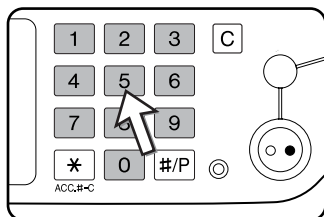

Up to 999 can be set.

If you are only making a single copy, the copy can be made with the copy number display showing "0". Use the [C] (clear) key to cancel an entry if a mistake has been made.

6. Press the [COLOUR COPY START (●●●●)] or [BLACK COPY START (○●)] key.

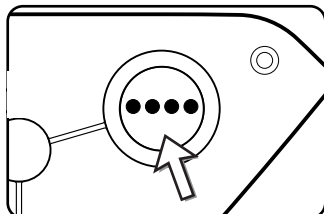

If the [C] key is pressed while originals are being scanned, scanning will stop. If copying had already started, copying and scanning will stop after the original in progress is output to the original exit area. In these cases the copy quantity will be reset to "0".

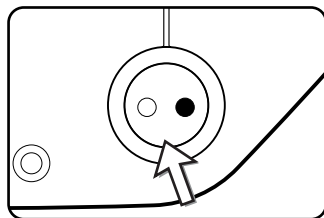

NOTE: The 1-sided to 1-sided copying mode is set as the default in the initial settings.

Copy mode output restrictions

			No added memory		Memory added (128 MB or 256 MB)	
Two-sided copying mode	Output mode	original/paper size	Sort	Group	Sort	Group
One-sided copying	Colour copying	Up to A3 (11" x 17")	○			
		A3W (12" x 18")*	○			
	Black and white copying	Up to A3 (11" x 17")	○			
		A3W (12" x 18")*	○			
Auto-matic two-sided copying	Colour copying	Up to A4 (8-1/2" x 11")	○			
		B4, A3 (8-1/2" x 14", 11" x 17")	○	×	○	
		A3W (12" x 18")*	×			
	Black and white copying	Up to A3 (11" x 17")	○			
		A3W (12" x 18")*	×			





○: Copying possible using selected settings ×: Copying not possible

* The DADF cannot be used to copy an A3W (12" x 18") size original.

Guidelines for the number of scannable originals during sort copying

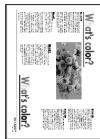
When using sort copy mode, the number of pages shown in the table below will all be scanned into memory and the set number of copies made.

(Note that the numbers shown below are general guidelines. The actual number of original pages that can be scanned into memory will vary depending on the content of the originals.)

Output mode	Original type	Original size	No added memory	Added memory	
				128 MB	256 MB
Colour copying	Full colour original (mostly text) 	Up to A4 (8-1/2" x 11")	100	180	
		B4, A3 (8-1/2" x 14", 11" x 17")	50	90	
		A3W (12" x 18")	41	74	
	Full colour original (text and photos) 	Up to A4 (8-1/2" x 11")	37	64	
		B4, A3 (8-1/2" x 14", 11" x 17")	18	32	
		A3W (12" x 18")	15	26	
	Full colour original (photo) 	Up to A4 (8-1/2" x 11")	21	37	
		B4, A3 (8-1/2" x 14", 11" x 17")	10	18	
		A3W (12" x 18")	8	15	
Black and white copying	Text original 	Up to A4 (8-1/2" x 11")	400	680	
		B4, A3 (8-1/2" x 14", 11" x 17")	200	340	
		A3W (12" x 18")	165	280	

Copy output (sort and group)

1. Place your original onto the document glass or the DADF tray.
2. On the numeric keys, enter the desired number of copies (<n>).
3. In the Output display, touch the [SORT] key or the [GROUP] key.

- NOTE:**
- "Sort" is automatically selected when the original is placed on the DADF tray of the DADF.
 - "Group" is automatically selected when the original is placed on the document glass.
4. Press the [COLOUR COPY START] key or the [BLACK COPY START] key.

Your copies are printed.

- If "Sort" was selected, <n> sets of copies will print.
- If "Group" was selected, <n> copies of each page will print.

About the offset function

This function offsets each set of copies from the previous set in the output tray, making it easy to separate sets of copies.

(Offset can function for output to the centre tray or in the offset tray of the Saddle Stitch Finisher.)

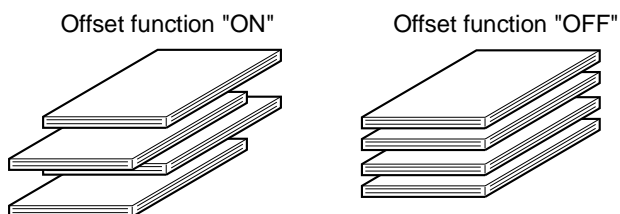

1. Touch the [More...] key in the Output display.

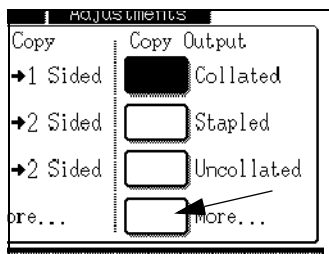

2. Touch [CENTRE TRAY].

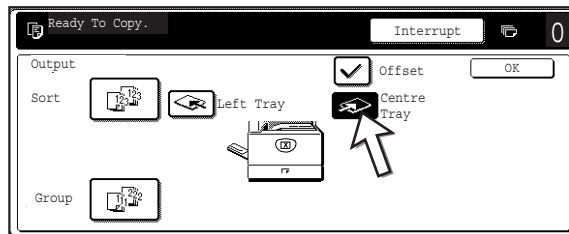

3. Touch [OFFSET].
4. Touch [OK].

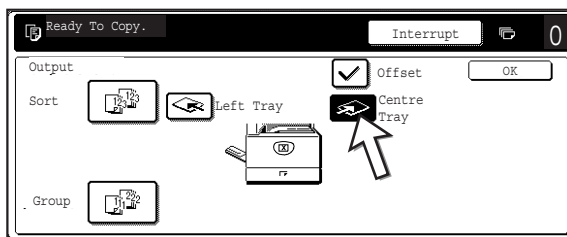

Selecting the output tray

When the [LEFT TRAY] key in the above illustration is highlighted, copies are output to the tray on the left side of the machine (the left tray). When the [CENTRE TRAY] key is highlighted, copies are output to the centre tray. Touch the key of the tray you wish to use for copy output.

Turning on the offset function

The offset function operates when a checkmark appears in the [OFFSET] checkbox, which is displayed by touching the [CENTRE TRAY] key. (If a checkmark doesn't appear, touch the checkbox.)

Offset width: Approximately 30 mm (1-3/10")

(A3W (12" x 18") paper cannot be offset.)

Automatic two-sided copying from the DADF

When a Duplex Module/2-Tray Unit and a Duplex Bypass/Inverter Unit are installed, the following automatic two-sided copy functions are possible. The copy paper is turned over automatically, allowing easy two-sided copying.

NOTE: *Certain restrictions exist depending on the amount of memory installed and the copy settings. (See "Copy mode output restrictions" on page 2-16 and "Guidelines for the number of scannable originals during sort copying" on page 2-17.)*

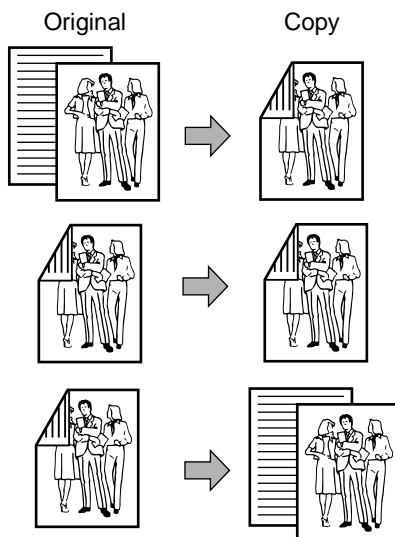

The following two-sided modes can be selected

1. Automatic two-sided copying from one-sided originals
 2. Automatic two-sided copying from two-sided originals
 3. Automatic one-sided copying from two-sided originals
- This function can be used even if a Duplex Module/2-Tray Unit and/or a Duplex Bypass/ Inverter Unit are not installed.

1. Place the originals in the DADF tray. (pages 2-4 to 2-10)
2. In the 2-Sided Copy display, select a duplex copy mode.

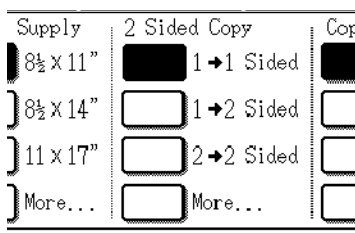

Note: If 2 → 1 Sided copy mode is desired, you must first touch the [More...] key.

3. Select the desired duplex copy mode.

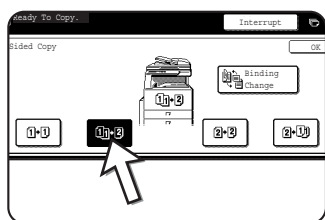

The left screen shows the display when a DADF, a Duplex Module/2-Tray Unit, and a Duplex Bypass/ Inverter Unit are installed. The display will vary depending on the equipment installed.

If a copy key is touched for a mode that cannot be selected, a double beep will be sounded.

Example of a portrait-oriented original

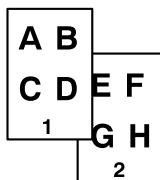

Example of a landscape-oriented original

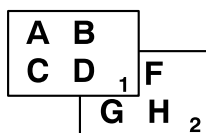

4. The image to be copied onto the second side of 2-sided copies can be inverted so that the resultant 2-sided copies are in the correct orientation for binding at the top. For top binding, touch the [BINDING CHANGE] key on the 2-sided copy selection screen.
5. Touch the [OK] key.

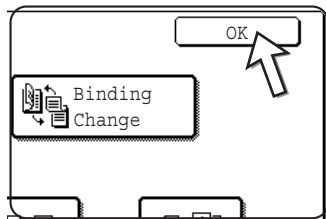

Make selections and proceed as in steps 3 to 6 on pages 2-14 and 2-15.

Copying from the document glass

When copying originals which cannot be fed from the DADF such as thick originals, open the document cover and copy the originals from the document glass.

NOTE: *Certain restrictions exist depending on the amount of memory installed and the copy settings. (See "Copy mode output restrictions" on page 2-16 and "Guidelines for the number of scannable originals during sort copying" on page 2-17.)*

1-sided copies of 1-sided originals

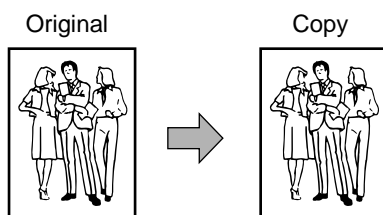

1. Set an original on the document glass (pages 2-4 to 2-10).

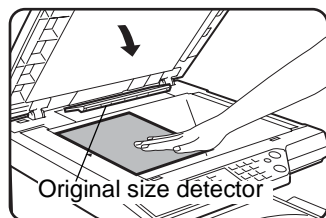

NOTE: *Do not place any objects under the original size detector, because they may damage it or the original size may not be detected properly.*

[How to place the original]

Place the original in the appropriate position shown below according to its size.

(▶ Centre the original on the centring scale.)

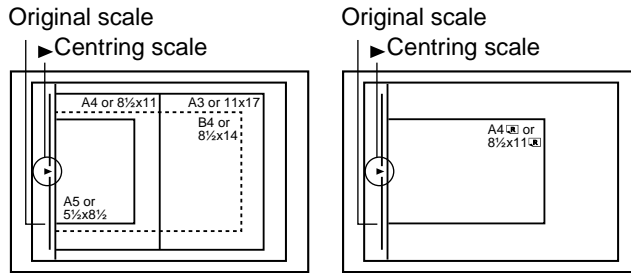

2. Ensure that the 1 → 1 Sided copy mode is selected.

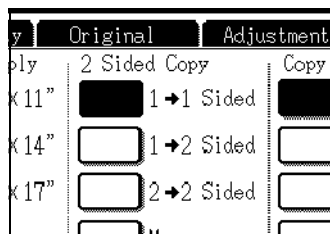

3. Ensure that paper of the same size as the original is automatically selected (set on the Original tab). (See note*.)

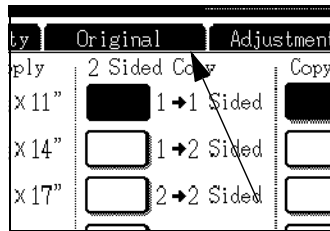

The selected tray will be highlighted or the message "LOAD xxxxxx PAPER." will appear. If the message appears, load paper in a paper tray with paper of the required size. Even if the message above is displayed, copying can be performed onto the currently selected paper.

(*Note) The following requirements must be satisfied:

Originals of a standard size (A3, B4, A4, A4R, B5, B5R or A5 (11" x 17", 8-1/2" x 14", 8-1/2" x 11", 8-1/2" x 11"R or 5-1/2" x 8-1/2")) are set and the auto paper select function is enabled.

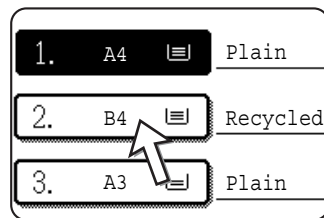

If originals of a size other than the sizes above are to be copied, manually select the desired paper size by touching the [More...] key in the Paper Select display, and then touching the desired paper size selection key.

The selected key will be highlighted and the paper selection screen will close. To close the paper selection screen without making a selection, touch the [OK] key.

4. Select the desired output mode. (See page 2-18.)

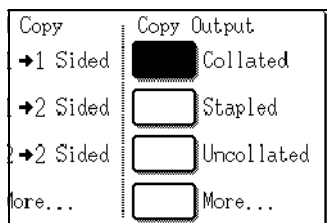

When a document is detected on the document glass, the group mode will be automatically selected.

To select sort copy, touch the [More...] key in the Output display, then touch the [SORT] key on the displayed screen, and then touch the [OK] key.

NOTE: If the [SORT] or [GROUP] key is touched, its corresponding icon is highlighted. To clear the icon display, press the [CLEAR ALL] key. Note that all selections made to that point will be cancelled.

5. Use the numeric keys to set the desired number of copies.

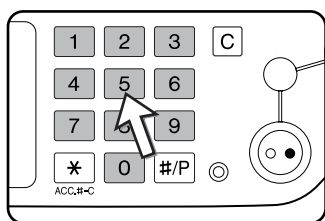

Up to 999 can be set.

If you are only making a single copy, the copy can be made with the copy number display showing "0".

Use the [C] (clear) key to cancel an entry if a mistake has been made.

6. Press the [COLOUR COPY START (●●●●)] or [BLACK COPY START (○●)] key.

Replace the original with the next original and press the [START] key. Repeat this operation until all originals have been scanned.

7. Touch the [READ-END] key.

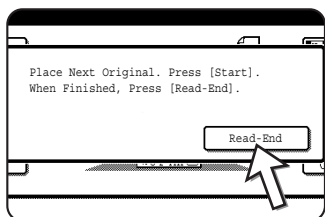

If you selected "Sort" for the output in step 4, it is necessary to touch the [READ-END] key.

Automatic two-sided copying from the document glass

When a Duplex Module/2-Tray Unit and a Duplex Bypass/Inverter Unit are installed, the following automatic two-sided copy function is possible. The copy paper is turned over automatically, allowing easy two-sided copying.

NOTE: *Certain restrictions exist depending on the amount of memory installed and the copy settings. (See “Copy mode output restrictions” on page 2-16 and “Guidelines for the number of scannable originals during sort copying” on page 2-17.)*

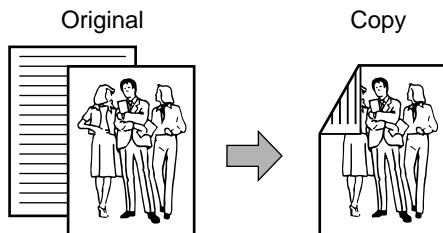

1. Place an original on the document glass. (pages 2-4 to 2-10)
2. On the 2-Sided Copy display, touch the [2 → 2 SIDED COPY] key.

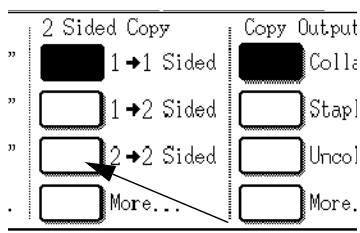

3. In the 2-Sided Copy display, touch the [1 → 2 Sided] key.

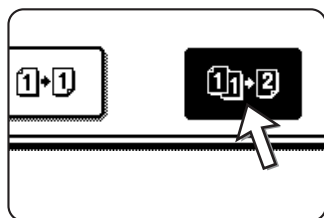

Example of a portrait-oriented original

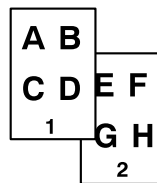

Example of a landscape-oriented original

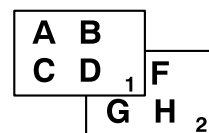

When making automatic two-sided copies of a one-sided A3 (11" x 17") or B4 (8-1/2" x 14") size portrait original, or when the front and back side of a two-sided original are copied backwards:

- a) In the 2-Sided Copy display, touch the [More...] key.
- b) Touch the [BINDING CHANGE] key.

4. Touch the [OK] key.

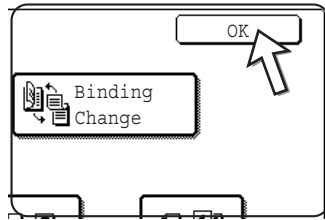

Make selections and proceed as in steps 3 to 7 on pages 2-22 and 2-23.

Exposure Adjustments

This copier has seven exposure modes to choose from: AUTO, TEXT/PRTD. PHOTO, TEXT/PHOTO, TEXT, PHOTO, PRINTED PHOTO and MAP.

[AUTO]

This is the standard initial setting for this copier. When a black and white copy is made, the exposure is automatically adjusted to obtain the best image quality. When a full-colour copy is made, the image is adjusted in the same way as when [TEXT/PRTD.PHOTO] (initial settings) is selected.

[TEXT/PRTD. PHOTO, TEXT/PHOTO, TEXT, PHOTO, PRINTED PHOTO and MAP.]

The exposure can be manually adjusted in 9 steps.

1. Touch the Exposure tab.

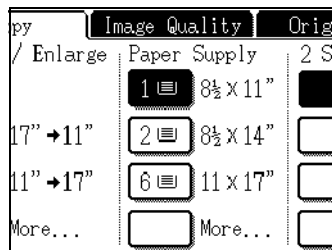

2. Select [AUTO], [TEXT/PRTD. PHOTO], [TEXT/PHOTO], [TEXT], [PHOTO], [PRINTED PHOTO], or [MAP] depending upon the original type.

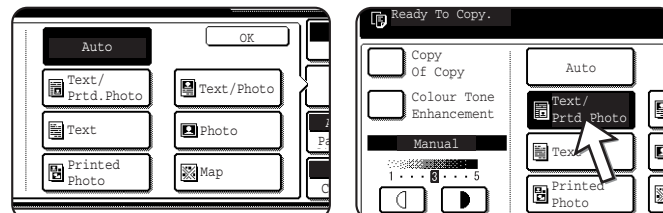

Example:

The [TEXT/PRTD.PHOTO] key is selected.

NOTES: • **Selecting the resolution**

Six resolution settings are available for both colour copying and black and white copying, depending on the contents of the original.

Original type	Contents of the original
AUTO	Normally this setting is selected. When a black and white copy is made, the exposure is automatically adjusted to obtain the best image quality. When a full-colour copy is made, the image is adjusted in the same way as when [TEXT/PRTD.PHOTO] (initial settings) below is selected.
TEXT/PRTD. PHOTO	This mode provides the best balance for copying an original which contains both text and printed photographs.
TEXT/PHOTO	This mode provides the best balance for copying an original which contains both text and photographs.
TEXT	This mode is useful in enhancing very low density areas of an original or in suppressing unusually high-density background areas.
PHOTO	This mode provides the best copies of photographs with fine details.
PRINTED PHOTO	This mode is useful for copying printed photographs.
MAP	This mode is useful to provide the best shading and fine details found on most maps.

- **Making a copy of a copy**

When making a copy of a copy made on this machine, touch the checkbox for COPY OF COPY to select the mode. Three resolution settings are available when this mode is selected: "TEXT/PRINTED PHOTO", "TEXT", and "PRINTED PHOTO".

- For brighter colours in colour copies, touch the COLOUR TONE ENHANCEMENT checkbox. The following restrictions apply when colour tone enhancement is selected:

Colour tone enhancement cannot be selected at the same time as COPY OF COPY mode (above).

Brightness adjustment (page 2-57) and single colour copying (page 2-60) are not possible.

The DADF cannot be used. (It can be used when making black and white copies.)

3. If a setting other than "AUTO" has been selected in step 2, manually adjust the copy exposure.

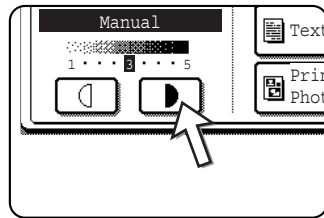

Touch the  key to make darker copies.

Touch the  key to make lighter copies.

NOTES:

- Recommended exposure levels for the text mode
 - 1 to 2: Dark originals such as newspaper
 - 3: Normal density originals
 - 4 to 5: Originals written with pencils or light colour characters
- Colour adjustment menu

As special functions for colour copying, the following colour image adjustments can be made (page 2-51).

 - RGB ADJUST
 - SHARPNESS
 - SUPPRESS BACKGROUND
 - COLOUR BALANCE
 - BRIGHTNESS
 - INTENSITY

4. Use the numeric keys to set the desired number of copies.

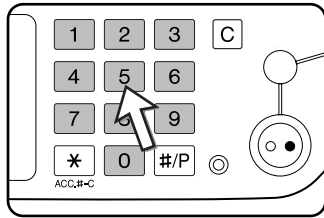

5. Press the [Colour Copy Start (●●●●)] or [Black Copy Start (○●)] key.

To return to the automatic exposure mode, touch the Exposure tab and select [AUTO].

NOTE: *The exposure level for automatic exposure adjustment can be changed using the "Image quality adjustment" key operator program.*

Reduction/Enlargement/Zoom

Reduction and enlargement ratios can be selected either automatically or manually as described in this section.

Automatic selection (auto image)

The reduction or enlargement ratio will be selected automatically based on the original size and the selected paper size.

1. Place the original in the DADF tray or on the document glass (pages 2-4 to 2-10).

NOTE: *Automatic ratio adjustment can only be used for the following original and paper sizes. It cannot be used for other sizes. However, in the case of non-standard original and paper sizes, the sizes can be entered to make automatic ratio adjustment possible for those sizes. (page 2-8)*

Original sizes: A3, B4, A4, A4R, B5, B5R, A5 (11" x 17", 8-1/2" x 14", 8-1/2" x 11", 8-1/2" x 11"R, 5-1/2" x 8-1/2")

Paper size: A3, B4, A4, A4R, B5, A5 (11" x 17", 8-1/2" x 14", 8-1/2" x 13", 8-1/2" x 11", 8-1/2" x 11"R, 5-1/2" x 8-1/2")

- Touch the appropriate key in the Paper Select display to select the desired paper size.

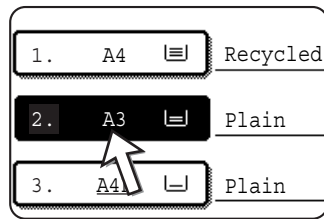

NOTE: *If paper of the desired size is not loaded in any tray, load paper of the required size in a paper tray or the Bypass Tray.*

- On the Copy Ratio display, touch the [More...] key.

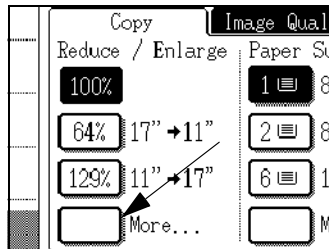

- Touch the [AUTO IMAGE] key.
- Touch [OK].

The [AUTO IMAGE] key will be highlighted and the best reduction or enlargement ratio for the original size and the selected paper size will be selected and displayed in the copy ratio display.

NOTE: *If the message "ROTATE ORIGINAL FROM [Portrait] TO [Landscape]" is displayed, change the orientation of the original as indicated in the message. When the message above is displayed, copying can be done without changing the orientation, but the image will not fit the paper correctly.*

- Use the numeric keys to set the desired number of copies.

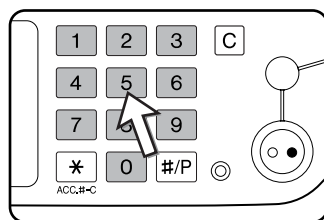

Up to 999 can be set.

If you are only making a single copy, the copy can be made with the copy number display showing "0".

Use the [C] (clear) key to cancel an entry if a mistake has been made.

- Press the [COLOUR COPY START (●●●●)] or [BLACK COPY START (○●)] key.

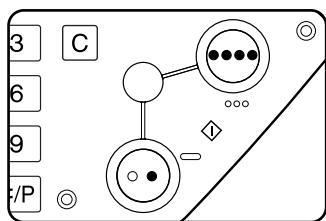

If you placed the original on the document glass, set the output to "Sort", you must touch the [READ-END] key after all pages of the original have been scanned (step 7 on page 2-23).

To cancel the auto image mode, touch [More...] on the Copy Ratio display, then touch the [AUTO IMAGE] key again to clear the highlighted display.

Manual selection

The preset ratios (maximum 400%, minimum 25%) can be selected with the enlargement and reduction keys. In addition, the zoom keys can be used to select any ratio from 50% to 200% in increments of 1%.

NOTE: When the DADF is used, the ratio can only be set within the range 50% to 200%.

- Place the original in the DADF tray or on the document glass (pages 2-4 to 2-10).
- Touch the [More...] key in the Copy Ratio display.

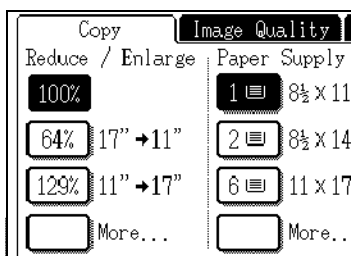

- Use the [MENU] key to select menu "1" or menu "2" for copy ratio selection.

Menu 1

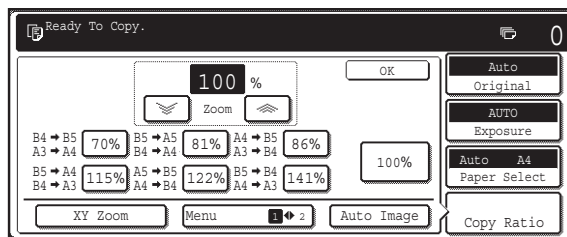

- A. Preset reduction copy ratios are: 70%, 81% and 86% (for the AB system). 77% and 64% (for the inch system).
- B. Preset enlargement copy ratios are: 115, 122% and 141% (for the AB system). 121% and 129% (for the inch system).

Menu 2

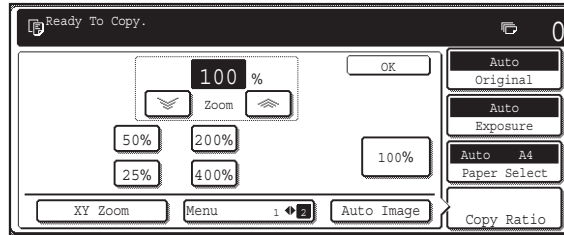

- A. Preset reduction copy ratios are: 50% and 25%*.
- B. Preset enlargement copy ratios are: 200% and 400%*.

* When the DADF is used, the ratio can only be set within the range 50% to 200%.

(The custom ratios set by the key operator appear in ratio menu 2.)

4. Use the reduction, enlargement, and [ZOOM] keys on the touch panel to set the desired copy ratio.

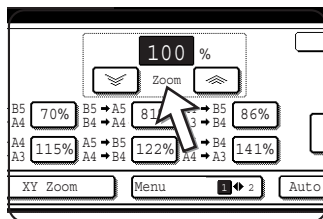
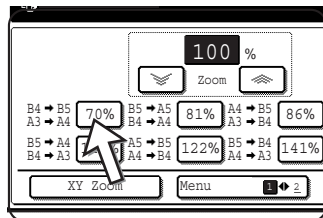

Zoom ratios: Any ratio from 50% to 200% can be set in 1% increments.

Touch the [] key to increase the ratio, or the [] key to decrease the ratio. If you continue to touch either key for 3 seconds, the ratio begins to change quickly.

- NOTES:**
- Touch a reduction or enlargement key to set the approximate ratio, then touch the [] key to decrease the ratio or the [] key to increase the ratio.
 - The message "IMAGE IS LARGER THAN COPY PAPER." may appear, indicating that the selected copy ratio is too large for the copy paper size. However, if you press the [START] key, a copy will be made.
 - To set the horizontal and vertical copy ratios separately, use the XY ZOOM feature. See page 2-33.

5. Ensure that the desired paper size has been automatically selected based on the selected copy ratio or select another size as needed.
6. Touch the [OK] key.

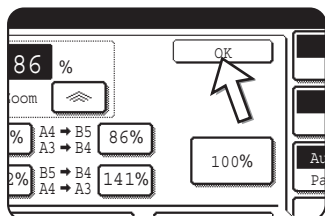

7. Use the numeric keys to set the desired number of copies.

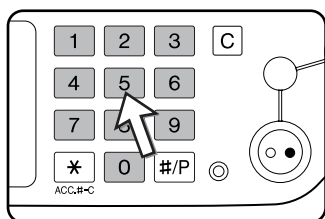

Up to 999 can be set.

If you are only making a single copy, the copy can be made with the copy number display showing "0".

Use the [C] (clear) key to cancel an entry if a mistake has been made.

8. Press the [COLOUR COPY START (●●●●)] or [BLACK COPY START (○●)] key.

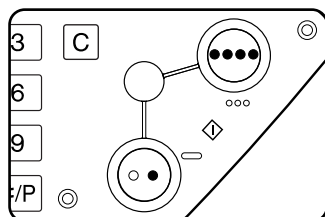

If you placed the original on the document glass, set the output to "Sort", you must touch the [READ-END] key after all pages of the original have been scanned (step 7 on page 2-23).

To return the ratio to 100%

To return the ratio setting to 100%, touch the [100%] key in the Copy Ratio display.

XY Zoom

The XY ZOOM feature allows the horizontal and vertical copy ratios to be changed independently.

The preset ratios (maximum 400%, minimum 25%) can be selected with the enlargement and reduction keys. In addition, the zoom keys can be used to select any ratio from 50% to 200% in increments of 1%.

NOTE: When the DADF is used, the ratio can only be set within the range 50% to 200%.

Example: Selecting 100% for the length and 50% for the width

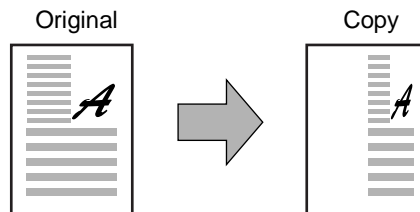

1. Place the original in the DADF tray or on the document glass. (pages 2-4 to 2-10)
2. Touch the [More...] key in the Copy Ratio display on the touch panel.

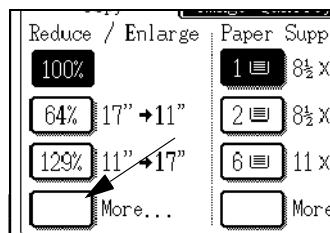

3. Touch the [XY ZOOM] key.

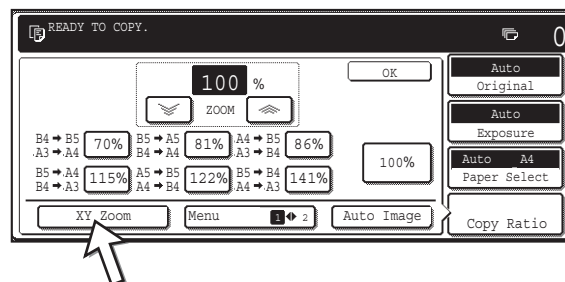

4. Touch the [X] key.

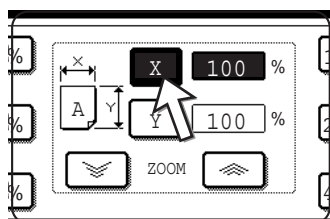

- Use the reduction, enlargement, and ZOOM ([≧], [≦]) keys to change the copy ratio in the horizontal (X) direction.

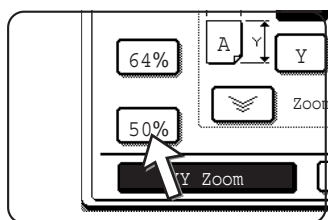

A fixed ratio key will not become highlighted when touched.

When the DADF is used, the ratio can only be set within the range 50% to 200%.

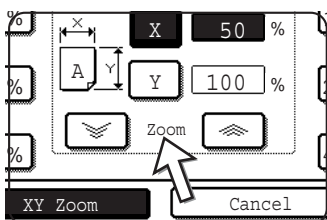

The zoom keys can be used to change the ratio from 50% to 200% in increments of 1%.

Touch the [≧] key to increase the ratio, or the [≦] key to decrease the ratio. If you continue to touch either key for 3 seconds, the ratio begins to change quickly.

NOTE: Touch a reduction key or an enlargement key to set the approximate ratio, then touch the [≧] key to decrease the ratio or [≦] key to increase the ratio.

- Touch the [Y] key.

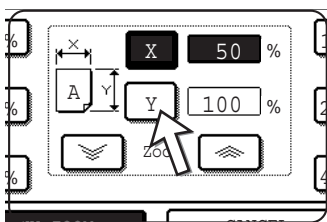

- Use the reduction, enlargement, and ZOOM ([≧], [≦]) keys to change the copy ratio in the vertical (Y) direction as you did for (X) in step 5.

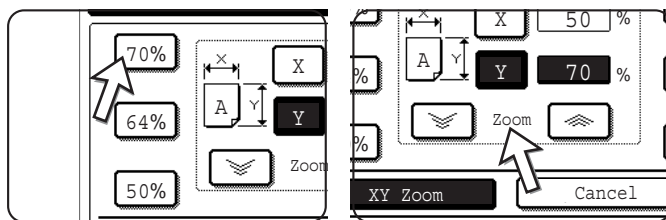

Either copy ratio can be changed for fine-tuning until the next step is performed.

8. Touch the [OK] key.

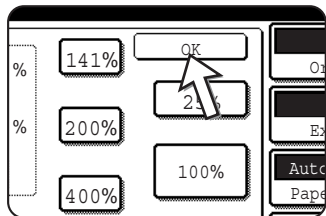

9. In the Paper Select display, select the paper tray with the desired paper size.

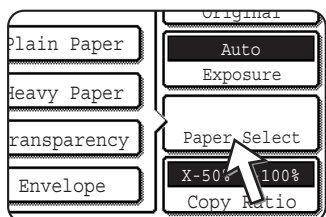

If the AUTO PAPER SELECT mode is on, the appropriate copy paper size will have been automatically selected based on the original size and selected copy ratios.

10. Make all other desired settings such as exposure, paper size and number of copies and then press the [COLOUR COPY START (●●●●)] or [BLACK COPY START (○●)] key.

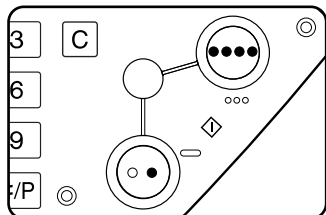

To cancel this function, touch the [CANCEL] key or the [XY ZOOM] key again as in step 3 on page 2-33 or step 5 on page 2-34. This must be done before you touch [OK] in step 8.

Special Papers

Special papers including transparency film, postcards and envelopes must be fed through the Bypass Tray.

1. Place the original in the DADF tray or on the document glass (pages 2-4 to 2-10).

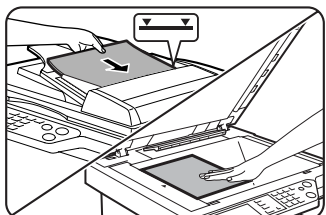

2. Load the special paper in the Bypass Tray.

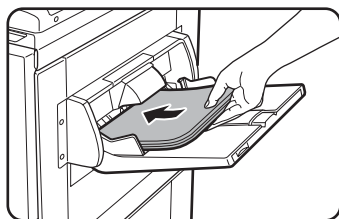

See pages 1-29 and 1-30 for the specifications of paper that can be used in the Bypass Tray.

For the paper loading instructions see "Loading paper in the Bypass Tray" on page 1-23.

3. Touch the [More...] key in the Paper Select display, and then select the Bypass Tray.

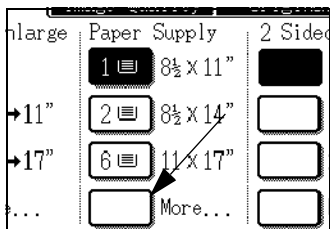

4. Select the type of paper that you inserted in the Bypass Tray.

5. Touch the [OK] key.

6. Make all other desired settings such as exposure or the number of copies, and press the [COLOUR COPY START (●●●●)] or [BLACK COPY START (○●)] key.

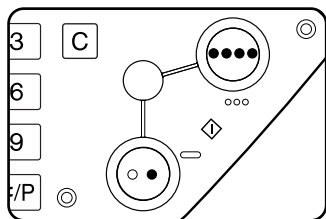

If you placed the original on the document glass, set the output to "Sort", you must touch the [READ-END] key after all pages of the original have been scanned (step 7 on page 2-23).

NOTES:

- **Output location for copies on heavy paper 2, transparencies, and envelopes**
Copies on these types of paper will be output face-up to the tray on the left side of the machine.

They cannot be delivered to the centre tray. Face-down delivery is not possible for these papers.

- **Colour adjustment menu**

As special functions of colour copying, the following colour image adjustments are available (page 2-51).

- RGB ADJUST
- SHARPNESS
- SUPPRESS BACKGROUND
- COLOUR BALANCE
- BRIGHTNESS
- INTENSITY

Convenient Copy Functions

This chapter explains special-purpose functions, storing of copy settings, and other convenient functions. Please select and read sections of this chapter as needed.

Special Modes

When the Special Modes tab on the main screen of copy mode is touched, the SPECIAL MODES screen containing several special function touch keys will appear. These functions are shown below.

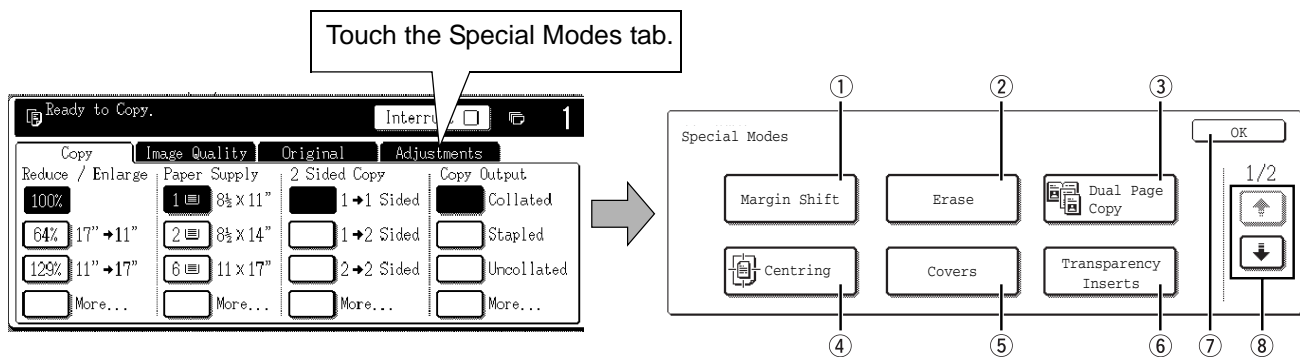

- ① **[MARGIN SHIFT] key** Use this to shift the image on the copy to create binding margins (page 2-39).
- ② **[ERASE] key** Use this to erase peripheral shadows that occur when making copies of books and other thick originals (page 2-41).
- ③ **[DUAL PAGE COPY] key** This is useful to copy the left and right pages of bound documents without shifting the document on the document glass (page 2-42).
- ④ **[CENTRING] key** Use this to centre the copied image on the paper (page 2-44).
- ⑤ **[COVERS] key** Use this to insert a different type of paper for use as front and back covers (page 2-47). (The DADF must be used.)
- ⑥ **[TRANSPARENCY INSERTS] key** When copying onto transparencies, use this to automatically insert a sheet of copy paper between transparency sheets (page 2-45).

⑦ **[OK] key on the special modes screen** Touch the [OK] key to return to the main screen of the copy mode.

⑧ **↑ / ↓ key** Touch these keys to switch between the special modes menu screens. The special modes menu consists of two screens.

Touch the ↓ key ⑧ to switch to the screen below.

The special modes below can be selected in the second screen (2/2).

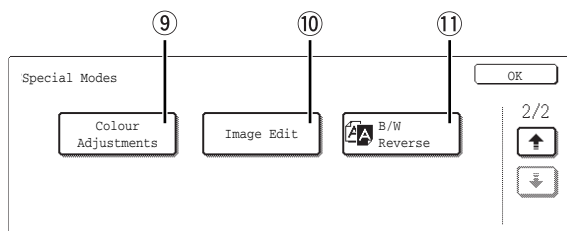

⑨ **[COLOUR ADJUSTMENTS] key** Touch this key to display the colour adjustments menu screen. This allows you to select the special functions shown below for colour adjustment when making colour copies (page 2-51).

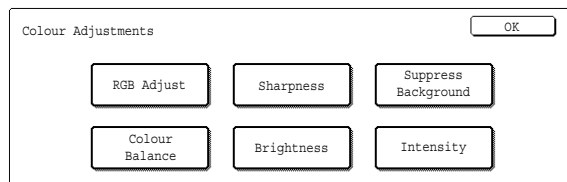

⑩ **[IMAGE EDIT] key** Touch this key to display the image edit menu screen. This allows you to select the special functions shown below for image editing (page 2-59).

⑪ **[B/W REVERSE] key** A copy can be made with black and white reversed (page 2-50). (This function can only be used for black and white copying.)

Common operation procedure for using the special functions

1. Touch the Special Modes tab.

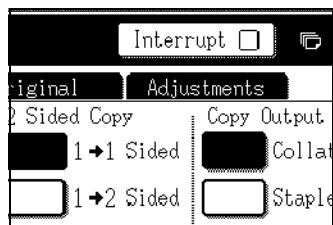

2. Touch the key for the desired special mode.

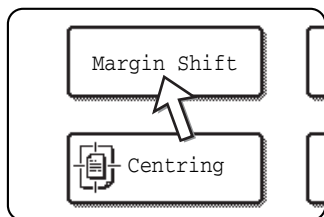

Example:

To set the margin shift function

If you touch the menu keys for colour adjustment or image editing, you will go to the menu screen for selection of the corresponding functions.

Setting procedures for modes requiring setting screens start on page 2-39.

The dual page copy, centring, transparency film with insert sheets, B/W reverse, mirror image and A3 (11" x 17") full-bleed functions do not require setting screens.

Margin shift

The margin shift function will automatically shift the text or image on the copy paper approximately 10 mm (1/2") in its initial setting.

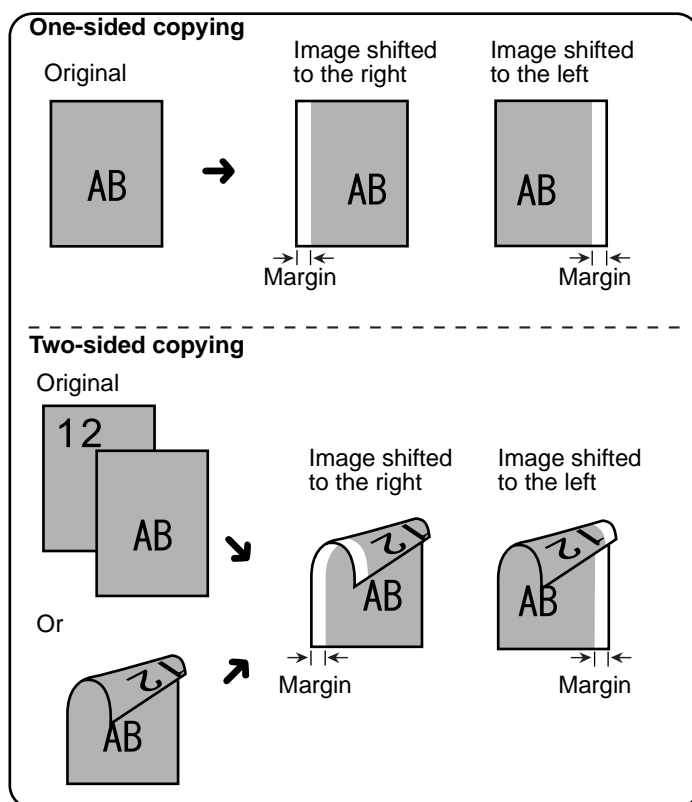

The shift direction can be selected from right or left shift as shown in the illustration.

1. Touch the [MARGIN SHIFT] key on the SPECIAL MODES screen.

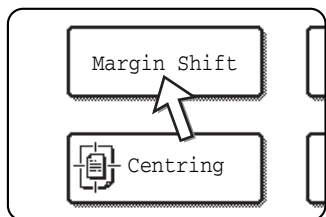

The margin shift setting screen will appear.

The margin shift icon () will also appear in the upper left of the screen to indicate that the function is turned on.

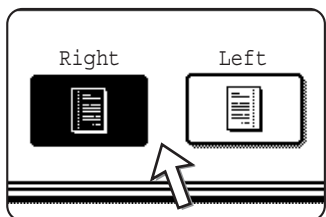

2. Select the shift direction.

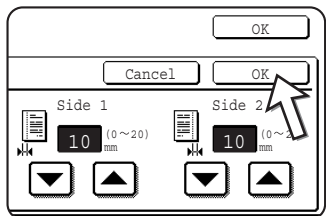

Touch a shift direction key to select right or left. The selected key will be highlighted.

3. Set the shift amount as needed and touch the lower [OK] key.



Use the  and the  keys to set the shift amount. The shift amount can be set from 0 to 20 mm in 1 mm increments.

If a Duplex Module/2-Tray Unit and Duplex Bypass/ Inverter Unit are not installed, the margin shift setting for back-side copies will not be displayed.

4. Touch the [OK] key on the SPECIAL MODES screen.

Return to the main screen of copy mode.

About the steps that follow

If a DADF is being used, see pages 2-13 through 2-19. If the document glass is being used, see pages 2-21 through 2-24.

To cancel the margin shift function, touch the [CANCEL] key on the margin shift setting screen. This must be done before you touch [OK] in step 4.

Erase

The erase function is used to erase the shadow lines on copies produced when copying thick originals or books. The erase modes that can be selected are shown below. The erase width is approximately 10 mm (1/2") in its initial setting.

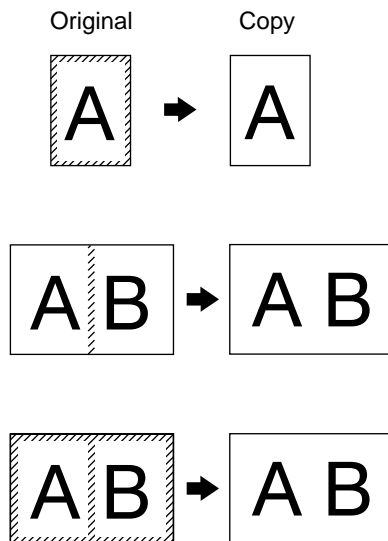

EDGE ERASE

Eliminates shadow lines around the edges of copies caused when heavy paper or a book is used as an original.

CENTRE ERASE

Eliminates shadow lines produced by the bindings of bound documents.

EDGE + CENTRE ERASE

Eliminates shadow lines around the edges of copies and eliminates the shadow at the centre of copies.

1. Touch the [ERASE] key on the SPECIAL MODES screen.

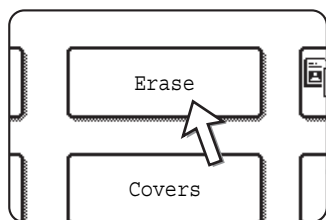

The erase setting screen will appear.

The erase icon () will also appear in the upper left of the screen to indicate that the function is turned on.

2. Select the desired erase mode.

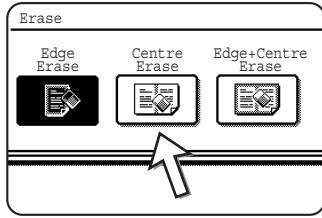

Select one of the three erase modes. The selected key will be highlighted.

3. Adjust the amount of erase and touch the [OK] key.

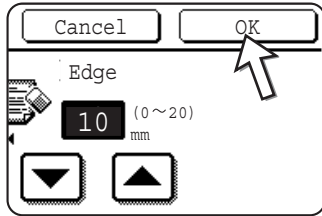

Use the \blacktriangledown and the \blacktriangle keys to adjust the erase width and then touch the [OK] key.

4. Touch the [OK] key on the SPECIAL MODES screen.

Return to the main screen of copy mode.

About the steps that follow

If a DADF is being used, see pages 2-13 through 2-19. If the document glass is being used, see pages 2-21 through 2-24.

To cancel the erase function, touch the [CANCEL] key on the erase setting screen.

Dual page copy

The dual page copy function produces separate copies of two documents placed side by side on the document glass. It is especially useful when copying books and other bound documents.

[Example] Copying right and left pages of a book

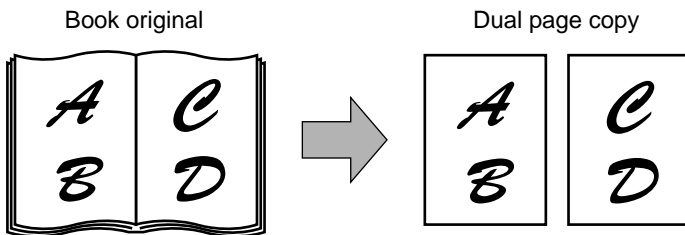

- The dual page copy function can be used with reduction copying but cannot be used with enlargement copying.
- The dual page copy function can be done only from the document glass. The DADF cannot be used with this function.
- Only A4 (8-1/2" x 11") paper can be used.

1. Touch the [DUAL PAGE COPY] key on the SPECIAL MODES screen.

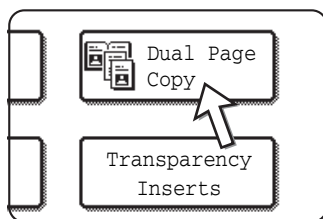

The [DUAL PAGE COPY] key will be highlighted to indicate that the function is turned on, and the dual page copy icon (📄📄) will appear in the upper left of the SPECIAL MODES screen.

2. Touch the [OK] key on the SPECIAL MODES screen.

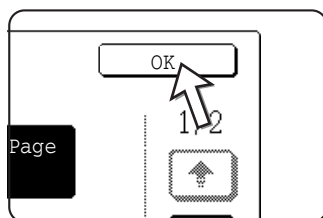

Return to the main screen of copy mode.

3. Place the originals on the document glass.

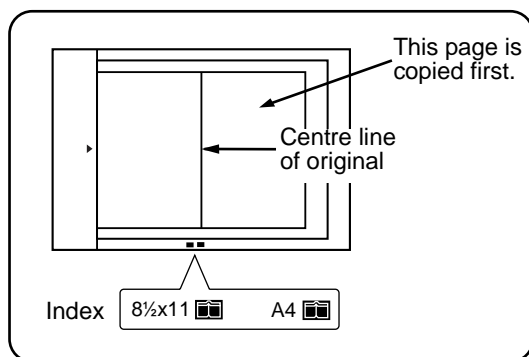

When copying book originals:

When copying a thick book, press down lightly on the book to flatten it against the document glass.

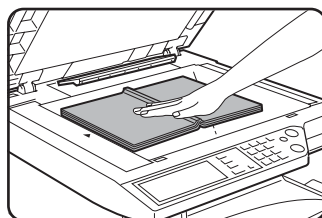

4. Ensure that A4 (8-1/2" x 11") size paper is selected.

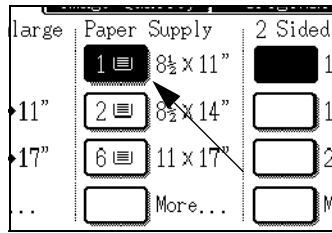

If A4 (8-1/2" x 11") size paper is not selected, touch the appropriate key in the Paper Select display to select A4 (8-1/2" x 11") size paper.

About the steps that follow

For two-sided copying, follow steps 2 through 4 beginning on page 2-24 and then follow steps 4 through 7 beginning on page 2-23.

For one-sided copying, follow steps 4 through 7 beginning on page 2-23.

To cancel the dual page copy function, touch the [DUAL PAGE COPY] key on the special modes screen (step 1). (The highlighted display will be cancelled.)

NOTE: To erase shadows caused by document binding, use the edge erase function (page 2-41). (Centre Erase and Edge + Centre Erase cannot be used in combination.)

Centring

When the original and copy paper are of different sizes, CENTRING is used to shift the image to the centre of the copy paper but only in the left to right direction.

[Example]

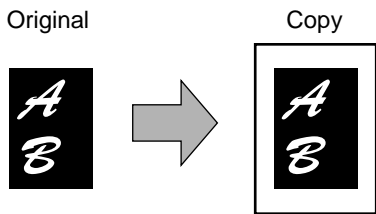

- This function can be used to reduce a larger sized original image and centre it on a copy of smaller paper size, as well as centre a smaller original onto a larger sized copy.
- This function will not work when non-standard size originals or copy paper are used. This function cannot be selected when enlargement copying has been selected.

1. Touch the [CENTRING] key on the SPECIAL MODES screen.

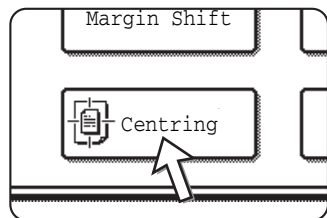

The [CENTRING] key is highlighted to indicate that the function is turned on, and the centring icon (☐) will appear in the upper left of the screen.

2. Touch the [OK] key on the SPECIAL MODES screen.

Return to the main screen of copy mode.

About the steps that follow

If a DADF is being used, see pages 2-13 through 2-19. If the document glass is being used, see pages 2-21 through 2-24.

To cancel the CENTRING function, touch the [CENTRING] key again on the SPECIAL MODES screen (step1).

Transparency film with insert sheets

When copying onto transparency film, blank insert sheets can be placed between transparent sheets.

Example: Inserting insert sheets between transparencies

Originals (1-sided)

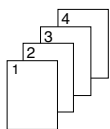

Originals (2-sided)

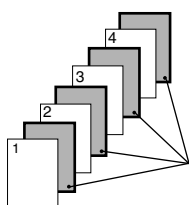

For two-sided originals, this is only possible when using a DADF.

- Insert sheets cannot be copied on in any mode.
- This mode can be selected only in the 1-sided to 1-sided and 2-sided to 1-sided modes.
- A multiple number of copies cannot be selected in this mode.
- Transparency film must be fed from the Bypass Tray.
- Insert sheets must be the same size (A4 or A4R (8-1/2" x 11" or 8-1/2" x 11"R)) as the transparency film.
- For best results, use Xerox-recommended transparency film.

Before performing the following procedure, touch the [More...] key in the Output display of the main screen of copy mode to display the OUTPUT settings screen (page 2-18), and then touch the [LEFT TRAY] key* to set the output tray to the left tray*.

* If the optional Saddle Stitch Finisher is installed, touch the [FINISHER TRAY] key to set the output tray to the finisher tray.

1. Touch the [TRANSPARENCY INSERTS] key on the SPECIAL MODES screen of the Special Modes tab.

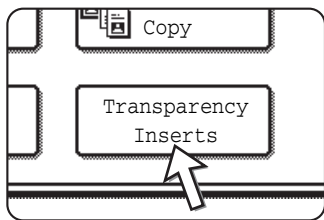

The [TRANSPARENCY INSERTS] key is highlighted to indicate that the function is turned on, and the transparency inserts icon (☐), etc.) appears in the upper left of the screen.

2. Touch the [OK] key on the SPECIAL MODES screen.

Return to the main screen of copy mode.

3. Load transparency film into the Bypass Tray.

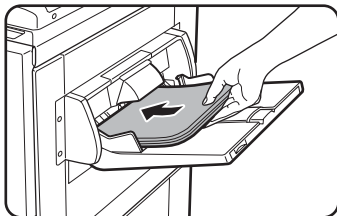

Remove any paper already in the Bypass Tray before loading the transparency film. (To load paper in the Bypass Tray, see page 1-23.)

4. Touch the [More...] key in the Paper Select display and select the transparency film loaded in the Bypass Tray.

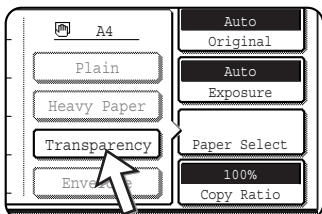

Touch the [TRANSPARENCY] key.

5. Touch the [SPEED MODE] key or the [QUALITY MODE] key for the transparency film.

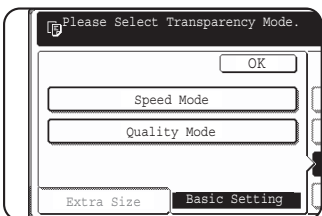

SPEED MODE is for fast printing.

QUALITY MODE is for a high quality image.

After touching either key followed by the [OK] key, you will return to the main screen of copy mode.

About the steps that follow

If a DADF is being used, see page 2-13. If the document glass is being used, see page 2-21.

To cancel the TRANSPARENCY INSERTS function, touch the [TRANSPARENCY INSERTS] key again on the SPECIAL MODES screen.

NOTE: When the copy job is finished, remove any transparencies that remain in the Bypass Tray.

Covers

The COVERS mode is used to place covers on the front, back, or both the front and back of multipage documents.

This function can only be used when the originals are placed in the DADF tray of the DADF. (The document glass cannot be used.)

Copying onto a cover

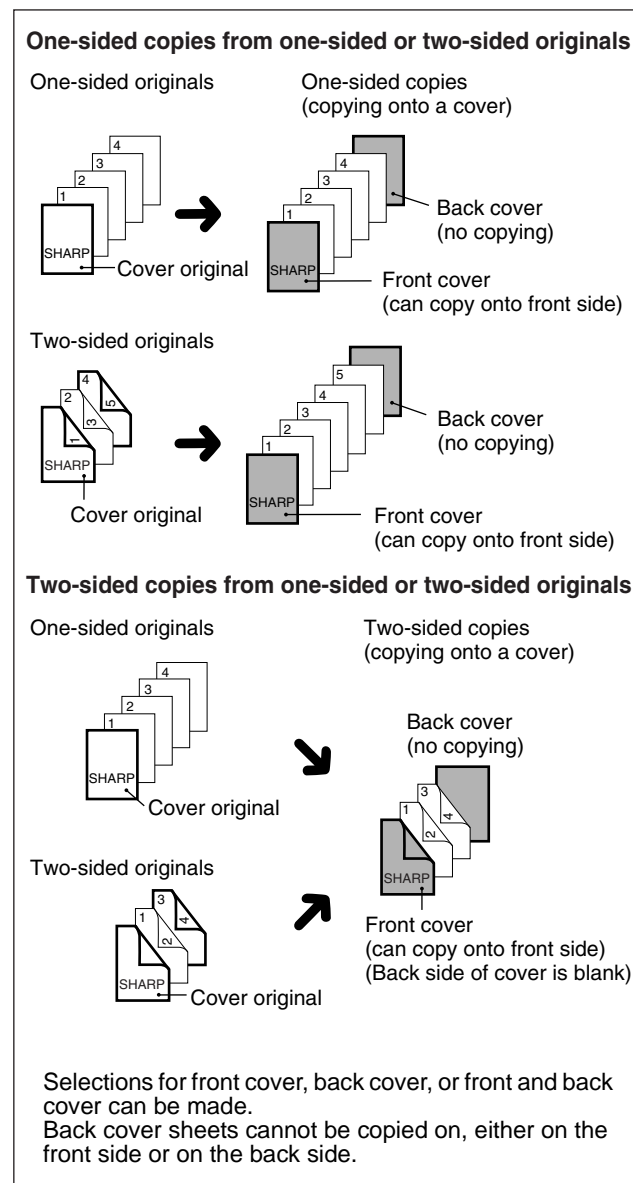

Not copying onto a cover

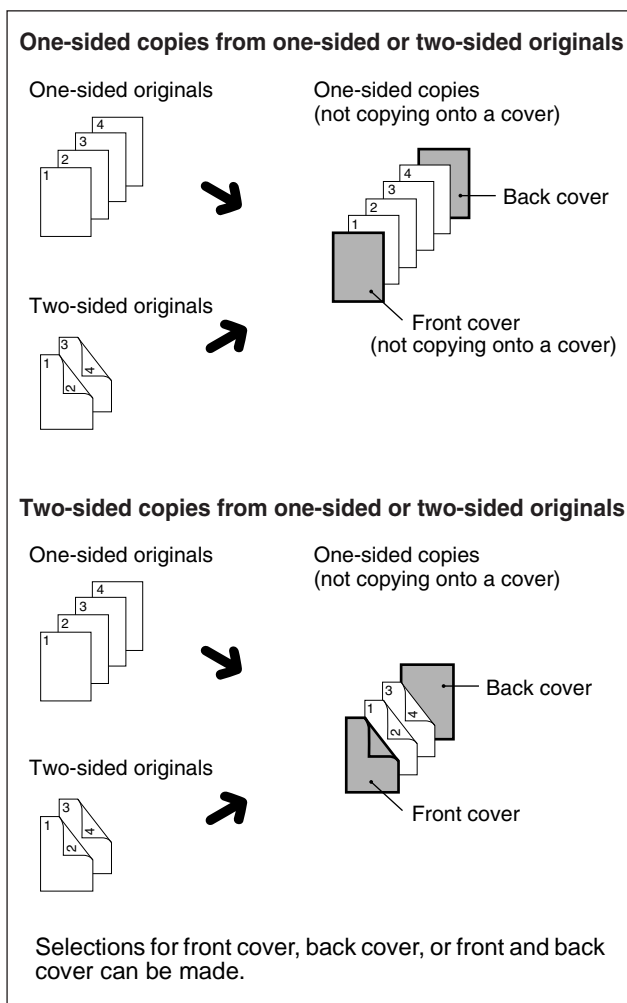

1. Touch the [COVERS] key on the SPECIAL MODES screen.

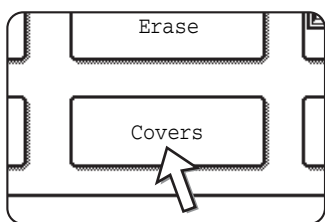

The COVERS setting screen will appear.

The covers icon (📄, etc.) will also appear in the upper left of the screen to indicate that the function is turned on.

2. Select cover placement.

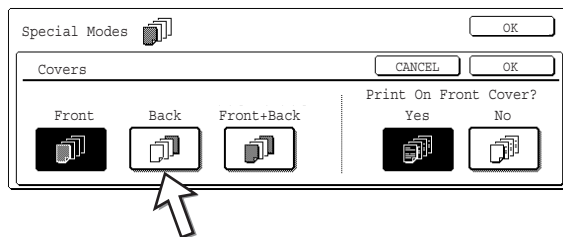

Select [FRONT], [BACK] or [FRONT+BACK] on the touch panel.

3. Indicate whether the front cover sheets are copied on or not.

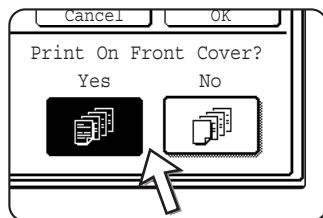

Select [YES] or [NO] on the touch panel. If [YES] is selected, the first page of the document will be copied onto the front cover sheet.

4. Touch the [OK] key on the COVER setting screen.

Return to the SPECIAL MODES screen.

5. Touch the [OK] key on the SPECIAL MODES screen.

Return to the main screen of copy mode.

6. Load the cover paper to be used into the Bypass Tray.

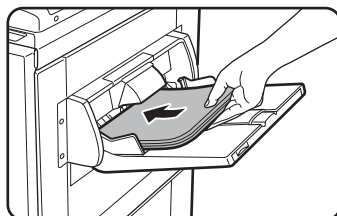

Load the same size of paper as the paper to be used for the copy job. If the Saddle Stitch Finisher is to be used for stapling, heavy stock cannot be used for the covers (see page 1-32). Paper within the range of the stapler must be used.

About the steps that follow

See pages 2-13 through 2-19.

NOTE: *Be sure to place the originals in the DADF tray of the DADF.*

The document glass cannot be used for this function.

- NOTES:**
- *During cover copying, the stream feeding mode will not function even if it is turned on by the program.*
 - *During cover copying, the pamphlet copy function (page 2-71) and the saddle stitch (pamphlet staple) function will not operate.*

To cancel the COVERS function, select the COVERS function again and touch the [CANCEL] key (step 2).

B/W reverse

Black and white are reversed in the copy to create a negative image. (This function can only be used for black and white copying.)

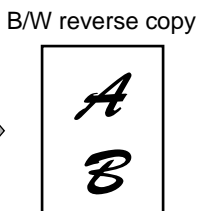

NOTE:

Originals with large black areas (which use a large amount of toner) can be printed with black/white reverse to reduce toner consumption.

1. Touch the  key to switch to the second SPECIAL MODES screen.

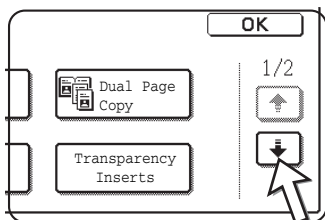

2. Touch the [B/W REVERSE] key in the second SPECIAL MODES screen.

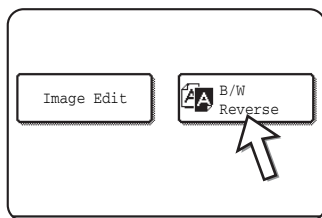

The [B/W REVERSE] key will be highlighted to indicate that the function is selected. In addition, the B/W reverse icon () will appear in the upper left-hand corner of the screen.

3. Touch the [OK] key on the SPECIAL MODES screen.
Return to the main screen of copy mode.

About the steps that follow

If a DADF is being used, see pages 2-13 through 2-19. If the document glass is being used, see pages 2-21 through 2-24.

To cancel the B/W reverse function, touch the [B/W REVERSE] key in the SPECIAL MODES screen (the screen of step 2).

Colour Adjustments Menu

The [COLOUR ADJUSTMENTS] menu in [SPECIAL MODES] enables the following parameters to be adjusted to modify the characteristics of a colour copy.

Settings adjusted with the colour adjustments menu do not affect black and white copying.

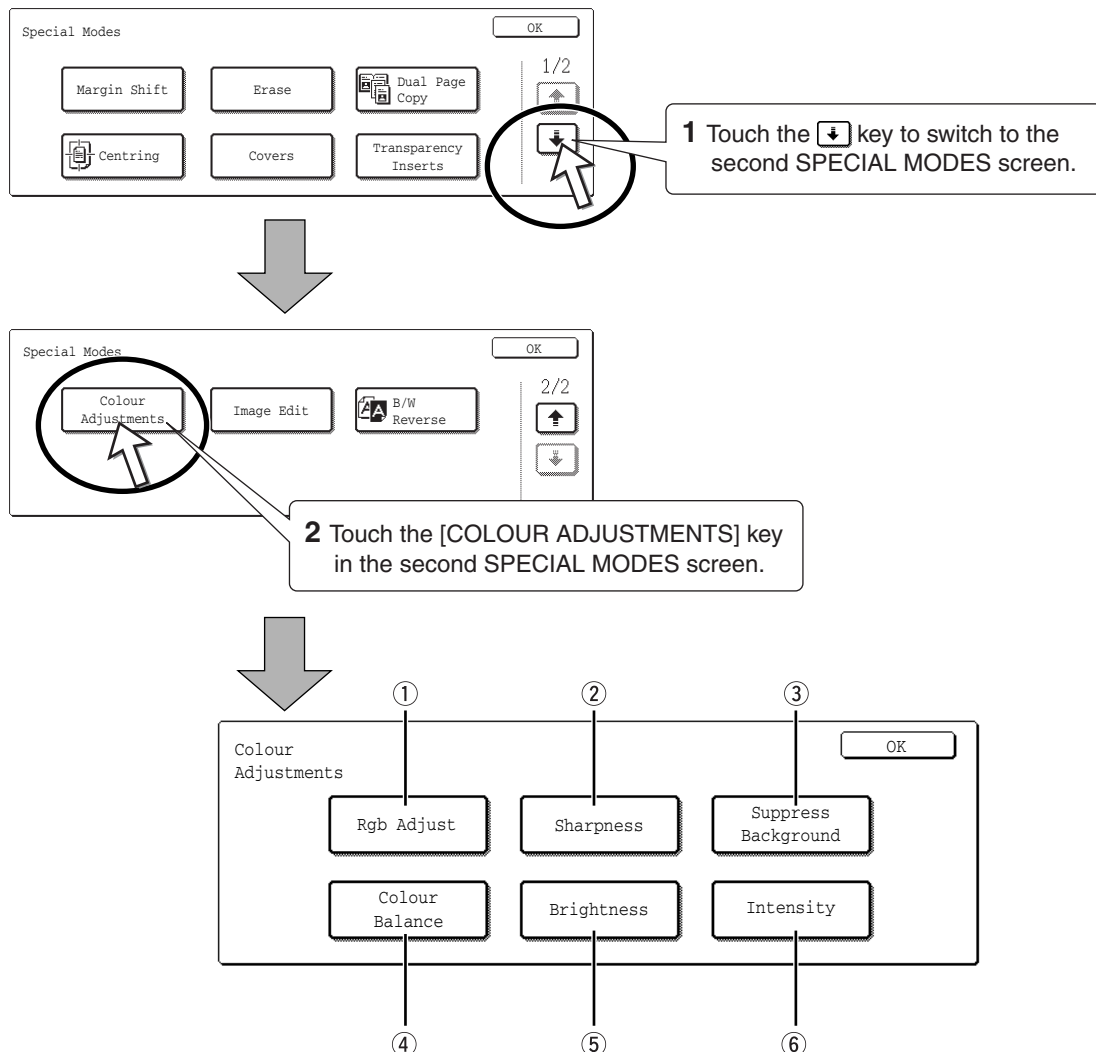

- ① **RGB ADJUST** Strengthens or weakens one of three primary colours, R (red), G (green), or B (blue) (page 2-52).
- ② **SHARPNESS** Sharpens or softens image outlines (page 2-53).
- ③ **SUPPRESS BACKGROUND** Suppresses copying of lighter background areas (page 2-54).

- ④ **COLOUR BALANCE** Adjusts the colour, tone, and density of colour copies (page 2-55).
- ⑤ **BRIGHTNESS** This copier allows the level of brightness to be adjusted. If brightness is selected, colour tone can be darkened or lightened (page 2-57).
- ⑥ **INTENSITY** This copier allows the level of intensity to be adjusted. If intensity is selected, colour saturation can be made to be more vivid or more dull (page 2-58).

RGB Adjust

Strengthens or weakens one of three primary colours, red (R), green (G), or blue (B).

1. Touch the [RGB ADJUST] key on the COLOUR ADJUSTMENTS menu screen.

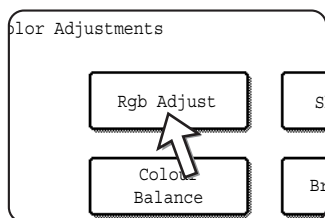

2. Select a colour from R (RED), G (GREEN), and B (BLUE).

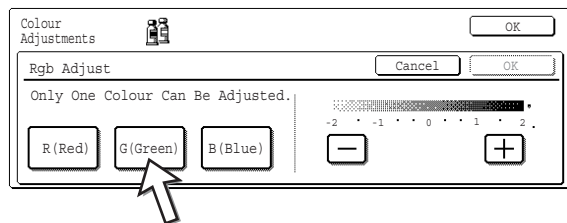

Only one primary colour can be adjusted.

3. Adjust the selected colour.

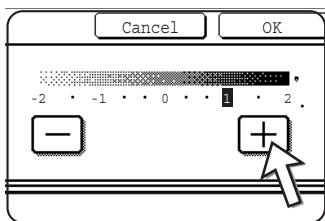

Touch the [+] to strengthen the selected colour or touch the [-] key to weaken the colour.

When the key is touched, the colour adjustments menu icon () will appear at the upper left of the screen to indicate that the function is turned on.

4. Touch the [OK] key (inside [OK] key) on the RGB ADJUST setting screen.
Return to the COLOUR ADJUSTMENTS menu screen.
5. Touch the [OK] key on the COLOUR ADJUSTMENTS menu screen.
Return to the SPECIAL MODES screen.
6. Touch the [OK] key on the SPECIAL MODES screen.
Return to the main screen of copy mode.

About the steps that follow

If a DADF is being used, see pages 2-13 through 2-19. If the document glass is being used, see pages 2-21 through 2-24.

In either case, press the [COLOUR COPY START] key to begin copying.

To cancel the RGB ADJUST function, select the RGB ADJUST function again and touch the [CANCEL] key (step 2 or 3).

Sharpness

Sharpens or softens image outlines.

1. Touch the [SHARPNESS] key on the COLOUR ADJUSTMENTS menu screen.

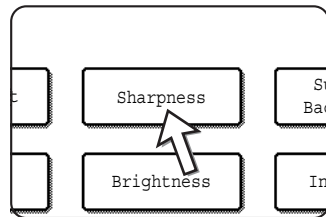

The SHARPNESS setting screen will appear. The colour adjustments icon () will also appear in the upper left of the screen to indicate that the function is turned on.

2. Touch the [SOFT] key to soften image outlines or touch the [SHARPEN] key to sharpen them.

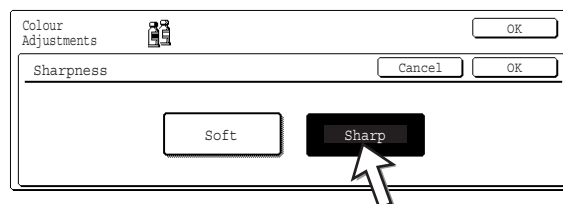

3. Touch the [OK] key (inside [OK] key) on the SHARPNESS setting screen.
Return to the COLOUR ADJUSTMENTS menu screen.

4. Touch the [OK] key on the COLOUR ADJUSTMENTS menu screen.
Return to the SPECIAL MODES screen.
5. Touch the [OK] key on the SPECIAL MODES screen.
Return to the main screen of copy mode.

About the steps that follow

If a DADF is being used, see pages 2-13 through 2-19. If the document glass is being used, see pages 2-21 through 2-24.

In either case, press the [COLOUR COPY START] key to begin copying.

To cancel the SHARPNESS function, select the SHARPNESS function again and touch the [CANCEL] key (step 2).

Suppress background

This copier can suppress unwanted background areas on the original images when copying.

1. Touch the [SUPPRESS BACKGROUND] key on the COLOUR ADJUSTMENTS menu screen.

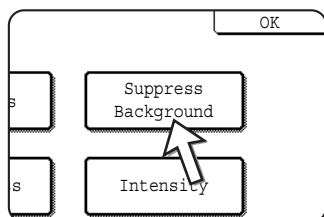

The SUPPRESS BACKGROUND setting screen will appear. The colour adjustments icon () will also appear in the upper left of the screen to indicate that the function is turned on.

2. Use the [+] and [-] keys to select the desired background suppression level.

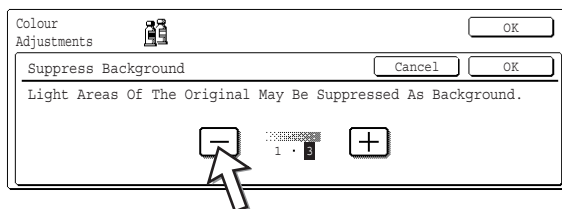

If level 1 is selected, darker background areas will be erased. The level can be adjusted in three steps. The default setting is level 3.

3. Touch the [OK] key (inside [OK] key) on the SUPPRESS BACKGROUND setting screen.
Return to the COLOUR ADJUSTMENTS menu screen.

4. Touch the [OK] key on the COLOUR ADJUSTMENTS menu screen.
Return to the SPECIAL MODES screen.
5. Touch the [OK] key on the SPECIAL MODES screen.
Return to the main screen of copy mode.

About the steps that follow

If a DADF is being used, see pages 2-13 through 2-19. If the document glass is being used, see pages 2-21 through 2-24.

In either case, press the [COLOUR COPY START] key to begin copying.

To cancel the SUPPRESS BACKGROUND function, select the SUPPRESS BACKGROUND function again and touch the [CANCEL] key (step 2).

Colour balance

This function is used to adjust the colour, tone, and density of colour copies.

1. Touch the [COLOUR BALANCE] key on the COLOUR ADJUSTMENTS menu screen.

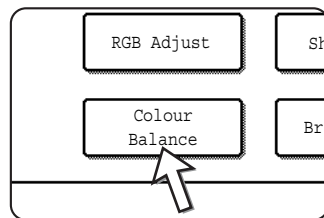

The COLOUR BALANCE setting screen will appear.

2. Use the keys indicated in the illustration below to adjust the colour balance settings.

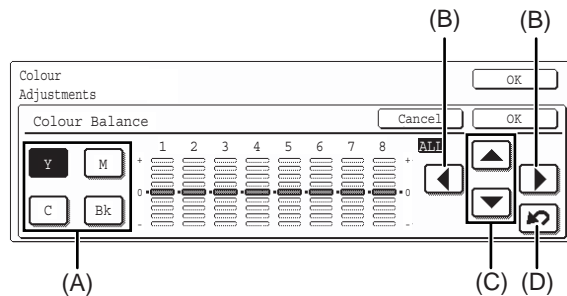

The Colour Balance setting allows you to adjust the densities of four colours: cyan, magenta, yellow, and black.

The density range is divided into eight levels for each colour, from 1 (lowest density areas) to 8 (highest density areas). The density can be adjusted one level at a time or eight levels at once.



- (A) Use these keys to select the colour to be adjusted ([C] = cyan, [M] = magenta, [Y] = yellow, [Bk] = black).

If only the area around the letter inside a key is highlighted, the settings have been changed from the factory default settings.

- (B) Use these keys to change the densities of all eight levels at once.

When either key is touched, the indicator lines of all eight levels will move up or down one step.

- (C) Use these keys to adjust the densities of each of the eight density levels.

When one of the keys is touched, the corresponding indicator line will move up or down one step. Touch the  key to increase the density of the corresponding level, or the  key to decrease the density.

- (D) Use this key to return the densities of all eight levels to the initial settings.

The initial colour balance settings are the values set with key operator program "Initial colour balance setting". For this reason, the initial settings may not necessarily be 0 (the middle indicator position) for all levels. The initial setting of each level is shown by a grey indicator.

When the colour balance setting is adjusted, the colour adjustments menu icon () will appear at the upper left of the screen to indicate that the function is turned on.

3. Touch the [OK] key (inside [OK] key) on the COLOUR BALANCE setting screen.

Return to the COLOUR ADJUSTMENTS menu screen.

4. Touch the [OK] key on the COLOUR ADJUSTMENTS menu screen.

Return to the SPECIAL MODES screen.

5. Touch the [OK] key on the SPECIAL MODES screen.

Return to the main screen of copy mode.

About the steps that follow

If a DADF is being used, see pages 2-13 through 2-19. If the document glass is being used, see pages 2-21 through 2-24.

In either case, press the [COLOUR COPY START] key to begin copying.

To cancel the COLOUR BALANCE function, select the COLOUR BALANCE function again and touch the [CANCEL] key (step 2).

Brightness

This copier allows the level of brightness of images to be adjusted.

1. Touch the [BRIGHTNESS] key on the COLOUR ADJUSTMENTS menu screen.

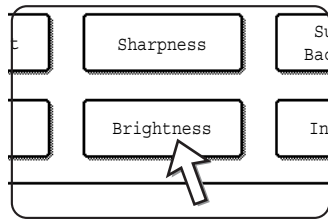

The BRIGHTNESS setting screen will appear.

2. Adjust the brightness.

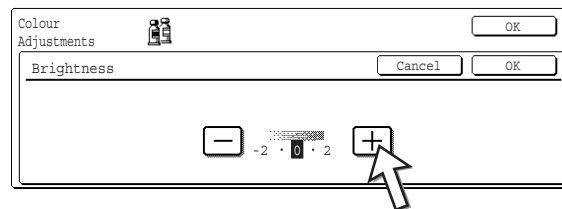

Use the [-] and [+] keys to adjust the level of the BRIGHTNESS.

When the key is touched, the colour adjustments menu icon () will appear at the upper left of the screen to indicate that the function is turned on.

3. Touch the [OK] key (inside [OK] key) on the BRIGHTNESS setting screen.
Return to the COLOUR ADJUSTMENTS menu screen.
4. Touch the [OK] key on the COLOUR ADJUSTMENTS menu screen.
Return to the SPECIAL MODES screen.
5. Touch the [OK] key on the SPECIAL MODES screen.
Return to the main screen of copy mode.

About the steps that follow

If a DADF is being used, see pages 2-13 through 2-19. If the document glass is being used, see pages 2-21 through 2-24.

In either case, press the [COLOUR COPY START] key to begin copying.

To cancel the BRIGHTNESS function, select the BRIGHTNESS function again and touch the [CANCEL] key (step 2).

Intensity

This copier allows the level of intensity of images to be adjusted.

This function can only be used when the original is placed on the document glass. (The DADF cannot be used.)

1. Touch the [INTENSITY] key on the COLOUR ADJUSTMENTS menu screen.

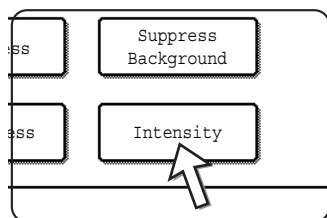

The INTENSITY setting screen will appear.

2. Adjust the intensity.

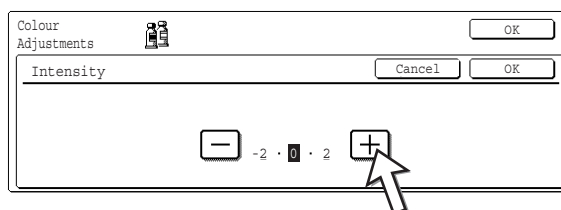

Use the [-] and [+] keys to adjust the level of the INTENSITY.

When the key is touched, the colour adjustments menu icon () will appear at the upper left of the screen to indicate that the function is turned on.

3. Touch the [OK] key (inside [OK] key) on the INTENSITY setting screen.
Return to the COLOUR ADJUSTMENTS menu screen.
4. Touch the [OK] key on the COLOUR ADJUSTMENTS menu screen.
Return to the SPECIAL MODES screen.
5. Touch the [OK] key on the SPECIAL MODES screen.
Return to the main screen of copy mode.

About the steps that follow

See pages 2-21 through 2-24, press the [COLOUR COPY START] key to begin copying.

To cancel the INTENSITY function, select the INTENSITY function again and touch the [CANCEL] key (step 2).

Image Edit Menu

To use the following convenient copy functions, touch the [IMAGE EDIT] key in [SPECIAL MODES].

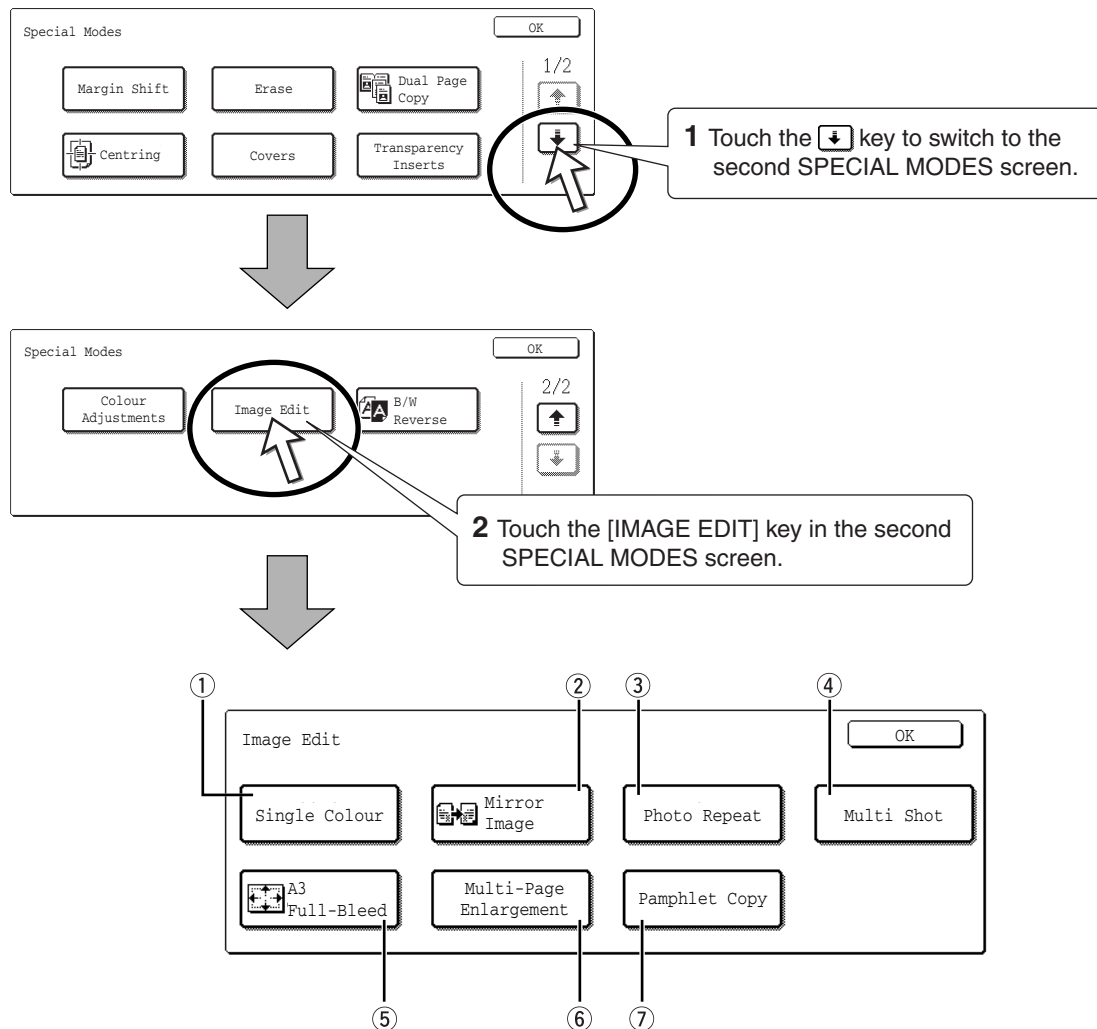

① **SINGLE COLOUR** Produces copies with a selected single colour (page 2-60).

② **MIRROR IMAGE** A mirror image of the original is printed (page 2-61).

③ **PHOTO REPEAT** Produces repeated images of a photo on a single sheet of copy paper (page 2-62).

④ **MULTI SHOT** The multi shot function is used to copy up to four originals, collectively in a specified order, per sheet of copy paper in any one of four layout patterns (page 2-64).

⑤ **A3 FULL-BLEED** Produces A3 (11" x 17") full image copies onto A3W (12" x 18") copy paper (page 2-66).

⑥ MULTI-PAGE ENLARGEMENT

Enlarges an original image to a size larger than A3 (11" x 17") and prints divided images onto multiple sheets of copy paper for assembly into large composite copy (page 2-68).

⑦ PAMPHLET COPY

The pamphlet copy function is used to arrange copies in proper order for eventual centre-stapling and folding into a booklet. Two original pages are copied onto each side of copy paper. Four pages are, therefore, copied onto one sheet (page 2-71).

(A Duplex Module/2-Tray Unit and a Duplex Bypass/Inverter Unit are required for this function.)

Single colour

Produces copies with a selected single colour.

1. Touch the [SINGLE COLOUR] key on the IMAGE EDIT screen.

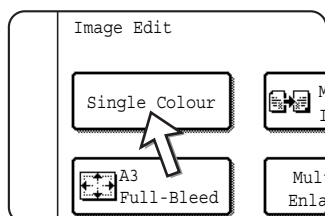

The SINGLE COLOUR setting screen will appear.

2. Select the desired colour.

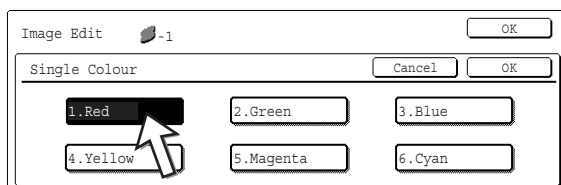

When one of the keys is touched, the single colour icon ( -1) will appear at the upper left of the screen to indicate that the single colour function is turned on. (The number that appears with the icon indicates the selected colour, and is the number on the key of the selected colour.)

3. Touch the [OK] key (inside [OK] key) on the SINGLE COLOUR setting screen.
Return to the IMAGE EDIT menu screen.
4. Touch the [OK] key on the IMAGE EDIT menu screen.
Return to the SPECIAL MODES screen.
5. Touch the [OK] key on the SPECIAL MODES screen.
Return to the main screen of copy mode.

About the steps that follow

If a DADF is being used, see pages 2-13 through 2-19. If the document glass is being used, see pages 2-21 through 2-24.

In either case, press the [COLOUR COPY START] key to begin copying.

To cancel the SINGLE COLOUR function, select the SINGLE COLOUR function again and touch the [CANCEL] key (step 2).

Mirror image

This function is used to print a mirror image of the original. The images will be inverted in the right to left direction on the copies.

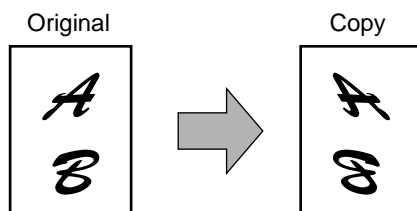

1. Touch the [MIRROR IMAGE] key on the IMAGE EDIT menu screen.

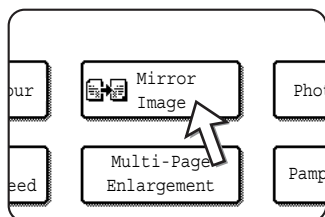

The [MIRROR IMAGE] key will be highlighted to indicate that the function is turned on, and the mirror image icon (🔄) will appear in the upper left of the screen.

2. Touch the [OK] key on the IMAGE EDIT menu screen.

Return to the SPECIAL MODES screen.

3. Touch the [OK] key on the SPECIAL MODES screen.

Return to the main screen of copy mode.

About the steps that follow

If a DADF is being used, see pages 2-13 through 2-19. If the document glass is being used, see pages 2-21 through 2-24.

To cancel the MIRROR IMAGE function, touch the MIRROR IMAGE again on the IMAGE EDIT menu screen (step 2).

Photo Repeat

PHOTO REPEAT is used to produce repeated images of a photo on a single sheet of copy paper.

- Up to 24 repeats can be made on a single copy sheet. The number of copies on a single sheet depends on the original size and copy paper size.
- Reduction or enlargement cannot be selected with this function. If reduction or enlargement has been selected, the copy ratio will be reset to 100% when this function is selected.
- This function will not work when non-standard size paper is used.
- This function can only be used with A4 (8-1/2" x 11") or A3 (11" x 17") paper.

● **Original size (to 130 x 90 mm (3" x 5"))**

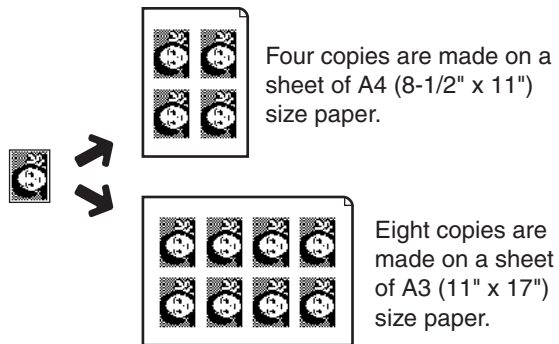

● **Original size (to 100 x 150 mm (5" x 7"))**

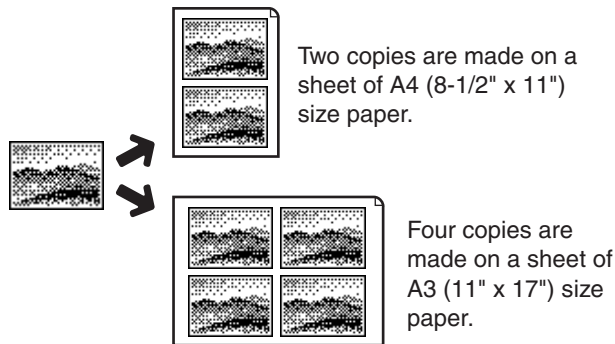

● **Original size (to 70 x 100 mm (2-1/2" x 4"))**

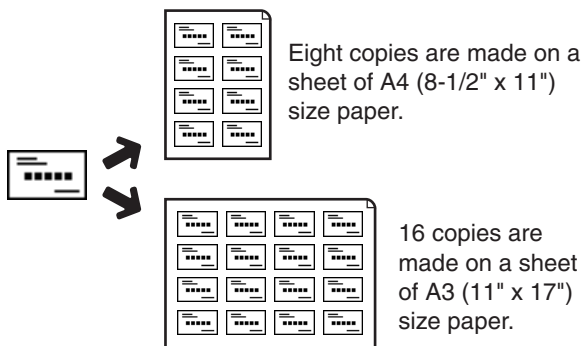

● **Original size (to 65 x 70 mm (2-1/2" x 2-1/2"))**

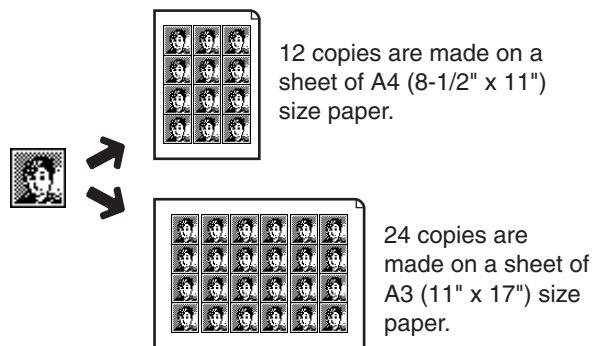

● **Original size (to 57 x 100 mm (2-1/8" x 3-5/8"))**

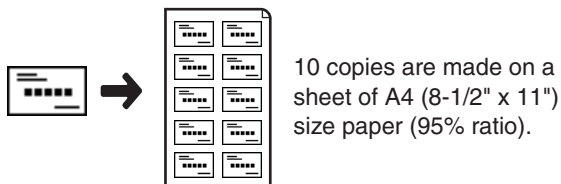

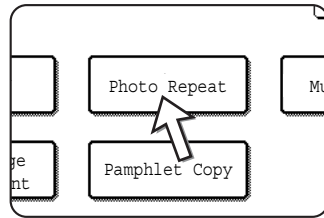

1. Touch the [PHOTO REPEAT] key on the IMAGE EDIT menu screen.



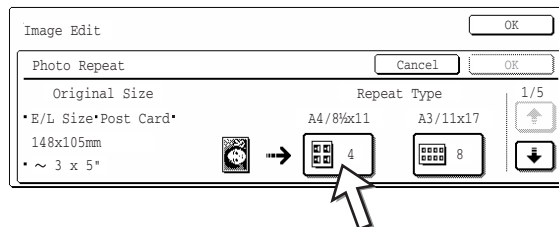

The PHOTO REPEAT setting screen will appear.

2. Touch the key for the desired combination of original type and paper size.



When any one of the keys is touched, the photo repeat icon (, etc.) will appear at the upper left of the screen to indicate that the function is turned on.

If the key for the desired combination doesn't appear, touch the  or  key to scroll, and then touch the desired repeat type key (A4 (8-1/2" x 11") or A3 (11" x 17")).

When making repeat copies of an original size (to 57 x 100 mm (2-1/8" x 3-5/8")), only A4 (8-1/2" x 11") can be selected for the paper size.

3. Touch the [OK] key (inside [OK] key) on the PHOTO REPEAT setting screen.
Return to the IMAGE EDIT menu screen.
4. Touch the [OK] key on the IMAGE EDIT menu screen.
Return to the SPECIAL MODES screen.
5. Touch the [OK] key on the SPECIAL MODES screen.
Return to the main screen of copy mode.

About the steps that follow

See pages 2-21 through 2-24.

- NOTES:**
- Be sure to place the original on the document glass, The DADF cannot be used for this function.

- Place ~70 x 100mm (2-1/2" x 4"), ~65 x 70mm (2-1/2" x 2-1/2") and ~57 x 100mm (2-1/8" x 3-5/8") originals as shown below.

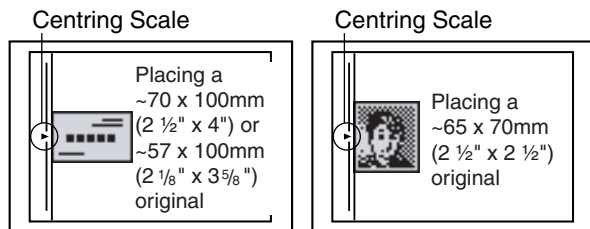

To cancel the PHOTO REPEAT function, select the PHOTO REPEAT function again and touch the [CANCEL] key (step 2).

Multi shot

The multi shot function is used to copy up to four originals, collectively in a specified order, per sheet of copy paper in any one of four layout patterns.

[Example] Copying seven originals using the 4 in 1 MULTI SHOT selection in a layout pattern starting from the upper left to lower right.

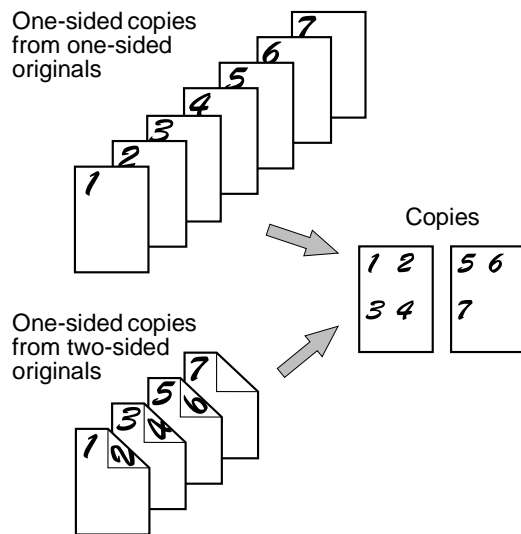

- When using the multi shot function, place the originals, select the desired paper size, and select the copying mode before selecting the multi shot function on the special modes screen.
- When using the multi shot function, the appropriate copy ratio will be automatically set based on the original size, paper size, and the number of originals to be copied onto one sheet. The minimum possible reduction ratio is 25%. Depending on the original size, paper size, and the number of originals to be copied onto one sheet, the copy ratio required to fit the original images onto one sheet may be smaller than 25%. In this case, a ratio of 25% will be used, and parts of the original images may be cut off.

1. Touch the [MULTI SHOT] key on the IMAGE EDIT menu screen.

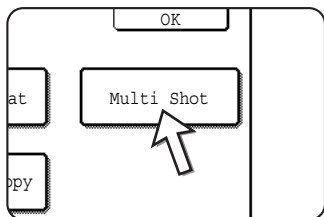

The MULTI SHOT setting screen will appear.

The multi shot icon ($\begin{smallmatrix} 1 & 2 \\ 3 & 4 \end{smallmatrix}$, etc.) will also appear in the upper left of the screen to indicate that the function is turned on.

2. Select the number of originals to be copied onto one sheet of copy paper on the multi shot selection screen.

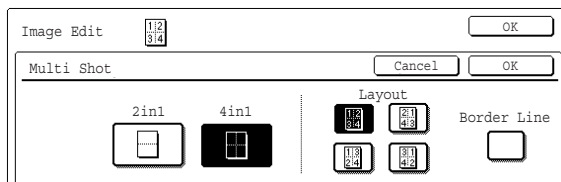

The orientation of copy paper and the image of the originals may be rotated as needed.

3. Select the layout.

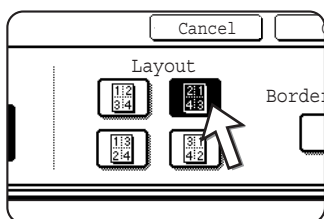

Select the order in which the originals will be arranged on the copy.

Shot number	Layout	
2in1		
4in1		

The arrows in the above diagram indicate the directions in which the images are arranged.

4. Select whether or not to add borderlines.

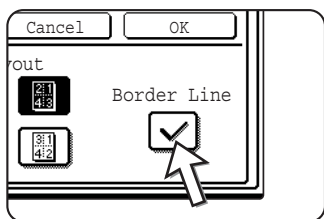

When the BORDER LINE checkbox is selected, borderlines are added around the borders of the images.

5. Touch the [OK] key (inside [OK] key) on the MULTI SHOT setting screen.
Return to the IMAGE EDIT menu screen.
6. Touch the [OK] key on the IMAGE EDIT menu screen.
Return to the SPECIAL MODES screen.
7. Touch the [OK] key on the SPECIAL MODES screen.
Return to the main screen of copy mode.

About the steps that follow

If a DADF is being used, see pages 2-13 through 2-19. If the document glass is being used, see pages 2-21 through 2-24.

To cancel the multi shot function, touch the [CANCEL] key on the multi shot setting screen (step 2).

A3 (11" x 17") Full-bleed

In other copy modes, image loss will occur along the copy edges. When the A3 (11" x 17") FULL-BLEED function is used, the full image of an A3 (11" x 17") size original will be copied onto A3W (12" x 18") size copy paper.

The A3 (11" x 17") FULL-BLEED function can only be used when the original is placed on the document glass. (The DADF cannot be used.)

Reduction or enlargement cannot be selected with this function. If reduction or enlargement has been selected, the copy ratio will be reset to 100% when this function is selected.

Automatic two-sided copying is not possible.

Original (A3 (11" x 17")) size

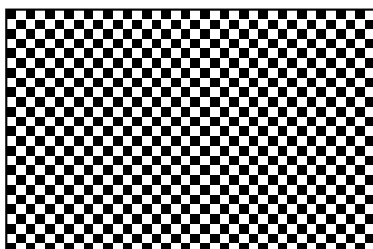

Copy (A3W (12" x 18")) size

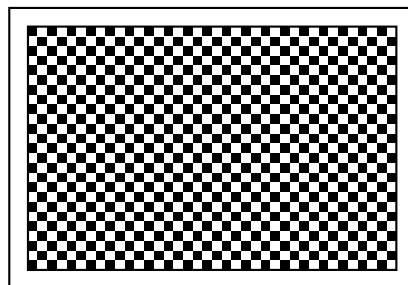

1. Touch the [A3 FULL-BLEED] key on the IMAGE EDIT menu screen.

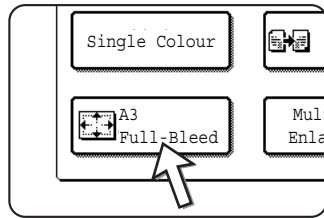

The [A3 FULL-BLEED] key will be highlighted to indicate that the function is turned on, and the full-bleed icon () will appear in the upper left of the screen.

2. Touch the [OK] key on the IMAGE EDIT menu screen.

Return to the SPECIAL MODES screen.

3. Touch the [OK] key on the SPECIAL MODES screen.

Return to the main screen of copy mode.

4. Load A3W (12" x 18") copy paper into the Bypass Tray.

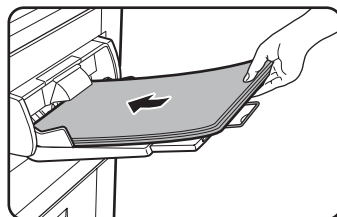

Adjust the Bypass Guide to A3W width before loading the paper. Remove any paper remaining in the tray.

Pull out the tray extension and wire extension (see page 1-23).

5. Touch the [More...] key in the Paper Select display and then select the paper type in the Bypass Tray.

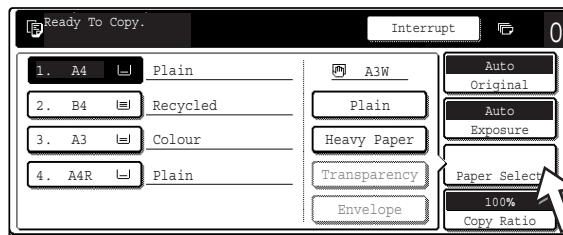

Touch the [PLAIN] key or the [HEAVY PAPER] key.

If you touched the [HEAVY PAPER] key, touch the [HEAVY PAPER1] key or the [HEAVY PAPER2] key as appropriate for the weight of the paper you loaded (see step 3 on page 1-36).

About the steps that follow

See page 2-21.

Extend the copy receptacle and then begin copying.

To cancel the A3 (11 x 17) FULL-BLEED function, touch the [A3 FULL-BLEED] key again on the IMAGE EDIT menu screen (step 1).

Multi-page enlargement

This function is used to enlarge an original image to a size larger than A3 (11" x 17") and print divided images onto multiple sheets of copy paper.

[Example]

Original
(A4 (8-1/2" x
11") size)



Copy (enlarged image
on 8 sheets of A3 (11" x
17") paper)

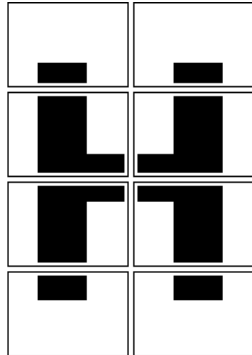

Overlap of sections of image

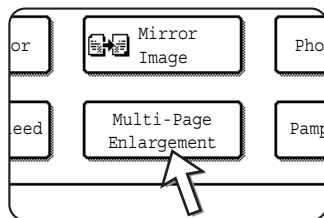

- There will be a margin around the edges of each copy.
- The original image will be divided and copied onto multiple sheets of paper. Areas for overlapping the copies will be made along the leading and trailing edges of each copy.

1. Touch the [MULTI-PAGE ENLARGEMENT] key on the IMAGE EDIT menu screen.



The MULTI-PAGE ENLARGEMENT setting screen will appear.

2. Select the size system for multi-page enlargement.

Touch the  or  key to display the size settings of the desired size system.

A system

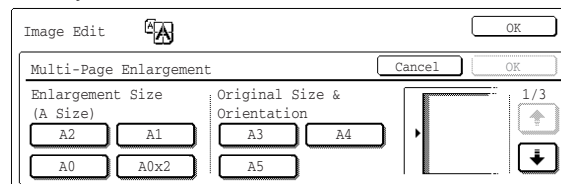

B system

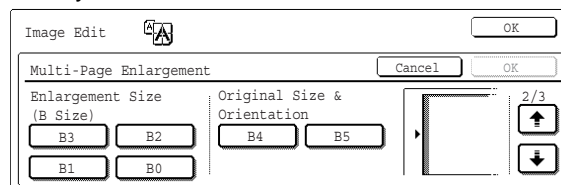

Inch system

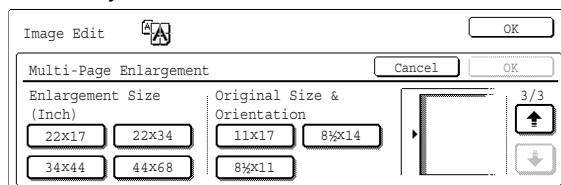

3. Set the enlargement size and the original size.

The order of selection can begin from the enlargement size or the original size. When the enlargement size and original size are set, the multi-page enlargement icon (A) will appear in the upper left of the screen to indicate that the function is turned on.

The combinations of original size and enlargement size for which multi-page enlargement is possible are as follows.

Enlargement size ↔ Original size	
A system	A2 ↔ A3/A4/A5
	A1 ↔ A3/A4/A5
	A0 ↔ A3/A4
	A0 x 2* ↔ A3
B system	B3 ↔ B4/B5
	B2 ↔ B4/B5
	B1 ↔ B4/B5
	B0 ↔ B4
Inch system	22 x 17 ↔ 11 x 17/8-1/2 x 14/8-1/2 x 11
	22 x 34 ↔ 11 x 17/8-1/2 x 14/8-1/2 x 11
	34 x 44 ↔ 11 x 17/8-1/2 x 14/8-1/2 x 11
	44 x 68 ↔ 11 x 17/8-1/2 x 14/8-1/2 x 11

Multi-page enlargement is not possible of an A-system size original to a B-system enlargement size, nor of a B-system size original to an A-system enlargement size.

*Indicates the size that is twice A0 size.

- NOTES:**
- If an original size is selected first, a message will indicate the enlargement sizes that can be selected. If an enlargement size is selected first, a message will indicate the original sizes that can be selected.
 - If a combination is selected for which multi-page enlargement is not possible, invalid selection beeps will be sounded.

4. Check the placement orientation and the number of copies

Example: Enlargement size = A2 (22" x 17"),
original size = A4 (8-1/2" x 11")

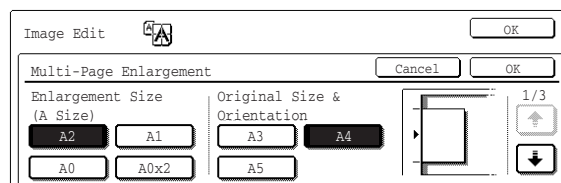

A suitable orientation for placement of the original and the number of sheets of paper required for the enlarged image are displayed based on the selected original size and enlargement size.

- NOTES:**
- *The paper size, number of sheets required for the enlarged image, and the ratio are automatically selected based on the selected original size and enlargement size. (The paper size and ratio cannot be selected by the operator.)*
 - *The relations between the original size and enlargement size selected by the operator and the automatically selected paper size, number of sheets, and ratio are shown on page 2-68.*
 - *If no paper trays have the size of paper that was automatically selected, "Load XXX paper" will appear. Change the paper in one of the trays or the Bypass Tray to the indicated size of paper.*
5. Place the original on the document glass in accordance with the indicated orientation. (page 2-4)

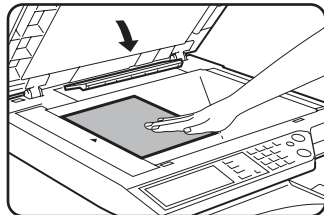

Multi-page enlargement is only possible using the document glass.

6. The DADF cannot be used for this function.

7. Touch the [OK] key (inside [OK] key) on the MULTI-PAGE ENLARGEMENT setting screen.
Return to the IMAGE EDIT menu screen.
8. Touch the [OK] key on the IMAGE EDIT menu screen.
Return to the SPECIAL MODES screen.
9. Touch the [OK] key on the SPECIAL MODES screen.
Return to the main screen of copy mode.

About the steps that follow

See page 2-21.

NOTE: *Be sure to place the original on the document glass. The DADF cannot be used for this function.*

To cancel the MULTI-PAGE ENLARGEMENT function, select the MULTI-PAGE ENLARGEMENT function again and touch the [CANCEL] key (step 4).

Pamphlet copy

The pamphlet copy function is used to arrange copies in proper order for eventual centre-stapling and folding into a booklet. Two original pages are copied onto each side of copy paper. Four pages are, therefore, copied onto one sheet.

This function is convenient for arranging copies into an attractive booklet or pamphlet.

[Example] Copying eight originals in the pamphlet copy mode

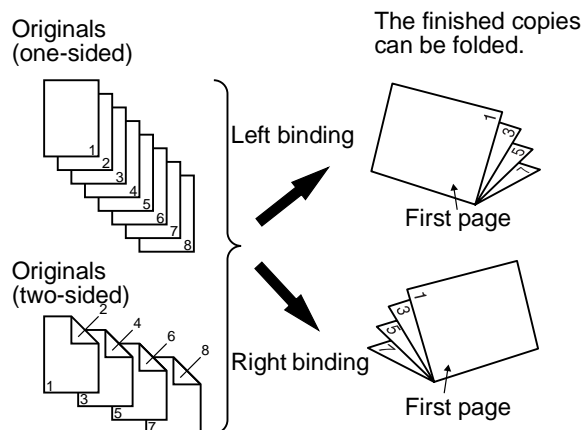

- Scan the originals in order from the first page to the last page. The order of copying will be automatically adjusted by the machine.
- Either left binding (opening from right to left) or right binding (opening from left to right) can be selected.
- Four originals will be copied onto one sheet. Blank pages may be automatically added at the end, depending on the number of the originals.
- A Duplex Module/2-Tray Unit and Duplex Bypass/Inverter Unit are required for this function.
- If a Saddle Stitch Finisher is installed, copies can be stapled in two positions along the centre of copies and folded at the centre.

1. Touch the [PAMPHLET COPY] key on the IMAGE EDIT menu screen.

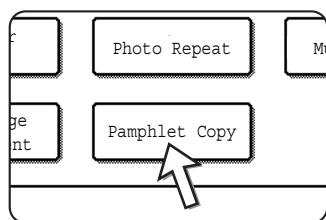

The PAMPHLET COPY setting screen will appear. The pamphlet copy icon , (, etc.) will also appear in the upper left corner of the screen to indicate that the function is turned on.

- Designate the type of originals to be copied: 1-sided or 2-sided.

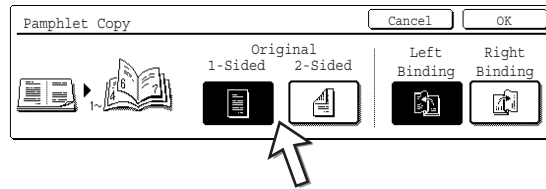

Select the [2-SIDED] key when you are using the DADF to scan a two-sided original.

- Select the binding position (left binding or right binding) and touch the [OK] key (inside [OK] key) on the PAMPHLET COPY setting screen.

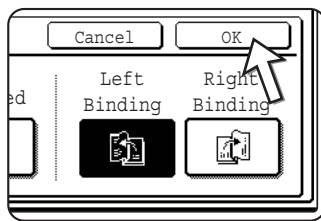

Return to the IMAGE EDIT menu screen.

- Touch the [OK] key on the IMAGE EDIT menu screen. Return to the SPECIAL MODES screen.
- Touch the [OK] key on the SPECIAL MODES screen. Return to the main screen of copy mode.
- Place the original in the DADF tray or on the document glass. (pages 2-4 to 2-10)
- Ensure that the desired paper size has been automatically selected based on the original size.

To select another size paper, touch the [More...] key in the Copy Ratio display, then select the desired size and touch the [AUTO IMAGE] key. The appropriate copy ratio will be selected automatically based on the original size and the paper size. (See step 2 on page 2-29.)

- Make all other desired settings such as exposure or the number of copies, and press the [START] key.

When using the DADF:

Copying will start after all originals have been scanned. (The next step is not needed.)

When using the document glass:

Replace the original with the next original and press the [START] key. Repeat this operation until all originals have been scanned. Then touch the [READ-END] key.

When the pamphlet copy function is set, the two-sided copying mode will be automatically selected.

To cancel the pamphlet copy function, touch the [CANCEL] key on the pamphlet copy setting screen (step 2).

Job Program Memory

Frequently used job programs can be stored in each of ten storage registers. This is convenient for quick job recall without losing time manually reprogramming each aspect of a job. Job programs can be recalled with ease, and the programs are retained even when the power is turned off. By programming frequently used copy settings, you can eliminate the bother of selecting the settings each time you use them for a copy job.

- Selection for functions stored as part of a job program, will not be recalled as part of the program if the function has been disabled or changed by a key operator program.
- To exit the job memory mode, press the [CLEAR ALL] key on the operation panel or touch the [EXIT] key on the touch panel.

Storing a job program

1. Press the [# / P] key.

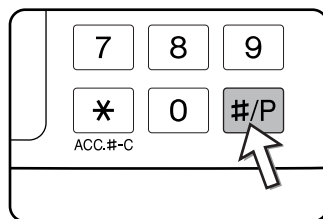

2. Touch the [STORE/DELETE] key to obtain the storage register screen.

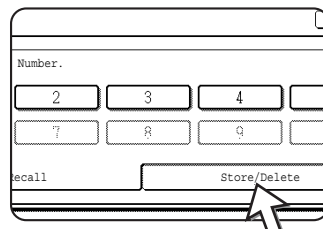

3. Touch a number key from 1 to 10 on the storage register screen.

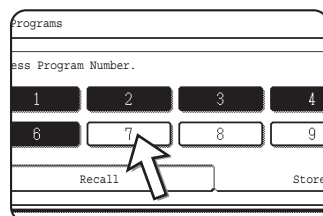

Highlighted storage register numbers are registers which already have programs stored.

4. Make all copier selections to be stored.

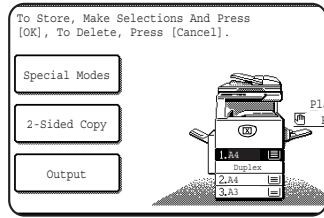

The number of copies cannot be stored.

5. Touch the [OK] key.

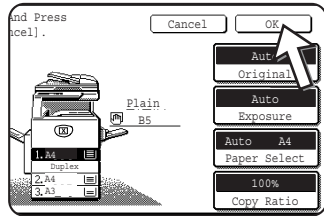

The selected settings will be stored under the register number selected in step 3.

If a number key is selected in step 3 that has already been programmed.

A setting confirmation screen will appear. To replace the existing program with the new program, touch the [STORE] key and continue from step 4. If you do not wish to replace the existing program, touch the [CANCEL] key to return to the screen of step 3 and select a different number key.

NOTE: *If overwriting of programmed copy settings has been prohibited in the key operator programs, you will not be able to store a job program.*

Recalling a job program

1. Press the [#P] key.

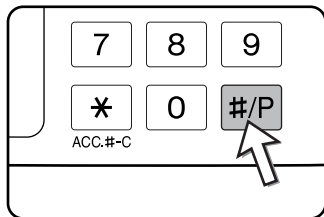

2. Touch the desired storage register number key to recall the job from memory.

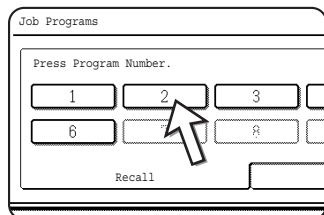

When a number key is touched, the selection screen will be closed and the stored job program will be recalled. A number for which no job program has been stored cannot be selected.

- Set the number of copies as needed and press the [COLOUR COPY START (●●●●)] or [BLACK COPY START (○●)] key.

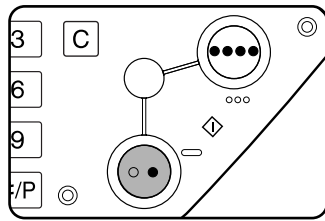

Copying will start with the settings of the recalled job program.

NOTE: *If any settings related to the contents of a job program were changed in the key operator programs after the job program was stored, the changed settings will not be included when the job program is recalled.*

Deleting a stored job program

- Press the [#/P] key.

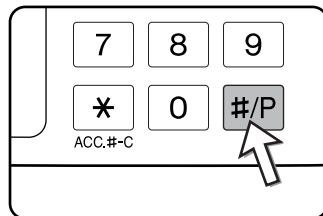

- Touch the [STORE/DELETE] key to obtain the storage register screen.

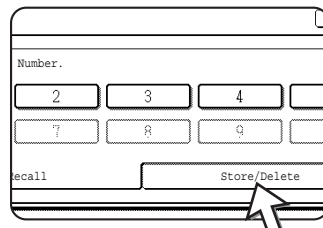

- Select a storage register number of the program to be deleted.

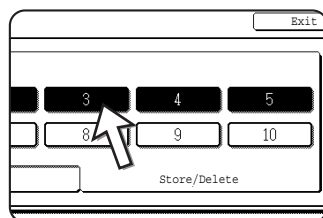

If a number key for which no job program has been stored is selected, the screen will change to the screen of step 4 on page 2-74 (for storing a job program).

4. Touch the [DELETE] key.

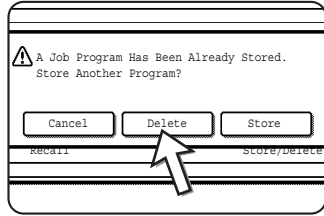

When the [DELETE] key is touched, the screen in step 3 will return and the program will be deleted. If the [CANCEL] key is touched, the screen in step 3 will return but the program will not be deleted. If no other programs are to be deleted, touch the [EXIT] key on the screen displayed in step 3 to exit the job program mode.

NOTE: *If overwriting of programmed copy settings has been prohibited in the key operator programs, you will not be able to clear a job program.*

Interrupting a Copy Run

INTERRUPT can be used to temporarily stop a long copy run so that another copy job can be run.

It is not possible to interrupt an automatic two-sided copy job.

1. Touch the [INTERRUPT] key.

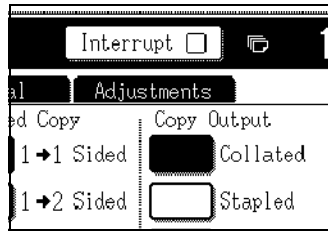

If the [INTERRUPT] key does not appear, interrupt copying is not possible.

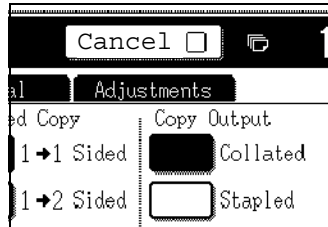

When the [INTERRUPT] key is touched in step 1, the [INTERRUPT] touch key will be replaced by the [CANCEL] key as shown in the illustration.

- NOTES:**
- If you touch the [INTERRUPT] key when the account counter function is turned on, the display will prompt you to enter your account number. Enter your account number with the numeric keys. The copies you make will be added to the count of the entered account number.
 - If the [INTERRUPT] key is touched while an original is being scanned, the interrupt state will begin after scanning is completed. If the [INTERRUPT] key is touched during copying, the interrupt state will begin after the copy is completed.
 - Interrupt copying is not possible during automatic two-sided copying using the optional Duplex Module/2-Tray Unit. In addition, automatic two-sided copying is not possible during interrupt copying.
2. Place the original for the interrupt copy job in the DADF or on the document glass (pages 2-4 to 2-10).

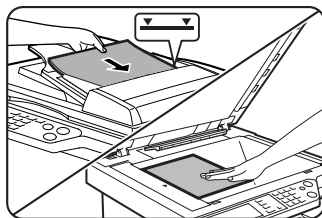

If a black and white copy job is being interrupted to run another black and white copy job, the number of originals that can be copied in the interrupt job is 35. (based on text original (A) on page 2-17)

3. Make all other desired settings such as exposure, paper size and number of copies and then press the [COLOUR COPY START (●●●●)] or [BLACK COPY START (○●)] key.

When making black and white copying using the document glass in the sort mode, replace the original with the next original and press the [BLACK COPY START] key. Repeat this operation until all originals have been scanned. Then, touch the [READ-END] key.

4. When the interrupt copy job is finished, touch the [CANCEL] key to turn off the interrupt copy state.

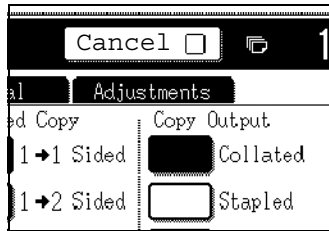

5. Resume the interrupted copy job.

If a colour copy job was interrupted, replace the originals that have not yet been copied and resume copying.

If a black and white copy job was interrupted, replace the originals that have not yet been copied and press the [BLACK COPY START] key to resume copying.

Machine Maintenance (for Copying)

This section explains procedures for removing misfeeds in a DADF, cleaning the machine, and troubleshooting.

Removing an Original Misfeed

Removing a misfed original from the DADF

If an original misfeed occurs in the DADF, follow the steps below to remove the misfed original.

- NOTES:**
- For misfeed removal in the main unit and other peripheral devices, see page 1-46.
 - When a misfeed occurs, touch the [INFORMATION] key to display detailed information for misfeed removal.

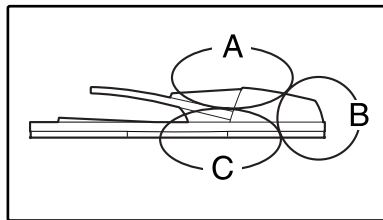

Check locations A, B, and C in the diagram at left to remove the original.

1. Removing misfeeds from each location

Check location A

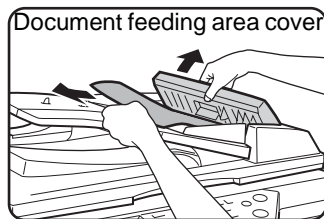

Open the document feeding area cover and gently remove the misfed original from the DADF tray. Close the document feeding area cover.

Check location B

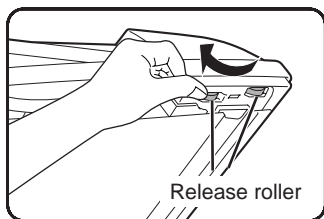

Open the DADF and rotate the two release rollers in the direction of the arrow to make the original feed out. Close the DADF and gently remove the original.

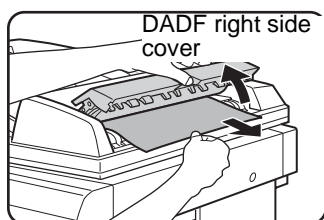
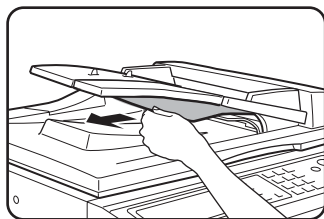

If the misfed original is small (such as an A5 original), or if the misfeed occurred in the reversing tray, open the DADF right side cover and gently remove the original. Close the DADF right side cover.

Check location C

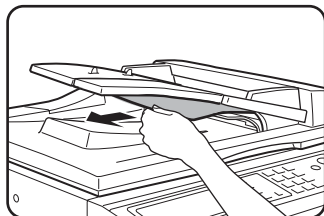

Remove the misfed original from the exit area.

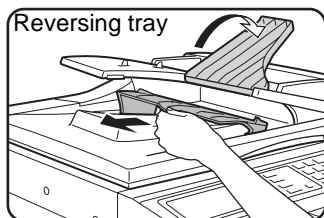

If the misfed original cannot be easily removed from the exit area, open the moveable part of the DADF tray and remove the reversing tray and then remove the original.

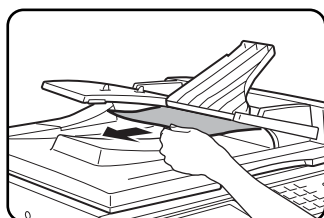

After removing a misfed original from the exit area, be sure to attach the reversing tray securely to the exit area.

2. Open and close the DADF cover.

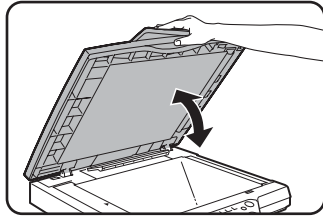

Opening and closing the cover clears the misfeed display. Copying cannot be resumed until this step is performed.

A message may appear indicating the number of originals which must be returned to the DADF tray. Return the originals to the DADF tray and press the [START] key for colour or black and white copying as appropriate for the job being resumed.

User Maintenance (for copying)

To ensure good service from this product over a long period of time, it is recommended that the following maintenance procedures be performed on a regular basis.

CAUTION Do not use flammable spray to clean the machine. If gas from the spray comes in contact with hot electrical components or the fusing unit inside the machine, fire or electrical shock may result.

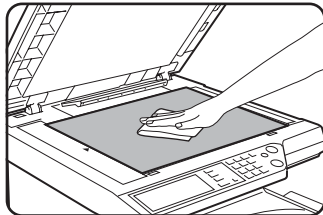

Wipe with a clean, soft cloth.

If necessary, moisten the cloth with water or a small amount of neutral detergent. When finished, wipe dry with a clean cloth.

NOTE: When cleaning, do not use thinner, benzene, or similar volatile cleaning agents. These may degrade or discolour the housing.

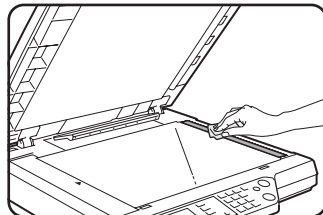

If you find that a dirty image results when a copies are made using the DADF, wipe the original scanning area (the area that contains the long narrow glass shown at left).

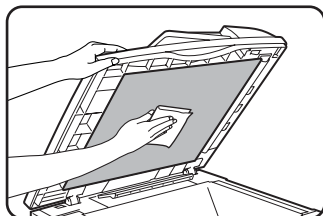

Cleaning the Original Scanning Area

If you find that black (or white) lines appear when you make copies using the DADF, use the accessory glass cleaning tool to clean the original scanning area.

1. Open the DADF and remove the glass cleaning tool.

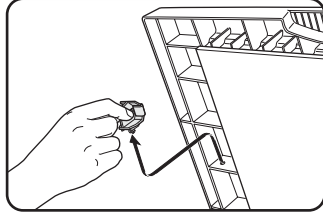

2. Clean the original scanning area with the glass cleaning tool.

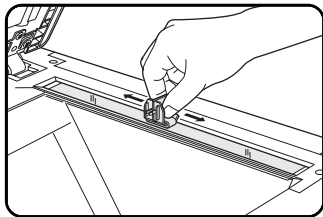

3. Replace the glass cleaning tool in its storage position.

Example of dirty print image

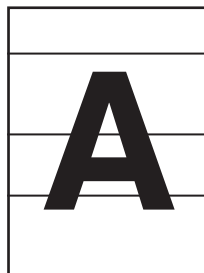

Black lines



White lines

Original feed direction



Troubleshooting

Whenever the machine stops or operation is not possible, check the operation panel display for messages. In most cases, these messages will give sufficient information to return the machine to an operating condition. In cases where this information is not enough, check the list below for more information. This section describes problems concerning copier features. For troubleshooting specific problems related to the printer, network scanner, and fax features, see the separate manuals provided for these features. For problems related to other peripheral devices, see page 1-56.

Problem	Check	Solution or cause
Machine does not operate.	Are the [START] keys indicators off?	If the indicators are not on, the machine may be warming up. Warm-up should be completed in 99 seconds or less.
Copies are too dark or too light.	Is the original image too dark or too light?	Select an appropriate resolution setting for the original being copied and adjust the copy exposure (see page 2-25).
	Is the exposure mode set to "AUTO"?	The exposure level for "AUTO" can be adjusted using the "Exposure adjustment" key operator program. Contact your key operator.
	An appropriate resolution setting for the original has not been selected.	Change the resolution setting to "AUTO" or manually select an appropriate resolution setting (see page 2-25).
Text is not clear on a copy.	An appropriate resolution setting for the original has not been selected.	Change the resolution setting to "TEXT"
Moiré appears on a copy of a magazine, catalogue, or other printed material.	An appropriate resolution setting for the original has not been selected.	Change the resolution setting to "PRINTED PHOTO".
Text overlaying a photo is not clear on a copy of a map, magazine or other printed material.	An appropriate resolution setting for the original has not been selected.	Change the resolution setting to "MAP".
Smudges appear on copies.	Document glass or document cover dirty?	Clean the surface of the document glass, and the original scanning area and original presser part of the DADF (see page 2-82).
	Black or white line appear on copies when the single pass feeding function is used.	Clean the original scanning area (see page 2-82).
	Original smudged or blotchy?	Use a clean original.

Problem	Check	Solution or cause
Image cannot be rotated.	Is the auto paper select or auto image function set?	Rotation copy functions only if the machine is either in the auto paper select mode or in the auto image mode (see page 2-8).
Part of original image is not copied.	Is the original positioned correctly?	Set the original properly (page 2-4).
	Is the copy ratio proper for the original and paper sizes?	Use the auto image function to select the appropriate copy ratio based on the original and copy sizes (see page 2-28).
Blank copies	Is the original placed correctly?	When using the document glass, place the original face down. When using the DADF, place original face up.
Order of copies incorrect	Is the order of originals correct?	When using the document glass, set the originals from the first page one sheet at a time. When using the DADF, set the originals with the first page up.
Job cancellation needed	Is a message requesting cancellation of job displayed?	Press the [CLEAR ALL] key to cancel the current job.
Scanning of originals is incomplete.	Is a message indicating memory is full displayed?	If the data amount exceeds the limit when using the pamphlet copy or multi shot copy which requires scanning of all originals, scanning will be cancelled and copying will not be performed. If you install an additional memory, the storage capacity will increase.
The selected number of sets of copies is not printed.	For an interrupt copy job, are you attempting colour copying in sort mode?	When colour copying is performed in sort mode for an interrupt copy job, only one set of copies can be made. If more than one set is needed, replace the original and repeat the copy procedure for each set needed.
Not all pages are copied	When making copies, the memory became full during scanning of the originals and a message appears asking you whether you want to continue copying or cancel.	When the memory becomes full during scanning of the originals, you can select whether you want to continue the job and print only those originals that were scanned, or cancel the job. If you continue the job, copies will only be made of the originals that were scanned, and thus all originals cannot be copied at once.

3 Printer Operation

Basic Printing Procedures

This section explains how to configure printer driver settings at your computer, and provides basic information on printing.

NOTE: *For printer driver installation, see the Xerox WorkCentre C226 Quick Start Guide.*

Setting the Printer Drivers

This section describes the method of changing the printer driver settings from your computer. If you have not yet installed the printer driver (PCL5c or PostScript), read the "Printer Installation" section in the WorkCentre C226 System Administration Guide and install the printer driver from the CD-ROM.

NOTE: *The WorkCentre C226 comes standard with a WorkCentre C226 PCL Print Drivers and Printer/Network Utilities CD-ROM. The WorkCentre C226 PS Driver CD-ROM is available with the purchase of the optional PostScript Kit.*

Printer driver settings in Windows (selecting and setting print conditions)

Change the settings using the printer properties.

Windows 95 / 98 / Me

The procedure for adjusting the settings in Windows Me is explained in the following.

1. On the [Start] menu, select [Settings] and then [Printers].
2. Right-click the installed printer driver and select [Properties].

3. Set each item.

For setting items, see the printer driver help. For information on viewing Help, see page 3-3. An example showing how to set [Color Mode] to [Automatic] printing is given on page 3-2.

4. Click the [OK] button.

Windows NT4.0 / 2000 / XP / Server 2003

The procedure for adjusting the settings in Windows XP is explained in the following.

1. Select [Printers and Faxes] from the [Start] menu.
2. Right-click the installed printer driver and select [Printing Preferences...].
3. Set each item.

For setting items, see the printer driver help. For information on viewing Help, see page 3-3. An example showing how to set [Color Mode] to [Automatic] printing is given on page 3-2.

4. Click the [OK] button.

NOTE: *Settings for the Duplex Module/2-Tray Unit, Saddle Stitch Finisher, 3-Tray Unit, and other optional peripheral equipment can be accessed by right-clicking the installed printer driver, selecting [Properties], and then selecting the [Configuration] tab. If you use this product as a network printer and you have installed the Xerox Print Status Monitor, the configuration of peripheral devices will be automatically set by clicking [Auto Configuration]. If you click the [Update Tray Status] button in the [Tray Status] dialog box of the [Paper] tab, the current tray information (paper size, paper type, and quantity of paper remaining) will be displayed.*

Selecting a Color Mode setting

The following example shows how to set [Color Mode] to [Automatic] printing in the Color tab of the printer driver properties.

1. Follow steps 1 and 2 on page 3-1.
2. Click the [Color] tab.

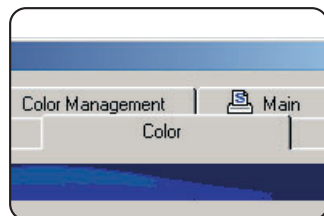

3. Select [Automatic] from the [Color Mode] list.

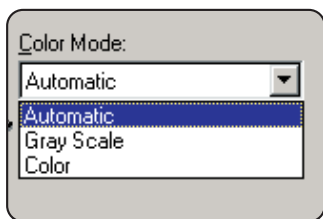

When [Color Mode] is set to [Automatic], the print driver identifies the colours in each page, and automatically switches to [Color] mode when colours other than black and white are used in a page, or [Gray Scale] when only black and white are used. To turn on automatic switching, select [Automatic] for the [Color Mode] setting.

When [Automatic] is selected and mixed black and colour pages are printed, a slower printing speed will result.

4. Click the [Apply] button.



5. Click the [OK] button.

Printing in [Color Mode] will now always take place [Automatic].

Using the Help file to view explanations of the settings

To view on-screen explanations of the settings in the printer driver, open the Help file.

Opening Help in Windows

The example screen shows the Xerox PCL5c in Windows Me.

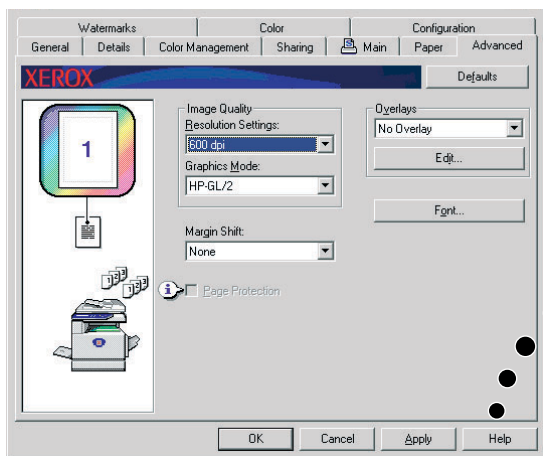

Click [Help] to display the Help screen.

You can search for information using various methods from the tabs.

Printing in black and white

The procedure for printing in black and white is explained below using WordPad*¹ as an example. If you do not have any documents created in WordPad, create a document that can be used for test printing.

To print in black and white, select [Gray Scale] for the [Color Mode] setting. [Gray Scale] uses only Bk (black) toner to produce a black and white image. Colour documents are also printed in black and white.

*1 This is a standard accessory program in Windows.

1. Open a document created in WordPad.
2. Select [Print] from the [File] menu of WordPad.

The Print window appears.

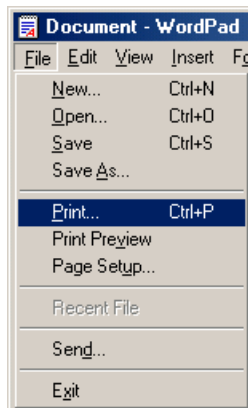

Print window in Windows Me

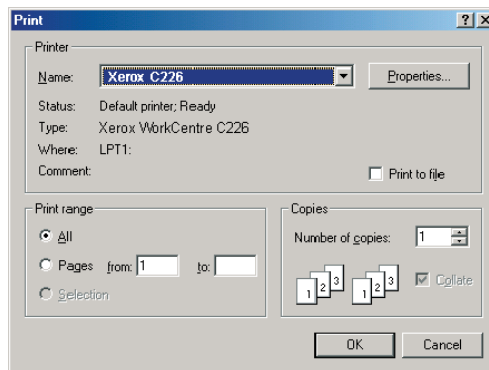

Print window in Windows XP

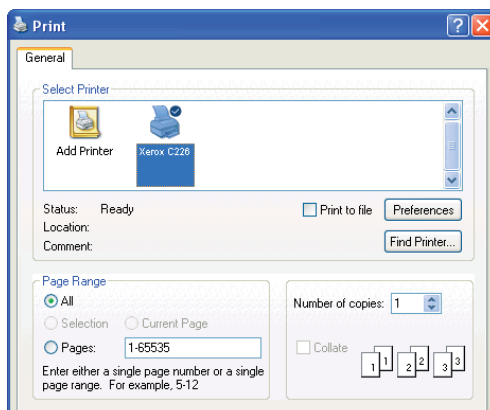

- In Windows 95/98/Me/NT 4.0, click the [Properties] button.

In Windows 2000, click the displayed tab. In Windows XP/Server 2003, click the [Preferences] button.

NOTE: For detailed explanations of the following settings, see “Setting the Printer Driver Properties” on page 3-15.

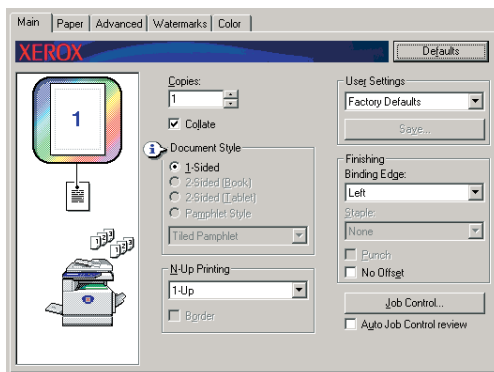

- Click the [Color] tab and select [Gray Scale] for the [Color Mode] setting.

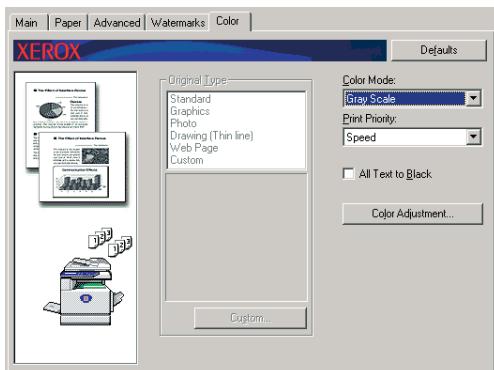

NOTE: *[Print Priority] lets you select whether priority is given to quality or speed during printing (page 3-38). Select the mode that is most suitable for your needs.*

5. If you need to adjust the black and white image quality (print contrast), perform the following step. If you do not need to adjust the image quality, go directly to step 6.

To adjust the black and white image quality (print contrast), click the [Color Adjustment] button. The following screen will appear. Adjust the brightness and contrast in the [Image] field at left (page 3-38). When finished, go to step 6.

6. Click the [Paper] tab.

Make sure that the paper size is correct. Next, configure the "Paper Selection" settings. "Auto Select" is normally used for both "Paper Source" and "Paper Type". When you have completed the settings, click the [OK] button to close the printer properties window.

NOTE: *Using the Bypass Tray*

When the paper source is set to the Bypass Tray, be sure to set the paper size and paper type on the machine's operation panel. This procedure is explained on page 1-23).

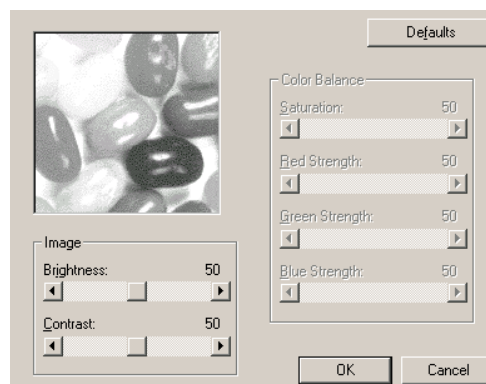

7. Click the [OK] button in the Print window in Windows 95/98/Me/NT 4.0, or the [Print] button in Windows 2000/XP/Server 2003.

Automatic switching between colour and black and white

The procedure for printing a document using automatic switching between colour and black and white is explained here using WordPad*¹ as an example. If you do not have any documents created in WordPad, create a document that can be used for test printing.

You can have the print driver identify the colours in each page, and automatically switch to [Color] mode when colours other than black and white are used in a page, or [Gray Scale] when only black and white are used. To turn on automatic switching, select [Automatic] for the [Color Mode] setting.

*1 This is a standard accessory program in Windows.

1. Open a document created in WordPad.
2. Select [Print] from the [File] menu of WordPad.

The Print window appears.

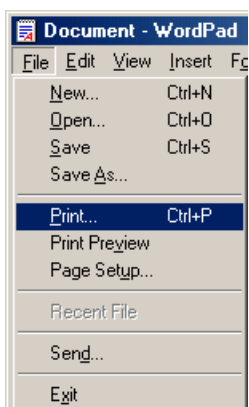

Print window in Windows Me

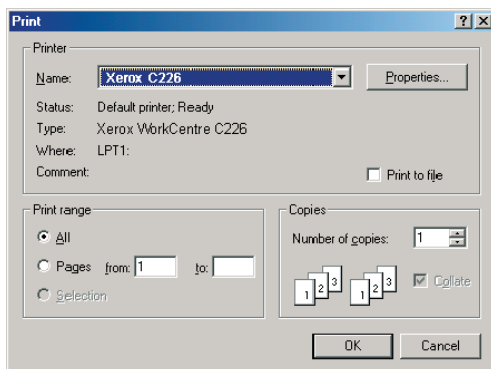

Print window in Windows XP

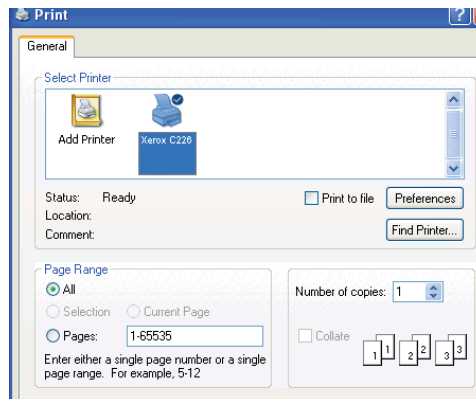

3. In Windows 95/98/Me/NT 4.0, click the [Properties] button.

In Windows 2000, click the displayed tab. In Windows XP/Server 2003, click the [Preferences] button.

NOTE: For detailed explanations of the following settings, see “Setting the Printer Driver Properties” on page 3-15.

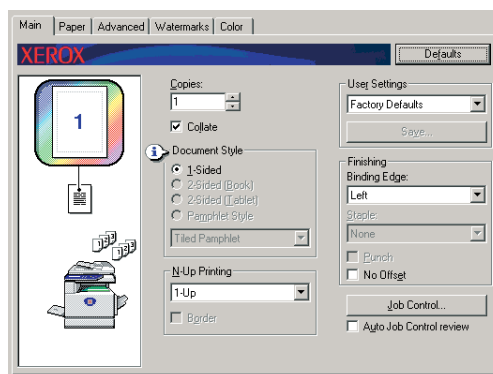

4. Click the [Color] tab and select [Automatic] for the [Color Mode] setting.

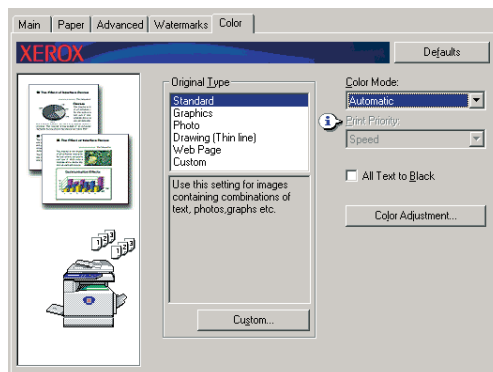

NOTE: Select the [Original Type] setting that most closely matches your document to obtain the best image quality (page 3-35).

5. If you need to adjust the colour image quality and/or the black and white image quality (print contrast), perform the following step. If you do not need to adjust the image quality, go directly to step 6.

To adjust the colour image quality and/or black and white image quality (print contrast), click the [Color Adjustment] button. The following screen will appear. Use the [Color Balance] field to adjust the saturation of colour images, and strengthen or weaken the RGB (red, green, and blue) colour components.

Use the [Image] field to adjust the brightness and contrast of both colour and black and white images (page 3-38).

When finished, go to step 6.

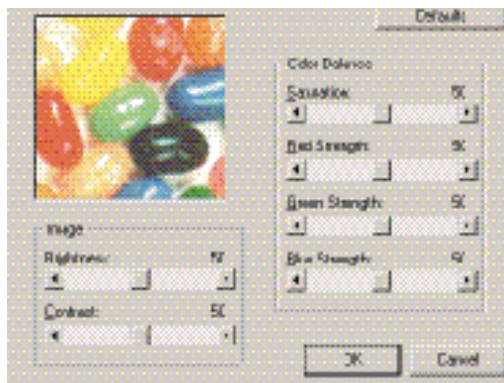

6. Click the [Paper] tab.

Make sure that the paper size is correct. Next, configure the "Paper Selection" settings. "Auto Select" is normally used for both "Paper Source" and "Paper Type". When you have completed the settings, click the [OK] button to close the printer properties window.

NOTE: Using the Bypass Tray

When the paper source is set to the Bypass Tray, be sure to set the paper size and paper type on the machine's operation panel. This procedure is explained on page 1-23.

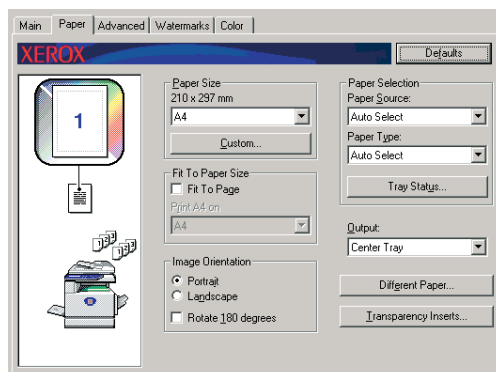

7. Click the [OK] button in the Print window in Windows 95/98/Me/NT 4.0, or the [Print] button in Windows 2000/XP/Server 2003.

Printing in colour

The procedure for printing a document in colour is explained here using WordPad*¹ as an example. If you do not have any documents created in WordPad, create a document that can be used for test printing.

To print in colour, set the [Color Mode] setting to [Color]. Both colour and black and white documents will be printed using Y (yellow), M (magenta), C (cyan), and Bk (black) toner.

*1 This is a standard accessory program in Windows.

1. Open a document created in WordPad.
2. Select [Print] from the [File] menu of WordPad.

The Print window appears.

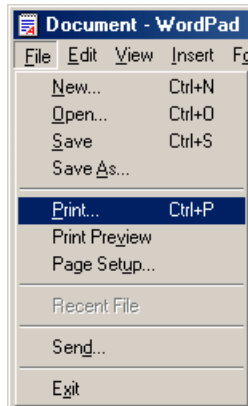

Print window in Windows Me

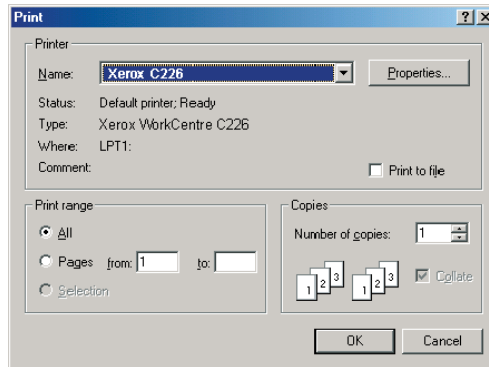

Print window in Windows XP

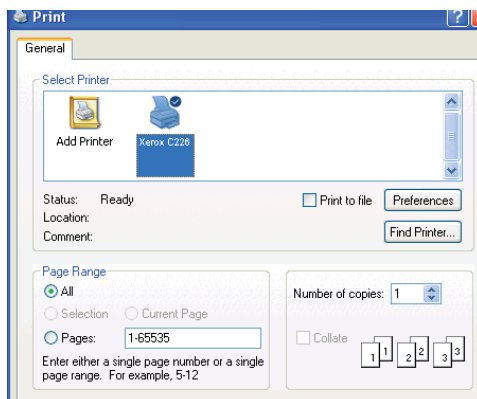

3. In Windows 95/98/Me/NT 4.0, click the [Properties] button.

In Windows 2000, click the displayed tab. In Windows XP/Server 2003, click the [Preferences] button.

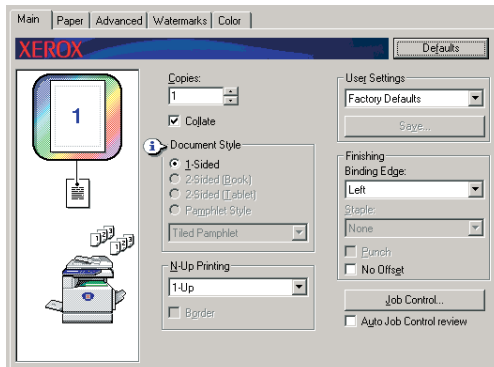

NOTE: For detailed explanations of the following settings, see “Setting the Printer Driver Properties” on page 3-15.

4. Click the [Color] tab and select [Color] for the [Color Mode] setting.

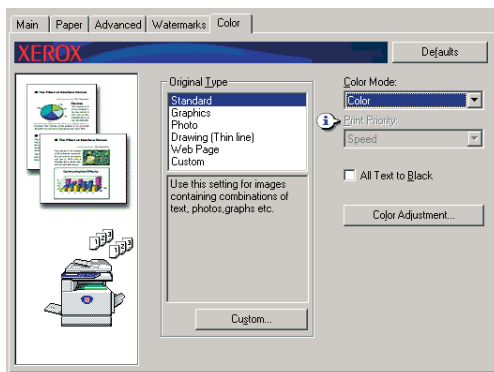

NOTE: Select the [Original Type] setting that most closely matches your document to obtain the best image quality (page 3-35).

5. If you need to adjust the colour image quality, perform the following step. If you do not need to adjust the image quality, go directly to step 6.

To adjust the colour image quality, click the [Color Adjustment] button. The following screen will appear. Use the [Color Balance] field to adjust the saturation of colour images, and strengthen or weaken the RGB (red, green, and blue) colour components.

Use the [Image] field to adjust the brightness and contrast of colour images. (page 3-38)

When finished, go to step 6.

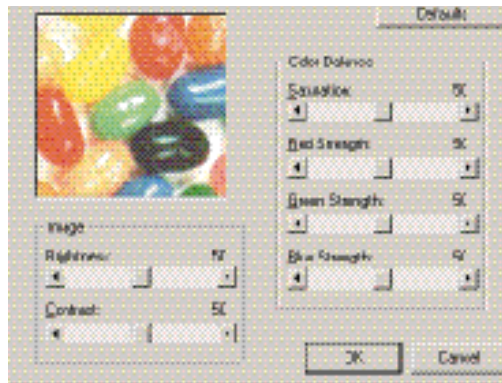

6. Click the [Paper] tab.

Make sure that the paper size is correct. Next, configure the "Paper Selection" settings. "Auto Select" is normally used for both "Paper Source" and "Paper Type". When you have completed the settings, click the [OK] button to close the printer properties window.

NOTE: Using the Bypass Tray

When the paper source is set to the Bypass Tray, be sure to set the paper size and paper type on the machine's operation panel. This procedure is explained on page 1-23).

7. Click the [OK] button in the Print window in Windows 95/98/Me/NT 4.0, or the [Print] button in Windows 2000/XP/Server 2003.

Printing using optional peripheral equipment

The procedure for printing from WordPad *1 using optional peripheral equipment is explained below. If you do not have any documents created in WordPad, create a document that can be used for test printing.

*1 This is a standard accessory program in Windows.

1. Open a document created in WordPad.

2. Select [Print] from the [File] menu of WordPad.

The Print window appears.

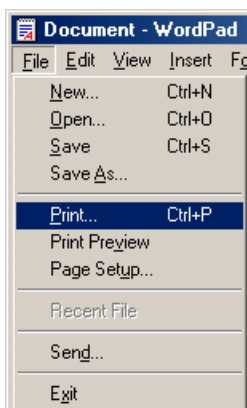

Print window in Windows Me

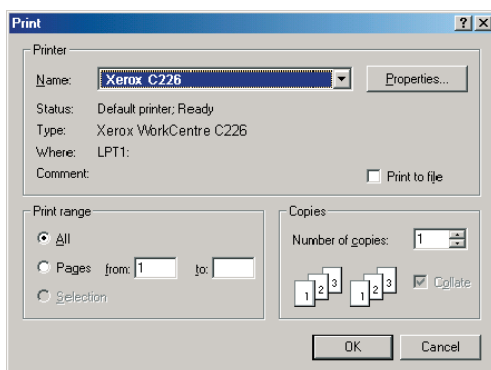

Print window in Windows XP

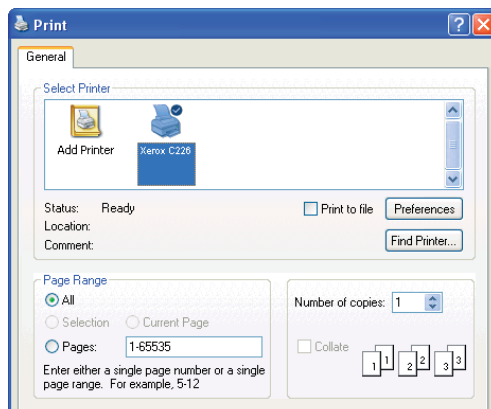

3. In Windows 95/98/Me/NT 4.0, click the [Properties] button.

In Windows 2000, click the displayed tab. In Windows XP/Server 2003, click the [Preferences] button.

NOTE: For detailed explanations of the following settings, see "Setting the Printer Driver Properties" on page 3-15.

To print using the two-sided printing function or the Saddle Stitch Finisher, select these options in the following window.

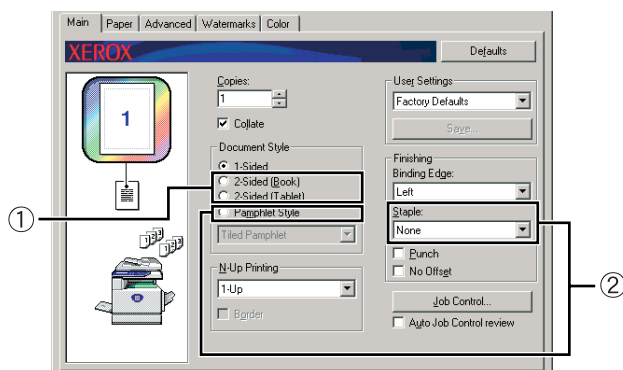

① For two-sided printing, select "2-Sided (Book)" or "2-Sided (Tablet)".

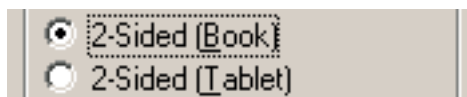

② To use the saddle stitch function, select "Pamphlet Style" and then set [Staple] to "2 Staples" in the [Finishing] field.

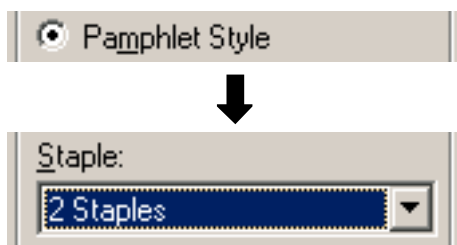

4. Click the [Paper] tab.

Make sure that the paper size is correct. Next, configure the "Paper Selection" settings. "Auto Select" is normally used for both "Paper Source" and "Paper Type".

If you wish to use the optional High Capacity Feeder, select it in the following window.

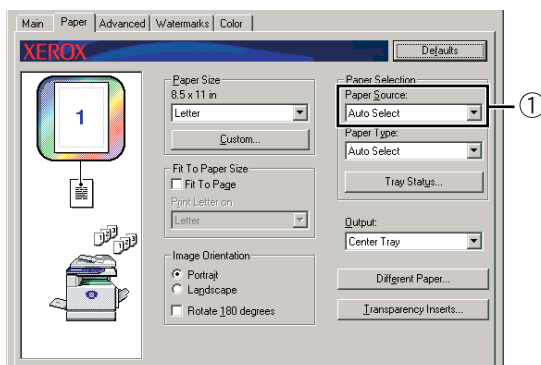

① If you wish to specify a paper tray, select the tray from the "Paper Source" list in the Paper Selection field.

Example: Selecting the "High Capacity Feeder"

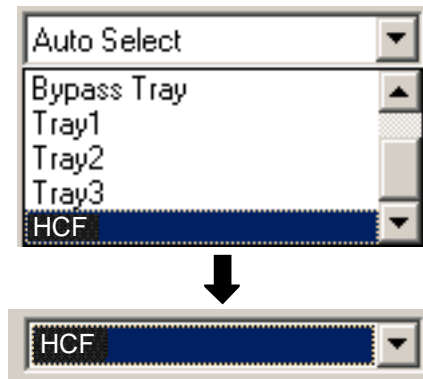

5. To change the colour mode, click the [Color] tab and select the desired mode from the [Color Mode] list.
6. Adjust the image quality settings as needed (page 3-38). (If not needed, go directly to step 7.)
7. Click the [OK] button in the Print window in Windows 95/98/Me/NT 4.0, or the [Print] button in Windows 2000/XP/Server 2003.

Setting the Printer Driver Properties

This section explains how to configure settings in the printer driver. The settings are changed in the software application.

Selecting Printing Functions

Almost all printer settings are configured in the printer driver properties window that appears when you print from an application or when you select [Properties] from the printer driver icon menu. Click a tab in the properties window to adjust the settings on that tab.

The following explains how to adjust settings when the properties window is opened from an application.

(The windows that are shown are the PCL5c printer driver in Windows Me.)

The printer driver window shown in the following explanation has the following options installed:

Duplex Module/2-Tray Unit + Duplex Bypass/Inverter Unit + Saddle Stitch Finisher + Punch Module

Frequently used settings

The following screen appears when the Main tab is selected. The settings and buttons in the screen are explained below.

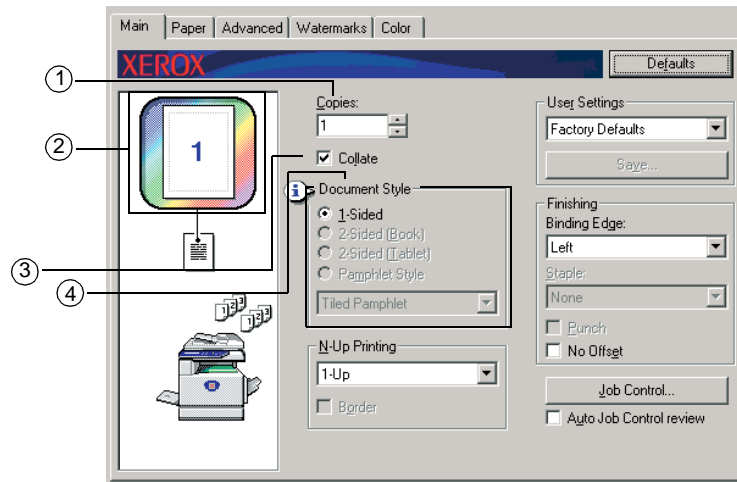

① Copies

Set the number of copies.

Any number from 1 to 999 can be set.

Default setting: 1

② Colour mode display

This displays the selected colour mode for printing. Three colour modes are available: "Automatic", "Color", and "Gray Scale" (see ④ on page 3-37).

③ Collate

Select this checkbox to collate the copies.

When the staple function or punch function is turned on, a checkmark automatically appears in the checkbox.

Default setting: Selected

④ **Document Style**

Select one-sided or two-sided printing.

[1-Sided] Print on one side of the paper.

[2-Sided (Book)] Print on both sides of the paper and bind at the side.

[2-Sided (Tablet)] Print on both sides of the paper and bind at the top.

[Pamphlet Style]*¹ Print on both sides of the paper and bind down the middle.

Default setting: 1-Sided

*1 The following two formats can be selected for middle binding.

[Tiled Pamphlet]

Print on paper double the size of the document size selected in the application.

The page order will be rearranged as required for the middle binding format.

[2-Up Pamphlet]

The document size selected in the application will be reduced in the same way as in 2-Up printing, and printing will take place using the selected paper size.

The page order will be rearranged as required for the middle binding format.

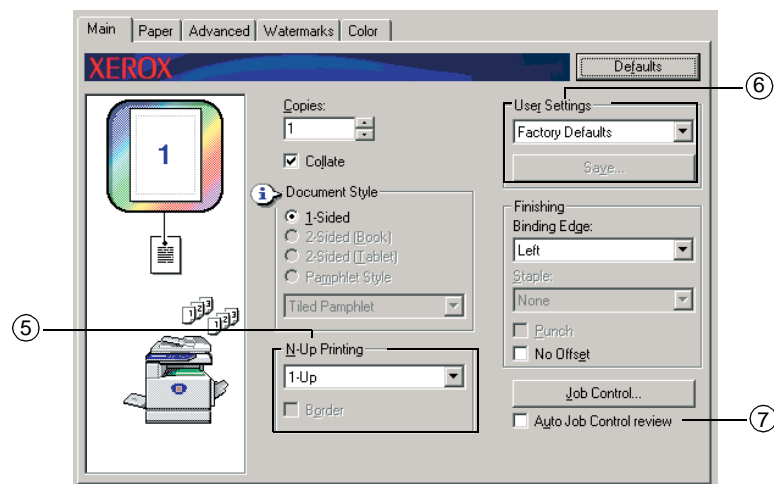

⑤ **N-Up Printing**

Each page is reduced to allow multiple pages to be printed on each sheet of paper. The pages are printed in "Z" order on each sheet.

The following five settings are available:

[1-Up], [2-Up], [4-Up], [6-Up], [8-Up].

Default setting: 1-Up

Example: 4-Up

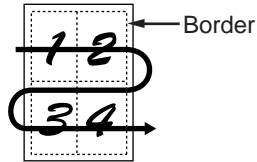

[Border]

This setting is greyed out when [1-Up] is selected. Select whether or not to print a border around each page when a setting other than 1-Up is selected.

Default setting: Not selected

⑥ **User Settings**

The user can store up to 30 sets of settings, allowing the settings to be easily changed by simply selecting the desired set.

Default setting: Factory Defaults

[Save]

Save the settings under the name that appears in "User Settings".

Up to 20 characters can be entered for the name. If none of the settings have been changed (the settings are still the factory defaults), this button will be greyed out.

When [Delete] appears in the button, it can be clicked to delete a stored set of user settings.

⑦ **Auto Job Control review**

Select this to have the job control screen constantly displayed when printing from the printer driver.

Default setting: Not selected

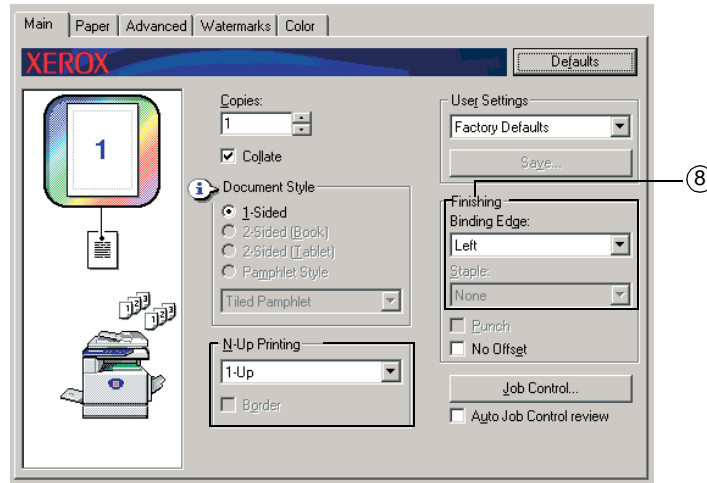

⑧ **Finishing**

Configure settings for staple or punch finishing.

[Binding Edge]

When automatic two-sided printing is performed, the [Binding Edge] setting is used to determine how the left, right and top edges of the front and back sides are positioned. The relation between the document and each of the settings is as follows:

Default setting: Left

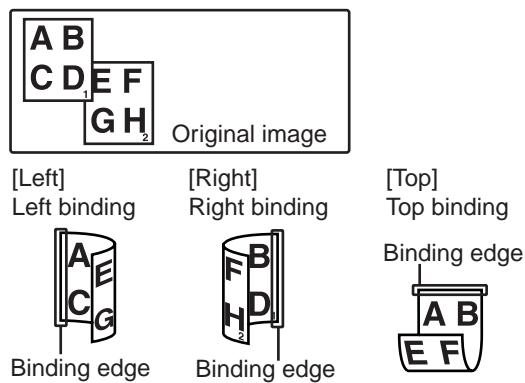

[Staple]

- [None] Do not staple.
- [1 Staple] Staple in one place.
- [2 Staples] Staple in two places.

When [1 Staple] or [2 Staples] is selected, the [Collate] setting is automatically activated.

Default setting: None

Saddle stitch function

The Saddle Stitch Finisher can automatically place two staples for centreline binding of prints or copies and fold them along the centreline.



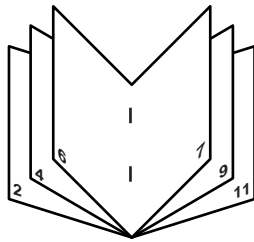

<Example>

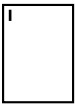
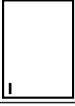
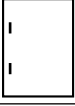
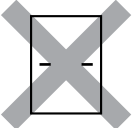

Staple sort mode

Collated sets of prints or copies will be stapled and delivered to the offset tray. When saddle stitching is selected, the prints or copies will be stapled at the centre and delivered to the saddle stitch tray. The stapling positions, orientation, paper size for stapling, and stapling capacity are shown below.

Stapling positions

Portrait orientation	Top left corner of printouts		Available paper sizes: A4, B5 and 8-1/2" x 11" Stapling capacity: For each size, up to 30 sheets can be stapled
	Lower left corner of printouts		Same as above
	Centre left two positions of printouts		Same as above
	Saddle stitch on centrefold line.		Paper in the portrait direction cannot be saddle stitched.
Landscape orientation	Top left corner of printouts		Available paper sizes: A3, B4, A4R, 11" x 17", 8-1/2" x 14", 8-1/2" x 13" and 8-1/2" x 11" R Stapling capacity: Up to 30 sheets of A4R or 8-1/2" x 11"R paper can be stapled, up to 25 sheets of other paper sizes
	Lower left corner of printouts		Same as above
	Centre left two positions of printouts		Same as above
	Saddle stitch on centrefold line.		Available paper sizes: A3, B4, A4R, 11" x 17" and 8-1/2" x 11"R Stapling capacity: For each size, up to 10 sheets can be stapled

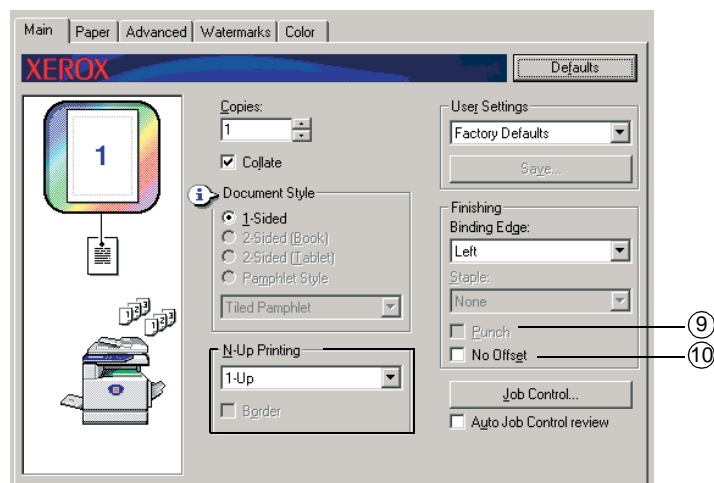

⑨ **[Punch]**

Configure the settings for the Punch function.

When this is selected, the document will be hole-punched. The Collate setting is automatically activated when Punch is selected.

Default setting: Not selected

Hole punching (only if a Hole Punch Module is installed)

If the Saddle Stitch Finisher is equipped with a Hole Punch Module, printed paper can be hole punched and delivered to the offset tray. Saddle stitching and hole punching cannot be selected at the same time. The automatic image rotation will not function when the hole punching function is used.

<Example>

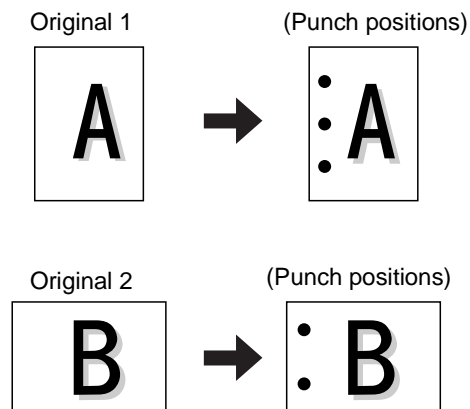

⑩ **[No Offset]**

Select this setting when you do not wish sets of collated or grouped output to be offset from each other.

Default setting: Not selected

Offset mode

When delivered to the tray, each set or group of pages will be offset from the previous set for easy separation.

(The offset function only operates in the offset tray.)

Stapled sets will not be offset.

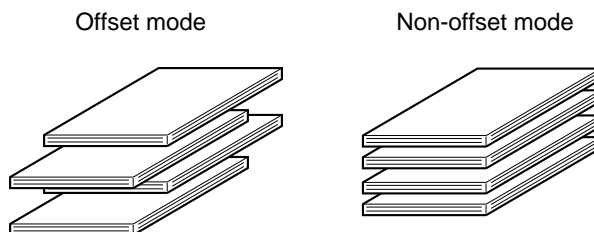

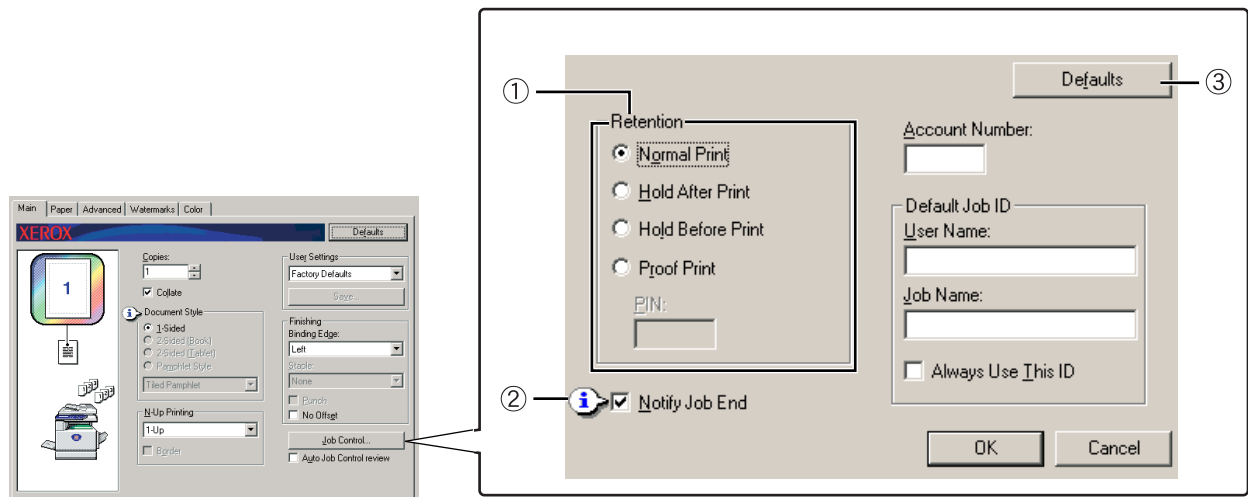

① Retention

[Normal Print]

When selected, it is not necessary to use the operation panel on the machine to begin printing. This setting is used for basic printing. As long as the machine is operating properly, printing can be executed entirely from the computer.

[Hold After Print]

When selected, the print job is retained in the machine's hold job list after being printed. This allows the user to print the job again if necessary, or delete the job if no longer needed.

[Hold Before Print]

This setting is used to prevent print jobs from being misplaced. When a print job is executed, the machine stores it in the hold job list rather than printing it. The user can then initiate printing from the machine's operation panel, or delete the job as needed.

[Proof Print]

This setting is used to prevent misprints when printing large numbers of copies. When printing is executed, the machine prints only one trial set of copies and then stores the remainder of the job in the hold job list. After the user has verified that the copies are acceptable, the job can be resumed from the machine's operation panel. (The trial set of copies is included in the total number of sets.) If the copies are not acceptable, the job can be deleted without printing.

[PIN] (5-digit identification number)

A PIN number can be programmed in the printer driver for increased security when printing jobs from the hold job list. When this is done, the PIN number must be entered at the machine's operation panel to print a job in the job hold list.

- "Hold After Print" mode with password:
Password entry on the operation panel of the printer is needed for additional printing of the hold job.
- "Hold Before Print" mode with password:
Password entry on the operation panel of the printer is needed to start printing.
- "Proof Print" mode with password:
Password entry on the operation panel of the printer is needed to print the remaining sets after printing one set. The first set is printed without password entry.

Default setting: Normal Print

② Notify Job End

Select whether or not you wish to be notified about printing completed.

This function only operates when the Xerox Print Status Monitor is running. Even if selected, the function will not operate when the Xerox Print Status Monitor is not running.

Default setting: Selected

③ Defaults

Returns the settings in the job control window to the default settings.

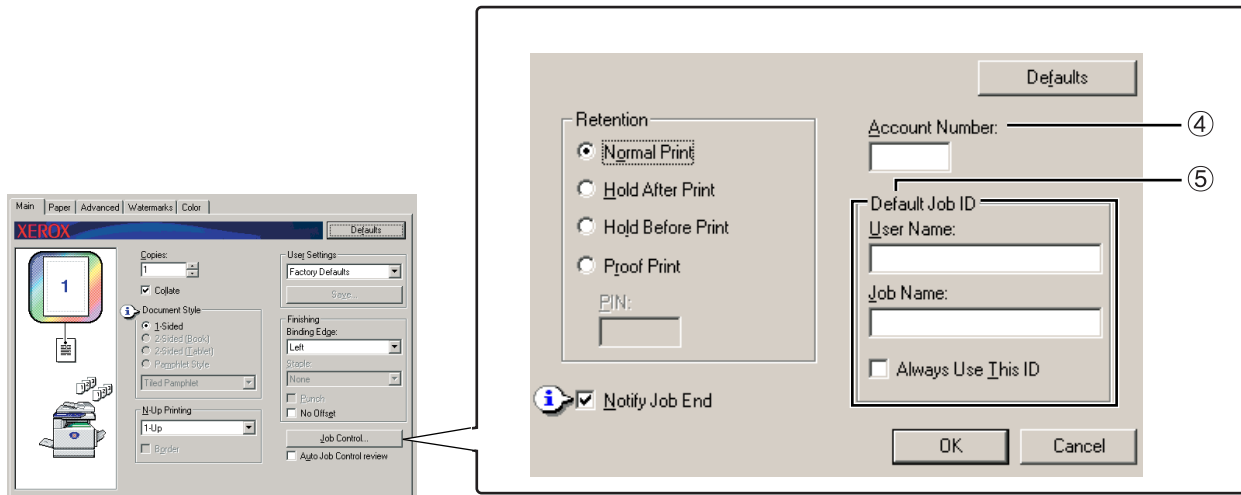

④ **Account Number**

When the "AUDITING MODE" of the key operator program is turned on, a count can be kept of the number of sheets printed by each account. Account numbers for this purpose are programmed using the key operator program for the printer sheet count. To program an account number, see "Key operator programs".

When the "ACCOUNT LIMIT SETTING" (key operator program) is turned on, printing is not permitted after the page count reaches the limit.

When the "CANCEL JOBS OF INVALID ACCOUNTS" of the key operator program is turned on, printing will not take place if an invalid account number is entered, or if printing is executed without entering an account number. If you want printing be allowed even if a valid account number is not entered, turn this setting off. In this case, pages printed by an invalid account number will be included in the "OTHERS" count.

⑤ **Default Job ID**

Use this setting to select the default user name and job name that appear in the machine's operation panel. Note that if "Always Use This ID" is not selected, the Windows login name and the job name set in the application will be automatically used.

The names that appear here will also appear in the operation panel in the dialog box that appears when printing is executed.

[User Name]

Use this setting to select the default "User Name" that appears in the machine's operation panel. If "Always Use This ID" is selected, the name entered here will appear in the machine's operation panel. If "Always Use This ID" is not selected, the Windows login name will be automatically used.

Up to 16 characters can be entered.

Default setting: User name unknown

[Job Name]

Use this setting to select the default "Job Name" that appears in the machine's operation panel. If "Always Use This ID" is selected, the name entered here will appear in the machine's operation panel. If "Always Use This ID" is not selected, the job name set in the application will be automatically used.

Up to 30 characters can be entered.

Default setting: Job name unknown

[Always Use This ID]

This allows you to select whether to automatically obtain the "User Name" and "Job Name" displayed in the machine's operation panel, or whether to use the names entered in this dialog box.

Not selected The Windows login name will be automatically used for the "User Name", and the job name set in the application will be automatically used for the "Job Name".

Selected The names entered in this dialog box will appear in the machine's operation panel.

Default setting: Not selected

Paper settings

The following screen appears when the Paper tab is selected. The settings and buttons in this screen are explained below.

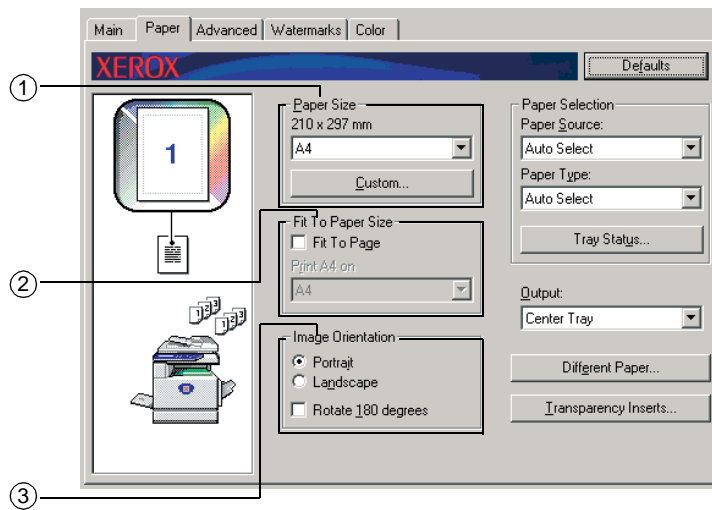

① **Paper Size**

Select the size of paper to be printed on.

Click one of the paper sizes that appear in the box.

Default setting: A4

[Custom]

A custom paper size can also be set.

Only one custom paper size can be stored.

Click this button to open the window for setting the custom paper size.

When printing with a custom paper size, there is limitation on paper orientation.

To print with a custom paper size, set the paper in horizontal orientation.

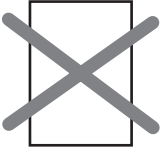
Correct	Wrong
<div style="text-align: center;">  <p>Horizontal loading</p> </div>	<div style="text-align: center;">  <p>Vertical loading</p> </div>

② **Fit To Paper Size**

This field is used for the Fit to Page function. This function automatically enlarges or reduces the printed image to match the paper being used. Enlargement or reduction takes place with the image centred on the page.

To use this function, select the "Fit to Page" checkbox and then select the size of paper to be used.

NOTE: *Printing normally takes place using the paper size set in the application, regardless of the paper size selected in the printer driver. When the paper size is not specified in the application, the paper size setting in the printer driver is used.*

[Fit To Page]

When this checkbox is selected, the print image corresponding to the paper size selected in [Paper Size] is automatically reduced or enlarged to fit the paper selected in [Fit To Paper Size].

Default setting: Not selected

③ **Image Orientation**

Set the orientation of the document.

Click the radio button for [Portrait] or the radio button for [Landscape].

[Portrait] Select portrait orientation.

[Landscape] Select landscape orientation.

Default setting: Portrait

[Rotate 180 degrees]

Rotate the image 180° before printing. This function rotates the image to enable correct printing on envelopes and other paper with flaps.

Default setting: Not selected

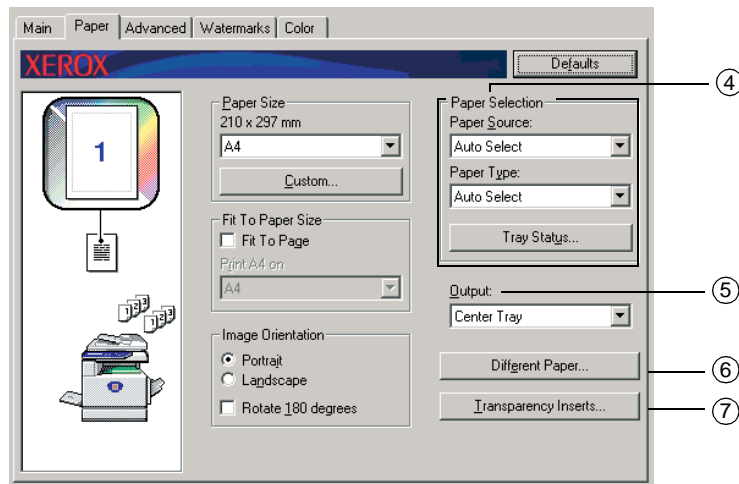

④ **Paper Selection**

Select the paper tray and paper type in this item.

[Paper Source]

Select the paper tray. When [Auto Select] is selected, the tray containing the paper specified in [Paper Size] and [Paper Type] is automatically used. If a setting other than [Auto Select] is selected, paper will be drawn from the selected source regardless of the [Paper Size] and [Paper Type] settings.

Default setting: Auto Select

[Paper Type]

Set the paper type. It is also necessary to set the paper type at the operation panel on the machine.

Default setting: Auto Select

[Tray Status]

Click this button to display the paper size, paper type, and paper remaining in the machine's paper trays.

This function operates when the Xerox Print Status Monitor is running in the user's PC and the printer is used on a network.

⑤ **Output**

This sets the exit tray for the printed output.

This cannot be selected when the staple function is turned on.

Default setting: Center Tray

⑥ **Different Paper**

This sets the paper tray from which the paper for the first page is drawn.

Click this button to open the window for selection of cover sheet settings.

⑦ **Transparency Inserts**

Select this setting when you wish to insert a different type of paper between pages.

Click this button to open the window for selection of transparency insert settings.

This cannot be selected when two-sided printing, the staple function, or the punch function is selected.

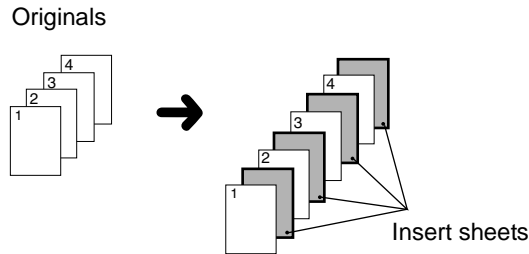

Advanced settings

PCL5c

The following screen appears when the Advanced tab is selected. The settings and buttons in this screen are explained below.

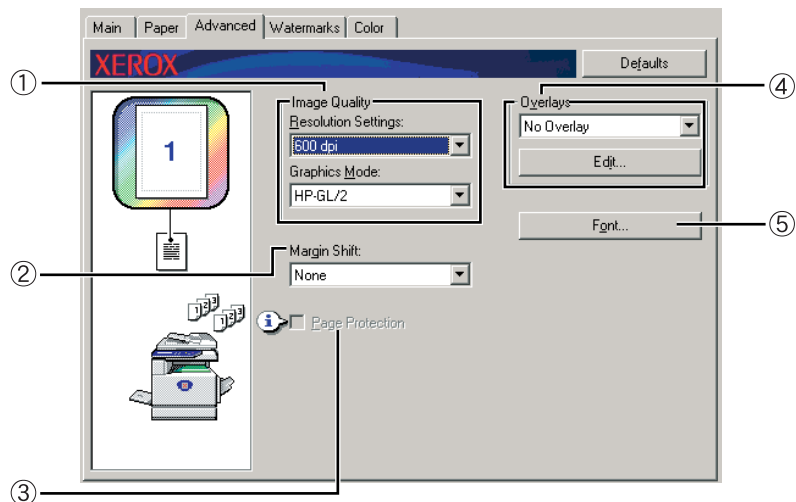

① **Image Quality**

This item is used to select the [Resolution Settings] and [Graphics Mode] for printing.

[Resolution Settings]

Select 300 dpi or 600 dpi.

Default setting: 600 dpi

[Graphics Mode]

Select [Raster] or [HP-GL/2]. Select [Raster] to print using raster graphics. Select [HP-GL/2] to print using HP-GL/2 commands.

Default setting: HP-GL/2

② **Margin Shift**

Use this setting to shift the document image to move the margin at the left, right, or top of the paper. Select from [None], [10 mm.], [20 mm.], or [30 mm.].

Default setting: None

One-sided copying

Original image



Image shifted to the right

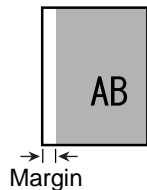

Image shifted to the left

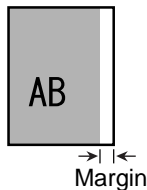
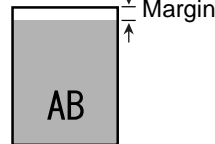

Image shifted to the bottom



Two-sided copying

Original image

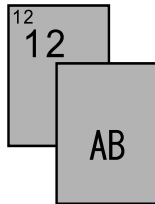

Image shifted to the right

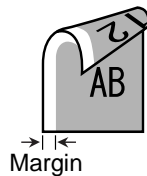

Image shifted to the left

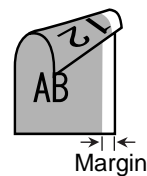
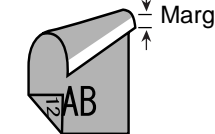

Image shifted to the bottom



③ **Page Protection**

If an error occurs because there is too much print data, selecting this checkbox may enable printing to take place. Try selecting this checkbox when a print error occurs. (If only standard memory is installed (128 MB), this setting cannot be selected.)

Default setting: Not selected

④ **Overlays**

Select this setting to print the document as an overlay on a previously created form. The form must have been previously stored.

Default setting: No Overlay

[Edit]

Click this button to open the overlay settings screen. The form selected in this screen will be used for the overlay.

⑤ **Font**

Click this button to change the font settings.

PostScript

The following screen appears when the Advanced tab is selected. The settings and buttons in this screen are explained below.

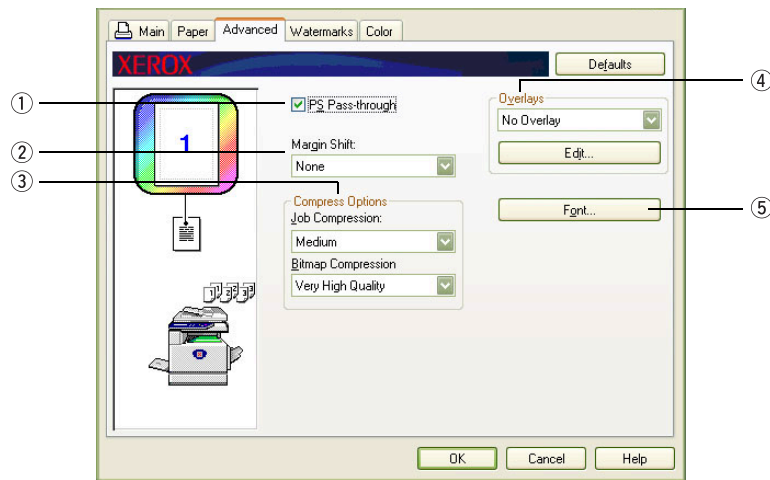

① **PS Pass-through**

Default setting: Selected

② **Margin Shift**

See the explanation for “Margin Shift” on page 3-30.

③ **Compress Options**

Select the [Job Compression] and [Bitmap Compression] options here. Using these options allow for smaller file sizes going across the network, thus reducing bandwidth drain.

[Job Compression]

Use this option to compress the entire job.

Default setting: Medium

[Bitmap Compression]

Use this option to compress bitmap images without compressing the entire job. Bitmap compression is similar to JPEG and/or G3/G4 (Fax) compression.

Default setting: Very High Quality

④ **Overlays**

See the explanation for “Overlays” on page 3-32

⑤ **Font**

See the explanation for “Font” on page 3-31.

Watermark settings

The following screen appears when the Watermarks tab is selected. The settings and buttons in this screen are explained below.

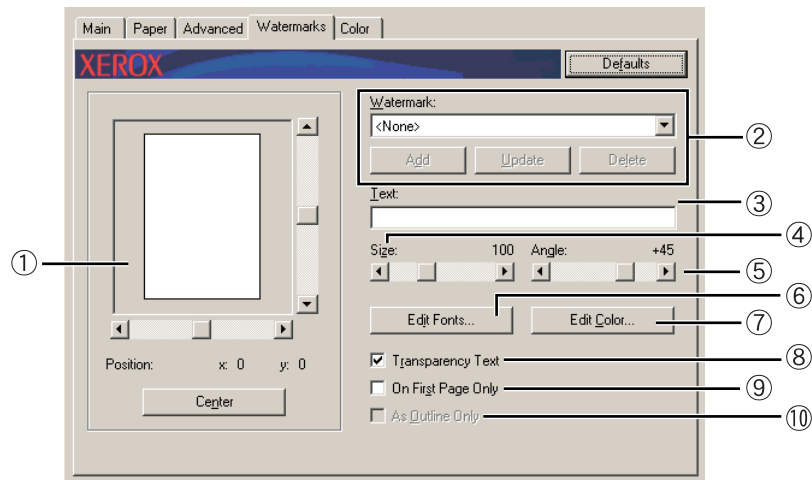

① Watermark preview

The watermark function is used to print a watermark (a faint, shadowlike text image) on the paper. This shows a preview of the currently selected watermark.

The position of the watermark can be adjusted by directly dragging the image with your mouse, or by using the scrollbars at the right and bottom of the preview screen.

Default setting: x: 0, y: 0

NOTE: *The image that appears in the Watermark Preview is an approximate representation of what will appear in the print.*

[Center]

Select this setting to have the watermark printed in the centre of the paper.

② Watermark

Select a watermark from the watermarks that appear in the box.

Default setting: None

[Add]

Click this button to create a custom watermark.

[Update]

Click this button to adjust the size or angle of the text of a stored watermark.

[Delete]

Click this button to delete a stored watermark.

③ **Text**

When you wish to create a custom watermark, enter the text of the watermark here. Up to 100 characters can be entered. To store the entered text as a watermark, click the [Add] button explained in above.

④ **Size**

Use this setting to adjust the size of the characters of the currently selected watermark.

Any number from 6 point to 300 point can be selected.

Default setting: 100 (point)

⑤ **Angle**

Use this setting to adjust the angle of the text of the currently selected watermark.

Select any angle from -90° to 90°.

Default setting: 45°

⑥ **Edit Fonts**

Use this setting to select the font of the currently selected watermark.

⑦ **Edit Color**

Use this setting to adjust the colour of the font of the currently selected watermark.

⑧ **Transparency Text**

Select this checkbox when you wish to have the characters of the watermark printed faintly in the background of the text.

Default setting: Selected

⑨ **On First Page Only**

Select this checkbox when you want to have a watermark printed on only the first page of a print job.

Default setting: Not selected

⑩ **As Outline Only**

Select this checkbox when you want to print only the outline of the characters of a watermark.

Default setting: Not selected

This setting cannot be selected when setting is selected.

Color settings

When the Color tab is selected, the following screen appears. The settings and buttons in this screen are explained below.

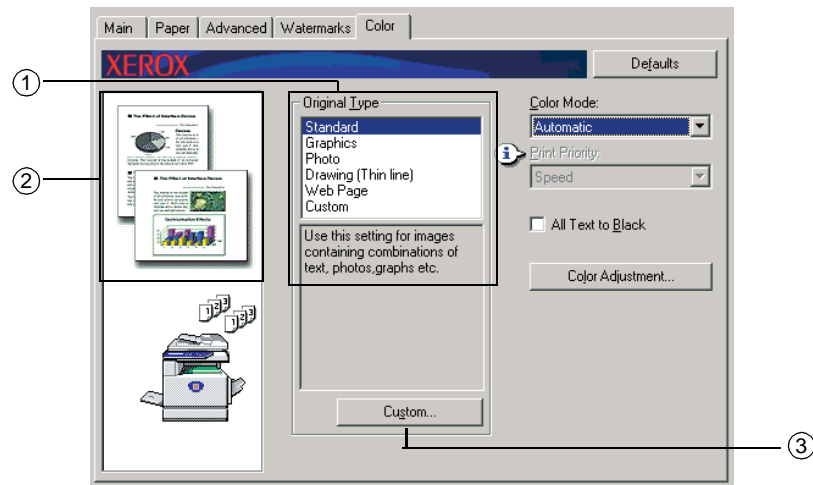

① Original Type

This displays the currently selected document type and an explanation. When [Gray Scale] is selected in setting ④ on page 3-37, this setting cannot be selected.

Default setting: Standard (The selected settings are the default settings.)

The default settings for the document types are as follows:

		Color Rendering *1	UCR Selection *2	Black Overprint*3	Screening*4	Pure Black Text*5
Original Type	Standard	Xerox Color	Standard	On	Automatic	On
	Graphics	Saturation Match	High Black	On	Text/ Graphics	Off
	Photo	Perceptual Match (Photo)	Low Black	Off	Photo	Off
	Drawing (Thin line)	Saturation Match	High Black	On	Automatic	On
	Web Page	Perceptual Match (Web)	Standard	Off	Automatic	On
	Custom	Xerox Color	Standard	On	Automatic	On

*1 Colour Rendering
Select colour matching settings.

*2 UCR (Under Colour Removable) Selection
Set the proportion of black toner to be used.

- *3 Black Overprint
Select whether or not black characters are overprinted on a colour background.
- *4 Screening
Select halftone settings.
- *5 Pure Black Text
Select whether to print black characters with black toner, or with 4-colour CMYK toner.









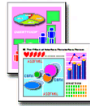

② **Custom**

Use these settings when you wish to change the default settings for each document type.

③ **Preview of document type**

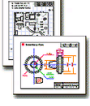
This shows a preview of the document type selected in ①.

Table of document type previews

		Color Mode		
		Color	Gray Scale	Automatic
Original Type	Standard			
	Graphics			
	Photo			
	Drawing (Thin line)			
	Web Page			
	Custom			

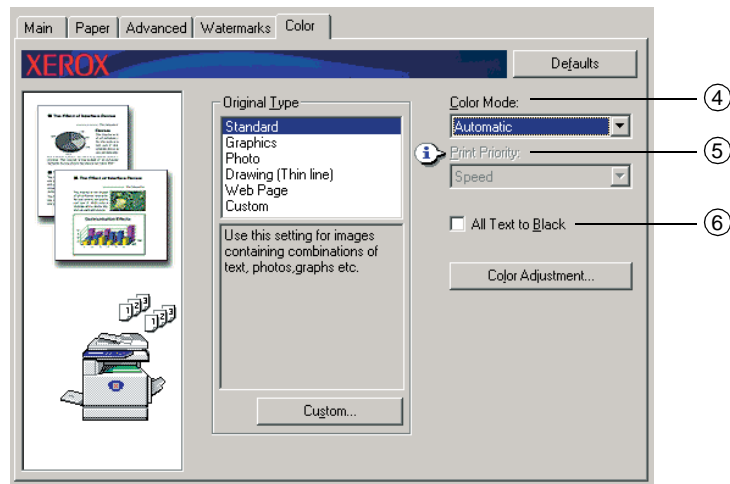

④ **Color Mode**

Select the colour mode for printing.

When Automatic is selected, a decision is made page by page. If colours other than black are used, colour printing takes place. If only black is used, black and white printing takes place. This is convenient when colour and black and white pages are mixed together, however, the print speed is slower.

Default setting: Color

The image of the page layout in ② on page 3-16 varies as follows depending on the colour mode setting.

(Displayed on tabs other than the Watermarks and Color tabs.)

When set to [Automatic]



When set to [Color]



When set to [Gray Scale]

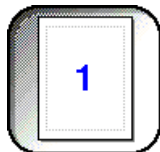

⑤ **Print Priority**

Select whether priority is given to speed or quality when printing.

[Quality]*¹ Select this when you want a high-quality image even if more time is required for printing.

*1 This cannot be selected if only standard memory (128 MB) is installed. This can only be selected when the [Color Mode] (④ above) is set to [Gray Scale].

[Speed] Select this when you wish to print quickly even if the image quality is inferior.

Default setting: Speed

⑥ **All Text to Black**

When you wish to have all colour text printed in black, select this checkbox.

Default setting: Not selected

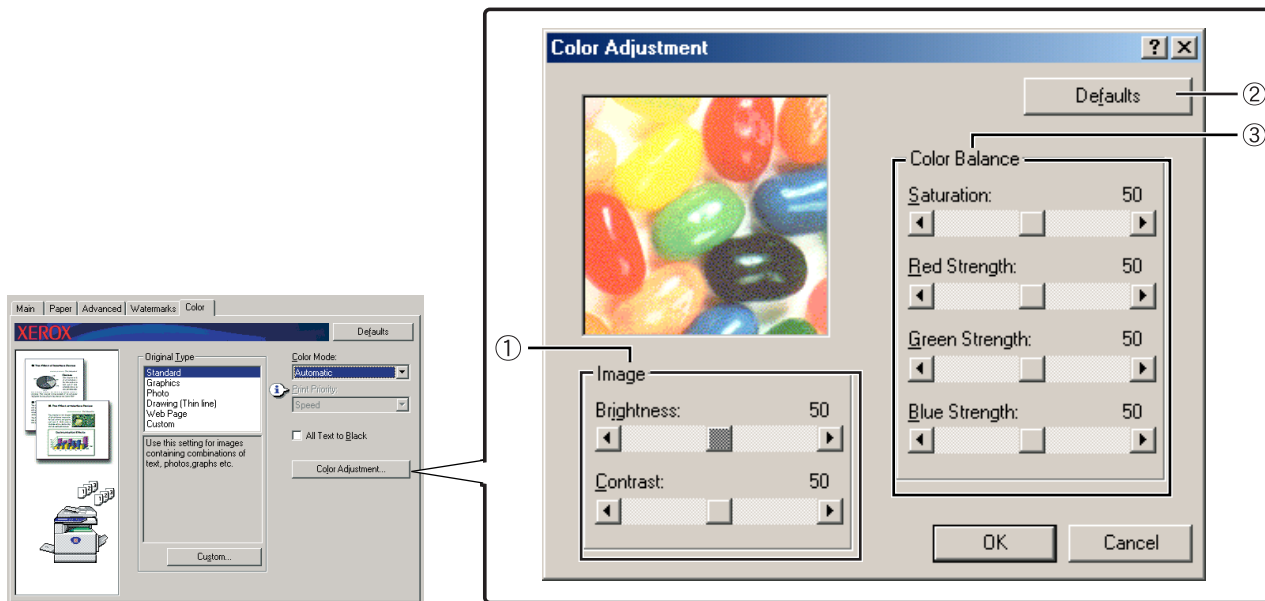

① **Image**

Use this item to adjust the brightness and contrast.

[Brightness]

This indicates the brightness of colours. The brightness can be set to a value from 0 to 100. Colours appear closer to white as the value is increased.

Default setting: 50

[Contrast]

This shows the amount of contrast between white and black. The contrast can be set to a value from 0 to 100. The contrast increases as the value is increased.

Default setting: 50

② Defaults

Returns the image adjustment settings to the default settings.

③ Color Balance

This item is used to adjust the colour saturation and strengthen or weaken the R (red), G (green), and B (blue) components of colour.

[Saturation]

This adjusts the colour saturation. Select a value between 0 and 100.

Default setting: 50

[Red Strength]

Strengthens or weakens red.

Default setting: 50

[Green Strength]

Strengthens or weakens green.

Default setting: 50

[Blue Strength]

Strengthens or weakens blue.

Default setting: 50

NOTE: *These cannot be changed if the colour mode was set to [Gray Scale] in step ④ on page 3-37.*

Web Pages in the Printer

This section explains various functions that allow you to access the Web pages in the printer from your computer.

Printer Configuration Through the Network

You can access the Web pages of the printer from your computer using a Web browser such as Netscape Navigator or Internet Explorer. This will allow you to adjust various settings through the network.

Environment required for accessing Web pages

The following equipment and programs are needed to access the Web pages in the printer:

Print server card (network interface card)

Recommended Web browser

Internet Explorer: 5.5 or higher (Windows), 5.1 or higher (Macintosh)

Netscape Navigator: 6.0 or higher (or equivalent)

NOTE: *The following characters cannot be input in the Web pages when setting the Web pages in the Web server located in this product. Input characters are case-sensitive.*

- *Characters that cannot be input:* < > " & #
- *Examples of improper input:* <abc> <abc "abc" "abc abc"

Accessing Web pages and displaying help

Use the following procedure to access the Web pages. If the help button under the menu frame is clicked, the help screen for description of various function settings that can be operated remotely from the Web pages for this product through the network will appear. For the setting of each function, see the detailed description.

1. Open the Web browser on your computer.

- Input the IP Address previously specified for this product to the ADDRESS field of the browser.

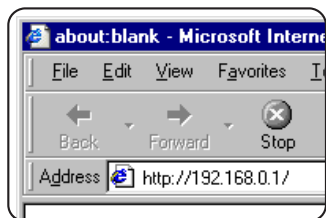

Input the IP address previously specified in this product.
If you do not know the IP address, see page 3-64.

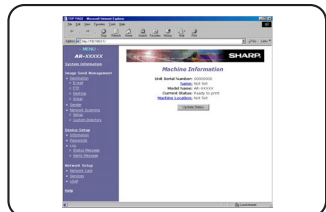

When the connection is completed, the Web page information of this product will be displayed.

(The Web page information is explained on page 3-42.)

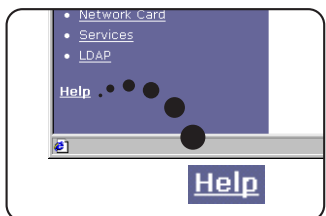

- Click the [Help] button under the menu frame.

For details of each function setting, see the help under the menu frame. The configuration settings are described in detail.

- Close the help.

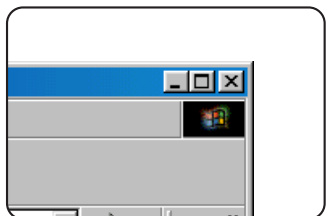

Select the setting or function you wish to use from inside the menu frame. When you have finished accessing the Web page, click the button in the upper right-hand corner of the window.

Items and outline of menu frame of Web pages

The optional scan kit is required to use the network scanner function described in this section.

Menu frame

Click the menu items displayed here to configure the corresponding settings.

Store destinations and configure settings for the network scanner function.

Configure settings for management of the machine.

Configure network settings.

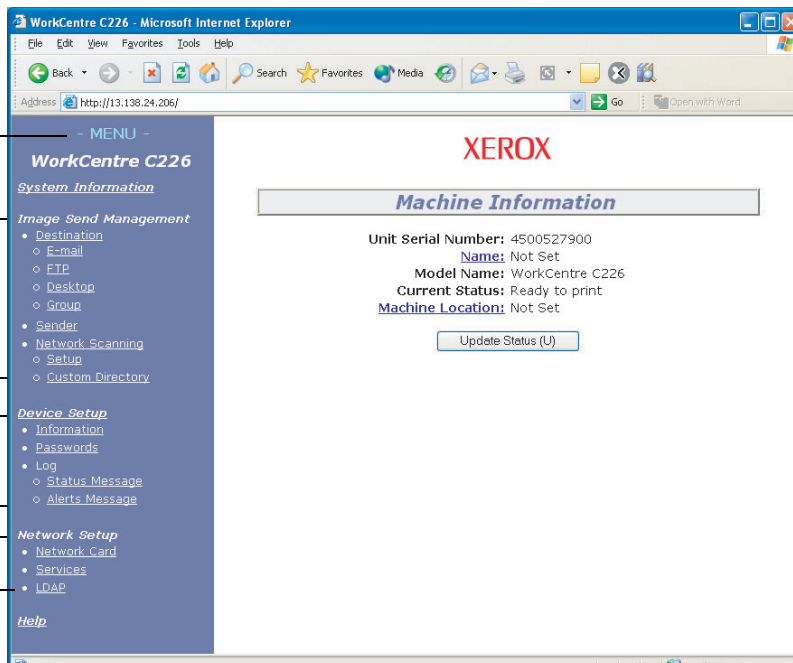

System Information

Image Send Management

Destination

This is the home page for storing, editing, and deleting destinations for images scanned with the network scanner.

A total of 500 destinations (including all types) can be stored. (A total of 100 file server and desktop destinations can be stored.)

E-mail

Sets the destination information for E-mail delivery from the network scanner.

Destination E-mail addresses and file types as well as information for destination control (destination name, index, name for front panel display, etc.) are configured by this control.

FTP

Sets the storage location information for file server storage of network scan data. File server information (such as host name) and file types as well as information for destination control (destination name, user index, name for front panel display, etc.) are configured by this control.

Group

Multiple e-mail destinations can be stored in one of the one-touch keys displayed in the touch panel. This is called storing a group. When sending an e-mail, the stored destinations can be selected by simply touching the one-touch key. This is convenient when you wish to send the same e-mail to multiple destinations.

Sender

The sender of E-mail transmissions from the network scanner is configured. The sender will be set as the "From" item of the E-mail header. Up to 20 senders can be registered and a sender can be selected among them from the operation panel.

Network Scanning

Setup

Basic setting screen for the network scanner. E-mail subject for scanner delivery, file name, etc. are set. To use the network scanner, you must set up SMTP Setup and DNS Setup. This screen displays the SMTP and DNS settings and provides a link to SMTP Setup and DNS Setup.

Custom Directory

User index names in the display list on the operation panel are set.

Device Setup

Information

Configure machine identification information for the status & alert E-mail function.

Password

The settings and programmed information in the Web page can be protected by clicking [Passwords] in the menu frame and establishing passwords. The administrator should change the initial password set at the factory to a new password. In addition, take care to remember the new password, as it must be entered the next time you open the Web page.

Two types of passwords can be established: one for users and one for the administrator.

When the Web page is accessed using the user password, the "Device Setup" and "Network Setup" cannot be configured.

The password is initially set to "Xerox". When you first establish the passwords, enter "Xerox" in "Administrator Password" and then enter the new password for the administrator and the password for users (maximum of 7 characters per password; passwords are case sensitive). Click [Submit] to save the new passwords. After setting the new passwords, turn off and then turn on the machine power.

The next time you open the Web page, you will be prompted to enter your password. When accessing the Web page as a user, enter "user" in "User Name". When accessing the Web page as an administrator, enter "admin" in "User Name".

Log

Status Message

Use this to set up a schedule for sending specified count information such as the total count and the output counts for the printer and copy functions. The e-mail addresses of the recipients and the schedule must be entered.

Alerts Message*

This is used to send information on error conditions such as when the machine runs out of paper or toner, or a misfeed or failure occurs. The e-mail addresses of the recipients of the information must be entered.

* This function cannot be used if the optional Fax Unit is installed.

Network Setup

Network Card

A link to the network card Web page for configuring the print server card (network interface card) is provided. The Admin password is the same as the Web Page password of the network card.

Services

Configure information concerning the e-mail system.

LDAP

This is used to configure advanced settings when using an LDAP server and user authentication.

Printer Configuration Settings

This section explains the printer configuration settings.

Making Configuration Settings

The printer configuration settings are used to configure basic printer settings. The following settings are available.

- Default settings: Basic settings used in printing (page 3-46)
- PCL settings: Set the PCL symbol set and fonts (page 3-47)

Operation procedure common to all printer configuration settings

These items can be set from the operation panel.

1. Touch the [CONDITION SETTINGS] key on the printer screen to display the configuration setting menu screen.

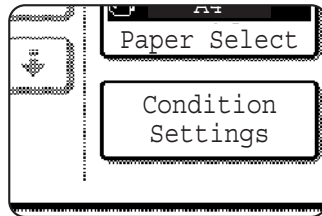

Any print jobs held in the printer and any job currently transmitted to the printer will be listed in the former print conditions.

2. Touch the key of the desired item to display its setting screen.

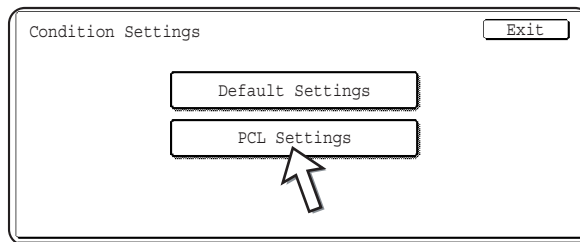

Detailed descriptions for configuration settings start on page 3-46.

3. Touch the desired setting item on the screen and touch the [OK] key.

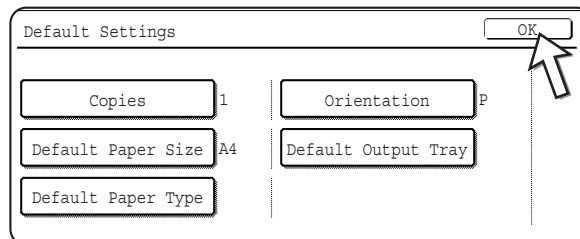

To set another item, repeat steps 2 and 3.

4. To finish the setting operation, touch the [EXIT] key.

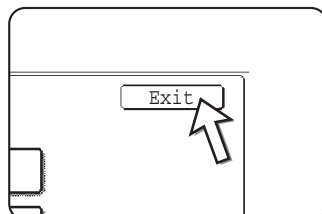

Default settings

The default settings are used to set specific print conditions for printing in an environment where the print driver is not used (such as printing from MS-DOS or from a computer that does not have the provided print driver installed).

NOTE: *When some items can be set both in the printer driver and on the operation panel, the values set in the printer driver override those set on the operation panel. For items that can be set in the printer driver, perform the settings in the printer driver.*

The following settings are available:

Copies

COPIES sets the number of print to make.

Default setting: 1

The number of copies can be set from 1 to 999.

Orientation

ORIENTATION allows portrait orientation or landscape orientation to be selected for printing.

Default setting: PORTRAIT

PORTRAIT or LANDSCAPE can be set.

Default paper size

The paper size to be used for printing under normal conditions is set.

Printing will be performed on the specified size of paper unless otherwise specified.

Default setting: A4 or 8-1/2X11

A3W, A3, B4, A4, B5, A5, 11X17, 8-1/2X14, 8-1/2X13, 8-1/2X11, 7-1/4X10-1/2, 5-1/2X8-1/2, 8K or 16K can be set.

Default output tray

The output tray to be used for printing under normal conditions is set. Printed sheets will be output to the specified tray unless otherwise specified by application software.

Default setting: CENTRE TRAY

The trays that can be selected depend on installation of peripheral devices.

Default paper type

The paper type to be used for printing under normal conditions is set. Printing will be performed on the specified type of paper unless otherwise specified.

Default setting: PLAIN

PLAIN, PRE-PRINTED, RECYCLED, LETTER HEAD, PRE-PUNCHED or COLOUR can be set.

PCL settings

PCL symbol set setting

This setting is used to select which country's characters are used for certain of the symbols in the character code table of the PCL symbol set. (Use this setting when you need to select symbols that differ by country.)

Default setting: "1" (Roman-8)

See page 3-67 for the symbol set settings.

You can also print the "PCL SYMBOL SET LIST" in "LIST PRINT" (see page 1-41) for a table that shows correspondences between numeric values and symbol sets.

PCL font settings

This setting is used to select the font for printing.

Default setting: "1" (Courier)

You can also print the "PCL FONT LIST" in "LIST PRINT" (see page 1-41) for a table that shows correspondences between numeric values and fonts.

Printing from the Operation Panel

This section explains the job retention function and other functions that enable printing to be executed from the machine's operation panel.

Hold Job List

If "Hold After Print", "Hold Before Print" or "Proof Print" operation is performed on the computer, print data will be held as a hold job. A maximum of 99 jobs can be held. Print data held by this function will not be erased even if the main switch is turned off.

If the number of jobs exceeds 99, the job is processed as follows.

- If Hold After Print is executed:
Printing will be executed but the job will not be held. (A notice page will be printed. See page 3-65.)
- If Hold Before Print is executed:
Printing will not be executed and the job will not be held. (A notice page will be printed. See page 3-65.)
- If Proof Print is executed:
Printing of one set will be executed but the job will not be held. (A notice page will be printed. See page 3-65.)

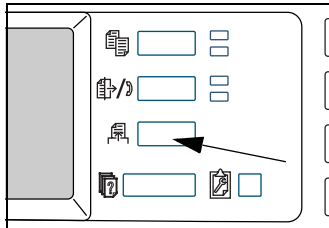

If the above error occurs and the Xerox Print Status Monitor has been installed, the error message will appear in the Xerox Print Status Monitor.

1. Press the [PRINT] key to display the printer basic screen.

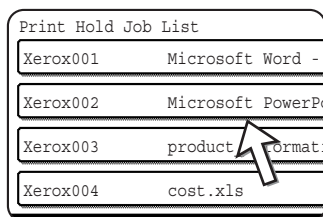

2. Select the desired data.



To switch the screen, touch the  or  key.



3. Use the [Numeric] keys to enter the 5-digit password (required only if a password has been set).

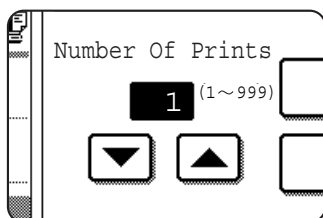

Be sure to enter the password that has been entered on the computer. If no password has been set, this step is not needed. Each time a number is entered, "-" will change to " ".

4. Ensure that the desired number of prints is set.



The number of prints can be changed by using the  or  key.

5. Execute printing.

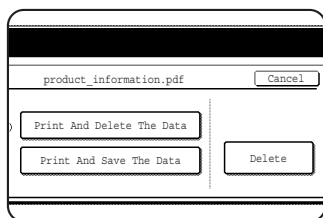

To delete the print data after completing the print job, touch the [PRINT AND DELETE THE DATA] key.

To keep the print data after printing, touch the [PRINT AND SAVE THE DATA] key.

To cancel printing and clear the print data, touch the [DELETE] key.

If you select execution of the print job, printing will start. If another job is being printed, your job will be stored as a print job. Your job will be printed after preceding jobs are completed.

Operation is now complete.

Key Operator Programs

This section explains the key operator programs for the printer function. Key operators should read this section to ensure correct use of the key operator programs.

Key operator programs related to the printer function are explained here. For information on key operator programs related to the copy function, and network scanner function, see “Key Operator Programs” in the WorkCentre C226 System Administration Guide.

NOTE: *The key operator programs that can be accessed depend upon how the product is configured with optional equipment.*

Key operator program list

Program name	Page
Printer Settings	
Default Settings	
Prohibit notice page printing	3-55
Prohibit test page printing	3-55
A4/letter size auto change	3-55
Delete the print hold data	3-55
Output method when memory is full	3-55
Default paper type for Bypass Tray	3-56
Job queuing	3-56
Interface settings	
Port switching method	3-56
Enable parallel port	3-56
Enable USB port	3-56
Enable network port	3-56
I/O timeout	3-57
Network settings	
IP address setting	3-57
Enable TCP/IP	3-57
Enable NetWare	3-57
Enable EtherTalk	3-58
Enable NetBEUI	3-58
Reset the NIC	3-58
Colour adjustments	

Program name	Page
Auto colour calibration	3-58
Initialize and/or store settings	
Restore factory defaults	3-59
Store current configuration	3-60
Restore configuration	3-60

Procedure for using key operator programs

The procedure for using key operator programs is explained here, using the "PRINTER SETTINGS" program as an example.

Follow the same steps to use the programs explained on page 3-55 and following.

1. Press the [CUSTOM SETTINGS] key.

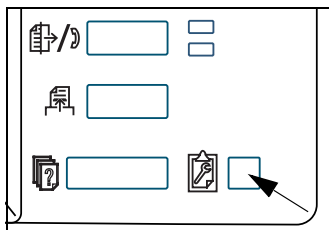

2. Touch the [KEY OPERATOR PROGRAMS] key.

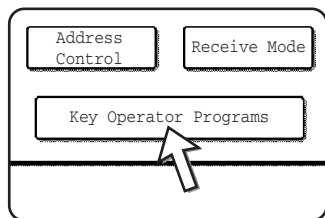

3. Use the numeric keys to enter the five-digit key operator code number.

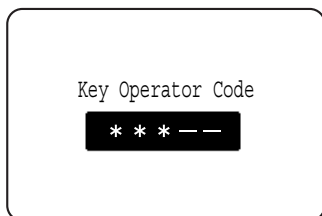

4. Touch the [PRINTER SETTINGS] key.

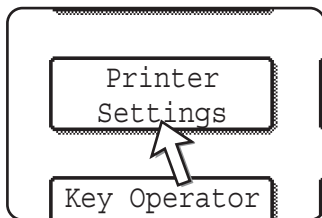

Follow these steps to select the program that you wish to use.

In the following steps, the setting screens for the selected program will appear. Refer to the program explanations on page 3-55 and following, and then follow these steps to select a setting for the program.

5. Make desired settings for the selected program.

Detailed descriptions for program settings start on page 3-55.

6. Press the [CLEAR ALL] key to exit the program.

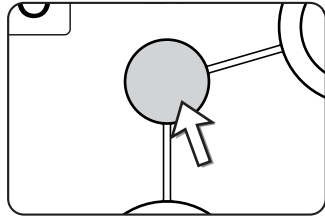

You will exit the key operator programs and return to the main screen.

Key operator program menu

The key operator programs are accessed via the following menu structure.

Refer to this menu when changing the settings explained on the following pages.

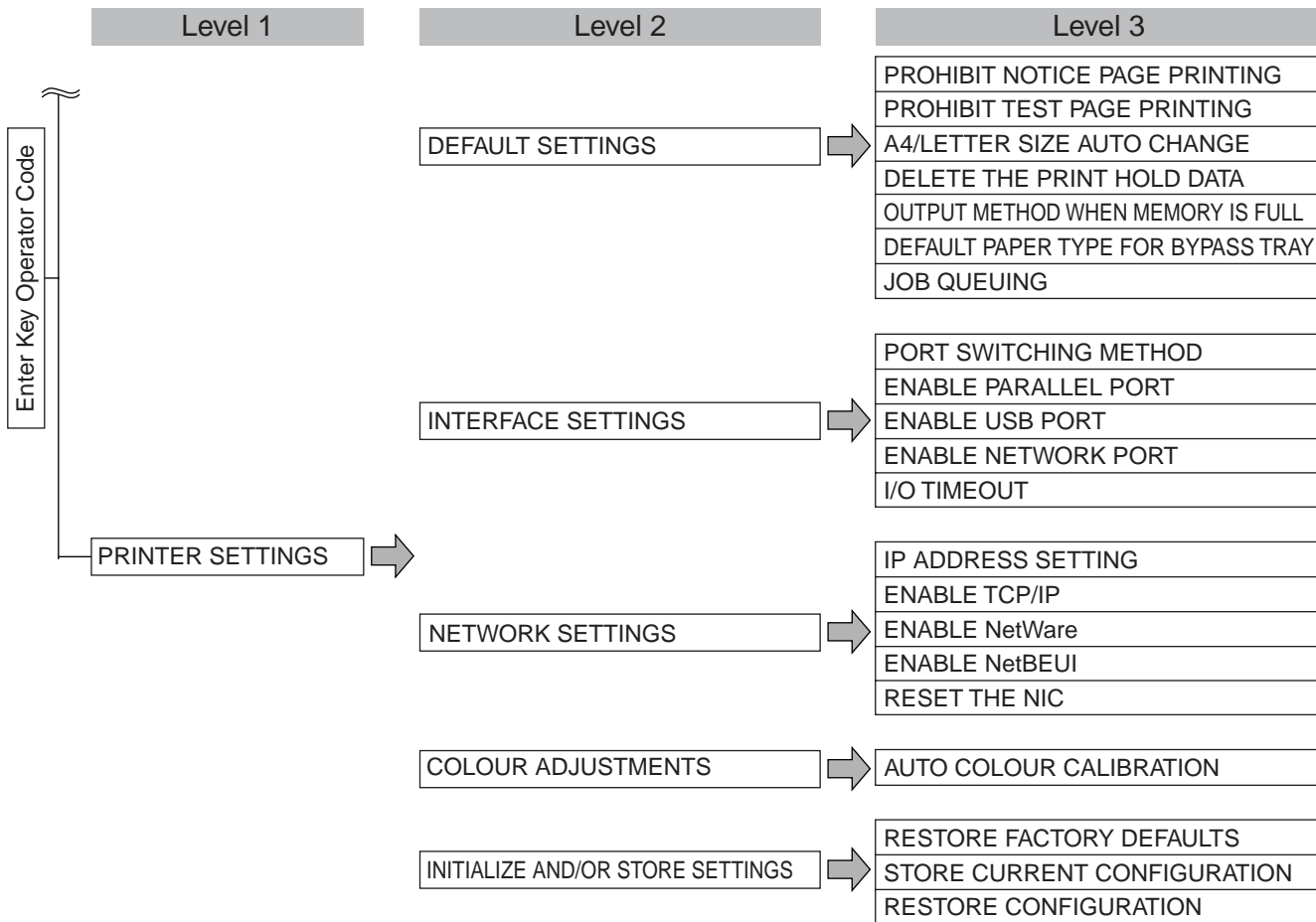

Description of Setting Programs

The key operator programs related to the printer function are explained here.

Printer settings

Default settings

These programs are used to adjust the settings of various printer functions.

Prohibit notice page printing

This program is used to disable notice page printing.

Turn on this program when you do not want the machine to print the notice page explained in "Notice Page Printing" on page 3-65.

Prohibit test page printing

This program is used to disable test page printing.

When the program is turned on, the PRINTER TEST PAGE in the user settings cannot be printed. (See page 1-41)

A4/letter size auto change

If this program is set, and printing onto 8-1/2" x 11" size paper is selected but not available, the printer will automatically substitute A4 size paper in place of 8-1/2" x 11" paper if A4 paper is available.

* 8-1/2" x 11" paper cannot be automatically selected in place of A4.

NOTE: *When 8-1/2" x 11" size is specified for a document attached to an E-mail that has been transmitted from a foreign country and A4 size paper is not installed in the printer, printing cannot be done without operator intervention. If this program is set, printing will be executed without intervention if a paper tray is loaded with A4 paper.*

Delete the print hold data

Use this program to manually delete all stored data from the hard disk.

When you touch this key, a message will appear to confirm that you want to delete the data. Check the message and then proceed with the deletion. If you are using the job retention function (page 3-48), exercise caution when using this program.

Output method when memory is full

When the internal memory becomes full with printer data, further printing is not possible, thus the print data stored to that point is printed. This program is used to set the condition for printing. The factory default setting is "1 SET".

Default paper type for Bypass Tray

This program is used to set the default paper type for paper loaded in the Bypass Tray in printer mode. "NONE" (a default paper type is not selected), "PLAIN", "HEAVY PAPER", or "TRANSPARENCY" can be selected. If "HEAVY PAPER" is selected, select "HEAVY PAPER 1" or "HEAVY PAPER 2". If "TRANSPARENCY" is selected, select "SPEED MODE" or "QUALITY MODE".

The factory default setting is "NONE".

Job queuing

This program is used to allow new print jobs to be received while a print job is in progress. Normally the program is enabled so that new print jobs can be received.

Interface settings

These programs are used to control data transmitted to the parallel port or network port of this printer.

Port switching method

The machine can use the three ports shown below for printing. This program is used to select when switching between ports will take place. "SWITCH AT END OF JOB" or "SWITCH AFTER I/O TIMEOUT" can be selected. When "SWITCH AT END OF JOB" is selected, the port will be automatically selected after each print job is completed. When "SWITCH AFTER I/O TIMEOUT" is selected, the port will be automatically selected if the time set in the I/O Timeout program elapses.

- Parallel port
- USB port
- Network port

Enable parallel port

This program is used to enable or disable printing from the parallel port.

Default setting: Enable

Enable USB port

This program is used to enable or disable printing from the USB port.

Default setting: Enable

Enable network port

This program is used to enable or disable printing from the network port.

Default setting: Enable

I/O timeout

This program is used to set the length of time to wait for an I/O to complete a job on the parallel port or the network port. If the data stream to the port does not transmit data for a length of time exceeding the timeout, the job will cancel and the next job will start processing.

The I/O timeout setting is used to set the amount of time after which an I/O timeout will occur when waiting for print data.

Default setting: 20 seconds

NOTE: *The allowable range of the time is 1 to 999 seconds.*

Network settings

These programs are set when this product is used as a network printer.

After you complete the setting for one program, you must exit the key operator programs, turn off the main switch, wait briefly, and then turn on the main switch again before any other programs can be set. The program that was set will be effective after the power is turned on.

NOTE: *For setting and modification of "Network settings", be sure to consult with the network administrator.*

IP address setting

When using this product in a network that uses the TCP/IP protocol, use this program to set the IP address (IP address, IP subnet mask, and IP gateway) of this product. The program is set to ENABLE DHCP by factory default setting, which obtains the IP address setting automatically. When using this product on a TCP/IP network, be sure to turn on the "Enable TCP/IP" program below.

If DHCP is used, the IP address assigned to the machine may be changed automatically on occasion. If this happens, printing will not be possible.

Enable TCP/IP

When using this product in a network that uses the TCP/IP protocol, set this program. Also set the IP address using the program "IP address setting" above.

Default setting: Enable

Enable NetWare

When using this product in a network that uses the NetWare protocol, set this program.

Default setting: Enable

Enable EtherTalk

When using this product in a network that uses the EtherTalk protocol, set this program.

Default setting: Enable

Enable NetBEUI

When using this product in a network that uses the NetBEUI protocol, set this program.

Default setting: Enable

Reset the NIC

This program is used to reset all setting items of NIC (Network Interface Card, namely Print Server Card) of this product to the factory default settings.

NOTE: *If any of the [NETWORK SETTINGS] were changed prior to execution of this program, you must turn off the main switch after exiting the key operator program, wait briefly, and then turn on the main switch to make the factory default settings take effect.*

Colour adjustments

This program is used to automatically adjust the colour tone of each colour (cyan, magenta, yellow, and black).

Auto colour calibration

The Auto Colour Calibration program enables automatic colour gradation correction when the colour is off.

NOTE: *The colour gradation may not be sufficiently corrected after one correction cycle. If so, execute the program again.*

When the [AUTO COLOUR CALIBRATION] key is touched, the following display will appear.

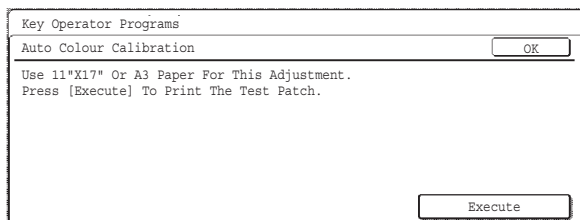

After the [EXECUTE] key is touched and a test patch printed, a message appears asking you to begin automatic adjustment. Place the test patch on the document glass as shown below and touch the [EXECUTE] key.

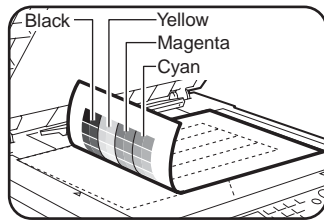

- NOTES:**
- *Correct adjustment will not be possible if you use the test patch that is printed for "Auto colour calibration" for the copy function or any other document. If you attempt to use the wrong test patch, you will return to the message screen that asks you to begin automatic adjustment. Be sure to place only the test patch printed out above on the document glass.*
 - *Lay approximately five sheets of copy paper that are the same size as the test patch on top of the set test patch, and gently close the original cover.*

When a message appears informing you that auto colour calibration is completed, touch the [OK] key to end the procedure.

- NOTE:** *Before using this program, make sure that the registration is correctly adjusted. If the registration is not correctly adjusted, perform [AUTO ADJUSTMENT] in "Registration adjustment" in the "Key Operator Programs" section of the WorkCentre C226 System Administration Guide.*

Initialize and/or store settings

You can restore the CONDITION SETTINGS (page 3-44) and the key operator program of the PRINTER SETTINGS of (page 3-55) to the factory default settings. You can also store the current configuration of these settings in memory, and restore a stored configuration at a later time.

Restore factory defaults

This restores the CONDITION SETTINGS (page 3-44) and the key operator program of the PRINTER SETTINGS of (page 3-55) to the factory default settings. If you need a record of the settings prior to restoration of the default settings, print the CUSTOM SETTINGS list (page 1-37) and the key operator program list (see "Key Operator Programs" in the WorkCentre C226 System Administration Guide).

This does not affect "Colour adjustments" in the PRINTER SETTINGS.

- NOTE:** *After this program is set, exit the key operator program, turn off the main switch, and then turn on the main switch again after at least 3 seconds. The program will be effective at this time.*

Store current configuration

This program is used to store the CONDITION SETTINGS (page 3-44) and the key operator program PRINTER SETTINGS of (page 3-55) in memory. The stored settings will remain in memory even if the main switch is turned off. To read the stored settings, use the following [RESTORE CONFIGURATION] program.

This does not affect "Colour adjustments" in the PRINTER SETTINGS.

Restore configuration

This program is used to read the configuration that was stored using the [STORE CURRENT CONFIGURATION] program and restore it as the current configuration.

The currently set configuration will change to the configuration read from memory.

Troubleshooting

This section provides solutions to problems you may encounter when using the machine. Be sure to read this section whenever you encounter a problem.

The following problems may not be due to a machine failure, so please check again before calling for service. In the event that service is required, turn off the main switch, unplug the power plug from the outlet. Problems related to the printer function are described in this section. For troubleshooting related to general machine use, the copier function or the network scanner function, please read "Troubleshooting" in the corresponding manuals.

Problem	Check	Solution or cause
Printer is on but data is not received.	Is the interface cable correctly connected?	Make sure the USB or parallel cable is correctly connected to the machine and your computer.
	Has the printer driver been installed correctly?	Install the appropriate printer driver. (See the "Printer Installation" section in the WorkCentre C226 System Administration Guide.)
	Is the printer driver correctly selected? / Has it been configured in the network (when using as a network printer)?	Make sure that this printer is selected in the software application software or use an appropriate utility to check that the printer is registered on the network.
Data is received but not printed.	Has the specified size and type of paper been loaded?	Load paper, select another paper size or cancel printing.
Printer cannot be selected from computer.	Has the printer driver been installed correctly?	Install the appropriate printer driver. (See the "Printer Installation" section in the WorkCentre C226 System Administration Guide.)
The orientation of the image is incorrect on the print.	Are the print orientation settings in the printer driver correct?	Correct the orientation in the printer driver.
The edges of the printed image are missing.	There are margins around the edges of the paper where printing is not possible. Does the image overlap those margins?	Change the print area or reduce the image size.
Printer prints in reverse order.	Has reverse page order been selected in the software application?	Cancel the reverse order printing in the application software.
Printer stops in the middle of a print job.	Has the tray full sensor activated and stopped printing because too many pages are in the exit tray?	Remove the paper from the exit tray.
	Is the tray out of paper?	Load paper. (See page 1-21.)

Problem	Check	Solution or cause
Printing is not on desired paper size.	Has paper selection been set to Auto-automatic in the printer driver?	Ensure that the desired paper is set in a paper tray of the printer and select "Auto Select" in the paper selection of the printer driver.
Printer write error occurs when printing from the parallel port.	Is the timeout setting for the printer driver too short?	Set a longer time in the timeout setting in the printer driver.
A notice page is printed when a print job is sent to the printer for retention.	Has the number of hold jobs reached 99?	Delete unneeded hold jobs. If you wish to delete all hold jobs, use the [DELETE THE PRINT HOLD DATA] key operator program (page 3-55).
Password entry is requested.	Did you enter a password for the retention function?	Password is needed when executing printing. If the password is not known, printing cannot be executed.
In some cases the printed image may be rotated 90 degrees with respect to paper placed horizontally in the Bypass Tray.	Did you run out of paper during printing?	<p data-bbox="911 783 1428 846">When using the Bypass Tray, it is recommended that paper be placed vertically.</p> <div data-bbox="962 867 1374 1073" style="text-align: center;"> <p data-bbox="1094 873 1209 926">Landscape orientation</p> <p data-bbox="1257 873 1374 926">Portrait orientation</p> </div>
Colour documents print in black and white.	Is the [Color Mode] setting set to [Color] in the Color tab of the printer driver?	Set the [Color Mode] to [Color] (page 3-37).
	Is the correct printer driver selected in the software application?	Select the correct printer driver.
Though selected in the software application, colour printing does not take place.	Does the application support colour printing?	Read the application manual to see if colour printing is supported.
	Is the correct printer driver selected?	Select the correct printer driver.
The colour balance cannot be adjusted.	Is the [Color Mode] setting set to [Color] in the Color tab of the printer driver?	Set the [Color Mode] to [Color] (page 3-37).

Additional information on selecting the paper type for the Bypass Tray when using the printer function

To set the paper type and size for the Bypass Tray, see page 1-23.

The procedure for setting the paper type for the Bypass Tray when using the printer function is explained here.

Touch the [PAPER SELECT] key in the main screen of printer mode to display the paper type selection screen. If the desired paper type is not selected, touch the desired paper type to highlight it.

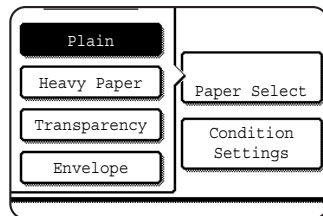

Paper types and keys to select are as follows:

Paper type	Keys
PLAIN	Select the [PLAIN] key.
LETTER HEAD	
PRE-PRINTED	
PRE-PUNCHED	
RECYCLED	
COLOUR	
POSTCARD	Touch the [HEAVY PAPER] key and then select [HEAVY PAPER1].
TRANSPARENCY	Touch the [TRANSPARENCY] key and then select [SPEED MODE] or [QUALITY MODE].
ENVELOPE	Touch the [ENVELOPE] key and then select the envelope type.

If the paper type setting in the "Paper Settings" screen of the printer driver is different from the paper type setting in the machine, printing will not take place. In this event, select the job key in the job status screen (page 1-17) and then touch the [DETAIL] key. Touch the [PAPER] key in the screen that appears and then either change the machine's paper type setting for the Bypass Tray or select a different paper tray.

Checking the IP address

There are three ways to check the IP address:

- Using [LIST PRINT] in [CUSTOM SETTINGS] in the operation panel
Select NIC PAGE to print a list of the machine settings. The IP address that has been set for the machine can be found in this list. Follow the procedure below to check the IP address using NIC PAGE.
- Using the key operator programs
The IP address can be verified using the key operator programs. To use this procedure, consult your key operator.
- How to use the "NIC Manager" utility on the WorkCentre C226 PCL Print Drivers and Printer/Network Setting Utilities CD-ROM
"NIC Manager" on the WorkCentre C226 PCL Print Drivers and Printer/Network Setting Utilities CD-ROM can be used to configure and check the IP address.

Checking the IP address from the [CUSTOM SETTINGS] screen of the operation panel

1. Press the [CUSTOM SETTINGS] key.

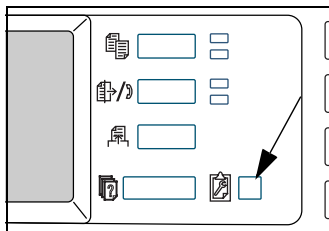

The custom setting menu screen will appear.

2. Touch the [LIST PRINT] key.

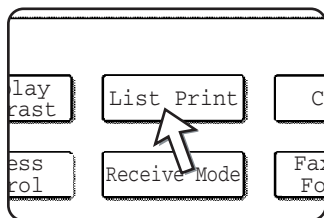

3. Touch the [PRINTER TEST PAGE] key.

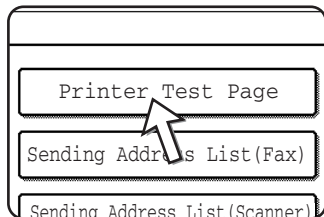

4. Touch the [NIC PAGE] key.

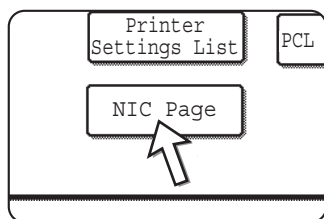

PROCESSING PRINT DATA appears in the message screen and printing begins. To cancel printing, touch the [CANCEL] key.

Appendix

This section contains product specifications and other technical information.

Notice Page Printing

A notice page will be printed when the current print job cannot be run due to a system limitation and an explanation of the limitation is too lengthy to be shown in the message display. A notice page will describe the limitation and other possible ways instead of possibilities to run the job.

A notice page will be printed in the following cases.

- When the print data of a single job is so large that it cannot be held in memory. (When there are other jobs occupying memory, notice pages may tend to be printed more frequently even for jobs with small amounts of data.)
- When a print job is sent to the printer and the number of print hold jobs has reached the maximum of 99 jobs.
- When different paper sizes have been selected for printing within a print job and one or more of the sizes cannot be delivered to the selected exit tray or to the stapler compiler. In these cases printed paper will be delivered partly to the specified destination (tray or compiler) and partly to another exit tray.
- When a function is selected that has been disabled using the key operator programs, such as disabling of two-sided printing, disabling of the staple function, or disabling of a specified exit tray.
- An invalid account number is entered when the auditing mode has been set.

Disabling of notice page printing

You can use the "PROHIBIT NOTICE PAGE PRINTING" of the key operator program to disable notice page printing (see page 3-55).

Print Area

The print area of this product is shown below.

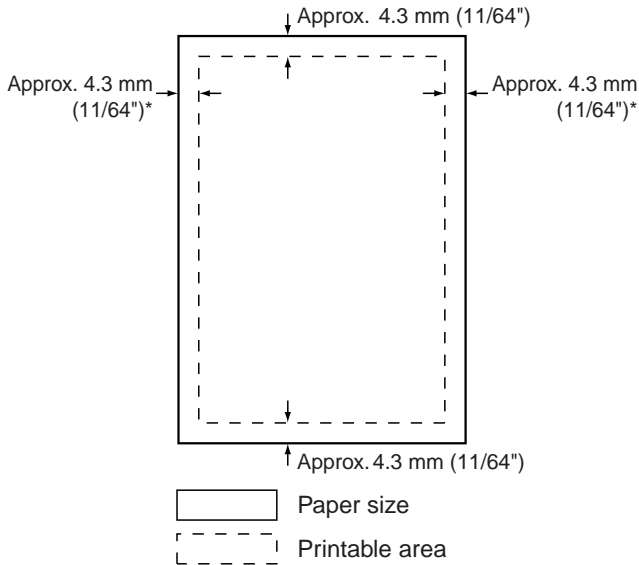

The print area is the entire page excluding a margin of 4.3 mm (11/64") at each edge. The actual print area may vary depending on the printer driver used and the type of software application.

* The print area of A3 wide paper is the entire page excluding a margin of approximately 3 mm (1/8") at each edge.

The print area is the entire page excluding a margin of 4.3 mm (11/64") at each edge. The actual print area may vary depending on the printer driver used and the type of software application.

* The print area of A3 wide paper is the entire page excluding a margin of approximately 3 mm (1/8") at each edge.

PCL symbol set

No.	symbol set
1	Roman-8
2	ISO 8859-1 Latin 1
3	PC-8
4	PC-8 Danish/Norwegian
5	PC-850
6	ISO 6 ASCII
7	Legal
8	ISO 21 German
9	ISO 17 Spanish
10	ISO 69 French
11	ISO 15 Italian
12	ISO 60 Norwegian v1
13	ISO 4 United Kingdom
14	ISO 11 Swedish : names
15	PC1004 (OS/2)
16	DeskTop
17	PS Text
18	Microsoft Publishing
19	Math-8
20	PS Math

No.	symbol set
21	Pi Font
22	ISO 8859-2 Latin 2
23	ISO 8859-9 Latin 5
24	ISO 8859-10 Latin 6
25	PC-852
26	PC-775
27	PC Turkish
28	MC Text
29	Windows 3.1 Latin 1
30	Windows 3.1 Latin 2
31	Windows 3.1 Latin 5
32	Windows Baltic (not 3.1)
33	Windows 3.0 Latin 1
34	Symbol
35	Wingdings

These symbol sets are trademarks or registered trademarks of their respective owners.

4 Network Scanner Operation

Introduction

An option is available that enables the machine to be used as a network scanner. This section explains only the network scanner functions of the product. For information on loading paper, replacing toner cartridges, clearing paper misfeeds, handling peripheral units, and other copier-related information, please refer to Chapter 1, "General Information" and Chapter 2, "Copier Operation".

- NOTES:**
- *Before using the network scanner feature, several settings must be established from the Web page. These settings are explained from page 4-3 on. The settings must be established by the network administrator. Such settings must be effected by the system administrator who has the special network related backgrounds.*
 - *The explanations in this section assume that the person who will install the product and the users of the product have a working knowledge of Microsoft Windows.*
 - *For information on the operating system, please refer to your operating system manual.*
 - *This section assumes that several options have been installed.*

Options required to use the network scanner function

- Scan kit
- Memory

To use the network scanner function in colour up to 300 dpi or B/W mode up to 600 dpi

For printer controller: Add one 256-MB module

To use the network scanner function in colour or B/W modes up to 600 dpi

For printer controller: Add two 256-MB modules.

For image memory: Add one 256-MB module

About the Network Scanner Function

The Scan Kit adds network scanner functionality to your machine. A machine with the network scanner functionality can scan a paper document, photograph, or other printed information into a data file, and send the file to a file server or personal computer over a corporate network (intranet) or the Internet.

You can select from the following two transmission methods, depending on where you wish to send the scanned image data.

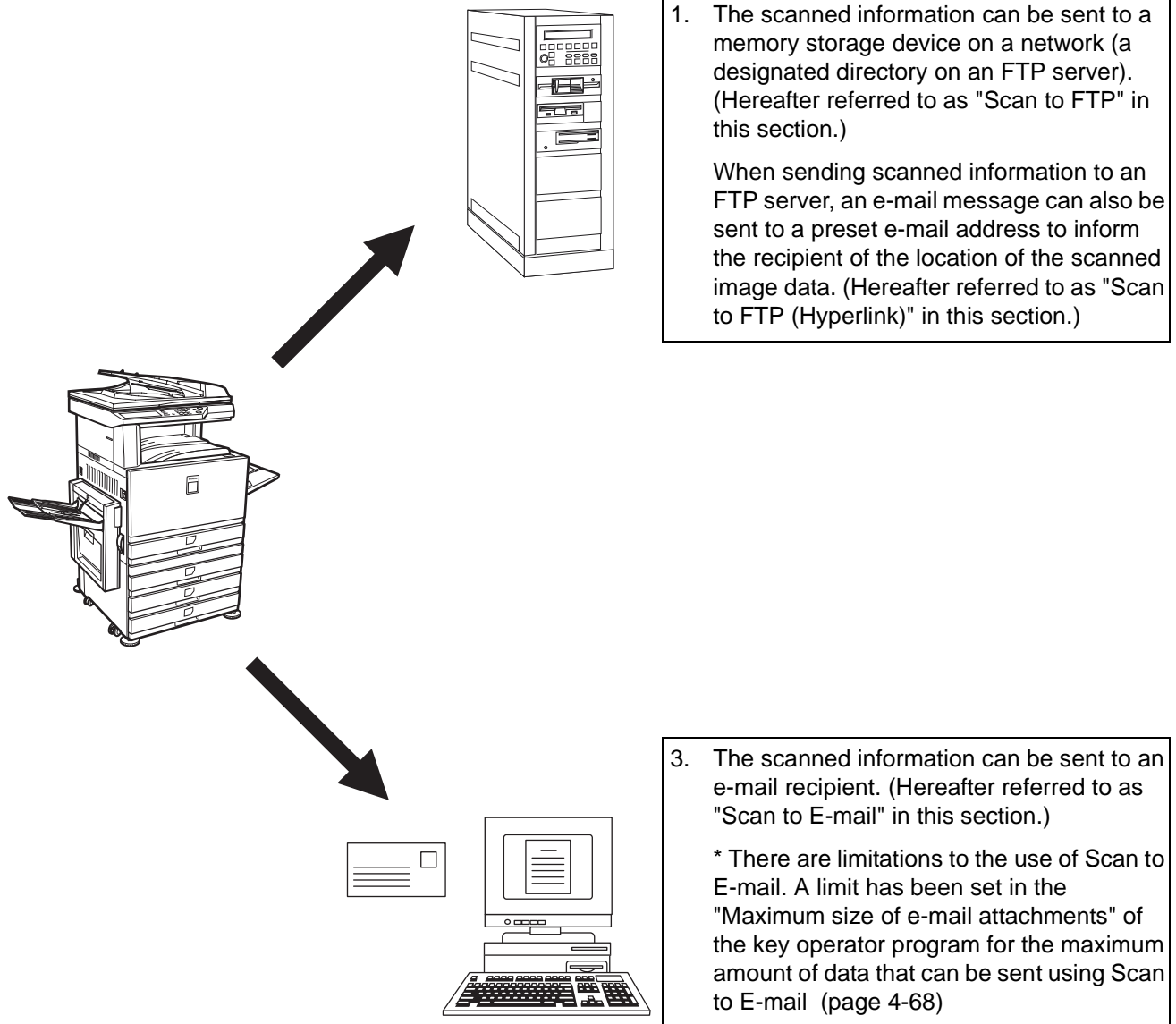

Settings and Programming Required for the Network Scanner Feature

To use the Network Scanner feature, settings for the E-mail server, DNS server, and destination addresses must be established.

To establish the settings, use a computer that is connected to the same network as the machine to access the machine's Web page. The Web page can be displayed with your Web browser (Internet Explorer 5.5 or later (Windows)/5.1 or later (Macintosh), or Netscape Navigator 6.0 or later).

Accessing Web Pages

Use the following procedure to access the Web pages.

1. Open the Web browser on your computer.

Supported browsers:

- Internet Explorer 5.5 or later (Windows)/5.1 or later (Macintosh)
- Netscape Navigator 6.0 or later

2. In the "Address" field of your Web browser, enter the IP address of the machine as a URL.

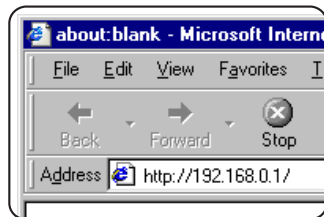

Input the IP address previously specified for this product.

If you do not know the IP address, see page 4-60.

When the connection is completed, the following Web page will appear in your Web browser.

About the Web Page

When you access the Web page in the machine, the following page will appear in your browser.

A menu frame appears on the left side of the page. When you click an item in the menu, a screen appears in the right frame that allows you to establish settings for that item.

For overviews of each of the menu items, refer to Chapter 3, "Printer Operation".

For detailed explanations of the procedures for establishing settings, click "Help" in the menu frame.

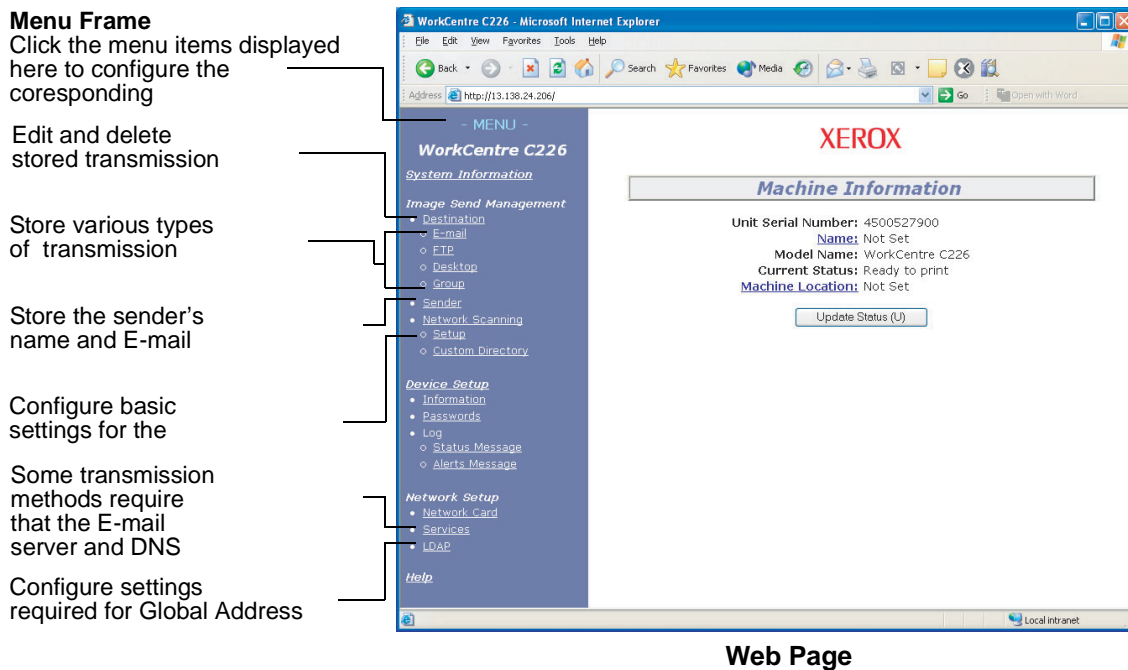

To use the network scanner function, you must configure basic network scanner settings (pages 4-6 to 4-9), store transmission destinations (pages 4-10 to 4-16), and program your sender's name (page 4-16).

Basic Settings for Network Scanning

Click "Network Scanning" in the menu frame, and then establish the required settings. These settings should only be established by the network administrator. After entering the settings, be sure to click "Submit" to store them. For detailed information on setting procedures, refer to "Help".

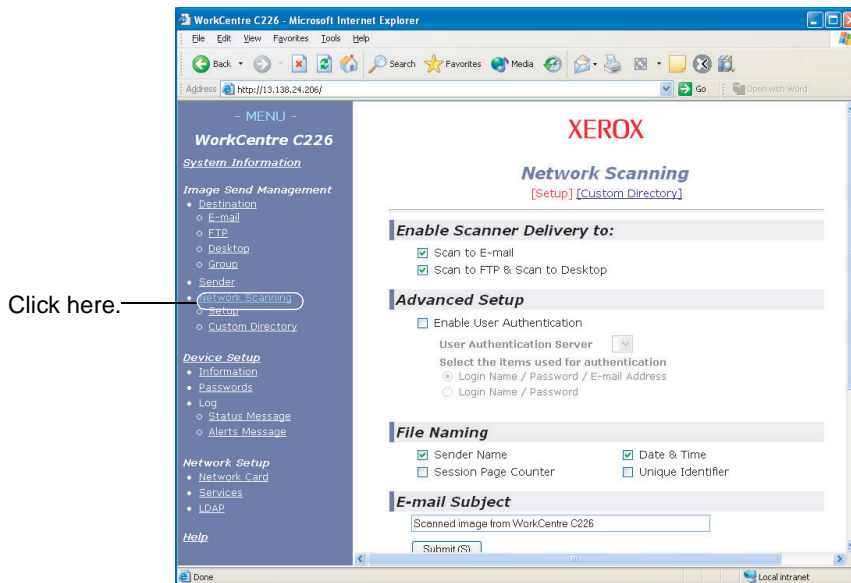

Network Scanning Setup screen

Enable scanner delivery methods ("Enable Scanner Delivery to")

Select the scanner delivery methods that you want to use. In the "Enable Scanner Delivery to:" field, click the checkbox next to each method that you want to use so that a checkmark appears in the checkbox.

"Scan to E-mail" and "Scan to FTP" are both initially selected.

Enabling user authentication ("Advanced Setup")

Select the authentication server and items used for authentication. In the screen that appears after you click "LDAP" in the menu frame, the authentication server is selected from the servers that have been stored in the Global Address Books List .

Select the method for assigning a file name to a scanned image ("File Naming")

Select the method for assigning a file name to a scanned image. In "File Naming", click the items that you wish to use in the file name. "Sender Name" and "Date & Time" are initially selected. If you are going to send images to the same recipient more than once, we recommend that you also select "Session Page Counter" or "Unique Identifier" to prevent sending multiple files with the same name, which would result in each successive file overwriting the previous file.

Selecting an e-mail subject ("E-mail Subject": only used for Scan to E-mail)

This setting is not necessary if you will not be using Scan to E-mail. The setting is used to enter the subject that appears in the recipient's e-mail program when you perform Scan to E-mail.

Enter a subject when using Scan to E-mail within 80 characters. Only one subject can be entered. If nothing is entered, "Scanned image from <Device Name>" will appear.

* The name that appears in <Device Name> is the name stored in "Name" in the screen that appears when you click "Information" in the menu frame. If a name has not been stored, the product name will appear.

E-mail Server and DNS Server Settings

Scan to E-mail and Scan to FTP use SMTP to transmit e-mail, therefore your SMTP server settings must be configured.

When configuring your SMTP server settings, your DNS server settings will also be necessary if you entered a host name in the "Hostname or IP Address" box when storing destinations for Scan to FTP.

To configure your e-mail server and DNS server settings, click "SMTP Setup" or "DNS Setup" in the Network Scanning Setup screen (see "Network Scanning Setup screen" on page 4-6), or click "Services" in the menu frame.

When you have completed all of the entries, click "Submit". The entries will be stored.

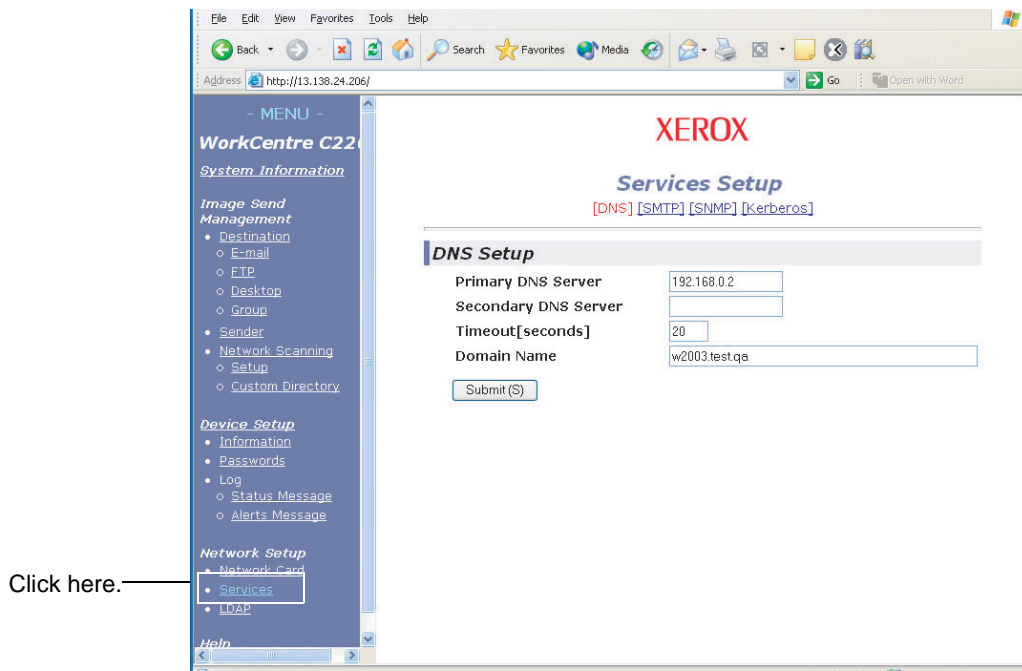

SMTP Setup

Item	Description
Primary SMTP Server	Enter an IP address for the primary e-mail server or a host name*. (If you will be using Scan to E-mail, be sure to enter this information.)
Secondary SMTP Server	Enter an IP address for the secondary e-mail server or a host name. No need to enter if a secondary e-mail server is not set up.
Port Number	Enter a Port Number for SMTP. The default is 25.
Timeout [seconds]	Enter a time out period, from 0-60 seconds, that the system will wait for as it attempts to connect to the primary server. The default is 20 seconds. If no connection is made, the system will then look for the secondary server if it has been set up. If not, the system will stop attempting to connect.
Reply E-mail Address	Enter an e-mail address to which the machine returns an unsuccessful delivery message when the distribution has failed. Only 1 e-mail address can be entered. The entered e-mail address is also used for the sender e-mail address.
Time Zone	Select the time zone of the place to use this Network Scanning System. A specific time zone is set after the selection.
SMTP Authentication	Select this checkbox if an SMTP server that authenticates users during SMTP authentication will be used. After selecting the checkbox, the User Name and Password text boxes under the checkbox are enabled. Enter the information necessary for authentication in these text boxes.

Item	Description
POP before SMTP	Select this checkbox if an SMTP server that authenticates users during the "POP before SMTP" procedure will be used. After selecting the checkbox, the POP3 Server, Port Number, APOP, User Name, and Password text boxes under the checkbox can be entered. Enter the information necessary for authentication in these text boxes.

* If you are entering a host name, be sure to enter the IP address of your DNS server in the DNS settings below.

DNS Setup

Item	Description
Primary DNS Server	Enter the IP address of your primary DNS server here if required.
Secondary DNS Server	Enter the IP address of your secondary DNS server here if required.
Timeout [seconds]	Enter a time out period, from 0-60 seconds, that the system will wait for as it attempts to connect to the primary server. The default is 20 seconds. If no connection is made, the system will then look for the secondary server if it has been set up. If not, the system will stop attempting to connect.
Domain Name	Enter the Domain Name of the DNS Server to be used to search for host names within 64 characters.

Setting Up Destination Information

To store the name and address of a destination as a one-touch key, click "Destination" or one of the transmission methods in the Web page menu frame. "Destination" can also be used to edit or clear stored destinations. (Refer to page 4-15.)

A total of 500 destinations can be stored, including E-mail, FTP, and Group destinations. Among these, a combined total of 100 Scan to FTP destinations can be stored.

The stored destinations appear as one-touch keys in the touch panel of the machine when you send an image, allowing you to select the destination.

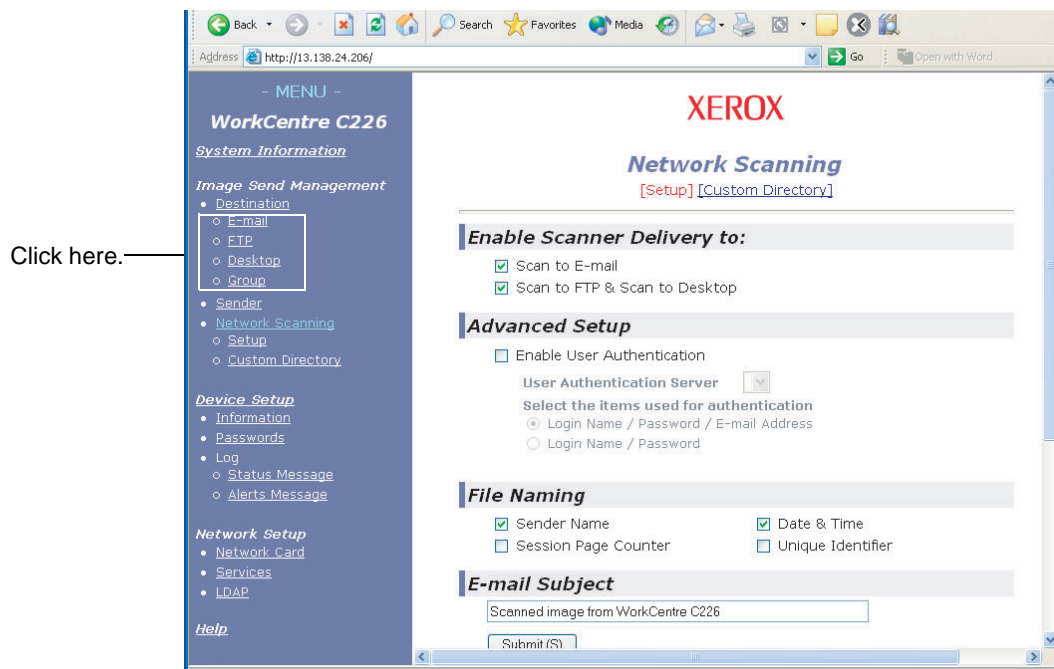

E-mail: Refer to page 4-11.

FTP: Refer to page 4-12.

Group: Refer to page 4-14.

For detailed information on setting up, editing, and deleting destinations, refer to "Help".

Storing destinations for Scan to E-mail

Click "E-mail" in the menu frame of the Web page to store destinations. Use this screen to enter the e-mail addresses of destinations for Scan to E-mail.

When you have completed all of the entries, click "Submit". The entries will be stored.

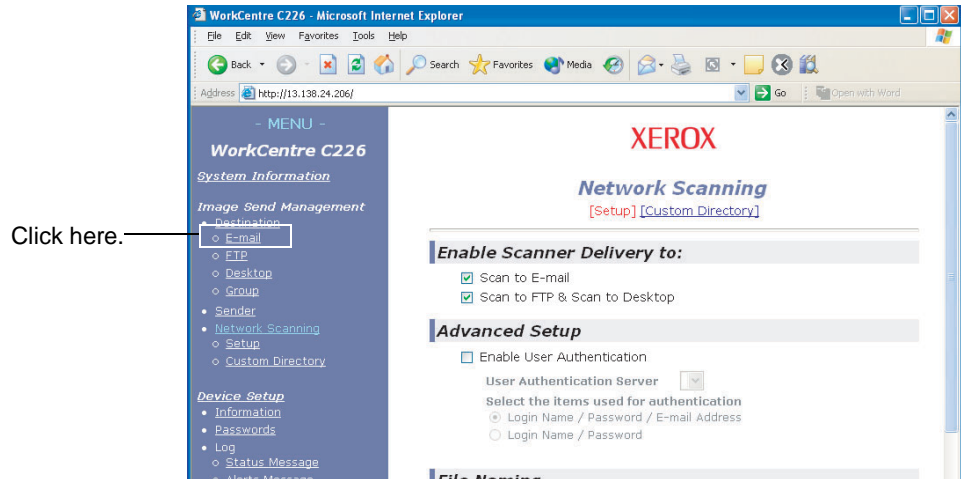

Item	Description
Full Name (Required)	Enter the full name of the destination (up to 36 characters).
Initial (Optional)	Enter the initial character of the stored destination name. This initial is used to place the destination in the ABC index of the machine's address directory screen. (page 4-23)
Custom Directory	Drop down list: Select one custom directory for this destination. Check box for Frequently-Used: The destination is set as Frequently-Used when checked on.
E-mail Address (Required)	Enter one address as an e-mail destination (up to 64 characters). If Global Address Search can be used, you can click "Global Address Search" to select an e-mail address from the Global Address Book.
Display Name (Optional)	Enter a key name (no more than 18 characters) for the destination. The key name will appear in the machine's touch panel. If you don't enter a key name, the initial 18 characters of the "Full Name" will be stored as the key name.
File Format for Colour	Select the file format and compression mode for transmission of images scanned in colour. "PDF Middle compression" is initially selected. The selections are as follows: PDF High compression/PDF Middle compression/PDF Low compression/ JPEG High compression/JPEG Middle compression/JPEG Low compression
File Format for B/W	Select the file format and compression mode for transmission of images scanned in black and white. "PDF G4" is initially selected. The selections are as follows: PDF uncompressed/PDF G3/PDF G4/TIFF uncompressed/TIFF G3/TIFF G4

Scan to E-mail destinations can also be stored, edited, and cleared from the touch panel of the machine. (pages 4-42 to 4-48)

To perform Scan to E-mail, the e-mail server settings must first be established. (Refer to page 4-7.)

Storing destinations for Scan to FTP

Click "FTP" in the menu frame of the Web page to store destinations.

Configure the settings for the destination FTP server for Scan to FTP in this screen.

When you have completed all of the entries, click "Submit". The entries will be stored.

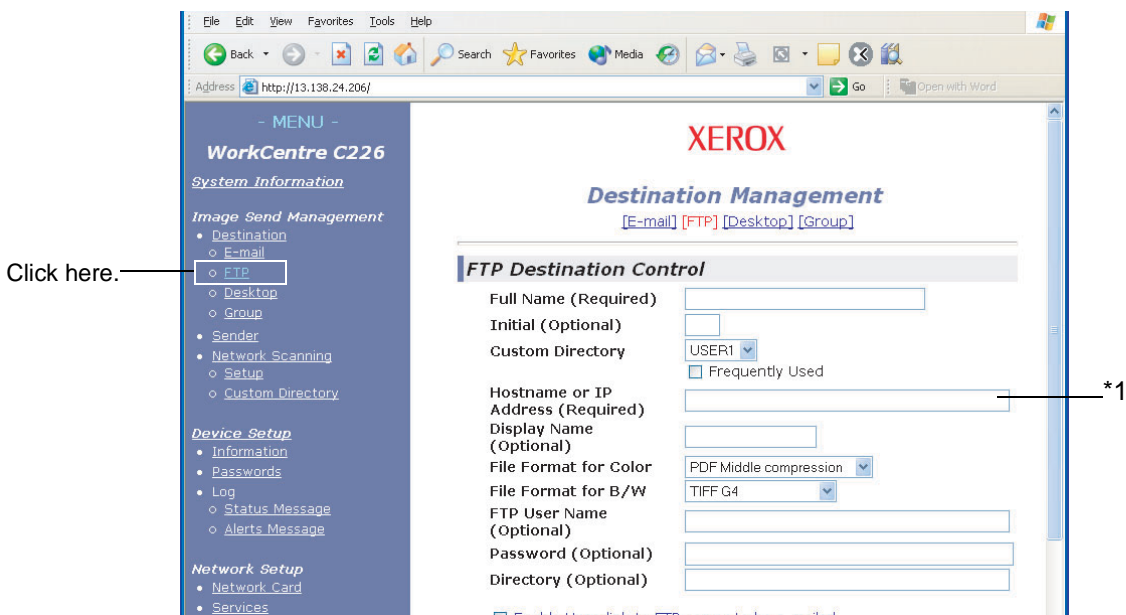

Item	Description
Full Name (Required)	Enter the full name of the destination (up to 36 characters).
Initial (Optional)	Enter the initial character of the stored destination name. This initial is used to place the destination in the ABC index of the machine's address directory screen. (page 4-21)
Custom Directory	Drop down list: Select one custom directory for this destination. Check box for Frequently-Used: The destination is set as Frequently-Used when checked on.
Hostname or IP Address (Required)*1	Enter the IP address of the FTP file server or the host name (maximum of 255 characters).
Display Name (Optional)	Enter a key name (within 18 characters) for the destination. The key name will appear in the machine's touch panel. If you don't enter a key name, the initial 18 characters of the "Full Name" will be stored as the key name.

Item	Description
File Format for Colour	Select the file format and compression mode for transmission of images scanned in colour. "PDF Middle compression" is initially selected. The selections are as follows: PDF High compression/PDF Middle compression/PDF Low compression/ JPEG High compression/JPEG Middle compression/JPEG Low compression
File Format for B/W	Select the file format and compression mode for transmission of images scanned in black and white. "TIFF G4" is initially selected. The selections are as follows: PDF uncompressed/PDF G3/PDF G4/TIFF uncompressed/TIFF G3/TIFF G4
FTP User Name (Optional)	Character field for the FTP user name within 50 characters.
Password (Optional)	Character field for the FTP password within 50 characters.
Directory (Optional)	Character field to specify a directory on the FTP server within 200 characters.
Enable Hyperlink to FTP server to be e-mailed (Checkbox)* ²	When you send a scanned file to an FTP server, you can have a transmission notification automatically sent to the file recipient by e-mail. To have transmission notifications sent, select the checkbox. The FTP server name will appear in the transmission notification as a hyperlink.
E-mail Destination	Select the recipient that you wish to notify of the file transmission to the FTP server. To select a recipient here, the recipient's e-mail address must have been previously stored. (page 4-12)

*1 If you entered a host name in "Hostname or IP Address", you will need to enter the DNS server settings. (Refer to page 4-11.)

*2 To perform Scan to FTP (Hyperlink), you must also enter the settings under "SMTP Setup" for the e-mail server.

If you select the "Enable Hyperlink to FTP server to be e-mailed" checkbox and select a previously stored recipient (page 4-11) from "E-mail Destination", you are able to have an e-mail sent to the recipient informing them of the file format and location of the scanned image data. A hyperlink to the file server to which the scanned image data was sent appears in the e-mail, and the recipient can click the hyperlink to go directly to the location where the image data is stored.

Storing Groups (Scan to E-mail)

If you are using Scan to E-mail, a scanned image can be sent to multiple destinations in a single operation. To use this function, you must first store the destinations in a group. Click "Group" and then select the Scan to E-mail destinations that you wish to store in the group. Up to 300 destinations can be stored in one group. Only destinations for E-mail can be stored in a group. Note that multiple destinations cannot be entered manually when sending an image.

When you have completed all of the entries, click "Submit". The entries will be stored.



Item	Description
Full Group Name (Required)	Enter the full group name of the destination (up to 36 characters).
Initial (Optional)	Enter the initial character of the stored destination name. This initial is used to place the destination in the ABC index of the machine's address directory screen. (page 4-21)
Custom Directory	Drop down list: Select one custom directory for this destination. Check box for Frequently-Used: The destination is set as Frequently-Used when checked on.
Address(es) (Required)	Select the address of the destination from the e-mail list box. Programmed e-mail destinations appear in each of the destination lists. To select multiple destinations, click each address while holding down the [Ctrl] key on the keyboard. If you need to cancel an address that has been selected, click the address again while holding down the [Ctrl] key. Up to 300 addresses can be programmed.
Display Name (Optional)	Enter a key name (within 18 characters) for the destination. The key name will appear in the machine's touch panel. If you don't enter a key name, the initial 18 characters of the "Full Group Name" will be stored as the key name.

Editing and deleting programmed transmission destinations

To edit or delete programmed destinations, click "Destination" in the menu frame of the Web page.

1. Click "Destination" in the menu frame of the Web page.

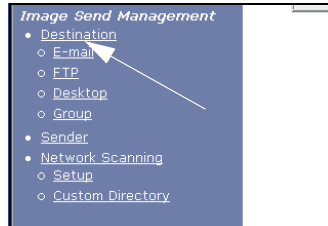

2. In the Destinations List, click the button of the destination that you want to edit or delete.

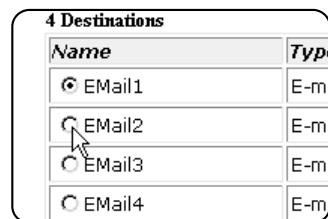

3. To edit the selected destination, click "Edit" under the Destinations List.

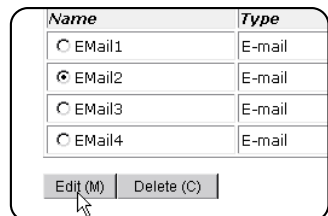

The programming screen of the destination selected in step 2 appears. Edit the information in the same way as you initially stored it.

When finished, be sure to click "Submit" to save your changes.

To delete the selected destination, click "Delete" under the Destinations List.

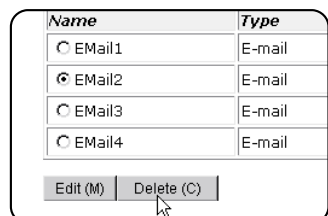

A message appears asking you to confirm the deletion. Click "Yes" to delete.

NOTE: *If you attempt to edit or delete a programmed destination in the following situation, a warning message will appear and editing/deletion will not be possible.*

The destination is included in a group.

If the destination is being used for a current transmission, cancel the transmission or wait until it is completed and then edit or delete the destination. If the destination is included in a group, delete the destination from the group and then edit or delete the destination.

Storing Sender Information (Scan to E-mail)

To store the sender information (Sender Name, E-mail Address) that is displayed when the recipient receives your e-mail, click "Sender" in the menu frame and then click "Add". Information for up to 20 different senders can be stored. Select a sender from the stored senders using the touch panel of the machine when you send an image (page 4-23). The selected sender appears in the sender column of the recipient's e-mail software program.

NOTE: *If you do not select a sender when sending an image, the default sender information stored with the key operator program "Default sender set" is automatically sent. (page 4-67)*

1. Click "Sender" in the menu frame of the Web page.

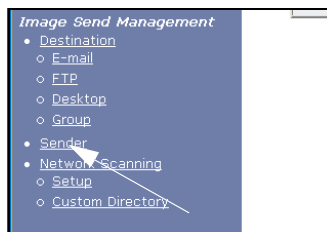

2. Click "Add" under "New Sender".

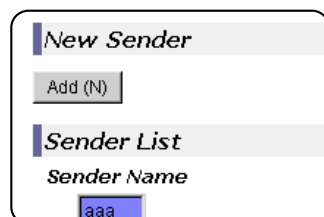

The sender programming screen appears.

3. Enter the name and e-mail address of the new sender. Be sure to click "Submit" after entering this information.

Editing and deleting programmed sender's information

1. Click "Sender" in the menu frame of the Web page.

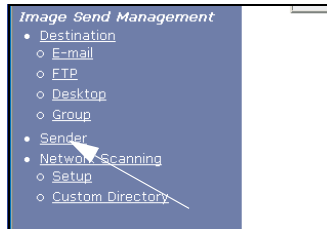

2. Click the sender that you wish to edit or delete from the "Sender List" menu so that it is highlighted, and then click "Edit" or "Delete".



If you clicked "Edit", edit the information in the same way that you initially programmed it and then click "Add" to save your changes. If you clicked "Delete", a message will appear asking you to confirm the deletion. Click "Yes" to delete.

Storing a Custom Directory

Programmed destinations appear as one-touch keys in the Address directory screen of the touch panel (page 4-21), and are normally included in the ABC index. Two types of indexes are available: the ABC index and group indexes (custom directories). Group indexes allow you to assign any index name to the destination for easy searching. Six group indexes are available, and a name up to six characters long can be assigned to each.

Click "Custom Directory" in the menu frame of the Web page to display the following screen. Group index names can be programmed and edited in this screen. Enter names for indexes 1 through to 6 and then click "Submit". If you wish to change a previously programmed name, enter the new name and save it.

For information on grouping destinations in a group index, see the appropriate pages for programming the transmission methods. For information on switching between the ABC index and group indexes, see page 4-22.

NOTE: You can also store indexes in the Custom Directory from the touch panel of the machine. (page 4-54)

Protecting Information Programmed in the Web Page ("Passwords")

Passwords can be set to restrict Web page access and protect settings. Note that it is not necessary to set passwords; the network scanner functionality can also be used without passwords.

A password can be set for the administrator and passwords can be set for each user. If you use a user password to access the Web page, you will be able to establish, edit, and delete destinations in the Scanner Destination Management menu; however, you will not be able to establish settings in the Setup menu.

The passwords for "user" and "admin" are both initially set to "Xerox". If you wish to change the passwords when first establishing the settings, enter "Xerox" in "Old Admin Password" before you establish the settings. A password must consist of alphanumeric characters and be no more than seven characters long. Passwords are case sensitive. After entering a password, click "Submit" to set it. After setting the password, turn the machine power off and then back on.

When a password is set, you will be prompted for the password when you attempt to access a Web page with protected settings. For the "User name", enter "user" if you are accessing the page as a user, or "admin" if you are accessing the page as an administrator. For detailed information on setting passwords, refer to "Help".

Condition Setting Screen of Scanner Mode

The condition setting screen of scanner mode is displayed by pressing the [IMAGE SEND] key (refer to page 1-14) while the print mode, copy mode, or job status screen appears in the touch panel*1. In the explanations that follow, it is assumed that the initial screen that appears after pressing the [IMAGE SEND] key is the condition setting screen (shown below). If you have set the display to show the address directory (page 4-21) when the [IMAGE SEND] key is pressed, touch the [CONDITION SETTINGS] key in the address directory to display the condition setting screen.

The key operator program "Default display settings" can be used to set the display to show either the condition setting screen (shown below) or the Address directory screen (page 4-21) when the [IMAGE SEND] key is pressed (refer to page 4-66).

*1 When the optional Fax Unit is installed, you will return to the condition setting screen of fax mode or scan/fax mode, depending on which mode was last selected. If the condition setting screen of fax mode appears, touch the key to switch to the base screen of scan/fax mode.

NOTE: For information on the parts of the unit and the operation panel that are used for network scanning, refer to pages 1-13 and 1-14. For parts that are used for both network scanning and printing, refer to page 3-40.

Condition setting screen

The display is initially set (factory setting) to show the following condition setting screen as the initial screen.

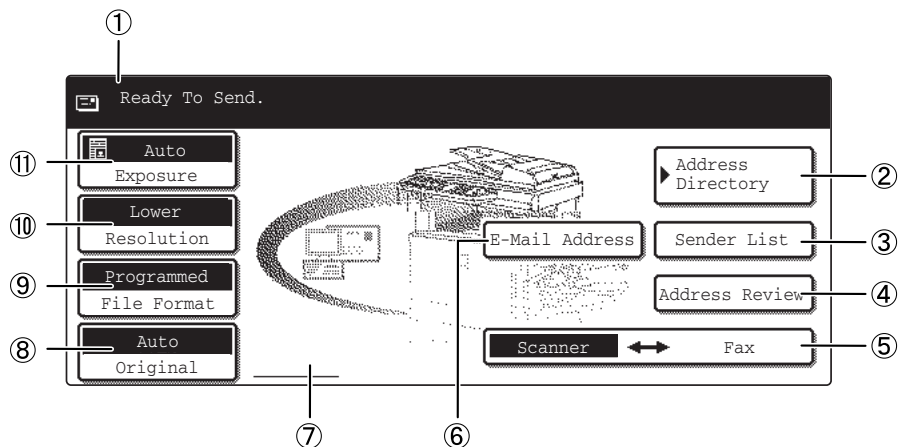

① **Message display** Messages appear here to indicate the current status of the machine.

② **[ADDRESS DIRECTORY] key** This displays the Address Directory screen (page 4-21). Touch this key when you wish to use a one-touch key that has a destination (or group) programmed in it (page 4-25).

③ **[SENDER LIST] key** Touch this key to select the sender when sending an image (page 4-24).

④ **[ADDRESS REVIEW] key** When performing Scan to E-mail broadcast transmission, touch this key to check your selected destinations. Your selected destinations will appear as a list, and the list can be edited (page 4-30).



⑤ When the optional Fax Unit is installed, touch this key to switch between scanner mode and fax mode.

⑥ **[E-MAIL ADDRESS] key**

When performing Scan to E-mail, touch this key if you wish to enter the e-mail address of the recipient manually instead of using an one-touch key (page 4-28).

⑦ **Two-sided scanning icon display**

Icons appear here when you touch the [ORIGINAL] key and select two-sided scanning. The icons can be touched to open function selection screens (page 4-32).

⑧ **[ORIGINAL] key**

Touch this key when you wish to manually set the size of the original to be scanned or scan both sides of the original (page 4-32).

⑨ **[FILE FORMAT] key**

Touch this key to set the file format of scan images that you transmit. The selected file format setting will be highlighted above the key. The initial factory setting is "PROGRAMMED" (page 4-39).

⑩ **[RESOLUTION] key**

Touch this key to change the resolution setting for the original to be scanned. The selected resolution setting will be highlighted above the key. The initial factory setting is "LOWER" (page 4-37).

⑪ **[EXPOSURE] key**

Touch this key to change the exposure setting for the original to be scanned. The selected exposure setting will be highlighted above the key. The initial factory setting is "AUTO" (page 4-36).

Address directory screen

Touch the [ADDRESS DIRECTORY] key in the Condition setting screen (page 4-19) to display the screen shown below at right.

If you have set the initial screen to the address directory screen using the key operator program, the initial screen will appear as follows.

Destinations stored using the Web page are grouped in indexes (⑨) according to the letter entered in "Initial" for each destination, and the name entered in "Display Name" is displayed in the one-touch key (④).

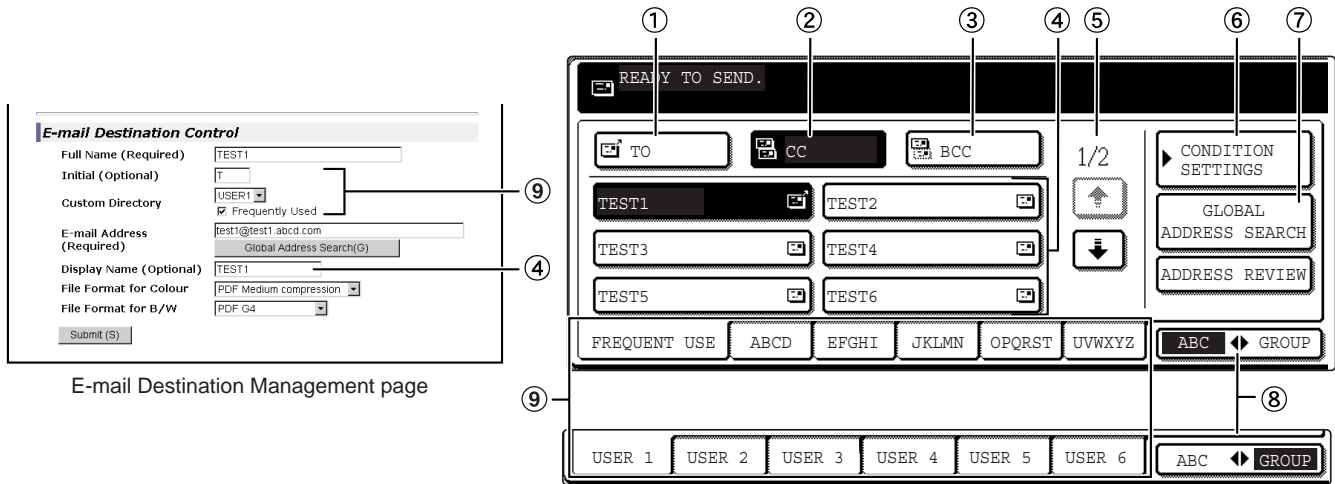

- ① **[TO] key** When selecting a destination for Scan to E-mail, make sure this key is highlighted (page 4-29). (If the key is not highlighted, touch it so that it is highlighted.)
- ② **[CC] key** If you wish to send "CC" ("Carbon Copy") copies of a Scan to E-mail transmission to other recipients in addition to the main recipient, touch this key so that it is highlighted and then select the "CC" destinations (page 4-29).
- ③ **[BCC] key** If you wish to send "BCC" ("Blind Carbon Copy") copies of a Scan to E-mail transmission to other recipients in addition to the main recipient, touch this key so that it is highlighted and then select the "BCC" destinations. Other recipients will not be informed that a copy was sent to the "BCC" recipients (page 4-29).



- ④ **One-touch key display** This shows the one-touch keys that have been stored on the selected "index card". The key type is indicated by the icon at the right.

- : Scan to E-mail (TO)
- : Scan to E-mail (CC)
- : Scan to E-mail (BCC)
- : Scan to FTP

This can be changed to 6 ,8, or 12 using the key operator program, "The number of direct address keys displayed setting" (page 4-66).

NOTE: *If desired, you can use the key operator program, "Default display settings" (page 4-66), to set the default screen to the group address directory.*

⑤ Display switching keys

In cases where the one-touch keys cannot all be displayed on one screen, this shows how many screens are left. Touch the "  " "  " keys to move through the screens.

⑥ [CONDITION SETTINGS] key

This displays the Condition setting screen (page 4-19), which is used to set various conditions.

⑦ [GLOBAL ADDRESS SEARCH] key

This feature makes it possible to search for an e-mail address in an Internet or intranet directory database (page 4-30).

To use this function, the IP address (or network name) of the LDAP server must be set, as well as an account name and password. These settings are configured by accessing the Web server in the machine from a computer. Click "LDAP" in the Web page menu frame to display the LDAP Setup screen.

⑧ [ABC ◀ ▶ GROUP] key

Touch this key to switch between the alphabetical index and the group index.

⑨ Index keys

One-touch key destinations are stored on each of these index cards (alphabetical index or group index). Touch an index key to display the card.

Group indexes make it possible to store one-touch keys by group with an assigned name for easy reference. This is done with the custom settings (refer to page 4-17). Frequently used one-touch key destinations can be stored on the FREQUENT USE card for convenient access.

Sending an Image

Basic Transmission Method

1. Make sure the machine is in scanner mode.

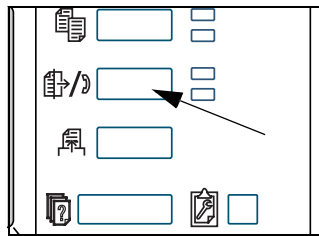

When the [IMAGE SEND] key light is on, the machine is in scanner mode. If the light is not on, press the [IMAGE SEND] key.

When the optional Fax Unit is installed, you will return to the base screen of fax mode or scan/fax mode, depending on which mode was last selected. If the base screen of fax mode appears, touch the



key (see *1 on page 4-19 to switch to the base screen of scan/fax mode.

2. Load the original.

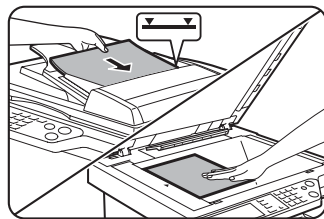

For detailed information on loading an original, refer to page 2-4.

NOTE: You cannot load documents in both the DADF and on the document glass and send them in a single transmission.

3. Check the original size.

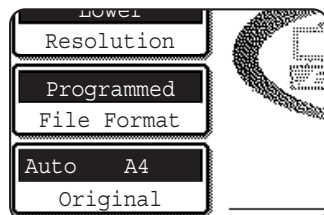

The original size is automatically detected.

If you loaded a non-standard size document or wish to change the scanning size, touch the [ORIGINAL] key and set the document size. (Refer to page 4-34.)

- NOTES:**
- To scan a two-sided original, refer to page 4-32.
 - To rotate the document image 90° before transmission, see page 4-34.

4. If required, adjust the resolution setting. (Refer to page 4-37.)

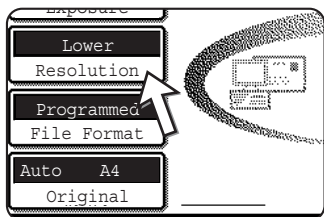

The initial factory setting is "LOWER".

5. If required, adjust the exposure setting. (Refer to page 4-36.)

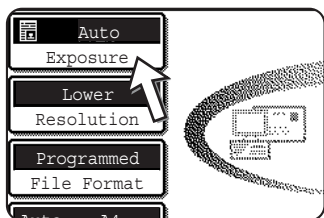

The initial factory setting is "AUTO".

6. If needed, select the file format. (Refer to page 4-38.)

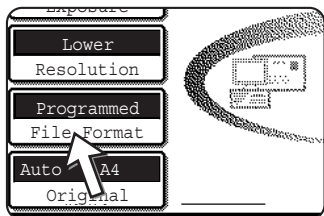

The initial factory setting is "PROGRAMMED".

7. Touch the [SENDER LIST] key.

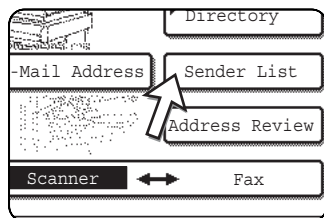

This step is not necessary for Scan to FTP. Go directly to step 10 (page 4-25).

- NOTES:**
- You can omit selection of a sender (go directly to step 10). In this case, the default sender information stored with the key operator program is automatically transmitted. (page 4-67)
 - Up to 20 senders can be stored using the Web page. (page 4-16)

8. Touch a key to select a sender.

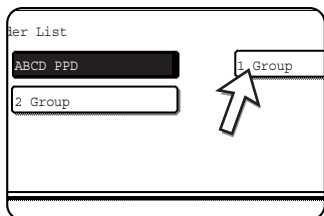

The touched key is highlighted. If you made a mistake, touch the correct key. The highlighting will move to the new key.

The selected sender will be the sender of the e-mail.

9. Touch the [OK] key.

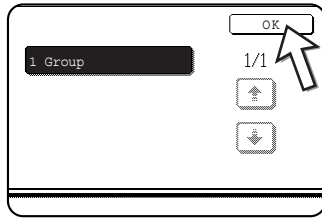

10. Touch the [ADDRESS DIRECTORY] key.

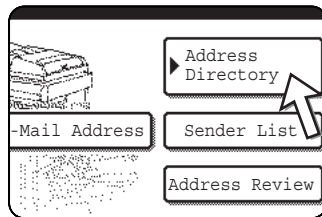

The address directory screen appears.

11. Touch the one-touch key for the desired destination.

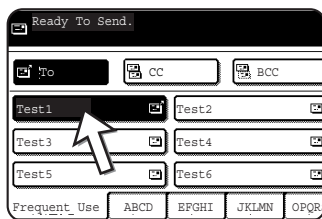

The key you touched is highlighted. If you touch the wrong key, touch the key again to cancel the selection. The key display will return to normal.

When transmitting by Scan to E-mail

Make sure that the [TO] key is highlighted and then touch the one-touch key of the destination. If you wish to perform a broadcast transmission, "CC" or "BCC" copies, touch the [CC] or [BCC] key and then touch the one-touch keys of the "CC" or "BCC" recipients.

- NOTES:**
- Refer to pages 4-10 to 4-15 for information on programming one-touch key destinations.
 - When touching a one-touch key, corresponding information from the email destination screen is shown in the message display. Up to 36 characters can be displayed in the message screen, regardless of the number of characters that have been entered (up to 50 characters of an e-mail address are displayed).
 - You can also manually enter the address of a Scan to E-mail destination, or select multiple destinations for a broadcast transmission. (page 4-27)

About pressing the [START] key in the following procedure

If you are scanning a colour original in colour, press the [COLOUR COPY START] key. If you are scanning a colour or black and white original in black and white, press the [BLACK COPY START] key.

Using the DADF

12. Press the [COLOUR COPY START] key or the [BLACK COPY START] key.

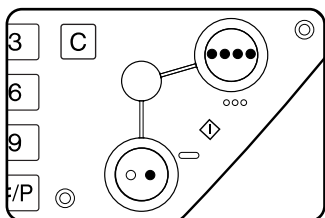

Scanning begins.

If scanning is completed normally, the machine sounds a beep and the image is transmitted.

Using the document glass

12. Press the [COLOUR COPY START] key or the [BLACK COPY START] key.

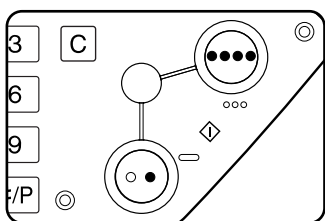

The original is scanned and the [READ-END] key appears.

13. If you have another page to scan, change pages and then press the [START] key.

Repeat this sequence until all pages have been scanned. You can change the exposure setting as needed for each page (refer to page 4-36).

If no action is taken for one minute, scanning automatically ends and the image is transmitted.

The time to transmission can be set using "Scanner mode timeout after last scan" (page 4-68) in the key operator programs. If the time is set to 0 seconds, the following step is not necessary.

14. After the final page is scanned, touch the [READ-END] key.

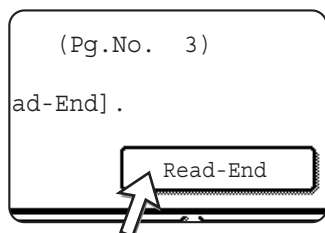

The machine sounds a beep and the image is transmitted.

Open the document glass cover and remove the document.

- NOTES:**
- **Cancelling transmission**
To cancel transmission while the [SCANNING ORIGINAL...] appears in the display or before the [READ-END] key is touched, press the [CLEAR ALL] key. To cancel a job after scanning is finished and transmission has begun, press the [JOB STATUS] key and cancel the job as explained on page 4-41.
 - **Important points when using Scan to E-mail**
Be very careful not to send image data files that are too large. Your mail server's system administrator may have placed a limit on the amount of data that can be sent in one e-mail transmission. If this limit is exceeded, the e-mail will not be delivered to the recipient. Even if there is no limit and your e-mail is successfully delivered, a large data file may take a long time to be received and place a heavy burden on the recipient's network, depending on the recipient's network (Internet) connection environment. If large image data files are repeatedly sent, the resulting burden on the network may slow down the speed of other, unrelated data transmissions and in some cases, may even cause the mail server or network to go down. In cases where you need to send multiple documents, try such measures as lowering the resolution mode.
 - *You can use the key operator program, "Maximum size of e-mail attachments" (page 4-68), to set a limit for the size of image files sent by Scan to E-mail.*
 - *If the power is turned off or a power failure occurs while a document is being scanned in the DADF, the machine will stop and a document misfeed will occur. After the power is restored, remove the document as explained on page 2-79.*

Destination Input Methods

In the section "Basic Transmission Method", a destination is specified with a one-touch key (steps 10 to 11). This machine, however, provides the following destination input methods.

- Manual entry: Enter the e-mail address directly. (only for Scan to E-mail)
- Global address search: Search for an e-mail address in an Internet or intranet directory database.

You can also enter multiple addresses for a broadcast transmission.

Destination address manual entry

1. Perform steps 1 through 9 of "Basic Transmission Method" on page 4-23.

2. Touch the [E-MAIL ADDRESS] key.

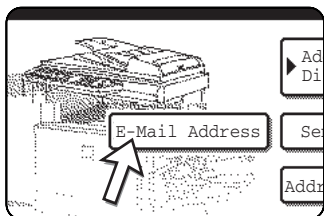

3. Enter the e-mail address.

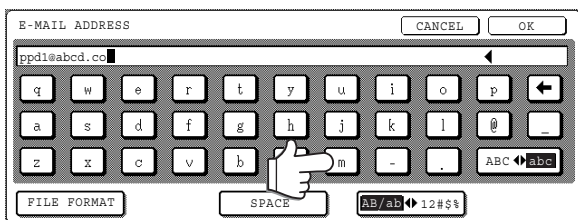

If you make a mistake, touch the key to move the cursor (n) back to the mistake and then enter the correct character.

4. Touch the [FILE FORMAT] key.

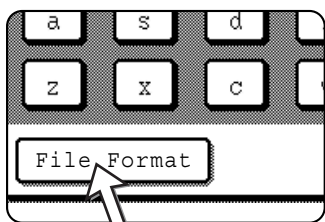

If you do not need to change the file format, go directly to step 7.

NOTE: The initial file format setting can be changed with the key operator program “Initial file format setting” (page 4-67).

5. If you wish to scan in colour, touch the [COLOUR] key. If you wish to scan in black and white, touch the [B/W] key.

The file format settings differ for colour and black and white. Be sure to select a correct file format for the type of scan you will perform.

- Select the file type and the compression mode.

Scanning in colour

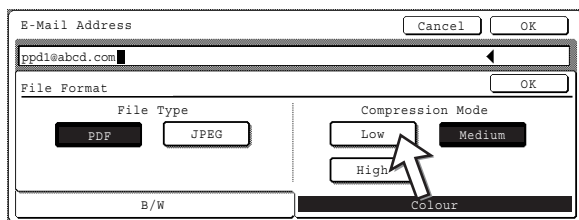

The file format is initially set to "File type: PDF, Compression mode: MEDIUM".

Scanning in black and white

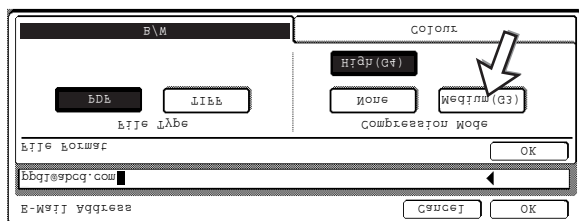

The file format is initially set to "File type: PDF, Compression mode: HIGH (G4)".

- Touch the outer [OK] key.

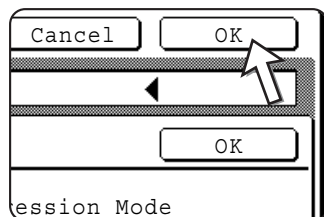

The destination selection screen will appear.

- Select where you put the destination.

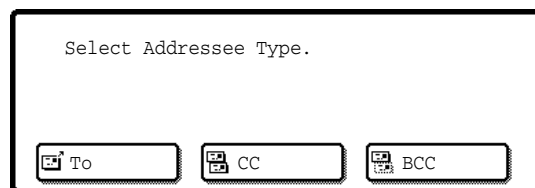

Normally touch the [TO] key. However, if you are performing a broadcast transmission and wish to "CC" or "BCC" the document to the entered e-mail address, touch the [CC] or [BCC] key.

After touching one of the keys, you will return to the initial screen.

- If you wish to enter another e-mail address, repeat steps 2 through 8.
If you are not performing a broadcast transmission, go directly to step 11.

NOTE: If you frequently use broadcasting to send documents to the same group of destinations, it is convenient to program those destinations into a group key. (page 4-14)

10. Touch the [ADDRESS REVIEW] key and check the destinations.

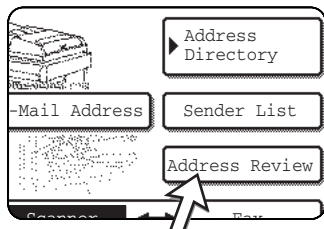

When the [ADDRESS REVIEW] key is touched, only the entered destinations are displayed. If you need to delete a destination, touch its key.

Touch the [OK] key to return to the initial screen.

11. Continue from step 12 of "Basic Transmission Method" (page 4-26).

- NOTES:**
- To cancel a broadcast transmission when selecting destinations, press the [CLEAR ALL] key.
 - When you perform a broadcast transmission, the compression mode set with the key operator program, "Compression mode at broadcasting" (page 4-67), is used as the file compression mode for all destinations. The default settings are "MEDIUM" for colour scanning and "HIGH (G4)" for black and white scanning.

Destination address entry with global address search

1. Touch the [GLOBAL ADDRESS SEARCH] key.

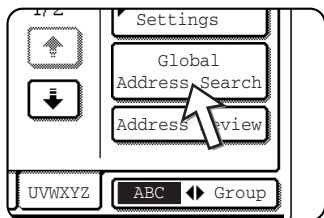

The server change screen is displayed. If only one LDAP server has been set, the global address search screen is displayed. Proceed to step 4.

2. Touch the desired LDAP server key.

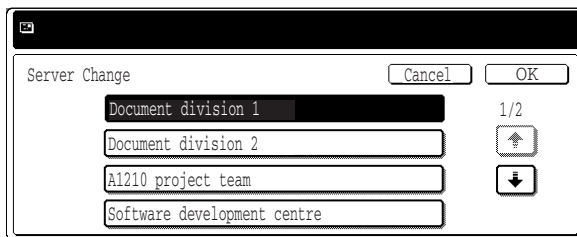

To search the highlighted server, proceed to step 3.

3. Touch the [OK] key.

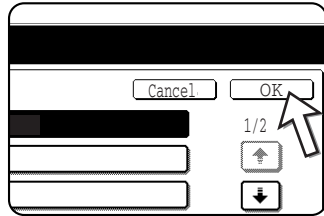

4. Enter a keyword for search.

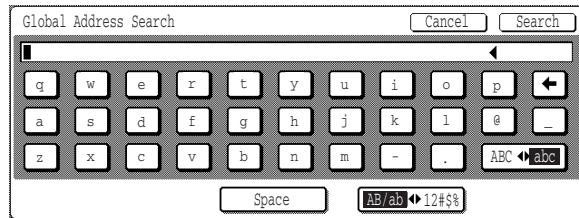

5. Touch the [SEARCH] key.

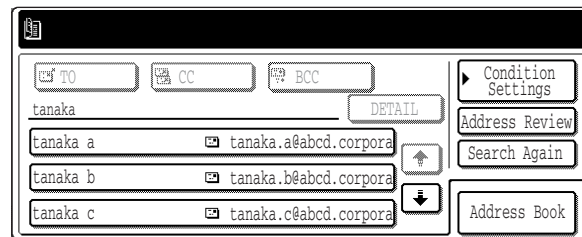
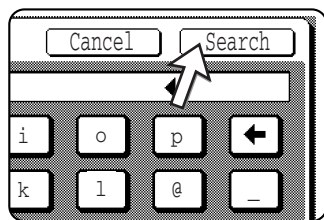

The search results appear as destination keys.

If matching addresses are not found, a message indicating the result is displayed. In this case, touch the [OK] key and touch the [SEARCH AGAIN] key to return to step 4.

6. Touch the desired destination key.

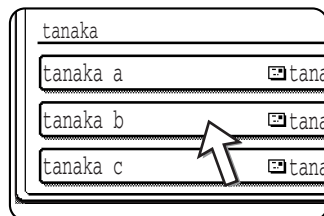

To display the remaining destinations, touch the [\downarrow] key.

For detailed information on the selected destination, touch the [DETAIL] key. You can also register the destination to the address book by touching the [REGISTER] key.

7. Select the destination type.

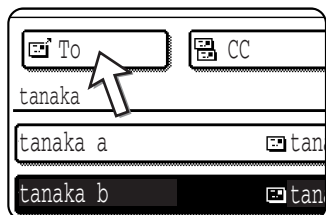

Normally touch the [TO] key. However, if you are performing a broadcast transmission and wish to "CC" or "BCC" the document to the entered address, touch the [CC] or [BCC] key.

8. If you wish to enter another address, repeat steps 6 and 7.
For Scan to FTP, multiple destinations cannot be specified.
9. Touch the [CONDITION SETTINGS] key.

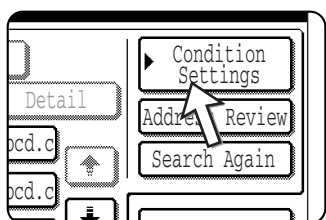

You will return to the condition setting screen.

Scanning and Transmitting a Two-sided Original

A two-sided original can be automatically scanned and transmitted using the DADF. Follow the steps below.

1. Make sure the machine is in scanner mode and then load the document in the DADF.
2. Touch the [ORIGINAL] key.

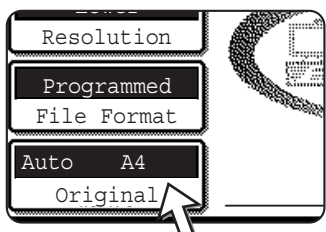

When you touch the [ORIGINAL] key, check the original size displayed in the key.

3. Touch the [2-SIDED BOOKLET] key or the [2-SIDED TABLET] key as appropriate for the original you loaded.

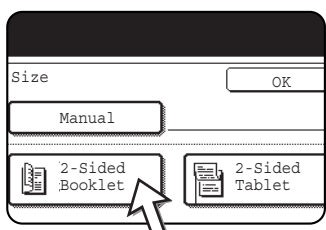

If necessary, touch the [MANUAL] key and set the original size. (page 4-34)

4. Touch the [OK] key.

You will return to the initial screen.

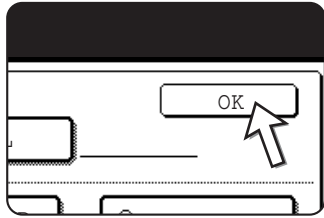

A two-sided original icon appears next to the [ORIGINAL] key.

(Example: The icon that appears when the [2-SIDED BOOKLET] key is touched.)

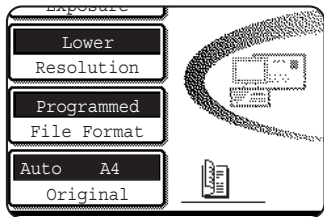

5. Continue from step 4 of “Basic Transmission Method” (page 4-24).

NOTES:

- **Booklets and tablets**

Two-sided originals that are bound at the side are booklets, and two-sided originals that are bound at the top are tablets.

- *Two-sided scanning turns off when transmission is finished. Pressing the [CLEAR ALL] key will also cancel two-sided scanning.*

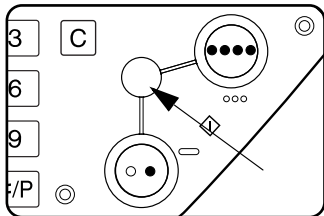

Scanning Settings

When sending an image, you can adjust the original size, exposure, resolution, and file format settings as needed.

Manually Setting the Scanning Size

If you load an original that is not a standard size (such as an inch size), or if you wish to change the scanning size, touch the [ORIGINAL] key and set the original size manually.

Perform the following steps after loading the document in the DADF or on the document glass.

NOTE: Standard sizes that can be detected are as follows:

A3, B4, A4, A4R, B5, B5R, A5. (11"x17", 8-1/2"x14", 8-1/2"x11", 8-1/2"x11"R, 5-1/2"x8-1/2")

If a non-standard size original is loaded (including special sizes), the closest standard size may be displayed, or the original size may not appear at all.

1. Touch the [ORIGINAL] key.

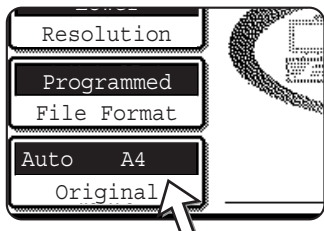

2. Touch the [MANUAL] key.

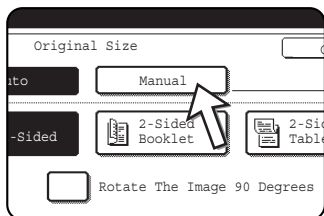

The sizes that can be selected are displayed.

[AUTO] is no longer highlighted. [MANUAL] is highlighted.

NOTE: If you wish to rotate the original 90° when creating an image file, click the "ROTATE THE IMAGE 90 DEGREES" checkbox (a checkmark should appear in the box).

3. Touch the desired original size key.

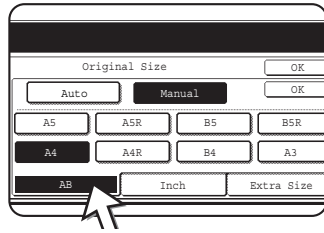

The original size key you touched are highlighted.

If you wish to select an inch size, touch the [INCH] key and then touch the desired original size key.

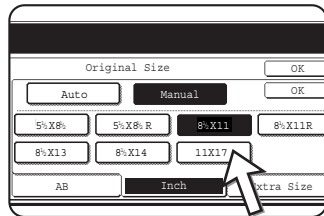

[INCH] is highlighted and inch size keys are displayed.

To return to the AB palette, touch the [AB] key once again.

If you wish to select a custom size, touch the [EXTRA SIZE] key and enter the size of the original.

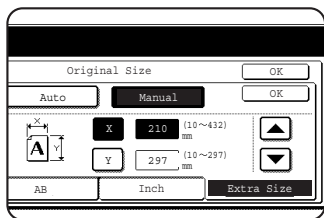

Touch the [X] key and use the ▲ or ▼ keys to set the length in the X direction, and then touch the [Y] key and do the same for the Y direction.

The length can be within the range 10 to 432 mm (1/2" to 17") in the X direction and 10 to 297 mm (1/2" to 11-5/8") in the Y direction, set in increments of 1 mm (1/8").

Depending on the amount of memory installed, it may not be possible to scan some original sizes (page 4-1).

4. Touch the outer [OK] key.

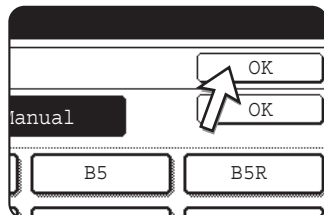

You will return to the initial screen.

Touching the inner [OK] key in the step above returns you to step 2.

The selected size appears in the top half of the [ORIGINAL] key.

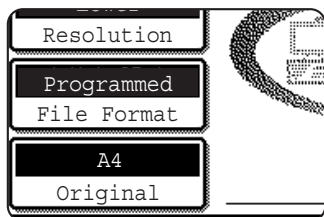

NOTE: You can return to automatic detection by pressing the [CLEAR ALL] key.

Selecting the Exposure

You can adjust the exposure manually to match the type of original. After loading the original in scanner mode, follow the steps below. The default setting for the exposure is "AUTO".

Change the exposure

1. Touch the [EXPOSURE] key.

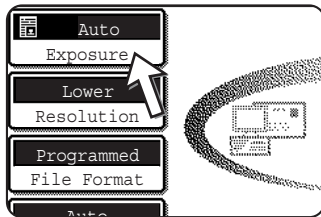



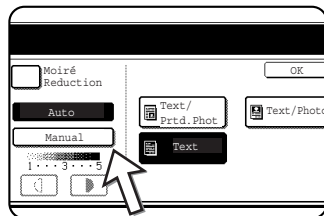

2. Select [AUTO] or [MANUAL].

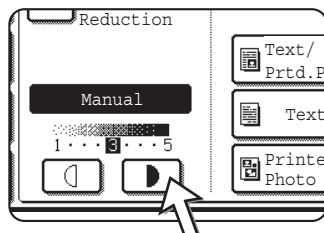

If you selected [AUTO], the exposure will be adjusted automatically. (Only for black and white scanning. If [AUTO] is selected for colour scanning, scanning will place at exposure level "3" of the manual settings.)



If you selected [MANUAL], touch the  or  key to adjust the exposure. (For darker contrast, touch the  key. For lighter contrast, touch the  key.)

3. Selecting the original type.

Touch the appropriate key for the type of original to be scanned. The image will be processed according to the selected type.

When [AUTO] is selected in step 2

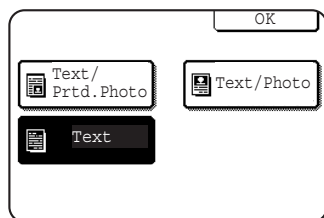

If "AUTO" is selected in step 2, you can select the original type from "TEXT/PRTD. PHOTO", "TEXT/PHOTO" or "TEXT".

When [MANUAL] is selected in step 2

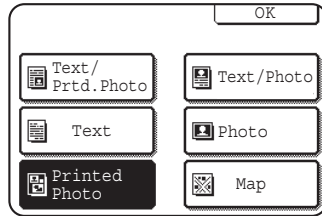

If "MANUAL" is selected, you can also select from "PHOTO", "PRINTED PHOTO" or "MAP", in addition to the selections available for AUTO.

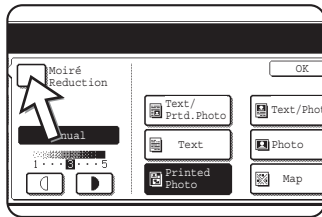

In the event that moiré occurs in the scanned image, touch the [MOIRÉ REDUCTION] checkbox to select it. This will help reduce the occurrence of moiré.

4. Touch the [OK] key.

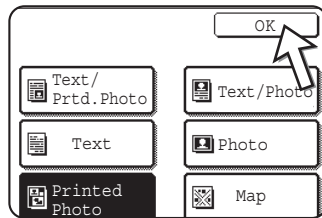

You will return to the initial screen.

Selecting the Resolution

The resolution for scanning an original can be selected. Load the original in scanner mode and then follow the steps below. The default setting for the resolution is "LOWER".

Change the resolution

1. Touch the [RESOLUTION] key.

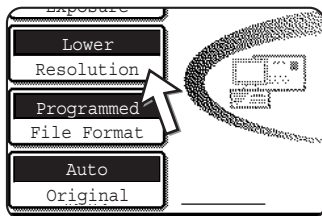

2. Touch the desired resolution key.

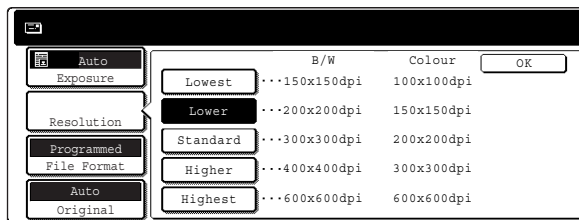

Five selections are available for the resolution. Touch the desired resolution key under black and white or colour, depending on the original to be scanned.

The selected key is highlighted.

NOTE: To use colour 600 x 600 dpi, one 256-MB and one 128-MB memory module (or two 256-MB memory modules) must be added to the printer controller, and one 128-MB or 256-MB memory module must be added for image memory. For more information, see page 4-1.

3. Touch the [OK] key.

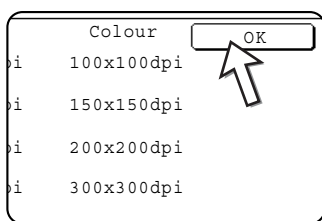

You will return to the initial screen.

- NOTES:**
- The initial factory resolution setting is *LOWER*. If desired, you can change the initial setting to a different setting using the key operator program, "Initial resolution setting" (page 4-66).
 - The resolution setting cannot be changed once scanning has begun.

Selecting the File Format

When you send an image to one or more recipients using Scan to E-mail or Scan to FTP, the [FILE FORMAT] key enables you to temporarily override the individual file format settings (FILE TYPE / COMPRESSION MODE) stored for each recipient and send the image to all of the recipients using a single file format setting.

"PROGRAMMED" is initially selected, which means that the file format settings stored for each recipient are used.

1. Touch the [FILE FORMAT] key.

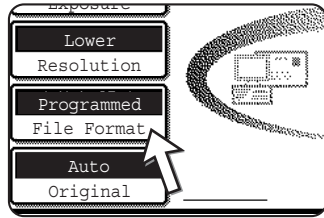

2. Remove the checkmark from the "PROGRAMMED" checkbox.

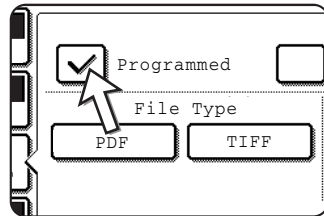

3. Select the file type and the compression mode.

The settings are selected separately for colour scanning and black and white scanning. Touch the [COLOUR] key or the [B/W] key to select the appropriate setting screen.

File format settings for colour scanning

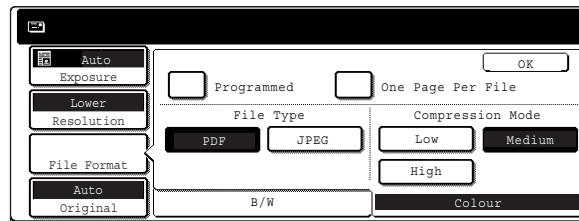

File format settings for black and white scanning

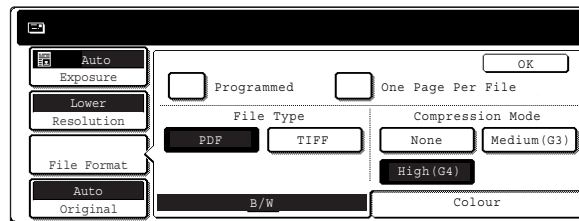

- NOTES:**
- When the "ONE PAGE PER FILE" checkbox is not selected, all scanned pages are combined into a single file. When the checkbox is selected, one file is created per page.
 - If the file format is set to "JPEG" in the file format settings for colour scanning, a checkmark automatically appears in the "ONE PAGE PER FILE" checkbox and one file is created for each page.
4. Touch the [OK] key.

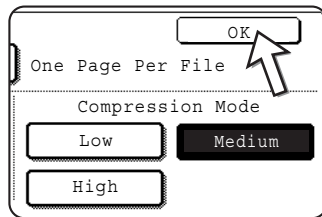

You will return to the initial screen.

- NOTES:**
- The initial file format setting can be changed with the key operator program "Initial file format setting" (page 4-67).
 - Even if you change the settings in the FILE FORMAT setting screen, you can return to the settings stored for each recipient by selecting "PROGRAMMED" once again.

Cancelling an E-Mail/FTP Transmission

You can cancel a transmission job that is in progress. Cancellation is done from the scanner job status screen.

1. Press the [JOB STATUS] key.

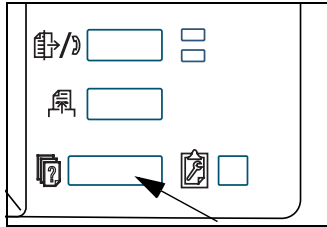

2. Touch the [SCANNER JOB] key.

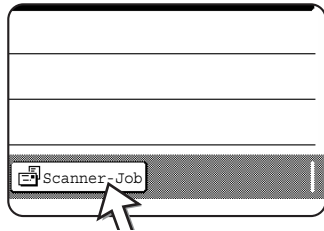

3. Touch the [STOP/DELETE] key.

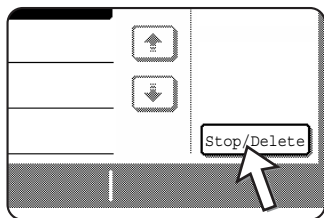

A message appears to confirm the cancellation. Touch the [YES] key to delete the selected job key and cancel the transmission.

NOTE: *If you do not wish to cancel the transmission, touch the [NO] key.*

Storing, Editing, and Deleting from the Touch Panel

One-touch and group keys for Scan to E-mail, group indexes, and senders can also be stored, edited and deleted from the touch panel of the machine.

Storing One-Touch Keys (Only Addresses for Scan to E-mail)

The touch panel of the machine can also be used to store destinations for Scan to E-mail. (Scan to FTP destinations must be stored using the Web page (page 4-12).)

1. Press the [CUSTOM SETTINGS] key.

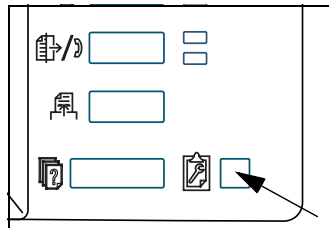

2. Touch the [ADDRESS CONTROL] key.

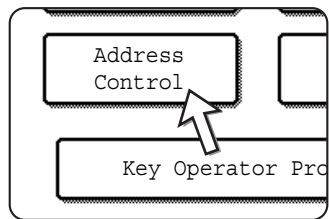

3. Touch the [DIRECT ADDRESS] key.

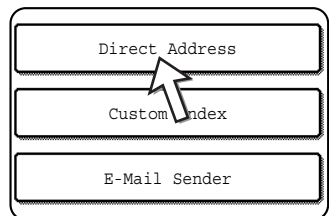

4. Touch the [INDIVIDUAL] key.

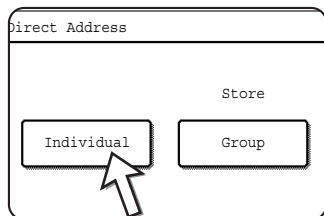

5. Touch the [NAME] key.

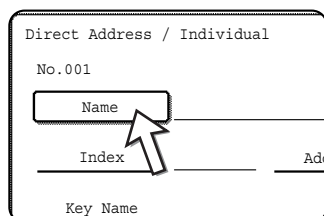

The "No." that automatically appears is the lowest number from 001 to 500 that has not yet been programmed. When [NAME] is touched, the letter-entry screen appears. Enter up to 36 characters for the name.

6. Touch the [INITIAL] key.

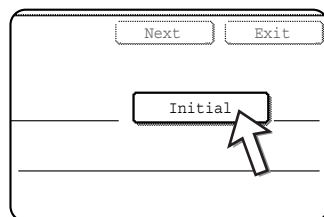

7. Touch a letter key.

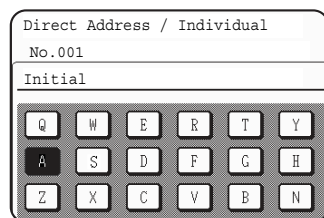

The first letter (initial) of the name entered in step 5 is initially selected and is highlighted. If you wish to change the letter, touch a different letter key.

NOTE: The initial you enter here determines the position of the one-touch key in the ABC index. For information on the ABC index, refer to page 4-22.

8. Touch the [OK] key.

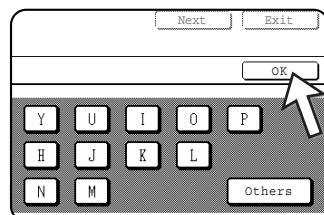

9. Touch the [INDEX] key.

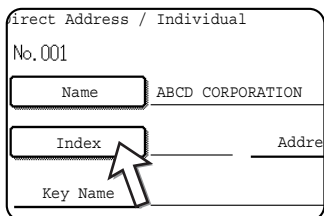

10. Touch an index key.

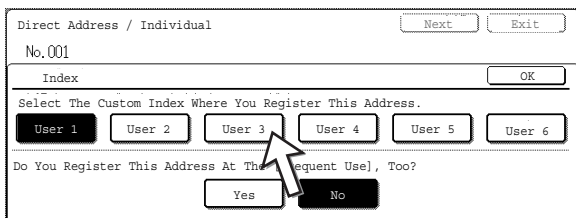

Select one of the upper row of keys ([USER 1] through [USER 6]) to determine the location of the one-touch key when the GROUP index is displayed instead of the ABC index (refer to page 4-22).

The lower keys are for selecting whether to include the one-touch key in the [FREQUENT USE] index.

If you touch the wrong key, simply touch the correct key.

11. Touch the [OK] key.

12. Touch the [ADDRESS] key.

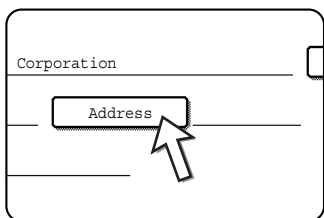

The E-mail address entry screen appears.

13. Enter the e-mail address of the destination.

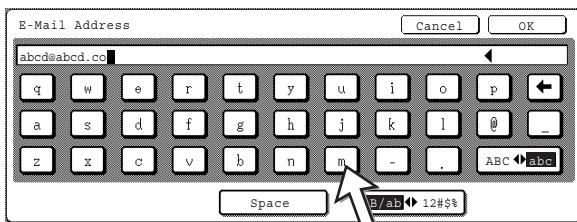

Up to 64 characters can be entered.

If you make a mistake, touch the  key to move the cursor back one space and then enter the correct character.

14. Touch the [OK] key.

You will return to the one-touch key programming screen.

REGISTRATION IS COMPLETED will appear highlighted to the right of "No.".

NOTE: The "ADDRESS" line only shows 32 digits, regardless of how many digits were actually programmed.

15. Check the key name.

The characters appearing next to the [KEY NAME] key will be displayed in the key. Only the first 18 characters of the name entered in step 5 will be displayed.

If you need to change the name that will be displayed in the key, touch the [KEY NAME] key.

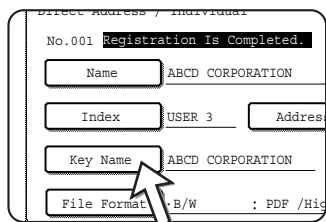

If you do not wish to change the name, this step is not necessary.

16. Check the file format and the compression mode.

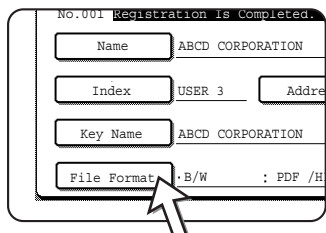

If you need to change these settings, touch the [FILE FORMAT] key.

If you do not need to change the settings, this step is not necessary.

Settings for colour scanning

File type: PDF*/JPEG

Compression mode: LOW/MEDIUM*/HIGH

Settings for black and white scanning

File type: PDF*/TIFF

Compression mode: NONE/MEDIUM (G3)/HIGH (G4)*

The default setting is indicated by an asterisk (*).

When you have completed the settings, touch the [OK] key.

17. When you have finished programming the one-touch key, touch the [EXIT] key.

If you wish to program another one-touch key, touch the [NEXT] key.

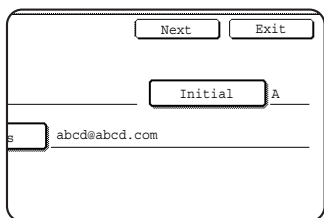

Touching the [EXIT] key returns you to the screen of step 4 on page 4-43.

Editing and Deleting One-Touch Keys

If you wish to delete a one-touch key or change the E-mail address, name, or other information programmed in a one-touch key, perform the following procedure.

1. Press the [CUSTOM SETTINGS] key, touch the [ADDRESS CONTROL] key, and then touch the [DIRECT ADDRESS] key (refer to steps 1 to 3 on page 4-42).
2. Touch the [AMEND/DELETE] key.

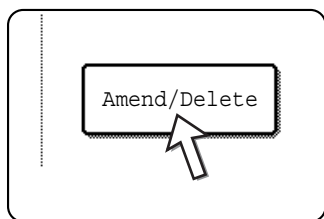

3. Touch the one-touch key you wish to edit or delete.

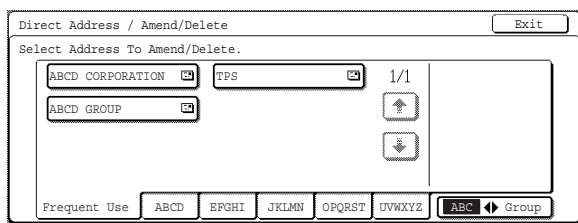

- To edit a one-touch key, follow steps 4 and 5.
- To delete a one-touch key, follow steps 6 and 7.
- When you have finished editing or deleting, touch the [EXIT] key.

- Touch the key corresponding to the information you wish to change (change the information in the same way as you stored the information on pages 4-42 to 4-46).

Direct Address / Amend/Delete Delete Exit

No.001

Name: ABCD CORPORATION Initial: A

Index: USER 3 Address: abcd@abcd.com

Key Name: ABCD CORPORATION

File Format: B/W : PDF / High(G4) .Colour : PDF / Medium

- Make sure that your changes are correct, and then touch the [EXIT] key.

Delete Exit

Initial A

COM

If you wish to change another one-touch key, repeat steps 3 through 5.

The following steps are for deleting a one-touch key

- Touch the [DELETE] key.

Delete Exit

Initial A

COM

- Touch the [YES] key.

Delete The Address?

ABCD CORPORATION

No Yes

B/W : PDF / High (G4) .Colour :

If you wish to delete another one-touch key, repeat steps 3, 6, and 7.

- NOTES:**
- *If you cannot edit or delete a one-touch key*
If you attempt to edit or delete a one-touch key in the following situation, a warning message will appear and editing/deletion will not be possible. In this event, delete the one-touch key from the group or cancel or change the hyperlink e-mail selection.
The one-touch key is included in a group key.
The one-touch key is included as a hyperlink e-mail destination for Scan to FTP.
 - *Destinations for Scan to FTP that are stored in one-touch keys cannot be edited or deleted from the touch panel of the machine. Use the Web page to edit or delete these destinations. (page 4-15)*

Programming a Group Key

Scan to E-mail destinations that have been stored in one-touch keys can be stored in group keys. Up to 300 destinations can be stored in a group key.

To program a group key from the Web page, refer to page 4-14.

NOTE: *Only one-touch key destinations can be stored in a group key. If you wish to store a destination that is not programmed in a one-touch key, first program the E-mail destination in a one-touch key (refer to pages 4-42 to 4-46) and then store it in the group key.*

1. Press the [CUSTOM SETTINGS] key, touch the [ADDRESS CONTROL] key, and then touch the [DIRECT ADDRESS] key (refer to steps 1 to 3 on page 4-42).
2. Touch the [GROUP] key.

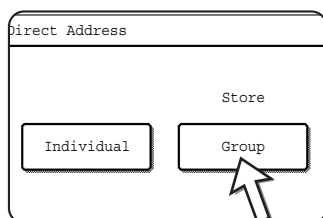

3. Follow steps 5* through 11 of "Storing one-touch keys" (pages page 4-43 to 4-44) to enter a GROUP NAME, INITIAL, and INDEX.
 * In step 5, touch the [GROUP NAME] key instead of the [NAME] key.
4. Touch the [ADDRESS] key.

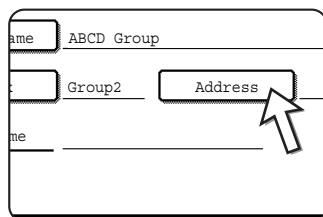

5. Touch the index and keys as required, and then touch the one-touch keys of the destinations that you wish to store in the group.

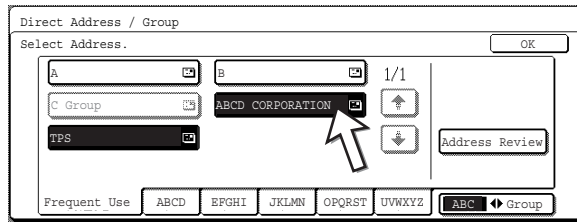

One-touch keys that have been touched are highlighted.

If you touch the wrong key, simply touch it again to cancel the highlighting and remove the destination from the group.

NOTE: One group key cannot be stored in another group key. Group keys appear greyed out and cannot be selected.

6. To check the destinations that you have stored in the group, touch the [ADDRESS REVIEW] key.

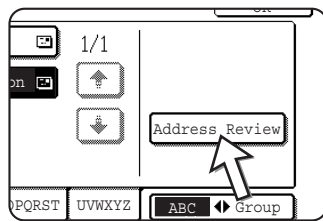

A list of your selected destinations is displayed.

You can delete a displayed destination by touching it. When a message appears asking if you want to delete the destination, touch the [YES] key.

7. Touch the outer [OK] key.

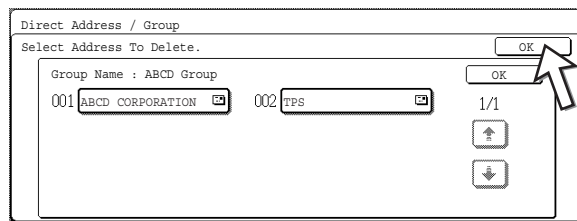

The number of destinations in the group appears to the right of the [ADDRESS] key.

8. Check the name of the key (refer to step 15 on page 4-45).

The characters appearing next to the [KEY NAME] key will be displayed in the group key. To change these characters, touch the [KEY NAME] key. This step is not necessary if you do not wish to change the characters.

9. Touch the [EXIT] key when you have finished programming the group key.

If you wish to program another group key, touch the [NEXT] key.

When you touch the [EXIT] key, you will return to the screen of step 2.

Editing and Deleting Group Keys

If you need to delete group key or change its name or one of its stored destinations, perform the following procedure.

1. Press the [CUSTOM SETTINGS] key, touch the [ADDRESS CONTROL] key, and then touch the [DIRECT ADDRESS] key (refer to steps 1 to 3 on page 4-42).
2. Touch the [AMEND/DELETE] key.

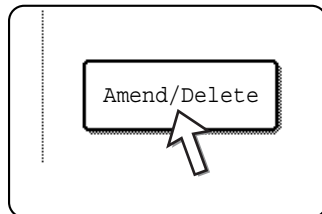

3. Touch the group key you wish to edit or delete.

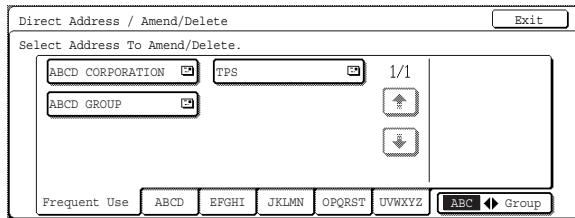

- To edit a group key, follow steps 4 and 5.
 - To delete a group key, follow steps 6 and 7.
 - When you have finished editing or deleting, touch the [EXIT] key.
4. Touch the key of the item you wish to change (to edit the item, follow the same steps as for one-touch keys on page 4-42).

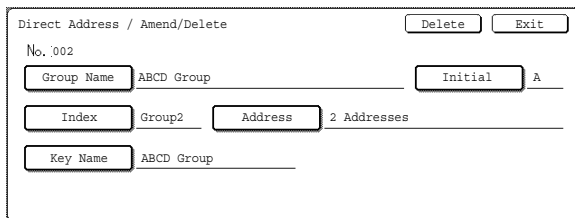

To edit a destination stored in a group key, touch the [ADDRESS] key. The following screen appears.

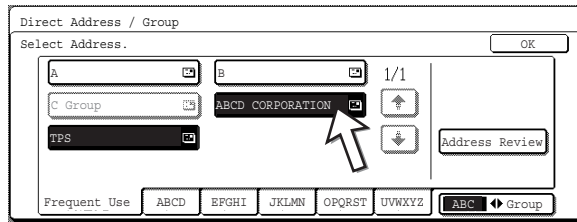

The one-touch keys stored in the group are highlighted. To add another one-touch key to the group, touch the key to highlight it.

To delete a one-touch key from the group, touch the key so that it is no longer highlighted.

5. Make sure the edited information is correct, and then touch the [EXIT] key.

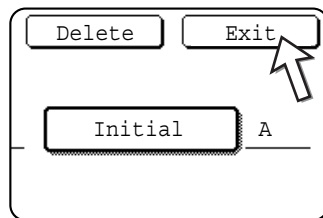

If you wish to change another group key, repeat steps 3 through 5.

The following steps are for deleting a group key

6. Touch the [DELETE] key.

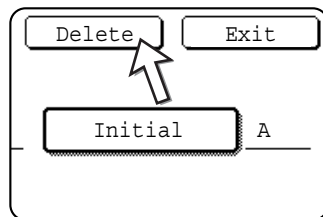

7. Touch the [YES] key.

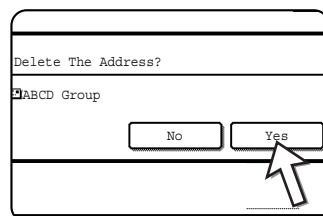

If you wish to delete another group key, repeat steps 3, 6, and 7.

NOTE: If you cannot edit or delete a group key

If you attempt to edit or delete a group key in the following situation, a warning message will appear and editing/deletion will not be possible.

The one-touch key you wish to change or delete is currently being used for transmission.

If the key is being used for a current transmission, cancel the transmission or wait until it is completed and then edit or delete the key.

Storing Sender Information

Use this procedure to store the sender information (sender name and e-mail address) that is displayed when the recipient receives your e-mail. Information for up to 20 different senders can be stored. Select a sender from the stored senders using the touch panel of the machine when you send an image (page 4-23). The selected sender appears in the sender column of the recipient's e-mail software program.

If you prefer to store sender information from the Web page, refer to page 4-16.

1. Press the [CUSTOM SETTINGS] key, and then touch the [ADDRESS CONTROL] key (refer to steps 1 and 2 on page 4-42).
2. Touch the [E-MAIL SENDER] key.

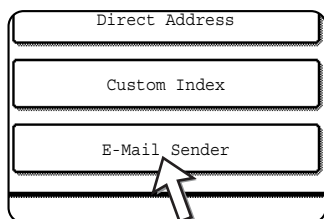

3. Touch the [STORE] key.

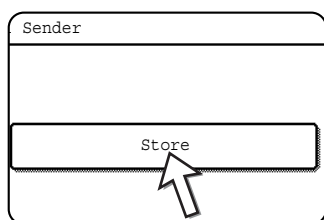

4. Touch the [SENDER NAME] key.

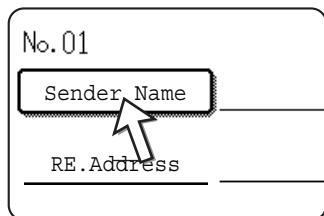

The "No." that automatically appears is the lowest number from 01 to 20 that has not yet been programmed. When [SENDER NAME] is touched, the letter-entry screen appears. Enter up to 20 characters for the name.

5. Touch the [RE.ADDRESS] key.

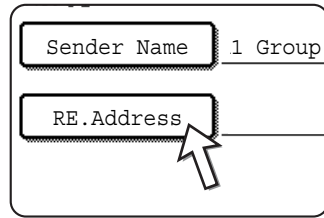

The display changes to the address entry screen when you touch the [RE.ADDRESS] key. Up to 64 characters can be entered for the sender's e-mail address. When finished, touch the [OK] key to return to the original screen.

6. If you have finished storing senders, touch the [EXIT] key. If you wish to store another sender, touch the [NEXT] key.

Editing and Deleting Sender Information

Use this procedure when you need to edit sender information or delete a sender.

1. Perform steps 1 and 2 of "Storing Sender Information".
2. Touch the [AMEND/DELETE] key.

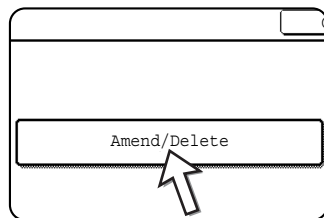

The stored senders appear.

3. Touch the one-touch key of the sender that you wish to edit or delete.

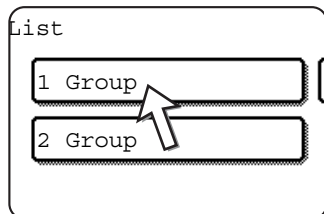

The edition/deletion screen of the touched sender appears.

4. Edit or delete the sender.

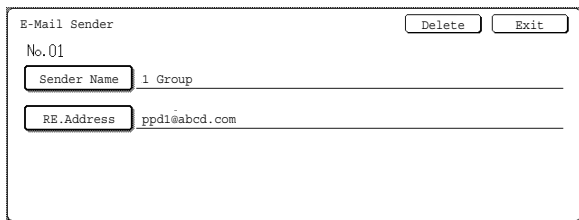

Edit sender information in the same way that you stored it. When finished, touch the [EXIT] key to return to the screen of step 3.

To delete the sender, touch the [DELETE] key. A message appears asking you to confirm your selection. Touch the [YES] key to delete the sender and return to the screen of step 3.

Storing a Group Index

You can assign any name up to 6 characters long to each of the USER indexes ([USER 1] to [USER 6]).

To perform this procedure from the Web page, refer to page 4-17.

1. Press the [CUSTOM SETTINGS] key, and then touch the [ADDRESS CONTROL] key (refer to steps 1 and 2 on page 4-42).
2. Touch the [CUSTOM INDEX] key.

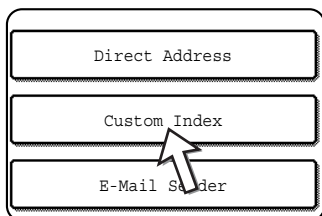

3. Touch an index key ([USER 1] to [USER 6]).

You can enter a name for the selected index.

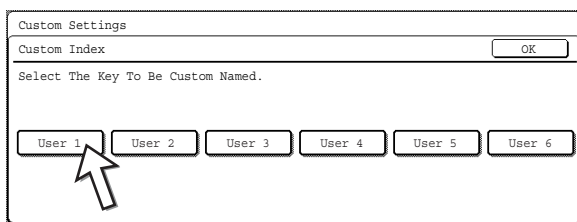

When touched, the letter entry screen appears.

4. Enter a maximum of 6 characters for the index name.
 Use the  key to clear the displayed name and then enter the desired name.
 When finished, touch the [OK] key. The new name appears in the screen of step 3.
5. If you wish to program another index name, repeat steps 3 and 4.
 When finished, touch the [OK] key.

Printing Programmed Information

You can print out lists of the one-touch keys and group keys that have been stored in the machine.

1. Press the [CUSTOM SETTINGS] key.

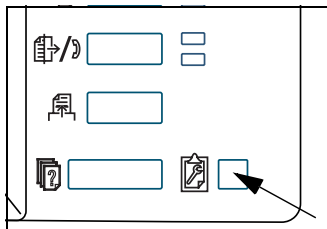

2. Touch the [LIST PRINT] key.

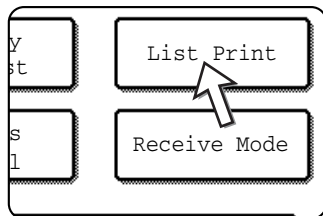

3. Touch the [SENDING ADDRESS LIST (SCANNER)] key.

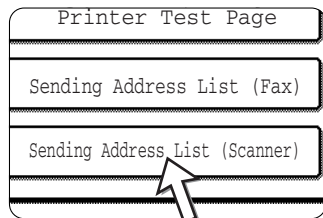

4. Touch the key of the list you wish to print.

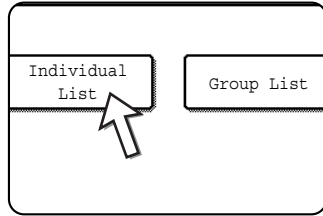

[PROCESSING PRINT DATA] appears in the message display and printing begins.

To cancel printing, touch the [CANCEL] key.

NOTE: *If you attempt to print a list when no data exists, a warning message will appear.*

Troubleshooting

If a problem or question arises, try to solve the situation using the following information before contacting your authorised Xerox dealer.

The image cannot be scanned.

Cause: The original is loaded upside down.

Solution: If you are using the document glass, the original must be placed face down. If you are using the DADF, the original must be inserted face up.

A moiré (stripe pattern) appears on the scanned image.

Cause: A slight amount of moiré sometimes appears when printed originals are scanned.

Solution: The screen that appears when the [EXPOSURE] key is touched includes a [MOIRÉ REDUCTION] checkbox. Selecting this checkbox can reduce the occurrence of moiré. (page 4-36) If you are using the document glass, also try shifting the position and/or angle of the original on the document glass.

The scanned image is fuzzy or has smudges.

Cause: The document glass or the underside of the document cover is dirty.

Solution: To clean the document glass and the underside of the document cover, see page 2-81.

The scanned image is clipped.

Cause: The set original scanning size is smaller than the actual original size.

Solution: Set the actual original size. (page 4-34)

If you have intentionally set a smaller size than the actual original size, place the original taking into account the guides for the set original size. For example, when scanning an A4 (8-1/2" x 11") original using a B5 (5-1/2" x 8-1/2") setting, align the original using the scale at the left edge to fit the area you wish to scan into the B5 (5-1/2" x 8-1/2") scanning area.

The scanned image is upside down or on its side.

Cause: The original was not placed in the correct orientation.

Solution: Place the original in the correct orientation. (Refer to page 2-7.)

You wish to rotate the scanned image 90°.

Cause: The orientation of the placed document cannot be changed.

Solution: Use the "ROTATE THE IMAGE 90 DEGREES" checkbox. (page 4-34)

The scanned image range is on the opposite side of the selected image range.

Cause: The original was placed with the left and right sides reversed.

Solution: Place the original in the correct orientation. (Refer to page 2-4.)

The received image data cannot be opened.

Cause: The viewer program used by the recipient does not support the format of the received image data.

Solution: Try selecting a different file type (TIFF, JPEG, or PDF) and/or a different compression format (NONE, MEDIUM (G3), or HIGH (G4)) when sending the image data. (Refer to page 4-38.)

The recipient does not receive transmitted data.

Cause: An incorrect destination was selected.

Otherwise, there is a mistake in the information stored for the destination (e-mail address or FTP server information).

Solution: Select the correct destination and make sure the correct information is stored for the destination. (Refer to page 4-10.)

If delivery by e-mail (Scan to E-mail) is unsuccessful, an error message such as "Undelivered Message" may be sent to the designated administrator's e-mail address. This information may help you determine the cause of the problem.

The recipient does not receive data sent by e-mail (Scan to E-mail).

Cause: A limit has been set in the "Maximum size of e-mail attachments" of the key operator program for the maximum size of an image file that can be sent using Scan to E-mail (the initial setting is 2 MB).

Solution: The limit can be set from 1 MB to 10 MB in the key operator program. Consult your key operator and select a suitable limit.

Cause: The amount of data that can be sent in one e-mail transmission is sometimes limited by the administrator of the mail server. Even if the amount of data sent is within the limit setting explained above, if it exceeds the limit set by the administrator of the mail server, the data will not be delivered to the recipient.

Solution: Decrease the amount of data sent in the e-mail transmission (reduce the number of pages scanned). (Ask your mail server administrator what the data limit is for one e-mail transmission.) (Refer to page 4-62.)

Transmission takes a long time.

Cause: When there is a large amount of image information, the data file is also large and transmission takes a long time.

Solution: In order to select resolution and data compression settings that are suited to the purpose of transmission and create image data that is well-balanced in terms of resolution and file size, pay attention to the following points:

Resolution ("STANDARD", "HIGHER", "HIGHEST")

The default setting is "LOWER". If the original does not contain photographs, illustrations, or other halftone images, "STANDARD" mode will give you a more workable scanned image. "HIGHER" or "HIGHEST" should only be selected when the original includes a photograph and you want to give priority to the quality of the photograph. Note that scanning in "HIGHER" or "HIGHEST" mode will produce a larger file size than the other modes.

If Your E-Mail Is Returned

If a Scan to E-mail is not successfully transmitted, an e-mail informing you of this fact is sent to the sender selected at the time of transmission. If this happens, read the e-mail and determine the cause of the error, and then repeat the transmission.

If a Transmission Error Occurs

If a transmission error occurs when you send a scanned image, a message informing you of the error and an error code will appear in the touch panel on the machine.

Error Code Table

Error Code	Description of the Error
CE-01	The optional network interface card (Print Server Card) is not installed or is out of order.
CE-02	Cannot find the specified mail server or FTP server.
CE-03	The server was unavailable during the scanning of the original.
CE-04	An invalid account name or password for the FTP server has been entered.
CE-05	An invalid directory of the FTP server has been entered.
CE-06	Cannot find the specified mail server (POP3 server).
CE-07	The account name or password for the POP3 server is invalid.
CE-00	An error other than the above has occurred.

Checking the IP Address

There are three ways to check the IP address:

1. Using [LIST PRINT] in [CUSTOM SETTINGS] in the operation panel

Select NIC PAGE to print a list of the machine settings. The IP address that has been set for the machine can be found in this list. Follow the procedure below to check the IP address using NIC PAGE.

2. Using the key operator programs

The IP address can be verified using the key operator programs. To use this procedure, consult your key operator. (The key operator programs cannot be used when DHCP is being used.)

3. How to use the "NIC Manager" utility on the "Software" CD-ROM

"NIC Manager" on the "Software" CD-ROM can be used to configure and check the IP address.

For detailed instructions, see the online manual (Print Server Card Users Manual) on the "Software" CD-ROM. To view the online manual (Print Server Card Users Manual), specify the following path (substitute the letter of your CD-ROM drive for "R"):

R:/Tool/Manual/English

Checking the IP address from the [CUSTOM SETTINGS] screen of the operation panel

1. Press the [CUSTOM SETTINGS] key.

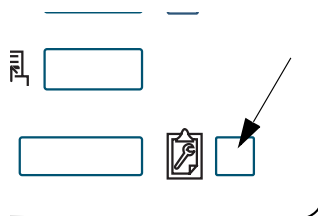

The custom setting menu screen will appear.

2. Touch the [LIST PRINT] key.

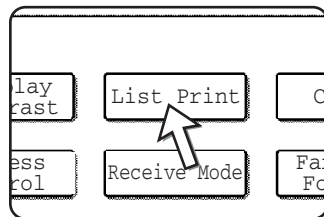

3. Touch the [PRINTER TEST PAGE] key.

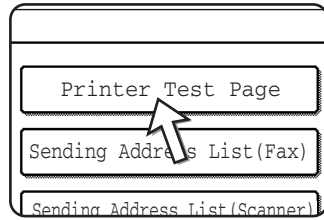

4. Touch the [NIC PAGE] key.

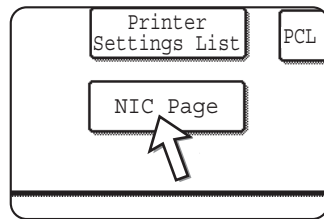

PROCESSING PRINT DATA appears in the message screen and printing begins. To cancel printing, touch the [CANCEL] key.

Important Points When Using Scan to E-Mail

Be very careful not to send image data files that are too large.

Your mail server's system administrator may have placed a limit on the amount of data that can be sent in one e-mail transmission. If this limit is exceeded, the e-mail will not be delivered to the recipient. Even if there is no limit and your e-mail is successfully delivered, a large data file may take a long time to be received and place a heavy burden on the recipient's network, depending on the recipient's network (Internet) connection environment.

If large image data files are repeatedly sent, the resulting burden on the network may slow down the speed of other, unrelated data transmissions and in some cases, may even cause the mail server or network to go down.

The example images below will produce the following file sizes when scanned as A4 (8-1/2" x 11") size originals:

Resolution	File size of text original A when scanned	File size of photo original B when scanned	
		Black and white scanning	Colour scanning
[LOWER]	Approx. 26 KB (TIFF HIGH (G4) format)	Approx. 300 KB (TIFF HIGH (G4) format)	Approx. 1200 KB (JPEG MEDIUM compression)
[HIGHER]	Approx. 43 KB (TIFF HIGH (G4) format)	Approx. 700 KB (TIFF HIGH (G4) format)	Approx. 3500 KB (JPEG MEDIUM compression)

If multiple images are scanned, the file size will be approximately (Size of each image as indicated above) x (Number of images scanned).

Although the actual limitation depends on your network environment, a general guideline for the maximum file size for Scan to E-mail is 2000 KB. In cases where you need to send multiple documents, try such measures as lowering the resolution mode.

Key Operator Programs

This section explains the key operator programs that are related to the network scanner feature of the machine. For key operator programs that are related to the printer and copy functions of the machine, refer to the Chapter 3, "Printer Operation", and WorkCentre C226 System Administration Guide.

Key Operator Program List

Program name	Page
Network scanner settings	
Default display settings	
The number of direct address keys displayed setting	
Initial resolution setting	
Scan complete sound setting	
Default sender set	
Compression mode at broadcasting	
Initial file format setting	
Maximum size of e-mail attachments	
Scanner mode timeout after last scan	
Default exposure settings	
Disable of address direct entry	

Using the Key Operator Programs

Follow the steps below to use the key operator programs.

1. Press the [CUSTOM SETTINGS] key.

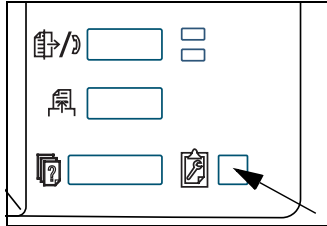

2. Touch the [KEY OPERATOR PROGRAMS] key.

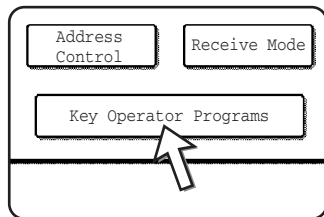

3. Use the numeric keys to enter the five-digit key operator code number.



Each time a number is entered, the dashes (-) in the display will change to asterisks (*).

4. Touch the [N/W SCANNER SETTINGS] key, depending on the program you wish to use.

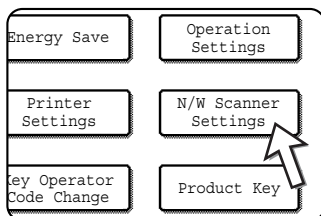

5. Make desired settings for the selected program.

Detailed descriptions for program settings start on page 4-65.

6. Touch the [OK] key to return to the screen of step 4.

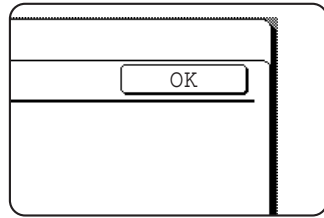

If you wish to use another program, touch the key for that program in the screen of step 4.

7. Press the [CLEAR ALL] key to exit the program.

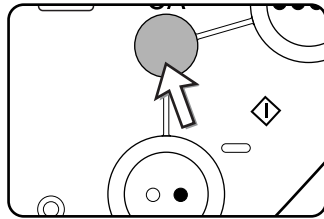

Setting Programs

The setting programs for the network scanner feature of the machine are explained here.

Network scanner settings

The following programs are available:

- Default display settings
- The number of direct address keys displayed setting
- Initial resolution setting
- Scan complete sound setting
- Default sender set
- Compression mode at broadcasting
- Initial file format setting
- Maximum size of e-mail attachments
- Scanner mode timeout after last scan
- Default exposure settings
- Disable of address direct entry

Default display settings

You can select the initial display that appears when you press the [IMAGE SEND] key to change to scanner mode or when you press the [CLEAR ALL] key in scanner mode. Normally the initial display is set to the Condition setting screen (page 4-19).

The following three selections are available:

- Condition setting screen
- Address directory (ABC)
- Address directory (Group)

When an address directory (ABC or Group) is selected, the selected index of that address directory (page 4-22) is set as the initial screen.

When [SWITCH AUTOMATICALLY TO COPY MODE SCREEN] is selected, the display will automatically switch to the copy mode screen if no action is taken in the scan/fax mode screen for 20 seconds.

The number of direct address keys displayed setting

The number of one-touch keys displayed in each address directory screen can be changed from 6 (the normal setting) to 4 or 9.

Touch [4], [6], or [9] to select the desired number.

NOTE: *For the key name that appears in each one-touch key, a maximum of 18 characters can appear when the number of one-touch keys displayed is set to 4 or 6. A maximum of 10 characters can appear when the number of one-touch keys displayed is set to 9.*

Initial resolution setting

This is used to change the default resolution setting for transmission in network scanner mode. The default resolution is initially set to "LOWER". To change the setting, touch the desired resolution key.

- [LOWEST]
(B/W: 150 x 150dpi, Colour: 100 x 100dpi)
- [LOWER]
(B/W: 200 x 200dpi, Colour: 150 x 150dpi)
- [STANDARD]
(B/W: 300 x 300dpi, Colour: 200 x 200dpi)
- [HIGHER]
(B/W: 400 x 400dpi, Colour: 300 x 300dpi)
- [HIGHEST]
(B/W: 600 x 600dpi, Colour: 600 x 600dpi)

Scan complete sound setting

This program is used to set the volume of the beep sound that informs you that the original has been scanned. Two volume levels are available, or the beep can be turned off.

Default sender set

If you do not select a sender when performing a Scan to E-mail operation, the sender information stored with this setting is automatically used. You can check the stored sender information by printing the SENDER list.

1. Touch the [SENDER NAME] key and then enter the sender name.
The sender name entry screen appears
Up to 20 characters can be entered.
2. Touch the [OK] key.
3. Touch the [RE.ADDRESS] key and then enter the return address.
Up to 64 characters can be entered.
4. Touch the [OK] key.
The entered return address appears. Check the address to make sure it is correct.

Compression mode at broadcasting

This setting selects the compression mode for broadcasting using Scan to E-mail. The compression mode set here is used for all destinations regardless of their individual compression mode settings.

The initial settings are as follows:

- Black and white scanning: HIGH (G4)
- Colour scanning: MEDIUM

Initial file format setting

These programs are used to set the file format of the transmitted image and the number of images per file.

- The file type and compression mode is set in "FILE FORMAT (FILE TYPE / COMPRESSION MODE)". The setting takes effect in the following situations:
 - A file format is not selected when sending a image.
 - A file format setting was not included when the destination was stored.
 - If the file format is set when sending an image or storing a destination, the settings apply to the default file format settings.

- The "ONE PAGE PER FILE (YES/NO)" setting is used to select how files are created when multiple pages are scanned. Select "YES" to have an individual file created for each scanned page (so that multiple files are created). Select "NO" to have all scanned pages combined into a single file.
- The initial settings for the above programs are as follows
 - Black and white scanning
File type: PDF
Compression mode: HIGH (G4)
One page per file: No
 - Colour scanning
File type: PDF
Compression mode: MEDIUM
One page per file: No

Maximum size of e-mail attachments

To prevent the size of image files transmitted by Scan to E-mail from becoming too large, you can set a size limit.

If the total size of the image files created by scanning the original exceeds the limit, the image files are discarded. The limit can be set from 1 MB to 10 MB in increments of 1 MB. The initial setting is 2 MB. The limit cannot be disabled.

Scanner mode timeout after last scan

If no action is taken after scanning an original from the document glass, transmission of the original will begin automatically after the time set with this program. The time can be set from 0 to 60 seconds in increments of 10 seconds. When "0" is selected, transmission begins immediately after scanning from the document glass ends. The default setting is 60 seconds. This setting cannot be disabled.

Default exposure settings

This program is used to configure the default exposure settings.

The default settings are initially configured as follows:

- Exposure: AUTO
- Original type: TEXT
- MOIRÉ REDUCTION: Not selected

To change the "MOIRÉ REDUCTION" setting, touch the checkbox.

When the exposure is set to "AUTO", the original type can be set to [TEXT/PRTD. PHOTO], [TEXT/PHOTO], or [TEXT].

When the exposure is set to "MANUAL", the exposure can be adjusted to one of nine levels from "1" to "5". "1" is light and "5" is dark. [TEXT/PRTD. PHOTO], [TEXT/PHOTO], [TEXT], [PHOTO], [PRINTED PHOTO] or [MAP] can be selected for the original type.

Disable of address direct entry

This program is used to disable direct entry of e-mail addresses when performing e-mail transmission. To disable direct entry of e-mail addresses, touch the checkbox so that a checkmark appears. When direct entry of e-mail addresses is disabled, only stored e-mail addresses can be used as destinations. This allows e-mail destinations to be restricted and prevents accidental transmission to the wrong address due to incorrect entry of an address. The following operations are also disabled:

- Storing, editing, and deleting one-touch keys at the operation panel.
- Storing, editing, and deleting groups at the operation panel.

NOTE: *To prohibit direct entry of destinations in the Web page, select the "Enable Password Protection of this Web Site" checkbox in the screen that appears when "Passwords" is selected in the menu frame. Enter the administrator password in the "Old Admin Password" text box and click the "Submit" button.*

Specifications

Type	Colour scanner
Two-sided originals	Possible
Optical resolution	600dpi
Output resolution	Colour: 100 x 100, 150 x 150, 200 x 200, 300 x 300, 600 x 600dpi Black and white: 150 x 150, 200 x 200, 300 x 300, 400 x 400, 600 x 600dpi
Output modes	1bit/pixel (Black and white) 24bit/pixel (Colour: 8 bits per colour)
Halftone processing	Error dispersion (Black and white 150/200/300/400/600dpi)
File format	Colour scanning File type: PDF/JPEG Compression mode: LOW/MEDIUM/HIGH Black and white scanning File type: PDF/TIFF Compression mode: NONE/MEDIUM (G3)/HIGH (G4)
File creation method*1	One page per file/One file for all pages
Scan destinations	Scan to FTP Scan to E-mail
Supported client PC operating systems	Windows 95/Windows 98/Windows Me/Windows NT Workstation 4.0 (Service Pack 6 or later)/Windows 2000 Professional/Windows XP Home Edition/Windows XP Professional/Windows Server 2003
Management system	Uses built-in Web server
Web browser	Internet Explorer 5.5 or later (Windows)/5.1 or later (Macintosh), Netscape Navigator 6.0 or later
Network protocol	TCP/IP, UDP/IP
LAN connectivity	10Base-T/100Base-TX
Supported mail system	Mail servers supporting SMTP
Number of destinations	500 maximum*2
Number of senders	20 maximum

Scanning margins

When scanning an original, the area indicated in the following diagram cannot be scanned.

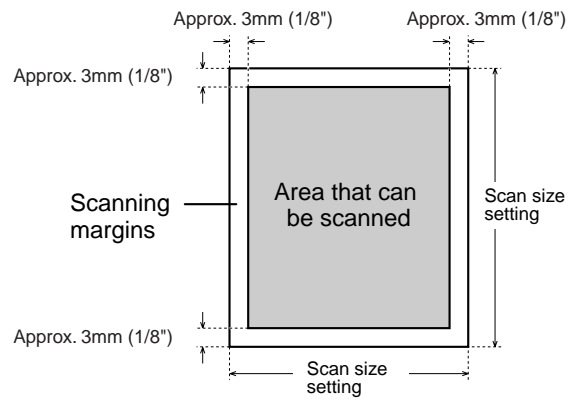

5 Fax Unit

This section explains the fax functions of the product. For safety precautions and general information on using the machine such as loading paper, clearing misfeeds, handling peripheral units, and other functions, see Chapter 1.

The explanations in this manual assume that certain peripheral units are installed.

To Use this Product Correctly as a Fax Device

Several points must be kept in mind when using this product as a fax device.

Please note the following:

Line connection

Use the telephone cable supplied to connect the machine to a telephone line. Insert the end of the line cord with the core into the LINE socket on the machine as shown. Insert the other end into the telephone line socket.

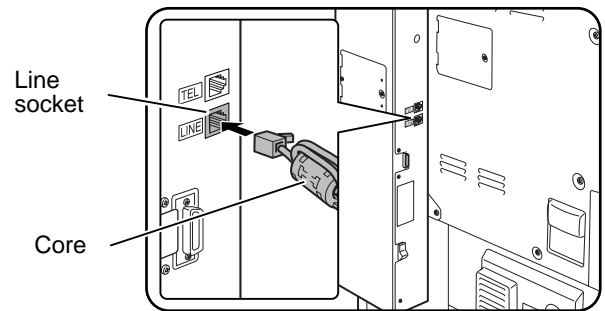

In some countries, an adapter is required to connect the telephone line cable to the wall telephone socket, as shown in the illustration.

For United Kingdom

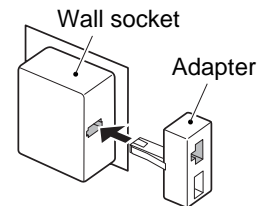

Fax power switch

When using the machine, be sure to keep the fax power switch turned on at all times. The fax power switch must be turned on to receive faxes at night or send timer transmission faxes at night.

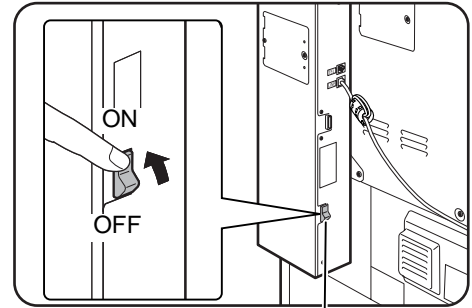

Fax power switch

Settings and programming

Information about settings and programming that are required before the fax functionality can be used is located in “Points to Check and Program After Installation” on page 5-3 of this manual. Please read this section and perform the required settings and programming.

Lithium battery

A lithium battery inside the machine keeps key operator program settings for the fax function in memory.

When the battery dies, settings and programmed information will be lost. Be sure to keep a written record of the settings and programmed information. (Refer to page 5-89.)

The life of the lithium battery is approximately 5 years if the machine power switch and fax power switch are kept continually off.

Other information

If a thunderstorm occurs, we recommend that you unplug the power cord from the power outlet. Information will be retained in memory even if the power cord is unplugged.

Important Safety Information

- If any of your telephone equipment is not operating properly, you should immediately remove it from your telephone line, as it may cause harm to the telephone network.
- The AC power outlet shall be installed near the equipment and shall be easily accessible.
- Never install telephone wiring during a lightning storm.
- Never install telephone jacks in wet locations unless the jack is specifically designed for wet locations.
- Never touch uninsulated telephone wires or terminals unless the telephone line has been disconnected at the network interface.

- Use caution when installing or modifying telephone lines.
- Avoid using a telephone (other than a cordless type) during an electrical storm. There may be a remote risk of electric shock from lightning.
- Do not use a telephone to report a gas leak in the vicinity of the leak.
- Do not install or use the machine near water, or when you are wet. Take care not to spill any liquids on the machine.

Before Using the FAX Feature

This section contains basic information about using the fax features of this product. Please read this section before using the fax features.

Points to Check and Program After Installation

After installing the unit and before using it as a fax machine, check the following points and program the required information.

Make sure the fax power switch is turned on

In addition to the machine power switch, the machine also has a fax power switch (see page 5-2). When using the machine, be sure to keep the fax power switch turned on at all times.

Make sure the correct date and time have been set

Make sure the correct date and time have been programmed in the unit. If the date and time are wrong, please correct them (see page 1-39).

It is important to set the correct date and time because they are used for such features as Timer Transmission (page 5-32).

Program the sender's name and sender's number

The name and fax number of the user of the machine is programmed in "Own number and name set" in the "Fax Unit" section of the Xerox WorkCentre C226 System Administration Guide.

The programmed name and number are printed at the top of each transmitted fax page. The sender's number is also used as an identification number when you use the Polling function to request transmission from another fax machine (See "Using the Polling Function" on page 5-36.)

NOTE: *You can check your programmed name and number by printing out the Sender List.*

Connecting an Extension Phone

You can connect a telephone to the machine and use it as an extension phone to place and receive calls like any normal phone. When the other party has made the call, the extension phone can be used to activate fax reception (remote operation).

NOTE: *If you connect a combination telephone/answering machine to the machine, you will not be able to use the answering machine function.*

You can place calls from the phone even during a power failure.

Connecting an Extension Phone

Insert the end of the extension phone cord into the extension phone socket on the rear of the machine.

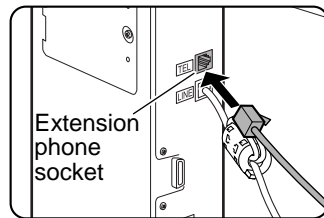

Make sure you hear a "click" sound indicating that the cord is securely connected.

A Look at the Operation Panel

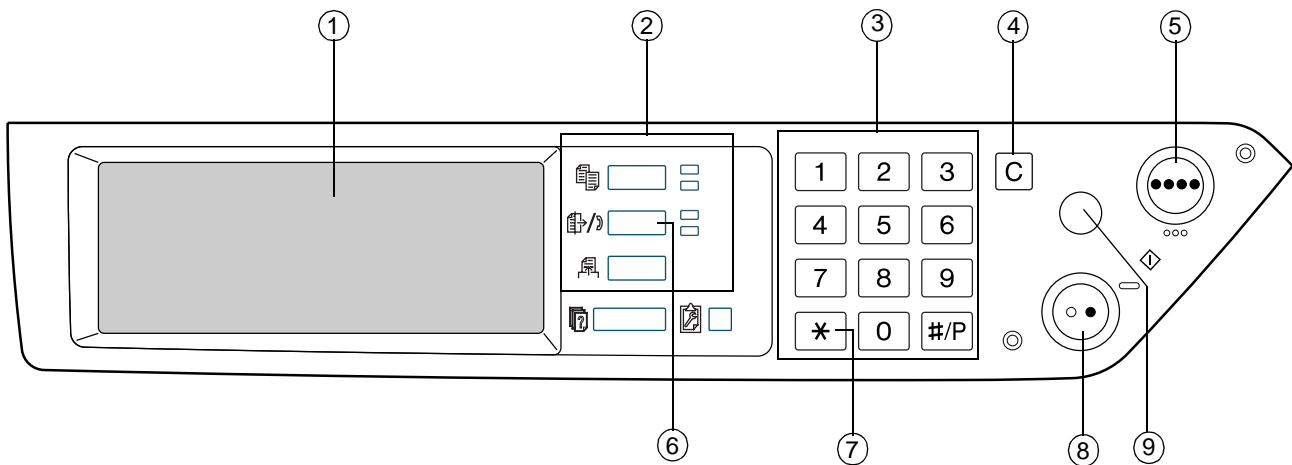

- ① **Touch panel**

 - Messages and keys appear on the touch panel. Key input is accomplished by touching the keys.
 - When a key in the touch panel is touched, a beep sounds and the key is highlighted.
 - Keys that cannot be selected in a screen are greyed out. If touched, a double-beep will sound to alert you that the key cannot be selected.

- ② **Mode select keys**

Use these keys to change modes. (See step 1 on page 5-19.)

- ③ **Numeric keys**

Use to enter fax numbers, sub-addresses, passcodes, and numerical settings (see page 5-49.)

- ④ **[C] Clear**

Use to clear a mistake when entering fax numbers, sub-addresses, passcodes, and numerical settings. One digit is cleared each time you press the key.

When an original is being scanned, this key can also be used to cancel scanning.

- ⑤ **[COLOR COPY START]**

Not used when using the machine as a fax machine. (For information on this key, see page 1-9.)

- ⑥ **[IMAGE SEND]**

Press to switch to fax mode. The initial screen of fax mode will appear.

When the network scanner option is installed, touch this key to return to the initial screen of fax mode or scanner mode, whichever mode was selected last. (Pressing the [IMAGE SEND] key in a copy screen or printer screen returns you to the initial screen of fax mode.) To switch to the initial screen of fax mode from the initial screen of scanner mode, touch the [SCANNER/FAX] key (see page 5-7).

- ⑦ **[*]**

This is used to produce tone signals when you are on a pulse dial line.

- ⑧ **[BLACK COPY START]** Press to begin scanning an original for fax transmission.

- ⑨ **[CLEAR ALL]** Use to cancel a transmission or programming operation. When this key is pressed, the operation is cancelled and you return to the initial screen described on the page 5-6.

This key is also used to cancel a resolution, paper size, or special function setting that was selected when sending a fax.

NOTE: *For the names and functions of the parts of the machine, see page 1-14.*

Fax Mode (Condition Settings Screen)

The condition settings screen of fax mode is displayed by pressing the [IMAGE SEND] key while the print mode, copy mode, or job status screen appears in the touch panel. In the explanations that follow, it is assumed that the initial screen that appears after pressing the [IMAGE SEND] key is the condition settings screen (page 5-7). If you have set the display to show the address directory screen (page 5-9) when the [IMAGE SEND] key is pressed, touch the [CONDITION SETTINGS] key in the address directory screen to display the condition settings screen.

“Default display settings” in the “Fax Unit” section of the WorkCentre C226 System Administration Guide can be used to select whether the condition settings screen appears or the address directory screen appears as the initial screen when the [IMAGE SEND] key is pressed.

NOTE: *When the network scanner option is installed, you will return to the initial screen of fax mode or scanner mode, whichever mode was selected last. (Pressing the [IMAGE SEND] key in a copy screen or printer screen returns you to the initial screen of fax mode.)*

Condition settings screen

The display is initially set (factory setting) to show the following condition settings screen as the initial screen.

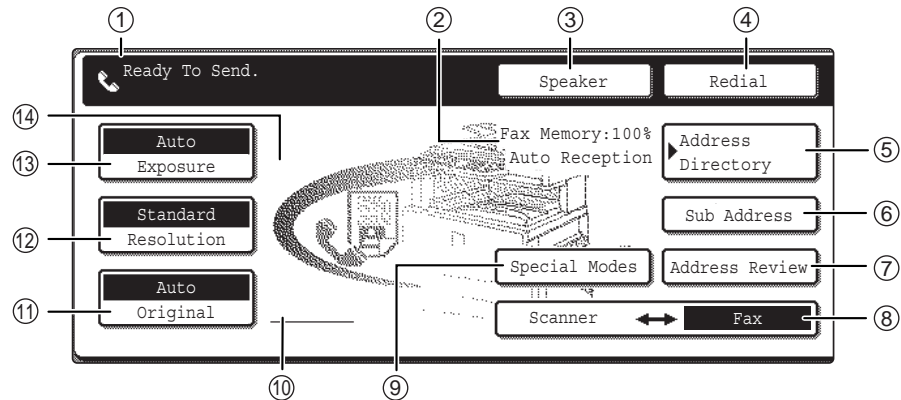

- ① **Message display** Messages appear here to indicate the current status of the machine. The icon at left (☎) indicates fax mode.
- ② **Memory and reception mode display** This shows the amount of fax memory that is free and the currently selected reception mode.
- ③ **[SPEAKER]** Touch the [SPEAKER] key to dial and transmit a fax manually. During dialing it changes into the [PAUSE] key, and after touching the [SUB ADDRESS] key it changes into the [SPACE] key.
- ④ **[REDIAL]** Touch this key to redial the number most recently dialed with the numeric keys or a one-touch key. After dialing, this key changes into the [NEXT ADDRESS] key.
- ⑤ **[ADDRESS DIRECTORY]** Touch this key to display the address directory screen. Touch this key when you want to use an auto-dial number (one-touch dialing or group dialing).
- ⑥ **[SUB ADDRESS]** Touch this key to enter a sub-address and passcode when using F-code transmission (page 5-56).
- ⑦ **[ADDRESS REVIEW]** When performing a broadcast transmission (page 5-30), touch this key to check your selected destinations. The selected destinations will appear and any unneeded destinations can be deleted.
- ⑧ **[SCANNER/FAX]** This key appears when the network scanner option is installed. Touch the key to switch between the scanner screen and the fax screen. When the fax screen appears, "FAX" is highlighted. When the scanner screen appears, "SCANNER" is highlighted.



- ⑨ **[SPECIAL MODES]** Touch this key to set one of the following special functions:
- Timer transmission (page 5-32)
 - Polling (page 5-34)
 - Dual page scan (page 5-43)
 - Program (page 5-44)
 - Memory box (page 5-38)
- ⑩ **Two-sided original icon display** Icons appear here when you touch the [ORIGINAL] key and select two-sided scanning. The icons can be touched to open function selection screens.
- ⑪ **[ORIGINAL]** Touch this key when you wish to manually set the size of the original to be scanned or scan both sides of the original.
- ⑫ **[RESOLUTION]** Touch this key to change the resolution setting for the original to be scanned. The selected resolution setting will be highlighted above the key. The initial factory setting is [STANDARD].
- ⑬ **[EXPOSURE]** Touch this key to change the exposure setting for the original to be scanned. The selected exposure setting will be highlighted above the key. The initial factory setting is [AUTO].
- ⑭ **Special function icon display** When a special function such as polling or dual page scan is selected, a special function icon appears here.

Address directory screen (alphabetically ordered)

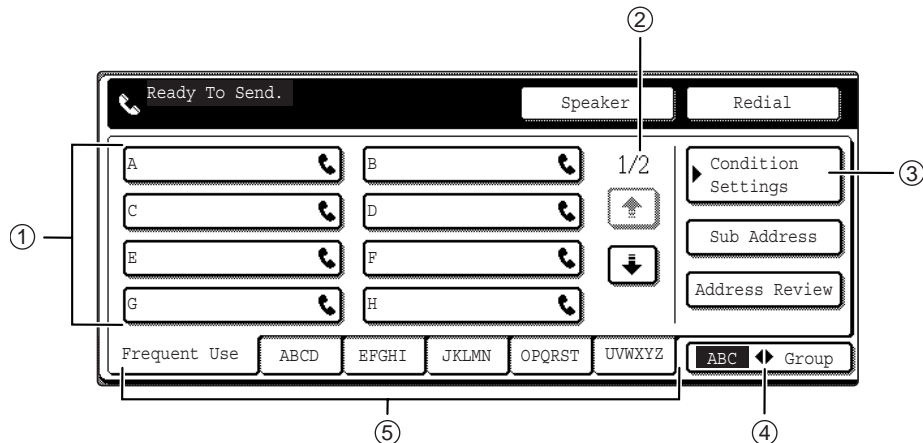
The screen below appears initially when the address directory is set as the initial screen using "Default display settings" in the "Fax Unit" section of the WorkCentre C226 System Administration Guide.



- ① **One-touch key display** This shows the one-touch keys that have been stored on the selected "index card". The key type is indicated by the icon at the right. One-touch keys in which a fax number is stored are indicated by a "☎" icon. The display is initially set to show 8 keys. This can be changed to 6 or 12 using the key operator program.

- ② **Display switching keys** In cases where the one-touch keys cannot all be displayed on one screen, this shows how many screens are left. Touch the   keys to move through the screens.

- ③ **[CONDITION SETTINGS]** This displays the condition settings screen, which is used to set various conditions.

- ④ **[ABC GROUP]** Touch this key to switch between the alphabetical index and the group index.

- ⑤ **Index keys** One-touch key destinations are stored on each of these index cards (alphabetical index or group index). Touch this key to switch between the indexes.

Group indexes make it possible to store one-touch keys by group with an assigned name for easy reference. This is done with the custom settings (refer to pages 5-68 and 5-74). Frequently used one-touch key destinations can be stored on the [FREQUENT USE] card for convenient access.

NOTE: *The screen shown above is the alphabetical address directory. If desired, the initial screen can be set to the group address directory.*

Originals that Can Be Faxed

Original sizes

NOTE: In table below, width is the first measurement, and length is the second.

	Minimum original size	Maximum original size
Using the DADF	<ul style="list-style-type: none"> A5: 210 mm x 148 mm 8-1/2" x 5-1/2" A5R: 148 mm x 210 mm 	297 mm x 800 mm* 11" x 31-1/2"* * Long documents can be loaded.
Using the document glass	<ul style="list-style-type: none"> 5-1/2" x 8-1/2" 	297 mm x 432 mm 11" x 17"

NOTE: Originals that are not a standard size (A5, B5, B5R, A4, A4R, B4, A3, 5-1/2"x8-1/2", 8-1/2"x11", 8-1/2"x11"R, 8-1/2"x14", 11"x17") can also be faxed.

Scanning area of original

Note that the edges of an original cannot be scanned.

Area that cannot be scanned:
 2mm ± 2mm from the edges of the original.



Automatic reduction of faxed document

If the size (width) of the faxed document is greater than the receiving machine's paper size, the size will be automatically reduced.

Faxed document width	Receiving machine's paper width	Reduced size	Ratio (Area ratio)
A3 (11"x17")	B4 (8-1/2"x14")	B4 (8-1/2"x14")	1 : 0.78 (1 : 0.64)
A3 (11"x17")	A4 (8-1/2"x11")	A4R (8-1/2"x11"R)	1 : 0.5 (1 : 0.5)

A document can also be faxed without reducing its size. In this case, the left and right edges will not be transmitted.

Loading a Document

A document can be loaded in the DADF or on the document glass. Use the DADF when faxing a large number of sheet originals. Use the document glass to fax originals that cannot be scanned using the DADF such as thick or thin sheet originals or bound originals such as books.

Using the DADF

1. Lift the document glass cover and make sure a document is not placed on the document glass. Gently close the cover.

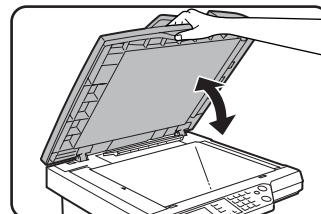

2. Adjust the document guides on the DADF tray to the width of the document.

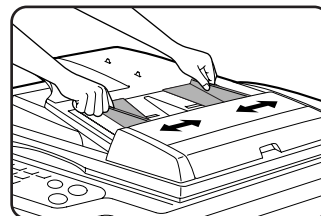

3. Align the edges of the document pages and then insert the stack in the DADF tray so that the first page is face up.

Insert the stack into the DADF tray until it stops.



NOTE: Use the DADF for long originals. The document glass cannot be used.

Using the Document Glass

Open the document glass cover, and place the document face down on the document glass. Gently close the cover.

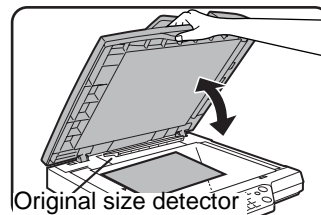

NOTE: Do not place any objects under the original size detector plate. Closing the document glass cover with an object underneath may damage the original size detector plate and prevent correct detection of the document size.

Regardless of the size of the original, place the original on the left side of the document glass. (Align the original with the document glass scale and centering mark.)

Place the original in the appropriate position for its size as shown below.

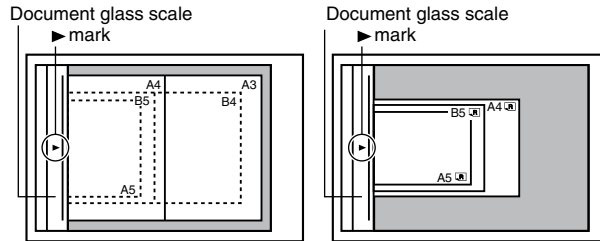

Checking the Size of a Loaded Original

When a standard-size* original is placed, the original size is automatically detected (automatic original detection function) and displayed in the top half of the [ORIGINAL] key. Check the key to make sure that the original size has been correctly detected.

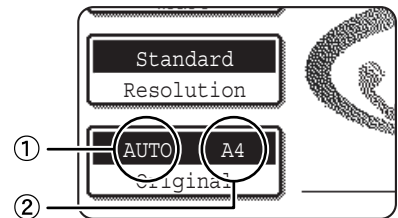

①: [AUTO] appears when the automatic original detection function is operating.

②: Displays the original size.

If a non-standard size original is placed or if you wish to change the scanning size, follow the steps below to manually set the original scanning size

NOTE: * Standard sizes that can be detected are as follows:

A5, B5, B5R, A4, A4R, B4, A3, 5-1/2"x8-1/2", 8-1/2"x11", 8-1/2"x11"R, 8-1/2"x14", 11"x17". If a non-standard size original is loaded (including special sizes), the closest standard size may be displayed, or the original size may not appear at all.

Manually Setting the Scanning Size

If you load an original that is not a standard size (such as a long original or an INCH size), or if the size is not detected correctly, you must touch the [ORIGINAL] key and set the original size manually. Perform the following steps after loading the document in the DADF tray or on the document glass (see the previous page).

1. Touch the [ORIGINAL] key.

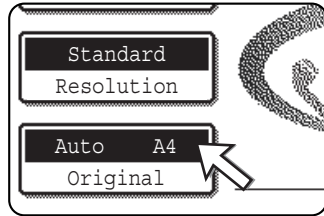

If the address directory screen appears, touch the [CONDITION SETTINGS] key to display the condition settings screen.

2. Touch the [MANUAL] key.

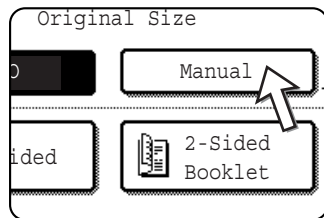

The sizes that can be selected are displayed

3. Touch the desired original size key.

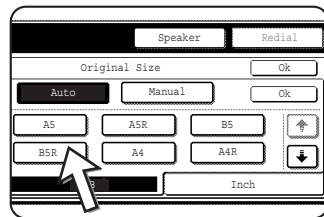

[AUTO] is no longer highlighted. [MANUAL] and the original size key you touched are highlighted.

To select B4 (8x1/2"x14"), A3 (11"x17"), or "LONG SIZE", touch the  key and then touch the appropriate original size key.

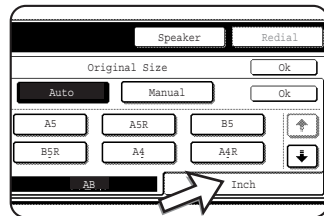

To select an inch size, touch the [INCH] tab.

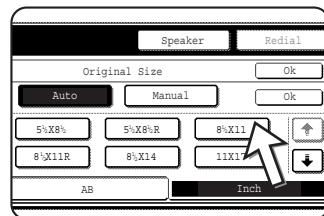

Touch the appropriate inch original size key. The selected key is highlighted. To return to the AB original size palette, touch the [AB] tab.

4. Touch the outer [OK] key.

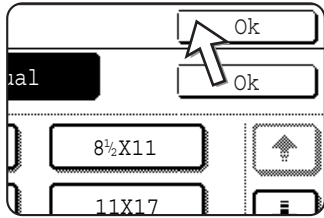

You will return to the initial screen. (Touching the inner [OK] key in the step above returns you to step 2.)

5. The selected size appears in the top half of the [ORIGINAL] key.

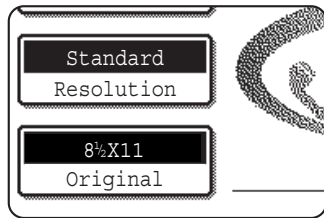

Selecting Resolution and Exposure Settings

After loading an original, you can adjust the resolution and exposure settings to match the condition of the original --for example, if it has small or faint characters, or if it is a photo. After loading the original in fax mode, adjust the settings as explained below.

Selecting the Resolution

The initial resolution setting is STANDARD. To change the setting, follow these steps:

Change the resolution.

1. Touch the [RESOLUTION] key.

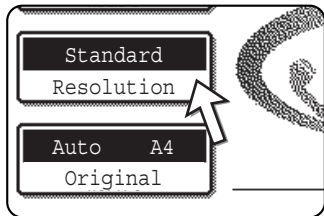

2. Touch the [STANDARD] key, [FINE] key, [SUPER FINE] key, or [ULTRA FINE] key.

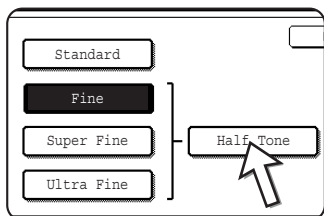

The selected key is highlighted.

If you touched the [FINE] key, [SUPER FINE] key, or [ULTRA FINE] key, you can also select halftone by touching the [HALF TONE] key.

3. Touch the [OK] key.

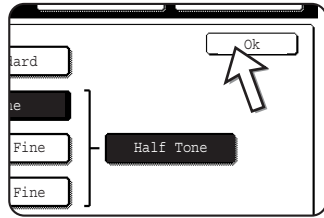

You will return to the initial screen.

- NOTES:**
- The factory default setting for the initial resolution is [STANDARD]. The initial resolution can be changed to a different setting in the key operator programs .
 - When using the DADF, the resolution setting cannot be changed once scanning has begun.
 - When a fax is sent at [ULTRA FINE], [SUPER FINE], or [FINE] resolution, a lower resolution will be used if the receiving machine does not have that resolution.

Resolution settings

Standard	Touch this key if your original consists of normal-sized characters (like those in this manual).
Fine	Touch this key if your original has small characters or diagrams. The original will be scanned at twice the resolution of the [STANDARD] setting.
Super fine	Touch this key if your original has intricate pictures or diagrams. A higher-quality image will be produced than with the [FINE] setting.
Ultra fine	Touch this key if your original has intricate pictures or diagrams. This setting gives the best image quality. However, transmission will take longer than with the other settings.
Half-tone	Touch this key if your original is a photograph or has gradations of colour (such as a colour original). This setting will produce a clearer image than [FINE], [SUPER FINE], or [ULTRA FINE] used alone. Half tone cannot be selected if [STANDARD] has been selected.

Selecting the Exposure

The initial exposure setting is AUTO. To change the setting, follow these steps:

Change the exposure.

1. Touch the [EXPOSURE] key.

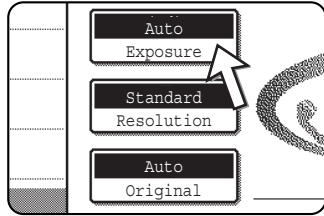

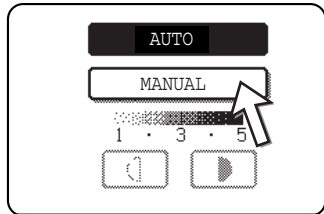

2. Touch the [MANUAL] key.

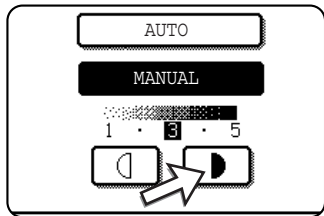

3. Touch the desired exposure key.



To darken the exposure, touch the  key. To lighten the exposure, touch the  key. To return to auto exposure, touch [AUTO].

4. Touch the [OK] key.

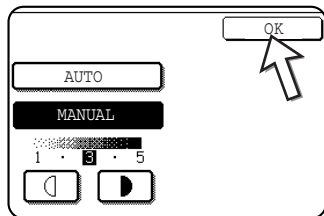

You will return to the initial screen.

NOTE: When using the document glass to scan pages, the exposure setting can be changed each time you change pages. When using the DADF, the exposure setting cannot be changed once scanning has begun.

Exposure settings

1 to 2	Select this setting if your original consists mostly of dark characters.
Auto	This setting automatically adjusts the exposure for light and dark parts of the original.
4 to 5	Select this setting if your original consists mostly of faint characters.

Convenient Dialing Methods

The fax function includes a convenient auto dial feature (one-touch dialing and group dialing). By programming frequently dialed numbers, you can call and send documents to these locations by means of a simple dialing operation (see page 5-22). There are two types of auto-dialing: one-touch dialing and group dialing. To program auto-dial numbers, refer to pages 5-68 and 5-74.

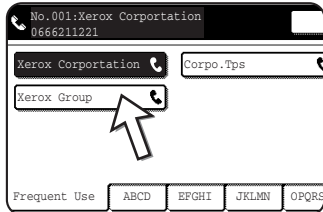
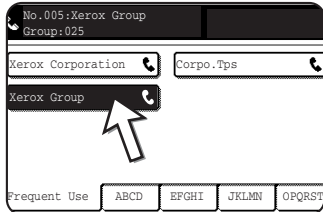
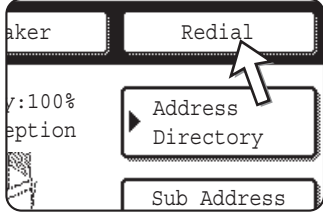
<p>One-touch dialing</p> <p>Simply press a one-touch key and then press the [BLACK COPY START] key to dial the programmed location. A name of up to 36 characters can be programmed for the location (a maximum of 18 characters are displayed). When using F-code transmission, a sub-address and passcode can also be programmed (see page 5-49).</p>	 <p>Touch the [ADDRESS DIRECTORY] key in the initial screen to display the above screen.</p>
<p>Group dialing</p> <p>Multiple one-touch dial locations can be programmed into a single one-touch key. This is convenient for successively sending a document to multiple locations. Full fax numbers entered with the numeric keys cannot be stored in a group key. First program the number in a one-touch key and then store it in a group key.</p>	
<p>Redialing</p> <p>The machine keeps the last fax number dialed with the numeric keys in memory. You can redial the last number dialed by simply touching the [REDIAL] key.</p>	

On-hook dialing

Touch the [SPEAKER] key, listen for the dial tone through the speaker, and then dial.

Faxes must be sent manually when using on-hook dialing (see page 5-62).

On-hook dialing is not possible using a one-touch key that includes a sub-address and passcode, or a group key.

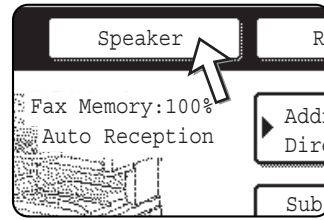

- NOTES:**
- *A total of 500 one-touch dial and group keys can be programmed (see page 5-66).*
 - *Programmed one-touch keys and group keys are stored on "index cards". A one-touch key or group key can be easily accessed by touching the index key. (Refer to page 5-9.)*
 - *To prevent calling or sending a fax to a wrong number, look carefully at the touch panel and make sure you program the correct number when programming an auto-dial number. After storing a number, you can also print out the stored number (see page 5-89) to make sure it was stored correctly.*

Basic Operations

This section explains basic operations such as sending and receiving faxes.

Sending a Fax

Basic Procedure for Sending Faxes

1. Make sure the machine is in fax mode.

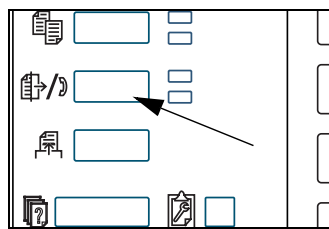

When the [IMAGE SEND] key light is on, the machine is in fax mode. If the light is not on, press the [IMAGE SEND] key.

When the network scanner option is installed, touch this key to return to the initial screen of fax mode or scanner mode, whichever mode was selected last. To switch to fax mode from scanner mode, touch the [SCANNER/

FAX] key (see page 5-7).

2. Load the original.
 - Using the DADF: page 5-11
 - Using the document glass: page 5-11

If you are using the document glass to send multiple pages, load the first page first.

NOTE: *You cannot load documents in both the DADF tray and on the document glass and send them in a single fax transmission.*

3. Check the original size.

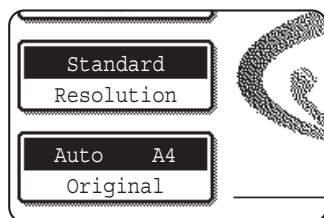

If the address directory screen appears, touch the [CONDITION SETTINGS] key to display the condition settings screen.

If the original is not a standard size or the size was not detected correctly, touch the [ORIGINAL] key to specify the original size. (See "Manually Setting the Scanning Size" on page 5-13.)

- If needed, adjust the resolution setting (see page 5-14).

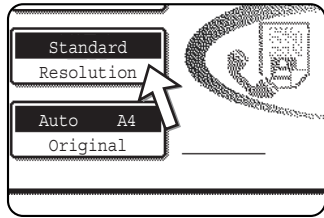

- If needed, adjust the exposure setting (see page 5-16.)

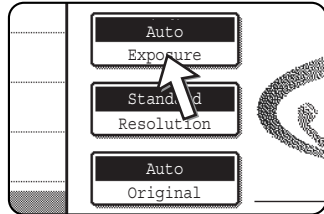

- Dial the fax number.

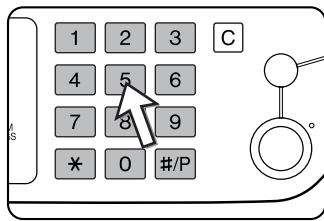

The number that you entered appears in the message display. If it is not correct, press the [C] key and re-enter the number. You can also use the [REDIAL] key or an auto-dial number

Entering a Pause

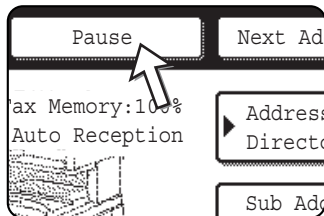

If you need to insert a pause between digits when dialing out from a PBX or when dialing an international number, touch the [PAUSE] key in the upper right corner of the screen.

Each time you touch the [PAUSE] key, a hyphen ("-") appears and a 2-second pause* is inserted.

The [PAUSE] key is also used to link numbers together (this is called chain dialing). Enter a number, touch the [PAUSE] key to enter a hyphen "-", and then enter another number with the numeric keys or by pressing a one-touch key. The linked numbers will be dialed as one number.

* The duration of each pause can be changed with the key operator program.

Using the DADF

7. Press the [BLACK COPY START] key.

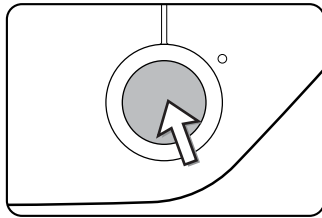

Scanning begins.

If there are no previous jobs in progress and the line is free, the machine will dial the receiving machine and begin transmission as soon as the first page is scanned. Transmission will take place while any remaining pages are scanned (See "Quick On-line" on page 5-24).

If there is a previously stored job or a job is in progress, or if the line is being used, all pages of the document are scanned into memory and stored as a transmission job. (This is called memory transmission: the destination is automatically called and the document transmitted after previously stored jobs are completed.)

If scanning is completed normally, the machine makes a beep sound to inform you that the transmission job is stored and "JOB STORED." appears in the message display.

Using the document glass

7. Press the [BLACK COPY START] key.

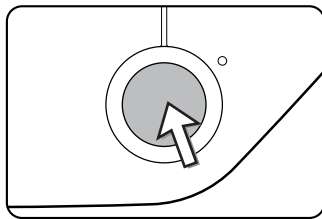

The original is scanned and the [READ-END] key appears in the touch panel.

8. If you have another page to scan, change pages and then press the [BLACK COPY START] key.

Repeat this sequence until all pages have been scanned. You can change the resolution and exposure settings as needed for each page (see pages 5-15 and 5-17).

If the [BLACK COPY START] key is not pressed within approximately one minute, scanning will end automatically and the transmission will be stored.

9. After the last page is scanned, touch the [READ-END] key.

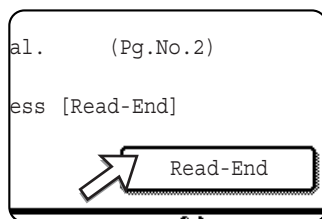

The machine makes a beep sound to inform you that the transmission job is stored and "JOB STORED." appears in the message display. (The destination is automatically called and the document transmitted after previously stored jobs are completed.) Open the document glass cover and remove the document.

NOTES: • **Cancelling transmission**

To cancel transmission while "SCANNING ORIGINAL." appears in the display or before the [READ-END] key is touched, press the [C] key or the [CLEAR ALL] key. To cancel a transmission job that is already stored, press the [JOB STATUS] key and cancel the job as explained on page 5-27.

- If the machine makes two beeps during or at the end of transmission and an error message appears in the message display, refer to page 5-98 to fix the problem.
- If the power is turned off or a power failure occurs while a document is being scanned in the DADF, the machine will stop and a document jam will occur. After power is restored, remove the document.
- A job number appears in the screen together with "JOB STORED." when a transmission job is stored. If you make a note of this number after performing a broadcast transmission, you can use the number to check the results of the transmission for each destination in the transaction report or activity report.

Transmission by Auto-Dialing (One-Touch Dialing and Group Dialing)

To dial by touching an auto dial key (one touch key or group key) instead of pressing the numeric keys, follow the steps below. To use an auto dial number, the name and fax number of the destination must first be stored. For information on auto dial numbers, see page 5-17. To store an auto dial number, see pages 5-68 and 5-74.

1. Perform steps 1 through 5 of "Basic Procedure for Sending Faxes" on page 5-19.
2. Touch the [ADDRESS DIRECTORY] key.

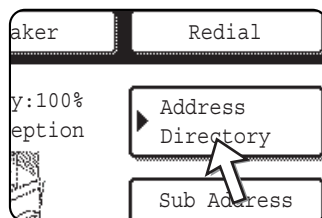

The address directory screen appears.

This step is not necessary if the address directory already appears. Go to step 3.

3. Touch the one-touch key for the desired destination.

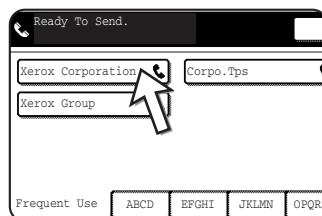

(Refer to page 5-9 for information on using the address directory screen.)

The key you touched is highlighted. If you touch the wrong key, touch the key again to cancel the selection. The key display will return to normal.

4. Continue from step 7 of "Basic Procedure for Sending Faxes" (page 5-21).

Faxing a Two-Sided Original

Follow the steps below to automatically send a two-sided document.

1. Make sure the machine is in fax mode.

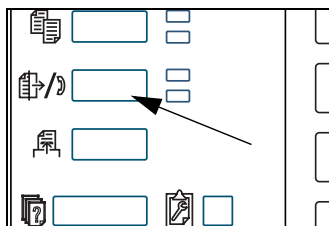

When the [IMAGE SEND] key light is on, the machine is in fax mode. If the light is not on, press the [IMAGE SEND] key.

When the network scanner option is installed, touch this key to return to the initial screen of fax mode or scanner mode, whichever mode was selected last. (Pressing the [IMAGE SEND] key in a copy screen or printer screen returns you to the initial screen of fax mode.) To switch to fax mode from scanner mode, touch the [SCANNER/FAX] key (see 8 on page 5-7).

2. Place the original in the DADF tray (see "Using the DADF" on page 5-11).
3. Touch the [ORIGINAL] key.

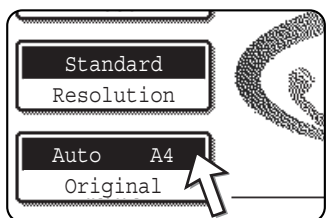

If the address directory screen appears, touch the [CONDITION SETTINGS] key to display the condition settings screen.

When you touch the [ORIGINAL] key, check the original size that appears in the key. If the size was not detected correctly, specify the correct size. (See "Manually Setting the Scanning Size" on page 5-13.)

4. Touch the [2-SIDED BOOKLET] key or the [2-SIDED TABLET] key as appropriate for the original you loaded.

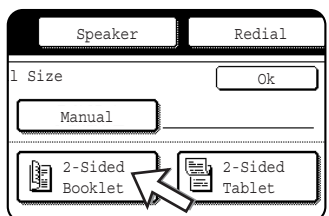

5. Touch the [OK] key.

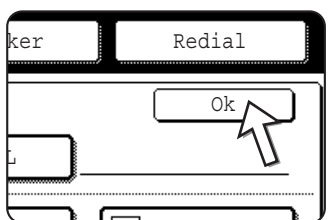

You will return to the initial screen.

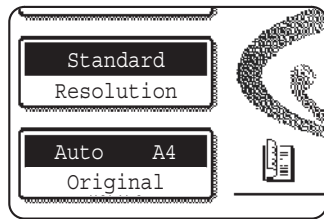

A two-sided original icon appears next to the [ORIGINAL] key.

Example:

The icon that appears when the [2-SIDED BOOKLET] key is touched.

6. Continue from step 4 of “Basic Procedure for Sending Faxes” (page 5-20).

NOTES:

- *Booklets and tablets*
- Two-sided originals that are bound at the side are booklets, and two-sided originals that are bound at the top are tablets.
- *Two-sided scanning turns off after the document is stored in memory. Pressing the [CLEAR ALL] key will also cancel two-sided scanning.*

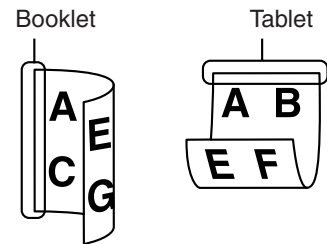

Quick On-line

When you use the DADF to send a multi-page document and there are no previously stored jobs waiting or in progress (and the line is not being used), the machine dials the destination after the first page is scanned and begins transmitting scanned pages while the remaining pages are being scanned. This transmission method is called Quick On-line. The messages "SCANNING ORIGINAL." and "SENDING." both appear until scanning of the final page is completed.

If the receiving party is busy, the transmission will switch to a memory transmission. (Refer to the following section, “Storing transmission jobs (memory transmission)”.)

NOTE: *The machine is initially set (factory setting) to perform Quick On-line transmission. If desired, you can turn off this function with the key operator program.*

When a document is transmitted using the following methods, the job will be stored in memory (Quick On-line transmission will not be performed):

- *Sending from the document glass / broadcast transmission (page 5-30)*
- *Timer transmission (page 5-32)*
- *F-code transmission (page 5-49)*

Storing transmission jobs (memory transmission)

When a document is sent from the document glass, or when the telephone line is in use, the document is scanned into memory and then automatically transmitted after previously stored transmission jobs are completed. (This is called memory transmission.) This means that transmission jobs can be stored in memory by performing a transmission operation while the machine is occupied with another transmission/reception operation. This is called storing transmission, and up to 50 jobs can be stored in memory at once. After transmission, the scanned document data is cleared from memory.

- NOTES:**
- You can check transmission jobs stored in memory in the job status screen. (Refer to page 1-17.)
 - If the memory becomes full while a document is being scanned, a message will appear in the display. You can cancel the transmission by touching the [CANCEL] key, or send only the pages already scanned by touching the [SEND] key. The page that was being scanned when the memory became full will be cleared from memory. If the memory becomes full while scanning the first page of a document, the transmission job is automatically cancelled.
 - The number of jobs that can be stored will depend on the number of pages in each job and the transmission conditions. The number of storable jobs will increase if the optional expansion memory is installed.

If the receiving party is busy

If the receiving party is busy, the transmission is temporarily cancelled and then automatically re-attempted after a brief interval (two attempts are made at intervals of 3 minutes*). If you do not want the machine to re-attempt the transmission, press the [JOB STATUS] key and cancel the job (see page 5-27).

* This setting can be changed with the key operator program.

If a transmission error occurs

If an error occurs that prevents transmission or the receiving machine does not answer the call within 45 seconds*, then transmission is stopped and then automatically re-attempted later. (two recall attempts are made at an interval of 1 minute*) Automatic recalling can be stopped by pressing the [JOB STATUS] key and cancelling as explained on page 5-26. This machine also supports error correction mode (ECM) and is set to resend any part of a fax that is distorted due to noise on the line.

* The settings can be changed in the key operator programs. (See "Call timer at memory sending" and "Recall in case of communication error" in the "Fax Unit" section of the WorkCentre C226 System Administration Guide.)

Image rotation

The machine is initially set to rotate a vertically-placed (⌘) document 90° so that it is oriented horizontally (⌘) before transmission (A4 (8-1/2"x11") originals are rotated to A4R (8-1/2"x11"R) and B5R or A5R (5-1/2"x8-1/2"R) originals are rotated to B5 or A5 (5-1/2"x8-1/2")). A4R (8-1/2"x11"R) originals and B5 or A5 (5-1/2"x8-1/2") originals are not rotated. If desired, you can turn this function off with the key operator program as explained in "Rotation sending setting" in the "Fax Unit" section of the WorkCentre C226 System Administration Guide.

- NOTE:** Place A5 (5-1/2"x 8-1/2") size originals so that they are oriented vertically (⌘). If oriented horizontally, (⌘ A5R (5-1/2"x 8-1/2"R) orientation), the original size will be detected as a different size, and thus it will be necessary to touch the [ORIGINAL] key and specify the correct original size (touch the [A5R] ([5-1/2"x 8-1/2"R]) key). (See "Manually Setting the Scanning Size" on page 5-13.)

Priority Transmission of a Stored Job

If you have an urgent transmission job and multiple transmission jobs have already been stored, you can give priority to the urgent job so that it will be transmitted immediately after the job currently being executed. This is done from the job status screen.

1. Press the [JOB STATUS] key.

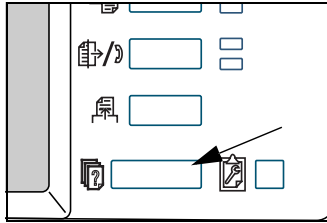

2. Touch the [FAX JOB] key.

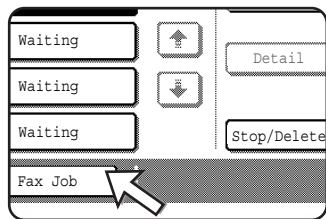

3. Touch the key of the job to which you wish to give priority. The touched key is highlighted.
4. Touch the [PRIORITY] key.

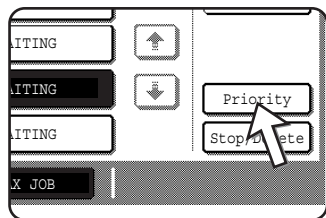

The selected job moves up to the next position after the job currently being executed.

When the current job is completed, execution begins of the job selected in step 3.

NOTE: *If the job in progress is a broadcast transmission job (see page 5-30) or a serial polling job (see page 5-35), the priority job will temporarily interrupt the job after the transmission currently in progress is finished. When the priority job is finished, the broadcast transmission or serial polling job will resume. However, if the priority job is also a broadcast transmission or serial polling operation, the job is begun after all transmissions of the current broadcast or serial polling job are completed.*

Cancelling a Fax Transmission

1. Press the [JOB STATUS] key.

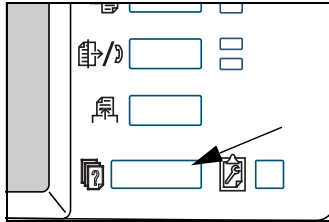

2. Touch the [FAX JOB] key.

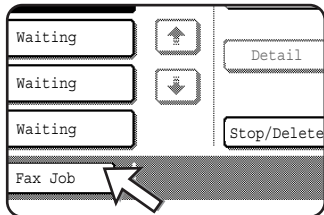

3. Touch the key of the job that you wish to cancel from among the stored fax jobs or the fax job in progress. The touched key is highlighted.
4. Touch the [STOP/DELETE] key.

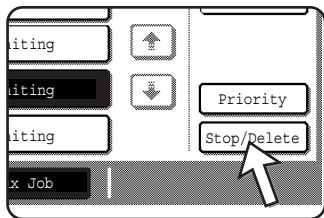

A message appears to confirm the cancellation. Touch the [YES] key to delete the selected job key and cancel the transmission.

- NOTES:**
- If you do not wish to cancel the transmission, touch the [NO] key.
 - "CANCEL" will appear in the Transaction Report of a job that is cancelled

Cancelling On-Hook Dialing

To cancel on-hooking dialing (dialing by touching the [SPEAKER] key and then the numeric keys) when you need to redial the number or because transmission was interrupted, touch the [SPEAKER] key once again.

Receiving Faxes

When another fax machine sends a fax to your machine, your machine will ring*, automatically receive the fax, and begin printing (this is called automatic reception).

- NOTES:**
- You can store a transmission job while fax reception is in progress (See "Storing transmission jobs (memory transmission)" on page 5-24.)
 - To receive faxes, sufficient paper must be loaded in the paper tray. Refer to "Loading Paper" on page 1-21 for information on loading appropriate paper. Incoming faxes that are A4 (8x1/2"x11") or B5 size will be automatically rotated to match the orientation of the paper, so there is no need to load both horizontally (☐) and vertically (☐) oriented A4 (8-1/2"x11") and B5 paper.
However, if you receive a fax that is smaller than A4 (8-1/2"x11") or B5 size, the paper size used to print the fax will depend on how the original was oriented (vertically or horizontally) in the sending fax machine.

Receiving a Fax

1. The machine will ring* and reception will automatically begin.

*Number of rings

The machine has been set to ring twice before beginning automatic reception. You can use the key operator program to change the number of rings to any number from 0 to 15*¹.

If the number of rings is set to 0*², the machine will receive faxes without ringing.

*¹ The number varies by region.

*² In some regions "0" cannot be selected.

2. Reception ends.

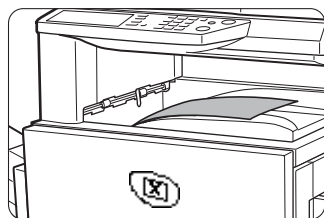

When reception ends, the machine makes a "beep" sound.

The received fax is delivered to the top tray.

- NOTES:**
- If the machine has multiple output trays, the key operator program can be used to change the output tray for fax reception.
 - Each fax is offset from the previous fax in the output tray to allow easy separation.

If received data cannot be printed

If the machine is out of paper or toner, or if a paper jam occurs or the machine is busy printing a copy or print job, received faxes will be stored in memory until printing is possible. When printing is possible, the faxes will print automatically (however, if the machine has run out of paper, touch the [OK] key in the touch panel after adding paper). When a received fax is stored in memory, the "DATA" light to the right of the [IMAGE SEND] key will blink.

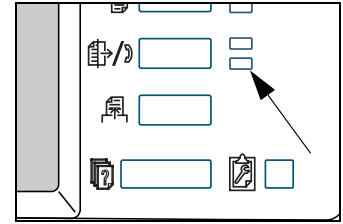

You can also use the transfer function to have another fax machine print the received data. (See "Using the Transfer Function" on page 5-47.)

Advanced Transmission Methods

This section explains fax features for special situations and purposes. Please read those sections that are of interest to you.

Sending the Same Document to Multiple Destinations in a Single Operation (Broadcast Transmission)

This feature is used to send a document to multiple destinations in a single operation. The document to be transmitted is scanned into memory and then successively transmitted to the selected destinations. This feature is convenient for such purposes as distributing a report to company branches in different locations. Up to 100 destinations can be selected. When transmission to all destinations has been completed, the document is automatically cleared from memory.

- NOTES:**
- *If you frequently use broadcasting to send documents to the same group of destinations, it is convenient to store those destinations in a group key. Group dialing is an auto dial function that enables multiple destinations to be stored in a single one-touch key. The procedure for programming group keys is explained on page 5-74.*
 - *When using a group key to send a fax, the destinations programmed in the group key are counted as broadcasting destinations. For example, if five destinations are programmed in a group key and the key is touched for a broadcast transmission, the broadcast transmission will have five destinations.*

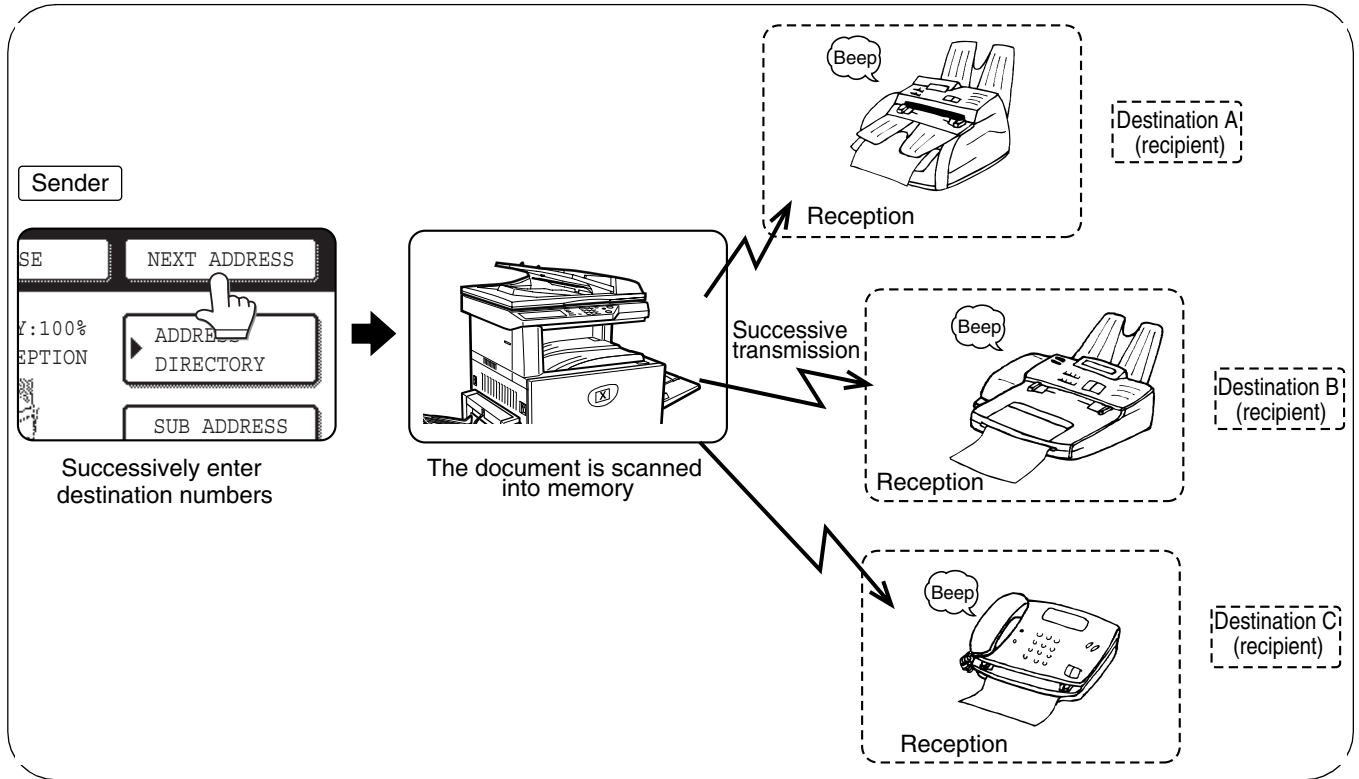

Using Broadcast Transmission

1. Perform steps 1 through 5 of "Basic Procedure for Sending Faxes" (page 5-19).
2. Dial the fax number of the first destination or touch an auto-dial key (one-touch key or group key). (Refer to page 5-22.)

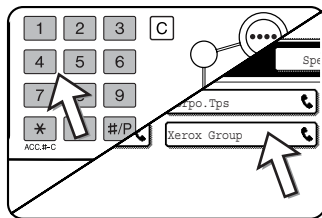

If the condition settings screen appears, touch the [ADDRESS DIRECTORY] key to display the address directory screen.)

An auto-dial key is highlighted when touched.

3. Touch the [NEXT ADDRESS] key and then dial the fax number of the next destination or touch an auto-dial key.

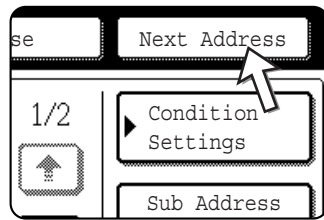

Repeat this step for each of the remaining destinations.

- NOTES:**
- *If you enter an incorrect number*
If you make a mistake while entering a number, press the [C] key and then re-enter the correct digit(s).
If you have already completed entry of a fax number, you can delete the number using steps 4 and 5.
 - *If you select an incorrect auto-dial key*
Simply touch the incorrect key one more time to cancel the selection.
 - *The [NEXT ADDRESS] key only needs to be touched when successively dialing fax numbers with the numeric keys.*

Example:

XXXX (NEXT ADDRESS) XXXX

Dial ↑ Dial

Cannot be omitted.

XXXX (NEXT ADDRESS) (One-touch) (NEXT ADDRESS) (One-touch)

Dial ↑ ↑ Dial

Can be omitted.

Can be omitted.

If desired, you can use the key operator program to set the machine so that the [NEXT ADDRESS] key must always be touched.

4. Touch the [ADDRESS REVIEW] key to display the list of destinations.

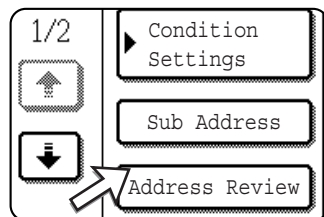

When the [ADDRESS REVIEW] key is touched, only the entered and selected destinations are displayed.

5. Check the destinations.

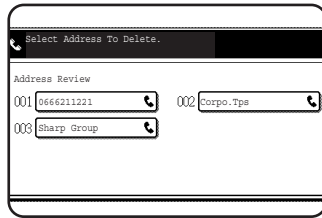

When you have finished checking the destinations, touch the [OK] key to return to the screen of step 4.

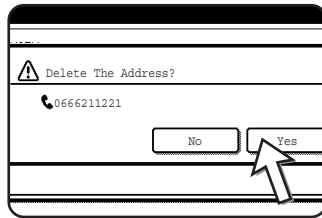

If you wish to delete a destination, touch the displayed one-touch key. A message will appear to confirm the deletion. Touch [YES] and the destination will be deleted from the destination list. To cancel instead of deleting, touch the [NO] key.

6. Continue from step 7 of “Basic Procedure for Sending Faxes” (page 5-19).

NOTE: *To cancel a broadcast transmission*

To cancel a broadcast transmission when selecting destinations, press the [CLEAR ALL] key. To cancel after all steps of the transmission have been completed, see “Cancelling a Fax Transmission” on page 5-27.

Automatic Transmission at a Specified Time (Timer Transmission)

This feature enables you to set up a transmission or polling operation to be performed automatically at a specified time up to a week in advance. This is convenient when you will be out of the office or for transmission at off-peak nighttime rates. A combined total of 50 timer transmission and memory transmission jobs can be stored.

- NOTES:**
- *After a timer transmission is performed, the information (image, destination, etc.) is automatically cleared from memory.*
 - *To perform a timer transmission, the document must be scanned into memory. It is not possible to leave the document in the DADF tray or on the document glass and have it scanned at the specified time of transmission.*
 - *To set the date and time in the machine, refer to page 1-39 . You can check the machine's currently set time in the screen of steps 3 and 4 below.*
 - *Only one polling timer operation can be set up at a time. If you wish to set up multiple timer polling operations, combine the machines to be polled into a serial polling operation with a timer setting (see page 5-34).*

Setting Up a Timer Transmission

1. In fax mode, touch the [SPECIAL MODES] key.

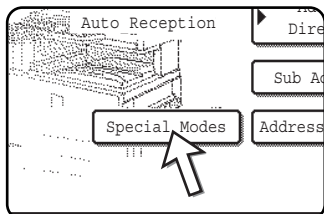

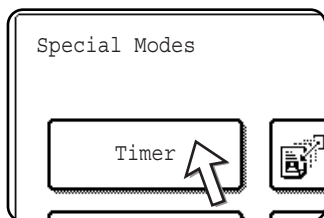

If the address directory screen appears, touch the [CONDITION SETTINGS] key to display the condition settings screen.

2. Touch the [TIMER] key.



The timer transmission screen appears.

3. Select the day of the week. (Touch the  key or the  key until the desired day is selected.)

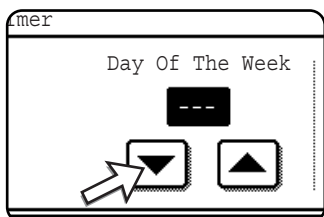

The initial setting is "---" (no selection). If you select this setting, the transmission will be performed as soon as the specified time arrives.

Select the time. (Touch the  key or the  key until the desired time appears.)

4. Select the time in 24-hour format.

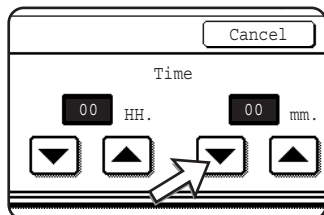

Example:

11:00 P.M. 23:00

The current time appears at the top of the screen. If the time is not correct, press the [CLEAR ALL] key to stop operation and adjust the date and time. (Refer to page 1-39.)

5. Touch the outer [OK] key.

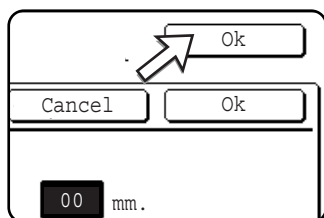

You will return to the screen of step 1 and a timer transmission icon will appear next to the [EXPOSURE] key.

To cancel timer, touch the [CANCEL] key.

6. Perform the desired transmission operation.

The steps that follow will depend on the type of transmission. The following operations can be performed in a timer transmission:

- Normal transmission
- Broadcast transmission
- Polling
- Serial polling
- F-code polling
- F-code confidential transmission
- F-code relay request transmission

- NOTES:**
- *Other operations can be performed after a timer transmission is set up. If another operation is in progress when the specified time arrives, the timer transmission will begin when the job in progress is completed.*
 - *If a timer transmission job is given priority in the fax job status screen (see "Priority Transmission of a Stored Job" on page 5-26), the time setting will be cancelled and the job performed as soon as the current job is completed.*

Transmission and Reception Using the Polling Function

This function can only be used if the other machine is a Super G3 or G3 machine and supports the polling function. The polling function allows your machine to call a fax machine that has document data set and initiate reception of the document. You can also perform the reverse operation: scan a document into the memory of your machine so that another machine can call your machine and initiate reception of the document.

This function whereby your machine calls the sending machine and asks the sending machine to begin transmission of a loaded document is called the polling function. Scanning a document into memory and automatically sending it when the receiving machine calls and "polls" your machine is called polling memory.

- NOTE:** *For information on polling and polling memory using F-codes, refer to "F-Code Polling Memory" on page 5-52. This section only explains normal polling and normal polling memory.*

Polling

This function allows your machine to call a sending machine and initiate reception of a document loaded in that machine. A timer setting can also be established to have the operation take place at night or another specified time (see page 5-33).

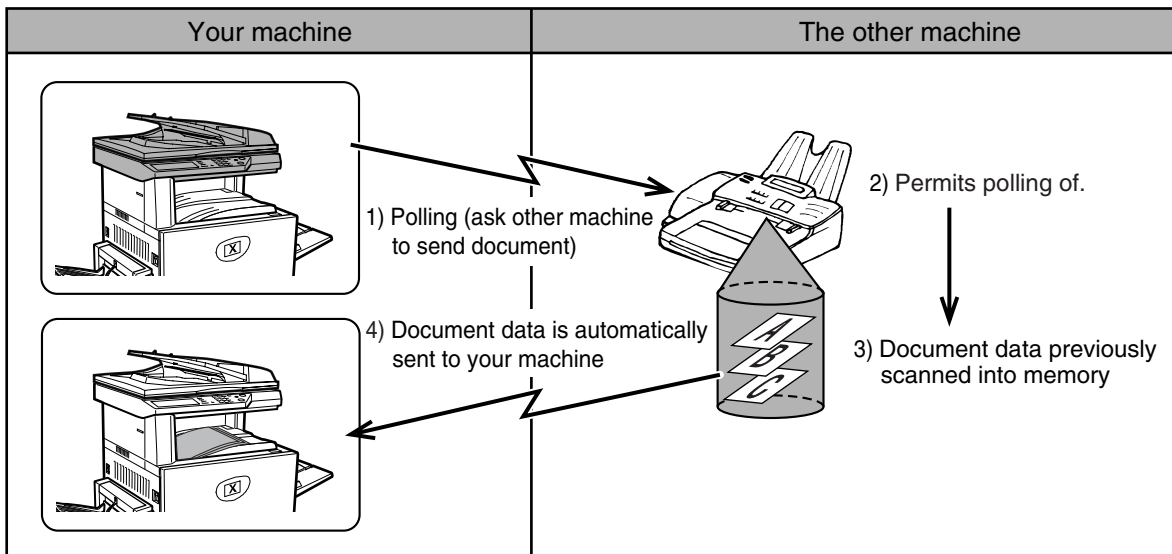

Serial Polling: Group keys and the broadcast transmission function (page 5-30) can be used to successively poll multiple fax machines in a single operation. Up to 100 machines can be polled. In this case, the sequence of operations in the above diagram is successively repeated for each sending machine selected.

NOTE: *The receiving machine bears the expense (phone charges) of polling transmission.*

Polling memory

This feature allows your machine to automatically send a document previously scanned into memory when another machine calls and polls your machine.

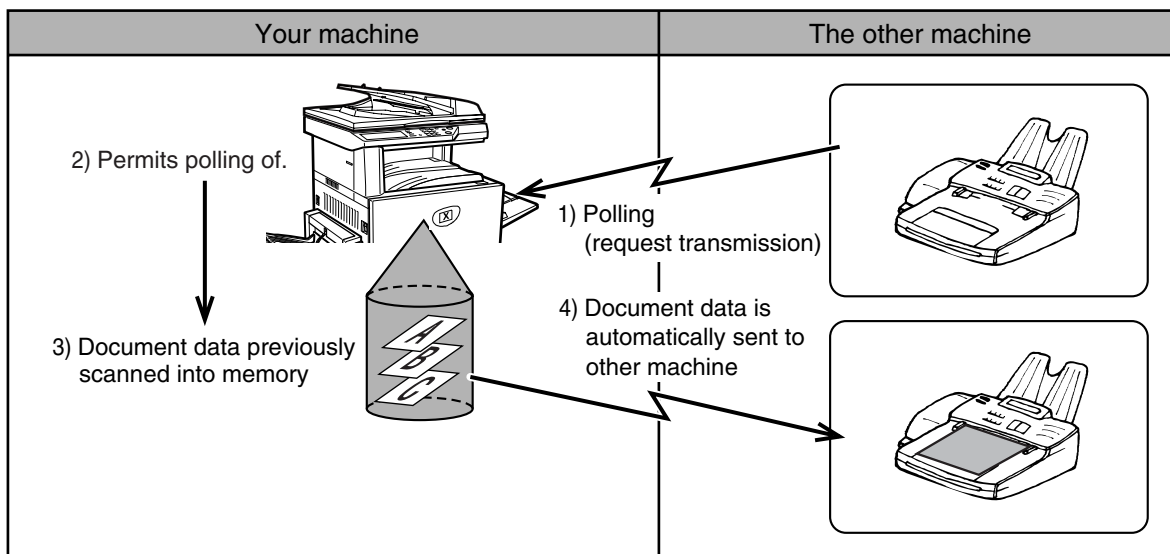

Using the Polling Function

A document should not be loaded in the machine when the following operation is performed. When used in conjunction with the timer transmission function, only one polling job can be stored.

NOTE: *If the other machine has a polling security function (see “Restricting polling access (polling security)” on page 5-42), use the key operator program to program your own fax number, and ask the operator of the other machine to appropriately program your fax number in that machine.*

1. In fax mode, touch the [SPECIAL MODES] key and then touch the [POLLING] key.

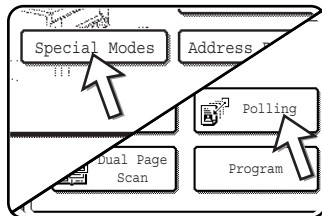

If the address directory screen appears, touch the [CONDITION SETTINGS] key to display the condition settings screen.

The [POLLING] key is highlighted and the polling icon appears.

To cancel polling, touch the [POLLING] key once again so that it is not highlighted.

2. Touch the [OK] key.

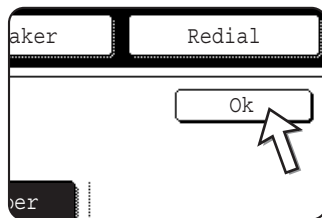

You will return to the initial screen.

3. Dial the number of the other fax machine or touch an auto-dial key (one-touch or group key).

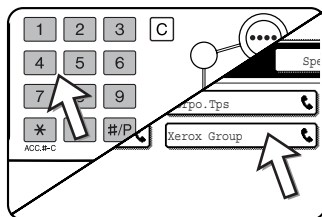

If the condition settings screen appears, touch the [ADDRESS DIRECTORY] key to display the address directory screen.

If you are performing serial polling, touch the [NEXT ADDRESS] key and repeat this step.

NOTE: *When performing serial polling, an auto-dial key that includes a sub-address or passcode (page 5-49) cannot be selected.*

- When you have finished entering the destination(s), press the [BLACK COPY START] key.

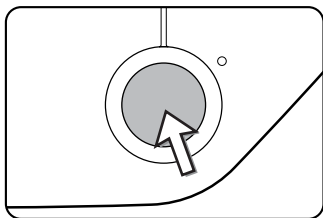

"JOB STORED." appears in the touch panel.

The fax is received from the other machine and printed out.

NOTE: *To cancel the operation*

Press the [JOB STATUS] key and then cancel the operation. (See "Cancelling a Fax Transmission" on page 5-27.)

Manual Polling

A document should not be loaded in the machine when the following operation is performed. Manual polling is begun on the signal of the other party.

- Touch the [SPEAKER] key in fax mode, and dial the number of the other machine.

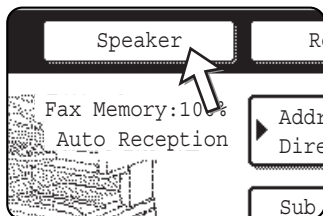

A one-touch key or the [REDIAL] key can also be used.

- Touch the [SPECIAL MODES] key.

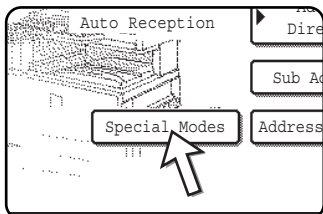

If the address directory screen appears, touch the [CONDITION SETTINGS] key to display the condition settings screen.

- When you hear the fax tone from the other machine, touch the [POLLING] key.

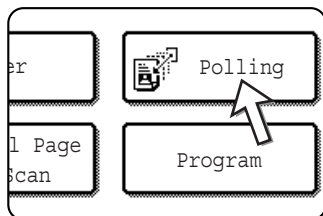

"JOB STORED." appears in the touch panel.

Polling reception begins.

Your machine prints the fax after receiving it from the sending machine.

NOTE: *Serial polling cannot be performed manually. When polling reception ends, repeat steps 1 through 4.*

Using Polling Memory

This function sends a document previously scanned into memory to a receiving machine when the receiving machine calls and polls your machine. (If desired, you can restrict polling to fax machines whose fax number you have programmed in your machine. This machine has "memory box", which is memory used for such functions as the normal polling memory function, F-code polling memory, F-code confidential transmission, and F-code relay transmission (see "Memory Boxes and Sub-Addresses/Passcodes Required for F-code Transmission" on page 5-49). The polling memory function explained here uses a memory box called the "PUBLIC BOX".

NOTE: *When using the polling memory function, do not set the reception mode to MANUAL RECEPTION (see "Using an Extension Phone to Receive a Fax" on page 5-63).*

Scanning a document into memory (Public Box) for polling memory

This procedure is for scanning a document into the Public Box. If other document data has already been stored in the Public Box, the new document will be added after that data. If the previous document data is no longer needed, delete that data first (see "Deleting document data from the Public Box" on page 5-41) and then follow the steps below.

1. Make sure the machine is in fax mode.

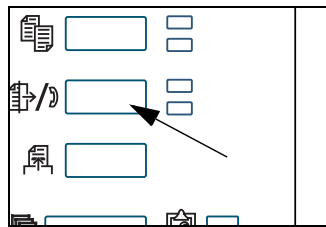

When the [IMAGE SEND] key light is on, the machine is in fax mode. If the light is not on, press the [IMAGE SEND] key.

When the network scanner option is installed, touch this key to return to the initial screen of fax mode or scanner mode, whichever mode was selected last. To switch to fax mode from scanner mode, touch the [SCANNER/FAX]

key.

2. Place the original in the DADF tray.
3. In fax mode, touch the [SPECIAL MODES] key and then touch the [MEMORY BOX] key.

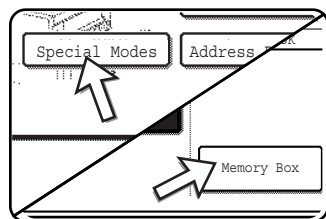

If the address directory screen appears, touch the [CONDITION SETTINGS] key to display the condition settings screen.

To cancel the operation, touch the [CLEAR ALL] key.

4. Touch the [DATA STORE] key.

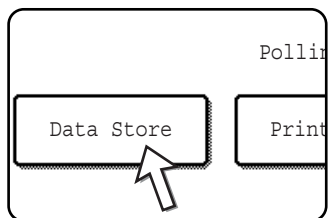

5. Touch the [PUBLIC BOX] key.

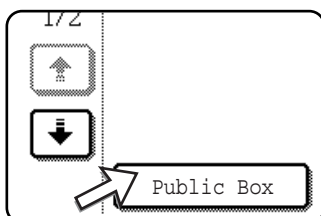

This specifies that the document will be scanned into the Public Box.

6. Set the original size, resolution, exposure and other scanning conditions as needed. (See "Manually Setting the Scanning Size" on page 5-13.)
7. Press the [BLACK COPY START] key.

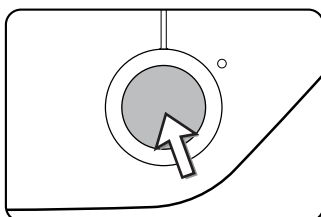

The document is scanned. If other document data has previously been stored, the new data will be added on after the old data.

If you used the document glass and have another page to scan, change the pages and then press the [BLACK COPY START] key again. Repeat this procedure until all pages have been scanned, and then touch the [READ-END] key that appears in the message screen. When the document data has been stored in the Public Box, "JOB STORED." appears on the screen, after which you will return to the initial screen.

NOTE: *To cancel scanning*

To cancel scanning of a document while scanning is in progress, press the [C] key. To delete a document that has already been scanned, see "Deleting document data from the Public Box" on page 5-41.

- NOTE:** *The machine has been initially set to automatically clear document data from the Public Box after polling takes place and the data is sent to the polling machine. You can use the key operator program to change this setting so that the data is not automatically cleared and polling can take place repeatedly.*

Printing document data in the Public Box

To check a document that is stored in the public box, follow these steps to print it out. If no documents have been stored, the [PUBLIC BOX] key will be greyed out.

1. In fax mode, touch the [SPECIAL MODES] key and then touch the [MEMORY BOX] key.

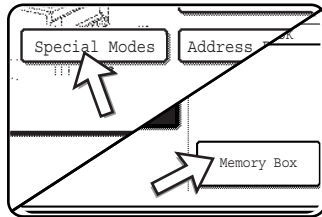

If the address directory screen appears, touch the [CONDITION SETTINGS] key to display the condition settings screen.

2. Touch the [PRINT DATA] key.

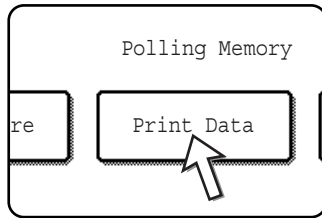

3. Touch the [PUBLIC BOX] key.

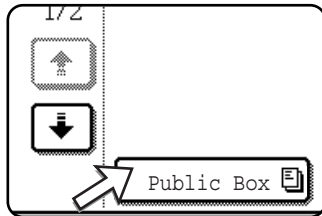

Touching the [CANCEL] key will return you to the screen of step 2.

4. Press the [BLACK COPY START] key.

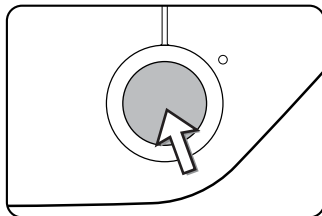

The message screen appears and the Public Box data is stored as a print job.

To cancel printing, touch the [CANCEL] key.

Deleting document data from the Public Box

This procedure is used to delete document data from the Public Box when it is no longer needed.

1. In fax mode, touch the [SPECIAL MODES] key and then touch the [MEMORY BOX] key.

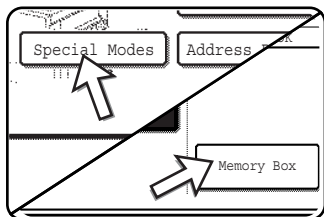

If the address directory screen appears, touch the [CONDITION SETTINGS] key to display the condition settings screen.

2. Touch the [DELETE DATA] key.

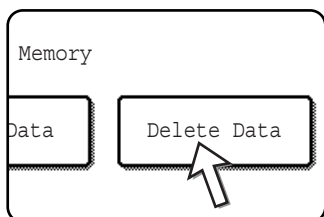

3. Touch the [PUBLIC BOX] key.

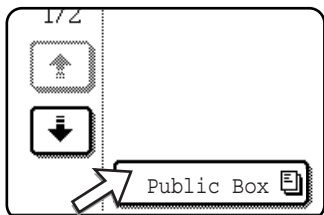

The message screen appears.

4. Touch the [YES] key.

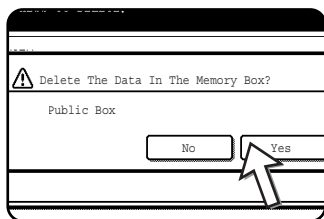

All data in the Public Box is deleted and you return to the screen of step 2.

If you touch the [NO] key, you will return to the screen of step 2 without deleting the data.

Restricting polling access (polling security)

If you wish to prevent unauthorised fax machines from polling your machine, turn on the polling security function. When this function is turned on, polling permission will only be granted if the fax number of the polling machine (as programmed in that machine) matches one of the fax numbers you have programmed in your machine as passcode numbers. Up to 10 fax numbers can be programmed as passcode numbers.

To turn on the polling security function and program passcode numbers, use the key operator program as explained in "Passcode number setting" in the "Fax Unit" section of the WorkCentre C226 System Administration Guide.

- NOTES:**
- *If you do not use the polling security function, the document will be sent to any fax machine that polls you.*
 - *To use polling memory with polling security enabled, the sender's number of the polling machine must be programmed in that machine and in your machine.*

Own Number Sending

This function prints the date, time, your programmed name, your programmed fax number, and the transmitted page number at the top centre of each page that you fax. All pages that you fax include this information.

Example of fax page printed out by the receiving machine

11/JUN/2004/FRI 15:00	XEROX PLANNING DIV.	FAX No. 0666211221	P. 001/001
↑	↑	↑	↑
(1)	(2)	(3)	(4)

- (1) Date and time: programmed in the custom settings (see "Custom Settings" on page 1-37).
- (2) Own name: programmed with the key operator program. (See the "Fax Unit" section of the WorkCentre C226 System Administration Guide.)
- (3) Own fax number: programmed with the key operator program.
- (4) Transmitted page number: 3-digit number appearing in the format, "page number/total pages" (only the page number appears if you use manual transmission or Quick On-Line transmission). If desired, you can use the key operator program to omit the page number.

Position of sender's information

The key operator program can be used to select whether the sender's information is added outside the original data or inside the data. (See the "Fax Unit" section of the WorkCentre C226 System Administration Guide). The initial factory setting is outside the data.

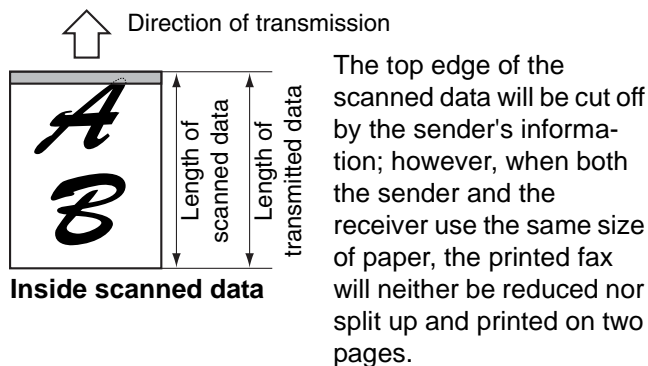
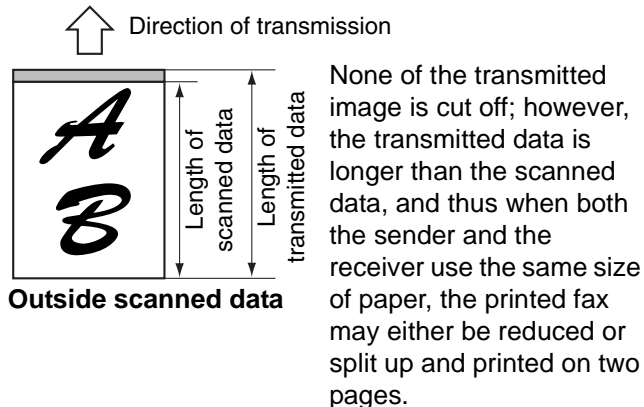

Faxing a Divided Original (Dual Page Scan)

When an open book is scanned and faxed, you can use this function to divide the two open pages of the book into two separate fax pages.

This function can only be used when the original is scanned using the document glass.

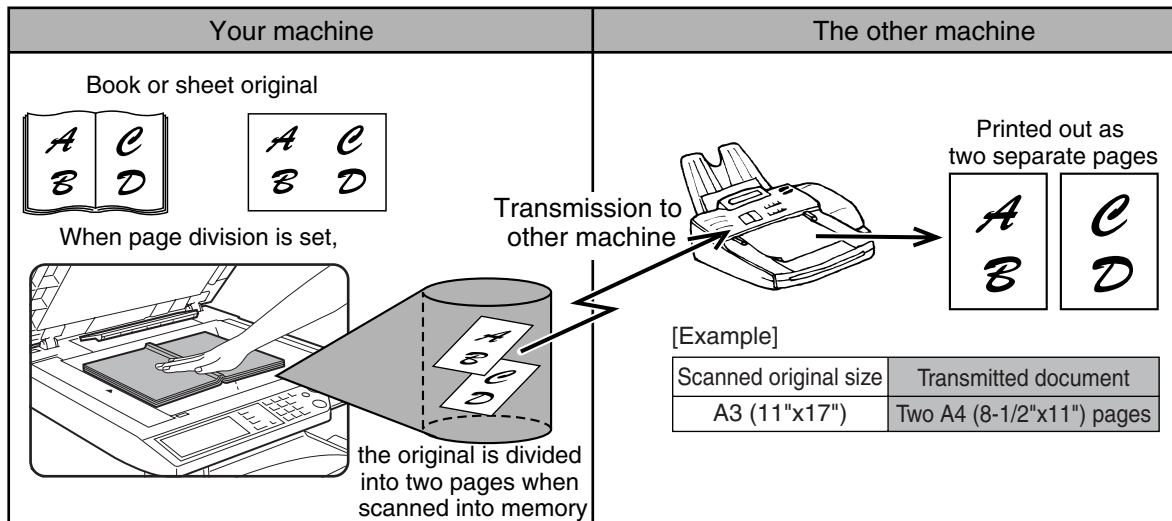

Selecting Dual Page Scan

Follow the steps below and then send the fax.

1. In fax mode, touch the [SPECIAL MODES] key and then touch the [DUAL PAGE SCAN] key.

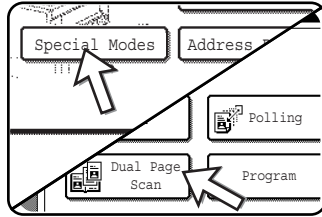

If the address directory screen appears, touch the [CONDITION SETTINGS] key to display the condition settings screen.

2. Touch the [OK] key.

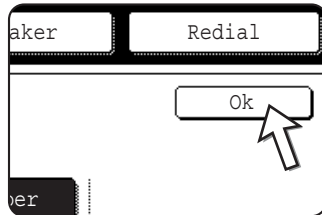

You will return to the initial screen.

3. Place the original on the document glass, and perform the transmission operation.

If you have more originals to scan after pressing the [BLACK COPY START] key and scanning the first original, change originals and repeat scanning until all originals have been scanned. When finished, touch the [READ-END] key that appears in the message display.

NOTE: *To cancel Dual Page Scan:*

Press the [CLEAR ALL] key.

Programming Frequently Used Operations

This function allows you to store the steps of an operation, including the destination and scanning settings, into a program. This function is convenient when you frequently send documents, such as a daily report, to the same destination. Up to eight programs can be stored.

Programs can be stored using the custom settings, and a name up to 18 characters long can be assigned.

For information on storing, editing, and deleting programs, refer to "Storing a Program" on page 5-78, and "Editing and Deleting Programs" on page 5-80.

The following settings can be stored in a program:

- Destination fax number
- Polling
- Dual Page Scan
- Resolution and exposure

Auto-dial keys (one-touch or group keys) are used to store the destination fax number. A full number cannot be entered using the numeric keys. When storing a broadcast transmission or serial polling operation in a program, up to 100 destination fax numbers can be stored.

- NOTES:**
- *A program differs from a timer transmission in that it is not cleared from memory after transmission takes place. A program thus allows you to repeatedly perform the same type of transmission. Note, however, that programs do not allow you to establish a timer setting for transmission.*
 - *With the exception of polling, reception operations cannot be stored in a program.*

Using a Program

1. In fax mode, load the document.

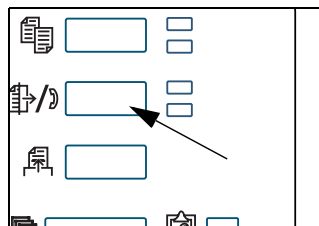

Do not load a document if you are performing a polling operation.

If you are going to use Dual Page Scan, place the document on the document glass.

2. Touch the [SPECIAL MODES] key and then the [PROGRAM] key.

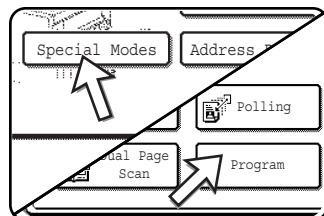

If the address directory screen appears, touch the [CONDITION SETTINGS] key to display the condition settings screen.

3. Touch the program key you wish to execute. Make sure the key is highlighted and then touch the [OK] key.

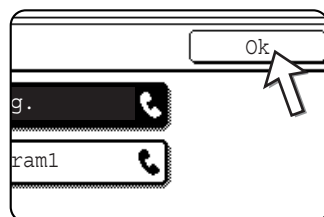

The program key you touched is selected and you return to the screen of step 2.

The [PROGRAM] key is highlighted.

4. Touch the [OK] key.

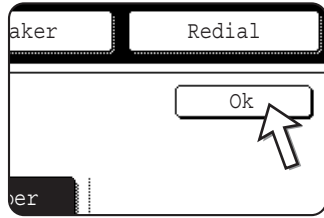

You will return to the initial screen.

5. If needed, set the original size and other settings, and then press the [BLACK COPY START] key.

Transmission takes place according to the program.

NOTE: Select functions that cannot be stored in a program before you press the [BLACK COPY START] key in step 5. These functions include specifying the original size (see "Manually Setting the Scanning Size" on page 5-13), two-sided scanning (see "Faxing a Two-Sided Original" on page 5-23), and timer transmission (see "Setting Up a Timer Transmission" on page 5-33.)

Transferring Received Faxes to Another Machine When Printing Is Not Possible (Forwarding Function)

When printing is not possible because of a paper, toner, or other problem, you can transfer received faxes to another fax machine if that machine has been appropriately programmed in your machine. This function can be conveniently used in an office or other workplace where there is another fax machine connected to a different phone line. When a fax has been received to memory, the DATA light to the right of the [IMAGE SEND] key blinks. (See "If received data cannot be printed" on page 5-29.)

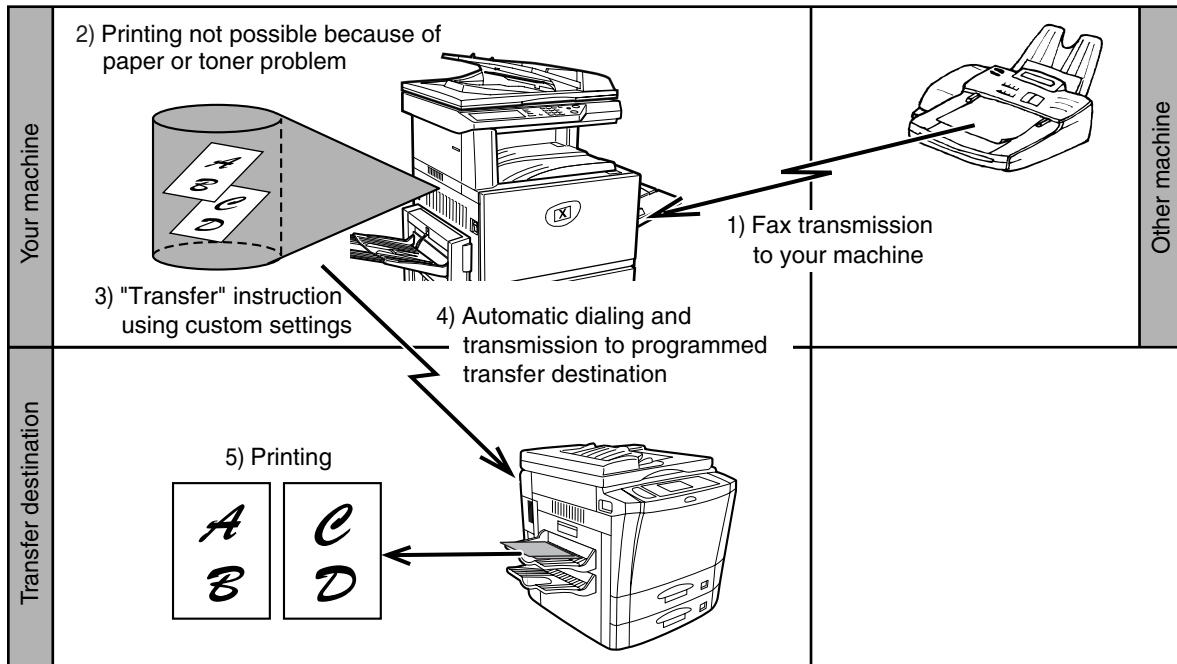

- NOTES:**
- *When the transfer instruction is issued, all data that has been received in memory to that point is transferred. The page that was being printed when the problem occurred and all following pages will be transferred.*
 - *Data cannot be selected for transfer. Data received to a confidential memory box cannot be transferred. (See “F-Code Confidential Transmission” on page 5-56.)*
 - *The result of transfer is indicated on an activity report. (See “Viewing the Communication Activity Report” on page 5-98.)*

Using the Transfer Function

Program the fax number of the transfer destination

Use the key operator program to program the number of the transfer destination. (See the “Fax Unit” section of the WorkCentre C226 System Administration Guide.) Only one fax number can be programmed. The transfer function cannot be used unless a number is programmed.

Transferring received data

1. Press the [CUSTOM SETTINGS] key.

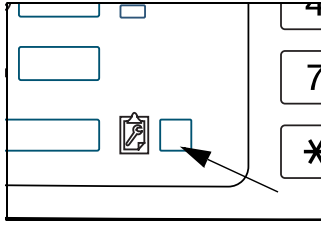

2. Touch the [FAX DATA FORWARD] key.

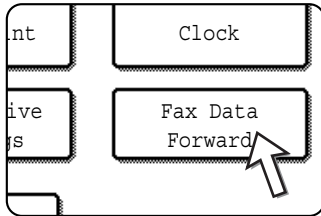

If there is no data to transfer or a transfer number has not been programmed (See the "Fax Unit" section of the WorkCentre C226 System Administration Guide.), a message will appear and transfer will not be possible.

3. Touch the [YES] key.

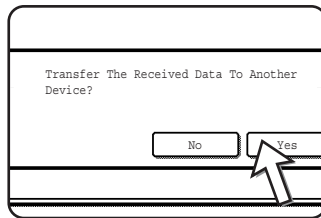

The machine automatically dials the transfer destination programmed with the key operator program and begins transfer.

If you do not wish to transfer the data, touch the [NO] key.

NOTES:

- **To cancel transfer**

Press the [JOB STATUS] key, and then cancel the transfer in the same way as a transmission. (See "Cancelling a Fax Transmission" on page 5-27.)

The data that was going to be transferred will return to print standby status in your machine.

- *If the transfer is not possible because the line is busy or a transmission error occurs, the data returns to print standby status in your machine.*

Transmission Using F-Codes

This section explains F-code transmission, which gives you a convenient means of performing advanced operations such as relay broadcast transmission and confidential transmission. Normally these functions require that the other fax machine be a similar Xerox machine; however, F-code transmission enables these functions to be performed with any other machine that supports F-code transmission. Please read those sections which are of interest to you.

Transmission Between Machines Supporting F-codes

This machine supports the "F-code" standard as established by the ITU-T*.

Operations such as relay broadcast transmission and confidential transmission previously could only be performed with another Xerox fax machine; however, F-Code communication makes it possible to perform these operations with fax machines of other manufacturers that support F-Code communication.

Before using the functions explained in this section, make sure that the other fax machine supports F-Code communication and has the same functions as your machine. (the other machine may use a different name for the function).

* The ITU-T is a United Nations organization that establishes communications standards. It is a department of the International Telecommunication Union (ITU), which coordinates global telecommunications networks and services.

Memory Boxes and Sub-Addresses/Passcodes Required for F-code Transmission

"Memory boxes" can be created in the memory of fax machines that support F-Code communication. These boxes are used to store faxes received from other machines and documents to be transmitted when a polling request is received.

Fax machines that support F-code transmission enable the creation of a "**memory box**" in the unit's memory. Up to 50 memory boxes can be created for a variety of purposes, and a name can be assigned to each box. A "**sub-address**" that indicates the box's location in memory must be programmed, and if desired, a passcode can also

be programmed to control access to the box. (A sub-address must be programmed, however, a passcode can be omitted.)

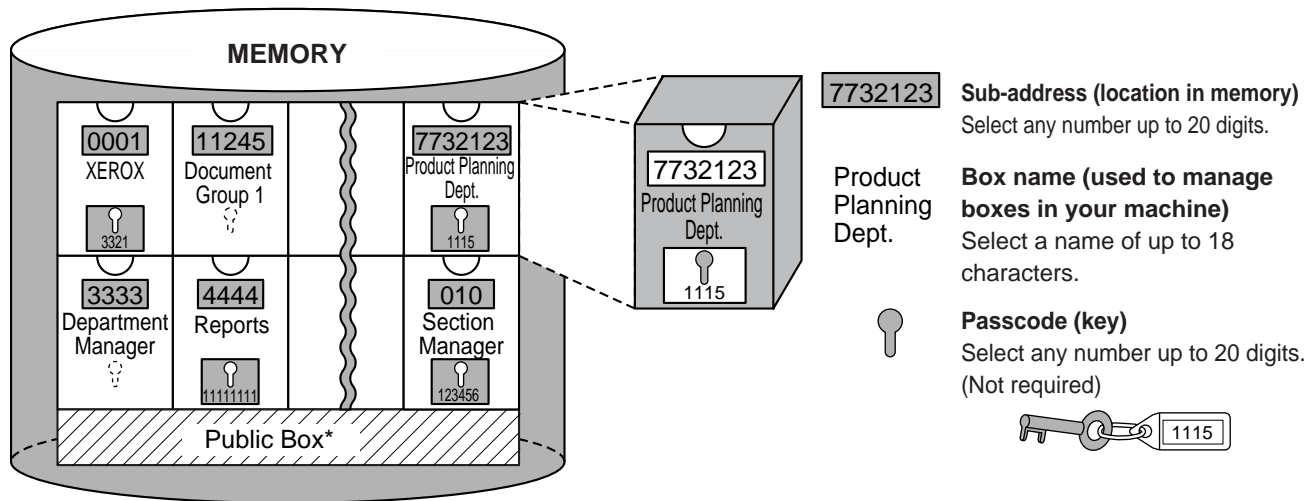

* The Public Box is used for normal serial polling (see "Using Polling Memory" on page 5-38).

When communication occurs involving a memory box, the communication will only take place if the sub-address and passcode that the other machine sends match the sub-address and passcode programmed in your machine for that box. Therefore, to allow communication, you must inform the other party of the sub-address and passcode of the memory box. Likewise, to send a document to a memory box in another machine or use polling to retrieve a document from that memory box, you must know the sub-address and passcode of that memory box. (Box names are used only to manage boxes in the machine; you do not need to inform the other party of a box name the other party only needs to know the sub-address and passcode.)

This machine uses the term "sub-address" for the location of the memory box and the term "passcode" for the authorization number of the memory box; however, the products of other manufacturers may use different terms. When asking the other party for a sub-address and passcode, you may find it useful to refer to the 3-character alphabetical terminology used by the ITU-T.

This machine	ITU-T		
		F-code polling memory box	F-code Confidential box
Sub-address	SEP	SUB	SUB
Passcode	PWD	SID	SID

Entering (Dialing) a Fax Number with a Sub-Address and Passcode

When transmitting to a memory box in another fax machine, the sub-address and passcode must be entered after the other machine's fax number. Enter the other machine's fax number as explained for a normal transmission or for a polling operation (see "Using the Polling Function" on page 5-36), and then enter the sub-address and passcode as follows:

1. Dial the fax number of the other machine, or touch a one-touch key.

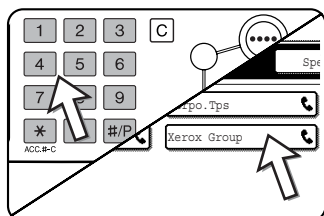

If the condition settings screen appears, touch the [ADDRESS DIRECTORY] key to display the address directory screen.

If the sub-address and passcode have been programmed into the one-touch key, the following steps are not needed.

2. Touch the [SUB ADDRESS] key.

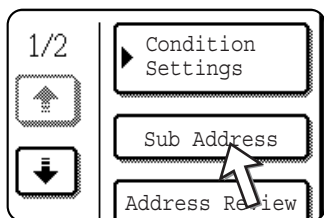

When the [SUB ADDRESS] key is touched, a slash "/" appears at the end of the fax number. If you make a mistake, press the [C] key to clear the mistake.

3. Use the numeric keys to enter the sub-address of the other machine's memory box (max. 20 digits).

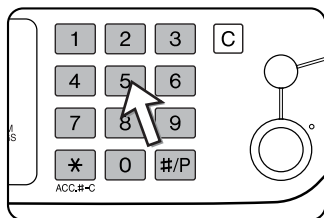

If you make a mistake, press the [C] key and re-enter the correct digit(s).

4. Touch the [SUB ADDRESS] key once again.

A slash "/" appears at the end of the sub-address.

5. Use the numeric keys to enter the passcode of the other machine's memory box (max. 20 digits)

If a passcode has not been established for the other box, this step is not necessary.

- NOTES:**
- You can program a sub-address and passcode into a one-touch key along with the fax number (see "Storing One-Touch Keys" on page 5-68).
 - Manual transmission (on-hook dialing) using a sub-address and Passcode Is Not Possible.

Creating a Memory Box for F-Code Transmission

Operations that use F-Code memory boxes include F-Code polling memory (page 5-52), F-Code confidential transmission (page 5-56), and F-Code relay broadcast transmission (page 5-59). To perform these operations, a memory box for each type of transmission must be created.

Memory boxes are created in the custom settings. Up to 50 boxes can be created.

The information programmed in each memory box varies slightly depending on the type of operation. Refer to pages 5-81 to 5-88 for the procedures for creating, editing, and deleting memory boxes.

After you have programmed a memory box, inform the other party of the box's sub-address and passcode.

NOTE: *If you attempt to create a box when 50 boxes have already been created, a message will appear and you will not be able to create the box. First delete an unused box (see "Editing and Deleting a Memory Box" on page 5-88), and then create the new box.*

F-Code Polling Memory

F-code polling memory allows one fax machine to call another fax machine and activate reception of a document that has been scanned into the other machine's F-code polling memory box. Calling another machine and activating reception is called F-code polling, and scanning a document into a memory box for another machine to retrieve by polling is called F-code polling memory. This function is approximately the same as normal polling explained on page 5-34; however, it uses an F-code polling memory box and is always protected by means of the sub-address and passcode.

How F-code polling memory works

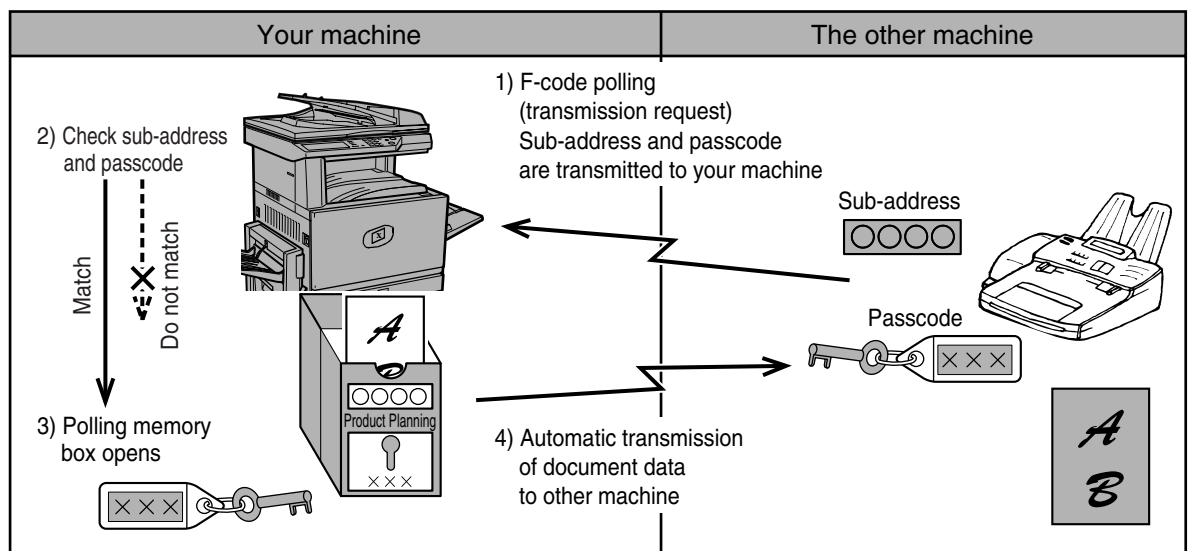

F-code polling is when your machine calls another machine and retrieves a document that was scanned into the polling memory box of that machine (the reverse of the above diagram).

- NOTES:**
- To perform polling or polling memory without using an F-code, refer to page 5-34.
 - To create an F-code memory box for polling memory, refer to page 5-81 and “Setting for F-Code Polling Memory Boxes (Polling Times)” on page 5-84.
 - Unlike normal polling, the other machine's fax number is not programmed as a passcode for F-code polling memory. The sub-address and passcode of the polling memory box are always used for polling security.
 - The receiving machine bears the expense (phone charges) of the transmission.

Using F-Code Polling Memory

In order for another machine to retrieve a document from your machine, you must first scan the document into the F-code polling memory box.

You can check scanned document data by printing it out (refer to “Checking and clearing document data in a memory box” on page 5-54).

- NOTE:** When using F-code polling memory, do not set the reception mode to manual reception.

Scanning a document into an F-code polling memory box

The procedure for scanning a document into an F-Code polling memory box (page 5-82) is similar to the procedure for scanning a document into the polling memory public box. Instead of touching the [PUBLIC BOX] key in step 5 of “Scanning a document into memory (Public Box) for polling memory” on page 5-38, touch the key of the memory box into which you wish to scan the document. If document data has already been stored in that box, a new document data will be added on to the existing data. If you no longer need the existing data, delete it as explained in “Checking and clearing document data in a memory box” on page 5-54.

When you touch the memory box into which you wish to scan the document, the key is highlighted and selected as the scanning destination.

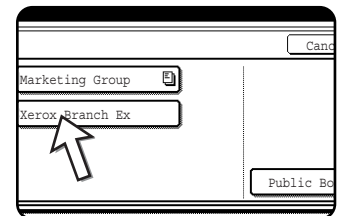

- NOTE:** When creating the memory box, you can select whether to have the scanned document data automatically cleared after polling, or left it in the box to allow repeated polling.

Checking and clearing document data in a memory box

The procedure for checking document data in an F-code polling memory box by printing it and the procedure for clearing data from a box are almost the same as the procedures for printing and clearing document data from the Public Box.

Instead of touching the [PUBLIC BOX] key in step 3 of "Printing document data in the Public Box" on page 5-40 or "Deleting document data from the Public Box" on page 5-41, touch the key of the desired memory box.

If a document icon () appears to the right of a memory box key, document data has been stored in that box and you can print it out.

However, the contents cannot be printed or deleted while the memory box is being used for transmission.

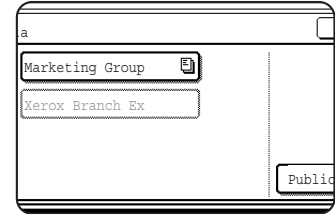

Procedure for F-Code Polling

Make sure that a document has not been loaded in the DADF tray or on the document glass, and then follow the steps below.

- NOTES:**
- You must know the sub-address (SEP) and passcode (PWD) of the other machine's F-code polling memory box.
 - Serial polling (selecting multiple fax machines to be polled using a group key or by touching the [NEXT ADDRESS] key) is not possible with F-code polling.

1. In fax mode, touch the [SPECIAL MODES] key and then the [POLLING] key.

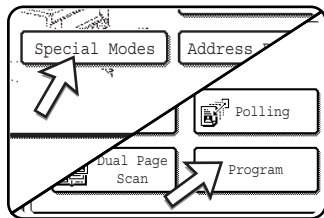

so that it is not highlighted.

If the address directory screen appears, touch the [CONDITION SETTINGS] key to display the condition settings screen.

The [POLLING] key is highlighted and the polling icon appears.

To cancel polling, touch the [POLLING] key once again

2. Touch the [OK] key.

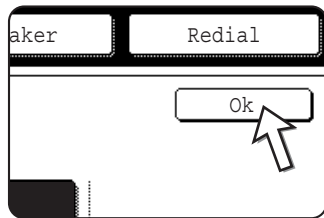

You will return to the initial screen.

3. Enter the fax number, sub-address, and passcode of the other fax machine.

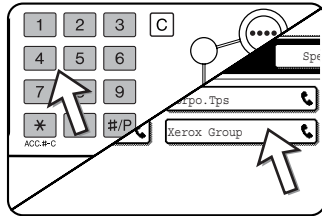

To use a one-touch key, touch the [ADDRESS DIRECTORY] key to display the address directory.

Refer to steps 2 through 5 of "Entering (Dialing) a Fax Number with a Sub-Address and Passcode" on page 5-51 for the procedure for entering sub-addresses and passcodes.

4. Press the [BLACK COPY START] key.

"JOB STORED." appears on the screen.

After communicating with the other machine, your machine prints the received document data.

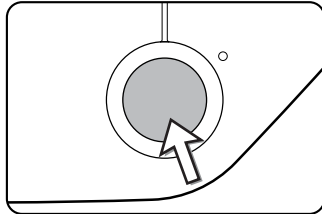

- NOTES:**
- **Cancelling a transmission**
 - Press the [JOB STATUS] and cancel the transmission in the same way as when cancelling a stored transmission. (See "Cancelling a Fax Transmission" on page 5-27.)
 - Only one F-code polling timer operation can be stored (see page 5-33).

F-Code Confidential Transmission

F-Code confidential transmission provides a secure means of faxing confidential documents. The sub-address and passcode programmed in the memory box restrict the recipients of the fax, and once received in the memory box, the fax can only be printed by someone who knows the print passcode (see "Setting for F-Code Confidential Transmission Memory Boxes (Print PIN)" on page 5-85).

This function is convenient when sending important documents that you only want a specific person to see, or when multiple departments share a single fax machine.

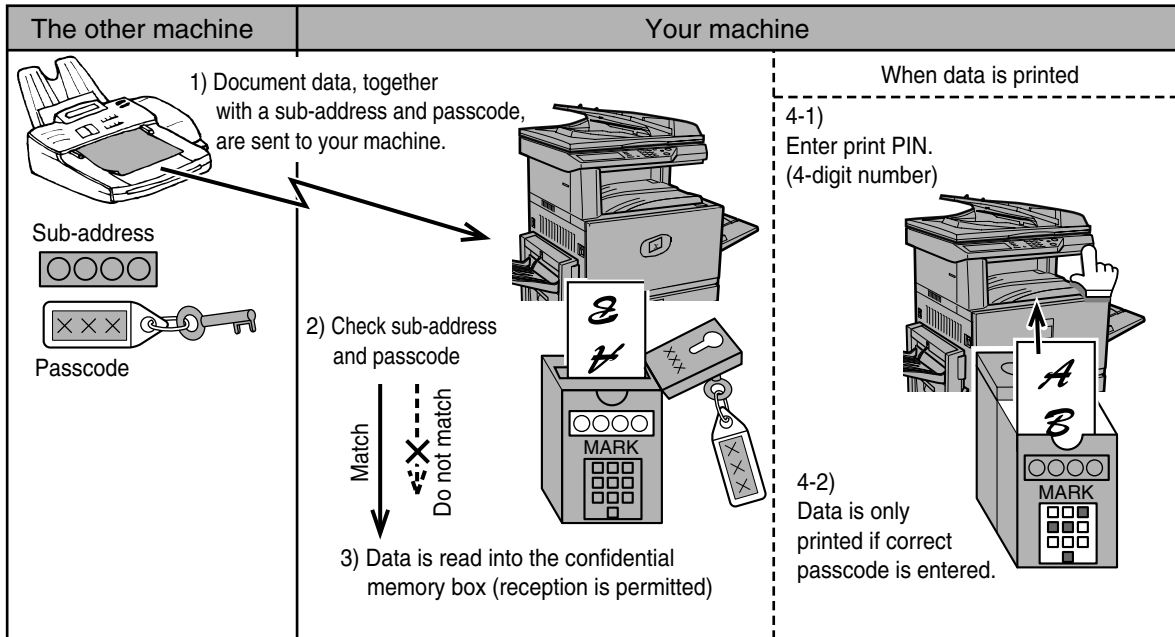

As the above diagram shows, receiving document data to the machine's F-code confidential memory box is called F-code confidential reception, and sending document data to another machine's F-code confidential memory box is called F-code confidential transmission.

- NOTES:**
- Refer to pages 5-81 through 5-88 for the procedures for creating, editing, and deleting F-code confidential memory boxes.
 - Take care not to forget the print PIN. programmed in the F-code confidential memory box. If you forget the passcode, consult your dealer.

F-Code Confidential Transmission

F-code confidential transmission is performed in the same way as a normal transmission; however, you must enter the sub-address (SUB) and passcode (SID) after the fax number of the other machine. (You can omit the passcode if the other machine does not use a passcode.)

For the procedure for entering sub-addresses and passcodes, see “Entering (Dialing) a Fax Number with a Sub-Address and Passcode” on page 5-51.

F-code confidential reception is performed in the same way as normal reception (see “Basic Operations”); however, you must inform the other party of the sub-address (SUB) and passcode (SID) of your confidential memory box. (If a passcode is not programmed in the confidential memory box, only inform the other party of the sub-address (SUB).)

NOTE: *An F-code confidential transmission can be used in combination with the broadcast transmission function (page 5-30) or timer transmission function (page 5-33), and can be stored in a program (page 5-85).*

Printing a Document Received to an F-Code Confidential Memory Box

Faxes received in an F-Code confidential memory box are printed out by entering the PRINT PIN 4-digit passcode (0000 to 9999) that was programmed when the box was created.

- NOTES:**
- *You can have a transaction report printed each time a fax is received in an F-Code confidential box to inform you of the reception. This setting is enabled in the key operator programs (see the “Fax Unit” section of the WorkCentre C226 System Administration Guide).*
 - *Document data received to an F-code confidential memory box is automatically cleared after printing.*
 - *When a new fax is received to an F-code confidential box while a previously received fax is still stored in the box, the new fax is added on after the previous fax.*
1. In fax mode, touch the [SPECIAL MODES] key and then touch the [MEMORY BOX] key.

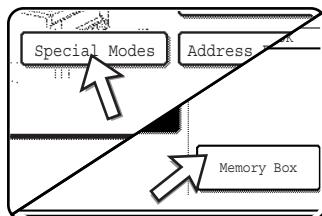

If the address directory screen appears, touch the [CONDITION SETTINGS] key to display the condition settings screen.

The memory box menu screen appears.

To cancel the operation, touch the [CANCEL] key.

2. Touch the [PRINT DATA] key.

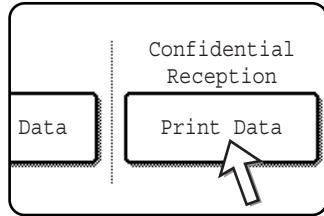

3. Touch the memory box key that has the document data you wish to print.

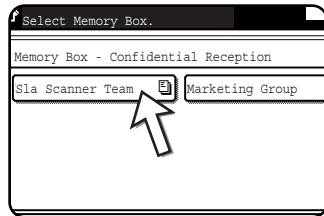

A  mark appears to the right of memory boxes that have received document data.

A memory box cannot be selected while it is being used for transmission.

4. Press the numeric keys to enter the 4-digit print PIN.

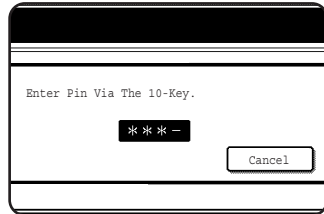

As each digit is entered, "-" changes to " * ".

If the print PIN you entered is correct, the message "PRESS [START] TO PRINT DATA." appears.

If the print PIN is not correct, the message "PIN IS NOT VERIFIED." appears and you return to the entry screen.

To return to the screen of step 3, touch the [CANCEL]

key.

5. Press the [BLACK COPY START] key.

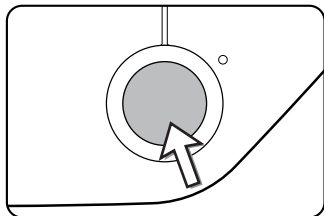

Printing begins.

NOTE: *If received data remains in an F-code confidential memory box, the memory box cannot be deleted.*

F-Code Relay Broadcast Transmission

The F-Code relay broadcast function allows the machine to act as a relay machine for a broadcast transmission. The end receiving machines are stored in the machine's F-Code relay memory box, and when the machine receives a relay request from another F-Code machine, it will relay the fax to all of the stored end receiving machines.

The relay machine and the originating machine that requests the relay transmission must both support F-codes; however, the end receiving machines programmed in the F-code relay broadcast memory box do not need to support F-codes.

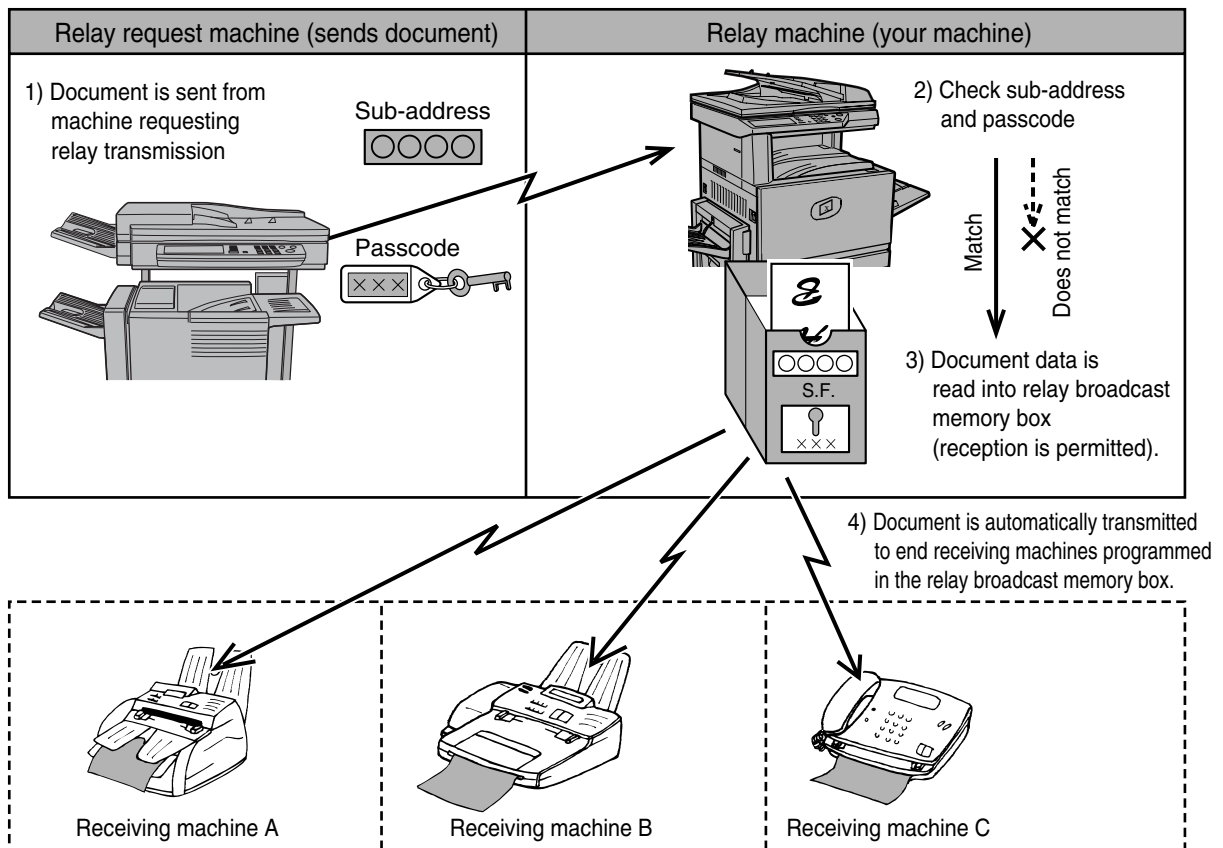

The machine that originally sends the document is called the relay request machine, and the machine that has a memory box containing the end receiving machines and which relays the received document to those machines is called the relay machine.

The relay machine also prints the document sent by the relay request machine.

For example, corporate headquarters in Seattle wants to send the same document to branch offices in San Francisco, Oakland, Berkeley, and San Jose. If the San Francisco office creates a relay broadcast memory box and programs the Oakland, Berkeley, and San Jose offices as end receiving destinations, the overall phone charges will be lower than if the Seattle office uses the normal broadcast transmission function (page 5-30). This function can also be combined with a timer setting (page 5-33) to take advantage of off-peak rates, allowing a further reduction in phone charges.

Transmission by the relay machine is called "F-code relay broadcast transmission", and transmission from the relay request machine to the relay machine is called "relay request transmission".

- NOTES:**
- *To create an F-code relay broadcast memory box and program, edit, and delete end receiving machines, refer to pages 5-81 to 5-88. When creating a box, a passcode (SID) can be omitted.*
 - *The relay request machine only bears the expense of sending the document to the relay machine. The relay machine bears the expense of sending the document to each of the end receiving machines.*

Using the F-Code Relay Broadcast Function

(your machine is the relay machine)

When a document is received from a relay request machine, the F-code relay broadcast function transmits the document to the end receiving machines using a memory box only if the sub-address and passcode sent by the relay request machine are correct.

Refer to pages 5-81 through 5-88 for the procedures for creating, editing, and deleting memory boxes.

Up to 30 end receiving machines (30 one-touch keys or group keys) can be programmed in the F-code relay broadcast memory box.

A document received from a relay request machine is initially stored in the memory box of your machine. Your machine (the relay machine) also prints the document, thus the document is first stored as a print job and then as transmission jobs to each of the programmed end receiving machines. The document data is automatically cleared after transmission to all end receiving machines is completed.

- NOTE:** *End receiving machines are programmed using auto-dial keys (one-touch keys or group keys). If you need to program an end receiving machine that has not been programmed in a one-touch key, program the number in a one-touch key first and then create the memory box.*

Using the F-Code Relay Request Function

(your machine requests a relay broadcast)

Ask the operator of the other F-Code machine (the relay machine) to create an F-Code relay broadcast memory box that contains the end receiving machines to which you wish to send a fax, and ask for the sub-address (SUB) and passcode (SID) of that box.

When you dial the relay machine to send the fax, enter the sub-address and passcode after the fax number. The fax will be stored in the relay machine's memory box, and the relay machine will call each of the programmed end receiving machines and relay the fax to those machines. (If a passcode (SID) is not programmed in the memory box, enter only the sub-address when dialing.)

Aside from the method of dialing the relay machine, the transmission procedure is the same as for a normal transmission.

Refer to “Entering (Dialing) a Fax Number with a Sub-Address and Passcode” on page 5-51 for the procedure for entering a sub-address and passcode after the fax number of the other machine.

Convenient Methods of Use

This section explains functions that widen the scope of use of the fax machine. Please read those sections that are of interest to you.

Using an Extension Phone

You can connect a telephone to the machine and use it as an extension phone to place and receive calls like any normal phone. You can also activate fax reception from the phone (remote operation).

NOTE: *If you connect a combination telephone/answering machine to the machine, you will not be able to use the answering machine function.*

Sending a Fax after Talking (Manual Transmission)

If the other fax machine is set to manual reception, you can talk to the other party and then send a fax without breaking the connection. This procedure is called manual transmission.

NOTE: Automatic redialing (see “If the receiving party is busy” on page 5-25) will not take place if the line is busy.

1. Make sure the machine is in fax mode.

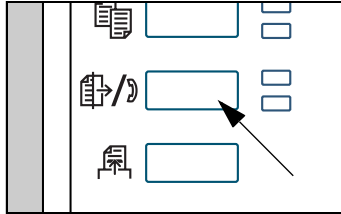

When the [IMAGE SEND] key light is on, the machine is in fax mode. If the light is not on, press the [IMAGE SEND] key.

When the network scanner option is installed, touch this key to return to the initial screen of fax mode or scanner mode, whichever mode was selected last. To switch to fax mode from scanner mode, touch the [SCANNER/

FAX] key.

2. Load the original.

NOTE: If you have loaded the original on the document glass, you can only send one page by manual transmission.

3. Set the original size, resolution, exposure and other scanning conditions as needed.

- Manually Setting the Scanning Size (see page 5-13)
- Selecting the Resolution (see page 5-14)
- Selecting the Exposure (see page 5-16)

4. Lift the extension phone.

The [SPEAKER] key can also be used. (See “One-touch dialing” on page 5-17.)

5. Dial the number of the other party or touch a one-touch key.

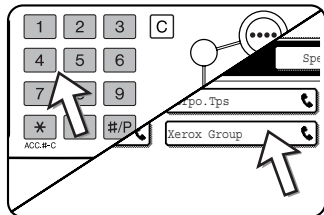

If the condition settings screen appears, touch the [ADDRESS DIRECTORY] key to display the address directory screen.

You cannot use a group key or a one-touch key that includes a sub-address and passcode.

6. Speak to the other party when they answer.

If you used the [SPEAKER] key to dial, lift the extension phone to talk.

- After the other party switches to fax reception, press your [BLACK COPY START] key.

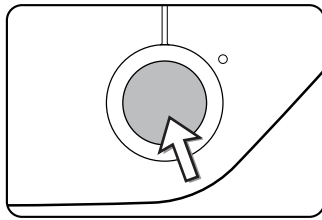

Transmission begins.

- Replace the extension phone.

Using an Extension Phone to Receive a Fax

The machine normally receives faxes automatically after ringing (page 5-28); however, when an extension phone is connected, you can set the reception mode to "MANUAL RECEPTION". This will allow you to talk to the other party first and then receive a fax.

This is convenient when you only have one telephone line and receive more voice calls than faxes. You must answer all calls on the extension phone, and activate fax reception after you verify that a call is a fax transmission.

NOTE: *The reception mode is initially set to "AUTO RECEPTION". If you have not connected an extension phone, keep the reception mode set to "AUTO RECEPTION".*

Changing the reception mode to "MANUAL RECEPTION"

- Press the [CUSTOM SETTINGS] key.

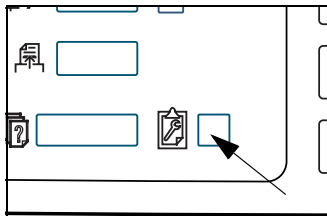

- Touch the [RECEIVE MODE] key.

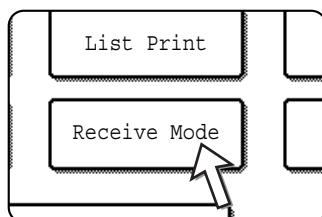

3. Touch the [MANUAL RECEPTION] key.

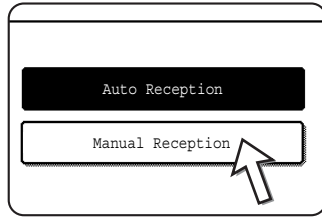

The [MANUAL RECEPTION] key is highlighted.

4. Touch the [OK] key.

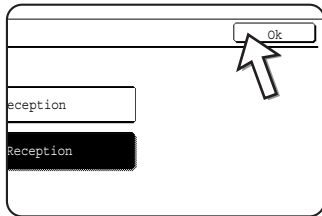

The reception mode is set to "MANUAL RECEPTION".

NOTE: To return the reception mode to AUTO RECEPTION, touch the [AUTO RECEPTION] key in step 3 above.

Receiving a Fax After Talking (Manual Reception)

When an extension phone is connected to the machine and you have set the reception mode to "MANUAL RECEPTION" (page 5-63), you can talk to a person sending a fax manually and then begin fax reception without breaking the connection.

When the extension phone is in Fax mode

A fax can be received manually even when transmission is in progress.

1. When the extension phone rings, lift the extension phone and speak.

If you hear a fax tone through the extension phone, do not speak and proceed to the next step.

2. With the extension phone still lifted, touch the [FAX RECEIVE] key.

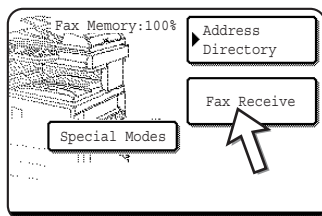

Reception begins when the other party begins transmission.

3. Replace the extension phone.

A beep sounds when reception ends. The received fax is printed.

- NOTES:**
- *If there are stored print jobs, the fax is printed after the stored print jobs.*
 - *You can also talk on the extension phone and manually receive a fax while the machine is printing.*

If the extension phone rings during printing, lift the extension phone and speak. To receive a fax, press the [IMAGE SEND] key with the extension phone still lifted. When you hear a fax tone through the extension phone, touch the [FAX RECEIVE] key.

Activating fax reception from an extension phone (remote reception)

After speaking on the extension phone, you can activate fax reception from the extension phone. This is called "remote reception". After speaking, or when you hear a fax tone through the extension phone, perform the following procedure with the extension phone still lifted. ("Remote reception" is only possible when the call is made by the other party.)

- NOTE:** *The following procedure is not possible if you are on a pulse dial line and your extension phone cannot produce tone signals. To find out whether your extension phone can produce tone signals, refer to the manual for your extension phone.*

1. If you are on a pulse dial line, set your phone to issue tone signals.
Refer to your phone's manual to set the phone to issue tone signals.
If your phone is already set to issue tone signals, proceed to the next step.
2. Press the **5** key on the extension phone's keypad, and then press the ***** key twice.
Fax reception is activated.
3. Replace the extension phone.

- NOTE:** *The one-digit number that is used to activate fax reception from an extension phone (initially set to "5") is called the "remote reception number". You can change this number to any number from 0 to 9 with the key operator program. (See the "Fax Unit" section of the WorkCentre C226 System Administration Guide.)*

Programming

This section explains the procedures for programming and the information programmed in auto dial keys (one-touch and group keys), programs, user indexes, and memory boxes.

Auto dial keys (one-touch keys and group keys), user indexes, and memory boxes are stored, edited and deleted at the operation panel of the machine. This section explains the procedures for storing, editing, and deleting using the operation panel.

Storing, Editing, and Deleting Auto Dial Keys and Programs

This section explains the procedures for storing, editing, and deleting auto-dial keys (one-touch keys and group keys) and programs, which simplify the transmission procedure. (The procedure for using one-touch keys and group keys is explained in "Transmission by Auto-Dialing (One-Touch Dialing and Group Dialing)" on page 5-22 and the procedure for using programs is explained in "Using a Program" on page 5-45.)

A combined total of 500 one-touch keys and group keys can be stored, and eight programs can be stored. If you attempt to store more than this, a warning message will appear. In this case, delete any auto-dial keys or programs that are no longer needed (one-touch keys: page 5-72; group keys: page 5-76; programs: page 5-80), and then store the new auto-dial key or program.

NOTE: To cancel a storing, editing, or deleting operation, press the [CLEAR ALL] key. You will return to the initial screen.

To store, edit, or delete an auto-dial key (one-touch key or group key) or program, first follow steps 1 through 4 below. In the screen of step 4, touch the appropriate key for storing, editing, or deleting.

1. Press the [CUSTOM SETTINGS] key.

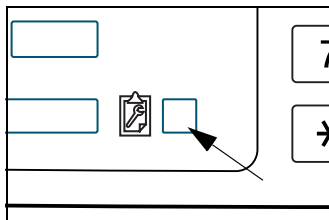

- Touch the [ADDRESS CONTROL] key.

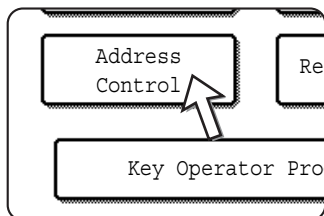

- Touch the [DIRECT ADDRESS / PROGRAM] key.

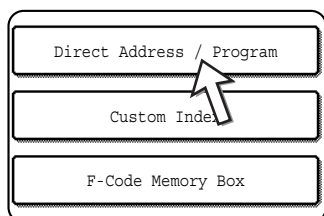

The direct address / program menu appears.

- Touch the desired key and perform the programming operation.

Refer to the pages indicated below for the operation you wish to perform.

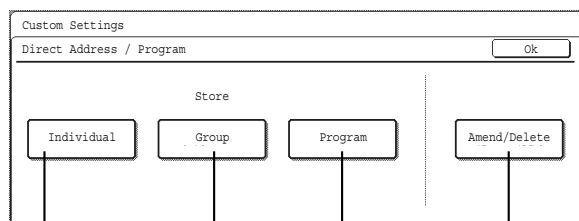

[INDIVIDUAL] key
Store a one-touch
key (page 5-68)

[PROGRAM] key
Store a program
(page 5-78)

[GROUP] key
Store a group key
(page 5-74)

[AMEND/DELETE] key

- One-touch key (page 5-72)
- Group key (page 5-76)
- Program (page 5-80)

NOTE: One-touch keys are used to select destinations for group dialing and programs. If no one-touch keys have been stored, the [GROUP] key and [PROGRAM] key will be greyed out and it will not be possible to store a group or a program.

Storing One-Touch Keys

Follow the steps below to store a one-touch key after you have completed steps 1 through 4 beginning on page 5-66.

1. Touch the [NAME] key.

The "No." that automatically appears is the lowest number from 001 to 500 that has not yet been programmed. When [NAME] is touched, the letter-entry screen appears. Enter up to 36 characters for the name.

Refer to page 5-90 for the procedure for entering letters.

2. Touch the [INITIAL] key.

3. Touch a letter key.

The first letter (initial) of the name entered in step 1 is initially selected and is highlighted. If you wish to change the letter, touch a different letter key.

NOTE: The initial you enter here determines the position of the one-touch key in the ABC index. For information on the ABC index, refer to ⑤ Index keys on page 5-9.

4. Touch the [OK] key.

5. Touch the [INDEX] key.

No. 001

Name Xerox Corporation

Index _____ Fax No. _____

Key Name _____

6. Touch an index key.

Direct Address / Individual

No. 001

Index _____

Select The Custom Index Where You Register This Address.

User 1 User 2 User 3 User 4 User 5 User 6

Do You Register This Address At The [Frequent Use], Too?

Yes No

- Select one of the upper row of keys ([USER 1] through [USER 6]) to determine the location of the one-touch key when the GROUP index is displayed instead of the ABC index (refer to page 5-9).
- The lower keys are for selecting whether to include the one-touch key in the [FREQUENT USE] index.
- If you touch the wrong key, simply touch the correct key.

7. Touch the [OK] key.

8. Touch the [FAX No.] key.

Corporation

Fax No. _____

Mode _____

The fax number entry screen appears.

9. Use the numeric keys to enter the fax number.

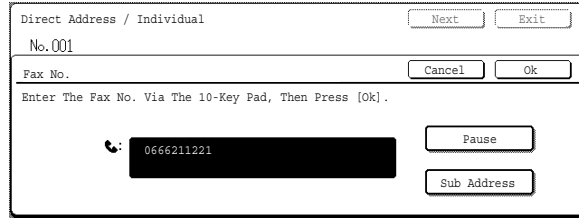

To insert a pause between digits of the number, touch the [PAUSE] key. The pause appears as a hyphen "-". Refer to "Pause time setting" in the "Fax Unit" section of the WorkCentre C226 System Administration Guide to set the duration of the pause.

If you make a mistake, press the [C] key to clear one digit at a time, and then enter the correct digit(s).

If you are not going to enter a sub-address and passcode after the fax number, proceed to step 12.

- NOTES:**
- For information on sub-addresses and passcodes, see "Transmission Between Machines Supporting F-codes" on page 5-49.
 - A maximum of 64 digits can be entered, including the fax number, sub-address, passcode, any pauses (hyphens), and slashes "/" (to separate the sub-address and passcode).

10. If you need to enter a sub-address, touch the [SUB ADDRESS] key and then enter the sub-address with the numeric keys.

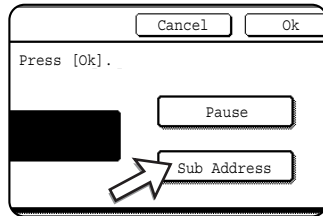

When you touch the [SUB ADDRESS] key, a slash is entered after the fax number. Continue by entering the sub-address (max. 20 digits).

If you do not wish to enter a passcode, proceed to step 12.

11. If you wish to enter a passcode, touch the [SUB ADDRESS] key once again and enter the passcode with the numeric keys.

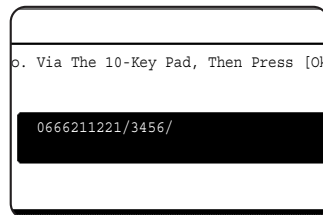

When you touch the [SUB ADDRESS] key, a slash is entered after the sub-address. Continue by entering the passcode (max. 20 digits).

12. Touch the [OK] key.

You will return to the one-touch key programming screen. "REGISTRATION IS COMPLETED" will appear highlighted to the right of "No."

NOTE: The "FAX No." line only shows 32 digits, regardless of how many digits actually programmed.

13. Check the key name.

The characters appearing next to the [KEY NAME] key will be displayed in the key. Only the first 18 characters of the name entered in step 1 will be displayed. If you need to change the name that will be displayed in the key, touch the [KEY NAME] key.

If you do not wish to change the name, this step is not necessary.

Refer to page 5-90 for the procedure for entering characters.

14. Check the transmission settings.

The initial transmission settings are "TRANSMISSION SPEED: 33.6 kbps" and "INTERNATIONAL CORRESPONDENCE MODE: NONE". To change either of the settings, touch the [MODE] key.

If you do not wish to change the settings, this step is not necessary.

After touching the [MODE] key, you can change either of the two settings. When finished, touch the [OK] key.

Transmission speed

Speed selections are 33.6 kbps, 14.4 kbps, 9.6 kbps, and 4.8 kbps. The higher the number, the faster the transmission speed.

NOTE: Set the transmission speed only when you know what speed is most suitable, such as when you are sending a fax to a foreign country and telephone line conditions are bad. If you do not know the line condition, do not change this setting.

International correspondence mode

Selections are NONE, MODE 1, MODE 2, and MODE 3.

- NOTES:**
- When sending a fax to a foreign country, telephone line conditions can sometimes distort the fax or interrupt the transmission. Selecting the right international correspondence mode can help alleviate these problems.
 - If errors frequently occur when sending a fax to a foreign country, try each of modes 1 to 3 and select the mode that enables the best transmission.

15. When you have finished programming the one-touch key, touch the [EXIT] key. If you wish to program another one-touch key, touch the [NEXT] key.

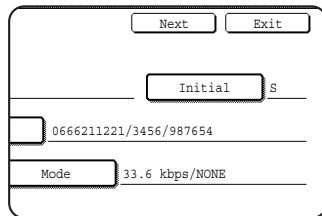

Touching the [EXIT] key returns you to the screen of step 2 on page 5-67.

Touching the [NEXT] key returns you to the screen of step 1 on page 5-68.

Editing and Deleting One-Touch Keys

If you wish to delete a one-touch key or change the fax number, name, or other information programmed in a one-touch key, follow steps 1 through 3 beginning on page 5-67 and then perform the following procedure.

1. Touch the [AMEND/DELETE] key.

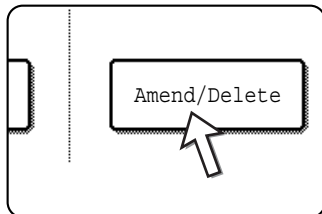

2. Touch the one-touch key that you wish to edit or delete.

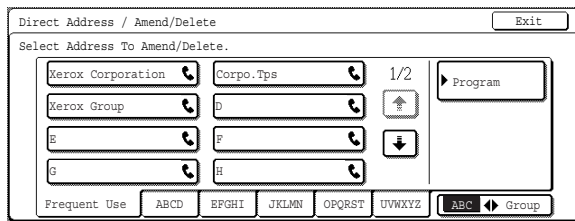

- To edit a one-touch key, follow steps 3 and 4.
- To delete a one-touch key, follow steps 5 and 6.
- When you have finished editing or deleting, touch the [EXIT] key.

3. Touch the key corresponding to the information you wish to change (change the information in the same way as you stored the information on page 5-68).

4. Make sure that your changes are correct, and then touch the [EXIT] key.

You will return to the screen of step 2.

If you wish to change another one-touch key, repeat steps 2 through 4.

5. Touch the [DELETE] key.

6. Touch the [YES] key.

You will return to the screen of step 2.

If you wish to delete another one-touch key, repeat steps 2, 5, and 6.

If you cannot edit or delete a one-touch key

If you attempt to edit or delete a one-touch key in the following situations, a warning message will appear and editing/deletion will not be possible.

- The one-touch key you wish to edit or delete is currently being used for transmission or is used in a currently stored transmission job (including a timer transmission). (See “Cancelling a Fax Transmission” on page 5-27.)

- The one-touch key is included in a group key. (See “Editing and Deleting Group Keys” on page 5-76.)
- The one-touch key is included in a group of end receiving machines for an F-code relay broadcast operation. (See “Editing and Deleting a Memory Box” on page 5-88.)
- The one-touch key is included in a program. (See “Editing and Deleting Programs” on page 5-80.)
- If the key is being used for a transmission currently in progress or a stored transmission, cancel the transmission or wait until it is completed and then change or delete the key. If the key is included in a group, delete the key from the group and then change or delete it.

Storing a Group Key

Up to 100 destinations can be stored in a group key.

To program a group key, follow steps 1 through 3 beginning on page 5-66, touch the [GROUP] key in step 4, and then follow these steps.

NOTE: Only one-touch key destinations can be stored in a group key. If you wish to store a destination that is not programmed in a one-touch key, first program the destination in a one-touch key and then store it in the group key.

1. Follow the same steps 1 through 7 of “Storing One-Touch Keys” (page 5-68) to enter a [GROUP NAME], [INITIAL], and [INDEX].

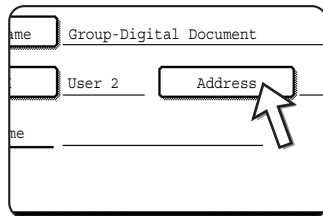

* In step 1 on page 5-68, touch the [GROUP NAME] key instead of the [NAME] key.

2. Touch the [ADDRESS] key.



The screenshot shows a menu titled "Group-Digital Document". The menu has several rows, each with a small square icon on the left and text on the right. The first row has the text "Group-Digital Document". The second row has the text "User 2" and "Address". The "Address" text is enclosed in a rectangular box, and a white arrow points to the bottom-right corner of this box. Below the "Address" row, there are two more rows, each with a small square icon on the left and a blank line on the right.

3. Touch one-touch keys of the destinations that you wish to store in the group.

Touch index keys and the   keys as needed.

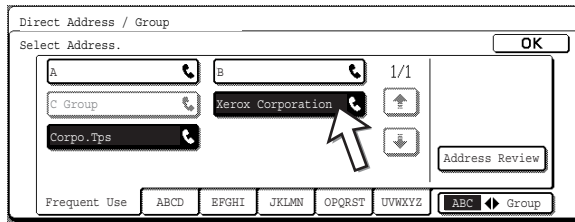

- One-touch keys that have been touched are highlighted.
- If you touch the wrong key, simply touch it again to cancel the highlighting and remove the destination from the group.

NOTE: *Keys that are greyed out are group keys. Group keys cannot be selected.*

- To check the destinations that you have stored in the group, touch the [ADDRESS REVIEW] key.

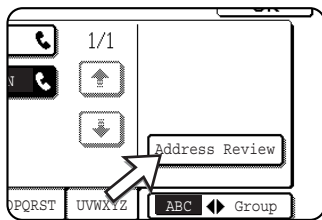

A list of the destinations appears.

To delete a destination, touch the key of the destination and then touch the [YES] key in the message that appears.

4. Touch the [OK] key in the screen of step 3.

You will return to the screen of step 2. The number of selected destinations will appear next to the [ADDRESS] key.

5. Check the name of the key (refer to step 13 on page 5-71).

The characters appearing next to the [KEY NAME] key will be displayed in the group key. To change these characters, touch the [KEY NAME] key. This step is not necessary if you do not wish to change the characters.

The procedure for entering characters is explained on page 5-90.

6. Touch the [EXIT] key when you have finished programming the group key.

If you wish to program another group key, touch the [NEXT] key.

When you touch the [EXIT] key, you will return to the screen of step 4 on page 5-67.

To store another group, touch the [NEXT] key.

Editing and Deleting Group Keys

If you need to delete a group key or change its name or a one of its stored destinations in a group key, first follow steps 1 through 3 beginning on page 5-66, and then perform the following procedure.

1. Touch the [AMEND/DELETE] key.

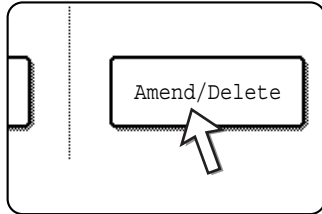

2. Touch the group key that you wish to edit or delete.

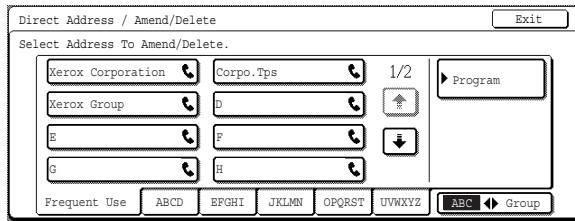

- To edit a group key, follow steps 3 and 4.
 - To delete a group key, follow steps 5 and 6.
 - When you have finished editing or deleting, touch the [EXIT] key.
3. Touch the key of the item you wish to change (to edit the item, follow the same steps as for one-touch keys on page 5-72).

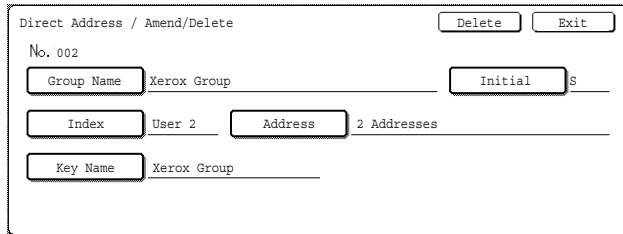

- To edit the destinations stored in the group key, touch the [ADDRESS] key. The following screen appears.

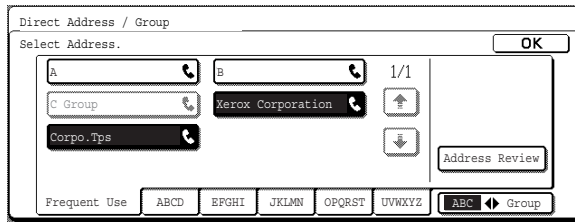

- The one-touch keys stored in the group are highlighted. To add another one-touch key to the group, touch the key to highlight it.
 - To delete a one-touch key from the group, touch the key so that it is no longer highlighted.
 - To show a list of the destinations stored in the group key, touch the [ADDRESS REVIEW] key.
4. When you have finished editing the group key, touch the [EXIT] key in the screen of step 3.

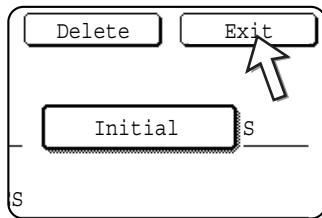

If you wish to edit another group key, repeat steps 2 through 4.

Deleting a group key

5. Touch the [DELETE] key.

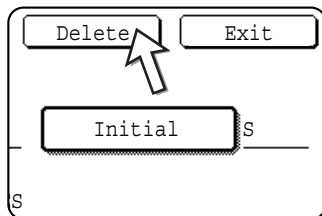

6. Touch the [YES] key.

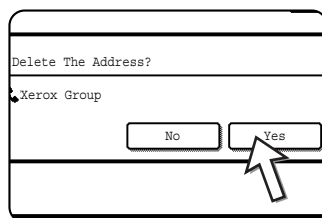

If you wish to delete another group key, repeat steps 2, 5, and 6.

NOTE: *If you cannot edit or delete a group key*

If you attempt to edit or delete a group key in the following situations, a warning message will appear and editing/deletion will not be possible.

If the group is being used for a transmission currently in progress or a stored transmission, cancel the transmission or wait until it is completed and then change or delete the group. If the group is included in a group of end receiving machines for the F-code relay broadcast function or a program, delete the group from the end receiving machines or the program and then change or delete it.

- *The one-touch key you wish to change or delete is currently being used for transmission or is used in a currently stored transmission job (including a timer transmission). (See "Cancelling a Fax Transmission" on page 5-27.)*
- *The group key is included in the end receiving machines for an F-code relay broadcast operation. (See "Editing and Deleting a Memory Box" on page 5-88.)*
- *The group key is included in a program. (See "Editing and Deleting Programs" on page 5-80.)*

Storing a Program

You can store a destination fax number, polling, dual page scan, and resolution and exposure settings in a program. This enables you to call up the program and perform the transmission by means of a simplified operation. (See "Using a Program" on page 5-45.)

To store a program, follow steps 1 through 3 beginning on page 5-66, touch the [PROGRAM] key in step 4, and then follow these steps.

NOTE: *A timer setting (page 5-33) cannot be included in a program.*

When storing a program for an F-Code operation, one touch keys for destinations must include sub-addresses.

1. Touch the [PROGRAM NAME] key.

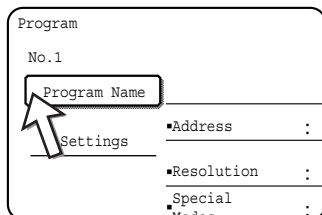

The "No." that automatically appears is the lowest number from 1 to 8 that has not yet been programmed. When the [PROGRAM NAME] key is touched, the letter-entry screen appears. Enter up to 18 characters for the name.

Refer to page 5-90 for the procedure for entering letters.

2. Touch the [SETTINGS] key.

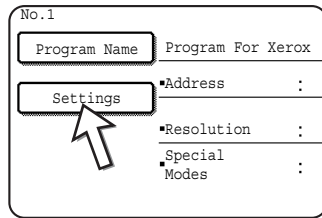

3. Touch the keys as appropriate to store the frequently used settings.

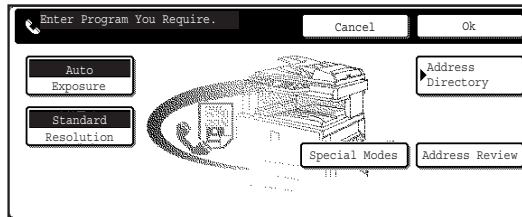

For the detailed procedures for each of the settings, refer to the explanations of those features on the following pages.

- [RESOLUTION](page 5-14)
- [EXPOSURE](page 5-16)
- [ADDRESS DIRECTORY] (page 5-30)
- [SPECIAL MODES]
- POLLING (page 5-36)
- DUAL PAGE SCAN (page 5-44)

NOTE: Up to 100 destinations can be stored in a program. However, you cannot directly enter fax numbers with the numeric keys. A destination must be programmed in an auto dial key (one-touch key or group key) before it can be stored in a program.

4. Touch the [OK] key.

Your settings are displayed. Make sure they are correct.

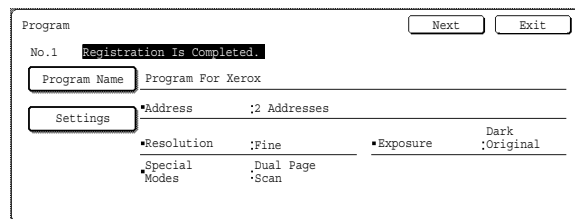

5. When you are finished, touch the [EXIT] key.

If you wish to store another program, touch the [NEXT] key.

Touching the [EXIT] key returns you to the screen of step 4 on page 5-67.

Touching the [NEXT] key returns you to the screen of step 1.

Editing and Deleting Programs

To edit or delete a previously stored program, follow steps 1 to 3 beginning on page 5-66, touch the [AMEND/DELETE] key in the screen of step 4, and then follow these steps.

1. Touch the [PROGRAM] key.

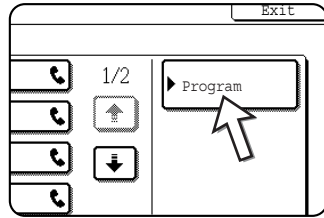

2. Touch the program you wish to edit or delete.

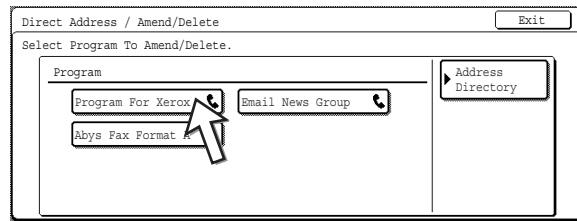

- When you touch the program name, the edit/delete screen for the selected program appears.
 - Touching the [ADDRESS DIRECTORY] key returns you to the screen of step 1.
3. To edit the program, follow the same procedure as for storing the program. To delete the program, touch the [DELETE] key and then touch the [YES] key in the confirmation screen that appears.

Storing a Group Index

Auto dial keys (one-touch keys and group keys) are normally stored in the ABC index. To make auto dial keys more convenient to use, you can store a group of auto dial keys in a group index and assign a name to that index. When you switch to the group indexes, [USER 1], [USER 2], [USER 3], [USER 4], [USER 5], and [USER 6] appear. You can assign any name up to 6 characters long to each of the USER indexes.

The procedure for storing auto dial numbers in a group index is explained in step 6 on page 5-69, and the procedure for switching between the ABC index and the group indexes is explained on page 5-9.

1. Press the [CUSTOM SETTINGS] key, and then touch the [ADDRESS CONTROL] key (refer to steps 1 and 2 on page 5-67).
2. Touch the [CUSTOM INDEX] key.

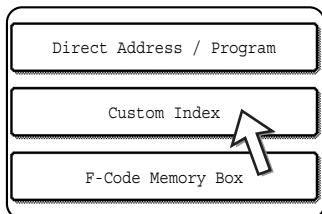

3. Touch an index key ([USER 1] to [USER 6]).
You can enter a name for the selected index.

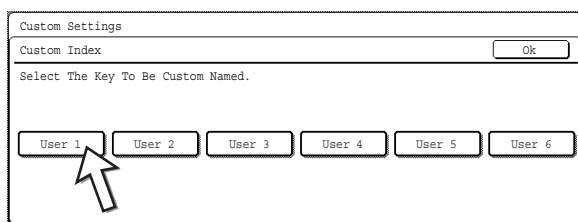

When touched, the letter entry screen appears.

4. Enter a maximum of 6 characters for the index name.

Use the  key to clear the displayed name and then enter the desired name. Refer to page 5-90 for the procedure for entering letters.

When finished, touch the [OK] key. The new name appears in the screen of step 3.

5. If you wish to program another index name, repeat steps 3 and 4.

When finished, touch the [OK] key.

To change a user index name, re-enter the name as explained in steps 3 and 4.

Programming, Editing, and Deleting F-Code Memory Boxes

The procedure for programming a memory box for F-code transmission is explained here. There are three types of F-code memory boxes: F-code polling memory (page 5-52), F-code confidential transmission (page 5-56), and F-code relay broadcast (page 5-59). Memory boxes are programmed, edited, and deleted as follows.

Programming an F-Code Memory Box

A box name, sub-address/passcode, and function must be programmed in a memory box.

- NOTES:**
- When programming a new memory box, a sub-address that is being used for another box cannot be used. The passcode, however, can be the same as a passcode used in another box.
 - A passcode can be omitted.
 - Up to 50 F-code memory boxes can be programmed. If 50 F-code memory boxes have already been programmed, a warning message will appear and you will not be able to program a new box. First delete an unused F-code memory box (page 5-88) and then program the new box.
1. Press the [CUSTOM SETTINGS] key and then touch the [ADDRESS CONTROL] key (refer to steps 1 and 2 on page 5-67).
 2. Touch the [F-CODE MEMORY BOX] key.

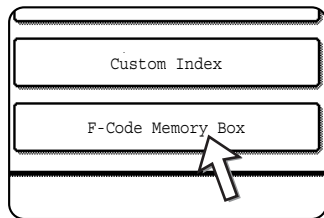

3. Touch one of the memory box keys ([POLLING MEMORY], [CONFIDENTIAL], or [RELAY BROADCAST]) on the store (upper) line.

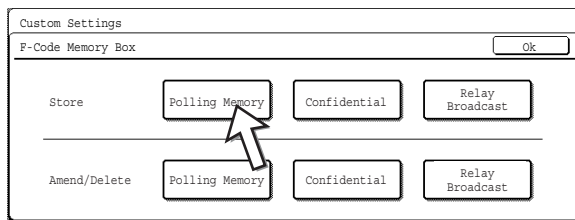

([POLLING MEMORY] is touched in the example here.)

The F-code memory box programming screen appears.

4. Touch the [BOX NAME] key.

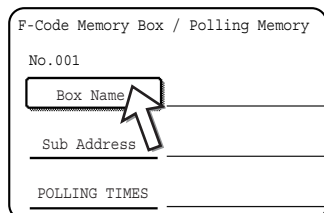

The "No." that automatically appears is the lowest number from 001 to 050 that has not yet been programmed. When the [BOX NAME] key is touched, the letter-entry screen appears. Enter up to 18 characters for the name.

Refer to page 5-90 for the procedure for entering letters.

5. Touch the [SUB ADDRESS] key.

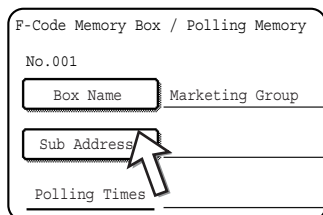

The sub-address/passcode entry screen appears.

6. Use the numeric keys (0 through 9) to enter a sub-address (max. 20 digits).

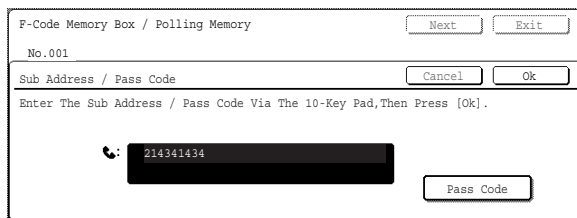

- The characters " * " and "#" cannot be used in a sub-address.
- If you enter an incorrect digit, press the [C] key and re-enter the correct digit.
- If you do not wish to enter a passcode, proceed to step 9.

7. To set a passcode, touch the [PASS CODE] key.

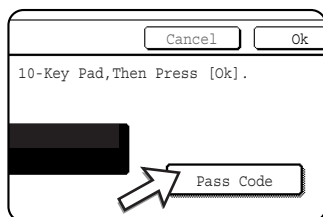

A slash (/) appears after the sub-address.

If you enter an incorrect digit, press the [C] key and re-enter the correct digit.

8. Use the numeric keys to enter a passcode (max. 20 digits).

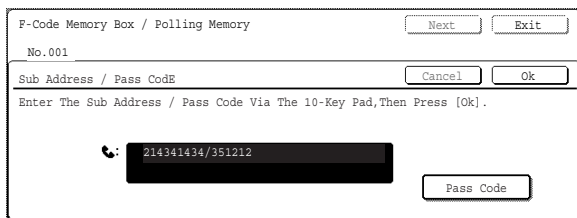

- In addition to numbers, the characters " * " and "#" can be used in a pass-code.
- If you make a mistake, press the [C] key to clear the mistake and re-enter the correct digits.

9. Touch the [OK] key.

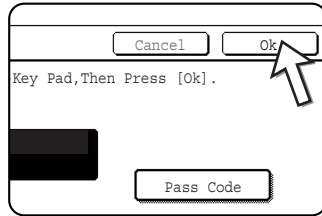

You will return to the memory box programming screen. The entered sub-address and passcode are displayed. "REGISTRATION IS COMPLETED." appears to the right of the box number. (Only for F-Code polling memory.)

Continue programming the settings that are particular to each type of memory box. Go to the appropriate page below:

- F-code polling memory (Polling times: page 5-84)
- F-code confidential transmission (Print PIN: page 5-85)
- F-code relay broadcast transmission (Recipient: page 5-86)

Setting for F-Code Polling Memory Boxes (Polling Times)

You can select whether to have document data that was scanned into an F-code polling memory box automatically cleared after one transmission, or to leave the document data in the box and allow an unlimited number of transmissions when polled. (The initial setting is "ONCE". Change the setting as needed.)

1. Touch the [POLLING MEMORY] key in step 3 of "Programming an F-Code Memory Box" on page 5-82 and store a box name, sub-address, and passcode.
2. Touch the [POLLING TIMES] key.

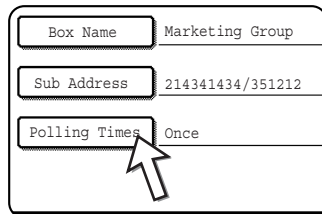

3. Touch the key for the desired polling times.

If you do not wish to erase the document after polling takes place, touch the [UNLIMITED] key so that it is highlighted.

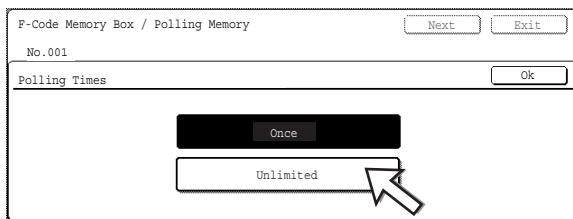

4. Touch the [OK] key.

You will return to the screen of step 2 and the selected polling times will appear.

5. To exit, touch the [EXIT] key.

To program another memory box, touch the [NEXT] key.

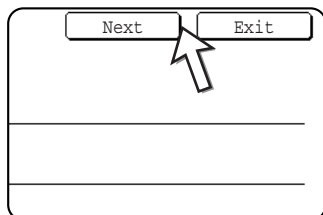

Touching the [EXIT] key returns you to the screen of step 3 on page 5-82.

Touching the [NEXT] key returns you to the screen for programming a new memory box (the screen of step 4 on page 5-82).

Setting for F-Code Confidential Transmission Memory Boxes (Print PIN)

Program the print PIN (Personal Identification Number) that is used to print a document that has been received to an F-code confidential memory box. For information on using a print PIN, refer to "Printing a Document Received to an F-Code Confidential Memory Box" on page 5-57.

- NOTES:**
- Program a 4-digit number for the print PIN. The characters "" and "#" cannot be used.
 - The print PIN can not be omitted.
 - Take care not to forget the print PIN that you have programmed. If you forget the passcode, consult your dealer.
1. Touch the [CONFIDENTIAL] key in step 3 of "Programming an F-Code Memory Box" on page 5-82 and store a box name, sub-address, and passcode.
 2. Touch the [PRINT PIN] key.

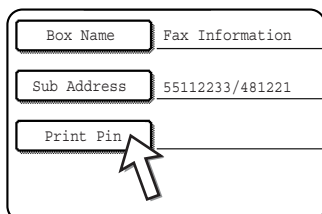

3. Use the numeric keys to enter a 4-digit number.

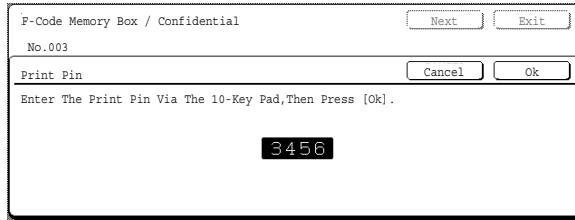

- If you make a mistake, press the [C] key. All digits will be cleared, so you will need to re-enter the number from the first digit.
 - To cancel entry of the print PIN, touch the [CANCEL] key. You will return to the screen of step 2 without programming a print PIN.
4. Touch the [OK] key.

You will return to screen of step 2 and the entered print PIN will appear.

5. To exit, touch the [EXIT] key.

To program another memory box, touch the [NEXT] key.

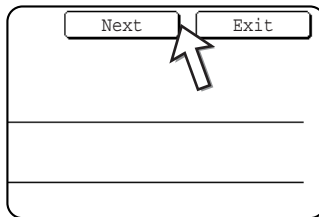

Touching the [EXIT] key returns you to the screen of step 3 on page 5-82.

Touching the [NEXT] key returns you to the screen for programming a new memory box (the screen of step 4 on page 5-82).

Setting for F-Code Relay Broadcast Memory Boxes (Recipient)

Program the end receiving machines to which document data received in the F-code relay broadcast memory box will be transmitted when your machine is a relay machine.

- NOTES:**
- *Up to 30 end receiving machines (30 one-touch keys or group keys) can be programmed. If you attempt to program more than this number, a message will appear and programming will not be possible.*
 - *Only destinations that have been programmed in auto dial keys (one-touch keys or group keys) can be selected. If you need to include a destination that has not been programmed in an auto dial key, first program it in a one-touch key (page 5-68) and then program the destination as an end receiving machine.*

1. Touch the [RELAY BROADCAST] key in step 3 of "Programming an F-Code Memory Box" on page 5-82 and store a box name, sub-address, and passcode.
2. Touch the [RECIPIENT] key.

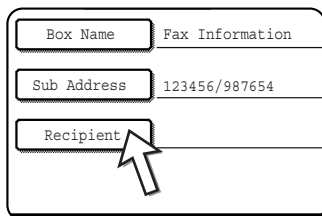

The address selection screen appears.

3. Touch the one-touch keys you wish to include as end receiving machines.

Touch indexes and the   keys as needed.

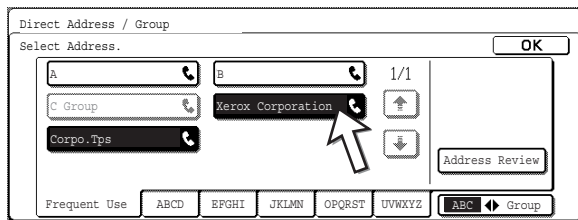

- The selected one-touch keys are highlighted and programmed as end receiving machines.
 - If you touch an incorrect key, touch the key again to remove the highlighting and delete the destination.
4. To check the destinations that have been selected as end receiving machines, touch the [ADDRESS REVIEW] key.

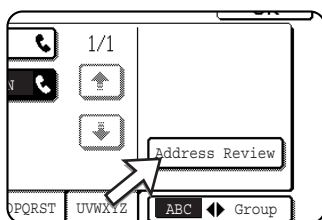



You can delete a destination from the list of end receiving machines by touching it. When the confirmation message appears, touch the [YES] key to confirm the deletion.

5. Touch the [OK] key in the screen of step 3.
You will return to the screen of step 2 and the number of stored as end receiving machines will appear.
6. To exit, touch the [EXIT] key. To program another memory box, touch the [NEXT] key.
Touching the [EXIT] key returns you to the screen of step 3 on page 5-82.
Touching the [NEXT] key returns you to the screen for programming a new memory box (the screen of step 4 on page 5-82).

Editing and Deleting a Memory Box

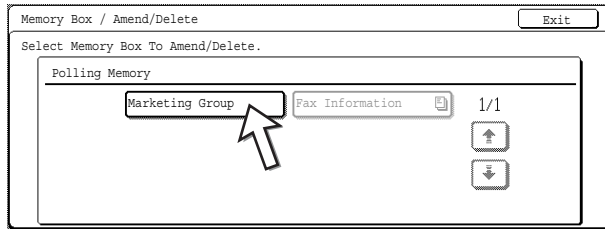
1. Press the [CUSTOM SETTINGS] key and then touch the [ADDRESS CONTROL] key (refer to steps 1 and 2 on page 5-67).
2. Touch the [F-CODE MEMORY BOX] key (refer to step 2 on page 5-82).
3. Touch one of the memory box keys ([POLLING MEMORY], [CONFIDENTIAL], or [RELAY BROADCAST]) on the amend/delete line (lower line) (see step 3 on page 5-82).
4. Touch the memory box key that you wish to edit or delete.



- The memory box edit/delete screen appears.
 - () mark indicates that data has been stored.
 - A memory box cannot be edited or deleted when data is stored in the box.
5. Touch the keys as needed to edit or delete the information.

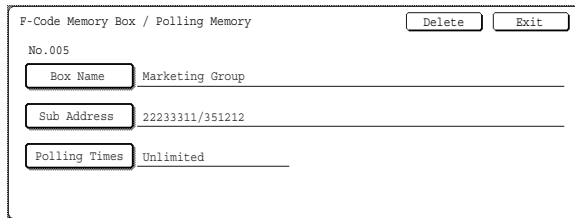

- Edit a memory box in the same way as you programmed it.
- To delete a memory box, touch the [DELETE] key at the upper right of the screen (a message will appear asking you to confirm the deletion).
- The print PIN must be entered to edit or delete a confidential memory box.
- A memory box cannot be edited or cleared while it is being used for transmission.

Printing Programmed Information

You can print out lists of the One-touch keys, Group keys, Programs, Memory boxes that have been stored in the machine.

1. Press the [CUSTOM SETTINGS] key.

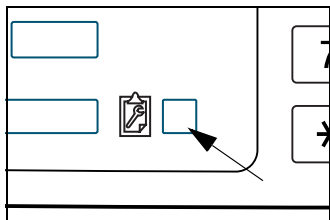

2. Touch the [LIST PRINT] key.

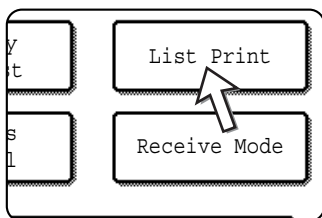

3. Touch the [SENDING ADDRESS LIST (FAX)] key.

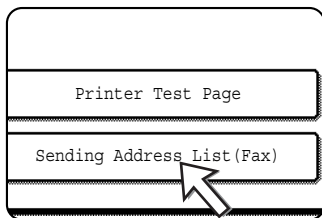

4. Touch the key of the list you wish to print.

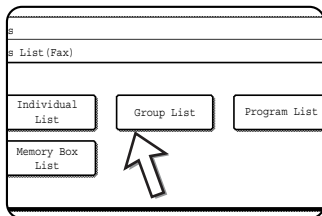

Printing begins.

To cancel printing after it has begun, touch the [CANCEL] key in the message screen.

NOTE: If you attempt to print a list when no data exists, a warning message will appear.

Entering Characters

To enter or edit characters in setting screens such as auto dial key programming screens, follow the steps below. Characters that can be entered are alphabetical characters, special characters, numbers, and symbols.

Entering alphabetical characters

(Example: Xerox äÄ)

1. Touch the [X] key.

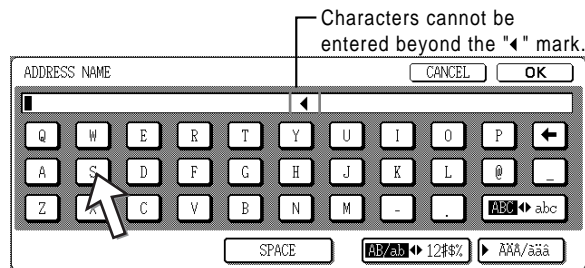

To switch between upper case and lower case, touch the [ABC ◀ abc] key. When ABC is highlighted, upper case letters are entered.

2. Touch the [ABC ◀ abc] key.

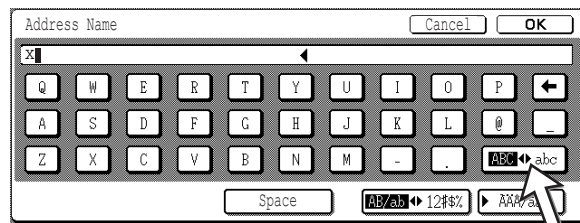

3. Touch the [e] key, [r] key, [o] key, and [x] key.

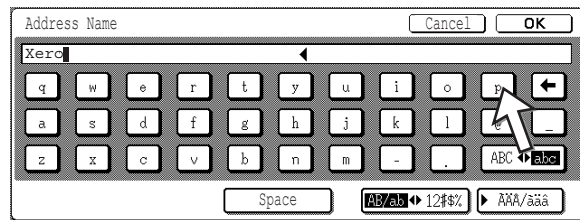

If you make a mistake, touch the [←] key to move the cursor (█) back one space and then enter the correct character. You can also touch the [AB/ab ▶ 12#\$%] key during entry to enter a number or symbol.

4. Touch the [SPACE] key.

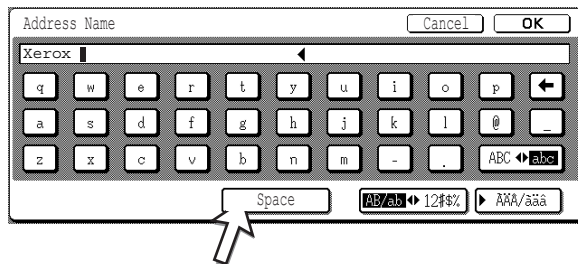

The cursor (█) moves forward and a space is entered.

5. Touch the [▶ ÃÄÂ/ääâ] key.

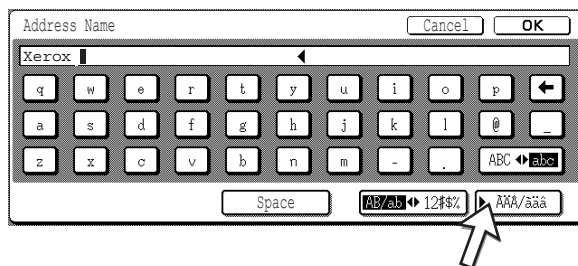

6. Touch the [ä] key.

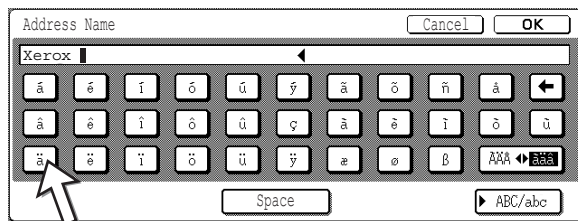

To switch between upper case and lower case, touch the [ÃÄÂ ◀ äää] key. When äää is highlighted, lower case letters are entered.

7. Touch the [ÃÄÂ ◀ äää] key.

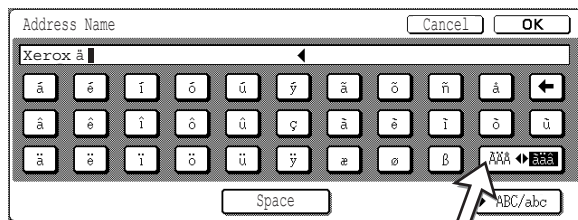

- 8. Touch the [Ä] key.

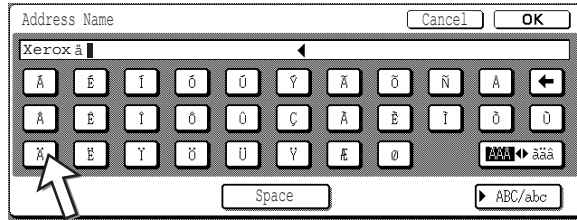

You can touch the [ABC/abc] key during entry to return to alphabetical character entry. You can also enter numbers and symbols.

- 9. When finished, touch the [OK] key.

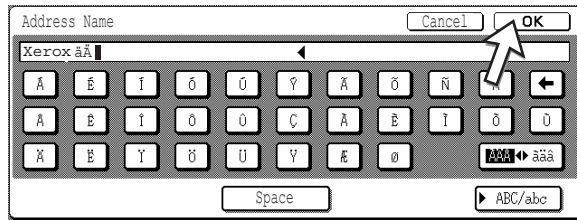

You will exit the character entry screen and return to the programming screen. If you touch the [CANCEL] key, you will return to the programming screen without storing the entered characters.

Entering numbers and symbols

1. Touch the [AB/ab ◀▶ 12#\$\$%] key.

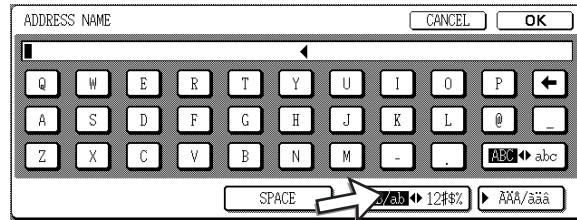

When the characters "12#\$\$%" are highlighted, number/symbol entry mode is selected.

2. Enter the desired number or symbol.



Numbers and symbols that can be entered are as follows:

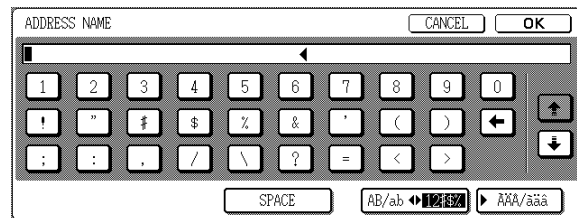

Screen 1/2

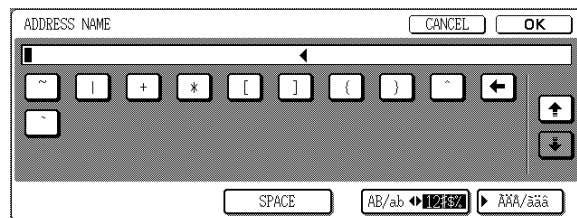

Screen 2/2



* Change screens by touching the  key or  key displayed in the screen. If you make a mistake, touch the  key to move the cursor (█) back one space and then enter the correct character.

You can continue touching keys to enter characters. You can also touch another character type selection key (  key or [AB/ab ◀▶ 12#\$\$%] key) to enter characters other than numbers and symbols.

3. When you have finished entering characters, touch the [OK] key.

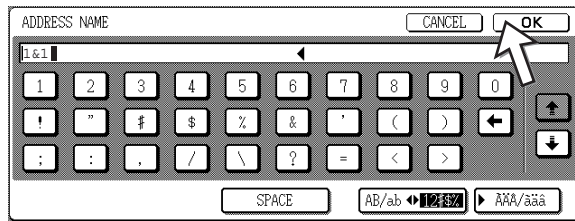

You will exit the character entry screen and return to the programming screen. If you touch the [CANCEL] key, you will return to the programming screen without storing the entered characters.

Troubleshooting

This section contains information to help you make efficient use of the fax features of the machine, including solutions to common problems.

When a Transaction Report Is Printed

The machine has been set to automatically print a Transaction Report when a transmission is not successful or when the Broadcast transmission function is used. The Transaction Report informs you of the result of the operation. When the machine prints a Transaction Report, be sure to check the contents.

The initial settings (factory settings) for printing Transaction Reports are indicated by shading below. You can use the key operator program to change the settings (See "Transaction report print select setting" in the "Fax Unit" section of the WorkCentre C226 System Administration Guide).

- Single sending: Print out all report / Print out error report only / No printed report
- Broadcasting: Print out all report / Print out error report only / No printed report
- Receiving: Print out all report / Print out error report only / No printed report
- Confidential reception: Print out notice page / Not print out notice page

The Transaction Report shows the date of transmission, the time transmission began, the other party's name, the duration of the operation, the number of pages, and the result.

- NOTES:**
- *The list count appears in the "#" column of the Transaction Report and a serial number appears in the FILE column. (These numbers are not related to the transaction.)*
 - *If desired, you can have part of the document printed on the transaction report. This setting is enabled in the key operator programs. (See "Original print on transaction report" in the "Fax Unit" section of the WorkCentre C226 System Administration Guide.)*

Information appearing in the TYPE/NOTE column

Information such as the type of transmission and type of error appears in the TYPE/NOTE column of the Transaction Report or Activity Report. The following notes may appear.

Note	Explanation
OK	The transaction was completed normally.
G3	Communication took place in G3 mode.
ECM	Communication took place in G3 ECM mode.
SG3	Communication took place in Super G3 mode.
FW.	The received data was forwarded.
NO RESPONSE	No response from the receiving party.
BUSY	Transmission was not possible because the other party was already using the line.
CANCEL	A transmission was cancelled while in progress, or a stored transmission job was cancelled.
MEMORY OVER	The memory became full during quick on-line transmission.
MEM. FULL	The memory became full during reception.
LENGTH OVER	The transmitted document was over 1500 mm (59") long and therefore could not be received.
ORIGINAL ERROR	Manual transmission was not successful because a jam occurred.
PASS# NG	The connection was broken because the polling passcode was not correct.
NO RX POLL	The machine that was polled does not have a polling function.
RX POLL FAIL	The other machine refused the polling operation, or your machine broke the connection when polled because no data was in memory.
NO F-CODE POLL	The other machine refused an F-code polling operation, or your machine broke the connection when polled because no data was in its F-code memory polling box.
RX POLL# NG	Your machine broke the connection because the other machine specified an F-code polling sub-address that does not exist in your machine.
F PASS# NG	Your machine broke the connection because an incorrect passcode was sent for an F-code transmission.
BOX NO. NG	Your machine broke the connection because the specified sub-address for an F-code memory box does not exist.
F POLL PASS# NG	Your machine broke the connection because the other machine sent an incorrect passcode for F-code polling.
RX NO F-CODE POLL	F-code polling was attempted, however, the other machine did not have an F-code polling memory box.

Note	Explanation
NO F FUNC	F-code transmission was attempted, however, the other machine does not support F-code communication.
NO F-CODE	An F-code transmission was refused by the other machine because of an incorrect sub-address or other reason.
M. BOX: [xxxxxx] *****	Data was received to a confidential or relay broadcast memory box, or data was sent from a memory polling box. The name of the memory box appears in [xxxxxx], and the type of F-code operation (relay request reception, polling memory transmission, or confidential reception) appears in *****.
FAIL xx(xxxx)	The communication handshake signals or image signals were distorted due to line conditions or other reasons, and communication was not successful. First two digits of communication error number: Error code from 00 to 31 appears. Last four digits of communication error number: Codes for use by service technicians.
REJECTED	A fax was sent from a party that has been blocked by the anti junk fax function.

Viewing the Communication Activity Report

Your machine keeps a record of the most recent 50 transactions (both transmissions and receptions) that were performed. The record includes the date of the transaction, the other party's name, the duration, and result. You can have the report automatically printed when the number of transactions exceeds 50, or at a specified time. This allows you to check the machine's activity at regular intervals.

The machine is initially set (factory setting) to not print the report. To have the report printed, change the setting with the key operator program (See "Activity report print select setting" in the "Fax Unit" section of the WorkCentre C226 System Administration Guide).

- NOTES:**
- After printing, the data is cleared from memory, so the report cannot be printed a second time.
 - Refer to the table in "When a Transaction Report is printed" on the previous page for the notes that appear in the TYPE/NOTE column.

When an Alarm Sounds and a Warning Message Is Displayed

When an error occurs during a transaction, an alarm will sound and a message will appear in the display. Take action as explained in the following table.

Message screen (Alarm)	Meaning of message	Action	Page/Guide
ADD xxxxxxxx PAPER.	A received fax cannot be printed because there is no suitable paper.	Add the indicated paper.	"Loading Paper" on page 1-21
CHANGE THE TONER CARTRIDGE.	The machine is out of toner and the received document cannot be printed.	Replace the toner cartridge.	"Replacing the Toner Cartridges" on page 1-42
PLEASE RETURN xx ORIGINALS TO THE DADF, THEN PRESS [START].	An original misfeed occurred in the DADF during scanning.	Reload the indicated original.	"Using the DADF" on page 5-11
THE MEMORY BECOMES FULL. SEND SCANNED DATA? OR CANCEL THE JOB?	The memory became full while the original was being scanned.	Send only the pages that were already scanned, or cancel the entire transmission.	"Storing transmission jobs (memory transmission)" on page 5-24
POLLING IS NOT POSSIBLE WITH THE AVAILABLE MEMORY.	Polling is not possible because there is not enough space in memory.	Try polling again after currently stored jobs are completed.	"Polling" on page 5-35

Message screen (Alarm)	Meaning of message	Action	Page/Guide
<p>MANUAL RECEIVE IS DISABLED. DUE TO OUT OF MEMORY.</p>	<p>Manual reception was not possible because there was not enough free space in memory.</p>	<p>Try manual reception again after currently stored jobs have been completed.</p>	<p>—</p>
<p>CLOSE THE xxxx COVER.</p> <p>CLOSE THE DADF.</p> <p>CLOSE THE LOWER RIGHT SIDE COVER.</p>	<p>The indicated cover is open.</p>	<p>Close the indicated cover.</p>	<p>—</p>
<p>CALL FOR SERVICE. CODE:xx-xx FAX FUNCTION TROUBLE.</p>	<p>The self-diagnosis function has activated and automatically stopped operation. An error code appears in xx-xx.</p>	<p>Turn off the power and then turn it back on. If the same message still appears, contact your dealer.</p>	<p>—</p>

Problems and Solutions

If you experience a problem with the fax function, first check the following table. If you cannot solve the problem using the following table, see your Xerox WorkCentre C226 System Administration Guide.

Problem	Check	Solution	Page
The machine does not operate.	Is the fax power switch turned on?	Turn on the fax power switch.	"Fax power switch" on page 5-2
Dialing is not possible.	Is the telephone line properly connected?	Check the connections.	"Line connection" on page 5-1
	Is the machine power switch turned on?	Turn the machine power switch on.	Page 1-9
	Is the machine in fax mode?	Press the [IMAGE SEND] key to set the machine to fax mode.	"Basic Procedure for Sending Faxes" on page 5-19
The receiving machine does not receive your fax.	Does the receiving fax machine have paper?	Check with the operator of the receiving machine.	—
	Does the receiving machine support G3 transmission?		
	Are the sub-address and passcode correct?		
	Is the receiving machine ready to receive?		
	Was the original size detected correctly?	Check the transmittable sizes.	"Checking the Size of a Loaded Original" on page 5-12
The transmitted image prints out blank at the receiving side.	Was the original placed so that the correct side is scanned?	Make sure the original is placed so that the correct side is scanned.	"Loading a Document" on page 5-11
	If the receiving machine is using thermal paper, was the thermal paper loaded with the wrong side out?	Check with the operator of the other machine.	—
The transmitted image is distorted.	Were line conditions poor due to thunder or another reason?	Try the transmission again.	—
	Were the resolution and exposure settings suitable?	Check the resolution and exposure settings.	"Selecting Resolution and Exposure Settings" on pages 5-14 and 5-16.
Transmission does not take place at the specified time.	Is the machine's clock set to the correct time?	Set the clock to the correct time.	"Operation procedure common to all custom settings" on page 1-39

Problem	Check	Solution	Page	
Printing does not take place after reception.	Does a message appear in the display instructing you to add toner or paper? (Printing is not possible.)	Restore printing capability as instructed by the display message. Printing will begin	"When an Alarm Sounds and a Warning Message Is Displayed" on page 5-98	
A received image prints out blank.	Was the wrong side of the original scanned in the transmitting machine?	Check with the operator of the transmitting machine.	–	
The received image is faint.	Is the original faint?	Ask the other party to re-send the document using a suitable exposure setting.	–	
The received image is distorted.	Were line conditions poor due to thunder or another reason?	Ask the other party to send the document again.	–	
White or black lines appear in the transmitted image.	Is the document glass dirty?	Clean the document glass .	Pages 2-81 and 2-82	
Telephone	A dial tone is not heard through the speaker.	Is the volume set to "low"?	Set the speaker volume to "medium" or "high".	"Speaker volume setting" in the "Fax Unit" section of the Work-Centre C226 System Administration Guide
	A ringing sound is not made.	Has the ringer volume been turned off?	Set the ringer volume to "low", "medium", or "high".	"Speaker volume setting" in the "Fax Unit" section of the Work-Centre C226 System Administration Guide

Index

Symbols / Numerics

- #/P key **1-15**
- 1-sided copies **2-13, 2-21**
- 1-Tray Unit **1-12**
 - loading paper **1-28**
 - misfeed **1-52**
 - specifications **1-29**
- 256 MB Memory Kit **1-13**
- 2-Sided Copy display **2-3, 2-20**
- 2-Tray Unit
 - loading paper **1-29**
 - misfeed **1-53**
 - specifications **1-30**
- 2-Up Pamphlet **3-17**
- 3-Tray Unit **1-12**
 - loading paper **1-28**
 - misfeed **1-53**
 - specifications **1-29**

A

- A3 full-bleed **2-59, 2-66**
- A4/letter size auto change **3-55**
- ABC GROUP key **4-22**
- ACC.#-C **1-15**
- acceptable originals **2-3**
- Account Number **3-25**
- account number **1-19**
- address control **1-38**
- address directory **5-22**
- ADDRESS DIRECTORY key **4-19, 4-21**
- address directory screen **4-21, 5-7, 5-9**
- address review **5-7, 5-31**
- ADDRESS REVIEW key **4-19**
- addresses
 - disabling direct entry **4-69**
 - storing **4-42**

- Advanced tab
 - PCL5c **3-29**
 - PostScript **3-31**
- alarm **5-98**
- alerts message **3-44**
- All Text to Black checkbox **3-38**
- Always Use This ID **3-26**
- AMEND/DELETE key. **4-46**
- applicable paper sizes **1-30**
- applicable paper types **1-30**
- auditing mode **1-18**
 - Account Number **3-25**
- auto colour calibration **3-58**
- auto image **2-28, 2-71**
- Auto Job Control review **3-19**
- auto paper select **2-14, 2-22**
- auto power shut-off mode **1-8**
- auto resolution **2-26**
- auto size detection **1-37**
- auto-dialing **5-17, 5-22**
- automatic copy image rotation **2-8**
- automatic image quality adjustment **2-25**
- automatic reception **5-28**
- automatic reduction **5-10**
- automatic selection (reduction/enlargement) **2-28**
- automatic switching (B/W and colour) **3-7**
- automatic two-sided copying
 - from DADF **2-19**
 - from document glass **2-24**
- automatic two-sided printing **1-33**

B

- B/W reverse **2-50**
- B/W REVERSE key **2-38**
- BCC key **4-21**
- binding change **2-21, 2-24**
- Binding Edge **3-19**

Bitmap Compression **3-32**
 black and white printing **3-4**
 BLACK COPY START key **1-15, 5-6**
 Black Overprint **3-36**
 bleed **2-66**
 Blue Strength **3-39**
 book original **2-42**
 booklets and tablets **4-33**
 Border **3-18**
 brightness **2-52, 2-57**
 broadcast transmission **5-29–5-32**
 Scan to E-mail **4-25**
 Bypass Tray **1-10, 3-63**
 loading paper in **1-23**
 misfeed **1-48**

C

C (CLEAR) key **1-15, 5-5**
 CALL FOR SERVICE. CODE:**-** **1-56**
 cancelling
 dual page scan **5-44**
 fax transmission **5-27**
 F-code polling **5-55**
 polling **5-37**
 scan transmission **4-27, 5-22**
 scanning **5-39**
 transfer **5-48**
 transmission
 e-mail or FTP **4-41**
 CC key **4-21**
 centre erase **2-41**
 centre tray **1-9**
 CENTRE TRAY key **1-60**
 centring **2-44**
 CENTRING key **2-37**
 cleaning the scanning area **2-82**
 CLEAR ALL key **1-15, 5-6**
 CLEAR key **1-15, 5-5**
 clock adjust **1-37, 1-41**
 collate **3-16**
 COLOR COPY START key **5-5**
 color mode **3-37**
 black and white printing **3-4**
 document type preview **3-36**
 color mode setting, selecting **3-2**
 Color tab **3-35**
 COLOUR ADJUSTMENTS key **2-38**
 Colour Adjustments menu **2-51**
 colour adjustments, auto colour calibration **3-58**
 colour balance **2-52, 2-55**
 COLOUR COPY START key **1-15**
 colour mode display **3-16**
 colour printing **3-10**
 colour rendering **3-35**
 colour settings, default document types **3-35**
 communication activity report **5-98**
 Compress Options
 Bitmap Compression **3-32**
 Job Compression **3-32**
 compression mode at broadcasting **4-67**
 condition setting screen **4-18**
 condition settings
 restore configuration **3-60**
 restore factory defaults **3-59**
 store current configuration **3-60**
 CONDITION SETTINGS key **3-45, 4-22**
 condition settings screen **5-6, 5-7**
 connecting an extension phone **5-4**
 copies (printing) **3-16**
 copy image rotation, automatic **2-8**
 COPY key **1-14**
 copy mode output restrictions **2-16**
 copy output **2-18**
 copy quantity display **2-3**
 copy ratio **2-64**
 automatic selection **2-28**
 manual selection **2-30**
 Copy Ratio display **2-3**
 copy run, interrupting **2-77**
 copying
 copies **2-27**
 dual page **2-42**
 from document glass **2-21**
 transparency film **2-45**
 copying procedure **2-13**
 copying, automatic
 from DADF **2-19**
 from document glass **2-24**
 covers **2-47**
 COVERS key **2-37**
 custom directory, storing (scanning) **4-17**
 custom paper size **3-27**
 custom settings
 clock adjust **1-37, 1-41**
 display contrast **1-37, 1-41**
 key operator program **1-38**

list print **1-37, 1-41**
 total count **1-37, 1-40**
 tray settings **1-38, 1-41**
 CUSTOM SETTINGS key **1-15**

D

DADF **1-9, 2-1, 2-3**
 automatic copying from **2-19**
 copying from **2-13**
 scanning **4-26**
 default display settings (scanner) **4-66**
 Default Job ID **3-25**
 Always Use This ID **3-26**
 Job Name **3-26**
 User Name **3-25**
 default paper type for Bypass Tray **3-56**
 default sender set **4-67**
 delete the print hold data **3-55**
 deleting
 document data
 from F-code polling memory box **5-54**
 from Public Box **5-41**
 F-code memory box **5-81**
 group keys **4-50, 5-77**
 job program **2-75**
 memory box **5-88**
 one-touch keys **4-46, 5-72**
 programmed transmission destinations **4-15**
 programs **5-80**
 sender information **4-53**
 deleting programmed sender information **4-17**
 destination address entry
 manual **4-27**
 with global address search **4-30**
 destination information
 setting up **4-10**
 destination input methods **4-27**
 destinations, storing
 Scan to E-mail **4-11, 4-42**
 Scan to FTP **4-12**
 DETAIL key **1-18**
 Device Setup **3-43**
 Log **3-44**
 Password **3-43**
 Different Paper setting **3-28**
 direct address entry, disabling **4-69**
 DIRECT ADDRESS key. **4-42**

display contrast **1-37, 1-41**
 display switching keys **5-9**
 DNS server settings **4-7**
 DNS setup **4-9**
 document glass **2-2, 5-11**
 automatic 2-sided copying from **2-24**
 copying from **2-21**
 scanning **4-26**
 document style **3-17**
 2-Up Pamphlet **3-17**
 N-Up **3-18**
 Tiled Pamphlet **3-17**
 document type preview, color mode **3-36**
 dual page copy **2-42**
 DUAL PAGE COPY key **2-37**
 dual page scan **5-43**
 Duplex Automatic Document Feeder. See DADF
 Duplex Bypass/Inverter Unit **1-13**
 misfeed **1-53**
 Duplex Module/2-Tray Unit **1-12**
 loading paper **1-29**
 misfeed **1-53**
 specifications **1-30**

E

edge erase **2-41**
 editing
 F-code memory box **5-81**
 group keys **4-50, 5-76**
 memory box **5-88**
 one-touch keys **4-46, 5-72**
 programmed sender information **4-17**
 programmed transmission destinations **4-15**
 programs **5-80**
 sender information **4-53**
 E-MAIL ADDRESS key **4-20**
 e-mail server settings **4-7**
 e-mail subject **4-7**
 enable EtherTalk **3-58**
 enable NetBEUI **3-58**
 enable NetWare **3-57**
 enable network port **3-56**
 enable parallel port **3-56**
 enable TCP/IP **3-57**
 enable USB port **3-56**
 enlargement. See reduction/enlargement envelopes

- loading **1-26**
- printing **1-27**
- erase
 - centre **2-41**
 - edge **2-41**
- ERASE key **2-37**
- error code table (scanning) **4-59**
- exit area misfeed **1-50**
- exit tray **1-13, 3-28**
- exposure adjustment
 - copying **2-25**
 - fax **5-8, 5-16, 5-17**
 - scanning **4-36**
- EXPOSURE key **4-20**
- exposure settings, default (scanning) **4-68**
- Exposure tab **2-3, 2-25**
- extension phone
 - connecting **5-4**
 - using **5-61**

F

- face-up and face-down output **1-13**
- fax data forward **1-38**
- Fax Expansion Memory **1-13**
- FAX JOB key **1-18**
- fax mode **5-6**
- fax transmission, cancelling **5-27**
- Fax Unit **1-13**
- faxing a two-sided original **5-23**
- F-code
 - confidential transmission **5-56**
 - polling **5-54**
 - polling memory **5-52**
 - polling, cancelling **5-55**
 - relay broadcast function **5-60**
 - relay broadcast transmission **5-59**
 - relay request function **5-61**
 - transmission **5-49**
- F-code memory box
 - deleting **5-81**
 - editing **5-81**
- file format
 - selecting (scanning)scanning
 - file format, selecting **4-38**
- FILE FORMAT key **4-20**
- file naming, scanned image **4-7**
- file size limit (Scan to E-mail) **4-68**

- FINISHER TRAY key **1-60**
- Finishing **3-19**
 - Binding Edge **3-19**
 - Staple **3-20**
- Fit To Page **3-27**
- font set, PCL **3-47**
- forwarding function **5-46**
- fusing area misfeed **1-50**
- fusing unit **1-11**
- fusing unit pressure adjusting levers **1-27**

G

- GLOBAL ADDRESS SEARCH key **4-22**
- Graphics Mode **3-30**
- gray scale printing **3-4**
- Green Strength **3-39**
- group (copy output) **2-18**
- group dialing **5-17, 5-22, 5-74**
- group index, storing **4-54, 5-80**
- GROUP key **1-60**
- group keys
 - deleting **5-77**
 - editing **5-76**
 - editing and deleting **4-50**
 - programming **4-48**
 - storing **5-74**
- groups, storing (Scan to E-mail) **4-14**

H

- halftone settings **3-36**
- High Capacity Feeder **1-12, 1-74, 3-14**
 - loading paper **1-74**
 - misfeed **1-75**
- Hold After Print **3-23**
- Hold Before Print **3-23**
- Hold Job List **3-48**
- hole punch scrap disposal **1-66**
- hole punching **3-22**
 - settings for **3-22**
- host name **4-13**

I

- I/O timeout **3-57**
- IMAGE EDIT key **2-38**

Image Edit menu **2-59**
 image orientation (printing) **3-27**
 Image Quality
 Graphics Mode **3-30**
 Resolution Settings **3-30**
 image quality
 black and white, setting print contrast **3-6**
 colour, setting print contrast **3-9, 3-12**
 printing **3-29, 3-38**
 image quality adjustment **2-25**
 image rotation **5-25**
 IMAGE SEND key **1-14, 4-18, 5-5**
 Image Send Management **3-42**
 image sending (scanning) **4-23**
 index keys **4-22**
 initial file format setting **4-67**
 initial resolution (scanner) **4-66**
 initialize settings **3-59**
 insert sheets for transparencies **2-45**
 installation requirements **1-1**
 intensity **2-52, 2-58**
 interface settings
 enable network port **3-56**
 enable parallel port **3-56**
 enable USB port **3-56**
 I/O timeout **3-57**
 port switching method **3-56**
 INTERRUPT key **2-2, 2-77**
 Inverter Unit **1-13**
 misfeed **1-53**
 IP address **3-64, 4-60**
 IP address setting **3-57**

J

jam, staple **1-63**
 Job Compression **3-32**
 job list **1-17**
 Job Name **3-26**
 job program
 deleting **2-75**
 recalling **2-74**
 storing **2-73**
 job program memory **2-73**
 job queuing **3-56**
 JOB STATUS key **1-15**
 job status screen **1-17**

K

key operator programs
 A4/letter size auto change **3-55**
 custom setting **1-38**
 default paper type for Bypass Tray **3-56**
 delete the print hold data **3-55**
 job queuing **3-56**
 output method when memory is full **3-55**
 printing **3-50**
 prohibit notice page printing **3-55**
 prohibit test page printing **3-55**
 restoring factory default settings **3-59**
 scanning **4-63, 4-65**
 keyboard select **1-38, 1-41**

L

list print **1-37, 1-41**
 loaded original, checking size of **5-12**
 loading documents **5-11**
 loading envelopes **1-26**
 loading paper **1-21**
 1-Tray Unit **1-28**
 3-Tray Unit **1-28**
 Bypass Tray **1-23**
 Duplex Module/2-Tray Unit **1-29**
 Paper Tray 1 **1-21**
 loading postcards **1-26**
 Log **3-44**
 lower tray, misfeed **1-55**

M

machine maintenance (for copying) **2-79**
 machine part names **2-1**
 Main tab **3-16**
 manual reception **5-63, 5-64**
 manual transmission **5-62**
 margin shift **2-39, 3-30**
 MARGIN SHIFT key **2-37**
 margins, scanning **4-71**
 maximum file size (Scan to E-mail) **4-68**
 media, special **1-32**
 memory box **5-49**
 editing and deleting **5-88**
 memory transmission **5-24**
 message display **2-2**

- scanning **4-19**
- mirror image **2-59, 2-61**
- misfeed
 - 3-Tray Unit **1-53**
 - Bypass Tray **1-48**
 - Duplex Bypass/Inverter Unit **1-53**
 - Duplex module/2-Tray Unit **1-53**
 - exit area **1-50**
 - fusing area **1-50**
 - High Capacity Feeder **1-75**
 - paper feed area **1-47**
 - reversing tray **2-2**
 - Saddle Stitch Finisher **1-67**
 - stand/1-Tray Unit **1-52**
 - transport area **1-49**
 - Tray 1 **1-47**
 - upper or lower tray **1-55**
- misfeed removal **1-46**
- mode select key **1-18**
- multi shot **2-59, 2-64**
- multi-page enlargement **2-60, 2-68**

N

- network printer configuration **3-40**
- network scanner settings **4-65**
- Network Scanning Setup screen **4-6**
- network scanning. *See also* scanning
- network settings
 - enable EtherTalk **3-58**
 - enable NetBEUI **3-58**
 - enable netware **3-57**
 - enable TCP/IP **3-57**
 - IP address setting **3-57**
 - reset the NIC **3-58**
- network setup for Web page **3-44**
- No Offset **3-22**
- Normal Print **3-23**
- notice page **3-65**
- Notify Job End **3-24**
- number of direct address keys displayed **4-66**
- N-Up printing **3-18**
 - Border **3-18**

O

- offset function **2-18**
- OFFSET key **1-60**

- offset mode **3-22**
- one-touch dialing **5-17, 5-22**
- one-touch key display **4-21, 5-9**
- one-touch keys
 - deleting **5-72**
 - editing **5-72**
 - editing and deleting **4-46**
 - storing **5-68**
 - storing (Scan to E-mail) **4-42**
- on-hook dialing **5-18**
- operation panel **1-14, 5-5**
 - printing from **3-48**
- optional equipment **1-13**
- original
 - checking size of **5-12**
 - minimum/maximum size **5-10**
 - orientation **2-7**
 - scanning area **5-10**
- original guides **2-2**
- ORIGINAL key **4-20**
- original size
 - deleting **2-10**
 - selecting **2-8**
 - storing **2-10**
 - using stored **2-12**
- original size detection function **2-6**
- original sizes **1-6**
- Original tab **2-3, 2-8**
- originals, acceptable **2-3**
- originals, setting
 - using DADF **2-4**
 - using document glass **2-5**
- output (printing) **3-28**
- Output display **2-3**
- output method when memory is full **3-55**
- output restrictions, copy mode **2-16**
- output tray, default (printing) **3-46**
- overlays **3-31**
- own number sending **5-42**

P

- Page Protection checkbox **3-31**
- pamphlet copy **2-60, 2-71**
- Paper Select display **2-3, 2-14, 2-22**
- paper select, auto **2-14, 2-22**
- paper settings **3-26**
- paper size settings **3-26**

- custom **3-27**
 - default **3-46**
- paper size, changing **1-22**
- paper sizes **1-6, 1-30**
- Paper tab **3-26**
- paper trays
 - selecting **3-28**
 - specifications for **1-30**
- paper type **3-63**
 - default **3-47**
 - setting
 - (except Bypass Tray) **1-33**
 - Bypass Tray **1-35**
- paper types **1-30**
 - selecting **3-28**
 - special **2-35**
- paper, loading **1-21**
 - 1-Tray Unit **1-28**
 - 3-Tray Unit **1-28**
 - Bypass Tray **1-23**
 - Duplex Module/2-Tray Unit **1-29**
 - High Capacity Feeder **1-74**
 - Paper Tray 1 **1-21**
- passcodes **5-49–5-51**
- Password **3-43**
- passwords, protecting programmed information **4-18**
- pause **5-20**
- PCL settings
 - font set **3-47**
 - symbol set **3-47**
- PCL symbol set **3-67**
- photo repeat **2-59, 2-62**
- PIN **3-24**
- polling function **5-34–5-42**
 - F-code polling **5-54**
 - F-code polling memory **5-52**
 - manual polling **5-37**
 - polling memory **5-38**
- polling security **5-42**
- polling times **5-84**
- polling, cancelling **5-37**
- port switching method **3-56**
- postcards
 - loading **1-26**
 - printing **1-26**
- preheat mode **1-8**
- print
 - document data in Public Box **5-40**
 - F-code confidential memory box **5-57**
 - F-code polling memory box **5-54**
 - programmed information **5-89**
 - transaction report **5-95**
- print area **3-66**
- print contrast **3-6, 3-9, 3-12**
- PRINT JOB key **1-18**
- PRINT key **1-14**
- Print PIN **5-85**
- Print Priority **3-38**
- printer configuration settings **3-44**
 - common operation procedure **3-45**
 - default **3-46**
 - PCL **3-47**
- printer driver settings, using Help file **3-3**
- printer drivers
 - Main tab **3-16**
 - setting **3-1–3-2**
 - setting properties **3-15**
- printer Web pages **3-40**
- printing
 - black and white **3-4**
 - colour **3-10**
 - fit to page **3-27**
 - from operation panel **3-48**
 - image orientation **3-27**
 - image quality **3-38**
 - rotate image **3-27**
 - two-sided **3-14**
 - using High Capacity Feeder **3-14**
 - using optional peripheral equipment **3-12**
 - using Saddle Stitch Finisher **3-14**
- printing functions
 - Auto Job Control review **3-19**
 - collate **3-16**
 - document style **3-17**
 - Finishing **3-19**
 - Main tab **3-16**
 - Notify Job End **3-24**
 - Retention **3-23**
 - selecting **3-15–3-39**
 - User Settings **3-18**
- PRIORITY key **1-18**
- priority transmission **5-26**
- programmed information, printing **4-55**
- programming
 - F-Code Confidential Transmission Memory Box **5-85**
 - F-code polling memory box **5-84**

F-Code Relay Broadcast Memory Box **5-86**
 frequently used operations **5-44**
 group index **5-80**
 group keys **4-48**
 programs
 deleting **5-80**
 editing **5-80**
 storing **5-78**
 prohibit notice page printing **3-55**
 prohibit test page printing **3-55**
 Proof Print **3-23**
 PS Kit **1-13**
 PS Pass-through **3-31**
 Public Box
 deleting document data from **5-41**
 printing document data in **5-40**
 Punch **3-22**
 PUNCH key **1-60**
 Pure Black Text selection **3-36**

Q

Quick On-line **5-24**

R

READ-END key **5-21**
 receive mode **1-38**
 receiving party is busy **5-25**
 reception
 automatic **5-28**
 manual **5-63**
 recipient **5-86**
 Red Strength **3-39**
 redialing **5-17**
 reduction/enlargement **2-28**
 reduction/enlargement, automatic selection **2-28**
 relay machine **5-59–5-60**
 replacing, staple cartridge **1-61**
 reset the NIC **3-58**
 RESOLUTION key **4-20, 5-8**
 resolution settings
 copying **2-26**
 fax **5-14, 5-15**
 printing **3-30**
 scanning **4-37**
 restore configuration **3-60**
 restricting polling access **5-42**

Retention **3-23**
 Hold After Print **3-23**
 Hold Before Print **3-23**
 Normal Print **3-23**
 PIN **3-24**
 Proof Print **3-23**
 returned e-mail **4-59**
 reversing single pass feeder **5-11**
 reversing tray **2-2**
 RGB adjust **2-51, 2-52**
 rotate image (printing) **3-27**
 rotation, automatic copy image **2-8**

S

Saddle Stitch Finisher **1-12, 1-59, 3-14, 3-20**
 misfeed **1-67**
 pamphlet style **3-14**
 part names **1-59**
 staple jam removal **1-63**
 troubleshooting **1-70**
 SADDLE STITCH key **1-60**
 Saturation **3-39**
 scan complete sound setting **4-67**
 Scan Kit **1-13**
 Scan to E-mail **4-3, 4-62**
 default sender set **4-67**
 DNS setup **4-9**
 editing and deleting programmed sender information **4-17**
 e-mail server and DNS server settings **4-7**
 e-mail subject **4-7**
 file size limit **4-68**
 group keys
 editing and deleting **4-50**
 programming **4-48**
 SMTP setup **4-8**
 scompression mode at broadcasting **4-67**
 storing one-touch keys **4-42**
 storing sender information **4-16**
 transmission **4-25**
 Scan to FTP **4-3**
 scanner function, requirements **4-1, 4-4**
 SCANNER JOB key **1-18**
 scanner mode timeout **4-68**
 scanner, transmission methods **4-3**
 scanning
 basic settings **4-6**

- broadcast transmission **4-25**
- cancelling **5-39**
- cancelling transmission (e-mail or FTP) **4-41**
- condition setting screen **4-18**
- error code table **4-59**
- sending an image **4-23**
- storing a custom directory **4-17**
- storing destinations **4-11, 4-12**
- storing groups **4-14**
- transmission method **4-23**
- using document glass **4-26**
- using the DADF **4-26**
- scanning area, cleaning **2-82**
- scanning margins **4-71**
- scanning size, setting manually **4-34, 5-13**
- Screening (halftone) **3-36**
- secure print (PIN) **3-24**
- sender information
 - editing and deleting **4-17, 4-53**
 - storing **4-16, 4-52**
- SENDER LIST key **4-19, 4-24**
- sender's name **5-3**
- sender's number **5-3**
- sending
 - auto-dialing **5-22**
 - cancelling **5-22**
 - dual page scan **5-44**
 - F-code transmission **5-49**
 - image rotation **5-25**
 - manual transmission **5-62**
 - own number sending **5-42**
 - priority transmission **5-26**
 - Quick On-line **5-24**
 - storing transmission jobs (memory transmission) **5-24**
 - timer transmission **5-32**
 - two-sided original **5-23**
- setting
 - destination information (Scan to E-mail) **4-10**
 - paper type
 - (except Bypass Tray) **1-33**
 - Bypass Tray **1-35**
 - print contrast
 - black and white **3-6**
 - colour **3-9, 3-12**
 - printer drivers **3-1–3-2**
 - scanning size manually **4-34, 5-13**
- settings
 - colour, default document types **3-35**
 - e-mail server and DNS server **4-7**
 - exposure default (scanning) **4-68**
 - paper size **3-26**
 - sharpness **2-51, 2-53**
 - SHARPNESS key **2-53**
 - single colour copying **2-59, 2-60**
 - size of loaded original **5-12**
 - SMTP setup **4-8**
 - sort (copy output) **2-17, 2-18**
 - SORT key **1-60**
 - special media **1-32**
 - Special Modes tab **2-3, 2-37**
 - special papers **2-35**
 - specifications
 - 1-Tray Unit **1-29**
 - 3-Tray Unit **1-29**
 - Duplex Module/2-Tray Unit **1-30**
 - paper trays **1-30**
 - stand/1-Tray Unit **1-12**
 - Staple **3-20**
 - staple cartridge, replacing **1-61**
 - staple jam removal **1-63**
 - STAPLE SORT key **1-60**
 - staple sort mode **3-20**
 - stapling position reference **1-72**
 - stapling positions **3-21**
 - stapling. See Saddle Stitch Finisher
 - status message **3-44**
 - STOP/DELETE key **1-18**
 - store current configuration **3-60**
 - store settings **3-59**
 - stored original size
 - deleting **2-10**
 - using **2-12**
 - storing
 - custom directory (scanning) **4-17**
 - F-code confidential transmission memory box **5-85**
 - F-code polling memory box **5-84**
 - F-code relay broadcast memory box **5-86**
 - group index **4-54, 5-80**
 - group keys **5-74**
 - job program **2-73**
 - one-touch keys **5-68**
 - one-touch keys (Scan to E-mail) **4-42**
 - programs **5-78**
 - sender information **4-16, 4-52**
 - transmission jobs **5-24**
 - storing destinations

FTP **4-12**

Scan to E-mail **4-11**

storing groups, Scan to E-mail **4-14**

sub address **5-7, 5-51**

supplies, storing **1-45**

suppress background **2-51, 2-54**

symbol set

PCL **3-47, 3-67**

T

Tiled Pamphlet **3-17**

timeout, scanner mode **4-68**

timer transmission **5-32**

TO key **4-21**

toner cartridge **1-11**

replacing **1-42**

total count **1-37, 1-40**

touch panel **1-14, 1-16, 2-2, 5-5**

transaction report **5-95**

transmission

cancelling (e-mail or FTP) **4-41**

cancelling (Scan to E-mail) **4-27**

Scan to E-mail **4-25**

transmission destinations, editing and deleting **4-15**

transmission error **4-59, 5-25**

transmission method, scanner **4-23**

transmission methods, scanner **4-3**

transparency film, copying onto **2-45**

transparency inserts **3-29**

TRANSPARENCY INSERTS key **2-37**

Transparency Text **3-34**

transport area, misfeed **1-49**

tray settings **1-38, 1-41**

Tray Status button **3-28**

troubleshooting **1-56**

two-sided copying, automatic

from DADF **2-19**

from document glass **2-24**

two-sided original

booklets and tablets **4-33**

faxing **5-23**

scanning and transmitting **4-32**

two-sided printing **3-14**

two-sided scanning icon display **4-20**

TYPE/NOTE column **5-96**

U

UCR (Under Colour Removable) **3-35**

upper tray, misfeed **1-55**

user maintenance (for copying) **2-81**

User Name **3-25**

User Settings **3-18**

Save **3-18**

W

warning message **5-98**

Watermark

As Outline Only **3-34**

On First Page Only **3-34**

Transparency Text **3-34**

watermark preview **3-33**

Watermark tab **3-33**

Web page passwords **4-18**

Web pages

accessing **3-40**

printer **3-40**

required environment **3-40**

X

XY Zoom **2-33**

Free Manuals Download Website

<http://myh66.com>

<http://usermanuals.us>

<http://www.somanuals.com>

<http://www.4manuals.cc>

<http://www.manual-lib.com>

<http://www.404manual.com>

<http://www.luxmanual.com>

<http://aubethermostatmanual.com>

Golf course search by state

<http://golfingnear.com>

Email search by domain

<http://emailbydomain.com>

Auto manuals search

<http://auto.somanuals.com>

TV manuals search

<http://tv.somanuals.com>