



YAMAHA

T50/T80

OWNER'S MANUAL

2FM-28199-20

IDENTIFICATION NUMBERS RECORD

1. KEY NUMBER:

2. FRAME NUMBER AND ENGINE NUMBER:

Your key identification number is stamped on your key as shown in the following illustration. Record this number in the space provided for reference if you need a new key.

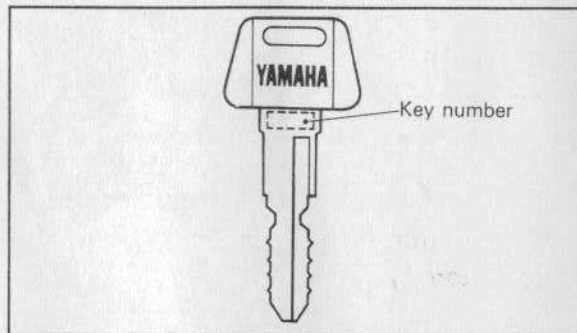

Record your frame and engine number in the spaces provided to assist you in ordering spare parts from your Yamaha dealer or for reference in case your vehicle is stolen. (See page 2-1)

A-001

T50/T80

OWNER'S MANUAL

©1986 by Yamaha Motor Co., Ltd.

1st Edition, March 1986

**All rights reserved. Any reprinting or
unauthorized use without the written
permission of Yamaha Motor Co., Ltd,
is expressly prohibited.**

Printed in Japan

INTRODUCTION

Congratulations on your purchase of the Yamaha T50/T80. This model is the result of Yamaha's vast experience in the production of fine sporting, touring, and pacesetting racing machines. It represents the high degree of craftsmanship and reliability that have made Yamaha a leader in these fields.

This manual will give you an understanding of the operation, inspection, and basic maintenance of this motorcycle. If you have any questions about the operation or maintenance of your motorcycle, please consult a Yamaha dealer.

NOTE: _____

Some data in this manual may become outdated due to future improvement on this model. If you have any questions about this manual or your motorcycle, please consult a Yamaha dealer.

**TECHNICAL PUBLICATIONS
SERVICE DIVISION
MOTORCYCLE OPERATIONS
YAMAHA MOTOR CO., LTD.**

WARNING: _____

PLEASE READ THIS MANUAL CAREFULLY AND COMPLETELY BEFORE OPERATING THIS MOTORCYCLE.

Particularly important information is distinguished in this manual by the following notations:

NOTE:

A NOTE provides key information to make procedures easier or clearer.

CAUTION:

A CAUTION indicates special procedures that must be followed to avoid damage to the motorcycle.

WARNING:

A WARNING indicates special procedures that must be followed to avoid injury to a motorcycle operator or person inspecting or repairing the motorcycle.

NOTE: _____

This manual should be considered a permanent part of this motorcycle and should remain with it even if the motorcycle is subsequently sold.

CONTENTS

DESCRIPTION	1-1	PRE-OPERATION CHECKS	4-1
MOTORCYCLE IDENTIFICATION	2-1	Brakes	4-3
Frame serial number	2-1	Throttle grip	4-3
Engine serial number	2-1	Engine oil	4-3
CONTROL FUNCTIONS	3-1	Tires	4-4
Main switch	3-1	Wheels	4-7
Indicator lights	3-1	Fittings/Fasteners	4-7
Speedometer	3-2	Lights and signals	4-7
Fuel meter	3-2	Switches	4-7
Handlebar switches	3-3	Battery	4-7
Change pedal	3-3	Fuel	4-8
Front brake lever	3-4	OPERATION AND IMPORTANT	
Rear brake pedal	3-4	RIDING POINTS	5-1
Fuel cock	3-4	Starting and warming up a cold	
Starter lever	3-5	engine	5-1
Kick starter	3-6	Engine warm-up	5-2
Steering lock	3-6	Starting a warm engine	5-2
Seat	3-7	Shifting	5-2
Helmet holder	3-7	Engine break-in	5-3
Rear shock absorber	3-8	Parking	5-4

PERIODIC MAINTENANCE AND

MINOR REPAIR.....6-1

Tool kit6-1

Periodic maintenance/lubrication6-3

Torque specifications6-5

Engine oil6-6

Fuel cock cleaning6-8

Air filter6-8

Carburetor adjustment6-10

Spark plug inspection6-10

Front brake adjustment6-11

Rear brake adjustment6-12

Brake light switch adjustment.....6-13

Checking the brake shoes6-13

Cable inspection and lubrication.....6-14

Throttle cable and grip lubrication ...6-14

Brake and change pedals.....6-14

Rear shock absorber adjustment6-15

Steering inspection6-15

Wheel bearings6-16

Battery.....6-16

Replenishing the battery fluid6-17

Fuse replacement6-18

Troubleshooting.....6-19

Troubleshooting chart.....6-20

CLEANING AND STORAGE.....7-1

A. Cleaning7-1

B. Storage7-2

SPECIFICATIONS8-1

DESCRIPTION

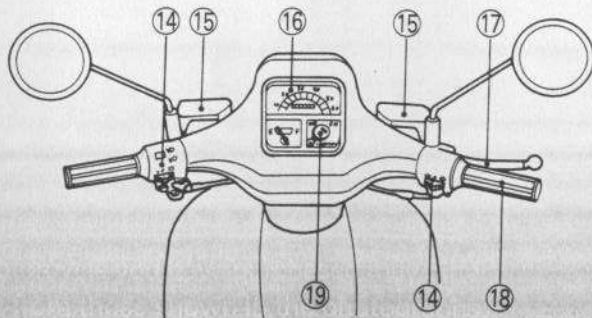
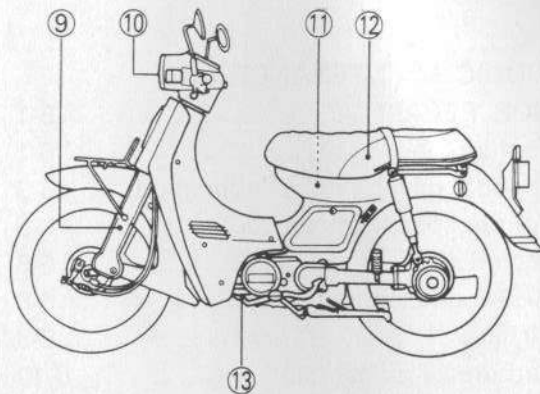
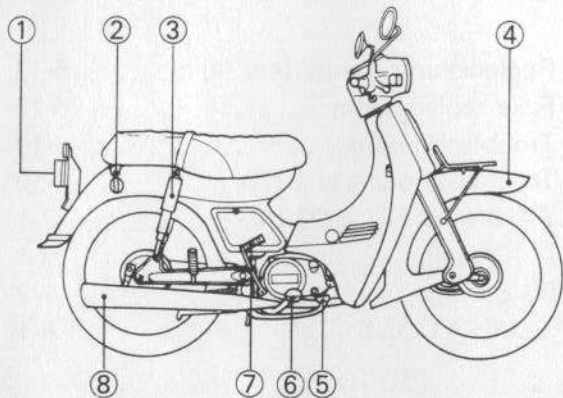

- | | |
|------------------------|-------------------------|
| 1. Tail/brake light | 11. Fuel tank |
| 2. Rear flasher light | 12. Seat |
| 3. Rear shock absorber | 13. Change pedal |
| 4. Front fender | 14. Handlebar switch |
| 5. Rear brake pedal | 15. Front flasher light |
| 6. Footrest | 16. Speedometer |
| 7. Kick starter | 17. Front brake lever |
| 8. Muffler | 18. Throttle grip |
| 9. Front fork | 19. Main switch |
| 10. Headlight | |

U-002

NOTE: _____

The motorcycle you have purchased may differ slightly from those shown in the photographs.

MOTORCYCLE IDENTIFICATION

A-606K

Frame serial number

The frame serial number is stamped into the left side of the frame.

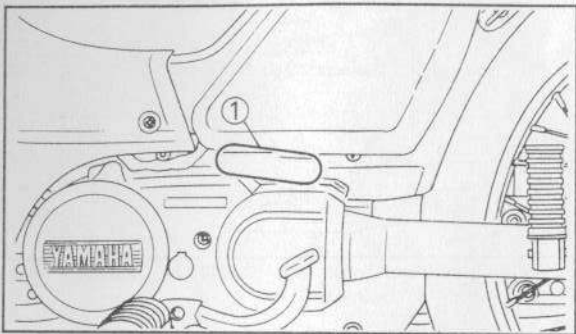

1. Frame serial number

V-720

Engine serial number

The engine serial number is stamped into the left side of the engine.

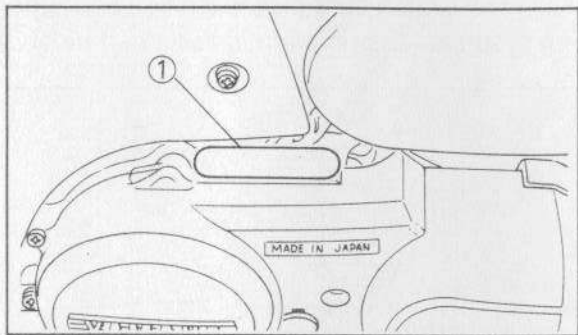

1. Engine serial number

U-003

NOTE: _____

The first three digits of these numbers are for model identification; the remaining digits are the unit production number. Keep a record of these numbers for reference when ordering parts from a Yamaha dealer.

CONTROL FUNCTIONS

Main switch

The main switch controls the ignition and lighting systems; its operation is described below.

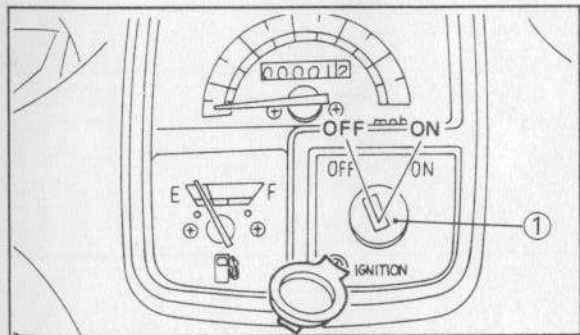

1. Main switch

ON:

Electrical circuits are switched on. The engine can be started. The key cannot be removed in this position.

OFF:

All electrical circuits are switched off. The key can be removed in this position.

Indicator lights

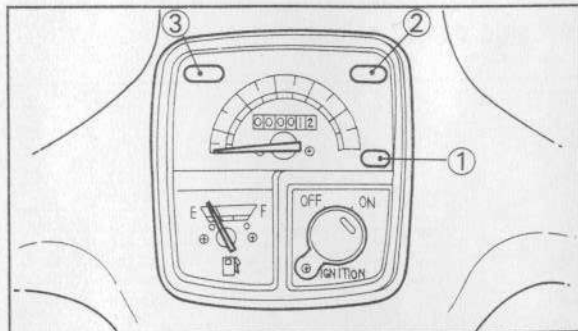

1. "TURN" indicator light 2. "NEUTRAL" indicator light
3. "HIGH BEAM" indicator light

"TURN" indicator light (orange):

This indicator flashes when the turn switch is "ON".

B-102

“NEUTRAL” indicator light (green):

This indicator comes on when the transmission is in neutral.

B-103

“HIGH BEAM” indicator light (blue):

This indicator comes on when the headlight high beam is used.

B-407K

Speedometer

The odometer is built into the speedometer.

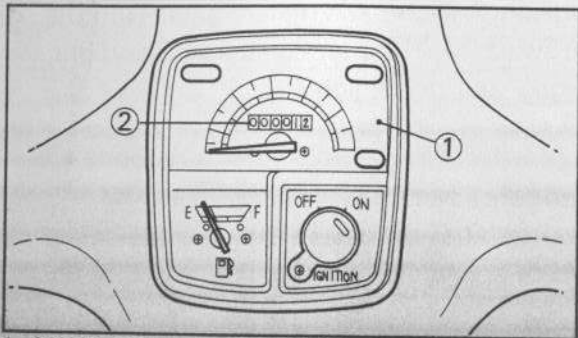

1. Speedometer

2. Odometer

Fuel meter

This model is equipped with an electric fuel meter so the rider can monitor the fuel level in the fuel tank.

When the needle moves to the “RED LINE” (refueling line), add fuel as soon as possible.

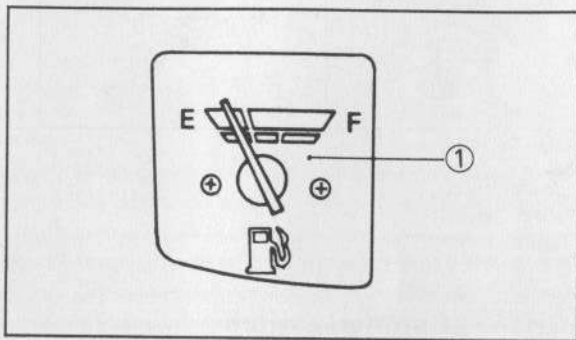

1. Fuel meter

Handlebar switches:

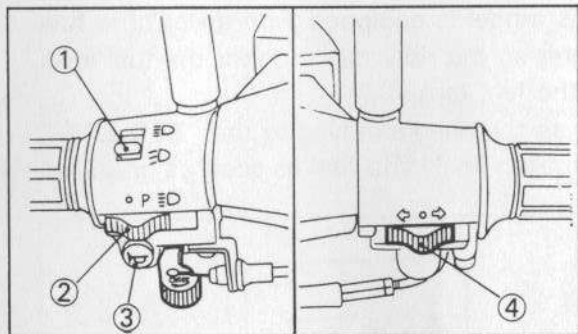

1. "LIGHTS" (Dimmer) switch
2. "LIGHTS" switch
3. "HORN" switch
4. "TURN" switch

"LIGHTS" (Dimmer) switch

Turn the switch to "☰D" for the high beam and to "☷D" for the low beam.

"TURN" signal switch

This is a three-way switch: the center position is off; turn to the "←" to turn on the left flasher and to the "→" for the right flasher. Be sure to turn the switch off after completing a turn.

B-602

"HORN" switch

Press the switch to sound the horn.

"LIGHTS" switch

Turn the light switch to "☰D" to turn on the headlight, taillight, and meter lights. Turn the light switch to "P" to turn on the auxiliary light, taillight, and meter lights.

Change pedal

The gear ratios of the constant-mesh 3-speed (T50), 4-speed (T80) transmission are ideally spaced. The gears can be shifted by using the change pedal on the left side of the engine.

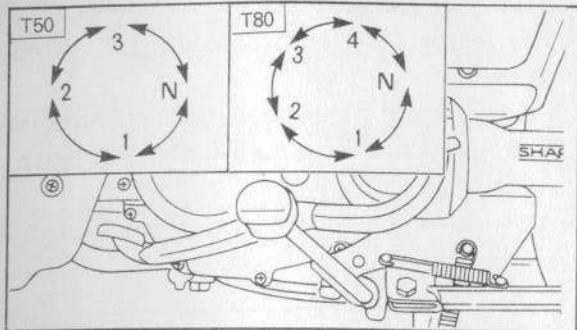

N. Neutral

WARNING:

During operation, avoid shifting from 4th gear to first as it will cause an abrupt braking action on the bike due to sudden engine compression buildup; this may cause the bike to skid out of control or create engine problems.

B-900

Front brake lever

The front brake lever is located on the right handlebar. Pull it toward the handlebar to activate the front brake.

B-901

Rear brake pedal

The rear brake pedal is on the right side of the motorcycle. Press down on the brake pedal to activate the rear brake.

C-103K

Fuel cock

The negative pressure fuel cock supplies fuel from the tank to the carburetors and also filters the fuel. The fuel cock has the following two positions:

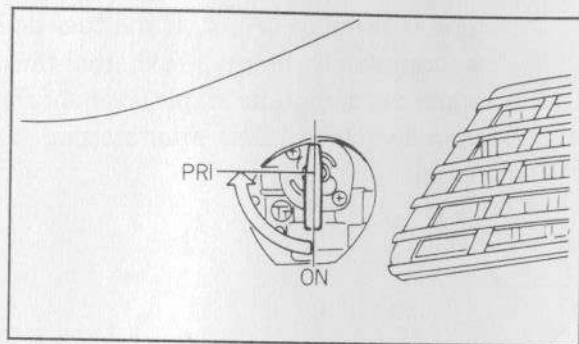

ON: With the lever in this position, fuel flows if the engine is running but stops if the engine is not running.

NOTE: _____

The fuel cock operates on vacuum from the engine when set at "ON". If the line connecting the cock to the carburetor intake manifold is not connected or has a leak, the cock will not function properly.

PRI: This indicates prime. With the lever in this position, fuel flows whether the engine is running or not. If the fuel tank is completely empty, refill the tank, prime the carburetor in this position, and then switch to "ON" after starting the engine.

Starter lever (CHOKE)

The starter lever is located on the left handlebar.

Starting a cold engine requires a richer fuel mixture. In such a case, turn the starter lever to the left.

After the engine is warm, turn the lever to its original position.

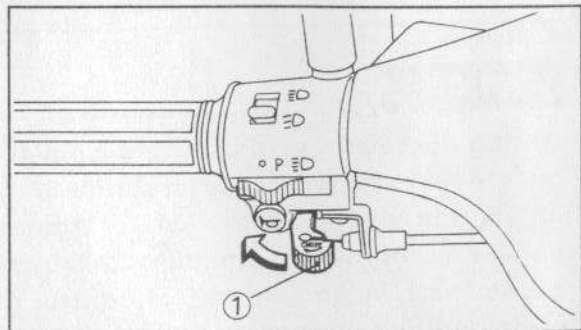

1. Starter lever

NOTE: _____

Refer to "Starting and warming up a cold engine" for proper operation.

Kick starter

Rotate the kick starter away from the engine. Push the starter down lightly with your foot until the gears engage, then kick smoothly and forcefully to start the engine. This model has a primary kick starter so the engine can be started in any gear if the clutch is disengaged. In normal practices, however, shift to neutral before starting.

Steering lock

To lock the steering, turn the handlebars all the way to the left. Insert the key into the steering lock under the head pipe, and turn the key 1/2 turn in either direction. After checking to see that the lock is engaged, remove the key from the lock. To release the lock, insert the key, and turn it 1/2 turn in either direction.

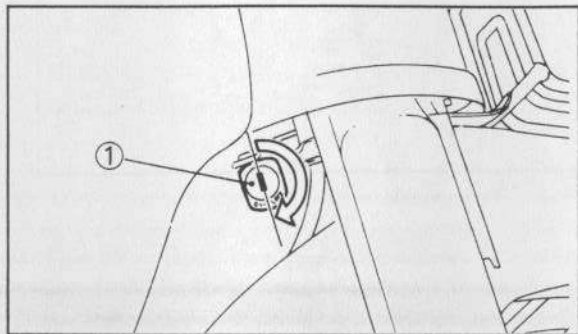

1. Steering lock

Seat

To open the seat, turn the knob as shown. To lock the seat, install the seat in its original position.

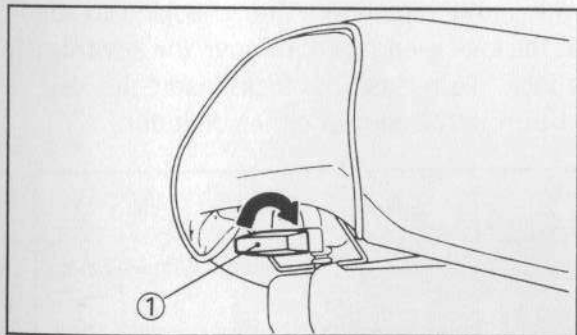

1. Seat lock

Helmet holder

To open the helmet holder, insert the key in the lock and turn it as shown. To lock the helmet holder, replace the holder in its original position.

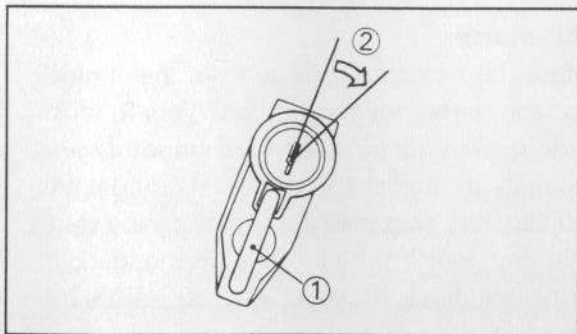

1. Helmet holder

2. Open

WARNING:

Never ride with a helmet in the helmet holder. It could interfere with rear wheel movement, causing loss of control and possibly an accident.

Rear shock absorber

The spring preload of the rear shock absorber can be adjusted to suit motorcycle's load (ex: optional accessories etc.) and riding conditions. Refer to page 6-15 for proper adjustment procedures.

PRE-OPERATION CHECKS

Before using this motorcycle, check the following points:

Item	Routine	Page
Front and rear brakes	Check operation, condition and free play. Adjust if necessary.	4-3, 6-11 ~ 6-13
Throttle grip/Housing	Check for smooth operation. Lubricate/Adjust if necessary.	4-3, 6-14
Engine oil	Check oil level/add oil as required.	4-3 ~ 4-4, 6-6 ~ 6-7
Final gear oil	Check for leakage visually.	—
Wheels/Tires	Check tire pressure, wear, damage and spoke tightness.	4-4 ~ 4-7
Control/Meter cables	Check for smooth operation. Lubricate if necessary.	6-14
Brake and change pedal shafts	Check for smooth operation. Lubricate if necessary.	6-14
Brake lever pivots	Check for smooth operation. Lubricate if necessary.	—
Centerstand pivot	Check for smooth operation. Lubricate if necessary.	—
Fittings/fasteners	Check all chassis fittings and fasteners. Tighten/Adjust , if necessary.	4-7, 6-5
Fuel tank	Check fuel level/top-up as required.	4-8
Lights and signals	Check for proper operation.	4-7
Battery	Check fluid level, top-up with distilled water if necessary.	4-7, 6-16 ~ 6-17

NOTE:

Pre-operation checks should be made each time the motorcycle is used. Such an inspection can be thoroughly accomplished in a very short time; and the added safety it assures is more than worth the time involved.

WARNING:

If any item in the Pre-Operation Check is not working properly, have it inspected and repaired before operating the motorcycle.

Brakes (See page 6-11 for more detail)

1. Brake lever and brake pedal

Check for correct free play in the front brake lever and rear brake pedal. Make sure they are working properly. Check the brakes at low speed shortly after starting out. If the free play is incorrect, adjust it.

2. Check the brake shoes.

Refer to page 6-13.

NOTE: _____

When this brake service is necessary, ask a Yamaha dealer.

Throttle grip (See page 6-14 for more detail)

Turn the throttle grip to see if it operates properly, and check the free play. Make sure the grip returns by spring force when released. Ask a Yamaha dealer to make any necessary adjustments.

Engine oil (See page 6-6 for more detail)

Make sure the engine oil is at the specified level. Add oil as necessary.

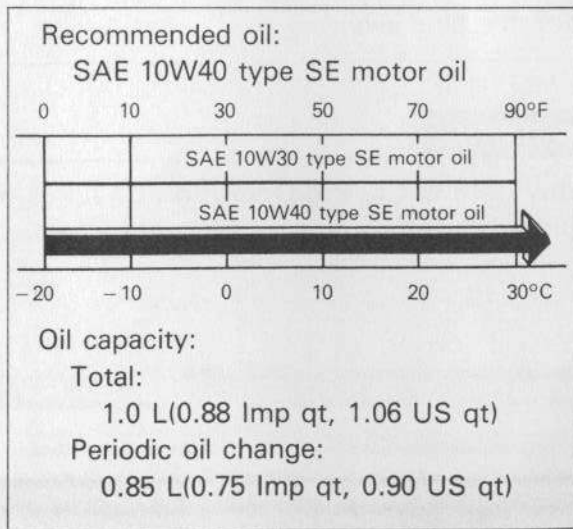

NOTE: _____

Recommended engine oil classification; API Service "SE", "SF" type or equivalent (e.g. "SF-SE", "SF-SE-CC", "SF-SE-SD" etc.).

Tires

To ensure maximum performance, long service, and safe operation, note the following:

1. Tire air pressure

Always check and adjust the tire pressure before operating the motorcycle.

WARNING: _____

Tire inflation pressure should be checked and adjusted when the temperature of the tire equals the ambient air temperature.

Tire inflation pressure must be adjusted according to total weight of cargo, rider, passenger, and accessories (fairing, saddlebags, etc. if approved for this model), and vehicle speed.

Basic weight: With oil and full fuel tank	87 kg (187 lb)	
Maximum load*	150 kg (331 lb)	
Cold tire pressure	Front	Rear
Up to 75 kg (165 lb) load*	147 kPa (1.5 kg/cm ² , 22 psi)	196 kPa (2.0 kg/cm ² , 28 psi)
75 kg (165 lb) ~ Maximum load*	147 kPa (1.5 kg/cm ² , 22 psi)	274 kPa (2.8 kg/cm ² , 40 psi)

*Load is the total weight of cargo, rider, passenger, and accessories.

WARNING:

Proper loading of your motorcycle is important for the handling, braking, and other performance and safety characteristics of your motorcycle. Do not carry loosely packed items that can shift. Securely pack your heaviest items close to the center of the motorcycle, and distribute the weight evenly from side to side. Properly adjust the suspension for your load, and check the condition and pressure of your tires. **NEVER OVERLOAD YOUR MOTORCYCLE.** Make sure the total weight of the cargo, rider, passenger, and accessories (fairing, saddlebags, etc. if approved for this model) does not exceed the maximum load of the motorcycle. Operation of an overloaded motorcycle could cause tire damage, an accident, or even injury.

2. Tire inspection

Always check the tires before operating the motorcycle. If a tire tread shows crosswise lines (minimum tread depth), if the tire has a nail or glass fragments in it, or if the side wall is cracked, contact a Yamaha dealer immediately and have him replace the tire.

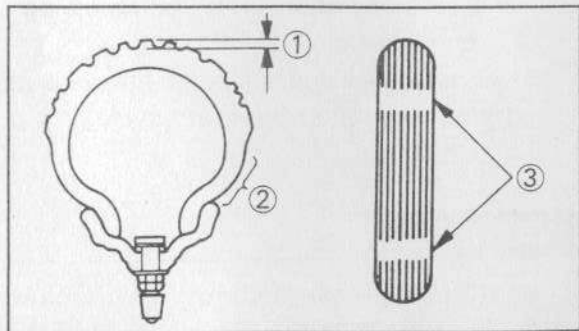

1. Tread depth

2. Side wall

3. Wear indicator

WARNING:

After extensive tests, the tires mentioned below have been approved by Yamaha motor Co., Ltd. for this model. No guarantee for handling characteristics can be given if tire combinations other than what is approved are used on this motorcycle. The front and rear tires should be of the same manufacture and design.

FRONT:

Manufacture	Size
Inoue	2.50-17-4PR

REAR:

Manufacture	Size
Inoue	2.50-17-6PR

Minimum tire tread depth (front and rear)	1.0 mm (0.04 in)
---	------------------

WARNING:

1. It is dangerous to ride with a worn-out tire. When a tire tread begins to show lines, have a Yamaha dealer replace the tire immediately. Brakes, tires, and related wheel parts replacement should be left to a Yamaha Service Technician.
2. Patching a punctured tube is not recommended. If it is absolutely necessary to do so, use great care and replace the tube as soon as possible with a good quality replacement.

Wheels

To ensure maximum performance, long service, and safe operation, note the following:

1. Always inspect the wheels before a ride. Check for cracks, bends, or warpage of the wheel; be sure the spokes are tight and undamaged. If any abnormal condition exists in a wheel, consult a Yamaha dealer. Do not attempt even small repairs to the wheel. If a wheel is deformed or cracked, it must be replaced.
2. Tires and wheels should be balanced whenever either one is changed or replaced. Failure to have a wheel balanced can result in poor performance, adverse handling characteristics, and shortened tire life.
3. After installing a tire, ride conservatively to allow the tire to seat itself on the rim properly. Failure to allow proper seating may cause tire failure, resulting in damage to the motorcycle and injury to the rider.

Fittings/Fasteners

Always check the tightness of chassis fittings and fasteners before a ride. Use the chart on page 6-5 to find the correct torque.

Lights and signals

Check the headlight, flasher lights, taillight, brake light, meter lights, and all the indicator lights to make sure they are in working condition.

Switches

Check the operation of the headlight switch, turn switch, brake light switch, horn switch, main switch, etc.

Battery (See page 6-16 for more detail)

Check the fluid level and top-up if necessary. Use only distilled water if refilling is necessary.

Fuel

Make sure there is sufficient fuel in the tank.

U-610

WARNING:

Do not overfill the fuel tank. Avoid spilling fuel on the hot engine. Do not fill the fuel tank above the bottom of the filler tube as shown in the illustration or it may overflow when the fuel heats up later and expands.

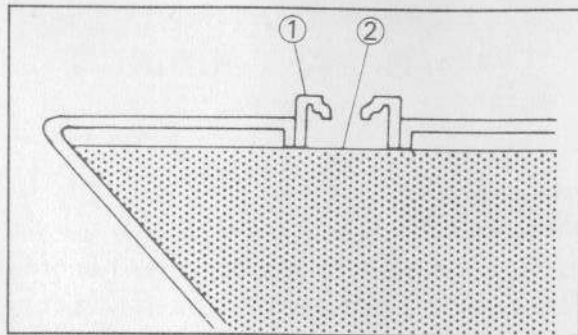

1. Filler tube

2. Fuel level

E-803

Recommended fuel: Regular gasoline
Fuel tank capacity:

Total:

5.0 L (1.1 Imp gal, 1.3 US gal)

OPERATION AND IMPORTANT RIDING POINTS

U-672

WARNING:

Before riding this motorcycle, become thoroughly familiar with all operating controls and their function. Consult a Yamaha dealer regarding any control or function that you do not thoroughly understand.

U-629

WARNING:

Never start your engine or let it run for any length of time in a closed area. The exhaust fumes are poisonous and can cause loss of consciousness and death within a short time. Always operate your motorcycle in an area with adequate ventilation.

Starting and warming up a cold engine

1. Turn the fuel cock to "ON."
2. Turn the ignition key to "ON".
3. Shift transmission into neutral.

U-030

NOTE:

When the transmission is in neutral, the neutral indicator light (green) should be on. If the light does not come on, ask a Yamaha dealer to inspect it.

4. Turn the starter (CHOKE) lever all the way to the left and completely close the throttle grip.
5. Kick the kick starter to start the engine.
6. After starting the engine, turn back the starter lever (CHOKE) to warming up position (about halfway).

U-026

NOTE: _____

To get maximum engine life, always warm up the engine before starting off. Never accelerate hard with a cold engine!

7. After warming up the engine, turn off the starter lever by pushing it back completely.

U-027

NOTE: _____

The engine is warm when it responds normally to the throttle with the starter turned off.

F-110

Engine warm-up

To ensure maximum engine life, always warm up the engine before riding your motorcycle. Never accelerate hard with a cold engine. An engine is warm if it responds normally to the throttle when the starter (CHOKE) is turned off.

F-108

Starting a warm engine

The starter (CHOKE) is not required when the engine is warm.

U-314

CAUTION: _____

See "Break-in section" prior to operating the motorcycle for the first time.

F-200

Shifting

The transmission lets you control the amount of power you have available at a given speed for starting, accelerating, climbing hills, etc. The use of the change pedal is shown in the illustration. (Page 3-4)

To shift into NEUTRAL, depress the change pedal repeatedly until it reaches the end of its travel (you will feel a stop when you are in first gear) then raise the pedal slightly.

CAUTION: _____

1. Do not coast for long periods with the engine off, and do not tow the motorcycle a long distance. Even with gears in neutral, the transmission is only properly lubricated when the engine is running. Inadequate lubrication may damage the transmission.
 2. Always use the clutch when changing gears. The engine, transmission, and driveline are not designed to withstand the shock of forced shifting and can be damaged by shifting without the clutch.
-

Engine break-in

There is never a more important period in the life of your motorcycle than the period between zero and 1,000 km (600 mi). For this reason we ask that you carefully read the following material. Because the engine is brand new, you must not put an excessive load on it for the first 1,000 km (600 mi). The various parts in the engine wear and polish themselves to the correct operating clearances. During this period, prolonged full throttle operation or any condition which might result in excessive heating of the engine, must be avoided.

1. 0 ~ 500 km (0 ~ 300 mi):
It is very good for the engine, if it is allowed to cool about 10 minutes for each hour of operation.

During this period the engine should not be operated at a constant speed. Vary the speed occasionally. Do not exceed 1/2 throttle.

2. 500 ~ 1,000 km (300 ~ 600 mi):
Avoid cruising speeds in excess of 3/4 throttle.

U-404K

CAUTION: _____

After 1,000 km (600 mi) of operation, be sure to replace the engine oil.

3. 1,000 km (600 mi) and beyond:
The engine can be operated occasionally at full throttle but be careful of the engine condition and check for noises, etc.

U-522

CAUTION: _____

If any engine trouble should occur during the break-in period, consult a Yamaha dealer immediately.

F-400

Parking

When parking the motorcycle, stop the engine and remove the ignition key.

U-630

WARNING: _____

The muffler and exhaust pipe are hot. Park the motorcycle in a place where pedestrians or children are not likely to touch the motorcycle.

Do not park the motorcycle on a slope or soft ground; the motorcycle may overturn.

PERIODIC MAINTENANCE AND MINOR REPAIR

H-004

Periodic inspection, adjustment, and lubrication will keep your motorcycle in the safest and most efficient condition possible. Safety is an obligation of the motorcycle owner. The maintenance and lubrication schedule chart should be considered strictly as a guide to general maintenance and lubrication intervals. **YOU MUST TAKE INTO CONSIDERATION THAT WEATHER, TERRAIN, GEOGRAPHICAL LOCATIONS, AND A VARIETY OF INDIVIDUAL USES ALL TEND TO DEMAND THAT EACH OWNER ALTER THIS TIME SCHEDULE TO SHORTER INTERVALS TO MATCH HIS ENVIRONMENT.** The most important points of motorcycle inspection, adjustment, and lubrication are explained in the following pages.

WARNING:

If you are not familiar with motorcycle service, this work should be done by a Yamaha dealer.

H-101

Tool kit

The service information included in this manual is intended to provide you, the owner, with the necessary information for completing some of your own preventive maintenance and minor repairs. The tools provided in the owner's tool kit are sufficient for most of these purposes; however a torque wrench is also necessary to properly tighten nuts and bolts.

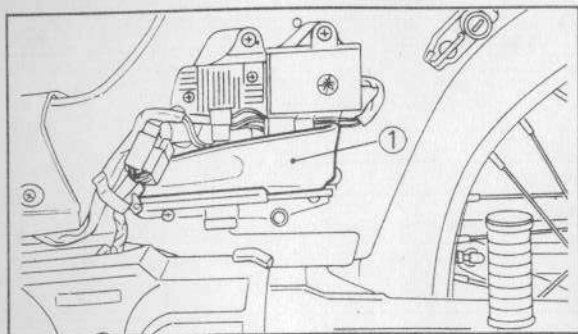

1. Tool kit

U-060

NOTE: _____

If you do not have a torque wrench available during a service operation requiring one, take your motorcycle to a Yamaha dealer to check the torque settings and adjust them as necessary.

U-071

WARNING: _____

Modifications to this motorcycle not approved by Yamaha may cause loss of performance, and render it unsafe for use. Consult a Yamaha dealer before attempting any changes.

PERIODIC MAINTENANCE/LUBRICATION

Unit: km (miles)

ITEM	REMARKS	BREAK-IN 1,000 (600)	EVERY	
			6,000 (4,000) or 6 months	12,000 (8,000) or 12 months
Valve(s)*	Check valve clearance. Adjust if necessary.	<input type="radio"/>	<input type="radio"/>	<input type="radio"/>
Cam chain*	Check chain tension. Adjust if necessary.	<input type="radio"/>	<input type="radio"/>	<input type="radio"/>
Spark plug(s)	Check condition. Clean or replace if necessary.	<input type="radio"/>	<input type="radio"/>	<input type="radio"/>
Air filter	Clean. Replace if necessary.		<input type="radio"/>	<input type="radio"/>
Carburetor*	Check idle speed/starter operation. Adjust if necessary.	<input type="radio"/>	<input type="radio"/>	<input type="radio"/>
Fuel line*	Check fuel hose and vacuum pipe for cracks or damage. Replace if necessary.		<input type="radio"/>	<input type="radio"/>
Engine oil	Replace (Warm engine before draining).	<input type="radio"/>	<input type="radio"/>	<input type="radio"/>
Oil strainer*	Check/clean/replace if necessary.	<input type="radio"/>	<input type="radio"/>	<input type="radio"/>
Brake	Check operation. Adjust if necessary.		<input type="radio"/>	<input type="radio"/>
Rear arm pivot*	Check rear arm assembly for looseness. Correct if necessary. Moderately repack every 24,000 (16,000) or 24 months.			<input type="radio"/> <input type="radio"/>
Wheels*	Check balance/damage/runout/spoke tightness. Repair if necessary.		<input type="radio"/>	<input type="radio"/>
Wheel bearings*	Check bearings assembly for looseness/damage. Replace if damaged.	<input type="radio"/>		<input type="radio"/>

ITEM	REMARKS	BREAK-IN 1,000 (600)	EVERY	
			6,000 (4,000) or 6 months	12,000 (8,000) or 12 months
Steering bearing*	Check bearings assembly for looseness. Correct if necessary. Moderately repack every 24,000 (16,000) or 24 months.**		○	○
Front forks*	Check operation/oil leakage. Repair if necessary.		○	○
Rear shock absorber*	Check operation/oil leakage. Repair if necessary.		○	○
Fittings/Fasteners*	Check all chassis fittings and fasteners. Correct if necessary.	○	○	○
Center sidestand*	Check operation. Repair if necessary.	○	○	○
Battery*	Check specific gravity. Check breather pipe for proper operation. Correct if necessary.		○	○

*: It is recommended that these items be serviced by a Yamaha dealer.

** : Medium weight wheel bearing grease.

Torque specifications

Use a torque wrench to tighten these items. It is recommended that these items be checked occasionally, especially before a long trip. Always check the tightness of these items whenever they are loosened for any reason.

A (Nut)	B (Bolt)	General torque specifications		
		Nm	m•kg	ft•lb
10 mm	6 mm	6	0.6	4.3
12 mm	8 mm	15	1.5	11
14 mm	10 mm	30	3.0	22
17 mm	12 mm	55	5.5	40
19 mm	14 mm	85	8.5	61
22 mm	16 mm	130	13.0	94

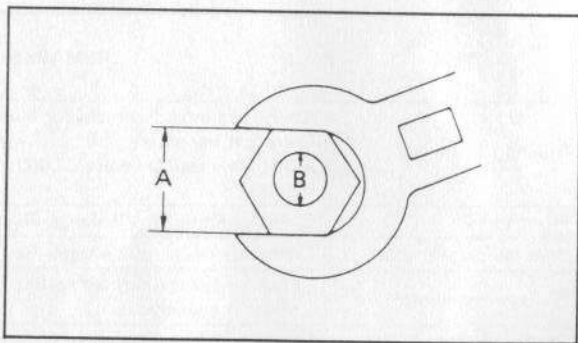

Item	Torque		
	Nm	m•kg	ft•lb
Spark plug	12.5	1.25	9.0
Drain plug-Transmission	20	2.0	14

Engine oil

1. Oil level measurement
 - a. Place the motorcycle on the centerstand.
Warm up the engine for several minutes.

U-039

NOTE: _____

Be sure the motorcycle is positioned straight up when checking the oil level; a slight tilt toward the side can produce false readings.

- b. With the engine stopped, check the oil level through the level window located at the lower part of the right side crankcase cover.

U-040

NOTE: _____

Wait a few minutes until the oil level settles before checking.

- c. The oil level should be between maximum and minimum marks. If the level is low, add sufficient oil to raise it to the proper level.

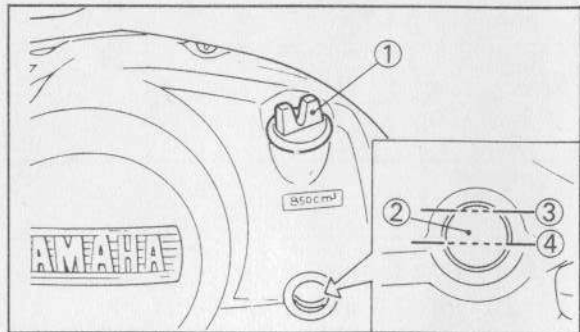

1. Oil filler cap
2. Level window
3. Maximum mark
4. Minimum mark

2. Engine oil and oil filter replacement
 - a. Warm-up the engine for a few minutes.
 - b. Stop the engine. Place an oil pan under the engine, and remove the oil filler cap.
 - c. Remove the drain plug and drain the oil.
 - d. Reinstall the drain plug (make sure it is tight).

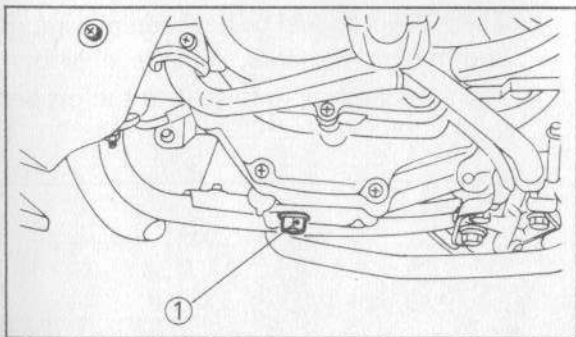

1. Drain plug

Drain plug torque:

20 Nm (2.0 m•kg, 14 ft•lb)

e. Add oil through the oil filler hole.

Periodic oil change:

0.85 L (0.75 Imp qt, 0.90 US qt)

Recommended oil: See page 4-3.

CAUTION: _____

Do not add any chemical additives. Engine oil also lubricates the clutch and additives could cause clutch slippage.

U-324

CAUTION: _____

Be sure no foreign material enters the crankcase.

f. After replacement of engine oil, be sure to check the oil leakage.

Fuel cock cleaning

1. Turn the cock lever to the "ON".
2. Remove the drain screw and clean it with solvent. If gasket is damaged, replace.

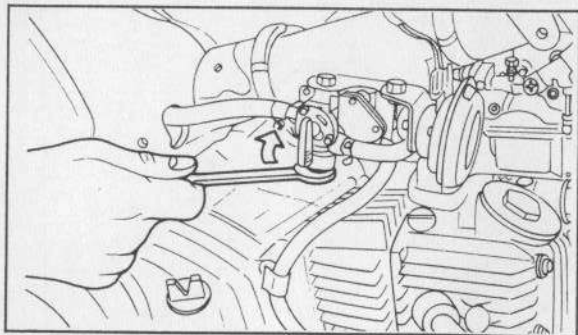
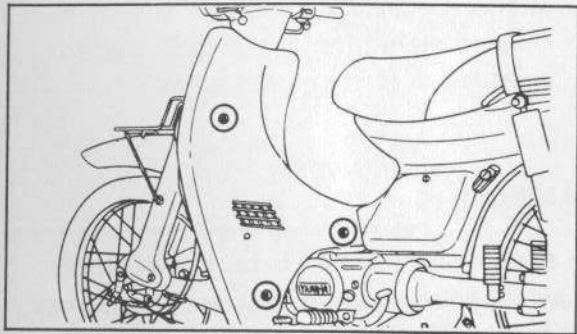

H-631K

Air filter

1. Remove the front panel and the legshield by removing the screws.
2. Remove the air filter case fitting screws and the filter case cover.
3. Remove the air filter element from its case, and clean it with solvent. After cleaning, remove the remaining solvent by squeezing the element.

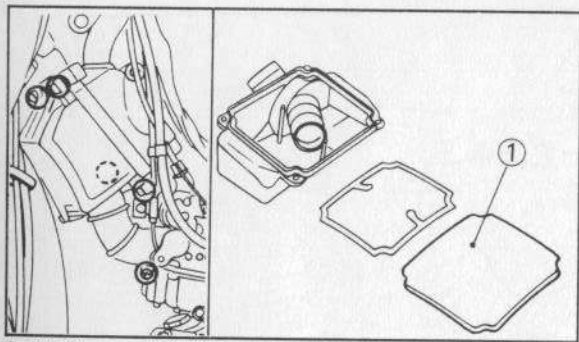

1. Air filter element

4. Apply recommended oil to the entire surface of the filter and squeeze out the excess oil. The element should be wet but not dripping.

Recommended oil:

Yamaha oil 2T or equivalent air-cooled 2-stroke engine oil

5. When installing the air filter element in its case, be sure its sealing surface matches the sealing surface of the case so there is no air leak.
6. The air filter element should be cleaned at the specified intervals. It should be cleaned more often if the motorcycle is operated in dusty or wet areas.

U-326

CAUTION: _____

The engine should never be run without the air cleaner element; excessive piston and/or cylinder wear may result.

Carburetor adjustment

The carburetor is a vital part of the engine and requires very sophisticated adjustment. Most adjustments should be left to a Yamaha dealer who has the professional knowledge and experience to do so. However, the following point may be serviced by the owner as part of this routine maintenance.

CAUTION:

The carburetor was set at the Yamaha factory after many tests. If the settings are disturbed, poor engine performance and damage may result.

Spark plug inspection

The spark plug is an important engine component and is easy to inspect. The condition of the spark plug can indicate something of the condition of the engine.

The ideal color on the white porcelain insulator around the center electrode is a medium to light tan color for a motorcycle that is being ridden normally. Do not attempt to diagnose any problems yourself. Instead, take the motorcycle to a Yamaha dealer. You should periodically remove and inspect the spark plug because heat and deposits will cause the spark plug to slowly break down and erode. If electrode erosion becomes excessive, or if carbon and other deposits are excessive, you should replace the spark plug with a proper type plug.

Standard spark plug:
T50: CR6HS (NGK),
T80: CR7HS (NGK)

Before installing the spark plug, measure the electrode gap with a wire thickness gauge; adjust the gap to specification as necessary.

Spark plug gap:
0.6 ~ 0.7 mm (0.024 ~ 0.028 in)

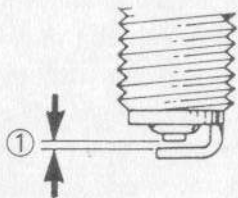

1. Spark plug gap

When installing the plug, always clean the gasket surface and use a new gasket. Wipe off any grime from the threads, and torque the spark plug properly.

Spark plug torque:
12.5 Nm (1.25 m•kg, 9.0 ft•lb)

U-038

NOTE: _____

If a torque wrench is not available when you are installing a spark plug, a good estimate of the correct torque is 1/4 to 1/2 turns past finger tight. Have the spark plug torqued to the correct value as soon as possible with a torque wrench.

H-855K

Front brake adjustment

The front brake should be adjusted to suit the rider's preference; but free play at the brake lever pivot point should be 5 ~ 8 mm (0.2 ~ 0.3 in). Adjustment is accomplished at the front brake hub.

To adjust, turn the adjuster clockwise to reduce play; turn it counterclockwise to increase play.

WARNING:

When it is impossible to make the proper adjustment, ask a Yamaha dealer.

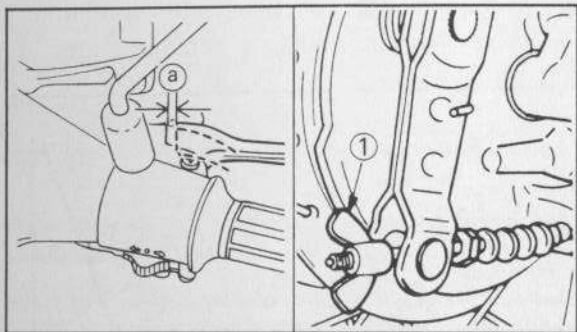

a. 5 ~ 8 mm (0.20 ~ 0.31 in) 1. Adjuster

Rear brake adjustment

The rear brake should be adjusted to suit the rider's preference; but free play at the brake pedal end must be 20 ~ 30 mm (0.8 ~ 1.2 in). To adjust, turn the adjuster clockwise to reduce play; turn it counterclockwise to increase play.

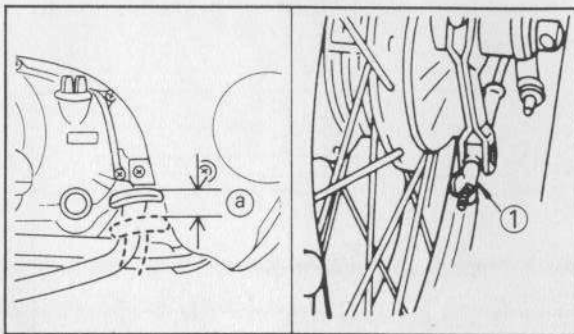

a. 20 ~ 30 mm (0.8 ~ 1.2 in) 1. Adjuster

WARNING:

Check the operation of the brake light after adjusting the rear brake.

Brake light switch adjustment

The brake light switch is operated by movement of the brake pedal. To adjust, hold the main body of the switch with your hand so it does not rotate and turn the adjusting nut. Proper adjustment is achieved when the brake light comes on just before the brake begins to take effect.

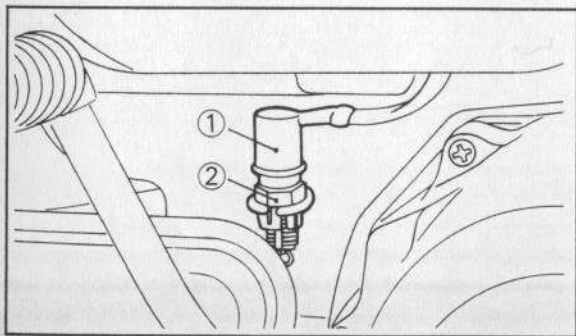

1. Main body

2. Adjusting nut

Checking the brake shoes

A wear indicator is attached to each brake to facilitate brake shoes check. This indicator permits a visual check without disassembling the brake.

To check, look at the wear indicator while depressing the brake pedal or pulling the brake lever. If the indicator reaches to the wear limit line, ask a Yamaha dealer to replace shoes.

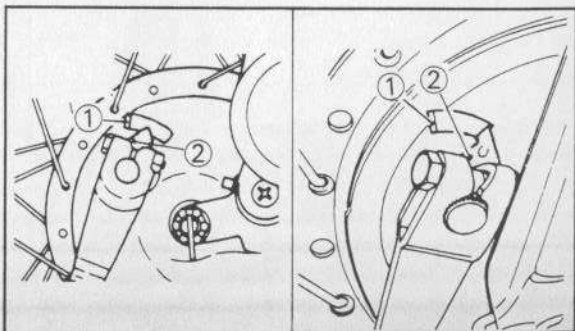

1. Wear limit

2. Wear indicator

Cable inspection and lubrication

U-646

WARNING:

Damage to the outer housing of the various cables may cause corrosion and interfere with the movement of the cable. An unsafe condition may result so replace such cables as soon as possible.

Lubricate the inner cable and the cable end. If they do not operate smoothly, ask a Yamaha dealer to replace them.

Recommended lubricant:
SAE 10W30 motor oil

I-102

Throttle cable and grip lubrication

The throttle twist grip assembly should be greased at the time that the cable is lubricated, since the grip must be removed to get at the end of the throttle cable. Two screws clamp the throttle housing to the handlebar. Once these two are removed, the end of the cable can be held high to pour in several drops of lubricant. With the throttle grip disassembled, coat the metal surface of the grip assembly with a suitable all-purpose grease.

I-306

Brake and change pedals

Lubricate the pivoting parts.

Recommended lubricant:
SAE 10W30 motor oil

Rear shock absorber adjustment

Spring preload

If the spring seat is raised, the spring becomes stiffer, and if lowered, it becomes softer.

Standard position: C

- A. — Softest
- E. — Stiffest

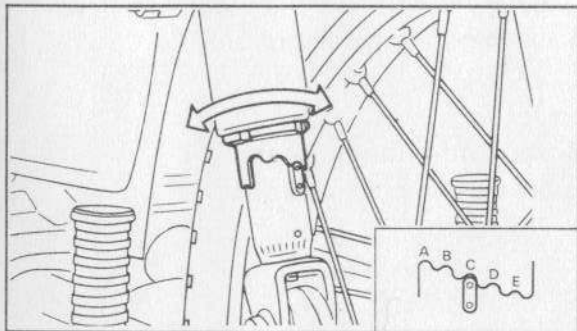

WARNING:

Always adjust each shock absorber to the same setting. Uneven adjustment can cause poor handling and loss of stability.

I-603

Steering inspection

Periodically inspect the condition of the steering. Worn out or loose steering bearings may be dangerous.

Place a block under the engine to raise the front wheel off the ground.

Hold the lower end of the front forks and try to move them forward and backward. If any free play can be felt, ask a Yamaha dealer to inspect and adjust the steering. Inspection is easier if the front wheel is removed.

U-657

WARNING:

Securely support the motorcycle so there is no danger of it falling over.

Wheel bearings

If the wheel bearings in the front or rear wheel allow play in the wheel hub or if the wheel does not turn smoothly, have a Yamaha dealer inspect the wheel bearings. The wheel bearings should be inspected according to the Maintenance Schedule.

Battery

Check the level of the battery electrolyte and see that the terminals are tight. Add distilled water if the electrolyte level is low.

CAUTION:

When inspecting the battery, be sure the breather pipe is routed correctly. If the breather pipe touches the frame or exits in such a way as to cause battery electrolyte or gas to exit onto the frame, structural and cosmetic damage to the motorcycle can occur.

WARNING:

Battery electrolyte is poisonous and dangerous, causing severe burns, etc. It contains sulfuric acid. Avoid contact with skin, eyes or clothing.

Antidote: **EXTERNAL**-Flush with water. **INTERNAL**-Drink large quantities of water or milk. Follow with milk of magnesia, beaten egg, or vegetable oil. Call a physician immediately.

Eyes: Flush with water for 15 minutes and get prompt medical attention. Batteries produce explosive gases. Keep sparks, flame, cigarettes etc., away. Ventilate when charging or using in an enclosed space. Always shield your eyes when working near batteries.

KEEP OUT OF REACH OF CHILDREN.

Replenishing the battery fluid

A poorly maintained battery will deteriorate quickly. The battery fluid should be checked at least once a month.

1. The level should be between the upper and lower level marks. Use only distilled water if refilling is necessary.

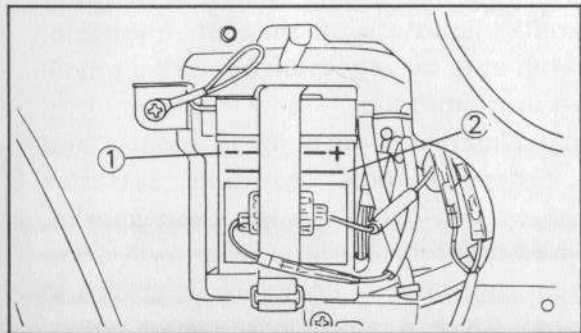

1. Upper level

2. Lower level

CAUTION:

Normal tap water contains minerals which are harmful to a battery; therefore, refill only with distilled water.

2. When the motorcycle will not be used for a month or longer, remove the battery and store it in a cool, dark place. Completely recharge the battery before reusing.
3. If the battery will be stored for a longer period than the above, check the specific gravity of the fluid at least once a month and recharge the battery when it is too low.
4. Always make sure the connections are correct when putting the battery back in the motorcycle.

Make sure the breather pipe is properly connected and is not damaged or obstructed.

Fuse replacement

If a fuse is blown, turn off the ignition switch and the switch in the circuit in question. Install a new fuse of proper amperage.

Turn on the switches, and see if the electrical device operates. If the fuse immediately blows again, consult a Yamaha dealer.

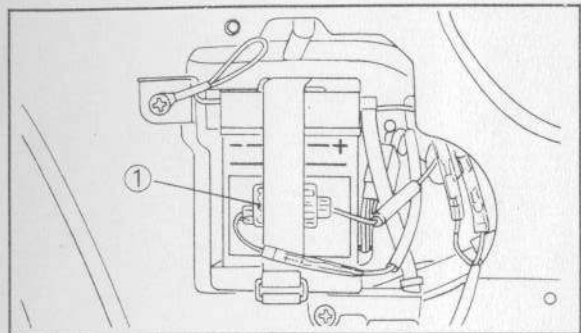

1. Fuse

CAUTION:

Do not use fuses of higher amperage rating than those recommended. Substitution of a fuse of improper rating can cause extensive electrical system damage and possibly a fire.

Troubleshooting

Although Yamaha motorcycles receive a rigid inspection before shipment from the factory, trouble may occur during operation. Any problem in the fuel, compression, or ignition systems can cause poor starting and a loss of power. The troubleshooting chart describes a quick, easy procedure for checking these systems.

If your motorcycle requires any repair, bring it to a Yamaha dealer. The skilled technicians at a Yamaha dealer have the tools, experience, and know-how to properly service your motorcycle. Use only genuine Yamaha parts on your motorcycle. Imitation parts may look like Yamaha parts, but they are often inferior. Consequently, they have a shorter service life and can lead to expensive repair bills.

Troubleshooting chart

U-663

WARNING:

Never check the fuel system while smoking or in the vicinity of an open flame.

1. Fuel

Check if there is fuel in the fuel tank

2. Compression

Kick the kick lever to see if there is compression

3. Ignition

Remove spark plug(s) and check electrode

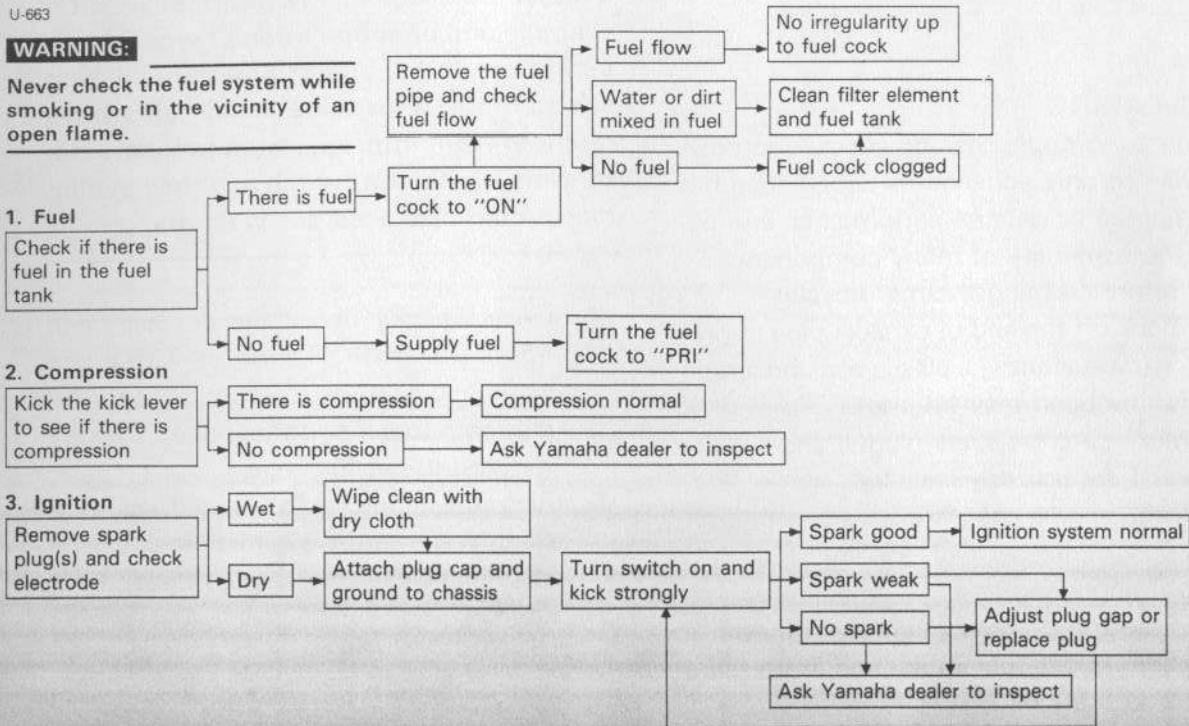

CLEANING AND STORAGE

K-011

A. CLEANING

Frequent thorough cleaning of your motorcycle will not only enhance its appearance but will improve its general performance and extend the useful life of many components.

1. Before cleaning the motorcycle:
 - a. Block off the end of exhaust pipe to prevent water entry; a plastic bag and strong rubber band may be used.
 - b. Make sure the spark plug(s) and all filler caps are properly installed.
2. If the engine case is excessively greasy, apply degreaser with a paint brush. Do not apply degreaser to wheel axles.
3. Rinse the dirt and degreaser off with a garden hose, use only enough pressure to do the job.

CAUTION:

Excessive hose pressure may cause water seepage and contamination of wheel bearings, front forks, brakes and transmission seals. Many expensive repair bills have resulted from improper high pressure detergent applications such as those available in coin-operated car washers.

4. Once the majority of the dirt has been hosed off, wash all surfaces with warm water and mild, detergent-type soap. An old tooth brush or bottle brush is handy for hard-to-get-to places.
5. Rinse the motorcycle off immediately with clean water and dry all surfaces with a chamois, clean towel, or soft absorbent cloth.

6. Clean the seat with a vinyl upholstery cleaner to keep the cover pliable and glossy.
7. Automotive-type wax may be applied to all painted and chrome-plated surfaces. Avoid combination cleaner-waxes. Many contain abrasives which may mar the paint or protective finish. When finished, start the engine and let it idle for several minutes.

K-014K

B. STORAGE

Long term storage (60 days or more) of your motorcycle will require some preventive procedures to guard against deterioration. After thoroughly cleaning the motorcycle, prepare for storage as follows:

1. Drain the fuel tank, fuel lines, and carburetor float bowl(s).
2. Remove the spark plug, pour about one tablespoon of SAE 10W30 or 20W40 motor oil in the spark plug hole and reinstall

the spark plug. Kick the engine over several times (with ignition off) to coat the cylinder walls with oil.

3. Lubricate all control cables.
4. Block up the frame to raise both wheels off the ground.
5. Tie a plastic bag over the exhaust pipe outlet to prevent moisture from entering.
6. If storing in a humid or salt-air atmosphere, coat all exposed metal surfaces with a light film of oil. Do not apply oil to any rubber parts or the seat cover.
7. Remove the battery and charge it. Store it in a dry place and recharge it once a month. Do not store the battery in an excessively warm or cold place (less than 0°C(30°F) or more than 30°C(90°F)).

U-058

NOTE: _____

Make any necessary repairs before storing the motorcycle.

SPECIFICATIONS

Model	T50	T80
Dimension:		
Overall length	1.860 mm (73.2 in)	←
Overall width	670 mm (26.4 in)	←
Overall height	1.050 mm (41.3 in)	←
Seat height	750 mm (29.5 in)	←
Wheel base	1.180 mm (46.5 in)	←
Minimum ground clearance	130 mm (5.1 in)	←
Basic weight:		
With oil and full fuel tank	87 kg (192 lb)	←
Minimum turning radius:	1.800 mm (70.9 in)	←
Engine:		
Type	Air cooled 4-stroke, gasoline, SOHC	←
Model	2FM	35T
Cylinder arrangement	Single cylinder Forward inclined	←
Displacement	49 cm ³	79 cm ³
Bore × Stroke	39 × 41.4 mm (1.54 × 1,63 in)	47 × 45.6 mm (1.85 × 1.80 in)
Compression ratio	10.3:1	9.6:1
Starting system	Kick starter	←

Model	T50	T80
Engine oil: Type	See page 4-3	←
Capacity		
Periodic oil change	0.85 L (0.75 Imp qt, 0.90 US qt)	←
Total amount	1 L (0.88 Imp qt, 1.06 US qt)	←
Air filter:	Wet type element	←
Fuel:		
Type	Regular gasoline	←
Tank capacity	5 L (1.1 Imp gal, 1.3 US gal)	←
Carburetor: Type/manufacturer	VM14SH/MIKUNI	VM16SH/MIKUNI
Spark plug: Type/manufacturer	CR6HS/NGK	CR7HS/NGK
Gap	0.6~0.7 mm (0.024~0.028 in)	←
Clutch type:	Wet, centrifugal, automatic	←
Transmission:		
Primary reduction system	Spar gear	←
Primary reduction ratio	67/18 (3.722)	65/20 (3.250)
Secondary reduction system	Shaft drive	←
Secondary reduction ratio	19/18×34/10 (3.589)	19/18×33/11 (3.166)

Model	T50	T80
Transmission type Operation	Constant mesh 3-speed Left foot operation	Constant mesh 4-speed ←
Gear ratio 1st 2nd 3rd 4th	39/12 (3.250) 29/16 (1.812) 24/20 (1.200) —	39/11 (3.545) 34/18 (1.888) 29/23 (1.260) 26/25 (1.040)
Chassis: Frame type Caster angle Trail	Pressed underbone 26.5° 74 mm (2.9 in)	← ← ←
Tire: Type Size - Front Rear	With tube 2.50-17-4PR 2.50-17-6PR	← ← ←
Brake: Front brake type Operation Rear brake type Operation	Drum brake Right hand operation Drum brake Right foot operation	← ← ← ←

Model	T50	T80
Suspension:		
Front	Bottom link fork	←
Rear	Swing arm	←
Shock Absorber:		
Front	Coil spring, Oil damper	←
Rear	Coil spring, Oil damper	←
Wheel travel:		
Front	80 mm (3.1 in)	←
Rear	70 mm (2.8 in)	←
Electrical:		
Ignition system	CDI magneto	←
Generator system	Flywheel magneto	←
Battery type/capacity	6N4-2A/6V4AH	←
Headlight type:	Bulb	←
Bulb wattage/quantity:		
Headlight	25W/25W	←
Tail/brake light	5W/21W	←
Flasher light	21W × 4	←
Auxiliary light	3W	←
Meter light	3W	←

Model	T50	T80
Indicator light wattage/ quantity:		
"NEUTRAL"	3W	←
"HIGH BEAM"	3W	←
"TURN"	3W	←

MEMO

MEMO

A series of horizontal dotted lines for writing.



YAMAHA MOTOR CO.,LTD.

IWATA, JAPAN

PRINTED IN JAPAN

86・3-2.0×1 □

(英)

Free Manuals Download Website

<http://myh66.com>

<http://usermanuals.us>

<http://www.somanuals.com>

<http://www.4manuals.cc>

<http://www.manual-lib.com>

<http://www.404manual.com>

<http://www.luxmanual.com>

<http://aubethermostatmanual.com>

Golf course search by state

<http://golfingnear.com>

Email search by domain

<http://emailbydomain.com>

Auto manuals search

<http://auto.somanuals.com>

TV manuals search

<http://tv.somanuals.com>