



POWER AMPLIFIER

TX6n/TX5n/TX4n

Owner's Manual
Bedienungsanleitung
Mode d'emploi
Manual de instrucciones
Manuale di istruzioni
Руководство пользователя



English

Deutsch

Français

Español

Italiano

Русский

EN
DE
FR
ES
IT
RU

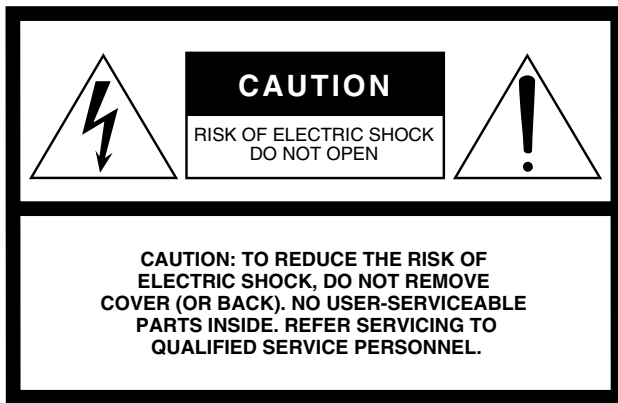

Explanation of Graphical Symbols

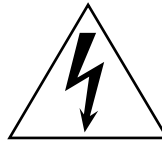

The lightning flash with arrowhead symbol within an equilateral triangle is intended to alert the user to the presence of uninsulated “dangerous voltage” within the product’s enclosure that may be of sufficient magnitude to constitute a risk of electric shock to persons.



The exclamation point within an equilateral triangle is intended to alert the user to the presence of important operating and maintenance (servicing) instructions in the literature accompanying the product.

The above warning is located on the top of the unit.

IMPORTANT SAFETY INSTRUCTIONS

- 1 Read these instructions.
- 2 Keep these instructions.
- 3 Heed all warnings.
- 4 Follow all instructions.
- 5 Do not use this apparatus near water.
- 6 Clean only with dry cloth.
- 7 Do not block any ventilation openings. Install in accordance with the manufacturer’s instructions.
- 8 Do not install near any heat sources such as radiators, heat registers, stoves, or other apparatus (including amplifiers) that produce heat.
- 9 Do not defeat the safety purpose of the polarized or grounding-type plug. A polarized plug has two blades with one wider than the other. A grounding type plug has two blades and a third grounding prong. The wide blade or the third prong are provided for your safety. If the provided plug does not fit into your outlet, consult an electrician for replacement of the obsolete outlet.
- 10 Protect the power cord from being walked on or pinched particularly at plugs, convenience receptacles, and the point where they exit from the apparatus.
- 11 Only use attachments/accessories specified by the manufacturer.
- 12 Use only with the cart, stand, tripod, bracket, or table specified by the manufacturer, or sold with the apparatus. When a cart is used, use caution when moving the cart/apparatus combination to avoid injury from tip-over.
- 13 Unplug this apparatus during lightning storms or when unused for long periods of time.
- 14 Refer all servicing to qualified service personnel. Servicing is required when the apparatus has been damaged in any way, such as power-supply cord or plug is damaged, liquid has been spilled or objects have fallen into the apparatus, the apparatus has been exposed to rain or moisture, does not operate normally, or has been dropped.



WARNING

TO REDUCE THE RISK OF FIRE OR ELECTRIC SHOCK, DO NOT EXPOSE THIS APPARATUS TO RAIN OR MOISTURE.

(UL60065_03)

FCC INFORMATION (U.S.A.)

1. IMPORTANT NOTICE: DO NOT MODIFY THIS UNIT!

This product, when installed as indicated in the instructions contained in this manual, meets FCC requirements. Modifications not expressly approved by Yamaha may void your authority, granted by the FCC, to use the product.

2. IMPORTANT: When connecting this product to accessories and/or another product use only high quality shielded cables. Cable/s supplied with this product **MUST** be used. Follow all installation instructions. Failure to follow instructions could void your FCC authorization to use this product in the USA.

3. NOTE: This product has been tested and found to comply with the requirements listed in FCC Regulations, Part 15 for Class "B" digital devices. Compliance with these requirements provides a reasonable level of assurance that your use of this product in a residential environment will not result in harmful interference with other electronic devices. This equipment generates/uses radio frequencies and, if not installed and used according to the instructions found in the users manual, may cause interference harmful to the opera-

tion of other electronic devices. Compliance with FCC regulations does not guarantee that interference will not occur in all installations. If this product is found to be the source of interference, which can be determined by turning the unit "OFF" and "ON", please try to eliminate the problem by using one of the following measures:

Relocate either this product or the device that is being affected by the interference.

Utilize power outlets that are on different branch (circuit breaker or fuse) circuits or install AC line filter/s.

In the case of radio or TV interference, relocate/reorient the antenna. If the antenna lead-in is 300 ohm ribbon lead, change the lead-in to co-axial type cable.

If these corrective measures do not produce satisfactory results, please contact the local retailer authorized to distribute this type of product. If you can not locate the appropriate retailer, please contact Yamaha Corporation of America, Electronic Service Division, 6600 Orangethorpe Ave, Buena Park, CA90620

The above statements apply **ONLY** to those products distributed by Yamaha Corporation of America or its subsidiaries.

* This applies only to products distributed by YAMAHA CORPORATION OF AMERICA.

(class B)

COMPLIANCE INFORMATION STATEMENT (DECLARATION OF CONFORMITY PROCEDURE)

Responsible Party : Yamaha Corporation of America
Address : 6600 Orangethorpe Ave., Buena Park,
Calif. 90620
Telephone : 714-522-9011
Type of Equipment : Power Amplifier
Model Name : TX6n/TX5n/TX4n

This device complies with Part 15 of the FCC Rules.

Operation is subject to the following two conditions:

- 1) this device may not cause harmful interference, and
- 2) this device must accept any interference received including interference that may cause undesired operation.

See user manual instructions if interference to radio reception is suspected.

* This applies only to products distributed by
YAMAHA CORPORATION OF AMERICA.

(FCC DoC)

This product contains a battery that contains perchlorate material.

Perchlorate Material—special handling may apply,
See www.dtsc.ca.gov/hazardouswaste/perchlorate.

* This applies only to products distributed by
YAMAHA CORPORATION OF AMERICA.

(Perchlorate)

ADVARSEL!

Lithiumbatteri—Eksplodingsfare ved fejlagtig håndtering. Udskiftning må kun ske med batteri af samme fabrikat og type. Levér det brugte batteri tilbage til leverandoren.

VARNING

Explosionsfara vid felaktigt batteribyte. Använd samma batterityp eller en ekvivalent typ som rekommenderas av apparatillverkaren. Kassera använt batteri enligt fabrikantens instruktion.

VAROITUS

Paristo voi räjähtää, jos se on virheellisesti asennettu. Vaihda paristo ainoastaan laitevalmistajan suosittelemaan tyyppiin. Hävitä käytetty paristo valmistajan ohjeiden mukaisesti.

(lithium caution)

NEDERLAND / THE NETHERLANDS

- Dit apparaat bevat een lithium batterij voor geheugen back-up.
- This apparatus contains a lithium battery for memory back-up.
- Raadpleeg uw leverancier over de verwijdering van de batterij op het moment dat u het apparaat aan het einde van de levensduur of gelieve dan contact op te nemen met de vertegenwoordiging van Yamaha in uw land.
- For the removal of the battery at the moment of the disposal at the end of life please consult your retailer or Yamaha representative office in your country.
- Gooi de batterij niet weg, maar lever hem in als KCA.
- Do not throw away the battery. Instead, hand it in as small chemical waste.

(lithium disposal)

PRECAUTIONS

PLEASE READ CAREFULLY BEFORE PROCEEDING

* Please keep this manual in a safe place for future reference.



WARNING

Always follow the basic precautions listed below to avoid the possibility of serious injury or even death from electrical shock, short-circuiting, damages, fire or other hazards. These precautions include, but are not limited to, the following:

Power supply/Power cord

- Only use the voltage specified as correct for the device. The required voltage is printed on the name plate of the device.
- Do not place the power cord near heat sources such as heaters or radiators, and do not excessively bend or otherwise damage the cord, place heavy objects on it, or place it in a position where anyone could walk on, trip over, or roll anything over it.
- Be sure to connect to an appropriate outlet with a protective grounding connection. Improper grounding can result in electrical shock.

Do not open

- Do not open the device or attempt to disassemble the internal parts or modify them in any way. The device contains no user-serviceable parts. If it should appear to be malfunctioning, discontinue use immediately and have it inspected by qualified Yamaha service personnel.

Water warning

- Do not expose the device to rain, use it near water or in damp or wet conditions, or place containers on it containing liquids which might spill into any openings. If any liquid such as water seeps into the device, turn off the power immediately and unplug the power cord from the AC outlet. Then have the device inspected by qualified Yamaha service personnel.
- Never insert or remove an electric plug with wet hands.

If you notice any abnormality

- If the power cord or plug becomes frayed or damaged, or if there is a sudden loss of sound during use of the device, or if any unusual smells or smoke should appear to be caused by it, immediately turn off the power switch, disconnect the electric plug from the outlet, and have the device inspected by qualified Yamaha service personnel.
- If this device should be dropped or damaged, immediately turn off the power switch, disconnect the electric plug from the outlet, and have the device inspected by qualified Yamaha service personnel.



CAUTION

Always follow the basic precautions listed below to avoid the possibility of physical injury to you or others, or damage to the device or other property. These precautions include, but are not limited to, the following:

Power supply/Power cord

- Remove the electric plug from the outlet when the device is not to be used for extended periods of time, or during electrical storms.
- When removing the electric plug from the device or an outlet, always hold the plug itself and not the cord. Pulling by the cord can damage it.

Location

- Before moving the device, remove all connected cables.
- When setting up the device, make sure that the AC outlet you are using is easily accessible. If some trouble or malfunction occurs, immediately turn off the power switch and disconnect the plug from the outlet. Even when the power switch is turned off, electricity is still flowing to the product at the minimum level. When you are not using the product for a long time, make sure to unplug the power cord from the wall AC outlet.
- If the device is mounted in an EIA standard rack, carefully read the section "Precautions when rack-mounting the unit" on page 6. Inadequate ventilation can result in overheating, possibly causing damage to the device(s), malfunction, or even fire.
- Do not use the device in a confined, poorly-ventilated location. If this device is to be used in a small space other than an EIA-standard rack, make sure that there is adequate space between the device and surrounding walls or other devices: at least 10cm at the sides, 15cm behind and 40cm above. Inadequate ventilation can result in overheating, possibly causing damage to the device(s), or even fire.
- Do not expose the device to excessive dust or vibrations, or extreme cold or heat (such as in direct sunlight, near a heater, or in a car during the day) to prevent the possibility of panel disfiguration or damage to the internal components.
- Do not place the device in an unstable position where it might accidentally fall over.

- Do not block the vents. This device has ventilation holes at the front/rear to prevent the internal temperature from becoming too high. In particular, do not place the device on its side or upside down. Inadequate ventilation can result in overheating, possibly causing damage to the device(s), or even fire.
- Do not use the device in the vicinity of a TV, radio, stereo equipment, mobile phone, or other electric devices. Doing so may result in noise, both in the device itself and in the TV or radio next to it.

Connections

- Before connecting the device to other devices, turn off the power for all devices. Before turning the power on or off for all devices, set all volume levels to minimum.
- Use only speaker cables for connecting speakers to the speaker jacks. Use of other types of cables may result in fire.
- Do not place the device in a location where it may come into contact with corrosive gases or salt air. Doing so may result in malfunction.

Maintenance

- Inspect the cooling fan air filter and clean it periodically (see the reference manual (PDF file)). Dust and dirt can seriously degrade the effectiveness of the cooling fan and result in malfunction or fire.
- Remove the power plug from the AC outlet when cleaning the device.

Handling caution

- When turning on the AC power in your audio system, always turn on the device LAST, to avoid speaker damage. When turning the power off, the device should be turned off FIRST for the same reason.

- Condensation can occur in the device due to rapid, drastic changes in ambient temperature – when the device is moved from one location to another, or air conditioning is turned on or off, for example. Using the device while condensation is present can cause damage. If there is reason to believe that condensation might have occurred, leave the device for several hours without turning on the power until the condensation has completely dried out.
- Do not insert your fingers or hands in any gaps or openings on the device (vents, ports, etc.).
- Avoid inserting or dropping foreign objects (paper, plastic, metal, etc.) into any gaps or openings on the device (vents, ports, etc.) If this happens, turn off the power immediately and unplug the power cord from the AC outlet. Then have the device inspected by qualified Yamaha service personnel.
- Do not use the device or headphones for a long period of time at a high or uncomfortable volume level, since this can cause permanent hearing loss. If you experience any hearing loss or ringing in the ears, consult a physician.
- Do not rest your weight on the device or place heavy objects on it, and avoid use excessive force on the buttons, switches or connectors.
- Do not use this device for any purpose other than driving loudspeakers.

Backup battery

- This device has a built-in backup battery that maintains data in internal memory even when the device's power is switched off. The backup battery will eventually become depleted, however, and when that happens the contents of the internal memory will be lost.* To prevent loss of data be sure to replace the backup battery before it becomes fully depleted. When the remaining capacity of the backup battery becomes so low that it needs to be replaced a "Critical Battery" or "No Battery" message will appear on the display during operation or when the device is powered on. If either of these messages appears do not turn off the power and immediately transfer any data you want to save to a computer or other external storage device, then have qualified Yamaha service personnel replace the backup battery. The average life of the internal backup battery is approximately 5 years, depending on operating conditions.

* Data items maintained in the internal memory by the backup battery are as follows:

- Current scene parameters and number.
- Device parameters (Utility, AnalogInputMeter, SpeakerOut meter, etc.).
- Event log.

Data items other than those described above are stored in memory that does not require backup power, and will be retained even if the backup battery fails.

XLR-type connectors are wired as follows (IEC60268 standard): pin 1: ground, pin 2: hot (+), and pin 3: cold (-).
Use only Neutrik NL4 plugs for connecting Speakon connectors.

Yamaha cannot be held responsible for damage caused by improper use or modifications to the device, or data that is lost or destroyed.

Always turn the power off when the device is not in use.

The performance of components with moving contacts, such as switches, volume controls, and connectors, deteriorates over time. Consult qualified Yamaha service personnel about replacing defective components.

Windows is a registered trademark of Microsoft® Corporation in the United States and other countries.

The bitmap fonts used in this device have been provided by and are the property of Ricoh Co., Ltd.

The company names and product names in this manual are the trademarks or registered trademarks of their respective companies.

Specifications and descriptions in this owner's manual are for information purposes only.

Yamaha Corp. reserves the right to change or modify products of specifications at any time without prior notice. Since specifications, equipment or options may not be the same in every locale, please check with your Yamaha dealer.

European models

Purchaser/User Information specified in EN55103-1 and EN55103-2.

Inrush Current: 17A

Conforms to Environments: E1, E2, E3, E4

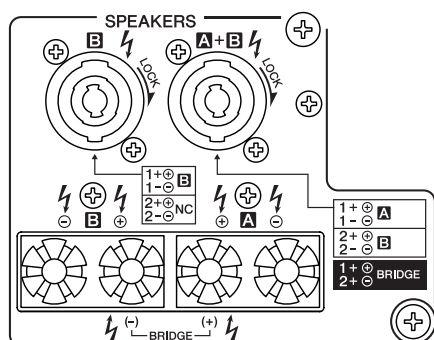

This ⚡ mark indicates a dangerous electrically live terminal. When connecting an external wire to this terminal, it is necessary either to have "a person who have received appropriate guidance on handling" make the connection or to use leads or a cord that have been manufactured in such a way that the connection can be made simply and without problem.

(hazardous)

IMPORTANT NOTICE FOR THE UNITED KINGDOM

Connecting the Plug and Cord

WARNING: THIS APPARATUS MUST BE EARTHED

IMPORTANT. The wires in this mains lead are coloured in accordance with the following code:

GREEN-AND-YELLOW : EARTH
BLUE : NEUTRAL
BROWN : LIVE

As the colours of the wires in the mains lead of this apparatus may not correspond with the coloured markings identifying the terminals in your plug proceed as follows:

The wire which is coloured GREEN-and-YELLOW must be connected to the terminal in the plug which is marked by the letter E or by the safety earth symbol ⊕ or colored GREEN or GREEN-and-YELLOW.

The wire which is coloured BLUE must be connected to the terminal which is marked with the letter N or coloured BLACK.

The wire which is coloured BROWN must be connected to the terminal which is marked with the letter L or coloured RED.

• This applies only to products distributed by Yamaha Music U.K. Ltd.

(3 wires)

Contents

Introduction	7
Features.....	7
About Setup.....	7
Related manuals and software	7
Firmware Updates	8
Preparation	8
Basic Operation of the TXn.....	9
Panel Operations.....	9
Operations that can be Performed from the Panel	10
Audio I/O Settings.....	11
Wiring of the [SPEAKERS] Connectors.....	13
5-way Binding Post Connectors.....	13
Speakon Connectors	13
Network Connection Example	14
Troubleshooting.....	15
Initializing the internal memory	15
Specifications.....	16
General Specifications.....	16
Block Diagram	18
Level Diagram.....	19
DSP Block Diagram	19
Dimensions	20
Current Draw	21
Performance Graph	21

Included Accessories

- Owner's Manual
- Two handles
- Four flat-head screws
- Euroblock connector (3P)
- Four Rubber feet

Precautions when rack-mounting the unit

Operation of this device is guaranteed for an environmental temperature range of 0 – 40°C. If you are mounting only this device in an EIA standard rack, you may mount multiple units without leaving a space between them. If you are mounting this device along with other types of device in an EIA standard rack, the ambient temperature inside the rack may rise due to heat produced from the other devices, preventing this device from performing as designed. To ensure that heat does not build up inside this device, you must observe the following conditions when mounting it in a rack.

- If you mount this device in a rack together with heat-generating devices such as power amps made by other companies, you must leave 1U or more space between this device and other devices. You should also install a ventilation panel in this space or leave it open to ensure adequate ventilation.
- Leave the back of the rack open, and allow 10 cm or more distance between the rack and the wall or ceiling to ensure adequate ventilation. If you are unable to leave the back of the rack open, you must install a commercially available fan kit or other forced air circulating system to the rack. If you have installed a fan kit, there may be cases in which closing the back of the rack will provide better cooling. For details, refer to the instructions that came with the rack system or fan kit.

Introduction

Thank you for purchasing the Yamaha TX6n, TX5n, TX4n Power Amplifier. In order to take full advantage of the TX6n/TX5n/TX4n's (TXn) functionality and to ensure trouble-free operation, please read this owner's manual carefully before use. After you have read the manual, keep it in a safe place for reference when needed.

Features

The TXn series are high audio quality, high efficiency, high reliability, low impedance drive power amplifiers that utilize Yamaha's famed DSP and digital audio networking technology.

■ Flexible support for analog and digital audio formats

In addition to two-channel analog input, these amplifiers come with an AES/EBU card installed in their MY card slot, allowing digital signals to be input and output. Separately sold MY cards can be installed in this MY slot to support a variety of digital audio formats.

■ Monitor and control from Amp Editor

By connecting a computer in which the "Amp Editor" application software is installed, the computer can be used to monitor the TXn units, or to control the TXn units such as switching the amplifier power's Standby/On and mute status. This monitoring and control can also be performed from the panel of the TXn unit.

■ Versatile speaker processing

Since signal processors such as equalizer, delay, and crossover are built in, the use of external equipment can be minimized. These can be controlled from the panel of the TXn unit or via Amp Editor. Speaker processor libraries created on the Yamaha DME series or the SP2060 can also be used.

About Setup

■ Attaching the handles

You can attach the handles to the amplifier using the supplied flat-head screws.

Follow the steps below to attach the handles:

1. Remove the rack mount brackets.
2. Attach the handles to the amplifier by tightening the flat-head screws into the four screw holes for each handle.
3. Replace the rack mount brackets.

■ Adjusting the position in the rack

If there is insufficient space between the rear of the amplifier and the rack, you can adjust the position of the rack mount brackets so that the front panel of the amplifier protrudes from the front of the rack by 22 mm.

Related manuals and software

This manual primarily explains how to set up the TXn at the time of installation. Manuals that contain detailed explanations of the TXn and Amp Editor, as well as Amp Editor itself, can be downloaded from the following website.

<http://www.yamahaproaudio.com/>

• List of related manuals

TX6n/5n/4n Reference Manual	Provides a detailed explanation of the TXn's panel operations, etc.
Amp Editor Installation Guide	Explains the installation and uninstallation procedures for Amp Editor.
Amp Editor Owner's Manual	Explains how to use Amp Editor.

NOTE • In order to view the downloaded manuals, Adobe Reader must be installed in your computer. If you don't have Adobe Reader, please access the Adobe Corporation's website at the following URL, and download Adobe Reader (free of charge).

<http://www.adobe.com/>

Firmware Updates

The firmware version of the TXn itself can be checked from the TXn's panel and from Amp Editor. You can update the firmware via Amp Editor. For the update procedure, refer to the Amp Editor Owner's Manual. You can download the latest firmware from the "Downloads" page on the following website.

<http://www.yamahaproaudio.com/>

Preparation

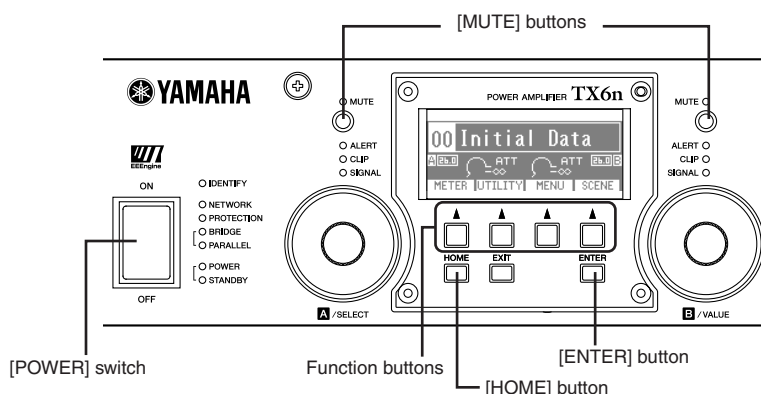

Connecting the AC Power Cable



- Be sure to turn all devices OFF before connecting AC mains power.

Insert the plug into an AC outlet. Be sure to use an AC outlet of the voltage specified for the device.

Turning the Power on and off



- To prevent the initial power-on surge from generating a large noise spike or damaging your speaker system, turn the devices on in the following order: audio sources, mixer (such as M7CL or PM5D), and finally power amplifiers. Reverse this order when turning power off.

1. Press the front panel [POWER] switch to the "ON" position to turn the power on.
2. Press the [POWER] switch to the "OFF" position to turn off the power.

NOTE

- The settings at the time you powered-off are remembered. When you turn on the power to the TXn, it will start up with the same settings. You can use the "Last Mem. Resume" setting to set up the TXn so that at startup it will recall the scene number selected before you turned off the power to the device.



- Do not turn off the power while the upper part of the display indicates "Do Not Turn Off!" Otherwise, a malfunction may occur.



- A small amount of current is flowing even when the power switch is off. If you will not be using this device for an extended period of time, be sure to disconnect the power plug from the AC outlet.

Switching the Power Status between Standby and On

1. Hold down the panel [HOME] button for at least three seconds.

The TXn's display will show the HOME screen, and then a message of "Turning power on: Are you sure?" or "Going Standby: Are you sure?" will appear.

2. Press the panel [ENTER] button, and the power status will switch between Standby and On.

NOTE • Standby is a state in which the speaker output's power amp section is off (operation other than speaker output will continue).

Switching Mute on/off

Hold down the [MUTE] button of the channel you want to mute for at least one second.

The channel's output will be muted, and the [MUTE] indicator will light.

To switch mute off, press the [MUTE] button again for at least one second.

Basic Operation of the TXn

Panel Operations

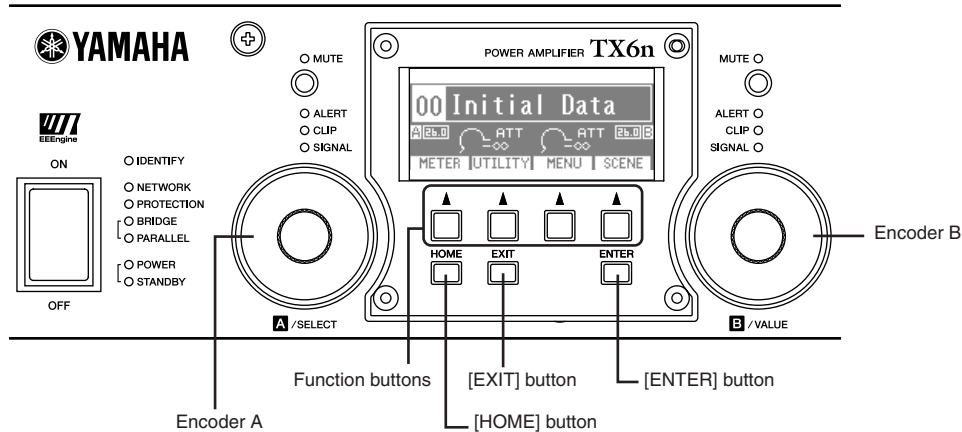

About the Display

Shows an alert message if a problem occurs or if a user-specified event occurs.



Shows the contents of the selected screen.

Shows the names of the screens assigned to the function buttons.

Switching Screens

By pressing a function button you can move to the screen indicated above that button. By pressing the [HOME] button you can move to the HOME screen. By pressing the [EXIT] button you can move to the screen one level above.

Editing the Parameters

Use encoders A and B to move to the parameter that you want to edit, and use encoder B to edit the value.

NOTE • When you edit a parameter in the UTILITY screen, press the [ENTER] button to confirm it after you finish editing. A parameter that has not been confirmed will flash. If you move the cursor or move to a different screen without confirming the parameter, your change will not be applied.

Adjusting the Attenuator

When the display shows the attenuator (i.e., in the HOME screen or the METER screen), you can use encoders A and B to adjust each channel's attenuation.

NOTE • If the display shows a screen other than the HOME screen or METER screen, encoders A and B are used to set parameters.

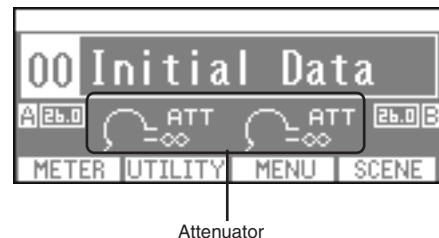

Displaying the Meter

To display the meter, access the HOME screen and press the left-most function button (METER). You can change the meter type by using the left-most function button (PREV) and the right-most function button (NEXT).

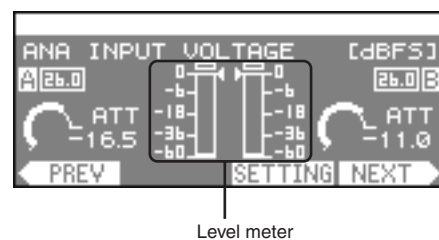

Operations that can be Performed from the Panel

NOTE • For details, refer to the TX6n/5n/4n Reference Manual.

Category	Subcategory	Explanation	
METER	ANA INPUT VOLTAGE	Shows the input level from the analog input connectors.	
	SLOT INPUT VOLTAGE	Shows the input level from the slot.	
	SP OUTPUT VOLTAGE	Shows the output level from the [SPEAKERS] connectors.	
	SP OUTPUT POWER	Shows the output power from the [SPEAKERS] connectors.	
	SP OUTPUT IMPEDANCE	Shows the output impedance from the [SPEAKERS] connectors.	
	SLOT OUTPUT METER	Shows the output level to the slot.	
	THERMAL	Shows the heat sink temperature.	
UTILITY	Device Setup	Makes settings to distinguish the amplifier on a network.	
	Word Clock Setup	Sets the word clock.	
	Information	Shows information about the amplifier.	
	Network Setup	Specifies the IP address and other settings for using the amplifier in a network.	
	LCD Setup	Specifies the display settings.	
	Front Panel Operation	Turns panel operation lock on/off.	
	Scene Setup	Makes scene* settings.	
	Misc Setup	Sets the amplifier's internal clock, etc.	
MENU	General	Sensitivity/Amp Gain	Sets the input sensitivity/gain.
		Stereo/Bridge/Parallel	Specifies the amplifier's mode (Stereo/Bridge/Parallel).
		Attenuation Link	Specifies whether attenuator operation will be linked between channels A and B.
		Input Redundancy	Specifies the redundant connection mode, etc.
	Signal Path		Makes settings for the equalizer, delay, crossover, and others that process the audio signal. Speaker Processor libraries can also be recalled.
	Signal Chain	Analog Input Signal Chain	Makes settings for checking whether the audio signal is being correctly input from the analog connectors.
		Slot Input Signal Chain	Makes settings for checking whether the audio signal is being correctly input from the slot.
		Output Signal Chain	Makes settings for checking the status of output from the [SPEAKERS] connectors.
	Calibration	Calibrate by Pilot Tone	Uses a pilot tone to measure the impedance of the connected speakers.
		Calibrate by Program Source	Uses an audio signal to measure the impedance of the connected speakers.
	Limiter	Voltage Limiter	Makes settings for the limiter.
		Power Limiter	
		Limiter Gain Reduction	Specifies whether the limiter will be linked between channels A and B.
SCENE	Recall	Recalls a scene*.	
	Store	Stores a scene*.	
	Edit	Edits a scene*.	
	Clear	Clears a scene*.	

*Scene.....The settings listed above, such as power Standby/On or mute (with the exception of UTILITY), are called a "scene". By recalling a scene, the saved settings can be immediately applied to the amplifiers.

Audio I/O Settings

The TXn can be operated in one of three audio input/output modes: Stereo mode, Parallel mode, or Bridge mode. Make audio input/output connections and settings as follows.

- NOTE**
- With the factory settings, if both analog and digital (input from the slot) signals are input simultaneously, the two signal will be mixed and output. This setting can be changed from the panel of the TXn or via Amp Editor. For details on making this setting, refer to “TX6n/5n/4n Reference Manual” or “Amp Editor Owner’s Manual.”
 - Use 110-ohm AES/EBU digital cables for digital audio connections. Using analog cables may degrade the sonic quality.

Stereo Mode

Channels A and B (analog) or channels 1 and 2 (digital) will operate independently in stereo.

5-way binding post connectors

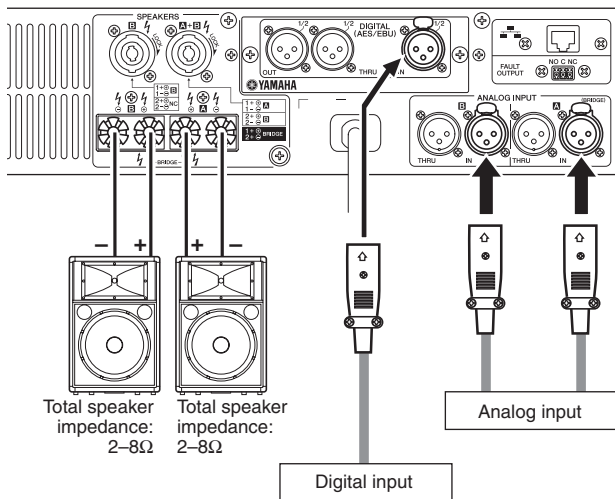

Speakon connectors

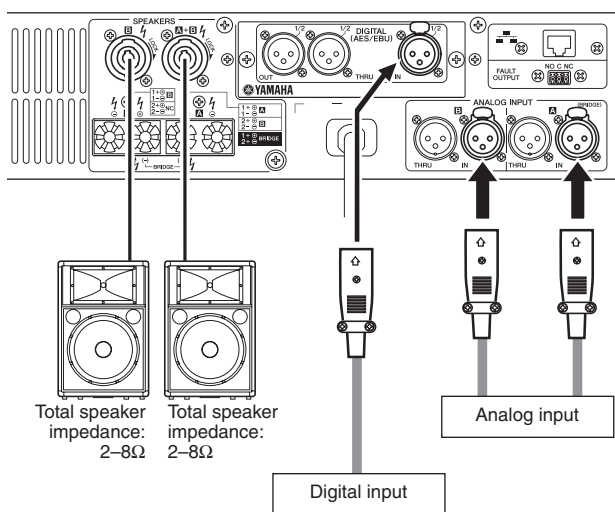

- NOTE**
- Each of 5-way binding post connectors and Speakon connectors are internally parallel-connected. When using both connectors simultaneously, total speaker impedance of each connector must be 4–16 Ω.

Parallel Mode

The amplifier will operate as a two-channel monaural amp, with the input signal of channel A (analog) or channel 1 (digital) as the source. Channel B (analog) and channel 2 (digital) will not be used.

5-way binding post connectors

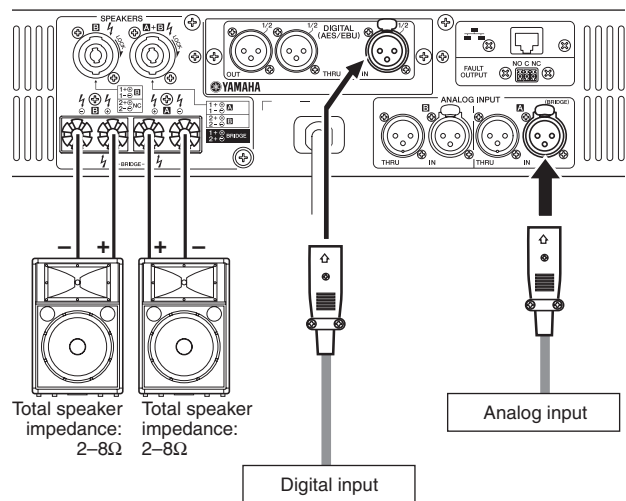

Speakon connectors

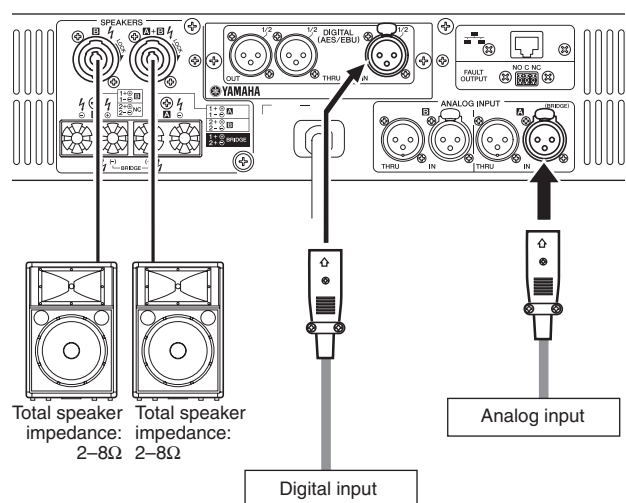

- NOTE**
- Each of 5-way binding post connectors and Speakon connectors are internally parallel-connected. When using both connectors simultaneously, total speaker impedance of each connector must be 4–16 Ω.

Bridge Mode

The amplifier will operate as a monaural high-power amp, with the input signal of channel A (analog) or channel 1 (digital) as the source.

5-way binding post connectors

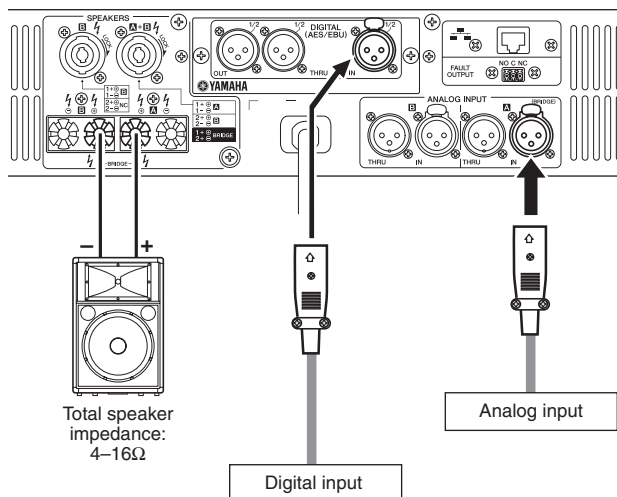

Speakon connectors

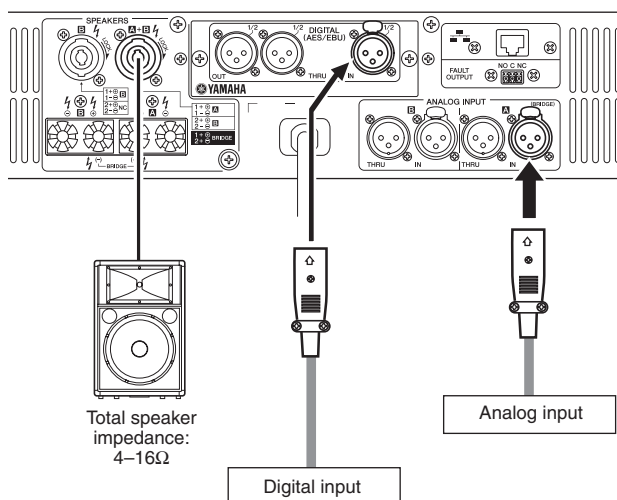

NOTE • Each of 5-way binding post connectors and Speakon connectors are internally parallel-connected. When using both connectors simultaneously, total speaker impedance of each connector must be 8–32 Ω.

Mode Setting

Select the power amp mode according to the type of connections you've made.

1. Press the [HOME] button to access the HOME screen, and press the third function button from the left (MENU) to access the MENU screen.

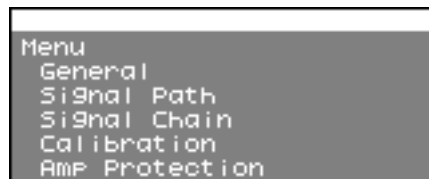

2. Use the encoder A to move the cursor (the blinking frame) to “General,” and press the [ENTER] button.
3. Use the function buttons (PREV/NEXT) to access Stereo/Bridge/Parallel screen.

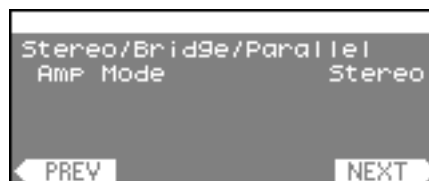

4. Use the encoder B to select the desired mode, and press the [ENTER] button to confirm.

Gain Setting

Set the amplifier gain.

1. Follow the steps 1 and 2 of the above “Mode Setting” to select “MENU” → “General.”
2. Use the function buttons (PREV/NEXT) to access the Sensitivity/Amp Gain screen.

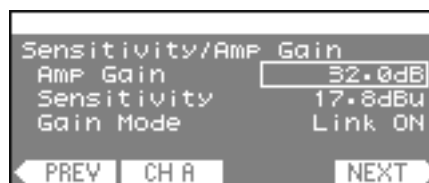

3. Use encoder A to move the cursor to Amp Gain or Sensitivity, and encoder B to edit the parameter value.
4. If the parameter value is blinking, press the [ENTER] button to confirm the value.

NOTE • Refer to the TX6n/5n/4n Reference Manual for details on the gain.

Word Clock Setting

If you want to input or output digital audio signals, you must check the word clock settings as necessary. Refer to the TX6n/5n/4n Reference Manual for details on how to check these settings. The factory setting is “Auto Scan Mode: ON.”

Wiring of the [SPEAKERS] Connectors

Turn off the POWER switch before connecting external devices to the TXn.

5-way Binding Post Connectors

No Plugs

Remove about 13mm of insulation from the end of each speaker cable, and pass the bare wire through the holes in the appropriate speaker terminals. Tighten the terminals to securely clamp the wires. Be sure that the bare wire ends do not jut out from the terminals and touch the chassis.

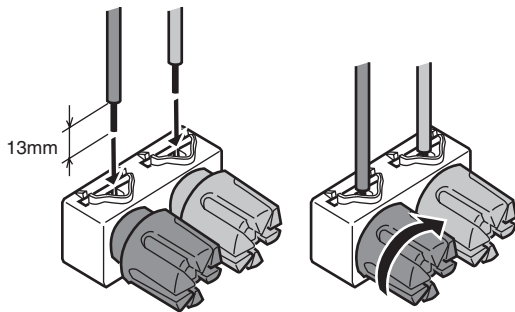

Y-plugs

From above, insert the Y-plugs all the way into the opening, and tighten the terminals.

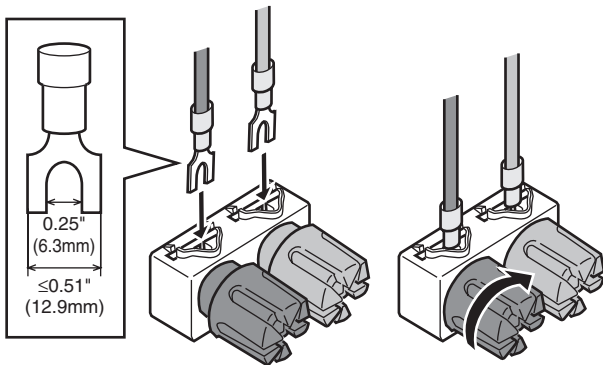

Speakon Connectors

Insert the Speakon cable plug (Neutrik NL4) into the connector, and turn it to the right to lock it.

Neutrik NL4 plugs

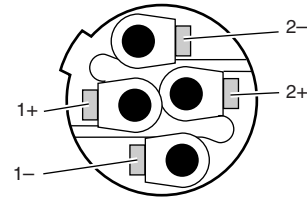

CHANNEL A

Stereo/Parallel Mode

Neutrik	Amplifier
1+	A+
1-	A-
2+	B+
2-	B-

Bridge Mode

Neutrik	Amplifier
1+	+
1-	
2+	-
2-	

CHANNEL B

Neutrik	Amplifier
1+	B+
1-	B-

Network Connection Example

If you connect the TXn units' [NETWORK] connector to a computer via an Ethernet cable, you'll be able to monitor/control the TXn units from Amp Editor. Including computers and other equipment, a total of up to 253 units can be connected in a single network.

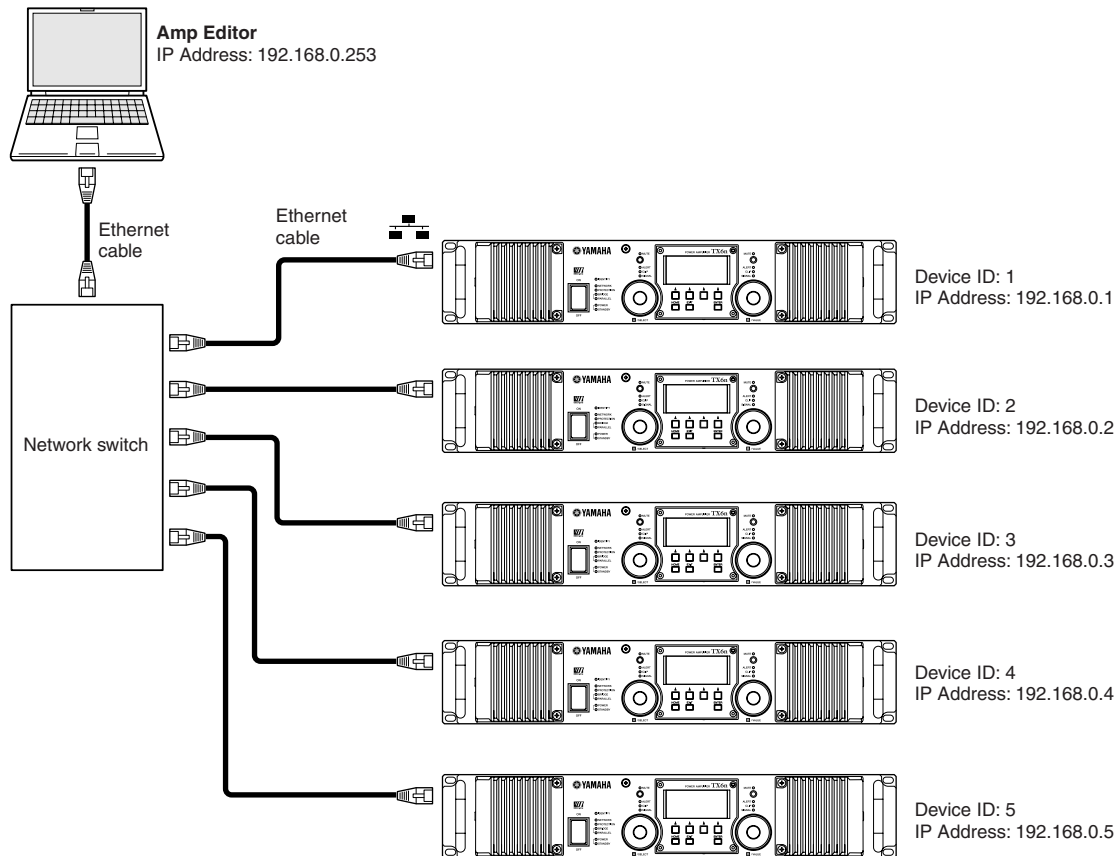

- NOTE**
- If you wish to connect multiple TXn units, use a network switch that supports 100Base-TX/10Base-T.
 - The Ethernet cable between the network switch and the TXn can be up to 100 meters long. Due to the quality of cables and network switch performance, however, proper operation at the maximum length cannot be guaranteed in some cases.
 - Since the TXn supports Auto MDI/MDI-X, it will automatically detect whether the connected cable is of the straight type or crossover type, and will configure itself to create the optimal connection. Therefore, you can use either a straight or crossover cable.
 - To prevent electromagnetic interference, use an STP (Shielded Twisted Pair) cable.
 - Refer to the Amp Editor Installation Guide and the Amp Editor Owner's Manual for information on the TXn initial setup for using the TXn in a network.

Troubleshooting

Symptom	Possible causes	Response
No sound from the speaker	The cable is not connected properly.	Make the correct connections to the audio input jack and the speaker output jack.
	The gain or attenuator setting has lowered the level.	Gain is adjusted by the MENU screen → General → Sensitivity/Amp Gain. Attenuator is adjusted by turning the encoder in the HOME screen.
	The [MUTE] button is on.	If the front panel [MUTE] indicator is on, hold down the [MUTE] button for one second or longer to cancel muting.
	The protection circuit has operated, muting the output.	If the amplifier has overheated, clean the filter elements and improve the ventilation around the amplifier. If the power supply has malfunctioned, contact your Yamaha dealer.
Noise from the speaker	The word clock from the slot input is not synchronized with the master clock.	Select the word clock from the slot as the master clock, or turn Auto Scan Mode on.
	Analog input level is exceeding the input sensitivity setting.	Adjust MENU screen → General → Sensitivity/Amp Gain setting according to the input level.
An alert message is displayed	An amplifier malfunction or other alert event related to the amplifier audio has occurred.	For details on the meaning of each alert message and the appropriate measures to take, refer to the Amp Editor Owner's Manual.
Panel operations are not accepted	The unit is locked.	Refer to "Front Panel Operation" in the TX6n/5n/4n Reference Manual.
A scene can be saved but not recalled	Scene Recall Enable is turned OFF.	Turn the UTILITY screen → Scene Setup → Scene Recall Enable setting ON.
Library can be recalled, but not saved	You cannot save library data from the TXn front panel.	Save the library data from Amp Editor.
All scene data saved in the TXn has disappeared	The power was turned off while the TXn's data was being saved.	If you saved the project in Amp Editor, synchronize from Amp Editor to the TXn.
To return to the default parameter values	–	Recalling a scene 00 (default setting scene) will return all the parameters other than those in the UTILITY settings to their default values. The TXn allows you to edit a wide variety of parameters, but can also be used as an analog amplifier by returning to the default parameter values. Default values of the main parameters are STEREO for amplifier mode, 26dB for gain, and -∞dB for attenuation. Refer to the TX6n/5n/4n Reference Manual for detailed information on scenes.

Initializing the internal memory

You can initialize the amp's internal memory. As desired, you can initialize the following two types of data.

- **User Data:** Initialize all user data except for the event log and speaker processor library.
- **Library:** Initialize only the speaker processor library.



- When you initialize the internal memory, the settings that had been stored will be lost. Use the following procedure with caution.

1. Power-off the TXn.
2. While holding down the [HOME] key, turn on the power; the Initialize screen will appear.
3. Use encoder A to select the data that you want to initialize, and press the [ENTER] button to execute initialization.

When initialization is completed, the amp will automatically restart.



- During initialization, the display will show the message "Do not turn off!" Never turn off the amp while this message is displayed.

Specifications

General Specifications

			TX6n		TX5n		TX4n	
			120V	230V (*1)	120V	230V (*1)	120V	230V (*1)
Output Power	1kHz, THD + N = 1%	8Ω per channel	1800W	1800W	1300W	1300W	1100W	1100W
		4Ω per channel	3000W	3000W	2200W	2300W	1900W	2000W
		2Ω per channel	2750W	2750W	2500W	2500W	2200W	2200W
		8Ω bridge	6000W	6000W	4400W	4600W	3800W	4000W
		4Ω bridge	5500W	5500W	5000W	5000W	4400W	4400W
	20ms burst	2Ω per channel	4100W	4120W	3480W	3600W	2990W	3050W
		4Ω bridge	8200W	8240W	6960W	7200W	5980W	6100W
Constant voltage line		—		STEREO mode : 100V line, 1250W / 8Ω BRIDGE mode : 200V line, 2500W / 16Ω		—		
Voltage Gain	RL = 8Ω Analog input to speaker output		43.8dB – 19.8dB, 0.1dB step		43.8dB – 19.8dB, 0.1dB step		43.8dB – 19.8dB, 0.1dB step	
Input Sensitivity	RL = 8Ω Analog input to speaker output		0.0dBu – 24.0dBu, 0.1dB step		-1.4dBu – 22.6dBu, 0.1dB step		-2.6dBu – 21.4dBu, 0.1dB step	
SN Ratio	20Hz – 20kHz, DIN AUDIO	Analog input to speaker output (Input sensitivity = +24dBu)	103dB		102dB		101dB	
		AES/EBU input to speaker output	108dB		107dB		106dB	

All Models			
THD + N	1kHz, half power	RL = 4Ω, 8Ω	≤0.2%
		RL = 2Ω	≤0.4%
Intermodulation Distortion	60Hz : 7kHz, 4 : 1, Half power (*2), RL = 4Ω, 8Ω		≤0.25%
Frequency Response	RL = 8Ω, Po = 1W, 20Hz – 20kHz		+0dB, -1.0dB
Channel Separation	Att. max, half power (*3), RL = 8Ω, 1kHz, input 600Ω shunt		65dB
Damping Factor	RL = 8Ω, ≤100Hz		>300
Maximum Input Level			+24dBu (*4)
Attenuation			0dB – -80dB, -∞dB (0.5dB step)
Input Impedance			20kΩ (balanced), 10kΩ (unbalanced)
A/D, D/A Converter			24-bit
Sampling Frequency			96k, 88.2k, 48k, 44.1kHz
Signal Processing			32bit DSP
Signal Delay	Analog input to speaker output	fs = 96kHz	729us
		fs = 48kHz	1.13ms
	AES/EBU input to speaker output	fs = 96kHz	708us
		fs = 48kHz	1.02ms
	Analog input to AES/EBU output	fs = 96kHz	396us
		fs = 48kHz	583us
	AES/EBU input to AES/EBU output	fs = 96kHz	365us
		fs = 48kHz	479us
AES/EBU input to AES/EBU though output			0.04us
Controls	Front panel		POWER switch (rocker), Rotary encoder x 2, Function button x 4, HOME button x 1, EXIT button x 1, ENTER button x 1, Mute button x 2

Connectors	Analog input	In	XLR-3-31 type x 2	
		Thru	XLR-3-32 type x 2	
	AES/EBU input/output	In	XLR-3-31 type x 1 (2 channels, 24-bit 96kHz – 44.1kHz)	
		Thru	XLR-3-32 type x 1 (2 channels)	
		Out	XLR-3-32 type x 1 (2 channels, 24-bit 96kHz – 44.1kHz)	
	Speaker output		Neutrik® Speakon® NL4 x 2, 5-way binding post x 2 pairs	
	Ethernet		RJ45 x 1	
Fault output		Euroblock connector (3P) x 1		
Indicators	LCD		160 x 64 Full dot type	
	LED	POWER	x 1 (White)	
		STANDBY	x 1 (Orange)	
		PARALLEL	x 1 (Orange)	
		BRIDGE	x 1 (Green)	
		PROTECTION	x 1 (Red)	
		NETWORK	x 1 (Green)	
		IDENTIFY	x 1 (Blue)	
		SIGNAL	x 1 (Green)	
		CLIP	x 1 (Red)	
		ALERT	x 1 (Orange)	
MUTE	x 2 (Red)			
Load Protection		POWER switch ON / OFF mute DC-fault : Amplifier shuts down automatically. Clip limiting : THD ≥ 0.5%		
Amplifier Protection		Thermal : Output mute (heatsink temp. ≥ 90°C) (return automatically.) VI limiter(RL ≤ 1Ω) : Limit the output		
Power Supply Protection		Thermal : Amplifier shuts down automatically. (heatsink temp. ≥ 100°C)		
Cooling		Variable speed fan : x 2		
Power Requirements		120V, 220V–240V; 50Hz/60Hz (120V models use 30A twist lock connector)		
Power Consumption		TX6n: 1800W, TX5n: 1600W, TX4n: 1500W		
Power Cord Length		1.5m		
Dimensions (W x H x D)		480 x 88 x 461 mm (18-7/8" x 3-7/16" x 18-1/8")		
Weight		16.0 kg (35.3 lbs)		
Operation free-air Temperature Range		0°C to +40°C		
Storage Temperature Range		-20°C to +60°C		
Accessory		Handle x 2 (with flat-head screw x 4), Euroblock connector (3P) x 1, Rubber feet x 4, Owner's Manual		

(*1) Output power depends on the power supply voltage. These figures are based on 230V.

If the power supply voltage is 220V, output power will be about 8% less than the power shown in the table. Output power will be about 7% more in case of 240V.

(*2) 1/8 power = 9dB below rated power

(*3) Half power = 3dB below rated power

(*4) 0dBu = 0.775Vrms

Trademarks notice :

Neutrik®, Speakon® are used for information only and are the property of their respective companies.

Block Diagram

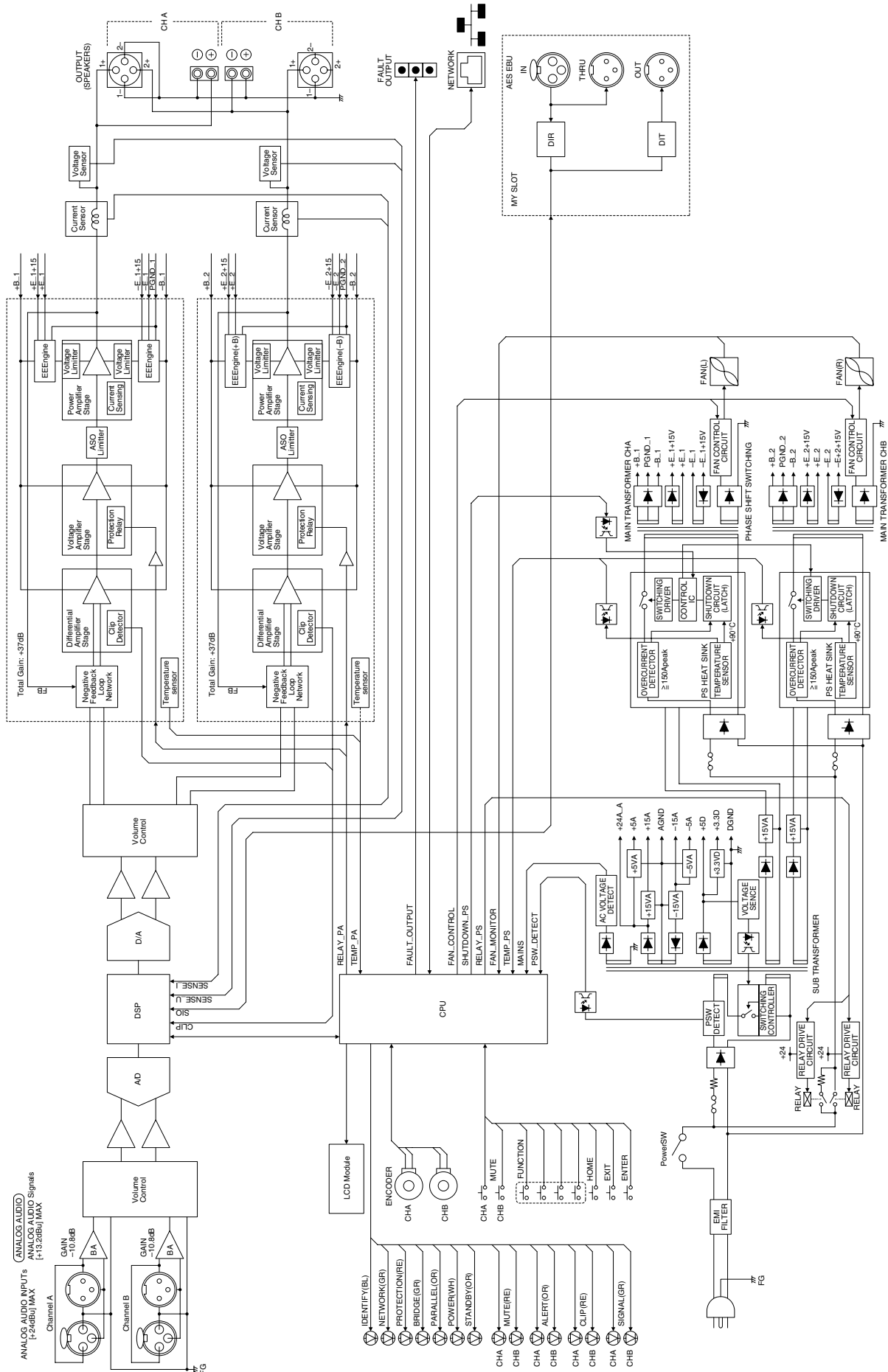

Level Diagram

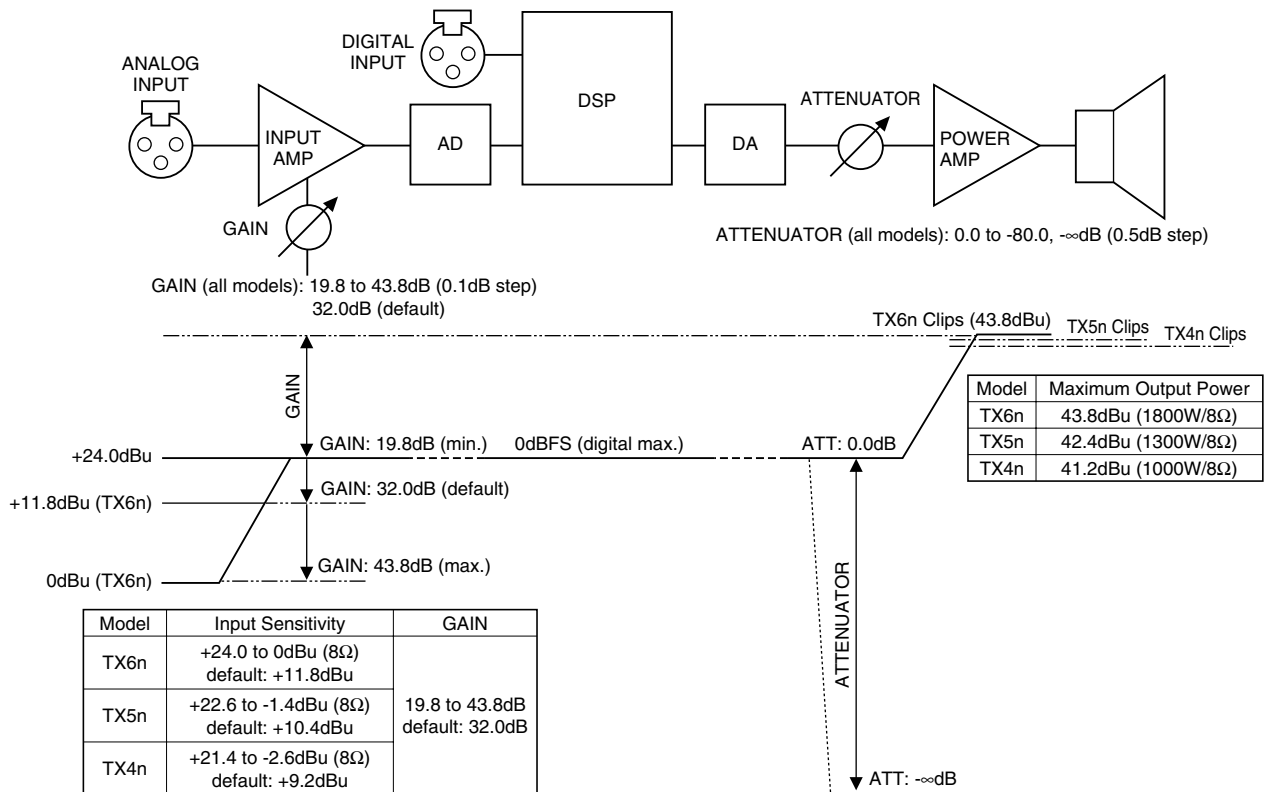

DSP Block Diagram

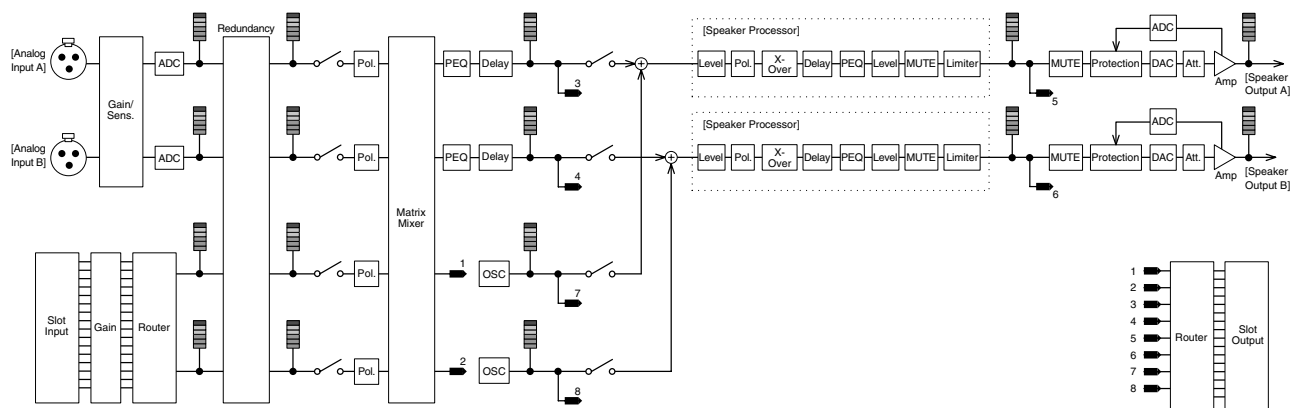

Dimensions

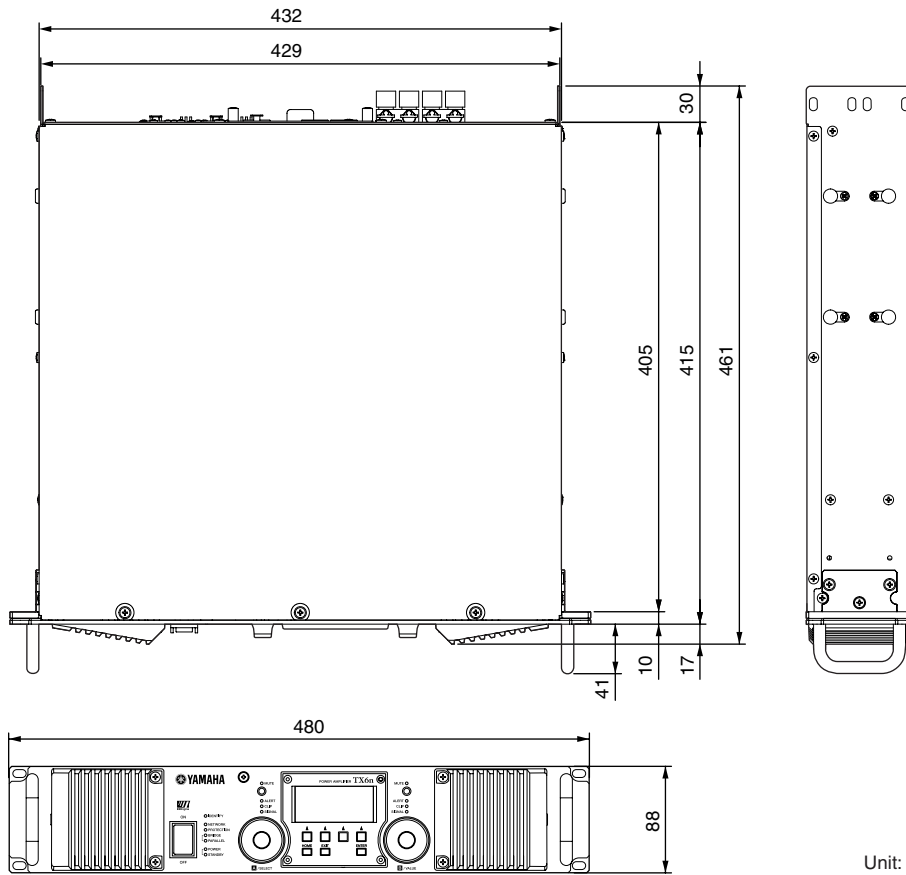

Unit: mm

Current Draw

		Line Current (A)		Power (W)			Thermal Dissipation		
		100/120V	230/240V	In	Out	Dissipated	Btu/h	kcal/h	
TX6n	standby		0.36	0.20	19	0	19	65	16
	idle		1.6	0.88	75	0	75	256	605
	1/8 power	8ohms/ch	13.7	7.5	833	425	408	1390	351
		4ohms/ch	19.2	10.6	1250	688	563	1920	484
		2ohms/ch	22.0	12.1	1432	688	745	2540	641
	1/3 power	8ohms/ch	26.9	14.8	1828	1133	695	2370	597
4ohms/ch		40.4	22.2	2910	1833	1077	3670	926	
2ohms/ch		44.7	24.5	3216	1833	1383	4720	1190	
TX5n	standby		0.36	0.20	19	0	19	65	16
	idle		1.6	0.9	75	0	75	256	65
	1/8 power	8ohms/ch	10.4	5.7	637	325	312	1070	269
		4ohms/ch	14.7	8.1	955	525	430	1470	369
		2ohms/ch	20.0	11.0	1302	625	677	2310	582
	1/3 power	8ohms/ch	20.6	11.3	1398	867	531	1810	457
4ohms/ch		30.9	17.0	2222	1400	822	2810	707	
2ohms/ch		40.6	22.3	2924	1667	1257	4290	1080	
TX4n	standby		0.36	0.20	19	0	19	65	16
	idle		1.6	0.9	75	0	75	256	65
	1/8 power	8ohms/ch	8.0	4.4	490	250	240	820	207
		4ohms/ch	12.2	6.7	795	438	358	1220	308
		2ohms/ch	17.6	9.7	1146	550	596	2030	512
	1/3 power	8ohms/ch	15.8	8.7	1075	667	409	1390	351
4ohms/ch		25.7	14.1	1852	1167	685	2340	589	
2ohms/ch		35.7	19.6	2573	1467	1106	3780	952	

1/8 power is typical of program material with occasional clipping. Refer to these figures for most applications.

1/3 power represents program material with extremely heavy clipping.

Test signal: Pink Noise, bandwidth limited from 22Hz to 22kHz

1W = 0.860kcal/h, 1BTU = 0.252kcal

Note that Line Voltage [V] x Line Current [A] = [VA], not equals to [W].

Inrush current: 8A (100V), 9A (120V), 17A (240V)

Performance Graph

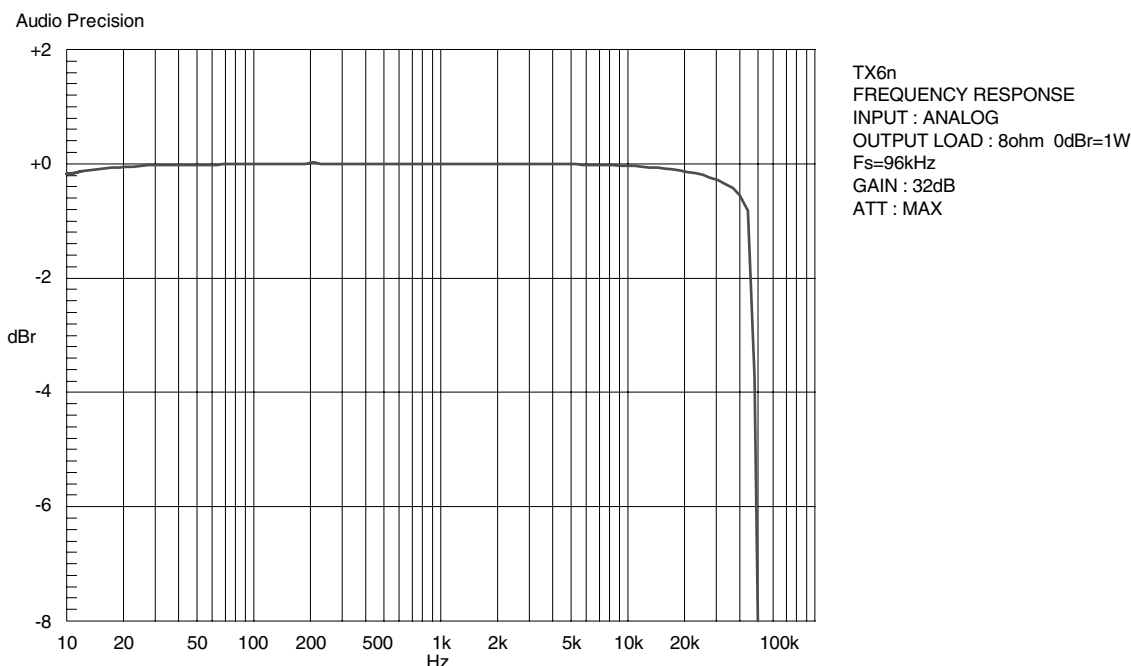

EN



Information for Users on Collection and Disposal of Old Equipment

This symbol on the products, packaging, and/or accompanying documents means that used electrical and electronic products should not be mixed with general household waste.

For proper treatment, recovery and recycling of old products, please take them to applicable collection points, in accordance with your national legislation and the Directives 2002/96/EC.

By disposing of these products correctly, you will help to save valuable resources and prevent any potential negative effects on human health and the environment which could otherwise arise from inappropriate waste handling.

For more information about collection and recycling of old products, please contact your local municipality, your waste disposal service or the point of sale where you purchased the items.

[For business users in the European Union]

If you wish to discard electrical and electronic equipment, please contact your dealer or supplier for further information.

[Information on Disposal in other Countries outside the European Union]

This symbol is only valid in the European Union. If you wish to discard these items, please contact your local authorities or dealer and ask for the correct method of disposal.

DE



Verbraucherinformation zur Sammlung und Entsorgung alter Elektrogeräte

Befindet sich dieses Symbol auf den Produkten, der Verpackung und/oder beiliegenden Unterlagen, so sollten benutzte elektrische Geräte nicht mit dem normalen Haushaltsabfall entsorgt werden.

In Übereinstimmung mit Ihren nationalen Bestimmungen und den Richtlinien 2002/96/EC, bringen Sie alte Geräte bitte zur fachgerechten Entsorgung, Wiederaufbereitung und Wiederverwendung zu den entsprechenden Sammelstellen.

Durch die fachgerechte Entsorgung der Elektrogeräte helfen Sie, wertvolle Ressourcen zu schützen und verhindern mögliche negative Auswirkungen auf die menschliche Gesundheit und die Umwelt, die andernfalls durch unsachgerechte Müllentsorgung auftreten könnten.

Für weitere Informationen zum Sammeln und Wiederaufbereiten alter Elektrogeräte, kontaktieren Sie bitte Ihre örtliche Stadt- oder Gemeindeverwaltung, Ihren Abfallentsorgungsdienst oder die Verkaufsstelle der Artikel.

[Information für geschäftliche Anwender in der Europäischen Union]

Wenn Sie Elektrogeräte ausrangieren möchten, kontaktieren Sie bitte Ihren Händler oder Zulieferer für weitere Informationen.

[Entsorgungsinformation für Länder außerhalb der Europäischen Union]

Dieses Symbol gilt nur innerhalb der Europäischen Union. Wenn Sie solche Artikel ausrangieren möchten, kontaktieren Sie bitte Ihre örtlichen Behörden oder Ihren Händler und fragen Sie nach der sachgerechten Entsorgungsmethode.

FR



Information concernant la Collecte et le Traitement des déchets d'équipements électriques et électroniques

Le symbole sur les produits, l'emballage et/ou les documents joints signifie que les produits électriques ou électroniques usagés ne doivent pas être mélangés avec les déchets domestiques habituels.

Pour un traitement, une récupération et un recyclage appropriés des déchets d'équipements électriques et électroniques, veuillez les déposer aux points de collecte prévus à cet effet, conformément à la réglementation nationale et aux Directives 2002/96/EC.

En vous débarrassant correctement des déchets d'équipements électriques et électroniques, vous contribuerez à la sauvegarde de précieuses ressources et à la prévention de potentiels effets négatifs sur la santé humaine qui pourraient advenir lors d'un traitement inapproprié des déchets.

Pour plus d'informations à propos de la collecte et du recyclage des déchets d'équipements électriques et électroniques, veuillez contacter votre municipalité, votre service de traitement des déchets ou le point de vente où vous avez acheté les produits.

[Pour les professionnels dans l'Union Européenne]

Si vous souhaitez vous débarrasser des déchets d'équipements électriques et électroniques veuillez contacter votre vendeur ou fournisseur pour plus d'informations.

[Information sur le traitement dans d'autres pays en dehors de l'Union Européenne]

Ce symbole est seulement valable dans l'Union Européenne. Si vous souhaitez vous débarrasser de déchets d'équipements électriques et électroniques, veuillez contacter les autorités locales ou votre fournisseur et demander la méthode de traitement appropriée.

ES



Información para Usuarios sobre Recolección y Disposición de Equipamiento Viejo

Este símbolo en los productos, embalaje, y/o documentación que se acompaña significa que los productos electrónicos y eléctricos usados no deben ser mezclados con desechos hogareños corrientes.

Para el tratamiento, recuperación y reciclado apropiado de los productos viejos, por favor llévelos a puntos de recolección aplicables, de acuerdo a su legislación nacional y las directivas 2002/96/EC.

Al disponer de estos productos correctamente, ayudará a ahorrar recursos valiosos y a prevenir cualquier potencial efecto negativo sobre la salud humana y el medio ambiente, el cual podría surgir de un inapropiado manejo de los desechos.

Para mayor información sobre recolección y reciclado de productos viejos, por favor contacte a su municipio local, su servicio de gestión de residuos o el punto de venta en el cual usted adquirió los artículos.

[Para usuarios de negocios en la Unión Europea]

Si usted desea deshacerse de equipamiento eléctrico y electrónico, por favor contacte a su vendedor o proveedor para mayor información.

[Información sobre la Disposición en otros países fuera de la Unión Europea]

Este símbolo sólo es válidos en la Unión Europea. Si desea deshacerse de estos artículos, por favor contacte a sus autoridades locales y pregunte por el método correcto de disposición.

IT



Informazioni per gli utenti sulla raccolta e lo smaltimento di vecchia attrezzatura

Questo simbolo sui prodotti, sull'imballaggio, e/o sui documenti che li accompagnano significa che i prodotti elettriche e elettroniche non dovrebbero essere mischiati con i rifiuti domestici generici.

Per il trattamento, recupero e riciclaggio appropriati di vecchi prodotti, li porti, prego, ai punti di raccolta appropriati, in accordo con la Sua legislazione nazionale e le direttive 2002/96/CE.

Smaltendo correttamente questi prodotti, Lei aiuterà a salvare risorse preziose e a prevenire alcuni potenziali effetti negativi sulla salute umana e l'ambiente, che altrimenti potrebbero sorgere dal trattamento improprio dei rifiuti.

Per ulteriori informazioni sulla raccolta e il riciclaggio di vecchi prodotti, prego contatti la Sua amministrazione comunale locale, il Suo servizio di smaltimento dei rifiuti o il punto vendita dove Lei ha acquistato gli articoli.

[Per utenti imprenditori dell'Unione europea]

Se Lei desidera disfarsi di attrezzatura elettrica ed elettronica, prego contatti il Suo rivenditore o fornitore per ulteriori informazioni.

[Informazioni sullo smaltimento negli altri Paesi al di fuori dell'Unione europea]

Questo simbolo è validi solamente nell'Unione europea. Se Lei desidera disfarsi di questi articoli, prego contatti le Sue autorità locali o il rivenditore e richieda la corretta modalità di smaltimento.

For details of products, please contact your nearest Yamaha representative or the authorized distributor listed below.

Pour plus de détails sur les produits, veuillez-vous adresser à Yamaha ou au distributeur le plus proche de vous figurant dans la liste suivante.

Die Einzelheiten zu Produkten sind bei Ihrer unten aufgeführten Niederlassung und bei Yamaha Vertragshändlern in den jeweiligen Bestimmungsländern erhältlich.

Para detalles sobre productos, contacte su tienda Yamaha más cercana o el distribuidor autorizado que se lista debajo.

NORTH AMERICA

CANADA

Yamaha Canada Music Ltd.
135 Milner Avenue, Scarborough, Ontario,
M1S 3R1, Canada
Tel: 416-298-1311

U.S.A.

Yamaha Corporation of America
6600 Orangethorpe Ave., Buena Park, Calif. 90620,
U.S.A.
Tel: 714-522-9011

CENTRAL & SOUTH AMERICA

MEXICO

Yamaha De México, S.A. de C.V.
Av. Insurgentes Sur 1647 "Prisma Insurgentes",
Col. San José Insurgentes, Del. Benito Juárez,
03900, México, D.F.
Tel: 55-5804-0600

BRAZIL

Yamaha Musical do Brasil Ltda.
Rua Joaquim Floriano, 913 - 4º andar, Itaim Bibi,
CEP 04534-013 Sao Paulo, SP. BRAZIL
Tel: 011-3704-1377

ARGENTINA

Yamaha Music Latin America, S.A.
Sucursal de Argentina
Olga Cossettini 1553, Piso 4 Norte
Madero Este-C1107CEK
Buenos Aires, Argentina
Tel: 011-4119-7000

PANAMA AND OTHER LATIN AMERICAN COUNTRIES/ CARIBBEAN COUNTRIES

Yamaha Music Latin America, S.A.
Torre Banco General, Piso 7, Urbanización Marbella,
Calle 47 y Aquilino de la Guardia,
Ciudad de Panamá, Panamá
Tel: +507-269-5311

EUROPE

THE UNITED KINGDOM/IRELAND

Yamaha Music Europe GmbH (UK)
Sherbourne Drive, Tilbrook, Milton Keynes,
MK7 8BL, England
Tel: 01908-366700

GERMANY

Yamaha Music Europe GmbH
Siemensstraße 22-34, 25462 Rellingen, Germany
Tel: 04101-3030

SWITZERLAND/LIECHTENSTEIN

Yamaha Music Europe GmbH
Branch Switzerland in Zürich
Seefeldstrasse 94, 8008 Zürich, Switzerland
Tel: 044-387-8080

AUSTRIA/BULGARIA

Yamaha Music Europe GmbH Branch Austria
Schleiergasse 20, A-1100 Wien, Austria
Tel: 01-60203900

CZECH REPUBLIC/HUNGARY/ ROMANIA/SLOVAKIA/SLOVENIA

Yamaha Music Europe GmbH
Branch Austria (Central Eastern Europe Office)
Schleiergasse 20, A-1100 Wien, Austria
Tel: 01-602039025

POLAND/LITHUANIA/LATVIA/ESTONIA

Yamaha Music Europe GmbH
Branch Poland Office
ul. Wrotkowa 14 02-553 Warsaw, Poland
Tel: 022-500-2925

MALTA

Olimpus Music Ltd.
The Emporium, Level 3, St. Louis Street Msida
MSD06
Tel: 02133-2144

THE NETHERLANDS/ BELGIUM/LUXEMBOURG

Yamaha Music Europe Branch Benelux
Clarissenhof 5-b, 4133 AB Vianen, The Netherlands
Tel: 0347-358 040

FRANCE

Yamaha Music Europe
7 rue Ambroise Croizat, Zone d'activites Pariest,
77183 Croissy-Beaubourg, France
Tel: 01-64-61-4000

ITALY

Yamaha Music Europe GmbH, Branch Italy
Viale Italia 88, 20020 Lainate (Milano), Italy
Tel: 02-935-771

SPAIN/PORTUGAL

Yamaha Music Europe GmbH Ibérica, Sucursal en España
Ctra. de la Coruna km. 17, 200, 28230
Las Rozas (Madrid), Spain
Tel: +34-902-39-8888

GREECE

Philippos Nakas S.A. The Music House
147 Skiathou Street, 112-55 Athens, Greece
Tel: 01-228 2160

SWEDEN/FINLAND/ICELAND

Yamaha Music Europe GmbH Germany filial Scandinavia
J. A. Wettergrens Gata 1, Box 30053
S-400 43 Göteborg, Sweden
Tel: 031 89 34 00

DENMARK

Yamaha Music Europe GmbH, Tyskland – filial Denmark
Generatorvej 6A, DK-2730 Herlev, Denmark
Tel: 44 92 49 00

NORWAY

Yamaha Music Europe GmbH Germany - Norwegian Branch
Grini Næringspark 1, N-1345 Østerås, Norway
Tel: 67 16 77 70

RUSSIA

Yamaha Music (Russia)
Room 37, bld. 7, Kievskaya street, Moscow,
121059, Russia
Tel: 495 626 5005

OTHER EUROPEAN COUNTRIES

Yamaha Music Europe GmbH
Siemensstraße 22-34, 25462 Rellingen, Germany
Tel: +49-4101-3030

AFRICA

Yamaha Corporation,
Asia-Pacific Sales & Marketing Group
Nakazawa-cho 10-1, Naka-ku, Hamamatsu,
Japan 430-8650
Tel: +81-53-460-2303

MIDDLE EAST

TURKEY

Yamaha Music Europe GmbH
Merkezi Almanya Türkiye İstanbul Şubesi
Maslak Meydan Sokak No:5 Spring Giz Plaza
Bağımsız Bol. No:3, 34398 Şişli İstanbul
Tel: +90-212-999-8010

CYPRUS

Yamaha Music Europe GmbH
Siemensstraße 22-34, 25462 Rellingen, Germany
Tel: 04101-3030

OTHER COUNTRIES

Yamaha Music Gulf FZE
LOB 16-513, P.O.Box 17328, Jubel Ali,
Dubai, United Arab Emirates
Tel: +971-4-881-5868

ASIA

THE PEOPLE'S REPUBLIC OF CHINA

Yamaha Music & Electronics (China) Co., Ltd.
2F, Yunhedasha, 1818 Xinzha-lu, Jingan-qu,
Shanghai, China
Tel: 021-6247-2211

INDIA

Yamaha Music India Pvt. Ltd.
Spazedge building, Ground Floor, Tower A, Sector
47, Gurgaon- Sohna Road, Gurgaon, Haryana, India
Tel: 0124-485-3300

INDONESIA

PT. Yamaha Musik Indonesia (Distributor)

PT. Nusantik

Gedung Yamaha Music Center, Jalan Jend. Gatot
Subroto Kav. 4, Jakarta 12930, Indonesia
Tel: 021-520-2577

KOREA

Yamaha Music Korea Ltd.
8F, 9F, Dongsung Bldg. 158-9 Samsung-Dong,
Kangnam-Gu, Seoul, Korea
Tel: 02-3467-3300

MALAYSIA

Yamaha Music (Malaysia) Sdn., Bhd.
Lot 8, Jalan Perbandaran, 47301 Kelana Jaya,
Petaling Jaya, Selangor, Malaysia
Tel: 03-78030900

SINGAPORE

Yamaha Music (Asia) PRIVATE LIMITED
Blk 202 Hougang Street 21, #02-00,
Singapore 530202, Singapore
Tel: 6747-4374

TAIWAN

Yamaha KHS Music Co., Ltd.
3F, #6, Sec.2, Nan Jing E. Rd. Taipei.
Taiwan 104, R.O.C.
Tel: 02-2511-8688

THAILAND

Siam Music Yamaha Co., Ltd.
4, 6, 15 and 16th floor, Siam Motors Building,
891/1 Rama 1 Road, Wangmai,
Pathumwan, Bangkok 10330, Thailand
Tel: 02-215-2622

VIETNAM

Yamaha Music Vietnam Company Limited
15th Floor, Nam A Bank Tower, 201-203 Cach
Mang Thang Tam St., Ward 4, Dist.3,
Ho Chi Minh City, Vietnam
Tel: +84-8-3818-1122

OTHER ASIAN COUNTRIES

Yamaha Corporation,
Asia-Pacific Sales & Marketing Group
Nakazawa-cho 10-1, Naka-ku, Hamamatsu,
Japan 430-8650
Tel: +81-53-460-2303

OCEANIA

AUSTRALIA

Yamaha Music Australia Pty. Ltd.
Level 1, 99 Queensbridge Street, Southbank,
Victoria 3006, Australia
Tel: 3-9693-5111

COUNTRIES AND TRUST TERRITORIES IN PACIFIC OCEAN

Yamaha Corporation,
Asia-Pacific Sales & Marketing Group
Nakazawa-cho 10-1, Naka-ku, Hamamatsu,
Japan 430-8650
Tel: +81-53-460-2303



Yamaha Pro Audio global web site:
<http://www.yamahaproaudio.com/>

Yamaha Manual Library:
<http://www.yamaha.co.jp/manual/>

C.S.G., Pro Audio Division
© 2009-2011 Yamaha Corporation

305POZCx.x-01E0
Printed in Indonesia

WP58530

Free Manuals Download Website

<http://myh66.com>

<http://usermanuals.us>

<http://www.somanuals.com>

<http://www.4manuals.cc>

<http://www.manual-lib.com>

<http://www.404manual.com>

<http://www.luxmanual.com>

<http://aubethermostatmanual.com>

Golf course search by state

<http://golfingnear.com>

Email search by domain

<http://emailbydomain.com>

Auto manuals search

<http://auto.somanuals.com>

TV manuals search

<http://tv.somanuals.com>