

La version française du Mode d'emploi se trouve au verso.

PRECAUTIONS

PLEASE READ CAREFULLY BEFORE PROCEEDING
* Please keep this manual in a safe place for future reference.

WARNING

Always follow the basic precautions listed below to avoid the possibility of serious injury or even death from electrical shock, short-circuiting, damages, fire or other hazards. These precautions include, but are not limited to, the following:

Do not open

This device contains no user-serviceable parts. Do not open the device or attempt to disassemble the internal parts or modify them in any way. If it should appear to be malfunctioning, discontinue use immediately and have it inspected by qualified Yamaha service personnel.

Water warning

Do not expose the device to rain, use it near water or in damp or wet conditions, or place on it any containers (such as vases, bottles or glasses) containing liquids which might spill into any openings. If any liquid such as water seeps into the device, have the device inspected by qualified Yamaha service personnel.

CAUTION

Always follow the basic precautions listed below to avoid the possibility of physical injury to you or others, or damage to the device or other property. These precautions include, but are not limited to, the following:

Location

- Do not place the device in an unstable position where it might accidentally fall over.
- Do not use the speaker's handles for suspended installation. Doing so can result in damage or injury.
- Do not place the device in a location where it may come into contact with corrosive gases or salt air. Doing so may result in malfunction.
- Always consult qualified Yamaha service personnel if the device installation requires construction work, and make sure to observe the following precautions:
 - Choose mounting hardware and an installation location that can support the weight of the device.
 - Avoid locations that are exposed to constant vibration.
 - Use the required tools to install the device.
 - Inspect the device periodically.

Connections

- Before connecting the device to other devices, turn off the power for all the other devices. Before turning the power on or off for all devices, set all volume levels to minimum.
- Use only speaker cables for connecting speakers to the speaker jacks. Use of other types of cables may result in fire.

Handling caution

- Do not insert your fingers or hands in any gaps or openings on the device (ports).
- Do not rest your weight on the device or place heavy objects on it.
- Do not operate the device if the sound is distorting. Prolonged use in this condition could cause overheating and result in fire.
- Do not pull the cables connected.
- When choosing a power amplifier for use with this device, make sure that the output power of the amplifier is lower than the power capacity of this device (see "Specifications"). Even if the output power of the amplifier is lower than the power capacity of this device (program), use of excessive input signals resulting in clipping may cause damage to the device. Malfunction or fire may occur especially when the following sounds or noises are generated:
 - feedback, when using a microphone
 - continuous and extreme volume sound from a musical instrument
 - extreme continuous distorted sound

- noise caused by plugging/unplugging the cable while the amplifier is turned on

Yamaha cannot be held responsible for damage caused by improper use or modifications to the device.

NOTICE

To avoid the possibility of malfunction/damage to the product or damage to other property, follow the notices below.

Handling and maintenance

- Do not expose the device to excessive dust or vibration, or extreme cold or heat (such as in direct sunlight, near a heater, or in a car during the day), in order to prevent the possibility of panel discoloration, unstable operation, or damage to the internal components.
- Do not place vinyl, plastic or rubber objects on the device, since this might discolor the panel.
- When cleaning the device, use a dry and soft cloth. Do not use paint thinners, solvents, cleaning fluids, or chemical-impregnated wiping cloths.
- When turning on the AC power in your audio system, always turn on the power amplifier LAST, to avoid speaker damage. When turning the power off, the power amplifier should be turned off FIRST for the same reason.
- Be sure to observe the amplifier's rated load impedance (see "Specifications"), particularly when connecting speakers in parallel. Connecting an impedance load outside the amplifier's rated range can damage the amplifier.
- When connecting the speakers with high impedance, be sure that the total rated input capacity of the speakers does not exceed the output power of the amplifier.
- When using a high-impedance speaker connection, make sure the audio signal is passed through an 80 Hz or above high-pass filter before being input to the speakers.
- Do not swing the speaker by its carrying band.
- Do not place the speaker face down with the grille attached, as deformation of the grille may result.
- When placing the speaker face down, always place it on a flat and smooth surface.
- Do not touch the speaker driver unit.

Protective circuit

This speaker system has an internal protection circuit that shuts off the speaker unit when an excessive input signal is applied. If the speaker unit emits no sound, reduce the volume level of the amplifier immediately. The sound will return automatically in several seconds.

About this manual

- The illustrations as shown in this manual are for explanation only, and may appear somewhat different from your device.
- The company names and product names in this manual are the trademarks or registered trademarks of their respective companies.

Yamaha Pro Audio global web site
<http://www.yamahaproaudio.com/>
Yamaha Manual Library
<http://www.yamaha.co.jp/manual/>

Supplied Items

Unpack the contents and confirm that all the following items are included.

- Speaker × 2
- Tile Rail × 4
- Terminal cover × 2
- Grille × 2
- Screw (4 × 8) × 12
- Owner's Manual (this manual)
- O-ring × 2
- Cutout Template × 1
- Technical Specifications (English only)

* Speaker cable and safety wire are not supplied.

Specifications

Model	VXC4-VA / VXC4-VAW	
Type	Full range with back can, acoustic suspension	
Component	4" (10 cm) full range	
Coverage angle (-6 dB) ^{*1}	Horizontal: 180° (500 Hz), 180° (1 kHz), 160° (2 kHz), 85° (4 kHz) Vertical: 180° (500 Hz), 180° (1 kHz), 160° (2 kHz), 85° (4 kHz)	
Rated impedance	8 Ω (without transformer) 100 V line: 330 Ω (30 W), 670 Ω (15 W), 1.3 kΩ (7.5 W) 70 V line: 170 Ω (30 W), 330 Ω (15 W), 670 Ω (7.5 W), 1.3 kΩ (3.8 W)	
Power rating	NOISE (IEC, 100h) ^{*2}	30 W
	PGM	60 W
	MAX	120 W
Sensitivity ^{*1}	87 dB (1 W, 1 m, 100 Hz to 10 kHz pink noise)	
	75 dB (1 W, 4 m, 100 Hz to 10 kHz pink noise)	
Maximum SPL ^{*3}	100 dB (30 W, 1 m, 100 Hz to 10 kHz pink noise at 30 W tap)	
	88 dB (30 W, 4 m, 100 Hz to 10 kHz pink noise at 30 W tap)	
	108 dB (120 W, 1 m, 100 Hz to 10 kHz pink noise at 8 Ω)	
	96 dB (120 W, 4 m, 100 Hz to 10 kHz pink noise at 8 Ω)	
Frequency range (-10 dB) ^{*1, *4}	80 Hz - 20 kHz	
Connector	Ceramic terminal block (3 pin) × 1 (input: +/-, Earth) Applicable wire size AWG 26-12 (4.0 mm ²), wire outer diameter Ø6.5 - Ø12.5 mm	
Transformer taps	70 V	30 W, 15 W, 7.5 W, 3.8 W
	100 V	30 W, 15 W, 7.5 W
Overload protection	Full-range power limiting to protect network and transducers	
Magnetically shielded	No	
Dust and water resistant	IP32	
Enclosure	Back can	Steel (t=1 mm), electrodeposition coating, black
	Baffle	ABS (UL94-SVB), black
Grille	Metal grille	Powder coated perforated steel (t=0.6 mm), aperture ratio: 51%
	Trim	ABS
Outer color (grille)	VXC4-VA	Black (approximate value: Munsell N3)
	VXC4-VAW	White (approximate value: Munsell 9.3)
Dimensions (with grille)	Ø225 × 232 D mm (Ø8 7/8" × 9 3/16" D)	
Net weight (with grille, 1 piece)	2.6 kg (5.7 lbs)	
Cutout size	Ø186 mm (Ø7 5/16")	
Required ceiling board thickness	5 mm - 35 mm	
Packaging	Packaged in pair	
Standards	Certified to the European Standard EN 54-24: 2008 0359-CPR-00405 Certified year: 14	
	Loudspeaker for voice alarm systems for fire detection and fire alarm systems	
	Environment type: A	
	Certified to the European Standard EN60849:1998 Sound systems for emergency purposes	
	Certified to the International Standard ISO 7240-24: 2010 Sound-system loudspeaker for fire detection and fire alarm systems	
	In compliance with the British Standard BS-5839-8: 2008 14.8	

The specifications data was measured in an anechoic chamber, according to EN 54-24. Reference axis: Axis is on the center of grille surface and perpendicular to the grille surface. Reference plane: Plane is on the grille surface and perpendicular to the reference axis. Horizontal plane: Plane is containing the reference axis and perpendicular to the reference plane.

- *1: Half-space (2π)
- *2: IEC shaped pink noise with 6 dB crest factor.
- *3: Calculated based on power rating and sensitivity, exclusive of power compression.
- *4: When connecting with low impedance.

The contents of this manual apply to the latest specifications as of the printing date. Since Yamaha makes continuous improvements to the product, this manual may not apply to the specifications of your particular product. To obtain the latest manual, access the Yamaha website then download the manual file. Since specifications, equipment or separately sold accessories may not be the same in every locale, please check with your Yamaha dealer.

The dimensions are shown in "Technical Specifications".

Connecting the Multiple Speakers

When installing the multiple speakers, connect them in parallel way.

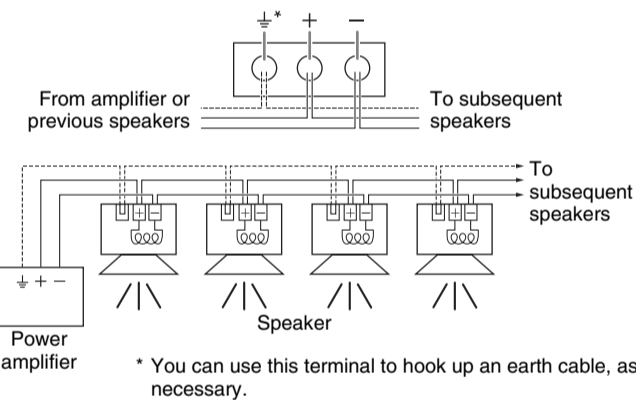

CAUTION

When connecting with low impedance, take note of the combined resistance.

Note

When connecting with high impedance, refer to "Better Sound for Commercial Installations" (English only) of the Yamaha Pro Audio web site, at the following URL:
http://www.yamahaproaudio.com/global/en/training_support/better_sound/

Installing the Speakers

Install the speakers onto the ceiling with the supplied hardware. Ensure that the strength of the ceiling rail is sufficiently strong.

Pre-installation (Preparation of the Cable)

Use stranded wire for cables attached to the ceramic terminal. Strip their insulation as shown in the figure and connect them.

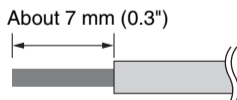

Note

Do not plate stranded wires by solder. Doing so will cause the wire to break.

1 Cut Out a Hole in the Ceiling

- Put the supplied cutout template to the ceiling and draw a circle by tracing it. Make sure to use the cutout template so that hole is the correct diameter.

Note

If you use a circular cutter, set the diameter with the cutout template.

- Cut the hole by tracing the circle. Be careful to prevent chips or powder entering your eyes while cutting the hole.

2 Install the Tile Rails and O-ring

- Insert the two tile rails through the cut hole and place them on the ceiling surface within your reach. Be sure that each tile rails are oriented as shown below.
- Insert the folded O-ring through the cut hole and open it in the ceiling.
- Secure the O-ring and tile rails with supplied two screws through either slot of both O-ring brackets.

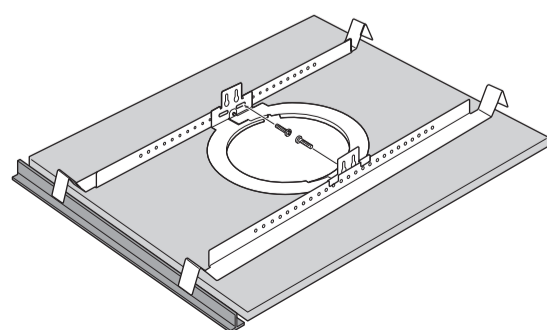

3 Connecting the Wiring to the Speakers

- Pull the wiring from the amplifier through the cut hole.
- Pass the cables through the cable gland attached to the terminal cover.

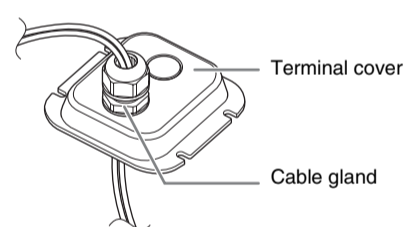

If it is difficult to pass all the cables through a single cable gland, open the hole in the terminal cover and attach a commercially available cable gland.

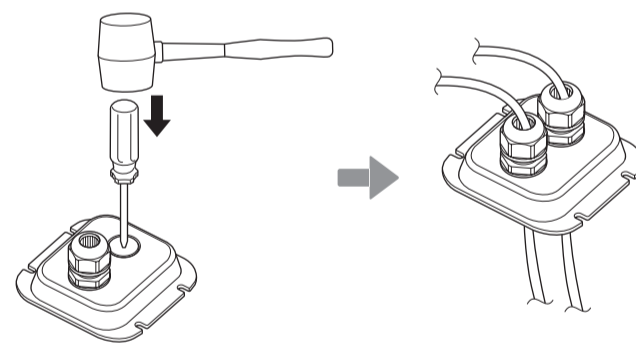

Note

Prepare a cable gland of AVC part no. PGB 13.5-12B.

CAUTION

Use an appropriate tool for opening the hole. Otherwise, you may be injured if you open the hole with your bare hands.

- Loosen the terminal screws of the ceramic terminal with a flat-blade screwdriver, insert the cables into each terminal and tighten the screws. Pull on the cables to make sure they are tightly secured and will not come loose.

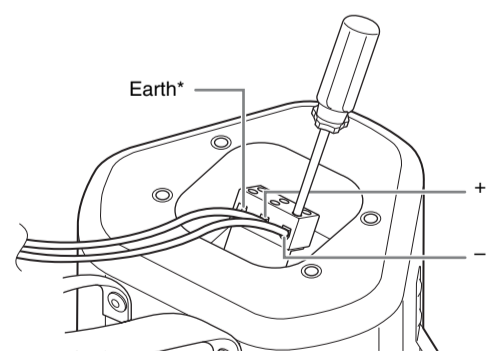

Note

Use a flat-blade screwdriver with a blade less than 3 mm (0.1 in.).

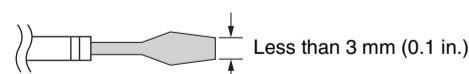

- Close the terminal cover and tighten the screws.

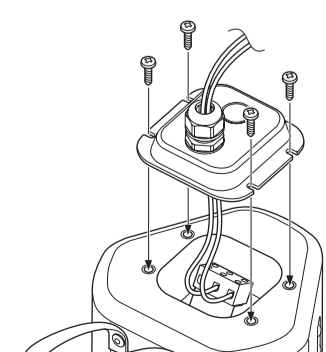

- Tighten the cap of the cable gland.

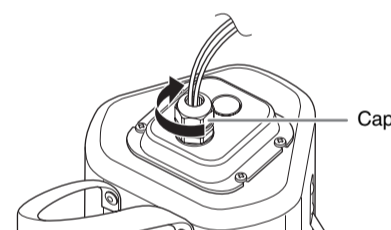

4 Fix the Speakers onto the Ceiling

- Attach the safety wire to the safety wire ring, and connect the wire to an independent support point, such as a joist.

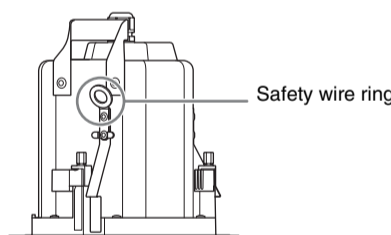

CAUTION

Always take measures to prevent the speaker falling down. If the safety wire is too short, prepare another wire appropriate for the speaker weight and installation conditions. If the wire is too long, should the speaker fall, the wire may break as a result of too much strain.

- Push up the speaker slowly into the ceiling, taking care not to trap the cable.

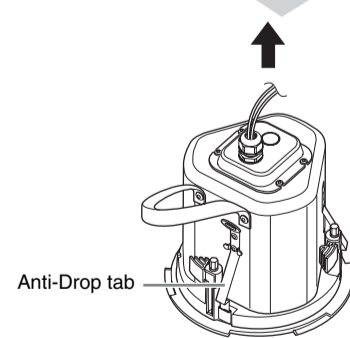
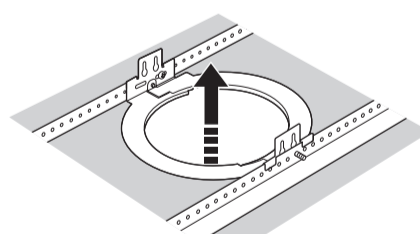

When all the Anti-Drop tabs cross over the O-ring, the speaker is held temporarily.

To release the speaker from the O-ring, press the Anti-Drop tabs. These are located above the ▲ mark near the edge of the baffle's face.

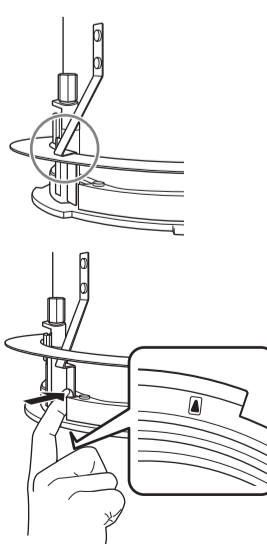

- Turn the screwdriver a half turn counterclockwise to loosen the attachment screw (located beside the ▲ mark). This makes the clamp easier to align in the channel.

- Turn the screwdriver clockwise to tighten the attachment screw. The first turn of the attachment screw aligns the clamp with the channel. Further turns move the clamp down the channel to pull the speaker up into the ceiling.

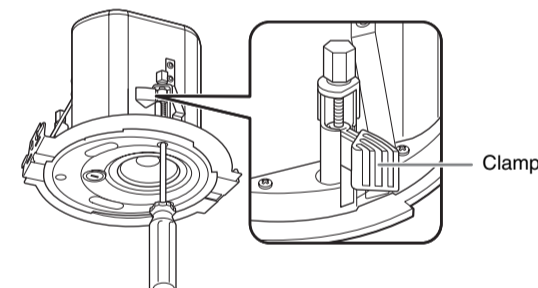

CAUTION

- Do not over-tighten the attachment screw. Otherwise, the attachment screw and clamp will break.
- Do not turn any screws other than attachment screw (located beside the ▲ mark). Otherwise, the speaker may fall or malfunction.

5 Set the Line Voltage/Impedance and Power

Select the line voltage/impedance (100V/70V/8Ω) and power tap for 100V/70V line distributed system, by rotating the tap selector switch on the front side of the speaker with a flat-blade screwdriver.

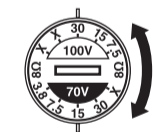

The illustration indicates the setting at 30 W for 100 V line and 15 W for 70 V line.

CAUTION

- The "X" position should not be selected. The 8Ω position should be selected for 8Ω audio systems only. If the setting is incorrect, it may cause malfunction of the speaker and amplifier.
- Make sure the amplifier is switched off before operating the tap selector switch.

6 Attach the Grille

Fit the grille to the baffle front and turn it clockwise.

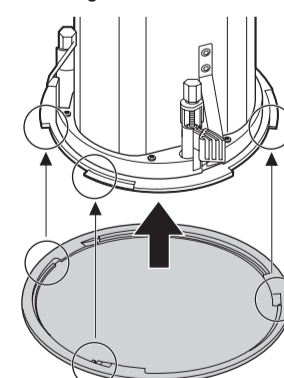

CAUTION

The grille may fall down if it is attached inadequately. Attach it firmly.

The installation is complete.

Free Manuals Download Website

<http://myh66.com>

<http://usermanuals.us>

<http://www.somanuals.com>

<http://www.4manuals.cc>

<http://www.manual-lib.com>

<http://www.404manual.com>

<http://www.luxmanual.com>

<http://aubethermostatmanual.com>

Golf course search by state

<http://golfingnear.com>

Email search by domain

<http://emailbydomain.com>

Auto manuals search

<http://auto.somanuals.com>

TV manuals search

<http://tv.somanuals.com>