



102 motorcycle

OWNER'S MANUAL

XT

XT350M
XT350MC

LIT-11626-13-18

Dear Yamaha ATV Owner: Please Review this IMPORTANT SAFETY CARD before operating your ATV (if card is not attached, call 1-800-344-6418).

Dear New Yamaha ATV Owner:

CONGRATULATIONS ON THE PURCHASE OF YOUR NEW YAMAHA ATV. You have purchased a quality Yamaha product that, with proper use and care, will provide hours of riding pleasure. **BEFORE YOU OPERATE YOUR NEW ATV, Yamaha recommends these important points:**

- READ YOUR OWNER'S MANUAL
- A CHILD UNDER 12 YEARS OLD SHOULD NOT OPERATE AN ATV WITH ENGINE SIZE 70CC OR GREATER
- A CHILD UNDER 16 YEARS OLD SHOULD NOT OPERATE AN ATV WITH ENGINE SIZE GREATER THAN 90CC
- TAKE THE FREE HANDS-ON TRAINING COURSE OFFERED BY YAMAHA — ASK YOUR DEALER FOR DETAILS OR CALL 1-800-887-2887

If you have any questions about these points, **or if you purchased your ATV from an authorized Yamaha dealership and were not informed of the age recommendation for your ATV by the dealership**, please fill out the information below and mail this card to Yamaha **today**.

Name:

ATV Model:

Purchase Date:

Address:

Primary I.D. (Engine Number):

MO. DAY YR.

Telephone:

() _____

Dealer Name & Address:

READ CAREFULLY



NO POSTAGE
NECESSARY
IF MAILED
IN THE
UNITED STATES

BUSINESS REPLY MAIL
FIRST CLASS PERMIT NO. 4 CYPRESS, CA

POSTAGE WILL BE PAID BY ADDRESSEE

**YAMAHA MOTOR CORPORATION U.S.A.
P.O. BOX 6555
CYPRESS, CALIFORNIA 90630-9989**

ATTN: SALES ADMINISTRATION



Congratulations on your purchase of the Yamaha XT350/XT350C. This model is the result of Yamaha's vast experience in the production of fine sporting, touring, and pacesetting racing machines. It represents the high degree of craftsmanship and reliability that have made Yamaha a leader in these fields.

This manual will give you an understanding of the operation, inspection, and basic maintenance of this motorcycle. If you have any questions about the operation or maintenance of your motorcycle, please consult a Yamaha dealer.

The design and manufacture of this Yamaha motorcycle fully comply with the emissions standards for clean air applicable at the date of manufacture. Yamaha has met these standards without reducing the motorcycle's performance or economy of operation. To maintain these high standards, it is important that you and your dealer pay close attention to the recommended maintenance schedules and operating instructions contained within this manual.

IMPORTANT MANUAL INFORMATION

EAU00003*

Particularly important information is distinguished in this manual by the following notations:



The Safety Alert Symbol means **ATTENTION! BECOME ALERT! YOUR SAFETY IS INVOLVED!**

WARNING

Failure to follow **WARNING** instructions could result in severe injury or death to the motorcycle operator, a bystander or a person inspecting or repairing the motorcycle.

CAUTION:

A **CAUTION** indicates special precautions that must be taken to avoid damage to the motorcycle.

NOTE:

A **NOTE** provides key information to make procedures easier or clearer.

NOTE:

- This manual should be considered a permanent part of this motorcycle and should remain with it even if the motorcycle is subsequently sold.
 - Yamaha continually seeks advancements in product design and quality. Therefore, while this manual contains the most current product information available at the time of printing, there may be minor discrepancies between your motorcycle and this manual. If there is any question concerning this manual, please consult your Yamaha dealer.
-

IMPORTANT MANUAL INFORMATION

EW000000

⚠ WARNING

PLEASE READ THIS MANUAL AND THE "YOU AND YOUR MOTORCYCLE: RIDING TIPS" BOOKLET CAREFULLY AND COMPLETELY BEFORE OPERATING THIS MOTORCYCLE. DO NOT ATTEMPT TO OPERATE THIS MOTORCYCLE UNTIL YOU HAVE ATTAINED A SATISFACTORY KNOWLEDGE OF ITS CONTROLS AND OPERATING FEATURES AND UNTIL YOU HAVE BEEN TRAINED IN SAFE AND PROPER RIDING TECHNIQUES. REGULAR INSPECTIONS AND CAREFUL MAINTENANCE, ALONG WITH GOOD RIDING SKILLS, WILL ENSURE THAT YOU SAFELY ENJOY THE CAPABILITIES AND THE RELIABILITY OF THIS MOTORCYCLE.

AFFIX DEALER

LABEL HERE

EAU01399

XT350M/XT350MC

OWNER'S MANUAL

©1999 by Yamaha Motor Corporation, U.S.A.

1st Edition, July 1999

**All rights reserved. Any reprinting or
unauthorized use without the written
permission of Yamaha Motor Corporation,
U.S.A. is expressly prohibited.**

P/N LIT-11626-13-18

TABLE OF CONTENTS

1	SAFETY INFORMATION	1-1	Fuel.....	3-6	
	Safe riding	1-1	Fuel cock.....	3-7	
	Protective apparel	1-3	Starter (choke) “ ”	3-8	
	Modification.....	1-3	Kick starter.....	3-9	
	Loading and accessories	1-3	Helmet holder.....	3-9	
	Gasoline and exhaust gas	1-5	Storage pouch.....	3-9	
	Location of the important labels.....	1-7	Rear shock absorber adjustment.....	3-10	
2	DESCRIPTION	2-1	Sidestand.....	3-12	
	Left view.....	2-1	Sidestand switch operation check.....	3-12	
	Right view	2-2	4	PRE-OPERATION CHECKS	4-1
	Controls/Instruments	2-3		Pre-operation check list	4-1
3	INSTRUMENT AND CONTROL		5	OPERATION AND IMPORTANT RIDING	
	FUNCTIONS	3-1		POINTS	5-1
	Main switch/Steering lock	3-1		Starting and warming up a	
	Indicator lights.....	3-2		cold engine	5-1
	Speedometer	3-2		Starting a warm engine	5-3
	Tachometer.....	3-3		Shifting.....	5-4
	Handlebar switches.....	3-3		To start out and accelerate.....	5-4
	Clutch lever.....	3-4		To decelerate	5-5
	Shift pedal.....	3-4		Recommended shift points	5-5
	Front brake lever	3-5		Engine break-in	5-5
	Rear brake pedal	3-5		Parking	5-6
	Fuel tank cap.....	3-5			

TABLE OF CONTENTS

6

PERIODIC MAINTENANCE AND MINOR

REPAIR	6-1
Periodic maintenance	6-1
Tool kit	6-1
Periodic maintenance chart for emission control system.....	6-3
General maintenance and lubrication chart....	6-4
Cowling A	6-7
Panel A and B	6-7
Spark plug.....	6-8
Canister (for california only).....	6-9
Engine oil	6-10
Air filter	6-13
Spark arrester cleaning.....	6-14
Carburetor adjustment	6-15
Valve clearance adjustment	6-15
Decompression cable adjustment	6-16
Tires.....	6-16
Wheels	6-18
Accessories or replacement parts	6-18
Clutch lever free play adjustment.....	6-19
Front brake lever free play adjustment	6-20
Rear brake pedal height and free play adjustment.....	6-20
Brake light switch adjustment.....	6-22
Checking the front brake pads and rear brake shoes.....	6-22

Inspecting the brake fluid level.....	6-23
Brake fluid replacement.....	6-24
Drive chain slack check.....	6-24
Drive chain slack adjustment	6-25
Drive chain lubrication.....	6-26
Cable inspection and lubrication	6-26
Throttle cable and grip lubrication	6-27
Brake and shift pedal lubrication	6-27
Brake and clutch lever lubrication	6-27
Sidestand lubrication.....	6-28
Rear suspension lubrication.....	6-28
Front fork inspection.....	6-28
Steering inspection	6-29
Wheel bearings	6-30
Battery	6-30
Fuse replacement.....	6-32
Headlight bulb replacement.....	6-33
Turn signal light bulb replacement	6-34
Taillight bulb replacement	6-35
Supporting the motorcycle	6-35
Front wheel removal.....	6-36
Front wheel installation	6-37
Rear wheel removal	6-38
Rear wheel installation	6-38
Troubleshooting.....	6-39
Troubleshooting chart	6-40

TABLE OF CONTENTS

7	CLEANING AND STORAGE	7-1
	A. Cleaning	7-1
	B. Storage	7-2
8	SPECIFICATIONS.....	8-1
9	CONSUMER INFORMATION	9-1
	Identification number records.....	9-1
	Key identification number	9-1
	Vehicle identification number	9-1
	Model label	9-2
	Reporting safety defects.....	9-3
	Motorcycle noise regulation	9-4
	Maintenance record	9-5
	Street and enduro motorcycle limited warranty	9-7
	Yamaha extended service	9-9



SAFETY INFORMATION

TWO-WHEELED MOTORCYCLES ARE SINGLE TRACK VEHICLES. THEIR SAFE USE AND OPERATION ARE DEPENDENT UPON THE USE OF PROPER RIDING TECHNIQUES AS WELL AS THE EXPERTISE OF THE OPERATOR. EVERY OPERATOR SHOULD KNOW THE FOLLOWING REQUIREMENTS BEFORE RIDING.

HE OR SHE SHOULD:

1. OBTAIN THOROUGH INSTRUCTIONS FROM A COMPETENT SOURCE ON ALL ASPECTS OF MOTORCYCLE OPERATION.
2. OBSERVE THE WARNINGS AND MAINTENANCE REQUIREMENTS IN THE OWNER'S MANUAL.
3. OBTAIN QUALIFIED TRAINING IN SAFE AND PROPER RIDING TECHNIQUES.
4. OBTAIN PROFESSIONAL TECHNICAL SERVICE AS INDICATED BY THE OWNER'S MANUAL AND/OR WHEN MADE NECESSARY BY MECHANICAL CONDITIONS.

Safe riding

1. Always make pre-operation checks. Careful checks may help prevent an accident.
2. This motorcycle is designed to carry the operator and a passenger.
3. The failure of motorists to detect and recognize motorcycles in traffic is the predominating cause of automobile/motorcycle accidents. Many accidents have been caused by an automobile driver who did not see the motorcycle. Making yourself conspicuous appears to be very effective in reducing the chance of this type of accident.

Therefore:

- a. Wear a brightly colored jacket.
- b. Use extra caution when you approach and pass through intersections, since intersections are the most likely places for motorcycle accidents.
- c. Ride where other motorists can see you. Avoid riding in another motorist's "blind spot".



4. Many accidents involve inexperienced operators. In fact, many operators who have been involved in accidents do not even have a current motorcycle license.
 - a. Make sure you are qualified. Also, only lend your motorcycle to experienced operators.
 - b. Know your skills and limits. Staying within your limits may help you to avoid an accident.
 - c. We recommend that you practice riding your motorcycle where there is no traffic until you have become thoroughly familiar with your motorcycle and all of its controls.
5. Many motorcycle accidents have been caused by motorcycle operator errors. A typical error made by the operator is veering wide on a turn due to EXCESSIVE SPEED or undercornering (insufficient lean angle for the speed).
 - a. Always obey the speed limits and never travel faster than warranted by road and traffic conditions.
 - b. Always signal before turning or changing lanes. Make sure other motorists see you.
6. The operator's and passenger's posture are important for proper control.
 - a. The operator should keep both hands on the handlebars and both feet on the operator footrests during operation to maintain control of the motorcycle.
 - b. The passenger should always hold on to the operator, or the seat strap or grab bar if the motorcycle is so equipped with both hands and keep both feet on the passenger footrests.
 - c. Never carry a passenger unless he or she can firmly place both feet on the passenger footrests.
7. Never ride under the influence of alcohol or drugs.



SAFETY INFORMATION

Protective apparel

The majority of fatalities from motorcycle accidents are the result of head injuries. The use of a safety helmet is the single most critical factor in the prevention or reduction of head injuries.

1. Always wear an approved helmet.
2. Wear a face shield or goggles. Wind on your unprotected eyes could contribute to an impairment of vision which could delay seeing a hazard.
3. The use of heavy boots, jacket, trousers, gloves, etc. is effective in preventing or reducing abrasions or lacerations.
4. Never wear loose fitting clothing. It could catch on the control levers, footrests, or wheels and cause injury or accident.
5. Never touch the engine or exhaust system during or after operation. They become very hot and can cause burns. Always wear protective clothing that covers your legs, ankles, and feet.
6. A passenger should also observe the above precautions.

Modification

Modifications made to the motorcycle not approved by Yamaha, or the removal of original equipment, may render your motorcycle unsafe for use and may cause severe personal injury. Modifications may also make your motorcycle illegal to use.

Loading and accessories

Adding accessories or cargo to your motorcycle can adversely affect stability and handling if the weight distribution of the machine is changed. To avoid the possibility of an accident, extreme caution should be used if adding cargo or accessories to your motorcycle. Use extra care if riding a motorcycle which has added cargo or accessories. Here are some general guidelines to follow if loading cargo or adding accessories to your motorcycle:



Loading

The total weight of the operator, passenger, accessories and cargo must not exceed the maximum load limit of 348 lbs. (158 kg) XT350/346 lbs (157 kg) XT350C.

When loading within these weight limits, keep the following in mind:

1. Cargo and accessory weight should be kept as low and close to the motorcycle as possible. Be sure to distribute the weight as evenly as possible on both sides of the machine to minimize imbalance or instability.
2. Shifting weights can create a sudden imbalance. Make sure that accessories and cargo are securely attached to the motorcycle before riding. Recheck accessory mounts and cargo restraints frequently.
3. Never attach any large or heavy items to the handlebars, front forks, or front fender. These items, including such cargo as sleeping bags, duffle bags, or tents, can create unstable handling or slow steering response.

Accessories

Genuine Yamaha accessories have been specifically designed for use on this motorcycle. Since Yamaha cannot test all other accessories which may be available, you must personally be responsible for the proper selection, installation and use of non-Yamaha accessories. You should use extreme caution when selecting and installing any accessories.

Keep in mind these guidelines for mounting accessories in addition to those provided under "LOADING".

1. Never install accessories or carry cargo that would impair the performance of your motorcycle. Carefully inspect the accessory before using it to make sure it does not in any way reduce ground clearance or cornering clearance, limit suspension travel, steering travel or



SAFETY INFORMATION

- a. Accessories fitted to the handlebar or the front fork area can create instability due to improper weight distribution or aerodynamic changes. If accessories are added to the handlebar or front fork area, they must be as lightweight as possible and should be kept to a minimum.
 - b. Bulky or large accessories may seriously affect the stability of the motorcycle due to aerodynamic effects. Wind may attempt to lift the motorcycle, or the motorcycle may become unstable in cross winds. These accessories may also cause instability when being passed by or passing large vehicles.
 - c. Certain accessories can displace the operator from his or her normal riding position. This improper position limits the freedom of movement of the operator and may limit control ability. Therefore such accessories are not recommended.
2. Caution must be used if adding electrical accessories. If these accessories exceed the capacity of the motorcycle's electrical system, an electric failure could result, which could cause a dangerous loss of lights or engine power.

Gasoline and exhaust gas

1. **GASOLINE IS HIGHLY FLAMMABLE:**
 - a. Always turn off the engine when refueling.
 - b. Take care not to spill any gasoline on the engine or exhaust system when refueling.
 - c. Never refuel while smoking or in the vicinity of an open flame.
2. Never start the engine or let it run for any length of time in a closed area. The exhaust fumes are poisonous and may cause loss of consciousness and death within a short time. Always operate your motorcycle in an area that has adequate ventilation.
3. Always turn off the engine before leaving the motorcycle unattended and remove the ignition key. When parking the motorcycle, note the following:



SAFETY INFORMATION

- a. The engine and exhaust system may be hot. Park the motorcycle in a place where pedestrians or children are not likely to touch these hot areas.
 - b. Do not park the motorcycle on a slope or soft ground; the motorcycle may fall over.
 - c. Do not park the motorcycle near a flammable source, e.g. a kerosene heater, or near an open flame. The motorcycle could catch fire.
4. When transporting the motorcycle in another vehicle, be sure it is kept upright and that the fuel cock(s) is turned to "ON" or "RES" (for vacuum type)/"OFF" (for manual type). If it should lean over, gasoline may leak out of the carburetor or fuel tank.
 5. If you should swallow any gasoline, inhale a lot of gasoline vapor, or allow gasoline to get in your eyes, see your doctor immediately. If any gasoline spills on your skin or clothing, immediately wash it off with soap and water and change your clothes.



SAFETY INFORMATION

EAU02977

Location of the important labels

Please read the following labels carefully before operating this motorcycle.

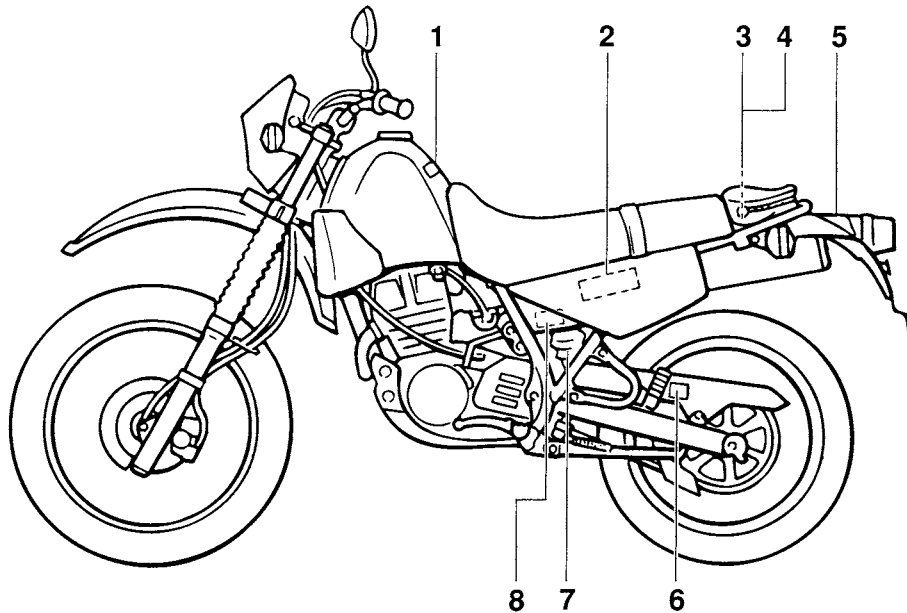



SAFETY INFORMATION

1

⚠ WARNING

- **BEFORE YOU OPERATE THIS VEHICLE. READ THE OWNER'S MANUAL AND ALL LABELS.**
- **ALWAYS WEAR AN APPROVED MOTORCYCLE HELMET**, eye protection, and protective clothing.

3MX-2118K-A0

2

CAUTION

- Read owner's manual before servicing battery.
- Electrolyte will damage metal parts or paint. If electrolyte spills, wash area with fresh water immediately.
- Be sure to connect breather hose after installing battery.

3JL-28177-A0

3

⚠ WARNING

Improper loading can cause loss of control. Read owner's manual for proper loading.

3JJ-28446-A0

4

LOAD LIMIT

3 kg {7 lbs}

3TB-24877-A0

5

⚠ WARNING

NEVER sit here.

3MX-24875-A0

6

TIRE INFORMATION

Cold tire normal pressure should be set as follows.

- Up to 90 kg (198 lbs) load
- FRONT** : 125 kPa, {1.25 kgf/cm²}, 18 psi
- REAR** : 150 kPa, {1.50 kgf/cm²}, 22 psi
- 90 kg (198 lbs)~maximum load
- FRONT** : 150 kPa, {1.50 kgf/cm²}, 22 psi
- REAR** : 175 kPa, {1.75 kgf/cm²}, 25 psi

3MH-21668-A0

7

⚠ WARNING

This unit contains high pressure nitrogen gas. Mishandling can cause explosion.

- Read owner's manual for instructions.
- Do not incinerate, puncture or open.

YAMAHA 4AA-22259-00

8 For California only

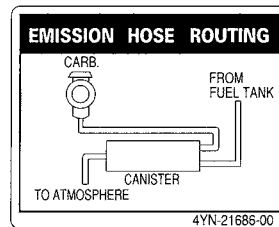

DESCRIPTION

Left view

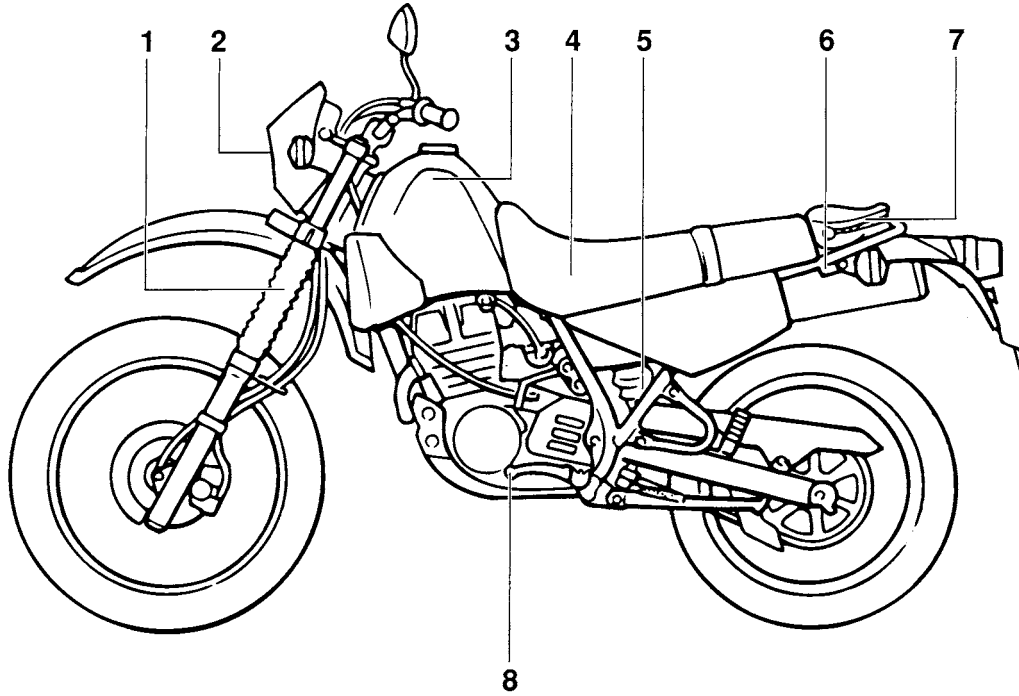

1. Front fork (page 6-28)
2. Headlight (page 6-33)
3. Fuel tank (page 3-5)
4. Seat
5. Rear shock absorber damping force adjuster (page 3-10)

6. Helmet holder (page 3-9)
7. Storage porch (page 3-9)
8. Shift pedal (page 3-4, 5-4)

Right view

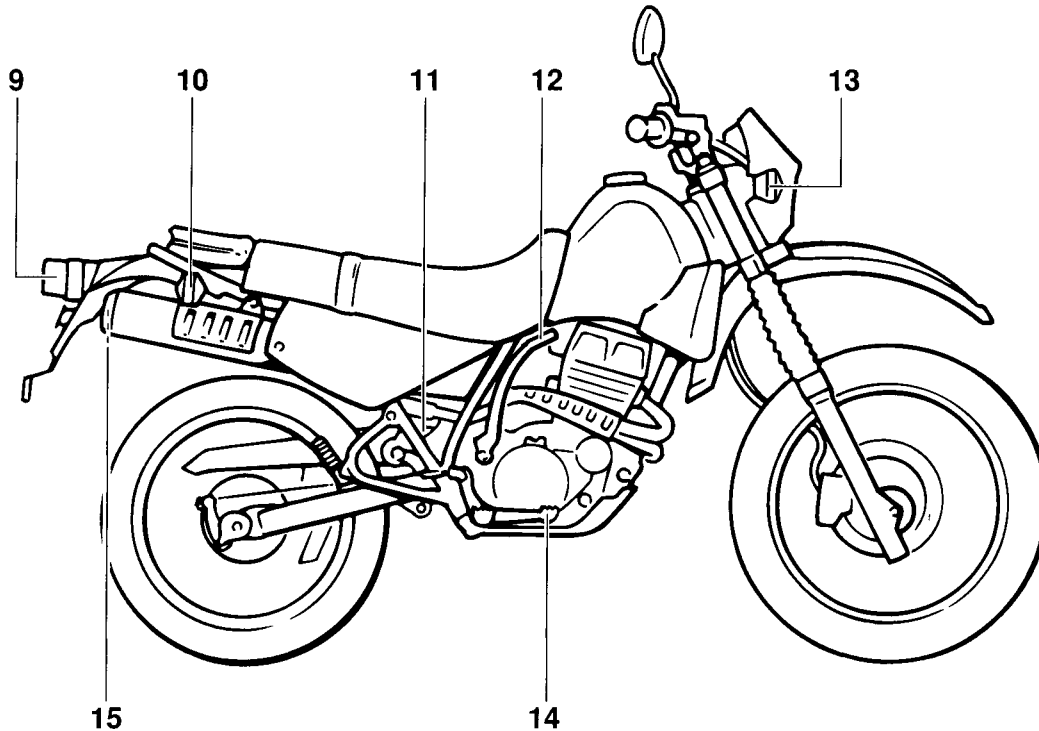

- 9. Tail/brake light (page 6-35)
- 10. Rear turn signal light (page 6-34)
- 11. Rear shock absorber spring preload adjusting nut (page 3-10)

- 12. Kick starter (page 3-9)
- 13. Front turn signal light
- 14. Rear brake pedal (page 3-5, 6-20)
- 15. Spark arrester (page 6-14)

DESCRIPTION

Controls/Instruments

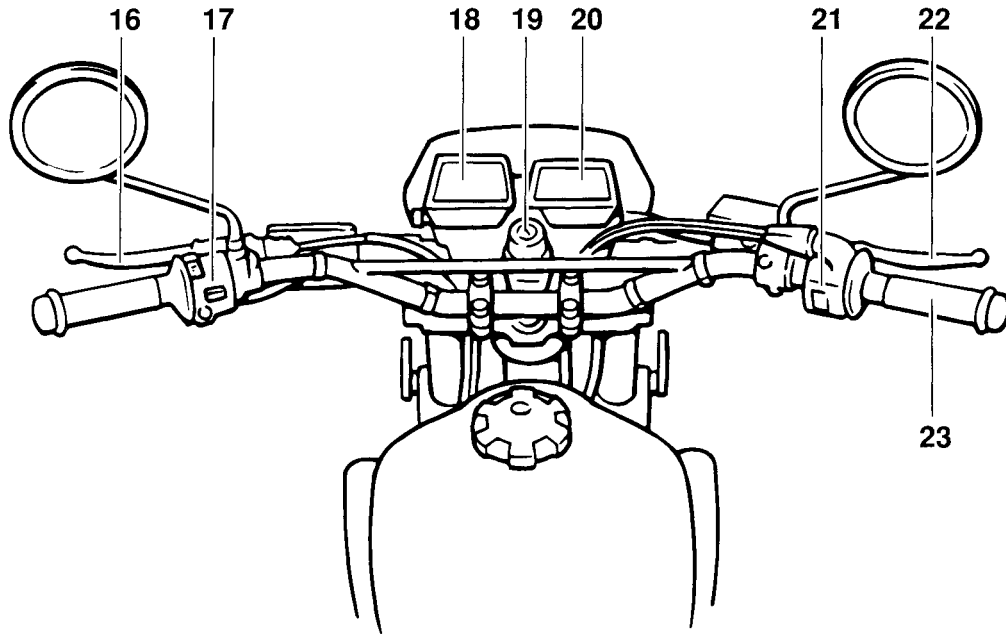

- 16. Clutch lever (page 3-4, 6-19)
- 17. Left handlebar switches (page 3-3)
- 18. Speedometer (page 3-2)
- 19. Main switch (page 3-1)

- 20. Tachometer (page 3-3)
- 21. Right handlebar switches (page 3-4)
- 22. Front brake lever (page 3-5, 6-20)
- 23. Throttle grip (page 6-27)

INSTRUMENT AND CONTROL FUNCTIONS

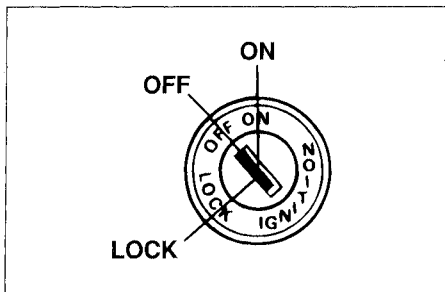

EAU00029

Main switch/Steering lock

The main switch controls the ignition and lighting systems. Its operation is described below.

EAU00035

ON

Electrical circuits are switched on and the taillight comes on. The engine can be started. The key cannot be removed in this position.

NOTE:

When the engine is started, the headlight and meter lights come on automatically, and the lights stay on until the main switch is turned to "OFF" even if the engine stalls.

EAU00038

OFF

All electrical circuits are switched off. The key can be removed in this position.

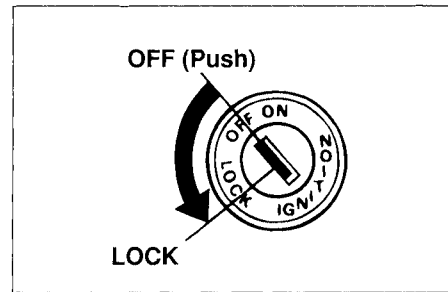

EAU00041

LOCK

The steering is locked in this position and all electrical circuits are switched off. The key can be removed in this position.

To lock the steering, turn the handlebars all the way to the left or right. While pushing the key into the main switch, turn it from "OFF" to "LOCK" and remove it.

To release the lock, turn the key to "OFF" while pushing.

INSTRUMENT AND CONTROL FUNCTIONS

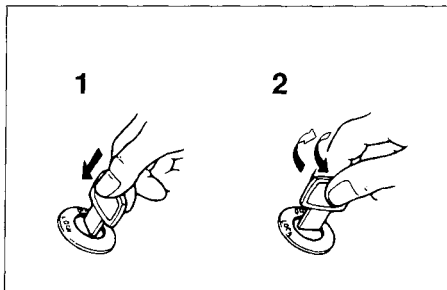

1. Push
2. Turn

EW000016

⚠ WARNING

Never turn the key to “OFF” or “LOCK” when the motorcycle is moving. The electrical circuits will be switched off which may result in loss of control or an accident. Be sure the motorcycle is stopped before turning the key to “OFF” or “LOCK”.

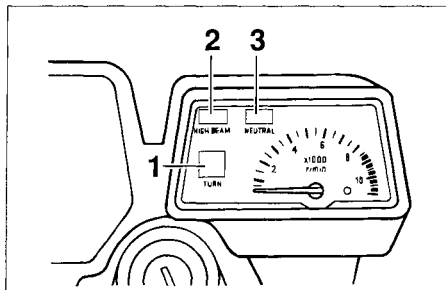

1. Turn indicator light “TURN”
2. High beam indicator light “HIGH BEAM”
3. Neutral indicator light “NEUTRAL”

EAU00056

Indicator lights

EAU00059

Turn indicator light “TURN”

This indicator flashes when the turn switch is moved to the left or right.

EAU00064

High beam indicator light “HIGH BEAM”

This indicator comes on when the headlight high beam is used.

EAU00062

Neutral indicator light “NEUTRAL”

This indicator comes on when the transmission is in neutral.

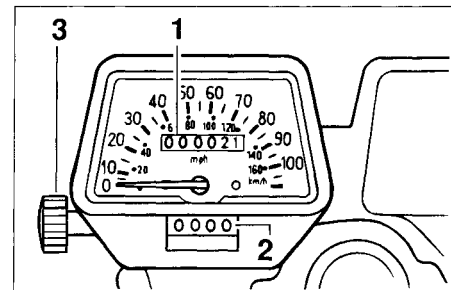

1. Odometer
2. Trip odometer
3. Reset knob

EAU00095

Speedometer

The speedometer shows riding speed. This speedometer is equipped with an odometer and trip odometer. The trip odometer can be reset to “0” with the reset knob. Use the trip odometer to estimate how far you can ride on a tank of fuel. This information will enable you to plan fuel stops in the future.

INSTRUMENT AND CONTROL FUNCTIONS

EAU00130

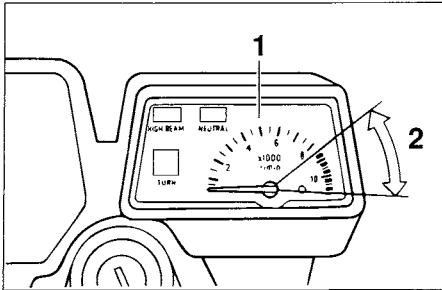

1. Tachometer
2. Red zone

EAU00102

Tachometer

This model is equipped with a tachometer so the rider can monitor the engine speed and keep it within the ideal power range.

EC000003

CAUTION:

Do not operate in the red zone.
Red zone: 8,500 r/min and above

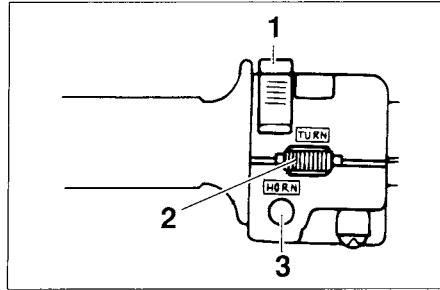

1. Dimmer switch "LIGHTS"
2. Turn signal switch "TURN"
3. Horn switch "HORN"

EAU00118

Handlebar switches

EAU00122

Dimmer switch "LIGHTS"

Turn the switch to "HI" for the high beam and to "LO" for the low beam.

EAU00128

Turn signal switch "TURN"

This is a three-position switch. The center position is off.

Turn to "←" to turn on the left flasher, and to "→" for the right flasher. Be sure to turn the switch off after completing a turn.

Horn switch "HORN"

Press the switch to sound the horn.

INSTRUMENT AND CONTROL FUNCTIONS

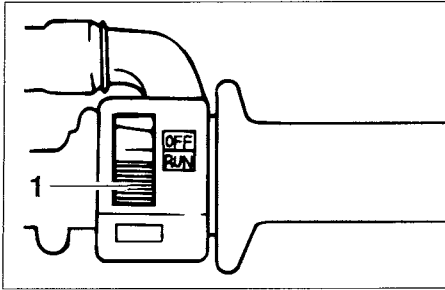

1. Engine stop switch "ENGINE STOP"

EAU00137

Engine stop switch "ENGINE STOP"

The engine stop switch is a safety device for use in an emergency such as when the motorcycle over-turns or if trouble occurs in the throttle system. Turn the switch to "RUN" to start the engine. In case of emergency, turn the switch to "OFF" to stop the engine.

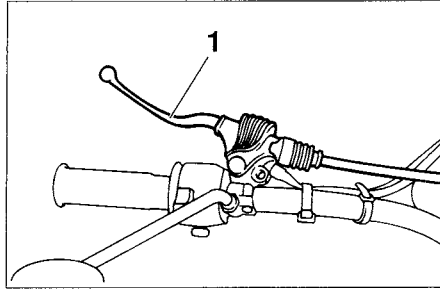

1. Clutch lever

EAU00155

Clutch lever

The clutch lever is located on the left handlebar. Pull the clutch lever to the handlebar to disengage the clutch, and release the lever to engage the clutch. The lever should be pulled rapidly and released slowly for smooth clutch operation.

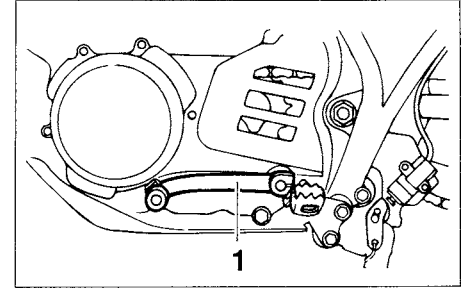

1. Shift pedal

EAU00157

Shift pedal

This motorcycle is equipped with a constant-mesh 6-speed transmission.

The shift pedal is located on the left side of the engine and is used in combination with the clutch when shifting.

INSTRUMENT AND CONTROL FUNCTIONS

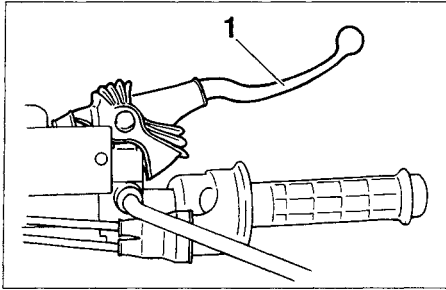

1. Front brake lever

EAU00158

Front brake lever

The front brake lever is located on the right handlebar. Pull it toward the handlebar to apply the front brake.

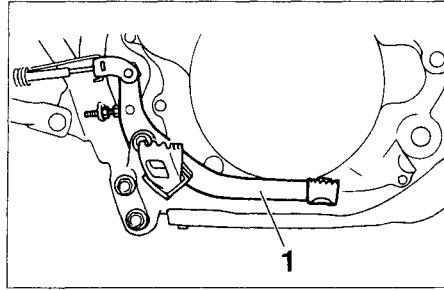

1. Rear brake pedal

EAU00162

Rear brake pedal

The rear brake pedal is on the right side of the motorcycle. Press down on the brake pedal to apply the rear brake.

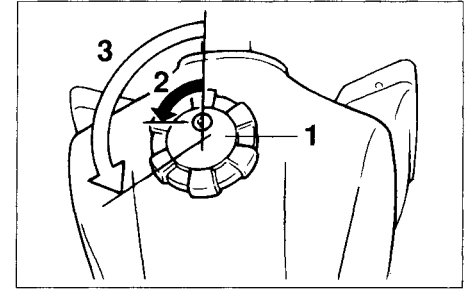

1. Fuel tank cap
2. Unlock
3. Open

EAU00177

Fuel tank cap

To open

Insert the key and turn it 1/4 turn counterclockwise. Turn the cap 1/3 turn counterclockwise and remove it from the tank.

To close

Put the cap in the filler neck and turn it 1/3 turn clockwise. Lock the cap by turning the key 1/4 turn clockwise, and remove the key.

INSTRUMENT AND CONTROL FUNCTIONS

NOTE:

The tank cap cannot be reinstalled unless it is unlocked. The key must remain in the cap until the cap is properly installed and locked onto the fuel tank.

EW000023

⚠WARNING

Be sure the cap is properly installed and locked in place before riding the motorcycle.

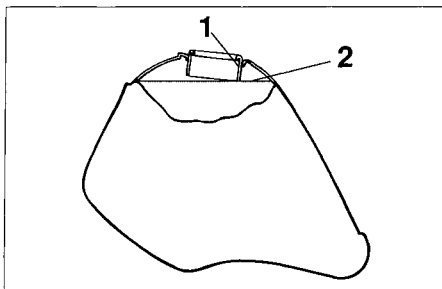

1. Filler tube
2. Fuel level

EAU01183

Fuel

Make sure there is sufficient fuel in the tank. Fill the fuel tank to the bottom of the filler tube as shown in the illustration.

EW000130

⚠WARNING

Do not overfill the fuel tank. Avoid spilling fuel on the hot engine. Do not fill the fuel tank above the bottom of the filler tube or it may overflow when the fuel heats up later and expands.

EAU00185

CAUTION:

Always wipe off spilled fuel immediately with a dry and clean soft cloth. Fuel may deteriorate painted surfaces or plastic parts.

INSTRUMENT AND CONTROL FUNCTIONS

EAU00189

Recommended fuel:

UNLEADED FUEL

Fuel tank capacity:

Total:

12.0 L (2.6 Imp gal, 3.2 US gal)

Reserve:

2.0 L (0.4 Imp gal, 0.5 US gal)

Your Yamaha engine has been designed to use regular unleaded gasoline with a pump octane number $([R+M]/2)$ of 86 or higher, or research octane number of 91 or higher. If knocking or pinging occurs, use a different brand of gasoline or premium unleaded fuel. Unleaded fuel will give you longer spark plug life and reduced maintenance cost. If unleaded gasoline is not available, then leaded regular gasoline can be used.

Gasohol

There are two types of gasohol; gasohol containing ethanol and that containing methanol. Gasohol containing ethanol can be used if ethanol content does not exceed 10%. Gasohol containing methanol is not recommended by Yamaha because it can cause fuel system damage or vehicle performance problems.

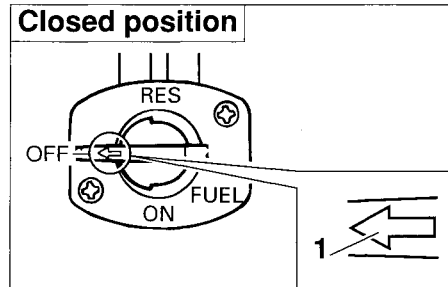

1. Arrow mark over "OFF"

EAU03050

Fuel cock

The fuel cock supplies fuel from the tank to the carburetor while filtering it also.

The fuel cock has three positions:

OFF

With the lever in this position, fuel will not flow. Always return the lever to this position when the engine is not running.

INSTRUMENT AND CONTROL FUNCTIONS

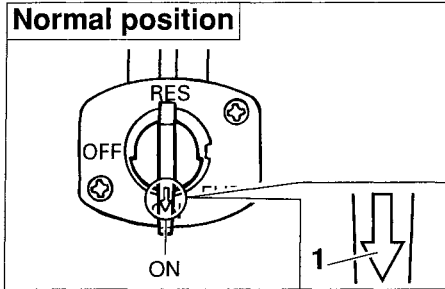

1. Arrow mark over "ON"

ON

With the lever in this position, fuel flows to the carburetor. Normal riding is done with the lever in this position.

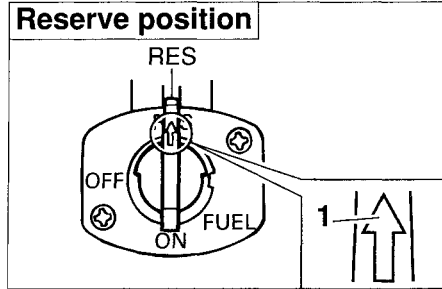

1. Arrow mark over "RES"

RES

This indicates reserve. If you run out of fuel while riding, move the lever to this position. Fill the tank at the first opportunity. Be sure to set the lever back to "ON" after refueling!

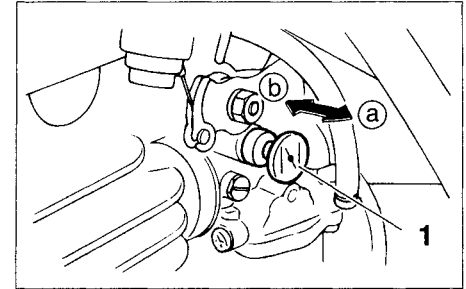

1. Starter(choke) "↓"

Starter (choke) "↓"

Starting a cold engine requires a richer air-fuel mixture. A separate starter circuit supplies this mixture. Move in direction (a) to turn on the starter (choke). Move in direction (b) to turn off the starter (choke).

EAU02976

INSTRUMENT AND CONTROL FUNCTIONS

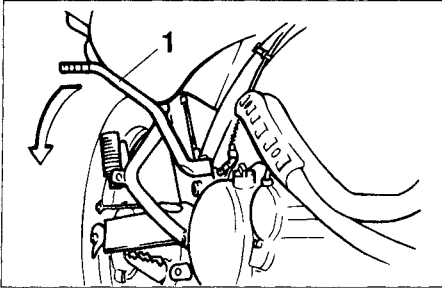

1. Kick starter

EAU00212

Kick starter

Rotate the kick starter away from the engine. Push the starter down lightly with your foot until the gears engage, then kick smoothly and forcefully to start the engine. This model has a primary-coupled kick starter so the engine can be started in any gear if the clutch is disengaged. However, shifting to neutral before starting is recommended.

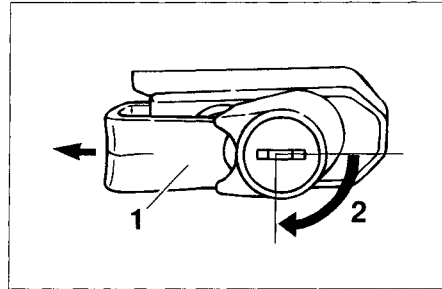

1. Helmet holder
2. Unlock

EAU00261

Helmet holder

To open the helmet holder, insert the key in the lock and turn it as shown.

To lock the helmet holder, turn the key to its original position.

EW000030

⚠ WARNING

Never ride with a helmet in the helmet holder. The helmet may hit objects, causing loss of control and possibly an accident.

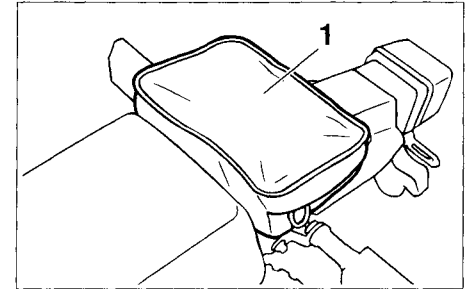

1. Storage pouch

EAU00280*

Storage pouch

EW000032*

⚠ WARNING

Do not exceed the load limit of 3 kg (7 lb).

INSTRUMENT AND CONTROL FUNCTIONS

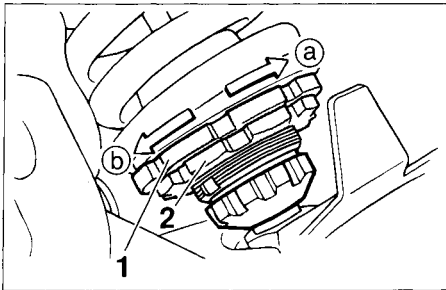

1. Adjusting nut
2. Locknut

EAU00302

Rear shock absorber adjustment

This shock absorber is equipped with a spring preload and damping adjuster.

1. Adjust spring preload as follows.
 - a. Loosen the locknut.
 - b. Turn adjusting nut in direction (a) to increase spring preload and in direction (b) to decrease spring preload.

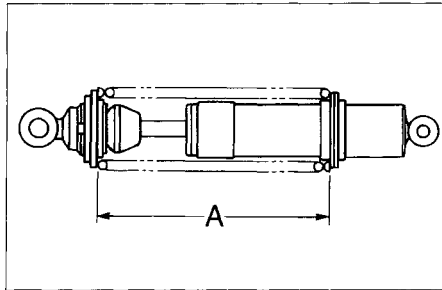

Measurement "A"

- Minimum length (hard):
213 mm (8.4 in)
- Standard length:
225.5 mm (8.9 in)
- Maximum length (soft):
234 mm (9.2 in)

EC000019

CAUTION: _____

Never attempt to turn the adjusting nut beyond the maximum or minimum setting.

- c. Tighten the locknut to the specified torque.

Tightening torque:

Locknut:

70 Nm (7.0 m·kg, 50 ft·lb)

EC000018

CAUTION: _____

Always tighten the locknut against the spring adjusting nut and tighten the locknut to the specified torque.

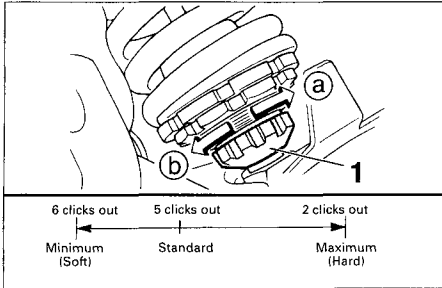

1. Damping force adjuster

2. Adjust damping force as follows.

Turn adjuster in direction (a) to increase damping force and in direction (b) to decrease damping force.

Minimum (soft):	6 clicks out*
Standard:	5 clicks out*
Maximum (hard):	2 clicks out*

*From the fully turned-in position

CAUTION: _____

Never attempt to turn the adjuster beyond the maximum or minimum setting.

⚠ WARNING _____

This shock absorber contains highly pressurized nitrogen gas. Read and understand the following information before handling the shock absorber. The manufacturer cannot be held responsible for property damage or personal injury that may result from improper handling.

- Do not tamper with or attempt to open the cylinder assembly.
- Do not subject the shock absorber to an open flame or other high heat source. This may cause the unit to explode due to excessive gas pressure.
- Do not deform or damage the cylinder in any way. Cylinder damage will result in poor damping performance.
- Take your shock absorber to a Yamaha dealer for any service.

INSTRUMENT AND CONTROL FUNCTIONS

Sidestand

EAU00330

This model is equipped with an ignition circuit cut-off system. The motorcycle must not be ridden when the sidestand is down. The sidestand is located on the left side of the frame. (Refer to page 5-1 for an explanation of this system.)

⚠ WARNING

EW000044

This motorcycle must not be operated with the sidestand in the down position. If the stand is not properly retracted, it could contact the ground and distract the operator, resulting in a possible loss of control. Yamaha has designed into this motorcycle a lockout system to assist the operator in fulfilling the responsibility of retracting the sidestand. Please check carefully the operating instructions listed below and if there is any indication of a malfunction, return the motorcycle to a Yamaha dealer immediately for repair.

EAU00333*

Sidestand switch operation check

Check the operation of the sidestand switch against the information below.

TURN THE MAIN SWITCH TO "ON" AND THE ENGINE STOP SWITCH TO "RUN".

TRANSMISSION IS IN NEUTRAL AND THE SIDESTAND IS DOWN.

KICK THE KICK STARTER.

ENGINE WILL START.

PULL IN THE CLUTCH LEVER AND PUT THE TRANSMISSION IN GEAR.

INSTRUMENT AND CONTROL FUNCTIONS

ENGINE WILL STALL.



SIDESTAND SWITCH IS OK.

EW000045

⚠ WARNING

If improper operation is noted, consult a Yamaha dealer immediately.

PRE-OPERATION CHECKS

Owners are personally responsible for their vehicle's condition. Your motorcycle's vital functions can start to deteriorate quickly and unexpectedly, even if it remains unused (for instance, if it is exposed to the elements). Any damage, fluid leak or loss of tire pressure could have serious consequences. Therefore, it is very important that, in addition to a thorough visual inspection, you check the following points before each ride.

PRE-OPERATION CHECK LIST

ITEM	CHECKS	PAGE
Front brake	<ul style="list-style-type: none"> • Check operation, free play, fluid level and vehicle for fluid leakage. • Fill with DOT 4 (or DOT 3) brake fluid if necessary. 	6-20, 6-22 ~ 6-24
Rear brake	<ul style="list-style-type: none"> • Check operation, condition and free play. • Adjust if necessary. 	6-20 ~ 6-23
Clutch	<ul style="list-style-type: none"> • Check operation, condition and free play. • Adjust if necessary. 	6-19
Throttle grip and housing	<ul style="list-style-type: none"> • Check for smooth operation. • Lubricate if necessary. 	6-27
Engine oil	<ul style="list-style-type: none"> • Check oil level. • Fill with oil if necessary. 	6-10 ~ 6-13
Drive chain	<ul style="list-style-type: none"> • Check chain slack and condition. • Adjust if necessary. 	6-24 ~ 6-26
Wheels and tires	<ul style="list-style-type: none"> • Check tire pressure, wear, damage and spoke tightness. • Tighten spokes if necessary. 	6-16 ~ 6-18
Chassis fasteners	<ul style="list-style-type: none"> • Make sure that all nuts, bolts and screws are properly tightened. • Tighten if necessary. 	—

PRE-OPERATION CHECKS

ITEM	CHECKS	PAGE
Lights, signals and switches	• Check for proper operation.	3-3 ~ 3-4, 6-33 ~ 6-35
Battery	• Check fluid level. • Fill with distilled water if necessary.	6-30 ~ 6-32

NOTE: Pre-operation checks should be made each time the motorcycle is used. Such an inspection can be thoroughly accomplished in a very short time; and the added safety it assures is more than worth the time involved.

⚠ WARNING

- The engine, exhaust system will be very hot after the engine has been run. Be careful not to touch them or to allow any clothing item to contact them during inspection or repair.
- If any item in the PRE-OPERATION CHECKS is not working properly, have it inspected and repaired before operating the motorcycle.

OPERATION AND IMPORTANT RIDING POINTS

EAU00373

⚠ WARNING

- Before riding this motorcycle, become thoroughly familiar with all operating controls and their functions. Consult a Yamaha dealer regarding any control or function that you do not thoroughly understand.
- Never start your engine or let it run for any length of time in a closed area. The exhaust fumes are poisonous and can cause loss of consciousness and death within a short time. Always operate your motorcycle in an area with adequate ventilation.
- Before starting out, always be sure the sidestand is up. Failure to retract the sidestand completely can result in a serious accident when you try to turn a corner.

EAU00376

CAUTION:

- Be careful where you store personal items on the motorcycle. Avoid blocking the air cleaner intake or performance will suffer.
- Be careful not to put anything near the battery and its terminals. Electrical failure and acid corrosion may result.

EAU01427

Starting and warming up a cold engine

NOTE:

This motorcycle is equipped with an ignition circuit cut-off system. The engine can be started only under one of the following conditions:

- The transmission is in neutral.
- The sidestand is up, the transmission is in gear and the clutch is disengaged.

The motorcycle must not be ridden when the sidestand is down.

EW000056

⚠ WARNING

Before going through the following steps, check the function of the sidestand switch. (Refer to page 3-12.)

OPERATION AND IMPORTANT RIDING POINTS

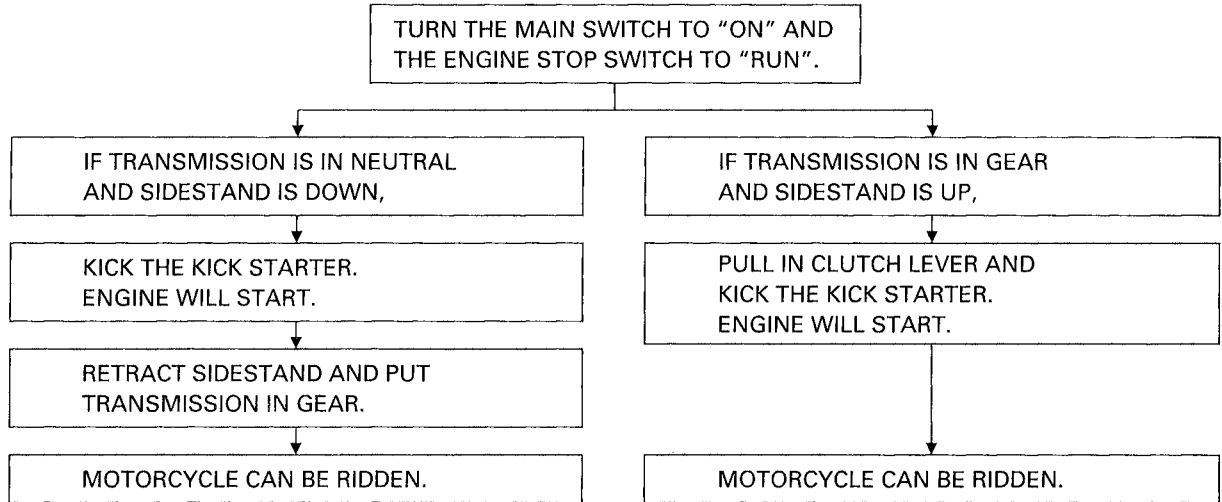

OPERATION AND IMPORTANT RIDING POINTS

1. Turn the fuel cock to "ON".
2. Turn the main switch to "ON" and the engine stop switch to "RUN".
3. Shift transmission into neutral.

NOTE:

When the transmission is in neutral, the neutral indicator light should be on. If the light does not come on, ask a Yamaha dealer to inspect it.

4. Turn on the starter (choke) and completely close the throttle grip.
5. Kick the kick starter to start the engine.
6. After starting the engine, turn off the starter (choke). The starter operation periods differ with the ambient temperature, so refer to the following notes.

NOTE:

- The engine is warm when it responds normally to the throttle with the starter turned off. To avoid the possibility of excessive exhaust emissions, never leave the starter circuit on longer than necessary. The length of time the starter is needed depends upon the ambient temperature. Warm ambient temperatures (above 10°C/50°F) require about 25 seconds of starter use. Cold ambient temperatures (below 10°C/50°F) require about 35 seconds with the starter turned on, then about 2.5 minutes with the starter in the halfway position.
- For maximum engine life, always warm up the engine before starting off. Never accelerate hard with a cold engine.

EAU01439

Starting a warm engine

Do not use the starter(choke). Instead, start the engine with the throttle grip slightly opened.

NOTE:

If the engine does not start after several kicks, open the throttle grip 1/4 to 1/2 and try starting again.

EC000046

CAUTION:

See the "Engine break-in" section prior to operating the motorcycle for the first time.

OPERATION AND IMPORTANT RIDING POINTS

EC000048

EAU02988

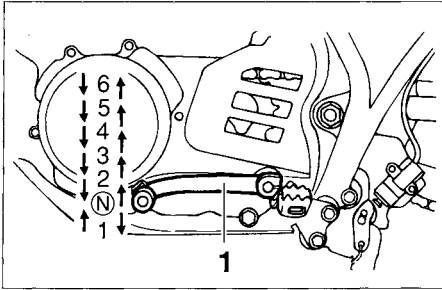

N. Neutral
1. Shift pedal

EAU00423

Shifting

The transmission lets you control the amount of power you have available at a given speed for starting, accelerating, climbing hills, etc. The use of the shift pedal is shown in the illustration.

To shift into neutral, depress the shift pedal repeatedly until it reaches the end of its travel, then raise the pedal slightly.

CAUTION: _____

- Do not coast for long periods with the engine off, and do not tow the motorcycle a long distance. Even with gears in neutral, the transmission is only properly lubricated when the engine is running. Inadequate lubrication may damage the transmission.
- Always use the clutch when changing gears. The engine, transmission, and driveline are not designed to withstand the shock of forced shifting and can be damaged by shifting without using the clutch.

To start out and accelerate

1. Pull the clutch lever to disengage the clutch.
2. Shift into first gear. The neutral indicator light should go out.
3. Open the throttle gradually, and at the same time, release the clutch lever slowly.
4. At the recommended shift points shown in the table on page 5-5, close the throttle, and at the same time, quickly pull in the clutch lever.
5. Shift into second gear. (Be careful not to shift into neutral.)
6. Open the throttle part way and gradually release the clutch lever.
7. Follow the same procedure when shifting to the next higher gear.
Always shift gears at the recommended shift points.

OPERATION AND IMPORTANT RIDING POINTS

EAU00427

To decelerate

1. Apply both the front and the rear brakes at the same time to slow the motorcycle.
2. When the motorcycle reaches 20 km/h (12.5 mi/h), shift into first gear. Any time the engine is about to stall or runs very roughly, pull in the clutch and use the brakes to stop.
3. When the motorcycle is almost completely stopped, shift into neutral. The neutral indicator light should come on.

EAU02989

Recommended shift points

	Acceleration shift point km/h(mi/h)	Deceleration shift point km/h(mi/h)
1st → 2nd	20 (12.5)	20 (12.5)
2nd → 3rd	30 (18.6)	20 (12.5)
3rd → 4th	40 (24.9)	20 (12.5)
4th → 5th	50 (31.0)	20 (12.5)
5th → 6th	60 (37.0)	20 (12.5)

EAU00436

Engine break-in

There is never a more important period in the life of your motorcycle than the period between zero and 1,000 km (600 mi). For this reason we ask that you carefully read the following material. Because the engine is brand new, you must not put an excessive load on it for the first 1,000 km (600 mi). The various parts in the engine wear and polish themselves to the correct operating clearances. During this period, prolonged full throttle operation, or any condition which might result in excessive heating of the engine, must be avoided.

OPERATION AND IMPORTANT RIDING POINTS

EAU00449

0 ~ 500 km (0 ~ 300 mi)

Avoid operation above 4,000 r/min. Stop the engine and let it cool for 5 to 10 minutes after every hour of operation. Vary the speed of the motorcycle from time to time. Do not operate it at one set throttle position.

500 ~ 1,000 km (300 ~ 600 mi)

Avoid prolonged operation above 5,000 r/min. Rev the motorcycle freely through the gears, but do not use full throttle at any time.

EC000057

CAUTION: _____

After 1,000 km (600 mi) of operation, be sure to replace the engine oil and clean the oil filter element and oil strainer.

1,000 km (600 mi) and beyond

Full throttle can be used.

EC000053

CAUTION: _____

- **Never let engine speeds enter the red zone.**
 - **If any engine trouble should occur during the break-in period, consult a Yamaha dealer immediately.**
-

EAU00457

Parking

When parking the motorcycle, stop the engine and remove the ignition key. Turn the fuel cock to "OFF" whenever stopping the engine.

EW000058

⚠ WARNING _____

The exhaust system is hot. Park the motorcycle in a place where pedestrians or children are not likely to touch the motorcycle. Do not park the motorcycle on a slope or soft ground; the motorcycle may overturn.

PERIODIC MAINTENANCE AND MINOR REPAIR

EAU01790

Periodic inspection, adjustment, and lubrication will keep your motorcycle in the safest and most efficient condition possible. Safety is an obligation of the motorcycle owner. The most important points of motorcycle inspection, adjustment, and lubrication are explained in the following pages.

Maintenance, replacement, or repair of the emission control devices and systems may be performed by any repair establishment or individual that is certified (if applicable).

EW000060

⚠ WARNING

If you are not familiar with motorcycle service, this work should be done by a Yamaha dealer.

EAU00467

PERIODIC MAINTENANCE

PROPER PERIODIC MAINTENANCE OF YOUR MOTORCYCLE IS IMPORTANT IN ORDER TO ENJOY LONG, PLEASURABLE SERVICE. ESPECIALLY IMPORTANT ARE THE MAINTENANCE SERVICES RELATED TO EMISSIONS CONTROL. THESE CONTROLS NOT ONLY FUNCTION TO ENSURE CLEANER AIR BUT ARE ALSO VITAL TO PROPER ENGINE OPERATION AND MAXIMUM PERFORMANCE. IN THE FOLLOWING TABLES OF PERIODIC MAINTENANCE, THE SERVICES RELATED TO EMISSIONS CONTROL ARE GROUPED SEPARATELY. THESE SERVICES REQUIRE SPECIALIZED DATA, KNOWLEDGE, AND EQUIPMENT. YAMAHA DEALERS ARE TRAINED AND EQUIPPED TO PERFORM THESE PARTICULAR SERVICES.

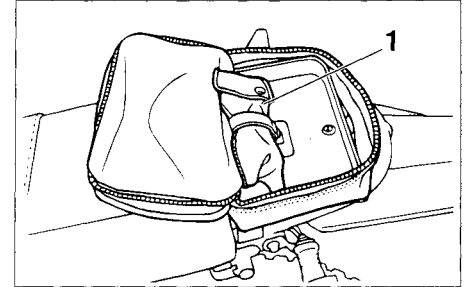

1. Tool kit

EAU00468

Tool kit

The service information included in this manual is intended to provide you, the owner, with the necessary information for completing some of your own preventive maintenance and minor repairs. The tools provided in the owner's tool kit are to assist you in the performance of periodic maintenance. However, some other tools such as a torque wrench are also necessary to perform the maintenance correctly.

PERIODIC MAINTENANCE AND MINOR REPAIR

NOTE: _____

If you do not have necessary tools required during a service operation, take your motorcycle to a Yamaha dealer for service.

EW000062

⚠ WARNING _____

Modifications to this motorcycle not approved by Yamaha may cause loss of performance, excessive emissions, and render it unsafe for use. Consult a Yamaha dealer before attempting any changes.

PERIODIC MAINTENANCE AND MINOR REPAIR

EAU00471

PERIODIC MAINTENANCE CHART FOR EMISSION CONTROL SYSTEM

NO.	ITEM	ROUTINE	INITIAL	ODOMETER READINGS					
			600 mi (1,000 km) or 1 month	4,000 mi (7,000 km) or 6 months	8,000 mi (13,000 km) or 12 months	12,000 mi (19,000 km) or 18 months	16,000 mi (25,000 km) or 24 months	20,000 mi (31,000 km) or 30 months	
1 *	Valve clearance	<ul style="list-style-type: none"> Check and adjust valve clearance when engine is cold. 	○	○	○	○	○	○	
2	Spark plug	<ul style="list-style-type: none"> Check condition. Adjust gap and clean. Replace at 13,000 km (or 13 months) and thereafter every 12,000 km (or 12 months). 		○	Replace	○	Replace	○	
3 *	Crankcase ventilation system	<ul style="list-style-type: none"> Check ventilation hose for cracks or damage. Replace if necessary. 		○		○		○	
4 *	Fuel line	<ul style="list-style-type: none"> Check fuel hose for cracks or damage. Replace if damage. 		○	○	○	○	○	
5 *	Exhaust system	<ul style="list-style-type: none"> Check for leakage. Retighten if necessary. Replace gasket (s) if necessary. 		○	○	○	○	○	
6	Spark arrester	<ul style="list-style-type: none"> Clean. 		○	○	○	○	○	
7 *	Idle speed	<ul style="list-style-type: none"> Check and adjust engine idle speed. Adjust cable free play. 		○	○	○	○	○	
8 *	Decompression	<ul style="list-style-type: none"> Check and adjust decomp-cable free play after velve clearance maintenance. 		○	○	○	○	○	
9 *	Evaporative emission control system**	<ul style="list-style-type: none"> Check control system for damage. Replace if necessary. 					○	○	

* Since these items require special tools, data and technical skills, they should be serviced by a Yamaha dealer.

** For California.

PERIODIC MAINTENANCE AND MINOR REPAIR

EAU00472

GENERAL MAINTENANCE AND LUBRICATION CHART

NO.	ITEM	ROUTINE	TYPE	INITIAL	ODOMETER READINGS					
				600 mi (1,000 km) or 1 month	4,000 mi (7,000 km) or 6 months	8,000 mi (13,000 km) or 12 months	12,000 mi (19,000 km) or 18 months	16,000 mi (25,000 km) or 24 months	20,000 mi (31,000 km) or 30 months	
1	Engine oil	<ul style="list-style-type: none"> Warm-up engine before draining. 	See page 8-1	○	○	○	○	○	○	
2	Oil filter/ strainer	<ul style="list-style-type: none"> Replace filter element and clean oil strainer. Replace oil strainer if damaged. 	—	○		○		○		
3	* Air filter	<ul style="list-style-type: none"> Wet type filter must be washed and dampened with oil. 	Yamaha foam-air-filter oil or SAE 10W30 motor oil		○	○	○	○	○	
4	* Brake system	<ul style="list-style-type: none"> Adjust free play. Check fluid leakage. (Front) (see NOTE page 6-6) Correct if necessary. Replace pads if necessary. (Front) Replace shoes if necessary. (Rear) 	—	○	○	○	○	○	○	
5	* Clutch	<ul style="list-style-type: none"> Adjust free play. 	—	○	○	○	○	○	○	
6	Drive chain	<ul style="list-style-type: none"> Check chain condition. Adjust and lubricate chain thoroughly. 	SAE 30 ~ 50W motor oil or chain lubricants suitable for "O-ring" chains.	Every 300 mi (500 km)						
7	* Control and meter cable	<ul style="list-style-type: none"> Apply chain lube thoroughly. 	Yamaha chain and cable lube or SAE 10W30 motor oil	○	○	○	○	○	○	

PERIODIC MAINTENANCE AND MINOR REPAIR

NO.	ITEM	ROUTINE	TYPE	INITIAL	ODOMETER READINGS					
				600 mi (1,000 km) or 1 month	4,000 mi (7,000 km) or 6 months	8,000 mi (13,000 km) or 12 months	12,000 mi (19,000 km) or 18 months	16,000 mi (25,000 km) or 24 months	20,000 mi (31,000 km) or 30 months	
8	* Rear arm pivot shaft and suspension link pivots	<ul style="list-style-type: none"> Apply until new grease shows. 	Lithium soap base grease.		○	○	○	○	○	○
9	Brake/Clutch lever pivot shaft	<ul style="list-style-type: none"> Apply chain lube lightly. 	Yamaha chain and cable lube or SAE 10W30 motor oil.		○	○	○	○	○	○
10	Brake pedal and shift pedal shaft	<ul style="list-style-type: none"> Lubricate. Apply chain lube lightly. 	Yamaha chain and cable lube or SAE 10W30 motor oil.		○	○	○	○	○	○
11	Sidestand pivot and kick crank boss	<ul style="list-style-type: none"> Check operation and lubricate. Apply chain lube lightly. 	Yamaha chain and cable lube or SAE 10W30 motor oil.		○	○	○	○	○	○
12	* Front fork	<ul style="list-style-type: none"> Check operation and leakage. 	—		○	○	○	○	○	○
13	* Steering bearings	<ul style="list-style-type: none"> Check bearing assembly for looseness. Moderately repack every 24,000 km (15,000 mi) 	Medium weight wheel bearing grease.		○	○	○	Repack	○	○
14	* Wheel bearings	<ul style="list-style-type: none"> Check bearing for smooth rotation 	—		○	○	○	○	○	○
15	Battery	<ul style="list-style-type: none"> Check specific gravity. Check that the breather hose is working properly. Correct if necessary. 	—		○	○	○	○	○	○

PERIODIC MAINTENANCE AND MINOR REPAIR

NO.	ITEM	ROUTINE	TYPE	INITIAL	ODOMETER READINGS					
				600 mi (1,000 km) or 1 month	4,000 mi (7,000 km) or 6 months	8,000 mi (13,000 km) or 12 months	12,000 mi (19,000 km) or 18 months	16,000 mi (25,000 km) or 24 months	20,000 mi (31,000 km) or 30 months	
16	* Sidestand switch	• Check and clean or replace if necessary.	—	○	○	○	○	○	○	

* Since these items require special tools, data and technical skills, they should be serviced by a Yamaha dealer.

EAU01695

NOTE: _____

For odometer readings or time periods higher than 20,000 mi (31,000 km) or 30 months, repeat the same maintenance as listed in the chart from the 4,000 mi (7,000 km) or 6 month interval.

EAU02970*

NOTE: _____

- The air filter needs more frequent service if you are riding in unusually wet or dusty areas.
- Hydraulic brake system
 - When disassembling the master cylinder or caliper cylinder, always replace the brake fluid. Check the brake fluid level regularly and fill as required.
 - Replace the oil seals on the inner parts of the master cylinder and caliper cylinder every two years.
 - Replace the brake hoses every four years or if cracked or damaged.

PERIODIC MAINTENANCE AND MINOR REPAIR

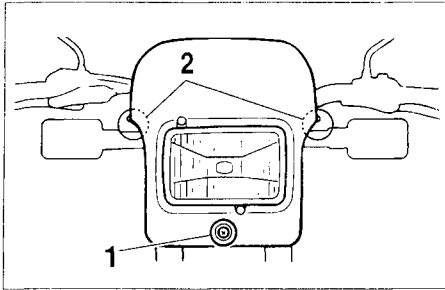

1. Screw
2. Pull

EAU001145

Cowling A

To remove

Remove the cowling screw and pull outward on the areas shown.

To install

Place in the original position and install the screw.

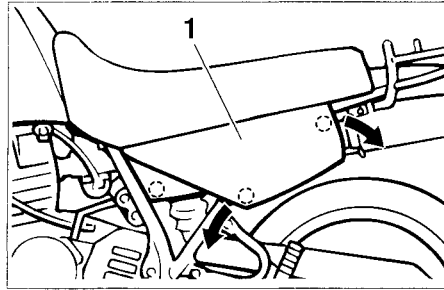

1. Panel A

EAU00494

Panel A and B

To remove

Pull outward on the areas shown.

To install

Place the panel in its original position.

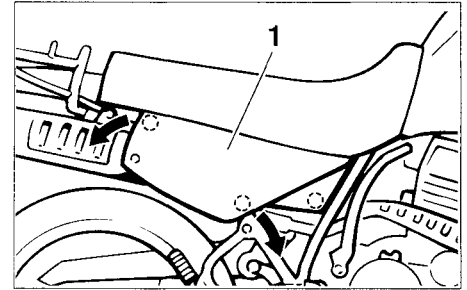

1. Panel B

PERIODIC MAINTENANCE AND MINOR REPAIR

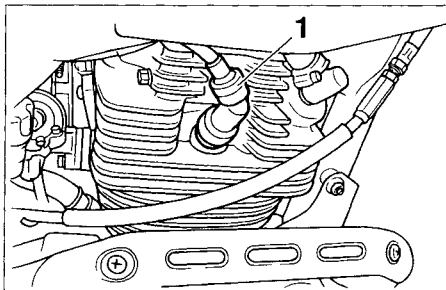

1. Spark plug cap

EAU01833

Spark plug

Removal

1. Remove the spark plug cap.
2. Use the spark plug wrench in the tool kit to remove the spark plug as shown.

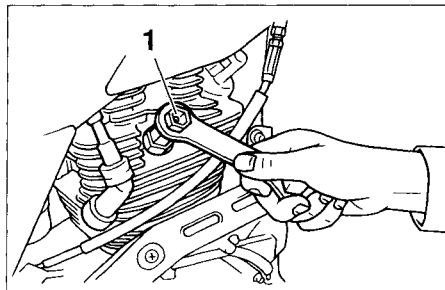

1. Spark plug wrench

Inspection

The spark plug is an important engine component and is easy to inspect. The condition of the spark plug can indicate the condition of the engine.

The ideal color on the white insulator around the center electrode is a medium-to-light tan color for a motorcycle that is being ridden normally.

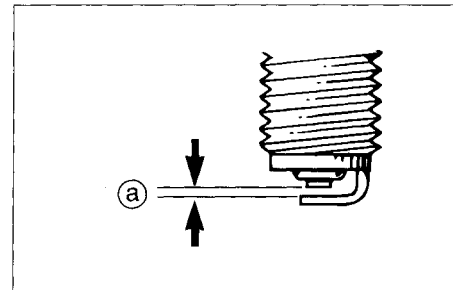

a. Spark plug gap

Do not attempt to diagnose such problems yourself. Instead, take the motorcycle to a Yamaha dealer. You should periodically remove and inspect the spark plug because heat and deposits will cause any spark plug to slowly break down and erode. If electrode erosion becomes excessive, or if carbon and other deposits are excessive, you should replace the spark plug with the specified plug.

Specified spark plug:

D8EA / D9EA (NGK) or
X24ES-U / X27ES-U (DENSO)

PERIODIC MAINTENANCE AND MINOR REPAIR

Installation

1. Measure the electrode gap with a wire thickness gauge and, if necessary, adjust the gap to specification.

Spark plug gap:

0.6 ~ 0.7 mm (0.024 ~ 0.028 in)

2. Clean the gasket surface. Wipe off any grime from the threads.
3. Install the spark plug and tighten it to the specified torque.

Tightening torque:

Spark plug:

17.5 Nm (1.75 m·kg, 12.5 ft·lb)

NOTE:

If a torque wrench is not available when you are installing a spark plug, a good estimate of the correct torque is 1/4 to 1/2 turn past finger tight. Have the spark plug tightened to the specified torque as soon as possible.

4. Install the spark plug cap.

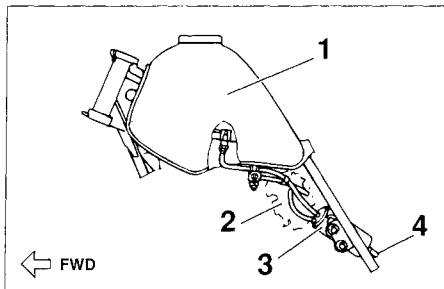

1. Fuel tank
2. Carburetor
3. Canister
4. Vent hose

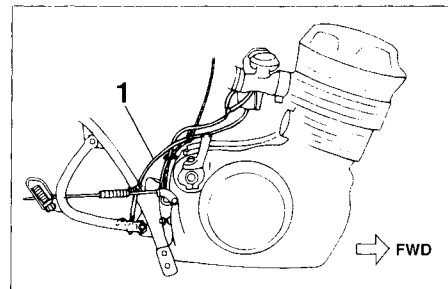

1. Overflow pipe

EAU01796

Canister (for California only)

This model is equipped with a canister to prevent the discharging of fuel vapor into the atmosphere.

- Check each hose connection.
- Check each hose and canister for cracks or damage. Replace if damaged.
- Make sure the vent hose is not blocked. Clean it if necessary.

PERIODIC MAINTENANCE AND MINOR REPAIR

EAU01440

Engine oil

Oil level measurement

1. Place the motorcycle on a level place and hold it in an upright position. Warm up the engine for several minutes.

NOTE:

Be sure the motorcycle is positioned straight up when checking the oil level. A slight tilt toward the side can result in false readings.

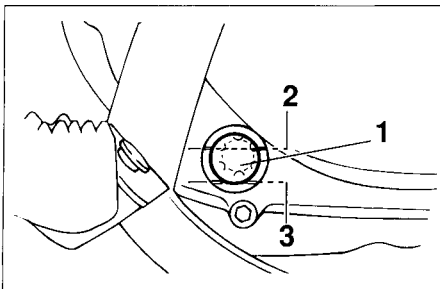

1. Level window
 2. Maximum level mark
 3. Minimum level mark
2. With the engine stopped, check the oil level through the level window located at the lower part of the right side crankcase cover.

NOTE:

Wait a few minutes until the oil level settles before checking.

3. The oil level should be between the maximum and minimum marks. If the level is low, add sufficient oil to raise it to the proper level.

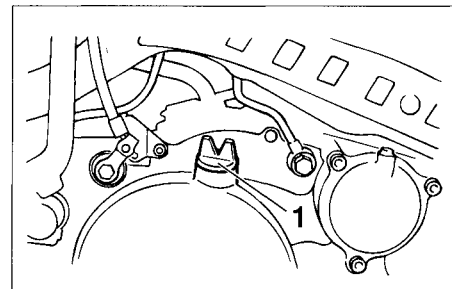

1. Engine oil filler cap

Engine oil replacement

1. Warm up the engine for a few minutes.
2. Stop the engine. Place an oil pan under the engine and remove the oil filler cap.

PERIODIC MAINTENANCE AND MINOR REPAIR

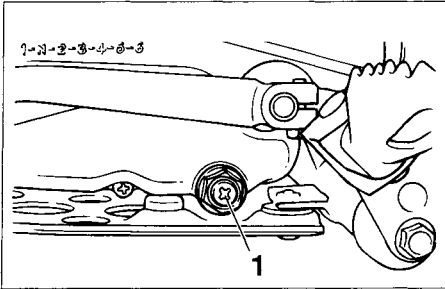

1. Engine oil drain bolt

3. Remove the drain bolt and air bleed screw.

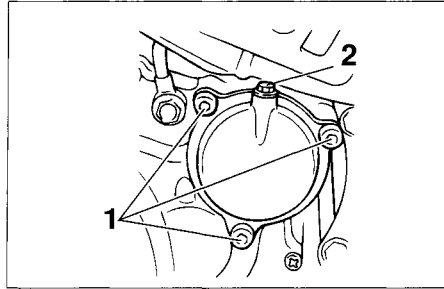

1. Filter cover screw (x3)

2. Air bleed screw

4. Check each gasket. If damaged, replace.

5. Remove the filter cover screws and the oil filter cover.

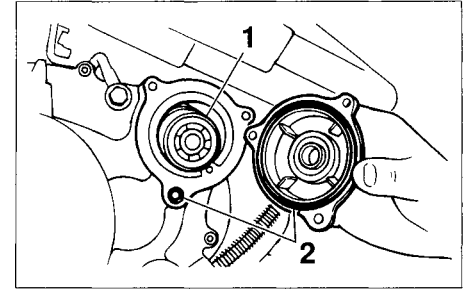

1. Filter element

2. O-ring (x2)

NOTE:

The oil filter cover is secured by three screws. The lower one should be removed first so that the filter cavity will drain.

6. Clean the filter element with solvent. Replace if necessary.

7. Check the O-ring. If damaged, replace.

8. Install the drain bolt, filter cover, screws and air bleed screw.

PERIODIC MAINTENANCE AND MINOR REPAIR

EC000066

NOTE: _____

Make sure the O-ring is seated properly.

Tightening torque:

Drain bolt:

43 Nm (4.3 m·kg, 31 ft·lb)

Filter cover screw:

10 Nm (1.0 m·kg, 7.2 ft·lb)

Air bleed screw:

5 Nm (0.5 m·kg, 3,6 ft·lb)

Recommended oil:

See page 8-1

Oil quantity:

Total amount:

1.6 L (1.4 Imp qt, 1.7 US qt)

Periodic oil change:

1.3 L (1.1 Imp qt, 1.4 US qt)

With oil filter replacement:

1.4 L (1.2 Imp qt, 1.5 US qt)

CAUTION: _____

- **Do not put in any chemical additives. Engine oil also lubricates the clutch and additives could cause clutch slippage.**
- **Be sure no foreign material enters the crankcase.**

9. Fill engine with oil. Install the oil filler cap and tighten.

10. Start the engine and warm up for a few minutes. While warming up, check for oil leakage. If oil leakage is found, stop the engine immediately and check for the cause.
11. Stop the engine and check the oil level.

PERIODIC MAINTENANCE AND MINOR REPAIR

EC000076

CAUTION:

After replacing the engine oil, be sure to check the oil pressure as described below.

- Remove the air bleed screw from the oil filter cover.
- Start the engine and keep it idling until oil flows out of the bleed hole. If no oil comes out after one minute, turn off the engine immediately so it will not seize. In such a case go to the nearest Yamaha dealer for repairs.
- After checking, tighten the air bleed screw securely.

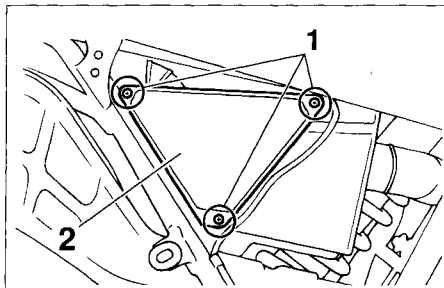

1. Air filter case fitting screw (×3)
2. Air filter case cover

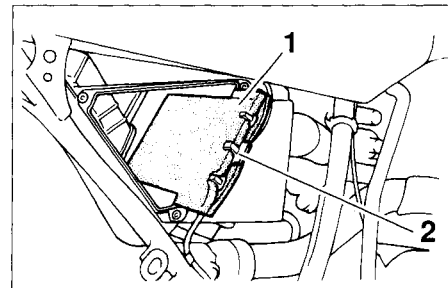

1. Air filter element
2. Guide

EAU01438

Air filter

The air filter should be cleaned at the specified intervals. It should be cleaned more frequently when riding in unusually wet or dusty areas.

1. Remove panel B. (See page 6-7 for removal and installation procedures.)
2. Remove the air filter case fitting screws and the filter case cover.
3. Remove the air filter from the case.

4. Remove the air filter element from its guide and clean it with solvent. After cleaning, remove the remaining solvent by squeezing the element.

PERIODIC MAINTENANCE AND MINOR REPAIR

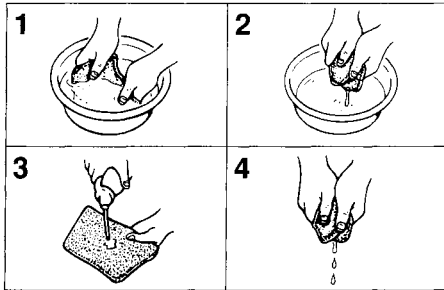

EC000082

CAUTION: _____

- Make sure the air filter is properly seated in the air filter case.
- The engine should never be run without the air filter installed. Excessive piston and/or cylinder wear may result.

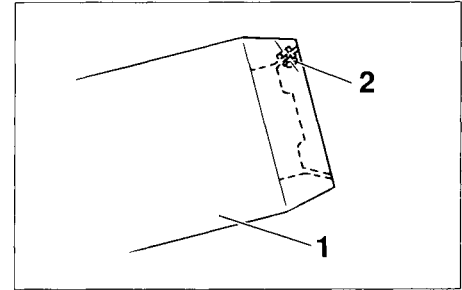

1. Muffler
2. Screw

EAU01549

Spark arrester cleaning

Be sure the exhaust pipe and muffler are cool before cleaning the spark arrester.

1. Remove the screw.

5. Apply recommended oil to the entire surface of the element and squeeze out the excess oil. It should be wet but not dripping.

Recommended oil:

Yamaha foam air filter oil or other quality air filter oil

6. Insert the air filter guide into the air filter and install it in the case.
7. Install the air filter case cover and panel.

PERIODIC MAINTENANCE AND MINOR REPAIR

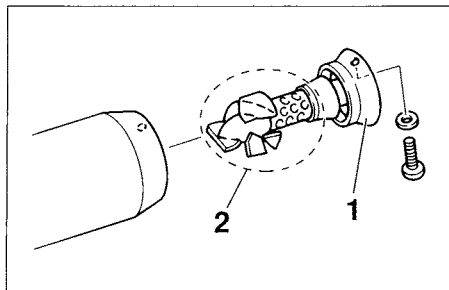

1. Tailpipe
2. Spark arrester

2. Remove the tailpipe by pulling it out of the muffler.
3. Tap the tailpipe lightly, then use a wire brush to remove any carbon deposits from the spark arrester portion of the tailpipe.
4. Insert the tailpipe into the muffler and align the screw holes.
5. Install the screw and tighten it.

EWA00007

⚠WARNING

- Always let the exhaust system cool prior to touching exhaust components.
- Do not start the engine when cleaning the exhaust system.

EAU01752

Carburetor adjustment

The carburetor is an important part of the engine and its emission control system. Adjusting should be left to a Yamaha dealer with the professional knowledge, specialized data and equipment to do so properly.

EAU00637

Valve clearance adjustment

The correct valve clearance changes with use, resulting in improper fuel/air supply or engine noise. To prevent this, the valve clearance must be adjusted regularly. This adjustment however, should be left to a professional Yamaha service technician.

EAU00638

Decompression cable adjustment

The decompression cable stretches with use, resulting in improper decompression function. To prevent this, the decompression cable must be adjusted regularly. This adjustment, however, should be left to a Yamaha dealer.

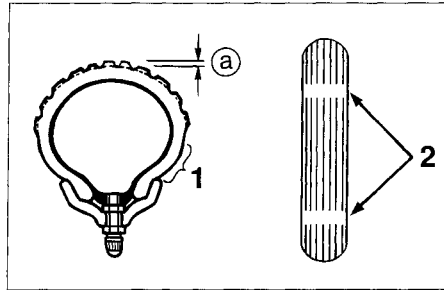

- a. Tread depth
 1. Side wall
 2. Wear indicator

EAU00645

Tires

To ensure maximum performance, long service, and safe operation, note the following:

Tire air pressure

Always check and adjust the tire pressure before operating the motorcycle.

EW000082

⚠ WARNING

Tire inflation pressure should be checked and adjusted when the temperature of the tire equals the ambient air temperature. Tire inflation pressure must be adjusted according to total weight of cargo, rider, passenger, and accessories (fairing, saddlebags, etc. if approved for this model), and vehicle speed.

Maximum load*	158 kg (348 lb) (XT350) 157 kg (346 lb) (XT350C)	
Cold tire pressure	Front	Rear
Up to 90 kg (198 lb) load* (198 lb) load*	125 kPa (1.25 kgf/cm ² , 18 psi)	150 kPa (1.50 kgf/cm ² , 22 psi)
90 kg (198 lb) load ~ Maximum load*	150 kPa (1.50 kgf/cm ² , 22 psi)	175 kPa (1.75 kgf/cm ² , 25 psi)

* Load is the total weight of cargo, rider, passenger and accessories.

PERIODIC MAINTENANCE AND MINOR REPAIR

EW000083

⚠ WARNING

Proper loading of your motorcycle is important for several characteristics of your motorcycle, such as handling, braking, performance and safety. Do not carry loosely packed items that can shift. Securely pack your heaviest items close to the center of the motorcycle, and distribute the weight evenly from side to side. Properly adjust the suspension for your load, and check the condition and pressure of your tires. **NEVER OVERLOAD YOUR MOTORCYCLE.** Make sure the total weight of the cargo, rider, passenger, and accessories (fairing, saddlebags, etc. if approved for this model) does not exceed the maximum load of the motorcycle. Operation of an overloaded motorcycle could cause tire damage, an accident, or even injury.

Tire inspection

Always check the tires before operating the motorcycle. If a tire tread shows crosswise lines (minimum tread depth), if the tire has a nail or glass fragments in it, or if the side wall is cracked, contact a Yamaha dealer immediately and have the tire replaced.

FRONT

Manufacturer	Size	Type
BRIDGESTONE	3.00-21 51P	TRAIL WING-25

REAR

Manufacturer	Size	Type
BRIDGESTONE	110/80-18 58P	TRAIL WING-26

Minimum tire tread depth (front and rear)	1.0 mm (0.04 in)
---	------------------

EAU00680

⚠ WARNING

- It is dangerous to ride with a worn-out tire. When a tire tread begins to show lines, have a Yamaha dealer replace the tire immediately. Brakes, tires, and related wheel parts replacement should also be left to a Yamaha dealer.
- Patching a punctured tube is not recommended. If it is absolutely necessary to do so, use great care and replace the tube as soon as possible with a good quality replacement.

EAU00685

Wheels

To ensure maximum performance, long service, and safe operation, note the following:

- Always inspect the wheels before a ride. Check for cracks, bends or warpage of the wheel. Be sure the spokes are tight and undamaged. If any abnormal condition exists in a wheel, consult a Yamaha dealer. Do not attempt even small repairs to the wheel. If a wheel is deformed or cracked, it must be replaced.
- Tires and wheels should be balanced whenever either one is changed or replaced. Failure to have a wheel balanced can result in poor performance, adverse handling characteristics, and shortened tire life.

- Ride at moderate speeds after changing a tire since the tire surface must first be broken in for it to develop its optimal characteristics.

EAU00691

Accessories or replacement parts

EW000098

⚠ WARNING

This motorcycle is not designed to pull a trailer or to be attached to a sidecar. The accessories or replacement parts you choose for your motorcycle should be designed specifically for it, and they must be securely mounted to maintain the inherent stability of the original design. Genuine Yamaha Parts and Accessories are designed and tested to be compatible with your motorcycle. Please consider Genuine Yamaha Parts and Accessories before making an accessory purchase. Use of non-Yamaha-approved parts or accessories may cause loss of handling stability and riding safety. Since Yamaha cannot control the quality of parts or accessories manufactured by other companies, Yamaha cannot be held liable for any con-

PERIODIC MAINTENANCE AND MINOR REPAIR

sequences caused by the use of items which have not been approved by Yamaha.

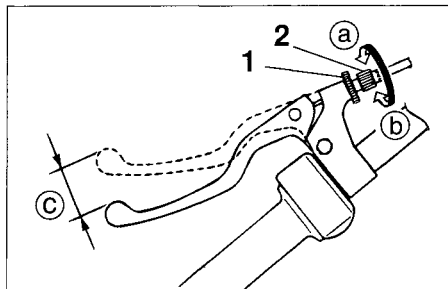

1. Locknut
2. Adjusting bolt
- c. Free play

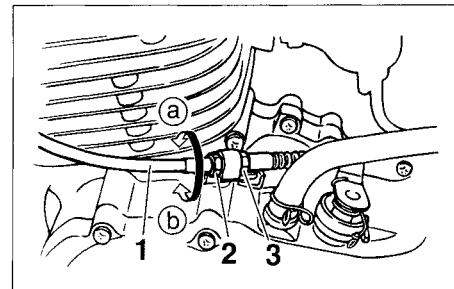

1. Clutch cable
2. Adjusting nut
3. Locknut

Clutch lever free play adjustment

EAU00694

The clutch lever free play should be adjusted to 10 ~ 15 mm (0.39 ~ 0.59 in).

1. Loosen the locknut at the clutch lever.
2. Turn the adjusting bolt at the clutch lever in direction (a) to increase free play or in direction (b) to decrease free play.
3. Tighten the locknut at the clutch lever.

If the specified free play cannot be obtained, proceed with the following steps.

4. Loosen the locknut at the clutch lever.
5. Turn the adjusting bolt at the clutch lever in direction (a) to loosen the cable.
6. Loosen the locknut at the crankcase side.
7. Turn the adjusting nut at the crankcase in direction (a) to increase free play or in direction (b) to decrease free play.
8. Tighten the locknut at the crankcase and the clutch lever.

PERIODIC MAINTENANCE AND MINOR REPAIR

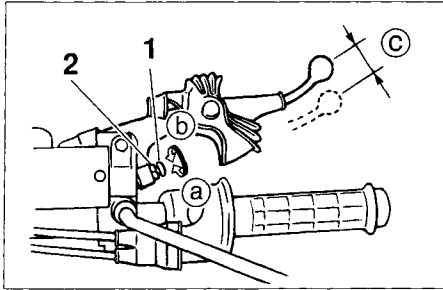

1. Adjusting bolt
2. Locknut
- c. Free play

EAU00696

Front brake lever free play adjustment

The free play at the front brake lever should be 5 ~ 8 mm (0.20 ~ 0.31 in).

1. Loosen the locknut.
2. Turn the adjusting bolt in direction (a) to increase free play or in direction (b) to decrease free play.
3. After adjusting, tighten the locknut.

EW000099

⚠ WARNING

- Check the brake lever free play. Be sure the brake is working properly.
- A soft or spongy feeling in the brake lever can indicate the presence of air in the brake system. This air must be removed by bleeding the brake system before the motorcycle is operated. Air in the system will cause greatly diminished braking capability and can result in loss of control and an accident. Have a Yamaha dealer inspect and bleed the system if necessary.

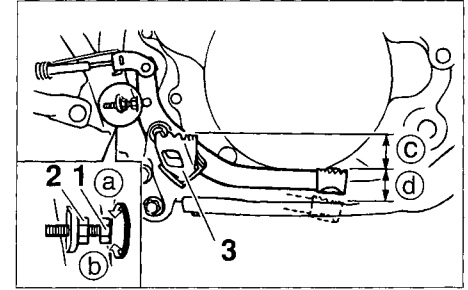

1. Brake pedal height adjusting bolt
2. Locknut
3. Footrest
- c. Pedal height
- d. Free play

EAU00707

Rear brake pedal height and free play adjustment

EW000104

⚠ WARNING

It is advisable to have a Yamaha dealer make this adjustment.

Pedal height

The brake pedal should be positioned so that its top end is approximately 15 mm (0.6 in) below the top of the footrest.

PERIODIC MAINTENANCE AND MINOR REPAIR

1. Loosen the locknut.
2. Turn the adjusting bolt in direction (a) to raise pedal height or in direction (b) to lower pedal height.
3. Tighten the locknut.

EW000105

⚠WARNING

After adjusting the pedal height adjust brake pedal free play.

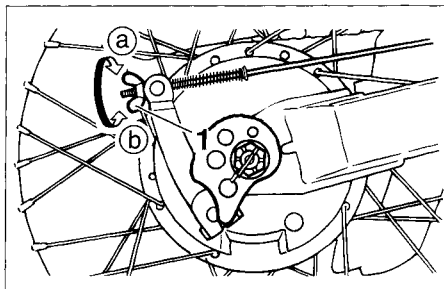

1. Brake pedal free play adjusting nut

Free play

The rear brake pedal free play should be adjusted to 20 ~ 30 mm (0.8 ~ 1.2 in) at the brake pedal end. Turn the adjusting nut on the brake rod in direction (a) to increase free play or in direction (b) to decrease free play.

EW000106

⚠WARNING

- Brake pedal free play should be checked whenever the chain is adjusted or the rear wheel is removed and then reinstalled.
- Check the operation of the brake light after adjusting the rear brake.
- If it is impossible to make proper adjustment, consult a Yamaha dealer.

PERIODIC MAINTENANCE AND MINOR REPAIR

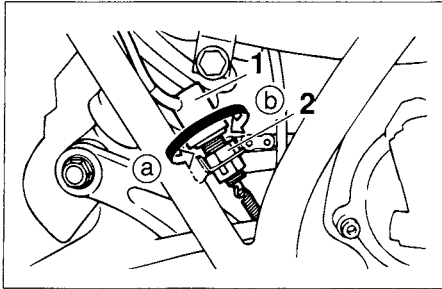

1. Brake light switch
2. Adjusting nut

EAU00713

Brake light switch adjustment

The rear brake light switch is activated by the brake pedal and is properly adjusted when the brake light comes on just before braking takes effect. To adjust the rear brake light switch, hold the switch body so it does not rotate while turning the adjusting nut.

Turn the adjusting nut in direction (a) to make the brake light come on earlier.

Turn the adjusting nut in direction (b) to make the brake light come on later.

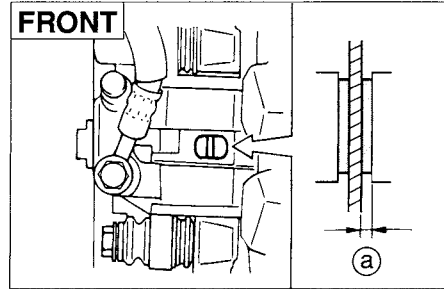

- a. Thickness

EAU00720

Checking the front brake pads and rear brake shoes

EAU01436

Front brake

Check the brake pads for damage and wear. If the thickness is less than 0.8 mm (0.031 in), have a Yamaha dealer replace the pads.

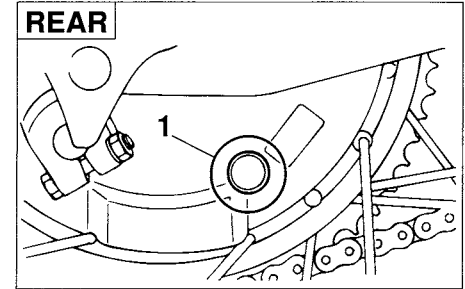

1. Cap

EAU01431

Rear brake

Remove the cap and inspect the brake shoe. If the thickness is less than 2 mm (0.08 in), have a Yamaha dealer replace the shoes.

PERIODIC MAINTENANCE AND MINOR REPAIR

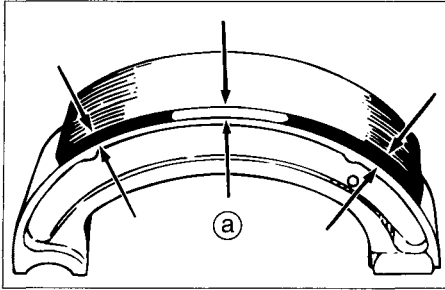

a. Thickness

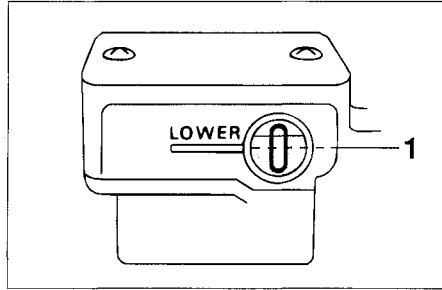

1. Minimum level mark

EAU00732

Inspecting the brake fluid level

Insufficient brake fluid may let air enter the brake system, possibly causing the brakes to become ineffective.

Before riding, check that the brake fluid is above the minimum level and fill when necessary.

Observe these precautions:

- When checking the fluid level, make sure the top of the master cylinder is level by turning the handlebars.

- Use only the designated quality brake fluid. Otherwise, the rubber seals may deteriorate, causing leakage and poor brake performance.

Recommended brake fluid:
DOT 4

NOTE: _____
If DOT 4 is not available, DOT 3 can be used.

- Refill with the same type of brake fluid. Mixing fluids may result in a harmful chemical reaction and lead to poor brake performance.
- Be careful that water does not enter the master cylinder when refilling. Water will significantly lower the boiling point of the fluid and may result in vapor lock.

PERIODIC MAINTENANCE AND MINOR REPAIR

- Brake fluid may deteriorate painted surfaces or plastic parts. Always clean up spilled fluid immediately.
- Have a Yamaha dealer check the cause if the brake fluid level goes down.

Brake fluid replacement

The brake fluid should be replaced only by trained Yamaha service personnel. Have the Yamaha dealer replace the following components during periodic maintenance or when they are damaged or leaking:

- oil seals (every two years)
- brake hoses (every four years)

EAU00742

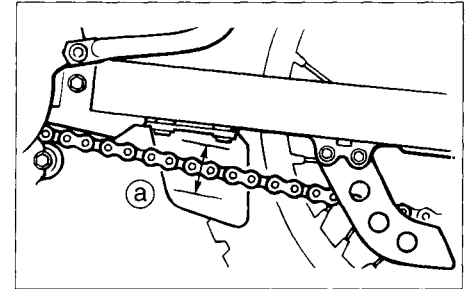

a. Chain slack

EAU00744

Drive chain slack check

NOTE:

Spin the wheel several times and find the tightest position of the chain. Check and/or adjust the chain slack while it's in this tightest position.

To check the chain slack the motorcycle must be held straight up with both wheels on the ground and without rider. Check the slack at the position shown in the illustration. Normal slack is approximately 30 ~ 40 mm (1.2 ~ 1.6 in). If the slack exceeds 40 mm (1.6 in), adjust.

PERIODIC MAINTENANCE AND MINOR REPAIR

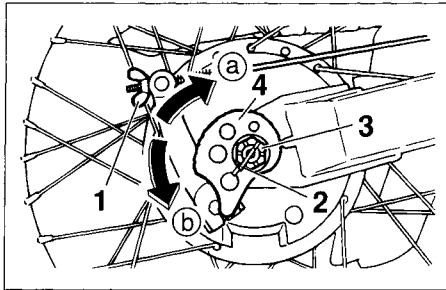

1. Rear brake pedal free play adjusting nut
2. Cotter pin
3. Axle nut
4. Chain adjusting plate

EAU01502

Drive chain slack adjustment

1. Loosen the rear brake pedal free play adjusting nut.
2. Remove the cotter pin from the axle nut.
3. Loosen the axle nut.
4. Turn both left and right chain adjusting plates the same amount. Make sure that they are in the same position for proper wheel alignment. To tighten the chain, turn in direction (a). To loosen the chain, turn in direction (b).

EC000096

CAUTION:

Too little chain slack will overload the engine and other vital parts. Keep the slack within the specified limits.

5. After adjusting, be sure to tighten the axle nut to the specified torque.

Tightening torque:

Axle nut:

110 Nm (11 m·kg, 80 ft·lb)

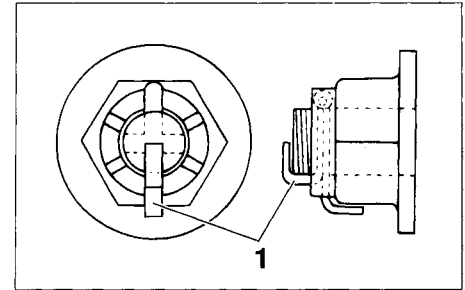

1. Cotter pin

6. Insert a new cotter pin into the axle nut and bend the end of the cotter pin as shown in the illustration. If the notch in the nut and cotter pin hole do not match, tighten the nut slightly to align them.

EW000110

WARNING

Always use a new cotter pin on the axle nut.

7. Adjust the free play in the brake pedal. (See page 6-20.)

PERIODIC MAINTENANCE AND MINOR REPAIR

EW000103

⚠ WARNING

Check the operation of the brake light after adjusting the rear brake.

EAU03006

Drive chain lubrication

The chain consists of many parts which work with each other. If the chain is not maintained properly, it will wear out quickly. Therefore, the chain must be serviced regularly. This service is especially necessary when riding in dusty areas. This motorcycle is equipped with a sealed type chain. Steam cleaning, high-pressure washers, and solvents can damage the drive chain, so do not use these for cleaning it. Use only kerosene to clean the drive chain. Wipe it dry, and thoroughly lubricate it with SAE 30 ~ 50W motor oil. Do not use any other lubricants on the drive chain. They may contain solvents that could damage the sealed chain.

EC000097

CAUTION:

Be sure to oil the chain after washing the motorcycle or riding in the rain.

EAU01541

Cable inspection and lubrication

EW000111

⚠ WARNING

Damage to the outer housing of cables may allow internal rusting and cause interference with cable movement. Replace damaged cables as soon as possible to prevent unsafe conditions.

Lubricate the cables and cable ends. If a cable does not operate smoothly, ask a Yamaha dealer to replace it.

Recommended lubricant: Yamaha Chain and Cable Lube or SAE 10W30 motor oil

PERIODIC MAINTENANCE AND MINOR REPAIR

EAU00773

Throttle cable and grip lubrication

The throttle twist grip assembly should be greased at the time that the cable is lubricated, since the grip must be removed to get at the end of the throttle cable. After removing the screws, hold the end of the cable up in the air and put in several drops of lubricant. With the throttle grip disassembled, coat the metal surface of the grip assembly with a suitable all-purpose grease.

EAU00775

Brake and shift pedal lubrication

Lubricate the pivoting parts.

Recommended lubricant:
Yamaha Chain and Cable
Lube or SAE 10W30 motor oil

EAU00777

Brake and clutch lever lubrication

Lubricate the pivoting parts.

Recommended lubricant:
Yamaha Chain and Cable
Lube or SAE 10W30 motor oil

PERIODIC MAINTENANCE AND MINOR REPAIR

EAU001542

Sidestand lubrication

Lubricate the sidestand pivoting point and metal-to-metal contact surfaces. Check that the sidestand moves up and down smoothly.

Recommended lubricant:
Yamaha Chain and Cable
Lube or SAE 10W30 motor oil

EW000113

⚠WARNING

If the sidestand does not move smoothly, consult a Yamaha dealer.

EAU00791

Rear suspension lubrication

Lubricate the pivoting parts.

Recommended lubricant:
Lithium soap base grease

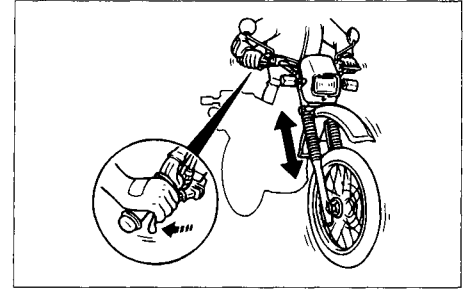

EAU02939

Front fork inspection

Visual check

EW000115

⚠WARNING

Securely support the motorcycle so there is no danger of it falling over.

Check for scratches or damage on the inner tube and excessive oil leakage from the front fork.

PERIODIC MAINTENANCE AND MINOR REPAIR

Operation check

1. Place the motorcycle on a level place.
2. Hold the motorcycle in an upright position and apply the front brake.
3. Push down hard on the handlebars several times and check if the fork rebounds smoothly.

EC000098

CAUTION:

If any damage or unsmooth movement is found with the front fork, consult a Yamaha dealer.

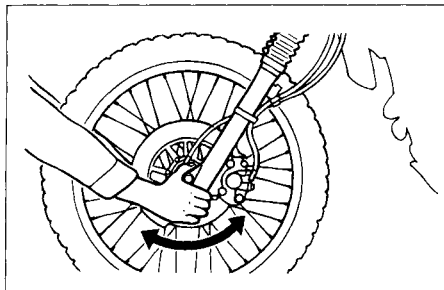

EAU00794

Steering inspection

Periodically inspect the condition of the steering. Worn out or loose steering bearings may be dangerous. Place a stand under the engine to raise the front wheel off the ground. Hold the lower end of the front forks and try to move them forward and backward. If any free play can be felt, ask a Yamaha dealer to inspect and adjust the steering. Inspection is easier if the front wheel is removed.

EW000115

WARNING

Securely support the motorcycle so there is no danger of it falling over.

PERIODIC MAINTENANCE AND MINOR REPAIR

Wheel bearings

EAU01144

If there is play in the front or rear wheel hub or if the wheel does not turn smoothly, have a Yamaha dealer inspect the wheel bearings.

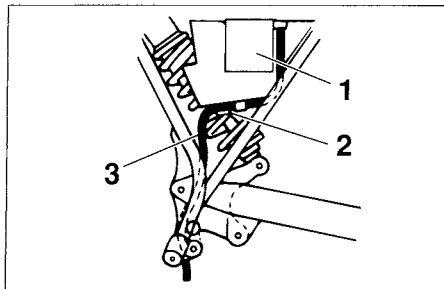

1. Battery
2. Guide
3. Battery breather hose

EAU01071

Battery

Check the level of the battery electrolyte and make sure that the terminals are tight.

Fill with distilled water if the electrolyte level is low.

EC000099

CAUTION: _____

When inspecting the battery, be sure the breather hose is routed correctly. If the breather hose is positioned in such a way as to cause battery electrolyte or gas to exit onto the frame, structural and cosmetic damage to the motorcycle can occur.

PERIODIC MAINTENANCE AND MINOR REPAIR

EW000116

⚠ WARNING

Battery electrolyte is poisonous and dangerous, causing severe burns, etc. It contains sulfuric acid. Avoid contact with skin, eyes or clothing.

ANTIDOTE:

- **EXTERNAL:** Flush with water.
- **INTERNAL:** Drink large quantities of water or milk. Follow with milk of magnesia, beaten egg, or vegetable oil. Call a physician immediately.
- **EYES:** Flush with water for 15 minutes and get prompt medical attention.

Batteries produce explosive gases. Keep sparks, flame, cigarettes etc., away. Ventilate when charging or using in an enclosed space. Always shield your eyes when working near batteries.

KEEP OUT OF REACH OF CHILDREN.

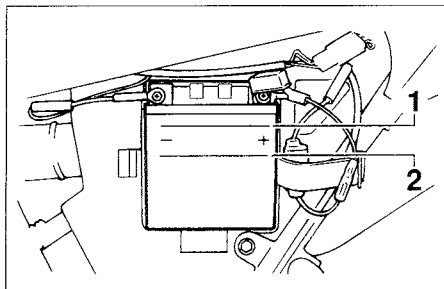

1. Maximum level mark
2. Minimum level mark

Replenishing the battery fluid

A poorly maintained battery will corrode and discharge quickly. The battery fluid should be checked at least once a month. The level should be between the minimum level and maximum level marks. Use only distilled water if refilling is necessary.

EC000100

CAUTION:

Normal tap water contains minerals which are harmful to a battery; therefore, refill only with distilled water.

EW000117

⚠ WARNING

Take care not to spill battery fluid on the chain. Battery fluid may weaken the chain causing shorter chain life and possibly result in an accident

PERIODIC MAINTENANCE AND MINOR REPAIR

EC000103

Battery storage

- When the motorcycle will not be used for a month or longer, remove the battery, fully charge it and store it in a cool, dry place. Completely recharge the battery before reinstallation.
- If the battery will be stored for longer than two months, check the specific gravity of the fluid at least once a month and fully recharge the battery when it is too low.
- Always make sure the connections are correct when putting the battery back in the motorcycle. Make sure the breather hose is properly connected and is not damaged or obstructed.

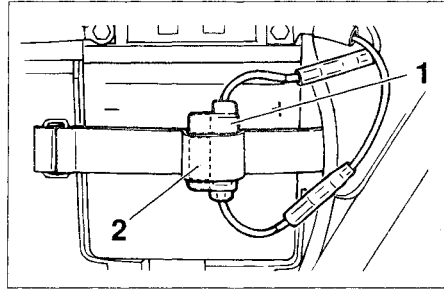

1. Fuse
2. Spare fuse

EAU00804

Fuse replacement

If the fuse is blown, turn off the main switch and the switch of the circuit in question. Install a new fuse of specified amperage. Turn on the switches and see if the electrical device operates. If the fuse immediately blows again, consult a Yamaha dealer.

CAUTION: _____

Do not use fuses of higher amperage rating than those recommended. Substitution of a fuse of improper rating can cause extensive electrical system damage and possibly a fire.

Specified fuse: 10A

PERIODIC MAINTENANCE AND MINOR REPAIR

EAU01158

Headlight bulb replacement

If the headlight bulb burns out, replace the bulb as follows:

1. Remove cowling A. (See page 6-7 for removal and installation procedures.)

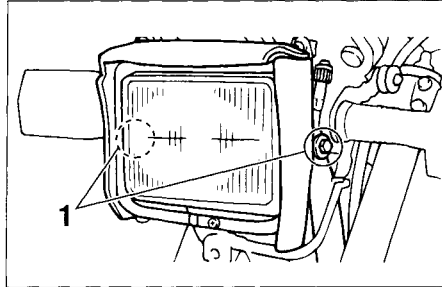

1. Bolt (x2)

2. Remove the headlight unit by removing the bolts.

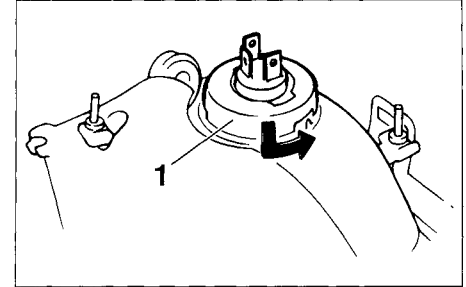

1. Bulb holder

3. Remove the headlight connector and the bulb holder cover.
4. Turn the bulb holder counter-clockwise to remove it and then remove the defective bulb.

PERIODIC MAINTENANCE AND MINOR REPAIR

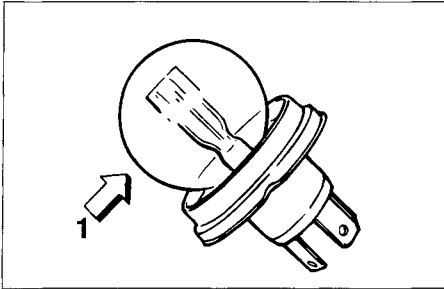

1. Don't touch

EW000119

⚠ WARNING

Keep flammable products and your hands away from a bulb while it is on, as it is hot. Do not touch a bulb until it cools down.

5. Put a new bulb into position and secure it in place with the bulb holder.
6. Install the bulb holder cover, connector and headlight unit.
7. Install the cowling.
8. If the headlight beam adjustment is necessary, ask a Yamaha dealer to make that adjustment.

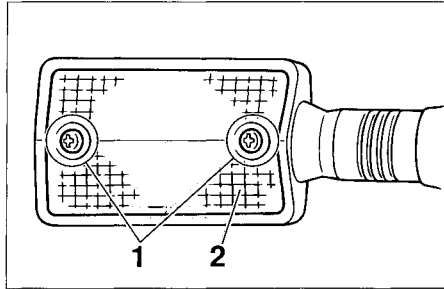

1. Screw (x2)
2. Lens

EAU03010

Turn signal light bulb replacement

1. Remove the screws and the lens.

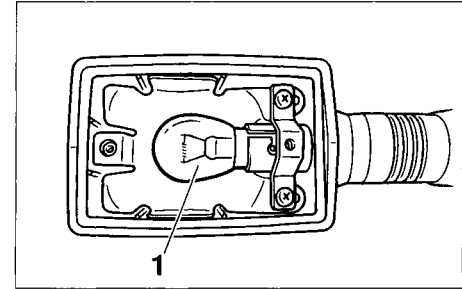

1. Bulb

2. Remove the defective bulb by pushing it inward and turning it counterclockwise.
3. Install a new bulb by pushing it inward and turning it clockwise.
4. Install the lens and tighten the screws.

PERIODIC MAINTENANCE AND MINOR REPAIR

EAU01579

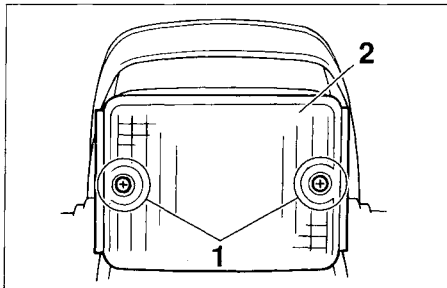

1. Screw (x2)
2. Lens

EAU01623

Taillight bulb replacement

1. Remove the screws and the lens.

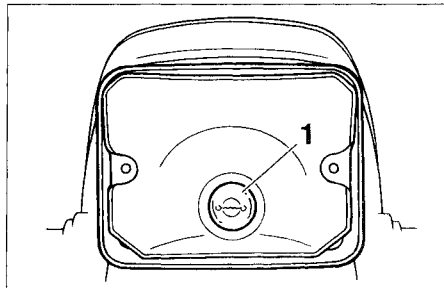

1. Bulb
2. Remove the defective bulb by pushing it inward and turning it counterclockwise.
3. Install a new bulb by pushing it inward and turning it clockwise.
4. Install the lens and tighten the screws.

EC000108

CAUTION: _____

Do not over-tighten the screws as the lens may break.

Supporting the motorcycle

Since the Yamaha XT350 has no centerstand, follow these precautions when removing the front and rear wheel or performing other maintenance requiring the motorcycle to stand upright. Check that the motorcycle is in a stable and level position before starting any maintenance. A strong wooden box can be placed under the engine for added stability.

Front wheel service

To stabilize the rear of the motorcycle, either use a motorcycle stand or place a motorcycle jack under the frame in front of the rear wheel to prevent it from moving from side to side. Then use a motorcycle stand to elevate the front wheel off of the ground.

PERIODIC MAINTENANCE AND MINOR REPAIR

Rear wheel service

Use a motorcycle stand or motorcycle jack to elevate the motorcycle so the rear wheel is off the ground. Alternatively, two jacks can be placed under the frame or swingarm.

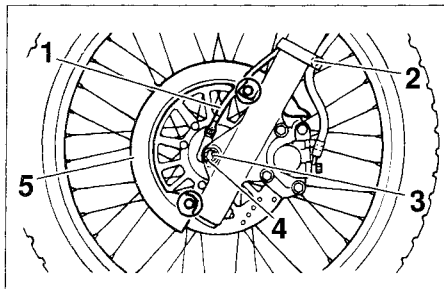

1. Speedometer cable
2. Speedometer cable holder
3. Axle nut
4. Cotter pin
5. Disc cover

EAU00905

Front wheel removal

EW000122

⚠ WARNING

- It is advisable to have a Yamaha dealer service the wheel.
- Securely support the motorcycle so there is no danger of it falling over.

2. Remove the speedometer cable from the front wheel side.
3. Remove the disc cover.
4. Remove the cotter pin and wheel axle nut.
5. Elevate the front wheel by placing a suitable stand under the engine.
6. Remove the wheel axle and the front wheel. Make sure the motorcycle is properly supported.

NOTE:

Do not depress the brake lever when the disc and caliper are separated.

1. Remove the speedometer cable holder.

PERIODIC MAINTENANCE AND MINOR REPAIR

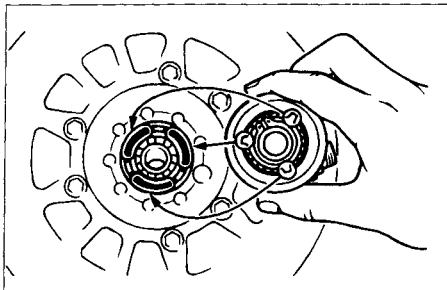

EAU01420

Front wheel installation

1. Install the speedometer gear unit housing into the wheel hub. Make sure the projections are meshed into the slots.

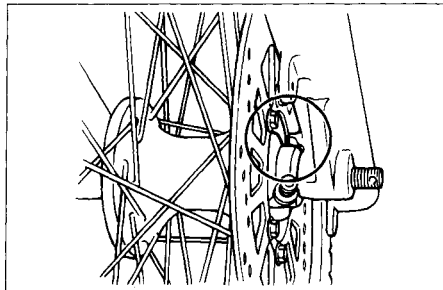

2. Lift up the wheel between the front fork legs. Make sure that there is enough gap between the brake pads before inserting the brake disc and that the slot in the speedometer gear unit housing fits over the stopper on the front fork outer tube.
3. Install the wheel axle and axle nut. Then let the motorcycle down.
4. Tighten the axle nut to the specified torque.

Tightening torque:

Axle nut:

110 Nm (11 m·kg, 80 ft·lb)

5. Install the speedometer cable.
6. Install a new cotter pin.

EW000124

WARNING

Always use a new cotter pin.

PERIODIC MAINTENANCE AND MINOR REPAIR

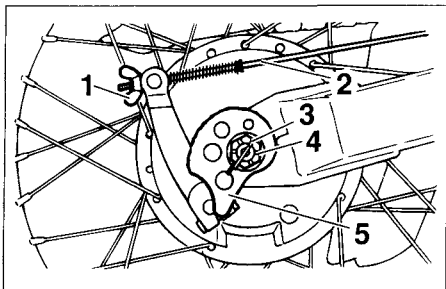

1. Rear brake pedal free play adjusting nut
2. Brake rod
3. Cotter pin
4. Axle nut
5. Chain adjusting plate

EAU01505

Rear wheel removal

EW000122

⚠ WARNING

- It is advisable to have a Yamaha dealer service the wheel.
- Securely support the motorcycle so there is no danger of it falling over.

1. Remove the rear brake pedal free play adjusting nut and brake rod from the brake cam lever.

2. Remove the wheel axle nut cotter pin and loosen the wheel axle nut.
3. Loosen the chain adjusting plates.
4. Elevate the rear wheel by placing a suitable stand under the engine.
5. Push the wheel forward and remove the drive chain.
6. Remove the wheel axle nut.
7. Pull out the wheel axle and remove the wheel assembly.

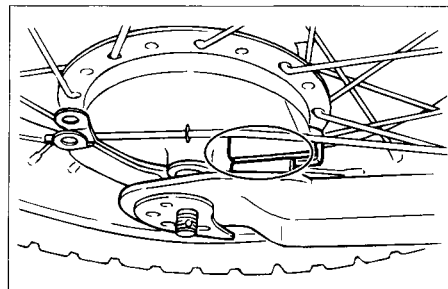

EAU01308

Rear wheel installation

1. Install the wheel assembly and insert the axle from the left-hand side. Be sure that the chain adjusting plates are installed with the punched side outward and the slot in the brake shoe plate is fit over the stopper on the swingarm.
2. Install and adjust the drive chain. (See page 6-24 for details about adjusting the drive chain slack.)

PERIODIC MAINTENANCE AND MINOR REPAIR

3. Install the axle nut and let the motorcycle down.
4. Tighten the axle nut to the specified torque and install the axle nut cotter pin.

Tightening torque:

Axle nut:

110 Nm (11.0 m·kg, 80 ft·lb)

EW000110

⚠WARNING

Always use a new cotter pin on the axle nut.

5. Insert the brake rod into the brake cam lever and install the brake pedal free play adjusting nut.
6. Adjust the rear brake pedal free play. (See page 6-20.)

EW000103

⚠WARNING

Check the operation of the brake light after adjusting the rear brake.

EAU01008

Troubleshooting

Although Yamaha motorcycles receive a rigid inspection before shipment from the factory, trouble may occur during operation.

Any problem in the fuel, compression, or ignition systems can cause poor starting and loss of power. The troubleshooting chart describes a quick, easy procedure for making checks.

If your motorcycle requires any repair, bring it to a Yamaha dealer. The skilled technicians at a Yamaha dealership have the tools, experience, and know-how to properly service your motorcycle. Use only genuine Yamaha parts on your motorcycle. Imitation parts may look like Yamaha parts, but they are often inferior. Consequently, they have a shorter service life and can lead to expensive repair bills.

PERIODIC MAINTENANCE AND MINOR REPAIR

EAU01532

Troubleshooting chart

EW000125

⚠ WARNING

Never check the fuel system while smoking or in the vicinity of an open flame.

1. Fuel

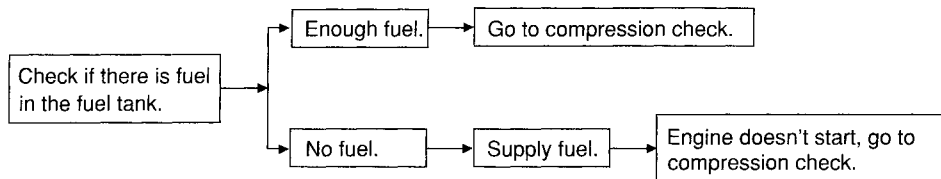

2. Compression

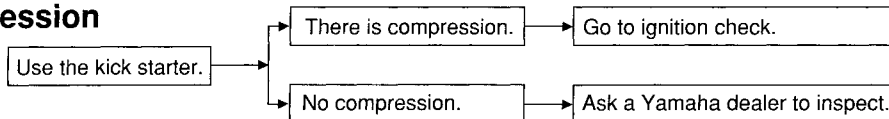

3. Ignition

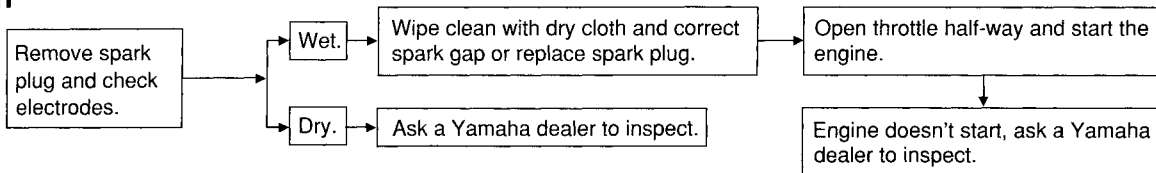

CLEANING AND STORAGE

A. CLEANING

EAU01327

Frequent, thorough cleaning of your motorcycle will not only enhance its appearance but will improve its general performance and extend the useful life of many components.

ECA00002

CAUTION: _____

- **Improper cleaning can damage the cowlings, panels and other plastic parts. Use only a soft, clean cloth or sponge with mild detergent and water to clean plastic.**
 - **Do not use any harsh chemical products on plastic parts. Be sure to avoid using cloths or sponges which have been in contact with strong or abrasive cleaning products, solvent or thinner, fuel (gasoline), rust removers or inhibitors, brake fluid, antifreeze or electrolyte.**
-

1. Before cleaning the motorcycle:
 - a. Block off the end of the exhaust pipe to prevent water entry; a plastic bag and strong rubber band may be used.
 - b. Make sure the spark plug and all filler caps are properly installed.
2. If the engine case is excessively greasy, apply degreaser with a paint brush. Do not apply degreaser to the chain, sprockets, or wheel axles.
3. Rinse the dirt and degreaser off with a garden hose. Use only enough pressure to do the job.

EC000111

CAUTION: _____

Excessive hose pressure may cause water seepage and deterioration of wheel bearings, front fork, brakes, transmission seals and electrical parts.

Many expensive repair bills have resulted from improper high pressure detergent applications such as those available in coin-operated car washers.

4. After riding on salted roads, wash the motorcycle with cold water immediately. Do not use warm water as it increases the chemical reaction of the salt.
5. Once the majority of the dirt has been hosed off, wash all surfaces with warm water and mild, detergent-type soap. An old toothbrush or bottle brush is handy for hard-to-get-at places.

6. Rinse the motorcycle off immediately with clean water and dry all surfaces with a chamois, clean towel, or soft absorbent cloth.
7. Dry the chain and lubricate it to prevent rust.
8. Clean the seat with a vinyl upholstery cleaner to keep the cover pliable and glossy.
9. Automotive-type wax may be applied to all painted and chrome-plated surfaces. Avoid combination cleaner-waxes. Many contain abrasives which may mar the paint or protective finish. When finished, start the engine and let it idle for several minutes.

B. STORAGE

EAU01504

Long term storage (60 days or more) of your motorcycle will require some preventive procedures to guard against deterioration. After thoroughly cleaning the motorcycle, prepare for storage as follows:

1. Fill the fuel tank with fuel and add fuel stabilizer (if available).
2. Remove the spark plug, pour about one tablespoon of engine oil in the spark plug hole and reinstall the spark plug. Turn the engine over several times (ground the spark plug lead) to coat the cylinder wall with oil.
3. Clean the chain and lubricate it (refer to "Drive chain lubrication").
4. Lubricate all control cables.
5. Block up the frame to raise both wheels off the ground.

6. Tie a plastic bag over the exhaust pipe outlet to prevent moisture from entering.
7. If storing in a humid or salt-air atmosphere, coat all exposed metal surfaces with a light film of oil. Do not apply oil to any rubber parts or the seat cover.
8. Remove the battery and fully charge it. Store it in a cool, dry place and recharge it once a month. Do not store the battery in an excessively warm or cold place (less than 0°C (30°F) or more than 30°C (90°F)). See page 6-32 for battery storage procedures.

NOTE: _____
Make any necessary repairs before storing the motorcycle.

SPECIFICATIONS

Specifications

Model	XT350M/XT350MC
Dimensions	
Overall length	2,240 mm (88.2 in)
Overall width	865 mm (34.1 in)
Overall height	1,210 mm (47.6 in)
Seat height	855 mm (33.7 in)
Wheelbase	1,420 mm (55.9 in)
Ground clearance	275 mm (10.8 in)
Minimum turning radius	2,100 mm (82.7 in)
Basic weight (with oil and full fuel tank)	130 kg (287 lb) XT350M 131 kg (289 lb) XT350MC
Engine	
Engine type	Air-cooled 4-stroke, DOHC
Cylinder arrangement	Forward inclined single cylinder
Displacement	346 cm ³
Bore × Stroke	86.0 × 59.6 mm (3.39 × 2.35 in)
Compression ratio	9:1
Starting system	Kick starter
Lubrication system	Wet sump

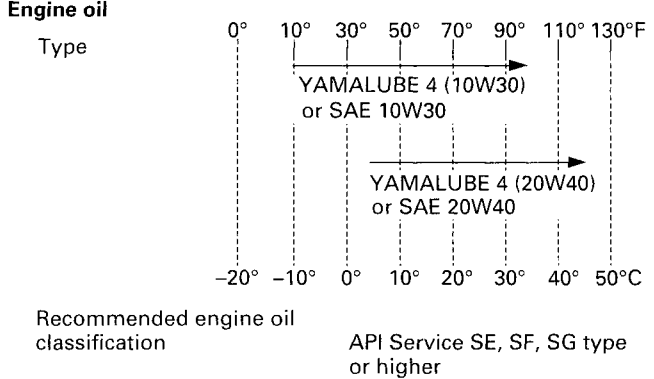

CAUTION: _____

Be sure to use motor oils that do not contain anti-friction modifiers. Passenger car motor oils (often labeled "Energy Conserving") contain anti-friction additives which will cause clutch and/or starter clutch slippage, resulting in reduced component life and poor engine performance.

Quantity	
Periodic oil change	1.3 L (1.14 Imp qt, 1.37 US qt)
With oil filter replacement	1.4 L (1.23 Imp qt, 1.48 US qt)
Total amount	1.6 L (1.41 Imp qt, 1.69 US qt)

Air filter	Wet type element
Fuel	
Type	Unleaded fuel
Fuel tank capacity	12 L (2.6 Imp gal, 3.2 US gal)
Fuel reserve amount	2 L (0.4 Imp gal, 0.5 US gal)
Carburetor	
Type × quantity	Y24PV × 1
Manufacturer	TEIKEI
Spark plug	
Type / Manufacturer	D8EA, D9EA / NGK or X24ES-U, X27ES-U / DENSO
Gap	0.6 ~ 0.7 mm (0.024 ~ 0.028 in)
Clutch type	Wet, multiple-disc
Transmission	
Primary reduction system	Spur gear
Primary reduction ratio	3.130
Secondary reduction system	Chain drive
Secondary reduction ratio	2.894
Number of sprocket teeth	
Rear / Front	55 / 19
Transmission type	Constant mesh 6-speed
Operation	Left foot operation

Gear ratio	1st	2.466
	2nd	1.812
	3rd	1.363
	4th	1.080
	5th	0.888
	6th	0.758

Chassis

Frame type	Diamond
Caster angle	27.17°
Trail	107 mm (4.21 in)

Tire

Front	Type	With tube
	Size	3.00-21 51P
Rear	Manufacture/ model	Bridgestone / TRAIL WING-25
	Size	110/80-18 58P
Maximum load*	Manufacture/ model	Bridgestone / TRAIL WING-26
		158 kg (348 lb) XT350M 157 kg (346 lb) XT350MC

SPECIFICATIONS

Air pressure (cold tire)

Up to 90 kg (198 lb) load*

Front 125 kPa; 1.25 kgf/cm²; 18 psi

Rear 150 kPa; 1.50 kgf/cm²; 22 psi

90 kg (198 lb) load ~

maximum load*:

Front 150 kPa; 1.50 kgf/cm²; 22 psi

Rear 175 kPa; 1.75 kgf/cm²; 25 psi

*Load is total weight of cargo, rider, passenger and accessories.

Wheels

Front

Type Spoke

Size 1.60 × 21

Rear

Type Spoke

Size 2.15 × 18

Brakes

Front

Type Single disc brake

Operation Right hand operation

Fluid DOT 4 or DOT 3

Rear

Type Drum brake

Operation Right foot operation

Suspension

Front

Type Telescopic fork

Rear

Type Swingarm (new monocross)

Shock absorbers

Front

Coil spring / oil damper

Rear

Coil spring / gas-oil damper

Wheel travel

Front

255 mm (10.04 in)

Rear

220 mm (8.66 in)

Electrical system

Ignition system

C.D.I.

Charging system

Type

C.D.I. magneto

Standard output

14V, 2A @ 3,000 r/min

Battery

Type

GM3-3B, FB3L-B

Voltage, capacity

12V, 3 AH

Headlight type	Bulb type
Bulb voltage, wattage × quantity	
Headlight	12V, 45W / 40W × 1
Tail / brake light	12V, 8W / 27W × 1
Turn signal light	12V, 27W × 4
Meter light	12V, 3.4W × 2
Neutral indicator light	12V, 3.4W × 1
High beam indicator light	12V, 3.4W × 1
Turn indicator light	12V, 3.4W × 1
Fuse	
Main fuse	10A

CONSUMER INFORMATION

EAU02944

Identification number records

Record the key identification number, vehicle identification number and model label information in the spaces provided for assistance when ordering spare parts from a Yamaha dealer or for reference in case the vehicle is stolen.

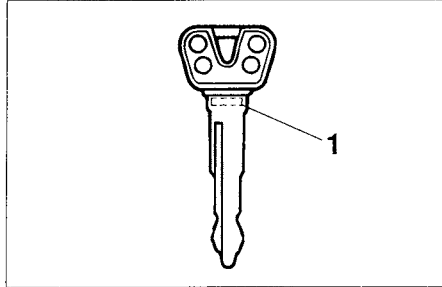

1. Key identification number

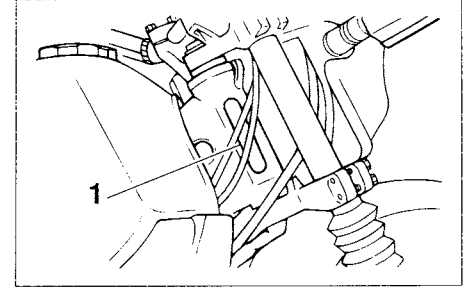

1. Vehicle identification number

EAU01042

EAU01043

1. KEY IDENTIFICATION NUMBER:

2. VEHICLE IDENTIFICATION NUMBER:

3. MODEL LABEL INFORMATION:

Key identification number

The key identification number is stamped on the key. Record this number in the space provided and use it for reference when obtaining a new key.

Vehicle identification number

The vehicle identification number is stamped into the steering head pipe. Record this number in the space provided.

NOTE: _____

The vehicle identification number is used to identify your motorcycle and may be used to register your motorcycle with the licensing authority in your state.

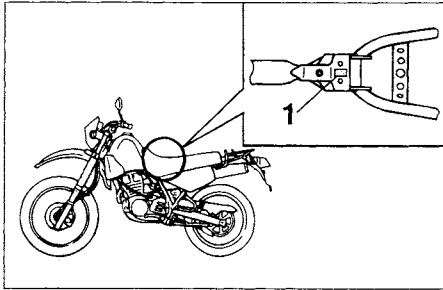

1. Model label

EAU01049

Model label

The model label is affixed to the location shown in the figure. Record the information on this label in the space provided. This information will be needed to order spare parts from your Yamaha dealer.

CONSUMER INFORMATION

EAU01051

Reporting safety defects

If you believe that your vehicle has a defect which could cause a crash or could cause injury or death, you should immediately inform the National Highway Traffic Safety Administration (NHTSA) in addition to notifying YAMAHA MOTOR CORP. U.S.A. If NHTSA receives similar complaints, it may open an investigation, and if it finds that a safety defect exists in group of vehicles, it may order a recall and remedy campaign. However, NHTSA cannot become involved in individual problems between you, your dealer, or YAMAHA MOTOR CORP. U.S.A.

To contact NHTSA, you may either call the Auto Safety Hotline toll-free at 1-800-424-9393 (or 366-0123 in Washington, D.C. area) or write to: NHTSA, U.S. Department of Transportation, Washington, D.C. 20590. You can also obtain other information about motor vehicle safety from the Hotline.

Motorcycle noise regulation

TAMPERING WITH NOISE CONTROL SYSTEM PROHIBITED:

Federal law prohibits the following acts or the causing thereof: (1) The removal or rendering inoperative by any person other than for purposes of maintenance, repair, or replacement of any device or element of design incorporated into any new vehicle for the purpose of noise control prior to its sale or delivery to the ultimate purchaser or while it is in use or (2) the use of the vehicle after such device or element of design has been removed or rendered inoperative by any person.

“AMONG THOSE ACTS PRESUMED TO CONSTITUTE TAMPERING ARE THE ACTS LISTED BELOW”.

These acts include tampering with the following systems; i.e., modification, removal, etc.

Exhaust system	Muffler Exhaust pipe Silencer
Intake system	Air cleaner case Air cleaner element Intake duct

CONSUMER INFORMATION

EAU01874

MAINTENANCE RECORD

Copies of work orders and/or receipts for parts you purchase and install will be required to document that maintenance has been completed in accordance with the emission warranty. The chart below is printed only as a reminder to you that the maintenance work is required. It is not acceptable proof of maintenance work.

MAINTENANCE INTERVAL	DATE OF SERVICE	MILEAGE	SERVICING DEALER NAME AND ADDRESS	REMARKS
600 mi (1,000 km) or 1 mo.				
4,000 mi (7,000 km) or 6 mos.				
8,000 mi (13,000 km) or 12 mos.				
12,000 mi (19,000 km) or 18 mos.				
16,000 mi (25,000 km) or 24 mos.				

CONSUMER INFORMATION

MAINTENANCE INTERVAL	DATE OF SERVICE	MILEAGE	SERVICING DEALER NAME AND ADDRESS	REMARKS
20,000 mi (31,000 km) or 30 mos.				
24,000 mi (37,000 km) or 36 mos.				
28,000 mi (43,000 km) or 42 mos.				
32,000 mi (49,000 km) or 48 mos.				
36,000 mi (55,000 km) or 54 mos.				
40,000 mi (61,000 km) or 60 mos.				

CONSUMER INFORMATION

EAU02918

YAMAHA MOTOR CORPORATION, U.S.A. STREET AND ENDURO MOTORCYCLE LIMITED WARRANTY

Yamaha Motor Corporation, U.S.A. hereby warrants each new model Yamaha motorcycle will be free from defects in material and workmanship for the period of time stated herein, subject to certain stated limitations.

THE PERIOD OF WARRANTY for Yamaha motorcycles originally equipped with headlight, stoplight, and turn signals shall be one (1) year from the date of purchase, with no mileage limitation.

MODELS EXCLUDED FROM WARRANTY include those used for non-Yamaha-authorized renting, leasing, or other commercial purposes, and TZ models.

DURING THE PERIOD OF WARRANTY any authorized Yamaha motorcycle dealer will, free of charge, repair or replace any part adjudged defective by Yamaha due to faulty workmanship or material from the factory. Parts used in warranty repairs will be warranted for the balance of the product's warranty period. All parts replaced under warranty become property of Yamaha Motor Corp. U.S.A.

GENERAL EXCLUSIONS from this warranty shall include any failures caused by:

- a. Competition or racing use.
- b. Installation of parts or accessories that are not qualitatively equivalent to genuine Yamaha parts.
- c. Abnormal strain, neglect, or abuse.
- d. Lack of proper maintenance.
- e. Accident or collision damage.
- f. Modification to original parts.

SPECIFIC EXCLUSIONS from this warranty shall include parts replaced due to normal wear or routine maintenance.

THE CUSTOMER'S RESPONSIBILITY under this warranty shall be to:

1. Operate and maintain the motorcycle as specified in the appropriate Owner's Manual, and
2. Give notice to an authorized Yamaha motorcycle dealer of any and all apparent defects within ten (10) days after discovery, and make the machine available at that time for inspection and repairs at such dealer's place of business.

WARRANTY TRANSFER: To transfer the warranty from the original purchaser to any subsequent purchaser, it is imperative that the machine be inspected and registered for warranty by an authorized Yamaha motorcycle dealer. In order for this warranty to remain in effect, this inspection and registration must take place within ten (10) days after transfer. An inspection and registration fee will be charged for this service.

EMISSIONS CONTROL SYSTEM WARRANTY

Yamaha Motor Corporation, U.S.A. also warrants to the ultimate purchaser and each subsequent purchaser of each Yamaha motorcycle covered by this warranty with a displacement of 50cc or greater, that the vehicle is designed, built, and equipped so as to conform at the time of sale with all U.S. emissions standards applicable at the time of manufacture and that it is free from defects in materials and workmanship which would cause it not to meet these standards within the periods listed immediately below. Failure other than those resulting from defects in material or workmanship which arise solely as a result of owner abuse and / or lack of proper maintenance are not covered by this warranty.

ENGINE DISPLACEMENT	PERIOD
50cc to 169cc	12,000 km (7,465 miles) or five years, whichever occurs first
170cc to 279cc	18,000 km (11,185 miles) or five years, whichever occurs first
280cc or over	30,000 km (18,641 miles) or five years, whichever occurs first

YAMAHA MOTOR CORPORATION, U.S.A. MAKES NO OTHER WARRANTY OF ANY KIND, EXPRESSED OR IMPLIED. ALL IMPLIED WARRANTIES OF MERCHANTABILITY AND FITNESS FOR A PARTICULAR PURPOSE WHICH EXCEED THE OBLIGATIONS AND TIME LIMITS STATED IN THIS WARRANTY ARE HEREBY DISCLAIMED BY YAMAHA MOTOR CORPORATION, U.S.A. AND EXCLUDED FROM THIS WARRANTY.

SOME STATES DO NOT ALLOW LIMITATIONS ON HOW LONG AN IMPLIED WARRANTY LASTS, SO THE ABOVE LIMITATION MAY NOT APPLY TO YOU. ALSO EXCLUDED FROM THIS WARRANTY ARE ANY INCIDENTAL OR CONSEQUENTIAL DAMAGES INCLUDING LOSS OF USE. SOME STATES DO NOT ALLOW THE EXCLUSION OR LIMITATION OF INCIDENTAL OR CONSEQUENTIAL DAMAGES, SO THE ABOVE EXCLUSION MAY NOT APPLY TO YOU.

THIS WARRANTY GIVES YOU SPECIFIC LEGAL RIGHTS, AND YOU MAY ALSO HAVE OTHER RIGHTS WHICH VARY FROM STATE TO STATE.

YAMAHA MOTOR CORPORATION, U.S.A.
P.O. Box 6555
Cypress, California 90630

WARRANTY QUESTIONS AND ANSWERS

- Q. What costs are my responsibility during the warranty period?
- A. The customer's responsibility includes all costs of normal maintenance services, non-warranty repairs, accident and collision damages, and oil, oil filters, air filters, spark plugs, and brake shoes.
- Q. What are some examples of "abnormal" strain, neglect, or abuse?
- A. These terms are general and overlap each other in areas. Specific examples include: Running the machine out of oil, sustained high-rpm, full-throttle, operating the machine with a broken or damaged part which causes another part to fail, damage or failure due to improper or careless transportation and or tie down. If you have any specific questions on operation or maintenance, please contact your dealer for advice.
- Q. Does the warranty cover incidental costs such as towing or transportation due to a failure?
- A. No. The warranty is limited to repair of the machine itself.
- Q. May I perform any or all of the recommended maintenance shown in the Owner's Manual instead of having the dealer do them?
- A. Yes, if you are a qualified mechanic and follow the procedures specified in the Owner's and Service Manual. We do recommend, however, that items requiring special tools or equipment be done by Yamaha Motorcycle dealer.
- Q. Will the warranty be void or cancelled if I do not operate or maintain my new motorcycle exactly as specified in the Owner's Manual?
- A. No. The warranty on a new motorcycle cannot be "voided" or "cancelled." **However, if a particular failure is caused by operation or maintenance other than as shown in the Owner's Manual, that failure may not be covered under warranty.**
- Q. What responsibility does my dealer have under this warranty?
- A. Each Yamaha Motorcycle dealer is expected to:
1. Completely set up every new machine before sale.
 2. Explain the operation, maintenance, and warranty requirements to your satisfaction at the time of sale, and upon your request at any later date.
 3. Each Yamaha Motorcycle dealer is held responsible for his setup, service and warranty repair work.
- Q. Is the warranty transferable to second owners?
- A. Yes. The remainder of the existing warranty can be transferred upon request. The unit has to be inspected and re-registered by an authorized Yamaha Motorcycle dealer for the policy to remain effective.

CUSTOMER SERVICE

If your machine requires warranty service, you must take it to any authorized Yamaha Motorcycle dealer within the continental United States. Be sure to bring your warranty registration card or other valid proof of the original date of purchase. If a question or problem arises regarding warranty, first contact the owner of the dealership. Since all warranty matters are handled at the dealer level, this person is in the best position to help you. If you are still not satisfied and require additional assistance, please write:

YAMAHA MOTOR CORPORATION U.S.A.
CUSTOMER RELATIONS DEPARTMENT
P.O. Box 6555
Cypress, California 90630

When contacting Yamaha Motor Corporation, U.S.A. don't forget to include any important information such as names, addresses, model, V.I.N. (frame number), dates, and receipts.

CHANGE OF ADDRESS

The federal government requires each manufacturer of a motor vehicle to maintain a complete, up-to-date list of all first purchasers against the possibility of a safety-related defect and recall. This list is compiled from the purchase registrations sent to Yamaha Motor Corporation, U.S.A. by the selling dealer at the time of your purchase.

If you should move after you have purchased your new motorcycle, please advise us of your new address by sending a postcard listing your motorcycle model name, V.I.N. (frame number), dealer number (or dealer's name) as it is shown on your warranty card, your name and new mailing address. Mail to:

YAMAHA MOTOR CORPORATION, U.S.A.
P.O. Box 6555
Cypress, California 90630
Attention: Warranty Department

This will ensure that Yamaha Motor Corporation, U.S.A. has an up-to-date registration record in accordance with federal law.

YAMAHA EXTENDED SERVICE (Y.E.S.)

Keep your Yamaha protected even after your warranty expires with genuine Yamaha Extended Service (Y.E.S.).

- Y.E.S. is designed and administered by Yamaha Motor Corporation to provide maximum owner satisfaction. You get uninterrupted factory-backed coverage for extra peace of mind.
- Y.E.S. is flexible. You choose the plan that's right for you: 12 months, 24 months, or 36 months beyond your warranty period.
- Y.E.S. is designed and administered by the same Yamaha people who handle your warranty – and it shows in the comprehensive coverage benefits. There are no mileage limitations. Coverage isn't limited to "moving parts" or the "drive train" like many other plans. And Y.E.S. covers manufacturing defects just like the warranty. See the sample contract at your Yamaha dealer to see how comforting uninterrupted factory-backed protection can be.
- You don't have to pay anything for covered repairs. There's no deductible to pay, and repairs aren't "pro-rated." You don't have any "out-of-pocket" expenses for covered repairs.

- In addition, Travel and Recreation Interruption Protection (TRIP) is included at no extra cost. TRIP gives you up to \$150 reimbursement per occurrence for any reasonable expenses you incur because your Yamaha needs covered service: replacement vehicle rental, emergency towing, phone calls, even food and lodging when you are away from home. This superb coverage goes into effect when you purchase Y.E.S., so it applies to any warranty repairs as well as covered repairs during your entire Y.E.S. plan period.
- Y.E.S. coverage is honored at any authorized Yamaha dealer nationwide.
- Y.E.S. coverage is transferable to a new owner if you sell or trade-in. That can make your Yamaha much more valuable!

This excellent Y.E.S. plan coverage is only available to Yamaha owners like you, and only while your Yamaha is still within the Yamaha Limited Warranty period. So visit your authorized Yamaha dealer to get all the facts. He can show you how easy it is to protect your investment with Yamaha Extended Service.

CONSUMER INFORMATION

We urge you to act now. You'll get the excellent benefits of TRIP coverage right away, and you'll rest easy knowing you'll have strong factory-backed protection even after your Yamaha Limited Warranty expires. You can also save money: Y.E.S. costs less within the first 90 days after you buy your Yamaha. See your dealer today!

A special note:

If visiting your dealer isn't convenient, contact Yamaha with your Primary ID number (your frame number). We'll be happy to help you get the Y.E.S. coverage you need.

Yamaha Service Marketing
P.O. Box 6555
Cypress, CA 90630



YAMAHA EXTENDED SERVICE

PROTECT YOUR INVESTMENT
Use Genuine YAMAHA Parts And Accessories

**See your Authorized YAMAHA Dealer for a Genuine
YAMAHA Service Manual.**

 **YAMAHA**
YAMAHA MOTOR CO., LTD.



LIT-11626-13-18

Free Manuals Download Website

<http://myh66.com>

<http://usermanuals.us>

<http://www.somanuals.com>

<http://www.4manuals.cc>

<http://www.manual-lib.com>

<http://www.404manual.com>

<http://www.luxmanual.com>

<http://aubethermostatmanual.com>

Golf course search by state

<http://golfingnear.com>

Email search by domain

<http://emailbydomain.com>

Auto manuals search

<http://auto.somanuals.com>

TV manuals search

<http://tv.somanuals.com>