

**YAMAHA**

**XYLOPHONE**

**OWNER'S MANUAL**

**YX-335**

Thank you for selecting a Yamaha musical instrument. We are confident that the instrument will bring you years of musical enjoyment and satisfaction.

Please read through this booklet carefully. It contains important information about your instrument's care. Your new Yamaha instrument, like all Yamaha musical instruments, is the result of careful planning, testing and assembly using select materials. Proper care will ensure that your Yamaha instrument will deliver its full and rich sound for years to come.

## Contents

NOMENCLATURE .....	2
ASSEMBLY .....	3
PRECAUTIONS AND CARE .....	7
SPECIFICATIONS .....	8
YAMAHA MALLETS .....	9

# NOMENCLATURE

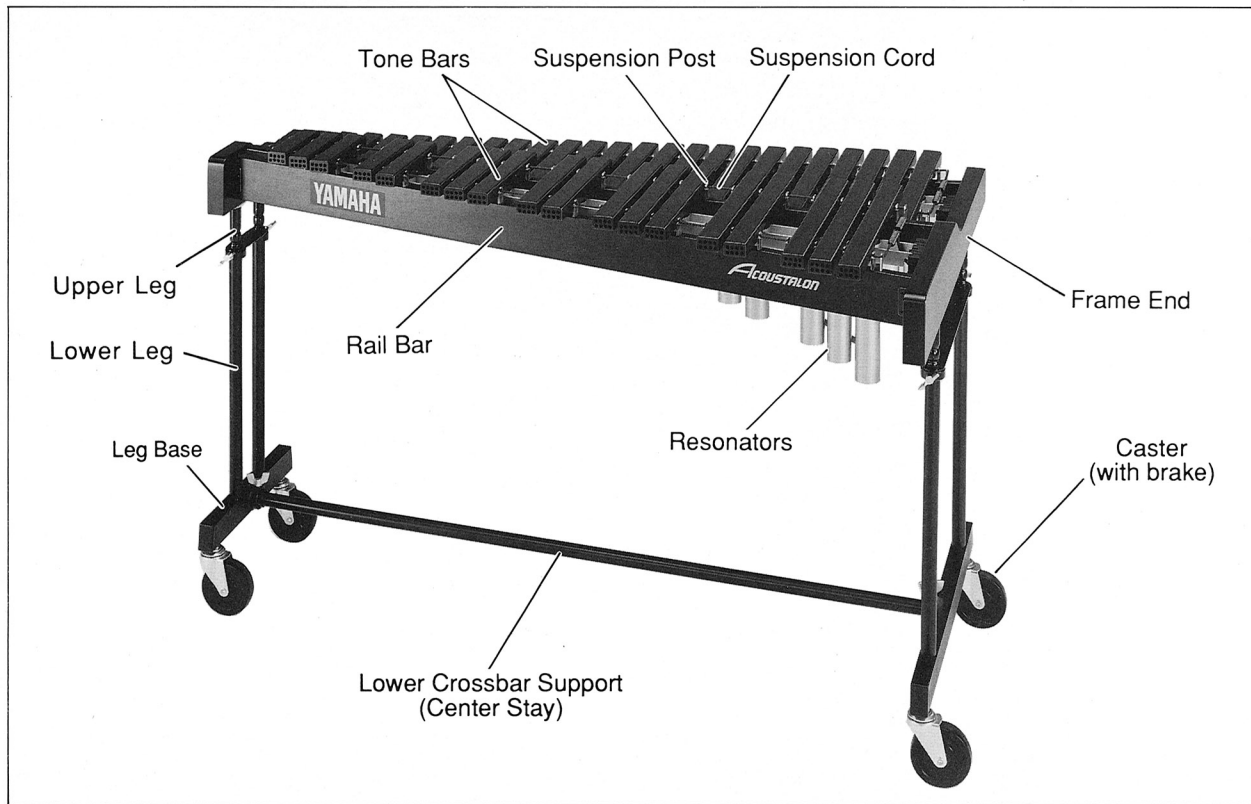

## 1

Insert the lower crossbar support into the couplers on the high end and low end leg bases. Make sure the indentations on either end of the lower crossbar upward. Securely tighten the wing bolt into the indentation. (Fig. 1)

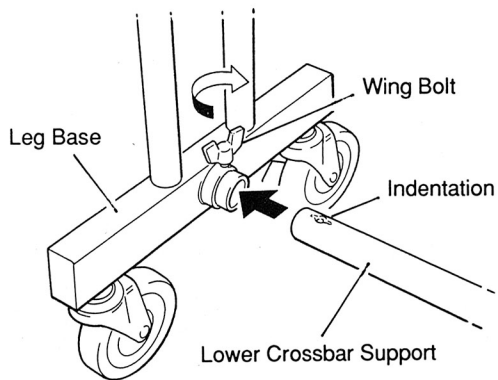

(Fig. 1)

## 2

Loosen the wing bolt and completely remove the upper leg from the lower leg. (Fig. 2)

Screw the upper legs into the holes provided on the underside of the frame ends. (Fig. 3)

There are four upper legs altogether.

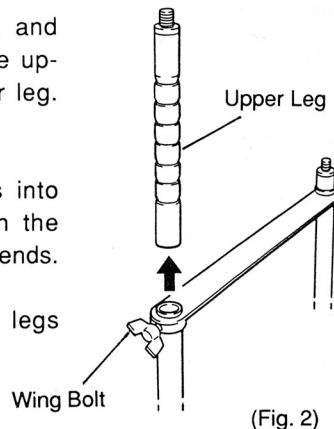

(Fig. 2)

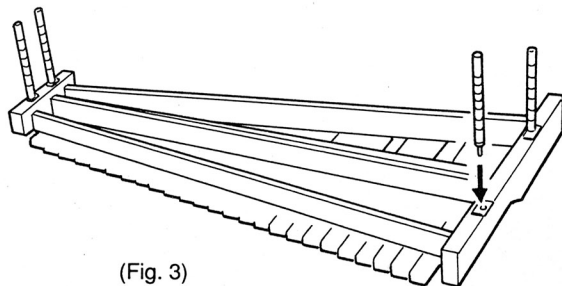

(Fig. 3)

# 3

Make sure the wing bolts are loosened fully and, with the help of another person, carefully lower the leg assembly onto the upper legs. Adjust the leg height as desired, and securely tighten the wing bolts. (Fig. 4)

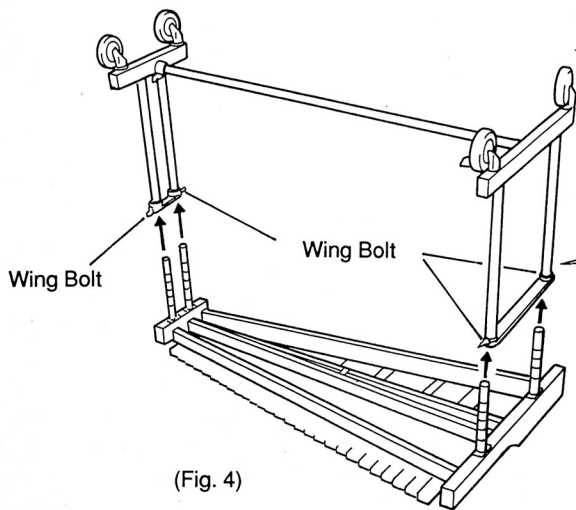

Make sure to tighten the wing bolts into the grooves of the slide pins. Initially adjust the height so that the wing bolt is in the third notch from the top. (Fig. 5)

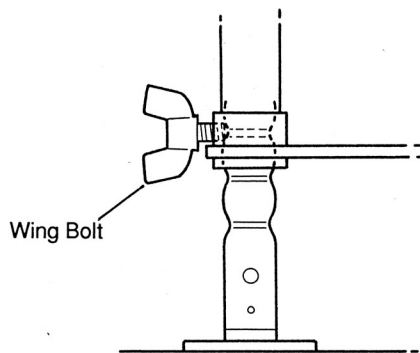

# 4

Stand the instrument in upright position.

Insert the resonators from the bottom side of the instrument. (Fig. 6)

Place the resonators on the treble side first, then on the bass end. (Fig. 7)

When placing the resonators on the bass end, slide them through the groove in the center of the resonator holder. (Fig. 8)

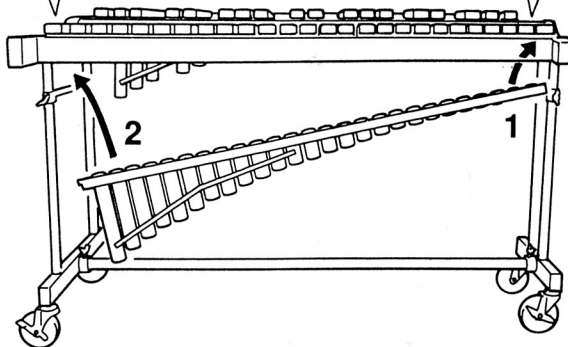
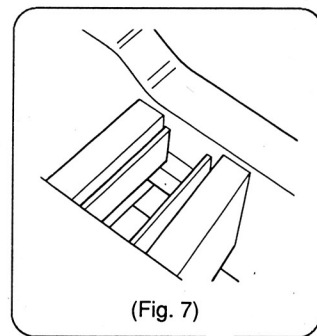
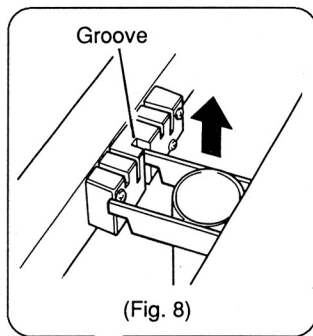

# 5

If the room temperature is higher than 22°C (72°F), place the resonators in the shallower groove. (Fig. 9) If the room temperature is lower than 22°C (72°F) place them in the deeper groove. (Fig. 10)

Check again that the suspension cord is tight and that the screws are securely fastened. If the tone bars are dirty, wipe them with a soft, dry cloth.

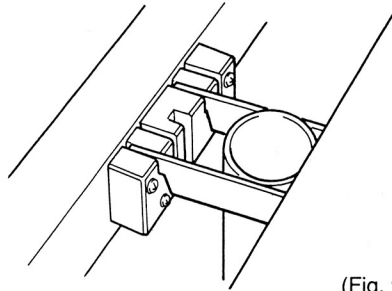

(Fig. 9)

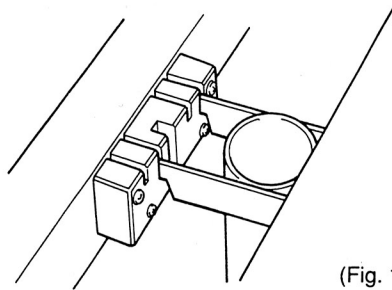

(Fig. 10)



# PRECAUTIONS AND CARE

1. Do not use extra hard-head mallets or other hard materials to strike the tone bars. This could scratch or dent them.
2. If the suspension cords are loose or unseated, resonance will be reduced. Check that the suspension cord is properly seated on each suspension post.
3. Avoid placing heavy objects on the tone bars as this may bend or twist the frame and loosen the suspension cords.
4. When transporting long distances, disassemble and pack carefully. Disassemble by reversing the assembly procedure.
5. Extremes in temperature will adversely affect the sound quality. Avoid high temperatures and do not store in direct sunlight.
6. Clean the instrument with a soft dry cloth. Do not use cloths dampened with chemical cleaning agents.
7. Always apply the caster brakes when instrument is stationary.

# SPECIFICATIONS

<b>Instrument</b>	<b>YX-335</b>
<b>Scale Range</b>	f1 ~ c5 3-1/2 octaves
<b>Tone Bar Material</b>	Acoustalon
<b>Tone Bar Size (Width x Thickness)</b>	1-1/2" x 7/8" 38 mm x 23 mm
<b>Dimensions (Width x Depth x Height)</b>	54" x 31-1/2" x 32-5/8" ~ 37-3/8" 1,373 mm x 800 mm x 830 ~ 950 mm
<b>Weight</b>	78.7 lbs 35.7 kg
<b>Pitch</b>	A = 442 Hz

## SCALE RANGE

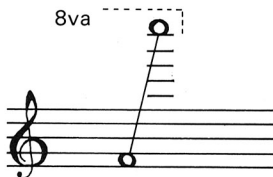

**YX-335**

YAMAHA mallets are built to the same exacting standards as your instrument, featuring high-quality rattan or plastic shafts and a variety of heads to meet your playing needs.

## Rattan Shaft Mallets

Head	Plastic	Rubber	Yarn Wound			Cord Wound		Felt
Hard	# 1000	# 1010	# 4000H	# 4010		# 5010		FH30
		# 1020	# 4000M	# 4020		# 5020	JA20	
		# 1030	# 4000S (Dual tone)	# 4030		# 5030	JA30 (Jazz)	
		# 1040		# 4040	# 6040 # 6050	# 5040		
	Soft				# 8050		# 7040	FS10

# YAMAHA

YAMAHA CORPORATION  
P.O.Box 1, Hamamatsu, Japan

 Printed in Japan 05.92

## Free Manuals Download Website

<http://myh66.com>

<http://usermanuals.us>

<http://www.somanuals.com>

<http://www.4manuals.cc>

<http://www.manual-lib.com>

<http://www.404manual.com>

<http://www.luxmanual.com>

<http://aubethermostatmanual.com>

Golf course search by state

<http://golfingnear.com>

Email search by domain

<http://emailbydomain.com>

Auto manuals search

<http://auto.somanuals.com>

TV manuals search

<http://tv.somanuals.com>