



**2000 Series UPS**  
Operation and Reference Guide

Second Edition (October 1999)  
Part Number 341252-002  
Compaq Computer Corporation

## Notice

The information in this publication is subject to change without notice.

COMPAQ COMPUTER CORPORATION SHALL NOT BE LIABLE FOR TECHNICAL OR EDITORIAL ERRORS OR OMISSIONS CONTAINED HEREIN, NOR FOR INCIDENTAL OR CONSEQUENTIAL DAMAGES RESULTING FROM THE FURNISHING, PERFORMANCE, OR USE OF THIS MATERIAL. THIS INFORMATION IS PROVIDED "AS IS" AND COMPAQ COMPUTER CORPORATION DISCLAIMS ANY WARRANTIES, EXPRESS, IMPLIED OR STATUTORY AND EXPRESSLY DISCLAIMS THE IMPLIED WARRANTIES OF MERCHANTABILITY, FITNESS FOR PARTICULAR PURPOSE, GOOD TITLE AND AGAINST INFRINGEMENT.

This publication contains information protected by copyright. No part of this publication may be photocopied or reproduced in any form without prior written consent from Compaq Computer Corporation.

© 1999 Compaq Computer Corporation.

All rights reserved. Printed in the U.S.A.

The software described in this guide is furnished under a license agreement or nondisclosure agreement. The software may be used or copied only in accordance with the terms of the agreement.

Compaq, Deskpro, Fastart, Compaq Insight Manager, Systempro, Systempro/LT, ProLiant, ROMPaq, QVision, SmartStart, NetFlex, QuickFind, PaqFax, ProSignia, registered United States Patent and Trademark Office.

Netelligent, Systempro/XL, SoftPaq, QuickBlank, QuickLock are trademarks and/or service marks of Compaq Computer Corporation.

Neoserver is a trademark of Compaq Information Technologies Group.

Microsoft, MS-DOS, Windows, and Windows NT are registered trademarks of Microsoft Corporation.

Pentium is a registered trademark and Xeon is a trademark of Intel Corporation.

Other product names mentioned herein may be trademarks and/or registered trademarks of their respective companies.

Compaq 2000 Series UPS Operation and Reference Guide  
Second Edition (October 1999)  
Part Number 341252-002

# Contents

## About This Guide

Text Conventions.....	vii
Symbols in Text.....	viii
Symbols on Equipment.....	viii
Precautions.....	ix
Getting Help .....	x
Compaq Technical Support .....	x
Compaq Website.....	xi
Compaq Authorized Reseller.....	xi

## Chapter 1

### Overview

Compaq 2000 Series UPS Models.....	1-2
Front Panels .....	1-3
Rear Panels .....	1-4
Standard UPS Features .....	1-6
Communications Port .....	1-7
Power Management Software.....	1-7
Hardware Option Cards .....	1-8
Network Transient Protector.....	1-10
Warranties.....	1-10
\$25,000 Computer Load Protection Guarantee .....	1-10
Pre-Failure Battery Warranty .....	1-10

## Chapter 2

### Installation

Installation Requirements .....	2-2
Item(s) not supplied with the UPS kit.....	2-2
Item(s) supplied with the UPS kit.....	2-2

## Installation

*continued*

Before Starting the UPS .....	2-3
Connecting the External Battery Module.....	2-3
Connecting to the Communications Port .....	2-4
Connecting the Network Transient Protector.....	2-5
Starting the UPS.....	2-6
Checking the Battery Recharge Date Label .....	2-6
Connecting the UPS to Utility Power .....	2-7
Connecting Devices to the UPS .....	2-7
Powering up the UPS.....	2-8
Completing the Installation.....	2-10
Placing the UPS in Operate mode.....	2-10

## Chapter 3

### Operation

Precautions.....	3-2
Modes of Operation .....	3-2
Front Panel Controls .....	3-3
Front Panel Indicators .....	3-5
Front Panel LEDs in the Standby and Operate Modes.....	3-5
Overcurrent Protection.....	3-8
Placing the UPS in Operate Mode .....	3-8
Returning to Standby Mode .....	3-9
Initiating a Self-test.....	3-11
Audio Alarm .....	3-12
Silencing an Audio Alarm .....	3-13

## Chapter 4

### Configuration

Placing the UPS in Configure Mode.....	4-2
Configuration Parameters and their LED Indicators .....	4-3
Changing Configuration Parameters .....	4-6
Optimizing Battery Life by Matching the Utility Voltage .....	4-7

## Chapter 5

### Battery Maintenance

Precautions.....	5-2
Charging Batteries.....	5-3
When to Replace Batteries .....	5-3
Pre-Failure Battery Warranty.....	5-4
Obtaining a New Battery Module .....	5-4

**Battery Maintenance**

*continued*

Replacing an External Battery Module..... 5-5  
 Step 1: Preparing the UPS ..... 5-5  
 Step 2: Removing the External Battery Module..... 5-6  
 Step 3: Installing a New Battery Module..... 5-7  
 Step 4: Testing a New Battery Module..... 5-8  
 Step 5: Disposing of Used Battery Modules..... 5-8  
 Care and Storage of Batteries ..... 5-9

*Chapter 6*

**Troubleshooting**

Troubleshooting During Start ..... 6-2  
 Troubleshooting After Start ..... 6-3  
 Repairing the UPS ..... 6-5

*Appendix A*

**Regulatory Compliance Notices**

Federal Communications Commission Notice .....A-1  
 Class A Equipment .....A-2  
 Class B Equipment .....A-2  
 Modifications.....A-3  
 Cables .....A-3  
 Canadian Notice (Avis Canadien) .....A-3  
 Class A Equipment .....A-3  
 Class B Equipment .....A-4  
 European Union Notice .....A-4  
 Japanese Notice .....A-5  
 Taiwanese Notice.....A-5  
 Battery Replacement Notice .....A-5

*Appendix B*

**Electrostatic Discharge**

Grounding Methods .....B-2

## *Appendix C*

### **Specifications**

Physical Specifications .....	C-2
Input Specifications.....	C-3
Output Specifications.....	C-4
Output Specifications.....	C-5
Overcurrent Protection.....	C-6
Battery Specifications .....	C-7
Battery Runtime .....	C-8
Environmental Specifications .....	C-9

### *Index*

# About This Guide

This guide is designed to be used as step-by-step instructions for installation and as a reference for operation, troubleshooting, and future upgrades.

## Text Conventions

This document uses the following conventions to distinguish elements of text:

<b>Keys</b>	Keys appear in boldface. A plus sign (+) between two keys indicates that they should be pressed simultaneously.
USER INPUT	User input appears in a different typeface and in uppercase.
<i>FILENAMES</i>	File names appear in uppercase italics.
Menu Options, Command Names, Dialog Box Names	These elements appear in initial capital letters.
COMMANDS, DIRECTORY NAMES, and DRIVE NAMES	These elements appear in uppercase.
Type	When you are instructed to <i>type</i> information, type the information <b>without</b> pressing the <b>Enter</b> key.
Enter	When you are instructed to <i>enter</i> information, type the information and then press the <b>Enter</b> key.

## Symbols in Text

These symbols may be found in the text of this guide. They have the following meanings.



**WARNING:** Text set off in this manner indicates that failure to follow directions in the warning could result in bodily harm or loss of life.

---



**CAUTION:** Text set off in this manner indicates that failure to follow directions could result in damage to equipment or loss of information.

---

**IMPORTANT:** Text set off in this manner presents clarifying information or specific instructions.

---

**NOTE:** Text set off in this manner presents commentary, sidelights, or interesting points of information.

## Symbols on Equipment

These icons may be located on equipment in areas where hazardous conditions may exist.



Any surface or area of the equipment marked with these symbols indicates the presence of electrical shock hazards. Enclosed area contains no operator serviceable parts.

**WARNING:** To reduce the risk of injury from electrical shock hazards, do not open this enclosure.

---



79 to 97 lb

36 to 44 kg

Any product or assembly marked with these symbols indicates that the component exceeds the recommended weight for one individual to handle safely.

**WARNING:** To reduce the risk of personal injury or damage to the equipment, observe local occupational health and safety requirements and guidelines for manual material handling.

---





Any RJ-45 receptacle marked with these symbols indicates a Network Interface Connection.

**WARNING:** To reduce the risk of electrical shock, fire, or damage to the equipment, do not plug telephone or telecommunications connectors into this receptacle.

---



Any surface or area of the equipment marked with these symbols indicates the presence of a hot surface or hot component. If this surface is contacted, the potential for injury exists.

**WARNING:** To reduce the risk of injury from a hot component, allow the surface to cool before touching.

---

## Precautions



**WARNING:** There is a risk of electric shock from high earth conductor leakage current when connecting multiple pieces of Information Technology Equipment to Compaq 2000 Series Uninterruptible Power Systems (UPS):

The summation of the input power for multiple pieces of Information Technology Equipment through the use of a UPS can result in high earth conductor leakage current. For UPS products that have detachable AC power cords, the total combined earth conductor leakage current should not exceed 3.5 mA.

---



**WARNING:** There is a risk of personal injury from the hazardous energy levels associated with UPS batteries. The maintenance and replacement of batteries must be carried out by qualified service personnel.

---



**WARNING:** The 2000 Series UPS models weigh between 79 and 97 lb (36 to 44 kg) when fully assembled.

T2000 and T2000j:

UPS	32 lb (15 kg)	Battery	47 lb (21 kg)
-----	---------------	---------	---------------

T2400h and T2400h-NA:

UPS	34 lb (15 kg)	Battery	63 lb (29 kg)
-----	---------------	---------	---------------

To reduce the risk of personal injury or damage to the equipment:

- Observe local occupational health and safety requirements and guidelines for manual material handling.
  - Obtain adequate assistance to lift and stabilize the chassis during installation or removal.
  - Remove the battery pack to reduce the overall weight of the product.
- 

**IMPORTANT:** Please refer to the  **Important Safety Information** (included with the UPS kit) before installing this product.

---

## Getting Help

If you have a problem and have exhausted the information in this guide, you can get further information and other help in the following locations.

## Compaq Technical Support

You are entitled to free hardware technical telephone support for your product for as long as you own the product. A technical support specialist will help you diagnose the problem or guide you to the next step in the warranty process.

In North America, call the Compaq Technical Phone Support Center at 1-800-OK-COMPAQ<sup>1</sup>. This service is available 24 hours a day, 7 days a week.

Outside North America, call the nearest Compaq Technical Support Phone Center. Telephone numbers for world wide Technical Support Centers are listed on the Compaq website. You can access the Compaq website at: <http://www.compaq.com>

Be sure to have the following information available before you call Compaq:

---

<sup>1</sup> For continuous quality improvement, calls may be recorded or monitored.

- Technical support registration number (if applicable)
- Product serial number(s)
- Product model name(s) and number(s)
- Applicable error messages
- Add-on boards or hardware
- Third-party hardware or software
- Operating system type and revision level
- Detailed, specific questions

## **Compaq Website**

The Compaq website has information on this product as well as the latest drivers and Flash ROM images. You can access the Compaq website at:  
<http://www.compaq.com>

## **Compaq Authorized Reseller**

For the name of your nearest Compaq authorized reseller:

- In the United States, call 1-800-345-1518.
- In Canada, call 1-800-263-5868.
- Elsewhere, access the Compaq website at:  
<http://www.compaq.com>

# *Chapter 1*

## **Overview**

This chapter contains information on the following topics:

- Compaq 2000 Series Uninterruptible Power System (UPS) models
- 2000 Series UPS front panels
- 2000 Series UPS rear panels
- 2000 Series UPS features
- Warranties

## Compaq 2000 Series UPS Models

The 2000 Series includes the following UPS models:

**Table 1-1**  
**2000 Series UPS Models**

UPS Model	Part Number	Comments
T2000	242688-005	Domestic; low voltage; Tower
T2000j	242688-295	Japanese; low voltage; Tower
T2400h	242688-006	International; high voltage; Tower
T2400h-NA	242688-007	Domestic; high voltage; Tower

## Front Panels

The 2000 Series UPS models are all tower configuration, with companion external battery modules.

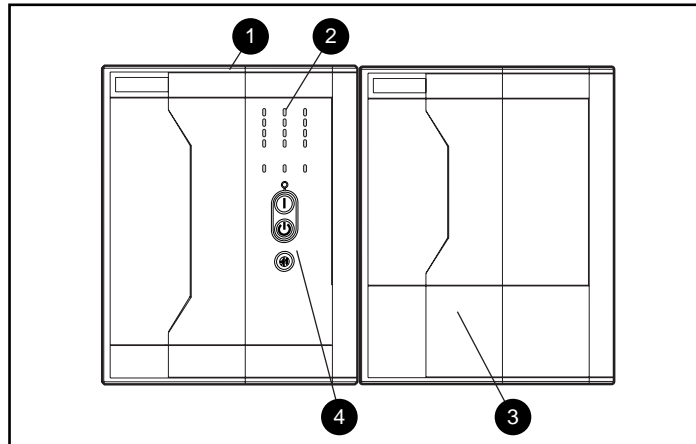

Figure 1-1. Front panel configuration

- ① UPS
- ② Front panel LED display
- ③ External battery module
- ④ Button controls

## Rear Panels

The 2000 Series UPS models feature the following rear panel configurations:

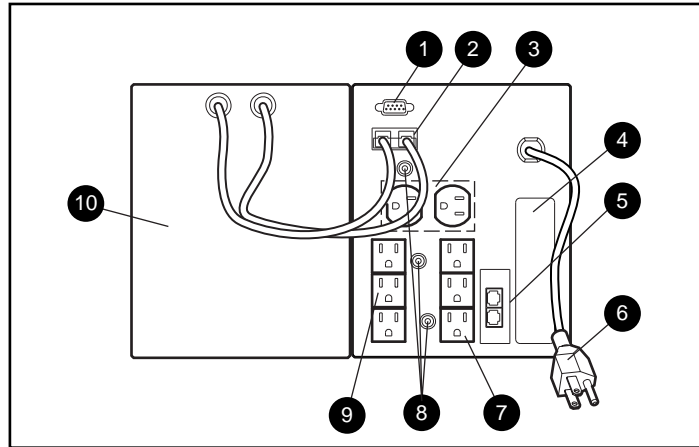

Figure 1-2. Rear panel of T2000 and T2000j

- |                               |                              |
|-------------------------------|------------------------------|
| ① Communications port         | ⑥ Power cord with 5-20p plug |
| ② Battery connector           | ⑦ Load segment 2             |
| ③ Load segment 3              | ⑧ 10A circuit breakers       |
| ④ Option slot                 | ⑨ Load segment 1             |
| ⑤ Network Transient Protector | ⑩ External battery module    |

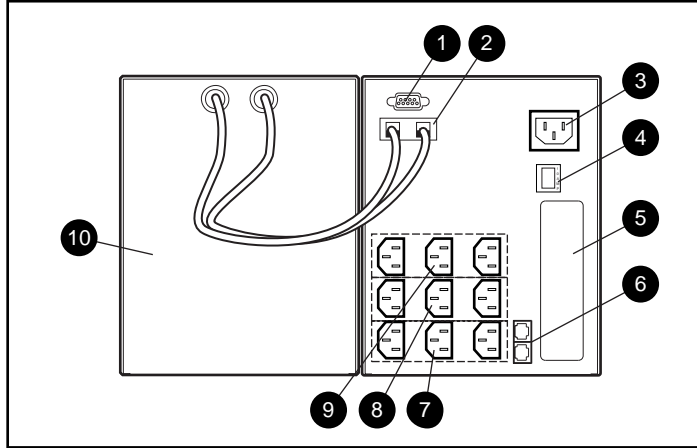

Figure 1-3. Rear panel of T2400h

- |                       |                               |
|-----------------------|-------------------------------|
| ① Communications port | ⑥ Network Transient Protector |
| ② Battery connector   | ⑦ Load segment 3              |
| ③ IEC-320 power inlet | ⑧ Load segment 2              |
| ④ 10A circuit breaker | ⑨ Load segment 1              |
| ⑤ Option slot         | ⑩ External battery module     |

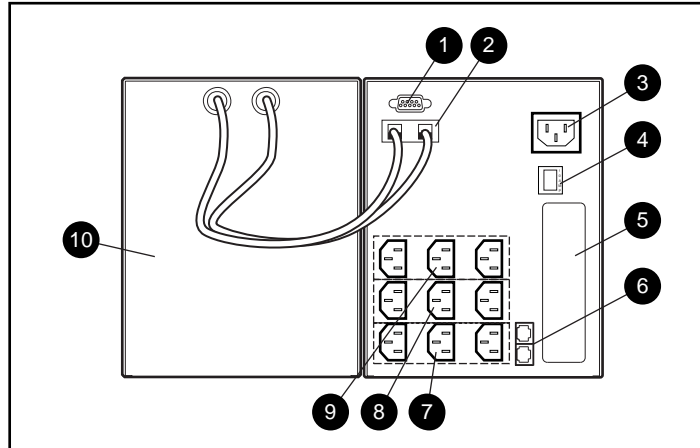

Figure 1-4. Rear panel of T2400h-NA

- |                       |                               |
|-----------------------|-------------------------------|
| ① Communications port | ⑥ Network Transient Protector |
| ② Battery connector   | ⑦ Load segment 3              |
| ③ IEC-320 power inlet | ⑧ Load segment 2              |
| ④ 10A circuit breaker | ⑨ Load segment 1              |
| ⑤ Option slot         | ⑩ External battery module     |

## Standard UPS Features

The 2000 Series UPS models provide the following features:

- Communications port for data exchange with the host computer
- Power protection for loads up to 2000VA
- Load segment control
- Support for power management software
- Support for Compaq hardware option cards that extend the power management capabilities of the UPS
- Network Transient Protector (for network surge protection)



## Communications Port

The 2000 Series UPS models include a communications port that allows the UPS to exchange data with the host computer. Power management software (supplied by Compaq) gives users access to status reporting and power management features.



**CAUTION:** Use only cables supplied by Compaq to connect the communications port to the host computer. Use of standard RS-232 cables may cause equipment damage.

---

## Power Management Software

With each UPS, Compaq supplies a CD containing several power management software applications, to address a variety of installations:

- Compaq Power Management Software is a comprehensive Microsoft Windows-based power management application that is tightly integrated with Compaq Insight Manager.
- LanSafe III provides UPS power management capabilities in a network environment.
- FailSafe III provides UPS power management capabilities in a standalone computer environment.
- Compaq OnliNet Centro provides UPS power management capabilities in a multi-platform network environment (supplied only with the Compaq SNMP-EN Internal Adapter).

### Compaq Power Management Software

Compaq Power Management Software allows system administrators to monitor, and to manage, the power being supplied to an entire network of servers and workstations.

Software capabilities include:

- Monitoring utility power, and the power supplied by the UPS.
- Logging events, such as utility power blackouts and brownouts.
- Prioritizing protected devices.
- Powering up and powering down protected devices.

For example, if Compaq Power Management Software detects an extended utility power blackout, it will initiate the prioritized shutdown sequence specified by the system administrator.

This sequence might include:

- Saving work-in-progress throughout the network.
- Powering down non-critical devices, to extend the battery power available to other devices.
- After saving the necessary information, completing the orderly device shutdown.

For more information on using Compaq Power Management Software, refer to the Compaq Power Products Software Reference Guide section of the Power Products Documentation CD (included with the UPS kit).

## Hardware Option Cards

The 2000 Series UPS models include an option slot that will accommodate one of these hardware option cards:

- Compaq Multi-Server UPS Card (option kit part number 123508-B21)
- Compaq Scalable UPS Card (option kit part number 123509-B21)
- Compaq SNMP-EN Internal Adapter (option kit part number 347225-B21)

### Compaq Multi-Server UPS Card

A standard UPS can communicate directly with a single host computer. A Compaq 2000 Series UPS with the Multi-Server UPS Card installed has expanded communication capability, and can exchange data with up to three host computers.

Compaq Power Management Software enables a single UPS, with a Multi-Server UPS Card, to protect up to three servers. By connecting servers to separate load segments, the UPS can provide individual server control.

For example, if a network includes three servers (with one running Windows NT, one running Unix, and one running NetWare), a Multi-Server UPS Card can be used to establish direct communications between the UPS and all three servers. Allocate a separate UPS load segment to supply power to a particular server and to the devices associated with that server.

### Compaq Scalable UPS Card

The Scalable UPS Card makes up to three UPS units appear as a single virtual UPS to the host computer and, with Compaq Power Management Software, allows scaling up the level of power protection available to the system.

For example, connecting three T2000 UPS units to a Scalable UPS Card creates a virtual 6000VA UPS. Since the T2000 UPS each have three load segments, the virtual UPS will have nine independently controlled load segments.

However, no single load can be greater than the lowest rated UPS. For instance, connecting three 1KVA UPS units with a Scalable UPS Card could not support a single 1200VA load.

### Compaq SNMP-EN Internal Adapter

In a network environment, the SNMP-EN Internal Adapter provides a user interface, allowing communication between the UPS and the server (when the SNMP-based power management software, Compaq OnliNet Centro, is installed). For workstations or other peripheral equipment that cannot be interrupted by a network management system, a UPS with the SNMP-EN Internal Adapter option installed can also provide a power management solution.

Using the SNMP-EN Internal Adapter SNMP communication interface, system administrators can quickly ascertain if power-related problems exist anywhere on the network. A Compaq UPS, connected by an SNMP-EN Internal Adapter to power management software, can virtually eliminate costly downtime due to power outages or surges, and decrease day-to-day network management annoyances like spontaneous rebooting, lost files and corrupted data—issues resulting from inconsistent power.

Compaq OnliNet Centro software is a versatile application that can schedule network component shutdowns or, in case of a utility power outage, perform graceful, sequential shutdown of network components.

## Network Transient Protector

The 2000 Series UPS models include a Network Transient Protector that provides protection for communications equipment (such as network devices, a fax machine, or a modem) from surges.



**CAUTION:** To avoid damaging the equipment, do not connect the Network Transient Protector to a digital PBX line. Connect either to an analog phone line or to a network.

---

## Warranties

### \$25,000 Computer Load Protection Guarantee

To back up the wide range of features offered with the UPS, Compaq provides a three-year limited warranty. In addition, Compaq offers a \$25,000 Computer Load Protection Guarantee (provided by the original equipment manufacturer).

---

**IMPORTANT:** The warranty card supplied with the UPS must be filled in and returned to qualify for the \$25,000 Computer Load Protection Guarantee.

---

The \$25,000 Computer Load Protection Guarantee only applies if:

- The UPS is plugged into a suitably grounded and wired outlet using no extension cords, adapters, other ground wires, or other electrical connections.
- The UPS installation complies with all applicable electrical and safety codes specified by the National Electrical Code (NEC).
- The UPS is used under normal operating conditions. Users comply with all instructions and labels.
- The UPS is not damaged by accident (other than a utility power transient), misuse, or abuse.

### Pre-Failure Battery Warranty

The Pre-Failure Battery Warranty, standard on all Compaq Uninterruptible Power System (UPS) units, extends the advantage of a Compaq three-year limited warranty by applying it to the battery before it actually fails. Specifically, the Pre-Failure Battery Warranty ensures that when customers receive notification from Compaq Power Management Software that the battery may fail, the battery is replaced free of charge under the warranty.

Compaq maintains the highest standards in the industry, as evidenced by the Compaq Pre-Failure Battery Warranty. The Pre-Failure Battery Warranty is beneficial in at least two significant ways:

- Reduced total cost of ownership
- Reduced downtime

# *Chapter 2*

## **Installation**

This chapter provides information on the following topics:

- Installation requirements
- Procedures to complete before starting the UPS
- Starting the UPS
- Completing the installation

## Installation Requirements

This section lists items needed to install the Compaq 2000 Series UPS models.

### Item(s) not supplied with the UPS kit

#### Tools

A medium flat-bladed and Phillips screwdriver may be needed.

### Item(s) supplied with the UPS kit

The UPS kit should contain the following components:

#### Software/Reference Material

- The Power Products Documentation CD containing the 2000 Series UPS Operation and Reference Guide and the Compaq Power Products Software Reference Guide
- The *Compaq Power Management Software Installation Instructions* (a booklet included with the CD) containing information on the installation requirements for Compaq Power Management Software
-  **Important Safety Information** to be reviewed before installing this product

#### Hardware

The UPS ships with one or more of the following:

- The T2000 and T2000j models ship with a non-detachable input power cord and a 6-foot UPS/computer interface cable, Compaq part number 295245-003.
- The T2400h model ships with a detachable input power cord; a 6-foot UPS/computer interface cable, Compaq part number 295245-003; and two 6-foot IEC to IEC power cords, Compaq part number 142263-001, for load equipment power.
- The T2400h-NA model ships with a detachable input power cord, Compaq part number 162536-001; a 6-foot UPS/computer interface cable, Compaq part number 295245-003; and two 6-foot IEC to IEC power cords, Compaq part number 142263-001; for load equipment power.

All models ship with a computer interface cable. The computer interface cable is not needed for normal operation. If power management of the UPS is desired, connect the interface cable between the UPS communications port and the serial port on the host computer.

---

**IMPORTANT:** If the UPS does not include a power cord that is suitable for your application, contact an authorized Compaq service representative to obtain the appropriate power cord. Please refer to the "Precautions for Power Products" section of the  **Important Safety Information** (included with the UPS kit).

---

## Before Starting the UPS

This section provides procedures to be carried out before starting the UPS.

Determine the steps required for the application:

- Connecting the external battery module
- Connecting the UPS communications port to the host computer
- Connecting the UPS Network Transient Protector

**NOTE:** Although these steps can be carried out after the UPS is installed, the UPS will need to be powered down to safely perform these tasks.

## Connecting the External Battery Module

The 2000 Series UPS models feature an external battery module. This modular design makes the UPS easier to handle, by distributing the total weight of the unit into two components.

To assemble the unit, connect the battery cables from the battery module to the battery receptacle on the rear panel of the UPS.



---

**CAUTION:** It is normal for a small amount of electrical arcing to occur when connecting external batteries to a UPS. To minimize the amount of arcing, insert the battery cables into the receptacle on the UPS quickly and firmly.

---

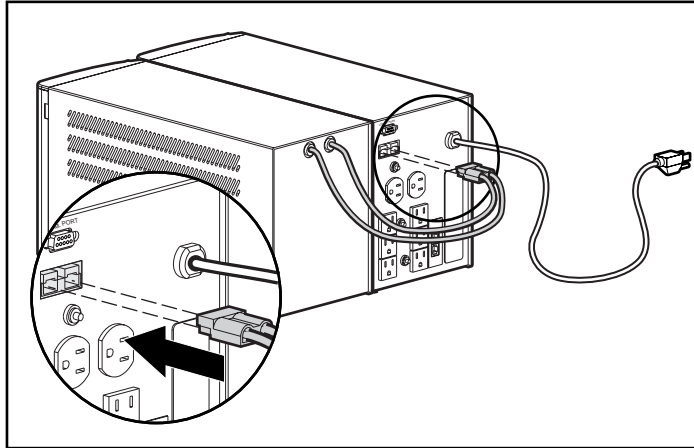

Figure 2-1. Connecting the external battery module

## Connecting to the Communications Port

The 2000 Series UPS models include a communications port for data exchange with the host computer.

---

**IMPORTANT:** Compaq Power Management Software, LanSafe III, and FailSafe III require the communications port to be appropriately cabled to the host computer.

---

Connect the UPS/computer interface cable (supplied) from the communications port on the UPS to the appropriate communications port on the host computer.



---

**CAUTION:** To avoid damaging the equipment, do not use the communications cables (part numbers 142260-001 and 142260-002) supplied with earlier UPS models. The UPS/computer interface cable is required to carry power and is wired differently than earlier communications cables.

---



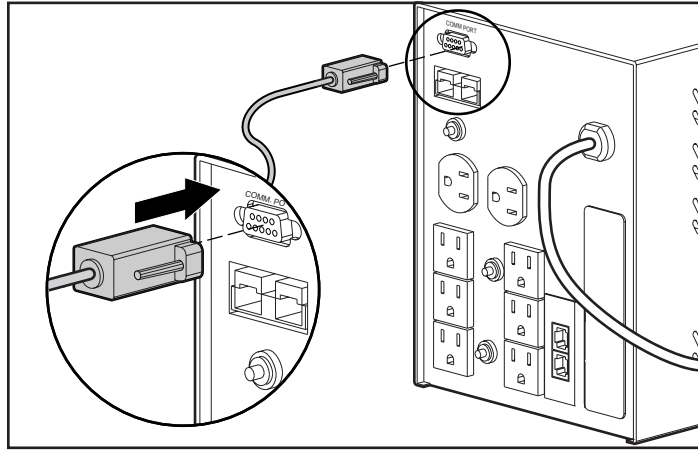

Figure 2-2. Connecting the UPS/computer interface cable

## Connecting the Network Transient Protector

The 2000 Series UPS models include a Network Transient Protector to provide surge protection for connected communications devices.

**IMPORTANT:** Use the Network Transient Protector with a standard telephone line only—not with a digital PBX.

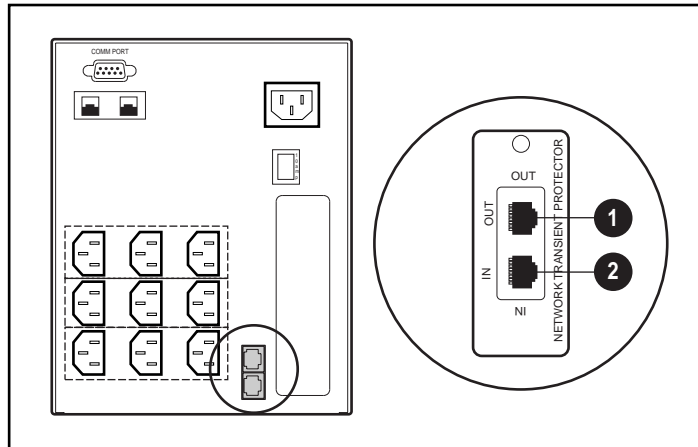

Figure 2-3. Connecting the Network Transient Protector

- ❶ Network cable OUT jack
- ❷ Network cable IN jack

## Starting the UPS

Starting the UPS for the first time requires the following procedures:

- Checking the Battery Recharge Date label on the UPS shipping carton
- Connecting the UPS to utility power via the input power cord
- Connecting devices to the UPS
- Powering up the UPS
- Monitoring the automatic self-test to verify that the installation was successful

## Checking the Battery Recharge Date Label

Check the battery recharge date specified on the Battery Recharge Date label. This label is affixed to the UPS shipping carton.

---

**IMPORTANT:** Do not use the UPS if the battery recharge date has expired. If the date on the Battery Recharge Date label has passed without the batteries being recharged, contact an Authorized Compaq Service Representative.

---

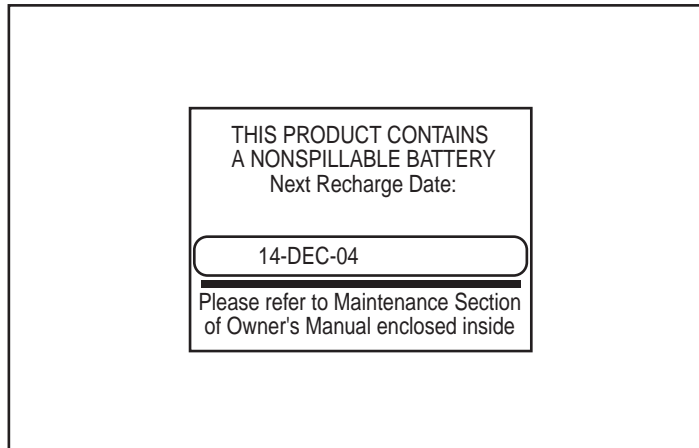

Figure 2-4. The Battery Recharge Date label

## Connecting the UPS to Utility Power

Connect the UPS to a grounded utility power outlet.



**WARNING:** To reduce the risk of electric shock or damage to the equipment, take these precautions:

- Plug the input line cord into a grounded (earthed) electrical outlet that is installed near the equipment and is easily accessible.
  - Do not disable the grounding plug on the input line cord. The grounding plug is an important safety feature.
  - Do not use extension cords.
- 

## Connecting Devices to the UPS

Before connecting load equipment, verify that the UPS will not be overloaded by the total VA rating of the devices. The load must not exceed the VA rating of the UPS.

$$\text{Volts} \times \text{Amps} = \text{VA per device}$$

If the devices list the power in Watts, use the following conversion equation:

$$\begin{aligned} \text{Watts} \times 1.35 &= \text{VA} \\ \text{VA}/1000 &= \text{KVA} \end{aligned}$$

After verifying that the UPS will not be overloaded by the cumulative VA rating of all load equipment, connect the power cords from the devices to the appropriate output receptacles on the UPS.



**WARNING:** To reduce the risk of electric shock, the combined earth conductor leakage current from all connected devices must not exceed 3.5 mA.

---



**CAUTION:** Do not plug laser printers into the UPS. The instantaneous current drawn by this type of printer may overload the UPS.

---

## Powering up the UPS

When the unit is plugged in for the first time, the UPS automatically initiates a self-test. The front panel LED display lights will go on and off during the self-test. If the self-test is completed successfully, the UPS enters Standby mode.

**NOTE:** The self-test initiates when the UPS is plugged in for the first time. Afterward, when the UPS is disconnected from utility power, the unit will come back up in the mode it was in when utility power was lost.

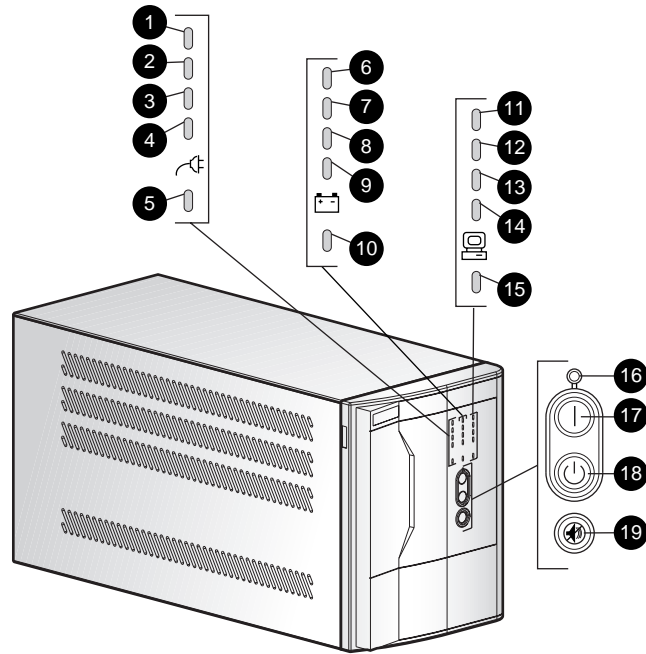





Figure 2-5. The front panel LED display and controls

		<b>Symbol</b>
<b>1-4</b>	AC Input level	Power cord
<b>5</b>	Site Wiring Fault indicator	
<b>6-9</b>	Battery Charge level	Battery
<b>10</b>	Battery Service indicator	
<b>11-14</b>	Load level	Load devices
<b>15</b>	Communications	
<b>16</b>	ON LED	
<b>17</b>	ON button	
<b>18</b>	STANDBY button	
<b>19</b>	TEST/ALARM RESET button	

Check the front panel LED display:

- LED 16 (ON LED, ) should be off, indicating that no power is available at the UPS output receptacles.
- Either AC Input LED 2 or 3 should be green, indicating the utility voltage is suitable.
- LEDs 6, 7, 8, and 9 indicate the battery charge level.
  - LED 9 warns that the batteries are low—approximately three to five minutes of battery backup remain
  - LED 8 only = 33 percent charged
  - LEDs 7 and 8 = 66 percent charged
  - LEDs 6, 7, and 8 = 67 percent to 100 percent charged

For more information on the front panel LED display, see Chapter 3, “Operation.”

---

**IMPORTANT:** If any of the LEDs on the front panel are red (indicating an alarm condition), press the TEST/ALARM RESET button to clear the red LEDs. If this does not clear the red LEDs, see Chapter 6, “Troubleshooting.”

Red LEDs may be accompanied by an audio alarm. For information on silencing the alarm, see Chapter 3, “Operation.”

---

## Completing the Installation

With the UPS in Standby mode, allow the batteries to charge before putting the UPS into service.

---

**IMPORTANT:** The batteries will charge to 90% of their capacity within approximately 4 hours. Compaq recommends allowing the batteries to charge for 24 hours before using them to supply backup power to the devices.

---

## Placing the UPS in Operate mode

Press and hold the ON button (②) until the LED 16 (①, ON LED) turns green, indicating that power is available at the UPS output receptacles. The UPS will acknowledge compliance with a short beep.

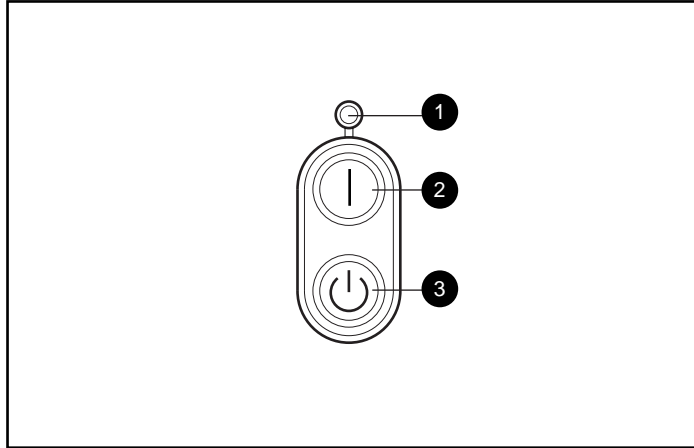

Figure 2-6. Operate mode controls

- ① ON LED
- ② ON button
- ③ STANDBY button

### The Installation is Now Complete

- For information on operating the UPS, see Chapter 3, “Operation.”
- For information on changing the configuration of the UPS, see Chapter 4, “Configuration.”
- Use the Compaq website as an additional information source:  
<http://www.compaq.com>

# *Chapter 3*

## **Operation**

This chapter contains information on:

- Precautions to be observed when using the UPS
- UPS modes of operation
- Front panel controls
- Front panel indicators
- Overcurrent protection
- Placing the UPS in Operate mode
- Returning to Standby mode
- Initiating a self-test
- The audio alarm

## Precautions

Observe these precautions when using the Compaq 2000 Series UPS models.



**WARNING:** To reduce the risk of electrical shock from earth conductor leakage current:

- Do not operate a UPS that is disconnected from the utility power source.
  - Disconnect protected devices from the UPS before disconnecting the UPS from utility power.
  - Use the TEST/ALARM RESET button to test the batteries rather than unplugging the UPS. See "Initiating a Self-test" in this chapter for more information.
- 

## Modes of Operation

The 2000 Series UPS models have four modes of operation:

### Standby Mode

- No power is available at the UPS output receptacles.
- The UPS charges the batteries as necessary.

### Operate Mode

- Power is available at the UPS output receptacles.
- The UPS charges the batteries as necessary.

### Configure Mode

- Power is available at the UPS output receptacles.
- The UPS charges the batteries as necessary.
- The user can update the UPS configuration.

**NOTE:** For more information on configuring the UPS, see Chapter 4, "Configuration."



## Sleep Mode

By default, the Sleep mode is disabled.

When the Sleep mode is disabled:

- If the batteries have been fully discharged, power may not be automatically restored to the output receptacles when utility power is restored.



**CAUTION:** The UPS Sleep mode default setting is OFF (disabled). When Sleep mode is OFF (disabled), if the UPS is supplying battery power, the batteries can be fully discharged before the UPS will shut down. If the batteries become fully discharged, they may be unrecoverable (damaged).

---

**NOTE:** For information on enabling Sleep mode, see Chapter 4, "Configuration."

When Sleep mode is enabled:

- If the UPS is supplying battery power and the load on the UPS is less than 10 percent, the UPS shuts down.
- Power is automatically restored to the output receptacles when utility power is restored.

## Front Panel Controls

The 2000 Series UPS models front panel includes the controls required to:

- Place the UPS in Operate mode.
- Place the UPS in Standby mode.
- Place the UPS in Configure mode.
- Initiate a self-test.
- Silence an audio alarm.

**NOTE:** For information about changing the configuration on the UPS, or simply checking the current configuration, see Chapter 4, "Configuration."

The front panel includes the following controls and indicators:

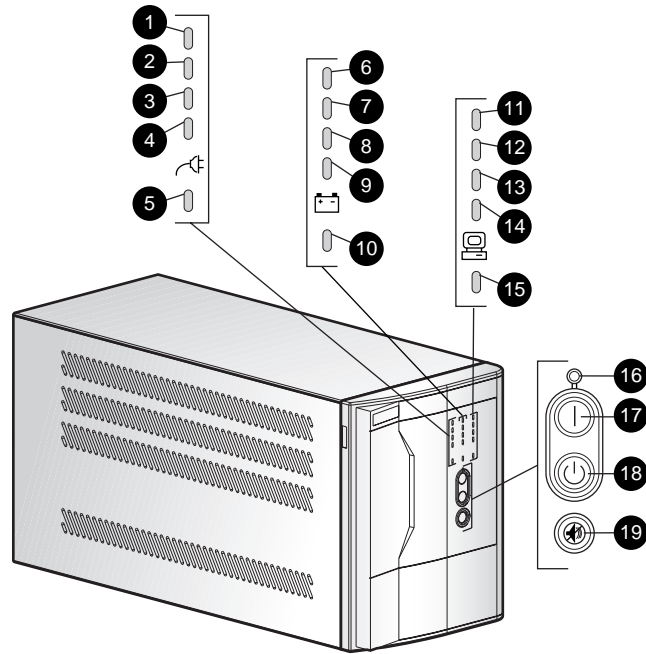

Figure 3-1. The front panel LED display and controls

		<b>Symbol</b>
①-④	AC Input level	Power cord
⑤	Site Wiring Fault indicator	
⑥-⑨	Battery Charge level	Battery
⑩	Battery Service indicator	
⑪-⑭	Load level	Load devices
⑮	Communications	
⑯	ON LED	
⑰	ON button	
⑱	STANDBY button	
	TEST/ALARM RESET button	

## Front Panel Indicators

The front panel LED display colors indicate the UPS status:

- Green LEDs indicate normal conditions.
- Red LEDs provide warning of existing or potential problems.

LEDs are referred to as LED 1 through 16, as described in this documentation.

When the UPS is in Configure mode, the LEDs do not operate as they do in the Standby and Operate modes (see Chapter 4, “Configuration”).

### Front Panel LEDs in the Standby and Operate Modes

Each LED (and the condition it indicates in the Operate and Standby modes) is described in the following tables:

#### AC Input (LEDs 1-4)

**Table 3-1  
AC Input LEDs**

LED	Color	Meaning
1	Red	The utility voltage is higher than the voltage range for which the UPS has been configured. The UPS is supplying battery power. The audio alarm will sound.
	Flashing Red	Utility voltage has returned to the voltage range for which the UPS has been configured. The UPS is supplying utility power. The audio alarm should be reset.
2	Green	Utility voltage is within the voltage range for which the UPS has been configured.
3	Green	Utility voltage is lower than the current UPS configuration expects. The UPS is compensating and providing power to the loads without the use of batteries.
4	Red	The utility voltage is lower than the voltage range for which the UPS has been configured. The UPS is supplying battery power. The audio alarm will sound.
	Flashing Red	Utility voltage has returned to the voltage range for which the UPS has been configured. The UPS is supplying utility power. The audio alarm should be reset.

**Site Wiring Fault (LED 5)**

**Table 3-2  
Site Wiring Fault LED**

LED	Color	Meaning
5	Red	No ground connection between utility power and the UPS. The line and neutral connections between utility power and the UPS are reversed. The UPS voltage configuration may be incorrect.

**Note:** For units factory-configured for 208V, the Site Wiring Fault function has been disabled. If reconfiguring a 230V unit to operate at 208V, the Site Wiring Fault function must be manually disabled. See the section "Changing Configuration Parameters" in Chapter 4, "Configuration."

**Battery Charge (LEDs 6-9)**

**Table 3-3  
Battery Charge LEDs**

LED	Color	Meaning
6	Green	Batteries are between 67% and 100% charged. (LEDs 7 and 8 are also green)
7	Green	Batteries are approximately 66% charged. (LED 8 is also green)
8	Green	Batteries are approximately 33% charged.
9	Red	Batteries are low; approximately three to five minutes of battery backup remain.

**Battery Service (LED 10)**

**Table 3-4  
Battery Service LED**

LED	Color	Meaning
10	Red	Potential battery failure.

**Note:** When LED 10 is red, the audio alarm will sound, indicating the UPS has detected a potential battery failure. The UPS batteries may need to be replaced in 30 to 60 days.

**Load Level (LEDs 11-14)**

**Table 3-5  
Load Level LEDs**

LED	Color	Meaning
11	Red	Load on the UPS exceeds the maximum power available.
12	Green	Load on the UPS is approximately 67% to 100% of the maximum power available. (LEDs 13 and 14 are also green)
13	Green	Load on the UPS is approximately 66% of the maximum power available. (LED 14 is also green)
14	Green	Load on the UPS is approximately 33% of the maximum power available.

**Communication (LED 15)**

**Table 3-6  
Communication LED**

LED	Color	Meaning
15	Green	The communication link between the UPS and the host computer is active.
	Flashing Green	Data is being transferred between the UPS and the host computer.

**On (LED 16)**

If LED 16 is green, power is available at the UPS output receptacles.

## Overcurrent Protection

Overcurrent protection is provided using the resettable circuit breakers located on the rear panel. The following models have overcurrent protection:

**Table 3-7**  
**Overcurrent Protection**

UPS Model	Device
T2000	Circuit breakers for each load segment
T2000j	Circuit breakers for each load segment
T2400h	Input circuit breaker No protection for load segments
T2400h-NA	Input circuit breaker No protection for load segments

## Placing the UPS in Operate Mode

The 2000 Series UPS may be placed in Operate mode if either of the following conditions apply:

- The UPS is powered up and in Standby mode (LED 16 is off)
- The UPS is powered off; no utility power is available

Press and hold the ON button (②) until the LED 16 (ON LED ①) turns green, indicating that power is available at the UPS output receptacles. The UPS acknowledges compliance with a short beep.

---

**IMPORTANT:** If using battery power (no utility power present), press the ON button and hold for three seconds. The UPS will conserve battery power by omitting the self-test.

---

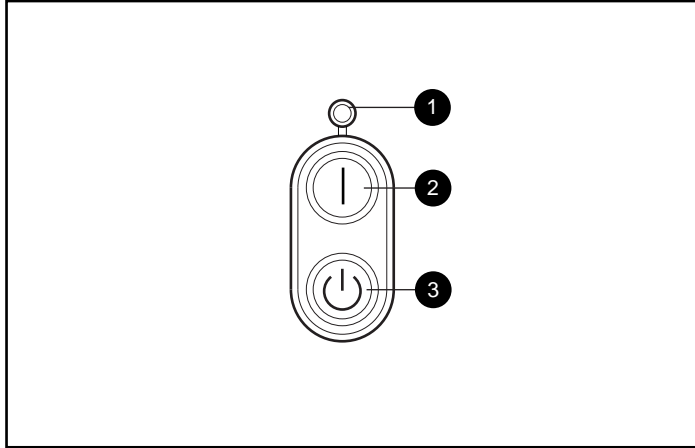

Figure 3-2. Operate mode controls

- ❶ ON LED
- ❷ ON button
- ❸ STANDBY button

## Returning to Standby Mode

When the UPS is in Operate mode (LED 16, ❶, is green), pressing the STANDBY button (❸) will place the UPS in Standby mode. The UPS will acknowledge compliance with a short beep. LED 16 (❶) will extinguish, and power to the loads will cease.

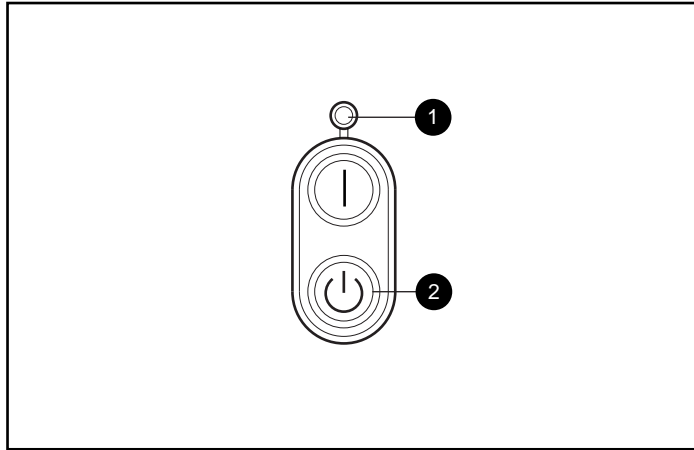

Figure 3-3. Standby mode controls

- ❶ ON LED
- ❷ STANDBY button

---

**IMPORTANT:**

- While in Standby mode, the UPS maintains the charge on the batteries, but no power is available at the output receptacles.
  - The UPS remains in Standby mode until an alternate mode is selected, or utility power is removed.
-



## Initiating a Self-test

To initiate a self-test, press the TEST/ALARM RESET button (❶) and hold for three seconds. The UPS acknowledges compliance with five beeps.

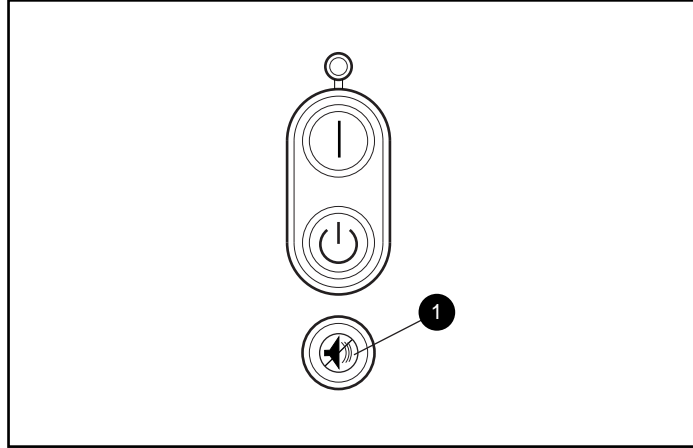

Figure 3-4. TEST/ALARM RESET button

- ❶ TEST/ALARM RESET button

---

**IMPORTANT:** A portion of the self-test requires battery power; the self-test cannot be initiated if the batteries are less than 90% charged.

---

During the self-test, it is normal for the UPS to turn on individual LEDs momentarily; however, if an alarm condition is detected, the UPS will turn on the appropriate red LED and may sound an audio alarm.



**WARNING:** To reduce the risk of electric shock from earth conductor leakage current, use the self-test procedure to check the UPS batteries (rather than unplugging the UPS).

---

- For the meaning of individual LEDs, see “Front Panel LEDs in the Standby and Operate Modes,” in this chapter.
- For information on what to do if the self-test detects a problem, see Chapter 6, “Troubleshooting.”

## Audio Alarm

The UPS may sound an audio alarm to warn the user that an alarm condition exists.

---

**IMPORTANT:** Certain audio alarms can be disabled. See Chapter 4, "Configuration," for more information.

---

---

**Table 3-8**  
**Audio Alarm Conditions**

<b>Alarm Condition</b>	<b>LED Activity</b>	<b>Can be disabled?</b>
Utility power failure	LED 1 or LED 4 red	Yes
Site Wiring Fault	LED 5 on red	Yes
Battery Service	LED 10 on red	Yes
Internal UPS overvoltage	LED 10 flashing red	No

## Silencing an Audio Alarm

To silence an audio alarm, press the TEST/ALARM RESET button.

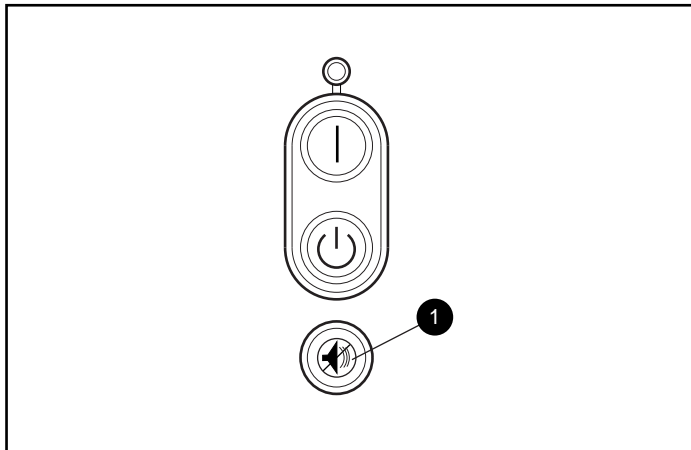

Figure 3-5. TEST/ALARM RESET button

- 1 TEST/ALARM RESET button

---

**IMPORTANT:**

- Even though an audio alarm may be silenced, the condition that caused the alarm may still exist. For information on procedures to follow if the UPS detects an alarm condition, see Chapter 6, "Troubleshooting."
  - If a utility power failure caused the alarm (AC Input LED 1 or LED 4 red), the alarm will be silenced after utility power is restored.
-

# Chapter 4

## Configuration

This chapter contains information on the following topics:

- Placing the UPS in Configure mode
- Configuration parameters and their LED indicators
- Using the front panel LED display and controls to monitor and change configuration parameters
- Using the UPS configuration parameters to optimize battery life by matching utility voltage

## Placing the UPS in Configure Mode

The Compaq 2000 Series UPS models can enter the Configure mode while in the Operate or Standby mode.

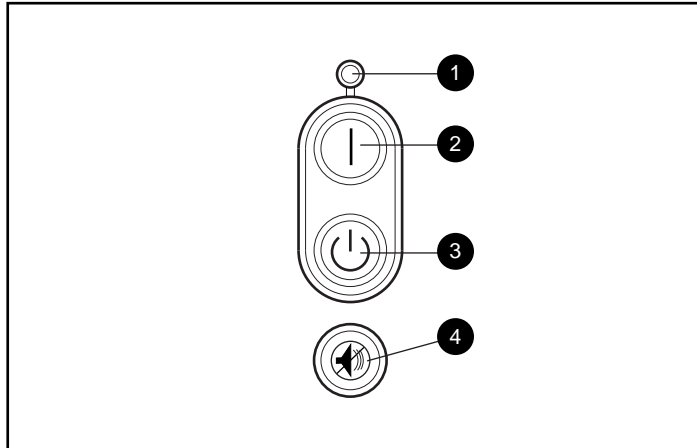

Figure 4-1. Configure mode controls

- ❶ ON LED (LED 16)
- ❷ ON button
- ❸ STANDBY button
- ❹ TEST/ALARM RESET button

To place the UPS in Configure mode, press the ON (❷) and TEST/ALARM RESET (❹) buttons simultaneously. Release the buttons when the acknowledgement beep sounds.

---

**IMPORTANT:** If the STANDBY button is pressed while in the Configure mode, the UPS will enter Standby mode, and power to the load segments will cease.

---

In the Configure mode, the front panel LED display changes function. The LED display and button controls allow the user to monitor, and to change, the UPS configuration parameters.

# Configuration Parameters and their LED Indicators

In the Configure mode, the front panel LEDs 1 to 15 are assigned to eleven configuration parameters<sup>1</sup>, detailed in the following table. (LED 16 indicates the ON or OFF status of each parameter.)

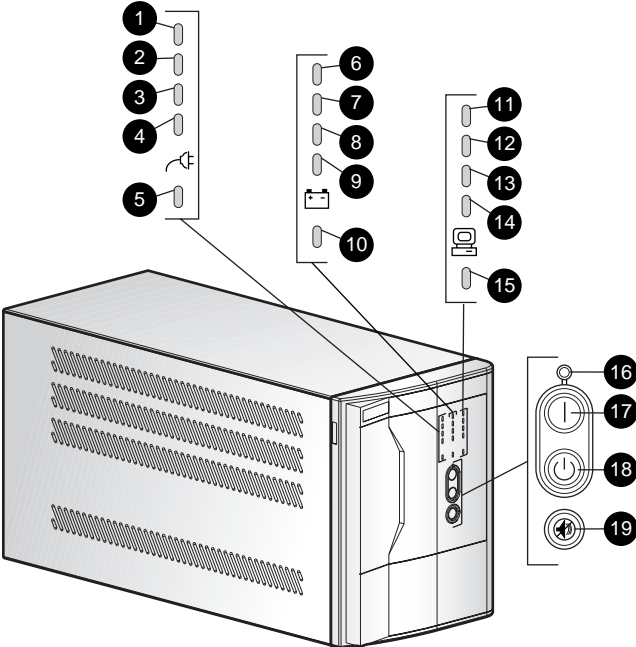

Figure 4-2. The front panel LED display and controls

---

<sup>1</sup> Configuration parameters 11 to 14 are reserved for future use.

**Table 4-1**  
**Configuration Parameters/LED Indicators**

Parameter (LED)	Parameter Name	LED 16 Status	Explanation
1	120/230 Nom	On <sup>1</sup>	Nominal utility voltage level is 120/230 VAC.
2	110/220 Nom	On <sup>1</sup>	Nominal utility voltage level is 110/220 VAC.
3	127/240 Nom	On <sup>1</sup>	Nominal utility voltage level is 127/240 VAC.
10	100/208 Nom	On <sup>1</sup>	Nominal utility voltage level is 100/208 VAC.
4	Extended Voltage	On	UPS will supply utility power if the utility voltage is within +20% to -35% of the nominal voltage. If the utility voltage is outside this range, the UPS will supply battery power.
		Off (default)	UPS will supply utility power if the utility voltage is within $\pm 20\%$ of the nominal voltage. If the utility voltage is outside this range, the UPS will supply battery power.
5	Wiring Fault	On (default)	Enables an audio alarm if ground is missing, or if line and neutral connections have been reversed.
		Off	Disables the audio alarm for this event.
6	Low Battery	On (default)	Enables an audio alarm 3 minutes before battery shutdown.
		Off	Enables an audio alarm 5 minutes before battery shutdown.
7	Shutdown Delay	On (default)	Enables a 5-second delay before turning off power to the output receptacles after receiving a shutdown command from the host.
		Off	Enables a 3-minute delay.

*continued*

**Table 4-1**  
**Configuration Parameters/LED Indicators** *continued*

Parameter (LED)	Parameter Name	LED 16 Status	Explanation
8	AC Input Failure	On (default)	Enables an audio alarm when the utility voltage is outside the UPS operating range.
		Off	Disables the audio alarm for this event.
9	Sleep Mode	On	Enables Sleep mode.
		Off (default)	Disables Sleep mode.
11-14	Reserved		Reserved for future use.
15	Reset Defaults	On	Defaults are restored <sup>2</sup> .
		Off	Configuration selected by the user overrides defaults.

**Notes:** <sup>1</sup> Only one nominal utility voltage can be configured.

<sup>2</sup> If model T2000j voltage defaults to 120, change the voltage to 100.

If model T2000h-NA voltage defaults to 230, change the voltage to 208.



## Changing Configuration Parameters

The Configure mode can be entered from the Operate or Standby mode.

---

**IMPORTANT:** If the STANDBY button is pressed while in the Configure mode, the UPS will enter Standby mode, and power to the load segments will cease.

---

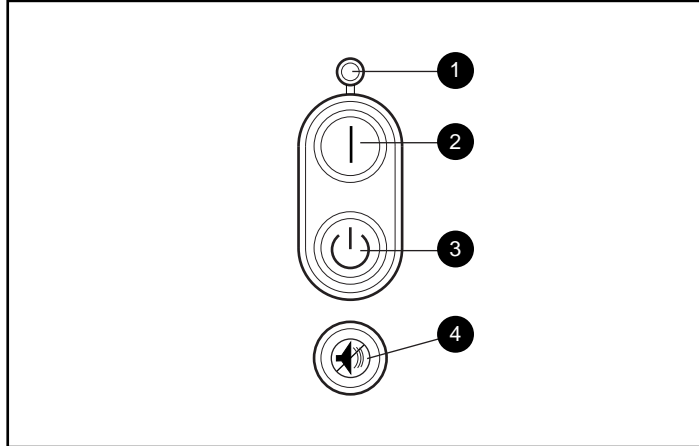

Figure 4-3. Configure mode controls

- ❶ ON LED (LED 16)
- ❷ ON button
- ❸ STANDBY button
- ❹ TEST/ALARM RESET button

To change configuration parameters:

1. Place the UPS in Configure mode by pressing the ON (❷) and TEST/ALARM RESET (❹) buttons simultaneously. Release the buttons when the acknowledgement beep sounds.
2. The top left LED on the front panel LED display should begin to blink, indicating that configuration parameter 1 is selected.
3. To determine if the selected configuration parameter value is ON or OFF, check LED 16 (❶)—if LED 16 is ON, the selected parameter is also ON.
4. To toggle the selected configuration parameter value, press the TEST/ALARM RESET button (❹). The UPS will acknowledge compliance with a short beep.

**NOTE:** For nominal voltage configuration parameters 1, 2, 3, and 10—selecting an ON value for any one parameter automatically sets the other three possibilities to OFF.

5. To scroll through the configuration parameters, press the ON button (Ⓜ). The UPS acknowledges compliance with a short beep. Monitor the LED display (see Figure 4-2; LED 1 blinks to indicate that parameter 1 is selected, LED 2 blinks when parameter 2 is selected, and so on).
6. Repeat Steps 2 through 5 as required. Continue until all changes have been made.
7. To exit the Configure mode at any time:
  - Press the ON (Ⓜ) and TEST/ALARM RESET buttons (Ⓞ) simultaneously, or
  - after parameter 15 is accessed, press the ON (Ⓜ) button.

The UPS will acknowledge compliance with a short beep.

## Optimizing Battery Life by Matching the Utility Voltage

Optimize UPS battery life by using the configuration parameters to select the best nominal voltage range for the UPS installation.

When utility voltage is outside the selected operating range, the UPS supplies battery power to the output receptacles. Maximize the UPS battery life by configuring the UPS so that the utility voltage is normally within the selected operating range.

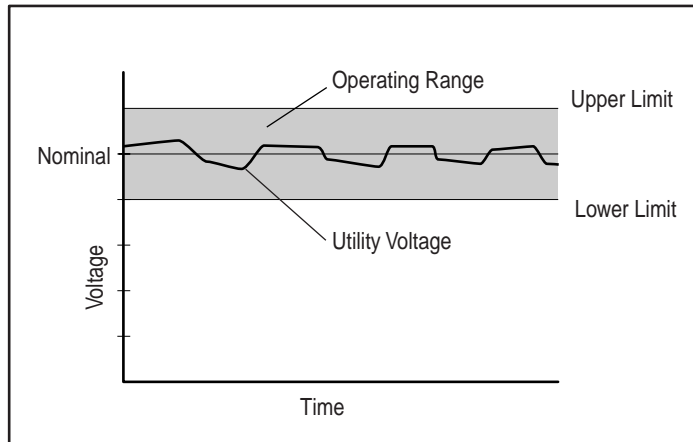

Figure 4-4. Optimal—Utility voltage fluctuating within the UPS operating range

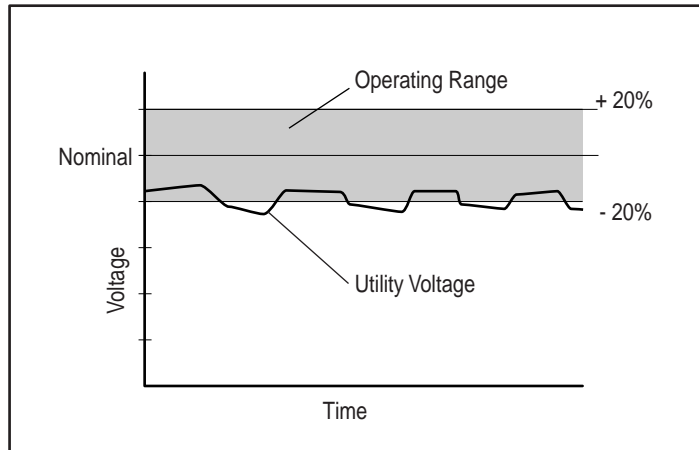

Figure 4-5. Utility voltage fluctuation indicating a shift in nominal voltage range may be necessary

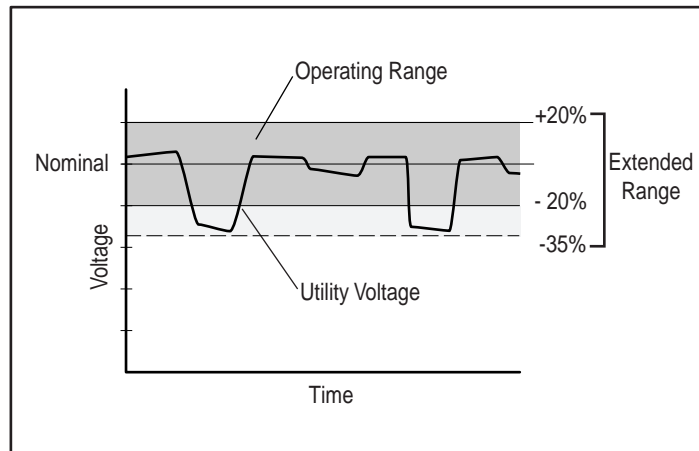

Figure 4-6. Utility voltage fluctuation indicating a possible need for extended range setting

To match the utility voltage, the UPS operating range can be modified in two ways:

- If the utility voltage differs from the currently configured nominal voltage, but stays within a  $\pm 20\%$  band (see Fig 4-5), consider shifting the nominal voltage parameter selection to match the measured utility voltage range.

- If the utility voltage frequently varies outside the UPS operating range (see Fig 4-6), consider changing from normal to extended range (+20% to -35%). This provides more tolerance to brief utility voltage fluctuations.

To update the nominal voltage and operating range parameters:

1. Have a qualified electrician monitor utility voltage.
2. Use the following tables to identify the operating range that most closely matches requirements:

**Table 4-2**  
**Operating Ranges (VAC) - T2000 and T2000j Models**

Nominal Level	Normal Range	Extended Range
100	80 to 120	Not applicable
110	88 to 132	72 to 132
120	96 to 144	78 to 144
127	102 to 152	83 to 155

**Table 4-3**  
**Operating Ranges (VAC) - T2000h and T2000h-NA Models**

Nominal Level	Normal Range	Extended Range
208	166 to 250	Not applicable
220	176 to 264	143 to 264
230	184 to 276	150 to 276
240	192 to 288	156 to 288

3. For nominal voltage level setting, select configuration parameters 1, 2, 3, or 10 (see Table 4-1).
4. Access parameter 4 to switch from normal to extended range (see Table 4-1).

## *Chapter* **5**

# Battery Maintenance

This chapter contains information on the following topics:

- Precautions to be observed when maintaining or replacing external battery modules
- Charging batteries
- When to replace batteries
- Pre-Failure Battery Warranty
- Obtaining a new battery module
- Replacing an external battery module
- Care and storage of batteries

## Precautions



**WARNING:** There is a risk of personal injury from the hazardous energy levels associated with UPS battery modules. The maintenance and replacement of battery modules must be carried out by qualified service personnel.

Replace the battery module with the Compaq spare designated for the UPS. Spare battery kit part numbers are:

- T2000 models – 242713-001
  - T2400 models – 295461-001
- 



**WARNING:** The UPS contains sealed lead-acid batteries. To reduce the risk of fire or chemical burns take the following precautions:

- Do not attempt to recharge batteries after removal from the UPS.
  - Do not disassemble, crush, or puncture the batteries.
  - Do not short the external contacts of the batteries.
  - Do not immerse the batteries in water.
  - Do not expose to temperatures higher than 60°C.
- 



**WARNING:** To reduce the risk of personal injury from hazardous energy, take these precautions:

- Remove watches, rings, or other metal objects.
  - Use tools with insulated handles.
- 



**WARNING:** The 2000 Series UPS models weigh between 79 and 97 lb (36 to 44 kg) when fully assembled.

T2000 and T2000j:

UPS	32 lb (15 kg)	Battery	47 lb (21 kg)
-----	---------------	---------	---------------

T2400h and T2400h-NA:

UPS	34 lb (15 kg)	Battery	63 lb (29 kg)
-----	---------------	---------	---------------

To reduce the risk of personal injury or damage to the equipment:

- Observe local occupational health and safety requirements and guidelines for manual material handling.
  - Obtain adequate assistance to lift and stabilize the chassis during installation or removal.
  - Remove the battery pack to reduce the overall weight of the product.
-

---

**IMPORTANT:** Before handling a tower UPS, make sure that the UPS is on a flat, stable surface.

---

## Charging Batteries

The Compaq 2000 Series UPS models automatically charge the batteries when connected to utility power. No user intervention is required while the UPS is in use.

- For information on charging the batteries when installing the UPS, see “Completing the Installation” in Chapter 2, “Installation.”
- For information on keeping the batteries charged while the UPS is in extended storage, see “Care and Storage of Batteries,” in this chapter.

## When to Replace Batteries

When the Battery Service indicator (LED 10) turns red, the external battery module may need to be replaced within 30 to 60 days.

**NOTE:** If the audio alarm parameter is enabled, the Battery Service indicator will be accompanied by an audio alarm.

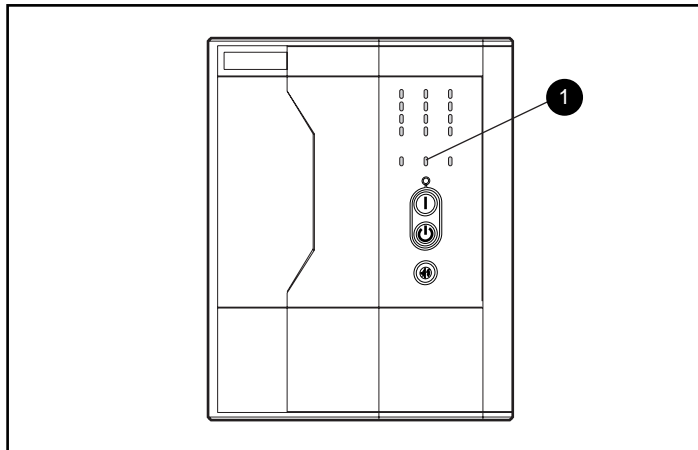

Figure 5-1. Battery Service indicator (LED 10)

- ❶ Battery Service indicator (LED 10)

Verify that battery module replacement is required by initiating a UPS self-test. If LED 10 remains red, replace the battery module.

**NOTE:** Depending on usage and environmental conditions, the battery module should last three to six years.

For information on initiating a self-test, see Chapter 3, “Operation.”

## Pre-Failure Battery Warranty

The Pre-Failure Battery Warranty, standard on all Compaq Uninterruptible Power System (UPS) units, extends the advantage of a Compaq three-year, limited warranty by applying it to the battery before it actually fails. Specifically, the Pre-Failure Battery Warranty ensures that when customers receive notification from Compaq Power Management Software that the battery may fail, the battery is replaced free of charge under the warranty.

Compaq maintains the highest standards in the industry, as evidenced by the Compaq Pre-Failure Battery Warranty. The Pre-Failure Battery Warranty is beneficial in at least two significant ways:

- Reduced total cost of ownership
- Reduced downtime

## Obtaining a New Battery Module

Compaq supplies spare external battery modules for all Compaq 2000 Series UPS models. Obtain a replacement module for the UPS when the Battery Service indicator (LED 10) illuminates, meaning that new batteries may be required in 30 to 60 days.

The spare battery kit for a T2000 or T2000j is part number 242713-001.

The spare battery kit for a T2400h or T2400h-NA is part number 295461-001.

---

**IMPORTANT:** Compaq recommends that an inventory of spare battery modules not be maintained onsite unless a procedure to keep the modules charged while in storage is implemented.

---

For more information on the Battery Service LED function, see Chapter 3, “Operation.”



## Replacing an External Battery Module

There are two options for replacing a UPS external battery module:

- Powering off the UPS before removing the battery module
- In certain circumstances, hot-swapping the battery module without powering off the UPS



**CAUTION:** While hot-swapping batteries, there is no protection in the event of a utility power failure.

---

### Step 1: Preparing the UPS

#### To replace batteries with the UPS Off

1. Shut down all load devices.
2. Press the STANDBY button to take UPS out of Operate mode. The ON LED extinguishes, and power to the load receptacles ceases.
3. Disconnect the UPS from utility power.
4. Wait at least 60 seconds, while the UPS internal circuitry discharges.

#### To replace batteries with the UPS in Operate mode (hot-swapping)

Batteries may be replaced (hot-swapped) without powering off the UPS if both of the following conditions are met:

- The UPS is not charging the batteries (Battery Charge LEDs 6, 7, and 8 are all green, indicating that the batteries are fully charged).

**NOTE:** Older batteries may be fully charged but still incapable of providing adequate backup for devices. Therefore, the battery charge LEDs can indicate the batteries are fully charged, while the UPS diagnostics have determined that the batteries need to be replaced.

- The UPS is not supplying battery power to devices (AC Input LEDs 1 and 4 are green, indicating that the UPS is supplying utility power).

## Step 2: Removing the External Battery Module

Use this procedure to remove the external battery module:

1. Disconnect the battery cables from the UPS.



**CAUTION:** It is normal for a small amount of electrical arcing to occur when disconnecting an external battery module from a UPS. To minimize the amount of arcing, remove the battery cables quickly and firmly.

---

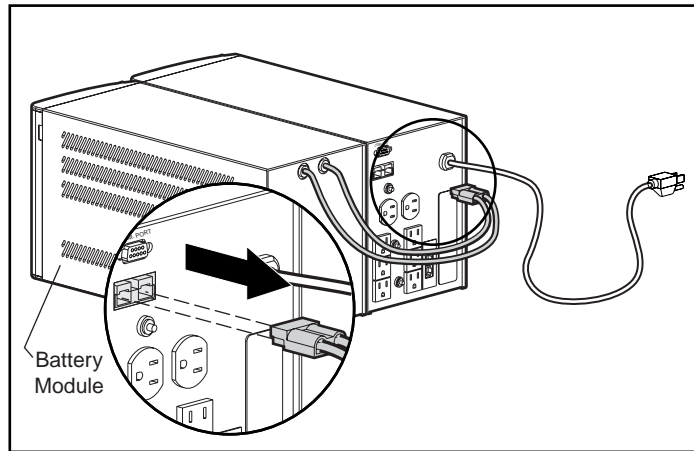

Figure 5-2. Disconnecting an external battery module

2. Set the used external battery module aside to install the replacement module.



**CAUTION:** Load devices will not be protected from utility power failure until the battery module is successfully replaced.

---

### Step 3: Installing a New Battery Module

Connect the battery cables from the new external battery module to the battery receptacle on the UPS.



**CAUTION:** It is normal for a small amount of electrical arcing to occur when connecting an external battery module to a UPS. To minimize the amount of arcing, insert the battery cables into the receptacles on the UPS quickly and firmly.

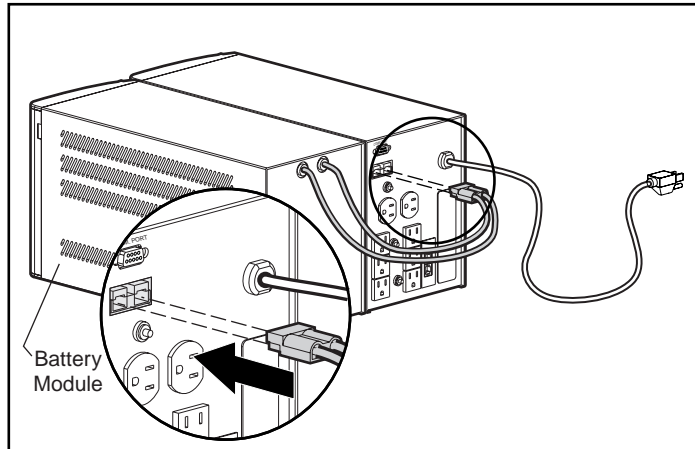

Figure 5-3. Connecting an external battery module

If the installation has been successful, the green Battery Charge indicators (LEDs 6 to 8) show that the UPS is charging the batteries. This means that the installation is now complete.

## Step 4: Testing a New Battery Module

After installing the new battery module, press the TEST/ALARM RESET button.

For information on running a self-test, see Chapter 3, "Operation."

---

**IMPORTANT:** The UPS will not execute a self-test until the batteries are 90% charged.

---

If the installation has been successful, the green Battery Charge indicators (LEDs 6 to 8) show that the UPS is charging the batteries.

If the installation has not been successful, the Battery Service indicator (LED 10) will turn red. If this occurs, check the battery connections. If the Battery Service LED is still red, see Chapter 6, "Troubleshooting," for more information.

## Step 5: Disposing of Used Battery Modules

The spare battery module kit includes the instructions and packaging required to return your used battery module to the appropriate location for disposal.

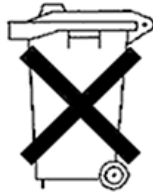

Do not dispose of the used battery module with general office or household waste. Return the module for proper disposal to either:

- Compaq, authorized Compaq Partners, or their agents.
- A recycling center that meets all local environmental standards.

## Care and Storage of Batteries

To maximize battery life:

- Minimize the amount of time the UPS is using battery power. Match UPS configuration with the utility voltage. See Chapter 4, “Configuration,” for more information.
- Keep the area around the UPS clean and dust-free. If the environment is very dusty, clean the outside of the UPS regularly with a vacuum cleaner.
- Maintain the ambient temperature at 25°C (77°F).
- If storing a UPS for an extended period, recharge the batteries every six months:
  - a. Connect the UPS to utility power.
  - b. Allow the UPS to remain in Standby mode.
  - c. Allow the UPS to charge the batteries for 24 hours.
  - d. Update the Battery Recharge Date label.

# Chapter 6

## Troubleshooting

This chapter provides information on the following topics:

- Troubleshooting problems that occur during UPS start
- Troubleshooting problems that occur after UPS start
- Repairing the UPS

## Troubleshooting During Start

If problems occur when starting the Compaq 2000 Series UPS models, select the appropriate symptom for possible causes and actions suggested.

**Table 6-1**  
**Troubleshooting Guide (UPS Start)**

Symptom	Possible Cause	Suggested Action
UPS will not start	No utility power	Check power at the utility power receptacle or contact a qualified electrician.
	UPS power cord disconnected	Connect the power cord.
	UPS input circuit breaker open	Press the circuit breaker button to reset. If the breaker trips repeatedly, contact an authorized service provider.
LED 5 is red (Site Wiring Fault)	Utility power receptacle ungrounded, or no ground wire in UPS power cord	Contact a qualified electrician to correct the condition.
	Line and neutral wires reversed in utility power receptacle or in UPS power cord	For units factory configured for 208V, the Site Wiring Fault function has been disabled. If reconfiguring a 230V unit to operate at 208V, the Site Wiring Fault function must be manually disabled. (high models only)
LED 10 is red (Battery Service)	Battery voltage is low because the UPS has been out-of-service for a long period	Allow the UPS to charge the batteries for 24 hours. Initiate a self-test: if LED 10 does not turn off, replace the batteries.
	The UPS was powered on with the Sleep mode disabled, draining the batteries	

## Troubleshooting After Start

For problems that occur after the UPS has gone through the startup self-test sequence, these suggested actions address possible causes.

**Table 6-2**  
**Troubleshooting Guide (After Start)**

Symptom	Possible Cause	Suggested Action
Audio Alarm	Alarm condition exists	Identify the red LED associated with this alarm condition. Check this troubleshooting guide to determine the cause of the alarm.
LED 1 is red (Input Power)	Utility voltage is too high	The utility voltage is higher than the UPS operating range. The UPS switches to battery power. If this happens repeatedly, update the configuration.  Contact a qualified electrician to make sure that utility power is suitable for the UPS.
LED 1 is flashing red	Alarm may need to be reset	The utility voltage has returned within the UPS operating range. Press the TEST/ALARM RESET button.
LED 4 is red (Input Power)	Utility voltage is too low	The utility voltage is lower than the UPS operating range. The UPS switches to battery power. If this happens repeatedly, update the configuration.  Contact a qualified electrician to make sure that utility power is suitable for the UPS.
LED 4 is flashing red	Alarm may need to be reset	The utility voltage has returned within the UPS operating range. Press the TEST/ALARM RESET button.

*continued*



**Table 6-2**  
**Troubleshooting Guide (After Start)** *continued*

Symptom	Possible Cause	Suggested Action
UPS frequently switches between utility and battery power	Utility power variations	The utility voltage is frequently outside the UPS operating range. Update the configuration.
		Contact a qualified electrician to make sure that utility power is suitable for the UPS.
LED 11 is red (Load Level)	Protected devices are exceeding the UPS power rating	Remove one or more devices to reduce the power requirements.
		Make sure that devices are not defective.
LED 9 is red (Battery Charge)	Low battery voltage	If the UPS is supplying battery power, save current work and shut down the system. Allow the batteries to charge.
		If the UPS is supplying utility power, no user intervention is required. Allow the batteries to charge.
Insufficient warning of low batteries	Battery service required	Allow batteries to charge for 24 hours, then initiate self-test. If LED 10 is red, replace batteries.
	Shutdown Delay configuration inappropriate	Update the Shutdown Delay from 5-seconds to 3-minutes. Use Compaq Power Management Software to specify a suitable delay.
LED 10 is red (Battery Service)	Potential battery failure detected	Allow batteries to charge for 24 hours, then initiate self-test. If LED 10 is red, replace batteries.
	New batteries improperly connected	Check connections.

*continued*

**Table 6-2**  
**Troubleshooting Guide (After Start)** *continued*

Symptom	Possible Cause	Suggested Action
LED 10 is flashing red; audio alarm cannot be silenced	Internal UPS overvoltage condition exists	Shut down the UPS. Contact an authorized service provider.

## Repairing the UPS

Repairs to the UPS must be carried out by Compaq or a Compaq Authorized Service Provider. Other than battery replacement, there are no user-serviceable parts.

# Appendix **A**

## Regulatory Compliance Notices

### Federal Communications Commission Notice

Part 15 of the Federal Communications Commission (FCC) Rules and Regulations has established Radio Frequency (RF) emission limits to provide an interference-free radio frequency spectrum. Many electronic devices, including computers, generate RF energy incidental to their intended function and are, therefore, covered by these rules. These rules place computers and related peripheral devices into two classes, A and B, depending upon their intended installation. Class A devices are those that may reasonably be expected to be installed in a business or commercial environment. Class B devices are those that may reasonably be expected to be installed in a residential environment (that is, personal computers). The FCC requires devices in both classes to bear a label indicating the interference potential of the device as well as additional operating instructions for the user.

The rating label on the device shows which class (A or B) the equipment falls into. Class B devices have an FCC logo or FCC ID on the label. Class A devices do not have an FCC logo or FCC ID on the label. Once the class of the device is determined, refer to the following corresponding statement.

## Class A Equipment

This equipment has been tested and found to comply with the limits for a Class A digital device, pursuant to Part 15 of the FCC Rules. These limits are designed to provide reasonable protection against harmful interference when the equipment is operated in a commercial environment. This equipment generates, uses, and can radiate radio frequency energy and, if not installed and used in accordance with the instructions, may cause harmful interference to radio communications. Operation of this equipment in a residential area is likely to cause harmful interference, in which case the user will be required to correct the interference at personal expense.

## Class B Equipment

This equipment has been tested and found to comply with the limits for a Class B digital device, pursuant to Part 15 of the FCC Rules. These limits are designed to provide reasonable protection against harmful interference in a residential installation. This equipment generates, uses, and can radiate radio frequency energy and, if not installed and used in accordance with the instructions, may cause harmful interference to radio communications. However, there is no guarantee that interference will not occur in a particular installation. If this equipment does cause harmful interference to radio or television reception, which can be determined by turning the equipment off and on, the user is encouraged to try to correct the interference by one or more of the following measures:

- Reorient or relocate the receiving antenna.
- Increase the separation between the equipment and receiver.
- Connect the equipment into an outlet on a circuit different from that to which the receiver is connected.
- Consult the dealer or an experienced radio or television technician for help.

## **Declaration of Conformity for Products Marked with the FCC logo - United States Only**

This device complies with Part 15 of the FCC Rules. Operation is subject to the following two conditions: (1) this device may not cause harmful interference, and (2) this device must accept any interference received, including interference that may cause undesired operation.

For questions regarding your product, contact:

Compaq Computer Corporation  
P. O. Box 692000, Mail Stop 530113  
Houston, Texas 77269-2000

or call 1-800-652-6672 (1-800-OK COMPAQ<sup>1</sup>). For questions regarding this FCC declaration, contact:

Compaq Computer Corporation  
P. O. Box 692000, Mail Stop 510101  
Houston, Texas 77269-2000

or call (281) 514-3333.

To identify this product, refer to the Part, Series, or Model number found on the product.

## **Modifications**

The FCC requires the user to be notified that any changes or modifications made to this device that are not expressly approved by Compaq Computer Corporation may void the user's authority to operate the equipment.

## **Cables**

Connections to this device must be made with shielded cables with metallic RFI/EMI connector hoods in order to maintain compliance with FCC Rules and Regulations.

---

<sup>1</sup> For continuous quality improvement, calls may be recorded or monitored.

## Canadian Notice (Avis Canadien)

### Class A Equipment

This Class A digital apparatus meets all requirements of the Canadian Interference-Causing Equipment Regulations.

Cet appareil numérique de la classe A respecte toutes les exigences du Règlement sur le matériel brouilleur du Canada.

### Class B Equipment

This Class B digital apparatus meets all requirements of the Canadian Interference-Causing Equipment Regulations.

Cet appareil numérique de la classe B respecte toutes les exigences du Règlement sur le matériel brouilleur du Canada.

## European Union Notice

Products with the CE Marking comply with both the EMC Directive (89/336/EEC) and the Low Voltage Directive (73/23/EEC) issued by the Commission of the European Community.

Compliance with these directives implies conformity to the following European Norms (in brackets are the equivalent international standards):

- EN55022 (CISPR 22) - Electromagnetic Interference
- EN50082-1 (IEC801-2, IEC801-3, IEC801-4) - Electromagnetic Immunity
- EN60950 (IEC950) - Product Safety

## Japanese Notice

ご使用になっている装置にVCCIマークが付いていましたら、次の説明文をお読み下さい。

この装置は、情報処理装置等電波障害自主規制協議会（VCCI）の基準に基づくクラスB情報技術装置です。この装置は、家庭環境で使用することを目的としていますが、この装置がラジオやテレビジョン受信機に近接して使用されると、受信障害を引き起こすことがあります。

取扱説明書に従って正しい取り扱いをして下さい。

VCCIマークが付いていない場合には、次の点にご注意下さい。

この装置は、情報処理装置等電波障害自主規制協議会（VCCI）の基準に基づくクラスA情報技術装置です。この装置を家庭環境で使用すると電波妨害を引き起こすことがあります。この場合には使用者が適切な対策を講ずるよう要求されることがあります。

## Taiwanese Notice

**警告使用者：**

這是甲類的資訊產品，在居住的環境中使用時，可能會造成射頻干擾，在這種情況下，使用者會被要求採取某些適當的對策。

## Battery Replacement Notice

Your UPS is provided with a Sealed Lead Acid battery pack. There is a danger of explosion and risk of personal injury if the battery is incorrectly replaced or mistreated. Replacement is to be done by a Compaq authorized service provider using the Compaq spare designated for this product. For more information about battery replacement or proper disposal, contact your Compaq authorized reseller or your authorized service provider.



**WARNING:** Your UPS contains a Sealed Lead Acid battery pack. There is risk of fire and burns if the battery pack is not handled properly. To reduce the risk of personal injury:

- Do not attempt to recharge the battery.
  - Do not expose to temperatures higher than 60°C.
  - Do not disassemble, crush, puncture, short external contacts, or dispose of in fire or water.
  - Replace only with the Compaq spare designated for this product.
- 

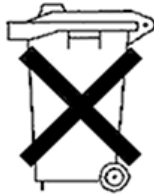

Batteries, battery packs, and accumulators should not be disposed of together with the general household waste. In order to forward them to recycling or proper disposal, please use the public collection system or return them to Compaq, your authorized Compaq Partners, or their agents.



## *Appendix* **B**

# Electrostatic Discharge

To prevent damaging the system, be aware of the precautions you need to follow when setting up the system or handling parts. A discharge of static electricity from a finger or other conductor may damage system boards or other static-sensitive devices. This type of damage may reduce the life expectancy of the device.

To prevent electrostatic damage, observe the following precautions:

- Avoid hand contact by transporting and storing products in static-safe containers.
- Keep electrostatic-sensitive parts in their containers until they arrive at static-free workstations.
- Place parts on a grounded surface before removing them from their containers.
- Avoid touching pins, leads, or circuitry.
- Always be properly grounded when touching a static-sensitive component or assembly.

## Grounding Methods

There are several methods for grounding. Use one or more of the following methods when handling or installing electrostatic-sensitive parts:

- Use a wrist strap connected by a ground cord to a grounded workstation or computer chassis. Wrist straps are flexible straps with a minimum of 1 megohm  $\pm 10$  percent resistance in the ground cords. To provide proper ground, wear the strap snug against the skin.
- Use heel straps, toe straps, or boot straps at standing workstations. Wear the straps on both feet when standing on conductive floors or dissipating floor mats.
- Use conductive field service tools.
- Use a portable field service kit with a folding static-dissipating work mat.

If you do not have any of the suggested equipment for proper grounding, have a Compaq authorized reseller install the part.

**NOTE:** For more information on static electricity, or assistance with product installation, contact your Compaq authorized reseller.

# *Appendix* **C**

## **Specifications**

This appendix provides specifications that apply to Compaq 2000 Series UPS models:

- Physical specifications
- Input specifications
- Output specifications
- Overcurrent protection
- Battery specifications
- Battery runtime
- Environmental specifications

## Physical Specifications

**Table C-1**  
**Physical Specifications - Models T2000 and T2000j**

Device	Feature	U.S.	Metric	
UPS	Dimensions	Width	7.0 in	178 mm
		Height	8.8 in	224 mm
		Depth	17.1 in	444 mm
		Weight	32 lb	15 kg
External Battery Module	Dimensions	Width	7.0 in	178 mm
		Height	8.8 in	224 mm
		Depth	17.1 in	444 mm
		Weight	47 lb	21 kg

**Table C-2**  
**Physical Specifications - Models T2400h and T2400h-NA**

Device	Feature	U.S.	Metric	
UPS	Dimensions	Width	7.0 in	178 mm
		Height	8.8 in	224 mm
		Depth	17.1 in	444 mm
		Weight	34 lb	15 kg
External Battery Module	Dimensions	Width	7.0 in	178 mm
		Height	8.8 in	224 mm
		Depth	17.1 in	444 mm
		Weight	63 lb	29 kg

## Input Specifications

**Table C-3**  
**Input Specifications – Per Model**

UPS Model	Utility Voltage Frequency (Hz)	Nominal Utility Voltage (VAC)	Power Cord Supplied
T2000	50	100, 110	Non-detachable cord with 5-20p plug
	60	100, 110 120, 127	
T2000j	50	100, 110	Non-detachable cord with 5-20p plug
	60	100, 110 120, 127	
T2400h	50/60	208, 220 230, 240	Detachable cord with country-specific plug
T2400h-NA	50/60	208, 220 230, 240	Detachable cord with 6-15p plug

## Output Specifications

**Table C-4**  
**Output Specifications – Per Model**

UPS Model	Nominal Power Rating (VA)	Load Segment #	Output Receptacles
T2000	1920	1	3 x 5-15R
		2	3 x 5-15R
		3	2 x 5-15R
T2000j	1920	1	3 x 5-15R
		2	3 x 5-15R
		3	2 x 5-15R
T2400h	2300	1	3 x IEC-320
		2	3 x IEC-320
		3	3 x IEC-320
T2400h-NA	2300	1	3 x IEC-320
		2	3 x IEC-320
		3	3 x IEC-320

**Table C-5  
Output Specifications – 2000 Series UPS Models**

<b>Characteristics</b>	<b>Utility Voltage (VAC)</b>	<b>Nominal Output Voltage (VAC)</b>
Voltage	100	102
	110 to 127	115
	208	204
	220 to 240	230
Output	<b>Source of Power</b>	
	<b>Regulation</b>	
	Utility power (normal range)	±8% of nominal output voltage rating (within the guidelines of the Computer Business Equipment Manufacturers Association)
	Utility power (extended range)	+10% to -15% of nominal output voltage rating (within the guidelines of the Computer Business Equipment Manufacturers Association)
	Battery power	±5% of nominal output voltage rating
Other features	<b>Feature</b>	
	<b>Specification</b>	
	On-line efficiency	96%
	Voltage wave shape	Sine wave; less than 3% distortion with linear load
	Surge suppression	High energy 6500A peak
	Noise filtering	MOVs and line filter for normal and common mode use

## Overcurrent Protection

**Table C-6**  
**Overcurrent Protection – Per Model**

UPS Model	Input Protection
T2000	Circuit breakers for each load segment
T2000j	Circuit breakers for each load segment
T2400h	Input circuit breaker No protection for load segments
T2400h-NA	Input circuit breaker No protection for load segments

## Battery Specifications

**Table C-7**  
**Battery Specifications – 2000 Series UPS Models**

Feature	Specification
Type	Sealed lead-acid; maintenance-free
Voltage	External module - 24 VDC
Charging	3 to 8 hours to full charge Less than 3 hours to 90% capacity at default nominal utility voltage and no load



## Battery Runtime

**Table C-8**  
**Estimated Battery Runtime (Minutes)**

Load (VA)	2000 Models	2400 Models
450	58	108
500	51	97
600	36	81
700	30	62
800	26	54
900	23	48
1000	20	43
1200	14	36
1400	12	24
1500	10	23
1800	8	19
2000	7	16
2200		14
2400		13

If a device list the power in Watts, use the following conversion equation:  
Volts x Amps = VA per device

If only Watts are given:  
Watts x 1.35 = VA  
VA/1000 = KVA

## Environmental Specifications

**Table C-9**  
**Environmental Specifications – 2000 Series UPS Models**

<b>Feature</b>	<b>Specification</b>
Operating temperature	0° to 40°C (32° to 104°F) UL-tested at 25°C (77°F)
Relative humidity	0% to 95%; non-condensing
Operating altitude	Up to 3000 m (10,000 ft) above sea level
Audible noise	Less than 45 dBA

# Index

## Numbers and Symbols

2000 Series UPS *See*  
Uninterruptible Power System  
2000 Series

## A

AC Input Failure  
  disabling audio alarm 4-5  
  enabling audio alarm 4-5  
AC Input LEDs  
  explained 3-5  
  meaning when UPS powered  
  up 2-10  
  troubleshooting alarm  
  conditions 6-3  
alarm *See* audio alarm  
audio alarm  
  ability to disable 3-12  
  conditions causing an  
  alarm 3-12  
  features 3-12  
  how to respond 6-3  
  silencing 3-3, 3-13  
    after utility power restored 3-13  
    requirement to address alarm  
    condition 3-13

## B

batteries  
  changing *See also* replacing  
  battery module  
  procedures 5-5  
  warning on weight 5-2  
  warning to use qualified service  
  personnel ix  
  warning to use qualified service  
  personnel 5-2  
  warnings on risk of fire or  
  burns 5-2  
  warnings on risk of personal  
  injury 5-2  
  when to change 5-3  
charging 5-3, 5-9  
maintaining  
  care and storage 5-9  
  warning on weight 5-2  
  warning to use qualified service  
  personnel ix  
  warning to use qualified service  
  personnel 5-2  
  warnings on risk of fire or  
  burns 5-2  
  warnings on risk of personal  
  injury 5-2

- new
  - recommendation against keeping spares 5-4
  - when to obtain 5-4
- recharge date *See* Battery Recharge Date label
- runtime specifications C-8
- spare part number 5-2, 5-4
- specifications C-7
- testing 5-8
- Battery Charge LEDs
  - display explained 2-10
  - explained 3-6
  - troubleshooting alarm condition 6-4
- battery module *See* external battery module
  - replacing *See* replacing battery module
- Battery Recharge Date label
  - checking the battery recharge date, illustrated 2-6
  - where to find the label 2-6
- Battery Service LED
  - explained 3-6
  - troubleshooting alarm conditions 6-2, 6-4
- C**
- Canadian Notice (Avis Canadien) A-3
- care and storage of batteries 5-9
  - ambient temperature 5-9
  - charging stored batteries 5-9
  - preventive maintenance 5-9
- CE Marking A-4
- changing batteries 5-1
- changing the UPS
  - configuration 4-2, 4-6
- charging the batteries
  - in storage 5-9
- Comm port *See* communications port
- Communication LED, explained 3-7
- communications port
  - caution on cable use 1-7
  - connecting to the host
    - computer 2-4
    - caution against using older communications cables 2-4
    - illustrated 2-5
  - features 1-7
  - overview 1-7
- Compaq 2000 Series UPS *See* Uninterruptible Power System 2000 Series
- Compaq authorized reseller xi
- Compaq Multi-Server UPS Card *See* option card
- Compaq OnliNet Centro
  - example of use 1-9
  - overview 1-7
- Compaq Power Management Software
  - capabilities 1-7
  - example of shutdown sequence 1-8
  - installation requirements 2-2
  - integration with Compaq Insight Manager 1-7
  - overview 1-7
  - using a Compaq Multi-Server UPS Card 1-8
  - using a Compaq Scalable UPS Card 1-9
- Compaq Scalable UPS Card *See* option card
- Compaq SNMP-EN Internal Adapter *See* option card
- Compaq website xi
- completing the installation
  - charging batteries 2-10
  - placing the UPS in Operate mode 2-10
- configuration
  - AC Input Failure

- disabling audio alarm 4-5
  - enabling audio alarm 4-5
- changing 4-6
- Low Battery
  - configuration parameters
    - explained 4-4
    - specifying audio alarm 4-4
  - nominal utility voltage level
    - related configuration
      - parameters 4-4
  - nominal utility voltage range
    - related configuration
      - parameters 4-4
- overview 4-1
- parameters 4-3
- Reset Defaults, restoring 4-5
- Shutdown Delay
  - enabling 3-minute 4-4
  - enabling 5-second 4-4
- Sleep mode
  - disabling 4-5
  - enabling 4-5
- warning about pressing
  - STANDBY 4-2, 4-6
- Wiring Fault audio alarm
  - disabling 4-4
  - enabling 4-4
- Configure mode
  - exiting 4-7
  - explained 3-2
  - initiating 3-3
- connecting
  - battery cables 2-3
  - devices to UPS 2-7
  - external battery module 2-3
  - Network Transient
    - Protector 2-5
  - UPS to utility power 2-7
  - UPS/computer interface
    - cable 2-4
- controls and indicators *See* front panel, indicators
- converting Watts to VA 2-7

## D

- Declaration of Conformity A-2
- disposing of used battery
  - module 5-8

## E

- environmental specifications C-9
- European Union Notice A-4
- external battery module
  - care and storage of
    - batteries 5-9
  - caution concerning arcing 2-3
  - disconnecting, illustrated 5-6
  - disposing of used module 5-8
  - features 2-3
  - installing 2-3
  - installing, illustrated 2-4
  - removing 5-6
  - testing new module 5-8

## F

- FailSafe III
  - overview 1-7
  - requirement for cabling to host
    - computer 2-4
- features
  - Compaq 2000 Series UPS 1-6
    - battery maintenance 5-1
    - communications port 1-7
  - Compaq Multi-Server UPS
    - Card 1-8
  - Compaq OnliNet Centro 1-7
  - Compaq Power Management
    - Software 1-7
  - Compaq Scalable UPS Card 1-9
  - Compaq SNMP-EN Internal
    - Adapter 1-9
  - FailSafe III 1-7
  - LanSafe III 1-7
  - Network Transient
    - Protector 1-10

- warranties 1-10
- Federal Communications
  - Commission (FCC) notice A-1
  - cables A-3
  - FCC Class A compliance A-2
  - FCC Class B compliance A-2
  - modifications to equipment A-3
- front panel
  - AC Input LEDs, explained 3-5
  - Battery Charge LEDs, explained 3-6
  - Battery Service LED, explained 3-6
  - Communication LED, explained 3-7
  - illustrated 1-3
  - indicating battery charge 5-7, 5-8
  - indicators 3-5
  - LED display and controls, illustrated 2-9
  - Load Level LEDs, explained 3-7
  - meaning of LED display in Configure mode 4-6
  - meaning of LED display in Standby and Operate modes 3-5
  - ON LED, explained 3-7
  - reading the LED display 3-5
  - Site Wiring Fault LED, explained 3-6

## G

- getting help x
- Grounding Methods B-2
- guarantee *See* warranties

## H

- hardware option card *See* option card
- help
  - additional sources x
  - Compaq authorized resellers xi
  - Compaq website xi
  - technical support telephone numbers x
- hot-swapping *See* replacing battery module
- http
  - //www.compaq.com xi

## I

- icons
  - symbols on equipment viii
-  **Important Safety Information** x, 2-2, 2-3
- indicators *See* front panel, indicators
- input specifications C-3
- installing a UPS
  - before starting the UPS 2-3
  - caution against using older communications cables 2-4
  - caution concerning arcing 2-3
  - checking the load 2-7
  - completing the installation 2-10
  - connecting the communications port 2-4
  - connecting the communications port, illustrated 2-5
  - connecting the devices 2-7
    - caution against plugging in laser printers 2-7
    - warning on earth conductor leakage current 2-7

- connecting the Network Transient Protector 2-5
  - connecting the Network Transient Protector, illustrated 2-5
  - connecting to utility power 2-7
  - installing an external battery module 2-3
  - installing an external battery module, illustrated 2-4
  - requirements 2-2
    - hardware 2-2
    - software 2-2
    - tools 2-2
  - silencing the audio alarm 2-10
  - starting the UPS
    - checking the Battery Recharge Date label 2-6
    - checking the battery recharge date, illustrated 2-6
    - for the first time 2-6
  - warning concerning grounding 2-7
  - warning concerning red LEDs 2-10
- J**
- Japanese Notice A-5
- L**
- LanSafe III
  - overview 1-7
  - requirement for cabling to host computer 2-4
- LED 01 *See* AC Input LEDs
- LED 02 *See* AC Input LEDs
- LED 03 *See* AC Input LEDs
- LED 04 *See* AC Input LEDs
- LED 05 *See* Site Wiring Fault LED
- LED 06 *See* Battery Charge LEDs
- LED 07 *See* Battery Charge LEDs
- LED 08 *See* Battery Charge LEDs
- LED 09 *See* Battery Charge LEDs
- LED 10 *See* Battery Service LED
- LED 11 *See* Load Level LEDs
- LED 12 *See* Load Level LEDs
- LED 13 *See* Load Level LEDs
- LED 14 *See* Load Level LEDs
- LED 15 *See* Communication LED
- LED 16 *See* ON LED
- LED display *See* front panel, indicators
- Load Level LEDs
  - explained 3-7
  - troubleshooting alarm condition 6-4
- Low Battery
  - configuration parameters explained 4-4
  - specifying audio alarm 4-4
- M**
- maintenance, battery 5-9
- matching, utility voltage with UPS configuration 4-7
- modes of operation *See* Standby mode, Operate mode, Configure mode, Sleep mode
- modifications to equipment *See* Federal Communications Commission (FCC) notice
- N**
- Network Transient Protector
  - connecting 2-5
  - connecting, illustrated 2-5
  - features 1-10
  - not connecting to a digital PBX 2-5
  - overview 1-10
- nominal utility voltage level

- explained 4-4
- related configuration
  - parameters 4-4
- nominal utility voltage range
  - explained 4-4
  - related configuration
    - parameters 4-4

## 0

- ON button
  - exiting Configure mode 4-7
  - initiating Configure mode 4-2, 4-6
  - selecting configuration
    - parameters 4-7
- ON LED
  - explained 3-7
  - indicating Operate mode 2-10
  - meaning when UPS powered up 2-10
- Operate mode
  - explained 3-2
  - initiating 2-10, 3-3, 3-8
    - conserving battery power 3-8
    - LED display 3-8
- operating range
  - configuring 4-7
  - matching 4-7
  - matching the utility voltage 4-9
  - supplying battery power 4-7
  - tabulated for all
    - configurations 4-10
- operating the UPS
  - modes of operation 3-2
  - warning on earth conductor leakage current 3-2
- option card
  - Compaq Multi-Server UPS Card
    - example of use 1-8
    - overview 1-8
  - Compaq Scalable UPS Card

- example of use 1-9
- overview 1-9
- Compaq SNMP-EN Internal Adapter
  - example of use 1-9
  - overview 1-9
- overview 1-8
- protecting multiple servers 1-8
- scaling up UPS
  - capabilities 1-9
- output specifications C-4
- overcurrent protection 3-8
- overview
  - battery maintenance 5-1
  - communications port 1-7
  - Compaq Multi-Server UPS Card 1-8
  - Compaq OnliNet Centro 1-7
  - Compaq Power Management Software 1-7
  - Compaq Scalable UPS Card 1-9
  - Compaq SNMP-EN Internal Adapter 1-9
  - FailSafe III 1-7
  - installation 2-1
  - LanSafe III 1-7
  - Network Transient Protector 1-10
  - operating the UPS 3-1
  - option card 1-8
  - specifications C-1
  - troubleshooting 6-1
  - UPS 1-1

## P

- PBX, caution on connecting to
  - Network Transient Protector 1-10
- physical specifications C-2
  - T2000 and T2000j C-2
  - T2400h and T2400h-NA C-2



power cord  
 cords shipped with the  
 UPS 2-2  
 requirement for additional  
 cord 2-3  
 solution for additional  
 cord 2-3  
 Power Management Software *See*  
 Compaq Power Management  
 Software  
 Power Products Documentation CD  
 viewing  
 Compaq 2000 Series UPS  
 Operation and Reference  
 Guide 2-2  
 Compaq Power Products  
 Software Reference  
 Guide 2-2  
 powering the UPS off *See*  
 STANDBY button  
 problems *See* troubleshooting

## R

range *See* operating range  
 rear panels, illustrated 1-4  
 recharge date *See* Battery  
 Recharge Date label  
 reference material  
 Compaq Power Management  
 Software Installation  
 Instructions 2-2  
 Compaq Power Products  
 Software Reference  
 Guide 2-2  
 ▲ **Important Safety Information** x,  
 2-2, 2-3  
 repairing the UPS 6-5  
 replacing battery module  
 conditions for  
 hot-swapping 5-5  
 connecting external battery  
 module, illustrated 5-7  
 disposing of used module 5-8

installing new battery  
 module 5-7  
 options 5-5  
 procedure 5-5  
 removing the external battery  
 module 5-6  
 testing new module 5-8  
 when to replace 5-3  
 with the UPS in Operate  
 mode 5-5  
 with the UPS off 5-5  
 Reset Defaults, restoring 4-5  
 RJ-45 receptacle ix  
 RS-232 port *See* communications  
 port

## S

safety precautions  
 battery handling ix  
 earth conductor leakage  
 current ix  
 ▲ **Important Safety Information** x,  
 2-2, 2-3  
 weight x  
 when using the UPS 3-2  
 self-test  
 initiating *See* TEST/ALARM  
 RESET button  
 meaning of LED display 3-11  
 serial port *See* communications  
 port  
 Shutdown Delay, selecting 4-4  
 shutdown sequence  
 specifying 1-8  
 Site Wiring Fault LED  
 explained 3-6  
 function disabled for 208V  
 configuration 6-2  
 troubleshooting alarm  
 condition 6-2  
 Sleep mode  
 disabling 4-5  
 enabling 4-5

- explained 3-3
- specifications
  - battery C-7
  - battery runtime C-8
  - environmental C-9
  - input C-3
  - output C-4
  - overcurrent protection C-6
  - overview C-1
  - physical C-2
- STANDBY button
  - powering the UPS off 3-9, 5-5
  - warning concerning use in Configure mode 4-2, 4-6
- Standby mode
  - automatically maintaining battery charge 3-10
  - exiting from 3-10
  - explained 3-2
  - initiating 3-3
  - returning to, from Operate mode 3-9
- starting the UPS for the first time 2-6
- switching the UPS off *See* STANDBY button
- symbols in text viii
- symbols on equipment viii
- system administrator
  - specifying the shutdown sequence 1-8
  - using Compaq Power Management Software 1-7

## T

- technical support x
- telephone numbers xi
- TEST/ALARM RESET button
  - exiting Configure mode 4-7
  - initiating a self-test 3-11
  - initiating Configure mode 4-2, 4-6

- testing new battery module 5-8
- tooggling a configuration parameter 4-6
- testing
  - initiating a self-test 3-11
  - new battery modules 5-8
- text conventions vii
- troubleshooting
  - after start 6-3
  - during start 6-2

## U

- Uninterruptible Power System 2000 Series
  - connecting UPS/computer interface cable 2-4
  - features 1-6
  - front panel 1-3
  - front panel,illustrated 1-3
  - items not supplied with the UPS kit 2-2
  - items supplied with the UPS kit 2-2
  - models 1-2
  - rear panels 1-4
- updating the UPS configuration 4-2, 4-6
- utility voltage
  - configuring the UPS to match 4-9
  - matching with UPS configuration 4-7
  - monitored by qualified electrician 4-9
- utility voltage range *See* operating range

## V

- VCCI Notice for Japan A-5
- voltage level, nominal,
  - configuring 4-4
- voltage range, nominal,
  - configuring 4-4

## W

- warning
  - battery handling ix
  - electrical shock ix
  - high earth conductor leakage current ix
  - weight x
- warranties
  - \$25,000 Computer Load Protection Guarantee 1-10
  - applicability 1-10
  - limited warranty 1-10
  - pre-failure battery 1-10, 5-4
  - qualifying 1-10
  - three-year limited 1-10
- Wiring Fault
  - audio alarm disable 4-4
  - audio alarm enable 4-4
- www.compaq.com x

## Free Manuals Download Website

<http://myh66.com>

<http://usermanuals.us>

<http://www.somanuals.com>

<http://www.4manuals.cc>

<http://www.manual-lib.com>

<http://www.404manual.com>

<http://www.luxmanual.com>

<http://aubethermostatmanual.com>

Golf course search by state

<http://golfingnear.com>

Email search by domain

<http://emailbydomain.com>

Auto manuals search

<http://auto.somanuals.com>

TV manuals search

<http://tv.somanuals.com>