

Document Centre C400/320 Series

One Point Guide

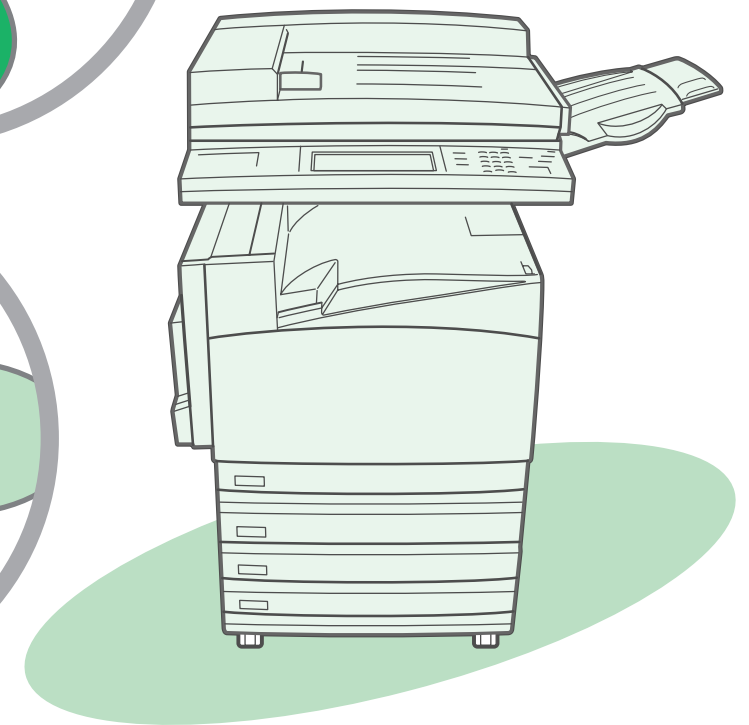

THE DOCUMENT COMPANY
FUJI XEROX

Removing Paper Jam

See "4.5 Paper Jams" in "Part 1 Hardware" of the User Guide (Copier).

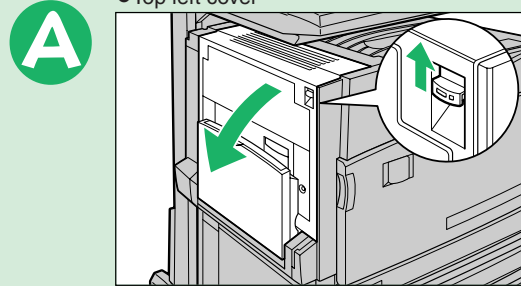

●Top left cover

Gently open the top left cover while lifting up the release lever.

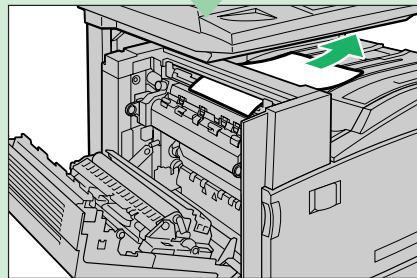

If the edge of the jammed paper can be reached at the output tray, pull the jammed paper in the direction of the feed-out area.

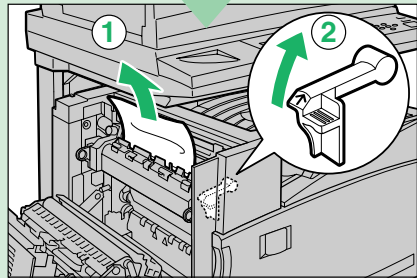

If you cannot remove jammed paper inside the fuser unit, lift up the lever and remove the jammed paper.

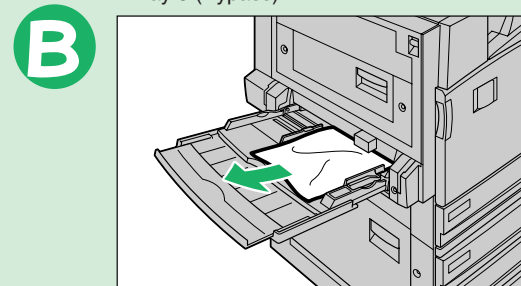

●Tray 5 (Bypass)

Inspect the inside (paper feed entrance) of Tray 5 (Bypass), and remove any jammed paper.

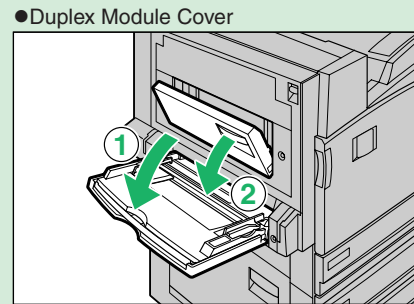

●Duplex Module Cover

Open the Tray 5 (Bypass) and gently open the duplex module cover.

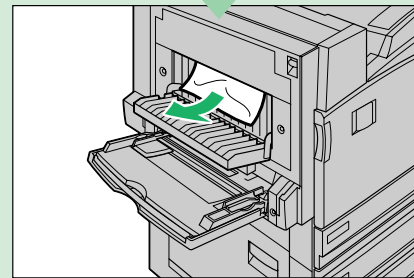

Remove the jammed paper.

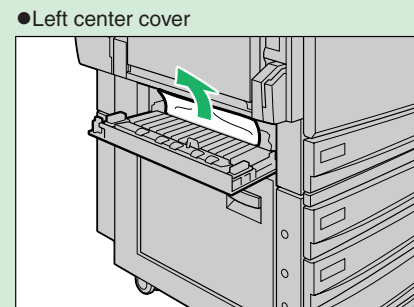

●Left center cover

Remove the jammed paper.

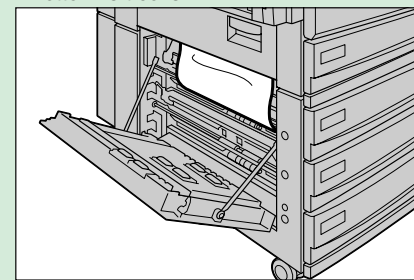

●Bottom left cover

Remove the jammed paper.

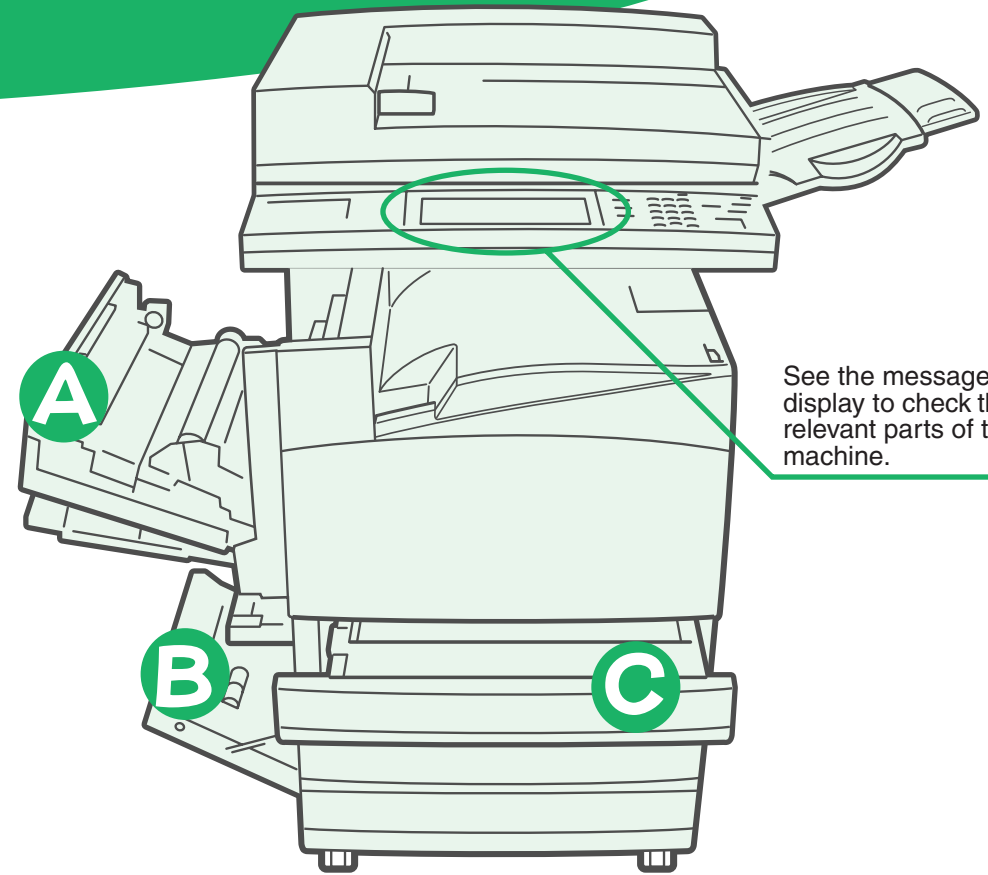

See the message on the display to check the relevant parts of the machine.

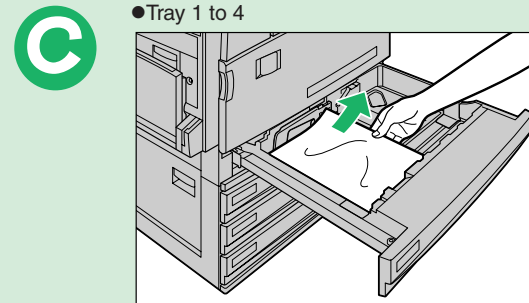

●Tray 1 to 4

Remove the jammed paper.

Loading Documents

See "Chapter 1 Loading Documents" in "Part 2 Copier" of the User Guide (Copier).

Load documents into the Document Feeder.

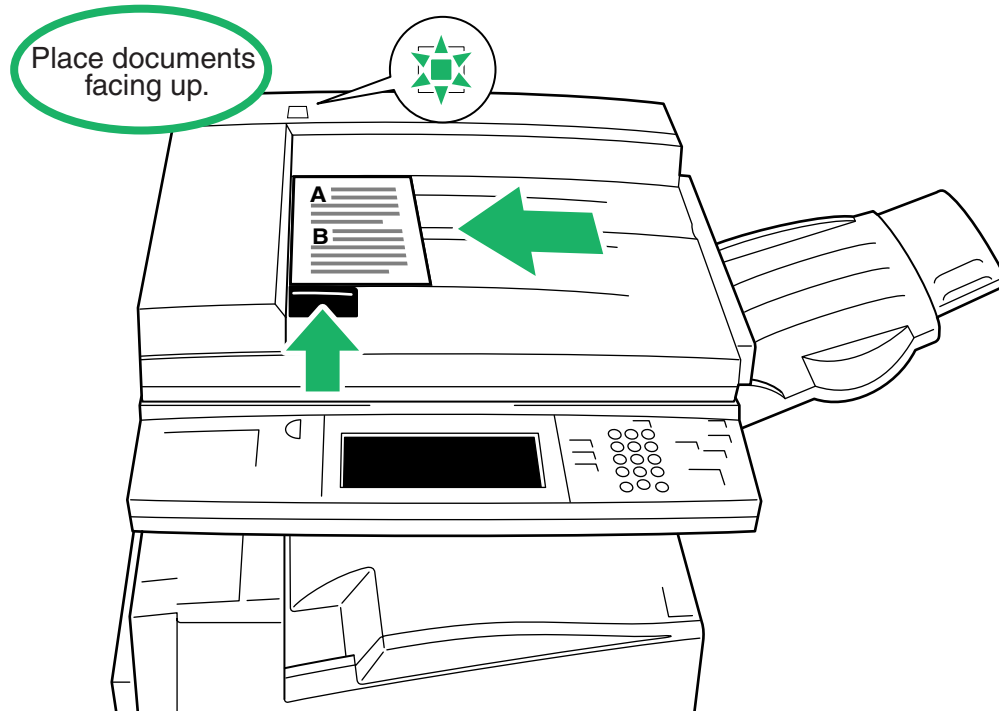

About Original Orientation when Loading Documents

If you copy using the function, such as "Margin Shift", which needs to set the top, bottom, left and right positions of documents correctly, specify the orientation of the original by using Original Orientation button.

Load the documents in Head to Top Orientation.

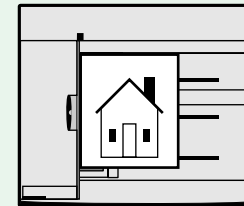

Loading documents on the Document Feeder.

Load the documents in Head to Left Orientation.

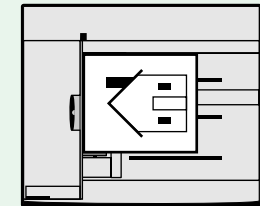

Loading documents on the Document Feeder.

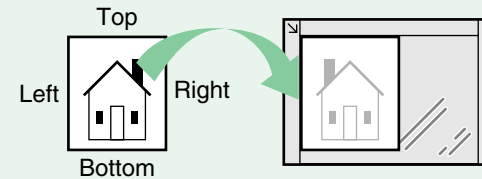

Placing Documents on the Document Glass.

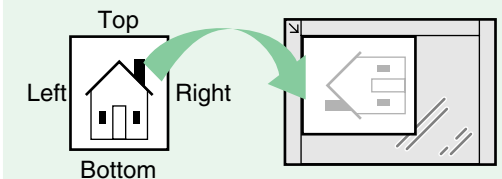

Placing Documents on the Document Glass.

Placing documents (such as B4, A3) in the Document Feeder

Placing Documents on the Document Glass

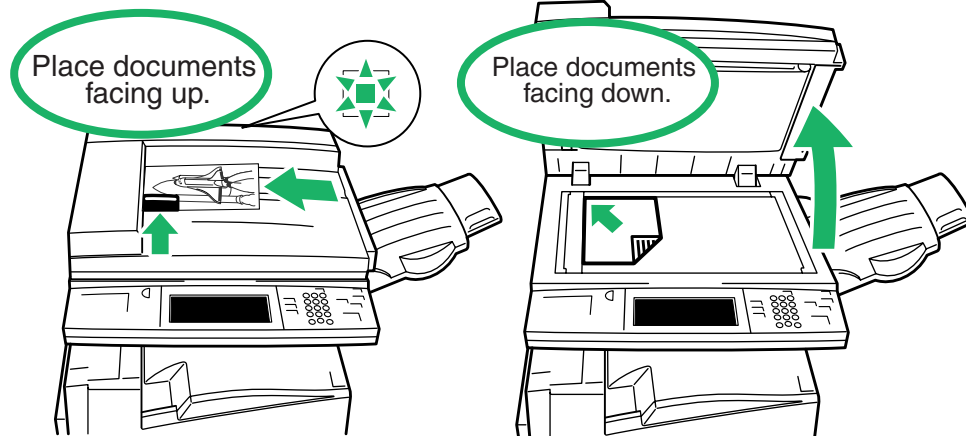

Loading Paper

See "Chapter 2 Loading Paper" in "Part 1 Hardware" of the User Guide (Copier).

●Tray 5 (Bypass)

When loading paper onto the Tray 5 (Bypass), insert the paper with the copy side facing down.

Transparency

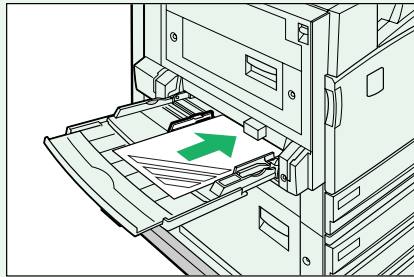

Heavyweight paper

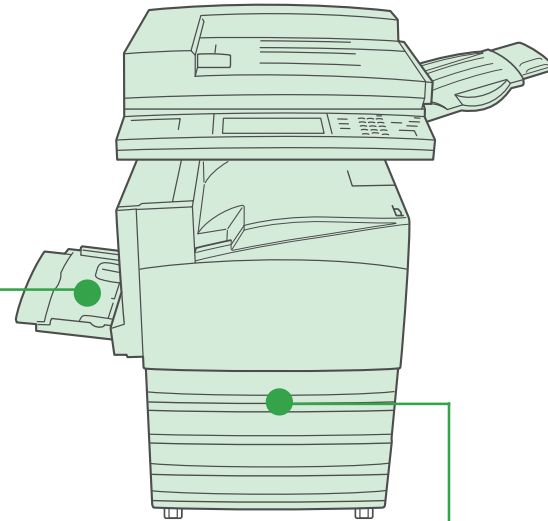
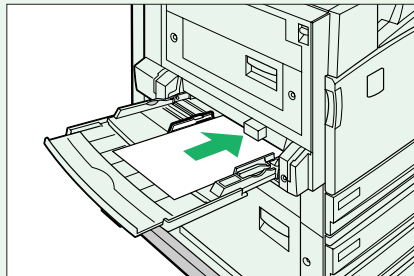

●Trays 1, 2, 3, 4

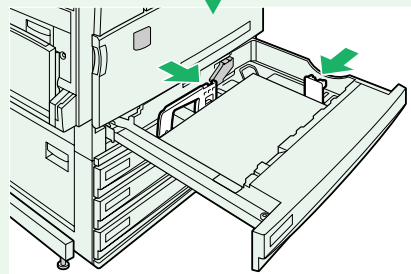
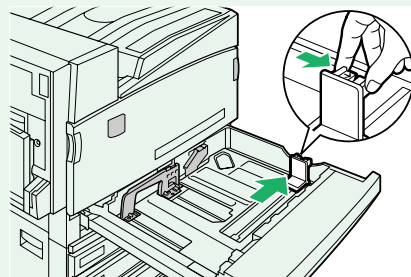

Note If you change the type of paper to be loaded in trays, set the paper type on the Control panel. See "Setting the Paper Type" (P. 8) for details.

Papers that can be / cannot be loaded in Tray 5 (Bypass)

●Transparency

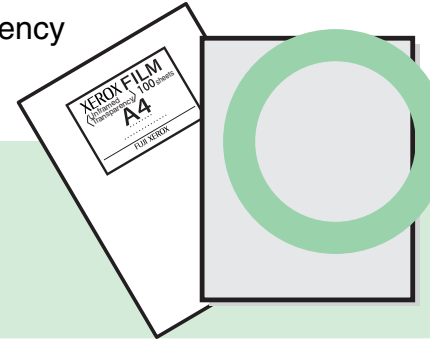

Black and white/Unframed transparencies

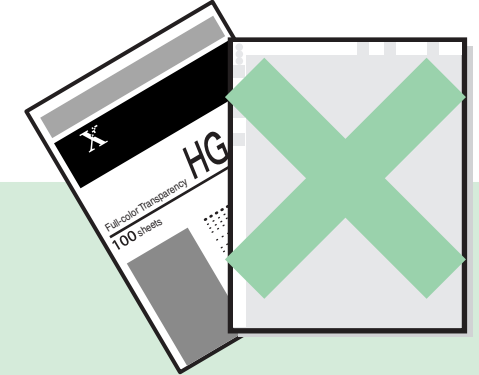

Full-color transparencies (with white frame)

●Label paper



Single-label type

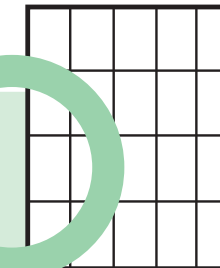

20-label type



Paper base not entirely covered with labels

●Other Paper

Already printed or copied paper

Inkjet exclusive paper

Setting the Paper Type

See "2.3 Changing Paper Settings" in "Part 1 Hardware" of the User Guide (Copier).

1

Press  on the Control Panel.

If the Password Entry screen is displayed, enter the password and select Confirm. And then, select **System Settings**.

2

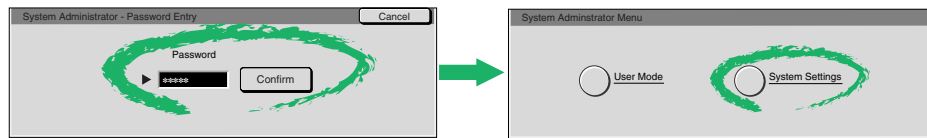

 **Note** If the Password Entry screen is not displayed, proceed to Step 3.

3

Select **System Settings**.



4

Select **Common Settings**.

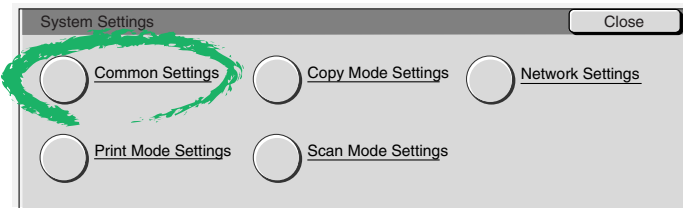

5

Select **Paper Tray Attributes**.

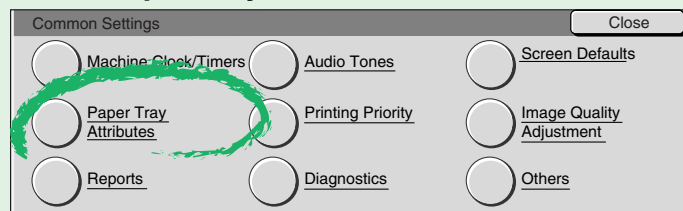

6

Select **Paper Type**.

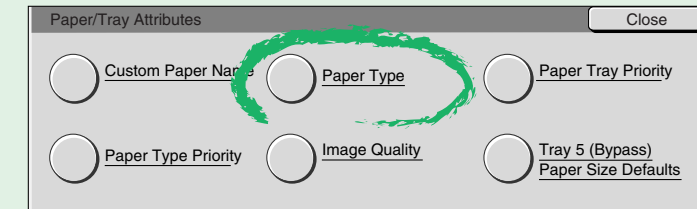

7

Select the paper tray whose paper type setting is to be changed at Items, and select **Change Settings**.

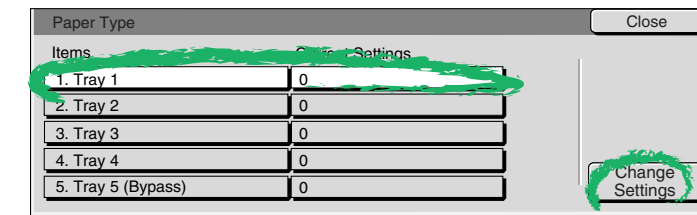

8

Enter the setting value of the paper type to be changed using Numeric Keypad, and select **Save**.

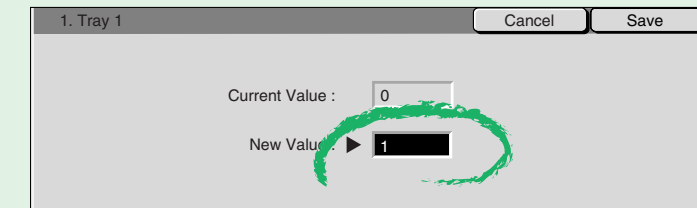

 **See** See "5.4.4 Setting Paper Tray Attributes" in "Part 1 Hardware" of the User Guide (Copier) for details on value of paper type.

9

Select Close repeatedly until the System Settings screen is displayed, and then select **Exit**.

This exits the System Administration Mode.

Changing Screens

See "1.1 Main Components and Their Functions" in "Part 1 Hardware" of the User Guide (Copier).

Note How these features buttons are displayed differs according to which optional accessories are installed.

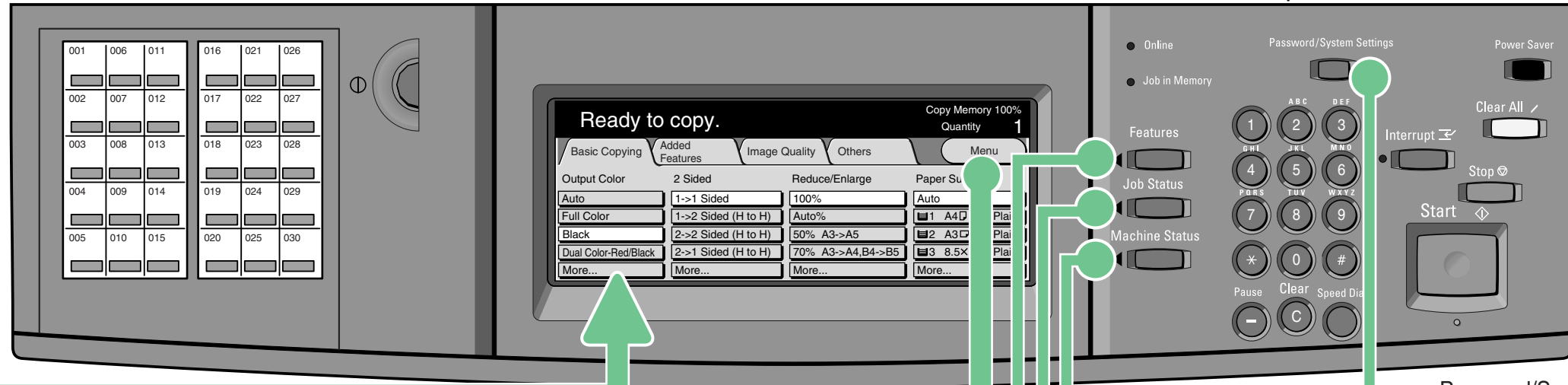

Changing to the Menu screen.

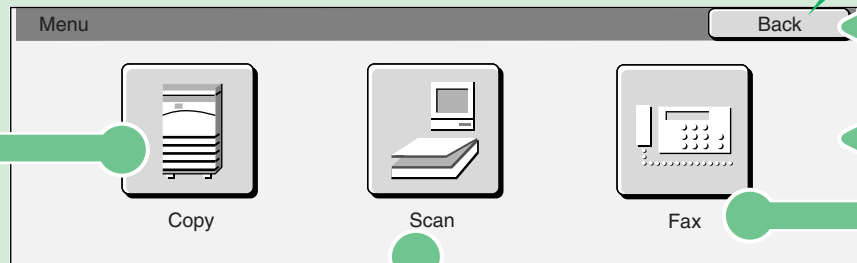

This button is to return to the screen that is displayed when you select the Menu button.

Machine Status

You can check machine status, meters, consumables and print reports.

Job Status

You can check Job status such as Secure Print.

Features

You can operate copy, scanner and facsimile.

Password/System Settings

The Password Entry screen is displayed to enter the System Administration Mode.

See "1.4 Using the Touch Panel Display" of the User Guide (Facsimile) for details on the Fax screen.

Changing to the Scan screen.

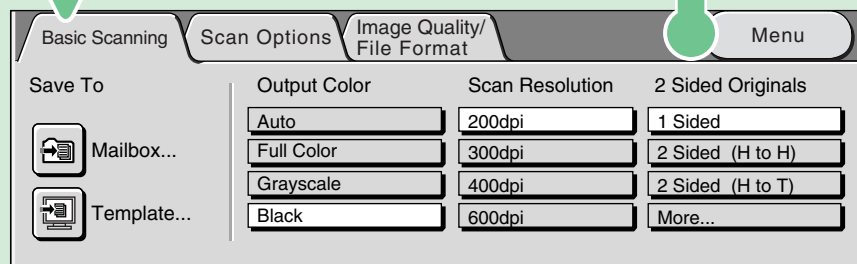

Changing to the Fax screen.

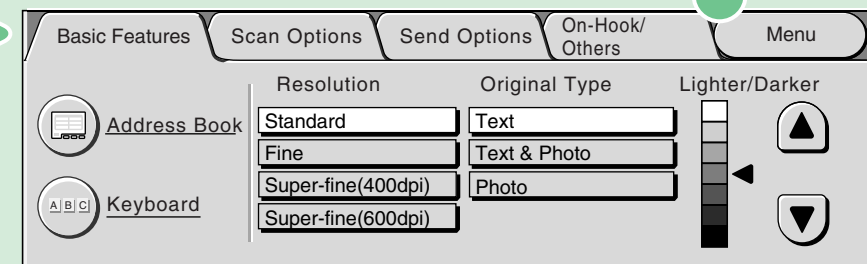

Getting know the Features

See "Chapter 3 User Friendly Features" in "Part 2 Copier" of the User Guide (Copier).

Note Reference number (Example: 3.2, 3.3, etc.,) represents the heading number of "Chapter 3 User Friendly Features" in "Part 2 Copier" of the User Guide (Copier).

Basic Copying screen

The screenshot shows the Basic Copying screen with four callout boxes:

- Output Color:** Selecting the color to copy. See 3.2
- 2 Sided:** Making Onesided/Two-sided copies. See 3.3
- Reduce/Enlarge:** Making enlarged/reduced copies. See 3.4
- Paper Supply:** Selecting paper (trays). See 3.5

Added Features screen

The screenshot shows the Added Features screen with nine callout boxes:

- Output:** Copies can be outputted collated, stacked, or stapled. See 3.6, 3.7
- Original Size:** Scanning non-standard size documents to copy. See 3.10
- Multiple Up:** Two or four document sheets can be copied together onto a single sheet of paper. See 3.13
- Margin Shift:** Copying with the position of the image in the document shifted. See 3.8
- Mixed Size Originals:** Simultaneously scanning different size documents. See 3.11
- Separators:** Printing with a blank sheet inserted as a transparency separator between transparencies. See 3.14
- Border Erase:** Erasing black shadows that appear in the paper when copying. See 3.9
- Bound Originals:** Copying facing papers of a document in page order. See 3.12
- Image Rotation:** Copying with the document image automatically rotated so that the orientation of the document matches that of the paper. See 3.15

Image Quality screen

The screenshot shows the Image Quality screen with seven callout boxes:

- Original Type:** Copies can be made at the image quality corresponding to each type of document. See 3.16
- Sharpness/Saturation:** The contours and brightness of images can be adjusted. See 3.19
- Image Quality Presets:** Copies can be made at a quality appropriate for the image of documents. See 3.22
- Auto Exposure:** Copies can be made with the background color of the document such as newspapers. See 3.17
- Color Shift:** The tone of document can be adjusted. See 3.20
- Light/Dark/Contrast:** The color density and contrast can be adjusted. See 3.18
- Color Balance:** The strength of the four colors (yellow, magenta, cyan, and black) can be adjusted for each density level. See 3.21

Others screen

The screenshot shows the Others screen with nine callout boxes:

- Covers:** Make copies with a cover on different type of paper of the document. See 3.23
- Repeat Image:** The image of a document on one sheet of paper can be copied repeatedly for the specified number of times. See 3.26
- Stored Jobs:** Frequently used job setups can be stored to job memory and called up by a single button operation. See 3.29
- Booklet Creation:** Copies can be made in a way such that paper can be folded along the center and made into a booklet. See 3.24
- Poster:** An enlarged copy of a document can be made spread over multiple sheets. See 3.27
- Build Job:** Documents with different settings can be copied in a single operation. See 3.30
- Book Duplex:** Copies can be made with pages assigned so that they are in the same facing state as the books. See 3.25
- Mirror/Negative Image:** Copies can be made with the left and right sides of the document image reversed or the colors of the document reversed in the color mode. See 3.28
- Original Orientation:** The Original Orientation is set to instruct the top of the document. See 3.31

Note How these feature buttons are displayed differs according to which optional accessories are installed.

Replacing Toner Cartridges



See "3.2.3 Replacing Toner Cartridges" in "Part 1 Hardware" of the User Guide (Copier).

1

Make sure that the machine has stopped before opening the front cover.

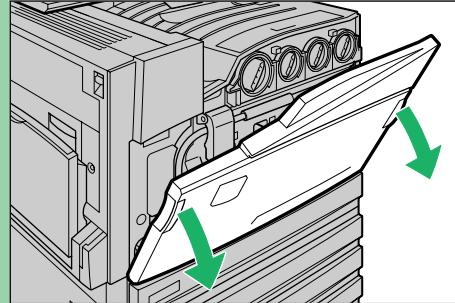

2

Turn the toner cartridge of the color indicated in the message to the left up to the key mark (open).

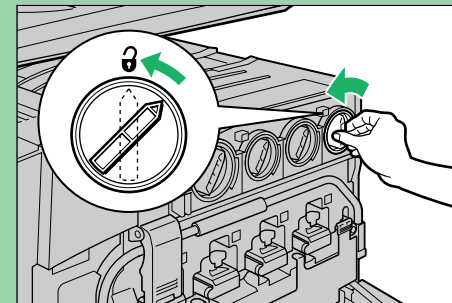

Note "Y" stands for Yellow, "M" for Magenta, "C" for Cyan, and "K" for Black.

3

Gently pull the toner cartridge towards you to remove.

Warnings Do not throw toner cartridges into an open fire. Toner remaining in the cartridge can cause an explosion and you can get burnt.

- Note**
- Pull out toner cartridges gently. Otherwise, toner may fly out of the cartridges.
 - Return used toner cartridges to our Customer Support Center for disposal.

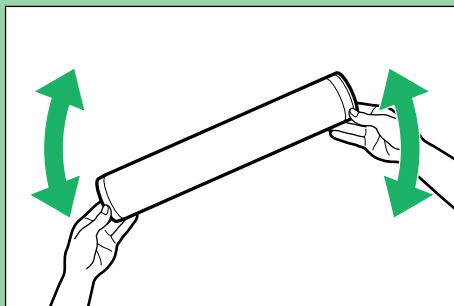
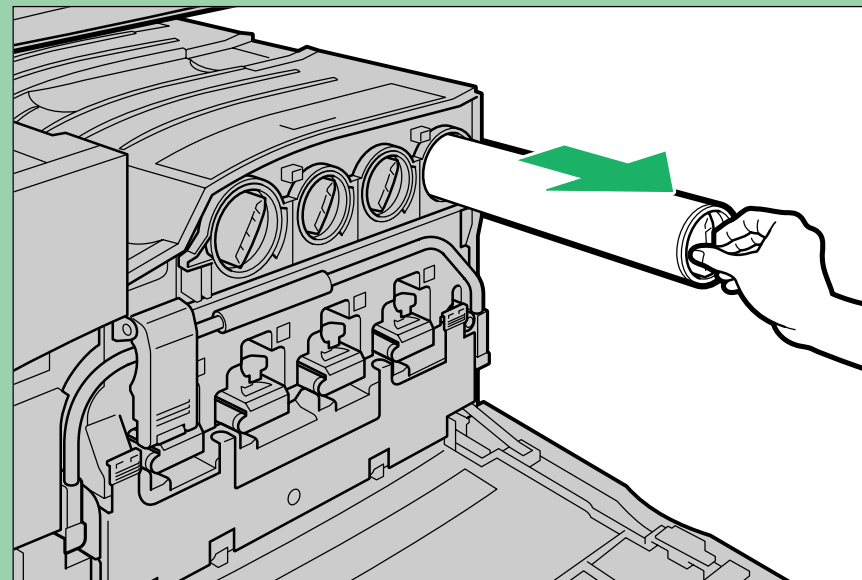

4

Lightly shake the new toner cartridge three or four times up and down to the left and right.

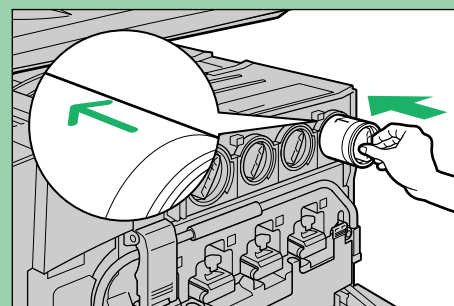

5

Insert the toner cartridge as far as possible with the arrow (↑) on the cartridge facing up.

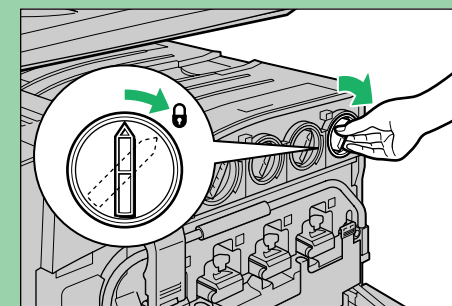

6

Turn the toner cartridge to the right up to the key (closed).

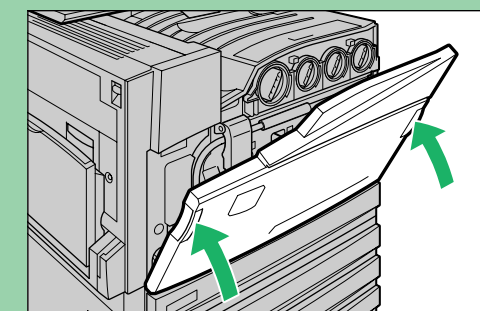

7

Close the front door.

Note A message will be displayed and the machine will not operate if the front cover is even slightly open.

Copy Ratio Quick Reference Matrix

Making Copies by Selecting a Specified Size/Ratio (Standard Scaling Ratios)

Ratio (%)	Paper Size
141	A 4 → A 3 / B 5 → B 4
122	A 4 → B 4 / A 5 → B 5
115	B 4 → A 3 / B 5 → A 4
86	A 3 → B 4 / A 4 → B 5
81	B 4 → A 4 / B 5 → A 5
70	A 3 → A 4 / B 4 → B 5
50	A 3 → A 5

Making Copies by Selecting a Variable Ratio (Zoom)

Copy Document	A5	B5	A4	B4	A3
A 6	141%	173%	200%	245%	282%
B 6	115%	141%	163%	200%	231%
A 5	100%	122%	141%	173%	200%
B 5	81%	100%	115%	141%	163%
A 4	70%	86%	100%	122%	141%
B 4	58%	70%	81%	100%	115%
A 3	50%	61%	70%	86%	100%

This Guide describes as the example where an optional Offset Catch Tray is installed.

Free Manuals Download Website

<http://myh66.com>

<http://usermanuals.us>

<http://www.somanuals.com>

<http://www.4manuals.cc>

<http://www.manual-lib.com>

<http://www.404manual.com>

<http://www.luxmanual.com>

<http://aubethermostatmanual.com>

Golf course search by state

<http://golfingnear.com>

Email search by domain

<http://emailbydomain.com>

Auto manuals search

<http://auto.somanuals.com>

TV manuals search

<http://tv.somanuals.com>